



WORLD



RADIO



TENTH



ANNIVERSARY



NUMBER





A harmonium player of Leicester,
 When the zest of Schweppes Tonic
 possessed her,

Used to stand up and beat
 On the keys with her feet
 Till the Vicar and Sidesmen
 suppressed her.

Schweppes
 TONIC WATER

- does you Good

**The essential link in
 Short-wave listening
 —Your Headphones**



—they simply must be

Ericsson

A short-wave set, however good, with poor 'phones is like a man with one ear. You simply cannot pull in the distant stations on any wavelength at decent strength, and short waves are tricky things.

So hook up Ericsson Telephones on your present set you'll be pleasantly surprised at the wonderful difference they make. Their sensitivity is positively uncanny.

Three resistances—
 one price
 120, 2,000 and
 4,000 ohms.

12'6

Sturdily built to stand up to the hardest wear, they retain their sensitivity, and rest very comfortably on the head over long spells. Buy a pair today and try for yourself.

At all good radio dealers. If you have any difficulty in procuring, write direct to:—

ERICSSON TELEPHONES, Ltd.
 67-73 Kingsway, London, W.C.2, Eng.
 Telephones: 3271/3 Holborn.

Ericsson

**BRITISH
 SUPERSENSITIVE
 HEADPHONES**

Memories

recalled by the tenth anniversary of the appearance of
World-Radio by *A. R. BURROWS, Director, International Broadcasting Office, Geneva*

WORLD-RADIO, I am agreeably surprised to learn, is just completing ten years of life. It has performed good service in the interest of broadcasting by recording in considerable detail not merely the progress of the art in Great Britain but that made also in other countries. WORLD-RADIO, by placing on record the achievements of broadcasters and the ideas of listeners in many parts of the world, has accomplished a work of even greater value than is at once apparent.

In sending congratulations to WORLD-RADIO on the tenth anniversary of its birthday, a whole series of events are reconstructed rapidly in my mind. Some relate to 1925 (the natal year alike of WORLD-RADIO and the International Broadcasting Union); others to years, but slightly more distant, when the voice of man and the stirring music of great orchestras could be heard, faithfully, over a radius of a few yards only.

Broadcasting, unlike many other applications of science, was not developed secretly in some obscure laboratory and launched suddenly upon a gasping world. It was the outcome of years of experiments in wireless telephony, which experiments were followed by quite a number of people.

The reception of wireless time signals and weather forecasts from telegraphic stations abroad, notably in France and Germany, was already before the War a hobby of young folk with a scientific bent. The "Pips" and "Squeaks" of Poldhu, Nauen, and the *Tour Eiffel* were as keenly sought for in certain circles as the direct short-wave broadcasts to-day from Australia and Japan. But they were "Pips" and "Squeaks" only. They indicated, it is true, the exact time, and foretold (to those who could read morse) the trouble ahead through the antics of an "anticyclone" off Iceland; but of speech and music there was none. To misquote Shakespeare, "The isle was full of noises," but the sounds and sweet airs that were to give delight had yet to hum about one's ears.

In 1912 there was excitement among the wireless amateurs of the Midlands. Several avowed, in all sobriety, that they had heard voices addressing them through their headphones. They were not mistaken.

Whether these voices would have become rapidly more numerous and more clear—not the War burst upon the world in these early days of wireless telephony—must be a matter for speculation. Many believe that the requirements of modern warfare gave an impetus to this form of scientific research. What happened between 1914 and 1919 is still in some respects a State secret. The day War was declared, the receiving sets in all belligerent



(Photo: Gulliland)

Mr. A. R. Burrows pointing out League personalities to Mr. Vernon Bartlett, who was about to broadcast a commentary

countries were "rounded up" by the Post Office authorities, and the possessor of a sparking coil or any apparatus that might be used directly or indirectly for the transmission or reception of wireless signals was the object of close vigilance. So it came about that the first trans-Atlantic telephonic message (from Arlington, U.S.A. to the Eiffel Tower, in October, 1916) was heard by a few privileged persons only.

When the wireless sets came home again from "cold storage" at the G.P.O. they were soon made obsolete by the appearance of the "valve" as a sensitive detector of signals. The "valve" transformed the whole business of wireless reception although the "crystal" detector still has its champions. The "valve" brought into the home of the energetic experimenter frequent examples of wireless speech and music. Some came from "professionals" constructing and testing commercial wireless telephone stations; others came from amateurs. I can still hear the repeated appeal, "How's this, old man?" and "Over"—the latter being the "cue" for the answer from the co-experimenter.

How many, I imagine, realise that the first extensive order for wireless telephones (one for 200 transmitters) was given by China, even before the days of broadcasting?

It was in 1919 that wireless telephony became really interesting to eavesdroppers in Great Britain. Chelmsford was building up experience which was to result in the next year in a number of epoch-making broadcasting experiments—the Melba concert, the North Atlantic broadcasts from the *Victorian* and a series of tests upon the possibility of news distribution in Great Britain from the London offices of the Press Association to the leading provincial dailies. Somewhere among my treasures is a letter from Melba giving her impressions of her first broadcast. To-night I have looked out a photograph of the wireless telephone transmitter of the C.P.O.S *Victorian* by means of which rather ragtime concerts were given in mid-ocean in July, 1920. It would be unwise to talk of the "quality" of those early transmissions but I can vouch for the speech having proved understandable and the "music" having provoked "encores" from wireless operators on ships 800 miles away.

By 1925, broadcasting had taken a definite form. It had gained public attention in many countries and was already forcing its way to recognition as a public service of first importance. WORLD-RADIO's appearance indicated an appreciation in Great Britain, as far back as 1925, of the international public interest in broadcasting.

I have interrupted the writing of these notes to listen to a relay by Droitwich, from Italy, of a programme of military-band music by the Banda del Corpo Agenti di Pubblica Sicurezza which, I am sure, must have given great pleasure to lovers of martial airs. I am living roughly midway between London and Rome, and out of curiosity rapidly switched over my receiver on several occasions from the Droitwich to the Rome transmissions of the same programme. It was astonishing how little was the difference in quality between the Rome and Droitwich versions, despite the employment of approximately 1,200 miles of international telephonic circuit.

Earlier this week I had the curiosity to examine the first Bulletin sent out by the International Broadcasting Office to its members. It is a simple, duplicated document, dated August 8, 1925, and therefore was almost contemporaneous with the first number of WORLD-RADIO. The text of one of the items seems worthy of reproduction to-day. It records that on August 6, 1925, the Zürich broadcasting company made an interesting experiment in the relay of a programme from Munich to Zürich. Two telephone lines were employed *which were almost free from foreign noises*. The Zürich

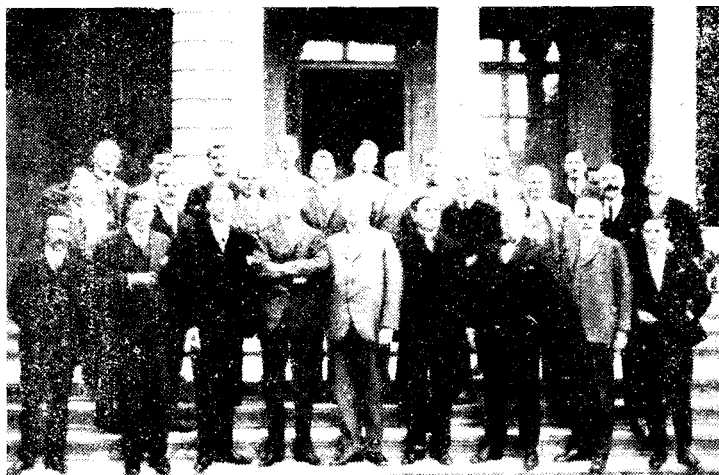

Members of the first conference at Geneva, in 1925, of the International Broadcasting Union

transmission was as clear as if the programme had been of local origin... The paragraph concludes by announcing that a similar experiment is to be made in the reverse direction!

Such was the state of affairs when WORLD-RADIO appeared ten years ago to interest listeners in broadcasting abroad and to place on record what is being said and done in the world of broadcasting. The ten years have been truly ten years of great progress. We begin the next ten years with promises of television!

Ten Years of Long-Distance Work

By "THE SEARCHER"

THIS week WORLD-RADIO celebrates its tenth birthday. Well do I remember the appearance of the first number, though the paper originated not as WORLD-RADIO but as the *Radio Supplement*. To long-distance enthusiasts, of whom I was even then one of many years' standing, it came as a boon and a blessing, for previously it had been a matter of the utmost difficulty to discover any particulars of the programmes of Continental stations. It is rather interesting to note that in 1925 many important people in the world of wireless were inclined to pour scorn upon the fascinating hobby of long-distance reception. I have before me as I write a cutting of that period which classes DX work as a mere passing craze, and predicts that within a year or two listeners, having achieved a measure of sanity, will have settled down contentedly to the programmes of their local station! When WORLD-RADIO was first seen on bookstalls it was freely prophesied that its life would be a very short one. This proved to be correct, though not in a way anticipated by its authors—the *Radio Supplement* ceased to exist as such, and within a few months became WORLD-RADIO. The new title indicated the wider scope of the paper.

I must be one of the very few writers who have contributed regularly to the publication since its pre-WORLD-RADIO days. It was in April, 1926, that I called on the Editor and suggested to him a weekly feature to be called "Stations Worth Trying For." The first article under this title appeared in the middle of the aforementioned month, and the feature, though the title was subsequently changed to "Last Week's Log," continued until the make-up was entirely changed only a month or two ago. At first I conducted it every week, but later on I alternated with a colleague, "Northerner," who, as his pen-name implied, wrote of long-distance reception in the north of England, whilst I recorded what I had heard in one of the home counties.

The change that has come over long-distance work during the nine years in which it was my privilege to report for WORLD-RADIO readers is simply astonishing. Until comparatively recently, for instance, all of the sets that I used were home-made. I should estimate that ninety per cent. of the long-distance work undertaken prior to about 1931 was done with the aid of home-built receivers. The kind of set that was then looked upon as the last word in efficiency was a "straight" containing four or five valves. The 4-valve set had, as a rule, two high-frequency stages and one L.F. stage; in the 5-valve set a second low-frequency stage was to be found, though there was generally some means of putting it out of action when the signal strength of certain stations made it unnecessary. My first superheterodyne, installed only about five years ago, had seven valves, and would have cost about £10 per valve to buy if bought ready-made. To-day good superhets with all kinds of refinements, some of which were then undreamt of—automatic volume control, tone control, band-pass tuning, and so on—can be purchased for a little more than £2 per valve. There was no such thing as an all-wave set. If my fellow-searchers and I wished to indulge in short-wave reception we had to build special sets for the purpose; and queer, cranky things they were. You might have to use four or five sets of coils to cover the entire short-wave band, and body-capacity effects were so much in evidence that it used to be said you could change from PCJ to 2XAF (it hadn't a W in those days), by the simple process of crossing your knees.

When I first began to write "Stations Worth Trying For" few transmitters in Europe had a power output exceeding 2 kilowatts. Those which boasted from 15 to 25 were regarded as giants. Curiously enough, it was far easier in the days of low power to hear the smaller stations than it is now. Anyone who cares to turn back into the "ancient" files of WORLD-RADIO will discover that I used regularly to report reception of the ¼-kilowatt Swedish relays. Nürnberg, then as now a 2-kilowatt station, was at one time the most strongly received of European transmitters.

Another interesting point is the way in which numerous stations were received with overpowering strength when they first came into action, and then gradually dwindled into something quite feeble. Perhaps the most outstanding instance is Motala. When the 30-kilowatt transmitter first took over the long-wave programme service it was far stronger in my home than was the old Daventry 5XX, though the latter was but forty-five miles away in a straight line. To-day Motala, though using 150 kilowatts, is by no means an easy station to receive with respectable quality and volume.

I could give many other instances. Suffice it to mention Radio Iberia, Madrid, the old Vienna station, the original 18-kilowatt Budapest transmitter, and the 8-kilowatt Hilversum then operating on about 1,070 metres.

Truly there have been vast changes. When WORLD-RADIO was a lusty infant it took an expert to tune in distant stations and to "work them up" to good volume. To-day the veriest beginner using a good commercial set has the greater part of Europe at his command. No feats of hair's-breadth tuning are necessary. To adapt an old saying, "You turns your tuning knob and takes your choice."

Far from being a passing craze, long-distance wireless reception is now indulged in by nearly every owner of a receiving set. In the near future I expect to see the all-wave set becoming the standard household receiving appliance. When this comes to pass the world will indeed be the oyster, not just of the skilled wireless enthusiast, but of the man and the woman in the street.



U.S.A.: an early microphone in use by WJZ, Newark, N.J.

World-Radio Events: 1925-1935

A Note on the Illustrations on adjoining Page

WHAT might be termed dimensional achievements have a fascination for our age. Adventurous men who fly the highest, descend the lowest, stay in the air longest, compel our interest, particularly when their daring serves science.

M. Auguste Piccard, as a pioneer of the stratosphere, and Mr. William Beebe, pursuing knowledge in the opposite direction in his bathosphere—each has a logical place, from this point of view, in the sort of visual reminiscence of the past eventful decade of radio that is here presented.

Sir Malcolm Campbell, making a new speed record in his *Blue Bird* at Daytona Beach, has a similar obvious claim for inclusion. Certain other items need a word of explanation, although it is hoped our readers may find it stimulating to wander at leisure among the artist's visualisations, and interpret things somewhat for themselves.

For example, the sinister, dark doorway is that of the Ravag Building in Vienna, scene of the most extraordinary occurrence of its kind since radio developed into an agency of national and international importance—the attempt in July of last year to capture the Austrian broadcasting headquarters.

Technically, as to the broadcasting methods employed, as well as in its broad significance, the inauguration of President Roosevelt stands out, and the use of radio in forming or influencing public opinion on the subject of the New Deal is illustrated by the inclusion of the twin arch-critics of the American administration—Father Coughlin and Senator Huey Long.

A Reminder of Headphone Days

In these days when explorers—as with Byrd in the Antarctic—are almost elaborately linked with home and actually listen to specially-prepared New York programmes of musical entertainment, the view shown of the MacMillan expedition is a reminder of the relatively primitive conditions of a decade ago, when headphones were used in reception.

The picturesque figure of a Papal Guard typifies the notable broadcasts which have gone out from the Vatican short-wave station. And so on; the reader will discover for himself similar suggestive reminders. The Italian dirigible *Norge* flies Pole-ward, passing on its way (for such are the privileges permitted the artist's brush!) Radio City. The bell that hangs beneath the sketch of Broadcasting House, and beneath the tiny "candle-snuffer" steeple of All Souls' Church, Langham Place, London, is the Bell of Bethlehem, which sounded a Christmas greeting to the nations. Contrasting with transmissions of years ago is an event which took place only this month—the broadcasts from Vesuvius.

H.M. the King placing a memorial tribute of flowers at the Cenotaph; a Test Match; aircraft in impressive force reviewed at Hendon; the lyre-bird broadcast from Australia; the group of typical Indian villagers listening at a community loudspeaker; all these are significant of the great network of common interest that broadcasting increasingly uses to link the Empire. It is as regrettable as it is inevitable that there should be space for only a few among the hundreds of events that during the past decade have linked British listeners throughout the world.

Finally, to avoid a possible mystery, the white border symbols are simply the words "World Radio" in morse.

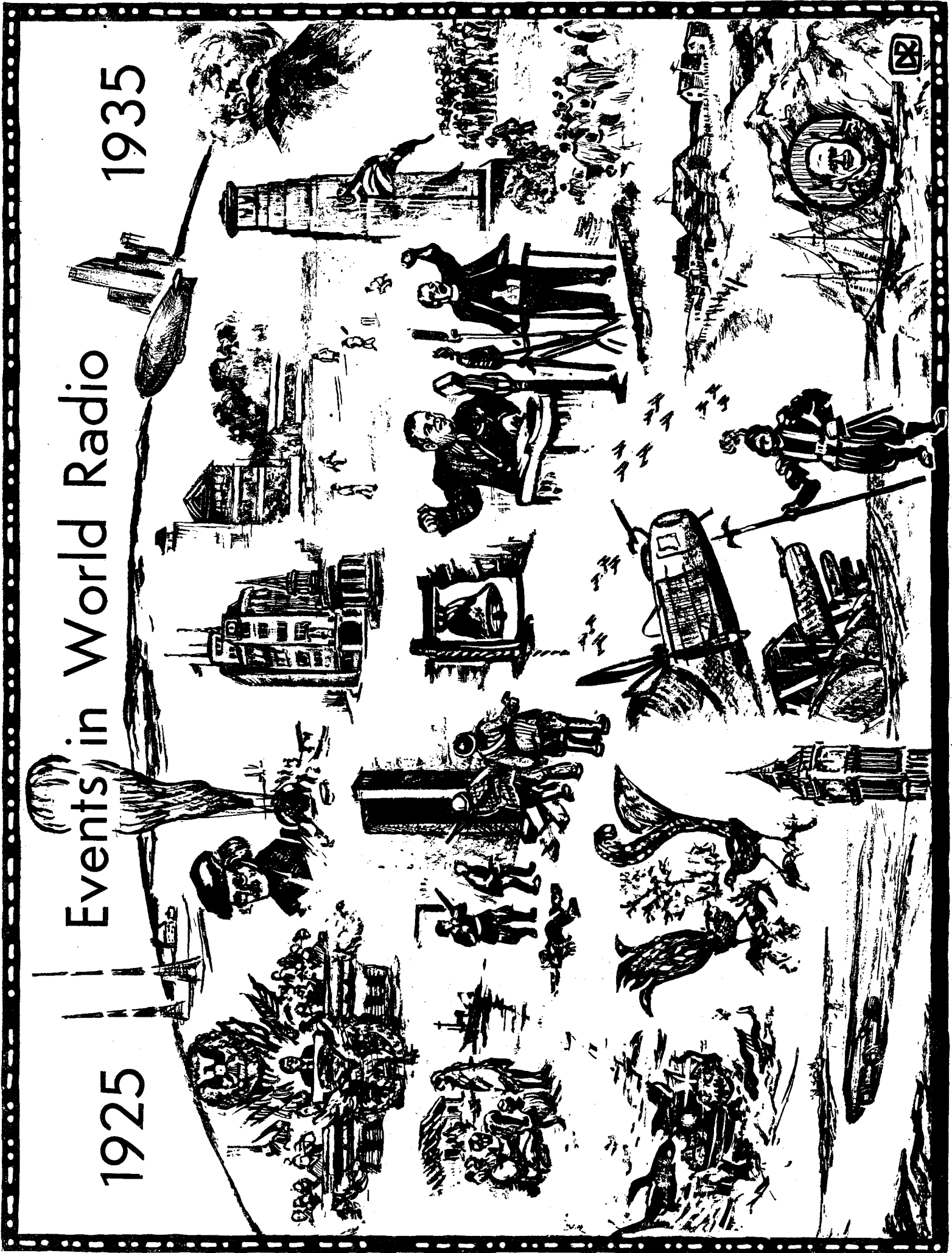

The "events in world radio" illustrated above are explained in an article on the opposite page

Those Were the Days!

By JAY COOTE

WHEN the Editor telephoned me, a few days ago, inviting me, as one of the oldest contributors, to pen a short article for the tenth anniversary number of WORLD-RADIO, the line was a poor one; apparently, when referring to my work for his journal he did not use the word "decadent," but "decade," although it sounded like that!

Ten years in the history of broadcasting is a long period, and in that time much has happened. I can well recall the first occasion on which I brought "wireless" home to the household. It was a simple crystal set, costing £5; a weird contraption which, although in a sealed case, I opened immediately, to find a criss-crossing network of wires radiating from a curiously-shaped basket coil. This, on a wet night, I had lugged home from the West End, further encumbered with two pairs of headphones (then cheap at forty shillings each), added to which, over my arm, as a bracelet, I had slung a coil of rubber-covered wire over a hundred feet long for the aerial and earth.

The radio bug had bitten me. Dinner—or

at least my dinner—lasted ten minutes, and I rushed out into the garden (it was still raining heavily) to sling the aerial over the branch of a tree and push the earth wire down into one of the wet flower beds. Another rush back to the room, a hasty reading of instructions, a feverish connecting up of wires to elusive terminal knobs, and then—nothing! If you can recall the old crystal days, you will remember how delicately you had to adjust the cat's-whisker. Everybody standing around was hushed to silence; no one dared move, for to walk across the room resulted in immediate expulsion. Then, suddenly the cat's-whisker connected and faint signals were heard. From stud to stud the lever was moved until they were readable—2LO was broadcasting! Was there ever a greater thrill? The headphones were passed on amidst gasps of amazement from listener to listener. Why, even Cook, who turned the scale at fifteen stone, ponderously ascended the kitchen stairs to share the wonder of it all. Her pronouncement on hearing voices "out of nowhere" as she termed it, was "a fair corker," That was in 1922.

Good old crystal set, you were the forerunner of many interesting nights.

By July 17, 1925, when the first issue of *The Radio Supplement* (now WORLD-RADIO) appeared, many of radio's infantile diseases had been conquered. The casual perusal of my log for that summer—I possessed then a multi-valve superhet—showed what was then considered a big bag—some twelve or fifteen stations nightly. Those were the days when the owner of such a receiver was envied by his neighbours, who usually found some excuse to pay a visit during the hours that foreign broadcasting programmes were "on the air." Also, I notice that it was in the autumn of that year that I first gathered a Yankee call in the ether: I picked up KDKA.

We were still in the days of stunts—at least, as regards broadcast programmes. The BBC, older than the rest of the existing European organisations, possessed a more regular schedule, but the Continental studios, and in particular those operated by private associations, vied with one another in devising original transmissions.

I recall a Paris station giving dancing lessons by wireless. Listeners were instructed to chalk out on the floor of their rooms a square the sides of which were about two feet long, the four corners containing circles marked A, B, C, and D. In this way the step was taught: "Both feet on A, now right foot on B, left on C, left on D," and so on. Tuition was given to a musical background, and the novelty of the broadcast appealed to the French public. Imagine the surprise of a casual visitor who, calling to pay his respects to *la famille Dumont*, found *Monsieur, Madame, and la Tante Amélie* executing a new version of hopscotch on a chalked drawing-room carpet!

The German authorities, as in all things, took the matter seriously. The listener's licence, needed by what was officially termed the *Rundfunkempfangsanlagenbesitzer*, was an official document which, for its name alone, must have been of great value: it was called an *Unterhaltungsrundfunkteilnehmergenehmigung*, and, in my opinion, was the most efficient test for sobriety any man could have evolved.

To-day we have grown wiser, but in 1925 we tried to be technically-minded. On the 8.50 a.m. to Town, wireless discussions were rife; the electrician's jargon had become an alternative language. Everybody seemed to be building a wireless receiver, and many were the heated arguments that arose over the pros and cons of a straight three-valver, or other type of set. Technical terms were explained by papers to their readers, and somehow or other there were only two classes of listeners: those who admitted they knew nothing of wireless and wanted to learn, and those who thought they did and expatiated at great length in a condescending manner to friends who expressed awe at their supernatural knowledge. One Italian paper, in its endeavour to enlighten its readers, pub-

BELGIUM:

The first Belgian O.B. (commentary on a football match), and (below) an early control-room, with M. Denis at the controls

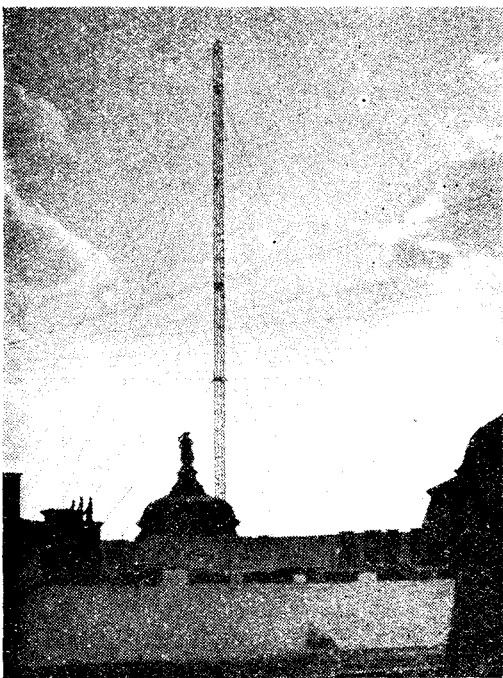

AUSTRIA: Ravag's first aerial on the roof of the War Office in Vienna, 1925; (below) Ravag's first studio, 1925

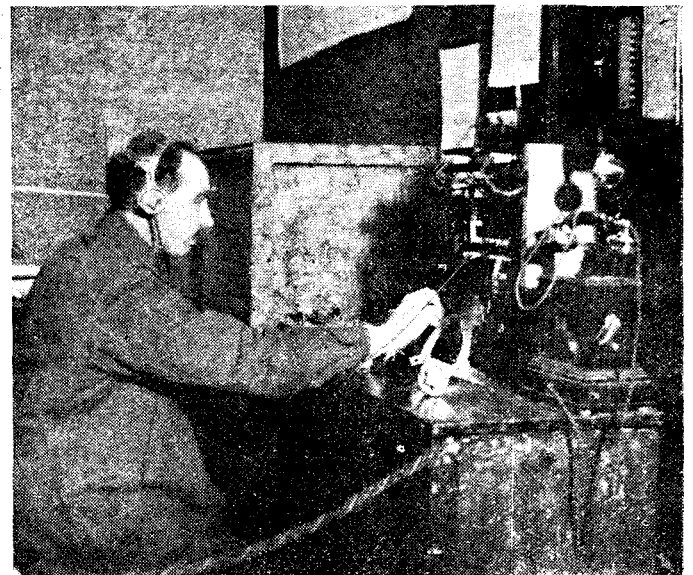
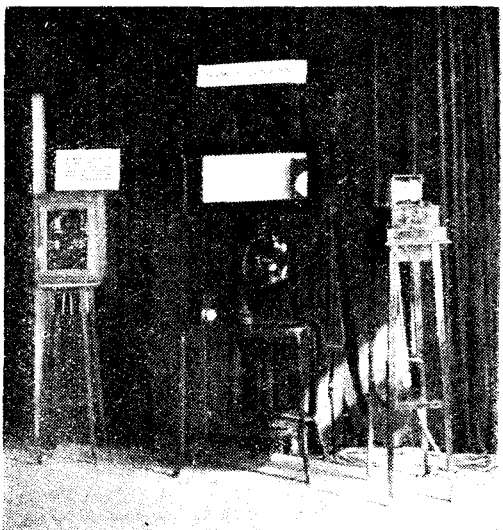

lished the following explanation: "You have a cold in your head; you kiss your best girl and pass it on to her. Later you get rid of that cold and a kiss from your beloved gives it back to you. That is reaction coupling."

It is amusing to look back ten years and to realise at the same time the rapid improvements which have been made in both transmitting and receiving apparatus. The newcomer to wireless to-day, in the most matter-of-fact manner, can tune in some forty or fifty broadcasts nightly at full loudspeaker strength, and is disappointed when atmospheric conditions are unfavourable.

But, in my opinion, the early days brought with them a greater thrill; the listener in 1935 misses the excitement we had when, with headphones glued to our ears, we captured, after infinite patience, the signals of some little one-horse station in the South of France, or some other fairly distant locality in Europe. Believe me, those were the days!

Some Birthday Messages

AUSTRIA

HERR OSKAR CZEJJA,
*Director-General, Oesterreichische Radio Verkehrs,
A.G. (Ravag), Vienna, Austria.*

The great importance of your weekly journal has surely caused you to receive congratulations from all over the world on the tenth anniversary of its foundation. WORLD-RADIO not only tells us all that is worth knowing from all parts of the world, but is read all over the world. A good radio periodical is an indispensable adjunct of broadcasting. Besides programmes it gives us all that the Radio cannot say itself. The remarkably large number of subscribers to your paper, which is a model for all countries, proves how valuable it has become to its readers.

Also, Austrian Radio Broadcasting has every reason to recall with gratitude on this occasion the sympathy which you have always shown towards its efforts. Since the inception of Ravag we have been enabled, through the pains taken by your honoured correspondent, Mr. Banister, to report to the great British public continually upon our work. Whatever interest exists among the wide circles of listeners in Great Britain for Austrian transmissions is due, above all, to your kind co-operation.

With the warmest feelings of sympathy I, therefore, join with the many others who are congratulating you upon this day of festival and honour, and are thanking you for your consistent representation of the interests of the broadcasting of the world.

BELGIUM

M. MARCEL VAN SOUST DE BORKENFELDT,
*Directeur-Général de l'Institut National Belge de
Radiodiffusion, Brussels, Belgium.*

Ten years already! The broadcasting Press is becoming venerable, as are also broadcasting and its pioneers!

It is a pleasure to me, on the occasion of such an anniversary, to be able to congratulate WORLD-RADIO, so faithful both to its comprehensive title and in its sympathetic attention towards our Belgian broadcasting.

Spectator, listener, and critic of the world's broadcasting activities—WORLD-RADIO has filled this rôle, right up to the present time, with beneficent and fruitful authority and purpose. My good wishes for a long and very prosperous career.

CZECHOSLOVAKIA

RADIOJOURNAL
*(the Czechoslovak Broadcasting Corporation),
Prague.*

Czechoslovak Broadcasting Corporation joins ranks of those who are these days celebrating tenth anniversary of WORLD-RADIO. In paying this tribute we are aware that we render homage to spirit of journalistic integrity, strict impartiality, and whole-hearted devotion to cause of world peace. (TELEGRAM.)

HOLLAND

M. DUBOIS,
*President of the Committee of the Netherlands
broadcasting organisations.*

It is a great pleasure to me to congratulate the Editor and the staff of WORLD-RADIO on the occasion of the tenth anniversary of WORLD-RADIO. I think that the world-wide circulation of this periodical—also in countries where the

English language is not the native language—may be taken as a proof of the great satisfaction this paper is giving to its readers.

The sincere wish that the next decennium may show an increasing prosperity of the journal is certainly justified by the record of the journal in the past.

HUNGARY

THE HUNGARIAN TELEPHONIC NEWS AND
BROADCASTING CO., LTD.,
Budapest, Hungary.

We are glad to convey our best wishes to WORLD-RADIO, the excellent BBC journal, on the occasion of its tenth anniversary.

The first ten years of its existence witnessed an unparalleled development of broadcasting, both in respect of popularity and as regards scientific research, and history will reveal the importance the columns of WORLD-RADIO have contributed to this end.

With hearty congratulations and wishes for a future which, we are sure, will be not less significant.

POLAND

M. ROMAN STARZYNSKI,
General Manager, Polskie Radjo, Warsaw, Poland.

On the occasion of the tenth anniversary of WORLD-RADIO Polskie Radjo tenders its best wishes for further success in bringing about closer cultural relations between nations, a cause which WORLD-RADIO so faithfully and successfully serves. (TELEGRAM.)

SPAIN

SEÑOR RICARDO M. DE URGOITI,
Managing Director of Union Radio, Madrid, Spain.

In order that Radio may accomplish its great task of bringing the peoples of the world into closer contact with one another, it is first necessary to solve the technical problems of transmission-reception, and afterwards to keep alive in the public an interest in the broadcasts of other countries.

That we can listen is not enough. The vitally important thing is that we have the desire to listen. To this second requirement, without which the first would be useless, WORLD-RADIO has effectively contributed during the ten years of its existence; for which all of us who are responsible for broadcasting owe a debt of gratitude and friendly appreciation.

SWITZERLAND

DR. KURT SCHENKER,
Director of Programmes of Berne Station, Schweizerischer Landessender, Beromünster.

You are celebrating your birthday and there are surely a great many wellwishers attending. Let me be one of them and send you a congratulatory message. WORLD-RADIO has greatly influenced the considerable development of broadcasting.

M. FELIX POMMER,
Director of the Geneva Broadcasting Society.

I hear from the Geneva correspondent of WORLD-RADIO that your magazine will celebrate within three days the tenth anniversary of its foundation, and I take the opportunity to express

my most sincere congratulations for the work you accomplish.

I greatly appreciate your paper, which contains articles on the most various subjects written in a way that appeals to every reader. Personally, I was particularly interested by your "News from Abroad," and have often found information which was of a real value for my own work.

You know as well as I do how difficult it is to be "universally" successful in the field of broadcasting. But I am glad to declare that you have succeeded!

Wishing you the most brilliant future.

THE EDITOR OF "LE RADIO"

The official organ of the French-speaking broadcasting organisations of Switzerland.

We are informed that WORLD-RADIO will celebrate in a near future the tenth anniversary of its foundation. We take this opportunity to congratulate you heartily for your work. The articles published in your magazine and the information given are always of a real value and every listener is enabled to appreciate fully the interest of the different topics you write about.

We sincerely do hope that you and your collaborators will find the necessary strength to develop an activity which was so successful in its beginnings, and we wish long life and prosperity to WORLD-RADIO.

UNITED STATES

MR. MERVYN H. AYLESWORTH,
*President of the National Broadcasting Company,
New York.*

Hearty congratulations on tenth year of your great achievement in WORLD-RADIO. (TELEGRAM.)

MR. JOHN F. ROYAL,
*Vice-President and Head of the Programme
Division of the NBC, New York.*

Extend heartiest congratulations BBC on tenth anniversary its exceptional publication WORLD-RADIO. We of NBC read it with great interest. It is excellently edited and a great credit to the art of radio. (TELEGRAM.)

MR. RICHARD C. PATTERSON,
*Executive Vice-President of the National Broad-
casting Company.*

Congratulations to the BBC on the successful completion of a decade of great service to radio through the splendid publication WORLD-RADIO.

MR. CÉSAR SAERCHINGER,
European Director, Columbia Broadcasting System.

May I, on the occasion of WORLD-RADIO's tenth anniversary, congratulate you on the accomplishment of a decade of splendid pioneer work in the cause of radio and international relations? WORLD-RADIO has filled a genuine want in Great Britain, and its record in spreading technical knowledge about broadcasting, and stimulating interest in radio as a medium of international understanding, is unique in the English-speaking world. Its high standard of journalism and the steadfast idealism of its editorial policy have done much to cement friendship between the peoples of the Empire and the American Continent. On behalf of the Columbia Broadcasting System and its listeners I extend sincere wishes for continued prosperity and many more decades of useful endeavour.



Ten Years Old! by an Old Contributor

WHEN this journal first made its appearance ten years ago, broadcasting was on an established basis in many countries. In Great Britain there were over 1,300,000 licensed listeners, to say nothing of those who had conscientious or other objections to paying for their wireless fare. There were at least sixty stations in Europe which became a source of interest and excitement to that ever-growing army of listeners whose favourite indoor hobby was "reaching out."

It must be confessed that in those days the principal delight of listening was the satisfaction of getting as many stations as possible, not the joy of assimilating the music and culture of foreign countries. Reversing the dictum of Stevenson, to arrive was better than to travel hopefully.

In order to meet the requirements of those adventurers of the ether, a page of *The Radio Times* was devoted to a list of European and other stations with certain programme details and other information. This feature became so popular that the only way of meeting the demand for it was to provide a special journal: hence *The Radio Supplement*, as *WORLD-RADIO* was originally named. The first words of the new paper were: "It is our privilege to present to our readers the first issue of a journal which, we hope, will be of as much assistance to those who are able to tune into the programmes of foreign stations as is *The Radio Times* to listeners who are concerned only with British programmes."

Those words imply two categories of listeners: those who were able to tune into foreign stations and those who were not. Roughly, those categories were equivalent to valve-set owners and crystal-set owners.

The whole broadcasting organisations of Europe were established on a basis of crystal-set reception. In other applications of science to the needs of the community—motoring for example—it was necessary to begin by appealing to the wealthier classes. From the first, and this is perhaps its greatest glory, broadcasting has been within the reach of those of very moderate means. When a new station was erected, its radius was always spoken of in terms of crystal-set reception.

Crystal-set users were in the majority in those days, and so continued for several years. Even to-day, surprising as it may seem, the crystal enjoys a considerable vogue, and, owing to the enormous power of many foreign stations, it is often possible to hear a few European stations on a crystal set. But, ten years ago, crystal reception was of a strictly local character, international reception was practicable only by means of valve sets. In its opening message

WORLD-RADIO said: "We are now definitely entering the international era of broadcasting."

International broadcasting has assumed a magnitude and importance never dreamed of ten years ago. One is inclined to imagine that it also is being taken as a matter of course. We have lost the first fine careless rapture. Who can ever forget the first thrills of trans-Atlantic reception? How many listeners commanded silence in the home while they tried to get KDKA or WGY? It might be only a few gurgles and splutters with an occasional mutilated word like that which issues from a venerable and badly scratched gramophone record. None the less, they were "hearing America." They were pioneers in the new era of international communications.

There is no doubt that those early trans-Atlantic reception experiences provided the fillip which international broadcasting needed.

The man of moderate means was able to take advantage of the delights of international broadcasting owing to the cheapness of sets and the great epidemic of home construction. These were the days when the voice of the home constructor was heard in the land singing hymns of praise to the prowess of the set which he had made or assembled. It was about this time that angling yarns began to disappear and tall stories of long-distance reception became common.

The members of the younger generation, brought up in an age when European reception is as easy as switching on the light, have no idea of the joy of logging yet another station. Older readers will be able to recall some of the favourites. Radio-Wien, 8.5 kW; Radio-Belgique, 2 kW; Petit Parisien, .5 kW; Königsberg, 1 kW; Voxhaus, 4.5 kW; Hilversum 4 kW; and, of course, Radio-Paris, 8 kW, which was one of the "giants" of those days.

In the second page of *WORLD-RADIO* the question was asked: Which station was that? Every issue of *WORLD-RADIO* and its auxiliary publications have evidently been designed to answer that question more fully; to tell everything about "that" station, its power, its wavelength, its equipment, its organisation, its home listeners, their language, their musical and literary tastes.

In attempting to estimate the forces that have been in operation since the inauguration of the era of international broadcasting, it is possible, in the course of a brief survey, only to note a few outstanding features. One of the most notable has been that the progress made has far outstripped the imagination of the most sanguine expert. The Chief Engineer of the BBC wrote in one of the earliest numbers:

"Who will deny the possibility of a programme S.B. to Europe? I shall die happy when I see a programme S.B. to the main stations of the world." When one thinks of what happened on the numerous occasions on which the King has spoken to the ends of the earth, culminating in the Jubilee broadcast—the greatest in history—it is easy to see how far actuality has exceeded anticipation.

This is even more true in the realm of short-wave broadcasting. Ten years ago many experts were exceedingly dubious about the practical value of short-wave transmissions. They were considered to be quite unreliable, and so they were in those days. It was thought that they might be good enough for the amusement of amateurs. Now the short-wave transmissions are among the most important, both in broadcasting and in wireless telephony. The Daventry Empire service has been followed by other highly organised short-wave transmissions to and in all parts of the world. In this particular development, *WORLD-RADIO* can claim to have played a consistently far-seeing part. It has certainly devoted more space, over a longer period of time, to short-wave activities than any other journal.

The development in the complexity of musical transmissions has also been amazing. Musical opinion in the early days was strongly against the possibility of broadcasting ever being other than a poor substitute for the original. Such has been the development in transmission and reception that all save one or two diehards admit that the performance the listener hears loses little in quality.

These facts need not be stressed. They are obvious to every intelligent listener, but there are a few other considerations which are perhaps worthy of note. One of the most significant is the situation revealed by the licence figures. In the last ten years BBC licences have risen from 1,300,000 to over 7,000,000. In Germany the increase has been from one million to over six and a half million; in Austria, from 150,000 to 525,000. In almost every country there has been a steady and uniform growth of licences. This has been achieved in spite of the world economic crisis.

The licence figure is a fair index of the prosperity of broadcasting in countries where this system of revenue is in vogue.

In Italy at the end of last year there were 430,000 licensed listeners. Each licence costs about 25 shillings. As only a limited amount can be devoted to programmes, it would be impossible for E.I.A.R. to maintain the high musical standard for which the Italian programmes are so noteworthy were it not for the

magnificent operatic resources of Rome, Naples, and Milan.

Denmark has always occupied the proud position of having more licences per thousand of the population than any other country. In 1926 the total of licences was 121,264. By the end of 1934 that number had risen to 568,175. Broadcasting in Denmark makes a strongly utilitarian appeal. Much useful information is sent out about agriculture and other staple industries. Even if there were no excellent musical programmes, a receiving set would be a necessity because of the important topical information broadcast.

The licence figures afford an insight into many broadcasting problems. They explain why in some countries so much of the time is devoted to talks and gramophone records. They also have some bearing on the important problem of high-power stations, which are very expensive. Until recently there were no stations in the British Dominions of more than 10 kW. Of course, there are countries with high-power stations and a relatively small licensing revenue, but in such cases the Government of the country has often financed the construction of the stations.

As a means of raising revenue for broadcasting, the sponsored programme is the only serious alternative to the licence system. France is making a strong effort to prove that the imposition of a tariff on components may be sufficient, but there are not enough data available to make an authoritative statement.

In view of the difficulties that nearly all countries have had with regard to finance, it is surprising that sponsored programmes have not been more in evidence in Europe. The tendency is all the other way.

The causes are partly commercial and partly political. The average European does not seem to be so responsive to microphone advertising as the average listener in the United States. In almost every European country some form of State control of broadcasting has been introduced, and this has tended towards the adoption of the licensing system.

In some countries the two systems have been

tried simultaneously, but as a rule they do not run well in double harness. The private stations of France were never on the happiest of terms with the PTT stations. The experiment was tried with Athlone, but it has been abandoned. The same is true of the South African stations, and, to a lesser extent, of those of New Zealand. The dual system still exists in Canada. The only place where it seems to work is in Australia.

South America and the United States find the sponsored programme more suited to their requirements. The United States is the paradise of the programme sponsor. Within certain limits of doctrine and decency, anyone who has the money can broadcast in the land where the first canon of broadcasting is the doctrine of the inviolability of free speech. Senator Huey Long and Father Coughlin have exploited this doctrine to such an extent that one can imagine President Roosevelt, when reminded of it, saying "You're telling me!" Sponsored programmes will probably continue in the United States, but the number of listeners who recognise the limitations of this system is increasing.

Power Increases

One of the unobtrusive but powerful factors making for the comfort of listeners has been the work of the U.I.R., which began to function shortly before *The Radio Supplement* appeared. In 1925 there were about a hundred European stations with a total power of about 100 kW. To-day there are over 200 stations with a total power of about 8,000 kW. The U.I.R. has had many meetings and has evolved three great plans, Geneva, Prague, and Lucerne, which have been mainly responsible for the wonderful results obtained. Without the work of the U.I.R., there would have been intolerable chaos in the ether.

As has been said, the progress that has been made in broadcasting has far surpassed the most sanguine expectations, but it is interesting to note that there have been disappointments. WORLD-RADIO was only a few weeks old when the news came from America that the problems of television had been overcome and that it would not be long before sets would be on the market. Again and again this elusive invention has been just round the corner.

Then there was a time when the broadcasting of pictures seemed about to be realised on a wide scale. Somehow the invention never quite caught on, though modifications of the process have recently been very much in evidence for newspaper purposes.

Individual stations and countries have not come up to expectations as regards broadcasting. Ten years ago the Spanish stations were exceedingly popular. Everyone imagined that Spain would be one of the leading broadcasting countries.

The Feast and the Menu.

But these are only tiny shadows in a great picture that only a Shakespeare could adequately create. What an enrichment of life international broadcasting has brought! Artistically we have been fed with the finest of the wheat. We have had the opportunity of listening to the greatest artists, the finest orchestras, the most distinguished public men of Europe. We have been thrilled by the festivals of Salzburg and Bayreuth; enlivened by the waltzes from Vienna, the gipsy music of Hungary, the folk songs of Norway, the impressive military music of Germany, the glorious operas of Italy. We have been moved by the moral eloquence of Pèrè Lhande, impressed by the earnestness of Herr Hitler. For ten years we in this country have had a glorious *pot-pourri*, and WORLD-RADIO has been the menu.

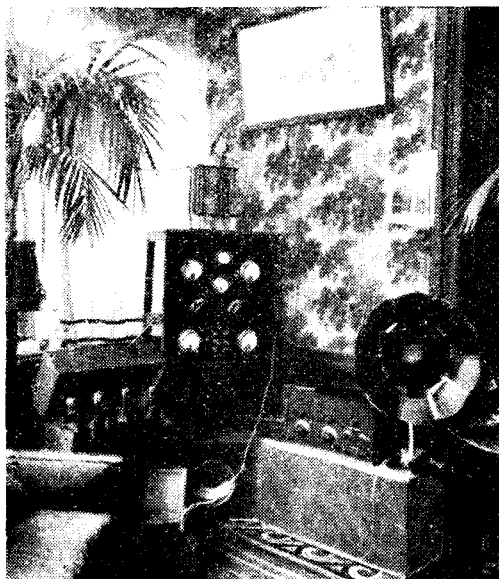
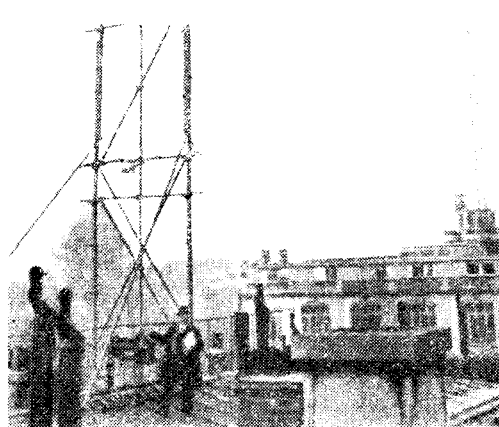

FRANCE: (upper) Paris PTT's early aerial mast; (lower) transmitting and receiving apparatus at the Radio-Normandie station in 1925

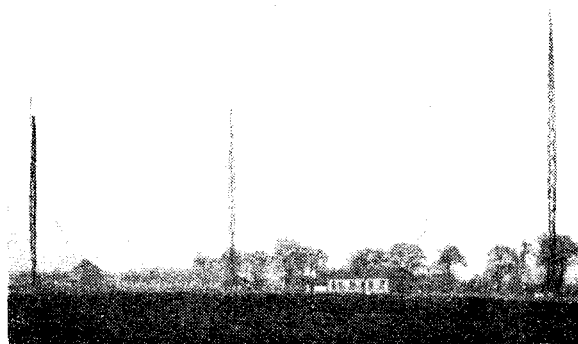

CZECHOSLOVAKIA: masts of the Kbely wireless station, which was formerly used for broadcasting



DENMARK: Mr. Emil Holm, Programme Director of Danish broadcasting, filling in a gap by singing "Flight of the Bumble Bee"



GERMANY: (above) a broadcast dancing lesson in one of the Munich studios in 1928; (below) Dr. Joseph Rauscher, who was a specialist in preparing news for broadcasting, dictating to a recording machine

Viâ Ether

LETTERS TO THE EDITOR

Ten Years

WITH this issue begins the eleventh year of what is, I believe, an uninterrupted series of "Viâ Ether" paragraphs. It has been both an interesting and instructive experience to read some of the earliest and subsequent contributions under this heading. I am told that other contributors to this issue have similarly derived benefit from their necessary researches into the files of WORLD-RADIO, and have been impressed by the extent of the progress, not only technical, but in international understanding, to which these pages have borne witness during the ten years since 1925. I hope I may be in a position to read the Twenty-Fifth Anniversary Number of WORLD-RADIO.

* * *

Too Much Music

The late George Grossmith, invited to criticise the broadcasts of ten years ago, gave his considered verdict in a few words: "There is too much music in the programmes." What he would have said now, when the volume and the quality of broadcast music have advanced beyond all comparison with those early days, is difficult to guess, and in one way most listeners are bound to agree with him. Week by week there is far more not only of music, but of drama and talk, of instruction and entertainment of every order, than any one listener may hope to assimilate, or even to hear. The choice offered, week by week, by the programmes set out in these pages is a truly embarrassing one, and if a similar advance be made in the course of the next ten years, it may well be overwhelming. Broadcasting may look back with some confidence on the strides it has made since these pages first presented the world's programmes: it must have some trepidation as it looks forward.

* * *

Folk Music

One thing for which broadcasters throughout the world may claim credit is that they have done much to revive popular interest in folk music. Most countries have rich stores of national melody, but, until quite recent times, it was so little thought of that it might well have been lost but for the enthusiasm of a few eager spirits: folk-song societies and solitary collectors have done splendid work in many lands, but without arousing any widespread interest in what might have become a self-conscious cult. Broadcasting has prevented that, and week by week, folk song and dance have a large share in the whole world's broadcasts. Sung and played by peasants and mountaineers, with the instruments which simple people have made their own throughout the ages, such broadcasts can do much to bring the very atmosphere of one land to the people of others: it must be one of the best influences for promoting mutual understanding. How much it has attracted composers is constantly obvious, too, in the programmes: the French PTT stations offer a conspicuous example of that on TUESDAY evening, July 23, with a programme drawn from the concert music of many lands, almost all of it based on melodies which are national possessions.

ETHERVIATOR.

"CONTRASTS IN PRESENTATION"

SIR,—Re the article under the above title, which appeared in the issue of June 28, I have now been in England for two years, after spending ten years in the U.S.A., and my own opinion is that no one system of broadcasting can satisfy everybody.

I note that from time to time the BBC is subject to severe criticism, but, then, so is every other system of broadcasting, so that the BBC and the NBC both have their good and weak points. The Americans are ahead of us in at least two ways, however—in every city the listener has five or six alternative local programmes and they put over their variety better.

Yours faithfully,

H. MOXHAM.

Walthamstow, London, E.17.

DAYLIGHT STATIONS

At Any Time of Day

SIR,—I have read with great interest the various letters that have appeared in your paper recently relating to daylight reception of foreign stations, and I should like, if I may, to submit to you a list of stations I can receive now any time between 7 a.m. and 7 p.m. at good loudspeaker strength.

Long Wave (in order of volume): Radio-Paris, Luxembourg, Kootwijk, Kalundborg, Motala, Deutschlandsender, Oslo, and Warsaw.

Medium Wave (in order of volume): Cologne, Hilversum, Brussels 1, Hamburg, Athlone, Brussels 2, Poste Parisien, Radio-Normandie, and Stuttgart. Set is a 1933 six-valve superhet.

It might also interest you to know that all the British stations are heard very well here, except the low-powered stations of Bournemouth, Plymouth, and Belfast. Newcastle is received at R5 in daylight and Belfast R3.

Comparing foreign and home daylight stations, London Regional and Cologne are equal and so are Brussels 1 and West Regional.

Yours faithfully,

VERNON D. CLARKE.

Brough, East Yorkshire.

WORLD-RADIO PROGRAMMES

SIR,—I should like to express my appreciation of the improvement you have introduced of printing the Sunday programmes in larger type.

I much regret, however, that you no longer arrange programmes according to time. I am sure that the majority of readers, when they have leisure to listen, must look to see what there is to choose from at a given time; this is a laborious proceeding when the programmes are arranged according to station. Surely listeners in general are more interested in finding the best programme than in consistently following the broadcast of any particular station. When arranged according to hour, it was perfectly easy to find what any station was doing at any particular time.

While realising that it is impossible to please everybody, I hope you will soon come to the conclusion that arrangement by the hour is the more convenient method for the majority.

Yours faithfully,

H. WALTER.

Beckenham, Kent.

Letters should be addressed to the Editor, "WORLD-RADIO," Broadcasting House, London, W.1. Letters intended for publication should be as brief as possible, and should always be accompanied by the full name and address of the writer, though not necessarily for publication.

SUBSCRIPTION RATES

12 months Inland and Canadian, 13s.
12 months (Foreign), 15s.

Other periods pro rata. Prices include postage.

Subscriptions to Publications Dept., Broadcasting House, London, W.1, or 8-11, Southampton St., London, W.C.2

SIR,—I must say how delighted I was, when looking at this week's issue of the WORLD-RADIO, to see you had gone back to the old idea, by giving the station wavelength and programme all in one, instead of hour-by-hour. Also the large print. Please do keep this up, if only during the summer months, when there is not so much on. The large print saves me putting on my glasses.

Yours faithfully,

A. W. LOVELL.

Bristol.

SIR,—If the rearrangement of the lay-out had been deliberately undertaken with the idea of making reference to the programmes as inconvenient, irritating, and time-wasting as possible, you could not have achieved greater success. Doubtless it may serve for the Listener who has nothing else to do but tinker with his set, or who has a passion for the programmes radiated by some particular transmitter; but the average listener (who is presumably in the vast majority) wants to know what is going on at a particular time, and he is now doomed to resort to knob-twiddling or to wade all through the day's programmes—and then probably pitch on something that was sent out at 9.30 a.m.

The indication of wave-lengths, etc., at the head of programmes is an improvement, but the little occasional time and trouble saved thereby are swallowed up hundreds of times over by the needle-in-haystack business.

Yours faithfully,

C. J. OLIVE.

London, N.W.5.

POINTS FROM LETTERS

Daylight Stations

Long Waves: Kalundborg, Luxembourg, Motala, Radio-Paris—all very strong; Kootwijk, transmitting Hilversum, not so strong; Oslo, Leningrad—weak; Deutschlandsender—strong before Droitwich starts transmitting, after which it is no good. Medium Wave: Athlone, Northern Ireland—strong; Bordeaux-Lafayette—not so strong; Brussels (No. 1), Hamburg, Dublin—very weak. My receiver is a 1934 5-valve superhet., battery driven, with an 80ft. double wire aerial.—F. J., Borrowdale, Cumberland.

The receiver is a 4v. superhet, home-designed, employing multiple valves. Medium waves: Brussels 1, Cologne, Paris (PTT), Berlin, Hamburg, Brussels 2, Breslau, Poste Parisien, Hilversum, Radio-Normandie, Frankfurt, Lille PTT (all at programme strength), together with the following upon occasions: Athlone, Stuttgart, Lyons, Munich, Leipzig, Strasbourg, Heilsberg, Rennes, Bordeaux, and Hörby. Long waves: Huizen, Radio-Paris, Deutschlandsender, Luxembourg, Kalundborg, Oslo, and (weakly) Warsaw and Motala. Of these stations Radio-Normandie, Hilversum, Poste Parisien and Brussels No. 2 are easily the strongest.—A. F. D., Westcliff-on-Sea, Essex.

My log for daylight reception other than BBC stations is as follows: Long waves: Huizen, Radio-Paris, Motala, and Luxembourg. Medium waves: Fécamp and Athlone are outstanding. Königsberg is usually good. The much-talked-of Cologne I can never receive; my set is a five valve superhet of well-known make, using a 60 ft. outdoor aerial.—A. C. K., Plymouth.

My situation is a high one in Ealing, and though using an outdoor aerial, my 5-valve commercial superhet, which, at night, will receive most of the worth-while stations, will, during daylight, obtain only Luxembourg, Radio-Paris, Huizen, Radio-Normandie, Cologne, and, occasionally, Poste-Parisien.—L. S. E., London, W.5.



1



2



3



5

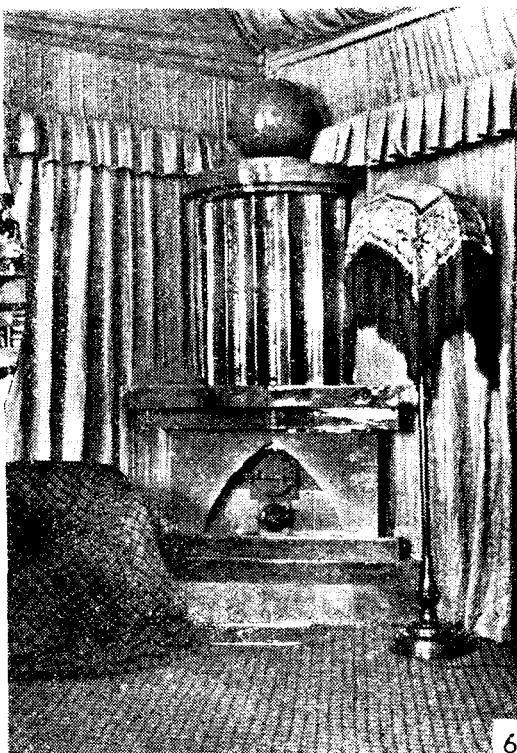

6



7

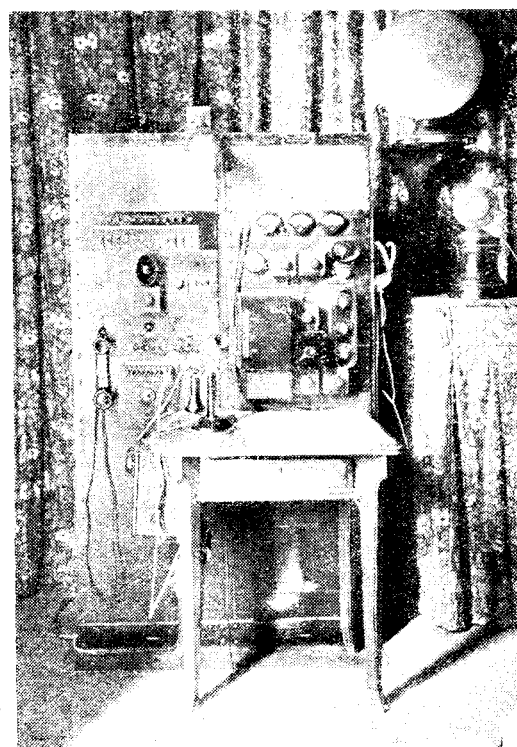

8

1 ITALY.—Rome's first transmitter. Note the unpretentious transmitter hut

2 HOLLAND.—A Dutch studio scene in 1924. The microphone on the right is of the magnetophone type, as used in the early days of British broadcasting. It is referred to in the article on p. 17

3 & 4 Mr. Sig. Cithurus, of Warsaw, and Mr. John Banister, O.B.E., of Vienna, two of WORLD-RADIO's correspondents who share in our present anniversary. Both have represented the paper in their respective capitals since 1925

5 HUNGARY.—Mr. E. Szöts, who was the Director of Radio-Budapest from 1925 until his death in 1932

6 POLAND.—From 1925 to 1926 this was the Warsaw station's only studio

7 SWITZERLAND.—Another early studio—at Lausanne

8 SPAIN.—The small studio of Radio-Barcelona. As will be seen, it contains the amplifying panel, which is connected with the transmitter on Monte Tibidabo, as well as with various churches and theatres of Barcelona

NEWS FROM ABROAD

(From our Correspondents)

Ravag Funkhaus Plans on View

The plans and designs for the new *Funkhaus* ("Broadcasting House") to be erected in Vienna are so extensive that Ravag has arranged a special exhibition of them, open to the public free of charge. Many thousands of listeners have taken the opportunity of inspecting them. The cost of the building's construction and equipment will be not less than £250,000 sterling, and the work will take nearly two years to complete. Provision is made in the plans for eighteen studios and fifteen other large rooms for rehearsals and other purposes. The business and other departments have been allotted equally liberal accommodation.

International Relays from Austria

Relays of the Salzburg Musical and Dramatic Festival have been requested by forty countries, representing 286 stations, two relays being taken by more than 200 stations in the United States. Before the Salzburg Festival begins, the Anton Bruckner Festival at Linz and St. Florian takes place, and on July 26 and 27 a large number of foreign stations will relay the Festival programmes. The Philharmonic concert conducted by Bruno Walter at Linz, at 8 p.m. on July 26, will be taken by Italian, Swedish, Norwegian, Czechoslovak, and Hungarian stations.

A Decree for Radio-Vitus

In 1930 Radio-Vitus built a new transmitting station at Romainville and began experimental transmissions. Unfortunately, the permission of the postal authorities had not been obtained, and, although the new station promised to be much better than the old, orders were received that its transmissions had to cease. Changes in wavelengths since that date have altered the situation, and it has been found that Radio-Vitus is now a source of interference in its immediate neighbourhood. The Minister of P.T.T. has written to the local Deputy, stating that he is preparing a Decree to authorise the station to transfer to Romainville the equipment actually installed at Paris. The letter does not state that the former Romainville equipment can be used, but presumably that has been dismantled and used in Paris during the last five years, or is now out of date.

Another Tenth Anniversary

Marseilles PTT station celebrates its tenth anniversary at about the same time as WORLD-RADIO, its service having begun on June 25, 1925.

Nice-Juan-les-Pins Closing Signal

Radio-Nice-Juan-les-Pins has just adopted as a transmission closing signal an excerpt from *Coupo Santo*, the well-known hymn of the Provençal poet, Mistral. The adoption of this signal seems particularly appropriate for a station that radiates over Provence and the Mediterranean seaboard. Henceforth, at the end of each transmission, Radio-Nice-Juan-les-Pins will give a few bars of this hymn, which, at the end of the evening's programme, will be followed by the *Marseillaise*.

German Reports on Legion Visit

A number of broadcasts associated with the present visit to Germany of a British Legion Delegation are being made from German stations. In the words of an official announcement: "German broadcasting considers it a natural duty to permit all Germans to take part in this important event, which brings together former enemies. . . ." Various reports will have been radiated by the *Deutschlandsender*, and on

July 19 from 7.45 to 8 p.m., B.S.T., a running commentary on the Delegation's visit to a Hitler Youth Camp and a Work Service Camp will be transmitted. At the same hour on Sunday, July 21, the *Deutschlandsender* will give a report on the Delegation's drive over the new national motor-road from Munich to Holzkirchen, and on the following day, again at the same time, listeners will hear a report on the departure of the Delegation for London. This report will be relayed from Cologne, and will give the Delegation's members an opportunity of stating their general impressions before leaving.

Fewer German Listeners

On July 1 German listeners numbered 6,589,454—a decrease of 82,937 during the month of June. The total includes 458,213 free licences. The fall in the figures, however, is seasonal, and occurs every year. From July 1 onwards, licences for sets installed in Hitler Youth club rooms are being issued free of charge.

Kenya Licence-Fee Reduction

The cost of a listener's licence in Kenya, which hitherto has been £2 10s. a year, is now to be reduced to £1 10s., according to *East Africa*.

More O.B.'s in Poland

More outside broadcasts, it is reported, are to be included in the Polish programmes. All stations are being provided with special amplifying equipment with which, it is claimed, reports and events of interest may be broadcast without the use of special high-frequency cable

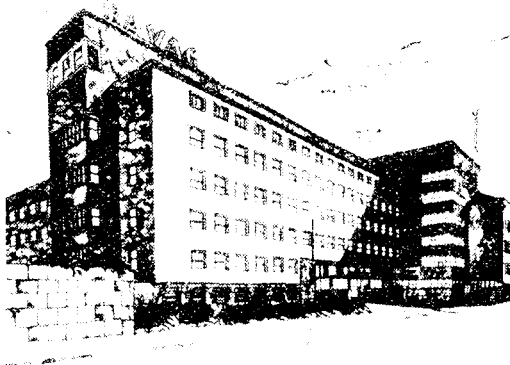

Ravag's new home: an artist's impression of the proposed headquarters of the Austrian service. (See report in col. 1)

connexions between the O.B. amplifiers and microphones at one end and the transmitting stations at the other. In addition, mobile units in special motor vans, provided with similar amplifying equipment as well as with microphones, loudspeakers, and sound recording apparatus, are being constructed.

Emissora Nacional: Official Opening

The experimental period of the *Emissora Nacional* (Portugal's National Station), which has continued since the handing over of the station by the contractors last year, is to be concluded, and the *Emissora* will be officially opened on August 1. Senhor M. Bivar, the station's former Chief Engineer, has been appointed Director of all State Radio Services under the Portuguese Post Office, but for the time being is retaining his old appointment. Captain Henrique Galvão (who was the organiser of the Colonial Exhibition held in Oporto last year) has taken the place of Dr. A. Joyce, the *Emissora's* former Artistic Director.

Romanian Studio Network

A network of studios—one in every big town in the country—is being established by the Romanian broadcasting authorities. The studios will be linked with Bucharest by landline, and the broadcasting company hopes to relay a programme from each town at least once monthly. Work on the network has already begun, and it is hoped to have the system in operation by the autumn. An experimental programme is shortly to be relayed from Cluj, where a vacant theatre has been converted into a studio. Romanian listeners will also hear transmissions from the Cluj Opera.

"Pirates" in Romania

During 1934, 840 "pirate" listeners were discovered in Romania, the majority of whom defended themselves by stating that their receiving sets were on a fortnight's trial. An amnesty was granted to those who, within eight days of being discovered, paid the licence fee for one year. Fines were imposed upon 76 offenders, who were warned that, if their offence were repeated, their sets would be confiscated and they would forfeit the right to apply for a licence at any time in the future.

Press Tribute to News Broadcasting

In recognition of its broadcast of the Stratosphere Flight in 1934, the NBC (New York) was recently awarded a bronze plaque (received on its behalf by Mr. Burke Miller, Director of Special Events at that time), as "the first radio news award" by the Atlantic City Press Club. The award recorded the fact that it was the first time that the world had heard from a balloonist, twelve miles above the earth, his own story of his preparations to "abandon ship" as the balloon was ripping apart and falling.

Extracts from

"The Radio Supplement" (Vol. I)

A New Use for Broadcasting

A MAN was arrested recently in New York on the charge of loitering, and it was found impossible to understand what he was saying. Several professors of languages were called, but no one could understand or determine which language he was using. The police then caused him to speak before the microphone, and invited listeners' reports. By this means it was discovered that the man was a Lapp, and was also quite harmless. (July 17, 1925.)

Abd-el-Krim's Wireless

The secret of how the Riffian leader is able to keep in close contact with the very extensive fronts over which he is fighting the troops of France and Spain has now been discovered. It appears that Abd-el-Krim is a wireless enthusiast and experimenter. His troops are equipped with portable radio receiving sets attached to the saddles of the officers, together with headphones and aerial equipment. Installed in the palace occupied by Abd-el-Krim as his headquarters is a very powerful receiving set, by means of which he is able to pick up special items of news. (August 28, 1925.)

Radio in Sing Sing Prison

Radio is installed at Sing Sing Prison, New York, and prisoners with good records are permitted to have receiving sets in their cells. The radio receiver is situated on the warden's table, and the amplifier is carried to various parts of the prison for the entertainment of prisoners. Many of the inmates have built their own receivers, and so great is the natural desire to know what is going on outside and to become a member of the privileged class, that this inducement to good behaviour has had a remarkably beneficial result on the discipline of the prison. (August 28, 1925.)

AN OPEN LETTER from Shanghai to the Lighthouse Keeper, Isle of May

THIS is Shanghai Calling. For the past half-hour I have been listening to the broadcast from the Isle of May in the Firth of Forth, so the commentator told me. I have a hazy recollection of having heard of this island when I was at school some thirty years ago in Stoke-on-Trent, but I cannot say that the name impressed itself on my memory very distinctly. However, your talk this evening, Mr. MacKiness, was most interesting and enlightening, and I wish immediately to wish you the Good Luck which you sent to all the lighthouses round Scotland, particularly, and then to the whole world and again to all boys on the other side of the world.

As I happen to be one of them, I thought you might like to hear that your kindly thought for other people, when you were left alone with the microphone, came right out to Shanghai, 11,000 miles away from you by ship. (I know this very well, having travelled the distance a number of times, counting each mile either way, the going home way with eagerness and joy, and the other way just the reverse). I feel perfectly certain that millions of people heard that message, yet I doubt whether it fell on more receptive ground than it did in this room, sitting alone with my — (possibly I had better not mention the name of the set; otherwise the Editor might think I was advertising, and that would never do) at a quarter to four in the morning of a fine day. I just happened to get up this morning at 3 a.m., as I find that the wireless comes through from the BBC excellently at that hour on most days, and I just love, as we all do out here, to listen to the voices coming from home. Your voice was particularly pleasant on the radio this evening. Its delightful hint of Scotland gave me a thrill, and your obvious enjoyment of your job made me feel that so long as the Empire has men like you at its outposts we have nothing at all to fear in the future. You may say, of course, that you are not on any outpost and that it is I who am more in that position. I don't agree. We have every amenity that is known to modern civilisation here in the Far East, excepting perhaps a lack of good motoring roads, homeside scenery, pleasant country scents and sights, and general cleanliness. However, we have a lot to be thankful for, and the general kindness of the Chinese people themselves makes up for what we have to put up with in other directions.

I expect many people are envious of your job. I am, for one. I'd like to get away from the turmoil of business in Shanghai for a while, as we are in the midst of a most fearful depression due to the high price of silver, which has just smashed one of the best American Banks in the Far East, together with three American allied companies built up by a man who came here over thirty years ago as an engineer.

He made millions by his foresight and real, hard slogging work, and he made money for hundreds of people, too. Now it is the other way round, and thousands of people have been suddenly faced with losses they can ill afford, and the whole of the town has been knocked sideways by this blow. Business is stagnant. People are worried to death about the future, as they can see no signs of improvement whilst this gambling in the price of silver goes on.

So you see your job makes me rather envious. You may have no cinemas to go to (we have about thirty in Shanghai), but you certainly have a million rabbits and you can get out with a gun or a line for fishing any time you care to. (I say this advisedly, of course, as I mustn't give people the impression that you said this over the mike; otherwise they may think you neglect your job, which I am very certain you do not from all you said to-night.)

You tickled me when you said that you were not going to butter up the BBC and that they gave you too much jazz. I cannot say that I altogether agree with you. Unfortunately, I cannot get enough of the BBC. I can only hear it well from 7 o'clock in the evening. I go to bed around nine and get up at all hours of the night to listen in whenever I wake, quite a frequent occurrence these trying days, and I cannot say that I find a preponderance of jazz. I listened to the whole of the Derby broadcast straight from the course the other night, although it meant my sitting up till 10.30—an unusual hour for me. I got it again at 7 in the morning and I was mighty grateful to the BBC, just as you must be in spite of your kick. I'm listening to *Carmen*, coming from Covent Garden, as I sit typing this, and it is coming through almost as well as it is coming through in your rose-coloured rooms.

The commentator amused me when he came out with the fact that he thought you must have led a frantic sort of life, and I rather feel that most of us felt that too before the broadcast. Now we none of us feel anything of the sort, as I have said above, and I would very willingly change places with you for a year. Listening to the cries of seagulls, which came over the mike quite plainly here, I imagined the tang of the sea coming to me (we have only the Yellow Sea here all round us, just like coffee with cream in it, and the sight of good clean ocean is something we get only when we leave for home), and felt happier because of it. Your good wife was sick at the time of the broadcast, and I trust she is well now. She seems to be a wonderful sort of woman to be able to keep bread ten days without you knowing it. (I'll pass the tip about the oven on to my wife, as I hate stale bread. We rarely get it here as a matter of fact. Too many dogs to eat up what's left.)

You'd feel quite at home if ever you came to Shanghai. Most of the good jobs are held down by Scotsmen. I happen to be one of the few English *taipans* here (*taipan* is just the Chinese name for head of the firm). Most of them are from across the border, be it banker or accountant, merchant or engineer. You cannot take a trip away from here without coming across a Scot either in charge of the engine room or on the bridge. What a country!

And now I think I'll get off back to bed. It is almost dawn; it IS dawn. I see the light breaking through the windows in the East and Toreador is shouting at me from the wireless in rather a loud fashion. So cheerio from China, Mr. MacKiness, and Good Luck to ye all on the Isle of May. F. C. M.

Emile Jaques-Dalcroze

The Creator of Eurhythmics

THE seventieth birthday of Professor Jaques-Dalcroze—the originator of Eurhythmics and *le chansonnier du pays romand*, as he is called in Switzerland—was celebrated recently by the broadcast of a programme of his music from Sottens. A few days later the Professor chanced to be in London, and at a reception given at the School of Dalcroze Eurhythmics I had a brief conversation with this surprisingly young septuagenarian. Originally a student and professor of music, he told me how, as a very young man, he conducted an oratorio of his own composition at the Queen's Hall in the second year of that hall's existence, how he gradually evolved his method of Eurhythmics, and how he decided to make this his life's work, realising that—to use his own words—"on ne peut pas servir deux maîtres au même temps." His struggles against prejudice and his disappointments were numerous, but he persisted with undaunted tenacity, and was well rewarded. Pupils came from all over the world, and to-day Eurhythmics forms part of the curriculum in many schools throughout Europe and the United States.



A Sedative to Nervous Children

His compositions include comic operas, orchestral and instrumental pieces written in the traditional style, music written for pageants and festivals, and innumerable folk-songs which have given him the title "le chansonnier du pays romand." Listeners who have heard some of Dalcroze's music may have discerned the beginnings of Eurhythmics in the folk-festival music, and few will disagree with the statement he made to me that in an age when the machine plays an increasingly important part in our life and even in art itself, it is more than ever imperative that the utmost efforts should be made by educationists and parents alike to calm the nervous system of our children, which is so adversely affected by the noise and rush of modern life. We must endeavour to give them a stable mental and physical equilibrium, and to perpetuate in their souls and minds the same desires and ideals that have proved of great value to the race.

M. Jaques-Dalcroze is a vivacious personality, and a lively and amusing conversationalist. He expressed very clearly his conception of the purpose and functions of musical art. I soon recognised that M. Dalcroze embodies two personalities: on the one hand, the educationist, the aesthetic, the creator of Eurhythmics, and on the other, Dalcroze the composer, the poet, the writer of folk-songs.

His seventieth birthday will be officially celebrated in his home-town, Geneva, during August, and some of these celebrations will, I have no doubt, again be broadcast from Sottens. Among other presentations to be made to him then is that of a book containing the signatures, collected from every part of the world, of all those who have learnt Eurhythmics.

N. M.

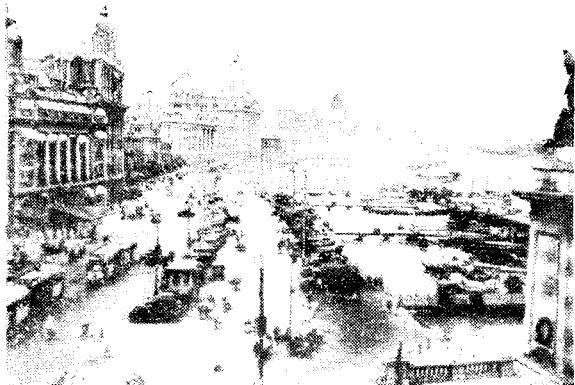

The waterfront at Shanghai

MIDWEST RADIO
ALL WAVE RECEIVERS
ALL MODELS NOW ON VIEW
(5, 7, 10, 16 and 18 VALVES)
—AT—
82, HIGH STREET, CLAPHAM, S.W.4.
Phone Macaulay 4948. Fully Illustrated Catalogue on Request.

TELEVISION

European Television through American Eyes

[Extracts from an address given by Mr. Andrew W. Cruse, Chief of the Electrical Equipment Division, Bureau of Foreign and Domestic Commerce, U.S.A. Department of Commerce, before the Thirteenth Annual Convention of the National Association of Broadcasters, at Colorado Springs, Colorado, on July 8, 1935. Mr. Cruse has just returned to America after a two months' study of television developments in England, Germany, and France.]

It was early in 1925 that Baird in England and Jenkins in this country succeeded in demonstrating the practicability of television, and almost hourly since then we have read that "television in the home is just round the corner"! For some unaccountable reason, this mirage of visual transmissions which has been dangled before the eyes of the public has failed to lose its novelty, despite this repetition.

On May 14, 1934, a new note crept into this "Television Story," when the British House of Commons announced the appointment of a Television Committee. This theme was built up to a terrific crescendo when, on January 14 of this year, the British Television Committee rendered its report.

But in the United States could be heard those incredulous persons who were—and, for that matter, still are—demanding: "What are we going to do about it? When are we going to have television in our homes? What is to be our answer to this challenge of our recognised leadership in the field of science?"

That, in brief, was the situation when, early in May, the U.S. Department of Commerce decided to make a study of the television situation in Europe—because by that time Germany and France were also in the picture—and advise the electrical and radio industries in this country of the exact state of affairs.

In England, the BBC is now offering low-definition programmes lasting from half to three-quarters of an hour twice each week. In this connexion, I wish to say that I think the BBC is doing an excellent job on these programmes, and I was pleasantly surprised to discover that, despite the low definition and objectionable flicker, these programmes do have an entertainment value for short periods—let us say of the order of half an hour.

When I inquired about the number of television receiving sets in service in the British Isles, the British Post Office people, who are in the best position to make an estimate, gave a figure of less than one hundred.

Now, as to the prospects for increasing the scope of British television in the near future. On June 7 the Postmaster-General announced that he had received "a communication from the Television Advisory Committee regarding the choice of a site for the projected London television station and other matters relative to the proposed experimental television service." You will note that the Postmaster-General refers to this as the "proposed experimental television service." The announcement goes on to state that the Alexandra Palace has been selected as the location, and that Baird and E.M.I. have been called upon to submit bids for transmitters to be used at that location. High-definition television receiving sets are expected to make an appearance about the time the bids for the transmitters are actually accepted. It is anticipated that their minimum price will be the equivalent of \$250.

You will probably be interested in the attitude which the motion-picture industry in Great Britain has taken toward television. I had the pleasure of discussing this question at some length with Mr. Alexander Korda, the well-

known film director. His reaction is that, at the present time, television is a distorted art, in that it presents figures on a small screen accompanied by sound on a normal level. It is his feeling—and he emphasised the fact that he is not a technical man—that some new development will be made which will permit the showing of television images on a large screen in the home, but even then he feels that the human psychological urge which has always made people enjoy their entertainment in groups in the atmosphere of the theatre will prevent television from becoming a serious competitor of the motion picture for a long, long time. On the other hand, Mr. Korda suggests that the motion-picture industry has developed so much in the technique of lighting, staging, and sound that it is to be expected they will be called upon to a great extent to assist in the development of studio technique for television.

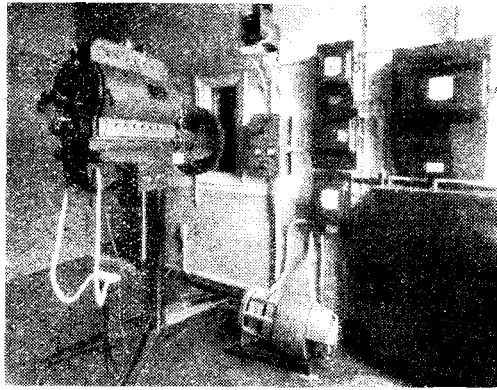

The scanning-room of W2XAB, a CBS television station

Ultimate plans call for the erection of transmitters to cover the principal population centres of Great Britain. The confidence of the prospective manufacturers of television receivers is reflected in the prediction that 50,000 of those sets will be in service by the end of 1936, and from five to ten times that number by the end of 1937.

One thing which impressed me greatly was that in all of these rather optimistic plans for the future of British television, the ability of the BBC to provide interesting programmes seems to be taken for granted. To my mind the whole success or failure of the project hinges on this point.

From London I went to Berlin, where I was most graciously received by everyone having anything to do with the development of television in Germany. At the present time they are giving 180-line, 25-frame sequentially-scanned transmissions from a 7-metre transmitter in Berlin. The Broadcasting Company provides a two-hour programme three nights a week, and the Post Office supplies programmes in the mornings and afternoons and on alternate evenings. Inasmuch as practically all the programme material is provided by films, repetition is not infrequent, and, occasionally, an old film leaves much to be desired. Generally speaking, however, the quality of these transmissions is excellent, and impresses one with the high entertainment value which can be secured with a 180-line picture. While the German engineers expect to carry on their experiments using 180 lines, they plan eventually to go to 270-line pictures.

The German Ministry of Propaganda are most interested in securing broadcast coverage in those areas which are now in "dead spots." They expect to cover those "dead spot" areas with ultra-short waves, probably using 7 metres, and equipping each new location with both sound

and television transmitters at the same time. In order to secure television coverage of the principal population centres of the entire country, it is estimated that twenty-five 20-kW ultra-short-wave transmitters will be required. A survey of the location of these transmitters has already been started, using a full power (20 kW) "transportable" transmitter for both sound and television. It is anticipated that these field-strength surveys will require approximately two weeks for each locality, and as soon as a locality has been approved, work on the permanent transmitter will be started.

At the present time, no high definition television receivers are being sold, but all the principal manufacturers are planning to show models at the August Radio Show—at which time they will be available for sale. They are estimating their 1935 sales to be one thousand receivers in the Berlin area, and it is anticipated that television receivers which will be adaptable to the 270-line standard will sell for from \$240 to \$500. In order to get these prices reduced as quickly as possible, one company has already laid out an assembly line, and is ready to go into quantity production in a very short time.

The Broadcasting Company have a very interesting piece of equipment which they call their "television truck," and which they use to cover news events. This truck consists of a low-powered, ultra-short-wave transmitter for both sound and television, using the intermediate-film method. The delay between the taking of the picture by the camera mounted on top of the truck and the time when that picture has been televised is approximately ninety seconds.

Television is moving ahead in Germany on what certainly appears to be a most thorough basis.

In France, the Ministry of Posts, Telegraphs, and Telephones is extremely interested in having its country match the television developments in England and Germany, and is doing everything in its power to speed up this work. They have started experimental 60-line 25-frame transmissions on 175 metres, and hope to be able to go to 90 lines, and then to 180 lines, as quickly as practicable, but I seriously doubt whether much progress in this direction will be made before 1936.

That, gentlemen, is the present stage of development of television in Europe. I might also mention that some work is being carried on in other European countries, notably Russia and Italy. So far, these developments do not appear to have progressed very far—but, mark my words, we are due to see an entirely different picture in the next two years, particularly in England and Germany.

Now then, what are we going to do about television in the United States? It is my own opinion that we should continue along our present line, and, in addition, closely observe the European picture. If I may be permitted to make a suggestion, I think you would be wise to appoint a committee here, at this Convention, whose duty it would be to keep you advised of developments. I might even go so far as to suggest the employment of an observer in Europe as an assistant to such a television committee.

In Europe, the Governments are directly or indirectly supporting and operating broadcasting and television; in the United States, it is my own personal belief that the interests of both broadcasting and television can best be served without Government assistance. With Recovery, and when you feel that the time is ripe for it, you will undoubtedly be able to add television to your present service. In the meantime, let us be patient observers!



JOHN BARTHOLOMEW & SON LTD
 DUNCAN STREET EDINBURGH
 Map Makers since 1826

FOR more than 100 years the Bartholomews of Edinburgh have been actively engaged in making the world's finest maps. Their name has always been identified with accuracy, clearness, beauty, and all that stands for progress in Cartography.

Write Now for Free 20 Page List

Are you an Athletic Man?
 ..then Benson's "TROPICAL" is the wrist watch for YOU!

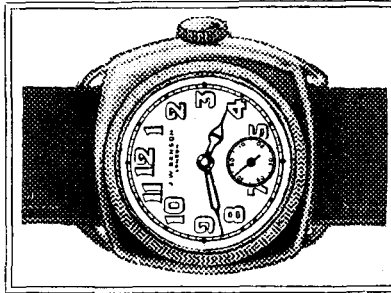

Benson's "Tropical" Wrist Watch. Supplied with crocodile, suede, pigskin or white linen strap. Solid 9-ct. gold £10.10.0. Silver £6.6.0.

IT'S YOUR ABSOLUTE PROPERTY for 6/- down

Benson's had the "Tropical" Wrist Watch specially designed for the active, outdoor man. It has a fully-jewelled, shockproof lever movement; a waterproof and sandproof case; and it is severely tested before receiving Benson's written guarantee of accuracy. For a reduced first payment of 6/- with order, the solid silver "Tropical" Watch is your absolute property. Balance of cash price of £6.6.0. payable in 12 monthly sums of 10/-; Solid 9ct. Gold Model (£10.10.0.) for 10/- down, 13 monthly sums of 15/- and final sum of 5/-. No interest charged. Post coupon NOW for FREE Wrist Watch Catalogue and Special Order Form.

WATERPROOF : SANDPROOF SHOCKPROOF

N.B. Overseas orders can be executed for cash on the C.O.D. or V.P.P. System where available. Benson's pay charges, postage and insurance.

OTHER BENSON OFFERS. Benson's also offer Pocket or Wrist Watches, Chains, Jewellery, Silver, Vitted Dressing Cases, etc., on easy monthly terms at cash prices. Post coupon for catalogues or call at Benson's showrooms in Ludgate Hill.

POST COUPON FOR FREE ILLUSTRATED CATALOGUES

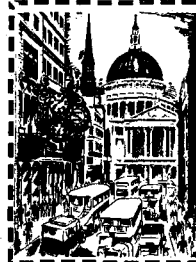

BENSON'S

THE ORIGINAL FIRM FOUNDED A.D. 1749

J. W. BENSON, LTD.

62 & 64, LUDGATE HILL, LONDON, E.C.4

Please send me, post free, the illustrated catalogue(s) I have indicated, together with full particulars of your "Times" System of Monthly Payments.

- A Pocket Watches Chains, etc.
- B Wristlet Watches
- C Rings & Jewellery
- E Plate, Cutlery, etc.
- F Clocks

Please put a **X** against Catalogue(s) required

NAME..... W.R. 19-7-35

ADDRESS.....

MAVOX
SHORT-WAVE
SUPREMACY

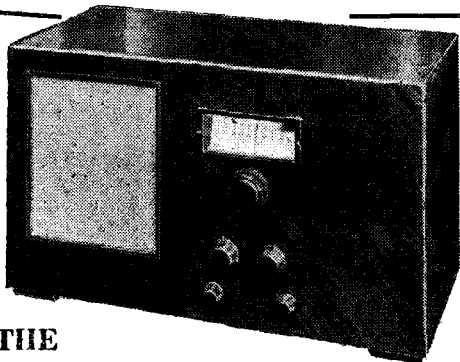

THE 'ETHER-CRUISER' 7

Powerful 9-Stage Superhet incorporating most modern multi-electrode valves, Tone Control, and A.V.C. Circuits.

Principal Short-wave Stations: —New York, Paris, Sydney, Bombay, etc., are actually named on the dial. They are as easy to tune to as your local Station. TYPE M7SA: 15-550 m., or ALL-WAVE, 15-2,000 m. figured walnut or mahogany cabinet.

A/C Mains from £29 - 8 - 0 Universal AC/DC £1 extra.

Battery Model £27 - 6 - 0

MAVOX RADIO (M.R.S.) Ltd.
 15-16, Alfred Place, London, W.C.1.

Telephone: Museum 7651 (5 lines)
 Cables: Mavradio

SPECIAL TROPICAL SHORT-WAVE MODEL

5-Stage Superhet in metal cabinet, separate M/C Speaker in teak, 15-550 m.

£18 : 18 : 0
 Battery or Mains.

B7S: 7-Stage Superhet in two-piece teak, 13-68 m.

£27 : 6 : 0

RADIOGRAMS: with "Ether Cruiser" chassis from

£44 : 2 : 0

Produced by Engineers with actual overseas experience.

Different clothes - but the same underwear

FREEDOM:

No 'binding' at the arms, no bunching at the waist. Small wonder sportsmen prefer this athletic underwear made of Courtaulds Rayon.



COMFORT:

Business men 'hard at it' in the City also choose this underwear. It never slides up your back. It never pulls round the legs.



YOUR underwear doesn't catch across the shoulders — doesn't restrict at the waist — when it's made of Courtaulds Rayon. That's because it's cut to give maximum freedom for movement—as desirable to business men as to sportsmen on the courts.

Even in the hottest weather this Rayon fabric keeps you fresh and cool — yet it gives you just the complete protection you need for sudden chilly days. It wears and washes wonderfully.

Get this new underwear today. It costs no more than you usually pay. You recognise Courtaulds by the Housemark inside each garment.



LOOK FOR COURTAULDS NAME AND HOUSEMARK

COURTAULDS OF COVENTRY

THE FIRM THAT PUT POWER IN A PACKET

Intricate masses of revolving, screaming metal and a million hands reaching for a million switches. Electricity—that was the name they gave it. And then—*Ever Ready made it portable!* The firm that filled cardboard packets with live, active, power-generating chemicals so that more than a million people might have radio in their homes—that was Ever Ready! To-day Ever Ready batteries are more than 30 years improved. They are produced from the biggest battery laboratories in Europe. Their power is greater. Their life is longer. They cost you less. *So today it is truer than ever that you can't do better for your set or yourself than depend on Ever Ready batteries.*

ASK FOR THE EVER READY 'WINNER'—
120 VOLTS 7/6 OR 'RADIO'—120 VOLTS 6/-

[Prices do not apply in Irish Free State]

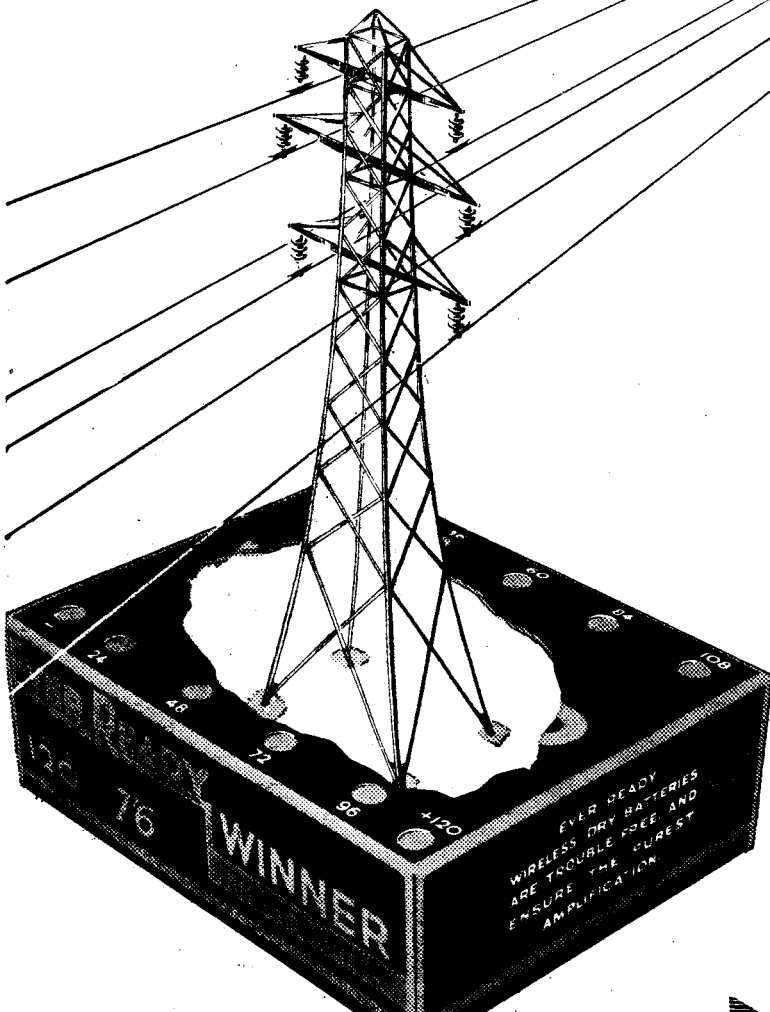

EVER READY
Regd. Trade Mark
RADIO BATTERIES

MADE BY THE EVER READY CO. (GT. BRITAIN) LTD., HERCULES PLACE, LONDON, N.7

World-Radio Station Identification Panels Booklet

New, completely revised edition

A practically complete list of Continental stations (in all 96 are listed) giving every detail—frequency, wavelength, power, call-sign, interval, and closing signal, distance and bearing from London, relays—that will assist reception and identification. Complete lists are given in order of wavelengths and frequencies of short, medium, and long wave stations. Ample margins are allowed for the entry of notes and dial readings: and an extremely useful broadcasting map (size 18" x 15") is included. Price 1/- post free from the B B C, Broadcasting House, W.1, or obtainable by order from your local newsagent or bookseller.

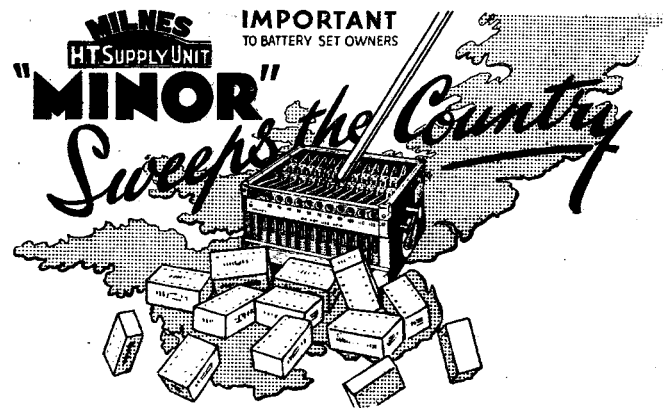

In seven years, 100,000 Milnes Units have been sold. But that success is as nothing compared with the future of the newly-introduced Milnes "Minor." It is possible, now, for every battery set owner to use a Milnes H.T. Supply Unit—to enjoy all-mains performance for years and years and to save money all the time. The Milnes Unit delivers ample, steady voltage H.T. current to any make or type of battery set, recharging itself automatically from the L.T. at a totally negligible running cost. It never runs down. It never wears out.

The "Minor" is smaller (no larger than many dry batteries) more efficient than ever on sets using up to 15 milliamps average H.T. current and much easier to buy. 120 volt model, £3.7.6 or 6/4 deposit and 12 monthly payments of 6/1.

Ask your radio dealer to demonstrate it on your own set or
POST THE COUPON
FOR FREE DESCRIPTIVE BOOK:

MILNES RADIO CO. LTD., Church Street,
BINGLEY, YORKS.
Please send your FREE BOOK about the
Milnes Unit. No obligation.

Name

Street

Town

County

PLEASE WRITE IN BLOCK LETTERS.
Stick coupon to envelope flap to avoid loss.

SEE IT AT
RADIOLYMPIA
AUG. 14 - 24
STAND 204

Keir Dawson—Bradford

TEN YEARS OF TECHNICAL PROGRESS

Microphone and Studio Problems

During the past ten years WORLD-RADIO has kept its readers informed of the latest technical developments in broadcast transmission and reception. Much of this information was given in a series of articles with the general heading of "The Technique of Broadcasting." It is interesting, at the present juncture, to see what advance has been achieved, in various respects, during the whole decade.

At the time that WORLD-RADIO was first published, the BBC was using, almost exclusively, studios whose acoustical treatment consisted of draping the walls and ceiling with light curtains hung in folds. Often several layers of curtains were used, because it was considered that the slightest "echo" was detrimental to quality in broadcasting; the idea that a certain amount of reverberation was necessary for the proper rendering of music was only beginning to be appreciated by broadcasting technicians.

One difficulty which was experienced in the use of these curtained studios was known as "bass blasting," or the excessive reproduction of the lower frequencies—at least so far as the electrical circuits were concerned. Thus, at the time in question, the over-modulation of transmitters owing to the effect of the bass instru-

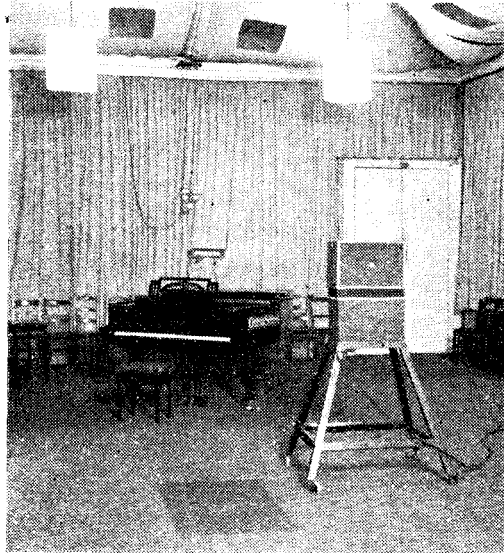

No. 1 studio and microphone at Savoy Hill in September, 1930

ments in an orchestra was by no means an infrequent occurrence, in spite of the care and dexterity of the controlling engineer. Many expedients, such as tents erected round the bass instruments in the studio, were tried but were only partially successful in overcoming the difficulty.

The reason for bass blasting is now known to be the comparative lack of the sound-absorbing properties of curtains for the lower frequencies, so that the old studios were not by any means free from reverberation, or "echo," in the bass register, and the intensity of the lower notes was correspondingly high.

Bass heaviness was partly compensated, however, by the lack of low-frequency response of the microphones used at the time and known as "magnetophones." This microphone was used in 1925 at nearly all BBC stations and consisted of a flat coil of fine aluminium wire moving, under the influence of the sound waves, in a magnetic field provided by an electromagnet. The latter was in the form of a "pot"

rather like that of the larger kind of modern moving-coil loud-speaker. The magnetophones were very insensitive and were troublesome to maintain, as the moving coil, mounted on thin paper, was stuck to a felt pad, between the pole pieces of the magnet, by vaseline associated with tufts of cotton-wool. The coil was very liable to become detached during transmission, as the studio, itself too small, became overheated, so melting the vaseline!

At the same time the Reisz carbon microphone, now rapidly becoming obsolete as far as broadcasting is concerned, was beginning to be considered as the last word in microphone design. As its response for the lower frequencies in particular was much better than that of the magnetophone, its use, although resulting in a general improvement of quality, tended to make the bass blasting problem even more troublesome than before. Thus the use of an improved microphone was partly responsible for the greater interest in studio acoustics which came to be taken about this time.

Considering for a few moments the end of the broadcasting chain remote from the microphone, the reader will remember that a good deal of listening was still done with headphones, whilst the average loudspeaker consisted of a somewhat elaborated and enlarged telephone earpiece attached to a horn of such dimensions as to reproduce very little below about 250 cycles per second, the frequency, approximately, of the fundamental component of "middle C." A few reed-driven disc or cone loudspeakers were beginning to be available, but they were practically unknown to the general listening public. The coil-driven cone loudspeaker, which to-day is almost universally used for broadcast reproduction, had, in 1925, still to be placed on the market in this country. It is perhaps not surprising that whenever critical listening was attempted, headphones were used.

As a contrast we may review, very generally, the lines on which development has taken place during the succeeding years. Considering studio acoustics first, studios are now specially built with a view to the exact purpose for which they are to be used and acoustical treatment is specified accordingly. Whereas, in the old days the only limit to the capacity of a studio was the number of performers that could possibly be crushed into the available floor space, the cubic capacity is now determined so as to give the optimum acoustical effect with the largest orchestra to be accommodated. The large Maida Vale studio, for example, has a volume of about 225,000 cubic feet and is suitable for up to 110 performers. The original "large" studio at Savoy Hill was only approximately 10,000 cubic feet in volume and suitable in reality for a maximum of 15 performers, though it was habitually used for many more than this number.

Measurements of the sound-absorbing properties of materials available for studio treatment and of the reverberation periods of completed studios have enabled studios to be designed and constructed so that the result heard by the listener is at least as good, acoustically, as that originating from a good concert hall. Many



Broadcasting House studio No. 8A

problems in building construction have been involved in the attainment of such a result, particularly in regard to the elimination of structural resonance.

Microphones of many types have succeeded the "magnetophone" and Reisz microphones. These have included about half-a-dozen different types of condenser microphone, but, strangely enough, the microphones most used to-day are really modifications of the magnetophone. Thus their principle of operation is the movement, under the influence of sound waves, of a coil or conductor in a strong magnetic field. Careful scientific design has, however, ensured that the response is practically independent of pitch or frequency over the important range. This was certainly not the case with the original magnetophone.

The latest type used is known as the ribbon microphone, in which the moving element consists of a ribbon of duralumin foil only one five-thousandth of an inch in thickness. This microphone possesses a great advantage over most earlier types in that its directional properties are such as not to distort the effect of reverberation, the result being a very natural acoustical effect.

The developments which have taken place in loudspeaker design are known, in general terms,

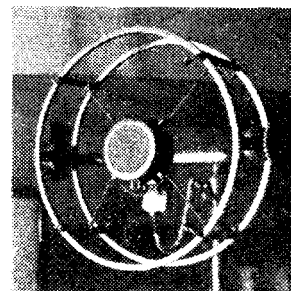

Modern moving-coil microphone in studio stand

to all listeners who take an interest in technical matters relating to broadcasting. The horn type of speaker has practically entirely disappeared for home use, on account of the large size of a horn necessary for good frequency response. It has been superseded

finally by the coil-driven-cone speaker, mounted on some kind of baffle to give adequate low-frequency response and sometimes accompanied by a special type of speaker to give good reproduction of the higher audible frequencies.

The improvements in the acoustical factors described—namely, studios, microphones and loudspeakers—have been responsible for not a little of the improvement in the quality of broadcast reproduction which has taken place during the past ten years.

Transmitters and Aerials

The first event of importance in a review of the progress of broadcast transmitter engineering during the past ten years is the opening of the long-wave National transmitter at Daventry in July, 1925. This station, known to listeners as 5XX, replaced an experimental transmitter at Chelmsford. The 5XX Daventry transmitter—which was replaced by Droitwich in 1934—was, at its inception, the most powerful telephony transmitter built up to that time, and the first broadcasting transmitter in this country in which the then new water-cooled-anode valve was used. In most other respects, however, the design and power plant followed the practice of that time, and the station as a whole possessed few novel features.

One very interesting point, however, which always attracted the attention of visitors, was the method adopted for insulating the anode water jackets from the water-cooling system. As is well known, the water jackets of the valves are at high potential above earth and the remainder of the water system at earth potential. In order to overcome this difficulty the water from the cooling system was sprayed into small insulated tanks which were, in turn, connected by pipes to the anode water jackets; the water leaving the jackets was similarly sprayed into other tanks. In this connexion it is interesting to note that water broken into a fairly coarse spray is a complete insulator provided the length of the column of spray is not less than 14in. This fact explains why a

fireman can turn a jet of water from a fire hose on to a 66,000 volt line without experiencing an electric shock. Although successful from the electrical point of view, this system was discontinued because the spray resulted in intense aeration of the water, with resultant troubles due to corrosion of the valve anodes.

The next important event was the decision to adopt the Regional scheme of transmission, which necessitated the establishment of 5GB, an experimental high-power medium-wave station. The design and construction of 5GB was begun in the latter part of 1926, and the design evolved served as a basis for the medium-wave transmitters used in the Regional scheme. In this transmitter certain new engineering features were introduced, some of which were evolved by BBC engineers. For instance, this was the first BBC station in which the process of modulation was effected at relatively low power. In this particular case, the power of the modulated amplifier was 100 watts. The 100-watt amplifier fed two further amplifiers, the final amplifier having an output of 25 kW.

This system has proved to be extremely reliable and satisfactory, although it may become obsolete in the future owing to the fact that new systems of modulation have been introduced which are more economical on the basis of power consumption and, at the same time, retain the high fidelity of reproduction afforded by the low-power modulation system.

At 5GB the BBC made use, for the first time, of direct-current generators to supply the necessary high potential for the anode of the

high-power valves. Two experimental machines were constructed, each having an output of 40 kW at 10,000 volts from one commutator. The experience gained from the use of these machines led to the decision to adopt this form of high-tension supply for the Regional transmitters. At this date many considered the use of this type of machine as entirely novel, but it is interesting to note that direct-current machines generating potentials of 10,000 volts were used at wireless stations as early as 1908. High-voltage machines of this type are almost entirely a British development, and have not been used to any extent in America or the Continent.

As mentioned previously, the Regional transmitters were designed as an outcome of experience gained in the operation of 5GB, and the construction of the twin transmitter at Brookmans Park was started late in 1928—the Regional transmitter began regular programmes in November 1929, while the National transmitter began in March 1930. This was the first station in which the BBC installed complete

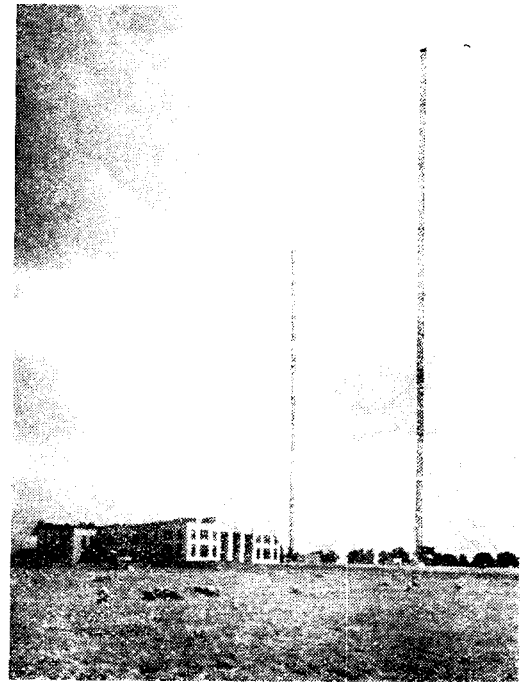

General view of Droitwich station

generating equipment—four 300 H.P. Diesel engines driving 220-volt D.C. generators.

The design of this station was adopted as standard for the Regional transmitters constructed at Moorside Edge, Falkirk, and Washford Cross. These stations were constructed at intervals during the ensuing three years.

Design work in connexion with the new Droitwich station was begun in 1932. This station represents another step in the evolution of the broadcast transmitter, the most important advance being the adoption of what is called the "series modulation" system. In this system the modulator valves are placed directly in series with the oscillator valves instead of being coupled in parallel by a high inductance which was the system adopted hitherto.

Further, the question of the effect of the electrical characteristic of the aerial upon the frequency response of the station was taken in hand, and the BBC Research Department evolved an electrical network which had the effect of improving the response up to 7,000 cycles per second. The Droitwich station, working on a wavelength of 1,500 metres, gives quality comparable with that obtained from stations working at wavelengths within the medium waveband. Local generation was again adopted at Droitwich and four 750 H.P. Diesel engines were installed. Owing to the higher output it was decided to adopt alternating current at 415 volts, 3 phase, 50 cycles.

The design and construction of a further series of stations to serve Northern Ireland, North Scotland and the area around Newcastle was begun in 1934.

An important development in broadcasting engineering occurred in 1932 when the Empire short-wave transmitter was constructed at Daventry. This station was opened in December, 1932, and replaced the G5SW experimental transmitter which had been operated at Chelmsford from November, 1927. Two transmitters were installed, each having a power output of about 10 kW and provided with rapid wave-change facilities, enabling the transmitters to be worked on a number of wavelengths from 13 to 49 metres. Associated with the transmitters was a complete system consisting of 14 directional aerials.

Since the inauguration of this station, the BBC has conducted a long series of experiments to determine the most suitable type of short-wave directional aerial for broadcasting to the Empire, and the design of the new Empire station which is contemplated will be based on the result of these experiments.

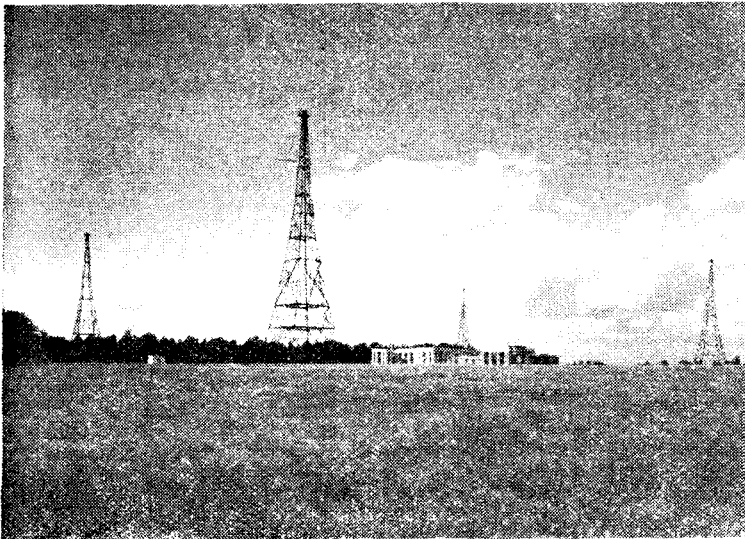

(Above)—Brookmans Park, the first dual-transmitter Regional station. (Below)—Original 2LO transmitter

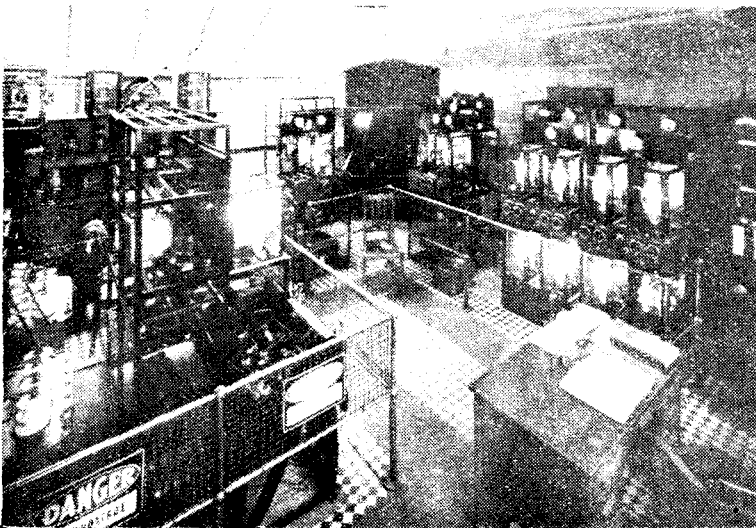

Valve Development

It is of great interest to glance through a list of valves issued in 1925. The old war-time "R" valve was still being marketed, but at the much reduced figure of 8s. "Dull emitter" valves such as the D.E.6 and D.E.3 were at the peak of their popularity. On the transmitting side, silica and metal-glass valves had already made their appearance, but the very largest of these could not handle a power of more than 10 kW. The first four-electrode receiving valve was already on the market at that time, and sold for nearly £2, but the object of the extra electrode was not so much to act as a screen between grid and anode as to enable a very low anode voltage to be employed, which was often obtained from a dry battery of about 4½ volts. It should be especially noted that so far as the so-called "dull emitter" valves were concerned, these were nearly all made with thoriated tungsten filaments, and were much less efficient than the modern coated filaments. Even so, valves taking such a small filament current as 0.06 ampere were very popular. This popularity was, however, very short lived, owing to their extremely fragile nature and very low efficiency.

Valves fitted with indirectly-heated cathodes did not make their appearance for some years after this time, and they were preceded by small directly-heated valves with short, thick filaments which to some extent tended to eliminate the ripple caused by heating filaments with alternating current.

Undoubtedly the two greatest contributions to receiving valve technique have been the development of the indirectly-heated cathode and the screened-grid valve; and from these two developments all major improvements proceeded. The indirectly-heated cathode enabled an equipotential emitting surface with a much more copious emission to be produced, while the screened-grid valve led to the development of stable H.F. amplifiers with very large stage gains and very little feedback.

It is interesting to trace the developments step by step. First, it was found that coating a tungsten wire with certain oxides and rare earths produced an emission many times greater than could be obtained even from a heated thoriated tungsten wire. While this discovery alone enabled directly-heated valves with much improved performance to be produced, it also prompted the idea of insulating the heated tungsten wire from the emitting oxides and thus the first indirectly-heated valves were produced. In these, the tungsten heater was actually air-insulated from the rare earths which were coated on a metal tube. Silica insulators were introduced and latterly the insulation has been obtained by coating the heater wire with magnesia and threading it without further insulation into the tube on which the emitting oxides are pasted.

Concurrently with the improvement of the indirectly-heated cathode, the development of the screened-grid valve was taking place. The discovery that a screen could be introduced between the grid and anode, and connected to the high-tension supply so that it did not impede the progress of electrons from cathode to anode, removed almost completely the back-coupling due to the capacity between anode and grid. Previously this back-coupling had to be "neutralised" by means of small condensers, but such an arrangement was unsatisfactory, as only quite small stage gains could be employed. The introduction of the screen, however, enabled

valves to be produced having close-mesh grids and very high stage-gains were available.

The development of the pentode, the heptode and the other multi-electrode valves soon followed, and necessitated bases and holders having more than five contacts. To-day the seven-contact base is common, while the nine-contact appeared a year ago. Many minor improvements in technique have taken place which are too numerous to mention in detail, but the greatly-improved rigidity of modern valves and the absence of microphonic trouble is largely due to the mica bridges used for spacing and bonding the electrodes, while improved "gettering" technique has enabled a much-improved vacuum to be obtained.

No less remarkable improvements have taken place in the development of transmitting valves. Valves can now handle a power of 150 kW, and work with anode voltages of 20,000 volts or more. Smaller dull-emitter filament valves can handle power up to 2 kW, while screened-grid transmitting valves have been developed for use in the early stages of transmitters, thereby saving one or more stages. The air-cooled-anode type of transmitting valve for small powers has also recently been developed. This is a valve made on precisely similar lines to the larger water-cooled anode

valve, but has its anode ribbed and cooled either by free radiation or by a forced blast of air. This type of construction has many advantages, par-

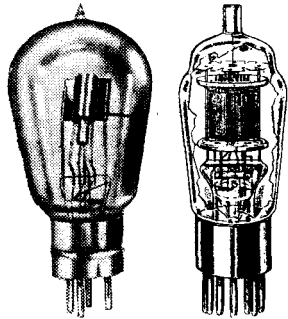

First indirectly-heated valve and (right) octode electron-coupled frequency changer

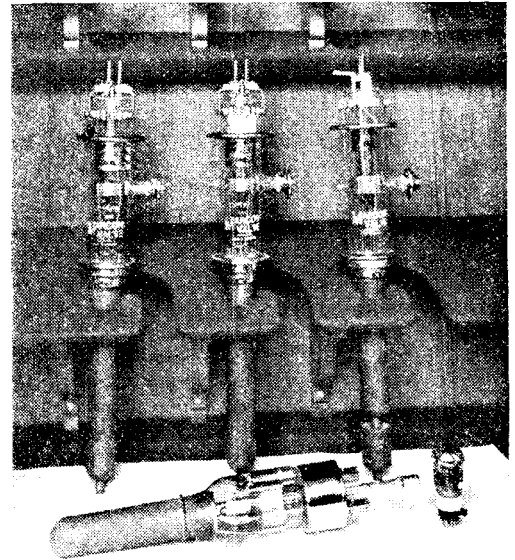

Spare water-cooled transmitting valves at Brookmans Park and a typical receiving valve

ticularly for use in aircraft and similar positions where the saving of space is of first importance.

Developments in valve technique go on unabated, and to-day developments in cathode-ray tubes and photo-electric cells have enlarged the field still further. On both the transmitting and receiving side, development of special valves for ultra-short-wave transmission and reception is being actively pursued, and undoubtedly there will be much activity in this direction for the next few years.

Receiver Design

An important characteristic of the changes that have occurred in receiver development during the past decade is the gradual elimination of the amateur's individual efforts by the professional mass-produced article. Broadcasting was supported, during its initial period, as much by the novelty and the technical interest which it aroused, as by the entertainment value of the programmes. A considerable proportion of listeners gained pleasure—and profit—equally from their constructive efforts at receiver design as from the programme matter to which they listened.

The commercial receiver of the period was limited by restricted sales and lack of technical development to a performance easily equalled, and a design easily copied, by the home constructor at a considerable saving in cost. There was, therefore, at this period, a ready sale for kit-sets and components.

A wireless dealer was, in the main, a stockist of component parts, such as condensers, valve holders, terminals, and ebonite sheets. The steadily increasing market for the commercial product has, however, enabled the manufacturer to introduce constructional methods that are not available to the amateur. The adoption of the press tool and the drilling jig now permit quantity production and competitive prices.

The continuous technical development and the resulting complexity of circuits, together with the institution of standards of performance and the utilisation of reliable testing equipment, have all combined to revolutionise the commercial product. The manufacturer can now produce a

receiver which—when housed together with the loudspeaker in an attractive cabinet—has very little in common with its forerunner of ten years ago, either in regard to performance or appearance. The technical developments that have taken place throughout the last ten years represent a continuous progress towards the ideals of simplicity and efficiency.

The early receivers had everything adjustable. Filament resistances were provided to every valve, ganged condensers were unknown, and plug-in coils, with all their attendant inconveniences, were in general use. The first to disappear were the filament controls, which became unnecessary when valve manufacturers appreciated the convenience of standardising filaments in terms of lead accumulator voltages. Plug-in coils were gradually replaced by more compact dual-wave components, and the development of ganged condensers with ganged switch-coil assemblies increased considerably the compactness of receiver design. The progress of eliminating unnecessary controls developed from the obvious to the ingenious. In order to reduce the number of knobs to an absolute minimum, devices such as mounting a wavechange switch on a condenser shaft or combining the volume control with the battery switch, were produced.

Receiver circuits in 1925 were restricted by the limited choice of valves. High-frequency amplification, using the triodes which were available at that period, was a process which required considerable technical skill to achieve satisfactorily. The neutrodyne circuit was developed as an aid to stability, but complications of adjustment prevented its universal adoption. Intermediate-frequency amplification was found to be practicable, and this period saw the develop-

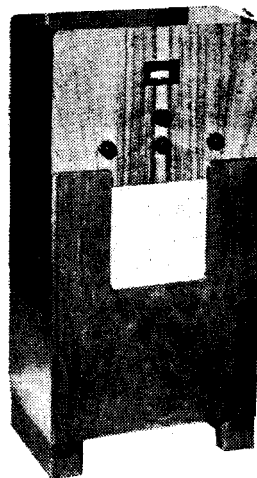

A good example of a modern mains-driven receiver

ment of imposing superheterodyne receivers using seven or eight valves with as many as three stages of intermediate-frequency amplification. The overall sensitivity was, however, no better than a modern four-valve receiver, and the standard of reproduction was appreciably lower.

Such receivers fell into disrepute by reason of the excessive sideband cutting occurring in the intermediate-frequency circuits. It is only recently that the development of band-pass tuning and tone-correcting circuits has provided the means of restoring the superheterodyne receiver to general popularity. The difficulties of obtaining satisfactory high-frequency amplification also encouraged the production of sets having an abnormal degree of audio-frequency amplification. The resulting low signal level at which rectification took place, together with the unsatisfactory response curves of many commercial transformers, produced a very inferior type of reproduction.

The advent of the screened-grid valve gave an impetus to the development of a three-valve receiver circuit in which one high-frequency amplifying stage was provided and one audio-frequency stage. This type of receiver enjoyed considerable popularity for a number of years, and is only now being deposed by the modern superheterodyne with its very much greater sensitivity and selectivity—a development which has been greatly facilitated by the introduction of the new and efficient multi-electrode valves.

Improvements in loudspeaker design have proceeded simultaneously with receiver development, and a state of technical development has at last been reached where ideal reproduction may be claimed as a commercial possibility. The weaknesses of modern receivers—which still have their faults—are due to the vagaries of the public demand and to the conditions of operation rather than any lack of technical knowledge or development on the part of the commercial designers.

The Growth of Television

By 1925 the experiments of Mr. John Logie Baird had reached the stage when he could give a demonstration of the transmission of the outlines of the simplest subjects. This was given in April of that year and was the first public demonstration of television in this country. The apparatus used, which is now in the South Kensington Museum, had much in common with that used in the present 30-line system, but differed in that the "floodlight" instead of the "spotlight" method was used. It was not at this time possible to televise the human face, but this rapidly followed and was demonstrated in January of the following year. Continuing his work Baird transmitted television across the Atlantic early in 1928. Later in that year he

marked the beginning of experimental public television in this country. These transmissions were unaccompanied by sound, but by the following year the London Regional dual-wave station was in existence. This provided the two channels, which were used for the first simultaneous vision and sound transmissions on March 31, 1930.

These transmissions originated in the Baird studio in Long Acre, being treated as outside broadcasts. Meanwhile, Broadcasting House was being erected and provision was made for the possible transmission of television from one of the basement studios. In the summer of 1932 this studio was fitted with Baird 30-line apparatus, and regular transmissions started on

August 22 of that year. These are still continuing, although not from this particular studio, as the BBC constructed a studio, specially designed for television and incorporating the results of their experience, at 16, Portland Place, this studio being brought into use in February, 1934.

As a result of research on cathode-ray tubes, A. C. Cossor, Ltd., in 1931, conceived an entirely new system of television known as the "velocity modulation" system. A paper describing the system was read before the Institution of Electrical Engineers in February, 1934.

In 1931 also, Electrical and Musical Industries, Ltd., demonstrated a system of television at the exhibition of the Physical

Society. In this system the principle of dividing the picture into a number of zones, and of transmitting each zone individually over a separate channel, was used to increase the definition. Experimental work using 120 lines soon followed, to be superseded in turn by systems employing 180 lines, 240 lines, and eventually 405 lines interlaced to give fifty pictures per second; which is the present standard adopted by that company.

The Baird company had also been developing improved systems employing 120 lines, 180 lines, and eventually 240 lines at twenty-five pictures per second, which is their present standard.



Louie Frear, in first television broadcast—August 22, 1932

With the adoption by these and other investigators of progressively higher standards of definition, it became clear that, apart from the fact that the sound broadcasting waveband of 200-2,000 metres was already fully occupied, it was impossible to design a station for such wavelengths which would transmit high-definition television, and that such stations would have to operate on wavelengths not longer than about eight metres. Concurrently with research on the studio requirements of television, much attention was given to the special problems of ultra-short-wave transmission.

The nature of public television necessitates the avoidance of frequent changes in technique which would be liable to involve the immediate obsolescence of receivers. Consequently, any improvement in the present low-definition service must be effected, preferably, in one single leap to a higher standard. The position by the summer of 1934 was that the experimental low-definition service was carrying on, though without any guaranteed duration. A number of firms had vastly improved systems available at their laboratories, and were naturally anxious to commercialise the results of their efforts.

The Postmaster-General, in May, 1934, appointed a Committee "To consider the development of Television and to advise the Postmaster-General on the relative merits of the several systems and on the conditions under which any public service of Television should be provided." In January, 1935, this Committee reported that high-definition television had reached such a stage of development as to justify the first steps being taken towards the early establishment of a television service of this type, and that a start should be made by the erection of a station to provide a public experimental service for London. Further, Baird Television, Ltd., and Marconi-E.M.I. Television Co., Ltd., should both be asked to provide apparatus for this station, which would divide its programme time between the two systems.

A further provision was that the P.M.G. should appoint an Advisory Committee to plan and guide the initiation and early development of the television service and that the service be entrusted to the BBC. The report was accepted and development is proceeding on these lines. The Advisory Committee have announced that the Baird system will make use of sequential scanning in 240 lines at twenty-five pictures per second, while the Marconi-E.M.I. Co. will use interlaced scanning in 405 lines and fifty pictures per second.

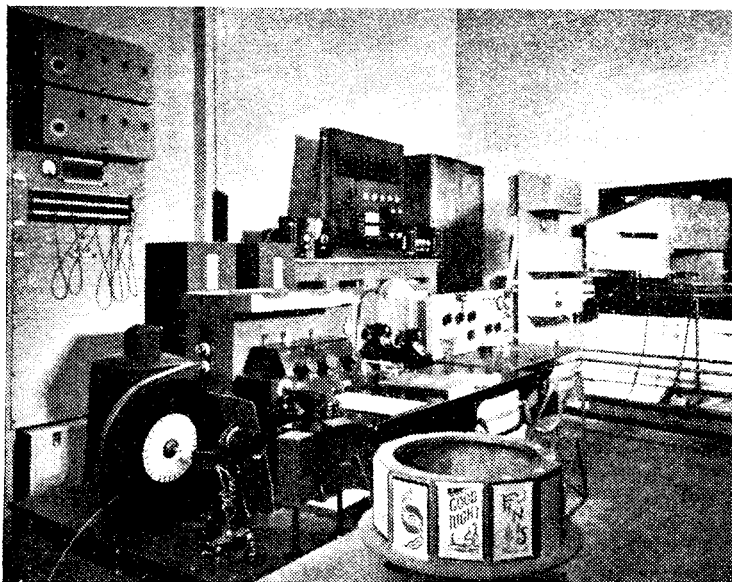

Present television control room with scanning projector on right

demonstrated the possibility of televising objects in ordinary daylight, also colour and stereoscopic television.

Negotiations were begun with a view to instituting regular broadcasts of television by the BBC, and these came to a successful conclusion in 1929. It will be remembered that, at that time, the London Regional Station at Brookmans Park was not in existence, and that London was served by the relatively low-power station (2LO) situated on the roof of Selfridge's building in Oxford Street. On September 30, 1929, the first television programme was radiated from Oxford Street and

Short-Wave Progress

THE first ten years of WORLD-RADIO's life has coincided with a revolution in the art of communications engineering, brought about almost exclusively by the use of short waves. Communications engineering includes broadcasting, and in the field of inter-continental broadcasting—for which short waves are used—the present position in 1935 is not dissimilar in some ways from the position of national broadcasting at the birth of WORLD-RADIO in 1925.

The short-wave "revolution" as it may well be called, had started before 1925, signals from America on wavelengths under 200 metres had been heard in Europe in 1921, while they were heard at the Antipodes in 1922 and 1923. By 1925 there were already one or two experimental short-wave broadcasting stations—the most noteworthy from the British listener's point of view being KDKA at Pittsburgh, Pennsylvania, which worked on 62.7 metres, and which was heard in this country with some regularity, if not with great clarity.

The British Broadcasting Company, as it then was, attempted to relay programmes from this station, and although partially successful, the results were not particularly good. In striking contrast, ten years later, in 1935, the "Five Hours Back" series was sufficiently well received to form a definite programme feature. The modern counterpart of KDKA, the present-day short-wave broadcasting station W8XK at Pittsburgh, was used for some of these relays.

Other early experimental short-wave broadcasting stations which soon became well known to the early short-wave listener were 2XAD and 2XAF at Schenectady, working on approximately 31 and 20 metres respectively; PCJ at Eindhoven, Holland; VK2ME, Sydney, Australia; and, at the end of 1927, G5SW at Chelmsford.

This last station was the forerunner of the Empire broadcasting service established by the BBC at Daventry in December, 1932. Two transmitters were installed there, each capable of working on wavelengths in all the short-wave bands, namely, 14, 17, 20, 25, 31 and 49 metres, the signals being directed to the five zones into which the Empire was initially divided. This service has received the compliment of imitation in other countries, until to-day short-wave listeners in almost every part of the world can receive one or more broadcast programmes at some period of each day, generally at a convenient local listening time. Further developments of these short-wave broadcasting services have recently been announced, and WORLD-RADIO of May 24, 1935, contained a description of those which are in process of being carried out at Daventry.

An account of the development of short-wave broadcasting would be incomplete without some reference to the receiving side. On the transmitting side, development has been very largely the application of broadcasting of principles and methods already fully exploited in commercial telegraphy and telephony. On the receiving side it is a little different, since the recent rapid growth in the number of short-wave listeners is, to some extent, the result of the production of very efficient and easily-operated receivers in large numbers by mass production methods

previously developed for the manufacture of medium- and long-wave broadcasting receivers. Indeed, the present trend is for broadcast receivers to be "all-wave," and in the United States of America and Canada very few receivers are now sold which do not include one or more short-wave bands.

The modern American superheterodyne receiver covers a band of wavelengths from 9-2,000 metres in five switched ranges, the only gap being between 600 and 800 metres, where the intermediate frequency is placed. From ten to twenty valves are used, automatic volume control, visual tuning indication, variable selectivity, single-knob tuning and all-mains operation are provided. In 1925 a short-wave receiver generally used a single-valve detector with reaction, followed sometimes by one low-frequency amplifier. Head-phone reception was the rule, and hand-capacity effects generally made the operation of the receiver rather difficult. To-day, all-wave receivers can be operated by the unskilled, but tuning on the short-wave bands still requires more

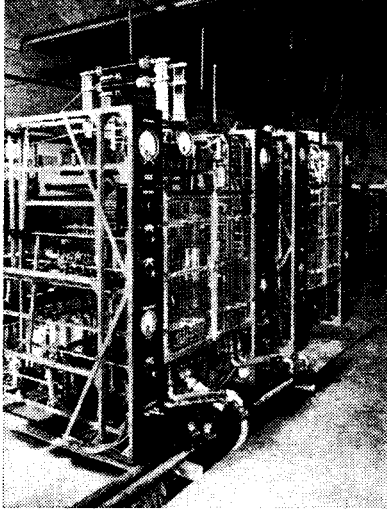

A British short-wave pioneer transmitter—G5SW

care than is desirable, and future development will undoubtedly be towards further simplification of tuning.

In writing for WORLD-RADIO of ten years' development of short waves, it is natural to consider first the developments in short-wave broadcasting. This review would, however, be incomplete without reference to the commercial communication services. In July, 1924—just prior to the opening of the last decade—the outstanding landmark in short-wave development was the signing of the Marconi beam contract with the British Post Office. The Beam telegraph stations were developed and built during the ensuing two years, and the services were opened—to Canada in October, 1926, to Australia in April, 1927, to South Africa in July, 1927, and to India in November, 1927.

The guaranteed traffic capacity of these short-wave channels was far greater than anything before known in wireless or submarine cable circuits, and their opening and successful operation resulted in considerable loss of traffic to the cable companies. It was obviously better that both methods of Empire communication should co-operate rather than compete, and in consequence a Government sponsored merger was planned—Imperial and International Communications taking over the cables of the Eastern Telegraph Company, the Imperial Cables, the Beam stations and the Marconi Services in 1928.

Apart from broadcasting, the development of short-waves which has been followed with greatest interest by the general public is undoubtedly the extension of the telephone services of the British General Post Office to the point reached to-day, where it is possible to talk from any telephone in this country to most countries of the world. Short-wave radio links, from the Post Office transmitting station at Rugby and to the receiving station at Baldock, link up the telephone systems of this country with those of countries in North and South America, with the Dominions, with India, with Egypt, Palestine, and with Japan. Furthermore, it is possible to talk over the telephone to certain ships at sea which carry the necessary apparatus.

The opening ceremonies of many of these links have been broadcast to British listeners, and they are frequently used to bring contributions to BBC programmes from all over the

world. The Christmas Day and Jubilee "Twenty-Five Year" broadcasts were made possible only by the use of these radio links. The rapid development of these services is illustrated by their opening dates, which are as follows:—to the U.S.A., January, 1927. This was a long-wave single-side-band circuit which was followed later by short-wave circuits, so that there are several circuits to New York and a twenty-four-hour service is available. To Australia, April, 1930; to South America, December, 1930; to New Zealand, July, 1931; to South Africa, February, 1932; to Canada (direct), July, 1932; to Egypt, June, 1932 (later extended to Palestine); to India, May, 1933; and to Japan, March, 1935. The service to ships at sea in the North Atlantic was inaugurated in 1930, and at the present time some fifteen ships are fitted. These radio-telephone services are available to all European countries through the G.P.O. international exchange in London.

We have dealt with short-wave development from the practical point of view, but it must not be inferred that great strides have not also been made on the scientific side. In fact, the past ten years have furnished a mass of information and evidence on the influence of the ionosphere on the propagation of wireless waves. The work of Appleton and T. L. Eckersley in particular has been of major importance in this sphere. The term "ionosphere" was originally suggested by R. A. Watson Watt.

The application of short waves to radio telephony and broadcasting has revolutionised the art of communications in the last decade by making speech communication possible from one end of the world to the other.

Space and Matter

By "NEUTRON"

A New Electrical Unit System

THE International Electrical Commission, which has just concluded meetings at The Hague and Brussels, has decided to adopt the Giorgi-MKS system of electrical units, the proposals for which were first published by Professor Giorgi in 1901. This system is based on the metre, kilogram, and second, and existing electrical units can easily be expressed in terms of it as it is essentially composed of units already in practical use. Existing practical units instead of being 10^8 , 10^9 , 10^1 , etc., times the absolute units, as they are in the old C.G.S. system, will bear a one-to-one relation so that there will be no need to memorise the numerical conversion factors as in the past. The introduction of this additional system of units might appear to a harassed student to add still more confusion to that which exists as a result of the various different systems already in use. It is to be hoped, however, that the purpose of the new system will be fulfilled, and that easy conversion from one system to another will be possible without considerable mental effort and recourse to tables of units.

Photo-Cells and Escalators

Wear and tear on escalators such as those used on underground railways can be minimised by keeping the speed slow during slack periods. This is being done by the use of photo-electric cells. A beam of light across the entrance to the escalator is interrupted when a passenger arrives, and the photo-cell on which the light normally falls then speeds up the escalator. This is done in several stages so that the passenger does not notice any sudden change in speed. When he arrives at the top the speed falls again unless other passengers have arrived in the meantime, in which case the high speed continues until the last passenger has had time to reach the top.

WORLD RADIO RESEARCH LEAGUE: SECRETARY'S REPORT

News from Everywhere

Argentina

OUR Hon. Secretary for Argentina, Mr. G. Hunt, has been in the wars. Somebody started an argument in the Buenos Aires *Herald* as to who hears Big Ben first—a passer-by on Westminster Bridge or a listener in Buenos Aires. A number of people aired their views, some taking the part of the night stroller on Westminster Bridge, some defending the Argentine listener. Up to the moment, nobody has won, the last word being with Mr. Hunt, who suggested that if there were any doubt, their best plan is to join the W.R.R.L. and learn all about it. Mr. Hunt, who is an Englishman residing for the last thirteen years in Argentina, is the official listener out there for one of the largest news agencies and a number of newspapers. He has an elaborate listening equipment, and his reports go to all corners of the earth.

He tells me that as far as Argentina is concerned there are some eighteen broadcasting stations working between 222 and 508 metres in Buenos Aires alone, with some nineteen low-power transmitters scattered all over the Republic, most of which are inaudible in the capital. At the present moment there is only one short-wave transmitter utilised for broadcasting purposes, this being LSX of the "Transradio Internacional," working on 28.99 metres. A further short-wave transmitter is under construction, and will be operated by one of the local newspapers, the *El Mundo*. Mr. Hunt promises to send full particulars when this station is in operation. Reception conditions in Argentina are generally bad, and as far as our friend's experience goes, are second only to those experienced in the Persian Gulf. The atmospheric conditions are rarely good, there being seldom a day entirely free from atmospheric disturbances, even in mid-winter, when such disturbances are at a minimum. In spite of all these difficulties our Argentine members are doing excellent work under the leadership of Mr. Hunt, whose reports are invaluable.

I have just received another letter from Mr. Hunt in which he tells me that preliminary tests of the *El Mundo* transmitter will be taking place about now. I do not yet know the wavelength, but I wonder if our short-wave operators will hunt for the station in question and discover it. Unfortunately, listening will have to be done after midnight at about 04.00 (G.M.T.), and is only possible for early risers.

Belgium

OUR Hon. Secretary for Belgium, Mr. G. Ashdown, is once more in the throes of his examinations and is taking his final this time. As on completion of his studies he hopes to find a position at home, and settle permanently in this country, his duties as Hon. Secretary of the W.R.R.L. and the *Ligue Universelle de Recherches Radioelectriques* will be taken over by his colleague, M. Roger Allard, whose call-sign is ON4RA. M. Allard, in addition to his engineering qualifications, is a possessor of a telegraphy certificate (École Professionnelle de Radiotelegraphie de Bruxelles) and is thus an expert wireless operator. His address is 131, Rue Vanderkindere, Bruxelles.

I thank M. Allard on behalf of all the members of the League for taking up our interests in Belgium and for consenting to become our Representative there in an honorary capacity. At the same time I wish to express to Mr. G. Ashdown our warmest thanks for all he has done for us during the last year and to tell him that we shall be delighted to see him back in this country.

Finland

MR. Walter Sarkki, of Helsinki, Finland, whose name many of you remember from my past reports, has been good enough to send me copies of a local paper, *Radio Oh*, in which appear a three-page article on W.R.R.L., written by Mr. Sarkki in one issue, and a two-page article under the title, *Suomalaiset radioamatoorit mukaan radiokauka tutkimaan* (this is surely self-explanatory!), and which deals with our tests on echoes of long delay, written by Eng. Sainio, the President of the Finnish Radio Amateur League. I am very grateful to these two gentlemen for their work on our behalf in Finland and trust that very shortly we shall be welcoming a large number of Finnish experimenters within our ranks. I can assure them they will meet with a very warm welcome indeed. I must add that, thanks to our friend, I am a proud possessor of a beautiful album of views of Finland which is one of the most picturesque countries in the world.

France

I am happy to be able to announce that I had the honour of receiving a letter from M. M. Tourrou, Vice-President of the R.E.F. at Bordeaux, who offered us the co-operation of the Bordeaux section of the R.E.F. The local transmitting circle is doing great work in day-to-day observations of propagation of wireless waves and we have been offered a regular supply of their reports in the immediate future. This unexpected addition to our forces is of the greatest possible value to the W.R.R.L., and our thanks are due to M. M. Tourrou not only for his kind interest in our work and his help, but also for placing the W.R.R.L. on the mailing list of the paper, *Radio-Ref*, which is highly interesting from the technical point of view.

Our thanks are also due to M. Ch. Lambert, *Secrétaire Général de Réseau des Emetteurs français*, of Paris, who is sending us the copies of the *Radio-Ref*.

Philippine Islands

OUR energetic ex-Hon. Representative for Spain (and our present Hon. Representative for the Philippine Islands) has safely arrived at Manila and has already started sending in the names of new members from that town. The gentleman in question is, of course, our old friend, Señor F. Michel de Champourcin, of whom you have heard from me before. Our good friend does not let the grass grow under his feet, and his letters and reports are as lively as ever. We wish Señor de Champourcin every success in his new sphere of action, success that he so richly deserves. We shall soon be having some interesting news from Philippine Islands!

Malta

OUR Hon. Representative for Malta, Mr. Joseph Mercieca, has been having a very rough time, as Mrs. Mercieca has just gone through a dangerous illness. I am pleased to be able to say that the good lady is well on the road to complete recovery and, with her husband, is having a holiday. Mr. Mercieca has done some exceedingly good work in Malta. His weekly reports, usually of full column length, in the *Malta Chronicle*, and his articles in the Italian journal, *Radiocorriere*, have done a great deal in the cause of the W.R.R.L. It is interesting to note that Mr. Mercieca is ably supported in the latter journal by our Hon. Representative for Sweden, Mr. Eric Italianer, who also contributes from time to time.

RALPH STRANGER.

Technical Reminiscences

ELSEWHERE in this tenth anniversary issue of *WORLD-RADIO* the technical progress of broadcasting is reviewed in considerable detail. In this short article I propose to refer to a few of the more familiar technical matters which have affected the ordinary listener. In so doing I shall, no doubt, remind some of the old readers of what we—for I also am one of the old hands—look back upon as "those days" and may, at the same time, cause the newer generation to appreciate the present-day facilities for work which has been done to make present-day wireless reception so satisfactory.

It will, no doubt, surprise many to learn that in the first issue of *The Radio Supplement* (July 17, 1925) the elementary principles of the superhet were described and a 7-valve receiver, complete with necessary frame aerial, was illustrated.

The lot of the distant listener was not altogether a happy one in 1925, the use of sensitive but very unselective receivers giving rise to a long correspondence, the nature of which will be understood from the following short extracts from the issues of September 25 and October 2, 1925:—

"... in order to enable listeners to receive foreign programmes, it would only be necessary to close down each local station for a period of two hours on one evening every week."

"It is all very well to consider the democratic crystal sets, but not to let them swamp the valves; it is neither businesslike nor fair."

And does not the following, on the same subject, illustrate the spirit of *WORLD-RADIO* readers—present and past?—

"I must say that though 2LO is everything that can be desired, we old hands are not satisfied with having ourselves fed, so to speak, but wish to search for our programmes. Getting a station from far off in your 'phones has more thrill attached to it than just putting on your 'phones or loudspeaker and getting your local station without asking for it."

Imagine a properly-equipped listener of to-day having to wait until London closed down before he could listen to the late-night concert from Cologne!

Technical, as well as general, interest in the development of European broadcasting has been provided for from the earliest days of *WORLD-RADIO* by detailed descriptions of the various stations and their equipment, both British and Continental. Among many such descriptions occurs one referring to Prague, with a new high-power transmitter of 5 kW, which amongst other technical details of the Muenster station, given in the issue of March 5, 1926, I note that the transmitting microphones comprised "two cathodophones, one telegraphone, and one Reisz."

Practical and helpful technical advice to the listener—particularly the beginner—was then, as now, a feature of *WORLD-RADIO*'s columns, and there is both humour and food for reflection in the following extract from an article in March, 1926, in which, under the title of "Distant Listening De-Luxe," the author discussed neutrodyne and superhet receivers, and referred to the reaction sets of "a year or so ago":—

"... and the more switches and knobs the set had, the better it pleased him. His skill at tuning-in distant stations could almost be measured by the length of the handle on his reaction coil. . . . There was perhaps a charm, the charm of the unexplored, about the old reaction receiver. We never knew 'what we were about to receive' and we returned thanks if we succeeded in hearing it."

Interference problems were prominent in 1926 and were due, primarily, to mutual interference between stations—despite the efforts of the Office International de Radiophonie of Geneva—to the oscillation of valve receiving sets, and to the Continental spark stations. Nowadays the Lucerne Wavelength Plan has regulated the positions of the European broadcasting stations, one scarcely ever hears a "local oscillation," and most of the old spark stations now use valve transmitters.

As practical aids to the long-suffering listener, details of a wave-trap and a simple buzzer wavemeter were published on June 18, 1926—the date on which the present title of *WORLD-RADIO* was adopted—and since that date the great variety of technical articles published must have informed all classes of listeners upon almost every aspect of broadcast transmission and reception, not forgetting the pioneer work accomplished in the field of the now popular short-wave broadcasting. E. R.

SIDELIGHTS ON BROADCAST ENGINEERING

5. The Equipment Department

EQUIPMENT—control positions, amplifiers, fade units, mixers, gramophones, valves, and the hundred-and-one items used in the business of broadcasting—is supplied and handled by the Equipment Department. The Department is of considerable size and occupies extensive premises in the South of London. It is divided into a number of sections—namely, Designs, Testing, Experimental Workshops, Central Stores, Transport, and Receivers.

When it is decided to equip a station with new speech-input equipment, instructions are received by the Equipment Department to prepare a scheme. Accordingly, the Designs Section studies the requirements of the particular station—such as the number of studios to be equipped; gramophone facilities, mixers, fade units, the number of incoming and outgoing lines, etc.—and proceeds to design the equipment in skeleton form, bearing in mind that standard equipment must be used as far as possible in order to facilitate future maintenance and additions, and to equip the station as economically as is possible, consistent with efficiency.

Design and Production

When the preliminary designs and requirements have been formulated, they are reduced to a complete schedule of equipment, which is then passed to the estimators for costing, and, immediately financial approval has been given, the production work begins. Requisitions are prepared and orders have to be placed for the supply of the various units and components, and, while delivery is awaited, the technical designers are hard at work preparing wiring diagrams, "cable-form" information, and the like.

A "cable-form" is a number of screened and braided wires lashed together in the form of

when its performance comes up to the test standards is it assembled upon its appropriate steel bay and connected by means of the cable-form "skimmers." Even then the completed bays of units are passed into the Test Rooms for a final test, the results of which are again recorded for future reference.

Immediately the equipment has been passed into Central Stores as a tested and completed whole, the Transport Section arranges for vans to convey it to the site of installation, and wiremen are instructed to proceed to the site to undertake the installation of the apparatus under the supervision of a member of the staff of the Designs Section. After installation, further exhaustive tests are carried out, and when every link in the chain from the microphone to the outgoing line is satisfactory, the completed equipment is handed over to the Engineer-in-Charge of the station, together with complete wiring diagrams, curves, etc., for service use.

The drawing office, which is attached to the Designs Section, is a very busy spot. Drawings are prepared here for all the Corporation equipment, with the exception of transmitting plant, and copies are issued to all those concerned with the operation and maintenance of the equipment.

Test Room, Workshop, and Stores

The test section is responsible for ascertaining that every component bought for service falls within the specified requirements. Thus, every gridleak, every small condenser, and even valveholders, are subjected to the most rigid tests, as it will be readily appreciated that the smallest component, if faulty, may ultimately have the most disastrous effects upon the whole chain of broadcasting. Faulty apparatus, when

in the event of an emergency, extensive work may have to be undertaken at very short notice in order to cope with the situation.

The Central Stores carries a very complete stock of all component parts and complete units such as spare amplifiers, microphones, repeaters, etc., which are used in the Engineering Branch, and is always ready at a moment's notice to despatch equipment to any station requiring it. There is also kept in the Central Stores the public address and power amplifier equipment which has been used for several consecutive years at the Radiolympia, Manchester, and Glasgow Radio Exhibitions; in fact, there are few requirements of the Engineering Branch which cannot be supplied from Central Stores. Everything likely to be required by the Experimental Workshops is also carried in stock.

Transport Problems

The Transport Section comprises a fleet of vehicles of various types, some of which are used for general transport of apparatus and personnel, while others are designed for special purposes. There is, for instance, the large transmitter lorry used for site-testing. The function of this is to radiate signals from a site chosen tentatively as likely to be suitable for a future transmitting station. The signals are picked up by field-strength measuring apparatus mounted in smaller vans which travel around the site, so that at the conclusion of the tests a polar diagram can be drawn showing the strength of the signal received in the area surrounding the transmitter lorry. By this means, the signal strength which would be provided by a high-power transmitter with an aerial of a certain type can be interpolated and the relative merits of different sites determined.

There are large pantechnicons which are used for transporting the instruments of the various orchestras from studio to studio. It may be interesting to note in this connexion that the instruments of the BBC Symphony Orchestra, comprising 114 players, were transported in two vans to Brussels and back recently within seventy-two hours by utilising the Zeebrugge Ferry. Incidentally, this was done without the slightest damage of any description occurring to any of the large number of delicate musical instruments transported.

The O.B. control van and the light vans used for transport in connexion with outside broadcasts, which were referred to in the article on outside broadcasts (No. 3 in this series), are housed and maintained by the Transport Section, as also is the mobile recording van used for obtaining sound pictures of topical events.

The function of the Receiver Section is to supply and maintain in proper working order a number of receivers which are used for the purpose of listening to and checking the programmes broadcast. These receivers are situated in different places spread over a very wide area.

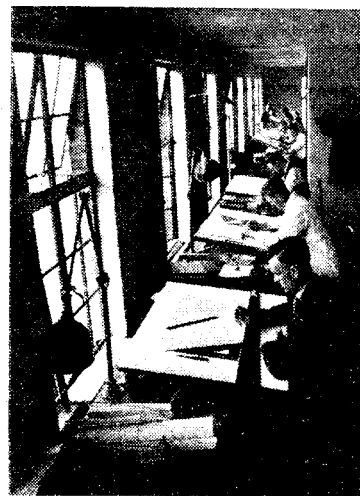

Designs Section drawing office

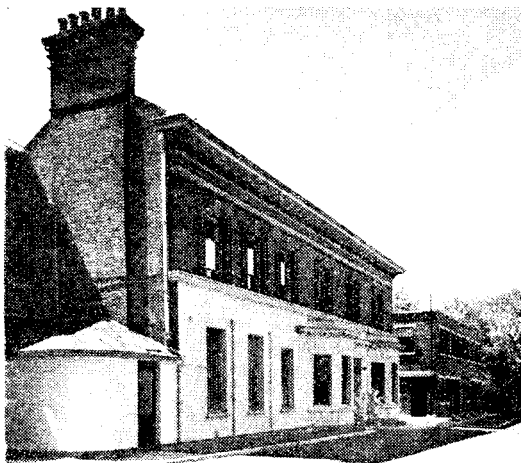

Equipment Department premises

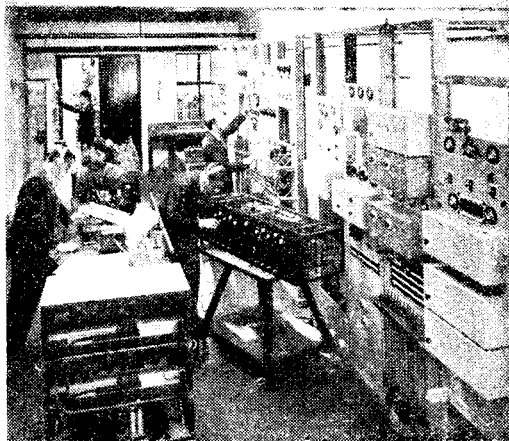

General view of test room

a vertical trunk, from which are led out numbers of wires termed "skimmers," the outer covering of each skimmer being of a specified colour. This colour scheme is maintained throughout the equipment, and thus it is a simple matter, upon reference to the wiring charts, to know the destination of a wire bearing any particular coloured covering.

The cable-form is prepared in the equipment workshops, and is fastened to steel bays which are made up in readiness for fitting the individual units of the equipment when it is received. Before being fitted to the bays, however, each individual unit is passed to the Test Rooms, where it is fully tested, and curves showing its performance are taken and recorded. Only

returned for repair or renovation, goes first of all to the Test Rooms, where the trouble is diagnosed, instructions for its rectification prepared, and passed to the workshops for attention. The apparatus is, of course, returned to the Test Rooms, after repair, for thorough testing before again being put into commission.

The Experimental Workshops are equipped with the up-to-date plant and tools necessary to undertake a large variety of work. Amplifiers and associated equipment need renovation or modification from time to time, and there is, therefore, a constant flow of this class of work through the shops, such work having to be carried out accurately and quickly. Experimental amplifiers, etc., have to be made up, and,

WIRELESS TOPICS by "ION"

A MIDGET RECEIVER

I AM asked by Handisets, Ltd., manufacturers of portable radio receivers, of 21, Lime Street, London, E.C.2, to announce that they have introduced a midget portable receiver priced at £3 15s. The receiver is fitted with three Hivac valves of the midget type. A Drydex H.T. battery and an Exide jelly-filled (unspillable) low-tension accumulator are used for supply. The set is self-contained in an oak carrying case 9½ in. high, 5 in. wide, and 4 in. deep, and is fitted with a single headphone earpiece. The makers state that six stations can be received under normal conditions and that the circuit is so stable that reception can be carried on while the receiver is being carried. The H.T. consumption is only 1 milliamp, and the H.T. battery should last about four months. They also say that signals from a local station are sufficiently loud to be intelligible when the ear-piece is lying on the table.

A MAGNUM YACHT RECEIVER

This is a three-valve, battery-operated receiver using a variable- μ high-frequency pentode, detector valve, and quiescent push-pull output. The controls comprise: master switch, tuning, sensitivity, and volume controls. The receiver unit is sealed within a cellulosed metal container and is housed in a solid oak case fitted with three keyhole-type hanging plates. It is easily accessible for inspection or adjustment. The tuning scale can be illuminated at will and is provided with a glass viewing panel, part of which is frosted for marking the tuning points of any station required for reference. The loudspeaker unit consists of a moving-coil loudspeaker contained in an oak case of special design to exclude damp when closed. It is fitted with three keyhole-type hanging plates and is easily movable to any part of the vessel.

The batteries are two triple-capacity high-tension batteries supplying 168 volts, and a heavy-duty 2-volt accumulator, all enclosed in a watertight case, if required, so that they may be stored out of the way, say, beneath bunkboards. The aerial is directional, of the folding frame type, and is fitted with a compass. There is also a gramophone disc playing unit, comprising a folding turntable, electrical pick-up, and a double spring motor. This is housed in a solid oak case and occupies very little space. An instructional chart is fitted to the folding front of the receiver unit and contains a tuning graph for each of the three tuning ranges.

The receiver will deal with broadcast programmes on all wavelengths within the limits of 150 to 2,000 metres. It also covers commercial shipping and the coastal telephony wavebands. It is interesting to note that advantage can be taken of the G.P.O. facilities whereby a telegram for you, handed in at a Post Office or telephoned, is transmitted for reception at stated hours from the coastal transmitter nearest your supposed vicinity. Such a service is of great importance to professional or business men who, although afloat, are thus still within reach of their office or home. The directional aerial enables one to fix position by taking bearings on any known coastal wireless beacon or a broadcasting station. This can be done under condition of no visibility and is extremely useful for checking one's position in thick weather. Provision is made for the use of a second loudspeaker or headphones. The latter are useful when taking bearings or listening to distant or low-powered stations. If required the receiver can be arranged to run from the yacht's

electrical supply instead of the batteries. All enquiries to Messrs. Burne-Jones and Co., 296, Borough High St., London, S.E.1.

A NEW McMICHAEL RECEIVER

I am informed by Messrs. McMichael Radio, Ltd., of Danes Inn House, 265, Strand, London, W.C.2, that they have released, on July 10, a new 1936 design superhet, operated from A.C. mains, at the price of 12 guineas. This is known as "Model 235." The circuit is of the four-valve, seven-stage superheterodyne type with selected multi-electrode valves, band-pass tuning, full automatic volume control, and mains static suppression. Level performance is claimed over the whole of both wavebands, 2½ watts output, and only 60 watts consumption.

The makers state that the sensitivity of the receiver is so phenomenally high that an indoor aerial of only 15 ft. of wire gives entirely satisfactory results, with a full choice of foreign programmes, in almost any part of this country. They mention that a new and most important refinement which they describe as "constant-gain auto-compensated-aerial-network" — provided for the first time—gives a uniform performance over the whole waveband, receiving a station on, say, 200 metres with the same efficiency as one on 500 or 1,500 metres, thus greatly increasing the choice of satisfactory alternative programmes. It is also stated that station selection is enormously simplified by the incorporation for the first time of an ingenious "precise-indication" station scale in which the exact tuning point is indicated by the intersection of a travelling pointer with a shadow-line projected from behind the scale on to the station name.

The selectivity of the new set is stated to be so high that stations on adjacent wavelengths can normally be received without mutual interference. The quality of reproduction is claimed to be fully in accordance with the high McMichael standard and many refinements include tone control, three-point speaker switching, pick-up sockets, etc. The set is designed to work on A.C. supply—200-250 volts, 50-100 cycles per second. All enquiries to the makers.

A MAVOX TROPICAL RECEIVER

The Mavox tropical model, type B4S, receiver consists of two units—a chassis in metal case and a loudspeaker in a teak case. The chassis is totally enclosed in the metal cabinet after the top has been screwed up when the valves are first fitted, and is, therefore, immune from dust, insects, and damp. No perishable materials such as rubber, silk, etc., are used, and all coils, transformers, chokes, and fixed condensers are impregnated, while the low-loss coil-holders, valve bases and holders ensure maximum efficiency on short wavebands.

The top and bottom of the cabinet are removable for fitting the valves and for servicing. The size of the cabinet is 12½ in. by 8½ in. by 8 in. The loudspeaker is of the permanent-magnet moving-coil type and is also impregnated and has a special doped cone. It is connected by a length of triple flex with a four-prong plug which simply fits into the four-pin socket provided at the back of the chassis. The size of the speaker cabinet is 11½ in. by 9½ in. by 6 in.

In the overseas standard model the chassis and the loudspeaker are housed in the same mahogany cabinet. This cabinet is of sound construction, screwed, and cemented. Except for other slight differences in the materials

and components used, this model is the same in circuit details as the tropical model.

The circuit of both models comprises a five-stage superhet designed primarily for use in the Dominions and Dependencies. It employs a tuned high-frequency stage with triode-pentode frequency changer, tuned intermediate-frequency stage (110 kc/s), detector valve, low-frequency amplifier, and a pentode output. The wavelengths covered are from 13 to 550 metres, taking in only the bands at present used for broadcasting. The set is calibrated in wavelengths which are marked on a tuning chart fixed to the face of the cabinet of the tropical model. In this manner there is no moving band or delicate pointer, dial light, etc., to form a source of trouble when the set is exposed to damp or is roughly treated.

Wave-changing is carried out with the help of a robust self-wiping positive-action switch of low-capacity with noiseless movement. The following controls are incorporated in the set: Large tuning dial mounted on the spindle of the main tuning condenser and giving a two-ratio drive; the H.F. tuning dial—which tunes the high-frequency stage and is not very critical. When a station is tuned in with the help of the main dial, reception and selectivity can be improved by rotating the H.F. dial until unwanted signals are tuned out, or volume improved. There is also a wave-change switch with three positions, each position covering an appropriate waveband as follows: 13 to 31 metres, 31 to 80 metres, and 220 to 550 metres. (Special models covering intermediate bands have a fourth position of the switch.) The last control is the off-on volume control.

A socket is provided at the back of the chassis for use with an electrical pick-up. Two sockets or terminals are fitted to the back of the chassis: a red one for the aerial and a black one for the earth connexion. The receiver works from a two-volt accumulator, a 6-volt grid-bias battery, and a 120 or 150-volt high-tension battery. A fuse is provided in the negative H.T. lead. Automatic volume control is provided to assist in reducing fading on short waves, but this will not operate on stations below a certain strength of signal—stations which are not of entertainment value, in any case. The output of the set is a little over 1 watt, undistorted.

The makers state that quite good reception can be obtained on only a small indoor aerial on the best short-wave stations, but it is better to have a good outdoor aerial of 40 to 60 feet in length, and as high as possible. The aerial and down-lead should be kept clear of trees and houses and other screening obstructions. It is stated that the set can be used without an earth, but a good earth connexion will improve reception. The makers strongly recommend the use of Milnes H.T. units for the high-tension supply. They say that these units give reliable service in tropical climates and are conveniently recharged from a large-capacity 6-volt or 12-volt accumulator—such as a car battery. All enquiries to Mavox Radio Ltd., 15/16, Alfred Place, London, W.C.1.

KOLSTER-BRANDES 1936 RECEIVERS

I have received full details of the new range of Kolster-Brandes receivers for the season 1935/1936, some of which have already been released and others are being released on July 22. As it is too early to announce these particulars this week, I shall deal with them extensively in the next issue of this journal, giving full technical details.

THE SHORT WAVES

Hints on Short-Wave Receivers

Some practical notes concerning the use and operation of short-wave receivers.

Tuned-Anode Coupling

WHEN the "tuned anode" method of coupling a high-frequency valve to the detector stage is used, it is customary to insert a fixed condenser in series with the tuning condenser in order to prevent possible accidents should the condenser plates touch at any time and so cause the high-tension supply to be short-circuited. A better method, however, is to connect the condenser as shown in the accompanying diagram.

This method automatically provides better insulation for the grid circuit of the detector valve because normally, when tuned anode coupling is used, the only insulation existing between the grid of the detector valve and the high-tension supply (*via* the tuning coil) is that provided by the grid condenser, and so the slightest fault in the insulation of this condenser would be quite enough to cause a sufficient positive grid potential to put the detector valve entirely out of action.

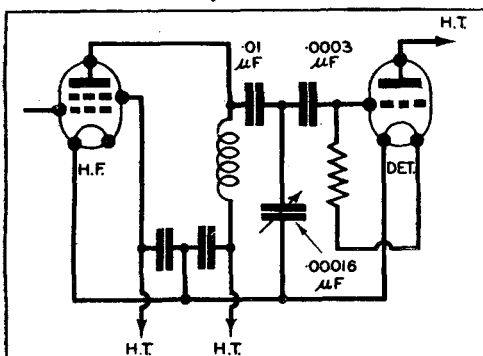

Connexion of tuned-anode coupling condensers

With the arrangement shown, the possibilities of this happening are halved and at the same time, without the use of extra components, the possibility of damage caused by the anode tuning condenser is prevented.

Mounting Short-Wave Coils

When short-wave coils of the plug-in type are employed, it is extremely important to ensure that the coils shall not be too near any metal screening when correctly placed in their sockets. Any metal objects, such as tuning condensers and even small fixed condensers, must be considered in the same light as a sheet metal screen as far as this is concerned, and the coils should preferably be kept at least two inches away from the nearest metal object. In the case of homemade tuning coils, it is well to note that the reaction winding should always be wound at the end of the former nearest to the pins. This automatically ensures that the tuning or grid coil shall be as far away as possible from the base and any surrounding metal.

Where a metal baseplate or chassis is used, it is inadvisable to use a chassis-type socket for the coil as this places the whole coil too near the metal. Alternatively, the socket may be raised upon sections of ebonite rod or a small wooden block, about one and a half inches between the bottom of the coil former and the baseplate being sufficient gap. An ordinary baseboard type of socket will automatically raise the coil to a better height above the metal, but care should be taken to ensure that it is not possible for the coil pins to make contact with the metal base below the socket.

Where moulded formers of about three inches in length are used, the small coils for the lower wavelengths should preferably be wound as near the centre of the former as possible. If

they are wound near the top of the former—with the object of reducing losses caused by the proximity of the metal base—long leads from the socket to the coil will result. In the case of six-pin coils, the primary or aerial winding should be at the top of the former—long leads generally being least objectionable here—with the secondary or grid coil in the centre, and the reaction at the bottom.

Band-Spread Tuning

A band-spread tuning condenser can be a very valuable addition to the tuning system of any short-wave receiver and is not at all a difficult matter to add to existing receivers, providing there is sufficient panel space for the extra condenser and dial. However, some little difficulty may be caused where a tuned H.F. stage is used and the reader may wonder whether to add a band-spread condenser to the H.F. stage as well as to the detector stage.

Where the H.F. and detector stages are tuned by individual condensers (not ganged), an extra condenser across the H.F. stage will certainly not be necessary, and where the two tuning condensers are ganged a small-capacity trimming condenser—connected across the H.F. stage condenser and mounted on the panel—should provide a sufficiently wide range of capacity variation to ensure that the two circuits are accurately tuned over the whole of the range provided by the band-spread condenser. In any case, even if a second control on the H.F. stage is used, another tuning dial will be unnecessary; only the primary band-spread condenser across the detector stage requiring any type of indicating dial additional to that of the main tuning condenser or condensers.

In designing a short-wave receiver incorporating ganged tuning it is necessary to consider that unless the aerial is very loosely coupled, the H.F. and detector stages will refuse to "track" correctly owing to the damping caused by the aerial. A trimming condenser, controllable from the front panel, will therefore often be necessary, apart from the use of any band-spread arrangements, in order to compensate for the different degree of damping on the two circuits.

A. W. B.

Correspondence

Iceland On The Short-Waves

SIR,—The time was 22.50 (B.S.T.), Wednesday, July 10, and I was just "leaving" Moscow, on 25 metres, to pay a visit to W8XX, when I ran into a powerful transmission on about 24 metres. I did not catch the initial announcement very fully, and at first assumed it to be of German origin. The second announcement was better comprehended—"Hier ist der Reykjavik, Iceland—Here is the new short-wave transmitter at Reykjavik, Iceland, testing on a wavelength of 24.52 metres—we are now going over to a wavelength of 33.11 metres, and shall be on the air again in about 10 minutes."

At 23.15 I found Reykjavik again, this time on its new wavelength. The same announcements were made, after which followed a few minutes' relay of the long-wave station's programme. It was stated that they were using about 7 kW in the aerial, and would be on the air again on July 11 at the same hour and on the same wavelength. The 24-metre transmission was about R9, with excellent quality and no fading. On 33 metres, the strength was R8-R9, with quality somewhat marred by adjacent "commercials."

Yours faithfully,

Leek, Staffs.

T. S.

BELOW 100 METRES

This feature is unavoidably held over this week.

LEARN A FOREIGN LANGUAGE

IT is easy to acquire a smattering of a foreign language, but if you must know the language and be able to speak, read and write it correctly the Pelman Method is the easiest, quickest and most efficient. Gramophone records prepared under the direction of Dr. W. G. Hartog are used in the instruction in so far as they are of assistance to the student. The Course is given by Correspondence Instruction and on terms which are easy for all who wish to master properly another language.

LEARN

FRENCH GERMAN SPANISH ITALIAN

(Also Courses in Afrikaans and Urdu)

By the New Pelman Method

Write for free booklet stating which language you wish to learn.

Address: The Secretary,

87, Pelman Languages House,
Bloomsbury Street, London, W.C.1.

PELMAN (OVERSEAS) INSTITUTES:

PARIS, 80 Boulevard Haussmann. NEW YORK, 271 North Avenue, New Rochelle. MELBOURNE, 396 Flinders Lane. JOHANNESBURG, P. O. Box 4928. DURBAN, Natal Bank Chambers, (P. O. Box 1489). DELHI, 10 Alipore Road. CALCUTTA, 102 Clive Street. AMSTERDAM, Damrak 68.

"Listen . . . here's AMERICA . . . on your set!"

Imagine the thrill as you tune in America, across three thousand miles of space . . . on your own set! Fit an Ealex Short-Wave Converter to your present set, and programmes from America, Australia—in fact, the whole world, are at your finger-tips.



Easy to fit—Easy to operate; an Ealex Short-Wave Converter will give you the joys of all-world radio! Write for full details and copy of booklet D.37.

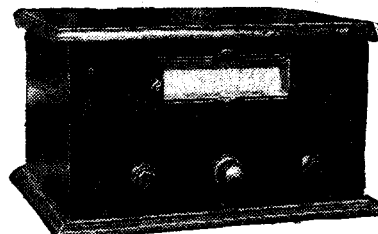

Prices from **52/6** without Valves

J. J. EASTICK & SONS
118, Bunhill Row, London, E.C.1 (Met. 0314, 6 lines.)

Short-Wave News Reel

VK2ME—Evening Programme

At 19.00 on Sunday, July 14, atmospherics were so bad on both the medium and long waves, that listening was not really worth while, and so it was to the short waves that I turned for my evening's entertainment, having noted on previous occasions, when atmospherics were tiresome on local reception, that short waves were comparatively free from "fireworks."

On tuning around 31 m. the strains of military music came from the loudspeaker, and I thought, surely this must be Germany, but I waited, and presently a voice announced: "This is VK2ME, Sydney, the time is 4.0 a.m., Monday. You will now hear a programme of gramophone records." Then followed excerpts from *Show Boat*, played on a cinema organ, military bands rendering martial melodies, and a short news summary; altogether it was a most enjoyable and thrilling experience, the more so, because this was the first time I had heard Australia, having always been under the impression that the early morning was the most suitable time. The volume was very good throughout the programme, with atmospherics practically nil.

The programme concluded with the announcer asking for reports, and the playing of "God Save the King."

Needless to say my letter of appreciation is already in the post.

Southampton.

F. G. R.

U.S. Stratosphere Flight

On Friday morning, July 12, W3XL, on 46.69 m., was on the air with an R9 signal, and from 05.15 to 05.45 (B.S.T.) provided a broadcast of unusual interest—the preparations for the Stratosphere ascent from the "stratos" Bowl near Rapid City, in South Dakota. Two NBC commentators gave graphic descriptions of the busy scene as the giant balloon was slowly filled with helium, instead of the hydrogen used in the 1934 attempt. It was a chilly morning, and they were envious of the overcoats worn by the 300 soldiers who were assisting in the exacting operations. The Bowl is surrounded on three sides by high cliffs, and on the fourth by a canyon, and on the cliff-tops could be seen the headlights of many cars driven over from Rapid City about twelve miles distant. It was an ideal morning for the flight, being very calm in the Bowl with a gentle breeze high above the earth, which was expected to take the daring aviators in a south-easterly direction, with a possible landing about 300 miles away in Nebraska. It was anticipated that the flight would start at 04.00 (local time), as the preliminary work was proceeding in a very satisfactory manner.

Many of the leading lights in this great venture, including the two pilots, Captains Stevens and Anderson, were persuaded to address a few words to the "radio audience." Some extremely interesting facts about the gondola, instruments, etc., were given by the scientists connected with the Explorer II flight.

Parachutes were of triangular shape, and several instruments were also provided with "chutes." Southsea. R. T. C.

[It is rather surprising that no reference is made to the bursting of the balloon before the flight began.—ED.]

Australian Premier in U.S.A.

WHILST listening to W2XAD on 19.56 m. at 21.15 on Saturday, July 6, an item in the nature of a "surprise" was the presentation before the American microphone of Mr. J. A. Lyons, Prime Minister of Australia, on the occasion of his first visit to the States.

Having landed at New York only a few hours earlier, accompanied by Mrs. Lyons, from the Continent by the Italian liner s.s. *Rex* in which they had enjoyed a wonderful trip, they were favourably impressed by the sights of the "skyline" as they approached New York.

He spoke of the many things which were shared in common by America and Australia, apart from the fact that the Pacific Ocean washed the shores of both countries, and the common ideals shared by the English-speaking peoples for the cultural benefit of the world as a whole. A pleasant recollection was the sincere hospitality extended to him

by the British public and the Press during his recent visit to England for the Jubilee celebrations, and above all, the loyalty of Britishers to Their Majesties, which he witnessed on this occasion.

After a short stay in New York he intended leaving for Washington to visit President Roosevelt at the White House for a friendly talk before leaving for home.

Mr. Lyons having suitably responded to the welcome he had received from Americans, this short but interesting broadcast terminated.

Loughborough.

G. W. H.

At the Circus

After the Short-Wave Mail-Bag, on Tuesday night, July 9, from W2XAF, we heard a novel broadcast from Barnum and Bailey's Circus in Schenectady, New York. The commentator, with a portable transmitter, took us round the side shows to hear the showmen haranguing the crowd about the Tattooed Lady, the Three-Legged Man, the Midgets, etc. At the commentator's invitation to say, "Hello to the World," one of the circus people spoke to her friends who live near Regent's Park, London, hoping they were still up and heard her broadcast. Then the Three-Legged Man spoke in his native Italian; the commentator told him he thought it would carry to Italy. Then into the menagerie past the lions, tigers, elephants, camels and giraffes, whose feeding box is a few feet from the ground.

At last we enter the Big Top, where acrobats on the trapeze do their stuff "with the greatest of ease." The Three-Legged Man was kicking a football to show the crowd he was not a fake. Then the commentator with his ever-ready "Say Hello to the World" got the programme-seller and some real Wild West men to speak into the microphone. As the programme was nearly finished, he thanked the

management and staff for their help in making a very interesting half-hour's programme.

Hawick, Scotland.

W. L.

Among the American Amateurs

IN recent issues of WORLD-RADIO I have noticed answers to queries regarding American amateur radio stations. When things are quiet on the usual broadcast bands I generally turn to the twenty-metre waveband for entertainment, and I am seldom disappointed. Besides the U.S.A. amateurs, there are others from all over the world to be heard after about eleven at night.

Nearly always among the first to be heard is W3MD, of Vineland, New Jersey. His call is an amusing one. This is how it goes: "This is W3MD . . . 'M' for mud, 'D' for dud."

A good signal is W8GOY, of Martinsburg, Philadelphia. Rivalling these two is W4CRE, a Tennessee amateur. W2VC is also a very good signal. A Rhode Island station, W1GCE, comes over fairly good, but W2HFS is better. A Connecticut amateur, W1CJV, is heard quite often, as are W2FLO, W2ZT, W3LL, W1SZ, and a host of others. A Carolina station came in at surprising strength on the night of July 4. It was W4AHH. I must not forget to mention the only lady amateur I have heard so far. She is situated at Palm Beach, Florida, and, being a lady, she never has to give her "CQ" call more than once!

An amateur who is heard surprisingly well is situated in Costa Rica, Central America. Costa Rica is 4,500 miles away. I also heard the British amateur G5NI one night trying to get in touch with the Americans. He must have been heard well in the States because I counted no less than nine stations answering his call. Among them was our friend W3MD. He did not get in touch, as I heard him shortly after seeking fresh fields. The same night I heard two amateurs side by side; one was West Indian, and the other was a Lithuanian. Yes, there is certainly plenty to interest one on the amateurs' wavelengths.

A. W.

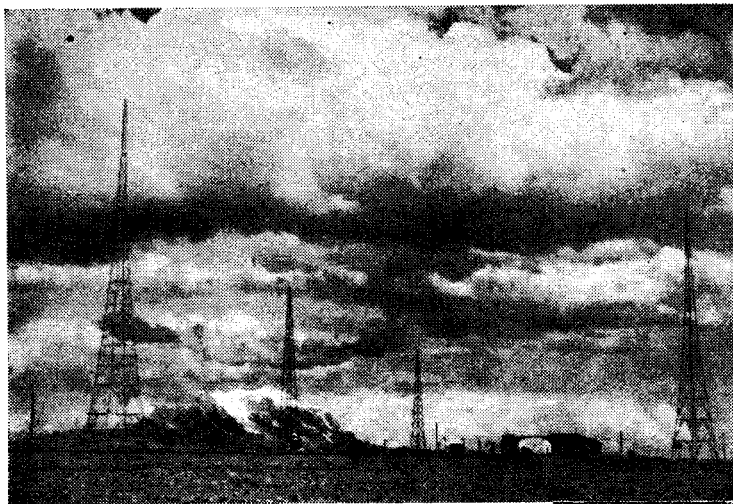

General view of La Paz station showing transmitter building and aerials with Mount "Illimani" (21,000 ft. high) in the background, and (below) aerials for transmitters CP4 (288 m.) and CP5 (49.33 m.)

LA PAZ (BOLIVIA)

22

Call-Sign:	CP5, CP7.
Wavelengths:	49.33 m., 19.6 m.
Frequencies:	6,080 kc/s, 15,300 kc/s.
Power:	1 kW.
Opening Call:	"CP5 Radio Illimani, La Paz, Bolivia."
Interval Signal:	None.
Closing Announcement:	"A los radioescuchas de onda corta; Buenas Noches."
Announcers:	Man and Woman.
Languages used for announcements:	Spanish and English.
Postal Address:	Radio Illimani, Casilla No. 637, La Paz, Bolivia, South America.

(Reception reports are invited.)

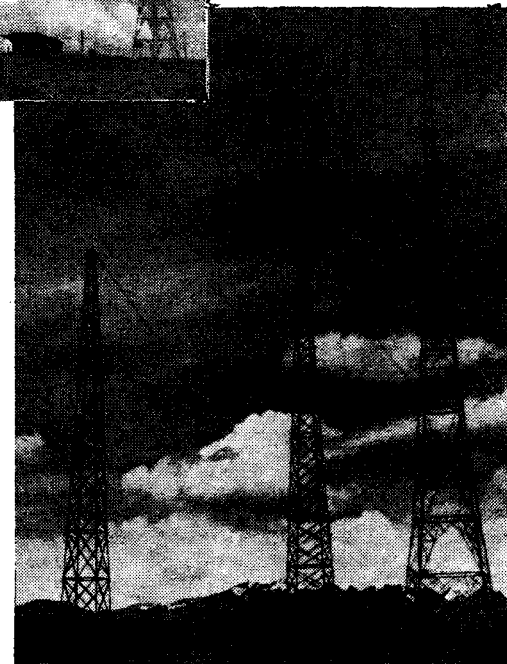

SHORT-WAVE BROADCASTING STATIONS

Times of operation are given on the "twenty-four-hour clock" system, B.S.T. (one hour ahead of C.M.T.)

m.	kc/s	kW	Station	Dial Reading	m.	kc/s	kW	Station	Dial Reading
84.67	3543	0.15	Mozambique (East Africa) CR7AA. MON., THURS., SAT., 19.30—21.30.	38.48	7797	20	Radio Nations HBP. SAT., 23.30—00.15.
75	4000	0.05	Ponta Delgada (Azores) CT2AJ. WED., SAT., 23.00—01.00.	37.33	8035	10	Rabat CNR. SUN., 21.00—23.30
70.2	4273	20	Kharbarovsk RV15. 07.00—15.00.	36.5	8214	0.15	Quito (Ecuador) HCJB. TUES. to SAT., 01.45—05.45; SUN., 22.45—05.15.
67.11	4470	1	Sourabaya (Java) YDB. 10.30—15.30 (SAT. to 17.30).	32.88	9134	20	Budapest (Hun'y) HAT4. SUN., 00.00—01.00.
58.31	5145	..	Prague OKIMPT. Experimental.	31.8	9428	..	Havana (Cuba) COH. 17.00—18.00; 23.00—00.00; 02.00—03.00.
51.28	5850	..	Maracaibo (Venez.) YV5RMO. 23.00—03.00	31.58	9501	15	Rio de Janeiro PRF5. 23.30—00.15.
50.42	5950	0.05	Medellin (Colombia) HJ4ABE. D'ly 17.30—18.30 MON., WED., FRI., 00.30—04.00. TUES., THURS., SAT., 01.15—05.00.	31.55	9510	15	*Daventry GSB.
50.26	5969	10	Vatican City (Italy) HVJ. Daily 20.00—20.15. SUN., 11.00.	31.54	9518	1.5	Melbourne (Australia) VK3ME. WED., THURS., FRI., SAT., 11.00—13.00.
50.16	5980	0.2	Santo Domingo (D.R.) HIX. D'ly at 13.00 WED., SAT., 02.08; SUN., 01.38.	31.49	9526	1	Jeløy (Norway) LKJ1. 17.00—00.00.
50	6000	20	Moscow RW59.	31.48	9530	40	Schenectady (N.Y.) W2XAF. 23.30—05.00 (SUN. 22.15—06.00).
49.96	6005	4	Montreal VE9DN. 04.30—05.00.	31.45	9540	5	Zeeseen (Germany) DJN. 09.45—13.15; 23.05—04.30.
49.92	6010	0.5	Bogotá (Colombia) HJ3ABH.	31.38	9560	5	Zeeseen (Germany) DJA. 23.05—03.15.
49.85	6018	0.09	Havana (Cuba) COC. 22.00—00.00; 02.00—04.00. SUN., 05.30—07.30 also.	31.36	9565	4.5	Bombay VUB. SUN., 14.30—16.30; WED., THURS., SAT., 17.30—18.30 (Irreg. MON.)
49.83	6020	5	Singapore (S.S.) ZHI. MON., WED., THURS., 00.00—02.30; SUN., 04.40—06.10.	31.35	9570	10	Springfield (Mass.) W1XK. 12.00—06.00.
49.75	6030	0.1	Zeeseen DJC. 23.05—04.30; 18.00—22.30.	31.32	9580	15	*Daventry GSC.
49.67	6040	5	Panama City HP5B. 18.00—19.00; 02.00—04.30.	31.28	9590	1	Lyndhurst (Australia) VK3LR. MON. to FRI., 09.15—13.30; SUN., 04.00—13.30.
49.59	6050	15	Calgary (Alberta) VE9CA. THURS. 15.00—08.00. SUN. 18.00—06.00. Irreg. 15.00—06.00	31.27	9595	20	Philadelphia (Pa.) W3XAU. 17.00—01.00.
49.5	6060	0.5	Boston (Mass.) W1XAL. SUN., 22.00—00.00; WED., FRI., 00.30—01.45.	31.23	9637	20	Sydney (Australia) VK2ME. SUN., 06.00—08.00; 10.30—14.30; 17.30—19.30.
49.42	6070	0.25	Pernambuco PRAB. Daily 21.00—01.30.	31.13	9677	20	Radio Nations (Switzerland) HBL. SAT., 11.30—12.15.
49.4	6072	2	*Daventry GSA.	30.43	9860	20	Rome (Italy) 2RO. SUN., 01.45—03.15; MON., from 00.00; WED. and FRI., 01.45—03.15, and from 00.00.
49.33	6080	0.5	Cincinnati W8XAL. 12.00—01.00; 04.00—06.00	29.04	10,330	9	Lisbon (Portugal) CT1CT. THURS., 21.00—23.00; SUN., 12.00—14.00.
49.3	6085	20	Philadelphia (Pa.) W3XAU. 01.00—04.00.	25.65	11,695	0.2	Madrid (Spain) EAQ. 23.15—01.30; SAT., 19.00—21.00 also.
49.2	6097	5	Skamlebaek (Denmark) OXY. 19.00—01.00; SUN., from 17.00.	25.6	11,720	10	Ruysselede (Belgium) ORK. 18.30—20.00.
49.18	6100	10	Nairobi (Kenya) VQ7LO. SUN. 17.00—20.00. MON. to FRI., 11.45—12.15 and 17.30—20.30. TUES. and THURS., 14.30—15.30. SAT., 17.30—21.30.	25.53	11,750	15	Caracas (Venezuela) YV3RC.
49.1	6110	0.5	Vienna Experimental OER2. D'ly (ex.SUN.) 15.00—23.00; SAT., 15.00—00.00.	25.49	11,770	5	Winnipeg CJRX, D'ly, 00.00—05.00; SAT., 21.00—06.00; SUN., 22.00—03.30.
49.08	6112	0.25	Lisbon (Portugal) CT1AA. TUES., THURS., SAT., 21.30—00.00.	25.45	11,790	5	Radio Colonial (Paris) FYA. 01.00—04.00; 05.00—07.00.
49.02	6120	1	Chicago (Ill.) W9XAA. SUN., 19.00—20.30.	25.42	11,801	9	*Daventry GSD.
48.92	6132	0.18	La Paz (Bolivia) CP5. 02.00—03.30.	25.36	11,828	2	Zeeseen (Germany) DJD. 18.00—22.30.
48.86	6140	40	Rome (Italy) 2RO.	25.32	11,830	1	Boston (Mass.) W1XAL. 22.00—00.30.
48.78	6150	0.5	St. John (New Brunswick) VE9BJ. Daily 00.00—01.30.	25.29	11,860	15	Rome (Italy) 2RO. 18.00—19.00; 19.45—20.30.
48.4	6198	0.35	Bowmanville (Canada) VE9GW. MON., TUES., WED., 21.00—06.00; THURS., FRI., SAT., 13.45—06.00. SUN., 19.00—03.00.	25.27	11,870	40	Lisbon (Portugal) CT1AA.
47.5	6316	..	Johannesburg (S.A.) ZTJ. (Experimental)	25.23	11,880	10	Wayne (N.J.) W2XE. 20.00—22.00.
47.05	6375	..	Bound Brook (N.J.) W3XAL. MON., WED., SAT., 22.00—23.00. SAT. 05.00—06.00.	25	12,000	20	*Daventry GSE.
46.69	6425	18	Chicago (Ill.) W9XF. D'ly 03.00—04.00 and 07.00—08.00 (SUN. to 08.30).	24.83	12,082	0.5	Pittsburgh W8XK. 01.15—04.00.
46.52	6447	0.3	*Daventry GSL.	24.2	12,396	0.35	Radio Colonial (Paris) FYA. 17.15—20.15; 21.00—00.00.
46.21	6490	0.1	Calcutta (India) VUC. D'ly 08.06—09.06; Irreg. 14.06—17.36; SUN. 05.36—08.36.	23.39	12,830	10	Moscow (Russia) RW59. SUN., 04.00—05.00; 12.00—13.00; 16.00—17.00.
46	6520	0.5	Caracas (Venezuela) YV2RC. Daily (ex. SUN.), 16.30—18.30; 22.00—04.00. SUN., 15.30—16.30.	22.94	13,075	..	Lisbon (Portugal) CT1CT. SUN., 14.00—16.00; THURS., 20.00—21.00.
45.31	6620	..	Caracas (Venez.) YV4RC. 22.30—04.30.	19.84	15,123	10	Parede (Portugal) CT1GO. SUN., 15.00—16.30. TUES., THURS., FRI., 18.00—19.15.
45	6667	0.2	Bound Brook (N.J.) W3XL. Experimental.	19.82	15,140	10	Rabat CNR. SUN., 13.30—15.00.
42.02	7140	0.3	Barranquilla HJ1ABB. D'ly 22.30—04.00.	19.74	15,200	5	Suva (Fiji) VPD. D'ly (ex. SUN.) 06.30—07.30.
41.8	7177	0.5	Cali (Colombia) HJ5ABD. 01.00—04.00.	19.72	15,210	40	Vatican City HVJ. 11.00; 16.30—16.45.
			Valencia (Venezuela) YV6RV. 18.00—19.00; 00.00—04.00.	19.71	15,220	18	*Daventry GSF.
			Riobamba (Ecuador) PRADO. FRI., 03.00—05.30.	19.68	15,243	10	Zeeseen (Germany) DJB. 14.00—17.30; 18.30—08.00.
			Guayaquil (Ecuador) HC2RL. SUN., 23.45—13.45; WED., 03.15—05.15.	19.67	15,250	5	Pittsburgh W8XK. 13.00—01.15.
			Manizales (Colombia) HJ4ABB.	19.66	15,260	10	Eindhoven (Holland) PCJ. Experimental. TUES., 09.00—12.00; WED., 13.00—17.00.
			Lobito (Angola) CR6AA. WED., SAT., 20.30—22.30.	19.64	15,270	1	Radio Colonial (Paris) FYA. 13.00—17.00.
				19.63	15,280	5	Boston (Mass.) W1XAL. 15.50—18.30.
				19.6	15,300	1	*Daventry GSI.
				19.56	15,330	20	Wayne (N.J.) W2XE. 16.00—20.00.
				19.52	15,370	6	Zeeseen (Germany) DJQ. 05.30—07.00.
				17.33	17,310	20	La Paz (Bolivia) CP7.
				16.89	17,760	5	Schenectady W2XAD. 20.00—21.00.
				16.88	17,770	23	SUN. 16.30—22.00.
				16.87	17,780	15	Budapest (Hungary) HAS3. SUN., 15.00—16.00.
				16.86	17,790	10	Bound Brook (N.J.) W3XL.
				13.97	21,470	10	Zeeseen (Germany) DJE. 14.00—17.30.
				13.93	21,530	10	Huizen (Holland) PH1.D'ly (ex. Tues., Wed.) 14.30—16.30; SAT. to 17.30; SUN. to 17.10.
				13.93	21,540	40	Bound Brook (N.J.) W3XAL. D'ly (ex. SUN.) 14.00—15.05. 20.00—21.00.
							*Daventry GSG.
							*Daventry GSH.
							*Daventry GSJ.
							Pittsburgh W8XK. 13.00—15.00.

* For transmission times see Short-wave Programmes.

Short-Wave Programmes

Call	kc/s	m.	Call	kc/s	m.
Daventry GSB	9,510	31.55	Parede (Portuguese Radio-Club)	CTIGO (a)	12,396 24.2
Daventry GSC	9,580	31.32		(b)	6,198 48.4
Daventry GSD	11,750	25.53	Paris (France) (Radio-Colonial)	FYA (a)	11,720 25.6
Daventry GSF	15,140	19.82		(b)	11,880 25.23
Daventry GSG	17,790	16.86	Pittsburgh (Pa., U.S.A.)	W8XK (a)	6,140 48.86
Daventry GSI	15,260	19.66		(b)	11,870 25.27
Daventry GSJ	21,530	13.93		(c)	15,210 19.72
Daventry GSL	6,110	49.10	Rio de Janeiro (Brazil)	PRF5	9,501 31.58
Bombay (India) VUB	9,565	31.36	Rome (Italy)	2RO	9,637 31.13
Bombay (India) WIXAL (a)	6,040	49.67	Rome (Italy)	2RO	11,801 25.42
Bombay (India) WIXAL (b)	11,790	25.45	Ruyselede (Belgium)	ORK	11,801 25.42
Bombay (India) WIXAL (c)	15,250	19.67	Schenectady (New York, U.S.A.)	W2XAD (a)	15,330 19.56
Budapest (Hungary) HAS3	15,370	19.52	Schenectady (New York, U.S.A.)	W2XAF (b)	9,530 31.48
Budapest (Hungary) HAT4	9,134	32.88	Skamlebaek (Denmark)	OXY	6,060 49.5
Caracas (Venezuela) YV2RC	6,112	49.08	Suva (Fiji)	VPD	13,075 22.94
Caracas (Venezuela) YV3RC	6,150	48.78	Vatican City (Italy)	HVJ (a)	5,969 50.26
Caracas (Venezuela) YV3RC	11,695	25.65		(b)	15,123 19.84
Caracas (Venezuela) YV4RC	6,375	47.05	Zeesen (Germany)	DJA	9,560 31.38
Eindhoven (Holland) PCJ	15,220	19.71	Zeesen (Germany)	DJB	15,200 19.74
Huizen (Holland) PHI	17,770	16.88	Zeesen (Germany)	DJC	6,020 49.83
Madrid (Spain) EAQ	9,860	30.43	Zeesen (Germany)	DJD	11,770 25.49
Moscow (U.S.S.R.) RW59	6,000	50	Zeesen (Germany)	DJN	9,540 31.45
Moscow (U.S.S.R.) RW59	12,000	25	Zeesen (Germany)	DJO	15,280 19.63

*Electrical Recording.
†Gramophone Records.
All Times in 24 Hour B.S.T.

SUNDAY, July 21

EMPIRE

Transmission 1 (GSD, GSB), 05.30—Big Ben. The Davis Cup.* 05.45—Nancy Read (Pfte.). 06.00—The King's Prize.* 06.30—Service.* 07.15—Newsletter; Sports Summary. 07.35—Close.

Transmission 2 (GSG, GSJ), 12.00—Big Ben. See 06.00. 12.30—Band. Harry Howson (Tenor). 12.50—See 05.30. 13.05—Band. 13.30—Quintet. 14.15—Newsletter; Sports Summary. 14.35—Records. 14.45—Close.

Transmission 3 (GSG, GSF), 15.00—Big Ben. Service.* 15.45—Bala-laika Orchestra. Olga Alexeeva (Soprano); Max Turgenoff (Tenor). 16.30—Kendall Taylor (Pfte.). 17.00—Military Band. Foster Richardson (Bass). 17.30—Newsletter; Sports Summary. 17.50—Mandoliers. Don Carlos (Tenor). 18.00—Close.

Transmission 4 (18.15-21.00 GSD, GSB); 21.15-22.40 GSF, GSB). 18.15—Big Ben. Newsletter; Sports Summary. 18.35—Recital. 18.45—Orchestra. 19.30—Recital. 19.55—Service. 19.45—Newsletter; 21.00—Close. 21.15—Orchestra; Singers. 21.45—Orchestra. 22.30—Epilogue. 22.40—Close.

Transmission 5 (GSD, GSC), 00.00—Big Ben. Orchestra. 00.45—"The Countryside."* 01.00—Service.* 01.45—Newsletter; Sports Summary. 02.05—Close.

Transmission 6 (Two of GSD, GSD, GSL), 04.00—Big Ben. Service.* 04.45—Newsletter; Sports Summary. 05.05—Close.

BUDAPEST (19.52 m.), 15.00—Lugossy (Tárogató). 15.45—News. **BUDAPEST (32.88 m.)**, 00.00—Lugossy (Tárogató). 00.45—News; National Hymn.

CARACAS, 14.30—Records. 15.30—Baseball. 17.30—Music. 20.15—Racing. 23.30—Music. 00.30—Dance Music. 02.00-04.30—Band.

EINDHOVEN (PCJ)—Relays Huizen (PHI).

HUIZEN (PHI), 13.30—Announcements. 13.40—Hijman (Pfte.). 14.00—Talk. 14.15—Hijman (Pfte.). 14.30—News. 14.45—Records. 14.50—Talk. 15.05—Records. 15.10—K.R.O. Programme. 16.10—Report: Rowing and Swimming Contests. 16.25-16.30—Records.

MADRID (EAQ), 23.15—News. 23.30—Spanish Music. 23.45—News. 00.00—From Madrid (EAJ7). 00.30—Bullfighting. 00.45-01.30—Light Music.

MOSCOW (25 m.), 12.00—English Talk; The Revolutionary Movement; Review and Letter-box. 13.00—Spanish Programme. 16.00—See 12.00. 21.00—German Programme. 22.05—English Review and Letter-box. 23.05—German Programme.

PARIS (Radio-Colonial), (b) 17.00—From Paris (Radio-Paris). 19.00—News; Review; Talk. 20.00—Cycle Tour of France. 20.15—News. 22.30—Talks. (a) 00.00—News. 00.45—Economics. 01.00—News (English). 01.15—Review; Talk. Literary Notes. 02.00—Records. 04.00—News. 04.30—Talk; Literary Notes. 05.00—Records. 05.45—News.

PITTSBURGH, (c) 18.30—Hymns. 18.45—While the City Sleeps. 19.00—Your English. 19.15—Dilling (Harp). 19.30—Guild.

20.30—Vespers. 21.30—Uncle Ned. 21.45—Command Performance. 22.00—Roses and Drums. 22.30—Turner (Soprano). 22.45—Dog Stories. 23.00—Baseball. 23.15—Comedy Stars. 23.30—Grand Hotel. 00.00—Jack Benny. (b) 01.00—Strings. 01.30—Van Loon. 01.45—Choir. 02.00—Strings. 02.30—Skinner. 02.45—Brownell (Tenor). 03.00—Road to Yesterday. 03.30—Y.M.C.A. Programme. (a) 04.00—Singers. 04.15—Mac and Bob. 04.30-06.00—Orchestra.

PORTUGUESE RADIO CLUB (CTIGO), (a) 16.00—Music. (b) 17.30-19.00—Music.

ROME (25.42 m.), 14.15-15.00—Mediterranean Programme. 18.00-19.00 and 19.45-20.30—Relays Rome (420.8 m.).

RUYSSELEDE, 19.30—News (Flemish, French). 20.00—Brussels No. 2 Programme. 20.45-21.00—Records.

SCHENECTADY, (a) 18.00—Road to Romany. 18.30—Words and Music. 19.00-21.00—Music; Songs. 21.00—Orchestra. 21.30—The Wise Man. 21.45-22.00—Music. (b) 22.15—Music. 22.30—Variety. 23.00—Roman Catholic Hour. 23.30—Horse-Sense Philosophy. 23.45—04.30—Variety. 04.30—News. 04.35—Revue. 05.00—Orchestra. 06.00—Résomé.

SKAMLEBAEK (OXY), 14.00-15.30 and 19.00—Close; Kalundborg Programme.

ZEESEN (DJB, DJN), 09.45—Announcements (German, English). 10.00—For Children. 10.30—News (English). 10.45—Chamber Music. 11.30—Reading. 11.45—News. 12.00—Music. 13.00—News (English).

ZEESEN (DJQ, DJB), 14.00—Announcements (German, English). 14.15—Service. 14.30—Fairly Tales. 14.45—News in English (DJQ) and Dutch (DJB). 15.00—Orchestra. 16.00—Topical. 16.15—News; Events. 16.40—"Queen Louise of Prussia"—Sequence. 17.15—See 14.45.

ZEESEN (DJD, DJC), 18.00—Announcements (German, English). 18.15—News. 18.30—Service. 18.45—For Children. 19.00—Concert. 20.00—News (English). 20.15—Sports. 20.30—Troubadour Songs to the Harp. 21.15—Talk: Mother's Day. 21.30—German Music. 22.00—News (German, English). 23.05—See 18.00. 23.10—For Children. 23.45—News. 00.00—Service. 00.15—Concert. 01.15—See 21.15. 01.30—See 20.30. 02.15—News (English). 02.30—German Music. 03.00—News; Sports. 03.30—Variety. 04.30—See 18.00.

ZEESEN (DJA), 23.05—Announcements (German, Span.). 23.10—For Children. 23.40—Interlude. 23.45—News. 00.00—Service. 00.15—Concert. 01.15—News (Span.). 01.30—Troubadour Songs to the Harp. 02.15—Talk: Mother's Day. 02.30—Chamber Music. 03.00—See 23.05.

MONDAY, July 22

EMPIRE

Transmission 1 (GSD, GSB), 05.30—Big Ben. Jessie King (Contralto); Hubert Carta (Tenor); Bruno Raikin (Pfte.). 06.15—Records. 06.30—Sports Talk.* 06.45—Mirthful Miscellany. 07.15—Empire News; Dairy Produce Notes. 07.30—Close.

Transmission 2 (GSG, GSJ), 12.00—

Big Ben. Orchestra. 12.30—Band. 13.15—Orchestra. 14.00—Empire News. 14.15—Orchestra. 14.45—Close.

Transmission 3 (GSG, GSF), 15.00—Big Ben. "Remote Corners." 15.15—Orchestra. Harry Dyson (Flute). 16.00—Gipsy Band. 16.45—Ballad Concert. 17.15—Celeste Octet. Leonard Gowings (Tenor). 17.30—Empire News. 17.45—Octet. 18.00—Close.

Transmission 4 (18.15-22.05 GSD, GSB); 22.20-23.45 GSF, GSB). 18.15—Big Ben. Empire News; Dairy Produce Notes. 18.30—Dance Music. 19.05—Davis Cup.* 19.15—Orchestra. Enid Cruickshank (Contralto). 20.00—Trio. 20.30—Variety. 21.30—Band. Frank Titterton (Tenor). 21.50—"Foreign Affairs." 22.05—Close. 22.20—Antoni Sala (Cello); Katherine Goodson (Pfte.). 23.00—Empire News. 23.15—Dance Music. 23.45—Close.

Transmission 5 (GSD, GSC), 00.00—Big Ben. Davis Cup.* 00.10—Ballad Concert. 01.00—Sports Talk.* 01.15—Audrey Piggott (Cello); Dorothea Aspinall (Pfte.). 01.45—Empire News; Dairy Produce and Pig and Poultry Notes. 02.00—Close.

Transmission 6 (Two of GSD, GSD, GSL), 04.00—Big Ben. Orchestra. 04.45—Empire News. 05.00—Davis Cup.* 05.10—Close.

CARACAS, 17.00-19.30—Records. 22.00—Music; Songs. 23.15—For Children. 23.30—Dance Music; Songs; News; Music. 01.00-04.00—Variety.

HUIZEN (PHI), 13.30—Announcements. 13.40—Records. 13.55—Letter-box. 14.20—Records. 14.30—News. 14.45—Records. 15.00—Sports. 15.15-15.30—Dance Records.

MADRID (EAQ), 23.15—News. 23.30—Spanish Music. 23.45—News (Spanish, English, French). 00.00—Catalan Programme. 01.01—Sports. 01.10—Light Music. 01.20-01.30—Bullfighting.

MOSCOW (25 m.), 21.00—German Programme. 22.05—English Literary Programme. 23.05—Hungarian Talk.

PARIS (Radio-Colonial) (b) 20.00—Cycle Tour of France. 20.15—News; Exchange. 22.30—Shipping. 22.45—Government Notes. (a) 00.00—News; Exchange. 00.15—News (Spanish). 00.45—Shipping. 01.00—News (English). 01.15—Review; Government Notes; Sports. 02.00—Records. 04.00—News; Exchange. 04.30—Shipping; Government Notes. 05.00—Records. 05.45—News; Exchange.

PITTSBURGH, (c) 18.00—News. 18.15—Kilmer Family. 18.30—Farm and Home. 19.30—Home Forum. 20.00—Human Values. 20.15—Chuck Wayne. 20.30—Dan and Sylvia. 20.45—Charm. 21.00—Betty and Bob. 21.15—Mac and Bob. 21.30—Markets. 21.45—Jackie Heller. 22.00—Plough Boys. 22.15—Kiddies' Klub. 22.30—Singing Lady. 22.45—Orphan Annie. 23.00—News. 23.10—Baseball. 23.15—Band. 23.30—Salt and Peanuts. 23.45—Lowell Thomas. 00.00—Dot and Will. 00.15—Tony and Gus. 00.45—Dangerous Paradise. (b) 01.00-04.15—Variety. (a) 04.15—Mac and Bob. 04.30—Orchestra. 05.00—Shandor (Violin). 05.08-06.00—Orchestra.

PORTUGUESE RADIO CLUB

(CTIGO), (b) 01.20—Music. 02.00-02.30—News; Dance Music.

RIO DE JANEIRO (PRF5), 23.30—News (Portuguese). 00.00—Talks (Various Languages).

ROME, (31.13 m.) 23.59—American Hour, from Rome. Announcements. Talk. "Ave Maria"—Opera (Allegro). Conductor: The Composer. Italian Lesson. Folk Songs. News. **ROME (25.42 m.)**, 14.15-15.00—Mediterranean Programme. 18.00-19.00 and 19.45-20.30—Relays Rome (420.8 m.).

RUYSSELEDE, 19.30—News (Flemish, French). 20.00-21.00—Brussels No. 1 Programme.

SCHENECTADY, (a) 20.00—Sketches. 20.45—The Sizzlers. 20.55—Talk. (b) 23.30—News. 23.35—Soprano. 23.45—Lang Sisters. 23.55—Baseball. 00.00—Amos 'n' Andy. 00.15—Variety. 00.30—Stocks; Baseball. 00.50—News. (Spanish). 01.00—Music. 02.00—A. & P. Gypsies. 02.30—Music. 03.00-05.00—Variety. 05.00—Résomé.

SKAMLEBAEK (OXY), 19.00—Close; Kalundborg Programme.

SUVA, FIJI, 05.30-06.30—Records.

VATICAN CITY, (b) 11.00—Religious Notes (Italian). (a) 20.00—Religious Notes (Italian).

ZEESEN (DJB, DJN), 09.45—Announcements (German, English). 10.00—Folk Music. 10.30—News (English). 10.45—Topical. 11.00—Pfte. 11.45—News. 12.00—Music. 13.00—News (English).

ZEESEN (DJQ, DJB), 14.00—Announcements (German, English). 14.15—Folk Songs. 14.45—News in English (DJQ) and Dutch (DJB). 15.00—Operetta (Snaga). 16.15—News; Topical. 16.45—Humour. 17.00—Violin. 17.15—See 14.45.

ZEESEN (DJD, DJC), 18.00—Announcements (German, English). 18.15—News. 18.30—Music. 18.45—Periodicals. 19.00—Folk Songs. 19.30—Talk: German Laws. 19.45—Folk Music. 20.00—News (English). 20.15—Topical. 20.20—Serenade in D (Beethoven). 20.45—Political Talk. 21.00—Band. 22.00—News (German, English). 23.05—See 18.00. 23.10—Music. 23.20—Periodicals. 23.35—Economics; Interlude. 23.45—News. 00.00—Topical. 00.15—Band. 01.00—Political Talk. 01.15—News (Span.). 01.30—Folk Songs. 02.00—Legal Talk. 02.15—Music. 03.00—Topical. 03.05—See 23.05.

TUESDAY, July 23

EMPIRE

Transmission 1 (GSD, GSB), 05.30—Big Ben. Davis Cup.* 05.40—Chamber Music. 06.25—"Foreign Affairs."* 06.40—May, June, and Julie. 07.15—Empire News. 07.30—Close.

Transmission 2 (GSG, GSJ), 12.00—Big Ben. Orchestra. 12.20—Davis Cup.* 12.30—Octet. Herbert Thorpe (Tenor). 13.00—Sports Talk.* 13.15—Orchestra. 13.45—Organ. 14.00—Empire News. 14.15—Orchestra. 14.45—Close.

Transmission 3 (GSG, GSF), 15.00—Big Ben. Orchestra. Jessie King (Contralto). 16.00—See 06.25. 16.15—Trio. Gwladys Garside (Contralto). 17.15—Dance Music. 17.30—Empire News. 17.45—Dance Music. 18.00—Close.

Transmission 4 (18.15-22.00 GSD, GSB); 22.15-23.45 GSF, GSB). 18.15—Big Ben. 18.30—Septet. 18.55—Davis Cup.* 19.15—Orchestra. 20.00—Variety. 20.15—"Remote Corners." 20.30—Orchestra. 20.15—Orchestra. 21.50—The Ceremony of the Keys. 22.00—Close. 22.15—Septet. 23.00—Empire News. 23.15—Dance Music. 23.45—Close.

Transmission 5 (GSD, GSC), 00.00—Big Ben. Davis Cup.* 00.20—Trio. 00.50—See 21.50.* 01.00—Ivy Tresmand. 01.15—Organ. 01.45—Empire News. 02.00—Close.

Transmission 6 (Two of GSD, GSD, GSL), 04.00—Big Ben. "Remote Corners."* 04.15—Irene Crowther (Pfte.). 04.30—Empire News. 04.45—Davis Cup.* 05.05—Close.

BOMBAY, 17.00-18.00—Eighth Anniversary Special Programme.

CARACAS, 17.00-19.30—Records. 22.00—Music; Songs. 23.15—For Children. 23.30—Dance Music; Songs; News; Music. 01.00-04.00—Variety; Onera Records.

MADRID (EAQ), 23.15—News. 23.30—Spanish Music. 23.45—News. 00.00—Talk. 00.10—Light Music. 00.30—News (Spanish, English, French). 00.45—Light Music. 01.00-01.30—For English Listeners. **MOSCOW (25 m.)**, 21.00—German Talks. 22.05—French Talks. 23.05—Dutch Talk.

PARIS (Radio-Colonial), (b) 20.00—Cycle Tour of France. 20.15—News; Exchange. 20.30—From Paris (PTT). 22.30—Shipping. 22.45—Review. (a) 00.00—News; Exchange. 00.45—Shipping. 01.00—News (English). 01.15—Review; Talk. 01.45—Legal Review. 02.00—Records. 04.00—News; Exchange. 04.30—Shipping; Review. 05.00—Records. 05.45—News; Exchange.

PITTSBURGH, (c) 18.00—News. 18.15—Kilmer Family. 18.30—Farm and Home. 19.30—Home Forum. 20.00—Sammy Fuller. 20.15—Chuck Wayne. 20.30—Dan and Sylvia. 20.45—Charm. 21.00—Betty and Bob. 21.15—Easy Aces. 21.30—Markets. 21.45—Plough Boys. 22.00—Your Health. 22.15—Kiddies' Klub. 22.30—Singing Lady. 22.45—Orphan Annie. 23.00—News. 23.10—Baseball. 23.15—Comedy Stars. 23.30—Topical. 23.35—Salt and Peanuts. 23.45—Lowell Thomas. 00.00—Dot and Will. 00.15—Tony and Gus. 00.30—Variety. 01.00—Crime Clues. (b) 01.30-04.00—Variety. (a) 04.00—Sports. 04.15—Mac and Bob. 04.30—Orchestra. 05.00—Shandor (Violin). 05.08-06.00—Orchestra.

PORTUGUESE RADIO CLUB (CTIGO), (a) 19.00-20.15—Music. **RIO DE JANEIRO (PRF5), 23.30**—News (Portuguese). 00.00—Talks (Various Languages).

ROME, (31.13 m.), 01.31-03.00—Announcements (Ital., Span., Port.). Talk. Cimarosa Concert. News (Span., Port.). Folk Songs. **ROME (25.42 m.)**, 14.15-15.00—Mediterranean Programme. 18.00-19.00 and 19.45-20.30—Relays Rome (420.8 m.).

RUYSSELEDE, 19.30—News (Flemish, French). 20.00-21.00—Brussels No. 1 Programme.

SCHENECTADY, (a) 20.00—Sketches. 20.45-21.00—Dream come true. (b) 22.00-22.30—Pan-American Programme. 23.30—News. 23.35—Short Wave Mail Bag. 00.00—Amos 'n' Andy. 00.15—Hall and Gruen. 00.30—Stocks; Baseball. 00.50—News (Spanish). 01.00—Spanish Music. 01.30—Wayne King's Orchestra. 02.00-05.00—Variety. 05.00—Résomé.

SKAMLEBAEK (OXY), 19.00—Close; Kalundborg Programme.

SUVA, FIJI, 05.30-06.30—Records.

VATICAN CITY, (b) 11.00—Religious Notes (Italian). (a) 20.00—Religious Notes (Italian).

ZEESEN (DJB, DJN), 09.45—Announcements (German, English). 10.00—Music. 10.30—News (English). 10.45—Talk: Mother's Day. 11.0—Troubadour Songs to the Harp. 11.45—News. 12.00—Music. 13.00—News (English).

ZEESEN (DJQ, DJB), 14.00—Announcements (German, English). 14.15—Music. 14.30—Periodicals. 14.45—News in English (DJQ) and Dutch (DJB). 15.00—Troubadour Songs to the Harp. 15.45—Music. 16.15—News; Topical. 16.35—Serenade in D (Beethoven). 17.00—Talk: Mother's Day. 17.15—See 14.45.

ZEESEN (DJD, DJC), 18.00—Announcements (German, English). 18.15—News. 18.30—Folk Music. 19.00—Topical. 19.15—"Old Berlin"—Sequence. 20.00—News (English). 20.15—Topical. 20.25—Music. 20.45—Drwenski Organ Music, played by the Composer. 22.00—News (German, English). 23.05—See 18.00. 23.10—Folk Music. 23.35—Economics; Interlude. 23.45—News. 00.00—See 20.45. 01.00—Music. 01.15—Topical. 01.30—See 19.15. 02.15—News (English). 02.30—Dance Music. 03.00—News; Topical. 03.25-04.30—Variety.

ZEESEN (DJA), 23.05—Announcements (German, Port.). 23.10—Folk Music. 23.35—Economics; Interlude. 23.45—News. 00.00—Drwenski Organ Music, played by the Composer. 01.00—Music. 01.15—News (Port.). 01.30—"Old Berlin"—Sequence. 02.15—Topical. 02.30—Dance Music. 03.00—Topical. 03.10—See 23.05.

WEDNESDAY, July 24

EMPIRE

Transmission 1 (GSD, GSB), 05.30—Big Ben. Davis Cup.* 05.50—Orchestra. 06.10—Ceremony of the Keys.* 06.20—Orchestra. 06.45—"Remote Corners."* 07.00

—Arthur Brough (Baritone). 07.15—Empire News. 07.30—Close.
Transmission 2 (GSG, GSJ), 12.00—Big Ben. Davis Cup.* 12.20—Orchestra. 12.45—Orchestra. 13.15—“Patrolling the South Seas.” Jerry Nunn. 13.30—Organ. 14.00—Empire News. 14.15—Orchestra. 14.45—Close.
Transmission 3 (GSG, GSF), 15.00—Big Ben. Orchestra. 15.15—Orchestra. 16.15—“The Seaside.” 16.30—Mixed Pickles.* 17.15—Dance Music. 17.30—Empire News. 17.45—Dance Music. 18.00—Close.
Transmission 4 (18.15-22.00 GSD, GSB; 22.15-23.45 GSF, GSB), 18.15—Big Ben. Empire News. 18.30—Orchestra. 19.00—Empire Bookshelf. 19.15—Variety. 20.00—Lilias Mackinnon (Pfte.). 20.30—Orchestra and Chorus. 21.00—Harry Gordon and Company. 21.40—Orchestra. 22.00—Close. 22.15—Quintet. Mignon Nevada (Soprano). 23.00—Empire News. 23.15—Dance Music. 23.45—Close.
Transmission 5 (GSD, GSC), 00.00—Big Ben. Concert Party. 01.00—“Remoté Corners.”* 01.15—Lilias Mackinnon (Pfte.). 01.45—Empire News. 02.00—Close.
Transmission 6 (Two of GSC, GSD, GSL), 04.00—Big Ben. “The Seaside.”* 04.15—Phyllis Scott and John Rorke. 04.45—Empire News. 05.00—Close.
CARACAS, 17.00-19.30—Records. 22.00—Music; Songs. 23.15—For Children. 23.30—Dance Music; Songs; News; Music. 01.00-03.30—Variety.
MADRID (EAQ), 23.15—News. 23.30—Spanish Music. 23.45—News. 00.00—Talk. 00.15—Spanish Music. 00.30—News (Spanish, English, French). 00.45-01.30—Light Music.
MOSCOW (25 m.), 12.00—English Talk with Soviet Folk Music; Sports. 21.00—Czech Talk. 22.05—See 12.00. 23.05—German Talk.
PARIS (Radio-Colonial), (b) 20.00—Cycle Tour of France. 20.15—News; Exchange. 22.30—Shipping; Films. (a) 00.00—News; Exchange. 00.45—Shipping. 01.00—News (English). 01.15—For Americans. 02.15—Science. 02.30—Review; Films. 04.00—News; Exchange. 04.30—Shipping; Films. 05.00—Records. 05.45—News; Exchange.
PITTSBURGH (c), 18.00—News. 18.15—Kilmer Family. 18.30—Farm and Home. 19.30—Home Forum. 20.00—Soloist. 20.15—Chuck Wayne. 20.30—Dan and Sylvia. 20.45—Charm. 21.00—Betty and Bob. 21.30—Markets. 21.45—Platt and Nierman. 22.00—Plough Boys. 22.15—Kiddies Klub. 22.30—Singing Lady. 22.45—Orphan Annie. 23.00—News. 23.15—Dudley Bros. 23.30—Salt and Peanuts. 23.45—Lowell Thomas. 00.00—Dot and Will. 00.15—Tony and Gus. 00.30—Miller and Rosey Rowsell. 00.45—Dangerous Paradise. 01.00—Orchestra. (b) 01.30-04.00—Variety. (a) 04.00—Squire Hawkins. 04.15—Mac and Bob. 04.30—Orchestra. 05.00—Shandor (Violin). 05.08-06.00—Orchestra.
PORTUGUESE RADIO CLUB (CTIGO), (b) 01.20—Spanish Music. 02.00—News; Dance Music.
RIO DE JANEIRO (PRFS), 23.30—News (Portuguese). 00.00—Talks (Various Languages).
ROME (31.13 m.), 23.59—American Hour from Rome. Announcements. Talk. Talk for Italians in the United States. Variety. Duets in English. Italian Lesson. Moschetti (Organ). News.
ROME (25.42 m.), 14.15-15.00—Mediterranean Programme. 18.00-19.00 and 19.45-20.30—Relays Rome (420.8 m.).
RUYSSELEDE, 19.30—News (Flemish, French). 20.00-21.00—Brussels No. 1 Programme.
SCHENECTADY (a), 20.00—Sketches. 20.45—Songs. (b) 23.30—News. 23.35—Orchestra. 23.45—Songs. 23.55—Baseball. 00.00—Amos n' Andy. 00.15—Uncle Ezra. 00.30—Stocks; Baseball. 00.50—News (Spanish). 01.00—Spanish Music. 02.00—Variety. 03.00—Band. 03.30—Ray Noble's Orchestra. 04.00-05.05—Orchestra; Variety.
SKAMLEBAEK (OXY), 19.00—Close; Kalundborg Programme.
SUVA, FIJI, 05.30-06.30—Records.
VATICAN CITY (b), 11.00—Religious Notes (Spanish). (a) 20.00—Religious Notes (Italian).
ZEESEN (DJB, DJN), 09.45—Announcements (German, English). 10.00—Music. 10.15—Topical. 10.30—News (English). 10.45—Band. 11.45—News. 12.00—Music. 13.00—Light Music.
ZEESEN (DJQ, DJB), 14.00—Announcements (German, English). 14.15—Folk Music. 14.45—News

in English (DJQ) and Dutch (DJB). 15.00—Political Talk. 15.15—Band. 16.15—News; Events. 16.40—Topical. 16.55—Mandoline Band. 17.15—See 14.45.
ZEESEN (DJD, DJC), 18.00—Announcements (German, English). 18.15—News. 18.30—Talk: Friedrich List. 19.00—Talk: Careers. 19.15—Music. 20.00—News (English). 20.15—Topical. 20.30—Variety. 22.00—News (German, English). 23.05—See 18.00. 23.10—See 18.30. 23.35—Economics; Interlude. 23.45—News. 00.00—Variety. 01.15—Talk: Careers. 01.30—Chamber Music. 02.15—News (English). 02.30—Music. 03.00—News; Topical. 03.30—Variety. 04.15—Topical; Letter-box.
ZEESEN (DJA), 23.05—Announcements (German, Spanish). 23.10—Talk: Friedrich List. 23.35—Economics; Interlude. 23.45—News. 00.00—Variety. 01.15—News (Span.). 01.30—Chamber Music. 02.15—Talk: Careers. 02.30—Music. 03.00—Events. 03.15—See 23.05.

THURSDAY, July 25
EMPIRE

Transmission 1 (GSD, GSB), 05.30—Big Ben. Dance Music.* 06.15—See Wednesday, 13.15.* 06.30—Ballet Music. 07.15—Empire News. 06.30—Close.
Transmission 2 (GSG, GSJ), 12.00—Big Ben. Orchestra. 12.30—“Foreign Affairs.”* 12.45—Orchestra. Rosemary Dinsmore (Mezzo). 13.15—Orchestra. 14.00—Empire News. 14.15—Orchestra. 14.45—Close.
Transmission 3 (GSG, GSF), 15.00—Big Ben. See Wednesday, 13.15.* 15.15—Band. 16.00—“Enchantments Die”—a play. 16.40—Light Programme. 17.15—Dance Music. 17.30—Empire News. 17.45—Dance Music. 18.00—Close.
Transmission 4 (18.15-22.00 GSD, GSB; 22.15-23.45 GSF, GSB), 18.15—Big Ben. Empire News. 18.30—Cinema Organ. 19.00—Orchestra. Albert V. Froggatt (Baritone). 20.00—Quintet; Brian Lawrence. 20.15—International Camp Fire. 20.35—Quintet; 20.40—Greta Keller. 21.00—Men's Chorus; Arthur Cranmer (Baritone). 21.30—Recital. 22.00—Close. 22.15—Orchestra. 23.00—Empire News. 23.15—Dance Music. 23.45—Close.
Transmission 5 (GSD, GSC), 00.00—Big Ben. Orchestra. Cyril Smith (Pfte.). 01.00—“The Seaside.”* 01.15—“Dizzy Fingers.” 01.45—Empire News. 02.00—Close.
Transmission 6 (Two of GSC, GSD, GSL), 04.00—Big Ben. See Wednesday, 13.15.* 04.15—Cinema Organ. 04.45—Empire News. 05.00—Close.
BOMBAY, 17.00-18.00—Indian Programme. Bai Sunderabai.
CARACAS, 17.00-19.30—Records. 22.00—Music; Songs. 23.15—For Children. 23.30—Dance Music; Songs; News; Music. 01.00-04.00—Variety.
HUIZEN (PHI), 13.30—Announcements. 13.40—Violin and Pfte. 14.00—Talk. 14.20—Records. 14.30—News. 14.45—Records. 15.00—Violin. 15.20-15.30—Dance Records.
MADRID (EAQ), 23.15—News. 23.30—Spanish Music. 23.45—News; From Madrid (EAJ7). 00.15—Talk. 00.30—News (Spanish, English, French). 00.45—Light Music. 01.00-01.30—For English Listeners.
MOSCOW (25 m.), 21.00—French Programme. 22.05—German Talk. 23.05—Spanish Programme.
PARIS (Radio-Colonial), (b) 20.00—Cycle Tour of France. 20.15—News; Exchange. 22.30—Request. (a) 00.00—News; Exchange. 00.30—Request. 01.00—News (English). 01.15—Songs. 01.45—Shipping; Events. 02.15—Sports; Records. 04.00—News; Exchange. 04.30—Request. 05.00—Shipping; Records. 06.00—News.
PITTSBURGH (c), 18.00—News. 18.15—Kilmer Family. 18.30—Farm and Home Hour. 19.30—Home Forum. 20.00—Sammy Fuller. 20.15—Chuck Wayne. 20.30—Dan and Sylvia. 20.45—Topical. 21.00—Betty and Bob. 21.15—Aces. 21.30—Melody. 22.00—Plough Boys. 22.15—Kiddies Klub. 22.30—Singing Lady. 22.45—Orphan Annie. 23.00—News. 23.15—Comedy Stars. 23.30—Salt and Peanuts. 23.45—Lowell Thomas. 00.00—Dot and Will. 00.15—Tony and Gus. 00.30—Floyd Gibbons. 00.45—Singers. 01.00—Pastorale. (b) 01.30-04.00—Variety. (a) 04.00—Sports. 04.15—Mac and Bob.

04.30—Orchestra. 05.00—Shandor (Violin). 05.08-06.00—Orchestra.
PORTUGUESE RADIO CLUB (CTIGO), (a) 19.00-20.15—Portuguese Music. (b) 01.20—Dance Music. 02.00-02.30—News; Dance Music.
RIO DE JANEIRO (PRFS), 23.30—News (Portuguese). 00.00—Talks (Various Languages).
ROME (31.13 m.), 01.31 (Fri.)-03.00—Announcements (Ital, Span., Port.). Talk. Moschetti (Organ). Choir. News (Ital., Span., Port.).
ROME (25.42 m.), 14.15-15.00—Mediterranean Programme. 18.00-19.00 and 19.45-20.30—Relays Rome (420.8 m.).
RUYSSELEDE, 19.30—News (Flemish, French). 20.00—Brussels No. 2 Programme. 20.45-21.00—Records.
SCHENECTADY (a), 20.00—Sketches. 20.45—Songs. (b) 23.30—News. 23.35—Songs. 23.55—Baseball. 00.00—Amos n' Andy. 00.15—Variety. 00.30—Stocks; Baseball. 00.50—News (Spanish). 01.00—Variety; Rudy Vallee's Orchestra. 03.00—Music Hall. 04.00—Spanish Music. 04.30-05.05—Forum.
SKAMLEBAEK (OXY), 19.00—Close; Kalundborg Programme.
SUVA, FIJI, 05.30-06.30—Records.
VATICAN CITY (b), 11.00—Religious Notes (French). (a) 20.00—Religious Notes (Italian).
ZEESEN (DJB, DJN), 09.45—Announcements (German, English). 10.00—For Hitler Youth. 10.30—News (English). 10.45—Serenade in D (Beethoven). 11.00—“Old Berlin”—Scenes. 11.45—News. 12.00—Music. 13.00—News (English).
ZEESEN (DJQ, DJB), 14.00—Announcements (German, English). 14.15—Talk: Friedrich List. 14.45—News in English (DJQ) and Dutch (DJB). 15.00—Variety. 16.15—News; Events. 16.45—Folk Songs. 17.15—See 14.45.
ZEESEN (DJD, DJC), 18.00—Announcements (German, English). 18.15—News. 18.30—For Women. 19.00—Music. 20.00—News (English). 20.15—Topical. 20.20—Homeland. 21.20—Industry and Landscape. 21.35—Dance Music. 22.00—News (German, English). 23.05—See 18.00. 23.10—For Women. 23.35—Economics; Interlude. 23.45—News. 00.00—Music. 00.15—Homeland. 01.15—See 21.20. 01.30—Music. 02.15—News (English). 02.30—Dance Music. 03.00—News; Topical. 03.20-04.30—Variety.
ZEESEN (DJA), 23.05—Announcements (German, Port.). 23.10—For Women. 23.35—Economics; Interlude. 23.45—News. 00.00—Events. 00.15—Homeland. 01.15—News (Port.). 01.30—Pfte. 02.15—Industry and Landscape. 02.30—Dance Music. 03.00—Events. 03.05—See 23.05.

FRIDAY, July 26
EMPIRE

Transmission 1 (GSD, GSB), 05.30—Big Ben. Cinema Organ. 06.05—See Thursday, 16.00.* 06.45—Lavender Potpourri. 07.15—Empire News; Announcements; Fruit Market Notes. 07.35—Close.
Transmission 2 (GSG, GSJ), 12.00—Big Ben. Organ. 12.30—Dance Music. 13.15—“Remoté Corners.”* 13.30—String Orchestra; Lilian Niblette (Pfte.). 14.00—Empire News; Announcements. 14.20—Orchestra. 14.45—Close.
Transmission 3 (GSG, GSF), 15.00—Big Ben. Orchestra. 15.45—Sports Talk.* 16.00—Symphony Concert. 17.15—Sextet. Leonie Zifado (Soprano). 18.00—Close.
Transmission 4 (18.15-22.00 GSD, GSB; 22.15-23.45 GSF, GSB), 18.15—Big Ben. Empire News; Announcements; Fruit Market Notes. 18.35—Haydn Hemery (Baritone); Bertha Hagart (Pfte.). 19.00—“The Seaside.”* 19.15—Dance Music. 20.00—Band. 20.40—“The Mystery of the Seven Cafés”—3. 21.00—Louis Godowsky (Violin). 22.00—Close. 22.10—“1066 and All That.” 22.35—Dance Music. 22.45—“1066 and All That.” 23.00—Empire News; Announcements. 23.20—Dance Music. 23.45—Close.
Transmission 5 (GSD, GSC), 00.00—Big Ben. “The Casting of an Asperion.” 00.30—See Wednesday, 13.15.* 00.45—See Thursday, 16.00.* 01.25—Enid Tait (Violin). 01.45—Empire News; Announcements. 02.05—Close.
Transmission 6 (Two of GSC, GSD, GSL), 04.00—Big Ben. See Thursday, 16.00.* 04.40—Variety.† 04.45—Empire News; Announcements. 05.05—Close.
CARACAS, 17.00-19.30—Records. 22.00—Music; Songs. 23.15—For

Children. 23.30—Dance Music; Songs; News; Music. 01.00-03.30—Variety.
HUIZEN (PHI), 13.30—Announcements. 13.40—Records. 13.50—Talk. 14.10—Orchestra. 14.30—News. 14.45—Records. 15.00—Orchestra. 15.20-15.30—Dance Records.
MADRID (EAQ), 23.15—News. 23.30—Spanish Music. 23.45—News. 00.00—Spanish Music. 00.15—Literary Talk. 00.25—Spanish Music. 00.30—News (Spanish, English, French). 00.45—Spanish Music. 01.15-01.30—Light Music.
MOSCOW (25 and 50 m.), 21.00—Czech Programme. 22.05—English Talk: Moscow Shops. 23.05—German Talk.
PARIS (Radio-Colonial), (b) 20.00—Cycle Tour of France. 20.15—News; Exchange. 20.30—From Paris (PTT). 22.30—Shipping; Science. (a) 00.00—Concert from Paris (Radio-Paris). 01.00—News; Exchange. 01.30—News (English). 01.45—Shipping; Amusements; Events. 02.45—Science. 04.00—News; Exchange. 04.30—Shipping; Science; Amusements. 05.15—Records. 05.45—News; Exchange.
PITTSBURGH (c), 18.00—News. 18.15—Kilmer Family. 18.30—Farm and Home Hour. 19.30—Home Forum. 20.00—Sammy Fuller. 20.15—Chuck Wayne. 20.30—Dan and Sylvia. 20.45—Charm. 21.00—Betty and Bob. 21.15—Jackie Heller. 21.30—Markets. 21.45—Topical. 22.00—Plough Boys. 22.15—Kiddies Klub. 22.30—The Singing Lady. 22.45—Orphan Annie. 23.00—News. 23.15—Ensemble. 23.30—Salt and Peanuts. 23.45—Lowell Thomas. 00.00—Dot and Will. 00.15—Tony and Gus. 00.30—John Herrick (Baritone). 01.00-06.00—Variety.
PORTUGUESE RADIO CLUB (CTIGO), (a) 19.00-20.15—Portuguese Music. 02.00-02.30—News; Dance Music.
RIO DE JANEIRO (PRFS), 23.30—News (Portuguese). 00.00—Talks (Various Languages).
ROME (31.13 m.), 23.59—American Hour. Announcements. Talk. “Il Ballo delle Ingrate”—Opera (Monteverdi), from Turin. Italian Lesson. Violin. News.
ROME (25.42 m.), 14.15-15.00—Mediterranean Programme. 18.00-19.00 and 19.45-20.30—Relays Rome (420.8 m.).
RUYSSELEDE, 19.30—News (Flemish, French). 20.00-21.00—Brussels No. 2 Programme.
SCHENECTADY (a), 20.00—Sketches. 20.45—Topical. (b) 23.30—News. 23.35—Songs. 23.45—Music. 23.55—Baseball. 00.00—Spanish Music. 00.30—Stocks; Baseball. 00.50—News. 01.00-05.05—Variety.
SKAMLEBAEK (OXY), 19.00—Close; Kalundborg Programme.
SUVA, FIJI, 05.30-06.30—Records.
VATICAN CITY (b), 11.00—Religious Notes (German). (a) 20.00—Religious Notes (Italian).
ZEESEN (DJB, DJN), 09.45—Announcements. 10.00—For Women. 10.30—News. 10.45—Homeland. 11.45—News. 12.00—Music. 13.00—News.
ZEESEN (DJQ, DJB), 14.00—Announcements. 14.15—For Women. 14.45—News. 15.00—Organ Music. 16.15—News; Events. 16.35—Music. 17.15—See 14.45.
ZEESEN (DJD, DJC), 18.00—Announcements. News. 18.30—Music. 18.45—Topical. 19.00—Schumann. 19.30—Books. 19.45—Folk Music. 20.00—News. 20.15—Topical. 20.25—Music. 21.00—“Léonce and Lena”—Comedy (Büchner). 22.00—News. 23.05—See 18.00. 23.10—Serenade in D (Beethoven). 23.35—Economics; Interlude. 23.45—News. 00.00—Books. 00.15—See 21.00. 01.15—Music. 01.30—Schumann. 02.00—Topical. 02.15—News (English). 02.30—Music. 03.00—News; Topical. 03.30-04.30—Music.
ZEESEN (DJA), 23.05—Announcements. 23.10—Serenade in D (Beethoven). 23.35—Economics; Interlude. 23.45—News. 00.00—Books. 00.15—“Léonce and Lena”—Comedy (Büchner). 01.15—News (Span.). 01.30—Schumann. 02.00—Topical. 02.15—Music. 03.00—Events. 03.15—See 23.05.

SATURDAY, July 27
EMPIRE

Transmission 1 (GSD, GSB), 05.30—Big Ben. Scottish Music. 06.30—“The Riverside.”* 06.45—Piping, Fiddling, and Songs. 07.15—Empire News. 07.30—Close.
Transmission 2 (GSG, GSJ), 12.00—Big Ben. Band. 12.45—See 06.30.

13.00—Orchestra. 13.30—England v. S. Africa. 13.40—Orchestra. 14.00—Empire News. 14.15—Orchestra. 14.45—Close.
Transmission 3 (GSG, GSF), 15.00—Big Ben. Cinema Organ. 15.30—Band. 16.30—See 13.30. 16.40—Interlude.† 16.45—Orchestra. 17.15—Dance Music. 17.30—Empire News. 17.45—Dance Music. 18.00—Close.
Transmission 4 (18.15-22.00 GSD, GSB; 22.15-23.45 GSF, GSB), 18.15—Big Ben. Empire News. 18.25—See 13.30. 18.35—Empire News. 18.40—Interlude.† 18.45—Cinema Organ. 19.00—Band. Joseph Farrington (Bass). 19.25—Dais Cup.* 19.35—Band. 20.00—Jubilee Gala. 21.30—Harp Quintet. 22.00—Close. 22.15—Dance Music. 23.00—Empire News. 23.15—Dance Music. 23.45—Close.
Transmission 5 (GSD, GSC), 00.00—Big Ben. See 13.30.* 00.15—Friendly Harmony. 00.45—“Foreign Affairs.”* 01.00—Orchestra. 01.45—Empire News. 02.00—Close.
Transmission 6 (Two of GSC, GSD, GSL), 04.00—Big Ben. See 13.30.* 04.15—Harp Quintet. 04.45—Empire News. 05.00—Close.
BOMBAY, 17.00-18.00—Indian Programme. Shamsadabai of Delhi.
CARACAS, 17.00—Records. 22.00—Music. 23.15—For Children. 23.30—Dance Music; Songs; News. 01.00—Variety.
HUIZEN (PHI), 13.30—Announcements; Records; News. 14.00—Orchestra; Records. 14.30—News. 14.45—Records; Orchestra. 15.10—Talk. 15.25—Records. 16.20-16.30—Dance Records.
MADRID (EAQ), 19.00—Spanish Music. 20.45—Light Music. 23.15—News. 23.30—Music. 23.45—News. 00.00—Music; Talk. 00.30—News. 00.45—Light Music. 01.00-01.30—For English Listeners.
MOSCOW (25 and 50 m.), 18.30—Concert. 21.00—German Programme. 22.05—French and Swedish Talks.
PARIS (Radio-Colonial), (b) 20.00—Cycle Tour of France. 20.15—News. 22.30—Shipping; Talk. (a) 00.00—News. 00.45—Shipping. 01.00—News. 01.15—Talks. 02.00—Records. 04.00—News. 04.30—Shipping; Talks. 05.15—Records. 05.45—News.
PITTSBURGH (c), 18.00—News. 18.15—Orchestra. 18.30—Farm and Home. 19.30-06.00—Variety.
PORTUGUESE RADIO CLUB (CTIGO), (b) 01.20—Spanish Music. 02.00-02.30—News; Music.
RIO DE JANEIRO (PRFS), 23.30—News (Portuguese). 00.00—Talks—Announcements. Talk: Wine. Two Acts. “Scampolo”—Opera (Camussi). News; Violin; News.
ROME (25.42 m.), 18.00-19.00 and 19.45-20.30—Relays Rome (420.8 m.).
RUYSSELEDE, 19.30—News. 20.00—Brussels No. 2 Programme. 20.45-21.00—Records.
SCHENECTADY (a), 20.00—Revue. 20.30—Music. (b) 23.30—News. 23.35—Songs. 23.55—Baseball. 00.00—Variety. 00.30—Stocks; Baseball. 00.45-06.05—Variety.
SKAMLEBAEK (OXY), 19.00—Close; Kalundborg Programme.
SUVA, FIJI, 05.30-06.30—Records.
VATICAN CITY (b), 11.00—Religious Notes (Various Languages). (a) 20.00—Religious Notes (Italian).
ZEESEN (DJB, DJN), 09.45—Announcements (German, English). 10.00—Music; Topical. 10.30—News. 10.45—Variety. 11.45—News. 12.00—Music. 13.00—News.
ZEESEN (DJQ, DJB), 14.00—Announcements. 14.15—Music. 14.30—Topical. 14.45—News in English (DJQ) and Dutch (DJB). 15.00—Homeland; Topical. 16.15—News; Topical. 16.40—Dance Music. 17.15—See 14.45.
ZEESEN (DJD, DJC), 18.00—Announcements. 18.15—News. 18.30—Summer Songs. 19.00—Literature and Music. 20.00—News (English). 20.30—Dance Music; Variety. 22.00—News. 23.05—See 18.00. 23.10—Summer Songs. 23.35—Economics; Interlude. 23.45—News. 00.00—See 20.30. 01.15—Topical. 01.30—See 19.00. 02.15—News (English). 02.30—Concert. 03.00—News; Topical. 03.30-04.30—Dance Music.
ZEESEN (DJA), 23.05—Announcements. 23.10—Summer Songs. 23.35—Economics; Interlude. 23.45—News. 00.00—Dance Music; Variety. 01.15—News (Span.). 01.30—Literature and Music. 02.15—Topical. 02.30—Concert. 03.00—Events. 03.15—See 23.05.

Calling You!

AND so we shall hear the voice of Huizen no more, unless, perhaps, it is retained as a standby transmitter for use should Kootwijk be undergoing repairs or alterations. It was not nearly as old as Hilversum: some readers may remember the Sunday-afternoon English programmes given during the summer of 1922 by that station, which was then known as PCGG. Hilversum then worked on about 1,100 metres, and, since the first of the B.B.C. stations was yet unborn, the Eiffel Tower and Hilversum provided the bulk of broadcast entertainment, except for the Tuesday evening transmissions from the half-kilowatt station at Writtle. Incidentally, Huizen's closing down removes the problem of the pronunciation of its name: many of us called it "Wheezzen," others "Hoyzen," others again, "Howzen." Dutch friends tell me that the correct pronunciation is very difficult for English tongues.

For One Night Only

Many readers, I expect, have noticed on Wednesday evenings of late the phenomenal loudness of the German stations in general. On July 10, for instance, even Leipzig, which has been in eclipse for some time during the rebuilding of its aerial, was coming through at great strength. Nearly every German station was receivable at full loudspeaker volume from an early hour in the evening. My own log records full volume from Stuttgart, Cologne, Munich, Leipzig, Berlin, Hamburg, Breslau, Frankfurt, and Nürnberg. Others were strong, but not well received owing to heterodyne or other interference troubles.

The reason for this weekly common effort appears to be the broadcasts for the Youth of Germany, which are sent out from all stations. Possibly it is brought about by deepening the modulation rather than by any actual increase in power.

The Close Season

At last Continental countries appear, for the time being, to have finished playing serious Association football. It seemed quite strange last Sunday not to find in progress a single relay of a big match; but even the heroes who play summer-time soccer have to give in when the thermometer is in the 80's and the sun-baked ground is like iron!

There was, however, plenty of other sport going on, as one gathered from the evening talks and reports. The close season for soccer lasts only a couple of months in many Continental countries; early in September you will find the running commentaries being resumed.

"Dx" Television

By the end of the year high-definition television services may be in operation in several European countries, and when ultra-short-wave television receivers find their way into British homes, it will be interesting to see at what ranges reception of both sound and vision are possible. It used to be held that transmissions on wavelengths between 5 and about 9 metres could not be received in places very far outside the visual range from the aerial. Recent experiences, however, seem to show that much greater distances may be covered in certain circumstances. With the coming of regular high-definition services, and the big increase in the number of privately-owned ultra-short-wave receivers that is bound to follow, I am confident that the ranges of "wavelet" signals will have some big surprises in store for us.

SEECUE.

LISTENERS' QUERY SERVICE

Which station was that?

Free Queries

Each query should be numbered and the questions on the coupon carefully answered. Letters must be addressed to the Editor, WORLD-RADIO, Broadcasting House, London, W.1.

The Alternative Postal Service

In addition to the free service of "Which Station Was That?" printed in these columns, replies to station identification queries can be obtained within forty-eight hours of receipt of details on payment of 6d. per query, in stamps or P.O., accompanied by stamped addressed envelope (marked in left-hand top corner "Postal Query Service"), and coupon as per conditions for "Free Queries."

Times of Reception

The identification of stations will be greatly facilitated if readers, in answering the first question in the Identification Coupon, will always add a.m. or p.m. to the hour of reception—e.g., 12.5 a.m. to indicate five minutes after midnight.

TROTTER (Blean): Can trace the following calls (wavelengths are given where possible): XGM, Shanghai, 17 m.; KRB, Salinas (Cal.); SAG, Göteborg Radio (Sweden), 23.63 m.; INTER-ESTED (Coventry); Radio-Maroc, Rabat; selection from "Carmen" (Bizet); CURIOUS (Giffnock); (a) IAC, Coltano (Italy), 16.9 and 16.95 m.; (b) PPZ, Sepetiba (Brazil), 16.52 m.; station transmitting telephony was possibly CGA, Drummondville (Que.), c. 16.5 m., which works with Great Britain; (c) apparently DIQ, Königs Wusterhausen (Germany), 29.16 m.; (d) GMX, Dorchester, 19.97 m.; XDA, Chapultepec (Mexico), 20.65 m. **ZERO (Birkenhead):** Addresses required are as follows: WIBC, E. McAviney, 105, Central Avenue, Hamden (Conn.); W3BOF, E. Harrison, 104, Frazier Avenue, Arlington Ridge (Va.); W4CRE, W. Montgomery, Jr., Radio Station WSM, R. 5, Franklin (Tenn.); see footnote. **INQUISITIVE (S.W.1.):** Rennes-Bretagne, 288.6 m. **D.S.D. (Ash Vale):** Apparently a station testing, but details too vague to trace. **BM/HEZI (Aberdeen):** PRAS, Pernambuco (Brazil), on approximately 49.5 m.; time in Brazil is four hours behind B.S.T. **WOGGIE (Berkhamsted):** OA4X, Tronsberg (Norway); OA4X, Lima (Peru); see footnote. **RADIO CITY (Doddington-hurst):** (1) see footnote; (2) addresses required: VEICR, C. R. Rogers, 55, Milton Street, Sydney, Nova Scotia; PAODK, M. de Koster, Bolwerk Noord, 49, Bergen-op-Zoom, Holland. **CIRCUIT (Dublin):** Since publishing your reply in "World-Radio" of July 5, station has been identified as LKJ1, Jeløy (Norway), working on higher wavelength—i.e., approximately 31.5 m. **SCHOOLBOY (Acton):** Test by the new 2-kW Air Ministry transmitter at Borough Hill, near Daventry, on 1,186 m. **AMATEUR CHASER (Angmering-on-Sea):** The prefix "LY" belongs to Lithuania, and "LZ" to Bulgaria; LY1J is at Kaunas (Lithuania). **SEA SWEEPER (Brentwood):** (1) can trace the following calls (wavelengths are given where possible): FXC, Beyrouth Khaldé (French Levant), 37.57 m.; cannot trace FZR, but if FZR2, Saigon (French Indo-China), 31.19 m.; CIJ, Oxford, 42.95 m.; CUY, Alfragide-Lisbon (Portugal), 32.63 m.; OSA, Antwerp Radio (Belgium), 600 m. and other channels; OSU, Ostend Radio (Belgium), 180 m.; (2) W9AAI, Fort Wayne (Ind.); see footnote. **FADDY (Farnham):** W6APL, Huntington Park (Cal.); see footnote. **SCOTTIE (Eltham):** Many thanks for information; yes, LKJ1, Jeløy (Norway), on higher wavelength—i.e., approximately 31.5 m. **PHILOLOGIAN (W.1.):** (1) would appear to be an harmonic, as there are no telegraphy transmissions in that band, which is devoted entirely to broadcasting; (2) possibly Kharkov (U.S.S.R.), telegraphy transmissions on 1,875 m., but cannot confirm. **TEMPUS FUGIT (Borrowdale):** You do not state whether a.m. or p.m.; cannot trace. **P. METCALFE (South Shields):** Can trace the following calls (wavelengths are given where possible): WKI, Sayville (N.Y.), 20.39 m.; WKJ, New Brunswick (N.J.), 31.71 m.; WHR, Rocky Point (N.Y.), 22.35 m.; WJH, Sayville (N.Y.), 23.05 m.; WCC, Chatham (Mass.), on many channels, including: 13.453, 24.15, 35.5, and 47.17 m.; WIX, Sayville (N.Y.), 27.73 m.; WQP, Rocky Point (N.Y.), 21.58 m.; EDZ, Vallecás Radio (Spain), 31.65 and 32.93 m.; PYZZ, Rio de Janeiro; LQA, Monte Grande (Buenos Aires), 30.93 m.; DIS, DFH, DHA, DGD, Nauen (Germany), on 29.56, 40.92,

27.47, and 29.38 m., respectively; RKD, Moscow, 31.58 and 28.14 m.; WAE and WDU, Brentwood (N.Y.); HJO, believe Bogota (Col.); DHB, Nauen (Germany); JNB, Nagoya (Japan), 21.61 m.; OEJ, Deutsch Altenburg (Austria), 39.31 m.; FYM2, Croix d'Hins (France); FZR2, Saigon (French Indo-China), 31.19 m.; FZR3, also Saigon, 18.5 m.; SPW, Warsaw, 22 m. **BALWATNEW (Newton-le-Willows):** Addresses required: VP6YB, T. A. Archer, Craigston, Aquatic Gardens, Garrison, Barbados; OK2KO, A. Kolar, Radiostanic Svinov u Moravske Ostravy, Slezsko, Czechoslovakia; LSL2, Hurlingham (Buenos Aires), 29.13 m. **SEA SWEEPER (Brentwood):** (1) VP1ZR (not VP1CR), Radio VPZ, Zanzibar; (2) VE2DF, Montreal (P.Q.); see footnote. **YUAN (Reading):** Yes, all details would point to YV2RC, Caracas (Venezuela), working a little later than advertised. **SEECUE (Cambridge):** Would appear to be an amateur transmitter in your immediate neighbourhood, but cannot trace call, which is mutilated.

AMATEUR TRANSMITTERS

The identity of amateur transmitters may be found in the "Radio Amateur Call Book," the Spring Edition of which can now be obtained, price 6s. 6d., post free, from the Radio Society of Great Britain, 53, Victoria St., London, S.W.1. Copies of the "Radio Amateur Handbook" (12th Edition), price 5s., post free, may also be obtained from the Society's offices.

WAVELENGTH DEVIATIONS

The following list shows the deviations of stations as measured at the Tatsfield Checking Station during the past week:—

	kc/s	m
Moscow I (U.S.S.R.)	172	1,744
Milan 2 (Italy)	1,363.2	220.6
Binche (Belgium)	1,489	201.4

Esperanto Transmissions

Sunday—Lille, 9.30 a.m., Course. Parolado, Minsk, 9.45 p.m., Parolado pri Rusujo. Monday—Rome and relays, 6.30 p.m. Informoj pri la Universala Esperanto-Kongreso kaj Turismo. Tuesday—Tallinn, 7.50 p.m., Informoj pri Estonio. Wednesday—Leningrad (1,224 m.), 10.20 p.m., Notoj kaj aktualaj de Rusujo. Vienna, 10.50 p.m., R. Kreutel; Junulsporto en Aŭstrio. Thursday—Paris PTT, 5.40 p.m., Course. Minsk, 9.45 p.m., Parolado. Friday—Rome and relays, 6.30 p.m., Same kiel lunde. Nice-Juan-les-Pins, 7.40 p.m., G. Avril. Rakontoj por progresantoj. Lisbon (271 m.), 10.0 p.m., S. Carriera; Parolado. Saturday—Huizen, 7.10 p.m., S-ro Degenkamp; Pri la Esperanta Literatura. Leningrad (1,224 m.), 10.20 p.m., Soveta Informaro.

Federation of Festivals Courses

We are asked by the Federation of Festivals (48, Devonshire Street, London, W.C.1) to remind Madrigal singers and Chamber Music players that entries are due for the Madrigal Summer School from August 7 to August 14, and for the Summer School of Chamber Music from August 16 to August 30. Full details of these courses, open to all singers and players, and all held at Bangor, may be obtained from the Secretary of the Federation at the above address.

STATION IDENTIFICATION PANEL

POZNAŃ (POSEN) (POLAND)

FREQUENCY: 868 kc/s; WAVELENGTH: 345.6 m.; POWER: 16 kW.
 DISTANCE AND BEARING FROM LONDON: 728 miles; 79°.
 OPENING SIGNAL: Relay of a clock gong, or chimes from Poznań Town Hall, or occasionally from St. Mary's Church, Cracow.
 CALL: "Hallo! Hallo! Polskie Radio Poznań!"
 INTERVAL SIGNAL: Metronome.
 Man and woman announcers.
 Apart from transmitting its own programmes, also relays Warsaw and other Polish stations.
 News bulletins are given in both the Polish and French languages.
 Closes down with the words "Zytshymy vshystkim dobrej notsy!" followed by a few bars of the Polish National Anthem, "Dombrowski Mazurka."

IDENTIFICATION COUPON (No. 336)

This coupon is valid for ONE QUESTION only and should be cut out and attached to a separate sheet, upon which the following questions should be answered in the order shown. A copy of the answers should be enclosed with FREE queries. No coupon more than one month old is valid. A coupon is not required from readers living in countries outside Europe who desire identification of transmissions.

1. Time and date of reception.
2. Approximate frequency in kilocycles per sec. (or wavelength in metres).
3. Nearest known stations, above and below.
4. Call or interval signal, if heard.
5. Language.
6. Type of receiver in use and strength of signals.
7. Details of programme or signal received.
8. Name and address.
9. Nom de plume. (Proprietary names must not be used.)

NEXT WEEK: HOUR BY HOUR

Sunday

- a.m.
11 Organ Recital, RADIO-PARIS
noon Orchestra, songs, RADIO-PARIS
Orchestra, violin, WARSAW
p.m.
2 Scheveningen Kurhaus concert, HILVERSUM
3 Relay from Vichy, PARIS (PTT)
Quartets (Dvořák, Schumann), VIENNA
4 Band concert, KALUNDBORG
Debussy's pfte. music, WARSAW
5 Cigány band, BUDAPEST 1
Quartet, songs, NATIONAL
Two plays, PARIS (PTT)
6 Radio orchestra, BRUSSELS 1
Orchestra, songs, PRAGUE
7 Breton folk songs, EIFFEL TOWER
Variety concert, FRANKFURT
Goldmark and Smetana, HILVERSUM
Pianoforte and song recital, NATIONAL
Song and guitar, PARIS (PTT)
Bilboquet, RADIO-PARIS
8 "The Taming of the Shrew" (opera) BERLIN
Light Belgian music, BRUSSELS 1
Variety concert, COLOGNE
Folk Festival, DEUTSCHLANDSENDER
Opera music, HAMBURG
Greta Keller, HILVERSUM
Band concert, KÖNIGSBERG
Orchestral concert, OSLO
Operetta excerpts, PARIS (PTT)
"Denise" (play, Dumas fils), RADIO-PARIS
Orchestra, conductor, Selvaggi, ROME
Symphony concert, SOTTENS
Orchestra, Andresen, STOCKHOLM
"Cinderella" (opera, Massenet), TURIN
Chamber orchestra, WARSAW
9 German songs, BEROMÜNSTER
Hubay concerto, BUDAPEST 1, VIENNA
L.S.O. (Harty), REGIONAL
Wagner programme, WARSAW
10 Mozart, Joh. Strauss, Weill, KALUNDBORG
Orchestral dances, POSTE PARISIEN
Light music, STOCKHOLM
Strauss and Lanner, VIENNA
Marine band, WARSAW
midnight Operetta music, STUTTGART, FRANKFURT

Monday

- noon Light orchestral music, POSTE PARISIEN
p.m.
3 Radio orchestra, KALUNDBORG
4 Band concert, DEUTSCHLANDSENDER
5 Orchestra, pfte., STUTTGART, FRANKFURT
6 Trios (Mozart and Smetana), BRUSSELS 2
7 Pfte. duets and songs (Schubert), BERLIN
Edward German programme, NATIONAL
8 Military band, BUDAPEST 2
Frederick the Great's music, DEUTSCHLANDSENDER
Opera music, KALUNDBORG
Orchestra, songs, MUNICH
"The Duchess of Hollywood" (operetta, Ranzato), ROME
9 Mozart programme, HILVERSUM
Trios (Turina, Beethoven), HUIZEN
Variety concert, RADIO-NORMANDIE
10 Orchestral serenade, BRESLAU
Symphony concert, TURIN
Light and dance music, WARSAW
11 Light orchestral music, HAMBURG
midnight Old music, and Brahms programme, FRANKFURT, STUTTGART

Tuesday

- noon French programme, RADIO-PARIS
p.m.
1 Organ and violin recital, HILVERSUM
3 Light classical music, KALUNDBORG
4 Open air music, DEUTSCHLANDSENDER
5 Organ recital from Brussels, RADIO-PARIS
6 Opera music, HILVERSUM
7 Irish music from Galway, ATHLONE
Symphony orchestra, HUIZEN
8 Defauw conducts Franck, etc., BUDAPEST 1
Scandinavian music, FRANKFURT
Folk music, FRENCH PTT STATIONS
"The Merry Widow," RADIO-NORMANDIE
Opera music, VIENNA
9 Community singing, BRESLAU
Two one-act plays, EIFFEL TOWER
Ceremony of the Keys, NATIONAL
Station orchestra, OSLO
"Musical Bagatelles," PRAGUE
An Offenbach operetta, WARSAW
10 Folk music, MUNICH
Chamber music, ROME
11 Hungarian music (pfte.), BUDAPEST 1

Wednesday

- noon Orchestra, songs, RADIO-PARIS
p.m.
3 Radio orchestra, KALUNDBORG
Bournemouth concert, NATIONAL
4 Band concert, DEUTSCHLANDSENDER
5 Light music, FRANKFURT, etc.
6 Pfte. quartet, op. 25 (Brahms), BRUSSELS 1
7 Folk music, COLOGNE
Orchestra, arias, PRAGUE
8 Orchestra, choir, BRUSSELS, SOTTENS
Vichy Casino relay, EIFFEL TOWER
"The First Mrs. Fraser," STOCKHOLM
Song, waltz, duet, STUTTGART
"Anna Karenina" (opera), Turin
9 Popular orchestral music, HILVERSUM
Franck Quintet, POSTE PARISIEN
Ketelbey programme, REGIONAL
Symphony concert (Mascagni), ROME
10 Serenade and dance music, COLOGNE, etc.
American light music, NATIONAL
11 Cigány band, BUDAPEST 1
midnight Chamber music, STUTTGART, FRANKFURT

Thursday

- p.m.
3 Vichy Casino relay, RADIO-PARIS
Schubert pfte. music, WARSAW
4 Outdoor concert, DEUTSCHLANDSENDER
5 Light orchestral, BRESLAU, LEIPZIG
Light music, HILVERSUM
6 Pianoforte, songs (7 p.m.), STRASBOURG
7 Gamba and harpsichord, BERLIN
Hungarian songs, BUDAPEST 1
8 "Il Trovatore" (records), BUCHAREST
Wagner concert, COLOGNE
Mozart, Beethoven, FRANKFURT
Modern operetta music, KALUNDBORG
"L'amour mouillé," (opéra-comique), PARIS (PTT)
"Cinderella" (opera, Massenet), ROME
Beethoven concert, VIENNA
9 Wagner, Kodály, Beethoven, BUDAPEST 1
The National Orchestra, RADIO-PARIS
10 "La Traviata" records, BRUSSELS 2
Beethoven recital (Dohnányi), BUDAPEST 1
11 Chamber music, DEUTSCHLANDSENDER
midnight Schumann, FRANKFURT, STUTTGART.

Friday

- noon Orchestra, songs, RADIO-PARIS
p.m.
1 Birmingham Phil. strings, NATIONAL
3 Preil's Orchestra, KALUNDBORG
4 Band concert, DEUTSCHLANDSENDER
5 Czech music, WARSAW
6 Pfte. recital (Chopin, Liszt), BRUSSELS 1
7 "Der betrogene Cadi" (Gluck), HAMBURG
Choral concert, HUIZEN
French songs, RADIO-PARIS
8 Brahms, Mozart, etc., BERLIN
Orchestra, pianoforte, EIFFEL TOWER
Dumas programme, FRENCH PTT STATIONS
Schuricht conducts, HILVERSUM
"Ames Sœurs" (operetta, Waltham), POSTE PARISIEN
Relay from Vichy, RADIO-PARIS
Bruckner Festival, VIENNA AND SEVERAL EUROPEAN STATIONS
9 "Betrothal by Lantern Light" (operetta, Offenbach), BEROMÜNSTER
"Wagadu" (oratorio, Vogel), BRUSSELS 2
Düsseldorf music, COLOGNE
Atterberg, Delius, programme, LEIPZIG
Goldmark, Massenet, etc., WARSAW
10 Hungarian music, HUIZEN
11 Orchestral concert, COLOGNE, ETC.
midnight Operetta music, STUTTGART, FRANKFURT

Saturday

- a.m.
11 Test match (also later), NATIONAL
noon Light orchestral music, POSTE PARISIEN
1 Operetta music, WARSAW
2 The Davis Cup, NATIONAL
3 Radio orchestra, KALUNDBORG
4 Variety concert, GERMAN STATIONS
Spanish music, STOCKHOLM
5 Cigány band, BUDAPEST 1
Johann Strauss programme, WARSAW
6 Swiss programme, BRUSSELS 1
Folk music, LEIPZIG
7 Orchestra, waltzes, ATHLONE
German pastoral songs, BRESLAU
Marches, FRANKFURT, DEUTSCHLANDSENDER
"Crossing the Line," HAMBURG
Concert from Baden Baden, STUTTGART
"Ball at the Savoy" (Abraham), VIENNA
Polish songs, WARSAW
8 Operetta music, BERLIN, ETC.
"Prince Chéri" (operetta), BRUSSELS 1
Brahms Violin Concerto, etc., BRUSSELS 2
"The Geisha" (Jones), BUDAPEST 1
Drama evening, EIFFEL TOWER
Band and orchestra, HAMBURG
Jubilee Variety Gala, NATIONAL
Variety concert, OSLO
"The Little Duke" (Lecocq), RADIO-PARIS
Variety concert, STUTTGART, FRANKFURT
9 Songs, harp music, stories, ATHLONE
"A Swiss Picture-book," BEROMÜNSTER
Czech operetta music, BRATISLAVA, PRAGUE
Light orchestral music, HILVERSUM
Symphony concert (Mascagni), TURIN
"Echoes of the Country," WARSAW
10 Variety concert, BERLIN
Slav orchestra, BRUSSELS 2
The K.R.O. Boys, HUIZEN
Brahms, Beethoven, Liszt, Wagner, VIENNA
midnight Brahms concert, STUTTGART, FRANKFURT
"Bar Music," VIENNA

PROGRAMMES SUNDAY July 21

SERVICES AND SACRED MUSIC

A.M.
9.40 Hilversum: Church service.
10.0 Kalundborg: Church service.
11.0 Italian stations: Mass.
11.45 Radio-Paris: Père Avril.

SYMPHONY CONCERTS

P.M.
8.0 Stockholm: Hellman, Andresen.
8.30 Sottens: Orchestra, violin.
9.20 Regional: L.S.O. (Harty).
9.30 Budapest 1, Vienna: Hubay.

LIGHT CONCERTS

12.15 Radio-Paris: Orchestra, songs.
12.20 Warsaw: Orchestra, violin.
2.40 Hilversum: From Scheveningen.
3.30 Paris (PTT): Vichy relay.
4.0 Kalundborg: Band concert.
5.0 Radio-Paris: Light orchestral.
5.30 Budapest 1: Cigány band.
6.0 Brussels 1: Radio orchestra.
6.0 Prague: Orchestra, song.
7.0 Frankfurt: Variety concert.
7.50 Beromünster: Choir, orchestra.
7.55 Hilversum: Goldmark, Smetana.
7.55 Huizen: Orchestra.

8.0 Brussels 1: Light Belgian music.
8.0 Brussels 2: Symphony orchestra.
8.0 Cologne, etc.: Variety concert.
8.0 Hamburg, etc.: Opera music.
8.0 Königsberg: Band concert.
8.0 Oslo: Orchestra.

8.15 Bucharest: Light orchestral.
8.40 Rome: Orchestra (Selvaggi).
9.0 National: Light music.
9.0 Warsaw: Wagner programme.
10.0 Poste Parisien: Orchestra.
10.0 Stockholm: Light music.
10.10 Kalundborg: Mozart, Joh. Strauss, Weill.

10.20 Warsaw: Marine band.
10.25 Budapest 1: Cigány band.
10.25 Vienna: Strauss, Lanner.

12.0 Stuttgart, Frankfurt: Operetta music.

OPERAS

8.15 Berlin: "The Taming of the Shrew" (Goetz) (records).

8.40 Turin: "Cinderella" (Massenet)

OPERETTAS

8.30 Paris (PTT): Operetta Excerpts.

CHAMBER MUSIC

3.40 Vienna: Quartets.
5.30 Brussels 1: Violin, pft. (Lekeu).
5.30 National: Quartet, songs.
6.40 Hilversum: Violin, pft.

8.10 Warsaw: Chamber orchestra.

RECITALS

11.15 Radio-Paris: Organ.
2.10 Hilversum: Choir, men's voices.
2.15 Radio-Paris: Songs and duets.

3.0 Leipzig: Gamba, harpsichord.
4.0 Warsaw: Pft. (Debussy).

6.15 Strasbourg: Soprano songs.
7.15 National: Pft., songs.

7.30 Paris (PTT): Song, guitar.
7.45 Eiffel Tower: Breton Songs.

8.55 Hilversum: Greta Keller.
9.10 Beromünster: German songs.

PLAYS

5.0 Paris (PTT): Two plays.
7.20 Vienna: "Der grosse Bluff."

8.30 Brussels 1: "1830" (Tumerelle).

8.45 Radio-Paris: "Denise" (Dumas fils).

DANCE MUSIC

10.10 Brussels 1, 2; 10.30, Breslau, Munich, Oslo; 10.45, Paris (PTT), Prague; 10.50, Radio-Paris, Strasbourg; 11.0, Deutschlandsender, Kalundborg; 11.5, Warsaw; 11.20, Budapest 1; 12.0, Radio-Normandie.

MISCELLANEOUS

7.0 Radio-Paris: Bilboquet.
8.0 Deutschlandsender: Folk fête.
9.0 Stuttgart, etc.: Revue.

NATIONAL

Time Signals: Big Ben.—12.30 p.m. Greenwich.—10.30 a.m., 4.30 p.m., 9.0 p.m. D=Droitwich.

10.30-10.45 a.m. (D)—Weather.
12.30 p.m. (D)—Penketh Tannery Band.

Harry Howson (Tenor).
1.30 (D)—Bernard Crook Quintet.

2.15 (D)—Records.
2.45 (D)—N. Ireland Orchestra.

3.45 (D)—Medvedeff's Balalaika Orchestra; Olga Alexeeva (Soprano); Max Turganoff (Tenor).

4.30—For the Children.
4.50—"We have Reason to Believe."

4—"Consciences Good and Bad."
5.10—"Can we be Materialists?"—5: Kenneth Ingram.

5.30—Griller String Quartet; Maria Basilides (Contralto).

6.45—"The Empire at Work"—8.
7.15—Eric Marshall (Baritone); Irene Kohler (Pianoforte).

8.0—Service from the Studio.
8.15—The Way to God, Section 5: "Abundant Life." Answers to Questions.

8.45—An appeal on behalf of the Youth Hostels Association by Ishbel MacDonald.

8.50—"The News."

9.0—B B C Theatre Orchestra and Singers (A). Overture, Carnival in Rome (Strauss). Love is meant to make Us Glad (Merrie England) (Edward German). Hungarian Rhapsody No. 5 (Liszt); Selection, 1066 and All That (Reynolds). The Bells of Aberdovey (Dibdin); Comin' thro' the Rye (Trad.). Gasteiner Walzer. (Kern). The Old Folks at Home (Foster); Polly Wolly Doodle. Suite, Holiday Sketches (Foulds).

10.0—Gershom Parkington Quintet.

10.30—Epilogue.

REGIONAL

Time Signals: Big Ben.—12.30 p.m. Greenwich.—4.30 p.m., 9.0 p.m.

12.30-4.30 p.m. (ex. Midland)—Droitwich.

4.30 (except Northern and Western)—Kendall Taylor (Pianoforte).

4.30 (Northern)—Male Choir.
4.30 (Western)—Cantata: "Gloria."

5.0 (ex. Western)—B B C Military Band. Foster Richardson (Bass).

5.15 (Western)—Leonard Carrodus (Violin); Melville Cook (Pft.).

5.45—Troise and his Mandoliers. Don Carlos (Tenor).

6.15 (except Midland and Northern)—Song recital.

6.15 (Midland)—Records.
6.15 (Northern)—Joseph Farrington.

6.45 (Regional, Scottish)—Orchestra.
6.45-7.45 (Midland)—Amington Band. Charles Dean (Baritone).

6.45 (Northern)—Rotherham Orchestra.
6.45 (Western)—Records.

7.0 (N. Ireland)—Service.
7.30 (Western)—Carolare.

7.55 (Regional)—Roman Catholic Service; (Northern) Service; (Scottish) Service; (Western) Methodist Service; 8.0 (Midland)—Service.

8.0-8.45 (N. Ireland)—See National.

8.45—Appeals: (Regional) Factory Girls' Country Holiday Fund; (Midland) Seaside Home for Nottingham Cripples; (Northern) Bradford Poor Children's Mission; (Scottish) Youth Hostels; (Western) Children's Holiday Home, Llangennith; (N. Ireland) North Belfast Mission.

8.50—"The News."

9.0 (ex. Midland)—Short Story.

9.0 (Midland)—Celtic Songs.

9.20—London Symphony Orchestra, conducted by Sir Hamilton Harty. Symphony No. 7 (Sibelius); Symphony No. 4 (Tchaikovsky).

10.30—Epilogue.

Hours of Transmission in British Summer Time

ATHLONE (Ireland)

565 kc/s (531 m.); 60 kW. Relayed by Dublin, 1,348 kc/s (222.6 m.), and Cork, 1,240 kc/s (241.9 m.).

1.0-3.0 p.m.—Records.

8.30—Station Orchestra. A. J. O'Farrell (Baritone). 9.45—What happened to-day. 10.0—Variety. 10.30—Sports Talk by Sean O'Ceallachain. 10.40-11.0—Irish Music.

BARCELONA (EAJI) (Spain)

795 kc/s (377.4 m.); 5 kW. Transmits at intervals from 8.15 a.m.

8.0—Station Orchestra. 8.30—Montserrat Miró (Soprano). 9.0—Dance Band. 10.0—Chimes; Records. 10.15—For Students. 10.45—Records. 11.0—Report; Talk; Records. 11.45—Chess. 12.0 m't-1.0 a.m. (Monday)—Records.

BERLIN (Germany)

841 kc/s (356.7 m.); 100 kW.

6.0 a.m.—Hymn; Motto; Gym.

6.15-8.0—Concert from Hamburg. 8.0—Gym. 8.20—Readings and Pft. Music. 8.55—Chimes. 9.0—Service from Potsdam Garrison Church. 9.55—Cathedral Chimes.

10.0—See Deutschlandsender. 10.30—Weather. 11.0—Readings by Oskar Holthausen and Theodor Eickmann; Prof. Georg Vollerthun (Pft.) plays his own Music.

11.30—Käte Grandt (Violin); Helmut Hidegheti (Pft.). Sonata in E flat (Mozart). Excerpts, My Country (Smetana).

12.0 noon—Band—Conductor: Friedrich Ahlers; Small Station Orchestra—Conductor: Steiner; Willy Grundmann (Accordion); Willi Kleinert (Saxophone). March (Hauser). March, Standartenweihe (Have-mann). Waltz, Accelerationen (Strauss). Schelmengaugen (Uschmann). Argonne March (Männecke).

Das Lieben bringt gross' Freud' (Gnauck). Unter dem Balkon (Wis-mar). Badener Grüsse (Kauler).

Alsatian Peasant Dances (Merkling). March, King Albert (Philipp). The Blue Pavilion (Armandola). Accordion Solo, Gladiola (Alex). Die kleine Garde kommt (Golwyn). March, Königsgross (Sommerlatt). Harzer-Marsch (Gerold). Saxophone: Valse vanité (Wiedoeff). Waltz, Golden Rain (Waldteufel). Overture, "The Bohemian Girl" (Balfe). March, Vereinte Fahnen (Gabriel). Accordion Solo, Dizzy Fingers (Confrey). Selection, "Der arme Jonathan" (Millöcker). March, Castaldo (Novacek). Traum in der Sommernacht (Lautenschläger). March, Die Leiber in Serbian (Fürst).

2.0—Sports Talk. 2.15-3.0—Sound-Film Tunes by the Hans Bund Band, with Eric Helgar (Songs). 3.30—For Smallholders.

4.0-6.0—See Munich. 6.0—"Vivat, die Eisenbahn!"—Sequence (Lange) Music by Willy Hahn (on Records).

6.45—Sunday Sports.

7.0—Concert from Leipzig. 7.30—To be announced. 7.45—Sports.

8.15—"The Taming of the Shrew"—Opera in Four Acts (Goetz). 10.0—News.

10.30-12.0 m't—See Munich.

BEROMÜNSTER (Switzerland)

556 kc/s (539.6 m.); 100 kW. Relayed by Basle and Berne, 1,375 kc/s (218.2 m.).

9.30 a.m.-12.0 noon—Programme from Basle. 9.30—Münchenstein Music Society. Conductor: Imark.

10.0—Roman Catholic Address. 10.45—Hans Vogt (Harpsichord), Felix Brade, Arthur Müller and Albert Knausz (Clarinets). 11.30—Martha Ringier reads.

12.0 noon (from Zürich)—Small Station Orchestra. In the interval at



M. Maurice Tumerelle, author of the play which Brussels No. 1 broadcasts at 8.30 p.m.

12.30 p.m.: News. 1.30 (from Basle)—For Country People. 2.30-3.0—Old Dances by the Station Orchestra.

6.0-7.5—Programme from Basle. 6.0—Records. 6.20—Talk with Records: One Piece—two Conductors.

7.0—Weather; Sports. 7.5—Operetta Music by the Small Station Orchestra. 7.30-9.0—Programme from Basle. 7.30—Geological Talk.

7.50—Swiss Songs by the Riehen Mixed Choir and the Small Station Orchestra. 9.0—News.

9.10 (from Basle)—"Das Rosenband"—Songs of the German Rococo Period,

with Incidental Music (arr. Gehly). 10.15 (from Basle)—Sports Notes.

BRATISLAVA (Czechoslovakia)

1,004 kc/s (298.8 m.); 13.5 kW. Transmits at intervals from 6.30 a.m.

9.20 p.m.—Variety. Station Orchestra. Conductor: Odcházal. 10.15—See Prague. 10.35—News (Hungarian). 10.50-11.30—See Prague.

BRESLAU (Germany)

950 kc/s (315.8 m.); 100 kW. Relayed by Gleiwitz, 1,231 kc/s (243.7 m.).

5.0 a.m. till Close Down—German Peasants' Day.

5.0 a.m.—Orchestra.

6.0-8.0—See Hamburg. 8.0—Greetings.

8.10—Silesian Pictures. 8.30—The Radio Players. 9.0—Protestant Service. 9.45—To be announced.

10.0—See Deutschlandsender. 10.30—To be announced. 11.0—German Peasant Literature—Programme arranged by Dr. Hanns Morawetz. Station Choir. Conductor: Wirth. 11.45—Popular Music. 2.0 p.m.—News. 2.10—For Country Women. 2.30—Call of Youth. 2.35—Greetings. 2.40—Weather. 2.50—Usinger Quartet and Soloists. 3.30—Songs and Tales by Peasant Children, from Seidorf. 4.0—Light Music. Small Station Orchestra—Conductor: Rischka; Station Choir; and Soloists.

6.0—"Die gefuppte Verwandtschaft"—Silesian Play (Schenke). Music by Sczuka.

6.50—Lobeda Choir. Conductor: Hansel. O Deutschland (arr. Rein). Richtung (arr. Knorr). Feuerspruch (arr. Knab). Flamme empor (arr. Kickstat). Der Winter ist vergangen (arr. Rein). Grüss Gott, du schöner Maien (arr. Lang). All mein Gedanken (arr. Rein). Muss i denn (arr. Rein). Frisch auf in Gottes Namen (arr. Knab). Kein schöner Land

(arr. Lang). Wenn alle Brunnlein fließen (arr. Lang). Steh auf hohem Berge (arr. Lang). Heurigen (arr. Lang). Im März der Bauer (arr. Rein).

7.30—Sports Notes. 8.0—Dance Music. 10.0—News. 10.30-12.0 m't—Station Dance Band.

BRNO (Czechoslovakia)
922 kc/s (325.4 m.); 32 kW.
Transmits at intervals from 6.30 a.m.

4.0 p.m.—Luhacovice Municipal Orchestra. Conductor: Elsnic. 5.30—Records. 5.45—Talk. 6.0—See Prague. 7.50—A Scene in Dialect.

8.20—Station Orchestra. Conductor: Janota. Slav Rhapsody (Dvořák). Dances, "Prince Igor" (Borodin). Breton Rhapsody (Saint-Saëns). Irish Dances (Grainger). Hungarian Rhapsody (Liszt).

9.5—See Prague. 9.20—Variety from Bratislava. 10.15-11.30—See Prague.

BRUSSELS (No. 1) (Belgium)
620 kc/s (483.9 m.); 15 kW.

10.0 a.m.—Walloon Music. Conductor: Walpot. Toutenel (Baritone). 11.0—Records: Light Belgian Music.

12.0 noon—Belgian Music. Radio Orchestra. Conductor: Douliez. Folk Songs (Sarly). Old Flemish Songs (arr. Douliez). Les cramignons liégeois (arr. Meuron). Binche (Grillaert). Fête des accordailles (De Taeye). Procession flamande (Leemans). Almeria (Mahy). Symphonic Intermezzo (Desprez). Insalah (d'Agrèves). March (Ackermans). In the interval at 12.20 p.m.: "Belgium"—Poetry Reading.

1.0—News. 1.10-2.0—Request Records. 5.0—Belgian Dance Records. 5.30—Sonata (Lekeu) by Bouquet (Violin) and Wilmars (Pfte.).

6.0—Belgian Music. Radio Orchestra. Conductor: Douliez. Bethume (Violin). Fantasia on Tournai Folk Songs (Daneau). Theme and Variations on an Old Ballad (Schoemaker). Violin Concerto in A Minor (Vieuxtemps). Suite, Paysages wallons (De Taeye). 7.0—Religious Address.

7.15—Song Records. Two Songs (Bernier). Song, "Kaatje" (Buffin). Berceuse, "La route d'Émeraude" (De Boeck). Romanian Song (Jongen). Les petits ânes (Rass). 7.30—Music Review.

8.0—Belgian Light Music. 8.30—"1830"—Play (Tumerelle). 9.45—Records: Psyche (César Franck). 10.0—News. 10.10—Dance Music by the Maggiano Orchestra, from the Exhibition. 11.0-12.0 m't—Dance Records.

BRUSSELS (No. 2) (Belgium)
932 kc/s (321.9 m.); 15 kW.
Programme in Flemish.
10.0 a.m.—Records.

8 P.M. BRUSSELS NO. I

Belgian Light Music

CONDUCTED BY CHARLES WALPOT
Radio-Belgica, Foxtrot on folk-song themes, *Topp and Bemers*
The Brussels Waltz, *Grillaert*
Flemish Cradle Song, *Crabbé*
Humorous Piece, *Caludi*
Concerto under the Trees, *Gobbaerts*
(piccolo solo, François Gilman)
Czardas for Accordion and orchestra, *René Segers*
(accordion, the composer)

11.0—Flemish Music. Orchestra. Conductor: Walpot. Toutenel (Baritone) and Ferari (Violin). Le trompette amoureux (Leo Walpot). Fantasia canadienne (Gilson). Baritone: Fantasia on Flemish Songs (Karel Walpot). Violin and Orchestra: Meditation (Maes). Overture, "La chanson de Louvain" (van Oost). Songs. Siskiou (De Boeck). Ballet miniature (Candaël).

11.57—Weather. 12.0 noon—Records. 1.0 p.m.—News.

1.10-2.0—Radio Orchestra. Conductor: Douliez. Scherzo, Humoresque and Graziella (De Taeye). Ballet, "Le poète mort" (Baeyens). Petite Suite (Kalkman). Don Quichotte rêve (Dejoncker). Intermezzo on the Folk Song, Vogeltje, gij zijt gevangen (Monnier). Pluck et Plouck (Smisen). Jazz Divertissement (Brusselmans). March of the Bogies (Dame).

5.0—Maggiano Orchestra, from the Exhibition. In the interval: Sports.

6.0—Belgian Music. Radio Orchestra. Conductor: Walpot. Gilman (Flute). March (Karel Walpot). Overture, "L'Oncle Mathurin" (Weyts). Waltz, Tendre passion (Lauwerijns). Ode à Terpsichore (De Taeye). Flute and Orchestra: Fanfaluca (Gilson). Maïta (La Gye). Chevauchée fantastique (Brenta).

6.45—Francine Bruylants (Songs).

7.0—Talk by the Abbé Crols: The Beatitudes. 7.15—Records: Le chasseur maudit (Franck). 7.30—Music Review by Paul Gilson.

8.0—Symphony Orchestra from the Exhibition. Conductor: André. Thelma (Songs) and Bouquette (Cello). Fanfare on old Flemish Songs (Van Hoof). Overture, "Mijn-ramp" (Albert). Flemish Rhapsody (Brusselmans). Songs. Danceries (Gervaise-Souris). Suite, Colombia (Bosmans). Cello and Orchestra: Poem (Buffin). Suite (Handel-Baeyens). Songs. Ronde wallonne (Jongen). In the interval at 8.45: Hélène Douliez (Recitations).

10.0—News. 10.10-12.0 m't—See Brussels (No. 1).

BUCHAREST (Romania)
823 kc/s (364.5 m.); 12 kW.

11.0 a.m.—Religious Address. 11.15—Religious Address. 11.30—Choir. 12.0 noon—Water Level; Amusement Guide. 12.5 p.m.—Luza Iovitzka Orchestra. 12.45—Sports. 12.55—Orchestra (contd.). 1.15—Weather; News. 1.35—Orchestra (contd.). 4.0—For Farmers. 5.0—Ionitza Baditza Orchestra. 6.0—News. 6.15—Orchestra (contd.). 7.0—Talk. 7.20—Roumanian Folk Songs by Silvan Florin. 7.50—Programme Notes. 8.0—Talk.

8.15—Radio Orchestra. Overture, "Im Reiche des Indra" (Lincke). Selection, "Lakmé" (Delibes). Lehár Potpourri (Hruby). Viennese Waltzes (Komzak). Humorous Potpourri (Klein). Ballet Airs (Demaret). Foxtrot (Weiss). Blues (Bee). Tango (Himmel). Paso doble (Grothe). March (Steinbrecher). In the interval at 9.0—Sports.

10.0—News. 10.20—Records.

BUDAPEST (No. 1) (Hungary)
546 kc/s (549.5 m.); 120 kW.

9.15 a.m.—News. 10.0—Protestant Service. 11.0—High Mass. 12.20 p.m.—Weather. 12.30—Opera Orchestra. Conductor: Rajter. 2.0—Records. 3.0—For Farmers. 3.50—Bachmann Chamber Orchestra. 4.30—Talk: Famous Hungarian Orchards.

5.30—Imre Magyari Cigány Band. In the interval: Commentary on the International Regatta. 7.0—Talk: Copperplate Engraving. 7.30—Koréh (Songs). 8.10—Talk.

8.35—Berend Chamber Orchestra from the Hotel Palatinus. Selection, "Die Verliebte Königin" (Brodzski).

Polonaise (Roland). Waltz (Nádas). 9.0—News.

9.30—László Szentgyörgyi (Violin) and Otto Herz (Pianoforte).

10.25—Sárközi Cigány Band. 11.20—Heilig Jazz Band. 12.5 a.m. (Monday)—News.

BUDAPEST (No. 2) (Hungary)
359.5 kc/s (834.5 m.); 20 kW.

11.10 a.m.—Orchestra. 3.0—Lugossy (Tárogato) with the Béla Kiss Cigány Band. 5.40—A Story.

6.30—Municipal Orchestra. Conductor: Bor. Illus Szabó (Songs). Overture, "Banditenstreiche"

9.30 P.M. BUDAPEST NO. I

Hubay

Violin Concerto in A

Rhapsody Liszt-Hubay

played by László Szentgyörgyi

Otto Herz at the Pianoforte

(Vienna relays the Concerto)

(Suppé). Waltz, "Die schöne Polin" (Lehár). Intermezzo, "The Arabian Nights" (Strauss). Aria, "A Masked Ball" (Verdi). Song, "The Violin-Maker of Cremona" (Hubay) and "Die Fledermaus" (Strauss). Fantasia, A Honey-moon in Scandinavia (Juel-Frederiksen). Overture, "The Italian Girl in Algiers" (Rossini). Peer Gynt Suite No. 2 (Grieg). Variations on a German Folk Song (Ochs).

8.35—News. 9.0—Jazz Band. 9.35—Records.

COLOGNE (Germany)
658 kc/s (455.9 m.); 100 kW.

6.0-8.0 a.m.—See Hamburg. 8.0—For Farmers. 8.30—Surprise Programme. 9.15-9.45—Roman Catholic Service. 10.0—See Deutschlandsender.

10.30—Stauch Trio. 11.10—Poems (Gath).

11.20—Harmonia Male Voice Choir from Aachen. Hans Haass (Pfte.). Des Deutschen Vaterland (Reichardt). The Sailor's Prayer (Pestalozzi). Pfte.: Berceuse (Chopin). Abschied (Kirchl). Liebeswerbung (Hegar). Liebeskummer (Othegraven). Pfte.: Rhapsody No. 13 (Liszt). Trübsinn (Othegraven). Der Jäger aus Kurpfalz (Othegraven).

12.0 noon—See Berlin.

1.50—See Stuttgart. 2.0—For Children. 2.45—Guessing Competition.

3.15—Rural Programme.

4.0—Station Chamber Orchestra—The Rhine Vocal Trio; Franz Kürten (Entertainer). 6.0—Report: The Women's Light Athletic Championship.

6.20—Station Chamber Quintet. Der kleine Reiter (Lincke). Anita (Meisel). Tango, Kreuz des Südens (Blaauw). Gavotte, Liebesgeflüster (Erbe). Zug der Kieselmannchen über den Rheinberg (Erbe). Canto amoroso (Sammartini). Song and Czardas, "Mariska" (Lehár). Waltz, The First Letter (Reggova). Zug der Gnomen (Blon). Murrelndes Lüftchen (Jensen). Cowboy Games (Lautenschläger).

7.0—Report: The Düsseldorf Festival. 7.30—"The Wagner Festival Week in Detmold"—Festival Overture (August Weweler). 7.45—Sports.

8.0—Concert. Small Station Orchestra—Conductor: Eysoldt; Dortmund Mandoline Band. Conductor: Ritter, and the "Six Merry Singers." Prelude, Die Fledermaus (Strauss). Waltz, The Secrets of the Adige (Carena). The Old Chiming Clock (Humphries).

SUNDAY (July 21)

Songs: (a) Der verliebte Bua, (b) Ein Edelmann ritt zum Tore hinaus. Romance, Viktoria, regia (Seifert). Concert Waltz in A (Althoff). Diavoletta (Lindemann). Der verliebte Jim (Königsberger). Songs (Hartmann): (a) Ich spiel Euch eins auf, (b) A Busserl. Biedermeiertanz (Pöhland). Zauberglöckchen (Ritter). Der Blumen Pracht (Klose). Folk Songs: (a) Zum Tanze da geht ein Mädél, (b) Thuringian Dance Song. Waltz, Feenreigen (Ritter). Edith-Polka (Scherrer). Paraphrase on "Grün ist die Heide" (Blume-Mausz). Folk Songs: (a) Kirb, (b) Mit frischem Mut. Dance Humoresque (Ritter). Selection, "The Geisha" (Jones). Folk Songs: (a) Das Huhn und der Karpfen, (b) Ein Jüngling wollt auf Reisen. March, Frohes Wandern (Frantzen). 10.0—News.

10.30-12.0 m't—See Munich.

DEUTSCHLANDSENDER (Germany)
191 kc/s (1,571 m.); 60 kW.

6.0-8.0 a.m.—See Hamburg. 8.0—Rural Programme. 9.0—Service. 9.45—Talk. 10.0—Transmission for all German Stations. Excerpts, Das "Deutsche Bekenntnis" (Spitta) by Hitler Youth. 10.30—Horst Schimmelpfennig (Wurlitzer Organ). 11.0—Herbert Molenaar reads his own Poems. 11.15—Weather. 11.30—Records.

12.0 noon—Variety. In the interval at 12.55 p.m.: Time and at 1.0: Greetings. 2.0—Play for Children. 2.40—Light Music and Dance Music from Amsterdam (Records). 3.35—"Die Bauern wollten Freie sein"—Play (von Vacano). Music by Georg Blumen-saat (on Records).

4.0—Open-Air Concert from the Krollgarten.

6.0—See Cologne. 6.20—"A Trip to the South"—Otto Dobrindt Band. 7.30—Sports Review. 8.0—"Fireworks in Runxendorf"—Folk Fête (Manfred Lommel). 10.0—News. 10.30—Curt Hosemann (Cello); Herbert Jäger (Pfte.). 10.45—Weather. 11.0-12.55 a.m. (Monday)—Robert Gaden Dance Band.

FRANKFURT (Germany)
1,195 kc/s (251 m.); 25 kW. Relayed by Cassel, Coblenz, Freiburg, Kaiserslautern and Trier, 1,195 kc/s (251 m.).

6.0-8.0 a.m.—See Hamburg. 8.0—Water Level; Weather. 8.5-8.25—Gym. 8.45—Fanfare. 9.0—Roman Catholic Service. 9.45—An Address. 10.0—See Deutschlandsender.

10.30—Male Voice Choir. Conductor: Simons. Wanderers Nachtlied (Schubert-Werner). Kaiser Karl (Hegar). Der kleine Tambour Veit (Kieslich). Es geht nichts über die Gemütlichkeit (Nellius). Der Mühljüng (Schneider). Ständchen (Wickenhauser). Mein Truserlein (Wickenhauser). 11.15—Eberhard Wolfgang Moeller reads. 11.30—Alfred Wang (Pfte.). Variations on "Mein junges Leben hat ein End" (Sweetinck). Variations on "Auff die Mayerin" (Froberger). Andante with Variations in F minor (Haydn).

12.0 noon—See Berlin. 2.0—For Children. 2.45—Talk by a Saar Miner. 3.0—Rural Programme.

4.0—Military Band from Bad Soden. Conductor: Wanitzek. Part I. March, King Ludwig II (Seifert). Overture, "Light Cavalry" (Suppé). Selection, "The Gipsy Baron" (Strauss). Waltz, Beautiful Spring (Lincke). Five Military Marches. Part II. Overture, Wallenstein's Camp (Kerling). Tone Poem, Ein Morgen in Sanssouci (Kockert). Kuss-Walzer (Strauss). Adolf - Hitler - Fanfare

SUNDAY (July 21)

(Blume). Volk ans Gewehr (Schmidt). Potpourri, Erinnerungen aus dem Militärleben (Reckling).
6.0—For Girls. 6.30 (from Freiburg)—Report from Waldkirch: Baden Militia Meeting.
7.0—Variety (arr. Erwin Albrecht).
7.50—Sports Notes.
8.0—See Cologne. 10.0—News. 10.15—Weather; Sports; Local News. 10.25—Sports Review.
10.45—Dance Music from Munich.
12.0 m't—See Stuttgart.

HAMBURG (Germany)
 904 kc/s (331.9 m.); 100 kW.
 Relayed by Bremen, Flensburg,

2.40 PM HILVERSUM

Scheveningen KURHAUS concert

THE HAGUE ORCHESTRA

Conductor, Ignaz Neumark; Gerrit Visser, tenor

WAGNER

Overture, Rienzi; Grail Narration, Parsifal; Siegfried's Rhine Journey; March, Tannhäuser

INTERMEZZO, RECORDS

Overture, The Merry Wives of Windsor *Nicolai*
 Intermezzo, Cavalleria rusticana *Mascagni*
 Arias, Carmen *Bizet*
 Aida *Verdi*
 Suite No. 1, Carmen *Bizet*

Hanover, Magdeburg and Stettin, 1,330 kc/s (225.6 m.).
6.0-8.0 a.m.—Harbour Concert. 8.0—News. 8.15—Gym. 8.30—Wireless Technics. 8.45—Art Notes.
9.0—Old and New Operetta Music. Stettin Concert Orchestra. Conductor: Plato.
10.0—See Deutschlandsender. 10.30—11.0—Meditation. 11.30—"The Lime Tree"—Sequence of Literature and Folk Songs of Seven Centuries (Baron von Schröder). Bernhard Jakschat (Songs); Secker (Pfte.).
12.0 noon—See Berlin. In the interval at 12.55 p.m.: Weather. 2.0—"Die Katzenprinzessin"—Play for Children, with Music. 3.0—"Emden"—a Sequence on Records.
4.0—Light Music. Otto Fahldiek Band; the Station Dance Band. In the interval: "The Rescuer"—Sketch (Kunze). 6.0—Talk: Monkeys.
6.25—Light Music. Helmuth Eggers (Oboe), Hugo Ullrich (Clarinet), Emil Manz (Saxophone), Rio Gebhardt (Pfte. and Celesta) and Gustav Schlemm (Pfte.). Pfte. Duet: Military March (Florent Schmitt). Oboe Solo: Romance (Paladilhe). Saxophone Solo: Romance (Gaubert). Celesta and Pfte.: Klangstück (Girnatis). Clarinet and Pfte.: Allegretto (Schmid). Oboe Solo: Légende pastorale (Godard). Saxophone Solo: Waltz (Blumer). Pfte. Duet: Alt Wien (Lanner-Pillnery).

6.55—New Lyrics.
7.5—Johann Sebastian Bach—Organ Recital by Hans Ziehm, from St. Jacob's Church, Stettin. Toccata, Adagio and Fugue in C. Choral: Ich ruf zu dir, Herr Jesu Christ. Choral: In dir ist Freude. Toccata in F.
7.35—Sports Notes; Weather.
8.0—Opera Music. Station Orchestra. Conductor: Siedler. Bernhard Jakschat (Baritone). Overture and Ballet Music from "Donna Diana" (Reznicek). Aria, "Il Seraglio" (Mozart). Old Dances from "Madame Liselott" (Gerster). Overture, "The Taming of the Shrew" (Goetz). Aria, "Czar and Carpenter" (Lortzing). Suite, "Der Bäbu" (Marschner-Clarmann).
9.0—See Stuttgart. 10.0—News. 10.30-12.0 m't.—See Munich.

HILVERSUM (Holland)
 160 kc/s (1,875 m.). Transmitted on Kootwijk on 120 kW.

8.35-9.40 a.m.—Programme of the Workers' Radio Society (V.A.R.A.). 8.35—Jong (Organ). 8.40—Pigeon Flying Notes. 8.45—Gardening. 9.10—Jong (Organ and Pfte.); Records.
9.40-11.40—Programme of the Liberal Protestant Radio Society (V.P.R.O.). 9.40—Service from Drachten. 11.0—Records.

11.40-4.40 p.m.—Programme of the General Broadcasting Society (A.V.R.O.). 11.40—Talk by Prof. Zeeman. 12.10 p.m.—Groningen Orchestra. Conductor: Kuiler. Military March (Schubert). Overture, "Boccaccio" (Suppé). Waltz from "Die Fledermaus" (Joh. Strauss). Harlequin's Wedding (Thomé). Records. Le Carnaval ture (Luigini). Meditation from "Thaïs" (Massenet). Bacchanale from "Samson and Delilah" (Saint-Saëns). Overture, "William Tell" (Rossini). 1.40—Book Talk. 2.10—Male Voice Choir. Conductor: Maassen.

2.40—The Hague Municipal Orchestra. Records in the interval. 4.10—Dance Music by the A.V.R.O. Decibels.
4.40-7.40—V.A.R.A. Programme. 4.40—V.A.R.A. Orchestra. Conductor: de Groot. Overture, "The Merry Wives of Windsor" (Nicolai). Waltz from "Die Puppenfee" (Bayer). Selection, "Mignon" (Thomas). Three Dances from "Nell Gwyn" (German).

5.10—Sports Talk. 5.30—Sports Notes.
5.40—V.A.R.A. Orchestra. Conductor: de Groot. Overture, "Tancred" (Rossini). Suite, "Carmen" (Bizet). Selection, "Eugene Onegin" (Tchaikovsky). 6.20—Recitations.
6.40—Walis (Violin) and Rossican (Pfte.). Andante (Hubay). Jazzette (Goldbergh). Cavatina (Cui). Tango fantastico (Goldbergh). Serenade (Pergament). Scherzo diabolique (Hubay). 7.10—Records.
7.40 till close down—A.V.R.O. Programme. 7.40—News.

7.55—Concert from the Kurhaus, Scheveningen. The Kurhaus Orchestra—Conductor: Schuricht. Overture, "Sakuntala" (Goldmark). The Moldau (Smetana).

8.25—Records. 8.40—News. 8.55—Dance Music by the A.V.R.O. Decibels. Greta Keller (Songs). 9.25—Light Music by the Aeolian Orchestra. 10.15—New Records. 10.40—News. 10.50-11.40—Light Music by Kovacs Lajos Orchestra.

HUIZEN (Holland)
 995 kc/s (301.5 m.); 20 kW.
8.10-9.10 a.m.—Programme of the Christian Radio Society (N.C.R.V.). Religious Transmission; Mme. de Wolf-Wuite (Contralto); Kloek (Organ).
9.10-4.40 p.m.—Programme of the Catholic Radio Society (K.R.O.). 9.10—Records. 10.10—Pontifical High Mass

from St. John's Cathedral, Bois-le-duc. **11.55**—Light Music. K.R.O. Orchestra. Conductor: Gerritsen. 12.40 p.m.—Literary Talk.

1.0—K.R.O. Boys. Conductor: Lustenhouwer. Good-bye, Hawaii (Leon). Piece (Lincke). I was lucky (Stern). Butterfly love (Grit). Potpourri (Schneider). Narcissus (Nevin). You and the night and the music (Schwartz). Spring Serenade (Heykens).

1.40—Report on Records: The Bois-le-duc Festival.

2.10—K.R.O. Boys (contd.). Lookie, here comes the cookie (Gordon). On an old paddle steamer (Sarony). Viennese Potpourri (Morena). Got me doin' things (Gordon). Serenade d'amour (Waldau). The words are in my heart (Warren). Fahrende Volk (Leuschner). Suppé Waltz Potpourri (Thiele). Sicilia (Apollonio). 3.0—Records.

3.40—St. Catherine Orchestra. Conductor: Koppens. 4.10—For Invalids. **4.40-7.25**—N.C.R.V. Programme. 4.40—Service from Hillegom.

6.10—Visser (Organ). Prelude in E flat (Bach). Prayer (Boëllmann). Chant and Hymns. Fantasia in Toccata Style (Kee). 6.40—Records.

7.25 till Close Down—K.R.O. Programme. 7.25—Records. 7.30—Talk. 7.50—News.

7.55—K.R.O. Orchestra. Conductor: Gerritsen. Overture, "Zanetta" (Auber). Valse fantastique (Glazunov).

8.10—Light Music from Bois-le-duc. Conductor: Ogier. 8.40—The Bois-le-duc Festival.

9.10—K.R.O. Orchestra. Conductor: Gerritsen. Notenreigen (Urbach). The singing stream (Carr). Weaner Mehlspeis (Dufort). Lustige Brüder (Vollstedt). Im siebenten Himmel (Fétras).

9.55—Records. 10.10—News. 10.15—Records. 10.20-10.40—Epilogue by the Small K.R.O. Choir.

JUAN-LES-PINS (Radio Côte d'Azur) (France)
 1,249 kc/s (240.2 m.); 2 kW.

Transmits at intervals from 12.15 p.m. **8.0 p.m.**—Report on the Cycle Tour of France. 8.15—News. 8.30—Variety. 9.0—News. 9.15—Request Programme. 10.30—Variety. 11.0—Military Band. 11.30—Orchestra. 12.0 m't—Dance Music. 1.0 a.m.—Musical Time Signal, Coupo santo (Mistral).

KALUNDBORG (Denmark)
 238 kc/s (1,261 m.); 60 kW. Relayed by Copenhagen. 1,176 kc/s (255.1 m.).

8.0 a.m.—Gym. 8.30—Weather. 9.15-9.45—Gardening Talk.

10.0—Service from Odense Cathedral. 11.30—News.

12.0 noon—Radio Orchestra. Con-

6.30 P.M. LEIPZIG

LIGHT music

KURT BLACHMANN AND HIS ORCHESTRA

Dramatic Overture *Von Blon*
 Serenade *Robrecht*
 Potpourri *Lehár*
 Gipsy Romance *Hanschmann*
 Japanese Suite *Yoshitomo*
 Romance *Svendson*
 Melody *Denza*
 Silver Bells, Mazurka *Ramthor*
 (Xylophone Solo)
 Humoresque *Reger*

ductor: Gröndahl. Biche (Songs). Overture, "Idomeneo" (Mozart). Selection, "Love without Stockings" (Scalabrini). Waltz Suite (Schubert). Theme with Variations from the Emperor Quartet (Haydn). Selection, "The Robber Stronghold" (Kuhlau). Overture, "Norma" (Bellini). Songs (Rosenfeld): (a) Herre taend din Stjerner, (b) Blomsterne sove, (c) Asali, (d) Navnlös, (e) Laeg Öret til mit Hjerte, (f) Og vi to vil traede Dansen i Nat. Overture, "King Stephen" (Beethoven). Andante and Minuet, Clock Symphony (Haydn). Selection, "Youth and Madness" (Dupuy). Gavotte (Martini). March (Gungl). 2.0—Service from Christiansborg Castle Church. 3.30—

10.10 P.M. KALUNDBORG

POPULAR ORCHESTRAL CONCERT

CONDUCTOR, FRITZ MAHLER

Serenade *Mozart*
 Waltz, "Wo die Citronen blüh'n" } *Johann Strauss*
 Russian March }
 Suite from "Die Dreigroschenoper" ("The Three-halfpenny opera") *Kurt Weill*

Hasselgren and Nielsen (Accordions). **4.0**—Open-Air Concert. Conductor: Hye-Knudsen. Military March in E flat (Schubert). Overture, Fingal's Cave (Mendelssohn). Selection, "Figaro" (Mozart). Serenade (Haydn). Leonora Overture No. 3 (Beethoven). Knightsbridge March (Coates). Aurora Borealis Waltz (Lumbye). Overture, "The Daughter of the Regiment" (Donizetti). Polka, Amalie (Jensen). Serenade, "Les millions d'Arlequin" (Drigo). Piece (Bece). Hands across the ocean (Souza).

6.0—Reading in Jutland Dialect. 6.20—Talk: Musicians. 6.50—Weather. 7.0—News; Sports Results. 7.30—Children's Radio Ball. Preil's Dance Band. In the interval: Reading. 9.30—Talk by Franz von Jessen: Reminiscences of the Russo-Japanese War, 1905. 10.0—News.

10.10—Radio Orchestra.
11.0-12.30 a.m. (Monday)—Tuxen Dance Band and Cornelius Pfte. Ensemble from the Arena.

KÖNIGSBERG (Germany)
 1,031 kc/s (291 m.); 60 kW. Relayed by Danzig, 1,303 kc/s (230.2 m.).

6.0 a.m.—See Hamburg.
8.10 (from Danzig)—Roman Catholic Service. 9.0—Protestant Service. 10.0—See Deutschlandsender. 10.40—For Children. 10.50—Weather; Programme Notes. 11.0—Songs by Jensen, Herbert Brust and Gerhard Wiemar—Recital by Lotte Rosenow (Contralto). 11.30—Reading, Literature of the German Baltic Provinces.

12.0 noon—See Berlin. 2.0—Chess Lesson. 2.30—Sonata in C minor (Biber) by Clementine and Leopoldine Hermann (Violin and Pfte.). 3.0—For Women. 3.30 (from Danzig)—Reading. Späte Rosen (Theodor Storm). **4.0-6.0**—See Munich. 6.0—Sports Talk. 6.10—Talk: Age.
6.25—Margarete Krämer-Bergau (Contralto); Ernst Rudolph (Pfte.). Songs: (a) Ich hab' meine Lieb, (b) Am Wege (Korman), (c) Reinigung (Bungert), (d) Sonst, (e) Abendrot, (f) Gretel

SUNDAY (July 21)

(Pfitzner). Pfte.: Fantasia in C (Schumann).
 7.25—Talk: German Names. 7.40—Talk: Riding Tournaments.
 8.0—Königsberg Band. Conductor: Hennig. The Danzig Police Band Conductor: Stieberitz. Adler von Lille (Blankenburg). Dorfschwalben aus Oesterreich (Strauss). Overture. "The Barber of Seville" (Rossini). Dessau Castle Music (Heyse). Military Fanfare (Hofmann). Ballet Scene (Bériot). Die Nachtschwärmer (Ziehrer). Erzherzog - Albrecht - Marsch (Komzak). Finale from "Ariele, die Tochter der Luft" (E. Bach). An der Rawka 1914-1915 (Stieberitz). Czardas, "Der Geist des Wojwoden" (Grossmann). Overture, "Gri-gri" (Lincke). La Graziosa (Nehf). Musica proibita (Gastaldon). Hochzeitsweisen (Reckling). Loin du bal (Gillet). Fantasia on Auch ich war ein Jüngling (Lortzing). March (Moltke).
 10.0—News. 10.20—Report: The Young People's Swimming Gala at Allenstein.
 10.45-12.0 m't—Dance Music from Munich.
LEIPZIG (Germany)
 785 kc/s (382.2 m.); 120 kW. Relayed by Dresden, 1,285 kc/s (233.5 m.).
 6.0-8.0 a.m.—See Hamburg. 8.0—Service. 8.30—Programme Notes. 9.0—Literary Programme. 10.0-10.30—See Deutschlandsender. 11.0—(from Dresden)—Band.
 12.0 noon—See Berlin. 2.0 p.m.—Weather. 2.5—Talk: Erasmus Gerber, the Peasant Leader. 2.30—Programme Notes.
 3.0—Old German Music. Folkmar Längin (Viola da Gamba) and Gerhard Burgert (Harpischord). Choral

Sonata on "Herr Jesu Christ, du höchstes Gut" (Kühnel-Längin). Fantasia for Viola da Gamba (Schenk-Längin). Sonata in G (Telemann-Längin). Divertissement in A (Haydn).
 3.30—Talk: The Saxon Landscape round Königswartha.
 4.0-6.0—See Munich.
 6.0—See Cologne.
 6.30—Kurt Blachmann's Orchestra. 7.30 (from Dresden)—Kurt Martens reads from his book, "Gabriele Bach." 7.50—Sports Notes.
 8.0—See Hamburg.
 9.0—Concert from Cologne. 10.0—News.
 10.30-12.0 m't—See Munich.

LISBON (Portugal)
 629 kc/s (476.9 m.); 20 kW. Transmits at intervals from 12.0 noon.
 7.0 p.m.—Music. 7.55—News; Portuguese Music. 8.50—Talk. 9.0—Orchestra. In the interval at 9.30—News. 10.0—Political Notes; Music. 10.30—News; Music. 11.0—Dance Music.

MADRID (EAJ7) (Spain)
 1,095 kc/s (274 m.); 7 kW. Transmits at intervals from 8.0 a.m.
 8.0 p.m.—Dance Music. 10.0—Station Sextet. 11.0—Ramón Gómez de la Serna. 11.30—Municipal Band from Rosales. Conductor: Domingo. 1.0 a.m. (Monday)—Chimes.

MONTE CENERI (Switzerland)
 1,167 kc/s (257.1 m.); 15 kW.
 12.0 noon—Announcements. 12.2 p.m.—Records: Soloists of the Scala, Milan. 12.33—Records. 12.55—News. 1.5-1.30—Records.
 7.0—Records. Marche militaire (Schubert-Guiraud). Valse triste (Sibelius). Song from "Hollywood Conquests" (Burton-Giubra). Waltz, "The Arabian Nights" (Strauss).

Tango. Rintocchi (Zamuso-Tully). In a Persian Market (Ketelbey).
 7.45—News. 8.0—To be announced. 10.0—Pianoforte Jazz Records. 10.20-10.30—Sports.
MORAVSKÁ-OSTRAVA (Czechoslovakia)
 1,113 kc/s (269.5 m.); 11.2 kW. Transmits at intervals from 6.30 a.m.
 7.50 p.m.—"Pasture Land"—Scene in Dialect.
 8.20—See Brno. 9.5—Reading. 9.20—See Bratislava. 10.15-11.30—See Prague.



E.N.A.
 Ivar Andresen, who sings from Stockholm at 8.0 p.m.

MOSCOW (No. 1) (Russia)
 174 kc/s (1,724 m.); 500 kW. Transmits at intervals from 3.45 a.m.
 2.0 p.m.—Swedish Programme. 2.45—Announcements. 3.0—An Aviator's Dictionary. 3.15—For Children. 4.0—News. 4.13—Educational Programme. 4.30—Talks: (a) Race, (b) Malaria. 5.30—Concert. In the intervals: Announcements.

7.0—Symphony Concert. Conductor: Moussine. Jocheles (Pfte.). Sinfonietta (Gelobinsky). Pfte. Concerto in F (Chopin). Overture, "Tannhäuser" (Wagner)
 9.0—German Programme for Children. 10.5—English Review and Letter-box. 11.5—German Programme: War and Post-War Literature.

MUNICH (Germany)
 740 kc/s (405.4 m.); 100 kW. Relayed by Nürnberg, 1,267 kc/s (236.8 m.).
 6.0-8.0 a.m.—See Hamburg. 8.0-8.20—Wireless Notes. 8.55—Roman Catholic Service. 9.30—Station Choir and Soloists. 10.0—See Deutschlandsender. 10.30—Zither Music. 11.0—Talk by Julius Nitsche; Music by Richard Staab.
 11.30—Max Reger Organ Music—Recital by Gustav Schoedel. Prelude and Fugue in C minor. Introduction and Passacaglia in F minor.
 12.0 noon—Band from the Feldherrnhalle. Conductor: Kiessling. Germania-Marsch (Keil). Overture, "Maritana" (Wallace). Selection, "The Valkyrie" (Wagner). Swabian Rhapsody (Kämpfert). Waltz, Enfants de Printemps (Waldteufel). March, Mein Regiment (Blankenburg). 12.55—Weather; Programme Notes.
 1.0—Concert from Berlin.
 2.0—See Frankfurt. 2.45—Talk: Autumn Customs and Mythology.
 3.5 (from Nürnberg)—Elfriede Glockzin (Contralto), Inge Richter (Pfte.), Max Lanz (Violin), Karl Brehm (Cello) and Robert Spilling (Pfte.). Trio for Violin, Cello and Pfte. (Graener). Lieder des Glückes (Haas). Piano-

Armchair travel beats the Clock

R·A·P

LONG DISTANCE RADIO brings you "five hours back" at ANY TIME

MANY a man pays hundreds of pounds to travel to the other side of the world. Yet, you, in your armchair, can roam the length and breadth of the globe. As many countries as you wish for a mere £12 12 0—the price of your "Transatlantic" Superhet. Armchair Travel is inexpensive in the extreme, and need not strain the most slender purse, for deferred weekly payments work out at approximately **5/-**

"TRANSATLANTIC"
 All-Wave, 9-Stage AC/DC Superhet
 Band pass preselector feeding into pentagrid frequency changer giving a high ratio of signal strength to noise and freedom from whistles.
 Intermediate frequency stage consists of a variable-mu high frequency pentode and two band pass units tuned to 117.5 k.c. giving high gain and selectivity.
 Distortionless rectification, automatic volume control and audio frequency amplification are obtained from a multi purpose valve feeding into a low frequency pentode which delivers approximately 3000 milliwatts of power to an energised moving coil loud speaker.
 Wave range:—19.5—52, 200—550, 1000—2000 metres
 Supplied in two models—AC/DC 200-250 v. and AC only 200-250 volts, 50-100 cycles. Price only £12 12 0.

GET YOUR free PASSPORT

CENTRAL EQUIPMENT LTD.,
 188 London Road, Liverpool.
 Please send free copy of R.A.P. "Passport" Catalogue to:—

Name

Address

W.R./5
 carew wilson

SUNDAY (July 21)

forte Suite, Herbstblätter (Wüst). 3.40—Talk: Hassfurt.

4.0—Station Symphony Orchestra. Conductor: Rammelt. Mimi Thoma (Contralto), Probst and Frank (Accordion Duets) and Fred Rüffer (Zither). Marsch der Kreuzritter (Liszt). Waltz, The Wedding of the Winds (Hall). Festival Overture (Lassen). Träumerei (Holz). Könntest Du in meinen Augen lesen (Kleine). Introduction, Act III of "Tannhäuser" (Wagner). Waltz, The Blue Danube (Strauss). Zither Solo: Spanish Serenade (Kollmaneck). Selection, "Tiefand" (d'Albert). Flattern zum Abschied die Fahnen (Kleine). Frühlingssehnen (Mickenschreiber). Hungarian Comedy Overture (Kéler-Béla). Waltz, "Die Fledermaus" (Strauss). Zither Solos (Degen): (a) Humoresque, (b) Pierrette. Piece (Popper). Overture, "Light Cavalry" (Suppé). March, In Treue fest (Teike).

6.0—Hugo Reker (Violin); Richard Staab (Pfte.). Prelude, Fugue and Variations (Franck). Scherzo in F sharp minor (Windsperger). Sonatina (Schubert).

6.30—"Thunder and Hail"—Comedy (Fritz Meingast). 7.40—Sports.

8.0—Variety. 10.0—News. 10.20—Report on the German Wrestling Championship (on Records). 10.30-12.0 m't—Station Dance Band.

OSLO (Norway)

260 kc/s (1,154 m.); 60 kW. Relayed by Frederikstad, 776 kc/s (386.6 m.); Hamar, 510.5 kc/s (587.7 m.); Notodden, 1,357 kc/s (221.1 m.); Porsgrund, 850 kc/s (352.9 m.); Rjukan, 1,348 kc/s (222.6 m.); Trøndelag, 629 kc/s (476.9 m.).

9.30 a.m.—News. 9.32—Records. 10.0—Talk. 10.30—Service. 12.45 p.m.—News. 1.0—Report: The Sandnes Exhibition.

5.0—Records: Light Music. 6.0—Report: The Sandnes Exhibition.

6.30—Erling-Krogh (Songs) and Rustad (Cello). Songs: (a) Oslo Song (Bodom), (b) If I were King (Torjussen), (c) Olsok (Torjussen), (d) Gloria in excelsis (Hurum). Cello: (a) Nina (Pergolesi), (b) Old French Song (arr. Burmester), (c) Cherry Ripe (Cyril Scott), (d) Minuet (Valensin). Songs: (a) Ave Maria (Schubert), (b) Elegy (Massenet). Aria, "Rigoletto" (Verdi). 7.10—News. 7.30—Talk by Sven Stolpe: Nathan Söderblom.

8.0—Station Orchestra. Conductor: Fjeldstad. Overture, "The Peasant Rogue" (Dvořák). Symphony in A (Mendelssohn). Canto amoroso (Sammartini-Ellman). Gavotte (Gossec). Chant du voyageur (Paderewski). Norwegian Rhapsody (Svendson). Chant russe (Lalo). Berceuse and Rocooco Melody (Burmester). Polovtsovian Dances (Borodin). Slav March (Tchaikovsky). 9.40—News. 10.0—Topical Talk. 10.15—Sports Talk. 10.30-11.30—Dance Records.

PARIS (Eiffel Tower) (France)

1,456 kc/s (206 m.); 5 kW.

1.0 p.m.—News.
1.20—Ibós Orchestra. Budapest (Leoni). Hungarian Dances (Brahms). Selection, "The Dollar Princess" (Fall), and "The Thieving Magpie" (Rossini). Arabesques (Debussy). Saxophone Solo. Sevilla (Albéniz). Selection, "Frasquita" (Lehár). Serenade (d'Ambrosio). Zou, le midi bouge (Scott-Salabert). Spanish Dances (Moszkowsky).
2.30-5.0—Concert.
6.30—See Paris (PTT). 6.45—News.

6.55—Racing Results; Weather. 7.5—News.

7.45—Breton Folklore Programme by Jean Suscinio, Mme. Coudray and Mlle. Marcelle de Beyre. 8.15—News.

8.30-10.0—Records: Russian Music.
PARIS (Poste Parisien) (France)
959 kc/s (312.8 m.); 60 kW.
9.0 a.m.—News. 9.22—For Housewives. 9.30—Messenger Records. 10.0—Records.

10.35—Lucien Bellanger Instrumental Ensemble. Bellanger (Violin), Cruque (Cello). 11.33—Records. 11.50-12.0 noon—Cinema Organ (Records). 12.5 p.m.—Records. 12.45—An Interview. 12.50-1.20—Concert by Rosette Guy and Jean Clément. 1.30-2.30—Listeners' Association Concert. 5.0—Records. 7.0—News. 7.20—Amusement Guide.

7.22—Records. 7.35—Commentary on the Cycle Tour of France.

7.50-8.0—Fauré Records. Impromptu for Harps. Clair de Lune. Barcarolle No. 2.

8.15-8.45—"Le Mystère des Yeux"—One-Act Play (Caillas). 9.0-9.45—"Mireille and her Friends."

10.0—Orchestra. Marche des petits pierrots (Bosc). Waltz, Dolores (Waldteufel). Mazurka, La Fringante (Filippucci). Tango, Jealousy (Gade). Waltz, Toujours ou jamais (Waldteufel). Piece (Tellam). 10.30-12.0 m't—Records.

PARIS (PTT) (France)

695 kc/s (431.7 m.); 7 kW.

Transmits at intervals from 8.0 a.m. 12.15 p.m.—Derveaux Jazz Band. In the interval at 1.20: News. 2.0—Concert.

3.30—Open-Air Casino Concert from Vichy. Conductor: Fourestier. Overture, "Mirella" (Gounod). Selection, "Carmen" (Bizet). Pierrette (Chaminade). Ballet Music, "Faust" (Gounod). Entr'acte and Sevilliana, "Don César de Bazan" (Massenet). La housarde (Ganne). Hungarian March (Berlioz). 4.45—Records: Poems (La Fontaine and Frémine) recited by Silvain.

5.0—One-Act Plays: (a) "La signature" (de Bussy), (b) "Le commissaire est bon enfant" (Courteline). 6.0—Records. 6.30—News; Review.

7.30—Scotts Songs by Cora Madou, accompanied by the Composer (Guitar) and his Orchestra. 8.0—Report: The Cycle Tour of France. 8.15—Sports.

8.30—Operetta Excerpts. "La fiancée du Scaphandrier" (Terrasse). "Le diable galant" (Piermé). "Les charmeurs" (Poise). Orchestra and Soloists. Conductor, Rosenthal. 10.30—News.

10.50—See Paris (Radio-Paris.)

PARIS (Radio-Paris) (France)

182 kc/s (1,648 m.); 80 kW.

7.0 a.m.—Records. 7.15—News. 7.45—Gym. 8.0—French Opera Records. 8.35—Records. 11.0—Records of Famous French Artists.

11.15—Contemporary Belgian Music. Martha Bracquemond (Organ), from the Schola Cantorum. Theme and Variations (Mawet). Cantabile and Choral (Jongen). Movements, Symphonie de l'Agneau mystique (Maleingreau).

11.45—Address by the Rev. Fr. Avril, O.P. 12.5 p.m.—Records: Sacred Music. 12.15—Concert. Conductor: Guillou. Suzanne Vidal (Songs). Titto-Strozzi (Zerco). Barcarolle (Porret). Suite, Les forains (Berger). Rêve d'enfant (Antréas). Selection, "Mamie Rosette" (Lacôme). Songs: (a) La Fauvette (Gounod), (b) Le bobo de sa fille (Laparra), (c) La petite maison (Beydts), (d) La chanson des noisettes (Dupont). Russian Overture (Michiels).

Scènes d'atelier (Guillou). Gounod Potpourri. La pluie (David). Dance and Cortège (Leblanc). Waltz Potpourri (Gult). Tarantella (Chillemont). In the interval at 1.20: News. 2.0—Bilboquet.

2.15—Pierrette Madd, Sorbier and Clément (Songs, Duets). Voulez-vous Lisette? (Claret). Elle ne viendra pas (Ackermans). Je cherche un amour (Alongi). Ma Lola (Yvain). C'est toute ma vie (Calmes). Chansons d'Actualité (Souplex-Claret).

MIDNIGHT STUTTGART FRANKFURT

Operetta music

Excerpts from "Die Fledermaus" (Johann Strauss)

"The Merry Widow," "The

Count of Luxembourg" (Lehár)

"The Beggar-Student" (Millöcker)

And from the Ballet "Coppelia"

(Delibes)

And the Opera "Donna Diana"

(Reznicek)

Interludes:—Violin Solo (Eduard

Oswald)

Czardas (Hubay)

Flute Quartet (Fürstenau)

Folie (Nilson-Fisher). Bonjour Suzon (Lacôme). Tu reviendras (Claret). Lentement dans la nuit (Bixio). Le printemps n'est pas loin (Boyer). C'est bien vrai (Wal-Berg). Pour se promener sur l'eau (Briez-Gabriello).

3.0—Variety.

4.0—Plays: "La voiture versée"

(Courteline). "La paix chez soi"

(Courteline). "L'élève Chochotte"

(Duvernois).

5.0—Light Music. Goldy Orchestra.

Sorbier (Songs), Guilevitch (Violin).

7.0—Radio-Paris Circus, with Bilboquet.

7.35—Records: Classical Dances.

Minuet (Mozart). Tambourin (Grétry).

Passépied and Pavane (Delibes).

Divertissement dans le style Louis XV (Tailleferre). 8.0—Records.

8.30—Press Review.

8.45—"Denise"—Play in Four Acts

(Dumas Fils). In the interval, News.

10.50-12.0 m't: Pascal Dance Band.

PRAGUE (Czechoslovakia)

638 kc/s (470.2 m.); 120 kW.

6.30 a.m.—Gym; Music; News.

7.0—Karlsbad Municipal Orchestra.

8.20—Police Messages. 8.30—Vojtek

(Organ). 9.0—For Workers. 9.15—

See Brno. 10.0—"Songs of the High

Road"—Marie Fleischerova (Soprano)

and Bruder-Rujan (Baritone). 10.25—

Talk and Reading: With Jan Neruda

to Stambul. 10.55—Book Review.

11.0—Military Band from Podedbrady.

Conductor: Blazek.

12.0 noon—Cathedral Chimes. 12.5

p.m.—News.

12.15—Military Band. Conductor:

Uhlir. Homage March (Aust). Overture,

"The Secret" (Smetana). Song

(Sermak). Slav Dance (Dvořák).

Selection, "Carmen" (Bizet). Children's

March (Potuznik). Song

Potpourri (Maly). March (Mach).

Waltz, "The Gipsy Baron" (Strauss).

War March (Zita).

1.15—Records. 1.30—For Farmers.

1.45—Records. 1.55—For Farmers

(German). 2.10—Records. 2.15-3.0—

"Swimming"—Revue. 4.0—See Brno.

5.30—Talk: Legal Tender in China. 5.45—Records.

6.0—German Transmission: Czech Philharmonic Orchestra. Conductor: Swoboda. Grete Rieger-Miksch (Songs). German Dances (Schubert-Webern). Dance Suite (Béla Bartók). Two Songs (Kornauth). Magna Mater (Tcherepnin). Scherzo (Suk).

7.0—News (German). 7.5—Record News.

7.15—Muzik Orchestra. Overture, "Czar and Carpenter" (Lortzing). Souvenir (Blahnik). Einie Sängerfahrt Nach Wien (Silving). Waltz Boston (Kuckynka).

7.50—See Moravská-Ostrava. 8.20—See Brno. 9.5—Reading. 9.20—See Bratislava. 10.15—News. 10.35—Record. 10.40—News and Sports in German. 10.45-11.30—Czech Dance Bands.

RADIO-NORMANDIE (France)

1,113 kc/s (269.5 m.); 10 kW.

7.0 a.m.—Records. 7.20—News. 7.45—

Records. 7.48—Racing Results. 7.50—

Records. 7.53—Cookery. 8.0—Re-

records. 8.15—Orchestra. 8.45—Sacred

Music. 9.0—Records. 9.30—Banjo.

9.45—Records. 10.15—Dance Music.

10.30—Records. 11.0—Military Music.

11.30—Sacred Music. 12.0 noon—

Request Music. 2.0-2.30: The

"Circuit de Dieppe" Motor Race.

3.0—Dances. 3.15—Orchestra. 3.30—

Records. 4.15—For Children. 4.30—

The "Circuit de Dieppe" Motor Race.

5.15—Light Music. 5.30—Records.

6.0—Light Music. 6.30—Records.

7.0—Request Music. Excerpt, "Car-

men" (Bizet). Tango (Ouvrad).

Chez le photographe (Manse). Ex-

cerpt, "The Gipsy Princess" (Kal-

man), and "La vie parisienne"

(Offenbach). Chantez pour mio,

violons (Deutsch). Un Million

(Moretti). On n'a pas tous les jours

vingt ans (Raiter). Recitation:

Tirade des neys from "Cyrano de

Bérgérac" (Rostand). Excerpt,

"La poupée" (Audran). Valse

militaire belge (Fremaux). 8.15—

Sports.

8.30—Opera and Operetta Music. Ex-

cerpt, "Couchette No. 3" (Szulc).

Duet "Thaïs" (Massenet). Excerpts,

"La belle Hélène" (Offenbach),

"Les noces de Jeannette" (Massé),

"Viktoria and her Hussar" (Abra-

ham). Good night (Mauprey). Ex-

cerpts, "Don Quixote" (Massenet),

"L'étoile du nord" (Meyerbeer),

"Samson and Delilah" (Saint-Saëns),

"La grande-duchesse de Gérolstein"

(Offenbach) and "Le postillon de

Longjumeau" (Adam).

9.30—Opera Music. Selection. "Aida"

(Verdi). Intermezzo, "Cavalleria

rusticana" (Mascagni). Barcarolle,

"Tales of Hoffmann" (Offenbach).

One Fine Day, "Madame Butterfly"

(Puccini).

9.45—Records. 10.30—Light Music.

11.0—Orchestra. 11.30—Songs.

12.0 m't-2.0 a.m.—Dance Music.

ROME (Italy)

713 kc/s (420.8 m.); 50 kW. Relayed

by Naples, 1,104 kc/s (271.7 m.);

Milan (No. 2), 1,348 kc/s (222.6 m.);

Turin (No. 2), 1,357 kc/s (221.1 m.);

and Bari, 1,059 kc/s (283.3 m.).

9.20 a.m.—French Lesson. 9.40—

News. 10.0—Rural Programme.

11.0—See Turin. 12.0 noon-12.15 p.m.

—Bible Reading. 12.30—Records.

1.0—Announcements. 1.10-2.15—See

Turin. 2.15-3.0—Mediterranean

Programme. 4.0—Records; Sports Notes.

5.30-6.45—Germano Arnaldi (Pfte.) and

Maria Fersula (Soprano). In the interval

at 6.0—Sports Notes and Weather.

7.30—Sports Notes; News.

8.40—Symphony Concert. Conductor:

Rito Selvaggi. Prelude and Allegro

(Martini-Selvaggi). Symphony in G.

(Gluck). Carnival Overture (Dvořák). En Saga (Sibelius). Prelude to the Mass of St. Anthony (Selvaggi). The Circus Rider (Larmanjat). In the interval: Cinema Review.
10.0—"Menzogne di bordo"—One Act Play (de Stefani). **11.0**—News.

SOTTENS (Switzerland)

677 kc/s (443.1 m.); 25 kW.
9.40 a.m.—Chimes. 9.45—Service from the Cathedral, Lausanne. **11.0**—Moser (Organ). **11.30**—Classical Records 12.30 p.m.—News. 12.40-2.0—Records. 3.0-5.0—"High Summer in the Alps"—Report from Châtel St. Denis. 6.0—Records: "Carmen"—Opera (Bizet). 7.0—Protestant Address. 7.30—Pfte. Records. 7.45—Sports Notes. 8.0—Literary Programme.
8.30-10.15—Radio-Suisse Romande Orchestra. Conductor: de Ribaupierre. Madeleine Gonser (Violin). The Clock Symphony (Haydn). Violin Concerto in A (Mozart). Chaconne and Rigaudon (Monsigny). Suite Pastorale (Chabrier). In the interval at 9.20—News.

STOCKHOLM (Sweden)

704 kc/s (426.1 m.); 55 kW. Relayed by Motala, 216 kc/s (1,389 m.); Göteborg, 941 kc/s (318.8 m.); Hörby, 1,131 kc/s (265.3 m.); and Boden, 392 kc/s (765 m.). Transmits at intervals from 9.15 a.m.
11.0—Service. 3.0—Swedish Music. Sjöbom Orchestra.
4.0 p.m.—Folk Songs, Peterson-Berger and Söderman Songs. Björling Quartet. 4.30—For Children. 5.0—Weather.



E. N. A.

A Breton peasant. Eiffel Tower devotes its programme at 7.45 p.m. to Breton folk-lore

5.5—Records. 6.0—Evensong. 7.15—News. 7.30—Talk.
8.0—Radio Orchestra. Conductor: Hellman. Soloist: Andrésen. In the interval: Reading. 9.45—News.
10.0-11.0 (from Göteborg)—Orchestra. Overture, "Il Turco in Italia" (Rossini). Mein Lebenslauf ist Lieb und Lust (Jos. Strauss). Suite, On the Banks of the Nile (Platen). West Gothland Rhapsody (Löfgren). Rakoczy March (Berlioz).

STRASBOURG (France)

859 kc/s (349.2 m.); 35 kW.
9.30 a.m.—High Mass from the French Eucharistic Congress. **11.0**—Records.

11.15—Protestant Service. 12.0 noon—Records. 12.45—p.m.—News. 1.0—Time: Records.
3.0-6.0—See Paris (Radio-Paris). 6.0—Medical Talk. 6.15—Mme. Malnory-Marseillac (Soprano).
7.0—See Paris (Radio-Paris). 7.45—News in German. 8.0—Report: The Cycle Tour of France—The Day of Rest. 8.15—News in German; Records. 8.30—Alsation Evening. 10.30—News. **10.50**—See Paris (Radio-Paris).

STUTTGART (Germany)

574 kc/s (522.6 m.); 100 kW.
6.0-8.0 a.m.—See Hamburg. 8.0—Weather. 8.5—Gym. 8.25—For Farmers. 8.45-9.30—Roman Catholic Service from St. George's Church.
10.0—See Deutschlandsender. 10.30—Report: Final Rehearsal for the Schwenningen Gymnastic Festival.
11.0 (from Karlsruhe)—Band. Conductor: Heisig.
12.0 noon—See Berlin. In the interval at 1.0 p.m.—Reading. 1.50—Rehearsals for the Heidelberg Festspiele. Excerpts, "Götze von Berlichingen" (Goethe).
2.0—See Frankfurt. 2.45—For Artisans.
3.0—Choir. Ich sah ein Bild. Die zwei Tugendwege (Schubert). Haus der Reinen (Herrmann). Nachtgruss (Zuccalmaglio). Feldeinsamkeit (Wendel). Mein Herz hat sich gesellet (Rein). Heissa zur Linde (Löffler). Auferstanden (Gambke). Auf Wiedersehen (Vignau). Schönster Schatz, mein Augentrost (arr. Zutter). 3.30 (from Karlsruhe)—Report: Sulphur Springs in Baden.
4.0-6.0—See Munich. 6.0—Allgau Dairy-Farming—Sequence.
6.20—See Deutschlandsender. 7.30—Sports Talk.
8.0—See Hamburg. 9.0—"Kitsch and Co."—A Revue (Hofbauer-Reimann). 10.0—News.
10.30—Berlin State Opera. Wind-Instrument Ensemble. Trio in E flat for Clarinet, Bassoon and Pfte. (Kreutzer). Quintet in C minor (Spohr).
11.15—Dance Music from Munich.
12.0 m't-2.0 a.m. (Monday)—Station Orchestra.

TOULOUSE (Radio Toulouse) (France)

913 kc/s (328.6 m.); 60 kW.
11.0 a.m.—Dance Refrains. **11.15**—Symphony Orchestra. **11.30**—Roman Catholic Service. **11.45**—Viennese Orchestra. **12.0 noon**—Songs. **12.15 p.m.**—Light Music. **12.30**—News. **12.45**—Light Orchestral Music. **1.0**—News. **1.5**—Opera Music. **1.15**—Orchestra. **1.30**—Film Music. **1.50**—Marches. **1.55**—News. **2.0-2.15**—Protestant Service. **6.0**—News.
6.15—Cigány Band. Czardas (Monti). Selection, "Countess Maritza" (Kálmán). The Two Guitars (Makarov). Serenade, "Frasquita" (Lehár).
6.30—Tyrolese Music.
6.45—Violin. Variations on a Corelli Theme (Kreisler). Largo (Handel). Minuet (Beethoven). Tambourin chinois (Kreisler). Plaisir d'amour (Martini). 7.0—Chansonnettes. 7.15—Operetta Music. 7.30—News. 7.45—Humorous Scenes. 8.5—Hawaiian Guitars.
8.15—Opera and Operetta Music. Airs from "La Mascotte" (Audran), "Bégonia" (Mercier), "Rip" (Planquette), "Les Mousquetaires au Couvent" (Varney), and "La fille de Madame Angot" (Lecocq).
8.30—Military Marches.
9.0—Concert Version, "Tosca"—Opera (Puccini).
9.50—Popular Classical Melodies. **10.20**

—Argentine Orchestra. **10.30**—News. **10.45**—Cinema Organ.
11.0—Songs. **11.15**—Dance Music. **11.35**—Film Music. **11.45**—Marches. **12.0 m't**—Popular Melodies. **12.15 a.m.** (Monday)—News. **12.20-12.30**—Hunting Horns.

TURIN (No. 1) (Italy)

1,140 kc/s (263.2 m.); 7 kW. Relayed by Milan (No. 1), 814 kc/s (368.6 m.); Genoa, 986 kc/s (304.3 m.); Florence, 610 kc/s (491.8 m.); and Trieste, 1,222 kc/s (245.5 m.).

10.25 P.M. VIENNA

STRAUSS and LANNER

"Forgotten" music by members of the Strauss family and Lanner, played by the "Wiener Symphoniker," conducted by Max Schönherr

9.10 a.m.—Announcements. 9.20—French Lesson. 9.40—News. 10.0—Rural Programme.
11.0—Mass from the Church of the Annunciation, Florence. **12.0 noon-12.15 p.m.**—Bible Reading. **12.30**—Records. **1.0**—Announcements.
1.10—Variety. 1.40-2.15—Records. **4.0**—Records; Sports Notes.
5.30—Orchestra. In the interval at 6.0—Sports Notes and Weather. 6.45-7.0—Sports Notes. 7.30—Announcements; Records. 8.0—Records; Sports Notes. 8.30—Announcements; Records.
8.40—"Cendrillon"—Opera in Four Acts (Massenet). In the interval: Report of the Italian Aero Club and News.

VIENNA (Austria)

592 kc/s (506.8 m.); 100 kW. Relayed by Graz, 886 kc/s (338.6 m.); Innsbruck, 519 kc/s (578 m.); Dornbirn, Klagenfurt and Linz, 1,294 kc/s (231.8 m.) and Salzburg, 1,348 kc/s (222.6 m.).
8.15 a.m.—Announcements. 8.20—Gym. 8.45—Service from St. Peter's Abbey, Salzburg. **10.0**—Records. **10.45**—Hints for the Week. **11.0**—Talk: Harvest Festivals and Customs.
12.0 noon—Consecration of the Dollfuss Church on the Hohe Wand.
12.45-2.15 p.m.—Vienna Chamber Orchestra. Conductor: Jascha. Old Austrian Folk Dances (Schönherr). Waltz, Bei uns z' Haus (Strauss). Serbian Melodies (Gál). Rondo in D (Andress). Selection, "Die Brasilianerin" (Jascha). Waltz, Enfants du printemps (Waldteufel) Selection, "The Land of Smiles" (Lehár). Overture, "Pique Dame" (Suppé). 3.0—News. 3.15—Book Review.
3.40—Chamber Music by the Sedlak-Winkler Quartet. String Quartet in F (Dvořák). String Quartet in A minor (Schumann). 4.35—Talk: Our Wooded Homeland.

SUNDAY (July 21)

5.0—Vienna Symphony Orchestra. Conductor: Schönherr. March, Das ist der Zauber der Montur (Ziehrer). Rakoczy Overture (Kéler-Béla). Lagunen-Walzer (Strauss). Czardas, "Der Geist des Wojewoden" (Grossmann). Elfenreigen (Hellmesberger). Erinnerung an Bayreuth (Morena). Waltz, "Der Rosenkavalier" (Strauss). Potpourri, Für meine Freunde (Komzák). 6.15—Talk.
6.40—Talk: The World's Largest Telescope. 7.0—Programme Announcements. 7.15—Motto. 7.20—"Der grosse Bluff"—Play in Three Acts (Heller-Schütz).
9.30—See Budapest. **10.0**—News; Sports.
10.25—Strauss and Lanner.
11.30—Announcements. **11.45-1.0 a.m.** (Monday)—Emil Thiel Jazz Band.

WARSAW (Poland)

224 kc/s (1,339 m.); 120 kW. Relayed by Katowice, 759 kc/s (395.8 m.); Lwów, 795 kc/s (377.4 m.); Poznań, 868 kc/s (345.6 m.); and Wilno, 536 kc/s (559.7 m.).
8.30 a.m.—Hymn; Gym; Records. **9.15**—News. **9.25**—Records. **9.50**—Sports and Tourist Notes. **9.55**—Announcements. **10.0**—Mendelssohn Records. **10.30**—Service. **12.0 noon**—Fanfare. **12.3**—Talk: The Steppes of Uruguay.
12.20 p.m.—Station Symphony Orchestra. Conductor: Oziminski. Sznajderman (Violin). Overture, "Carnival in Venice" (Thomas). Ballet, "The Demon" (Rubinstein). Violin Concerto in D (Paganini-Wilhelmy). Bacchanal, "Samson and Delilah" (Saint-Saëns). Symphonic Poem, Turkish Carnival (Luigini). Minuet (Bolzoni). Scènes pittoresques (Massenet). In the interval at 1.0: Scenes from "The Life Income"—Comedy (Fredro).
2.0—Chamber Music by Marek Weber's Orchestra (Records). 2.47—Weather; For Farmers. 3.10—Records. 3.45—For Women.
4.0—Szpinalski (Pfte., Debussy). 4.30—Aston (Songs). 4.45—Reading.
5.0—Light Music. Small Station Orchestra. Conductor: Górzyński.
6.0—Relay from Braslaw Physical Training Camp.
6.15—Records: "Toi, c'est moi"—Operetta (Simons-Duvernois). 6.30—Polish Songs, from Cracow. 6.45—Report: The Polish Frontier. 7.0—Announcements. 7.25—Lehár Records. 7.50—Wireless Talk. 8.0—Talk: Joseph Pilsudski in 1920.
8.10—Chamber Orchestra, Wilno. 8.45—Pilsudski Sayings. 8.50—News. **9.0**—Wagner.
9.30—Variety, from Lwów. **10.0**—Sports.
10.20—Marine Band from Gdynia. **11.5**—Dance Records.

9 P.M. WARSAW

Wagner ORCHESTRA

CONDUCTED BY OZIMINSKI

I. Dygas, tenor.

Introduction Act 3, Lohengrin

Tannhäuser's Pilgrimage

Spinning Music, The Flying Dutchman

Spring Song, The Valkyrie

MONDAY July 22

SYMPHONY CONCERTS

P.M.
8.2 Sottens: Haydn, Weber, Franck.
8.30 Strasbourg: Cathedral Choir, Orchestra.
8.45 Radio Paris: Strauss, Liszt, Fauré (from Vichy).
9.0 Warsaw: Polish music.
9.30 Prague: Beethoven.
10.25 Turin: Conductor, Parodi.

LIGHT CONCERTS

12.5 Poste Parisien: Light orchestral.
12.15 Radio Paris: Orchestra, songs.
12.20 Hamburg, etc.: Hanover Castle Concert.
3.30 Kalundborg: Radio Orchestra.
4.0 Deutschlandsender: Band concert.
5.0 Stuttgart, Frankfurt: Orchestra, pft. e.
6.15 Budapest 2: Cigány Band.
7.0 Frankfurt, etc.: Light orchestral.
7.0 Stuttgart, etc.: From Karlsruhe.
7.15 Athlone: Orchestra, soprano songs.
7.15 National: Edward German prog.
7.45 Huizen: Choir, Women's voices.
7.50 Vienna: Light music.
8.0 Brussels 1: Radio Orchestra.
8.0 Brussels 2: Strauss, Waldteufel, etc.
8.0 Budapest 2: Military Band.
8.0 Kalundborg: Opera music.
8.10 Cologne: Popular orchestral.
8.10 Frankfurt: Folk music.
8.10 Munich: Orchestra, songs.
8.30 Eiffel Tower: Light orchestral.
9.0 Hamburg: Popular orchestral.
9.0 Radio-Normandie: Variety Concert.
9.15 Regional: BBC Military Band.
9.55 Hilversum: Mozart programme.
10.0 Stockholm: Light music.
10.10 Warsaw: Light and Dance music.
10.20 Budapest 1: Cigány Band.
10.30 Breslau, etc.: Orchestral srenade.
11.0 Hamburg: Light orchestral.

OPERA

8.40 Rome: "The Duchess of Hollywood" (Ranzato).

CHAMBER MUSIC

P.M.
5.40 Warsaw: Quartet (del Campo).
6.30 Brussels 2: Trios (Mozart, Smetana).
8.10 Deutschlandsender: Frederick the Great's Music.
8.15 Athlone: Old Italian Music.
9.40 Huizen: Trios (Turina, Beethoven).
9.45 Poste Parisien: Saxophone quartet.
10.5 National: 'Cello, pianoforte.
10.30 Kalundborg: Quartet (Schubert).
12.0 Frankfurt, Stuttgart: Part I, Old Music; Part II, Brahms.

RECITALS

4.15 Radio Paris: Songs.
5.0 Beromünster: Violin; 5.30 Song.
6.30 Brussels 1: 'Cello.
6.30 Strasbourg: Pianoforte and Song.
7.0 Berlin: Pfte. duets, songs (Schubert).
8.0 Radio Paris: Organ, song, flute.
8.15 Bucharest: Violin, song. 9.5, Two pftes.
10.10 Vienna: Guitar solos.
10.30 Leipzig: Siegfried Kuhn prog.
11.10 Berlin: Pfte. (Beethoven), Songs.

PLAYS

8.20 Paris (PTT): Relay from l'Odéon.
8.40 Turin: "La signorina Lievito" (Felyne).
9.30 Beromünster: A Gogol play.

TALKS

8.30 Stockholm: "The Lapps" (Prof. Collinder).
11.0 Budapest 1: "Summer in Hungary" (in Italian).

DANCE MUSIC

10.10 Brussels 2; 10.20, Regional; 10.50, Radio Paris; 11.0, Deutschlandsender, Munich; 11.15, National; 11.30, Vienna; 12.0, Radio-Normandie.

MISCELLANEOUS

8.15 Poste Parisien: Variety.

NATIONAL

Time Signals: Big Ben.—10.15 a.m., 5.15 p.m., 6.30 p.m., 12 midnight.
Greenwich.—10.30 a.m., 2.0 p.m., 6.0 p.m., before the Second News (normally 9.30 p.m.), 11.30 p.m.
10.15 a.m. (Droitwich)—Service.
10.30 (Droitwich)—Weather Forecast.
10.45—"Some Country People." A. G. Street.
11.0—Records.
11.30—Organ (John Pulein).
12.0—Scottish Studio Orchestra.
12.45 p.m.—Miscellaneous Records.
1.15—B C Midland Orchestra.
2.15—Records.
3.0—Heworth Colliery Band.
3.45—Audrey Piggott ('Cello); Dorothea Aspinall (Pianoforte).
4.15—Hotel Metropole Orchestra.
5.15—J. H. Squire Celeste Octet. Leonard Gowings (Tenor).
6.0—"The First News."
6.25—Interlude.
6.30 (Droitwich)—BBC Dance Orchestra, directed by Henry Hall.
7.15 (Droitwich)—Music by Edward German: Orchestra (Section C), conducted by Warwick Braithwaite. Enid Cruickshank (Contralto). Overture, Richard III. O Peaceful England (Merrie England). Pavane, Romeo and Juliet. Love the Pedlar; Restless River. March Rhapsody.
8.0—The Celebrity Trio.
8.30—"Our First Broadcast." Tom Drew (Comedian); Bobbie Farrell (Irish Singer); Stanley Kirkby (Entertainer); Joan Rawlings (Crooner); George Lane (Comedian); Introduced by Lawrence Baskcomb. Variety Orchestra.
9.0—Anona Winn and her Winners.
9.20—Navarre (Round the World in Song).
9.30—"The Second News."
9.50—"Foreign Affairs." F. A. Voigt.
10.5—Antoni Sala ('Cello); Katherine Goodson (Pianoforte). Sonata in A, Op. 69 (Beethoven). Intermezzi, Op. 117, No. 1, Op. 118, No. 1, Capriccio, Op. 76, No. 2, Rhapsodie, Op. 79, No. 1 (Brahms). Arioso (Bach); Allegro Spiritoso (Senaille); Evening Song (Schumann); Mazurka (Popper).
11.0—"Marpessa," a Poem by Stephen Phillips, read by Lewis Casson.
11.15-12.0 (Droitwich)—Dance Music: Grosvenor House Dance Band.
11.15-12.0 (London)—Television.

REGIONAL

Time Signals: Big Ben.—10.15 a.m., 5.15 p.m., 6.30 p.m., 12 midnight.
Greenwich.—10.30 a.m., 2.0 p.m., 6.0 p.m., before the Second News (normally 10.0 p.m.), 11.30 p.m.
10.15-10.45 a.m. (except Midland)—Droitwich.
10.45—Cinema Organ.
11.15—Whitby Municipal Orchestra.
12.15 p.m.—Haydn Heard's Band.
1.15—Miscellaneous Records.
2.0—Arthur Salisbury and Orchestra.
3.0—Royal Music: N. Ireland Orchestra. Harry Dyson (Flute).
4.0—The Hungaria Gipsy Band.
4.45—Ballad Concert.
5.15—The Children's Hour.
6.0—"The First News."
6.30-8.0 (ex. Midland; N. Ireland till 7.15)—Droitwich.
7.15 (N. Ireland)—Frank Rea and his Orchestra.
8.0—"Through the Looking-Glass." An Adaptation of Lewis Carroll's Book, made for the Microphone by Cecil Lewis, with Incidental Music by Victor Hely-Hutchinson.
9.15 (Regional, N. Ireland)—BBC Military Band. Frank Titterton (Tenor). Band: Cornish Rhapsody (Geehl). Frank Titterton and Band: My Heart a Ship at Anchor Lies (A Princess of Kensington) (Edward German). Frank Titterton: Songs of Araby (Clay). Band: Russian Scenes (Bantock); Irish Dance, Wicklow Fair (Dalmaine).
9.15 (Midland)—"Overheard in the Pavilion."
9.15 (Northern)—Dance Music.
9.15 (Scottish)—Chamber Music Players: Quartet in F (Mozart); Berceuse (Osten-Sacken); Scherzo (Sokolov).
9.15 (Western)—"Exploring the Mendip Caves." H. G. Knight.
9.30 (Western)—Cardiff Banjo, Mandoline and Guitar Club. Sidney Evans (Entertainer).
9.45 (Scottish)—Here awa, There awa.
9.50 (Midland)—Margaret Ablethorpe (Pianoforte).
10.0—News Summary; Sports Bulletin.
10.20 (Scottish from 10.50)—Grosvenor House Dance Band.
10.20 (Scottish)—The Reel Players.
11.0—Dance Records.
11.15-12.0 (ex. Midland)—Grosvenor House Dance Band.
11.15-12.0 (Midland)—Television.

Hours of Transmission in British Summer Time.

ATHLONE (Ireland)

565 kc/s (531 m.); 60 kW. Relayed by Dublin, 1,348 kc/s (222.6 m.), and Cork, 1,240 kc/s (241.9 m.).
1.30-2.30 p.m.—Records. 6.0—For Children. 6.45—News. 7.0—Irish Book Review. 7.15—Station Orchestra. Gladys MacNevin (Soprano).
8.0—Talk: Humour of an Irish Parish—The Chapel Gardener.
8.15—Old Italian Music. Station Strings. 8.45—Play. 9.15—Programme Announcements. 9.30—Irish Music. Carl Hardebeck (Pfte.). 9.45—What happened to-day. 10.0—Variety.
10.30-11.0—Sean Dempsey's Ceilidhe Band.

BERLIN (Germany)

841 kc/s (357.7 m.); 100 kW. Transmits at intervals from 6.0 a.m. to 12.0 noon—Light Music.
12.20 p.m.—See Hamburg. In the interval at 1.0—Midday Echoes. 2.0—News. 2.15—Bund Dance Band. 3.0—Exchange; Markets. 4.0—"Maultrömmeln und Tintenlecke" (Gunter) with Music. 4.30—"The Children's Splash Pool"—Report.
5.0—See Stuttgart. 6.30—Talk. 6.40—Topicalities.
7.0—Schubert Recital by Bronsgeest (Baritone) and Prudentia Olbrich and Ecklebe (Pfte. Duets). Fantasia in F minor. Songs: Der Wanderer, Seimir gegrüsst, Der Doppelgänger, Der Lindenbaum, Die Stadt, Die Post. Rondo brilliant.
7.40—Evening Echoes. 8.0—News.
8.10—See Stuttgart. 10.0—News.
10.20—To be announced.
10.30—"The Genius' Sister"—Play about Frederick the Great and Wilhelmine of Bayreuth (Hoeffert).
11.10-12.0 m't—Wührer (Pfte.) and Andresen (Baritone). Sonata in C (Beethoven). Songs (Wendland): (a) Una, (b) Liebe, (c) Sehnsucht, (d) Wehgetan, (e) Die alte Geige, (f) Der Unzufriedene. Polonaise in C (Beethoven).

BEROMÜNSTER

(Switzerland)
556 kc/s (539.6 m.); 100 kW. Relayed by Basle and Berne, 1,357 kc/s (218.2 m.).
Transmits at intervals from 12.0 noon. 12.40 p.m. (from Basle)—Orchestra. Conductor: Thoms. 1.25—Weather.

Exchange. 4.0-5.0 (from Basle)—Records: Armin Weltner (Songs). 4.30 (from Basle)—Viennese Light Music by the Radio Orchestra. 5.0—Rothpletz (Violin). 5.30—Gisela Baumann-Vaugoin (Soprano). 6.0 (from Basle)—For Children.
6.30-8.5—Programme from Berne.
6.30—Berne Pfte. Trio. 7.0—Talk: Wind Bands in Switzerland. 7.20—Light Music. Conductor: Jaeggi. 7.45—Talk: 1934 State Finances.
8.5—German Opera Music—Station Orchestra. 8.30 (from Berne)—Talk: Swiss Character and Swiss Literature—From Spitteler to the Present Day.
9.0—News. 9.10—Russian Music—Station Orchestra.
9.30 (from Berne)—"How the two Iwans quarrelled"—Play (Gogol). 10.15—Weather.

BRESLAU (Germany)

950 kc/s (315.8 m.); 100 kW. Relayed by Gleiwitz, 1,231 kc/s (243.7 m.).
Transmits at intervals from 5.0 a.m. to 12.0 noon—Light Music.
12.20 p.m.—See Hamburg. 2.0—News. 2.10—Exchange. 2.15—Announcements. 3.10—Book Review. 3.30—Elisabeth Klaus (Soprano). 4.0—History Talk. 4.20—Reading. 4.30 (from Gleiwitz)—Talk: Mediaeval Silesian Laws.
5.0—See Stuttgart.
6.30—A Visit to an Anti-Gas School.
6.50—News; Markets.
7.0—See Cologne.
7.15—See Königsberg. 8.0—News.
8.10—"A Summer Night's Dream"—Station Choir, Orchestra and Dance Band. Elinor Hansen (Soprano). Hallendorff (Tenor). Rothensee (Baritone) and Huber (Viennese Folk Songs). Conductor: Weisshaupt. 10.0—News.
10.30-12.0 m't—Orchestra. Conductor: Weisshaupt. Overture, "Il Seraglio" (Mozart). Oriental Impressions (Amadei). Lagunenwalzer (Strauss). Selection, "Le Cid" (Massenet). Serenade for Strings (Goetze). The Japanese Screen (Ketelbey). Festival Overture, Vivat academia (Zimmer). Waltz, "Der Puppenfee" (Bayer). Delibes Potpourri (Urbach). Turkish March (Mozart).

BRUSSELS (No. 1) (Belgium)

620 kc/s (483.9 m.); 15 kW. 12.0 noon—Records. 12.30 p.m.—

Radio Orchestra. Conductor: Gason. In the interval at 1.0: News. 1.30-2.0—Records. 4.55—Announcements. 5.0—Mendelssohn Records. 5.45—For Children. 6.15—Talk: Woman and the Labour Party.
6.30—Mme. Sangier Hans ('Cello). 7.0—Labour Review. 7.15—Request Records. 7.30—Sports.
8.0—Radio Orchestra. Conductor: Gason. Mile. Darteville (Songs). March (Fucik). Waltz, Le rêve d'amour (Gauwin). Strauss Potpourri (Weber). Songs. Sevilla (Albeniz). Selection, "Rose-Marie" (Frim). Provence (Fourdrain). The Death of Minnehaha (Coleridge-Taylor). 9.0—Talk: Jean Prolo.
9.15—Operetta Music. Radio Orchestra. Conductor: Gason. Selection, "Schön ist die Welt" (Lehár). "The Merry Peasant" (Fall). "The Gipsy Princess" (Kálmán), and "La Princesse de Trébizonde" (Offenbach). 10.0—News.
10.10-11.0—Records. Part I, Wagner. Part II, Richard Strauss. Part III, Dance Songs.

BRUSSELS (No. 2) (Belgium)

932 kc/s (321.9 m.); 15 kW. Programme in Flemish.
12.0 noon - 2.0 p.m.—Max Alexys Orchestra. In the interval at 1.0: News. 4.55—Announcements. 5.0—Dance Records. 6.0—Broeckx Songs for Children. 6.15—Tolkowsky (Songs).
6.30—Antwerp Trio. Trios in B flat (Mozart) and G minor (Smetana). 7.15—Discussion: The International Railway Exhibition. 7.30—News.
8.0—Orchestra from the Exhibition. Conductor: Walpot. Corry Couvreur (Songs), Ferrari (Tenor), and Segers (Accordion). Overture, "Prince Methusalem" (Strauss). Je t'aime (Waldteufel). In the Harbour of Port Said (Armandola). Selection, "Carmen" (Bizet-Tavan). Two Songs, "Die Fledermaus" (Strauss). Song, "The Land of Smiles" (Lehár). Rhythmic Paraphrase on Fibich's Poème (Berners). Pomp and Circumstance (Elgar). Overture, "Si j'étais roi" (Adam).
9.0—Report from the Exhibition.
9.20—Orchestra (contd.). Stolz Potpourri (Dostal). Songs: (a) Mei Muatterl was a Wienerin (Gruber). (b) Ich muss wieder einmal in Grinzling sein (Benatzky). Dorfschwalben aus Oesterreich (Strauss). Tenor: Torno a Surriento (de

Curtis). Accordion Serenade (Voss). Grenadiers March, "The Love Parade" (Scherzinger).

BUCHAREST (Romania)

823 kc/s (364.5 m.); 12 kW. Transmits at intervals from 12.0 noon. 6.0 p.m.—News. 6.15—Iancou Constantinesco Orchestra. 7.0—Talk. 7.20—Records. 7.50—Press Review. 8.0—Talk.
8.15—Sandu Albu (Violin) and Alexandrescu (Songs). Concerto in A Minor (Vivaldi-Nachez). Songs: (Brahms): (a) Mainacht, (b) Nocturne. En bateau (Debussy). Piece (Fall). Two Songs (Fauré). Turkish March (Beethoven-Auer). Moto perpetuo (Novacek). Songs (Chausson): (a) Le colibri, (b) Au temps des lilas. Romance (Mezzetti).
9.5—Cosma and Chirculesco (Pftes.). 9.30—News. 9.50—Music. In the interval at 10.15: News in French and German.

BUDAPEST (No. 1) (Hungary)

546 kc/s (549.5 m.); 120 kW. Transmits at intervals from 6.45 a.m. to 12.5 p.m.—Eta: Markó and Kertay (Songs). In the interval at 12.30—News. 1.20—Weather. 1.30—Hungarian Quintet. 2.40—Announcements. 4.10—For Schools. 4.45—Weather. 5.0—Reading. 5.30—Kola Jazz Band from the Rajna Park. 6.30—Talk.
6.50—Opera Orchestra. Conductor: Fridl. Overture, Das Nachtlager von Granada (Kreutzer). Nuit à Lisbon (Saint-Saëns). Greenland Suite (Juel-Fredriksen). Algerian Nights (Grieg). In the Steppes of Central Asia (Borodin). Ukrainian Pictures (Akinenko). Scenes napolitaines (Massenet).
8.10—Play (Csányó). 10.0—News.
10.20—Müller Cigány Band from the Café Emke. 11.0—Talk in Italian: Summer in Hungary. 11.20—Records. 12.5 a.m. (Tuesday)—News.

BUDAPEST (No. 2) (Hungary)

559.5 kc/s (534.5 m.); 20 kW. 5.5 p.m.—Setét Jazz Band. 5.40—Programme by Dr. Trocsányi. 6.15—Jenő Pertis Cigány Band. 7.25—Programme by Dr. Noszlopy.
8.0—Military Band. Conductor: Fidy-Fichtner. American March (Souza). Elegiac Overture (Mikuscák). Waltz, "Faust" (Gounod).

Song Potpourri (Donath). Waltz, La Housarde (Ganne). Potpourri (Komzak). March (Blankenburg). 9.25—News.

COLOGNE (Germany)

658 kc/s (455.9 m.); 100 kW. Transmits at intervals from 6.0 a.m. to 12.0 noon—Light Music.
12.20 p.m.—See Hamburg. 2.0—News. 2.15—Variety from Deutschlandsender. 2.45—Exchange; Markets. 3.0—For Boys. 3.20—A Visit to a Bathing Beach. 3.30—Exchange. 3.50—Talk.
4.0—Contemporary Music. Gerda Schüter-Rehm (Soprano) and Haass (Pfte.). 4.35—Reading.
5.0—See Stuttgart. 6.30—Talk. 6.45—Weather; Exchange; Sports.
7.0—Station Orchestra. Conductor: Eysoldt.
7.30—See Königsberg. 8.0—News.
8.10—Osnabrück Theatre Orchestra. Conductor: Brück. Military March (Schubert). Overture, "The Merry Wives of Windsor" (Nicolai). Tales from the Vienna Woods (Strauss). Clog Dance, "Czar and Carpenter" (Lortzing). Two Hungarian Dances (Brahms). Overture, "Die Fledermaus" (Strauss). Selection, "The Land of Smiles" (Lehár). March (Herzer).
9.25—Legend in Münster Dialect (Dinkhoff); Music by Rudolf Petzoldt. 10.0—News. 10.20—Weekly Review.
10.50-12.0 m't—Concert from Breslau.

DEUTSCHLANDSENDER

(Germany)
191 kc/s (1,571 m.); 60 kW. Transmits at intervals from 5.55 a.m. to 12.0 noon—Dobrindt's Orchestra. 1.45—News.
2.0—Variety. 3.0—Announcements. 3.15—For Boys. 3.45—A Legend. 4.0—Pick's Band. 5.45—Talk. 6.0—Old Folk Music. 6.30—Sports Report. 6.40—Do you know...? 6.50—"Holidays at Home" (Nadolny).
7.0—See Stuttgart. 7.45—News. 8.0—Announcements.
8.10—"His Majesty plays the Flute"—Music of Frederick the Great's Time by the Station Chamber Orchestra. Conductor: Vack. Laux (Flute). Mürsch-Riccus (Harpischord). Commentary by Paul Klose. Symphony No. 2 in G (Frederick the Great). Flute Concerto in G (Quantz). Scherzo for Two Violins, Double Bass and Harpsichord

(Graun). Sinfonietta No. 3 (P. E. Bach). 9.0—"Life's Seasons"—Singspiel (Prugel); Music by Bern Scherz. 10.0—News. 10.30—Erna Oetterer-Konopka (Songs). 11.0-12.0 m't—Hendrik's Dance Band.

FRANKFURT (Germany)

1,195 kc/s (251 m.); 25 kW. Relayed by Cassel, Coblenz, Freiburg, Kaiserslautern and Trier, 1,195 kc/s (251 m.). Transmits at intervals from 6.0 a.m. 12.0 noon—Light Music. 12.20 p.m.—See Hamburg. In the interval at 1.0: News. 2.0—News. 2.30—Exchange. 2.40-2.45—Weather. 3.15—Open-Air Games for Children. 3.30—Pictures of Daily Life. 4.0—Weber, Schubert and Dvorak

Eise Rucker (Soprano), Mara Rucker (Contralto) and Braun (Pfte.). 4.30—"Ripe stands the Corn"—Literary Sequence. 4.50—Book Review: "Wesen und Wort am Oberrhein" (Adolf v. Grolman). 5.0—See Stuttgart. 6.30 (from Trier)—For Girls. 6.50—Report; Weather; Exchange; Announcements. 7.0—Orchestra. Conductor: Cornelius. March and Gavotte from the Suite der Freude (Scheinflug). Overture, "Le femmine litigiose" (Cardoni). Violin Solo, "The Violin Maker of Cremona" (Hubay)

Frauenliebe und-Leben (Blon). Improvisation and Variations, Lied im Volksmund (Kick-Schmidt). Folk Dance (Kienzl). Tone Picture, Oase (Wisnar). Blumen der Liebe (Rust). 7.50—News. 8.10 (from Cassel)—Folk Music. Bandionin, Mandoline and Zither Orchestra. Clos (Songs to the Lute). Vater Rhein (Porschmann). Nixen-reigen (Schmidt). Springwurz (Clos). Lotus Blossoms (Ohlsen). Freiheitsmarsch (Laukien). In die weite Welt (Kramer). Trompeters Abschied (Harlinger). Intermezzo (Mens). Heckenkind (Rüdiger-Starklov). Czardas (Schmidt). Am Lagerfeuer (Siede). Hosenknopfballade (Kramer). Schmeichelkätzchen (Harlinger). Gopak. March (Gunkel).

9.10—"Boats and Cranes"—The Song of an Inland Harbour. 9.35—Girls' Choir. 10.0—News. 10.20 (from Trier)—Orchestra. Conductor: Bachmann. Strauss Potpourri (Hilmer Weber). Neue Liebe, neues Leben (Huppertz). March Potpourri (Recktenwald). 11.0—Concert from Breslau. 12.0 m't-2.0 a.m. (Tuesday)—Concert. Part I: Chamber Music. Hoefs (Flute), Geis (Viola d'amore) and Merten (Harpischord). Sonata in A for Viola d'amore and Harpischord (Benda). Sonata in D for Flute and Harpischord (Quanz). Trio in F (Heinichen). Part II: Brahms. Margret Langen (Contralto). Lenzewski (Violin), Leonards (Horn), Merten and Braun (Pftes). Songs: (a) Steig auf, geliebter Schatten, (b) Willst du, dass ich geh? (c) Ach wende diesen Blick, (d) Bittres zu sagen denkst du, (e) Von waldbekränzter Höh'. Trio in E flat.

Exchange. 3.30—Brazilian Exchange. 3.40—Shipping. 4.0—"Great Philosophers"—Talk and Reading. 4.40—Scandinavian Folk Songs by Jennie von Thillot. 5.0—See Stuttgart. 6.30—Radio Review. 6.45—Exchange; Shipping; Weather. 7.0—For Women. 7.15—Flying Reminiscences by Gert Sascha. 7.30—See Königsberg. 8.0—News. 8.10—"A City's Bathing Beaches"—Report. 9.0—Station Orchestra. Conductor: Secker. Overture, "The Flying Dutchman" (Wagner). Excerpts, Pan Suite (Graener). Italian Caprice (Tchaikovsky). Heiteres Spiel (Blumer). Ballet, "Carmen" (Bizet). Prelude, "Hansel and Gretel" (Humperdinck). 10.0—News. 10.25—Light Music. 11.0-12.0 m't—Stettin Concert Orchestra. Conductor: Plato. Wre-sinski and Kowalski (Trumpets). Overture, "Der Wildschütz" (Lortzing). Waltz (Becker). Jagd-Fantasia (Zickov). Paraphrase on "Warnung" (Löhr). Trumpets: (a) Die Waldvögelin (Mayr). (b) Die Post im Walde (Schäffer). Potpourri (Lossner). March (Reckling).

Records. 2.15—Gardening. 2.55-3.25—Records. 3.40—Bible Reading; Mlle. de Jager (Songs); v. Drieënhuizen (Organ). 4.40—Orchestra. Conductor: Adam. 6.10—Letter-box. 6.40—Announcements. 6.55—Report. 7.10—Letter-box. 7.40—News. 7.45—"Veendam - Wildervanck" Ladies' Choir. Mme. Schmidt-Marlissa-Gelzenleucher (Contralto); Schmidt-Marlissa (Baritone). Gott, deine Güte reicht so weit (Hauptmann). Wenn ich mit Menschen und Engelzungen redete (Ekkert). Im Abendrot (Schubert). Stil, o stil (Schmidt-Marlissa). Twenty-third Psalm (Schubert). Allmacht (Schubert). Tragödie (Schumann). So war die Sonne scheint (Schu-

HILVERSUM (Holland)

160 kc/s, (1,875 m.). Transmitted on Kootwijk on 120 kW. 7.40-9.40 a.m.—Programme of the Workers' Radio Society (V.A.R.A.). 7.40—Records; Rossican (Pfte.). 8.10—Records. 9.40—Religious Programme of the Liberal Protestant Radio Society (V.P.R.O.). 9.55 (till Close Down)—V.A.R.A. Programme. 9.55—Recitations. 10.15—Records. 10.40—Recitations. 10.55—Orchestra. Conductor: Horst. 11.40—Orchestra. Conductor: Steyn. 12.25—Records. 12.55—Orchestra. Conductor: Walis. 1.40—Records. 3.10—For Women. 3.40—Wiggelaar (Violin) and Jong (Pfte.). 4.10—For Women. 4.40—Orchestra. Conductor: Wins. 5.10—Huy (Saxophone) and Ciere (Pfte.). 5.25—Walis Orchestra. 5.55—Märchenbilder (Schumann) by Smit (Viola) and Schoute (Pfte.). 6.10—Music Talk. 6.50—Talk. 7.10—Natascha Strachoff (Contralto); Records. 7.40—S.O.S. Announcements. 7.45—News. 7.50—Orchestra. Conductor: Horst. Wenn ein Torero verliebt ist (Eberhard-Glombig). Traumedeale (Fucik). Die launische Spieluhr (Kark-Fresco). By a Waterfall (Fain). Tyrol in Song and Dance (Fetras). Play to me Gipsy (Vael). The Coon among the Chickens (Ives). The Blue Pavilion (Armandola). Over the Waves (Rosas). The Dancing Clock (Ewing). 8.30—Orchestra. Conductor: Walis. Waltz, Flattergeister (Jos. Strauss). Song of the Violin (Schebek). Das Weiber und das Weinerl (Fall). Selection, "The Barber of Seville" (Rossini). Cymbal Solo. Russian and Hungarian Songs. 9.10—"Humour in Literature"—Sequence (arr. Cohen). Hetty Beck

mann). Wedding March (Söderman). Still wie die Nacht (Götze). Lente (v. Rennes). Maiglöckchen (Mendelssohn). Das Aehrenfeld (Mendelssohn). In the interval: Records. 8.40—Talk. 9.10—Records. 9.35—News. 9.40—Van Renesse-Helmann-Van Wezel Trio. Trio in B minor (Turina). Canzone (Landré). Trio in D (Beethoven). In the interval: Records. 10.40-11.10—Records. KALUNDBORG (Denmark) 238 kc/s (1,261 m.); 60 kW. Relayed by Copenhagen, 1,176 kc/s (255.1 m.). Transmits at intervals from 7.0 a.m. 12.0 noon-2.0 p.m.—Andersen String Ensemble from the Bellevue Strandhotel. 3.30—Radio Orchestra. Conductor: Gröndahl. In the interval at 4.15: For Women; Adele Lungstrup Harlou (Pfte.). 5.30—Exchange; Markets. 5.45—Literary Talk in German. 6.12—Poem. 6.15—Records. 6.45—Announcements. 7.0—News. 7.30—

the Broadcasting Camp at Warnicken. 8.0—News. 8.10—See Stuttgart. 10.0—News. 10.20—Leo Guttman and Gustav Pitow—Readings. 10.45-12.0 m't—Concert from Breslau. LEIPZIG (Germany) 785 kc/s (382.2 m.); 120 kW. Relayed by Dresden, 1,285 kc/s (233.5 m.). Transmits at intervals from 5.50 a.m. 12.0 noon—Light Music. 12.20 p.m.—See Hamburg. In the interval at 1.0: News. 2.0—News; Exchange. 2.15—Variety from Deutschlandsender. 3.0—Art Review. 3.15—Songs and Stories for Children. 3.40—Exchange. 4.0—Concert Etudes by Udo Dammer (Pfte.). 4.35—Poems. 4.50—Weather; Exchange; Brazilian Exchange. 5.0—See Stuttgart. 6.30—Talk: Wilhelm Lampadius, the Mining Expert. 6.50—See Deutschlandsender. 7.0—"Fountains"—Sequence (Metelmann). 7.30—See Königsberg. 8.0—News. 8.10—March Potpourri (Kretzschmer) by Ulbricht (Tenor). Göpelt (Baritone), the Station Chamber Choir and the Leipzig Symphony Orchestra. 9.10—"The Potash Mines of Stassfurt"—Report. 10.0—News. 10.30—Siegfried Kuhn. Seipt (Baritone), Burgert (Pfte.) and Strobach (Organ). Pfte. Variations on Old German Love Songs. Songs: (a) Liebesweh, (b) Ein kleines Lied, (c) Kurze Fahrt, (d) Vöglein Schwermut, (e) Abendhimmel, (f) Durch die Nacht. Prelude and Fugue in A for Organ. 11.0-12.0 m't—Concert from Breslau. LISBON (Portugal) 629 kc/s (476.9 m.); 20 kW. Transmits at intervals from 12.0 noon. 9.0—Orchestra. In the interval at 9.30: News. 10.0—Political Notes. 10.5—Maria Tavares (Songs); News. 10.30—Portuguese Music. 11.0—Dance Music. MONTE CENERI (Switzerland) 1,167 kc/s (257.1 m.); 15 kW. Transmits at intervals from 12.0 noon. 7.30—Records of English Conductors. Dr. Adrian Boul: Pomp and Circumstance (Elgar). Albert Coates: Selection, "Ivan the Terrible" (Rimsky-Korsakov). 7.45—News. 8.0—To be announced. 10.5-10.30—Records. MOSCOW (No. 1) (Russia) 174 kc/s (1,724 m.); 500 kW. Transmits at intervals from 3.45 a.m. 6.0 p.m.—Concert. In the intervals: Announcements. 7.0—Concert. 9.0—German Newspaper Programme. 10.5—English Literary Programme. 11.5—Hungarian Talk: Soviet Summer Sports.

Records. 2.15—Gardening. 2.55-3.25—Records. 3.40—Bible Reading; Mlle. de Jager (Songs); v. Drieënhuizen (Organ). 4.40—Orchestra. Conductor: Adam. 6.10—Letter-box. 6.40—Announcements. 6.55—Report. 7.10—Letter-box. 7.40—News. 7.45—"Veendam - Wildervanck" Ladies' Choir. Mme. Schmidt-Marlissa-Gelzenleucher (Contralto); Schmidt-Marlissa (Baritone). Gott, deine Güte reicht so weit (Hauptmann). Wenn ich mit Menschen und Engelzungen redete (Ekkert). Im Abendrot (Schubert). Stil, o stil (Schmidt-Marlissa). Twenty-third Psalm (Schubert). Allmacht (Schubert). Tragödie (Schumann). So war die Sonne scheint (Schu-

mann). Wedding March (Söderman). Still wie die Nacht (Götze). Lente (v. Rennes). Maiglöckchen (Mendelssohn). Das Aehrenfeld (Mendelssohn). In the interval: Records. 8.40—Talk. 9.10—Records. 9.35—News. 9.40—Van Renesse-Helmann-Van Wezel Trio. Trio in B minor (Turina). Canzone (Landré). Trio in D (Beethoven). In the interval: Records. 10.40-11.10—Records. KALUNDBORG (Denmark) 238 kc/s (1,261 m.); 60 kW. Relayed by Copenhagen, 1,176 kc/s (255.1 m.). Transmits at intervals from 7.0 a.m. 12.0 noon-2.0 p.m.—Andersen String Ensemble from the Bellevue Strandhotel. 3.30—Radio Orchestra. Conductor: Gröndahl. In the interval at 4.15: For Women; Adele Lungstrup Harlou (Pfte.). 5.30—Exchange; Markets. 5.45—Literary Talk in German. 6.12—Poem. 6.15—Records. 6.45—Announcements. 7.0—News. 7.30—

the Broadcasting Camp at Warnicken. 8.0—News. 8.10—See Stuttgart. 10.0—News. 10.20—Leo Guttman and Gustav Pitow—Readings. 10.45-12.0 m't—Concert from Breslau. LEIPZIG (Germany) 785 kc/s (382.2 m.); 120 kW. Relayed by Dresden, 1,285 kc/s (233.5 m.). Transmits at intervals from 5.50 a.m. 12.0 noon—Light Music. 12.20 p.m.—See Hamburg. In the interval at 1.0: News. 2.0—News; Exchange. 2.15—Variety from Deutschlandsender. 3.0—Art Review. 3.15—Songs and Stories for Children. 3.40—Exchange. 4.0—Concert Etudes by Udo Dammer (Pfte.). 4.35—Poems. 4.50—Weather; Exchange; Brazilian Exchange. 5.0—See Stuttgart. 6.30—Talk: Wilhelm Lampadius, the Mining Expert. 6.50—See Deutschlandsender. 7.0—"Fountains"—Sequence (Metelmann). 7.30—See Königsberg. 8.0—News. 8.10—March Potpourri (Kretzschmer) by Ulbricht (Tenor). Göpelt (Baritone), the Station Chamber Choir and the Leipzig Symphony Orchestra. 9.10—"The Potash Mines of Stassfurt"—Report. 10.0—News. 10.30—Siegfried Kuhn. Seipt (Baritone), Burgert (Pfte.) and Strobach (Organ). Pfte. Variations on Old German Love Songs. Songs: (a) Liebesweh, (b) Ein kleines Lied, (c) Kurze Fahrt, (d) Vöglein Schwermut, (e) Abendhimmel, (f) Durch die Nacht. Prelude and Fugue in A for Organ. 11.0-12.0 m't—Concert from Breslau. LISBON (Portugal) 629 kc/s (476.9 m.); 20 kW. Transmits at intervals from 12.0 noon. 9.0—Orchestra. In the interval at 9.30: News. 10.0—Political Notes. 10.5—Maria Tavares (Songs); News. 10.30—Portuguese Music. 11.0—Dance Music. MONTE CENERI (Switzerland) 1,167 kc/s (257.1 m.); 15 kW. Transmits at intervals from 12.0 noon. 7.30—Records of English Conductors. Dr. Adrian Boul: Pomp and Circumstance (Elgar). Albert Coates: Selection, "Ivan the Terrible" (Rimsky-Korsakov). 7.45—News. 8.0—To be announced. 10.5-10.30—Records. MOSCOW (No. 1) (Russia) 174 kc/s (1,724 m.); 500 kW. Transmits at intervals from 3.45 a.m. 6.0 p.m.—Concert. In the intervals: Announcements. 7.0—Concert. 9.0—German Newspaper Programme. 10.5—English Literary Programme. 11.5—Hungarian Talk: Soviet Summer Sports.

the Broadcasting Camp at Warnicken. 8.0—News. 8.10—See Stuttgart. 10.0—News. 10.20—Leo Guttman and Gustav Pitow—Readings. 10.45-12.0 m't—Concert from Breslau. LEIPZIG (Germany) 785 kc/s (382.2 m.); 120 kW. Relayed by Dresden, 1,285 kc/s (233.5 m.). Transmits at intervals from 5.50 a.m. 12.0 noon—Light Music. 12.20 p.m.—See Hamburg. In the interval at 1.0: News. 2.0—News; Exchange. 2.15—Variety from Deutschlandsender. 3.0—Art Review. 3.15—Songs and Stories for Children. 3.40—Exchange. 4.0—Concert Etudes by Udo Dammer (Pfte.). 4.35—Poems. 4.50—Weather; Exchange; Brazilian Exchange. 5.0—See Stuttgart. 6.30—Talk: Wilhelm Lampadius, the Mining Expert. 6.50—See Deutschlandsender. 7.0—"Fountains"—Sequence (Metelmann). 7.30—See Königsberg. 8.0—News. 8.10—March Potpourri (Kretzschmer) by Ulbricht (Tenor). Göpelt (Baritone), the Station Chamber Choir and the Leipzig Symphony Orchestra. 9.10—"The Potash Mines of Stassfurt"—Report. 10.0—News. 10.30—Siegfried Kuhn. Seipt (Baritone), Burgert (Pfte.) and Strobach (Organ). Pfte. Variations on Old German Love Songs. Songs: (a) Liebesweh, (b) Ein kleines Lied, (c) Kurze Fahrt, (d) Vöglein Schwermut, (e) Abendhimmel, (f) Durch die Nacht. Prelude and Fugue in A for Organ. 11.0-12.0 m't—Concert from Breslau. LISBON (Portugal) 629 kc/s (476.9 m.); 20 kW. Transmits at intervals from 12.0 noon. 9.0—Orchestra. In the interval at 9.30: News. 10.0—Political Notes. 10.5—Maria Tavares (Songs); News. 10.30—Portuguese Music. 11.0—Dance Music. MONTE CENERI (Switzerland) 1,167 kc/s (257.1 m.); 15 kW. Transmits at intervals from 12.0 noon. 7.30—Records of English Conductors. Dr. Adrian Boul: Pomp and Circumstance (Elgar). Albert Coates: Selection, "Ivan the Terrible" (Rimsky-Korsakov). 7.45—News. 8.0—To be announced. 10.5-10.30—Records. MOSCOW (No. 1) (Russia) 174 kc/s (1,724 m.); 500 kW. Transmits at intervals from 3.45 a.m. 6.0 p.m.—Concert. In the intervals: Announcements. 7.0—Concert. 9.0—German Newspaper Programme. 10.5—English Literary Programme. 11.5—Hungarian Talk: Soviet Summer Sports.

the Broadcasting Camp at Warnicken. 8.0—News. 8.10—See Stuttgart. 10.0—News. 10.20—Leo Guttman and Gustav Pitow—Readings. 10.45-12.0 m't—Concert from Breslau. LEIPZIG (Germany) 785 kc/s (382.2 m.); 120 kW. Relayed by Dresden, 1,285 kc/s (233.5 m.). Transmits at intervals from 5.50 a.m. 12.0 noon—Light Music. 12.20 p.m.—See Hamburg. In the interval at 1.0: News. 2.0—News; Exchange. 2.15—Variety from Deutschlandsender. 3.0—Art Review. 3.15—Songs and Stories for Children. 3.40—Exchange. 4.0—Concert Etudes by Udo Dammer (Pfte.). 4.35—Poems. 4.50—Weather; Exchange; Brazilian Exchange. 5.0—See Stuttgart. 6.30—Talk: Wilhelm Lampadius, the Mining Expert. 6.50—See Deutschlandsender. 7.0—"Fountains"—Sequence (Metelmann). 7.30—See Königsberg. 8.0—News. 8.10—March Potpourri (Kretzschmer) by Ulbricht (Tenor). Göpelt (Baritone), the Station Chamber Choir and the Leipzig Symphony Orchestra. 9.10—"The Potash Mines of Stassfurt"—Report. 10.0—News. 10.30—Siegfried Kuhn. Seipt (Baritone), Burgert (Pfte.) and Strobach (Organ). Pfte. Variations on Old German Love Songs. Songs: (a) Liebesweh, (b) Ein kleines Lied, (c) Kurze Fahrt, (d) Vöglein Schwermut, (e) Abendhimmel, (f) Durch die Nacht. Prelude and Fugue in A for Organ. 11.0-12.0 m't—Concert from Breslau. LISBON (Portugal) 629 kc/s (476.9 m.); 20 kW. Transmits at intervals from 12.0 noon. 9.0—Orchestra. In the interval at 9.30: News. 10.0—Political Notes. 10.5—Maria Tavares (Songs); News. 10.30—Portuguese Music. 11.0—Dance Music. MONTE CENERI (Switzerland) 1,167 kc/s (257.1 m.); 15 kW. Transmits at intervals from 12.0 noon. 7.30—Records of English Conductors. Dr. Adrian Boul: Pomp and Circumstance (Elgar). Albert Coates: Selection, "Ivan the Terrible" (Rimsky-Korsakov). 7.45—News. 8.0—To be announced. 10.5-10.30—Records. MOSCOW (No. 1) (Russia) 174 kc/s (1,724 m.); 500 kW. Transmits at intervals from 3.45 a.m. 6.0 p.m.—Concert. In the intervals: Announcements. 7.0—Concert. 9.0—German Newspaper Programme. 10.5—English Literary Programme. 11.5—Hungarian Talk: Soviet Summer Sports.

the Broadcasting Camp at Warnicken. 8.0—News. 8.10—See Stuttgart. 10.0—News. 10.20—Leo Guttman and Gustav Pitow—Readings. 10.45-12.0 m't—Concert from Breslau. LEIPZIG (Germany) 785 kc/s (382.2 m.); 120 kW. Relayed by Dresden, 1,285 kc/s (233.5 m.). Transmits at intervals from 5.50 a.m. 12.0 noon—Light Music. 12.20 p.m.—See Hamburg. In the interval at 1.0: News. 2.0—News; Exchange. 2.15—Variety from Deutschlandsender. 3.0—Art Review. 3.15—Songs and Stories for Children. 3.40—Exchange. 4.0—Concert Etudes by Udo Dammer (Pfte.). 4.35—Poems. 4.50—Weather; Exchange; Brazilian Exchange. 5.0—See Stuttgart. 6.30—Talk: Wilhelm Lampadius, the Mining Expert. 6.50—See Deutschlandsender. 7.0—"Fountains"—Sequence (Metelmann). 7.30—See Königsberg. 8.0—News. 8.10—March Potpourri (Kretzschmer) by Ulbricht (Tenor). Göpelt (Baritone), the Station Chamber Choir and the Leipzig Symphony Orchestra. 9.10—"The Potash Mines of Stassfurt"—Report. 10.0—News. 10.30—Siegfried Kuhn. Seipt (Baritone), Burgert (Pfte.) and Strobach (Organ). Pfte. Variations on Old German Love Songs. Songs: (a) Liebesweh, (b) Ein kleines Lied, (c) Kurze Fahrt, (d) Vöglein Schwermut, (e) Abendhimmel, (f) Durch die Nacht. Prelude and Fugue in A for Organ. 11.0-12.0 m't—Concert from Breslau. LISBON (Portugal) 629 kc/s (476.9 m.); 20 kW. Transmits at intervals from 12.0 noon. 9.0—Orchestra. In the interval at 9.30: News. 10.0—Political Notes. 10.5—Maria Tavares (Songs); News. 10.30—Portuguese Music. 11.0—Dance Music. MONTE CENERI (Switzerland) 1,167 kc/s (257.1 m.); 15 kW. Transmits at intervals from 12.0 noon. 7.30—Records of English Conductors. Dr. Adrian Boul: Pomp and Circumstance (Elgar). Albert Coates: Selection, "Ivan the Terrible" (Rimsky-Korsakov). 7.45—News. 8.0—To be announced. 10.5-10.30—Records. MOSCOW (No. 1) (Russia) 174 kc/s (1,724 m.); 500 kW. Transmits at intervals from 3.45 a.m. 6.0 p.m.—Concert. In the intervals: Announcements. 7.0—Concert. 9.0—German Newspaper Programme. 10.5—English Literary Programme. 11.5—Hungarian Talk: Soviet Summer Sports.

the Broadcasting Camp at Warnicken. 8.0—News. 8.10—See Stuttgart. 10.0—News. 10.20—Leo Guttman and Gustav Pitow—Readings. 10.45-12.0 m't—Concert from Breslau. LEIPZIG (Germany) 785 kc/s (382.2 m.); 120 kW. Relayed by Dresden, 1,285 kc/s (233.5 m.). Transmits at intervals from 5.50 a.m. 12.0 noon—Light Music. 12.20 p.m.—See Hamburg. In the interval at 1.0: News. 2.0—News; Exchange. 2.15—Variety from Deutschlandsender. 3.0—Art Review. 3.15—Songs and Stories for Children. 3.40—Exchange. 4.0—Concert Etudes by Udo Dammer (Pfte.). 4.35—Poems. 4.50—Weather; Exchange; Brazilian Exchange. 5.0—See Stuttgart. 6.30—Talk: Wilhelm Lampadius, the Mining Expert. 6.50—See Deutschlandsender. 7.0—"Fountains"—Sequence (Metelmann). 7.30—See Königsberg. 8.0—News. 8.10—March Potpourri (Kretzschmer) by Ulbricht (Tenor). Göpelt (Baritone), the Station Chamber Choir and the Leipzig Symphony Orchestra. 9.10—"The Potash Mines of Stassfurt"—Report. 10.0—News. 10.30—Siegfried Kuhn. Seipt (Baritone), Burgert (Pfte.) and Strobach (Organ). Pfte. Variations on Old German Love Songs. Songs: (a) Liebesweh, (b) Ein kleines Lied, (c) Kurze Fahrt, (d) Vöglein Schwermut, (e) Abendhimmel, (f) Durch die Nacht. Prelude and Fugue in A for Organ. 11.0-12.0 m't—Concert from Breslau. LISBON (Portugal) 629 kc/s (476.9 m.); 20 kW. Transmits at intervals from 12.0 noon. 9.0—Orchestra. In the interval at 9.30: News. 10.0—Political Notes. 10.5—Maria Tavares (Songs); News. 10.30—Portuguese Music. 11.0—Dance Music. MONTE CENERI (Switzerland) 1,167 kc/s (257.1 m.); 15 kW. Transmits at intervals from 12.0 noon. 7.30—Records of English Conductors. Dr. Adrian Boul: Pomp and Circumstance (Elgar). Albert Coates: Selection, "Ivan the Terrible" (Rimsky-Korsakov). 7.45—News. 8.0—To be announced. 10.5-10.30—Records. MOSCOW (No. 1) (Russia) 174 kc/s (1,724 m.); 500 kW. Transmits at intervals from 3.45 a.m. 6.0 p.m.—Concert. In the intervals: Announcements. 7.0—Concert. 9.0—German Newspaper Programme. 10.5—English Literary Programme. 11.5—Hungarian Talk: Soviet Summer Sports.

the Broadcasting Camp at Warnicken. 8.0—News. 8.10—See Stuttgart. 10.0—News. 10.20—Leo Guttman and Gustav Pitow—Readings. 10.45-12.0 m't—Concert from Breslau. LEIPZIG (Germany) 785 kc/s (382.2 m.); 120 kW. Relayed by Dresden, 1,285 kc/s (233.5 m.). Transmits at intervals from 5.50 a.m. 12.0 noon—Light Music. 12.20 p.m.—See Hamburg. In the interval at 1.0: News. 2.0—News; Exchange. 2.15—Variety from Deutschlandsender. 3.0—Art Review. 3.15—Songs and Stories for Children. 3.40—Exchange. 4.0—Concert Etudes by Udo Dammer (Pfte.). 4.35—Poems. 4.50—Weather; Exchange; Brazilian Exchange. 5.0—See Stuttgart. 6.30—Talk: Wilhelm Lampadius, the Mining Expert. 6.50—See Deutschlandsender. 7.0—"Fountains"—Sequence (Metelmann). 7.30—See Königsberg. 8.0—News. 8.10—March Potpourri (Kretzschmer) by Ulbricht (Tenor). Göpelt (Baritone), the Station Chamber Choir and the Leipzig Symphony Orchestra. 9.10—"The Potash Mines of Stassfurt"—Report. 10.0—News. 10.30—Siegfried Kuhn. Seipt (Baritone), Burgert (Pfte.) and Strobach (Organ). Pfte. Variations on Old German Love Songs. Songs: (a) Liebesweh, (b) Ein kleines Lied, (c) Kurze Fahrt, (d) Vöglein Schwermut, (e) Abendhimmel, (f) Durch die Nacht. Prelude and Fugue in A for Organ. 11.0-12.0 m't—Concert from Breslau. LISBON (Portugal) 629 kc/s (476.9 m.); 20 kW. Transmits at intervals from 12.0 noon. 9.0—Orchestra. In the interval at 9.30: News. 10.0—Political Notes. 10.5—Maria Tavares (Songs); News. 10.30—Portuguese Music. 11.0—Dance Music. MONTE CENERI (Switzerland) 1,167 kc/s (257.1 m.); 15 kW. Transmits at intervals from 12.0 noon. 7.30—Records of English Conductors. Dr. Adrian Boul: Pomp and Circumstance (Elgar). Albert Coates: Selection, "Ivan the Terrible" (Rimsky-Korsakov). 7.45—News. 8.0—To be announced. 10.5-10.30—Records. MOSCOW (No. 1) (Russia) 174 kc/s (1,724 m.); 500 kW. Transmits at intervals from 3.45 a.m. 6.0 p.m.—Concert. In the intervals: Announcements. 7.0—Concert. 9.0—German Newspaper Programme. 10.5—English Literary Programme. 11.5—Hungarian Talk: Soviet Summer Sports.

the Broadcasting Camp at Warnicken. 8.0—News. 8.10—See Stuttgart. 10.0—News. 10.20—Leo Guttman and Gustav Pitow—Readings. 10.45-12.0 m't—Concert from Breslau. LEIPZIG (Germany) 785 kc/s (382.2 m.); 120 kW. Relayed by Dresden, 1,285 kc/s (233.5 m.). Transmits at intervals from 5.50 a.m. 12.0 noon—Light Music. 12.20 p.m.—See Hamburg. In the interval at 1.0: News. 2.0—News; Exchange. 2.15—Variety from Deutschlandsender. 3.0—Art Review. 3.15—Songs and Stories for Children. 3.40—Exchange. 4.0—Concert Etudes by Udo Dammer (Pfte.). 4.35—Poems. 4.50—Weather; Exchange; Brazilian Exchange. 5.0—See Stuttgart. 6.30—Talk: Wilhelm Lampadius, the Mining Expert. 6.50—See Deutschlandsender. 7.0—"Fountains"—Sequence (Metelmann). 7.30—See Königsberg. 8.0—News. 8.10—March Potpourri (Kretzschmer) by Ulbricht (Tenor). Göpelt (Baritone), the Station Chamber Choir and the Leipzig Symphony Orchestra. 9.10—"The Potash Mines of Stassfurt"—Report. 10.0—News. 10.30—Siegfried Kuhn. Seipt (Baritone), Burgert (Pfte.) and Strobach (Organ). Pfte. Variations on Old German Love Songs. Songs: (a) Liebesweh, (b) Ein kleines Lied, (c) Kurze Fahrt, (d) Vöglein Schwermut, (e) Abendhimmel, (f) Durch die Nacht. Prelude and Fugue in A for Organ. 11.0-12.0 m't—Concert from Breslau. LISBON (Portugal) 629 kc/s (476.9 m.); 20 kW. Transmits at intervals from 12.0 noon. 9.0—Orchestra. In the interval at 9.30: News. 10.0—Political Notes. 10.5—Maria Tavares (Songs); News. 10.30—Portuguese Music. 11.0—Dance Music. MONTE CENERI (Switzerland) 1,167 kc/s (257.1 m.); 15 kW. Transmits at intervals from 12.0 noon. 7.30—Records of English Conductors. Dr. Adrian Boul: Pomp and Circumstance (Elgar). Albert Coates: Selection, "Ivan the Terrible" (Rimsky-Korsakov). 7.45—News. 8.0—To be announced. 10.5-10.30—Records. MOSCOW (No. 1) (Russia) 174 kc/s (1,724 m.); 500 kW. Transmits at intervals from 3.45 a.m. 6.0 p.m.—Concert. In the intervals: Announcements. 7.0—Concert. 9.0—German Newspaper Programme. 10.5—English Literary Programme. 11.5—Hungarian Talk: Soviet Summer Sports.

the Broadcasting Camp at Warnicken. 8.0—News. 8.10—See Stuttgart. 10.0—News. 10.20—Leo Guttman and Gustav Pitow—Readings. 10.45-12.0 m't—Concert from Breslau. LEIPZIG (Germany) 785 kc/s (382.2 m.); 120 kW. Relayed by Dresden, 1,285 kc/s (233.5 m.). Transmits at intervals from 5.50 a.m. 12.0 noon—Light Music. 12.20 p.m.—See Hamburg. In the interval at 1.0: News. 2.0—News; Exchange. 2.15—Variety from Deutschlandsender. 3.0—Art Review. 3.15—Songs and Stories for Children. 3.40—Exchange. 4.0—Concert Etudes by Udo Dammer (Pfte.). 4.35—Poems. 4.50—Weather; Exchange; Brazilian Exchange. 5.0—See Stuttgart. 6.30—Talk: Wilhelm Lampadius, the Mining Expert. 6.50—See Deutschlandsender. 7.0—"Fountains"—Sequence (Metelmann). 7.30—See Königsberg. 8.0—News. 8.10—March Potpourri (Kretzschmer) by Ulbricht (Tenor). Göpelt (Baritone), the Station Chamber Choir and the Leipzig Symphony Orchestra. 9.10—"The Potash Mines of Stassfurt"—Report. 10.0—News. 10.30—Siegfried Kuhn. Seipt (Baritone), Burgert (Pfte.) and Strobach (Organ). Pfte. Variations on Old German Love Songs. Songs: (a) Liebesweh, (b) Ein kleines Lied, (c) Kurze Fahrt, (d) Vöglein Schwermut, (e) Abendhimmel, (f) Durch die Nacht. Prelude and Fugue in A for Organ. 11.0-12.0 m't—Concert from Breslau. LISBON (Portugal) 629 kc/s (476.9 m.); 20 kW. Transmits at intervals from 12.0 noon. 9.0—Orchestra. In the interval at 9.30: News. 10.0—Political Notes. 10.5—Maria Tavares (Songs); News. 10.30—Portuguese Music. 11.0—Dance Music. MONTE CENERI (Switzerland) 1,167 kc/s (257.1 m.); 15 kW. Transmits at intervals from 12.0 noon. 7.30—Records of English Conductors. Dr. Adrian Boul: Pomp and Circumstance (Elgar). Albert Coates: Selection, "Ivan the Terrible" (Rimsky-Korsakov). 7.45—News. 8.0—To be announced. 10.5-10.30—Records. MOSCOW (No. 1) (Russia) 174 kc/s (1,724 m.); 500 kW. Transmits at intervals from 3.45 a.m. 6.0 p.m.—Concert. In the intervals: Announcements. 7.0—Concert. 9.0—German Newspaper Programme. 10.5—English Literary Programme. 11.5—Hungarian Talk: Soviet Summer Sports.

the Broadcasting Camp at Warnicken. 8.0—News. 8.10—See Stuttgart. 10.0—News. 10.20—Leo Guttman and Gustav Pitow—Readings. 10.45-12.0 m't—Concert from Breslau. LEIPZIG (Germany) 785 kc/s (382.2 m.); 120 kW. Relayed by Dresden, 1,285 kc/s (233.5 m.). Transmits at intervals from 5.50 a.m. 12.0 noon—Light Music. 12.20 p.m.—See Hamburg. In the interval at 1.0: News. 2.0—News; Exchange. 2.15—Variety from Deutschlandsender. 3.0—Art Review. 3.15—Songs and Stories for Children. 3.40—Exchange. 4.0—Concert Etudes by Udo Dammer (Pfte.). 4.35—Poems. 4.50—Weather; Exchange; Brazilian Exchange. 5.0—See Stuttgart. 6.30—Talk: Wilhelm Lampadius, the Mining Expert. 6.50—See Deutschlandsender. 7.0—"Fountains"—Sequence (Metelmann). 7.30—See Königsberg. 8.0—News. 8.10—March Potpourri (Kretzschmer) by Ulbricht (Tenor). Göpelt (Baritone), the Station Chamber Choir and the Leipzig Symphony Orchestra. 9.10—"The Potash Mines of Stassfurt"—Report. 10.0—News. 10.30—Siegfried Kuhn. Seipt (Baritone), Burgert (Pfte.) and Strobach (Organ). Pfte. Variations on Old German Love Songs. Songs: (a) Liebesweh, (b) Ein kleines Lied, (c) Kurze Fahrt, (d) Vöglein Schwermut, (e) Abendhimmel, (f) Durch die Nacht. Prelude and Fugue in A for Organ. 11.0-12.0 m't—Concert from Breslau. LISBON (Portugal) 629 kc/s (476.9 m.); 20 kW. Transmits at intervals from 12.0 noon. 9.0—Orchestra. In the interval at 9.30: News. 10.0—Political Notes. 10.5—Maria Tavares (Songs); News. 10.30—Portuguese Music. 11.0—Dance Music. MONTE CENERI (Switzerland) 1,167 kc/s (257.1 m.); 15 kW. Transmits at intervals from 12.0 noon. 7.30—Records of English Conductors. Dr. Adrian Boul: Pomp and Circumstance (Elgar). Albert Coates: Selection, "Ivan the Terrible" (Rimsky-Korsakov). 7.45—News. 8.0—To be announced. 10.5-10.30—Records. MOSCOW (No. 1) (Russia) 174 kc/s (1,724 m.); 500 kW. Transmits at intervals from 3.45 a.m. 6.0 p.m.—Concert. In the intervals: Announcements. 7.0—Concert. 9.0—German Newspaper Programme. 10.5—English Literary Programme. 11.5—Hungarian Talk: Soviet Summer Sports.

the Broadcasting Camp at Warnicken. 8.0—News. 8.10—See Stuttgart. 10.0—News. 10.20—Leo Guttman and Gustav Pitow—Readings. 10.45-12.0 m't—Concert from Breslau. LEIPZIG (Germany) 785 kc/s (382.2 m.); 120 kW. Relayed by Dresden, 1,285 kc/s (233.5 m.). Transmits at intervals from 5.50 a.m. 12.0 noon—Light Music. 12.20 p.m.—See Hamburg. In the interval at 1

MONDAY (July 22)

8.45—Concert from Vichy. Conductor: Cooper. Don Juan (Strauss). Tasso (Liszt). Till Eulenspiegel's Merry Pranks (Strauss). La naissance de Venus (Faure). Mephisto-Walzer (Liszt). In the interval, News.

10.50—Andolfi Dance Band.

PRAGUE (Czechoslovakia)

638 kc/s (470.2 m.); 120 kW. Transmits at intervals from 6.0 a.m. 3.0 p.m.—Orchestra from Bratislava. 4.0-4.10—Exchange; Weather. 4.30—Drábek's Orchestra. 5.40—Talk: Alfons Mucha. 5.50—Records. 6.0—For Housewives; Records. 6.15—For Farmers. 6.20—German Transmission: Art Talk; Schwarz (Pfte.). 7.0—News (German). 7.10—Record; News. 7.25—"A Prague Sunday"—Talk and Songs. 8.15—Legal Discussion. 8.30—Saxophone. 8.45—Act II, "The Trial of Dolores Divine"—Play (Kenneth Ellis). 9.30—Beethoven, Czech Philharmonic Orchestra. Conductor: Singer. Mikeelka (Pfte.). Overture, "Coriolanus." Pfte. Concerto in E flat. 10.15—News. 10.30—Records. 10.45-11.0—News (German).

RADIO-NORMANDIE

(France)

1,113 kc/s (269.5 m.); 10 kW. 7.0 a.m.—Records. In the intervals, News. 8.15—Light Music. 8.30—Records. 10.0—Mozart. 11.0—Chansonettes. 12.0 noon—Military Music. 12.40 p.m.—News. 12.45—Light Music. 4.0—Dance Music. 4.45—For Children. 5.0—Dance Music. 5.15—Records. 5.30—Strauss. 6.0—For Children. 6.45—Talk. 7.0—Light Music. 8.30—Talk. 8.45—Accordion.

9.0—Part I. Heme (Violin), Alix (Pfte.), Mlle. Olga Anderson (Songs). Violin: Bourrée (Bach). Prelude, Suite Bergamasque (Debussy). Abend (Haydn). Barcarolle (Tchaikovsky). Soir d'automne (Pugno). Song (Haydn). Bohemian Song (Dvořák). Sicilienne and Rigaudon (Francoeur-Kreisler).

Pastorale (Scarlatti). Altes Märchen (Grieg). Vergebliches Ständchen (Brahms). Romance (Wieniawsky). Concerto (Wieniawsky). Prelude (Rachmaninov). Part 2. Saxophone Quartet. To Else (Beethoven). Scherzo (Heller). Largo (Maniére). Finale from Quartet No. 1 (Chauvet). Der Fremde (Schumann). Moment musical (Schubert). Impromptu (Maniére). 11.0—Records. 11.30—Light Music.

12.0 m't—Dance Music. 12.30 a.m. (Tuesday)—Records. 1.0-2.0—Dance Music.

ROME (Italy)

713 kc/s (420.8 m.); 50 kW. Relayed by Naples, 1,104 kc/s (271.7 m.); Milan (No. 2), 1,348 kc/s (222.6 m.); Turin (No. 2), 1,357 kc/s (221.1 m.); and Bari, 1,059 kc/s (283.3 m.).

Transmits at intervals from 7.30 a.m. 5.10 p.m.—Caporali (Pfte.), Edma Limberti (Soprano), Meletti (Bartitone). 5.55—Corn Prices. 6.35—News in Esperanto. 6.45—Tourist Report; Dopolaro Notes. 7.0-8.15—Announcements. 8.30—News; Topical.

8.40—"The Duchess of Hollywood"—Operetta in Three Acts (Ranzato). Conductor: Lombardo. In the intervals: Dialogue; Announcements. 11.0—News.

SOTTENS (Switzerland)

677 kc/s (443.1 m.); 25 kW. Transmits at intervals from 12.30 p.m. 4.30-6.0 p.m.—See Beromünster. 6.0—For Women. 6.30—Records. 7.0—Sonia Grell (Violin). Sonata (Locatelli). Songs of Spain (Nin).

7.35—For Peasants. 7.40—Radio Review. 8.0—Report of the Cycle Tour of France. 8.2—Radio-Suisse Romande Orchestra. Conductor: Baud-Bovy. Geispieler (Clarinet) and Schmidt (Pfte.). Symphony in E flat (Haydn). Clarinet Concerto in F minor (Weber). Pfte. and Orchestra: Les Djinns (Franck).

9.5—Tichy (Organ). Pontifical Procession (Bossi). Prelude, Herzliebster Jesu (Brahms). Double Fugue (Bach). Meditation (de Sévèrac). Toccata in D minor (Vierne). 9.20—News.

9.30-10.30—"Le Pendu conduit le Bal"—Comedy (Mahert).

STOCKHOLM (Sweden)

704 kc/s (426.1 m.); 55 kW. Relayed by Motala, 216 kc/s (1,389 m.); Göteborg, 941 kc/s (318.8 m.); Hörby, 1,131 kc/s (265.3 m.), and Boden, 392 kc/s (765 m.).

Transmits at intervals from 7.45 a.m. 5.5 p.m.—Sörmland Folk Songs and Stories. 5.45—Records. 6.45—Talk: Fishing. 7.15—News.

7.30 (from Göteborg)—Liseberg Orchestra. Conductor: Mayerhauser. 8.30 (from Boden)—Talk: The Lapps.

9.0—Records: Acts II and III, "Tosca" (Puccini), by the Cast of the Scala, Milan. 9.45—News.

10.0-11.0—England's Orchestra. Overture, "Tancred" (Rossini). Waltz (Strauss). Excerpts, Woodland Sketches (MacDowell). Russian Ballad, Sonia (Pärtos). Potpourri (Morena). Serenade (Tosti). Selection, "The Little Dutch Girl" (Kálmán).

STRASBOURG (France)

859 kc/s (349.2 m.); 35 kW.

Transmits at intervals from 9.0 a.m. 6.30—Mlle. Manlet (Mezzo-Soprano) and Mlle. Wolfersaedter (Pfte.). Pfte.: Spanish Dances (Granados). Recitative and Cavatina, "Ceres" (Paisiello), Aria, "Proserpine" (Paisiello). (Pfte.: (a) Mouvement perpétuel (Poulenc), (b) Fire Danec (Falla), Four Songs (Ropartz).

7.30—News. 7.45—News in German. 8.0—Report: The Cycle Tour of France—Luchon-Pau. 8.15—News in German.

8.30—Municipal Orchestra and Cathedral Choir from the Municipal Theatre. Conductor: Abbé Hoch. Mme. Mallnory-Marseillac (Soprano), Mlle. Rauh (Contralto), Anspach (Tenor) and Hazart (Bartitone). Excerpts, "Le déluge" (Saint-Saëns) and "L'Enfance du Christ" (Berlioz). Ave verum (Mozart). Tu es Petrus (Liszt). In the interval at 9.30: News.

STUTTGART (Germany)

574 kc/s (522.6 m.); 100 kW. Transmits at intervals from 6.0 a.m. 12.0 noon—Light Music.

12.20 p.m.—See Hamburg. In the interval at 1.0: News.

2.0—See Deutschlandsender. 3.0-3.5—For Ex-Servicemen.

4.0—Light Orchestral Music from Baden-Baden.

5.0—Württemberg-Hohenzollern Provincial Orchestra. Conductor: Schröder. Haagen (Pfte). 6.30—For Boys.

7.0—"The Black Forest"—A Musical Menu from Karlsruhe. Hollinger Dance Band and Accordion Band. 8.0—News.

8.10—"July Fireworks"—Variety. 10.0—News. 10.20—Talk by Dr. Röchling: Saar Light Industries.

10.30—See Breslau. 12.0 m't-2.0 a.m. (Tuesday)—See Frankfurt.

TOULOUSE (Radio-Toulouse) (France)

913 kc/s (328.6 m.); 60 kW. Transmits at intervals from 8.0 a.m. 7.0 p.m.—Songs. 7.20—Band. 7.30—News. 7.45—Medical Talk. 7.55—Variety. 9.45—Excerpts, "Azor" Operetta (Gabaroché). 10.20—Songs from Films. 10.30—News. 10.45—Light Music.

12.0 m't—"Au Caveau de minuit"—Fantasy. 12.15 a.m. (Tuesday)—News. 12.20-12.30—Band.

TURIN (No. 1) (Italy)

1,140 kc/s (263.2 m.); 7 kW. Relayed by Milan (No. 1), 814 kc/s (368.6 m.); Genoa, 986 kc/s (304.3 m.); Florence, 610 kc/s (491.8 m.); and Trieste, 1,222 kc/s (245.5 m.).

5.5 p.m.—Sextet. 5.55-6.10—For Farmers. 6.35—News in Esperanto. 6.45—Tourist Report; Dopolaro Notes. 7.0—News in Foreign Languages; Italian Lesson.

8.15—Report on the Cycle Tour of France. 8.20—News. 8.30—Announcements; Topical Talk.

8.40—"La signorina Lievito"—Three-Act Play (Felyne). 10.25—Orchestra. Conductor: La Rosa Parodi. Prelude to a Requiem Mass (Amfitheatrof). Pezzo concertante (Ghedini). Siegfried Idyll (Wagner). 11.0—News. 11.15—News (Spanish).

VIENNA (Austria) 592 kc/s (506.8 m.); 100 kW. Relayed by Graz, 886 kc/s (338.6 m.); Innsbruck, 519 kc/s

578 m.); Dornbirn, Klagenfurt and Linz, 1,294 kc/s (231.8 m.), and Salzburg, 1,348 kc/s (222.6 m.).

Transmits at intervals from 9.10 a.m. 5.0 p.m.—Talk by Dr. Alfred Rosenzweig: The Opera Chorus. 5.20—Natural Science Review. 5.30—Gretl Wanecek (Soprano) and Edmund Samato (Tenor). 6.0—Talk: The Lainz Deer Park. 6.25—Talk: The Vineyards of Burgenland. 6.50—Talk. 7.0—News. 7.10—Talk: The Coin Collection in the Mint. 7.30—To be announced.

7.50—Vienna Symphony Orchestra. Conductor: Schönherr. Maisy Brauner (Soprano), Bilokapa (Bartitone), Turroweroff (Balalaika) and the "Humoreskimos." In the interval at 9.0: Variety. 10.0—News.

10.10—Scheit (Guitar). Movements from the Partita in E (Bach). Minuet (Sor). Concert Etude (Coste). Lagrima, Adelita and Sueño (Tárrega).

10.40—Song Records. 11.15—Announcements. 11.30-1.0 a.m. (Tuesday)—Geiger Jazz Band.

10.10—Scheit (Guitar). Movements from the Partita in E (Bach). Minuet (Sor). Concert Etude (Coste). Lagrima, Adelita and Sueño (Tárrega).

10.40—Song Records. 11.15—Announcements. 11.30-1.0 a.m. (Tuesday)—Geiger Jazz Band.

10.40—Song Records. 11.15—Announcements. 11.30-1.0 a.m. (Tuesday)—Geiger Jazz Band.

WARSAW (Poland)

224 kc/s (1,339 m.); 120 kW. Relayed by Katowice, 759 kc/s (395.8 m.); Łwów, 795 kc/s (377.4 m.); Poznań, 868 kc/s (345.6 m.); and Wilno, 536 kc/s (559.7 m.).

Transmits at intervals from 6.30 a.m. 3.30 p.m.—Orchestra. 4.0 (from Wilno)—For Children. 4.15—Dance Music. 4.50—Recitations. 5.0—Bielakow (Songs). 5.15—Rimsky-Korsakov Opera Records.

5.40—Caprichos Romanticos (del Campo) by the Warsaw Philharmonic Quartet. 6.0—Talk. 6.15—Katowice Choir. 6.30—To be announced. 6.40—Talk. 6.45—Viennese Waltz Records. 7.5—Announcements. 7.30—"The Banks of the Vistula"—Report. 7.50—Book Talk.

8.0—Farmers' Letter-box. 8.10—Chamber Music Records. 8.45—News. 8.55—Poland Yesterday and To-day.

9.0—Polish Music. Station Orchestra. Conductor: Fitelberg. Kaminski (Violin). Overture (Kurpinski). Overture on Polish Themes (Joteyko). Violin Concerto (Mlynarski). 10.0—Sports.

10.10—Station Orchestra. Conductor: Górzynski. Light and Dance Music.

Face the day with confidence

A comfortable shave means a good start to the day. If you find shaving a bore in the morning, give Parke-Davis Shaving Cream a trial. It really does soften the beard quickly and effectively, and yet protects the skin from irritation. Sold in large 1s.6d. tubes by all chemists.

PARKE-DAVIS Shaving Cream

Write to Box 137/40, Euthymol, 50, Beak Street, London, W.1, for a free 7-day sample of Parke-Davis Shaving Cream.



★HYVOLTSTAR★

LUXURY RADIO SUPERHET

Tuning Range of 13-2,000 metres

A superb, scientific, inexpensive creation of Balanced Radio bringing within the reach of all a beautifully constructed receiver of unsurpassed tone and volume. Featuring audi-torium speaker with automatic record changer with Piezo-Electric Pickup. **PRICE 50 gns.**

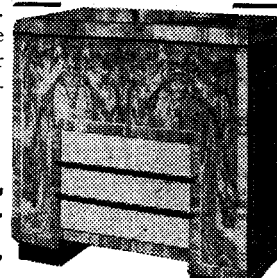

UNIVERSAL HIGH VOLTAGE RADIO, Ltd.,
28/29, Southampton Street, Strand, London, W.C.2.
Telephone: TEMple Bar 4985.

"HAVE A SET ON APPROVAL."

DON'T RISK IT

Lightning may strike your Home through your wireless aerial.

Gard protects your aerial from the Lightning peril and does not affect reception. You listen in safety through the worst of storms. Before you go on holiday fit GARD and leave your aerial permanently SAFE.

FREE £200 GUARANTEE AGAINST LIGHTNING DAMAGE

2/- GARD AUTOMATIC LIGHTNING ARRESTER

2/- at all Dealers or post free from sole manufacturers: **GRAHAM FARISH Ltd.,** Masons Hill, Bromley, Kent.

BOOKS

FOYLES FOR BOOKS. New and Secondhand on all subjects. Catalogues free on mentioning interests. 119-125, Charing Cross Rd., W.C.2.

SPECIALISED TRAINING

WIRELESS.—Youths trained for all Branches of this progressive profession under ideal conditions. Boarders accepted. Training fee can be paid after appointment. Prospectus free.—Wireless College, Colwyn Bay.

a binding case to hold current copies of "World-Radio"

stoutly made, from good quality binding cloth, distinctly blocked in gold, corded so that the journal remains in place, and provided with a convenient pencil—it costs 2s. 6d. by post direct from the B.B.C. Publications Dept., Broadcasting House, Portland Place, W.1.

T U E S D A Y July 23

NATIONAL

For Time Signals, see Monday.
 10.15 a.m. (Droitwich)—Service.
 10.30 (Droitwich)—Weather Forecast.
 10.45—"Good Meals and Little Cooking"—Prof. V. H. Mottram.
 11.0—Cinema Organ.
 11.30—Records.
 12.0—Frank Walker Octet. Herbert Thorpe (Tenor).
 1.0 p.m.—Joseph Muscant and the Troxy Grand Orchestra.
 2.0—Miscellaneous Records.
 2.45—Eugene Pini Tango Orchestra.
 3.30—Miscellaneous Records.
 4.15—The Dorothy Hogben Trio. Gwladys Garside (Contralto).
 5.15—The B B C Dance Orchestra.
 6.0—"The First News."
 6.25—Interlude.
 6.30 (Droitwich)—Broadhurst Septet. Nuit d'Amour (Ganne). Intermezzo (Corri). Sweet Thoughts in a Dream (White). Serenade (Schubert). Waltz, Sleeping Beauty (Tchaikovsky). Norwegian Melody. Rondo (Mozart). Spring Song (Schumann). Humoresque (Dvorak). Minuet (Bolzoni). Waltz, Der Rosenkavalier (Strauss).
 7.15 (Droitwich)—Midland Orchestra, conducted by H. Foster Clark. Overture, Idomeneo (Mozart). Suite, Pélleas et Mélisande (Fauré). Mediterranean (Bax). Water Music (Handel).
 8.0—Beryl Orde and Eddie Pola in "Hollywood Headlights."
 8.15—"Through the Looking-Glass" (See Monday, Regional, 8.0).
 9.30—"The Second News."
 9.50—The Ceremony of the Keys, carried out by the Chief Warden in Conjunction with the 3rd Bn. Coldstream Guards, relayed from the Tower of London.
 10.0—Serge Krush Septet. Memories of Tchaikovsky (Krush). Mighty lak a rose (Nevin). Entr'acte (Carmen) (Bizet). Hungarian Serenade (Joncieres). Waltz in E minor (Chopin). Mari! Mari! (di Capua). Roundelay (Popper). Shenandoah (Fletcher). Dainty Lady (Wright). Danza del Ondine (Catalani). Hungarian Rhapsody No. 6 (Liszt). Deep River (arr. Krush).
 11.0-12.0 (Droitwich)—Dance Music: Jack Jackson and his Band, relayed from the Dorchester Hotel.

REGIONAL

For Time Signals, see Monday.
 10.15-10.30 a.m. (except Midland)—Droitwich.
 10.45—The Scottish Studio Orchestra.
 11.45—Commodore Grand Orchestra.
 12.45 p.m.—Miscellaneous Records.
 1.15—Organ (Albert Taylor).
 2.0—Birmingham Theatre Royal Orchestra.
 3.0 (Northern till 4.0)—Torquay Municipal Orchestra. Jessie King (Contralto). Overture, Prometheus (Beethoven); Waltz, A Thousand and One Nights (Strauss). Aria, O Mio Fernando (La Favorita) (Donizetti). Selection, Love and Laughter (Strauss); Tango Serenade (Barsotti); The Statue in the Garden (Hoepf). Flower Song (Faust) (Gounod). Suite, Beautiful Napias (Ferraris); Spanish Serenade (Eilenberg). Earl Bristol's Farewell. See where my Love a-maying Goes (Lidgey); The Rider of the Forest (Bullock). Selection, The Pirates of Penzance (Sullivan).
 4.0 (Northern)—Evensong.
 4.30 (Northern from 4.45)—Records.
 5.15—The Children's Hour.
 6.0—"The First News."
 6.30-8.0 (except Midland; N. Ireland from 7.15)—Droitwich.
 7.15 (N. Ireland)—Royal Opera House Orchestra.
 8.0 (Regional)—Campoli Trio.
 8.0 (Midland)—"Looking to the Air"—6: "Forecast for To-morrow."
 8.0 (Northern)—Legends Alive—2.
 8.0 (Scottish)—"Dominie Days." Sangs an' Stories about some Auld Skewies o' Langsinsyne.
 8.0 (Western)—Spencer Thomas (Tenor); Hywel Hughes (Pfte.).
 8.0 (N. Ireland)—Records.
 8.15 (N. Ireland)—"The Fermanagh Lakes"—Harold Weston.
 8.20 (Midland)—Records.
 8.30—Harold Ramsay's Rhythm Symphony.
 9.15 (Regional, Scottish, N. Ireland)—B B C Orchestra (Section C), conducted by Arthur Collingwood.
 9.15 (Midland)—The Radio Folies.
 9.15 (Northern)—Buxton Orchestra.
 9.15 (Western)—"Gaffer Without Gavotte": A West Country Programme of Simple Humour.
 10.0—News Summary; Sports Bulletin.
 10.20—Dance Records.
 10.30-12.0 (Midland till 11.0)—Jack Jackson and his Band.

SYMPHONY CONCERTS

8.50 Budapest 1: Franck, etc. (Defauw).
 9.0 Brussels 1: Roussel, Bach, Milhaud, etc.
 9.0 Stuttgart, Frankfurt: J. C. Bach, Mozart, Berlioz.

10.0 Warsaw: Polish music.

12.0 Stuttgart, Frankfurt: Schubert.

LIGHT CONCERTS

12.15 Radio-Paris: French programme.
 3.30 Kalundborg: Light classical music.
 3.30 Warsaw: Banjo orchestra.

4.0 Deutschlandsender: Open air music.

5.0 Cologne: Orchestra, light music.

5.0 Warsaw: Light orchestral.

6.55 Hilversum: Opera music.

7.0 Frankfurt: Marches and dances.

7.5 Munich: Band concert.

7.15 Athlone: Irish music from Galway.

7.30 Stockholm: Choir, folk songs.

7.45 Huizen: Symphony Orchestra.

8.0 Brussels 1: Russian and French music.

8.10 Deutschlandsender: Variety Concert.

8.10 Frankfurt: Scandinavian music.

8.15 Breslau: An Iceland programme.

8.15 Poste Parisien: Orchestra, flute.

8.15 Vienna: Opera music.

8.30 French P.T.T. Stations ex. Radio-Paris: European folk music.

8.30 Stockholm: Military Band.

8.40 Rome: Variety concert.

8.45 Radio-Paris: Light music.

9.0 Breslau: Community singing.

9.5 Oslo: Station Orchestra.

9.15 Regional: Condr., Arthur Collingwood.

9.35 Prague: "Bagatelles."

10.0 Bucharest: Restaurant orchestra.

10.30 Munich: Folk music.

OPERA

8.0 Monte Ceneri: "Lucia di Lammermoor" (on records).
OPERAETAS
 8.0 Brussels 2: "Chanson d'Amour" excerpts (Schubert-Berte).

8.40 Turin: "Amore tra i pampini" (Micheli).
 8.45 Radio - Normandie: "The Merry Widow."

9.0 Warsaw: "The Fiddler" (Offenbach).

CHAMBER MUSIC

3.10 Hilversum: Violin and pfe.
 8.30 Eiffel Tower: Delvincourt programme.
 9.0 Königsberg: Quintet, songs.
 10.0 Rome: Quartet (Napravnik), vocal duets.

RECITALS

1.40 Hilversum: Organ, violin.
 4.10 Munich: Organ, soprano songs.
 5.0 Radio-Paris: Organ, from Brussels.
 6.30 Brussels 1: Guillaume songs.
 6.30 Strasbourg: Song and pianoforte.
 7.0 Berlin: German songs.
 7.0 Hamburg: Pianoforte.
 7.0 Leipzig, etc.: Pfte, 'cello, song.
 7.30 Oslo: Sacred music.
 7.30 Warsaw: Pianoforte.
 8.0 Sottens: Chansonniers.
 8.30 Beromünster: Berne Cathedral Organ.
 10.0 Stockholm: Organ, song, violin.
 10.10 Vienna: Pianoforte (Brahms).
 11.30 Budapest 1: Pfte. (Hungarian music).

PLAYS

8.10 Hamburg: A play for Yachtsmen.
 8.10 Königsberg: "Vagabunden" (farce).
 9.0 Eiffel Tower: Two one-act plays.

TALKS

7.30 Brussels 1: Holland at the Exhibition.
 8.0 Stockholm: "François Villon."
 10.30 Cologne: English and French talks.

DANCE MUSIC

10.20, Budapest 1, Regional; 10.40, Warsaw; 10.50, Hilversum, Radio-Paris; 11.0, Deutschlandsender (Kalundborg relay). National; 12.0, Radio-Normandie.

MISCELLANEOUS

8.15 Kalundborg: Revue.
 9.50 National: Ceremony of the Keys.

Hours of Transmission in British Summer Time.

ATHLONE (Ireland)
 565 kc/s (531 m.); 60 kW. Relay by Dublin, 1,348 kc/s (222.6 m.); and Cork, 1,240 kc/s (241.9 m.).
 1.30-2.30 p.m.—No. 1 Army Band.
 6.0—For Children, 6.45—News, 7.0—Book Review.
 7.15—Vocal and Instrumental Concert of Irish Music, from Galway, 9.45—What happened to-day, 10.0—Variety, 10.30-11.0—C. T. Allmann and his Dance Band.

BERLIN (Germany)
 841 kc/s (356.7 m.); 100 kW. Transmits at intervals from 6.0 a.m.
 12.0 noon—See Leipzig. In the interval at 1.0 p.m.—Midday Echoes, 2.0—News, 2.15—Dance Band, 3.0-3.30—Exchange; Markets.
 4.0—"Contemporary Music in the Old Style"—Bertha Gunderloh (Soprano) and Fritz Dütterbernd (Baritone), 4.35—Hitler Youth Programme, 5.0—See Königsberg, 6.30—A Labourer from the Tegel Gasworks at the Microphone.
 7.0—Ida Harth zur Nieden (Soprano) and Waldemar von Vultée (Pfte.). Part I, Folk Songs. Heimlicher Liebe Pein (Weber). Der Mond ist aufgegangen (Schulz). In einem kühlen Grunde. Minnelied. Gute Nacht. Part II, Pfte.: Intermezzo (Brahms). Part III, Franz Songs. Aus meinen grossen Schmerzen. Die Lotosblume. Gute Nacht. Liebchen ist da. Mutter, o sing mich zur Ruh. Ständchen. 7.30—Holidays at Home (Anni Nadolny). 7.40—Evening Echoes, 8.0—News.
 8.10—"Guessing Competition"—Variety with the Small Station Orchestra and Soloists, 10.0—News, 10.30—Talk: Martin Luther and the German Language.
 11.0-12.0 m't—Programme from Munich.

BEROMÜNSTER (Switzerland)
 556 kc/s (539.6 m.); 100 kW. Relay by Basle and Berne, 1,375 kc/s (218.2 m.).
 12.0 noon—Zürich Station Orchestra, 12.29 p.m.—News, 12.40—Zürich Station Orchestra, 1.25-1.35—Weather; Exchange, 4.0—Records.

BORDEAUX-LAFAYETTE (France)
 1,077 kc/s (278.6 m.); 30 kW. Transmits at intervals from 8.0 a.m.
 8.0 p.m.—See Paris (PTT).
 8.15—Records. Waltz, Potpourri (Robrecht). Selection, "The Merry Widow" (Lehar-Robrecht). Neapolitan Nights (Zamecnik).
 8.30—See Paris (PTT). 10.30—News.

BRATISLAVA (Czechoslovakia)
 1,004 kc/s (298.8 m.); 13.5 kW. Transmits at intervals from 6.0 a.m.
 8.5—Light Music, 8.40—Art Talk, 8.55—Weiss (Slav Songs), 9.20—Sketch (Humberger), 9.35—Trio, 10.15—See Prague, 10.30—News in Hungarian, 10.45-11.0—Records.

BRESLAU (Germany)
 950 kc/s (315.8 m.); 100 kW. Relay by Gleiwitz, 1,231 kc/s (243.7 m.).
 Transmits at intervals from 5.0 a.m.
 12.0 noon—Orchestra, 2.0 p.m.—News, 2.10—Exchange, 2.15—Announcements, 2.45—Markets, 3.10—Beethoven Recital by Johanna Sauerland (Pfte.). 3.40—Report from a Whisky Distillery, 4.5—Talk: Cholera, 4.30—Reading: Der Oberschlesier, 4.50—Talk: The Press and Women.
 5.0—See Königsberg, 6.30—Reading (Schleinitz), 6.50—Announcements, 7.0—Otto Groh reads; Clotilde Kux-Drossbach (Songs), 7.50—Talk: Holidays at home, 8.0—News, 8.15—"A Radio Expedition to Iceland"—The Station Choir and Soloists.
 9.0—Community Singing from the Open-Air Theatre, Scheitniger Park.

BRNO (Czechoslovakia)
 922 kc/s (325.4 m.); 32 kW. Transmits at intervals from 6.0 a.m.
 8.5—Baticistic (Folk Songs), 8.25—"Summer Twilight"—Literary and Musical Sequence, 9.20-11.0—See Prague.
BRUSSELS (No. 1) (Belgium)
 620 kc/s (483.9 m.); 15 kW. 12.0 noon-2.0 p.m.—Orchestra. Conductor: Walpot. Mlle. Struelens (Songs). In the interval at 1.0—News, 4.55—Announcements, 5.0—Brahms and Fauré Records, 5.45—"Les hôtes de la nuit"—Play (Viñes-Mugnier), 6.10—Record: Air from the Suite in D (Bach), 6.15—Literary Talk: The 1830 Revolution, 6.30—Guillaume Songs by Max Clément, the Composer accompanying, Rondeau, Qui veut avoir liesse, Chanson, Chants de foire: (a) Chant d'honneur, (b) Chant de tir, (c) Chant de lutte, (d) Chant clos. Les âmes sourient. Trois enfants. Bulles.
 7.0—Talk: The Prince de Ligne Bicentenary, 7.15—Finale, "Salomé" (Strauss) (Records), 7.30—Exhibition Report: Holland; Science Review, 8.0—Symphony Orchestra, Conductor: André. Mme. Dauby (Songs), Overture, "A Life for the Czar" (Giinka), In the Steppes of Central Asia (Borodin). Arias, The St. Matthew Passion (Bach), Les Éolides (César Franck), Songs: (a) Letter Aria, "Werther" (Masset), (b) Lamento (Fauré), Suite, "Namouna" (Lalo).
 9.0-11.0—Brussels Symphony Orchestra from the Exhibition. Conductor: de Thoran. Berthe Bernard and Hélène Dinsart (Pftes.), Sinfonietta (Roussel), Concerto in C minor (Bach), Three Impressions (Chevreuille), Poème héroïque (Van Durme), Overture, "Eumenides" (Milhaud), Course du printemps (Koechlin); News; Records.
BRUSSELS (No. 2) (Belgium)
 932 kc/s (321.9 m.); 15 kW. Programme in Flemish.
 12.0 noon—New Records, 12.30 p.m.—"The Strauss Family"—Concert, with Commentary, Radio Orchestra,

Conductor: Douliez. Records. In the interval at 1.0—News, 1.30-2.0—Records, 4.55—Announcements, 5.0—Records: Le carnaval des animaux (Saint-Saëns), 5.30—For Children, 6.15—Records: Symphony and Hungarian Music, 7.0—Economics Talk, 7.15—Music of Distant Lands—Records, 7.30—Science Review, 8.0—Excerpts, "Chanson d'Amour"—Operetta (Schubert-Berte) Mme. De Ceulaerde-Monder, Henk Didama and the Radio Orchestra. Conductor: Douliez. In the interval: Talk, 10.0—News, 10.10-11.0—Records.

BUCHAREST (Romania)
 823 kc/s (364.5 m.); 12 kW. Transmits at intervals from 12.0 noon.
 6.0 p.m.—News, 6.15—Radio Orchestra, 7.0—Talk, 7.20—Operetta Records, 7.50—Programme Notes, 8.15—Records: Symphony Music. In the interval at 9.0: Talk, 9.45—News, 10.0—Restaurant Orchestra. In the interval at 10.15: News in French and German.

BUDAPEST (No. 1) (Hungary)
 546 kc/s (549.5 m.); 120 kW. 10.20 a.m.—Hungarian Fairy Tales, 10.45—Talk, 12.5 p.m.—Police Band, 12.30—News, 1.20—Weather, 1.30—Balalaika Orchestra, 2.0—For Women, 4.10—Talk, 4.45—Weather, 5.0—Talk, 5.35—Records, 6.30—Talk, 7.0—Toll Cigány Band, 8.15—Talk, 8.50—Opera Orchestra, Conductor: Defauw, Symphony in D minor (Franck), La mer (Gillon), Fugato (Poot), Fantasia (Jongen).
 10.0—News, 10.20—Mándits Jazz Band, 11.30—Hungarian Songs by Zoltán Kárpát and Jenő Paksy (Two Pftes.), 12.5 a.m. (Wednesday)—News.

BUDAPEST (No. 2) (Hungary)
 359.5 kc/s (834.5 m.); 20 kW. 6.35 p.m.—Choir, 7.25—For Farmers, 8.0—Péter Solymos (Pfte.), 8.45—News, 9.10—Berci Ráczy Band.

COLOGNE (Germany)
 658 kc/s (455.9 m.); 100 kW. Transmits at intervals from 6.0 a.m.
 12.0 noon—See Leipzig, 2.0 p.m.—News, 2.15—Variety from Deutschlandsender, 3.0—Talks, 4.0—Lecture

Conductor: Douliez. Records. In the interval at 1.0—News, 1.30-2.0—Records, 4.55—Announcements, 5.0—Records: Le carnaval des animaux (Saint-Saëns), 5.30—For Children, 6.15—Records: Symphony and Hungarian Music, 7.0—Economics Talk, 7.15—Music of Distant Lands—Records, 7.30—Science Review, 8.0—Excerpts, "Chanson d'Amour"—Operetta (Schubert-Berte) Mme. De Ceulaerde-Monder, Henk Didama and the Radio Orchestra. Conductor: Douliez. In the interval: Talk, 10.0—News, 10.10-11.0—Records.

DEUTSCHLANDSENDER (Germany)
 191 kc/s (1,571 m.); 60 kW. Transmits at intervals from 5.55 a.m.
 12.0 noon—See Munich, 1.45 p.m.—News, 2.0—Variety, 3.0—Exchange; Announcements, 3.15—Talk: Hölderlin's Mother, 3.45—Records, 4.0—Bands from the Tiergarten, 5.30—"Learning to Fly"—Report, 5.45—Concert from Königsberg, 6.20—Political Press Review, 6.40—To be announced, 7.5—See Munich, 7.45—News, 8.0—Motto; Announcements, 8.10—"Perpetuum mobile"—Dobrinde's and Gaden's Bands, 10.0—News, 10.30—Narath (Neo-Bechstein Pfte.), 10.45—Weather, 11.0-12.0 m't—Dance Music from Kalundborg.

FRANKFURT (Germany)
 1,195 kc/s (251 m.); 25 kW. Relay by Cassel, Coblenz, Freiburg, Kaiserslautern, and Trier, 1,195 kc/s (251 m.).
 Transmits at intervals from 6.0 a.m.
 12.0 noon—See Leipzig. In the interval at 1.0 p.m.: News, 2.0—News, 2.15—Industrial Review, 2.30—Exchange, 2.40-2.45—Weather, 3.15—For Women, 4.0—Fritz von Bose plays his own Pfte. Music, Three Preludes, Theme and Variations, Two Etudes, Scherzo, 4.30—Geology, 4.45—Psychology, 5.0—See Königsberg, 6.30—Talk: The Low Birth-rate—Europe's Doom, 6.45—Topicalities, 6.55—Weather; Exchange; Announcements, 7.0—Marches, Dances, Hauck Band, 7.40—Talk, 7.50—News,

RECITAL: Buscheid's Musical History.
 4.30—An Interview with an old Brickmaker, 4.45—Students at the Microphone.
 5.0—Light Music. Gelsenkirchen Orchestra, from Bad Salzuflen. Conductor: Friedrich. Pfaffenbach (Violin).
 6.30—Talk by Richard Euringer: Lending Libraries, 6.45—Weather; Exchange; Sports, 7.0—German Folk Dances, 7.30—To be announced, 7.50—Snapshots, 8.0—News, 8.10—See Deutschlandsender, 10.0—News, 10.20—Chess, 10.30—English 10.45-11.0—French.

TUESDAY (July 23)

8.10 (from Cassel)—Scandinavian Music, from Wilhelmshöhe. Conductor: Møthes. Swedish Wedding March (Söderman). Suite, "Peer Gynt" (Grieg). Swedish Dance Song (Thyrolf). Halling (Thyrolf). Fantasia, A Summer Day in Norway (Willmers).

9.0—See Stuttgart. **10.0**—News. **10.20**—Military Report by Paul Laven.

11.0—Folk Music from Munich. **12.0 m't-2.0 a.m.** (Wednesday)—See Stuttgart.

HAMBURG (Germany)

904 kc/s (331.9 m.); 100 kW. Relayed by Bremen, Flensburg, Hanover, Magdeburg and Stettin, 1,330 kc/s (225.6 m.).

Transmits at intervals from 5.40 a.m. **12.0 noon**—Shipping. **12.10 p.m.**—Concert from Leipzig. In the interval at 1.0: News. 2.0—News. 2.20—Light Music. 3.0—Exchange. 3.30—Brazilian Exchange; Shipping.

4.0—Orchestra. Conductor: Rudolph. 4.45—Talk: The Earth's Origin.

5.0—See Königsberg. **6.30**—"Village Children visit the Town"—Report. 6.45—Exchange; Shipping; Weather. **7.0** (from Hanover)—Gisela Sott (Pfte). Impromptu (Schubert). Romance (Schumann). Caprice (Brahms). Barcarolle (Chopin). Waltz in A flat (Chopin).

7.30—Girls' Choir. **8.0**—News.

8.10—"Deerns and Deck"—Play for Yachtsmen (Dinklage-Maack). **9.0**—Old Hamburg—Sequence. **10.0**—News. **10.25**—Light Music.

11.0-12.0 m't—Folk Music from Munich.

HILVERSUM (Holland)

160 kc/s (1,875 m.).

Transmitted on Kootwijk on 120 kW. Programme of the General Broadcasting Society (A.V.R.O.).

7.40 a.m.—Records. **8.40**—Light Music by the Octophonikers. Conductor: Drukker. **9.40**—Service. **9.55**—Records. **10.10**—Light Music by the Cantabile Orchestra. Conductor: Beekman. **10.40**—Talk arranged by the R.V.U. **11.10**—Light Music (cont'd.). **12.10 p.m.**—Records. **12.40**—Light Music by Kovacs Lajos Orchestra. **1.20**—Egbert Veen (Pfte). **1.40**—Piet van Egmond (Organ) and Suzu Tak (Violin). **2.40**—Records. **3.10-3.40**—Sonatas. Jan Felderhof (Violin) and Veen (Pfte). **3.55**—Records. **4.10**—Children's Choir. Conductor: Hamel. **4.40**—For Children. **5.10**—Renova Quintet. **6.10**—Talk arranged by the R.V.U. **6.40**—Records.

6.55—Groningen Orchestra. Conductor: Kuiler. Gerrit Kijk in den Vegte (Tenor). Overture and Aria. "Joseph" (Méhul). Overture and Aria. "The Merry Wives of Windsor" (Nicolai). Overture and Aria. "Martha" (Flotow). Overture. "The Daughter of the Regiment" (Donizetti). Aria, "L'elisir d'amore" (Donizetti).

7.40—News. **7.50**—Records.

8.30—Groningen Orchestra. Conductor: Kuiler. Radezky March (Strauss). Wine, Women and Song (Strauss). March. "The Gipsy Baron" (Strauss). Minuet and Gavotte. "I Pagliacci" (Leoncavallo). Le pas des fleurs, from "Naila" (Delibes). Two Pieces from "Caucasian Sketches" (Ippolitov-Ivanov).

9.10—The Mills Brothers. **9.55**—Light Music by Kovacs Lajos Orchestra. **10.40**—News. **10.50-11.40**—Dance Music by the A.V.R.O. Decibels. Conductor: Meenk.

HUIZEN (Holland)

995 kc/s (301.5 m.); 20 kW.

Programme of the Catholic Radio Society (K.R.O.).

7.40-8.55 a.m.—Records. **9.40**—Records. **10.10**—Concert. **10.40**—Records. **11.10**—Religious Talk. **11.40**—Police Messages. **11.55**—Records. **1.40 p.m.**—For Women. **2.40**—Children's Choir from Bois-le-Duc Festival. **3.10-3.40**—Records. **3.55**—K.R.O. Boys. Conductor: Lustenhouwer. In the interval: Records. **6.40**—Police Messages. **6.55**—Talk. **7.15**—Report from Bois-le-Duc Festival. **7.40**—News.

7.45—Wagenaar. K.R.O. Symphony Orchestra. Conductor: Van Otterloo. Overture, "Cyrano de Bergerac." In Wiener Dreiviertelakt.

8.15—Sports.

8.30—K.R.O. Symphony Orchestra. Conductor: Van Otterloo. Overture, "Hansel and Gretel" (Humperdinck). Herzvunden (Grieg). Letzter Frühling (Grieg). On hearing the first Cuckoo in Spring

(Delius). Italian Caprice (Tchaikovsky). **9.10**—Records.

9.25—Concert from Bois-le-Duc. Bois-le-Duc Mixed Choir. Conductor: Gevers—Rotterdam Philharmonic Orchestra. Jo Vincent (Soprano), Jo Immink (Contralto), Kees Smulders (Tenor) and Louis Bogtman (Bariitone). **10.10**—News. **10.15-11.40**—Rosenberg Orchestra from the Heck Restaurant, Amsterdam. In the interval at 10.55: Records.

KALUNDBORG (Denmark)

238 kc/s (1,261 m.); 60 kW. Relayed by Copenhagen, 1,176 kc/s (255.1 m.).

Transmits at intervals from 7.0 a.m. **12.0 noon-2.0 p.m.**—Bendix String Ensemble from the Wivex.

3.30—Light classics. Conductor: Olsen. Fabricius ('Cello). Interval: Reading (Haanpää). **5.30**—Exchange; Markets. **6.12**—Poem (Nielsen-Stevens). **6.15**—Talk: Gymnastics Week in Aalborg. **6.45**—Announcements. **7.0**—News. **7.15**—Talk: Maribo Open Air Museum. **7.30**—Talk: Folk Tales. **8.0**—Talk on the following Transmission. **8.15**—"The Apollo Revue," from the Apollo Theatre. In the interval at 9.30 (approx.): News. **10.50-12.30 a.m.** (Wednesday)—Petersen Dance Band from the Wivex.

KÖNIGSBERG (Germany)

1,031 kc/s (291 m.); 60 kW. Relayed by Danzig, 1,303 kc/s (230.2 m.).

Transmits at intervals from 4.58 a.m. **12.0 noon-2.0 p.m.**—See Leipzig. In the interval at 1.0: News. **2.0**—News. **2.15**—Announcements. **2.45**—Reading (Bock). **3.0**—Exchange; Markets. **3.10**—For Children. **3.35**—Fashion Talk. **3.45**—Book Review. **4.0**—See Deutschlandsender. **4.50**—Talk: Statistics.

5.0—Erich Börscher Band and a Military Band. Conductor: Wisch. **6.30**—Markets. **6.40**—Talk. **7.0**—News. **7.10**—Talk: The Master Tailor.

7.30—Folk Songs by Hermine Behn (Mezzo-Contralto). Ich spring in diesem Ringe. Es hat ein Bauer. Der Schlossgesell. Phyllis und die Mutter. Mädele ruck, ruck, ruck. Och Moder. Weisser Rosenbaum. Schifferlied. Der schöne Müller. Der Storch. An dem Rhein. **8.0**—News.

8.10—"Vagabonds"—Farce (Colberg). **9.0**—The Karl Ninke Chamber Music Quintet, with Georg Höller (Bariitone). Songs (Schmalstich): (a) Siehst du die Sonne, (b) Nun darfst du weinen, (c) Ich trage von deiner Seele. Songs (Trunk): (a) Den Anderen, (b) Stilles Lied. Songs (Pfützner): (a) Zorn, (b) Klage. Pfte. Quintet in G minor (Grammann). **10.0**—News.

10.20—See Frankfurt.

11.0-12.0 m't—Concert from Munich.

LEIPZIG (Germany)

785 kc/s (382.2 m.); 120 kW. Relayed by Dresden, 1,295 kc/s (233.5 m.).

Transmits at intervals from 5.50 a.m. **12.0 noon**—Leipzig Symphony Orchestra and Soloists. Conductor: Weber. In the interval at 1.0 p.m.: News. **2.0**—News; Exchange. **2.15**—Variety from Deutschlandsender. **3.0-3.20**—For Women. **3.40-4.0**—Exchange. **4.30**—Book Review. **4.50**—Weather; Exchange; Brazilian Exchange. **5.0**—See Königsberg. **6.30**—Talk: Folk Instruments and Music. **6.50**—The Call of Youth.

7.0—Walter (Pfte.), Emmy Daehle (Mezzo-Soprano) and Wawrowsky ('Cello). Cello and Pfte.: Sarabande (Bach). Songs (Cornelius): (a) Liebe ohne Heimat, (b) Wiegenglied. Pfte.: (a) Piece from Picture Books (Mraczek), (b) Dance of the Gnomes (v. Bose), (c) Klavierstücke fürs Haus (Berger). Songs (Franz): (a) Bitte, (b) In meinen Garten die Nelken. Cello and Pfte.: Twelve Variations on "A Maiden or Wife," from "The Magic Flute" (Mozart-Bethoven). Songs (Franz): (a) Gute Nacht, (b) Mutter, o sing mich zur Ruh'. Pfte.: (a) Lockruf (Johansen), (b) Rigaudon and Musette (Müller), (c) Humoresque and Dance (Reger). Songs (Cornelius): (a) Untreu, (b) In Lust und Schmerzen. Cello and Pfte.: (a) Waldesruhe (Dvofák), (b) Caprice (Reger).

8.0—News. **8.10**—See Berlin. **10.0**—News.

10.30-12.0 m't—See Munich.

LISBON (Portugal)

629 kc/s (476.9 m.); 20 kW. Transmits at intervals from 12.0 noon. **7.0 p.m.**—Music. **7.55**—News; Music. **8.25**—Exchange; Music. **8.50**—

Talk. **9.0**—Orchestra. In the interval at 9.30: News. **10.0**—Political Notes; Portuguese Music. **10.30**—News; Records. **11.0**—Dance Music.

MONTE CENERI (Switzerland)

1,167 kc/s (257.1 m.); 15 kW. Transmits at intervals from 12.0 noon. **4.30-6.0**—See Sottens. **7.30**—Italian Marches. Coppa Pro-Radio (Vicari). Bianco-Neri (Mastelli). Bella Lugano (Mastelli) Friborgo (Mantegazzi). Il carabinieri (Mantegazzi). **7.45**—News. **8.0**—"Lucia di Lammermoor"—

4.10—Liselotte Schirmer (Soprano) and Schoedel (Organ). **4.40**—Talk. **5.0**—See Königsberg. **6.30**—Talk: Field-Marshal von Moltke. **6.50**—Announcements. **7.0**—The Call of Youth.

7.5—Wind Band. Conductor: Lange. Fanfare March (Port). Overture, "Mignon" (Thomas). Selection, "The Flying Dutchman" (Wagner). Mazurka, Auf der Zwieselalm (Kretzner).

7.40—Talk: Johann Gottfried Herder. **8.0**—News.

8.10—Wind band (cont'd.). Waltz.

8.30 p.m. FRENCH P.T.T. STATIONS ex. RADIO-PARIS

European FOLK MUSIC

Czechoslovakia

DVORÁK

Switzerland

DORET

Hungary

KODÁLY

Spain

ALBENIZ

England

DELIUS

Russia

LIADOV

Brazil

MILHAUD

Norway

GRIEG

Canada

VUILLERMOZ

France

KOECHLIN, EMMANUEL

Italy

TOMMASINI

France

CANTELOUBE

Austria

JOHANN STRAUSS

Madeleine Grey, Singer

J. Neitz, Cellist

The National Orchestra and Felix Raugel Choir
Conductor, Inghelbrecht

Opera (Donizetti), by the Cast of La Scala, Milan (Records). **9.45**—To be announced. **10.30**—Weather.

MORAVSKÁ-OSTRAVA (Czechoslovakia)

1,113 kc/s (269.5 m.); 11.2 kW. Transmits at intervals from 6.0 a.m. **7.25**—Play (Vakou). **8.5**—See Brno. **9.20**—See Prague. **10.45-11.0**—Talk in Esperanto: Moravian and Silesian Folklore.

MOSCOW (No. 1) (Russia)

174 kc/s (1,724 m.); 500 kW. Transmits at intervals from 3.45 a.m. **6.0 p.m.**—Concert. Announcements in the intervals.

7.0—Symphony Concert. Conductor: Georgeskou. Kaplan (Pfte.). Symphony in D (Brahms). Pfte. Concerto No. 2 (Rachmaninov). L'apprenti sorcier (Dukas).

9.0—German Programme: For Farmers; Letter-box; Wireless Talk. **10.5**—French Talk: Soviet Agrarian Policy. **11.5**—Dutch Talk: Bolshevist in Czarist Russia.

MUNICH (Germany)

740 kc/s (405.4 m.); 100 kW. Relayed by Nürnberg, 1,267 kc/s (236.8 m.).

Transmits at intervals from 6.0 a.m. **12.0 noon**—Reich Symphony Orchestra. Conductor: Hoernes. In the interval at 1.0 p.m.—News. **2.0-2.20**—News; Exchange. **3.0**—Talk: Travelling with Children; "The Office New-Comer" Sketch (Engelhardt). **3.40**—Talk and Reading: Bathing Pleasures of the Past. **4.0**—Announcements.

Les sirènes (Waldteufel). Two Marches (Ewers).

8.30—"Das grosse Heymonsspiel"—Play (Münsterer). **10.0**—News; Exchange; Sports. **10.20**—To be announced. **10.30-12.0 m't**—Folk Music by the Small Station Schrammel and Soloists. Conductor: Kloss.

OSLO (Norway)

260 kc/s (1,154 m.); 60 kW. Relayed by Frederikstad, 776 kc/s (386.6 m.); Hamar, 510.5 kc/s (587.7 m.); Notodden, 1,357 kc/s (221.1 m.); Porsgrund, 850 kc/s (352.9 m.); Rjukan, 1,348 kc/s (222.6 m.); Trøndelag, 629 kc/s (476.9 m.).

Transmits at intervals from 11.10 a.m. **7.30**—Sacred Music. Solveig Sandvold (Songs), Arild Sandvold (Organ), and Fieldstad (Violin). Organ Prelude in B minor (Bach). Violin: (a) Larghetto (Handel), (b) Adagio (Sinding). Organ Sonata (Mendelssohn). Aria from a Mass (Bach). Organ: Gothic Suite (Boëlmann). **8.15**—Talk.

8.45—Dramatic Programme.

9.5—Station Orchestra. Conductor: Fieldstad. Overture, "The Daughter of the Regiment" (Donizetti). Selection, "The Desert Song" (Romberg). Narcissus (Nevin). Norwegian Dance (Andersen). Country Idyll (Hansen). **9.40**—News. **10.0**—Topical Talk.

10.15-11.0—Station Orchestra (cont'd.). March (Berlioz). Overture, Venus auf Erde (Lincke). Selection, "Countess Mariza" (Kálmán). Old Dances (Pachernegg).

PARIS (Eiffel Tower) (France)

1,456 kc/s (206 m.); 5 kW. Transmits at intervals from 1.0 p.m. **8.0 p.m.**—News. **8.30**—Claude Delvincourt Concert. The Composer (Pfte.) and Temerson (Violin). Sonata for Violin and Pfte. Pfte.: Danceries. **9.0-10.0**—One Act Plays: (a) "Les Tourterelles" (Albert Jean), (b) "Les Assureurs" (Claude Rolland-d'Herவில்lez).

PARIS (Poste Parisien) (France)

959 kc/s (312.8 m.); 60 kW. Transmits at intervals from 7.10 a.m. **12.0 noon**—Exchange. **12.5 p.m.**—Request. **12.25**—An Interview. **12.35-1.5**—Records. **1.15**—Exchange. **1.19**—Records; Solos. **1.30**—Records. **2.0**—Exchange. **3.15**—Exchange. **3.45**—Exchange. **4.35**—Exchange. **6.25**—Exchange. **6.30**—Religious Address. **6.50**—Records: Sonata in B flat minor (Chopin) by Brailowsky (Pfte.). **7.7**—Sports. **7.10**—News. **7.25**—Amusement Guide. **7.27**—Legal Talk. **7.35**—Cycle Tour of France—Pau. **7.50-8.0**—Records. **8.10**—Exchange. **8.15-9.45**—Station Orchestra. Conductor: Balay. L'avallotte (Flute). Overture, A May Day (Haydn Wood). Flute Concertino (Chaminade). Impressions d'Italie (Charpentier). Petite Suite (Ducasse). Aux étoiles (Duparc). Ballet, "Antar" (Dupont). Fête Polonoise (Chabrier). In the interval at 8.50—Exchange.

10.0—Programme arranged by Jean Franc-Nohain and Christiane Dix, with Blanche Montel and Licette Limozin. **10.30-11.0**—Records.

PARIS (PTT) (France)

695 kc/s (431.7 m.); 7 kW. Transmits at intervals from 8 a.m. **6.0 p.m.**—Talk: Travel and Exploration. **6.20**—Talk: Art. **6.30**—News. **7.45**—Science Talk. **8.0**—Report on the Cycle Tour of France. **8.15**—Records: Classic Dances. Tambourin (Grétry) by the Conservatoire Concert Orchestra. Sicilienne (Paradis) by Thibaud (Violin). Rigaudon (Rameau) by the Godwin Quintet. **8.30**—European Folk Music. **10.30**—News.

PARIS (Radio-Paris) (France)

182 kc/s (1,648 m.); 80 kW. **6.45 a.m.**—Gym; Records. **7.15**—News. **7.45**—Gym; Song Records. **12.15 p.m.**—Krettly Orchestra. Mlle. Boulesteix (Songs); Bouleme ('Cello). French Music. **1.20**: News; Exchange. **3.45**—Exchange. **5.0**—Mihatsch (Organ), from Brussels. **6.0**—Ibsen Dramatic Programme. **6.30**—For Farmers; Exchange; Markets; Racing. **6.45**—Announcements. **6.50**—Talk: How to read Poetry. **7.5**—Shipping. **7.20**—Talk. **7.40**—Review of the Humorous Press. **7.50**—Sports. **8.0**—Reading (de Croisset). **8.30**—Press Review. **8.45**—Orchestra and Soloists. Conductor: André. Overture, "Tutti in Maschera" (Pedrotti). Songs. La cinquantaine (Gabriel-Marie). Songs. Overture, "Boccaccio" (Suppé). Songs. Waltz Suite, "Der Rosenkavalier" (Strauss). Songs. Tango (Paradis). French March (Ganne). In the interval: News. **10.30**—Adison Dance Band.

PRAGUE (Czechoslovakia)

638 kc/s (470.2 m.); 120 kW. Transmits at intervals from 6.0 a.m. **3.0**—Orchestra. Conductor: Händl. **4.0-4.10**—Exchange; Weather. **4.30**—Variety. **5.40**—For Housewives; Record. **5.50**—For Workers. **6.0**—Records. **6.10**—Markets. **6.20**—German Transmission: Economic Notes; Silesian Songs. **7.0**—News (German). **7.10**—Record; News. **7.25**—See Moravská-Ostrava. **8.5**—Records. **8.25**—See Brno. **9.20**—Medical Talk. **9.35**—Philharmonic Orchestra. Conductor: Smetacek. "Musical Bagatelles." Serenade for Winds (Iša Krejci). Mokrovraty Serenade. (Miroslav Krejci). Polka, Ella (Suk). Souvetská (Suk). Bagatelles for Wind Instruments (Zelinka). **10.15**—News. **10.30**—Records. **10.45-11.0**—News (English).

RADIO-NORMANDIE (France)

1,113 kc/s (269.5 m.); 10 kW. **7.0 a.m.**—Records. **7.20**—News. **7.45**—Records. **7.48**—Racing; Records. **7.53**—Cookery; Records. **8.15**—Dance Music. **8.30**—Songs. **8.45**—Records. **10.0**—Symphony Orchestra. **11.0**—Chansonnettes. **12.0 noon**—Records. **12.40 p.m.**—News. **12.45**—Request. **4.0**—Dance Music. **4.45**—For Children. **5.0**—Dance Music. **5.15**—Songs. **5.30**—Records. **6.0**—For Children. **6.45**—Talk: Vegetables. **7.0**—Request. **8.15**—Chansonnettes. **8.30**—Topical.

8.45—"The Merry Widow"—Operetta (Lehár), from the Casino, Fécamp. Orchestra and Choirs. Conductor: Herbay. 11.0—Records. 12.0 m't.—2.0 a.m. (Wednesday)—Dance Music.

ROME (Italy)

713 kc/s (420.8 m.); 50 kW. Relayed by Naples, 1,104 kc/s (271.7 m.); Milan (No. 2), 1,348 kc/s (222.6 m.); Turin (No. 2), 1,357 kc/s (221.1 m.); and Bari, 1,059 kc/s (283.3 m.). Transmits at intervals from 7.30 a.m. 5.5 p.m.—Poetry Reading. 5.15—Music. 6.0–6.10—Corn Prices. 6.45—Tourist Report; Dopolavoro Notes. 7.0—News in Foreign Languages; Italian Lesson. 8.15—News; Records. 8.30—Announcements; Talk. 8.40—Variety, with Gisella Carmi. Conductor: Lombardo. In the interval: Talk.

10.0—Chamber Music. Brunetti (Pfte.), Manno (Violin), Seveso (Viola), Martorana (Cello), Uccia Cattaneo (Soprano) and Ada Fulloni (Mezzo-Soprano). Quartet (Naprawick). Song Duets: (a) Quando lo stral spezzai (Paisiello), (b) Duet, "Figaro" (Mozart), (c) Guitar (Widor), (d) The Pine and the Palm (Novikov). In the interval: Talk: Alaska. 11.0—News.

SOTTENS (Switzerland)

677 kc/s (443.1 m.); 25 kW. Transmits at intervals from 12.30 p.m. 4.30 p.m.—Radio Suisse Romande Orchestra. Conductor: Echenard. 5.15—Dance Music by the Magnolians, from the Casino, Montbenon. 6.0—Reading. 6.30—Records. French Music. 7.0—Talk: The Landscape. 7.20—Records. Waltz (Mendes). Song of Capri. Two Spanish Songs (De Angelis). Xylophone Solos. 7.40—Talk: The Theatre in Summer. 8.0—Chansonniers. In the interval at 9.20: News. 10.15—Weather.

STOCKHOLM (Sweden)

704 kc/s (426.1 m.); 55 kW. Relayed by Motala, 216 kc/s (1,389 m.); Göteborg, 941 kc/s (318.8 m.); Hörby, 1,131 kc/s (265.3 m.); and Boden, 392 kc/s (765 m.). Transmits at intervals from 7.45 a.m. 5.55—German Talk: Hermann Hesse. 6.15—Records. 7.15—News.

7.30—Folk Songs of Many Lands. Halmstad Choir. Conductor: Körning. 8.0 (from Göteborg)—Talk: J. François Villon. 8.30—Military Band. Conductor: Widner. Overture, "Ruy Blas" (Mendelssohn). Two Dances (Rubinstein). Selection, "The Pearl Fishers" (Bizet). Estudiantina (Waldteufel). Paraphrase on Home sweet Home (Nehl). Piece (Fritzell). Hail to the Spirit of Liberty (Souza). 9.30—Practical Corner. 9.45—News.

10.0–11.0—John Hult (Organ), Ernst Törnqvist (Violin), and Elin Törnqvist from Sundsvall Church. Organ: Chaconne (Buxtehude). Songs: (a) Caro mio ben (Giordani), (b) Amarilli (Callini). Violin: Adagio (Brahms). Organ: Pregiata (Ravanello). Songs: (a) Paradisets blomma (Nordqvist), (b) Du, som är min Herre (Lundvik), (c) Min själ är en blomma (Lundvik). Violin: (a) Nocturne (Dahl), (b) Adagio (Sinding). Organ: March (Delvincourt).

STRASBOURG (France)

859 kc/s (349.2 m.); 35 kW. Transmits at intervals from 10.45 a.m. 6.0 p.m.—Legal Talk in German. 6.15—Topical Talk in German.

6.30—Jean Hazart (Songs) and Lisbeth Eschrich (Pfte.). (a) Allemande and Gavotte (d'Albirt), (b) Pastorale and Caprice (Scarlati). Songs: (a) Trois petits oiseaux (Ravizé), (b) L'imprudent crapaud (Ravizé), (c) Les cloches du soir (Lambotte), (d) L'Angelus (Fourdrain). Pfte.: Romance and Scherzo (Mendelssohn). Songs: (a) Automne (Beydts), (b) Melody (Woodlett), (c) Sur une tombe (Leken), (d) Les reliques, (de la Tombelle). Pfte.: (a) Two Alsatian Waltzes (Erb), (b) Staccato caprice (Vozrich).

7.30—Time; News. 7.45—News in German. 8.0—Report: The Cycle Tour of France. 8.15—News in German. 8.30—See Paris (PTT). 10.30 (approx.)—News.

STUTTGART (Germany)

574 kc/s (522.6 m.); 100 kW. Transmits at intervals from 5.45 a.m. 12.0 noon—See Leipzig. In the interval at 1.0 p.m.: News. 2.0–3.0—See Deutschlandsender. 3.15—For Flower

Lovers. 3.45—For Animal Lovers. 4.0—Heidelberg Municipal Orchestra. 5.0—See Königsberg. 6.30—French. 6.50—Talk: Holidays at Home. 7.0—See Leipzig. 8.0—News. 8.15—See Breslau.

9.0—Station Orchestra. Conductor: Drost. Schimmer (Violin). Sinfonia (J. C. Bach). Violin Concerto in A (Mozart). Excerpts, "The Damnation of Faust" (Berlioz). 10.0—News. 10.30—See Munich.

12.0 m't.—2.0 a.m. (Wednesday)—Schubert Concert. Symphony in E. String Quartet in D minor, Death and the Maiden. The "Unfinished" Symphony.

TOULOUSE (Radio-Toulouse) (France)

913 kc/s (328.6 m.); 60 kW. Transmits at intervals from 8.0 a.m. 7.0—Songs. 7.20—Viennese Orchestra. 7.30—News. 7.45—Songs. 8.5—Duets. 8.15—Light Music. 8.30—Operetta Songs. 9.0—Excerpts, "Rigoletto" (Verdi). 9.35—Operetta Music. 9.45—"Le moulin de la chanson"—Music Hall. 10.20—Argentine Orchestra. 10.30—North African News. 10.45—Hawaiian Guitars. 11.0—Film Songs. 11.15—Dance Music. 11.35—Band. 11.45—Songs. 12.0 m.t.—"Au Caveau de Minuit"—Fantasy. 12.15 a.m. (Wednesday)—News. 12.20–12.30—Viennese Orchestra.

TURIN (No. 1) (Italy)

1,140 kc/s (263.2 m.); 7 kW. Relayed by Milan (No. 1), 814 kc/s (368.6 m.); Genoa, 986 kc/s (304.3 m.); Florence, 610 kc/s (491.8 m.); and Trieste, 1,222 kc/s (245.5 m.).

7.30 a.m.—Gym. 7.45—News. 11.30—Descriptive Music—Limentia Quintet. 12.45 p.m.—News. 1.0—Announcements. 1.5—Ambrosiana Orchestra. Conductor: Culotta. 2.0–2.25—Exchange; Records. 4.40—For Children.

5.5—Malatesta Chamber Orchestra. 6.0—For Farmers; Corn Prices. 6.10–6.20—For Women. 6.45—Tourist Report; Dopolavoro Notes. 7.0—News in Foreign Languages; Italian Lesson. 8.15—News. 8.30—Announcements; Talk.

8.40—"Amore tra i pampini"—Operetta in Three Acts (de Micheli). Conductor: Petralia. In the interval: Film Notes. 11.0—News. 11.10—News (Spanish).

VIENNA (Austria)

592 kc/s (506.8 m.); 100 kW. Relayed by Graz, 886 kc/s (338.6 m.); Innsbruck, 519 kc/s (578 m.); Dornbirn, Klagenfurt, and Linz, 1,294 kc/s (231.8 m.); and Salzburg, 1,348 kc/s (222.6 m.).

Transmits at intervals from 9.10 a.m. 5.00 p.m.—Music of the Emperor Franz Joseph's Time, relayed from the Emperor Franz Joseph Exhibition, Schönbrunn. Vienna Symphony Orchestra. Conductor: Schönherr. 6.15—Talk: Chemical Warfare. 6.35—Talk: The Painted Houses of Krems and Stein. 7.0—News. 7.10—Announcements. 7.30—Talk: Newspapers and the Public.

7.45—Marian Rawicz and Walter Landauer (Pftes.). Slav Dance No. 1 (Dvořák). Italian Caprice (Tchajkovsky). Emperor Waltz (Strauss). Jazz Potpourri (Rawicz-Landauer). Poika, Tritsch-Tratsch (Strauss). 8.15—Opera Music. Vienna Symphony Orchestra. Conductor: Audieth. Dora With (Contralto), Ernő Garay (Tenor) and Georg Punschart (Bass). Overture and Duet, "The Bartered Bride" (Smetana). Aria, "Il Trovatore" (Verdi). Aria, "L'Africaine" (Meyerbeer). Duet, "Mignon" (Thomas). Overture and Aria, "Figaro" (Mozart). Aria and Duet, "Il Trovatore" (Verdi). Prelude and Prayer, "Lohengrin" (Wagner). Duet and Overture, "Der Waffenschmied" (Lortzing). 10.0—News.

10.10—Brahms Recital. Julius Isserlis (Pfte.). Two Caprices. Four Intermezzi. Part II, Variations on a Paganini Theme.

10.50—Talk: The Salzburg Festival. 11.0—Records of Vienna State Opera Singers. Piccaver, Aria, "The Girl of the Golden West" (Puccini). Lotte Lehmann: Aria, "Lohengrin" (Wagner). Schipper Valentine's Death from "Faust" (Gounod). Marie Jeritza: Aria, "Die tote Stadt" (Korngold). Rosette Anday: Aria, "Samson

TUESDAY (July 23)

and Delilah" (Saint-Saëns). Kolo-man von Pataky: Aria, "La Traviata" (Verdi). Leo Slezak: Aria, "Othello" (Verdi). Hans Duhan: Der Wanderer (Schubert). Elisabeth Schumann: Song, "Die Fledermaus" (Strauss).

11.35—Talk in Esperanto: Sports in Austria. 11.45—Announcements. 12.0 m't.—1.0 a.m. (Wednesday)—Viennese Music. Bert Silving Quartet. Bert Silving and Karl Scherry (Violins). Emmerich Gara (Cello), and Rudolf Wallner (Pfte.).

WARSAW (Poland)

224 kc/s (1,339 m.); 120 kW. Relayed by Katowice, 758 kc/s (395.8 m.); Lwów, 795 kc/s (377.4 m.); Poznan, 868 kc/s (345.6 m.); and Wilno, 536 kc/s (559.7 m.).

Transmits at intervals from 6.30 a.m. 12.15 p.m.—Jazz Records. 1.0—For Housewives. 1.5—Grossman Ensemble. 1.30—Exchange. 3.15—Exchange; News. 3.30—Pokrowski Banjo Orchestra. 4.0—Financial Letter-box. 4.15—Records. 4.30—Olga Lada (Songs). 4.50—Humorous Prose.

5.0—Station Light Orchestra. Conductor: Gorzyński. 6.0 (from Wilno)—Talk: Astronomy. 6.10—Recitations. 6.15—Community Singing from Cracow. 6.30—Letter-box. 6.40—Literary and Art Review. 6.45—Records: Film Music. 7.5—Announcements. 7.30—Burkath (Pfte.). Excerpts, Suite in E (Bach-Melartin). Gavotte (Henriques). Procession (Class). Chanson triste (Burkath). Auprés du piano (Burkath). Romance (Schumann). The Prophet Bird (Schumann). 7.50—Topical. 8.0—For Farmers.

8.10—Small Station Orchestra. Conductor: Gorzyński. 8.45—News. 8.55—Poland Yesterday and To-day. 9.0—"The Fiddler"—Operetta (Offenbach). Conductor: Gorzyński. 10.0—Station Orchestra. Conductor: Oziminski. Chinese Suite (Wasilenko). Ballet Music, "Harun al Raschid" (Lutoslawski). 10.30—Sports. 10.40—Dance Records.

NATIONAL

For Time Signals, see Monday. 10.15 a.m. (Droitwich)—Service. 10.30 (Droitwich)—Weather Forecast. 10.45—"Food to Music." Philip Thornton. 11.0—Records. 11.30—Cinema Organ. 12.15 p.m.—Charles Manning and his Orchestra. 1.15—Organ (Harold Rhodes). 2.0—The Scottish Studio Orchestra. 2.50—Israel Hoffman (Pianoforte). 3.15—Bournemouth Municipal Orchestra. Conductor, Richard Austin. Norena Semino (Cello). Italian Symphony (Mendelssohn). Wand of Youth (Suite No. 2) (Elgar). Concerto (Schumann). La Valse (Ravel). 4.45—Records. 5.15—The BBC Dance Orchestra. 6.0—"The First News." 6.30 (Droitwich)—Reginald King and his Orchestra. Carnival (Guirand). A June Night (Hurst). Fairy Pipers (Brewer). Reverie du Soir, Bacchanale (Saint-Saëns). Adoration (Redman). Mannin Veen (Haydn Wood). 7.15 (Droitwich)—Variety, relayed from Birkenhead. 8.0—Lilias Mackinnon (Pianoforte). 8.30—First Performance of "City of Music," a Potpourri of Viennese Music, by Julius Burger, Joan Coxon (Soprano); Jan van der Gucht (Tenor); Thorpe Bates (Baritone); Chorus and Orchestra. 9.30—"The Second News." 9.50—Trans-Atlantic Bulletin: Raymond Swing (from America). 10.5—American Light Music: Leslie Bridgewater Quintet. Mignon Nevada (Soprano). Quintet: Valse Lucille (Suite Mélodique) (Friml); Violets, Lily of the Valley, Dafodils, (Ballet of the Flowers) (Hadley); Canzonetta (Herbert). Mignon Nevada: Beneath a Weeping Willow Tree (Hopkinson); Monody (van Hagen); Give Me thy Heart (Hopkinson). Quintet: Shadow Dance, Forgotten Fairy Tales (MacDowell). Mignon Nevada: Ave Maria, Willow, Willow (Carr); Dry Those Eyes (Pelissier). Quintet: Little Dancer (Carpenater); Sob Sister (Grofé); Similitude (Sims). 11.0–12.0 (Droitwich)—Sydney Kyte. 11.0–11.45 (London)—Television.

REGIONAL

For Time Signals, see Monday. 10.15–10.45 a.m. (except Midland)—Droitwich. 10.45—Jack Martin and his Hotel Majestic Orchestra. 11.45—Records. 12.30 p.m.—Alfredo Campoli and his Orchestra. 1.30—Miscellaneous Records. 2.15—Birmingham Hippodrome Orchestra. 3.15—Nobert Wethmar Trio. Dorothy Donaldson (Mezzo-Soprano). 4.15—Northampton Theatre Orchestra. 5.15—The Children's Hour. 6.0—"The First News." 6.30–8.0 (ex. Midland; Western from 7.0)—Droitwich. 6.30 (Western)—Relay from the Show Ground of the Royal Welsh Agricultural Show, Haverfordwest. 8.0 (Regional, Midland, Northern)—"The Music of Mussorgsky." A Talk by Leslie Heward, with Roy Henderson (Baritone), and Midland Orchestra. 8.0 (Scottish)—Annabelle Currie (Soprano); Gaelic Songs. 8.0 (Western)—Variety from Weston-super-Mare. 8.0 (N. Ireland)—Records. 8.20 (Scottish)—The Muckle Toun o' the Langholm Common Riding Concert, relayed from Buccleuch Hall. 8.45 (Regional)—May Sabeston Walker (Soprano); Harry Isaacs (Pfte.). 8.45 (Midland)—"A Press Correspondent in Troubled Lands." Patrick Maitland. 8.45 (Northern)—Topical Talk. 8.45 (N. Ireland)—N. Ireland Orchestra. Rispah Goodacre (Contralto). 8.50 (Scottish)—Summer Poetry. 9.0 (Midland, Scottish)—Harry Gordon and his Company, relayed from Aberdeen. 9.0 (Western)—Dance Records. 9.5 (Regional, Northern)—Buxton Spa Orchestra: Albert Keteibey Concert, conducted by the Composer. 9.15 (Western)—Bristol Choral Society Choir. Henry Wendon (Tenor). 9.40 (Midland)—Records. 9.40 (Scottish)—Piping and Fiddling. 10.0—News Summary; Sports Bulletin. 10.20—Sydney Kyte and his Band. 10.45—Dance Records. 11.0–12.0 (ex. Midland)—Sydney Kyte. 11.0–11.45 (Midland)—Television.

WEDNESDAY July 24

SYMPHONY CONCERTS

P.M. 3.15 National: Bournemouth Orchestra. 9.0 Hamburg: Mozart programme. 9.30 Rome: From the Basilica di Massenzio (Mascagni). LIGHT CONCERTS 12.15 Radio-Paris: Orchestra, songs. 3.30 Kalundborg: Radio orchestra. 4.0 Deutschlandsender: Band concert. 5.0 Frankfurt and most German Stations: Light music. 5.0 Munich: Orchestra. 5.20 Warsaw: Light orchestra. 6.30 Leipzig: Variety concert. 7.0 Athlone: Band concert. 7.0 Breslau: Variety concert. 7.0 Cologne: Folk music. 7.0 Frankfurt, etc.: Popular orchestral. 7.0 Munich: Orchestra, songs. 7.40 Prague: Orchestra, arias. 7.45 Huizen: Orchestra, violin. 8.0 Brussels 1, Sottens: Orchestra and choir. 8.0 Oslo: Station orchestra. 8.25 Kalundborg: Danish ballet music. 8.30 Eiffel Tower: Vichy Casino relay. 8.30 Strasbourg: Band, from Metz. 8.45 Frankfurt, etc.: Variety concert. 8.45 Stuttgart: Song, waltz, duet. 9.5 Bucharest: Saion orchestra. 9.5 Regional: Keteibey programme. 9.15 Brussels 1: Radio orchestra, songs. 9.40 Hilversum: Popular orchestral. 10.5 National: American light music. 10.20 Warsaw: Light orchestra. 10.30 Cologne, etc.: Serenade and dance music. 10.30 Leipzig: Telemann, Bach. 11.30 Budapest 1: Cigány band. OPERA 8.40 Turin: "Anna Karenina" (Robbiani). CHAMBER MUSIC 4.0 Stuttgart: Vocal and instrumental. 6.30 Brussels 1: Pfte. Quartet Op. 25 (Brahms).

8.0 Stockholm: Violin, pfte. (Handel). 8.30 Paris (PTT): Vocal and instrumental. 9.5 Poste Parisien: Pfte. Quintet (Franck). 9.40 Warsaw: Serenade (trio) (Tansman). 10.35 Budapest 1: Violin, pfte. sonatas. 12.0 Stuttgart, Frankfurt: Winds, harpsichord. RECITALS 5.0 Brussels 1: Organ (Exhibition). 5.0 Warsaw: Cello. 5.30 Brussels 2: Feremans programme. 6.15 Brussels 2: Harp: 7.0, songs. 6.30 Strasbourg: Cello and pianoforte. 7.10 Königsberg: Organ. 7.30 Warsaw: Songs. 8.0 Brussels 2: Pianoforte, songs. 8.15 Bucharest: Song, pianoforte. 9.0 Vienna: In Memory of Dollfus; Addresses and sacred music. 9.0 Warsaw, Budapest 1, Breslau: Chopin. 9.15 Kalundborg: Songs (Grieg, Heise). 9.30 Breslau: Girls' choir. 9.45 Paris (PTT): Folk music. 9.50 Prague: Pfte. (modern English). 10.30 Vienna: The St. Florian Organ. PLAYS 8.15 Stockholm: "The First Mrs. Fraser." 8.40 Rome: "La giara" (Pirandello). 8.45 Radio-Normandie: "La Dame de Vittel." 8.45 Radio-Paris: "Flipote" (Lemaître). 9.10 Berlin: "Farmer Wittow." 9.10 Beromünster: "The Bottle Imp" (R.L.S.) TALK 7.30 Beromünster: "Chinese drama in New York." DANCE MUSIC 10.0 Stockholm; 10.10, Brussels 2; 10.30, Strasbourg; 10.45, Oslo, Regional; 10.50, Radio-Paris; 11.0, Deutschlandsender, Kalundborg, Munich, National; 12.0, Radio-Normandie. MISCELLANEOUS 7.30 Stockholm: Cabaret. 8.30 Brno, Prague: Theatrical Party.

WEDNESDAY (July 24)

Hours of Transmission in British Summer Time.

ATHLONE (Ireland)

565 kc/s (531 m.); 60 kW. Relayed by Dublin, 1,348 kc/s (222.6 m.), and Cork, 1,240 kc/s (241.9 m.). 1.30-2.30 p.m.—Records. 6.0—For Children. 6.45—News. 7.0—Glasgow St. Francis' Prize Silver Band. 7.40—Discussion: Films and Theatres. 8.0—P. J. O'Toole (Songs). 8.15—Mrs. Miley (Pfte.); Thompson (Violin). 8.45—Orchestral Records. 9.15—Talk: Gaels and the Wireless. 9.30—Grennon (Songs). 9.45—What happened to-day. 10.0—Variety. 10.30-11.0—Ceilidhe Music. Siamsa Gaedhel Band.

BERLIN (Germany)

841 kc/s (356.7 m.); 100 kW. Transmits at intervals from 6.0 a.m. 12.0 noon—See Breslau. In the interval at 1.0 p.m.: Midday Echoes. 2.0—News. 2.15—Small Station Orchestra. Conductor: Steiner. 3.0-3.30—Exchange; Markets. 4.0—"Far from the madding Crowd"—Sequence (Brink). 4.30—A Cabaret about Husbands (Girgenson), with Music. 5.0—See Frankfurt. 6.0—Concert. Part I—Community Singing (on Records). Part II—Classical Vocal and Instrumental Music. 7.0—A Visit to Berlin Sports Grounds. 7.20—Dance Music by the Henze Mandoline Quartet. 7.40—Evening Echoes. 8.0—News. 8.15—See Königsberg. 8.45—Johann Strauss Records. 9.10—"Farmer Christian Wittow"—Play (Hershe). 10.0—News. 10.30-12.0 m.t.—See Cologne.

BEROMÜNSTER

(Switzerland)

556 kc/s (539.6 m.); 100 kW. Relayed by Basle and Berne, 1,375 kc/s (218.2 m.). 12.0 noon (from Berne)—Band Records. 12.29 p.m.—News. 12.40 (from Berne)—Schubert Records. 1.25—Exchange. 4.0-6.30—Programme from Berne. 4.0—Talk: Summer Fruit and Drinks. 4.30—Operetta Music. Small Radio Orchestra. 5.0—Bernese Humour. 5.15—Humour in Chamber Music. Dora Garraux (Soprano), Hegi (Bari-tone), Sibiglia (Violin). 5.45—Mozart Records. 6.0—For Children. 6.30—Close—Programme from Basle. 6.30—Lecture-Recital: Handel's Pfte. Music. 7.0—Markets. 7.10—Records: Symphonic Jazz. 7.30—New York's Chinese Theatre Report with Records. 8.0—Foxtrots. Stirnimann (Pfte.) and the Small Radio Orchestra. 9.0—News. 9.10—"The Bottle Imp"—Play after R.L.S. (Mack). 9.55-10.15—Records: Light Music.

BORDEAUX-LAFAYETTE

(France)

1,077 kc/s (278.6 m.); 30 kW. Transmits at intervals from 8.0 a.m. 8.0—Commentary on the Cycle Tour of France—Bordeaux. 8.15—For Farmers. 8.30—"Pytheas"—Three-Act Comedy (Brauquier). After the Play, News; Dance Music.

BRATISLAVA

(Czechoslovakia)

1,004 kc/s (298.8 m.); 13.5 kW. Transmits at intervals from 6.0 a.m. 6.35 p.m.—Talk. 6.45—Records. 7.0—See Prague. 8.30—See Brno. 9.50—To be announced. 10.15—See Prague. 10.30—News (Hungarian). 10.45-11.0—Records.

BRESLAU (Germany)

950 kc/s (315.8 m.); 100 kW. Relayed by Gleiwitz, 1,231 kc/s (243.7 m.). Transmits at intervals from 5.0 a.m. 12.0 noon—Small Station Orchestra and Silesian Symphony Orchestra. Conductors: Rischka and Wappaus. 2.10—Exchange; Announcements. 2.45—Markets. 3.10—Reading. 3.30—For Children. 4.0—Talk. 4.20—Eugenics. 4.40—A Story (Baur). 5.0—See Frankfurt. 6.30—Talk: The Industrial Revival. 6.40—Do you know...? 6.50—Announcements. 7.0 (from Gleiwitz)—Upper Silesian Schrammel Quartet, Lipp and Billner (Zither Duets), the Ortelys (Xylophone), Magdalena Bartusch, Eduard Przbiliski and Eibisch (Folk Songs). 8.0—News. 8.15—See Königsberg. 8.45—Topical Review. 9.0—See Warsaw. 9.30—Songs by a Girls' Choir. 10.0—News.

10.30-12.0 m.t.—Station Dance Band and Hilde Sterk (Soprano).

BRNO (Czechoslovakia)

922 kc/s (325.4 m.); 32 kW. Transmits at intervals from 6.0 a.m. 6.20 p.m.—Records. 6.30—News. 6.35—For Workers. 6.45—Records. 7.0—See Prague. 8.30—Theatrical Party. 9.50-11.0—See Prague.

BRUSSELS (No. 1) (Belgium)

620 kc/s (483.9 m.); 15 kW. 12.0 noon—Records. 12.30 p.m.—Radio Orchestra. Conductor: Gason. 1.0—News. 1.10—Chabrier. Radio Orchestra. Conductor: Gason. 1.30-2.0—Records. 4.55—Announcements. 5.0—Desmet (Organ) from the Exhibition. 5.30—Records. 5.45—For Children. 6.20—Talk: Religious Orders and The Blessed Sacrament. 6.30—Pianoforte Quartet in G minor (Brahms). 7.0—Labour Review; Announcements. 7.15—Records: Negro Spirituals. Old Folks at home (Bruce). Deep river (Burdette). Poor old Joe (Bruce). Heav'n, Heav'n (Burdette). 7.30—For Ex-Servicemen; Medical Talk. 8.0—Songs of the Borinage. Borin Choir; Radio Orchestra. Conductor: Gason. March, "Myrtis" (Daneau). Choir: (a) Sérénade d'hiver (Saint-Saëns), (b) Elans du cœur (Weitys). Commemoration March (Gilsen). Choir: Hymne de paix (Tilman). March, Klokke Roeland (Tinell). Choir: Invoocation (Jouret). Charleroi Songs (Wangermée). 9.0—Talk. 9.15—Radio Orchestra. Conductor: Gason. Bracony (Songs). Alla turca (Beethoven). Aria, "Phoebus and Pan" (Bach). Scherzo, "A Midsummer Night's Dream" (Mendelssohn). Aria, "St. Paul" (Mendelssohn). Hungarian March in E flat (Schubert). Aria, "The Seasons" (Haydn). Turkish March (Mozart). Recitative, "Tannhäuser" (Wagner). 10.0—News. 10.10—Request Records. 10.55-11.0—Christus vincit (Liszt).

BRUSSELS (No. 2) (Belgium)

932 kc/s (321.9 m.); 15 kW. Programme in Flemish. 12.0 noon - 2.0 p.m. — Records: "Tannhäuser"—Opera (Wagner). In the interval at 1.0 p.m.: News. 4.55—Announcements. 5.0—Dance Records. 5.30—Gaston Feremans Songs by Borgers (Tenor), the Composer accompanying. Herfst. Parabel. Klacht. Het avond uit al de wolken. Part III, "Johannes de Dooper." 6.0—Talk: The Censuring of the Press and Books. 6.15—Mlle. Rocher (Harp). 6.45—Records: Lyric Suite (Grieg). 7.0—Paula de Backer (Songs). Part I: Mahler. Rheinlegendchen. Wo die schönen Trompeten blasen. Wer hat dies Liedlein erdacht? Lied der Verfolgten im Turm. Part II, Reger. Mein Traum. Wenn die Linde blüht. Maria Wiegenlied. 7.30—For Gardeners. 8.0—Mlle. Moldawsky (Pfte.). Prelude (Glière). Idyll (Médner). votte (Prokofiev). Caucasian Dance Lesghinka (Liaupunov). Corova (Albeniz). Fire Dance (Fall). In the interval at 8.15: Schubert Songs by Frederick Anspach (Tenor). 8.45—Cauwenberg (Recitations). 9.0—Records. 10.0—News. 10.10-11.0—De Kers Dance Band.

BUCHAREST (Romania)

823 kc/s (364.5 m.); 12 kW. Transmits at intervals from 12.0 noon. 6.0 p.m.—News. 6.15—Sandu Marcou Orchestra. 7.0—Talk. 7.20—Records: Italian Music. 7.50—Technical Letter Box. 8.0—Talk. 8.15—Grofman (Songs) and Miletin-canu (Pfte.). Arias, "Ernani" and "Don Carlos" (Verdi). Pfte.: (a) Adagio (Mozart), (b) Ecossaise and Andante (Beethoven). Aria and Monologue, "Boris Godunov" (Mussorgsky). Pfte.: (a) Aria (Liszt), (b) Rhapsody No. 3 (Liszt). Arias, "Lakmé" (Delibes). "Tales of Hoffmann" (Offenbach). 9.5—Salon Orchestra. Spanish Comedy Overture (Keler-Bela). Mendelssohn Potpourri (Urbach). Potpourri (Kozmak). Tango (Raszat). In the interval at 9.30: News. 10.15—News in French and German. 10.30—Dance Music.

BUDAPEST (No. 1) (Hungary)

546 kc/s (549.5 m.); 120 kW. 10.20 a.m.—Talks. 12.5 p.m.—Lajos Rácz Cigány Band. 12.30—News. 1.20—Weather. 1.30—Vocal Quintet. 2.40—Hints for Housewives. 4.10—Talk. 4.45—Weather.

5.0—Opera Orchestra. Conductor: Fridl. 6.15—Talk. 6.45—Kalmár-Balázs Quintet. 7.20—Dialogue. 8.10—Records. 9.0—See Warsaw. 9.35—News. 9.55—Erszö Jazz Band. 10.35—Jenő Takács (Pfte.) and Ede Zathureczky (Violin). Sonata in C (Mozart). Sonata in A (Brahms). Oriental Rhapsody (Takács). 11.30—Béla Kiss Cigány Band from the Gellért Hotel. 12.5 a.m. (Thursday)—News.

BUDAPEST (No. 2) (Hungary)

359.5 kc/s (834.5 m.); 20 kW. 6.5 p.m.—Maria Budanovits (Songs). 6.50—Talk. 7.25—Sárközi Cigány Band. 8.45—News.

COLOGNE (Germany)

658 kc/s (455.9 m.); 100 kW. Transmits at intervals from 6.0 a.m. 12.0 noon—See Breslau. 2.0—Announcements. 2.15—Variety from Deutschlandsender. 2.45—Genealogy. 3.0—Songs. 3.30—Exchange. 3.50—Talk. 4.0—Classical Music. Henry Schulte-Schmitt (Contralto), Gertrud Maria Kisselbach (Violin) and Haas (Harp-sichord). 4.30—Book Review and Poetry Reading. 5.0—See Frankfurt. 6.30—Talk: Racial Policy is a Peace Policy. 6.45 Talk: Holidays at Home. 7.0—Folk Music. 7.50—A Snapshot. 8.0—News. 8.15—See Königsberg. 8.45—"To Horse! To Horse!"—Military Programme. 10.0—News. 10.30-12.0 m.t.—Bonn Municipal Orchestra, Small Station Orchestra and Cologne Pfte. Trio. Conductors: Knapstein and Eysoldt. Overture, "Donna Diana" (Reznicek). Waltz, "The Arabian Nights" (Strauss). Two Dances. Suite Campestre (Scassola). First Dance Suite for Three Pftes. (Kowalski). Wedding Waltz (Dohnányi). March of the Dwarfs (Grieg). Two Dances Second Polonaise (Liszt). March of the Caucasian Chief (Ippolitov-Ivanov). Two Dances. Freundschaftsmarsch (Zeh).

DEUTSCHLANDSENDER

(Germany)

191 kc/s (1,571 m.); 60 kW. Transmits at intervals from 5.55 a.m. 12.0 noon—Light Music. 1.45—News. 2.0—Variety. 3.0—Weather; Exchange; Announcements. 3.15—Records. 4.0—Band Concert from the Spreegarten. 5.30—Wireless Hints. 5.45—Talk: Foreign Ships in German Docks. 6.0—Folk Songs and Ballads by Johanna Augermann and Theodor Schlott. 6.30—Who's Who? 6.45—Talk: The Grand Prix of Germany at the Nürnberg Ring. 6.55—Poem; Weather. 7.0—See Frankfurt. 7.45—News. 8.0—Motto; News. 8.15—See Königsberg. 10.0—News. 10.30—Serenade. Köpke (Xylophone) and Jäger (Neo-Bechstein Pfte.). 10.45—Weather. 11.0-12.0 m.t.—Robert Gaden Dance Band.

FRANKFURT (Germany)

1,195 kc/s (251 m.); 25 kW. Relayed by Cassel, Coblenz, Freiburg, Kaiserslautern and Trier, 1,195 kc/s (251 m.). Transmits at intervals from 6.0 a.m. 12.0 noon—See Breslau. In the interval at 1.0 p.m.: News. 2.0—News. 2.15—Industrial Reports: (a) Matches and Spirits, (b) Situations wanted. 2.30-2.45—Exchange; Weather. 3.15 (from Freiburg)—"The Hohentwiel"—Sequence (Künzig). 4.0—Grete Krüger (Soprano), Han-nappel (Baritone), Finken (Pfte.) and Klehammer (Guitar). 4.30—Talk: German Wine. 5.0—Franz Hauck Band. Schmitt-Walter (Baritone), the "Sorgenbrecher" (Song Hits), Cassedanne (Violin), Emil Franz (Xylophone) and Kullmann (Pfte.). 6.30—Topical Talk. 6.45—Two Talks. 6.55—Announcements. 7.0—Orchestra. Conductor: Schmit-tenbecher. Overture, "The King's Lieutenant" (Titt). Two Miniatures (Rust). Waltz, Dame in braun (Robrecht). Cannibals' Dance (Bece). Witches' Procession (Bece). Neapolitan Suite No. 10 (de Micheli). 7.40—For Farmers. 7.50—Topical Talk. 8.0—News. 8.15—See Königsberg. 8.45—Variety (arr. Holz). Franz Hauck Band, Grüters and Zehlen (Compères), Schmid-Berikoven (Tenor), Lilli Schönborn (Soprano), Two Vegas (Banjos) and Cassedanne (Violin). 10.0—News. 10.20—Talk: The German Grand Prix Race at the Nürburgring.

10.30—See Cologne. 12.0 m.t. 2.0 a.m. (Thursday)—See Stuttgart.

HAMBURG (Germany)

904 kc/s (331.9 m.); 100 kW. Relayed by Bremen, Flensburg, Hanover, Magdeburg, and Stettin, 1,300 kc/s (225.6 m.). Transmits at intervals from 5.40 a.m. 12.0 noon—Announcements. 12.10 p.m.—Concert from Breslau. In the interval at 1.0: Announcements. 2.0—News. 2.20—Music. 3.0—Exchange. 3.30—Brazilian Exchange. 3.40—Shipping. 4.0—Dialect Programme: Reading; Songs; and Pfte. 4.40—Story (Heinecke). 5.0—See Frankfurt. 6.30—Things worth knowing. 6.40—Talk for Farmers. 6.50—Announcements. 7.0—See Stuttgart. 8.0—Announcements. 8.15—See Königsberg. 8.45—Talk: Poultry-keeping. 9.0—Mozart. Station Orchestra. Conductor: Seidler. Hamann (Violin). Violin Concerto in B flat. Haffner Serenade in D. 10.0—News. 10.25—Music. 11.0-12.0 m.t.—Concert from Cologne.

HILVERSUM (Holland)

160 kc/s (1,875 m.). Transmitted on Kootwijk on 120 kW. 7.40-9.40 a.m.—Programme of the Workers' Radio Society (V.A.R.A.). 7.40—Records. 9.40—Religious Programme of the Liberal Protestant Radio Society. Conductor: Wins. 12.40—Records. 12.55—Walis Orchestra. 1.40—Records. 2.10—Steyn (Organ). 2.40—For Children. 5.10—V.A.R.A. Orchestra. Conductor: de Groot. In the interval at 5.40—Recitations. 6.25—Sports. 6.40—Records. 6.55—Talk. 7.10—Emeljanoff (Songs). 7.30—Talk. 7.40—S O S Announcements. 7.43—News. 8.55—Records; Steyn (Organ). 8.40—"Two Living and One Dead"—Play after Christensen (Niennhuys). 9.40—V.A.R.A. Orchestra. Conductor: de Groot. Overture, "Robespierre" (Litloff). Andante cantabile (Tchaikovsky). Kleiner Wiener Marsch (Kreiser). The Traveller's Song (Paderewski). Song (Paderewski). Two Spanish Dances (Moszkowski). Selection, "Louise" (Charpentier). 10.40-11.40—Records; Rossican (Pfte.).

HUIZEN (Holland)

995 kc/s (301.5 m.); 20 kW. Programme of the Christian Radio Society (N.C.R.V.). 7.40 a.m.—Bible Reading; Meditation. 7.55-9.10—Records. 10.10—Religious Programme. "Excelsior" 10.40—Barndrecht. "Excelsior" Choir. Conductor: Linnemann. 11.40—Police Messages. 11.55—Records. 12.20 p.m.—Report: The Open-air Meeting of Frisian Protestant Boys' and Girls' Associations. 1.40—Parker (Organ). 2.40-3.25—Bible Reading; Records. 3.40—Rie de Geus (Soprano). 4.40—For Children. 5.40—Records. 6.10—To be announced. 6.40—Police Messages; Church Notes. 6.55—Report. 7.10—For Farmers. 7.40—News. 7.45—N.C.R.V. Orchestra. Conductor: v. d. Hurk. Jo Hekker (Violin). Los Banderilleros (Vol-patti). Overture, "Fra Diavolo" (Auber). Czardas (Monti). March Potpourri (Morena). Song (Schram-mel). Tales from the Vienna Woods (Strauss). Petite suite (de Micheli). Overture, "The Magic Flute" (Mozart). Violin Concerto in A (Mozart). Impressions d'Italie (Charpentier). In the intervals at 8.40: Talk and at 9.40: News. 10.10-11.10—Records.

KALUNDBORG (Denmark)

238 kc/s (1,261 m.); 60 kW. Relayed by Copenhagen, 1,176 kc/s (255.1 m.). Transmits at intervals from 7.0 a.m. 12.0 noon-2.0 p.m.—Thyregod String Ensemble from the Angleterre. 3.30—Radio Orchestra. Conductor: Mahler. In the interval: Reading. 5.30—Exchange; Markets. 6.15—Records. 6.45—Announcements. 7.0—News. 7.30—For Farmers. 8.0—Auber. Radio Orchestra. Conductor: Gröndahl. Overture, "Le maçon" (Auber). Selection, "Fra Diavolo." Tarantella, "Mansiello." 8.25—Galeotti, the Founder of Danish Ballet. Radio Orchestra. Conductor: Gröndahl. Introductory Talk. Overture, "Sigrid" (Schall). Dance, "Amors og Balletmesterens Luner" (Lolle). Overture, "Fanden er løs" (Schall). Gothic Minuet, "Sigrid" (Schall). Excerpts, "Romeo and Juliet"

(Schall). Finale, "Amors og Balletmesterens Luner" (Lolle). 9.15—Grieg and Heise. Karen Kaysen (Songs). Part I, Grieg. Med en primula veris. To Spring, A Dream. Part II, Heise. Hvor trinder nu min Stjerne. Aften paa Loggien. 9.35—Talk: Currency.

10.5—Records: Frederic Lamond: Concert Etude in D flat (Liszt). Bronislaw Gimpel: Prelude and Allegro (Paganini-Kreisler). 10.15—News. 10.30—Mandoline and Guitar Orchestra. Les Voila (Macciocchi). A Swiss Morning (Krug). Rimembranza d'amore (Manucelli). Two Italian Folk Songs. Aubade printanière (Lacombe). Spanish Ballad, Juanita. Mandoline Gallop (Bröndberg). 11.0-12.30 a.m. (Thursday)—Twork Dance Band from the National Scale.

KÖNIGSBERG (Germany)

1,031 kc/s (291 m.); 60 kW. Relayed by Danzig, 1,303 kc/s (230.2 m.). Transmits at intervals from 4.58 a.m. 12.0 noon—See Breslau. In the interval at 1.0 p.m.: Time; News. 2.0—News. 2.15—Announcements. 2.45—Reading (Nowakowsky). 3.0—Markets; Exchange. 3.10—Household Hints. 3.20—Reading for Girls. 3.45—Book Review. 4.0—Hans Pfitzner and Paul Graener Songs by Hanna Richtsmeier (Soprano). 4.30—Talk: Camp Cooking. 5.0—See Frankfurt. 6.30—Markets. 6.40—Talk: Holidays at Home. 6.50—Topical Report. 7.0—News. 7.10—Callaerts Recital by Oertel (Organ). Canzono. Sortie sciennelle. Short Fantasia. Finale. 7.30—Talk and Reading (Augustiny). 8.0—News. 8.15—Transmission for all German Stations: Patriotic Programme for Young People. 8.45—See Frankfurt. 10.0—News. 10.20—Talk: Soldiers Sports. 10.35-12.0 m.t.—Concert from Cologne.

LEIPZIG (Germany)

785 kc/s (382.2 m.); 120 kW. Relayed by Dresden, 1,285 kc/s (233.5 m.). Transmits at intervals from 5.50 a.m. 12.0 noon (from Dresden)—Police Band. 1.0 p.m.—News. 1.15—Freund-dorfer Instrumental Quartet. Mirz and Mandl Dreher (Yodels). 2.0—News; Exchange. 2.15—Variety from Deutschlandsender. 3.0-3.15 Art Review. 3.30—See Stuttgart. 4.0—Exchange. 4.20—Concert from Deutschlandsender. 4.50—Weather; Exchange; Brazilian Exchange. 5.0—See Frankfurt. 6.0—Talk: Germany and British India. 6.20—Topical Talk. 6.30—Variety by the Heinz Fuchs Band. Conductor: Havik. Gerti Dallwisch, Fred Kurt and Hugo Fiedler. 8.0—News. 8.15—See Königsberg. 8.45—See Frankfurt. 10.0—News. 10.30—Leipzig Symphony Orchestra. Conductor: Weisbach. Fritz Clausen (Soprano) and Alois Heid-rieh (Oboe). Oboe Concerto (Telemann). Cantata, Weichet nur, betrübte Schatten (Bach). 11.0-12.0 m.t.—Concert from Cologne.

LISBON (Portugal)

629 kc/s (476.9 m.); 20 kW. Transmits at intervals from 12.0 noon. 7.0 p.m.—Music. 7.55—News; Portuguese Music. 8.25—Exchange. 8.30—Music-Hall. 8.50—Talk. 9.0—Orchestra. In the interval at 9.30: News. 10.0—Political Notes; Classical Music. 10.30—News; Folk Music. 11.0—Dance Music.

LYONS (La Doua) (France)

648 kc/s (463 m.); 100 kW. Transmits at intervals from 7.15 a.m. 8.0 p.m.—Cycle Tour of France. 8.15—Records. 8.30—Hahn—Grieg. Conductor: Novina. After the Concert, News.

MADRID (EAJT) (Spain)

1,095 kc/s (274 m.); 7 kW. Transmits at intervals from 9.0 a.m. 8.15 p.m.—Interludes by Ramón Gómez de la Serna. 8.30 (approx.)—Station Sextet. In the interval at 9.15: News. 10.0—Talk: Educational Films. 10.15—Angel Ferrara and Vicente Gómez (Guitar Duets). 11.0—Chimes: News. 11.15 (approx.)—Records: Act II, "Faust"—Opera (Gounod). 12.15 a.m. (Thursday)—Dance Music. 12.45—News. 1.0—Chimes.

MONTE CENERI (Switzerland)

1,167 kc/s (257.1 m.); 15 kW. Transmits at intervals from 12.0 noon. 4.30-6.0 p.m.—See Beromünster. 7.30—Neapolitan Song Records. 7.45—News. 8.0—To be announced. 10.0—Weather.

10.5-10.30—Records. Jungle Drums (Ketebe). Orientalia (Rapato). The Vision of Fuji San (Ketebe). In a Chinese Temple Garden (Ketebe). Ishmael (Jalowitz-Lotter). Dance of the Odalisk (Sandro). Chinese Street Serenade (Sieley).

MORAVSKÁ-OSTRAVA (Czechoslovakia)
1,113 kc/s (267.5 m.); 11.2 kW.
Transmits at intervals from 6.0 a.m. 6.0 p.m.—Local News. 6.5—Baltarian Poetry and Songs. 6.40—For Workers. 6.55—Records. 7.0—See Prague. 8.30—See Brno. 9.50—See Prague. 10.45-11.0—Records.

MOSCOW (No. 1) (Russia)
174 kc/s (1,724 m.); 500 kW.
Transmits at intervals from 3.45 a.m. 7.0 p.m.—Vocal and Instrumental. 9.0—Tchekov, Programme in Czech. 10.5—English Talk and Soviet Folk Music; Sports. 11.5—German Talk; Women in the Great War.

MUNICH (Germany)
740 kc/s (405.4 m.); 100 kW.
Relayed by Nürnberg, 1,267 kc/s (236.8 m.).
Transmits at intervals from 6.0 a.m. 12.0 noon—Station Orchestra. Conductor: Kloss. In the interval at 1.0 p.m.: News. 2.0-2.20—News; Exchange. 3.0—Talk: Würzburg in Franconia. 3.20—Sonata in D, No. 2 (Beethoven), by Troibner ("Cello") and Staab (Pfte.). 3.40—"A Mountain Climb"—Sequence. 4.0—Announcements. 4.10—Grosch (Pfte.). Fantasia in F minor (Chopin). Polonaise (Weber). 4.30—Play for Children (Amann). 5.0—Station Orchestra. Conductor: Kloss. 6.30—History Discussion: Wars Expansion. 6.50—Announcements. 7.0 (from Nürnberg)—Orchestra. Conductor: Böhm. Ernestine Reuter (Contralto) and Franz Bork (Bass). Overture, "Il Seraglio" (Mozart). Aria, "Figaro" (Mozart). Gounod Potpourri (Rhode). Duet, "Martha" (Flotow). Gipsy Scenes (Bizet). Aria, "Mignon" (Thomas). Overture, "Abu Hassan" (Weber). 7.50—Topical Talk. 8.0—News. 8.15—See Königsberg. 8.45—See Frankfurt. 10.0—News; Exchange; Sports. 10.20—Talk: Roman Roads and Castles between Altmühl and the Danube. 10.50—To be announced. 11.0-12.0 m't—Station Dance Band.

OSLO (Norway)
260 kc/s (1,154 m.); 60 kW.
Relayed by Fredrikstad, 776 kc/s (386.6 m.); Hamar 510.5 kc/s (587.7 m.); Notodden, 1,357 kc/s (221.1 m.); Porsgrund, 850 kc/s (352.9 m.); Rjukan, 1,348 kc/s (222.6 m.); Trøndelag, 629 kc/s (476.9 m.).
Transmits at intervals from 11.10 a.m. 7.30 p.m.—For Farmers. 7.40—Legal Talk. 8.0—Station Orchestra. Conductor: Fjeldstad. Overture, "Oberon" (Weber). Indian Lament (Dvořák). Violin Solo (Wenninger). Three English Dances (German). Musette (Offenbach). Los Banderillos (Volpatti). Overture, "Marinarella" (Fucik). Norwegian National Airs (Haaland). Die Lotusblume (Lincke). Lullaby (Clutsum). Waltz (Rosas). In the interval at 8.40: Reading. 9.40—News. 10.0—Topical Talk. 10.15—Old Dance Music. 10.45-11.0—Dance Records.

PARIS (Eiffel Tower) (France)
1,456 kc/s (206 m.); 5 kW.
Transmits at intervals from 1.0 p.m. 8.0 p.m.—News. 8.30—Concert from Vichy.

PARIS (Poste Parisien) (France)
959 kc/s (312.8 m.); 60 kW.
Transmits at intervals from 7.10 a.m. 12.0 noon—Exchange. 12.5 p.m.—New Records. 12.25—An Interval. 12.35—Records of Bach and Laverne. 12.45—Bullion Orchestra. In the interval at 1.15: Exchange. 2.0—Exchange. 3.15—Exchange. 3.45—Exchange. 4.0—Report: The Cycle Tour of France—Arrival at Bordeaux. 4.35—Exchange. 6.25—Exchange. 6.30—Lehár Operetta Records. 7.7—Sports Notes. 7.10—News. 7.25—Amusement Guide. 7.27—Records. 7.35—Report: The Cycle Tour of France—Luchon-Bordeaux. 7.50—Tango Records. 8.0—Interlude. 8.10—Exchange. 8.15—Variety. 8.45—Talk. 8.50—Exchange. 9.5—Quintet in F minor (Franck) by Béhé (Pfte.), Bellanger and Saury (Violins), Villain (Viola) and Cruque ("Cello"). 9.45—News. 10.0—Cabane Cubaine Orchestra. 10.30-11.0—Records.

PARIS (PTT) (France)
695 kc/s (431.7 m.); 7 kW.
Transmits at intervals from 8.0 a.m. 6.30—News. 7.45—Tourist Talk. 8.0—Report: The Cycle Tour of France. 8.15—Soloists. 8.30—Chamber Music. Alice Hena (Songs), Marcel Moysé (Pfte.) and the Reiflinger Quartet. Quartet (Mozart). Songs: (a) Revenez amours (Lully), (b) Phydilé (Duparc). Flute and Pfte. Sonata (Golestan). Quartet: Three Pieces (de la Presle). Songs: (a) Cavatina (Bizet), (b) Le mariage des roses (Franck), (c) Aimons-nous (Saint-Saëns). Flute: Hungarian Pastoral Fantasia (Schumann). Trio: Fantasia (Schumann). 9.45—Burgundian Folklore Programme. M. Hérent, Marguerite Piteau, Loyano, Jean Doyen (Pfte.) and a Vocal Quartet. 10.30—News.



A scene from "The First Mrs. Fraser," which Stockholm broadcasts at 8.15 p.m.

programme. M. Hérent, Marguerite Piteau, Loyano, Jean Doyen (Pfte.) and a Vocal Quartet. 10.30—News.

PARIS (Radio-Paris) (France)
182 kc/s (1,648 m.); 80 kW.
6.45 a.m.—Gym; Records. 7.15—News. 7.45—Gym; Records. 12.0 noon—Talk: Education. 12.15 p.m.—Orchestra. Conductor: Touche. Lucie Rauh (Songs). In the interval at 1.20: News; Exchange. 3.45—Exchange. 5.30—Adam Records. 6.0—Talk with Readings: Victor Hugo's Youth. 6.30—For Farmers; Exchange; Markets; Racing. 6.45—Medical Talk. 7.0—Books. 7.20—Reading (Fleuret). 7.30—Talk: Nineteenth Century French Poetry. 7.50—Review by Paul Reboux. 8.0—"Fairies at the Cradle of a Bourbon Prince"—Musical Sketch; "Accord Parfait" Vocal Quartet; Chamber Orchestra. 8.30—Press Review. 8.45—"Flipote"—Play (Lemaître). 10.50—Bailly Dance Band.

PRAGUE (Czechoslovakia)
638 kc/s (470.2 m.); 120 kW.
Transmits at intervals from 6.0 a.m. 12.30 p.m.—Station Symphonic Jazz Band. Conductor: Hertl. 1.20—Talk: The Professions and Practical Life. 1.30—Labour Exchange. 1.40—Labour Exchange in German. 1.50—Exchange. 1.55-2.0—Exchange and Weather in German. 3.0—Orchestra from Brno. 4.0-4.10—Exchange; Weather. 4.30—Military Band Concert of Dance Music. 5.40—For Housewives. 5.45—Talk. 5.55—Records. 6.10—For Farmers. 6.15—Record. 6.20—German Transmission: Topical Talk: For Workers; News. 7.0—Time; News in German. 7.10—Record. 7.15—News. 7.25—Record. 7.30—Topical Talk. 7.40—Czech Philharmonic Orchestra. Conductor: Stupka. Ivan Baklanov (Songs). Overture, "Othello" (Dvořák). Prologue, "I Pagliacci" (Leoncavallo). Monologue, "Boris Godunov" (Mussorgsky). Night on the Bare Mountain (Mussorgsky). Overture, Serenade and Aria, "Don Giovanni" (Mozart). 8.30—See Brno. 9.50—Modern English Music by Anthony Baldwin (Pfte.). Three Pieces (Whittaker): (a) Satyrs, (b) A Trill, (c) Lament. Preludes Nos. 3 and 4 (Baldwin). Follifairns Fair (Adamson). Amberley Wild Brooks (Ireland). The Liner (Goossens). 10.15—News. 10.30—Records. 10.45-11.0—News in French.

RADIO-NORMANDIE (France)
1,113 kc/s (267.5 m.); 10 kW.
7.0 a.m.—Records. 7.20—News. 7.45—Records. 7.48—Racing. 7.50—Records. 7.53—Cookery. 8.0—Records. 8.45—Songs. 10.0—Chansonnettes. 11.0—Orchestra. 12.0 noon—Light Music. 12.40 p.m. News. 12.45—Request. Piece (Erwin). The Whistler's Serenade (Perry). Let's say Goodbye (Moretti). Piece (Heymann). Quand on s'aime bien tous les deux (Scotti). Pour rire en société (Bach-Laverne). Mimolette (Chabran). Selection, "La belle Hélène" (Offenbach). You you, you (Marafioti). Piece (Spencer). Träumerei (Schumann).



A scene from "The First Mrs. Fraser," which Stockholm broadcasts at 8.15 p.m.

Song, "White Horse Inn" (Stoż-Benatzky).

4.0—Dance Music. 4.30—Records. 4.45—For Children. 5.0—Records. 5.15—Light Music. 6.0—For Children. 6.45—Talk. 7.0—Request Music. 8.0—Hawaiian Guitar Music. 8.30—Dues. 8.45—"La dame de Vittel"—Comedy in Three Acts (Ferdinand). 11.0—Light Music. 11.30—Opera Music. Selection, "Cavalleria rusticana" (Mascagni), "La Bohème" (Puccini), "Barber of Seville" (Rossini), "Tannhäuser" (Wagner), and "Rigoletto" (Verdi), Barcarolle, "Tales of Hoffmann" (Offenbach). Flower Song, "Carmen" (Bizet). Selection, "Madame Butterfly" (Puccini). 12.0 m't-2.0 a.m. (Thursday)—Dance Music.

REYKJAVIK (Iceland)
208 kc/s (1,442 m.); 16 kW.
Transmits at intervals from 12.0 noon. 9.20 p.m.—Music. 9.50—Announcements. 10.0—News. 10.30—Reading. 11.0—Gudmundsson (Violin); Beethoven. Records.

ROME (Italy)
713 kc/s (420.8 m.); 50 kW. Relayed by Naples, 1,104 kc/s (271.7 m.); Milan (No. 2), 1,348 kc/s (222.6 m.); Turin (No. 2), 1,357 kc/s (221.1 m.); and Bari, 1,059 kc/s (283.3 m.).
Transmits at intervals from 7.35 a.m. 5.10—Elvira Primo (Pfte.), Luisa Carivarini (Violin) and Adriana Teodorici-Graziosi (Soprano). 5.55—Weather. 6.0-6.10—Corn Prices. 6.45—Tourist Report; Dopolavoro Notes; Report of the Royal Geographical Society. 7.0—News in Foreign Languages. 8.15—News; Records. 8.30—Time; Announcements; Topical Talk. 8.40—"La giana"—One-Act Play (Pirandello). 9.30—Symphony Concert from the Basilica di Massenzio. Conductor: Mascagni. In the interval: Talk. 11.0—News.

SOTTENS (Switzerland)
677 kc/s (443.1 m.); 25 kW.
Transmits at intervals from 12.30 p.m. 4.30-6.0 p.m.—See Beromünster. 6.0—Scenes from French Plays—Records. 7.0—Talk. 7.20—Song Records. 7.35—Talk. 8.0-10.15—Italian Music from the Palais des Beaux Arts, Brussels. Part I. Conductor: Oreste Piccardi. Rappresentazione di Anima e di

Corpo (Cavaleiri). Excerpts, "Il Ballo delle Ingrate" (Monteverdi). Part II. Conductor: Scherchen. Excerpts, "Pantea" (Malipiero). In the interval at 9.20 (approx.): News.

STOCKHOLM (Sweden)
704 kc/s (426.1 m.); 55 kW. Relayed by Motala, 216 kc/s (1,389 m.); Göteborg, 941 kc/s (318.8 m.); Hörby, 1,131 kc/s (265.3 m.); and Boden, 392 kc/s (765 m.).
Transmits at intervals from 7.45 a.m. 5.5—Carin Edelberg (Folk Songs). 5.25—Reading. 5.45—Records. 6.45—Talk: Old Student Traditions. 7.15—News. 7.30—Cabaret. 8.0—Sonata in E (Handel) by Lottie Andréason (Violin) and Martin Andréason (Pfte.). 8.15—"The First Mrs. Fraser"—Comedy (St. John Ervine). 9.45—News. 10.0-11.0—Dance Music from the Grand Hotel.

STRASBOURG (France)
859 kc/s (349.2 m.); 35 kW.
Transmits at intervals from 10.45 a.m. 6.0 p.m.—Talk: Martinique. 6.15—Gardening Talk in German. 6.30—Raymond ("Cello") and Fernand Rich (Pfte.). Cello Sonata in G minor (Handel). Pfte.: (a) Toccata (Paradies), (b) Sonata (Scarlatti). "Cello": Suite française (Bazelaire). Pfte.: (a) La mélodieuse (Daquin), (b) Le ramage (Dandrieu), (c) Les tourbillons (Dandrieu). Cello: Three Pieces (Bazelaire): (a) Yamilé, (b) Burlesque, (c) Cache-cache. Pfte.: (a) Etude rythmique (Godard), (b) Etude de concert (Godard). 7.30—Time; News. 7.45—News in German. 8.0—Report: The Cycle Tour of France-Pau-Bordeaux. 8.15—News in German. 8.30—Municipal Band and Soloists from Metz. Conductor: Narbonne. English March, Royal Hussars (Aveland). Ballet Music, "La Korrigane" (Widor). Selection, "Lohengrin" (Wagner). La Matichiche (Borel-Clerc). French Soldiers' March (Perrin-Granger). Selection, "Coppélia" (Delibes). Horn: Fantasia, Le diadème (Sali). Waltz, Très jolie (Waldteufel). Gavotte, Confidences (Wealy). Aubade printanière (Lacôme). March, "Tannhäuser" (Wagner). In the interval at 9.30: News. 10.30—Dance Music.

STUTTGART (Germany)
574 kc/s (522.6 m.); 100 kW.
Transmits at intervals from 5.45 a.m. 12.0 noon—See Breslau. In the interval at 1.0 p.m.: News. 2.0-3.0—See Deutschlandsender. 3.30—For Boys. 4.0—Johanna Staudenmayer (Contralto), Margarete Hofmann (Flute), Traute Zarges (Pfte.), Koch (Violin) and Seitz ("Cello"). 5.0—See Frankfurt. 6.15—Opening of the Stausee Gardens in Höffen. 6.30—Morse. 6.45—Discussion: Swabia's Mountains and Rivers. 7.0—Military Band. Conductor: Vogel. March, Victoria (Blon). Swabian Rhapsody (Kämpfer), March, In Treue fest (Teike), Waltz, Les sirènes (Waldteufel). Interlude: "The Interview" Sketch (Mathias). Military March (Lothmann). In a Persian Market (Ketebe). Fantasia on "Das Heidenröslein" (Latern). Musicians-Marsch (Carl). 8.0—News. 8.15—See Königsberg. 8.45—"A Thousand Golden Notes"—Songs, Waltzes and Duets. Station Orchestra. Conductor: Görlich. Maria Madlen-Madson (Soprano), Jautz (Tenor) and Wistinghausen (Baritone). 10.0—News. 10.20—Saarland Notes. 10.30—See Cologne. 12.0 m't-2.0 a.m. (Thursday)—Concert. Württemberg Theatre Players. Dittich and Wolf (Flutes), Krümming and Kresse (Oboes), Bayer (Bassoon) and Keller (Harpischord). Two Oboes, Bassoon and Harpischord: Trio Sonata in G (Handel). Flutes, Oboes and Harpischord: Twelve Short Pieces (P. E. Bach). Two Flutes, Bassoon and Harpischord: Trio Sonata in G (Bach). Clarinet and Bassoon: Duet (Beethoven). Two Clarinets and Bassoon: Trio (Mozart).

TOULOUSE (Radio-Toulouse) (France)
913 kc/s (328.6 m.); 60 kW.
Transmits at intervals from 8.0 a.m. 7.0 p.m.—Popular Songs. 7.20—Folk Music. 7.30—News. 7.45—Operetta

WEDNESDAY (July 24)
Music. 8.5—Orchestra. 8.15—Viennese Orchestra. 8.30—Bach and Laverne Humorous Programme. 9.0—Holidays—Radio Fantasy. 9.35—Cigany Band, 9.45—Excerpts, "The Magic Flute" (Mozart). 10.20—Cinema Organ. 10.30—North African News. 10.45—Dance Music. 11.0—Request Music. 11.15—Film Songs. 11.35—Rumbas. 11.45—Solos. 12.0 m't—"Au Caveau de minuit"—Fantasy. 12.15 a.m.—News. 12.20-12.30—Military Marches.

TURIN (No. 1) (Italy)
1,140 kc/s (263.2 m.); 7 kW. Relayed by Milan (No. 1), 814 kc/s (368.6 m.); Genoa, 986 kc/s (304.3 m.); Florence, 910 kc/s (491.8 m.); and Trieste, 1,222 kc/s (245.5 m.).
7.35 a.m.—Gym. 7.45-8.0—Time; News. 11.30—Chesi-Zanardelli-Cassone Trio. 12.45 p.m.—News. 1.0—Time; Announcements. 1.5—Consiglio Orchestra, 2.0—Exchange; Records. 2.15-2.25—Exchange. 4.30—News. 4.40—For Children. 5.0—Report: The Cycle Tour of France. 5.5—Orchestra. 5.55—Weather. 6.0-6.10—Corn Prices. 6.45—Tourist Report; Dopolavoro Notes. 7.10—News in Foreign Languages. 8.15—Report: The Cycle Tour of France. 8.20—News. 8.30—Time; Announcements; Topical Talk. 8.40—"Anna Karenina"—Opera in Three Acts after Tolstoj (Robbiani). Orchestra and Choirs. Conductors: Antonicelli and Veneziani. In the interval: Topical Talk. After the Opera: News; Announcements in Spanish.

VIENNA (Austria)
592 kc/s (506.8 m.); 100 kW.
Relayed by Graz, 886 kc/s (338.6 m.); Innsbruck, 519 kc/s (578 m.); Dornbirn, Klagenfurt and Linz, 1,294 kc/s (231.8 m.) and Salzburg, 1,348 kc/s (222.6 m.).
Transmits at intervals from 9.10 a.m. 5.0 p.m.—Topical Talk. 5.25—Folk Songs by Josef Papier (Baritone). 5.40—Talk: Theatricals in the Italian "Dopolavoro Movement." 6.0—Arias by Beate Grenelli (Soprano). 6.15—Talk: With a Camera in the Burgenland. 6.25—Talk: On a Motor Bike to North Cape. 6.50—Science Review. 7.0—News. 7.10—Topical Talk. 7.20—Talk: Art and Culture in Upper Austria. 7.30—"The Kahleberg"—Sequence. 8.30—Records of Lotte Lehmann (Soprano). 9.0—Memorial Concert for Dr. Dollfuss. The "Dreizehnhinden" Choir and Vienna Symphony Orchestra. Conductor: Habel. Maria Schubert (Soprano), Emilie Rutschka (Contralto), Markl (Tenor) and Brand (Recitations). Address by Walder Adam. Contralto, Choir and Orchestra: Requiem (Regier). Dedicatory Poem (Waldeck). Soloists, Choir and Orchestra: "A German Stabat Mater" (Frank). 10.20—News. 10.30-11.0—Austrian Organ Sonata (Neuhöfer) from St. Florian.

WARSAW (Poland)
224 kc/s (1,339 m.); 120 kW.
Relayed by Katowice, 758 kc/s (395.8 m.); Lwów, 795 kc/s (377.4 m.); Poznań, 868 kc/s (345.6 m.); and Wilno, 536 kc/s (559.7 m.).
Transmits at intervals from 6.30 a.m. 12.15 p.m.—Orchestra. 1.0—For Housewives. 1.6-1.30—Song Records. 3.15—Exchange; News. 3.30—Pfte.; Songs. 4.0—Talk: Child Welfare. 4.15—Symphony Records. 4.50—Humorous Prose. 5.0 (from Katowice)—Drohomiczek ("Cello"). 5.20 (from Wilno)—Light Orchestra. 6.0—"The Sign"—Humorous Sketch after Maupassant (Zrebowski). 6.15—Choir from Wilno. 6.30—Story for Children. 6.40—Literary and Art Review. 6.45—Records: Light Music. 7.5—Announcements. 7.30—Bender (Songs). 7.50—Talk: French Political Humour. 8.0—For Farmers. 8.10—Records. 8.45—News. 8.55—Poland Yesterday and Today. 9.0—Chopin. Jonasówna (Pfte.). 9.30—Talk: Pilsudski. 9.40 (from Lwów)—Serenade for Trio (Tanzman). 10.10—Sports. 10.20-11.0—Station Light Orchestra. Conductor: Górznyński. Overture, "Donna Juanita" (Suppé). Waltz (Lincke). Arabian Nights (Profes). Viennese Potpourri (Komzak). Serenade, Marie (Lezczowski). Fox-trot (de Kers). Tina (Grosz). English Waltz (Fekl). Berceuse (Cowler). Mazurka (Lewandowski)

T H U R S D A Y J u l y 2 5

SYMPHONY CONCERTS

P.M.
 8.10 Frankfurt: Mozart, Beethoven.
 8.10 Vienna: Beethoven.
 8.40 Turin: Beethoven's 4th Symphony, etc.
 8.55 Kalundborg: Serenade Op. 16 (Brahms).
 9.0 Budapest 1: Wagner, Kodály, Beethoven.
 9.45 Radio-Paris: National Orchestra (Inghelbrecht).

10.5 National: Conductor, Barbirolli.

LIGHT CONCERTS

3.30 Kalundborg: Instrumental music.
 3.30 Radio-Paris: From Vichy Casino.
 4.0 Deutschlandsender: Outdoor concert.
 5.0 Breslau: Orchestra, light music.
 5.0 Leipzig, etc.: Light orchestral.
 5.0 Warsaw: Orchestra, songs.
 5.55 Hilversum: Light music.
 7.0 Frankfurt: Light orchestral.
 7.0 National: Orchestra, songs.
 7.15 Hamburg, etc.: Folk music.
 8.0 Brussels 2: Symphony orchestra.
 8.0 Kalundborg: Modern operetta music.
 8.2 Sottens: Orchestra, songs, organ.
 8.10 Cologne: Wagner.
 8.10 Warsaw: Orchestra, light music.
 8.30 Stockholm: Cornelius, Mozart, etc.
 8.30 Strasbourg: From Plombiers Casino.
 9.0 Warsaw: Opera music.
 9.10 Hilversum: Orchestra, pft.
 9.15 Brussels 1: From the Exhibition.
 10.10 Warsaw: Light and dance music.
 10.15 Stockholm: Military band.
 10.20 Kalundborg: Popular orchestral.

OPERAS

8.15 Bucharest: "Il Trovatore" (on records).
 8.30 Paris (PTT): "L'amour mouillé" (Varney).
 8.40 Rome: "Cinderella" (Massenet).
 10.10 Brussels 2: "La Traviata" records.

CHAMBER MUSIC

12.15 Radio-Paris: Harp, pft., strings.

P.M.

5.45 Brussels 1: 'Cello, pft.
 7.15 Berlin: Gamba, harpsichord.
 8.0 Brussels 1: Chausson, Fauré.
 10.30 Cologne: Old music.
 10.30 Leipzig: Flute, viola, guitar.
 10.30 Stuttgart: Winds and pianoforte.
 11.0 Deutschlandsender: Haydn, Respighi.
 12.0 Frankfurt, Stuttgart: Schumann.

RECITALS

3.30 Warsaw: Pianoforte (Schubert).
 4.0 Breslau: Violin, Pianoforte.
 4.10 Munich: Pft. (MacDowell's Celtic Sonata).
 5.0 Brussels 1: Organ (Exhibition).
 5.0 Brussels 2: Choir, boys' voices.
 6.30 Strasbourg: Pianoforte; 7.0, songs.
 6.40 Hilversum: Organ.
 7.0 Budapest 1: Hungarian songs.
 7.30 Stockholm: Songs.
 8.30 Oslo: Pianoforte, song.
 9.5 Prague: 'Cello; 10.35, songs.
 10.30 Budapest 1: Dohnányi (Beethoven Sonatas).
 11.0 Håmberg: Bass songs; 11.30, Violin.

PLAYS

4.50 Radio-Paris: Classical matinée.
 8.0 Beromünster: "Tratsch," a radio idyll.
 8.30 Poste Parisien: "Comme la Vic."
 8.45 Brussels 1: "La paix chez soi" (Courteline).
 8.45 Radio-Paris: Two plays.
 9.0 Deutschlandsender: "Mann im Netz."

DANCE MUSIC

8.10 Berlin, Hamburg, Leipzig; 10.10, Brussels 1; 10.20, Regional; 10.30, Athlone, Berlin, etc.; 10.50, Hilversum; 11.5, Kalundborg; 11.10, Budapest 1; 11.15, National; 12.0, Radio-Normandie.
MISCELLANEOUS
 7.0 Brussels 1: European Water-polo championship.
 9.0 Radio-Normandie: Cabaret.

NATIONAL

For Time Signals, see Monday
 10.15 a.m. (Droitwich)—Service.
 10.30 (Droitwich)—Weather Forecast.
 10.45—"Through an Author's Eyes."
 Marjorie Bowen.
 11.0—Cinema Organ.
 11.45—Rutland Square and New Victoria Orchestra.
 12.30 p.m.—New Records.
 1.15—Pattison's Salon Orchestra.
 2.15—Records.
 3.0—Evensong (Westminster Abbey).
 3.50—Herman Darewski and his Band.
 4.45—Organ (Phillip Taylor).
 5.15—Jack Jackson and his Band.
 6.0—"The First News."
 6.30 (Droitwich)—Cinema Organ (Reginald Dixon). St. James's Park (Connor). Overture, Poet and Peasant (Suppé). Malola (Wayne). Un Peu d'Amour (Sileus). Selection, The Desert Song (Romberg).
 7.0 (Droitwich)—BBC N. Ireland Orchestra, conducted by Peter Montgomery. Albert V. Froggatt (Baritone). Tone Poem, With the Wild Geese (Harty); Two Aubades (Lalo). The Fox, The Kerry Recruit, Johnny Cope; The Jolly Waggoner (T. Woods). Valse, Wood Nymphs (Coates); Ballet Music, Le Cid (Massenet).
 8.0—Fred Hartley and his Novelty Quintet with Brian Lawrence. Hawaiian Medley. My Song without a Name (Hartley). Serenade (Drigo). Lullaby of Broadway (Warren). I hear You calling Me (Marshall). The Cowboy's Dance (Adams). Sally (Towers). Kalna (Kern). Butterflies in the Rain (Myers). Songs of the Old Plantation.
 8.40—Greta Keller.
 9.0—Students' Songs: BBC Men's Chorus; Arthur Cranmer (Baritone).
 9.30—"The Second News."
 9.50—A Short Mid-week Service, conducted by the Rev. W. H. Elliott, relayed from St. Michael's, Chester Square.
 10.5—BBC Orchestra (Section C), conducted by John Barbirolli. Overture, Rübezahl (Weber). Morceau Symphonique (Redemption) (Franck). Fantastic Dance (Debussy). Suite, La Korrigane (Widor).
 11.15-12.0 (Droitwich)—Dance Music: BBC Dance Orchestra.

REGIONAL

For Time Signals, see Monday
 10.15-10.45 a.m. (except Midland)—Droitwich.
 10.45—Buxton Spa Orchestra.
 11.45—Miscellaneous Records.
 12.15 p.m.—N. Ireland Orchestra, conducted by Peter Montgomery. Rosemary Dinsmore (Mezzo).
 1.20—Organ (R. Rufus Burgess).
 1.50 approx. (N. Ireland)—Account of Irish Open Golf Championship.
 2.0—The Scottish Studio Orchestra.
 3.0 (Scottish till 3.25)—Central Band of H.M. Royal Air Force.
 3.30 (Scottish)—Mid-week Service.
 4.0—Records.
 4.30—New Light Trio.
 5.15—The Children's Hour.
 6.0—"The First News."
 6.30-8.0 (ex. Midland)—Droitwich.
 8.0 (ex. N. Ireland)—"City of Music" (See National, Wednesday, 8.30).
 8.0 (N. Ireland)—Account of Irish Open Golf Championship.
 8.15 (N. Ireland)—Broadcast from the International Girl Guides and Girl Scout Camp at Wilmont.
 9.0 (ex. Northern and Scottish)—"Ribbons Roads from the Air." Filsen Young.
 9.0 (Northern)—Speeches by Lord Tweedsmuir, G.C.M.G., C.H. and Rt. Hon. Sir Philip Cunliffe-Lister, G.B.E., M.C., from the Society of Yorkshiremen in London and the Yorkshire Society's Annual Banquet.
 9.0 (Scottish)—New Light Orchestra. Conductor, Ian Whyte. Catherine Stewart (Contralto).
 9.15 (Regional)—Emilio Colombo (Violin); Orazio Fagotti ('Cello); Edgar Lacey (Pianoforte).
 9.15 (Midland)—Relay from the Tewkesbury Festival.
 9.15 (Western)—Tom Williams (Baritone); Swansea and District Male Choir.
 9.15 (N. Ireland)—"Round the Albert." Twenty-four Hours in the Life of Belfast's Big Ben.
 9.30 (Northern)—City of Sheffield Police Band.
 9.45 (Midland)—Records.
 10.0—News Summary; Sports Bulletin.
 10.20—BBC Dance Orchestra.
 11.0—Dance Records.
 11.15-12.0 (except Midland)—BBC Dance Orchestra, directed by Henry Hall.
 Week in Detmold. 10.0—News Review.
 10.30-12.0 m't—"Come, silent Night"—Literary and Musical Programme, Part I. Seven Harpsichord Pieces (Purcell). Part II. Treasures of German Literature and Music. Part III. Sonatina for Harpsichord and Guitar (Henckel). Sonata in C minor (Quantz). Minuet in C for Flute and Harpsichord (Haydn).

Hours of Transmission in British Summer Time.

ATHLONE (Ireland)

565 kc/s (531 m.); 60 kW. Relayed by Dublin, 1,340 kc/s (222.6 m.); and Cork, 1,240 kc/s (241.9 m.).
 1.30-2.30 p.m.—Records. 6.0—For Children. 6.45—News.
 7.0—"The Mastersin Merry Mood"—Station Orchestra. Mollie Phillips (Soprano). 8.15—Talk. 8.30—Victor Love (Pfte.). 8.50—Talk.
 9.10—Irish Music. Station Strings.
 9.35—Talk: Irish Farm Produce in British Markets. 9.45—What happened to-day. 10.0—Variety. 10.30-11.0—Dance Music. Cyril Gibson and his Aristocrats.

BERLIN (Germany)

841 kc/s (356.7 m.); 100 kW.
 Transmits at intervals from 6.0 a.m.
 12.0 noon—Variety.
 12.30 p.m.—Orchestra from Munich. In the interval at 1.0: Midday Echoes. 2.0—News. 2.15—Raue Orchestra. 3.0—Exchange; Markets. 4.0—Riepert (Baritone). Ruth Rutowski (Harp). Wentzel (Clarinet), Puchelt (Pfte.). 4.30—Windsperger Recital by Maria Neuss (Violin), Hoppe (Pfte.). Pfte. Sonata in C. Excerpts, Fantasietten. 5.0—See Leipzig. 6.30—Sports Talk. 6.45—Music by Girls. 7.0—Talk: Finnish Art.
 7.15—Schulz (Viola da Gamba) and Milli Lohmann (Harpsichord). Sonata in D (Hammer). Divertissement in D (Haydn). Idyll (Marais).
 7.40—Evening Echoes. 8.0—News; Announcements.
 8.10—A Kurhaus Dance Programme. Small Station Orchestra. Conductor: Steiner. Sokoloff Balalaika Orchestra. Grete Weiser, Paul Dorn and Erich Kestin. 10.0—News; Sports.
 10.30-12.0 m't—Bund Dance Band; Sokoloff Balalaika Orchestra.

BEROMÜNSTER (Switzerland)

556 kc/s (539.6 m.); 100 kW. Relayed by Basle and Berne, 1,375 kc/s (218.2 m.).
 12.0 noon—Small Radio Orchestra. In the interval at 12.29 p.m.: News. 1.25—Exchange. 4.0 (from Basle)—Records: Light Music.
 4.30-6.0—See Sottens.
 6.0 till Close. Programme from Basle. 6.0—Records: Folk Songs. 6.30—Travel Reminiscences. 7.0—Announcements. 7.5—Instrumental Music. 7.40—Medical Talk.

8.0—"Tratsch"—Idyll (Hugin). 9.0—News. 9.10-10.30—For Swiss Nationals Abroad.

BRATISLAVA (Czechoslovakia)

1,004 kc/s (298.8 m.); 13.5 kW.
 Transmits at intervals from 6.0 a.m.
 6.35 p.m.—Talk. 6.50—Records. 7.0—See Prague. 7.25—See Moravská Ostrava. 8.0—Talk. 8.15—See Prague. 9.5—Loris Margaritis (Pfte.). 9.35—See Brno. 10.15—News. 10.35—News (Hungarian). 10.50-11.0—Records.

BRESLAU (Germany)

950 kc/s (315.8 m.); 100 kW. Relayed by Gleiwitz, 1,231 kc/s (243.7 m.).
 Transmits at intervals from 5.0 a.m.
 12.0 noon—Station Dance Band. Conductor: Rau. 2.0—News. 2.10—Exchange; Announcements. 2.40—Greetings. 2.45—Markets. 3.10—Review of Periodicals. 3.30—Play. 4.0—Schöll (Violin). Evers (Pfte.). 4.30—Reading. 4.50—Talk: Welfare Work. 5.0—Station Light Orchestra. Conductor: Rischka. 6.30—Typical. 6.50—Announcements; Markets.
 7.0—Folk Music.
 7.15—See Hamburg. 7.50—Discussing Broadcasting. 8.0—Announcements. 8.15—See Stuttgart. 10.0—News. 10.30-12.0 (m't)—See Berlin.

BRNO (Czechoslovakia)

922 kc/s (325.4 m.); 32 kW.
 Transmits at intervals from 6.0 a.m.
 6.20 p.m.—Records. 6.30—News. 6.35—Talk. 6.45—Records. 7.0—See Prague. 7.25—See Moravská Ostrava. 8.0—See Prague.
 8.15—Scheidt (Guitar). Suite (Visée). Prelude and Fugue in G minor (Bach). Concert Etude (Schaller). Catalan Folk Dance (Llobet). Spanish Fantasy (Vinas).
 8.40—Light Music. Moravian Wind Quintet. 9.5—Folk Play. 9.35—Kalivoda Dance Band. 10.15-11.0—See Prague.

BRUSSELS (No. 1) (Belgium)

620 kc/s (483.9 m.); 15 kW.
 12.0 noon—Alexys Orchestra. 1.0 p.m.—News. 1.10-2.0—Alexys Orchestra. 4.55—Announcements.
 5.0—Funk (Organ), from the Exhibition. 5.45—Mme. Husson-Michaux (Pfte.); Frezin ('Cello). 6.15—Literary Talk: The Romantic School.

6.30—Records: Meyerbeer Potpourri (Urbach). 6.40—Literary Talk with Readings: De Wandelers. 6.55—Record: Prelude, "Le Déluge" (Saint-Saëns). 7.0—Commentary on the European Water-Polo Championships at Evère. 7.30—Literary Review; Tourist Report.
 8.0—French Chamber Music from the Exhibition. Dyva Register ('Cello), Koch, Beck and Hosselet (Violins), Jean Register (Viola); Van Lancker (Pfte.). Concerto in D (Chausson). Quartet in C minor (Fauré).
 8.45—"La paix chez soi"—One-Act Play (Courteline).
 9.15—Orchestra from the Exhibition. Conductor: Walpot. Durand (Songs), and Bemers (Saxophone). Semper fidelis (Sousa). Selection, "Hans the Flute-Player" (Ganne). Tales from the Vienna Woods (Strauss). In the mystic land of Egypt (Ketelbey). Dance of the Hours, "La Gioconda" (Ponchielli). Beebe (Dorsay). Sambre et Meuse (Planquette). 10.0—News. 10.10-11.0—Der Kers Dance Band from the Exhibition.

BRUSSELS (No. 2) (Belgium)

932 kc/s (321.9 m.); 15 kW.
 Programme in Flemish.
 12.0 noon—Opera Records. 12.30 p.m.—Orchestra. Conductor: Walpot. In the interval at 1.0: News. 1.30-2.0—Records. 4.55—Announcements. 5.0—Boys' Choir. Conductor: Van Tilborg. 5.30—For Children. 6.15—For Young People. 7.0—Roman Catholic Review.
 7.15—Records of Joseph Schmidt. 7.30—News.
 8.0—Symphony Orchestra. Conductor: Kumps. Beets (Songs). Symphony in B (Borodin). Songs (Wagner): (a) Grail Narrative "Lohengrin." (b) Aria, "Tannhäuser." Ride of the Valkyries. "The Valkyrie" (Wagner). 8.45—Talk: The Catholic Union.
 9.0—Orchestra (contd.). Overture, "Semiramis" (Rossini). Arias: (a) "La Favorita" (Donizetti). (b) "I Pagliacci" (Leoncavallo). Flemish Dance (Devreese). Two Basque Airs (Kumps). Valse nobles et sentimentales (Ravel). 9.50—The Angelus. 10.0—News.
 10.10-11.0—Records: "La Traviata" (Verdi).

BUCHAREST (Romania)

823 kc/s (364.5 m.); 12 kW.
 Transmits at intervals from 12.0 noon.
 6.0 p.m.—News. 6.15—Fania Louca Orchestra. 7.0—Talk. 7.20—Records. 7.50—Programme Announcements. 8.0—Book Review.
 8.15—Records: "Il Trovatore"—Opera in Four Acts (Verdi). In the intervals: News.

BUDAPEST (No. 1) (Hungary)

546 kc/s (549.5 m.); 120 kW.
 10.20 a.m.—Talks. 12.5 p.m.—Records. In the interval at 12.30: News. 1.20—Weather. 1.40—Margit Garai ('Cello). 2.40—For Housewives. 4.10—Talk. 5.30—Lantos Dance Band. 6.30—Travel Talk.
 7.0—Hungarian Songs. Csenlényi with the Kurina Cigány Band. 8.10—Play (Stella).
 9.0—Opera Orchestra. Conductor: Vaszy. Overture, "Fannhäuser" (Wagner). Sommernacht (Kodály). Symphony No. 5 (Beethoven). 10.0—News.
 10.30—Beethoven Sonatas by Dohnányi (Pfte.). Sonata in D minor. Sonata in G. 11.10—Baker Dance Band from the Hotel Dunapalota. 12.5 a.m. (Friday)—News.

BUDAPEST (No. 2) (Hungary)

359.5 kc/s (835.4 m.); 20 kW.
 6.0 p.m.—Poems. 6.35—Records. 7.35—Talk: Dr. Dollfuss. 8.15—Bachmann Jazz Band. 9.15—News.

COLOGNE (Germany)

658 kc/s (455.9 m.); 100 kW.
 Transmits at intervals from 6.0 a.m.
 12.0 noon—Small Station Orchestra. Conductor: Eysoldt. Maximus and Erika Hunyadi (Songs to the Lute). 2.0—News.
 2.15—Variety from Deutschlandsender. 3.0—Musical Fairy Tales. 3.30—Exchange. 3.45—Travel Hints.
 4.0—Pfte. Trio in E flat (Schubert) by the Fassbender Trio. 4.35—Topical.
 5.0—See Leipzig. 6.30—Talk. 6.45—Exchange; Sports.
 7.0—Engels (Tenor); Haass (Pfte.). (a) Komm liebe Zither. German Dances (Schubert). Songs (Brahms): (a) Meine Liebe ist grün. (b) Tambourliederchen, (c) Heimkehr.
 7.30—Hitler Youth Report. 7.50—Snapshots. 8.0—News.
 8.10—Relay from the Wagner Festival

DEUTSCHLANDSENDER (Germany)

191 kc/s (1,571 m.); 60 kW.
 Transmits at intervals from 5.55 a.m.
 12.0 noon—Gaden Band. In the interval at 1.0 p.m.: Greetings. 1.45—News. 2.0—Variety. 3.0—Exchange; Announcements. 3.15—Talk. 3.45—Books.
 4.0—Open-air Concert. Schneidewind Orchestra. 5.45—Genealogy.
 6.0—Schubert-Brahms. Else Blatt (Pfte.). 6.35—Report: The Berlin State Museums. 6.50—Discussion: German Broadcasting.
 7.0—"Wanderlust." Small Station Orchestra. Verses (Pitow). 7.45—News. 8.0—Motto; Announcements.
 8.10—"Mountain Echoes"—Yodels, Zither and Tyrolean Harp Music, and Country Bands. Readings from "Da lacht Tirol" (Springenschmidt). 8.40—Songs.
 9.0—"A Man in the Net!"—Play about Deep-sea Fishing (Schmidt). 10.0—News. 10.30—Serenade on Records: Schimmelpfennig (Organ).
 11.0-12.0 m't—Dresden String Quartet. Lark Quartet (Haydn). Doric Quartet in E minor (Respighi).

FRANKFURT (Germany)

1,195 kc/s (251 m.); 25 kW. Relayed by Cassel, Coblenz, Freiburg, Kaiserslautern and Trier, 1,195 kc/s (251 m.).
 Transmits at intervals from 6.15 a.m.
 12.0 noon—See Munich. In the interval at 1.0 p.m.: News. 2.0—News. 2.15—Talk: The Bankruptcy Laws. 2.30—Exchange. 3.0—Announcements. 3.15—For Children. 4.0—Elisabeth Bischoff (Violin). 4.30—Books. 4.45—Talk: Rügen a century ago.
 5.0—Spa Orchestra from Badenweiler. Conductor: Hitzig. 6.30—For Garden-Lovers. 6.40—Reading. 6.55—For Farmers; Exchange.
 7.0 (from Kaiserslautern)—Light Music. Conductor: Schmidt.

Freundschaftsmarsch (Zeh). Selection, "Aennchen von Tharau" (Strecker). "Die Werber (Lanner). Overture, "Der Göttergatte" (Lehár). Sphärenklänge (Strauss). March (Friedemann). 7.50—Today's Mirror. 8.0—News. 8.10—Symphony Concert from Bad Nauheim. Spa Symphony Orchestra. Conductor: Jochum. Leonora Overture No. 2 (Beethoven). Symphony in G minor (Mozart). Symphony in A (Beethoven). 10.0—News; Sports. 10.20 (from Trier)—Light Music. Conductor: Bachmann. European Ballet (Leuschner). An Evening in St. Petersburg (Meyer-Helmund). Gruss an Siede (Stözlíng). 11.0—Dance Music from Berlin. 12.0 m't-2.0 a.m. (Friday)—Schumann. Lenzewski Quartet. Henry Schmitt (Contralto), Schäfer (Bass),

4.25—Play for Children (Schuil). 5.10 Dance Music by the A.V.R.O. Decibels. Conductor: Meenk. 5.55—Lyrá Trio: Light Music. 6.40—Mihatsch (Organ). Prelude and Fugue in C minor (Schmidt). Prelude and Fugue in E flat (Schmidt). 7.10—Talk by Dr. Schmidt Degener: The Rembrandt Exhibition at the Rijksmuseum. Amsterdam. 7.40—News. 7.45—Pali Orchestra from Arnhem. 8.10—Operetta Music by Kovacs Lajos Orchestra. Kiveron (Tenor). 8.55—To be announced. 9.10—Groníngen Municipal Orchestra. Conductor: Kuiler. Zonderland (Pfte.). Hollandia Suite (van Katwijk). Pfte. Concerto in G (Tchaikovsky). Suite, "L'Arlesienne" (Bizet). In the interval: Sports Commentary.

tion, "Viktoria and her Hussar" (Abraham). 8.50—Poems (Schade). 8.55—Serenade in A (Brahms). Radio Orchestra. Conductor: Mahler. 9.30—Tourist Talk in German: Copenhagen. 9.45—Danish Folk Songs by Peter Jensen. Dejlige Danmark (Rasmussen). Den gamle Rónne. Gyldenlakken (Hansen). Jeg syngte vil en Vise. Min Amanda. Snedkerens Vise (Jespersen). 10.5—News. 10.20—Radio Orchestra. Conductor: Mahler. Overture, "The Thieving Magpie" (Rossini). Entr'acte, "Rosamunde" (Schubert). Selection, "Eugene Onegin" (Tchaikovsky). Intermezzo, "Háry Janos" (Kodály). Overture, "The Gipsy Baron" (Strauss). 11.5-12.30 a.m. (Friday)—Juel-Thomson Dance Band from the Lorry.

Records. 8.25—Exchange; Records. 8.50—Talk. 9.0—Folk Music. 9.30—News; Band. In the interval at 10.0: Political Review. 10.30—News; Music. 11.0—Dance Music. **MONTE CENERI** (Switzerland) 1,167 kc/s (257.1 m.); 15 kW. Transmits at intervals from 12.0 noon. 4.30-6.0 p.m.—See Sottens. 7.30—Harp and Flute Records. 7.45—News. 8.0—To be announced. 10.0—Weather; Sports. 10.10-10.30—Records. **MORAVSKÁ-OSTRAVA** (Czechoslovakia) 1,113 kc/s (269.5 m.); 11.2 kW. Transmits at intervals from 6.0 a.m. 6.10 p.m.—Record. 6.15—Local News. 6.20—German Transmission. Film Review; Records; Wireless Notes. 7.0—See Prague. 7.25—Military Band. 8.0—See Prague. 8.15—Sec Brno. 10.15-11.0—See Prague. **MOSCOW (No. 1) (Russia)** 174 kc/s (1,724 m.); 500 kW. Transmits at intervals from 3.45 a.m. 6.15 p.m.—Bach. Goutman (Organ); Khachatouron (Arias). 6.40—For Collective Farmers. 7.30—Concert. 9.0—French Talk: Maternity and Child Welfare; Letter-box. 10.5—German Economics Review. 11.5—Spanish Talk: Maternity and Child Welfare. **MUNICH (Germany)** 740 kc/s (405.4 m.); 100 kW. Relay by Nürnberg, 1,267 kc/s (236.8 m.). Transmits at intervals from 6.0 a.m. 12.0 noon—Reich Symphony Orchestra and Soloists. Conductor: Kloss. 2.0—News. Exchange. 2.10-2.20—A Week-end Excursion from Augsburg. 3.0—Pultz reads. 3.20—Grauert (Baritone). 3.40—Reading. 4.0—For Farmers. 4.10—Keltic Sonata (MacDowell), by Staab (Pfte.). 4.40—Talk: Bavaria as a Film Setting. 5.0—See Leipzig. 6.30—"A Sing-Song on the East Prussian Amber Coast"—Relay from a Warnicken Labour Camp. 7.0—See Deutschlandsender. 7.45—Talk: Accidents. 8.0—News. 8.15—See Stuttgart. 10.0—News; Exchange; Sports. 10.20—To be announced. 11.0-12.0 m't—Dance Music from Berlin.

THURSDAY (July 25)

Hygiene. 7.53—Talk: The Colonies. 8.0—Report on the Cycle Tour of France. 8.15—Wireless Review. 8.30—"L'amour mouillé"—Opéramaque in Three Acts (Varney). Conductor: Géoris. 10.30—News.

PARIS (Radio-Paris) (France)

182 kc/s (1,648 m.); 80 kW. 6.45 a.m.—Gym; Records. 7.15—News. 7.45—Gym; Records. 11.45—Protestant Address. 12.15 p.m.—Harp, pfte., strings. In the interval at 1.20: News; Exchange. 3.30—Casino Concert from Vichy. Conductor: Fourstier. In the interval: Exchange. 4.50—Plays. "Les folies amoureuses"—Three Acts in Verse (Regnard). "L'école des mères"—One Act (Marivaux). 6.30—For Farmers; Exchange; Markets; Racing. 6.50—For Ex-Servicemen. 7.0—Economics. 7.35—Review by Arnyvelde. 7.40—Tunisian Impressions. 8.0—Reading (Myriam Harry). 8.30—Press Review. 8.45—Plays. "Manu militari" (Gavault). "La rente viagère" (d'Hervilliez). 9.45—National Orchestra. Conductor: Inghelbrecht. Doyen (Pfte.). Overture, "Il Seraglio" (Mozart). Contre rimes (Delage). Cançunik (Florent Schmitt). Pelléas et Mélisande (Fauré). Fantasia (Aubert). Pastorale (Auric). Ballet Music, "Namouna" (Lalo).

PRAGUE (Czechoslovakia)

638 kc/s (470.2 m.); 120 kW. Transmits at intervals from 6.0 a.m. 3.0 p.m.—Orchestra. Conductor: Hertl. 4.0-4.10—Exchange; Weather. 4.30—Orchestra from Brno. 5.40—For Housewives. 5.45—Records. 5.50—For Farmers. 6.0—Records. 6.10—Talk for Workers; Camping. 6.20—German Transmission: Reifner Songs by Helena Sachser; For Farmers. 7.0—News (German). 7.10—Records. 7.15—News. 7.25—See Moravská-Ostrava. 8.0—Talk: Thunderstorms and Lightning Conductors. 8.15—"Annie"—Literary and Musical Programme. 9.5—Cerny ("Cello). Ballad and Serenade (Suk). Adagio (Grecchi). Allegro appassionato (Saint-Saëns). 9.30—Book Review. 9.35—See Brno. 10.15—News. 10.35-11.0—Scandinavian Songs by Hilmar Biehl. Serenade. "Once upon a time" (Lange-Müller). Aria, "The Witch" (Enna). Min Ungdoms Dröm (Gram). Serenade (Börresen). Aria (Atterberg). De ligger en Sö (Nielsen).

RADIO-NORMANDIE

(France) 1,113 kc/s (269.5 m.); 10 kW. 7.0 a.m.—Records. 7.20—News. 7.45—Records. 7.48—Racing Notes. 7.50—Records. 7.53—Cookery Hints. 8.0—Records. 8.15—Orchestra. 8.30—Light Music. 8.45—Records. 10.0—Symphony Orchestra. 11.0—Chansonnettes. 12.0 noon—Military Band. 12.40 p.m.—News. 1.0—Programme for Children. 4.0—Dance Music. 4.45—For Children. 5.0—Dance Music. 5.15—Violin, 'Cello, and Pfte. 5.30—Records. 6.0—Opera and Operetta Music. Selection, "The Gipsy Baron" (Strauss), and "The Merry Widow" (Lehár-Robrecht). Overture, "Beneditenstreiche" (Suppé). Overture, "Zampa" (Hérold). Selection, "The Czarevitch" (Lehár). Overture, "La petite Bohème (Hirschmann). Selection, "Le voyage en Chine" (Bazin). Selection, "The Gipsy Princess" (Kálmán). 6.45—Talk: Vipers. 7.0—Request Music. Boulicot astro-nome (Recordier). Alain Gerbault Potpourris (Willemetz). Le pays des roses (Petit). Folies musicales. Selection, "White Horse Inn" (Stolz-Benatzky). Antonio (Menichetti). Excerpts, "Coups de roulis" (Messager). Les joyeux forgerons (Messier). 8.0—Records. 8.15—Soloists. Couiawiak-Mazurka in A minor (Wieniawski). Marche des petits tambours (Poliakín). Hungarian Dance No. 1 (Brahms). Song of the Nightingale (Ross).

8.30—Songs. Sur l'herbe (Ravel). Capucin et Capucine (Auráin). Histoires naturelles (Ravel). Petites files (Urget). 8.45—Talk. 9.0—Cabaret. 11.0—Records. 12.0 m't-2.0 a.m. (Friday)—Dance Music.



Plombières, from which the Strasbourg concert comes at 8.30 p.m.

E.N.A.

Schróter (Pfte.). Excerpts, Fantasiestücke. Song Cycle, Frauenliebe und leben. Quartet in A minor. Husarenlied. Romance in F sharp. Excerpts, Albumblätter.

HAMBURG (Germany)

904 kc/s (331.9 m.); 100 kW. Relay by Bremen, Flensburg, Hanover, Magdeburg and Stettin, 1,330 kc/s (225.6 m.). Transmits at intervals from 5.40 a.m. 12.0 noon—Shipping. 12.10 p.m.—Concert from Munich. In the interval at 1.5—Review. 2.0—News. 2.20—Music. 3.0—Exchange. 3.30—Brazilian Exchange. 3.40—Shipping. 4.0—"Summer Fruit"—Variety. 4.45—Books. 5.0—See Leipzig. 6.30—Review. 6.45—Exchange; Shipping. 7.0—Talk on Records: The German Microphone. 7.15 (from Bremen)—Folk Music. Weser Mandoline and Guitar Club. Conductor: Beermann; Bremen Concertina and Bandionon Club. Conductor: Meyer. March (Sörtschmann). Fantasia, Flora (Farranti). Aus froher Kinderzeit (Lübbe). Weaner Madln (Zehrer). Capriccio and Mazurka (Stefanowski). Pizzicati. "Sylvia" (Delibes). March. 8.0—News. 8.10—Station Dance Band and Soloists. Conductor: Bolt. In the interval at 10.0—News. 11.0—Strienz (Songs). Part I. Kilpenen; White Towns. Summer Night. Miracle. Part II. Gretchaninov: The Dreary Steppe. Death. Home. Part III. Moussorgsky: The Seminarist. Song of the Flea. 11.30-12.0 m't—Hamann (Violin). Improvisation, Violin Sonata in E flat (Strauss). Valse caprice and Mazurka (Wieniawski). Elegy (Bazzini). Tango (Albeniz). Spanish Dance (Fal-la). **HILVERSUM (Holland)** 160 kc/s (1,875 m.). Transmitted on Koortwijk on 120 kW. Programme of the General Broadcasting Society (A.V.R.O.). 7.40 a.m.—Records. 8.40—Cantor Orchestra. 9.40—Service. 9.55—Records. 10.10—Cantor Orchestra. 10.40—Variety. Oosthoek (Recitations). Gebgart (Cello). Klitgaard (Songs); Records. 12.10 p.m.—Keth Ensemble. In the interval: Records. 1.40—Schubert-Debussy. Luyken (Pfte.); Dora Wallant (Recitations). 2.40-3.25—Kovacs Lajos Orchestra. 3.40—For Hospitals. 4.10—Records.

10.50-11.40—Jack de Vries and his Internationals from Nymwegen.

HUIZEN (Holland)

995 kc/s (301.5 m.); 20 kW. 7.40-8.55 a.m.—Programme of the Catholic Radio Society (K.R.O.). Records. 9.40-10.40—Programme of the Christian Radio Society (N.C.R.V.). 9.40—Records. 9.55—Religious Programme. 10.25—Records. 10.40-1.40 p.m.—K.R.O. Programme. 10.40—Records. 11.10—Religious Address. 11.40—Police Messages. 11.55—K.R.O. Boys. Conductor: Lustenhouwer. 1.40 till Close Down—N.C.R.V. Programme. 1.40—Handicrafts. 2.40-3.25—Visser (Organ). 3.40—Bible Reading; J. Smit Duyzentkunst (Baritone); H. Smit Duyzentkunst (Organ). 4.40—Handwork for Children. 5.10—Keereweer (Songs). 6.10—Records. 6.40—Police Messages; Religious News. 6.55—Report. 7.10—Press Review. 7.40—News. 7.45—Records. 8.10—"Ars et Labor" Mandoline Ensemble. Conductor: Mme. de Wal-Tapking. Blaauw (Organ). Overture, "Myrthalla" (Maciocchi). Menuet des petites précieuses (Pares). Overture in B minor (Wólki). Overture in A (Wólki). Piece (Bambina). March of the Templars (Benedict). A Memory (Frim). Fantasia (Schubert). Die grosse Stunde (Wólki). In the intervals at 8.40: Talk, and at 9.35—News. 10.10-11.40—Records.

KALUNDBORG (Denmark)

238 kc/s (1,261 m.); 60 kW. Relay by Copenhagen, 1,176 kc/s (255.1 m.). Transmits at intervals from 7.0 a.m. 12.0 noon-2.0 p.m.—Anderson String Ensemble from the Bellevue Strandhotel. 3.30—Rydahl Instrumental Ensemble. Helge Rungwald (Songs). 5.30—Exchange; Markets. 6.12—Poem. 6.15—Talk: Robert Burns. 6.45—Announcements. 7.0—News. 7.20—Tourist Talk. 7.30—Talk: A Centre of Religious Thought. 8.0—New Operetta Music—Radio Orchestra. Conductor: Máhler. Else Marie Hansen (Songs). Hungarian March, "Der Teufelsreiter" (Kálmán). Songs, "Mister Cinders" (Ellis). Selection, "The Land of Smiles" (Lehár). Songs from (a) "Frederica" (Lehár), (b) "Spring in Heidelberg" (Raymond). Selec-

KÖNIGSBERG (Germany)

1,031 kc/s (291 m.); 60 kW. Relay by Danzig, 1,303 kc/s (230.2 m.). Transmits at intervals from 4.53 a.m. 12.0 noon-2.0 p.m.—See Munich. In the interval at 1.0: News. 2.0—News. 2.15—Variety from Deutschlandsender. 3.0—Markets. 3.10—Eurhythmic for Children. 3.40—Technical Talk. 4.0—See Deutschlandsender. 4.25—Gudian (Guitar). 4.45—Report: The Tiefenau Sports Instructor. 5.0—See Leipzig. 6.30—Markets. 6.40 (from Danzig)—For Farmers. 7.0—Announcements. 7.10—To be announced. 7.30—Modern Songs by Girls. Conductor: Bless. 8.0—News. 8.15—See Stuttgart. 10.0—News; Sports. 10.20—"Take your Seats!"—Report from a Railway Station. 10.45-12.0 m't—Dance Music from Berlin.

LEIPZIG (Germany)

785 kc/s (382.2 m.); 120 kW. Relay by Dresden, 1,285 kc/s (233.5 m.). Transmits at intervals from 5.50 a.m. 12.0 noon—See Munich. In the interval at 1.0 p.m.: News. 2.0—News; Exchange. 2.15—Variety from Deutschlandsender. 3.0—"The Hohentwiel"—Sequence (Günther), on Records. 3.45—Exchange. 4.0—Irngard Eitzdorf (Contralto), Blumer (Pfte.). 4.30—Talk: Weinlig, Wagner's Teacher. 4.50—Exchange. 5.0—Leipzig Symphony Orchestra and French Horn Quartet. Conductor: Blumer. Band. Conductor: Krüger-Burghardt. 6.30—Talk: Landworkers in Summer. 6.50—See Deutschlandsender. 7.0—"The North Sea"—Sequence (Ball). 7.45—Report on Records: The Tribschen Wagner Museum. 8.0—News. 8.10—See Hamburg. 10.0—News. 10.30—Old and New Chamber Music with Guitar. Rümmler (Flute), Pohlmann (Viola), Neemann (Guitar). German Dances (Schubert). Minuet (Weber). Serenade (Neemann). Trio in E minor (Fiebíng). 11.0-12.0 m't—Dance Music from Berlin.

LISBON (Portugal)

629 kc/s (476.9 m.); 20 kW. Transmits at intervals from 12.0 noon. 7.0 p.m.—Music. 7.55—News;

8.25—Exchange; Records. 8.50—Talk. 9.0—Folk Music. 9.30—News; Band. In the interval at 10.0: Political Review. 10.30—News; Music. 11.0—Dance Music. **MONTE CENERI** (Switzerland) 1,167 kc/s (257.1 m.); 15 kW. Transmits at intervals from 12.0 noon. 4.30-6.0 p.m.—See Sottens. 7.30—Harp and Flute Records. 7.45—News. 8.0—To be announced. 10.0—Weather; Sports. 10.10-10.30—Records. **MORAVSKÁ-OSTRAVA** (Czechoslovakia) 1,113 kc/s (269.5 m.); 11.2 kW. Transmits at intervals from 6.0 a.m. 6.10 p.m.—Record. 6.15—Local News. 6.20—German Transmission. Film Review; Records; Wireless Notes. 7.0—See Prague. 7.25—Military Band. 8.0—See Prague. 8.15—Sec Brno. 10.15-11.0—See Prague. **MOSCOW (No. 1) (Russia)** 174 kc/s (1,724 m.); 500 kW. Transmits at intervals from 3.45 a.m. 6.15 p.m.—Bach. Goutman (Organ); Khachatouron (Arias). 6.40—For Collective Farmers. 7.30—Concert. 9.0—French Talk: Maternity and Child Welfare; Letter-box. 10.5—German Economics Review. 11.5—Spanish Talk: Maternity and Child Welfare. **MUNICH (Germany)** 740 kc/s (405.4 m.); 100 kW. Relay by Nürnberg, 1,267 kc/s (236.8 m.). Transmits at intervals from 6.0 a.m. 12.0 noon—Reich Symphony Orchestra and Soloists. Conductor: Kloss. 2.0—News. Exchange. 2.10-2.20—A Week-end Excursion from Augsburg. 3.0—Pultz reads. 3.20—Grauert (Baritone). 3.40—Reading. 4.0—For Farmers. 4.10—Keltic Sonata (MacDowell), by Staab (Pfte.). 4.40—Talk: Bavaria as a Film Setting. 5.0—See Leipzig. 6.30—"A Sing-Song on the East Prussian Amber Coast"—Relay from a Warnicken Labour Camp. 7.0—See Deutschlandsender. 7.45—Talk: Accidents. 8.0—News. 8.15—See Stuttgart. 10.0—News; Exchange; Sports. 10.20—To be announced. 11.0-12.0 m't—Dance Music from Berlin. **OSLO (Norway)** 260 kc/s (1,154 m.); 60 kW. Relay by Frederikstad, 776 kc/s (386.6 m.); Hamar, 510.5 kc/s (587.7 m.); Notodden, 1,357 kc/s (221.1 m.); Porsgrund, 850 kc/s (352.9 m.); Rjukan, 1,348 kc/s (222.6 m.); Trøndelag, 629 kc/s (476.9 m.). Transmits at intervals from 11.10 a.m. 6.30 p.m.—Service. 6.55—News. 7.30—Norwegian Music. 8.0—Talk: Industrial Norway. 8.30—Hilda Waldeland (Pfte.) and Andresen (Songs). Pfte.: Italian Concerto (Bach). Songs: (a) Serenade (Widéen). (b) The Sea (Melling). (c) Song (Danning). Pfte.: (a) Ballad in C minor and Etude (Chopin). (b) Perpetuum mobile (Weber). Song: "Das Grab auf der Heide (Heiser). Songs (Kjerulf): (a) Av maanens silvergloed, (b) Visste du vei, (c) Ved sjen den mørke, (d) Mitt hjerte og min lycr. 9.40—News. 10.0—Topical Talk. 10.15-10.45—Variety. **PARIS (Eiffel Tower) (France)** 1,456 kc/s (206 m.); 5 kW. Transmits at intervals from 1.0 p.m. 8.0 p.m.—News. 8.30-10.0—Records. Part I. Messenger. Part 2. Light Music. Part 3. Dance Music. **PARIS (Poste Paris) (France)** 959 kc/s (312.8 m.); 60 kW. Transmits at intervals from 7.10 a.m. 12.0 noon—Exchange. 12.5 p.m.—Records: Military Music. 12.15—A Film for Children. 12.25—An Interview. 12.35—Concert. In the interval at 12.45: Report on the Cycle Tour of France. 1.15—Exchange. 1.20—Interlude. 1.45—Records. 2.0 and 3.15—Exchange. 3.45—Report: Cycle Tour of France. 4.35 and 6.25—Exchange. 6.30—Records. 7.7—Sports. 7.10—News. 7.25—Amusement Guide. 7.27—Cycle Tour of France. 7.40—Variety Concert by The Melodians. 8.10—Talk. 8.30—"Comme la vie" or "L'amour manqué"—Play in Three Acts (Mercier). In the interval at 8.50: Exchange. 10.30-11.0—Records: Light Music. **PARIS (PTT) (France)** 695 kc/s (431.7 m.); 7 kW. Transmits at intervals from 8.0 a.m. 6.30 p.m.—News. 7.45—Talk: Social

THURSDAY (July 25)

ROME (Italy)

713 kc/s (420.8 m.); 50 kW. Relayed by Naples, 1,104 kc/s (271.7 m.); Milan (No. 2), 1,348 kc/s (222.6 m.); Turin (No. 2), 1,357 kc/s (221.1 m.); and Bari, 1,059 kc/s (283.3 m.). Transmits at intervals from 7.30 a.m. 5.5 p.m.—Music. 6.0-6.10—Corn Prices. 6.45—Tourist Report; Announcements. 7.0—News in Foreign Languages; Italian Lesson. 8.15—News. 8.30—Announcements. 8.40—"Cinderella"—Opera in Four Acts (Massenet). Conductor: Parelli. In the intervals: Talk; Announcements. After the Opera: News.

SOTTIENS (Switzerland)

677 kc/s (443.1 m.); 25 kW. Transmits at intervals from 12.30 p.m. 4.30—Mme. Audemars-Capt (Songs). 5.0—Dance Music. 6.0—For Women. 6.30—Viennese Records. 7.0—Reading. 7.25—Violin Records. 7.40—Talk. 8.0—Report of the Cycle Tour of France.

8.2—Radio Suisse Romande Orchestra. Conductor: Moser. Sandoz (Baritone) and Tichy (Organ). Overture, "L'isola disabitata" (Haydn). Arias (Handel): (a) "Alexander's Feast," (b) "Bernice." Concerto for Organ and Strings (Malipiero). Aria, "Elijah" (Mendelssohn). Concerto for Organ and Strings (Scarlati-Malipiero). Arias (Gounod): (a) "Faust," (b) "Romeo and Juliet." Tarantella for Flute, Clarinet and Orchestra (Saint-Saëns). Aria, "Tales of Hoffmann" (Offenbach). Overture, "La belle Hélène" (Offenbach). 9.20—News.

STOCKHOLM (Sweden)

704 kc/s (426.1 m.); 55 kW. Relayed by Motala, 216 kc/s (1,389 m.); Göteborg, 941 kc/s (318.8 m.); Hörby, 1,131 kc/s (265.3 m.), and Boden, 392 kc/s (765 m.). Transmits at intervals from 8.10 a.m. 7.15 p.m.—Talk.

7.30—Carl Richter (Songs). Bella porta (Falconieri). Songs (Scarlatti): (a) Recitative and Aria, (b) Sento nel core, (c) Gia il sole del Gange. Selve amiche (Caldara). Come raggio di sol (Caldara). O nuit, déesse du mystère (Piccini). Danza, danza fanciulla (Durante). Arias (Massenet): (a) "The King of Lahore," (b) "Hérodiade." 8.0—Talk: The Protection of Nature. 8.30—Radio Orchestra. Conductor: Thierfelder. Overture, "The Barber of Bagdad" (Cornelius). Suite in G (Mozart-Göhler). Nocturne (Trapp). Variations and Fugue on a German Folk Melody (Müller). Overture, "Kätzchen von Heilbronn" (Pfitzner). 9.45—News. 10.0—Reading.

10.15-11.0 (from Göteborg)—Military Band. Conductor: Lundström. Florentine March (Fučík). Valse militaire (Waldteufel). Potpourri of Old Melodies (Olausson). Song Potpourri (Lundström). Tango doloroso (Murzilli). March (Damberger).

STRASBOURG (France)

859 kc/s (349.2 m.); 35 kW. Transmits at intervals from 10.45 a.m. 6.0 p.m.—Gérolid (Songs). 6.15—Records.

6.30—Suzanne Ducas (Pfte.). Sonata (Beethoven). Aria (Schumann). Etude (Chopin). Tango (Ducas). Mystères (Ducas). Prelude (Morel). 7.0—Marthe Hengel (Soprano). Spanish Songs (Falla). Songs (Vuillemoz): (a) Les trois princesses, (b) Jardin d'amour, (c) Ronde des filles de Quimper. Song (Schubert). La chimère (Terestchenko). Que dira-t-elle (Busser). 7.30—News. 7.45—News in German. 8.0—Report: "The Cycle Tour of France—Bordeaux-Rochefort-La Rochelle." 8.15—News in German.

8.30—Concert from the Casino, Plombières. Conductor: Muller. Selection, "The Damnation of Faust" (Berlioz). "La Traviata" (Verdi) and "Oberon" (Weber). Träumerei (Schumann). Spring Song (Mendelssohn). Selection, "L'Africaine" (Meyerbeer). In the interval: Talk. 10.25—News. 10.30—See Paris (Radio-Paris).

STUTTGART (Germany)

574 kc/s (522.6 m.); 100 kW. Transmits at intervals from 5.45 a.m. 12.0 noon—See Munich. In the interval at 1.0 p.m.: News. 2.0—See Deutschlandsender. 3.0-3.45—"The Hohenwiel"—Sequence (Günther), on Records. 4.0—Symphony Orchestra from Baden Baden. Conductor: Asmus. 5.0—See Leipzig. 6.30—Spanish. 6.45—For Gardeners. 7.0—See Deutschlandsender. 7.45—To be announced. 8.0—News. 8.15—Wende Dance Band. Nothelfer (Refrains). In the interval: "The Whip"—Cabaret (Horn). 10.0—News; Sports. 10.30—Berlin Opera Wind Ensemble and Pfte. Trio in A minor (Reinecke). Quintet in E flat (Beethoven). 11.15—Dance Music from Berlin. 12.0-2.0 a.m. (Friday)—See Frankfurt.

TOULOUSE (Radio-Toulouse) (France)

913 kc/s (328.6 m.); 60 kW. Transmits at intervals from 8.0 a.m. 7.0 p.m.—"Father Ganfron's Nephew"—Sketch. 7.20—Operetta Music: 7.30—News. 7.45—Sound Film Music. 8.5—Soloists. 8.15—Chansonnettes. 8.30—Orchestra. 9.0—Concert Version of "L'Africaine"—Opera (Meyerbeer). 9.35—Humorous Sketches. 9.45—Lalo. Ballet, "Namouna." Overture, "Le roi d'Ys." Norwegian Rhapsody. Aubade, "Le roi d'Ys." 10.20—Light Music. 10.30—News. 10.45—Songs. 11.0—Dance Music. 11.15—Tyroliennes. 11.35—Dance Music. 11.45—Military Marches. 12.0 m.—"Au caveau de minuit"—Fantasy. 12.15 a.m. (Friday)—News. 12.20-12.30—Orchestra. Freudensalven (Strauss). Toréador et andalous (Rubinstein).

TURIN (No. 1) (Italy)

1,140 kc/s (263.2 m.); 7 kW. Relayed by Milan (No. 1), 814 kc/s (368.6 m.); Genoa, 986 kc/s (304.3 m.); Florence, 610 kc/s (491.8 m.); and Trieste, 1,222 kc/s (245.5 m.). 7.35 a.m.—Gym. 7.45—News. 11.30—Ambrosiana Orchestra. Con-

ductor: Culotta. 12.45 p.m.—News. 1.5—Light Music. 1.30—Lonardi (Violin). 2.0-2.25—Exchange; Records. 4.30—News. 4.40—For Children. 5.0—Report on the Cycle Tour of France. 5.5—Manassero (Tenor). 6.0-6.10—For Farmers; Corn Prices. 6.45—Tourist Report; Announcements. 7.0—News in Foreign Languages; Italian Lesson. 8.15—Report on the Cycle Tour of France. 8.20—News. 8.30—Announcements; Talk. 8.40—Orchestra. Oriental March Eritrea (D'Elia). Symphony No. 4 in F (Beethoven). Prelude, Presso il clitumno (Gasco). Selection, "La Bohème" (Puccini). Overture, "Oberon" (Weber). 10.10—Orchestra. In the interval: Talk. 10.30—Concert by the Chigiana Academy, Siena. 11.0—News. 11.10—News (Spanish).

VIENNA (Austria)

592 kc/s (506.8 m.); 100 kW. Relayed by Graz, 886 kc/s (338.6 m.); Innsbruck, 519 kc/s (578 m.); Dornbrunn, Klagenfurt and Linz, 1,294 kc/s (231.8 m.); and Salzburg, 1,348 kc/s (222.6 m.). Dr. Dollfuss Commemoration Programme. 8.50 a.m.—News. 9.0-10.30—"Requiem" (Mozart). Cathedral Orchestra. Conductor: Habel. Else Schmid (Soprano), Emilie Rutschka (Contralto), Georg Maiki (Tenor), Hans Loibenecker (Bass). 11.30—Talk: Leadership. 12.0 noon—Vienna Chamber Orchestra. Conductor: Auerheth. Lorenzi (Baritone). In the interval at 1.0 p.m.: News. 2.0—Grail Scene, "Parsifal" (Wagner) on Records. 2.20—Announcements. 2.45—Weather. 3.15—"At this Hour Engelbert Dollfuss died." 3.20—Two Minutes' Silence. 3.22—Chimes from St. Stephen's Cathedral. 3.35—String Quartet in E minor (Beethoven), by the Mildner Quartet. 4.15—Dollfuss and the Future. 4.45—Walter (Organ). 5.20—Reading: Dollfuss. 6.0—Dollfuss Memorial Demonstration in the Heiden-Platz. 8.0—News. 8.10—Beethoven. Vienna Symphony Orchestra. Conductor: Konrath. Franz Schmidt (Pfte.). Overture,

Coriolanus. Pfte. Concerto in E flat. Symphony No. 5 in C minor. 9.30—Records of Dr. Dollfuss' Speeches, with Commentary. 10.10—News. 10.20-11.30—"Austria's Immortal Song"—Recitations from "Das grosse Händelfalten" and "Redeliber Oesterreich" (Anton Wildgans). Allegro moderato and Andante con moto from the Eighth Symphony in B minor (Schubert) by the Vienna Symphony Orchestra. Conductor: Konrath.

WARSAW (Poland)

224 kc/s (1,339 m.); 120 kW. Relayed by Katowice, 758 kc/s (395.8 m.); Lwów, 795 kc/s (377.4 m.); Poznań, 868 kc/s (345.6 m.); and Wilno, 536 kc/s (559.7 m.). Transmits at intervals from 6.30 a.m. 12.15 p.m.—Song Records. 1.0—For Women. 1.5-1.30—from Katowice—Mandoline Orchestra. 3.15—Exchange. 3.25—Announcements. 3.30—Schubert. Irena Kaszowska (Pfte.). 4.0—For Children. 4.15—Records of Edith Lorand's Orchestra. 4.50—Prose Recitations. 5.0—Light Music. Station Orchestra. Conductor: Rybicki. Kaupa (Songs). 6.0—Talk: Reinhardt's Book, "Eleonora Duse." 6.10—Poems. 6.15—Choir. Conductor: Hynk. 6.30—Holiday Hints. 6.40—Art Review. 6.45—Records. 7.5—Announcements. 7.30—Records. 7.50—Topical. 8.0—For Country Youth. 8.10—Light Music. Small Station Orchestra. Conductor: Górzynski. Zyski (Pfte.). 8.45—News. 8.55—Poland Yesterday and To-day. 9.0—Station Orchestra. Conductor: Oziminski. Wolinski (Tenor). Overture, "Das Nachtlager von Granada" (Kreutzer). Aria, "The Mastersingers" (Wagner). Rhapsody, "España (Chabrier). Arias: (a) "Des Grieux" (Massenet), (b) "Manru" (Paderewski). 9.30—Dramatic Programme. 10.0—Sports. 10.10—Small Station Orchestra. Conductor: Górzynski. Gipsy March (Jarno). Overture, Miramare (Fučík). Viennese Waltz (Ziehrer). Gavotte (Lincke). Selection, "The Grand Duchess of Gerolstein" (Offenbach). Pierrot and Colombine (Korngold). Novlette (Moret). Mountain Dances (Rybicki). Waltz (Translauteur). Potpourri (Morena).

FRIDAY July 26

SYMPHONY CONCERTS P.M.

- 8.0 Vienna and Several European Stations: Bruckner Festival relayed from Linz: the Philharmonic (Walter). 8.10 Berlin: Brahms, Mozart, etc. 8.30 Eiffel Tower: Conductor, Flament; Doyen, pianoforte. 9.0 Brussels 2: "Wagadu," oratorio (Vogel). 9.0 Leipzig: Atterberg, Delius. 10.15 Kalundborg: Boccherini, Haydn.

LIGHT CONCERTS

- 12.15 Radio-Paris: Orchestra, songs. 1.15 National: Birmingham Phil. strings. 3.30 Kalundborg: Preil's Ensemble. 4.0 Deutschlandsender: Band concert. 5.0 Brussels 1: Delcroix programme. 5.0 Hamburg, etc.: Light music. 5.0 Warsaw: Czech music. 6.15 Brussels 2: Light music. 7.0 Breslau, etc.: Band concert. 7.10 Leipzig: Folk music. 7.55 Huizen: Choral concert. 8.0 Brussels 1: Ex-Service Men's hour. 8.0 Brussels 2: Light orchestral. 8.0 National: BBC Military Band. 8.10 Frankfurt: Folk music. 8.10 Hilversum: Conductor, Schuricht. 8.35 Radio-Paris: Relay from Vichy. 8.40 Rome: Orchestra, violin, pfte., song. 8.45 Athlone: Irish music. 9.0 Cologne: Düsseldorf music. 9.0 Königsberg: Elbing orchestra. 9.0 Warsaw: Goldmark, Massenet, etc. 9.5 Bucharest: Salon orchestra. 9.10 Munich: Paul Graener programme. 10.0 Stockholm: Light music. 10.15 Huizen: Hungarian music. 10.30 Budapest 1: Cigány band. 10.30 Munich, etc.: A Summer Night programme. 10.30 Stuttgart, etc.: Variety concert.

11.0 Cologne, etc.: Orchestra.

- 12.0 Stuttgart, Frankfurt: Operetta music.

OPERA

- 7.0 Hamburg: "Der betrogene Cadi" (Gluck).

OPERETTAS

- 8.20 Poste Parisien: "Ames sœurs" (Waltham).

- 9.10 Beromünster: "Betrothal by Lantern Light" (Offenbach).

- 10.10 Regional: "1066 and all that," excerpts.

CHAMBER MUSIC

- 1.40 Hilversum: Hofstad Quartet. 6.50 Strasbourg: Violin, pfte. (Beethoven, Debussy). 8.15 Bucharest: Quartet (Debussy). 9.50 National: Pfte. quartet, songs. 11.0 Radio-Paris, Strasbourg: Chamber Orchestra, songs.

RECITALS

- 3.30 Warsaw: Pianoforte (Schumann). 4.0 Breslau: Pianoforte. 4.10 Munich: Cello, pianoforte. 5.20 Vienna: Violin, pfte., song. 6.30 Brussels 1: Pfte. (Chopin, Liszt). 7.30 Prague: Songs. 7.30 Warsaw: Songs, Arias. 7.35 Radio-Paris: French song. 9.30 Regional: Louis Godowsky (violin). 10.15 Oslo: Songs (Brahms, Grieg). 10.30 Turin: Violin. 11.20 Budapest 1: Songs.

PLAYS

- 8.30 Frankfurt, Stuttgart: Alpine comedy, with song interludes. 8.30 French P.T.T. Stations ex. Radio-Paris: Dumas (fils) programme. 9.10 Hamburg: "Bismarck and Nikolsburg."

DANCE MUSIC

- 10.10 Warsaw; 10.25, Brussels 1; 10.45 Paris (PTT); 11.0, Deutschlandsender, Kalundborg, Regional; 11.15, National; 11.50, Vienna; 12.0, Radio-Normandie.

NATIONAL

- For Time Signals, see Monday 10.15 a.m. (Droitwich)—Service. 10.30 (Droitwich)—Weather Forecast. 10.45—"Getting Your First Job." Sir Herbert Morgan, K.B.E. 11.0—Cinema Organ (Reginald New). 11.30—Trocadero Cinema Orchestra. 12.30 p.m.—BBC Dance Orchestra. 1.15—Birmingham Philharmonic String Orchestra. Conductor, Johan Hock. Lilian Niblette (Pfte.). Toccata (Frescobaldi). Concerto in D minor (Bach). Serenade (Redman). Tarantelle (Castaldi). 2.0—Pavilion Theatre Orchestra. 3.0—Harrogate Municipal Orchestra. Scenes Napolitaines (Massenet). Selection, The Three Musketeers (Friml). Overture, The Italian in Algiers (Rossini). Four English Dances (Cowen). Gavotte (Mignon) (Thomas). Valse Fantaisie (Glinka). Selection, Aida (Verdi). 4.15—Hotel Metropole Orchestra. 5.15—Cedric Sharpe Sextet. Leonie Zifado (Soprano). 6.0—"The First News." 6.25—Bulletin of Special Notices. 6.30 (Droitwich)—Victor Olof Sextet. Selection, The Fantastic Toyshop (Rossini-Respighi). Romance, Juliet (Ffoolkes). Handel in the Strand (Grainger). Meeting of the Waters, The Lass of Richmond Hill (Trad.). Air de Ballet (Phillips). Tina (Rubens). Czardas (Michiels). 7.15 (Droitwich)—Dance Orchestra. 8.0—BBC Military Band. Conductor, B. Walton O'Donnell. Overture, The Bartered Bride (Smetana). Selection, Carmen (Bizet). Waltz, The Grenadiers (Waldteufel). Habanera (Chabrier). March, Castaldo (Novacek). 8.40—"The Mystery of the Seven Cafés"—3: Budapest. 9.30—"The Second News." 9.50—Chamber Music: The English Ensemble. Herbert Heyner (Baritone). Quartet in C minor (Op. 15) (Fauré). Minnelied, Die Mainacht, Auf dem Kirchhofe, Mein Mädel hat einen Rosenmund (Brahms). Trio in G (Op. 9, No. 1) (Beethoven). Les deux Ménétriers (Cui). Only the Longing Heart, Don Juan's Serenade (Tchaikovsky). Quartet in One Movement (Bax). 11.15-12.0 (Droitwich)—Dance Music: Harry Roy and his Band.

REGIONAL

- For Time Signals, see Monday 10.15-10.45 a.m. (except Midland)—Droitwich. 10.45—Light Orchestra. 11.30—Records. 12.0—Mendelssohn Organ Recital. 12.30 p.m.—Records. 1.0—Coventry Hippodrome Orchestra. 2.0—Miscellaneous Records. 2.30—New Georgian Trio, Toni Farrell (Pianoforte). 3.30—Dance Records. 4.0—BBC Midland Orchestra, conducted by Leslie Heward. 5.15—"The Children's Hour." 6.0—"The First News." 6.30-8.0 (ex. Midland); Northern from 7.15; Scottish from 7.0)—Droitwich. 6.30 (Northern)—Gardening Talk. 6.30 (Scottish)—Next week you'll hear... 6.40 (Scottish)—Topical Talk. 6.50 (Northern)—Rochdale Co-operative Pioneers Society. 6.50 (Scottish)—For Farmers. 8.0 (Regional, Northern, Western)—"The Judgment of Paris." A Masque by William Congreve, set to Music by John Eccles. Transcribed and arranged by Anthony Bernard. 8.0 (Midland)—"The Langleys." 8.0 (Scottish)—Studio Orchestra. Maurice Clare (Violin). 8.0 (N. Ireland)—"Jubilee Follies." 8.30 (N. Ireland)—Topical Talk. 8.45 (Midland)—Jack Wilson and his Versatile Five with Alex Penney. 8.45 (Scottish)—"Return to Clyde." A Play by Edward Shiel. 8.45 (N. Ireland)—N. Ireland Orchestra. Hooten Mitchell (Baritone); Frederick Stone (Pianoforte). 9.0 (Regional)—Records. 9.0 (Northern)—"The Bouquets." 9.0 (Western)—"Yr Hen Broffwyd." 9.15 (Western)—"Fools in Fantasy." 9.30 (Regional)—Louis Godowsky (Violin). 9.30 (Midland)—Hawaiian Islanders. John Bentley (Baritone). 9.30 (Scottish)—Margaret Allan (Soprano); Philip Malcolm (Baritone); Studio Orchestra. 10.0—News Summary. 10.10—Excerpt from "1066 and All That." Relayed from The Strand Theatre. 10.35—Sports Bulletin. 10.45—A Further Excerpt from "1066 and All That." 11.0-12.0 (Midland till 11.15)—Harry Roy and his Band.

Hours of Transmission in British Summer Time.

ATHLONE (Ireland)

565 kc/s (531 m.); 60 kW. Relayed by Dublin, 1,348 kc/s (222.6 m.) and Cork, 1,240 kc/s (241.9 m.). 1.30-2.30 p.m.—Records. 6.0—For Children. 6.45—News. 7.0—Male Voice Choir: Student Songs. 7.30—Debate by Donagh MacDonogh and Noel Hartnett. 8.0—Station Orchestra. 8.30—Gaelic Reading. 8.45—Irish Music. Station Orchestra. Terry Lane (Accordion). 9.45—What happened to-day. 10.0—Variety. 10.30-11.0—Ceilidhe Music. A. L. Molloy's Band.

BERLIN (Germany)

841 kc/s (356.7 m.); 100 kW. Transmits at intervals from 6.0 a.m. 12.0 noon—See Frankfurt. In the interval at 1.0 p.m.: Midday Echoes. 2.0—News. 2.15—Opera Ballet Music. Small Station Orchestra. Conductor: Steiner. 3.0—Exchange. 4.0—"Painting the Town Red"—Sequence (Rose). 4.30—"Life on a Balcony"—Sequence (Heynicke), with Music by Langer. 5.0—See Hamburg. 6.30—Books. 7.5—See Munich. 7.30—Discussion: Broadcasting. 7.40—Evening Echoes. 8.0—News. 8.10—Orchestra. Conductor: Havemann. Zernick (Violin). Serenade in D (Brahms). Invitation to the Dance (Weber). Violin Concerto in D (Mozart). Piece (Havemann). Symphonic Poem, Tasso (Liszt). Hungarian March (Berlioz). 10.0—News: Sports. 10.20—Sports Talk. 10.30—Reading (Meyer). 11.0-12.0 m't—See Cologne.

BEROMÜNSTER (Switzerland)

556 kc/s (539.6 m.); 100 kW. Relayed by Basle and Berne, 1,375 kc/s (218.2 m.). 12.0 noon (from Basle)—Records. In the interval at 12.29 p.m.: News. 1.25—Exchange. 4.0-6.30—Programme from Basle. 4.0—Dance Records. 4.30—Songs. von Schenk (Tenor) and the Small Radio Orchestra. 5.30—Leontina Durandi (Pfte.). 6.0—Fairy Tales. 6.30-8.35—Programme from Berne. 6.30—Talk: Exports. 7.0—Markets; Tourist Report. 7.20—French. 7.50—Folk Music. Chüjer Yodelling Club and a Village Band. 8.20—Talk: Juvenile Welfare Institutions. 8.35—Small Radio Orchestra. 9.0—News. 9.10-10.5 (from Berne)—"The Betrothal by Lantern light"—One-Act Operetta (Offenbach). Berne Municipal Orchestra. Conductor: Lertz.

BRATISLAVA (Czechoslovakia)

1,004 kc/s (298.8 m.); 13.5 kW. Transmits at intervals from 6.0 a.m. 6.35 p.m.—Talk. 6.50—Records. 7.0—See Prague. 8.45—Sylvia and Rudolf Macduzinski (Two Pfters.). 9.10—Part Relay of the Bruckner Festival from Linz (See Vienna). 10.15—See Prague. 10.30—News (Hungarian). 10.45-11.0—Records.

BRESLAU (Germany)

950 kc/s (315.8 m.); 100 kW. Relayed by Gleiwitz, 1,231 kc/s (243.7 m.). Transmits at intervals from 5.0 a.m. 12.0 noon—See Frankfurt. 2.0—News. 2.10—Exchange; Announcements. 2.40—Greetings. 2.45—Markets. 3.10—Books. 3.30—Dialogue: The Stratosphere. 3.50—Reading. 4.0—Nora Wallosek (Pfte.). Schumann and Chopin. 4.30—Reading. 4.45—Book Review. 5.0—See Hamburg. 6.30—"We discover an Island!"—Play (Kuhnert). 6.50—Announcements; For Farmers. 7.0—Band. Conductor: Ulrich. Friderichs-Rex (Radeck). Eifermarsch (Reindel). Helenenmarsch (Lübbert). Pepita-Marsch (Neumann). March (Faust). March and Theme, "Indra" (Neumann) Preussens Gloria (Piefke). Alexander March (Leonhardt). March on Themes from "Le brasseur de Preston" (Adam). Victoria March (Neumann). March. Der Jäger aus Krupfalz (Rhode). Soldatenklänge (Buchholz). Swedish Cavalry March. 8.0—News. 8.10—"A Soldier's Life"—Humorous Sequence. 9.10—Marches. Military Band. Conductor: Ulrich. 10.0—News. 10.30—See Munich. 11.30-12.0 m't—Music from Stuttgart.

BRNO (Czechoslovakia)

922 kc/s (325.4 m.); 32 kW. Transmits at intervals from 6.0 a.m. 6.20 p.m.—Records. 6.30—News. 6.35—Tourist Report. 6.40—Talk. 6.50—Records. 7.0—See Prague.

7.25—Talk. 8.0 See Prague. 8.45—Bagpipes. 9.10—Part Relay of the Bruckner Festival from Linz (See Vienna). 10.15-11.0—See Prague.

BRUSSELS (No. 1) (Belgium)

620 kc/s (483.9 m.); 15 kW. 12.0 noon—"Birds"—Records. 12.20 p.m.—Deleuze (Accordion). 12.30—Film Records. 1.0—News. 1.10—Records; Swedish and Norwegian Music. 1.30—Myriam d'Orion (Songs). 1.40-2.0—Italian Opera Records. 4.55—Announcements. 5.0—Delcroix. Symphony Concert from the Exhibition. Conductor: Andr. 6.0—Request Records. 6.15—Talk: Careers for Girls. 6.30—Chopin. Liszt. Mary Delporte (Pfte.). Polonaise in C sharp and Berceuse (Chopin). Spozalizio and Pesther Karneval (Liszt). 7.0—Talk: "Electric Gadgets on Cars. 7.15—Nineteenth Century Poems to the Pfte. 7.30—Colonial Review. 8.0—Ex-Servicemen's Programme. Pages of War History. Part I, Allied Cavalry. Part II, Allied Infantry.

6.15—Talk. 6.45—Records. 7.15—Rózsa Ignác and Lajos Köpeczi-Boócz. 8.0—See Vienna. 10.10—News. 10.30—Vidák Cigány Band. 11.20—Somló (Songs). 12.5 a.m. (Saturday)—News.

BUDAPEST (No. 2) (Hungary)

359.5 kc/s (835.4 m.); 20 kW. 6.5—Bertha Orchestra. 7.20—Lajos Veres Cigány Band. 8.35—News. 8.55—Records.

COLOGNE (Germany)

658 kc/s (455.9 m.); 100 kW. Transmits at intervals from 6.0 a.m. 12.0 noon—See Frankfurt. In the interval at 1.0 p.m.: News; Greetings. 2.0—News. 2.15—Variety from Deutschlandsender. 3.0—Books. 3.15—Talk. 3.30—Exchange. 3.50—Talk. 4.0—Grieg-Dvořák. Johanna Voss (Soprano). Josefa Kastert (Violin). Haass (Pfte.). 4.30—Literary Talk: Heinrich Federer. 4.50—Dialect Verse (Halbach). 5.0—See Hamburg. 6.30—Variety.

Transmits at intervals from 6.0 a.m. 12.0 noon—Orchestra. Conductor: Priedöhl. Hauck Dance Band. Hartung (Refrains). Franz (Xylophone). 1.0 p.m.—News. 1.15—Hauck Dance Band; Hartung (Refrains). 2.0—News. 2.15—Talk: The German Sparkling Wine Trade; Labour Exchange. 2.30—Exchange. 3.15—For Women. 4.0—Hildegard von Buttler (Contralto) Heimpel (Bass). 4.30—Financial Talk: The Motor Industry. 4.45—History Talk. 5.0—See Hamburg. 6.30—Talk: Numerology. 6.45—Topical. 6.55—Exchange; Announcements. 7.5—See Munich. 7.40—Talk on Records: The German Microphone. 7.50—Topical. 8.0—News. 8.10 (from Freiburg)—Folk Music. Freiburg Mandoline and Guitar Society. Conductor: Köhler. Wenner (Accordion). Echtes Wiener Blut (Komzak). Immer gemütlich (Wenner). Japanese Spring Festival (Köhler). Am Trapez (Wenner).

FRIDAY (July 26)

11.40-3.40 p.m.—Programme of the General Broadcasting Society (A.V.R.O.). 11.40—Records. 12.10 p.m.—Kovacs Lajos Orchestra; Records. 1.40—Chamber Music. Hofstad String Quartet. String Quartet (Beethoven). Records. Sonata (Fasch). Sinfonia in C (Bach).

2.40—Dance Music. A.V.R.O. Decibels. Conductor: Meenk. 3.40—7.40—V.A.R.A. Programme. 3.40—Records. 4.40—For Children. 5.10—Light Music. 6.40—Talk. 7.0—Light Music. Conductor: Walis. Never Blue (Ansaldo). Kennst du die Liebe (Schmideder). Tell me tonight (Spoliansky). Invention (Kwadijk). Humoresque (Dvořák-Rossican). Potpourri, Servus Wien (Dostal).

7.30—News: S O S Messages. 7.40—V.P.R.O. Programme. Talk. 8.10-10.10—A.V.R.O. Programme. Concert from the Kurhaus Scheveningen. The Hague Municipal Orchestra. Conductor: Schuricht. In the intervals at 8.55 and 9.55: Talks arranged by the V.P.R.O. 10.40-11.40—V.A.R.A. Programme. Records.

10.40-11.40—V.A.R.A. Programme. Records.

HUIZEN (Holland)

995 kc/s (301.5 m.); 20 kW. Programme of the Catholic Radio Society (K.R.O.). 7.40-8.55 a.m.—Records. 9.40—Records. 10.10—Concert. 10.40—Records. 11.10—Programme for Invalids. 11.40—Police Messages. 11.55—Records. 1.40 p.m.—"Golden Shoes"—Operetta in Two Acts (Brandts Buys Jr.). Schiebroek Children's Choir. Conductor: de Vaal. 't Hardt (Pfte.). 2.40—Records. 2.55—Nelly Verkroost (Soprano) and Nelly Hugues (Contralto). 3.10-3.40—Records. 3.55—Nelly Verkroost (Soprano) and Nelly Hugues (Contralto). 4.10—Records. 4.40—Gardening Talk. 5.10—K.R.O. Boys. Conductor: Lustenhouer. In the interval: Records. 6.40—Police Messages. 6.55—Talk. 7.15—Records. 7.40—News. 7.45—Records. 7.55—"Arti and Charitate"—Mixed Choir. Conductor: Jopp Goosen. Bois-le-Duc Male Voice Choir. Conductor: Kallenbach. Rotterdam Philharmonic Orchestra. Jose Candel (Soprano). Jem Immink (Contralto). Rob Gevers (Baritone). Ogier Jr. (Violin). Piet Hörmann (Pfte.). Kyrie and Agnus Dei from the "Missa Simplex" (Andriessen). Gloria (Caplet). Hymn (Diepenbroek). Frithjof auf seines Vaters Grabhügel (Bruch). Cantique de Pâques (Honegger). Rhapsody (Brahms). Schön Ellen (Bruch). Römischer Triumphgesang (Bruch). In the interval at 8.55: Records. 10.10—News. 10.15—Hungarian Music. Laci Farcas Orchestra. 11.25-11.40—Records.

KALUNDBORG (Denmark)

238 kc/s (1,261 m.); 60 kW. Relayed by Copenhagen, 1,176 kc/s (255.1 m.). Transmits at intervals from 7.0 a.m. 12.0 noon-2.0 p.m.—Nielsen String Ensemble from the Ritz. 3.30—Preil Instrumental Ensemble. In the interval at 4.15 (approx.): Talk: Oehlenschläger's Home. 5.30—Exchange; Markets. 6.10—Reading. 6.45—Announcements. 7.0—News. 7.30—Talk. 8.0—Folk Music. Radio String Orchestra. Conductor: Gröndahl. Ravnebryllup i Kragelund (arr. Halvorsen). Langeland Folk Song (arr. Gröndahl). German Folk Dances (arr. Hensel). Strathspey (arr. Bantock). 8.25—Humorous Political Anecdotes. 8.45—Banner-Jensen (Saxophone). 9.0—Et Uhyre—One-Act Farce (Bögh), with Music by Lumbye. 9.40—Chopin. Brodersen (Pfte.). Mazurka. Etudes in F. E minor, and C. Ballad in G minor. 10.0—News. 10.15—The Radio Symphony Orchestra. Conductor: Gröndahl. Lützöft (Cello). Cello Concerto in B flat (Boccherini). Symphony in C minor (Haydn). 11.0-12.30 a.m. (Saturday)—Dance Music from the Ritz.

KÖNIGSBERG (Germany)

1,031 kc/s (291 m.); 60 kW. Relayed by Danzig, 1,303 kc/s (230.2 m.). Transmits at intervals from 4.58 a.m. 12.0 noon-2.0 p.m.—See Frankfurt. In the interval at 1.0: News. 2.0—News. 2.15—Announcements. 2.45—Reading. 3.0—Exchange. 3.10—Riddles for Children. 3.40—Talk: A Woman in Africa. 4.0—Eighteenth Century Songs by Hildegard Tumm (Soprano). 4.30

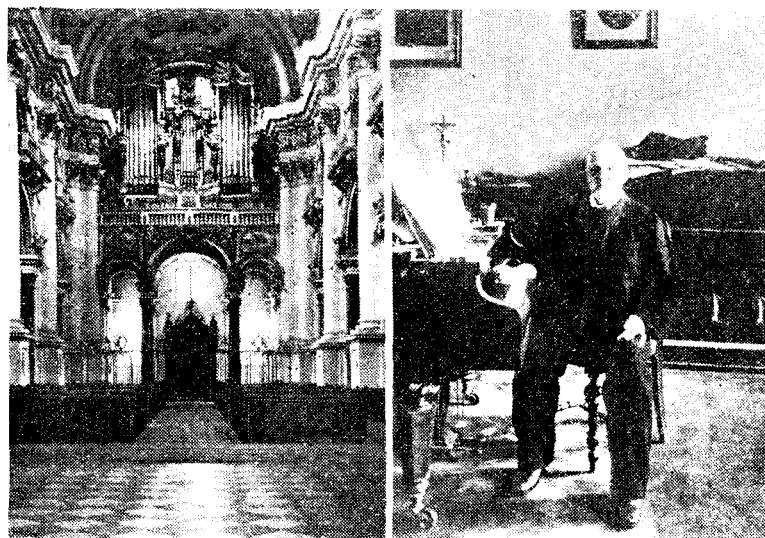

Bruckner and the Organ in the St. Florian Church which he played and beneath which he is buried. Several stations relay part of the Linz Bruckner Festival this evening

Part III, The British Dominions—New Zealand, South Africa, India, and Newfoundland. Radio Orchestra. Conductor: Gason; Announcements. 9.20—Suzanne Storga (Songs). Aria, "Sigurd" (Reyer). Heidenröslein (Schubert). Phidyle (Duparc). 9.40—Interlude. 10.0—News. 10.10—Request Records. 10.25—Dance Records. 11.0—La Brabançonne.

BRUSSELS (No. 2) (Belgium)

932 kc/s (321.9 m.); 15 kW. Programme in Flemish. 12.0 noon-2.0 p.m.—Radio Orchestra. Conductor: Gason. In the interval at 1.0—News. 4.55—Announcements. 5.0—Records. 6.0—Talk: Paul Kenis. 6.15—Light Music. 7.15—Records of Marian Anderson. 7.30—News. 8.0—Orchestra. Gilman (Flute) and Derissen (Cello). March (Schögel). Overture, "Alessandro Stradella" (Flotow). La Gitana (Bucalossi). Carnival of the Gnomes (Raasch). Selection, "Nina Rosa" (Romberg). Flute and 'Cello: Souvenir du Rigi (Doppler). Intermezzo (Ganglberger). Le tour du monde en zeppelin (Mannecke). 8.45—Recitation (Baillon) by Victor Collet. 9.0—"Wagadu"—Oratorio (Vogel) from the Palais des Beaux-Arts: Ilona Durigo, Mia Peltenberg, Félix Loeffel and the Sterksche Pivatorch of Basle. Conductor: Scherchen. After the Programme: News. Records.

BUCHAREST (Romania)

823 kc/s (364.5 m.); 12 kW. Transmits at intervals from 12.0 noon. 6.0 p.m.—Time; News. 6.15—Motzoi Orchestra. 7.0—Talk. 7.20—Records. 7.50—News. 8.0—Talk. 8.15—Quartet in G (Debussy). 8.45—Constance Badesco (Songs). Lullaby (Reger). Piece (Abt). The Nightingale (Alabiev). Waitzes (Lefhar). 9.5—Light Music by the Salon Orchestra. In the interval at 9.30: Time; News and at 10.15: News in French and German.

BUDAPEST (No. 1) (Hungary)

546 kc/s (549.5 m.); 120 kW. 10.20 a.m.—Topical Talk. 10.45—Talk for Children. 12.5 p.m.—Eva Baráth (Pfte.) and Maria Pálffy (Songs). In the interval at 12.30 p.m.: News. 1.20—Weather. 1.30—Military Band. Conductor: Seregi. 2.40—For Housewives. 4.10—For Schools. 4.45—Weather. 5.0—Talk. 5.20—Bertha Orchestra. 6.0—Sports.

6.45—Discussion: Broadcasting. 6.55—Exchange; Sports. 7.0—Station Quintet. 7.30—To be announced. 7.45—Sports Talk. 8.0—News. 8.10—"Country Fairs"—Sketches (Müller-Schlösser).

9.0—"Düsseldorfer Conductors as Composers"—Concert from the Düsseldorfer Tonhalle. Düsseldorfer Concert Orchestra. Conductor: Artz. Eine grosse Konzertouverture (Rietz). Rheinische Lieder-Walzer (Zerbe). Festouverture (Tausch). Rheinlust-Walzer (Zerbe). Overture, "Manfred" (Schumann). 10.0—News. 10.20—Films.

HAMBURG (Germany)

904 kc/s (331.9 m.); 100 kW. Relayed by Bremen, Flensburg, Hanover, Magdeburg and Stettin, 1,330 kc/s (225.6 m.). Transmits at intervals from 5.40 a.m. 12.0 noon—Shipping. 12.10 p.m. (from Bremen).—Niemann Wind Band from the Town Hall. In the interval at 1.0: Review. 2.0—News. 2.20—Music. 3.0—Exchange. 3.30—Brazilian Exchange. 3.40—Shipping. 4.0—Kiel Orchestra. Conductor: Döring. 4.45—We visit Cornils, the Sculptor. 5.0—Light Music. "Hansa" Band. Conductor: Rusch. "Arcari"—Mandoline Quartet. Station Dance Band. Conductor: Gebhardt (Pfte.). 6.30—Sports for Girls. 6.45—Exchange. 7.0—"Der brotogene Cadi"—One-Act Comic Opera (Gluck). Conductor: Schlemm. 8.0—News. 8.10 (from Stettin). Fantasias on German Songs.—Stettin Concert Orchestra. Conductor: Plato. Ebel (Bassoon). Overture, "Franz Schubert" (Suppé). German Rhapsody (Köhler). Bassoon Variations on "In Celler Cool" (Junge). Lied im Volksmund (Kick-Schmidt). Aus Deutschlands Liederhain (Fetras). Overture. Dem deutschen Volke (Zimmer). 9.10—"Bismarck's Nikolshurg Victory"—Play (Heuer). 10.0—News. 10.25—Music. 11.0-12.0 m't—Concert from Stuttgart.

DEUTSCHLANDSENDER (Germany)

191 kc/s (1,571 m.); 60 kW. Transmits at intervals from 5.55 a.m. 12.0 noon—See Hamburg. 1.45 p.m.—News. 2.0—Variety. 3.0—Exchange; Announcements. 3.15—Sailor Songs. 3.45—For Girls. 4.0—Band Concert from the Tiergarten. 5.20—"Boy's Travel Adventures." 5.50—Grete Eweler (Violin). 6.25—Letter-box. 6.40—A Poem. 6.45—To be announced. 7.0—See Breslau. 7.45—News. 8.0—Motto; News. 8.10—An Armchair Tour (on Records). We visit: (a) The "Riviera," Grünau. (b) The "Seeschloss," Pichelsberge. (c) "Uncle Tom's Cabin" Krumme Lanke. (d) The Zoological Gardens, Berlin. (e) "Dreamland," Schönholz. (f) "The Abbey," Treptow. (g) The Brandenburg Lakes by Steamer. 10.0—News. 10.30—Krüger (Clarinet and Bassoon). 11.0-12.0 m't—Dance Music.

FRANKFURT (Germany)

1,195 kc/s (251 m.); 25 kW. Relayed by Cassel, Coblenz, Freiburg, Kaiserslautern and Trier, 1,195 kc/s (251 m.).

Puppentanz (Köhler). Schnelle Fahrt (Wenner).

8.30—"Auf der Alm, do gib'ts koa Sünd"—Comedy about Alpine Holiday-makers (Graff), with Songs (Diekmann). 10.0—News; Sports. 10.45—Report from the Nürnbergring: Training for the German Grand Prix. 11.0—With the Microphone at Variety Shows. 12.0 m't-2.0 a.m. (Saturday)—See Stuttgart.

HAMBURG (Germany)

904 kc/s (331.9 m.); 100 kW. Relayed by Bremen, Flensburg, Hanover, Magdeburg and Stettin, 1,330 kc/s (225.6 m.). Transmits at intervals from 5.40 a.m. 12.0 noon—Shipping. 12.10 p.m. (from Bremen).—Niemann Wind Band from the Town Hall. In the interval at 1.0: Review. 2.0—News. 2.20—Music. 3.0—Exchange. 3.30—Brazilian Exchange. 3.40—Shipping. 4.0—Kiel Orchestra. Conductor: Döring. 4.45—We visit Cornils, the Sculptor. 5.0—Light Music. "Hansa" Band. Conductor: Rusch. "Arcari"—Mandoline Quartet. Station Dance Band. Conductor: Gebhardt (Pfte.). 6.30—Sports for Girls. 6.45—Exchange. 7.0—"Der brotogene Cadi"—One-Act Comic Opera (Gluck). Conductor: Schlemm. 8.0—News. 8.10 (from Stettin). Fantasias on German Songs.—Stettin Concert Orchestra. Conductor: Plato. Ebel (Bassoon). Overture, "Franz Schubert" (Suppé). German Rhapsody (Köhler). Bassoon Variations on "In Celler Cool" (Junge). Lied im Volksmund (Kick-Schmidt). Aus Deutschlands Liederhain (Fetras). Overture. Dem deutschen Volke (Zimmer). 9.10—"Bismarck's Nikolshurg Victory"—Play (Heuer). 10.0—News. 10.25—Music. 11.0-12.0 m't—Concert from Stuttgart.

HILVERSUM (Holland)

160 kc/s (1,875 m.); Transmitted on Kootwijk on 120 kW. 7.40-9.40 a.m.—Programme of the Workers' Radio Society (V.A.R.A.). 7.40—Jong (Organ). 8.10—Records. 9.40-9.55—Religious Programme of the Liberal Protestant Radio Society (V.P.R.O.). 9.55-11.40—V.A.R.A. Programme. 9.55—Recitations. 10.15—Records. 10.40—Recitations. 11.0—Records.

FRIDAY (July 26)

(from Danzig) - Reading (Hans Grimm).

5.0-See Hamburg. 6.30-Markets. 6.40-Between Town and Country. 7.0-Announcements. 7.10-Call of Youth.

7.20-Dance Music from Munich. 8.0-News. 8.10 (from Danzig)-In a Canoe-Sequence (Federau).

9.0-Elbing Municipal Theatre Orchestra. Conductor: von Gersdorff. Overture, "Martha" (Flo-tow). Selection, "Czar and Carpenter" (Lortzing). Künstlerleben (Strauss).

9.40-Talk on Physical Culture. 10.0-News; Sports. 10.20-Talk: East Prussian Chronology. 10.35-Report: The East Prussian Boxing Championship. 10.45-12.0 m-t-Concert from Stuttgart.

LEIPZIG (Germany) 785 kc/s (382.2 m.); 120 kW. Relayed by Dresden, 1,285 kc/s (233.5 m.).

Transmits at intervals from 5.50 a.m. 12.0 noon-Orchestra from Merseburg. Conductor: Schmidt. 1.0 p.m.-News.

1.15-See Frankfurt. 2.0-News. 2.15-Variety from Deutschlandsender. 3.0-3.20-For Women. 3.40-Exchange. 4.0-Burgert (Pfte.), Radelow (Violin), Wawrowski (Cello). 4.30 (from Dresden)-Reading. 4.50-Exchange.

5.0-See Hamburg. 6.30-Talk: Chodowiecki, Painter and Etcher. 6.50-Books for Young People. 7.10-Concert. Part I: Leipzig Concertina Band. Conductor: Frey. Stimmt an mit hellem, hohen Klang (Hofmann). Styrian Dances (Lanner). Aus dem Hochgebirge (Kanter). Part II: Kollmanek plays his own Zither Music, with Rudolf Kross. Concerto in A. An die Freude. Hungarian Fantasia in D minor. 8.0-News.

8.10-"Klein-Paris an der Pleisse"-Sequence about Rococo Leipzig (Görner).

9.0-Leipzig Symphony Orchestra. Conductor: Weisbach. Kopatschka (Violin). Sinfonia piccola in G minor (Atterberg). Violin Concerto (Delius). 10.0-News; Sports. 10.30-12.0 m-t-See Stuttgart.

LISBON (Portugal) 629 kc/s (476.9 m.); 20 kW.

Transmits at intervals from 12.0 noon. 7.0 p.m.-Records. 7.55-News; Folk Music. 8.25-Exchange; Folk Music. 8.50-Talk. 9.0-Inez da Mota (Pfte.); Leonro da Mota (Songs); Music. In the interval at 9.35: News. 10.0-Political Review; Symphony Orchestra. In the interval at 10.30: News. 11.15-Dance Music.

MONTE CENERI (Switzerland) 1,167 kc/s (257.1 m.); 15 kW.

Transmits at intervals from 12.0 noon. 4.30-6.0 p.m.-See Beromünster. 7.30-Records. 7.45-News. 8.0-10.30-Request Programme. In the interval at 10.0: News.

MORAVSKÁ-OSTRAVA (Czechoslovakia) 1,113 kc/s (269.5 m.); 11.2 kW.

Transmits at intervals from 6.0 a.m. 6.0 p.m.-Local News. 6.5-Tourist Report. 6.15-Record. 6.20-Three Talks in German. 7.0-See Prague. 7.25-See Brno. 8.0-9.10-See Prague. 9.10-Part Relay of the Bruckner Festival from Linz (see Vienna). 10.15-11.0-See Prague.

MOSCOW (No. 1) (Russia) 174 kc/s (1,724 m.); 500 kW.

Transmits at intervals from 3.45 a.m. 6.0 p.m.-Concert. 7.0-"Manon"-Opera (Massenet), on Records. 9.0-Czech Sports Talk; Letter-box. 10.5-English Talk: Moscow Shops. 11.5-German Talk: Science and Socialism.

MUNICH (Germany) 740 kc/s (405.4 m.); 100 kW.

Relayed by Nürnberg, 1,267 kc/s (236.8 m.). Transmits at intervals from 6.0 a.m. 12.0 noon (from Nürnberg)-Orchestra. Conductor: Böhm. 1.0 p.m.-News. 1.15-Quartet. 2.0-News; Exchange. 3.0-For Women. 3.40-Songs (Wolf). 4.0-For Farmers. 4.10-Troibner (Cello); Staab (Pfte.). 4.40-Reading. 5.0-Station Orchestra. Conductor: Kloss. 6.30-For Mountaineers. 6.50-For Farmers. 6.55-Discussion: Broadcasting. 7.5-Station Dance Band. 8.0-News.

7.10-"Form Fours!"-A Burlesque Military Review-A.D. 1682.

9.10 (from Nürnberg)-Graener Concert. Conductor: The Composer. Lissy Bühler (Mezzo-Soprano). Sinfonia breve. Lönslieder. Waldmusik. 10.0-News; Exchange. 10.20-To be announced.

10.30-"Summer Night"-Literary and Musical Programme. Reich Symphony Orchestra. Conductor: Adam. Julia Prosel (Soprano), Burkart and Fiedler (Speakers). 11.30-To be announced. 11.40-12.0 m-t-Concert from Stuttgart.

OSLO (Norway) 260 kc/s (1,154 m.); 60 kW.

Relayed by Fredrikstad, 776 kc/s (386.6 m.); Hamar, 510.5 kc/s (587.7 m.); Notodden, 1,357 kc/s (221.1 m.); Porsgrund, 850 kc/s (352.9 m.); Rjukan, 1,348 kc/s (222.6 m.); Trøndelag, 629 kc/s (476.9 m.).

Transmits at intervals from 10.0 a.m. 5.0 p.m.-Grönlund Orchestra. 6.0-Talk in English: The Radio City of New York. 6.30-Concert. 6.55-News. 7.30-Talk.

8.0-See Vienna. 9.5-Talk. 9.40-News. 10.0-Topical Talk.

10.15-10.45-Brahms and Grieg. Anna Tibell (Songs). Part I: Brahms. Mädchenlied. Wie bist du meine Königin. Mondnacht. Vergebliches Ständchen. Dein blaues Auge. Der Jäger. Mainacht. Part II: Grieg. Auf der Reise zur Heimat. Die Prinzessin. Takk for ditt raad.

PARIS (Eiffel Tower) (France) 1,456 kc/s (206 m.); 5 kW.

Transmits at intervals from 1.0 p.m. 8.0 p.m.-News.

8.30-10.0-Symphony Orchestra. Conductor: Flamant. Jean Doyen (Pfte.). Overture, "Anacreon" (Cherubini). Pfte. Concerto in B flat (Beethoven). Les Eolides (Frankl). Pfte. Concerto (Ravel). Suite, "Izeyl" (Pigné). In the interval at 9.15: News.

PARIS (Poste Parisien) (France) 959 kc/s (312.8 m.); 60 kW.

Transmits at intervals from 7.10 a.m. 12.0 noon-Exchange. 12.5 p.m.-To be announced. 12.25-An Interview. 12.35-Records. 12.45-Report: Cycle Tour of France. 1.5-Interlude. 1.15-Records. 2.0, 3.15, 3.45 and 4.45-Exchange.

4.45-Cycle Tour of France. 6.25-Exchange. 6.29-For Farmers. 6.30-Records. 6.50-Talk. 6.57-Records. 7.7-Sports. 7.10-News. 7.25-Amusement Guide. 7.27-Talk. 7.31-Record. 7.35-Cycle Tour of France. 7.50-Records. 8.0-Talk. 8.10-Exchange.

9.20-"Ames soeurs"-Operetta (Waltham). Station Orchestra and Soloists. Conductor: Balay. In the interval at 8.50, Exchange. 9.35-Interlude. 9.50-A Film. 10.30-11.0-Records: Light Music.

PARIS (PTT) (France) 695 kc/s (431.7 m.); 7 kW.

Transmits at intervals from 8.0 a.m. 6.30 p.m.-News. 7.45-Talk: French Museums. 7.53-Review of Foreign Politics. 8.0-Report on the Cycle Tour of France. 8.15-Records. 8.30-Alexandre Dumas fils and his Influence in Europe-Literary Programme. 10.45-Goldy Dance Band.

PARIS (Radio-Paris) (France) 182 kc/s (1,648 m.); 80 kW.

6.45 a.m.-Gym; Records. 7.15-News. 7.45-Gym; Folk Song Records. 8.15 p.m.-Orchestra. Conductor: Gaillard. Jeanne Guionie (Songs); Vaccellier (Clarinet). In the interval at 1.20: News; Exchange. 3.0-Records of French Music. In the intervals: News; Exchange. 5.35-Records: "Parsifal" (Wagner). 5.55-Announcements. 6.0-Announcements; Gilberte Lyon (Pfte.); Talks: (a) Virginia Woolf's Books; (b) The Woman Surgeon. 6.30-For Farmers; Exchange; Markets; Racing. 6.45-Assurance Societies' Report. 6.50-Theatres. 7.0-Colonial Review. 7.20-Review of Periodicals. 7.30-Dietetics.

7.35-"The French Song"-Recital by Madeleine Grey, with Commentary by Samazeuilh. Guignolet de Saint-Lazant (Emmanuel). Poème de la rose (Klingsor-Migot). caphéno (God-Satie). Two Lise Hirtz Songs (Auric). Basque Song (Cocteau-Durey). Il Maestro Capriccioso (Nino-Larmanjat). Capricioso Song (Delannoy). Song of the Marionnettes (Barrain). Two Corsican Songs (Tomasi). Les deux présents (Tailleferre). Berceuse (Louys-Dandelot). Pourquoi le sourire? (Messiaen). Abat-jour (Reverdy-Barraud). Mickey (Franc-aix). 8.15-Press Review.

8.35-Casino Concert from Vichy. Conductor: Cooper. Overture, "Phèdre" (Massenet). Passacaglia (Bach). Sauge fleurie (d'Indy). The Tale of the Isar Saltan (Rimsky-Korsakov). In the interval: News. 10.35-Andolfi Dance Band.

11.0-Chamber Orchestra. Conductor: Clergue. Mlle. Cottavoz (Songs). Navarra (Cello). Krettly (Violin). Blot (Horn). Overture, "Le roi l'a dit" (Delibes). Ballet Music, "Les fêtes d'Hébé" (Rameau). "Les maisons de l'Eternité" (Bloch). Horn Trio (Brahms). Masques et bergamasques (Fauré). Songs. French Folk Dances (Tiersot). Romance (Kunc). Divertissement (Mihalovici). Songs. Selection, "Ciboulette" (Hahn).

PRAGUE (Czechoslovakia) 638 kc/s (470.2 m.); 120 kW.

Transmits at intervals from 6.0 a.m. 12.30 p.m.-Military Band. Conductor: Pesta. 1.30-Labour Exchange. 1.40-Records. 1.50-Exchange. 1.55-2.0-Exchange and Weather in German.

3.0-Czech Philharmonic Orchestra. Conductor: Heller. 4.0-4.10-Exchange; Weather. 4.30-Orchestra from Bratislava. 5.40-For Housewives. 5.45-Records. 6.0-Review of Foreign Affairs. 6.5-Record. 6.10-Market Prices. 6.20-German Transmission: Talk: German Radio Clubs; For Workers. 7.0-News in German. 7.10-Record. 7.15-News. 7.25-Balsanek Orchestra. Mejnec and Zeman (Songs).

8.0-Act III, "The Trial of Dolores Divine"-Play (Ellis). 8.45-Albert Bursik (Flute). Andante and Allegro vivace (Masson). Introduction and Variations (Schubert). Hungarian Fantasia (Andersen).

9.10-Part Relay of the Bruckner Festival from Linz (see Vienna). 10.15 News. 10.30-Records. 10.45-11.0-Russian News.

RADIO-NORMANDIE (France) 1,113 kc/s (269.5 m.); 10 kW.

7.0 a.m.-Records. 7.20-News. 7.45-Record. 7.48-Racing Notes. 7.50-Record. 7.53-Cookery Hints. 8.0-Records. 8.30-Popular Songs. 10.0-Tchaikovsky. 10.45-Chansonettes.

12.0 noon-Records. 12.40 p.m.-News. 12.45-Request. 4.0-Dance Music. 4.45-For Children. 5.0-Dance Music. 5.15-Records. 5.30-Orchestra. 6.0-For Children. 6.45-Talk: Royal Jubilees.

7.0-Concert. 8.15-Topical Talk. 8.30-Gilberte Legrand and Willy Maury.

9.0-Concert. Rose Deschamps (Soprano), Marcelle Roger (Pfte.), Lucien Pailier (Tenor), Marcelly (Songs), Géo. Andrel (Variety Items), Carp and Pippo (Clowns). 11.0-Light Music. 11.30-Records. 12.0 m-t-2.0 a.m. (Saturday)-Dance Music.

ROME (Italy) 713 kc/s (420.8 m.); 50 kW.

Relayed by Naples, 1,104 kc/s (271.7 m.); Milan (No. 2), 1,348 kc/s (222.6 m.); Turin (No. 2), 1,357 kc/s (221.1 m.); and Bari, 1,059 kc/s (283.3 m.).

Transmits at intervals from 7.30 a.m. 5.5 p.m.-Tina Bari (Violin), Gina Schelini (Pfte.), Matilde (Capponi (Mezzo-Soprano). 6.0-6.10-Cornet. Prices. 6.15-News in Esperanto. 6.45-Tourist Report; Dopolarov Notes. 7.0-8.15-News in Foreign Languages; Italian Lesson. 8.30-Announcements; Talk.

8.40-Orchestral Concert. Lina Spera (Violin); Ornella Santoliquido (Pfte.). Cavanigs (Tenor). Sinfonietta veneziana (Prinsep). Les Néréides (Brussemans). Violin: (a) Nocturne (Sibelius), (b) Melody (Achron). (c) Moto perpetuo (Novak). Pfte.: (a) Ricordo (Novak), (b) e petite ane blanc (Ibert), (c) The Juggler (Toch). Four Songs. Violin: (a) Baal Schem Bunko, (b) Improvisations on "Moses" (Rossini-Paganini). Excerpts, Peer Gynt Suite No. 1 (Grieg). Overture, "La dame blanche" (Boildieu). In the interval: Talk. After the Concert: Dance Music. 11.0-News.

8.40-Orchestral Concert. Lina Spera (Violin); Ornella Santoliquido (Pfte.). Cavanigs (Tenor). Sinfonietta veneziana (Prinsep). Les Néréides (Brussemans). Violin: (a) Nocturne (Sibelius), (b) Melody (Achron). (c) Moto perpetuo (Novak). Pfte.: (a) Ricordo (Novak), (b) e petite ane blanc (Ibert), (c) The Juggler (Toch). Four Songs. Violin: (a) Baal Schem Bunko, (b) Improvisations on "Moses" (Rossini-Paganini). Excerpts, Peer Gynt Suite No. 1 (Grieg). Overture, "La dame blanche" (Boildieu). In the interval: Talk. After the Concert: Dance Music. 11.0-News.

8.40-Orchestral Concert. Lina Spera (Violin); Ornella Santoliquido (Pfte.). Cavanigs (Tenor). Sinfonietta veneziana (Prinsep). Les Néréides (Brussemans). Violin: (a) Nocturne (Sibelius), (b) Melody (Achron). (c) Moto perpetuo (Novak). Pfte.: (a) Ricordo (Novak), (b) e petite ane blanc (Ibert), (c) The Juggler (Toch). Four Songs. Violin: (a) Baal Schem Bunko, (b) Improvisations on "Moses" (Rossini-Paganini). Excerpts, Peer Gynt Suite No. 1 (Grieg). Overture, "La dame blanche" (Boildieu). In the interval: Talk. After the Concert: Dance Music. 11.0-News.

8.40-Orchestral Concert. Lina Spera (Violin); Ornella Santoliquido (Pfte.). Cavanigs (Tenor). Sinfonietta veneziana (Prinsep). Les Néréides (Brussemans). Violin: (a) Nocturne (Sibelius), (b) Melody (Achron). (c) Moto perpetuo (Novak). Pfte.: (a) Ricordo (Novak), (b) e petite ane blanc (Ibert), (c) The Juggler (Toch). Four Songs. Violin: (a) Baal Schem Bunko, (b) Improvisations on "Moses" (Rossini-Paganini). Excerpts, Peer Gynt Suite No. 1 (Grieg). Overture, "La dame blanche" (Boildieu). In the interval: Talk. After the Concert: Dance Music. 11.0-News.

8.40-Orchestral Concert. Lina Spera (Violin); Ornella Santoliquido (Pfte.). Cavanigs (Tenor). Sinfonietta veneziana (Prinsep). Les Néréides (Brussemans). Violin: (a) Nocturne (Sibelius), (b) Melody (Achron). (c) Moto perpetuo (Novak). Pfte.: (a) Ricordo (Novak), (b) e petite ane blanc (Ibert), (c) The Juggler (Toch). Four Songs. Violin: (a) Baal Schem Bunko, (b) Improvisations on "Moses" (Rossini-Paganini). Excerpts, Peer Gynt Suite No. 1 (Grieg). Overture, "La dame blanche" (Boildieu). In the interval: Talk. After the Concert: Dance Music. 11.0-News.

8.40-Orchestral Concert. Lina Spera (Violin); Ornella Santoliquido (Pfte.). Cavanigs (Tenor). Sinfonietta veneziana (Prinsep). Les Néréides (Brussemans). Violin: (a) Nocturne (Sibelius), (b) Melody (Achron). (c) Moto perpetuo (Novak). Pfte.: (a) Ricordo (Novak), (b) e petite ane blanc (Ibert), (c) The Juggler (Toch). Four Songs. Violin: (a) Baal Schem Bunko, (b) Improvisations on "Moses" (Rossini-Paganini). Excerpts, Peer Gynt Suite No. 1 (Grieg). Overture, "La dame blanche" (Boildieu). In the interval: Talk. After the Concert: Dance Music. 11.0-News.

8.40-Orchestral Concert. Lina Spera (Violin); Ornella Santoliquido (Pfte.). Cavanigs (Tenor). Sinfonietta veneziana (Prinsep). Les Néréides (Brussemans). Violin: (a) Nocturne (Sibelius), (b) Melody (Achron). (c) Moto perpetuo (Novak). Pfte.: (a) Ricordo (Novak), (b) e petite ane blanc (Ibert), (c) The Juggler (Toch). Four Songs. Violin: (a) Baal Schem Bunko, (b) Improvisations on "Moses" (Rossini-Paganini). Excerpts, Peer Gynt Suite No. 1 (Grieg). Overture, "La dame blanche" (Boildieu). In the interval: Talk. After the Concert: Dance Music. 11.0-News.

8.40-Orchestral Concert. Lina Spera (Violin); Ornella Santoliquido (Pfte.). Cavanigs (Tenor). Sinfonietta veneziana (Prinsep). Les Néréides (Brussemans). Violin: (a) Nocturne (Sibelius), (b) Melody (Achron). (c) Moto perpetuo (Novak). Pfte.: (a) Ricordo (Novak), (b) e petite ane blanc (Ibert), (c) The Juggler (Toch). Four Songs. Violin: (a) Baal Schem Bunko, (b) Improvisations on "Moses" (Rossini-Paganini). Excerpts, Peer Gynt Suite No. 1 (Grieg). Overture, "La dame blanche" (Boildieu). In the interval: Talk. After the Concert: Dance Music. 11.0-News.

8.2-Madeleine Renaud and Company. 9.20-News.

9.30-Montreux Orchestra. Conductor: Held. Overture, "The Thieving Magpie" (Rossini). Invitation to the Dance (Weber). Ballet, "Isoline" (Messager). Hungarian March, "The Damnation of Faust" (Berlioz). 10.15-Weather.

STOCKHOLM (Sweden) 704 kc/s (426.1 m.); 55 kW.

Relayed by Motala, 216 kc/s (1,389 m.); Göteborg, 941 kc/s (318.8 m.); Hörby, 1,131 kc/s (265.3 m.), and Bøden, 392 kc/s (765 m.). Transmits at intervals from 8.10 a.m. 7.15 p.m.-News. 7.30 (from Malmö)-Bellman Songs to the Lute by Claesson. 8.0-See Vienna.

9.5-Talk with Choral Illustrations: Jesper Svedberg-Bishop, Preacher and Hymn Writer. 9.45-News.

10.0-11.0-Septiman Orchestra. Cosatschesque (Dargomijsky). Bellman Fantasia (Sköld). Romance (Sibelius). Minuet (Ohlsson). Folk Scenes (Beöerez). Serenade (Borodin). The Old Folks at Home (arr. Sköld). Bagatelle (Yngve Sköld). Intermezzo (Ek). Serenade on the Bosphorus (Poldini). Desire (Hansson).

10.0-11.0-Septiman Orchestra. Cosatschesque (Dargomijsky). Bellman Fantasia (Sköld). Romance (Sibelius). Minuet (Ohlsson). Folk Scenes (Beöerez). Serenade (Borodin). The Old Folks at Home (arr. Sköld). Bagatelle (Yngve Sköld). Intermezzo (Ek). Serenade on the Bosphorus (Poldini). Desire (Hansson).

10.0-11.0-Septiman Orchestra. Cosatschesque (Dargomijsky). Bellman Fantasia (Sköld). Romance (Sibelius). Minuet (Ohlsson). Folk Scenes (Beöerez). Serenade (Borodin). The Old Folks at Home (arr. Sköld). Bagatelle (Yngve Sköld). Intermezzo (Ek). Serenade on the Bosphorus (Poldini). Desire (Hansson).

10.0-11.0-Septiman Orchestra. Cosatschesque (Dargomijsky). Bellman Fantasia (Sköld). Romance (Sibelius). Minuet (Ohlsson). Folk Scenes (Beöerez). Serenade (Borodin). The Old Folks at Home (arr. Sköld). Bagatelle (Yngve Sköld). Intermezzo (Ek). Serenade on the Bosphorus (Poldini). Desire (Hansson).

10.0-11.0-Septiman Orchestra. Cosatschesque (Dargomijsky). Bellman Fantasia (Sköld). Romance (Sibelius). Minuet (Ohlsson). Folk Scenes (Beöerez). Serenade (Borodin). The Old Folks at Home (arr. Sköld). Bagatelle (Yngve Sköld). Intermezzo (Ek). Serenade on the Bosphorus (Poldini). Desire (Hansson).

10.0-11.0-Septiman Orchestra. Cosatschesque (Dargomijsky). Bellman Fantasia (Sköld). Romance (Sibelius). Minuet (Ohlsson). Folk Scenes (Beöerez). Serenade (Borodin). The Old Folks at Home (arr. Sköld). Bagatelle (Yngve Sköld). Intermezzo (Ek). Serenade on the Bosphorus (Poldini). Desire (Hansson).

10.0-11.0-Septiman Orchestra. Cosatschesque (Dargomijsky). Bellman Fantasia (Sköld). Romance (Sibelius). Minuet (Ohlsson). Folk Scenes (Beöerez). Serenade (Borodin). The Old Folks at Home (arr. Sköld). Bagatelle (Yngve Sköld). Intermezzo (Ek). Serenade on the Bosphorus (Poldini). Desire (Hansson).

10.0-11.0-Septiman Orchestra. Cosatschesque (Dargomijsky). Bellman Fantasia (Sköld). Romance (Sibelius). Minuet (Ohlsson). Folk Scenes (Beöerez). Serenade (Borodin). The Old Folks at Home (arr. Sköld). Bagatelle (Yngve Sköld). Intermezzo (Ek). Serenade on the Bosphorus (Poldini). Desire (Hansson).

10.0-11.0-Septiman Orchestra. Cosatschesque (Dargomijsky). Bellman Fantasia (Sköld). Romance (Sibelius). Minuet (Ohlsson). Folk Scenes (Beöerez). Serenade (Borodin). The Old Folks at Home (arr. Sköld). Bagatelle (Yngve Sköld). Intermezzo (Ek). Serenade on the Bosphorus (Poldini). Desire (Hansson).

10.0-11.0-Septiman Orchestra. Cosatschesque (Dargomijsky). Bellman Fantasia (Sköld). Romance (Sibelius). Minuet (Ohlsson). Folk Scenes (Beöerez). Serenade (Borodin). The Old Folks at Home (arr. Sköld). Bagatelle (Yngve Sköld). Intermezzo (Ek). Serenade on the Bosphorus (Poldini). Desire (Hansson).

10.0-11.0-Septiman Orchestra. Cosatschesque (Dargomijsky). Bellman Fantasia (Sköld). Romance (Sibelius). Minuet (Ohlsson). Folk Scenes (Beöerez). Serenade (Borodin). The Old Folks at Home (arr. Sköld). Bagatelle (Yngve Sköld). Intermezzo (Ek). Serenade on the Bosphorus (Poldini). Desire (Hansson).

10.0-11.0-Septiman Orchestra. Cosatschesque (Dargomijsky). Bellman Fantasia (Sköld). Romance (Sibelius). Minuet (Ohlsson). Folk Scenes (Beöerez). Serenade (Borodin). The Old Folks at Home (arr. Sköld). Bagatelle (Yngve Sköld). Intermezzo (Ek). Serenade on the Bosphorus (Poldini). Desire (Hansson).

10.0-11.0-Septiman Orchestra. Cosatschesque (Dargomijsky). Bellman Fantasia (Sköld). Romance (Sibelius). Minuet (Ohlsson). Folk Scenes (Beöerez). Serenade (Borodin). The Old Folks at Home (arr. Sköld). Bagatelle (Yngve Sköld). Intermezzo (Ek). Serenade on the Bosphorus (Poldini). Desire (Hansson).

10.0-11.0-Septiman Orchestra. Cosatschesque (Dargomijsky). Bellman Fantasia (Sköld). Romance (Sibelius). Minuet (Ohlsson). Folk Scenes (Beöerez). Serenade (Borodin). The Old Folks at Home (arr. Sköld). Bagatelle (Yngve Sköld). Intermezzo (Ek). Serenade on the Bosphorus (Poldini). Desire (Hansson).

10.0-11.0-Septiman Orchestra. Cosatschesque (Dargomijsky). Bellman Fantasia (Sköld). Romance (Sibelius). Minuet (Ohlsson). Folk Scenes (Beöerez). Serenade (Borodin). The Old Folks at Home (arr. Sköld). Bagatelle (Yngve Sköld). Intermezzo (Ek). Serenade on the Bosphorus (Poldini). Desire (Hansson).

10.0-11.0-Septiman Orchestra. Cosatschesque (Dargomijsky). Bellman Fantasia (Sköld). Romance (Sibelius). Minuet (Ohlsson). Folk Scenes (Beöerez). Serenade (Borodin). The Old Folks at Home (arr. Sköld). Bagatelle (Yngve Sköld). Intermezzo (Ek). Serenade on the Bosphorus (Poldini). Desire (Hansson).

10.0-11.0-Septiman Orchestra. Cosatschesque (Dargomijsky). Bellman Fantasia (Sköld). Romance (Sibelius). Minuet (Ohlsson). Folk Scenes (Beöerez). Serenade (Borodin). The Old Folks at Home (arr. Sköld). Bagatelle (Yngve Sköld). Intermezzo (Ek). Serenade on the Bosphorus (Poldini). Desire (Hansson).

10.0-11.0-Septiman Orchestra. Cosatschesque (Dargomijsky). Bellman Fantasia (Sköld). Romance (Sibelius). Minuet (Ohlsson). Folk Scenes (Beöerez). Serenade (Borodin). The Old Folks at Home (arr. Sköld). Bagatelle (Yngve Sköld). Intermezzo (Ek). Serenade on the Bosphorus (Poldini). Desire (Hansson).

10.0-11.0-Septiman Orchestra. Cosatschesque (Dargomijsky). Bellman Fantasia (Sköld). Romance (Sibelius). Minuet (Ohlsson). Folk Scenes (Beöerez). Serenade (Borodin). The Old Folks at Home (arr. Sköld). Bagatelle (Yngve Sköld). Intermezzo (Ek). Serenade on the Bosphorus (Poldini). Desire (Hansson).

10.0-11.0-Septiman Orchestra. Cosatschesque (Dargomijsky). Bellman Fantasia (Sköld). Romance (Sibelius). Minuet (Ohlsson). Folk Scenes (Beöerez). Serenade (Borodin). The Old Folks at Home (arr. Sköld). Bagatelle (Yngve Sköld). Intermezzo (Ek). Serenade on the Bosphorus (Poldini). Desire (Hansson).

10.0-11.0-Septiman Orchestra. Cosatschesque (Dargomijsky). Bellman Fantasia (Sköld). Romance (Sibelius). Minuet (Ohlsson). Folk Scenes (Beöerez). Serenade (Borodin). The Old Folks at Home (arr. Sköld). Bagatelle (Yngve Sköld). Intermezzo (Ek). Serenade on the Bosphorus (Poldini). Desire (Hansson).

10.0-11.0-Septiman Orchestra. Cosatschesque (Dargomijsky). Bellman Fantasia (Sköld). Romance (Sibelius). Minuet (Ohlsson). Folk Scenes (Beöerez). Serenade (Borodin). The Old Folks at Home (arr. Sköld). Bagatelle (Yngve Sköld). Intermezzo (Ek). Serenade on the Bosphorus (Poldini). Desire (Hansson).

10.0-11.0-Septiman Orchestra. Cosatschesque (Dargomijsky). Bellman Fantasia (Sköld). Romance (Sibelius). Minuet (Ohlsson). Folk Scenes (Beöerez). Serenade (Borodin). The Old Folks at Home (arr. Sköld). Bagatelle (Yngve Sköld). Intermezzo (Ek). Serenade on the Bosphorus (Poldini). Desire (Hansson).

10.0-11.0-Septiman Orchestra. Cosatschesque (Dargomijsky). Bellman Fantasia (Sköld). Romance (Sibelius). Minuet (Ohlsson). Folk Scenes (Beöerez). Serenade (Borodin). The Old Folks at Home (arr. Sköld). Bagatelle (Yngve Sköld). Intermezzo (Ek). Serenade on the Bosphorus (Poldini). Desire (Hansson).

10.0-11.0-Septiman Orchestra. Cosatschesque (Dargomijsky). Bellman Fantasia (Sköld). Romance (Sibelius). Minuet (Ohlsson). Folk Scenes (Beöerez). Serenade (Borodin). The Old Folks at Home (arr. Sköld). Bagatelle (Yngve Sköld). Intermezzo (Ek). Serenade on the Bosphorus (Poldini). Desire (Hansson).

10.0-11.0-Septiman Orchestra. Cosatschesque (Dargomijsky). Bellman Fantasia (Sköld). Romance (Sibelius). Minuet (Ohlsson). Folk Scenes (Beöerez). Serenade (Borodin). The Old Folks at Home (arr. Sköld). Bagatelle (Yngve Sköld). Intermezzo (Ek). Serenade on the Bosphorus (Poldini). Desire (Hansson).

10.0-11.0-Septiman Orchestra. Cosatschesque (Dargomijsky). Bellman Fantasia (Sköld). Romance (Sibelius). Minuet (Ohlsson). Folk Scenes (Beöerez). Serenade (Borodin). The Old Folks at Home (arr. Sköld). Bagatelle (Yngve Sköld). Intermezzo (Ek). Serenade on the Bosphorus (Poldini). Desire (Hansson).

10.0-11.0-Septiman Orchestra. Cosatschesque (Dargomijsky). Bellman Fantasia (Sköld). Romance (Sibelius). Minuet (Ohlsson). Folk Scenes (Beöerez). Serenade (Borodin). The Old Folks at Home (arr. Sköld). Bagatelle (Yngve Sköld). Intermezzo (Ek). Serenade on the Bosphorus (Poldini). Desire (Hansson).

10.0-11.0-Septiman Orchestra. Cosatschesque (Dargomijsky). Bellman Fantasia (Sköld). Romance (Sibelius). Minuet (Ohlsson). Folk Scenes (Beöerez). Serenade (Borodin). The Old Folks at Home (arr. Sköld

SATURDAY July 27

NATIONAL

For Time Signals, see Monday
 10.15 a.m. (Droitwich)—Service.
 10.30 (Droitwich)—Weather Forecast.
 10.45—"The Week in Westminster."
 E. L. Maljaieu, M.P.
 11.0—Records.

Test Match, England v. S. Africa.
 Commentaries at 11.30 a.m., 1.30,
 4.30, and 6.25 p.m. And possibly
 between 11.30 a.m. and 6.0 p.m.

11.35—Imperial Hydro Hotel Orchestra, Blackpool.
 12.30 p.m.—Miscellaneous Records.
 1.0—Commodore Grand Orchestra.
 2.0—Records.
 2.30—Davis Cup Challenge Round. Commentaries from Wimbledon.
 5.15—The Children's Hour.
 6.0—"The First News."
 6.35 (Droitwich)—Sports Talk; "The Davis Cup—Then and Now."
 6.45 (Droitwich)—Welsh Interlude; Major Goronwy Owen, M.P.
 7.0 (Droitwich)—Central Band of H.M. Royal Air Force. Joseph Farrington (Bass). March, Washington Grays (Gräfala); Overture, Russian and Ludmilla (Glinka). Serenade (Faust), Calf of Gold (Faust), Vulcan's Song (Philemon et Baucis) (Gounod), Cornet Solo, I know of two Bright Eyes (Clut-sam); Waltz, Tout passe (Berger). D'Artagnan's Ride (Bruce); Mandala-y (Cobb); Woo Thou thy Snowflake (Ivanhoe) (Sullivan). Selection, Dorothy (Cellier).
 8.0—Jubilee Gala: Noel Coward, Gertrude Lawrence, Erna Sack, Jack Mackintosh, Charlotte Greenwood, The Street Singer, Elisabeth Welch, Brian Lawrence and his Dance Orchestra; Theatre Orchestra.
 9.30—"The Second News."
 9.50—BBC Orchestra (Section C), conducted by Clarence Raybould. Overture, The Mock Doctor (Gounod), Fairy Tale Suite, Cinderella (Massenet), Norwegian Rhapsody No. 3 (Svendsen), Two Pieces (Schmitt), Ballet Music, Ritter Pas-man (Strauss).
 11.0-12.0 (Droitwich)—Ambrose.

REGIONAL

For Time Signals, see Monday
 10.15-10.45 a.m. (except Midland)—Droitwich.
 10.45—John MacArthur Quintet.
 11.30—Cinema Organ.
 12.0—Callender's Senior Band.
 1.0 p.m.—Commodore Grand Orchestra.
 2.0—N. Ireland Orchestra.
 3.0—Cinema Organ.
 3.30—Sydney Baynes and his Band.
 4.45—John Reynders with his Orchestra.
 5.15—The Children's Hour.
 6.0—"The First News."
 6.25—England v. S. Africa.
 6.35 (ex. Northern, Western)—See Droitwich.
 6.35 (Northern)—Account of Lancashire County Women's Amateur Athletic Association Contest.
 6.35 (Western)—Records.
 6.45 (ex. Scottish, Western)—Records.
 6.45 (Scottish)—Cinema Organ.
 6.45 (Western)—See Droitwich.
 7.0-8.0 (ex. Midland)—Droitwich.
 8.0 (except Scottish and Western)—Doda Conrad (Baritone); Marie Korchinska (Harp).
 8.0 (Scottish)—Ian Sadler.
 8.0 (Western)—Rownd y Glannau—4.
 8.15 (Scottish)—Daisy Badger and Ruby Dunn (Pianofortes).
 8.45 (Scottish)—Heather Sextet. Flora Blythman (Contralto); Alan Montgomery (Tenor).
 8.45 (Western)—"On Foot Over Dartmoor." Raleigh Phillipotts.
 9.0 (except Midland and Scottish)—"Sindbad the Sailor"—3; Extracts from the "Arabian Nights," read by V. C. Clinton-Baddeley.
 9.0 (Midland)—Burton Excelsior Band; Midland Singers; Patricia Rossborough (Pianoforte).
 9.30 (Regional)—Bridgewater Harp Quintet.
 9.30 (Northern)—"The Music Shop"—a Musical Extravaganza.
 9.30 (Western)—Madge Thomas (Contralto); Winifred Davey (Pfte.).
 9.30 (N. Ireland)—Sibbald Treacy and his Rhythm Kings.
 9.45 (Scottish)—Week in Scotland.
 10.0—News Summary; Sports Bulletin.
 10.20 (N. Ireland till 10.40)—Ambrose and his Embassy Club Orchestra.
 10.40 (N. Ireland)—Charles Hayes.
 10.50 (ex. N. Ireland)—Dance Records.
 11.0-12.0 (ex. Midland)—Ambrose.

SYMPHONY CONCERTS

P.M.
 8.0 Brussels 2: Brahms Violin Concerto, etc.
 9.30 Turin: From the Basilica di Massenzio (Mascagni).
 10.35 Vienna: Brahms, Beethoven, Liszt, Wagner.
LIGHT CONCERTS
 12.15 Radio-Paris: Orchestra, songs.
 12.35 Poste Parisien: Light orchestral.
 1.5 Warsaw: Operetta music.
 3.30 Kalundborg: Radio Orchestra.
 4.0 Cologne, etc.: Variety concert.
 4.0 Munich: Light music.
 5.0 Warsaw: Joh. Strauss programme.
 5.20 Budapest 1: Cigany band.
 6.30 Brussels 1: Swiss programme.
 6.50 Leipzig: Folk music.
 7.0 Frankfurt, etc.: Marches.
 7.0 Stuttgart: Variety concert relayed from Baden-Baden.
 7.30 Athlone: Orchestra, waltzes.
 8.0 Oslo: Variety concert.
 8.10 Berlin, etc.: Operetta music.
 8.10 Hamburg: Band, orchestra.
 8.10 Königsberg: Light and dance music.
 8.10 Stuttgart, Frankfurt: Variety concert.
 8.30 Strasbourg: Band, from Colmar.
 8.40 Turin: Variety concert.
 9.5 Bratislava, Prague: Czech operetta music.
 9.30 Warsaw: "Echoes of the Country."
 9.50 Hilversum: Light orchestral.
 10.15 Brussels 2: Slav Orchestra.
 10.15 Huizen: The K.R.O. Boys.
 10.30 Berlin: Variety concert.
 12.0 Vienna: "Bar Music."
OPERA
 8.45 Radio-Paris: "Le petit Duc" (Lecocq).
OPERETTAS
 7.35 Vienna: "Ball at the Savoy" (Abraham).
 8.10 Munich: "Das leichte Glück" (Eichhorn).
 8.15 Budapest 1: "The Geisha" (Jones).

8.40 Rome: "Giocondo e il suo Re" (Jachino).
 8.45 Brussels 1: "Prince Chéri" (Renieu).
CHAMBER MUSIC
 4.30 Stockholm: Spanish music.
 7.5 Munich: String quartet (Mojsisovics), Pfte. quartet (Mozart).
 12.0 Stuttgart, Frankfurt: Brahms.
RECITALS
 4.15 Warsaw: Song and violin.
 4.30 Beromünster: Song, flute, harpsichord.
 6.15 Strasbourg: Mezzo-soprano songs.
 7.15 Breslau: German pastoral songs (contralto and baritone).
 7.20 Königsberg: "Cello, pfte., song."
 7.30 Warsaw: Polish songs.
 8.0 Regional: Harp, songs.
 8.10 Breslau: Orchestra and Willi Domgraf-Fassbaender (songs).
 9.15 Athlone: Songs, harp, stories.
PLAYS
 7.20 Hamburg: "Crossing the Line."
 8.0 Radio-Paris: Comedy dialogues.
 8.30 Eiffel Tower: Dramatic evening.
TALKS
 6.20 Munich: "The Homeland Trees."
 9.10 Beromünster: "Swiss Picture Book."
DANCE MUSIC
 8.0 Kalundborg: Radio Ball; 8.5, Bucharest; 9.0, Poste Parisien; 10.0, Stockholm; 10.15, Beromünster; 10.20, Regional; 10.30, Athlone, Breslau, Leipzig, Strasbourg, Warsaw; 10.45, Oslo, Paris (PTT); 10.50, Radio-Paris; 11.0, Kalundborg, National; 11.15, Budapest 1; 12.0, Hamburg, Radio-Normandie.
MISCELLANEOUS
 11.30 (a.m.)-1.30 etc., National: Test Match
 2.30 National: Davis Cup.
 8.0 National: Jubilee Variety Gala.
 8.15 Brussels 1: "Prince de Ligne" Fête.
 8.30 Paris (PTT): Cabaret.

Hours of Transmission in British Summer Time.

ATHLONE (Ireland)
 565 kc/s (531 m.); 60 kW. Relay by Dublin, 1,348 kc/s (222.6 m.); and Cork, 1,240 kc/s (241.9 m.).
 1.30-2.30 p.m.—Records. 6.0—Records. 6.45—News. 7.0—Topical. 7.15—News. 7.30—Waltzes by the Station Orchestra. 8.0—Variety by the Radio Radiants. 9.0—Irish Violin Music by Tadhg Small. 9.15—Mairin NíSheaghdha (Songs to the Harp). 9.25—Songs and Stories by Cathal O'Byrne. 9.45—What happened today. 10.0—Variety. 10.30-11.0—Billy Withers and his Dance Band.
BARCELONA (EAJ1) (Spain)
 795 kc/s (377.4 m.); 5 kW.
 Transmits at intervals from 8.15 a.m. 7.0 p.m.—News; Records. 7.15—Talk in Catalan. 7.30—For Children; Records. 8.15—News; Records. 8.45—Exchange. 9.0—News; Sports Notes; Records. 9.45—Press Review. 9.55—Exchange. 10.0—Chimes; Weather.
 10.5—Serrano Concert. Station Orchestra. Serenade from "La Canción del Olvido." Song from "La Alegria del Batallón." Gipsy Dance from "El solo de trompa." Veneziana from "El Carro del Sol." Selection, "Los Claveles." Jota

8.10 P.M. BERLIN, LEIPZIG
from operettas old and new
 The Wireless Orchestra
 Conductor, Willy Steiner
 The Dietrich "Schrammel" Quartet
 Traute Rose, soprano

from "La Casita Blanca." 11.5—News.
 11.20—Opera Arias by Francisco Martinez (Tenor). Romance, "Tosca" (Puccini). Siciliana, "Cavalleria Rusticana" (Mascagni). Aria, "La Gioconda" (Ponchielli).
 11.30—Verdi Concert. Station Orchestra. Excerpts from "Rigoletto," "La Traviata" and "Il Trovatore."
 12.20 a.m. (Sunday)—Dance Records. 1.0—News.
BERLIN (Germany)
 841 kc/s (356.7 m.); 100 kW.
 6.0 a.m.—Hymn; Motto. 6.10—Gym.
 6.30-8.0—See Breslau. In the interval at 7.0: News. 8.0-8.35—Gym. 9.40—Gym. 10.0—Weather; Markets. 10.30—Announcements. 11.55—Weather.
 12.0 noon-2.0 p.m.—See Stuttgart. In the interval at 1.0: Mid-day Review. 2.0—News; Water Level. 2.15—Soloists of the Hans Bund Band. 3.0—Exchange; Markets. 3.30—Music by a Peasants' Choir.
 4.0-6.0—See Cologne. 6.0—Sports Talk. 6.15—"Summer"—a Literary Sequence.
 7.0—Band from Tegernsee. 7.40—News. 8.0—Announcements.
 8.10—Operetta Music. 10.0—News.
 10.30-1.0 a.m. (Sunday)—"A Happy Week End." Fritz Domina Band; Instrumental Melodists; Humoresk Melodios; Hilde Schönborn and Albert Bräu (Saxophone).

BEROMÜNSTER (Switzerland)
 556 kc/s (539.6 m.); 100 kW.
 Relay by Basle and Berne, 1,375 kc/s (218.2 m.).
 12.0 noon-2.30—Programme from Berne. Cigany Music Records. 12.29 p.m.—Time; News. 12.40—Records: Light Music. 1.15—Talk. 1.25—Weather; Exchange. 1.30—Parliamentary Review. 1.45—Records. 2.0-2.30—Reading (Bräker).
 4.0-4.29—Programme from Berne. 4.0—Talk; Switzerland. 4.10—Yodelling and Hurdy-Gurdy Music. 4.29—Time. 4.30—Music from 1650-1750. Marta Walter (Soprano), Albert Zellweger (Flute), Kaethe Möller (Harpichord). Records in the intervals.
 6.0-7.0—Programme from Basle. 6.0—Wind-Band Records. 6.30—A

Sequence. 7.0—Chimes from Zürich Churches. 7.15 (from Basle)—Weather; Markets. 7.20 (from Zürich)—St. Gall Band. Conductor: Heusser. 8.0 (from Basle)—"Liebi vor Grich"—Sketch (Schnura). 9.0—News.
 9.10-11.0—Programme from Basle.
 9.10—"A Swiss Picture Book"—Sequence (Meyer-Gutzwiller). 10.15-11.0—Weather; Dance Records.

BORDEAUX-LAFAYETTE (France)

1,077 kc/s (278.6 m.); 30 kW.
 Transmits at intervals from 7.45 a.m. 12.0 noon—News; Records.
 12.15 p.m.—Orchestra. Conductor: Guitraud. Russian March (Garne), La Ceylanaise (Courtioux), Chinese March (Lincke), The Ballad of Reading Gaol (Hahn), Badinage (Wattelle). Selection, "Les Bavards" (Offenbach). Ordre de l'Empereur (Clérice). Ballet, "Manon" (Massenet). Two-Step, Golden Rod (Thony), Lagunen-Walzer (Strauss). Suite, At the Circus (Armandola), Muguet (Missa). In the interval at 1.20: News; Commentary on the Cycle Tour of France.
 2.0-6.0—See Paris (PTT). 6.0—Talk. 6.30—See Paris (PTT). 7.45—Talk: Venezuela. 8.0—Commentary on the Cycle Tour of France. 8.15—News. 8.30-10.45—See Paris (PTT).

BRATISLAVA (Czechoslovakia)

1,004 kc/s (298.8 m.); 13.5 kW.
 Transmits at intervals from 6.0 a.m. 11.0 a.m.—Water Level. 11.5—See Moravská-Ostrava. 12.0 noon—See Prague. 12.10 p.m.—News. 12.15—Records. 12.20—See Prague. 12.30—See Brno. 1.25—See Prague. 1.35—News; Weather (German, Hungarian). 1.45—See Prague. 1.55-2.0—Shipping. 3.0-4.10—See Prague. 4.30—See Prague. 5.40—Records.
 5.50—Play in Hungarian. 6.35—For Workers. 6.50—Records. 7.0—See Prague. 7.30—Skukák (Slovak Folk Songs). 7.55—Literary Talk.
 8.10—See Brno.
 8.45—"Geordie"—Sketch (Avertchenko). 9.5—Czech Operetta Music. The Station Orchestra and Soloists. Conductor: Odcházel. 10.15—See Prague. 10.30—News (Hungarian). 10.45-11.30—See Prague.

BRESLAU (Germany)

950 kc/s (315.8 m.); 100 kW. Relay by Gleiwitz, 1,231 kc/s (243.7 m.).
 5.0 a.m.—See Königsberg. 6.0—Hymn; Motto; Gym. 6.30-8.0—Light Music. 8.0—Local News. 8.5-9.0 (from Gleiwitz)—Records. 10.45-11.15—For Children. 11.30—Weather; Water Level.
 12.0 noon-2.0 p.m.—See Stuttgart. In the interval at 1.0: News. 2.0—News. 2.10—Exchange. 2.15—Announcements. 2.40—Greetings. 2.45—Markets. 3.10—Talk: Magic Lanterns, Marionettes and Punch and Judy Shows. 3.25—Reading (Dressler). 3.35—Reading (Close).
 4.0-6.0—See Cologne.
 6.0—Topical Report. 6.30—Talk: The Development of Industry in Brieg. 6.50—Programme Notes;

8.15 P.M. BUDAPEST NO. 1

THE
Geisha
 (SIDNEY JONES)
 relayed from the Zoological Park
 (Cast to be announced)

Weather. 7.0—Chimes from Grüssau Monastery. 7.5—Reading, "Die letzte Garbe" (Brenner).
 7.15—German Pastoral Songs. Johanna Hoppe (Contralto) and Gerhard Bertermann (Baritone). Phyllis and die Mutter (arr. Reimann). Schäferlied (Hurlerbusch). Melisse. Sagt mir, o schönste Schäferin (arr. Brahms). Schäfers Klage (Schubert). Schäferlied (Haydn). An Thyrsis (Beethoven). Der Kuss (Beethoven). Der Schäfer (Wolf).
 7.40—Weekly Review. 8.0—News.

8.10—Waldenburg and Bad Salz-brunn Orchestras. Conductor: Kaden. Willi Domgraf-Fassbaender (Songs). Overture, "The Magic Flute" (Mozart). Songs: (a) Pie'a Signore (Stradella), (b) Amarielli (Caccini), (c) Vittoria mio core (Carissimi). Ballet Music, "Undine" (Lortzing). Songs (Brahms): (a) Mimmelied, (b) Ständchen, (c) Meine Liebe ist grün. Songs (Wolf): (a) Und steht ihr früh am Morgan auf, (b) Dass doch gemalt all deine Reize wären, (c) Seemanns Abschied. Serenade for Strings (Strauss). Songs (Strauss): (a) Morgen, (b) Traum durch die Dämmerung, (c) Zuignung. Overture, "Rienzi" (Wagner). Aria, "Figaro" (Mozart). O, Star of Eve, "Tannhäuser" (Wagner). Aria, "A Masked Ball" (Verdi). Overture, "Stiffelio" (Verdi).
 10.30-12.0 m't—Station Dance Band.

BRNO (Czechoslovakia)

922 kc/s (325.4 m.); 32 kW.
 Transmits at intervals from 6.0 a.m. 11.0 a.m.—See Moravská-Ostrava. 12.0 noon—See Prague.
 12.30 p.m.—Military Band. Conductor: Krenovský. Overture, Fingal's Cave (Mendelssohn). Selection, "Mignon" (Thomas). Grotesque (Zimmer). Selection, "Giuditta" (Lehár). Melancholy Serenade (Fučík). Intermezzo (Leopold).
 1.25—Talk. 1.35—For Farmers. 1.40—Record. 1.45-1.55—See Prague. 3.0-4.10—See Prague. 4.30—See Prague. 5.30—Report. 6.0—Records. 6.30—Local News. 6.35—For Workers. 6.45—Records. 7.0—See Prague. 7.30—Report. 7.55—See Prague.
 8.10—Nevoral and his Band. 8.45—"The Course of Life"—Comedy in One Act (Hasek). 9.5—See Bratislava. 10.15-11.30—See Prague.

BRUSSELS (No. 1) (Belgium)
 620 kc/s (483.9 m.); 15 kW.
 12.0 noon-2.0 p.m.—Orchestra. Conductor: Walpot. Blaimont (Songs). Marche des poilus (Ackermans). Overture, "The Caliph of Bagdad" (Boieldieu). Waltz, Vision of Salomé (Joyce). Chasse joyeuse (Heller). Selection, "Les vingt-huit jours de Clairette" (Roger). Songs. Overture, "Madame Favart" (Offenbach). Ballet Music, "The

SATURDAY (July 27)

Four Seasons" (Missa). Perfume Waltz (Ziehner). Selection, "The Gipsy Baron" (Strauss). Songs. Overture, "Frau Meisterin" (Suppé). Largo religieux (Crabb). Balletrompetten (Jessel). Revels Dances (Montague Philips). In the interval at 1.0: News. 4.0—Talk: Unemployment.

BRUSSELS (No. 2) (Belgium)

932 kc/s (321.9 m.); 15 kW. Programme in Flemish. 12.0 noon—Records. 12.30 p.m.—Radio Orchestra. Conductor: Douliez. Marcia (Scotti). Selection, Rozemarijntje (van Oost). Selection, "Wonder Bar" (Katscher). Ballet, "Callirhoé" (Chaminade). 1.0—News. 1.10—Orchestra (contd.). Nigger's Dream (Myddleton). Love Song (Albeniz). Promenade au printemps (Albert). A Naples (Leleu). Potpourri (Robrecht).

1.30-2.0—Records. 4.0—Records. 4.15—Talk. 4.30—Records: Quartet in E flat (Lalo). 4.55—Announcements. 5.0—Opera Records. 5.30—For Children. 6.15—Records. 7.0—Talk. 7.15—Records: Jazz on Two Pines. 7.30—Film Review. 8.0—Symphony Orchestra from the Exhibition. Conductor: André Melin (Violin). Marche tryenne (Berlioz). Violin Concerto (Brahms). Andantino and Scherzo (Lalo). 8.45—Talk: Garden Insect Pests. 9.0—Symphony Orchestra from the Exhibition. Conductor: André Jacqueline de Kessel (Songs). Theatre Overture (Kodaly). Aria, "Fidelio" (Beethoven). Polonaise No. 2 (Liszt). Elsa's Dream, "Lohengrin" (Wagner). Excerpts, "Sigurd" (Reyer). Song, L'Emir d'amour (Knosp). Dances, "Samson and Delilah" (Saint-Saëns). 10.0—News. 10.10—Records. 10.15 (approx.)—12.0 m.t.—Kouznetzov-Chakorsky Slav Orchestra from the Exhibition.

BUCHAREST (Romania)

823 kc/s (364.5 m.); 12 kW. Transmits at intervals from 12.0 noon. 6.0 p.m.—Time; News. 6.15—Military Music. 7.0—Talk. 7.20—Records. 7.35—Letter-box. 8.5—Station Jazz Band 9.30—Time; News. 9.50—Orchestra. In the interval at 10.15: News in French and German.

BUDAPEST (No. 1) (Hungary)

546 kc/s (549.5 m.); 120 kW. 10.20 a.m.—Talk. 10.45—Programme Announcements. 12.5 p.m.—Loseneci-Schweitzer Orchestra. In the interval at 12.30: News. 1.20—Time; Weather. 1.30—Records. 2.40—Household Hints. 4.0—Fairy Tales (Sofmay). 4.45—Time; Weather. 5.20—József Czizica Giganý Band. 6.0—Report. 6.40—Records. 6.55—János Zakariás. 7.40—Talk: Carducci. 8.15—"The Geisha" (Jones). 11.10—Weather. 11.15—Pataky Jazz Band from the Gellert Hotel. 12.5 a.m. (Sunday)—News.

BUDAPEST (No. 2) (Hungary)

359.5 kc/s (834.5 m.); 20 kW. 5.30 p.m.—Programme by Károly Horváth. 6.5—Opera Orchestra. Conductor: Fridl. Overture, "Barones Lili" (Huszka). Selection, "Lilac-Time" (Schubert-Berté). Selection, "The Fair Maid of Perth" (Bizet). Waltz, "Der lustige Geigenspieler" (Eysler). Selection, "Die Puppenfee" (Bayer). Potpourri (Peregrin). 7.35—For Farmers. 8.20—String Quartet. 9.35—News.

COLOGNE (Germany)

658 kc/s (455.9 m.); 100 kW. 6.0 a.m.—Hymn; Motto; Gym. 6.30-8.0—See Breslau. 8.0—Gym. 8.15—Water Level. 8.20-8.30—For Women. 10.0—Water Level. 10.10—For Children. 10.30—Topical Talk. 11.0—Richard Wagner Festival Week

in Detmold 1935. Hans Pfitzner Programme, by Gisela Derpsch (Soprano), Otto Daube (Pfte.), Erwin Kerschbäumer (Violin) and Iwan Zibulka ('Cello). Songs: (a) Ist der Himmel darum im Lenzo blau? (b) Unter der Linden, (c) Immer leiser wird mein Schlummer, (d) Sonst, (e) Gretel. Trio in F.

12.0 noon-2.0 p.m.—See Stuttgart. In the interval at 1.0: News; Greetings. 2.0—News. 2.15—Variety from Deutschlandsender. 3.0—Talk. 3.15—Talk: The Strunderbach. 3.30—Markets. 3.40—For Workers. 4.0-6.0—Variety. Station Orchestra and Soloists. 6.0—Reading (Otto Klein). 6.20—Music. 6.30—Report: The Regatta on the Baldeney-See, Essen. 6.50—Weather; Markets;

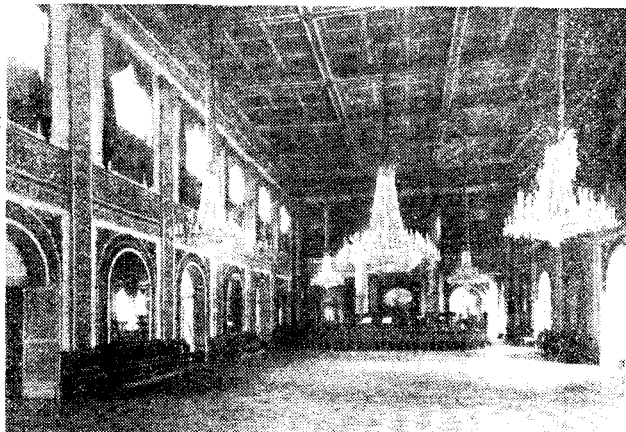

The concert room in Baden-Baden Kurhaus, from which Stuttgart relays a concert at 7 p.m.

ports. 7.0—"Between the Eiffel and the Ardennes"—Sequence, with Records. 7.50—Snapshots. 8.0—News. 8.10—See Stuttgart. 10.0—News. 10.20—For Ex-Servicemen. 11.0—See Deutschlandsender.

DEUTSCHLANDSENDER (Germany)

191 kc/s (1,571 m.); 60 kW. 5.55 a.m.—Chimes; Motto; Hymn; Weather. 6.5—Gym. 6.30—Light Music. In the interval at 7.0: News. 8.20-9.0—Concert from Breslau. 9.40-10.0—Gym. 10.45—For Children. 11.15—Weather. 11.30—Talk on Science. 11.40—For Peasants. 12.0 noon—Arthur Jander Band. Marche lorraine (Ganne). Overture, "Euryanthe" (Weber). Swabian Rhapsody (Kämpfert). Waltz, Künstlerleben (Strauss). Fantasia on "Tannhäuser" (Wagner-Hamm-Burald). March, Frühling im Zoo (Jander). Overture, "Die schöne Galathée" (Suppé). Waltz, Verschmähte Liebe (Lincke). Potpourri, Musikalische Extrablätter (Thiele). March, Im grünen Hain (Kröger). In the interval at 12.55 p.m.: Time and Greetings. 1.45—News. 2.0—Variety. 3.0—Weather; Exchange; Programme Notes. 3.10—For Girls. 3.30—Markets. 3.45—Talk on Business. 4.0-6.0—See Cologne. 6.0—Weekly Sports Review. 6.20—Topical Talk. 6.30—Sports Notes. 6.50—Records of Horst Schimmelfennig at the Wurthler Organ of the Zoo. 7.0—See Frankfurt. 7.45—Discussions on Topical Subjects. 8.0—Motto; News. 8.10—See Stuttgart. 10.0—News. 10.30—Herbert Jäger (Pfte.). 10.45—Weather. 11.0-12.55 a.m. (Sunday)—Robert Gaden Dance Band.

FRANKFURT (Germany)

1,195 kc/s (251 m.); 25 kW. Relayed by Cassel, Coblenz, Freiburg, Kaiserslautern, and Trier, 1,195 kc/s (251 m.). 6.0 a.m.—Hymn; Motto; Gym. 6.30-8.0—See Breslau. 8.0—Water Level; Weather. 8.10-8.30—Gym. 9.0—News. 9.15—Emmy Weber (Contralto), George Ripperger (Tenor) and Hermann Sommer (Pfte.). 9.45-10.0—Talk: Ludwig Hebold. 11.0—Music. 11.25—Programme Notes; Markets; Weather. 11.30—Announcements. 11.45—For Farmers. 12.0 noon-2.0 p.m.—See Stuttgart. In the interval at 1.0: News. 2.0—News. 2.15—Economic Review. 2.30—Markets. 2.35—Weather. 2.45—Nature Talk. 3.0—For Young People. 4.0-6.0—See Cologne. 6.0—Report: A trip through South West Germany. 6.20—Surprise Programme. 6.30—Saar Relay. 7.0 (from Cassel)—Marches. Military Band. Conductor:

Schröder. 7.45—Weekly Review. 8.0—News. 8.10—See Stuttgart. 10.0—News. 10.15—Local News: Sports; Weather. 10.20 (from Freiburg)—Report from Lake Constance: The Meersburg Summer Festival. 10.45—Report from the Nürburgring: Test Commentaries at different stages for the German Grand Prix. 11.0—Dance Music from Leipzig. 12.0 m't-2.0 a.m. (Sunday)—See Stuttgart.

HAMBURG (Germany)

904 kc/s (331.9 m.); 100 kW. Relayed by Bremen, Flensburg, Hanover, Magdeburg and Stettin, 1,330 kc/s (225.6 m.). 5.40 a.m.—Weather; Markets. 6.0—

Ensemble and Orchestra; and Mlle. To v.d. Sluys (Soprano). 11.55—Light Music. Conductor: Wins. Kleine Wiener Skizzen (Reinl). Czardas (Rinesch). Some day perhaps (Hawley). Marechiare (Tosti). Love Song (Suk). Lehár Potpourri (Robrecht). Vertigo (Berger). Andalusian Serenade (Culotta). 12.40 p.m.—Records. 12.55—Orchestra. Conductor: Walis. Overture, "Marinarella" (Fučík). Deliriumwalzer (Strauss). Fortissimo (Kálmán). Vénitienne (de Taeye). Gemullehoeken (Opstal). 1.40—Records. 2.0—Wiggelaar (Violin) and Schoute (Pfte.). Spanish Suite (Marien). Pale Moon (Logan-Kreiser). Deep in my heart, dear (Romberg-Wiggelaar). 2.25—Records. 3.10—Eva Busch (Songs); Records. 3.40—Talk. 4.0—Light Music. Conductor: v.d. Horst. Blumen der Liebe (Rust). Salut d'amour (Elgar). Serenade (Eilenberg). Viennese Dance (Friedmann-Gärtner). Polka (Hilmar). Ceska Polka (Balling). Mesiana noc (Novak). Sympathy (Mezzacapo). Tango (Albeniz). 4.40—de Booy (Songs). Im wunderschönen Monat Mai (Schumann). Ich grolle nicht (Schumann). Ich liebe dich (Grieg). 4.50—Light Music. Conductor: Walis. Only a bunch of daffodils (Cowler). Ilijana (de Leur). Hokius Pokus (Mohr-Marbot). Play of the Butterflies (Heykens). Good night Vienna (Posford). Spanish Gipsy Dance (Marquina). 5.20—Literary Talk. 5.40—Blez (Obõe) and Schoute (Pfte.). Piece (Blumer). 5.55—de Kleyn (Violin) and Vogel (Pfte.). Sonata in A (Handel). Adagio from the Concerto in G (Mozart). Minuet (Debussy). Orientale (Vogel). Tambourin (Rameau-Kreiser). 6.25—Heide (Clarinet) and Schoute (Pfte.). Two Epigrams (Mirandolle). Suite (Murrill). Allegretto (Porpora). 6.40—Talk on Economics. 7.0—Steyn (Organ). Selection, "Tip Toes" (Gershwín). Clouds (Donaldson). Caprice viennois (Kreiser). Tiger Rag (Rocca). Smoke gets in your eyes (Kern). Ill wind (Arlén). I can't dance (Williams). Selection, "Rio Rita" (Thierney). 7.40—S.O.S. Messages. 7.55—Records. 8.10—V.A.R.A. Orchestra. Conductor: de Groot. Overture, "The Grand Duchess of Gérolstein" (Offenbach). Valse poudrée (Popy). Aljuparra (de Anduaga). Good-bye (Tosti). Serenata (Tosti). Mid-sommarvaka (Alfvén). Caucasian Sketches (Ippolitov-Ivanov). 9.10—Recitations. 9.40—Johnny Johnson Dance Band.

[E.N.A.]

Hymn; Motto; Gym. 6.30-8.0—See Breslau. In the interval: News. 8.0-8.15—For Housewives. 11.0—Announcements. 12.0 noon—Shipping. 12.10-2.0 p.m.—Concert from Stuttgart. In the interval at 1.0: Weather and Midday Review. 2.0—News. 2.20—Musical Interlude. 3.0—Wireless Notes. 3.15—Exchange. 3.30—Brazilian Economic Report. 3.40—Shipping. 4.0-6.0—See Cologne. 6.0—Reading (Martha Jochens). 6.30—Military Programme. 6.50—Weather; Harbour Notes. 7.0—Frido Grothey (Accordion). 7.20—"Crossing the Line." 8.0—News. 8.10 (from Bremen)—Military Band. Conductor: Voigt; The Bremen "Stadtmusikanten." Conductor: Krug; the Arion Choir, Domrose (Trombone), Kurapka (Xylophone). Military Band: (a) March, Mit Vollandampf voraus (Voigt). (b) Dramatic Overture (Blon). (c) Czardas "Der Geist des Waidwoden" (Grossmann). March (Stumpf). Choir: (a) Zieh' hinaus (Angerer). (b) Die Mühle im Tale (Wesseler). The Bremen Stadtmusikanten: (a) Overture, "The Hermit's Bell" (Maillart). (b) Waltz (Carina). (c) Selection, "La Traviata" (Verdi). Choir: (a) Das Wandern ist des Müllers Lust (Zöllner). (b) Nachtwandler (Rinkens). (c) Die Grenadiere (Spreckelsen). Military Band: (a) Army March (Piefke). (b) Trombone Solo, Das Herz am Rhein (Herzer). (c) Waltz, Red Orchids (Voigt). (d) Xylophone Solo: Fantasia on Jetzt gang i an's Brünnele and 's kommt ein Vogerl geflogen" (Pelzer). Choir: (a) Rose Marie, (b) Abmarsch (Voigt). Bremen Stadtmusikanten: (a) Selection, "Aennchen von Tharau" (Herd-Warden). (b) Polka, Bahn frei (Strauss). Military Band: (a) Kürassier-Marsch (Simon). (b) Brautwerber-Marsch (Becker).

7.20 P.M. HAMBURG

CROSSING THE LINE

A nautical Fantasy in which The Captain, First Officer, Chief Steward, Ship's Doctor, Cabin Boy, Herr, Frau, and Fräulein Kruse, Neptune, Neptuna, an actuary, and a barber take part, with the Station Dance Band lending its aid.

9.50—Light Music. Conductor: v.d. Horst. Kirchweih in Tyrol (Krome). Waltz Potpourri (Ciere). Capri (Licht). Gee Whizz (Brooke-Cyron). Viens près de moi (Danterl-Meilink). Nola (Arndt-Vogel). Till we meet again (Akst-Vogel). Auf dem Rummelplatz (Mohr). Forget me not (Richards-Vogel). 10.30—Light Music. Conductor: Walis. Dolores (Waldteufel). Avant de mourir (Boulinger). Cymbal Solo. Russian Piece. Selection, "The Girl in the Taxi" (Gilbert). All unghere. 11.10-11.40—Records.

HUIZEN (Holland)

995 kc/s (301.5 m.); 20 kW. Programme of the Catholic Radio Society (K.R.O.). 8.0-8.10—Prayers. 8.30-9.0—Gym. 10.40-11.0—Weather. 11.55—Weather.

Records. 10.10—Concert for Workers. 10.40—Records. 11.10—Religious Address. 11.40—Police Messages. 11.55—K.R.O. Boys. Conductor: Lustenhouwer. Scala Erinnerung (Neumann). Potpourri (Borchert). Roses of Picardy (Haydn Wood). Potpourri, Streiffichter (Morena). Why do I dream those dreams (Warren). Traumdeale (Fučík). Selection, "Ein Winternachtsraum" (Grothe). Nur ein kleiner Strauss Narzissen (Cowler). Stéphanie Gavotte (Czibulka). 1930 Selection (Nicholls). Verschmähte Liebe (Lincke). Try to see it my Way (Wrubel). Warum (Brodzsky). Don't say Goodnight (Warren). Finale. In the interval: Records; Announcements. 1.40 p.m.—For Young People. 2.10—Sports. 2.40-3.40—For Children 3.55—Records. 4.25—Flower's Harmony Five Ensemble. Okay-Toots (Donaldson). Butterflies in the Rain (Myers). Schade kleine Frau (Uher). Selection, "One Night of Love" (Scherzinger). Minuet (Filippucci). Say a Little Prayer for me (Nicholls). Blue Cloud (Ewing). 4.55—Records. 5.10—News in Esperanto. 5.25—Flower's Harmony Five Ensemble (contd.). The Wedding of the Painted Doll (Brown). Roses of Picardy (Haydn Wood). Bolivia (Castaldon). London on a Rainy Night (Steph). Paraphrase on Peer Gynt (Grieg). Piece (Meisel). Minuet (Paderewski-Kreiser). Have a Little Dream of me (Baxter). 6.0—Press Review. 6.25—Records. 6.40—Police Messages. 6.55—Talk. 7.15—Records. 7.30—Talk. 7.40—News. 7.45—Excerpts, "Hou doe wor" Revue (de Rooy) for the Bois-le-Duc Festival. Conductor: Spiero. Chorus Master: Goosen. 9.40—Report: The Bois-le-Duc Festival. 10.10—News. 10.15-11.40—K.R.O. Boys. Conductor Lustenhouwer. Amsterdam (Haas). Hands across the Table (Delettre). Dutch Fisher Girls (Fresco). In the Valley of Yesterday (Johnson). Potpourri, Saschinka (Schirmann). Piece (Theunisse). Blue Moon (Rodgers). A Lamp of Love (May). Records. Soon (Rodgers). Barcarolle (Offenbach-Fetras). Mado (Liogar). Wo beim Wein ein Walzer klingl (May). Ein Stern fällt vom Himmel (May). Snowman (Archer).

JUAN-LES-PINS (Radio Côte d'Azur) (France)

1,249 kc/s (240.2 m.); 2 kW. Transmits at intervals from 12.15 p.m. 7.30 p.m.—Press Review. 7.35—Talks. 8.0—Report on the Cycle Tour of France. 8.15—News; Exchange. 8.30—Cigany Music. 9.0—News. 9.15—Orchestra.

KALUNDBORG (Denmark)

238 kc/s (1,261 m.); 60 kW. Relayed by Copenhagen, 1,176 kc/s (255.1 m.). 7.0 a.m.—Gym. 8.30—Copenhagen Cathedral Service. 11.0—Weather; Fish Prices. 12.0 noon-2.0 p.m.—Bendix String Ensemble from the Wivex. 3.30—Radio Orchestra. Conductor: Gröndahl. Ruth Dietzmann ('Cello). Prelude, "Snefrid" (Nielsen). Selection, "La Bohème" (Puccini). Danish Folk Melodies (Tarp). La Czarine (Ganne). Albumblatt (Wagner). Ballet, "Aladdin" (Horneman). Humoresque (Dvořák). Burlesque (Söderman). Oriental March (Andersen). Cello: (a) Prayer and Tarantella (Popper). (b) Elegy and Saltarello (van Goens). Waltz, "The Count of Luxembourg" (Lehár). Cradle Song (Andersen). Selection, "Carmen" (Bizet). Irish Song from County Kerry (Grainger). Swedish Folk Melodies (arr. Meisner). Serenade for Cor Anglais and Viola (Saint-Saëns). Galop (Lincke). 5.30—Exchange; Markets. 6.12—Poem (Rode). 6.15—Talk: A Summer Night on the Danish Highroads. 6.45—Weather. 7.0—News. 7.30—Talk: Scandinavian Youth and Democracy. 8.0-11.0—"A Jutland Ball"—from the Traedballhus. Vejle. Folk Dances, Songs and Poems. In the interval at 10.0: News. 11.0-12.15 a.m. (Sunday)—Donde's Dance Band from the Hotel Royal, Aarhus.

KÖNIGSBERG (Germany)

1,031 kc/s (291 m.); 60 kW. Relayed by Danzig, 1,303 kc/s (230.2 m.). 4.58 a.m.—Weather. 5.0—Hohncr Accordion Band. 5.45—For Farmers. 6.0—Gym. 6.30-8.0—See Breslau. 8.0-8.10—Prayers. 8.30-9.0—Gym. 10.40-11.0—Weather. 11.55—Weather.

12.0 noon-2.0 p.m.—See Stuttgart. In the interval at 1.0: Weather, Programme Notes and News. 2.0—News. 2.15—Announcements. 2.45—Pictures of Summer (Brandenburg). 3.0—Markets; Exchange. 3.10—For Women. 3.20—For Children. 3.45—Book Review.

4.0-6.0—See Cologne. 6.0—Film Review. 6.15—Markets.

6.20—Heinz-Georg Oertel (Organ). Prelude and Fugue in G (Brahms). Miserere and Ave verum (Mozart-Liszt). Angelus (Liszt).

6.45—Topical Report. 7.0—Weather; Local News. 7.10—The German Microphone—a non-technical Discussion.

7.20—Karl-Oskar Dittmer (Baritone). Walter Biller ("Cello) and Mara Kremer (Pfte.). Songs (Kienzl): (a) Meine Mutter, (b) Lied des Steinklopfers, (c) Meine Lust ist Leben, (d) Jetzt rede du, (e) Abendgang. "Cello Solos: (a) Minstrel's Song (Glazunov), (b) Cradle Song (Klengel), (c) Rondo (Boccherini) Pfte. Solos: (a) Etude in E (Chopin), (b) Etude in D flat (Liszt), (c) Waldesrauschen (Liszt). 8.0—News.

8.10—Light music and Dance Band. 10.0—News. 10.20—Reading (Solon). 10.30-12.0 m't—See Leipzig.

LAHTI (Finland)

166 kc/s (1,807 m.); 40 kW. Relay by Helsinki, 895 kc/s (335.2 m.) Transmits at intervals from 7.5 a.m. 5.0 p.m.—Records. 5.30—For Boys. 5.40—Talk. 5.50—News. 6.10—News (Swedish). 6.15—Radio Sextet. 7.5—Talk. 7.25—Heikki Korthe (Songs). 7.45—Talk. 8.0—Kuosma (Organ). 8.45—News. 9.0—News (Swedish).

LEIPZIG (Germany)

785 kc/s (382.2 m.); 120 kW. Relay by Dresden, 1,285 kc/s (233.5 m.).

5.50 a.m.—For Farmers. 6.0—Hymn; Motto; Gym. 6.30-8.0—See Breslau. In the interval at 7.0: News. 8.0—Gym. 8.20-9.0 (from Dresden)—Heinz Futschke Orchestra. 10.0-10.15—Water Level; Weather; Economic and Programme Notes. 11.0—Announcements. 11.30—Weather. 11.45—For Farmers.

12.0 noon-2.0 p.m.—See Stuttgart. In the interval at 1.0: News. 2.0-2.15—News; Exchange. 2.20—Nordic Philosophy—Review of Periodicals. 3.0—For Children. 3.40—Weather; Markets; and Brazilian Economic Report. 6.0—A Modern Dictionary. 6.15—Call of Youth. 6.30—See Cologne. 6.50—"An Evening in Grumbach"—Folk Music. 8.0—News. 8.10—See Berlin. 10.0—News. 10.30-12.0 m't—Erwin Steinbach Dance Band.

LISBON (Portugal)

629 kc/s (476.9 m.); 20 kW. Transmits at intervals from 12.0 noon. 7.0 p.m.—Folk Music; 7.55—News; Music. In the interval at 8.25: Exchange. 8.50—Orchestra. In the interval at 9.20: News. 9.50—Talk. 10.0—Political Review; Folk Music. 10.30—News; Records. 11.0—Dance Music.

LYONS (La Doua) (France)

648 kc/s (463 m.); 100 kW. Transmits at intervals from 7.15 a.m. 12.0 noon—News. 12.15 p.m.—Racing. 12.20-1.20—Records. In the interval at 1.0: Financial Notes. 1.20—News. 1.30—Cycle Tour of France; Records. 2.0—See Paris (PTT). 4.15—Cycle Tour of France. 6.0—See Paris (Radio Paris). 6.30—News; Review. 7.30—Local and Tourist Notes. 7.50—Sports. 8.0—Cycle Tour of France. 8.15—Records. 8.30—See Paris (PTT); News.

MONTE CENERI (Switzerland)

1,167 kc/s (257.1 m.); 15 kW. 12.0 noon—Announcements; Records. 12.33—Records. 12.55—News. 1.5—For Motorists. 1.15-1.30—Records. 4.30-6.0—See Beromünster. 7.30—Records of Ticino Children's Choirs. Gli Stornelli della Mamma. Il fumatore. In mezzo al mare. Avevo un fratellino. Ceresio. Inno alla scuola. 7.45—News. 8.0—To be announced. 10.0 Weather.

MORAVSKÁ-OSTRAVA (Czechoslovakia)

1,113 kc/s (269.5 m.); 11.2 kW. Transmits at intervals from 6.0 a.m. 11.0 a.m.—Record. 11.5—Military Band. Conductor: Michálek. March (Horak). Czech Song Potpourri (Leopold). Waltz, "Die Puppefee" (Bayer). Polka (Jankovec). Silesian Songs and Dances (Sudek). Duet, "Slovak Princess" (Piskáček).

12.0 noon—See Prague. 12.30 p.m.—See Brno. 1.25-1.55—See Prague. 3.0-4.10—See Prague. 4.30—See Prague. 5.40—Topical Talk. 5.50—Record. 5.55—Local News. 6.0—Talk. 6.10—See Prague.

6.20—Orchestra. Russian Song Potpourri (Wilke). Waltz, "Princess Hyacinth" (Nedbal). Suite, At the Circus (Armandola). Spanish Intermezzo (Kockert). Waltz (Leopold). March (Tichy). 7.0—See Prague. 7.30—See Brno. 7.55—See Prague. 8.10—See Brno. 9.5—See Bratislava. 10.15-11.30—See Prague.

MOSCOW (No. 1) (Russia)

174 kc/s (1,724 m.); 500 kW. Transmits at intervals from 3.45 a.m. 6.0 p.m.—Army Announcements. 6.15—Rabinovitch (Pfte.); Levichenko (Songs). 6.40—For Collective Farmers. 7.30—Dance Music. 9.0—German Review and Letter-box. 10.5—French Review and Sports Notes. 11.5—Swedish Talk: The Russian Revolution; Review.

MUNICH (Germany)

740 kc/s (405.4 m.); 100 kW. Relay by Nürnberg, 1,267 kc/s (236.8 m.).

6.0 a.m.—Motto; Gym. 6.30—See Breslau. 7.0—News. 7.10—Orchestra. 8.0-8.20—Gym. 9.40-10.15—Announcements. 11.0—For Country People. Markets; Village Music; Talk; News.

12.0 noon-2.0 p.m.—See Stuttgart. In the interval at 1.0: News. 2.0—News; Programme Notes; Exchange. 2.10—Sports Review. 2.20—A Sequence for Boys (on Records). 2.50—Chess Talk. 3.20—Zither Music, with Interludes in Dialect. 3.50—Weather; Markets.

4.0—Leo Schneider Band and Soloists. March, Mit Mut and Kraft (Blon). Overture, "Der Waffenschmied" (Lortzing). Songs. Rondo (Gabriel-Marie). Waltz, "Die Puppefee" (Bayer). Mouth Organ Solos. Selection, "The Bird Fancier" (Zeller). Slow Waltz (Schütt). Songs. Indian Juggler (Siede). Humorous Interlude. Waltz, Es rauscht die grüne Isar (Preissler). Duets. Baci al buio (de Micheli). Accordion Solos. Tango (Rodriguez).

6.0—Songs by Girls. 6.20—Talk: "The Homeland Trees." 6.40—Ruth Herell (Coloratura Soprano). Tales from the Vienna Woods (Strauss). Gavotte (Gossec). 6.50—Topical Talk. 7.0—Call of Youth. 7.5—Chamber Music by the Reker Quartet. String Quartet in C minor

8.0—Station Orchestra. Conductor: Fjeldstad. Wölner-Hansen (Pfte.), de Vries (Saxophone) and Schubert (Marimba and Xylophone). The Merry-makers (Coates). Waltz (Zeller). Strauss Potpourri (Grosz). Marimba: (a) Auld Lang Syne (Robbins), (b) The Beautiful Jap (Siede). Pfte.: Rhapsody in Blue (Gershwin). Der kleine Postillon (Krome). Saxophone: (a) Vanity (Wiedoft), (b) Hindu Song (Rimsky Korsakov), (c) Bitter Sweets (Wiedoft), (d) Negro Spirituals (Foulds). Xylophone: (a) Equilibristique (Golwyn), (b) Gallop (Krüger). Waltz (Waltheufel). Singoalla (Larento). March Potpourri (Rolland). 9.35—News. 10.0—Topical Talk. 10.15—Reading. 10.45-11.30—Dance Records.

11.45-12.00—Dance Records.

PARIS (Eiffel Tower) (France)
1,456 kc/s (206 m.); 5 kW
1.0 p.m.—Market Prices. 1.15—News. 1.30—For Farmers. 1.40—Report for Workers. 1.50—Economics. 2.0—Notes on Education; For Women. 2.10—Naval and Colonial Report. 2.20—Literary Notes. 2.30—Jazz Music and Songs from Paris (Radio Colonial). 4.0—Tourist Notes. 4.10—Tourist Talk in Esperanto. 4.20—Markets. 6.30—See Paris (PTT). 6.45—News. 7.30—News. 7.45—Records. 8.0—News.

PARIS (Poste Parisien) (France)

959 kc/s (312.8 m.); 60 kW.
7.10 a.m.—Fanfare; Commentary: Cycle Tour of France. 7.20—Records. In the intervals at 7.30 and 8.20: News. 12.0 noon—Report: Cycle Tour of France. 12.15 p.m.—New Records. 12.25—An interview. 12.35—Bellanger Instrumental Ensemble. Waltz, Roses (Metra). Selection, "The Italian Girl in Algiers" (Rossini). Chicken Pie (Ducot). Andante from the Quartet (Debussy). Ballet, "La Gioconda" (Ponchielli). Pfte. Solo. Mascarde (Laéomé). Letzige Liebe (Gungl). In the interval at 1.15: Exchange. 2.0 and 3.15—Exchange. 3.30—Cycle Tour of France. 3.45 and 6.25—Exchange. 6.30—Roman Catholic Talk. 6.55—Talk. 7.2—Sports. 7.5—News. 7.20—Amusement Guide. 7.22—The Event of the Week. 7.30—Cycle Tour of France. 7.45—The Cuban Trio (Records).

8.0—Interlude. 8.10—Exchange. 8.15—Records. 8.30—Records of Maurice Chevalier. 8.45—Interlude. 8.50—Exchange. 9.0—Dance Records. 9.35—News. 9.50—Dance Records. 10.30-11.45—Records: Light Music.

PARIS (PTT) (France)

695 kc/s (431.7 m.); 7 kW. Transmits at intervals from 7.45 a.m. 12.15 p.m.—National Orchestra. Conductor: Mangeret. Mlle. Deliége (Songs). Marche lorraine (Ganne). Overture, "La Fille de Madame Angot" (Lecocq). First Waltz (Durand). Petite Suite (Debussy). Marche héroïque (Saint-Saëns). Songs: (a) La lettre, (b) Berceuse du Marin (Aubert), (c) Mets tes beaux sabots (Casadesu), (d) L'Heure exquise (Hahn), (e) Evening (Albert Wolff). Chanson d'amour (Nougues). Scènes alsaciennes (Massenet). In the interval at 1.20: News, and at 1.30, Report on the Cycle Tour of France.

2.0—Songs, with Eugène Yoos (Accordion). In the interval: Report on the Women's Radio Competition. 4.15—Report: The Cycle Tour of France. 5.0—Concert. 6.0—Science and Literary Review. 6.30—News. 7.45—Legal Talk. 8.0—Report on the Cycle Tour of France.

8.15—"Dreams"—Records. Song, Frühlingstraum (Schubert). Liebestraum (Liszt). Selection, "A Waltz Dream" (Straus). 8.30—Cabaret. Songs by Rocca, Philippe Olive, and Paul Clérouc; "Vivent les Vacances"—Radio Revue (René-Paul Groffe). 10.30—News. 10.45—Bailly Dance Band.

PARIS (Radio-Paris) (France)
182 kc/s (1,648 m.); 80 kW.
6.45 a.m.—Gym. 7.0—Records. 7.15—Press Review; Weather. 7.45—Gym. 8.0—Weather; Viennese Waltz Records.

12.15 p.m.—Concert. Conductor: Doyen. Mme. Lucie Kerckhoff (Songs). Overture, "Manfred" (Schumann). Pastel d'enfants (Brun). Minuet and Rigaudon (Ravel). Waltz in A minor (Chopin). Songs: (a) Von ewiger Liebe, (b) Sapphische Ode (Brahms), (c) Rencontred, (d) Les Roses d'Isphahan (Fauré). Two Pieces (Nivard). La

OSLO (Norway)

260 kc/s (1,154 m.); 60 kW. Relay by Fredrikstad, 776 kc/s (386.6 m.); Hamar, 510.5 kc/s (587.7 m.); Notodden, 1,357 kc/s (221.1 m.); Porsgrund, 850 kc/s (352.9 m.); Rjukan, 1,348 kc/s (222.6 m.); Trondelag, 629 kc/s (476.9 m.). Transmits at intervals from 11.10 a.m. 5.0 p.m.—Records. 6.0—For Children. 6.35—Talk: Economics. 6.55—News. 7.30—Talk.



M. André, conductor of the Symphony Orchestra at Brussels No. 2 (8.0 p.m.)

(Mojsisovics). Pianoforte Quartet in D (Mozart). 8.0—News. 8.10—"Das leichte Glück"—Operetta (Eichhorn). 10.0—News. 10.20—To be announced. 11.0-12.0 m't—Dance Music from Leipzig.

Belle aux bois dormant (Debussy). Ballet Music from "Hérodiade" (Massenet). Chanson bretonne (Florent-Schmitt). Valse triste (Sibelius). Excerpts, "Pepita Jimenez (Albeniz). In the intervals at 12.45: Weather and at 1.20: News.

3.0—Sketch for Children. 6.0—Reading by Mlle. Violette Sarailhon. 6.15—Talk: Richard Desvallières. 6.30—For Farmers; Markets; Racing Results. 6.45—Talk by M. François de Téramond. 7.0—Talk: Writers of Adventure-Stories. 7.15—Talk by M. Chanlaine. 7.30—Weather. 7.35—Horse Racing. 7.55—Review by Bonnaud.

8.40 p.m. ROME

Gioconda and his King

COMIC OPERA IN 3 ACTS (Carlo Jachino)

The King Gherardini
Gioconda Merino
Greco Nino Mazziotti
The Royal Envoy Adolfo Zagonara
Paolo Guidi (speaking part) Ridolfi

Fiammetta Gianna Perea Labia
Ginevra Maria Fersula
The Queen Angela Rositani
Oste Arturo Pellegrino
Conductor, Antonicelli

8.0—Comedy Dialogues from "Celle qu'on ignore" (Marni), and "Eux" (Donnay). 8.45—"Le petit Duc"—(Lecocq). 10.45—Weather. 10.50—Fred Adison Dance Band.

PRAGUE (Czechoslovakia)

638 kc/s (470.2 m.); 120 kW. 6.0-7.30 a.m.—Gym; Music; News. 9.35—Police Notes. 9.45—Press Review; Weather. 10.5—Press Review and Weather in German. 10.10—Water Level. 10.11-10.15—Record. 10.50—For Women. 11.0-12.0 noon—See Moravská-Ostrava. 12.0 noon—For Farmers. 12.10 p.m.—Water Level. 12.11—Records. 12.20—News. 12.30—See Brno. 1.25—Industrial Review. 1.35—Records. 1.45—Exchange. 1.50-1.55—Exchange and Weather in German. 3.0—FOK Orchestra. Conductor: Smetáček. March (Petke-Smeták). Waltz, Tales from the Vienna Woods (Strauss). Overture, "Les deux Savoyards" (Offenbach). Selection, "Tosca" (Puccini). Slav Dances (Dvořák). Spanish Dances (Moszkowski). Hungarian Dances (Brahms). 4.0-4.10—Weather; Records. 4.30—Dvorský Dance Band from Karlsbad. 5.40—For Housewives. 5.45—Records. 5.55—For Farmers. 6.0—Records. 6.10—For Workers. 6.20—German Transmission. Folk Music and Songs. 7.0—News in German. 7.10—Records. 7.15—News, Weather, Economic and Political Review. 7.30—Spanish Songs by Josip Batistič. 7.55—Talk. 8.10-9.5—See Brno. 9.5—See Bratislava. 10.15—News. 10.30—Records. 10.45-11.30—Hermann Schrammel Band.

RADIO-NORMANDIE (France)

1,113 kc/s (269.5 m.); 10 kW. 7.0 a.m.—Records; News. 7.48—Racing; Records; For Housewives. 8.15—Dance Music. 8.30—Records. 8.45—Popular Songs. 10.0—Orchestra. 11.0—Songs. Aubade (Livschadoff). Die Spinnerin (Mendelssohn). Gipsy Serenade (Powell). Romances. tziganes (Boulanger). Avant de mourir (Boulanger). Flute: Fan-

SATURDAY (July 27)

tasia and Variations (Reichert). Serenade (Grünfeld). Spring Song (Mendelssohn). La précieuse (Couperin). Hungarian Dance (Boulanger). Flowers of the Fields (Westling). Souvenir de Gand (Sechser).

12.0 noon—Dance Music. 12.40 p.m.—News.

12.45—Request. Wien bleibt Wien (Schrammel). Piece (Gardoni). Un mariage manqué (Laverne). Le coeur de Jeanette (de Buxeuil). Selection, "Un soir de réveillon" (Moretti). Venise chante (Goullier fils). Boulicot à l'école (Recordier). C'est un oiseau qui vient de France (Boissière). Aria, "Tosca" (Puccini). There's a song in my heart (Campbell).

4.0—Dance Music. 4.45—For Children. 5.0—Dance Music. 5.15—Records. 6.0—For Children. 6.45—Talk for Hotel-keepers.

7.0—Request. Wedding Waltz (Solter) Viennese Waltz (Strauss). Derrière les volets (Valdy). Piece (Pick). La chanson des Terre-Neuves (Léojac). La Bénédiction (Coppée). Les rêves sont des bulles de savon (Hermitte). Adieu, mein kleiner Gardeoffizier (Stolz). Sous les toits de Paris (Moretti). Une bonne cuite (Pauley). C'étaient deux amoureux (Faler).

8.0—Cabaret. 10.0—Light Music. 11.0—Records. Ha-cha-cha. With my Eyes wide open. Her Name is Mary. Fine Old English Gentleman. Ain't she the dainty? Come up and see me sometime. It's Home. Oh! Fred.

11.30—Vaudeville. Accordion Joe. Voices of Spring (Strauss). Humpty Dumpty. The Lonesome Yodeler. Things might have been so different. Cinema Stars. He's been on the Bottle since a Baby. If you knew Susie.

12.0 m't—Dance Music. Rhythm is our Business. A Little Golden Locket. Rehearsing a Lullaby. I love you, Gipsy. Mr. and Mrs. is the Name. All through the Night. La Cachimba. One little Moment. Talkin' to myself.

12.30 a.m. (Sunday)—Dance Music. B'Wanga. Marie Louise. I'll take the South. Way Back Home. I get a kick out of you. Tamara. Clouds. My Girl don't love me. Cherokee.

1.0—Dance Music. Breaking the Ice. Memories of Horatio Nicholls. El Besco. A Beggar who's in Love can be a King. On the Good Ship Lollipop. Let me sing you to sleep with a Love Song. I'm Misunderstood. Would there be Love? The Guards' Parade.

1.30-2.0—Dance Music. The Ghost of Dinah. Lady, sing your Gipsy Song. The Gentleman obviously doesn't believe. La Morocha. Here comes Cookie. Old Mammy mine. When my Prince Charming comes along. Easter Parade.

REYKJAVIK (Iceland)

208 kc/s (1,442 m.); 16 kW. Transmits at intervals from 12.0 noon. 9.20 p.m.—Music. 9.50—Announcements. 10.0—News. 10.30—Reading. 11.0—Radio Orchestra; Records; Dance Music.

8.45 P.M. RADIO-PARIS

The little duke

Opéra-comique in 3 acts by MEILHAC AND HALÉVY
Music by Charles Lecocq
Montlandry M. Lovano
Frimousse M. René Hérent
The Little Duke Mme. Renée Camia
The Duchess Mme. Renée Sénac
Diane Mme. Jane Morlet
Conductor, M. Raoul Labis

NEWS IN THE INTERVALS

SATURDAY (July 27)**ROME (Italy)**

713 kc/s (420.8 m.); 50 kW. Relayed by Naples, 1,104 kc/s (271.7 m.); Milan (No. 2), 1,348 kc/s (222.6 m.); Turin (No. 2), 1,357 kc/s (221.1 m.); and Bari, 1,059 kc/s (283.3 m.).

7.30 a.m.—Gym. 7.45—8.0—News. 12.30 p.m.—Records. 1.0—Announcements.

1.5—Light Music. Serenade, Vi amo signora (Amadei). Waltz, Ninfe, libellule (Frossard). Selection, "Iris" (Mascagni). Idyll (Mascagni). Mezzanotte a Venezia (Ranzato). Arabesque (Amud). Serenade (Giannini). The Nightingale in the Lilac Bush (Krome).

2.0-2.15—News. 4.30—News; Exchange. 4.40—For Children. 5.5—Lottery Notes.

5.10—Luigi Biondi (Violin), Dina Fiumana (Soprano) and Edoardo Faticanti (Baritone). Violin: (a) Minuet (Porpora), (b) Chant espagnol (Chaminade). Aria, "The Secret Marriage" (Cimarosa). Monologue, "André Chénier" (Giordano). Violin: (a) Allegretto (Beethoven), (b) Die Biene (Schubert), (c) Caprice viennois (Kreisler). Duet, "The Barber of Seville" (Rossini).

5.55—Weather. 6.0-6.10—Markets. 6.45—Tourist Report; Announcements. 7.0—News in Foreign Languages. 8.15—News. 8.30—Announcements; Sports Talk.

8.40—"Giocondo e il suo Re" (Jachino). In the intervals: Report of the Italian Aero Club and Book Review. News after the Programme.

SOTTENS (Switzerland)

677 kc/s (443.1 m.); 25 kW. 12.30 p.m.—News. 12.40—Opera Records. 1.15—Records. 1.40-2.0—Chamber Music Records.

4.30-6.0—See Beromünster. 6.0—For Children. 6.20—Dance Records.

7.0—Talk: Rowing and Swimming across Lake Geneva.

7.25—Song Records. L'air (Hahn). Le printemps (Hahn). Song (Tosti). Over there (O'Conen).

7.40—Medical Talk. 8.0—Report on the Cycle Tour of France.

8.2—Radio Suisse Romande Orchestra. 9.20—News.

9.30—Songs by René Bersin and Company.

10.30-11.30—Dance Music by the Melodians, from Montreux.

STOCKHOLM (Sweden)

704 kc/s (426.1 m.); 55 kW. Relayed by Motala, 216 kc/s (1,389 m.); Göteborg, 941 kc/s (318.8 m.); Hörby, 1,131 kc/s (265.3 m.); and Boden, 392 kc/s (765 m.).

Transmits at intervals from 7.45 a.m.

2.0 p.m.—Elsa Ekendahl (Songs), Vecchi (Cello), Procene (Oboe) and Ebersen (Pfte.). Sarabande and Finale, Oboe Concerto in G minor (Handel). "Cello: (a) Ballad (Fabricius), (b) Russian Song (Lalo); (c) Simple aueu (Thomé). Five Gipsy Songs (Dvořák). Oboe and Pfte.: (a) Réverie (Saleski), (b) Serenade (Cassado), (c) Malaguena (Albeniz).

3.0—Light Music. Waldmիր Orchestra. 4.0—Reading.

4.30—Spanish Music. Eckerberg (Pfte.), Nielsen (Violin) and Dukstulsky (Cello). Trio (Turina). Pfte.: (a) The Harbore (Albeniz), (b) Andaluza and Fire Dance (Falla), 5.0—Weather. 5.5—For Children.

7.35 P.M. VIENNA

Ball at the Savoy

Operetta in a prelude and three acts by Paul Abraham

Conductor, Max Schönherr

Cast to be announced

5.30—Sports Notes. 5.45—Records. 6.45—Talk: Dalecarlian Dialects. 7.15—News. 7.30—Cabaret (Records). 8.30 (from Göteborg)—Talk: A Visit to Red Indians in Columbia. 9.0—Old Dances. Pinet Orchestra. 9.45—News. 10.0-11.0—Lindberg Dance Band.

RADIO**Suisse****Romande****Orchestra**

CONDUCTOR, ROBERT ECHENARD

Excerpts, Louise

Charpentier

Fair Parade and Fête Lalo

Elegy Templeton Strong

(Cello, Paul Burger)

Two Sketches for Winds

Templeton Strong

Romanian Rhapsody

Enesco

Petite Suite No. 2

Stravinsky

8.2 P.M. SOTTENS

STRASBOURG (France)

859 kc/s (349.2 m.); 35 kW. 7.45 a.m.—Report: The Cycle Tour of France. 10.45—Cotton Market Prices; Records. 11.0—Concert from Grenoble. 12.0—Records. 12.45 p.m.—News. 1.0—Time; Records. 1.30—Report: The Cycle Tour of France. 2.0-4.15—See Paris (PTT). 4.15—Report: The Cycle Tour of France. 5.30—Records. 6.0—Talk for Women. 6.15—Mlle. Genya-Marat (Mezzo-Soprano). Heures claires (Verhaeren-Sauvrezis). Aubade (d'Erlander). Les seuls pleurs (d'Erlander). Le retour du beau soldat (Brunau). L'adieu au troupier (Delmas). Chanson douce (Rhené-Baton).

6.45—"Devertra"—Sketch (Marinier); followed by "Brelan de Bègues"—One Act Operetta (Hubans).

7.30—News. 7.45—News in German. 8.0—Report: The Cycle Tour of France. 8.15—Press Review in German; Sports Notes in French and German.

8.30—Military Band from Colmar.

In the interval at 9.30 (approx.): News.

10.30—Dance Music from the Caveau de l'Aubette.

STUTT GART (Germany)

574 kc/s (522.6 m.); 100 kW. 5.45 a.m.—Hymn: Motto; Weather; For Farmers. 6.0 Gym. 6.30-8.0—See Breslau. 8.0—Water Level. 8.10—Gym. 8.30-9.0—Music. 10.15-10.45—"Lisa and the Butterflies"—Nature Story (Hofmeier).

11.0—The Labourer in Town and Country—Sequence. 12.0 noon—"A Happy Week-End." Station Orchestra. Conductor, Görlich. The Willi Wende Band; Hermann Schittenhelm (Accordion), and Carla Spletter (Soprano). In the interval at 1.0 p.m.: News.

2.0—See Deutschlandsender. 3.0—For Hitler Youth.

4.0-6.0—See Cologne. 6.0—Weekly Sound News.

6.30—See Frankfurt.

7.0—Concert from Baden-Baden. Waldmann-Gietmann Dance Band; Ruth Herell (Coloratura-Soprano); Else Zettler, Ilse Vitzen and Artur Hoger (Poems in Dialect). 8.0—News.

8.10—"Summer Land"—Variety. 10.0—News.

10.30—See Leipzig.

12.0 m't-2.0 a.m. (Sunday)—Brahms Concert. Trio in B for Pfte., Violin, and Cello. Songs. Symphony in C Minor (on Records).

TOULOUSE (Radio-Toulouse) (France)

913 kc/s (328.6 m.); 60 kW. 8.0 a.m.—Overture. 8.5—News. 8.10—Dance Refrains. 8.40—News. 8.45-9.0—Accordion. 12.0 noon—Orchestra. Pizzicati. "Sylvia" (Delibes). Selection, "The Queen of Spades" (Tchaikovsky). Entry of the Gladiators (Fučík).

12.15 p.m.—Opera Arias. Arias, "Lakmé" (Delibes), "Marouf" (Rabaud), "Mirella" (Gounod) and "Thais" (Massenet).

12.30—News. 12.45—Request Music. 1.0—Markets. 1.5—Military Marches. 1.15—Chansonnettes. 1.30—Viennese Orchestra. 1.50—Orchestra. 1.55—News; Exchange; Amusement Guide. 6.0—News; Racing Results. 6.15—Orchestra.

6.30—Operetta Songs. Songs from "Les soeurs Hortensias" (Moretti), "Le printemps chante" (Maupré), "Dédé" (Christiné), "Mitsi-Mitsou" (Marbot) and "Dix-neuf ans" (Bastia). 6.45—Orchestra. La voix des cloches (Luigini). Mascarae (Lacôme). 7.0—Songs.

7.20—Cigány Band. Sweet Illusions (Marinovic). Selection, "A Waltz Dream" (Straus). Selection, "Countess Maritza" (Kálmán). Babillage (Gillet).

7.30—News. 7.45—Humorous Sketches. 8.5—Sound Film Music.

8.15—Opera Arias. Arias from "The Magic Flute" (Mozart), "Penelope" (Fauré), "The Bartered Bride" (Smetana), "Parsifal" (Wagner) and "Siegfried" (Wagner).

8.30—Viennese Orchestra. Dorf-schwalben aus Österreich (Strauss). Bruissement sous bois (Razigade). Piece (Erwin). Excerpt, "The Geisha" (Jones). Coucou tsoin tsoin (Bereins).

9.0—Concert version of "La fille de Madame Angot"—Operetta (Lecocq). 9.55—Music-Hall. 10.20—Spanish Songs. 10.30—News. 10.35—Dance Music from the Blue Pavilion.

10.45—Opera Arias. Arias, "William Tell" (Rossini), "Les huguenots" (Meyerbeer), "Messaline" (de Lara) and "Le châtelet" (Adam).

11.0—Request Music. 11.15—Viennese Orchestra. 11.30—Orchestra. Waltz No. 2 (Godart). Indian March (Sellenick). Polka. Terminus (Curti). 11.45—Songs.

12.0 m't—"Au caveau de minuit"—a Fantasy. 12.15 a.m. (Sunday)—News. 12.20-12.30—Military Marches

TURIN (No. 1) (Italy)

1,140 kc/s (263.2 m.); 7 kW. Relayed by Milan (No. 1), 814 kc/s (368.6 m.); Genoa, 986 kc/s (304.3 m.); Florence, 610 kc/s (491.8 m.); and Trieste, 1,222 kc/s (245.5 m.).

7.45-8.0 a.m.—News. 11.30—Mario Consiglio Orchestra. Lehár Operetta Music. Poeta galante (Ancillotti). Letizia (Aviatibile). Duet (Consiglio). 12.45 p.m.—News. 1.0—Announcements. 1.5—Fashion Talk.

1.10-2.0—Chesi-Zanardelli-Cassone Trio. Look into my eyes (Wassil). Tre giorno (Pergolesi). Serenade (d'Ambrosio). Selection, "The Merry Widow" (Lehár). Legend (Wienawski). Ochsenmuett (Haydn). Gavotte (Ferrara).

4.30—News. 4.40—For Children. 4.55—For Women. 5.5—Dance Music. In the interval: Report of the Cycle Tour of France. 5.55—Weather. 6.0-6.10—Markets; Lottery Notes. 6.45—Tourist Report; Announcements. 7.0—News in Foreign Languages. 8.15—Report on the Cycle Tour of France. 8.20—News. 8.30—Announcements; Sports Talk. 8.40—Variety. 9.20—Book Review.

9.30—Symphony Concert from the Basilica di Massenzio, Rome. Conductor: Mascagni. 11.0—News. 11.10—News in Spanish.

VIENNA (Austria)

592 kc/s (506.8 m.); 100 kW. Relayed by Graz, 886 kc/s (338.6 m.); Innsbruck, 519 kc/s (578 m.); Dornbirn, Klagenfurt, and Linz, 1,294 kc/s (231.8 m.); and Salzburg, 1,348 kc/s (222.6 m.).

9.10 a.m.—News; Markets; Weather. 10.0—Bruckner Festival from the Abbey Church, St. Florian. Organ Prelude by Ludwig Daxperger. Address by Dr. Vincenz Hardt. String Quintet in F. Motets by the St. Florian Abbey Choir. 11.55—Weather.

12.0 noon—Operetta Records. Selection, "Barbe Bleue" (Offenbach), "The Mikado" (Sullivan), "The Gipsy Baron" (Strauss), "The Land of Smiles" (Lehár). Two Songs, "Schön ist die Welt" (Hawár). Selection, "The Flower of Helah" (Abraham), and "Venus in Seide" (Stolz).

1.0 p.m.—Weather; News; Programme Notes.

1.10—Records. Movements from the Symphony in G (Hadya). Waltz Scene, "Intermezzo" (Strauss). Dance, "Salome" (Strauss). Kuss-Walzer (Strauss).

2.0—Records of Ivar Andresen (Bass). Recitative and Aria, "Macbeth" (Verdi). Aria, "La Juive" (Halévy). Aria, "The Mastersingers" (Wagner). Songs (Strauss): (a) Nachtesang, (b) Ruhe, meine Seele.

2.20—Announcements. 3.0—Weather; Exchange.

3.15—Reading in English from Act II of "Justice" (John Galsworthy).

3.35—Mandoline Band. Overture, Gabella (Galanti). Nadedja (Maciocchi). Waltz, Frühlingstoten (Grestenberger). Waltz, Frauenlist (Aletter). Lisonja (Armandola).

4.20—News; Exchange. 4.25—Talk: Austrian Poets and Authors—Fink.

4.55—Band. Conductor: Pauscher. March, Frühjahrsparade (Stolz). Strauss Potpourri (Kliment). March, Unter dem Doppeladler (Josef Wagner). Overture "Les deux savoyards" (Offenbach). March, Prinz Starhernberg (Ritzberger). March, Major Emil Fey (Altman). Tone Picture, Soldatenleben (Kéler-Béla). March, Alt-Starhernberg (Schneider). Potpourri of Viennese Songs, Lustig und fidel (Kliment).

5.35—Talk: Sport in America.

6.0—Records: European Songs. Italy: Mandolinata a Napoli (Tagliaferri). Spain: Ay, Ay, Ay, (Freire). France: Parlez-moi d'amour (Lenoir). English: Home, Sweet Home. Germany: Das Herz am Rhein. Russia: Song of the Volga Boatman. The Blue Danube (Strauss).

6.35—Topical Talk. 7.0—News. 7.35—"Ball at the Savoy" (Abraham). In the interval at 9.50: News.

10.35—Vienna Symphony Orchestra. Conductor: Konrath. Marthta Jirasek (Soprano). Tragic Overture (Brahms). Leonora's Aria, "Fidelio" (Beethoven). Symphonic Poem, Tasso (Liszt). Prelude and Death of Isolda, "Tristan and Isolda" (Wagner).

11.45—Announcements. 12.0 m't-1.0 a.m. (Sunday)—Fritz Wolfert Quartet. "Bar Music."

WARSAW (Poland)

224 kc/s (1,339 m.); 120 kW. Relayed by Katowice, 758 kc/s (395.8 m.); Lwów, 795 kc/s (377.4 m.); Poznań, 868 kc/s (345.6 m.); and Wilno, 536 kc/s (559.7 m.).

6.30 a.m.—Hymn; Gym. 6.50—Records. 7.20—News; Sports. 8.20 Announcements. 12.0 noon—Fanfare; News.

12.15 p.m.—Records: Symphonie concertante (Mozart). 1.0—For Housewives.

1.5-1.30—Operetta Music by the Small Station Orchestra. Selection, "Wild Violets" (Stolz-Benatzky) and "Rose-Marie" (Friml).

2.30—New Records. 3.15—Exchange.

3.25—Talk: Overseas Trade. 3.30 (from Lwów)—For children. 4.0—Letter-box.

4.15—Filing-Kulikowska (Songs); Herman (Violin). Prelude (Bach-Kreisler). Danse ancienne (Dussek-Burmester). Caprice (Paganini). Aria, "Manon" (Massenet). Two Songs (Wertheim). Melody (Nick-Frenkiel). In the Cane Brake

5 P.M. WARSAW

Johann STRAUSS

SYMPHONY ORCHESTRA

Conductor, Oziminski

Overture, Carnival of Rome

Waltz, Artists' Life

Waltz, Wo die Citronen blüh'n

Potpourri, The Gipsy Baron

Egyptian March,

Waltz, Roses of the South

(Gardner). Perpetuum mobile (Novacek). Aria, "Martha" (Flotow). Two Songs (Rybicki).

4.50—Reading.

5.0—Johann Strauss music. Conductor: Oziminski.

6.0—Sports. 6.10—Recitations. 6.15—Songs. 6.30—Book Review. 6.40—Literary and Art Review. 6.45—Violin Records. 7.5—Announcements.

7.30 (from Poznań)—Roessler-Stokowska (Songs). The Enchanted Princess (Zelenki). Two Songs (Niewiadomski). The Fly (Gall). In the Twilight (Gall). Song (Nowkowski).

7.50—Topical. 8.0—Farmers' Book Review. 8.10—Music. 8.45—News.

8.55—Poland Yesterday and To-day. 9.0—Military Programme for Poles Abroad.

9.30—Station Symphony Orchestra Conductor: Oziminski. Harvest Festival (Maklakiewicz). "Echoes of the Country" Dance (Kondracki).

10.0—Sports Notes. 10.10—Humorous Programme.

10.30—Dance Music. Small Station Orchestra. Conductor: Górzynski.

11.0—Weather.



DOUGLAS.

Our artists' idea of the light music which forms a large share of the Saturday programmes

STATIONS IN ORDER OF FREQUENCIES AND WAVELENGTHS

Corrected in accordance with the latest official information available at the time of going to press

Table with columns: kc/s, m, kW, Station, Band No., 150-300 kc/s, Dial Reading, kc/s, m, kW, Station, Dial Reading. It lists radio stations across various bands and frequencies.

Table Models
from £11.

Cabinet Models
from £14.15s.

Radiogramophones
from £24.10s.

All Murphy sets, exclusive of valves and batteries, guaranteed for a year. All models available on Hire Purchase Terms. These prices do not apply in I.F.S. Station Chart, giving list of stations and wavelengths, supplied with each set.

MURPHY

Perhaps I did not say it clearly enough!



VERY LARGE LOUDSPEAKER
WEIGHING 18½ LBS

1" THICK LINING
OF SOUND
ABSORBENT
MATERIAL

SIDE ONLY
10½" DEEP

NO FLOOR
OR BACK
TO SOUND
CHAMBER

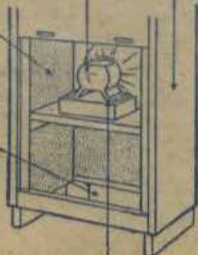

SPEAKER MOUNTED AS HIGH
AS POSSIBLE FROM FLOOR

In the last few days I have come across quite a number of people who did not realise how good the reproduction of the Murphy Console and Radiogram really is. As I have apparently not made myself very clear on this point before, I will say again (in big type)

"IN MY OPINION THE REPRODUCTION OF THE CONSOLE AND RADIOGRAM IS BETTER THAN YOU HAVE EVER HEARD IN ANY SET GENERALLY AVAILABLE TO THE PUBLIC."

And you can soon see whether that is just an idle claim, by going to your Murphy dealer and hearing one of these sets for yourself.

I haven't the space here to explain all the technical reasons as to why it should be better reproduction, but to give you an idea of the thought and work that has been put into the acoustics of the cabinet alone, I have included an explanatory diagram at the side. The exact size and shape of the cabinet, the lining of sound deadening material, the special loudspeaker, all play a very necessary part in securing this natural reproduction.

Frank Murphy

FOR THE NAME OF YOUR NEAREST MURPHY DEALER PLEASE WRITE TO MURPHY RADIO LTD., WELWYN GARDEN CITY, HERTS.