



WORLD-RADIO

DOMINION & FOREIGN PROGRAMMES

The Official Foreign & Technical
Journal of the B.B.C.

Vol. XIII No. 334

Registered at the G.P.O.
as a Newspaper.

FRIDAY, DECEMBER 18, 1931

Two Pence

PRINCIPAL CONTENTS

Continental Christmas Programmes

A Mexican Christmas

By J. W. Brown

Coupled Circuits in Broadcast
Receivers

From the Swiss Alps: a Review
of November Programmes

WORLD-RADIO

Station Identification Panel

NAPLES (1NA)

(Revised)

Frequency: 941 kc/s.

Wavelength: 319 m.

Power (Aerial): 1.7 kW.

Approximate Distance from London:
1,003 miles.

True Bearing from London: 132°.

Preliminary Signal: Bell (gramophone).

Call: "Ente Italiano Audizioni Radio-
foniche EIAR (pronounced Eh-yar)
Radio Roma-Napoli!"

Interval Signal: Popular air played
in three different keys.

Interval Calls: Before each item,
"Radio-Roma-Napoli!"

Woman announcer.

Closes down with words: "Ente Italiano
Audizioni Radiofoniche EIAR Radio
Roma-Napoli. Fine della trasmissi-
one!" followed by Royal Italian
March, Fascist Hymn, and "Signori,
buona notte!" ("Goodnight, every-
body!").

This station works in conjunction with
Rome.

Copyright

A booklet containing a reprint of these panels can
be obtained from the B.B.C. Publications, Savoy
Hill, W.C.2. Price 1s.

Letters should be addressed to The Editor,
"WORLD-RADIO," Savoy Hill, Strand, London,
W.C.2.

RATES OF SUBSCRIPTION to "World-Radio" (including
postage). Twelve Months: Inland, 13s.; Canadian, 13s.;
Foreign, 14s. Six months: Inland, 6s. 6d.; Canadian, 6s. 6d.;
Foreign, 7s. Address: "World-Radio," 8-11, Southampton
Street, Strand, London, W.C.2.

SOMEBODY'S GOT BETTER RADIO!

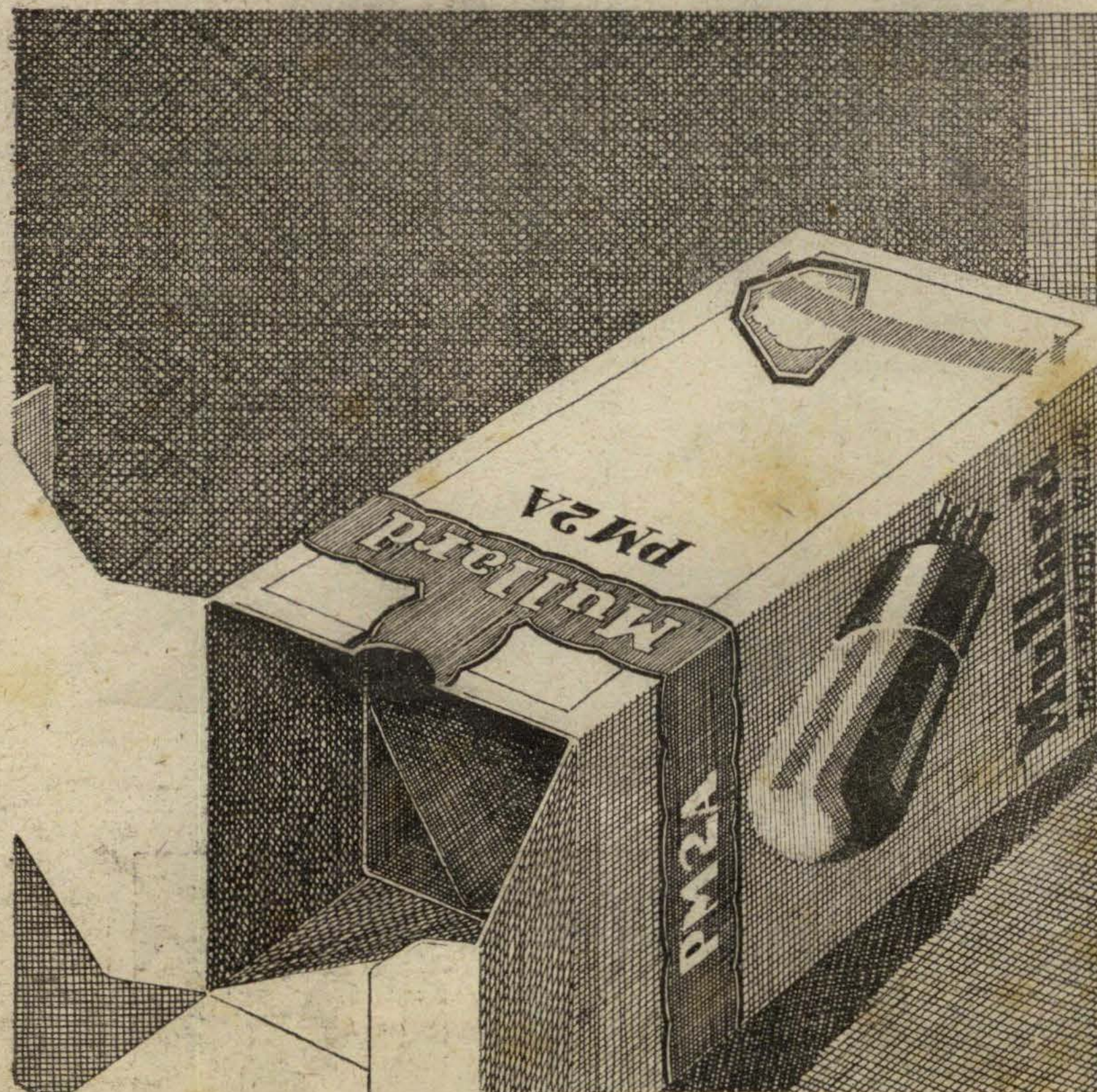

Mullard

THE · MASTER · VALVE

MADE IN ENGLAND

Advt. The Mullard Wireless Service Co., Ltd., Mullard House, Charing Cross Road, London, W.C.2.

Arks.

"Yes" says Aunt Margaret



"I've got a good idea. I'm giving them all Exide Batteries this Christmas!"

Give Exide Batteries and give clearer reception. Here are some popular types and sizes.

"D" TYPE FOR L.T.

DTG	20 amp. hrs.	4/6
DFG	45 amp. hrs.	8/6
DMG	70 amp. hrs.	11/-
DHG	100 amp. hrs.	14/6

"C" TYPE FOR L.T.

CZ3	30 amp. hrs.	11/-
CZ4	40 amp. hrs.	13/-
CZ6	60 amp. hrs.	17/-
Other sizes up to 120 amp. hrs.		

H.T. BATTERIES

WJ	60 volts	£1 17 6
WH	60 volts	£2 6 6
WT	30 volts	£2 4 0

L.T. PORTABLE BATTERIES

"Gel-Cel" Jelly Acid and Unspillable Liquid Acid Type to fit all sets from 9/-

These prices do not apply in the Irish Free State.

GIVE AN

Exide

BATTERY

AS BRITISH AS THE B.B.C.

From Exide Service Stations or any reputable dealer. Exide Service Stations give service on every make of battery. Exide Batteries, Exide Works, Clifton Junction, nr. Manchester. Branches at London, Manchester, Birmingham, Bristol, Glasgow, Dublin, Belfast

WORLD-RADIO

Vol. XIII No. 334

Registered at the G.P.O.
as a Newspaper.

FRIDAY, DECEMBER 18, 1931

TWO PENCE

A Mexican Christmas

By J. W. BROWN

Mr. J. W. Brown, who was formerly Secretary of the International Federation of Trade Unions, has travelled much in Mexico and has an intimate knowledge of the daily life and picturesque customs of the Mexicans.

MEXICO to many people—and especially English people—means no more than an arid stretch of country inhabited by fierce and merciless tribes of revolutionaries; and mention of Christmas celebrations in such a land may serve merely to call up a smile, while the imagination dallies with scenes of debauched bandits who have only suspended their terrorising exploits for a few hours to indulge in a midnight orgy of feasting and drinking. But these are only extravagant fancies. Actually, Mexico is a land of beauty and glamour, mystery and fascination, weaving spells of magic and enchantment, and its people share all the atmosphere of romance that the country itself possesses in such abundance. Their costumes, too, are in complete harmony with their colourful and picturesque surroundings. Large numbers of the men are dressed in *Zarapes*, or brightly-coloured cloaks, and wear huge sombreros sometimes measuring nearly a yard across. Such are the unwieldy proportions of these hats that they have to be tipped to one side or taken off in public vehicles. In fact, they were found to be such a nuisance in one town that the local authorities imposed a tax of 1 peso for 10 centimetres of brim beyond a certain width. The Mexicans possess an inordinate love of all bright things, and the pedlar often includes amongst his stock-in-trade bright pottery, opals, and camelias.

Display and colour are, in short, a vital part of life for the Mexicans. You would not doubt this, if for one moment you could glimpse the *charro*, resplendent in his full costume, mounted upon his horse and joyful in the knowledge that he makes a goodly sight. The horsemanship of the *charro* is perfect. At a gallop all that is needed is the little finger on the reins; for the rest, the guidance is done with the legs.

The love of bright things is one of the simple traits of their character. But something of the spirited side of their nature is apparent in their love of the contest of *Jarapeo*, which is considerably more humane than the repulsive butchery of the bull-fights, a popular national sport. Between two files of Indians bulls are driven at full speed. The animals, urged on by the Indians, are followed by horsemen. Each horseman gallops till he is abreast of the bull, usually on the left-hand side; then, in a twinkling of an eye, he swings his right leg over the head of the horse, retains his balance, while with the right hand he reaches down, catches the tail of the bull, and with a single movement swings the animal completely over, to the delight of the spectators, whose cheers for the horseman are mingled with jeers at the bull. It is a perfect exhibition of superb horsemanship; if the rider's pace is a fraction too fast or too

slow, it is he who is made to look ignominious. The excitement of the crowd is intense, and the yelling and shouting deafening. The victors in this feat do not go away unrewarded, and it has been my privilege to present the "prizes" on one such occasion in Zacatecas. These consist of sashes worn over the shoulder and down by the side—very reminiscent of the insignia of office used by the Ancient Order of Oddfellows.

With all his wild nature, the friendship of the Mexican is a thing worth having. Nor have I ever had experience of a more gracious, hospitable, and courteous race. In this connexion one incident comes to my mind. There exists in Mexico an old custom, which requires the host to say to any guest who may admire something in his house: "*a la orden de Usted*"—"It is yours." This is intended merely as a formal and courteous phrase; but on one occasion, to my horror, an American colleague of mine took our host at his word, and accepted a fine

This period of rejoicing is religious in its origin. The story of the Virgin Mary, wandering about for eight days and nights, seeking lodging before she found shelter at length in the stable, has given rise to a quaint ceremony among these people. Carrying an effigy of the Virgin from room to room in their house, they knock at each door praying for shelter, using old Biblical words and phrasing. This practice is continued each night till Christmas Eve, when the request for shelter is granted, and a Crib and Manger are set up in the house. The birth of the Child is symbolised by a cake being placed in the room with a china doll in it—or, should the means of the family permit, the doll may be of gold or silver. They call it "the baby in the cake." The ceremony has, of course, by this time, largely lost its religious character, and is carried on mainly as an old Christmas custom. But for us, at least, it becomes richer in meaning when we know in what tradition it has its roots.

A great feature of these evening entertainments is provided by the *pinato*. The *pinato* is a huge, balloon-like receptacle which is filled with candy, figs, nuts, and presents of all descriptions. It is often shaped like a human head, or like an animal, or perhaps some grotesque creature. It is suspended from the ceiling, and, in turn, boys and girls alternately are blindfolded, twisted round and round, after the manner of our blind-man's buff; then a stick, which might be described as a cross between a copper-stick and a policeman's truncheon, is put in their hands, and they aim a blow at the *pinato*. Sometimes they are allowed three tries, and misdirected hits are greeted with hilarious laughter, except on those occasions when the stick descends on the head of some unlucky spectator. When one of the children succeeds in breaking

it there is a great rush to get the presents, which are scattered all over the floor. It is only among what might be described as the middle classes of Mexico that a Christmas-tree is found. The Christmas-tree custom has probably been introduced from the United States; the ceremony is very similar to our own. A ribbon is attached to the tree with a number on it, which corresponds to one of the presents which, at the appropriate moment, is delivered to the lucky person.

At midnight on Christmas Eve the great feast of the season takes place, the chief dish being a salad of the manifold fruits of Mexico. It is called a *Bunuelos*, and besides fruit contains also beetroot. It is made in a great bowl, measuring two to three feet across. In addition, a very crisp kind of cake bread is provided, which is broken into a plate and dipped into honey. This ceremony is called the *Misa de Gallo*, or, translated literally, the Cock's Mass.

During this whole period of merrymaking there are fairs in the market places, and present-buying goes on apace. The fairs, which

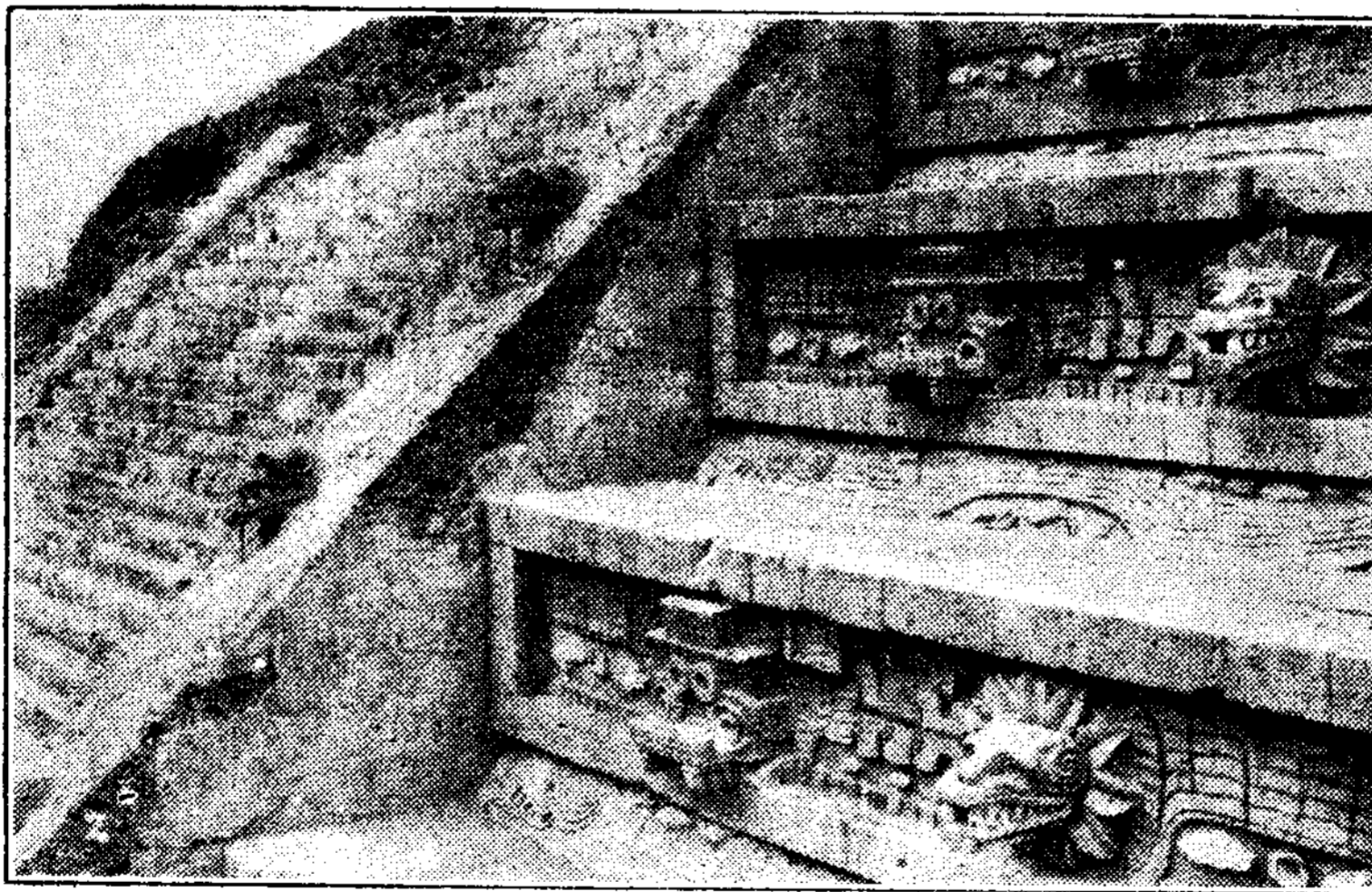

Detail of pyramids at San Juan, Teotihuacan, Mexico

old piece of pottery. It required all my tact and diplomacy to persuade him that it was possible that our host might be perturbed by the loss of his treasure, and that it might be a mark in our favour if he returned it.

These people celebrate the Christmas season in their own picturesque fashion. In Mexico Christmastide, or, as they say, *Posados*, extends over eight days, or, to be more precise, I should say eight nights, from December 16 to Christmas Eve. And during that time there is a continual round of parties, dancing, music, drinking, and fun of all kinds. Parties gather in the house of a friend, who for one evening acts as host and bears all the expense of the festivities. But the next evening, when the revellers gather in the house of another friend, it is his turn to be guest. And thus the round of merriment goes on. The guests often attend their many parties in fancy costume—a picturesque people in a picturesque country. The *Posados* is the great event of the year with the Mexicans, and even the poorest families save up for this occasion so that they may take their part in the revels.

continue till Christmas Eve, do all their trade in the evenings. The crowds which throng there are in right good humour. The boys are for the most part engaged in letting off fireworks, and the louder the bangs the faster the fun; those who happen to have revolvers on them sometimes discharge them, adding not a little to the general disturbance. I remember one year, when I was in hospital in Mexico City at this season; it was the time when the revolutionaries had a good part of the country in their hands. The roars of the crowd and the reports of the fireworks seemed all the greater as I lay in the quiet ward, and more than once I was convinced that the rebels must have taken possession, and that I and the rest of the patients were not long for this world. I was always assured that everything was as it should be, but the tumult was not conducive to a quiet recovery after a severe operation.

On the last day of the year, the majority of the population attend Church service to give thanks for the health they have enjoyed during the year. This seems to me a most appropriate and necessary *finale* to such a consistent period of feasting. But festivities are not quite at an end even yet. There still remains the ceremony of the cake and the baby. The Virgin found refuge in the stable on Christmas Eve, and the Child born that night remained in the manger till *Santa Res* (January 6). The cake with the tiny china doll in it is cut on *Santa Res* Day. The person, whose luck it is to secure the slice containing the baby, has the honour of giving a further party. From time to time the baby is eaten, just as threepenny-bits in Christmas puddings are swallowed, and I am personally convinced that to omit the little doll would mean more whole-hearted enjoyment of the cake.

These people, generous at all times, genial and hospitable by nature, readily and deeply appreciate the meaning of friendship, and Christmas-tide, or *Posados*, affords an opportunity for them to give free play to all these qualities. Anglo-Saxons, in their contact with this race, should always remember that the Mexican is a *caballero*—a gentleman. And should he be treated as such, then the visitor will be welcomed with gracious cordiality; he will be allowed to take part in the customs of the people; he will learn of their traditions, and thus will he be led inevitably to an appreciation of Mexican ideals and culture, and will gain, moreover, an intimate knowledge of the most fascinating country in the world.

Advertising and Mexican Broadcasting Stations

(From a Correspondent)

The majority of Mexican broadcasting stations have their own advertising staffs, and only in a few cases do they contract with independent advertising agencies. It is reported that advertising by means of broadcast programmes is growing as a practice in Mexico, and competition among the various stations is becoming keen. Charges for time are on the increase, and it is sold usually on a basis which provides that the station shall furnish the artists as well as the use of the studios and equipment.

(Continued from column 3)

I do not find the new Radio-Paris station any stronger. I have tried several times for the new high-power Russian station advertised to work on, or near, Madrid's wavelength on some unheard-of power, but all I can get—even with a borrowed super-het. (eight valves)—is a beautiful heterodyne note and a series of hoarse grunts, groans, and cackles. Perhaps, however, that is merely the Russian propaganda broadcasts!

From the Swiss Alps

A Review of the November European Programmes
By "YODELLER"

MY prophecy in a recent issue, of an early and a severe winter, seems likely to go unfulfilled. November in the Alps has been a marvellous month. We have had much sunshine and at times it has been almost summer-like. On the 29th, we had a small snow fall, and it is a little colder as I write these notes.

Sunday, 1st.—I found the long waves free from atmospheric, so tuned in Königs Wusterhausen for a concert by the Berlin Philharmonic and heard, amongst other items, Pfitzner's Overture, "Käthchen von Heilbronn," Boccherini's famous "Minuet," and selections from Berlioz's *The Damnation of Faust*.

Monday, 2nd.—Picked up a relay by Vienna from the Imperial Vaults of the Capuchin Monastery on the occasion of the All Souls' Day commemoration service. The organ—a magnificent one—formed an impressive background for the slow, low-voiced commentary given by the Ravag announcer describing the proceedings.

Tuesday, 3rd.—Spent the evening listening to a concert from Warsaw, which included Bériot's *Scènes de ballet* for Violin and Orchestra, Tchaikovsky's "Romance," and Liszt's Second Hungarian Rhapsody. This concert ended, I stayed on at Warsaw for the harpsichord recital which followed.

Friday, 6th.—Called in on the Berne Municipal Theatre for a Swiss version of Johann Strauss's *Wienerblut*, which the Schweizerische Landessender was putting out with great vigour. Incidentally, I am rather surprised that this station is heard so well by my friends in England.

Saturday, 7th.—Heard the international relay by Vienna—a concert relay which, the announcer stated, in several languages, including English, was being taken by 113 stations. I tried a few of these, finally settling down to Vienna direct—although in many cases, there was little to choose between the relays and the original. The rebroadcast by the long-wave Daventry came back to me very well out here.

Wednesday, 11th.—Armistice Day. While I went to the local Armistice Day service (conducted by the Wartime Boulogne "Padre"), a member of my family listened to the Cenotaph relay from London. In the evening, I listened to the Albert Hall for the Legion "Festival of Remembrance."

Thursday, 12th.—One of the most reliable transmitters these days is Ljubljana, which station I found retransmitting a Yugoslav symphony concert from the National Theatre, Zagreb. The concert included Anton Lajovic's "Caprice," and Skerjanc's Lyric Overture, which—to be quite frank—although I listened to it very carefully, I could not grasp or follow.

Saturday, 14th.—Spent a delightful hour or two at Vienna, listening to a performance from the State Opera House of Gounod's *Faust*. This came through in the usual faultless way one has grown to expect from these Vienna Opera House relays.

Sunday, 15th.—Commenced the evening at Gleiwitz, which for once was free of its heterodyne trouble, and enjoyed a fine broadcast of Lehár's *The Merry Widow*.

Monday, 16th.—Tuned in the London National in order to hear the "Buy British" speeches by the Prince of Wales and Mr. Thomas, both of which came through excellently. I only wish our radio manufacturers would make an attempt to *Sell British* out here!

Wednesday, 18th.—Listened to the whole of Bizet's *Carmen* from the National Theatre, Munich. In the fifteen minute interval between Acts III and IV, I stumbled on Leipzig giving out Haydn's *Harmonie-Messe* in B Flat Major, the day being Germany's "Day of Penance." This relay was from the St. Thomas's Church,

Leipzig, and was provided by the local Riedel Society.

Thursday, 19th.—Heard, from Milan, one of the best versions of Mascagni's short opera *Cavalleria Rusticana* I have ever come upon.

Friday, 20th.—Early in the evening heard a fine military band concert from Bucharest, then changed up to Budapest for the song and cello recital from the High School of Music, one of the regular Hungarian broadcasting features I never miss. I liked, particularly, Tartini's 'Cello Concerto, which I heard for the first time on this occasion. This concert ended, turned to Strasbourg for the last part of Humperdinck's *Hänsel and Gretel*, but was rather disappointed in it.

Saturday, 21st.—From an old Rugger man's point of view, the relay from America (one of the best relays we have ever had!) of the Harvard-Yale football match was most interesting, particularly the quaint technical words, "Huddle" and so forth, used by the American commentator. I thought the game much slower than our handling code, but perhaps my American friends would disagree—emphatically—with this!

Monday, 23rd.—Spent one of the most enjoyable evenings I have known for some time at the Saalbau, listening, *via* Mühlacker, to a relay of the Fifth Monday Concert by the Frankfurt Orchestral Society. Beethoven's Pianoforte Concerto No. 4 in G Major was a veritable feast for the gods, whilst Bruckner's Third Symphony in D Minor was magnificent. May I draw my readers' attention to these concerts, and suggest that they tune in Stuttgart on forthcoming Monday evenings?

Tuesday, 24th.—My set broke down, and with a "dug-out" slider-and-bar crystal set, I listened to Radio Suisse Romande giving a symphony concert under the bâton of Ernst Ansermet. Reception was not too strong, but amazingly pure. I also logged Prague and Rome at excellent strength with my old "poste à galène."

Wednesday, 25th.—Again a symphony concert from Vienna drew me, of which the principal item—to me—was Schubert's Eighth Symphony, the "Unfinished"—incidentally, I like the French title better—"Symphonie Inachévé," which seems more romantic as well as more expressive.

Saturday, 28th.—Budapest advertised a symphony concert, but on tuning in this station, I found it giving forth a concert by Jack Hylton and his orchestra. The audience present in the hall from which this broadcast emanated were wildly enthusiastic, encoring item after item with delirious insistence.

Sunday, 29th.—My last notes of the month refer to Radio-Paris, from which station I heard, in the early evening, one of its famous Poulet concerts relayed from the Sarah Bernhardt Theatre. The orchestra treated us to an excellent rendering of Beethoven's Fifth Symphony.

Summary

At times, atmospheric have been troublesome, much more so than one would expect at this time of the year. The interference of one station with another appears to be increasing. The best thing one can do is to pick out the strongest and the best signals and stick to these as much as possible. I notice the long-wave Daventry is badly heterodyned on frequent occasions, whilst a morse station frequently blots it out completely. This is a great pity. I can no longer separate the Northern Regional from Prague with my old set, although this can be done with a good super-het.—of which there is no British make on sale out here. To anyone who has a set which is inclined to "spread" a little, the giant Czechoslovak transmitter is a nuisance—yet, I am told, it is still to increase its power.

(Continued at foot of column 1)

Via Ether

Carmen from Frankfurt

ON SUNDAY next *Carmen* will be relayed at 7.30 p.m. from the Frankfurt studio. An interesting thing about this production, which is by Carl Stüber, is the restoration of the original spoken dialogue as it was used in the ill-fated Paris presentation of March 3, 1875. Beaumarchais, the author of *The Marriage of Figaro* and *The Barber of Seville*, is supposed to have said that words were only sung when they were too stupid to be spoken. (Oddly enough, his two best works have managed to survive only through the medium of song.) Whether the libretto of *Carmen* can be classed as stupid or not, it has been found that a spoken dialogue is more effective for broadcasting than the singing on the musical register called recitative. After that March première, Bizet sat in the directors' room at the back of the theatre and received the congratulations of the few friends present. He knew they meant well, but he was stunned by the hostility of the public. Presently he and Ernest Guiraud left the theatre together, and for a long time walked about the deserted streets, almost in silence. This original *Carmen*, when given on the 20th, will find a rather different audience. The recitatives usually sung in *Carmen* were written by his friend Guiraud for the more successful Vienna production in October of the same year, which Bizet did not see. He died in the previous June.

Dr. Curtius to Broadcast

ON the same afternoon (the 20th) *Kasperl's Theater* (a Punch and Judy show for children) will be broadcast. Kasperl is own brother to the more phlegmatic Punch and the more sentimental Petrouschka, and in the difficult situations in which he is always finding himself he is no less likeable. In the evening at 6.45 Dr. Curtius—until recently German Foreign Secretary—will speak on Franco-German relations. On MONDAY, the 21st, the Amar Quartet, often heard from Stuttgart, will play the Brahms Op. III.

The Florence Station

No doubt many readers have heard the new Florence station testing. These special transmissions have been taking place each day shortly after 1 p.m. and again after midnight on Milan's old frequency of 599 kc/s. The official inauguration of the station is likely, I believe, to take place between now and Christmas Day. The Genoa station will also be using its increased power of 12 kW., I am informed, during the course of the next week or so. There is some doubt at the time of writing, as to which station—Milan, Turin, or Naples—is using which wavelength, and it is possible that Turin is temporarily broadcasting on Milan's old wave. The calls and interval signals being identical, one cannot say for certain.

Turin's Christmas Day Rest

Do not wonder what has happened to Turin if you cannot find that station on Christmas Day. It seems that during the Christmas holidays each one of the three Northern Italian stations, Milan, Turin, and Genoa, will

take a day's rest, and Christmas Day will be Turin's turn. On Christmas Eve, at 7.30 p.m., the Northern Italian stations will relay the ringing of the famous bell of Rovereto. Readers may remember that a little more than a year ago I mentioned this bell in these notes, and a picture of it was printed. The bell, called "La Campana dei Caduti," which is erected on the bastion of Rovereto Castle, was inaugurated in October, 1925, by the King of Italy and was cast from the metal of guns given by the Allies of the Great War. The bell itself weighs ten tons and it is rung in honour of those who fell in the War. At 8 p.m. on the same evening these stations will broadcast a symphony concert conducted by Otterino Respighi and, still later, will relay Midnight Mass from a Turin church.

"Bells! Bells! Bells!"

THE relay of Italy's memorial bell will not be the only broadcast of this nature. Indeed, the music of famous bells will be a prominent feature of Frankfurt's Christmas Eve programme, which will be broadcast also by Stuttgart-Mühlacker as well, probably, as other German stations. Between 8 p.m. and 9 p.m. will be heard Germany's most famous bells. Thirty cathedrals will be laid under contribution, including those of St. Lawrence, Nürnberg (1392), Freiburg (1258), Erfurt (1497), and Würzburg (1706), which are famous for their ancient bells. There will be a running commentary by Carl Stüber, who will have some interesting things to say about the homes of these bells. For instance, the Cathedral of Trier—which was built by Helena of York, the wife of Constantine the Great, and has a bell, dating from 1628, which is named after her—is the resting-place of St. Matthew the Apostle. The largest bell, in St. Stephen's Cathedral at Vienna, will not be heard. It has not been rung for fifty years because the bell tower is not strong enough to stand the vibrations.

Broadcasting Germany's Greatest Peal

THE heaviest bell in Germany, one of those to be heard, is that in Cologne Cathedral; it weighs 541 cwt and is the seventh largest in the world, the largest being that in the Kremlin in Moscow, weighing 3,600 cwts. In the Cathedral at Fulda lies St. Boniface, who was the first to convert the Germans to Christianity and was killed here by the Saxons. The bells at Mainz (Mayence) were cast from guns which had been used at the Battle of Jena. They were installed by the French, whose territory at that time extended to the Rhine and therefore included Mainz. The greatest peal in Germany will be heard from the Marienkirche, in Dantzig. The carillon of thirty-seven bells will play Christmas tunes. From Hamburg will be heard the Bell of St. Michaelis, a famous landmark to German sailors. Frankfurt was for long the capital of the so-called Holy Roman Empire, and in the Cathedral here many of the emperors were crowned after being chosen by the Electors in the Kaisersaal. A good many of the old emperors were buried in the Cathedral at Speyer. Other cathedrals whose bells will be relayed on Christmas Eve are the Kreuzkirche, in

Dresden, the Frauenkirche, in Munich, the cathedrals of Bremen, Bonn, and Berlin, and the monastery of Beyron, in Württemberg.

Christmas Programmes

THE Christmas programmes will be worthily inaugurated by two transmissions on SUNDAY next. One is Hilversum's relay of Bach's Mass in B Minor from the Concertgebouw, Amsterdam, where it is to be rendered under the direction of Willem Mengelberg. The other is the relay by Leipzig of Bach's Christmas Oratorio from the St. Thomas Church, at Leipzig, of which he was Precentor. Other outstanding transmissions on Sunday are the relay of the "Concert Poulet" by Radio-Paris, the broadcast from Vienna of a song recital by a great favourite of mine, Frau Lotte Lehmann; the above-mentioned relay of *Carmen* by the Frankfurt, Stuttgart, and Heilsberg stations; and finally a relay by Brussels No. 2 of Mascagni's *L'Amico Fritz* from the Antwerp Opera House. THURSDAY'S programmes, needless to say, are largely influenced by the Christmas season. The Symphony Concerts announced from Bucharest for 7 p.m., and from Radio-Paris for 9 p.m., attract my special attention. Romanian Christmas music is then to be heard at the former, while at the latter the well-known German conductor, Herr Max Klemperer, is to conduct the Paris Symphony Orchestra. Two performances of *Tannhäuser* from two houses of Opera steeped in the Wagner tradition—i.e., Dresden and Munich—are to be relayed on FRIDAY and SATURDAY respectively. Leipzig will take the former and Munich the latter.

More about Figaro

A PROPOS of my reference to the *Marriage of Figaro*, last Sunday's broadcast from Langenberg of Mozart's comic opera *chef d'œuvre*, which was relayed by all German stations, with one exception, was made notable by the fact that an entire new libretto was then used for the first time. As is well known, Mozart wrote the music to an Italian version of Da Ponte's, who, as is equally well known, based his story on Beaumarchais' comedy. Since then various German versions of Da Ponte's libretto have been rendered at Continental opera-houses, none of which, has, however, been quite satisfactory, since all aimed at being too literal. Cologne's able producer, Dr. Siegfried Anheisser, has just completed a new German version to which he had devoted many years' work and for which the claim is made that, while it retains the spirit of the original, the musically-illustrated words remain in the same place in the German text. I listened to Dr. Anheisser's introductory talk, as well as to two acts of the opera, on Sunday week. I had not an old textbook by me, and, therefore, could not make any comparison. Musically, however, the performance went with a great swing, and once again we were made aware that the *Marriage of Figaro* is Mozart's most valuable and most mature comic opera. Dr. Anheisser produced the work in the Cologne studio, Dr. Buschkötter conducted, and the singing of the artists was excellent.

ETHERVIATOR

Dominion and Foreign Broadcasting Intelligence

Extension of U.S.A. Opera Broadcasts

(From our New York Correspondent.)

The decision of the Board of New York Metropolitan Opera to allow its performances to be broadcast opens one more avenue to those interested in hearing good music "on the air." American listeners have been very fortunate of late in the musical programmes which have been presented and they are congratulating themselves that this new source—perhaps unique in the musical world for the perfection of its rendering—will shortly be available. The engineers at present engaged in installing the necessary equipment expect to have everything ready for the first broadcast early in January, 1932, if not before. When that occurs the New York Opera will join the Chicago Opera, which for some time past has permitted broadcasts of its performances. Among the outstanding programmes enjoyed during the past fortnight may be mentioned Shura Cherkassky, Russian boy pianist (Nov. 22, WEA);

Symphony orchestra, Walter Damrosch, conductor (Nov. 22, WJZ);

Margaret Matzenauer, former leading contralto of the Metropolitan Opera Company (Nov. 22, WABC);

Chamber music: violin recital by Toscha Seidel (Nov. 24, WOR);

A dramatic musicale devoted to Saint-Saëns by a symphony orchestra (Nov. 26, WEA);

New York Philharmonic Symphony Orchestra, Toscanini conducting, at the Metropolitan Opera House, was broadcast throughout the United States, France, Hungary and Czechoslovakia (Nov. 29, WABC);

Beniamino Gigli, Metropolitan Opera tenor, recital of Italian melodies (Nov. 29, WEA);

Symphony concert, directed by Maurice Baron (Jacques Gosselin, soloist) (Nov. 29, WABC);

Toscha Seidel, violinist, and Egon Kornstein, cellist (Nov. 30, WABC);

Elisabeth Schumann, prima donna soprano of the Vienna Staatsoper, sang for the first time for American broadcasting in an orchestral concert, conducted by her husband, Dr. Alwin (Dec. 2, WABC);

Dramatic musicale of Mozart's work (Dec. 3, WEA);

Rochester Philharmonic Orchestra, Fritz Reimer, conductor; George McNab, pianist (Dec. 4, WJZ);

Philadelphia Orchestra, Leopold Stokowski, conductor. Programme: Weber, Schubert, Berlioz, Mendelssohn, and Schumann (Dec. 5, WABC).

AUSTRALIA

A National Broadcasting Service

(From our Australian Correspondent)

It is now understood that the intention of the Commonwealth Government is to set up a board to control broadcasting in Australia. How far this new authority is to be independent of Ministerial control is not yet clear. The board will take over the programme side of broadcasting from the Australian Broadcasting Company, whose contract expires at the end of June, 1932. Meanwhile, the Government will have to pass certain legislation providing for the change. At present the licence fee in

Australia is 24s. a year, and many listeners have hoped for a reduction, but it is now announced that a reduction is exceedingly unlikely as it is intended to establish a National Broadcasting Orchestra, for which one shilling per licence will be required. The new board will also control the "B" Class (privately owned) stations, with which they are in competition.

CANADA

The "National Service Loan"

(From our Montreal Correspondent)

Full use was made of broadcasting in advertising Canada's "National Service Loan," and much

been so presented for centuries. On Christmas Day peace and good-will speeches will be broadcast, and a concert by the Philharmonic Orchestra will be relayed. A lively operetta will be broadcast from the studio in the evening, but the difficult selection cannot be made perhaps until the last moment. On December 25 there will be a concert of records taken at Bayreuth of a festival performance of *Tannhäuser*.

GERMANY

Opera Relay

(From our Frankfurt Correspondent)

On Christmas Day the third act of the *Meistersinger* will be relayed from the Landestheater of Hessen at Darmstadt. Weingartner will conduct. The opera will begin at about 4 o'clock in the afternoon, and the final act is timed to last from 7 p.m. to 9 p.m. Apart from anything else, the presence of Felix Weingartner is an assurance that this will be a brilliant finale to the Christmas programme.

Christmas Relays

(From our Leipzig Correspondent)

Two programme items of recent years which had met with listeners' particular approval will be relayed again this Christmas. On December 20, at 7.15 p.m., the Christmas Oratorio by J. S. Bach will be transmitted from St. Thomas's Church in Leipzig, at which Bach was the Precentor for many years. On Christmas Day the Central German Broadcasting Company will relay Matins from the village church in Sehma, a small place in the Saxon Erzgebirge. In the evening of Christmas Day Leipzig and Dresden are to transmit, at 5.30 p.m., *Tannhäuser* from the Dresden State Opera.

POLAND

Christmas Programmes

(From our Warsaw Correspondent)

Special items chosen for the Christmas holidays are included in Thursday's programme. The morning will begin, as usual, with the time signal and the chimes from Cracow—from 10.58 a.m. until 11.5 a.m. (Greenwich Time). In the afternoon a Christmas Eve radio play for children, *Christmas in the Woods*, will be broadcast from Warsaw, followed

by a concert of children's choir relayed from Katowice. During the evening programme a mixed choir will be rebroadcast from Cracow. A programme of Christmas songs—called in Polish, "Kolendy"—sung by a chorus, will be relayed from Lwów at 10.25 p.m. The first day's Christmas programme will close at 11 p.m. with a relay of "Pasterka"—a special Christmas Service—from Notre Dame in Cracow. On December 25 the programme opens about 10 a.m. with a relay of a Christmas service from the Ostra Brama Cathedral in Wilno. Saturday, December 26, opens at 9.50 a.m. with a relay of a service from the Katowice Cathedral. At 6.45-7.15 p.m., Charles Dickens's *Christmas Carol* will be broadcast, and the second part, from 9.10 p.m., will be devoted to Chopin's masterpieces.



St. Thomas's Church in Leipzig, from which Bach's Christmas Oratorio will be transmitted by Central German Broadcasting Company on December 20. J. S. Bach was Precentor of this church

of the success which that issue achieved must be attributed to the publicity so obtained. On one evening nine Provincial Premiers and the Acting Premier of the Dominion broadcast appeals to the public to take advantage of the excellent investment offered, and thus aid both themselves and the country, as the greater part of the loan will go to provide work for the unemployed, and will be used for road-making and other public undertakings. The amount asked for was \$150,000,000, and it was over-subscribed.

AUSTRIA

Vienna's Christmas Items

(From our Vienna Correspondent)

On December 23 there is to be a relay of a Christmas performance of The Adoration of the Shepherds, from a country village where it has

The Tribulations of Must-Avva Dinn

An (Almost) Oriental Fable, with copious Notes by the Translator

ONCE upon a Time in the far-famed City of *Saa-Voi* there dwelt a Wealthy Merchant whose Son, Must-Avva Dinn, much to the Chagrin of his Parents, by Evil Association with other Youths of his Age had been led to live a very Careless and Idle Life. It is said that he was of an Obstinate Disposition and that gainsaying all Wise Counsels tendered to him by his Elders he did refuse to learn a useful Trade wherefore in this Way he had acquired the Vicious Habit of shutting himself up in a Closet during a great Part of the Day and Night whereby he asserted he did hear Music disseminated from the local Bazar and even Voices from Distant Places far beyond the Confines of the City. It is also stated in the Annals of the Period that to satisfy his Desire in this Direction he did sell some of the Treasures most prized by his Parents "for" he observed, "by so doing shall I provide the Wherewithal to purchase from Foreign Places clever Devices which will permit me to listen to the *wyse-kraks* of he-men from *Kay-dee-kay-ay* and *Mos-kō* (1) in the Still Hours of the Night. And oft would he indulge in these Wild Orgies in the Society of Worthless Companions, wherefore the Neighbours who heard of these Things shook their Heads dubiously for albeit the Youths did meet secretly their Fraternity was recognised by the Sign of a *Radiant Fan* which they displayed as a Token on the Hem of their Garments.

Now it came to pass that in this Land of *Saa-Voi* there appeared one Day an Elderly Man of not unprepossessing Appearance who forthwith on his Arrival in the Market Square did display a black Box of curious Form and in which there glowed dimly Magic Lamps wherewith by artful Means he cast upon a small Silver Screen Pictures and Designs which were strange to the Eyes of the Populace. Must-Avva Dinn who had been apprised of the new Magic which the Stranger had exhibited wended his Way quickly to the Place and without haggling over the Price demanded of him did give the Vendor *um-teen* sequins (2) in Exchange for the Wonderful Box. Concealing It under his Garments he quickly carried It to the House of his Father and proceeded in all Haste to hide his valuable Purchase in his private Closet for, as it is said, he was a Youth of great Wisdom and it came to his mind that the Magic he had acquired from the Foreign Merchant would vouchsafe to him the *Bul-ge* (3) over his less-favoured Friends. After Sunset having made all due Preparations he invited his Companions to a light Collation, telling Them that all was *o-kay* (4) as his Father and Mother had been bidden by the *Sen-Sor* to witness some *Fill-ums* before they were shown to the Sultan at the Royal *See-nec-ma* Palace. Whereupon much to the Surprise of Must-Avva Dinn and equally to the Astonishment of his Friends who had disbelieved All that which he had promised them by Virtue of the Magic Box there was *bared to their Vision* a Picture of a Most Wondrous Nature. For albeit it was slightly veiled as in a Mist they did easily recognise the Face of a Lovely Woman far more beautiful than any *Houri* of the Innumerable Nights of Araby wherefore they did give forth pleasant Noises and laughing did slap Must-Avva Dinn on the Back saying the while that for a Certainty he had delivered the *Gūds* and was ITT. And the Taleteller says that Must-Avva Dinn had no Eyes but for that Fair Vision and in his Abstraction was deaf to all Remarks made around him. And I as a Poor and Humble Scribe do not possess Expressions strong enough nor sufficient Knowledge to paint in words any Resemblance of the Beautiful Object which

appeared before his Eyes. But it is said that her Hair was of a Golden Tint yet of two Colours that her Eyes were black and full of Fire her Nose of Perfect Proportion her Mouth small of vermilion Hue and that when she smiled her Lips revealed a complete *Gimmy-Sett* (5). When Must-Avva Dinn heard her speak her Voice emitted the Sweet Tones of the *Ee-yan-kay Būl-Būl*, a Bird which was oft heard in the Land of *Saa-Voi* and the Verses she sang indicated the Vivacity of her Wit. But, alas, the noisy Chatter of his Bosom Friends was such that he was unable to understand all the Words of his Charmer's song a Fact which he sorely regretted inasmuch as she frequently repeated endearing Terms such as *Hun-nic*, *Bay-bee* and described *blew skies*, *Luv*, *Lon'liness* and *Thrills* which wrapt him in Ecstasy. Whereupon when the little Lamps dimmed and the Picture faded away Must-Avva Dinn did recover his wandering Senses and did exhort his Companions to depart forthwith to leave him with his Thoughts which with artful Noddings of their Heads and Hearty Laughter they proceeded to do.

Now, for many Days Must-Avva Dinn's Mind was as disordered as a *Kros-wurd* anagram. He refused both Food and Drink and would have no Discourse with the other Members of his Family the which caused to his Parents great Anxiety and Chagrin. "For" said his Father, "it is not meet that so young a Youth should spend Hours alone on the bank of the *Tem-se* albeit it is the Place where People of the Best Fashion do walk." And for many nights Must-Avva Dinn seeking no Rest did remain in his Closet in the Hope that he might again see the Vision which had ravished his Heart. But Fate was unkind and the Magic Box did not reveal the features of his Charmer whereupon on one morning as Day was breaking he hied to the Bazar and there sought a Public Letter-Writer whom he conjured to indite without Delay a Message to the Lady of his Dreams. The Scribe who took Pity on the Youth did use all his Knowledge and his Art to make the Terms sufficiently endearing to soften the Maiden's Heart. And the Narrator relates that the Letter was of so beautiful a Nature and couched in such exquisite Form that for the Benefit of Future Lovers it was later engraved in letters of Gold on the Portals of the House which disseminates all Good Things to the Four Winds (6). He wrote: *This Love-Sick Swain will not trouble you with a Recital of the exquisite Pains he has endured since the fatal Evening on which through the Magic of the Ee-Thur your melodious Voice and Beauteous Features deprived him of a Heart which he had resolved to preserve as long as he lived. He has presumed to present you with a Token of his Passion. If you will condescend to meet him he will esteem himself the happiest of all Lovers; if not the Sentence of Death which your denial would bring will be received with all Resignation as he dies for Love of You. He will wait outside the Estu-dee-oh* (7) for your Answer and with this Burning Message Must-Avva Dinn did send one hundred *Ku-pons* (8). The Letter-Writer who was justly proud of his Composition faithfully promised his Patron that without Dalliance he would make a fair Copy and by Means only known to Pliers of his Trade would convey the Message to Must-Avva Dinn's *gy-url friend* which so pleased the Youth that in the Goodness of his Heart he emptied the Contents of his Purse in the Lap of the Scribe. Whereupon inflamed by his Devastating Love he could hardly contain his Impatience until the next Day and returning to

(Continued at foot of col. 3.)

Letters to the Editor

To the Editor of WORLD-RADIO

Broadcasting and Languages

DEAR SIR,—I read the article "The Linguist Rejoices" with much interest, and, would like to express my deep appreciation of wireless as a means of perfecting one's knowledge of foreign tongues. I have derived great benefit through listening to most of the stations mentioned in the article and shall not hesitate to adopt the advice given with reference to lessons from Continental stations.

I take this opportunity of suggesting that enthusiasts should use headphones (rather than a loud speaker) when listening to speech, as reception is usually sharper and, therefore, easier to follow.

Yours faithfully,
Chester Road, Stretford. "A LINGUIST."
December 4, 1931.

Transatlantic Wireless: 30th Anniversary

TO mark the thirtieth anniversary of Marchese (then Signor) Marconi's first test in trans-Atlantic wireless telegraphy between Cornwall and Newfoundland, with the now famous "S" signal, the American stations organised a commemorative programme on December 12 last, in which a number of European stations participated.

Signor Marconi had met with many disappointments, culminating in the complete wrecking, by a gale, first of the transmitting station on this side and then of the receiving installation at Cape Cod, Massachusetts, U.S.A. Rather than wait yet another year for the reconstruction of the two stations, Signor Marconi decided to make a preliminary trial between England and Newfoundland. On Thursday morning, December 12, 1900, on Signal Hill, Newfoundland, despite a gale, he managed to fly a kite to a height of about 400 feet. It had been agreed that a series of "S's," at a given speed, should be transmitted from Poldhu at prearranged intervals. At 12.30 p.m. his hopes and efforts were rewarded by the reception of a succession of three faint clicks.

his Closet he seized the Magic Box and begged It to vouchsafe unto him the Reply his Heart so violently craved. And later in the still Night, as before he saw the Pleasant Vision and to his Ears came that Beloved Voice. "Must-Avva Dinn, Jewel of my Life" it said, "I have not the Courage to keep Thee in Suspense but will quickly put an End to Thy Anguish" and in a few well-chosen Words the Fair one told him the Hour at which he could meet her at the *Estū-dee-o*. "O! Happy Mortal that I am. O! Allah be praised for evermore" cried Must-Avva Dinn and as the Hour grew near without waiting to don more fitting Apparel he made his Way in all Haste to the chosen Trysting Place on the bank of the *Tem-se*. And although the Portals of the Great House were guarded by Attendants he was able to slip past them unmolested. Whereupon as he approached the Room he heard a male Voice say: "And that, Ladies and Gentlemen, concludes the second Television broadcast of Mr. Bill Higgins, the renowned Female Impersonator."

Moral: *All is not Bold that Titters.*

JAY COOTE.

TRANSLATOR'S NOTES:

(1) Not mentioned in the maps of the period; (2) at the present rate of exchange, roughly 8s. 4d.; (3) in the original manuscript, the word *Wun-nup* is given as an alternative and might denote: an advantage; (4) presumably an Arabic dialect; (5) in his excellent treatise on Levantine Customs, Professor Bolony (Chicago University) uses the word to denote a suite of dining-room furniture; this is in accordance with the Translator's reading; (6) a Temple of Music, Poetry, Science and Letters of which there remain no traces to-day; (7) a well-known meeting place on the banks of the *Tem-se*; (8) the Oriental scholars Fagg and To-Bak explain this term as a measurement for costly tissues and valuable china wares such as grace the Sultan's Palace.

Broadcasting and Languages

FRENCH

(Supplementary Notes in connexion with the French Talk, Tuesday, December 15)

(A).—*Emploi des pronoms se et soi.*

(a) *Se* est la forme atone du pronom réfléchi de la troisième personne; *se* est des deux genres et des deux nombres; il se dit également des personnes et des choses. Sa syntaxe est la même que celle de *me* et *te*; il se place donc toujours devant le verbe, et bien qu'il soit quelquefois complément indirect, il est essentiellement complément direct: Ex. *il se promène, elles se sont levées, ces fleurs se flétrissent, ils se sont arrogés des droits, etc.* . . .

L'emploi de ce pronom ne présente aucune difficulté. Rappelons, qu'en parlant des choses, nous avons fréquemment recours à la conjugaison pronominale avec *se*, alors que logiquement nous devrions nous servir du passif: Ex. *ce roman ne se lit plus, cela ne se dit pas, ces choses se feront bientôt, cela s'est fait par erreur, du temps que ces habits se portaient, etc.* . . .

(b) *Soi* est la forme tonique du pronom réfléchi; il est des deux genres et se dit des personnes et des choses; aujourd'hui il s'emploie généralement au singulier. De plus, en principe il n'a rapport qu'à un sujet indéfini ou indéterminé, exprimé ou sous-entendu, comme *on, quelqu'un, chacun, nul, aucun, personne, tout le monde, tout homme, celui qui, etc.* . . . Il est généralement complément direct avec une préposition: Ex. *Chacun pour soi et Dieu pour tous, il faut prendre garde à soi, celui qui ne pense qu'à soi est malheureux, il est bon de rentrer en soi, être trop mécontent de soi est une faiblesse, le beau en soi, l'amour de soi, etc.* . . .

Appliqué aux choses, le pronom *soi* peut se rapporter à un sujet déterminé, surtout avec les expressions de *soi et en soi*: Ex. *Cela va de soi, des choses qui sont belles en soi, la franchise est bonne en soi, un bienfait porte sa récompense avec soi, etc.* . . .

On peut aussi avoir besoin de *soi* pour l'opposer à *lui*, ou pour éviter une équivoque: Ex. *L'avare qui a un fils prodigue n'amasse ni pour soi ni pour lui, un fils qui travaille pour son père travaille pour soi, etc.* . . .

Enfin *soi* s'emploie dans les cas où *lui, eux, elle, elles* seraient trop faibles: Ex. *L'égoïste ne pense qu'à soi.*

L'ancienne syntaxe nous a donné l'expression *soi-disant*, qu'on emploie souvent à tort et à travers. *J'ai rencontré un soi-disant acteur, de soi-disant officiers*, est fort bien dit. On peut même dire *je suis un soi-disant poète, tu es un soi-disant docteur*; mais il ne faut pas dire: *je suis soi-disant riche, tu es soi-disant généreux*. D'autre part, *soi-disant* ne devrait pas s'employer en parlant des choses, puisque les choses ne parlent pas; ne disons donc pas: *il m'a rendu un soi-disant service, c'est un soi-disant piano, etc.* . . . Puisque nous avons le mot *prétendu*, pourquoi ne pas nous en servir?

(B).—Le Comte Alfred de Vigny naquit à Loches en 1797. Il était issu d'une famille de soldats, et se sentant porté vers la carrière militaire il entra, en 1814, comme sous-lieutenant dans le corps très aristocratique des *Compagnies rouges*. Quand les *Gendarmes rouges* furent licenciés, il passa dans la *Garde royale*. Pour chasser l'ennui de cette vie de caserne, Vigny travailla beaucoup, il lut, il médita et il composa. En 1822 il publia, sans nom d'auteur, un recueil de *Poèmes*. Les *Poèmes*, malgré la haute valeur de certaines pièces, passèrent à peu près inaperçus. Pour être certain de prendre part à l'expédition d'Espagne, Vigny alla rejoindre, au mois de mars 1823, le 55^{ème} régiment d'infanterie de ligne. Son régiment quitta Bordeaux et partit pour Orthez, mais la compagnie de Vigny fut envoyée à Oloron, puis revint à Orthez, et enfin son régiment, qui décidément n'allait pas en Espagne, fut envoyé

à Pau. C'est ici qu'il écrivit le poème intitulé "*Le Cor*." Son séjour dans les Pyrénées fut très fructueux; il avait consacré ses loisirs à l'étude, à la méditation et à la composition; et en 1826 il publia les *Poèmes antique et modernes* qui, outre les poèmes de 1822 contenaient six poèmes nouveaux: *Le Trappiste, Dolorida, Moïse, le Déluge, le Cor, la Neige*.

De nombreux reproches ont été adressés au poème qui nous occupe. Pourquoi, dit-on, Vigny a-t-il pris comme thème de son poème *le Cor* un des épisodes les moins caractéristiques de *la Chanson de Roland*? Pourquoi cette composition dé cousue? Surtout, pourquoi cette inégalité et ce manque de lien entre les différentes parties? Ces critiques tombent toutes pourvu qu'on n'oublie pas que ce poème est une "symphonie" sur le son du cor. Vigny l'a composé comme un musicien compose une symphonie musicale. Une fois ceci bien compris, tout s'explique.

Au moment où Vigny écrivit *le Cor*, la vieille épopée, *la Chanson de Roland*, n'était pas encore connue, puisqu'elle ne fut publiée que douze ans plus tard (1837). Le poète ne lui doit donc rien; mais la légende de Roland était bien connue. Dans *la Chanson de Roland*, l'évêque Turpin est resté avec Roland et Olivier, et comme eux, il a été tué. Dans son poème, Vigny s'écarte du récit épique: Turpin accompagne Charlemagne et traverse les Pyrénées avec le gros de l'armée.

(C).—"*Que de fois seul dans l'ombre à minuit demeuré.*"

Vigny aimait le crépuscule et la nuit. C'était le moment favorable pour rêver et travailler. Dans *la Maison du Berger* ne nous parle-t-il pas du *crépuscule ami*? et dans *Stello*, ne nous dit-il pas? "Les heures de la nuit, quand elles sonnent, sont pour moi comme les voix douces de quelques tendres amies qui m'appellent et me disent, l'une après l'autre: *Qu'as-tu?* . . ."

Et c'est sans doute pour cela que Vigny a toujours mieux réussi la peinture des crépuscules et des nuits que celle des aurores.

E. M. STÉPHAN.

GERMAN

A.—Compound Verbs—(III)

1 (b) *durch* (separable).—Remember that the tonic accent is on *durch*, e.g., *dürchfahren*: *ich fahre bis Berlin durch—ich fuhr . . . durch—ich bin . . . durchgefahren, um . . . durchzufahren*. Separable compounds of verbs which are intransitive can also become transitive, but in the first place only if stress is laid on the notion of "*durch*" (through), e.g., *dürchsitzen* (to pierce by sitting): *Die Schwerenöter (young scamps) haben die Seide des Stuhls durchgesessen—dürchliegen*: *Sie liegen sich die Haut durch (they have been lying so long that they got bed-sores)—dürchtanzen*: *sie haben die Dielen (floor) durchgetanzt—dürchlaufen*: *er hat sich die Füße durchgelaufen (He has walked until his feet became sore)*. Then by extension when the Accusative denotes the object which has been completely mastered, e.g., *dürcharbeiten* (to work through thoroughly): *Ich habe die Grammatik durchgearbeitet—Er arbeitet das Pensum (task, lesson) durch—dürchgehen* (to go through): *Wir gingen das Pensum noch einmal durch*. Slightly different is the case when the Accusative is not the object through which the action passes, but with regard to which one reaches one's aim, e.g., *dürchkämpfen* *durchfechten*, (to fight through to victory): *Sie haben den schweren Kampf durchgekämpft or durchgefochten—Separable Reflexive verbs with durch* are very common, e.g., *sich durcharbeiten*: *Er hat sich wacker durchgearbeitet (He has bravely struggled through)—sich durchbetteln*: *Sie betteln sich so durch (They work their way through by asking alms)—sich durchlügen*: *Er lügt sich immer durch (He always manages to come through all right by telling lies)—*

sich durchschlagen: *ich schlage mich schon durch (I shall manage to get through all right, don't worry)—sich durchfinden*: *ich finde mich schon durch (I shall find my way through all right, don't you trouble)—sich durchfragen*: *er hat sich einfach durchgefragt (He has reached his goal simply by asking and asking the way to it)—sich durchfressen (to eat through)*: *Er wird sich schon durchfressen (He is sure to get through all right by struggling on)*. Sometimes the meaning of the preposition *durch* (separable) used in a *local* sense is intensified by adding the adverb *hindurch*, e.g., *durchblicken*: *Die Sonne blickte durch die Wolken hindurch—durchfliegen*: *Der Stein war durch das Fenster hindurchgeflogen—durchziehen*: *Sie zogen durch die Stadt hindurch*. In a *temporal* sense the Preposition *durch* is left out—e.g., *Viele Jahre hindurch* (through or for many years)—*wir sassen Monate hindurch in der Klemme* (We were in a fix for months). Let us now take the most common of the separable verbs with *durch* and students should place them in the categories explained above to which they belong:—

durcharbeiten (to work through): *Er hat das Kapitel durchgearbeitet.*

sich durcharbeiten (to make his way through):

Er wird sich schon durcharbeiten (or durchbeissen) durchbeissen (to bite in two): *Er biss den Apfel mitten durch und gab mir eine Hälfte.*

durchblasen (to blow through): *Blasen Sie den Rauch durch (i.e., durch den Ring, etc.)*.

durchbleuen (to give a sound thrashing): *Er hat ihn gehörig durchgebleut (likewise durchgerben, durchhauen, durchholzen, durchprügeln).*

durchblicken (to peep through): *!In diesen Worten blickt die Absicht durch.*

durchbohren (to bore through): *Bohren Sie doch ein Loch durch.*

durchbraten (to roast thoroughly): *Das Fleisch ist nicht durchgebraten (underdone).*

durchbrechen (to break in two): *Er brach den Stock durch und warf ihn fort.*

durchbringen (to get through with, squander): *Er hat das ganze Vermögen (fortune) durchgebracht.*

Der Arzt hat ihn durchgebracht (cured)—Er bringt die Familie kaum durch (He finds it difficult to make ends meet)—Er bringt sich ehrlich durch!

durchdrängen (to push one's way through): *Drängen wir uns durch!*

durchdringen (to work its way through): *Die Flüssigkeit dringt nicht durch—Damit dringt er nicht durch (He will not carry that through, i.e., succeed with it).*

durchfahren (to travel through): *Der Zug fährt hier durch, aber hält nicht—Sie haben die Strasse durchgefahren (made holes)—Wir fahren durch (do not stop).*

durchfallen (to fall through, fail): *Der Stein fiel durch—Er ist im Examen (in der Prüfung) durchgefallen—Wenn er drauf steht, fällt er durch.*

durchfechten (to fight through to the end): *Wir fechten die Sache durch (likewise durchkämpfen).*

durchfeilen (to file through): *Er hat den Draht durchgefeilt.*

durchfinden (to find one's way through): *Ich habe den Weg durch gefunden.*

durchfliessen (to flow through): *Der Rhein fließt da nicht durch.*

durchführen (to lead (take) through, execute): *Führen Sie ihn durch zum Minister—Er führt seinen Plan durch, koste es, was es wolle.*

durchgehen (to go through, run away): *Gehen Sie, bitte, durch—Der Gaul (steed) geht immer durch—Das geht durch (is allowed to pass).*

durchgreifen (to grip through, to prevail): *Er griff nicht durch (das Hindernis)—Das greift nicht durch. (That sort of thing does not prevail).*

B.—EXERCISE 18 (Achtzehnte Aufgabe)

II (a).—Wilhelm der Erste—Wilhelm der Zweite—Georg der Fünfte—Friedrich der Dritte—der zweiundzwanzigste März—am ersten April—London, den neunten Mai neunzehnhundert elf.

(b).—Wieviel Uhr ist es? Es ist ein Uhr (or eins)—um zehn Minuten nach zwei—es ist halb acht—um fünfundzwanzig Minuten nach acht—um halb zehn—um zwanzig Minuten vor zehn—es ist zehn (Minuten) vor elf—um viertel vor zwölf—um ein Uhr sechsdreissig—vor vierzehn Tagen—über vierzehn Tage (or in vierzehn Tagen)—heute über acht Tage (or in acht Tagen or über acht Tage)—vor acht Tagen—auf drei Tage—drei Wochen lang.

IV.—(1) Am Montag den ersten Januar neunzehnhundert zwölf um halb sieben. (2) Napoleon der Dritte ergab sich am zweiten September achtzehnhundert siebzig mit vierundachtzig tausend Mann. (3) Fürst Bismarck ist am ersten April achtzehnhundert fünfzehn geboren. (4) Am achtzehnten Juni desselben Jahres erlitt Napoleon der Erste bei Waterloo eine vollständige Niederlage. (5) König Georg der Fünfte ist sechs Jahre (und) fünf Monate jünger als Kaiser Wilhelm der Zweite. (6) Goethe und Schiller waren grosse Freunde; Goethe war vierundachtzig Jahre alt, als er starb; Schiller fünfundvierzig. (7) Die französische Revolution brach am vierzehnten Juli siebzehnhundert neunundachtzig aus, als die Bastille erstürmt wurde. (8) Dreissigtausend Hugenotten wurden in Frankreich in der Nacht vom dreiundzwanzigsten August fünfzehnhundert zweiundsiebzig ermordet. (9) Prinz Albert, der Gemahl der (or von) Königin Victoria ist am vierzehnten Dezember achtzehnhundert einundsechzig gestorben. (10) Luther ist im Jahre vierzehnhundert dreiund-

achtzig geboren, im selben Jahre wie Rabelais und Raphael.

O. S.

SPANISH

Sobre algunas consultas.

VOLVIENDO sobre lo de (*reverting to the matter of*) las múltiples funciones del pronombre *se*, me complace contestar hoy a un lector que, entre otras preguntas, me hace la siguiente:—

“Tratándose, por ejemplo, de artículos de comercio ¿no estaría bien decir: ‘*se los hace en el extranjero*’ en vez de: ‘*son hechos*’?”

No, señor. En este caso sería un galicismo emplear *se* como sujeto indefinido; es decir, como *on* en francés. En español esto se hace únicamente (*only*) cuando el objeto, directo o indirecto, es personal. Ejemplos: Se les escribirá (*they shall be written to*) Se la vió (*she was seen*). En la frase que cita mi correspondiente, siendo *inanimado* el objeto—los artículos—hay que decir: “*se hacen o son hechos en el extranjero.*”

A muchos estudiantes del español, incluso mi correspondiente, no les resulta nada (*at all*) fácil traducir correctamente *to be pleased, to be sorry, etc.* A estos les aconsejo que se fijen bien en los ejemplos que doy a continuación (*below*) y en los que aparecerán en mi próximo artículo

Nos alegramos mucho *del* resultado.

Nos alegra mucho *el* resultado.

Celebramos mucho *el* resultado.

Estamos muy contentos *del* resultado.

En todas estas frases se expresa alegría (*rejoicing*), pero en una frase como: “We shall be pleased or glad if you will kindly send us a copy” lo que se expresa es más bien *agradecimiento* que alegría, y tendríamos que decir:—

Agradeceremos o estaremos a Vds. (que) se sirvan mandarnos una copia (We shall be grateful *that*, or esteem—as a favour—*that*, you kindly send us a copy).

Lectura. ¿Cuántas personas hay que sepan el origen de la antigua costumbre del “Christmas Box” (“*aguinaldo*” en español)? ¿Y cuántas saben el verdadero significado de esas dos palabras?

Según un periódico semanal, hace más de mil años, cuando toda Europa era católica romana, se estableció la costumbre de colocar cajitas (*boxes*) bajo la protección de algún santo, para que los pobres contribuyesen sus peniques hacia el costo de las misas (*Masses*) que decían los sacerdotes en sufragio de sus almas. Estas cajitas eran en verdad “*Mass Boxes*,” y la costumbre se fué extendiendo hasta que la petición de este donativo, primero para pagar las misas en general, y más tarde para la misa de Cristo (*Christ Mass*) en particular, llegó a ser cosa habitual entre toda la gente de clase humilde.

Pero con el tiempo se olvidó el objeto a que iba destinado el dinero recaudado (*collected*), pasando éste a ser una dádiva o regalo de los ricos a los pobres. Antiguamente, las cajitas se abrían (eran abiertas) el día después de Navidad (*Christmas-day*). De aquí (*hence*) el nombre de “*Boxing Day*.”

W. F. BLETCHER.

Esperanto Transmissions December 20-26

Sunday.—Langenberg, etc., 7.30 a.m., Course (S-ro Wingen). Lille, 8.30 a.m., News (A. Troitin). Leipzig, 1.30 p.m., Course (Prof. Dietterle).
Tuesday.—Leningrad, 9.5 p.m., News.
Wednesday.—Stuttgart, “El originala Verkaro” (Dr. Vogt).
Thursday.—Vienna, 3.45 p.m., Austrian news (Smital). Paris PTT, 5.45 p.m., Course (Ptof. Rousseau). Radio Suisse Romande, 6.20 p.m., Course (Prof. P. Bouvier). Kaunas, 8.20 p.m., News.
Friday.—Stuttgart-Frankfurt, 6.30 p.m., Week's Programme (Prof. Christaller). Leningrad, 10.5 p.m., News.
Saturday.—Helsberg, 5.40 p.m., Week's Programme (Fino Wermke). Huizen, 6.20 p.m., Course (P. Heilker). Lyon-la-Doua, 8.15 p.m., News (M. Borel). Strasbourg gives news once or twice a week in Esperanto.



Are you disinterested at the foreign words that are emitted from your loud speaker? They could be just as interesting to you as English if you would only take the trouble to learn a foreign language in your leisure hours—and remember a man is worth as many men as he knows languages

WRITE NOW (or call) for BOOKLET “W.R.” EXPLAINING THE WORLD-FAMOUS BERLITZ METHOD.

BERLITZ SCHOOLS OF LANGUAGES

LONDON: 321, OXFORD ST., W.1 (Head Office) 8, Bucklersbury, Queen Victoria St. (City) 3, Harrington Rd. (South Kensington) 2, Queen's Road (Bayswater) BIRMINGHAM: 52, Paradise St. MANCHESTER: 126, Portland St. LIVERPOOL: May Buildings, 51, North John St. BRADFORD: Central Chambers, Market St. SHEFFIELD: 44, Fargate NEWCASTLE-ON-TYNE: Claremont Bldgs., Barras Bridge EDINBURGH: 75, Princes St. GLASGOW: 206, Sauchiehall St.

CONVERT YOUR SET NOW! FOR 60/-

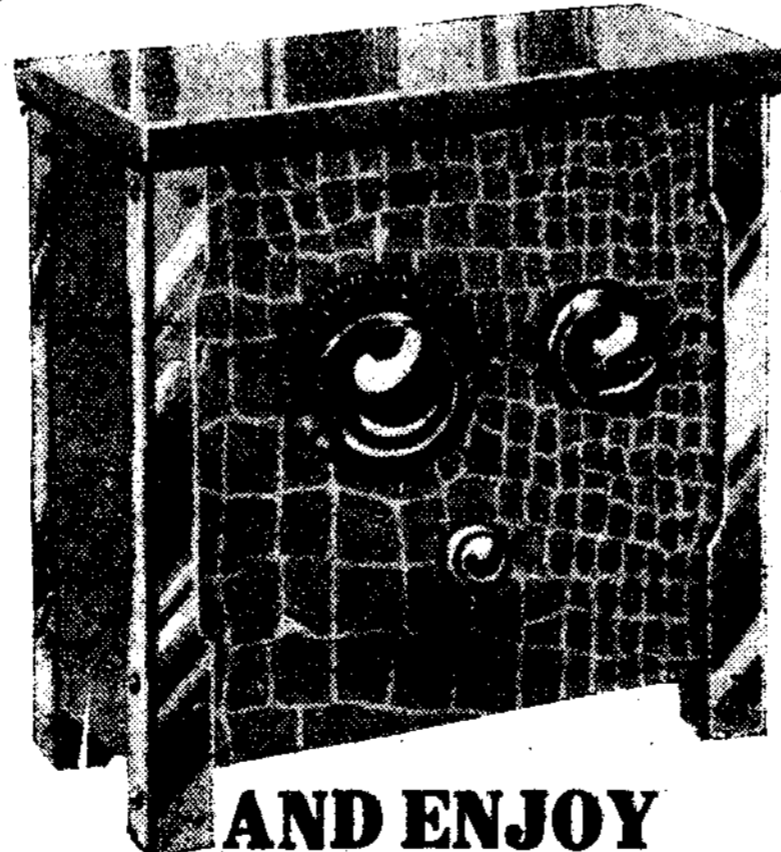

AND ENJOY THE PROGRAMMES ON THE SHORT WAVES

Just put the Eelex Short Wave Converter in front of your set—no alteration necessary—and you will then get stations on the 16-60 metre band. Additional coil for the 140-190 metre band, 5/- extra. All-Mains model, 65/- complete. Additional Coil, 5/- extra.

WRITE FOR LIST D16

EELEX SHORT WAVE CONVERTOR

J. J. EASTICK & SONS, Eelex House, 118, Bunhill Row, London, E.C.1.

Phone: Metropolitan 0314-5-6

WILL YOU LIGHT A CANDLE?

THE BITTER WINDS OF ADVERSITY HAVE LEFT MANY CHILDREN IN THE DARKNESS AND COLD DURING THE YEAR THE NEW ADMISSIONS TO THE NATIONAL CHILDREN'S HOME AND ORPHANAGE HAVE BROUGHT IT TO A TOTAL FAMILY OF 3958 BOYS AND GIRLS

EVERY DAY ADDS NEW NAMES TO THE WAITING LIST

AND WE WANT YOUR HELP TO CLEAR IT BY CHRISTMAS

AN ADMISSION GIFT OF FIVE GUINEAS

Will Remove One Name from a List of 177 NOW AWAITING ASSIGNMENT

If you desire it, particulars of the child received will be forwarded to you.

Please use the attached form and Light a Candle in a dark place.



MY CHRISTMAS CANDLE

I enclose Five Guineas to Light a Candle for me by the admission of a child into the Children's Home.

Name
Address

Principal: REV. W. HODSON SMITH.
General Treasurers: THE RT. HON. LORD WAKEFIELD OF HYTHE, C.B.E., LL.D.; SIR THOMAS BARLOW, Bt., M.D., F.R.S.

NATIONAL CHILDREN'S HOME AND ORPHANAGE
30 Branches (Founded by Dr. Stephenson). 4,000 Children
Chief Offices: Highbury Park, London, N.5

Remittances may be forwarded through any Branch of the Midland Bank, Ltd.

TECHNICAL SECTION

Notes on Coupled Circuits in Broadcast Receivers

IN the writer's opinion the least developed, or the least satisfactorily developed, parts of a modern receiver are those for obtaining selectivity. The difficulty is, of course, to obtain selectivity and at the same time to retain good quality. It is unfortunate that these two considerations are mutually antipathetic in the ordinary tuned circuit. This article, however, will not consider the selectivity of one-tuned circuit, but rather what can be achieved by the use of coupled circuits, and will suggest some of the considerations which point to a practical solution of our difficulties along one or other line. It is to be emphasised that a *practical* solution is the real difficulty, for a broadcast receiver must be capable of being handled by people who have neither knowledge of the details of its working nor the necessary skill to operate complicated controls.

Fig. 1 shows six different methods of coupling two circuits together. These six methods by no means exhaust all the possibilities, but they are representative of three general methods of coupling—viz., inductance, capacity, and resistance. Fig. 1 (a) shows the ordinary conventional inductive coupling which has been used in commercial wireless telegraph receivers for many years. It has the advantage of simplicity, and the coupling is easily variable by an alteration of the relative positions of the two coils. If variable coupling is required in a receiver, this method has many advantages but suffers from difficulties of mechanical arrangement. While these can, with mechanical ingenuity, be overcome in the construction of a new receiver, it is not usually possible to make a good job of applying this form of coupling to an existing receiver. The use of modern dual-range coils increases this difficulty considerably.

Fig. 1 (b) shows the simplest method of capacity coupling, which is very useful in that it allows a coupled circuit to be applied to an existing receiver quite simply. It is sometimes referred to as "Top" capacity coupling. The extra tuned circuit can be made up separately, care being taken that there is no inductive coupling between the coils. A small condenser of the neodyne type connected as shown will then provide the necessary coupling. On the broadcast wave-band a value of about 10 micro-microfarads will be found suitable with ordinary coils.

Fig. 1 (c) shows another form of capacity coupling—"Bottom" coupling—which has become popular recently. It generally forms the basis of the so-called "band-pass" filter, and if the capacity is associated with some inductance coupling as shown in the "link" circuit of Fig. 1 (f) it is often termed a "constant bandwidth" filter. But more of this later.

Fig. 1 (d) and (e) show resistance coupling. In these, as well as in the others, the coupling component is shown as being fixed, but for particular circuit arrangements it can equally

well be made variable, except that mechanical difficulties may be introduced thereby.

Let us consider how capacity coupling works by referring to Fig. 1 (c). If there is an oscillatory current in the left-hand circuit consisting of the tuning condenser C_1 , the inductance L_1 , and the condenser C_3 , there will, of course, be a difference of potential across C_3 which will be a fraction of the total potential across the circuit. But C_3 also forms part of the circuit C_2 , L_2 , C_3 , and this second circuit will, therefore, have a potential across it and a current will flow in it, by virtue of the common capacity C_3 . It should be noted that apart from this common capacity the circuits are isolated one from the other, and in practice it is necessary to screen the coils so that there is no inductive coupling. Obviously the value of the voltage across C_3 will, other things being equal, depend on its impedance. If the impedance is high the voltage will be large; if it is low, the voltage will be small. In the limit we have, firstly, the case where the impedance is infinite (*i.e.*, an open circuit, or $C_3 = 0$), or, secondly, the case

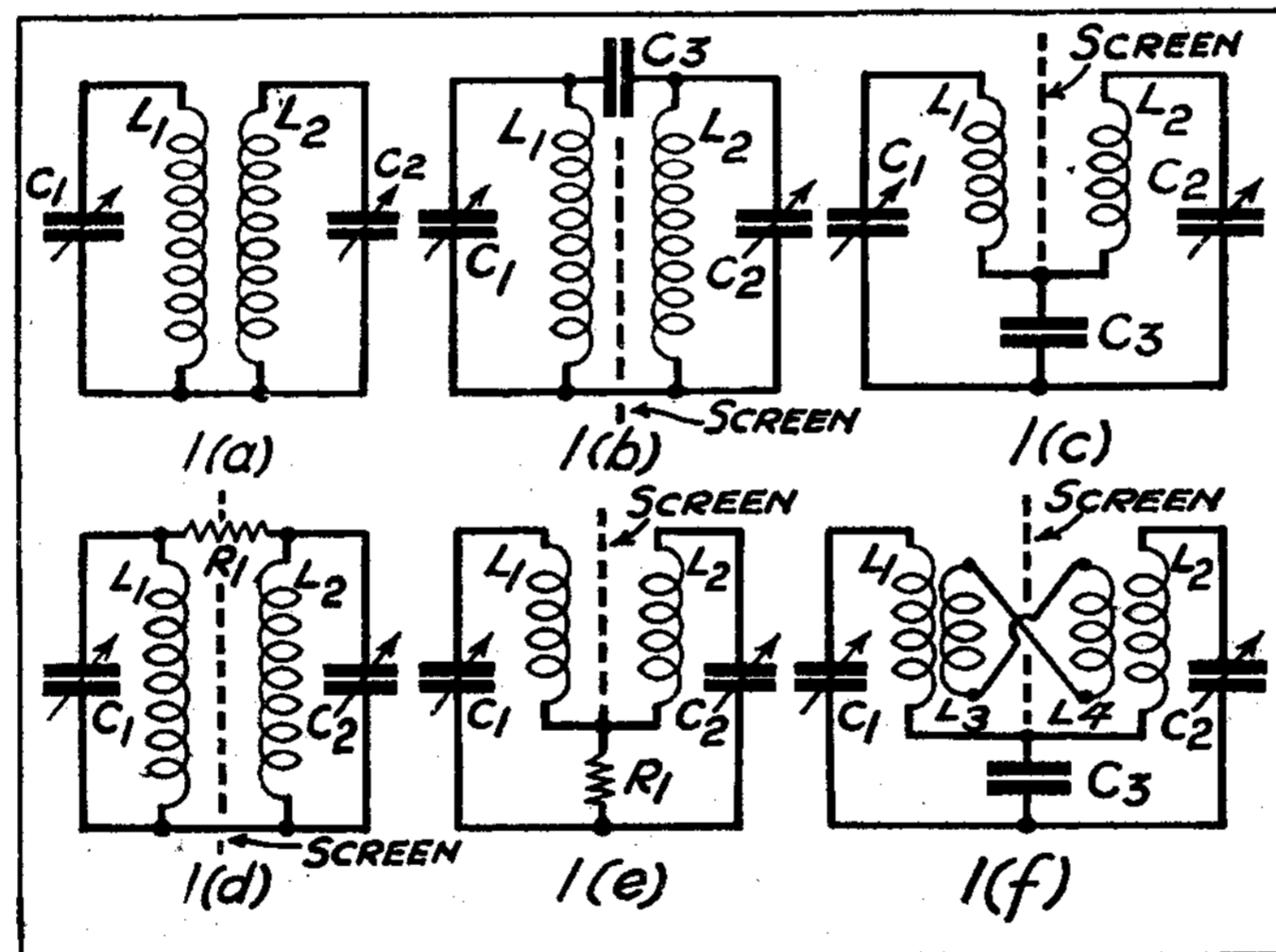

Fig. 1. Six alternative H.F. couplings

where it is zero (*i.e.*, a short circuit to alternating currents, or $C_3 = \text{infinity}$). At the first of these two limits, we have very tight coupling, while at the second we have zero coupling. Note that the coupling increases as the condenser C_3 is made smaller.

If we consider the alternative scheme in Fig. 1 (b), it will be seen that the reverse will happen, for here the path from one circuit to the other is through condenser C_3 , and obviously the smaller its impedance the tighter will be the coupling. In other words, the more nearly the potential at the top of inductance L_2 approaches to the potential of the top of L_1 the tighter will be the coupling. So, in this case of "top" or "series" capacity coupling (as it is variously called) the coupling will increase as the condenser C_3 is made larger. For a given degree of coupling in the two cases 1 (b) and 1 (c) the condenser C_3 will not, of course, have the same value, for it is its value relative to the other impedances in the circuit which determine the degree of coupling. In 1 (b) we have to consider the parallel impe-

dance of the circuit, and this may be of the order of 50,000 to 100,000 ohms for a normal tuned circuit in the broadcast band, whereas in 1 (c) we must consider the series impedance of the circuit, which under similar conditions may be of the order of 20 down to 5 ohms. There are other considerations to be taken into account, but very roughly we may expect the same coupling to be given by a condenser in 1 (c) which is of the order of 1,000 times the capacity of the one necessary in 1 (b)—*i.e.*, if we use .01 microfarad for 1 (c) we shall want about .0001 microfarad (10 micro-microfarads) in 1 (b).

Up to the present we have not considered a very important point of which we must take account in a broadcast receiver which necessarily has to be capable of tuning to a fairly wide range of wavelengths. We must realise that the impedance offered by a condenser to an alternating current does not depend only on the size of the condenser, but that it depends also on the frequency of that current. In fact the impedance Z is given by the simple formula

$$\frac{1}{2\pi fC}$$

where π is 3.14, f is the frequency in cycles per second, and C is the capacity of the condenser in farads. We normally think in microfarads, and so we have to remember that there are one million of these in one farad. Alternatively,

we can write our formula as $\frac{1,000,000}{2\pi fC}$ where C is in microfarads. If we do this small sum for a condenser of .01 microfarad and a frequency of 1,500 kilocycles per second (wavelength of 200 metres) we shall find that the Z will come out at about 10 ohms if we have worked it out correctly.

If we do another sum for the same condenser at a frequency of 500 kilocycles per second (wavelength of 600 metres), we shall find that its impedance is about 30 ohms—exactly three times as much, because we have reduced the frequency by three times. If this .01 microfarad condenser is our coupling condenser, C_3 in Fig. 1 (c), we shall then see that the value of our coupling impedance has changed very considerably as we tune our receiver over the whole medium-wave broadcast band. We shall also note that coupling has become much tighter as the wavelength is increased. This means that a broadcast receiver which is quite selective enough at 300 metres might well not be so at 500 metres, while at 200 metres it might be too selective. Actually, this is by no means the whole story of selectivity, and there are many other variables, such as the capacity—inductance—resistance ratio in each circuit, which modify the magnitude of the ultimate change in selectivity, the order of which is indicated by this simple numerical example.

The reader may by now have noticed a possible means of compensation for this change in impedance of the coupling condenser. If we use top and bottom capacity coupling together, then the top series capacity will provide coupling at the short-wave or high-frequency end of the scale, while the bottom shunt capacity will provide it at the longer wave or lower frequency end, and so by the proper proportioning of the two a compromise can be reached. Such an arrangement is in use at the present time in the writer's receiver with fair success—the bottom capacity being .02 mfd, and the top capacity being given by three turns of flex twisted together.

There is another method which makes use of inductance as well as capacity with the same

(Continued on page 1048)

High-Quality Receivers

4.—Practical Arrangements of Detectors

(Continued from page 933, December 4)

AS modern transmitters are capable of modulating up to 100 per cent. and regularly modulate up to 75 per cent. or 80 per cent., it is now more important than it was a few years ago to ensure that the detector is linear up to high degrees of modulation. Practical methods of obtaining such linear rectification will now be discussed.

At the present time thermionic valve detectors are the only kind of detectors used to any appreciable extent in high-quality receivers. Crystal detectors at one time were considered to give very good quality, but as they are liable to lose adjustment easily they are not as satisfactory as valves. There is no doubt, however, that if they are used under proper conditions they give distortionless reception, even on fairly heavy modulation. It seems quite possible that if crystal detectors were properly studied in the light of present-day knowledge of the requirements of rectifiers for distortionless rectification of modulated signals, a very satisfactory detector of this type could be produced. However, the crystal seems to have been discarded in favour of the valve for the time being, at any rate, and practical forms of valve rectifiers only will be described in this article.

The Diode

A two-electrode valve, or two electrodes of a valve with three or more electrodes, can be made to give practically linear rectification. Modern diodes used for rectification of alternating current for H.T. supply to receivers, have a very low resistance; they can therefore be used with load resistances of comparatively low value to give fairly linear rectification of high-frequency signals, particularly at large inputs. Rectifiers of this type do not easily saturate, and, therefore, they can be worked at large inputs in order to make the bend in the characteristic at low inputs negligible over the working range. By using higher values of load resistance this bend at low inputs can

farads if audio frequencies up to 10,000 cycles are to be reproduced equally. If some sacrifice of the higher audio notes is permissible the load resistance can be increased to half a megohm or one megohm without appreciable loss of high notes, but with appreciably better linearity at low inputs.

Methods of connecting a diode are shown in Fig. 1. They are all the same in principle, but are slightly different in operation. If the load resistance is connected across the rectifier as in Fig. 1 (b) the rectified voltage is not affected, but H.F. voltages are present as well and are not shunted by the condenser as in (a). A condenser is still required, however, as shown, to prevent the load resistance being shunted by the input circuit which will have low impedance at audio frequencies; the condenser is therefore effectively in parallel with the load resistance at audio frequencies, but not at radio frequencies. Further by-pass circuits will therefore be required if the H.F. voltages are not to be passed on to the low frequency stages.

Fig. 1 (c) shows the arrangement usually adopted. Care must be taken to ensure that the by-pass condenser, and the coupling condenser and grid leak of the L.F. stage, which are effectively across the load resistance, do not affect the total effective impedance sufficiently to upset the response at any frequencies within the audio band. The L.F. voltages could be taken off across the rectifier in Fig. 1 (a) in which case the same filter circuits would be required as in (c) to remove the H.F. voltages.

An alternative arrangement is shown in (d); this does away with the necessity for circuits to filter out the H.F., as the condenser performs this function. The steady voltage across the resistance due to the unmodulated carrier can be made to bias the L.F. valve to the required amount, and the audio-frequency voltages are then applied about this value in the usual way.

With this arrangement the tuned input circuit cannot have an "earth" on it if the filament (or cathode) of the detector or L.F. valve is earthed, as will usually be the case, otherwise the load resistance would be short-circuited. Stray capacity to earth of the tuned circuit will be effectively across the load resistance, and must therefore be allowed for when choosing the value of the by-pass condenser to avoid loss of high notes. Grid bias can be inserted in the lead to the grid of the L.F. valve if desired, but the battery must have low capacity to earth. Alternatively a coupling condenser and

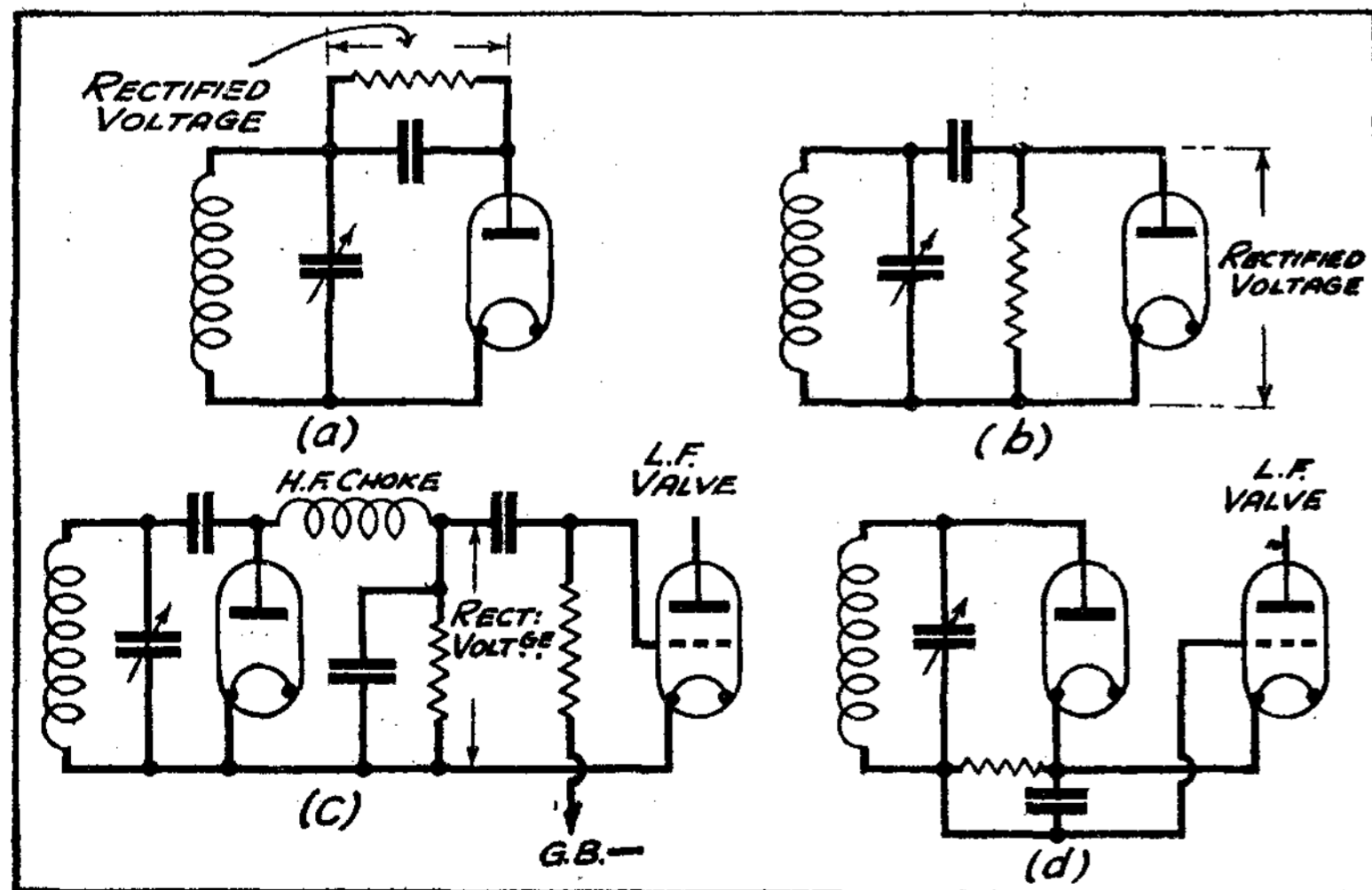

Fig. 1.—Four methods of using a diode detector:

be made still more negligible, and practically linear rectification can be obtained for H.F. carrier inputs of considerably less than one volt, even when modulated 100 per cent.

A load resistance of 100,000 ohms is usually very satisfactory, and this requires a condenser across it of not greater value than 0.0001 micro-

grid leak can be used as at (c). Three electrode valves can be used as diodes, either by connecting the grid and anode together or by using the grid and filament only.

The grid rectifier, or so-called grid-leak rectifier, is no different in principle from the diode rectifier. It makes use of the rectifying properties of the grid-to-filament path of a triode,

or of a valve with four or more electrodes, but instead of using a separate valve to amplify the rectified voltages it makes use of the amplifying properties of the same valve. The rectified voltages are produced between the grid and filament acting as an ordinary diode, and are then fed into the anode circuit as in an ordinary amplifier. Provided the anode circuit is not overloaded there will then be distortionless amplification of the rectified signals.

The Grid Detector

There is a difference, however, between this arrangement and an ordinary L.F. amplifier in that the H.F. voltages are usually by-passed in the latter case before they reach the amplifying valve. In the case of the grid rectifier, however, they cannot be by-passed before they are amplified; consequently the anode circuit has to handle both L.F. and H.F., and the H.F. is then filtered out before the signals are

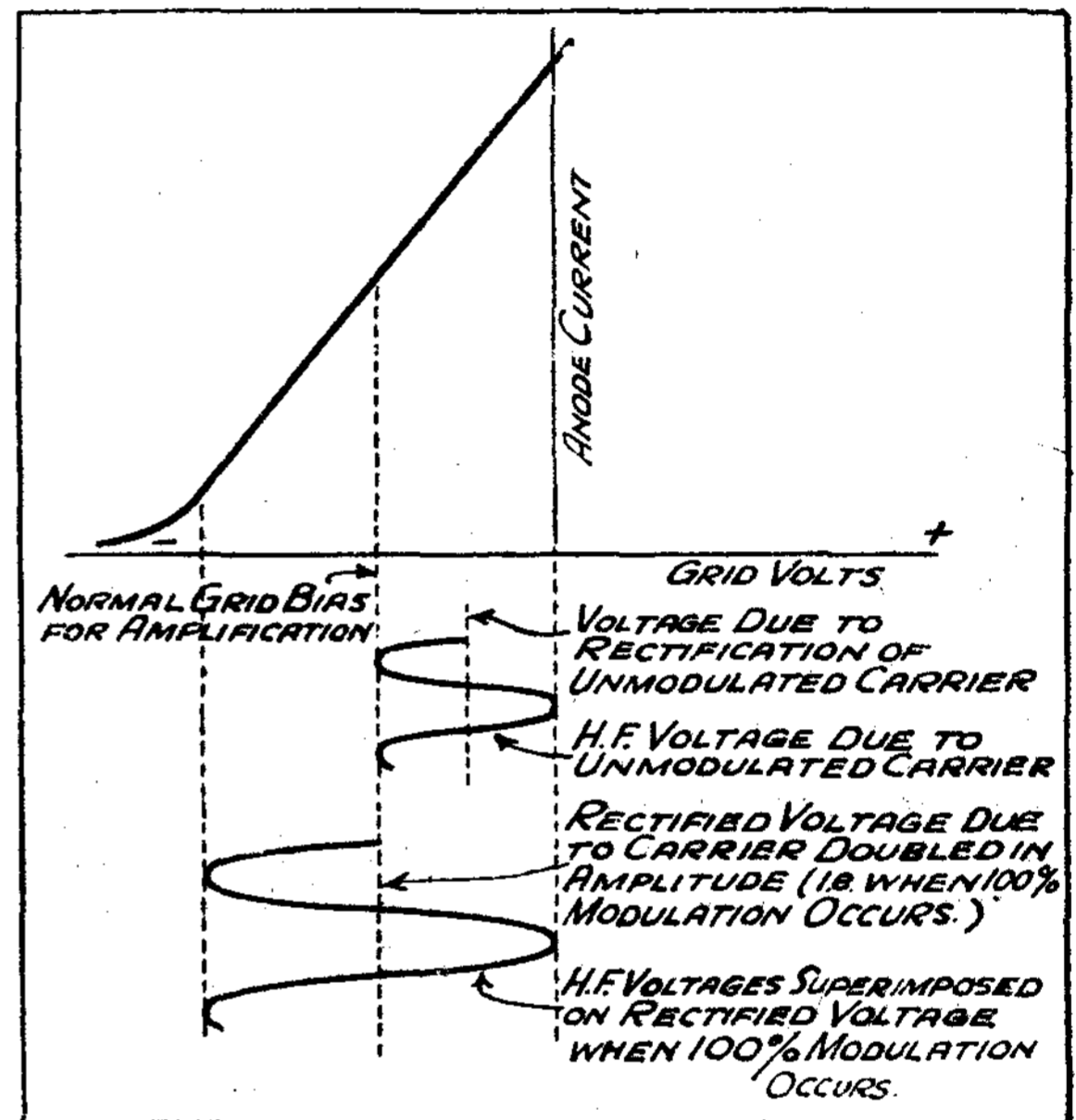

Fig. 2.—Illustrating voltage swing on modulation

passed on to the next L.F. stage. Particular care must be taken that overloading does not occur in the anode circuit of the detector valve, owing to the presence of the H.F. component.

If overloading occurs this means that anode rectification is taking place in the anode circuit of the detector valve, and the signals will be distorted just as they would be if anode rectification took place in any L.F. stage. Thus the H.F. signal applied to the grid of the detector must be such that its maximum peak amplitude on modulation, plus the rectified voltage due to it does not exceed the maximum peak amplitude which the valve can handle when operated as a straightforward amplifier. This means that the rectified voltage produced by the unmodulated carrier must not exceed half of the steady grid bias required to make the valve operate as a straight line amplifier if no distortion is to occur when the carrier is modulated 100 per cent. This can be seen from Fig. 2.

In the case of indirectly-heated valves it is not usually necessary to apply any polarising voltage to obtain the best working point on the grid-filament characteristic, and the grid leak can be brought direct to the cathode. In the case of directly-heated valves, however, a positive polarising voltage is usually necessary for best results, and this can be obtained by connecting the grid leak to the positive end of the filament.

For more accurate work, especially with 6-volt valves, this may give rather too high (Continued in col. 3, page 1050)

NOTES ON COUPLED CIRCUITS IN BROADCAST RECEIVERS

(Continued from page 1046)

object in view. This is shown in Fig. 1 (f) and the inductance in question may take the form either of a separate winding on each coil, cross connected as shown, or, alternatively, of fixed mutual inductance the value of which is determined by the relative positions and sizes of the two coils. The latter has the advantage of simplicity, but the disadvantage of the difficulty in mounting the coils clear of screens and other metal objects; for, unless care is taken, the value of the inductance of the coils and therefore of their mutual inductance will be changed.

There is yet another method of coupling, in which the impedance of the coupling unit remains constant with change of frequency—viz., the use of pure resistance. It was used in one form many years ago, and I believe Mr. J. H. Reyner suggested it again as a possible way out of the difficulty a year ago. However, as far as the writer is aware, no commercial application of this had been made to broadcast receivers or their components until recently, when this scheme was put forward by Capt. P. P. Eckersley and Mr. Rupert Carpenter. Resistance coupling in two forms is shown in Fig. 1 (d) and (e). It is true that the ideal coupling should not remain of constant impedance over the whole wave-band, for the impedance of the tuned circuits themselves varies and thus, to keep constant selectivity, the coupling impedance should vary too. But where there are so many variables it is exceedingly useful to be able to eliminate one of them, especially if it is one which, under certain conditions, may vary in the wrong direction.

And so a compromise which works and has the additional advantage of extreme simplicity

is very welcome. There is a further advantage which resistance coupling would appear to possess. In general, the performance of coupled circuits—especially those in which the coupling is adjusted to be fairly tight, with the object of obtaining a so-called "band-pass" filter due to the double-humped resonance curve—is profoundly modified by mistuning of the circuits owing to errors in ganging. The writer has found that with capacity-coupled circuits it is possible to obtain almost any shape of resonance curve by slight changes in ganging, and that even if the ganging is correctly set at the low end of the wave-band, it is most unlikely that it will hold over the majority of the wave-band. It is not only that tuning will become flat, but extraordinarily unsymmetrical resonance curves will result. With resistance coupling, however, this should not be so, and if ganging is not correct, then the only bad result will be a broadening of the overall resonance curve, manifested by less selectivity and better quality instead of by bad quality.

The reader may care to try out various schemes of coupling over the Christmas holiday. It is a most amusing and interesting pastime. The best way is to lay out the components of a simple H.F. and detector set on a board so that they can be got at easily to allow changes to be made. It is not necessary to possess many measuring instruments: one—viz., a detector feed meter—is, however, essential if one is to obtain any quantitative idea of what is happening. The present-day power grid detector will have an anode current of between 5 to 10 milliamperes, and so a D.C. milliammeter 0/10 milliamperes will be required. If a new instrument is to be bought it would be worth while getting one of the special type made for this work, in which the zero is suppressed and the scale reads from 5 to 10 milliamperes. In this way the scale is more open and the change in anode current, due to rectified current, is more easily read. This change should be of the order of one-tenth to one-eighth of the total feed for linear detection with the average valve used in this position. The two condensers of the filter circuit can well be ganged, the trimmer being adjusted carefully at a low wavelength, the exact optimum tuning point being observed by means of the detector feed meter. This meter will show the performance of the circuit as other stations are tuned in. If no meter is available then the ear must be used, but a qualitative opinion only as to relative selectivity with different couplings will be obtained. Those who wish to try out this "top" resistance coupling, as shown in Fig. 1 (d), may want some indication of the order of value of resistance they should use. Perhaps they would like to work out another little sum to make quite sure they have understood how it is done. I am going to try it out too, and I shall provide myself with some of the grid-leak types of resistance to start with (they must be non-inductive and non-capacitive), of such values in ohms that they would approximately equal the impedance offered by 10, 8, 5 and 3 micro-microfarads at 300 metres (1,000 kilocycles per second). If they can't work it out, they will find the values of resistance I have in mind on page 1051 of this issue. L. W. H.

(Continued from col. 3.)

To the Editor of WORLD-RADIO

SIR,—With reference to your request for reports of reception, I give below details of transmissions recently received at 3 o'clock in the afternoon:—

Station. Sydney VK2ME (31.28 metres). Strength. R6. No fading. Receiver. O-V-2. Details of Transmission (gramophone records). Organ solo: "Indian Love Lyrics," "Memory Land," Old fashioned songs with Dance Band accompaniment. Orchestral rendering of "Nearer, My God, to Thee," followed by talk on "Australia." Yours faithfully, W. W. A.

Wolverton, Bucks.

Correspondence

Short-Wave Reception

To the Editor of WORLD-RADIO

SIR,—Perhaps you may be interested in my ramblings round the short waves on Sunday, Nov. 29, when I had the good fortune to enjoy broadcast reception from transmitters in Europe, Asia, Africa, America and Australasia. All times are given in G.M.T.:—

13.23 G.M.T. VK2ME, Sydney. 31.28 metres (9,590 kc/s).—Annt.: "VK2ME, Sydney. The time is twenty-three minutes past eleven, Sunday evening in Sydney," and details of pgm. Followed by waltz. Gramophone records. (R4-5 'phones. Usual interference from Morse transmitter.)

15.45 G.M.T. Annt.: "VK2ME, Sydney, on a wavelength of 31.28 metres. The time is a quarter to two, Monday morning in Sydney." Orch. selections, lady singer. Annt. of time, etc., at 16.15. (R5-6 'phones. Still heterodyned.)

14.42 G.M.T. F3ICD, Radio Saigon, 49.05 metres (6,116 kc/s).—News bulletin in English, including results of the Dublin sweepstake for the Manchester November Handicap. Annt. in French, then in English: "Good afternoon, everybody. You will now hear — by the Radio Saigon Orchestra." Stroke on gong between each item; all selections by station orchestra. Annts. in French and English, followed by "Marseillaise," at 15.15, close down. (R6, with high speed fading to R4, 'phones. No static. Morse interference at times.)

15.20 G.M.T. Eindhoven Exptl. 50.1 metres (5,988 kc/s).—Running commentary, in Dutch, on the International Soccer match, France v. Holland, from the Colombes Stadium, Paris. Also heard at 14.05, when the relay started. (R8, 'phones. Morse interference at times.)

17.47 G.M.T. W2XAD, Schenectady. 19.56 metres (15,340 kc/s).—Pgm. of the Near East, by orch. trio. 18.00—Air report. 18.05—Piano solos, and piano and violin duets by the Morensky Bros. 18.30—Travers Wells—talk, "In Dark Africa." 18.45—Old Co's Lunch time hour, presumably. (R8 on L.S. till approx. 18.45, when fading getting bad, and loss of signal strength. Given up at 18.52 when R4-5 on L.S.).

20.00 G.M.T. Rabat (Radio Maroc). 32.26 metres (9,300 kc/s).—Usual Sunday evening concert by "L'Orchestre de Radio Maroc." Int. signal, metronome, between some items (R7-8 on L.S. Interference from morse transmitter at times.).

My object in writing was that it might be of interest to would-be short-wave "fans," and programme details are given only for checking purposes. The receiver used was o-v-2, with S.W. adaptor and outdoor 60ft. aerial with down lead 15ft. Other stations also heard included REN and RFN (Moscow), Zeesen, and Pontoise on his 25.2 metre wave, as well as English, French (and a Portuguese) amateurs, Rugby testing, and Mr. Hugh Walpole, over the N.B.C. network!

I am pleased to see that you intend to resume the publication of "Readers' S.W. Reception Reports," as I want very much, if possible, to find out if anyone else notices the interference on VK2ME's wavelength when broadcasting. These Readers' Reports are a great help for keeping an eye on short-wave work in general.

Yours faithfully,

St. Albans, Herts.

J. W. B.

To the Editor of WORLD-RADIO

SIR,—The following may be of interest to some of your readers. American stations I have received during the week ending November 29 on the "One-Valve Super-Het. Adaptor," described in your issue of February 13 last, and in the current copy (November 27):—

W2XAD, W3XAL, W8XAL, W8XK, W2XAF; all of which were at good strength; W2XAD was at good loud speaker volume on each evening except Thursday, November 26; Sunday, November 29, 2.50 p.m. to 4.30 p.m.; VK2ME, Sydney, the programme from which consisted principally of gramophone records. This is certainly the simplest "short waver" I have handled.

Yours faithfully,

Eastbourne.

W. M.

(Continued at foot of previous col.)

JUST THE THING!

HANG FOR THE XMAS STOCKING IT UP!

SEE AT-A-GLANCE

NO TURNING OVER LEAVES OF BOOKS AND PAPERS

DAILY MAIL RADIO WHEEL

HELPS YOU TO LOCATE AND IDENTIFY IMMEDIATELY 76 RADIO STATIONS BY A TURN OF THE WHEEL

Dia. 9½ ins. -sided.

OVER 500 FACTS "At-a-Glance"

Dia. 10 ins Coloured

About each of the following:—

EUROPE—BRITISH EMPIRE—ENGLAND & WALES—SCOTLAND—IRELAND—N. & S. AMERICA—U.S.A., &c.

By POINTING the ARROW to the COUNTRY REQUIRED.

GEOGRAPHY MADE EASY

Get them at Stationers. If any difficulty, write direct to Frank Pitchford & Co., Ltd., Well Street, London, E.C.1.

PROGRAMME SECTION

Continental Programme Events

SUNDAY, DECEMBER 20

Concerts

- 10.30 a.m. Leipzig, Schweizerischer Landessender and all German stations: Bach Cantata.
- 11.15 ,, Warsaw: Philharmonic Orchestra.
- 4.45 p.m. Warsaw: Orchestral concert.
- 5.0 ,, Rome: Symphony concert from the "Augusteo."
- 5.30 ,, Radio-Paris: Relay of "Concert Poulet."
- 6.10 ,, Vienna: Lotte Lehmann song recital.
- 7.10 ,, Hilversum: Bach's Mass in B Minor.
- 7.15 ,, Leipzig: Bach's Christmas Oratorio.
- 7.45 ,, Copenhagen: Danish Christmas programme.

Operas and Operettas

- 7.0 p.m. Bucharest: "Eva" (Lehár).
- 7.30 ,, Frankfurt, Stuttgart, Heilsberg: "Carmen" (Bizet).
- 8.0 ,, Brussels No. 2: "L'Amico Fritz" (Mascagni).

Other Events

- 6.45 p.m. Frankfurt, Stuttgart: Dr. Curtius speaks on "Germany and France."

MONDAY, DECEMBER 21

Concerts

- 7.25 p.m. Schweizerischer Landessender: Songs from opera.
- 7.41 ,, Hilversum: Orchestral and vocal.
- 8.20 ,, Heilsberg: Chamber music.

Plays

- 8.5 p.m. Brussels No. 1: "Colonel Chabert" (Balzac).
- 8.30 ,, Radio-Paris: Two comedies relayed from the Odéon.

TUESDAY, DECEMBER 22

Concerts

- 7.0 p.m. Berne, Schweizerischer Landessender: Haydn concert.
- 7.0 ,, Vienna, Heilsberg: Excerpts from Viennese operettas.
- 7.15 ,, Warsaw: Orchestral concert.
- 7.40 ,, Hilversum: Orchestral concert.
- 8.0 ,, Brussels No. 1: Christmas programme.
- 8.0 ,, Milan, Turin: Respighi concert conducted by Composer.
- 8.10 ,, Stuttgart, Frankfurt: Symphony concert.
- 9.30 ,, Copenhagen: Chamber music for wind instruments (Mozart).
- 11.30 ,, Stuttgart: "Late" concert.

Operas and Operettas

- 8.0 p.m. Radio-Paris: "Tristan and Isolde" (Wagner) on gramophone records by the Bayreuth cast.

Plays

- 7.0 p.m. Munich: "Frau Holle" (a fairy-tale play).

WEDNESDAY, DECEMBER 23

Concerts

- 8.0 p.m. Brussels No. 1: Walloonian Christmas music.
- 8.0 ,, Schweizerischer Landessender: Orchestral and choral concert.
- 8.15 ,, Frankfurt, Stuttgart: Haydn chamber music.
- 8.15 ,, Warsaw: Violin recital by Roman Totenberg.

- 9.5 p.m. Copenhagen: Orchestral and soloist concert.

Plays

- 8.10 p.m. Heilsberg: "Christmas" (a radio sequence).
- 8.45 ,, Radio-Paris: "Les Folies Amoureuses" (Regnard).

THURSDAY, DECEMBER 24

Concerts

- 7.2 p.m. Copenhagen: Christmas concert.
- 7.10 ,, Hilversum: Choral and chamber music orchestral concert.
- 7.30 ,, Stockholm: Christmas programme.
- 7.40 ,, Vienna: "Gloria in Excelsis."
- 8.0 ,, Frankfurt, Stuttgart, Königs Wusterhausen: The Bells of 30 German Cathedrals.
- 8.0 ,, Milan, Turin: Christmas concert.
- 8.0 ,, Rome: Christmas concert.
- 8.20 ,, Munich: Christmas concert.
- 9.0 ,, Brussels No. 2: Christmas programme.
- 9.0 ,, Radio-Paris: Symphony concert.
- 9.20 ,, Warsaw: Christmas concert.

Plays

- 9.30 p.m. Heilsberg, Berlin, Breslau, Leipzig: "Die Heilige Nacht" (a Nativity play).
- 9.30 ,, Stuttgart, Frankfurt: "The Shepherd's Play."

Other Events

- 7.0 p.m. Hamburg: Christmas programme for lonely people.

FRIDAY, DECEMBER 25

Concerts

- 10.30 a.m. Leipzig, Schweizerischer Landessender and all German stations: Bach Cantata.
- 11.30 ,, Leipzig, Frankfurt, Stuttgart: Johann Strauss Concert.
- 6.30 ,, Stockholm: Handel's "Messiah."
- 8.0 ,, Milan-Turin: Chamber Music.
- 8.15 ,, Schweizerischer Landessender: Christmas oratorio.
- 8.45 ,, Radio-Paris: Gramophone records for children.
- 9.40 ,, Copenhagen: Classical dances by Viennese composers.

Operas and Operettas

- 6.30 p.m. Leipzig: "Tannhäuser" (from Dresden Opera House).
- 6.30 ,, Vienna: "The Bajadere" (Kálmán).
- 7.0 ,, Berlin, Königs Wusterhausen: "Il Trovatore" (from State Opera House).
- 7.15 ,, Frankfurt, Stuttgart: Act 3 of "The Mastersingers of Nuremberg."
- 8.0 ,, Rome: "The Blue Mazurka" (Lehár).

SATURDAY, DECEMBER 26

Concerts

- 7.15 p.m. Warsaw: Orchestral and soloist concert.
- 9.10 ,, Warsaw: Chopin pianoforte recital.
- Operas and Operettas**
- 6.35 p.m. Munich, Langenberg: "Tannhäuser" (from National Opera House).
- 7.0 ,, Stockholm: "La Bohème" (from Royal Opera House).

Plays

- 8.45 p.m. Brussels No. 1: "Eros and Psyché" (Giraud).

YOUR SET WILL LOOK WORTH DOUBLE THE PRICE IN THIS OSBORN READY-TO-ASSEMBLE CABINET

Model No. 200.

A Modern Jacobean Radio or Radio-Gramophone Cabinet. 3ft. 10ins. high, 2ft. 2ins. wide, 1ft. 6ins. deep. Baffle behind fret, 24ins. x 20ins., opening at back and top. Takes panel 24ins. x 13ins. Vignette supplied for any smaller size. First-class British workmanship throughout. The largest makers of Radio Cabinets in the British Isles, Chas. A. Osborn alone can produce a Cabinet of this quality at such a low price.

PRICES:

MACHINED READY TO ASSEMBLE, Oak, £4.0.0.

ASSEMBLED READY TO POLISH, Oak, £5.5.0.

ASSEMBLED AND POLISHED, Oak, £6.10.0.

All Models Carriage Paid.

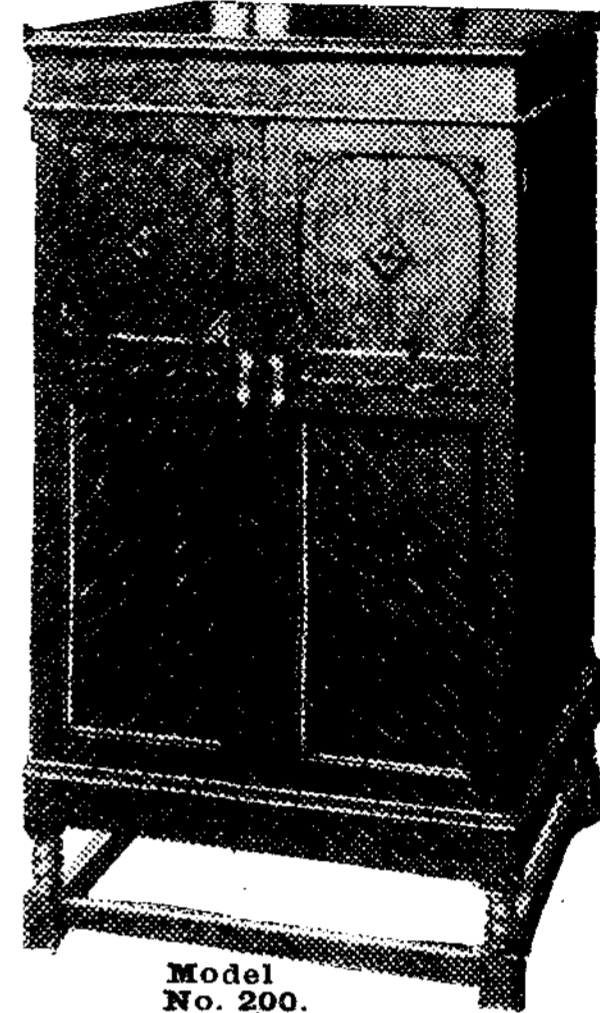

Model No. 200.

Send 3d. in Stamps for 56-page illustrated catalogue.

CHAS. A. OSBORN
LARGEST MAKERS OF RADIO CABINETS IN THE BRITISH ISLES

DEPT. W.R., THE REGENT WORKS, ARLINGTON ST., LONDON, N.1. Telephone: CLERKENWELL 5095.

and at 21, ESSEX ROAD, ISLINGTON, N.1.

(1 minute from the Agricultural Hall.) Telephone: CLERKENWELL 5634.

every **SUNDAY**
2 P.M. — 3 P.M.
RADIO
PARIS

DECCA
CONCERT

arranged
and
directed
by

CHRISTOPHER
STONE

Full programmes and catalogues from
THE DECCA RECORD CO., LTD. (Dept. 233), 1-3, BRIXTON RD., LONDON, S.W.9.

SHORT-WAVE STATIONS

The times quoted are reduced to G.M.T.

M.	Kc/s	Station	Power	Time
80	3750	Rome (Italy) 2RO	14 kW. (Aer.)	
70.2	4273	Khabarovsk (U.S.S.R.)	20 kW.	9 a.m. to 12 p.m.
62.5	4800	Long Island, W2XV	FRI., 11 p.m.	1.30 a.m.
58	5172	Prague	TUES. and FRI., 7.30-9.30 p.m.	
54.52	5502	Brooklyn (N.Y.) W2XBH	Relays WCGU.	
51.22	5857	Chapultepec (Mexico) XDA	20 kW. Daily	3-4 p.m.
50	6000	Barcelona Radio Club EAJ25	SAT 8-9 p.m.	
50	6000	Bucharest (Romania)	0.3 kW.	
50	6000	Moscow (Relays Moscow T.U.)	8.0 p.m.	
49.96	6005	Tegucigalpa (Honduras), HRB	2.5 kW. Daily (except SUN.), 12 m't.	5 a.m.
49.83	6020	Chicago (Ill.) W9XF	5 kW. Relays WENR	SUN. 5-7 a.m., 1-5.30 p.m., 8.30-11 p.m. and 1-6 a.m. (MON). Weekdays, 3.15-4.45 p.m., 8.30 p.m.-12 m't. and (ex. SAT.) 1.30-6 a.m.
49.67	6040	New York (W2XAL)	0.25 kW. TUES., 12 m't.-5 a.m. WED., 12 m't.-2 a.m. FRI., 12 m't.-4 a.m. SAT., 12 m't.-3 a.m.	
49.5	6060	Cincinnati, W8XAL	10 kW. Relays WLW.	
49.5	6060	Nairobi (Kenya)	7 LO.	
49.5	6060	Philadelphia (Pa.) W3XAU	0.5 kW. Relays WCAU.	Daily 2-9 p.m. THURS. and FRI., 2 p.m.-6 a.m.
49.43	6069	Vancouver (B.C.) VE9CS.		
49.4	6072	Johannesburg (S. Africa) D'ly	3.30-8.30 p.m.	
49.34	6080	Chicago (Ill.) W9XAA	0.5 kW. Relays WCFL.	Daily 2-5 a.m.
49.22	6095	Bowmanville (Canada) VE9GW	0.028 kW. Weekdays, 11.45 a.m.-3 p.m.; and 8 p.m.-3 a.m. SUNDAYS, 5.30 p.m.-4.15 a.m.	
49.18	6100	Bound Brook (N.J.) W3XAL	12 kW. MON. TUES., WED. and THURS., 6.30-11.45 p.m. and 4-6 a.m. Sun., 1-7.30 p.m.	
49.05	6116	Saigon (French-Indo-China) F31CD	Daily	12 noon-3.45 p.m.
49.02	6120	Richmond Hill (N.Y.) W2XE	0.5 kW. Relays WABC.	D'y 1 p.m.-5 a.m. next day.
48.86	6140	Pittsburgh East (W8XK)	Relays KDKA.	WED and SAT., 10 p.m.-5 a.m.
48.8	6147	Winnipeg (Canada) VE9CL	2 kW. Daily (except SUN.)	from 12.30-2.30 a.m.
48.65	6167	Mexico City XIF		
48.35	6205	Bogotá (Colombia) HKC	Daily, 3 p.m.	
48.05	6243	Barranquilla (Colombia), HKD.		
48	6250	Casablanca (N. Africa) CN8MC	Relays Rabat, MON., 8-9 p.m. TUES., 12 noon-1 p.m. and 8-9 p.m.	
46.69	6425	Bound Brook (N.J.) W3XL	FRI. 10-11.45 p.m. and 4-6 a.m. SAT. 6.30-11.45 p.m. and 4-6 a.m.	
45.39	6611	Moscow (Russia)		
45	6667	Constantine (Algeria) 8KR	0.2 kW. MON. and FRI., 11 p.m.	
43	6976	Madrid (EAR 110)	TUES. & SAT., 10.30 p.m.	
42.9	6991	Lisbon CT1AA	2 kW. FRI., 10 p.m.	
41.7	7195	Singapore VSA B	SUN. & WED. 2.30-4 p.m.	
41.6	7211	Tenerife Radio Club EAR58	0.05 kW.	
41	7313	Bangkok HSP2	2.5 kW. (Testing). MON. only 1-4 p.m.	
39.7	7556	Bogotá (Colombia) HKF		
39.4	7612	Nuevo Laredo (Mex.) X26A	THUR., 4-5 p.m.	
34.68	8650	Long Island W2XV	FRI. 11 p.m.-1.30 a.m.	
33	9090	Radio LL (France)	0.5 kW. DAILY 12.30-1 p.m. and 6-6.30 p.m. SUN., MON., WED. and FRI., 8-10 p.m. SAT., 7-8.30 p.m. SUN., 10 a.m.-12.30 p.m. and 2.30-4 p.m.	
32.5	9230	Paris (FLJ)	Time Sig. 8.56 a.m. and p.m.	
32.26	9300	Rabat (Radio Maroc)	6 kW. SUN. 7-9 p.m.	
31.75	9450	Rio de Janeiro (Brazil)	9.30-11.30 p.m.	
31.55	9510	Melbourne (Australia) VK3ME	5 kW. WED. and SAT., 10 a.m.-11.30 a.m.	
31.51	9520	Skamlebak (Denmark) OXY	0.5 kW. Relays Copenhagen. Daily from 6 p.m.	
31.48	9530	Schenectady, N.Y. (W2XAF)	10 kW. (Aer.) Relays WGY. Weekdays 10.30 p.m.-4 a.m. SAT. and SUN., 9 p.m.-4 a.m.	
31.38	9560	Zeesen (Germany)	8 kW. Relays various stations, generally 1 p.m.-12.30 a.m.	
31.35	9570	Poznań (Poland) SR1	1 kW. TUES., 6.45-9.45 p.m. THURS., 6.30 p.m.-1 a.m.	
31.35	9570	Springfield (Mass.) W1XAZ		
31.3	9582	Philadelphia (Pa.) W3XAU	0.5 kW. Daily (except THURS. and FRI.), 9 p.m.-6 a.m.	
31.28	9590	Melbourne (Australia) VK3ME	20 kW. WED. and SAT., 10 a.m.-11.30 a.m.	
31.28	9590	Sydney (Australia) VK2ME	20 kW. SUN., 10 a.m.-2 p.m.; 2.30-4.30 p.m.; and 6-8 p.m.	
31.28	9590	Eindhoven (Holland) PCJ	25 kW. (Closed for six months.)	
30.75	9756	Agen	TUES. and FRI., 9-10.15 p.m.	
30	10,000	Belgrade	MON. only, 8-9 p.m.	
29.3	10,238	Heredia (Costa Rica) NRH	7.5 watts. Daily 10-11 p.m. and 2-3 a.m.	
28.98	10,350	Buenos Aires LSX	20 kW. 8.30 p.m.-12.30 p.m.	
26.46	11,338	Saigon (French Indo-China)	12 kW. Fridays from 3.30 p.m.	
25.63	11,705	Pontoise (Paris)	Daily 9 p.m.-12 m't.	
25.53	11,750	Chelmsford (G5SW)	16 kW. (Aerial). 12.30-1.30 p.m. and 6.45 p.m.-12 m't. MON., TUES. and WED., Reg. prog., THURS. and FRI., Nat. Programme.	
25.5	11,763	Chapultepec XDA	20 kW. Daily, 8-9 p.m.	
25.43	11,795	Bowmanville (Canada)	VE9GW. (Exp't'l).	
25.34	11,840	Chicago (Ill.) W9XAA	Relays WCFL.	
25.27	11,870	Calcutta (India) VUC	0.5 kW. Weekdays, 2.45-3.15 a.m. and 3.15-5 p.m.	
25.25	11,880	Pittsburgh East (W8XK)	5 p.m.-3 a.m.	
25.2	11,905	Pontoise (Paris)	Daily 5.30-8.30 p.m.	
24	12,500	Funchal (Madeira) CT3AQ	0.05 kW.	
23.8	12,605	Rabat (Radio Maroc)	6 kW. SUN., 11.30 a.m.	
21.5	13,950	Bucharest	0.3 kW. WED. and SAT., 7.10 p.m.	
20.5	14,030	Chapultepec XDA	20 kW. D'y 7.30-8 p.m.	
19.72	15,210	Pittsburgh East (W8XK)	Relays KDKA	WED. and SAT., 12 noon-4 p.m.
19.68	15,234	Pontoise (Paris)	Daily 2-5 p.m.	
19.56	15,340	Schenectady (W2XAD)	20 kW. Weekdays, 6-8 p.m. SAT. and SUN., 6-9 p.m.	
16.57	18,105	Chicago (Ill.) W9XAA	Relays WCFL.	
15.93	18,830	Bandoeng (PLE)	80 kW. TUES., 1.40-3.40 p.m.	
15.5	19,355	Nancy (France)		

Last Week's Log

(December 6-12)

By "NORTHERNER"

IT is to be wished that the very excellent conditions we have experienced during the last few weeks could remain unchanged throughout the whole year: reception from many Continental stations is as easily attained as in the case of our own Regional transmitters. Again, there has not been the slightest trace of atmospheric interference, and, whenever necessary, it was possible to take full advantage of the maximum amplification in the receiver while tuning in to the weaker stations. A brief comparison with the results obtainable for the same period last year shows a distinct improvement, for fading, according to my log, was rather troublesome throughout the greater part of last winter season. No doubt, we can attribute this improvement to the increased power now being used, which, in all cases, is not so much evidenced by a stronger signal from the station as by a more consistent one.

The greater number of the long-wave stations are now at their best, with ample volume for first-rate daylight reception. The new Radio-Paris is excellent, and while the increase in strength is not so great as had been expected, an improvement in quality is noticeable. Warsaw is an easy first for strength in the north, and except for an occasional heterodyne—presumably of Russian origin—leaves little to be desired, while Kalundborg has been unusually good for some time, and offers fine reception during the afternoon as well as in the evening. Oslo was well received during the period under review, and interference is now much less than was once the case. For a long-wave station Leningrad has varied considerably in strength during the last few days—in fact, on two occasions he was heard at enormous strength quite clear of the morse interference which usually mars reception, and the signals, particularly on the Tuesday, gave every indication of an increase in power. Huizen is quite as good as he was, and on the whole, gives a splendid result; and Motala, although weaker is always worth trying for.

On the medium-wave band Toulouse seems to have improved slightly, and there is little trouble in picking up the new high-power station of Moscow-Stalin nightly. Budapest was most disappointing, especially after I was able to give him such a good report in my last log, when even in the forenoon his signals were readily received. His night strength was occasionally too poor to resolve into an audible signal, and the sudden relapse was quite puzzling. It would be interesting to know whether other listeners had a similar experience.

Rome and Stockholm were both excellent signals, while Suisse-Romande and Schweizerischer Landessender are now two of the best-heard stations. Sundsvall is again worth attention, but one must listen regularly for him, as his improvements are quite sudden and unexpected.

Prague, who now claims to be one of Europe's most powerful stations, is received at really first-rate strength, and can be counted amongst the star stations in our list, and Langenberg still comes through in his old consistent way—not with an excess of volume, but sufficient for fairly pleasant results. Milan, having now changed his wavelength to 331.5 metres, is a little more difficult to capture free from interference, but his signals are nevertheless very good.

Hörby was an excellent station during the week, and he now appears to be at the top of his form; Brno and Moravská-Ostrava are both well received at the moment, but Trieste is persistently interfered with by a bad heterodyne.

HIGH-QUALITY RECEIVERS

(Continued from page 1047)

a positive voltage, and a potentiometer may be necessary to obtain less than 6 volts. Indirectly-heated valves are found to be slightly better than 2-volt valves and 2-volt valves appreciably better than 6-volt valves as grid rectifiers. Where there is appreciable difference in potential along the filament as in a 6-volt valve, there is a corresponding difference in potential between each part of the filament and the grid, and it is impossible to arrange for every part of the filament to be at the best potential with respect to the grid for efficient rectification. Hence a unipotential cathode, as in an indirectly-heated valve, is the best.

In the case of high-impedance valves the grid is effectively in close proximity to the filament to give the greater control over the anode current necessary for high amplification. Hence one would expect the grid-filament path to have less resistance in these valves than in valves with less amplification, and consequently to give more linear rectification at low inputs. This is found to be the case, and linear rectification can be obtained with high-impedance valves with low inputs and with low-impedance valves at large inputs.

In both cases, of course, precautions must be taken to ensure that the anode circuit is not overloaded, and the anode circuit must be arranged in both cases to give linear amplification by employing the correct anode impedance and sufficient anode volts. Grid rectifiers cannot give distortionless reproduction if the valve is not operated properly as an amplifier as well as a rectifier, and linear amplification cannot be expected with very low H.T. voltage.

(To be continued)

Interference between Stations

(December 3-10)

WILNO, the Polish station, by working round 608 kc/s, has lately been the cause of many serious interferences. Apart from that experienced by Trondheim, there is also the heterodyne caused by Prague. However, on the 3rd Wilno moved to 605 kc/s, and it was then Florence (599 kc/s) who was interfered with. By the way, Florence is the new Italian station using Milan's wavelength. It was heard for the first time on the 3rd, coming in at good strength. Genoa has been heard at several times with an unusual strength. He was probably making tests with his new 12 kW transmitter. Turin, which was using 1,096-1,097 kc/s and was thus keeping eleven or twelve kilocycles from Heilsberg, went back to 1,094 kc/s on the 8th, and the separation between the two is now nine kilocycles.

L. B.

Year Books and Diaries

THE 1932 edition of the "Wireless and Gramophone Trader" Year Book (Trader Publishing Co., Ltd., St. Bride's House, E.C.1, 5s. 6d.) contains a number of new features of interest and usefulness—e.g., a directory of mains-supply voltages in Great Britain and in certain towns in the Dominions. Another Year Book received is the *Tit-Bits Year Book* for 1932 (Geo. Newnes, Ltd., 1s.), which at first glance appears to contain information on every conceivable subject from Hospital Services to Criminal Records.

Two pocket diaries, compiled particularly for the wireless listener, have reached us. These are the "Wireless World" Diary (Hiffe and Sons, Ltd.) and the *Wireless Diary* (Chas. Letts and Co.). The former contains, in addition to a store of useful technical tables and information, a list of European broadcasting stations with their frequencies. While such a list is useful, it has, of course, the drawback that several of these frequencies have already been altered, and many more will be changed during the year. The latter diary contains a mass of information of everyday use to the listener which, while highly compressed, is nevertheless valuable.

Which Station Was That?

Answers to Correspondents

BIG EARS (Goldthorpe): (1) and (2) cannot trace the transmission as French stations did not advertise a relay on that night, but your wavelengths would tally with Toulouse and Limoges, P.T.T. **STEELE (Skegness)**: Yes, Sydney, VK2ME which works for the benefit of U.S.A. listeners occasionally on 30.75 m. **MIDNIGHT OIL (Cheadleholme)**: Yes, Reykjavik. Local time is one hour behind G.M.T. **HIGH FREQUENCY (Morpeh)**: Moscow (T.U.) on 45.38 m. **RHOASTER (Cambridge)**: Wavelength vague; if p.m. might tally with Leningrad. **TERRY BOY (Drury Lane)**: (1) Brno; opera: "Othello" from local theatre; (2) Trieste; (3) Hilversum testing on 20 kW. **SPARKS (Morecambe)**: Vatican (Rome) on 50.26 m. **DON Q (Tralee, I.F.S.)**: Reykjavik. **CURIOUS (Cafford)**: Hilversum testing. **MUIR (Inverness)**: Altered programmes: Frankfurt-am-Main (Memorial Hour to St. Elizabeth); Mühlacker (Christmas Cantata from St. Mark's Church, Stuttgart); Heilsberg (an Advent programme from Danzig). **NOVICE (Machynllech)**: Milan on 331.5 m. **WOP (West Calder)**: Boden relaying Stockholm. **BRACING (Skegness)**: a test by Hörby. **STRANGER (Liverpool)**: (1) Stavanger; (2) Hörby. **GLANSMAN (West Kilbride)**: possibly VK2ME, Sydney (N.S.W.). **ABOU-ABAS (Scarborough)**: Apparently a test, possibly by Hörby. **WATES (Plumstead)**: Proprietary names must not be used as *noms-de-plume*. Very vague; see previous reply. **JEFF (Greenwich)**: Cannot confirm as you give no indication of wavelength, but VK2ME, Sydney, now broadcasts on Sundays between 2.30 and 4.30 p.m., G.M.T. **TIMBER (Leeds)**: a test by Hilversum now using 20 kW. **V.H.N.C. (Leeds)**: Radio Normandie (Fécamp) on 245.9 m. (sponsored concert). **INTERESTED SCOT (Kintore)**: Hörby testing. **CARRINGTON (Ashton-upon-Mersey)**: Regret, cannot trace; no station advertised a relay of the Riga programme. **SMITH (Lincoln)**: Proprietary names must not be used as *noms-de-plume*. Direct "pick-up" on your receiver, on lower end of long wave coil, of B.B.C. station. **EASTON (Bristol)**: Moscow; early morning exercises and concert. **STODGER (Hessle)**: Probably U.S.A. station, but wavelength estimate too vague to trace transmitter. **ROBBO (Derby)**: Scheveningen-Haven (Holland); commercial transmitter only. **EX-CHAR (Cowfold)**: Vatican (Rome), on 50.26 m. **A. C. M. (Eastbourne)**: Leningrad; English lesson. **RABOONA (Upper Teddington)**: Brussels (No. 1). **NETTLEHAM (Sunderland)**: Hörby testing. **HUNSLET (Leeds)**: Radio-Idzerda, private transmitter, The Hague. Proprietary names must not be used as *noms-de-plume*. **HORKY (Glasgow)**: Hörby testing. **SCRUBBER (Southport)**: (1) Possibly Moscow (T.U.) on 45.38 m.; (2) Radio-Toulouse is occasionally relayed by a local station on 39.45 m. **MAC (Suffolk)**: Leningrad; English lesson. **LO-DOWN (Woodchester)**: Moscow (T.U.) on 45.38. **BEACH WAVES (Southsea)**: Hilversum. **WAS IST? (Hove)**: (1) Moscow (T.U.); (2) Kalundborg relaying Copenhagen. **ENQUIRER (S.W.7)**: (a) Flensburg relaying Hamburg; (b) Königsberg direct; (c) wavelength wrong; Radio-Normandie, Fécamp. **DIAL (Conon Bridge)**: WTIC, Hartford (Conn.) U.S.A., relaying National Broadcasting Company's programme from WEAF, New York. **FIVER (Birmingham)**: Radio Idzerda, private transmitter, The Hague. **GHOSTLY (Bristol)**: Cannot trace; apparently a test by some transmitter. **RUBBRA (London, S.E.)**: Vague; possibly WGY, Schenectady. **SAN TOY (W.1)**: Yes, Reykjavik. **MAC (Portobello)**: Without

doubt, a test; it has been heard by many listeners. Possibly from Stavanger or Christiansand. **STILLWELL (Hove)**: Moscow (T. U.). **KILLOCH (Glasgow)**: Yes, Radio Sagon (Indo-China). **NEMINEM (Bretton)**: French amateur experimental transmitter. **WANJAC (Letchworth)**: Prague relaying Brno (musical play). **WYLEY (Coventry)**: Schweizerischer Landessender relaying gramophone records from Basle. **IMP (Aberdeen)**: Wilno relaying Warsaw. **???? (Waterford)**: Reykjavik. **LOCKARDION (Lockerbie)**: Hilversum; gramophone records. **N. S. C. (Midlothian)**: Reykjavik. Icelandic time is one hour behind G.M.T. **THREE VALVER (Weymouth)**: (1) LN, Radio Splendide, Buenos Aires; (2) Norddeich (Germany); transmission to ships. **BEN DEE (Sheffield)**: Reykjavik. **AERIAL BUG (Bromley)**: EAQ, Aranjuez, Madrid (30.42 m.). **KILLOCH (Glasgow)**: Sundsvall relaying Stockholm. **MUG (Argyll)**: Test by Falun. **RED SEA ROVER (Gravesend)**: Hilversum; gramophone records, Dutch local time is 20 minutes in advance of G.M.T. **SEARCHING (Battersea)**: Cracow relaying Warsaw. **PETER PAN (Crosby)**: LN, Radio Splendide, Buenos Aires (315.8 m.). **DRUMMER (Fife Keith)**: PLE, Bandoeng, on 15.93 m. There are other Java transmitters, but you do not say near which "logged" U.S.A. station this broadcast was picked up. **OIDARDLOW (Salford)**: More likely Kiev on 1,034 m. **VICCO (Jersey, G.I.)**: Caracas, Venezuela, working with Nauen (Germany). Usual wavelengths 25.6 and 28.9 m., but possibly another channel may have been used. **AWDAWIT (Aberdeen)**: Please number your queries. We are replying to them in order of wavelength. (1) Göteborg relaying Stockholm; (2) Breslau relaying *The Marriage of Figaro* from Cologne; (3) probably Poznan. **SLEEPLESS (Norwich)**: Too vague; regret, cannot trace. **DODO (Heckington)**: Berlin (common-wave stations) on 283 m. **ELMDENE (Harrow)**: Reykjavik. **TENNIS (Derby)**: Not advertised, but certainly Kalundborg relaying Copenhagen. **SWIFTY (Glaccon-on-Sea)**: Regret, cannot trace. **LINTO (Govan)**: Wilno on its new wavelength. **BONN (Blackpool)**: Regret, cannot trace. There is no Dutch station working on that wavelength. We very much doubt whether you would hear Radio Schaeerbeek. **A. D. (Stockport)**: Milan testing. See under "Deviations" in current issue. **A. C. W. (Nottingham)**: (1) might tally with Radio-España, Madrid; (2) Katowice; "Letter Box" (answers to correspondents via microphone). **ONE VALVE (Letchworth)**: Not a broadcast; regret, cannot trace. **OOISIT (Ilford)**: Copenhagen. **JUMBO (Ashby-de-la-Zouch)**: (1) (2) and (3) these would appear to be transmissions by amateurs; if you can pick up call-signs would advise you to write to Radio Society of Great Britain, 53, Victoria Street, London, S.W.1. **QUESTION MARK (Sidcup)**: Lille P.T.T. **COPPER (Paris XVI)**: (148) this was Kalundborg relaying a late transmission from Copenhagen; (149) Radio-Maroc (Rabat). **INTRIGUE (Chelsea)**: (1) Radio-Idzerda, private transmitter at The Hague; (2) and (3) according to details given these transmissions do not appear to have been broadcast by stations over 1,000 metres. Are you sure that your receiver was not switched over to the lower broadcasting band? No. 3 might tally with Radio Normandie, Fécamp.

[The values of resistance indicated at the end of the article on Notes on Coupled Circuits in Broadcast Receivers are 15,000, 20,000, 30,000 and 50,000 ohms respectively.]

READ INSTRUCTIONS IN IDENTIFICATION COUPON

Free Query Service

Each query should be numbered and the questions on the coupon carefully answered. Letters must be addressed to the Editor, *World-Radio*, Savoy Hill, W.C.2.

The Alternative Postal Service

In addition to the free service of "Which Station was That?" printed in these columns, replies to queries can be obtained within forty-eight hours of receipt of details, on payment of 6d. per query, in stamps or P.O., accompanied by stamped addressed envelope (marked in left hand top corner "Postal Query Service"), and coupon as per conditions for "Free Queries."

IDENTIFICATION COUPON (No. 151)

This coupon is valid for ONE QUESTION only, and should be cut out and attached to a separate sheet, upon which the following questions should be answered in the order shown, and in the case of FREE queries a duplicate copy of questions and answers enclosed. No coupon more than one month old is valid.

1. Time and Date of reception.
2. Approximate frequency in kilocycles per sec. (or wavelength in metres).
3. Nearest known stations, above and below.
4. Call or interval signal, if heard.
5. Language.
6. Type of receiver in use and strength of signal.
7. Details of programme or signal received.
8. Name and address.
9. Nom de plume. (*Proprietary names must not be used.*)

Schedule of Advance Programmes

(STRICTLY COPYRIGHT)

For the benefit of traders who may wish to make arrangements for demonstrating, we are printing each week a schedule of the programmes to be transmitted by the National and Regional stations. It will be noticed that these schedules concern programmes to be transmitted a fortnight hence, and it is felt that they will also be of particular service to those of our readers living abroad who will be able to use them in connexion with the reception of the Experimental Short Wave Station, G5SW, which relays either the National (5XX) or London Regional programme from 7 p.m.

SUNDAY, JANUARY 3

	NATIONAL	LONDON REG.	MIDLAND REG.	NORTH REG.
AFTERNOON	Music by Roger Quilter	As London Reg.	Organ and Violin Recital	Band Concert
EVENING PROGRAMME	Military Band Oratorio	J. C. Bach music Hotel Orchestra	As London Reg.	As London Reg. Orchestral Con.

MONDAY, JANUARY 4

	NATIONAL	LONDON REG.	MIDLAND REG.	NORTH REG.
MORNING	Studio Concert	As Midland Reg.	Cinema Orch.	As Midland Reg.
AFTERNOON	Cinema Orch. Gram. Records Hotel Orchestra	As North Reg. As Midland Reg. As National	As North Reg. Studio Orchestra	Hotel Orchestra As Midland Reg. As National
1ST EVENING PROGRAMME	Talks Vaudeville	Band Concert Literary Snow Scenes	Organ Recital Military Band	Studio Orchestra Hotel Orchestra
2ND EVENING PROGRAMME	Chamber Music Dance Music	Light Music Dance Music	As London Reg. As London Reg. (till 11 p.m.)	Talk As London Reg.

TUESDAY, JANUARY 5

	NATIONAL	LONDON REG.	MIDLAND REG.	NORTH REG.
MORNING	Cinema Organ	Ballad Concert	As London Reg.	As London Reg.
AFTERNOON	Hotel Orchestra Gram. Records Cinema Orch.	As North Reg. As Midland Reg. As National	As North Reg. Studio Orchestra	Instrumental Con As Midland Reg. Evensong
1ST EVENING PROGRAMME	French Talk Orchestral Con.	Orchestral Con. Dance Music	Light Music As London Reg.	Organ Recital As London Reg.
2ND EVENING PROGRAMME	Orchestral Con. Dance Music	Play Dance Music	As London Reg.	As London Reg. As London Reg.

WEDNESDAY, JANUARY 6

	NATIONAL	LONDON REG.	MIDLAND REG.	NORTH REG.
MORNING	Cinema Organ	As North Reg.	As North Reg.	Studio Orchestra
AFTERNOON	Gram. Records String Orchestra Symphony Con.	As Midland Reg. As Midland Reg. As National	Organ Recital Studio Orchestra	As Midland Reg. As Midland Reg. As National
1ST EVENING PROGRAMME	Talks Operatic Excerpts	Light Music Vaudeville	Band Concert As London Reg.	As London Reg. As London Reg.
2ND EVENING PROGRAMME	Play Dance Music	Military Band Dance Music	A Ballad Concert As London Reg. (till 11.5 p.m.)	Studio Orchestra As London Reg.

THURSDAY, JANUARY 7

	NATIONAL	LONDON REG.	MIDLAND REG.	NORTH REG.
MORNING	Cinema Organ	Cinema Orch.	As London Reg.	As London Reg.
AFTERNOON	As Midland Reg. Abbey Evensong Hotel Orchestra	As Midland Reg. As North Reg. As National	Pianoforte and V'cello Rec. As North Reg.	As Midland Reg. Hotel Orchestra As National
1ST EVENING PROGRAMME	German Talk Orchestral Con.	Orchestral Con. Organ Recital	"Request" Con. Dance Music	Studio Orchestra Hallé Orchestra
2ND EVENING PROGRAMME	Vocal and Instr. Recital Dance Music	Musical Com. d. Dance Music	As London Reg.	Choral Concert As London Reg.

FRIDAY, JANUARY 8

	NATIONAL	LONDON REG.	MIDLAND REG.	NORTH REG.
MORNING	Gram. Records	As Midland Reg.	Cinema Organ	As Midland Reg.
AFTERNOON	Organ Recital Gram. Records Hotel Orchestra	Cinema Orch. As Midland Reg. As National	As London Reg. Cinema Orch.	As London Reg. As Midland Reg. As National
1ST EVENING PROGRAMME	Talks Military Band	Light Music Gram. Records	Light Music Revue	Theatre Relay Band Concert
2ND EVENING PROGRAMME	Vaudeville Dance Music	Orchestral Con. Dance Music	As London Reg.	A Comedy As London Reg.

SATURDAY, JANUARY 9

	NATIONAL	LONDON REG.	MIDLAND REG.	NORTH REG.
MORNING	Cinema Orch.	As National		As National
AFTERNOON	As North Reg. Cinema Organ	As North Reg. As National	Studio Orchestra Cinema Organ	Band Concert As National
1ST EVENING PROGRAMME	Talks Musical Comedy	Orchestral Con. Pianoforte Rec.	Light Music Dance Music	Studio Orchestra Symphony Con.
2ND EVENING PROGRAMME	Light Music Dance Music	As Midland Reg. Dance Music	Orchestral Con.	Vaudeville As London Reg.

THE BEST receiver is only as good as its speaker. The Best Speaker has the name of Edison Bell behind it. Therefore, the Best Wireless Receiving-set is that equipped with one of

The new
EDISON BELL
Permanent Magnet
Moving Coil
Models

universally admitted by Trade, Press and Public to be **EASILY FIRST.**

Says the
WIRELESS RETAILERS ASSOCN

"At the Radio Eisteddfod held in Bristol your Permanent Magnet Moving-coil Speaker was placed first by popular vote."

Two types are available—as illustration, in finely grained walnut cabinet. Model 553 with tapped transformer to which the connections may be adjusted in order to match various power-valves, and Model 553a fitted with Transformer suitable for use with Pentode and small power-valves.

**WHEN ITS BEST BUY BRITISH
EDISON BELL IS BOTH**

Prices:
In Walnut Cabinet
£4 : 15 : 0
No. 456 & 456a
Chassis only
£3 : 7 : 6
Write for folder of
Pick-ups, etc.

Edison Bell
Manufactured by
EDISON BELL LTD
Glengall Road. S.E.15

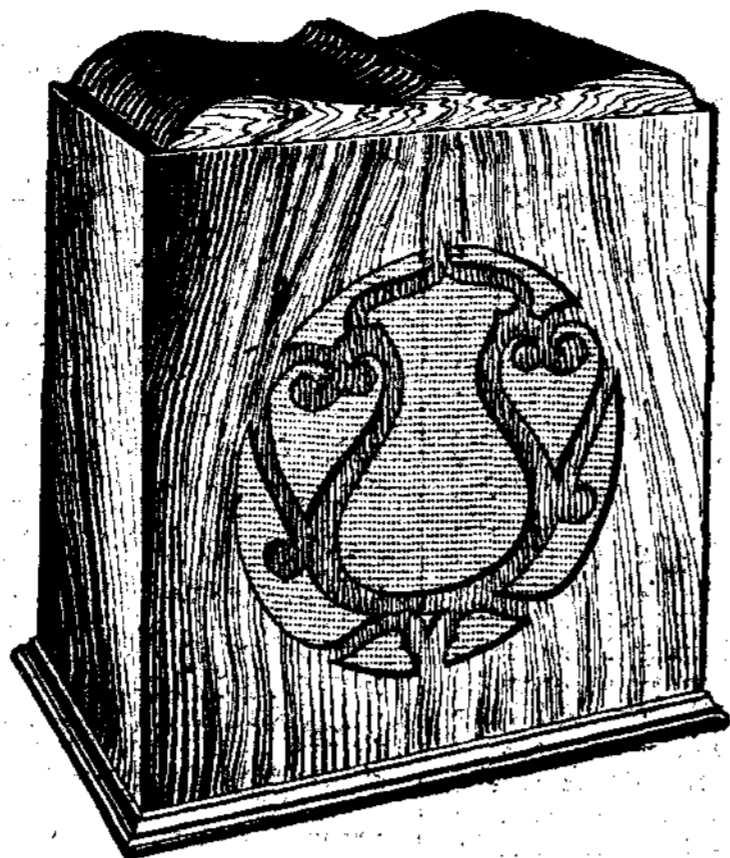

**P
P
M**

PERMANENT

MAGNET

MOVING COIL

SPEAKER

47'6

**including
TRANSFORMER**

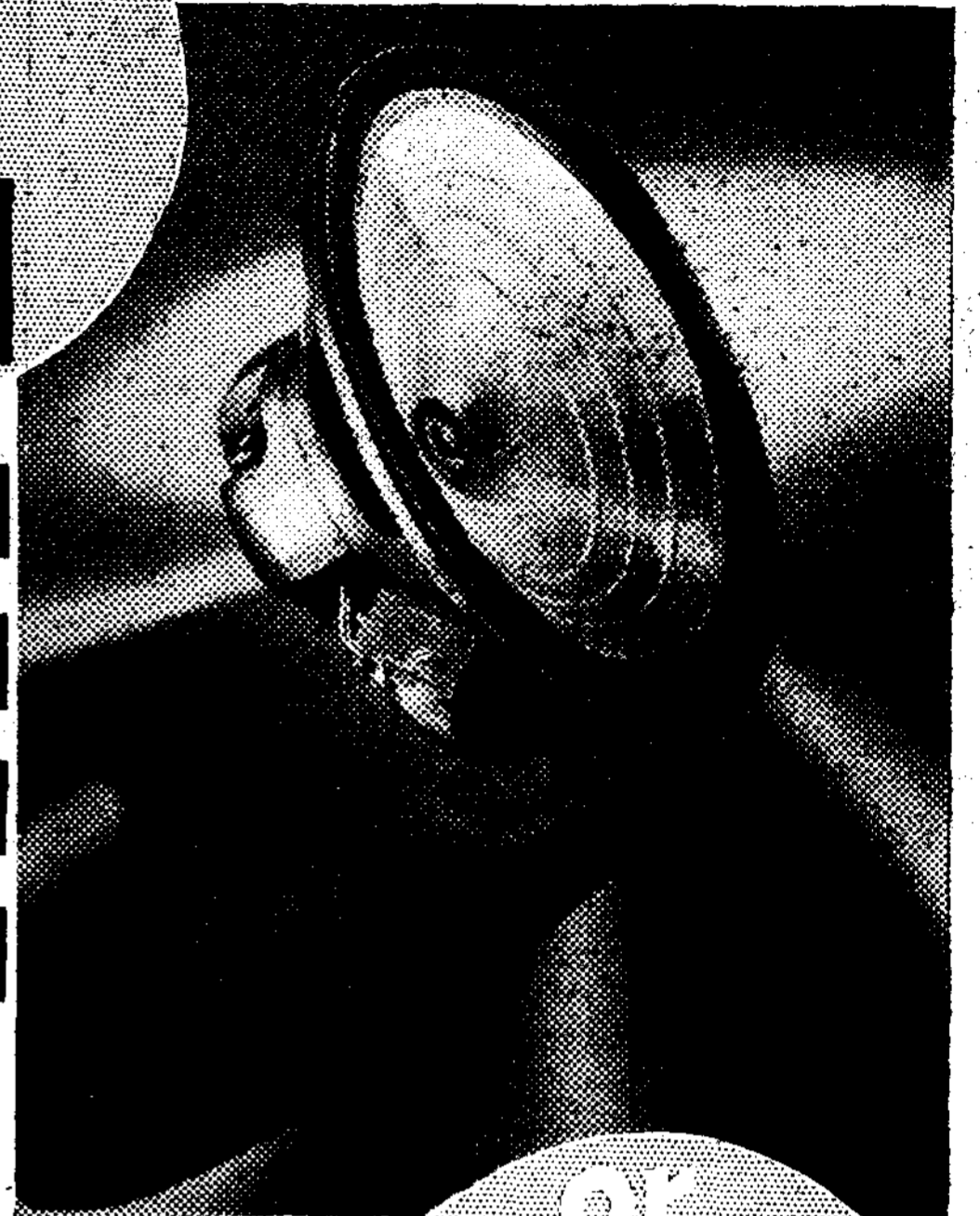

of
10%
DOWN

The Celestion P.P.M. Speaker has been designed to provide very high sensitivity with correct tone balance when operated on relatively small inputs, such as is obtained from the majority of sets in common use. It is a speaker of outstanding merit in that these qualities are combined with those of robust construction and low price. Hear this amazing achievement demonstrated to be convinced of its exceptional value. Write for fuller particulars.

**AND SIX
MONTHLY
PAYMENTS
OF 8/-**

The P.P.M. Speaker incorporates an impregnated diaphragm, and a patented twin suspension permitting large cone movements without undue distress. The new patented cobalt content steel magnet produces a very high flux density. Housed in a strong metal chassis. Dual impedance output transformer included. (Pentode supplied only if specified).

Also ask to hear the J.12 Cabinet Speaker
at 38/6, or 8/- down and 4 monthly
payments of 9/-

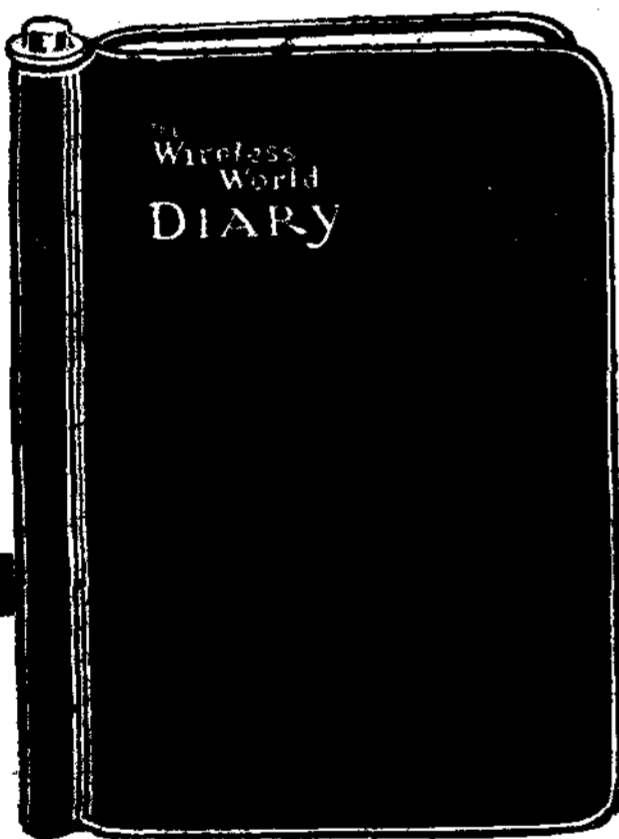

**80 pages
of invaluable
wireless
information**

Size 3½ x 4½ inches, 192 pages.
Bound leather cloth, back-loop
with pencil, round corners and
gilt edges.

**Read this List of Contents
comprising 80 pages**

- List of valves with working details
 - Sixteen circuit diagrams with notes
 - Dial settings for European Stations
 - Data for Coil Construction
 - A series of twelve Abacs
 - Regulations Controlling Receiving Licences
 - Broadcasting Stations of Europe
 - Principal Short-Wave Broadcasting Stations of the World
 - Copper Wire Tables — Sizes, Weights and Resistance
 - Conversion Tables
 - Symbols in Common Use
 - Symbols Used in Wireless Diagrams
 - Practical Hints and Tips
 - Matching Output Valve and Loud Speaker
 - Morse Code
- Also in addition the usual Diary Pages.

**The
Wireless
World**

DIARY for 1932

Price 1'6

Obtainable from the
Publishers, post free 1/7.
Or from Bookstalls and
Stationers.

**LILIFFE & SONS
LIMITED,
DORSET HOUSE,
TUDOR STREET,
LONDON, E.C.4.**

CELESTION

The Very Soul of Music
LOUD-SPEAKERS

**CELESTION LTD.,
LONDON ROAD,
KINGSTON - ON -
THAMES**

London Showrooms:
106, Victoria Street,
London, S.W.1.

(London)

NATIONAL PROGRAMMES

(Northern)

1,148 kc/s (261.3 m.)
(68 kW.)

(Davertry) 193 kc/s (1,554.4 m.) (35 kW.)

995 kc/s (301.5 m.)
(70 kW.)

SUNDAY (DEC. 20th)

8.0 p.m.—Church Cantata, No. 110 (Bach). Unser Mund sei voll Lachens (Then was our Mouth filled with Laughter). Singers: Freda Townson (Contralto), Walter Glynn (Tenor), Frank Phillips (Bass). The Wireless Chorus. Players: John Field (Oboe d'Amore), Herbert Dawson (Organ). The B.B.C. Bach Orchestra (Trumpets, Oboes, Bassoon, Flutes, Timpani and Strings) conducted by Stanford Robinson.

3.45—Bible Reading.

4.0—Missionary Talk. The Rev. W. B. Gill, of the Church Missionary Society Uganda Mission: "Christmas on the Equator."

4.15 p.m.—The Wireless Military Band. Conductor, B. Walton O'Donnell. Dorothy Bennett (Soprano).

5.30 p.m.—A Recital by Stuart Robertson (Bass-Baritone).

6.0—6.20 p.m.—For the Children. A Christmas Message to the Children.

7.55 p.m.—A Religious Service. Relayed from Cransley Church, Kettering.

8.45 p.m.—The Week's Good Cause. Appeal on behalf of The Elderly Nurses' Fund, inaugurated by the *Nursing Mirror* in 1925, by Mr. Sydney Walton, C.B.E.

8.50 p.m.—"The News." Weather Forecast, General News Bulletin; Shipping Forecast.

9.5 p.m.—Tom Jones and The Grand Hotel, Eastbourne, Orchestra. John Morel (Baritone).

10.30 p.m.—Epilogue.

MONDAY (21st)

10.0 a.m.—King's College Commemoration Service. Relayed from St. Clement Danes.

10.45—11.0 a.m.—Mr. V. C. Clinton Baddeley. Pickwick Readings—I.

12 noon.—A Light Classical Concert. Fedora Roselli (Mezzo-Soprano), The Bronkhurst Trio.

1.0 p.m.—The Commodore Grand Orchestra, directed by Joseph Muscant.

2.0—2.30 p.m.—Gramophone Records.

4.0 p.m.—Moschetto and his Orchestra, from The Dorchester Hotel.

5.15 p.m.—The Children's Hour.

6.0 p.m.—"The First News."

6.30 p.m.—The Foundations of Music. Music for Two Pianofortes, played by Carl Weber and Maud Dixon.

6.50 p.m.—"New Books." Mr. Desmond MacCarthy.

7.10—7.25 p.m.—Mr. Ralph Dunstan, Mus. Doc.: "Typical Cornish Curls," with Illustrations by a select Choir from Mutley Wesleyan Church, Plymouth.

7.30 p.m.—An Organ Recital by Guy Weitz.

(London)

REGIONAL PROGRAMMES

(Northern)

842 kc/s (356.3 m.)
(70 kW.)

(Midland) 752 kc/s (398.9 m.) (38 kW.)

626 kc/s (479.2 m.)
(70 kW.)

SUNDAY (DEC. 20th)

3.0 p.m. (London).—The B.B.C. Theatre Orchestra. Conductor, Leslie Woodgate. Trefor Jones (Tenor).

3.0 p.m. (Midland).—Chamber Music. The Alex. Cohen Quartet: Alex. Cohen (1st Violin), Rowland Sirrell (2nd Violin), Lena Wood (Viola), Haydn York (Violoncello).

3.0 p.m. (Northern).—The Studio Orchestra, directed by John Bridge. Fred Tilsley (Oboe).

4.0 p.m. (Northern).—A Chamber Concert. The Yorkshire Trio: Reginald Stead (Violin), Ronald Townend (Violoncello), Henry A. Leah (Pianoforte). Rispah Goodacre (Contralto).

4.15 p.m. (London).—A Violoncello and Harpsichord Recital by Sheridan Russell and Jean Hamilton.

4.15 p.m. (Midland).—The Studio Orchestra.

5.0—5.30 p.m.—"The Modern Dilemma"—XII. The Rev. Nathaniel Micklem.

7.50 p.m. (Midland).—A Religious Service. Conducted by the Rev.

Canon Guy Rogers, M.A., M.C. From St. Martin's Parish Church, Birmingham.

7.50 p.m. (Northern).—The Northern Studio Orchestra, directed by John Bridge. Pastoral Symphony. (Messiah) (Handel), followed by a Studio Service.

8.0 p.m. (London).—A Religious Service. (From the Studio.) Conducted by the Rev. F. W. Chudleigh.

8.45 p.m.—Davertry National Programme.

8.50 p.m.—"The News," Weather Forecast, General News Bulletin; Regional News.

9.5 p.m.—Sunday Orchestral Concerts—X. Percy Heming (Baritone). The B.B.C. Studio Symphony Orchestra (Leader, Arthur Catterall), conducted by John Barbirolli. Orchestra: Concerto Grosso for Strings, Op. 6, No. 7 (Handel). Percy Heming and Orchestra: Two Arias (Figaro) (Mozart). Orchestra: In a Summer Garden (Delius); Symphony, No. 2, in D (Brahms).

10.30 p.m.—Epilogue.

MONDAY (21st)

10.0—11.0 a.m. (London and Northern).—Davertry National Programme.

11.30 a.m.—12 noon (London).—Experimental Television Transmission by the Baird Process (356.3 m. Vision; 261.3 m. Sound).

12 noon.—The Regal Orchestra, conducted by Ernest Parsons.

1.0 p.m.—Reginald Dixon at the Organ.

1.45—3.0 p.m.—Jack Martin and his Hotel Majestic Orchestra.

4.0 p.m. (London and Northern).—Davertry National Programme.

5.15 p.m.—"The Children's Hour."

6.0 p.m.—"The First News."

6.30 p.m. (London).—The B.B.C. Theatre Orchestra, conducted by Stanford Robinson. Raie da Costa (Pianoforte).

6.30 p.m. (Midland).—Pattison's Salon Orchestra, under the direction of Norris Stanley.

6.30 p.m. (Northern).—The Studio Orchestra, directed by John Bridge. Florence Fielden (Contralto).

7.30 p.m. (Midland).—The Birmingham Military Band, conducted by

W. A. Clarke. Charles Dean (Baritone). Mason and Armes (Entertainers with a Piano).

7.40 p.m. (Northern).—Mr. G. J. M. Fitzjohn: "Historic Houses of the North"—Cumberland and Westmorland.

7.45 p.m. (London).—The B.B.C. Light Orchestra. Conductor, Adrian Boult. Ursula Greville (Soprano).

8.0 p.m. (Northern).—The Merseyside Military Band, conducted by Gordon Stuteley. Harry Howson (Tenor).

9.0 p.m.—Vaudeville. Bransby Williams in "Scrooge," from "A Christmas Carol," by Charles Dickens. The Savoy Hotel Orpheans. Alexander and Mose, "Dark Subjects." Jeanne de Casalis and Partner in another "Mrs. Feather" Episode. Stainless Stephen's Pantomime. The Revue Chorus will sing Pantomime Choruses during the programme. Orchestra under the direction of S. Kneale Kelley.

10.15 p.m.—"The Second News."

10.35 p.m.—12 midnight (London and Northern).—Dance Music.

10.35—11.0 p.m. (Midland).—As London.

TUESDAY (22nd)

10.15 a.m. (London and Northern).—The Daily Service.

10.30—11.5 a.m.—(London and Northern).—Davertry National Programme.

11.30 a.m.—12 noon (London).—Experimental Television Transmission by the Baird Process (356.3 m. Vision; 261.3 m. Sound).

12 noon.—A Ballad Concert.

1.15 p.m. (London and Midland).—A Recital of Gramophone Records by Christopher Stone.

1.15 p.m. (Northern).—The Manchester Tuesday Middy Society's Concert. Christmas Carols, sung by the Manchester Cathedral Choir, conducted by Dr. A. W. Wilson.

2.0—3.0 p.m. (Midland and London).—The Midland Studio Orchestra.

2.0—3.0 p.m. (Northern).—Davertry National Programme.

4.0 p.m. (London).—Davertry National Programme.

4.0 p.m. (Northern).—Evensong from York Minster, York.

8.0 p.m.—"Bethlehem." A Nativity Play in Three Scenes by Bernard Walke. Relayed from the Parish Church of St. Hilary, Cornwall.

9.0 p.m.—"The Second News."

9.15 p.m.—Shipping Forecast; New York Stock Market Report.

9.20 p.m.—"War or Peace?"—VII. The Viscount Cecil of Chelwood: "The World and the League."

9.35 p.m.—Chamber Music. Herbert Heyner (Baritone). The Brosa String Quartet (Brosa—Pougnnet—Wise—Pini): Quartet in C Sharp Minor (Op. 131) (Beethoven). Herbert Heyner: A Recital of Christmas Songs. Quartet: Quartet (Prokofiev).

11.0 p.m.—12 midnight.—Dance Music. Roy Fox's Band, from Monseigneur.

TUESDAY (22nd)

10.15 a.m.—The Daily Service.

10.45 a.m.—Mr. V. C. Clinton Baddeley: Pickwick Readings—II.

11.0—11.5 a.m.—Housewives' News.

12 noon.—Edward O'Henry, at the Organ.

1.0 p.m.—Leonardo Kemp and his Piccadilly Hotel Orchestra.

1.55 p.m.—Experimental Transmission for the Radio Research Board by the Fultograph Process.

2.5—2.30 p.m.—Gramophone Records.

4.0 p.m.—A Sonata Recital. Sybil Eaton (Violin); Reginald Paul (Pianoforte).

4.30 p.m.—The Trocadero Cinema Orchestra, directed by Alfred Van Dam.

5.15 p.m.—The Children's Hour.

6.0 p.m.—"The First News."

6.30 p.m.—The Foundations of Music. Music for Two Pianofortes, played by Carl Weber and Maud Dixon.

6.50 p.m.—Mr. Roger Fry: "Characteristics of French Art."

7.20 p.m.—Gramophone Records.

7.45 p.m.—"Holly Ho! The Holly," or "Christmas as we Imagine it." Leaves from a Winter Album. Arranged by M. H. Allen and C. Denis Freeman.

8.45 p.m.—Reminiscences of Piano Humour. Devised and Illustrated by Tom Clare.

9.0 p.m.—"The Second News."

9.15 p.m.—Shipping Forecast; New York Stock Market Report.

9.20 p.m.—An Orchestral Concert. In Fairyland. The B.B.C. Orchestra, conducted by Joseph Lewis.

10.15 p.m.—Mosaic—VIII.

10.30 p.m.—12 midnight.—Dance Music. Ambrose's Blue Lyles, from the Dorchester Hotel.

WEDNESDAY (23rd)

10.15 a.m.—The Daily Service.

10.45—11.0 a.m.—Mr. V. C. Clinton Baddeley. Pickwick Readings—III.

12 noon.—Quentin Maclean at the Organ.

12.45 p.m.—Gramophone Records.

1.30—2.15 p.m.—The Northern Studio Orchestra, directed by John Bridge.

3.30 p.m.—The Bournemouth Municipal Orchestra. Conductor, Sir Dan Godfrey. Sonia Moldawsky (Violin). Sonia Moldawsky and Orchestra: Symphonie Espagnole (Lalo). Orchestra: Symphony, No. 9, in D Minor (Beethoven) (omitting the Choral Movement).

4.45 p.m.—Regional New at the Organ.

5.15 p.m.—The Children's Hour.

6.0 p.m.—"The First News."

6.30 p.m.—The Foundations of Music. Music for Two Pianofortes, played by Carl Weber and Maud Dixon.

6.50 p.m.—"New Novels." Mr. Michael Sadleir.

7.10—7.25 p.m.—Talk on Farming. Sir Daniel Hall, K.C.B., F.R.S.

TIME SIGNALS (Greenwich)

Sunday: 10.30 a.m., 3.0 p.m., 9.0 p.m.

Weekdays: 10.30 a.m. 1.0 p.m., 4.45 p.m., 6.30 p.m., 9.0 p.m., 11.30 p.m.

DANCE MUSIC

5.15—6.0 p.m., each weekday from London and Northern National transmitters.

Chief Scientific Adviser, Ministry of Agriculture.

7.30 p.m.—Talk.

8.0 p.m.—Sydney Baynes and his Orchestra.

9.0 p.m.—"The Second News."

9.15 p.m.—Shipping Forecast; New York Stock Market Report.

9.20 p.m.—"Idle Thoughts." Mr. E. L. Grant Watson.

9.35 p.m.—Massenet's "Cinderella." A Fairy Tale in Four Acts and Six Tableaux. Poem by Henri Cain (after the Tale of Perrault). English Translation by Henry Grafton Chapman. Acts I and II. Conducted by Percy Pitt. (Acts III and IV will be broadcast on the Regional wavelength on Christmas Day from 9.0—10.15 p.m.)

10.45 p.m.—12 midnight.—Dance Music. Jack Harris's Band from Grosvenor House, Park Lane.

THURSDAY (24th)

10.15 a.m.—The Daily Service.

10.45—11.0 a.m.—Miss Rhoda Power: "Christmas."

12 noon.—An Organ Recital by Walter Vale.

2.0—2.30 p.m.—A Recital by David Evans (Baritone), Paul Belinfante (Violin).

3.30 p.m.—A Festival of Nine Lessons and Carols, from King's College Chapel, Cambridge.

4.45 p.m.—Marius B. Winter and his Dance Orchestra.

5.15 p.m.—The Children's Hour.

6.0 p.m.—"The First News."

6.30 p.m.—The Foundations of Music. Music for Two Pianofortes. Played by Carl Weber and Maud Dixon.

6.50 p.m.—Mr. R. H. Wilenski: "French Painting and the Painters' Lives."

7.20 p.m.—The Weekly Bulletin of Special Notices. Notices of Service Reunions. General Notices connected with Government and other Public Services.

7.30 p.m.—"Songs from the Shows"—No. IV.

8.30 p.m.—Carol Service by Members of the Wireless Choir and the Wireless Military Band, conducted by Stanford Robinson.

9.0 p.m.—"The Second News."

9.15 p.m.—Shipping Forecast; New York Stock Market Report.

9.20 p.m.—The Way of the World. Mr. Vernon Bartlett.

9.35 p.m.—The Wireless Military Band. Conductor, B. Walton O'Donnell. Parry Jones (Tenor).

10.30 p.m.—Short Mid-Week Service, conducted by the Rev. W. H. Elliott. Relayed from St. Michael's Chester Square.

10.45 p.m.—12 midnight.—Dance Music. Ambrose and his Orchestra, from The May Fair Hotel.

12 midnight—12.5 a.m. (Friday).—Experimental Transmission for the Radio Research Board by the Fultograph Process.

FRIDAY (25th)

10.30—11.15 a.m.—A Christmas Service from York Minster.

12 noon.—Frank Newman at the Organ of Lozells Picture House, Birmingham.

1.0 p.m.—The Trocadero Cinema Orchestra, directed by Alfred Van Dam.

2.0 p.m.—The Regal Orchestra, conducted by Ernest Parsons.

3.0 p.m.—Reginald Foort at the Organ.

4.0 p.m.—Moschetto and his Orchestra, from the Dorchester Hotel.

5.15 p.m.—The Children's Hour.

5.50 p.m.—Birthdays.

6.0 p.m.—General Sports Bulletin.

6.10 p.m.—Interval.

6.15 p.m.—Gramophone Records.

6.30 p.m.—A Service from the Studio, conducted by the Rev. Canon C. S. Woodward, M.C.

7.30 p.m.—Ernest Longstaffe presents the Popular Oriental Pantomime "Aladdin."

9.0 p.m.—Weather Forecast, followed by Shipping Forecast. (If any news of importance is received during

the day, it will be broadcast at 9.0 p.m.)

9.5 p.m.—Appeal on behalf of the British Wireless for the Blind Fund by the Right Hon. the Viscount Snowden of Ickornshaw.

9.20 p.m.—Christmas Songs by John Coates: Welcome Yule (Fifteenth Century Carol—Air from Deuteromelia, 1609); Cristemas (Gerrard Williams); The Monkey's Carol (Stanford); The Oxen (Edward Dent); Voici Noël (Christmas is here) (Weckerlin); Ships of Yule (Martin Shaw); Mistletoe (Armstrong Gibbs); New Year's Waving Song (Mallinson); A Carol for the New Year (Greensleeves, 1580) (arr. J. F. Bridge).

9.45 p.m.—Half the World Away. An Experiment with Time and Christmas.

10.30 p.m.—Dance Music. The Savoy Hotel Orpheans, from The Savoy Hotel.

12 midnight—1.0 a.m. (Saturday).—Jack Payne and his B.B.C. Dance Orchestra.

SATURDAY (26th)

10.15 a.m.—The Daily Service.

10.45—11.0 a.m.—Mr. Gillie Potter: "Christmas at Hogsorton."

1.0—2.0 p.m.—The Commodore Grand Orchestra, directed by Joseph Muscant.

3.45 p.m.—The Wireless Military Band. Conductor, B. Walton O'Donnell. Archibald Winter (Tenor).

4.45 p.m.—Reginald Foort at the Organ.

5.15 p.m.—The Children's Hour.

6.0 p.m.—"The First News."

6.25 p.m.—Interval.

6.30 p.m.—The Foundations of Music. Music for Two Pianofortes, played by Carl Weber and Maud Dixon.

6.50—7.5 p.m.—"The Week in the Garden."

7.10 p.m.—"Healthy, Wealthy and Wise"—IX. Conclusion.

7.30 p.m.—Vaudeville. Cicely Courtneidge. Ernest Butcher. Mr. Flotsam and Mr. Jetsam. Tommy Handley. Elsie and Doris Waters. Clapham and Dwyer. With Remarks from The Buggins Family. Jack Payne and his B.B.C. Dance Orchestra will play during the programme.

9.0 p.m.—"The Second News."

9.15 p.m.—Shipping Forecast; New York Stock Market Report.

9.20 p.m.—A Pianoforte Recital by Cecil Dixon.

9.45 p.m.—"The Clock." A Fantasy on a familiar Sound.

10.15 p.m.—12 midnight.—Dance Music. Ambrose and his Orchestra, from The May Fair Hotel.

Regional Programmes—(Cont.)

5.15 p.m.—The Children's Hour.
 5.0 p.m.—"The First News" and Bulletin for Farmers.
 6.35 p.m. (Northern and London).—Reginald Dixon at the Organ.
 6.35 p.m. (Midland).—The Studio Chorus.
 7.0 p.m. (London).—The Pall Mall Players. Gwladys Naish (Soprano).
 7.0 p.m. (Midland).—Organ Recital by Dr. Harold Rhodes.
 7.0 p.m. (Northern).—The Studio Orchestra.
 7.45 p.m. (Midland).—The Regal Orchestra, conducted by Ernest Parsons.
 8.15 p.m. (Northern and London).—A Discussion between Mr. L. du Garde Peach and Mr. Gerald Barry: "Northern and Southern Manners."
 8.45 p.m. (Midland).—A Violin Recital by Harold Mills.
 9.0 p.m. (London).—Band of H.M. Grenadier Guards. Director of Music, Captain G. Miller. Foster Richardson (Bass). Band: Marche, Pompeuse (Becker, arr. Winterbottom); Overture, Prince Igor (Borodin, arr. Hibbert). Foster Richardson: Is my Team ploughing? (Butterworth); Dear Jane (Butler). Band: Suite, Op. 39 (Dvorak, arr. Barker). Foster Richardson: She is Far from the Land (Lambert); Far across the Desert Sands (Woodforde-Finden). Band: You are my Heart's Delight (Lehar). Two Kentish Idylls: Morning Pastorale, and A Song in a Bowery (Graham Gill, arr. Hind). Foster Richardson: If thou wert blind (Johnson); Sons of the Sea (Coleridge-Taylor). Band: Fantasy on Seventeenth-Century Music (arr. Miller).
 9.0 p.m. (Northern).—"Northern Notions"—A Revue. Book by Henrik Ege, Richard Fisher, Clifford Grey, Edwin Lewis, and H. C. G. Stevens. Music by well-known Composers. Produced by Victor Smythe.
 9.20 p.m. (Midland).—The Studio Orchestra and "Delicate Ground." A Comic Drama, by Charles Dance. Presented by the Birmingham Repertory Theatre Co., in conjunction with Sir Barry Jackson.

10.15 p.m.—"The Second News."
 10.35 p.m.—12 midnight (London and Northern).—Dance Music.
 10.35—11.0 p.m. (Midland).—As London.
WEDNESDAY (23rd)
 10.15 a.m. (London and Northern).—The Daily Service.
 10.30—11.0 a.m. (London and Northern).—Daventry National Programme.
 11.30 a.m.—12 noon (London).—Experimental Television Transmission by the Baird Process (356.3 m. Vision; 261.3 m. Sound).
 12 noon.—The Northern Studio Orchestra, directed by John Bridge. Zelda Bock (Pianoforte).
 1.15 p.m. (Midland and London).—Organ Recital by S. D. Cunninghamham.
 1.15 p.m. (Northern).—A Cello Recital by Harold Warburton.
 1.30 p.m. (Northern).—The Bradford Midday Concert. A Carol Concert given by Members of the Bradford Festival Choral Society, directed by G. W. Douglas.
 2.15—3.0 p.m.—Gramophone Records.
 3.30 p.m. (London and Northern).—Daventry National Programme.
 5.15 p.m.—The Children's Hour.
 6.0 p.m.—"The First News."
 6.30 p.m. (London).—The Leslie Bridgewater Quintet. Winifred Bury (Soprano).
 6.30 p.m. (Midland).—The Studio Orchestra. Leslie Bennett (Baritone).
 6.30 p.m. (Northern).—Relays from The Paramount Theatre, Manchester; The Palace Theatre, Manchester; and the Argyle Theatre, Birkenhead.
 8.0 p.m. (London).—Miss Helen Clarke: "An English Woman in Russia during the War and the Revolution."
 8.0 p.m. (Midland).—The Cathedral Choristers' Carol Concert, from The Chapter House of Gloucester Cathedral.
 8.0 p.m. (Northern).—Mr. W. Haworth: "The Northern Householder's Budget."
 8.20 p.m. (Northern).—The Studio

Orchestra. The City of Bradford Co-operative Choir, conducted by J. W. Horsfall.
 8.30 p.m. (London).—The B.B.C. Light Orchestra, conducted by Victor Hely-Hutchinson. Owen Bryngwyn (Baritone).
 9.0 p.m. (Midland).—Vaudeville.
 9.45 p.m. (Northern and London).—A Violin Recital by Henry Holst.
 10.15 p.m.—"The Second News."
 10.35 p.m.—12 midnight (London and Northern).—Dance Music.
 10.35 p.m. (Midland).—Experimental Transmission for the Radio Research Board by the Fultograph Process.
 10.40—11.0 p.m. (Midland).—As London.

THURSDAY (24th)

10.15 a.m. (London and Northern).—The Daily Service.
 10.30—11.0 a.m. (London and Northern).—Daventry National Programme.
 11.30 a.m.—12 noon (London).—Experimental Television Transmission by the Baird Process (356.3 m. Vision; 261.3 m. Sound).
 12 noon.—The Shepherd's Bush Pavilion Orchestra, conducted by Harry Fryer.
 1.15 p.m. (London and Northern).—Dorothy Kitchen (Mezzo-Soprano). Ernest Lush (Pianoforte).
 1.15 p.m. (Midland).—A Carol Service from St. Martin's Parish Church, Birmingham.
 2.0—3.0 p.m.—Laddie Clarke's Imperial Hydro Hotel Orchestra.
 3.0 p.m. (Northern).—The Studio Orchestra.
 3.30 p.m. (London and Northern).—Daventry National Programme.
 5.15 p.m.—The Children's Hour.
 6.0 p.m.—"The First News."
 6.30 p.m. (London and Northern).—The Doveholes Public Band, conducted by J. Fletcher. Fred Sugden (Baritone).
 6.30 p.m. (Midland).—Bulletin for Midland Farmers.
 6.35 p.m. (Midland).—The City of Birmingham Orchestra (Leader, Paul Beard), conducted by Leslie Heward. Eda Kersey (Violin). Emily Broughton (Soprano).
 7.30 p.m. (London).—Music for the Theatre. Henry Ainley. The

B.B.C. Light Orchestra, conducted by Norman O'Neill.
 7.30 p.m. (Northern).—Carols, sung by the Choir of St. Asaph Cathedral, relayed from the Cathedral, St. Asaph. Conductor, Dr. H. C. L. Stocks.
 8.0 p.m. (Northern).—The Studio Orchestra.
 8.30 p.m. (Midland).—Dance Music.
 9.0 p.m. (London).—Chamber Music: Robert Maitland (Baritone). The International String Quartet: André Mangeot (Violin); Walter Price (Violin); Eric Bray (Viola); Jack Shinebourne (Violoncello).
 9.0 p.m. (Northern).—"The World of Sam Shorrocks," a Radio Play by Edwin Lewis.
 9.30 p.m. (Midland).—A Carol Concert from The Church of The Messiah, Birmingham.
 10.15 p.m.—"The Second News."
 10.35 p.m.—12 midnight (London and Northern).—Dance Music.
 10.35—11.0 p.m. (Midland).—As London.

FRIDAY (25th)

10.15—11.15 a.m.—Daventry National Programme.
 10.15 a.m. (Midland).—A Seasonable Greeting to Midland Hospital Patients by the Rt. Rev. the Lord Bishop of Birmingham (Dr. E. W. Barnes).
 12 noon.—Daventry National Programme.
 5.15 p.m.—The Children's Hour.
 5.50 p.m.—Birthdays.
 6.0 p.m.—First General News Bulletin.
 6.10 p.m.—Regional Sports Bulletin.
 6.15 p.m.—Daventry National Programme.
 7.15 p.m.—Reginald King and his Orchestra. Kate Winter (Soprano).
 8.30 p.m.—A Violin Recital by Albert Sammons.
 9.0 p.m.—Massenet's "Cinderella," a Fairy Tale in four Acts and six Tableaux. Poem by Henri Cain, after the Tale of Perrault (English Translation by Henry Grafton Chapman). Acts III and IV. The Wireless Chorus. The B.B.C. Studio Symphony Orchestra, conducted by Percy Pitt.
 10.15 p.m.—Gramophone Records of

Dance Music, preceded by News, if any.
 10.45 p.m.—Dance Music. The Savoy Hotel Orpheans, from the Savoy Hotel.
 10.45—11.0 p.m. (Midland).—As London.
 12 midnight—1.0 a.m. (Saturday).—Jack Payne and his B.B.C. Dance Orchestra.

SATURDAY (26th)

10.15 a.m. (London and Northern).—The Daily Service.
 10.30—11.0 a.m. (London and Northern).—Daventry National Programme.
 1.0—2.0 p.m. (London and Northern).—Daventry National Programme.
 2.0—3.45 p.m. (London).—Daventry National Programme.
 2.0—3.45 p.m. (Northern).—The Studio Orchestra. John Baron (Baritone).
 3.30 p.m. (Midland).—Dance Music.
 3.45 p.m. (London and Northern).—Daventry National Programme.
 4.45 p.m. (Midland).—Reginald New at the Organ.
 5.15 p.m.—The Children's Hour.
 6.0 p.m.—"The First News."
 6.30 p.m.—Ernest Longstaffe presents the Popular Oriental Pantomime, "Aladdin." Written, produced, conducted, orchestrated and, with the exception of certain interpolated numbers, composed by Ernest Longstaffe.
 8.0 p.m. (London).—The Gershom Parkington Quintet.
 8.0 p.m. (Midland).—Dance Music.
 8.0 p.m. (Northern).—A Concert. Laddie Clarke's Imperial Hotel Orchestra.
 9.0 p.m.—An Orchestral Concert. "Memories." Mary Hamlin (Soprano). Doris Owens (Contralto). Bradbridge White (Tenor). Stanley Riley (Bass). The Wireless Chorus. The B.B.C. Light Orchestra, conducted by Joseph Lewis.
 10.15 p.m.—"The Second News."
 10.35 p.m.—12 midnight.—(London and Northern).—Dance Music.
 10.35—10.40 p.m. (Midland).—Experimental Transmission for the Radio Research Board by the Fultograph Process.
 10.40—11.0 p.m.—(Midland).—As London.

ONLY THE BEST WILL DO

An H. F. Choke must have: HIGH INDUCTANCE, LOW D. C. RESISTANCE, LOW SELF-CAPACITY. The last Factor is most important; look for the data and buy the best. We know that you will "BUY BULGIN AND BRITISH."

STANDARD H.F. CHOKE (illustrated above) D. C. Resistance 300 ohms. Inductance 85,000 m/h. Self Capacity 3 mmf. 4/6 EACH	S.G. H.F. CHOKE (bottom left) D. C. Resistance 500 ohms. Inductance 200,000 m/h. Self Cap. 3 mmf. 5/6 Aluminium Screens for above, 2/-.	MAINS H.F. CHOKE (bottom right) Inductance 40,000 m/h. D.C. Resistance 120 ohms. Carries 100 m/a. 7/6 EACH
---	---	--

Send 2d. postage for 75 pp. Catalogue and Manual.

A. F. BULGIN & CO., LTD., Abbey Works, Abbey Road, Barking, Essex

Telephones: Grange Wood 3266 & 3267

London Showrooms: 9, 10, 11, Cursitor Street, Chancery Lane, E.C.4. Telephone: Holborn 2072.

A NECESSITY— NOT A LUXURY!

You owe it to yourself, your family and friends to see they are provided with better results from your Speaker. This can easily be assured by fixing your Speaker into the Camco Melodee Cabinet—which is obtainable in Oak, Mahogany and Walnut—from 22/-.
A "SOUND" INVESTMENT for a small outlay.

CARRINGTON MFG. CO., LTD.
 Showrooms: 24, Hatton Garden, London, E.C.1.
 Phone: HOL 8202.
 Works: S. Croydon.

PLEASE SEND ME YOUR CATALOGUE.

Name

Address

W.P.25.

PROGRAMMES FOR SUNDAY (December 20)

The Frequencies and Wavelengths given in the following programmes are those published by the stations in question. For more accurate measurements, readers are referred to our Table of Frequencies and Wavelengths.

NOTE: THE HOURS OF TRANSMISSION ARE REDUCED TO GREENWICH MEAN TIME

BARCELONA (Spain)

Radio-Barcelona (EAJI). 860 kc/s (349 m.); 8 kW.
7.30-8.30 a.m.—Topical Review.
11.0 a.m.—Chimes and Weather.
1.0 p.m.—Light Music on Gramophone Records.
1.30 p.m.—Sextet Concert.
2.0 p.m.—Theatre Notes, Gramophone Records and Film Review.
2.20 p.m.—Sextet Concert (continued).
2.50 p.m.—Labour Market Report.
3.0 p.m.—Programme for Hospitals and Benevolent Institutions, with Gramophone Records.
4.0-5.30 p.m.—Interval.
5.30 p.m.—Agricultural Report in Catalan, followed by Part Relay of an Opera, from the Gran Teatro del Liceo.
9.0 p.m. (approx.).—Close Down.

BERLIN (Germany)

Königs Wusterhausen. 183.5 kc/s (1,635 m.); 75 kW.
Transmits at intervals from 5.45 a.m. (Witzleben Relay)
10.30 a.m.—See Berlin (Witzleben)
1.0 p.m.—Reading from his own Works by Gustav Kohnke.
1.25 p.m.—Talk: The meaning of Distress.
1.50 p.m.—See Berlin (Witzleben).
3.30 p.m.—Dialogue: The Children's Theatre on the Wireless and the Stage.
4.0 p.m.—See Breslau.
5.15 p.m.—Talk: The War Destiny of an East Prussian Girl.
5.35 p.m.—Talk: Trade in the Crisis.
6.5 p.m.—See Langenberg.
6.30 p.m.—See Berlin (Witzleben).
8.0 p.m.—News Bulletin.

8.10 p.m.—Concert from Hamburg.
9.10 p.m.—News Bulletin.
9.30 p.m.—Concert from Langenberg.
11.0 p.m. (approx.).—Close Down.

BERLIN (Germany)

Witzleben. 715 kc/s (418 m.); 1.7 kW.
Transmits at intervals from 5.45 a.m. (Gymnastics).
10.30 a.m.—See Leipzig.
11.10 a.m.—Orchestral Concert, conducted by Bruno Seidler-Winkler, relayed from the Kroll-Oper
1.0 p.m.—Programme for Children.
1.50 p.m.—Concert of Light Music.
3.30 p.m.—Christmas Stories.
4.0 p.m.—Orchestral Concert, conducted by Eugen Sonntag.
6.0 p.m.—Talk: The Intellectual Needs of the Age.
6.25 p.m.—Sports Notes.
6.30 p.m.—"A Nativity Play"—relayed from the Kreuzkirche, Schmargendorf.
7.55 p.m.—See Leipzig.
9.55 p.m.—News, followed by Dance Music.
11.30 p.m. (approx.).—Close Down.

BORDEAUX-LAFAYETTE (France)

(PTT). 986 kc/s (304 m.); 35 kW.
12 noon.—Concert relayed from Paris (Ecole Supérieure), 671 kc/s (447.1 m.).
2.0 p.m.—Relay from Paris or Relay of a Local Festival.
4.30 p.m.—Pasdeloup Symphony Concert relayed from the Théâtre des Champs Elysées, Paris.
6.20 p.m.—Sports Notes.
6.30 p.m.—Radio Journal.
8.0 p.m.—Boxing Report.
8.10 p.m.—Results of the Prize Draw.
8.15 p.m.—Gramophone Records.
8.30 p.m.—Comedy Programme, followed by Amusement Guide and Time Signal.

BRESLAU (Germany)

923 kc/s (325 m.); 1.7 kW. Relayed by Gleiwitz, 1,184 kc/s (253 m.).
Transmits at intervals from 6.0 a.m. 10.30 a.m.—See Leipzig.
11.10 a.m.—Concert by the Silesian Philharmonic Orchestra.
1.0 p.m.—Mid-day Report.
1.10 p.m.—The Rhymed Unrhymed, by Traugott Conrad.
1.25 p.m.—Agricultural Talk.
1.40 p.m.—Talk: How to make a Gingerbread House.
1.55 p.m.—Reading: Breslau Industries 130 Years Ago.
2.15 p.m.—Talk: Christmas on the High Seas.
2.40 p.m.—Cabaret of Unemployed Artists.
4.0 p.m.—Wind Instrument Concert.
6.0 p.m.—Weather and Dialogue: Christmas Presents.
6.25 p.m.—Weather; Sports Notes.
6.35 p.m.—Soprano Recital of Christmas Carols. In the interval, Silesian Winter Relief Talk.
7.30 p.m.—Variety Programme.
9.10 p.m.—Time and News.
9.40 p.m.—Legal Letter Box.
10.0 p.m. (approx.).—Dance Music from Berlin (Witzleben).
11.30 p.m. (approx.).—Close Down.

BRUSSELS (Belgium) (No. 1)

I.N.R. 590 kc/s (509 m.); 20 kW.
12.15-1.45 p.m.—Gramophone Records.
5.0 p.m.—Orchestral Concert.
6.0 p.m.—Gramophone Records.
7.15 p.m.—Religious Talk.
7.30 p.m.—Le Journal Parlé.
8.0 p.m.—Orchestral Concert. Soloist: Mme. Floriaval (Vocalist). Marche aux Flambeaux (Meyerbeer). Wedding Cake, for Pianoforte and Orchestra (Saint-Saëns). Two Songs (Mozart). Ballet Music from "Cydalise et le chèvre-pied" (Pierné). Military March (Schubert). Selection from "Faust" (Gounod). Orientale (Cui). Hindu Song (Rimsky-Korsakoff). Selection from "Manon Lescaut" (Auber). Dances from "Prince Igor" (Borodin). In the intervals at 8.45 p.m.—Reading of Poems dedicated to Christmas, and at 9.30 p.m.—Reading of Christmas Prose.
10.0 p.m.—Le Journal Parlé.

10.0 p.m.—Le Journal Parlé.

BRUSSELS (Belgium) (No. 2)

N.I.R. 887 kc/s (338.2 m.); 20 kW.
Programme in Flemish.
12.15-1.45 p.m.—Gramophone Records.
5.0 p.m.—Orchestral Concert.
6.0 p.m.—Gramophone Records of Ballet Music.
7.15 p.m.—Religious Talk: Eternity.
7.30 p.m.—Music Review.
8.0 p.m.—Programme relayed from the Flemish Royal Opera House, Antwerp. Two Operas: (a) "L'Amico Fritz" (Mascagni), (b) "Jean Marie" (Verbeeck). In the intervals, Reading and Le Journal Parlé.

BUCHAREST (Romania)

Radio-Bucarest. 761 kc/s (394 m.); 16 kW.
Transmits at intervals from 9.15 a.m. 6.0 p.m.—Educational Programme.
6.40 p.m.—Gramophone Records.
7.0 p.m.—"Eva"—Operetta in Three Acts (Lehár). News in the intervals.

BUDAPEST (Hungary)

545 kc/s (550 m.); 23 kW.
8.0 a.m.—Press Review and Beauty Culture.
9.0 a.m.—Reformed Church Service.
10.0 a.m.—Sacred Songs and Music, followed by a Concert by the Royal Hungarian Opera House Orchestra.
1.0 p.m.—Gramophone Concert.
2.0 p.m.—Agricultural Notes.
2.45 p.m.—Choral Selections and Address.
4.0 p.m.—Hungarian Provincial Relay.
5.0 p.m.—Concert by the Royal Hungarian Opera House Orchestra.
6.10 p.m. (approx.).—A Studio Play. News in the interval.
9.30 p.m. (approx.).—Concert and Tzigane Music with Vocal Selections from the Café Ostende.

COLOGNE (Germany)

Westdeutscher Rundfunk. 1,319 kc/s (227 m.); 1.7 kW.
See Langenberg.

COPENHAGEN (Denmark)

1,067 kc/s (281 m.); 0.75 kW. Relayed by Kalundborg, 260 kc/s (1,153 m.).
Transmits at intervals from 7.30 a.m. (Gymnastics).
10.30 a.m.—Weather and News.
11.0 a.m.—Town Hall Chimes.
11.2 a.m.—Instrumental Concert.
12 noon.—Talk in English: British Statesmen of Yesterday and Today—The Duke of Wellington.
12.20 p.m.—Talk in German: Christmas.
12.40 p.m.—Reading in French (F. Coppée).
1.0 p.m.—Divine Service from the Garrison Church.
2.30 p.m.—Programme for Children.
3.0-5.0 p.m.—Concert for the benefit of the Children's Bureau, relayed from the Holberg Hall.
3.0 p.m.—Concert by Jacob Gade's Orchestra.
3.40 p.m.—Gramophone Records from the Axelborg Studio.
4.10 p.m.—Concert from the Holberg Hall.
5.20 p.m. (from the Esbjerg Studio).—Talk.
5.50 p.m.—Weather and News.
6.15 p.m.—Time; Sports Notes.
6.30 p.m.—Talk: Radio Technical Experts in Scandinavia.
7.0 p.m.—Town Hall Chimes.
7.2 p.m.—Weber Concert by the Radio Orchestra, conducted by Launy Grøndahl. Overture, "Euryanthe." Rondo from the Concerto for Bassoon and Orchestra in F Major. Overture, "Der Freischütz." Romance and Polonaise from the Concerto for Clarinet and Orchestra in C Major. Overture, "Oberon."
7.45 p.m.—Danish Christmas Programme.
8.30 p.m.—"A Child is born"—Radio Play (Soya).
8.50 p.m.—News Bulletin.

This is the way to Start your Car on a Cold and Frosty morning

FIT THE NEW SELF STARTING SOLEX "F" TYPE CARBURETTOR

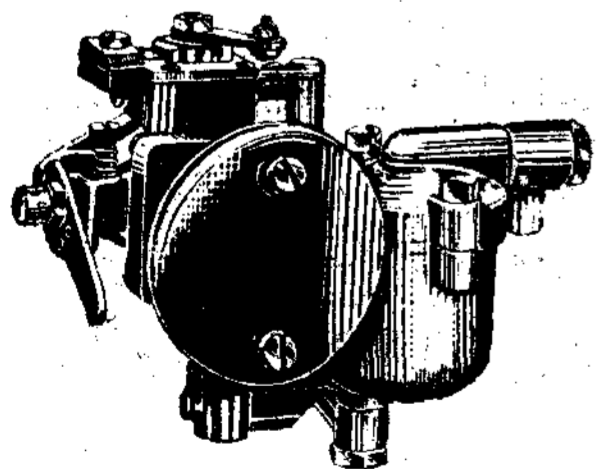

USERS' OPINIONS

(Originals can be seen at our offices.)
"Fitted on 1930 12 h.p. 4-cyl. Austin, starting from cold far better than other carburettors. No spitting back afterwards; can drive car away directly after starting. I am delighted." Starting troubles entirely disappeared. An amazing device. I think you are too modest in your published claims."

It incorporates an automatic and scientifically accurate mixture control which will give you

INSTANT STARTING AND "GET AWAY"

with full power under any weather conditions, and, in addition, better petrol consumption.

NO "STRANGLING"—NO "FLOODING"

NO "JUGGLING" with controls.

Test the new Self-Starting 'Solex' for 30 DAYS FREE. We offer generous allowances for old 'Solex' and other carburettors.

SOLEX LTD.,

SOLEX WORKS, 223-231, MARYLEBONE ROAD, LONDON, N.W.1.

Please send me, post free, your illustrated catalogue and full details of your 30 DAYS' FREE TRIAL OFFER.

Name.....

Address.....

Make of Car..... H.P..... Year..... W.R.I.

Programmes for Sunday—(Cont.)

9.0 p.m.—Concert of Danish Romantic Ballet Music.
9.45 p.m.—Dance Music from the Wivex Restaurant.
11.0 p.m. (in an interval).—Town Hall Chimes.
11.30 p.m. (approx.).—Close Down.

DUBLIN (Ireland)

(2RN). 725 kc/s (413 m.); 1.5 kW. Relayed by Cork, 1,337 kc/s (224.4 m.).
8.30 p.m.—Time Signal.
8.32 p.m.—Concert. Tom Collins and his Orchestra. The Orchestra with H. Brindle (Bass), Joan de Ferrars (Soprano), and David Grundy (Tenor).
9.0 p.m.—"Maurice Harte"—Play (T. C. Murray), presented by Gabriel Fallon and Company.
10.0 p.m.—The Orchestra with Vocalists.
11.0 p.m.—Time, News, Weather and Close Down.

FÉCAMP (France)

Radio Normandie. 1,364 kc/s (219.9 m.); 1 kW.
8.0 p.m.—News Bulletin.
8.30 p.m.—Concert relayed from the Theatre at Eu.
10.30 p.m.—2.0 a.m. (Monday).—Concert.
2.0 a.m. (approx.).—Close Down.

FRANKFURT-am-MAIN (Germany)

770 kc/s (390 m.); 1.7 kW. Relayed by Cassel, 1,220 kc/s (246 m.). Transmits at intervals from 6.0 a.m. (Hamburg Relay).
10.30 a.m.—See Leipzig.
11.10 a.m.—See Berlin (Witzleben).
12.50 p.m.—Talks, arranged by the Wiesbaden Board of Agriculture.
1.0 p.m.—Programme for Children.
2.0 p.m.—Rural Programme: (a) Old Christmas Songs by Anne Lönhold (Soprano), (b) "Our Caroline"—a Sketch.
3.0 p.m.—See Stuttgart.
4.30 p.m.—See Langenberg.
5.50 p.m.—"The Twilight Hour."
6.30 p.m.—Sports Notes.
6.45 p.m.—Talk.
7.30 p.m.—"Carmen"—Opera in Four Acts (Bizet). In the interval at 9.0 p.m. (approx.).—Time and News.
10.30 p.m.—Orchestral Concert.
11.0 p.m. (approx.).—Close Down.

HAMBURG (Germany)

Norag (ha, in Morse). 806 kc/s (372 m.); 1.7 kW. Relayed by Bremen, 1,112 kc/s (270 m.); Flensburg, 1,373 kc/s (218 m.); Hanover, 530 kc/s (566 m.); and Kiel, 1,292 kc/s (232.2 m.). Transmits at intervals from 6.0 a.m. (Bremen Harbour Hour).
10.30 a.m.—See Leipzig.
11.15 a.m.—"The Winter Solstice"—Orchestral Concert with Recitations and Address.
12 noon.—Weather Report.
12.5 p.m. (from Kiel).—Midday Concert.
1.20 p.m. (from Kiel).—Zither Concert.
1.50 p.m.—Sing-Song for Children in North-German Dialect.
2.20 p.m.—"Aladdin's Lamp"—Fairy Play (A. Müller).
3.20 p.m.—Song Recital by Frau Marta Adam from the Works of Dr. Emil Mattiesen—the Composer at the Pianoforte.
4.0 p.m.—North German Dialect Programme—Readings and Songs to the Lute.
5.0 p.m.—Animal Talk by Karl Peter: My Mongoose.
5.30 p.m.—Concert by the Lübeck Chamber Music Society. Pianoforte Quartet in C Minor, Op. 15 (Faure). Pianoforte Quintet in F Minor (César Franck).
6.30 p.m.—Talk on North West German Towns and their Sports Grounds—VI, Lübeck.
6.40 p.m.—Sports Notes.
6.55 p.m.—Weather Report.
7.0 p.m.—"The Development of the Military March"—Concert by a Hamburg Police Band, conducted by Schierhorn. In the intervals at 8.0 p.m.—First News and at 9.15 p.m.—Second News.
9.35 p.m.—Topical Talk.
9.45 p.m.—Dance Music from the Café "Haus Siegler."

HEILSBURG (Germany)

1,085 kc/s (276.5 m.); 75 kW. Relayed by Danzig, 662 kc/s (453.2 m.). Transmits at intervals from 5.45 a.m. (Concert).
10.30 a.m.—See Leipzig.
11.0 a.m.—Concert by the Königsberg Opera House Orchestra, conducted by Werner Franz.
1.0 p.m.—Chess Lesson.

1.30 p.m.—Talk for Young People.
2.0 p.m.—Alfred Hein reads from his own Works.
2.30 p.m.—"Der Struwwelpeter"—Musical Picture Book for Children after Hoffmann (Music by Fritz Reuter), followed by Orchestral Concert.
4.30 p.m.—See Langenberg.
5.30 p.m.—Talk: Winter Distress in Christmas Literature.
5.55 p.m.—Review of New Radio Literature.
6.20 p.m.—Sports Notes.
6.30 p.m.—Advent Concert by the Königsberg Opera House Orchestra, conducted by Erich Seidler, with Soloists.
7.30 p.m.—See Frankfurt.
10.30 p.m. (approx.).—News, followed by Dance Music from Berlin (Witzleben).
11.30 p.m. (approx.).—Close Down.

HILVERSUM (Holland)

1,004 kc/s (298.8 m.); 20 kW.
7.55—11.40 a.m.—Programme of the Workers' Radio Society (V.A.R.A.).
7.55 a.m.—Gymnastics.
8.10 a.m.—Esperanto Lesson.
8.35 a.m.—Football Notes.
8.40 a.m.—Horticultural Talk.
9.5 a.m.—Variety Items.
9.10 a.m.—Orchestral Concert.
9.50 a.m.—Recitations.
10.10 a.m.—Recital of Contemporary Music.
10.50 a.m.—Address by M. Zwertbroek.
11.10 a.m.—Contemporary Music (contd.).
11.40 a.m.—4.40 p.m.—Programme of the Algemeene Vereeniging Radio Omroep (A.V.R.O.).
11.40 a.m.—Orchestral Concert, conducted by Nico Treep. Overture, "The Caliph of Bagdad" (Boieldieu). Minuet (Bolzoni). Douce Rencontre (Gabriel-Marie). Valse des brunettes (Ganne). Selection from "Faust" (Gounod). Overture, "Maritana" (Wallace). Waltz Potpourri (Robrecht).
12.40 p.m.—Talk on Films.
1.10 p.m.—Concert (contd.). The Stars and Stripes (Souza). Offenbachiana (Conradi). Berceuse de Jocelyn (Godard). Overture, "The Merry Wives of Windsor" (Nicolai).
1.40 p.m.—Weekly Book Talk.
2.10 p.m.—Gramophone Records.
2.25 p.m.—"Scrooge and Marley"—a Radio Play after "The Christmas Carol" by Charles Dickens.
3.55 p.m.—Gramophone Records and Sports Notes.
4.40—5.40 p.m.—V.A.R.A. Programme for Children.
5.40—7.10 p.m. (approx.).—Programme of the Liberal Protestant Radio Society (V.P.R.O.).
5.40 p.m.—Talk by Dr. Tenhaeff.
6.10 p.m.—Religious Programme.
7.10 p.m. till Close Down.—Programme of the A.V.R.O.
7.10 p.m.—"Hohe Messe" (J. S. Bach) by the Concert Hall Orchestra conducted by Dr. Willem Mengelberg, Choir and Soloists.
10.10 p.m.—Gramophone Records.
10.25 p.m.—Concert by Kovacs Lajos and his Orchestra. Songs by Bob Scholte.
11.40 p.m. (approx.).—Close Down.

HUIZEN (Holland)

160 kc/s (1,875 m.); 8.5 kW.
8.10—9.10 a.m.—Religious Programme by the Catholic Radio Society (K.R.O.).
9.10—11.55 a.m.—Programme of the Christian Radio Society (N.C.R.V.). Divine Service from the Dutch Protestant Church at Vlaardingen, followed by Organ Recital.
11.55 a.m.—4.40 p.m.—K.R.O. Programme.
11.55 a.m.—Sextet Concert.
1.15 p.m.—Talk by M. J. Vriens.
1.40 p.m.—Literary Talk.
2.10 p.m.—Concert by the "Schola Cantorum," conducted by Hubert Cuypers.
4.10 p.m.—Programme for Hospitals.
4.40—7.25 p.m.—N.C.R.V. Programme.
4.40 p.m.—Sacred Music.
5.30 p.m.—Divine Service from the Lutheran Church at Amsterdam, followed by Sacred Music Recital.
7.25 p.m. till Close Down.—K.R.O. Programme.
7.25 p.m.—Talk.
7.50 p.m.—Football Results.
7.55 p.m.—Orchestral Concert. Soloist: M. J. Moes (Tenor). March, Roomsche Blijdschap (Blokker). Overture, "Sakuntala" (Goldmark). Aria for Tenor and Orchestra from "Tannhäuser" (Wagner). Selection from "Königs-kinder" (Humperdinck). Prelude

to "The Cricket on the Hearth" (Goldmark). Tenor and Orchestra: Walter's Prize Song from "The Mastersingers" (Wagner). Tenor Solos: (a) Des Grieux's Aria from "Manon Lescaut" (Puccini), (b) Arioso from "Fedora" (Giordano), (c) Prayer from "Le Cid" (Massenet). Christmas Fantasia (Grit). Selection from "The Messiah" (Händel). Selection from "Rigoletto" (Verdi). Waltz, Gold and Silver (Lehár). Einzug der Rosenkönigin (Rhode). Selection from "Der Rastelbinder" (Lehár). In the interval at 8.40 p.m.—News.
10.20 p.m.—Choral Epilogue.
10.40 p.m. (approx.).—Close Down.

KALUNDBORG (Denmark)

Kalundborg Radio. 260 kc/s (1,153 m.); 7.5 kW. See Copenhagen.

KATOWICE (Poland)

734 kc/s (408 m.); 16 kW. Transmits at intervals from 9.0 a.m.
7.30 p.m.—Popular Concert.
8.55 p.m.—Gramophone Records.
9.10 p.m.—Harpichord Recital.
10.0 p.m.—Concert from the Café Astoria.

LANGENBERG (Germany)

Westdeutscher Rundfunk. 635 kc/s (473 m.); 17 kW. Relayed by Aachen, Cologne and Münster, 1,319 kc/s (227 m.). Transmits at intervals from 6.0 a.m. (Hamburg Relay).
10.30 a.m.—See Leipzig.
11.5 a.m.—Concert under the Christmas Tree on the Hindenburg Mound, Düsseldorf.
12 noon.—Orchestral Concert.
1.30 p.m.—Shorthand Dictation.
1.50 p.m.—Talk by Karl Wagenfeld: My Homeland.
2.25 p.m.—Talk: The Last Night of Advent.
2.50 p.m.—Talk for Workers.
3.10 p.m.—Talk: A Magic City.
3.30 p.m.—Advent—Choral and Organ Recital with Address, relayed from Paderborn Cathedral.
4.30 p.m.—"Jack and John—the Youngest Limited Liability Company"—a Modern Fairy Play for Young People (Josef Otto). Music by Hans Ebert.
5.55 p.m.—Sports Notes.
6.5 p.m.—Talk: Christmas Thoughts for the Winter Relief Fund.
6.30 p.m.—Review of Books.
7.0 p.m.—An Entertainment.
7.40 p.m.—"The Birth of Christ"—the Oberufer Medieval Christmas Play. Music after Old Songs by Ludwig Weber.
8.45 p.m.—Concert of Music from German Fairy Operas by the Orchestra, Mimi Berger (Soprano) and Josef Schömmel (Tenor).
9.15 p.m. (in the interval).—News Bulletin.
11.0 p.m. (approx.).—Close Down.

LEIPZIG (Germany)

1,157 kc/s (259 m.); 2.3 kW. Relayed by Dresden, 941 kc/s (319 m.). Transmits at intervals from 5.45 a.m. (Witzleben Relay).
10.30 a.m.—Bereitet die Wege, bereitet die Bahn—Cantata by the Municipal and Gewandhaus Orchestras, the Choir of St. Thomas' and Soloists (Bach).
11.5 a.m.—Reading.
11.30 a.m.—Orchestral Concert with Flute Solos.
1.0 p.m.—Weather, Time and Topical Talk.
1.15 p.m.—Agricultural Notes.
1.30 p.m.—Esperanto Lesson.
2.0 p.m.—"The Fairy Beauty"—a Fairy Tale in Three Acts, arranged as a Radio Play, with Music by Humperdinck.
3.30 p.m.—"The Animal"—a Christmas Story.
4.0 p.m.—See Breslau.
6.0 p.m.—Talk and Readings in Memory of Ferdinand Avenarius.
6.30 p.m.—Three Tales (Colette).
7.0 p.m.—Talk: Remember the Unemployed!
7.15 p.m.—"The Christmas Oratorio" (Bach), by the Municipal and Gewandhaus Orchestras and Soloists.
9.55 p.m.—News, followed by Gramophone Concert.
11.0 p.m. (approx.).—Close Down.

LJUBLJANA (Yugoslavia)

522 kc/s (574.7 m.); 2.8 kW. Transmits at intervals from 7.0 a.m.
7.0 p.m.—Choral Concert.
8.0 p.m.—Quintet Concert.
9.0 p.m.—Weather, News and Light Music.

LWÓW (Poland)

788 kc/s (381 m.); 21 kW. Transmits at intervals from 9.0 a.m.

6.10 p.m.—Miscellaneous Items.
6.35 p.m.—Sports Notes and Gramophone Records.
6.45 p.m.—Literary Programme from Wilno, 1,229 kc/s (244.1 m.).
7.30 p.m.—See Warsaw.
10.0 p.m.—Dance Music from the Bagatela Variety Theatre.
11.0 p.m. (approx.).—Close Down.

MADRID (Spain)

Union Radio (EAJ7). 707 kc/s (424.3 m.); 2 kW.
8.0—9.30 a.m.—Topical Review.
2.30 p.m.—Chimes, Time, Wireless Exchange and Mart and Sextet Concert.
3.55 p.m.—Theatre Notes.
4.0—7.0 p.m.—Interval.
7.0 p.m.—Chimes and Request Gramophone Records.
8.30—10.0 p.m.—Interval.
10.0 p.m.—Chimes, Time and Sound Film Music, followed by Soprano and Tenor Song Recital.
12 midnight.—Chimes and Dance Music.
12.30 a.m. (Monday).—Close Down.

MILAN (Italy)

Ente Italiano Audizioni Radiofoniche. 905 kc/s (331.5 m.); 8.5 kW. Relayed by Turin, 1,094 kc/s (274.2 m.); and Genoa, 959 kc/s (312.8 m.). Transmits at intervals from 9.15 a.m.
11.30 a.m.—Concert of Light Music.
12 noon.—Time and Programme Notes.
3.0 p.m.—Sports Notes.
3.10 p.m.—"La piccola felicità"—Comedy (G. Adami). Sports Notes and Gramophone Records in the intervals.
4.30 p.m.—Gramophone Records.
5.30 p.m.—Giornale Radio and Sports Notes.
5.45 p.m. (from Turin).—Variety Programme.
6.5 p.m.—Gramophone Records. In the intervals, at 6.40 p.m.—Announcements, and at 7.0 p.m.—Time and News.
7.35 p.m.—Choral and Orchestral Concert, conducted by A. Pedrillo, followed by Talk.
8.30 p.m.—"Il cuore di Wanda"—Italian Opera in One Act (Carmine Guarino), followed by "Bruschino"—Opera in One Act (Rossini). Theatre Notes and Giornale Radio in the interval. After the Programme, News Bulletin.

MUNICH (Germany)

563 kc/s (533 m.); 1.7 kW. Relayed by Augsburg and Kaiserslautern, 536 kc/s (560 m.); and Nürnberg, 1,256 kc/s (239 m.). Transmits at intervals from 9.0 a.m.
10.30 a.m.—See Leipzig.
11.5 a.m.—See Stuttgart.
12.5 p.m.—Time and Announcements.
12.15 p.m.—Talk: Pig-keeping.
12.35 p.m.—Gramophone Concert.
1.30 p.m.—Talk on Chess.
2.15 p.m. (from Nürnberg).—Baritone and Pianoforte Recital.
2.45 p.m.—Orchestral Concert. In the interval, a Performance by Prize-Winning Canaries.
4.0 p.m.—Talk: The Laughing Brahms.
4.20 p.m.—"Die Christrose"—Christmas Fairy Play for Children, with Music.
5.15 p.m.—"Famous Dilettanti"—a Radio Sequence with Compositions by Leopold I of Habsburg, Anna Amalia, Jean Jacques Rousseau, Bettina von Arnim-Brentano, Walther v. Goethe, Baroness Rothschild and Friedrich Nietzsche. Soloists: Lissy Sanden (Mezzo-Soprano), Anton Gronen-Kubicki (Baritone) and R. Staab (Piano).
6.10 p.m.—Weather and Sports Notes.
6.25 p.m.—Talk: Curicities of London.
6.45 p.m.—Orchestral Concert, with Selections by a Children's Choir. Soloist: Clara Haskill (Pianist).
7.50 p.m.—Poems (H. O. Münsterer).
8.5 p.m.—Orchestral Concert. Soloist: V. Härtl (Violin).
9.20 p.m.—Time and News.
9.45 p.m. (from Nürnberg).—Military Band Concert from the Café Königshof.
11.0 p.m. (approx.).—Close Down.

OSLO (Norway)

Kringkastingselskapet. 277 kc/s (1,083 m.); 75 kW. Relayed by Fredrikstad, 816 kc/s (367.6 m.); Hamar, 536 kc/s (560 m.); Notodden, 671 kc/s (447.1 m.); Porsgrun, 662 kc/s (453.2 m.); and Rjukan, 671 kc/s (447.1 m.).
9.20 a.m.—Divine Service from a Church in Boddø, 662 kc/s (453.2 m.).
4.0 p.m.—Orchestral Concert.
5.0 p.m.—Talk.
5.30 p.m.—Recital of Sacred Songs.

6.0 p.m.—Gramophone Records.
6.15 p.m.—News Bulletin.
6.30 p.m.—Recitations.
7.0 p.m.—Time Signal.
7.2 p.m.—"A Christmas Oratorio" for Soloists, Choir and Orchestra, relayed from a Church in Drammen.
8.35 p.m.—News Bulletin.
8.50 p.m.—Topical Talk.
9.5 p.m.—Recitations.
9.35 p.m.—Concert and Dance Music from the Grand Hotel.
11.0 p.m. (approx.).—Close Down.

PARIS (France)

Eiffel Tower (FLE). 207.5 kc/s (1,445.7 m.); 15 kW. Time Signals (on 2,650 m.) at 9.26 a.m. and 10.26 p.m. (preliminary and 6-dot signals).
12.30 p.m.—Symphony Concert, conducted by M. E. Flament. In the interval at 1.0 p.m.—News Bulletin.
5.45 p.m.—Je Journal Parlé.
7.20 p.m.—Weather Forecast.
7.30 p.m.—Gramophone Concert.

PARIS (France)

Poste Parisien. 914 kc/s (328.2 m.); 1.2 kW.
8.15 p.m.—Gramophone Records, Talk and News.
9.0 p.m.—Concert. Overture, "Tannhäuser" (Wagner). First Waltz Suite, Liebeslied (Brahms). Rhapsodie d'Auvergne, for Pianoforte and Orchestra (Saint-Saëns). Finale from "Scheherazade" (Rimsky-Korsakoff). Danseuse de Delphes, from the Préludes (Debussy). Nocturne and Petite Valse (Tchaikovsky). Scherzo (Lalo).

PARIS (France)

Radio-Paris (C.F.R.). 174. kc/s (1,725 m.); 80 kW.
7.45 a.m.—Gramophone Records.
8.0 a.m.—News Bulletin.
8.30 a.m.—Physical Culture Lesson.
10.50 a.m.—Book-keeping Lesson.
11.10 a.m.—Spanish Lesson.
11.30 a.m.—Concert.
12 noon.—Religious Address.
12.30 p.m.—Organ Recital. Offertoire (Guilmant). Berceuse (Wheeler).
12.45 p.m.—News Bulletin.
1.0 p.m.—Concert.
2.0 p.m.—Gramophone Records.
3.0 p.m.—Gramophone Concert.
4.0 p.m.—Gramophone Records.
5.30 p.m.—Concert arranged by the Association des Concerts Poulet, relayed from the Sarah Bernhardt Theatre.
7.0 p.m.—Agricultural Report, Market Prices, Racing Results and Weather Report.
7.15 p.m.—Economic and Social Notes and News.
8.0 p.m.—Variety Programme, with Georges Flateau and Jean Sorbier.
8.30 p.m.—News Bulletin.
8.45 p.m.—Radio-Paris Café Concert. In the interval at 9.15 p.m.—News and Time.

ROME (Italy)

Ente Italiano Audizioni Radiofoniche. (IRO). 680 kc/s (441 m.); 75 kW. Relayed by Naples, 941 kc/s (319 m.); and 2RO, 3,750 kc/s (80 m.).
9.0 a.m.—Reading from the Bible.
9.15 a.m.—Gramophone Records of Sacred Music.
9.45—10.0 a.m.—Sports Notes and Amusement Guide.
11.55 a.m.—German Lesson on Gramophone Records.
12 noon—1.15 p.m.—Gramophone Concert. In the interval at 12.30 p.m.—Time and News.
3.15 p.m. (from Naples).—Programme for Children, followed by Weather and Sports Notes.
4.0 p.m.—Symphony Concert from the Augusteo. In the interval: Reading.
6.55 p.m. (from Naples).—Shipping.
7.0 p.m.—Sports Notes; News.
7.30 p.m.—Time, Announcements and Gramophone Records.
8.0 p.m.—Concert. Concerto in E Minor, Op. 64, for Violin and Orchestra (Mendelssohn). Soprano Solos: (a) Mamma, il giovane principe and (b) Egli mormorò: Amor mio (Alfano), (c) Wiegenlied (Reger), (d) Recitative and Aria from "L'Enfant prodigue" (Debussy). "Un Signore che non parla"—Comedy in One Act (Falena). Soprano, Baritone and Tenor Selections from "Marcella" (Giordano). Humorous Talk. Selections from "La boutique fantasque" (Rossini-Respighi).
9.55 p.m.—News Bulletin.

SCHENECTADY (U.S.A.)

General Electric Company (WGY). 790 kc/s (379.5 m.); 50 kW. Relayed at intervals by W2XAF, on 9,530 kc/s (31.48 m.) and by W2XAD on 15,340 kc/s (19.56 m.). Transmits at intervals from 1.0 p.m.
7.15 p.m.—5.0 a.m. (Monday).—New York Relay.
7.15 p.m.—Sunday Bright Spots.

Programmes for Sunday—(Cont.)

7.30 p.m.—Moonshine and Honey-suckle.
 8.0 p.m.—Wayne King's Orchestra.
 8.30 p.m.—National Sunday Forum.
 9.0 p.m.—Florsheim Frolic.
 9.30 p.m.—Wonder Programme.
 10.0 p.m.—International Gypsies.
 10.30 p.m.—General Electric Twilight Hour.
 11.0 p.m.—Catholic Hour.
 12 midnight.—Through the Opera Glass.
 12.15 a.m. (Monday).—Jolly Time Revue.
 12.30 a.m.—Iodent Club of the Air.
 1.0 a.m.—Chase and Sanborn Programme.
 2.0 a.m.—Talk: Our Government.
 2.15 a.m.—American Album of Familiar Music.
 2.45 a.m.—Buick Musical Comedy Programme.
 3.15 a.m.—National Oratorio Society.
 3.45 a.m.—Sunday at Seth Parker's.
 4.15 a.m.—Ralph Kirbery (Baritone).
 4.30 a.m.—Jesse Crawford (Organist).
 5.0 a.m.—Orchestral Music.
 6.0 a.m. (approx.).—Close Down.

SCHWEIZERISCHER LANDESSENDER (BEROMÜNSTER) (Switzerland)

653 kc/s (459 m.); 75 kW.;
 Basle, 1,229 kc/s (244.1 m.); and
 Berne, 1,220 kc/s (246 m.).
 9.30 a.m. (from Basle).—Protestant Address.
 10.10 a.m. (from Basle).—Gramophone Records.
 10.30 a.m.—See Leipzig.
 11.28 a.m.—Time and Weather.
 11.30 a.m.—News Bulletin.
 11.40 a.m.—Orchestral Concert.
 12.35—2.30 p.m.—No Transmission.
 2.30 p.m. (from Basle).—Popular Concert.
 3.15 p.m. (from Basle).—Reading in Dialect.
 3.45 p.m.—Gramophone Dance Records.
 4.30—5.30 p.m.—No Transmission.
 5.30 p.m. (from Basle).—Chess Lesson.
 6.0 p.m.—Gramophone Dance Records.
 6.25 p.m.—Sports Results.
 6.28 p.m.—Time and Weather.
 6.30 p.m. (from Basle).—Dialogue: Plastic Art.

7.0 p.m. (from Berne).—Talk on Solothurn and the Swiss Federation.
 7.20 p.m. (approx.).—Popular Concert.
 8.0 p.m.—Schubert Song Recital by Ernst Schläfli (Baritone).
 8.25 p.m.—Folk Music from the Tessin.
 9.0 p.m.—Weather, News and Close Down.

STOCKHOLM (Sweden)

Radiotjänst (SASA). 689 kc/s (436 m.); 75 kW. Relayed by Boden, 244 kc/s (1,229.5 m.); Göteborg, 932 kc/s (322 m.); Hörby, 1,166 kc/s (257 m.); Motala, 222.5 kc/s (1,348 m.); Östersund, 389 kc/s (770 m.); and Sundsvall, 554 kc/s (542 m.).
 10.0 a.m.—Divine Service Relay.
 11.45 a.m.—Weather Report.
 1.30 p.m.—Choral Concert relayed from Göteborg.
 2.15 p.m.—Variety Programme relayed from Malmö, 1,301 kc/s (231 m.).
 3.0 p.m.—Programme for Children, relayed from Sundsvall.
 3.30 p.m.—Gramophone Records.
 4.30 p.m.—Talk: Children in Swedish Poetry, relayed from Uppsala, 662 kc/s (453.2 m.).
 4.55 p.m.—Chimes.
 5.0 p.m.—Evensong.
 6.15 p.m.—Weather and News.
 6.30 p.m.—Talk on Franz Berwald.
 7.0 p.m.—Symphony Concert from the Works of Franz Berwald. Soloists: Greta Söderman (Vocalist) and Astrid Berwald (Pianoforte).
 8.15 p.m.—"Columbus"—a Play (Hentzel).
 8.45 p.m.—Weather and News.
 9.0 p.m.—Concert of Light Music.
 10.0 p.m. (approx.).—Close Down.

STRASBOURG (France)

Radio-Strasbourg (P.T.T.). 869 kc/s (345 m.); 15 kW.
 Transmits at intervals from 10.45 a.m.
 6.0 p.m.—Instrumental Concert.
 6.45 p.m.—Sports Notes.

6.50 p.m.—Sports Talk in French.
 7.0 p.m.—Instrumental Concert.
 7.30 p.m.—Time Signal.
 7.32 p.m.—News in French and German.
 7.45 p.m.—Gramophone Records.
 8.30 p.m.—Two Plays: (a) "The Pretext"—in Two Acts (Riche), (b) "The Pascha" in Two Acts (Benjamin).
 10.30 p.m.—Dance Music from the Savoy.
 12 midnight (approx.).—Close Down.

STUTT GART (MÜHLACKER) (Germany)

Süddeutscher Rundfunk. 832 kc/s (360.5 m.); 75 kW. Relayed by Freiburg, 527 kc/s (570 m.).
 Transmits at intervals from 6.0 a.m.
 10.30 a.m.—See Leipzig.
 11.5 a.m.—Promenade Concert from the Schlossplatz.
 12 noon.—Topical Talk.
 12.15 p.m. (from Karlsruhe).—Choral Concert.
 1.0 p.m.—See Frankfurt.
 2.0 p.m.—Talk on Forestry.
 2.30 p.m.—Readings (G. von der Vring).
 3.0 p.m.—Chamber Music from a Private House in Stuttgart.
 4.30 p.m.—See Langenberg.
 6.0 p.m.—A German Choral Mass in Seven Movements for Soprano, Contralto, Tenor and Bass a cappella, with Prelude and Entrance, to Text by Silesius (Jos. Haas), by the Ulmer Madrigal Choir.
 6.30 p.m.—Sports Notes.
 6.45—11.0 p.m.—See Frankfurt. In the interval at 9.45 p.m.—News.
 11.0 p.m. (approx.).—Close Down.

TOULOUSE (France)

Radiophonie du Midi. 779 kc/s (385 m.); 8 kW.
 12.30 p.m.—Catholic Service.
 1.0 p.m.—Military Music.
 1.15 p.m.—Sound Film Music.
 1.30 p.m.—Agricultural Report.
 1.45 p.m.—Protestant Service.
 5.0 p.m.—Transmission of Pictures.
 5.15 p.m.—Three Selections from the Quintet in A Major (Schubert).
 5.30 p.m.—Dance Music.
 5.45 p.m.—Orchestral Selections.
 6.0 p.m.—Operetta Songs.
 6.15 p.m.—Dance Music.
 6.30 p.m.—News Bulletin.
 6.45 p.m.—Cello Recital.
 7.0 p.m.—Concert.

7.30 p.m. (in the interval).—News Bulletin.
 10.0 p.m.—Orchestral Selections.
 10.30 p.m.—News Bulletin.
 10.40 p.m.—Concert arranged by the Vocalion Gramophone Company of Hayes.
 11.15 p.m.—North African News.
 11.30 p.m.—Opéra-Comique Songs.
 11.45 p.m.—Orchestral Selections.
 12 midnight.—Weather, Announcements and Close Down.

TRIESTE (Italy)

Ente Italiano Audizioni Radiofoniche. 1,211 kc/s (247.7 m.); 15 kW.
 8.55 a.m.—Chimes and Missa Cantata from the S. Giusto Cathedral.
 11.30 a.m.—Giornale Radio and Gramophone Records.
 11.55 a.m.—German Lesson on Gramophone Records.
 12 noon.—Time and Announcements.
 12.2—12.45 p.m.—Light Music.
 3.30 p.m.—Dance Music. Sports Notes in the interval.
 7.15 p.m.—News Bulletin.
 7.30 p.m.—Gramophone Records.
 8.0 p.m.—Time and Announcements.
 8.5 p.m. (approx.).—Variety Concert. Theatre Notes in the interval.
 9.25 p.m.—Light Music or Gramophone Records.
 9.55 p.m. (approx.).—News.

VIENNA (Austria)

Radio-Wien. 581 kc/s (517 m.); 20 kW. Relayed by Graz, 852 kc/s (352.1 m.); Innsbruck, 1,058 kc/s (283 m.); Klagenfurt, 662 kc/s (453.2 m.); Linz, 1,220 kc/s (246 m.) and Salzburg, 1,373 kc/s (218 m.).
 9.0 a.m.—Organ Recital.
 9.30 a.m.—Talk: Love in German Lyrics.
 10.0 a.m.—Christmas Festivities of the Vienna Branch of the Society for the Protection of Animals, relayed from the Volksgarten.
 10.15 a.m.—Orchestral Concert, conducted by Dr. L. Kaiser. Soloists, Serge Bortkiewicz (Pianist) and Hans Skriwanek (Tenor).
 12 noon.—Zither Concert, by the Central Branch of the Workers' Musical Associations of Austria.
 2.0 p.m.—Time and Announcements.
 2.5 p.m.—Readings: Children and Childhood.
 2.30 p.m.—Orchestral Concert.

4.10 p.m.—Higher Grade English.
 4.30 p.m.—The Schwarz Trio.
 5.0 p.m.—"Mount Altwater"—the Land and People.
 5.30 p.m.—"Don't stand still, go forward!"—a Well-Known Story.
 6.0 p.m.—Time and News.
 6.10 p.m.—Lotte Lehmann Song Recital. Erich Meller at the Pianoforte.
 7.0 p.m.—Folk Singer Anecdotes (Josef Koller).
 7.30 p.m.—"Viennese Folk Singers" (Viktor Leon).
 9.0 p.m.—News Bulletin.
 9.15 p.m.—Dance Music, with Vocal Refrains.

WARSAW (Poland)

Polskie Radio, 212.5 kc/s (1,411 m.); 158 kW.
 9.15 a.m.—Divine Service relayed from Lwów.
 10.58 a.m.—Time Signal and Bugle Call from the Tower of St. Mary's Church, Cracow.
 11.5 a.m.—Programme Announcements.
 11.10 a.m.—Weather Report.
 11.15 a.m.—Concert by the Warsaw Philharmonic Orchestra. Soloist: Ela Kafarska (Pianoforte).
 1.0 p.m.—Dialogue for Country Housewives.
 1.25 p.m.—Gramophone Records.
 1.40 p.m.—Talk.
 2.0 p.m.—Concert of Polish Music by Mme. R. Benzel (Pianoforte) and H. Merkel (Bass).
 2.55 p.m.—Programme for Children.
 3.20 p.m.—Gramophone Records.
 3.40 p.m.—Talk: Iron and Steel.
 3.55 p.m.—Gramophone Records.
 4.15 p.m.—Talk from Lwów.
 4.30 p.m.—Useful Hints.
 4.45 p.m.—Orchestral Concert. Soloist: L. Rudkiewicz (Cello).
 6.0 p.m.—Miscellaneous Items.
 6.25 p.m.—Gramophone Records.
 6.40 p.m.—Programme Announcements.
 6.45 p.m.—Literary Programme, relayed from Wilno, 1,229 kc/s (244.1 m.).
 7.30 p.m.—Orchestral Concert. Soloist: Mme. Zmigrod-Fedyczkowska (Soprano).
 8.55 p.m.—Reading.
 9.10 p.m.—Harpsichord Recital by Mme. M. Trombini-Kazuro.
 9.40 p.m.—News Bulletin.
 10.0 p.m.—Dance Music.
 11.0 p.m. (approx.).—Close Down.

Trouble free reception

That's what Xmas Revellers can bank on if their radio sets and mains units incorporate



METAL RECTIFIERS

THE WESTINGHOUSE BRAKE & SAXBY SIGNAL CO. LTD.,
 82, YORK ROAD, KING'S CROSS, LONDON, N.1. Phone: North 2415.

PROGRAMMES FOR MONDAY (December 21)

NOTE: THE HOURS OF TRANSMISSION ARE REDUCED TO GREENWICH MEAN TIME

BARCELONA (Spain)

Radio-Barcelona. (E.A.J.). 860 kc/s (349 m.); 8 kW.
Transmits at intervals from 11.0 a.m.
7.0 p.m.—Trio Concert.
7.30 p.m.—Exchange Quotations.
8.0 p.m.—Sports Notes and Trio Concert (cont'd.).
8.30 p.m.—French Lesson and News.
9.0 p.m.—Chimes, Weather and Exchange.
9.5 p.m.—Humorous Review of the Week's Events in Verse.
9.20 p.m.—Orchestral Concert.
10.0 p.m.—Selection from "Bohémios"—Musical Comedy (Vives), on Gramophone Records.
11.0 p.m.—Gramophone Records.
11.30 p.m.—Dance Music from the Café Catalán.
12 midnight (approx.)—Close Down.

BERLIN (Germany)

Königs Wusterhausen. 183.5 kc/s (1,635 m.); 75 kW.
Transmits at intervals from 5.30 a.m. (Witzleben Relay).
3.30 p.m.—Concert from Berlin (Witzleben).
4.30 p.m.—Talk: Playing Music with Invisible Partners.
5.0 p.m.—Educational Talk: The Psychology of the Child and the Adolescent.
5.30 p.m.—Elementary Spanish Lesson.
5.55 p.m.—Weather for Farmers.
6.0 p.m.—Agricultural Talk.
6.20 p.m.—"Without Work"—a Radio Sequence (Otto Berg).
7.0 p.m.—Concert from the Hotel Bristol.
7.40 p.m.—Dialogue: The Psychological Need of the Unemployed.
8.15 p.m.—See Leipzig.
9.35 p.m. (in the interval)—News.
11.0 p.m. (approx.)—Close Down.

BERLIN (Germany)

Witzleben. 715 kc/s (418 m.); 17 kW.
Transmits at intervals from 5.30 a.m. (Gymnastics).
3.30 p.m.—Carl Nielsen Pianoforte Recital. Selections from the Suite Op. 45. Theme and Variations, Op. 42.
4.0 p.m.—Concert of Choral Cantatas.
4.30 p.m.—Talk for Young People: The Wireless Receiver.
4.50 p.m.—Review of Books—Love Novels.
5.0 p.m.—Concert of Dances.
6.0 p.m.—Topical Talk.
6.10 p.m.—Poems by Adolf Köster.
6.35 p.m.—Talk: Travelling in Winter.
7.0 p.m.—See Breslau.
8.10 p.m.—Concert from the Works of Viennese Composers, conducted by Selmar Meyrowitz. Introductory Talk. Overture, "Der Rauchfangkehrer" (Salieri). Two Arias for Tenor and Soprano, from "Oberon, King of the Elves" (Wranitzky). Overture, "Der Augenarzt" (Gyrowetz). Soprano Solo from "Hieronimus Knicker" (v. Dittersdorf). Two Scenes from "Alpenkönig und Menschenfeind" (Wenzel Müller). Overture, "Das rote Käppchen" (v. Dittersdorf). Symphony in D Major (Anton Eberl).
9.35 p.m.—News, followed by Dance Music.
11.30 p.m. (approx.)—Close Down.

BORDEAUX-LAFAYETTE (France)

(PTT) 956 kc/s (304 m.); 35 kW.
Transmits at intervals from 12.45 p.m.
6.0 p.m.—Talk: French West Africa considered from an Economic Point of View.
7.30 p.m.—News, Exchange and Market Prices.
7.40 p.m.—Sports Notes.
7.55 p.m.—Results of the Prize Draw.
8.0 p.m.—Talk on Social Hygiene.
8.15 p.m.—Charades.
8.25 p.m.—Relay from Paris (Ecole Supérieure), 671 kc/s (447.1 m.). After the Programme, Amusement Guide and Time Signal.

BRESLAU (Germany)

923 kc/s (325 m.); 1.7 kW. Relayed by Głowicz, 1,184 kc/s (253 m.).
Transmits at intervals from 5.30 a.m.
5.55 p.m.—Weather for Farmers.
6.0 p.m.—Popular Concert for Zither and Concertina Trios. Schiffel-scher Zither-Vereins-Marsch

(Schiffel). Idyll (Mickenschreiber). Potpourri of Alpine Songs (Sieg-mund). Rheinländer-Potpourri (Kernbach). The Merry Boys (Rau). Old Bavarian Wedding Dances (Haas).

6.40 p.m.—Weather and Surprise Programme.
7.0 p.m.—"The Toy Shop"—a Christmas Play for the Radio with Music by Ernst A. Voelkel.
8.10 p.m.—News Bulletin.
8.20 p.m.—Pianoforte Recital. Thirty-Two Variations in C Minor (Beethoven). Sonata Op. 110 in A Flat Major (Beethoven). Four Selections. (Brahms): (a) Intermezzo, Op. 116, No. 4 in E Major; (b) Caprice, Op. 76, No. 5 in C Sharp Minor, (c) Intermezzo, Op. 118, No. 6 in E Flat Minor, (d) Rhapsody, Op. 119, No. 4 in E Flat Major.
9.10 p.m.—Time and News.
9.30 p.m.—Winter Sports Talk.
9.45 p.m.—Theatre Talk.
10.0 p.m.—The Letter Box.
10.10 p.m. (approx.)—Close Down.

BRUSSELS (Belgium) (No. 1)

I.N.R., 590 kc/s (509 m.); 20 kW.
12.15—1.45 p.m.—Gramophone Records dedicated to Winter.
5.0 p.m.—Pianoforte Recital.
5.30 p.m.—Gramophone Records.
6.15 p.m.—Talk: Home Comforts.
6.30 p.m.—Rossini Gramophone Records, with Introductory Talk.
7.15 p.m.—Talk: Christmas Customs.
7.30 p.m.—Theatre Review.
8.0 p.m.—Gramophone Record.
8.5 p.m.—"Colonel Chabert"—Radio Play (Théo Fleischmann, after the Novel by Balzac).
9.0 p.m.—Beethoven Recital. Sonata No. 2, Op. 5. Sonata No. 5, Op. 102.
9.45 p.m.—Gramophone Dance Records.
10.0 p.m.—Le Journal Parlé.

BRUSSELS (Belgium) (No. 2)

N.I.R., 887 kc/s (338.2 m.); 20 kW. Programme in Flemish.
12.15—1.45 p.m.—Gramophone Records.
5.0 p.m.—Dance Music from the Hotel Atlanta.
6.0 p.m.—Gramophone Records.
6.15 p.m.—Reading (Hans von Eckhardt).
6.30 p.m.—Violin Recital by M. Barenblat Litman. Poème (Chausson). Suite (Szymanovsky). The Fountains of Arethusa (Szymanovsky). Die Biene (Schubert).
7.0 p.m.—Gramophone Records.
7.15 p.m.—Lesson in Correct Pronunciation.
7.30 p.m.—Variety Items.
8.0 p.m.—Trio Concert. M. Weyler (Violin), M. Felleman (Cello) and M. Jef Alpaerts (Pianoforte). Trio (Van Durme). Trio (Brahms).
8.45 p.m.—Reading of Mark Antony's Speech from "Julius Caesar" (Shakespeare).
9.0 p.m.—Orchestral Concert, conducted by M. Arthur Meulemans. Soloist: Mr. Rubeau (Tenor).
10.0 p.m.—Le Journal Parlé.

BUCHAREST (Romania)

Radio-Bucarest. 761 kc/s (394 m.); 16 kW.
Transmits at intervals from 11.0 a.m.
5.10 p.m.—Orchestral Concert. Waltz, Accelerationen (Joh. Strauss), Overture (Kostal). Dances from "Feramors" (Rubinstein).
6.0 p.m.—Educational Programme.
6.40 p.m.—Gramophone Records.
7.0 p.m.—Chamber Music by the Sarvas Quartet.
7.30 p.m.—Talk.
7.45 p.m.—Song Recital. Waldeinsamkeit (Reger). Hansel and Gretel (Mahler). Parlez-moi d'amour (Lenoir). Ronde d'amour (Chaminade). Romanian Song (Kiriak). Romanian Song (Brailoiu). El vito and Granadina (Nih).
8.15 p.m.—Chamber Music (continued).
8.45 p.m.—News Bulletin.

BUDAPEST (Hungary)

545 kc/s (550 m.); 23 kW.
Transmits at intervals from 8.15 a.m.
4.30 p.m.—Concert by the Weidinger Salon Orchestra. Selection from "Das Nachtlager von Granada" (Kreutzer). Selection from "La Juive" (Halévy). Serenade, Spanish Waltz (Metra). Ballet Suite (Siede). Fiddling the Fiddle (Rubinoff). Selection from "The Land of Smiles" (Lehár). Overture, "Loreley" (Litzke).
5.40 p.m.—German Lesson.
6.10 p.m.—Pianoforte Recital by Lili Markus. Barcarolle, Waltz in C Sharp Minor, and Nocturne in

B Major (Chopin). Libellenreigen and Etude in A Flat Major (Marius). Liebestraum and Rakoczy March (Liszt).

6.40 p.m.—Reading.
7.0 p.m.—Concert by the Royal Hungarian Opera House Orchestra, conducted by Otto Berg. Soloist: Elisabeth Bodo. Selection from "Tannhäuser" (Wagner). Aria from "Rigoletto" (Verdi). Eine Nacht auf dem Kahlenberg (Mousorgsky) Selection from "Andrea Chénier" (Giordano). Symphony, Salambo (Butykai).
8.45 p.m.—Concert by a Tzigane Orchestra from the Café Baross.
9.20 p.m.—Impressions of Hungary by a Javancse Pathfinder and Journalist.

COLOGNE (Germany)

Westdeutscher Rundfunk. 1,319 kc/s (227 m.); 1.7 kW.
See Langenberg.

COPENHAGEN (Denmark)

1,067 kc/s (281 m.); 0.75 kW. Relayed by Kalundborg, 260 kc/s (1,153 m.).
Transmits at intervals from 6.30 a.m. (Gymnastics).
2.30 p.m.—Orchestral Concert, conducted by Launy Gröndahl. Soloist: Adolf Brandt (Pianist). Overture, "Jeanne d'Arc" (Verdi). Ballet Music from "Rienzi" (Wagner). Two Selections from the "Novelletten" for Strings (Gade). Waltz, Loreley-Rheinklänge (Strauss). Toréador et Andalouse from the Suite "El Costumé" (Rubinstein). Pianoforte Solos: (a) Prelude and Intermezzo (Lauridsen), (b) Holiday Scenes (C. Cohn Haste), (c) Five Selections (Adolf Brandt). March (Ole Olsen). Norwegian Rhapsody No. 1 (Svendsen). Waltz, A Day in Seville (Waldeufel). Oriental Suite (Popy). Gallop (Lumbye).
4.40 p.m.—Exchange; Market Prices.
4.50 p.m.—Reading.
5.20 p.m.—Talk: Outstanding Works in Danish Literature.
5.50 p.m.—Weather and News.
6.15 p.m.—Time Signal.
6.20 p.m.—Talk: The Danish Artists' Aid Fund for the Cancer Campaign.
6.30 p.m.—Medical Talk.
7.0 p.m.—Town Hall Chimes.
7.2 p.m.—"A Christmasless Christmas"—Programme arranged by a Newspaper.
7.45 p.m.—A Debate: Dramatist and Critic.
8.45 p.m.—Cello Recital by Fritz Dietzmann. Concert Polonaise, Op. 28 (Popper). Ave Maria (Bach-Gounod). Papillon (Popper). Nocturne in E Flat Major (Chopin). Saltarello (Van Goens).
9.10 p.m.—News Bulletin.
9.30 p.m.—Symphony Concert, conducted by Emil Reesen. Symphony in D Minor (César Franck).
10.5 p.m.—Dance Music from the Nimb Restaurant.
11.0 p.m. (in an interval)—Town Hall Chimes.
11.30 p.m. (approx.)—Close Down.

DUBLIN (Ireland)

(2RN) 725 kc/s (413 m.); 1.5 kW. Relayed by Cork, 1,337 kc/s (224.4 m.).
1.30—2.0 p.m.—Time, Weather, Stock Report and Gramophone Records.
6.0 p.m.—Gramophone Records.
6.15 p.m.—Programme for Children.
7.0 p.m.—Gramophone Records.
7.20 p.m.—News Bulletin.
7.30 p.m.—Time Signal.
7.32 p.m.—Irish Lesson.
7.45 p.m.—Recitations by Mrs. Lyle Donaghy.
8.0 p.m.—Concert. Treasa Ni Cormaic (Harp). Variety by Fay Sargent and Joan Burke. The Station Sextet. David Grundy (Tenor). Sketch by the Dublin Repertory Company.
9.30 p.m.—Sponsored Programme.
10.30 p.m.—Time, News, Weather and Close Down.

FÉCAMP (France)

Radio Normandie. 1,364 kc/s (219.9 m.); 1 kW.
12 noon.—Concert of Light Music.
8.0 p.m.—Exchange and News.
8.30 p.m.—Concert.

FRANKFURT-am-MAIN (Germany)

770 kc/s (390 m.); 1.7 kW. Relayed by Cassel, 1,220 kc/s (246 m.).
Transmits at intervals from 5.15 a.m. (Weather and Gymnastics).
4.5—5.30 p.m.—See Stuttgart.
5.30 p.m.—Economic Notes.

5.45 p.m.—Talk: Modern French Literature.

6.5 p.m.—English Language Lesson.
6.30 p.m.—Time and News.
6.35 p.m.—Johann Strauss Senior—Concert. Reise-Galopp. Odeon-Tänze. Waltz, Die Unbedeutenden. Epigonen-Tänze. Grazien-Tänze. Salon-Polka. Wiener Carnevals-Quadrille. Künstlerball-Tänze.
7.30 p.m.—Reading. (Otto Ernst).
7.50 p.m.—Chamber Music from the Saalbau. String Quintet in G Major, Op. 111 (Brahms).
8.20 p.m.—Variety Programme.
9.20 p.m.—Time and News.
9.40 p.m.—"The Author's Gallery"—Hans Carossa.
10.10 p.m.—Concert from the Hermann Casino.
11.0 p.m. (approx.)—Close Down.

HAMBURG (Germany)

Norag (ha, in Mersc). 806 kc/s (372 m.). 1.7 kW. Relayed by Bremen, 1,112 kc/s (275 m.); Flensburg, 1,373 kc/s (218 m.); Hanoer, 530 kc/s (566 m.); and Kiel, 1,292 kc/s (232.2 m.).
Transmits at intervals from 5.30 a.m.
5.55 p.m.—Talk: Foreign Capital fights for Political Influence.
6.20 p.m.—Exchange, Market Prices and Weather.
6.30 p.m.—"Christmas Carols of Europe"—Song Recital, by Olga Milesch and Olga Spannuth, with Commentary by K. Anders. Gerhard Maasz at the Pianoforte. Er ist gewaltig und stark (Minnesinger Spervogel). Lippai, steh auf vom Schlaf (Sudetie German). Als wir dar seyn gekommen (Flanders). Voici le Noël (Old French). La nativité (France, 1550 approx.). Entre le boeuf et l'âne gris (Burgundian). Neapolitan Christmas. Catalan Christmas Dance. St. Stephen (Old Swedish). Danish Christmas.
7.0 p.m.—Knights, Death and the Devil—Concert of Old Songs and Melodies for Choir and Soloists, with Introductory Talk. Choral Selection: Mitten wir im Leben. Song to Lute Accompaniment: In den Rosen (15th Century, arr. E. L. v. Wolzogen). Choral Selection, Ein feste Burg (Luther). Setting by H. L. Hassler. Old German Song Melodies with Pianoforte Accompaniment (arr. H. J. Moser). Choral Selection: Easter Anthem. Baritone Solos: (a) Das Hildebrand-Lied, (b) Landsknechtslied. Old Dances—Passamezzo and Saltarello (B. Schmidt). Old Folk Songs to the Lute (arr. E. L. v. Wolzogen): (a) Flemish Danse macabre, (b) The King's Daughter and Death. Folk Songs for Choir: (a) Ritter Schenkenbachslied, (b) Spielmann und Mägdelein. Baritone Solos: Old German Folk Melodies with Pianoforte Accompaniment (arr. H. J. Moser): (a) Spottlied auf Rudolf v. Habsburg, (b) The Battle of Pavia, (c) The Brussels Martyrs (Luther). Choral Selection: Wach auf, du deutsches Land (Joh. Walther, arr. Max Pohl).
8.15 p.m.—The Background of the Genius—"Dr. Martin Luther" (Robert Walter), by the Norag Choir, Soloists and Cinema Organ.
9.0 p.m.—News Bulletin.
9.20 p.m.—Relay of Foreign Stations.
9.50 p.m.—Ice Report.
10.0 p.m.—Silent Night for Distant Reception.

HEILSBURG (Germany)

1,085 kc/s (276.5 m.); 75 kW. Relayed by Danzig, 662 kc/s (453.2 m.).
Transmits at intervals from 5.30 a.m. (Gymnastics).
3.45 p.m.—Concert from the Park Hotel, Königsberg.
4.15 p.m.—Christmas Celebration of the East Prussian Institute of the Blind. Readings and Choral and Soloist Selections.
4.50 p.m.—Book Review.
5.15 p.m.—Ice Report and Market Prices.
5.25 p.m. (from Danzig)—Carl Lange (of Danzig) reads from his own Works.
5.50 p.m.—Talk: Memorable Days of the Week.
6.0 p.m.—Shorthand Dictation.
6.30 p.m.—Recital of Christmas Carols by Mia Neusitzer-Thoenissen.
6.55 p.m.—Weather Forecast.
7.0 p.m.—See Breslau.
8.10 p.m.—Announcements.
8.20 p.m.—Concert of Chamber Music. Septet, Op. 20 (Beethoven).
9.10 p.m. (approx.)—News Bulletin.

HILVERSUM (Holland)

1,004 kc/s (298.8 m.); 20 kW. Programme of the Algemeene Vereniging Radio Omroep (A.V.R.O.)
7.40 a.m.—Time Signal.
7.41 a.m.—Gramophone Records.
9.40 a.m.—Daily Service.
9.55 a.m.—Gramophone Records.
10.10 a.m.—Talk.
10.40 a.m.—Organ Recital by Piet van Egmond, Jr., with Songs by Sitske Bolten. Prelude and Fugue in G Major (Bach). Songs: (a) Buss und reu (Bach), (b) Gott ist mein Hirte (Dvcrák), (c) Caro mio ben (Giordano), (d) All rselen (Lassen), Passacaglia, Chrcalc and Fugue (Wolf). (e) Dank sei Dir Herr (Händel), (f) Paysage triste (Hahn), (g) Traum durch die Dämmerung (R. Strauss), (d) Mondnacht (Brahms). Improvisation (v. Egmond).
11.40 a.m.—Time Signal.
11.41 a.m.—Trio Concert. In the interval, Gramophone Records.
1.40—2.10 p.m.—Interval.
2.10 p.m.—Gramophone Records.
2.40 p.m.—Talk.
3.10 p.m.—Orchestral Concert, relayed from the Café Central, The Hague.
4.10 p.m.—Programme for Children.
5.10 p.m.—Orchestral Concert. Soloist: Bob Scholte (Vocalist).
6.10 p.m.—Gramophone Records.
6.40 p.m.—Weekly Book Talk.
7.10 p.m.—Gramophone Records.
7.20 p.m.—Talk.
7.40 p.m.—Time Signal.
7.41 p.m.—Concert by the Wireless Orchestra, Inger Raasloff and Anita Jakobi (Vocalists) and the Terek Cossacks Choir. Paraphrase on a Dutch Soldier Song (Terog). Dutch Peasant Dances (Siep). Danish Songs by Inger Raasloff. Scandinavian Rhapsody (Svendsen). Danish Songs by Inger Raasloff. Russian Potpourri (Bernards). Choral Selection. Selection (Nacf). Songs by Anita Jakobi. Dances (Lanner). Songs by Anita Jakobi. March (Wagner).
9.45 p.m.—Weather and News.
9.55 p.m.—Orchestral Concert. Overture, "Masaniello" (Auber). Pomone (Waldeufel). American Parol (Meacham). Selection from "The Maid of the Black Forest" (Jessel). Hoch Heidecksburg (Herzer).
10.40 p.m.—Gramophone Records.
11.40 p.m. (approx.)—Close Down.

HUIZEN (Holland)

160 kc/s (1,875 m.). 8.5 kW. Programme of the Christian Radio Society (N.C.R.V.).
7.40 a.m.—Reading.
7.55—9.25 a.m.—Concert.
10.10 a.m.—Service for Hospitals.
10.40 a.m.—Reading.
11.10 a.m.—Gramophone Records.
11.40 a.m.—Police Notes.
12.10 p.m.—Organ Recital from a Church in Amsterdam. Suite, Kerstfeest I (Jan Zwart). Choral Preludes (Bach): (a) Vom Himmel hoch, (b) In dulci Jubilo, (c) Es ist das Heil uns kommen her. Pastorale (Franck). Grand Chœur (Guilmant). Prayer and Cradle Song (Guilmant). Suite, Kerstfeest II (Jan Zwart).
1.25 p.m.—Gramophone Records.
1.40 p.m.—Talk for Schools.
2.15 p.m.—Gramophone Records.
3.25 p.m.—Talk (to be announced).
3.40 p.m.—Service for Hospitals.
4.40 p.m.—Concert. Sonata for Flute, Oboe and Pianoforte (Loellet). Sonata for Flute, Viola and Pianoforte (Leclair). Sonata for Flute and Viola (Kraus). Trio for Flute and Pianoforte (Mozart). Suite for Flute, Oboe, Clarinet and Pianoforte (Johan Amberg). Flute Solos with Pianoforte accompaniment: (a) Romance (Reger), (b) Andante (Zagwijn). Caprice on Danish and Russian Airs for Flute, Oboe, Clarinet and Pianoforte (Saint-Saëns).
6.10 p.m.—Talk for Young People.
6.40 p.m.—Talk: The Music of the Reformation Period.
7.10 p.m.—Police Notes.
7.25 p.m.—News Bulletin.
7.40 p.m.—Orchestral Concert. Christmas Concerto (Manfredini). Fantasia on Christmas Carols (Manfredi). Introduction to "Joseph" (Méhul). Divertissement in D Major (Haydn). Das Deutsche Volkslied (Rhode).
8.40 p.m.—Talk.
9.10 p.m.—Concert (continued). Overture, "Si j'étais roi" (Adam). Scandinavian Suite (Juel-Frederiksen). Selection from "Das Glöckchen des Eremiten" (Maillart). Selections from "Madame Büttner

Programmes for Monday—(Cont.)

fly" (Puccini). In the interval from 9.40-9.50 p.m.—News. 10.10 p.m.—Gramophone Records. 11.10 p.m. (approx.)—Close Down.

KALUNDBORG (Denmark) Kalundborg Radio. 260 kc/s (1,153 m.); 7.5 kW. See Copenhagen.

KATOWICE (Poland) 734 kc/s (408 m.); 16 kW. Transmits at intervals from 10.58 a.m. 3.20 p.m.—French Lesson. 3.40 p.m.—Gramophone Records. 4.35 p.m.—See Warsaw. 7.15 p.m.—See Warsaw. 9.50 p.m.—Music Interlude. 10.0 p.m.—Talk in Greek: "The Polish Sea Coast and Gdynia." 10.30 p.m.—Light Music and Dance Music.

KAUNAS (Lithuania) 155 kc/s (1,935 m.); 7 kW. 4.0 p.m.—Gramophone Records. 4.30 p.m.—Two Talks. 5.10 p.m.—Variety Items. 5.30 p.m.—Weather Report. 6.10 p.m.—Talk on Young People. 6.30 p.m.—Concert. Potpourri, Echoes of the World (Zimmer). Waltz, Du und du (Strauss). Boston Romance (Lindsay). Intermezzo (Castro). Baltic Suite (Morena). Waltz (Heinecke). Spanish Caprice, Alhambra (Semler). Character Piece (Ecklebe). 8.40 p.m.—Talk: Gymnastics on the Stage. 9.0 p.m.—Educational Talk. 9.30 p.m.—Chamber Music. Sonata for Cello and Pianoforte (Rachmaninoff).

LANGENBERG (Germany) Westdeutscher Rundfunk. 635 kc/s (473 m.); 17 kW. Relayed by Aachen, Cologne and Münster, 1,319 kc/s (227 m.). Transmits at intervals from 5.45 a.m. (Gymnastics). 4.5-5.0 p.m. See Stuttgart. 5.0 p.m.—Talk: Wit and Repartee in Political Campaigns. 5.20 p.m.—Talk for Women. 5.40 p.m.—Talk for Parents. 6.0 p.m.—Time and News. 6.10 p.m.—Economic Review. 6.30 p.m.—Talk: Street Traffic Regulations. 6.55 p.m.—News Bulletin. 7.0 p.m.—Talk: From the Flute to the Kettledrum—with Illustrations. 7.35 p.m.—"The Experience of Love"—in Tales, Verse, Letters and Diaries—Last Sequence (Rudolf Rieth). 9.0 p.m.—News, followed by Concert. 11.0 (approx.)—Close Down.

LEIPZIG (Germany) 1,157 kc/s (259 m.); 2.3 kW. Relayed by Dresden, 941 kc/s (319 m.). Transmits at intervals from 5.30 a.m. 6.0 p.m.—Talk: Modern Welfare. 6.30 p.m.—Christmas Carols to the Lute. 7.0 p.m.—See Breslau. 8.0 p.m.—Talk: Remember the Unemployed! 8.15 p.m.—Concert from Richard Wagner's Dramatic Works, by the Leipzig Symphony Orchestra conducted by Dr. Ludwig Neubeck. Soloist: Max Hirtzel (Tenor). Overture, "The Flying Dutchman." Cavatina from "The Flying Dutchman." Prelude to the Third Act of "Lohengrin." Song from "Lohengrin." Prelude to the Third Act, Dance of the Apprentices, and Procession of the Guilds, from "The Mastersingers." Walter's Prize Song from "The Mastersingers." The Entry of the Gods, from "The Rhinegold." Siegmund's Love Song from "Die Walküre." Overture, "Tannhäuser." 9.35 p.m.—News, followed by Concert by the Emde Orchestra. 11.0 p.m. (approx.)—Close Down.

LJUBLJANA (Yugoslavia) 522 kc/s (574.7 m.); 2.8 kW. Transmits at intervals from 11.15 a.m. 7.0 p.m.—Song Recital. 8.0 p.m.—Quintet Concert. 9.0 p.m.—News Bulletin.

LWÓW (Poland) 788 kc/s (381 m.); 21 kW. Transmits at intervals from 10.40 a.m. 6.15 p.m.—See Warsaw. 6.25 p.m.—Songs and Ballads for Bass. 6.45 p.m.—See Warsaw. 11.0 p.m. (approx.)—Close Down.

MADRID (Spain) Union Radio (EAF). 707 kc/s (424.3 m.); 2 kW. Transmits at intervals from 11.45 a.m. 7.0 p.m.—Chimes, Exchange, Market

Prices and Request Gramophone Records. 8.0 p.m. (in the interval).—News. 8.30 p.m. (approx.)—Close Down.

MILAN (Italy) Ente Italiano Audizioni Radiofoniche. 905 kc/s (331.5 m.); 8.5 kW. Relayed by Turin, 1,094 kc/s (274.2 m.), and Genoa, 959 kc/s (312.8 m.). Transmits at intervals from 7.15 a.m. 6.0 p.m.—Agricultural Notes and Report of the Royal Geographical Society. 6.20 p.m.—Concert of Light Music. 6.40 p.m.—Announcements. 6.45 p.m.—Gramophone Records. In the interval at 7.0 p.m.—Time and News. 8.0 p.m.—Francesco Pastonchi in Recitations from the Eighth Canto of the "Inferno," with Commentary. 8.30 p.m.—Orchestral Music. 9.0 p.m.—Chamber Music Recital.

MUNICH (Germany) 503 kc/s (533 m.); 1.7 kW. Relayed by Augsburg and Kaiserslautern, 536 kc/s (560 m.) and Nürnberg, 1,256 kc/s (239 m.). Transmits at intervals from 5.45 a.m. 6.30 p.m.—"The Sebruck Pastoral Play" (from Hartmann's Bavarian Christmas Plays), relayed from Sebruck am Chiemsee. 7.30 p.m.—Orchestral Concert, conducted by Erich Kloss. Overture, "Die Abreise" (E. d'Albert). Fantasia on the Works of Haydn (Urbach). Suite for Two Violins and Pianoforte (Moszkovsky). Granada (Albeniz). Arabesque, No. 2 (Debussy). Suite from "Der Rosenkavalier" (R. Strauss). 8.20 p.m.—Josef Martin Bauer reads from his own Works. 8.50 p.m. (from Nürnberg).—Choral Concert. 9.20 p.m.—Time and News.

OSLO (Norway) Kringkastingsselskapet. 277 kc/s (1,083 m.); 75 kW. Relayed by Fredrikstad, 816 kc/s (367.6 m.); Hamar, 536 kc/s (560 m.); Notodden, 671 kc/s (447.1 m.); Porsgrund, 662 kc/s (453.2 m.); and Rjukan, 671 kc/s (447.1 m.). Transmits at intervals from 10.10 a.m. 4.0 p.m.—Instrumental Concert. Overture, "Das Modell" (Suppé). Hoch lebe der Tanz (Waldteufel). Neapolitan Serenade (Sgabati). Impromptu (Schubert). Japanese Suite (Yoshitomo). Selection (Peterson-Berger). Quant Madelon... (Robert). 4.45 p.m.—Programme for Boys relayed from Hamar. 5.30 p.m.—Norwegian Song Recital. 6.0 p.m.—News Bulletin. 6.30 p.m.—Agricultural Talk. 7.0 p.m.—Time Signal. 7.2 p.m.—Popular Concert by a Horn Quintet. 7.30 p.m.—Reading. 8.0 p.m.—Talk: Prisoners and Prisons. 8.35 p.m.—News Bulletin. 8.50 p.m.—Topical Talk. 9.5 p.m.—Choral Concert. Selections from the Works of Staver, Grieg, Wikner, Hegar, Schubert and Praetorius. 9.45 p.m. (approx.)—Close Down.

PARIS (France) Eiffel Tower (FLE). 207.5 kc/s (1,445.7 m.); 15 kW. Time Signals (on 2,650 m.) at 9.26 a.m. and 10.26 p.m. (preliminary and 6-dot signals). 5.45 p.m.—Le Journal Parlé. 7.20 p.m.—Weather Forecast. 7.30 p.m.—Hungarian Concert. Soloist: M. Laszlo Neuman. Variations on a Hungarian Theme (Hubay). Valse triste (Vecsey). The Dancing Doll (Poldini). Hungarian Dances Nos. 1 and 5 (Brahms). Selections (Hubay): (a) Zephyr, (b) Scenes from the Czardas. 8.0 p.m.—Gramophone Concert.

PARIS (France) Poste Parisien. 914 kc/s (328.2 m.); 1.2 kW. 8.15 p.m.—Gramophone Records and News. 9.0 p.m.—Concert. Overture, "Le Carnaval de Venise" (Thomas). Waltz from "Monsieur l'Amour" (Lattès). Suite, Le Calife Cigogne (L. Poujet). Elevation (Chaminade). Dances from "Carmosine" (Février). Sonata in A for Cello and Pianoforte (Beethoven)—Soloists: M. Cruque and M. Jacquinet. Selection from "Tip-Toes" (Gershwin). Sentimental Reverie (Barlow). Russian Rhapsody, Svetiana (Weksler). Rondo, May Day (Flament). Derviches tourneurs (Delmas).

PARIS (France) Radio-Paris. (CFR). 174 kc/s (1,725 m.); 80 kW. Transmits at intervals from 6.45 a.m. (Physical Culture).

12.30 p.m.—Gramophone Records. 1.0 p.m.—Exchange and News. 1.5 p.m.—Gramophone Concert. Selections from (a) "Carmen" (Bizet), (b) "Coppelia" and (c) "Lakmé" (Delibes), (d) "Faust," and (e) "Romeo and Juliet" (Gounod). In the intervals at 1.30 p.m. and 2.0 p.m.—Exchange Quotations. 3.35 p.m.—Exchange; Market Prices. 3.45 p.m.—Concert dedicated to Avesnes, Maubeuge and Hainault. 6.30 p.m.—Agricultural Report, Market Prices, Racing Results and Weather Report. 7.0 p.m.—Film Review. 7.10 p.m.—Book Review. 7.30 p.m.—Gramophone Records. 7.45 p.m.—Commercial Prices, Economic and Social Notes and News. 7.50 p.m.—Horticultural Talk. 8.0 p.m.—Gramophone Records: Le Camp de Wallenstein (d'Indy). 8.15 p.m.—News Bulletin. 8.25 p.m.—Talk. 8.30 p.m.—Programme from the Odeon: (a) "Louison"—Comedy in Two Acts in Verse (Alfred de Musset), (b) "Le Légataire Universel"—Comedy in Five Acts in Verse (Regnard). In the interval at 9.15 p.m.—News and Time.

RIGA (Latvia) 572 kc/s (525 m.); 15 kW. Transmits at intervals from 10.0 a.m. 6.0 p.m.—Weather Report. 6.5 p.m.—Vincent d'Indy Commemoration Concert. 7.0 p.m.—News Bulletin. 7.30 p.m.—Bass and Violin Recital. 8.0 p.m.—Weather Report. 8.5 p.m.—Light Concert. 8.30 p.m.—Evening Concert. 9.30 p.m. (approx.)—Close Down.

ROME (Italy) Ente Italiano Audizioni Radiofoniche (IRO). 680 kc/s (441 m.); 75 kW. Relayed by Naples, 941 kc/s (319 m.), and 2RO, 3,750 kc/s (80 m.). Transmits at intervals from 7.15 a.m. (Giornale Radio). 12.15-1.15 p.m.—Concert of Light Music. Good Comrades (Blankenburg). Enrichetta (Boottz). Wild Rose (Ganglberger). Piccola czarda (Crisuolo). Il mio amore! (Margutti). Selection from "La donna perduta" (Pietri). Balletto rustico (Mule). La sombra (Ramploldi). Constantinople (Carlton). 12.30 p.m. (in the interval).—Time and News. 4.0 p.m.—Exchange and Announcements. 4.30 p.m. (approx.)—Concert from the Royal Philharmonic Academy, with the Collaboration of Saga Leander (Soprano). 6.15 p.m. (from Naples).—Shipping and Sports Notes. 6.20 p.m.—News Bulletin. 7.0 p.m.—Sports Notes; Press Review. 7.30 p.m.—Time, Announcements and Gramophone Records. 8.0 p.m.—Concert of Light Music and Folk Music. In the interval, Fashion Review. 9.0 p.m. (approx.) (in the interval).—News. 9.55 p.m.—Second News.

SCHENECTADY (U.S.A.) General Electric Company (WGY). 790 kc/s (379.5 m.); 50 kW. Relayed at intervals by W2XAF on 9,530 kc/s (31.48 m.) and by W2XAD, on 15,340 kc/s (19.56 m.). Transmits at intervals from 11.45 a.m. 9.0 p.m.—Garden Melodies from New York. 9.30 p.m.—Stock Reports and Police Notes. 9.45 p.m.—Carmelo Cascio (Blind Pianist). 10.0 p.m.—News Bulletin. 10.5 p.m.—Musical Ad Men. 10.30 p.m.—Sweetheart Programme from New York. 10.45 p.m.—Russ Colombo and his Orchestra, from New York. 11.0 p.m.—Weather Report. 11.1 p.m.—Jack Miles and his DeWitt Clinton Orchestra. 11.29 p.m.—Time Signal. 11.30 p.m.—Bluc Coal Fireside Reveries. 11.45 p.m.—The Stebbins Boys from New York. 12 midnight (WGY only).—Vermont Lumber Jacks, from New York. 12 midnight (W2XAF only).—Stock Reports and News. 12.15 a.m. (Tuesday)—4.15 a.m.—New York Relay. 12.15 a.m.—Campbell's Orchestra. 12.30 a.m.—Prince Albert Programme. 12.45 a.m.—Trials of the Goldbergs. 1.0 a.m.—Soconyland Sketch.

1.30 a.m.—Voice of Firestone. 2.0 a.m.—A and P Gypsies. 2.30 a.m.—General Motors Programme. 3.0 a.m.—True Story Programme. 3.45 a.m.—Lee Morse (Crooner). 4.0 a.m.—Hotel New Yorker Orchestra. 4.15 a.m.—Comedy Skit—"Bob and Janitor." 4.30 a.m.—Clyde Kittell (Tenor). 4.45 a.m.—Cotton Club Orchestra. 5.0 a.m.—Jack Miles and his DeWitt Clinton Orchestra. 5.30 a.m.—Doc Peyton and his Kenmore Orchestra. 6.0 a.m. (approx.)—Close Down.

SCHWEIZERISCHER LANDESSENDER (BEROMÜNSTER) (Switzerland) 653 kc/s (459 m.); 75 kW.; Basle, 1,229 kc/s (244.1 m.); and Berne, 1,220 kc/s (246 m.). Transmits at intervals from 11.28 a.m. 2.30 p.m.—Orchestral Concert of Dances. 2.58 p.m.—Time Signal. 3.0 p.m.—Gramophone Records. 4.0 p.m. (from Berne).—Programme for Children. 4.30 p.m.—Weather. 4.35-5.30 p.m.—Interval. 5.30 p.m.—Gramophone Records. 6.0 p.m. (from Berne).—Talk: Wireless for Schools. 6.20 p.m. (from Berne).—Reminiscences. 6.28 p.m.—Time and Weather. 6.30 p.m. (from Berne).—Talk: The Life and Work of Rasputin. 7.0 p.m. (from Zürich).—Orchestral Concert—Symphonies (Haydn). 7.25 p.m. (approx.).—Songs from "Der Waffenschmied"—Opera (Lortzing). 9.0 p.m.—Weather and News. 9.15 p.m. (approx.)—Close Down.

STOCKHOLM (Sweden) Radiotjänst (SASA). 680 kc/s (436 m.); 75 kW. Relayed by Boden, 244 kc/s (1,220.5 m.); Göteborg, 932 kc/s (322 m.); Hörby, 1,166 kc/s (257 m.); Motala, 222.5 kc/s (1,348 m.); Östersund, 389 kc/s (770 m.); and Sundsvall, 554 kc/s (542 m.). Transmits at intervals from 6.45 a.m. 4.0 p.m.—Folk Music and Stories, relayed from Boden. 4.30 p.m.—Gramophone Records. 5.15 p.m.—Talk: Swedish Merchandise. 5.30 p.m.—Variety Concert. 6.15 p.m.—Weather and News. 6.30 p.m.—Talk: The Bible as a Cultural Factor, relayed from Uppsala, 662 kc/s (453.2 m.). 7.0 p.m.—A Visit with a Microphone to a Swedish U-Boat Fleet. 7.30 p.m.—Symphonic Jazz Music. 8.15 p.m.—Talk on Legislation. 8.45 p.m.—Weather and News. 9.0 p.m.—Gramophone Records. 10.0 p.m. (approx.)—Close Down.

STRASBOURG (France) Radio-Strasbourg (PTT). 869 kc/s (345 m.); 15 kW. Transmits at intervals from 11.30 a.m. 6.0 p.m.—Instrumental Concert. Overture, "Czar and Carpenter" (Lortzing). Salut d'amour (Elgar). Waltz, Habanera (Waldteufel). Selection from "Lucia di Lammermoor" (Donizetti). Selection (Rust). March (Pischek). 6.45 p.m.—Talk in German. 7.0 p.m.—Concert. Overture, "Les Cloches de Corneville" (Planquette). Aria from "La Gioconda" (Ponchielli). Selection from "François les bas bleus" (Messager). Aria from "La Vivandière" (Goddard). March, Viens, Nina (Mouton). 7.30 p.m.—Time Signal. 7.32 p.m.—News in French and German. 7.45 p.m.—Gramophone Records. 8.30 p.m.—"The Twilight of the Gods"—Opera (Wagner), on Gramophone Records. 10.30 p.m. (approx.)—Close Down.

STUTTGART (MÜHLACKER) (Germany) Süddeutscher Rundfunk. 832 kc/s (360.5 m.); 75 kW. Relayed by Freiburg, 527 kc/s (570 m.). Transmits at intervals from 5.15 a.m. 4.5 p.m. (from Freiburg).—Christmas Concert by the Freiburg Concert Orchestra, conducted by Richard Fried. Overture, "The Nuremberg Doll" (Adam). Marquisette (Lindsay-Theimer). Parade of the Tin Soldiers (Jessel). Valse des Poupées (Delibes). Selection from "Hansel and Gretel" (Humperdinck). Waltz, The Skaters (Waldteufel). The Clock (Powell). Tone Picture, Happy Christmas (E. Koedel). 5.0 p.m.—Song and Ballad Recital by Margarete Wetter (Soprano) and Karl Hauser (Baritone). Arthur

Haagen at the Pianoforte. Selections from the Song-Cycle, Die schöne Müllerin (Schubert): (a) Das Wandern, (b) Wohin? (c) Ungeduld. Soprano Solos (Brahms): (a) Auf dem Schiffe, (b) Salome. The Two Grenadiers (Schumann). Soprano Solos: (a) Stilles Lied (R. Trunk), (b) Wiegenlied der Jungfrau Maria (G. Boeck). Heinrich der Vögler (Loewe).

5.30 p.m.—Time and Agricultural Notes. 5.40 p.m.—Talk: Swabian Christmas and Twelfth Night Customs. 6.5 p.m.—See Frankfurt. 6.30 p.m.—Time and Weather. 6.35-10.10 p.m.—See Frankfurt. In the interval at 9.20 p.m.—News. 10.10 p.m.—Chess for Beginners. 10.35 p.m. (approx.)—Close Down.

TOULOUSE (France) Radiophonie du Midi. 779 kc/s (385 m.); 8 kW. Transmits at intervals from 12.45 p.m. 6.0 p.m.—Sound Film Music. 6.15 p.m.—Two Movements from the Sixth Symphony (Beethoven). 6.30 p.m.—News Bulletin. 6.45 p.m.—Orchestral Selection from "La Vie Parisienne" (Offenbach). 7.0 p.m.—Gramophone Records. 7.30 p.m.—News Bulletin. 7.45 p.m.—Accordion Solos. 8.0 p.m.—Military Music. 8.15 p.m.—Songs from (a) "The Barber of Seville" (Rossini), and (b) "Manon" (Massenet). 8.30 p.m.—Orchestral Selections. 9.15 p.m.—Chansonnets. 9.30 p.m.—Ballet Music from "Faust" (Gounod). 9.45 p.m.—Accordion Solos. 10.0 p.m.—Songs from (a) "The Drum-Major's Daughter" (Offenbach), (b) "Le Comte Obligado" (Moretti). 10.15 p.m.—Dance Music. 10.30 p.m.—News Bulletin. 10.45 p.m.—Orchestral Selections. 11.0 p.m.—Concert. In the interval at 11.15 p.m.—North African News. 12 midnight.—Weather, Announcements and Close Down.

TRIESTE (Italy) Ente Italiano Audizioni Radiofoniche. 1,211 kc/s (247.7 m.); 15 kW. Transmits at intervals from 11.30 a.m. 7.15 p.m.—News Bulletin. 7.30 p.m.—Gramophone Records. 8.0 p.m.—Time and Announcements, followed by Programme to be announced. Notes on Art in the interval. 9.15 p.m.—Light Music. 9.55 p.m. (approx.)—News.

VIENNA (Austria) Radio-Wien. 581 kc/s (517 m.); 20 kW. Relayed by Graz, 852 kc/s (352.1 m.); Innsbruck, 1,058 kc/s (283 m.); Klagenfurt, 662 kc/s (453.2 m.); Linz, 1,220 kc/s (246 m.), and Salzburg, 1,373 kc/s (218 m.). Transmits at intervals from 8.20 a.m. 5.55 p.m.—Talk: Books in connection with the Talks of the Week. 6.5 p.m.—English Language Lesson. 6.35 p.m.—Time and Weather. 6.45 p.m.—Jazz Music by Charly Gaudriot and Austin Egen. 7.45 p.m.—Wind Instrument Chamber Music. 8.45 p.m.—News Bulletin. 9.0 p.m.—Concert of Light Music.

WARSAW (Poland) Polskie Radio. 212.5 kc/s (1,411 m.); 158 kW. Transmits at intervals from 10.45 a.m. 1.10 p.m.—Gramophone Records. 1.15 p.m.—Talk: Children in the Country. 1.30 p.m.—Announcements. 1.35-1.50 p.m.—Interval. 1.50 p.m.—Gramophone Records. 2.15 p.m.—Announcements. 2.25 p.m.—Talk: Christmas Books. 2.45 p.m.—Exchange and Announcements. 2.50 p.m.—Gramophone Records. 3.10 p.m.—Elementary French Lesson. 3.40 p.m.—Gramophone Records. 4.10 p.m.—Talk relayed from Wilno, 1,229 kc/s (244.1 m.). 4.35 p.m.—Concert from the Café Gastronomja. 5.50 p.m.—Miscellaneous Items. 6.15 p.m.—Agricultural Report. 6.25 p.m.—Programme Announcements. 6.30 p.m.—Gramophone Records. 6.45 p.m.—Radio Journal. 7.0 p.m.—Talk on Music. 7.15 p.m.—"Zuzza"—Operetta in Three Acts (Renyi)—arranged for Radio by Mme. M. Makowiecka. 9.15 p.m.—Talk on Greta Garbo. 9.30 p.m.—Radio Journal. 9.35 p.m.—Announcements. 9.45 p.m.—Dance Music. 11.0 p.m. (approx.)—Close Down.

PROGRAMMES FOR TUESDAY

(December 22)

NOTE: THE HOURS OF TRANSMISSION ARE REDUCED TO GREENWICH MEAN TIME

BARCELONA (Spain)

Radio-Barcelona (E.A.J.I.). 860 kc/s (349 m.); 8 kW.
Transmits at intervals from 7.30 a.m.
7.0 p.m.—Trio Concert.
7.30 p.m.—Exchange and Gramophone Records.
8.30 p.m.—Elementary English Lesson, followed by News.
9.0 p.m.—Chimes, Weather and Exchange.
9.5 p.m.—Part Relay of an Opera from the Gran Teatro del Liceo.
12. midnight (approx.)—Close Down.

BERLIN (Germany)

Königs Wusterhausen. 183.5 kc/s (1,635 m.); 75 kW.
Transmits at intervals from 5.30 a.m. (Witzleben Relay).
3.30 p.m.—Concert from Leipzig.
4.30 p.m.—Book Review.
5.0 p.m.—Talk: Christmas throughout the Ages.
5.30 p.m.—Educational Talk: The Geographical Causes of the Great War.
5.55 p.m.—Weather for Farmers.
6.30 p.m.—Talk: Swift or Thorough Justice?
7.0 p.m.—See Vienna.
8.0 p.m. (in the interval)—News.
9.30 p.m.—News Bulletin.
9.50 p.m.—Concert from the Central Hotel.
11.30 p.m. (approx.)—Close Down.

BERLIN (Germany)

Witzleben. 715 kc/s (418 m.); 1.7 kW.
Transmits at intervals from 5.30 a.m. (Gymnastics).
6.0 p.m.—Topical Talk.
6.10 p.m.—"Christmas in a City"—Programme for Soloists, Choir and Orchestra (Werner Egk). Text by Robert Seitz; followed by "Vom Himmel hoch da komm ich her"—Cantata for Solo Voices, Choir, Two Violins and Organ (Max Reger).
6.35 p.m.—Talk: England during the Past Month.
7.0 p.m.—See Vienna. In the interval at 8.0 p.m.—News Bulletin.
9.30 p.m.—Second News.

BORDEAUX-LAFAYETTE (France)

(P.T.T.). 986 kc/s (304 m.); 35 kW.
Transmits at intervals from 12 noon.
6.0 p.m.—Talk: French West Africa considered from an Economic Point of View.
7.30 p.m.—News and Exchange.
7.40 p.m.—Talk on Aviation: How to obtain a Tourist Certificate.
7.55 p.m.—Results of the Prize Draw.
8.0 p.m.—Scientific Talk: Turpentine.
8.15 p.m.—News Bulletin.
8.25 p.m.—Relay from Paris (Ecole Supérieure), 671 kc/s (447.1 m.).
8.35 p.m.—Gramophone Concert. After the Programme, Amusement Guide and Time Signal.

BRESLAU (Germany)

923 kc/s (325 m.); 1.7 kW.
Relayed by Gleiwitz, 1,184 kc/s (253 m.).
Transmits at intervals from 5.30 a.m.
5.35 p.m.—Weather, followed by Talk for Women.
6.0 p.m.—Weather Forecast.
6.5 p.m.—The Gramophone Records of the Month.
7.5 p.m.—Talk on the following transmission.
7.15 p.m.—"The Flower of Hawaii"—Operetta in Three Acts (Abraham), relayed from the Municipal Theatre, Beuthen, Upper Silesia. In the intervals at 8.20 p.m. and 9.45 p.m.—News.
10.30 p.m.—Notes for Cyclists.
10.45 p.m. (approx.)—Close Down.

BRUSSELS (Belgium) (No. 1)

I.N.R. 590 kc/s (509 m.); 20 kW.
12.15—1.45 p.m.—Gramophone Records.
5.0 p.m.—Orchestral Concert. Selection from "La Poupée" (Audran). Old French Airs (Broustet). Sérénade à Lisette (Caludi). Ein souper bei Suppé (Morena). Glow-Worm Gavotte (Lincke). Jeunesse dorée (Waldteufel).
5.45 p.m.—Programme for Children.
6.20 p.m.—Literary Review.
6.30 p.m.—Gramophone Records.
7.15 p.m.—Report of the Belgian Catholic Radio Society.
7.30 p.m.—Talk for Women.
8.0 p.m.—Orchestral Concert with Choral Selections of Christmas Music. In the interval, Talk: The New Belgium.

BRUSSELS (Belgium) (No. 2)

N.I.R. 887 kc/s (338.2 m.); 20 kW.
Programme in Flemish.
12.15—1.45 p.m.—Gramophone Records.
5.0 p.m.—Orchestral Concert. Neapolitan March (Baldi). Waltz from "Gipsy Love" (Lehar). Overture, "Le Petit Faust" (Hervé). Humorous Interlude (Monnier-Ackermans). Selection from "Flup" (Szulc). Character Piece (Neudo). Le Pas des fleurs (Delibes).
5.45 p.m.—Programme for Children.
6.30 p.m.—Gramophone Records.
7.15 p.m.—Meteorological Talk.
7.30 p.m.—Sports Review.
8.0 p.m.—Orchestral Concert. In the intervals, Address and Dramatic Programme.

BUCHAREST (Romania)

Radio-Bucarest. 761 kc/s (394 m.); 16 kW.
Transmits at intervals from 11.0 a.m.
6.0 p.m.—Educational Programme.
6.40 p.m.—Gramophone Records.
7.0 p.m.—Orchestral Concert.
7.30 p.m.—Talk.
7.45 p.m.—Song Recital.
8.15 p.m.—Orchestral Concert.
8.45 p.m.—News Bulletin.

BUDAPEST (Hungary)

545 kc/s (550 m.); 23 kW.
Transmits at intervals from 8.15 a.m.
4.25 p.m.—Concert by a Tzigane Orchestra.
5.30 p.m.—French Language Lesson.
6.0 p.m.—Song Recital by Aranka Stranzky. T. Polgar at the Piano-forte. Aria from "A Masked Ball" (Verdi). Aria from "Il Seraglio" (Mozart). Song from Ave Maria (Abranyi). Song (Polgar). Song from "The Merry Widow" (Lehar).
6.30 p.m.—Programme by T. Moly.
7.0 p.m.—Concert from Vienna, followed by Tzigane Music from the Hotel Royal.

COLOGNE (Germany)

Westdeutscher Rundfunk. 1,319 kc/s (227 m.); 1.7 kW.
See Langenberg.

COPENHAGEN (Denmark)

1,067 kc/s (281 m.); 0.75 kW.
Relayed by Kalundborg, 260 kc/s (1,153 m.).
Transmits at intervals from 6.30 a.m. (Gymnastics).
11.0 a.m.—1.0 p.m.—Concert from the Palace Hotel.
1.40 p.m.—Orchestral Concert conducted by Launy Gröndahl. Soloist: Inger Stockmarr Hermann (Vocalist). March, Olger the Dane (Norup). Waltz from "Der Rosenkavalier" (R. Strauss). Ballet Music from "Le Cid" (Massenet). Prelude to the Second Act of "Saul and David" (Carl Nielsen). Dance from "Maskarade" (Carl Nielsen). Five Christmas Songs. Overture, "Le Maçon" (Auber). Orientale (Cui). Theme and Variations from the Emperor Quartet (Haydn). Selection from "Samson and Delilah" (Saint-Saëns). Waltz from "Eugen Onegin" (Tchaikovsky). Czar-das from "Der Geist des Wojewoden" (Grossmann).
3.40 p.m.—Programme for Children: "The Journey to Bethlehem"—a Christmas Play for the Radio with Music.
4.40 p.m.—Exchange; Market Prices.
4.50 p.m. (from the Aarhus Studio)—Talk.
5.20 p.m.—Gardening Talk.
5.50 p.m.—Weather and News, and Report of the Danish Radio Club.
6.15 p.m.—Time Signal.
6.30 p.m.—Talk by A. Rantö.
7.0 p.m.—Town Hall Chimes.
7.2 p.m.—Concert of Modern Operetta Music, conducted by Emil Reesen. Shimmy Foxtrot from "Die tolle Lola" (Hirsch). Selection from "The Three Musketeers" (Friml). Selection from "Tip Toes" (Gershwin).
7.25 p.m.—"Il faut qu'une porte soit ouverte ou fermée"—Proverb in One Act (de Musset).
7.50 p.m.—Concert of French Music, by the Radio Orchestra, conducted by Emil Reesen. Arabesque in D Major and Two Selections from the "Petite Suite" (Debussy). Five Selections from "Soirs" (Schmitt).
8.15 p.m.—"A Caprice"—Play in One Act (de Musset).
8.55 p.m.—Recital of Danish Songs by Lilly Lamprecht.
9.15 p.m.—News Bulletin.

9.30 p.m.—Chamber Music for Wind Instruments. Divertissement No. 8 in F Major for Wind Instruments (Mozart). Sonata for Flute and Cembalo in E Flat Major (Bach). Divertissement No. 14 for Wind Instruments in B Flat Major (Mozart).
10.10 p.m.—Dance Music from the Palace Hotel.
11.0 p.m. (in an interval)—Town Hall Chimes.
11.30 p.m. (approx.)—Close Down.

DUBLIN (Ireland)

(2RN). 725 kc/s (413 m.); 1.5 kW.
Relayed by Cork, 1,337 kc/s (224.4 m.).
1.30—2.0 p.m.—Time, Weather, Stock Report and Gramophone Records.
6.0 p.m.—Gramophone Records.
6.15 p.m.—Programme for Children.
7.0 p.m.—Gramophone Records.
7.15 p.m.—News Bulletin.
7.30 p.m.—Time Signal.
7.32 p.m.—Leigheacht Gaedhulge.
7.45 p.m.—Talk by Nora Patricia Morrow: Christmas in Germany.
8.0 p.m.—Lecture Recital by Carl Hardebeck.
8.30 p.m.—Concert. German Songs by Mme. Mahr (Contralto). Patricia Ward (Violin). Hilda Dobbs (Soprano). The Station Sextet. A. W. Deale (Baritone).
9.30 p.m.—Sponsored Programme.
10.30 p.m.—Time, News, Weather and Close Down.

FÉCAMP (France)

Radio Normandie. 1,364 kc/s (219.9 m.); 1 kW.
12 noon.—Gramophone Concert.
8.0 p.m.—Exchange and News.
8.30 p.m.—Wireless Notes.
9.0 p.m. (from Le Havre)—Le Havre Chronicle, followed by Dramatic Programme.

FRANKFURT-am-MAIN (Germany)

770 kc/s (390 m.); 1.7 kW.
Relayed by Cassel, 1,220 kc/s (246 m.).
Transmits at intervals from 5.15 a.m. (Weather and Gymnastics).
4.5 p.m.—Concert from Wiesbaden. In the interval, Report by Dr. A. Paquet and Herr Schröder on the Frankfurt National Relief Work.
5.0 p.m.—Concert from the Café Bauer.
5.30 p.m.—Economic Notes.
5.45 p.m.—Talk: Musical Aphorisms.
6.5 p.m.—See Stuttgart.
6.30 p.m.—Time and News.
6.35 p.m.—Christmas Book Review.
6.45—9.30 p.m.—See Stuttgart.
9.30 p.m.—Time and News.

HAMBURG (Germany)

Norag (ha, in Morse). 806 kc/s (372 m.); 1.7 kW. Relayed by Bremen, 1,112 kc/s (270 m.); Flensburg, 1,373 kc/s (218 m.); Hanover, 530 kc/s (566 m.) and Kiel, 1,292 kc/s (232.2 m.).
Transmits at intervals from 5.30 a.m.
4.50 p.m.—Variety Programme.
5.30 p.m. (from Hanover)—Talk: The Life of Hunted Animals.
5.55 p.m.—Talk: Asia as an Industrial Area.
6.20 p.m.—Exchange, Market Prices and Weather.
6.30 p.m.—"Station 3" (Ernst Johannsen)—Dialogue on the Novel between the Author and H. Günther Marek, with Readings by the Author.
7.0 p.m.—"Christmas Music"—Choral and Orchestral Concert from the Works of German Composers. Strep. Singers, for Five-Part Choir, Piano, Orchestra and Organ (Franz Tunder). Motet for Six-Part Choir, God so loved the World (H. Praetorius). Magnificat anima mea, for Five-Part Choir, String Orchestra and Organ (Buxtehude). Ein kleines Kindelein—Aria for Soprano, String Orchestra and Organ (Franz Tunder). In dulci Jubilo, for Eight-Part Choir (Praetorius). Willkommen, süsser Bräutigam—Cantata for Two Sopranos, Two Violins and Organ (V. Lübeck). Lobet Christen, euren Heiland—Cantata for Two Sopranos and Bass, Two Violins and Organ (Buxtehude).
8.0 p.m.—See Vienna.
9.0 p.m.—News Bulletin.
9.20 p.m.—Topical Talk.
9.30 p.m.—"A Christmas Stroll"—Visits to the Restaurant Ostermann, the Reichshof Hotel and the Alsterpavillon.
10.30 p.m.—Ice Report.

HEILSBURG (Germany)

1,085 kc/s (276.5 m.); 75 kW.
Relayed by Danzig, 662 kc/s (453.2 m.).

Transmits at intervals from 5.30 a.m. (Gymnastics).

3.0 p.m.—Concert by the Königsberg Opera House Orchestra, conducted by Karl Hrubetz. March, Kopf hoch (Mannfred). Overture, "Ilka" (Doppler). Kometen-Walzer (Holländer). Potpourri, Viribus unitis (Richter). Overture to an Operetta (Lincke). Waltz, Deutsche Lieder (Weinberger). Potpourri, Fröhliche Weihnachten (Ködel). English Waltz, Spiel mir das Lied noch einmal (Strecker). Character Piece, Das Glockenspiel der Potsdamer Garnisonkirche (Steger). March, Kapitäl (Rusch).
4.25 p.m.—Book Review.
4.50 p.m. (from Danzig)—Agricultural Talk.
5.15 p.m.—Ice Report and Market Prices.
5.25 p.m.—Talk: Training in Domestic Economy.
5.50 p.m.—Book Review.
6.5 p.m.—Christmas Concert, relayed from the Treudank, Allenstein.
6.55 p.m.—Weather Report.
7.0 p.m.—See Vienna. Announcements in the interval.
9.30 p.m. (approx.)—Second News.

HILVERSUM (Holland)

1,004 kc/s (298.8 m.); 20 kW.
Programme of the Algemeene Vereeniging Radio Omroep (A.V.R.O.).
7.40 a.m.—Time Signal.
7.41 a.m.—Gramophone Records.
9.40 a.m.—The Daily Service.
9.55 a.m.—Gramophone Records.
10.10 a.m.—Piano-forte Recital by Egbert Veen. Sonata, Op. 10, in D Major (Beethoven). Rondo capriccioso (Mendelssohn).
10.40 a.m.—Talk.
11.10 a.m.—Gramophone Records.
11.40 a.m.—Time Signal.
11.41 a.m.—Trio Concert. In the interval, Gramophone Records.

1.40—2.10 p.m.—Interval.
2.10 p.m.—Gramophone Records.
2.40 p.m.—Instrumental Concert. G. Stotijn-Molenaar (Vocalist), Ellen Stotijn (Harp and Piano-forte), S. Rodriguez (Violin) and Jaap Stotijn (Oboe). Sonata for Violin, Oboe and Piano-forte (Loeillet). Aria for Soprano, Violin and Piano-forte from "Il re pastore" (Mozart). Sonatina for Harp (Nademann). Violin and Piano-forte Duets: (a) Melody (Gluck-Kreisler), (b) Chanson Louis XIII et Pavane (Couperin-Kreisler). Selections for Soprano and Harp (Grieg): (a) The Princess, (b) A Swan, (c) Solveig's Song. Pastorale for Oboe and Piano-forte Duet (Saint-Saëns). Nocturne for Soprano, Oboe and Piano-forte (Röntgen). Improvisation (Bloch). Aria for Soprano, Violin, Oboe and Piano-forte: Ruhet hier matter Sinne (Bach).
4.10 p.m.—Concert by a Children's Choir.
4.40 p.m.—Gramophone Records.
5.10 p.m.—Orchestral Concert. Soloist: Bob Scholte (Songs).
6.10 p.m.—Talk.
6.40 p.m.—Cello Sonata (Debussy), with Introductory Talk.
7.10 p.m.—Talk.
7.40 p.m.—Time Signal.
7.41 p.m.—Orchestral Concert. March, Unter dem Doppeladler (Wagner). Mikado Waltz (Komzak). A Perfect Day (Jacobs Bond). Slavonic Rhapsody (Friedemann). Selection from "Cavalleria Rusticana" (Mascagni). March, Bella Vista (Morena).
8.25 p.m.—Gramophone Records.
8.40 p.m.—Concert (continued). Schatzwalzer (Strauss). Love Song (Caludi). Dornröschen's Brautfahrt (Rhode). Potpourri, Rendez-vous bei Lehar (Hruby).
9.10 p.m.—Recitations.
9.25 p.m.—Concert (continued). Parade im Märchenland (Noack). Waltz, La Barcarolle (Offenbach-Fetras). Gänsemarsch (Helm-burgh-Holmes).
9.40 p.m.—Weather and News.
9.55 p.m.—Concert (continued). March, Hurrah! die Musik kommt! (Zimmer). Recitations. Selection from "Countess Maritza" (Kálmán). March, Hoch Heidecksburg (Herzer).

HUIZEN (Holland)

160 kc/s (1,875 m.); 8.5 kW.
7.40 a.m. till Close Down.—Programme of the Catholic Radio Society (K.R.O.).
7.40—8.55 a.m.—Gramophone Records.
11.10 a.m.—Religious Address.

11.40 a.m.—Police Notes.

11.55 a.m.—Trio Concert. March, Groot Rotterdam (Schootemeyer). Serenade (Widor). Waltz, Transaktionen (Strauss). Leuchtkäferchens Stelldichein (Siede). Selection from "Il Trovatore" (Verdi). Sailors' Song (Schumann). Mosaique sur Mozart (Tavan). Spring Song (Stabel). Waltz (Brahms). Signorina de Brioni (Rotter). Unter vier Augen (Stolz).
1.25 p.m.—Gramophone Records.
1.40 p.m.—Talk for Women.
2.40 p.m.—Dressmaking Lesson.
3.40—3.55 p.m.—Interval.
3.55 p.m.—Violin and Piano-forte Recital. Sonata No. 5, Op. 24—Spring Sonata (Beethoven). Sonata in A Major, Op. 100 (Brahms).
4.40 p.m.—Gramophone Records.
5.40 p.m.—Educational Talk.
6.10 p.m.—Gramophone Records.
6.25 p.m.—English Language Lesson.
6.50 p.m.—Talk by Dr. Deflandre.
7.10 p.m.—Police Notes.
7.25 p.m.—Talk (to be announced).
7.40 p.m.—"When the Star stood still"—Christmas Play (Felix Timmermans). News in the interval.
10.10 p.m.—Orchestral Concert. Gavotte (Gossec). Pizzicato from "Sylvia" (Delibes). Fantasia on the Works of Grieg (Urbach). Fiesta (Samuels). Potpourri, Hals- und Beinbruch (Morena). Serenade (Heykens). Selection from "The Pearl Fishers" (Bizet). Rose mousse (Bosc). 1900—Popular Song Potpourri (Renaud-Lustenhauer). Idylle passionnelle (Razigade). Finale.
11.40 p.m. (approx.)—Close Down.

KALUNDBORG (Denmark)

Kalundborg Radio. 260 kc/s (1,153 m.); 7.5 kW.
See Copenhagen.

KATOWICE (Poland)

734 kc/s (408 m.); 16 kW.
Transmits at intervals from 10.58 a.m.
3.40 p.m.—Gramophone Records.
4.35 p.m.—Symphony Concert.
7.15 p.m.—Popular Concert.
9.10 p.m.—Viola Recital.
10.0 p.m.—Light Music and Dance Music.
KAUNAS (Lithuania)
155 kc/s (1,935 m.); 7 kW.
4.0 p.m.—Talk: The House and the Woman.
4.30 p.m.—Lithuanian Lessons.
5.0 p.m.—Agricultural Talk.
5.20 p.m.—Soloist Concert.
5.30 p.m.—Weather Report.
6.15 p.m.—Review of Foreign Affairs.
6.30 p.m.—Concert. Comedy Overture (Lincke). Waltz, Golden Rain (Waldteufel). Serenade, Amina (Lincke). Einzug der Rosenkönigin (Rhode). Suite, Straussferdem (Morena).
8.10 p.m.—Review of New Books.
8.30 p.m.—Talk in Esperanto.
8.45 p.m.—Concert. Overture, "Si j'étais Roi" (Adam). Waltz, Die Romantiker (Lanner). Lyric Intermezzo, Dolorosa (Lindemann). Valse triste (Arnold). Selection from "The Queen of Spades" (Tchaikovsky).

LAHTI (Finland)

167 kc/s (1,796 m.); 54 kW. Relayed by Helsinki, 815 kc/s (368.1 m.).
Transmits at intervals from 10.0 a.m.
4.0 p.m.—Scout Programme.
5.15 p.m.—Talk (to be announced).
5.40 p.m.—Violin Recital.—Adagio from the Violin Concerto (Sibelius). Sarabande and Chaconne for Solo Violin (Bach).
6.5 p.m.—Talk (to be announced).
6.30 p.m.—Orchestral Concert, relayed from the Conservatoire. Homage to Händel (Klami). Music of the Blue Mountains and Witches' Dance (Ranta). Romance for String Orchestra (Sibelius). Grand Fantasia for Piano-forte and Orchestra—Der Wanderer (Schubert-Liszt). Abendlied (Schumann). Waltz, Tales of the Vienna Woods (Joh. Strauss).
7.45 p.m.—News in Finnish.
8.0 p.m.—News in Swedish and Close Down.

LANGENBERG (Germany)

Westdeutscher Rundfunk. 635 kc/s (473 m.); 17 kW. Relayed by Aachen, Cologne and Münster. 1,319 kc/s (227 m.).
Transmits at intervals from 5.45 a.m. (Gymnastics).
4.0 p.m.—Vocal and Instrumental Concert.
5.0 p.m.—Talk: Books for Young People—Nature and Technics.
5.20 p.m.—Agricultural Talk.

Programmes for Tuesday—(Cont.)

5.40 p.m.—French Conversation.
6.0 p.m.—Time and News.
6.15 p.m.—The Mystery of Christmas—An Introduction to the Three Christmas Masses, by Herr von Lassaulx and the Choir of the Catholic Church Music Section of the Cologne Academy of Music.

LEIPZIG (Germany)
1.157 kc/s (259 m.); 2.3 kW. Relayed by Dresden, 941 kc/s (319 m.).
Transmits at intervals from 5.30 a.m.

4.30 p.m.—Weather and Time.
4.50 p.m.—Economic Notes.
5.5 p.m.—Announcements.
5.15 p.m.—Talk: Remember the Unemployed!

LJUBLJANA (Yugoslavia)
522 kc/s (574.7 m.); 2.8 kW. Transmits at intervals from 10.30 a.m.

7.0 p.m.—Wireless Notes.
7.30 p.m.—Programme (not yet announced) relayed from Zagreb, 977 kc/s (307 m.).

LWÓW (Poland)
788 kc/s (381 m.); 21 kW. Transmits at intervals from 10.45 a.m.

MADRID (Spain)
Union Radio (EAJ7). 707 kc/s (424.3 m.); 2 kW. Transmits at intervals from 8.0 a.m.

MILAN (Italy)
Ente Italiano Audizioni Radiofoniche. 905 kc/s (331.5 m.); 8.5 kW. Relayed by Turin, 1,004 kc/s (274.2 m.) and Genoa, 959 kc/s (312.8 m.).

6.0 p.m.—Agricultural Notes.
6.15 p.m.—Concert of Light Music.
6.40 p.m.—Announcements.
6.45 p.m.—Gramophone Records.

7.30 p.m.—English Lesson on Gramophone Records.
7.45 p.m.—Talk on Science.
8.0 p.m.—Respighi Concert, conducted by the Composer. Suite, The Birds. Gregorian Concerto for Violin and Orchestra.

8.0 p.m.—Tristan und Isolde—Opera (Wagner) on Gramophone Records by the Bayreuth Cast. In the intervals at 8.30 p.m.—Sports Results, Weather and Talk, and at 9.15 p.m.—News and Time.

MUNICH (Germany)
563 kc/s (533 m.); 1.7 kW. Relayed by Augsburg and Kaiserslautern, 536 kc/s (560 m.); and Nürnberg, 1,256 kc/s (239 m.).

6.0 p.m.—Talk: Rossini on a Visit to Beethoven.
6.20 p.m.—Talk: The New form of Popular Oratorio.
6.40 p.m.—Psychological Talk.

7.0 p.m.—Frau Holle—a Fairy Play (Joseph Steck). Music by Karl List.
8.0 p.m.—Orchestral Concert.
9.0 p.m.—A Dialogue on Welfare Work.
9.20 p.m.—Time and News.

OSLO (Norway)
Kringkastingsselskapet, 277 kc/s (1,083 m.); 75 kW. Relayed by Fredrikstad, 816 kc/s (367.6 m.); Hamar, 536 kc/s (560 m.); Notodden, 671 kc/s (447.1 m.); Porsgrund, 662 kc/s (453.2 m.); and Rjukan, 671 kc/s (447.1 m.).

5.45 p.m.—Accordion Recital.
6.0 p.m.—News Bulletin.
6.30 p.m.—Talk: The History of Whaling.
7.0 p.m.—Time Signal.
7.2 p.m.—Orchestral Concert. Overture, "Alceste" (Gluck). Concerto for Piano and Orchestra in A Major (Mozart). Suite, Mother Goose (Ravel). Unfinished Symphony in B Minor (Schubert).

PARIS (France)
Eiffel Tower (FLE). 207.5 kc/s (1,445.7 m.); 15 kW. Time Signals (on 2,650 m.) at 9.26 a.m. and 10.26 p.m. (preliminary and 6-dot signals).

5.45 p.m.—Le Journal Parlé.
7.5 p.m.—Gramophone Records.
7.20 p.m.—Weather Forecast.
7.30 p.m.—Pianoforte Recital by Mme. Marie-Antoinette Pradier, with Introductory Talk. Two Sonatas (Solér). Selections (Albeniz): (a) Cordoba, (b) Cadiz. Two Dances (Granados).

PARIS (France)
Poste Parisien. 914 kc/s (328.2 m.); 1.2 kW.
8.15 p.m.—Gramophone Records and News.
8.45 p.m.—Sports Talk, Gramophone Records and News.

9.0 p.m.—Concert with the collaboration of Artists from the Opéra and Opéra-Comique. Overture, "The Cunning Peasant" (Dvorák). Minuet and Gavotte (Schreker). Cuadros—Spanish Scenes (Laparra). Symphonic Poem, La chasse fantastique (Guiraud), conducted by M. Théodore Mathieu. Ballad (Liadoff). Selection from "Le Luthier de Crémone" (Hubay). Concert Waltz (Glazounoff). Cortège burlesque (Chabrier).

PARIS (France)
Radio-Paris (CFR). 174 kc/s (1,725 m.); 80 kW. Transmits at intervals from 6.45 a.m. (Physical Culture).

12.30 p.m.—Gramophone Records.
1.0 p.m.—Exchange and News.
1.5 p.m.—Gramophone Concert of Chamber Music. Quintet in E Flat for Wind Instruments and Pianoforte (Mozart). Ballet Music from "Rosamunde" (Schubert). Perpetual Movement for Pianoforte (Weber). Songs (R. Strauss): (a) Cécilie, (b) Befreit. Quartet in G Major (Beethoven). In the intervals at 1.30 p.m. and 2.0 p.m.—Exchange Quotations.

3.35 p.m.—Exchange; Market Prices.
4.20 p.m.—Elementary English Lesson.
6.30 p.m.—Agricultural Report, Market Prices, Racing Results and Weather Report.
7.0 p.m.—Theatre Review.
7.15 p.m.—Talk on Art: Coins and Medals.

7.30 p.m.—Gramophone Records.
7.45 p.m.—Commercial Prices, Economic and Social Notes and News.
8.0 p.m.—"Tristan und Isolde"—Opera (Wagner) on Gramophone Records by the Bayreuth Cast. In the intervals at 8.30 p.m.—Sports Results, Weather and Talk, and at 9.15 p.m.—News and Time.

RADIO-SUISSE ROMANDE (SOTTENS) (Switzerland)
743 kc/s (403 m.); 25 kW.; Lausanne, 442 kc/s (680 m.); and Geneva, 395 kc/s (760 m.). Transmits at intervals from 11.30 a.m.

6.0 p.m.—Weather Forecast.
6.1 p.m.—(from Lausanne)—Organ Recital from the Capitol Cinema.
6.30 p.m.—(from Lausanne)—German Lesson.
6.55 p.m.—News Bulletin.

7.0 p.m.—(from Neuchâtel)—Talk: Fighting Noise in Towns.
7.25 p.m.—(from Neuchâtel)—Organ and Cello Recital.
8.0 p.m.—(from Genova)—Christmas Carols.
8.15 p.m.—Orchestral Concert.
9.15 p.m.—News Bulletin.
9.30 p.m.—(approx.)—Close Down.

RIGA (Latvia)
572 kc/s (525 m.); 15 kW. Transmits at intervals from 10.0 a.m.
6.0 p.m.—Weather Report.
6.5 p.m.—Popular Orchestral Concert. Overture, "Iphigenia in Aulis" (Gluck). Song without Words and Nocturne (Mendelssohn). Songs. Waltz from "The Count of Luxembourg" (Lehár). Symphonic Suite (Garcin).

ROME (Italy)
Ente Italiano Audizioni Radiofoniche. (IRO). 680 kc/s (441 m.); 75 kW. Relayed by Naples, 941 kc/s (319 m.); and 2RO, 3,750 kc/s (80 m.). Transmits at intervals from 7.15 a.m. (Giornale Radio).

4.30—5.15 p.m.—Vocal and Instrumental Concert.
6.20 p.m.—Announcements.
6.32 p.m.—Atmospheric Signals, followed by Shipping and Sports Report from Naples.
6.40 p.m.—News Bulletin.

7.0 p.m.—Sports; Press Review.
7.30 p.m.—Time, Announcements and English Lesson, followed by Gramophone Music.
8.0 p.m.—Concert. Violin Solos by Mary Sardo: (a) Aria in Old Style (Gabriel-Marie), (b) Tzigane (Ravel), (c) The Flight of the Bumble Bee, from "The Tale of Czar Saltana" (Rimsky-Korsakoff). Reading. Pianoforte Solos by Clara Sardo: (a) Les cyclopes (Rameau), (b) Witches' Dance (MacDowell). Popular Tuscan Songs for Two Sopranos. Violin Solos by Mary Sardo: (a) Romance in F (Beethoven), (b) Caprice (Paganini-Auer), "A colpi di spillo"—Play in One Act (Gino Rocca). Gramophone Records.

9.55 p.m.—News Bulletin.
SCHENECTADY (U.S.A.)
General Electric Company (WGY). 790 kc/s (379.5 m.); 50 kW. Relayed at intervals by W2XAF on 9,530 kc/s (31.48 m.), and by W2XAD on 15,340 kc/s (19.56 m.). Transmits at intervals from 11.45 a.m.

9.0 p.m.—Bridge Lesson.
9.30 p.m.—Stock Reports and Police Notes.
9.45 p.m.—Roger Sweet (Tenor).
10.0 p.m.—News Bulletin.
10.5 p.m.—Studio Ensemble.
10.30 p.m.—Rinso Talkie, relayed from New York.

10.45 p.m.—Giovannina de Blasiis (Piano).
11.0 p.m.—Doc Peyton and his Kenmore Orchestra.
11.30 p.m.—Time Signal.
11.31 p.m.—Jeanette Getz (Pianist).
11.44 p.m.—Weather Report.
11.45 p.m.—The Stebbins Boys from New York.

12 midnight (WGY only)—General Electric Programme.
12 midnight (W2XAF only)—Stock Reports and News.
12.30 a.m.—(Wednesday)—4.15 a.m.—New York Relay.
12.30 a.m.—Prince Albert Programme.
12.45 a.m.—Trials of the Lindbergs.
1.0 a.m.—Blackstone Plantation.
1.30 a.m.—Goodyear Programme.
2.0 a.m.—McKesson Musical Magazine.

2.30 a.m.—The Fuller Man.
3.0 a.m.—Lucky Strike Dance Hour.
4.0 a.m.—Marion Harris (Crooner).
4.15 a.m.—Leonard and Sherman—Piano Twins.
4.30 a.m.—Organ Recital from Proctor's Theatre.
5.0 a.m.—Jack Miles and his DeWitt Clinton Orchestra.
5.30 a.m.—Doc Peyton and his New Kenmore Orchestra.
6.0 a.m.—(approx.)—Close Down.

SCHWEIZERISCHER LANDESENDER (BERO-MÜNSTER) (Switzerland)
653 kc/s (459 m.); 75 kW.; Basle, 1,229 kc/s (244.1 m.); and Berne, 1,220 kc/s (246 m.). Transmits at intervals from 11.28 a.m.

2.30 p.m.—Gramophone Records.
2.58 p.m.—Time Signal.
3.0 p.m.—Orchestral Concert.
4.0 p.m.—(from Zürich)—Talk for Women.
4.30 p.m.—Weather Report.

4.35—5.30 p.m.—Interval.
5.30 p.m.—Gramophone Records.
6.0 p.m.—(from Basle)—Talk: Switzerland, the Newspaper Country of the World.
6.28 p.m.—Time and Weather.
6.30 p.m.—(from Basle)—Talk: Post-War Music, with Gramophone Illustrations.

7.0 p.m.—(from Berne)—Haydn Concert by the Schiffmann String Quartet and the Station Orchestra.
8.0 p.m.—"Aus dem Hohelied Salomonis"—Song Cycle for Contralto, Bass, String Quartet and Pianoforte (Zilcher).
8.30 p.m.—Orchestral Concert.
9.0 p.m.—Weather and News.
9.15 p.m.—(approx.)—Close Down.

STOCKHOLM (Sweden)
Radiotjänst (SASA). 689 kc/s (436 m.); 75 kW. Relayed by Boden, 244 kc/s (1,229.5 m.); Göteborg, 932 kc/s (322 m.); Hörby, 1,166 kc/s (257 m.); Motala, 222.5 kc/s (1,348 m.); Östersund, 389 kc/s (770 m.) and Sundsvall, 554 kc/s (542 m.). Transmits at intervals from 6.45 a.m.

4.0 p.m.—Programme for Children.
4.30 p.m.—Gramophone Records.
5.30 p.m.—The Practical Corner.
5.45 p.m.—Song Recital by Artur Rolén.
6.0 p.m.—Talk, relayed from Boden.
6.15 p.m.—Weather and News.
6.30 p.m.—A Play (Oscar Rydqvist).
7.45 p.m.—Pianoforte Recital from the Works of Henning Mankell. Ballad No. 3 in G Sharp Minor. Sonata Fantasia, Op. 76.
8.15 p.m.—Literary Review relayed from Malmö, 1,301 kc/s (231 m.).
8.45 p.m.—News and Weather.
9.0 p.m.—Orchestral Concert. Carnival Overture (Dvorak). Waltz, Frühlingsstimmen (Strauss). An den Frühling (Grieg). Humoresque (Aulin). Tango (Friedmann). Söderman Mosaik (E. Rudolf). Russian Mazurka (Glinka). Bizet Potpourri (Urbach).

10.0 p.m.—(approx.)—Close Down.
STRASBOURG (France)
Radio-Strasbourg (PTT). 869 kc/s (345 m.); 15 kW. Transmits at intervals from 11.30 a.m.

6.0 p.m.—Instrumental Concert. Macedonian March (Millöcker). Valse des brunes (Ganne). Festival Overture (Lortzing). Minuet (Kostal). Selection from "Madame Butterfly" (Puccini). Persian Dance (Guiraud).

6.45 p.m.—Talk in French.
7.0 p.m.—Gramophone Records.
7.30 p.m.—Time Signal.
7.32 p.m.—News in French and German.
7.45 p.m.—Gramophone Records.
8.30 p.m.—Concert by the Wireless Orchestra, conducted by Maurice de Villers: Soloists: Mlle. Arcos and M. Hazart (Vocalists). Overture to and Aria from "Iphigenia in Aulis" (Gluck). Les Préludes (Liszt). Die Loreley (Liszt). Three Selections (Saint-Saëns): (a) Ballet Music from "Henry VIII," (b) Le Pas d'armes du Roi Jean, (c) Algerian Suite.

10.30 p.m.—(approx.)—Close Down.
STUTTGART (MÜHL-ACKER) (Germany)
Süddeutscher Rundfunk. 832 kc/s (360.5 m.); 75 kW. Relayed by Freiburg, 527 kc/s (570 m.). Transmits at intervals from 5.15 a.m. (Frankfurt Relay).

6.5 p.m.—Talk: Is Winnetou still alive?
6.30 p.m.—Time and News.
6.45 p.m.—Unfamiliar Songs of Christian F. D. Schubart, composed during his captivity at Hohensasperg. Introductory Talk: An Unknown Schubart Song Manuscript. Soprano Solos: Ten Songs from this Manuscript.

7.25 p.m.—German Humorists—Hans Reimann.
7.50 p.m.—"Berthold und Binchen"—a Little Christmas Piece of the Rococo Period (Eric Fischer). Music by Gluck.
8.10 p.m.—Concert by the Stuttgart Philharmonic Orchestra, conducted by Hermann Scherchen. Romantic Suite (Reger). Orchestral Study (Vogl). Third Symphony in E Flat Major, Op. 97—the Rhenish (Schumann). Orchestral Etudes (Vladimir Vogel).

9.30 p.m.—Time and News.
11.30 p.m.—Late Concert.
12.30 a.m.—(Wednesday)—Close Down.
TOULOUSE (France)
Radiophonie du Midi. 779 kc/s (385 m.); 8 kW. Transmits at intervals from 12.45 p.m.

5.45 p.m.—Orchestral Selections. Overture, Leonore (Beethoven). Allegro vivace from the Symphony No. 34 in C (Mozart).

6.0 p.m.—Songs from (a) "Scheherazade" (Ravel), (b) "Boris Godounoff" (Moussorgsky), (c) "The Tales of Hoffmann" (Offenbach).
6.15 p.m.—Accordion Solos.
6.30 p.m.—News Bulletin.
6.45 p.m.—Orchestral Selections from "Carmen" (Bizet) and "I Pagliacci" (Leoncavallo).

7.0 p.m.—Light Music.
7.15 p.m.—Sound Film Music.
7.30 p.m.—News Bulletin.
7.45 p.m.—Orchestral Selections.
8.15 p.m.—Military Music.
8.30 p.m.—Gramophone Records.
9.0 p.m.—Concert.
10.0 p.m.—Dance Music from the Café Sion. In the interval at 10.30 p.m.—News Bulletin.
11.0 p.m.—Chansonnettes.
11.15 p.m.—North African News.
11.30 p.m.—Orchestral Selections: Scènes alsaciennes (Massenet).
11.45 p.m.—Polovtsian Dances from "Prince Igor" (Borodin).
12 midnight.—Weather, Announcements and Close Down.

TRIESTE (Italy)
Ente Italiano Audizioni Radiofoniche. 1,211 kc/s (247.7 m.); 15 kW. Transmits at intervals from 11.30 a.m.

7.15 p.m.—News Bulletin.
7.25 p.m.—English Lesson on Gramophone Records.
7.30 p.m.—Gramophone Records.
8.0 p.m.—Time and Announcements.
8.5 p.m.—"Manon"—Opera (Puccini). News after the Opera.

VIENNA (Austria)
Radio-Wien. 581 kc/s (517 m.); 20 kW. Relayed by Graz, 852 kc/s (352.1 m.); Innsbruck, 1,058 kc/s (283 m.); Klagenfurt, 662 kc/s (453.2 m.); Linz, 1,220 kc/s (246 m.); and Salzburg, 1,373 kc/s (218 m.). Transmits at intervals from 8.20 a.m.

6.5 p.m.—Gymnastics, by Käthe Hye.
6.30 p.m.—Popper Lynkeus, on the Tenth Anniversary of his Death—"Fantasies of a Realist" with Introductory Talk.
6.50 p.m.—Time; Announcements.
7.0 p.m.—Concert of Music from Viennese Operettas, for Soprano, Tenor and Orchestra.
9.30 p.m.—News Bulletin.
9.45 p.m.—Dance Music from the "Oase."

WARSAW (Poland)
Polskie Radio. 212.5 kc/s (1,411 m.); 158 kW. Transmits at intervals from 10.45 a.m.

1.45 p.m.—Gramophone Records.
2.15 p.m.—Talk on Aviation.
2.25 p.m.—Talk: Reflections before the Carnival.
2.45 p.m.—Exchange and Announcements.
2.50 p.m.—Programme for Children.
3.20 p.m.—Talk relayed from Lodz.
3.40 p.m.—Gramophone Records.
4.10 p.m.—Astronomical Talk, relayed from Wilno, 1,229 kc/s (244.1 m.).
4.35 p.m.—Concert by the Warsaw Philharmonic Orchestra. Soloist: Ruta Krongold (Violin). Selections (Beethoven): (a) Overture, "Coriolanus" (b) Allegretto from the Seventh Symphony. Concerto No. 4 in D Major for Violin (Mozart). Suite No. 2 from "L'Arlesienne" (Bizet). Rakoczy March (Berlioz).
5.50 p.m.—Miscellaneous Items.
6.15 p.m.—Agricultural Talk.
6.25 p.m.—Programme Announcements.
6.30 p.m.—Gramophone Records.
6.45 p.m.—Radio Journal.
7.0 p.m.—Talk.
7.15 p.m.—Orchestral Concert. Soloist: M. Bojar-Przemieniecka (Soprano) and B. Jakowenko (Trumpet). Overture, "Der Schauspieldirektor" (Mozart). Selection from "La Traviata" (Verdi). Selection from "I Lombardi" (Verdi). Two Songs from "The Force of Destiny" (Verdi). Selection from "Mignon" (Thomas). Fantasia for Trumpet and Orchestra: The Pearl of the Ocean (Otterer). Songs: (a) Evening (Noszkovsky), (b) Sans toi (Zarzycki), (c) Brunette (Zelensky). Selections (Chopin): (a) Nocturne in G Minor, Op. 15, (b) Mazurka in D Major. Trumpet Solo: L'abricot (Moniuszko). Waltz and Cracovienne from "Pan Twardovsky" (Rozycki). Mazurka from "The Siren" (Maliszewsky).
8.55 p.m.—Correspondence and Technical Notes.
9.10 p.m.—Viola Recital.
9.40 p.m.—Radio Journal.
9.45 p.m.—Announcements.
10.0 p.m.—Dance Music.
11.0 p.m.—(approx.)—Close Down.

PROGRAMMES FOR WEDNESDAY

(December 23)

NOTE: THE HOURS OF TRANSMISSION ARE REDUCED TO GREENWICH MEAN TIME

BARCELONA (Spain)

Radio-Barcelona (E.A.J.), 860 kc/s (349 m.); 8 kW.
Transmits at intervals from 7.30 a.m.
7.0 p.m.—Trio Concert.
7.30 p.m.—Exchange and Request Concert of Gramophone Records.
8.0 p.m.—Talk in Catalan.
8.15 p.m.—Request Gramophone Records.
8.30 p.m.—Catalan Lesson.
9.0 p.m.—Chimes, Weather and Exchange.
9.5 p.m.—Orchestral Concert.
9.30 p.m.—Song Recital.
10.0 p.m.—Reading.
10.15 p.m.—Trio Concert from the Granja Royal.
12 midnight (approx.)—Close Down.

BERLIN (Germany)

Königs Wusterhausen, 183.5 kc/s (1,635 m.); 75 kW.
Transmits at intervals from 5.30 a.m. (Witzleben Relay).
3.30 p.m.—See Hamburg.
4.30 p.m.—"Des Knaben Wunderhorn," by Love Kornell, Dr. F. Günther and Dr. H. Michaelis.
5.0 p.m.—Talk: The Conquest and Opening-up of Siberia and Manchuria.
5.30 p.m.—Talk: The Old Masters and Ourselves.
5.55 p.m.—Weather for Farmers.
6.0 p.m.—Talk for Civil Servants.
6.30 p.m.—See Breslau.
7.30 p.m. (approx.)—See Munich.
9.20 p.m.—Political Press Review and News, followed by Dance Music from Berlin (Witzleben).
11.30 p.m. (approx.)—Close Down.

BERLIN (Germany)

715 kc/s (418 m.); 1.7 kW.
Transmits at intervals from 5.30 a.m. (Gymnastics).
6.0 p.m.—Topical Talk.
6.10 p.m.—Organ Recital.
6.30 p.m.—Reading.
7.0 p.m.—"The Play of the Three Kings" (Felix Timmermans), translated from the Flemish by Anton Kippenberg. Music by Walter Gronostay.
8.15 p.m.—News Bulletin.
8.25 p.m.—Recital of Christmas Carols, followed by "Christmas"—a Song Cycle (Peter Cornelius), for Soloists, Mixed Choir, String Quintet, Oboe and Clarinet (arranged by J. Dantonello).
9.10 p.m.—News, followed by Dance Music.
11.30 p.m. (approx.)—Close Down.

BORDEAUX-LAFAYETTE (France)

(P.T.F.), 986 kc/s (304 m.); 35 kW.
Transmits at intervals from 12.45 p.m.
7.30 p.m.—News and Market Prices.
7.40 p.m.—Gramophone Records.
7.55 p.m.—Results of the Prize Draw.
8.0 p.m.—Agricultural Report.
8.20 p.m.—News Bulletin.
8.25 p.m.—Relay from Paris (Ecole Supérieure), 671 kc/s (447.1 m.).
8.35 p.m.—Comedy Programme, followed by Amusement Guide and Time Signal.

BRESLAU (Germany)

923 kc/s (325 m.); 1.7 kW.
Relayed by Gleiwitz, 1,184 kc/s (253 m.).
Transmits at intervals from 5.30 a.m.
6.0 p.m.—That will interest you!—Surprise Programme.
6.25 p.m.—Weather Forecast.
6.30 p.m.—Concert by the Silesian Philharmonic Orchestra, conducted by Franz Marszalek. Overture, "The Black Domino" (Auber). Petite Suite (Debussy). Selection from "Hansel and Gretel" (Humperdinck). Dance Suite (v. Frankenstein). Waltz, Sinnen und Minnen (Strauss). Overture, "Pique Dame" (Suppé). Jubelfest-Marsch (Strauss).
8.0 p.m.—News Bulletin.
8.10 p.m.—The Silesian Broadcasting Authorities wish everyone a Merry Christmas. Concert, with Variety Items in the interval.
9.30 p.m.—Time and News.
9.50 p.m.—A Talk by E. Ernst.
10.5 p.m.—Concert of Light Music.
11.0 p.m. (approx.)—Close Down.

BRUSSELS (Belgium) (No. 1)

I.N.R., 590 kc/s (509 m.); 20 kW.
12.15—1.45 p.m.—Gramophone Records.
5.0 p.m.—Dance Music from the Atlanta Hotel.
6.0 p.m.—Gramophone Concert.
6.15 p.m.—Talk: Helping Crippled Children.

6.30 p.m.—Modern Operetta Concert on Gramophone Records, with Commentary.
7.15 p.m.—"The Microphone Investigates"—Great Belgian Scientific Institutions—The University Foundations.

7.30 p.m.—Le Journal Parlé.
8.0 p.m.—Programme of Walloon Christmas Carols for Soloists and Choirs.
9.0 p.m.—Concert relayed from the "Augustins."
10.0 p.m.—Le Journal Parlé.

BRUSSELS (Belgium) (No. 2)

N.I.R., 887 kc/s (338.2 m.); 20 kW.
Programme in Flemish.
12.15—1.45 p.m.—Gramophone Records.
5.0 p.m.—Sonata for Violin and Pianoforte (Marsick) by MM. Wagemans and Scharrés.
5.30 p.m.—Gramophone Records.
6.15 p.m.—Talk on Economics.
6.30 p.m.—Gramophone Records.
7.15 p.m.—Talk: Art and Life.
7.30 p.m.—Review of International Events.
8.0 p.m.—Pianoforte Recital by Mlle. Tambuyser. Selections (Scarlati): (a) Gigue in G Major, (b) Sicilienne in F Major. Les tourbillons (Dandrieu). La mélodieuse (Daquin). Les Maillotins (Couperin). Rhapsody in G Minor (Brahms). En tartane (de Sévèrac). Prelude in G Major (Rachmaninoff). Triana (Albeniz).
8.30 p.m.—A Play in One Act.
9.0 p.m.—Concert relayed from Antwerp.
10.0 p.m.—Le Journal Parlé.

BUCHAREST (Romania)

Radio-Bucarest, 761 kc/s (394 m.); 16 kW.
Transmits at intervals from 11.0 a.m.
6.0 p.m.—Educational Programme.
6.40 p.m.—Gramophone Records.
7.0 p.m.—Violin Recital.
7.30 p.m.—Talk.
7.45 p.m.—Pianoforte Recital.
8.45 p.m.—News Bulletin.

BUDAPEST (Hungary)

545 kc/s (550 m.); 23 kW.
Transmits at intervals from 8.15 a.m.
5.30 p.m.—Orchestral Concert of Operetta Music, conducted by Sigismund Vincze. Soloist: Ila Verböczy. Overture (Maillart). Selection from "Endlich allein" (Lehár). Selection from "Zigeunerprimas" (Kálmán). Selection from "Ein Herbstmanöver" (Kálmán). Miami (Jacobi-Vincze). Song from "Habanita" (Kiszely). Selection from "Die geschiedene Frau" (Fall).
6.45 p.m.—Programme by E. Ybl.
7.10 p.m.—Concert by a Tzigane Orchestra.
8.0 p.m.—Recital by Arpad O. Iry.
9.0 p.m.—Hungarian String Quartet. String Quartet in D Major (Mendelssohn). String Quartet in D Minor (Haydn).
10.0 p.m.—Concert by the Imre Magyari Tzigane Orchestra.

COLOGNE (Germany)

Westdeutscher Rundfunk, 1,319 kc/s (227 m.); 1.7 kW.
See Langenberg.

COPENHAGEN (Denmark)

1,067 kc/s (281 m.); 0.75 kW.
Relayed by Kalundborg, 260 kc/s (1,153 m.).
Transmits at intervals from 6.30 a.m. (Gymnastics).
2.0 p.m.—Wind Instrument Concert, conducted by Johannes Andersen. March, Hoch Habsburg (Kral). Overture, "Flotte Bursche" (Suppé). Britta-Polka and Nordlys Waltz (Lumbye). Selection from "Gluntarne" (Wennerberg). O Star of Eve from "Tannhäuser" (Wagner). Dances from "Giselle" (Adam). March, Per aspera ad astra (Urbach). Regina March (Urbach). Overture, Nordisk Saeterreise (Gade). Waltz, Wienerblut (Strauss). Polka, Les petites Zouaves trompettes (Meyer). Two Selections from "Carmen" (Bizet). Selection from "King and Marshall" (Heise). Tivoli Vauxhall Polka (Heise). King Christian IX March.
2.45 p.m. (in the interval)—Talk for Women.
4.0 p.m.—Gramophone Records.
4.40 p.m.—Exchange, Market Prices.
5.20 p.m.—Talk: National Types as seen by Foreigners: The Irish in English Literature.
5.50 p.m.—Weather and News.
6.15 p.m.—Time Signal.
6.30 p.m.—Agricultural Talk.
7.0 p.m.—Town Hall Chimes.
7.2 p.m.—Concert of Danish Music,

conducted by Emil Reesen. Four Selections (J. P. E. Hartmann): (a) Overture, "Corregio," (b) Waltz from "Küchlein," (c) Dance from "Little Christie," (d) Prelude, "St. Swithin's Day." Selection from the Music to "Gurre" (Horneman). Prelude and Evening Music from "Once upon a time" (Lange-Müller). Prelude to "Wayland the Smith" (Henriques).
7.45 p.m.—Reading.
8.15 p.m.—"Christmas Cantata" (Poul Schierbeck), conducted by the Composer.
8.30 p.m.—Talk: Old Christmas Plays.
8.50 p.m.—News Bulletin.

9.5 p.m.—Orchestral and Soloist Concert, conducted by Emil Reesen. Overture, "Die beiden Husaren" (Doppler). Valse des blondes (Ganne). Caprice for Three Solo Violins (Hermann). Selection from "The Daughter of the Regiment" (Donizetti). English Horn Solo: Berceuse russe (Gröndahl). Ballet égyptien (Luigini). Fugue for Oboe, Clarinet and Bassoon (Lachner). Polka from "The Bartered Bride" (Smetana).
10.0 p.m.—Dance Music from the Lodberg Restaurant.
11.0 p.m. (in an interval)—Town Hall Chimes.
11.30 p.m. (approx.)—Close Down.

DUBLIN (Ireland)

(2RN), 725 kc/s (413 m.); 1.5 kW.
Relayed by Cork, 1,337 kc/s (224.4 m.).
1.30—2.0 p.m.—Time, Weather, Stock Report and Gramophone Records.
6.0 p.m.—Gramophone Records.
6.15 p.m.—Programme for Children.
7.0 p.m.—Gramophone Records.
7.20 p.m.—News Bulletin.
7.30 p.m.—Time Signal.
7.32 p.m.—Irish Lesson.
7.45 p.m.—German Lesson.
8.0 p.m.—Concert. The Station Sextet. W. F. Watt (Tenor). Seamus Mac Aonghusa (Pipe Selections). Lena Munro (Soprano). The Station Sextet. Frank Cowle (Baritone).
9.30 p.m.—"Commencing 23rd December," presented by Ian Priestly Mitchell.
10.30 p.m.—Time, News, Weather and Close Down.

FÉCAMP (France)

Radio Normandie, 1,364 kc/s (219.9 m.); 1 kW.
12 noon.—Concert.
8.0 p.m.—Exchange and News.
8.30 p.m.—Variety Programme.

FRANKFURT-am-MAIN (Germany)

770 kc/s (390 m.); 1.7 kW.
Relayed by Cassel, 1,220 kc/s (246 m.).
Transmits at intervals from 5.15 a.m. (Weather and Gymnastics).
4.5 p.m.—Concert from Wiesbaden.
5.45 p.m.—Educational Talk.
6.5 p.m.—See Stuttgart.
6.45 p.m.—Talk by Hans Rosbaud: The Fundamental Principles of Music.
7.15—8.15 p.m.—See Stuttgart.
8.15 p.m.—Haydn Chamber Music.
9.20 p.m.—Time and News.

HAMBURG (Germany)

Norag (ha, in Mersce), 806 kc/s (372 m.); 1.7 kW. Relayed by Bremen, 1,112 kc/s (270 m.); Flensburg, 1,173 kc/s (218 m.); Hanover, 1,273 kc/s (218 m.) and Kiel, 1,322 kc/s (232.2 m.).
Transmits at intervals from 5.30 a.m.
3.30 p.m.—Concert by the Band of the Liner "Europa," conducted by F. Koennecke, with Songs by the "Europa" Choral Society. Overture, Quo vadis (Scassola). Invitation to the Dance (Weber). Selection from "Christelfein" (Pfitzner). Choral Selections: (a) Gruss an das Meer (Paulsen), (b) Wie's daheim war (Wohlgemuth), (c) Wie könnt' ich dein vergessen (C. Trunk). Legend: Und der Berggeist sprach (Franz Koennecke)—Soloist: Willy Weiss. Albumblatt (Wagner). Choral Selections: (a) Es ist ein Ros' entsprungen, (b) Stille Nacht, heilige Nacht. Christmas Potpourri, Peace on Earth (Oscheit).
5.5 p.m.—Talk: A Calendar for 1932.
5.30 p.m.—Dialogue: German River-Navigation.
5.55 p.m.—Talk in North German Dialect: Settlement Names.
6.20 p.m.—Exchange and Weather.
6.30 p.m.—"The Romantics"—Orchestral Concert, conducted by Fritz Gartz. Overture, Meerestille und glückliche Fahrt (Mendelssohn). Fantasia on Themes from "Das Nachtlager in Granada" (Kreutzer). Nocturne in C Minor, Op. 48, No. 1 (Chopin). Overture, "Peter Scholl" (Weber). Moment musical (Schubert). Fantasia on Themes from "The Pearl Fishers" (Bizet). Selection from "Der Trompeter von Säckingen" (Nessler).
7.30 p.m.—"How North German Poets celebrated Christmas" (Ehrlich Gaedchens)—Song Recital by Erna Kroll-Lange (Soprano), with the collaboration of Hans Langmaack (Speaker).
8.10 p.m.—"Christmas, 1931"—Radio Play in Dialect (H. Behnken).
9.0 p.m.—News Bulletin.
9.20 p.m.—Topical Talk.
9.30 p.m.—Dance Music from the Café "Haus Steglar."
10.20 p.m.—Ice Report.

HEILSBURG (Germany)
1,085 kc/s (276.5 m.); 75 kW.
Relayed by Danzig, 662 kc/s (453.2 m.).
Transmits at intervals from 5.30 a.m. (Gymnastics).
3.30 p.m.—Concert from the Alhambra Café, Königsberg.
4.50 p.m.—Talk: The Running of an Ocean Liner.
5.15 p.m.—Ice Report and Market Prices.
5.30 p.m.—Book Review.
6.0 p.m.—Dialogue for Business Men.
6.25 p.m.—Weather Report.
6.30 p.m.—(from Danzig)—Concert by the Danzig Municipal Theatre Orchestra, conducted by Otto Selberg. Overture, "Martha" (Flotow). Abendlied and Träumerei (Schumann). Spring Song (Mendelssohn). A Wedding Day on Troldhaugen (Grieg). Nocturne, Op. 9 (Chopin). Two Hungarian Dances (Brahms). Waltz, "The Arabian Nights" (Strauss). March, Per Aspera ad Astra (Urbach).
8.0 p.m.—Announcements.
8.10 p.m.—(from Danzig)—"Christmas"—a Radio Sequence.
9.10 p.m. (approx.)—News, followed by Dance Music.
11.0 p.m. (approx.)—Close Down.

HILVERSUM (Holland)

1,004 kc/s (298.8 m.); 20 kW.
6.25—9.40 a.m.—Programme of the Workers' Radio Society (V.A.R.A.).
6.25—6.40 a.m. and 7.10—7.25 a.m.—Gymnastics.
7.40 a.m.—Gramophone Records.
9.40 a.m.—Religious Programme by the Liberal Protestant Radio Society (V.P.R.O.).
9.55 a.m.—till Close Down. V.A.R.A. Programme.
9.55 a.m.—Septet Concert, Recitations and Gramophone Records.
11.40 a.m.—Quintet Concert. Overture, "Edelweiss" (Komzak). Waltz, Himmel voller Geigen (Ziehrer). Selection from "La Fille de Madame Angot" (Lecocq). Gramophone Records. Elégie (Massenet). Serenade (Monti). Salut d'amour (Elgar). Strauss Waltz Potpourri (Bittner-Korngold-Hruthy). Gramophone Records. Four Songs from "Zur gold'nen Liebe" (Benatzky). Ich hab' ein Herz, dass sich nach Liebe sehnt (May). Finale (May).
1.25—1.55 p.m.—Interval.
1.55 p.m.—Talk for Women.
2.40 p.m.—Gramophone Records.
3.10 p.m.—Programme for Children.
4.0 p.m.—Selections by a Musical Box.
4.10 p.m.—Question Time.
5.10 p.m.—Septet Concert. Selection (Petras). Mikado Waltz (Komzak). Overture, "The Huguenots" (Meyerbeer). In a Turkish Tea Garden (Siede). Gramophone Records. Waltz Potpourri No. 3 (Robrecht). Funk mir was mein Liebchen (Egen). Oriental Suite (Poppy). Les amours sont des fleurs (Goublier).
6.25 p.m.—Talk on Capitalism.
6.45 p.m.—Concert (cont'd.). Selection from "I Pagliacci" (Leoncavallo), Tango, In Santa Lucia (Strancky). Pizzicato (Meyer-Helmund). Souvenir de Capri (Bece). Potpourri of the Works of Mozart (Urbach). Tango, "To a Rose" (Simons). The Storks' Promenade (Collin). March, Blaze Away (Holzmann).
7.40 p.m.—Programme to be announced.
8.40 p.m.—A Radio Play in Nine Tableaux (Alfred Wolfenstein).
9.55 p.m.—Orchestral Concert, conducted by Hugo de Groot. Persian Dance from "Khovantschina" (Moussorgsky). Three Intermezzi from "The Jewels of the Madonna"

(Wolf-Ferrari). Bacchanal from "Samson and Delilah" (Saint-Saëns). Two Selections from "Der Rosenkavalier" (R. Strauss). Hymn to the Sun, from "Le Coq d'or" (Rimsky-Korsakoff). Polonaise from "Eugen Onegin" (Tchaikovsky).
10.40 p.m.—News Bulletin.
10.50 p.m.—Concert (cont'd.). Marche Lorraine (Ganne). Overture, "Martha" (Flotow). Waltz, Weaner Mad'ln (Ziehrer). Geburtstagsständchen (Lincke). Sie kommen (Lincke). The Nigger's Dream (Myddleton). Selection from "The Bird Fancier" (Zeller).
11.40 p.m. (approx.)—Close Down.

HUIZEN (Holland)

160 kc/s (1,875 m.); 8.5 kW. Programme of the Christian Radio Society (N.C.R.V.).
7.40 a.m.—Bible Reading.
7.55—9.25 a.m.—Gramophone Records.
9.40 a.m.—Selections by a Ladies' Choir.
10.10 a.m.—Programme for Hospitals.
10.40 a.m.—Harmonium Recital, with Soprano Solos.
11.40 a.m.—Police Notes.
11.55 a.m.—Gramophone Records.
12.10 p.m.—Recital for two Violins, Flute, Harmonium and Pianoforte.
1.40 p.m.—Gramophone Records.
2.10 p.m.—Reading.
2.40 p.m.—Vocal and Instrumental Concert. Sonata in E Minor for Violin and Pianoforte (Veracini). Four Songs (Jensen). Canonetta for Violin and Pianoforte (Palmgren). Songs: (a) Ein Schwan, and (b) Erstes Begegnung (Grieg). (c) Wenn du nur zuweilen lächelst, (d) In Waldeseinsamkeit, and (e) Meine Liebe ist grün (Brahms). Sonata for Violin and Pianoforte in G (Lekeu). Four Songs: (a) Lied, and (b) Nocturne (Franck), (c) Romance (Debussy), (d) Toujours (Fauré).
4.10 p.m.—Gramophone Records.
4.25 p.m.—Talk.
4.40 p.m.—Organ Recital from a Church in Haarlem. Prelude and Fugue in D Major (Bach). Three Choral Preludes (Bach): (a) Nun komm' der Heiden Heiland, (b) In dulci jubilo, (c) Komm, Gott Schöpfer, Heiliger Geist. Two Choral Preludes (Karg Elert). Prelude and Fugue in D Minor and in D Major (Reger). Three Choral Arrangements (Engels).
5.40 p.m.—Agricultural Talk.
6.40 p.m.—Horticultural Talk.
7.10 p.m.—Police Notes.
7.25 p.m.—Talk by M. Holsteyn.
7.40 p.m.—"The Christmas Oratorio" (Cuypers), conducted by the Composer, relayed from the Concert Hall, Amsterdam. Soloists: Jo Vincent (Soprano), Nora de Wal (Soprano), Jac. Ph. Caro (Bass and Recitations), Willem Doortmont (Organ). The Concert Hall Orchestra. The Christian Oratorio Society of Amsterdam.
9.55 p.m.—News Bulletin.
10.5 p.m.—Gramophone Records.
11.10 p.m. (approx.)—Close Down.

KALUNDBORG (Denmark)

Kalundborg Radio, 260 kc/s (1,153 m.); 7.5 kW.
See Copenhagen.

KATOWICE (Poland)

734 kc/s (408 m.); 16 kW.
Transmits at intervals from 10.58 a.m.
3.0 p.m.—Gramophone Records.
3.55 p.m.—Linguaphone English Lesson.
4.35 p.m.—Orchestral Concert.
7.15 p.m.—Light Music.
8.15 p.m.—Violin Recital.
9.0 p.m.—Italian Songs.
9.45 p.m.—Gramophone Records.
10.0 p.m.—The Letter Box in French.

LANGENBERG (Germany)

Westdeutscher Rundfunk, 635 kc/s (473 m.); 17 kW. Relayed by Aachen, Cologne and Münster, 1,319 kc/s (227 m.).
Transmits at intervals from 5.20 p.m.—"Matencote"—Two Mysteries from the Play by Reinhard Johannes Sorge.
6.0 p.m.—Time and News.
6.10 p.m.—Talk on Economics.
6.30 p.m.—Talk: England in the Crisis.
6.55 p.m.—News Bulletin.
7.0 p.m.—Orchestral Concert. Overture, "The Force of Destiny" (Verdi). Suite, In the Fjords of Norway (Frederiksen). Melodies from "La Tosca" (Puccini). The

Programmes for Wednesday—(Cont.)

Sixth Hungarian Rhapsody (Liszt). Waltz, Künstlerleben (Strauss). 8.0 p.m.—Songs and Rhymes of Westphalia throughout the Year. Introductory Talk and Commentary, Songs to the Lute, Solo Selections and Choral and Orchestral Music; followed by News, Concert and Dance Music, 11.0 p.m. (approx.)—Close Down.

LEIPZIG (Germany)

1,157 kc/s (259 m.); 2.3 kW. Relayed by Dresden, 941 kc/s (319 m.). Transmits at intervals from 5.30 a.m. 6.0 p.m.—Talk: Central Germany as an Industrial Centre. 6.30 p.m.—Concert by the Dresden Philharmonic Orchestra. 8.0 p.m.—Talk: Remember the Unemployed! 8.10 p.m.—Two Radio Plays: (a) "Die Verteidigung" (Fritz Mack), (b) "Die von nebenan" (Thad-daus Rittner). 9.10 p.m.—News Bulletin, followed by Concert and Dance Music. 10.30 p.m. (approx.)—Close Down.

LJUBLJANA (Yugoslavia)

522 kc/s (574.7 m.); 2.8 kW. Transmits at intervals from 11.15 a.m. 6.30 p.m.—Literary Programme. 7.0 p.m.—Mozart Programme. 9.0 p.m.—News Bulletin.

LWÓW (Poland)

788 kc/s (381 m.); 21 kW. Transmits at intervals from 10.45 a.m. 6.15 p.m.—Christmas Reading. 6.30 p.m.—Gramophone Records. 6.45 p.m.—See Warsaw. 9.30 p.m.—Gramophone Records. 9.40 p.m.—Answers to Correspondence. 10.0 p.m.—Dance Music from the Café Szkočka. 11.0 p.m. (approx.)—Close Down.

MADRID (Spain)

Union Radio (EAJ7). 707 kc/s (424.3 m.); 2 kW. Transmits at intervals from 8.0 a.m. 7.0 p.m.—Chimes, Exchange, Market Prices and Talk: The Life of a Poet; followed by Request Gramophone Records. 8.10 p.m.—News and Political Review. 8.30—10.0 p.m.—Interval. 10.0 p.m.—Chimes, Time, Political Review and "El Yermo de los seis caminos"—a Symbolic Poem for the Radio (Jose Enrique Gippini). 12 midnight.—Chimes and News. 12.30 a.m. (Thursday)—Close Down.

MILAN (Italy)

Ente Italiano Audizioni Radiofoniche. 905 kc/s (331.5 m.); 8.5 kW. Relayed by Turin, 1,094 kc/s (274.2 m.), and Genoa, 959 kc/s (312.8 m.). Transmits at intervals from 7.15 a.m. 4.10 p.m.—Chamber Music. 5.0 p.m.—Giornale Radio and News. 6.0 p.m.—Agricultural Notes. 6.10 p.m.—Gramophone Records. In the intervals at 6.25 p.m.—Announcements, at 7.0 p.m.—Time and News, and at 7.15 p.m.—Medical Talk. 7.45 p.m.—Two Operettas (Dall'Argine): (a) "The Three Serenades," (b) "Corporal Susina." Conductor: M. Nicola Ricci. Talk and Literary Review in the intervals. Giornale Radio after the Programme.

MUNICH (Germany)

563 kc/s (533 m.); 1.7 kW. Relayed by Augsburg and Kaiserslautern, 536 kc/s (560 m.) and Nürnberg, 1,256 kc/s (239 m.). Transmits at intervals from 5.45 a.m. 6.30 p.m.—Military Band Concert. Fest-Fanfane (Fürst). Prelude to "Lohengrin" (Wagner). Selection from "Madame Butterfly" (Puccini). Waltz, Freut euch des Lebens (Joh. Strauss). Wind Instrument Music, No. 2 (Egk). March, Tapfere Wehr (Stubenhofer). 7.30 p.m.—"Christmas among Other Nations"—At Capri, In New York, In a Gold-Mining Camp, On an Ocean Liner, In the Desert, In Japan, At the South Pole, In the Tropics. 8.0 p.m.—"Decorating the Christmas Tree." 9.20 p.m.—Time and News. 9.45 p.m.—Concert from the Café Luitpold. 11.0 p.m. (approx.)—Close Down.

OSLO (Norway)

Kringkastingsselskapet. 277 kc/s (1,083 m.); 75 kW. Relayed by Fredrikstad, 816 kc/s (367.6 m.); Hamar, 536 kc/s (560 m.); Notodden, 671 kc/s (447.1 m.); Porsgrund, 662 kc/s (453.2 m.) and Rjukan, 671 kc/s (447.1 m.). Transmits at intervals from 10.10 a.m. 4.0 p.m.—Gramophone Records. 5.0 p.m.—Talk. 5.30 p.m.—Programme for Girls. 6.0 p.m.—News Bulletin. 6.30—9.20 p.m.—Vilhelm Krag Programme on his 60th Birthday. 6.30 p.m.—Address by M. R. Faugen, Chairman of the Norwegian Authors' Society. Prologue by R. H. Schøyen, read by the Author. 7.0 p.m.—Time Signal. 7.2 p.m.—"Christmas in the Olden Days"—a Play (Vilhelm Krag). 7.50 p.m.—Baritone Song Recital. Words by Vilhelm Krag. 8.10 p.m.—Recitations from the Works of Vilhelm Krag. 8.35 p.m.—News Bulletin. 8.50 p.m.—Topical Talk. 9.5 p.m.—Choral Concert from Christiansand, 1,274 kc/s (235.5 m.). Songs to Words by Vilhelm Krag. 9.20 p.m.—Orchestral Concert. Overture, "Ruslan and Ludmilla" (Glinka). Russian Fantasia (Schirman). Romance (Neupert). Selection (Hurum). An den Frühling (Grieg). Four Old Dances (Ursin). 10.0 p.m.—Gramophone Dance Music. 11.0 p.m. (approx.)—Close Down.

PARIS (France)

Eiffel Tower (FLE). 207.5 kc/s (1,445.7 m.); 15 kW. Time Signals (on 2,650 m.) at 9.26 a.m. and 10.26 p.m. (preliminary and 6-dot signals). 5.45 p.m.—Le Journal Parlé. 7.20 p.m.—Weather Forecast. 7.30 p.m.—Programme for Young People. 8.0 p.m.—Symphony Concert, conducted by M. E. Flament. Menuet pompeux (Ganne). La maison grise (Messager-Delsaux). Zambra (Laparra-Grecourt). Violin Solo by M. Cantrelle. Babiole et Songe (Flament). Chansons petites russiennes (Delmas-Dofny). Overture, "Madame Favart" (Offenbach-Casadesus). Tales from the Vienna Woods (Strauss).

PARIS (France)

Poste Parisien. 914 kc/s (328.2 m.); 1.2 kW. 8.15 p.m.—Gramophone Records and News. 9.0 p.m.—Concert with the collaboration of Artists from the Opéra and Opéra-Comique. Overture, "La Fille de Figaro" (Xavier Leroux). Pianoforte Solo by M. Béché: Jeunes filles (G. Ropartz). Irish Melodies (Myddleton). Napolitana (Lehár). Pastels bleus d'Orient (Tchesnokoff). Flute and Pianoforte Selection: Joueur de flûte (Roussel) by M. Lavoillotte (Flute) and M. Béché (Piano). Selection from "The Czardas Princess" (Kálmán). Hymne à l'Unité (Florent Schmitt). Scène et ballet au clair de lune (Filippucci). Waltz, Illusions (Waldteufel). Les Bayadères from "La Burgonde" (Vidal).

PARIS (France)

Radio-Paris (CFR). 174 kc/s (1,725 m.); 80 kW. Transmits at intervals from 6.45 a.m. (Physical Culture). 12.30 p.m.—Gramophone Records. 1.0 p.m.—Exchange and News. 1.5 p.m.—Gramophone Concert. Impressions d'Italie (Charpentier). Song, Phidylé (Duparc). Finale for Pianoforte and Orchestra from the "Symphonie sur un chant montagnard français" (d'Indy). Prelude and Dance from "La Tragédie de Salomé" (Fl. Schmitt). Suite in F (Roussel). In the intervals at 1.30 and 2.0 p.m.—Exchange Quotations. 3.35 p.m.—Exchange; Market Prices. 6.30 p.m.—Agricultural Report, Market Prices, Racing Results and Weather Report. 7.0 p.m.—Radio Dialogue: Frédéric Lefèvre and Jacques Chardonne. 7.30 p.m.—Medical Talk. 7.45 p.m.—Commercial Prices, Economic and Social Notes and News. 8.0 p.m.—Readings from the Works of Pierre Loti. 8.30 p.m.—Sports Results and Weather. 8.40 p.m.—Fashion Review.

8.45 p.m.—"Les Folies Amoureuses"—Play (Regnard). In the interval at 9.15 p.m.—News and Time.

ROME (Italy)

Ente Italiano Audizioni Radiofoniche (IRO). 680 kc/s (441 m.); 75 kW. Relayed by Naples, 941 kc/s (319 m.), and 2RO, 3,750 kc/s (80 m.). Transmits at intervals from 7.15 a.m. (Giornale Radio). 12.10—1.15 p.m.—Concert of Light Music. 12.30 p.m. (in the interval)—Time, News and Weather. 4.0 p.m.—Exchange and Announcements. 4.30—5.15 p.m.—Variety Concert, conducted by Enrico Martucci. Comedy Overture (Lincke). Selection from "William Ratcliff" (Mascagni). The Vision of Fuji-San (Ketelbey). The Flower Suite (Siede). Norwegian Dances Nos. 3 and 4 (Grieg). Suite from the Ballet "Coppélia" (Delibes). 6.15 p.m. (from Naples)—Shipping. 6.20 p.m.—News Bulletin. 7.0 p.m.—Sports Notes; Press Review. 7.15 p.m.—Medical Talk. 7.30 p.m.—Time, Announcements and Gramophone Records. 8.0 p.m.—Concert from the Works of Alfredo Catalani, by the Orchestra, and Soloists. Selections from the Third Act of "Edmea." Cinema Notes. Selections from "La Wally." Talk: The Grand Passion of Adrienne Lecouvreur. "La Fiamminga"—Opera in One Act (Donaudy). News after the Programme.

SCHENECTADY (U.S.A.)

General Electric Company (WGY). 790 kc/s (379.5 m.); 50 kW. Relayed at intervals by W2XAF on 9,530 kc/s (31.48 m.), and by W2XAD on 15,340 kc/s (19.56 m.). Transmits at intervals from 11.45 a.m. 9.0 p.m.—Pop Concert from New York. 9.30 p.m.—Stock Reports and Police Notes. 9.45 p.m.—Phil Spitalny's Tea Dance from New York. 10.0 p.m.—News Bulletin. 10.5 p.m.—Musical Ad Men. 10.30 p.m.—Sam Loyd, the Puzzle Man, from New York. 10.45 p.m.—Aladdin Lamp Programme. 11.0 p.m.—Waldorf Empire Room Orchestra from New York. 11.15 p.m.—Time Signal. 11.16 p.m.—Health Talk. 11.20 p.m.—Ollie Yettru (Pianist). 11.29 p.m.—Weather Report. 11.30 p.m.—Willys Overland Programme. 11.45 p.m.—The Stebbins Boys, from New York. 12 midnight (WGY only).—New York State Educational Series. 12 midnight (W2XAF only).—Stock Reports and News. 12.15 a.m. (Thursday)—4.15 a.m.—New York Relay. 12.15 a.m.—Campbell's Orchestra. 12.30 a.m.—Prince Albert Programme. 12.45 a.m.—Trials of the Goldbergs. 1.0 a.m.—Snoop and Peep. 1.15 a.m.—Ohman and Arden. 1.30 a.m.—Mobiloil Concert. 2.0 a.m.—Halsey Stuart Programme. 2.30 a.m.—Palmolive Hour. 3.0 a.m.—Coca Cola Programme. 4.0 a.m.—Voice of Radio Digest. 4.15 a.m.—Mary Zoller (Xylophonist). 4.30 a.m.—Annette. 4.45 a.m.—Vincent Lopez and his Orchestra from New York. 5.0 a.m.—Jack Miles and his DeWitt Clinton Orchestra. 5.30 a.m.—Doc Peyton and his New Kenmore Orchestra. 6.0 a.m. (approx.)—Close Down.

SCHWEIZERISCHER LANDESSENDER (BEROMÜNSTER) (Switzerland)

653 kc/s (459 m.); 75 kW.; Basle, 1,229 kc/s (244.1 m.); and Berne, 1,220 kc/s (246 m.). Transmits at intervals from 11.28 a.m. 2.30 p.m.—Orchestral Concert. 2.58 p.m.—Time Signal. 3.0 p.m. (from Basle)—Orchestral Concert. 4.0 p.m. (from Basle)—Adolf Haller reads from his own Works. 4.30 p.m.—Weather and Market Prices. 4.35—5.30 p.m.—Interval. 5.30 p.m.—Gramophone Records—Bach Programme. 6.0 p.m. (from Berne)—Talk:

Changes in a Town—Berne Miniatures of the Nineteenth Century. 6.28 p.m.—Time and Weather. 6.30 p.m. (from Berne)—Alfred Huggenberger reads from his own Works. 7.0 p.m. (from Zürich)—"Christus-Spiel" (M. E. Liehburg). 8.0 p.m.—Choral and Orchestral Concert. 9.0 p.m.—Weather and News. 9.15 p.m. (from Basle)—Wireless Notes. 9.30 p.m. (approx.)—Close Down.

STOCKHOLM (Sweden)

Radiotjänst (SASA). 689 kc/s (436 m.); 75 kW. Relayed by Boden, 244 kc/s (1,229.5 m.); Göteborg, 932 kc/s (322 m.); Hörby, 1,166 kc/s (257 m.); Motala, 222.5 kc/s (1,348 m.); Östersund, 389 kc/s (770 m.) and Sundsvall, 554 kc/s (542 m.). Transmits at intervals from 6.45 a.m. 4.0 p.m.—Accordion Music. 4.30 p.m.—Reading. 4.45 p.m.—Light Music. 5.15 p.m.—Report. 5.30 p.m.—Light Music (continued). 5.45 p.m.—Agricultural Talk. 6.15 p.m.—Weather and News. 6.30 p.m.—Talk relayed from Malmö, 1,301 kc/s (231 m.). 7.0 p.m.—Concert, relayed from Sundsvall. Soloists: Hans Lampert (Organ). Göran Föllinger (Violin), Emma Lampert (Songs). Sonata in F Major for Organ (Hans Lampert). Violin Concerto in D Minor (Tartini). Organ Solos: (a) Aria from "Elijah" (Mendelssohn), (b) Panis Angelicus (C. Franck). Meditation for Organ and Orchestra (Guilmant). 8.0 p.m.—Talk on Foreign Politics. 8.20 p.m.—Choral Concert. 8.45 p.m.—Weather and News. 9.0 p.m.—Gramophone Records. 10.0 p.m. (approx.)—Close Down.

STRASBOURG (France)

Radio-Strasbourg (PTT). 869 kc/s (345 m.); 15 kW. Transmits at intervals from 11.30 a.m. 6.0 p.m.—Instrumental Concert. Overture, "The Italian Girl in Algiers" (Rossini). Selection from "Rigoletto" (Verdi). Selection from "Moravia" (Léopold). Suite, The Sleeping Beauty (Tchaikovsky). 6.45 p.m.—Talk in German. 7.0 p.m.—Gramophone Records. 7.30 p.m.—Time Signal. 7.32 p.m.—News in French and German. 7.45 p.m.—Gramophone Records. 8.30 p.m.—"Galatée"—Opera (Massé). 10.30 p.m.—Dance Music from the Savoy. 12 midnight (approx.)—Close Down.

STUTTGART (MÜHLACKER) (Germany)

Süddeutscher Rundfunk. 832 kc/s (360.5 m.); 75 kW. Relayed by Freiburg, 527 kc/s (570 m.). Transmits at intervals from 5.15 a.m. 6.5 p.m. (from Mannheim)—Ludwig Marcuse reads from his Heine Biography. 6.30 p.m.—Time and Announcements. 6.45 p.m.—Anticipated Christmas Joys—Concert by the Philharmonic Orchestra and Soloists. 7.45 p.m.—Choral Christmas Concert by the Baden Academy of Music, relayed from the Festhalle, Karlsruhe. Es steht ein' Lind' im Himmelreich. Ave Maria zart. Und unsrer lieben Frauen. Maria durch ein'n Dornwald ging. Macht hoch die Tür. Vom Himmel hoch, da komm' ich her. Vom Himmel hoch, o Englein kommt. Laufet ihr Hirten. Es blühen die Maien. Kommet, ihr Hirten. Wach, Nachtigall, wach auf. 8.0 p.m.—Topical Talk. 8.20 p.m.—See Frankfurt. 9.50 p.m.—Time and News.

TOULOUSE (France)

Radiophonie du Midi. 779 kc/s (385 m.); 8 kW. Transmits at intervals from 12.45 p.m. 6.0 p.m.—Orchestral Selections. 6.15 p.m.—Songs from (a) "Sigurd" (Reyer), (b) "Samson and Delilah" (Saint-Saëns), (c) "The Bartered Bride" (Smetana). 6.30 p.m.—News Bulletin. 6.45 p.m.—Light Music. 7.0 p.m.—Accordion Solos. 7.15 p.m.—Chansonnettes. 7.30 p.m.—News Bulletin. 7.45 p.m.—Dance Music. 8.0 p.m.—Orchestral Selections. 8.30 p.m.—Sound Film Music.

8.45 p.m.—Orchestral Selections. 9.0 p.m.—Operetta Music. Selections from (a) "Monsieur Beaucaire" (Messager), (b) "Die Teresina" (O. Strauss), (c) "Die Fledermaus" (Joh. Strauss). 9.15 p.m.—Accordion Solos. 9.30 p.m.—Light Music. 9.45 p.m.—Military Music. 10.0 p.m.—Gramophone Records. 10.30 p.m.—News Bulletin. 10.45 p.m.—Orchestral Selection: Concerto in F (Gershwin). 11.0 p.m.—Concert. In the interval at 11.15 a.m.—North African News. 12 midnight.—Weather, Announcements and Close Down.

TRIESTE (Italy)

Ente Italiano Audizioni Radiofoniche. 1,211 kc/s (247.7 m.); 15 kW. Transmits at intervals from 11.30 a.m. 7.15 p.m.—News Bulletin. 7.30 p.m.—Gramophone Records. 8.0 p.m.—Time, Announcements and Programme to be announced. Literary Notes in the interval. 9.15 p.m.—Light Music. 9.25 p.m.—News Bulletin.

VIENNA (Austria)

Radio-Wien. 581 kc/s (517 m.); 20 kW. Relayed by Graz, 852 kc/s (352.1 m.); Innsbruck, 1,058 kc/s (283 m.); Klagenfurt, 662 kc/s (453.2 m.); Linz, 1,220 kc/s (246 m.) and Salzburg, 1,373 kc/s (218 m.). Transmits at intervals from 8.20 a.m. 6.5 p.m.—French Lesson. 6.35 p.m.—Time; Announcements. 6.45 p.m.—Concert by the Vienna Symphony Orchestra, conducted by Martin Spörr. Comedy Overture (Rothberger). Suite No. 2 from "L'Arlesienne" (Bizet). Norwegian Rhapsody No. 2 (Svend-sen). Waltz, Sorgenbrecher (Joh. Strauss). Rhapsody, España (Chabrier). 7.45 p.m.—"Discord"—a Pastoral Play in Three Scenes (Fanny Wibmer-Pedit). 9.0 p.m.—News Bulletin. 9.15 p.m.—Concert by the Mathé Jazz Band.

WARSAW (Poland)

Polskie Radio. 212.5 kc/s (1,411 m.); 158 kW. Transmits at intervals from 10.45 a.m. 1.45 p.m.—Gramophone Records. 2.15 p.m.—Talk for Boy Scouts. 2.20 p.m.—Announcements. 2.25 p.m.—Talk: Christmas Books. 2.45 p.m.—Exchange and Announcements. 2.50 p.m.—Gramophone Records. 3.15 p.m.—Sports Report. 3.20 p.m.—Talk: The Seaside now. 3.40 p.m.—Gramophone Records. 3.55 p.m.—Linguaphone English Lesson. 4.10 p.m.—Talk: The Mystery and Magic of Christmas Eve. 4.35 p.m.—Orchestral Concert. Fox-trot Overture (Strasser). Serenade (Poltavsky). Potpourri, In the Seventh Heaven (Fetras). Selection from "Der Trompeter von Säckingen" (Nessler). Waltz Serenade, For Thee (Czibulka). Autumn Song (Tchaikovsky). Turkish Fairy Tale (Lincke). Fantasia, s kommt ein Vogel geflogen (Ochs). Romance sans paroles (Rebikoff). The Musical Box (Mikolajevsky). March on Polish Motives (Helmberger). 5.50 p.m.—Miscellaneous Items. 6.15 p.m.—Agricultural Report. 6.25 p.m.—Programme Announcements. 6.30 p.m.—Gramophone Records. 6.45 p.m.—Radio Journal. 7.0 p.m.—Talk on Music. 7.15 p.m.—Vocal and Orchestral Concert. 8.0 p.m.—Reading. 8.15 p.m.—Violin Recital by Roman Totenberg. Concerto in A Minor for Violin (Bach). Poème (Chausson). Chant de Roxane (Szymanovsky). Danse orientale (Wieniawsky). Perpetuum mobile (Novacek). 9.0 p.m.—Italian Song Recital by Umberto Macnez. Intorno all'idol mio (Cesti). O mio ben (Paisiello). O del mio dolce ardor (Glück). O cessate di piagarmi (Scarlatti). Song from "L'Amico Fritz" (Mascagni). Song from "Manon Lescaut" (Puccini). Song from "André Chénier" (Giordano). 9.15 p.m.—Radio Journal. 9.20 p.m.—Announcements. 9.30 p.m.—Gramophone Records. 9.45 p.m.—Talk: Contemporary Polish Literature. 10.0 p.m.—Dance Music. 11.0 p.m. (approx.)—Close Down.

PROGRAMMES FOR THURSDAY (December 24)

NOTE: THE HOURS OF TRANSMISSION ARE REDUCED TO GREENWICH MEAN TIME

BARCELONA (Spain)

Radio-Barcelona. (E.A.J.). 860 kc/s (349 m.); 8 kW.
 7.30 p.m.—Trio Concert.
 7.30 p.m.—Exchange and Programme for Children.
 8.0 p.m.—Request Concert of Gramophone Records.
 8.30 p.m.—Advanced English Lesson, followed by News.
 9.0 p.m.—Chimes, Weather and Exchange.
 9.5 p.m.—Orchestral Concert.
 10.0 p.m.—Recitations in Catalan.
 10.10 p.m.—Viola and Pianoforte Recital.
 10.30 p.m.—Orchestral Concert.
 11.30 p.m.—Dance Music from the Café Catalan.
 12 midnight (approx.)—Close Down.

BERLIN (Germany)

Königs Wusterhausen. 183.5 kc/s (1,635 m.); 75 kW.
 Transmits at intervals from 5.30 a.m. (Witzleben Relay).
 3.0 p.m.—See Berlin (Witzleben).
 5.50 p.m.—Extracts from "The Christ Child in Flanders" (Felix Immermans), with Quartet Selections and Songs.
 6.30 p.m.—Concert from Stuttgart.
 7.0—9.0 p.m.—See Frankfurt.
 9.15 p.m.—"The Christmas of the Lonely" from Hamburg.
 11.0 p.m. (approx.)—See Stuttgart.
 12 midnight (approx.)—Close Down.

BERLIN (Germany)

Witzleben. 715 kc/s (418 m.); 1.7 kW.
 Transmits at intervals from 5.30 a.m. (Gymnastics).
 3.0 p.m.—Service relayed from the Kaiser-Wilhelm Memorial Church.
 4.0 p.m.—Concert of Classical Music.
 5.10 p.m.—Dialogue: Christmas Thoughts on Winter Relief.
 5.35 p.m.—See Langenberg.
 5.50 p.m.—"The Quiet Hour."
 6.30 p.m.—See Breslau.
 7.30 p.m.—See Leipzig.
 8.0 p.m.—Concert of Christmas Music.
 9.30 p.m.—See Heilsberg.
 11.0 p.m.—See Stuttgart.
 12 midnight (approx.)—Close Down.

BORDEAUX-LAFAYETTE (France)

(P.T.T.). 986 kc/s (304 m.); 35 kW.
 Transmits at intervals from 12.45 p.m.
 7.30 p.m.—News and Exchange.
 7.40 p.m.—Talk: Emigration and Unemployment.
 7.55 p.m.—Results of the Prize Draw and Charades Competitions.
 8.0 p.m.—Talk on Wine.
 8.15 p.m.—News Bulletin.
 8.20 p.m.—Talk relayed from Paris (Ecole Supérieure), 671 kc/s (447.1 m.).
 8.35 p.m.—Orchestral Concert. After the Programme, Amusement Guide and Time Signal.

BRESLAU (Germany)

923 kc/s (325 m.); 1.7 kW.
 Relayed by Gleiwitz, 1,184 kc/s (253 m.).
 Transmits at intervals from 5.30 a.m.
 6.30 p.m.—A Programme of Christmas Folk Songs and Legends about the Birth of Christ.
 7.25 p.m.—Weather Forecast.
 7.30 p.m.—See Leipzig.
 8.0 p.m.—See Berlin (Witzleben).
 9.30 p.m.—See Heilsberg.
 11.0 p.m. (approx.)—Close Down.

BRUSSELS (Belgium) (No. 1)

I.N.R. 590 kc/s (509 m.); 20 kW.
 12.15—1.45 p.m.—Gramophone Records for Children, followed by Gramophone Dance Music.
 5.0 p.m.—Orchestral Concert. Overture, "Les Dragons de Villars" (Maillart). Selection from "Manon" (Massenet). A Triptych for Flute, Clarinet and Horn (Danhier): (a) Jeunesse, (b) Adolescence, (c) Maturité. Ballet Music from "Sleeping Beauty" (Tchaikovsky).
 5.45 p.m.—Programme for Children.
 6.15 p.m.—Cookery Notes.
 6.30 p.m.—Gramophone Records.
 7.30 p.m.—Review of International Events.
 8.0 p.m.—Orchestral Concert. Overture, "Mireille" (Gounod). Aubade printanière (Lacombe). Selection from "Les petites Michus" (Messenger). Ballet

russe (Luigini). Czardas Selections. Waltz, Wienerblut (Joh. Strauss).
 8.45 p.m.—Talk on Carols.
 9.0 p.m.—Concert (continued).
 10.0 p.m.—Le Journal Parlé, followed by Gramophone Records.
 12 midnight (approx.)—Close Down.

BRUSSELS (Belgium) (No. 2)

N.I.R. 887 kc/s (338.2 m.); 20 kW.
 Programme in Flemish.
 12.15—1.45 p.m.—Gramophone Records.
 5.0 p.m.—Orchestral Concert.
 6.0 p.m.—Gramophone Records.
 6.15 p.m.—Readings.
 6.30 p.m.—Gramophone Records.
 7.30 p.m.—Talk for Women.
 8.0 p.m.—Orchestral Concert. Marche russe (Ganne). Overture, "The Caliph of Bagdad" (Boieldieu). En Espagne (Lacôme). Selection from "I Pagliacci" (Leoncavallo). Waltz, Iberta (Grieg). Dances (Montague Phillips). Selection from "The Merry Widow" (Lehár).
 9.0 p.m.—Programme dedicated to Christmas—Talk and Musical Selections.
 10.0 p.m.—Le Journal Parlé.

BUCHAREST (Romania)

Radio-Bucarest. 761 kc/s (394 m.); 16 kW.
 Transmits at intervals from 11.0 a.m.
 6.0 p.m.—Christmas Readings and Recitations.
 7.0 p.m.—Symphony Concert.
 7.50 p.m.—Reading.
 8.5 p.m.—Christmas Choral Concert.
 8.45 p.m.—News Bulletin.

BUDAPEST (Hungary)

545 kc/s (550 m.); 23 kW.
 Transmits at intervals from 8.15 a.m.
 4.30 p.m.—Concert by the Royal Hungarian Opera House Orchestra, conducted by Ernst Dohnanyi. Talk in the interval.
 6.0 p.m.—Gramophone Concert and Close Down.

COLOGNE (Germany)

Westdeutscher Rundfunk. 1,319 kc/s (227 m.); 1.7 kW.
 See Langenberg.

COPENHAGEN (Denmark)

1,067 kc/s (281 m.); 0.75 kW.
 Relayed by Kalundborg, 260 kc/s (1,153 m.).
 Transmits at intervals from 6.30 a.m. (Gymnastics).
 11.0 a.m.—Concert from the Palace Hotel.
 1.30 p.m.—Orchestral Concert conducted by Emil Reesen. Soloist: Immanuel Franksen (Vocalist). Overture, "The Merry Wives of Windsor" (Nicolai). Russian Waltz, Pavlova (Scherapoff). Selection from "Aida" (Verdi). Serenade, Guitarras y Panderetas (Steger). Minuet for Strings (Simonetti). Wiener Wachtparade (Müller-Berghaus). Five Danish Songs. Overture, "Fatinizza" (Suppé). Frühlingsglaube—arranged for Strings (Schubert-Reesen). March of 1659, arranged for Wood-Wind instruments and Two Trumpets (Launy Gröndahl). Valse lyrique, and Love Scene from "Scaramouche" (Sibelius). Spanish Patrol (Deshayes). Russian Dance (Deshayes).
 3.30 p.m.—Christmas Eve Service from the Cathedral.
 5.0 p.m.—Town Hall Chimes.
 5.2 p.m.—Recital of Modern Danish Christmas Carols.
 5.20 p.m.—Reading.
 5.50 p.m.—Weather and News.
 6.15 p.m.—Time Signal.
 6.30 p.m.—Talk: Old Danish Christmas Customs.
 7.0 p.m.—Town Hall Chimes.
 7.2 p.m.—Christmas Concert. Fantasia on "Praise the Lord"—for Organ (N. W. Gade). Sonata for Two Violins, Cello and Organ in B Flat Major (Corelli). Three Christmas Carols. Reading: "The Little Match Girl" (H. C. Andersen). Sonata in G Minor for two Violins, Cello and Organ (Händel). Three Christmas Carols. Organ Solo: Fantasia on "Lovet vaere Du Jesus Krist" (Klaebel).
 8.15 p.m. (approx.)—Close Down.

DUBLIN (Ireland)

(2RN). 725 kc/s (413 m.); 1.5 kW.
 Relayed by Cork, 1,337 kc/s (224.4 m.).
 1.30—2.0 p.m.—Time, Weather, Stock Report and Gramophone Records.
 6.0 p.m.—Gramophone Records.
 6.15 p.m.—Programme for Children.
 7.0 p.m.—Gramophone Records.
 7.10 p.m.—News Bulletin.

7.30 p.m.—Time Signal.
 7.32 p.m.—French Lesson.
 7.45 p.m.—Literary and Dramatic Talk.

8.0 p.m.—Concert. The Station Sextet. Mme. A. Heffernan (Soprano). Variety by T. C. Earls and A. J. Thornton. The Station Sextet with Maestro A. G. Viani (Tenor) in Favourite Selections from Donizetti and Verdi.
 9.30 p.m.—"The Cherry Bough"—a Christmas Mystery Play (Cathal O'Byrne), presented by the Tar-sician Players.
 10.0 p.m.—Christmas Carols by a Choir of Men and Boys.
 10.30 p.m.—News Bulletin.
 10.45 p.m.—Gramophone Concert of Christmas Music.
 12 midnight.—Midnight Mass, relayed from Kilkenny Cathedral, and Close Down.

FÉCAMP (France)

Radio Normandie. 1,364 kc/s (219.9 m.); 1 kW.
 12 noon.—Concert.
 8.0 p.m.—Exchange and News.
 8.30 p.m. (from Rouen)—Concert of Christmas Carols.

FRANKFURT-am-MAIN (Germany)

770 kc/s (390 m.); 1.7 kW.
 Relayed by Cassel, 1,220 kc/s (246 m.).
 Transmits at intervals from 5.15 a.m. (Weather and Gymnastics).
 4.45 p.m.—Christmas Eve in Ilbenstadt Monastery.
 5.15—7.0 p.m.—See Stuttgart.
 7.0 p.m.—Christmas Carols sung by Two Children.
 7.30—8.0 p.m.—See Stuttgart.
 8.0 p.m.—Germany's Christmas Chimes—"Thirty German Cathedrals ring in Christmas Eve."
 9.0 p.m.—Organ Recital. Christmas Carol, A Solis ortus cardine (Praetorius). Choral Prelude, Wie schön leuchtet der Morgenstern (Buxtehude). Choral Prelude, Vom Himmel hoch, da komm ich her (Pachelbel). Two Choral Preludes: (a) Allein Gott in der Höh' sei Ehr. (b) Komm, heiliger Geist, Herre Gott.
 9.30 p.m. till Close Down.—See Stuttgart.

HAMBURG (Germany)

Norag (ha, in Morse). 806 kc/s (372 m.); 1.7 kW.
 Relayed by Bremen, 1,112 kc/s (270 m.); Flensburg, 1,373 kc/s (218 m.); Hanover, 530 kc/s (566 m.); and Kiel, 1,292 kc/s (232.2 m.).
 Transmits at intervals from 5.30 a.m.
 5.45 p.m.—Christmas Concert by the Scarpa Orchestra, conducted by Francesco Scarpa. Overture, "Rübezahl, Beherrscher der Geister" (Weber). Selection from "Die wunderlichen Geschichten des Kapellmeisters Kreisler" (Reznicek). Waltz, Angel of Love (Waldeufel). Tone Picture, Christmas (Königsberger). Bell Serenade (Kockert). Auszug der Teepuppen (Siede). March, In grosser Form (Bondy).
 6.50 p.m.—Exchange, Hamburg Egg-Market Prices and Weather.
 7.0 p.m.—"The Christmas of the Lonely"—The Station celebrates with its Listeners.
 9.0 p.m.—(In the Interval) News Bulletin.
 10.20 p.m.—Ice Report.

HEILSBURG (Germany)

1,085 kc/s (273 m.); 75 kW.
 Relayed by Leipzig, 662 kc/s (453.2 m.).
 Transmits at intervals from 5.30 a.m. (Gymnastics).
 3.0 p.m.—Christmas Service relayed from the Village church, Mühlhausen.
 3.45 p.m. (from Danzig)—Talk for Young People: Christmas Customs from Near and Far.
 4.15 p.m.—Literary Christmas Programme.
 5.0 p.m.—Christmas Concert from Leipzig. In the interval from 5.35—5.50 p.m.—See Langenberg.
 6.30 p.m.—See Breslau.
 7.30 p.m.—See Leipzig.
 8.0 p.m.—See Berlin (Witzleben).
 9.30 p.m.—"Christmas Eve"—the Birth of Christ after an Old Christmas Play (arranged by M. Timmler). Musical Arrangement by Erich Seidler, with the collaboration of the Königsberg Opera House Orchestra.
 11.0 p.m. (approx.)—Close Down.

HILVERSUM (Holland)

1,004 kc/s (298.8 m.); 20 kW.
 7.40 a.m. till Close Down.—Pro-

gramme of the Algemeene Vereeniging Radio Omroep.

7.40 a.m.—Time Signal.
 7.41 a.m.—Gramophone Records.
 9.40 a.m.—The Daily Service.
 9.55 a.m.—Gramophone Records.
 10.10 a.m.—Organ Recital by Pierre Palla, with Violin Solos by John Helden. Offertory on Christmas Carols (Boëllmann). Sonata in G Minor for Organ and Violin (Händel). Toccata in A Minor for Organ (Palla). Andante from the Violin Concerto (Wieniawsky). Organ Solo: Diamond Wedding (L. Roques). Violin and Organ Selections: (a) Nocturne (Sibelius), (b) Pale Moon (Logan-Kreisler), (c) Variations on a Theme by Corelli (Tartini-Kreisler). Organ Solo: Sortie solennelle (Callaerts).
 11.10 a.m.—Talk (to be announced).
 11.40 a.m.—Time Signal.

11.41 a.m.—Concert by the Radio Orchestra, conducted by Nico Treep. Overture, "La princesse jaune" (Saint-Saëns). Selection from "Samson and Delilah" (Saint-Saëns). Waltz for String Orchestra (Tchaikovsky). Russian Mazurka (Glinka). Gramophone Records. Fantasia on the Works of Bizet (Urbach). Waltz, The Blue Danube (Joh. Strauss). Gramophone Records. Fantasia, Im Rosengarten Mendelssohns (Urbach). Das Blumenmädel (Siede). Melody (Rubinstein). Storm Gallop (Komzak).
 1.40—2.10 p.m.—Interval.
 2.10 p.m.—Light Concert by the Luncheon Trio. Gramophone Records in the interval.
 3.40 p.m.—Programme for Hospitals.
 4.40 p.m.—Gramophone Records.
 5.10 p.m.—Concert of Light Music by Kovacs Lajos and his Orchestra. Songs by Bob Scholte. In the interval: Gramophone Records.
 6.40 p.m.—Sports Talk.
 7.0 p.m.—Gramophone Records.
 7.10 p.m.—Concert by the "Schola Cantorum" Choir, conducted by Hubert Cuypers. Het was een maghet. 't wijl in den nacht. Herders hij is geboren. Ons genaket die Avondstar. Adeste fidelis. Es ist ein Ros' entsprungen. Zu Bethlehem geboren.
 7.40 p.m.—Time Signal.
 7.41 p.m.—Concert by the Concert-Hall Chamber Orchestra, conducted by Albert van Raalte. Symphony No. 28 in C Major (Mozart).
 8.10 p.m.—Choral Concert (continued). Les rois mages. Noël's pastorals (arr. Gevaerts). Le Paradis terrestre. O! Journée désirée. Noël nouvelet. Il est né. Quittez, pasteurs. Transcamus.
 8.40 p.m.—Chamber Music (cont.). Serenade No. 7 (Mozart).
 9.25 p.m.—Christmas Carols.
 9.55 p.m.—Weather and News.
 10.10 p.m.—Gramophone Records.
 11.40 p.m. (approx.)—Close Down.

HUIZEN (Holland)

160 kc/s (1,875 m.); 8.5 kW.
 7.40—9.40 a.m.—Programme of the Catholic Radio Society (K.R.O.). Gramophone Records.
 9.40—10.40 a.m.—Programme of the Christian Radio Society (N.C.R.V.). Gramophone Records.
 9.40 a.m.—Gramophone Records.
 9.55 a.m.—Programme for Invalids.
 10.25 a.m.—Gramophone Records.
 10.40 a.m.—1.40 p.m.—K.R.O. Programme.
 10.40 a.m.—Gramophone Records.
 11.10 a.m.—Religious Address.
 11.40 a.m.—Police Notes.
 11.55 a.m.—Orchestral Concert. Overture, "Tantalusquälen" (Suppé). Waltz, Die Schönbrunner (Lanner). Eine Hochzeitsreise durch Skandinavien (Frederiksen). Moment musical (Schubert). Byzantine Suite, Ilys (Ganne). Overture, Au printemps de la Vie (Mouton). Selection from "Giroflé-Girofla" (Lecocq). Waltz, Pomona (Waldeufel). March, Viva el Torero (Popy).
 1.40 p.m. till Close Down.—N.C.R.V. Programme.
 1.40 p.m.—Handwork Lesson.
 2.25 p.m.—Gramophone Records.
 2.55 p.m.—Talk for Women.
 3.40 p.m.—Harmonium and Baritone Recital for Invalids.
 4.40 p.m.—Music for Children.
 5.40 p.m.—Pianoforte Recital. Italian Concerto (Bach). Tableaux des Pays-Bas (Voormolen). Dumka (Tchaikovsky). Selection (Bortkiewicz). Etude in C Sharp Major (Scriabin). Etude in D Sharp Minor (Scriabin).
 6.25 p.m.—Answers to Correspondence.
 7.10 p.m.—Police Notes.
 7.25 p.m.—Religious Notes.

7.40 p.m.—Orchestral Concert. Tone Poem, Kikimora (Liadoff). Fifth Symphony (Tchaikovsky).
 8.40 p.m.—Christmas Chimes from the Royal Palace, Amsterdam.
 9.40 p.m.—Concert (continued). Overture, "Coriolanus" (Beethoven). Second Symphony (Beethoven); followed by News and Gramophone Records.
 11.10 p.m. (approx.)—Close Down.

KALUNDBORG (Denmark)

Kalundborg Radio. 260 kc/s (1,153 m.); 7.5 kW.
 See Copenhagen.

KATOWICE (Poland)

734 kc/s (408 m.); 16 kW.
 Transmits at intervals from 10.58 a.m.
 7.30 p.m.—Choral Concert of Polish Religious Songs.
 9.20 p.m.—See Warsaw.
 9.55 p.m.—Programme to be announced.
 11.0 p.m.—Service from the Cathedral of St. Peter and St. Paul.

LANGENBERG (Germany)

Westdeutscher Rundfunk. 635 kc/s (473 m.); 17 kW.
 Relayed by Aachen, Cologne and Münster, 1,319 kc/s (227 m.).
 Transmits at intervals from 5.45 a.m. (Gymnastics).
 3.35 p.m.—"Der Struwwelpeter"—for Children's Solo Voices, Children's Choir and Orchestra (Hermann Reutter).
 4.30 p.m.—"Christmas Eve in Germany"—a Play with Music (Josef Otto-Hans Ebert).
 5.0 p.m.—Organ Recital of Christmas Carols by Prof. Hans Bachem, relayed from the Fair Hall, Cologne.

5.35 p.m.—"The Chimes of the German Bells on the Rhine."
 5.50 p.m.—"The Soest Gloria"—for Male Voice, Boys' and Treble-bone Choir, relayed from the Tower of St. Peter's Church, Soest.
 6.15—8.0 p.m.—Pause for the Giving Out of Presents.
 8.0 p.m.—Concert. Sonata quasi una Fantasia in C Sharp Minor, Op. 27, No. 2, for Pianoforte (Beethoven). Soprano Solos: (a) Nun wandre, Maria, (b) Ach, des Knaben Augen (Hugo Wolf), (c) Maria sitzt am Rosenhag (Reger). Sonata for Violin (Händel). Pianoforte Solos (Mendelssohn): (a) Six Children's Pieces, Op. 72, (b) Caprice, Op. 33, No. 1. Soprano Solos: (a) "Three Christmas Carols—Die heilige Nacht, Rauhreif, and Maria am Rocken (Gretschel) (b) Weihnachtslied (Berger). Pianoforte Solos: (a) Fantasia in F Minor, Op. 49, (b) Scherzo in C Sharp Minor, Op. 39 (Chopin).
 9.45 p.m. (approx.)—Close Down.

LEIPZIG (Germany)

1,157 kc/s (259 m.); 2.3 kW.
 Relayed by Dresden, 941 kc/s (319 m.).
 Transmits at intervals from 5.30 a.m.
 3.0 p.m.—Concert by the Leipzig Symphony Orchestra, conducted by Hilmar Weber.
 4.0 p.m.—See Berlin (Witzleben).
 5.0 p.m.—Christmas Music by the Leipzig Symphony Orchestra, conducted by Theodor Blumer. Soloists: Henriette Lehne (Contralto) and Alfred Zehmlisch (Viola). Friedbert Sammler at the Pianoforte. Christmas Concerto in C Major (Mantfredini). Two Songs for Contralto with Viola and Pianoforte, Op. 91 (Brahms). Three Selections for Wind Instruments and Women's Voices (Blumer). Christmas Music—Little Concerto in G Major, Op. 38b (Müller). In the interval from 5.35—5.45 p.m.—See Langenberg.
 6.30 p.m.—See Breslau.
 7.30 p.m.—Bach Organ Recital from St. George's Church at Rötha. Organist: Johannes Piersig.
 8.0 p.m.—See Berlin (Witzleben).
 9.30 p.m.—News Bulletin, followed by Programme from Heilsberg.
 11.0 p.m. (approx.)—Close Down.

LJUBLJANA (Yugoslavia)

522 kc/s (574.7 m.); 2.8 kW.
 Transmits at intervals from 11.15 a.m.
 6.0 p.m.—Slovene Christmas Carols for Tenor, Pianoforte and Harp.
 7.0 p.m.—Talk on Christmas.
 7.30 p.m.—Gramophone Records.
 8.0 p.m.—Dramatic Programme.
 9.30 p.m.—Christmas Concert for Quintet.
 10.30 p.m.—Relay of Chimes.
 11.0 p.m.—Midnight Mass on Gramophone Records.

Programmes for Thursday—(Cont.)

LWÓW (Poland)

788 kc/s (381 m.); 21 kW. Transmits at intervals from 10.45 a.m. 7.30 p.m.—Programme relayed from Katowice, 734 kc/s (408 m.). 7.55 p.m.—See Warsaw. 8.25 p.m.—Christmas Carols and Literary Programme relayed from Cracow, 959 kc/s (312.8 m.). 9.20 p.m.—See Warsaw. 9.55 p.m.—Programme (not yet announced) relayed from Katowice. 10.25 p.m.—Christmas Carols for Choir and String Quartet. 11.0 p.m.—Bugle Call from the Tower of St. Mary's Church, Cracow.

MADRID (Spain)

Union Radio (EAF7). 707 kc/s (424.3 m.); 2 kW. Transmits at intervals from 8.0 a.m. 7.0 p.m.—Chimes, Exchange, Market Prices and Request Gramophone Records. 8.10 p.m.—News and Political Review. 8.30 p.m. (approx.)—Close Down.

MILAN (Italy)

Ente Italiano Audizioni Radiofoniche. 905 kc/s (331.5 m.); 8.5 kW. Relayed by Turin, 1,094 kc/s (274.2 m.) and Genoa, 959 kc/s (312.8 m.). Transmits at intervals from 7.15 a.m. 4.0 p.m.—Gramophone Records. 4.10 p.m.—Programme from the Garden Club, Turin. 5.0—5.10 p.m.—Giornale Radio. 6.0 p.m.—Agricultural Notes. 6.15 p.m.—Gramophone Records. In the intervals at 6.40 p.m.—Announcements, and at 7.0 p.m.—Time and News. 7.20 p.m.—Hints for Housewives. 7.30 p.m.—Relay from Rovereto of the Chimes of the Bell of the Fallen. Opening Peals. Address by His Excellency Monsignore Bartolomasi. Pastorale, Il presepio del fante—the Prize-Winner in the International Competition. Peals for the Fallen: (a) For the Heroes in the Trenches, (b) For the Heroes at Sea, (c) For the Heroes of the Air. Closing Peals. 8.0 p.m.—Christmas Concert, conducted by M. Attilio Parelli. Christmas Pastorale (Bach-Cui). Selections from "L'Enfance du Christ" (Berlioz): (a) The Flight into Egypt, (b) The Shepherds' Farewell, (c) Trio for Two Flutes and Harp. Lauda per la Natività del Signore, for Soprano, Contralto, Tenor, Choir and Orchestra (Respighi). "At the Sign of the Ass and the Ox"—Comedy in One Act (Alberto Casella). The Ninety-Sixth Psalm, for Tenor Soloist, Choir and Orchestra (Sandro Fuga). Giornale Radio and News, followed by Midnight Mass.

MUNICH (Germany)

563 kc/s (533 m.); 1.7 kW. Relayed by Augsburg and Kaiserslautern, 536 kc/s (560 m.) and Nürnberg, 1,256 kc/s (239 m.). Transmits at intervals from 5.45 a.m. 6.5 p.m.—"Bells ring out from every tower"—a Christmas Variety Programme. 7.30 p.m.—Organ Recital by Gustav Schoedel. In dulci jubilo (Bach). Organ Chorale: Vom Himmel hoch (Pachelbel). Krippenlied, Op. 13, No. 4 (Piechler). Te Deum laudamus, Op. 59, No. 12 (Reger). 7.50 p.m.—"Die Nacht des Hirten"—Advent Play (Henry von Heiseler). 8.20 p.m.—Choral and Orchestral Concert of Christmas Music. Conductor: Hans Winter. Soloists: Margot Leander (Soprano), Anny Stang-Gress (Contralto), G. Schoedel (Organ). Pastorale for Organ and Orchestra (Rheinberger). Three Songs with Orchestral accompaniment (Wiener): (a) Hoffnung, (b) Die Weihnacht, (c) Klein Jesus im Hag. Stille Nacht, for Soprano, Mixed Choir and Chamber Orchestra (Huber-Anderach). Cradle Song from "Sursum corda" (Piechler). Magic Mirror Suite (Gal). Kyrie, Sanctus, Benedictus and Agnus Dei from the Mass "Zur Christnacht" (Jochum). Music for Strings in Three Movements (Thomassin). 10.0 p.m.—Christmas Chimes from Our Lady's Church.

OSLO (Norway)

Kringkastingselskapet, 277 kc/s (1,083 m.); 75 kW. Relayed by

Fredriksstad, 816 kc/s (367.6 m.); Hamar, 536 kc/s (560 m.); Notodden, 671 kc/s (447.1 m.); Porsgrund, 662 kc/s (453.2 m.) and Rjukan, 671 kc/s (447.1 m.). Transmits at intervals from 9.0 a.m. 2.0 p.m.—Christmas Carols for Children. 3.0 p.m.—Organ Recital from St. Saviour's Church. 3.20 p.m.—Christmas Service from St. Saviour's Church. 5.0 p.m.—Vocal and Orchestral Concert. 6.15 p.m.—News Bulletin. 6.30 p.m.—Recitations. 7.0 p.m.—Time Signal. 7.2 p.m.—Concert. Baritone Solos: (a) Caro mio ben (Giordano), (b) Arioso (Händel), (c) Nacht und Träume (Schubert). Violin Solos: (a) Romance (Bossi) (b) Ave Maria (Schubert), (c) Siciliano (Scarlati), (d) Synnöves sang (Kjerulf). Baritone Solos: (a) Song (Solheim) (b) Christmas Carol (Nistad), (c) Christmas Hymn (Egeberg). 8.0 p.m. (approx.)—Close Down.

PARIS (France)

Eiffel Tower (FLE). 207.5 kc/s (1,445.7 m.); 15 kW. Time Signals (on 2,650 m.) at 9.26 a.m. and 10.26 p.m. (preliminary and 6-dot signals). 5.45 p.m.—Le Journal Parlé. 7.20 p.m.—Weather Forecast. 7.30 p.m.—Gramophone Concert.

PARIS (France)

Poste Parisien. 914 kc/s (328.2 m.); 1.2 kW. 8.0 p.m.—Gramophone Records. 8.30 p.m.—News Bulletin. 8.45 p.m.—Film Talk, Gramophone Records and News. 9.0 p.m.—Concert arranged by the Association générale des auditeurs de la radiodiffusion française, with the collaboration of Artists from the Opéra and the Opéra-Comique. Overture, "Christmas Eve" (Rimsky-Korsakoff). Old Carol from "La Cigale" (Massenet). Orchestral Suite from "L'Enfance du Christ" (Berlioz). Allegro and Allegretto from the Eighth Symphony (Beethoven), conducted by M. Théodore Mathieu. Two Old Carols (César Franck). Christmas Carol (Augusta Holmes). Noël berrichon (M. S. Rousseau).

PARIS (France)

Radio-Paris (CFR). 174 kc/s (1,725 m.); 80 kW. Transmits at intervals from 6.45 a.m. (Physical Culture). 12.30 p.m.—Gramophone Records. 1.0 p.m.—Exchange and News. 1.5 p.m.—Gramophone Concert for Young People. In the intervals at 1.30 p.m. and 2.0 p.m.—Exchange Quotations. 3.35 p.m.—Exchange; Market Prices. 6.30 p.m.—Agricultural Report, Market Prices, Racing Results and Weather Report. 7.0 p.m.—Talk on Christmas. 7.30 p.m.—Gramophone Records. 7.45 p.m.—Commercial Prices, Economic and Social Notes and News. 8.0 p.m.—Gramophone Concert. The Country Church. Pastorale (Scarlati). Recitations (Paul Fort): (a) Le Dit du Vieux Pauvre, (b) La Complainte du petit cheval blanc. Turkish March (Mozart). Organ Solo: Cortège (Vierne). Selections from "King David" (Honegger). Four Selections from "The Messiah" (Händel). In the interval at 8.30 p.m.—News, Sports Results, Weather and Talk. 9.0 p.m.—Concert by the Paris Symphony Orchestra, conducted by M. Klemperer, relayed from the Pleyel Hall. Symphony in G (Mozart). Symphony No. 8 (Bruckner). In the interval, News and Time. After the Programme, Dance Music. 2.0 a.m. (Friday)—Close Down.

RIGA (Latvia)

572 kc/s (525 m.); 15 kW. Transmits at intervals from 10.0 a.m. 6.15 p.m.—News Bulletin. 6.30 p.m.—Christmas Eve Concert. In the interval, at 7.0—An Address. 8.0 p.m.—Weather Report. 8.5 p.m.—Concert (continued). 8.30 p.m.—Recitations. 9.0 p.m.—Organ Recital. 9.30 p.m.—Catholic Service. 11.0 p.m. (approx.)—Close Down.

ROME (Italy)

Ente Italiano Audizioni Radiofoniche (IRO). 680 kc/s (441 m.);

75 kW. Relayed by ZRO, 3,750 kc/s (80 m.). Transmits at intervals from 7.15 a.m. (Giornale Radio). 12.40—1.15 p.m.—Quintet Concert. Overture, "Boccaccio" (Suppé). Suite, Jeux d'enfants (Bizet). Selection from "Red Roses" (Lehár). Selections from "Lilac Time" (Schubert-Berthé). Intermezzo from "Tiefland" (d'Albert). Song without Words, No. 25 (Mendelssohn). Bolero (Liga). The Little Maid (Kollo). 4.0 p.m.—Exchange Quotations. 4.5 p.m. (from Naples)—Programme for children, followed by Sports Notes. 4.25 p.m.—Announcements. 4.30—5.15 p.m.—Vocal and Instrumental Concert. Pianoforte Solos: (a) Gavotte (Sgambati), (b) Toccata (Schumann). Soprano Solos: (a) Aria from "La Sonnambula" (Bellini), (b) Selection from "Sicilian Vespers" (Verdi). Baritone Solos: (a) Canzone all'antica (Respighi), (b) Serenade from "Le roi d'Ys" (Lalo), (c) Princesita (Padilla). Pianoforte Solos: (a) The Harmonious Blacksmith (Händel), (b) La danza d'Olaf (Pick-Mangiagalli). Soprano Solos: (a) Melodia (Silesu), (b) Two Spanish Songs (arr. Laparra). 5.55 p.m. (from Naples)—Shipping. 6.0 p.m.—News Bulletin. 6.20 p.m.—Gramophone Records. 6.50 p.m.—Sports Notes, Press Review and Talk for Housewives. 7.30 p.m.—Time and Announcements. 7.32 p.m.—See Milan. 8.0 p.m. (approx.)—Christmas Eve Concert, conducted by M. Rito Selvaggio. Concerto grosso for String Orchestra (Manfredini). The Flight into Egypt, from the Oratorio "L'Enfance du Christ" (Berlioz). Adorazione dei Magi, from "Trittico botticelliano" (Respighi). Indian Suite (MacDowell). Topical Review. Orchestral Suite from the Opera "Christmas Eve" (Rimsky-Korsakoff). 9.55 p.m.—News Bulletin.

SCHENECTADY (U.S.A.)

General Electric Company (WGY). 790 kc/s (379.5 m.); 50 kW. Relayed at intervals by W2XAF on 9,530 kc/s (31.48 m.); and by W2XAD on 15,340 kc/s (19.56 m.). Transmits at intervals from 11.45 a.m. 9.0 p.m.—Stephen St. John's Banjo Quintet. 9.30 p.m.—Stock Reports and Police Notes. 9.45 p.m.—Lois Hardesty (Soprano). 10.0 p.m.—News Bulletin. 10.5 p.m.—Musical Ad Men. 10.30 p.m.—Rinso Talkie, from New York. 10.45 p.m.—Russ. Colombo and his Orchestra, from New York. 11.0 p.m.—Weather Report. 11.1 p.m.—Doc Peyton and his New Kenmore Orchestra. 11.29 p.m.—Time Signal. 11.30 p.m.—The Golden Trail with Richfield. 11.45 p.m.—The Stebbins Boys from New York. 12 midnight (WGY only)—The Vermont Lumber Jacks from New York. 12 midnight (W2XAF only)—Stock Reports and News. 12.15 a.m. (Friday)—4.0 a.m.—New York Relay. 12.15 a.m.—Campbell's Orchestra. 12.30 a.m.—Pride of the Heart Programme. 12.45 a.m.—Trials of the Goldbergs. 1.0 a.m.—Fleischman Hour. 2.0 a.m.—Arco Dramatic Musicale. 2.30 p.m.—The Adventures of Sherlock Holmes. 3.0 a.m.—Lucky Strike Dance Hour. 4.0 a.m.—Organ Recital from the Ritz Theatre, Albany N.Y. 4.45 a.m.—Cotton Club Orchestra, from New York. 5.0 a.m.—Jack Miles and his DeWitt Clinton Orchestra. 5.30 p.m.—Doc Peyton and his New Kenmore Orchestra. 6.0 a.m. (approx.)—Close Down.

SCHWEIZERISCHER LANDESSENDER (BEROMÜNSTER) (Switzerland)

653 kc/s (459 m.); 75 kW.; Basle, 1,229 kc/s (244.1 m.); and Berne, 1,220 kc/s (246 m.). Transmits at intervals from 11.28 a.m. 2.30 p.m.—Orchestral Concert. 2.58 p.m.—Time Signal. 3.0 p.m.—Gramophone Records of Christmas Carols.

3.45 p.m. (from Berne)—Fairy Music for Children. 5.0—6.0 p.m.—Interval. 6.0 p.m. (from Zürich)—Christmas Programme for Children by Gobi Walder and Erika Fetscherin. 7.0 p.m. (from Basle)—An old German Christmas Play. 8.0 p.m.—Christmas Eve Service, relayed from St. Elizabeth's Church, with Selections by a Motet Choir and Soloists. 11.0 p.m.—Midnight Mass for Mixed and Boys' Choirs and Orchestra (Palestrina), relayed from a Church in Lucerne. 11.45 p.m. (approx.)—Close Down.

STOCKHOLM (Sweden)

Radiotjänst (SASA). 689 kc/s (436 m.); 75 kW. Relayed by Boden, 244 kc/s (1,229.5 m.); Göteborg, 932 kc/s (322 m.); Hörby, 1,166 kc/s (257 m.); Motala, 222.5 kc/s (1,348 m.); Östersund, 389 kc/s (770 m.); and Sundsvall, 554 kc/s (542 m.). Transmits at intervals from 6.45 a.m. 4.0 p.m.—Christmas Service, relayed from Karlstad. 5.15 p.m.—Christmas Eve in the Studio. 6.15 p.m.—Weather and News. 6.30 p.m.—Concert of Light Music. 7.30 p.m.—Christmas Programme. Choral Selections (Riedel): (a) Maria in the Wood, (b) Legend about the Infant Christ. Violin Solos by John Hylbom: (a) The Night (Rubinstein-Czerny), (b) Rondo (Schubert-Friedberg), (c) Sicilienne (Paradisi-Dushkin), (d) Scherzo (Dittersdorf-Kreisler). Three Songs by Set Svanholm. Reading (J. L. Runeberg). Violin Solos: (a) Scandinavian Poems (Westberg), (b) Sérénade à Lisette (Caludi). Four Songs by Set Svanholm. Choral Selections (Sibelius, Liszt and Vogler). 8.45 p.m.—Weather and News. 8.50 p.m.—Christmas Programme—Gramophone Records. 9.30 p.m. (approx.)—Close Down.

STRASBOURG (France)

Radio-Strasbourg (PTT). 869 kc/s (345 m.); 15 kW. Transmits at intervals from 11.30 a.m. 6.0 p.m.—Instrumental Concert. 6.45 p.m.—Talk in French: Christmas Day in St. Odile. 7.0 p.m.—Gramophone Records. 7.30 p.m.—Time Signal. 7.32 p.m.—News in French and German. 7.45 p.m.—Gramophone Records. 8.30 p.m.—Instrumental Concert. Overture (Händel). Aria from the "Messiah" (Händel). Selection (Liszt). La Procession and Pastorale (César Franck). Aria from "L'Enfance du Christ" (Berlioz). La Vierge à la Crèche (Franck). Aria from "The Redemption" (Franck). Alleluia from "The Messiah" (Händel). 10.30 p.m.—Gramophone Records. 11.0 p.m.—Gramophone Records. 11.55 p.m. (approx.)—Close Down.

STUTTGART (MÜHL-ACKER) (Germany)

Süddeutscher Rundfunk. 832 kc/s (360.5 m.); 75 kW. Relayed by Freiburg, 527 kc/s (570 m.). Transmits at intervals from 5.15 a.m. (Frankfurt Relay). 5.15 p.m.—Choral and Orchestral Concert. 6.15 p.m.—Christmas Wind Instrument Music by the Württemberg Musician's Orchestra. 7.0 p.m.—See Frankfurt. 7.30 p.m. (from Mannheim)—Christmas Music. Christmas Pastorale from "The Messiah" (Händel). Trio in D Major (Bach). Andantino from Trio No. 5 (Haydn). Christmas Pastorale (Valentini). 8.0 p.m.—See Frankfurt. 9.30 p.m. (from Freiburg)—"Pastoral Play" from Lope de Vega's Play on the Birth of Christ, translated by F. Walther. Arranged for Radio by K. Vetter. 10.15 p.m.—Christmas Mass by the Cannstatt Choral Society, relayed from the Parish Church, Cannstatt. 11.0 p.m.—Chimes from Freiburg Cathedral. 11.10 p.m.—Christmas Service, relayed from the Benedictine Abbey at Weingarten. 12.10 a.m. (Friday)—Close Down.

TOULOUSE (France)

Radiophonie du Midi. 779 kc/s (385 m.); 8 kW. Transmits at intervals from 12.45 p.m.

6.0 p.m.—Light Music. 6.15 p.m.—Orchestral Selections. 6.30 p.m.—News Bulletin. 6.45 p.m.—Orchestral Selections from "Ramuntcho" (Pierné) and "Si j'étais Roi" (Adam). 7.0 p.m.—Songs from "The Magic Flute" (Mozart), and "Philémon et Baucis" (Gounod). 7.15 p.m.—Accordion Solos. 7.30 p.m.—News Bulletin. 7.45 p.m.—Military Music. 8.0 p.m.—Songs from "Mireille" (Gounod), "La Basoche" (Messager), and "La Tosca" (Puccini). 8.15 p.m.—Orchestral Selections from "The Land of Smiles" (Lehár), "Brummel" (Hahn), and "Le Roi Pausole" (Honegger). 8.30 p.m.—Orchestral Selections. 8.45 p.m.—Sound Film Music. 9.0 p.m.—Orchestral Selections. 9.30 p.m.—Songs from "L'Africaine" (Meyerbeer), "La Juive" (Halévy) and "Siegfried" (Wagner). 9.45 p.m.—Accordion Solos. 10.0 p.m.—Gramophone Records. 10.15 p.m.—Orchestral Selections. 10.30 p.m.—News Bulletin. 10.45 p.m.—Concert. 11.15 p.m.—North African News. 11.30 p.m.—Songs from "La Mascotte" (Audran) and "Elle est à vous" (Yvain). 11.45 p.m.—Orchestral Selections. 12 midnight.—Weather and Announcements. 12.5 a.m. (approx.) (Friday)—Dance Music. 1.0 a.m. (approx.)—Close Down.

TRIESTE (Italy)

Ente Italiano Audizioni Radiofoniche. 1,211 kc/s (247.7 m.); 15 kW. Transmits at intervals from 11.30 a.m. 7.15 p.m.—News Bulletin. 7.30 p.m.—Talk for Housewives. 7.35 p.m.—Gramophone Records. 8.0 p.m.—Time, Announcements and Programme to be announced. Cinema Notes in the interval. 9.15 p.m.—Light Music. 9.55 p.m.—News Bulletin.

VIENNA (Austria)

Radio-Wien. 581 kc/s (517 m.); 20 kW. Relayed by Graz, 852 kc/s (352.1 m.); Innsbruck, 1,058 kc/s (283 m.); Klagenfurt, 662 kc/s (453.2 m.); Linz, 1,220 kc/s (246 m.) and Salzburg, 1,373 kc/s (218 m.). Transmits at intervals from 8.20 a.m. 6.25 p.m.—Time and Announcements. 6.35 p.m.—Gramophone Records. 7.15 p.m.—"The Wax Candle"—a Christmas Story (Manfred Hausmann). 7.40 p.m.—"Gloria in Excelsis"—for Choirs and Orchestras. Omnes de Saba venient (Eybler). Pueri concinite (Herbeck)—Coronation Mass in C Major and Te deum (Mozart). 8.30 p.m.—News Bulletin. 8.45 p.m.—Concert of Light Music. 10.40 p.m.—Wind Instrument Concert from the Ruprecht Church. 11.0 p.m.—Chimes.

WARSAW (Poland)

Polskie Radio. 212.5 kc/s (1,411 m.); 158 kW. Transmits at intervals from 10.45 a.m. 11.10 a.m.—Gramophone Records. 12.10 p.m.—Weather Report. 12.15 p.m.—Economic Notes. 12.20—3.0 p.m.—No Transmission. 3.0 p.m.—Talk: The Writings of Joseph Pilsudsky. 3.25 p.m.—Gramophone Records. 3.45 p.m.—Talk on Christmas Eve. 4.0 p.m.—Christmas Programme for Children. 4.30—7.30 p.m.—No Transmission. 7.30 p.m.—Christmas Carols relayed from Katowice, 734 kc/s (408 m.). 7.55 p.m.—"The Lonely People's Christmas Eve"—Programme by Mr. Kisielewsky. 8.25 p.m.—Christmas Carols relayed from Cracow, 959 kc/s (312.8 m.). 8.50 p.m.—Literary Programme relayed from Cracow. 9.20 p.m.—Christmas Concert by Mme. S. Rabcewicz (Pianoforte) and Maurice Janovsky (Tenor). Prelude and Fugue for Pianoforte, Noël en Pologne (Brzezinsky). Tenor Solos: Christmas Carols (arr. Niewiadomsky). Pianoforte Solo: Christmas Fantasia (Kamieniecki). Tenor Solos: Christmas Carols (Niewiadomsky). 9.55 p.m.—Literary Programme from Katowice. 10.25 p.m.—See Lubov. 11.0 p.m.—Bugle Call from the Tower, followed by Midnight Mass from St. Mary's Church, Cracow.

PROGRAMMES FOR FRIDAY (December 25)

NOTE: THE HOURS OF TRANSMISSION ARE REDUCED TO GREENWICH MEAN TIME

BARCELONA (Spain)

Radio-Barcelona (EAJ1). 860 kc/s (349 m.); 8 kW.
Transmits at intervals from 7.30 a.m.
7.0 p.m.—Recitations in Catalan.
7.15 p.m.—Gramophone Dance Music.
9.0 p.m.—“The Barber of Seville”—Opera (Rossini) on Gramophone Records.
12 midnight (approx.)—Close Down.

BERLIN (Germany)

Königs Wusterhausen. 183.5 kc/s (1,635 m.); 75 kW.
Transmits at intervals from 4.30 a.m. (Leipzig Relay).
10.30 a.m.—See Leipzig.
11.15 a.m.—Christmas Readings.
11.30 a.m.—See Leipzig.
1.30 p.m.—Reading for Young People.
2.0 p.m.—See Berlin (Witzleben).
2.30 p.m.—Talk: The Angel in German Art.
3.0 p.m.—See Frankfurt.
5.5 p.m.—See Langenberg.
6.0 p.m.—See Berlin (Witzleben).
6.30 p.m.—Talk on Music.
6.55 p.m. till Close Down.—See Berlin (Witzleben).

BERLIN (Germany)

Witzleben. 715 kc/s (418 m.); 1.7 kW.
Transmits at intervals from 4.30 a.m. (Leipzig Relay).
10.30 a.m.—See Leipzig.
11.15 a.m.—Reading of Lyrics.
11.30 a.m.—See Leipzig.
1.30 p.m.—Programme for Children.
2.0 p.m.—Walter Hirschberg Recital. Soprano Solos, accompanied by the Composer.
2.30 p.m.—“Dear Father . . .”—Letters of Famous Germans.
3.0 p.m.—See Frankfurt.
5.0 p.m.—Variety Programme.
6.0 p.m.—Sonata in C Minor, Op. 30, No. 2, for Violin and Piano-forte (Beethoven).
6.30 p.m.—“Lonely Forests”—Pictures from Canada and Alaska.
6.55 p.m.—Talk on the following transmission.
7.0 p.m.—“Il Trovatore”—Opera in Four Acts (Verdi), relayed from the Municipal Opera House, Charlottenburg. During an interval: Weather and News.
10.0 p.m.—Orchestral Concert.
11.0 p.m. (approx.)—Close Down.

BORDEAUX-LAFAYETTE (France)

(PTT). 986 kc/s (304 m.); 35 kW.
Transmits at intervals from 12 noon.
6.0 p.m.—Talk: The Intellectual Heritage of Virgil.
7.30 p.m.—News Bulletin.
7.40 p.m.—Gramophone Records.
8.10 p.m.—Results of the Prize Draw.
8.15 p.m.—News Bulletin.
8.30 p.m.—Talk relayed from Paris (Ecole Supérieure), 671 kc/s (447.1 m.).
8.40 p.m.—Dance Music. After the Programme: Amusement Guide and Time Signal.

BRESLAU (Germany)

923 kc/s (325 m.); 1.7 kW. Relay by Gleiwitz, 1,184 kc/s (253 m.).
Transmits at intervals from 6.0 a.m.
6.20 p.m.—Weather; Sports Notes.
6.30 p.m.—Wireless Notes.
7.0 p.m.—See Berlin (Witzleben).
7.15 p.m.—Time and News.
10.25 p.m.—Concert from Berlin (Witzleben).
11.0 p.m.—Sports Report from the Jahrhunderthalle.
11.30 p.m. (approx.)—Close Down.

BRUSSELS (Belgium) (No. 1)

I.N.R. 590 kc/s (509 m.); 20 kW.
12.15—1.45 p.m.—Gramophone Records.
5.0 p.m.—Orchestral Concert. Overture, “Light Cavalry” (Suppé). Suite algérienne (Saint-Saëns). Meditation from “Thais” (Massenet). Minuet (Boccherini). Selection from “Les Noces de Jeanette” (Massé). Pastorale from “Le Jongleur de Notre Dame” (Massenet). Divertissement (Lalo).
6.0 p.m.—Gramophone Records of Christmas Music.
6.15 p.m.—Talk.
6.45 p.m.—Gramophone Records.
7.15 p.m.—Talk: The Neapolitan Song.

7.30 p.m.—Music Review.
8.0 p.m.—Orchestral Selections.
8.15 p.m.—“Weihnachtsbaum”—Ten Pieces (Liszt), by M. Emile Bosquet (Pianoforte).
9.0 p.m.—Orchestral Concert. Soloist: M. Brogniez (Baritone).
10.0 p.m.—Le Journal Parlé.

BRUSSELS (Belgium) (No. 2)

N.I.R. 887 kc/s (338.2 m.); 20 kW.
Programme in Flemish.
12.15—1.45 p.m.—Schubert Gramophone Concert.
5.0 p.m.—Orchestral Concert.
5.45 p.m.—Programme for Children.
6.30 p.m.—Gramophone Records.
7.15 p.m.—Talk.
7.30 p.m.—Wireless Review.
8.0 p.m.—Symphony Concert. Overture, “Tannhäuser” (Wagner). Two Movements from the Unfinished Symphony (Schubert). Song. Les Préludes (Liszt). Song. Suite algérienne (Saint-Saëns).
9.55 p.m.—Evening Prayer.
10.0 p.m.—Le Journal Parlé.

BUDAPEST (Hungary)

545 kc/s (550 m.); 23 kW.
Transmits at intervals from 7.20 a.m.
5.0 p.m.—Orchestral Concert of Light Music, conducted by T. Polgar.
6.0 p.m.—Recital by Zs. Harsanyi.
6.30 p.m.—“Janos vitez”—Musical Play in Three Acts after a Story by Alexander Petöfi (Kacsóh Pongrácz, arr. Akos Butykal), relayed from the Royal Hungarian Opera House. After the Play, Concert by the Eugen Farkas Tzigane Orchestra from the Café Spolarich.

COLOGNE (Germany)

Westdeutscher Rundfunk. 1,319 kc/s (227 m.); 1.7 kW.
See Langenberg.

COPENHAGEN (Denmark)

1,067 kc/s (281 m.); 0.75 kW. Relay by Kalundborg, 260 kc/s (1,153 m.).
Transmits at intervals from 8.0 a.m.
2.20 p.m.—Choral and Orchestral Concert. Vocal Music of the Eleventh and Twelfth Centuries: (a) Kyrie Eleison (Buxtehude), (b) Der Tag ist so freudenreich (Gesius), (c) Ave gratia plena (C. Verdonck), (d) In dulci júbilo (J. Walther). Overture, “The Messiah” (Händel). Minuet from the Symphony in E Flat Major (Mozart). Overture to the Cantata, “Die Erde lacht, die Erde jubiliert” (Bach). Choral Music: (a) Af Høiheden oprunden (J. Orn), (b) Hodie Christus natus est (Marienzy), (c) Jubilate deo (O. di Lasso), (d) Wie schön singt uns der Engel Schar (C. Feund). Overture, “Et Eventyr i Rosenborg Have” (Weyse). Selection from “On the Bosphorus” (Lange-Müller). Selection from “King and Marshall” (P. Heise). Overture, “The Vikings at Helgeland” (E. Hartmann).
4.30 p.m.—Concert on the Historic Organ in the Castle Church, Frederiksborg.
5.0 p.m.—Gramophone Concert.
5.50 p.m.—Weather Report.
6.0 p.m.—News Bulletin.
6.15 p.m.—Time Signal.
6.30 p.m.—Jörgen Falk-Renne reads from his own Works.
7.0 p.m.—Town Hall Chimes.
7.2 p.m.—Concert of Old French Dances for Strings and Woodwind Instruments. Basse danse. Allemande. Courante. Sarabande. Bourrée. Allemande. Sarabande.
7.15 p.m.—A Mystery Play in Four Acts and a Prologue (Paul Claudel). Danish Translation by Anna Saxild.
9.15 p.m.—Cembalo Recital. Bible Sonata, No. 1.—The Fight between David and Goliath (Joh. Kuhnau).
9.30 p.m.—News Bulletin.
9.40 p.m.—Classical Dances by Viennese Composers. German Dance in E Flat Major (Mozart). Contredance and Minuet (Beethoven). Contredance for Strings (Mozart). Myrtle Waltz (Joh. Strauss). Military March (Schubert). Waltz, Die Schönbrunner (Lanner). Grätzer-Galop (Schubert).
10.10 p.m. (approx.)—Close Down.

DUBLIN (Ireland)

(2RN). 725 kc/s (413 m.); 1.5 kW. Relay by Cork, 1,337 kc/s (224.4 m.).
7.30 p.m.—Concert. The Artane Band. Vocal Quartet.
9.0 p.m.—Nativity Play by Gabriel Fallon and Company.

9.50 p.m.—Instrumental Trio.
10.15 p.m.—Vocal Quartet.
10.30 p.m.—Time, News, Weather and Close Down.

FÉCAMP (France)

Radio Normandie. 1,364 kc/s (219.9 m.); 1 kW.
12 noon.—Concert.
8.0 p.m.—Exchange and News.
8.30 p.m.—Concert of Fairy Tale Music.

FRANKFURT-am-MAIN (Germany)

770 kc/s (390 m.); 1.7 kW. Relay by Cassel, 1,220 kc/s (246 m.).
Transmits at intervals from 6.0 a.m. (Hamburg Relay).
3.0 p.m.—Orchestral Concert from Wiesbaden.
5.0 p.m.—Reading: “Heilige Nacht” (Ludwig Thoma).
6.0 p.m.—“The Twilight Hour”—Programme arranged by Falke-Leonhardt.
6.30 p.m.—Reading (Felix Timmermans).
7.15 p.m.—Third Act of “The Mastersingers”—Opera (Wagner), relayed from the Hessian Theatre, Darmstadt. Conductor: Felix von Weingartner.
9.0 p.m.—Time and News.
9.20 p.m.—Orchestral Concert.
11.0 p.m. (approx.)—Close Down.

HAMBURG (Germany)

Norag (ha, in Morse). 806 kc/s (372 m.); 1.7 kW. Relay by Bremen, 1,112 kc/s (270 m.); Flensburg, 1,373 kc/s (218 m.); Hanover, 530 kc/s (566 m.); and Kiel, 1,292 kc/s (232.2 m.).
Transmits at intervals from 6.0 a.m. (Hamburg Harbour Hour).
10.30 a.m.—See Leipzig.
11.15 a.m.—Concert from the Café Vaterland.

HAMBURG (Germany)

12.30 p.m.—Albrecht Janssen reads Three Christmas Legends.
1.0 p.m.—Orchestral Concert, conducted by Adolf Secker. Overture, “The Italian Girl in Algiers” (Rossini). Selection from “Don Juan” (Mozart). Clog Dance from “Czar and Carpenter” (Lortzing). Puppen-Menuett (v. Blon). Peer Gynt Suite No. 2 (Grieg). Selection from “Die Puppentheater” (Bayer). Three Pieces (Gerard Bunk): (a) Pastorale, (b) Canzone, (c) Allelujah. Waltz, Mon rêve (Waldteufel). Babillage (Gillet). Waltz from “The Geisha” (Jones). Bolero (Moszkovsky). Pianoforte Solos: (a) Song without Words (Mendelssohn), (b) Mazurka (Gardard). Overture, “Light Cavalry” (Suppé). Waltz: Wine, Woman and Song (Joh. Strauss). Selection from “The Maid of the Black Forest” (Jessel). Waltz, Gold and Silver (Lehár). Overture, “The Land of Smiles” (Lehár).
3.30 p.m.—“Christ is Born”—a New Christmas Play about Olden Times by Bernhard Seiffert. (Music by Max Maier).
4.45 p.m.—German Dance Music.
5.45 p.m.—“Gleaming Stars”—a Christmas Play in Dialect (Heinrich Deiters).
6.10 p.m. (from Hanover).—Old Christmas Music. Soloists: Emily Schade (Soprano), Margarete Kalm (Contralto), and Hans Meyer zu Spradow (Organ). Pastorale (Bach). Christmas Cantata for Contralto and Organ (Fr. Tunder). Fugue for Organ (Händel). Aria from the “Christmas Cantata”—Hymn of the Angels and Shepherds—for Soprano, Two Violins and Continuo (Cello and Organ) (Scarlatti). Variations on “Gelobet seist du, Jesus Christ (Samuel Scheidt). Christmas Cantata: Gesegnete Christen, glückselige Herde, for Two Voices, Two Violins, Cello and Organ (V. Lübeck).
6.55 p.m.—Weather Report.
7.0 p.m.—Popular Concert, conducted by Richard Richter, relayed from the Musikhalle. Soloist: Bernhard Hamann (Violin). Festival Overture (Lassen). Violin Solos: (a) Tango (Kreisler), (b) Valse caprice (Ries). Two Synchronic Dances (Grieg). The Nutcracker Suite (Tchaikovsky). Overture, “Maritana” (Wallace). In der Christnacht (Hanekam). Selections from “Lilac Time” (Schubert-Berté). Happy Christmas (E. Koedel). First News in the interval.
8.45 p.m.—Concert in the Reichshof. In an interval at 9.0 p.m.—News Bulletin.

9.20 p.m. (in the interval).—Topical Talk.
10.0 p.m.—Dance Music from the Trocadero. In an interval at 10.20 p.m.—Ice Report.

HEILSBURG (Germany)

1,085 kc/s (276.5 m.); 75 kW. Relay by Danzig, 662 kc/s (453.2 m.).
Transmits at intervals from 6.0 a.m. (Concert).
2.30 p.m.—Orchestral Concert, conducted by Eugen Wilcken. Overture, “Heimkehr aus der Fremde” (Mendelssohn). Fantasia, Dream Pictures (Lumbye). Waltz, Roses of the South (Joh. Strauss). Flower Suite (Siede). Amoretten-Reigen (Fucik). Souvenir de Mona Lisa (Schebek). Selection from “Il Trovatore” (Verdi). Overture, “Fra Diavolo” (Auber). The Nigger’s Dream (Myddleton). Waltz, Himmelsfunken (Waldteufel). Selection from “William Tell” (Rossini).
4.30 p.m.—The Programme of the Forgotten.
5.0 p.m.—Christmas Variety Programme from Berlin (Witzleben).
6.0 p.m. (from Danzig).—A Radio Play.
7.0 p.m.—Popular Concert by the Königsberg Opera House Orchestra, conducted by Georg Wöllner; in the interval at 8.0 p.m.—Announcements.
9.0 p.m.—News, followed by Concert and Dance Music from Hamburg.
11.0 p.m. (approx.)—Close Down.

HILVERSUM (Holland)

1,004 kc/s (298.8 m.); 20 kW.
7.25—9.40 a.m.—Programme of the Workers’ Radio Society (V.A.R.A.).
7.25 a.m.—Gymnastics.
7.40 a.m.—Gramophone Records.
7.55 a.m.—Address.
8.10 a.m.—Christmas Cantata (Vincent Lübeck).
8.40 a.m.—Recitations.
9.0 a.m.—Violin and Organ Recital from the Concert Hall, Amsterdam.
10.10 a.m.—Programme of the Liberal Protestant Radio Society (V.P.R.O.). Divine Service from Aerdenhout.
11.40 a.m.—1.40 p.m.—Programme of the Algemeene Vereeniging Radio Omroep (A.V.R.O.). Orchestral Concert, conducted by Nico Treep. Soloists: Hélène Cals (Soprano), Louis van Tulder (Tenor), Herman Leijdsendorff (Violin), and Jan Nieland (Organ). Fugue in A Minor (Bach). Elegy (Busch). Soprano Solos with Organ accompaniment: (a) Aria from “The Christmas Oratorio” (Bach), (b) Er weidet seine Herde from “The Messiah” (Händel). Canzone for Strings (Vranken). Songs, with Organ accompaniment. Sonata in G Minor for Violin and Organ (Borghi). Adagietto from “L’Arlésienne” (Bizet). Songs. Selections for Violin and Organ: (a) Sonata in A Major (Vivaldi), (b) March (Händel-Flesch). Waltz (Weber). Songs: (a) Maria auf dem Berge (Kienzl), (b) Simeon (Cornelius), (c) Wiegenlied der Hirten (Cornelius), (d) Kerstlied (Nieland). Fantasia on Christmas Carols (v. t. Kruijs).
1.40—7.40 p.m.—V.A.R.A. Programme.

1.40 p.m.—Relay of the Christmas Assembly of the Workers’ Socialist-Democrat Party from the Concert Hall, Amsterdam. Addresses and Music.

3.0 p.m.—Orchestral Concert, conducted by Hugo de Groot. Christmas Overture (Coleridge-Taylor). Four Parts of the Suite, The Christmas Tree (Rebikoff). Fantasia, Christmas (Rhode).
3.40 p.m.—Christmas Assembly Relay (continued).
4.25 p.m.—Gramophone Records.
4.40 p.m.—Christmas Recitations.
5.10 p.m.—Concert (continued). Overture, “Templeweih” (Kéler-Béla). Waltz, Transaktionen (Strauss). Ballet Suite from “Coppélia” (Delibes).
5.55 p.m.—Songs to the Lute, by Richard Germer. Lied des Sängers (Germer). Tanzweise im Maien (Germer). Die Musik kommt (O. Straus).
6.10 p.m.—“The Cricket on the Hearth” (Dickens), arranged for Radio.
7.25 p.m.—Songs (continued). Min Schapp (Germer). De Bur in’n Kroeg. Dance Music. Burlala.
7.40—10.40 p.m.—V.P.R.O. Programme.
7.40 p.m.—Concert from the English

Church at Amsterdam. Organ Solos: (a) Durch Adams Fall ist ganz verderbt (Buxtehude), (b) Wie schön leuchtet der Morgenstern (Buxtehude). Contralto Solos: (a) Aria from Cantata No. 175 (Bach), (b) Recitative and Aria from “The Christmas Cantata” (Bach).
8.10 p.m.—Reading.
8.30 p.m.—Concert (continued).
10.40 p.m.—V.A.R.A. Programme. Orchestral Concert, conducted by Hugo de Groot.
11.40 p.m. (approx.)—Close Down.

HUIZEN (Holland)

160 kc/s (1,875 m.); 8.5 kW.
6.40—9.10 a.m.—Programme of the Christian Radio Society (N.C.R.V.).
6.40 a.m.—Christmas Carols by a Wind Instrument Quartet.
7.10 a.m.—Christmas Service from the Reformed Church at Ryswick. —Selections for Children’s Choir. Mixed Choir and Organ.
8.10 a.m.—Religious Programme.
9.10—11.40 a.m.—Programme of the Catholic Radio Society (K.R.O.).
9.10 a.m.—Christmas Chimes from St. Vitus Church at Bussum, followed by Sacred Concert.
9.40—11.40 a.m.—Mass from the Church of Moses and Aaron at Amsterdam.
11.55 a.m. till Close Down.—N.C.R.V. Programme.
11.55 a.m.—Trio Concert. Trio Sonata (Albinoni). Sonata (Telemann). Trio Sonata (Corelli). Selection from “Manon” (Massenet). Poème (Drdla). Chant russe (Lalo). Selection from “La dame blanche” (Boieldieu).
1.10 p.m.—Talk: Bach’s Oratorios.
1.40 p.m.—Concert by the N.C.R.V. Symphony Orchestra, conducted by F. Schuurman. Soloist: M. J. Caro (Bass). Turmmusik (J. Pezel). Paraphrase, Eere zij God (C. Dopper). Two Arias from Cantata No. 57 (Bach). Suite in B Minor (Bach). Kleine Weihnachtsmusik (Kurt Thomas). Christmas Pastoral (J. D. Heinen). Bass Solos: (a) Noël (H. de Ries), (b) O Kerstnacht schooner dan de dagen (arr. Fl. v. Duyse), (c) Het wonder en de drie wijzen (C. J. Bute). The Brandenburg Concerto, No. 3 in G Major (Bach). Christmas Concerto (Corelli).

3.40 p.m.—Concert by a Mixed Choir. Soloist: M. H. A. Wegerif (Organ).
4.40 p.m.—Divine Service from the Reformed Church at Beverwijk. After the Service, Gramophone Records.
6.40 p.m.—Concert by the Hartvelt Quartet. String Quartet in B Flat Major—the Hunt (Mozart). String Quartet No. 3 in C Major, Op. 33—the Bird Quartet (Haydn).
7.40 p.m.—“Die fromme Ruth”—Cantata, Op. 17 (Hermann Müller), for Soloists, Choir and Pianoforte, by the Young Germans’ Choir at Castrop-Rauxel. Conductor: Dr. W. Kölsche.
8.40 p.m.—Recitations.
9.10 p.m.—Choral Concert. Soloist: M. J. A. Doorn (Organ).
10.10 p.m.—News Bulletin.
10.20 p.m.—Gramophone Records.
11.10 p.m. (approx.)—Close Down.

KALUNDBORG (Denmark)

Kalundborg Radio. 260 kc/s (1,153 m.); 7.5 kW.
See Copenhagen.

KATOWICE (Poland)

734 kc/s (408 m.); 16 kW.
Transmits at intervals from 10.0 a.m.
3.0 p.m.—Gramophone Records.
4.0 p.m.—Choral Concert relayed from Wilno, 1,220 kc/s (244.1 m.).
4.30 p.m.—Popular Concert.
5.45 p.m.—Soloist Concert relayed from Cracow, 959 kc/s (312.8 m.).
7.45 p.m.—Concert of Light Music.
10.0 p.m.—Programme for Listeners Abroad.

LANGENBERG (Germany)

Westdeutscher Rundfunk. 635 kc/s (473 m.); 17 kW. Relay by Aachen, Cologne and Münster, 1,319 kc/s (227 m.).
Transmits at intervals from 5.0 a.m. (Service).
3.30 p.m.—Concert from Frankfurt.
5.5 p.m.—“Das dumme Englein”—a Fairy Play (Vicki Baum).
6.0 p.m.—Talk and Readings: Masters of the Portrayal of Nature—Francis Jammes.

Programmes for Friday—(Cont.)

6.20 p.m.—An Entertainment.
7.0 p.m.—Christmas Concert by the Wireless Orchestra, conducted by Kühn; followed by "Macht hoch die Tür"—Cantata for Soprano, Choir and Orchestra (Julius Weismann), and a Programme for the Betrothed.
9.30 p.m.—News, followed by Concert of Old and New Dances.
11.0 p.m.—Gramophone Records—Masters of Jazz.
12 midnight (approx.)—Close Down.

LEIPZIG (Germany)

1,157 kc/s (259 m.); 2.3 kW. Relayed by Dresden, 941 kc/s (319 m.).
Transmits at intervals from 4.30 a.m. (Mass from Selma).
10.30 a.m.—"Christen ätzet diesen Tag"—Cantata for Soloists, Choir and Orchestra (J. S. Bach).
11.30 a.m.—Strauss Concert by the Leipzig Symphony Orchestra, conducted by Hilmar Weber. Radetzky—March (Joh. Strauss, Sen.) Overture, "Der lustige Krieg" (Joh. Strauss). Melodies from "Frühlingsluft" (Jos. Strauss). Waltz, Dem Mutigen gehört die Welt (Joh. Strauss). Polka, Schneesternchen (E. Strauss). Waltz from "Die Fledermaus" (Joh. Strauss). Mazurka, Aus der Ferne (Jos. Strauss). Galop, Mit Schick (E. Strauss). Overture, "Waldmeister" (Joh. Strauss). Waltz, Sorgenbrecher (Joh. Strauss, Sen.). Galop, Wo man lacht und lebt (E. Strauss). Quadrille from "The Queen's Kerchief" (Joh. Strauss). Waltz, Dorfschwalben aus Oesterreich (Jos. Strauss). Mazurka, Liebeszauber (E. Strauss). Melodies from "A Night in Venice" (Joh. Strauss).
1.30 p.m.—From Busch to Ringel-natz—a Variety Programme.
2.0 p.m.—Concert of Chamber Music.
3.0 p.m.—"Mariëchen von Nym-wegen"—an Old Flemish Miracle Play.
4.0 p.m.—Military Band Concert.
5.30 p.m.—"Lohengrin"—Opera (Wagner) relayed from the New Theatre.
9.30 p.m.—News Bulletin.
9.40 p.m. (approx.)—Concert by the Leipzig Symphony Orchestra, conducted by Hilmar Weber.
11.0 p.m.—Dance Music.
12 midnight (approx.)—Close Down.

LJUBLJANA (Yugoslavia)

522 kc/s (574.7 m.); 2.8 kW. Transmits at intervals from 9.0 a.m.
7.0 p.m.—Violin Recital.
8.0 p.m.—Guitar Trio Music.
9.0 p.m.—News and Light Music.

LWÓW (Poland)

788 kc/s (381 m.); 21 kW. Transmits at intervals from 10.0 a.m.
7.0 p.m.—Literary Programme relayed from Wilno, 1,229 kc/s (244.1 m.).
7.45 p.m.—Light Music for Orchestra, Choir and Soloists.
9.0 p.m.—Gramophone Dance Music.
10.0 p.m. (approx.)—Close Down.

MADRID (Spain)

Union Radio (EAJ7). 707 kc/s (424.3 m.); 2 kW. Transmits at intervals from 8.0 a.m.
7.0 p.m.—Chimes, Exchange, Market Prices and Request Gramophone Records.
7.30 p.m. (in the interval)—Educational Talk.
8.10 p.m.—News and Political Review.
8.30—10.0 p.m.—Interval.
10.0 p.m.—Chimes, Time, Political Review and a Christmas Comedy for the Wireless.
12 midnight.—Chimes, News and Programme Announcements for Listeners Abroad.
12.30 a.m. (Saturday)—Close Down.

MILAN (Italy)

Ente Italiano Audizioni Radiofoniche. 905 kc/s (331.5 m.); 8.5 kW. Relayed by Turin, 1,094 kc/s (274.2 m.); and Genoa, 959 kc/s (312.8 m.). Transmits at intervals from 10.15 a.m.
4.0 p.m. (from Genoa)—Light Music.
6.0 p.m.—Gramophone Records. In the intervals, at 7.0 p.m.—Time Signal, at 7.20 p.m.—Five Minutes for Wireless Amateurs, and at 7.35 p.m.—Talk: Culinary Art.
7.45 p.m.—Reading: A Christmas Tale.
8.0 p.m.—Instrumental Concert of Chamber Music. Eighth Christmas Concerto grosso for Strings (Corelli). Pastorale for Wind Instruments (Pierné). Songs by Rita

De Vincenzi: Voici Noël, from Yvette Guilbert's Collection of Légendes dorées" (Weckerlin): (a) Voyage à Bethlem, (b) Le bouef et l'âne gris, (c) Nous étions trois bergerettes, (d) Prontement levez-vous, mon voisin. The Little Windmill, Op. 12, for Flute, Oboe and Bassoon (Couperin). Abendlied (Schumann). Noël ancien (Respighi). Song by Rita De Vincenzi: Aria from "Rédemption" (César Franck). Orchestral Suite from "L'Arlesienne" (Bizet). News in the interval.

MUNICH (Germany)

563 kc/s (533 m.); 1.7 kW. Relayed by Augsburg and Kaiserslautern, 536 kc/s (560 m.), and Nürnberg, 1,256 kc/s (239 m.). Transmits at intervals from 9.0 a.m.
6.0 p.m.—Song Recital by Paul Bender (Baritone) of the State Opera House. Selections (Schumann): (a) Frühlingsfahrt, (b) Auf das Trinkglas eines verstorbenen Freundes. Selections (Schubert): (a) Greisingesang, (b) Ach, aus dieses Tales Gründen, (c) Geheimnis. Selections (Loewe): (a) Heimlichkeit, (b) In der Marienkirche, (d) Des fremden Kindes heiliger Christ. Selections (Brahms): (a) Sonntag, (b) Feld-einsamkeit, (c) Der Gang zum Liebchen, (d) Ständchen: Der Mond steht überm Berge.
6.35 p.m.—Events and Destinies, told by A. Czibulka.
7.0 p.m.—Concert by the Philharmonic Orchestra, relayed from the Tonhalle. Time and News in the Second Interval.
10.20 p.m.—Concert from the Café Stadt Wien.

OSLO (Norway)

Kringkastingselskapet. 277 kc/s (1,083 m.); 75 kW. Relayed by Fredriksstad, 816 kc/s (367.6 m.); Hamar, 536 kc/s (560 m.); Notodden, 671 kc/s (447.1 m.); Pors-grund, 662 kc/s (453.2 m.) and Rjukan, 671 kc/s (447.1 m.). Transmits at intervals from 9.0 a.m.
4.0 p.m.—Concert by the Radio Ensemble.
4.50 p.m.—Divine Service from the Cathedral, Trondheim, 608 kc/s (493.4 m.).
6.15 p.m.—News Bulletin.
6.20 p.m.—Talk: Scandinavian Christmas Carols.
7.0 p.m.—Time Signal.
7.2 p.m.—Chamber Music by the Philharmonic Quartet. Ave Verum (Mozart). Bourrée (Bach). Ave Maria for Harp and Quartet (Gounod). Moment musical (Schubert). Meditation (Massenet). Interlude (Glazounoff). Romance (Grieg).
7.30 p.m.—Recitations.
8.0 p.m.—Vocal and Instrumental Concert.
9.0 p.m. (approx.)—Close Down.

PARIS (France)

Eiffel Tower (FLE). 207.5 kc/s (1,445.7 m.); 15 kW. Time Signals (on 2,650 m.) at 9.26 a.m. and 10.26 p.m. (preliminary and 6-dot signals).
3.0 p.m.—See Strasbourg.
5.45 p.m.—Le Journal Parlé.
7.20 p.m.—Weather Forecast.
7.30 p.m.—Symphony Concert conducted by M. E. Flament. Le Chant des Bergers (Boisdeffre-Salabert). Noël (Gounod-Del-saux). Panis Angelicus (Franck). Preludes and Fugue from "Das wohltemperierte Klavier" (Bach), played by M. Flament. Le dernier sommeil de la vierge (Massenet). Cloches du soir (Ropartz-Chapel-lier). Ave Maria (Arcadelt-Lotter). La veillée de l'ange gardien (Pierné-Mouton). Adagio cantabile (Tartini-Salabert). La fête de Noël (Tchaikovsky-Salabert).
8.30 p.m.—Variety Programme.

PARIS (France)

Poste Parisien. 914 kc/s (328.2 m.); 1.2 kW.
8.15 p.m.—Gramophone Records and News.
9.0 p.m.—"The Christmas Oratorio" (Bach), for Soloists, Choirs and Orchestra.

PARIS (France)

Radio-Paris (CFR). 174 kc/s (1,725 m.); 80 kW. Transmits at intervals from 7.45 a.m. (Gramophone Records).
12.30 p.m.—Gramophone Records.

1.0 p.m.—Gramophone Records of Christmas Music. In the intervals News and Weather.
6.30 p.m.—Agricultural Report, Market Prices, Racing Results and Weather Report.
7.0 p.m.—Gramophone Concert. Amina (Lincke). Selections (Bruze-Nazolles), Madrigal (Simone), Emmène-moi (Pearly). Selection from "La Tosca" (Puccini). L'anneau d'argent (Chaminade). Le Beau Gondolier (Borel). Selection from "Le Déluge" (Saint-Saëns). Selections (Ibert): (a) La Cage de Cristal, (b) Le petit âne blanc. Au fond du square (Bousquet). Jeff in the Conservatory.
7.45 p.m.—Economic and Social Notes and News.
8.0 p.m.—Talk on Christmas Music.
8.30 p.m.—Sports Results and Weather.
8.40 p.m.—Gastronomic Review.
8.45 p.m.—Gramophone Records for Children.
9.15 p.m.—News and Time.
9.30 p.m.—Concert by Bela Rex (Violin) and his Viennese Orchestra.

ROME (Italy)

Ente Italiano Audizioni Radiofoniche (IRO). 680 kc/s (441 m.); 75 kW. Relayed by Naples, 941 kc/s (319 m.); and 2RO, 3,750 kc/s (80 m.).
12 noon.—Announcements.
12.10—1.15 p.m.—Concert of Light Music. Savoy, March (Fechner). Gigolo (Casucci). Selection (Siede). Festa di Maggio (Culotta). Trionfo di luci (Nucci). Selection from "Eva" (Lehár). Serenata gala (De Micheli). Selection (Engel-berger). El Caballero (Donati).
12.30 p.m. (in the interval)—Time and Announcements.
4.15 p.m. (from Naples)—Talk and Sports Notes.
4.30—5.15 p.m.—Instrumental Concert conducted by Enrico Martucci. Selection from "Zampa" (Hérold). Cello Solos: (a) Song without Words (Van Goëns), (b) La filieuse (Dunkler). Dance of the Waves from "Loreley" (Catalani). Violin Solos: (a) Largo (Veracini-Corti), (b) Tambourin chinois (Kreisler). Selection from "L'Amico Fritz" (Mascagni).
6.40 p.m.—(from Naples)—Shipping.
6.45 p.m.—News Bulletin.
7.0 p.m.—Sports Notes.
7.5 p.m.—Report of the International Institute of Agriculture (in Italian, French, English, German and Spanish).
7.30 p.m.—Time, Announcements, Talk and Gramophone Records.
8.0 p.m.—"The Blue Mazurka"—Operetta in Three Acts (Lehár). In the interval: Talk on Literature and Art and Topical Talk. News after the Programme.

SCHENECTADY (U.S.A.)

General Electric Company (WGY). 790 kc/s (379.5 m.); 50 kW. Relayed at intervals by W2XAF on 9,530 kc/s (31.48 m.) and by W2XAD on 15,340 kc/s (19.56 m.). Transmits at intervals from 1.0 p.m.
9.0 p.m.—Betty Moore, from New York.
9.15 p.m.—Twilight Voices, from New York.
9.30 p.m.—Musical Programme.
9.45 p.m.—Book Talk.
10.0 p.m.—Studio Ensemble.
10.30 p.m.—Dolly Connelly, from New York.
10.45 p.m.—Russ Colombo and his Orchestra, from New York.
11.0 p.m.—Weather Report.
11.1 p.m.—Organ Recital from Albany, N.Y.
11.29 p.m.—Time.
11.30 p.m.—The Three Mustachios, from New York.
11.45 p.m.—The Stebbins Boys, from New York.
12 midnight.—Stanley Hummel and Edward Morris (Pianists).
12.15 a.m. (Saturday)—With Gray McClintock in the Canadian Northwest.
12.30 a.m.—4.15 a.m.—New York Relay. In the interval at 1.30 a.m.—Agricultural Report.
12.30 a.m.—Prince Albert Programme.
12.45 a.m.—Trials of the Goldbergs.
1.0 a.m.—Cities Service Programme.
2.0 a.m.—Clicquot Club Eskimos.
2.30 a.m.—Pond's Programme.
3.0 a.m.—Silver Flute.
3.30 a.m.—RKO Programme.
4.0 a.m.—Marian Harris (Crooner).
4.15 a.m.—Mary Zoller (Xylophonist).
4.30 a.m.—Annette McCullough (Crooner).
4.45 a.m.—Vincent Lopez and his Orchestra from New York.

5.0 a.m.—Jack Miles and his DeWitt Clinton Orchestra.
5.30 a.m.—Doc Peyton and his New Kenmore Orchestra.
6.0 a.m. (approx.)—Close Down.

SCHWEIZERISCHER LANDESSENDER (BEROMÜNSTER) (Switzerland)

653 kc/s (459 m.); 75 kW.; Basle, 1,229 kc/s (244.1 m.); and Berne, 1,220 kc/s (246 m.).
9.0 a.m. (from Berne)—Protestant Service.
9.45 a.m.—"The Christmas Story"—for Soloists and Choir, arranged after Old Melodies by Hugo Keller.
10.15 a.m.—Organ Recital on Gramophone Records.
10.30 a.m.—See Leipzig.
11.10 a.m.—Gramophone Records of Chamber Music.
11.28 a.m.—Time and Weather.
11.30 a.m.—News Bulletin.
11.40 a.m.—Orchestral Concert.
12.35 p.m.—Weather Report.
12.40—2.30 p.m.—Interval.
2.30 p.m.—Gramophone Records of Opera Music.
3.0 p.m.—Gramophone Concert of Christmas Carols.
3.45 p.m. (from Berne)—Baritone, Violin and Harp Recital of Old German Christmas Carols.
4.15 p.m.—Gramophone Records of Sacred Music.
4.30—5.30 p.m.—Interval.
5.30 p.m. (from Berne)—Catholic Address.
6.15 p.m.—Christmas Concert by the Station Orchestra.
7.15 p.m. (from Berne)—"Das Apostelspiel"—Play (Max Mell).
8.15 p.m.—"Christmas Oratorio" for Soloists, Choir, Orchestra and Organ (Heinrich Schütz).
9.0 p.m. (approx.)—Weather and News.
9.15 p.m. (approx.)—Close Down.

STOCKHOLM (Sweden)

Radiotjänst (SASA). 689 kc/s (436 m.); 75 kW. Relayed by Boden, 244 kc/s (1,220.5 m.); Göteborg, 932 kc/s (322 m.); Hörby, 1,166 kc/s (257 m.); Motala, 222.5 kc/s (1,348 m.); Östersund, 389 kc/s (770 m.); and Sundsvall, 554 kc/s (542 m.). Transmits at intervals from 6.45 a.m.
6.0 a.m.—Divine Service Relay.
10.0 a.m.—Divine Service from St. Mary's Church, Hälsingborg, 1,301 kc/s (231 m.).
11.45 a.m.—Weather Report.
1.0 p.m.—Talk: Christmas Customs and Legends.
2.0 p.m.—Military Band Concert, with Soloist Selections. Johnny Schöning and Nils Alderling (Violinists), Roman Dukstulsky (Cello), Stig Rubbing (Pianoforte) and Readings by Märta Ekström.
4.0 p.m.—Programme for Children.
4.55 p.m.—Town Hall Chimes.
5.0 p.m.—Evensong Relay.
6.15 p.m.—Weather Report.
6.25 p.m.—Introductory Talk to the following Transmission.
6.30 p.m.—"The Messiah"—Oratorio for Soloists, Choir and Orchestra (Händel).
7.35 p.m.—Programme for Swedes Abroad.
8.45 p.m.—Weather and News.
8.50 p.m.—A Play (August Strind-berg).
10.0 p.m. (approx.)—Close Down.

STRASBOURG (France)

Radio-Strasbourg (PTT). 869 kc/s (345 m.); 15 kW. Transmits at intervals from 10.45 a.m.
3.0 p.m.—"Christmas Oratorio" (Saint-Saëns).
4.30 p.m.—Gramophone Records.
4.45 p.m.—Talk in French.
5.0 p.m.—Gramophone Records.
5.45 p.m.—Legal Talk in German.
6.0 p.m.—Chimes from Strasbourg Cathedral.
7.0 p.m.—Gramophone Records.
7.30 p.m.—Time Signal.
7.32 p.m.—News in French and German.
7.45 p.m.—Gramophone Records.
8.30 p.m.—"Faust"—Opera (Gounod) on Gramophone Records.
10.30 p.m. (approx.)—Close Down

STUTTGART (MÜHLACKER) (Germany)

Süddeutscher Rundfunk. 832 kc/s (360.5 m.); 75 kW. Relayed by Freiburg, 527 kc/s (570 m.). Transmits at intervals from 5.15 a.m.
3.0—11.0 p.m.—See Frankfurt.
11.0 p.m. (approx.)—Close Down.

TOULOUSE (France)

Radiophonie du Midi. 779 kc/s (385 m.); 8 kW.

Transmits at intervals from 12.30 p.m.
6.0 p.m.—Operetta Songs.
6.15 p.m.—Dance Music.
6.30 p.m.—News Bulletin.
6.45 p.m.—Light Music.
7.0 p.m.—Gramophone Records.
7.30 p.m.—News Bulletin.
7.45 p.m.—Accordion Solos.
8.0 p.m.—Orchestral Selections from "La Traviata" (Verdi), "Werther" (Massenet), "Cavalleria rusticana" (Mascagni) and "Werther" (Massenet).
8.15 p.m.—Songs from "Samson and Delilah" (Saint-Saëns), "Il Trovatore" (Verdi), "Die Walküre" (Wagner) and "Siegfried" (Wagner).
8.30 p.m.—Sacred Music.
8.45 p.m.—Orchestral Selections.
9.0 p.m.—Concert from the Café des Américains.
10.0 p.m.—Sponsored Programme.
10.30 p.m.—News Bulletin.
10.45 p.m.—Concert (continued).
11.0 p.m.—Chansonnettes.
11.15 p.m.—North African News.
11.30 p.m.—Songs from "Carmen" (Bizet) and "Madame Butterfly" (Puccini).
11.45 p.m.—Sacred Music.
12 midnight.—Weather, Announcements and Close Down.

TRIESTE (Italy)

Ente Italiano Audizioni Radiofoniche. 1,211 kc/s (247.7 m.); 15 kW. Transmits at intervals from 11.30 a.m.
7.15 p.m.—News Bulletin.
7.30 p.m.—Time and Announcements.
7.45 p.m.—Gramophone Records.
9.15 p.m.—Light Music.
9.55 p.m.—News Bulletin.

VIENNA (Austria)

Radio-Wien. 581 kc/s (517 m.), 20 kW. Relayed by Graz, 852 kc/s (352.1 m.); Innsbruck, 1,058 kc/s (283 m.); Klagenfurt, 662 kc/s (453.2 m.); Linz, 1,220 kc/s (246 m.), and Salzburg, 1,373 kc/s (218 m.). Transmits at intervals from 9.0 a.m.
2.5 p.m.—Orchestral Concert. Coronation March from "Die Folkunger" (Kretschmer). Overture, "Die Landstreicher" (Ziehrer). Waltz, Fesche Geister (E. Strauss). Selection from "Little Ida's Flowers" (Paul Klenau). Ballet Music from "La Gioconda" (Ponchielli). Serenade (Hruby). Waltz Idyll, Märchen aus dem Wienerwald (Max Ast). Selections from "The Grand Duchess of Gerolstein" (Offenbach). Napolitana from "The Czarevitch" (Lehár). Song and Czardas from "Gipsy Love" (Lehár). Waltz, Am Wörther See (Koschat). Potpourri, Alles singt mit (Recktenwald). Gallop, Sturm (Kcmzak).
4.0 p.m.—Talk: Christmas throughout the World.
4.30 p.m.—Quartet Concert.
5.30 p.m.—Talk: By Car from India to Europe.
6.0 p.m.—The Microphone Feuilleton of the Week.
6.20 p.m.—Time; Announcements.
6.30 p.m.—"The Bayadere"—Operetta in Three Acts (Kálmán), arranged for Radio by Max Ast.
8.50 p.m.—News Bulletin.
9.5 p.m.—Dance Music.

WARSAW (Poland)

Polskie Radio. 212.5 kc/s (1,411 m.); 158 kW.
10.0 a.m.—Divine Service from the Ostra Brama, Wilno, 1,229 kc/s (244.1 m.).
11.30 a.m.—Programme Announcements.
11.35 a.m.—2.30 p.m.—No Transmission.
2.30 p.m.—Gramophone Records.
3.30 p.m.—Programme for Children, relayed from Wilno.
4.0 p.m.—Choral Concert relayed from Wilno.
4.30 p.m.—Quartet Concert relayed from Wilno. Selection from "Hrabina" (Moniuszko). Zither Solos by Mr. Jodko. Walz, Flora (Leopold), Il est défendu d'aimer (Mikulsky). Zither Solos by Mr. Jodko. Puppentanz (Bayer). Selection (Müncheimer). Mazurka (Namyslovsky).
5.30 p.m.—Reading.
5.45 p.m.—Soloist Concert relayed from Cracow, 959 kc/s (312.8 m.).
7.0 p.m.—Dramatic Programme relayed from Wilno.
7.45 p.m.—See Lwów.
9.0 p.m.—Gramophone Dance Records.
10.0 p.m. (approx.)—Close Down.

PROGRAMMES FOR SATURDAY (December 26)

NOTE: THE HOURS OF TRANSMISSION ARE REDUCED TO GREENWICH MEAN TIME

BARCELONA (Spain)
Radio-Barcelona. (E.A.J.) 860 kc/s (349 m.); 8 kW.
Transmits at intervals from 7.30 a.m.
5.30 p.m.—Gramophone Records, followed by Part Relay of an Opera from the Gran Teatro del Liceo.
9.0 p.m.—Gramophone Records.
10.0 p.m.—See Madrid.

BERLIN (Germany)
Königs Wusterhausen. 183.5 kc/s (1,635 m.); 75 kW.
Transmits at intervals from 5.30 a.m. (Witzleben Relay).
3.30 p.m.—See Berlin (Witzleben).
6.10 p.m. (approx.)—See Hamburg.
7.0 p.m.—See Berlin (Witzleben).
11.30 p.m. (approx.)—Close Down.

BERLIN (Germany)
Witzleben. 715 kc/s (418 m.); 1.7 kW.
Transmits at intervals from 5.30 a.m. (Gymnastics).
3.30 p.m.—Concert from Breslau.
5.15 p.m.—Humorous Anecdotes.
5.45 p.m.—Haydn Quartets for Two Violins, Viola and Cello.
6.30 p.m.—Reading by the Author: "A German without Germany" (W. von Molo).
7.0 p.m.—Orchestral Concert, conducted by Bruno Seidler Winkler. Overture, Leonore No. 3 (Beethoven). Ballet Music from "Idomeneus" (Mozart). Tenor Solos: (a) Aria from "Idomeneus" (Mozart), (b) Aria from "Cosi fan tutte" (Mozart). Four Entr'actes from "Intermezzo" Op. 72 (R. Strauss). Suite from "Christmas Eve" (Rimsky-Korsakoff). Tenor Solos: (a) Aria from "Eugen Onegin" (Tchaikovsky), (b) The Flower Song from "Carmen" (Bizet). Emperor Waltz (Joh. Strauss).

8.35 p.m.—News Bulletin.
8.47 p.m.—Talk on the following transmission.
8.50 p.m.—Third Act of "The Mastersingers" (Wagner), relayed from the State Opera House, Unter den Linden. After the Programme, Dance Music.
11.30 p.m. (approx.)—Close Down.

BORDEAUX-LAFAYETTE (France)
(P.T.T.) 986 kc/s (304 m.); 35 kW.
Transmits at intervals from 12.45 p.m.
6.30 p.m.—Radio Journal.
7.50 p.m.—News, Exchange and Results of the Prize Draw.
7.55 p.m.—Sports Notes.
8.0 p.m.—Advanced English Lesson.
8.15 p.m.—News Bulletin.
8.25 p.m.—Relay from Paris (Ecole Supérieure), 671 kc/s (447.1 m.).
8.35 p.m.—Gramophone Records.
9.5 p.m.—Programme on the occasion of the Fifth Centenary of the Birth of François Villon. After the Programme, Amusement Guide and Time Signal.

BRESLAU (Germany)
923 kc/s (325 m.); 1.7 kW.
Relayed by Gleiwitz, 1,184 kc/s (253 m.).
Transmits at intervals from 7.0 a.m.
3.30 p.m.—Orchestral Concert. Overture, "Der Freischütz" (Weber). Peer Gynt Suite No. 1 (Grieg). Suite, Jeux d'enfants (Bizet). Overture, "The Merry Wives of Windsor" (Nicolai). Ballet Suite (Grétry-Mottl). Two Hungarian Dances (Brahms). Slavonic Dances (Dvorak). Waltz, Roses of the South and Radetzky March (Strauss).
5.30 p.m.—Weather Forecast.
5.35 p.m.—See Munich.
5.50 p.m.—See Leipzig.
6.10 p.m.—See Stuttgart.
6.35 p.m.—See Hamburg.
6.55 p.m.—Weather Forecast.
7.5 p.m.—See Stuttgart.
9.0 p.m.—Time and News.
9.30 p.m.—Dance Music.
11.30 p.m. (approx.)—Close Down.

BRUSSELS (Belgium) (No. 1)
I.N.R. 590 kc/s (509 m.); 20 kW.
12.15—1.45 p.m.—Opera Selection on Gramophone Records—"Carmen" (Bizet).
5.0 p.m.—Dance Music.
6.0 p.m.—Gramophone Records.
6.15 p.m.—Talk by M. Jean Dess.
6.30 p.m.—Gramophone Records.
7.15 p.m.—Talk on Banking.
7.30 p.m.—Literary Review.
8.0 p.m.—Orchestral Concert con-

ducted by Arthur Meulemans. Soloist: Mme. Claudine Boons (Songs). Overture and Aria from "Fidelio" (Beethoven). Rhapsodie Cambodgienne (Bourgault-Ducondray). Songs (Dvorak). Scherzo (Lalo). In the interval at 8.15 p.m.—Talk: The Anniversary of the Death of the Belgian Poet Albert Giraud.
8.45 p.m.—"Eros and Psyche"—an Old Mystery Play in Eight Scenes (Giraud) with Incidental Music by Paul de Maleingraue.
10.0 p.m.—Le Journal Parlé.

BRUSSELS (Belgium) (No. 2)
N.I.R. 887 kc/s (338.2 m.); 20 kW.
Programme in Flemish.
12.15—1.45 p.m.—Gramophone Records.
5.0 p.m.—Pianoforte Recital.
5.30 p.m.—Gramophone Records.
6.15 p.m.—Educational Talk.
6.30 p.m.—Gramophone Records.
7.15 p.m.—Talk.
7.30 p.m.—Film Review and Report on the Brussels Six Days' Racing.
8.0 p.m.—Mandoline Concert. Overture, "Il Seraglio" (Mozart). Minuet in D Major (Mozart). Andante cantabile con moto (Beethoven). Spanish Dance No. 5—Bolero (Moszkovsky). Lorely Paraphrase (Nesvadba). Aubade aux Mariés (Lacombe). Suite marinesca (Amadei).
8.45 p.m.—Reading.
9.0 p.m.—Concert relayed from the "Augustins."
10.0 p.m.—Le Journal Parlé.

BUCHAREST (Romania)
Radio-Bucarest. 761 kc/s (394 m.); 16 kW.
Transmits at intervals from 11.0 a.m.
6.0 p.m.—Readings and Recitations.
6.40 p.m.—Gramophone Records.
7.0 p.m.—"Everyman"—a Mystery Play (Hugo von Hofmannsthal).
8.0 p.m.—Romanian Concert.
8.50 p.m.—News Bulletin.

BUDAPEST (Hungary)
545 kc/s (550 m.); 23 kW.
Transmits at intervals from 9.0 a.m.
4.0 p.m.—Hungarian Folk Song Recital, by Isabelle Nagy to Accompaniment by a Tzigane Orchestra.
5.15 p.m.—Talk: Christmas in Rome.
5.30 p.m.—Orchestral Concert. Overture, (Keler Bela). Before the Altar (Sinigaglia). Dance of the Angels (Wolf-Ferrari). Morning, from the Peer Gynt Suite (Grieg). Stage Music to Jarnefelt's "Kuolema" (Sibelius). Petite Suite (Debussy). Ballad, Die Uhr (Loewe). Träumerei (Schumann). O, Star of Eve (Wagner).
6.45 p.m.—"Der Rastelbinder"—Operetta (Lehár), followed by Concert by the Alexander Bura Tzigane Orchestra, from the Café Emke.

COLOGNE (Germany)
Westdeutscher Rundfunk. 1,319 kc/s (227 m.); 1.7 kW.
See Langenberg.

COPENHAGEN (Denmark)
1,067 kc/s (281 m.); 0.75 kW.
Relayed by Kalundborg, 260 kc/s (1,153 m.).
Transmits at intervals from 9.0 a.m.
2.0 p.m.—Concert by Louis Preil's Instrumental Ensemble. Hungarian March (Lehár). Overture to an Operetta (Offenbach-Binder). Waltz, A Day in Seville (Waldteufel). Selection from "Thais" (Massenet). Violin Solo, Serenade (Padilla). Blancheffeur, from "The Dance at Koldinghus" (Kjerulf). Russian Dance. Waltz, Gebirgskinder (Ziehrer). Cortège (Windfeld). Selection from "Yes" (Yvain). Saenk kun dit Hoved, du Blomst (C. Nielsen). Columbine (Dufort). March, The Scorchers (Rosey). In the interval at 2.45 p.m.—Reading.
4.0 p.m.—Divine Service Relay.
5.20 p.m.—Talk (to be announced).
5.50 p.m.—Weather Report.
6.0 p.m.—News Bulletin.
6.15 p.m.—Time Signal.
6.30 p.m.—Talk by Frits Pullich.
7.0 p.m.—Town Hall Chimes.
7.2 p.m.—Reading.
7.20—11.15 p.m.—Christmas Radio Ball. Modern Dance Music by Louis Preil's Radio Dance Orchestra, with Vocal Refrains by Victor Cornelius. Viktor Fischer at the Pianoforte.
7.20—8.10 p.m.—Orchestral Dance Music.
8.10 p.m.—Modern Dance Songs by Ejner Jensen..

DUBLIN (Ireland)
(2RN). 725 kc/s (413 m.); 1.5 kW.
Relayed by Cork, 1,337 kc/s (224.4 m.).
7.20 p.m.—News Bulletin.
7.30 p.m.—Time Signal.
7.32 p.m.—Talk.
7.45 p.m.—Irish Lessons.
8.0 p.m.—Concert. The Station Sextet. Vocal Duets by E. Driscoll and Eira Haise. Cornet Duets by T. P. McCurtin and D. Nolan. Monica Warner (Soprano).
9.10 p.m.—A Pantomime presented by Dorothy Day and Company.
10.10 p.m.—The Station Sextet.
10.30 p.m.—Time, News, Weather and Close Down.

FÉCAMP (France)
Radio Normandie. 1,364 kc/s (219.9 m.); 1 kW.
12 noon.—Concert.
8.0 p.m.—Exchange and News.
8.30 p.m.—Agricultural Report.
9.0 p.m.—Concert of Light Music.

FRANKFURT-am-MAIN (Germany)
770 kc/s (390 m.); 1.7 kW.
Relayed by Cassel, 1,220 kc/s (246 m.).
Transmits at intervals from 8.0 a.m.
4.0 p.m.—See Stuttgart.
5.10 p.m.—"Tilman Riemenschneider"—a Radio Play (E. K. Fischer).
6.10—11.30 p.m.—See Stuttgart.
9.30 p.m. (in the interval).—News Bulletin.
11.30 p.m. (approx.)—Close Down.

HAMBURG (Germany)
Norag (ha, in Morse). 806 kc/s (372 m.); 1.7 kW. Relayed by Bremen, 1,112 kc/s (270 m.); Flensburg, 1,373 kc/s (218 m.); Hanover, 530 kc/s (566 m.) and Kiel, 1,292 kc/s (232.2 m.).
Transmits at intervals from 7.50 a.m.
2.0 p.m.—Christmas Carols sung to the Lute by Erika Beckert.
2.30 p.m.—"Winter"—a Recital by Karl Pündter and Bernhard Jakschat, with Pianoforte Accompaniment by Gerhard Maasz. Winter-Idyll (Karl Stieler). Song from the "Winterreise" (Schubert).
3.30 p.m. (from Bremen).—Concert by Two combined Military Bands, conducted by Carl Flick and Georg Voigt.
5.0 p.m.—Concert from Leipzig.
6.10 p.m.—Concert. Soloists: Erna Kroll-Lange (Soprano), Gertrud Schmidt (Contralto), Erwin Bolt (Tenor), Bernard Jakschat (Baritone), Gerhard Gregor and Gerhard Maasz (Pianists). Characteristic March for Pianoforte Duet (Schubert). Baritone Solo: Der Musensohn (Schubert). Soprano Solo: Einst träumte meiner selgen Base, from the Third Act of "Der Freischütz" (Weber). Aquarellen-Walzer, arranged for Two Pianofortes (Jos. Strauss-Grosz). Tenor and Baritone Duet from "Undine" (Lortzing). Duet from "Hansel and Gretel" (Humperdinck). Waltz for "Hansel and Gretel" (Schulhoff). Song from "Waltz Dream" (O. Straus). Song from "My Sister and I" (Benatzky). Liebeslieder-Walzer, for Two Pianofortes (Jos. Strauss-Grosz).
7.10 p.m.—Weather Report.
8.15 p.m.—Christmas Ball by the Hamburg Dance Orchestras—the Little Station Orchestra, the Jack Alban Orchestra from the Boccaccio, the Juan Llossas Orchestra from the Trocadero, and the Scarpa Orchestra from the Haus Sieglar.
10.20 p.m. (in an interval).—Ice Report.

HEILSBURG (Germany)
1,085 kc/s (276.5 m.); 75 kW.
Relayed by Danzig, 662 kc/s (453.2 m.).
Transmits at intervals from 6.0 a.m. (Gramophone Concert).
2.45 p.m.—Wind Instrument Concert, conducted by Felix Prawniczak. March, Mein Ostpreussen (Klaus). Waltz, Wiener Praterleben (Translator). Song, Das Herz am Rhein (Hill). Overture, "The Crown Diamonds" (Auber). An Evening in Toledo, and Spanish

Dance (Schmeling). Mussinan-Marsch (Carl). March, King Charles (Unrath). Serenade (Kockert). Selection from "The Merry Widow" (Lehár) March, Unter dem Doppeladler (Wagner).
4.30 p.m.—"Christmas in the Storm House"—arranged and read by Gerda von Bremen-Hirschheydt.
5.0 p.m.—Programme to be announced.
6.15 p.m.—Sports Notes.
6.30 p.m.—Monthly Review.
7.0 p.m.—Variety Programme, arranged by Kurt Lesing.
8.0 p.m. (in the interval).—Announcements. After the Concert: News, and Dance Music from Berlin (Witzleben).
11.30 p.m. (approx.)—Close Down.

HILVERSUM (Holland)
1,004 kc/s (298.8 m.); 20 kW.
7.25—9.40 a.m.—Programme of the Workers' Radio Society (V.A.R.A.).
7.25 a.m.—Gymnastics.
7.40 a.m.—Gramophone Records.
8.40 a.m.—Recitations.
8.55 a.m.—Choral Music.
9.10 a.m.—Recitations.
9.25 a.m.—Choral Music.
10.10—11.40 a.m. (approx.)—Programme of the Liberal Protestant Radio Society (V.P.R.O.). Divine Service from Amsterdam.
11.40 a.m.—1.25 p.m.—V.A.R.A. Programme.
11.40 a.m.—Orchestral Concert. Overture, "The Barber of Seville" (Rossini). Träumerei (Schumann). Gavotte (Lully). Colin Maillard (Guiraud). Selection from "Madame Butterfly" (Puccini).
12.25 p.m.—"A Modern Nurse"—Radio Play (Richard Elton).
12.45 p.m.—Concert (cont'd.). Overture from an Unfinished Comic Opera (Saint-Saëns). Solveig's Song (Grieg). Waltz, Neu-Wien (Strauss). Selection from "The Czardas Princess" (Kálmán). March, El Capitan (Souza).
1.40—3.40 p.m.—Programme of the Algemeene Vereeniging Radio Omroep (A.V.R.O.).
1.40 p.m.—"Busi's Christmas Dream"—a Play by Gustav Falke, Music by Humperdinck, for Choir and Soloists. After the Play: Gramophone Records.
3.40 p.m. till Close Down.—V.A.R.A. Programme.
7.40 p.m.—Programme for Children.
4.40 p.m.—Concert of Chamber Music, Quintet in D (Brandts-Buys).
5.10 p.m.—Wind Instrument Music, with Commentary.
5.25 p.m.—Quintet Concert. March of the Dwarves (Moszkovsky). Waltz, Mein Ideal (Blon). Caravan (Scassola). Gavotte tendre (Ganne). Ballet Divertissement (Blattermann).
5.55 p.m.—Literary Talk.
6.25 p.m.—Concert (cont'd.). Sérénade du Passant (Massenet). Chanson de Capri (Massenet). Extase (Rubinstein). Pantius vivante (Leoncavallo). Sérénade (Saint-Saëns). Danse Bosnique (Balleron). Petite Suite (Busser).
6.55 p.m.—Talk by Mr. Gerhard.
7.10 p.m.—Concert (cont'd.). L'île des Fées (Popy). Charme d'Espagne (Mezzacapo). Ma blonde zimée (Volpatti). De fleur en fleur (Gandolfo). Nuits algériennes (Grieg).
7.40 p.m.—Topical Talk.
7.55 p.m.—"An die Donau hab' ich mein Mädel geküsst"—Operetta (Stolz), relayed from The Hague.
9.25 p.m.—News Bulletin.
9.40 p.m.—Orchestral Concert conducted by Hugo de Groot.
10.10 p.m.—Recitations.
10.25 p.m.—Concert (cont'd.) and Gramophone Records.
11.40 p.m. (approx.)—Close Down.

KALUNDBORG (Denmark)
Kalundborg Radio. 260 kc/s (1,153 m.); 7.5 kW.
See Copenhagen.

KATOWICE (Poland)
734 kc/s (408 m.); 16 kW.
Transmits at intervals from 9.30 a.m.
3.20 p.m.—Gramophone Records.
4.45 p.m.—Light Music.
7.15 p.m.—Concert.
9.10 p.m.—Chopin Pianoforte Recital.
10.0 p.m.—Concert and Dance Music from the Café Atlantic.

LANGENBERG (Germany)
Westdeutscher Rundfunk. 635 kc/s (473 m.); 17 kW. Relayed by Aachen, Cologne and Münster, 1,319 kc/s (227 m.).
Transmits at intervals from 6.0 a.m. (Witzleben Relay).
3.30 p.m.—Military Band Concert relayed from the Zoological Gardens, Münster. March, Unter der Freundschaftsflagge (Blon). Festival Overture (Frank). Waltz, Seid umschlungen Millionen (Strauss). Selections from "Hansel and Gretel" (Humperdinck). March from the Suite in D Minor (Lachner). Military Overture (Mendelssohn). Fantasia on Weber's Works (Bach). Old Soldiers' Marches, Alte deutsche Treue (Franzen). Bleisoldat im Gefecht (Prager). Intermezzo, Goldregen (Kockert). Hungarian March (Baussner).
5.15 p.m.—See Munich. After the Relay, News.
10.30 p.m.—Dance Music by Ambrose and his Band from the Mayfair Hotel, London.
12 midnight (approx.)—Close Down.

LEIPZIG (Germany)
1,157 kc/s (259 m.); 2.3 kW.
Relayed by Dresden, 941 kc/s (319 m.).
Transmits at intervals from 6.0 a.m. (Concert).
3.0 p.m.—"Der Struwwelpeter" for Voices and Orchestra, Op. 28 (Fritz Reuter), by the Leipzig Symphony Orchestra, conducted by Theodor Blumer. Soloists: Edith Hasselmann (Soprano), Erika Wendorf (Contralto), Wilhelm Ulbricht (Tenor), and Philipp Göpelt (Bass).
4.15 p.m.—Concert by the Leipzig Symphony Orchestra, conducted by Theodor Blumer.
6.0 p.m.—"Artists out of School"—Amusing Interviews with Rastelli, the Fratellinis, Grock, Horace Goldin, Katie Sandwina, Urmann, Tarzan and others (Peter Peppermint).
6.45 p.m.—Remember the Unemployed.
7.5 p.m.—See Stuttgart.
9.0 p.m.—News Bulletin.
9.15 p.m. (approx.)—Dance Music.
11.0 p.m. (approx.)—Close Down.

LJUBLJANA (Yugoslavia)
522 kc/s (574.7 m.); 2.8 kW.
Transmits at intervals from 8.30 a.m.
7.0 p.m.—Military Music.

**DANCE (Schmeling). Mussinan-Marsch (Carl). March, King Charles (Unrath). Serenade (Kockert). Selection from "The Merry Widow" (Lehár) March, Unter dem Doppeladler (Wagner).
4.30 p.m.—"Christmas in the Storm House"—arranged and read by Gerda von Bremen-Hirschheydt.
5.0 p.m.—Programme to be announced.
6.15 p.m.—Sports Notes.
6.30 p.m.—Monthly Review.
7.0 p.m.—Variety Programme, arranged by Kurt Lesing.
8.0 p.m. (in the interval).—Announcements. After the Concert: News, and Dance Music from Berlin (Witzleben).
11.30 p.m. (approx.)—Close Down.**

HILVERSUM (Holland)
1,004 kc/s (298.8 m.); 20 kW.
7.25—9.40 a.m.—Programme of the Workers' Radio Society (V.A.R.A.).
7.25 a.m.—Gymnastics.
7.40 a.m.—Gramophone Records.
8.40 a.m.—Recitations.
8.55 a.m.—Choral Music.
9.10 a.m.—Recitations.
9.25 a.m.—Choral Music.
10.10—11.40 a.m. (approx.)—Programme of the Liberal Protestant Radio Society (V.P.R.O.). Divine Service from Amsterdam.
11.40 a.m.—1.25 p.m.—V.A.R.A. Programme.
11.40 a.m.—Orchestral Concert. Overture, "The Barber of Seville" (Rossini). Träumerei (Schumann). Gavotte (Lully). Colin Maillard (Guiraud). Selection from "Madame Butterfly" (Puccini).
12.25 p.m.—"A Modern Nurse"—Radio Play (Richard Elton).
12.45 p.m.—Concert (cont'd.). Overture from an Unfinished Comic Opera (Saint-Saëns). Solveig's Song (Grieg). Waltz, Neu-Wien (Strauss). Selection from "The Czardas Princess" (Kálmán). March, El Capitan (Souza).
1.40—3.40 p.m.—Programme of the Algemeene Vereeniging Radio Omroep (A.V.R.O.).
1.40 p.m.—"Busi's Christmas Dream"—a Play by Gustav Falke, Music by Humperdinck, for Choir and Soloists. After the Play: Gramophone Records.
3.40 p.m. till Close Down.—V.A.R.A. Programme.
7.40 p.m.—Programme for Children.
4.40 p.m.—Concert of Chamber Music, Quintet in D (Brandts-Buys).
5.10 p.m.—Wind Instrument Music, with Commentary.
5.25 p.m.—Quintet Concert. March of the Dwarves (Moszkovsky). Waltz, Mein Ideal (Blon). Caravan (Scassola). Gavotte tendre (Ganne). Ballet Divertissement (Blattermann).
5.55 p.m.—Literary Talk.
6.25 p.m.—Concert (cont'd.). Sérénade du Passant (Massenet). Chanson de Capri (Massenet). Extase (Rubinstein). Pantius vivante (Leoncavallo). Sérénade (Saint-Saëns). Danse Bosnique (Balleron). Petite Suite (Busser).
6.55 p.m.—Talk by Mr. Gerhard.
7.10 p.m.—Concert (cont'd.). L'île des Fées (Popy). Charme d'Espagne (Mezzacapo). Ma blonde zimée (Volpatti). De fleur en fleur (Gandolfo). Nuits algériennes (Grieg).
7.40 p.m.—Topical Talk.
7.55 p.m.—"An die Donau hab' ich mein Mädel geküsst"—Operetta (Stolz), relayed from The Hague.
9.25 p.m.—News Bulletin.
9.40 p.m.—Orchestral Concert conducted by Hugo de Groot.
10.10 p.m.—Recitations.
10.25 p.m.—Concert (cont'd.) and Gramophone Records.
11.40 p.m. (approx.)—Close Down.

HUIZEN (Holland)
160 kc/s (1,875 m.); 8.5 kW.
8.10—9.10 a.m.—Programme of the Catholic Radio Society (K.R.O.). Religious Programme.
9.10—11.55 a.m.—Programme of the Christian Radio Society (N.C.R.V.).
9.10 a.m.—Sacred Music.
9.30 a.m.—Divine Service from the Reformed Church, followed by Sacred Music.
11.55 a.m. till Close down.—K.R.O. Programme.
11.55 a.m.—Sextet Concert. Blaze away (Holzman). Murrelndes Lüftchen (Jensen). Waltz, Traumideale (Fucik). Baby spielt Soldat (Micheli). Pot-pourri, Streiflichter (Morena). A Perfect Day (Jacobs-Bond). Request Programme (Mohr). Narcissus (Nevin). Rund um die Wolga (Borchert). Melody (Rubinstein). Lady of Spain (Evans).
1.40 p.m.—Carillon Recital from the Cathedral of St. John, Bois-le-

**DANCE (Schmeling). Mussinan-Marsch (Carl). March, King Charles (Unrath). Serenade (Kockert). Selection from "The Merry Widow" (Lehár) March, Unter dem Doppeladler (Wagner).
4.30 p.m.—"Christmas in the Storm House"—arranged and read by Gerda von Bremen-Hirschheydt.
5.0 p.m.—Programme to be announced.
6.15 p.m.—Sports Notes.
6.30 p.m.—Monthly Review.
7.0 p.m.—Variety Programme, arranged by Kurt Lesing.
8.0 p.m. (in the interval).—Announcements. After the Concert: News, and Dance Music from Berlin (Witzleben).
11.30 p.m. (approx.)—Close Down.**

HILVERSUM (Holland)
1,004 kc/s (298.8 m.); 20 kW.
7.25—9.40 a.m.—Programme of the Workers' Radio Society (V.A.R.A.).
7.25 a.m.—Gymnastics.
7.40 a.m.—Gramophone Records.
8.40 a.m.—Recitations.
8.55 a.m.—Choral Music.
9.10 a.m.—Recitations.
9.25 a.m.—Choral Music.
10.10—11.40 a.m. (approx.)—Programme of the Liberal Protestant Radio Society (V.P.R.O.). Divine Service from Amsterdam.
11.40 a.m.—1.25 p.m.—V.A.R.A. Programme.
11.40 a.m.—Orchestral Concert. Overture, "The Barber of Seville" (Rossini). Träumerei (Schumann). Gavotte (Lully). Colin Maillard (Guiraud). Selection from "Madame Butterfly" (Puccini).
12.25 p.m.—"A Modern Nurse"—Radio Play (Richard Elton).
12.45 p.m.—Concert (cont'd.). Overture from an Unfinished Comic Opera (Saint-Saëns). Solveig's Song (Grieg). Waltz, Neu-Wien (Strauss). Selection from "The Czardas Princess" (Kálmán). March, El Capitan (Souza).
1.40—3.40 p.m.—Programme of the Algemeene Vereeniging Radio Omroep (A.V.R.O.).
1.40 p.m.—"Busi's Christmas Dream"—a Play by Gustav Falke, Music by Humperdinck, for Choir and Soloists. After the Play: Gramophone Records.
3.40 p.m. till Close Down.—V.A.R.A. Programme.
7.40 p.m.—Programme for Children.
4.40 p.m.—Concert of Chamber Music, Quintet in D (Brandts-Buys).
5.10 p.m.—Wind Instrument Music, with Commentary.
5.25 p.m.—Quintet Concert. March of the Dwarves (Moszkovsky). Waltz, Mein Ideal (Blon). Caravan (Scassola). Gavotte tendre (Ganne). Ballet Divertissement (Blattermann).
5.55 p.m.—Literary Talk.
6.25 p.m.—Concert (cont'd.). Sérénade du Passant (Massenet). Chanson de Capri (Massenet). Extase (Rubinstein). Pantius vivante (Leoncavallo). Sérénade (Saint-Saëns). Danse Bosnique (Balleron). Petite Suite (Busser).
6.55 p.m.—Talk by Mr. Gerhard.
7.10 p.m.—Concert (cont'd.). L'île des Fées (Popy). Charme d'Espagne (Mezzacapo). Ma blonde zimée (Volpatti). De fleur en fleur (Gandolfo). Nuits algériennes (Grieg).
7.40 p.m.—Topical Talk.
7.55 p.m.—"An die Donau hab' ich mein Mädel geküsst"—Operetta (Stolz), relayed from The Hague.
9.25 p.m.—News Bulletin.
9.40 p.m.—Orchestral Concert conducted by Hugo de Groot.
10.10 p.m.—Recitations.
10.25 p.m.—Concert (cont'd.) and Gramophone Records.
11.40 p.m. (approx.)—Close Down.

**DANCE (Schmeling). Mussinan-Marsch (Carl). March, King Charles (Unrath). Serenade (Kockert). Selection from "The Merry Widow" (Lehár) March, Unter dem Doppeladler (Wagner).
4.30 p.m.—"Christmas in the Storm House"—arranged and read by Gerda von Bremen-Hirschheydt.
5.0 p.m.—Programme to be announced.
6.15 p.m.—Sports Notes.
6.30 p.m.—Monthly Review.
7.0 p.m.—Variety Programme, arranged by Kurt Lesing.
8.0 p.m. (in the interval).—Announcements. After the Concert: News, and Dance Music from Berlin (Witzleben).
11.30 p.m. (approx.)—Close Down.**

HILVERSUM (Holland)
1,004 kc/s (298.8 m.); 20 kW.
7.25—9.40 a.m.—Programme of the Workers' Radio Society (V.A.R.A.).
7.25 a.m.—Gymnastics.
7.40 a.m.—Gramophone Records.
8.40 a.m.—Recitations.
8.55 a.m.—Choral Music.
9.10 a.m.—Recitations.
9.25 a.m.—Choral Music.
10.10—11.40 a.m. (approx.)—Programme of the Liberal Protestant Radio Society (V.P.R.O.). Divine Service from Amsterdam.
11.40 a.m.—1.25 p.m.—V.A.R.A. Programme.
11.40 a.m.—Orchestral Concert. Overture, "The Barber of Seville" (Rossini). Träumerei (Schumann). Gavotte (Lully). Colin Maillard (Guiraud). Selection from "Madame Butterfly" (Puccini).
12.25 p.m.—"A Modern Nurse"—Radio Play (Richard Elton).
12.45 p.m.—Concert (cont'd.). Overture from an Unfinished Comic Opera (Saint-Saëns). Solveig's Song (Grieg). Waltz, Neu-Wien (Strauss). Selection from "The Czardas Princess" (Kálmán). March, El Capitan (Souza).
1.40—3.40 p.m.—Programme of the Algemeene Vereeniging Radio Omroep (A.V.R.O.).
1.40 p.m.—"Busi's Christmas Dream"—a Play by Gustav Falke, Music by Humperdinck, for Choir and Soloists. After the Play: Gramophone Records.
3.40 p.m. till Close Down.—V.A.R.A. Programme.
7.40 p.m.—Programme for Children.
4.40 p.m.—Concert of Chamber Music, Quintet in D (Brandts-Buys).
5.10 p.m.—Wind Instrument Music, with Commentary.
5.25 p.m.—Quintet Concert. March of the Dwarves (Moszkovsky). Waltz, Mein Ideal (Blon). Caravan (Scassola). Gavotte tendre (Ganne). Ballet Divertissement (Blattermann).
5.55 p.m.—Literary Talk.
6.25 p.m.—Concert (cont'd.). Sérénade du Passant (Massenet). Chanson de Capri (Massenet). Extase (Rubinstein). Pantius vivante (Leoncavallo). Sérénade (Saint-Saëns). Danse Bosnique (Balleron). Petite Suite (Busser).
6.55 p.m.—Talk by Mr. Gerhard.
7.10 p.m.—Concert (cont'd.). L'île des Fées (Popy). Charme d'Espagne (Mezzacapo). Ma blonde zimée (Volpatti). De fleur en fleur (Gandolfo). Nuits algériennes (Grieg).
7.40 p.m.—Topical Talk.
7.55 p.m.—"An die Donau hab' ich mein Mädel geküsst"—Operetta (Stolz), relayed from The Hague.
9.25 p.m.—News Bulletin.
9.40 p.m.—Orchestral Concert conducted by Hugo de Groot.
10.10 p.m.—Recitations.
10.25 p.m.—Concert (cont'd.) and Gramophone Records.
11.40 p.m. (approx.)—Close Down.

HUIZEN (Holland)
160 kc/s (1,875 m.); 8.5 kW.
8.10—9.10 a.m.—Programme of the Catholic Radio Society (K.R.O.). Religious Programme.
9.10—11.55 a.m.—Programme of the Christian Radio Society (N.C.R.V.).
9.10 a.m.—Sacred Music.
9.30 a.m.—Divine Service from the Reformed Church, followed by Sacred Music.
11.55 a.m. till Close down.—K.R.O. Programme.
11.55 a.m.—Sextet Concert. Blaze away (Holzman). Murrelndes Lüftchen (Jensen). Waltz, Traumideale (Fucik). Baby spielt Soldat (Micheli). Pot-pourri, Streiflichter (Morena). A Perfect Day (Jacobs-Bond). Request Programme (Mohr). Narcissus (Nevin). Rund um die Wolga (Borchert). Melody (Rubinstein). Lady of Spain (Evans).
1.40 p.m.—Carillon Recital from the Cathedral of St. John, Bois-le-

**DANCE (Schmeling). Mussinan-Marsch (Carl). March, King Charles (Unrath). Serenade (Kockert). Selection from "The Merry Widow" (Lehár) March, Unter dem Doppeladler (Wagner).
4.30 p.m.—"Christmas in the Storm House"—arranged and read by Gerda von Bremen-Hirschheydt.
5.0 p.m.—Programme to be announced.
6.15 p.m.—Sports Notes.
6.30 p.m.—Monthly Review.
7.0 p.m.—Variety Programme, arranged by Kurt Lesing.
8.0 p.m. (in the interval).—Announcements. After the Concert: News, and Dance Music from Berlin (Witzleben).
11.30 p.m. (approx.)—Close Down.**

HILVERSUM (Holland)
1,004 kc/s (298.8 m.); 20 kW.
7.25—9.40 a.m.—Programme of the Workers' Radio Society (V.A.R.A.).
7.25 a.m.—Gymnastics.
7.40 a.m.—Gramophone Records.
8.40 a.m.—Recitations.
8.55 a.m.—Choral Music.
9.10 a.m.—Recitations.
9.25 a.m.—Choral Music.
10.10—11.40 a.m. (approx.)—Programme of the Liberal Protestant Radio Society (V.P.R.O.). Divine Service from Amsterdam.
11.40 a.m.—1.25 p.m.—V.A.R.A. Programme.
11.40 a.m.—Orchestral Concert. Overture, "The Barber of Seville" (Rossini). Träumerei (Schumann). Gavotte (Lully). Colin Maillard (Guiraud). Selection from "Madame Butterfly" (Puccini).
12.25 p.m.—"A Modern Nurse"—Radio Play (Richard Elton).
12.45 p.m.—Concert (cont'd.). Overture from an Unfinished Comic Opera (Saint-Saëns). Solveig's Song (Grieg). Waltz, Neu-Wien (Strauss). Selection from "The Czardas Princess" (Kálmán). March, El Capitan (Souza).
1.40—3.40 p.m.—Programme of the Algemeene Vereeniging Radio Omroep (A.V.R.O.).
1.40 p.m.—"Busi's Christmas Dream"—a Play by Gustav Falke, Music by Humperdinck, for Choir and Soloists. After the Play: Gramophone Records.
3.40 p.m. till Close Down.—V.A.R.A. Programme.
7.40 p.m.—Programme for Children.
4.40 p.m.—Concert of Chamber Music, Quintet in D (Brandts-Buys).
5.10 p.m.—Wind Instrument Music, with Commentary.
5.25 p.m.—Quintet Concert. March of the Dwarves (Moszkovsky). Waltz, Mein Ideal (Blon). Caravan (Scassola). Gavotte tendre (Ganne). Ballet Divertissement (Blattermann).
5.55 p.m.—Literary Talk.
6.25 p.m.—Concert (cont'd.). Sérénade du Passant (Massenet). Chanson de Capri (Massenet). Extase (Rubinstein). Pantius vivante (Leoncavallo). Sérénade (Saint-Saëns). Danse Bosnique (Balleron). Petite Suite (Busser).
6.55 p.m.—Talk by Mr. Gerhard.
7.10 p.m.—Concert (cont'd.). L'île des Fées (Popy). Charme d'Espagne (Mezzacapo). Ma blonde zimée (Volpatti). De fleur en fleur (Gandolfo). Nuits algériennes (Grieg).
7.40 p.m.—Topical Talk.
7.55 p.m.—"An die Donau hab' ich mein Mädel geküsst"—Operetta (Stolz), relayed from The Hague.
9.25 p.m.—News Bulletin.
9.40 p.m.—Orchestral Concert conducted by Hugo de Groot.
10.10 p.m.—Recitations.
10.25 p.m.—Concert (cont'd.) and Gramophone Records.
11.40 p.m. (approx.)—Close Down.

HUIZEN (Holland)
160 kc/s (1,875 m.); 8.5 kW.
8.10—9.10 a.m.—Programme of the Catholic Radio Society (K.R.O.). Religious Programme.
9.10—11.55 a.m.—Programme of the Christian Radio Society (N.C.R.V.).
9.10 a.m.—Sacred Music.
9.30 a.m.—Divine Service from the Reformed Church, followed by Sacred Music.
11.55 a.m. till Close down.—K.R.O. Programme.
11.55 a.m.—Sextet Concert. Blaze away (Holzman). Murrelndes Lüftchen (Jensen). Waltz, Traumideale (Fucik). Baby spielt Soldat (Micheli). Pot-pourri, Streiflichter (Morena). A Perfect Day (Jacobs-Bond). Request Programme (Mohr). Narcissus (Nevin). Rund um die Wolga (Borchert). Melody (Rubinstein). Lady of Spain (Evans).
1.40 p.m.—Carillon Recital from the Cathedral of St. John, Bois-le-

**DANCE (Schmeling). Mussinan-Marsch (Carl). March, King Charles (Unrath). Serenade (Kockert). Selection from "The Merry Widow" (Lehár) March, Unter dem Doppeladler (Wagner).
4.30 p.m.—"Christmas in the Storm House"—arranged and read by Gerda von Bremen-Hirschheydt.
5.0 p.m.—Programme to be announced.
6.15 p.m.—Sports Notes.
6.30 p.m.—Monthly Review.
7.0 p.m.—Variety Programme, arranged by Kurt Lesing.
8.0 p.m. (in the interval).—Announcements. After the Concert: News, and Dance Music from Berlin (Witzleben**

Programmes for Saturday—(Cont.)

9.0 p.m.—News Bulletin.
9.15 p.m.—Quintet Concert.

LWÓW (Poland)

788 kc/s (381 m.); 21 kW.
Transmits at intervals from 9.15 a.m.
6.0 p.m.—Miscellaneous Items.
6.25 p.m.—Reading.
6.45 p.m.—See *Warsaw*.
10.0 p.m.—Dance Music from the Bristol Palais de Danse.
11.0 p.m. (approx.)—Close Down.

MADRID (Spain)

Union Radio (EAJ7). 707 kc/s (424.3 m.); 2 kW.
Transmits at intervals from 8.0 a.m.
7.0 p.m.—Chimes, Exchange, Market Prices and Request Gramophone Records.
8.0 p.m. (in the interval)—News.
8.30—10.0 p.m.—Interval.
10.0 p.m.—Chimes, Time and Musical Comedy Selection.
12 midnight.—Chimes and News.
12.30 a.m. (Sunday)—Close Down.

MILAN (Italy)

Ente Italiano Audizioni Radiofoniche. 905 kc/s (331.5 m.); 8.5 kW. Relayed by *Turin*, 1,094 kc/s (274.2 m.); and *Genoa*, 959 kc/s (312.8 m.).
Transmits at intervals from 7.15 a.m.
4.5 p.m.—Gramophone Records.
4.10 p.m.—Concert from the Sala Gay, *Turin*.
5.0—5.20 p.m.—News Bulletin.
6.0 p.m.—Agricultural Notes.
6.15 p.m.—Concert of Light Music.
6.40 p.m.—Announcements.
6.45 p.m.—Gramophone Records. In the intervals at 7.0 p.m.—Time and News, and at 7.30 p.m.—A Language Lesson on Gramophone Records.
7.45 p.m.—Talk: Events and Problems.
8.0 p.m.—"The Cradle Song"—Comedy in Two Acts (F. Martinez Sierra), followed by Dance Music Relay.
10.0 p.m. (in the interval)—Giornale radio.
10.55 p.m.—News Bulletin.

MUNICH (Germany)

563 kc/s (533 m.); 1.7 kW. Relayed by *Augsburg* and *Kaiserslautern*, 536 kc/s (560 m.), and *Nürnberg*, 1,256 kc/s (239 m.).
Transmits at intervals from 9.0 a.m.
5.15 p.m.—Introductory Talk to the following Transmission.
5.35 p.m.—"Tannhäuser"—Opera in Three Acts (Wagner), relayed from the National Theatre. In the intervals, at 6.35 and 8.10 p.m.—Wireless Notes.
9.30 p.m.—Time and News.
9.45 p.m. (from *Nürnberg*)—Concert from the Café Königshof.
11.0 p.m. (approx.)—Close Down.

OSLO (Norway)

Kringkastingsselskapet, 277 kc/s (1,083 m.); 75 kW. Relayed by *Fredrikstad*, 816 kc/s (367.6 m.); *Hamar*, 536 kc/s (560 m.); *Notodden*, 671 kc/s (447.1 m.); *Porsgründ*, 662 kc/s (453.2 m.), and *Rjukan*, 671 kc/s (447.1 m.).
Transmits at intervals from 9.0 a.m.
3.0 p.m.—Orchestral Concert from the Wilhelm Olsen Restaurant.
4.0 p.m.—A Play for Children.
4.50 p.m.—Chimes and Service from the Fagerborg Church.
6.15 p.m.—Weather Report.
6.30 p.m.—Talk.
7.0 p.m.—Time Signal.
7.2 p.m.—"Die Geburt Christi"—Oratorio (Herzogenberg) for Soloists, Choir and Organ.
8.35 p.m.—News and Topical Talk.
9.5 p.m.—Variety Programme: Songs, Recitations and Mandoline Quartet Selections.
10.0 p.m.—Dance Music from the Hotel Bristol.
11.40 p.m. (approx.)—Close Down.

PARIS (France)

Eiffel Tower (FLE). 207.5 kc/s (1,445.7 m.); 15 kW. Time Signals (on 2,650 m.) at 9.26 a.m. and 10.26 p.m. (preliminary and 6-dot signals).
5.45 p.m.—Le Journal Parlé.
7.20 p.m.—Weather Forecast.
7.30 p.m.—Gramophone Records.
7.45 p.m.—Dramatic Programme: (a) "The Snow Man"—Play (Paul Castan, after the story by Hans Andersen), (b) "Remorse"—Radio

Drama (Berthe d'Yd), (c) "On the Boulevard"—an Acoustic Fantasy.

PARIS (France)

Poste Parisien. 914 kc/s (328.2 m.); 1.2 kW.
8.15 p.m.—Gramophone Records and News.
8.45 p.m.—Theatre Talk, Gramophone Records and News.
9.0 p.m.—Concert with the collaboration of Artists from the Opéra and Opéra-Comique. Prelude to "L'Ouragan" (Bruneau). Concert Piece in D, for Horn and Orchestra (Büsser)—Soloist: M. Vuillemoz. Symphonic Poem, *La Forêt enchantée* (d'Indy), conducted by M. F. Casadesus. Ballet Music from "Raymonda" (Glazounoff). The Swan of Tuonela (Sibelius). Basque Rhapsody from "Ramuntcho" (Pierné). Spanish Dance, No. 4 (Granados).

PARIS (France)

Radio-Paris (CFR). 174 kc/s (1,725 m.); 80 kW.
Transmits at intervals from 7.45 a.m. (Gramophone Records).
12.30 p.m.—Gramophone Concert. Scherzo and Nocturne from "A Midsummer Night's Dream" (Mendelssohn). Selections from "Werther" (Massenet). Cello Solo: *Après un Rêve* (Fauré). Selections (Gounod): (a) *Le Vallon* (b) *Serenade*. Selection from "Le Cid" (Massenet). *L'Absence* (Berlioz). *Valse triste* (Sibelius). Hymn to the Sun from "Le Coq d'Or" (Rimsky-Korsakoff). *Waltz, Frühlingsstimmen* (Strauss). Selection. *La Croix du Chemin* (Goublier). *Stances* (Flégier). *Ecos Españoles* (Marquina). In the intervals, News and Weather.
3.0 p.m.—Programme for Children.
4.45 p.m.—Concert by the Association des Concerts Lamoureux, relayed from the Salle Gaveau.
6.40 p.m.—Agricultural Report, Market Prices, Racing Results and Weather Report.
7.0 p.m.—Talk arranged by the Union des Grandes Associations, Françaises.
7.10 p.m.—Scientific Talk: With the Animals.
7.30 p.m.—Gramophone Records.
7.45 p.m.—Commercial Prices, Economic and Social Notes and News.
8.0 p.m.—Readings: Portraits (Saint-Simon).
8.30 p.m.—News, Sports Results and Weather Report.
8.40 p.m.—Talk.
8.45 p.m.—Variety Concert. In the interval at 9.15 p.m.—News and Time.

ROME (Italy)

Ente Italiano Audizioni Radiofoniche. (IRO). 680 kc/s (441 m.); 75 kW. Relayed by *Naples*, 941 kc/s (319 m.); and *2RO*, 3,750 kc/s (80 m.).
Transmits at intervals from 7.15 a.m.
12.35—1.15 p.m.—Quintet Concert. Overture, "La dame blanche" (Boieldieu). Cradle Song (Grieg). Gavotte (Sgambati). Cantata d'amore (Storti). Aquile d'Italia (Pennati-Malvezzi). Non danzar più (Sadun). The Musical Box (Nicolajevsky).
4.15 p.m.—Exchange; Announcements.
4.30—5.15 p.m.—Instrumental Concert conducted by Enrico Martucci. Overture, "Peter Schmolli" (Weber). Harp Solo: The Story of Christmas (Hasselmans). Hungarian Rhapsody No. 6 (Liszt). Variations on the Sextet from "Lucia di Lammermoor" (Donizetti). Celtic Suite (Foulds).
6.20 p.m.—Announcements.
6.32 p.m.—Atmospheric Signals, followed by Shipping (from *Naples*).
6.40 p.m.—News and Weather.
7.0 p.m.—Sports Notes; Press Review.
7.30 p.m.—Time, Announcements, French Lesson.
8.0 p.m. (approx.)—Relay of an Opera from a Theatre or Concert in the Studio. In the intervals: Review of New Books and Wireless Notes. News after the Programme.

SCHENECTADY (U.S.A.)

General Electric Company (WGY). 790 kc/s (379.5 m.); 50 kW. Relayed at intervals by W2XAF on

9,530 kc/s (31.48 m.) and by W2XAD on 15,340 kc/s (19.56 m.).
Transmits at intervals from 11.45 a.m.
9.0 p.m.—Phil Spitalny's "Tea Dance, from *New York*.
10.0 p.m.—Studio Ensemble.
10.30 p.m.—Uncle Jim.
11.0 p.m.—Jack Miller and his DeWitt Clinton Orchestra.
11.29 p.m.—Time Signal.
11.30 p.m.—American Trio.
11.45 p.m.—Municipal Series.
12 midnight (WGY only)—Bernard Silberg (Cello).
12 midnight (W2XAF only)—Stock Report and News.
12.15 a.m. (Sunday)—With Gray McClintock in the Canadian Northwest.
12.30 a.m.—Prince Albert Programme from *New York*.
12.45 a.m.—Trials of the Goldbergs.
1.0 a.m.—WGY Players.
1.30—4.0 a.m.—*New York* Relay.
1.30 a.m.—National Advisory Council Programme.
2.0 a.m.—Goodyear Programme.
2.30 a.m.—Club Valspar.
3.0 a.m.—Lucky Strike Dance Hour.
4.0 a.m.—Gordie Randall and his Van Curler Orchestra.
4.30 a.m.—Jack Miles and his DeWitt Clinton Orchestra.
5.0 a.m.—Rudy Vallee and his Connecticut Yankees from *New York*.
5.30 a.m.—Doc Peyton and his New Kenmore Orchestra.
6.0 a.m. (approx.)—Close Down.

SCHWEIZERISCHER LANDESENDER (BEROMÜNSTER) (Switzerland)

653 kc/s (459 m.); 75 kW; *Basle*, 1,229 kc/s (244.1 m.); and *Berne*, 1,220 kc/s (246 m.).
Transmits at intervals from 11.28 a.m.
2.30 p.m. (from *Basle*)—Accordion Recital.
2.58 p.m.—Time Signal.
3.0 p.m.—Gramophone Records.
4.0 p.m. (from *Zürich*)—Programme for Children.
4.30 p.m.—Weather and Market Prices.
4.35—5.30 p.m.—Interval.
5.30 p.m.—Gramophone Records: Concerto No. 2, in F Minor, for Piano and Orchestra (Chopin), by Marguerite Long and the Orchestra of the Société des Concerts du Conservatoire, in Paris.
6.0 p.m. (from *Zürich*)—Chimes from the Zürich Churches.
6.15 p.m. (from *Zürich*)—Talk: Reminiscences of Bethlehem.
7.0 p.m. (from *Basle*)—Choral Concert. Soloist, Dr. Ernst Reiter (Tenor).
9.0 p.m.—Weather and News.
9.15 p.m.—Gramophone Records.
10.0 p.m. (approx.)—Close Down.

STOCKHOLM (Sweden)

Radiotjänst (SASA). 689 kc/s (436 m.); 75 kW. Relayed by *Boden*, 244 kc/s (1,229.5 m.); *Göteborg*, 932 kc/s (322 m.); *Hörby*, 1,166 kc/s (257 m.); *Motala*, 222.5 kc/s (1,348 m.); *Östersund*, 389 kc/s (770 m.) and *Sundsvall*, 554 kc/s (542 m.).
Transmits at intervals from 6.45 a.m.
1.0 p.m.—Gramophone Records.
2.0 p.m.—Song Recital by Greta Kärtner, Readings by Albin Lindahl and Violin Solos by Karl Bornfors, relayed from *Göteborg*.
3.0 p.m.—Military Band Concert. March, *Donaugruss*. Overture, "Die Fledermaus" (Strauss). *Waltz, Der Obersteiger* (Zeller). *Potpourri* of Viennese Folk Music (Komzak). Selection from "Gasparone" (Millöcker). *Waltz, Veilchen aus dem Wienerwald* (Vollstedt). *Vindobona Marsch* (Komzak).
4.0 p.m.—Christmas Play (Ella Bystrom).
4.25 p.m.—Old German Sacred Songs by Erich Burger with Harp Accompaniment by Ursula Lentrodt-Burger.
4.55 p.m.—Town Hall Chimes.
5.0 p.m.—String Quartet in A Minor (Haquinus).
5.30 p.m.—*Brahms Song Recital* by Margit Sehlmark. Immer leiser wird mein Schlummer. Auf den Kirchhofe. Feldeinsamkeit. Der Schmied. Sapphic Ode.
5.45 p.m.—Talk.
6.15 p.m.—Weather and News.
6.30 p.m.—Reading.
7.0 p.m.—"La Bohème"—Opera (Puccini) relayed from the Royal Opera House. In the interval at 8.45 p.m.—Weather and News.
9.30 p.m.—Dance Music Relay.
11.0 p.m. (approx.)—Close Down.

STRASBOURG (France)

Radio-Strasbourg (PTT). 869 kc/s (345 m.); 15 kW.
Transmits at intervals from 11.30 a.m.
6.0 p.m.—Instrumental Concert.
6.45 p.m.—Gardening Talk in German.
7.0 p.m.—Gramophone Records.
7.30 p.m.—Time Signal.
7.32 p.m.—News in French and German.
7.45 p.m.—Gramophone Records.
8.30 p.m.—Concert from the Mulhouse Casino and the Café Moll.
10.30 p.m.—Dance Music from the Savoy.
12 midnight (approx.)—Close Down.

STUTTGART (MÜHLACKER) (Germany)

Süddeutscher Rundfunk. 832 kc/s (360.5 m.); 75 kW. Relayed by *Freiburg*, 527 kc/s (570 m.).
Transmits at intervals from 8.0 a.m.
4.0 p.m.—*Christmas Oratorio*—"Historie der freuden- und gnadenreichen Geburt Jesu Christi" (Heinrich Schütz), by the Christ Church Choir, relayed from Christ Church, *Freiburg*. Conductor: Wilhelm Ehmann. Soloists: Marta Martin (Soprano), Ernst Duis (Tenor). A String Ensemble, with Historic Instruments.
5.10 p.m.—"Tilman Riemenschneider"—a Radio Play (E. K. Fischer).
6.10 p.m. (from *Freiburg*)—Concert of Old Instrumental and Vocal Music by a Chamber Orchestra, conducted by Heinrich Pfaff. Soloist, F. Wiedemayer (Soprano). Sonata in G Minor for Three-Part String Orchestra and Cembalo (Johann Rosenmüller, 1619-1684). Three Songs for Soprano (Johann Jakob Löwe, 1628-1703): (a) *Wer sich aus den Sorgen*, (b) *Jetzt bin ich ohne Kraft*, (c) *Schönestes Dorile*. Recitative and Aria, *So wie die Taube*, from "Acis and Galathea" (Händel). *Don Quixote Suite* for String Orchestra and Cembalo (Telemann).
7.5 p.m.—Concert by the Augmented Philharmonic Orchestra in aid of the Würtemberg Winter Relief Fund, relayed from the Town Hall. Conductors: Hans Rosbald and Emil Kahn. Soloists: Marguerita Perras (Coloratura Soprano), Willy Domgraf-Fassbender (Baritone), of the Berlin State Opera House, and Herbert Groh (Tenor). *Homage March* (Wagner). Overture, "Rienzi" (Wagner). Tenor Solo: *Lohengrin's Farewell*, from "Lohengrin" (Wagner). Overture, "William Tell" (Rossini). Coloratura Soprano Solo: *Rosina's Aria* from "The Barber of Seville" (Rossini). Baritone Solo: *Cavatina* from "The Barber of Seville" (Rossini). Hungarian March from "The Damnation of Faust" (Berlioz). Tenor Solo: "The Duke's Aria from "Rigoletto" (Verdi). Baritone Solo: *Toreador Song* from "Carmen" (Bizet). Coloratura Soprano Solo: *Aria* from "Mignon" (Thomas). Triumphant March from "Aida" (Verdi).
9.40 p.m.—Announcements.
9.50 p.m.—Orchestral Concert.
11.30 p.m. (approx.)—Close Down.

TOULOUSE (France)

Radiophonie du Midi 779 kc/s (385 m.); 8 kW.
Transmits at intervals from 12.45 p.m.
6.0 p.m.—Songs from "La Juive" (Halévy). "Aida" (Verdi). "The Fair Maid of Perth" (Bizet) and "Die Walküre" (Wagner).
6.15 p.m.—Orchestral Selections.
6.30 p.m.—News Bulletin.
6.45 p.m.—Orchestral Selections.
7.0 p.m.—Light Music.
7.15 p.m.—Orchestral Selection: The Seventh Symphony (Beethoven).
7.30 p.m.—News Bulletin.
7.45 p.m.—Gramophone Records.
8.0 p.m.—Songs from "Mignon" (Thomas). "The Barber of Seville" (Rossini) and "Mignon" (Thomas).
8.15 p.m.—Military Music.
8.30 p.m.—Accordion Solos.
8.45 p.m.—Songs from "Die Teresina" (O. Strauss). "La Pêrigoise" (Offenbach) and "La Fille de Madame Angot" (Lecocq).
9.0 p.m.—Orchestral Selections.
9.0 p.m.—Selections from "Hérodiade" (Massenet).
10.30 p.m.—News Bulletin.
10.45 p.m.—"Hérodiade" Selection (continued).
11.0 p.m.—Concert. In the interval at 11.15 p.m.—North African News.
12 midnight.—Weather, Announcements and Close Down.

TRIESTE (Italy)

Ente Italiano Audizioni Radiofoniche. 1,211 kc/s (247.7 m.); 15 kW.
Transmits at intervals from 11.30 a.m.
7.15 p.m.—News Bulletin.
7.30 p.m.—French Lesson on Gramophone Records.
7.35 p.m.—Gramophone Records.
8.0 p.m.—Time and Announcements.
8.5 p.m. (approx.)—Programme to be announced. Review of New Books in the interval.
9.15 p.m.—Concert. Foxtrot (Lehár). *Waltz* from "Love in the Snow" (Benatzky). *Adagio cantabile* (Beethoven). *Waltz* (Cimatti). Hungarian Dances Nos. 5 and 6 (Brahms). *Barcarolle* (Mascagni).
9.55 p.m. (approx.)—News.

VIENNA (Austria)

Radio-Wien. 581 kc/s (517 m.); 20 kW. Relayed by *Graz*, 852 kc/s (352.1 m.); *Innsbruck*, 1,058 kc/s (283 m.); *Klagenfurt*, 662 kc/s (453.2 m.); *Linz*, 1,220 kc/s (246 m.), and *Salzburg*, 1,373 kc/s (218 m.).
Transmits at intervals from 8.30 a.m. (Concert).
4.55 p.m.—*Contralto Song Recital*. Aria from the Christmas Oratorio (J. S. Bach). Two Songs (Reger): (a) *Maria Wiegenlied*, (b) *Des Kindes Gebet*. Two Songs (Peter Cornelius): (a) *Christbaum*, (b) *Christkind*. *Lied des Weihnachtsengels* (Kienzl). Three Songs (Richard Trunk): (a) *Advent*, (b) *Weihnachten*, (c) *Idyll*. Wenn es schlummert auf der Welt (Hans Hermann).
5.30 p.m.—"The Star over the Manger at Bethlehem"—by Ferdinand Onno.
6.0 p.m.—Talk: Town and Suburb.
6.30 p.m.—Recital of Popular Songs.
7.0 p.m.—Time; Announcements.
7.15 p.m.—"The Senator"—a Comedy in Three Acts (F. von Schönthan and G. Kadelburg), followed by News Bulletin.
9.45 p.m. (approx.)—Concert of Viennese Music. Overture, "Gasparone" (Millöcker). *Waltz* from "Die Landstreicher" (Ziehrer). Selection from "Das Veilchen vom Montmartre" (Kálmán). Scenes from "The Gipsy Baron" (Strauss). *Waltz* from "Eva" (Lehár). *Potpourri, Wiener Spaziergänge* (Komzak). *March* from "A Day in Paradise" (Eysler).

WARSAW (Poland)

Polskie Radio, 212.5 kc/s (1,411 m.); 158 kW.
Transmits at intervals from 9.15 a.m.
11.15 a.m.—Concert by the Warsaw Philharmonic Orchestra. Soloist, M. Filar (Pianoforte). Overture, "Oberon" (Weber). Concerto in D Minor for Piano and Cembalo (Mozart). Suite, *Caucasian Sketches* (Ippolitoff-Ivanoff). Italian Caprice (Tchaikovsky).
1.0 p.m.—Agricultural Talk.
1.20 p.m.—Popular Music.
1.40 p.m.—Talk for the Country Housewife.
2.0 p.m.—Popular Music.
2.55 p.m.—Programme for Children, relayed from *Lwów*.
3.20 p.m.—Gramophone Records.
3.40 p.m.—Reading relayed from *Cracow*, 959 kc/s (312.8 m.).
3.55 p.m.—Gramophone Records.
4.15 p.m.—Talk, relayed from *Cracow*.
4.30 p.m.—Talk, relayed from *Lwów*.
4.45 p.m.—Concert of Light Music.
6.0 p.m.—Miscellaneous Items.
6.25 p.m.—Gramophone Records.
6.40 p.m.—Programme Announcements.
6.45 p.m.—"The Christmas Carol" (Charles Dickens), arranged for Radio.
7.15 p.m.—Orchestral Concert. Soloists: Mme. Radwan (Vocalist) and Mr. Lawrusiewicz (Guitar). Polonaise (Krupinsky). *Carol* (Worch). Selection from "The Christmas Tree" (Rebikoff). Two Songs from "Das Veilchen vom Montmartre" (Kálmán). *Guitar Solos*. Berceuse slave (Neruda). Suite from "The Christmas Tree" (Rebikoff). *Guitar Solos*. Songs (Lehár) from (a) "The Land of Smiles," (b) "The Czarevitch," (c) "Schön ist die Welt." Dances from "The Bartered Bride" (Smetana).
8.55 p.m.—Literary Programme.
9.10 p.m.—Chopin Piano Recital. Polonaise in A Major. *Ballad* in A Flat Major. *Nocturne* in D Flat Major. *Prelude* in A Flat Major. *Mazurka* in C Sharp Minor. *Scherzo* in B Minor.
9.40 p.m.—Announcements.
10.0 p.m.—Dance Music and Light Music.
11.0 p.m. (approx.)—Close Down.

Stations in Order of Frequencies and Wavelengths

Corrected in accordance with the latest official information available at the time of going to press

The figures in black type represent the power according to The Hague power-rating scheme

Kc/s	M.	Station	Dial Readings	Kc/s	M.	Station	Dial Readings	Kc/s	M.	Station	Dial Readings	
EUROPEAN												
(Including stations connected with the European System)												
155	1935	Kaunas (Lithuania), 7 kW.		770	390	{ Archangel (Russia), 10 kW.				Berne (Switzerland), 0.5 kW.		
160	1875	Huizen (Holland), 8.5 kW.		779	385	{ Frankfurt (Germany), 1.7 kW.				Cartagena (Spain), 0.4 kW.		
167	1796	Lahti (Finland) (relays Helsinki), 54 kW.		788	381	Toulouse (Radio) (France), 8 kW.				Cassel (Germany) (relays Frankfurt), 0.3 kW.		
174	1725	Radio Paris (CFR), 80 kW.		797	376.4	Lwów (Poland), 21 kW.				Eskilstuna (Sweden) (relays Stockholm), 0.25 kW.		
193.5	1635	Königs Wusterhausen (Zeeseen) (Germany), 75 kW. Relays Berlin.		806	372	Glasgow (SSC), 1.2 kW.				Kiruna (Sweden) (relays Boden), 0.25 kW.		
193	1554.4	Daventry National Station (Gt. Britain), 35 kW.		810	370.4	Hamburg (Germany), 1.7 kW.			1220	246	Linz (Austria) (relays Vienna), 0.6 kW.	
195	1538	Ankara (Turkey), 7 kW.		815	368.1	Radio LL (France), 0.5 kW.				Säffle (Sweden) (relays Stockholm), 0.4 kW.		
202.6	1481	Moscow (Old Komintern) (RV1) (Russia), 100 kW.		816	367.6	{ Bolzano (Italy) BZ, 0.2 kW.				Schaerbeck (Brussels) (Belgium), 0.1 kW.		
207.5	1445.7	Eiffel Tower (FLE), 15 kW.		824	364	Helsinki (Finland), 13.2 kW.				Turku (Åbo) (Finland) (relays Helsinki), 0.6 kW.		
212.5	1411	Warsaw No. 1 (Poland), 158 kW.		825.3	363.4	Seville (Union Radio) (EAJ5) (Spain), 1.5 kW.			1229	244.1	Basle (Switzerland), 0.5 kW.	
222.2	1350	Kashah (Tunis), 0.5 kW.		832	360.5	Fredriksstad (Norway), 0.8 kW. (relays Oslo).				Wilno (Poland), 0.5 kW.		
222.5	1343	Motala (Sweden) (relays Stockholm), 40 kW.		842	356.3	Bergen (Norway), 1.13 kW.			1238	242	Belfast (2BE) (Ireland), 1.2 kW.	
230.1	1304	Moscow (Trades Union), 100 kW.		852	352.1	Algiers (N. Africa), 13 kW.			1247	240.6	Stavanger (Norway), 0.63 kW.	
238.1	1260	Novosibirsk (Russia), 4 kW.		855.5	351	Stuttgart (Mühlacker) (Germany), 75 kW.			1250	240	Radio Beziers (France), 1.5 kW.	
242.5	1237	Vienna Experimental (Austria)		860	349	London Regional, 70 kW.			1256	239	Nürnberg (Germany) (relays Munich), 2.3 kW.	
244	1229.5	Boden (Sweden), 0.75 kW.		869	345	Graz (Austria) (usually relays Vienna), 9.5 kW.				Bordeaux Sud - Ouest (France), 3 kW.		
250	1200	{ Istanbul (Turkey), 5 kW. }		878	342	Leningrad (Russia), 1.2 kW.			1265	237.2	Radio-Nimes (France), 1 kW.	
260	1153	{ Reykjavik (Iceland), 21 kW. }		887	338.2	Barcelona (Radio Barcelona) (EAJ1) (Spain), 8 kW.				Örebro (Sweden), (relays Stockholm), 0.25 kW.		
268.5	1116	Kalundborg (Denmark) (relays Copenhagen), 7.5 kW.		896	335	Strasbourg-Brumath (France), 15 kW.			1274	235.5	Christiansand (Norway), 0.63 kW.	
277	1083	Moscow, Popoff, 40 kW.		905	331.5	Brno (Czechoslovakia), 3 kW.			1283	235	Lodz (Poland), 2 kW. Exp 1.	
284.9	1053	Oslo (Norway), 75 kW.		914	328.2	Brussels No. 2 (Belgium), 20 kW. (Flemish programme)			1292	232.2	Kiel (Germany) (relays Hamburg), 0.3 kW.	
300	1000	Tiflis (Russia), 10 kW.		923	325	{ Cadiz (Spain), 5.5 kW. }				Norrköping (Sweden), 0.25 kW.		
320	937.5	Leningrad (Russia), 100 kW.		932	322	{ Poznań (Poland), 1.9 kW. }			1301	231	Hälsingborg (Sweden), 0.25 kW.	
353.5	848.7	Kharkov (Russia), RV20.		941	319	Milan (Italy), 8.5 kW.			1310	229	Malmö (Sweden) (relays Stockholm), 1 kW.	
368.1	815	Rostov-Don (Russia), 4 kW.		950	315	{ Grenoble (PTT) (France), 1.2 kW. }			1319	227	Uddevala (Sweden), 0.1 kW.	
385	778	Kiev (Russia), 20 kW.		959	312.8	{ Poste Parisien (Paris), 1.2 kW. }			1337	224.4	Aachen (Germany), 0.3 kW.	
389	770	Petrozavodsk (Russia), 2 kW.		968	309.9	Breslau (Germany), 1.7 kW.			1364	219.9	Cologne (Germany), 1.7 kW.	
394	761.4	Östersund (Sweden), 0.75 kW. (relays Sundsvall).		977	307	Göteborg (Sweden) (relays Stockholm), 15 kW.				Münster (Germany), 0.6 kW.		
395	760	Nijni Novgorod (Russia), 1.8 kW.		986	304	Dresden (Germany) (relays Leipzig), 0.3 kW.			1373	218	Cork (6CK) (Ireland), 1.5 kW.	
416.7	720	Geneva (Switzerland), 1.5 kW.		995	301.5	Naples (I NA) (Italy), 1.7 kW.				Fécamp (Radio Normandie) (France), 1 kW.		
428.6	700	Moscow (Experimental), 20 kW.		1004	298.8	Sofia Rodno - Radio (Bulgaria), 1 kW.			1382	217	Flensburg (Germany) (relays Hamburg), 0.6 kW.	
442	680	Minsk (Russia), 4 kW.		1013	296.1	Marseilles (PTT) (France), 1.5 kW.			1391	216	Pori (Björneborg) (Finland) (relays Helsinki), 0.7 kW.	
516.3	581	Lausanne (Switzerland), 0.6 kW.		1022	293	Cracow (Poland), 1.5 kW.			1400	214.2	Salzburg, 0.6 kW. (relays Vienna).	
522	574.7	Wilno (Poland), 21.5 kW.		1031	291	Genoa (IGE) (Italy), 1.5 kW.			1412	212.4	Königsberg (Germany), 0.9 kW.	
527	570	Ljubljana (Yugoslavia), 2.8 kW.		1040	288.5	Radio-Vitus (France)			1450	207.8	Halmstad (Sweden), 0.25 kW.	
530	566	Freiburg-im-Breisgau (Germany) (relays Stuttgart), 0.3 kW.		1049	286	Cardiff (SWA), 1.2 kW.			1470	204	Radio Chatelneau (Belgium).	
531	565	Hanover (Germany), 0.3 kW. (relays Hamburg).		1058	283	Zagreb (Yugoslavia), 0.7 kW.			1480	203	Warsaw, No. 2 (Poland), 1.9 kW. Experimental.	
531	517	Smolensk (Russia), 2 kW.		1071	280	Bordeaux-Lafayette (PTT) (France), 35 kW.			1490	202	Palermo (Italy), 4 kW.	
545	550	Augsburg (Germany) (relays Munich), 1.7 kW.		1076	279	Falun (Sweden), 0.65 kW.			1530	196	Borås (Sweden), 0.12 kW.	
545	542	Kaiserslautern (Germany) (relays Munich), 0.3 kW.		1085	276.5	North National (Manchester), 70 kW.			1530	196	Gävle (Sweden) (relays Stockholm), 0.2 kW.	
563	533	Hamar (Norway) (relays Oslo), 0.8 kW.		1094	274.2	Hilversum (Holland), 20 kW.			1530	196	Kristinehamn (Sweden), 0.25 kW.	
572	525	Budapest (Hungary), 23 kW.		1103	272	Tallinn (Estonia), 10 kW.			1530	196	Jönköping (Sweden), 0.25 kW. (relays Stockholm).	
572	525	Sundsvall (Sweden), 15 kW.		1112	270	Kosice (Czechoslovakia), 2.5 kW.			1714	175	Karlskrona (Sweden) (relays Stockholm), 0.25 kW.	
572	525	Munich (Germany), 1.7 kW.		1121	267.6	Limoges (PTT) (France), 0.08 kW.				St. Quentin (France).		
572	525	Riga (Latvia), 15 kW.		1130	265.4	Pietarsaari (Jacobstad) (Finland) (relays Helsinki), 0.25 kW.						
572	525	Vienna (Rosenhügel) (Austria), 20 kW.		1137	263.8	Tampere (Finland) (relays Helsinki), 1 kW.						
590	509	Brussels No. 1 (Belgium), 20 kW.		1147	261.6	Viipuri (Viiborg) (Finland) (relays Helsinki), 13.2 kW.						
599	508.8	Florence (IFI), Italy (testing)		1157	259	Lisbon, Portugal, 2 kW.						
603.6	497	Moscow (Russia), 1.2 kW.		1166	257							
608	493.4	Trondheim (Norway), 1.35 kW.		1175	255							
614	488.6	Prague (Czechoslovakia), 120 kW.		1184	253							
625	480	North Regional (Manchester), 70 kW.		1193	252							
630.2	476	Sebastopol (Russia), 1.2 kW.		1205	249							
635	473	Langenberg (Germany), 17 kW.		1211	247.7							
644	465.8	{ Lyons (La Doua) France, 5 kW. (relays PTT). }										
653	459	Tartu (Estonia) 5 kW.										
653	459	Schweizerischer Landessender (Beromünster) Switzerland, 75 kW.										
653	459	Bodo (Norway), 0.63 kW.										
653	459	Danzig (Free City), 0.6 kW. (relays Königsberg).										
653	459	Klagenfurt (Austria), 0.6 kW. (relays Vienna).										
653	459	Porsgrund (Norway) (relays Oslo), 0.8 kW.										
653	459	Salamanca (Spain) (EAJ22), 1 kW.										
653	459	San Sebastian (Spain), 0.6 kW. (Mon., Wed. & Fri. 7.30 - 9 p.m. other days 10 p.m. to mid'n't.)										
653	459	Tromsø (Norway), 0.11 kW.										
653	459	Uppsala (Sweden), 0.2 kW. (relays Stockholm).										
666	450.4	Odessa (Russia), 4 kW.										
666	450.4	Aalesund (Norway), 0.4 kW.										
666	450.4	Notodden (Norway), 0.9 kW.										
671	447.1	Paris (PTT), (Ecole Supérieure) (France), 1 kW.										
671	447.1	Rjukan (relays Oslo) (Norway), 0.17 kW.										
680	441	Rome (IRO) (Italy), 75 kW.										
689	436	Malmberget (relays Boden) (Sweden), 0.25 kW.										
689	436	Stockholm (Sweden), 75 kW.										
697	430.4	Belgrade (Yugoslavia), 3 kW.										
697	430.4	Madrid (Union Radio) (EAJ7) (Spain), 2 kW.										
707	424.3	Moscow-Stalin (Russia) 100 kW.										
707	424.3	Radio-España (Spain)										
715	410	Berlin (Witzleben), 1.7 kW.										
721.1	416	Rabat (Morocco), 2.5 kW.										
725	413	Dublin (2RN) (Ireland), 1.5 kW.										
734	408	Katowice (Poland), 16 kW.										
743	403	Radio Suisse Romande (Sottens) Switzerland, 25 kW.										
752	398.9	Midland Regional Station (Gt. Britain), 38 kW.										
761	394	Bucharest (Romania), 18 kW.										

British Relay Stations

468	288.5	Aberdeen (2BD), 1.2 kW.
468	288.5	Bournemouth (6BM), 1.2 kW.
468	288.5	Dundee (2DE), 0.16 kW.
468	288.5	Edinburgh (2EH), 0.4 kW.
468	288.5	Newcastle (5NO), 1.2 kW.
468	288.5	Plymouth (5PY), 0.16 kW.
468	288.5	Swansea (5SX), 0.16 kW.
468	288.5	Lyons (Radio) (France) 0.8 kW.
468	288.5	Montpellier (France), 1.2 kW.
468	288.5	Berlin Relay (Germany), 0.6 kW.
468	288.5	Magdeburg (Germany), 0.6 kW.
468	288.5	Stettin (Germany) (relays Berlin), 0.6 kW.
468	288.5	Innsbruck (Austria) (relays Vienna), 0.6 kW.
468	288.5	Copenhagen (Denmark), 0.75 kW.
468	288.5	Radio Brno (Czechoslovakia), 1.2 kW.
468	288.5	Bratislava (Czechoslovakia), 1.4 kW.
468	288.5	Helsinki (Germany), 75 kW.
468	288.5	Relays Königsberg.
468	288.5	Turin (Italy), 8.7 kW.
468	288.5	Rennes (France), 1.2 kW.
468	288.5	Bremen (Germany) (relays Hamburg), 0.3 kW.
468	288.5	Oviedo (Spain), 0.7 kW.
468	288.5	Radio Valencia (Spain), 1.5 kW.
468	288.5	Lille (PTT) (France), 2 kW.
468	288.5	Moravská-Ostrava (Czechoslovakia), 11 kW.
468	288.5	London National, 68 kW.
468	288.5	Leipzig (Germany), 2.3 kW.
468	288.5	Hörby (Sweden) (relays Stockholm), 15 kW.
468	288.5	Toulouse (PTT) (France), 1 kW.
468	288.5	Gleiwitz (Germany) (relays Breslau), 5.6 kW.
468	288.5	Almeria (Spain) (EAJ18), 1 kW.
468	288.5	Barcelona (Association National) (EAJ15) 1 kW.
468	288.5	Trollhättan (Sweden), 0.3 kW.
468	288.5	Juan-les-Pins (Nice) (France)
468	288.5	Kálmár (relays Stockholm), 0.25 kW.
468	288.5	Trieste (Italy), 15 kW.

DEVIATIONS

The following are the actual deviations from the official frequencies, as noted during measurements made at the Tatsfield Checking Station. All differences of 1.0 kc/s and over are shown.

275.1	1090.5	Oslo (Norway)
605	495.9	Wilno (Poland)
812	368.4	Radio LL (France)
904	331.8	Milan (Italy)
916	327.5	Grenoble (France)
1005.9	298.5	Hilversum (Holland)
1045.8	287.1	Radio Lyon (France)
1096.2	273.7	Turin (Italy)

COMPELS

Your Set to Give
BETTER RESULTS!

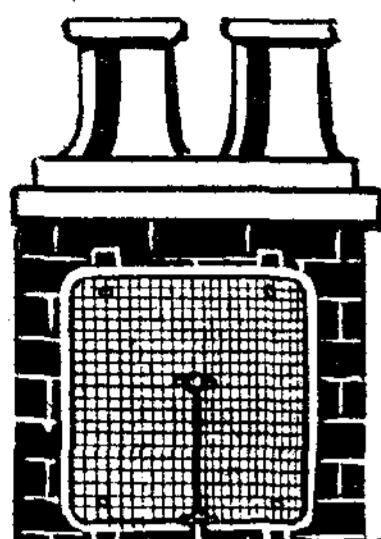

**The "GOLSTONE" (Regd.)
NEGROLAC
PLATE AERIAL**
IMPROVED 1932 MODEL.
BRINGS IN STATIONS HITHERTO
UNOBTAINABLE.
PROVIDES INCREASED VOLUME,
PURITY AND SELECTIVITY.
INTERFERENCE REDUCED TO A
MINIMUM.
NO POLES OR MASTS.
CANNOT BE BLOWN DOWN BY
STRONGEST GALE.

**THE "GOLSTONE" (Regd.)
NEGROLAC
PLATE AERIAL**

is Permanent and can be easily fitted without any technical knowledge. Obtainable from all First-Class Radio Stores. Refuse substitutes. Complete with famous "Negrolac" down-lead. Ready for use. Price ... **21/-**
No other Aerial Wire required. Write for Catalogue giving Full Particulars, with extracts from Technical Press Reports, and enthusiastic testimonials.



**"GOLSTONE" Daily Dispatch
SELECTOR UNIT**

Enables you to cut out interference, however powerful, and bring in the selected stations loudly and clearly. There is no need for you to lose your favourite distant stations with the opening of the high-power Regional Transmitters. Not alone a Wave Trap, but a Selector Unit combining a complete extra tuning stage. Stations that were a mere whisper will now come in at good strength. Connected in a few seconds to any set from a crystal to a multi-valve. Pamphlet with full particulars on request. Other Wave Traps from 2/6. From all first-class Radio Stores or direct from manufacturers. Refuse substitutes.
**R 48/66
6/6**
See the Trade Mark "GOLSTONE" on every genuine coil.



**"Negrolac" (REGD.)
INDOOR
AERIAL**

WHAT USERS SAY!

Mr. F. Fielding, "RADIDEA," Manchester
Evening Chronicle,
REPORT OF TEST.
"I have been testing one of the 'Negrolac' short indoor aerials for the short waves and find the Americans romping in on 12 feet of this aerial and an earth."
Mr. H. G., Scarsdale Rd., MANCHESTER,
writes:-
"The 'Negrolac' was stretched across the Dining Room, and fifty-five Stations were logged, all at full loud-speaker strength, i.e., equal in strength to ordinary gramophone volume.
"All the stations logged were free from interference, and could be thoroughly enjoyed from a musical point of view."

The "NEGROLAC" Indoor Aerial has proved as comparatively efficient as the outdoor type. A multi-stranded enamelled aerial, covered with a bright, flexible, glossy insulated fabric. **IT IS THE MOST EFFICIENT INDOOR AERIAL EVER OFFERED.** Pick-up 30 per cent. superior to ordinary stranded aerials.

R33/12	15 ft. lengths, complete	3/6
R33/180	18 ft. " "	4/-
R33/240	24 ft. " "	5/-

Each Aerial complete with Reel Insulators and insulated connection for down-lead. Your Radio Dealer can supply. Pamphlet with full particulars on request.

**"NEW RADIOS FOR OLD"
BE UP-TO-DATE**

WE TAKE YOUR OLD SET IN PART EXCHANGE FOR ANY 1932 MODEL

BEST ALLOWANCE GIVEN

Here is an example:— OLD COSSOR SET AND ELIMINATOR (Original cost approx. 12 guineas). EXCHANGED for 1932 Ekco R.S.3 model (list price 24 guineas). ALLOWANCE GIVEN £9/9/0. BALANCE paid £15/15/0. Difference payable Cash or Instalments.

Send for Free Bargain Lists.

Send full particulars of present set and new set you require, enclosing 1d. stamp for reply.

RADIALADDIN, LTD.

THE LARGEST RADIO EXCHANGE FIRM IN U.K.
Dept. "U," 47, Berners St., W.1. Museum 1821 4141.

a completely new edition

World-Radio

Station Identification Panels Booklet

The arrangement of this well-known booklet has been changed completely to make the entry of dial-readings easier, and to leave room for the writing-in of any other notes necessary. Details of new stations are given: and innumerable revisions made. Here, then, is the perfect log-book! Wave-lengths, frequencies, power, call-signs, interval signals of every European station worth receiving, and some American stations: with a small map. Buy it now, and have it marked up and ready for your winter listening:

price one shilling post free

FROM THE BRITISH BROADCASTING CORPORATION (PUBLICATIONS DEPT.), SAVOY HILL, W.C.2.

Harlie TONE SELECTOR AND SCRATCH FILTER
5 different tones from your speaker
NORMAL
BRILLIANT
BRIGHT
MELLOW
DEEP
PRICE 10/-
150,000 Satisfied users
Stocked by all Dealers
Just turn the knob
DEFINITELY IMPROVES EVERY LOUD-SPEAKER
7 DAYS FREE TRIAL

The Harlie Tone Selector definitely improves reproduction from all sets and speakers and is connected in a moment. Fill in the coupon—if you are not satisfied we guarantee to refund your money.

To Harlie Bros. (Edmonton) Ltd., Dept. T.W.R.1
Balam Road, Edmonton, London, N.9.
Please send me Harlie Tone Selector
(a) I enclose 10/-;
(b) I will pay 10/- on delivery.
If I am not entirely satisfied, and return the Harlie Tone Selector within 7 days of purchasing from you direct, you guarantee to refund my money in full.
Name
Address

SELECTIVITY—

to-day's great Radio problem

Station Overlap is often due to the use of inefficient and out-of-date Screened Grid Valves

THE separation of programmes is growing more difficult. Stations are daily increasing their power — Prague now radiates 200 kw., Warsaw 158 kw., Muhlacker 75 k.w.—all adding to the problem of preventing "station overlap."

Your Receiver cannot bring you crisp, clear-cut programmes unless it is really selective. And its selectivity will be poor if its Screened Grid Valve (or Valves) is inefficient or out-of-date. The S.G. Valve has a big influence on selectivity.

Because of their special design, their record low inter-electrode capacity (of the order of .001 m.m.f.) and unique Mica Bridge Construction Cossor S.G. Valves are exceptionally efficient. Their use ensures a marked improvement in the performance and selectivity of any Screened Grid Receiver.



NATIONAL

REGIONAL

COSSOR

ALL-BRITISH
SCREENED GRID
VALVES



A copy of the 72-page Cossor Wireless Book 811 will be sent you free on application to A. C. Cossor Ltd., Melody Dept. Highbury Grove, London, N.5.

A new edition of the Cossor Station Chart is now available, price 2d. Ask your Dealer for a copy of this useful novelty, or write us enclosing 2d. stamp.

THE VALVES WITH THE MICA BRIDGE CONSTRUCTION

9351