



WORLD-RADIO

DOMINION & FOREIGN PROGRAMMES

The Official Foreign & Technical
Journal of the B.B.C.

Vol. XIII No. 331

Registered at the G.P.O.
as a Newspaper.

FRIDAY, NOVEMBER 27, 1931

Two Pence

PRINCIPAL CONTENTS

- Broadcasting to the Empire
- Messages from Empire Representatives
- Illustrated Articles on the Empire and its Broadcasting
- Time-Zone Map of the British Empire
- Short-Wave Transmission
By Professor E. V. Appleton, F.R.S.
and
Other Short-Wave Articles
- Stations in Alphabetical and Frequency Order

WORLD-RADIO

Station Identification Panel

**SYDNEY (VK2ME),
Australia**

Frequency: 9,590 kc/s.

Wavelength: 31.28 m.

Power (Aerial): 20 kW.

Approximate Distance from London:
10,500 miles.

Opening Signal: Laugh of the Kookaburra (a native bird).

Station call letters and studio time is given after almost every item.

Times of Transmissions (from November 29):
Sunday, 10 a.m. to 2 p.m.;
2.30 p.m. to 4.30 p.m.; 6 p.m. to 8 p.m.

Copyright

A booklet containing a reprint of these panels can be obtained from the B.B.C. Publications, Savoy Hill, W.C.2. Price 1s.

Letters should be addressed to The Editor, "WORLD-RADIO," Savoy Hill, Strand, London, W.C.2.

RATES OF SUBSCRIPTION to "World-Radio" (including postage). Twelve Months: Inland, 13s.; Canadian, 13s.; Foreign, 14s. Six months: Inland, 6s. 6d.; Canadian, 6s. 6d.; Foreign, 7s. Address: "World-Radio," 8-11, Southampton Street, Strand, London, W.C.2.

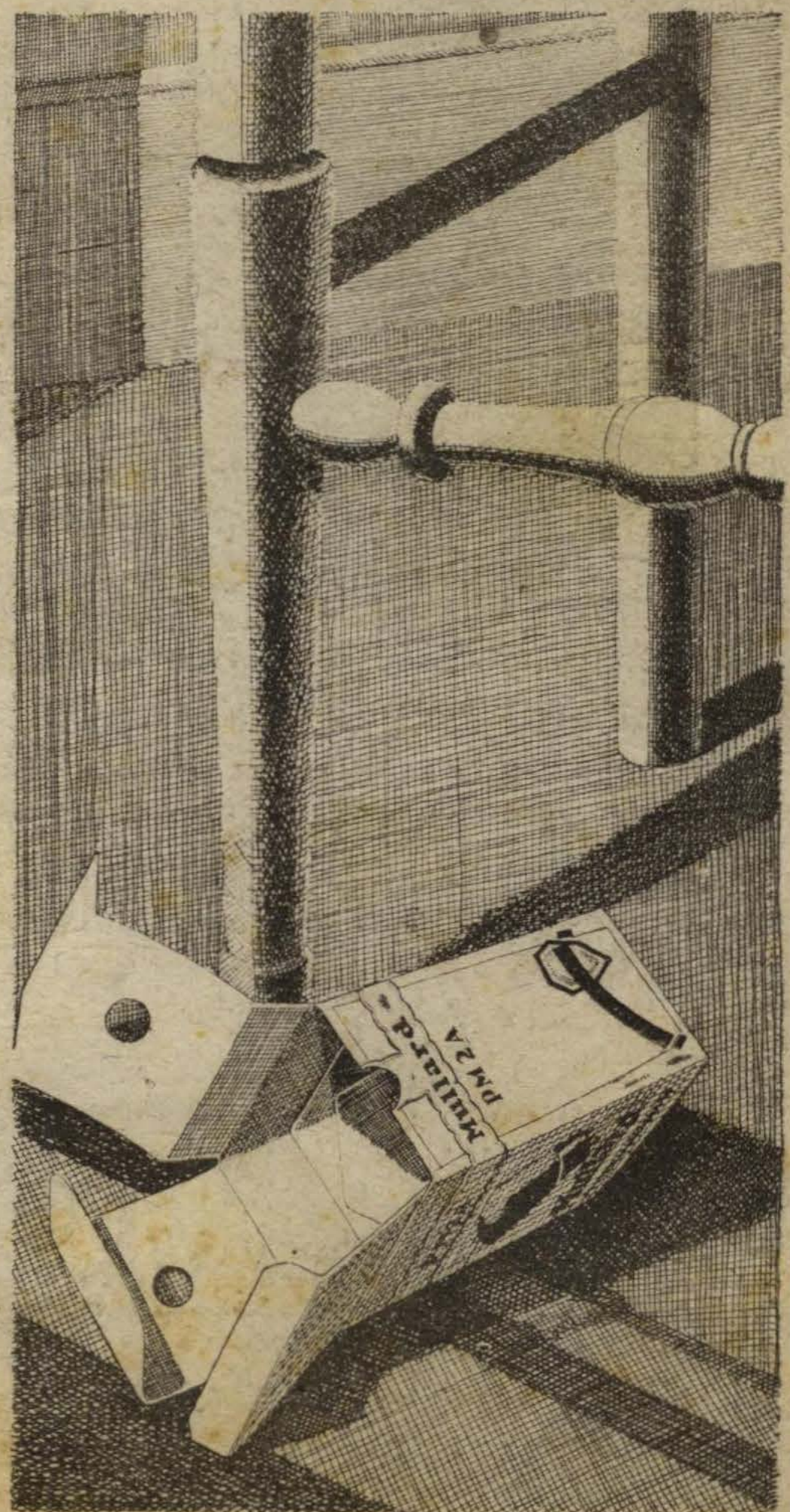

All the
evidence points
to someone else
getting better
radio!

Mullard

THE · MASTER · VALVE

MADE IN ENGLAND

Advt. The Mullard Wireless Service Co., Ltd., Mullard House, Charing Cross Road, London, W.C.2. ARKS

WIRELESS SET AND ACCESSORIES.

Free

RADIOPHONE



No. 950

STRAIGHT 2

WIRELESS SET

1250 COUPONS = 250 PACKETS OF 20 BLACK CAT RED BAND

Latest model with cone loud-speaker, two MULLARD VALVES and battery-cable complete in cabinet of polished oak. This set will tune from 230 to 550 metres on short waves and from 1,000 to 2,000 metres on long waves.

No. 627

OLDHAM 2-volt ACCUMULATOR

Type C.L.G.3. Complete with carrying handle
300 coupons (60 packets of 20 Black Cat Red Band)

No. 1035

'EVER-READY' WINNER H.T. BATTERY
120 Volts. Tapped every 12 volts

400 coupons (80 packets of 20 Black Cat Red Band)

No. 1034

'EVER-READY' WINNER GRID BIAS BATTERY. 9 volts. Tapped every 1½ volts

50 coupons (10 packets of 20 Black Cat Red Band)

No. 1033

'RADIOPHONE' CONE LOUD SPEAKER
9½" cone. Reed movement. Polished oak.
Resistance 1,000 ohms. d.c. 11¼" x 11¼" x 4"

450 coupons (90 packets of 20 Black Cat Red Band)

Black Cat

100% PURE

Quality



VIRGINIA

Cigarettes

5

COUPONS IN 20'S PACKETS OF BLACK CAT RED BAND



THIS VALVE EXTENDS RANGE

**THIS VALVE
DOUBLES VOLUME**

**ANY SET CAN
BE IMPROVED
BY FITTING THESE**

**LISSEN
VALVES**

HERE are two valves from the Lissen range which will be the making of any set. One extends the range and so adds to the number of stations which you can receive, and the other doubles the volume and so *more than doubles* the number of stations you can enjoy.

The Lissen Detector Valve gathers in the foreign stations with a crispness that makes your ordinary set rank with the distance-getters in the number of stations you can separate. Lively, responsive, *alert*—that is the best description of your tuning when you use this valve, Lissen H.L.210, price **5/6**

To enjoy the programmes of these new foreigners, you will want *extra* volume. That you can get simply by replacing your existing power valve with a Lissen Power Pentode. It *doubles* volume, and does not use any extra battery current to produce that extra volume. Ask for Lissen P.T.225, price **12/6**

You will never use ordinary valves in your set again after using these Lissen valves.

BETTER VALVES YOU CANNOT BUY

LISSEN LIMITED, WORPLE ROAD, ISLEWORTH, MIDDLESEX

"This accumulator speaks for itself—look!"

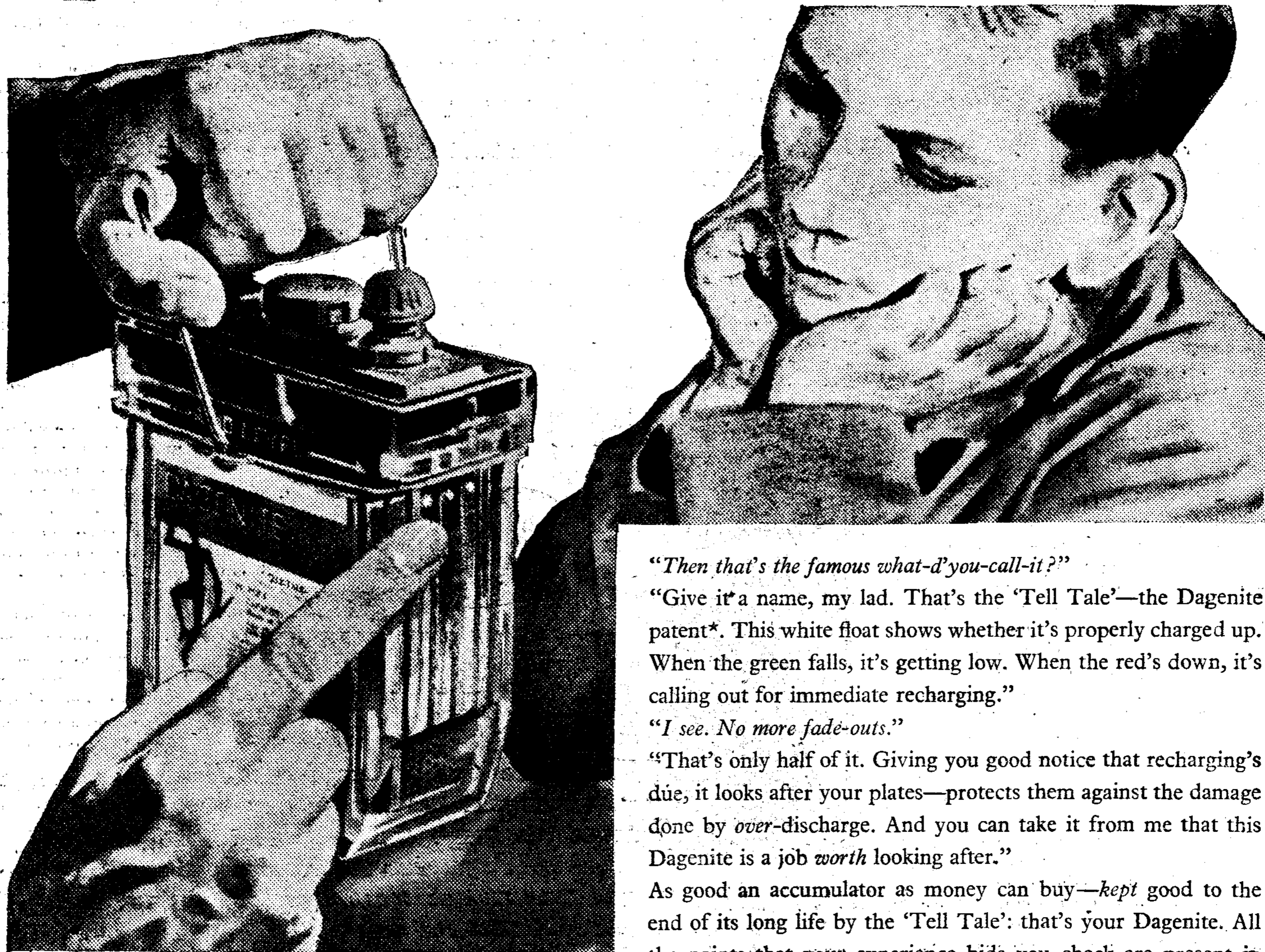

"Then that's the famous what-d'you-call-it?"

"Give it a name, my lad. That's the 'Tell Tale'—the Dagenite patent*. This white float shows whether it's properly charged up. When the green falls, it's getting low. When the red's down, it's calling out for immediate recharging."

"I see. No more fade-outs."

"That's only half of it. Giving you good notice that recharging's due, it looks after your plates—protects them against the damage done by *over*-discharge. And you can take it from me that this Dagenite is a job *worth* looking after."

As good an accumulator as money can buy—*kept* good to the end of its long life by the 'Tell Tale': that's your Dagenite. All the points that your experience bids you check are present in the Dagenite: stout interlocking grid plates, acid-proof glands, error-proof terminals.

Every Dagenite embodies the 40 years' experience of those two famous firms, the H&rt Accumulator Co., Ltd., and Peto & Radford.

**YES!
THIS IS
BRITISH!**

The Dagenite Accumulator is entirely British; made in a British factory, by British workmen, employing British capital.

Obtainable from
**Dagenite Service Stations
and radio dealers**

*The "Tell Tale" is Patent No. 139652. Compare prices and you'll find that in effect you're getting this invaluable device for nothing.

DAGENITE
The Dependable Accumulator

NATIONAL ACCUMULATOR CO. LTD., 93 GREAT PORTLAND STREET, LONDON, W.1
Branches: 107A FIMLICO RD., S.W.1 - 45 CLYDE PLACE, GLASGOW - 27 BURY ST., SALFORD, MANCHESTER

WORLD-RADIO

Vol. XIII No. 331

Registered at the G.P.O.
as a Newspaper.

FRIDAY, NOVEMBER 27, 1931

TWO PENCE

Broadcasting to the Empire

JUST over a year ago, in our issue of November 7, 1930, we gave an account of the position of the Empire Broadcasting scheme as it existed at that time. A further stage has now been reached.

The public announcement, a fortnight ago, of the intention of the B.B.C. immediately to proceed with plans for establishing a short-wave station to be used for broadcasting to the various parts of the Empire, has aroused a considerable degree of interest in this country, as may be seen from the Press extracts printed on another page. It may be expected that an equal measure of notice of the announcement will be taken by the Dominions and Colonies. Indeed, the messages sent to this journal by their representatives in this country indicate clearly the satisfaction with which the Empire in general has received the news.

Before dealing with the proposed scheme it is well to recapitulate briefly the events which have led to the recent decision and to complete the story as it was left in this journal a year ago.

By 1927 the transmission of broadcast programmes by short-wave transmitters, especially in the United States of America and in Holland, had indicated the possibilities of this form of broadcasting for spanning great distances. Such transmissions were, of course, received with some regularity by amateurs in many parts of the world, including the British Dominions and Colonies, but, of course, not with a quality comparable with local station reception. The request from parts of the Empire for transmission of British programmes on short waves was, therefore, a natural consequence, and the Colonial Conference of May, 1927, emphasised this desirability.

It is now a matter of history that the British Broadcasting Corporation arranged with the Marconi Company to establish an experimental short-wave transmitter at Chelmsford. This transmitter, G5SW, was capable of putting about 12 kW. into the aerial and was made up largely of existing apparatus. It transmitted on one wave only—viz., 24 metres, approximately—which was chosen as a compromise to give the best chance to most of the Empire to carry out reception experiments. The programme material used consisted generally of excerpts taken from the Daventry 5XX programme. Transmissions from this station started in November, 1927, under licence from the Postmaster-General, which made clear the experimental nature of the station. (The transmission of news was forbidden, for instance.)

By 1929 a considerable number of reports and data had been received by the British Broadcasting Corporation, from which several important conclusions resulted. Firstly, there was no doubt that a real listener, as apart from an amateur, interest existed and that there was a widespread hope that a service would be undertaken. Secondly, the interest was greatest in the Colonies, while the Dominions were interested mainly in the occasional transmission of special events—for instance, the Armistice Day Ceremony at the Cenotaph. On the basis of these reports and a detailed examination of the data, the B.B.C. was able to submit a fairly precise scheme to the Colonial Office, via the Post Office, in November, 1929.

This proposed scheme, together with two variants of it, were further considered by the Imperial Conference, 1930, but, as was expected, this Conference gave them but little support, passing the following resolution:—

"The Conference recognises the technical and financial difficulties of the scheme and feels that further information is required to determine whether they can be overcome. It recommends as a first step that His Majesty's Government in the United Kingdom should suggest to the British Broadcasting Corporation that that body should communicate particulars of the scheme to the broadcasting organisations or other appropriate

A Message from the Right Hon. Sir PHILIP CUNLIFFE-LISTER, G.B.E., M.C., Secretary of State for the Colonies.

It is one of the most pleasant duties which has fallen to my lot since I became Secretary of State for the Colonies to express my gratification at the decision of the British Broadcasting Corporation to erect a short-wave wireless station which will enable broadcasting stations in the Colonies and



[Lafayette]

individual listeners to receive programmes from the Old Country.

We live in an age of great and extraordinary inventions, but I count none greater nor more potent in uniting the bonds of Empire than those which will so soon enable lonely listeners in the heart of Africa and remote islands in tropical seas to hear with their own ears the familiar chimes of Big Ben and the same programmes which their own people are listening to in their own homes in distant England.

authorities through the Empire and should invite them to furnish their views (after any necessary consultation with their respective Governments) as to the value to them of such a service, and as to their readiness to make a contribution towards its cost in return for the right to relay any part of the service which they may require."

At the request of the Post Office, the B.B.C. acted on this resolution by communicating particulars of the three schemes to broadcasters in Canada, Australia, New Zealand, and South Africa; to the High Commissioners of Newfoundland and Southern Rhodesia; to the Ministry of Marine and Fisheries, Montreal (for communication to Canadian broadcasters other than the Canadian National Railways); to the Indian State Broadcasting service; and to the Broadcasting Department of the Department of Posts and Telegraphs, Irish Free State.

The position was becoming unsatisfactory. The existing station is not entirely representative

of modern technique—it can use but one wavelength, whereas several are essential—and restrictions on its use in any case deny the provision of a comprehensive short-wave "service" to the Empire. At the same time, its maintenance costs a considerable amount annually. It appeared that the time had come when a decision had to be made as to whether this experimental station should be definitely closed down or a new and adequate station provided.

Now, the need of an adequate Empire Broadcasting Service was not decreasing—quite otherwise, in fact. The B.B.C. decided, therefore, that in view of the urgency of the problem it must assume the necessary financial responsibility involved in going ahead with the scheme. Once it is in operation, it is hoped that the interest which it will undoubtedly arouse will result in some return on expenditure in the form of a contribution from the Colonial listener, possibly as a proportion of the licence fee paid by such a listener to his local administration. (Among the suggestions for financing Empire Broadcasting recommended by the Colonial Conference last year was that a special fee of 5s. per listener be charged.) And so after four years an Empire Broadcasting Service is to be inaugurated.

Technically, the following details will be of interest. Two separate transmitters will be used, arranged for simultaneous operation. They will be erected at Daventry, where a site is already available on the land owned there by the B.B.C. It will be possible to radiate separate programmes from the two transmitters at the same time, although normally it will not be necessary to do so. A number of aerials will be used to permit transmission on the various wavelengths necessary to reach any part of the world at a desired time of day. Although no wavelengths have yet been chosen, it is probable that one wave will be available in each of the bands of short waves allotted to broadcasting by the Washington Conference, viz.:—

- 6,000 to 6,150 kc/s (50 to 48.8 metres)
- 9,500 to 9,600 kc/s (31.6 to 31.2 metres)
- 11,700 to 11,900 kc/s (25.6 to 25.2 metres)*
- 15,100 to 15,350 kc/s (19.85 to 19.55 metres)
- 17,750 to 17,800 kc/s (16.9 to 16.85 metres)
- 21,450 to 21,550 kc/s (14 to 13.9 metres)

It is probable, therefore, that each transmitter will be able to transmit on three spot waves, arrangements being made for a fairly quick change from one wave to another. The transmitters will conform to modern standards of frequency, stability, modulation depth, and audio frequency characteristic, while their power will be of the order of 15 to 20 kilowatts supplied to the aerial in the carrier wave condition. The construction of the station will begin shortly and it should be complete in about one year's time.

In order to reach the ideal of each Dominion and Colony being given a programme during the whole of the hours from 6 p.m. to midnight local time, it would be necessary to run the transmitters for a very considerable part of the twenty-four hours. At the outset, however, the

(Continued at foot of col. 3, page 859)

* G5SW already uses a wave in this band—viz., 11,750 kc/s (25.53 metres).

The Empire Station: Newspaper Opinion

The Times

There can be no question of the advantage the whole Empire will gain from a broadcast service linking together all parts of his Majesty's Dominions and keeping in touch with affairs at home the loneliest exile in the most distant outpost.

Manchester Guardian

It [the B.B.C.] is attempting a bold move to bind a scattered Empire more closely together, and to strengthen its loyalties. In the days before the war this was a task that fell to the Navy, which sailed into a thousand ports as the symbol of Imperial solidarity. But times have changed. The new way may be less magnificent. If it includes, as it proposes to do, direct trade propaganda, it may savour even more of a "nation of shopkeepers." But that, unquestionably, is what we are, and at the moment sadly in need of customers. The wireless is a powerful vehicle for advertisement. We are proposing to do, on a national scale, what private business enterprise has long found profitable in other countries. The Empire Broadcasting Station may easily do as much to promote Empire trade as the most elaborate system of tariff preferences.

Morning Post

There is no Broadcasting Corporation in Canada, which listens in to the United States, although there is some talk in the Dominion of establishing their own; Australia and New Zealand have actually decided to establish a Broadcasting Corporation, and no doubt all the Dominions in time will have their own systems; but the Crown Colonies have also to be considered, and they have not, nor are likely to have, any service of their own. It is in these circumstances that the B.B.C. propose to build a high-power station at Daventry, which will give a daily programme of twenty-four hours on the short-wave system to the whole Empire. . . . Russia, which specialises in propaganda, broadcasts its praise of Communism and the Five Year Plan to receivers placed in every village hall; in India, at present, there is no broadcasting system, and Daventry might create and supply the want, with the co-operation of the Government of India. . . . The Soviet Government produces cinema-films calculated to fill the Chinese breast with hate of every European. We should be able to find appropriate replies, and a British gospel of sweetness and light on the short wavelength might penetrate the dark heart of Asia.

News-Chronicle

It is not only an important enterprise in itself, but it marks—or at any rate foreshadows—the beginning of a new era in news distribution. It has long been evident that a better knowledge of the affairs of the Empire, and of their own place in it, was urgently desirable both in India and in the Crown Colonies, which the new service is designed especially to serve; and in so far as it successfully achieves this end the experiment will be really valuable. The B.B.C. are taking a bold course and we think, on the whole, a right one. Empire broadcasting was bound to come. To attempt to resist it would be to try and deny to vast populations the ser-

vices of modern scientific invention. This cannot permanently be done. On the other hand, it is very important that it should be done in the right way.

Daily Telegraph

It is a bold and sportsmanlike step. . . . The news, however, from the Imperial point of view, is of higher value than the entertainment. Lonely settlers and remote exiles will be able to get one, two, or three bulletins of home news per day, and they will get the news direct, without its taking on another colour from translation and transmission through a non-British source.

Sunday Pictorial

The Dominions still offer work for the best of our youth, and such a move as this proposed by the B.B.C. will help to make that work more attractive. . . . In binding together the Empire, we have always laid stress on the tie of "Hands Across the Sea"; we can change that now for a newer and closer bond: "Ears Across the Ether."

Observer

Congratulations to the B.B.C. on its bid for the ear of the Empire. Wireless and the air-men's wings are two of the main hopes of Imperial oneness. The extended efforts of the B.B.C. will be welcomed far and wide, not only as a means of contact, but as an aid in the maintenance of standards.

Daily Express

That is a magnificent conception, and the carrying of it out will bring the Motherland home to her distant sons and daughters as nothing else could.

Daily Mirror

Immense possibilities are opened up by the scheme. Trappers in the frozen wastes of Northern Canada, hunters in the jungle in darkest Africa, and sheep farmers in the backwoods of Australia will in future be able to be in closest touch with the capital of the Empire.

Daily Mail

The news that the B.B.C. has decided to create a special station for this purpose will be received with satisfaction by British people throughout the Empire.

News of the World

It has long been the dream of those interested in the advancement of radio to establish a broadcasting station capable of linking all the rest of the Empire with Britain, and the first move is now to be made to bring this scheme into actual being.

Evening News

What is certain is that exiles in the far-flung outposts of Empire will feel less like exiles when the loud speaker keeps them in constant close touch with what is going on at home. . . . But the fact that these broadcasts necessarily will be on short waves should be a hint to British manufacturers of wireless apparatus to get busy at once on the making of short-wave sets. . . . The Americans have for many years gone in for short-wave sets, and are probably ready to jump in with supplies for our Overseas Dominions.

The Star

The latest and most powerful station has been built by Russia with the intention of flooding the East with Soviet propaganda. The B.B.C.'s station will be in a position to counteract this, as in India, for instance, reception should be extremely good. The Englishman has made many presents to the Empire, but the Christmas gift of a special broadcasting station with free programmes guaranteed crowns them all.

Birmingham Post

It is the British subject far away from civilisation, of necessity in arrears with the news and with access to little in the way of entertainment, who most of all desires to feel himself in contact with the centre of the Empire and the amenities which he has left behind.

East Anglian Daily Times

The decision of the British Broadcasting Corporation to bind the Empire together by a new link. . . . is one of the most commendable things the B.B.C. has done.

Sheffield Daily Telegraph

The announcement that the B.B.C. intends to commence immediately the erection of a short-wave Empire broadcasting station will, we think, be hailed with delight in most of our overseas possessions.

Leeds Mercury

The advantages of such a broadcast service will be great in binding the Empire in a living whole.

Birmingham Daily Mail

The initial cost of £40,000 and the annual maintenance cost, amounting to about the same sum, are to fall for the present on the shoulders of the B.B.C.; in other words the British listener is to share the burden of this new broadcasting enterprise. It is as well to remember these points, but they will not weigh heavily with far-seeing people who realise the potential value of the service. Naturally the programmes will be largely of entertainment interest, and one can imagine the joy of a settler in some remote part of the Empire in being reunited to the old country under such pleasurable circumstances.

Edinburgh Evening News

The B.B.C. themselves have complained of a shortage of income, and the cry among listeners for better programmes at home never ceases; and here is an additional yearly expenditure of £40,000 not only cheerfully contemplated but enthusiastically endorsed. We are hardly churlish enough, however, to be the lone voice protesting. The idea behind the new service is magnificent, no matter who is to foot the bill. In any case, after countenancing the spending of £1,000,000 a year in the advertising of Empire goods in Britain, it is not very polite to strain at a £40,000 gnat for a service which will keep the loneliest outpost of a far-flung Empire in constant touch with the Mother Country.

Eastern Evening News

To the settler in the bush, to the farmer in the prairies, or to the colonist in some remote island, the news will bring fresh hope and new inspiration. Loneliness and isolation are the chief enemies in the outposts of the Empire. Radio programmes from the home country will help to banish both.

Messages from Empire Representatives

The Hon. G. HOWARD FERGUSON, LL.D.,
High Commissioner for Canada



[Leatherdale, Toronto]

THE splendid project of erecting an Imperial Broadcasting station is unique in that there is simply nothing to be said against it, while its advantages are so obvious that their recitation would be superfluous. There is, however, as is manifestly the case with the other Dominions, a Canadian point of view in this development which may not occur to the modest citizen of the Old Country. There is nothing we desire more than the annihilation of the time and distance comprehended in the Atlantic.

The intervention of the ocean has perpetuated, I fear, many misconceptions on both sides. I wonder, for example, if the majority of people in the Old Country really understood how deep and abiding is the sentiment of loyalty in Canada; how progressive and extensive are its industries; how vast its area and resources? Every scientific and engineering development which diminishes the significance of the rolling wastes of water helps forward a mutual appreciation and a mutual understanding which bring nearer and yet nearer the realisation of the ideal of an Empire united and compact. I am convinced that the Imperial Broadcasting Station, linking the Dominion with Great Britain by the supreme bond of the spoken word will be one of the greatest accomplished miracles in an age of miraculous Imperial possibilities.

The Hon. Sir BHUPENDRA NATH MITRA,
K.C.S.I., K.C.I.E., High Commissioner for India

I AM extremely interested to learn that the B.B.C. are proceeding energetically to develop the project of erecting a Short-Wave Empire Broadcasting Station. The great possibilities of such a scheme must be apparent to all who wish to see



[Vandya]

drawn even closer together the ties which at present unite the various members of the British Empire. The project should have the blessing of all well-wishers of the Empire, and I welcome this opportunity afforded to me by the B.B.C., to wish long and lasting success to an enterprise of such importance.

Major General the Hon. Sir GRANVILLE RYRIE,
K.C.M.G., C.B., V.D., High Commissioner for Australia



THE decision of the B.B.C. to proceed with the erection of a Short-Wave Empire Broadcasting Station will be received with enthusiasm throughout the Empire. It will bring the Dominions and Colonies into more intimate touch with the Mother Country, and will, I feel sure, be a big factor in the develop-

ment of closer relations between the various units of the British Commonwealth of Nations.

The Hon. Sir THOMAS M. WILFORD, K.C.M.G.
K.C., High Commissioner for New Zealand

I AM delighted that at last the long-looked-for "Empire" Short-Wave Broadcasting Station is to materialise. By this progressive movement a "News Service," which has hitherto been lacking, will be given, and will provide a feature that dwellers in the Empire Overseas will greatly value; while the use of alternative wavelengths will make the transmissions much more effective than heretofore. The scheme sponsored by the B.B.C. has my sincere good wishes.



[Utay Wrightson]

Mr. D. JAMES DAVIES, C.B.E., Acting High Commissioner for Newfoundland



[J. Russell & Sons]

I HEARD with great pleasure of the B.B.C.'s decision to erect a short wave Empire Broadcasting Station. The idea of Empire Broadcasting was placed before the Communications Committee of the last Imperial Conference, when representatives from all parts of the Empire expressed their unqualified approval of the project. As the representative in London of the Empire's oldest colony—Newfoundland—I admire the fine Imperial spirit which led the B.B.C. to make this great Imperial gesture.

The Hon. J. W. DOWNIE, C.M.G., High Commissioner for Southern Rhodesia

I WELCOME this opportunity to express Rhodesia's good-will and appreciation of the British Broadcasting Corporation's project for the erection of a Short-Wave Empire Broadcasting Station and to *World-Radio* for so ably featuring the project to those numerous readers who take a great interest in short-wave development. Southern Rhodesia comprises that portion of the vast territory named after its founder, Cecil John Rhodes, which lies to the South of the Zambesi. It is bounded on the north by Northern Rhodesia and Portuguese East Africa, on the south and west by South Africa and Bechuanaland Protectorate, and on the east by Portuguese East Africa. Travelling by land from Salisbury, the capital, to Cape Town, thence by sea to England, Southern Rhodesia is approximately 7,650 miles from England. The direct route by wireless is about 5,000 miles. Rhodesia is a name to conjure with: it calls up pictures of great explorers, of the larger carnivora, of magnificent natural spectacles and far-flung horizons. Like radio, Rhodesia's history is short, but it is written in bold letters against a background of mystery, glamour, and achievement!



[Lafayette]

The Hon. Sir JAMES D. CONNOLLY, Agent-General for Malta

I CORDIALLY welcome the recent decision to establish a new broadcasting centre in England

which will send out daily programmes to the uttermost parts of our Empire. Malta herself will not be likely to reap as much benefit from this new project as will the more distant Dominions and Colonies. Malta, which consists of important but small islands in the Mediterranean, has no local station for the dissemination of broadcast entertainment. It is so near to the mainland of Europe that those among her residents who own good wireless receiving sets can daily "tune in" to London or to any other of the European capitals. Still, though Malta will gain no new facility from the Empire broadcasts we can, nevertheless, appreciate what a wonderful thing it will be for the whole Empire thus to be linked up daily for broadcasting purposes. I wish your new Empire project every success.

His Highness the RAJAH OF SARAWAK,
G.C.M.G.

I HAVE great pleasure in sending you the very best wishes of myself and Sarawak for the scheme of Empire broadcasting, which will help to keep in touch the four corners of the world and tend towards conciliation and the ultimate alliance of humanity.



[Hugh Cecil]

The Court of Directors of the British North Borneo (Chartered) Company

THE Court of Directors of the British North Borneo (Chartered) Company, which is responsible for the administration of the Protected State of North Borneo, desire me to convey to the *World-Radio* their best wishes for the success of the Empire Short-Wave Broadcasting scheme. The establishment of the new station will provide the small British community in that remote corner of the Empire with the means of maintaining closer contact with the homeland, to which their thoughts continually turn. North Borneo has always been in the van of progress in wireless telegraphy—its wireless stations were among the first in the Imperial chain to be erected—and it is deeply interested in this new development, which will confer on it such a material boon.

Mr. H. W. THOMSON, C.M.G., Agent, Malayan Information Agency

THE decision to proceed immediately with your scheme of Empire Broadcasting will be welcomed by every one of the numerous possessors of receiving sets in Malaya, and I wish it all success.

BROADCASTING TO THE EMPIRE

(Continued from page 857)

hours of working will depend on the initial success of the service and the demand it stimulates. In general, programmes will be composed of material available in the Home programmes, but the production of specially timed programmes would also be involved in any complete service to an Empire which covers some 300 degrees of longitude.

In concluding this brief survey of a wide subject, it is perhaps well to state, for the benefit of British listeners in this country, that, except in certain conditions, the Empire transmitters will not be generally receivable in the British Isles. The direct rays of the short waves in use will become attenuated very rapidly, while the indirect rays which will give the service to the Empire will not reach the earth again, after returning from the Heaviside Layer, within a distance of several hundreds of miles, the exact distance depending on the season of the year, the time of day, and the wavelength in use.

This British Empire

By DOUGLAS WOODRUFF

LIKE Gaul, of which the eagle eye of Julius Caesar noted that it was divided into three parts, the British Empire has three great divisions. There are the Dominions, there is India, and there are the Colonies properly so called. Although the Dominions include a whole continent in Australia and another vast area, reaching to the North Pole, in Canada their population is only

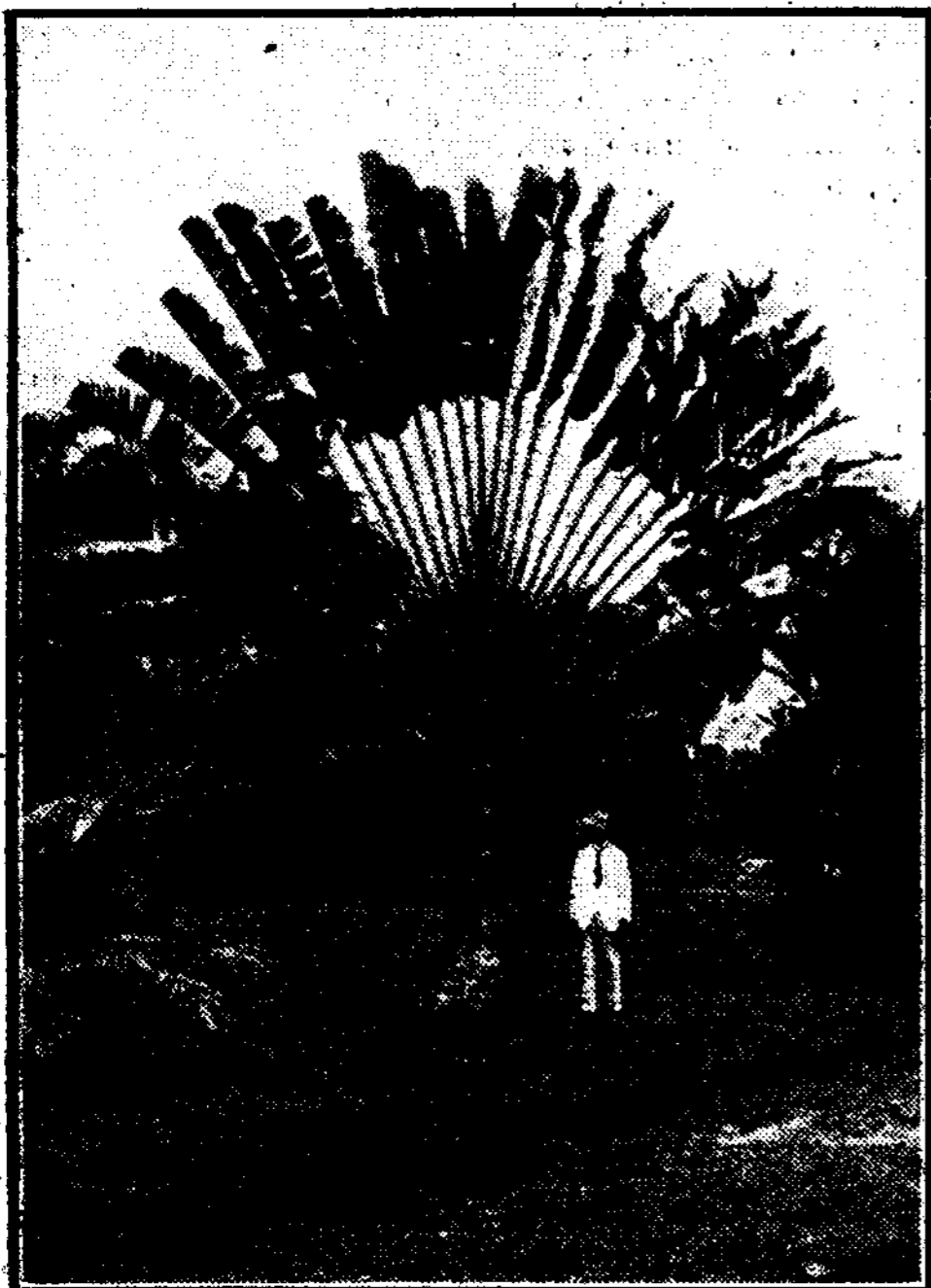

[Trade Commissioner, British Guiana

The Travellers' Palm, Demerara, W.I.

some twenty millions all told, less than half the population of the British Isles. If you choose to think, not in terms of area, but of numbers, India is by far the most important part of the Empire, and contains three out of every four British subjects. The contrast between the Dominions with their populations drawn from these islands and the Asiatic peoples of India is complete. The only bond of union between them is the British crown, which is constitutionally sovereign of them all, and the fact that the same square block of Government buildings in Whitehall is devoted to their affairs. That is the keynote of the Empire: diversity in unity; and we find it repeated on a smaller scale when we turn from the Dominions and India to the Colonies, which have little in common except the Colonial Office in Whitehall.

The Colonies are very numerous—there are over six hundred separate items in the Colonial Office Year-book—and are scattered all round the globe. They have come under the flag in different centuries for the most different reasons imaginable. In peroration in London they are easily grouped together, and their total trade or total population are treated as a unit, but in reality they know and care next to nothing about each other; each is only interested in Great Britain and is inclined to feel that the multiplicity of the British possessions prevents proper attention being paid to any one part. To such a vast and varied gathering of countries, little and big, as the British Empire, broadcasting is consequently of the greatest use. The most ardent internationalist has to recognise gratefully that the British Empire is a very faithful sample of the world as a whole, containing all creeds, all colours, all forms of

agriculture and industry, all linked together by nothing but historical accident, but enabled by that political linking to make experiments in mutual aid from which the world as a whole is precluded by the universality of jealous nationalism.

It is quite easy to grow impatient with the platitudes about kinship and co-operation which are the staple diet at Empire functions, but these politenesses, like all conventions, have a great deal more point than might appear. Negatively they say a great deal, and the day when several nations have achieved the attitude towards each other which is taken for granted inside the Imperial system to-day will mark an enormous change for the better in human relations. A constructive Imperialism is really the best contribution the countries inside the British system can make towards the stability and advance of mankind, because Imperialism calls for a subordination of local and nationalist feelings to wider but still clear and concrete ends. If in the Dominions and in India the relation of whole and part is uncertain, and if there are dangerous currents in the stream, the Colonies afford most admirable examples of the way local feeling and local life flourishes inside the larger union. A Dutch Professor, Dr. Haarhoff, of Johannesburg, has just published a book with the unusual title, *Vergil in South Africa*, which has among other theses this: that, like the Rome of Augustus, South Africa to-day has to achieve a blending of primitive agricultural and local culture with a wider, more cosmopolitan culture from outside. Rome succeeded, and the widely-diffused wealth and culture of the Hellenised Roman Empire laid the foundations of Europe. In slightly different forms all parts of the Colonial Empire enjoy a similar opportunity in the mechanical facilities of to-day to draw from the British connexion cultural and economic strength.

Thus, to give pride of place to seniority, is it with the oldest part of the Colonial Empire, the West Indies. The West Indies were acquired, little by little, for strategic naval reasons, in wars with Spain and France. Some are large islands, like Jamaica and Trinidad, others are small, like Barbados and the symmetrical groups known as the Windward and Leeward Islands. Two are on the mainland: British Guiana, a conquest from the Dutch at the time when Holland was part of the Napoleonic Empire, and British Honduras, almost the loneliest of all British colonies, set in among the little republics of Central America and against the Mexican border. The population of these islands are very largely black, the descendants of slaves we carried there to work the sugar plantations. All are governed by Governors sent from England, and are exceedingly loyal to the British connexion, although they have suffered and suffer to-day in comparison with the neighbouring islands that fly the French or

American flag and are inside the French or American custom walls. Sugar is the staple crop of the British West Indies, and the sugar position is desperate. While there is a free market for sugar in Great Britain and a subsidy for beet sugar grown at home, the West Indies have not derived any special economical advantage from the Empire, and their special product, rum, is taxed with extreme severity. The fruit trade is largely in the hands of a great American concern, the United Fruit Company. Yet the pride of the people in their membership of the Empire, made keener by the fear of excessive Americanisation, is in no way dimmed by these misfortunes, and of recent years a beginning has been made in the West Indian Conferences to bring the islands together and enable them to reap some of the advantages that a large concern can command. It takes a long time to go from one island to another, longer to go from Jamaica to Trinidad than to go from New York to London, and wireless has an enormous part to play in building an Imperial unit out of the West Indies, and keeping that unit in touch with Europe.

Yet more remote, the British islands in the Pacific contain peoples for whom it is a condition of survival in the modern world to be under the flag of a strong Power. Chief among them are the Fijians, some 80,000 natives living on two islands in a cluster of 250 little islands and rocks, with some 3,000 white men and a population of imported Indian labourers, some 60,000. That is a typical mixed colony, under the rule of the Colonial Office, in which a native population has to be safeguarded in its lands and liberties and given access to the ideas and practices of modern civilisation.

In tropical Africa the same question arises on a much larger scale. The Empire extends over much of West Africa, with the Colonies of the Gold Coast, Sierra Leone, and Nigeria, our most important African colony. For some thirty millions the simple problems of law and order have been solved in these colonies, and the primitive abominations of cannibalism and

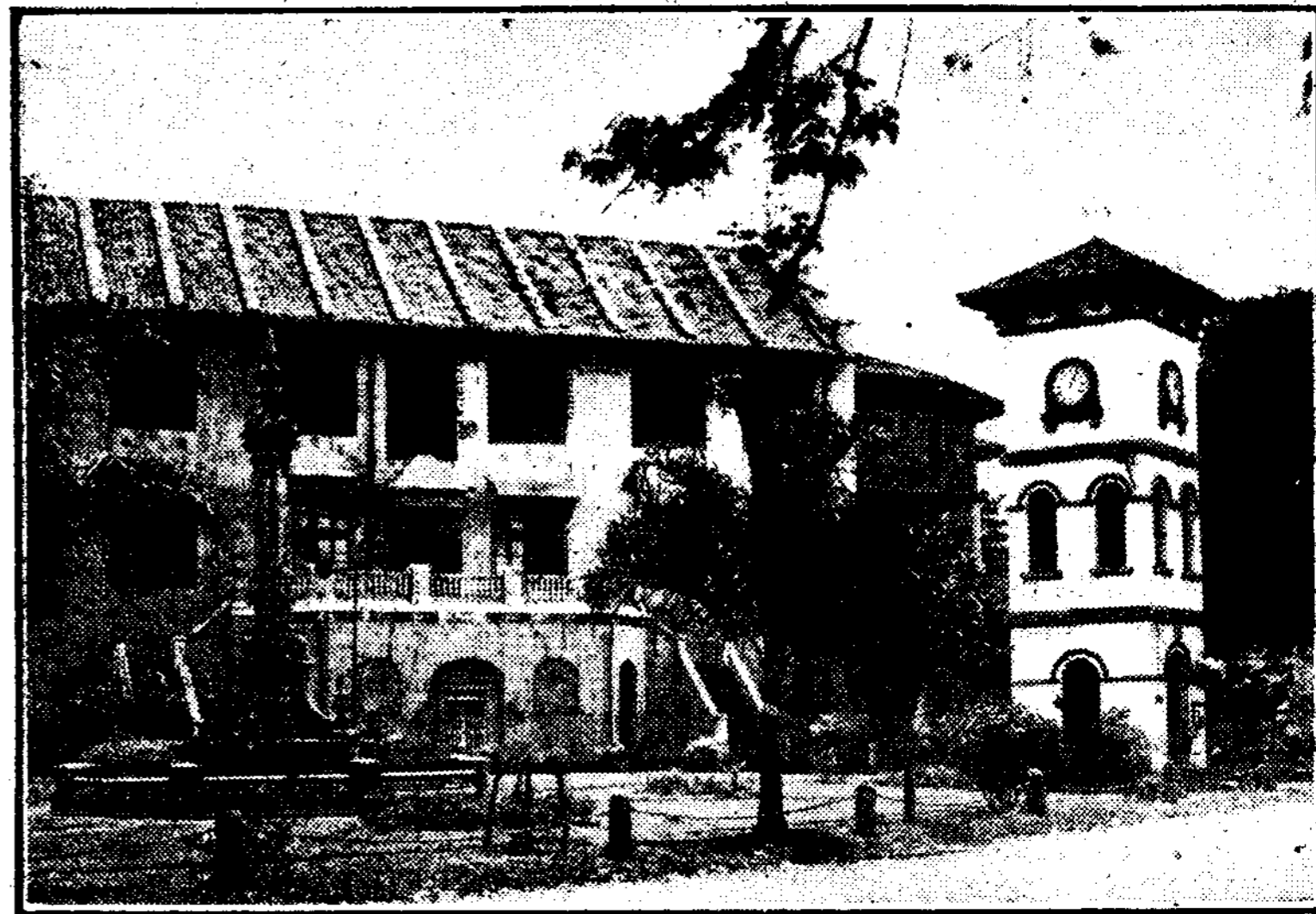

[Malay States Information Agency

The Old Dutch Stadthaus, Malacca

witchcraft have been suppressed. The economic development here is satisfactory, for a complementary trade is done with Great Britain. The colonies send cocoa and palm oil and other tropical products, and buy machinery and cotton goods, and this mutually beneficial trade is growing apace. But the centre of interest lies in the development of the natives as they are being brought into touch, inevitably, with the modern world. In East Africa, where we rule from the Sudan to Southern Rhodesia—the youngest of the self-governing off-shoots of

(Continued in column 3, page 862)

The Empire Social Link

By Commissioner DAVID LAMB

[Commissioner Lamb is the International Social Secretary of the Salvation Army, and was for twenty-five years Director of its Empire Migration and Settlement Work. As such he was responsible for the successful and happy transplanting of over 200,000 British men, women, and children from the Homeland to the Overseas Dominions. In the course of his work he paid frequent visits to the outposts of the Empire, and has four times circled the globe.]

I HAVE often been sea-sick, and I have been home-sick, too. Home-sickness is in some respects the more poignant and harder to thole, horrible as the other may be. Empire broadcasting will do nothing to alleviate

Shakespeare tells us through one of his characters to grapple our friends to our souls with hoops of steel. To-day, he might have said with wireless waves, for I see the lone scout in the backwoods bound more closely to us by means of them; solitary Salvationists as well as groups of our soldiers in parts of the Dominions listening at times to the leaders speaking in the Homeland. I see sailors in the night watches in our ships thanking God for the echo of home brought from far to their ears.



Australia: clearing the bush for the site of a homestead

the sufferings of the sea-sick; and I am led to wonder whether it will decrease or increase the home-sickness of our kith and kin overseas. In my opinion, the better the type of British emigrant the more likely he is, in any case, to suffer from home-sickness.

Anyhow, I am glad that the British Broadcasting Corporation, in launching Empire Broadcasting, did not delay while working out the financial side of the scheme. The foundations of the British Empire were not laid by men who sailed in ships with cash-books and ledgers at the masthead!

The late General Bramwell Booth addressed an appeal some years ago in connexion with the Army's Empire and settlement work "to those who have for long been labouring for the British Empire ideal, and hope soon to see their aspirations more fully realised." He went on to say: "It may be said with perfect truth that, hitherto, the British Empire has rested on a lively faith—the belief in British liberty, British institutions, British fair play, and British honour, holding the Overseas Dominions to the Motherland by links none the less binding because intangible. During recent months this faith has been translated into work and heroic deeds." And now, in the launching of this B.B.C. Empire broadcast, we have yet another example of faith translated into an heroic deed. The opportunities that it offers of binding together the different parts of the Empire, will be of incalculable value, and something of far greater worth than many battleships. It is to be remembered that the man-in-the-street and the woman-at-home are the people who count. A good average intelligence is what must be catered for; and on the more important issues which will arise from time to time fairly comprehensive statements of the *pros* and *cons* of the questions at issue will be eagerly looked for.

In studying closely the spiritual side of the emigrant movement, I early observed the general hunger for news from Home; and the Salvation Army authorities took steps to satisfy it by circulating newspapers among new arrivals overseas. But I think nothing was more appreciated, as the possibilities of wireless grew, than the arrangement we made to secure a *special* daily news service for emigrants in ships sailing under the Army flag.

And the Empire wavelength will be at once an anchorage and a stimulant—an anchorage for those who without it would drift from the fold of the Empire; a stimulant to those in whom

the fire of adventure lies smouldering. British emigrants in the future will doubtless come to regard a portable set as a regular item in their outfits.

The choice of times for broadcasting to the Empire will obviously present some difficulties; but experience will simplify the problem. The broadcast will, of necessity, be continuous, and the promoters do not need to be reminded that ours is an Empire upon which the sun never sets. The farmer on the western plains of Canada, pausing by his plough or thresher in the afternoon, will be able to hear our evening programmes; while folks in Australia will retire at night with our morning prayers and service. But I am afraid I can offer no suggestion to the B.B.C. with regard to the adjustment of times, for I confess, despite my travels all over the world—perhaps because of them—to being uncertain occasionally, whether, when it is six o'clock on Monday evening in London, it is, in Australia, six o'clock on Monday or Tuesday morning, or, perchance, evening, or even Sunday morning. I thought on one tour that I had boxed the compass, for I kept my diary daily and I also kept a watch at Greenwich Mean Time. Yet I was unable to adjust things, for in that particular year I found I had 367 days!

During recent years, the whole trend of invention has been towards the elimination of the human factor. And now the B.B.C., in a very remarkable manner, reintroduces it, for I know of no process in which it is so outstanding as broadcasting. Have we not all, for example, noticed, now and then, little asides in the studio, forming no part of the organised programme, which in being broadcast have imparted the essential human touch to it? But the personal side of broadcasting does not stop short at the human aspect of it. The description by a farmer on the Don-side (Aberdeen) of the thrill he felt on first hearing Big Ben was much the same as that given to me by a miner buried in the silver fields of Northern Canada. The sound of Big Ben thrilled me recently, too, when I was in a distant part of the Dominions. And if Big Ben is to be heard regularly in the Empire broadcast, then I can answer for it that there will be tens of thousands of the British family all over the world who will wait for the sound of the bell, and when they hear it feel that, after all, they are still near to the heart of Home. It is the atmosphere of home that listeners will hope to get on the Empire wavelength.

Then there are Empire interests to which our Homeland makes no sentimental call. There are the French Canadian and the Dutch Afrikaner

(Continued on page 863)



Australian settler's home: a model of self-help in building

India

DURING the last few years India has occupied an outstanding place in the news of the day. The ferment of the striving after self-expression, which is almost universal to-day, has been working within its life as effectually as in that of other countries. As a result a committee of investigation, under the chairmanship of Sir John Simon, was appointed, and in due course presented their monumental report. The Round Table Conference, having as its object the settlement of a form of representative Government with the ultimate aim of leading India to the status of a self-governing Dominion within the Empire is still sitting. But the difficulties presented by the claims of the followers of the two main



[Photos by courtesy of the High Commissioner for India]
Indian War Memorial, New Delhi

religions, Hinduism and Mohammedanism, and by those of the minority communities—domiciled Europeans, Anglo-Indians, the untouchables (that tragic class)—and others, are seemingly overwhelming; in addition there is the important question of the position of the native States. Nothing but the utmost patience and forbearance on the part of those charged with the holding of the scales of justice, combined with moderation and a sense of fair play on the part of the representatives of these rival claims can produce any useful result.

It is necessary to keep in mind a few facts relating to India. It is a territory of 1,800,000 square miles—that is, as large as the whole of Europe, excluding Russia. Of this territory almost two-thirds is administered by the Government of India, the rest being the care of the various Indian rulers. The total population is about 350 millions, of whom some 220 millions—over 70 per cent—are engaged in agriculture. The principal produce grown is rice, wheat, cotton, spices of various kinds, jute, and tea. The immense part played by irrigation in such a country as India needs no emphasis, and is a vital adjunct to the annual monsoon rainfall. The scheme of irrigation extends from great dams such as the Sukkur Barrage and canals, in the Sind Province, irrigating something like 14,000,000 acres, to private wells and "tanks"—the Indian tank being something like a pond.

In the welter of questions con-

cerning Indian politics the inestimable and unselfish work done by District Officers for the amelioration of the Indian peasant's lot, the even-handed justice dispensed, and the policing of the country are in danger of being underestimated. Only history will adequately paint the complete picture in true perspective.



Gate of Victory, Fatehpur Sikri

Broadcasting

In July of 1927 a system of broadcasting was started in India with the inauguration of the Bombay station, followed later in the year by the opening of a station at Calcutta, the European programme and technical staff being drawn from the B.B.C. personnel. The task undertaken was one of unexampled difficulty, since India presented a field like that of no other country. Perhaps Russia presents the closest parallel, but Russian broadcasting is undertaken by the Government, whereas in India the Government at the outset contributed nothing more than its good-will.

Two separate and distinct classes of programmes had to be organised—those for the European community and those for Indians. Talent, in an unexpected degree was forthcoming for both classes; but, unfortunately, the whole undertaking was handicapped by financial considerations. The original capital was six lakhs of rupees, about £50,000. This was frustrated the original plan which was comprised in the original scheme as outlined in these columns in May, 1928. It was there set forth that one of the most important developments to be undertaken was the communal listening set, installed in every village within reach of the transmitter, and maintained by Government assistance. The boon of broad-



The bazaar, Peshawar City

casting to women in purdah—similarly placed to the "shut-ins" in this country—was foreseen, while the value to the whole political life of the nation of reliable broadcast news bulletins was emphasised. Elementary education, too, was not overlooked. Certainly, an inspiring project, and one which was reasonably complete in its scope. The greater the misfortune, then, that the difficulty of collecting sufficient licence revenue and of combating the ever-present "pirate" nuisance doomed the plan to failure.

Later the Government decided to take the broadcasting into its own hands as a State service, and recently came to the melancholy decision to close the stations. It may still be hoped that out of the ashes of a generous and well-conceived scheme of broadcasting for India may yet arise a service which will be worthy both of that country and of broadcasting in general.

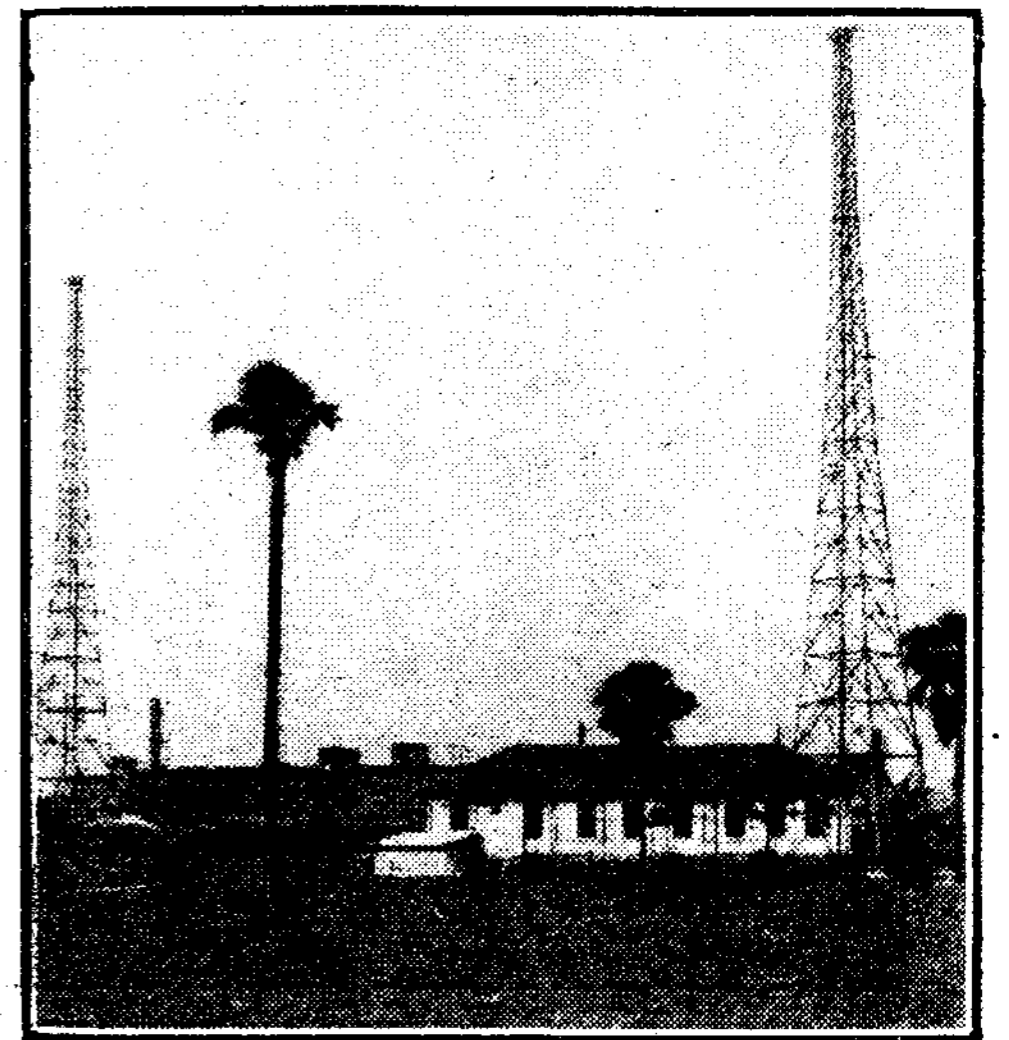

The Bombay Transmitting Station

THIS BRITISH EMPIRE

(Continued from page 860)

the British race—over some fifteen million people the outstanding question is the same. In general British policy is to work with native rulers wherever possible and to respect traditional forms. Throughout the Sudan, and Northern Nigeria in particular, we rule indirectly through native rulers, and in Asia our hold of the great Malay Peninsula running north of Singapore rests on our treaties with native rajahs. Malay is the great rubber and tin producing part of the Empire, with a rising population of Chinese immigrants whose future is a problem. There must also be named Mauritius and Seychelles, in the Indian Ocean, and Ceylon and Hong-Kong, the entrepôt for our China trade. To guard the route to the East, Gibraltar and Malta and Aden are held, and British policy has had to watch Port Said and the entrance to the Suez Canal. Our policy in Egypt and in Palestine rests upon our Eastern trade.

A triple motive runs through the history of all this expansion, the trader, the missionary, and the statesman. To-day, when the resources of government are so enhanced and the notion of the duties of government is continually widening, it is a difficult and momentous question how far the paternal government of backward or relatively helpless people ought to be pushed. But there can be no question that government must control plainly deleterious commercial influences, like bad films or bad drink, and equally no question that we have in our own economic arrangements to safeguard the economic well-being of people whom we have chosen to take under our flag.

Broadcasting in Canada

By M. S. WILDE

WITH an area practically as large as the United States of America and a population of only 10,000,000 scattered from the Atlantic to the Pacific within a broad band 800 miles wide, the problem of making broadcasts of any kind available to a measurable proportion of the population of Canada involves a degree of financial expenditure which many people believe to be beyond the resources of the country. Up to the present time nothing in the nature of a universal broadcasting system has been attempted: the most that has been considered possible has been the erection of low-powered stations in the larger cities from East to West, each of which serves a small area around the city in which it is placed. There are some thirty of these stations in the Dominion, and they have been erected by private enterprise which depends on the sale of broadcasting time to commercial organisations for its revenues. Apart from an inconsiderable number of programmes sponsored by local commercial firms in each city, the development of broadcasting in Canada has been the linking of all or most of these stations in a "national hookup," by means of the telegraph wires of the railway

companies, for the distribution of broadcasts originating in Montreal or Toronto and sponsored by commercial organisations which wish to make a nation-wide appeal for their products. The railway companies have played a conspicuous part in this development, and they have been the only agencies which have attempted anything in the nature of broadcasts which possessed some educative or cultural value. As instances of this may be given the broadcasting of the Toronto Symphony Orchestra over the "national hookup" by the Canadian National Railways, which also owns some broadcasting stations, and was the first British organisation to install radio in trains, and the programmes of French and English folk music and light opera broadcast by the Canadian Pacific Railway from their studios in the Royal York Hotel, Toronto, which have been relayed, *via* telegraph wires, to the principal broadcasting stations in the Dominion, the railway company purchasing time from each station for the purpose.

Apart from these purely Canadian efforts, American advertising programmes have penetrated to the Canadian "hookup" in the last few years. American stations can be heard in most parts of Canada, and in the more densely populated areas along the American boundary they constitute, indeed, the greater portion of the variety of programmes which are "on the air" every evening, but the American radio advertisers have not been content with this and have invaded the field of Canadian broadcasting proper for the purpose of extending the efficacy of their advertising. In order to do this they purchase time from the Canadian stations and lease telegraph wires from the railway companies, and these wires are then linked either with New York or Chicago, where the American programmes originate. It thus happens that the Canadian listener finds not only that the greater number of stations his set receives are American stations, but that he has to listen to American

programmes—even when he tunes in his local station—for the greater part of the broadcasting day.

This state of affairs has not developed without protest on the part of the Canadian listener, and in 1928 the Canadian Government sent a commission of inquiry around the world in order to study broadcasting developments in other countries and recommend on the basis of this knowledge a system which would be more suitable for Canada than the existing chaos. The committee, known as the Aird Committee—Sir John Aird was its chairman—recommended to the Canadian Government that the country should be provided with a nationally-owned broadcasting system closely following the conceptions of the B.B.C. The report suggested the erection of a chain of powerful stations throughout the country by co-operation between Federal and Provincial Governments and close Government control of all programmes to be broadcast from these stations, as well as a conscious, sustained, and intelligently-applied plan for broadcasting series of programmes of educative and cultural value by the Government itself.

This plan was not destined to be judged on its merits, however, because as soon as the principle of Government control of broadcasting

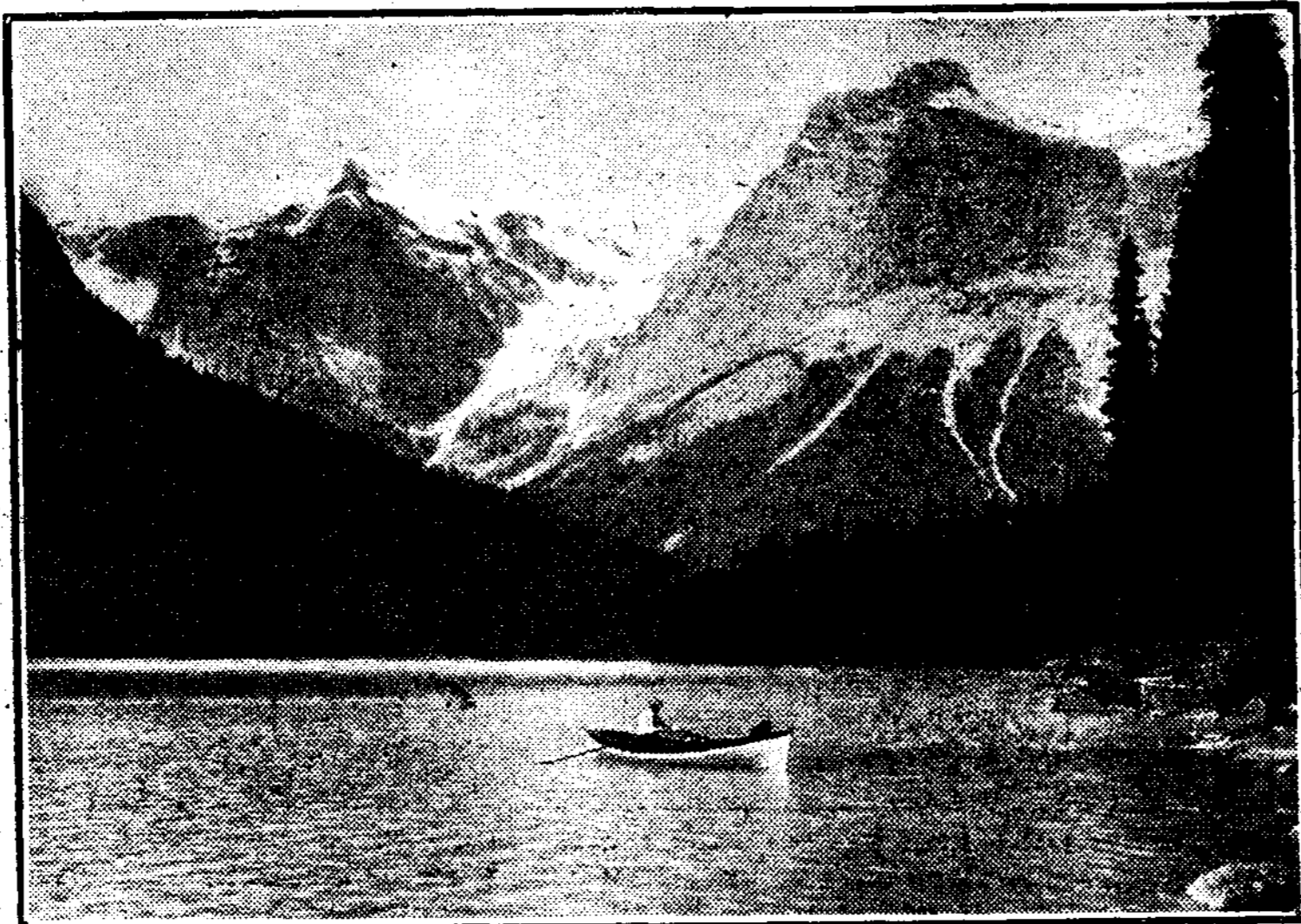

[By courtesy of C.N.R.]

Emerald Lake, British Columbia

was as much as suggested, there arose immediate reaction and resistance. The Government of the Province of Quebec immediately took the stand that the proposal contained in the Aird Committee report could not be carried out, because the jurisdiction over broadcasting was a Provincial and not a Federal affair. This opinion was carried before the Supreme Court of Canada, which expressly negated this contention, and at the present time the matter is before the Privy Council.

What with this political difference regarding broadcasting, the serious financial position of both Federal and Provincial Governments, and the sweeping economies which have been effected by the railway companies during the last year or so, the average listener in Canada is not optimistic regarding his chance to escape from the plethora of American programmes which now falls to his lot. The more enterprising among them have formed an organisation for the purpose of exerting pressure in favour of the recommendations contained in the Aird report, called the "Canadian Radio League." In so far as they represent public opinion in Canada, it may be definitely stated that the Canadian public recognises the educational possibilities of broadcasting, realises that in present circumstances they are deprived of these possibilities, and are not satisfied to be forced to listen to American advertisers' programmes.

EMPIRE SOCIAL LINK

(Continued from page 861)

who have differing sentimental ties which themselves differ, also, from those of our fellow citizens in India and of other Eastern peoples, though they are, all the same, influenced by our Empire thoughts and aspirations.

The children of the Empire, too, will find in the new broadcast an inspiration.



The "Hired Man" of Canada

We can imagine that Australians, sweltering in a temperature of something above 100 degrees in the shade, will be interested to learn, say, that at the time it is 40 degrees below zero on the Western plains of Canada—and *vice versa*. News, no doubt, will be an outstanding item in the Empire programme, and, as the appetite grows by what it feeds on, much will depend on the news sent out. It must not be concerned exclusively with London. It must not be too "highbrow"; it must have a good sprinkling of items from the provinces in it and news from overseas. Montreal must be told what Sydney is doing, and Melbourne must know what is going on in Pretoria; Wellington, N.Z., must feel that St. John, Newfoundland, is part of the Empire family.

In the course of my travels, I have interviewed more Cabinet Ministers of the Empire's Governments than most men probably, and in talking with them I have felt that I was welcome, not only for the Work's sake, but because I carried into their presence a breath of the Homeland. To them, and to others, I have urged more intercommunication between our public men in all parts of the Dominions, and they have always warmly endorsed my view. Such intercommunication the Empire broadcasts will foster.

Nor must the simple things of home be forgotten. The chimes from famous churches have been eagerly listened to; there are many who will hear with equal joy the pealing of the bell in the village steeple. But I can think of a hundred things that British people far away will like to have broadcast to them. My task, however, is not to compose a programme, but to suggest the broad lines on which they might be planned. Listeners in the Dominions will expect a broadcast that is up to date, diverse, and the product of intelligent and well-informed minds; one that is British through and through, and maintains the high standard that people in the Homeland have become accustomed to receiving. While we are all British, tastes differ in Dominions as they do even in cities at home. The B.B.C. has no light task in its selection of material; but it also has a great opportunity.

Australia: the Dominion Continent

SUNSHINE, cobalt skies, blue, bush-clad mountain ranges that roll away to infinity, tropical forests, boundless plains, the fragrance of eucalyptus and fairy wattle . . . Australia!

Although its atmosphere is not heavy with mediæval history and tradition, Australia is so old that it is new; so new that its antiquity amazes. Geologically it is incalculably the senior of Europe and America. Stone-age man, older than the Pyramids, with his firestick and totem and weird tribal customs, still lives in the same land which in a century has created centres of business, culture, and art, and has moulded them into some of the British Empire's greatest cities—cities that, like Sydney, which now spans its magnificent harbour with the world's largest single-arch bridge (if we except that which has just been completed at New York), or like picturesque Canberra, the infant modern capital where the soul of a nation is finding expression, reflect Australia's increasing urge to develop.

But it is beyond the cities that the spacious Australia of plain and forest, gorge and mountain, river and lake, begins. Through shimmering miles of golden wheat, past huge sheep and cattle stations, citrus groves, canefields, banana plantations, gold, silver, and copper mines, one feels the unique atmosphere of Australia.

Here one sees the Australian bush that pen and pigment have made famous—giant red and blue gums, mountain ash, golden wattle, and crimson waratah, the home of the kangaroo and wallaby, the emu, the parrot, the mocking lyre bird, the laughing kookaburra, the wombat, the opossum, the tiny native bear, the platypus—that furred, duck-billed, web-footed, egg-laying mammal freak at which scientists still marvel.

Population

It is not generally realised that the area of Australia is nearly as great as that of the United States of America, and that it is more than one-fifth of the area of the whole of the British Empire. It is this great size, taken together with the fact of the limited population, that gives to the problems of Australian development their unique character. The Commonwealth, which includes the island continent of Australia proper and the island of Tasmania, separated from the mainland by the Bass Strait, comprises about 2,948,366 square miles. From north to south the continent extends for nearly 2,000 miles, and its greatest breadth from east to west is about 2,400 miles. Although the population of Australia is still limited, the increase has been fairly rapid. While in January, 1788, it was estimated that there were only 1,204 persons (exclusive of aborigines) resident in the continent, in December, 1927, the population numbered 6,234,854. The aboriginal population before the foundation of settlement in 1788, was never large, and the life led by the aborigines was, in many parts of the country, a most precarious one. Although they were expert fishers and hunters, and were skilled in the use of implements of war and the chase, no traces of an agricultural instinct have ever been found in them. The tribes are very diverse in language, laws, customs, ceremonies, and beliefs.

Climate and Fauna

Australia may be divided roughly into three belts or zones marked by broad climatic differences. In the southern belt—comprising Tasmania, the greater part of the States of Victoria, New South Wales, South Australia, and Western Australia—the climate is similar in many respects to that of the south of France or the north of Italy. The middle part, com-

prising part of all the continental States, is devoted almost entirely to sheep runs, and the northern belt, or tropical zone, to the growth of mango, pineapple, coconut and banana, and the rearing of cattle.

The animals of Australia differ from those of other lands—so much so that Huxley proposed to divide the world, for natural history purposes, into Australia and not-Australia. The pouched mammals of Australia belong to a type that has long been extinct in other parts of the world (except in the case of the opossum in America), and Australia alone of all the world has egg-laying mammals. The ancient enigmatic Tasmanian "tiger," the bounding kangaroo and wallaby, the platypus that lays eggs and feeds its young by exuding milk on to the hair under its body, the bush-tongued honey-eating birds, the water-holding frog that lives for a year or more encased in thoroughly dried mud, the lung fish that comes to the surface to breathe through its lungs when the gills are inoperative owing to the water being fouled



Broadcasting the final gallops before a big meeting. Six judges, using stop watches, timed the horses. The broadcast commentator is seen using binoculars and standing before the microphone.

—these and many other unique and strange forms of fauna have made Australia the Mecca of zoologists. There are no wild beasts, the nearest approach being the dingo—immortalised by Kipling—a primitive canine that raids the sheep on the stations of the far interior.

Government

The Government of Australia is both State and Federal. Under the Commonwealth Constitution, the six contracting colonies remained Sovereign States under the Crown, but agreed to surrender certain legislative powers to the Federal authority. The Federal Government controls the Customs and Excise, the postal and telegraphic services, naval and military defence, and immigration, while the Governments of the various States control the departments of Lands, Agriculture, Fisheries, Forestry, Railways, Roads, Public Works, Education, and the Police.

From 1901 up to 1927, the Commonwealth Parliament met in Melbourne; but, owing to the intense rivalry existing between the cities of Melbourne and Sydney for the position of Federal capital, an area of approximately 900 square miles in extent was acquired from New South Wales as Federal Territory, and a new capital city established. On May 9, 1927, the first session of the Commonwealth Parliament held in the new Parliament Buildings at Canberra was opened by H.R.H. the Duke of York.

The Part Played by Wireless—

Wireless has played an important part in the development of Australia, not only in maintaining communication between the Commonwealth and abroad, but in establishing contact between the great cities of Australia and remote parts of the continent out of reach of the telegraph, the telephone, and other ordinary means of quick communication.

Many of the big cattle stations in the Northern Territory are one or two weeks' journey by horse or camel from a telegraph centre, and as a result it is often a month before a reply can be received even to a telegram. Under these conditions, it can easily be realised how beneficial wireless is proving. Many of the larger stations—or ranches—now possess private transmitters, which maintain communication with special stations in contact with the overland telegraph system and *vice versa*. A daily news bulletin is also broadcast by several stations, which is picked up by the lonely settler.

A unique application of wireless is the installation of the communication system in connexion with the great Burrenjack Hydro Electric scheme. A powerful transmitter is located at the Dam, with secondaries at the important centres of Gundagai, Murrumburrah, and Cootamundra, and working in conjunction with these are five portable transmitters. The object of these stations is to provide quick and efficient communication at all times, and to keep the power station at the Dam in constant touch with all points of the transmission line during periods of emergency.

Many lighthouses round the Australian coast are now equipped with wireless telephony, and similar apparatus has been fitted to many trawlers and small coastal steamers. Communication is maintained with one of the many transmitters at Radio Centre, Pennant Hills, N.S.W., and apart from being able to give information to the trawler-owners as to what stores are required by the vessels on arriving in port, this service has proved of outstanding value in enabling one vessel to inform another of the excellence or otherwise of a fishing ground in a particular locality.

—in Apprehending Criminals or Linking Nations

For some time past, wireless has been used by the Australian police to aid in the prevention and detection of crime. Telephony transmitters are operated from police headquarters both in Melbourne and Sydney, and constant communication is maintained not only with police cars, which are always on patrol, and rural police stations, but with police launches in both Sydney and Melbourne harbours. The apparatus is entirely concealed, and the appearance of the car is the same as that of any ordinary private vehicle. In the event of a fire or street accident being reported to police headquarters, instructions are immediately transmitted to one or more of the cars on patrol to hurry to the scene of the disaster.

It is wireless, also, which has put Australia in communication with the telephone systems of Europe, America, and Asia, and it is anti-

pated that the regular telephone service which is now in operation between the Commonwealth and London will be shortly extended to other parts of the world.

Australia's Broadcasting

Broadcasting in Australia has undergone several important changes since its inception nearly ten years ago.

For some years each State, in fact almost each station, was operated quite independently, and whilst operating under licence from the Postmaster-General's Department, the programmes were arranged by the individual proprietors of the stations. In 1928, however, the system was modified, and the technical operation of some of the stations was brought more directly under Governmental control.

To-day in the Commonwealth there are two classes of broadcasting stations, those of the "A" Class, which derive revenue from licence fees paid by listeners, and the self-supporting stations known as "B" Class. A little more than two years ago, tenders were called for the supply of programmes for the "A" Class stations, the contract subsequently being given to the Australian Broadcasting Company for a period of three years.

The "B" Class stations, which serve a large section of listeners throughout the continent, and are often well received in New Zealand, are left free to originate their own programmes.

In July of this year Australia inaugurated its first regular Empire broadcasting service, and now programmes are sent out regularly through powerful short-wave transmitters in New South Wales and Victoria, specially timed for convenient reception in various parts of the British Empire.

The times of the transmissions from the Sydney (2ME) station, which take place every Sunday on a wavelength of 31.28 metres, will be rearranged on November 29 to compensate for the change in reception conditions which takes place as the season advances. Programmes on and after November 29 will be sent out every Sunday between the undermentioned times (G.M.T.) for—

Canada and other British possessions on the American Continent	6-8 p.m.
New Zealand, Fiji, New Guinea and British possessions in the Western Pacific	10 a.m.-12 noon
Western Australia, Straits Settlements, Burma, and Ceylon..	12 noon-2 p.m.
Great Britain, Western Europe, South Africa, Egypt, and other African Countries	2.30-4.30 p.m.

The Melbourne (3ME) station radiates Australian programmes for British listeners abroad every Wednesday and Saturday on the same wavelength as that of the Sydney station between 10.0 and 11.30 a.m. G.M.T.

The laugh of the kookaburra—one of Australia's native birds—which precedes the transmission of every Sydney programme has been heard by many short-wave listeners in Britain, and may in time become as familiar to them as the chimes of Big Ben are to many in the cities and back-blocks of far-off Australia, which reach them over the ocean from the B.B.C.'s experimental station G5SW.

We have received a copy of *Shanghai Calling*, which is the official organ of the China Broadcast Association, and also a descriptive booklet concerning the Shanghai broadcasting station XCBL, which uses a frequency of 1,276 kc/s (235 m.) and a power output of 0.4 kW. This station, which began operations on May 14, 1931, transmits daily from 11.30 a.m. to 2 p.m., and from 4.30 p.m. till midnight (local time). Since there is no system of broadcast licences the station relies upon programmes sponsored by commercial firms. The book contains photographs of the stations' two studios, the station orchestra, and artists' waiting-room.

New Zealand

NEARLY a century ago enterprising Britons, learning of a new land in the Southern Seas, set out in the sailing ships of those days with their wives and families, at their own cost, and founded a colony. What romance there was in that venture! What greater romance there is in the realisation that this one of many adventures of British pioneers has resulted in the growth of a Dominion which, to-day, is supplying the Mother Country with more mutton and lamb than any country in the world, and is her second greatest contributor of wool, besides sending over a number of other essential commodities! It is not a little gratifying to Englishmen to know that, though later all British sections were united in developing and colonising the new land, Englishmen were the first in the field, that the earliest ships went to New Zealand from the Thames and southern ports.

Clearing dense forests to make their homes, surrounded by savages, working continually in

Broadcasting

The licence of the present broadcasting company expires next year, and the position in regard to the future control of New Zealand broadcasting is still indefinite. A year ago it was announced by the Postmaster-General that when the present contract with the Radio Broadcasting Company ran out, as it will do very shortly, the Government would not renew it, but would itself take over control. Up till a few weeks ago this course certainly seemed likely, although no legislation had actually been carried out in connexion with the matter. Then came the formation of the Coalition Government, and now it appears to have been decided that on the expiry of the present licence the Government will take over the broadcasting and will organise it on lines similar to those of the British Broadcasting Corporation.

The idea that a regular broadcasting service would be of immense value to the farming community first originated with Mr. William Goodfellow, a prominent representative of the New Zealand dairy industry. He further realised



[High Commissioner for New Zealand.]

A view of Wellington, North Island

lonely wilds, these early settlers and their descendants gradually built up a new civilised land.

To-day New Zealand is a Dominion of advanced civic and social culture. It has a definite place in the affairs and government of the British Empire, and no small share in its economic structure.

Agriculture is the chief industry of the Dominion, her comparatively small population being insufficient to support great manufacturing enterprises, though she provides with her own mills a fair share of internal requirements.

Her position in the economic affairs of the Empire to-day is that she is a leading exporter of foodstuffs to the Mother Country, and in return is the best *per capita* customer for our manufactures. What money New Zealand receives in this country for her butter, cheese, mutton and lamb, pork, honey, apples, wool, etc., she spends chiefly on our manufactures. No other country in the world spends anything like in the same degree with us the proceeds of her sales here.

H.T.B.D.

the importance of supplying reliable weather forecasts and market prices to farmsteads out of reach of the telegraph, the daily paper, and other means of quick communication.

In Rural Communities

The value of broadcasting in New Zealand will, therefore, be fully appreciated, and the extraordinary influence that it exerts over the rural population of New Zealand, members of which rely almost entirely on their wireless receivers for entertainment, will be obvious.

On July 18, 1925, the Postal Department entered into an agreement with Mr. Goodfellow and Mr. A. R. Harris for the formation of a company to operate a broadcasting service in the Dominion.

Owing, however, to several delays, chiefly in the delivery of the transmitters from America, it was not until August, 1926, that 1YA—the 500-watt Auckland transmitter—was officially opened, followed by 3YA, Christchurch, in September, and 2YA, Wellington, equipped

with a 5 kW. transmitter, twelve months later. 4YA, Dunedin, with a transmitter similar to those at Auckland and Christchurch, was opened at a later date.

From the very beginning of its existence the New Zealand Broadcasting Company has continued to make progress, although its revenue has always been limited. This has been due not only to the small number of householders, but to the high cost of complete receivers and components prevailing throughout the Dominion. The annual licence fee is £1 10s., of which 5s. is retained by the Postal Department to cover the cost of collecting the revenue.

Probably the most popular broadcasts in New Zealand are the running commentaries on sporting events, such as football, horse-racing, wrestling—which is very popular in Australasia—and boxing.

Paucity of Artists.

Owing to the limited revenue and talent, gramophone records play a large part in the New Zealand programmes, and because of the small number of landlines relays can be effected only between Christchurch and Dunedin; and so far the inauguration of a national programme has been an impossibility. Since, however, according to the terms of its licence, the broadcasting company is compelled to broadcast from each transmitter for a period of only twelve hours a week, but actually broadcasts for over forty, it cannot be said that it has in any way

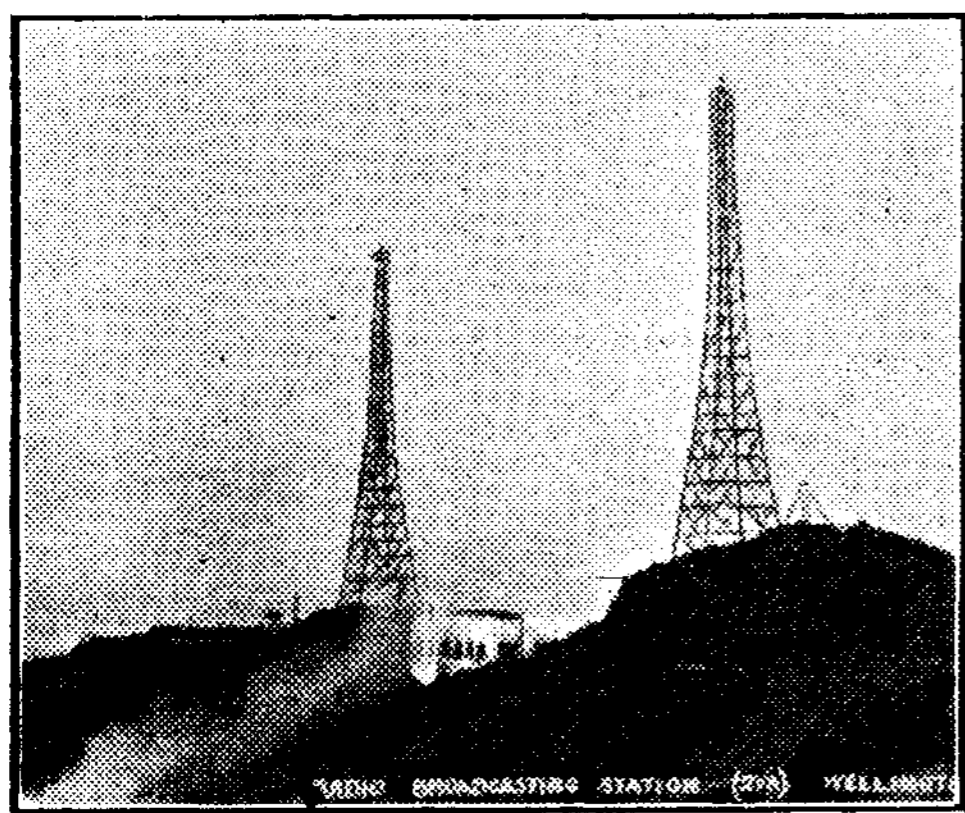

The Wellington (2YA) transmitter

failed to fulfil the terms of its licence. Between the hours of 8 and 10 p.m., however, gramophone records may occupy up to only 25 per cent. of the time on the programme.

It has been suggested by many listeners that were the stations allowed to accept sponsored programmes the revenue of the company would be increased, and consequently the quality of the programmes would become higher. This, however, owing to lack of suitable local talent, is not the case; since if wealthy American sponsors were to pay high fees to local artists, the latter would be unwilling to accept the comparatively low fees which they now receive from the broadcasting company. Also, overseas artists are usually forbidden by the terms of their contracts with New Zealand concert agents to broadcast, and would, therefore, be prevented from appearing before the microphone in sponsored programmes.

As in Australia, "B" Class stations, independently owned and operated, are licensed by the Government, but, unlike those in the Commonwealth, are not permitted to broadcast advertisements. Such transmitters are usually operated by gramophone, wireless, and sheet music stores, which gain advertisement without the spoken word. What will happen to these stations when the Government takes control of broadcasting has not yet been decided.

In the terrible earthquake which befell Napier

(Continued at foot of col. 3, page 868)

Ceylon Broadcasting

By E. HARPER, late Chief Engineer, Post and Telegraph Dept., and Controller of Broadcasting, Ceylon.

IN view of the decision of the Government of India, recently announced, to close down the two Indian broadcasting stations of Bombay and Calcutta, it will be interesting to note what effect, if any, this will have on the neighbouring service in Ceylon. For nearly three years before the opening of the Indian service, in 1927, Ceylon provided the only broadcasts available to listeners in Central and Southern India without, unfortunately, deriving any financial advantage from this fact.

When, in 1928, the Radio Club of Ceylon extended the field of its activities and became the Radio Club of Ceylon and South India, many listeners in the latter country became more closely in touch with the Ceylon service and contributed voluntarily to a programme fund organised by the club, while still paying their licence fees to the Indian Government.

Some of the difficulties confronting a broadcasting service in the East were referred to in an article on "Broadcasting in Ceylon" which appeared in *World-Radio* of October 10, 1930, and there can be no doubt it is these, with their natural effect of limiting public support, which have brought Indian broadcasting to a premature end or—shall we say?—to a state of suspended animation.

Like all other countries, Ceylon has been badly hit by the world-wide trade depression, and the Government is compelled drastically to curtail expenditure even on what, up to a short time ago, would have been regarded as necessities.

The capital expenditure on the broadcasting plant and the working expenses of the Ceylon broadcasting service, including outlay on programmes, are probably much lower than is the case with any other service producing equal results, but income and expenditure do not yet balance, and broadcasting might be thought, superficially, a fit subject for the axe. If, however, its value to the community is assessed in terms of income, a rather different picture will be presented.

Fortunately for the Ceylon service, it has from its inception in 1925 been under one control and thus able to pursue a consistent policy, which was to make it a really national service of the maximum utility to all the different communities in the Island rather than merely a new form of amusement.

Educational Broadcasting

Some indication of the scope of the programmes was given in the article referred to above. During the past year a very successful schools broadcasting service has been inaugurated, under the auspices of the Education Department, and attention is now being directed to the subject of adult education on the lines of community or group listening for the benefit of the large illiterate population of the Island. The talks programme has also been considerably extended to cover agricultural subjects, health, local industries, and archæology, practically all the technical departments of the Government contributing to these. Many of the talks given are worthy of the most extended publicity. It may be of interest to emphasise that all this is done on a purely voluntary basis.

The Radio Club of Ceylon

The Radio Club of Ceylon and South India deserves the utmost commendation for the admirable manner in which it collaborates with the Broadcasting Department in everything which may benefit the service, with the result that every member feels he has a personal share in the organisation and constitutes himself a propagandist rather than a critic. Notwithstanding its limited resources, it publishes

monthly, and issues free to its members, an excellent little magazine, the *Ceylon Radio Times*, which contains among other matters the month's official broadcasting programmes; it collects and publishes weekly a very useful bulletin or record of short-wave receptions and similar details which are of more than local interest and value, and has made substantial contributions to the cost of special items broadcast. About three years ago the club organised a Hospital Wireless Fund, with the object of equipping all the principal hospitals in Ceylon with suitable receivers, and some 1,500 patients are now enjoying the programmes.

Until a few months ago broadcasting hours were limited to periods which did not interfere with the commercial ship-to-shore telegraphy. Alterations to the transmitter in order to conform to the regulations under the Washington Convention have now been made and have permitted a complete separation of the telegraph work of the station from that of broadcasting. Like its predecessor, the new transmitter has been designed and built by the engineering staff of the Ceylon Telegraph Department. The new wavelength is 428.5 metres (700 kc/s), and the power into the aerial is 1.5 kW. A proposal to increase this to 10 kW. has been deferred owing to the financial stringency.

Empire Broadcasting

Ceylon listeners will welcome enthusiastically the news published a short time ago that the



Central Telegraph Office, Colombo

Empire broadcasting scheme is really to materialise in the near future. The delay in getting on with this scheme has greatly disappointed the large number of listeners in the Eastern Colonies, where the short-wave stations of nearly every country can be picked up more satisfactorily than the transmissions from G5SW. Ceylon is one of the very few Colonies which have a broadcasting service, and hence will be able to relay the Empire transmission to its own listeners.

These direct links with the home country are of much more than mere sentimental value, and it behoves this country to show the Empire what really can be done. Undoubtedly the opening of a powerful short-wave station operating on suitable wavelengths will greatly stimulate the interest of those waverers who ask in a superior manner, "What is there to listen to?" when invited to subscribe to the local service. One obvious result of the establishment of the Empire Station will be a large increase in the demand for short-wave receivers, and I would strongly urge on our manufacturers to be ready for this with apparatus *suitable for the tropics and at a suitable price*, otherwise they will lose a large potential market into which certain foreign manufacturers are already making serious inroads.

Ceylon has just recently become the proud possessor of a brand-new Constitution, complete with practically adult suffrage and a Board of Ministers. It can, therefore, be numbered among the most progressive of countries, and the writer feels no doubt that the further development of broadcasting in every way that the financial situation permits may be relied upon.



One Man To Another

- Mr. Youngerman:* So you are retiring, Sir? Well, I'll have to wait another 30 years before I get my pension.
- Mr. Elderman:* You're lucky to have one to look forward to. They don't give pensions in my line of business.
- Mr. Youngerman:* I'm sorry. Then it's a rather serious financial loss? I suppose it will be difficult to get another position at your age?
- Mr. Elderman:* Happily it isn't necessary. I took out an endowment policy when I was 30. Next week I shall be 65, and I shall get an income of £400 a year for the rest of my life.
- Mr. Youngerman:* By Jove! that sounds a useful proposition. I reckon on a pension, but one never knows. Besides, it would be a lot less than my salary.
- Mr. Elderman:* Yes, and during the whole of the time, if anything had happened to me, the wife would have had the sum insured and something substantial added each year by way of bonus.
- Mr. Youngerman:* Perhaps you wouldn't mind telling me the name of your insurance company. I'd like to know what it would cost me to fix up a similar proposition.
- Mr. Elderman:* My Company's the Prudential. It happens that I can tell you the figures, if you're interested—They're even better than they were in my day—My boy's the same age as you are, and I got their representative to work it out for him. Allowing for income-tax rebate it will cost him £61 19s. 7d. a year—not much more than £1 a week. And at age 65 he will get a guaranteed £414 a year. And he's insured the whole time for £2,000, with £60 guaranteed Bonus added each year.
- Mr. Youngerman:* Suppose I wanted to arrange to draw the money at 60? Could that be done do you think?
- Mr. Elderman:* Oh, yes; they advertise: Any age, Any term, Any amount:

If you would like a guaranteed income of £400 a year at age 65 or earlier, fill in and forward this coupon:—

To The Prudential Assurance Co. Ltd. Holborn Bars, London, E.C.1.

Please send me particulars of a Guaranteed Bonus Endowment Assurance Policy which will enable me to secure an assured income of £.....at age.....

My age next birthday is.....

Name.....
Mr., Mrs. or Miss.

Address.....

.....

.....

South Africa

THIS year marks the coming of age of the Union of South Africa. It is constituted under the South Africa Act, 1909, passed by Parliament on September 20, 1909, under the terms of which the self-governing Colonies of the Cape of Good Hope, Natal, the Transvaal, and the Orange River Colony became united on May 31, 1910, the former Colonies becoming original Provinces of the Union under the names of the Cape of Good Hope, Natal, the Transvaal, and Orange Free State. The Union covers an area of 471,917 square miles, with an estimated European population of 1,798,647, and of non-European approximately 6,215,000. On the subject of territory, it is perhaps not generally known that the Union holds one piece of land in France. The title-deeds of Delville Wood, where the South African troops who fell in battle on the Western front during the War are buried, are in the possession of the Government of the Union of South Africa, and this ground is part of South Africa.

The Union is administered by a Governor-General, as representative of the King, with a Cabinet of not more than eleven Ministers. Pretoria is the seat of administrative Government and Cape Town of legislative Government. Under the Act of 1930, European adult franchise became law in all Provinces alike. The advent of women's franchise does not alter the quota of votes in constituencies, which is still regulated by the number of male voters as laid down in the South Africa Acts. But the qualifications necessary for voters vary in the different provinces.

The gold and diamond industries are doubtless those which first leap to the mind of strangers to the country in thinking of South Africa, but its many exports include maize, wool, and, of course, fruit.

To the tourist, South Africa offers unrivalled attractions: a delightful climate and scenic contrasts from the wild expanse of the rolling veldt to the indescribable mountain grandeur or the peaceful charm of woodlands and a profusion of wild flowers.

Broadcasting

Broadcasting in South Africa began in September, 1924, the opening of Johannesburg station being followed soon after by that of Cape Town—entirely owing to the

enterprise of a few individuals who looked for no profit beyond the general advancement of Cape Town through such a powerful medium for publicity. Later, Durban station made a third. Each station remained under separate control until 1927, when Mr. I. W. Schlesinger formed the African Broadcasting Company and absorbed all three centres.

A Difficult Problem

The African Broadcasting Company has had much uphill work. It is not difficult to grasp something of the magnitude of their task when it is borne in mind that the shortest distance between the stations is 1,000 miles. With the problem of reaching scanty populations scattered over vast areas, it is inevitable that many thousands of people in South Africa have never heard broadcasting, though their numbers have been lessened by the recent addition of two subsidiary stations, in Pretoria and Bloemfontein.

The African Broadcasting Company was not granted a monopoly in the matter of broadcasting rights, and recently application was made by two other concerns for a licence to broadcast, but it was realised that the granting of such licences would entail great hardship for the existing company, which, having had to bear the brunt of much pioneer work, has weathered hard times, and now hopes to recover its losses and become established on a sound basis. Thus the company is now assured of a virtual monopoly unless, at some future date, the Government should take control. A proposal is at present under consideration for the appointment of an advisory committee, but the scope of its powers has not yet been defined.

Licence Fees

The Cape Town station is seriously handicapped, so far as range is concerned, by reason of its situation. Cape Town lies at the base of Table Mountain with two high peaks on either side, so that the areas beyond are badly screened. If Cape Town be taken as the centre of a fifty-mile circle, it will be seen that the area covered is in the proportion of three-quarters sea to one quarter land—and that quarter largely mountain. Yet the area over which subscribers to the Cape Town station are distributed is larger than the British Isles. Licence fees are scaled on a zoning system,

starting from 35s. a year within close range, and graduated down to 2s. 6d. for the far-distant listeners.

One of the more interesting education experiments, recently carried out by the Cape Town Station, was the broadcasting from the studio of a series of four lessons. The lessons were broadcast during the school hours and were picked up by selected schools, which were provided by the education authorities with receiving sets and loud speakers. The lectures were on biology, Afrikaans literature, musical appreciation, and history. So wide was the interest aroused by the experiments that the



Adderley Street, Cape Town, showing the aerial mast on the broadcasting station

principals of most of the schools sent in reports, and enthusiastic comments were also received from people who had been invited to the tests. The Superintendent-General of Education in the Cape appointed a special committee to consider the question of broadcasts to schools, and this reported that a "carefully organised series of broadcast lessons would be of value, provided that arrangements could be made for the provision of the necessary notes and diagrams beforehand, but the Department cannot undertake the organisation of such a scheme unless an additional officer is specially assigned to this work. It was suggested that some outside authority should take over the organisation, but, on account of the present economic situation, all action has been suspended, a decision much regretted by many teachers.

NEW ZEALAND BROADCASTING

(Continued from page 866)

last February, broadcasting played an invaluable part in bringing speedy assistance to the stricken areas. For two days following the disaster wireless was practically the only means of communication. Ships at Napier sent out messages to the rest of the Dominion, and the Government dispatched a special truck equipped with a short-wave transmitting and receiving set to the outskirts. One of the Hastings "B" Class Stations was still in action and established communication with Gisborne, which in turn passed messages on. Later in the evening a Napier short-wave amateur got his set in operation and he became the official channel of communication with the Post Office receiving station in Wellington. Thus the lot of those in the affected region was ameliorated, and for those outside the ordeal of suspense was relieved. And rapidly organisation conquered chaos.

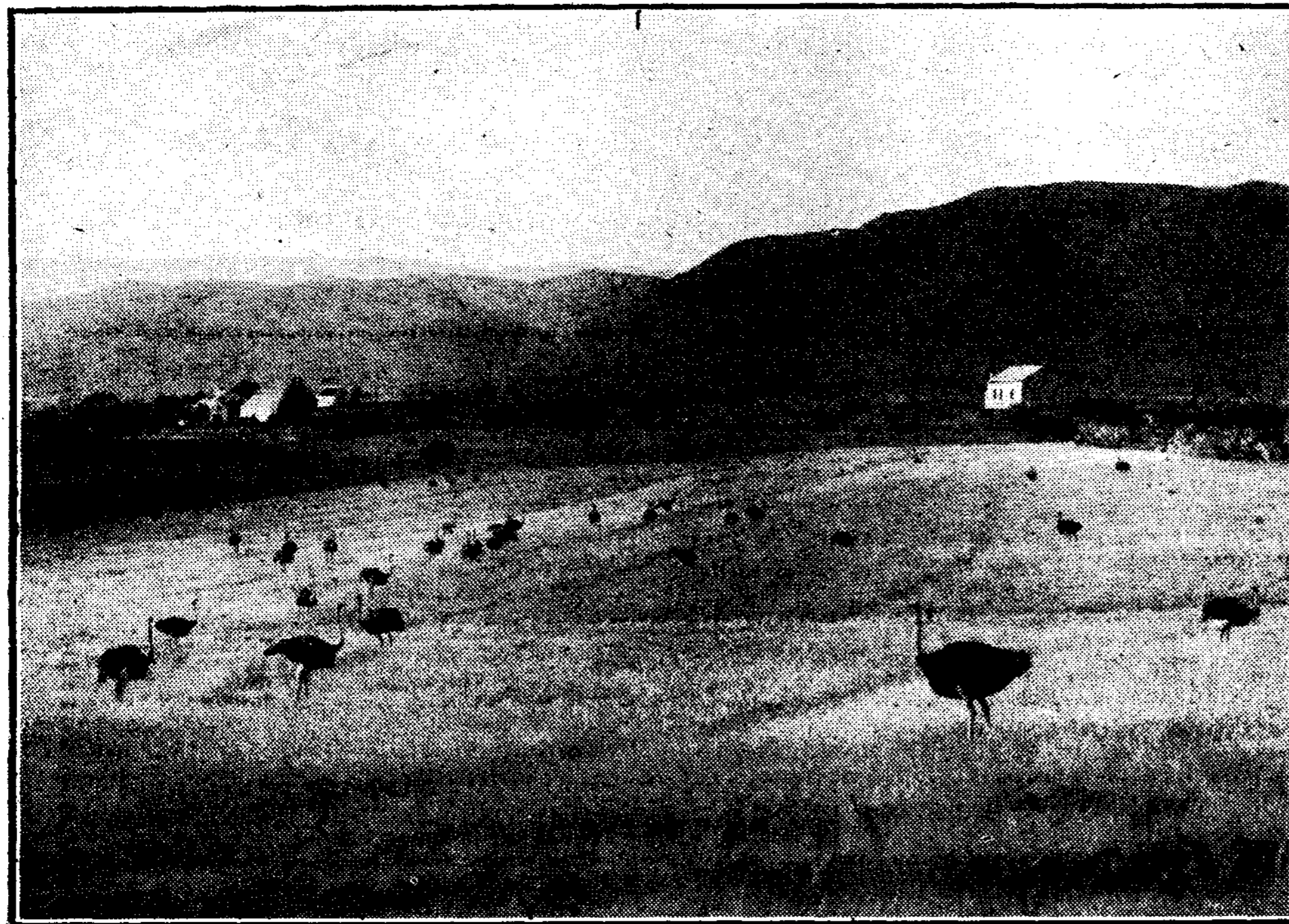

[By courtesy of the High Commissioner for South Africa.

Oudtshoorn: an Ostrich Farm

Letters to the Editor

"Ich Besuche England"

To the Editor of WORLD-RADIO

SIR,—The above article must have interested a vast number of readers. To see ourselves as others see us holds a most peculiar attraction for the average person, and when the observer has taken the trouble, as in the present case, to discover some of our good points, towards which a blind eye is so often turned, then the reading of such an article proves all the more interesting. We are so often reminded of our faults and failings that it is extremely gratifying to find that our virtues are also recognised.

More important still, this type of article does an enormous amount of good and helps greatly in the promotion of friendly and peaceful relationship between the peoples of the world.

Yours truly,

ERIC H. RUSSELL.

The Willows, Hale, Cheshire.

Nov. 21, 1931.

A Woman Explores the Short Waves

THE sound of music played by an orchestra in the terrace restaurant of a well-known New York hotel is filling the room at the moment of writing. My receiving set, situated in a London suburb, is tuned to W2XAD, and the magic of short-wave wireless has wafted me (in imagination, at least) across three thousand miles of sea to the land of skyscrapers, where an announcer has just informed me that this programme is coming to me by way of radio stations WGY or W2XAD of the General Electric in Schenectady, which are relaying the music from New York City.

The idea that long-distance wireless reception is a monopoly of menfolk has already been dispelled by various women listeners who have described their experiences of "searching" and foreign listening in the columns of *World-Radio* from time to time. Most of these feminine wireless enthusiasts, however, seem to have confined their attention to the ordinary broadcast wavelengths, and not attempted the reception of stations on the short waves below 100 metres.

A glance through the list of short-wave stations in a recent issue of *World-Radio* fired me with an ambition to explore these "wavelets"—though I must admit that the formidable and awe-inspiring names of stations such as Tegucigalpa, Chapultepec, Khabarovsk, etc., made me wonder whether, having adventured so far afield, I should ever find my way back again to the friendly circle of the B.B.C. stations, with their familiar Greenwich pips and Fat Stock prices!

However, I adapted my set for the short waves, and embarked on the adventure. I met with some success, as soon as I had mastered the art of balancing the receiving circuit on the crests of sharply-tuned carrier-waves. (Possibly carrier-waves do not have crests—but no matter: I do not pretend to be technically-minded.)

At first it was difficult to get farther afield than Europe, but I enjoyed hearing the rich contralto voice of the announcer at Rome, with her "Radio Roma-Napoli!" which came by way of the short-wave relay of the Rome programme. Then the *Kurzwellensender* at Zeesen entertained me with excellent music that came in very well at times.

Among other European stations I heard Pontoise; the Danish transmitter at Skamlebak; and last, but not least, the famous Dutch station PCJ at Eindhoven, with its cheerful,

friendly announcements. I found one thing about the PCJ transmission both puzzling and intriguing. After the final announcement at the end of the programme, the announcer exclaimed in a sonorous voice "Hullo transmitter, attention! One, two, three, stop!" Why this method of closing down was adopted by this station is a mystery, at least to me; perhaps some other listener can explain it.

After receiving the European stations I set out to discover America. The results of my efforts in this direction I have already described.

I had always longed to hear Australia. I tried for Sydney and Melbourne, but failed to get either at their scheduled times. I succeeded, however, in hearing a station nearly as far away as Australia. This was PLE, Bandoeng, Java, in the Dutch East Indies. I listened to some gramophone records and afterwards to some talking in Dutch, first by a man and then by a woman speaker, which alas! was *double* Dutch to me! At the end of the transmission, before the Dutch National Anthem, with its elusive and pleasing strains, brought the programme to a close, the announcer spoke in very good English. "This," he said, "is the studio of the Bandoeng Radio Club transmitting by short waves through the station PLE at Bandoeng in the Dutch East Indies." He then went on to say that they would welcome reports from listeners, announced the time at which their next transmission would take place, and ended with a cheerful "Good night everybody in the world. Good night!"

V. E. O.

Arctic Nights

And the Famous Royal "Mounties"

A CANADIAN correspondent writes that even now, in England's delightful autumn, the snows are deep and the blizzards frequent in the far-away posts of the Canadian Arctic. Fur traders, missionaries, and police feel the isolation that even airplanes have not yet tapped. Beyond the air routes of the Northlands for hundreds of miles stretch outposts of civilisation, where willing hands tune in radio stations from all parts of the world.

"Up in the northern reaches of Ellesmereland, where the farthest north police post of the world is situated, the 'Mounties' (a detachment of whom, it will be remembered by Londoners, was unable last year to find the Mansion House, and so missed an appointment with the Lord Mayor) tune in the broadcasts which bring personal messages from the stations of Canada and the United States. England, Germany, Australia, and Japan also reach there with good volume most of the winter. There, at the top of the world, careful fingering of a radio dial brings the news from all the world to the eager and enchanted listeners.

"The police post at Bache Peninsula is but one point in the Canadian Arctic where the closest possible reception awaits broadcasts. There are many such posts on Devon Island, Baffinland, along the Hudson Straits, along the Arctic shore of the North-west Territories, and on those islands to the north of the mainland where the isolated fur trader or missionary may be spending the winter.

Even the Eskimo Loves to Listen

"Radio reception is good in the north, despite the Northern Lights. Up there, where the Aurora Borealis in all its brilliant colours is a nightly affair, the stations from many parts of the world penetrate, as witness the diaries kept by the inhabitants of those regions. In these are listed the main stations of the North American continent.

"Not only the cities in Canada, but Cali-

fornia and the Southern States are receivable by the Arctic dwellers. Even the phlegmatic Eskimo knows the strains of dance orchestras originating in various parts of the Continent.

"An English listener who likes his programmes from points as distant as possible should spend the winter in one of the posts of the Arctic. Here is what one police post along the Arctic shore reports: American stations 169, Canadian stations 33, and foreign stations 16; all in one winter. Reception varied from JOAK, Japan, to Madrid.

British Broadcasts Picked Up

"Another Arctic police post has this nice line-up of stations received, the logs having been sent to the Radio Department at Ottawa to show what reception is like in the farthest reaches of Canada's north: American 70, Canadian 8, English 1, German 4, and one Japanese. Still another post pulls in signals from Mexico to Alaska and Honolulu with regularity.

"These lists are surely enough to arouse the jealousies of a radio fan with an eye to reception from great distances. The trans-Atlantic connexions of the past year came direct from their sources to the loud speakers of the Arctic. Every important broadcast in the British Isles is usually picked up direct in the Arctic.

"And not only is the variety in the Arctic great, but the service accorded through certain broadcasting stations in the United States and Canada affords at least a personal touch for these Arctic white pioneers and police who have their old homes far to the south. At regular intervals—and the schedules go into the Arctic with the annual summer supply ships—messages from friends and relatives wing their way in to these people. Word comes to them of news back home, and of doings in other parts of the Arctic nearer to civilisation, or which happen to be equipped with a transmitting station."

Wanted—an Address

LISTENERS to the London Children's Hour this afternoon, Friday, November 27, will hear an interesting little story combined with the request for the address of a small correspondent. The circumstances are these. The French General, Maréchal Lyautey, who was recently in England, received from a little girl, Miss Mary Ross, a letter by which he was much touched. Unfortunately, the writer did not give an address, and Maréchal Lyautey has been unable, as he would have wished, to send the writer a reply. The letter in question, which is written in French, is as follows:—

"Cher M. le Maréchal,

"Je suis une petite fille anglaise malade en hospital et on ne me permettra pas de sortir de vous voir. Mais j'ai appris un peu de français et je vous prie d'accepter l'hommage d'une anglaise et de vous remercier parceque mes parents disent que vous avez bien aidé de sauver notre pays. Les anglais aiment beaucoup extrêmement les français. Ne croyez pas les méchants qui disent des mensonges dans les journaux. Quand je suis plus âgée (j'ai 13 ans) j'espère visiter la France. Je connais l'histoire de Jeanne d'Arc et je l'admire mieux que tout autre personne. Cher Monsieur—c'est un grand désappointement de ne pas vous voir. J'espère que vous recevrez cette lettre. S'il vous plaît dites à vos compatriotes que nous aimons la France. Toujours je fais ma prière 'God bless France.' Vous comprenez ça? Voici ma fleur pour un soldat tombé en France.

"Toujours, avec grand respect,

"MARY ROSS."

We hope that as a result of the broadcast Miss Mary Ross will send her address to the B.B.C., and that, in consequence, she will, as we do not doubt, receive a reply from Maréchal Lyautey himself.

DOMINION AND FOREIGN INTELLIGENCE
(Continued from page 872)

lecture on this occasion. Professor Ostwald will no doubt do so with particular pride as this year two German chemists, Karl Bosch and Friedrich Bergius, have been granted the prize for Chemistry, and Professor Warburg, of Berlin, has carried off the prize for Medicine.

Free Licences for German Unemployed
(From our Berlin Correspondent)

Germany's unemployed who have been out of work so long that their insurance benefit is exhausted, and they themselves relegated to those dependent on the municipality for support, have been granted the privilege of listening to broadcasting without paying their sixpence a week for the licence. War pensioners or those unfortunate people whose local ratepayers could not support them were, however, obliged to pay. This hardship has now been remedied. Everybody whose financial position is on a par with that of the "emergency" and "welfare" recipients is to be relieved from paying. This, however, applies to German nationals only, Germany is full of indigent foreigners of all kinds trying to pick up a living, and these have been among the most enthusiastic listeners, and are now complaining.

Discontinuance of Midday Time Signal

The midday time signal ending at one o'clock, which was broadcast by all German stations, is to be continued in future by the Deutsche Welle, (Königs Wusterhausen), only, in future. Even then from 12.58 to 1 p.m. is considered sufficient, instead of the ten minutes as hitherto.

ITALY

Rome S.W. Station Changes Wavelength
(From our Turin Correspondent).

The short-wave station of Prato Smeraldo

(2RO) has just changed its wavelength, and now works on 80 metres (3,750 kc/s) with a power of 14 kW. The station of Prato Smeraldo is adapted for using two different wavelengths, one (80 m.), for a range up to distances of about 500 miles, and the other for greater distances. There is no special reason for this change of wavelength unless it is the desire to offer to the nearer foreign short-wave listeners the possibility of being able to receive the Rome programmes.

U.S.A.

Honours for Broadcasting
(From our New York Correspondent)

Leopold Stokowski, the famous conductor of the Philadelphia Orchestra, was on November 2, presented by Mr. William S. Paley, President of the Columbia Broadcasting System, with a medal in recognition of his services to broadcasting. Similar medals have already been awarded to Sir John Reith and Colonel Lindbergh. M. Stokowski receives the medal for the work he has done in developing the broadcasting technique of the symphony orchestra.

Harvard-Oxford Trans-Atlantic Debate

A debate between the Universities of Oxford and Harvard, to take place over the trans-Atlantic short-wave telephone service, has been arranged for December 8, from 11 p.m. to midnight. The subject of debate is to be "Debt Cancellation," and the three speakers on the Oxford side will be Mr. E. D. O'Brien, President of the Oxford Union; Mr. A. H. Irvine, Treasurer; and Mr. Brian Davidson, President of Oxford University Conservative Club.

On this side the B.B.C. is co-operating by providing studio and microphone facilities, and the American broadcast is being arranged by the N.B.C. The debate will not be broadcast

by the B.B.C., and the three British speakers will listen to the American side of the debate by means of headphones.

BROADCASTING AND LANGUAGES

(Continued from page 874)

addressed is ; words much used in correspondence).

Son famoso, poi, le parole da lui usate nel suo testamento : "... ordino al detto Don Diego (cioè il suo primogenito) . . . che procuri e lavori sempre per l'onore, il bene e l'accrescimento della città di Genova, e ponga tutte le sue forze e i suoi beni per difendere e aumentare il bene e l'onore di quella Repubblica."

Pure, non fu il figlio Diego quello che maggiormente onorò il nome dello Scopritore : ma bensì Fernando, suo figlio naturale. A lui dobbiamo il famoso racconto dei quattro viaggi del padre. Fernando lo accompagnò lui stesso nel quarto viaggio, e, benchè giovanissimo seppe aiutarlo e confortarlo nei momenti più difficili.

S. BREGLIA.

Esperanto Transmissions. Nov. 29—Dec. 5.

- Sunday.—Langenberg, 7.30 a.m., Course (W. Wingen).
Lille, 8.30 a.m., News (A. Trotin).
Vienna, etc., 3.30 p.m., "The secrets of the valley of death" (J. Scherer).
Kharkov, 8.30 p.m., Course.
Leningrad, 9.5 p.m., News.
 - Tuesday.—Tallinn, 7 p.m., News (Tartu-Dorpat).
 - Wednesday.—Leningrad, 9.5 p.m., News.
 - Thursday.—Vienna, 3.45 p.m., Austrian News (W. Smital).
Paris, P.T.T., 5.45 p.m., Course (Prof. Rousseau).
Radio Suisse-Romande, 6.20 p.m., Course (P. Bouvier).
Kaunas, 8 p.m., News.
 - Friday.—Stuttgart, 6.30 p.m., Week's programme (Prof. Cristaller).
Breslau, 9.45 p.m., 10 minutes Esperanto for Workers.
 - Saturday.—Heilsberg, 5.40 p.m., Week's Programme.
Huizen, 6.20 p.m., Course (P. Heilker).
Lyon-la-Doua, 8.15 p.m., News (M. Borel).
Leningrad, 9.5 p.m., News.
- NOTE.—After January 1 Esperanto course from Hilversum (1,875 m.) every Sunday, 8.10 a.m. (Jac. Lem.).

Your Gift



CLIX CONSTRUCTORS KIT
7 WIRE TERMINALS
7 SPARE TERMINALS
2 PLUGS
2 SOCKETS
2 WINDER PLUGS
ALL ENGRAVED

3/-

A useful and economical gift,
CLIX CONSTRUCTOR'S KIT
Contains an assortment of nineteen fittings specially selected for Home Constructed receivers.
3/5 VALUE FOR 3/-
See list of contents on lid.
From all dealers or direct. Folder 'W' Free.

Cheapest PERFECT Contact

Lectro Linx, Ltd., 254, Vauxhall Bridge Road, S.W.1

Subscription form for WORLD-RADIO

TO THE BRITISH BROADCASTING CORPORATION, SAVOY HILL, LONDON, W.C.2
Please enter my name as a subscriber for.....copies
of WORLD-RADIO for a period of.....months beginning
.....I enclose P.O. No.....or cheque value.....
in payment at the following rates :

TWELVE MONTHS:	(British Isles) 13s. od.	(Canada) 13s. od.	(Elsewhere) 14s. od.	
SIX MONTHS:	6s. 6d.	6s. 6d.	7s. od.	
THREE MONTHS:	3s. 3d.	3s. 3d.	3s. 6d.	

NAME

ADDRESS

COUNTRY DATE

PLEASE WRITE IN BLOCK CAPITALS

A specimen copy will be sent, on application, to the address of a friend. Additional names and addresses may be written on a separate sheet of paper, but payment of additional subscriptions must be sent with orders.

Via Ether

Empire Broadcasting

THE announcement, about a fortnight ago, that the B.B.C. intended to proceed immediately with plans for the erection of a new short-wave station to be used for broadcasting to the Empire must have been received by most people with great interest and by many with enthusiasm. Indeed, the comments of the Press which I have read confirm this opinion. Short-wave listening has been growing in favour very rapidly during the last few years, and I can imagine nothing which is calculated to foster this healthy practice among listeners in our Dominions and Colonies than the news which has recently been published. It must be remembered that, while the Dominions have their own broadcasting stations and their own programmes adapted to local tastes, the Colonies, for the most part, possess no such local transmitters and are dependent for their broadcasting fare upon distant stations. The attraction, therefore, of being able to rely upon a transmission which will bring them programmes direct from the Home Country is undeniable. I hope that many of them will have the opportunity of seeing this Special Empire Broadcasting and Short-Wave Number of *World-Radio*, and that they will feel that their interests are to be well served.

* * *

Vienna to Relay New York

IN the course of their European tour last year Toscanini and the New York Philharmonic Orchestra gave two concerts in Vienna, and the impression they made is not one which the musical world there can have forgotten in less than eighteen months. And when, on SUNDAY, Vienna, as well as several other European stations, relays from New York the New York Philharmonic Orchestra, conducted by Toscanini, the relay is sure to be followed with the keenest interest. Vienna has not had many chances of hearing for itself how great a conductor Toscanini is, the greatest of all conductors of our time, as many judges are assured. Gifted with an amazing memory, so that he can grasp and keep in mind the most complex score after reading it once; gifted, too, with that elusive quality of leadership which wins, rather than demands, implicit and even enthusiastic following, he was clearly destined to achieve a position of command. America has claimed a lion's share of his labours since 1886. When accident thrust him on to the conductor's desk of the Rio de Janeiro Opera in 1886 he was a 'cellist in the orchestra, and the swift, unexpected promotion found him ready to win an overwhelming success. From 1898 till he resigned in 1915, he was chief conductor of the Metropolitan Opera, New York, raising the performances there to a level which the old world has hardly ever reached. But he has found time, too, to do a great deal for opera in his native Italy; there, his word is law, and his wisdom unchallenged, and he is a hero to his own people as to his great following in the States. His orchestra in New York is one of the very best the world has ever had—worthy of its conductor.

The Programme

HIS programme is an international one, well designed to show how intimately he knows the spirits of the great masters of every race and school. Brahms's noble variations on a theme of Haydn are full of the master's strong, cheerful sanity, set forth with wonderful variety and resource, and with a shapeliness of design which of itself is a joy to all Brahms lovers. The theme, dignified in its straightforward simplicity, is from a little piece by Haydn which he called *Chorale St. Antonii*; nine variations follow, and the work is rounded off by a repetition of the breadth and bigness of Haydn's theme. The *Meditation* of César Franck's is, within its shorter compass, not less noble music. A symphonic interlude in *Redemption*, the second of his oratorios, it depicts the joy of a world which has been transformed by the coming of the Saviour—a message which Franck's own simple faith knew well how to enshrine in music of poetic eloquence. The symphonic poem by the conductor's fellow-countryman, Respighi, is one of three, dealing with different aspects of his native city of Rome—its fountains, its pines, its church windows: they have earned for him, from flippant people, the title of the Musical Baedeker to Rome. *The Pines* is likely to go down in history as the first serious concert piece which includes a gramophone as one of the orchestral instruments: it is used in the third of the four movements to let the voice of the nightingale sound in the moonlight. In the first movement children play among the trees, and the second takes us to the shadow of the Catacombs. The third is night on the Janiculum, and in the fourth, memories of older Rome wake amid the morning mists.

* * *

Curative Effect of Listening

ABOUT a fortnight ago an attack of influenza compelled me to take a short rest. The curative effects of music were never brought home to me more than during that period. I listened to a number of transmissions, and the effect produced by the hearing of a performance of *Don Pasquale* was perfectly amazing. On November 16, after being at home three days, and feeling somewhat shaky, I tuned in Heilsberg for the relay of this opera from the Danzig Opera House. Atmospheric conditions and technical arrangements were ideal. For two and a half hours I listened to this delightful music, so full of rollicking humour, sung by artists with fine voices and an enunciation that enabled me to follow almost every word. A wonderful tonic! At 7 p.m. on the following day I tuned in Schweizerischer Landessender, a station that is always extremely well heard. The occasion was the relay from Berne of a symphony concert conducted by Dr. Fritz Brun. The concert opened with Beethoven's Second Symphony. A fine orchestra gave a splendid rendering of this work, the second movement standing out particularly by reason of its melodious score. This was followed by Mozart's beautiful Concerto for Flute and Orchestra, the soloist being the famous French flautist, René Le Roy.

Il Trovatore from Prague

ON Thursday, November 19, I began the evening's listening by tuning in Prague to hear an Act from Verdi's *Il Trovatore*, relayed from the National Opera House. It is strange to hear Verdi in Czech. By way of reciprocity the symphony concert transmitted from Rome at 8 p.m. that evening began with the orchestra's playing of Dvorák's Fifth Symphony ("New World"). To my last week's remarks on Dvorák's Fourth Symphony I would only add that the Fifth, too, is a striking work. The second movement is particularly beautiful, and expresses the exile's longing for his homeland in a manner which I think is unequalled in musical literature. The second half of this concert concluded with a concert version of the second act of Massenet's *Manon*. I could not catch the tenor's name, but he is the possessor of a lyrical voice of great beauty and uses it well. Prague, by the way, appears to have been a week in advance in its announcement for last Sunday of the relay from New York of that city's Philharmonic Orchestra, which a number of stations, including Prague, are to broadcast on SUNDAY next, November 29. On the same evening (the 19th) I picked up a very fine performance of *Faust*, which was being relayed by San Sebastian. This station must have been working on a higher power than its advertised 0.6 kW., though, of course, I received it at 11 p.m., after most of the other stations on this common wave had ended their programmes. The performance concluded a little before midnight, and before closing down, the announcer, using several languages, including English, asked his listeners who had heard the station to report in writing.

* * *

Jewish Melodies

À PROPOS of a Jewish concert transmitted from Hilversum a week or two ago, under the conductorship of Ober-Cantor Engländer, of Hanover, a correspondent tells me that he regarded it as a great success. "It may not be inappropriate," he says, "to mention that our beloved Queen Victoria had a great partiality for Jewish sacred music, and I believe that her favourite cantata—if that term be applicable—was a certain *Kadosh* (Prayer for the Dead) which is peculiar to the New Year and the Day of Atonement. The period to which some of the compositions belong is controversial, and even the Babylonish Exile is, occasionally, put under contribution, though I cannot call to mind any great authority who has identified himself with the probability of such a remote date. Certain it is that a good few airs are of great age. Many, on the other hand, are, relatively speaking, quite modern and owe their arrangement at any rate to the famous Viennese Cantor, Singer. Another favourite among the old Jewish hymns is the 'Kol Nidrei,' which opens the proceedings of the Day of Atonement. Here there is internal evidence that the text of the Prayer is of the time of the Babylonish Captivity, with a strong probability that the tune, which, by the way, was arranged by Cantor Sulzer about 1830, also goes back to a remote period."

ETHERVIATOR

Dominion and Foreign Broadcasting Intelligence

Byrd Expedition and Broadcasting

Two Points of View

(From our Montreal Correspondent)

Captain A. Innis-Taylor, Canadian member of Rear-Admiral Byrd's last two-year expedition to the South Pole, is in Montreal, making arrangements for the next Antarctic expedition, which will set out in 1932. Speaking of the last expedition, he said that "Radio made the great difference." It kept up the morale to have letters broadcast from their relations, and sometimes even to hear them speaking. He expressed the opinion that "Wireless was the greatest thing in equipment, so far as the men were concerned."

On the other hand, Mr. G. A. Thorne, chief topographer of the previous expedition, expressed views very much to the contrary. "Far from finding radio a pleasant companion, the company hated it," he said. The expedition was made a sort of target for an endless number of publicity-seekers, who were captivated by the idea of sending their voices to the ends of the earth. He was told that the next expedition might have television: "I do not care what they are going to have," was his answer, "I would sooner have a few books." He concluded the interview by stating that reception in the Antarctic had been sometimes good, sometimes bad, with lots of static.

Census of Radio Receivers in U.S.A.

41 per Cent. of Population Listeners

(From our Washington Correspondent)

The National Census taken in 1930 made provision on the official form for a census of wireless sets in the United States as well as the total approximate number of listeners based on the size of the family. The Census Bureau has just released the official figures for forty-five States and the District of Columbia. Returns for Illinois, New York, and Pennsylvania are not yet available, but it is possible to estimate very closely the figures for these densely-populated States on the basis of data from surrounding States. It is estimated that these three States have more than one-fourth of the radio sets in the country and about one-third of probable listeners.

The final official figures will show that there were, in 1930, upwards of 12,500,000 sets in the country, with approximately 50,000,000 listeners. This latter figure represents 41 per cent. of the total population.

The following tables gives the total of radio sets by States, and the number of listeners on the basis of the Bureau of Census estimates as to average family sizes, varying according to States:—

STATE.	RADIO SETS.	LISTENERS (Estimated).
Alabama	56,491	254,210
Arizona	19,295	79,110
Arkansas	40,248	169,942
California	839,846	2,939,461
Colorado	101,376	495,366
Connecticut	213,821	876,666
Delaware	27,183	108,732
Dist. of Columbia	67,880	264,732
Florida	58,446	227,939
Georgia	64,908	292,086
Idaho	32,869	134,763
Illinois	1,144,597	4,573,388
Indiana	351,540	1,335,852
Iowa	309,237	906,204
Kansas	189,527	739,155
Kentucky	111,452	480,244
Louisiana	54,364	233,765
Maine	77,803	311,212
Maryland	156,465	657,153
Massachusetts	590,105	2,478,441
Michigan	599,196	2,456,704
Minnesota	287,880	1,208,096
Mississippi	25,475	109,543
Missouri	352,252	1,373,783
Montana	43,809	170,849
Nebraska	164,324	657,296
Nevada	7,869	27,452
New Hampshire	53,111	207,133
New Jersey	625,639	2,565,120

STATE	RADIO SETS	LISTENERS (Estimated)
New Mexico	11,404	49,937
New York	1,886,208	7,544,832
North Carolina	72,329	354,412
North Dakota	59,352	278,954
Ohio	816,767	3,161,991
Oklahoma	121,973	512,287
Oregon	116,299	418,676
Pennsylvania	1,444,704	5,778,816
Rhode Island	94,594	397,295
South Carolina	28,007	134,433
South Dakota	71,361	306,952
Tennessee	86,229	374,907
Texas	257,686	1,082,281
Utah	47,729	210,008
Vermont	39,913	159,652
Virginia	96,569	44,217
Washington	180,229	666,847
West Virginia	87,469	402,357
Wisconsin	364,425	1,494,143
Wyoming	19,482	75,980
United States	12,563,737	50,186,494

615 Licensed Stations

When the Federal Radio Commission was created in 1927 there were 733 broadcasting stations operating daily in the United States. The Commission at once undertook to clear up the chaotic conditions then existing by various arrangements. Time-sharing plans were put into effect and inefficient stations steadily eliminated, so that to-day there are 615 stations licensed in the entire country. Efforts are being made to reduce still further the congestion in the ether, and it is inevitable that a number of stations in the vicinity of the largest cities such as New York and Chicago will have to be weeded out in the coming months.

Many stations are now drastically restricted as to the hours of operation, especially at night, so that the total time "on the air" in the evening is equivalent to that of 450 stations broadcasting full time.

On June 22, 1932, a general order will take effect which is expected to minimise interference. All stations operating between 550 and 1,500 kilocycles will be required to keep a very careful check on their assigned frequency. Failure to do so will be a violation of a Commission regulation and will be subject to penalty.

If this new order does not prove effective in eliminating interference in congested areas, a further reduction of stations will be necessary. "This reduction will be felt in crowded zones in large cities," said Commissioner Lafount, "and, as conditions are now, seems inevitable in the progress toward an ideal broadcasting situation."

AUSTRALIA

(From our Australian Correspondent)

Broadcasting for Schools

Sporadic attempts have been made to introduce regular broadcasts into the State schools, but although the movement seemed to be taking root, the sessions had to be abandoned before they became definitely established. The best results have been obtained in the State of Victoria, and the syllabus of talks for the months of September to December is much more comprehensive than hitherto. One school has applied for fifty copies of the syllabus. There is a committee on educational broadcasting comprising representative teachers and others engaged in education in association with the Australian Broadcasting Company which supplies the talks through station 3AR Melbourne. They regard the school broadcasts still as experimental and the co-operation of teachers is being sought so that conclusions may be drawn as to the scope and methods that should be adopted.

CANADA

Increase in Sale of Receivers

(From our Montreal Correspondent)

It is reported that the sale of radio sets in the province of Quebec has already established a record, inasmuch as 103,265 sets have been

distributed during the past half-year as compared with 96,990 for the whole of the previous twelve months. Does this mean that many who have to economise in more expensive forms of entertainment are taking up wireless as an alternative?

SOUTH AFRICA

Bloemfontein's First Relay

(From a Correspondent)

On August 23 the first broadcast relay was made from the new relay station on Naval Hill, Bloemfontein, as the first test of the complete plant. The programme was relayed from Johannesburg station, and lasted from 3 p.m. to 5.15 p.m. This relay was made on a wavelength of 510 metres, but engineers have not yet decided whether this is the ideal wavelength for Bloemfontein relays of Johannesburg programmes. When testing has been carried on for several days more it will be possible to say when the regular service will be inaugurated.

AUSTRIA

(From our Vienna Correspondent)

Lectures for Schools

It has been decided to start at the beginning of the New Year the broadcasting of instructional lectures, specially intended for schools, which will each have their loud speakers. The Austrian Minister of Education, Dr. Czermak, making the announcement in Parliament, said that he had decided to grant permission for Ravag to do this for six months experimentally, but he considered that such broadcast education must be supplementary to the direct instruction by teachers.

Mozart Anniversary Programme

In celebration of the 140th anniversary of the death of Mozart, his opera *Titus* will be given in the Ravag studio at 7.15 p.m. on Saturday, December 5.

FRANCE

(From our Paris Correspondent)

Radio-Paris

Conflicting opinions are being expressed with regard to the efficacy of the St.-Rémy-l'Honoré station. Many of the complaints are that the new station is not heard more strongly than the old one. Some even state that the new station is more feeble than the old. The writer has noticed occasional inexplicable halts in the programme, but at the same time has found an increase in power, quality, and selectivity, at a spot outside the wipe-out area of the old station. On the other hand, Radio-Paris explains that up to the present it has not been possible to utilise the full power, nor to reach the full extent of the purity that will be ultimately reached. The first few weeks will be more in the nature of trial weeks, and the final stage will be reached gradually. Nevertheless the area of both strong reception and medium reception has been very considerably increased, and it is only in the "wipe-out" area of the old station that reception is weaker. Meanwhile Radio-Paris has made arrangements with the Opéra-Comique for the broadcasting of ten performances during the present season.

GERMANY

Nobel Prize Anniversary

(From our Leipzig Correspondent)

December 10 next is the thirtieth anniversary of the first distribution of Nobel prizes. The Central German Broadcasting Company has arranged for Professor Wilhelm Ostwald, of Leipzig University, who was awarded the Nobel prize for Chemistry in 1909, to give a

(Continued on page 870)

Broadcasting and Languages

FRENCH

(Supplementary Notes in connexion with the French Talk, Tuesday, November 24)
De l'élision de l'e muet (suite)

(A).—Nous avons déjà vu que dans certains cas l'e muet ne se prononce jamais dans le style rapide de la conversation, et que dans d'autres cas, au contraire, il se prononce toujours; et nous avons étudié les règles, ou plutôt les tendances générales, qui expliquent l'élision ou le maintien de l'e muet dans ces cas.

Il nous reste maintenant à étudier des cas plus difficiles encore. Nous avons en français certains mots, qui tantôt demandent l'élision l'e muet, et tantôt exigent son maintien. Ces mots, qui se prononcent de deux façons différentes, avec ou sans l'e muet, se répartissent en trois classes:

(a) Tous les mots qui ont à la première syllabe un e muet précédé d'un seul son-consonne: Ex. *demain, demander, petit, cheval, semaine*, etc. . . .

(b) Tous les monosyllabes contenant un e muet: Ex. *le, me, ne, que, de, se, ce, je, te*.

(c) Tous les mots qui se terminent par une consonne + le, ou une consonne + re: Ex. *simple, table, oncle, article, fenêtre, attendre, encre, chambre*, etc.

(B).—Règles générales expliquant l'élision et le maintien de l'e muet dans les mots de la première classe:

(1) Les mots du type de *petit, semaine*, etc. . . . perdent l'e muet de la première syllabe, quand le mot qui les précède dans le même groupe, se termine par un son-voyelle: Ex. *nous d(e)-mandons, deux ch(e)vau(x), la c(e)rise, trois s(e)maines*, etc. . . .

(2) Au contraire l'e muet se maintient (a) quand un mot de ce type commence un groupe, et aussi (b) quand le mot qui précède dans le même groupe se termine par un son-consonne: Ex (a) *demandez-le, demain matin, redites-moi, petit à p(e)tit*. (b) *une petite fille, elle demande, cette semaine, la belle cheminée*, etc. . . .

(C).—Règles générales expliquant l'élision et le maintien de l'e muet dans les mots de la deuxième classe.

(1) Les monosyllabes *le, me, ne, que*, etc. . . . perdent l'e muet quand le mot qui suit commence par un son-voyelle: Ex. *l'homme, j'aurai, qu'il vienne, s'il arrive, c'est lui, m'a-t-il vu?*

Rappelons-nous, toutefois, qu'il y a quelques rares exceptions à cette règle: *le onze, le un, le ouistiti, le uhlan, le huit*, etc. . . .

(2) Ces monosyllabes perdent l'e muet quand le mot qui précède, dans le même groupe, se termine par un son-voyelle: Ex. *quand j(e) vous dis, nous n(e) savons pas, vous l(e) faites, allez-y c(e) matin*, etc. . . .

(3) En général, il faut maintenir l'e muet dans les monosyllabes *le, me, ne*, etc. . . . (a) quand un de ces mots commence un groupe, et aussi (b) quand le mot qui précède, dans le même groupe, se termine par un son-consonne: Ex.

(a) *le voulez-vous? me comprend-il? ne bougez pas, je n'en sais rien, se souvient-elle?* etc.

(b) *il me parle, elle ne travaille pas, elle mange de bon appétit, Paul se lève*, etc. . . .

(D).—Règles générales expliquant l'élision et le maintien de l'e muet dans les mots de la troisième classe.

(1) Les mots du type de *simple, table, fenêtre, chambre*, etc. . . . perdent l'e muet (a) quand ils sont en position finale dans un groupe (c'est-à-dire suivis d'un arrêt), et aussi (b) quand le mot suivant, dans le même groupe, commence par un son-voyelle:

(a) *c'est possibl(e) mon oncl(e), ouvrez la fenêtr(e)*, etc. . . .

(b) *une chambr(e) à coucher, quatr(e) enfants*.

(Continued on page 874)



BARCELONA
—is saying "Goodnight"

Do you understand?

DON'T you wish you could understand what the announcers say when you pick up the "foreigners"? Why not master the language these foreign announcers speak and double your enjoyment of radio? By means of Linguaphone Language Records you can pick up Spanish or any language in a remarkably short time.

BARCELONA
(Radio-Catalana)
Medium Wave. 268 metres. Power 10 kW. Call Sign "Aquí estación EAJ 13 Unión Radio Catalana!"

It's so easy to pick up Languages by LINGUAPHONE

The Linguaphone method is the one short cut to learning languages. Linguaphone is a carefully graduated course of tuition spoken by the most eminent native linguists. As you listen to these records and follow the talks in the simple illustrated handbooks you find yourself speaking the language with a perfect accent because you have never heard a word wrongly pronounced. Even if you don't know a word of any foreign tongue you pass from one record to another so smoothly and your interest is so skilfully held that the short time it takes to speak fluently will astonish you.

COURSES IN
French
German
Spanish
Italian
Russian
Polish
Dutch
Swedish
Irish
English
Afrikaans
Esperanto
Persian
Chinese

Literary Courses and Travel Talks for Advanced Students.

TEST LINGUAPHONE FREE.

Linguaphone Language Records can be used on any Gramophone—why not try them free on yours? Post the coupon below and you will receive a 28-page FREE book which explains the Linguaphone method in detail and tells you how you can have the complete course on trial in your own home for a week free.

The Coming Boom in Export Trade
Follow H.R.H. The Prince's lead:
learn to speak foreign languages.

The Prince of Wales emphasised the importance of learning the languages of our customers. He said: "Where you are trying to sell something, try to learn the language as well. You will sell the thing better in the people's own language."
Learn languages by the quickest and easiest possible method—the Linguaphone Method.

The LINGUAPHONE LANGUAGE INSTITUTE

(LINGUAPHONE LTD.)

Post this Coupon To-day!

or if in London call for a personal demonstration at our Head Office, 24-27, High Holborn, W.C.1, or at 30, Victoria St., S.W. 1. or 90, Gracechurch St., E.C.3.

To THE LINGUAPHONE INSTITUTE, 444, Napier House, 24-27, High Holborn, LONDON, W.C.1

Please send me Free and Post Free your 28-Page Book about the quick, new and easy Linguaphone Method of learning languages.

I am interested in the Language.
My aim is (state here "Commerce," "Travel," "Science," "Exams," or other special aim).

Name Address

BROADCASTING AND LANGUAGES

(Continued from page 873)

le peupl(e) anglais, une tabl(e) en marbr(e), etc.

(2) Mais il faut maintenir l'*e muet* dans les mots de ce type lorsque, dans le même groupe, le mot suivant commence par un *son-consonne*: Ex. *une table de bois, l'oncle François, le peuple danois, de l'encre rouge, la chambre bleue, etc.* . . .

(E).—Quelqu'un m'écrit, me priant de lui expliquer pourquoi on écrit: *elle s'est laissé tromper* (*laissé* ne s'accorde pas), mais *elle s'est laissée mourir* (ici le participe passé s'accorde).

Le participe passé *laissé* suivi d'un infinitif rentre dans la règle générale du participe passé suivi d'un infinitif, malgré ce qu'en disent certains grammairiens qui lui consacrent un chapitre spécial comme s'il était soumis à une règle particulière.

Le participe passé d'un verbe transitif suivi d'un infinitif est tantôt variable, tantôt invariable:

(1) Il est variable lorsqu'il a pour complément direct le pronom qui le précède:

La dame que j'ai entendue chanter a une belle voix. Entendue s'accorde avec son complément direct *que*, mis pour *dame* dont il est précédé.

Je reconnais que le participe passé a pour complément direct le pronom qui le précède parce que je peux placer entre le participe et l'infinitif le nom que ce pronom remplace: *J'ai entendu la dame chanter*; j'ai en effet, entendu la dame qui chantait, la dame fait l'action exprimée par l'infinitif. L'exemple *elle s'est laissée mourir* rentre dans la même règle; le complément direct de *laissée* est *s'(se)* mis pour *elle*, c'est elle qui meurt, il y aura donc accord.

(2) Le participe est invariable lorsqu'il a pour complément direct l'infinitif qui le suit:

La chanson que j'ai entendu chanter m'a plu. Entendu est invariable parce que dans cette phrase, le pronom *que* lequel représente la *chanson*, n'a rien à voir avec *entendu*, mais est le complément direct de chanter. C'est chanter qui est le complément direct du participe passé *entendu*. Ici je ne peux pas placer entre le participe et l'infinitif le nom dont le pronom précédent tient la place; je ne peux pas dire: *j'ai entendu la chanson chanter*; la chanson ne chantait pas, elle était chantée, j'ai entendu chanter la chanson; donc pas d'accord. *Elle s'est laissé tromper* s'explique de la même façon.

E. M. STÉPHAN.

GERMAN

A. The Gender of Nouns

IF masculine nouns stood for male, feminine nouns for female beings, and neuter nouns for things, there could be no difficulty about knowing the gender of German nouns. As a matter of fact it is one of the most teasing things in learning German to know the correct gender of nouns otherwise familiar enough. It is therefore advisable to learn nouns in the first instance by attaching the definite article to each, so that the combination may become familiar, because the freakishness of genders is immense, e.g., *das Weib* (woman) and *das Mädchen* (girl) are neuter, *die Sache* (thing) is feminine.

How the distinction of genders in nouns has come about is not always clear, but there is no doubt that for living beings in the first instance sex was a decisive factor and that for things imagination, and the tendency to personify them which is active in primitive races, and the poetic conception of things by the Germans has something to do with the fact that the names for big, strong, active and vigorous things are mostly masculine, e.g., *der Berg, der Baum, der Wagen, der Donner, der Sturm, der Strom, der Hass, whilst beautiful, graceful, gentle, soft, weak and passive things are commonly feminine, e.g., die Sonne, die Liebe, die Luft, die Blume,*

die Geduld; on the other hand, *lifeless* things, presenting a *dead* mass, are mostly neuter, e.g., *das Holz, das Eisen, das Moos, das Gras, das Heu, das Stroh, das Fleisch*. Another very important factor in the determination of the gender of nouns has been their ending. All nouns in *ei, heit, keit, schaft* and most in *e* are feminine, e.g., *die Spielerei, die Dummheit, die Heiterkeit, die Wissenschaft, die Sache, die Traube, die Birne, die Freude, die Gabe, die Gnade, u. s. w.* For further information on this chapter, see Primary German Course, p. 299. Large numbers of nouns have changed their gender in the course of time, even in quite early periods of the language. At all times many new nouns have adapted their gender to a certain type, so one says *die Eins, die Zwei* (type: *die Zahl*), *der Mittwoch* (type: *der Tag in Montag, etc.*); names of countries: *das alte Preussen, das arme Deutschland, etc.* (type: *das Land*); names of mountain ranges and mountains: *der Himalaja, der Ätna* (type: *der Berg*). This change of gender is striking in many foreign nouns: *der Vokal, der Konsonant, der Diphthong* (type: *der Laut*), *das Messing* (das Metall); *die Rhone* (die Elbe, die Oder, etc.).

B.—Articulation of "l" and "z."—The German articulation of the sound for the letter "l" presents some difficulty to English students, who are inclined to articulate it like an English "l." This sounds very odd and wrong in German, especially when it is final. The "l's" of "Well, Bill," are quite ungerman. The German "l" is formed at the upper teeth and with much less blade of the tongue. (See Primary German Course, p. xxvii.) The German sound should be practised in sentences: "Lang lebe die Lebenslust" (Long live or here is to the *joie de vivre*). Or in the answer to the question "Wie geht's?" (How are you?), which may be "So la la!" (Fairly or middling or so so), or in the quotation: "Gottes Mühlen mahlen langsam, mahlen aber trefflich klein" ("God's mills grind slowly, but grind exceeding small"). And finally in the opening of the beautiful monologue of Schiller's *Jungfrau von Orleans*—

Lebt wohl, ihr Berge, ihr geliebten Triften
Farewell ye mountains ye beloved meadows
Ihr stillen Täler, lebet wohl!
Ye still valleys fare ye well.

Or in the song beginning as follows:—

Bekränzt mit Laub den lieben vollen Becher
Put garlands of vine-leaves around your beloved full drinking cups
Und trinkt ihn fröhlich leer!
And swill it down joyfully.

Though the German articulation of "z" is not difficult, as in *zahn, Katze, Schweiz*, the English learner by force of habit often slips into the English sound of z before he or she takes kindly to the German z (tset) pronounced as ts in *tsetsefly*. The following sentences should be repeated several times:—

Zweimal zwei ist vier.—Zweimal zweiundzwanzig ist vierundvierzig.—And the following verses from Schiller's *Braut von Messina* should be learnt by heart:—

Nicht an die Güter hänge dein Herz,
Do not set your heart on worldly possessions
Die das Leben vergänglich zieren!
Which adorn life with transitory lustre.
Wer besitzt, der lerne verlieren,
He who possesses, let him learn to lose.
Wer im Glück ist, der lerne den Schmerz!
He who is favoured by good fortune, let him learn sorrow.

And these two lines from the same work:—
Nicht zähmen will ich meine Zunge, laut,
I will not bridle my tongue, loud,
Wie mir das Herz gebietet, will ich reden.
As my heart bids me, I will speak.

Aufgabe 16 (page 182).—

I.—(1) *das grosse Schiff*; Acc. *das—e, —*; Gen. *des—en, —es*; N. Pl. *die—en, —e*. (2) *ein grosses Schiff*; Acc. *ein—s, —*; Gen. *eines—en, —es*; N. Pl. *—e, —(e)*. (4) *unser—es Schiff*; Acc. *unser—s, —*; Gen. *unsres, —en, —es*; *unsre—en, —e, etc.*

II.—(1) *dieses lange Ufer*; *solch ein langes Ufer*; *viele lange Ufer*. (2) *welche glückliche*

Reise; *unsre glückliche Reise*; *einige glückliche Reisen*. (3) *jener grosse Hafen*; *euer grosser Hafen*; *mehrere grosse Häfen*. (4) *mancher hohe Dreidecker*; *manch ein hoher Dreidecker*; *einige grosse Dreidecker*. (5) *jenes aufmerksame Auge*; *sein aufmerksames Auge*; *etliche aufmerksame Augen*. (6) *jeder blonde Deutsche*; *kein blonder Deutscher*; *einige blonde Deutsche, etc.*

III.—(1) *ein kalter Winter*. (2) *jenes arme Rotkehlchen*. (3) *dieses helle Fenster*. (4) *solch ein guter Landmann*. (5) *mancher kleine Vogel* or *manch ein kleiner Vogel*. (6) *sein einziger Sohn*. (7) *ein lieblichen kleiner Vogel*. (8) *unsre warme Stube* or *unser warmes Zimmer*. (9) *welch kalter Wind* or *welch ein kalter Wind* or *was für ein kalter Wind*. (10) *einige* (or *etliche*) *weisse Schneeflocken*. (11) *etwas tiefer Schnee*. (12) *euer* (or *Ihr*) *ganzes Land*. (13) *ihr hungriger Hund*. (14) *keinschönes Haus*. (15) *alle guten Leute*. (16) *solch ein* or *so ein lieblicher Frühling*. (17) *jeder freundliche Mann*. (18) *mehrere herrliche Gärten*. (19) *keine hohen Bäume*. (20) *einige lustige Lieder*. (21) *Welch ein grosser Reisender*. (22) *welcher grosse Reisende?*

V.—*Mehrere grosse Schiffe liegen im Hafen. Sie sind zur Abfahrt bereit. Viele Leute, jung und alt* (or *junge und alte*) *standen am Ufer* (or *auf dem Kai*), *um manchem* (or *manch einem*) *lieben Freund(e) gute Reise zu wünschen. Eines der grossen Schiffe geht* (or *fährt*) *nach Amerika. Wir beobachten die vielen Reisenden, welche* (or *die*) *an Bord gehen. Haben Sie den grossen blonden Deutschen mit einem grossen Handkoffer gesehen* (or *bemerkt*)? *Als er sich auf jene grüne Bank setzte, kam er auf einen spitzen* (or *scharfen*) *Nagel zu sitzen. Mit ärgerlicher Miene rückte er fort, ohne ein Wort zu sagen. Kurze Zeit* (or *Bald nachher*) (or *Etwas später*) *setzte sich ein unruhiger kleiner Franzose und dann ein Engländer auf dieselbe Stelle* (or *auf denselben Platz*). *Der Franzose sprang auf schimpfte und tobte und setzte sich dann auf einen andern Platz. Der ruhige Engländer bat um einen Hammer* (or *liess sich einen Hammer geben*), *schlug* (or *hämmerte*) *den Nagel ein und setzte sich bequem darauf.* O. S.

ITALIAN

La Patria di Cristoforo Colombo
(continuazione)

INUMEROSI documenti contenuti nel libro testè (*just now*) pubblicato dalla "Città di Genova" intorno a Cristoforo Colombo, non solo dimostrano in modo irrefutabile la sua appartenenza a Genova, ma confermano anche molte notizie, già note, circa la sua origine.

Quest'ultima fu, in verità, molto umile. Suo padre, Domenico Colombo, era un modesto tessitore (*weaver*) di panni. Cristoforo, uno dei suoi cinque figli, nacque nel 1451 (mille quattrocento cinquantuno) e al principio lavorò anche lui a Genova, seguendo lo stesso mestiere (*trade*) del padre.

Questa sua modestissima origine spiega il perchè della scarsa cultura del grande navigatore. E non si possono più accettare, quindi, le affermazioni dei primi biografi (come *Las Casas*), i quali, credendo forse di far cosa utile alla sua memoria presso i posteri, scrissero che Colombo aveva frequentato l'Università di Pavia!

Nel libro in parola, i documenti più interessanti sono quelli in cui Colombo ricorda la sua patria. Egli lo fa generalmente con espressioni piene di caldo affetto e di gratitudine, e usa talvolta delle belle immagini: magari un po' rozze, ma efficacissime. Come quando, scrivendo al Banco di San Giorgio a Genova, comincia la sua lettera dicendo: "Benchè il corpo cammini qui, il cuore è sempre costà" (costà or costì=*the place where the person*)
(Continued in column 3, page 870)

TECHNICAL SECTION

Modern Ideas on Short-Wave Transmission

By PROFESSOR E. V. APPLETON, F.R.S.

THE announcement that the B.B.C. intends to build a new high-power short-wave station for Empire broadcasting is an event which naturally prompts a survey, as up to date as possible, of our technical knowledge concerning the transmission of short waves over long distances.

As I have previously pointed out in this journal, there is a romance in connexion with short waves. During the years before the war, radio engineers concentrated their attention on developing communication with long waves. It is perhaps too much to say that the short wavelengths were despised, but they were certainly regarded with indifference by radio-engineers. Nowadays, all this is changed. At International Radio-telegraphic Conferences the short waves have come into their own, for their remarkable suitability for long-distance transmission is recognised, and each national representative seeks the allocation of short-wave channels to his own country.

Why is short-wave, long-distance transmission so different from long-wave transmission? This question is the most interesting and important one in connexion with present-day wireless theories, and in this article I shall do my best to answer it.

In the first place, it is important to note that, if we were to make experiments over a transmission distance of, say, 0.1 mile overland, we should notice differences between short and long-wave propagation, but there would be no difficulty in explaining them. For such short distances the radio-frequency energy would travel direct from sending to receiving station along the ground. In this case, we should find that the absorption of the waves steadily increases as the wavelength is decreased, exactly as predicted by theory. Communication gets steadily worse as shorter and shorter wavelengths are used. (In this connexion I ought to point out that, using the shortest of short waves, for example, of 15 to 18 centimetres in wavelength, Beauvais, in France, has carried out very successful tests in short-distance transmission, but in these experiments care was taken to prevent the waves travelling *along* the ground).

With transmission over much longer distances, quite different results are obtained. Here we know that transmission along the ground is not

so important as transmission through the atmosphere. We know that the upper atmosphere contains free electricity, which behaves as a kind of reflector to wireless waves, and deviates them back to the ground. To the upper atmosphere we must therefore look for an explanation of the excellent transmission qualities of the short-wave band of from 15 to 35 metres. We have to explain why this reflecting region treats long waves and short waves so differently.

Most of my readers are aware that both Kennelly and Heaviside, many years ago, made the suggestion that long-distance long-wave propagation was due to the influence of a conducting layer in the upper atmosphere. In 1924 the existence of this layer was proved, by direct experiment, in this country and its height above the ground was found to be about sixty miles. Recent experiments in America

in the preponderance) the reflection of wireless waves would be accompanied by practically no absorption. It is the presence of the air molecules which causes the intensity of the reflected waves to be diminished.

When the free electric charges vibrate under the influence of the electric forces in the waves, they are subjected to a kind of friction by the air molecules, the heat so generated being communicated to the molecules themselves. In other words, the passage of waves through the Kennelly-Heaviside layer warms it up slightly, the increase of temperature depending on the pressure of the air. We therefore see that the higher in the atmosphere the level at which waves are reflected, the lower is the absorption accompanying the reflection.

The experimental investigations of the last few years have not only confirmed the theory that short waves are reflected at higher atmospheric levels than are the long waves, but have shown us more clearly how the reflection is brought about. By extending the methods originally used to find the height of the Kennelly-Heaviside layer, and using shorter waves, it

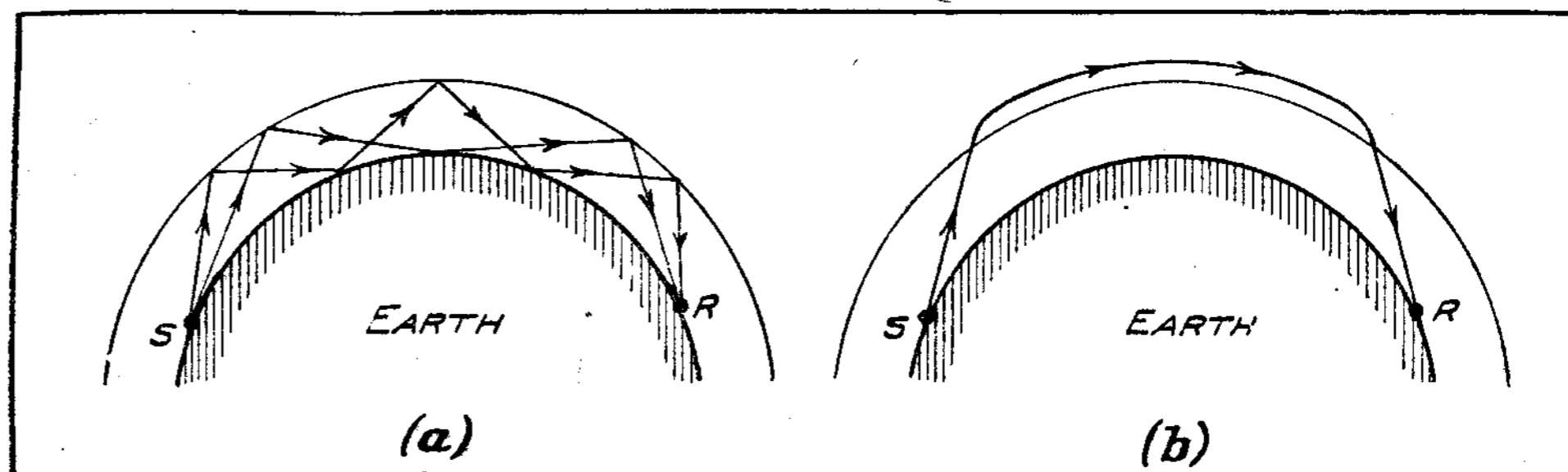

Fig. 2.—Illustrating alternative theories of long-distance propagation

and in Germany have confirmed this value. The question therefore arises: Can we explain the superiority of, say, 25 metres to, say, 200 metres for long-distance transmission as being due to the fact that the Kennelly-Heaviside layer reflects waves of 25 metres more efficiently than waves of 200 metres?

Various attempts have been made to answer this question and, although there has been a certain amount of controversy in connexion with them, I think it is now admitted that, if we assume that all wavelengths are reflected by the Kennelly-Heaviside layer, at a height of about sixty miles, we should still be in a difficulty; for calculations show that such a layer would still reflect long waves better than short waves. What, indeed, is the way out of such a quandary? We have been so accustomed to rely on the Kennelly-Heaviside layer as the way out of all our theoretical difficulties that it comes as a shock to find that it will not explain one of the most significant features of wireless transmission.

In 1927, in *The Electrician* for March 11, I pointed out that possibly a way out of the difficulty was to assume that short waves were reflected at much higher levels in the upper atmosphere than long waves. It is known that if the Kennelly-Heaviside layer consisted of electrified particles and not, as is actually the case, of a mixture of electrified particles and air molecules (the latter being greatly

has been found that there exists another reflecting region, richer in electricity, situated above the Kennelly-Heaviside layer.

It is this upper region which is responsible for the reflection of short waves, for they are able to penetrate the lower layer. If, therefore, we send out from a station, simultaneously, long waves and short waves (see Fig. 1), the long waves are reflected at the Kennelly-Heaviside layer at a height of about sixty miles, while the short waves are reflected at the upper region, which is situated at a height of about 130 miles. At the risk of being charged with heresy, I must say that, so far as short-wave propagation alone is concerned, I cannot regard the Kennelly-Heaviside layer as a blessing to mankind, for the chief absorption suffered by short waves is when they pass through it.

In connexion with short-wave transmission round the earth's surface, we therefore believe that the upper of the two reflecting regions is involved. The question, therefore, arises as to whether the waves make the journey by a series of multiple reflections, as illustrated in Fig. 2a, or in a single jump, as illustrated in Fig. 2b.

In connexion with the latter it was once naively asked: "How do the waves *know* when to come down?" The question is a very pertinent one and fastens on a real difficulty. At present, most of the available evidence suggests that the transmission actually takes place by a series of "hops," as shown in Fig. 2a.

Listeners in Great Britain will naturally be inclined to ask whether the new station will provide any kind of service for them. While it is true that there will be a local service provided by direct transmission along the ground, it is

(Continued at foot of column 3, page 880)

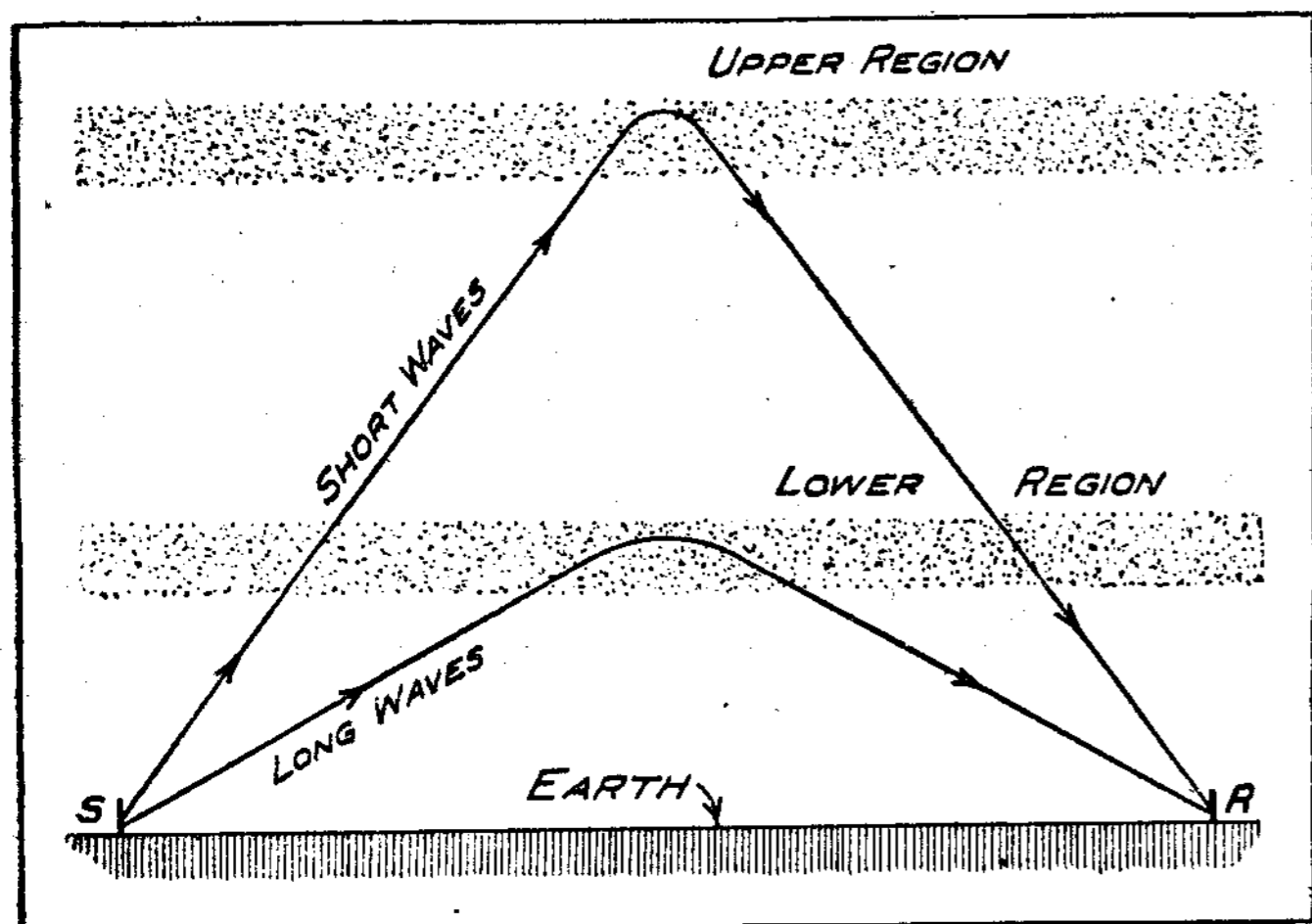

Fig. 1.—Reflection of long and short waves

Short-Wave Adaptors

PROBABLY the first thought which occurs to anyone whose attention is attracted towards the possibilities of short-wave broadcast reception is in connexion with the type of apparatus to be used. Is it necessary to construct a special and, perhaps, elaborate type of receiver? Can use be made of the existing broadcast receiver without serious modification? Is the art of operating a short-wave receiver difficult to acquire?

These and similar questions naturally occur, and, while those who are so inclined may build, or purchase, a special short-wave receiving set, the object of the present article is to explain the design and use of a type of apparatus now popularly known as an "adaptor," by means of which short-wave reception can be carried out very successfully in conjunction with the ordinary broadcast receiving set.

In previous issues of *World-Radio* separate articles have appeared from time to time, describing short-wave adaptors, and many of them have been constructed by readers, and proved to work in a satisfactory manner. In fact, continued applications are received from readers in various parts of the world for back numbers of this journal containing the articles in question. These, however, are no longer available, and the diagrams and photographs reproduced herewith, representing four types of short-wave adaptor are, in some cases, taken from the original articles.

For our present purpose all broadcast receivers may be regarded as falling into one of two classes, *i.e.*, those consisting of a detector valve followed by one or more low-frequency stages, and those in which the detector is preceded by one or more high-frequency stages.

For use with the former type of broadcast receiver the adaptor must, in effect, take the place of the detector valve and its associated tuned circuits. Two examples are shown diagrammatically in Figs. 1 and 2, and will be described in detail presently.

With the latter class of broadcast receiver (incorporating high-frequency amplification) an adaptor can be employed which makes use of the super-heterodyne principle. That is to say, the short waves are received in the tuned circuit of the adaptor, a locally generated oscillation is superimposed, thus giving rise to "beats" at, usually, a much lower frequency known as the "intermediate frequency." This new frequency is then fed to the tuned circuit of the broadcast receiving set (*via* the aerial

The adaptor shown in Fig. 1, which is really neither more nor less than an ordinary one-valve receiver provided with suitable short-wave coils, together with one or two minor additions such as extra filter condensers, etc., is provided with a 4-pin plug (P) to be placed into the detector-valve holder of the broadcast receiver, while the valve removed from that holder is to be fitted in the adaptor valve-holder. By this means high-tension and low-tension current for the adaptor is derived automatically from the broadcast receiver supply, and switching on or off the main set will also control the adaptor valve. Referring to Fig. 1, C_1 is a neodyne condenser; C_2 —a variable condenser, capacity 0.0001 mfd.; C_3 —variable condenser, capacity 0.0002 mfd.; C_4 —0.0003 mfd.; C_5 —0.01 mfd.; C_6 —2 mfd.; C_7 —0.001 mfd.; R_1 —4 megohms; R_2 —200 ohms.

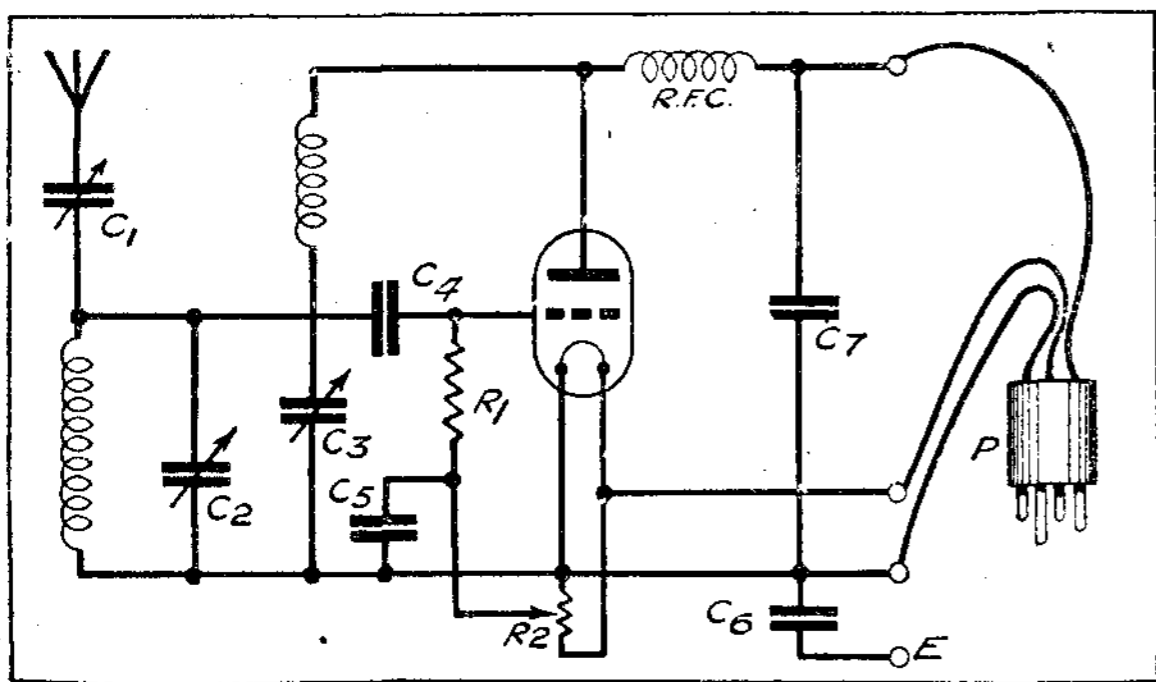

Fig. 1—Simple one-valve adaptor

terminal), and there undergoes a further high-frequency amplification, rectification and low-frequency amplification in the ordinary way. Short-wave adaptors embodying this principle are shown in the remaining diagrams (Figs. 3 and 4), and the accompanying photographs.

provided with a cross-piece at one end fitted with 4 valve-pins. Details of these larger coils are as follows:—

Coil No. 3 (Wave range 23 to 33 metres)
Grid coil—7 turns; Reaction—9 turns.

Coil No. 4 (Wave range 30 to 45 metres)
Grid coil—12 turns; Reaction—12 turns.

The small tuning range covered by each coil renders tuning less critical than would otherwise be the case. The grid coils are all wound with No. 22 S.W.G., d.c.c. copper wire, the

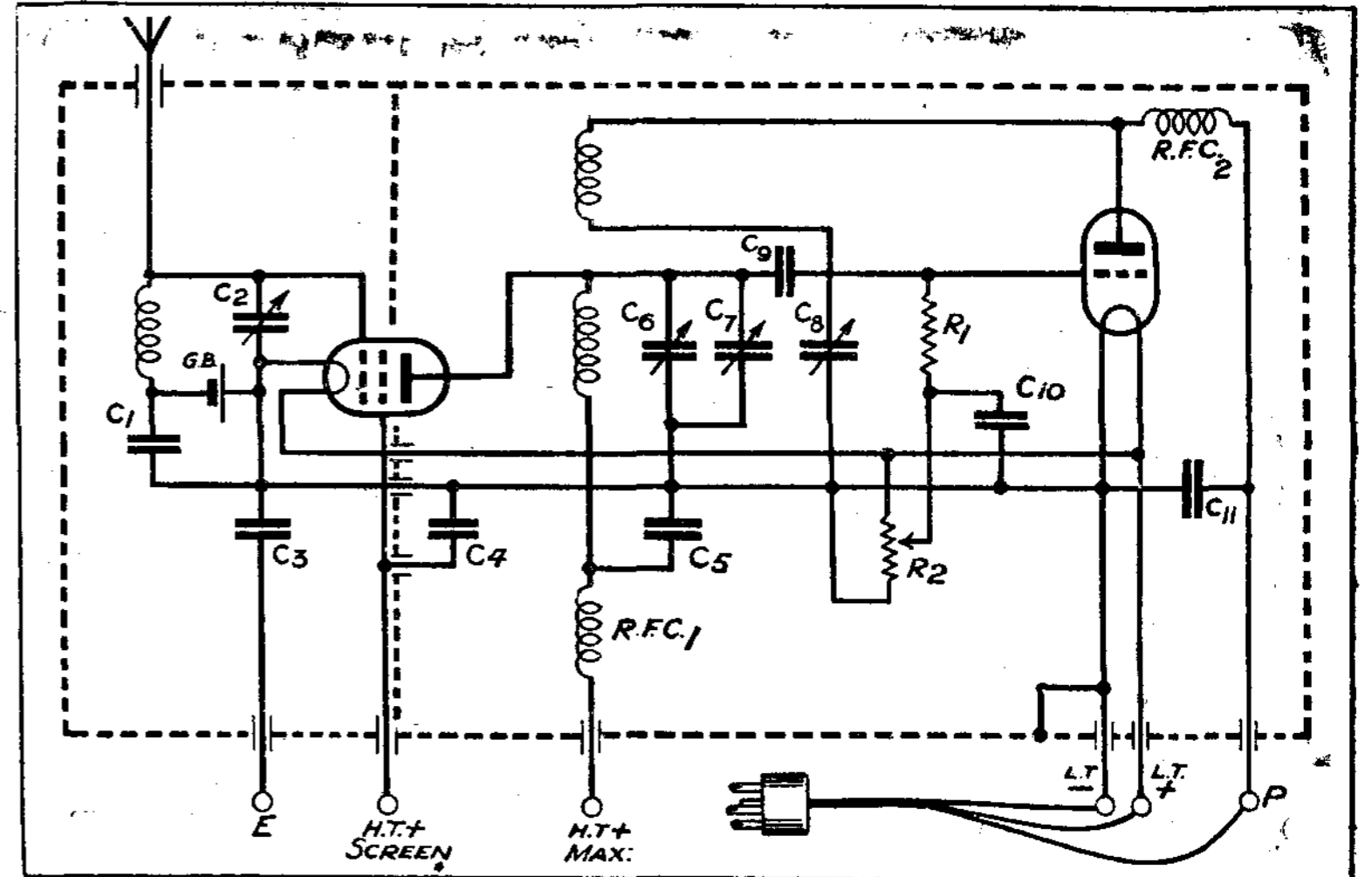

Fig. 2—Adaptor with screened-grid H.F. valve.

turns being spaced slightly. The reaction coils are all wound with No. 26 S.W.G. enamelled wire, and all windings are in the same "sense" or direction. It is preferable to leave a small space (about $\frac{3}{8}$ in.) between the two windings on each former. Should satisfactory oscillation not be obtained, however, the windings may be moved closer together after having first tried the effect of reversing the reaction coil connexions.

The short-wave high-frequency choke (R.F.C.) may be a standard commercial article, or can be made by winding one layer of No. 36 S.W.G., d.c.c. wire for a length of 3 ins. on an ebonite rod $\frac{1}{2}$ in. in diameter. The potentiometer (R_2) is desirable, because the lower end of the grid leak (R_1) must be connected to L.T. positive, and not everyone can ascertain exactly how his broadcast receiver is connected internally. The potentiometer should be adjusted

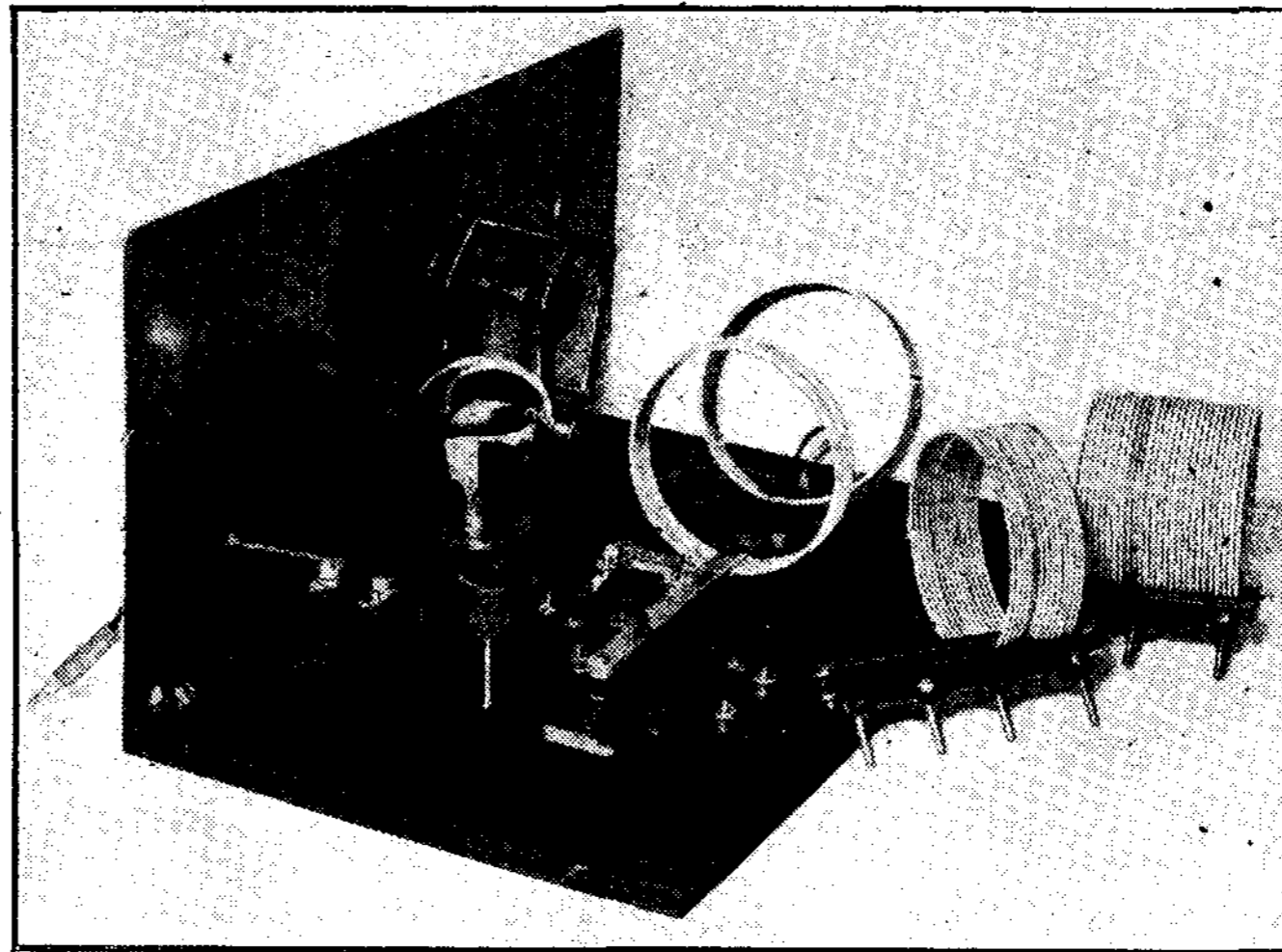

Fig. 4—Arrangement of one-valve super-het. adaptor

In the original model of this short-wave adaptor, four coils were used to cover the wave-lengths from 14 to 45 metres, with the variable condenser specified. While short-wave plug-in coils of standard manufacture may be used with suitable bases or holders, and will give perfectly satisfactory results, two of the original coils, covering the wave-band from 14 to 26 metres, were wound on valve bases, connexions being made to the valve-pins and the whole fitting into a standard valve-holder. These coils were wound as follows:—

Coil No. 1 (Wave range 14 to 20 metres) Grid coil—4 turns; Reaction—5 turns.

Coil No. 2 (Wave range 18 to 26 metres)
Grid coil—5 turns; Reaction—7 turns.

Valve bases are not large enough to take the wire required by the two larger coils, so formers are used, each consisting of a piece of ebonite tubing $1\frac{1}{2}$ ins. in diameter and $1\frac{1}{2}$ ins. long,

until satisfactory reaction effect is obtained, after which it will not require attention. It may also be necessary to vary the adjustment of the aerial-series condenser (C_1) in order to obtain oscillation over the complete wave-range. The terminal E should be connected to the earth terminal of the broadcast receiver.

Screened-Grid Adaptor

Fig. 2 is a circuit diagram of a more pretentious adaptor, incorporating a screened-grid high-frequency valve. As will be seen, the arrangement is fairly straightforward. Both stages are completely shielded in an aluminium box 14 ins. long, 7 ins. wide and 7 ins. deep, with a metal partition about 6 ins. from one end, in which a two-inch hole admits the screened-grid valve, which has to be mounted in a horizontal position half-way through the partition. The box itself is connected to L.T. negative so that all wires which should go to this point may be connected either to the negative filament lead or to the box itself.

The coils required in the detector circuit are exactly similar to those already specified

for use with the adaptor shown in Fig. 1. The remaining components are as follows:— C_1 —0.004 mfd.; C_2 —0.0003 mfd.; C_3 —2 mfd.; C_4 —1 mfd.; C_5 —0.004 mfd.; C_6 —0.0001 mfd.; C_7 —vernier or neutrodyne condenser; C_8 —0.0002 mfd.; C_9 —0.0003 mfd.; C_{10} —0.001 mfd.; C_{11} —0.001 mfd.; G.B.—1½ volts; R_1 —4 megohms; R_2 —200 ohms.

The high-frequency choke (R.F.C.₂) consists of one layer of No. 36 S.W.G. d.c.c. copper wire wound for a length of 3 ins. on an ebonite rod half-an-inch in diameter. R.F.C.₁ consists of one layer of No. 26 S.W.H.d. c.c. copper wire wound on an ordinary cotton-reel. Standard commercial short-wave chokes may be used.

In addition to the connexions provided by the 4-pin plug (P), which is to be fitted into the detector-valve socket of the existing broadcast receiver, it will be necessary to connect the 2 H.T. terminals (H.T. + Screen, and H.T. + Max.) to the H.T. battery. The former requires about seventy volts and the latter the maximum voltage available up to 150 volts.

It will be found that the screened-grid valve gives appreciable amplification and, incidentally, stabilises the receiver by reducing hand-capacity effects. The tuning of the aerial circuit will be found to be very broad, the critical adjustment being that of the detector tuning condenser (C_6) and vernier (C_7).

If desired, of course, either of the two adaptors so far described may be used in conjunction with a low-frequency amplifier to form a complete short-wave receiving equipment.

One-Valve Super-Het. Adaptor

The simplest form of super-heterodyne short-wave adaptor is illustrated diagrammatically in Fig. 3 which, when examined, will be seen to consist of an aperiodic aerial circuit loosely coupled to the tuned grid circuit of a triode, which, by virtue of the reaction coil L_3 and fixed condenser C_3 , will oscillate at a frequency determined by the values of inductance L_2 and variable capacity C_2 .

Actually, this arrangement can "detect" an incoming short-wave signal and, at the same time, can oscillate at a slightly different frequency, which oscillation, "beating" with the incoming signal, will produce radio-frequency currents capable of being amplified by the high-frequency stage, or stages, of a broadcast receiver. If, for example, the incoming signal is of a frequency of 10,000 kc/s (30 metres), and we "beat" with it a locally generated frequency of either 9,700 or 10,300 kc/s, a resulting frequency of 300 kc/s (1,000 metres) will be produced, and will form the input signal to the aerial terminal of the broadcast receiver.

In practice, the aerial is removed from the broadcast receiver and connected to the aerial coil L_1 of the adaptor. The adaptor should be placed fairly close to the broadcast receiver, in order to keep the connecting lead—from the output condenser C_4 of the adaptor to the aerial terminal of the broadcast receiver—as short as possible. The broadcast set is then tuned

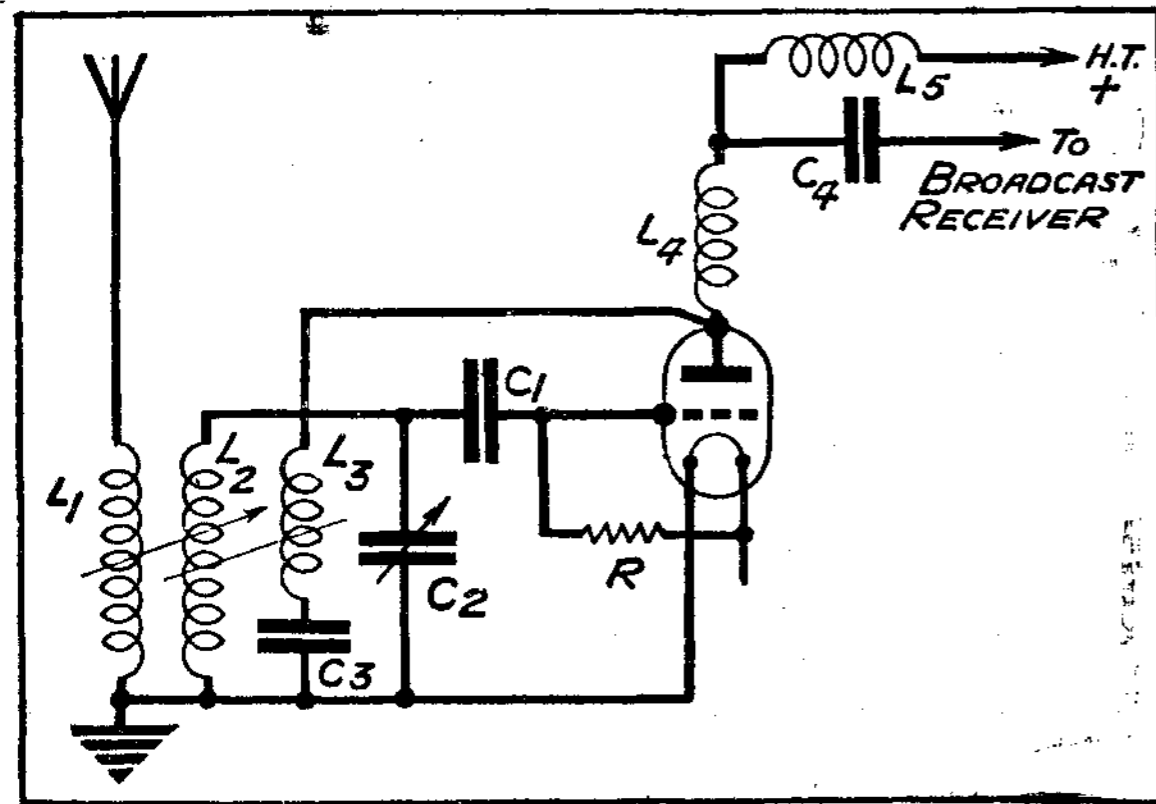

Fig. 3.—One-valve super-het. adaptor

to any wavelength in the neighbourhood of 1,000 metres which happens to be free from interference. Short-wave signals may then be tuned in by rotating slowly the condenser C_2 , while a useful "vernier" adjustment may be effected by means of a slight adjustment of the tuning on the broadcast receiver.

Referring to the diagram, Fig. 3, the coils L_1 , L_2 and L_3 may be commercially-made short-wave coils. The coupling between L_1 and L_2 should be fairly loose, and preferably variable. With the broadcast receiver tuned to approximately 1,000 metres, two sets of coils, as specified below, will cover the wavelength ranges 18-26 and 26-50 metres, if C_2 has a capacity of 0.00015 mfd.

If desired a small vernier condenser may be connected in parallel with C_2 for fine tuning adjustments.

18 to 26 Metres	26 to 50 Metres
L_1 8 spaced turns	L_1 8 spaced turns
L_2 3 " "	L_2 8 " "
L_3 4 " "	L_3 4 " "

All coils are wound upon 3 in. diameter formers, or, if made of fairly heavy gauge wire

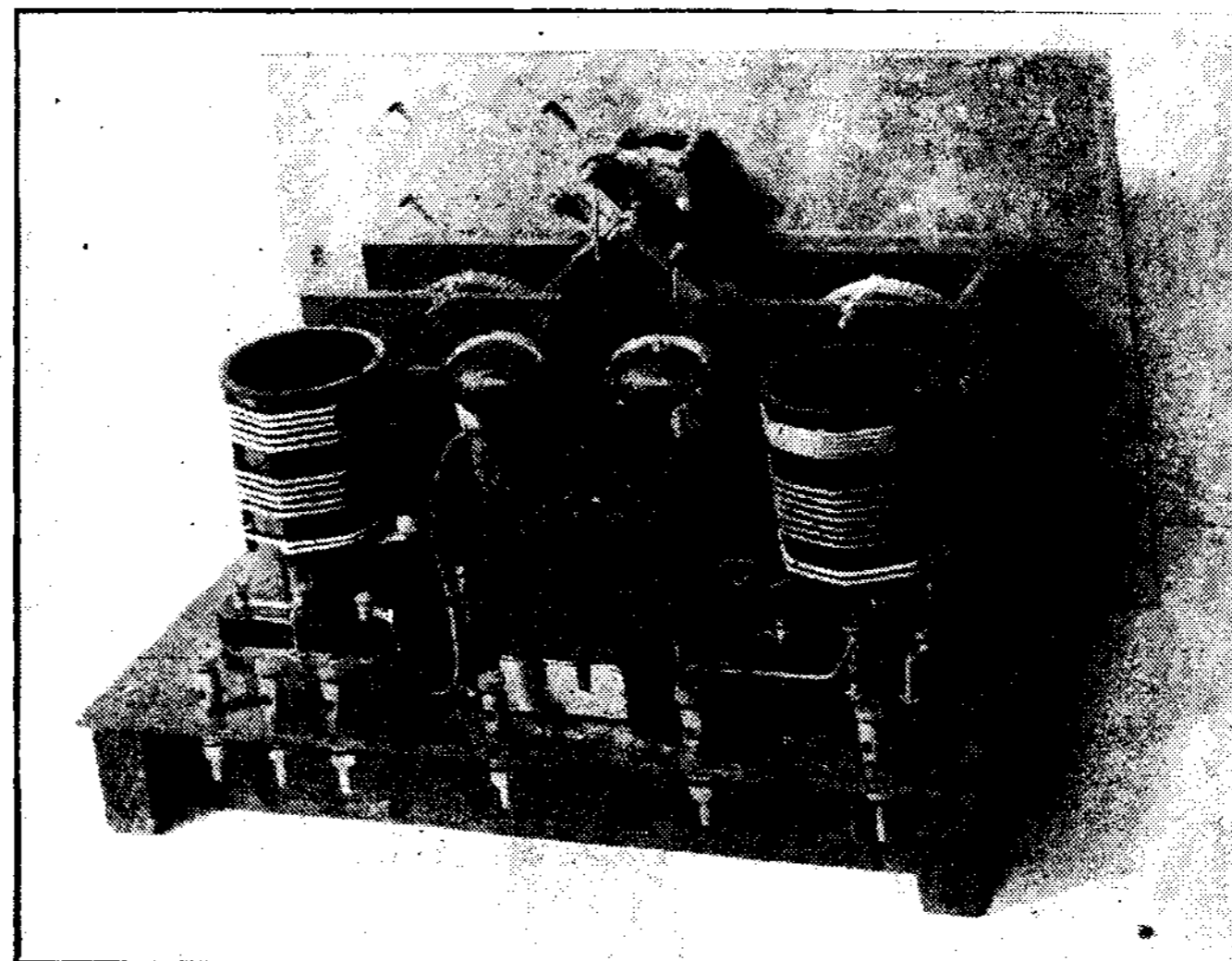

Fig. 6.—Rear view of two-valve super-het. adaptor

(say, No. 18, or No. 16 S.W.C., d.c.c.), they may be made self-supporting and air-spaced.

The values of the remaining components indicated in the diagram are as follows: C_1 —0.0003 mfd.; C_2 —0.00015 mfd.; C_3 —0.0001 mfd.; C_4 —0.0005 mfd.; L_4 —short-wave choke; L_5 —long-wave choke. The grid condenser and leak, C_1 and R respectively, are of the usual values, with R preferably low, say, 0.5 megohm. Almost any triode will operate satisfactorily, but a high-tension voltage of 100 is desirable.

The photograph (Fig. 4) shows a typical one-valve super-heterodyne adaptor constructed to the above diagram and specification. Particular note should be made of the "sense" or direction of winding of the coils which, in this instance, are of the plug-in type, all wound in the same direction, the connexions from right to left of the sockets in the coil base, as seen in the photograph, being as follows: aerial—earth—grid—earth—reaction condenser—anode.

The adaptor may be used with A.C. or D.C. mains-driven receivers, or with battery-

operated sets. In the latter event the same batteries may be used for both the adaptor and the set, but in this case it is important to note whether, in the broadcast receiver, the H.T. negative is connected to L.T.+ or L.T.—, as the adaptor must obviously be wired the same way.

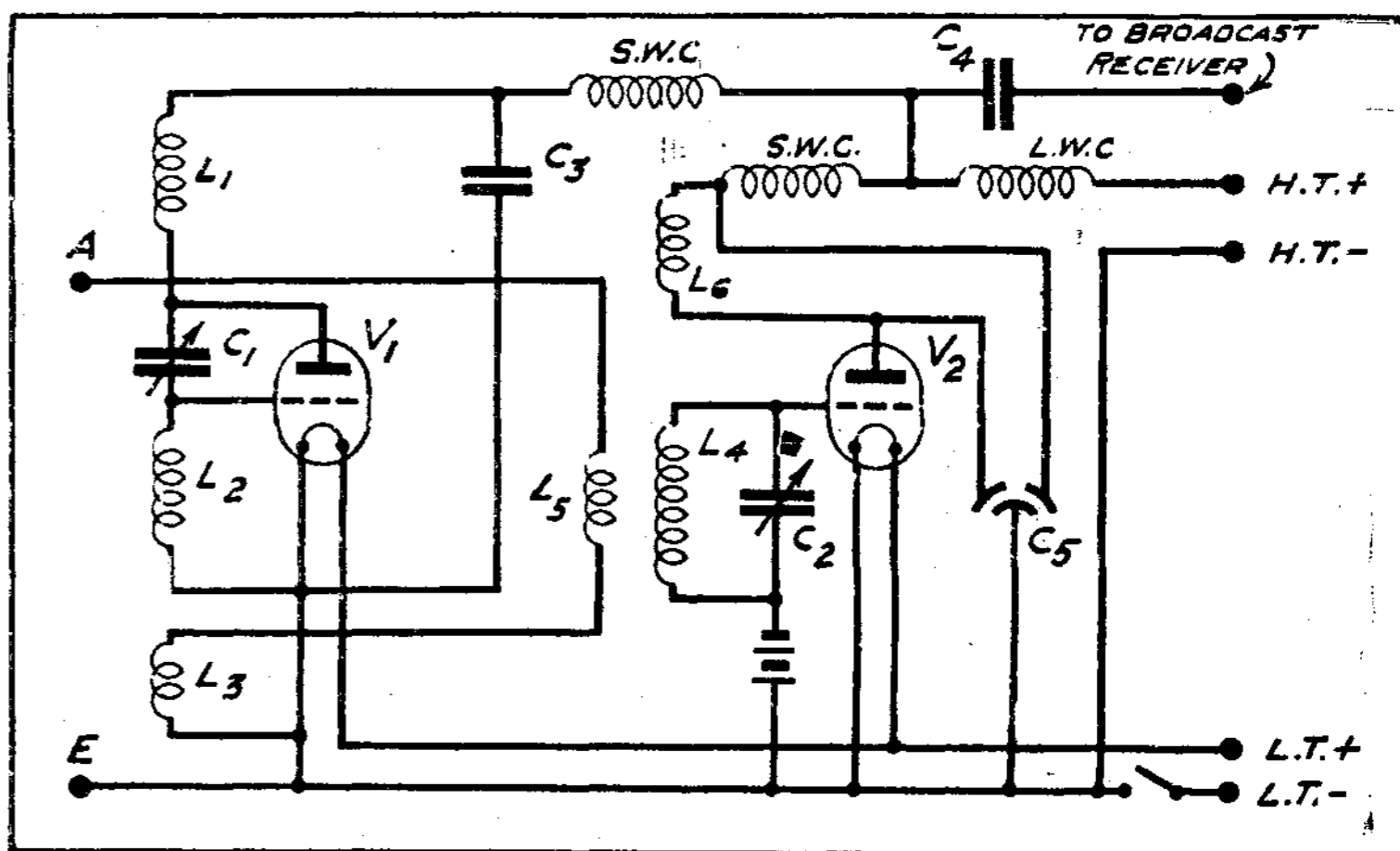

Fig. 5.—Circuit of two-valve super-het. adaptor

It may be found that there are certain points of the condenser scale where the set is "dead." This difficulty can be overcome by altering the coupling between the aerial and grid coils. In order to facilitate the change-over from "short-wave" to "ordinary broadcast" reception, it will be found convenient to install a double-pole change-over switch connected so as to transfer the aerial from one set to the other, and, at the same time, to disconnect the adaptor output lead from the aerial terminal of the broadcast receiver.

Two-Valve Super-Heterodyne Adaptor

The single-valve arrangement just described has the advantage of being simple and economical, and it gives quite satisfactory results. At the same time, however, there is a certain loss of efficiency owing to the fact that the circuit has to be detuned slightly in order to produce the beat-frequency oscillations. This difficulty can be overcome, at small expense, by the provision of a separate oscillator valve, the complete arrangement then being as shown in the circuit

diagram, Fig. 5, and illustrated in the photograph, Fig. 6.

Referring to the diagram, coils L_1 , L_2 , and L_3 are wound together upon one standard 6-pin former, and coils L_4 , L_5 , and L_6 are wound together on another similar former. The method of spacing the coils is clearly shown in the photograph, and the windings are as follows:—

DETECTOR COILS.	OSCILLATOR COILS.
Reaction 6 turns	Anode 5 turns
Grid 5 "	Grid 5 "
Aerial 2 "	Aerial 2 "

A wavelength range of from 18 to about 50 metres is covered without change of coil, but good slow-motion dials are desirable, particularly on the oscillator condenser. The aerial circuit is coupled to both tuned circuits by means of the coils L_3 and L_5 . The order of the three coils on each former is as tabulated above.

The values of the remaining components indicated in the circuit diagram, Fig. 5, are as follows:—

C_1 and C_2 —variable condensers (capacity 0.00025 mfd.) with good slow-motion dials;

(Continued in col. 1, page 884)

Technique of Broadcasting

The Acoustical Problems of Broadcasting Studios (3)

By NOEL ASHBRIDGE, Chief Engineer, B.B.C.

(Continued from page 823, November 20)

IF we can determine the optimum reverberation period for a concert hall when used for direct listening, we can afterwards consider what modification is necessary for broadcasting studios. Several authorities have investigated the problem, as applied to direct listening, by plotting curves showing the existing reverberation period in relation to the volume for a number of different concert halls, the musical performance of which was known. It was found that the values of reverberation period for those halls which were considered satisfactory by musicians, lay on a smooth curve, whereas those for halls giving poor acoustical quality lay either above or below the smooth curve. Fig. 3 shows two curves of optimum values plotted against volume, according to F. R. Watson. Curve A is only for music, and curve B is for halls intended both for music and speech.

Optimum Reverberation Period

Since the existence of reverberation involves an inter-mingling of any one particular sound with the sound immediately following it, it follows that if the value is excessive there is bound to be some blurring, and this effect is much more obvious in the case of speech than in music. Thus, if a hall is required for speech in addition to music, the reverberation period is usually fixed at a lower figure than might be considered the optimum for music only, as indicated by the two curves in Fig. 3. It will be noticed that the difference between the two curves is slight, but obviously curve B is in the nature of a compromise.

As already stated, the basis for these curves is mainly practical experience, and since the whole aim of the designer should be to satisfy musical taste, it is considered that this basis is a sound one. However, a paper by W. A. MacNair, entitled "Optimum Reverberation Time for Auditoriums," was recently published in the *Bell System Technical Journal*; this paper treats the matter from the more theoretical standard, and although there is some agreement with the empirical curve, it is doubtful whether, at the present state of development, it is possible to rely only on theoretical curves. There are, however, various other considerations to take into account before we can decide to what extent the curves intended for concert halls can be adopted for studios used only, or mainly, for indirect listening. These factors are dealt with in a subsequent section. It will be realised, however, that if we adopt the curves as shown in Fig. 3, or a variation of them, the reverberation time is fixed when once the size of the studio is fixed, and this will be irrespective of the different types of musical performance for which it may be used. If we can do this, all that remains is to provide the correct amount of such sound-absorbing material as will satisfy condition (4).

(4) Reverberation period in relation to frequency.

When the reverberation period is measured, for instance, by the method already described, it is obvious that any audio frequency may be chosen for the source of sound, but it does not follow that the same result will be obtained at other frequencies. In many cases, it appears to be the practice to make these measurements only at the frequency corresponding with one octave above middle C on the piano, that is to say 512 cycles per second. It is considered highly desirable, however, for broadcasting studios, that all frequencies between say 40 and 10,000 cycles per second should be considered, and that the curve should be level over this

range within a fairly wide tolerance, say of the order of 20 per cent. In practice, however, one has usually to be content with making measurements over the range of frequencies between about 100 and 6,000 cycles per second, owing partly to the difficulty of obtaining sufficient sound energy from loud speakers outside these limits, and partly to the fact that complications occur at frequencies above about 5,000 cycles, probably due to appreciable attenuation of sound waves in the air itself at these higher frequencies.

It would seem, moreover, that a slight slope downwards towards the high frequencies may be of some advantage for broadcasting, although a marked increase at the bass end, such as has been suggested by McNair in the paper already referred to on theoretical grounds, will give rise to what is usually termed "bass blasting," which as already stated gives a kind of "booming" effect. On the other hand, an excessively long period at the high frequencies gives a harsh effect to the stringed instruments, which is even more unpleasant to listen to.

The above remarks apply chiefly to broadcasting studios intended mainly for general purposes, there are however, several cases

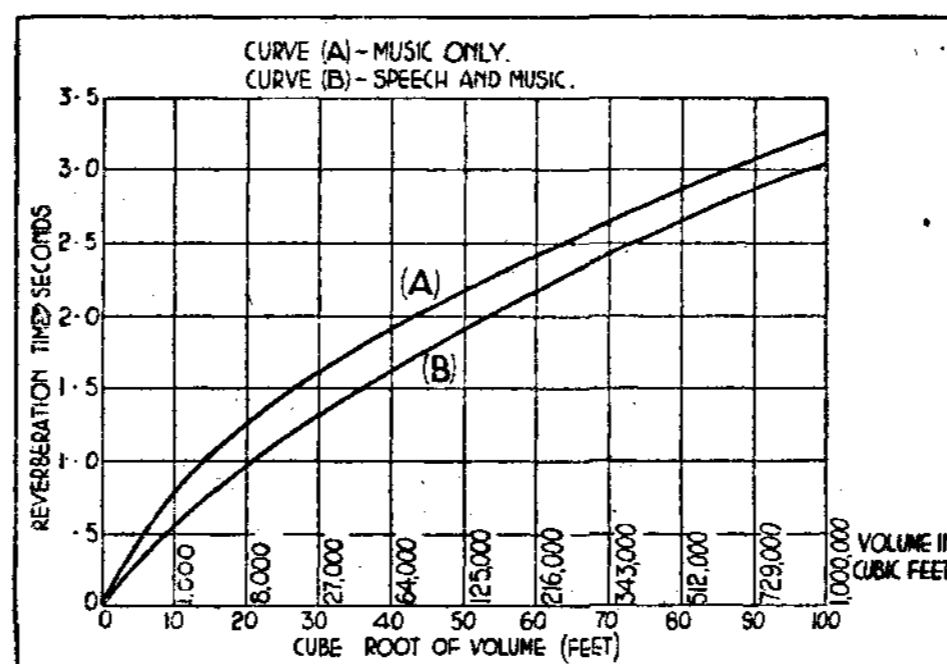

Fig. 3—Curves showing reverberation times plotted against volume

which require special treatment, for example, studios intended for the production of dramatic "effects." In this case, it is desirable to have a reverberation period which can be varied over very wide limits, and, for this reason, it is desirable to treat the studio itself with sufficient sound-absorbing material to remove practically all reverberation. The required amount can then be added by the artificial method already described, and because the latter is adjustable great advantage is gained by its use. The fact that artificial reverberation does not produce the same musical quality as a correctly designed studio is not serious for this purpose.

"Talks" Studios

Another special case arises in connexion with studios intended for talks or lectures only. In these circumstances, the speaker addresses the microphone in the same voice as he would address a friend when discussing a matter in his own sitting-room, and therefore, it would seem desirable that there should be practically no reverberation present in the studio at all, since the voice, as heard by the listener, should be modified only by the acoustics of his own room, whether the latter itself possesses practically no reverberation, as in the case of a small sitting-room, or is noticeably reverberant as in the case of a large room in a country house. It is thought, therefore, that possibly the best treatment for a studio of this kind is complete damping, but if this is done, particular care

must be taken to make certain that there is no reverberation at the bass frequencies only; otherwise a most unpleasant hollow effect will be obtained.

The choice of material for treatment of the wall surfaces of studios generally must take into account the above considerations, and the performance of different types of material can only be determined by actual tests in a room specially prepared for the purpose. Such a room must be constructed of absolutely rigid walls, ceiling and floor, as in the case of a studio, although, in this case, it is still more important. The whole surface of the room is covered with material which gives almost complete reflection to sound at all audio frequencies. Such a result can be obtained by covering the surfaces with plate glass, or glazed tiles, firmly embedded in cement, care being taken that there is no air space at any point between the wall and the covering material. When it is required to examine the properties of, say, a certain variety of building board, a sample of material of known area is introduced, and the change of the reverberation period which results is measured at different frequencies. From these tests it is possible to calculate the degree of absorption possessed by the material for each frequency considered. These measurements are, of course, based on the well-known work of Sabine and others.

Absorption Coefficient

The absorptive property of a given material is expressed quantitatively as an "absorption coefficient," which is the fraction of the total sound energy incident on the surface of the material, which is absorbed or transmitted. It is equal to unity minus the coefficient of reflection, or the fraction of the total sound energy which is reflected from the material. It must be understood that the value of both these coefficients is often modified appreciably by the method of fixing the material, and the nature of the wall surface to which it is fixed.

It is easy to calculate the reverberation period of a given room if we have an exact knowledge of the coefficients of absorption of all the materials in the room which are exposed to the sound waves. W. C. Sabine, early in the present century, arrived empirically at the following well-known expression, whereby

$$T = \frac{0.05 V}{a S}$$

T being the reverberation period expressed in seconds, V the volume of the room in cubic feet, a the average coefficient of absorption for all the surfaces in the room and S the total absorbing surface in square feet. a is obtained by adding together the absorbing powers of all the different absorbing surfaces of different materials in the room and dividing by the total surface. The absorbing power of a given surface is obtained by multiplying its absorption coefficient by its effective area. It will be seen that $a S$ is the total absorbing power in the room and may be said to be equal to A , expressed in "absorption units" in terms of the absorption of one square foot of open window as unity. Thus: $T = \frac{0.05 V}{A}$, and this is often a convenient form of Sabine's expression.

This simple expression is, however, only valid for comparatively lightly damped rooms. Several alternative expressions have been proposed from time to time, and the one which seems most nearly accurate and which is being most adopted at the present time is that due to C. F. Eyring, of the Bell Telephone Laboratories, and was suggested in a paper in the *Journal of the Acoustical Society of America*, 1930, Vol. 1,

p. 217. According to Eyring, $T = \frac{0.05 V}{S \log_e (1-a)}$. This expression reduces to that of Sabine if a is small compared with unity, and the difference is appreciable if a exceeds 0.25.

(To be continued)

A PLAN TO BRING GREATER HAPPINESS AND PROSPERITY TO THOUSANDS OF MEN AND THEIR FAMILIES

TALK IT OVER WITH YOUR WIFE

—it will solve many of your financial problems

Money enters into all your hopes and aims. The education of your children, the buying of your house, the extension of your business, and finally your retirement from business. How are you to get that money?

May we show you the way? May we show you how you can make sure of a substantial Capital Amount ten years from now, with another and larger sum five years later, and a very much larger sum five years after that?

START THIS "THREE STAGE" PLAN NOW, TO SECURE YOU 3 CASH PAYMENTS—

£440 AT END OF 10 YEARS

a further

£460 AT END OF 15 YEARS

and a final

£2400 AT END OF 20 YEARS

From your first deposit your life is insured for £2,000. That sum, plus accumulated profits, will be paid to your family should you not live to enjoy the benefits yourself.

You will save Income Tax on every deposit, thus adding to the profits of the Plan.

The Plan applies to any age and for any amount, the figures above being based on age 35 at present bonus rates and maturity dividends.

Behind the opportunity are assets exceeding £120,000,000, the investment of which is under Government Supervision. It is an opportunity not to be missed. Let us send you the full Plan, adapted to your own age and requirements, even though the amount you can spare from your income for the purpose is only small. You incur no obligation.

CUT OUT AND POST TO-DAY

To H. O. LEACH (General Manager),
SUN LIFE ASSURANCE CO. OF CANADA
(Incorporated in Canada in 1865 as a Limited Company),
 111 Sun of Canada House, Cockspur Street,
 Trafalgar Square, London, S.W.1.

Please furnish further details of your "Three Stage" Plan.

Name
 (Mr., Mrs. or Miss)

Address

Occupation.....

Exact date of birth

W.R.27/11/31.

International Short-Wave Reception

By KIRK L. RUSSELL of New York City, U.S.A.

A LOT of thrills are being missed by radio enthusiasts who do not know that a short-wave receiver can be purchased for the price of an ordinary broadcast receiver, or that a combination long and short-wave receiver can be had with which the average person may tune in, direct to their home, radio programmes broadcast on short waves from all the leading capitals of the world; not, of course, with the same excellence or clarity of a local broadcast, but marvellously well considering the vast distance and the atmospheric conditions which sometimes cause interruptions.

The medium and long broadcast bands on which regular programmes are received is above 200 metres. Below that and down to 10 metres is the short-wave band. Most of the foreign stations broadcast on the 25, 31 and 49-metre wavebands.

On Wednesday and Saturday mornings each week in my Scarsdale home, twenty miles north of New York City, I have a loud speaker on my breakfast table and at 6 a.m. Eastern Standard Time, I am often entertained with music, talk, news and travel descriptions from far-away Melbourne, Australia, 8,000 miles distant, through station VK3ME, the Experimental Station of the Amalgamated Wireless Australasian, Ltd., Melbourne. The announcer tells me at that time that it is "9 p.m. Eastern Australian Time," which means that he is shortly going to bed the same evening of the day in which I am just getting up. As I arise from the breakfast table at 6.30 a.m. my Australian friend says, "Good-night."

Every Sunday morning at breakfast time and until 8.30 a.m., my friend, the announcer (I wish I knew the names of foreign announcers as we know them in the United States) in Sydney, Australia, at station VK2ME, entertains me with music, talks, etc., similar to Melbourne. John Carlisle of the Australian National Travel Association has interested me much in his travel talks on Australia. The broadcast of records of the song of the Australian lyre bird, and the merry laugh of that other bird called the "laughing jackass" from these Australian stations are very interesting to the thousands of short-wave listeners everywhere. Why, even my parrot joins in the laugh of the "laughing jackass" when it comes over the air. The

practice of giving the time of day, and the day, too, is interesting to us in the United States, who are getting up when the Australians are going to bed. The Sydney station broadcasts the striking of a clock at 11 p.m. similar to "Big Ben" from London. These Australian stations work on the 31-metre band.

The Rome station, 2RO, in the 25-metre band, gives us some very interesting and much appreciated grand opera up to 6.30 p.m. Eastern Standard Time, and one feels like joining in the applause that comes swelling and fading over the air as the singers cease. The short-wave listeners in the United States would appreciate more announcements in English. Perhaps this would be practicable by using occasionally a gramophone record to broadcast, in English, the call letters of the station, where situated, address and wavelength, and any other standing information intended to interest us here in the United States.

The French station, Pontoise, in the 25-metre band, broadcasting programmes from Paris, is a newcomer on the short-wave ether, and is received with good volume on the loud speaker up to 6 p.m. Eastern Standard Time, at which time they close with the Marseillaise. They have been announcing, in English, requests to be advised of reception. The

suggestion made in connexion with a record in English of call letters, etc., also applies. Such announcements would be much appreciated.

From 8.15 to 8.30 p.m. Eastern Standard Time, a new short-wave station, EAQ of Madrid, Spain, in the 30-metre band, is received fairly well in Eastern United States. The

Spanish announcer is recognized by his "Hillo—Hillo—Hillo," and once in a while he gives, in English, station call letters and his address. He, too, might use a gramophone record occasionally to transmit a standard form of announcement in English.

The British Broadcasting Corporation's experimental short-wave station, G5SW, at Chelmsford, England, working in the 25-metre band, is the old standby for short-wave listeners in the United States. Every evening, excepting Saturdays and Sundays, that station is "on the air" until 7 p.m. Eastern Standard Time. I have put my loud speaker out in the front garden for my neigh-

bours to hear the booming of "Big Ben" at the midnight hour in London. In fact, I keep my watch regulated by "Big Ben" and by the boys in Australia. Rabat, Morocco, in North Africa, broadcasts a musical programme in the 32-metre band every Sunday afternoon which we hear on the Atlantic Coast of the United States fairly well.

The Bolinas, California, stations of the R.C.A. Communications, Inc., situated on the Pacific coast, frequently rebroadcast programmes from San Francisco for the benefit of listeners in Hawaii and Japan. Eastern listeners on the short-wave bands receive these broadcasts at good volume clear across the United States—about 3,000 miles. Generally these broadcasts are on the 20-metre band.

Station W8XK of the Westinghouse Co. of Pittsburgh, Pa., is heard regularly on the 25 and 49-metre bands. Station W2XAF of the General Electric Co., of Schenectady, N.Y.,



The 20 kW short-wave transmitter of VK3ME, 31.28 metres, at Melbourne, Australia

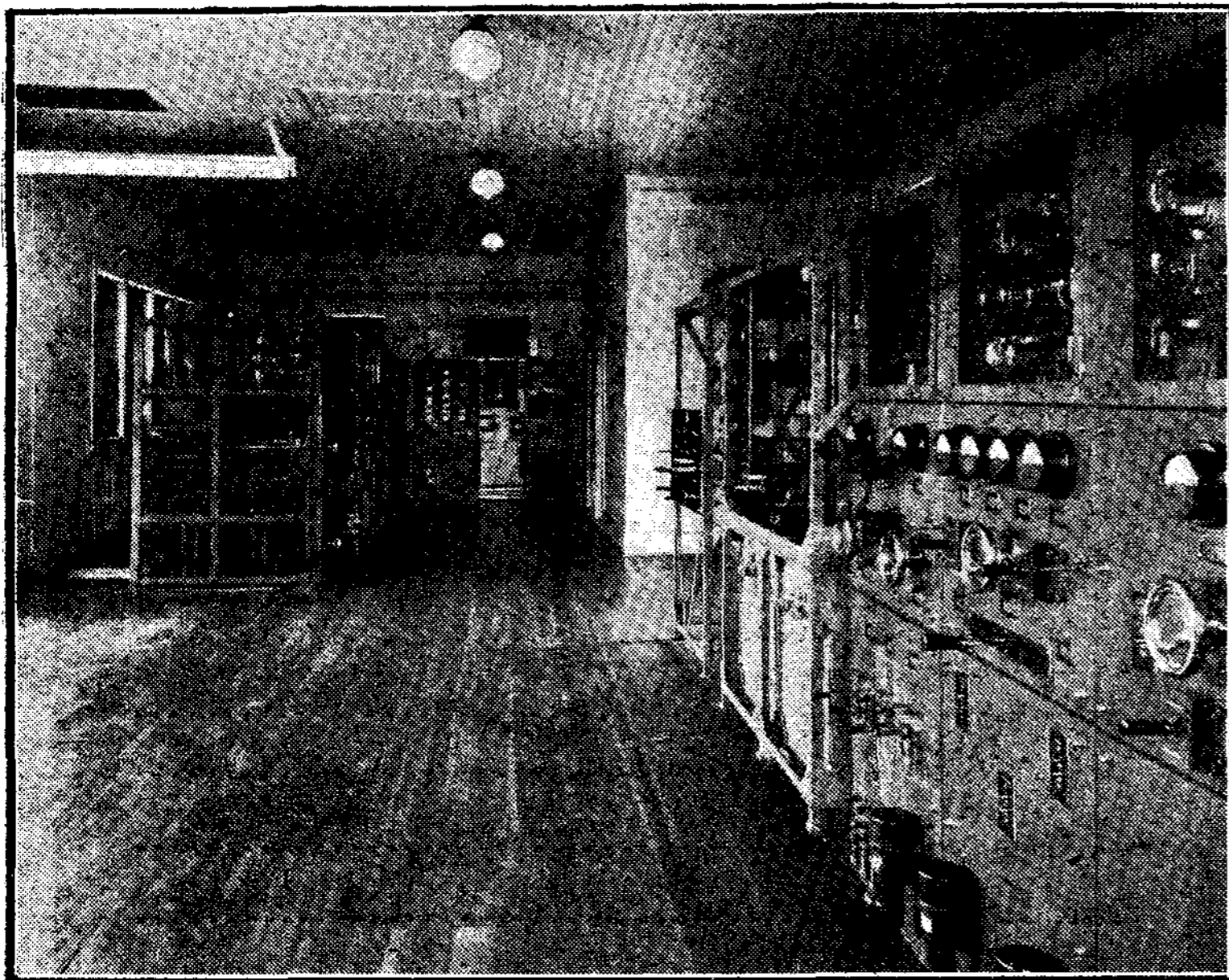

Short-wave transmitters of station VE9CL, 48.8 metres, at Winnipeg, Canada

is heard all over the world at all hours on the 31-metre band. There are other short-wave broadcasting stations in or near the 49-metre band in New York City, Springfield (Mass.), Bowmanville and Winnipeg (Canada), Cincinnati, Chicago, and Mexico City. Several Central and South American stations are also heard more or less regularly from sundown to midnight. The short-wave equipment used by the writer comprises a five-valve receiver with two variable *mu* valves, high-frequency and detector circuits, with two audio frequency stages, the output stage consisting of two valves connected in "push-pull."

MODERN IDEAS ON SHORT-WAVE TRANSMISSION

(Continued from page 875)

most probable that the greater part of this country will be within the so-called "skipped distance" area. In this region we shall have the waves passing over our heads, for even the upper reflecting region is not rich enough in electricity to bend back the waves at small angles of incidence. No, the really useful service given by short waves is at long distances, at places beyond the spot to which they are returned by the first reflection from the upper reflecting region. They thus appear to be specially suitable for communication with distant parts of the world. It has sometimes been said that the gift of wireless has been vouchsafed to mankind for the special benefit of the British Empire. If by "wireless" we understand "short-wave communication," the statement has still greater force.

High-Quality Receivers

2.—The Detector in Theory

(Continued from page 776, November 13)

THE process of rectification has been described in numerous articles in this journal, but as it is a subject upon which considerable confusion still appears to exist, a further description seems to be justified.

It should be realised right from the start that there is no fundamental difference between the various types of rectifier used in wireless receivers, whether as detectors, or as means of converting the supply from A.C. mains to D.C., crystal detectors, diodes, grid detectors and anode-bend detectors—all have the same fundamental property necessary for rectification. The difference lies in the manner in which this property is utilised, and in what other properties are associated with each type of detector. The crystal and diode merely rectify, and do not amplify at the same time, but when a three electrode valve, or in some cases a valve with four or more electrodes, is used, amplification, as well as rectification, takes place.

In the case of the grid rectifier, or, as it is commonly called, the "leaky-grid" detector, rectification takes place in the grid circuit of the valve, and the rectified voltage is applied *via* the grid to the anode circuit, thereby being amplified. The valve therefore acts as a rectifier followed by a low frequency amplifier.

cannot give any corresponding changes in the response of the loud speaker.

It is necessary, therefore, to produce from the modulated high-frequency carrier a voltage which is proportional to the variations in the amplitude of the carrier, and so proportional to the original modulating voltages produced by the sounds to be transmitted. The process by which this is achieved is that of rectification.

Now consider an alternating voltage of constant amplitude applied to some device which has the peculiar property of having no resistance to voltages applied to it in one direction and infinite resistance to voltages of the opposite sense, thus allowing current to flow through it in one direction only. The applied alternating voltage will, therefore, cause current to flow during the half-cycles when the voltage is in the proper direction for the device to allow current to flow. During the reverse half-cycles no current will flow. The result, therefore, is that there will be a unidirectional current flowing through the device in pulses corresponding to each half-cycle of the applied alternating voltage when current flows. (See Fig. 1.)

If a direct current meter is now connected in series with the device it will try to read these pulses of unidirectional current. If the pulses are sufficiently low in frequency for the needle to respond it will do so, but if they are not, the needle will take up a position corresponding to the mean value, and will fail to respond to the high-frequency variations about this mean value.

If the amplitude of the applied high-frequency

alternating voltage is now increased to say twice its value, the D.C. meter will read twice as much as it did previously, since there will be twice as much electricity flowing through it.

Now we see that we have a device which will respond to variations in the amplitude of the applied high-frequency voltage, provided that these variations are slow and give the needle time to respond. If, however, these variations take place at frequencies greater than a few cycles per second the needle will not be able to respond, but if the meter is replaced by a device such as a pair of telephones which can respond to these higher frequencies, then sounds will be heard in the telephones which will correspond to the variations in amplitude of the alternating voltage. Thus we have a device acting as a rectifier, and producing rectified currents corresponding to the modulating voltages produced by the original sounds to be transmitted.

If, however, we desire to amplify these currents to operate say a loud speaker, what is to be done? By connecting a resistance in place of the meter or telephones the rectified currents

will flow through this resistance and will produce corresponding rectified voltages which can be fed to the grid of an amplifying valve and amplified as required. This arrangement is fundamental to all detectors used in modern wireless receivers.

Now consider all the voltages set up across this resistance. It has been shown that the steady rectified current, and, therefore, the voltage developed across the resistance, is the mean of a series of unidirectional pulses produced by the half-cycles of applied alternating voltage causing current to flow. There will actually be high-frequency variations about

this mean value which are not required, and if fed to amplifying valves they will only be a nuisance. If, therefore, a condenser is connected across the resistance it will prevent these voltages being set up if its reactance at the frequencies concerned is low compared with the value of the resistance across which it is connected. (See Fig. 3.)

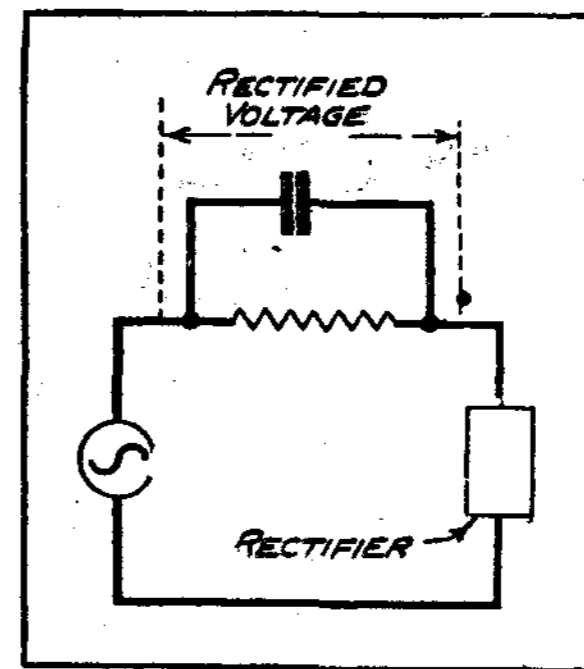

Fig. 3—Arrangement for obtaining rectified voltages without H.F. components

When the amplitude of the applied high-frequency alternating voltage is varying at audio frequencies, these audio-frequency voltages are set up across the resistance, and are the real voltages required. As these voltages may have frequencies ranging from about 50 to 10,000 cycles per second, it is necessary for the resistance or impedance across which they are to be developed to remain constant throughout this range if response is to be uniform at all these frequencies.

Hence, if the condenser which has been connected across the resistance to by-pass the radio frequency components of the rectified current is large, it will also reduce the voltage developed at the higher audio frequencies, consequently there will be loss of high notes. Therefore, the value of the by-pass condenser must be chosen so that its reactance at the higher audio frequencies is not so low compared with the resistance across which it is connected as to reduce the effectiveness of the latter.

Thus we have the simple theory of a perfect rectifier which has the property of having no resistance to voltages of one sense and infinite resistance to voltages of the opposite sense. Unfortunately, perfect rectifiers do not exist, and in the next article of this series the various methods of utilising imperfect rectifiers to make them as nearly perfect as possible will be considered.

(To be continued)

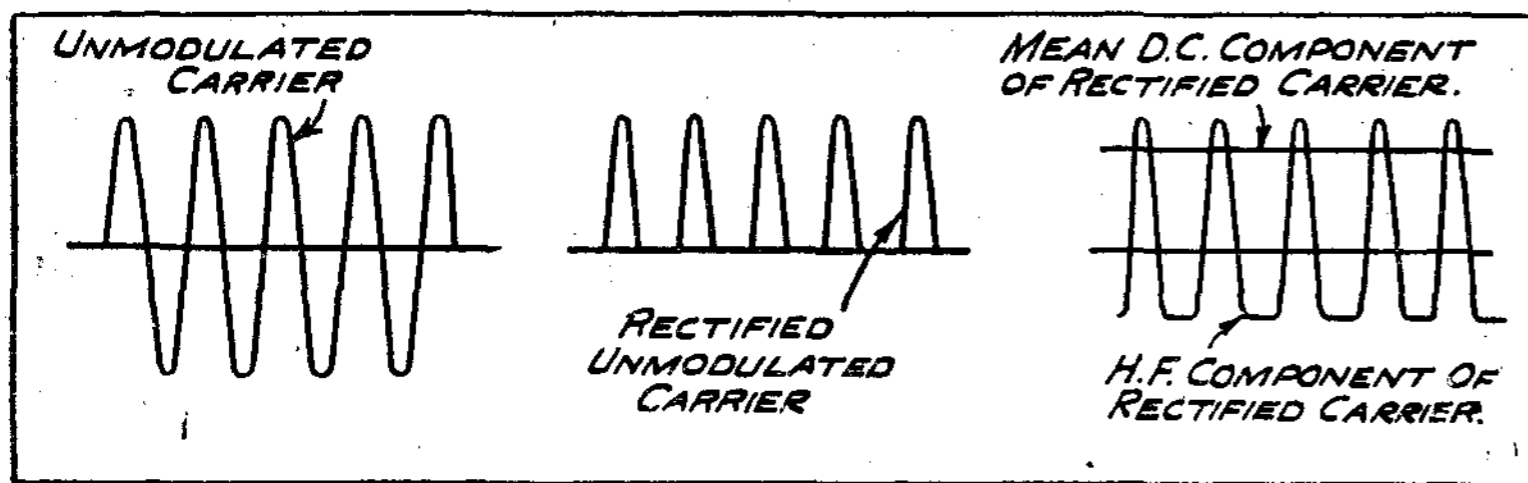

Fig. 1—Rectification of an unmodulated carrier

In the anode-bend detector H.F. amplification takes place before rectification, the amplified signals being introduced into the anode circuit, where they are rectified. The actual process of rectification is the same in principle in both cases.

Process of Rectification

What is the peculiar property necessary for a device to function as a rectifier? Also, why is rectification necessary in a receiver? The signals radiated by a broadcast transmitter consist of a high-frequency alternating carrier wave, the amplitude of which is varying in accordance with the audio-frequency modulation produced by the sounds to be transmitted. These variations in amplitude have therefore to be made to operate a device such as a loud speaker in order that sounds corresponding to the original sounds may be heard. It is useless to apply the modulated high-frequency carrier, even after amplification to a loud speaker, because this modulated carrier is alternating at such a high frequency that the loud speaker cannot respond to it, and, therefore, any changes in its amplitude

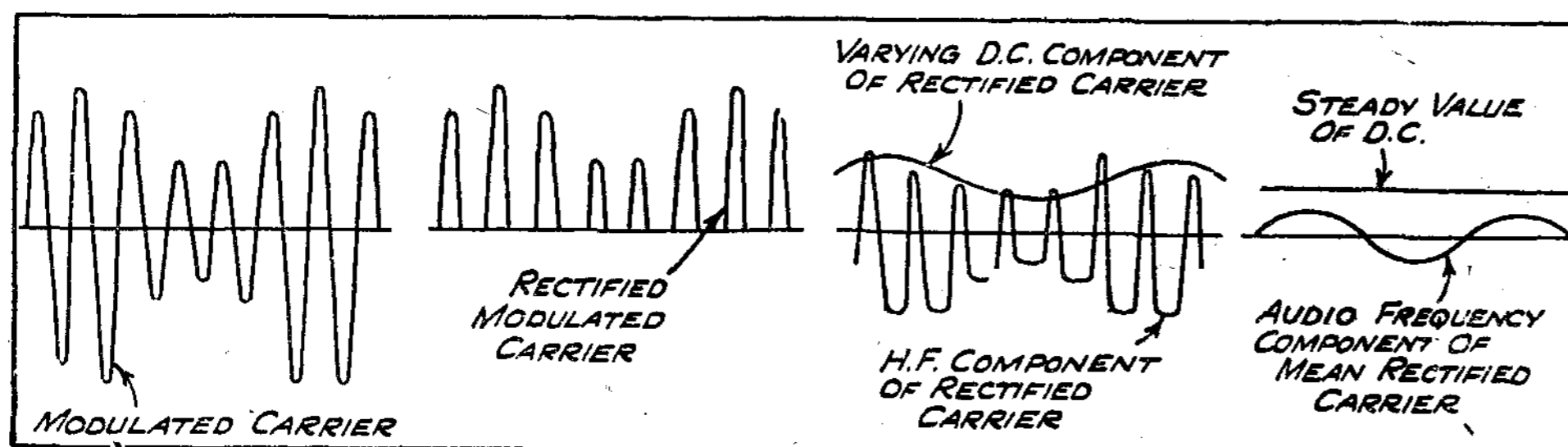

Fig. 2—Rectification of a modulated carrier

TO OUR NEW READERS.

If you are interested in our present serial articles—"Technique of Broadcasting" and "High-Quality Receivers"—back numbers containing the earlier articles may be obtained, price threepence each, post free, from the B.B.C. Publications Dept.

A complete six-valve super-heterodyne short-wave receiver was described in last week's issue. A copy can be obtained as mentioned above.

Although frequently asked, we do not publish "blue-prints" or wiring diagrams of receiver circuits described in *World-Radio*.

It is intended to resume the publication of "Readers' Short-Wave Reception Reports." Communications are invited from readers in all parts of the world.

To ensure the regular weekly supply of *World-Radio* either place a standing order with your newsagent, or enter a direct subscription. In the latter case, please use the form on page 870.

If, at the same time, you care to send us the name of a friend who you think would be interested, a specimen copy of *World-Radio* will be forwarded, free of charge.

October, 1931

Frequencies of European

Measured at the Brussels
 Technical Committee of the Union
 The letter T indicates wireless telegraphy transmission

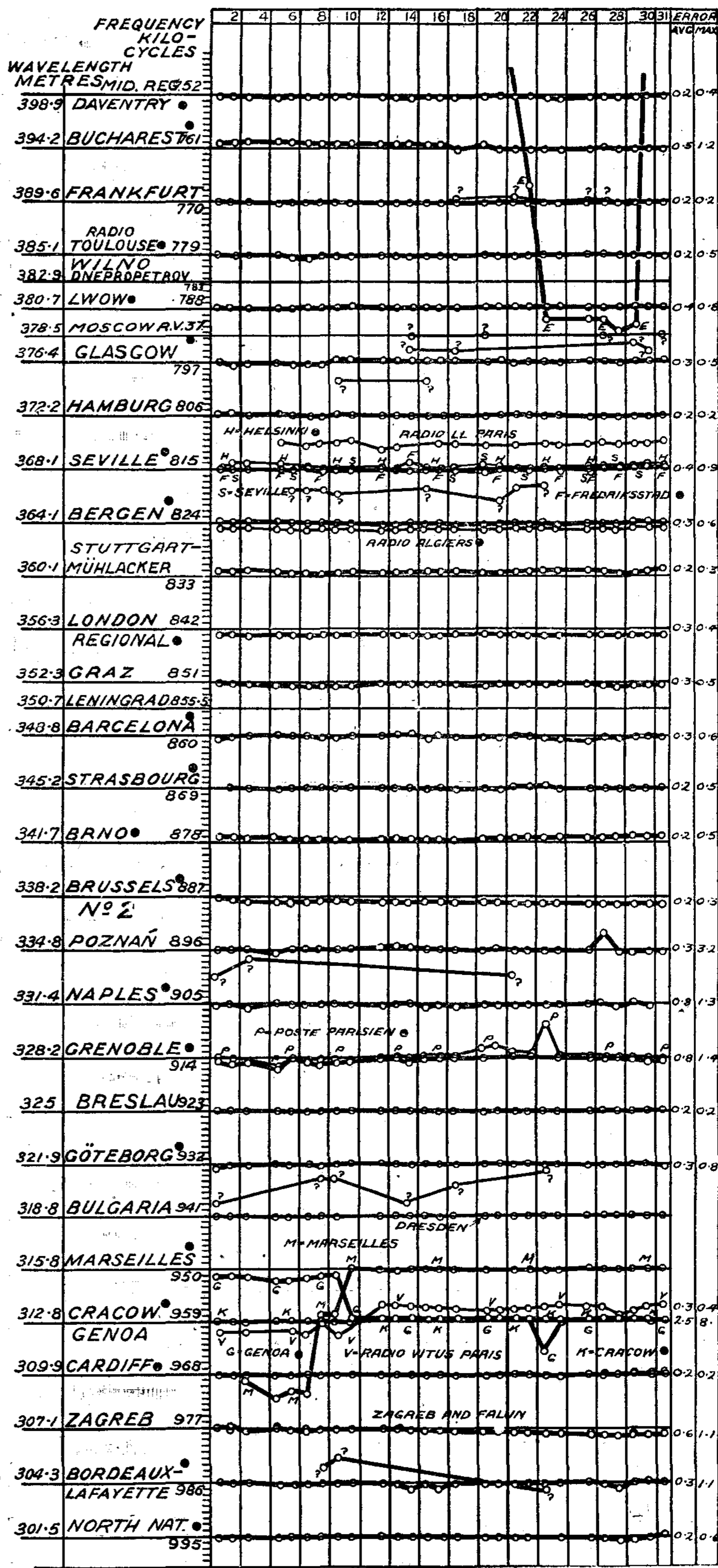
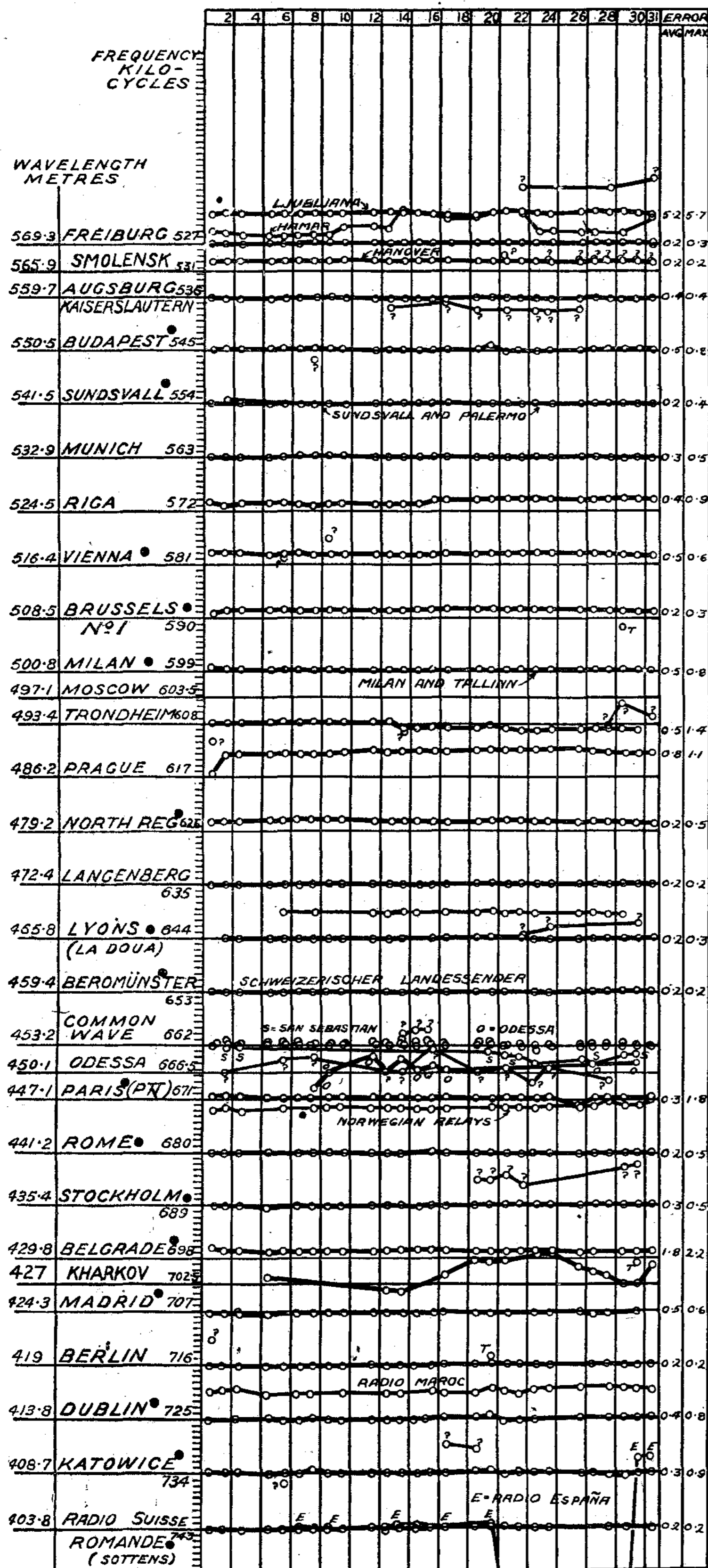

Broadcasting Stations

October, 1931

Laboratory of the
Internationale de Radiodiffusion

Stations marked ● are provided with U.I.R. wavemeter.

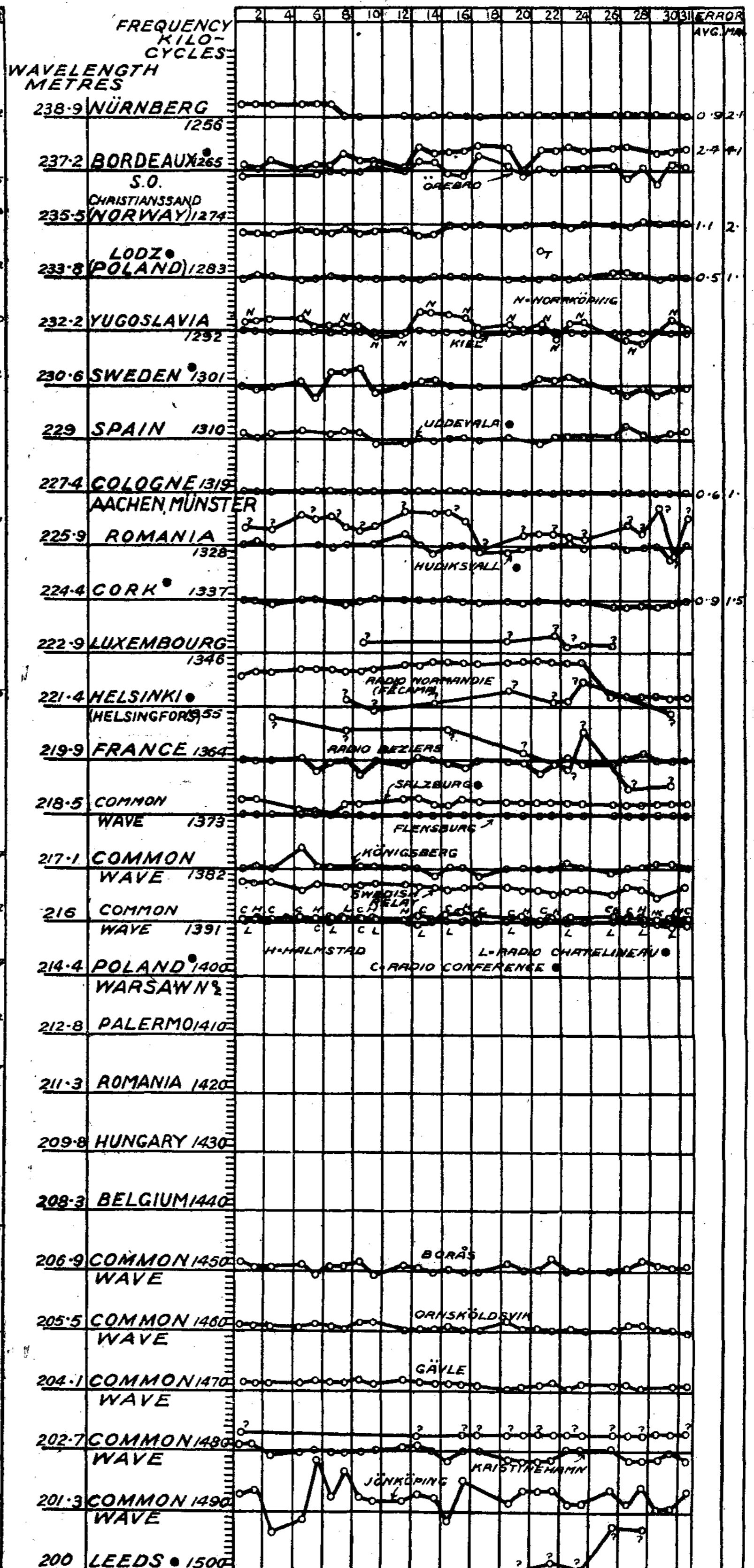
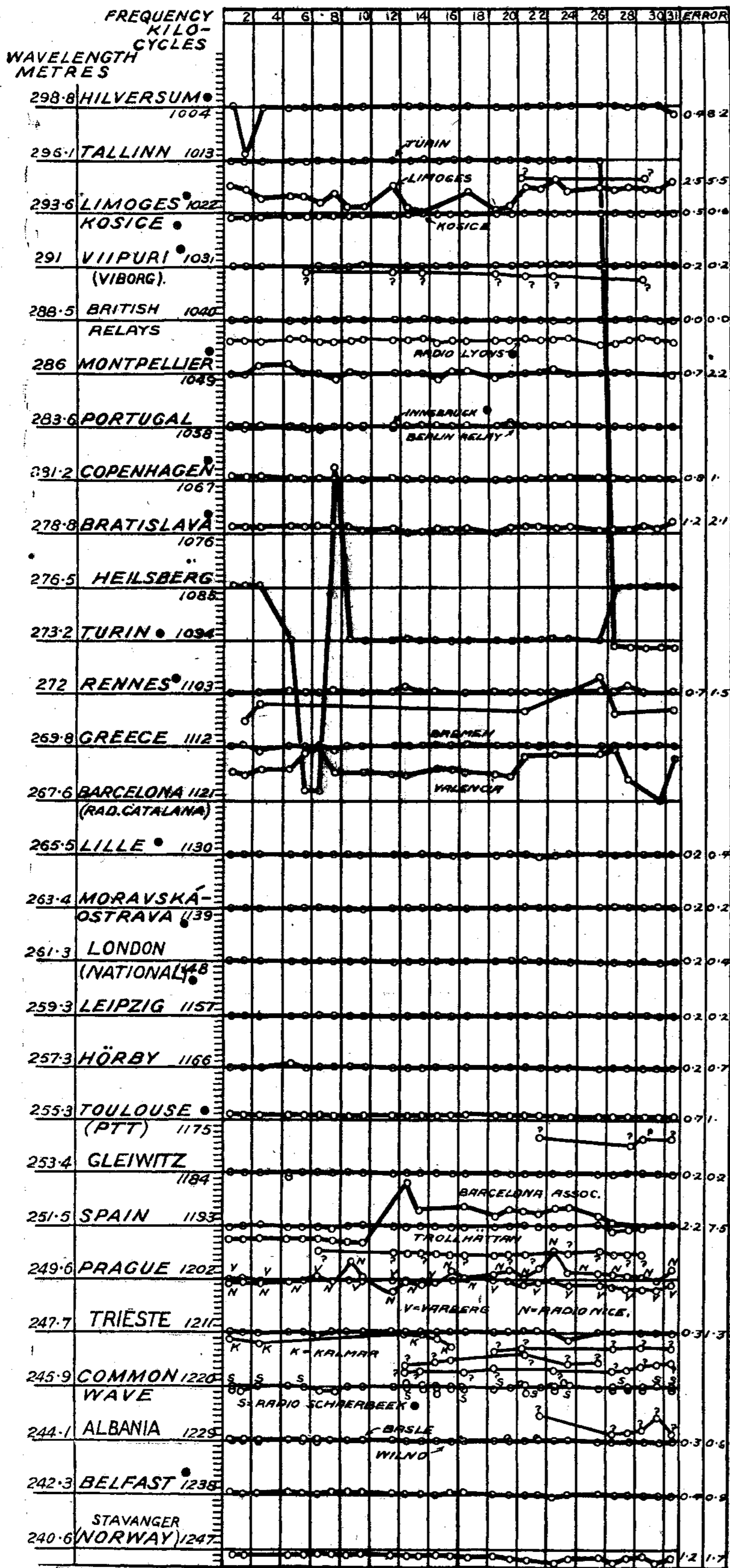

SHORT-WAVE ADAPTORS

(Continued from page 877)

C_3 —0.002 ; C_4 —0.0003 ; C_5 —differential reaction condenser (capacity 0.0001 mfd.) ; S.W.C.—two short-wave chokes ; L.W.C.—long-wave choke. V_1 is the oscillator valve and V_2 the detector valve, the latter having a $4\frac{1}{2}$ -volt grid-bias battery, and operating as an anode-bend detector. The method of connecting this adaptor to the broadcast receiving set is exactly similar to that of the one-valve super-heterodyne adaptor. In this case, however, the latter set may be tuned to a wavelength where the greatest amplification is obtainable, provided that the point selected is clear of interference.

Searching for short-wave stations should be carried out with the reaction condenser set at zero, and the two tuning dials should be rotated very slowly, approximately in step, and with the broadcast receiver just oscillating. This will not cause any interference as, of course, the broadcast set is not connected to the aerial. The adjustment of the detector variable condenser is not extremely critical, but that of the oscillator condenser is. It will be found that the carrier-wave of any particular short-wave station can be heard at two separate points on the oscillator condenser dial, probably some eight to ten degrees apart. Either adjustment may be selected, and, as reaction is reduced on the broadcast set until it ceases to oscillate, the programme of the short-wave transmitter should be heard.

The tuning operations described, although they will be found quite simple when a little experience is gained, call for a certain initial patience, and it is very desirable to make note of the dial settings for future reference. If the critical movement necessary in the case of the oscillator condenser dial makes the final tuning difficult, a fine adjustment can be obtained by slight movement of the tuning dial, or dials of the broadcast receiver.

BILLY MAYERL'S TUITION RECORDS

will teach
you how to play.

NO previous knowledge required.

Merely by listening to Billy Mayerl's special gramophone tuition records, and following his fascinating lessons in your own home and spare time, you will be amazed at the progress made after the first few weeks and the ease with which you can play your favourite songs or dance tunes. Billy Mayerl will teach you even though you cannot as yet play a single note.

Write now for free booklet, "Me and My Piano," marking your envelope "Beginner."

SECRET OF SYNCOPATION.

If you can already play a fox-trot from the printed music and want to learn the secret of Syncopation—how to get that marvellous up-to-date rhythm into your own playing—then ask Billy Mayerl to send you his well-known booklet, "Lightning Fingers," describing how you can learn to syncopate just as he does. Read the opinions of Jack Hylton and Jack Payne and testimonials from thousands of successful students.



**THE BILLY MAYERL
SCHOOL,**
Studio 7, 29, Oxford Street,
London, W.1.

Birmingham Branch: 49, St.
Albans Road, Smethwick.
Belfast Branch: Jack Sargent,
c/o Vincent and Sons, 80, Gt.
Victoria St., Belfast.

Short-Wave Reporting

A description of the wireless-link transmitter employed in connexion with an American outside broadcast

LAST May, the United States Air Corps decided to hold manœuvres over the city of Chicago, and arrangements were made by the local broadcasting stations to relay the proceedings. Numerous stations arranged to have commentators situated on the roofs of sky-scrapers in order that their relays should be as complete as possible. Station WCFL, owned by the Chicago Federation of Labour, decided that this method of reviewing the manœuvres would not allow of very much scope, and decided to get as near to the scene of action as possible. The show was to take place over the waterfront at Chicago and it was decided to take a small portable transmitter to the scene of action and erect it on a breakwater nearby.

The Federal Radio Commission gave authority for the WCFL engineers to design and construct a portable transmitter to operate on 2,368 and 1,564 kilocycles with the call sign of W9XAB. The higher frequency was finally selected as it was found to be free from local interference.

The transmitter, a short technical description of which follows, was designed and built within four days. A fixed frequency was assured by the use of a crystal-controlled valve oscillator. Even though the transmitter was a portable, a temperature control cabinet was built around the control crystal. A thermometer, adjusted to operate with changes of one half a degree centigrade, controlled a relay operating the heaters, which consisted of six automobile bulbs supplied with filament currents from accumulators. The output stage of the transmitter utilised a single valve with a plate circuit input of twelve watts, modulation being effected by means of two further valves. All the filaments operated at 7.5 volts direct current, and a 12-volt accumulator was used for this purpose. It was the most bulky and troublesome part of the whole equipment.

The morning of the manœuvres found four of the WCFL engineers in a six-seater lifeboat loaded with the portable transmitter. Across the waterfront, at the mouth of the Chicago river, runs a breakwater and this was selected as being the most suitable place for setting up the transmitter. Four 15 ft. poles, lashed to pilings, provided the masts. Two lengths of wire, each 198 ft. long, furnished the aerial system. Only twenty minutes were required to place the aerial in position and to have the transmitter operating.

A Successful Relay

The first transmission was scheduled for 9.15 a.m., and a little before this a tremendous group of bomber planes was coming up from the horizon on the north. A portable receiver provided a means of listening to the parent station, WCFL. At 9.15 the voice of the announcer from the station at Chicago was heard: "We are now taking you over to the breakwater opposite the mouth of the river, where a special portable transmitter will bring

you an actual eye-witness account of the flight of Uncle Sam's eagles over Chicago." The announcer stood ready, and waited: an operator raised his hand. He had detected the slight rushing noise of the distant short-wave receiver which was trying to pick up the portable. The announcer started to talk—it was coming through! Clear as a bell! The announcer's voice was going through the portable transmitter to a receiver on shore, within half a mile of the WCFL transmitter, thence over a short temporary wire to the main transmitter itself, and was then broadcast. The party on the breakwater listened to the main station by means of the portable medium wave receiver.

The short-wave receiver on shore was pre-adjusted by using a radio-frequency oscillator tuned to the transmitter's wavelength. While the men on the breakwater had been setting up their apparatus, the men on the shore had been listening.

The Portable Transmitter

The accompanying photograph shows the portable transmitter, W9XAB. The two wires leading upward from the white porcelain

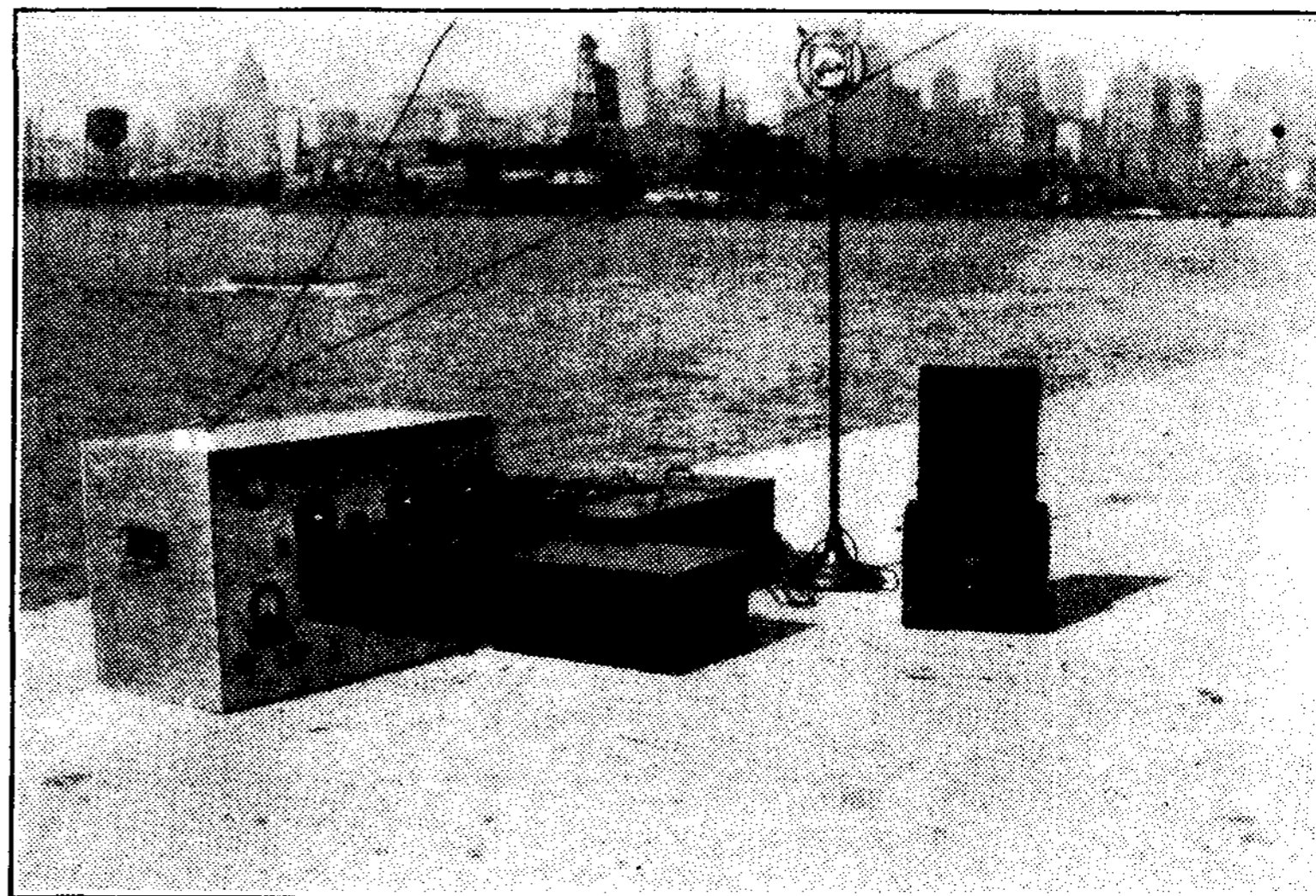

The short-wave transmitter (W9XAB), microphone and portable medium-wave receiver

insulator from the Hertz antenna. To the right of the microphone stand is the portable receiver used to check the quality of the transmission. In the background can be seen the skyscrapers of Chicago's "loop," the centre of the city.

The three dials on the front of the transmitter tune the oscillator, buffer-amplifier and last radio-frequency stage, respectively reading from left to right. The top meter is a radio-frequency ammeter, one ampere maximum, and the bottom meter indicates anode current, to 250 milliamperes. Below it is a jack-strip with jacks in the speech amplifier and modulator circuits. Jacks to enable measurements of current in the radio frequency stages to be made are mounted on the small rectangles of bakelite.

It is interesting to note that so accurate was the calibration of the receiver that the first moment of transmission was received; the dial was never varied, and the reception was so good that it was not necessary to manipulate any of the controls. At a later date, this transmitter will be installed on a boat cruising the Great Lakes, to determine its transmitting radius.

M. B.

READ WHAT USERS SAY!

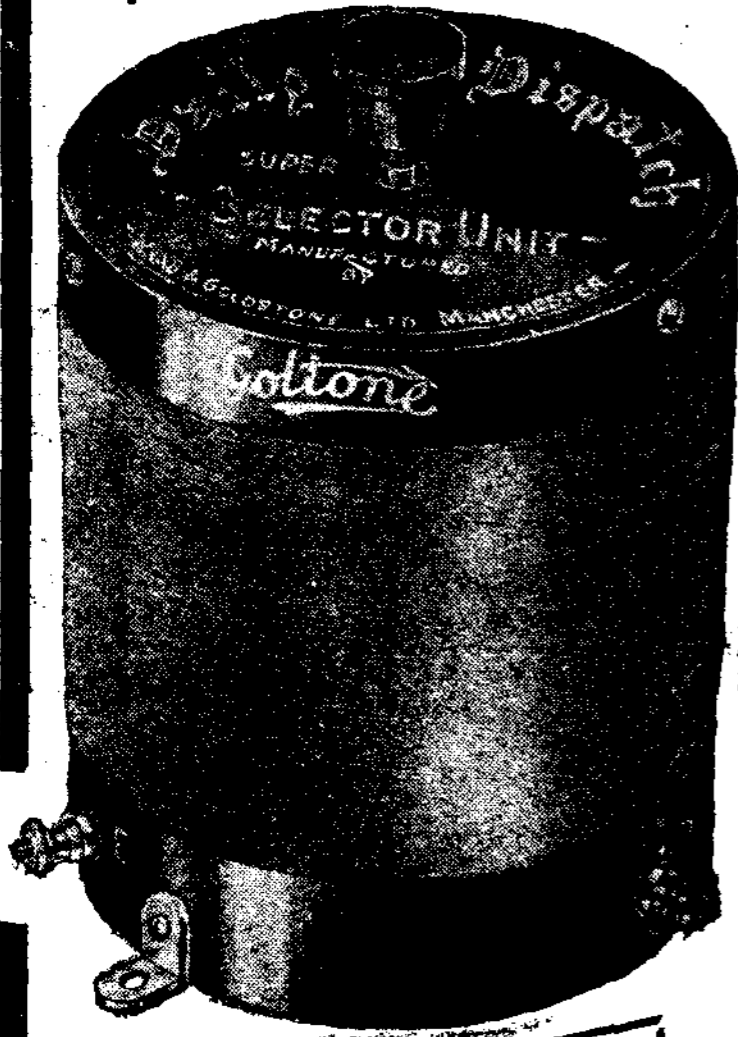

Mr. J. H. B., Broad Oak, Nr. Rye, Sussex, writes:—
 "It is like adding another valve to the set for results. As for interference, I get hardly any, and the number of stations are nearly doubled."
 Mr. W. T. L., s/s P., Fishguard, writes:—
 "Since using it I have logged countless stations, which before only came in faintly—now they come in at full loud-speaker strength. Another feature most noticeable is the increase in volume of reproduction without distortion."
 Mr. E. C., Cheetham Hill, Manchester, writes:—
 "By means of your new unit I am now able to remove all trace of interference, and, furthermore, I can fully substantiate your claim of increased volume, especially on distant transmissions."

"GOLTONE" Daily Dispatch Selector Unit

enables you to cut out interference, however powerful, and bring in, the selected stations loudly and clearly. There is no need for you to lose your favourite distant stations with the opening of the high-power Regional Transmitters. Not alone a Wave Trap, but a Selector Unit combining a complete extra tuning stage. Stations that were a mere whisper will now come in at good strength.

Connected in a few seconds to any set from a crystal to a multi-valve.
 Pamphlet with full particulars on request.
 Other Wave Traps from 2/6.
 From all first-class Radio Stores or direct from manufacturers.
 Refuse substitutes.

R 48/66
6/6



FEATURES

1. Complete elimination of interfering stations.
2. Sharper tuning, better quality and increased volume from all stations.
3. Increased number of stations received owing to ability to separate, or isolate, each one.
4. Selectivity without loss of volume.

See the Trade Mark "GOLTONE" on every genuine coil.

RECEIVE SHORT-WAVE STATIONS ON YOUR SUPER HET. USING THE GOLTONE MINIATURE FRAME AERIAL

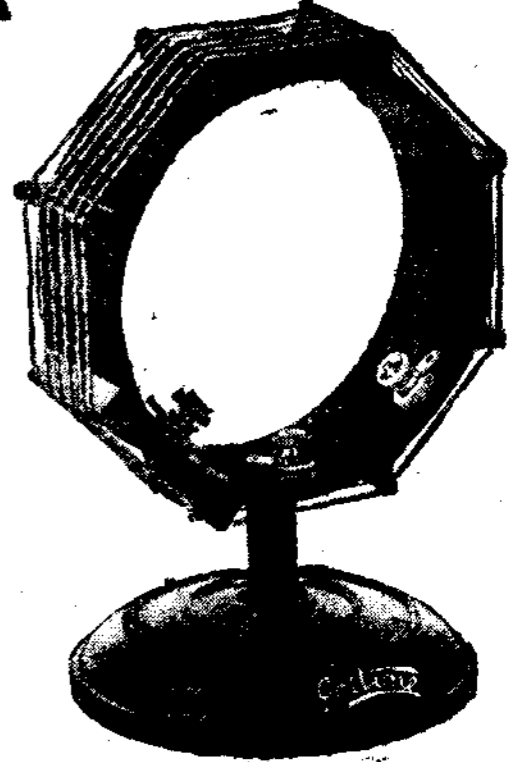

Specially designed for reception of short wave stations. Wound with A.S.C. Multi-strand Conductor on Ebonite Air Spaced Former. Height about 5ins. R22/22 **5/6**

Full particulars on request.

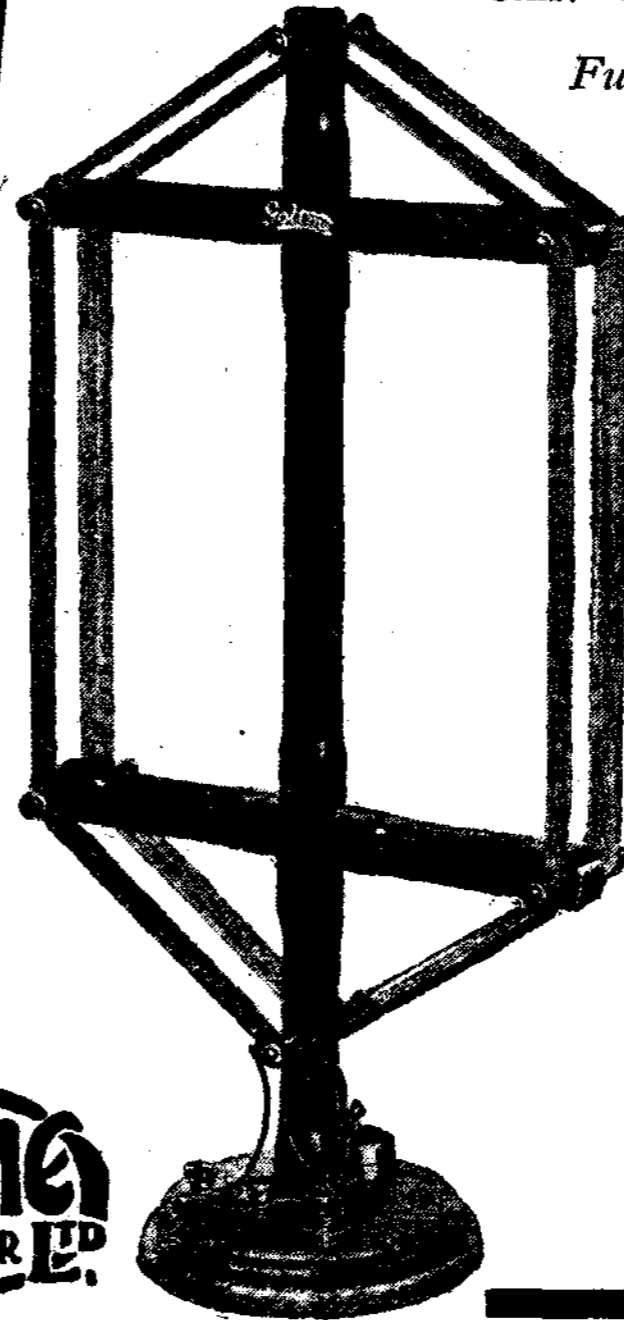

GOLTONE DUAL RANGE FRAME AERIAL

FOR MEDIUM AND LONG WAVE STATIONS.

RECOMMENDED by Amateur Wireless for use with the "CENTURY SUPER" and other circuits where a Frame Aerial can be utilised. Wound with special Multi-strand A.S.C. Wire. Wave Change Switch mounted on Base. Designed to ensure maximum results. A high-grade, well-finished product.

Full particulars on request. R22/21

From all First-class Radio Stores—Refuse substitutes; if any difficulty write direct. **15/-** Each.

Large Illustrated Radio Catalogue sent on request.

"IT'S A SMALL WORLD"

with an—

"Eddystone" Short Wave Converter within reach of your THUMB and FINGER!



You will be able to receive short wave broadcast transmissions from all over the world by a simple insertion of this converter in the aerial lead to your set. It can be used with any battery, D.C. or A.C. mains receiver providing one or more stages of H.F. amplification are present. It converts your present receiver into a short wave super-heterodyne following the latest practice.

Built to true short wave design by "EDDYSTONE," the Short Wave Specialists and guaranteed to give excellent results. Absolute simplicity in operation and no additional connections needed.

15-65 METRES. NO COIL CHANGING

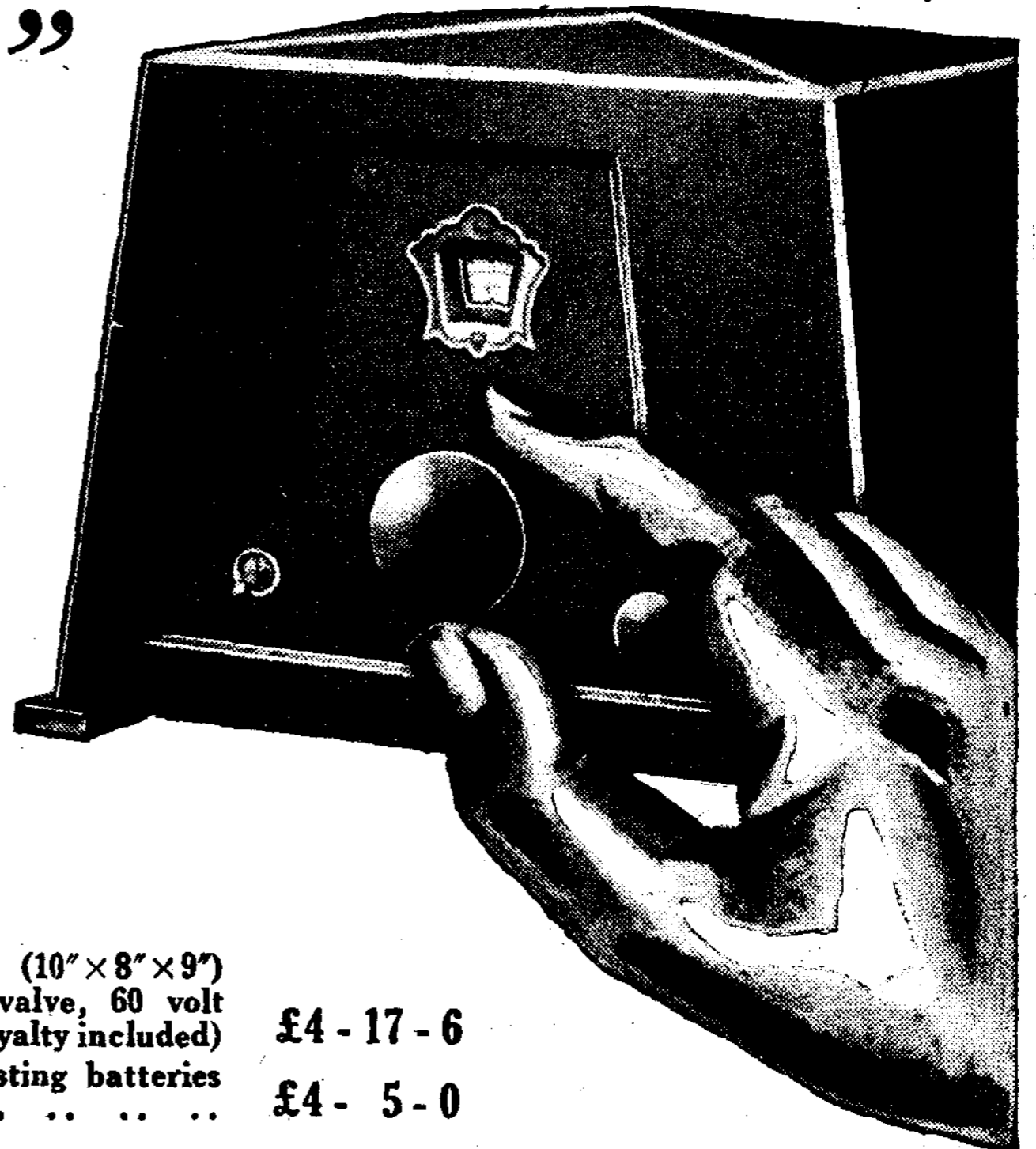

Complete in oak cabinet (10" x 8" x 9") including Mullard PM2DX valve, 60 volt Pertrix H.T., Exide L.T. (Royalty included) £4 - 17 - 6
 Or without batteries, if existing batteries are utilised £4 - 5 - 0

Sole Manufacturers:
STRATTON & CO., LTD.,
 BROMSGROVE STREET, BIRMINGHAM.

London Service Depot:
WEBB'S RADIO STORES,
 164, Charing Cross Road, W.C.2.
 Telephone: Temple Bar 2944.

EDDYSTONE
 SHORT WAVE
 CONVERTER



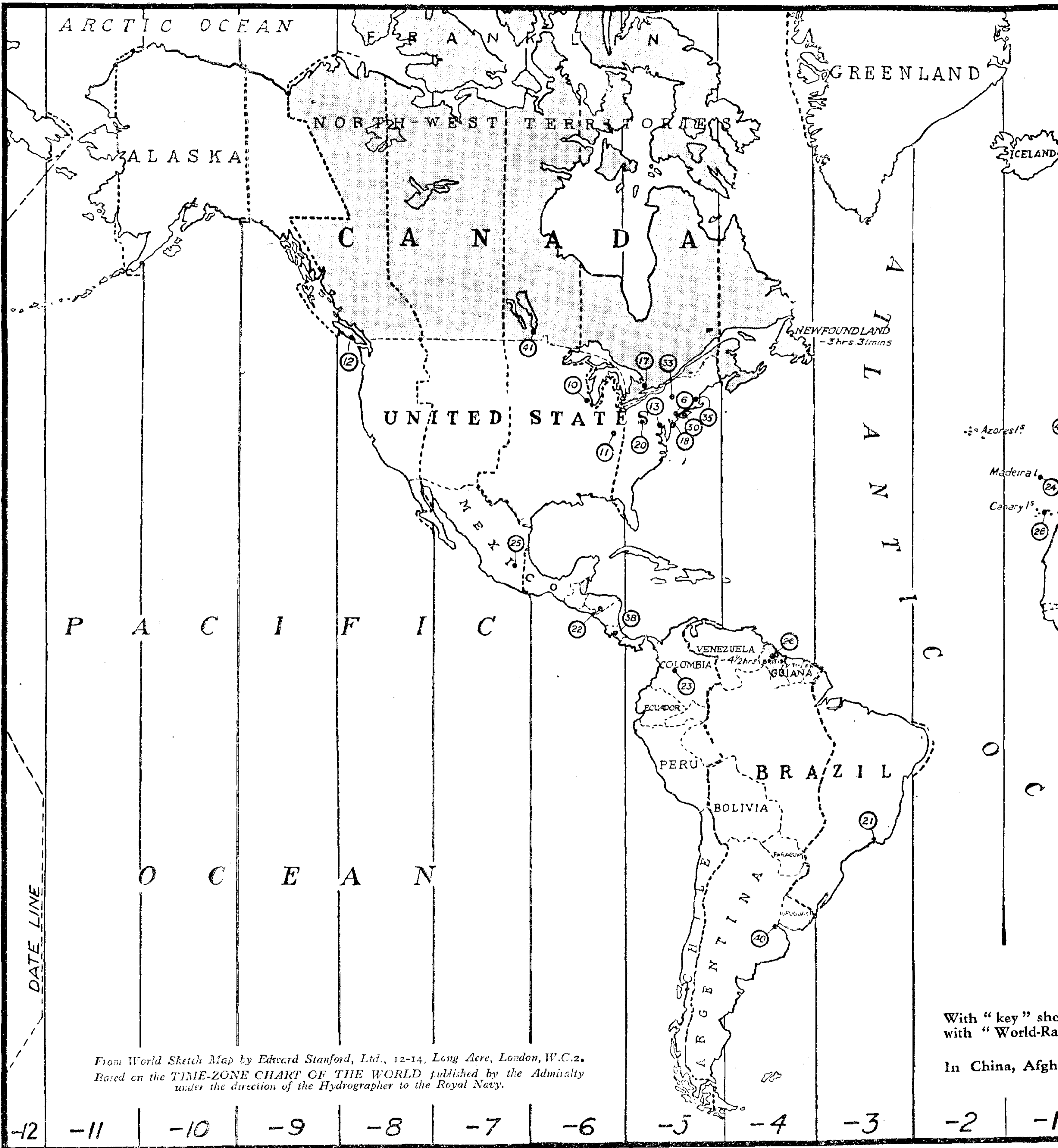

From World Sketch Map by Edward Stanford, Ltd., 12-14, Long Acre, London, W.C.2.
Based on the TIME-ZONE CHART OF THE WORLD published by the Admiralty under the direction of the Hydrographer to the Royal Navy.

With "key" shown with "World-Radio"

In China, Afghanistan

Ref.	Station	Call	M.	kW.
1	Constantine (Algeria) ..	SKR	45	0.2
2	Rome (Italy)	2RO	80	14
3	Kherbarovsk (Russia) ..	—	79.2	—
4	Radio LL (France)	—	33	0.5
4	Paris (France).....	FLJ	32.5	—
4	Pontoise (France).....	—	25.63	—
4	Pontoise (France).....	—	25.2	—
4	Pontoise (France).....	—	19.68	—
5	Prague (Czecho-slovakia)	OKIMP	58	—
6	Brooklyn (U.S.A.)	W2NBH	54.52	—
6	New York (U.S.A.)	W2XAL	49.67	0.25
6	Richmond Hill (U.S.A.) ..	W2ENE	49.02	0.5

Ref.	Station	Call	M.	kW.
7	Belgrade (Yugoslavia) ..	—	30	—
8	Moscow (Russia)	—	50	—
8	Moscow (Russia)	—	45.38	—
9	Barcelona Radio Club (Spain)	EAJ25	50	—
10	Chicago (U.S.A.)	W9NF	49.83	5
10	Chicago (U.S.A.)	W9XAA	49.34	0.5
10	Chicago (U.S.A.)	W9XAA	25.34	—
10	Chicago (U.S.A.)	W9XAA	16.57	—
11	Cincinnati (U.S.A.)	WSXAL	49.5	10
12	Vancouver (B.C.)	VEPCS	49.43	—
13	Philadelphia (U.S.A.) ..	W9NAU	49.5	0.5

Ref.	Station	Call	M.	kW.
13	Philadelphia (U.S.A.) ..	W2NAU	31.3	0.5
14	Johannesburg (S.A.)	—	49.4	—
15	Calcutta (India)	VUC	25.27	0.5
16	Bangkok (Siam)	HSP2	41	2.5
17	Bowmanville (Canada) ..	VE9GW	49.22	0.028
17	Bowmanville (Canada) ..	VE9GW	25.43	—
18	Bound Brook (U.S.A.) ..	W3XAL	49.18	—
18	Bound Brook (U.S.A.) ..	W3XL	46.60	—
19	Nairobi (Kenya)	7LO	49.5	—
20	Pittsburgh East (U.S.A.) ..	W8NK	48.86	—
20	Pittsburgh East (U.S.A.) ..	W8NK	25.25	—
20	Pittsburgh East (U.S.A.) ..	W8NK	19.72	—

Ref.	Station
21	Rio de J
22	Teguciga
23	Barrang
23	Bogotá
23	Bogotá
24	Funchal
25	Chapulte
25	Chapulte
25	Mexico
25	Nuevo L
27	Madrid

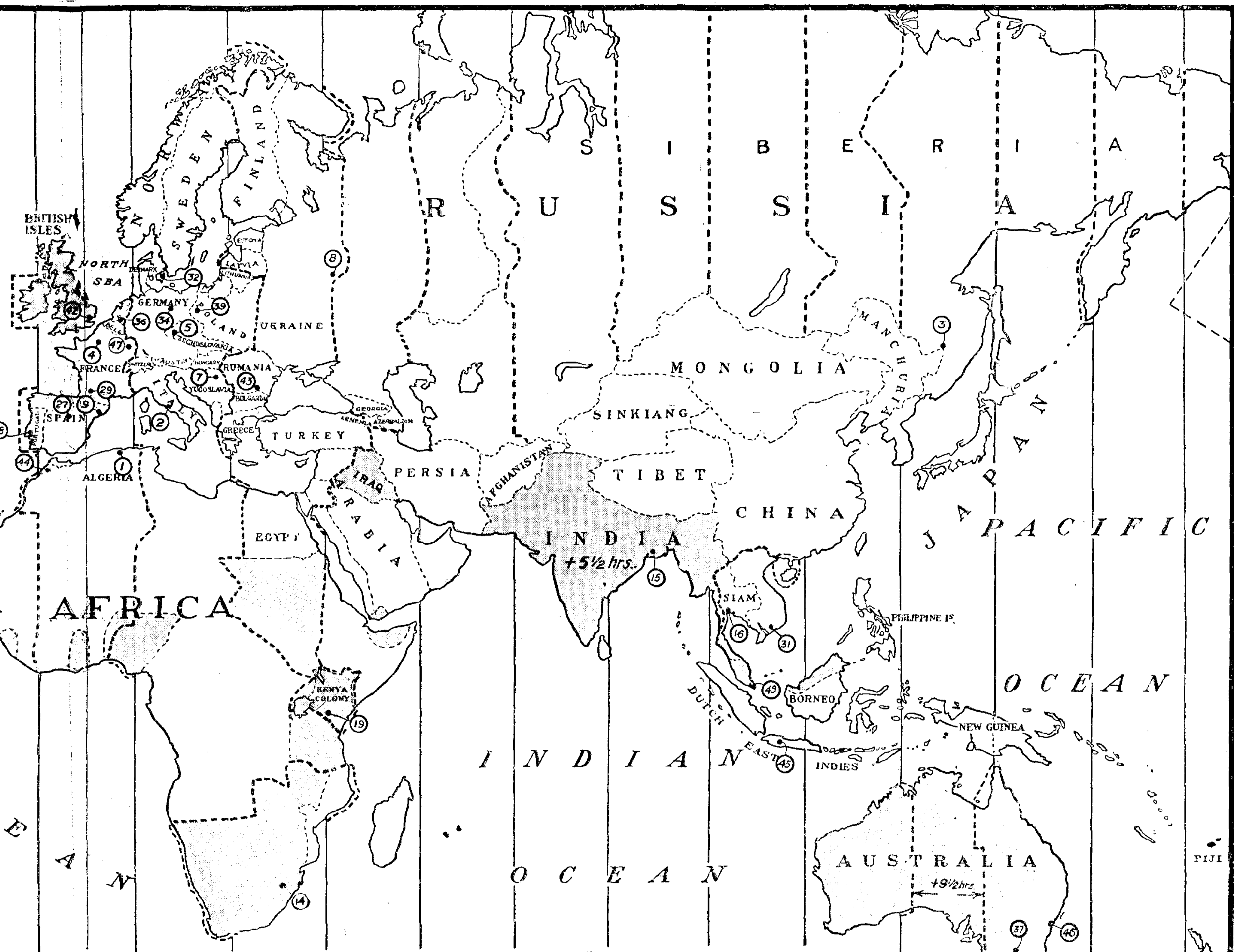

TIME-ZONE MAP OF THE WORLD

SHADED TO SHOW THE BRITISH EMPIRE AND BRITISH MANDATES

Using reference numbers, names of stations, call-letters, wavelengths in metres (M), and aerial power (kW) in accordance with the "Short Wave List." To ascertain the time at any station shown, add to or subtract from G.M.T. the appropriate zone number, except where "half-hour" times are indicated on the map (e.g. India).

India, Persia, Arabia, Abyssinia, Borneo, Sumatra, Venezuela, Bolivia, Guatemala, Franklin, most of Greenland, and part of New Guinea—either the legal time is not known, or no legal time is kept.

0	+1	+2	+3	+4	+5	+6	+7	+8	+9	+10	+11	+12
---	----	----	----	----	----	----	----	----	----	-----	-----	-----

Station	Call	M.	kW.
Belem (Brazil)	—	31.75	—
San Pedro de Macoris (Honduras)	HRB	49.96	2.5
Medellin (Colombia)	HND	48.05	—
Medellin (Colombia)	HKC	48.35	—
Medellin (Colombia)	HKF	39.7	—
Madeira	CFAQ	21	0.05
Mexico	NDA	51.22	20
Mexico	NDA	35.5	20
Mexico	NDA	29.5	20
Mexico	XIF	18.05	—
Mexico	XGSA	33.4	—
Spain	EAR110	45	—

Ref.	Station	Call	M.	kW.
28	Tenerife Radio Club (Canary Islands)	EAR58	41.6	0.05
29	Agen (France)	—	30.75	—
30	Long Island (U.S.A.)	W2XV	62.5	—
30	Long Island (U.S.A.)	W2XV	31.68	—
31	Saigon (French Indochina)	—	—	—
32	Schenectady (U.S.A.)	FRCD	49.05	—
33	Schenectady (U.S.A.)	ONY	31.51	0.5
33	Schenectady (U.S.A.)	W2XAF	31.48	10
33	Schenectady (U.S.A.)	W2XAD	19.56	20
34	Zeesen (Germany)	—	31.28	8

Ref.	Station	Call	M.	kW.
35	Springfield (U.S.A.)	WINAZ	31.35	—
36	Eindhoven (Holland)	PCJ	31.28	25
37	Melbourne (Australia)	VK3ME	31.55	5
37	Melbourne (Australia)	YK3ME	31.28	20
38	Heredia (Costa Rica)	NRH	29.3	0.067
39	Poznan (Poland)	SRI	31.37	1
40	Buenos Aires (Argentina)	—	—	—
41	Winnipeg (Canada)	LSX	28.98	20
42	Chelmsford (England)	VIKCL	18.8	2
42	Chelmsford (England)	G5SW	25.53	10
43	Bucharest (Romania)	—	50	0.5

Ref.	Station	Call	M.	kW.
43	Bucharest (Romania)	—	21.5	0.3
44	Casablanca (N. Africa)	CNSMC	48	—
44	Rabat (Radio Maroc) (Morocco)	—	32.26	6
44	Rabat (Radio Maroc) (Morocco)	—	23.3	6
45	Bandoeng (Java)	PLB	13.93	83
46	Sydney (Australia)	VK2ME	31.25	20
47	Nancy (France)	—	15.5	—
48	Lisbon (Portugal)	CTIAA	42.9	2
48	Singapore	VSIAP	41.7	—

"A Worthy Home for your Set."

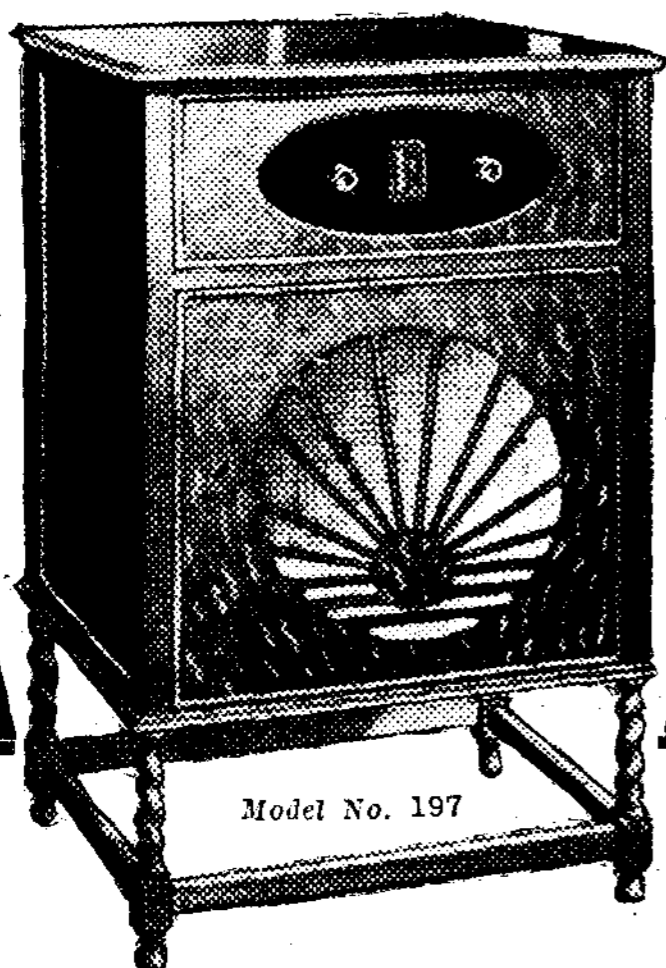

Model No. 197

OSBORN

READY - TO - ASSEMBLE
JACOBAN FIGURED OAK
RADIO CABINET
35/-

Model No. 197.
3ft. 6ins. High, 2ft. Wide,
1ft. 4ins. Deep. Opening at
top and back. To take a
panel 21ins. by 8ins. or
smaller. Baffle Board 1ft.
9ins. by 1ft. 6ins. Metallic
fabric for Front included
Free.

Prices.
Machined ready to assemble,
£1-15-0.
Assembled ready to polish,
£2-10-0.
Assembled and polished,
£3-5-0.

All models carriage paid.

Send 3d. in Stamps for 56-page illustrated catalogue.

CHAS. A. OSBORN

LARGEST MAKERS OF RADIO CABINETS IN THE BRITISH ISLES

DEPT. W.R., THE REGENT WORKS, ARLINGTON ST.,
LONDON, N.1.
Telephone: CLERKENWELL 5095.
and at 21, ESSEX ROAD, ISLINGTON, N.1.
(1 minute from the Agricultural Hall.)
Telephone: CLERKENWELL 5634.

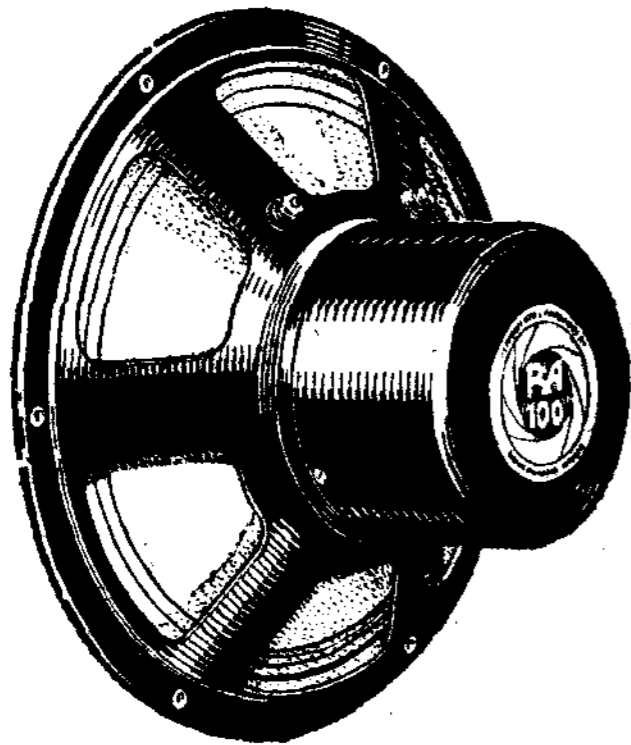

Pure Reproduction of Speech and Music.

"R. & A." Permanent Magnet Moving Coil Reproducers reproduce speech and music with a realism not surpassed by any other type of speaker. They are the result of design, materials and workmanship of the highest class, and are ideal for use with 2-valve receivers, as well as with large power amplifiers. The R. & A. "100" has many imitators; in your own interests, therefore, insist on R. & A. Get your dealer to demonstrate, and compare with any other speaker. If any difficulty, write us direct.

45/-

Complete in hand-
some Hand-
Polished Mahog-
any-Finished
Cabinet £4

Multi-ratio Trans-
former to suit all
Power Valves,
including 12/6
Pentodes

Fully descriptive and
illustrated literature,
containing complete
specification, sent post
free on request.

REPRODUCERS &
AMPLIFIERS, LTD.,
Frederick Street,
WOLVERHAMPTON

The
RA
"100"
PERMANENT MAGNET
MOVING COIL
REPRODUCER

PROGRAMME SECTION

Continental Programme Events

SUNDAY, NOVEMBER 29

Concerts

- 10.30 a.m. Leipzig and all German stations:
Bach Cantata.
11.15 ,, Warsaw: Philharmonic Orchestra.
5.0 p.m. Radio-Paris: Relay of "Concert
Poulet."
7.0 ,, Hamburg: Orchestral.
7.0 ,, Berlin, Königs Wusterhausen, Bres-
lau, Heilsberg: "North and
South" (a potpourri).
7.0 ,, Prague: Symphony Concert by
Czech Philharmonic Orchestra.
8.0 ,, Brussels No. 1: Orchestral and vocal.
9.0 ,, Copenhagen: Orchestral.
9.0 ,, Vienna, Budapest, Prague: Relay
of New York Philharmonic Con-
cert, conducted by Signor Tos-
canini.

Operas and Operettas

- 6.30 p.m. Brno: "Othello" (Verdi).
6.30 ,, Leipzig: "La Dame Blanche"
(Boieldieu).
7.30 ,, Frankfurt, Stuttgart, Heilsberg:
"Carmen" (Bizet).
8.0 ,, Brussels No. 2: "The Tales of
Hoffmann" (Offenbach).

Plays

- 8.0 p.m. Radio-Paris: "La Femme de Ta-
barin."

MONDAY, NOVEMBER 30

Concerts

- 7.0 p.m. Leipzig: Symphony concert.
7.0 ,, Oslo: Symphony concert.
7.0 ,, Schweizerischer Landessender:
Symphony concert.
8.0 ,, Brussels No. 2: Orchestral.
8.0 ,, Milan, Turin: Symphony concert.
8.10 ,, Berlin, Königs Wusterhausen: Orch-
estral. Slavonic Music.
8.30 ,, Brussels No. 1: Orchestral.
8.30 ,, Budapest: Symphony concert.

Operas and Operettas

- 7.0 p.m. Warsaw: "Manon" (Massenet)
(Gram. records).
8.0 ,, Radio-Paris: "La Tosca" (Gram.
records).

TUESDAY, DECEMBER 1

Concerts

- 8.0 p.m. Brussels No. 2: Orchestral.
8.0 ,, Rome: Ottorino Respighi conducts
own compositions.
9.0 ,, Copenhagen: Orchestral.
9.15 ,, Brussels No. 1: Orchestral.
9.15 ,, Hamburg: "Echoes from Scandi-
navia."
9.40 ,, Frankfurt, Stuttgart: Mozart piano-
forte music.

Plays

- 8.0 p.m. Radio-Paris: Four short plays.

WEDNESDAY, DECEMBER 2

Concerts

- 7.0 p.m. Schweizerischer Landessender:
Orchestral.
7.0 ,, Stockholm: Symphony concert.
8.0 ,, Hamburg: Josef Strauss Concert.
8.30 ,, Radio-Strasbourg: Symphony con-
cert.
8.45 ,, Radio-Paris: Chamber music.
9.30 ,, Copenhagen: Chamber music.

Operas and Operettas

- 6.30 p.m. Budapest: "The Land of Smiles"
(from Royal Opera House).
8.0 ,, Rome: "Cavalleria Rusticana" and
"Pagliacci."

Plays

- 7.0 p.m. Langenberg, Königs Wusterhausen:
"Prince Friedrich von Homburg."

THURSDAY, DECEMBER 3

Concerts

- 7.0 p.m. Schweizerischer Landessender:
Famous composers of the seven-
teenth and eighteenth centuries.
7.15 ,, Warsaw: Orchestral and vocal.
7.55 ,, Hilversum: Symphony concert.
8.0 ,, Rome: Gala concert relay.
8.30 ,, Frankfurt, Stuttgart: Mozart con-
cert.
9.25 ,, Copenhagen: Orchestral and Choir.
Operas and Operettas
6.55 p.m. Hamburg: "Othello" (Verdi).
7.0 ,, Heilsberg: "Neues vom Tage"
(Hindemith).
7.55 ,, Milan, Turin: "Maggiolata Vene-
ziana" (Salvaggi).

FRIDAY, DECEMBER 4

Concerts

- 7.0 p.m. Hamburg: Christmas Oratorio (K.
Thomas).
7.10 ,, Copenhagen: Johann Strauss and
Lehár concert.
7.15 ,, Warsaw: Symphony concert by
Philharmonic Orchestra.
7.45 ,, Heilsberg, Königs Wusterhausen:
Mozart Anniversary concert.
8.30 ,, Brussels No. 1: Orchestral (Con-
ductor, François Rasse).

Operas and Operettas

- 7.0 p.m. Schweizerischer Landessender:
"Der Kuhreigen" (Kienzl).
8.0 ,, Radio-Paris: "The Golden Cock-
erel" (Rimsky-Korsakoff).
8.0 ,, Rome: "Tuffolina" (Pietri).

SATURDAY, DECEMBER 5

Concerts

- 7.0 p.m. Copenhagen: Danish Folk Dance
music.
8.0 ,, Brussels No. 2: Orchestral and
vocal.
9.10 ,, Warsaw: Chopin pianoforte recital.

Operas and Operettas

- 8.0 p.m. Rome: "Adrienne Lecouvreur"
(Cilea).

Other Events

- 10.0 p.m. Budapest: Hungarian songs and
poetry in English.

Interference between Stations

(November 15-21)

TALLINN, which has used Milan's wave-
length for some time, went back, on
the 15th, to his allotted frequency of
1,013 kc/s, which he had left on account of
Turin using it arbitrarily. This move of
Tallinn ends the situation, with all its conse-
quences, which Turin created in November,
1930, when he began to work on Tallinn's allotted
wavelength.

Radio-Valencia, since the very beginning of
his transmissions, has worked on wrong wave-
lengths and has been unsteady. During the
above period, he has occupied different wave-
lengths from 1,109 to 1,117 kc/s, and on the
first-mentioned wavelength, which he used on
the 18th, he heterodyned the French station
Rennes P.T.T. (1,105).

Toulouse PTT, by working on 1,179 kc/s on
the 17th and 18th, caused interference to Gleis-
witz, which worked on 1,184 instead of 1,185,
(Continued in column 2, page 889)

SHORT-WAVE STATIONS

The times quoted are reduced to G.M.T.

M.	Kc/s	Station
80	3,750	Rome (Italy) 2RO, 14 kW. (Aer.).
70.2	4273	Khabarovsk (U.S.S.R.), 20 kW. 9 a.m. to 12 a.m.
62.5	4300	Long Island, W2XV. FRI., 11 p.m. 1.30 a.m.
58	5172	Prague. TUES. and FRI., 7.30-9.30 p.m.
54.52	5502	Brooklyn (N.Y.) W2XBH. Relays WCGU.
51.22	5857	Chapultepec (Mexico) XDA, 20 kW. Daily 3-4 p.m.
50	6000	Barcelona Radio Club EAJ25. SAT. 8-9 p.m.
50	6000	Bucharest (Romania), 0.3 kW.
50	6000	Moscow (Relays Moscow T.U.). 8.0 p.m.
49.96	6005	Tegucigalpa (Honduras) HRB, 2.5 kW. Daily (except SUN.), 12 m't. - 5 a.m.
49.83	6020	Chicago (Ill.) W9XF, 5 kW. Relays WENR SUN. 5-7 a.m., 1-5.30 p.m., 8.30-11 p.m. and 1-6 a.m. (MON). Weekdays, 3.15-4.45 p.m., 8.30 p.m. - 12 m't. and (ex. SAT.) 1.30-6 a.m.
49.67	6040	New York (W2XAL), 0.25 kW. TUES., 12 m't. - 5 a.m. WED., 12 m't. - 2 a.m. FRI., 12 m't. - 4 a.m. SAT., 12 m't. - 3 a.m.
49.5	6060	Cincinnati, W8XAL, 10 kW. Relays WLW.
49.5	6060	Nairobi (Kenya), 7 LO.
49.5	6060	Philadelphia (Pa.) W3XAU, 0.5 kW. Relays WCAU. Daily 2-9 p.m. THURS. and FRI., 2 p.m. - 6 a.m.
49.43	6069	Vancouver (B.C.) VE9CS.
49.4	6072	Johannesburg (S. Africa). Daily 3.30-8.30 p.m.
49.34	6080	Chicago (Ill.) W9XAA, 0.5 kW. Relays WCFL. Daily 2-5 a.m.
49.22	6095	Bowmanville (Canada) VE9GW, 0.028 kW. Weekdays, 11.45 a.m. - 3 p.m.; and 8 p.m. - 3 a.m. SUNDAYS, 5.30 p.m. - 4.15 a.m.
49.18	6100	Bound Brook (N.J.) W3XAL, 12 kW. MON. TUES., WED. and THURS., 6.30-11.45 p.m. and 4-6 a.m. Sun., 1-7.30 p.m.
49.05	6116	Saigon (French-Indo-China) F3ICD. Daily 12 noon - 3.45 p.m.
49.02	6120	Richmond Hill (N.Y.) W2XE, 0.5 kW. Relays WABC. D'y 1 p.m. - 5 a.m. next day.
48.86	6140	Pittsburgh East (W8XK). Relays KDKA. WED and SAT., 10 p.m. - 5 a.m.
48.8	6147	Winnipeg (Canada) VE9CL, 2 kW. Daily (except SUN.) from 12.30-2.30 a.m.
48.65	6167	Mexico City X1F.
48.35	6205	Bogotá (Colombia) HKC. Daily, 3 p.m.
48.05	6243	Barranquilla (Colombia), HKD.
48	6250	Casablanca (N. Africa) CNSMC. Relays Rabat, MON., 8-9 p.m. TUES., 12 noon - 1 p.m. and 8-9 p.m.
46.69	6425	Bound Brook (N.J.) W3XL. FRI. 10-11.45 p.m. and 4-6 a.m. SAT. 6.30-11.45 p.m. and 4-6 a.m.
45.38	6611	Moscow (Russia).
45	6667	Constantine (Algeria) 8KR, 0.2 kW. MON. and FRI., 11 p.m.
43	6976	Madrid (EAR 110). TUES. & SAT., 10.30 p.m.
42.9	6991	Lisbon CT1AA, 2 kW. FRI., 10 p.m.
41.7	7195	Singapore VS1AB. SUN. & WED. 2.30-4 p.m.
41.6	7211	Tenerife Radio Club EAR58, 0.05 kW.
41	7313	Bangkok HSP2, 2.5 kW. (Testing). MON. only 1-4 p.m.
39.7	7556	Bogotá (Colombia) HKF.
39.4	7612	Nuevo Laredo (Mex.) X26A. THUR., 4-5 p.m.
34.68	8650	Long Island W2XV. FRI. 11 p.m. - 1.30 a.m.
33	9090	Radio LL (France), 0.5 kW. DAILY 12.30-1 p.m. and 6-6.30 p.m. SUN., MON., WED. and FRI., 8-10 p.m. SAT., 7-8.30 p.m. SUN., 10 a.m. - 12.30 p.m. and 2.30-4 p.m.
32.5	9230	Rabat (FLJ). Time Sig. 8.56 a.m. and p.m.
32.26	9300	Rabat (Radio Maroc), 6 kW. SUN. 7-9 p.m.
31.75	9450	Rio de Janeiro (Brazil). 9.30-11.30 p.m.
31.55	9510	Melbourne (Australia) VK3ME, 5 kW. WED. and SAT., 10 a.m. - 11.30 a.m.
31.51	9520	Skamlebaek (Denmark) OXY, 0.5 kW. Relays Copenhagen. Daily from 6 p.m.
31.48	9530	Schenectady, N.Y. (W2XAF), 10 kW. (Aer.). Relays WGY. Weekdays 10.30 p.m. - 4 a.m. SAT. and SUN., 9 p.m. - 4 a.m.
31.38	9560	Zeesen (Germany), 8 kW. Relays various stations, generally 1 p.m. - 12.30 a.m.
31.35	9570	Poznań (Poland) SR1, 1 kW. TUES., 6.45-9.45 p.m. THURS., 6.30 p.m. - 1 a.m.
31.35	9570	Springfield (Mass.) W1XAZ.
31.3	9582	Philadelphia (Pa.) W3XAU, 0.5 kW. Daily (except THURS. and FRI.), 9 p.m. - 6 a.m.
31.28	9590	Melbourne (Australia) VK3ME, 20 kW. WED. and SAT., 10 a.m. - 11.30 a.m.
31.28	9590	Sydney (Australia) VK2ME, 20 kW. SUN., 10 a.m. - 2 p.m.; 2.30-4.30 p.m., and 6-8 p.m.
31.28	9590	Eindhoven (Holland) PCJ, 25 kW. (Closed for six months.)
30.75	9756	Agén. TUES. and FRI., 9-10.15 p.m.
30	10,000	Belgrade. MON. only, 8-9 p.m.
29.3	10,238	Heredia (Costa Rica) NRH, 7.5 watts. Daily 10-11 p.m. and 2-3 a.m.
28.68	10,350	Buenos Aires LSX, 20 kW. 8.30 p.m. - 12.30.
25.83	11,705	Pontoise (Paris). Daily 9 p.m. - 12 m't.
25.53	11,750	Chelmsford (G5SW), 16 kW. (Aerial). 12.30-1.30 p.m. and 6.45 p.m. - 12 m't. MON., WED. and THURS., Nat. programme. TUES. and FRI., Reg. programme.
25.5	11,763	Chapultepec XDA, 20 kW. Daily, 8-9 p.m.
25.43	11,795	Bowmanville (Canada), VE9GW. (Exp'tl).
25.34	11,840	Chicago (Ill.) W9XAA. Relays WCFL.
25.27	11,870	Calcutta (India) VUC, 0.5 kW. Weekdays, 2.45-3.15 a.m. and 3.15-5 p.m.
25.25	11,880	Pittsburgh East (W8XK). 5 p.m. - 3 a.m.
25.2	11,905	Pontoise (Paris). Daily 5.30-8.30 p.m.
24	12,500	Funchal (Madeira) CT3AQ, 0.05 kW.
23.8	12,605	Rabat (Radio Maroc), 6 kW. SUN., 11.30 a.m.
21.5	13,950	Bucharest, 0.3 kW. WED. and SAT., 7.10 p.m.
20.5	14,630	Chapultepec XDA, 20 kW. D'y 7.30-8 p.m.
19.72	15,210	Pittsburgh East (W8XK). Relays KDKA WED. and SAT., 12 noon - 4 p.m.
19.68	15,234	Pontoise (Paris). Daily 2-5 p.m.
19.56	15,340	Schenectady (W2XAD), 20 kW. Weekdays, 6-8 p.m. SAT. and SUN., 6-9 p.m.
16.57	18,105	Chicago (Ill.) W9XAA. Relays WCFL.
15.93	18,830	Bandoeng (PLE), 50 kW. TUES., 1.40-3.40 p.m.
15.5	19,355	Nancy (France).

For Long and Medium Wave Stations see page 814

Last Week's Log

(November 15-21)

By "THE SEARCHER"

THERE was only one night that was at all "atmosphericky" during the week. This was that of Friday, the 20th. Otherwise conditions have been distinctly good, though all-round signal strength is not perhaps quite so good as one would expect with a set employing one or two stages of high-frequency amplification. In the absence of atmospheric, though, super-heterodynes and "straight" receiving sets, with as many as three screen-grid high-frequency amplifiers, give a wonderful account of themselves. During the week, for instance, I was able to let my big super-heterodyne go "all out" and to obtain surprisingly good reception from seldom-heard stations such as Zagreb and the low-powered Scandinavian relays.

To turn to the other end of the scale, a small portable using its own built-in frame aerial gave me really good reception of Heilsberg in broad daylight quite early on the Saturday afternoon. One has, in fact, the impression that while general signal strength after dark may have been a little below normal, that in daylight has been distinctly above the average.

The medium wave-band has shown some rather curious cases of varying reception. Brussels No. 1, which had a weak period recently, has now returned to strength, but Milan, usually a very good transmission, has been poor for some days past. His only first-rate night during the week was the Thursday, though he was respectable on the following night. Budapest I have found a very good signal from dusk onwards, and Vienna is providing much better reception than for some while. Prague has been very powerful, and excellent quality is associated with the reception of his programmes. Langenberg is in first-rate form, and Beromünster is perhaps the strongest and most consistent Continental station on the medium wave-band, though Toulouse, Strasbourg, and Suisse Romande run him pretty close.

Rome is not up to the mark at the moment, though I have had good reception at various times. Stockholm is clear, but not so powerful as he was at this time last year. Witzleben is a weakish signal, though obtainable with plenty of H.F. amplification; Katowice was heard on most nights and came in excellently on the Saturday. Moscow-Stalin has snuffed out Madrid Union Radio. Bucharest is worth attention on good nights. Frankfurt has supplied excellent reception, but Hamburg is a little disappointing. Toulouse is generally good, though he was on the weak side on the Monday and not too good on the Wednesday. Brussels No. 2 showed a great improvement. Göteborg, Bordeaux, Hilversum, Breslau, Leipzig, Hörby, Bratislava, Gleiwitz, Nürnberg, Trieste, and Turin are all stations that have gained a very good mark in the log.

INTERFERENCE BETWEEN STATIONS

(Continued from page 888)

his new frequency. In fact, Gleiwitz, who is generally very stable, has been rather unsteady this week, having been successively on 1,185, 1,184, and 1,187 on the 20th, where he heterodyned Trollhattan (1,193).

On the 20th, San-Sebastian—which is a rather unexpectedly powerful signal for the power of 1 kW he is supposed to have—was off his allotted frequency of 662 kc/s (the International Common Wave) and used 658 kc/s. He was thus heterodyning the stations using 662, and also Schweizerischer Landessender, in spite of the latter's power. Fortunately, San-Sebastian was working only from 7.30 to 9 p.m.

L. B.

Heard on the Continent

By "CENTRAL EUROPEAN"

THE past fortnight has been an eventful period for the listener to distant stations. The important factor of the rearrangement of wavelengths resulted in the reception of stations which previously could only be heard with great difficulty. The period in question also stood out owing to the fact that two new transmitters entered the ether, both, however, being somewhat disappointing.

Radio-Paris was opened first. Everybody rushed to his wireless set in the hope of at last hearing this station. But the power of 80 kW appears to have effected little improvement. Reception of Radio-Paris is at the moment no better than that of the old transmitter. The second new high-power station, which I heard for the first time, was Moscow-Stalin. This transmitter is at present using a power of 100 kW which is to be increased in a few weeks' time to 300 kW. Its signal strength is quite considerable. But I find that, when it relays other stations, there is a great deal of interference, probably emanating from the land-lines.

The rearranging of wavelengths in the region London National-Leipzig has so far worked out excellently. Although all the stations in this region, such as Moravská-Ostrava, London, Leipzig, Hörby, Gleiwitz, are received with great strength, it has now been made possible to eliminate at least the stronger interferences and to get, at any rate, a clear reception, a fact which had previously been impossible. Finally, I would mention my first reception this year of a trans-Atlantic station. This is the South American transmitter, Radio-Splendide LN, Buenos Aires, using a frequency of about 912 kc/s. I heard this station in the night of November 15 to 16. While not a very strong signal, it was sufficiently loud to enable one to follow the programme and announcements quite easily.

Istanbul Heard

Reception on the longer wave-band continues to be quite constant. Warsaw still remains the station which I hear best. Istanbul is a station I have been able to hear for the first time this year, though its signal strength was hardly sufficient for good reception. Reykjavik, on the other hand, I have received with far better audibility than formerly.

On the medium wave-band I succeeded in logging Geneva for the first time. Riga's audibility continues to be good. Prague, though it has deviated somewhat from its wavelength, is the predominating station in this region and, during the evening hours especially, it is, next to Warsaw, the best-heard European station. Langenberg, always a strong signal and always subject to strong fading, was, in the period under review, considerably interfered with by a Russian transmitter. Rome was somewhat weaker than usual, and was frequently wiped out by Stockholm. Radio-Suisse Romande has been a splendid signal, except that the modulation left a little to be desired at times. Bucharest, too, has been a very strong signal; Frankfurt, on the other hand, has been very weak, while Radio Toulouse has not been long in regaining its good form of last winter. Another station heard extremely well and without any fluctuations was Lwów. The relations between London Regional and Stuttgart have greatly improved. The signal strength of the latter is very much greater it is true, but nautical interferences have been almost entirely eliminated. Strasbourg continues to be received with undiminished strength; the same applies to Brussels No. 1 and No. 2. Of the two Silesian transmitters, Breslau has been the better heard of the two during this period.

Which Station Was That?

Answers to Correspondents

KIDHAR (Dover): Surely Lympne aerodrome. **NOVICE (Dundee)**: This was Schweizerischer Landessender relaying Zürich. **CALCIS (Hford)**: Prague; gramophone records. **BAND PASS (Fleet)**: Please number your queries. (1) Langenberg; gramophone records; (2) Frankfurt; early morning broadcast. **PRANTO (Avening)**: Bucharest. **LONDON ROAD (Faversham)**: Apparently VE9CS (Vancouver, B.C.). **NODDY (Mitcham)**: Radio Normandie (Fécamp); the Sunday transmissions after 10.45 p.m. are on 245.9 m. **LURGAN (Ulster)**: Berlin (common-wave stations). **GRIDLEAK (Wandsworth)**: Local amateur transmitter. **STANLEY (S.W.19)**: Radio Normandie (Fécamp). **ALEXANDRIA (Egypt)**: There is no station of that wavelength reported in the official U.S.S.R. list, but a new 100 kW. transmitter has been opened at Moscow on 424.3 m. Are you sure you did not hear Warsaw (No. 2) on 214.2 m.? **DUFFER (Birmingham)**: Kalundborg; a relay from Copenhagen of a talk on William Pitt; (2) Radio-Paris; a sponsored broadcast of gramophone records; announcements by Mr. Christopher Stone (on records). **EARLY BIRD (Exeter)**: Possibly test by Radio Toulouse. **ROBERT-LE-DIABLE (S.E.23)**: Paris PTT. **EASTERN NIGHT (Cawnpore)**: As confirmed by programmes; (a) Viipuri (Finland), own organ recital; (b) Viipuri relaying recital from Helsinki. **STORM (Scotstoun)**: Belgrade. **MARVEL (Leyton)**: Although Madrid did not advertise an extended programme, gramophone records were broadcast until a late hour. **C. W. N. (Godalming)**: VE9CS (Vancouver, B.C.) on 49.43 m. (6069 kc/s). **SCAREY ANN (Headingley)**: (1) Königs Wusterhausen; elocution lesson; (2) Brno. **BELMONT (Belfast)**: Lahti relaying Helsinki. **SOLO (Drumcondra)**: CT1AA, experimental station at Lisbon. **ROBERTS (Finsbury Park)**: On that date several operas were advertised to be broadcast but not *Aida*. Cannot definitely confirm as you give no indication of wavelength, but possibly altered programme by Budapest or Copenhagen. **O-KAPARATE (Headingley)**: Moscow-Popoff, on 25.15 m. **NOVICE (Dundee)**: (2) possibly altered programme from Munich. **NIETCHEVO (Berkhamsted)**: Would tally with Sverdlovsk, on 825 m.; programmes are not available. **HOPEFUL (Harlow)**: (1) Hamburg (play); (2) Radio Toulouse. **MOUSEY (Millom)**: Radio Normandie (Fécamp). **HOGHTONIAN (Preston)**: Warsaw. Not a gramophone record. Singer: Bertha Crawford. **CROSS (Yorkshire)**: No European station advertised an opera at that time; if English, possibly WLW, Cincinnati (Ohio). **IN TROUBLE (Drury Lane)**: (97) Heilsberg; a variety concert from Königsberg studio; (98) Algiers; (99) Cuxhaven Radio German coastal station; News transmission to ships. **CARRINGTON (Sale)**: (1) cannot trace, as you give no estimate of wavelength; (2) Reykjavik. **NEWSET (South Norwood)**: Gleiwitz relaying Berlin or Leipzig direct; both broadcast dance music at that time. **PARK (Blackpool)**: Reykjavik. **ELMDENE (Harrow)**: Lyons (PTT). **MAYBE (Fulham)**: Hilversum; gramophone records. **CURIOUS (Swansea)**: Oslo relayed foreign transmissions on that night. **GALLIA (Nottingham)**: Local amateur transmitter. **SEARCHER (Wombly)**: Barcelona (EAJ 15). **ELKUB (West Norwood)**; **GREEN CARNATION (Plymouth)**: Regret cannot trace; some indication of wavelength must be given. **PEGGY (Waverley)**: Leipzig is the only station between Hörby and London National; the station broadcast gramophone records. If Spanish, however, probably Barcelona (EAJ 15). **RADIO KING (Edmonton)**: *Coquette* and *Salut à mon Hawaii* (Hawaiian guitar duets), Irving Berlin. **SLEEPLESS (Sion Mills)**: Possibly, Radio Idzerda, The Hague. **BRACING (Skegness)**: A test by Toulouse PTT reported by other listeners. **SWIVELS (Plymouth)**: Rennes (PTT). **JONES (Padiham)**: Proprietary names must not be used as *noms-de-plume*. PTT Toulouse. **EDGAR REWN (Sparkhill)**: Cork relaying Dublin. **RADIO ROVER (Glasgow)**: Radio Normandie (Fécamp); special broadcasts on 245.9 m. **ROMAN (Maidenhead)**: The times of the Vatican transmissions are: G.M.T. 10.0-10.30 (week-days) on 19.84 m.; 19.00-19.30 (week-days) on 50.26 m.; Sundays and Feast Days from 10.0-11.0 on 50.26 m. **LEARNER (Tufnell Park)**: (1) San Sebastian (EAJ 8); (2) Mühlacker relaying Frankfurt; extended transmission for local elections. **SPARK (Halifax)**: Apparently Kiev (U.S.S.R.), but cannot confirm as details of programmes are not available. **WAG (Ward End)**: Leipzig. **DRAGON (Hanwell)**: Vienna Experimental; piano-forte concerto with orchestra. **INTERESTED (Prittlewell)**: Brussels No. 2; gramophone records. Experimental transmissions. **SOLDIER (Leith Port)**: Leipzig relaying early-morning concert from Berlin. **ASOR (S.E.25)**: Apparently, a test; cannot trace. **P. A. V. (St. Leonards-on-Sea)**: 7LO, Nairobi (Kenya Colony). **A. D. (Grimby)**: Langenberg (2nd harmonic); (2) Radio Normandie (Fécamp); sponsored concert on 245.9 m. **LYRIC (Glasgow)**: Brussels (No. 2); gramophone records. **CAPS (Glasgow)**: Regret, cannot trace. **BILL (Stony Stratford)**: Radio-Idzerda, private transmitter, The Hague. **YLTRAG (Glasgow)**: Algiers. **TYRO (Thornton Heath)**: (1) possibly Madrid (EAJ 7); not advertised; (2) you do not say what you heard; regret, cannot trace. **RHONSTER (Cambridge)**: Stockholm, as programme. **RAY (Dover)**: Proprietary names must not be used as *noms-de-plume*. (1) Lightship-shore telephony; (2) Trieste. **NOSEY (Woodford)**: Issy-lez-Moulineaux (Paris); tests. **BETA (Worcester)**: Regret, cannot trace. **STUTTGART (Liverpool)**; **JUNO (Eastbourne)**: An outside broadcast taken by a number of French State stations; cannot trace, as no mention of this transmission was made in programmes. **EARLY TURN (W.8)**: Moscow-Komintern; early-morning physical exercises. **BULLER (Stretford)**: Copenhagen direct; a relay of a fête given at the Lorry Cabaret. **A. B. C. K. (Mumbles)**: **ORGAN (Sidcup)**: Cannot trace tests, which, obviously, are not mentioned in published programmes. Probably carried out by Lodz. **S. G. P. (Keynsham)**: This was again a running commentary on the Stuttgart Six Days' Cycle Races. **WIDEAWAKE (Bristol)**: Brno testing with Prague high-power transmitter. **CLIFTONIAN (Bristol)**; **BOOTS (Liverpool)**: Regret, cannot trace. **HOWARD (Newton Heath)**: Heilsberg relaying Film Ball from Berlin. **GEOF (Newcastle-on-Tyne)**: See previous reply; received through Breslau.

READ INSTRUCTIONS IN IDENTIFICATION COUPON

Free Query Service

Each query should be numbered and the questions on the coupon carefully answered. Letters must be addressed to the Editor, *World-Radio*, Savoy Hill, W.C.2.

The Alternative Postal Service

In addition to the free service of "Which Station was That?" printed in these columns, replies to queries can be obtained within forty-eight hours of receipt of details, on payment of 6d. per query, in stamps or P.O., accompanied by stamped addressed envelope (marked in left hand top corner "Postal Query Service"), and coupon as per conditions for "Free Queries."

IDENTIFICATION COUPON (No. 148)

This coupon is valid for ONE QUESTION only, and should be cut out and attached to a separate sheet, upon which the following questions should be answered in the order shown, and in the case of FREE queries a duplicate copy of questions and answers enclosed. No coupon more than one month old is valid.

1. Time and Date of reception.
2. Approximate frequency in kilocycles per sec. (or wavelength in metres).
3. Nearest known stations, above and below.
4. Call or interval signal, if heard.
5. Language.
6. Type of receiver in use and strength of signal.
7. Details of programme or signal received.
8. Name and address.
9. Nom de plume. (Proprietary names must not be used.)

TO OUR READERS

When replying to Advertisements please mention **WORLD-RADIO**

Schedule of Advance Programmes

(STRICTLY COPYRIGHT)

For the benefit of traders who may wish to make arrangements for demonstrating, we are printing each week a schedule of the programmes to be transmitted by the National and Regional stations. It will be noticed that these schedules concern programmes to be transmitted a fortnight hence, and it is felt that they will also be of particular service to those of our readers living abroad who will be able to use them in connection with the reception of the Experimental Short Wave Station, G5SW, which relays the National (5XX) programme from 7 p.m.

SUNDAY, DECEMBER 13

	NATIONAL	LONDON REG.	MIDLAND REG.	NORTH REG.
AFTERNOON	Church Cantata Orchestral Con.	Military Band	Studio Orchestra	As London Reg.
EVENING PROGRAMME	Hotel Orchestra	Symphony Con.	As London Reg.	As London Reg.

MONDAY, DECEMBER 14

	NATIONAL	LONDON REG.	MIDLAND REG.	NORTH REG.
MORNING	Studio Concert	As Midland Reg.	Cinema Orch.	As Midland Reg.
AFTERNOON	Cinema Orch. Gram. Records Hotel Orchestra	As North Reg. As North Reg. As National	As North Reg. As North Reg.	Organ Recital Hotel Orchestra As National
1ST EVENING PROGRAMME	Talks Vaudeville	Light Music Orchestral Con.	Light Music Symphony Con.	Studio Orchestra "The Messiah"
2ND EVENING PROGRAMME	Chamber Music Dance Music	As North Reg. Dance Music	Symphony Con. ctd. As London Reg. (till 11 p.m.)	"The Messiah" ctd. Dance Music

TUESDAY, DECEMBER 15

	NATIONAL	LONDON REG.	MIDLAND REG.	NORTH REG.
MORNING	Cinema Organ	Ballad Concert	As London Reg.	As London Reg.
AFTERNOON	Restaurant Music Sonata Recital Cinema Orch.	As North Reg. As Midland Reg. As National	As North Reg. Studio Orchestra	"Midday" Con. As Midland Reg. Abbey Evensong
1ST EVENING PROGRAMME	French Talk Military Band	As North Reg. Orchestral Con. As Midland Reg.	Light Music Chamber Music Opera Relay	Organ Recital Philharmonic Concert
2ND EVENING PROGRAMME	Opera Relay Dance Music	Vaudeville Dance Music	As London Reg.	Phil. Conct. ctd. As London Reg.

WEDNESDAY, DECEMBER 16

	NATIONAL	LONDON REG.	MIDLAND REG.	NORTH REG.
MORNING	Light Orch. Con.	Cinema Organ As Midland Reg.	As London Reg. Studio Orchestra	As London Reg. As Midland Reg.
AFTERNOON	Organ Recital	As North Reg. As North Reg. As National	As North Reg. As North Reg.	"Midday" Con. Studio Orchestra As National
1ST EVENING PROGRAMME	Talks Symphony Con.	Orchestral Con. Revue	Band Concert As London Reg.	Band Concert Studio Orchestra
2ND EVENING PROGRAMME	Symphony Con. ctd. Dance Music	Military Band Dance Music	Organ Recital Sketch	Concert Party As London Reg.

THURSDAY, DECEMBER 17

	NATIONAL	LONDON REG.	MIDLAND REG.	NORTH REG.
MORNING	Cinema Organ	Cinema Orch.	As London Reg.	As London Reg.
AFTERNOON	Orchestral Con. Abbey Evensong Hotel Orchestra	As Midland Reg. As North Reg. As National	"Midday" Con. As North Reg.	As Midland Reg. Hotel Orchestra As National
1ST EVENING PROGRAMME	German Talk Revue	Light Music European Con. from Brussels	Light Music Symphony Con.	Studio Orchestra As London Reg.
2ND EVENING PROGRAMME	Light Orch. Con. Dance Music	Gram. Records Dance Music	Symphony Con. ctd.	Gram. Records As London Reg.

FRIDAY, DECEMBER 18

	NATIONAL	LONDON REG.	MIDLAND REG.	NORTH REG.
MORNING	Studio Concert	As Midland Reg.	Cinema Organ	As Midland Reg.
AFTERNOON	Organ Recital Gram. Records Hotel Orchestra	Cinema Orch. As Midland Reg. As National	As London Reg. Cinema Orch.	As London Reg. As Midland Reg. As National
1ST EVENING PROGRAMME	Talks Play	As North Reg. The Wireless Chorus	Orchestral Con. Dance Music	Band Concert As London Reg.
2ND EVENING PROGRAMME	Violin Recital Dance Music	Contemporary Music Dance Music	As London Reg. (till 11 p.m.)	As London Reg.

SATURDAY, DECEMBER 19

	NATIONAL	LONDON REG.	MIDLAND REG.	NORTH REG.
MORNING	Cinema Orch.	As National		As National
AFTERNOON	Commentary on International Rugby Match Light Music	As National	Dance Music Cinema Organ	As National
1ST EVENING PROGRAMME	Talks Male Voice Choir Opera Relay	Light Orch. Con. R.A.F. Band	Military Band Mus. Com. Prog.	Studio Orchestra As London Reg.
2ND EVENING PROGRAMME	Vaudeville Dance Music	Play Dance Music	As London Reg.	As London Reg. As London Reg.

Stations in Alphabetical Order

(Above 100 metres)

Corrected according to the latest official information

EUROPEAN

(Including Stations connected with the European system)

	Kc/s	M.	kW.
Aachen (Germany)	1319	227	0.3
Aalesund (Norway)	671	447.1	0.4
Aberdeen, 2BD	1040	288.5	1.2
Algiers (North Africa)	825.3	363.4	13
Almeria (Spain), EAJ18	1193	252	1
Ankara (Turkey)	195	1538	7
Archangel (Russia)	585	511	1.2
Augsburg (Germany)	536	560	1.7
Barcelona, Radio Barcelona (Spain), EAJ1	860	349	8
Barcelona, Association National, EAJ15	1193	252	1
Basle (Switzerland)	1229	244.1	0.5
Belfast 2BE (N. Ireland)	1238	242	1.2
Belgrade (Yugoslavia)	697	430.4	3
Bergen (Norway)	824	364	1.13
Berlin Relay (Germany)	1058	283	0.6
Berlin (Witzleben)	715	418	1.7
Berne (Switzerland)	1220	246	0.5
Bodan (Sweden)	244	1229.5	0.75
Bodø (Norway)	662	453.2	0.63
Bolzano (Italy) 1BZ	815	368.1	0.2
Borås (Sweden)	1450	207	0.12
Bordeaux (Lafayette) PTT (France)	986	304	35
Bordeaux-Sud-Ouest (France)	1265	237.2	3
Bournemouth 6BM	1040	288.5	1.2
Bratislava (Czechoslovakia)	1076	279	14
Bremen (Germany)	1112	270	0.3
Breslau (Germany)	923	325	1.7
Brno (Czechoslovakia)	878	342	3
Brussels (No. 1) (Belgium)	590	509	20
Brussels (No. 2) (Belgium)	887	338.2	20
Bucharest (Romania)	761	394	16
Budapest (Hungary)	545	550	23
Cadiz (Spain)	896	335	5.5
Cardiff 5WA	968	309.9	1.2
Cartagena (Spain)	1220	246	0.4
Cassel (Germany)	1220	246	0.3
Catelineau (Belgium)	1391	216	0.25
Cologne (Germany)	1319	227	1.7
Copenhagen (Denmark)	1067	281	0.75
Cork (I.F.S.), 6CK	1337	224.4	1.5
Cracow (Poland)	959	312.8	1.5
Christiansand (Norway)	1274	235.5	0.63
Danzig (Free City)	662	453.2	0.6
Daventry National Stn. (Gt. Britain)	193	1554.4	35
Dresden (Germany)	941	319	0.3
Dublin (2RN Ireland)	725	413	1.5
Dundee 2DE	1040	288.5	0.16
Edinburgh 2EH	1040	288.5	0.4
Eskestuna (Sweden)	1220	246	0.25
Falun (Sweden)	986	304	0.65
Fécamp (Radio Normandie) (France)	1364	219.9	0.6
Flensburg (Germany)	1373	218	0.6
Frankfurt-on-Main (Germany)	770	390	1.7
Fredrikstad (Norway)	816	367.6	0.8
Freiburg-im-Breisgau (Germany)	527	570	0.3
Gävle (Sweden)	1470	204	0.2
Geneva (Radio-Genève) (Switzerland)	395	760	1.5
Genoa (I.G.E.) (Italy)	959	312.8	1.5
Glasgow 5SC	797	376.4	1.2
Gleiwitz (Germany)	1184	253	5.6
Göteborg (Sweden)	932	322	15
Graz (Austria)	851	352	9.5
Grenoble (France) PTT	914	328.2	1.2
Halmstad (Sweden)	1391	216	0.25
Hälsingborg (Sweden)	1301	231	0.25
Hamar (Norway)	536	560	0.8
Hamburg (Germany)	806	372	1.7
Hanover (Germany)	530	566	0.3
Heilsberg (Germany)	1085	276.5	75
Helsinki (Finland)	815	368.1	13.2
Hilversum (Holland)	1004	298.8	8.5
Hörby (Sweden)	1166	257	15
Huizen (Holland)	160	1875	8.5
Hull 6KH	1040	288.5	0.16
Innsbruck (Austria)	1058	283	0.6
Istanbul (Turkey)	250	1200	5
Jönköping (Sweden)	1490	202	0.25
Kaiserslautern (Germany)	536	560	0.3
Kalmar (Sweden)	1211	247.7	0.25
Kalundborg (Denmark)	260	1153	7.5
Karlskrona (Sweden)	1530	196	0.25
Kasbah (Tunis)	222.2	1350	0.5
Katowice (Poland)	734	408	16
Kaunas (Lithuania)	155	1935	7
Kharkov (Russia), RV29	320	937.5	10
Kiel (Germany)	1292	232.2	0.3
Kiev (Russia)	368.1	815	20
Kiruna (Sweden)	1220	246	0.25
Klagenfurt (Austria)	662	453.2	0.6
Königsberg (Germany)	1392	217	0.9
Königs Wusterhausen (Zeesen, Germany)	183.5	1635	75
Kosice (Czechoslovakia)	1022	293	2.5
Kristinehamn (Sweden)	1480	203	0.25
Lahti (Finland)	167	1796	54
Langenberg (Germany)	635	473	17
Lausanne (Switzerland), HB2	442	680	0.6
Leipzig (Germany)	1157	259	2.3
Leningrad (Russia)	300	1000	100
Leningrad (Russia)	855.5	351	1.2
Liège (Belgium)	1071	280	1.2
Lille, PTT	1130	265.4	2
Limoges (France)	1022	293	0.08
Linz (Austria)	1220	246	0.6
Lisbon (Portugal)	1033	290.5	2
Liverpool, 6LV	1040	288.5	0.16

	Kc/s	M.	kW.
Ljubljana (Yugoslavia)	522	574.7	2.8
London (Regional)	842	356.3	70
London (National)	1148	261.3	68
Lodz (Poland)	1283	235	2
Lwów (Poland)	788	381	21
Lyons (La Doua) (France), PTT	644	465.8	5
Lyons (Radio Lyons)	1049	286	0.8
Madrid (Union Radio), EAJ7	707	424.3	2
Magdeburg (Germany)	1058	283	0.6
Malmberget (Sweden)	689	436	0.25
Malmö (Sweden)	1301	231	1
Marseilles, PTT	950	315	1.5
Midland Regional Stn. (Gt. Britain)	752	398.9	38
Milan (Italy)	598	501.7	8.5
Minsk (Russia)	428.6	700	4
Montpellier (France)	1049	286	1.2
Moravská-Ostrava (Czechoslovakia)	1139	263	11
Moscow (Russia)	603.6	497	1.2
Moscow (Old Komintern), RVF	202.6	1481	100
Moscow (Trades Union)	230.1	1304	100
Moscow (Popoff)	268.5	1116	40
Moscow (Experimental)	416.7	720	20
Moscow-Stalin	707	424.3	100
Motala (Sweden)	222.5	1348	40
Munich (Germany)	563	533	1.7
Münster (Germany)	1319	227	0.6
Naples, INA	905	332	1.7
Newcastle, 5NO	1040	288.5	1.2
Nice (Juan-Jes-Pins) (France)	1205	249	1.8
Nijni Novgorod (Russia)	394	761.4	1.8
Nimes (France)	1265	237.2	1
Norrköping (Sweden)	1292	232.2	0.25
North National Stn. (Gt. Britain)	995	301.5	70
North Regional Stn. (Gt. Britain)	626	470.2	70
Notodden (Norway)	671	447.1	0.9
Novosibirsk (Russia), RA33	238.1	1260	4
Nürnberg (Germany)	1256	239	2.3
Odessa (Russia)	666	450.4	0.25
Örebro (Sweden)	1265	237.2	0.25
Oslo (Norway)	277	1083	75
Östersund (Sweden)	389	770	0.75
Oviedo (Spain)	1121	267.6	0.7
Palermo (Italy)	1412	212.4	4
Paris (Ecole Supérieure), PTT	671	447.1	1
Paris (Eiffel Tower), FLE	207.5	1443.7	15
Paris (Poste Parisien)	914	328.2	1.2
Paris (Radio LL)	810	370.4	0.5
Paris (Radio Paris), CFR	174	1725	80
Paris (Radio Vitus)	959	312.8	2
Petrozavodsk (Russia)	385	778	2
Pietarsaari (Jakobstad) (Finland)	1031	291	0.25
Plymouth, 5PY	1040	288.4	0.16
Pori (Björneborg)	1373	218	0.7
Porsgrund (Norway)	662	453.2	0.8
Poznan (Poland)	896	335	1.9
Prague (Czechoslovakia)	617	487	120
Rabat (Morocco)	721.1	416	2.5
Radio Beziens (France)	1250	240	1.5
Radio España (Spain)	707	424.3	1.5
Radio Suisse Romande (Sottens) (Switzerland)	743	403	25
Radio Valencia (Spain)	1121	267.6	1.5
Rennes (France)	1103	272	1.2
Reykjavik (Iceland)	250	1220	21
Riga (Latvia)	572	525	1.5
Rjukan (Norway)	671	447.1	0.17
Rome, IRO	680	441	75
Rostov/Don (Russia)	353.5	848.7	4
Saffe (Sweden)	1220	246	0.4
Salamanca (Spain), EAJ22	662	453.2	1
Salzburg (Austria)	1373	218	0.6
San Sebastian (Spain), EAJ8	662	453.2	0.6
Schaerbeck (Brussels, Belgium)	1220	246	0.1
Schweizerischer Landessender, Beromünster (Switzerland)	653	459	75
Seville (Spain), EAJ5	815	368.1	1.5
Sheffield, 6FL	1040	288.4	0.16
Sebastopol (Russia)	630.2	476	1.2
Smolensk (Russia)	531	565	2
Sofia (Rodno-Radio) (Bulgaria)	941	319	1
St. Quentin (France)	1714	175	0.63
Stavanger (Norway)	1247	240.6	0.63
Stettin (Germany)	1058	283	0.6
Stockholm (Sweden)	689	436	75
Stoke-on-Trent, 6ST	1040	288.4	0.16
Strasbourg-Brumath (France)	869	345	15
Stuttgart (Mühlacker) (Germany)	833	360	75
Sundsvall (Sweden)	554	542	15
Swansea, 5SN	1040	288.4	0.16
Tallin (Reval) (Estonia)	1013	296.1	10
Tampere (Tammerfors) (Finland)	1031	291	1
Tartu (Estonia)	644	465.8	5
Tiflis (Russia)	284.9	1053	10
Toulouse (France), PTT	1175	255	1
Toulouse (Radio du Midi)	779	385	8
Trieste (Italy)	1211	247.7	15
Troldhättan (Sweden)	1193	252	0.3
Trondheim (Norway)	662	453.2	0.11
Trondheim (Norway)	608	493.4	1.35
Turin (Italy)	1094	274.2	8.7
Turku (Åbo) (Finland)	1220	246	0.6
Uddévalia (Sweden)	1310	229	0.1
Uppsala (Sweden)	662	453.2	0.2
Varberg (Sweden)	1058	283	0.3
Vienna Experimental (Austria)	242.5	1237	20
Vienna (Rosenluge)	581	517	20
Viipuri (Viborg) (Finland)	1031	291	13.2
Warsaw, No. 1 (Poland)	212.5	1411	158
Warsaw, No. 2 (Poland)	1400	214.2	1.9
Wilno (Poland)	516.3	581	21.5
Wilno (Poland)	1229	244.1	0.5
Zagreb (Yugoslavia)	677	307	0.7

EXTRA-EUROPEAN

	Kc/s	M.	kW.
Adelaide (Australia), 5CL	730	411	5
Alexandria (Va) WJSV	460	205	10
Atlanta (Ga.), WSB	740	405	5
Atlantic City (N.J., U.S.A.), W.P.G.	1100	273	5
Auckland (New Zealand), 1YA	900	333	0.5
Baltimore (Md.) WBAL	1060	283	10
Bombay (India) VUB	840	357.1	3
Bound Brook (N.J., U.S.A.), WJZ	760	395	30
Brisbane (Australia), 4QG	759	395	5
Calcutta (India), VUC	810	370.4	3
Calgary (Canada), CFCN	690	435	1.8
Cape Town	800	375	1.5
Carthage (Radio Tunis), TNV	164	1829.1	2
Casablanca (Morocco)	984	305	2.5
Chicago (Ill.), KVAV-KFKX	1020	294	10
Chicago (Ill.), WMAQ	670	448	5
Chicago (Ill.), WGN-WLIB	720	417	25
Chicago (Ill.), WBBM	770	390	25
Chicago (Ill.), WLS	870	345	5
Chicago (Ill.), WENR	870	345	50
Christchurch (New Zealand), 3YA	980	306	0.5
Cincinnati (O.), WLW	700	429	50
Cleveland (O., U.S.A.), WTAM	1070	280	50
Colombo (Ceylon)	700	428.5	1.75
Dairen, JOAK	759	395	1
Dallas (Tex.), WFAA	800	375	50
Dallas (Tex.), KRLD	1040	288	10
Davenport (Ia.), WOC	1000	300	5
Denver (Colo.), KOA	830	361	12.5
Des Moines (U.S.A.), WHO	1000	300	5
Detroit (Mich., U.S.A.), WJR	750	400	5
Dunedin (New Zealand), 4YA	647	463	0.25
Durban (South Africa)	731	410	1.5
Edmonton (Canada), CHMA-CKUA	580	517	0.5
Fort Wayne (Ind.), WOWO	1160	259	107
Fort Worth (Texas), WBAP	800	375	10
Gainsville (Fla.), WRUF	830	361	5
Hartford (Conn.), WTIC	1060	283	50
Hiroshima (Japan) JOFK	849	353	10
Hobart (Australia), 7ZL	580	517	3
Hollywood, KNX	1050	286	5
Hong Kong (China), ZBW	845	355	1.5
Hot Springs (Col.), KTHS	1040	288	10
Johannesburg, JB	666.5	450	10
Kanazawa, JOJK	709	423	3
Keijyo (Japan), JODK	690	435	1
Kumamoto (Japan), JOGK	789	380	10
Lima (Peru), OAX	789	380	5
Lincoln (Neb.), KFAB	770	390	5
Los Angeles (Cal.), KFI	640	468	5
Louisville (Ken.), WHAS	820	366	10
Melbourne (Australia), 3AR	620	484	5
Melbourne (Australia), 3LO	800	375	5
Miami Beach (Florida), WIOD	1300	231	1
Millard (Kan.), KFKB	1050	286	5
Minneapolis (Min., U.S.A.), WCCO	810	370	7.5
Moosheart (Ill.), WJJD	1130	265	20
Muscataine (Ia.), KTNT	1170	256	5
Nagoya (Japan), JOCK	811	370.3	10
Nairobi (Kenya), 7LO	750	400	5
Nashville (Tenn.), WSM	650	461	5
Newark (N.J.), WOR	710	422	5
New Orleans, WWL	850	353	5
New York (N.B., Co.), WEAJ	660	455	50
New York City, WABC-WBOQ	860	349	50
New York City, WLWL	1100	273	5
Oakland (Cal., U.S.A.), KGO	709	380	10
Osaka (Japan), JOBK	750	400	10
Perth (Australia), 6WF	690	435	5
Philadelphia (Pa.), WCAU	1170	256	10
Pittsburg, East (Pa., U.S.A.) (Westinghouse Electric), KDKA	980	306	5

ORMOND SOLVES MODERN TUNING PROBLEMS!

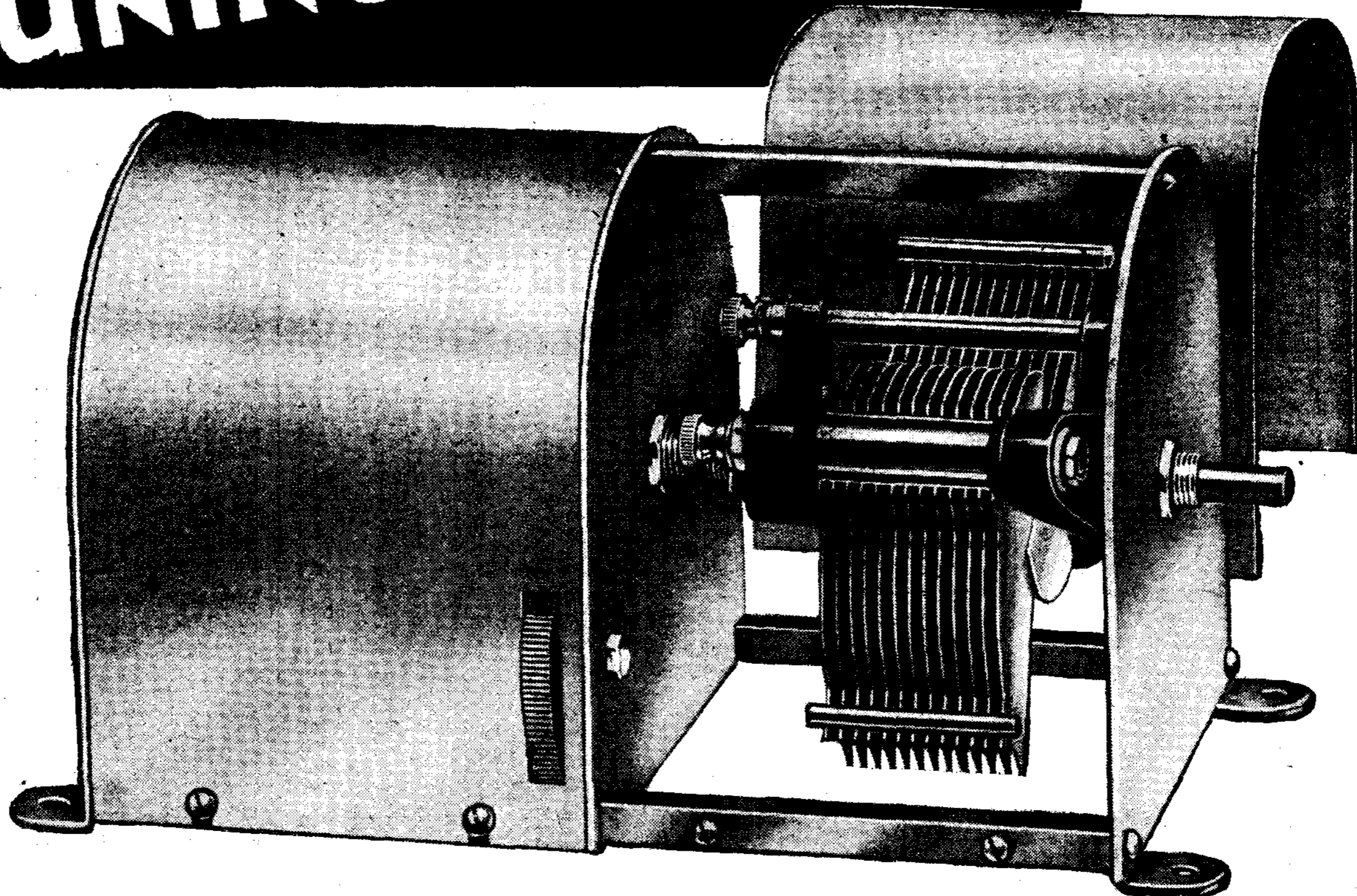

The ORMOND Screened Gang Condensers

Cat. No. R/429/S1
Single Screened
.0005
No. 4 Condenser.

7'-

Cat. No. R/429/S2
Two Gang Screened
.0005
No. 4 Condenser.

14'-

Cat. No. R/429/S3
Three Gang Screened
.0005
No. 4 Condenser.
Width 4 in., Height
4½ in. Length per
stage 3½ in.

21'-

THIS model is constructed with No. 4 Log Hollow Spindle condensers.

It is comprised of a rigid framework, the condensers being mounted between screening plates.

The screening covers are detachable, enabling easy connection of leads.

Trimmers, controlled by small Thumb wheels at side, are provided for adjustment, to compensate for stray capacities which may affect the accuracy of tuning ganged circuits.

Feet are fitted for securing the condenser to the baseboard. Dial spindle may be adjusted to a required position, to allow of attachment of control dial either in front or rear of panel.

THE ORMOND ENGINEERING CO., LTD.
Ormond House, Rosebery Avenue, LONDON, E.C.1.
Telephone: Clerkenwell 5334-5-6 and 9344-5-6. Telegrams: "Ormondengi, Isling."



FOR ACCURACY & EFFICIENCY!

(London)

1,148 kc/s (261.3 m.)
(68 kW.)

NATIONAL PROGRAMMES

(Daventry) 193 kc/s (1,554.4 m.) (35 kW.)

(Northern)

995 kc/s (301.5 m.)
(70 kW.)

SUNDAY (NOV. 29)

- 3.0 p.m.—Twenty-Eighth Annual Scottish Festival Service. Relayed from St. Columba's Church of Scotland, Pont Street.
- 4.0 p.m.—Messiah (Handel). Part I. Dora Labbette (Soprano); Betty Bannerman (Contralto); Eric Greene (Tenor); William Barrand (Bass). The B.B.C. Studio Symphony Orchestra and The Wireless Chorus, conducted by Stanford Robinson.
- 5.30 p.m.—A Pianoforte Recital by Gertrude Peppercorn.
- 6.0—6.20 p.m.—For the Children.
- 8.0 p.m.—A Religious Service from the Studio, conducted by Dr. Alexander D. Lindsay, C.B.E., Master of Balliol College, Oxford.
- 8.45 p.m.—The Week's Good Cause.
- 8.50 p.m.—"The News."
- 9.5 p.m.—Tom Jones and The Grand Hotel, Eastbourne, Orchestra. Joan Leggatt (Soprano).
- 10.30 p.m.—Epilogue.

MONDAY (30th)

- 10.15 a.m.—The Daily Service.
- 10.45—11.0 a.m.—"Great Occasions in Other Lands"—XII. Mrs. Noel Baker: "Greece."
- 12 noon.—A Light Classical Concert. Molly Mitchell (Contralto). The Wigmore Trio.
- 1.0 p.m.—The Commodore Grand Orchestra, directed by Joseph Muscant.
- 2.0 p.m.—Gramophone Records.
- 2.25 p.m.—For the Schools. Reception Test.
- 2.30 p.m.—World History. Mr. Norman H. Baynes, F.B.A.
- 3.40 p.m.—Interval.
- 3.45 p.m.—Kathleen Jacobs (Violoncello). Joyce Kadish (Pianoforte).
- 4.15 p.m.—Moschetto and his Orchestra.
- 5.15 p.m.—The Children's Hour.
- 6.0 p.m.—"The First News."
- 6.30 p.m.—The Foundations of Music. Beethoven's Pianoforte Sonatas, played by Dorothy Moggridge.
- 6.50 p.m.—"New Books." Miss V. Sackville-West.
- 7.10—7.25 p.m.—Topical Talk or Reading from New Books, by Miss V. Sackville-West.
- 7.30 p.m.—"Why does Poverty Continue?"—IV. Mr. D. H. Robertson.
- 8.0 p.m.—Frac a' the Airs. A Programme for St. Andrew's Night.
- 9.0 p.m.—"The Second News."
- 9.15 p.m.—Shipping Forecast; New York Stock Market Report.
- 9.20 p.m.—"War or Peace?"—IV. "The New Warfare"—III, Chemical Warfare."
- 9.50 p.m.—Chamber Music. The Pro Arte String Quartet: Alphonse Onnou (Violin), Laurent Halleux (Violin), Germain Prevost (Viola), Marcel Maas (Violoncello).

- 11.0 p.m.—12 midnight.—Dance Music. Roy Fox and his Band, from Monseigneur.

TUESDAY (DEC. 1st)

- 10.15 a.m.—The Daily Service.
- 10.45 a.m.—"British and Overseas Dishes"—VII.
- 11.0—11.5 a.m.—Housewives' News.
- 12 noon.—Edward O'Henry at the Organ.
- 1.0 p.m.—Leonardo Kemp and his Piccadilly Hotel Orchestra.
- 2.5 p.m.—For the Schools.
- 4.25 p.m.—Interval.
- 4.30 p.m.—The Trocadero Cinema Orchestra, directed by Alfred Van Dam.
- 5.15 p.m.—The Children's Hour.
- 6.0 p.m.—"The First News."
- 6.30 p.m.—The Foundations of Music. Beethoven's Pianoforte Sonatas, played by Dorothy Moggridge.
- 6.50 p.m.—French Talk. Monsieur E. M. Stéphan.
- 7.20 p.m.—Vaudeville. Jack Payne and his B.B.C. Dance Orchestra. Leslie Weston (Comedian). "The Kentucky Singers (by courtesy of Ciro's Club). Two Pairs: Claude Hulbert, Enid Trevor, Paul England, Pat Paterson. Jean Melville and Billy Thorburn at two Pianos. "O.K. With Me," by Philip Wade. The programme will be compiled by Mabel Constanduros and Michael Hogan.
- 8.30 p.m.—"The New Spirit in Literature"—X. The Hon. Harold Nicolson, C.M.G.: "Reading as a Means of Self-Education."
- 9.0 p.m.—"The Second News."
- 9.15 p.m.—Shipping Forecast; New York Stock Market Report.
- 9.20 p.m.—"A Voyage to Lilliput." From "Gulliver's Travels," by Jonathan Swift.
- 10.50 p.m.—12 midnight.—Dance Music.

WEDNESDAY (2nd)

- 10.15 a.m.—The Daily Service.
- 10.45—11.0 a.m.—"The Week in Westminster."
- 12 noon.—An Orchestral Concert. The Northern Studio Orchestra, directed by John Bridge. Meirion Morris (Bass-Baritone).
- 1.15—2.15 p.m.—Organ Recital by Dr. Harold Rhodes.
- 2.25 p.m.—For the Schools.
- 3.25 p.m.—Interval.
- 3.30 p.m.—The Bournemouth Municipal Orchestra. Conductor, Sir Dan Godfrey. Tom Bromley (Pianoforte).
- 4.45 p.m.—Reginald New at the Organ.
- 5.15 p.m.—The Children's Hour.
- 6.0 p.m.—"The First News."
- 6.30 p.m.—The Foundations of Music. Beethoven's Pianoforte Sonatas, played by Dorothy Moggridge.
- 6.50 p.m.—"Plays and the Theatre." Mr. James Agate.

- 7.10—7.25 p.m.—"The Countryside." Mr. Frank Prewett.
- 7.30 p.m.—"What is Man?"—IV. Dr. John Baker (University Demonstrator in Zoology, University Museum, Oxford): "The Evolution of Mind."
- 8.0 p.m.—Interval.
- 8.15 p.m.—B.B.C. Symphony Concert—VII. Relayed from The Queen's Hall, London. Myra Hess. The B.B.C. Symphony Orchestra (Leader, Arthur Catterall), conducted by Sir Landon Ronald. Orchestra: Overture, Egmont (Beethoven). Myra Hess and Orchestra: Concerto, No. 3, in C Minor, for Pianoforte and Orchestra (Beethoven).
- 9.5 p.m.—"The Second News."

TIME SIGNALS (Greenwich)

- Sunday: 10.30 a.m., 3.0 p.m., 9.0 p.m.
- Weekdays: 10.30 a.m. 1.0 p.m., 4.45 p.m., 6.30 p.m., 10.0 p.m., 11.30 p.m.

DANCE MUSIC

- 5.15—6.0 p.m. each weekday from London and Northern transmitters.
- 9.20 p.m.—Symphony Concert (continued). Orchestra: Symphony No. 2, in E Minor (Rachmaninov).
- 10.15 p.m.—Shipping Forecast; New York Stock Market Report.
- 10.20 p.m.—"Idle Thoughts."
- 10.35 p.m.—12 midnight.—Dance Music. Roy Fox and his Band from Monseigneur.

THURSDAY (3rd)

- 10.15 a.m.—The Daily Service.
- 10.45—11.0 a.m.—"The Child's World"—XIII. Professor S. J. Cowell: "Food that makes Bones."
- 12 noon.—Reginald Foort at the Organ of The Regal, Marble Arch.
- 1.0 p.m.—Gramophone Records.
- 1.15—2.0 p.m.—Lunch Hour Concert. From the Town Hall, Birmingham. The City of Birmingham Orchestra (leader, Paul Beard), conducted by Leslie Heward.
- 2.5 p.m.—For the Schools.
- 2.25 p.m.—Interval.
- 2.30 p.m.—Speech Training. Mr. A. Lloyd James: "King's English"—XI.
- 3.0 p.m.—Evensong. From Westminster Abbey.
- 3.45 p.m.—Interval.
- 3.50 p.m.—For Secondary Schools.
- 4.5 p.m.—Interval.

- 4.10 p.m.—Jack Payne and his B.B.C. Dance Orchestra.
- 4.30 p.m.—The Grosvenor House Orchestra, directed by Joseph Meeus.
- 5.15 p.m.—The Children's Hour.
- 6.0 p.m.—"The First News."
- 6.30 p.m.—The Foundations of Music. Beethoven's Pianoforte Sonatas. Played by Dorothy Moggridge.
- 6.50 p.m.—German Talk. Mr. Otto Siepmann.
- 7.20 p.m.—Notices of Service Reunions, etc.
- 7.30 p.m.—"Can Democracy Survive?"—X. The Rt. Hon. Lord Eustace Percy: "Patching."
- 8.0 p.m.—The Ridgeway Parade—V. Typists', Brunettes' and Dukes' Night (New Series). A Song and Dance Show. Written by Holt Marvell and Philip Ridgeway. Musical Arrangements by Dorothy Hogben.
- 9.0 p.m.—"The Second News."
- 9.15 p.m.—Shipping Forecast; New York Stock Market Report.
- 9.20 p.m.—"What I would do with the World"—IX. The Very Rev. W. R. Inge, K.C.V.O., D.D., Dean of St. Paul's.
- 9.50 p.m.—A Popular Recital. John Thorne (Baritone). Elsa Karen (Pianoforte).
- 10.30 p.m.—Short Mid-Week Service, conducted by the Rev. W. H. Elliott. Relayed from St. Michael's, Chester Square.
- 10.45 p.m.—12 midnight.—Dance Music. Jack Payne and his B.B.C. Dance Orchestra.
- 12 midnight—12.5 a.m. (Friday).—Experimental Transmission for the Radio Research Board by the Fultograph Process.

FRIDAY (4th)

- 10.15 a.m.—The Daily Service.
- 10.45—11.0 a.m.—"Grandmothers' Tales"—VI. Miss M. Sidgwick: "The Governess who became Famous."
- 12 noon.—A Concert. Cuthbert Reavely (Baritone). Margaret Haslett (Soprano). Muriel Hay (Violin).
- 12.45 p.m.—Organ Recital. By H. A. Bate.
- 1.30 p.m.—A Recital of Gramophone Records. By Christopher Stone.
- 2.25 p.m.—For the Schools.
- 3.45 p.m.—Concert to Schools. The Sybil Eaton Quartet.
- 4.30 p.m.—Moschetto and his Orchestra.
- 5.15 p.m.—The Children's Hour.
- 6.0 p.m.—"The First News."
- 6.30 p.m.—A Concert in aid of The League of Mercy, arranged by Lady Tree, O.B.E., and Mr. George Grossmith.
- 6.50—7.5 p.m.—"The Cinema." Mr. Frank Birrell.
- 7.10 p.m.—"This Surprising World." Mr. Gerald Heard.
- 7.30 p.m.—"Learning to Live"—X. Professor John MacMurray.

- 8.0 p.m.—The Wireless Military Band. Conductor, B. Walton O'Donnell. Phyllis Scott and John Rorke in Duets (with Phyllis Scott at the Pianoforte).
- 9.0 p.m.—"The Second News."
- 9.15 p.m.—Shipping Forecast; New York Stock Market Report.
- 9.20 p.m.—"The Way of the World." Mr. Vernon Bartlett.
- 9.35 p.m.—A Concert Version of the Comic Opera "Tantivy Towers." Libretto by A. P. Herbert. Music by Thomas F. Dunhill. The Wireless Chorus. The B.B.C. Light Orchestra, conducted by Thomas F. Dunhill.

- 11.5 p.m.—12 midnight.—Dance Music. The Savoy Orpheans from the Savoy Hotel.

SATURDAY (5th)

- 10.15 a.m.—The Daily Service.
- 10.45—11.0 a.m.—"What's in the Papers?"—XIII.
- 1.0—2.0 p.m.—The Commodore Grand Orchestra, directed by Joseph Muscant.
- 2.20 p.m.—Wales v. South Africa. A Running Commentary on the International Rugby Match, by Captain H. B. T. Wakelam. From St. Helen's Ground, Swansea.
- 4.0 p.m.—An Orchestral Concert. Edward German Programme. The B.B.C. Studio Symphony Orchestra. Conductor, Adrian Boult.
- 4.45 p.m.—Reginald Foort at the Organ.
- 5.15 p.m.—The Children's Hour.
- 6.0 p.m.—"The First News."
- 6.25 p.m.—Interval.
- 6.30 p.m.—The Foundations of Music. Beethoven's Pianoforte Sonatas, played by Dorothy Moggridge. Sonata in E, Op. 109. Vivace ma non troppo; Prestissimo; Theme and Variations.
- 6.50—7.5 p.m.—"The Week in the Garden." Mr. C. H. Middleton (Arranged after consultation with the Royal Horticultural Society).
- 7.10 p.m.—"The World of Business." Mr. A. P. L. Gordon.
- 7.30 p.m.—Vaudeville. Cicely Courtneidge (Comedienne); Syd Bright and Donald Thorne (Syncopated Piano Duets and Steel Guitar Solos); Mamie Soutter and Blake Adams: "An Omnibus Romance" (Episode III), by Daisy Fisher. Louis Hertel (Wit, Wizardry and Wisecracks). Valentine Dunn (Monologues). The Carlyle Cousins (Syncopated Songs). The New Alexander (Albert Whelan) and The Old Mose (Billy Bennett) in "Dark Subjects."
- 9.0 p.m.—"The Second News."
- 9.15 p.m.—Shipping Forecast; New York Stock Market Report.
- 9.20 p.m.—Talk.
- 9.35 p.m.—The Gershom Parkington Quintet. Bina Addy (Contralto).
- 10.30 p.m.—12 midnight.—Dance Music. Ambrose and his Orchestra, from The May Fair Hotel.

(London)

842 kc/s (355.3 m.)
(70 kW.)

REGIONAL PROGRAMMES

(Midland) 752 kc/s (398.9 m.) (38 kW.)

(Northern)

626 kc/s (479.2 m.)
(70 kW.)

SUNDAY (NOV. 29)

- 3.0 p.m.—(London and Northern).—The Wireless Military Band. Conductor, B. Walton O'Donnell, Juliette Alvin (Violoncello).
- 3.0 p.m. (Midland).—An Afternoon Concert. The Midland Studio Orchestra, directed by Frank Cantell. Eric Cross (Tenor); Harry Stanier (Violoncello).
- 4.0 p.m. (London).—The B.B.C. Theatre Orchestra.
- 4.0 p.m. (Northern).—The Northern Studio Orchestra, directed by John Bridge. Joseph Lingard (Flute) and Eric Fogg (Pianoforte).
- 4.30 p.m. (Midland).—Organ Recital by Henry O. Hodgson.
- 5.0—5.30 p.m.—"The Modern Dilemma"—IX.
- 7.55 p.m. (Northern).—A Religious Service, relayed from The Manchester Cathedral.
- 8.0 p.m. (London).—A Roman Catholic Service (from the Studio),

- conducted by The Rev. Father C. C. Martindale, S.J.
- 8.0 p.m. (Midland).—A Religious Service, conducted by the Rev. J. Davison Brown. From The Albert Hall, Nottingham.
- 8.45 p.m. (London).—The Week's Good Cause. An Appeal on behalf of The Baby Clinic and Hospital (in memory of Mary Middleton and Margaret MacDonald) by the Prime Minister, the Rt. Hon. J. Ramsay MacDonald.
- 8.45 p.m. (Midland).—The Week's Good Cause. An Appeal on behalf of The Church of St. Mary de Castro by Councillor H. Carver, J.P.
- 8.45 p.m. (Northern).—The Week's Good Cause. An Appeal on behalf of The Greengate Hospital and Open Air School by Mrs. Sidney Frankenburg.
- 8.50 p.m.—"The News." Weather Forecast, General News Bulletin; Regional News.

- 9.5 p.m.—Sunday Orchestral Concerts—VII (Second Season). Fanny Davies (Pianoforte). The B.B.C. Studio Symphony Orchestra (Leader, Arthur Catterall). Conductor, Adrian Boult.
- 10.30 p.m.—Epilogue.

MONDAY (30th)

- 10.15 a.m. (London and Northern).—The Daily Service.
- 10.30—11.0 a.m. (London and Northern).—Daventry National Programme.
- 11.30 a.m.—12 noon (London).—Experimental Television Transmission by the Baird Process (356.3 m. Vision; 261.3 m. Sound).
- 12 noon.—The Regal Orchestra, conducted by Ernest Parsons.
- 1.0 p.m.—Reginald Dixon at the Organ.
- 1.45 p.m.—3.0 p.m.—A Concert. Jack Martin and his Hotel Majestic Orchestra. Elsa Frood (Contralto).

- 3.45 p.m. (London and Northern).—Daventry National Programme.
- 5.15 p.m.—The Children's Hour.
- 6.0 p.m.—"The First News" and Bulletin for Farmers.
- 6.30 p.m. (London).—An Orchestral Concert. Elena Danieli (Soprano). The B.B.C. Light Orchestra, conducted by Joseph Lewis.
- 6.30 p.m. (Midland).—The Stanton Ironworks Band, conducted by John Turner. Samuel Saul (Baritone).
- 6.30 p.m. (Northern).—The Northern Studio Orchestra, directed by John Bridge. Tom Sherlock (Baritone).
- 8.0 p.m.—"A Voyage to Lilliput." Done into Dramatic Form with new songs and choruses by Lance Sieveking. From "Gulliver's Travels," by Jonathan Swift.
- 9.30 p.m. (London).—The Gershom Parkington Quintet.
- 9.30 p.m. (Midland).—Light Orchestral Novelties. The Midland

- Studio Orchestra, directed by Frank Cantell.
- 9.30 p.m. (Northern).—A Pianoforte Recital by Donald Hargreaves.
- 9.55 p.m. (Northern).—Mr. L. du Garde Peach: "Further Problems of the Amateur Actor."
- 10.15 p.m.—Second General News.
- 10.35 p.m.—12 midnight (London and Northern).—Dance Music.
- 10.35—11.0 p.m. (Midland).—As London.

TUESDAY (DEC. 1st)

- 10.15 a.m. (London and Northern).—The Daily Service.
- 10.30—11.5 a.m. (London and Northern).—Daventry National Programme.
- 11.30 a.m.—12 noon. (London).—Experimental Television Transmission by the Baird Process (356.3 m. Vision; 261.3 m. Sound).
- 12 noon.—A Ballad Concert.
- 1.15 p.m.—The Manchester Tuesday (Continued on page 895);

RADIO TIMES

(Conti

PROGRAMME

THE DAV

5 The Children's
'Frightfulness at the T
(S. G. Hulme J
Another Toytown
With Incidental
THE GERSHOM PAR
'The Fi

10.0 WEATHER FORECAST,
BULLETIN: London
and Bulletin for F
Time Sign

6.30 The Foy
BEETHOVEN'S
Played by
Sonata in A F
Andante
Marcia fur

6.50 Mr.
Sparrow E

7.20 Lt. C
'The N

7.30 Mr. D
Spirit of Mo
duction to the

MR. DESMOND
the most popula
over the wireless. He
literary criticisms and bo
every fortnight since 19
dramatic and literary critic
of that enterprising monthl
Letters, now in its fourth ye
He will introduce the
'Literature and
of the
The

he has
unction,
graceful
sanity,
and small
is Rach-
ne United
o has ex-
er had he
e interests
ssly jazzed
course from

9.55 Shipping Forecast; New York Stock Mark
Report
Time Signal, Greenwich, at 10.0

'MOSAIC'—I

10.0 IT seems possible—to judge from the vio
criticism of past broadcasts of poe
readings—that wireless is not a suitable med
for poetry, or at least that some other for
presentation might be more successful. A
from any question of the destruction of
intimate quality of poetry or of the difficul
finding suitable readers, it is doubtful wh
fifteen or twenty minutes of continuous poet
likely to appeal to any but confirmed
of poetry. It has, therefore, been decided
a new variation in the form in
poetry is broadcast. 'Mosaic
title of which is suggested by M
definition of music as 'mosaic
air'—is an experiment in which
and poetry are to be combi
express and interpret various
Lyric poems or short excerpts
by a unity of subject or feeling,
with pieces of music o
al appeal into a single w

.. Mossolov
which follows,
that it is full
etry of which
ntly a master.
f great energy.
bal excitement,
ative section in
the chief say.
bird great tune
s heard again in
t gives way soon
a which th
a whi

DANCE MU
x and his BAND,
MONSEIGNEUR
at, Greenwich, at 11

Get a **ARDDEX** as
British as the **B.B.C.!**

- ORCHEST. Traditional
- Song of t
- HAROLD W. and Orchestra
- Song of the Flea..... Mussorgsky
- SOLOMON and Orchestra
- Concerto, No. 2, in C Minor, for Pianoforte and Rachmaninov
- (alla marcia);

MOSSOLOV, though he
arty-one, has already made a nam
for even in that land of shattering
artistic revolutions; he has found a method
revolting which is all his own. This work, con
posed in 1928, is in the form of an overtu
and its programme is simply the steady rhytl
of a factory working at full pressure; thou
behind the mere picture there is conveyed
sense of awe and exaltation which cannot
to possess the man of imagination confro
with the powerful weapons of attack and def
man has set up under the very nose of an
onistic nature.

Symphony, No. 4, in F Minor (Op. 36)
Tchaik
Moderato con ar
Scherzo. Piz

The supreme
dry battery
by Exide

MADE ENTIRELY IN
ENGLAND
EMPLOYING BRITISH
LABOUR AND
BRITISH CAPITAL

Obtainable everywhere from all good dealers in sizes and types to suit every wireless set. Also for torches, pocket lamps, cycle lamps and bells.
Exide Batteries, Exide Works, Clifton Junction, near Manchester. Branches at London, Manchester, Birmingham, Bristol, Glasgow, Dublin and Belfast.

Regional Programmes—(Cont.)

Midday Society's Concert. Edith Winston (Contralto); Virginia McLean (Pianoforte).
 2.0—3.0 p.m.—The Midland Studio Orchestra.
 4.0 p.m. (Northern).—Evensong from York Minster, York.
 4.30 p.m. (London).—Daventry National Programme.
 5.15 p.m.—The Children's Hour.
 6.0 p.m.—"The First News."
 6.30 p.m.—Regional Bulletin for Farmers.
 6.35 p.m. (London).—"Memories." Another Programme of Old Favourites.
 6.35 p.m. (Midland).—The Regal Orchestra.
 6.35 p.m. (Northern).—Dance Music.
 7.20 p.m. (Northern).—Mr. W. P. Crozier: The Month in the North.
 7.30 p.m. (Midland).—Chamber Music Concert. Paul Beard (Violin); Frank Venton (Viola); Johan Hock (Violoncello); Leslie England (Pianoforte).
 7.45—10.15 p.m. (Northern).—The Liverpool Philharmonic Society's Concert. The Liverpool Philharmonic Orchestra and Chorus, conducted by Sir Henry Wood.
 8.0 p.m. (London).—Serenade. The B.B.C. String Orchestra, conducted by Victor Hely-Hutchinson.
 8.30 p.m. (approx.) (Midland).—The Studio Chorus.
 9.0 p.m. (Midland and London).—The City of Birmingham Police Band's Annual Concert. The City of Birmingham Police Band and Male Voice Choir, conducted by Richard Wassell. Frank Titterton (Tenor); Winifred Flavell (Violin).
 10.15 p.m.—"The Second News."
 10.35 p.m.—12 midnight (London and Northern).—Dance Music.

WEDNESDAY (2nd)

10.15 a.m. (London and Northern).—The Daily Service.
 10.30—11.0 a.m. (London and Northern).—Daventry National Programme.
 11.30 a.m.—12 noon (London).—Experimental Television Transmission by the Baird Process (356.3 m. Vision; 261.3 m. Sound).
 12 noon.—Quentin Maclean at the Organ.

12.45 p.m.—The Midland Studio Orchestra.
 1.30 p.m.—The Bradford Midday Concert. Herzl Leikin (Violin); Zerubbabel Leikin (Pianoforte).
 2.15—3.0 p.m.—The Northern Studio Orchestra.
 3.30 p.m. (London and Northern).—Daventry National Programme.
 5.15 p.m.—The Children's Hour.
 6.0 p.m.—"The First News."
 6.30 p.m. (London and Northern).—The Wireless Military Band. Conductor, B. Walton O'Donnell. Lenghi Cellini (Tenor); Alec Templeton (Pianoforte).
 6.30 p.m. (Midland).—Trans-Atlantic. A Pianoforte Recital depicting the influence of Jazz rhythms on contemporary American and European Composers, by Michael Mullinar.
 7.0 p.m. (Midland).—The Ross-on-Wye Orpheus Society's Concert, conducted by F. J. Parsons. Dale Smith (Baritone); Winifred Small (Violin).
 8.0 p.m. (London and Midland).—"The Ridgeway Parade."—V (New Series). "Typists", Brunettes", and Dukes' Night. A Song and Dance Show. Written by Holt Marvell and Philip Ridgeway.
 8.0 p.m. (Northern).—Operatic Excerpts. The Northern Studio Orchestra, directed by John Bridge. Soloist, Booth Unwin (Bass-Baritone).
 9.0 p.m. (London).—The B.B.C. Theatre Orchestra. Conductor, Leslie Woodgate. Kennedy Russell's Songs, sung by Robert Layton (Baritone).
 9.0 p.m. (Midland).—From the Light Operas and Musical Plays. The Midland Studio Orchestra. Bertram Newstead (Baritone).
 9.0 p.m. (Northern).—Mrs. Stocks: "The Northern Householder's Budget—A Preface."
 10.15 p.m.—"The Second News."
 10.35 p.m.—12 midnight (London and Northern).—Dance Music.

THURSDAY (3rd)

10.15 a.m. (London and Northern).—The Daily Service.
 10.30—11.0 a.m. (London and Northern).—Daventry National Programme.

11.30 a.m.—12 noon (London).—Experimental Television Transmission by the Baird Process (356.3 m. Vision; 261.3 m. Sound).
 12 noon.—The Shepherd's Bush Pavilion Orchestra, conducted by Harry Fryer.
 1.15 p.m.—The Philharmonic Midday Concert, under the direction of Johan Hock. From Queen's College, Birmingham, (from Midland Regional). Orrea Pernel (Violin). Johan Hock (Violoncello). Lilian Niblette (Pianoforte).
 2.0—3.0 p.m.—Laddie Clarke's Imperial Hydro Hotel Orchestra.
 3.0 p.m. (Northern).—The Studio Orchestra.
 3.30—3.45 p.m. (Northern).—Mrs. Storr-Best: Readings from "Cranford."
 4.10 p.m. (London and Northern).—Daventry National Programme.
 5.15 p.m.—The Children's Hour.
 6.0 p.m.—"The First News."
 6.30 p.m.—Regional Bulletin for Farmers.
 6.35 p.m. (London and Northern).—Reginald Dixon at the Organ.
 6.35 p.m. (Midland).—"Midland Towns and Cities"—VII, Lichfield.
 7.0 p.m. (London).—The B.B.C. Theatre Orchestra. Conductor, Leslie Woodgate. Eileen Pilcher (Contralto).
 7.0 p.m. (Northern).—Laddie Clarke's Imperial Hydro Hotel Orchestra. Jack Drysdale (Baritone). Russel Smythe (Violin).
 8.15—10.5 p.m. (London and Midland).—Royal Philharmonic Society Concert, from the Queen's Hall, London. Conductor, Basil Cameron. Orloff (Pianoforte).
 8.15 p.m. (Northern).—"The Use of Leisure." A Discussion by Professor T. H. Pear and the Rev. Leslie D. Weatherhead.
 9.0 p.m. (Northern).—An Instrumental Programme.
 9.30 p.m. (Northern).—The Studio Orchestra.
 10.15—"The Second News."
 10.35 p.m.—12 midnight (London and Northern).—Dance Music.

FRIDAY (4th)

10.15 a.m. (London and Northern).—The Daily Service.
 10.30—11.0 a.m. (London and Northern).—Daventry National Programme.

Northern).—Daventry National Programme.
 11.30 a.m.—12 noon (London).—Experimental Television Transmission by the Baird Process (356.3 m. Vision; 261.3 m. Sound).
 12 noon.—Frank Newman at the Organ.
 1.0 p.m.—The Trocadero Cinema Orchestra, directed by Alfred Van Dam.
 2.0—3.0 p.m.—The Regal Orchestra, conducted by Ernest Parsons. Music for the Children.
 4.30 p.m. (London and Northern).—Daventry National Programme.
 5.15 p.m.—The Children's Hour.
 6.0 p.m.—"The First News."
 6.30 p.m. (London).—Reginald King and his Orchestra. Mildred Watson (Soprano).
 6.30 p.m. (Midland).—Old English Music. The Studio Chorus.
 6.30 p.m. (Northern).—The Lowerhouse Mills Band, conducted by George Altham.
 7.0 p.m. (Midland).—"Mr. Pim Passes By." A Comedy in Three Acts by A. A. Milne. Presented by The Birmingham Repertory Theatre Company, in conjunction with Sir Barry Jackson.
 7.45 p.m. (London).—Chamber Music. The Pirani Trio: Leila Doubleday Pirani (Violin); Charles Ham-bourg (Violoncello); Max Pirani (Pianoforte). John Armstrong (Tenor).
 8.0 p.m. (Midland).—Schubert. The Studio Orchestra, directed by Frank Cantell. Helmar Fernback (Tenor).
 8.0 p.m. (Northern).—A Light Classical Concert. The Northern Studio Orchestra, directed by John Bridge. Evelyn Howarth (Contralto).
 9.0 p.m.—Vaudeville.
 10.15 p.m.—"The Second News."
 10.35 p.m.—12 midnight (London and Northern).—Dance Music. The Savoy Hotel Orpheans.
 10.35—11.5 p.m. (Midland).—As London.

SATURDAY (5th)

10.15 a.m. (London and Northern).—The Daily Service.
 10.30—11.0 a.m. (London and Northern).—Daventry National Programme.

1.0—2.0 p.m. (London and Northern).—Daventry National Programme.
 2.20 p.m. (London and Northern).—Wales v. South Africa. A Running Commentary on The International Rugby Match, by Captain H. B. T. Wakelam.
 3.30 p.m. (Midland).—Dance Music.
 4.0 p.m. (London and Northern).—An Orchestral Concert. Edward German Programme. The B.B.C. Studio Symphony Orchestra. Conductor, Adrian Boult.
 4.45 p.m. (London and Northern).—Reginald Foort at the Organ.
 4.45 p.m. (Midland).—Reginald New at the Organ.
 5.15 p.m.—The Children's Hour.
 6.0 p.m.—"The First News."
 6.25 p.m.—Regional Sports Bulletin.
 6.30 p.m. (London).—The Leslie Bridgewater Quintet. Guildford County School Choir. Conductor, Sybil Chesterfield.
 6.30 p.m. (Midland).—Light Music. The Studio Orchestra.
 6.30 p.m. (Northern).—Dances Old and New. The Studio Orchestra.
 7.30 p.m. (Midland and Northern).—The Rooster's Concert Party.
 8.0 p.m. (London).—A Concert Version of the Comic Opera "Tantivy Towers." Libretto by A. P. Herbert. Music by Thomas F. Dunhill.
 8.30 p.m. (Midland).—Gramophone Records.
 8.30 p.m. (Northern).—"Playing with Fire." A Village Comedy, by J. P. M. Lockwood and G. R. Estill.
 8.45—10.15 p.m. (Midland).—William Turner's Annual Concert. Olive Kavann (Contralto), Walter Glynn (Tenor), Maurice Cole (Pianoforte), Joseph Hitchener (Violin). William Turner's Ladies' Choir. The Nottingham Philharmonic Society.
 9.0 p.m. (Northern).—The Studio Orchestra. Rex Costello (Entertainer).
 9.30 p.m. (London).—A Recital of Gramophone Records.
 10.15 p.m.—"The Second News."
 10.35—10.40 p.m. (Midland).—Experimental Transmission for the Radio Research Board by the Fultograph Process.
 10.35 p.m.—12 midnight (London and Northern).—Dance Music.

PROGRAMMES FOR SUNDAY (November 29)

The Frequencies and Wavelengths given in the following programmes are those published by the stations in question. For more accurate measurements, readers are referred to our Table of Frequencies and Wavelengths.

NOTE: THE HOURS OF TRANSMISSION ARE REDUCED TO GREENWICH MEAN TIME

ALGIERS (N. Africa)
 825.3 kc/s (363.4 m.); 13 kW.
 Transmits at intervals from 11.30 a.m. to 7.0 p.m.—Concert of Dance Music.
 7.30 p.m.—Russian Songs.
 7.45 p.m.—Solo Selections.
 8.0 p.m.—Instrumental Concert.
 8.30 p.m.—Chansonnettes.
 8.45 p.m.—Request Concert.
 10.0 p.m.—Operatic Arias (Wagner).
 10.20 p.m.—Songs.
 10.35 p.m.—Concert of Dance Music.

BARCELONA (Spain)
 Radio-Barcelona (EAJI). 860 kc/s (349 m.); 8 kW.
 Transmits at intervals from 7.30 a.m. to 9.0 p.m.—Orchestral Music.
 6.30 p.m.—Tenor Song Recital.
 7.0 p.m.—Agricultural Talk.
 7.10 p.m.—Orchestral Music.
 7.40 p.m.—Tenor Song Recital.
 8.0 p.m.—Talk in Catalan.
 8.15 p.m.—Orchestral Music.
 8.30 p.m.—Gramophone Records.
 9.0 p.m. (approx.).—Close Down.

BERLIN (Germany)
 Königs Wusterhausen. 183.5 kc/s (1,635 m.); 75 kW.
 Transmits at intervals from 5.30 a.m. to 11.0 p.m.—See Leipzig.
 10.30 a.m.—See Leipzig.
 11.0 a.m.—Reading from the Works of Tolstoy.
 11.20 a.m.—Concert from Berlin (Witzleben).
 1.0 p.m.—Talk: About Common Sense.
 1.30 p.m.—Reading.
 2.0 p.m.—Talk: The Church Year.
 2.30—5.15 p.m.—See Berlin (Witzleben).
 5.15 p.m.—Talk on Stefan Zweig and Reading from his Works, for the Author's Fiftieth Birthday.
 5.55 p.m.—See Berlin (Witzleben).

6.20 p.m.—Talk: The Interior Ice Fields of Greenland.
 6.50 p.m.—See Berlin (Witzleben).
 11.30 p.m. (approx.).—Close Down.

BERLIN (Germany)
 Witzleben. 715 kc/s (418 m.); 1.7 kW.
 Transmits at intervals from 5.30 a.m. to 11.0 p.m.—See Leipzig.
 11.0 a.m.—Reading of Poems.
 11.15 a.m.—Concert of Popular Music by the Bernard Etté and Barnabas von Géczy Orchestras, relayed from the Theatre in the Admiralspalast.
 1.0 p.m.—Fairy Tales for Children.
 1.30 p.m.—Reading of Stories.
 2.0 p.m.—Talk: German Propaganda for Germany.
 2.30 p.m.—Contemporary Cembalo Music.
 3.0 p.m.—Berlin Theatres: the Volksbühne—"Der Kammer Sänger"—Play in Three Scenes (Frank Wedekind).
 3.50 p.m.—Concert of Light Music.
 5.30 p.m.—Reading of Ballads.
 5.55 p.m.—"Macht hoch die Tür"—Cantata for Mixed Choir, Orchestra and Soprano, Op. 34 (Julius Weismann).
 6.20 p.m.—Notes of the Day.
 6.50 p.m.—Sports Notes.
 7.0 p.m.—"North-South"—a Radio Potpourri for Soloists, Choir and Orchestra, conducted by Eduard Künneke.
 9.0 p.m.—News Bulletin, followed by Dance Music from the Hotel Excelsior.
 11.30 p.m. (approx.).—Close Down.

BORDEAUX-LAFAYETTE (France)
 (PTT). 986 kc/s (304 m.); 35 kW.
 12 noon.—Concert relayed from Paris (Ecole Supérieure), 671 kc/s (447.1 m.).
 2.0 p.m.—Relay from Paris, or Relay of a Local Festival.
 4.30 p.m.—Pasdeloup Symphony

Concert, relayed from the Théâtre des Champs Elysées, Paris.
 6.20 p.m.—Sports Notes.
 6.30 p.m.—Radio Journal.
 8.0 p.m.—Boxing Report.
 8.10 p.m.—Results of the Prize Draw.
 8.15 p.m.—Charades.
 8.30 p.m.—Dance Music. After the Programme, Amusement Guide and Time Signal.

BRATISLAVA (Czechoslovakia)
 1,076 kc/s (279 m.); 14 kW.
 Transmits at intervals from 6.30 a.m. to 9.0 p.m.—See Prague.
 10.0 a.m.—Quartet Concert.
 11.0 a.m.—See Prague.
 11.5 a.m.—See Moravská-Ostrava.
 12 noon.—Agricultural Report.
 12.30 p.m.—See Prague.
 2.50 p.m.—See Brno.
 3.0 p.m.—Orchestral Concert.
 4.30 p.m.—Gramophone Records.
 5.0 p.m.—Talk on Diluvial Man.
 5.20 p.m.—Pianoforte Recital.
 5.45 p.m.—Gramophone Records.
 6.20 p.m.—See Brno.
 9.0 p.m.—See Prague.

BRESLAU (Germany)
 923 kc/s (325 m.); 1.7 kW.
 Relayed by Gleiwitz, 1,184 kc/s (253 m.).
 Transmits at intervals from 6.0 a.m. to 11.0 p.m.—See Leipzig.
 10.30 a.m.—See Leipzig.
 11.15 a.m.—See Berlin (Witzleben).
 11.45 a.m.—Christening of the First Passenger Aeroplane of the Upper Silesian Aviation Group, relayed from the Aerodrome at Gleiwitz.
 12.15 p.m.—See Berlin (Witzleben).
 1.0 p.m.—News Bulletin.
 1.10 p.m.—Agricultural Talk.
 1.25 p.m.—Talk on Taxation.
 1.40 p.m.—Talk on Modern Dwellings.
 1.55 p.m.—Talk: The Campaign against Noise in Street, House and Factory.
 2.10 p.m.—Talk on Opera.
 2.30 p.m.—A Dialogue.
 2.50 p.m.—Orchestral Concert.
 3.30 p.m.—Reading.
 3.55 p.m.—Concert (continued).

4.55 p.m.—Weather for Farmers.
 4.45 p.m.—The Magazine of the Week.
 5.0 p.m.—Talk: The Psychology of Journalism.
 5.30 p.m.—Weather; Sports Notes.
 5.40 p.m.—Advent Music.
 6.25 p.m.—Talk: The Borderland of the West.
 7.0 p.m.—See Berlin (Witzleben).
 9.0 p.m.—News Bulletin.
 9.30 p.m.—Dance Music.
 10.45 p.m.—See Langenberg.
 11.10 p.m. (approx.).—Close Down.

BRNO (Czechoslovakia)
 878 kc/s (342 m.); 3 kW.
 Transmits at intervals from 6.30 a.m. to 9.0 p.m.—See Bratislava.
 3.0 p.m.—See Bratislava.
 4.30 p.m.—See Prague.
 4.45 p.m.—Programme for Children.
 5.0 p.m.—German Transmission—Orchestral Concert.
 5.45 p.m.—Talk: Photography in Winter.
 6.0 p.m.—Gramophone Records.
 6.20 p.m.—Introductory Talk to the following transmission.
 6.30 p.m.—"Othello"—Opera in Four Acts (Verdi), relayed from the National Theatre.
 9.0 p.m.—See Prague.

BRUSSELS (Belgium) (No. 1)
 I.N.R. 590 kc/s (509 m.); 20 kW.
 5.0 p.m.—Orchestral Concert.
 6.0 p.m.—Gramophone Dance Records.
 7.15 p.m.—Religious Talk.
 7.30 p.m.—Le Journal Parlé.
 8.0 p.m.—Orchestral Concert, with M. Maurice Dambois (Cello) and M. Bracony (Baritone). In the interval at 8.45 p.m.—Humorous Dialogue.
 10.0 p.m.—Le Journal Parlé.

BRUSSELS (Belgium) (No. 2)
 I.N.R. 887 kc/s (338.2 m.); 20 kW.
 Programme in Flemish.
 5.0 p.m.—Orchestral Concert. Overture, "The Secret Marriage" (Cimarosa). Selection from "Malbruck s'en va-t-en guerre" (Auric). Prelude and Scherzo (Brenta). Waltz, The Skaters (Waldteufel). Selection from

"Manon Lescaut" (Puccini) Divertissement et Musette (Samazeuilh). Ballet Music from "Faust" (Gounod).
 6.0 p.m.—Gramophone Records.
 7.15 p.m.—Religious Talk.
 7.30 p.m.—Music Review.
 8.0 p.m.—"The Tales of Hoffmann"—Opera in Five Acts (Offenbach), relayed from the Royal Flemish Opera House, Antwerp. In the intervals, Recitation and Le Journal Parlé.

BUCHAREST (Romania)
 Radio-Bucarest. 761 kc/s (394 m.); 16 kW.
 Transmits at intervals from 9.15 a.m. to 7.0 p.m.—Educational Talk.
 6.40 p.m.—Gramophone Records.
 7.0 p.m.—"Eva"—Operetta in Three Acts (Lehár), News in the intervals.

BUDAPEST (Hungary)
 545 kc/s (550 m.); 23 kW.
 8.0 a.m.—News and Beauty Hints.
 9.0 a.m.—Sacred Music and Sermon from the University Church.
 10.15 a.m.—Evangelical Service, followed by Vocal and Orchestral Concert. In the interval, Wireless Review.
 1.0 p.m.—Gramophone Concert.
 2.0 p.m.—Agricultural Programme.
 2.45 p.m.—Hungarian Folk Songs.
 4.0 p.m.—Microphone Report from a Hungarian Village.
 5.0 p.m.—Tzigane Concert.
 5.50 p.m.—Programme by L. Bibo.
 6.30 p.m.—Violin Recital by Daisy Kennedy.
 7.0 p.m.—Variety Programme.
 9.0 p.m. (approx.).—Concert by the New York Philharmonic Orchestra, conducted by A. Toscanini, relayed from New York. Variations on a Theme by Haydn (Brahms). Selection from "Rédemption" (C. Franck). Symphonic Poem, I Pini di Roma (Respighi), followed by Tzigane Concert from the Hotel Metropole.

COLOGNE (Germany)
 Westdeutscher Rundfunk. 1,319 kc/s (227 m.); 1.7 kW.
 See Langenberg.

Programmes for Sunday—(Cont.)

COPENHAGEN (Denmark)

1,067 kc/s (281 m.); 0.75 kW.
Relayed by Kalundborg, 260 kc/s (1,153 m.).
Transmits at intervals from 7.30 a.m. (Gymnastics).
10.30 a.m.—Weather and News.
11.0 a.m.—Town Hall Chimes.
11.2 a.m.—Instrumental Concert.
12 noon.—Reading in English: Poems by Thomas Hood.
12.20 p.m.—Talk in German.
12.40 p.m.—Talk in French.
1.0 p.m.—Gramophone Records.
1.30 p.m.—Programme for Children.
2.25 p.m.—Ninth Popular Concert from the Axelborg Studio, by the Radio Orchestra, conducted by Emil Reesen. Soloists: Johanne Karstens (Vocalist), and Folmer Jensen (Pianist).
4.0 p.m.—Divine Service from the Cathedral.
5.20 p.m.—Talk: The Crisis of Crises.
5.50 p.m.—Weather and News.
6.15 p.m.—Time; Sports Notes.
6.30 p.m.—Talk on the Atom.
7.0 p.m.—Town Hall Chimes.
7.2 p.m.—Concert of Music from the Time of Holberg, conducted by Launy Grøndahl.
7.20 p.m.—"Jeppe paa Bjerget"—or "The Peasant Transformed"—a Comedy in Five Acts (Ludwig Holberg) (arranged for Radio).
8.50 p.m.—News Bulletin.
9.0 p.m.—Orchestral Concert, conducted by Launy Grøndahl. Soloists: Rudolf Dietzmann ('Cello) and Louis Preil (Violin). Overture, "Martha" (Flotow). Babilage (Bossi). Canzonetta from the Violin Concerto in D Major (Tchaikovsky). Romanian Fantasia (Dimitrescu). Polonaise and Serenade for Cello from "Les Millions d'Arlequin" (Drigo). Selection from "Masaniello" (Auber). Divertissement for Trumpet and Orchestra (Suppé). Cadet March (Souza).
10.0 p.m.—Dance Music from the Industri Restaurant.
11.0 p.m. (in the interval).—Town Hall Chimes.
11.30 p.m. (approx.).—Close Down.

DUBLIN (Ireland)

(R.N.). 725 kc/s (413 m.); 1.5 kW.
Relayed by Cork, 1,337 kc/s (224.4 m.).
8.30 p.m.—Time Signal.
8.32 p.m.—Concert. Annie Fagan's Ladies' Orchestra. Mme. A. Heffernan (Soprano): Sacred Songs. Orchestral Selections. Richard Hayward and Company in Ulster Songs and Sketches. Jay Ryan (Baritone). Orchestral Selections. W. F. Watt (Tenor). Orchestral Selections.
11.0 p.m.—Time, News, Weather and Close Down.

FRANKFURT-am-MAIN (Germany)

770 kc/s (390 m.); 1.7 kW.
Relayed by Cassel, 1,220 kc/s (246 m.).
Transmits at intervals from 6.0 a.m. (Hamburg Relay).
10.30 a.m.—See Leipzig.
11.0 a.m.—Gramophone Records.
12 noon.—Dialogue: The Frankfurt Winter Relief Fund.
12.15 p.m.—Gramophone Records.
12.50 p.m.—Three Agricultural Talks.
1.0 p.m.—See Stuttgart.
2.0 p.m.—Rural Programme—Two Talks.
3.0 p.m.—See Stuttgart.
5.25 p.m.—Reading.
5.55 p.m.—"The Twilight Hour"—Variety Programme.
6.30 p.m.—Sports Notes.
6.35 p.m.—Saint Elizabeth Memorial Programme—Literary and Musical Selections.
7.30 p.m.—"Carmen"—Opera in Four Acts (Bizet).
9.30 p.m.—Time and News.
9.50 p.m.—Dance Music.
11.0 p.m. (approx.).—Close Down.

HAMBURG (Germany)

Norag (ha, in Morse). 806 kc/s (372 m.); 1.7 kW. Relayed by Bremen, 1,112 kc/s (270 m.); Flensburg, 1,373 kc/s (218 m.); Hanover, 530 kc/s (566 m.); and Kiel, 1,292 kc/s (232.2 m.).
Transmits at intervals from 6.0 a.m. (Hamburg Harbour Hour).
10.30 a.m.—See Leipzig.
11.0 a.m.—Talk: The Stars in December.
11.15 a.m. (from Hanover).—Address and Musical Programme.
12 noon.—Weather.
12.5 p.m. (from Hanover).—Mandoline Concert.
12.35 p.m.—Concert from the Works of Millöcker and Suppé.
1.30 p.m.—"The First Spoken Ship's Log Book," received by the Norag on the Liner "New York." II.—Cherbourg—New York.

2.0 p.m.—Talk: Are there still Dragons in the World?
2.30 p.m.—Dialect Songs for Children.
3.0 p.m.—Tea Dance.
4.45 p.m.—Fairy Stories for Children, with the assistance of the Orchestra.
5.30 p.m.—Recital of Classical Sonatas.
6.30 p.m.—Talk: The Hamburg University Ski-ing Course in Arosa.
6.40 p.m.—Sports Notes; Weather.
7.0 p.m.—Orchestral Concert. Soloist: Bernhard Hamann (Violin). News in the Interval.
8.45 p.m.—Second News.
9.5 p.m.—Topical Talk.
9.15 p.m.—Dance Music.

HEILSBURG (Germany)

1,085 kc/s (276.5 m.); 75 kW.
Relayed by Danzig, 662 kc/s (453.2 m.).
Transmits at intervals from 6.30 a.m. (Concert).
10.30 a.m.—See Leipzig.
11.15 a.m.—See Berlin (Witzleben).
1.0 p.m.—Chess Talk.
1.30 p.m.—Talk for Young People: Filming Experiences in Kashmir.
2.0 p.m.—Programme for Children.
2.30 p.m.—Orchestral Concert, conducted by Eugen Wilcken.
3.10 p.m. (in the interval).—Sports Notes.
4.0 p.m.—Talk: Gods and the Worship of Gods in Old Prussia Seven Hundred Years Ago.
4.30 p.m. (from Danzig).—Talk: Meteorological Observations and Forecasts.
5.0 p.m.—"Pictures from the Musical Past of East Prussia"—Music of Castle Schönberg, relayed from Königsberg Castle. Old Music, with Introductory Talk.
6.10 p.m. (from Danzig).—"Advent"—Programme of Music and Recitations.
7.15 p.m.—Sports Notes.
7.30 p.m.—See Frankfurt.
9.30 p.m. (approx.).—News, followed by Dance Music from Berlin (Witzleben).
11.30 p.m. (approx.).—Close Down.

HILVERSUM (Holland)

1,004 kc/s (298.8 m.); 8.5 kW.
7.55—9.40 a.m.—Programme of the Workers' Radio Society (V.A.R.A.).
7.55 a.m.—Physical Culture.
8.10 a.m.—Esperanto Lesson.
8.35 a.m.—Football Notes.
8.40 a.m.—Horticultural Talk.
9.10 a.m.—Musical Programme.
10.10 a.m.—11.40 a.m. (approx.).—Programme of the Liberal Protestant Radio Society (V.P.R.O.). Divine Service from a Church in Haarlem.
11.40 a.m.—4.40 p.m.—Programme of the Algemeene Vereeniging Radio Omroep (A.V.R.O.).
11.40 a.m.—Orchestral Concert conducted by Louis Schmidt. Gramophone Records in the interval.
1.40 p.m.—Weekly Book Talk.
2.10 p.m.—Running Commentary on the International Football Match, France v. Holland, relayed from the Colombes Stadium, Paris.
4.10 p.m.—Gramophone Records and Sports Notes.
4.40—7.40 p.m.—V.A.R.A. Programme.
4.40 p.m.—Programme for Children.
5.40 p.m.—Orchestral Concert conducted by Hugo de Groot.
6.25 p.m.—Address.
6.55 p.m.—Concert (contd.).
7.40 p.m. till Close Down.—A.V.R.O. Programme.
7.40 p.m.—Weather and News.
7.55 p.m.—Orchestral Concert, conducted by Nico Treep. Overture, A Norwegian Artists' Carnival (Svendsen). Second Peer Gynt Suite (Grieg). First Scandinavian Rhapsody (Halvorsen).
8.25 p.m.—Recitations.
8.35 p.m.—Concert (contd.). Spanish Suite, La Verbena (Lacôme). Two Slavonic Dances (Dvorak).
8.55 p.m.—Recitations.
9.5 p.m.—"The Ghost in the Mill"—Musical Comedy (Adam).
9.55 p.m.—Gramophone Records.
10.10 p.m.—Concert by Kovacs Lajos and his Orchestra. Songs by Bob Scholte.
11.40 p.m. (approx.).—Close Down.

HUIZEN (Holland)

160 kc/s (1,875 m.); 8.5 kW.
8.10—9.10 a.m.—Programme of the Christian Radio Society (N.C.R.V.). Sacred Concert.
9.10 a.m.—4.40 p.m.—Programme of the Catholic Radio Society (K.R.O.).
9.10 a.m.—Gramophone Records.
9.40 a.m.—Mass from the Franciscan Church, Weert.
11.10 a.m.—Gramophone Records.
11.40 a.m.—Sextet Concert.
1.10 p.m.—Religious Instruction.
1.30 p.m.—Gramophone Records.
1.50 p.m.—Literary Talk.
2.10 p.m.—Orchestral Concert.

4.10 p.m.—Programme for Invalids.
4.40—7.25 p.m.—N.C.R.V. Programme.
4.40 p.m.—Organ Recital.
5.30 p.m.—Divine Service relayed from the Reformed Church, Alphen, followed by Sacred Music.
7.25 till Close Down.—K.R.O. Programme.
7.25 p.m.—Talk by Professor Weve.
7.50 p.m.—Football Notes.
7.55 p.m.—Orchestral Concert. Soloist: F. Boshart (Piano). In the interval at 9.10 p.m.—News Bulletin.
10.20 p.m.—Choral Epilogue.
10.40 p.m. (approx.).—Close Down.

KALUNDBORG (Denmark)

Kalundborg Radio. 260 kc/s (1,153 m.); 7.5 kW.
See Copenhagen.

KATOWICE (Poland)

734 kc/s (408 m.); 16 kW.
Transmits at intervals from 9.15 a.m.
4.45 p.m.—Afternoon Concert.
7.30 p.m.—Popular Concert.
9.10 p.m.—Popular Italian Songs.
9.55 p.m.—Light Music and Dance Music.

LANGENBERG (Germany)

Westdeutscher Rundfunk. 635 kc/s (473 m.); 17 kW. Relayed by Aachen, Cologne and Münster, 1,319 kc/s (227 m.).
Transmits at intervals from 6.0 a.m. (Hamburg Relay).
10.30 a.m.—See Leipzig.
11.5 a.m.—Reading.
11.35 a.m.—Post Office Talk: Parcels which do not arrive at their Destination.
12 noon.—Orchestral Concert.
1.30 p.m.—Scherzband Lesson.
1.55 p.m.—Talk on the Rumba—the New Dance.
2.35 p.m.—My Native Place, by Otto Brües.
3.0 p.m.—Reading of a Story.
3.30 p.m.—Choral Concert from the Lessing Oberrealschule in Düsseldorf.
5.5 p.m.—Two Autumn Tales.
5.25 p.m.—Masters of the Portrayal of Nature—Reading from the Works of Friedrich Schack.
5.40 p.m.—Talk for Workers.
6.5 p.m.—An Entertainment.
6.45 p.m.—Sports Notes.
7.0 p.m.—"The Bird Fancier"—Operetta in Three Acts (Zeller).
9.15 p.m.—News followed by Concert and Dance Music.
10.45 p.m.—Report on the Cologne Six Days' Racing, relayed from the Rheinlandhalle.

LEIPZIG (Germany)

1,157 kc/s (259 m.); 2.3 kW. Relayed by Dresden, 941 kc/s (319 m.).
Transmits at intervals from 5.30 a.m. (Witzleben Relay).
10.30 a.m.—"Nun kommt der Heiden Heiland"—Cantata for the First Sunday in Advent (J. S. Bach) by the Municipal and Gewandhaus Orchestras, and the Choir of St. Thomas.
11.0 a.m.—"An Italian Autumn"—a Lyric Suite composed and recited by Ossip Kalenter.
11.30 a.m.—See Berlin (Witzleben).
1.0 p.m.—Weather, Time and Topical Talk.
1.15 p.m.—Agricultural Notes.
1.30 p.m.—Esperanto Lesson.
2.0 p.m.—Chamber Music. Sonata for Pianoforte and Cello in E Flat Major, Op. 12 (Max Fiedler).
2.30 p.m.—Great Towns: "Venice"—a Literary Sequence with Songs.
3.30 p.m.—Choral Concert.
4.15 p.m.—Reading.
5.0 p.m.—Concert by the Leipzig Symphony Orchestra.
6.30 p.m.—"La dame blanche"—Opera-Comique in Three Acts (Boieldieu), relayed from the New Theatre.
9.30 p.m.—News, followed by Dance Music from Berlin (Witzleben).
11.0 p.m. (approx.).—Close Down.

MADRID (Spain)

Union Radio (E.A.J.7). 707 kc/s (424.3 m.); 2 kW.
8.0—9.30 a.m.—Topical Review.
11.30 a.m.—Concert by the Municipal Band from the Retiro (Weather permitting).
2.30 p.m.—Chimes, Time, Information Bureau and Sextet Concert.
3.55 p.m.—Theatre Notes.
4.0—7.0 p.m.—Interval.
7.0 p.m.—Chimes and Request Gramophone Records.
8.30—10.0 p.m.—Interval.
10.0 p.m.—Chimes, Time and Band Concert.
12 midnight.—Chimes and Dance Music.
12.30 a.m. (Monday).—Close Down.

MILAN (Italy)

Ente Italiano Audizioni Radiofoniche. 598 kc/s (501.7 m.); 8.5 kW. Relayed by Turin, 1,094 kc/s (274.2 m.) and Genoa, 959 kc/s (312.8 m.).

9.15 a.m.—Giornale Radio.
9.30 a.m.—Bible Readings.
9.50 a.m.—Gramophone Records of Sacred Music.
10.15 a.m.—German Lesson on Gramophone Records.
10.20 a.m.—Agricultural Talk.
11.30 a.m.—1.0 p.m.—Concert. In the interval at 12 noon.—Time and Announcements.
3.0 p.m.—Sports Notes and Concert. In the interval, Art Notes.
5.30—5.45 p.m.—Giornale Radio and Sports Notes.
5.45 p.m. (from Turin).—Variety Items.
6.5 p.m.—Gramophone Records. In the interval at 6.40 p.m.—Announcements, and at 7.0 p.m.—Time and News.
7.35 p.m.—"Maggiolata veneziana"—Opera (Selvaggi), conducted by the Composer. In the intervals, Talk, Theatre Notes and Giornale Radio. After the Programme, News.

MORAVSKÁ-OSTRAVA (Czechoslovakia)

1,139 kc/s (263 m.); 11 kW.
Transmits at intervals from 6.30 a.m.
11.5 a.m.—Orchestral Concert.
12 noon.—See Prague.
5.0 p.m.—See Brno.
6.0 p.m.—See Prague.
9.0 p.m.—Announcements.
9.20 p.m.—See Prague.

MUNICH (Germany)

563 kc/s (533 m.); 1.7 kW.
Relayed by Augsburg and Kaiserslautern, 536 kc/s (560 m.); and Nürnberg, 1,256 kc/s (239 m.).
Transmits at intervals from 9.0 a.m.
10.30 a.m.—See Leipzig.
11.15 a.m.—Reading (Grimm).
11.35 a.m.—Cinema Organ Recital.
12.5 p.m.—Time and News.
12.15 p.m. (from Nürnberg).—Agricultural Talk.
12.35 p.m.—"The Age of Chivalry"—as it really was and as we see it—Gramophone Sequence.
1.30 p.m.—Chess Lesson.
2.15 p.m.—Talk for Women.
2.35 p.m. (from Nürnberg).—Band Concert.
3.35 p.m.—Talk.
3.55 p.m.—Duet Recital for Soprano and Baritone.
5.10 p.m.—Reading.
5.30 p.m.—See Leipzig.
6.30 p.m.—News Bulletin.
6.40 p.m.—Talk: Winter Relief 1931—1932.
7.0 p.m.—Talk on the following transmission.
7.5 p.m.—"The Cousin from Nowhere"—Operetta in Three Acts (Künneke), followed by Concert from the Café Königshof, Nürnberg.
9.20 p.m. (in the interval).—Time and News.
11.0 p.m. (approx.).—Close Down.

OSLO (Norway)

Kringkastingsselskapet, 277 kc/s (1,083 m.); 75 kW. Relayed by Fredrikstad, 816 kc/s (367.6 m.); Hamar, 536 kc/s (560 m.); Notodden, 671 kc/s (447.1 m.); Porsgrund, 662 kc/s (453.2 m.) and Rykan, 671 kc/s (447.1 m.).
9.20 a.m.—Chimes and Divine Service relayed from the Cathedral, Stavanger, 1,247 kc/s (240.6 m.).
12 noon—1.0 p.m.—Concert by the "Harmoni" Choir on its Twenty-Fifth Anniversary relayed from Fredrikstad.
3.0 p.m.—Orchestral Concert from the Wilhelm Olsen Restaurant.
4.0 p.m.—Recitations.
4.30 p.m.—Soprano and Cello Recital.
5.0 p.m.—A Comedy (Robert de Flers).
6.15 p.m.—News Bulletin.
6.30 p.m.—Illustrated Talk: Forgotten Songs.
7.0 p.m.—Time Signal.
7.2 p.m.—Orchestral Concert.
8.0 p.m.—Talk: General Gordon.
8.35 p.m.—News Bulletin.
8.50 p.m.—Topical Talk.
9.5 p.m.—American Concert by a Vocal Quartet and Orchestra.
10.0 p.m.—Gramophone Dance Music.
11.0 p.m. (approx.).—Close Down.

PARIS (France)

Eiffel Tower (FLE). 207.5 kc/s (1,445.7 m.); 15 kW. Time Signals (on 2,650 m.) at 9.26 a.m. and 10.26 p.m. (preliminary and 6-dot signals).
12.30 p.m.—Symphony Concert, conducted by M. E. Flament. In the interval at 1.0 p.m.—News.
1.30 p.m.—Medical Talk.
5.45 p.m.—Le Journal Parlé.
6.45 p.m.—Programme for Children.
7.20 p.m.—Weather Forecast.
7.30 p.m.—Gramophone Concert.

PARIS (France)

Poste Parisien. 914 kc/s (328.2 m.); 1.2 kW.
8.15 p.m.—Gramophone Records and News.
9.0 p.m.—Concert. Overture, "Peter Schmolli" (Weber). Serenade

(Dvorak). First Orchestral Suite from "Peer Gynt" (Grieg). Divertissement (Lalo). Entr'acte from "Galante Aventure" (Guiraud). Pavane (Dupont). Gipsy Dance from "Henry VIII" (Saint-Saëns).

PARIS (France)

Radio-Paris. (CFR). 174 kc/s (1,725 m.); 80 kW.
7.45 a.m.—Gramophone Records.
8.0 a.m.—News Bulletin.
8.30 a.m.—Physical Culture Lesson.
10.50 a.m.—Book-keeping Lesson.
11.15 a.m.—Spanish Lesson.
12 noon.—Religious Talk.
12.30 p.m.—Organ Recital. Sous la feuillée (Thomé). Andante religioso (Thomas).
12.45 p.m.—News Bulletin.
1.0 p.m.—Gramophone Records. In the interval, Bilboquet makes Soup.
2.0 p.m.—Concert of Decca Records.
3.0 p.m.—Relay of a Running Commentary on the Football Match, France v. Holland.
5.0 p.m.—Concert arranged by the Association des Concerts Poulet, relayed from the Sarah Bernhardt Theatre.
7.0 p.m.—Agricultural Report and Announcements.
7.15 p.m.—Economic and Social Notes and News.
7.30 p.m.—Radio-Paris Circus.
8.0 p.m.—"La Femme de Tabarin"—Play (Catulle Mendès), by M. Georges Colin and Company.
8.30 p.m.—News Bulletin.
8.45 p.m.—Gramophone Concert—Puccini Programme.
9.15 p.m.—News and Time.
9.30 p.m.—Gramophone Records.

PRAGUE (Czechoslovakia)

617 kc/s (487 m.); 120 kW.
Transmits at intervals from 6.0 a.m.
9.0 a.m.—Talk for Workers.
9.20 a.m.—Literary Talk.
9.35 a.m.—Literary Programme.
10.0 a.m.—See Bratislava.
11.0 a.m.—Time and News.
11.5 a.m.—See Moravská-Ostrava.
12 noon.—Agricultural Talks.
12.45 p.m.—Social Notes.
1.25 p.m.—Programme by the Prague National Theatre.
4.30 p.m.—Gramophone Records.
4.45 p.m.—Talk.
5.0 p.m.—See Brno.
6.0 p.m.—Band Concert.
7.0 p.m.—Concert from the Smetana Hall, by the Czech Philharmonic Orchestra, conducted by Alexander Zemlinsky. Soloist: Arthur Rubinstein.
9.0 p.m.—Concert by the New York Philharmonic Orchestra, conducted by Toscanini, relayed from New York. News after the Programme.

RADIO-SUISSE ROMANDE (SOTTENS) (Switzerland)

743 kc/s (403 m.); 25 kW.; Lausanne. 442 kc/s (680 m.); and Geneva, 395 kc/s (760 m.).
8.45 a.m. (from Lausanne).—Protestant Service relayed from the Cathedral.
10.0 a.m. (from Lausanne).—Gramophone Records.
11.30 a.m.—Time and News.
11.40 a.m.—1.0 p.m. (from Geneva).—Gramophone Records.
1.30 p.m. (from Basle).—Report in French on the International Football Match, Switzerland v. Austria, relayed from the Rankhof Stadium.
5.30 p.m. (from Geneva).—Religious Address.
6.0 p.m. (from Geneva).—Gramophone Records.
6.50 p.m. (from Geneva).—News Bulletin.
7.0 p.m. (from Lausanne).—Déodat de Séverac Concert, with Introductory Talk.
8.0 p.m.—Orchestral Concert.
9.15 p.m.—News Bulletin.
9.30 p.m. (approx.).—Close Down.

ROME (Italy)

Ente Italiano Audizioni Radiofoniche (IRO). 680 kc/s (441 m.); 75 kW. Relayed by Naples, 905 kc/s (332 m.) and 2RO, 11,810 kc/s (25.4 m.).
9.0 a.m.—Bible Reading.
9.15 a.m.—Gramophone Records of Sacred Music.
9.45—10.0 a.m.—Sports Notes and Amusement Guide.
11.55 a.m.—German Lesson on Gramophone Records.
12 noon.—1.15 p.m.—Gramophone Records. In the interval: Time and News.
3.0 p.m. (from Naples).—Programme for Children; followed by Weather and Sports Notes.
3.40 p.m. (approx.).—Vocal and Instrumental Concert.
5.0 p.m.—Sports Notes.
6.55 p.m. (from Naples).—Shipping.
7.0 p.m.—Sports Notes.
7.10 p.m.—Gramophone Records.

Programmes for Sunday—(Cont.)

7.30 p.m.—Time and News.
 8.0 p.m.—Variety Concert. Soloist: Eugenio Albini (Cello), followed by "For the Good of Everybody"—Play in One Act (Silvio Zambaldi), and Gramophone Records.
 9.55 p.m.—News Bulletin.
SCHWEIZERISCHER LANDESENDER (BEROMÜNSTER) (Switzerland)
 653 kc/s (459 m.); 75 kW.; Basle, 1,229 kc/s (244.1 m.); and Berne, 1,220 kc/s (246 m.).
 9.30 a.m. (from Basle).—Catholic Address.
 10.20 a.m. (approx.) (from Basle).—Chamber Music—the Pianoforte Trio.
 11.10 a.m.—Gramophone Concert.
 11.28 a.m.—Time and News.
 11.40 a.m.—Orchestral Concert.
 12.35 p.m.—Weather Report.
 12.40—1.30 p.m.—Interval.
 1.30 p.m. (from Basle).—Running Commentary on the International Football Match, Austria v. Switzerland, relayed from Rankhof.
 3.15 p.m.—Gramophone Dance Music.
 3.40 p.m. (from Basle).—Reading.
 4.0 p.m.—Folk Song Recital for Choir and Baritone Solo, relayed from St. Martin's Church, Basle.
 5.30 p.m. (from Basle).—Chess Talk.
 6.0 p.m. (from Basle).—Talk: Is Dipsomania curable?
 6.25 p.m.—Sports Notes.
 6.28 p.m.—Time and Weather.
 6.30 p.m.—Orchestral Concert.
 7.0 p.m. (from Berne).—"S'Dorngrüt"—Radio Drama in Dialect in Five Acts (Hans Corrodi), after Jeremias Gotthelf.
 9.0 p.m.—News Bulletin.
 9.15 p.m. (approx.).—Close Down.
STOCKHOLM (Sweden)
 Radiotjänst (SASA). 689 kc/s (436 m.); 75 kW. Relayed by Boden, 244 kc/s (1,229.5 m.); Göteborg, 932 kc/s (322 m.); Hörby, 1,166 kc/s (257 m.); Motala, 222.5 kc/s (1,348 m.); Östersund, 389 kc/s (770 m.) and Sundsvall, 554 kc/s (542 m.).
 9.30 a.m.—Topical Talk.
 10.0 a.m.—Divine Service Relay.
 11.45 a.m.—Weather Report.
 12.30 p.m.—Symphony Concert relayed from Malmö, 1,301 kc/s (231 m.).

2.0 p.m.—Concert by a Male Voice Choir, relayed from Boden.
 2.30 p.m.—Talk in Danish.
 3.0 p.m.—Programme for Children.
 3.30 p.m.—Gramophone Records.
 4.20 p.m.—Violin Sonatas (Beethoven) in (a) E Flat Major Op. 12, No. 3, and (b) G Major, Op. 30, No. 3.
 4.55 p.m.—Chimes from the Town Hall.
 5.0 p.m.—Evensong.
 6.15 p.m.—Weather and News.
 6.30 p.m.—"The Finances of the Grand Duke"—Play (after a Novel by Frank Heller, arranged for the Wireless by C. A. Dymling).
 8.0 p.m.—Orchestral Concert of Swedish Music.
 8.45 p.m.—Weather and News.
 9.0 p.m.—Popular Concert.
 10.0 p.m. (approx.).—Close Down.
STRASBOURG (France)
 Radio-Strasbourg (PTT). 869 kc/s (345 m.); 15 kW.
 10.45 a.m.—Protestant Service.
 11.30 a.m.—Catholic Service.
 12 noon.—Sacred Music on Gramophone Records.
 1.0 p.m.—Time Signal.
 1.2 p.m.—News in French and German.
 1.15 p.m.—Gramophone Records.
 2.0 p.m.—Agricultural Talk in French.
 3.15 p.m.—Talk for Workers in German.
 3.30 p.m.—Talk in French: The Boy Scout Movement.
 3.45 p.m.—Gramophone Dance Music.
 4.30 p.m.—Talk for Workers in German.
 4.45 p.m.—Talk in French: Diphtheria.
 5.0 p.m.—Instrumental Concert.
 5.45 p.m.—Agricultural Talk in German.
 6.0 p.m.—Instrumental Concert.
 6.45 p.m.—Sports Talk in French.
 7.0 p.m.—Dance Music.
 7.30 p.m. (approx.).—Time Signal.
 7.32 p.m.—News in French and German.
 7.45 p.m.—Gramophone Records.
 8.30 p.m.—Alsatian Evening—Musical and Literary Selections.
 10.30 p.m.—Dance Music from the Savoy.
 12 midnight (approx.).—Close Down.
STUTT GART (MÜHLACKER) (Germany)
 Süddeutscher Rundfunk. 833 kc/s

(360 m.); 75 kW. Relayed by Freiburg, 527 kc/s (570 m.).
 Transmits at intervals from 6.0 a.m. (Hamburg Relay).
 10.30 a.m.—See Leipzig.
 11.0 a.m.—Pianoforte Recital by Misca Rubasch.
 11.30 a.m.—Gramophone Records of Enrico Caruso.
 12 noon.—Topical Talk.
 12.15 p.m.—Zither Recital.
 12.35 p.m.—Reading.
 1.0 p.m.—A Play for Children.
 2.0 p.m.—Choral Concert.
 3.0 p.m. (from Freiburg).—"Our Homeland"—a Sequence of Relays arranged by Carl Struve—XXIX, in the Town of Freiburg.
 4.30 p.m. (from Karlsruhe).—Mandoline Concert.
 5.25 p.m.—"A German deprived of Germany" (F. Liszt)—a Radio Sequence from the Novel by Walter von Molo.
 6.15 p.m.—Sports Notes.
 6.30 p.m.—"Vom Himmel hoch, da komm' ich her"—Christmas Cantata for Women's and Men's Voices, two Lutes, Mixed Choir, Children's Choir and Organ (Oskar Besein-felder), relayed from St. Mark's Church, Stuttgart.
 7.30 p.m.—Wireless Potpourri from Berlin (Witzleben).
 9.0 p.m.—Talk: Nobel Prize Winners, VIII, Anatole France, with Readings from his Works.
 9.30 p.m.—News Bulletin.
 9.50 p.m.—Dance Music.
 11.0 p.m. (approx.).—Close Down.
TOULOUSE (France)
 Radiophonie du Midi. 779 kc/s (385 m.); 8 kW.
 12.30 p.m.—Catholic Service.
 1.0 p.m.—Dance Music.
 1.15 p.m.—Light Music.
 1.30 p.m.—Agricultural Report.
 1.45 p.m.—Protestant Service.
 5.0 p.m.—Transmission of Pictures.
 5.15 p.m.—Solo Selections.
 5.30 p.m.—News Bulletin.
 5.45 p.m.—Opera Music.
 6.0 p.m.—Dance Music.
 6.15 p.m.—Trio in B Flat (Schubert).
 6.30 p.m.—News Bulletin.
 6.45 p.m.—Vocal Tangos.
 7.0 p.m.—Orchestral Selections.
 7.15 p.m.—Military Music.
 7.30 p.m.—News Bulletin.
 7.45 p.m.—Gramophone Records.
 8.0 p.m.—Chansonnettes.
 8.15 p.m.—Orchestral Selections.

8.45 p.m.—Sound Film Songs.
 9.0 p.m.—Accordion Solos.
 9.15 p.m.—Concert.
 10.0 p.m.—Gramophone Records.
 10.30 p.m.—News Bulletin.
 10.45 p.m.—Concert arranged by the Vocalion Gramophone Company of Hayes.
 11.15 p.m.—North African News.
 11.30 p.m.—Allegro from the Fourth Concerto in G Major for Orchestra (Beethoven).
 12 midnight.—Weather, Announcements and Close Down.
TRIESTE (Italy)
 Ente Italiano Audizioni Radiofoniche. 1,211 kc/s (247.7 m.); 15 kW.
 8.55 a.m.—Chimes and Missa Cantata from the Cathedral of S. Giusto.
 11.30 a.m.—Giornale Radio and Gramophone Records.
 11.55 a.m.—German Lesson on Gramophone Records.
 12 noon.—Time and Announcements.
 12.5—12.45 p.m.—Musical Programme.
 3.30 p.m.—Dance Music.
 5.0 p.m.—Orchestral Concert from the Café Dante.
 5.30 p.m.—Sports Notes.
 7.15 p.m.—News Bulletin.
 7.30 p.m.—Gramophone Records.
 8.0 p.m.—Time and Announcements.
 8.5 p.m. (approx.).—Variety Programme.
 9.25 p.m.—Orchestral Concert from the Café Savoia.
 9.55 p.m.—News Bulletin.
VIENNA (Austria)
 Radio-Wien. 581 kc/s (517 m.); 20 kW. Relayed by Graz, 851 kc/s (352 m.); Innsbruck, 1,058 kc/s (283 m.); Klagenfurt, 662 kc/s (453.2 m.); Linz, 1,220 kc/s (246 m.); and Salzburg, 1,373 kc/s (218 m.).
 Transmits at intervals from 8.30 a.m.
 10.30 a.m.—Concert by the Vienna Symphony Orchestra. Soloists: Christa Richter (Violin), Richard Krottschak (Cello) and Edgar Schiffmann (Pianoforte).
 12.30 p.m.—Mandoline Concert.
 2.0 p.m.—Time and Programme Announcements.
 2.5 p.m.—Readings.
 2.30 p.m.—Orchestral Concert with Hans Wrana (Baritone).

4.0 p.m.—Talk by Josef Scherer o. Los Angeles: The Mystery of Death Valley.
 4.20 p.m.—String Quintet, Op. 16, for Two Violins, Viola, Cello and Double Bass (Prohaska).
 5.10 p.m.—Talk: A Visit to the Bear Country of Eastern Slovakia.
 5.35 p.m.—Josef Ponten reads from his own Works, with Introductory Talk by Dr. Adalbert Schmidt.
 6.5 p.m.—Time and Announcements.
 6.15 p.m.—A Humorous Programme.
 6.50 p.m.—"The Circle of Chalk"—Play in Five Acts after the Chinese (Klabund).
 8.45 p.m.—News Bulletin.
 9.0 p.m.—Concert by the New York Philharmonic Orchestra, conducted by Toscanini, relayed from New York. (For Details see Budapest).
 10.0 p.m.—Gramophone Dance Records.
WARSAW (Poland)
 Polskie Radio. 212.5 kc/s (1,411 m.); 158 kW.
 9.15 a.m.—Service relayed from Poznań, 896 kc/s (335 m.).
 10.35 a.m.—Missionary Talk.
 10.58 a.m.—Time Signal and Bugle Call from the Tower of St. Mary's Church, Cracow.
 11.5 a.m.—Programme Notes.
 11.10 a.m.—Weather Report.
 11.15 a.m.—Concert by the Warsaw Philharmonic Orchestra, with Angela Szleminska (Soprano).
 1.0 p.m.—Agricultural Talk.
 1.20 p.m.—Musical Programme. In the interval at 1.40 p.m.—Agricultural Talk.
 2.15 p.m.—Military Programme.
 2.55 p.m.—Programme for Children.
 3.20 p.m.—Gramophone Records.
 3.40 p.m.—Talk: Polish Literature.
 3.55 p.m.—Gramophone Records.
 4.15 p.m.—Talk on Bread.
 4.30 p.m.—Novelty Programme.
 4.45 p.m.—Orchestral Concert with Mlle Halina Jurkiewicz (Soprano).
 6.0 p.m.—Miscellaneous Items.
 6.25 p.m.—Gramophone Records.
 6.40 p.m.—Programme Notes.
 6.45 p.m.—Dramatic Programme, relayed from Wilno, 1,229 kc/s (244.1 m.).
 7.30 p.m.—Orchestral Concert. Soloist: Sophie Adamska (Cello).
 8.55 p.m.—Literary Programme.
 9.10 p.m.—Popular Italian Songs.
 9.40 p.m.—Announcements.
 10.0 p.m.—Light Music and Dance Music.

MULTI-GRID VALVES ENTIRELY SUPERSEDE THE PENTODES AT PRESENT ON THE MARKET

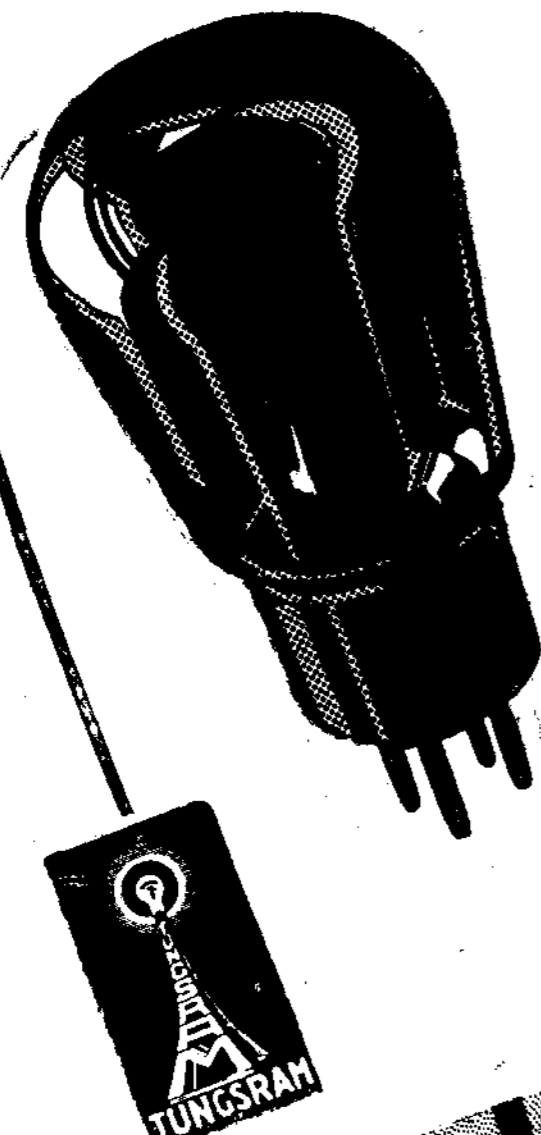

PP 230
PP 415
PP 430

An entirely new range of Tungram Multi-Grid Valves—the first of the new Tungram series. Of unique construction, they supersede entirely the pentodes at present on the market; they are so arranged internally that the electron stream is twice controlled by the grid. These new valves can be used in any existing pentode receiver without any circuit alteration whatsoever; in ordinary receivers only one connection is necessary. Three types of Multi-Grid Valves have been introduced: PP 230 (2-volt); PP 415 and PP 430 (4-volt). PP 230 will very materially increase the output of the small receiver, although the anode current consumption will in most cases be below that of the ordinary power valve. PP 415 and PP 430 will be found extremely efficient for the output stage of A.C. Receivers.
 All Tungram Multi-Grid Valves can be supplied with a 5-pin base, or 4-pin base with side terminal.
 Prices: Multi-Grid Valves, Type PP 230, 16/-; PP 415, 16/-; PP 430, 19/-.
 Other types from 5/6 to 19/-.

TUNGGRAM

For characteristic curves and other technical information, write to Dept. ST.5, **TUNGGRAM ELECTRIC LAMP WORKS (GT. BRITAIN), LTD.**, 11, Burgh Quay, Dublin. Radio Department, Commerce House, 72, Oxford Street, London, W.1.
 Makers of the famous Tungram Electric Lamps.
 Branches in Birmingham, Bristol, Glasgow, Leeds, Manchester, Newcastle, Nottingham, Southampton, Lamp, Valve and Glass Factories: Austria, Czechoslovakia, Hungary, Italy and Poland.
 I.F.S. Organisation, Tungram Lamps & Radio, Ltd., 11, Burgh Quay, Dublin.
 Tungram photo-electric cells: Nava "E" (for scientific measurement), £2 17s. 6d.; Nava "P" (for colour matching device), £3 3s.; Nava "EII" (for talk work), £5 15s. 6d.

PROGRAMMES FOR MONDAY (November 30)

NOTE: THE HOURS OF TRANSMISSION ARE REDUCED TO GREENWICH MEAN TIME

ALGIERS (N. Africa)

825.3 kc/s (363.4 m.); 13 kW. Transmits at intervals from 12.30 p.m.
7.10 p.m.—News Bulletin.
7.20 p.m.—Film Review.
7.30 p.m.—Chansonnettes.
7.45 p.m.—Piano Solos.
8.0 p.m.—Talk: The Ivory Coast.
8.15 p.m.—Military Music.
9.0 p.m.—For all Tastes—Variety Concert.
10.30 p.m.—Tyrolese Songs.
10.45 p.m.—Dance Music with Vocal Refrains.

BARCELONA (Spain)

Radio-Barcelona (E.A.J.R.) 860 kc/s (349 m.); 8 kW. Transmits at intervals from 11.0 a.m.
7.0 p.m.—Trio Music.
7.30 p.m.—Market Prices, Exchange and Gramophone Records.
8.20 p.m.—Sports Notes.
8.30 p.m.—French Lesson.
9.0 p.m.—Chimes, Weather, Exchange and Market Prices.
9.5 p.m.—Humorous Review of the Week's Events in Verse.
9.20 p.m.—Orchestral Music.
10.0 p.m.—Russian Song Recital.
10.25 p.m.—Chamber Music.
10.45 p.m.—Orchestral Selection: Dance of the Hours from "La Gioconda" (Ponchielli).
11.0 p.m.—Gramophone Records.
11.30 p.m.—Dance Music from the Café Catalan.
12 midnight (approx.)—Close Down.

BELGRADE (Yugoslavia)

697 kc/s (430.4 m.); 3 kW. Transmits at intervals from 10.0 a.m.
6.25 p.m.—Time and Programme Notes.
6.30 p.m.—French Lesson.
7.0 p.m.—Orchestral Concert. Overture, "Quo Vadis?" (Scassola). Operetta Fantasia, Dix millions de dot (Brunel). Tibetan Suite (Dreyer). Waltz, Hochzeitsreigen (Lincke). Türkisches Märchen (Lincke). Canto di passione (Malvezzi). Gallop (Gillet).
8.0 p.m.—Song Recital. Grauer Kopf and An die Musik (Schubert). Feldeinsamkeit and Mainacht (Brahms). Die Uhr (Löwe). Song (Jensen).
8.30 p.m.—Slavonic Concert. Sonata for Pianoforte and Violin, Op. 3 (Stojanovic). Nocturne for Pianoforte (Chopin). Meditation (Glazounoff). Violin Solo from "My Country" (Smetana). Miniatures for Pianoforte (Prokofieff).
9.0 p.m.—Time and News.
9.20 p.m.—Concert from the Café Moskva.

BERLIN (Germany)

Königs Wusterhausen. 183.5 kc/s (1,635 m.); 75 kW. Transmits at intervals from 5.30 a.m. (Witzleben Relay).
3.30 p.m.—See Berlin (Witzleben).
4.30 p.m.—Talk: Repetition in Music.
5.0 p.m.—Educational Talk: Mysticism in the Religions of the Peoples.
5.30 p.m.—Talk: From Biology to a Nature Philosophy.
5.55 p.m.—Weather for Farmers.
6.0 p.m.—Agricultural Talk.
6.30 p.m.—See Berlin (Witzleben).
7.0 p.m.—Concert from the Hotel Kaiserhof.
7.30 p.m.—Readings by Felix Timmermans, relayed from the Herrenhaus. Introductory Talk by Walter von Molo.
8.10 p.m.—See Berlin (Witzleben).
9.15 p.m.—Political Press Review, followed by News, and Dance Music from Berlin (Witzleben).
11.30 p.m. (approx.)—Close Down.

BERLIN (Germany)

Witzleben. 715 kc/s (418 m.); 1.7 kW. Transmits at intervals from 5.30 a.m. (Gymnastics).
3.30 p.m.—Soprano Song Recital from the Works of Finnish Composers, with Introductory Talk.
3.50 p.m.—Pianoforte Recital by Theophil Demetriescu. Partita in C Minor (Bach). Christmas Sonatina and Toccata (Busoni). Nos. 2, 3, 6 and 7 from the Ten Concert Etudes (Toch).
4.30 p.m.—Talk for Young People: Rugby—Sport for the Young.
4.50 p.m.—Talk: The Cultural Life of the Germans in the Border States.
5.10 p.m.—Talk: The Type of the Age.

5.35 p.m.—Concert from the Hotel Kaiserhof.
6.20 p.m.—Topical Talk.
6.30 p.m.—Talk: The Importance and Problems of Agricultural Settlement.
7.0 p.m.—See Breslau.
8.0 p.m.—News Bulletin.
8.10 p.m.—Orchestral Concert conducted by Dr. Julius Kopsch. Overture, "Beatrice and Benedict" (Berlioz). Concerto for Violin and Orchestra in A Minor, Op. 28 (Goldmark). Symphony No. 5, Op. 50 (Carl Nielsen).
9.15 p.m.—News, followed by Dance Music from the Café Berlin.
11.30 p.m. (approx.)—Close Down.

BORDEAUX-LAFAYETTE (France)

(P.T.T.) 986 kc/s (304 m.); 35 kW. Transmits at intervals from 12.45 p.m.
7.30 p.m.—News, Exchange; Market Prices.
7.40 p.m.—Sports Notes.
7.55 p.m.—Results of the Prize Draw.
8.0 p.m.—Programme for Children.
8.15 p.m.—Charades.
8.20 p.m.—News Bulletin.
8.30 p.m.—Instrumental Concert. After the Programme, Amusement Guide and Time Signal.

BRATISLAVA (Czechoslovakia)

1,076 kc/s (279 m.); 14 kW. Transmits at intervals from 10.0 a.m.
6.0 p.m.—See Prague.
6.5 p.m.—Popular Songs.
6.45 p.m.—"King Svatopluk"—Historical Drama in Three Acts (Stodola).
9.0 p.m.—See Prague.
9.15 p.m.—Programme Announcements.
9.20 p.m.—Brass Band Concert.

BRESLAU (Germany)

923 kc/s (325 m.); 1.7 kW. Relay by Gleiwitz, 1,184 kc/s (253 m.). Transmits at intervals from 5.30 a.m.
6.5 p.m.—Talk: Economics and the Primitive Peoples.
6.25 p.m.—Weather Forecast.
6.30 p.m.—See Berlin (Witzleben).
7.0 p.m.—"Das Stauwerk"—wireless Play (Gerhard Menzel).
8.0 p.m.—News Bulletin.
8.10 p.m.—Concert of Chamber Music. String Quartet in E Flat Major (Dittersdorf). Quartet for Guitar, Violin, Viola and Cello (Schnabel).
8.45 p.m.—Talk: On Horseback across the Andes.
9.20 p.m.—Time and News.
9.50 p.m.—Theatre Talk.
10.5 p.m.—Answers to Wireless Technical Queries.
10.15 p.m.—Talk: The Tasks of the Sports Critic.
10.35 p.m. (approx.)—Close Down.

BRNO (Czechoslovakia)

878 kc/s (342 m.); 3 kW. Transmits at intervals from 10.0 a.m.
6.5 p.m.—Talk.
6.20 p.m.—Radio Cabaret.
7.25 p.m.—See Prague.
8.0 p.m.—Yugoslavian Concert.
9.0 p.m.—See Prague.
9.15 p.m.—News Bulletin.
9.20 p.m.—See Bratislava.

BRUSSELS (Belgium) (No. 1)

I.N.R. 590 kc/s (509 m.); 20 kW. 5.0 p.m.—Gramophone Records of Operetta Music.
7.15 p.m.—Talk: Belgium; Natural Reserves.
7.30 p.m.—Theatre Review.
8.0 p.m.—Orchestral Selections: Petite Suite (Borodin).
8.15 p.m.—Walloon Programme.
8.30 p.m.—Programme dedicated to Hunting. Readings by Mme. Jeanne Bourtembourg. Hunting Horn Music. Symphony, La chasse (Haydn). Overture, "Le Jeune Henri" (Méhul). Gramophone Records: (a) Le Cor (Flégier), (b) The Hunt (Mendelssohn). The Hunters' Waltz (Sellenick). Halte des Chasseurs (Heller).
10.0 p.m.—Le Journal Parlé.

BRUSSELS (Belgium) (No. 2)

N.I.R. 887 kc/s (338.2 m.); 20 kW. Programme in Flemish.
5.0 p.m.—Sonata for Pianoforte and Violin Op. 82 (Wouters) by MM. Charles Scharré and Henry Wagemans.
5.30 p.m.—Gramophone Dance Records.
6.15 p.m.—Talk: Dramatic Criticism.
6.30 p.m.—Gramophone Records.
7.15 p.m.—Lesson in Correct Pronunciation of the Dutch Language.
7.30 p.m.—Le Journal Parlé.

8.0 p.m.—Orchestral Concert. Soloist: Mme. Alice Plato (Vocalist). In the interval at 8.40 p.m.—Recitation.
10.0 p.m.—Le Journal Parlé.

BUCHAREST (Romania)

Radio-Bucarest. 761 kc/s (394 m.); 16 kW. Transmits at intervals from 11.0 a.m.
6.0 p.m.—Educational Talk.
6.40 p.m.—Gramophone Records.
7.0 p.m.—Quartet for Two Violins, Viola and Cello (Dumitrescu).
7.30 p.m.—Talk (to be announced).
7.45 p.m.—Romanian Rhapsodies for Pianoforte (Fuchs).
8.15 p.m.—Quintet for Pianoforte, Two Violins, Viola and Cello (Frank).
8.45 p.m.—News Bulletin.

BUDAPEST (Hungary)

545 kc/s (550 m.); 23 kW. Transmits at intervals from 8.15 a.m.
6.0 p.m.—Hungarian Folk Songs of the 19th and 20th Centuries.
7.15 p.m.—Programme by L. Markus.
7.45 p.m.—Paderewsky Gramophone Records.
8.30 p.m.—Orchestral Concert conducted by Ernst Dohnanyi. Concerto grosso in F Major, No. 20 (Händel). Symphony in B Minor (Schubert). Second Symphony in D Major, Op. 36 (Beethoven).
9.45 p.m.—Zigane Concert from the Hotel Baross.

COLOGNE (Germany)

Westdeutscher Rundfunk. 1,319 kc/s (227 m.); 1.7 kW. See Langenberg.

COPENHAGEN (Denmark)

1,067 kc/s (281 m.); 0.75 kW. Relay by Kalundborg, 260 kc/s (1,153 m.). Transmits at intervals from 6.30 a.m. (Gymnastics).
2.30 p.m.—Instrumental Concert. Soloist: Vera Nielsen (Vocalist). Spanish March, Cartagena (Grit). Overture, "Les Savoyardes" (Offenbach-Binder). Suite of Viennese Waltzes (Gillon). Vidste du? (August Enna). Fantasia, Barnomsinder (C. A. Bruun). Russian Dance No. 1 (Bortkiewicz). Amoretto (Bullerian). Swedish Folk Songs. Spanish Serenade, Salamanca (Grit). Chanson Sérénade (Drigo). Selection from "The Indian Widow" (O. Strauss). Waltz, Hoch, lebe der Tanz (Waldteufel). Venetian Serenade (Svendsen). Blancheleur, from "The Dance at Koldinghus" (Kjerulf). March, Berliner Luft (Lincke).
4.40 p.m.—Exchange; Market Prices.
4.50 p.m.—Talk: Women of the East.
5.20 p.m.—Elementary English Lesson.
5.50 p.m.—Weather and News.
6.15 p.m.—Time Signal.
6.30 p.m.—Review of Politics for the Month of November.
7.0 p.m.—Town Hall Chimes.
7.2 p.m.—First Concert by the Cecilia Society, relayed from the Oddfellows' Hall. Conductor: Mogens Woldike. Soloist: Finn Viderö (Cembalo and Organ). Concerto in F Major for Strings, Oboes, Horn and Continuo (Händel). Concerto in G Minor for Oboe and Orchestra (Händel). Te Deum laudamus for Soloists, Choir and Orchestra (Händel). Recitative and Aria for Soprano from "La Clemenza di Scipione" (Bach). Symphony in D Major (Bach).
9.0 p.m.—News Bulletin.
9.15 p.m.—Dance Music by Watson's Band, relayed from the Wivex Restaurant.
11.0 p.m. (in the interval)—Town Hall Chimes.
11.30 p.m. (approx.)—Close Down.

DUBLIN (Ireland)

(2RN). 725 kc/s (413 m.); 1.5 kW. Relay by Cork, 1,337 kc/s (224.4 m.).
1.30—2.0 p.m.—Time, Weather, Stock Report and Gramophone Records.
6.0 p.m.—Gramophone Records.
6.15 p.m.—Programme for Children.
7.0 p.m.—Gramophone Records.
7.20 p.m.—News Bulletin.
7.30 p.m.—Time Signal.
7.32 p.m.—Irish Lesson.
7.45 p.m.—Talk.
8.0 p.m.—Concert. The Caledonian Male Voice Choir. The Station Sextet: Scottish Music. Choral Selections. P. J. Byrne (Baritone): Scottish Songs. The Station String Orchestra. M. I. Hipwell (Mezzo-Soprano).
9.15 p.m.—"Copy"—Play by the Dublin Repertory Company.

9.45 p.m.—Variety Programme by Fay Sargent and J. Burke.
10.5 p.m.—The Siamsa Gaedheal Band.
10.30 p.m.—Time, News, Weather and Close Down.

FRANKFURT-am-MAIN (Germany)

770 kc/s (390 m.); 1.7 kW. Relay by Cassel, 1,220 kc/s (246 m.). Transmits at intervals from 5.15 a.m. (Weather and Gymnastics).
4.5 p.m.—See Stuttgart.
5.30 p.m.—Economic Notes.
5.40 p.m.—Talk by Dr. G. Böse.
6.5 p.m.—English Lesson.
6.25 p.m.—Time and News.
6.30 p.m.—See Berlin (Witzleben).
7.0 p.m.—Concert by the Frankfurt Lute Choir.
7.30 p.m.—"Africa disenchanté"—a Radio Picture with Gramophone Records.
8.15 p.m.—Concert from the Works of Frankfurt Composers. Orchestral Selection from the Cantata, "Es ist vollbracht" (Bodo Wolf). Six Small Sketches for Clarinet and Pianoforte (Niederste-Schee). Three Songs, Op. 33 for Voice and Orchestra (Bodo Wolf). Selections from the Suite in D Minor, Op. 8 for Violin and Pianoforte (Scriba). Comedy Overture with "Triple Fugue for Orchestra, Op. 50 (Bodo Wolf).
9.20 p.m.—Time and News.
9.40 p.m.—The Letter Box.

HAMBURG (Germany)

Norag (ha, in Morse). 806 kc/s (372 m.); 1.7 kW. Relay by Bremen, 1,112 kc/s (270 m.); Flensburg, 1,373 kc/s (218 m.); Hanover, 530 kc/s (566 m.); and Kiel, 1,292 kc/s (232.2 m.). Transmits at intervals from 5.30 a.m. (Time and Weather).
6.5 p.m.—Talk on German Words.
6.20 p.m.—Exchange and Weather.
6.30 p.m.—See Berlin (Witzleben).
7.0 p.m.—"The Environment of Genius"—II, Mozart. Concert by the Orchestra, Choir and Soloists, with Commentary by Siegfried Scheffer. Overture, "Don Juan." Songs: (a) Die Verschweigung, (b) Das Veilchen. Scene from Act I of "The Magic Flute." Adagio and Allegro assai from the Hafner Serenade. Aria from the First Act of "The Magic Flute." Two Selections for Choir from the "Requiem": (a) Rex Aremendae, (b) Lacrimosa.
8.0 p.m.—(from Hanover)—Georg Philipp Telemann Memorial Programme on the 250th Anniversary of his Birth. "Die Tageszeiten"—Cantata for Soloists, Choir, and Orchestra.
9.0 p.m.—News Bulletin.
9.20 p.m.—Relay of Foreign Stations.
9.50 p.m.—Ice Report.
10.0 p.m.—Silent Night for Distant Reception.

HEILSBURG (Germany)

1,085 kc/s (276.5 m.); 75 kW. Relay by Danzig, 662 kc/s (453.2 m.). Transmits at intervals from 5.30 a.m. (Gymnastics).
3.15 p.m.—Tea Concert from the Alhambra Café, Königsberg.
4.45 p.m.—Talk: Mankind and the Daily Work of Electrons.
5.15 p.m.—Ice Report; Market Prices.
5.25 p.m.—(from Danzig)—Talk: The Danzig Marienkirche as an Example of Architecture.
5.50 p.m.—Shorthand Dictation.
6.15 p.m.—Talk: The Week's Commemoration Day.
6.30 p.m.—See Berlin (Witzleben).
7.0 p.m.—Weather Report.
7.5 p.m.—Talk on Ernst Stadler.
7.30 p.m.—Evening Entertainment with Gerd Niemar and the Small Orchestra, followed by Concert of Romantic Music by Leopold Premyslav (Violin) and Eugenie Premyslav (Cello). Caprices for Violin (Paganini): (a) In E Major Op. 9, (b) In B Minor, Op. 20, (c) In A Minor Op. 24. Pastorello (Couperin-Cassado). Intermezzo (Lalo). Spanish Dances (Sarasté).
9.15 p.m. (approx.)—News Bulletin.

HILVERSUM (Holland)

1,004 kc/s (298.8 m.); 8.5 kW. 6.25—9.40 a.m.—Programme of the Workers' Radio Society (V.A.R.A.). 6.25—6.40 a.m. and 7.10—7.25 a.m.—Physical Culture Lesson.
7.40 a.m.—Gramophone Records.
9.40 a.m.—Religious Programme by the Liberal Protestant Radio Society (V.P.R.O.).

9.55 a.m. till Close Down.—V.A.R.A. Programme.

9.55 a.m.—Recitations.
10.10 a.m.—Cello Recital. In the interval at 10.35 a.m.—Recitations.
11.20 a.m.—Recitations.
11.40 a.m.—Septet Concert. March The Victorious Eagle (Rosey). The Kiss Waltz (Strauss). Serenade (Tarenghi). Overture, "Ascanio in Alba" (Mozart). Selections (Gillet): (a) Au Moulin, (b) Douce Caresse. Gramophone Records. Mein Opernabend (Mannfred). Sweet Delusion (Marchetti). Dance from "Czar and Carpenter" (Lortzing). Potpourri of Russian Dances and Melodies. Saschinka (Schirmann). Gramophone Records.
1.40—2.10 p.m.—Interval.
2.10 p.m.—Gramophone Records.
2.25—Stijn Srevels reads from his own Works.
3.10 p.m.—Gramophone Records.
4.20 p.m.—Programme for Children.
4.40 p.m.—Septet Concert. Florentine March (Fucik). Walzerflut (Fetras). Chaconne (Gabriel Marie). Oriental Suite, Les Odaïques (Salabert). Andante (Mozart). Dance of the Gnomes (Oscheit). Gramophone Records. Selection from "Der Bettestudent" (Millöcker). Rendez-vous (Aletter). Selection from "Romeo and Juliet" (Gounod). Was ist der Frühling ohne dich (Stolz). Waltz, Te souviens-tu? (Tosti). March, En avant (Grit).
6.10 p.m.—Talk.
6.40 p.m.—Orchestra Concert. Introduction. Selection from "Romeo and Juliet" (Berlioz). Overture, Romeo and Juliet (Tchaikovsky).
7.40 p.m.—Talk.
8.0 p.m.—Orchestral Concert (continued). Overture, "Euryanthe" (Weber). Hungarian Dances, Nos. 5 and 6 (Brahms). The Nutcracker Suite (Tchaikovsky).
8.40 p.m.—"The Dream King"—a Radio Drama in Eight Scenes (Heyermans).
10.10 p.m.—News Bulletin.
10.20 p.m.—Gramophone Records.
11.40 p.m.—Time and Close Down

HUIZEN (Holland)

160 kc/s (1,875 m.); 8.5 kW. Transmits at intervals from 7.40 a.m. Programme of the Christian Radio Society (N.C.R.V.).
12.10 p.m.—Organ Recital from Amsterdam.
1.25 p.m.—Gramophone Records.
1.40 p.m.—Programme for Schools.
2.15 p.m.—Talk by A. J. Herwig.
2.55 p.m.—Gramophone Records.
3.25 p.m.—Talk (to be announced).
3.40 p.m.—Programme for Hospitals.
4.40 p.m.—Recital for Oboe, Flute, Viola d'amore and Pianoforte.
5.55 p.m.—Talk for Young People.
6.25 p.m.—Talk by Herr H. Amelink.
6.40 p.m.—Advanced English Lesson.
7.10 p.m.—Police Notes.
7.25 p.m.—News Bulletin.
7.40 p.m.—Concert by the N.C.R.V. Symphony Orchestra. Paraphrase on Four Songs (C. Doppler). Variations on a St. Nicholas Song (v. Gilse). Rhapsody, Piet Hein (V. Anrooy). March (Bruckner-Fock).
8.40 p.m.—Talk on the Dutch Indies.
9.10 p.m.—Concert (contd.). Overture, "Cyrano de Bergerac" (Wagenaar). Scènes pittoresques (Godard). Invitation to the Dance (Weber-Weingartner). After the Concert: News and Gramophone Records.

KALUNDBORG (Denmark)

Kalundborg Radio. 260 kc/s (1,153 m.); 7.5 kW. See Copenhagen.

KATOWICE (Poland)

734 kc/s (408 m.); 16 kW. Transmits at intervals from 10.58 a.m.
7.0—10.0 p.m.—See Warsaw.
10.0 p.m.—Light Music and Dance Music.

LANGENBERG (Germany)

Westdeutscher Rundfunk. 635 kc/s (473 m.); 17 kW. Relay by Aachen, Cologne and Münster, 1,319 kc/s (227 m.). Transmits at intervals from 5.45 a.m. (Gymnastics).
4.0 p.m.—Instrumental Concert—"From Tartini to Stravinsky"—V.
5.0 p.m.—Talk for Women.
5.20 p.m.—Reading of Poems.
5.40 p.m.—Talk by Hans Heister.
6.0 p.m.—News Bulletin.
6.10 p.m.—Talk. Contemporary Art Problems.
6.30 p.m.—See Berlin (Witzleben).

Every good portable deserves this famous **BRITISH** "non-spill"

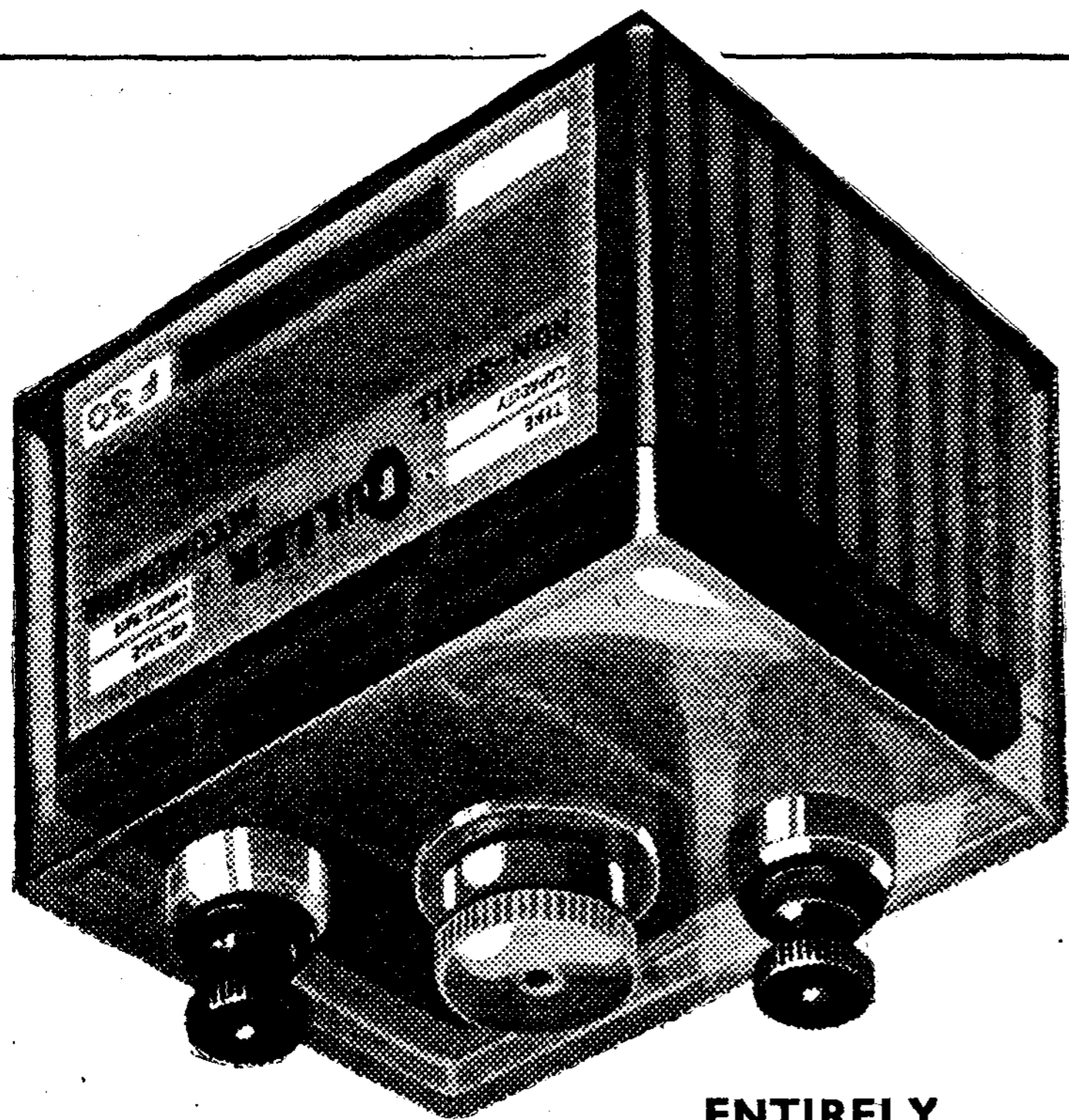

**ENTIRELY
BRITISH**

FULLER SUPER BATTERIES

YOUR PORTABLE SET makes great demands upon its L.T. Accumulator. With only a "frame" aerial, a lot of power is wanted; in a portable's restricted space you can't fit anything big.

That's why it ought to have a Fuller "Non-Spill." The "power for size" ratio of these famous jelly acid accumulators is far beyond the ordinary. You will discover your portable's full capabilities, for the first time, when you fit one.

Many special features exclusive to Fuller: micro-porous pasted plates, finer and smoother than the ordinary type, but much stronger in wear; patent double grease-cup terminals, indestructible separators, large non-spill vents, and strongly reinforced containers.

Fuller 'Sparta' 2-volt "Non-Spill" Accumulator for Portable Receivers. Type JUA9 11/6. Capacity 18 amp. hours. Overall size 4 $\frac{3}{4}$ " x 2 $\frac{9}{16}$ " x 3 $\frac{1}{2}$ ". Standard on well-known portables. There are 16 different types in all sizes and capacities and suitable for all popular suitcase and transportable receivers, from 9/- to 17/-. Full list of H.T. Dry Batteries and L.T. and H.T. accumulators on request.

LONDON AND PROVINCIAL DEPOTS:

LONDON: Hanover House, 73-78, High Holborn, W.C. 'Phone: Chancery 7453. BIRMINGHAM: 29, Guildhall Buildings, Navigation Street. 'Phone: Midland 3103. MANCHESTER: 19, Chapel Walks, Cross Street. 'Phone: City 0857. GLASGOW: 101, West Nile Street. 'Phone: Douglas 4367. BRISTOL: 28, Cumberland Street. 'Phone: Bristol 7958. LEEDS: 9, Mill Hill. 'Phone: Leeds 22865. SHEFFIELD: 48, Sandford Grove Road. 'Phone: Sheffield 51187. Hull: 69, Ryde Street. 'Phone: 502Y2. NEWCASTLE: 59, Side. 'Phone: Newcastle 24068/9. SWANSEA: 10-11, St. Helen's Road. 'Phone: Swansea 3208. BELFAST: 57, Dublin Road. 'Phone: Belfast 5552. IRISH FREE STATE: 4, Oliver Plunkett Street, Cork. 'Phone: Cork 425.

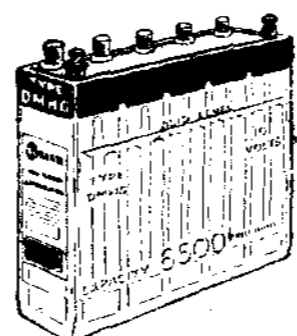

H.T. ACCUMULATORS

—Ensure perfect reception—Micro-porous pasted plates—High capacity—patent terminals. 10 volt units in moulded glass boxes from 3,000 to 10,000 milliamp hours. Prices from 5/- to 11/6 dry charged. List W.3.

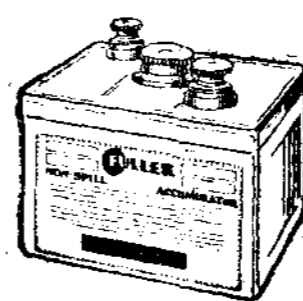

NON-SPILL L.T. ACCUMULATORS

(Jelly Acid Type)—safe in any position—Micro-porous pasted plates—indestructible separators—reinforced containers—non-spill vents—patent double grease-cup terminals. 16 sizes for all Portable receivers. From 14 to 40 A.H. Prices, 9/- to 17/-, fully charged. List W.3.



SUPER H.T. DRY BATTERIES

—Machine made and tested throughout—long life—emission up to 20 M/amps. From 60 to 120 volts. Prices, 7/5 to 15/3. Also complete ranges of Standard, Triple Portable, and Grid Bias Dry Batteries, etc. List D.3.

FULLER ACCUMULATOR CO. (1926) LTD., CHADWELL HEATH, ESSEX

'Phone: Seven Kings 1200. Telegrams: Fuller, Chadwell Heath, Essex. Contractors to British and Overseas Government Depts., Railways, etc.

Programmes for Monday—(Cont.)

7.0 p.m.—News Bulletin.
7.5 p.m. (approx.)—"From the Flute to the Kettledrum," by Hans Ebert.
7.30 p.m.—"The Experience of Love"—in Tales, Verse, Letters and Diaries—Second Sequence, by Rudolf Rieth.
9.0 p.m.—Second News.
9.20 p.m.—Concert from the Café Grafenbof, Dortmund.
10.45 p.m.—Report on the Cologne Six Days' Racing, relayed from the Rheinlandhalle.

LEIPZIG (Germany)

1,157 kc/s (259 m.); 2.3 kW. Relayed by Dresden, 941 kc/s (319 m.). Transmits at intervals from 5.30 a.m.
6.0 p.m.—Dialogue with a Worker from the Erz Gebirge.
6.30 p.m.—"Originals"—a Literary Programme by Peer Hallmann.
7.0 p.m.—Concert by the Leipzig Symphony Orchestra, conducted by Prof. Max Schillings. Soloist: Eduard Erdmann (Pianist). Symphony No. 101 in D Minor—the Clock Symphony (Haydn). Scherzo fantastique, Op. 3 (Stravinsky). Pianoforte Concerto (Prokofieff). Catalan Suite (Albéniz).
8.40 p.m.—Songs to the Lute by Ruth Kerster.
9.5 p.m.—Talk: The Importance and Problems of Agricultural Colonisation (reproduced on Gramophone Records).
9.25 p.m.—News Bulletin, followed by Concert by the Emdé Orchestra.
10.30 p.m. (approx.)—Close Down.

LJUBLJANA (Yugoslavia)

522 kc/s (574.7 m.); 2.8 kW. Transmits at intervals from 11.15 a.m.
7.0 p.m.—Quartet Concert.
9.0 p.m.—News Bulletin.

LWÓW (Poland)

788 kc/s (381 m.); 21 kW. Transmits at intervals from 10.40 a.m.
6.15—10.0 p.m.—See Warsaw.
10.0 p.m.—Concert of Light Music and Dance Music from the Hotel Bristol.
11.0 p.m. (approx.)—Close Down.

MADRID (Spain)

Union Radio (EAJ7). 707 kc/s (424.3 m.); 2 kW. Transmits at intervals from 11.45 a.m.
7.0 p.m.—Chimes, Exchange, Market Prices and Request Gramophone Records. In the interval at 8.0 p.m.—News Bulletin.
8.30 p.m. (approx.)—Close Down.

MILAN (Italy)

Ente Italiano Audizioni Radiofoniche. 598 kc/s (501.7 m.); 8.5 kW. Relayed by Turin, 1,094 kc/s (274.2 m.), and Genoa, 959 kc/s (312.8 m.).
Transmits at intervals from 7.15 a.m.
6.0 p.m.—Agricultural Notes and Report of the Royal Geographical Society.
6.20 p.m.—Light Music, Marquita (Marrone). Serenata spagnuola (Culotta), Addio sartine (Amadei). Monica come with me (Berger). La giava degli zoccoli (Bettinelli).
6.40 p.m.—Announcements.
6.45 p.m.—Gramophone Records. In the interval at 7.0 p.m.—Time and News.
7.45 p.m.—Talk by S. Gotta.
8.0 p.m.—Symphony Concert conducted by Arrigo Pedrollo. Soloists: Clelia Zotti (Soprano) and Arrigo Serrato (Violin). Two Selections (Liadoff): (a) The Enchanted Lake, (b) Kikimora. Concerto for Violin and String Orchestra (Vivaldi). Talk. Soprano Solos: (a) Vieni o sonno (Clausetti), (b) Two Songs (Gnechchi). Concerto in G Minor for Violin and Orchestra (Max Bruch). Symphonic Poem, L'Apprenti Sorcier (Dukas).
10.0 p.m.—Giornale Radio.

MORAVSKÁ-OSTRAVA

(Czechoslovakia)

1,139 kc/s (263 m.); 11 kW. Transmits at intervals from 10.0 a.m.
6.0 p.m.—See Prague.
6.20 p.m.—See Brno.
7.25 p.m.—See Prague.
9.15 p.m.—Announcements.
9.20 p.m.—See Bratislava.

MUNICH (Germany)

563 kc/s (533 m.); 1.7 kW. Relayed by Augsburg and Kaiserslautern, 536 kc/s (560 m.); and Nürnberg, 1,256 kc/s (239 m.).
Transmits at intervals from 5.45 a.m.
6.0 p.m.—Choral Concert conducted by Joseph Wismaier. Es ist ein

Reis entsprungen (Praetorius). Innsbruck, ich muss dich lassen (H. Isaac). Drei Laub von einer Linden (Thiessen). Kein Feuer, keine Kohle (Kieslich). Hab' mein' Wagen vollgeladen (Malden). The Little Flowers are sleeping (Zuccalmaglio). Morgen muss ich fort von hier (Silcher). Wohin mit der Freud' (Silcher).
6.30 p.m.—See Berlin (Witzleben).
7.0 p.m.—Concert by the Augsburg Concert Orchestra, conducted by Gustav Heuer, relayed from St. Anne's Hall, Augsburg.
8.0 p.m.—"The Apple Trees"—a Dialogue (Paul Ernst).
8.20 p.m.—Chamber Music. String Quartet, Op. 18, No. 4, in C Minor, and String Quartet, Op. 135, in F Major for Two Violins, Viola and Cello (Beethoven).
9.20 p.m.—Time and News.

OSLO (Norway)

Kringkastingselskapet. 277 kc/s (1,083 m.); 75 kW. Relayed by Fredrikstad, 816 kc/s (367.6 m.); Hamar, 536 kc/s (560 m.); Notodden, 671 kc/s (447.1 m.); Porsgrund, 662 kc/s (453.2 m.), and Rjukan, 671 kc/s (447.1 m.).
Transmits at intervals from 10.10 a.m.
4.0 p.m.—Chamber Music Concert.
5.0 p.m.—German Lesson.
5.30 p.m.—Theatre Review.
6.0 p.m.—News Bulletin.
6.30 p.m.—Talk, relayed from Trondheim, 608 kc/s (493.4 m.).
7.0 p.m.—Time Signal.
7.2 p.m.—Symphony Concert by the "Harmonie" Music Society, under the direction of Halrad Heide. Soloist: Prof. Georg Kuhlenskampf (Violin). Relayed from Bergen, 824 kc/s (364 m.). Symphony No. 5 in C Minor, Op. 17 (Beethoven). Concerto for Violin (Brahms).
8.35 p.m.—News Bulletin.
8.50 p.m.—Topical Talk.
9.5 p.m.—Political Review.

PARIS (France)

Eiffel Tower (FLE). 207.5 kc/s (1,445.7 m.); 15 kW. Time Signals (on 2,650 m.) at 9.26 a.m. and 10.26 p.m. (preliminary and 6-dot signals).
5.45 p.m.—Le Journal Parlé.
7.20 p.m.—Weather Forecast.
7.30 p.m.—Hawaiian Guitar Recital by Rose Cornaz.
8.0 p.m.—Gramophone Concert. In the interval, Talk.

PARIS (France)

Poste Parisien. 914 kc/s (328.2 m.); 1.2 kW.
8.15 p.m.—Gramophone Records and News.
9.0 p.m.—Concert. Overture, "Mariana" (Wallace). Pianoforte Solos: Clair de lune and Passepied from the Suite bergamasque (Debussy)—Pianist: M. M. Jacquinet. Selection from "Monsieur Beaucaire" (Messenger). Pavane (Dulaurens). Ballet Music from "Philemon and Baucis" (Gounod). Trio for Flute, Cello and Pianoforte (Weber). Second Orchestral Suite from "La Fête chez Thérèse" (R. Hahn). Nuages (Georges). Selection from "Zaza" (Leoncavallo). Valse lente (Lévaé). Indian Dance (Rimsky-Korsakoff).

PARIS (France)

Radio-Paris (CFR). 174 kc/s (1,725 m.); 80 kW. Transmits at intervals from 6.45 a.m. (Physical Culture).
12.30 p.m.—Gramophone Records.
1.0 p.m.—Exchange and News.
1.15 p.m.—Gramophone Concert of Organ Music. In the intervals at 1.30 and 2.0 p.m.—Exchange Quotations.
3.35 p.m.—Exchange; Market Prices.
3.45 p.m.—Concert dedicated to Vervins and Thiérache.
6.30 p.m.—Market Prices, Agricultural Report and Announcements.
7.0 p.m.—Talk: "The German Cinema."
7.10 p.m.—Literary Review.
7.30 p.m.—Elementary English Lesson.
7.45 p.m.—Commercial Prices, Economic and Social Notes and News.
7.50 p.m.—Talk: Fruit Growing.
8.0 p.m.—"La Tosca"—Opera (Puccini) on Gramophone Records by the Cast of the Scala, Milan. In the interval at 8.30 p.m.—News and Talk.
9.15 p.m.—News and Time.

PRAGUE (Czechoslovakia)

617 kc/s (487 m.); 120 kW. Transmits at intervals from 10.0 a.m.
6.0 p.m.—Time and News.

6.5 p.m.—Talk on Music.
6.20 p.m.—See Brno.
7.25 p.m.—Quartet in G Minor, Op. 77, No. 1 (Haydn).
7.55 p.m.—News Bulletin.
8.0 p.m.—Time and News.
8.5 p.m. (approx.)—Orchestral Concert conducted by Jeremias. Concerto for Pianoforte in G Major, No. 4, Op. 58 (Beethoven).
9.0 p.m.—Time and News.
9.15 p.m.—Announcements.
9.20 p.m.—See Bratislava.
10.0 p.m.—Chimes and News.

RADIO-SUISSE ROMANDE (SOTTENS) (Switzerland)

743 kc/s (403 m.); 25 kW. Lausanne, 442 kc/s (680 m.); and Geneva, 395 kc/s (760 m.).
Transmits at intervals from 11.30 a.m.
6.0 p.m.—Weather Forecast.
6.1 p.m. (from Lausanne)—Gramophone Records.
6.30 p.m. (from Lausanne)—Lesson in Commercial Law.
6.55 p.m.—News Bulletin.
7.0 p.m. (from Geneva)—Weekly Gazette.
7.10 p.m. (from Geneva)—A Guessing Competition.
7.45 p.m. (from Lausanne)—Trio Concert, relayed from the Conservatoire. Trio No. 1 in D Minor (Mendelssohn). Trio in G Minor (Chausson).
9.5 p.m.—News Bulletin.
9.15 p.m. (from Geneva)—Announcements.
9.30 p.m. (approx.)—Close Down.

RIGA (Latvia)

572 kc/s (525 m.); 15 kW. Transmits at intervals from 10.0 a.m.
6.0 p.m.—Weather Report.
6.5 p.m.—Orchestral Concert of Hebrew Music.
7.0 p.m.—News Bulletin.
7.30 p.m.—Orchestral Concert. Overture, "The Merry Wives of Windsor" (Nicola). Selection from "The Dollar Princess" (Fall). Foxtrot, Violin Solos. Ballet égyptien (Luigini). In the interval at 8.0 p.m.—Weather Report.
8.40 p.m.—Concert.
9.30 p.m. (approx.)—Close Down.

ROME (Italy)

Ente Italiano Audizioni Radiofoniche (IRO). 680 kc/s (441 m.); 75 kW. Relayed by Naples, 905 kc/s (332 m.) and 2RO, 11,810 kc/s (25.4 m.).
Transmits at intervals from 7.15 a.m. (Giornale Radio).
4.30—5.15 p.m.—Pianoforte Recital by Benno Moisevitich, relayed from the Royal Philharmonic Academy.
6.25 p.m. (from Naples)—Shipping and Sports Notes.
6.30 p.m.—Announcements.
6.50 p.m.—Gramophone Records.
7.10 p.m.—News Bulletin.
7.45 p.m.—Fashion Review.
8.0 p.m.—Concert of Light Music and Folk Music.
9.0 p.m. (in the interval)—Announcements.
9.55 p.m.—News Bulletin.

SCHENECTADY (U.S.A.)

General Electric Company (WGY). 790 kc/s (379.5 m.); 50 kW. Relayed at intervals by W2XAF on 9,530 kc/s (31.48 m.); and by W2XAD on 15,340 kc/s (19.56 m.).
Transmits at intervals from 11.45 a.m.
9.0 p.m.—New York Relay.
9.30 p.m.—Stock Reports and Police Notes.
9.45 p.m.—Carmelo Cascio (Blind Pianist).
10.0 p.m.—News Bulletin.
10.5 p.m.—Studio Ensemble.
10.30 p.m.—Uncle Jim.
11.0 p.m.—Weather Report.
11.1 p.m.—Jack Miles and his DeWitt Clinton Orchestra.
11.29 p.m.—Time Signal.
11.30 p.m.—Blue Coal Fireside Reveries.
11.45 p.m.—New York Relay.
12 midnight (WGY only)—New York Relay.
12 midnight (W2XAF only)—Stock Reports and Police Notes.
12.15 a.m. (Tuesday)—4.15 a.m.—New York Relay.
4.15 a.m.—Comedy Skit—"Bob and Janitor."
4.30 a.m.—Clyde Kittell (Tenor).
4.45 a.m.—New York Relay.
5.0 a.m.—Jack Miles and his DeWitt Clinton Orchestra.
6.0 a.m. (approx.)—Close Down.

SCHWEIZERISCHER LANDESENDER (BEROMÜNSTER) (Switzerland)

653 kc/s (459 m.); 75 kW.;

Basle, 1,229 kc/s (244.1 m.); and Berne, 1,220 kc/s (246 m.).
Transmits at intervals from 11.28 a.m.
3.0 p.m.—Gramophone Concert.
4.0 p.m. (from Berne)—Programme for Children.
4.30 p.m.—Weather Report.
4.35—5.30 p.m.—Interval.
5.30 p.m.—Swiss Authors speak to you (on Gramophone Records).
5.45 p.m.—Gramophone Records of Band Music.
6.5 p.m. (from Berne)—Reminiscences.
6.13 p.m.—Time and Weather.
6.15 p.m. (from Berne)—Programme in memory of Rainer Maria Rilke—Recitations and Rilke Poems set to Music.
7.0 p.m. (from Zürich)—Concert by the Tonhalle Society, conducted by Dr. Volkmar Andrea, relayed from the Tonhalle, Zürich. Soloists: Sigrid Onegin (Vocalist).
8.50 p.m. (approx.)—Reading.
9.0 p.m.—News Bulletin.
9.15 p.m. (approx.)—Close Down.

STOCKHOLM (Sweden)

Radiotjänst (SASA). 689 kc/s (436 m.); 75 kW. Relayed by Boden, 244 kc/s (1,229.5 m.); Göteborg, 932 kc/s (322 m.); Hörby, 1,166 kc/s (257 m.); Motala, 222.5 kc/s (1,348 m.); Östersund, 389 kc/s (770 m.), and Sundsvall, 554 kc/s (542 m.).
Transmits at intervals from 6.15 a.m. (Gymnastics).
4.0 p.m.—Accordion Music and Songs relayed from Göteborg.
4.30 p.m.—Reading.
5.0 p.m.—Gramophone Records.
5.45 p.m.—Elementary English Lesson.
6.15 p.m.—Weather and News.
6.30 p.m.—Music Talk: Percussion and Jazz Instruments.
7.0 p.m.—Talk on the British Empire, relayed from Malmö, 1,301 kc/s (231 m.).
7.30 p.m.—Concert. Soloists: Astrid Berwald (Piano). Charles Backel (Violin). Ossian Frumerie (Songs). Pianoforte Solos: (a) Fantasia (L. Norman), (b) Rondo (Franz Bersald), (c) Intermezzo in D Major (Stenhammer), (d) Intermezzo (Rosenberg). Pastoral Sonata for Violin and Pianoforte (Seymer). Six Songs.
8.20 p.m.—Talk: The State Railways.
8.45 p.m.—Weather and News.
9.0 p.m.—Orchestral Concert. March from "Athalie" (Mendelssohn). Waltz, Cagliostro (Joh. Strauss). Minuet (Sodström). Polonaise, No. 2 (Liszt). Tango (Svanfelt). Norwegian Rhapsody No. 3 (Svendsen). Potpourri, Pudding (Morena).
10.0 p.m. (approx.)—Close Down.

STRASBOURG (France)

Radio-Strasbourg (PTT). 869 kc/s (345 m.); 15 kW. Transmits at intervals from 11.30 a.m.
6.0 p.m.—Instrumental Concert. Overture, "Mäsaniello" (Auber). Selection from "Le roi d'Ys" (Lalo). Violin Solo: Meditation (Pyns). Simple aveu (Thomé). Selection from "The Last Waltz" (O. Straus).
6.45 p.m.—Talk in German.
7.0 p.m.—Dance Music.
7.30 p.m.—Time Signal.
7.32 p.m.—News in French and German.
7.45 p.m.—Gramophone Concert.
8.30 p.m.—Mandoline Concert. March L'esprit français (Mezzacapo). Overture (Lainé). Waltz, Gold and Silver (Lehár). Selection from "Der Freischütz" (Weber). Serenade-Barcarolle (Mezzacapo). Fantasia, Moorish Granada (Garcia). Selections (Schubert): (a) Moment musical, (b) Ave Maria, and (c) Military March.
9.30 p.m.—Gramophone Concert.
10.30 p.m. (approx.)—Close Down.

STUTTGART (MÜHLACKER) (Germany)

Süddeutscher Rundfunk. 833 kc/s (360 m.); 75 kW. Relayed by Freiburg, 527 kc/s (570 m.).
Transmits at intervals from 5.15 a.m. (Frankfurt Relay).
4.5 p.m.—Orchestral Concert from the Café Wilhelmsbau. Soloists: Sophie Eisenbraun (Soprano) and Eberhard Schrempf (Baritone). Overture, "Der Freischütz" (Weber). Songs: (a) Baritone Aria from "Czar and Carpenter" (Lortzing), (b) Recitative and Aria for Soprano from "Der Waffenschmied" (Lortzing). Selection from "Undine" (Lortzing). Baritone Solo: O Star of Eve, from "Tannhäuser" (Wagner). Soprano Solo from "Tannhäuser" (Wagner). Programme of Old Dances.
5.30 p.m.—Time Signal.

5.40 p.m.—See Frankfurt.
6.25 p.m.—Time and News.
6.30 p.m.—See Berlin (Witzleben).
7.0 p.m.—See Frankfurt.
9.20 p.m.—News Bulletin.
9.40 p.m.—Chess Lesson.
10.5 p.m. (approx.)—Close Down.

TOULOUSE (France)

Radiophonie du Midi. 779 kc/s (385 m.); 8 kW. Transmits at intervals from 12.45 p.m.
6.0 p.m.—Songs from "Tannhäuser" (Wagner).
6.15 p.m.—Dance Music.
6.30 p.m.—News Bulletin.
6.45 p.m.—Vocal Tangos.
7.0 p.m.—Orchestral Selections.
7.30 p.m.—News Bulletin.
7.45 p.m.—Dance Music.
8.0 p.m.—Songs from "Elle est à vous" (Yvain).
8.15 p.m.—Orchestral Selections.
8.45 p.m.—Sound Film Songs.
9.0 p.m.—Accordion Solos.
9.15 p.m.—Concert. Orchestral Selections from (a) "Rip van Winkle" (Planquette), (b) "Le Grand Mogol" (Audran), (c) "François les Bas Bleus" (Messager). Songs from (a) "Carmen" (Bizet), and (b) "La Tosca" (Puccini).
9.45 p.m.—Argentine Music.
10.0 p.m.—Concert from the Municipal Casino, Biarritz. In the interval at 10.30 p.m.—News Bulletin.
11.0 p.m.—Concert. In the interval at 11.15 p.m.—North African News.
12 midnight.—Weather, Announcements and Close Down.

TRIESTE (Italy)

Ente Italiano Audizioni Radiofoniche. 1,211 kc/s (247.7 m.); 15 kW. Transmits at intervals from 11.30 a.m.
7.15 p.m.—News Bulletin and Gramophone Records, followed by Symphony Concert. Literary Notes in the interval.

VIENNA (Austria)

Radio-Wien. 581 kc/s (517 m.); 20 kW. Relayed by Graz, 851 kc/s (352 m.); Innsbruck, 1,058 kc/s (283 m.); Klagenfurt, 662 kc/s (453.2 m.); Linz, 1,220 kc/s (246 m.); and Salzburg, 1,373 kc/s (218 m.).
Transmits at intervals from 8.20 a.m.
6.5 p.m.—English Lesson.
6.35 p.m.—Time and News.
6.45 p.m.—Concert of Folk Music.
7.35 p.m.—The Fifth Symphony (Mahler) by the Vienna Symphony Orchestra, conducted by Bruno Walter, relayed from the Music Society's Hall.
8.55 p.m.—News Bulletin.
9.10 p.m.—Dance Music from the Café de Paris.

WARSAW (Poland)

Polskie Radio. 212.5 kc/s (1,411 m.); 158 kW. Transmits at intervals from 10.40 a.m.
3.40 p.m.—Gramophone Records.
4.10 p.m.—Talk: The First Polish Explorer in the Reign of King Mieszko.
4.35 p.m.—Concert of Light Music.
5.50 p.m.—Miscellaneous Items.
6.15 p.m.—Agricultural Talk.
6.25 p.m.—Programme Announcements.
6.30 p.m.—Reading.
6.45 p.m.—Radio Journal.
7.0 p.m.—"Manon"—Opera (Massenet) on Gramophone Records by the Cast of the Opéra-Comique, Paris.
9.0 p.m.—Radio Journal.
9.45 p.m.—Announcements.
10.0 p.m.—Dance Music and Light Music.
11.0 p.m. (approx.)—Close Down.

ZAGREB (Yugoslavia)

977 kc/s (307 m.); 0.7 kW. Transmits at intervals from 11.20 a.m.
6.45 p.m.—Book Review.
7.0 p.m.—Elementary English Lesson.
7.15 p.m.—Announcements and News.
7.30 p.m.—Concert. Alice Schechter (Pianoforte), Victor E. Koscica (Cello), and Simon Zamola (Clarinet). Cello and Pianoforte Selections: (a) Berceuse slave, Op. 11 (Neruda), (b) Old Viennese Dance Melodies and Liebeslied (Kreisler), (c) Spanish Serenade (Giazounoff), (d) Tarantella, Op. 23 (Squire). Pianoforte Solos: (a) Sonata in E Flat Major (Beethoven), (b) Three Etudes (Chopin). Clarinet Solos: (a) Canto di Maggio, Op. 13 (Musoni), (b) Concert Fantasia (Cavallini).
9.0 p.m.—News Bulletin.
9.10 p.m.—Silent Night for Distant Reception.

PROGRAMMES FOR TUESDAY

(December 1)

NOTE: THE HOURS OF TRANSMISSION ARE REDUCED TO GREENWICH MEAN TIME

ALGIERS (N. Africa)

825.3 kc/s (363.4 m.); 13 kW.
Transmits at intervals from 12.30 p.m.
7.30 p.m.—Concert of Light Music.
7.55 p.m.—News and Time.
8.0 p.m.—Forgotten Song Successes.
8.30 p.m.—String Quartet, From out my Life (Smetana).
9.0 p.m.—Concert of Oriental Music.
10.30 p.m.—Gramophone Concert.
11.0 p.m. (approx.)—Close Down.

BARCELONA (Spain)

Radio-Barcelona (EAJI). 860 kc/s (349 m.); 8 kW.
Transmits at intervals from 7.30 a.m.
7.0 p.m.—Trio Music.
7.30 p.m.—Market Prices, Exchange and Gramophone Records.
8.0 p.m. (in the interval).—Football Report.
8.30 p.m.—Elementary English Lesson.
9.0 p.m.—Chimes, Weather, Exchange and Market Prices.
9.5 p.m.—Orchestral Music.
10.0 p.m.—Talk: Spanish Inventions and Inventors.
10.20 p.m.—Concert by a Mandoline Orchestra.
11.20 p.m.—Gramophone Records.
11.30 p.m.—Dance Music from the Café Catalan.
12 midnight (approx.)—Close Down.

BERLIN (Germany)

Königs Wusterhausen. 183.5 kc/s (1,635 m.); 75 kW.
Transmits at intervals from 5.30 a.m. (Witzleben Relay).
3.30 p.m.—See *Leipzig*.
4.30 p.m.—Talk on Lord Milner.
5.0 p.m.—Talk: Are there still Handicrafts in Germany?
5.30 p.m.—Talk: Changes in the Conception of an Economic Crisis since 1825.
5.55 p.m.—Weather for Farmers.
6.0 p.m.—Advanced English Lesson.
6.20 p.m.—Talk: The New Wireless Regulations of the German Post Office.

6.30 p.m.—See *Leipzig*.
7.15 p.m.—Talk: The Conservative Idea and the Intellectual Position of the Age.
8.0 p.m.—Christmas Carols.
8.35 p.m.—See *Munich*.
9.20 p.m.—News, followed by Concert from the Hotel Bristol.
11.0 p.m. (approx.)—Close Down.

BERLIN (Germany)

Witzleben. 715 kc/s (418 m.); 1.7 kW.
Transmits at intervals from 5.30 a.m. (Gymnastics).
6.0 p.m.—Topical Talk.
6.10 p.m.—Talk: The Intellectual Position of the Age and the Validity of Science.
6.35 p.m.—"Bep and Git" sing Humorous Duets.
7.5 p.m.—Pianoforte Recital of Waltzes.
7.30 p.m.—Part Relay of the Concert by the Magdeburg Teachers' Choral Society, from the Crystal Palace, Magdeburg.
8.0 p.m.—News Bulletin.
8.10 p.m.—A Man with Books and Gramophone Records.
9.15 p.m.—News Bulletin.

BORDEAUX-LAFAYETTE

(France)
(PTT). 986 kc/s (304 m.); 35 kW.
Transmits at intervals from 12 noon.
7.30 p.m.—News and Exchange.
7.40 p.m.—Talk: Tourist Aircraft in Bordeaux.
7.55 p.m.—Results of the Prize Draw.
8.0 p.m.—Talk on World Affairs.
8.15 p.m.—Charades.
8.25 p.m.—News Bulletin.
8.30 p.m.—Great Singers in Italian—Gramophone Concert. After the Programme, Amusement Guide and Time Signal.

BRATISLAVA

(Czechoslovakia)
1,076 kc/s (279 m.); 14 kW.
Transmits at intervals from 10.0 a.m.
6.5 p.m.—See *Prague*.
8.0 p.m.—Orchestral Concert. Selections (Blodek): (a) Overture, (b)

Concerto for Flute and Orchestra. Waltz, Olga (Bystry). Serenade for Strings (Horak).
9.0 p.m.—See *Prague*. In the interval at 9.15 p.m.—Programme Announcements.

BRESLAU (Germany)

923 kc/s (325 m.); 1.7 kW. Relayed by *Gleitwitz*, 1,184 kc/s (253 m.).
Transmits at intervals from 5.30 a.m.
6.35 p.m.—Weather Forecast.
6.40 p.m. (approx.)—Talk: Nomads and Shepherds.
7.0 p.m.—Wind Instrument Concert. In the interval from 8.0—8.10 p.m.—News Bulletin.
8.45 p.m.—A Wireless Report: Behind the Scenes of a Great City.
9.20 p.m.—Time and News.
9.40 p.m.—Talk: A Glance at the Breslau Carpenters' Hostel.
9.55 p.m.—Concert and Dance Music from the Café Hindenburg, *Beuthen*.
11.30 p.m. (approx.)—Close Down.

BRNO (Czechoslovakia)

878 kc/s (342 m.); 3 kW.
Transmits at intervals from 10.0 a.m.
6.5 p.m.—See *Prague*.
7.15 p.m.—Chess Lesson, followed by Concert.
8.0 p.m.—Concert by the Moravian Authors' Club.
9.0 p.m.—See *Prague*. In the interval at 9.15 p.m.—News.

BRUSSELS (Belgium) (No. 1)

I.N.R. 590 kc/s (509 m.); 20 kW.
5.0 p.m.—Orchestral Concert. Selections (Leemans): (a) Cortège oriental, (b) Gondoles Vénitiennes, (c) Croquis chinois. Selection from "Manon" (Massenet). Ballet russe (Luigini). In a Monastery Garden (Ketelbey). La Féria (Lacôme).
5.45 p.m.—Programme for Children.
6.15 p.m.—Readings.
6.20 p.m.—Literary Review.
6.30 p.m.—Gramophone Records.
7.15 p.m.—Report of the Belgian Catholic Radio Society.
7.30 p.m.—Talk for Women.

8.0 p.m.—Gramophone Records: Selections from "Cavalleria Rusticana" (Mascagni).
9.0 p.m.—Talk.
9.15 p.m.—Orchestral Concert. Soloist: M. Henri Wagemans (Violinist). Overture, "Raymond" (Thomas). Fantaisie appassionato for Violin and Orchestra (Vieuxtemps). Entr'acte from "Grise-lidis" (Massenet). Valse dolente (De Boeck). Valses romantiques (Chabrier).
10.0 p.m.—Le Journal Parlé.

BRUSSELS (Belgium) (No. 2)

N.I.R. 887 kc/s (338.2 m.); 20 kW. Programme in Flemish.
5.0 p.m.—Orchestral Concert. March, Toute pimpante (Maquet). Waltz, Pomone (Waldteufel). Overture, "Tancred" (Rossini). Selection from "Le Petit Duc" (Lecocq). Avril au Bois (Grieg). Suite carnavalesque (Gabriel Marie). Pot-pourri of Waltzes (Freudenthal).
5.45 p.m.—Programme for Children.
6.30 p.m.—Gramophone Records.
7.15 p.m.—Talk.
7.30 p.m.—Sports Review.
8.0 p.m.—Orchestral Concert. Overture, "Der Freischütz" (Weber). Andante from the Sixth Symphony in G (the Surprise) (Haydn). Songs by Mme Lamm: (a) Die böse Farbe (Schubert), (b) Lenz (Hildach). Largo (Händel). Songs by Mme Lamm (Händel); (a) Aria from "The Messiah", (b) Aria from "Samson" Overture, "Ruy Blas" (Mendelssohn).
9.0 p.m.—Talk: Classical Music.
9.15 p.m.—Gramophone Records.
10.0 p.m.—Le Journal Parlé.

BUCHAREST (Romania)

Radio-Bucarest. 761 kc/s (394 m.) 16 kW.
Transmits at intervals from 11.0 a.m.
6.0 p.m.—Educational Talk.
6.40 p.m.—Gramophone Records.
7.0 p.m.—Orchestral Concert.
7.30 p.m.—Talk (to be announced).
7.45 p.m.—Recital of Songs.
8.5 p.m.—Orchestral Concert.
8.45 p.m.—News Bulletin.

BUDAPEST (Hungary)

545 kc/s (550 m.); 23 kW.
Transmits at intervals from 8.15 a.m.
6.0 p.m.—Radio Report from the Stage of the National Theatre.
6.35 p.m.—Hungarian Folk Songs.
8.0 p.m.—Recital on Two Pianos.
9.15 p.m.—Concert from the Café Ostende.

COLOGNE (Germany)

Westdeutscher Rundfunk. 1,319 kc/s (227 m.); 1.7 kW.
See *Langenberg*.

COPENHAGEN (Denmark)

1,067 kc/s (281 m.); 0.75 kW. Relayed by *Kalundborg*, 260 kc/s (1,153 m.).
Transmits at intervals from 6.30 a.m. (Gymnastics).
2.0 p.m.—Instrumental Concert. Soloist: Børge Rosenbaum (Pianist). King Frederick VIII March (Dahl). Comedy Overture (N. W. Gade). Waltz, Les Fleurs (Waldteufel). Chant sans paroles (Tchaikovsky). Cradle Song (Danning). Ballet Suite (Oskar Gyldebrandt). Piano-forte Solos: (a) Fantaisie Impromptu (Chopin), (b) On Wings of Song (Mendelssohn-Liszt), (c) La plus que lente (Debussy), (d) Viennese Dance in G Major (Friedmann-Gärtner). Overture, "Poet and Peasant" (Suppé). Waltz, Queen Louise (Lumbye). Vaudeville Potpourri, Do you remember? Tango, The Gipsy Lad (Kemeny). Cradle Song (Fini Henriques). Spanish Dance, Toledo (Padilla). Exhibition March (Ryning).
4.0 p.m.—Programme for Children.
4.40 p.m.—Exchange; Market Prices.
4.50 p.m.—Gardening Talk (from the *Esbjerg* Studio).
5.20 p.m.—German Lesson.
5.50 p.m.—Weather and News.
6.15 p.m.—Time Signal.
6.30 p.m.—Talk: The Bedouins.
7.0 p.m.—Town Hall Chimes.
7.2 p.m.—Orchestral Concert, conducted by Thomas Jensen. French Military March from the Algerian Suite (Saint-Saëns). Overture, "Die Fledermaus" (Strauss).

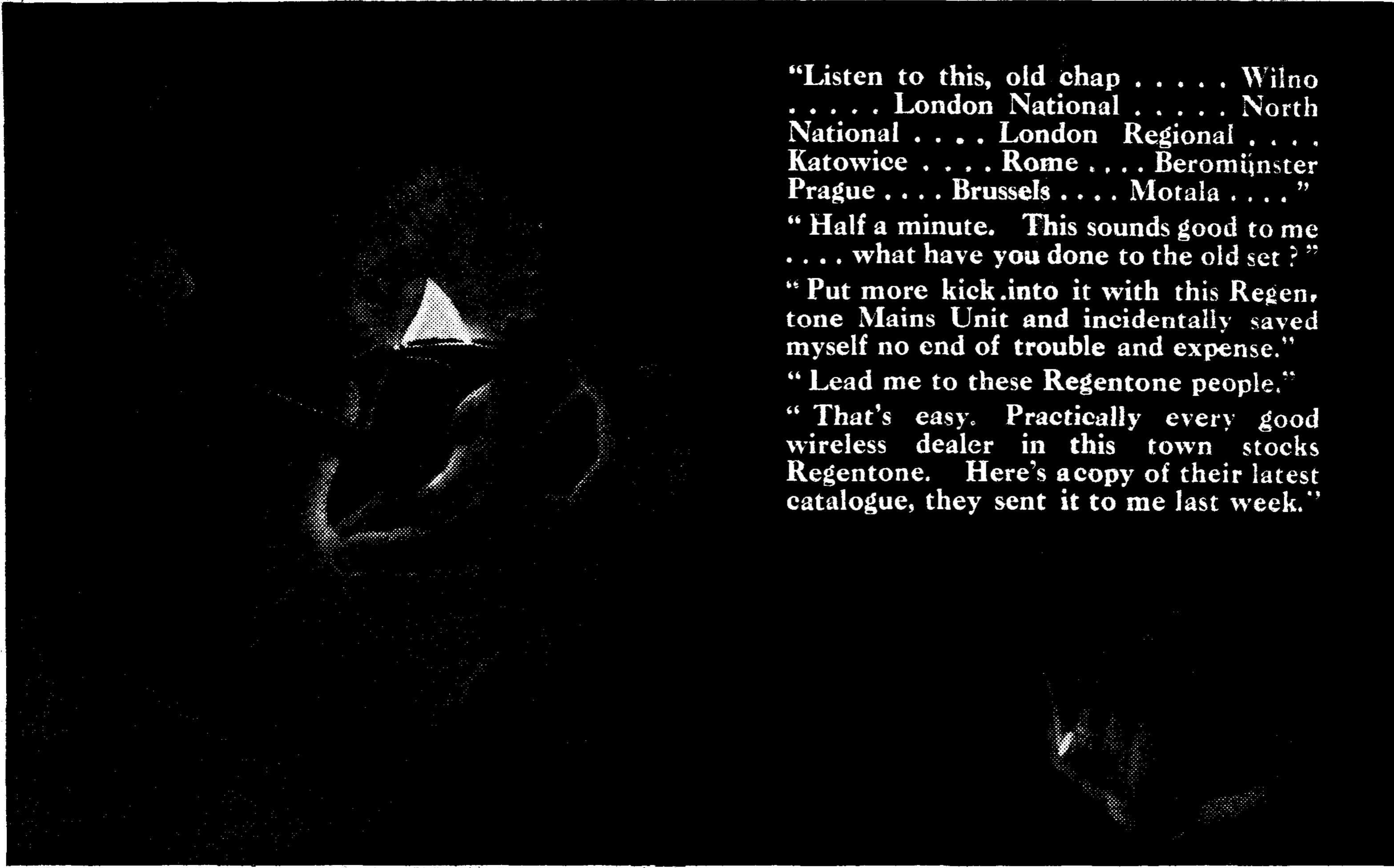

"Listen to this, old chap Wilno London National North National London Regional Katowice Rome Beromünster Prague Brussels Motala"

"Half a minute. This sounds good to me what have you done to the old set?"

"Put more kick into it with this Regentone Mains Unit and incidentally saved myself no end of trouble and expense."

"Lead me to these Regentone people."

"That's easy. Practically every good wireless dealer in this town stocks Regentone. Here's a copy of their latest catalogue, they sent it to me last week."

Programmes for Tuesday—(Cont.)

Waltz, Amelie (Lumbye). Selection from "Bitter Sweet" (Niel Coward). Berceuse and Prelude (Järnefeldt). Farandole from the Second Suite from "L'Arlesienne" (Bizet).

8.0 p.m.—Reading.

8.25 p.m.—Recital of Modern Danish Songs from the Works of Gunder Knudsen.

8.45 p.m.—News Bulletin.

9.0 p.m.—Orchestral Concert, conducted by Thomas Jensen. Overture, "The Marriage of Figaro" (Mozart). Minuet and Finale from the Symphony in D Major (Haydn). Selection from "La Boutique fantasque" (Rossini-Respighi). Suite No. 1 for Small Orchestra (Stravinsky). Nocturne from the Music to "King Christian II" (Sibelius). Russian Dance and Trepak from the Nutcracker Suite (Tchaikovsky).

10.0 p.m. (approx.)—Close Down.

DUBLIN (Ireland)
(2RN). 725 kc/s (413 m.); 1.5 kW. Relayed by Cork, 1,337 kc/s (224.4 m.).

1.30—2.0 p.m.—Time, Weather, Stock Report and Gramophone Records.

6.0 p.m.—Gramophone Records.

6.15 p.m.—Programme for Children.

7.0 p.m.—Gramophone Records.

7.15 p.m.—News Bulletin.

7.30 p.m.—Time Signal.

7.30 p.m.—Leigheacht Gaedhilg, by Cormac Breathnach.

7.45 p.m.—Recitations by Violet M. Powell.

8.0 p.m.—Concert. The No. 1 Army Band, conducted by Colonel Fritz Brase. Mollie Phillips (Soprano). Talk on Irish History by Dr. Eoin MacNeill. The Station Sextet. Dan McLoughlin (Baritone). The Station Sextet.

10.30 p.m.—Time, News, Weather and Close Down.

FRANKFURT-am-MAIN (Germany)
770 kc/s (390 m.); 1.7 kW. Relayed by Cassel, 1,220 kc/s (246 m.). Transmits at intervals from 5.15 a.m. (Weather and Gymnastics).

4.5 p.m.—See Stuttgart.

5.30 p.m.—Economic Notes.

5.40 p.m.—Dialogue: Why does Fashion change?

6.5 p.m.—See Stuttgart.

6.30 p.m.—Time and News.

6.35 p.m.—Talk: Christmas Books—Books on Religion.

6.45 p.m.—Orchestral Concert. Soloist: Karl Pistorius (Vocalist).

7.45 p.m.—"France as seen in her Art"—Literary and Musical Programme. Cortège and Dance from "L'Enfant Prodigue" (Debussy). Talk: France and "Surrealism" in Art. Pianoforte Pieces (Satie). Talk: Modern French Literature and "Surrealism." Songs (Jacob). Readings from (a) "Du côté de Guermantes" (Marcel Proust), (b) "Opium" (Cocteau), (c) "Poems" (Guillaume Apollinaire) and (d) "Le Paysan de Paris" (Aragon). Quartet, Op. 23, for Two Flutes, Clarinet and Bassoon (Ibert). Readings from (a) "Sous le soleil de Satan" (Bernanos), (b) "Adrienne Mesurat" (Julien Green). Forlane and Rigaudon from "Le Tombeau de Couperin" (Ravel).

9.20 p.m.—Time and News.

9.40 p.m.—Mozart Pianoforte Recital on the 140th Anniversary of his Death. Rondo in F Major. Minuet in D Major. Adagio in B Minor. Gigue in G Major. Ten Variations on a Theme from "La Rencontre imprévue" (Gluck).

10.30 p.m. (approx.)—Close Down.

HAMBURG (Germany)
Norag (ha, in Morse). 805 kc/s (372 m.); 1.7 kW. Relayed by Bremen, 1,112 kc/s (270 m.); Flensburg, 1,373 kc/s (218 m.); Hanover, 530 kc/s (566 m.); and Kiel, 1,292 kc/s (232.2 m.). Transmits at intervals from 5.30 a.m. (Time and Weather).

6.20 p.m.—Exchange and Weather.

6.30 p.m.—"Between the Primeval Forest and the Sugar-Loaf"—Through Brazil, by Julius Seelig.

7.30 p.m.—"Scheibe Steebeln"—Radio Play in North German Dialect (Otto Franz Grund).

8.45 p.m.—News Bulletin.

9.5 p.m.—Topical Talk.

9.15 p.m.—"Echoes from Scandinavia" by the Norag Orchestra, conducted by Fritz Gartz. Scandinavian Sketches (Juel-Frederiksen). Suite from the Music to "Belshazzar's Feast" (Sibelius). Norwegian Rhapsody No. 3 (Svendsen). Suite, Finnish Lyric Pieces (Palmgren). Canto patetico (Sind-

ing). A Norwegian Bridal Procession (Grieg).

10.20 p.m.—Ice Report.

HEILSBURG (Germany)
1,085 kc/s (276.5 m.); 75 kW. Relayed by Danzig, 662 kc/s (453.2 m.). Transmits at intervals from 5.30 a.m. (Gymnastics).

3.15 p.m.—Orchestral Concert, conducted by Eugen Wilcken. Overture, "Ilka" (Doppler). Moonlight in Venice (Armandola). Fantasia, A Godard Cycle (Urbach). Waltz, Wiener Blut (Joh. Strauss). Overture, "Der Göttergatte" (Lehár). Suite, The Minnesingers (Amadei). Waltz, Nordseestürme (Döring). Selection from "Gri-Gri" (Lincke).

4.45 p.m.—Book Review.

5.15 p.m.—Ice Report; Market Prices.

5.30 p.m.—Agricultural Talk.

5.55 p.m.—Talk for Workers.

6.25 p.m.—Weather Report.

6.40 p.m. (approx.)—See Munich.

8.15 p.m.—Ernst Wiechert reads from his own Works.

8.45 p.m. (from Danzig).—"The Shadow of the Glen"—Drama in One Act (J. M. Synge), translated and arranged by Dr. Ernst Leopold Stahl.

9.15 p.m. (approx.)—News Bulletin.

HILVERSUM (Holland)
1,004 kc/s (298.8 m.); 8.5 kW. Programme of the Algemeene Vereeniging Radio Omroep (A.V.R.O.).

7.40 a.m.—Gramophone Records.

9.40 a.m.—Daily Service.

9.55 a.m.—Gramophone Records.

10.10 a.m.—Organ Recital by Pierre Palla. Soloist: Marie Ohlsen (Vocalist).

10.40 a.m.—Talk (to be announced).

11.40 a.m.—Trio Concert. Soloists: G. v. d. Berk (Vocalist) and Egbert Veen (Pianoforte).

1.40—2.10 p.m.—Interval.

2.10 p.m.—Gramophone Records.

2.40 p.m.—Dressmaking Lesson.

3.40 p.m.—Pianoforte Recital, by Wilny Richard. Fantasia in C Minor (Bach-Busoni). Ballade in G Minor, Op. 23 (Chopin). Liebestraum (Liszt). Prelude in C Sharp Minor (Rachmaninoff). Minstrels (Debussy). España (Maduro).

4.10 p.m.—Programme for Children.

5.10 p.m.—Concert of Light Music.

6.10 p.m.—Two Talks.

7.10 p.m.—English Language Lesson.

7.40 p.m.—Orchestral Concert, conducted by Nico Trepp. Overture, "William Tell" (Rossini). Melancholy Waltz (Darsin).

7.55 p.m.—Talk (to be announced).

8.10 p.m.—Concert (contd.). Selection from "Der Freischütz" (Weber). Wine, Woman and Song (Strauss). Kirschblütenfest (Dicker).

8.40 p.m.—Songs and Recitations.

8.55 p.m.—Concert (contd.). Overture, "Der Göttergatte" (Lehár). Extase (Ganne). Ballet Scene (Luigini). Parade der Dickbäuche (Aubert). The Broken Melöde (v. Biene). March, Heldengrüsse (Mannfred).

9.25 p.m.—Songs and Recitations.

9.40 p.m.—Weather and News.

9.55 p.m.—Concert (contd.). Selection from "The Land of Smiles" (Lehár). Man lacht, man lebt, man liebt (Gilbert). The Caravan Procession (Rey). Selection from "Victoria and her Hussar" (Abraham). March, San Sebastian (Dufort).

10.40 p.m.—Gramophone Records.

11.40 p.m. (approx.)—Close Down.

HUIZEN (Holland)
160 kc/s (1,875 m.); 8.5 kW. Transmits at intervals from 7.40 a.m. Programme of the Catholic Radio Society (K.R.O.).

11.55 a.m.—Trio Concert. Heil Europa (von Blon). Song and Tango (Rotter). Waltz, Frauenlobgesänge (Sparry). Romance (Mozart). Potpourri, Musikalische Telegramme (Urbach). A Wedding Day on Troldhaugen (Grieg). Selection from "The Geisha" (Jones). Slumber Song (Demarcet). Waltz, Deutsche Grüsse (Lincke). Ständchen (Poepping). Finale.

1.25 p.m.—Gramophone Records.

1.40 p.m.—Programme for Women.

2.40 p.m.—Lesson in Dressmaking.

3.55 p.m.—Violin and Pianoforte Recital. Sonata in G Minor (Senallé). Sonata in C Minor (Leclair).

4.40 p.m.—Concert. Military Fanfare (Ascher). O Star of Eve (Wagner). Czardas (Kempner). Two Russian Songs (Glinka). Grieg Reminiscences (Urbach). Salut d'amour (Elgar). Delibes Fantasia (Urbach). Minuet (Bolzoni). Waltz, Schwert

und Leier (Strauss). Rustle of Spring (Sinding). March of the Dwarfs (Grieg).

6.0 p.m.—Talk.

6.25 p.m.—English Lesson.

6.50 p.m.—Talk.

7.10 p.m.—Police Notes.

7.25 p.m.—Talk.

7.40 p.m.—Orchestral Concert. Overture, "Iphigenia in Aulis" (Gluck). Andante from the Seventh Symphony (Schubert). Selection from "Fidelio" (Beethoven).

8.10 p.m.—"Poudre aux Yeux"—Comedy (Labiche, arr. Ed. Martin).

8.45 p.m. (in the interval).—News.

9.30 p.m.—Concert (continued). Overture, "Le Roi l'a dit" (Delibes). Suite, Jeux d'enfants (Bizet). Rigaudon from "Dardanus" (Rameau). Ballet Music from "Sylvia" (Delibes). Irish Tune from County Derry (Grainger). Selection from "The Girl of the Golden West" (Puccini). A Wedding Day on Troldhaugen (Grieg). Waltz, Hofballtänze (Lanner). Marche Lorraine (Ganne).

10.40 p.m.—Gramophone Records.

11.40 p.m. (approx.)—Close Down.

KALUNDBORG (Denmark)
Kalundborg Radio. 260 kc/s (1,153 m.); 7.5 kW. See Copenhagen.

KATOWICE (Poland)
734 kc/s (408 m.); 16 kW. Transmits at intervals from 10.58 a.m.

7.15 p.m.—Popular Concert.

9.10—10.0 p.m.—See Warsaw.

10.0 p.m.—Light Music and Dance Music.

LANGENBERG (Germany)
Westdeutscher Rundfunk. 635 kc/s (473 m.); 17 kW. Relayed by Aachen, Cologne and Münster, 1,319 kc/s (227 m.). Transmits at intervals from 5.45 a.m. (Gymnastics).

4.0 p.m.—Instrumental Concert.

5.0 p.m.—Agricultural Talk.

5.20 p.m.—Talk: Contemporary Art Questions.

5.40 p.m.—French Conversation.

6.0 p.m.—Time and Announcements.

6.15 p.m.—Wireless Notes.

6.30 p.m.—Talk: Work and the State.

6.55 p.m.—First General News.

7.0 p.m.—The World on Gramophone Records—"From Darkest Russia."

7.35 p.m.—Symphony Concert by the Station Orchestra, conducted by Büschkötter and Kuhn. Three Preludes to "Palestrina" (Pfitzner). Music for Orchestra (Stefan). Symphony No. 95 (the Third London) (Haydn). The Fifth Symphony in C Minor (Beethoven).

9.10 p.m.—Second News.

9.30 p.m. (approx.)—Report on the Six Days' Racing, relayed from the Rheinlandhalle.

9.50 p.m. (approx.)—Silent Night.

LEIPZIG (Germany)
1,157 kc/s (259 m.); 2.3 kW. Relayed by Dresden, 941 kc/s (319 m.). Transmits at intervals from 5.30 a.m.

3.30 p.m.—Concert by the Dresden Philharmonic Orchestra, conducted by Hilmar Weber. Overture, Champagne (von Baussnern). Arcadian Suite (Scharwenka). Slavonic Rhapsody in G Minor, Op. 45, No. 2 (Dvorák). Hungarian Dances Nos. 2 and 7 (Brahms).

4.30 p.m.—Weather, Time and Economic Notes.

5.5 p.m.—Talk for Women.

5.30 p.m.—French Lesson.

5.50 p.m.—An Introduction to the Gewandhaus Concert on December 3.

6.0 p.m.—Talk: Training for Welfare Work.

6.30 p.m.—Concert by the Leipzig Symphony Orchestra and the Leipzig Soloists' Choir, conducted by Theodor Blumer. Overture, "Undine" (Lortzing). Selection from "Oberon" (Weber). Five Tone Pictures (Carl Reinecke): (a) Romance from "King Manfred," (b) Lento from "King Manfred," (c) Idyll from "Tell," (d) Twilight from "Pictures of a Summer's Day," (e) Tanz unter der Dorflinde, from "Pictures of a Summer's Day." Intermezzo, Dance and Wedding March from "A Midsummer Night's Dream" (Mendelssohn). Harald—Ballad for Mixed Choir and Orchestra (Paul Hartig).

8.0 p.m.—An Address by the Dutch Writer, Felix Timmermans.

8.15 p.m.—"The Diamond"—a Fairy Comedy (Friedrich Hebbel), arranged for Wireless by Dr. Martin Kunath. Music by Alexander Schettler.

9.30 p.m.—News Bulletin.

9.45 p.m.—Pianoforte Humour by William Schuff.

10.30 p.m. (approx.)—Close Down.

LJUBLJANA (Yugoslavia)
522 kc/s (574.7 m.); 2.8 kW. Transmits at intervals from 8.0 a.m.

7.0 p.m.—Military Music.

9.0 p.m.—News Bulletin.

9.15 p.m.—Light Music.

LWÓW (Poland)
788 kc/s (381 m.); 21 kW. Transmits at intervals from 10.40 a.m.

7.0 p.m.—Special Programme arranged by the Polish-Yugoslavian League, relayed from the Town Hall. Music and Addresses.

8.55—11.0 p.m.—See Warsaw.

11.0 p.m. (approx.)—Close Down.

MADRID (Spain)
Union Radio (EAJ7). 707 kc/s (424.3 m.); 2 kW. Transmits at intervals from 8.0 a.m.

7.0 p.m.—Chimes, Exchange, Market Prices and Request Gramophone Records. In the interval at 7.30 p.m.—Shooting and Fishing Notes.

8.10 p.m.—News and Political Review.

8.30—10.0 p.m.—Interval.

10.0 p.m.—Chimes, Time, Political Review and Opera Selection: "Madame Butterfly" (Puccini) on Gramophone Records. In the interval at 12 midnight.—Chimes and News.

12.30 a.m. (Wednesday)—Close Down.

MILAN (Italy)
Ente Italiano Audizioni Radiofoniche. 598 kc/s (501.7 m.); 8.5 kW. Relayed by Turin, 1,094 kc/s (274.2 m.) and Genoa, 959 kc/s (312.8 m.). Transmits at intervals from 7.15 a.m.

6.0 p.m.—Announcements.

6.15 p.m.—Light Music. Valencia (De Micheli). Mattutino al villaggio (Ancillotti). Selection (Strauss). Vampa (Andronaco). Oriental Fantasia, Maharadska (Shirmann).

6.45 p.m.—Gramophone Records. In the interval at 7.0 p.m.—Time and News.

7.30 p.m.—English Lesson on Gramophone Records.

7.45 p.m.—"The Fantastics"—Comedy in Three Acts (Edmond Rostand), followed by Programme of Orchestral Music.

10.0 p.m.—Giornale Radio.

MUNICH (Germany)
563 kc/s (533 m.); 1.7 kW. Relayed by Augsburg and Kaiserslautern, 536 kc/s (560 m.), and Nürnberg, 1,256 kc/s (239 m.). Transmits at intervals from 5.45 a.m.

6.10 p.m.—English Language Lesson.

6.40 p.m.—Variety Concert.

8.15 p.m.—Contemporary Authors—Peter Dörfler.

8.35 p.m.—Secular Music of the Gothic and Renaissance Period (arranged by Bruno Steinbach). First Evening—Heinrich Isaac (Instrumental Music of the Late Gothic Period). In the intervals, Readings from Florentine and Munich Manuscripts.

9.20 p.m.—Time and News.

OSLO (Norway)
Kringkastingselskapet, 277 kc/s (1,083 m.); 75 kW. Relayed by Fredrikstad, 816 kc/s (367.6 m.); Hamar, 536 kc/s (560 m.); and Notodden, 671 kc/s (447.1 m.); Porsgrund, 662 kc/s (453.2 m.); and Rjukan, 671 kc/s (447.1 m.). Transmits at intervals from 10.10 a.m.

4.30 p.m.—Pianoforte Recital by Mme. Elizabeth Reiss-Faerden. Selections (Reger): (a) Romance No. 1, (b) Es war einmal, (c) Moment musical, (d) Hunting Piece. Nocturne in B Major and Grande Polonoise in E Flat (Chopin).

5.0 p.m.—Programme for Housewives.

5.45 p.m.—Gramophone Records.

6.0 p.m.—News Bulletin.

6.30 p.m.—English Lesson.

7.0 p.m.—Time Signal.

7.2 p.m.—Orchestral Concert of Norwegian Music.

8.0 p.m.—Talk on Literature.

8.35 p.m.—News Bulletin.

8.50 p.m.—Topical Talk.

9.5 p.m.—Talk: From Lyngenfjord to the Atlantic.

9.30 p.m.—Relay of Foreign Stations.

PARIS (France)
Eiffel Tower (FLE). 207.5 kc/s (1,445.7 m.); 15 kW. Time Signals (on 2,650 m.) at 9.26 a.m. and 10.26 p.m. (preliminary and 6-dot signals).

5.45 p.m.—Le Journal Parlé.

7.5 p.m.—Gramophone Records.

7.20 p.m.—Weather Forecast.

7.30 p.m.—Chopin Pianoforte Recital, by Mme. Marie-Antoinette Pradier, with Introductory Talk. Nocturne. Waltz. Etude. Berceuse. Fantaisie-Improptu.

8.0 p.m.—Quartet Concert. Quartet No. 17 (Mozart). Quartet, From out my Life (Smetana).

PARIS (France)
Poste Parisien. 914 kc/s (328.2 m.); 1.2 kW.

7.45 p.m.—Two One-Act Plays: (a) "The Haunted House" (Tony Tardy), and (b) "Le Voyage à Fontaines."

8.25 p.m.—Gramophone Records and News.

8.45 p.m.—Sports Talk, Gramophone Records and News.

9.0 p.m.—Concert. Overture, "The Cricket on the Hearth" (Goldmark). Waltz, Frühlingsstimmen (Joh. Strauss). Pastoral Suite (John Ansell). Ukrainian Suite (Rubinstein). Two Spanish Dances from "La vida breve" (de Falla). Evening Music (J. B. Foerster). March of the Highlanders (Godard).

PARIS (France)
Radio-Paris (CFR). 174 kc/s (1,725 m.); 80 kW. Transmits at intervals from 6.45 a.m. (Physical Culture).

12.30 p.m.—Gramophone Records.

1.0 p.m.—Exchange and News.

1.5 p.m.—Gramophone Concert of Operetta Music. In the intervals at 1.30 and 2.0 p.m.—Exchange Quotations.

3.35 p.m.—Exchange; Market Prices.

4.20 p.m.—Elementary English Lesson.

6.30 p.m.—Market Prices, Agricultural Report and Announcements.

7.0 p.m.—Theatre Review.

7.15 p.m.—Talk on Architecture.

7.30 p.m.—Advanced English Lesson.

7.45 p.m.—Commercial Prices, Economic and Social Notes and News.

8.0 p.m.—Dramatic Programme by M. Franceour and Company. Four Plays: (a) "Aunt Octavia" (Bonhomme-Funck-Brentano), (b) "Before the Door" (Duvernois), (c) "The Turtle Doves" (Albert Jean), (d) "The Accident" (Duvernois). In the intervals at 8.30 p.m.—Sports Results, Weather and Talk, and at 9.15 p.m.—News and Time.

PRAGUE (Czechoslovakia)
617 kc/s (487 m.); 120 kW. Transmits at intervals from 10.0 a.m.

6.5 p.m.—Talk by Prof. Slavik.

6.20 p.m.—A Play (Kuzickova-Stroziava).

7.15 p.m.—Concert by a Choir and the Czech Philharmonic Orchestra, conducted by Dr. Heinrich Svoboda, relayed from the Lucerna Palace. Concerto grosso in G Minor (Händel). Symphony (Stravinsky).

8.0 p.m.—Time, News and Accordion Recital.

8.30 p.m.—Violin Recital by Daisy Kennedy. Siciliano and Gigue (Dr. Arne). Gavotte with Variations (Pugnani-Corti). London-derry Air (Morris). Burlesque (Castelnuovo-Tedesco). Wicklow Fair (Dalmaine). Ballad and Polonoise (Vieuxtemps).

9.0 p.m.—Time and News.

9.15 p.m.—Announcements.

9.20 p.m.—Relay from the Hotel Esplanade.

10.0 p.m.—Time and News.

RADIO-SUISSE ROMANDE (SOTTENS) (Switzerland)
743 kc/s (403 m.); 25 kW. Lausanne, 442 kc/s (680 m.), and Geneva, 395 kc/s (760 m.). Transmits at intervals from 11.30 a.m.

6.0 p.m.—Weather Forecast.

6.1 p.m. (from Lausanne).—Organ Recital from the Capitol Cinema.

6.30 p.m. (from Lausanne).—German Lesson.

6.55 p.m.—News Bulletin.

7.0 p.m. (from Geneva).—Talk: The Effect of Migration on the World's Population.

7.30 p.m. (from Geneva).—Municipal Concert, relayed from the Victoria Hall. The Suisse Romande Orchestra, conducted by M. Fernand Closset. Mlle G. Dupont (Pianist).

9.0 p.m.—News Bulletin.

9.30 p.m. (approx.)—Close Down.

RIGA (Latvia)
572 kc/s (525 m.); 15 kW. Transmits at intervals from 10.0 a.m.

6.0 p.m.—Weather Report.

6.3 p.m.—Programme for Children.

7.0 p.m.—News Bulletin.

7.30 p.m.—Soloist Concert.

8.0 p.m.—Weather Report.

8.5 p.m.—Ballet Suite from "Naimona" (Lalo).

8.30 p.m.—Concert.

9.30 p.m. (approx.)—Close Down.

ROME (Italy)
Ente Italiano Audizioni Radiofoniche (IRO). 680 kc/s (441 m.); 75 kW. Relayed by Naples, 905 kc/s (332 m.), and 2RO, 11,810 kc/s (25.4 m.).

turne. Waltz. Etude. Berceuse. Fantaisie-Improptu.

8.0 p.m.—Quartet Concert. Quartet No. 17 (Mozart). Quartet, From out my Life (Smetana).

PARIS (France)
Poste Parisien. 914 kc/s (328.2 m.); 1.2 kW.

7.45 p.m.—Two One-Act Plays: (a) "The Haunted House" (Tony Tardy), and (b) "Le Voyage à Fontaines."

8.25 p.m.—Gramophone Records and News.

8.45 p.m.—Sports Talk, Gramophone Records and News.

9.0 p.m.—Concert. Overture, "The Cricket on the Hearth" (Goldmark). Waltz, Frühlingsstimmen (Joh. Strauss). Pastoral Suite (John Ansell). Ukrainian Suite (Rubinstein). Two Spanish Dances from "La vida breve" (de Falla). Evening Music (J. B. Foerster). March of the Highlanders (Godard).

PARIS (France)
Radio-Paris (CFR). 174 kc/s (1,725 m.); 80 kW. Transmits at intervals from 6.45 a.m. (Physical Culture).

12.30 p.m.—Gramophone Records.

1.0 p.m.—Exchange and News.

1.5 p.m.—Gramophone Concert of Operetta Music. In the intervals at 1.30 and 2.0 p.m.—Exchange Quotations.

3.35 p.m.—Exchange; Market Prices.

4.20 p.m.—Elementary English Lesson.

6.30 p.m.—Market Prices, Agricultural Report and Announcements.

7.0 p.m.—Theatre Review.

7.15 p.m.—Talk on Architecture.

7.30 p.m.—Advanced English Lesson.

7.45 p.m.—Commercial Prices, Economic and Social Notes and News.

8.0 p.m.—Dramatic Programme by M. Franceour and Company. Four Plays: (a) "Aunt Octavia" (Bonhomme-Funck-Brentano), (b) "Before the Door" (Duvernois), (c) "The Turtle Doves" (Albert Jean), (d) "The Accident" (Duvernois). In the intervals at 8.30 p.m.—Sports Results, Weather and Talk, and at 9.15 p.m.—News and Time.

PRAGUE (Czechoslovakia)
617 kc/s (487 m.); 120 kW. Transmits at intervals from 10.0 a.m.

6.5 p.m.—Talk by Prof. Slavik.

6.20 p.m.—A Play (Kuzickova-Stroziava).

7.15 p.m.—Concert by a Choir and the Czech Philharmonic Orchestra, conducted by Dr. Heinrich Svoboda, relayed from the Lucerna Palace. Concerto grosso in G Minor (Händel). Symphony (Stravinsky).

8.0 p.m.—Time, News and Accordion Recital.

8.30 p.m.—Violin Recital by Daisy Kennedy. Siciliano and Gigue (Dr. Arne). Gavotte with Variations (Pugnani-Corti). London-derry Air (Morris). Burlesque (Castelnuovo-Tedesco). Wicklow Fair (Dalmaine). Ballad and Polonoise (Vieuxtemps).

9.0 p.m.—Time and News.

9.15 p.m.—Announcements.

9.20 p.m.—Relay from the Hotel Esplanade.

10.0 p.m.—Time and News.

RADIO-SUISSE ROMANDE (SOTTENS) (Switzerland)
743 kc/s (403 m.); 25 kW. Lausanne, 442 kc/s (680 m.), and Geneva, 395 kc/s (760 m.). Transmits at intervals from 11.30 a.m.

6.0 p.m.—Weather Forecast.

6.1 p.m. (from Lausanne).—Organ Recital from the Capitol Cinema.

6.30 p.m. (from Lausanne).—German Lesson.

6.55 p.m.—News Bulletin.

7.0 p.m. (from Geneva).—Talk: The Effect of Migration on the World's Population.

7.30 p.m. (from Geneva).—Municipal Concert, relayed from the Victoria Hall. The Suisse Romande Orchestra, conducted by M. Fernand Closset. Mlle G. Dupont (Pianist).

9.0 p.m.—News Bulletin.

9.30 p.m. (approx.)—Close Down.

RIGA (Latvia)
572 kc/s (525 m.); 15 kW. Transmits at intervals from 10.0 a.m.

6.0 p.m.—Weather Report.

6.3 p.m.—Programme for Children.

7.0 p.m.—News Bulletin.

7.30 p.m.—Soloist Concert.

8.0 p.m.—Weather Report.

8.5 p.m.—Ballet Suite from "Naimona" (Lalo).

8.30 p.m.—Concert.

9.30 p.m. (approx.)—Close Down.

ROME (Italy)
Ente Italiano Audizioni Radiofoniche (IRO). 680 kc/s (441 m.); 75 kW. Relayed by Naples, 905 kc/s (332 m.), and 2RO, 11,810 kc/s (25.4 m.).

Programmes for Tuesday—(Cont.)

Transmits at intervals from 7.15 a.m. (Giornale Radio).
 4.30—5.15 p.m.—*Vocal and Instrumental Concert.* Sonata No. 8 for Violin and Pianoforte (Corelli). Soprano Solos: (a) An den Mond (Schubert), (b) Aria from "The Marriage of Figaro" (Mozart), (c) Piccolo sogno (Malena). Sonata in One Movement for Violin and Pianoforte (Arturo Siciliano). Baritone Solos: (a) Aria from "William Ratcliff" (Mascagni), (b) Aria from "Nero" (Rubinstein).
 6.20 p.m.—Announcements.
 6.32 p.m.—Atmospheric Signals.
 6.40 p.m.—Announcements.
 6.50 p.m.—Gramophone Records.
 7.10 p.m.—News Bulletin.
 7.35 p.m.—*English Lesson* on Gramophone Records.
 8.0 p.m.—*Concert from the Works of Respighi, conducted by the Composer.* Soloists: Maria Serra Masara (Soprano), Ofelia Parisini (Soprano) and Vincenzo Tanlongo (Tenor.) Antiche danze ed arie, transcribed for Orchestra—Second Suite. Toccata for Pianoforte and Orchestra. The Composer at the Pianoforte. Announcements and Talk. Four Selections for Choir, two Soprano and Tenor, from "Semirama." Topical Review. Symphonic Poem, Feste Romane.
 9.55 p.m.—News Bulletin.

SCHENECTADY (U.S.A.)
 General Electric Company (WGY). 790 kc/s (379.5 m.); 50 kW. Relayed at intervals by W2XAF on 9,530 kc/s (31.48 m.); and by W2XAD on 15,340 kc/s (19.56 m.). Transmits at intervals from 11.45 a.m.
 9.0 p.m.—Bridge Lesson.
 9.30 p.m.—Stock Reports and Police Notes.
 9.45 p.m.—Roger Sweet (Tenor).
 10.0 p.m.—News Bulletin.
 10.5 p.m.—Studio Ensemble.
 10.30 p.m.—New York Relay.
 11.0 p.m.—Doc Peyton and his Kenmore Orchestra.
 11.30 p.m.—Time Signal.
 11.31 p.m.—Jeanette Getz (Pianist).
 11.44 p.m.—Weather Report.
 11.45 p.m.—New York Relay.

12 midnight (WGY only).—General Electric Programme.
 12 midnight (W2XAF only).—Stock Reports and News.
 12.30—4.15 a.m. (Wednesday).—*New York Relay.*
 4.15 a.m.—Leonard and Sherman (Piano Twins).
 4.30 a.m.—Organ Recital from Proctor's Theatre.
 5.0 a.m.—Jack Miles and his DeWitt Clinton Orchestra.
 5.30 a.m.—Doc Peyton and his Kenmore Orchestra.
 6.0 a.m. (approx.).—Close Down.

SCHWEIZERISCHER LANDESSENDER (BEROMÜNSTER) (Switzerland)
 653 kc/s (459 m.); 75 kW; Basle, 1,229 kc/s (244.1 m.), and Berne, 1,220 kc/s (246 m.).
 Transmits at intervals from 11.28 a.m.
 3.0 p.m.—Orchestral Concert.
 4.0 p.m. (from Zürich).—Talk for Women: Cooking Recipes.
 4.30 p.m.—Weather Report.
 4.35—5.30 p.m.—Interval.
 5.30 p.m.—Choral Songs on Gramophone Records.
 6.0 p.m. (from Basle).—Reading.
 6.28 p.m.—Time and Weather.
 6.30 p.m. (from Basle).—Talk: Haller and the French.
 7.0 p.m. (from Berne).—Popular Music, conducted by Carl Friedemann.
 7.20 p.m. (from Berne).—Ballads by Carl Loewe, sung by Ernst Märki (Tenor).
 7.40 p.m. (from Berne).—Popular Music (continued).
 8.0 p.m.—Orchestral Selections.
 8.15 p.m. (from Berne).—Recital of German Melodies by Brahms for Mezzo-Soprano, Pianoforte, Violin and Cello.
 8.30 p.m.—Orchestral Interlude.
 8.40 p.m.—Songs to Words, by Tagore, set to Music by Julius Weismann, Op. 67, for Baritone, Pianoforte, Violin and Cello.
 9.0 p.m.—News Bulletin.
 9.15 p.m. (approx.).—Close Down.

STOCKHOLM (Sweden)
 Radiotjänst (SASA). 689 kc/s (436 m.); 75 kW. Relayed by Boden 244 kc/s (1,229.5 m.);

Göteborg, 932 kc/s (322 m.); Hörby, 1,166 kc/s (257 m.); Motala, 222.5 kc/s (1,343 m.); Östersund, 389 kc/s (770 m.); and Sundsvall, 554 kc/s (542 m.).
 Transmits at intervals from 6.15 a.m. (Gymnastics).
 4.0 p.m.—Talk for Young People.
 4.30 p.m.—Gramophone Records.
 5.30 p.m.—Song Recital.
 5.45 p.m.—Elementary French Lesson relayed from Malmö, 1,301 kc/s (231 m.).
 6.15 p.m.—Weather and News.
 6.30 p.m.—Talk: Bohr's Atom Theory.
 7.0 p.m.—The Practical Corner.
 7.15 p.m.—*Military Band Concert.* Overture, (Donizetti). Waltz, Elfentanz (Lehár). Selection from "La Tosca" (Puccini). 1812 Overture (Tchaikovsky).
 8.15 p.m.—Literary Review relayed from Göteborg.
 8.45 p.m.—Weather and News.
 9.0 p.m.—"Captain Nut"—Comedy (Jerzy Szaniawsky).
 10.0 p.m. (approx.).—Close Down.

STRASBOURG (France)
 Radio-Strasbourg (P.T.T.). 869 kc/s (345 m.); 15 kW.
 Transmits at intervals from 11.30 a.m.
 5.45 p.m.—Instrumental Concert.
 6.45 p.m.—Topical Talk in French.
 7.0 p.m.—Dance Music.
 7.30 p.m.—Time Signal.
 7.32 p.m.—News in French and German.
 7.45 p.m.—Gramophone Records.
 8.30 p.m.—Vocal and Instrumental Concert from the Town Hall, Metz.
 10.30 p.m. (approx.).—Close Down.

STUTTGART (MÜHLACKER) (Germany)
 Süddeutscher Rundfunk. 833 kc/s (360 m.); 75 kW. Relayed by Freiburg, 527 kc/s (570 m.).
 Transmits at intervals from 5.15 a.m. (Frankfurt Relay).
 4.5 p.m.—Military Band Concert from the Kurhaus, Glotterbad.
 5.30 p.m.—Time Signal.
 5.40 p.m.—Talk on Superannuation.
 6.5 p.m.—Talk: Literature and the Higher Grade Schools.
 6.30 p.m.—Time and News.
 6.46 p.m. (from Karlsruhe).—Vocal and Instrumental Concert.

7.45 p.m.—See Frankfurt.
 9.20 p.m.—News Bulletin.
 9.30 p.m.—See Langenberg.
 9.50 p.m.—Mozart Recital from Frankfurt.
 10.30 p.m. (approx.).—Close Down.

TOULOUSE (France)
 Radiophonie du Midi. 779 kc/s (385 m.); 8 kW.
 Transmits at intervals from 12.45 p.m.
 6.0 p.m.—Songs from "Faust" (Gounod), "The Tales of Hoffmann" (Offenbach) and "La Dame Blanche" (Boieldieu).
 6.15 p.m.—Concerto in A Major, for Violin (Mozart).
 6.30 p.m.—News Bulletin.
 6.45 p.m.—Orchestral Selections from "Cavalleria Rusticana" (Mascagni) and "Scheherazade" (Rimsky-Korsakoff).
 7.0 p.m.—Gramophone Records.
 7.30 p.m.—News Bulletin.
 7.45 p.m.—Dance Music.
 8.0 p.m.—Operetta Songs.
 8.15 p.m.—Orchestral Selections.
 8.30 p.m.—Gramophone Records.
 9.0 p.m.—Concert.
 10.0 p.m.—Gramophone Records.
 10.15 p.m.—Dance Music from the Café Sion. In the interval at 10.30 p.m.—News Bulletin.
 11.0 p.m.—Organ Solos.
 11.15 p.m.—News Bulletin.
 11.30 p.m.—Orchestral Selections.
 12 midnight.—Weather, Announcements and Close Down.

TRIESTE (Italy)
 Ente Italiano Audizioni Radiofoniche. 1,211 kc/s (247.7 m.); 15 kW.
 Transmits at intervals from 11.30 a.m.
 7.15 p.m.—News Bulletin.
 7.30 p.m.—Time, Announcements and English Lesson on Gramophone Records.
 7.35 p.m.—Gramophone Records.
 7.45 p.m.—See Milan. In the intervals and after the Relay, Musical Items.
 9.55 p.m.—News Bulletin.

VIENNA (Austria)
 Radio-Wien. 581 kc/s (517 m.); 20 kW. Relayed by Graz, 851 kc/s (352 m.); Innsbruck, 1,058 kc/s (283 m.); Klagenfurt, 662 kc/s (453.2 m.); Linz, 1,220 kc/s

(246 m.); and Salzburg, 1,373 kc/s (218 m.).
 Transmits at intervals from 8.20 a.m.
 6.5 p.m.—Gymnastics by Käthe Hye.
 6.25 p.m.—Time and News.
 6.35 p.m.—"The Inhabitants of Vienna as mirrored in Song"—a Recital by Fritz Lange.
 7.35 p.m.—Heinrich Lersch reads from his own Works, with Introductory Dialogue.
 8.5 p.m.—Concert by the Vienna Symphony Orchestra—Programme of Opera Music.
 9.5 p.m.—News Bulletin.
 9.20 p.m.—Dance Music from the Graben Café.

WARSAW (Poland)
 Polskie Radio. 212.5 kc/s (1,411 m.); 158 kW.
 Transmits at intervals from 10.40 a.m.
 3.40 p.m.—Gramophone Records.
 4.10 p.m.—Talk on Hare Coursing, relayed from Lwów.
 4.35 p.m.—*Concert by the Warsaw Philharmonic Orchestra,* conducted by G. Fitelberg, with G. Sadere (Vocalist). Overture, "Marya" (Statkovsky). Second Part of a Symphony (Stojovsky). Serenade (Casella). Five Popular Italian Songs.
 5.50 p.m.—Miscellaneous Items.
 6.15 p.m.—Agricultural Talk.
 6.25 p.m.—Programme Notes.
 6.30 p.m.—Gramophone Records.
 6.45 p.m.—Radio Journal.
 7.0 p.m.—Talk on Capitalism.
 7.15 p.m.—*Symphony Concert.* Soloists, J. Dvorakovsky (Violin), J. Krol (Clarinet) and L. Urstein (Pianoforte). Selections (Weber): (a) Overture, "Der Freischütz" (b) Invitation to the Dance, (c) Concerto for Clarinet and Pianoforte. Selections (Schubert): (a) Ballet Music from "Rosamunde," (b) Valse-Caprice from "Soirée de Vienne," (c) Erlkönig, (d) Two Serenades, (e) Ave Maria and Moment Musical for Violin, (f) Selection from "Lilac Time."
 8.55 p.m.—Wireless Correspondence and Technical Notes.
 9.10 p.m.—Soloist Concert.
 9.45 p.m.—Announcements.
 10.0 p.m.—Dance Music and Light Music.
 11.0 p.m. (approx.).—Close Down.



HEAR THE VOICE of the WORLD

For the listener who likes to indulge in radio-wandering, this new McMichael product is the radio *par excellence*. Built to achieve great results, it is the product of McMichael's unique designing talents. Ask your dealer to demonstrate this outstanding receiver.

THE McMICHAEL COLONIAL SUPERSONIC RECEIVER

Designed for listeners in any part of the World who want results, this unique receiver covers the ultra short wave range from 14 to 95 metres, and also the broadcast band, enabling the user to tune in stations from literally the most distant parts of the World.

Built into a handsome cabinet of solid teak, the set uses to full advantage two screened grid valves, one pentode and one triode.

Troublesome plug-in coils are replaced by an ingenious device which enables you to change wavebands immediately and without fuss. Requiring only a short aerial and a good earth, this set will give surprisingly clear and vigorous reception.

PRICE £15
 (including valves).
EXTRAS:
 120 Volt Battery 15/6
 2 Volt Accumulator 11/9

Telephone: **SLOUGH** 441-442
L.M. MICHAEL LTD
 Manufacturers of Wireless and Scientific Apparatus
WEXHAM ROAD, SLOUGH, BUCKS.
 Telegrams: **RADIETHER SLOUGH**
 London Showrooms: 179, STRAND, W.C.2. Telephone: Holborn 2466.

ALL BRITISH —built at our works at Slough and embodying the experience of eleven years' successful Radio manufacture.

PROGRAMMES FOR WEDNESDAY

(December 2)

NOTE: THE HOURS OF TRANSMISSION ARE REDUCED TO GREENWICH MEAN TIME

ALGIERS (N. Africa)

825.3 kc/s (363.4 m.); 13 kW.
Transmits at intervals from 12.30 p.m.
7.10 p.m.—News Bulletin.
7.35 p.m.—Concert of Viennese Music.
7.55 p.m.—News and Time.
8.0 p.m.—Humorous Gramophone Records.
8.30 p.m.—Weekly Book Review.
8.45 p.m.—Symphony Concert.
10.0 p.m.—Italian Songs.
10.15 p.m.—Military Music.
10.30 p.m.—Concert of Dance Music.

BARCELONA (Spain)

Radio-Barcelona (EAJR). 860 kc/s (349 m.); 8 kW.
Transmits at intervals from 7.30 a.m.
7.0 p.m.—Trio Music.
7.30 p.m.—Market Prices, Exchange and Gramophone Concert.
8.30 p.m.—Talk in Catalan.
9.0 p.m.—Chimes, Weather, Exchange and Market Prices.
9.5 p.m.—Orchestral Music.
9.30 p.m.—Song Recital.
10.5 p.m.—"La Garra"—Play in Two Acts (Manuel Linares Ribas).
11.30 p.m.—Dance Music from the Café Catalan.
12 midnight (approx.)—Close Down.

BERLIN (Germany)

Königs Wusterhausen. 183.5 kc/s (1,635 m.); 75 kW.
Transmits at intervals from 5.30 a.m.
3.30 p.m.—See Hamburg.
4.30 p.m.—Talk on Franz Liszt.
5.0 p.m.—Review of New Novels.
5.30 p.m.—Talk: 1931, an Intellectual Jubilee Year.
5.55 p.m.—Weather for Farmers.
6.0 p.m.—Talk for Civil Servants.
6.30 p.m.—Talk on Political Economy, followed by Weather for Farmers.
7.0 p.m.—See Langenberg.
9.15 p.m.—News Bulletin.
9.45 p.m. (approx.)—Dance Music from Berlin (Witzleben).
11.30 p.m. (approx.)—Close Down.

BERLIN (Germany)

Witzleben. 715 kc/s (418 m.); 1.7 kW.
Transmits at intervals from 5.30 a.m.
6.0 p.m.—Topical Talk.
6.10 p.m.—Recital of Jazz Songs by the Sylvia Singers and the Melodiegents.
7.0 p.m.—Variety Programme, arranged by Felix Mendelssohn.
8.0 p.m.—News Bulletin.
8.10 p.m.—Orchestral Concert, conducted by Alfredo Casella. Concerto in D Minor (Vivaldi). Overture, "La Cenerentola" (Rossini). Pause del silenzio—Seven Symphonic Pieces (Malipiero). Serenata (A. Casella).
9.15 p.m.—Political Press Review.
9.35 p.m.—News, followed by Dance Music by the Otto Kernbach Orchestra.
11.30 p.m. (approx.)—Close Down.

BORDEAUX-LAFAYETTE

(France)
(PTT). 986 kc/s (304 m.); 35 kW.
Transmits at intervals from 12.45 p.m.
7.30 p.m.—News; Market Prices.
7.40 p.m.—Dramatic Criticism.
7.55 p.m.—Results of the Prize Draw.
8.0 p.m.—Agricultural Report.
8.20 p.m.—News Bulletin.
8.30 p.m.—Glinka Concert. Talk on the History of Music, followed by Orchestral Selections and Bass Solos. After the Programme, Amusement Guide and Time Signal.

BRATISLAVA

(Czechoslovakia)
1,076 kc/s (279 m.); 14 kW.
Transmits at intervals from 10.0 a.m.
6.5 p.m.—Gramophone Records.
6.30 p.m.—See Prague.
7.30 p.m.—See Brno.
9.0 p.m.—See Prague.
9.15 p.m.—Programme Announcements.

BRESLAU (Germany)

923 kc/s (325 m.); 1.7 kW. Relayed by Gleiwitz, 1,184 kc/s (253 m.).
Transmits at intervals from 5.30 a.m.
6.15 p.m.—Chamber Music. Quintet in E Flat Major, Op. 24, for Piano-forte, Oboe, Clarinet, Horn and Bassoon (Volbach).
6.40 p.m.—(from Gleiwitz) Weather Report.
6.45 p.m. (approx.) (from Gleiwitz).—

Talk: Modern Catchwords in Economics.

7.0 p.m.—(from Gleiwitz).—Reading of Poems.
7.30 p.m.—Seven Hundred Years of the German Students' Song—Recital by Franz Baumann (Tenor), with Commentary.
9.0 p.m.—Time and News.
9.30 p.m.—Talk by E. Gotthold.
9.45 p.m.—Dance Music.
11.0 p.m. (approx.)—Close Down.

BRNO (Czechoslovakia)

878 kc/s (342 m.); 3 kW.
Transmits at intervals from 10.0 a.m.
6.5 p.m.—Gramophone Records.
6.20 p.m.—See Prague.
7.30 p.m.—A Musical Play in Four Acts (Erich Kastner, Music by Edmund Nick).
9.0 p.m.—See Prague.
9.15 p.m.—News Bulletin.

BRUSSELS (Belgium) (No. 1)

I.N.R. 590 kc/s (509 m.); 20 kW.
5.0 p.m.—Sonata for Pianoforte and Violin by MM. Charles Scharres and Henry Wagemans.
5.30 p.m.—Gramophone Records.
6.15 p.m.—Travelogue: From Spitzbergen to the North Pole.
6.30 p.m.—Gramophone Dance Records.
7.15 p.m.—Talk: Ruysbroeck.
7.30 p.m.—Le Journal Parlé.
8.0 p.m.—Military Band Concert.
9.30 p.m.—Recital of Sonatas by M. G. Lykoudi (Violin) and Mme. Lykoudi-Passet (Pianoforte). Sonata No. 15 (Mozart). Sonata in A (Brahms).
10.0 p.m.—Le Journal Parlé.

BRUSSELS (Belgium) (No. 2)

N.I.R. 887 kc/s (338.2 m.); 20 kW.
Programme in Flemish.
5.0 p.m.—Dance Music.
6.0 p.m.—Gramophone Records
6.15 p.m.—Talk: Ruysbroeck.
6.30 p.m.—Gramophone Records.
7.15 p.m.—Talk: The Importance of the Wool Trade to the Port of Antwerp.
7.30 p.m.—Theatre Review.
8.0 p.m.—String Quartet (C. Franck).
8.45 p.m.—Extracts from "Jean le Maufranc" or "The School of Hypocrisy"—Play (Jules Romain).
9.15 p.m.—Concert Relay.
10.0 p.m.—Le Journal Parlé.

BUCHAREST (Romania)

Radio-Bucarest. 761 kc/s (394 m.); 16 kW.
Transmits at intervals from 11.0 a.m.
6.0 p.m.—Educational Talk.
6.40 p.m.—Violin Recital. Andalusian Romance (Sarasate). Tango (Arbos). Valse Caprice (Wieniawsky). Romanian Caprice (Kolar).
7.0 p.m.—"Madame Butterfly"—Opera (Puccini) on Gramophone Records. News in the intervals.

BUDAPEST (Hungary)

545 kc/s (550 m.); 23 kW.
Transmits at intervals from 8.15 a.m.
6.0 p.m.—Programme by Herr Dekan.
6.30 p.m.—"The Land of Smiles"—Operetta (Lehár), relayed from the Royal Hungarian Opera House, followed by Tzigane Concert from the Café Spolarich.

COLOGNE (Germany)

Westdeutscher Rundfunk. 1,319 kc/s (227 m.); 1.7 kW.
See Langenberg.

COPENHAGEN (Denmark)

1,067 kc/s (281 m.); 0.75 kW. Relayed by Kalundborg, 260 kc/s (1,153 m.).
Transmits at intervals from 6.30 a.m. (Gymnastics).
2.0 p.m.—Orchestral Concert, conducted by Emil Reesen. Overture, "Tancred" (Rossini). Liebeswalzer and Selection from "Boris Godounoff" (Moszkovsky). Nocturne for Strings (Dvorák). Minuet from the Symphony No. 39 in E Flat Major (Mozart). Waltz, Scène dansante, and Gallop from "La forêt enchantée" (Drigo).
Talk for Women. Concert Overture, Meeresstille und glückliche Fahrt (Mendelssohn-Bartholdy). Chant sans paroles (Tchaikovsky). Two Selections from the "Bal costumé" (Rubinstein). Husarenritt (Spindler).
4.0 p.m.—Gramophone Records.
4.40 p.m.—Exchange; Market Prices.
4.50 p.m.—Talk in English by Vernon Bartlett: Some English Characteristics.
5.20 p.m.—French Lesson.
5.50 p.m.—Weather and News.
6.15 p.m.—Time Signal.
6.30 p.m.—Legal Talk.
7.0 p.m.—Town Hall Chimes.

7.2 p.m.—"The Hansen Family"—a Humorous Episode (Jens Locher).

7.15 p.m.—Concert of Danish Dramatic Music, conducted by Launy Gröndahl. Soloist: Lilly Ericson (Vocalist). Overture, "Oberon" (F. L. A. Kunzen). Romance from "Indtoget" (J. A. P. Schulz). Two Selections (F. L. E. Kunzen): (a) Overture, "Erik Ejegod," (b) Song from "Dragedukken." Two Selections (Kuhlau): (a) Overture, "William Shakespeare," (b) Romance from "Røverborgen." Wedding March from "Undine" (J. P. E. Hartmann).
8.15 p.m.—Talk: The Homeless.
8.45 p.m.—Saxophone Recital by Paul Ströbeck Kiesbye. Serenade (Braga). Selection from "FredERICA" (Lehár). At Eventide (Rudy Wiedoft). Tango, There's something in your eyes (Grothe).
9.0 p.m.—Reading.
9.15 p.m.—News Bulletin.
9.30 p.m.—String Quartet, Op. 51, No. 2 in A Minor for Two Violins, Viola and Cello (Brahms).
10.5 p.m. (approx.)—Close Down.

DUBLIN (Ireland)

(2RN). 725 kc/s (413 m.); 1.5 kW. Relayed by Cork, 1,337 kc/s (224.4 m.).
1.30—2.0 p.m.—Time, Weather, Stock Report and Gramophone Records.
6.0 p.m.—Gramophone Records.
6.15 p.m.—Programme for Children.
7.0 p.m.—Gramophone Records.
7.20 p.m.—News Bulletin.
7.30 p.m.—Time Signal.
7.32 p.m.—Gaadhilg by M. O'Maolain as Arainn.
7.45 p.m.—German Lesson.
8.0 p.m.—Concert by the Sligo Musical Society, relayed from the Town Hall, Sligo.
9.30 p.m.—Sponsored Programme.
10.30 p.m.—Time, News, Weather and Close Down.

FRANKFURT-am-MAIN

(Germany)
770 kc/s (390 m.); 1.7 kW. Relayed by Cassel, 1,220 kc/s (246 m.).
Transmits at intervals from 5.15 a.m. (Weather and Gymnastics).
4.5 p.m.—Orchestral Concert. Symphonic Poem, Tabor (Smetana). Suite algérienne, Op. 60 (Saint-Saëns). Old Dance Music.
5.30 p.m.—Economic Notes.
5.40 p.m.—Talk.
6.5 p.m.—See Stuttgart.
6.30 p.m.—Time and News.
6.35 p.m.—Theatre Talk.
6.45 p.m.—See Stuttgart.
7.5 p.m.—Rhenish Landscapes—II—the Hunsrück, Songs to the Lute and Recitations, with Commentary.
8.20 p.m.—See Stuttgart. In the interval at 9.30 p.m.—Time and News.
10.10 p.m. (approx.)—Close Down.

HAMBURG (Germany)

Norag (ha, in Morse). 806 kc/s (372 m.); 1.7 kW. Relayed by Bremen, 1,112 kc/s (270 m.); Flensburg, 1,373 kc/s (218 m.); Hanover, 530 kc/s (566 m.) and Kiel, 1,292 kc/s (232.2 m.).
Transmits at intervals from 5.30 a.m. (Time and Weather).
3.30 p.m.—(from Hanover).—Orchestral Concert from Bad Nenndorf. Overture, "Fra Diavolo" (Auber). Selection from "A Masked Ball" (Verdi). Ballade and Polonaise for Violin and Orchestra (Vieuxtemps). Invitation to the Dance (Weber). "The Soldiers' Chorus" from "Faust" (Gounod).
4.30 p.m.—Talk for Workers: Your Leisure Hours.
4.50 p.m.—Müller-Rastatt Memorial Programme.
5.30 p.m.—Talk: Dangers of the Streets.
5.55 p.m.—Talk: The North German Movement at the Turn of the Century.
6.20 p.m.—Exchange and Weather.
6.30 p.m.—Reading.
7.0 p.m.—(from Bremen).—Charity Concert for Male Voice Choir and Soloists. Introduction, with Music. Choral Selections: (a) Sanctus (Schubert), (b) Ewig jung ist nur die Sonne (Gust. Haug), (c) Des Liedes Kristall (Ferd. Schmidt). Selections for Violin and Piano-forte: (a) Heire Kati (Hubay), (b) Zigeunerweisen (Sarasate). Choral Selections: (a) Feldeinsamkeit (Wendel), (b) Hochamt im Walde (R. Becker), (c) Nachtzauber (A. M. Storch). Selections for Violin and Piano-forte: (a) La Capricciosa (Ries), (b) Liebesleid and Liebesfreud (Kreisler). Choral Selection: Deutschland, mein Deutschland (Trunk).

8.0 p.m.—Josef Strauss Concert by the Norag Orchestra, conducted by José Eibenschütz. Quadrille, Rendezvous. Waltz, Wiener Kinder. Scottish Dance. Waltz, Herbstrosen. Polka-Mazurka, Frauenherz. Aquarellen-Walzer. Transaktionen-Walzer.

9.0 p.m.—News Bulletin.
9.20 p.m.—Topical Talk.
9.30 p.m.—Concert from the Alster Pavilion.

HEILSBURG (Germany)

1,085 kc/s (276.5 m.); 75 kW. Relayed by Danzig, 662 kc/s (453.2 m.).
Transmits at intervals from 5.30 a.m. (Gymnastics).
3.15 p.m.—Orchestral Concert, conducted by Eugen Wilcken. Suite No. 2 (de Micheli). Overture—"Morning, Noon and Night" (Suppé). Gipsy Waltz, Fascination (Marchetti). Selection from "The Merry Wives of Windsor" (Nicolai). Waltz, Bei uns z'haus (Joh. Strauss). Selection from "Lilac Time" (Schubert-Berté). Slavonic Rhapsody (Friedemann). March, Germanentreue (Blankenburg).

4.45 p.m.—Talk on Health.
5.15 p.m.—Ice Report; Market Prices.

5.30 p.m.—Motet Concert by the Wireless Choir, relayed from the Neurosgärtter Church, Königsberg. Adventsmotette (Palestrina). Marienlieder. Motet Op. 74—O Heiland, reisse die Himmel auf (Brahms).
6.15 p.m.—Dialogue for Business Men.
6.45 p.m.—Miners' Literature (Paul Habraschka), with Introductory Talk.
7.15 p.m.—Weather Report.
7.20 p.m.—Dance Music by the Königsberg Opera House Orchestra conducted by Georg Wöllner and the Orag Orchestra, conducted by Eugen Wilcken.

8.5 p.m. (in the interval).—News.
9.15 p.m.—Second News.
9.40 p.m. (approx.)—Dance Music from Berlin (Witzleben).
11.30 p.m. (approx.)—Close Down.

HILVERSUM (Holland)

1,004 kc/s (298.8 m.); 8.5 kW.
6.25—9.40 a.m.—Programme of the Workers' Radio Society (V.A.R.A.).
6.25—6.40 a.m.—and 7.10—7.25 a.m.—Gymnastics.
7.40 a.m.—Gramophone Records.
9.40 a.m.—Religious Programme by the Liberal Protestant Radio Society (V.P.R.O.).
9.55 a.m. till Close Down.—V.A.R.A. Programme.
9.55 a.m.—Quintet Concert, Recitations and Address for Workers.
11.40 a.m.—Septet Concert and Gramophone Records.

HILVERSUM (Holland)

1.25—1.55 p.m.—Interval.
1.55 p.m.—Talk for Women.
2.40 p.m.—Pianoforte Recital. Sonatina (Ravel). Les Hirondelles, Op. 14; Gavotte, Op. 16 and Waltz, Op. 26 (Godard).
3.10 p.m.—A Play for Children.
4.10 p.m.—Gramophone Records.
4.25 p.m.—Question Time.
5.25 p.m.—Gramophone Records.
5.40 p.m.—Educational Talk.
6.10 p.m.—Gramophone Records.
6.25 p.m.—Talk: Capitalism.
6.55 p.m.—Gramophone Records.
7.40 p.m.—Talk for Teetotallers.
7.55 p.m.—Orchestral Concert. Overture, "Der Improvisator" (d'Albert). Two Selections from "A Ballet Suite" (Reger). Three Irish Melodies (arr. Grainger): (a) Mock Morris, (b) Irish Tune, (c) Shepherds Hey.
8.25 p.m.—Violin Recital. Concerto for Violin (Fitelberg).
8.40 p.m.—Recitations.
9.10 p.m.—Violin Recital (continued). Concerto for Violin and Orchestra (Frenkel). Overture to einem ritterlichen Spiel (Weinberger).
9.40 p.m.—News Bulletin.
9.50 p.m.—Gramophone Records.
10.0 p.m.—Orchestral Concert, conducted by Hugo de Groot. Overture, "La belle Hélène" (Offenbach). Waltz, The Skaters (Waldteufel). Circassian Dance (Ritter). Reminiscences of "Mignon" (Weninger).
10.40 p.m.—Gramophone Records.
11.40 p.m. (approx.)—Close Down.

HUIZEN (Holland)

160 kc/s (1,875 m.); 8.5 kW.
Transmits at intervals from 7.40 a.m. Programme of the Christian Radio Society (N.C.R.V.).
12.10 p.m.—Vocal and Instrumental Concert.

1.40 p.m.—Gramophone Records.

2.10 p.m.—Reading.
2.40 p.m.—Concert. Quartet, Op. 54, No. 1 (Haydn). Quartet in B Flat Major (Mozart). Quartet in B Flat Major (Schubert).
4.10 p.m.—Gramophone Records.
4.25 p.m.—Talk (to be announced).
4.40 p.m.—Programme for Children.
5.40 p.m.—Agricultural Programme.
6.40 p.m.—Talk: Music in the Time of the Reformation.
7.10 p.m.—Police Notes.
7.25 p.m.—News Bulletin.
7.40 p.m.—Folk Song Recital.
8.40 p.m.—Talk.
9.10 p.m.—Organ and Soprano Recital. Lobe den Herrn, den mächtigen König der Ehren (Joh. G. Walther). Soprano Solos (J. A. Hasse): (a) Lam Gods, (b) Kruisiging. Cantilène pastorale (Guilmant). Soprano Solos: Two Arias from "The Messiah" (Händel). Andantino (C. Franck). Choral Prelude (J. W. Gosens). Finale (Lefebure-Wély).
10.10 p.m.—News Bulletin.
10.20 p.m.—Gramophone Records.
11.10 p.m. (approx.)—Close Down.

KALUNDBORG (Denmark)

Kalundborg Radio. 260 kc/s (1,153 m.); 7.5 kW.
See Copenhagen.

KATOWICE (Poland)

734 kc/s (408 m.); 16 kW.
Transmits at intervals from 10.58 a.m.
7.15 p.m.—See Lwów.
7.45 p.m.—See Warsaw.
8.0—9.10 p.m.—See Lwów.
9.10 p.m.—Gramophone Records.
10.0 p.m.—The Letter-Box in French for Foreign Listeners.

LANGENBERG (Germany)

Westdeutscher Rundfunk. 635 kc/s (473 m.); 17 kW. Relayed by Aachen, Cologne and Münster, 1,319 kc/s (227 m.).
Transmits at intervals from 5.45 a.m. (Gymnastics).
4.0 p.m.—Orchestral Concert.
5.0 p.m.—Review of New German Novels.
5.20 p.m.—Talk: Contemporary Art Problems.
5.40 p.m.—Talk on Uniforms.
6.0 p.m.—Time: Announcements.
6.15 p.m.—Talk: Health before All.
6.30 p.m.—Talk: The Rise of the English Middle and Working Classes in the Nineteenth Century.
6.55 p.m.—First General News.
7.0 p.m.—"Prince Friedrich von Homburg"—Play (Heinrich von Kleist; Music by Hans Ebert).
9.15 p.m. (approx.)—News Bulletin, followed by Concert.
10.45 p.m.—Report on the Cologne Six Days' Racing, relayed from the Rheinlandhalle.

LEIPZIG (Germany)

1,157 kc/s (259 m.); 2.3 kW. Relayed by Dresden, 941 kc/s (319 m.).
Transmits at intervals from 5.30 a.m.
6.0 p.m.—Talk: Contemporary Problems of Municipal Politics.
6.30 p.m.—Recital for Harp and Solo Instruments. Sonata for Harp with Horn obbligato in F Major, Op. 3 (L. F. Dauprat). Sonata for Harp and Flute, Op. 95 (Joh. Aron).
7.0 p.m.—Advent Music by the Choir of St. Jacob's and Helmut Thöner (Organ), relayed from Chemnitz. Fantasia in G Major (Bach). Motet, Machet die Tore weit (Hammer-schmidt). Zwei der Seraphim (J. Gallus). Ubers Gebirg' Maria geht (Joh. Eccard). Advent Chorales for Organ by Bach, Brahms and Reger. Motet, O Heiland reiss die Himmel auf (Brahms). Chorale, Die Stadt liegt grau im Dämmerchein (Brahms). Fantasia and Fugue on "Wie schön leuchtet uns der Morgenstern" (Reger).
8.5 p.m.—Topical Talk.
8.15 p.m.—"Africa"—a Literary Sequence with Music (O. L. Brandt).
9.15 p.m.—News Bulletin.
9.30 p.m. (approx.)—Concert by the Leipzig Symphony Orchestra, conducted by Hilmar Weber. Overture, "Loreley" (I. Lachner). Selections from "Madame Butterfly" (Puccini). Suite, Aus dem Morgenlande (Heuberger). Intermezzo, Das getanzte Festmahl (A. Schettler). Three Selections (J. H. Ganglberger): (a) Im Märchenwald, (b) Idyll for Xylophone, Tirili, (c) Intermezzo, Die kleine Kompagnie. Waltz, Leben und Lieben (Fall). Melodies from the Works of Offenbach.
10.30 p.m. (approx.)—Close Down.

EVERYTHING **The G.E.C.** ELECTRICAL
your guarantee



Do your valves 'blast'?

Distorted reproduction is the price you have to pay for using unsuitable valves—valves that make wireless a nightmare.

OSRAM VALVES are expressly designed to give pure and lifelike reproduction. "Extra quality without extra cost," in other words. Get the type suitable for your requirements, and then ahead of you are months and months of pure enjoyable radio

OSRAM 2-volt battery valves are the valves with the NEW WEMBLEY FILAMENT which definitely means better all-round results.

Be sure of purity by using

OSRAM Valves

WRITE—

for the Osram Wireless Guide (1931 Edition) and also Station Indicator Card—sent Post Free.

**BRITISH PRODUCTS
DESIGNED FOR
BRITISH RADIO CONDITIONS**



Sold by all
Wireless
Dealers.

**SUPREMACY
IN RADIO—**

*G.E.C.
Radio*

Programmes for Wednesday—(Cont.)

LJUBLJANA (Yugoslavia)

522 kc/s (574.7 m.); 2.8 kW.
Transmits at intervals from 11.15 a.m.
7.0 p.m.—Music Lesson.
7.30 p.m.—Song Recital.
8.0 p.m.—Quintet Concert.
9.0 p.m.—News Bulletin.

LWÓW (Poland)

788 kc/s (381 m.); 21 kW.
Transmits at intervals from 10.40 a.m.
7.0 p.m.—Talk on Music.
7.15 p.m.—Choral Concert.
7.45 p.m.—See *Warsaw*.
8.0 p.m.—Concert of Chamber Music.
9.10 p.m.—Gramophone Records.
9.30 p.m.—See *Warsaw*.
9.45 p.m.—Talk on Russian Literature.
10.0 p.m.—See *Warsaw*.
11.0 p.m. (approx.)—Close Down.

MADRID (Spain)

Union Radio (EAJ7). 707 kc/s (424.3 m.); 2 kW.
Transmits at intervals from 8.0 a.m.
7.0 p.m.—Chimes, Exchange, Market Prices and Request Gramophone Records.
8.10 p.m.—News and Political Review.
8.30—10.0 p.m.—Interval.
10.0 p.m.—Chimes, Time, Political Review and "Las Lagrimas de la Trini"—Play (Carlos Arniches) performed by the Alvarez Quintero Society.
12.0 midnight.—Chimes and News.
12.30 a.m. (Thursday)—Close Down.

MILAN (Italy)

Ente Italiano Audizioni Radiofoniche. 598 kc/s (501.7 m.); 8.5 kW. Relayed by *Turin*, 1,094 kc/s (274.2 m.), and *Genoa*, 959 kc/s (312.8 m.).
Transmits at intervals from 7.15 a.m.
6.0 p.m.—Agricultural Report.
6.10 p.m.—Gramophone Records.
In the intervals at 6.25 p.m.—Announcements, at 7.0 p.m.—Time and News and at 7.18 p.m.—Medical Talk.
7.45 p.m.—Relay of an Operetta. In the intervals, Music Notes and Talk. After the Programme, Giornale Radio.

MORAVSKÁ-OSTRAVA

(Czechoslovakia)

1,139 kc/s (263 m.); 11 kW.
Transmits at intervals from 10.0 a.m.
6.5 p.m.—A Comedy in Three Acts.
7.25 p.m.—Violin Recital. Polonaise (Provaznik). My Country (Smetana). Elegy (Kocian). Melody (Kubelik). Selection (Nevcik).
7.55 p.m.—Orchestral Concert.
9.0 p.m.—See *Prague*.
9.15 p.m.—Announcements.

MUNICH (Germany)

563 kc/s (533 m.); 1.7 kW. Relayed by *Augsburg* and *Kaiserslautern*, 536 kc/s (560 m.), and *Nürnberg*, 1,256 kc/s (239 m.).
Transmits at intervals from 5.45 a.m.
6.10 p.m.—Talk: Woman's Share in Industrial Arts.
6.25 p.m.—Programme to be announced.
6.45 p.m.—Talk on the following transmission.
7.5 p.m.—"The Taming of the Shrew"—Comic Opera in Four Acts (Hermann Götz), relayed from the Municipal Theatre, *Kaiserslautern*.
10.0 p.m.—Time and News, followed by *Orchestral Concert*. Overture, "Mignon" (Beccce). Viennese Dance No. 2 (Friedemann-Gärtner). Suite No. 1, Children's Corner (Debussy). Selection from "Die toten Augen" (d'Albert). Spanish Dance from "La vida breve" (de Falla). Modern Dance Suite (W. Niemann). Four Items to be announced.
11.0 p.m. (approx.)—Close Down.

OSLO (Norway)

Kringkastingselskapet, 277 kc/s (1,083 m.); 75 kW. Relayed by *Fredriksstad*, 816 kc/s (367.6 m.); *Hamar*, 536 kc/s (560 m.); *Notodden*, 671 kc/s (447.1 m.); *Porsgrunn*, 662 kc/s (453.2 m.); and *Rjukan*, 671 kc/s (447.1 m.).
Transmits at intervals from 10.10 a.m.
4.0 p.m.—*Orchestral Concert*. Meeresstille und glückliche Fahrt (Mendelssohn). Valse lente (Delibes). Selections from "Hansel and Gretel" (Humperdinck). Pavane (Ravel). Serenade, Napoli (d'Ambrosio). Gavotte (Gabriel Marie). Mazurka (Ganne).
5.0 p.m.—French Lesson.
5.30 p.m.—Programme for Boys.
6.0 p.m.—News Bulletin.
6.30 p.m.—Talk arranged by the

University: The Races of Europe.

7.0 p.m.—Literary and Musical Programme relayed from the Logen Hall.
8.35 p.m.—News Bulletin.
8.50 p.m.—Topical Talk.
9.5 p.m.—*Tchaikovsky Concert*. Concerto in D for Violin and Orchestra. Italian Caprice.
10.0 p.m.—Gramophone Dance Music.
11.0 p.m. (approx.)—Close Down.

PALERMO (Italy)

Ente Italiano Audizioni Radiofoniche. 1,412 kc/s (212.4 m.); 4 kW.
Transmits at intervals from 11.45 a.m.
5.0—6.0 p.m.—Gramophone Records.
7.0 p.m.—News Bulletin.
7.20 p.m.—Gramophone Records.
8.0 p.m.—Time and Announcements.
8.5 p.m.—Variety Concert. In the intervals, Talk: Wedding Customs of Ancient Rome and Theatre Notes.
9.55 p.m.—News.

PARIS (France)

Eiffel Tower (FLE). 207.5 kc/s (1,445.7 m.); 15 kW. Time Signals (on 2,650 m.) at 9.25 a.m. and 10.26 p.m. (preliminary and 6-dot signals).
5.45 p.m.—Le Journal Parlé.
7.20 p.m.—Weather Forecast.
7.30 p.m.—Programme for Young People.
8.0 p.m.—*Symphony Concert* conducted by M. E. Flament. Overture, "The Secret Marriage" (Cimarosa-Delamarche). Spanish Symphony for Violin (Lalo), by M. Cantrelle. Norwegian Dances (Grieg).

PARIS (France)

Poste Parisien. 914 kc/s (328.2 m.); 1.2 kW.
8.15 p.m.—Gramophone Records, Talk and News.
9.0 p.m.—*Concert*. Overture, "Banditenstreich" (Suppé). Pianoforte Solo: Pièce en forme de mazurka (Aubert). Soloist: M. M. Béché. Selection from "Martha" (Flotow). La Fête dans les jardins du roi (M. d'Ollone). Selection from "Le Hulla" (M. S. Rousseau). Quintet, Après l'été (Florent Schmitt). Selection from "Proserpine" (Saint-Saëns). Stances gothiques (Van Dyck). Ballet égyptien (Luigini). Waltz, La plus belle (Waldteufel). Spanish Dance No. 3 (Moszkovsky).

PARIS (France)

Radio-Paris (CFR). 174 kc/s (1,725 m.); 80 kW.
Transmits at intervals from 6.45 a.m. (Physical Culture).
12.30 p.m.—Gramophone Records.
1.0 p.m.—Exchange and News.
1.5 p.m.—*Gramophone Concert*. Overture, "The Thieving Magpie" (Rossini), by the Berlin Opera House Orchestra. Selections from "The Damnation of Faust" (Berlioz). Symphony (Stravinsky). In the intervals at 1.30 p.m. and 2.0 p.m.—Exchange Quotations.
3.35 p.m.—Exchange; Market Prices.
6.30 p.m.—Market Prices, Agricultural Report and Announcements.
7.0 p.m.—Talk: The "Comédie Française."
7.30 p.m.—Medical Talk.
7.45 p.m.—Commercial Prices, Economic and Social Notes and News.
8.0 p.m.—Readings: The "Persian Letters" of Montesquieu.
8.30 p.m.—Sports Results and Weather.
8.40 p.m.—Fashion Review.
8.45 p.m.—*Concert*. Quintet for Harp, Two Violins, Viola and Cello (Inghelbrecht). Songs by Mme Germaine Féraldy. Cello Solos by M. Roger Boulmé: (a) Grave and Spiritoso (Rochini), (b) Slavonic Caprice (Scharwenka). String Quartet (d'Ollone). In the interval at 9.15 p.m.—News and Time.

PRAGUE (Czechoslovakia)

617 kc/s (487 n.); 120 kW.
Transmits at intervals from 10.0 a.m.
6.20 p.m.—A Sketch.
6.30 p.m.—Brass Band Concert.
7.30 p.m.—Time, News, Chimes.
7.40 p.m. (approx.)—Programme to be announced.
9.0 p.m.—Time, News, Chimes.
9.15 p.m.—Announcements.

RADIO-SUISSE ROMANDE (SOTTENS) (Switzerland)

743 kc/s (403 m.); 25 kW. *Lausanne*, 442 kc/s (680 m.); and *Geneva*, 395 kc/s (760 m.).
Transmits at intervals from 11.30 a.m.
6.0 p.m.—Weather Forecast.
6.1 p.m.—(from *Lausanne*).—Gramophone Records.

6.30 p.m. (from *Lausanne*).—Agricultural Talk.

6.55 p.m.—News Bulletin.
7.0 p.m. (from *Lausanne*).—Talk: The Nervous Child.
7.25 p.m. (from *Geneva*).—*Military Band Concert*, conducted by Marcel Welsch, relayed from the Victoria Hall. Soloists: Mme Bernadette Delprat, of the Opéra-Comique, and M. Georges Pileur (Pianist). Overture, "Le Roi de Lahore" (Massenet). Songs: (a) Atia from "Alceste" (Gluck), (b) Aria from "La Tosca" (Puccini), (c) Aria from "Louise" (Charpentier). Waltz, The Blue Danube (Joh. Strauss). Au pays basque (Fernand). Songs: (a) Gretchen am Spinnrade (Schubert), (b) Rencontre, (c) Toujours (Fauré), (d) Invitation au Voyage, (e) Phydilé, (f) Soupir (Duparc), (g) Caravane (Chausson). March from "Rienzi" (Wagner).
9.20 p.m.—News Bulletin.
9.30 p.m. (approx.)—Close Down.

RIGA (Latvia)

572 kc/s (525 m.); 15 kW.
Transmits at intervals from 10.0 a.m.
6.0 p.m.—Weather Report.
6.5 p.m.—*Schubert Concert*. Quartet, Death and the Maiden. Songs.
7.0 p.m.—News Bulletin.
7.30 p.m.—*Orchestral Concert*. Overture, "Le Roi d'Ys" (Lalo). Songs. Waltz, Schön Rosmarin (Kreisler). Intermezzo, Puppenspiele (Lederer). Selection from "The Merry Widow" (Lehar). Florentine March (Fucik). In the interval at 8.0 p.m.—Weather Report.
8.30 p.m.—Concert.
9.30 p.m. (approx.)—Close Down.

ROME (Italy)

Ente Italiano Audizioni Radiofoniche (IRO). 680 kc/s (441 m.); 75 kW. Relayed by *Naples*, 905 kc/s (332 m.), and *RO*, 11,810 kc/s (25.4 m.).
Transmits at intervals from 7.15 a.m. (Giornale Radio).
4.30—5.15 p.m.—*Concert*, conducted by Enrico Martucci. Overture, "Orpheus in the Underworld" (Offenbach). Gavotte for Saxophone and Orchestra (Ganglberger). In a Persian Market (Ketelbey). Three Hungarian Dances (Brahms). Suite, Sleeping Beauty (Tchaikovsky). Il Natale di Pierrot (Monti).
6.25 p.m.—(from *Naples*).—Shipping. Announcements.
6.50 p.m.—Gramophone Records.
7.10 p.m.—Sports Notes and Press Review.
7.15 p.m.—Medical Talk.
7.30 p.m.—Time and News.
8.0 p.m.—"Cavalleria rusticana" Opera in One Act (Mascagni). Announcements and Reading. "I Pagliacci"—Opera in Two Acts (Leoncavallo). News after the Programme.

SCHENECTADY (U.S.A.)

General Electric Company (WGY). 790 kc/s (379.5 m.); 50 kW. Relayed at intervals by W2XAF on 9,530 kc/s (31.48 m.), and by W2XAD on 15,340 kc/s (19.56 m.).
Transmits at intervals from 11.45 a.m.
9.0 p.m.—*New York Relay*.
9.30 p.m.—Stock Reports and Police Notes.
9.45 p.m.—*New York Relay*.
10.0 p.m.—News Bulletin.
10.5 p.m.—Studio Ensemble.
10.30—11.15 p.m.—*New York Relay*.
11.15 p.m.—Time Signal.
11.16 p.m.—Health Talk.
11.20 p.m.—Musical Interlude.
11.29 p.m.—Weather Report.
11.30 p.m.—Willys Overland Programme.
11.45 p.m.—*New York Relay*.
12 midnight.—Educational Programme.
12.15 a.m. (Thursday)—4.15 a.m.—*New York Relay*.
4.15 a.m.—Mary Zoller (Xylophonist).
4.30 a.m.—Annette McCullough (Crooner).
4.45 a.m.—*New York Relay*.
5.0 a.m.—Jack Miles and his DeWitt Clinton Orchestra.
5.30 a.m.—Doc Peyton and his Kenmore Orchestra.
6.0 a.m. (approx.)—Close Down.

SCHWEIZERISCHER LANDESSENDER (BEROMÜNSTER) (Switzerland)

653 kc/s (459 m.); 75 kW.; *Basle*, 1,229 kc/s (244.1 m.) and *Berne*, 1,220 kc/s (246 m.).
Transmits at intervals from 11.28 a.m.
3.0 p.m.—Military Band Concert, on Gramophone Records.
4.0 p.m. (from *Basle*).—Programme for Children.

4.30 p.m.—Weather and Market Prices.

4.40 (approx.)—5.30 p.m.—Interval.
5.30 p.m.—Slavonic Music for Choir and Orchestra, on Gramophone Records.
6.0 p.m. (from *Berne*).—Talk: The Economic Position of Switzerland at the Beginning of the Winter.
6.28 p.m.—Time and Weather.
6.30 p.m. (from *Berne*).—Report from a Police Barracks.
7.0 p.m. (from *Zürich*).—Fragments from "Peer Gynt"—Dramatic Poem (Henrik Ibsen). Music by Grieg.
8.0 p.m. (approx.)—Concerto for Cello and Orchestra (Haydn).
8.30 p.m.—Symphony No. 92 in G Major (Haydn), by the Radio Orchestra.
9.0 p.m.—News Bulletin.
9.15 p.m. (from *Basle*).—Wireless Notes.
9.30 p.m. (approx.)—Close Down.

STOCKHOLM (Sweden)

Radiotjänst (SASA). 689 kc/s (436 m.); 75 kW. Relayed by *Boden*, 244 kc/s (1,229.5 m.); *Göteborg*, 932 kc/s (322 m.); *Hörby*, 1,166 kc/s (257 m.); *Motala*, 222.5 kc/s (1,348 m.); *Östersund*, 389 kc/s (770 m.); and *Sundsvall*, 554 kc/s (542 m.).
Transmits at intervals from 6.15 a.m. (Gymnastics).
4.0 p.m.—Gramophone Records.
4.30 p.m.—Agricultural Talk.
5.0 p.m.—Gramophone Records.
5.30 p.m.—Talk on Legislation.
6.0 p.m.—*Pianoforte Recital* by Algot Haquinus. Hungarian Rhapsody, No. 11, and Waldesrauschen (Liszt). Preludes (Chopin).
6.15 p.m.—Weather and News.
6.30 p.m.—Psychological Talk relayed from *Sundsvall*.
7.0 p.m.—*Symphony Concert* by the *Stockholm Concert Society*. Soloist: Franz Wagner. Symphony No. 4 in E Flat Major (Bruckner). Concerto in E Flat Major, Op. 73, for Pianoforte and Orchestra (Beethoven).
8.30 p.m.—Reading.
8.45 p.m.—Weather and News.
9.0 p.m.—Gramophone Dance Records.
10.0 p.m. (approx.)—Close Down.

STRASBOURG (France)

Radio-Strasbourg (PTT). 869 kc/s (345 m.); 15 kW.
Transmits at intervals from 11.30 a.m.
5.0 p.m.—*Instrumental Concert*. Ballet Suite (Poppy). Serenade, Sous la fenêtre (Lachaume). Waltz, Roses of the South (Joh. Strauss). The Fate of a Butterfly (Jessel). Selection from "Passionément" (Messenger). March of the Hungarian Heroes (Fucik).
5.45 p.m.—Talk in French: Siena.
6.0 p.m.—*Instrumental Concert*. Overture, "Maritana" (Wallace). Poème d'amour (Engelman). Waltz, Violets (Waldteufel). Selection from "Hérodiade" (Massenet). Méditation (Scassola). Marche lorraine (Ganne).
6.45 p.m.—Talk in German.
7.0 p.m.—Gramophone Records.
7.30 p.m.—Time Signal.
7.32 p.m.—News in French and German.
7.45 p.m.—Gramophone Records.
8.30 p.m.—*Instrumental Concert*. Soloist: Nathalie Radisse. Symphony No. 3—the Eroica (Beethoven). Concerto in E Flat for Two Pianofortes and Orchestra (Mozart). Symphonic Poem, Les Eolides (César Franck). Symphonic Variations for Pianoforte and Orchestra (César Franck). Symphonic Piece, Rédemption (Franck).
10.30 p.m.—Gramophone Dance Records of Jack Hylton and his Band 12 midnight (approx.)—Close Down.

STUTTGART (MÜHLACKER) (Germany)

Süddeutscher Rundfunk. 833 kc/s (360 m.); 75 kW. Relayed by *Freiburg*, 527 kc/s (570 m.).
Transmits at intervals from 5.15 a.m. (*Frankfurt Relay*).
4.5 p.m.—See *Frankfurt*.
5.30 p.m.—Time Signal.
5.40 p.m.—Talk: Three Years of Wandering through Denmark, Norway and Sweden.
6.5 p.m.—Talk: Short Time Work and Shut-Downs.
6.30 p.m.—Time and News.
6.45 p.m.—Saxon Humour, by Gustav Herrmann.
7.5 p.m.—See *Frankfurt*.
8.20 p.m.—*Violin Recital* by Nathan Milstein, with the Stuttgart Philharmonic Orchestra, conducted by Emil Kahn. Symphony in D Major (Mozart). Concerto for Violin and Orchestra (Dvórák). Prélude à

l'après midi d'un faune (Debussy). Pieces for Violin and Pianoforte: (a) Nugun (Bloch), (b) The Flight of the Bumble Bee (Rimsky-Korsakoff, arr. Hartmann), (c) Melody (Gluck), (d) Polonaise (Weber).

9.40 p.m.—News Bulletin.
9.50 p.m. (from *Mannheim*).—*Recital of Old English Songs* by Emmy Joseph (Soprano) and Louise Schatt-Eberts (Pianoforte). A Pastoral (Carey). My lovely Celia (Monro). Phillis (Young). Shepherd, thy demeanour vary (Brown). I attempt from Love's Sickness to fly (Purcell).
10.10 p.m. (approx.)—Close Down.

TOULOUSE (France)

Radiophonie du Midi. 779 kc/s (385 m.); 8 kW.
Transmits at intervals from 12.45 p.m.
6.0 p.m.—Dance Music.
6.15 p.m.—Light Music.
6.30 p.m.—News Bulletin.
6.45 p.m.—Violin Solos.
7.0 p.m.—Hawaiian Guitar Selections.
7.15 p.m.—Orchestral Selections.
7.30 p.m.—News Bulletin.
7.45 p.m.—La boîte à jousoux for Orchestra (Debussy).
8.0 p.m.—Military Music.
8.15 p.m.—Orchestral Concert.
9.0 p.m.—Musical Programme.
10.30 p.m.—News Bulletin.
10.45 p.m.—Gramophone Records.
11.0 p.m.—Concert. In the interval at 11.15 p.m.—North African News 12 midnight.—Weather, Announcements and Close Down.

TRIESTE (Italy)

Ente Italiano Audizioni Radiofoniche. 1,211 kc/s (247.7 m.); 15 kW.
Transmits at intervals from 11.30 a.m.
7.15 p.m.—News and Gramophone Records.
8.0 p.m.—Time and Announcements.
8.5 p.m. (approx.)—Chamber Music Concert. Notes on Art in the interval.
9.25 p.m.—Variety Music or Gramophone Records.
9.55 p.m.—News Bulletin.

VIENNA (Austria)

Radio-Wien. 581 kc/s (517 m.); 20 kW. Relayed by *Grätz*, 851 kc/s (352 m.); *Innsbruck*, 1,058 kc/s (283 m.); *Klagenfurt*, 662 kc/s (453.2 m.); *Linz*, 1,220 kc/s (246 m.); and *Salzburg*, 1,373 kc/s (218 m.).
Transmits at intervals from 8.20 a.m.
5.55 p.m.—French Lesson.
6.20 p.m.—Time and News.
6.30 p.m.—Part Relay of a Choral Concert by the Vienna Schubert Society, for the 140th Anniversary of the Death of Mozart, relayed from the Concert House.
7.30 p.m.—Reading from the Works of Pirandello.
8.0 p.m.—"At the End"—a Sketch (Marie v. Ebner-Eschenbach).
8.35 p.m.—News Bulletin.
8.50 p.m.—*Orchestral Concert*. Overture, "The Crown Diamonds" (Auber). Waltz, Wiener Blut (Joh. Strauss). Selection from "Mephistopheles" (Boito). Ave Maria from "Othello" (Verdi). Grossmütchen will tanzen (Lange). Selection from "Gipsy Love" (Lehar). Xylophone Solo (Peter). Waltz, Mondsee (Morawetz). Song Potpourri (Rhode). Russian March, On the Don (Dostal).

WARSAW (Poland)

Polskie Radio. 212.5 kc/s (1,411 m.); 158 kW.
Transmits at intervals from 10.40 a.m.
3.40 p.m.—Gramophone Records.
3.55 p.m.—*Linguaphone English Lesson*.
4.10 p.m.—Talk.
4.35 p.m.—*Orchestral Concert*. Overture, "Die Fledermaus" (Joh. Strauss). Dream of Love after the Ball (Czibulka). Potpourri (Morena). Barcarolle, In a Gondola (Macura). The Procession of the Gnomes (Blon). Waltz, Autumn Dreams (Joyce). Czardas from "Die Fledermaus" (Joh. Strauss). Romance (Rubinstein). Potpourri, A.B.C. (Kozzak). Mazurka (Levandovsky).
5.50 p.m.—Miscellaneous Items.
6.15 p.m.—Agricultural Report.
6.25 p.m.—Programme Notes.
6.30 p.m.—Gramophone Records.
6.45 p.m.—Radio Journal.
7.0 p.m.—See *Lwów*.
7.45 p.m.—Literary Programme.
8.0 p.m.—See *Lwów*.
9.10 p.m.—Gramophone Records.
9.30 p.m.—Radio Journal.
9.35 p.m.—Announcements.
9.45 p.m.—Talk in English: Why has the Polish Currency not been threatened?
10.0 p.m.—Light Music and Dance Music.

PROGRAMMES FOR THURSDAY

(December 3)

NOTE: THE HOURS OF TRANSMISSION ARE REDUCED TO GREENWICH MEAN TIME

ALGIERS (N. Africa)

825.3 kc/s (363.4 m.); 13 kW.
Transmits at intervals from 12.30 p.m.
7.10 p.m.—Shipping Notes.
7.15 p.m.—Picture Transmission.
7.30 p.m.—Gramophone Records.
7.45 p.m.—Waltzes. Selections from "Gipsy Love" (Lchár), and "The Dollar Princess" (Fall). Du and du (Strauss).
7.55 p.m.—News and Time.
8.0 p.m.—Talk: The Manufacture of a Gramophone Record.
8.15 p.m.—Guitar and Mandoline Concert.
9.0 p.m.—Music Hall Programme.
10.0 p.m.—Instrumental Concert. Prelude, "Tristan und Isolde" (Wagner). The Death of Isolde, from "Tristan und Isolde" (Wagner). La santa espina (Morena). Song of the Volga Boatmen (Wood). Organ Solo: Christmas Fantasia. Ballet Music from "La Source" (Delibes). Moldavia (Smetana).

BARCELONA (Spain)

Radio-Barcelona (EAJI). 860 kc/s (349 m.); 8 kW.
Transmits at intervals from 7.30 a.m.
7.0 p.m.—Trio Music.
7.30 p.m.—Market Prices, Exchange and Programme for Children.
8.0 p.m.—Gramophone Records.
8.30 p.m.—Advanced English Lesson.
9.0 p.m.—Chimes, Weather, Exchange and Market Prices.
9.5 p.m.—Orchestral Music.
10.5 p.m.—Talk in Catalan.
10.15 p.m.—Concert relayed from the Granja Royal.
12 midnight (approx.)—Close Down.

BERLIN (Germany)

Königs Wusterhausen. 183.5 kc/s (1,635 m.); 75 kW.
Transmits at intervals from 5.30 a.m. (Witzleben Relay).
3.30 p.m.—See Berlin (Witzleben).
4.30 p.m.—Talk: Ten Years as a German in Sumatra.
5.0 p.m.—Educational Talk: The Wonders of Egypt.

5.25 p.m.—Spanish Lesson.
5.45 p.m.—Wireless Technical Talk.
6.0 p.m.—Agricultural Talk.
6.30 p.m.—Concert from Berlin (Witzleben).
7.55 p.m.—Talk: The Decline of the Birth Rate in Germany.
8.25 p.m.—See Breslau.
9.15 p.m.—News Bulletin.
9.30 p.m.—See Langenberg.
11.30 p.m. (approx.)—Close Down.

BERLIN (Germany)

Witzleben. 715 kc/s (418 m.); 1.7 kW.
Transmits at intervals from 5.30 a.m. (Gymnastics).
3.30 p.m.—Mozart Concert by the Fassbaender-Rohr Trio. Trio for Violin, Pianoforte and Cello in G Major. Sonata for Violin and Pianoforte in C Major. Trio in B Flat Major for Pianoforte, Violin and Cello.
4.30 p.m.—Talk for Young People: The Berlin Tiergarten.
4.50 p.m.—Review of Books.
5.0 p.m.—Talk: The Causes of Rust, and how to combat it.
5.25 p.m.—Talk: What has Germany accomplished in the way of Reconstruction?
5.50 p.m.—Reading of Prose.
6.10 p.m.—Topical Talk.
6.20 p.m.—Viennese Dance Evening, by the Berlin Concert Society and Otto Fassel (Tenor). Conductor: Dr. Wilhelm Grosz.
8.0 p.m.—News Bulletin.
8.5 p.m.—Talk on the following Transmission.
8.10 p.m.—Second Act of "The Bird-Fancier"—Operetta in Three Acts (Zeller), relayed from the Theater des Westens.
9.10 p.m.—Concerto for Pianoforte and Orchestra (Mossoloff), by the Berlin Wireless Orchestra, conducted by Michael Taube and Eduard Steuermann (Pianist).
9.40 p.m.—News, followed by Dance Music by the Paul Godwin Jazz Orchestra and the El Aguilar Tango Band, relayed from the Femina.
11.30 p.m. (approx.)—Close Down.

BORDEAUX-LAFAYETTE

(France)
(PTT). 986 kc/s (304 m.); 35 kW.
Transmits at intervals from 12.45 p.m.

7.30 p.m.—News and Exchange.
7.40 p.m.—Talk: Emigration and Unemployment.
7.55 p.m.—Results of the Prize Draw.
8.0 p.m.—Talk on Wine.
8.15 p.m.—News Bulletin.
8.30 p.m.—"Le Marquis de Villemer"—Comedy in Four Acts (Georges Sand). After the Programme, Amusement Guide and Time Signal.

BRATISLAVA

(Czechoslovakia)
1,076 kc/s (279 m.); 14 kW.
Transmits at intervals from 10.0 a.m.
6.0 p.m.—See Prague.
6.5 p.m.—Dramatic Programme.
7.0 p.m.—See Prague.
9.15 p.m.—Programme Announcements.
9.20 p.m.—See Prague.

BRESLAU (Germany)

923 kc/s (325 m.); 1.7 kW. Relayed by Gleiwitz, 1,184 kc/s (253 m.).
Transmits at intervals from 5.30 a.m.
6.30 p.m.—See Berlin (Witzleben).
8.0 p.m.—News Bulletin.
8.10 p.m.—Talk: Eliminating Wireless Disturbances.
8.25 p.m.—"Advent"—A Radio Sequence (Rudolf Mirbt).
9.15 p.m.—Time and News.
9.30 p.m.—Talk on Sports Arrangements for the Winter.
9.40 p.m. (from Gleiwitz)—St. Barbara's Eve Festival.
11.0 p.m. (approx.)—Close Down.

BRNO (Czechoslovakia)

878 kc/s (342 m.); 3 kW.
Transmits at intervals from 10.0 a.m.
6.5 p.m.—"The Brother of Prometheus"—Pictures from the Life of the Modern Magician T. A. Edison (Dalibor Chalupa).
7.0 p.m.—See Prague.
9.15 p.m.—News Bulletin.
9.20 p.m.—See Prague.

BRUSSELS (Belgium) (No. 1)

I.N.R. 590 kc/s (509 m.); 20 kW.
5.0 p.m.—Orchestral Concert. Two Hungarian Dances (Brahms). Spanish Dance (de Falla). Spanish Dance (Granados). Two Dances

(Ganne). Persian Dance (Mousorgsky). Dance Suite (Pierné). Dances (Moszkovsky).
5.45 p.m.—Programme for Children.
6.15 p.m.—Readings.
6.30 p.m.—Gramophone Records: Selection from "Pelléas et Mélisande" (Debussy).
7.15 p.m.—Talk.
7.30 p.m.—Wireless Review.
8.0 p.m.—Orchestral Concert.
8.45 p.m.—Talk.
9.0 p.m.—Gramophone Records.
10.0 p.m.—Le Journal Parlé.

BRUSSELS (Belgium) (No. 2)

N.I.R. 887 kc/s (338.2 m.); 20 kW.
Programme in Flemish.
5.0 p.m.—Orchestral Concert. Overture, "La Petite Mariée" (Lecocq). Selections (Saint-Saëns): (a) Danse macabre, (b) Bacchanale from "Samson and Delilah." Selection from "Hérodiade" (Massenet). Waltz, Roses of the South (Strauss). Ballet Music from "Sylvia" (Delibes). El mi amor (Margutti). La mia serenata (Staffeli). Russian Dance (Tchaikovsky). Selection from "Le Train Bleu" (Milhaud).
6.0 p.m.—Gramophone Records.
6.15 p.m.—Talk: Schools, Old and New.
6.30 p.m.—Gramophone Concert.
7.15 p.m.—Talk: Stockholm, the Home of Scandinavian Culture.
7.30 p.m.—Talk for Women.
8.0 p.m.—Orchestral Concert. In the interval at 8.45 p.m.—Reading.
10.0 p.m.—Le Journal Parlé.

BUCHAREST (Romania)

Radio-Bucarest. 761 kc/s (394 m.); 16 kW.
Transmits at intervals from 11.0 a.m.
6.0 p.m.—Educational Talk.
6.40 p.m.—Gramophone Records.
7.0 p.m.—Song Recital.
7.20 p.m.—Symphony Concert. Two Chorales (Bach-Cui). Concerto in A Major for Pianoforte and Orchestra (Liszt).
8.0 p.m.—Talk (to be announced).
8.15 p.m.—Concert (contd.)—Concerto grosso, No. 1, Op. 17 (Lazar). Symphonic Poem, Le Rouet d'Omphale (Saint-Saëns).
8.45 p.m.—News Bulletin.

BUDAPEST (Hungary)

545 kc/s (550 m.); 23 kW.
Transmits at intervals from 8.15 a.m.
6.10 p.m.—Programme by Herr Horvath.
6.45 p.m.—Concert.
7.50 p.m.—Tzigane Concert, followed by Orchestral Concert of Light Music, conducted by Josef Pecsí. Toreador (Dostal). Hungarian Overture (Pecsi). Selection (Lehár). Song (Huszka). Salut d'amour (Elgar). Round the World (Yoshitomo). Overture (Huszka). Song from "Der Opernball" (Hueberger). Kleines Geplander (Okil-Albin). Oriental Dance (Vollstedt). Radio Budapest (Pecsi). March (Hubertus).

COLOGNE (Germany)

Westdeutscher Rundfunk. 1,319 kc/s (227 m.); 1.7 kW.
See Langenberg.

COPENHAGEN (Denmark)

1,067 kc/s (281 m.); 0.75 kW. Relayed by Kalundborg, 260 kc/s (1,153 m.).
Transmits at intervals from 6.30 a.m. (Gymnastics).
1.40 p.m.—Instrumental Concert. March, Wien bleibt Wien (Schrammel). Barcarolle Waltz (Waldteufel). Selection from "The Little Dutch Girl" (Kálmán). Slavonic Dance (Glazounoff). Minuet, and Gavotte for Violin (Otto Olsen). Overture, "The Black Domino" (Auber). Reading. March, Le régiment de Sambret-Meuse (Turlet). Bella-Mazurka (Waldteufel). Serenade (Pierné). The Death of Aase and Solveig's Song from "Peer Gynt" (Grieg). Dance from "The Czardas Princess" (Kálmán). Polonaise from "Eugen Onegin" (Tchaikovsky).
3.40 p.m.—Programme for Children.
4.40 p.m.—Exchange; Market Prices.
4.50 p.m.—Talk: Pianoforte Instruction for Children.
5.20 p.m.—Elementary English Lesson.
5.50 p.m.—Weather and News.
6.0 p.m.—News Bulletin.
6.15 p.m.—Time Signal.
6.16 p.m. (from the Odense Studio)—Talk: Church and Parish Life in Denmark.



THERE IS NO ACID TO SPILL



R3.

Perfect for all Portables

..... this battery popularised jelly acid cells for portables

This C.A.V. Jelly Acid non-spillable L.T. cell has all the advantages of the ordinary free acid battery.

Buy one—use it in turn with your present battery. You will appreciate the difference and suffer no interruption to the continuity of programmes.

Put it in any position—it is quite safe. There is no acid to spill.

You will find it more convenient with any class of Receiver.

A post-card will bring you our Radio Battery Catalogue and a useful booklet on charging and maintenance

Have you tried the new C.A.V. Dry High Tension yet?



WELL ST, BIRMINGHAM.

Programmes for Thursday—(Cont.)

6.45 p.m.—Danish Lesson.
 7.10 p.m.—"The Orient in Dramatic Music"—Orchestral Concert, conducted by Launy Gröndahl. Entrée des quatre nations, Musette and Tambourin from "Les Indes galantes" (Rameau). Overture, "La rencontre imprévue" (Gluck). Selection from "Les deux avarés" (Grétry). Overture, "Il Seraglio" (Mozart). Ballet Music from "Ali Baba" (Cherubini). Turkish March from "The Ruins of Athens" (Beethoven). Overture, "Abu Hassan" (Weber).
 8.0 p.m.—"The Belated Sweetheart"—Radio Comedy in Four Acts (Gunnar Skoglund).
 8.45 p.m.—"Gourmand Dishes" for Pianoforte (Claude de Ivincourt): (a) Grenadine, (b) Croquignoles, (c) Omelette au rhum, (d) Meringue à la crème.
 9.0 p.m.—"Modern Stage Setting"—a Radio Sketch (Arkady Avtchenko).
 9.10 p.m.—News Bulletin.
 9.25 p.m.—Concert, conducted by Emil Reesen. Der Jäger aus Kurpfalz—for Strings and Wind Instruments (Paul Hindemith). Morgensang—for Choir and Instruments (Wilhelm Maler). Variations on the Folk Melody "Ebbe Skammelsön" (Jörgen Bentzon). We build a Town—Children's Piece for Choir, Soloists and Instruments (Paul Hindemith).
 10.0 p.m.—Dance Music from the Nimb Restaurant.
 11.0 p.m. (in an interval).—Town Hall Chimes.
 11.30 p.m. (approx.).—Close Down.

DUBLIN (Ireland)
 (2RN). 725 kc/s (413 m.); 1.5 kW. Relayed by Cork, 1,337 kc/s (224.4 m.).
 1.30—2.0 p.m.—Time, Weather, Stock Report and Gramophone Records.
 6.0 p.m.—Gramophone Records.
 6.15 p.m.—Programme for Children.
 7.0 p.m.—Gramophone Records.
 7.10 p.m.—News Bulletin.
 7.30 p.m.—Time Signal.
 7.32 p.m.—French Lesson.
 7.45 p.m.—Operatic Concert. The Station Sextet: Grand Opera Selection. Margaret Pigott (Soprano): Grand Opera Songs. The Station Sextet: Light Opera Selection. Marcus Ruddle (Bartone): Light Opera Songs.
 8.35 p.m.—A Play by Mary O'Hea and Company.
 8.55 p.m.—Literary and Dramatic Talk.
 9.10 p.m.—Programme to be announced.
 9.30 p.m.—Sponsored Programme.
 10.30 p.m.—Time, News, Weather and Close Down.

FRANKFURT-am-MAIN (Germany)
 770 kc/s (390 m.); 1.7 kW. Relayed by Cassel, 1,220 kc/s (246 m.). Transmits at intervals from 5.15 a.m. (Weather and Gymnastics).
 4.5 p.m.—See Stuttgart.
 5.30 p.m.—Economic Notes.
 5.40 p.m.—Topical Talk.
 6.5 p.m.—Microphone Report: The Andreas Market in Wiesbaden.
 6.30 p.m.—Time and News.
 6.45 p.m.—Talk: Fundamental Principles of Music.
 7.5 p.m.—See Stuttgart.
 8.30 p.m.—Mozart Concert. Maurerische Trauermusik. Recitative and Aria for Bass, Alcandro lo confesso and Non so, d'onde viene. Concerto for Two Violins, Oboe and Cello with Orchestra. Arietta for Bass, Un bacio di mano. Bass Solo: Rivolgete a lui lo sguardo. Serenade in D Major.
 9.30 p.m.—Time and News.
 9.50 p.m.—Concert.
 10.30 p.m. (approx.).—Close Down.

HAMBURG (Germany)
 Norag (ha, in Morse). 806 kc/s (372 m.); 1.7 kW. Relayed by Bremen, 1,112 kc/s (270 m.); Flensburg, 1,373 kc/s (218 m.); Hanover, 530 kc/s (566 m.), and Kiel, 1,292 kc/s (232.2 m.). Transmits at intervals from 5.30 a.m. (Time and Weather).
 6.20 p.m.—Exchange and Weather.
 6.30 p.m.—Reading.
 6.55 p.m. (from Bremen).—"Othello"—Opera in Four Acts (Verdi), relayed from the Municipal Theatre, Bremen.
 10.0 p.m.—News Bulletin.
 10.20 p.m.—Ice Report.

HEILSBURG (Germany)
 1,085 kc/s (276.5 m.); 75 kW. Relayed by Danzig, 662 kc/s (453.2 m.). Transmits at intervals from 5.30 a.m. (Gymnastics).

3.15 p.m.—Orchestral Concert. Overture, "Orpheus in the Underworld" (Offenbach). Aufzug der Stadtwahe (Jessel). Waltz, Golden Rain (Waldteufel). Selection from "The Arabian Nights" (Joh. Strauss). Overture, "Fräulein Loreley" (Lincke). Reminiscences of Franz Liszt (Morena). Waltz, The First Letter (Reggoff). March, Immer höher (Ganglberger).
 4.45 p.m.—Book Review.
 5.15 p.m.—Ice Report; Market Prices.
 5.30 p.m.—Agricultural Talk.
 6.0 p.m.—English Conversation.
 6.25 p.m.—Talk on the 7.0 p.m. Transmission.
 6.55 p.m.—Weather Report.
 7.0 p.m.—"Neues vom Tage"—Opera in Tree Acts (Hindemith) relayed from the Opera House, Königsberg.
 9.30 p.m. (approx.).—Weather and News.

HILVERSUM (Holland)

1,004 kc/s (298.8 m.); 8.5 kW. Programme of the Algemeene Vereeniging Radio Omroep (A.V.R.O.).
 7.40 a.m.—Gramophone Records.
 9.40 a.m.—The Daily Service.
 9.55 a.m.—Gramophone Records.
 10.10 a.m.—Recitations.
 10.40 a.m.—Song Recital.
 11.25 a.m.—Gramophone Records.
 11.40 a.m.—Trio Concert. Gramophone Records in the interval.
 1.25 p.m.—Gramophone Records.
 1.40—2.10 p.m.—Talk.
 2.40 p.m.—Dressmaking Lesson.
 3.25 p.m.—Gramophone Records.
 3.40 p.m.—Programme for Hospitals.
 4.40 p.m.—Orchestral Concert, conducted by Nico Treep. Overture, "Le roi s'amuse" (Delibes). Selection from "Turandot" (Puccini). Dance from "Dinorah" (Meyerbeer). Turkish Suite (Gawwin). Gramophone Records. Autumn Melodies (Waldteufel). Selection from "The Desert Song" (Romberg). Humoresque (Dvorak). March, Entry of the Gladiators (Fucik).
 6.10 p.m.—Sports Talk.
 6.40 p.m.—Concert (continued). Overture, "Der Schauspielerdirektor" (Mozart). Eine kleine Nachtmusik (Mozart). Overture, "Cosi fan tutte" (Mozart).
 7.10 p.m.—English Language Lesson.
 7.40 p.m.—Gramophone Records.
 7.55 p.m.—Concert by the Orchestra of The Hague conducted by Albert van Raalte. Soloist: Viola Mitchell (Violin). Symphony No. 13 (Haydn). Concerto for Violin in B Minor (Saint-Saëns). Talk. Prelude to "Lohengrin" (Wagner). Suite No. 1 from "L'Arlésienne" (Bizet). 1812 Overture (Tchaikovsky).
 9.55 p.m.—Weather and News.
 10.10 p.m.—Concert by Kovacs Lajos and his Orchestra, with Songs by Bob Scholte. Gramophone Records in the interval.
 11.40 p.m. (approx.).—Close Down.

HUIZEN (Holland)

160 kc/s (1,875 m.); 8.5 kW. Transmits at intervals from 7.40 a.m.
 1.40 p.m. till Close Down.—Programme of the Christian Radio Society (N.C.R.V.).
 1.40 p.m.—Handicrafts Lesson.
 2.40 p.m.—Talk for Women.
 3.25 p.m.—Talk (to be announced).
 3.40 p.m.—Programme for Hospitals.
 4.40 p.m.—Handwork Lesson for Young People.
 5.25 p.m.—Pianoforte Recital. Bagatellen (Beethoven).—Consolations (Liszt). Autumn (Chaminade). Mazurka (Saint-Saëns). Two Selections (Bortkiewicz): (a) Nocturne, (b) Sur les Rochers.
 6.25 p.m.—Dressmaking Lesson.
 6.40 p.m.—Question Time.
 7.10 p.m.—Police Notes.
 7.25 p.m.—News Bulletin.
 7.40 p.m.—Band Concert, with Gramophone Record Interludes. In the intervals, at 8.40 p.m.—Talk: Family Contact, and at 9.25 p.m.—News Bulletin.
 9.55 p.m.—Gramophone Records.
 11.10 p.m. (approx.).—Close Down.

KALUNDBORG (Denmark)

Kalundborg Radio. 260 kc/s (1,153 m.); 7.5 kW. See Copenhagen.

KATOWICE (Poland)

734 kc/s (408 m.); 16 kW. Transmits at intervals from 10.58 a.m.
 7.15 p.m.—Light Music.
 9.30 p.m.—Dance Music.

LANGENBERG (Germany)

Westdeutscher Rundfunk. 635 kc/s (473 m.); 17 kW. Relayed by Aachen, Cologne and Münster, 1,319 kc/s (227 m.).

Transmits at intervals from 5.45 a.m. (Gymnastics).

4.0 p.m.—Vocal and Instrumental Concert.
 5.0 p.m.—Talk: Rhenish Earthquakes.
 5.20 p.m.—Talk: Contemporary Art Problems.
 5.40 p.m.—Italian Lesson.
 6.0 p.m.—Time; Announcements.
 6.15 p.m.—Topical Talk.
 6.30 p.m.—Talk: German Youth.
 6.55 p.m.—News Bulletin.
 7.0 p.m.—"We dance through a Century"—Programme by Robert Koppel, Karl Schnog, and the Little Wireless Orchestra.
 9.5 p.m.—News Bulletin.
 9.30 p.m.—The Final Round of the Cologne Six Days' Racing, relayed from the Rheinlandhalle.
 10.10 p.m.—Concert by the Eysoldt Orchestra, conducted by Pensis.
 11.30 p.m. (approx.).—Close Down.

LEIPZIG (Germany)

1,157 kc/s (259 m.); 2.3 kW. Relayed by Dresden, 941 kc/s (319 m.). Transmits at intervals from 5.30 a.m.
 6.0 p.m.—Talk by J. Kretzen.
 6.30 p.m.—Concert by the Dresden Philharmonic Orchestra, conducted by Eugen Gottlieb-Hellmesberger. Overture, "Halka" (Moniuszko). Selection from "Tiefand" (d'Albert). Rhapsody (Eduard Lab). Melodies from "Fatinizza" (Suppé). Waltz, Mia bella Napoli (Ohlsen). March, Adlerflug (Blankenburg).
 7.30 p.m.—The Toy Industry of the Erz Gebirge—a Radio Report from Grünhainichen and Seiffen.
 8.0 p.m.—Sudatic—German Evening—"The Oberlansitz Borderland"—a Radio Sequence of Literature and Music (O. Schwär).
 9.10 p.m.—News, followed by Silent Night.

LJUBLJANA (Yugoslavia)

522 kc/s (574.7 m.); 2.8 kW. Transmits at intervals from 11.17 a.m.
 7.0 p.m.—Educational Talk.
 7.30 p.m.—Vocal Quartet from the Works of the Slovene Composer Ipvavic.
 8.15 p.m.—Cello Recital.
 9.0 p.m.—Quintet Concert.
 9.30 p.m.—News Bulletin.

LWÓW (Poland)

788 kc/s (381 m.); 21 kW. Transmits at intervals from 10.40 a.m.
 6.45—9.30 p.m.—See Warsaw.
 9.30 p.m.—Dance Music from the Szkoeka Café.
 11.0 p.m. (approx.).—Close Down.

MADRID (Spain)

Union Radio (EAJ7). 707 kc/s (424.3 m.); 2 kW. Transmits at intervals from 8.0 a.m.
 7.0 p.m.—Chimes, Exchange, Market Prices and Request Gramophone Records.
 8.10 p.m.—News and Political Review.
 8.30—10.0 p.m.—Interval.
 10.0 p.m.—Chimes, Time, Political Review and Musical Programme.
 10.30 p.m.—Band Concert from the Hotel Nacional.
 12 midnight.—Chimes and News.
 12.30 a.m. (Friday).—Close Down.

MILAN (Italy)

Ente Italiano Audizioni Radiofoniche. 598 kc/s (501.7 m.); 8.5 kW. Relayed by Turin, 1,094 kc/s (274.2 m.), and Genoa, 959 kc/s (312.8 m.). Transmits at intervals from 7.15 a.m.
 6.0 p.m.—Agricultural Report.
 6.15 p.m.—Gramophone Records. In the intervals, at 6.40 p.m.—Announcements, and at 7.0 p.m.—Time and News.
 7.30 p.m.—Talk for Housewives.
 7.35 p.m.—"Maggiolata veneziana"—Opera (Salvaggi) conducted by the Composer. In the intervals, Film Notes, Talk, Literary Review and Giornale Radio. After the Programme, News.

MORAVSKÁ-OSTRAVA (Czechoslovakia)

1,139 kc/s (263 m.); 11 kW. Transmits at intervals from 10.0 a.m.
 6.0 p.m.—See Prague.
 6.5 p.m.—See Brno.
 7.0 p.m.—See Prague.
 9.15 p.m.—Announcements.
 9.20 p.m.—See Prague.

MUNICH (Germany)

563 kc/s (533 m.); 1.7 kW. Relayed by Augsburg and Kaiserslautern, 536 kc/s (560 m.) and Nürnberg, 1,256 kc/s (239 m.). Transmits at intervals from 5.45 a.m.
 6.10 p.m.—Talk: The Civilisation of the Palatinate.
 6.30 p.m. (from Nürnberg).—Folk Music and Folk Songs in Franconia by a Girls' Choir and an Orchestra.
 7.15 p.m.—Symphony Concert, con-

ducted by H. W. von Waltershausen. Soloist: Mia Neusitzer-Thoennissen (Soprano). Overture, "The Flying Dutchman" (Wagner). Two Pieces from "Romeo and Juliet" (Berlioz). Eight Songs for Soprano, with Orchestral accompaniment, Op. 12 (von Waltershausen). Prelude to "The Mastersingers" (Wagner).
 8.50 p.m.—Dialogue on the Consignment of Goods.
 9.20 p.m.—Time and News.
 9.45 p.m.—Band Concert conducted by Ernst Hagel. Overture, "Le Postillon de Longjumeau" (Adam). Selection from "Lakmé" (Delibes). Nächtlicher Ritt (N. W. Gade). Waltz, Die Königsmägd (Fetras). Hungarian Fantasia (Grünfeld). Ein schöne Traum (Kochmann). Fantasia, Gaukler im Orient (Lindemann).
 11.30 p.m. (Only Munich and Zeesen, 31.38 m.).—Night Concert.
 12.30 a.m. (Friday).—Close Down.

OSLO (Norway)

Kringkastingselskapet. 277 kc/s (1,083 m.); 75 kW. Relayed by Fredriksstad, 816 kc/s (367.6 m.); Hamar, 536 kc/s (560 m.); Notodden, 671 kc/s (447.1 m.); Porsgrund, 662 kc/s (453.2 m.); and Rjukan, 671 kc/s (447.1 m.). Transmits at intervals from 9.0 a.m.
 4.0 p.m.—Gramophone Records of Classical and Operetta Music.
 4.30 p.m.—Talk on the League of Nations.
 5.0 p.m.—German Lesson.
 5.30 p.m.—Studio Service.
 6.0 p.m.—News Bulletin.
 6.30 p.m.—Literary Review.
 7.0 p.m.—Time and Agricultural Talk.
 7.30 p.m.—Choral Concert and Organ Music relayed from the Cathedral at Trondheim.
 8.35 p.m.—Weather and News.
 8.50 p.m.—Topical Talk.
 9.5 p.m.—Talk: From the Lungenfjord to the Atlantic.
 9.35 p.m. (approx.).—Close Down.

PALERMO (Italy)

Ente Italiano Audizioni Radiofoniche. 1,412 kc/s (212.4 m.); 4 kW. Transmits at intervals from 11.45 a.m.
 7.0 p.m.—News Bulletin.
 7.20 p.m.—Talk for Housewives.
 7.25 p.m.—Gramophone Records.
 8.0 p.m.—Time and Announcements.
 8.5 p.m.—Concert of Dramatic Music. Prelude to the Third Act of "La Wally" (Catalani). Vocal and Orchestral Selections from "Zaza" (Leoncavallo). Cinema Notes. Selections from "Thais" (Massenet).
 9.55 p.m.—News Bulletin.

PARIS (France)

Eiffel Tower (FLE). 207.5 kc/s (1,445.7 m.); 1.5 kW. Time Signals (on 2,650 m.) at 9.26 a.m. and 10.25 p.m. (preliminary and 6-dot signals).
 5.45 p.m.—Le Journal Parlé.
 7.20 p.m.—Weather Forecast.
 7.30 p.m.—Gramophone Concert.

PARIS (France)

Poste Parisien. 914 kc/s (328.2 m.); 1.2 kW.
 8.0 p.m.—Gramophone Concert.
 8.30 p.m.—Gramophone Records and News.
 8.45 p.m.—Film Talk, Gramophone Records and News.
 9.0 p.m.—Concert. Overture, "Idomeneo" (Mozart). Allegro from the Concerto in D Major, for Pianoforte and Orchestra (Beethoven). Concerto in D Minor, for Strings (Bach). Finale from the Fourth Symphony (Beethoven). Spring Song (Mendelssohn). Rondo from Serenade No. 7 (Mozart). Wedding March from "Lohengrin" (Wagner).

PARIS (France)

Radio-Paris (CFR). 174 kc/s (1,725 m.); 80 kW. Transmits at intervals from 6.45 a.m. (Physical Culture).
 12.30 p.m.—Gramophone Records.
 1.0 p.m.—Exchange and News.
 1.5 p.m.—Gramophone Concert. In the intervals at 1.30 and 2.0 p.m.—Exchange Quotations.
 3.35 p.m.—Exchange; Market Prices.
 6.30 p.m.—Market Prices, Agricultural Report and Announcements.
 7.0 p.m.—An Essay on French Literature in the 19th Century.
 7.30 p.m.—German Lesson.
 7.45 p.m.—Commercial Prices, Economic and Social Notes and News.
 8.0 p.m.—Variety Programme, arranged by the Palais de la Nouveauté.
 8.30 p.m.—News Bulletin.
 8.40 p.m.—Talk.

8.45 p.m.—"Esopé"—Play (de Bannville), by M. Denis d'Ines and Company.
 9.15 p.m.—News and Time.
 9.30 p.m.—Gramophone Concert of Operatic Music.

PRAGUE (Czechoslovakia)

617 kc/s (487 m.); 120 kW. Transmits at intervals from 10.0 a.m.
 6.0 p.m.—Time, News, Chimes.
 6.5 p.m.—See Brno.
 7.0 p.m.—Concert from the Municipal Building. In the interval, Addresses.
 8.0 p.m.—Time and News.
 9.15 p.m.—Announcements.
 9.20 p.m.—Concert from the Beranek Cinema. Elegy (Rachmaninoff). Sylvan Scenes (Fletcher). If I had you (Connelly). Opium (Tichy). Punch (Mayerl). Don't lament, Gigolette (Karel Pecke). Selection. When the Violets flourish (Warren).
 10.0 p.m.—Time, News, Chimes.

RADIO-SUISSE ROMANDE (SOTTENS) (Switzerland)

743 kc/s (403 m.); 25 kW. Lausanne, 442 kc/s (680 m.); and Geneva, 395 kc/s (760 m.). Transmits at intervals from 11.30 a.m.
 6.0 p.m.—Weather Forecast.
 6.1 p.m. (from Geneva).—Gramophone Records.
 6.15 p.m. (from Geneva).—Esperanto Lesson.
 6.30 p.m. (from Geneva).—English Lesson.
 7.0 p.m. (from Geneva).—"The Cabaret of Smiles."
 8.0 p.m. (from Geneva).—Fauré and Debussy Pianoforte Recital by Mme. Claire Croiza and M. Jean Doyen, relayed from the Conservatoire.
 9.15 p.m.—News Bulletin.
 9.30 p.m. (approx.).—Close Down.

RIGA (Latvia)

572 kc/s (525 m.); 15 kW. Transmits at intervals from 10.0 a.m.
 6.0 p.m.—Weather Report.
 6.5 p.m.—Orchestral Concert of Operetta Music and Waltzes.
 7.0 p.m.—News Bulletin.
 8.0 p.m.—Weather Report.
 8.30 p.m.—Concert.
 9.30 p.m. (approx.).—Close Down.

ROME (Italy)

Ente Italiano Audizioni Radiofoniche (IRO). 680 kc/s (441 m.); 75 kW. Relayed by Naples, 905 kc/s (332 m.), and 2RO, 11,810 kc/s (25.4 m.). Transmits at intervals from 7.15 a.m. (Giornale Radio).
 4.30—5.15 p.m.—Vocal and Instrumental Concert. Violin Solos: (a) Andante (M. Rossi), (b) Capriccio all'antica (Sinigaglia). Soprano Solos: (a) Song (Brahms), (b) Aria from "Don Pasquale" (Donizetti). Violin Solos: (a) Salut d'amour (Elgar), (b) Serenade (Saint-Saëns). Soprano Solos: (a) Two Irish Songs (C. V. Stanford), (b) La farfalla (Gelli). Violin Solo: Ronde des Lutins (Bazzini).
 6.25 p.m. (from Naples).—Shipping.
 6.30 p.m.—Announcements.
 6.50 p.m.—Gramophone Records.
 7.10 p.m.—News Bulletin.
 7.30 p.m.—Time, Announcements, and Talk for Housewives.
 8.0 p.m. (approx.).—Relay from the Goldoni Theatre at Leghorn of the Gala Concert conducted by Maestro Pietro Mascagni, on the Fiftieth Anniversary of the Foundation of the Royal Naval College. Cinema Notes in the intervals. News after the programme.

SCHENECTADY (U.S.A.)

General Electric Company (WGY). 700 kc/s (379.5 m.); 50 kW. Relayed at intervals by W2XAF on 9,530 kc/s (31.48 m.) and by W2XAD on 15,340 kc/s (19.56 m.). Transmits at intervals from 11.45 a.m.
 9.0 p.m.—Stephen St. John's Banjo Quintet.
 9.30 p.m.—Stock Reports and Police Notes.
 9.45 p.m.—Arthur Lane—Popular Melodies.
 10.0 p.m.—News Bulletin.
 10.5 p.m.—Studio Ensemble.
 10.30 p.m.—New York Relay.
 10.45 p.m.—Aladdin Lamp Programme.
 11.0 p.m.—Weather Report.
 11.1 p.m.—Doc Peyton and his Hotel Kenmore Orchestra.
 11.20 p.m.—Time Signal.
 11.30 p.m.—The Golden Trail with Richfield.
 11.45 p.m.—New York Relay.
 12 midnight (WGY only).—New York Relay.
 12. midnight (W2XAF only).—Stock Reports and News.
 12.15 a.m. (Friday).—With Gray McClintock in the Canadian Northwest.
 12.30—4.15 a.m.—New York Relay.

Programmes for Thursday—(Cont.)

4.15 a.m.—Organ Recital from the Ritz Theatre, Albany, N.Y.
 4.45 a.m.—New York Relay.
 5.0 a.m.—Jack Miles and his DeWitt Clinton Orchestra.
 5.30 a.m.—Doc Peyton and his Kenmore Orchestra.
 6.0 a.m. (approx.)—Close Down.

SCHWEIZERISCHER LANDESENDER (BEROMÜNSTER) (Switzerland)

653 kc/s (459 m.); 75 kW; Basle, 1,229 kc/s (244.1 m.), and Berne, 1,220 kc/s (246 m.).
 Transmits at intervals from 11.28 a.m.
 3.0 p.m.—Compositions by Modern Composers, on Gramophone Records.
 4.0 p.m. (from Berne).—Book Review.
 4.30 p.m.—Weather Report.
 4.35—5.30 p.m.—Interval.
 5.30 p.m.—Adolph Busch, Violin Solos on Gramophone Records.
 6.0 p.m. (from Zürich).—Reading.
 6.28 p.m.—Time and Weather.
 6.30 p.m. (from Zürich).—Talk: Alcohol and Education.
 7.0 p.m. (from Basle).—Works of Famous Composers of the Seventeenth and Eighteenth Centuries—by Marietta and Martha Amstad (Vocalists), Clara Hirt (Pianist), Paul Louis Neuberth (Viola and Viola d'amore), and the Orchestra.
 9.0 p.m.—News Bulletin.
 9.15 p.m. (approx.)—Close Down.

STOCKHOLM (Sweden)

Radiotjänst. (SASA). 689 kc/s (436 m.); 75 kW. Relayed by Boden, 244 kc/s (1,229.5 m.); Göteborg, 932 kc/s (322 m.); Hörby 1,166 kc/s (257 m.); Motala, 222.5 kc/s (1,348 m.); Östersund, 389 kc/s (770 m.); and Sundsvall, 554 kc/s (542 m.).
 Transmits at intervals from 6.15 a.m. (Gymnastics).
 4.0 p.m.—Religious Talk.
 4.30 p.m.—The Children's Post Box.
 4.45 p.m.—Gramophone Records.
 5.45 p.m.—Elementary German Lesson relayed from Göteborg.
 6.15 p.m.—Weather and News.
 6.30 p.m.—Choral Concert.
 7.0 p.m.—Topical Talk.
 7.15 p.m.—Pianoforte Recital by

Michael Zadora, relayed from Malmö, 1,301 kc/s (231 m.).
 Sonata in B Minor (Chopin).
 Selections (Delibes-Zadora): (a) Pizzicati, (b) Valse lente. La campanella (Liszt).
 7.50 p.m.—Song Recital by Grete Schou, relayed from Göteborg.
 8.15 p.m.—Talk on Esaias Tegner, relayed from Göteborg.
 8.45 p.m.—Weather and News.
 9.0 p.m.—Orchestral Concert of Light Music.
 10.0 p.m. (approx.)—Close Down.

STRASBOURG (France)

Radio-Strasbourg (PTT). 869 kc/s (345 m.); 15 kW.
 Transmits at intervals from 11.30 a.m.
 5.0 p.m.—Instrumental Concert. Rustic Overture (Scassola). Orchestral Suite, Fête galante (Lacôme).
 Langueur d'amour for String Quintet (Flament). Alsatian Waltz (Fourdrain). Selection from "Le jour et la nuit" (Lecocq).
 Printemps d'amour (Kalkman). Selection (Jessel).
 5.45 p.m.—Historical Talk in French.
 6.0 p.m.—Instrumental Concert. Ballet Fantasia (Parès). Suite exotique (Delmas-Popy). Overture, "The Barber of Seville" (Rossini).
 Selection from "La Traviata" (Verdi).
 6.45 p.m.—Talk in French: The Tatra Mountains.
 7.0 p.m.—Dance Music.
 7.30 p.m.—Time Signal.
 7.32 p.m.—News in French and German.
 7.45 p.m.—Gramophone Records.
 8.30 p.m.—Three Comedies: (a) "Monsieur Tranquille"—in One Act (Vily), (b) "Monsieur Lambert, marchand de tableaux"—in One Act (Maurey), (c) "L'Etincelle"—in One Act (Pailleron).
 10.30 p.m. (approx.)—Close Down.

STUTTGART (MÜHLACKER) (Germany)

Süddeutscher Rundfunk. 833 kc/s (360 m.); 75 kW. Relayed by Freiburg, 527 kc/s (570 m.).
 Transmits at intervals from 5.15 a.m. (Frankfurt Relay).
 4.5 p.m.—Orchestral Concert. Soloists: Martha Siegel (Contralto) and Fritz

Künstner (Violin). Sonatina for Violin and Pianoforte (Dvorak).
 Four Songs (Rücklos): (a) Requiem, (b) In der Nacht, (c) Schlafliedchen, (d) Nach Seseenheim.
 Hungarian Comedy Overture (Kéler Béla). Waltz from "The Rose of Stamboul" (Fall). Selection from "The Czardas Princess" (Kálmán).
 Waltz—Wine, Woman and Song (Joh. Strauss). March Potpourri, Jung Deutschland (Weninger).
 5.30 p.m.—Time and Agricultural Notes.
 5.40 p.m.—Talk: The Ur Ghetto in Rome.
 6.5 p.m. (from Freiburg).—Talk: The Life of Ants.
 6.30 p.m.—Time and Weather.
 6.45 p.m.—See Frankfurt.
 7.5 p.m.—Concert by Bereny's Tzigane Symphony Orchestra, relayed from the Saalbau, Pforzheim. Rakoczy Overture (Kéler-Béla). Waltz, The Blue Danube (Joh. Strauss). Echoes from the Puszta. Rhapsody No. 2 (Liszt). Pianoforte Solo by Roszi Cegledi: Gnomensreigen (Liszt).
 Hungarian Dances Nos. 5 and 6 (Brahms). Selections from "Paganini" (Lehár). Selections (Bereny): (a) Cinka Panna, (b) Csikosritt.
 8.30 p.m.—See Frankfurt.
 9.30 p.m.—News Bulletin, followed by Racing Relay from Langenberg.
 10.10 p.m.—See Frankfurt.
 10.30 p.m. (approx.)—Close Down.

TOULOUSE (France)

Radiophonie du Midi. 779 kc/s (385 m.); 8 kW.
 Transmits at intervals from 12.45 p.m.
 6.0 p.m.—Sound Film Music.
 6.15 p.m.—Orchestral Selections.
 6.30 p.m.—News Bulletin.
 6.45 p.m.—Cello Solos. Sarabande from the Suite in G (Bach). Serenade (Somazeuilh). Aubade d'amour (Montil). La Cinquantaine (Mariel).
 7.0 p.m.—Vocal Tangos.
 7.15 p.m.—Hawaiian Guitar Solos.
 7.30 p.m.—News Bulletin.
 7.45 p.m.—Dance Music.
 8.0 p.m.—Accordion Solos.
 8.15 p.m.—Light Music.
 8.30 p.m.—Concert. Radetzky March (Strauss). March (Meyerbeer). Selection from "Gipsy Love" (Lehár). Vienna (Hoffmann). Selection from "The Caliph of Bagdad" (Boieldieu). Overture (Finck).

9.0 p.m.—Songs from "Les Noces de Jeannette" (Massé) and "La Basoche" (Messager).
 9.15 p.m.—Light Music.
 9.30 p.m.—Orchestral Selections. Overture, "Zampa" (Hérold). Selection from "The Merry Widow" (Lehár).
 9.45 p.m.—Argentine Music.
 10.0 p.m.—Concert from the Palais des Pyrénées, Pau. In the interval at 10.30 p.m.—News.
 11.0 p.m.—Organ Solos.
 11.15 p.m.—North African News.
 11.30 p.m.—Orchestral Selections from "Marouf" (Rabaud), "Hans the Flute-Player" (Ganne), and "Hansel and Gretel" (Humperdinck).
 12 midnight.—Weather, Announcements and Close Down.

TRIESTE (Italy)

Ente Italiano Audizioni Radiofoniche. 1,211 kc/s (247.7 m.); 15 kW.
 Transmits at intervals from 11.30 a.m.
 7.15 p.m.—News Bulletin.
 10.0 p.m.—Talk for Housewives.
 7.35 p.m.—Time, Announcements and Gramophone Records.
 7.45 p.m.—Instrumental Concert. Fantasia for Pianoforte (Bach). Sonata for Violin in A Major, Op. 100 (Brahms). Pianoforte Solos: (a) Andante with Variations (Schubert), (b) Consolation No. 5 (Liszt).
 Violin Solos: (a) Danse triste (Cyril Scott), (b) Tango (Albéniz-Kreisler). Pianoforte Solo: Danse des clochettes (Rebikoff).
 Cinema Notes in the interval.
 9.25 p.m.—Musical Programme.
 9.55 p.m.—News Bulletin.

VIENNA (Austria)

Radio-Wien. 581 kc/s (517 m.); 20 kW. Relayed by Graz, 851 kc/s (352 m.); Innsbruck, 1,058 kc/s (283 m.); Klagenfurt, 662 kc/s (453.2 m.); Linz, 1,220 kc/s (246 m.); and Salzburg, 1,373 kc/s (218 m.).
 Transmits at intervals from 8.20 a.m.
 6.5 p.m.—An Interview with Three Shorthand-Typists.
 6.30 p.m.—Time and News.
 6.40 p.m.—Military Band Concert.
 7.40 p.m.—Talk: An Engineer in the Russia of To-day.
 8.10 p.m.—Concert by the Vienna Sym-

phony Orchestra, conducted by Theodor Christoph. Soloist: Daisy Kennedy (Violin). Overture, The Hebrides (Mendelssohn). Violin Concerto in D Major (Mozart). Selection from "The Queen of Spades" (Tchaikovsky). Hungarian Rhapsody No. 2 (Liszt).
 9.10 p.m.—News Bulletin.
 9.25 p.m.—Concert from the Café Palmhof.
 9.45 p.m. (approx.)—Song Recital by Oskar Karlweis.
 10.10 p.m. (approx.)—Concert (continued).

WARSAW (Poland)

Polskie Radio. 212.5 kc/s (1,411 m.). 158 kW.
 Transmits at intervals from 10.40 a.m.
 3.40 p.m.—Gramophone Records.
 4.10 p.m.—Talk from Lwów.
 4.35 p.m.—Chamber Music.
 5.50 p.m.—Miscellaneous Items.
 6.15 p.m.—Agricultural Correspondence.
 6.25 p.m.—Programme Notes.
 6.30 p.m.—Gramophone Records.
 6.45 p.m.—Radio Journal.
 7.0 p.m.—Reading.
 7.15 p.m.—Orchestral Concert. Soloist: S. Narocz-Nowicki (Tenor).
 Overture, "A Waltz Dream" (O. Straus). Lettre de Sorrento (Zerkowitz). Sérénade d'amour (Becce). Moonlight (Mario).
 Tenor Solos: (a) Les Lilas embaumant (Felix), (b) Song (Lehár), (c) Waltz Boston (Engel-Berger).
 Carnival Suite (Siede). Tenor Solos: (a) Song (Lehár), (b) Song (Heuberger) (c) Song from "The Czarevitch" (Lehár).
 Waltz, Golden Rain (Waldeufel). Polka (Eilenberg). Gallop (Lumbye).
 8.25 p.m.—Dramatic Programme.
 9.10 p.m.—Radio Journal.
 9.15 p.m.—Announcements.
 9.30 p.m.—Concert from the "Adria" Dance Hall.

ZAGREB (Yugoslavia)

977 kc/s (307 m.); 0.7 kW.
 Transmits at intervals from 11.20 a.m.
 6.30 p.m.—French Lesson.
 6.45 p.m.—Talk on Photography.
 7.0 p.m.—Talk: Modern Instruments.
 7.15 p.m.—Announcements and News.
 7.30 p.m.—See Ljubljana.
 9.30 p.m.—News and Weather.
 9.40 p.m.—Light Music.

Olympia's prizewinner brings in the world

THE RGD RADIO GRAMOPHONE



For those desiring the very best that both Radio and Gramophone can give, the R.G.D. De Luxe Radio-Gramophone is the ideal instrument. The Radio side of this instrument is so powerful that, given favourable atmospheric conditions, over 30 stations can be received with ample volume, including several American stations. The quality of reproduction from distant stations is equal to that of local stations.

PRICES:
 From 48 Gns.
 To 115 Gns.

WRITE NOW FOR DESCRIPTIVE LITERATURE.

RADIO GRAMPHONE DEVELOPMENT CO., LTD.,

17-20, Frederick St., Birmingham.

For that station out of "speaker range" use these sensitive 'phones



Ericsson Telephones pull in those distant foreigners—clear and pure. Comfortable for "long spells."

All good dealers stock them, or direct from

ERICSSON TELEPHONES, LTD.

67/73, Kingsway, London, W.C.2.

120, 2,000 and 4,000 ohms.

12'6



BRITISH SUPERSENSITIVE TELEPHONES.

PROGRAMMES FOR FRIDAY (December 4)

NOTE: THE HOURS OF TRANSMISSION ARE REDUCED TO GREENWICH MEAN TIME

ALGIERS (N. Africa)

825.3 kc/s (363.4 m.); 13 kW.
Transmits at intervals from 12.30 p.m.
7.10 p.m.—News Bulletin.
7.20 p.m.—Agricultural Talk.
7.35 p.m.—Songs from Operetta.
7.45 p.m.—Medical Talk: Advice to the Nervous.
7.55 p.m.—News and Time.
8.0 p.m.—Songs from French Provinces—Champagne, Poitou, Bresse Normandy, Flanders, Brittany and Provence.
8.30 p.m.—Lalo and Massenet Festival Concert by the Station Orchestra.
10.0 p.m.—Vocal Tangos.
10.15 p.m.—Popular Songs.
10.30 p.m.—Czechoslovakian Songs.
10.45 p.m.—Dance Music.

BARCELONA (Spain)

Radio-Barcelona (EAJI). 860 kc/s (349 m.); 8 kW.
Transmits at intervals from 7.30 a.m.
7.0 p.m.—Trio Music.
7.30 p.m.—Market Prices, Exchange and Programme for Women.
8.0 p.m.—Gramophone Records.
8.30 p.m.—French Lesson.
9.0 p.m.—Chimes, Weather, Exchange and Market Prices.
9.5 p.m.—Orchestral Music.
9.25 p.m.—Tenor Song Recital.
10.0 p.m.—Talk in Catalan on the Poet Salvador Albert, with Recitations from his Works.
10.15 p.m.—Concert from the Café Español.
12 midnight (approx.)—Close Down.

BERLIN (Germany)

Königs Wusterhausen. 183.5 kc/s (1,635 m.); 75 kW.
Transmits at intervals from 5.30 a.m. (Witzleben Relay).
3.30 p.m.—See Leipzig.
4.30 p.m.—Talk on Music.
5.0 p.m.—Talk: International Debates on the Reparations Question.
5.30 p.m.—Talk: Experiments on Animals in Medicine.
5.55 p.m.—Weather for Farmers.
6.0 p.m.—Talk for Doctors.
6.30 p.m.—Talk: A Visit to the Municipal Workers' Colony.
7.0 p.m.—See Hamburg.
7.50 p.m.—"The Quiet Hour"—The Love of God.
8.20 p.m.—Concert from Heilsberg.
9.15 p.m.—Till "Close Down."—See Berlin (Witzleben).

BERLIN (Germany)

Witzleben. 715 kc/s (418 m.); 1.7 kW.
Transmits at intervals from 5.30 a.m. (Gymnastics).
6.0 p.m.—Topical Talk.
6.10 p.m.—Concert of Rhapsodies, conducted by Bruno Seidler-Winkler. Swedish Rhapsody, Midsommarvaka, Op. 19 (Alfvén). Slavonic Rhapsody, Op. 45, No. 3 (Dvorák). Norwegian Rhapsody, No. 1, Op. 17 (Svendens). Hungarian Rhapsody, No. 3 in D Major (Liszt).
7.0 p.m.—November Review of Gramophone Records.
7.25 p.m.—Talk on the following transmission.
7.30 p.m.—"Carmen"—Opera in Four Acts (Bizet), relayed from the Opera House, Unter den Linden.
8.10 p.m.—News Bulletin.
8.20 p.m.—"Anabasis"—Play (Ernst Gläser and Wolfgang Weyrauch).
9.15 p.m.—News Bulletin, followed by Violin Recital by Stefan Frenkel. Chanson Louis XIII et Pavane (Couperin-Kreisler). Pastorale (Händel-Flesch). Canzonetta (Lopatnikoff). Tango (Fitelberg-Frenkel). Totentanz-Melodic (Teissen). Pieces after the "Dreigroschenoper" (Weill-Frenkel); followed by Orchestral Concert.

BORDEAUX-LAFAYETTE

(France)
(PTT). 986 kc/s (304 m.); 35 kW.
Transmits at intervals from 12 noon.
7.30 p.m.—News Bulletin.
7.40 p.m.—Educational Talk.
7.55 p.m.—Results of the Prize Draw.
8.0 p.m.—Spanish Lesson.
8.15 p.m.—News Bulletin.
8.30 p.m.—Vocal and Orchestral Concert. After the Programme, Amusement Guide and Time Signal.

BRATISLAVA

(Czechoslovakia)
1,076 kc/s (279 m.); 14 kW.
Transmits at intervals from 9.30 a.m.

6.0 p.m.—See Prague.
6.20 p.m.—Introductory Talk to the following transmission.
6.30 p.m.—"Il Trovatore"—Opera (Verdi) relayed from the National Theatre.
9.0 p.m.—See Prague.
9.15 p.m.—Programme Announcements.
9.20 p.m.—Tzigane Concert.

BRESLAU (Germany)

923 kc/s (325 m.); 1.7 kW. Relayed by Gleiwitz, 1,184 kc/s (253 m.).
Transmits at intervals from 5.30 a.m.
5.30 p.m.—Weather Forecast, followed by Orchestral Concert.
6.30 p.m.—Weather Report, followed by Talk.
7.0 p.m. (from Gleiwitz).—Quartet Concert.
7.45 p.m.—Topical Talk.
8.10 p.m.—News.
8.20 p.m.—Chamber Music.
9.5 p.m.—Time and News.
9.30 p.m.—Talk in Esperanto.
9.45 p.m.—See Berlin (Witzleben). In an interval at 10.10 p.m.—Weekly Sound Film News from the Ufa Theatre.
11.0 p.m. (approx.)—Close Down.

BRNO (Czechoslovakia)

878 kc/s (342 m.); 3 kW.
Transmits at intervals from 9.30 a.m.
6.0 p.m.—See Prague.
6.20 p.m.—Military Band Concert.
7.25 p.m.—One-Act Comedy (Kroupa)
7.55 p.m.—See Prague.
8.0 p.m.—Concert of Moravian Sacred Music.
9.0 p.m.—See Prague.
9.15 p.m.—News Bulletin.
9.20 p.m.—See Prague.

BRUSSELS (Belgium) (No. 1)

I.N.R. 590 kc/s (509 m.); 20 kW.
5.0 p.m.—Orchestral Concert.
6.0 p.m.—Gramophone Records.
6.15 p.m.—Talk. The Belgian Painter—Louis Thevenet.
6.30 p.m.—"Die Fledermaus"—Opera (Joh. Strauss), given in Abridged Form on Gramophone Records by the Cast of the National Opera House, Berlin.
7.15 p.m.—Talk: Worker's Pensioners.
7.30 p.m.—Music Review.
8.0 p.m.—Chamber Music by M. François Broos (Violin) and M. Armand Dufour (Pianoforte). Märchenbilder (Schumann). Sonata (Soulage).
8.30 p.m.—Concert relayed from the Royal Conservatoire of Music, Liège. Conductor: M. François Rasse. In the intervals, Gramophone Records of Recitations, and Le Journal Parlé.

BRUSSELS (Belgium) (No. 2)

N.I.R. 887 kc/s (338.2 m.); 20 kW. Programme in Flemish.
5.0 p.m.—Orchestral Concert. Overture, "The Gipsy Baron" (Joh. Strauss). Donauwellen (Ivanovici). Ballet égyptien (Luigini). Liebestraum (Liszt). Spanish Dances (Granados). Waltz, Du und du (Joh. Strauss). Nocturne in E Flat Major (Chopin). Overture, "Light Cavalry" (Suppé).
6.0 p.m.—Gramophone Records.
6.15 p.m.—Talk.
6.30 p.m.—Gramophone Records.
7.15 p.m.—Humorous Talk.
7.30 p.m.—Talk: What there is to see in Nature.
8.0 p.m.—Programme for the Festival of St. Nicholas, followed by Orchestral Concert conducted by M. Arthur Meulemans. Overture (Van Hoof). Overture, "Zampa" (Hérold). Mattinata (Leoncavallo). Ballet Music from "Faust" (Gounod). Plum-Pudding Potpourri (Morena). Le Cygne (Saint-Saëns). Selection from "A Waltz Dream" (O. Strauss). Dance of the Hours from "La Gioconda" (Ponchielli). Overture, "William Tell" (Rossini). Ballet Music from "Sylvia" (Delibes).
10.0 p.m.—Le Journal Parlé.

BUCHAREST (Romania)

Radio-Bucarest. 761 kc/s (394 m.); 16 kW.
Transmits at intervals from 11.0 a.m.
6.0 p.m.—Educational Talk.
6.40 p.m.—Gramophone Records.
7.0 p.m.—Flute Recital.
7.30 p.m.—Talk (to be announced).
7.45 p.m.—Pianoforte Recital. Two Waltzes, Two Mazurkas and Polonaise (Chopin). Etude in D Minor (Liszt). Etude in F Major (Chopin). Etude in C Sharp Minor (Scriabin).
8.15 p.m.—Violin Recital.
8.45 p.m.—News Bulletin.

BUDAPEST (Hungary)

545 kc/s (550 m.); 23 kW.
Transmits at intervals from 8.15 a.m.
5.35 p.m.—Choral and Instrumental Concert from a Church.
6.40 p.m.—Programme by Herr Lukinich.
7.10 p.m.—A Musical Play, followed by Tzigane Concert from the Hotel Pannonia. In the interval at 9.30 p.m.—Talk in French.

COLOGNE (Germany)

Westdeutscher Rundfunk. 1,319 kc/s (227 m.); 1.7 kW.
See Langenberg.

COPENHAGEN (Denmark)

1,067 kc/s (281 m.); 0.75 kW. Relayed by Kalundborg, 260 kc/s (1,153 m.).
Transmits at intervals from 6.30 a.m. (Gymnastics).
2.30 p.m.—Orchestral Concert from the "Wivex" Restaurant.
4.0 p.m.—Programme for Children.
4.40 p.m.—Exchange; Market Prices.
4.50 p.m.—Talk: Some Animal Lodgers.
5.20 p.m.—German Lesson.
5.50 p.m.—Weather and News.
6.15 p.m.—Time Signal.
6.30 p.m.—Agricultural Talk.
7.0 p.m.—Town Hall Chimes.
7.2 p.m.—Item by Per Knutzon.
7.10 p.m.—Tenth Concert from the State Broadcasting Building. The Symphony Orchestra conducted by Emil Reesen. Soloists: Vera Schwarz and Marcel Wittrisch (Vocalists) of Berlin. Operetta Evening. Part I. The Works of Johann Strauss. Overture, "Prince Methusalem." Songs: (a) Aria from "The Gipsy Baron." (b) Waltz from "Cagliostro in Vien." Ballet Music from "Ritter Pasmann." Songs: (a) Song from "The Gipsy Baron." (b) Song from "A Night in Venice." Overture, "Indigo." Part II. The Works of Franz Lehár. Overture, "Eva." Duet from "Paganini." Aria from "Eva." You are my heart's delight, from "The Land of Smiles." Waltz Intermezzo from "The Count of Luxembourg." Duet from "The Land of Smiles." Russian Peasant Dance from "Tatiana."
9.15 p.m.—News Bulletin.
9.30 p.m.—Dance Music from the Lodberg Restaurant.
11.0 p.m. (in the interval).—Town Hall Chimes.
11.30 p.m. (approx.)—Close Down.

DUBLIN (Ireland)

(2RN). 725 kc/s (413 m.); 1.5 kW. Relayed by Cork, 1,337 kc/s (224.4 m.).
1.30—2.0 p.m.—Time, Weather, Stock Report and Gramophone Records.
6.0 p.m.—Gramophone Records.
6.15 p.m.—Programme for Children.
7.0 p.m.—Gramophone Records.
7.20 p.m.—News Bulletin.
7.30 p.m.—Time Signal.
7.32 p.m.—Talk on Gardening.
7.45 p.m.—Talk.
8.0 p.m.—Concert by the Station Sextet and Vocalists.
9.0 p.m.—The Emer Comedy Company.
9.30 p.m.—Half-an-Hour from Ireland.
10.0 p.m.—Selections by a Male Voice Choir.
10.30 p.m.—Time, News, Weather and Close Down.

FRANKFURT-am-MAIN

(Germany)
770 kc/s (390 m.); 1.7 kW. Relayed by Cassel, 1,220 kc/s (246 m.).
Transmits at intervals from 5.15 a.m. (Weather and Gymnastics).
4.5 p.m.—Operetta and Popular Songs by Emil Seidenspinner (Tenor), followed by Gramophone Dance Records.
5.30 p.m.—Economic Notes.
5.40 p.m.—See Stuttgart.
6.30 p.m.—Time and News.
6.35 p.m.—Talk: Agriculture and the Industrial Crisis.
7.5—10.30 p.m.—See Stuttgart. In the interval at 9.30 p.m.—Time and News.
10.30 p.m. (approx.)—Close Down.

HAMBURG (Germany)

Norag (ha, in Morse). 806 kc/s (372 m.); 1.7 kW. Relayed by Bremen, 1,112 kc/s (270 m.); Flensburg, 1,373 kc/s (218 m.); Hanover, 530 kc/s (566 m.) and Kiel, 1,292 kc/s (232.2 m.).
Transmits at intervals from 5.30 a.m. (Time and Weather).
6.20 p.m.—Exchange and Weather.
6.30 p.m.—Lute Recital.

7.0 p.m.—"Christmas Oratorio" (Kurt Thomas) for Six-Part A-Capella Choir, relayed from the Musikhalle. The St. Michael's Church Choir, conducted by Alfred Sittard.
7.50 p.m.—"Comrades of the Sea"—Radio Play (Friedrich Lindemann).
9.0 p.m.—News Bulletin.
9.10 p.m.—Topical Talk.
9.20 p.m.—Concert from the Café Wallhof.
10.20 p.m.—Ice Report.

HEILSBURG (Germany)

1,085 kc/s (276.5 m.); 75 kW. Relayed by Danzig, 662 kc/s (453.2 m.).
Transmits at intervals from 5.30 a.m. (Gymnastics).
3.15 p.m.—Talk for Women, followed by Concert from the Alhambra Café, Königsberg.
4.45 p.m.—Agricultural Talk.
5.15 p.m.—Ice Report; Market Prices.
5.30 p.m.—Talk: The East Prussian Academy of Art.
6.0 p.m.—Contralto Song Recital by Ludmilla Schirmer—Schubert Programme. Erklärung. Am See. Der Sieg. Der Jüngling an der Quelle. Auflösung. An die Laute. Schwanengesang. Lied im Grünen.
6.35 p.m. (from Danzig).—"Die blaue Marie"—Play (Max Jungnickel).
7.40 p.m.—Weather Report.
7.45 p.m.—Symphony Concert on the 145th Anniversary of the Death of Mozart, by the Königsberg Opera House Orchestra, conducted by E. Seidler and Margarethe Schuchmann (Pianoforte). Introductory Talk. Mozart Variations (Röger). Selections (Mozart): (a) Serenata notturna; (b) Concerto in C Minor for Pianoforte and Orchestra; (c) Three German Dances. In the interval at 8.10 p.m. (approx.)—News Bulletin.
9.15 p.m.—Weather and News.

HILVERSUM (Holland)

1,004 kc/s (298.8 m.); 8.5 kW.
6.25—9.45 a.m.—Programme of the Workers' Radio Society (V.A.R.A.).
6.25—6.45 a.m. and 7.10—7.25 a.m.—Gymnastics.
7.40 a.m.—Gramophone Records.
9.40 a.m.—Religious Programme of the Liberal Protestant Radio Society (V.P.R.O.).
9.55—11.40 a.m.—Programme of the V.A.R.A.
9.55 a.m.—Recitations.
10.10 a.m.—Septet Concert.
10.55 a.m.—Recitations.
11.10 a.m.—Concert (continued).
11.40—3.40 a.m.—Programme of the Algemeene Vereeniging Radio Omroep (A.V.R.O.).
11.40 a.m.—Orchestral Concert, conducted by Nico Treep. Overture, "Oberon" (Weber). Grieg Memories (Urbach). Three Dances (Edward German): (a) Country Dance, (b) Pastoral Dance, (c) Merry-makers' Dance. Gramophone Records. Waltz, Gross Wien (Strauss). Selection from "The Rose of Stamboul" (Fall). Two Songs (Elgar): (a) Chanson de matin, (b) Chanson de nuit. Gramophone Records. The Graham Paige Legion March (Pryor and Donegan). Waltz, Kirmes am Rhein (Dreissen). Potpourri, Uns kennt jeder (Borchert).
1.40 p.m.—Talk for Schools.
2.10 p.m.—Gramophone Records.
2.40 p.m.—Concert by the Corner Orchestra, conducted by Joszi Baranyai, relayed from the Carlton Hotel, Amsterdam.
3.40—7.40 p.m.—V.A.R.A. Programme.
3.40 p.m.—Trio Concert. Serenade, Napoli (d'Ambrosio). Chanson tzigane (Boldi). Minuet (Bolzoni). Le Mariage des Roses (Franck). Si mes vers avaient des ailes (Hahn). Selection from "Manon" (Massenet). Adagio (Briegleb). Appassionata (Filippucci). Lotus Land (Scott-Kreisler). The Phantom Melody (Ketelbey). Only a Rose (Friml). Bei der Zigeunerkapelle (Meyer-Helmund).
4.40 p.m.—Programme for Children.
5.25 p.m.—Orchestral Concert, conducted by Hugo de Groot. March, kinderlieder (Ziehrer). Alle Hampelmannen tanzen (Lindemann). Marionetten Brautzug (Rathke). Potpourri of Dutch Melodies (de Groot).
6.25 p.m.—Talk on Capitalism.
6.55 p.m.—Concert (continued). Overture, "The Nuremberg Doll" (Adam). Selection from "La Mascotte" (Audran). Suite, In the Circus (Armandola). Selection

from "Die Puppenfee" (Bayer).
7.40—10.40 p.m.—V.P.R.O. Programme.
7.45 p.m.—Talk on Religious History.
8.10 p.m.—Concert of Chamber Music, by the Amsterdam Ensemble. Quintet, Op. 44, for two Violins, Viola, Cello and Pianoforte (Schumann).
8.40 p.m.—Talk by Dr. V. Senden.
9.10 p.m.—Concert (continued). Quintet in F Minor (Franck).
9.40 p.m.—Religious News.
9.45 p.m.—News Bulletin.
9.55 p.m.—Talk by Mme. den Hartog-Meyers.
10.25 p.m.—Gramophone Records.
10.40—11.40 p.m.—V.A.R.A. Programme. Gramophone Records.
11.40 p.m. (approx.)—Close Down.

HUIZEN (Holland)

160 kc/s (1,875 m.); 8.5 kW.
Transmits at intervals from 7.40 a.m. Programme of the Catholic Radio Society (K.R.O.).
11.55 a.m.—Quintet Concert. Hungarian March (Naef). It was a Dream (Lincke). Waltz from "The Rose of Stamboul" (Fall). Ballet, Nippfiguren (Schebek). Selection from "Les Cloches de Corneville" (Planquette). Tirilli (Ganglberger). Potpourri, Dividenden (Morena). Serenade (Rachmaninoff). Waltz from "Gri-Gri" (Lincke). Song and Dance (Reisfeld). Nimm in meinem Auto Platz (May).
1.25—2.40 p.m.—Gramophone Records.
2.55 p.m.—Soloist Concert.
3.40 p.m.—Gramophone Records.
4.40 p.m.—Military Band Concert and Gramophone Records.
6.40 p.m.—Horticultural Talk.
7.10 p.m.—Police Notes.
7.25 p.m.—Introductory Talk to the following transmission.
7.40 p.m.—Symphony Concert. Overture, "Don Juan" (Mozart). Andante, Minuet and Rondo from the Hafner Serenade (Mozart). Concerto in G Minor for Violin and Orchestra (Bruch): Symphony No. 4 (the Italian) (Mendelssohn). Tempo di Menuetto (Pugnani-Kreisler). Air (Tenaglia). Zigeunerweisen (Sarasate). In the interval at 8.55 p.m. (approx.)—News.
10.40 p.m.—Gramophone Records.
11.40 p.m. (approx.)—Close Down.

KALUNDBORG (Denmark)

Kalundborg Radio. 260 kc/s (1,153 m.); 7.5 kW.
See Copenhagen.

KATOWICE (Poland)

734 kc/s (408 m.); 16 kW.
Transmits at intervals from 10.58 a.m.
7.15 p.m.—See Warsaw.
10.0 p.m.—The Letter Box in French for Foreign Listeners.

LANGENBERG (Germany)

Westdeutscher Rundfunk. 635 kc/s (473 m.); 17 kW. Relayed by Aachen, Cologne and Münster, 1,319 kc/s (227 m.).
Transmits at intervals from 5.45 a.m. (Gymnastics).
5.0 p.m.—Review of Contemporary American Books.
5.20 p.m.—Talk: Poems in the Lower Rheinisch Dialect.
5.40 p.m.—English Conversation.
6.0 p.m.—Time; Announcements.
6.20 p.m.—Three Germans converse with one another.
6.55 p.m.—First General News.
7.0 p.m.—Concert by the Münster Municipal Orchestra, conducted by Herr Wolf. Overture, "A Midsummer Night's Dream" (Mendelssohn). Frauenliebe und Leben (Blon). Melodies from "Hansel and Gretel" (Humperdinck). Czardas (Michiels).
7.45 p.m.—Viennese Portraits—Franz Grillparzer, his Personality and Work. Incidental Music by Schubert and Beethoven. Commentary by Dr. Erich Fortner. After the Programme: News, and Concert from the Hotel zur Post, Elberfeld.
11.0 p.m. (approx.)—Close Down.

LEIPZIG (Germany)

1,157 kc/s (259 m.); 2.3 kW. Relayed by Dresden, 941 kc/s (319 m.).
Transmits at intervals from 5.30 a.m.
3.30 p.m.—Concert by the Leipzig Symphony Orchestra, conducted by Dr. Alfred Szendrei. Suite for Wind Instruments (R. Strauss). Intermezzo after Goldoni for Strings (E. Bossi).
4.30 p.m.—Review of Books.
4.50 p.m.—Economic Notes, Weather and Time.
5.0 p.m.—Talk: Modern Instructive Writers.
5.25 p.m.—English Language Lesson.

Programmes for Friday—(Cont.)

5.50 p.m.—Talk: In the Studio of a Stage Sculptor.
6.30 p.m.—Talk: The Experience of Chance.
7.10 p.m. (approx.)—See *Copenhagen*.
9.0 p.m.—News, followed by Concert by the Emde Orchestra.
10.30 p.m. (approx.)—Close Down.

LWÓW (Poland)

788 kc/s (381 m.); 21 kW.
Transmits at intervals from 10.40 a.m. 6.45—10.0 p.m.—See *Warsaw*.
10.0 p.m.—Recital of Songs and Arias by Alfred Piccaver and Umberto Urbano (on Gramophone Records).
11.0 p.m. (approx.)—Close Down.

MADRID (Spain)

Union Radio (EAJ7). 707 kc/s (424.3 m.); 2 kW.
Transmit at intervals from 8.0 a.m. 7.0 p.m.—Chimes, Exchange, Market Prices and Request Gramophone Records.
7.30 p.m. (in the interval).—Educational Talk.
8.10 p.m.—News and Political Review.
8.30—10.0 p.m.—Interval.
10.0 p.m.—Chimes, Time, Political Review and Symphony Concert on Gramophone Records.
12 midnight.—Chimes, News and Programme Announcements for Listeners Abroad.
12.30 a.m. (Saturday).—Close Down.

MILAN (Italy)

Ente Italiano Audizioni Radiofoniche. 598 kc/s (501.7 m.); 8.5 kW. Relayed by *Turin*, 1,094 kc/s (274.2 m.), and *Genoa*, 959 kc/s (312.8 m.).
Transmits at intervals from 7.15 a.m. 6.0 p.m.—Agricultural Notes and Report of the Royal Geographical Society.
6.20 p.m.—Gramophone Records. In the intervals at 7.0 p.m.—Time and News and at 7.20 p.m.—Wireless Notes.
7.45 p.m.—"In the Train"—Comedy in One Act (Alfredo Testoni).
8.15 p.m.—Chamber Music. In the Interval, Talk on Literature and Art.
10.0 p.m.—Giornale Radio.

MORAVSKÁ-OSTRAVA (Czechoslovakia)

1,139 kc/s (263 m.); 11 kW.
Transmits at intervals from 9.30 a.m. 6.0 p.m.—See *Prague*.
6.20 p.m.—Reading.
6.45 p.m.—Accordion Recital.
7.0 p.m.—Band Concert.
7.35 p.m.—Variety Items.
7.55 p.m.—See *Prague*.
8.0 p.m.—Orchestral Concert.
9.0 p.m.—See *Prague*.
9.15 p.m.—Announcements.
9.20 p.m.—See *Prague*.

MUNICH (Germany)

563 kc/s (533 m.); 1.7 kW. Relayed by *Augsburg* and *Kaiserslautern*, 536 kc/s (560 m.); and *Nürnberg*, 1,256 kc/s (239 m.).
Transmits at intervals from 5.45 a.m. 6.10 p.m.—Talk on Customs in the Animal World.
6.30 p.m.—Recital of German Folk Songs by Nora Wolff-Lingen. Das Schwalbe. Minnelied. Der schöne Traum. Die rechte Stimmung. Gut Nacht. Im Rosengarten.
6.45 p.m.—"The Twins"—Comedy in Three Acts (Theodor Tremmel).
8.15 p.m.—Talk: Everyday Observations.
8.35 p.m.—"Christmas Oratorio" for Six-Part Choir a capella, Op. 17 (Kurt Thomas).
9.20 p.m.—Time and News.

OSLO (Norway)

Kringkastingsselskapet, 277 kc/s (1,083 m.); 75 kW. Relayed by *Fredriksstad*, 816 kc/s (367.6 m.); *Hamar*, 536 kc/s (560 m.); *Notodden*, 671 kc/s (447.1 m.); *Porsgrund*, 662 kc/s (453.2 m.); and *Rjukan*, 671 kc/s (447.1 m.).
Transmits at intervals from 9.0 a.m. 4.0 p.m.—Gramophone Records.
4.30 p.m.—Talk from *Trondheim*, 608 kc/s (493.4 m.): Depression in Norway.
5.0 p.m.—French Lesson.
5.30 p.m.—Popular Melodies for Orchestra.
6.0 p.m.—News Bulletin.
6.30 p.m.—English Language Lesson.
7.0 p.m.—Time Signal.
7.2 p.m.—Symphony Concert by the Philharmonic Orchestra, conducted by M. Odd Gruner Hogge, relayed from the Logen Hall. Soloist: Madame Mayr Barrat (Pianist).
8.30 p.m.—Weather and News.
8.50 p.m.—Topical Talk.
9.5 p.m.—Talk (to be announced).
9.35 p.m. (approx.)—Close Down.

PALERMO (Italy)

Ente Italiano Audizioni Radiofoniche. 1,412 kc/s (212.4 m.); 4 kW.
Transmits at intervals from 11.45 a.m. 5.0—6.0 p.m.—Gramophone Records.
7.0 p.m.—News Bulletin.
7.20 p.m.—Gramophone Records.
7.35 p.m.—Talk by A. Wellner.
8.0 p.m.—Time and Announcements.
8.5 p.m. (approx.)—Concert. Pianoforte Solos: (a) La Danse des fées (Prudent), (b) Chorale (César Franck). Soprano Solos: (a) Ständchen (Brahms), (b) Gipsy Song (Taubert). Violin Solos: (a) Aria (Respighi), (b) Rondo (Mozart-Kreisler). Talk. Pianoforte Solos: (a) Etude No. 1 (Chopin), (b) Concert Etude No. 3 (Rubinstein). Soprano Solos (Joh. Strauss): (a) Gipsy Song, (b) Waltz, Dorfschwalben aus Oesterreich. Violin Solos: (a) Minstrels, and (b) Clair de Lune (Debussy), (c) Selection (Hubay).
Dance Music.
9.55 p.m.—News Bulletin.

PARIS (France)

Eiffel Tower (FLE). 207.5 kc/s (1,445.7 m.); 15 kW. Time Signals (on 2,650 m.) at 9.26 a.m. and 10.26 p.m. (preliminary and 6-dot signals).
5.45 p.m.—Le Journal Parlé.
7.20 p.m.—Weather Forecast.
7.30 p.m.—Symphony Concert conducted by M. E. Flament. Soloists: M. Bas (Violin) and M. Marchesini (Cello). Selection from "Marouf" (Rabaud-Leleu). Valse triste (Sibelius). Crépuscule oriental (Fosse). Violin Solo. Fantasia Villereccia (Fiorini). Chant d'automne (Tchaikovsky-Lotter). Selection from "L'amour masqué" (Messenger-Salabert). Cello Solo. Overture, "Kosiki" (Lecocq).
8.30 p.m.—Variety Programme.

PARIS (France)

Poste Parisien. 914 kc/s (328.2 m.); 1.2 kW.
7.25 p.m.—Gramophone Records and News.
8.0 p.m.—Concert of Dance Music.
9.15 p.m.—French Songs by Music Hall Artists.
10.30 p.m. (approx.)—Close Down.

PARIS (France)

Radio-Paris (CFR). 174 kc/s (1,725 m.); 80 kW.
Transmits at intervals from 6.45 a.m. (Physical Culture).
12.30 p.m.—Gramophone Records.
1.0 p.m.—Exchange and News.
1.5 p.m.—Gramophone Concert of Chamber Music. In the Intervals at 1.30 and 2.0 p.m.—Exchange Quotations.
3.35 p.m.—Exchange, Market Prices.
4.20 p.m.—Elementary English Lesson.
4.45 p.m.—Music Talk: Lully and Rameau.
6.30 p.m.—Market Prices, Agricultural Report and Announcements.
7.0 p.m.—Talk: The French Protectorate in Annam and Cambodia.
7.45 p.m.—Commercial Prices; Economic and Social Notes and News.
8.0 p.m.—"The Golden Cockerel"—Opera (Rimsky-Korsakoff). In the intervals at 8.30 p.m.—Sports Results, Weather and Gastronomic Review and at 9.15 p.m.—News and Time.

PRAGUE (Czechoslovakia)

617 kc/s (487 m.); 120 kW.
Transmits at intervals from 9.30 a.m. 6.0 p.m.—Time; News; Chimes.
6.5 p.m.—Reading.
6.20 p.m.—Variety Items.
6.40 p.m.—Mandoline and Guitar Recital.
7.25 p.m.—Song Recital.
7.55 p.m.—News Bulletin.
8.5 p.m. (approx.)—Saxophone Solos. Valse triste (Vecsey). Sarabande and Tambourin (Leclair). Sere-nade, "Les Millions d'Arlequin" (Drigo). Valse brillante (Kubin). Liebeslied (Kreisler).
8.20 p.m.—Violin and Cello Duets.
9.0 p.m.—Time and News.
9.20 p.m.—Gramophone Records.
10.0 p.m.—Time; News; Chimes.

RADIO-SUISSE ROMANDE (SOTTENS) (Switzerland)

743 kc/s (403 m.); 25 kW. *Lausanne*, 442 kc/s (680 m.); and *Geneva*, 395 kc/s (760 m.).
Transmits at intervals from 11.30 a.m. 6.0 p.m.—Weather Forecast.
6.1 p.m. (from *Geneva*).—Gramophone Records.

6.20 p.m. (from *Geneva*).—Sports Notes.
6.30 p.m. (from *Lausanne*).—Pianoforte Recital.
7.0 p.m. (from *Fribourg*).—St. Nicholas Programme. Talk and Selections by a Boys' Choir.
8.5 p.m. (from *Geneva*).—Concert by the *Romand Quartet*. Quartet (César Franck). Quartet (Rogister).
9.15 p.m.—News Bulletin.
9.30 p.m. (approx.)—Close Down.

RIGA (Latvia)

572 kc/s (525 m.); 15 kW.
Transmits at intervals from 10.0 a.m. 6.0 p.m.—Weather Report.
6.5 p.m.—Symphony Concert. Overture, "Manfred" (Schumann). Second Symphony (Beethoven). Concerto No. 2 for Pianoforte (Glazounoff). Ballet Suite from "Ascanio" (Saint-Saëns). In the intervals at 7.0 p.m.—News, and at 8.0 p.m.—Weather.
8.30 p.m.—Variety Music.
9.30 p.m. (approx.)—Close Down.

ROME (Italy)

Ente Italiano Audizioni Radiofoniche (IRO). 680 kc/s (441 m.); 75 kW. Relayed by *Naples*, 905 kc/s (332 m.), and *2RO*, 11,810 kc/s (25.4 m.).
Transmits at intervals from 7.15 a.m. (Giornale Radio).
4.30—5.15 p.m.—Instrumental Concert, conducted by Enrico Martucci. Selection from "Sicilian Vespers" (Verdi). Characteristic Intermezzo (Ganglbäcker). Lament and Berceuse from "L'Arlesiana" (Cilea). Cello Solos: (a) Cavatina (Raff), (b) Allegro appassionato Op. 43 (Saint-Saëns). First Suite from "The Nutcracker Ballet" (Tchaikovsky).
6.25 p.m. (from *Naples*).—Shipping 6.30 p.m.—Announcements
6.50 p.m.—Gramophone Records.
7.5 p.m.—Report of the International Institute of Agriculture (in Italian, French, English, German and Spanish).
7.30 p.m.—Time, News and Talk.
8.0 p.m.—"Tuffolina"—Operetta in Three Acts (Pietri). In the intervals: Talk on Literature and Art, Announcements and Topical Talk. News after the Programme.

SCHENECTADY (U.S.A.)

General Electric Company. (WGY). 790 kc/s (379.5 m.); 50 kW. Relayed at intervals by *W2XAF* on 9,530 kc/s (31.48 m.); and by *W2XAD* on 15,340 kc/s (19.56 m.).
Transmits at intervals from 11.45 a.m. 9.0 p.m.—New York Relay.
9.30 p.m.—Stock Reports and Police Notes.
9.45 p.m.—Talk on Books.
10.0 p.m.—News Bulletin.
10.5 p.m.—Studio Ensemble.
10.30 p.m.—New York Relay.
10.59 p.m.—Weather Report.
11.0 p.m.—Gothic Reveries by Lydia Stevens (Organist), from *Albany*, N.Y.
11.29 p.m.—Time Signal.
11.30 p.m.—Tebbut Memorial Artists from *Albany*, N.Y.
11.45 p.m.—New York Relay.
12 midnight (WGY only).—Stanley Hummel and Edward Morris (Pianists).
12 midnight (W2XAF only).—Stock Reports and Police Notes.
12.15 a.m. (Saturday).—With Gray McClintock in the Canadian Northwest.
12.30—1.30 a.m.—New York Relay.
1.30 a.m.—WGY Agricultural Programme.
2.0—4.15 a.m.—New York Relay.
4.15 a.m.—Mary Zoller (Xylophonist).
4.30 a.m.—Annette McCullough (Crooner).
4.45 a.m.—New York Relay.
5.0 a.m.—Jack Miles and his DeWitt Clinton Orchestra.
5.30 a.m.—Doc Peyton and his New Kenmore Orchestra.
6.0 a.m. (approx.)—Close Down.

SCHWEIZERISCHER LANDESENDER (BEROMÜNSTER) (Switzerland)

653 kc/s (459 m.); 75 kW.; *Basle* 1,229 kc/s (244.1 m.) and *Berne*, 1,220 kc/s (246 m.).
Transmits at intervals from 11.28 a.m. 3.0 p.m.—Gramophone Records of Operetta Music.
4.0 p.m. (from *Basle*).—Talk for Women: Chicago as a Swiss Woman who lives there sees it.
4.30 p.m.—Weather Report; Market Prices.
4.40—5.30 p.m.—Interval.
5.30 p.m.—Gramophone Records of the B.B.C. Wireless Orchestra.
6.0 p.m. (from *Basle*).—Talk on the

Exhibition of Children's Books and Dolls.
6.25 p.m.—Sports Talk.
6.28 p.m.—Time and Weather.
6.30 p.m. (from *Basle*).—Talk: Our other Selves.
7.0 p.m. (from *Berne*).—"Der Kuhreigen"—Opera (Kienzl) relayed from the Berne Municipal Theatre. News in the interval.
9.30 p.m. (approx.)—Tourist Bulletin.
9.40 p.m. (approx.)—Close Down.

STOCKHOLM (Sweden)

Radiotjänst (SASA). 689 kc/s (436 m.); 75 kW. Relayed by *Boden*, 244 kc/s (1,229.5 m.); *Göteborg*, 932 kc/s (322 m.); *Hörsby*, 1,166 kc/s (257 m.); *Motala*, 222.5 kc/s (1,384 m.); *Östersund*, 389 kc/s (770 m.); and *Sundsväl*, 554 kc/s (542 m.).
Transmits at intervals from 6.15 a.m. (Gymnastics).
4.0 p.m.—Programme for Children.
4.20 p.m.—Gramophone Records.
5.15 p.m.—Agricultural Talk.
5.30 p.m.—Folk Music.
5.45 p.m.—Talk on Venison—Reindeer, relayed from *Boden*.
6.15 p.m.—Weather and News.
6.30 p.m.—"Karl August Urbansson"—Play (Ove Ekelund).
7.30 p.m.—Orchestral Concert. Soloist: Emil Telmányi (Violin). Overture, "Estrella di Soria" (F. Berwald). Concerto, Op. 32, for Violin and Orchestra (C. Nielsen). Suite for String Orchestra (Sibelius). Danse capricieuse (Atterberg). Norwegian Rhapsody (Halvorsen).
8.45 p.m.—Weather and News.
9.0 p.m.—Road Report by the Royal Automobile Club.
9.5 p.m.—Quintet in A Major for Pianoforte, Two Violins, Viola and Cello (Dvorák).
9.40 p.m.—French Songs (Weckerlin), by Lisa Tunell. Par un matin. Que ne suis-je la fougère? Bergère légère. Maman, dites-moi. Philis, plus avare que tendre. Non, je ne crois pas. Venez, agréable printemps. Menuet tendre.
10.0 p.m. (approx.)—Close Down.

STRASBOURG (France)

Radio-Strasbourg (PTT). 869 kc/s (345 m.); 15 kW.
Transmits at intervals from 11.30 a.m. 5.0 p.m.—Instrumental Concert.
5.45 p.m.—Topical Talk in German.
6.0 p.m.—Instrumental Concert. Overture, "Si j'étais roi" (Adam). Waltz, Les Fleurs (Waldteufel). Selection from "Paganini" (Lehár). Intermezzo (Siedel). La Fête au Hameau (Gillet). Lion du Bal (Gillet). Spanish March, Oviedo (Kalkman).
6.45 p.m.—Legal Talk in German.
7.0 p.m.—Gramophone Records.
7.30 p.m.—Time Signal.
7.32 p.m.—News in French and German.
7.45 p.m.—Gramophone Records.
8.30 p.m.—Instrumental Concert. Viola Soloist: P. L. Neuberth. Viola Solos: (a) Sonata (Nardini), (b) Autumn (Albéniz). Interlude from the Sonata (Kunc), (d) Romance (Fauré), (e) Burlesque for Viola (Palaschko), (f) Finale from the Sonata No. 1, Op. 120 (Brahms). Three Duets for Two Violins and Pianoforte (Bach). Prelude and Fugue for Pianoforte from "Das wohltemperierte Klavier" (Bach). Two Duets for Two Violins and Pianoforte (Bach). Suite in B Minor for Flute (Bach). Two Sonatas for Two Violins (Leclair Sen.). Concerto for Four Violins and String Orchestra (Vivaldi). Symphony in G Minor (Mozart).
10.30 p.m. (approx.)—Close Down.

STUTTGART (MÜHLACKER) (Germany)

Süddeutscher Rundfunk. 833 kc/s (360 m.); 75 kW. Relayed by *Freiburg*, 527 kc/s (570 m.).
Transmits at intervals from 5.15 a.m. (Frankfurt Relay).
4.5 p.m.—See *Frankfurt*.
5.30 p.m.—Time and Agricultural Report.
5.40 p.m.—Talk: The History of Lithography.
6.5 p.m.—Health Talk.
6.30 p.m.—Time, Weather and Announcements in Esperanto.
6.35 p.m.—See *Frankfurt*.
7.5 p.m.—Concert by the Stuttgart Philharmonic Orchestra with Gerda Hansi (Soprano).
8.15 p.m.—Champions and Leaders—a Radio Sequence (Ernst Stockinger and Ilse Kamnitzer).
9.0 p.m.—Choral Concert. Vater Noah (Sekles). Die Beredsamkeit (Haydn). Von Erschaffung Adams und Evas (Rathgeber). Folk

Song: Bei dem Freien ist Gefahr (arr. v. Hausegger). Folk Song: Beim Tanze (arr. Ochs). Der Glückliche (Mendelssohn). Spielmanns Ständchen (Mozart). Wer sich die Musik erkauft (Goldmark).
9.30 p.m.—News Bulletin.
9.50 p.m.—Dance Music.
10.30 p.m. (approx.)—Close Down.

TOULOUSE (France)

Radiophonie du Midi. 779 kc/s (385 m.); 8 kW.
Transmits at intervals from 12.45 p.m. 6.0 p.m.—Orchestral Selections from (a) "The Thieving Magpie" and (b) "The Barber of Seville" (Rossini), (c) "Cavalleria rusticana" (Mascagni), (d) "L'Africaine" (Meyerbeer) and (e) "Hérodiade" (Massenet).
6.30 p.m.—News Bulletin.
6.45 p.m.—Light Music.
7.0 p.m.—Orchestral Selections.
7.15 p.m.—Organ Solos.
7.30 p.m.—News Bulletin.
7.45 p.m.—Selections from "Le Roi d'Ys" (Lalo) and "La Favorita" (Donizetti).
8.0 p.m.—Accordion Solos.
8.15 p.m.—Orchestral Selections from "Rigoletto" (Verdi) and "The Gipsy Baron" (Strauss).
8.30 p.m.—Vocal Tangos.
8.45 p.m.—Orchestral Selections.
9.0 p.m.—Concert from the Café des Américains.
10.0 p.m.—Light Music.
10.30 p.m.—News Bulletin.
10.45 p.m.—Concert from the Café des Américains (continued).
11.0 p.m.—Chansonnettes.
11.15 p.m.—North African News.
11.30 p.m.—Songs from "Pelléas et Mélisande" (Debussy) and "Thais" (Massenet).
12.0 p.m. midnight.—Weather, Announcements and Close Down.

TRIESTE (Italy)

Ente Italiano Audizioni Radiofoniche. 1,211 kc/s (247.7 m.); 15 kW.
Transmits at intervals from 11.30 a.m. 7.15 p.m.—News Bulletin.
7.30 p.m.—Gramophone Records.
8.0 p.m.—Time, Announcements and "La Traviata"—Opera (Verdi), on Gramophone Records.

VIENNA (Austria)

Radio-Wien. 581 kc/s (517 m.); 20 kW. Relayed by *Graz*, 851 kc/s (352 m.); *Innsbruck*, 1,058 kc/s (283 m.); *Klagenfurt*, 662 kc/s (453.2 m.); *Linz*, 1,220 kc/s (246 m.); and *Salzburg*, 1,373 kc/s (218 m.).
Transmits at intervals from 8.20 a.m. 6.0 p.m.—Talk by Hugo Adolff Bernatzik: My Expedition to West Africa, 1930—1931.
6.30 p.m.—Time and News.
6.40 p.m.—"Dream Songs"—Recital by Hans Duhan. Frühlingstraum (Schubert). The Dream (Rubinstein). Sandmännchen (Brahms). Schlummerlied (Schubert). Ein Traum (Grieg). Nacht und Träume (Schubert). Selige Nacht (Marx). O komm' in Traum (Liszt). Träume (Wagner).
7.10 p.m.—"Der Feldprediger"—Operetta in Three Acts (Millöcker), arranged for Radio by Dr. H. E. Heller. In the interval at 8.45 p.m. (approx.)—News.
9.30 p.m.—Dance Music with Vocal Refrains.

WARSAW (Poland)

Polskie Radio. 212.5 kc/s (1,411 m.); 158 kW.
Transmits at intervals from 10.40 a.m. 3.40 p.m.—Gramophone Records.
3.55 p.m.—Linguaphone English Lesson.
4.10 p.m.—Talk: King Alexander and Queen Elizabeth at Wilno Cathedral, relayed from *Wilno*, 1,229 kc/s (244.1 m.).
4.35 p.m.—Dance Music.
5.50 p.m.—Miscellaneous Items.
6.15 p.m.—Agricultural Report relayed from *Wilno*.
6.25 p.m.—Programme Notes.
6.30 p.m.—Gramophone Records.
6.45 p.m.—Radio Journal.
7.0 p.m.—Talk on Music.
7.15 p.m.—Concert by the *Warsaw Philharmonic Orchestra*. Soloist: Laelia Finneberg (Vocalist). Overture (Castellnuovo-Tedesco). Three Symphonic Sketches, La Mer (Debussy). Song, Ah Perfido! (Beethoven). Symphony No. 7 in A Major (Beethoven). In the interval, Literary Talk.
9.40 p.m.—Radio Journal.
9.45 p.m.—Announcements.
10.0 p.m.—Dance Music and Light Music.
11.0 p.m. (approx.)—Close Down.

PROGRAMMES FOR SATURDAY

(December 5)

NOTE: THE HOURS OF TRANSMISSION ARE REDUCED TO GREENWICH MEAN TIME

ALGIERS (N. Africa)

825.3 kc/s (363.4 m.); 13 kW.
Transmits at intervals from 12.30 p.m.
7.0 p.m.—News Bulletin.
7.15 p.m.—Talk for Bird Fanciers.
7.30 p.m.—Concert of Light Music.
7.55 p.m.—News and Time.
8.0 p.m.—Concert of Light Music by the Station Orchestra.
9.0 p.m.—Concert of Request Records.
10.30 p.m.—Concert of Dance Music.

BARCELONA (Spain)

Radio-Barcelona (E.A.J.I.). 865 kc/s (340 m.); 8 kW.
Transmits at intervals from 7.30 a.m.
7.0 p.m.—Trio Music.
7.30 p.m.—Market Prices, Exchange and Gramophone Records.
8.30 p.m.—Elementary English Lesson.
9.0 p.m.—Chimes, Weather, Exchange, Market Prices and Agricultural Report.
9.5 p.m.—Part Relay of an Opera from the Gran Teatro del Liceo.

BERLIN (Germany)

Königs Wusterhausen. 183.5 kc/s (1,635 m.); 75 kW.
Transmits at intervals from 5.30 a.m. (Witzleben Relay).
3.30 p.m.—See Hamburg.
4.30 p.m.—Talk on Health: Nerves.
5.0 p.m.—German Lesson.
5.30 p.m.—Educational Talk: Our Germanic Cultural Inheritance—Beliefs and Customs.
5.55 p.m.—Weather for Farmers.
6.0 p.m. (approx.)—Elementary English Lesson.
6.15 p.m.—Talk: Buy German!
6.30 p.m.—See Vienna.
7.15 p.m. (approx.)—See Langenberg.
9.45 p.m.—News Bulletin, followed by Dance Music from Berlin (Witzleben).
11.30 p.m. (approx.)—Close Down.

BERLIN (Germany)

Witzleben. 715 kc/s (418 m.); 1.7 kW.
Transmits at intervals from 5.30 a.m. (Gymnastics).
6.0 p.m.—Topical Talk.
6.10 p.m.—Talk on the Opera: "The Marriage of Figaro," to be relayed on Sunday, December 6.
6.30 p.m.—See Vienna.
7.15 p.m.—Reading by the Author: "Sleeping Beauty 1931." (André Baron Foelckersam).
7.45 p.m.—News Bulletin.
8.0 p.m.—"Home, Sweet Home" a Variety Programme.
9.15 p.m.—News, followed by Dance Music by the Barnabas von Gézy Band, from the Hotel Esplanade.
11.30 p.m. (approx.)—Close Down.

BORDEAUX-LAFAYETTE

(France)
(PTT). 986 kc/s (304 m.); 35 kW.
Transmits at intervals from 12.45 p.m.
5.0 p.m.—Pasdeloup Symphony Concert, relayed from the Théâtre des Champs Elysées, Paris.
6.30 p.m.—Radio Journal.
8.0 p.m.—News, Exchange and Results of the Prize Draw.
8.5 p.m.—Sports Notes.
8.10 p.m.—English Lesson.
8.25 p.m.—News Bulletin.
8.30 p.m.—Gramophone Concert. After the Programme, Amusement Guide and Time Signal.

BRATISLAVA

(Czechoslovakia)
1,076 kc/s (279 m.); 14 kW.
Transmits at intervals from 10.0 a.m.
6.0 p.m.—See Prague.
7.25 p.m.—Popular Songs.
7.55 p.m.—See Prague.
8.0 p.m.—Military Band Concert. Selection from "The Marriage of Figaro" (Mozart). The Whispering of Flowers (Blon). Danse macabre (Saint-Saëns). Reminiscences of Smetana (Urbach). The Tale (Chlup). Waltz; The Northern Star (Waldteufel).
9.0 p.m.—See Prague.
9.20 p.m.—Programme Announcements.
9.25 p.m.—See Moravská-Ostrava.

BRESLAU (Germany)

923 kc/s (325 m.); 1.7 kW. Relayed by Gleiwitz, 1,184 kc/s (253 m.).
Transmits at intervals from 5.30 a.m.
6.20 p.m.—Weather Forecast.

6.25 p.m. (approx.)—That will interest you—a Surprise Programme.
6.45 p.m.—Orchestral Concert. Selection from "I profughi fiamminghi" (Faccio). "Cello Solo: Krottschak Romanze (Recktenwald). Rhapsody in C Major (Dohnanyi). Waltz, Wiener Blut (Joh. Strauss).
7.15 p.m.—See Berlin (Witzleben).
7.45 p.m.—News Bulletin.
8.0 p.m.—See Berlin (Witzleben).
9.15 p.m.—Time and News.
9.45 p.m.—Dance Music from Berlin (Witzleben).
11.30 p.m. (also on Zeesen, 31.38 m.).—Orchestral Concert. Overture, "The Marriage of Figaro" (Mozart). Ox Minuet (Haydn). Scherzo for Violin and Pianoforte (Dittersdorf-Kreisler). Suite Goliardica (Amadei). Intermezzo (Gal). Waltz from the Ballet, "Raymonda" (Glazounoff). Humoresque (Reger). Rhapsody, España (Chabrier). Tales of Strauss (Korngold).
12.30 a.m. (Sunday)—Close Down.

BRNO (Czechoslovakia)

878 kc/s (342 m.); 3 kW.
Transmits at intervals from 10.0 a.m.
6.0 p.m.—See Prague.
8.0 p.m.—Talk: Popular Aesthetics.
8.20 p.m.—Gramophone Records.
8.45 p.m.—Chopin Recital. Nocturne in F Sharp Major. Waltz in C sharp Minor. Mazurka, Op. 41. Polonaise in C Sharp Minor. Berceuse Tarantella.
9.0 p.m.—See Prague.
9.20 p.m.—News Bulletin.
9.25 p.m.—See Moravská-Ostrava.

BRUSSELS (Belgium) (No. 1)

I.N.R. 590 kc/s (509 m.); 20 kW.
5.0 p.m.—Orchestral Concert.
6.0 p.m.—Gramophone Records.
6.15 p.m.—Talk on Folklore: St. Nicholas Customs.
6.30 p.m.—Gramophone Dance Music.
7.15 p.m.—Talk on Hygiene: Ventilation and Heating.
7.30 p.m.—Literary Review.
8.0 p.m.—Orchestral Concert.
8.45 p.m.—Talk: A Belgian Author—Thomas Braün, with Readings from his Works.
9.0 p.m.—Orchestral Concert from the "Ancienne Belgique."
10.0 p.m.—Le Journal Parlé.

BRUSSELS (Belgium) (No. 2)

N.I.R. 887 kc/s (338.2 m.); 20 kW.
Programme in Flemish.
5.0 p.m.—Orchestral Concert. Overture, "Oberon" (Weber). Scènes pittoresques (Massenet). Overture, "Orpheus in the Underworld" (Offenbach).
5.30 p.m.—Programme for the Festival of St. Nicholas.
7.15 p.m.—Talk.
7.30 p.m.—Agricultural Report.
8.0 p.m.—Orchestral Concert. K.V.R.O. Strijdlid (Meulemans). Overture, "Semiramis" (Rossini). Selections from "The Pearl Fishers" (Bizet). Humorous Songs by M. Jef Ariën. Minuet from the Jupiter Symphony (Mozart). Overture, "Tancred" (Rossini). Selection from "La Tosca" (Puccini). "Cello Solo: Réve (Leoncavallo). Songs by M. Jef Ariën. Suite orientale (Popy). Très jolie (Waldteufel). In the interval at 8.50 p.m.—Religious Talk.
9.55 p.m.—Evening Prayer.
10.0 p.m.—Le Journal Parlé.

BUCHAREST (Romania)

Radio-Bucarest. 761 kc/s (394 m.); 16 kW.
Transmits at intervals from 11.0 a.m.
5.50 p.m.—Educational Talk.
6.30 p.m.—Relay from the Romanian Opera House. News in the intervals.

BUDAPEST (Hungary)

545 kc/s (550 m.); 23 kW.
Transmits at intervals from 8.15 a.m.
6.0 p.m.—Orchestral Concert. Song (Vincze). Selections from (a) "The Girl of the Golden West" (Puccini), (b) "Prince Bob" (Huszka), and (c) "Mignon" (Thomas). Ave Maria (Schubert). Ich liebe dich (Grieg).
7.0 p.m.—Talk.
7.15 p.m.—Choral Concert of Hungarian Songs, relayed from the Redoute Building.
9.15 p.m.—Tzigane Concert from the Hotel Royal.
10.0 p.m.—English Programme from the National Theatre. Address by Herr Hevesi, Director of the

National Theatre. Reading in English from "The Tragedy of Mankind" (Emerich Madach). Seven Hungarian Folk Songs, sung in English by Imre Molnar. Hungarian Lyrics in English.

COLOGNE (Germany)

Westdeutscher Rundfunk. 1,319 kc/s (227 m.); 1.7 kW.
See Langenberg.

COPENHAGEN (Denmark)

1,067 kc/s (281 m.); 0.75 kW. Relayed by Kalundborg, 260 kc/s (1,153 m.).
Transmits at intervals from 6.30 a.m. (Gymnastics).
2.30 p.m.—Orchestral Concert, conducted by Launy Gröndahl. Soloist: Volmer Holbøll (Vocalist). Overture, "Silvana" (Weber). Ballet Music from "Czar and Carpenter" (Lortzing). Ecossaises (Beethoven). Elégie (Massenet). Ballet russe (Luigini). Songs: March, Défilé des Nations (Fremaux). Concert Waltz (Lehar). Serenade for Strings (Laszlo). Selection from "The Little Dutch Girl" (Kálmán). Song without Words (Mendelssohn-Bartholdy). Alexandra-March (Poulsen).
4.40 p.m.—Exchange; Market Prices.
4.50 p.m.—Talk (to be announced).
5.20 p.m.—French Lesson.
5.50 p.m.—Weather and News.
6.15 p.m.—Time Signal.
6.30 p.m.—Talk: The Evolution of the Danish Language from the Time of Hülberg up to the present Day.—I.
7.0 p.m.—Town Hall Chimes.
7.2 p.m.—Danish Folk Dances for Violin, Viola, Clarinet and Double Bass.
7.15 p.m.—A Discussion on Socialism and Capitalism in Modern Times; relayed from the Students' Society.
10.0 p.m.—News Bulletin.
10.15 p.m.—Dance Music from the Palace Hotel.
11.0 p.m. (in an interval)—Town Hall Chimes.
11.15 p.m. (approx.)—Close Down.

DUBLIN (Ireland)

(2RN). 725 kc/s (413 m.); 1.5 kW. Relayed by Cork, 1,337 kc/s (224.4 m.).
1.30—2.0 p.m.—Time, Weather, Stock Report and Gramophone Records.
7.20 p.m.—News Bulletin.
7.30 p.m.—Time Signal.
7.32 p.m.—Talk.
7.45 p.m.—Irish Lesson.
8.5 p.m.—"La Cigale"—Opera, by the Augmented Station Orchestra, the Station Opera Chorus and Principals, conducted by Vincent O'Brien.
10.30 p.m.—Time, News and Weather.
10.40 p.m.—Weekly Sports Review by Seamus Laverty, and Close Down.

FRANKFURT-am-MAIN

(Germany)
770 kc/s (390 m.); 1.7 kW. Relayed by Cassel, 1,220 kc/s (246 m.).
Transmits at intervals from 5.15 a.m. (Weather and Gymnastics).
4.30 p.m.—See Stuttgart.
5.30 p.m.—Economic Notes.
5.40 p.m.—Talk: The Fluctuation of Population between Town and Country.
6.5 p.m.—Spanish Lesson.
6.35 p.m.—Talk: Christmas Books for Women.
6.45 p.m.—Microphone Report: From the Workshop of Käthe Kruse.
7.15—11.30 p.m.—See Stuttgart. In the interval at 9.20 p.m.—Time and News.
11.30 p.m. (approx.)—Close Down.

HAMBURG (Germany)

Norag (ha, in Morse). 806 kc/s (372 m.); 1.7 kW. Relayed by Bremen, 1,112 kc/s (270 m.); Flensburg, 1,373 kc/s (218 m.); Hanover, 530 kc/s (566 m.); and Kiel, 1,292 kc/s (232.2 m.).
Transmits at intervals from 5.30 a.m. (Time and Weather).
3.30 p.m.—Orchestral Concert, conducted by Fritz Gartz. Hungarian Comedy Overture (Kéler-Héla). Waltz, Braun oder blond (Waldteufel). Potpourri of Strauss Operettas (Schlöger). The Caravan Procession (Krüger). Romance, Op. 45, No. 3 (Schmalstich). First Suite from the Ballet égyptien (Luigini). Myrthenblüten. (J. Strauss). Suite, Caucasian Sketches (Ippolitoff-Ivanoff). Goldoliera (Bossi). March, Einigkeit macht stark (Görgel).
5.0 p.m.—Variety Programme.

6.55 p.m.—Weather Report.
7.0 p.m.—"Artists"—the Discovery of a World of Gaiety in Scenes, Verse and Reports.
9.0 p.m.—News Bulletin.
9.20 p.m.—Topical Talk.
9.30 p.m.—Dance Music from the Boccaccio Casino.
10.20 p.m.—Ice Report.

HEILSBURG (Germany)

1,085 kc/s (276.5 m.); 75 kW. Relayed by Danzig, 662 kc/s (453.2 m.).
Transmits at intervals from 5.30 a.m. (Gymnastics).
3.15 p.m. (from Danzig)—Wind Instrument Concert. March, Treu-Deutsch alle Wege (Rusch). Overture, "King Midas" (Eilenberg). National Songs in the Form of a Suite (Tchaikovsky). Spatenparade (Rathke). Reminiscences of Franz Schubert (Fetras). Polka from "Schwanda the Piper" (Weinberger-Putzenhardt). Old Scottish Ballad, Tom, the Rhymer (Loewe). Regimental March (Moltke). Potpourri of Johann Strauss' Waltzes (Bohne). Parade March No. 1 (Wollendorf). March, Preussens Gloria (Piefke). In the interval at 4.0 p.m. (approx.)—(from Danzig)—Film Review.
4.45 p.m.—Talk: The French Opinion of Germany.
5.15 p.m.—Ice Report; Market Prices.
5.30 p.m.—International Market Report.
5.40 p.m.—Programme Announcements in Esperanto and German.
6.0 p.m.—Pianoforte Recital by Sigfried Schultze.
6.30 p.m.—"Um sieben Duettchen"—Three Short Scenes (Karl Lubovskiy).
7.5 p.m.—Weather Report.
7.10 p.m.—Popular Programme. In the interval at 8.5 p.m.—Announcements.
9.10 p.m.—News, followed by Dance Music from Berlin (Witzleben).
11.30 p.m. (approx.)—Close Down.

HILVERSUM (Holland)

1,004 kc/s (298.8 m.); 8.5 kW.
6.25—9.40 a.m.—Programme of the Workers' Radio Society (V.A.R.A.).
6.25—6.40 a.m. and 7.10—7.25 a.m.—Gymnastics.
7.40 a.m.—Gramophone Records.
9.40 a.m.—Religious Programme by the Liberal Protestant Radio Society (V.P.R.O.).
9.55 a.m. till Close Down.—V.A.R.A. Programme.
9.55 a.m.—Programme for Workers.
11.40 a.m.—Septet Concert, with Gramophone Records. Potpourri, Kinderlieder (Robrecht). Waltz, Du liebes Wien (Stolz). Overture, "Prince Carnival" (Schreiner). Souvenir de Capri (Bece). Fox-trot, Looking for You (Gottler). Gramophone Records. Overture, "Flotte Bursche" (Suppé). Minuet (Volpatti). Potpourri, Tipperary Land. (Baynes). Waltz, Sympathie (Mezzacapo). Gramophone Records. Potpourri (Richter). Melody (Rubinstein). When Yankee Doodle learns "Parlez-vous français" (Nelson). Sous l'ombrage (Gillet). La dernière lettre de Manon (Gillet). Spanish March, Carmencita (Ciappi).
1.25—1.55 p.m.—Interval.
1.55 p.m.—Educational Talk for Workers.
2.10 p.m.—Gramophone Records.
2.30 p.m.—Talk by Mr. Thijssen.
2.50 p.m.—Concert of Chamber Music for Pianoforte, Flute, Oboe, Clarinet, Bassoon and Cornet. Sonata in C (Telemann). Trio in G (Beethoven). Bagatelles, Op. 119 (Beethoven). Quintet (Ingenhoven). Divertissement, Op. 6 (Roussel).
4.10 p.m.—Talk.
4.40 p.m.—Concert of Chamber Music.
5.20 p.m.—Songs and Pianoforte Recital.
5.40 p.m.—Mandoline Concert. March Auf Wache (Rasey). Pizzicati from "Sylvia" (Delibes). Mattinata (Leoncavallo). Hawaiian Interlude.
5.55 p.m.—Political Talk.
6.10 p.m.—Concert (continued). Overture, "Nakisir Hochzeit" (Lincke). Der Blumen Pracht (Klose). March, Vara here! (de Groot).
6.25 p.m.—Literary Talk.
6.55 p.m.—Variety Items.
7.0 p.m.—Talk by Mr. de Vries.
7.15 p.m.—Variety Programme for the Festival of St. Nicholas.
11.40 p.m. (approx.)—Close Down.

HUIZEN (Holland)

160 kc/s (1,875 m.); 8.5 kW.
Transmits at intervals from 7.40 a.m. Programme of the Catholic Radio Society (K.R.O.).
11.55 a.m.—Sextet Concert. In Budapest (Plessow). Murmurando (Racho). Waltz, O Frühling wie bist du so schön! (Lincke). Musikant, wo is diene Heimat? (Stolz). The Festival of St. Nicholas (Grit). Waltz Song (Holländer). Potpourri, Uns kennt jeder (Borchert). Die Mühle im Tale (Rhode). Hals und Beinbruch! (Morena). Whimsical Charms (Fresco). Fiesta (Samuels).
1.25 p.m.—Concert relayed from the Concert Hall, Bois-le-Duc. March Potpourri (Ciére). Lady of Spain (Evans). Die Walzer der Welt (Robrecht). Ich bin ja heut' so glücklich (Abraham). Mein Herz hab' ich gefragt (Abraham). Ein spanischer Tango (Rotter). Hoch Heidecksburg.
1.55 p.m.—Gramophone Records.
2.10 p.m.—St. Nicholas Festival relayed from the Concert Hall, Bois-le-Duc. Choral and Orchestral Selections.
3.20 p.m.—Programme for Children.
3.55 p.m.—Esperanto Report.
4.10 p.m.—Concert. The Troubadour's Serenade (Amadei). Chanson triste (Tchaikovsky). Le Pas des fleurs (Delibes). Minuet (Mozart). Nüsse-Regen (Urbach). Melody (Rubinstein). Zurück zum Walzer (Freudenthal). Potpourri, Contrasts (Robrecht). Gipsy Song (Baldi). Geburtstagständchen (Lincke). Finale.
5.30 p.m.—Talk on Politics.
6.20 p.m.—Esperanto Lesson.
6.50 p.m.—Sports Notes.
7.5 p.m.—Gramophone Records.
7.10 p.m.—Police Notes.
7.25—11.40 p.m.—St. Nicholas Festival Programme. In the intervals at 8.40 p.m.—News, and at 8.55 p.m.—Reading.
11.40 p.m. (approx.)—Close Down.

KALUNDBORG (Denmark)

Kalundborg Radio. 260 kc/s (1,153 m.); 7.5 kW.
See Copenhagen.

KATOWICE (Poland)

734 kc/s (408 m.); 16 kW.
Transmits at intervals from 10.58 a.m.
7.15 p.m.—Light Music.
9.10 p.m.—Chopin Concert.
10.0 p.m.—Light Music and Dance Music.

LANGENBERG (Germany)

Westdeutscher Rundfunk. 635 kc/s (473 m.); 17 kW. Relayed by Aachen, Cologne and Münster, 1,319 kc/s (227 m.).
Transmits at intervals from 5.45 a.m. (Gymnastics).
4.0 p.m.—Orchestral Concert.
5.0 p.m.—A St. Nicholas Play.
5.20 p.m.—A Discussion on Employees' Insurance.
6.0 p.m.—Time; Announcements.
6.15 p.m.—Wireless Notes.
6.30 p.m.—See Vienna.
7.15 p.m.—Variety Programme by the Wolf and Eysoldt Orchestras, Josef Plaut and other Artists, relayed from the Schützenhof-Saal, Münster.
9.40 p.m.—News Bulletin.
10.0 p.m.—Masters of Jazz—Gramophone Records.
12 midnight (approx.)—Close Down.

LEIPZIG (Germany)

1,157 kc/s (259 m.); 2.3 kW. Relayed by Dresden, 941 kc/s (310 m.).
Transmits at intervals from 5.30 a.m.
6.0 p.m.—Talk: Modern Acoustic Problems.
6.30 p.m.—Pianoforte Recital from the Works of Mozart, on the 140th Anniversary of the Composer's Death. Sonata in C Minor. Sonata in D Major.
7.0 p.m.—Concert of Old and New Dances by the Wako Ottersdorf Orchestra. Waltz; Tales from the Vienna Woods (Strauss). Valse-Blues, Goldene Leyer (Jo Rixner). Waltz, Ganz allerliebste (Waldteufel). March, Tandler Holzhaacker Baum (J. F. Wagner). Tango classique (Dazar and Benoit). Waltz from "A Waltz Dream" (O. Straus). Rumba, Bianca (Samuels and Witoup). Waltz, Ein Liebesmärchen (Naß). Fox-trot, Im Mai, im Mai (Roland-Cowler). By the Waters of Mingotanka (Lawrence). Waltz, Sirenenzauber (Waldteufel). Das Lied der Heimat (Dazar and Benoit). Bussi-Rheinländer (Holländer). Tango, Mi

Programmes for Saturday—(Cont.)

termente (Lucchesi). English Waltz (Paul Abraham). Waltz, Immer oder nimmer (Waldteufel).
 8.15 p.m.—Festive Concert by the Teachers' Choral Society of Gera, on its Fiftieth Anniversary, relayed from Gera. "Vom deutschen Rhein"—a Cycle of Choral Selections, Duets and Solo Songs, with Pianoforte accompaniment (Hugo Kaun).
 9.5 p.m.—News, followed by Dance Music.
 11.0 p.m. (approx.)—Close Down.

LJUBLJANA (Yugoslavia)
 522 kc/s (574.7 m.); 2.8 kW. Transmits at intervals from 11.15 a.m.
 7.0 p.m.—Concert.
 8.0 p.m.—Light Music.
 9.0 p.m.—News Bulletin.
 9.15 p.m.—Yugoslavian Music.

LWÓW (Poland)
 788 kc/s (381 m.); 21 kW. Transmits at intervals from 10.40 a.m.
 6.45—9.55 p.m.—See Warsaw.
 10.0 p.m.—Programme for Young People: (a) Literary Programme, (b) Jazz Music, (c) Pianoforte Duets.
 11.0 p.m. (approx.)—Close Down.

MADRID (Spain)
 Union Radio (EAJ7). 707 kc/s (424.3 m.); 2 kW. Transmits at intervals from 8.0 a.m.
 7.0 p.m.—Chimes, Exchange, Market Prices and Request Gramophone Records.
 8.0 p.m. (in the interval)—News.
 8.30—10.0 p.m.—Interval.
 10.0 p.m.—Chimes, Time and Musical Comedy Selection.
 12 midnight.—Chimes and News.
 12.30 a.m. (Sunday)—Close Down.

MILAN (Italy)
 Ente Italiano Audizioni Radiofoniche. 508 kc/s (501.7 m.); 8.5 kW. Relayed by Turin, 1,094 kc/s (274.2 m.) and Genoa, 959 kc/s (312.8 m.).
 Transmits at intervals from 7.15 a.m.
 6.0 p.m.—Agricultural Report.
 6.15 p.m.—Concert of Light Music.
 6.40 p.m.—Announcements.
 6.45 p.m.—Gramophone Records. In the intervals at 7.0 p.m.—Time and News and at 7.30 p.m.—French Lesson on Gramophone Records.
 7.45 p.m.—Talk: Events and Problems.
 8.0 p.m.—Variety Concert. In the interval, Book Review.
 10.0 p.m.—Giornale Radio and Dance Music.
 10.55 p.m.—News Bulletin.

MORAVSKÁ-OSTRAVA (Czechoslovakia)
 1,139 kc/s (263 m.); 11 kW. Transmits at intervals from 10.0 a.m.
 6.0 p.m.—See Prague.
 8.0 p.m.—See Bratislava.
 9.0 p.m.—See Prague.
 9.20 p.m.—Announcements.
 9.25 p.m.—Variety Programme: A Comedy, Songs and News.

MUNICH (Germany)
 563 kc/s (533 m.); 1.7 kW. Relayed by Augsburg and Kaiserslautern, 536 kc/s (560 m.) and Nürnberg, 1,256 kc/s (239 m.).
 Transmits at intervals from 5.45 a.m.
 6.0 p.m.—St. Nicholas comes to the Children.
 6.30 p.m.—Wireless Notes.
 6.45 p.m.—Orchestral Concert. Overture, "The Marriage of Figaro" (Mozart). March from "The Damnation of Faust" (Berlioz). Waltz from "Die Puppenfee" (Bayer). Humorous Duets and Trios. Strauss Operetta Potpourri (Schlögel). March from "The Merry Widow" (Lehár). Humorous Duets. March, Tiroler Holzackerbauam (Fr. Wagner). Waltz, Münchener Kindl (Komzak). Schützenmarsch (Krettner).
 8.10 p.m.—Announcements.
 8.15 p.m.—Cabaret Programme, followed by Orchestral Concert from the Café Luitpold. In the interval at 9.20 p.m.—Time and News.
 11.0 p.m. (approx.)—Close Down.

OSLO (Norway)
 Kringkastingselskapet. 277 kc/s (1,083 m.); 75 kW. Relayed by Fredrikstad, 816 kc/s (367.6 m.); Hamar, 536 kc/s (560 m.); Notodden, 671 kc/s (447.1 m.); Porsgrund, 662 kc/s (453.2 m.) and Rjukan, 671 kc/s (447.1 m.).
 Transmits at intervals from 10.10 a.m.
 3.30 p.m.—Orchestral Concert from the Olsen Restaurant.
 4.15 p.m.—Programme for Children.
 5.15 p.m.—Recital of National Songs and National Music on the Hardanger Fiddle.

6.0 p.m.—News Bulletin.
 6.30 p.m.—Talk on Police Work.
 7.0 p.m.—Time Signal.
 7.2 p.m.—Concert of Popular Music by the Balalaika Orchestra, with Baritone Solos.
 8.35 p.m.—Weather and News.
 8.50 p.m.—Topical Talk.
 9.5 p.m.—Recital of Songs.
 9.35 p.m.—Gramophone Dance Music.
 11.0 p.m. (approx.)—Close Down.

PARIS (France)
 Eiffel Tower (FLE). 207.5 kc/s (1,445.7 m.); 15 kW. Time Signals (on 2,650 m.) at 9.26 a.m. and 10.26 p.m. (preliminary and 6-dot signals).
 5.45 p.m.—Le Journal Parlé.
 7.20 p.m.—Weather Forecast.
 7.39 p.m.—Gramophone Records.
 7.45 p.m.—"Burglary"—Comedy in One Act, followed by "Un rotisseur dans l'embaras"—Farce (Eugène Chavette).

PARIS (France)
 Poste Parisien. 914 kc/s (328.2 m.); 1.2 kW.
 8.15 p.m.—Gramophone Records and News.
 8.45 p.m.—Theatre Talk, Gramophone Records and News.
 9.0 p.m.—Concert. Prelude to "Nais Micoulin" (Bruneau). Divertissement grec for Flute and Orchestra (Gaubert)—Soloist: M. Lavaillette. Le Verger and La Ducasse from "Cachaprés" (Casadesus)—the Composer conducting. Lied, for Cello and Orchestra (V. d'Indy)—Soloist: M. Laggé. Ballet Music from "Siang-Sin" (Hüe). Foxtrot, Five O'Clock (Ravel). La Grand'Route from "La Croisade des enfants" (Pierne).

PARIS (France)
 Radio-Paris (CFR). 174 kc/s (1,725 m.); 80 kW. Transmits at intervals from 6.45 a.m. (Physical Culture).
 12.30 p.m.—Gramophone Concert. In the intervals at 1.0 p.m.—Exchange and News, and at 1.30 p.m.—Exchange Quotations.
 2.0 p.m.—Exchange Quotations.
 3.0 p.m.—Programme for Children.
 3.45 p.m.—Exchange; Market Prices.
 5.0 p.m.—Concert arranged by the Association des Concerts Colonne, relayed from the Théâtre du Châtelet.
 6.40 p.m.—Agricultural Report, Announcements and Market Prices.
 7.0 p.m.—Talk arranged by the Union des Grandes Associations Françaises.
 7.10 p.m.—Talk on Astronomy.
 7.30 p.m.—Book-keeping Lesson.
 7.45 p.m.—Commercial Prices, Economic and Social Notes and News.
 8.0 p.m.—Readings: Letters of the Marquise de Mertenil after the "Liaisons dangereuses" of Laclos.
 8.30 p.m.—News Bulletin.
 8.40 p.m.—Talk.
 8.45 p.m.—A Revue by the Humorous Cartoonist, Morris, and the Little Gisèle Party.
 9.15 p.m.—News and Time.
 9.30 p.m.—Gramophone Concert.

PRAGUE (Czechoslovakia)
 617 kc/s (487 m.); 120 kW. Transmits at intervals from 10.0 a.m.
 6.0 p.m.—Time, News, Chimes.
 6.5 p.m.—Talk: The Origin of Man.
 6.20 p.m.—Popular Programme.
 7.55 p.m.—News Bulletin.
 8.0 p.m.—See Bratislava.
 9.0 p.m.—Time, Chimes, and News.
 9.25 p.m.—See Moravská-Ostrava.

RADIO-SUISSE ROMANDE (SOTTENS) (Switzerland)
 743 kc/s (403 m.); 25 kW. Lausanne, 442 kc/s (680 m.); and Geneva, 395 kc/s (760 m.).
 Transmits at intervals from 11.30 a.m.
 6.0 p.m.—Weather Forecast.
 6.1 p.m. (from Lausanne)—Gramophone Records.
 7.0 p.m. (from Lausanne)—Literary Programme.
 7.35 p.m.—Concert by the Montreux Municipal Orchestra.
 9.5 p.m.—News Bulletin.
 9.15 p.m. (from Geneva)—Dance Music from the Moulin Rouge.
 10.0 p.m. (approx.)—Close Down.

RIGA (Latvia)
 572 kc/s (525 m.); 15 kW. Transmits at intervals from 10.0 a.m.
 6.0 p.m.—Weather Report.
 6.5 p.m.—Dramatic Programme.
 7.0 p.m.—News Bulletin.
 7.30 p.m.—Concert.
 8.0 p.m.—Weather Report

8.5 p.m.—Dramatic Programme.
 8.30 p.m.—Dance Music.
 10.0 p.m. (approx.)—Close Down.

ROME (Italy)
 Ente Italiano Audizioni Radiofoniche (IRO). 680 kc/s (441 m.); 75 kW. Relayed by Naples, 905 kc/s (332 m.), and 2RO, 11,810 kc/s (25.4 m.).
 Transmits at intervals from 7.15 a.m. (Giornale Radio).
 4.30—5.15 p.m.—Instrumental Concert conducted by Enrico Martucci. Overture, "Cleopatra" (Mancinelli). Variations for Harp on the Old Song, "Santa Lucia" (Valenza). Hungarian Rhapsody No. 13 (Liszt). Harp Solo, Pattuglia spagnuola. (Tedeschi). Selection from "Manon Lescaut" (Puccini).
 6.20 p.m.—Announcements.
 6.32 p.m.—Atmospheric Signals.
 6.40 p.m.—Announcements.
 6.50 p.m.—Gramophone Records.
 7.10 p.m.—News Bulletin.
 7.35 p.m.—French Lesson on Gramophone Records.
 8.0 p.m.—"Adrienne Lecouvreur"—Opera in Four Acts (Cilea). In the intervals: Review of New Books, Announcements and Talk. News after the Programme.

SCHENECTADY (U.S.A.)
 General Electric Company (WGY). 790 kc/s (379.5 m.); 50 kW. Relayed at intervals by W2XAF on 9,530 kc/s (31.48 m.) and by W2XAD on 15,340 kc/s (19.56 m.).
 Transmits at intervals from 11.45 a.m.
 9.0 p.m.—New York Relay.
 10.0 p.m.—Studio Ensemble.
 10.30 p.m.—New York Relay.
 11.0 p.m.—Jack Miles and his DeWitt Clinton Orchestra.
 11.29 p.m.—Weather Report.
 11.30 p.m.—WGY Players.
 12 midnight (WGY only)—Time Signal.
 12 midnight (W2XAF only)—Stock Reports and News.
 12.1 a.m. (Sunday)—Football Scores.
 12.6 a.m.—American Trio.
 12.15 a.m.—Municipal Series.
 12.30—4.30 a.m.—New York Relay.
 4.30 a.m.—Gordie Randall and his Van Curler Orchestra.
 5.0 a.m.—Jack Miles and his DeWitt Clinton Orchestra.
 5.30 a.m.—Doc Peyton and his Kenmore Orchestra.
 6.0 a.m. (approx.)—Close Down.

SCHWEIZERISCHER LANDESSENDER (BEROMÜNSTER) (Switzerland)
 653 kc/s (459 m.); 75 kW; Basle, 1,229 kc/s (244.1 m.); and Berne, 1,220 kc/s (246 m.).
 Transmits at intervals from 11.28 a.m.
 3.0 p.m.—Songs on Gramophone Records.
 4.0 p.m. (from Zürich)—Talk for Young People.
 4.30 p.m.—Weather; Market Prices.
 4.40—5.30 p.m.—Interval.
 5.30 p.m.—Chamber Music on Gramophone Records.
 6.0 p.m. (from Zürich)—Chimes from the Zürich Churches.
 6.15 p.m. (from Zürich)—Talk: Police Women at Work.
 6.28 p.m.—Time and Weather.
 6.30 p.m. (from Zürich)—Talk on Paul Hug.
 7.0 p.m. (from Basle)—Concert by the Concordia Music Society, relayed from the Isaak Iselin Schulhaus.
 8.0 p.m. (from Basle)—Variety Programme: Swiss Songs, Dialect Items and Folk Music.
 9.0 p.m.—News Bulletin.
 9.15 p.m. (from Basle)—Gramophone Dance Music.
 10.0 p.m. (approx.)—Close Down.

STOCKHOLM (Sweden)
 Radiotjänst (SASA). 689 kc/s (436 m.); 75 kW. Relayed by Boden, 244 kc/s (1,220.5 m.); Göteborg, 932 kc/s (322 m.); Hörby, 1,166 kc/s (257 m.); Motala, 222.5 kc/s (1,348 m.); Östersund, 389 kc/s (770 m.) and Sundsvall, 554 kc/s (542 m.).
 Transmits at intervals from 6.15 a.m. (Gymnastics).
 3.0 p.m.—Programme for Children.
 3.30 p.m.—Literary and Musical Programme from the Angerman District, relayed from Sundsvall.
 4.30 p.m.—Gramophone Records.
 5.30 p.m.—Talk on Alcohol.
 6.0 p.m.—Accordion Recital of Swedish Folk Music and Modern Dance Music.
 6.15 p.m.—Weather and News.
 6.30 p.m.—Vocal and Orchestral Concert.
 7.15 p.m.—Running Commentary on the Wrestling Match, Sweden v. Finland, relayed from Helsinki. 815 kc/s (368.1 m.).

8.15 p.m.—Concert. Milte Janine Moreau (Harp) and Oluf Nielsen (Violin). Fantasia for Violin and Harp (Saint-Saëns). Two Preludes for Violin and Harp (Tournier). Harp Solos: (a) Trois Nœls (Tournier), (b) Rhapsody (Grandjany). Selections for Violin and Harp: (a) Sicilienne et Rigaudon (Francoeur), (b) Le Cygne (Saint-Saëns).
 8.45 p.m.—Weather and News.
 9.0 p.m.—Modern Dance Music Relay.
 10.0 p.m. (approx.)—Close Down.

STRASBOURG (France)
 Radio-Strasbourg (PTT). 869 kc/s (345 m.); 15 kW. Transmits at intervals from 11.30 a.m.
 5.0 p.m.—Instrumental Concert. Overture, "Raymond" (Thomas). Selection from "Die Walküre" (Wagner). Symphonic Poem, Helvetia (Scassola). Hungarian Dances (Brahms).
 5.45 p.m.—French Lesson given in German.
 6.0 p.m.—Instrumental Concert. Retour à la France (Mezzacapo). Waltz, Hyménée (Périneau). Birthday Serenade (Lincke). Selection from "Les Dragons de Villars" (Maillart). Norwegian Suite (Danglas). Marche sportive (Popy).
 6.45 p.m.—Gardening Talk in German.
 7.0 p.m.—Dance Music.
 7.30 p.m.—Time Signal.
 7.32 p.m.—News in French and German.
 7.45 p.m.—Gramophone Concert.
 8.30 p.m.—Concert Relay from Mulhouse. Overture, "Le nouveau seigneur du village" (Boieldieu). Little Waltz (Meyer-Helmund). Waltz from "Polenblut" (Nedbal). Waltz (Fetras). Selection from "Le Comte Obligado" (Moretti). Grossmütterchen (Langer). Selection from "La Bohème" (Puccini). Selection from "Werther" (Massenet). Adagio and Allegro (Boccherini). Selection from "Sappho" (Massenet). Overture, "William Tell" (Rossini). Luna Waltz (Lincke). Selection from "Lilac Time" (Schubert). Selection from "The Girl in the Taxi" (Gilbert). Waltz, Delilah (Nicholls).
 10.30 p.m.—Dance Music from the Savoy.
 12 midnight (approx.)—Close Down.

STUTT GART (MÜHLACKER) (Germany)
 Süddeutscher Rundfunk. 833 kc/s (360 m.); 75 kW. Relayed by Freiburg, 527 kc/s (570 m.).
 Transmits at intervals from 5.15 a.m. (Frankfurt Relay).
 3.20 p.m.—Song Recital. O del mio dolce ardor (Gluck). Se tu m'ami (Pergolesi). Songs (Hirschberg): (a) Das selige Schiff, (b) Marienbild, (c) Stabat Mater, (d) Erntesege, (e) Schutzpatronin. Songs (Hugo Wolf): (a) Wie glänzt der helle Mond, (b) Über Nacht kommt still das Leid.
 3.50 p.m.—Orchestral Concert of Marches. March of the First Battalion of Guards. Der Rheinströmermarsch. Finnish Cavalry March. Kürassiermarsch (Simon). Mit Eichenlaub und Schwertern (v. Blon). Kaiser Friedrich Marsch (Friedemann). Geburtstagmarsch (Kühne). Die Freundschaftsflagge (v. Blon).
 4.30 p.m.—Chamber Music from a Private House in Stuttgart. Conversation galante et amusante, Op. 12, No. 1, for Flute, Violin, Viola and Pianoforte (Guillemin). Symphony, No. 1 (Haydn).
 5.30 p.m.—Time Signal.
 5.40 p.m.—Talk: Experiments in Boating on Lake Constance.
 6.5 p.m.—See Frankfurt.
 6.30 p.m.—Time, Weather and Sports Notes.
 6.45 p.m.—See Frankfurt.
 7.15 p.m.—Variety Programme.
 8.15 p.m.—Orchestral Concert of Old Dance Music.
 8.45 p.m.—Manfred Lemmel Programme.
 9.20 p.m.—News Bulletin.
 9.40 p.m.—Dance Music.
 10.0 p.m.—Cabaret Relay.
 11.30 p.m. (approx.)—Close Down.

TOULOUSE (France)
 Radiophonie du Midi. 779 kc/s (385 m.); 8 kW. Transmits at intervals from 12.45 p.m.
 6.0 p.m.—Chansonnettes.
 6.15 p.m.—Solo Selections.
 6.30 p.m.—News Bulletin.
 6.45 p.m.—Impressions d'Italie (Charpentier) for Orchestra.
 7.15 p.m.—Light Music.
 7.30 p.m.—News Bulletin.

7.45 p.m.—Gramophone Records.
 8.0 p.m.—Military Music.
 8.15 p.m.—Sound Film Songs.
 8.30 p.m.—Orchestral Selections.
 9.0 p.m.—Concert. Selections from (a) "The Count of Luxembourg" and (b) "The Merry Widow" (Lehár). Pomona (Waldteufel). Chantilly (Waldteufel). Selection from "A Waltz Dream" (O. Straus). Die Rekruten (Lanner). Sur la Côte Lorraine (Kirmse). Heil Europa (Blon). Selections from (a) "The Drum-Major's Daughter" (Offenbach), (b) "La Bohème" (Puccini), and (c) "La Belle Hélène" (Offenbach).
 10.0 p.m.—Gramophone Records.
 10.30 p.m.—News Bulletin.
 10.45 p.m.—Orchestral Selections from "Don Juan" (Strauss) and "Cavalleria rusticana" (Mascagni).
 11.15 p.m.—North African News.
 11.30 p.m.—Instrumental Concert.
 12 midnight.—Weather, Announcements and Close Down.

TRIESTE (Italy)
 Ente Italiano Audizioni Radiofoniche. 1,211 kc/s (247.7 m.); 15 kW.
 Transmits at intervals from 11.30 a.m.
 7.15 p.m.—News Bulletin.
 7.30 p.m.—French Lesson on Gramophone Records.
 7.35 p.m.—Gramophone Records.
 8.0 p.m.—Time and Announcements.
 8.5 p.m. (approx.)—Band Concert. Review of New Books in the interval.
 9.25 p.m.—Gramophone Records.

VIENNA (Austria)
 Radio-Wien. 581 kc/s (517 m.); 20 kW. Relayed by Graz, 851 kc/s (352 m.); Innsbruck, 1,058 kc/s (283 m.); Klagenfurt, 662 kc/s (453.2 m.); Linz, 1,220 kc/s (246 m.); and Salzburg, 1,373 kc/s (218 m.).
 Transmits at intervals from 8.20 a.m.
 6.15 p.m.—Time and News.
 6.30 p.m.—Mozart Programme on the 140th Anniversary of his Death: "From Mozart's Last Days" (Bernhard Paumgartner), with Introductory Talk by the Author.
 7.15 p.m.—"Titus"—Opera in Two Acts (Mozart), arranged for Radio by Dr. J. Braunstein.
 9.15 p.m.—News Bulletin.
 9.30 p.m.—Orchestral Concert from the Hotel Krantz-Ambassador. Overture, "Die Landstreicher" (Ziehrer). Waltz, Transaktionen (Jos. Strauss). Selection from "Faust" (Gounod). Waltz Song, Mädel aus Wien (Hügel). Selection from "The Merry Widow" (Lehár). Pasodoble, Bolero (Hügel).

WARSAW (Poland)
 Polskie Radio. 212.5 kc/s (1,411 m.); 158 kW.
 Transmits at intervals from 10.40 a.m.
 3.20 p.m.—Wireless Review.
 3.40 p.m.—Gramophone Records.
 4.0 p.m.—Service from the Ostro Brama, Wilno, 1,229 kc/s (244.1 m.).
 5.5 p.m.—Programme for Children.
 5.30 p.m.—Concert for Children.
 5.50 p.m.—Miscellaneous Items.
 6.15 p.m.—Agricultural Correspondence.
 6.25 p.m.—Programme Notes.
 6.30 p.m.—Gramophone Records.
 6.45 p.m.—Radio Journal.
 7.0 p.m.—"On the Horizon."
 7.15 p.m.—Orchestral Concert with Mme. I. Carnero (Soprano) and H. Domanski (Mouth Organ and Songs).
 8.55 p.m.—Talk on Bells.
 9.10 p.m.—Chopin Pianoforte Recital. Two Nocturnes in G Major, Op. 37, and F Sharp Major, Op. 15. Two Etudes in F Minor, No. 25, and F Minor, Op. 25. Two Impromptus in F Sharp Major, Op. 36, and A Flat Major, Op. 29. Two Waltzes in D Flat Major, Op. 70, and D Flat Major, Op. 64.
 9.40 p.m.—Radio Journal.
 9.45 p.m.—Announcements.
 10.0 p.m.—Dance Music and Light Music.
 11.0 p.m. (approx.)—Close Down.

ZAGREB (Yugoslavia)
 977 kc/s (307 m.); 0.7 kW. Transmits at intervals from 11.20 a.m.
 6.30 p.m.—Announcements and News.
 6.45 p.m.—Talk on Mozart on the 140th Anniversary of his Death.
 7.5 p.m.—Introductory Talk to the following transmission.
 7.15 p.m.—See Vienna. After the Programme, News and Silent Night for Distant Reception.

Stations in Order of Frequencies and Wavelengths

Corrected in accordance with the latest official information available at the time of going to press

The figures in black type represent the power according to The Hague power-rating scheme

Kc/s	M.	Station	Dial Readings	Kc/s	M.	Station	Dial Readings	Kc/s	M.	Station	Dial Readings
EUROPEAN											
		(Including Stations connected with the European System)									
155	1935	Kaunas (Lithuania), 7 kW.		797	376.4	Glasgow (5SC), 1.2 kW.				Berne (Switzerland), 0.5 kW.	
160	1875	Huizen (Holland), 8.5 kW.		806	372	Hamburg (Germany), 1.7 kW.				Cartagena (Spain), 0.4 kW.	
167	1796	Lahti (Finland) (relays Helsinki), 5.4 kW.		810	370.4	Radio LL (France), 0.5 kW.				Cassel (Germany) (relays Frankfurt), 0.3 kW.	
174	1725	Radio Paris (CFR), 80 kW.	85.19.95	815	368.1	Bolzano (Italy) (BZ), 0.2 kW.				Eskilstuna (Sweden) (relays Stockholm), 0.25 kW.	
183.5	1835	Königs Wusterhausen (Zeeseen) (Germany), 75 kW. Relays Berlin.	88.28.180	816	367.6	Helsinki (Finland), 13.2 kW.				Kiruna (Sweden) (relays Boden), 0.25 kW.	
193	1554.4	Dayentry National Station (Gr. Britain), 35 kW.	85.10.180	824	364	Seville (Union Radio) (EAJ5) (Spain), 1.5 kW.				Linz (Austria) (relays Vienna), 0.6 kW.	
195	1538	Ankara (Turkey), 7 kW.		825.3	363.4	Fredriksstad (Norway), 0.8 kW. (relays Oslo).				Säffle (Sweden) (relays Stockholm), 0.4 kW.	
202.6	1481	Moscow (Old Komintern) (RV1) (Russia), 100 kW.		833	360	Bergen (Norway), 1.13 kW.				Schäerbeek (Brussels) (Belgium), 0.1 kW.	
207.5	1445.7	Eiffel Tower (ELE), 15 kW.		842	356.3	Algiers (N. Africa), 13 kW.				Turku (Abo) (Finland) (relays Helsinki), 0.6 kW.	
212.5	1411	Warsaw No. 1 (Poland), 158 kW.		851	352	Stuttgart (Mühlacker) (Germany), 75 kW.	67.56.128			Basle (Switzerland), 0.5 kW.	
222.2	1388	Kasbah (Tunis), 0.5 kW.		855.5	351	Graz (Austria) (usually relays Vienna), 9.5 kW.	72.45.50			Wilno (Poland), 0.5 kW.	
222.5	1348	Motala (Sweden) (relays Stockholm), 40 kW.		860	349	Leningrad (Russia), 1.2 kW.	73.48.102			Belfast (2BE) (Ireland), 1.2 kW.	
230.1	1304	Moscow (Trades Union), 100 kW.		869	345	Barcelona (Radio Barcelona) (EAJ1) (Spain), 8 kW.	66.37.25			Stavanger (Norway), 0.63 kW.	
238.1	1288	Novosibirsk (Russia), 4 kW.		878	342	Strasbourg-Brumath (France), 15 kW.				Radio Beziere (France), 1.5 kW.	
242.5	1237	Vienna Experimental (Austria)		887	338.2	Berno (Czechoslovakia), 3 kW.				Nürnberg (Germany) (relays Munich), 2.3 kW.	
244	1229.4	Boden (Sweden), 0.75 kW.		896	335	Brussels No. 2 (Belgium), 20 kW. (Flemish programme)				Bordeaux Sud-Ouest (France), 3 kW.	
250	1209	Istanbul (Turkey), 5 kW.		905	332	Cadiz (Spain), 5.5 kW.				Radio Nimes (France), 1 kW.	
250	1153	Reykjavik (Iceland), 21 kW.		914	328.2	Poznan (Poland), 1.9 kW.				Örebro (Sweden) (relays Stockholm), 0.25 kW.	
263.5	1119	Kalundborg (Denmark) (relays Copenhagen), 7.5 kW.		923	325	Naples (1 NA) (Italy), 1.7 kW.				Christiansand (Norway), 0.63 kW.	
277	1083	Moscow, Popoff, 40 kW.		932	322	Grenoble (PTT) (France), 1.2 kW.				Lodz (Poland), 2 kW. Exp'l.	
284.8	1053	Oslo (Norway), 75 kW.		932	322	Poste Parisien (Paris), 1.2 kW.				Kiel (Germany) (relays Hamburg), 0.3 kW.	
294.8	1009	Tiflis (Russia), 10 kW.		941	319	Breslau (Germany), 1.7 kW.				Norrköping (Sweden), 0.25 kW.	
300	1000	Leningrad (Russia), 100 kW.		950	315	Goteborg (Sweden) (relays Stockholm), 15 kW.				Helsingborg (Sweden), 0.25 kW.	
309	937.8	Khar'kov (Russia), RV20.		959	312.8	Dresden (Germany) (relays Leipzig), 0.3 kW.				Malmö (Sweden) (relays Stockholm), 1 kW.	
323.5	846.7	Rostov-Don (Russia), 4 kW.		968	309.9	Sofia Rodno-Radio Bulgaria, 1 kW.				Uddevala (Sweden), 0.1 kW.	
323.1	815	Kiev (Russia), 20 kW.		977	307	Marseilles (PTT) (France), 1.5 kW.				Aachen (Germany), 0.3 kW.	
328	778	Petrozavodsk (Russia), 2 kW.		986	304	Cracow (Poland), 1.5 kW.				Cologne (Germany), 1.7 kW.	
329	770	Ostersund (Sweden), 0.75 kW. (relays Sundsvall).		995	301.5	Genoa (GE) (Italy), 1.5 kW.				Münster (Germany), 0.6 kW.	
334	761.4	Nijni Novgorod (Russia), 1.8 kW.		1004	298.8	Radio-Vitus (France), 1.5 kW.				Cork (6CK) (Ireland), 1.5 kW.	
335	760	Geneva (Switzerland), 1.5 kW.		1013	296.1	Cardiff (SWA), 1.2 kW.				Fecamp (Radio Normandie) (France).	
336.7	729	Moscow (Experimental), 20 kW.		1022	293	Zagreb (Yugoslavia), 0.7 kW.				Flensburg (Germany) (relays Hamburg), 0.6 kW.	
338.8	700	Minsk (Russia), 4 kW.		1031	291	Bordeau-Lafayette (PTT) (France), 35 kW.				Pori (Björneborg) (Finland) (relays Helsinki), 0.7 kW.	
342	689	Lausanne (Switzerland), 0.6 kW.		1033	290.5	Falun (Sweden), 0.65 kW.				Salzburg, 0.6 kW. (relays Vienna).	
346.3	631	Wino (Poland), 21.5 kW.		1040	288.5	North National (Manchester), 79 kW.				Königsberg (Germany), 0.9 kW.	
348	622	Ljubljana (Yugoslavia), 2.8 kW.		1049	286	Hilversum (Holland), 8.5 kW.				Halmstad (Sweden), 0.25 kW.	
353.5	574.7	Freiburg-im-Breisgau (Germany) (relays Stuttgart), 0.3 kW.		1058	283	Tallinn (Estonia), 10 kW.				Radio Chatelineau (Belgium).	
353.1	570	Hanover (Germany), 0.3 kW. (relays Hamburg).		1067	281	Kosice (Czechoslovakia), 2.5 kW.				Warsaw, No. 2 (Poland), 1.9 kW. Experimental.	
358	565	Smolensk (Russia), 2 kW.		1076	279	Limoges (PTT) (France), 0.8 kW.				Palermo (Italy), 4 kW.	
359	560	Augsburg (Germany) (relays Munich), 1.7 kW.		1085	276.5	Pietarsaari (Jacobstad) (Finland) (relays Helsinki), 0.25 kW.				Borås (Sweden), 0.12 kW.	
363.8	545	Kaiserslautern (Germany) (relays Munich), 0.3 kW.		1094	274.2	Tampere (Finland) (relays Helsinki), 1 kW.				Gävle (Sweden) (relays Stockholm), 0.2 kW.	
364	542	Hamar (Norway) (relays Oslo), 0.8 kW.		1103	272	Viiipuri (Viborg) (Finland) (relays Helsinki), 13.2 kW.				Kristinehamn (Sweden), 0.25 kW.	
365	542	Budapest (Hungary), 23 kW.		1112	270	Viipuri (Viborg) (Finland) (relays Helsinki), 13.2 kW.				Jönköping (Sweden), 0.25 kW. (relays Stockholm).	
368	533	Sundsvall (Sweden), 15 kW.		1121	267.6	Lisbon, Portugal, 2 kW.				Karlskrona (Sweden) (relays Stockholm), 0.25 kW.	
372	533	Munich (Germany), 1.7 kW.		1130	265.4	British Relay Stations				St. Quentin (France).	
378	525	Riga (Latvia), 15 kW.		1139	263	Aberdeen (2BD), 1.2 kW.					
381	517	Vienna (Rosenhügel) (Austria), 20 kW.	46.38.62	1148	261.3	Bournemouth (6BM), 1.2 kW.					
385	511	Archangel (Russia), 1.2 kW.		1157	259	Dundee (2DE), 0.16 kW.					
385	509	Brussels No. 1 (Belgium), 20 kW.		1166	257	Edinburgh (2EH), 0.4 kW.					
388	507.7	Milan (Italy), 8.3 kW.		1175	255	†Hull (6KH), 0.16 kW.					
393.8	497	Moscow (Russia), 1.2 kW.		1184	253	†Liverpool (6LV), 0.16 kW.					
398	493.4	Freidheim (Norway), 1.35 kW.		1205	249	Newcastle (5NO), 1.2 kW.					
401	487	Prague (Czechoslovakia), 120 kW.		1211	247.7	Plymouth (5PY), 1.5 kW.					
406	479.2	North Regional (Manchester), 70 kW.	90.45.180			†Sheffield (6FL), 0.16 kW.					
430.2	476	Sebastopol (Russia), 1.2 kW.				†Stoke-on-Trent (6ST), 0.16 kW.					
435	473	Langenberg (Germany), 17 kW.				Swansea (5SX), 0.16 kW.					
444	465.8	Lyons (La Doua) France, 5 kW. (relays PTT).				Lyons (Radio) (France), 0.8 kW.					
453	459	Tartu (Estonia), 5 kW.				Montpellier (France), 1.2 kW.					
462	453.2	Schweizerischer Landessender (Beromünster) Switzerland, 75 kW.				Berlin Relay (Germany), 0.8 kW.					
		Bodo (Norway), 0.63 kW.				Magdeburg (Germany), 0.6 kW.					
		Danzig (Free City), 0.6 kW. (relays Königsberg).				Stettin (Germany) (relays Berlin), 0.6 kW.					
		Klagenfurt (Austria), 0.6 kW. (relays Vienna).				Innsbruck (Austria) (relays Vienna), 0.6 kW.					
		Porsgrund (Norway) (relays Oslo), 0.8 kW.				Varberg (Sweden), 0.3 kW.					
		Salamanca (Spain) (EAJ22), 1 kW.				Copenhagen (Denmark), 0.75 kW.					
		San Sebastian (Spain), 0.6 kW.				Radio Liège (Belgium).					
		Tromsø (Norway), 0.11 kW.				Bratislava (Czechoslovakia), 14 kW.					
		Uppsala (Sweden), 0.2 kW. (relays Stockholm).				Heilsberg (Germany), 75 kW. Relays Königsberg.					
466	450.4	Odessa (Russia).				Turin (Italy), 8.7 kW.					
		Aalesund (Norway), 0.4 kW.				Rennes (France), 1.2 kW.					
		Notodden (Norway), 0.9 kW.				Bremen (Germany) (relays Hamburg), 0.3 kW.					
471	447.1	Paris (PTT), (Ecole Supérieure) (France), 1 kW.				Oviedo (Spain), 0.7 kW.					
		Rjukan (relays Oslo) (Norway), 0.17 kW.				Radio Valencia (Spain), 1.5 kW.					
489	441	Rome (1RO) (Italy), 75 kW.				Lille (PTT) (France), 2 kW.					
489	436	Malmberget (relays Boden) (Sweden), 0.25 kW.				Moravská-Ostrava (Czechoslovakia), 11 kW.					
497	430.4	Stockholm (Sweden), 75 kW.				London National, 88 kW.					
707	424.3	Belgrade (Yugoslavia), 3 kW.				Leipzig (Germany), 2.3 kW.					
		Madrid (Union Radio) (EAJ7) (Spain), 2 kW.				Hörby (Sweden) (relays Stockholm), 15 kW.					
		Moscow-Stalin (Russia) 100 kW.				Toulouse (PTT) (France), 1 kW.					
		Radio-España (Spain)				Gleiwitz (Germany) (relays Breslau), 5.6 kW.					
715	418	Berlin (Witzleben), 1.7 kW.	81.51.68			Almeria (Spain) (EAJ18), 1 kW.					
721.1	416	Rabat (Morocco), 2.5 kW.				Barcelona (Association National) (EAJ15) 1 kW.					
728	413	Dublin (2RN) (Ireland), 1.5 kW.				Trollhättan (Sweden), 0.3 kW.					
734	408	Katowice (Poland), 16 kW.				Juan-les-Pins (Nice) (France)					
733	403	Radio Suisse Romande (Sottens) Switzerland, 25 kW.				Kálmár (relays Stockholm), 0.25 kW.					
752	398.0	Midland Regional Station (Gr. Britain), 38 kW.	80.65.180			Trieste (Italy), 15 kW.					
761	394	Bucharest (Romania), 16 kW.									
770	380	Frankfurt (Germany), 1.7 kW.									
779	385	Toulouse (Radio) (France), 8 kW.									
788	381	Lwow (Poland), 21 kW.									

†Not Radiating.

DEVIATIONS
The following are the actual deviations from the official frequencies, as noted during measurements made at the Tatsfield Checking Station. All differences of 1.0 kc/s and over are shown

271.9	1100	Tiflis (Russia)
515.5	581.9	Hamar (Norway)
613.8	488.7	Prague (Czechoslovakia)
1006	298.2	Hilversum (Holland)
1996	273.7	Turin (Italy)
1249.2	240.2	Stavanger (Norway)

BRITISH DOMINIONS AND COLONIES

AUSTRALIA

580	517	Hobart (7ZL), 3 kW.
620	484	Melbourne (3AR), 5 kW.
665	451	Sydney (2FC), 5 kW.
690	435	Perth (6WF), 5 kW.
730	411	Adelaide (5CL), 5 kW.
759	395	Brisbane (4QG), 5 kW.
800	375	Melbourne (3LO), 5 kW.
855.5	351	Sydney (2BL), 5 kW.

CANADA

730	411	St. Hyacinthe (CKAC), 5 kW.
780	385	Winnipeg (CKS-CNRW), 5 kW.
841	357	Toronto (CKGW), 5 kW.

CHINA

845	355	Hong Kong (ZBW), 1.5 kW.
887.3	338	Shanghai (KRC), 0.15 kW.

EAST AFRICA

750	400	Nairobi, Kenya (7 LO)
-----	-----	-----------------------

INDIA

810	370.4	Calcutta (VUC) 3 kW.
840	257.1	Bombay (VUB) 3 kW.

NEW ZEALAND

714	420	Wellington (2YA), 5 kW.
-----	-----	-------------------------

SOUTH AFRICA

668.5	450	Johannesburg (JB), 10 kW.
731	410	

For the
RADIO-GRAM
you are making

**FIT A
 BRITISH
 MADE**

**DAPTACON
 PICK-UP**

Vide
"Amateur Wireless"

"An interesting development in gramophone pick-up manufacture is embodied in the new Daptacon pick-up. The designers have set out to produce an instrument which is sensitive enough to be used with even the most modest amplifying arrangements.

"The design of the pick-up is generous and tidy. The winding is tapped to enable the best input impedance arrangement to be employed.

"On test the pick-up was found to be very sensitive. The average voltage output is well in excess of 2 volts R.M.S. from 100 cycles to 1,000 cycles, while at 3,000 cycles the output is still of the order of 1 volt R.M.S. A measurable output was obtained up to 5,000 cycles.

"On connecting the pick-up by means of a 2:1 transformer to an output valve of the P215 type, good volume was obtained. Used with a pentode, results should be sufficient for all ordinary purposes."



**THE
 "DAPTACON"
 JUNIOR**

If you have a Gramophone and a Radio Set you can quite easily and inexpensively combine the two so that records can be electrically reproduced. The New "Daptacon" Junior Pick-Up is designed on sound technical engineering lines and incorporates a **BRITISH COBALT STEEL MAGNET** of everlasting strength.

So sensitive is this Pick-Up that even with a low-powered set a perfectly clear and strong reproduction is obtainable. You will be amazed at the reproduction, for the bass, treble and middle registers are rendered with utmost clarity and without the least distortion. The "Daptacon" Junior is British made throughout of the finest materials and finished in a combination of Nickel and Antique Bronze.

Cash Price
17/6

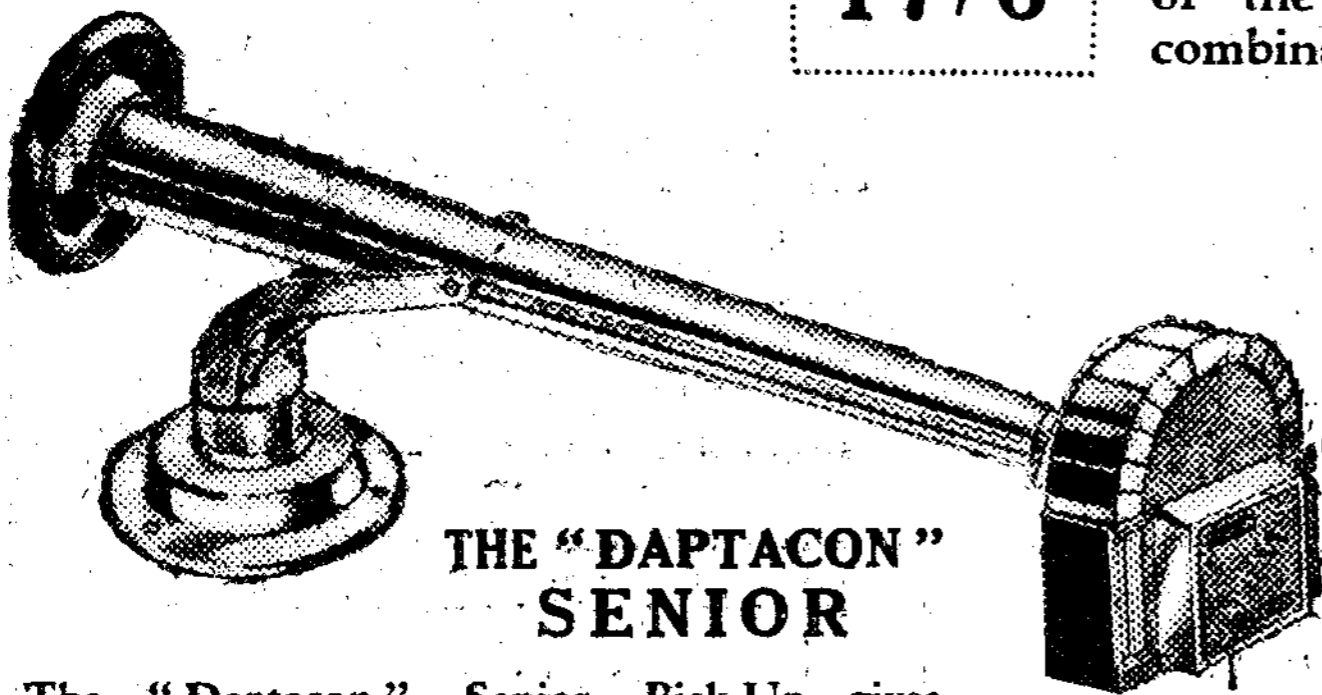

**THE "DAPTACON"
 SENIOR**

The "Daptacon" Senior Pick-Up gives remarkable results even when used with a one-valve set. Supplied with three separate leads, giving low, medium and high output for use with different power sets; beautifully finished in Florentine Bronze. Sent on 7 days approval for only 1s. deposit, if satisfied remit further 4s. at once and complete purchase by 3 monthly payments of 5s.

Cash Price
32/6

Send only 1s. deposit and have a week's free trial. If satisfied, remit further 4s. at once and complete purchase by 3 monthly payments of 5s. We have absolute confidence in making this offer, for this Pick-Up has been tested, criticised, improved and retested, and we know that there is nothing better at its price on the market.

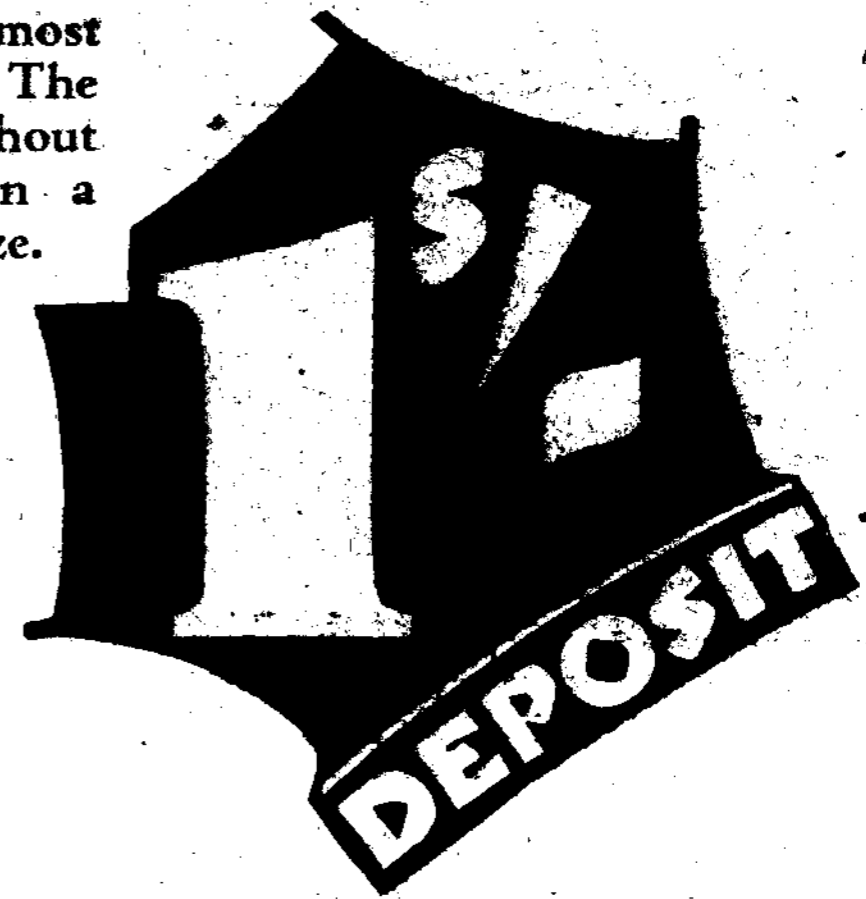

POST THIS FOR 7 DAYS FREE TRIAL

To **E. J. HERAUD**, Dept. W.R. 8, NUMBER ONE, EDMONTON, LONDON, N.18.
 (Our full postal address)

Please send me post paid for Seven Days Trial, one

"DAPTACON" JUNIOR PICK-UP Name
 " " SENIOR PICK-UP
 (Cross cut that not required)

for which I enclose Postal Order for ONE SHILLING as deposit. It is understood that if after 7 days trial I am not satisfied I will return the Pick-Up undamaged.

Address

* Volume Control for either model can be supplied at 2s. 6d. extra. Please state if required.

Trade enquiries to the manufacturers:
BRITISH IDEAL PATENTS, LTD.,
 Green Street, Brimsdown, Middlesex.
 Phone: Enfield 1741-1863. Or to the Usual Factors.

CONVERT YOUR SET INTO A SHORT WAVE RECEIVER WITH A KELSEY ADAPTOR AND LISTEN ALL OVER THE WORLD

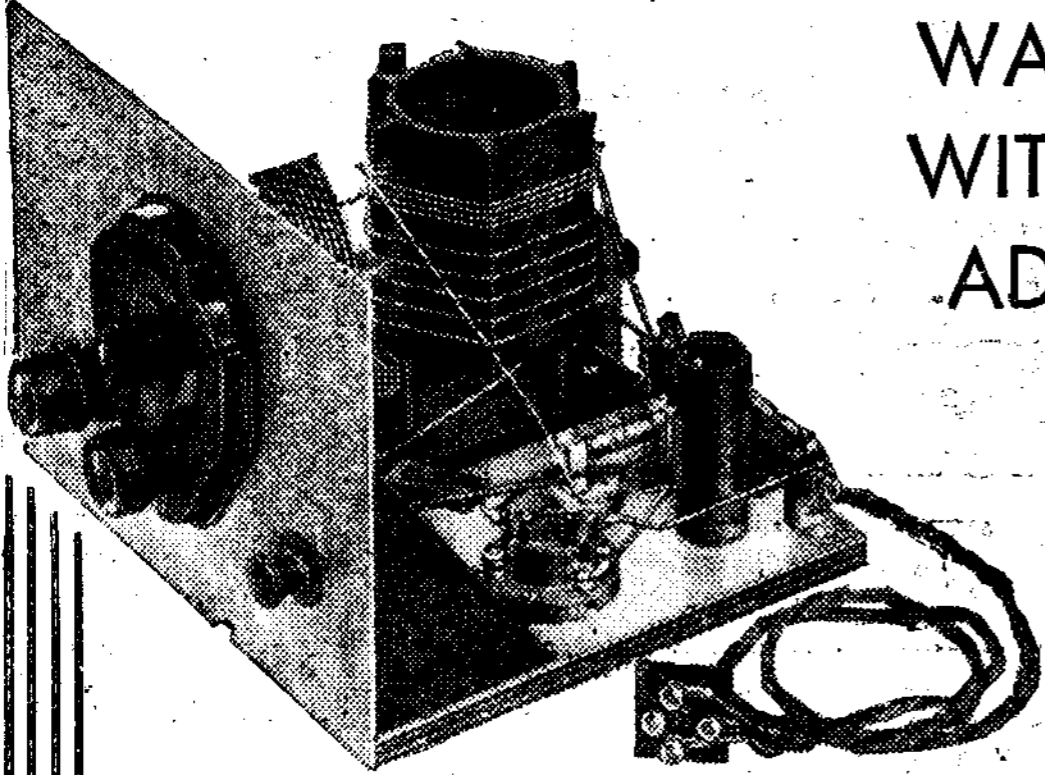

ADD MORE STATIONS TO YOUR SET

By placing the plug from the Kelsey Short Wave Adaptor into the detector valve socket of your set and the detector valve into the Adaptor itself, your set is then converted into a short wave receiver, capable of picking up stations between 16 to 55 metres from all over the world. **No further batteries or valves are needed, no alterations to your set are necessary;** simply insert the Kelsey Short Wave Adaptor between your aerial and set and you will get new thrills out of radio.

For Battery or Eliminator fed Receivers.

KELSEY SHORT WAVE ADAPTOR
Assembled ready for use and specially packed for immediate delivery.
Sent C.O.D., you pay the postman.

37/6

Mahogany Cabinet
7/6 EXTRA

PETO-SCOTT

PETO-SCOTT CO. LTD.

77, City Rd., London, E.C.1. Phone: Clerkenwell 9406-7-8.
62, High Holborn, London, W.C.1. Phone: Chancery 8266.
33, Whitelaw Rd., Chorlton-cum-Hardy, Manchester.
Phone: Chorlton-cum-Hardy 2028.
7, Albany Road, Newcastle, Staffs.

Please send me, CASH or C.O.D., complete Kelsey Short Wave Adaptor.

NAME

ADDRESS

W.R. 27/11/1931.

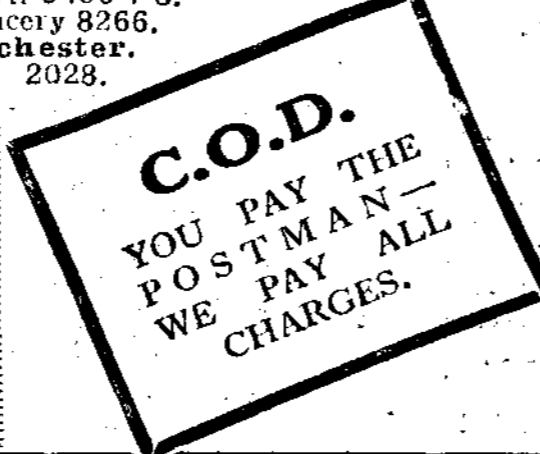

FOR THE S.W. SET

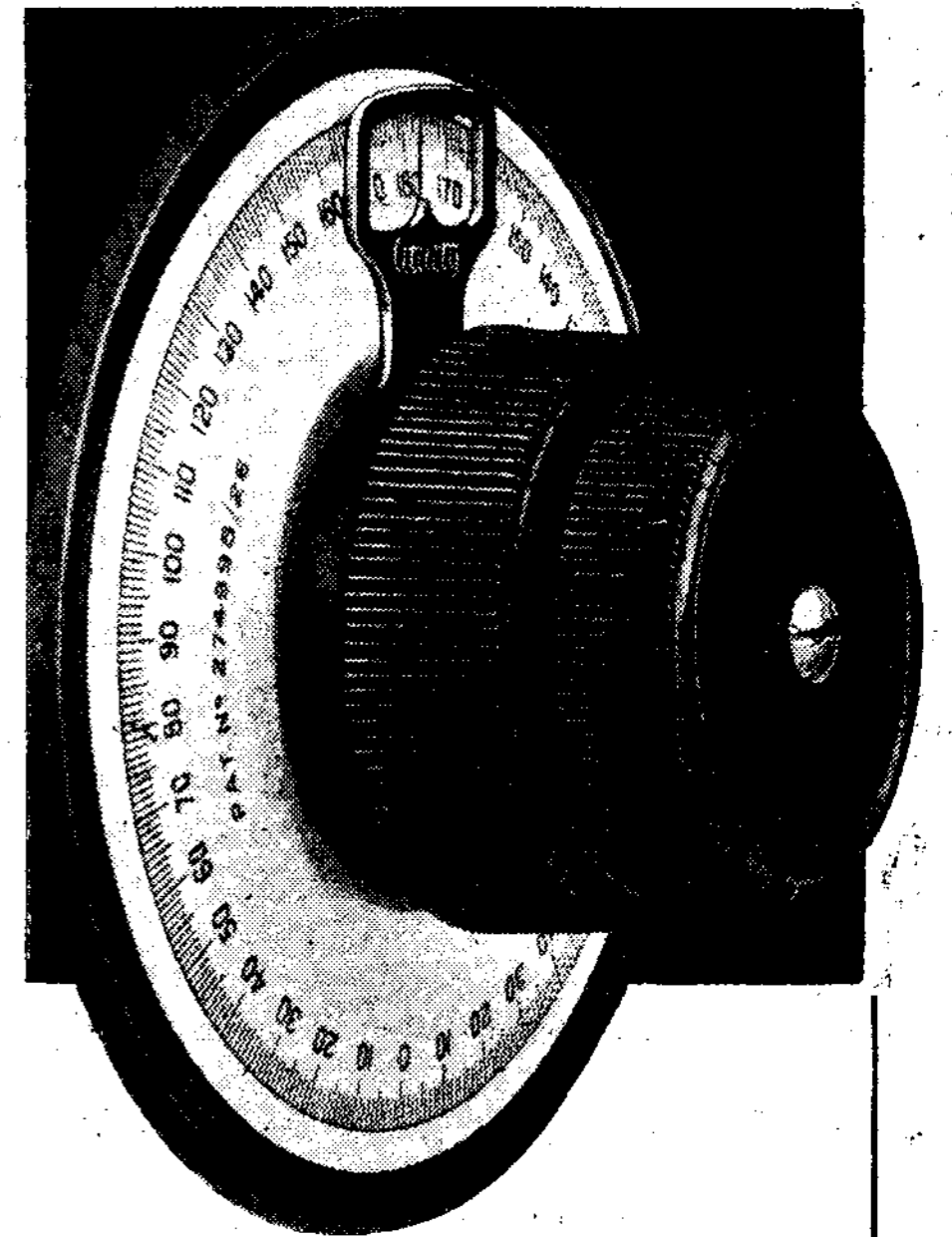

A GOOD DIAL

A good dial is W 181. Being free of gadgets and without complications it suits the womenfolk who want only the local station. Being free of the snags that usually go with a S.M. dial it suits the S.W. worker who wants the best control available.

W 181 is a true micro dial. The ratio is 100 to 1—the drive is frictional and guaranteed free from backlash. The open scale is surveyed by line and cursor, and as the line is a real hair line without appreciable thickness, very accurate readings can be taken even of the subdivisions.

A GOOD CONDENSER

W 187, our short-wave condenser, is equally good. Designed by S.W. experts for the use of S.W. experts, it is the ideal condenser for workers in this field. It is built with the precision of laboratory apparatus, yet is sold at a price which competes with the ordinary type of condenser.

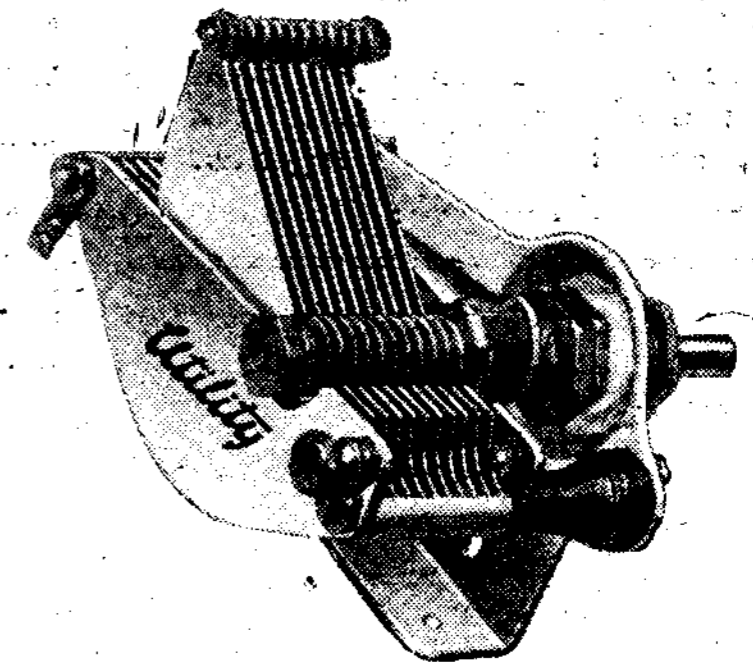

- W 181 S.M. Dial'... .. 7/6.
- W 187 S.W. Condenser ... 6/6.
- The two together... .. 13/-.

From all good dealers or post free from the makers of the world's finest condensers.

WILKINS & WRIGHT, LTD.
UTILITY WORKS, HOLYHEAD ROAD, BIRMINGHAM.

AGENTS—London: E. R. Morton, Ltd., 22 Bartlett's Buildings, Holborn Circus, E.C.1; Scottish: E. B. Hammond, 113 Vincent Street, Glasgow; Lancashire and Cheshire: J. R. Lister, 93, Old Road, Blatchley, Manchester; Westmorland, Cumberland, Durham, Northumberland, Yorkshire and Derbyshire: H. C. Rawson Ltd., 100 London Rd., Sheffield; South Western: Lawrence Fraser, Chelsea House, Lansdown Road, Bath.

PERFECT RECEPTION

FROM THE "WORLD RADIO" "SHORT WAVE ADAPTOR"

described in this issue

Can ONLY be obtained with the use of

STANDARD

Leclanche H.T. Batteries
High Tension at Even Tension

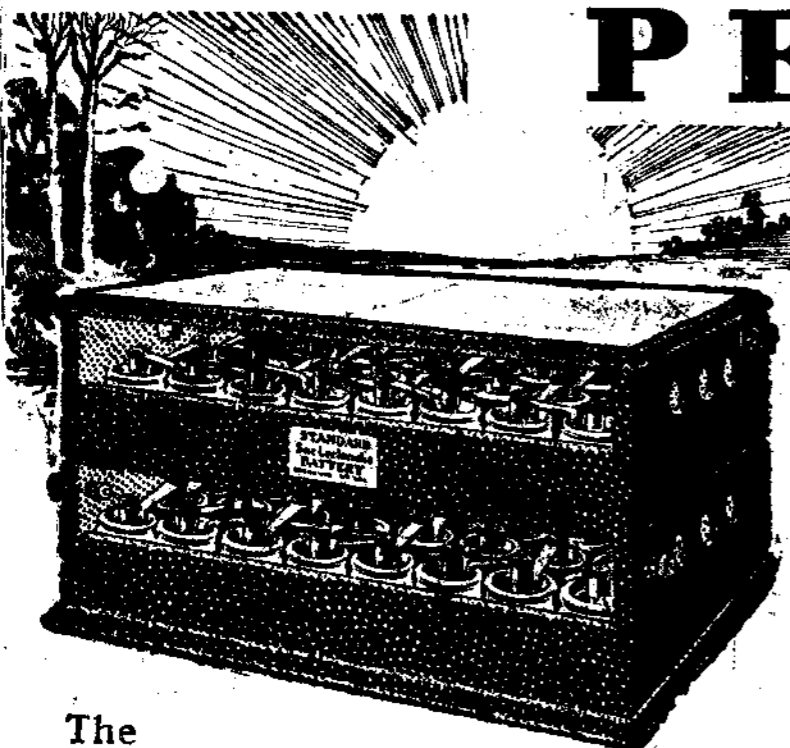

The Self-Charging Battery that is always "as fresh as the Dawn."

MAINS cause "HUM,"
DRY BATTERIES cause "BACKGROUND."

The high capacity self-charging Standard Battery provides the steady flow of "constant pressure" voltage so essential for clear, efficient reception on all short wave sets.

No matter how much you use it, it constantly provides abundant H.T. current without any attention for years. The secret IT RE-CHARGES ITSELF OVERNIGHT and is fresh as the dawn every morning.

Send for **FREE BOOKLET** describing every detail for installing this super-efficient and money-saving Battery.

SPECIAL BATTERY SUITABLE FOR THE "Short Wave Adaptor" Type H.5. 126 Volts, 84 Cells, complete with chemical (Trays extra) Cash 53/- or 5/- **DOWN SECURES**, balance in easy monthly payments. Single Cells at 1½ Volts each from 4½d. each.

All types of the battery are obtainable from Halford's and Curry's Cycle Stores and all Wireless Dealers.

Leaflets from **STANDARD BATTERY CO.,**
184-188, Shaftesbury Avenue, W.C.2.

DEALER'S NOTE:—You are losing business if you do not stock the Standard Battery.



CALIBRATE YOUR SET NOW!

The possibilities of distant listening (particularly in the winter) are very great. This entirely new booklet, just published, explains how you can arrange the tuning of your set on a definite, systematic basis, so that any station required can be tuned to immediately; and any station accidentally obtained whilst tuning is readily identified! The process of calibration, as described, is perfectly simple, and requires no technical knowledge. The booklet, which is in the shape of a wallet, and incorporates a pocket in which notes may be kept, is called

WORLD-RADIO CALIBRATION CHARTS WALLET

It costs one shilling post free, from the B.B.C. (Publications Department), Savoy Hill, London, W.C.2.

Camco Cabinets for YOUR Philips' Set and Speaker!

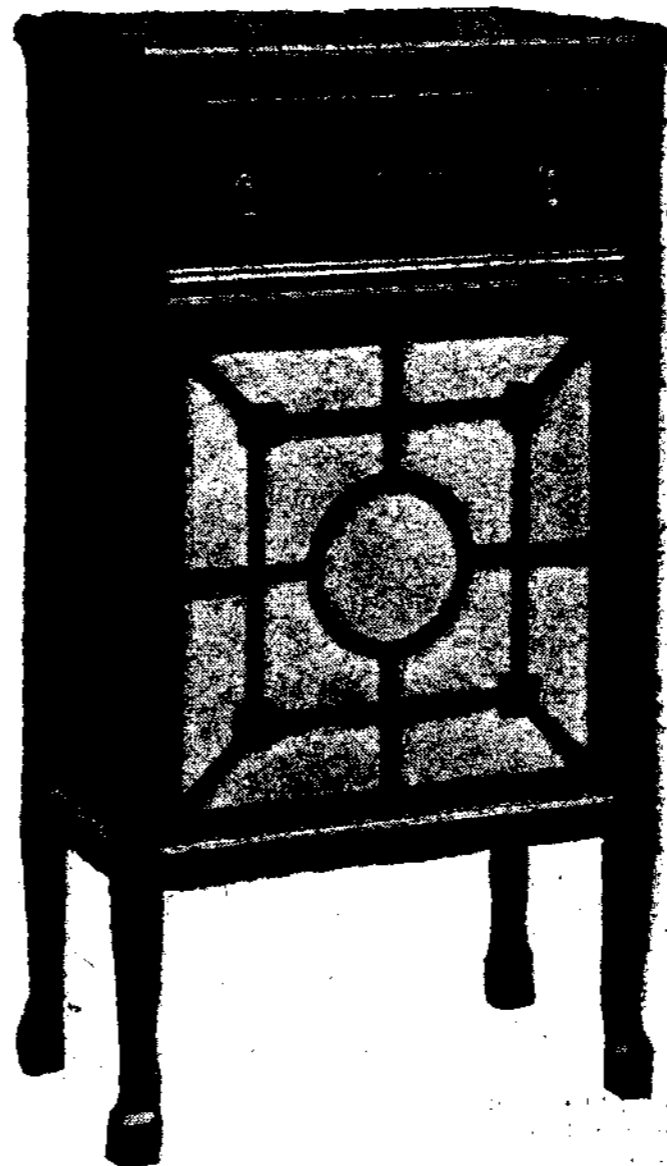

Make your Philips' 3 or 4-valve set more in keeping with the furnishing of your room. By housing it in a Camco Cabinet you can convert it into a handsome self-contained Console Receiver. No drilling or fixing required. Just place your set and speaker in the Cabinet and connect up—that's all! In Oak or Mahogany from £6. Write for FREE copy of the new 24-page Catalogue giving full particulars and details of the Cameo range.

10% DISCOUNT IF ORDERED BEFORE DECEMBER 15th. FREE DELIVERY IN ENGLAND, SCOTLAND AND WALES.



CARRINGTON MFG. CO., LTD.,

Showrooms:—
24, Hatton Garden, London, E.C.1.

Phone: HOLBORN 8202.
Works: S. Croydon.

NAME.....

ADDRESS.....

W.R. 22.

TRUSSES ABOLISHED

The Great British RUPTURE Treatment supported by the MEDICAL PROFESSION

If you are ruptured, send now for Free Booklet describing the most wonderful appliance ever invented for your relief and comfort. It is just a neat, washable little belt with a pad you inflate in a second to just the pressure required. You can adjust it in a moment, and it cannot possibly slip out of place. It is so light and comfortable that you positively will not know you have it on. Indeed, you will forget the rupture altogether. It holds the Hernia with such gentle firmness that in nearly every case the broken tissues re-unite, and the rupture is conquered for ever. No wonder doctors everywhere recommend it. "The Lancet" has endorsed it. Write now to:—

Beasley Surgical Appliance Co., Dept. 103, 26, Charing Cross Rd., London.

SLIM SAFELY

WITHOUT MEDICINE OR EXERCISE IN A Beasley REDUCING BELT-SUPPORTER

This Belt slips on over the hips and instantly conforms to the outline of the figure. No fasteners, no straps, no lacing. An excellent general purpose belt for either sex. Ideal for reducing obesity. Ensures fitness and support. Made of stout woven Elastic Webbing. 4 suspenders fitted to women's model. Money refunded if unsuitable.

Send p.o. 4/11 now to
BEASLEY BELT DEPT. 103A,
26 CHARING CROSS ROAD,
LONDON, W.C.2.
This Belt also supplied in Superior Quality 7/11, 0/S. 9/11. Fine Quality Silk Elastic 12/11, 0/S. 14/11.

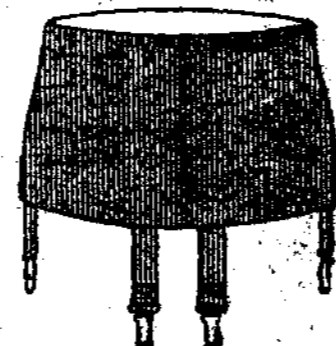

for men and women

Now Reduced from 6/11 to 4/11 9" or 11" depth

Over 36in. 1/9 extra.

A Crystal Set can operate it as well as the most powerful Amplifier!

It makes a poor set good and a good set better. The HYPER Reproducer is entirely British and is used as the standard of efficiency in the laboratories of numerous leading wireless manufacturers in this country and abroad.

Have the same efficiency in your own home. For power and purity the Colassion Hyper challenges any speaker, irrespective of type. Height 18 1/2 in., diam. 16 1/2 in. Depth 9 in. Diam. of Cone 1 1/2 in. Five years' guarantee. £3. 10s.

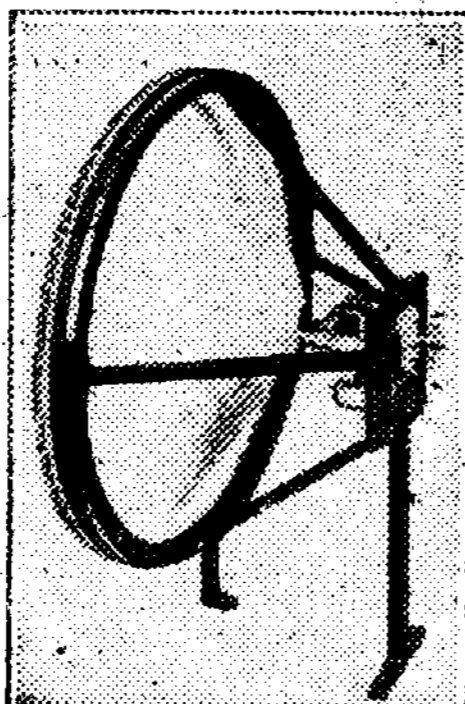

COLASSION

Also try the Colassion Pick-up—a wonderful production—complete with Tone-arm, £1 7s. 6d. Post Free. Send for particulars to W. L. COLASSI, A.I.P.I., Mark Lane, Station Buildings, London, E.C.3.

Name

Address

H Y P E R
MOVING-IRON
LOUDSPEAKER
C H A S S I S

Play your records through your Radio Set—Two minutes alteration only—The Harlie Booklet tells you how—

POST COUPON FOR YOUR COPY-FREE



All Harlie Pick Ups feature amazing feather-weight adjustment on Needle Point.

THE FAMOUS HARLIE PICK UP IS NOW STOCKED BY EVERY DEALER. ASK FOR A DEMONSTRATION.

To Harlie Bros. (Edmonton) Ltd. Dept. W.R. Balham Road, Edmonton, London, N.9.

Please send me the Harlie "Pick Up" Booklet.

NAME.....

ADDRESS.....

**ENERGISE YOUR MAGNAVOX
FROM THE MAINS**

The Magnavox range of Mains-energised Speakers consists of three models, styled D.C.140, D.C.142, D.C.143, cone diameters being respectively 7, 8 $\frac{1}{2}$ and 10 $\frac{1}{2}$ inches. Each model is obtainable in two types. Type "H" is suitable for direct connection to D.C. mains of 190 to 250 volts, while type "L" is suitable for use with A.C. sets, the field coil being used as a smoothing choke as described in "The Wireless World," July 15, 1931. In every model, input is through a universal transformer having Permalloy core and capable of taking up to 50 m/a. Centre tapping makes this transformer suitable for either High or Low Impedance Power Valves or Pentodes.

D.C.140 "H"	£2 12 6	D.C.140 "L"	£2 10 0
D.C.142 "H"	£2 17 6	D.C.142 "L"	£2 15 0
D.C.143 "H"	£3 2 6	D.C.143 "L"	£3 0 0

Write for full literature :

MAGNAVOX • (GREAT BRITAIN) LTD
89 Kingsway - - - - - London, W.C.2

THE BBC YEAR BOOK IS PUBLISHED TO-DAY!

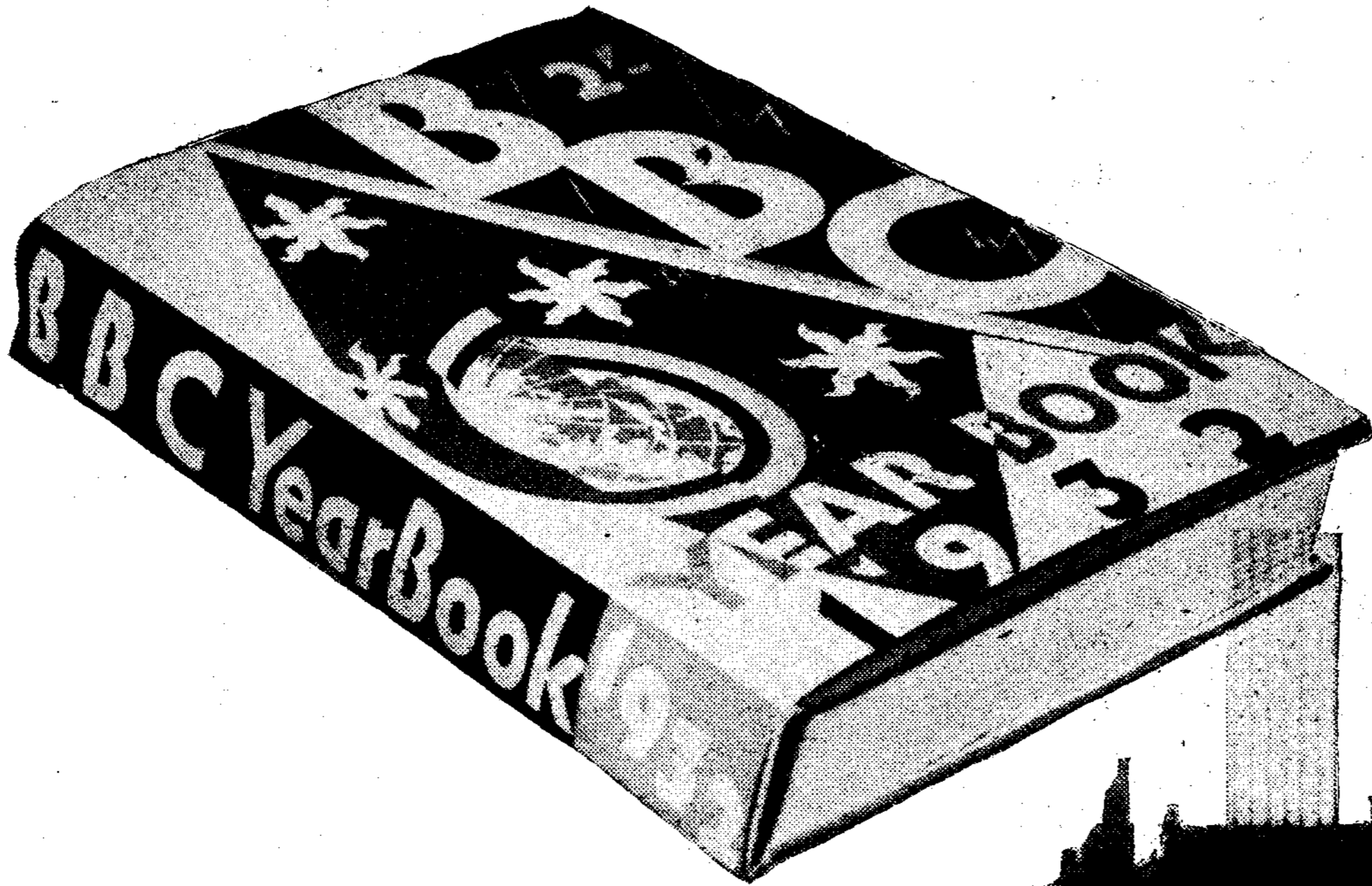

Here is the whole story of modern broadcasting told in four hundred and eighty pages, pictured in more than a hundred and fifty magnificent illustrations. For the radio enthusiast there is a technical section of a hundred and fifty pages, containing unique diagrams. The general listener will learn all he wishes to know from this, and from the two hundred pages of the programmes section.—The demand for the 1932 Year Book will be enormous. The retailers have taken practically the whole edition. Make sure TO-DAY of your copy! Order it now. It costs TWO SHILLINGS!

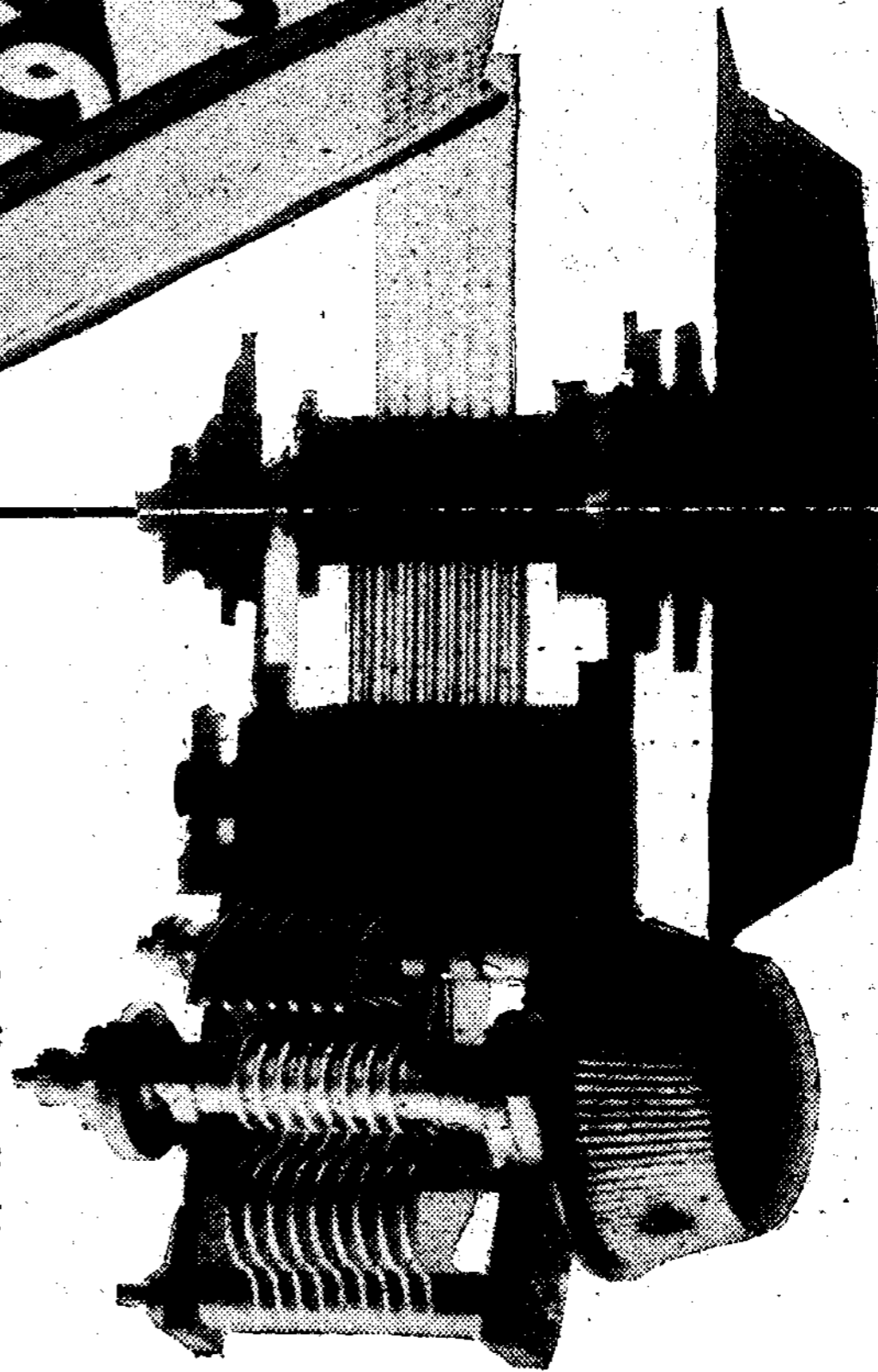

PRICE

TWO SHILLINGS

FROM BOOKSELLERS, NEWSAGENTS & BOOKSTALLS THROUGHOUT THE COUNTRY

THE MICA BRIDGE WHICH MEANS BETTER RADIO

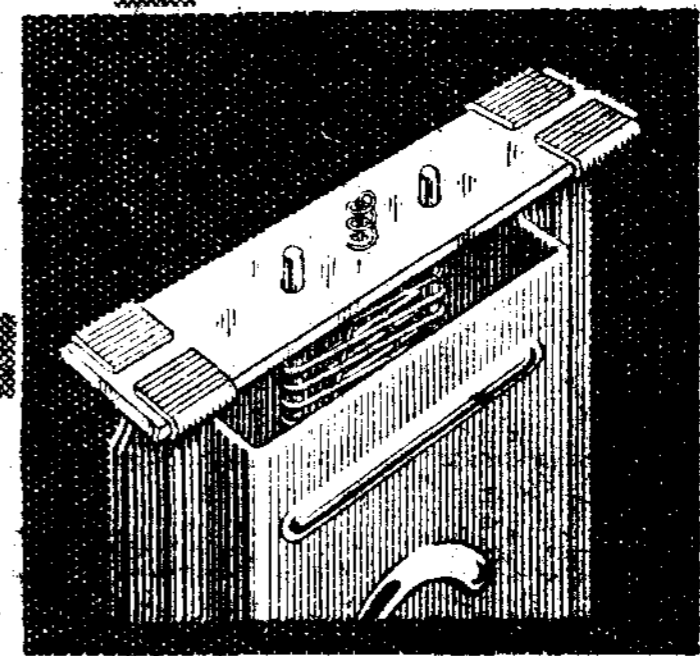

YOU can considerably improve the performance of your Receiver by fitting Cossor Valves. This is made possible by their outstanding efficiency which is largely due to the Mica Bridge method of mounting and Multiple Point Suspension—advanced constructional features now employed in all Cossor Types.

**— a high-efficiency
multi-purpose valve**

Used in the H.F. stages of non-screened grid Receivers the Cossor 210 H.L. gives considerably greater amplification. Used as a Detector it ensures distortionless rectification and high sensitivity. And as a first L.F. amplifier it gives excellent results in either transformer or R.C.C. stages.

A new edition of the Cossor Station Chart is now available, price 2d. Ask your Dealer for a copy of this useful novelty, or write us enclosing 2d. stamp,

THE COSSOR

**ALL BRITISH
210 H.L.**

A. C. COSSOR LTD., Highbury Grove, London, N.5. Depots at Birmingham, Bristol, Glasgow, Leeds, Liverpool, Manchester, Newcastle, Sheffield and Dublin. 15 ♡ 9407

To: **Mrs. A. C. COSSOR LTD., Ma'ody Dept., Highbury Grove, London, N.5.**

Please send me, free of charge, a copy of the 72-page Cossor Valve and Wireless Book, B11.

Name.....

Address.....

W.R. 27/11/31.