

WIRELESS, incorporating 'Wireless Weekly,' NOVEMBER 6, 1926.

# WIRELESS



INCORPORATING  
WIRELESS WEEKLY



Vol. V.] NOVEMBER 6, 1926 [No. 12

## HOW TO WORK YOUR MONODIAL

CAN WE RUN OUR  
VALVES ON A.C.?

By J. H. REYNER, B.Sc. (Hons.), A.M.I.E.E.

[Registered at the G.P.O. as a Newspaper.]

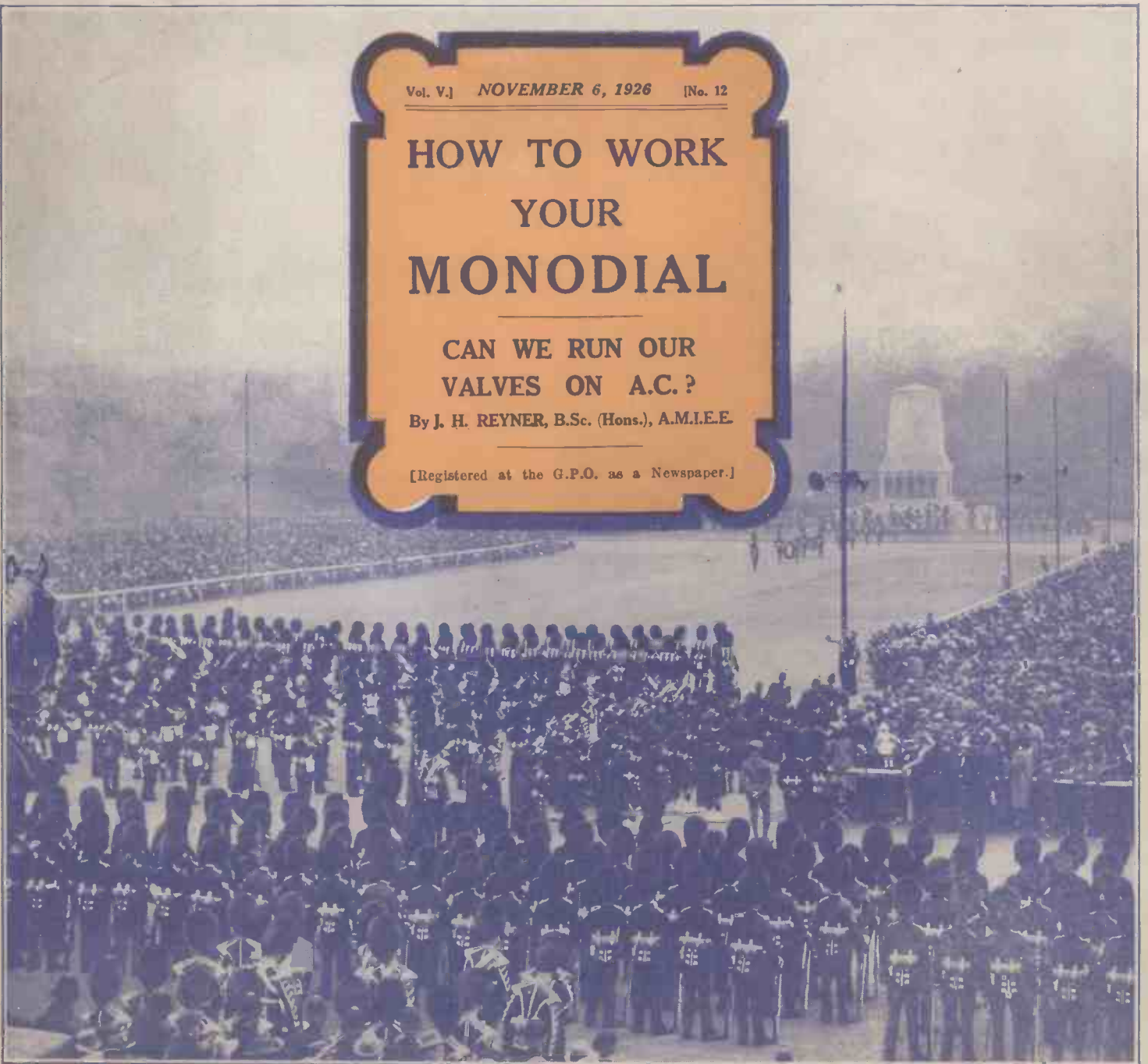

# Two interesting receivers published in Issue Now on Sale

**THE "DRAWING ROOM FIVE."** The set described by John Underdown has been designed with the object of giving good all-round results. It will give excellent reproduction from the local station and very good loud-speaker signals on many British and Continental stations. As will be seen from the accompanying illustration, the L.F. Coupling is by the resistance-capacity method. A volume control is provided which enables very loud signals to be adjusted to the strength required.

**A "PUSH-PULL THREE."** This receiver, incorporating the push-pull method of amplification, has been specially designed for those home constructors who, possessing a number of general purpose valves, desire to obtain power valve results without purchasing special L.F. Power Valves. Mr. Stanley G. Rattee is the author.

**BUY YOUR COPY TO-DAY**

**1/-**  
MONTHLY

**MODERN  
WIRELESS**

Obtainable from all Newsagents, Booksellers or Bookstalls, or direct from the Publishers, Radio Press, Ltd., Bush House, Strand, London, W.C.2. Subscription Rates 15/- per annum (13/6 per annum Canada and Newfoundland). Lesser periods *pro rata*.

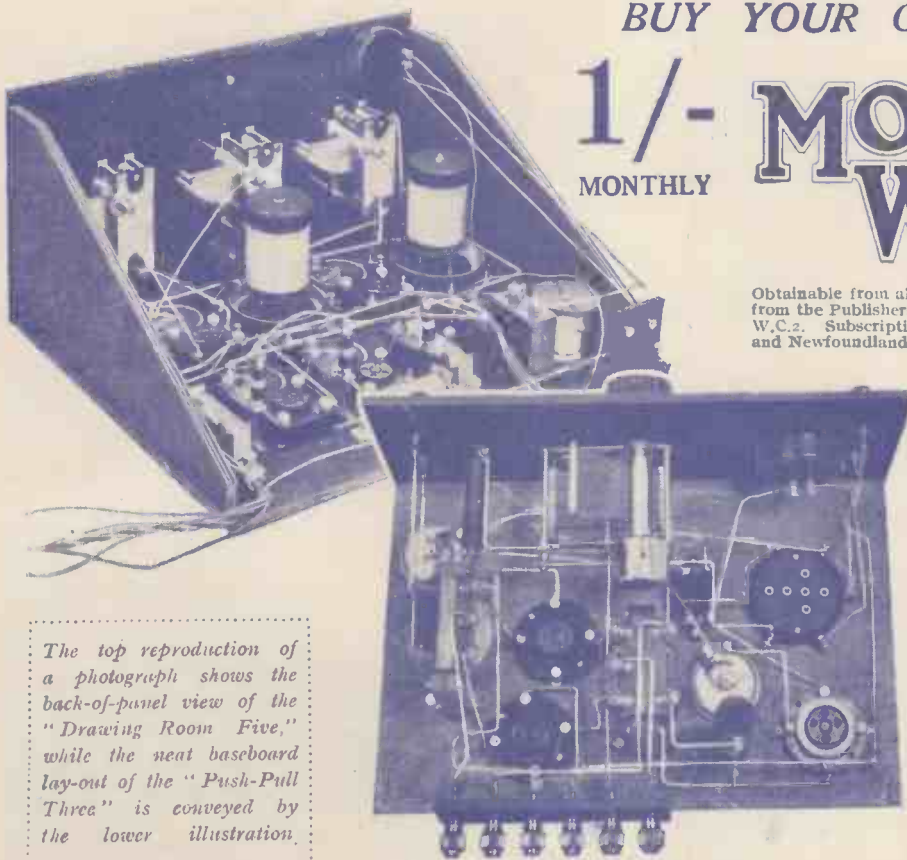

The top reproduction of a photograph shows the back-of-panel view of the "Drawing Room Five," while the neat baseboard lay-out of the "Push-Pull Three" is conveyed by the lower illustration.

**Contents of this issue also include:**

Some Further Notes on the "Solodyne"

The "Elstree Six" (Further Hints on Operation, etc.)

Day and Night Effects

By G. P. Kendall, B.Sc.

What-Jack Shall I Need?

By A. V. D. Hort, B.A.

Neatness and Efficiency (A Crystal Set)

By H. Bramford.

For the Short-Wave Novice

By L. H. Thomas (6 QB.)

Points about Battery Eliminators

By J. H. Reynier, B.Sc. (Hons.).  
A.M.I.E.E.

*This Magazine published "The Elstree Six"*

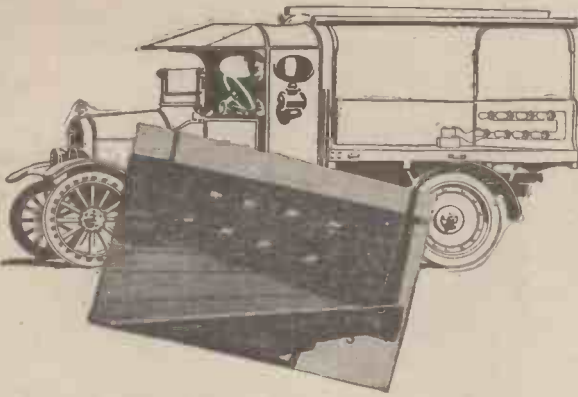

*Here's Proof that  
the 'LOTUS' Survives  
Shock and is  
anti-microphonic*

**E**IGHT 'Lotus' Valve Holders fitted with large power valves and fixed to tailboard of a Ford motor lorry, driven over rough roads for 30 miles, survived the test.

At the finish each spring was as it started—perfect. No damage or looseness at the connection of leg socket and spring—no valve became loose from the holder. Both were electrically perfect all the way.

That is why we guarantee the security of 'Lotus' Valve Holders against shocks and vibration. Fit the 'Lotus' to your set and protect your valves.

*From all Radio Dealers.*

**LOTUS**

BUOYANCY  
**VALVE HOLDER**  
ANTI-MICROPHONIC

Pat. No. 256833.

Made from best bakelite moulding with springs of nickel silver and phosphor bronze valve sockets.

**GARNETT, WHITELEY & CO., LTD.,**  
Lotus Works, Broadgreen Rd., Liverpool.  
*Makers of the famous "Lotus" Vernier Coil Holder*

**Prices:**  
Combina-  
tion Grid  
Leak and  
Valve  
Holder

**3/9**

VALVE  
HOLDER  
With  
Terminals

**2/6**

VALVE  
HOLDER  
Without  
Terminals

**2/3**



**The World's Ears  
in the making**

**L**ONG before Broadcasting was ever thought of in England, the name Brown was indubitably bound up with Wireless Headphones.

On the high seas, ships' operators relied upon them to receive vital messages; on the fields of war, when thousands of precious lives depended upon messages going through, the Army put their faith in Brown A type 'phones; the Navy, many other Government services, and the World's Cable Companies—all have for long chosen the Brown as the supremely sensitive and utterly dependable Headphone.

What better recommend-  
ation could you desire

than the faith so many vital Services have placed in the Brown? Whether you buy the famous original A-type, the new A2 (unequalled anywhere at thirty shillings) or the popular Featherweights, you know you are getting a headphone constructed on the same unique Brown principles, with the same Brown high standard of manufacture, and which, you can be sure, will give the same Brown incomparable service. Don't ask for Head-  
phones—follow the experts' choice and say "Brown!"

**Type A2  
Headphones**

Brown A2 Headphones are famous for their astonishing sensitiveness, astounding responsiveness, and superior tone. Many crystal users have obtained a large increase in volume by their use, while valve users in many countries prefer them for long distance reception. In re-  
sistance of 2,000 ohms. Price **30/-**

**Brown**

**S. G. BROWN, LTD., NORTH ACTON, LONDON, W.3**

*Retail Showrooms:* 19, Mortimer Street, W.1. 15, Moorfields, Liverpool  
67, High Street, Southampton. *Wholesale Depots:*—2, Lansdowne Place West,  
Bath; 120, Wellington St., Glasgow; 5-7, Godwin St., Bradford; Cross  
House, Westgate Road, Newcastle; Howard S. Cooke & Co., 59, Caroline St.,  
Birmingham. N. Ireland: Robert Garmany, Union Chambers, 1, Union St.,  
Belfast. G.A. 6163.

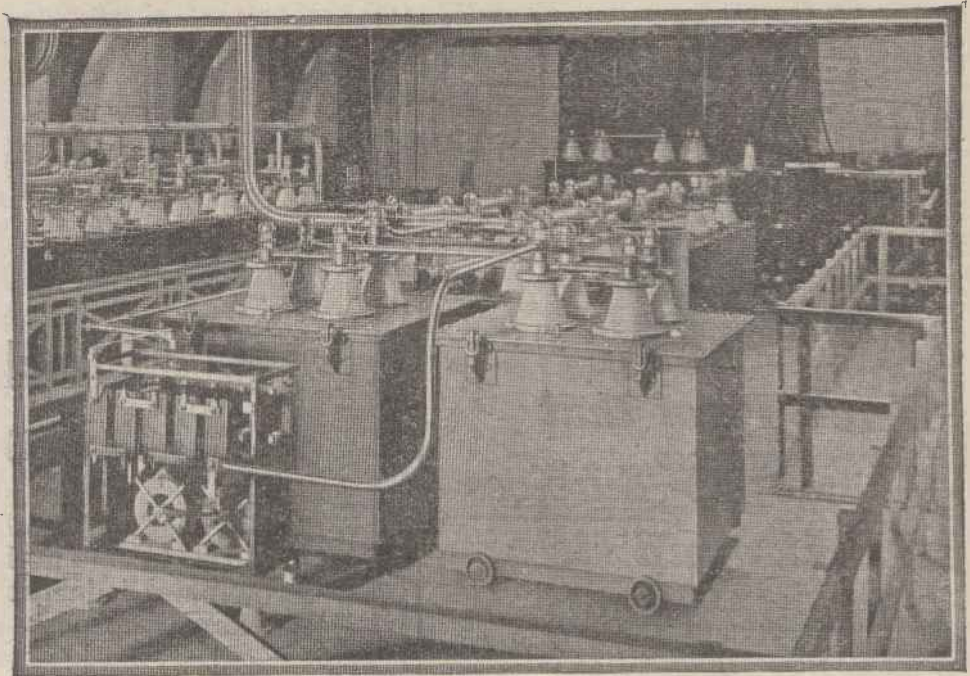

## Specify Dubilier!

**NATIONAL  
WIRELESS WEEK—**  
*Let your Friend  
Listen.*

Sixteen years ago we commenced manufacturing wireless condensers.

In those days, electrical condensers certainly existed but they were totally unsuitable for wireless purposes. Accordingly we made a minute study of the subject and, as a result of careful observations over long periods, we were enabled to design condensers in which hysteresis losses, insulation leakage and numerous other factors opposed to condenser efficiency were either reduced to the minimum or eliminated completely. The small, meticulously sealed groups of mica and metal plates which form the essential units of the familiar 600 Type condensers are the direct outcome of these observations.

They represent the very high standard of electrical efficiency to which modern science has brought the condenser, and it is interesting to note that these identical units grouped in their tens of thousands, make up the Condenser Banks of the world's principal wireless stations.

In the Condenser equipment of the Government Radio Station at Rugby, of which we show a view above, there

are in each of the large "tanks" over half a million of such mica and metal plates grouped into hundreds of condenser units.

Each of the many millions of plates was individually selected and tested before being collected into groups, and each group was again subjected to frequent and stringent tests during the successive stages of assembly.

This ritual of tests, tests, and more tests is observed in the case of every single product bearing the Dubilier name.

Our long experience has taught us that if we are to make condensers which will be satisfactory in service whether they are designed for High Power Stations or for Broadcast Receivers, we must take precautions to eliminate every possible cause of failure. As Condenser Specialists we know these precautions to be not only desirable but essential.

Governments and Manufacturers of Broadcast Receivers all over the world, agreeing with us in this matter, specify Dubilier.

Are there Dubilier Condensers in your set?



Specify—



ADVERT. OF THE DUBILIER CONDENSER CO. (1925) LTD.,  
BUZON WORKS, VICTORIA ROAD, NORTH ACTON, W.2.  
TELEPHONE: CHISWICK 2241-2-3.



# WIRELESS

INCORPORATING  
WIRELESS WEEKLY

Published by  
RADIO PRESS, LTD.,  
Bush House, Strand, London, W.C.2.

All communications concerning contributions should be addressed to the Editor and must be accompanied by a stamped addressed envelope if the return of MSS. is desired.

Nothing contained herein is to be regarded as encouragement or permission to infringe any patent rights.



## THIS WEEK'S NOTES AND NEWS

### Beam Achievements

**A**T last "Beam Wireless" is a fact, and no longer a vision of the future! Judging from the early results, too, it is a very real fact—not much room for doubt is left when one can send a twenty-word telegram to Canada for 2s. 6d.! Telegrams are sent in just the ordinary way, but marked "Via Empiradio." I understand that the Beam Radio and the existing cable will be used "on parallel lines." If one is blocked with traffic the other will come into action, and vice versa.

### A Puzzle

**H**AVE you listened to the Communist propaganda broadcast from Moscow? What started the idea that it was from Moscow that it came I really don't know, but certain worthy gentlemen now seem to think that Hilversum is the guilty one, broadcasting religious and political propaganda. Personally, I am inclined to think the offending transmission came from Mars!

### Perhaps!

**I**NCIDENTALLY, did you hear Mars last week? I wonder whether the Martians were listening for us with their 14-valve super-heterodynes? I am at present trying hard to receive them on the "Monodial."

### Thanks

**A**GENTLEMAN has been so good as to write and enlighten me on the subject of M. Verdan's atmospheric eliminator, which, in reality, can only be used in conjunction with the Baudot system of signalling. I was very interested in my correspondent's letter, but I hope he did

not take my remarks too seriously! I never do myself!

### A New Station

**A** NEW broadcasting station for Kallundborg, Denmark, is just being built by Messrs. Standard Telephones and Cables, Ltd., and will shortly commence operation, it is hoped, with a power of 5 kilowatts.

### To Come

**I**AM informed that on November 10, at 7 p.m., Mr. A. H. A. C. Cran-

from the Lisbon station. In case you think this time is rather late, I had better remind you that the Portuguese do not believe in "early to bed and early to rise." They get up very, very late in the morning and dine at about 9 p.m. This bulletin reaches them just as their evening is getting well under way.

### We Hope So

**I**UNDERSTAND that it is possible that the Rev. H. R. L. Sheppard, well known to regular listeners and to all who know St. Martin-in-the-Fields, may associate himself fairly closely with the B.B.C. in future. He may truly be said to be the first clergyman to realise the great congregations that could be reached by wireless, and the first broadcast service in this country was, of course, from St. Martin's in 1924.

### A Common Mistake

**A** PARAGRAPH I was reading a little while ago states, very truly, that nearly everyone makes the mistake of buying an accumulator that is too small for his needs, and has to replace it with a larger battery later on. I think this applies especially to those just making a start in wireless, since they do not realise what their needs will be until too late!

### A Suggestion

**A** FRIEND of mine, who is by nature rather inclined to "grouse" at everything without really meaning anything, tells me that he is going to record any specially good broadcast programmes ("if there ever are any," as he says) and "put them on" again when the evening's programme seems to be particularly

(Continued on next page.)



The scene in the studio at 2LO during the transmission of "The Passing of The Third Floor Back," the radio play recently broadcast from the London station.

mer will read a paper entitled "High-Speed Transmission" before the Institute of Wireless Technology. Any particulars of this lecture or of the Institute may be obtained from the Hon. Assistant Secretary at 71, Kingsway, W.C.2.

### Late Hours

**T**HE Portuguese Government has just commenced broadcasting a special bulletin of political and other information, commencing at 11 p.m.,

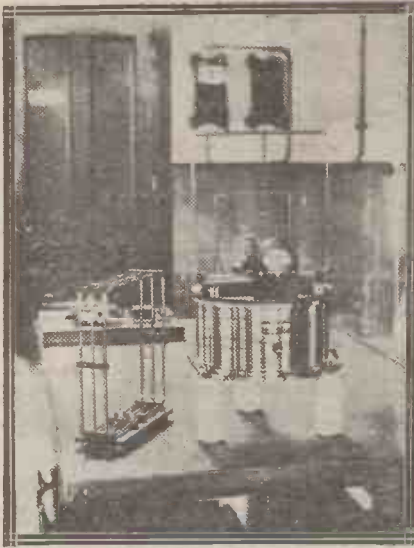

The "beam" wireless service between England and Canada is now in operation, and our picture shows the standard wavemeter which is in use at Bodmin.

boring. I think he would be more on the right road if he recorded a boring programme, put it on when anything particularly good was being broadcast, and said, "How they have improved!" Auto-suggestion counts for a lot in radio.

#### A New Voice

MR. ERIC DUNSTAN'S successor at 2LO is the Hon. David Tennant, brother of Lord Glenconner. He has already made several announcements from 2LO, but I doubt if listeners have yet succeeded in identifying him.

#### A Contrast

TRANSATLANTIC telephony is going strong now, although short waves are not used! Rugby continues to transmit our dear old friend, "speech in the experimental stage," and the Radio Corporation of America is experimenting on the other side. It is rather interesting to note that

## THIS WEEK'S NOTES AND NEWS

(Continued)

atmospherics are the chief trouble in connection with this work, whereas they were hardly considered at all when the beam system to Canada started up!

#### A Grievance

A FRIEND of mine, who has recently been doing an enormous amount of short-wave work, poured out his troubles a few nights ago. "These short waves," he said, "kill that itch for distance completely. When you hear an Australian station coming in as if he were next door you do get a thrill at first; but afterwards you get so used to it that you think nothing of hearing the Antipodes every evening. When you come back to the broadcasting band you are simply bored stiff when you pick up a station and find that it is only Madrid or Oslo!"

#### An Interesting Talk

ON December 2 we are to hear Mr. Ramsay MacDonald from 2LO. He will broadcast a talk on "Forty Days and Forty Nights in the Sahara," dealing with the desert holiday which he is taking at the present time.

#### A Real Puzzle

DO any of the B.B.C. announcers speak correct English? This old question has cropped up again. Londoners are apt to think that 2LO's announcer is speaking perfect English, but what do our Northern friends



Another picture taken at the Bodmin Beam Transmitting Station, showing the box in which the aerial coupling coils are housed.

think about them? And is John Henry's English any less correct than that of the chief announcer at 2LO? Personally, I think this question will be unanswered until someone answers the other one, "What is correct English?"

#### Be Careful

NEXT week, November 7-13, is "National Wireless Week." The slogan is "Let your friends listen." This is all right, but my advice is, "Let your friends listen, but for Heaven's sake don't let them oscillate, or do it yourself, either!" Even a most refined, subdued screech on the part of a set is most upsetting to some, and the one thing we must not do during the week is to give bad impressions of radio. Also, don't let your friends listen if your loud-speaker bears any resemblance to the now proverbial "bad gramophone."

CALL-SIGN.

### AT THE UNVEILING



The impressive scene at the unveiling of the Guards' Memorial on the Horse Guards' Parade. Large banks of public-address loud-speakers were employed so that all might follow the service. A particularly elaborate installation of loud-speakers was used, another view of which may be seen on our cover this week.

# TRACKING THEM DOWN!

## THE MONODIAL IN ACTION

### How to Operate "The Set Which Realises Your Ambitions"

This week's article on the "Wireless" Star Single-Dial Receiver gives full and complete instructions for neutralising the set, balancing the circuits, searching for distant stations and generally getting the best results.



HAVING completed the construction and wiring of the Monodial, checked over the connections and tested the L.T. and H.T. circuits, we must now decide on what valves are to be employed. Those who have the requisite valves or who know exactly what different kinds will be needed may like to skip the following paragraph, since it will deal broadly with the valves wanted in the Monodial.

#### Types

Later in the article some kinds of valve which have been tried out in this set will also be given, but what is to be determined at present is the actual type of valve that is to be used in different positions. For the high-frequency and detector valves I have found that best results are to be obtained with valves having a high impedance and a high amplification factor, and the beginner to valve work should bear in mind that the two do not always go hand in hand. A glance through the specifications of different types and makes of valves will show that though two valves may have exactly the same impedance, totally different amplification factors are obtained. As a guide to the uninitiated I may mention that suitable valves will be those having impedances in the neighbourhood of 20,000 to 30,000 ohms together with an amplification factor in the region of

15 to 25. These figures are, of course, intended only as a rough indication of what to use.

In many cases it will be found that general-purpose valves may be used with quite satisfactory results in the two positions given, while a valve of this description will usually do quite well for the first low-frequency amplifier.

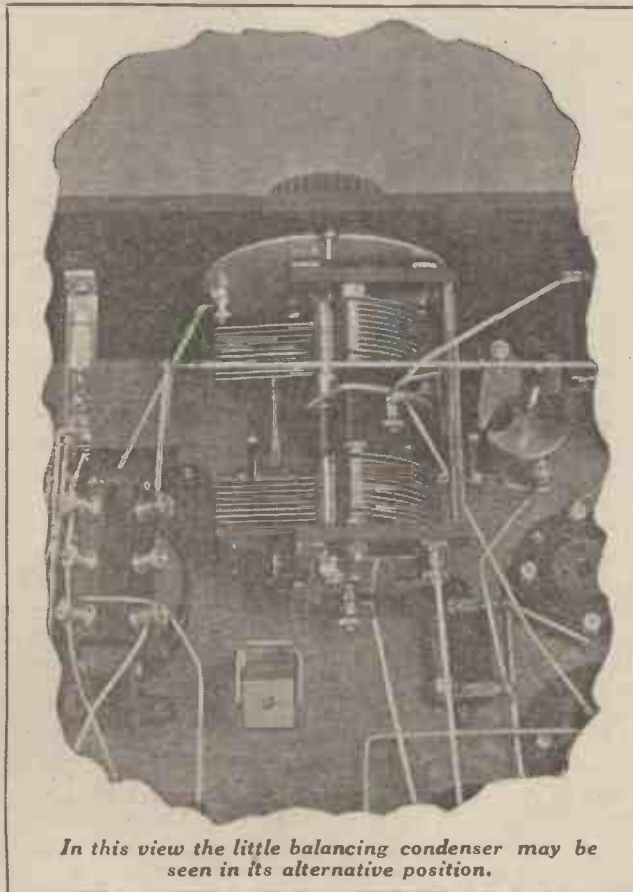

In this view the little balancing condenser may be seen in its alternative position.

#### The Last Valve

For the second low-frequency valve it is desirable that a small power valve be used, since it will have to handle quite a fair amount of volume, especially on the local station.

The type of valve having been decided on, it only remains to determine what filament voltage will be most convenient, and this, of course, depends on the experimenter's personal preference. This may frequently be influenced by the fact that the nearest charging station may be a five-mile walk, and a 6-volt accumulator which appears fairly light during the first half mile speedily increases in weight.

#### Filament Resistances

These points having been settled, you will now know what resistance will be required to run the filaments of the valves at the correct temperatures, but if there is any doubt as to what value of resistance to use with any particular valve and its associated battery, it will be as well to consult the makers of the valve you intend to use.

If it is desired to experiment with one or two different types of valves it will be as well to have a selection of resistors on hand. In this case considerable care should be exercised when changing over valves, else damage may result when trying to run a 2-volt valve off a 6-volt battery with a resistance suitable for working a 4-volt valve.

(Continued on next page.)

## Tracking Them Down!—continued

### The First Test

I will now assume that the valves together with the fixed resistors have been obtained and the set is about to be tested out on the aerial.

Connect the batteries, aerial and earth leads, insert the valves and coils and screw the resistors into the correct adaptors. Tune in the local station by turning the tuning dial to the reading given in the list of stations obtained.

together and adjust the two halves separately by means of the tommy-bar provided and the dial controlling the condenser nearest the panel till the local station is heard at its greatest strength.

The high-frequency valve should now be neutralised. Turn out this valve by removing the left-hand fixed resistor from its socket. It may be found that, as soon as this is done,

approximate setting for valves such as the D.E.5B, P.M.5, S.T.61, Cleartron C.T. 25B, etc., will be with the moving vanes halfway in.

For valves of lower capacity the moving vanes will only need to be about a third the way in or only just entering. The exact setting will, of course, have to be determined by experiment, but the above will give a rough idea of what to expect.

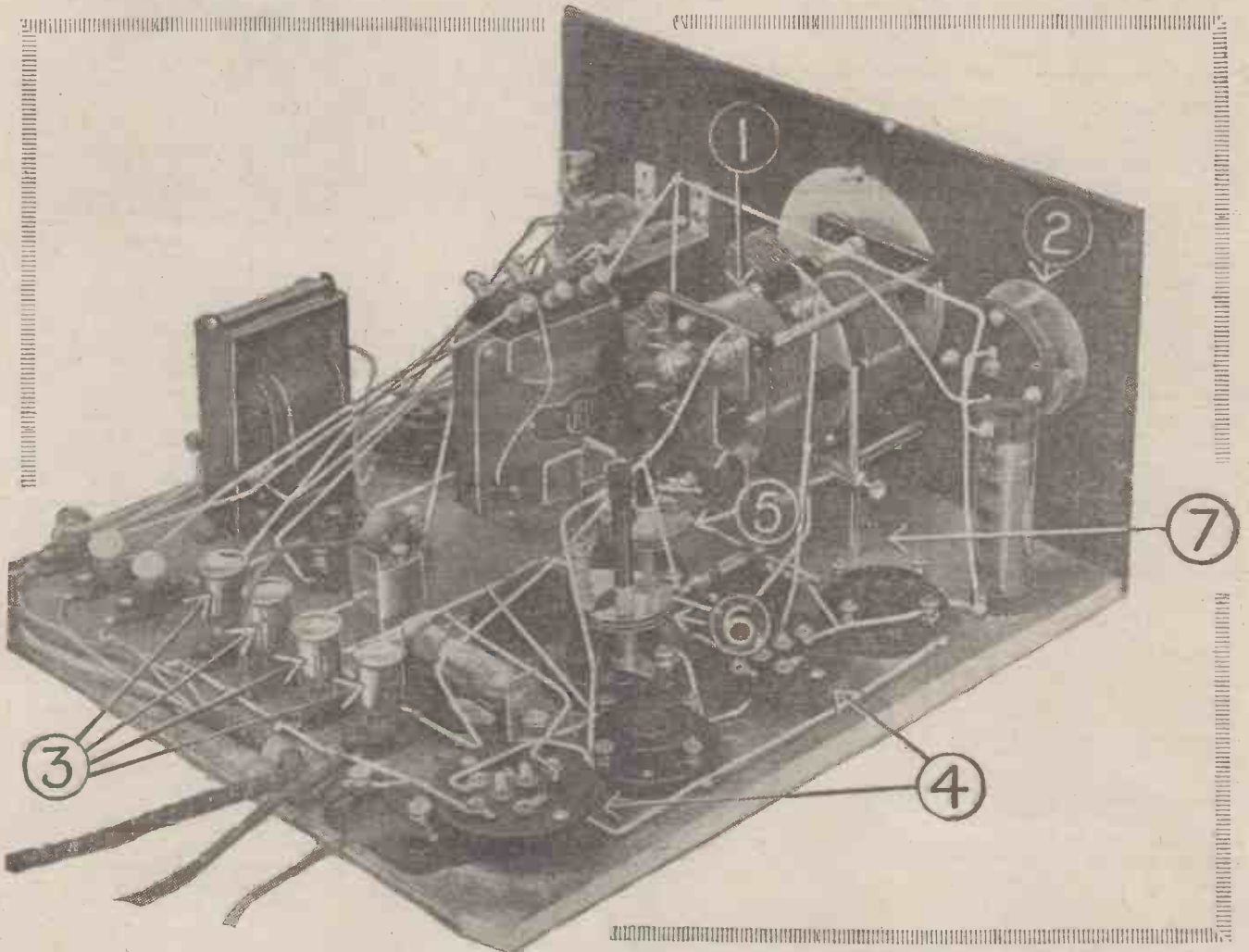

In this photo the figure "7" denotes the position reserved upon the baseboard for the balancing condenser if it is desired to use it in the alternative position.

It may be that a discrepancy of several degrees will be noticed, but this is quite natural, for it is not to be expected that every set constructed will tune in any station at exactly the same dial reading.

### Balancing

Having picked up the local, the two halves of the tuning condenser may be given their first adjustment. To do this loosen the set screw in the ebonite tube which couples the two condensers

even though the reaction condenser is set at zero, the detector valve will commence to oscillate. If this occurs, reduce the H.T. voltage applied to the detector valve till stability is obtained.

### Neutralising

Now rotate the neutralising condenser N.C. which is mounted against the H.F. valve till the signal either disappears or becomes very weak. This should occur at one setting only of the neutralising condenser. An

If it is found that though valves with a fairly high capacity are used the signal gets weaker as the neutralising condenser is turned towards its minimum without any sign of a minimum signal position being obtained it is probably due to the anode winding on the H.F. transformer being reversed.

### Grid Bias

Next turn the H.F. valve on again  
(Continued on next page.)



## How to Operate Your Monodial

and adjust the grid bias battery till the purest reproduction is obtained. Two negative tappings are allowed for on the receiver, notwithstanding the fact that a common value of H.T. is applied to both low-frequency valves. This is done so that in the event of two valves of different types being used on the L.F. side, each may be given the correct value of bias for the most efficient working. The actual values required will depend on the valves used and the amount of H.T. available.

### Final Balancing

After this has been done you will want to turn your attention to the final adjustment of the gang condenser and the compensation of any excess load in either of the grid circuits.

The first step is to tune in one of the transmissions taking place on the higher broadcast wavelengths, a suitable transmission being Frankfurt or Birmingham. To do this it will probably be necessary to increase reaction somewhat, and if this fails to bring in the station being searched for it may be necessary to make the detector valve oscillate. No fear need be entertained that this will disturb anyone, since a neutralised circuit is being used. Having picked up the carrier, that portion of the gang condenser which tunes the H.F. circuit should be adjusted till the carrier is heard at its loudest. It should then be resolved by reducing reaction and the gang condenser readjusted again so that the transmission is tuned in as strongly as possible.

### A Rule

Now tune in a convenient station somewhere near the lower end of the wavelength scale, Elberfeld on 259 metres, for example, and try if the H.F. half of the gang condenser needs readjusting more than a few degrees. If it needs its capacity decreasing, the capacity load in the high-frequency circuit due to the aerial is predominating and the compensating condenser needs to be connected across the detector portion. If, however, it has to be increased, then the detector load is the greater and the compensating condenser must be connected across the H.F. half of the gang.

An examination of the photograph shown on page 422 will show this condenser connected in this position, and it is indicated as number 5. To the left of the H.F. choke is seen a space,

and this has been left so that the little condenser used for compensation may be connected across the detector section of the tuning condenser.

### The Compensating Condenser

Having determined where it is necessary to connect this condenser, it should be put into position and placed in circuit. Its correct adjustment will be found by tuning in the high- and low-wave stations alternately using a gradually increasing value for the compensation condenser till a value is found at which the readjustment at opposite ends of the scale of the tuning condenser is a minimum.

Under working conditions it is not probable that an exact balance will be obtained at all dial readings, but it should be possible to get it within a few degrees.

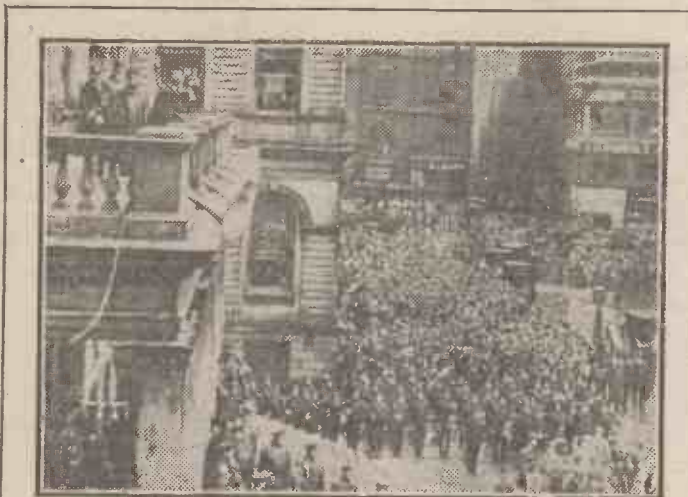

Queen Marie of Rumania's speech of appreciation in reply to her enthusiastic welcome in New York was delivered to the vast crowd by means of the large loud-speakers seen in this photograph.

## COME AND HEAR IT!

We are anxious to give our readers an opportunity of really hearing for themselves the remarkable results which can be obtained from the Monodial by relatively unskilled operators, and a demonstration is being arranged to take place at the Elstree Laboratories in the near future. Invitations to attend this first demonstration will be extended in due course to the first hundred applicants for free blue prints of the receiver, and these columns should be watched for future developments.

### Another Rule

I would like to repeat here—if the first valve half of the condenser appears to have moved too rapidly (when wavelengths at opposite ends of the scale are being received as a test for balance) then the compensating condenser should be connected across this half. If, however, it appears to have moved too slowly, i.e., its value needs to be decreased compared with the detector portion, then it should be connected across the detector half.

The final adjustment of the two halves of the gang condenser should be made on a wavelength round about the 450-metre mark. The balance will then hold almost exactly down to about 300 metres and up to about 550 metres, if the set is correctly adjusted; while below the 300-metre mark the aerial tends to pull into tune, thus flattening the tuning and reducing to a practically negligible quantity any lack of balance that may be making itself felt.

### Valves Tried

I have tried a fair number of valves in this receiver, and among the 2-volt valves that I have used successfully are Cossors, the P.M.1 and 2 H.F. and L.F., and the new S.T. valves. I used the S.T.21 for H.F. and detector, an S.T.22 for the first L.F., and the S.T.23 for the second L.F. With these valves a high degree of H.F. amplification was obtained, while the volume and purity on the L.F. side left little to be desired.

Among the 4-volt valves I tried the P.M.3 and 4, the Ediswan G.P.4 and P.V.4, and the S.T. range.

Satisfactory results were obtained with all these, while the S.T.43, a super-power valve, was found to be desirable for the second stage of L.F.

A number of 6-volt valves were also tried, among which were the D.E.5B. for H.F. and detector, D.E.5 for L.F., P.M.5 and 6, B.T.H. B.4 for L.F., and the S.T.61, 62 and 63.

Average values of H.T. used in the Monodial with the various makes of valves were H.F. 80 volts, detector 40 volts and L.F. 120 volts. If purity and volume are to be obtained it is certainly to be recommended that less than this value do not be used.

(Owing to lack of space we are unable to include the results obtained on the long wavelengths and some operating notes dealing with reception of the Daventry transmissions, and these are therefore unavoidably held over till next week.)





# A CONVINCING TEST

—now build your own loud-speaker *this week-end*

WHEN we first offered the public a full-powered loud speaking unit for 13/6 people were frankly incredulous. "No doubt it's excellent value for the money," they said, "but you can't expect it to equal an instrument costing several pounds."

So we invited four entirely disinterested judges to sit behind a screen while we carried out a simple test. We put on a well-known and expensive loud speaker and carefully noted the quality and volume of reproduction. Then the horn was removed from it and attached to the "Lissenola" and the result again carefully noted. This was repeated with half-a-dozen expensive loud speakers. It was found impossible to say which gave the better result—the original loud speaker bases or the "Lissenola." This is a test you can make at home yourself.

The "Lissenola" is a universal fitment; you can attach it to any type of loud speaker horn or gramophone horn, or to the tone-arm of any gramophone, and get faultless results. You can easily follow the simple instructions and full sized diagrams enclosed with every "Lissenola" and make yourself—for a few pence—a handsome full-powered horn of tested and proved efficiency, giving you a complete loud speaker equal to any high-priced senior model you can buy and saving you many pounds.

## SEVEN DAYS' TEST AT HOME.

Your dealer will demonstrate, but better than all, take the LISSENOLA home—put it on your set—put it on your friend's set—try it with the horn of an expensive speaker fitted to it—test it for seven days—then if you are not satisfied take it back to your dealer's or send it back to us.

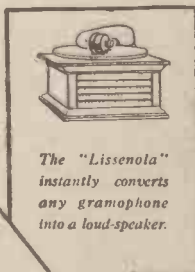

The "Lissenola" instantly converts any gramophone into a loud-speaker.

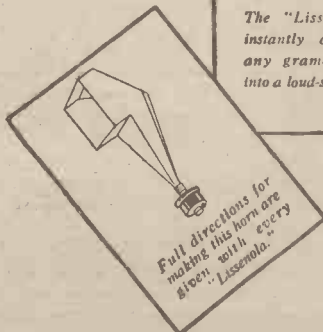

Full directions for making this horn are given with every Lissenola.

# 13/6

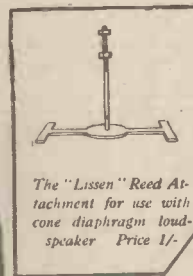
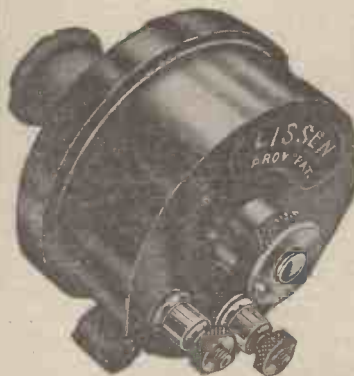

The "Lissen" Reed Attachment for use with cone diaphragm loud-speaker Price 1/-

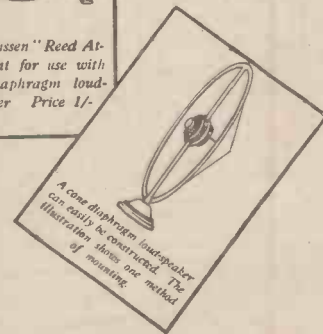

A cone diaphragm loudspeaker can easily be converted. The illustration shows one method of mounting.

# THE LISSENOLA

Hear it before you buy at your dealer's — *this week-end.*  
LISSEN LTD., 18-22, Friars Lane, RICHMOND, SURREY.

Managing Director: T. N. COLE.

# MORE PARALLEL-FEED CIRCUITS TO TRY

By GEOFFREY ELTRINGHAM.



In Vol. 5, No. 9, of "Wireless" our contributor gave some parallel-feed circuits to try. In the article below suggestions are given for trying some further circuits on these lines.



**A** CIRCUIT which lends itself particularly well to conversion to the parallel-feed type is that employing tuned - transformer intervalve coupling

with one of the early types of barrel plug-in transformers. Such a circuit is illustrated in Fig. 1, and it will be seen that a potentiometer is provided to stabilise the H.F. valve, and also that reaction is provided direct upon the grid circuit of the same valve. In general, of course, the potentiometer control alone would be sufficient, but reaction is also often provided to allow for the different behaviour of various valves and so on. Such a circuit gives quite a fair degree of amplification, although not so much as one of the modern versions, but selectivity is usually poor.

### The Simplest Form

Such a circuit is very easy to convert to the parallel-feed type, and reference to Fig. 2 will show how it is done in one form. The usual H.F. choke is placed in the anode circuit of the H.F. valve, in place of the

that it is best with most transformers to make this winding the same one as that which was tuned in the original circuit, namely, the primary. In other

### Better Selectivity

The potentiometer is left in circuit in case the circuit should show any

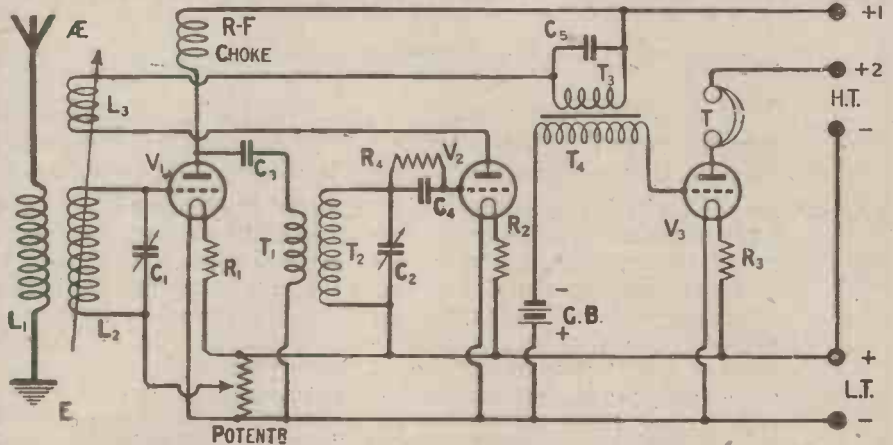

Fig. 2—This is the simplest version of a parallel-feed circuit developed from the Fig. 1 circuit. The size of the winding T1 has been reduced to improve the selectivity and stability of the circuit.

words, the primary is now used as the secondary. What was previously the

tendency to self-oscillation, but it is not likely that more than a very small positive bias will be needed to stop any self-oscillation, and selectivity will be found to be considerably improved.

To obtain still better results, it is advisable to reduce somewhat the size of the winding T1 on the transformer, that is to say, the winding which was originally the secondary.

It is quite easy to pull wire out of the secondary of the great majority of transformers, and at least one slot should be emptied. The reaction arrangements, it will be observed, are left unaltered, and will be found quite useful in bringing the circuit to the most sensitive condition.

### Neutralising

The obvious logical step to take on having reached this point in the conversion to a parallel-feed circuit is to neutralise the arrangement, and Fig. 3 has been drawn to show how this may be done. It will be observed that what is called the split-grid method is used, the coil which forms the grid circuit of the H.F. valve, namely, L2, being now one of the centre-tapped (Continued on page 428)

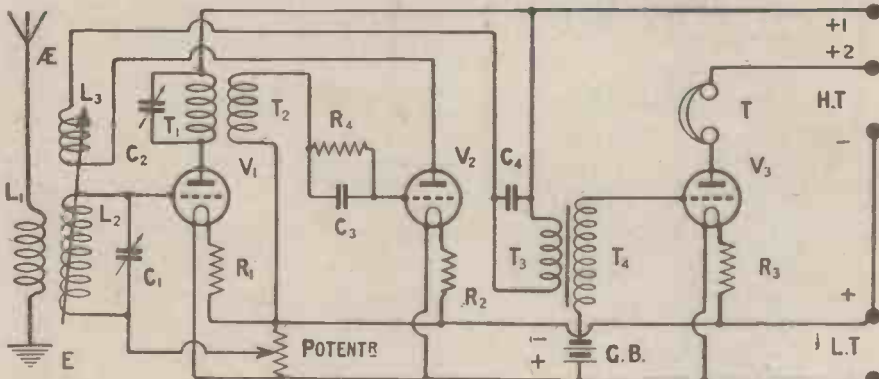

Fig. 1—This is the circuit taken as a starting point for the modifications described by the author this week.

primary winding of the transformer, and the tuned winding of the H.F. transformer is now connected directly between the grid and filament of the detector valve with the usual grid condenser and leak. It is to be noted

secondary is now used as the primary, and is placed in circuit between the anode of the H.F. valve and the filament circuit, with the usual blocking condenser of .0003 or thereabouts in series.

# CARBORUNDUM STABILISING DETECTOR UNIT

**Ensures Greater Sensitivity—Increases Selectivity—Crystal Clear Tones**

There is no denying the pure, true quality of crystal reception, and it is now possible to get such reception on any set without the fuss and trouble of a nervous cat's whisker jumping off the sensitive spot.

The Carborundum Stabilising Detector Unit has revolutionised crystal reception. It is built around the fixed permanent Carborundum Detector—NO CAT'S WHISKER—NO ADJUSTMENTS—and retains its sensitivity, and simply cannot burn out.

The Stabiliser gives you a resistance controlling feature through which the Detector can be made to match the impedance of any circuit—think what this means on reflex sets.

For the reception of tones of natural quality equip your set with the CARBORUNDUM STABILISING DETECTOR UNIT, which is the only really permanent Detector, and the only perfect Detector for crystal and reflex receivers. **BRITISH MADE.**

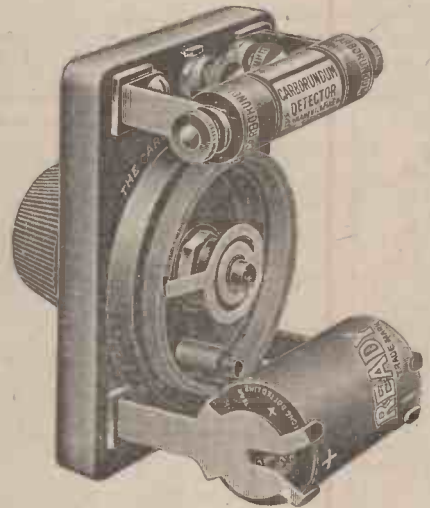

ONE HOLE FIXING.

**PRICES, INCLUDING POSTAGE:**

- No. 32—Carborundum Stabilising Detector Unit, complete with No. 30 Carborundum Detector, but without Dry Cell 12/6
- Ever-Ready Dry Cell U.W.5 (price extra) .. .. . 5d.
- No. 30—Carborundum Detector .. .. . 5/-

Send for Descriptive Folder W5

**THE CARBORUNDUM COMPANY, LIMITED**  
**TRAFFORD PARK - - - MANCHESTER**

*The  
 Best  
 Home  
 Construction  
 Receiver.*



*National  
 Wireless  
 Week  
 Nov. 7-13.  
 Let your  
 friends listen!*

## BURNDEPT All-Wave Super-Heterodyne Receiver

IF you desire to construct your own Super-Heterodyne Receiver we supply the Burndept Transformers singly and also in Kits of three and four perfectly matched, comprising respectively two and three intermediate frequency amplifier valves. With each Kit we supply a detailed constructional diagram panel lay-out, list of parts and full instructions. For all waves from 50 to 3,000 metres, with Frame or short Indoor aerial, or wire round picture rail. We also supply suitable cabinets and front panels. Send for full details or

**ASK YOUR LOCAL DEALER**

*Head Office and Factory:  
 BLACKHEATH, LONDON, S.E.3.  
 Telephone: Lee Green 2100.  
 Grams: Burndept, Phone, London.  
 London Office & Showrooms:  
 15, BEDFORD ST., STRAND, W.C.2.  
 Telephone: Gerard 9072.  
 Grams: Burndept, Westrand, London.  
 Agents and Branches everywhere.*



- No. 913. Kit of Three £3 15 0
- No. 914. Kit of Four £5 5 0
- No. 916. Envelope containing Drawings, Diagrams, Instructions (W.P. 106), etc., 2/6. Supplied free with Kits.

**WIRELESS LIMITED**

# More Parallel-Feed Circuits to Try—continued from page 426

variety. The actual arrangement of the grid circuit which is suggested is the same as that employed in the Monodial, a high-frequency choke being included in the return lead between the centre tapping on the coil and the filament circuit. It will be interesting to experiment here and note whether a high-frequency choke or a high resistance of the order of 100,000 ohms gives the best results.

Seccotine to hold it together. When this has set, it can be slipped off the pencil and wound with about 40 turns of Number 34 double silk-covered wire, the two ends being brought out to flexible connections.

### Fine Adjustment

If any difficulty is experienced in operating this circuit as regards the manipulation of the reaction coil,

consists in the insertion in series with the reaction coil in the anode circuit of the detector valve of a high-frequency choke, shunted across which is a variable condenser.

### Reinartz Reaction

The actual expedient to adopt in inserting a scheme for producing reaction will naturally depend to a large extent upon the available panel space on the existing set. If there is room for another variable condenser of .0003 capacity, a very attractive scheme is to use the primary coupling coil also as a reaction winding, using the form of reaction which is usually associated with the name of Reinartz.

Such an arrangement is shown in Fig. 4, where it will be seen that the necessary extra components for this particular method have been inserted. In the anode circuit of the detector valve there is now a high-frequency choke, and between the anode of the valve and the upper end of the primary coupling coil will be seen a variable condenser for the purpose of producing reaction. This method is probably the best of those which we have so far discussed, since there are no variable couplings between coils to be arranged, and the control of reaction is particularly smooth and gradual.

### A Good Method

A further advantage of this method is that the reaction adjustment has very little effect upon the tuning of the grid circuits, and it is possible to search for very weak carrier waves

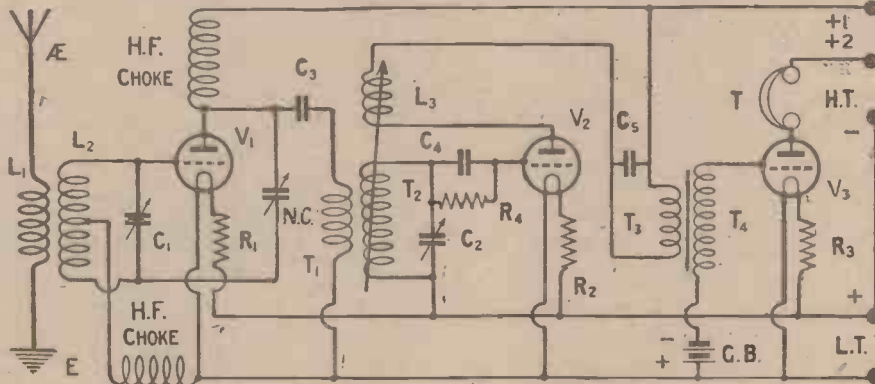

Fig. 3.—The circuit can be improved further by transferring the reaction to the intervalve circuit. The receiver can be allowed to oscillate without any serious risk of causing interference.

The circuit is neutralised in the ordinary manner with the small condenser N.C., and the parallel-feed coupling arrangements are obtained as in the previous example.

In the Fig. 3 circuit reaction is applied to the secondary of the transformer—that is to say, to the intervalve circuits—it is evident that some special arrangement of the reaction coil will be needed. (To remove the possibility of misunderstanding I should remind the reader that when I now speak of the secondary of the transformer, I refer to the winding which is now being used as the secondary, and which is tuned by the variable condenser, but which was originally the primary winding.)

### Reaction Coil

With most of the barrel type of H.F. transformers it is a fairly easy matter to arrange a reaction coil to couple with the windings, since many of them are bored out down the centre, so that a coil can be inserted. At least one maker of H.F. transformers markets a little attachment consisting of a sliding coil which fits into this hollow core, and enables reaction to be obtained in a very simple manner.

If such an attachment is not available it is quite an easy matter to make a little coil for the purpose by constructing a small paper tube to slip easily inside the transformer. You can make such a tube by rolling paper round a fountain pen or pencil of suitable size, with the aid of a little

which is not perhaps the easiest way of getting a fine adjustment of reaction, some one of the well-known devices for obtaining a fine control can be incorporated in the set.

For example, one could incorporate what is called "throttle control," which is well known to be a particu-

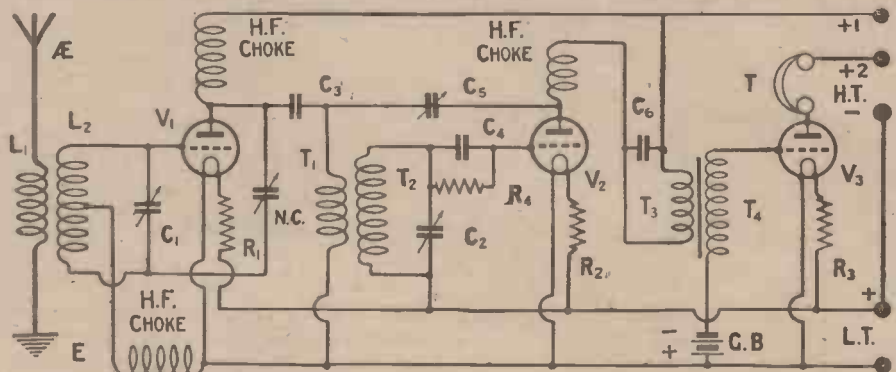

Fig. 4.—If there is room upon the panel for an additional variable condenser, a better method of reaction control can be used. Here the so-called Reinartz method is indicated.

larly pleasant and smooth control of reaction independent of any moveable coil. In this method the coil is inserted fairly well inside the winding upon which it is reacting, so that the set would normally be thrown into oscillation, and then an auxiliary method of control is introduced. This

with the set in the oscillating condition (remember that it is now non-radiating), and when the carrier wave has been found the reaction adjustment can be decreased until the receiver just ceases to oscillate, whereupon the signals will be heard at their loudest.



## If you had met Scott-Taggart—

**S**UPPOSING a month ago you had been on your way to a dealer to buy a valve and you had met Scott-Taggart. If he had recommended a certain valve as ideal for your purpose, would you have taken his advice? Supposing he had said: "When you get it, I shall be happy to test it out thoroughly and, after I am satisfied it is up to standard, give you a personally signed certificate to that effect," would you have accepted this offer?

You would not consciously have analysed the reputation he has built up as the best-known expert on valves in this country. You probably did not even know that his books on the subject have been a guide to over 500,000 readers of them. It might flash across your mind that he was the head of the great Elstree Laboratories and the keenest of critics of valves and apparatus. How far would his opinion have influenced your judgment? Would you have put his recommended and tested valve in your valve holder with confidence?

*To-day you have actually to answer this question. John Scott-Taggart has relinquished all his former activities to produce the best valve he can. It is available in every type, and the designer personally initials every box to certify that the S.T. valve inside has been tested dynamically (i.e., under actual operating conditions) under his own supervision.*

You are about to buy a new valve. Let it be an S.T.—the valve which, as its dynamic curve shows, gives high amplification and wonderful purity of reproduction. Thanks to the torodium filament and the high constant vacuum, its performance will be maintained, for S.T. valves are built—like the Pyramids—to last.

*S.T. Valves are now on Sale! In case of any difficulty or when seeking advice on types to use in your set write to me at S.T. Ltd., 2, Melbourne Place, London, W.C.2*



## Scott-Taggart makes them

THE S.T. valves described in these pages have been manufactured in England by, and to the specification of, John Scott-Taggart, M.C., F.Inst.P., A.M.I.E.E., whose name is probably more familiar than that of any other expert on the valve.

Before entering the valve manufacturing industry, Mr. Scott-Taggart was the head of the group of wireless periodicals which included *Modern Wireless*, *Wireless*, and *The Wireless Constructor*. In addition, he was the founder and head of the Elstree radio research and test laboratories, where part of the work consisted in the critical testing of valves, sets and components of the leading manufacturers in this country. Before these activities, Mr. Scott-Taggart was in charge of the manufacture of valves made for the British Government.

Mr. Scott-Taggart is the author of the leading text-books on the valve, his *Thermionic Tubes in Radio Telegraphy and Telephony* being the standard and most comprehensive work on this subject. In addition, his books, *Elementary Textbook on Wireless Vacuum Tubes*, *Practical Wireless Valve Circuits*, *More Practical Valve Circuits*, *Radio Valves and How to Use Them* have helped in no small measure the present generation of valve users. More than half a million of his books have been sold, excluding foreign translations, indicating to some extent the confidence of the wireless public in his work, his judgment, and his knowledge and experience.

More than fifty patents, all concerned with valves, stand in his name, some proof of the inventive genius of one whose whole technical life has been concerned entirely with this branch of radio.



JOHN SCOTT-TAGGART,  
F.Inst.P., A.M.I.E.E.

Having already firmly established the design and processes of manufacture, Mr. Scott-Taggart (whose initials S.T. give the valves their name) determined, in spite of the laborious work involved, to see that each and every valve sent out by S.T. Ltd. should be tested by electrical measurements and on actual signals under his own supervision. Each valve box has a space on it where Mr. Scott-Taggart personally initials a test certificate for the valve inside. The firm of S.T. Ltd. and its Managing Director feel that valves should not be regarded as a kind of lamp or as so much merchandise. They feel that the manufacture and testing of valves require the undiluted attention of those who have devoted their lives to this industry and have no subsidiary interests.

However casually one may regard a valve, the fact remains that no two makers' valves are the same. Outwardly and in actual operation the S.T. valve is robust, highly efficient and foolproof. A child can buy one and fit it in the family set. But inside that glass bulb all the ingenuity of modern science, the precision of specially designed machinery and painstaking care in testing have contributed to make a valve which stands out head and shoulders above others.

In the early stages, the designer of the S.T. valve refused to proceed unless he was entirely unhampered and able to use any invention he desired. As a result, S.T. Ltd. are operating under all the leading patents which have contributed to the advancement of the valve. Nothing has been sacrificed in design through inability to use some invention essential to achieve the best results.

## Reasons why you'll prefer S.T. Valves

### (1) *The Name behind them*

They bear the imprint of John Scott-Taggart and all that this name has come to mean in the valve world.

### (2) *Possess the right Dynamic curves*

They are designed and tested on the basis of Dynamic characteristic curves. The common method is to have regard only to the static or ordinary curve. The ordinary curve, while valuable for some purposes, ignores working conditions, since it is taken with a fixed anode voltage. Every valve in a wireless receiver has, however, a constantly fluctuating anode voltage which, when the grid is made more positive, becomes less than the H.T. voltage, while when the grid is more negative, the anode voltage rises to a value higher than that of the H.T. battery. This is due to the variation in current through the impedance always in the anode circuit of the valve. This impedance may, for example, be an H.F. or L.F. transformer, a choke, a resistance or a loudspeaker.

This phenomenon is generally overlooked by both manufacturers and many valve users. Every type of S.T. valve, however, is designed to give the right

*Advt. of S. T. Ltd., 2, Melbourne Place, W.C.2.*

Dynamic curve which represents the conditions with the impedance in circuit. The valve, moreover, is tested dynamically, i.e., under operating conditions.

### (3) *It is their curves that count*

All the operating merits of a valve, whatever the type may be, are reflected in the characteristic curves of the valve—provided, of course, that the right curves are taken. The effect of electron emission, the shape, sizes and spacing of electrodes, for example, all produce an effect on efficiency which is noticeable in the characteristic curves of the valve. That is why S.T. Ltd. lay so much store by the curves of their valves. Anyone can claim perfection and this or that merit, but in the end the curves show defects or merits. The Dynamic curve of a valve cannot lie. It's the curve that counts!

### (4) *Like the Pyramids, they last*

However good a valve may work and however good a curve it may have, this is no consolation if the valve only lasts a few days or a few weeks. This brings us to what many people regard as the most important factor—the life of the valve. About 50 per cent. of the valves sold use

thoria in their filaments and often the power of emitting electrons seriously falls off. The valve remains alight, but the emission falls below the safe limit and signals become—to many—unaccountably weak, and distortion also arises. The S.T. valve has a *torodium* filament and has a very long and useful life. If you buy your valves on the basis of the length of service they give, you will always choose S.T.'s, for they are built like the Pyramids—to last.

### (5) *The Torodium filament*

The secret of the long life of the S.T. valve lies first in the filament and secondly in the vacuum. The filament is made of torodium, a recently invented alloy of precious metals which gives off, when heated, a copious stream of electrons. This power of emitting a generous supply of electrons remains throughout the life of the valve, and, moreover, breakages through the brittleness of the filament are unknown, as even after being used for a long period it retains a strength and pliability comparable to that of a steel cable. The life is also largely attributable to the fact that the torodium filament



operates at so very low a temperature that it gives no visible glow.

(6) *Extremely high vacuum due to the Baret process*

The vacuum in a valve is a feature which greatly influences not merely the initial operation of the valve, but also its life. After a time, there is a tendency for gases absorbed or "occluded" by the metal electrodes in the valve to leak out into the space in the bulb and partially spoil the vacuum. It has been proved beyond question that the slightest traces of oxygen, water vapour and other gases greatly affect the electron emission and the life of the filament. In the case of S.T. valves, the electrodes are heated to a very high temperature to drive out every particle of gas. These gases are then withdrawn from the bulb by the Baret process of evacuation, which produces the highest vacuum known to science. This high vacuum is retained, and is a potent factor in giving the S.T. valve a long and efficient useful life.

(7) *Economical, as they take very little current*

Economy in upkeep is a vital factor in the choice of a valve. Hence the great popularity of dull-emitter valves. Many so-called dull-emitters are, however, very extravagant in current consumption in comparison with the S.T. valves, which only take 0.1 ampere in most cases and 0.15 ampere in the case of one of the power valves. Work out how much this saves you in the cost of accumulator charging and the fatigue of carrying accumulators to be charged. The smallest increase above these figures means greater cost and trouble.

(8) *Not critical to work*

One of the most delightful features of the S.T. valve is the fact that it is not critical to work. You can, in fact, be careless. For example, the torodium filament will work efficiently with or without a rheostat or resistor. Many valves are very critical on filament voltage, but the 6 volt S.T., for example, will work off any

voltage between about 4.5 and 6 volts. Some valves only work at their best when the accumulator is absolutely fully charged, and signals "go off" after a time. The S.T. valve, however, will continue at work until the accumulator runs down.

(9) *Non-microphonic and robust*

The S.T. valve is non-microphonic. You can tap it with impunity. It is very strongly made. Built like a chronometer for accuracy and uniformity, it is yet robust. Each electrode is supported in several places to give strength.

(10) *Every valve certified O.K. by John Scott-Taggart*

Every valve is tested under Mr. Scott-Taggart's supervision and every carton is personally initialed by him to certify the satisfactory characteristic of the valve. The valves are uniform and every one is a "picked" valve. Any valve not coming up to the required standard is destroyed.

## Specifications and Characteristic Curves

(The curves given are static curves to serve as some comparison with other-valves. Dynamic curves are obtainable on application)

### VALVES FOR 2-VOLT BATTERIES

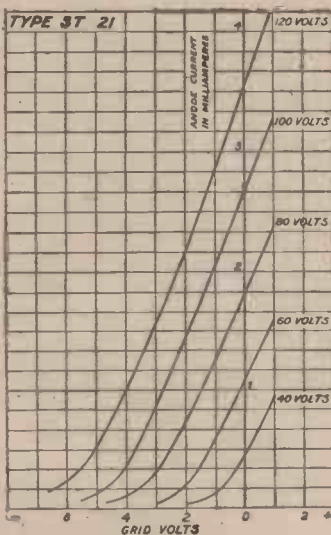

**S.T. 21**  
**H.F.**

Filament 1.8 volts.  
" 0.1 amp.  
Anode 40-120 volts.  
Impedance 26,000 ohms.  
Amplification 16.

An excellent valve for H.F. amplification and resistance capacity coupling. It is also to be recommended as a detector valve.

Price 14/-

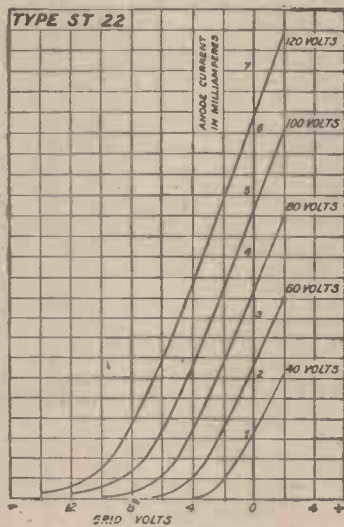

**S.T. 22**  
**L.F.**

Filament 1.8 volts.  
" 0.1 amp.  
Anode 40-120 volts.  
Impedance 16,000 ohms.  
Amplification 10.

This valve is for the first stage of a low frequency amplifier and will give undistorted reproduction. It may also be used for H.F. amplification, especially in neutrodyne circuits, and for detection.

Price 14/-

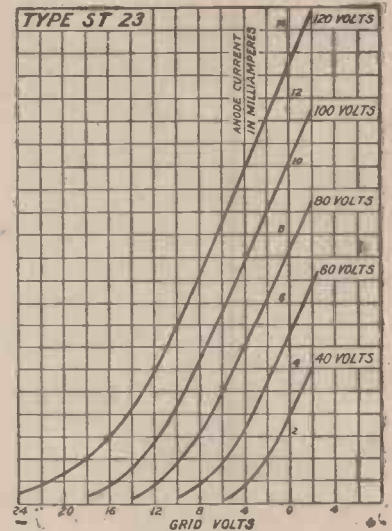

**S.T. 23**  
**POWER**

Filament 1.8 volts.  
" 0.15 amp.  
Anode 80-120 volts.  
Impedance 6,000 ohms.  
Amplification 6.

A magnificent 2 volt power valve giving superb reproduction when used as the last valve of a set when a loudspeaker is employed. Note its low impedance and the high amplification factor for such a valve.

Price 18/6

VALVES FOR 4-VOLT BATTERIES.

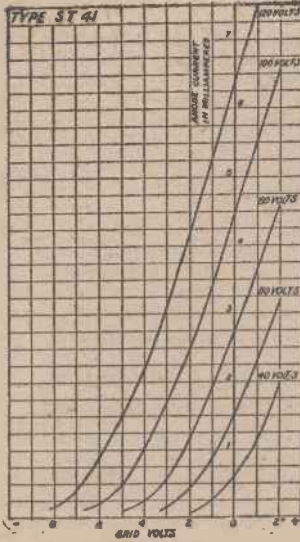

S.T. 41

H.F.

Filament 3.7 volts.  
 " 0.1 amp.  
 Anode 40-120 volts.  
 Impedance 16,000 ohms.  
 Amplification 13.

This is an efficient H.F. valve more particularly designed for neutrodyne circuits. It brings in the distant stations with ease. This valve may be used as the first L.F. and as the detector valve. It is the valve for resistance capacity coupling.

Price 14/-

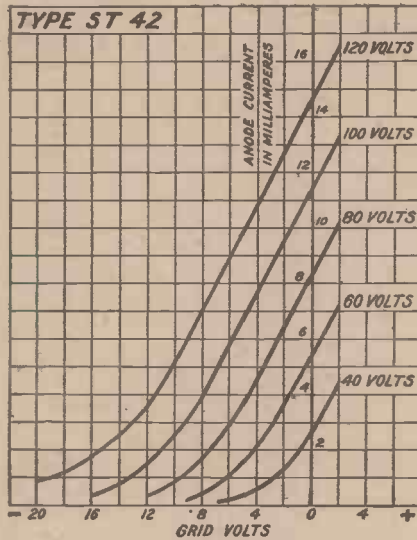

S.T. 42

POWER

Filament 3.8 volts.  
 " 0.1 amp.  
 Anode 40-120 volts.  
 Impedance 6,000 ohms.  
 Amplification 6.

An excellent power amplifier recommended for first aud also the second stage of L.F. although the S.T. 43 is the ideal loudspeaker valve in the 4 volt class.

Price 18/6

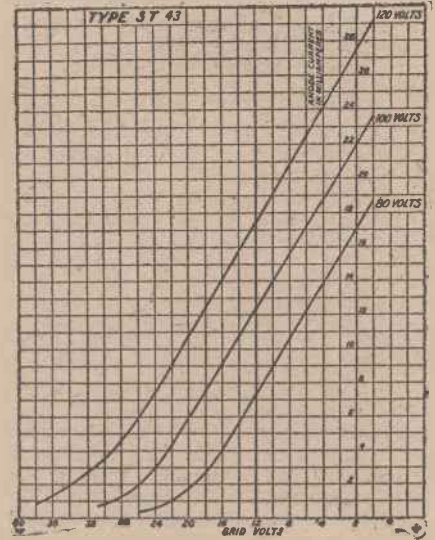

S.T. 43

SUPER POWER

Filament 3.8 volts.  
 " .25 amp.  
 Anode 120 volts.  
 Impedance 4,000 ohms.  
 Amplification 3.33

This valve is the only standard 4-volt valve in the super-power class, hitherto confined to 6 volt valves. It is "the valve with the golden voice" and is capable of great volume and exceptional purity of tone.

Price 22/6

VALVES FOR 6-VOLT BATTERIES.

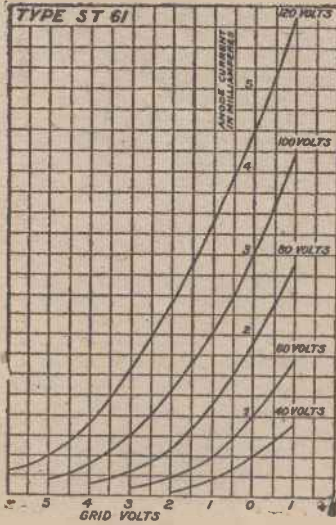

S.T. 61

H.F.

Filament 5.6 volts.  
 " 0.1 amp.  
 Anode 50-120 volts.  
 Impedance 20,000 ohms.  
 Amplification 20.

This efficient H.F. valve is particularly to be recommended for all neutrodyne types of circuit, while it may also be used for resistance capacity coupling. It makes an excellent detector.

Price 18/6

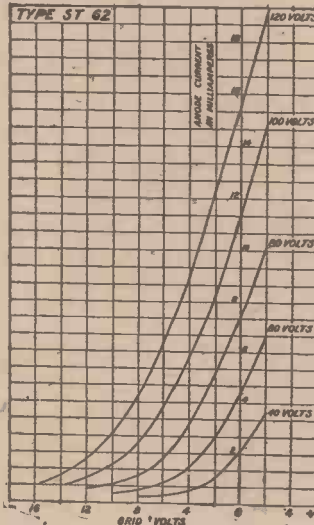

S.T. 62

POWER

Filament 5.6 volts.  
 " 0.1 amp.  
 Anode 80-120 volts.  
 Impedance 6,000 ohms.  
 Amplification 8.3

This power valve is the best of its class and makes a good first and second L.F. valve. It is intended especially as a good all-round power valve.

Price 18/6

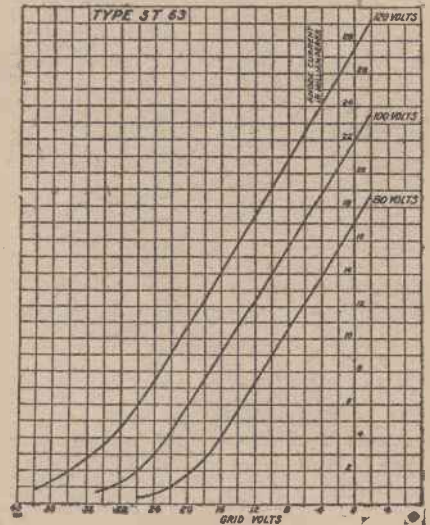

S.T. 63

SUPER POWER

Filament 5.6 volts.  
 " .25 amp.  
 Anode 120 volts.  
 Impedance 4,000 ohms.  
 Amplification 3.33

This is "the valve with the golden voice." It is an entirely new class of valve having very long dead-straight dynamic curve giving exquisitely pure loudspeaker reproduction.

Price 22/6

**GENERAL NOTES.**—S.T. valves operate at the lowest temperature of any valve made. Do not assume that because you cannot see the filament alight that the valve is not working. Any of the valves will work directly off an accumulator or with a rheostat or fixed resistor. Under no circumstances should a valve be worked with a rheostat off a battery of higher than the rated voltage, e.g., do not work an S.T. 23 off a 6 volt accumulator through a rheostat. No responsibility can be taken for valves spoilt by over-running—so liable to occur in such cases. Where it is desired to work, say, a 2 volt valve from a 6 volt battery (an undesirable practice) a fixed resistor should be used and suitable values (and the resistors themselves, if desired) will be supplied on application. A rheostat or fixed resistor may always be used with, say, a 2 volt valve when working off a 2 volt accumulator, but neither is essential. The life of the valve will be increased if the filament current is kept as low as is consistent with good results.

The valves used for L.F. amplification should always be operated with a grid bias battery which should be variable, and give not less than a maximum of 9 volts. The S.T. 43 and S.T. 63 valves require a grid bias battery giving up to 18 volts.

Note that both the S.T. 41 and S.T. 61 valves, though marked H.F., may be used as general purpose valves. The marking of the valves H.F. and L.F. is adhered to, although this arbitrary labelling is really inaccurate, as the valves can often be used for different purposes. We shall always be happy to give individual customers advice on the choice of valves. A high-tension battery of 120 volts will be found the most useful.

Advt. of S. T. Ltd., 2, Melbourne Place, W.C.2,

**WHY MUSIC MAKES RADIO SUCCESSFUL**

*(Continued from page 424)*

against it, but on the whole the effect should be good. First and most important, good transmission is essential. If, through faulty transmission, fine renderings are spoiled, more harm than good is done, for listeners misjudge the quality both of the music and of the musicians.

There is no doubt, I believe, that concert receipts are adversely affected. It is no more than logical for people who naturally have only a certain amount to spend on amusements to hear all they can on the wireless, and spend the money saved on the cinema, etc., which radio cannot give them. Still, the concert atmosphere is unobtainable, even with a valve set, and as long as programmes are given a proper amount of thought, then the good influence of the new armies of music-lovers which radio will make should eventually more than counteract the suggested tendency to stay at home for one's music.

**A Good Influence**

How the construction and composition of music will be affected by the new influence is another and altogether bigger question. Nothing can so far alter human nature that the old, beautiful music will be allowed to pass into oblivion. Wireless enthusiasts, like everyone else, soon become aware of the deficiencies in such crazes as jazz, whose all-metal bands can never achieve the variation and range which a complete orchestra finds necessary to render the music properly. In the demand for music, popular taste can never be led far astray for long.

As a very general conclusion, one might almost say that if wireless is properly conducted and great attention paid to the transmission, it can be a great influence for good in the realm of music. So that, in time, music-lovers in their millions, all over the world, will demand a goodly proportion of real music in all broadcast programmes, or else cease to interest themselves in their sets. Since the music at least stands entirely on its merits, the right decision is certain to be reached in time, as it is in every problem which has a world-interest.

**IMPORTANT NOTICE**

Readers are reminded that they can obtain a free blueprint of either the back or front of panel of the Monodial, the Radio Press Star Set described last week in this journal. When making application, the coupon given in our last issue must be enclosed, and the number of the blueprint required should be quoted. This offer is limited to one blueprint for each applicant. Additional blueprints can be obtained for 1/6 post free

**EXPERTS IN RADIO ACOUSTICS SINCE 1908**

**SEE FOR YOURSELF....**

SEE and hear for yourself. Go to a Brandes Dealer and look over the Brandes range. Get him to demonstrate, and make your own comparisons. Not many instruments of such good class are so reasonably priced. Observe that the cost of the Brandola is considerably reduced.



**THE BRANDOLA**

Specially built to bring greater volume with minimum current input and exceptional clarity over the full frequency range. A large diaphragm gives new rounded fullness to the low registers and

new clarified lightness to the high. Reproduction controlled by a thumb screw on the base. Polished walnut plinth with electro-plated fittings. Height 26 ins., bell 12 ins. **75/-**



**THE TABLE-TALKER**

The new goose-neck design is the result of research in radio acoustics, which definitely establishes its value in relation to the diaphragm fitted. Patent material used in the construction of the horn eliminates metallic harshness. Volume and

sensitivity controlled with small lever located at the rear of the base. Elegantly shaped, tasteful neutral brown finish, felt-padded base. Height 18 ins., bell 30/- 20 ins. **30/-**

**Brandes**

*From any reputable Dealer.*

**BRANDES LIMITED • 296 REGENT ST. • W.1**

# CAN WE RUN OUR VALVE FILAMENTS ON A.C. ?

By J. H. REYNER,  
B.Sc. (Hons.), A.M.I.E.E.

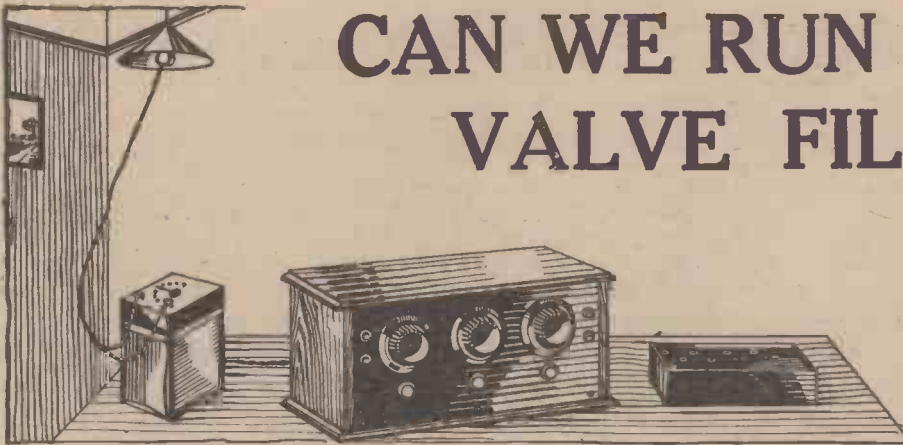

A very fascinating possibility of some of the modern types of valve filaments concerns their use with an A.C. supply.



THE question of operating wireless receivers from the electric light mains has a considerable fascination for the wireless enthusiast. Perhaps an even

greater advocate of such a practice is the housewife, who would welcome any device by means of which the cumbersome array of batteries usually associated with a wireless receiver could be dispensed with.

The problem of the supply of high-tension voltage has been tackled and satisfactorily overcome. Whether the present-day units are all that are to be desired is a different matter, and there is no doubt that considerable improvement will be made in the future. This, however, is an aspect of the question which need not be discussed in this article.

## Filament Difficulties

Even if a satisfactory H.T. supply is obtained there still remains the low-tension supply for the filaments which usually has to be obtained from an accumulator. Even with the modern dull-emitter valves which enable the accumulator to be used for a much longer period without re-charging, there is nevertheless the trouble and bother associated with the re-charging, to say nothing of the inconvenience of having to connect separate accessories to what would otherwise be a complete instrument.

When looked at in this light it is really surprising what one will endure without question. Would the gramophone, for example, be as popular as it is to-day if it were necessary to carry about two other small boxes in addition to the gramophone itself, and to connect these up before any results could be obtained? Yet this, in effect, is what is necessary in the case of a wireless receiver, and the necessity for these accessories is very rarely questioned.

## D.C. Possibilities

Now, provision of a supply for lighting the filaments is a matter of a little difficulty with direct current mains, owing to the fluctuations which are

always present. When we come to look into it, what are the possibilities of supplying the filament current direct from the mains? In the case of D.C. mains the problem is fairly simple in point of actual accomplishment, although the results when obtained are perhaps not satisfactory on account of the comparative expense.

All that is necessary is to connect the filaments across the mains in series with a suitable resistance which will cut the current down to the required value. A suitable smoothing arrangement may be necessary in order to choke out any hum due to slight variation caused by commutator ripple

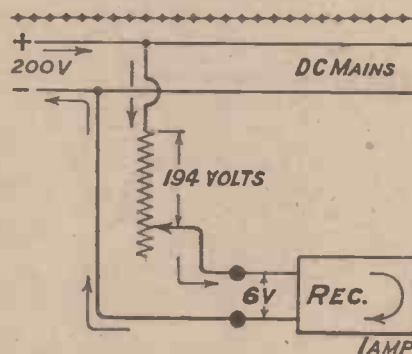

Fig. 1.—With D.C. the mains have to supply the full current taken by the receiver.

or other fluctuations, such as are usually experienced with the average D.C. supply.

## Wasteful

It will immediately be clear, however, that this is a wasteful method since the full filament current has to pass through a large resistance, and the majority of the energy is thus absorbed in heat, only a small proportion serving to do useful work in lighting the filaments. For example, if we have a receiver requiring 1 ampere at 6 volts the total energy consumption of the receiver itself is 6 watts. If we are, however, to light it from a 200-volt D.C. main then we are going to take 1 ampere at 200 volts, which is 200 watts. We only make use of 6

watts, giving us an efficiency of 3 per cent. only, 97 per cent. of the energy being wasted.

The problem may be solved to some extent by running the several valves in series, so that the voltage is increased, whereas the actual current demand is reduced, but in the case of multi-valve receivers there are several difficulties which present themselves if such a course of action is adopted. This question of D.C. supply, however, will probably be discussed in greater detail in a future article. In the present instance it is desired more particularly to refer to the question of filament supply from alternating-current mains.

## A.C. Superior

This is in many ways a much more practical proposition. One of the greatest advantages of alternating current lies in the possibility of stepping the voltage up or down as required. Such changes in the voltage are accomplished by means of a transformer, which simply consists of two coils of wire placed in proximity. If the first one is supplied with alternating current (which is continually and periodically changing both in strength and direction) then similar alternating voltages will be produced in the secondary coil.

The two coils are usually wound on an iron core similar to an intervalve transformer, since the iron assists the magnetic effect existing between the two coils. Moreover, this tends to ensure that the energy in the primary circuit is nearly all transferred to the secondary, with only a small loss.

## Transformer Ratios

In such circumstances it is possible fairly easily to design a transformer such that the voltage produced at the secondary terminals shall bear any desired relation to the voltage at the primary terminals. If, for example, we connect the primary of such a transformer to a 200 volts main, then we can quite easily arrange that the voltage on the secondary terminals shall be of the order of 6 to 8 volts. Such an arrangement, therefore, would

(Continued on page 436.)



# FELLOWS WIRELESS



## THE FINEST H.T. BATTERY IN THE WORLD—Post Free!

**4** good reasons why it will pay you to order your H.T. Batteries from us.

1. Your battery will reach you as "fresh as a crisp roll," because we send out such large numbers DAILY—no lost voltage through standing about on shelves.
2. You get your full money's worth of battery by ordering from us—there are no middlemen's profits for you to pay.
3. You get an H.T. Battery that is made in London, and everything about it, Capital, Materials, Labour, is British—with a capital "B."
4. You get a Battery that will give the longest possible life of perfect reception, because it has been scientifically designed, and the "elements" are so generously proportioned—nothing is skimped.

Get your Fellophone Battery either from one of our seven branches (see below) or direct from us. Just send Postal Order, Money Order, Cheque, or (registered) Cash. But do it now.

<b>54 Volt</b>	(with 3-volt tap for grid bias)	<b>6/6</b>
<b>60 Volt</b>	(tapped every 3 volts and complete with 2 wander plugs)	<b>8/9</b>
<b>108 Volt</b>	(tapped every 6 volts and complete with 2 wander plugs)	<b>13/-</b>

**Fellows, Park Royal, N.W. 10**

*Branches:*

LONDON: 20, Store Street, Tottenham Court Road, W.C. (Museum 9200).  
 BIRMINGHAM: 248, Corporation Street. (Central 435).  
 BRIGHTON: 31, Queen's Road. (Brighton 899).  
 CARDIFF: Dominions Arcade, Queen Street. (Cardiff 7685).  
 LEEDS: 65, Park Lane (Opposite Town Hall).  
 NOTTINGHAM: 30, Bridlesmith Gate. (Nottingham 5551).  
 TONBRIDGE: 34, Quarry Hill, (Tonbridge 172).

Send for  
48-page  
Catalogue  
No. 34  
FREE

**BUY DIRECT, AND SAVE MONEY**

E.P.S. 266.

# The Duvolcon



Control the volume of your loud speaker without altering the tuning of your set by fitting a Duvolcon.

## AN APOLOGY

Our first advertisements announcing the Duvarileak and the Duvolcon met with such eager response on all hands as to swamp even the extensive production arrangements which we had made.

We wish to apologise for any delays experienced and to say that since we have promptly arranged to increase the production several fold, normal supplies will again be available by the time this announcement appears.

**The Duvarileak.** By evolving, after three years of laboratory experiments, a special resistance material of agate hardness, and by arranging a frictionless ball-contact (see cut-away view) we have succeeded at last in producing the perfect Variable Grid Leak—the Duvarileak. This Grid Leak has no granules to cohere, its velvet control makes it silent in action, and the elimination of wear and friction means that it will retain indefinitely its variable properties. You can set the resistance value by the scale, and in two, four, six, eight months the Duvarileak will still give the same resistance for that particular setting.

**The Duvolcon.** Control the volume of your loud speaker without altering the tuning of your set.

Frequently your loud speaker may be at some distance from the set, you do not wish to upset your tuning, yet you wish to have perfect control over the volume.

The Duvolcon will give you this whatever the type of your loud speaker. You can also employ the Duvolcon as a Reaction Control in the manner shown on the leaflet which accompanies each instrument.

Both the Duvarileak and the Duvolcon—they are similar in appearance—have one-hole fixing, they carry our full guarantee, are obtainable of all dealers, and cost

**7/6 each**

**Specify—**



Advt. of Dubilier Condenser Co. (1925), Ltd., Ducon Works, Victoria Road, North Acton, W.3.

National Wireless Week—Let Your Friend Listen  
E.P.S. 239.

# Can We Run Our Valve Filaments on A.C. ?—cont. from page 434

enable us to obtain a source of supply suitable for lighting the filaments of the valves without very much difficulty.

Moreover, it is a property of a transformer that, allowing for a certain amount of loss of efficiency in the transference from the primary to the secondary coil, the energy taken from the primary circuit is very nearly the same as that in the secondary circuit. Therefore, if we consider the previous example where the filament circuit required an energy of 6 watts only, then the energy to be taken from the mains would also be of the same order, say 10 watts, allowing for the efficiency of the transformer. This would only require, approximately, 50 milliamperes from the mains instead of 1 ampere as in the case of direct current. A system such as this is thus very considerably more efficient.

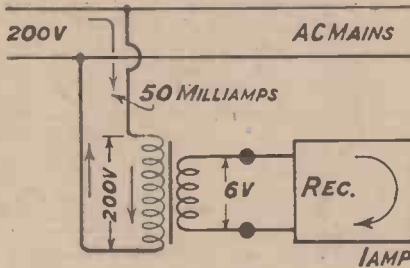

Fig. 2.—With A.C. the mains supply a small current at high voltage, which is transformed to a large current at a much lower voltage.

### A Difficulty

We are, however, faced with another problem, which arises from the fact that the voltage is not constant, but is varying. An alternating current is one which flows first in one direction and then in the other. It rises to a maximum value, falls to zero, and then goes through a similar cycle, as it is called, in the opposite direction. Moreover, this complete cycle of events takes place something like 50 times per second.

Now, it is well known that a thermionic valve is extremely sensitive to any changes in the potential difference between the grid and the filament. Normally we have the filament of the valve at a fixed potential, and we vary the voltage on the grid. If we, however, keep the grid fixed, and we cause the potential of the filament to vary from time to time, then obviously we are obtaining the same effect. In the case just considered, therefore, we are in danger of producing a voltage variation at this frequency of 50, per second (or whatever

the frequency of the particular mains happens to be).

### Humming

Let us consider a simple circuit such as that shown in Fig. 3. If we take

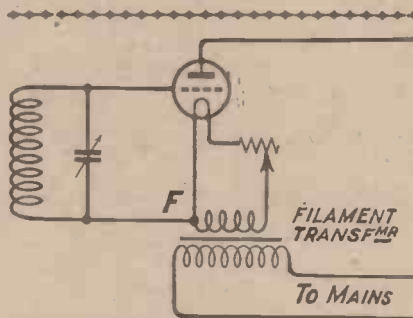

Fig. 3.—The point F is at a varying potential, so that a connection such as this would give rise to a powerful hum.

the earth return of the grid circuit direct to the filament, the point F is going to vary its potential 50 times per second, and we shall obtain a powerful hum in the receiver which would completely swamp any telegraphic or telephonic signals.

We can overcome this difficulty by arranging to connect the earth return to the centre point of the filaments. This is actually impracticable, but we can utilise a tapping at the centre point of the filament transformer. This point does not vary in potential. At one moment one end of the filament transformer is at a positive potential and the other is at a negative potential. At the next instant the positions are reversed, but in each case the potential of the centre point of the transformer does

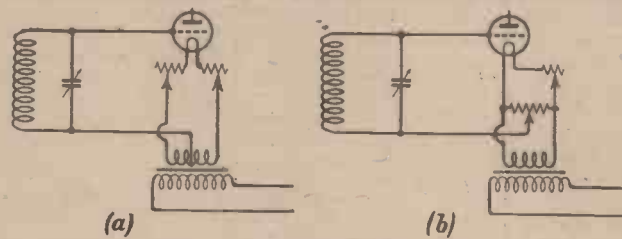

Fig. 5.—Two ways of obtaining a centre tap when using a transformer on A.C. mains.

not vary. This will be clear from Fig. 4. Hence if we can obtain a tapping at this point, we can connect the earth return to such a point with satisfactory results, and we shall not be bothered with this hum.

### A Difficult Provision

In practice the satisfactory tapping of the transformer at the exact electrical point is a matter of difficulty, and

requires very careful construction. Nevertheless, it can be done, and such transformers are available on the market. Another way of overcoming the difficulty, however, which is one of more general application, is to connect a potentiometer across the filament transformer, and find the point of zero potential by actual trial and error until satisfactory results free from hum are obtained. This method, of course, requires a potentiometer, but does not necessitate the use of a special centre-tapped filament transformer.

### Temperature Fluctuations

A centre connection such as this overcomes the difficulty of the hum due to the varying potentials at the ends of the filament transformer, but we are still left with the problem of the current through the filament itself, which is not steady but alternating.

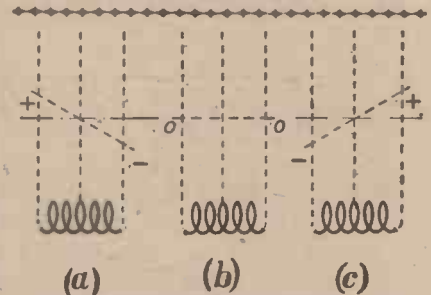

Fig. 4.—Illustrating the distribution of potential on the secondary of the filament transformer at three distinct points in the cycle.

The question is how far any such variations in the current will give rise to interference in the receiver.

Now, under any given conditions the anode current depends on the emission, which, in turn, varies as the temperature of the filament. The latter effect is dependent to a very marked degree on the filament current, which, as we have seen, is rapidly varying both in strength and direction. Obviously, therefore, the varying filament current will give rise to ripples in the anode current, the severity of the hum produced depending on the relative strength of these ripples and the variations of anode current produced by the legitimate signal.

### Dull-Emitter Possibilities

With the old bright emitters the fluctuation of filament current gave rise to variations in the anode current which altogether precluded the use of A.C. for filament lighting, the residual hum, even when all precautions had been taken, being far too great for

(Continued on page 460.)

# ECONOMY IN H.F.

BY THE LABORATORY STAFF

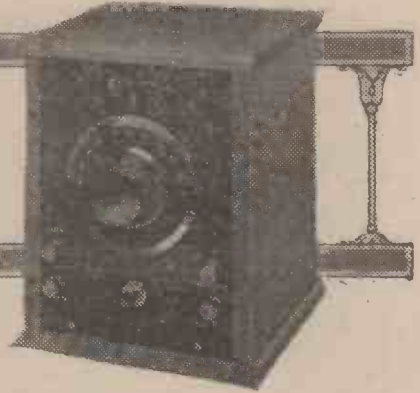

Some useful suggestions for the economical use of an extra H.F. valve.



RECENT issues of this journal have contained descriptions of apparatus by which a single high-frequency stage could be added to an existing receiver. A particular example was that described by Mr. J. H. Reyner, who gave details of a simple unit so designed as to be satisfactory for use with any existing single-valve receiver.

Mr. G. P. Kendall described a Neutrodapter which achieved similar results in a different manner, and these units have been used by various readers with success. Their principal advantage lies in the fact that distant stations are brought within easy reach. The operation of the receiver remains exactly the same as before except that the high-frequency circuit has also to be tuned in, but the greatest advantage of the whole arrangement is that if it is correctly adjusted it is to all intents and purposes non-radiating.

### The Usual Method

One of the commonest methods of neutralising any high-frequency valve is by tuning the whole system to the local station, extinguishing the filaments of the high-frequency valves and then adjusting the neutralising condenser until no signals are heard. This ensures that the system is correctly balanced, and when this is the case it is also balanced for any reverse action, so that any oscillations which occur in a later part of the receiver are not transferred back to the aerial circuit.

This means, therefore, that the distant stations may be picked up with greater ease and no damage is done or interference caused to one's neighbours if the set inadvertently oscillates.

### Other Possibilities

Many readers, however, while they like to tune in occasional distant stations, they do not feel justified in going to the extra expense of a high-

frequency unit just for the purpose of making the receiver non-radiating. The actual increase in strength produced in the reception of the local station is not very great, and consequently the scheme is turned down as not being sufficiently productive of results.

It is possible, however, to make this extra valve do work other than that of simply amplifying at H.F. We can, for example, arrange to utilise the

reason for this latter switch will be quite clear after a moment's thought. When we are using the receiver as detector and note magnifier we require the grid leak on the first valve to be connected to the positive filament leg, and that on the second valve to be connected to the negative. When we are using the receiver as a high-frequency and detector arrangement, the position of affairs has to be reversed, since the first high-frequency valve has to be operated with the grid at a slightly negative potential, while the grid of the second valve must be slightly positive in order to obtain the necessary rectification effect.

A simple reversal of the connections to the battery will produce the required changing round, and this, coupled with the replacement of the tuned circuit by the resistance or vice-versa, is all the switching that is necessary. Moreover, this switching can be so arranged that no deleterious effects result, and a satisfactory receiver may be built up in such a manner.

### Valves

This circuit requires the use of a high-impedance valve for the first stage in order that full amplification may be obtained from either the tuned-anode or the resistance-coupled arrangement, both of which should follow a high-impedance valve. The second stage requires a compromise. When used as a detector a fairly high impedance is required, whereas if it is used as a L.F. amplifier followed by loud-speaker, a low-impedance valve is required. Some valve, therefore, having an average impedance should be used in this stage.

Those readers who do not like switching may use the scheme shown in Fig. 2, which is a reflex arrangement. Many people still feel that reflex receivers are not worth while, and that the troubles which are usually associated with them are too numerous to make the saving in other directions economical.

(Continued on page 440.)

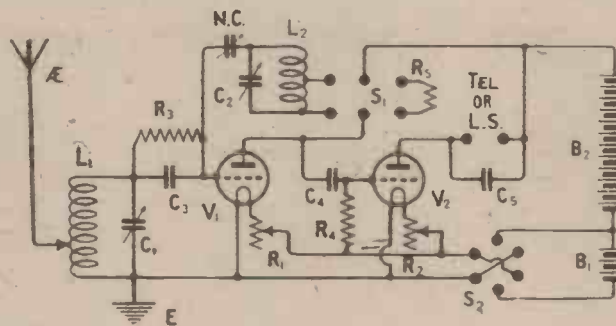



Fig. 1.—This circuit illustrates an economical method of using an additional valve, so that the combination of H.F. and detector can be converted into detector and note magnifier for local work.

additional valve for low-frequency purposes as well as for high-frequency by some form of reflex arrangement, or we can by some slight readjustment of the circuit so arrange that the instrument acts either as a detector and note magnifier or as H.F. and detector.

### A Simple Expedient

Considering the second arrangement first as being in some respects simpler, one form of circuit which may be adopted is that shown in Fig. 1. Here we have a circuit which can be arranged either as a straightforward detector with a resistance-coupled note magnifier or as a high-frequency valve followed by a tuned-anode, the second valve in this case acting as a detector.

All that is necessary is a simple change-over switch which replaces the tuned circuit with a high resistance, and, secondly, a simple reversing switch on the L.T. battery. The



# Built like the Pyramids



## NOW ON SALE

PERHAPS the most interesting of all the S.T. Valves are the S.T.43 and S.T.63. The reason for this is that they are pioneers of a new super-power class of valves which is designed solely and exclusively for loud-speaker use. On normal signals they only give the amplification of the power valve class (of which the S.T.62 is the best example to-day) or even slightly less. For sheer beauty of tone, however, they are incomparable. The reason is that their dynamic curves are designed to be dead straight and to allow for a wide grid swing of at least 15 volts on each side of the normal grid bias which is about 18 volts when 120 volts H.T. is used.

Probably most of the distortion generally experienced is due to a "curve" which really *does* curve, or because when a stronger portion of the music comes along—e.g., a full-sustained high note, you "run off the curve." This, of course, may mean that the grid variations are so great—

momentarily—that proportionate changes in anode current are not produced. Another cause of valve distortion is that on strong signals or on certain notes or phases of the music the grid voltage actually goes momentarily positive, even though substantial negative grid bias is used. The moment the grid becomes positive, a grid current is set up which damps down the positive half-cycles and causes distortion. The remedy for this is to use more grid bias, but power-valves will not stand more than a certain grid bias, because you then get rectification at the so-called bottom bend, and the normal anode current is brought too low. Hence you get another form of distortion.

The solution is to use an S.T.43 or S.T.63 (according to whether you use a 4-volt or 6-volt accumulator). Both valves have similar characteristics, and with -18 volts on the grid you can get, with 120 volts H.T. voltage, a total grid voltage range on the dynamic curve of from -1 volt to -35 volts,



*mid's—to last*



the dynamic curve being as straight as a ruler over this range.

Some readers of "WIRELESS" will ask whether this range is really necessary. It is not required for medium loud-speaker results, but where great output combined with purity is required, it is essential.

Where then is the value for domestic use over the ordinary power valve? It lies in the fact that in practically all music there are certain parts which cause increases in grid voltage swing as much as 1,000 per cent. more than in the case of other parts. The rattle of the drums, the robust music of a brass band or the long, high note of a soprano, heard with an ordinary power valve, often play havoc with the sensitive ear. The loud-speaker makes a noise as though the diaphragm is rattling and everything sounds mushy for the moment. The high note sounds cracked and the drums sound like a roar. Perhaps you blame your loud-speaker, but the choice of

the valve is usually at fault. The ordinary power-valve may be all right for 90 per cent. of the music you hear, but if you want to get the illusion that you are hearing the *original* performance, you must get 100 per cent. perfect reproduction.

Fit an S.T.43 or S.T.63, and your friends will wonder what magical change has taken place in your set. People will listen at your gate at night without knowing that it is broadcasting. They hear the living voice because you are using the valve with the big factor of safety—"the valve with the golden voice."

These valves cost you a little more, but if you order one to-day, your critical attitude and that of your friends towards the purity of broadcasting reception will change at once.

S.T. 43 (4 volts  
0.2 to 0.25 amp.) Price 22/6 S.T. 63 (6 volts  
0.2 to 0.35 amp.)

# SOLDERING SUPERSEDED



Simple, easily applied, effective, neat, ensure better results.  
 Perfect joints. A "KRISCROS" for every contact.  
 Prices from 1/- per doz. Send for List.  
 KRISCROS COMPANY, 50, GRAY'S INN ROAD, LONDON, W.C.1

## PHONE REPAIR SERVICE

Headphones rewound and Remagnetised 4/6. Loud Speaker  
 rewound 4/6. Transformers rewound 5/- Remagnetising  
 only 2/-. All work guaranteed. Postage extra. Write for  
 trade terms:—H. E. P. Co., 1, Cottrill Road, Spurstowe  
 Terrace, Hackney, E.8.

## ALL MANUFACTURERS' GOODS ADVERTISED IN THIS PAPER

Can be obtained C.O.D. or Cash with Order, per return, from

# YOUNG'S

(GLASGOW), LIMITED,  
 40, STOCKWELL ST., GLASGOW.  
 Write To-day for Big Free Catalogue.

**1/9 AERMONIC**  
 DON'T PAY MORE  
 VALVE HOLDER.  
 Anti-capacity. Anti-Phonic.  
 Don't pay more than 1/9.  
 If hard to get, drop us a line.  
**J. CHRISTIE & SONS, LTD.,**  
 248, West Street, Sheffield.  
 London Agents: A. F. Bulgin & Co.,  
 10, Curstior Street, London, E.C.4

**WIRELESS.**—Capable trustworthy men with spare time who wish to substantially increase income required where we are not fully represented. Applicants must have practical knowledge of installation of Set and Aerial, be a householder or live with parents, and be able to give references; state age and experience. Address: Dept. 38, GENERAL RADIO COMPANY, LIMITED, Radio House, Regent Street, London, W.1.

**BUILD A LOUDSPEAKER**  
 WITH OUR NEW SEAMLESS MOULDED CONE (Prov. Patent) and a BROWN A. or LISSEOLA. You will obtain PERFECT RESULTS. Successful Construction for a minimum outlay is ensured with our Specialities. Illustrated Lists and full particulars for Stamp.  
**GOODMAN'S, 27 Farringdon St. E.C.4**  
 Also obtainable from Spencer's Stores, 4-5, Mason's Avenue, E.C.2

## BOARD OF GUARDIANS, ST. MARYLEBONE. WIRELESS.

Tenders are invited to supply, fix, equip and wire the Wards, etc., with wireless and certain other work connected therewith, at St. Marylebone Hospital, Rackham Street, W. Particulars upon application in writing to me, accompanied by a stamped addressed envelope.  
 Tenders to be delivered endorsed "Tender for Wireless" at my office not later than Wednesday, the 17th November.

October, 1926. By Order, EDWARD A. FRITH, Clerk to the Guardians.  
 Administrative Offices, Northumberland Street, W.1.

# Economy in H.F.

(Continued from page 437)

## Improved Reflexes

With the modern circuit this is not the case, and at any rate with one reflex stage, perfectly stable amplification at high frequencies, coupled with good and pure reproduction, may be suitably combined in the one valve. An arrangement such as this is particularly suitable for the case in point, where we may obtain all the advantages of the non-radiating arrangement coupled with the extra amplification at low frequency enabling the local station to be received on the loud-speaker. Moreover, both these advantages can be obtained simultaneously, so that the advantage of the extra low-frequency amplification is obtained on the distant stations as well.

The circuit is actually shown in

The telephones may then be inserted in the anode circuit of the reflex valve and the low-frequency portion of the circuit tried out. In the majority of cases it will be found that no adjustment whatever has to be made, and the receiver reflexes straight away without any trouble. Possibly a change-over of the connections on the transformer may be necessary, but this as a rule is all that is found to be required.

These are two methods whereby high-frequency amplification may economically be provided for an existing single valve receiver, and in view of the really good amplification which can be obtained from the modern high-frequency valve utilising the modern circuits this is the procedure which is to be recommended.

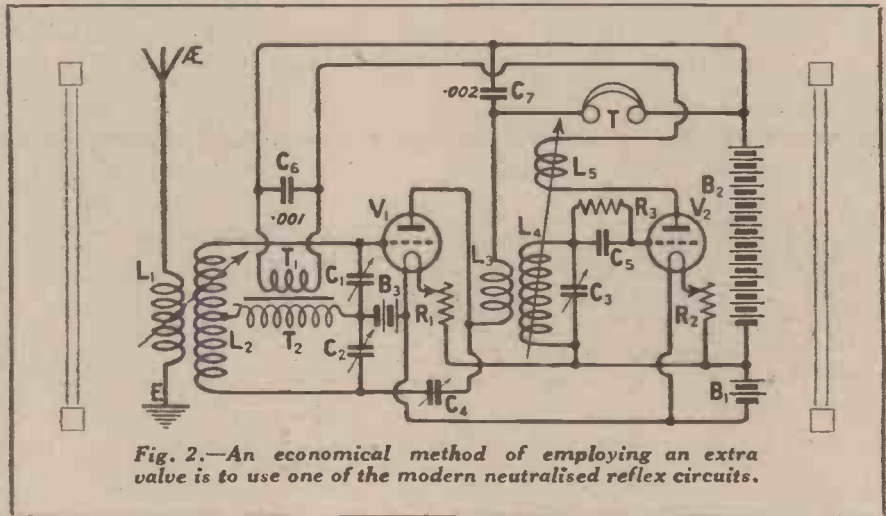

Fig. 2.—An economical method of employing an extra valve is to use one of the modern neutralised reflex circuits.

Fig. 2, and it will be seen that the well-known split-condenser principle has been employed. As has been explained previously in these columns in connection with the "Elstreflex" receiver, this arrangement gives us a very satisfactory system. The points across which the low-frequency transformer is connected are both at the same high-frequency potential, and therefore the interaction between the circuits is reduced to the minimum.

## Practical Details

If a valve such as this arranged to act in a dual capacity is coupled to an existing single valve receiver, the adjustment is very simple. The telephones may first of all be inserted in the anode circuit of the single-valve receiver, so cutting out the low-frequency action of the reflex valve, and the high-frequency circuits may then be correctly adjusted, properly stabilised and tried out first of all.

## WHAT DO YOU DO?

In a recent paragraph mention was made of a plebiscite taken by an amateur in Jersey of the listeners who stood by 6BM, 5XX, or both. We have received a letter from the gentleman in question, who states that he has since then organised another ballot, the new results being as follows:—

- Listeners to Daventry only: 8½ per cent.
- Listeners to Bournemouth only: 58½ per cent.
- Listeners to both stations: 33½ per cent.

This was a vote on popularity only, the first one being concerned somewhat with spark interference on Bournemouth's wavelength.

**The NATIONAL  
WIRELESS WEEK**  
NOV. 7<sup>th</sup> - 13<sup>th</sup>.  
*Let your Friends Listen*

WRITE FOR THE  
NEW IGRANIC  
CATALOGUE

**A  
Permanent  
Record.**

The Igranic Indi-  
graph Vernier  
Knob and Dial  
with its smooth,  
silky movement  
and reduction  
ratio of 8:1 makes  
tuning wonder-  
fully easy.



Every station tuned in can be logged on the dial opposite the dial setting so that tuning records are always where they are wanted—on the dial. If necessary they can be erased with a soft rubber. The Indi-graph Vernier Knob and Dial is . . . 7/6

SEND FOR LIST NO. S.37.

**IGRANIC ELECTRIC Co., Ltd.,**

149, Queen Victoria St., LONDON.

Works: Elstow Road, BEDFORD.



**RECUPERATING AGENT**  
in the

**HELLESEN  
DRY BATTERIES**

**Foresight!**

Five years ago the manufacturers of Helleesen dry Batteries realised that specialisation was necessary in Wireless types if the needs of to-day were to be efficiently and economically met.

A longer life to meet the long and frequent periods of use which you demand to-day without sacrificing in the slightest the smooth uniform supply which has made Helleesen Dry Batteries known as the *Best in the World*.

**60 volt "WIRIN" 12/6**

**99 volt "WIRUP" 21/-**

POSTAGE EXTRA.

All types, voltages, etc., in Double and Treble capacities for H.T. and L.T. Supply. Ask your dealer for the type to suit your set and get the maximum service or write us for full particulars.

Obtainable at all Radio, Electrical and General Stores, Harrods, Selfridge's, etc., or direct from

**A. H. HUNT LTD., DEPT 15 CROYDON, SURREY**

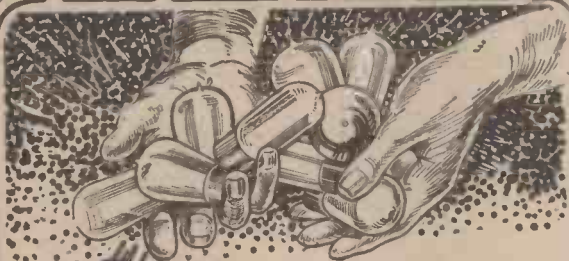

**A MISER IN CURRENT  
A TROJAN IN SERVICE**

Frelat, the world's best dull emitter, costs only 4/11.

Costed low so that millions can buy it. Thousands of satisfied users will buy no other: next time specify Frelat.

In the extensive Frelat range there is a new 2-volt power valve at 8/6—it cannot be equalled at the price.

Valves will be sent C.O.D.  
Type "K" 5/3 post free  
"D.K.P." 8/10  
(New 2-volt power Valve)

**4/11 Type K—2 volt .3 amp. 4/11**

If your Dealer cannot supply, write to the:  
CONTINENTAL RADIO IMPORT CO., LTD., 8, SPITAL SQUARE, LONDON, E.1

*Frelat*

TRADE

**HUNTS**

MARK

*They Last Longer*



## 1927 IMPROVED MODEL H.T. ACCUMULATOR

SUPPLIED READY FOR USE.

NO FILLING WITH ACID. NO CHARGING.

MODEL H.T.4. 30 VOLTS .. 30/-  
MODEL H.T.5. 90 VOLTS .. 90/-

Have you considered the advantages of C.A.V. H.T. Accumulators as compared with dry batteries for your H.T. Supply? Do you know that your radio reception can be vastly improved by using the C.A.V. 1927 Model H.T. Accumulator, and that your H.T. Supply will then actually cost less? Study the following points, and get your local Radio Dealer to demonstrate with a difference they make to reception, and you will not only be convinced that they satisfy in every way, but you will also wonder why you did not use one long before.

### WHY YOU SHOULD CHOOSE C.A.V. H.T. ACCUMULATORS.

1. C.A.V. H.T. Accumulators will last for years, and only require recharging every four to six months (any C.A.V. Service Station will recharge a 60-volt Assembly for 2s. 6d. or less).
2. They are cheaper in the long run than continually buying new dry batteries.
3. The chemical action of dry batteries causes crackling background noises with reception. C.A.V. H.T. Accumulators are absolutely silent in operation.
4. C.A.V. H.T. Accumulators give a constant voltage pressure, not varying as with dry batteries, a consistent signal strength is therefore maintained during reception.
5. They have no shelf life (it is possible to lose a considerable part of the useful life of a dry battery if it is kept standing idle for any length of time). Although H.T. Accumulators will discharge in the same way, but to a much lesser degree, this loss can be replenished by a freshening charge.
6. This is a super charged battery, it being given several cycles of charge and discharge during the initial charging process. By this method, retention of charge over a long period is obtained.
7. Used by the majority of leading experimenters, C.A.V. H.T. Accumulators have also been supplied to over 100 of the London Hospitals in which Receiving Apparatus has been installed for the benefit of the patients.

### COMPETITION OPEN TO USERS OF THIS ACCUMULATOR.

Owing to the various special features of our H.T. Accumulator, we desire to give it a distinctive name, and invite suggestions.

Prizes will be awarded as follows:—

- 1st PRIZE .. 75 GUINEAS.  
To the entrant of name adjudged the best.  
2nd PRIZE .. 25 GUINEAS.  
To the trader from whom the first Prize Winner purchased his Accumulator.

Full particulars including conditions of competition will be forwarded on application.

### SALES DEPOTS.

BIRMINGHAM—Great Hampton Street.  
BRISTOL—7-25, Temple Street.  
DUBLIN—Taylor Bros., 41, Middle Abbey St.  
GLASGOW—227-229, St. George's Road.  
LEEDS—117, Park Lane.  
LONDON—224, Shaftesbury Avenue, W.C.2.  
LONDON—90, High Street, Camden Town, N.W.1.  
MANCHESTER—191-3 and 277, Deansgate.  
NEWCASTLE-on-TYNE—88, St. Mary Place.

Also supplied by all C.A.V. Service Stations and recognised Wireless Dealers.

Write for copy of C.A.V. Illustrated Radio Catalogue.

**C.A. Vandervell & Co. Ltd.**  
ACTON VALE, LONDON W.3

Telephone: Chiswick 3801 (Private Branch Exchange). Telegrams: "Vanteria, Act, London."

# EFESCA



## "CENTADYNE" Screened Coils

### FOR NEUTRALISED CIRCUITS

Made to Elstree Laboratories specification and officially approved.

SUITABLE for all star and other circuits described in "Modern Wireless," "Wireless Constructor," and "Wireless," employing 6-pin standard coils.

#### PRICES OF COILS WITH 6-PIN PLUGS.

	250 to 550, 1,000 to 2,000 metres.	4/6 each	7/6 each	7/6 each	15/- each	4/- each
Aerial Coils, split primary .. .. .	4/6	7/6	7/6	15/-	4/-	
H.F. Transformers, split primary and optional reaction ..	7/6	7/6	7/6	15/-	4/-	
H.F. Transformers, split secondary .. .. .	7/6	7/6	7/6	15/-	4/-	
Reinartz Coils .. .. .	7/6	7/6	7/6	15/-	4/-	
Copper Screen with 6-pin base .. .. .	7/6	7/6	7/6	15/-	4/-	
Unshielded 6-pin base for standard Coils when used without screen .. .. .	7/6	7/6	7/6	15/-	4/-	

Ask your retailer, or write for catalogue 573/3 of Efesca Components and circuits employing them.

**FALK STADELMANN & Co. Ltd.**  
83-93, FARRINGTON ROAD, E.C.1  
and at Glasgow, Manchester, Birmingham, Newcastle, and Dublin.

## EFESCA NEW TYPE Neutralising Condenser



A new departure in design. The moving electrode telescopes into a fixed cylindrical plate, being operated by a wormed spindle with long insulated handle, providing 6 to 1 ratio vernier movement.

While designed for neutralising, it is equally suitable for use as a midget reaction Condenser, as used in the Monodial Receiver, Elstree Six and the Solodyne.

Arranged for either baseboard or panel mounting.

PRICE  
6/-  
EACH.

# ARTIFICIAL "ATMOSPHERICS"!

Noisiness in a valve receiving set is most unpleasant. Often it is put down to atmospherics, but in nine cases out of ten the crackles and the fryings that are heard in the receiving set are due to some quite definite cause.

The most likely culprit is the high tension battery, especially if it is of small size or if it has seen a good deal of work. When the battery is in use little bubbles of hydrogen gas try to collect upon the carbon rod which forms the positive element. They are prevented from doing so, so long as the battery is in good condition, by the action of the depolariser, which consists of manganese dioxide. The oxygen of this chemical combines with the hydrogen to form water, which helps to moisten the cell.

### Depolarising

When the battery has seen a good deal of work, or if it is overloaded,

are much below their proper voltage. As a rule, if the whole or any portion of a battery has fallen to two-thirds of its nominal voltage it should be discarded, for it is almost certain to be noisy.

### Grid Leaks

Other noises, very similar both to atmospherics and to high-tension battery noises, are those caused by faulty anode resistances or grid-leaks. Both resistances and leaks of good make last as a rule for a long time, and may be relied upon. Even the best, however, may give out after a great deal of work, especially in the case of resistances, if they have been subjected to heavy loads. Cheap leaks and resistances are often noisy from the outset. If any grid-leak or anode resistance is suspected of noisiness the best way to test it out is by the substitution method recommended for the high-tension battery.



☺ ☺

*M. Hoffman, the famous pianist who recently gave a recital at 2LO, is here seen before the microphone.*

☺ ☺

The depolariser cannot deal effectively with the hydrogen. Bubbles collect upon the carbon rod, increasing the internal resistance of the cell. This causes a drop in the voltage. The bubbles are eventually disposed of and a minute rise in voltage takes place, followed by a drop as fresh bubbles collect. Hence the voltage of the cell in question is continually rising and falling.

If all the cells of a battery are in this condition the set to which it is attached is bound to be noisy. Even a single bad cell in a battery will cause noisiness, since its variations affect the output of the whole battery. The only way of discovering whether the high-tension battery is responsible for noisiness is either to try it upon a friend's set or to borrow a battery known to be in good condition and to try it against your own. A test with a good voltmeter cell by cell will show whether any portions of the battery

### Valves

Valves, particularly those of the bright emitter type, may be responsible for noisiness if their filaments are run too brightly. The cure is obvious. The most unpleasant noises of a violent kind will take place should there be a complete or partial break in the leads of the telephones or loud-speaker.

The last kind of noisiness is that produced by microphonic valves. Dull emitters are much more prone to microphonic noises than bright. The symptoms are that whenever a valve is lightly flicked with the finger a pong is heard in the telephones or loud-speaker. If it is not heard except when this is done it does not matter very much; but sometimes valves are so microphonic that the slightest jarring of the table upon which the wireless set stands may start the noise.

R. W. H.

Ashley  
Radio

## JACKS

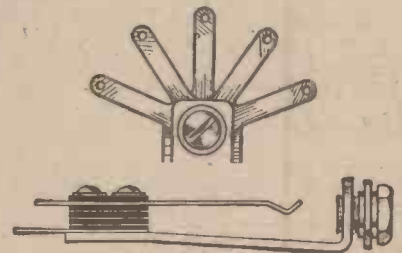

—are made of nickel silver springs, with pure silver contact, and Bakelite insulation throughout. Tags are tinned and spread fan-wise for easy soldering.

JACK No. 1 Single Circuit (open)	<b>1/3</b>	JACK No. 2 Single Circuit (closed)	<b>1/6</b>
JACK No. 3 Double Circuit	<b>1/9</b>	JACK No. 4 Filament Single Control	<b>1/9</b>
		JACK No. 5 Filament Double Control	<b>2/3</b>

TELEPHONE PLUG, 1/6

## CLARITONE LOUD SPEAKERS

Senior Model, 2,000 ohms, } **£5 00**  
 W.2.5. 120 ohms, W.266 }  
 Junior Model, 2,000 ohms, } **£2 15 0**  
 W.267. 120 ohms, W.268 }

## CLARITONE HEADPHONES

W.216 .. 20/-

## ASHLEY WIRELESS TELEPHONE CO., LTD.

17, Finch Place,  
London Road,  
LIVERPOOL



# A constant High Tension Supply for a Lifetime

## “Goltone” (Regd.) HIGH TENSION BATTERY ELIMINATORS



First cost saved in a short time. Gives increased volume and purity of tone. Simply plug-in to any convenient lampholder. Complete with Lampholder Adaptor and Flexible Cord, ready for use.

**DIRECT CURRENT TYPE**  
Model “D.J.” Approx. tappings 45 and 100 volts.  
Price 32/3

Model “D.” Standard Type.  
Approx. tappings 30, 50, 75, 90, and 120 volts.  
Price £3 0 0

**ALTERNATING CURRENT TYPE**  
Approx. voltage tappings, 30, 60, 90 and 130 volts.  
Dual tappings are taken from each voltage, thus providing eight separate tappings.

Price £5 10 0 including Valve.

Please state Voltage and Frequency of Lighting Mains when ordering.  
“CONSTRUCTIONAL KITS” also supplied. See Catalogue for full details.

Large fully illustrated Catalogue, No. R/116, on request. “Goltone” Products are stocked by the Leading Stores. Refuse Substitutes.

## ACCUMULATOR CHARGING SETS FOR HOME SERVICE. SIMPLE, RELIABLE AND EFFICIENT



### EASIFIX “CO RT” RADIO ASSEMBLIES.

33 inches overall.  
Eliminates ugly loose wires and minimises the risk of burning out valves. Each Conductor is distinctively coloured and the whole enclosed within a strong outer braiding. Fitted with Spade Terminals and Wander Plugs.  
4 Ways, 2/-; 5 Ways, 2/3  
6 Ways, 2/9; 7 Ways, 3/6  
Refuse Substitutes.

TO  
HIGH & LOW  
TENSION  
PANEL  
TERMINALS.



Mr. J. W. D., Ormskirk Rd., Aintree, writes: “I bought an ‘Alterno’ and tried it yesterday and was quite surprised at the results. I think it the most wonderful and simple arrangement I ever saw for so little money.”



Goltone “Pendelton” Charger showing Cover removed.

No technical knowledge or attention required. Simply connect to any convenient lampholder. Complete with Adaptor, Connecting Cord and full instructions.

**“Indispenso”**  
(Direct Current.)  
Charges the High Tension Accumulator at no extra cost when light is in use.  
Price 6/-

**“Alterno”**  
(Alternating Current.)  
Charges the High Tension Accumulator at negligible cost.  
Price 7/1-

**Goltone “Pendelton”**  
Patent App.  
(Alternating Current.)  
Charges the Low Tension 2, 4 or 6-volt Accumulator economically and effectively.  
Charging rate approx. 2 amps.  
Price £2 12 6

Fitted with Ammeter, as illustrated, £3 7 6

Please state Voltage and Frequency of Lighting Mains when ordering.

## “GOLTONE” RADIO METERS

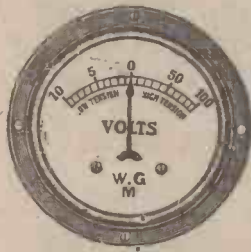

BRITISH MADE. Double reading, 10 volts and 100 volts.

**POCKET TYPES.**  
Insulated Bodies.

Side Reading .. 8/6  
Centre Zero Reading, Patent App. .. 10/6

**PANEL MOUNTING.**  
Flush Type. Dia. of Dial 1 1/2 in.  
Centre Zero Reading. Patent App. Price 12/9

Panel Mounting Push Buttons .. 1/6 pair  
See List R/115 for wide range.



## Don't forget to use GLAZITE BRITISH MADE REGD.

COLOURED CONNECTING WIRE

[ RED · YELLOW · BLUE · BLACK · WHITE and GREEN ]

Write for descriptive leaflet to  
The LONDON ELECTRIC WIRE CO & SMITHS LTD  
Playhouse Yard, Golden Lane, London, E.C.1.

Makers of Electric Wire for over 40 years

## SPECIFY



## PRODUCTS

A LEADING valve manufacturer reports that “exceptionally good loud speaker results” were obtained with the Wattmel Auto - Choke. “Speech was clear and sharp and music free from distortion.”  
Get full particulars of Wattmel Auto-Choke, Grid Leak, and Combined Fixed Grid Leak and Fixed Condenser from your dealer, or write direct to manufacturers.

THE WATMEL WIRELESS CO., LTD.,

332a, GOSWELL ROAD, LONDON, E.C.1.

Telephone: Clerkenwell 7980.

Representative for Lancs, Yorks and Cheshire:  
Mr. J. B. LEVEE, 23, Hariley Street, Levenshulme, Manchester.



**I**NTERFERENCE, more particularly that caused by shipping, can quite easily spoil the reception of the local station. Although with any crystal receiver it is impossible to eliminate completely such interference, the use of a selective circuit should bring about a considerable reduction, and the receiver, of which a description is to follow, has been designed primarily to meet the needs of people resident in coastal districts, a choice of circuits being a feature. The receiver is also capable of receiving a programme from one of two local stations, as in the recent tests from Oxford Street and Marconi House in the London area.

A list of the components used in the set is given below. The manufacturers of those used in the original receiver are also given, but other suitable components may, of course, be used.

**Making the Basket-Coils**

Before making the receiver the special basket-coils should be wound. The formers are prepared by cutting

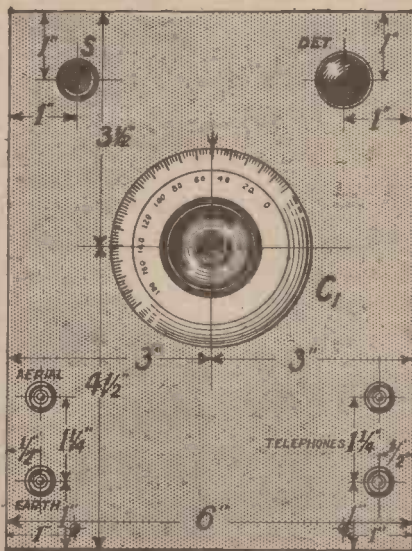

Fig. 1.—Nine holes require to be drilled in the panel, the positions of which may be obtained from this dimensioned drawing.

# A Crystal Receiver for Home-made Basket-Coils

By C. J. VANN

This simple receiver, which possesses the outstanding feature of easy construction, employs home-made basket coils in such a manner that a good degree of selectivity is obtained.

out a piece of thin, stout cardboard to form a disc 5 in. in diameter cut radially to produce the usual seven-armed former. The positions of the slits can be found by stepping off seven distances of about 2 1/4 in. round the

through each slit in turn until the requisite number of turns has been put on. The end of the winding is passed underneath the turns to the

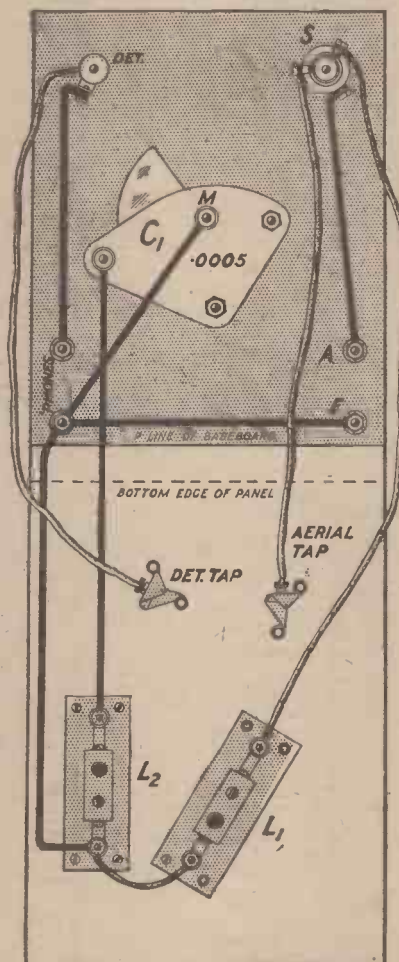

Fig. 2.—Variation of coupling between L1 and L2 is obtained by altering the position of the L1 coil base, this being secured by a single screw only.

circumference. Two of these formers will be required.

Thirty-five turns of the cotton-covered wire are put on one of the formers. This is the primary coil. The wire is first secured to the former by passing it twice through a pair of holes at the centre. It is then wound

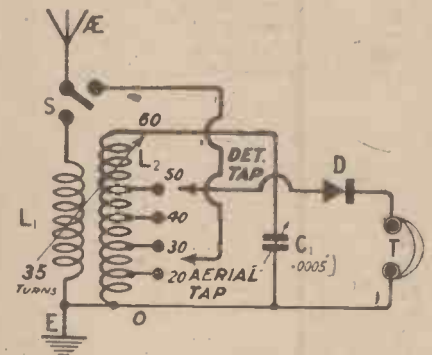
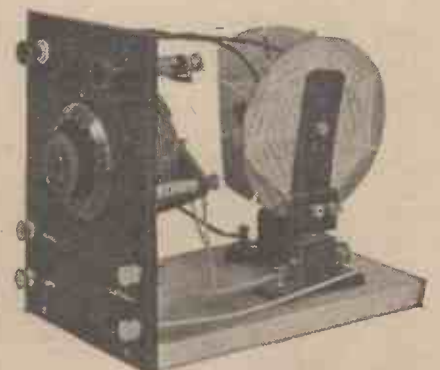

Fig. 3.—A so-called "aperiodic" aerial circuit may be obtained by bringing into use the switch "S."

centre of the coil where it is secured in a similar manner to the commencement of the winding.

The other former is used for the secondary coil which consists of 60 turns of the copper wire. After the first 20 turns have been wound on, a tapping is taken. This is done by twisting a small loop in the wire and continuing the winding. Other tappings are taken at every successive ten turns. When the coil is completed the loops must be cleaned. This is done best by scraping up the cotton covering with a knife and burning away the frayed ends with a lighted match. If the wire underneath is enamelled, this insulating covering

(Continued on next page.)



The method of mounting the basket coils may be seen in this photograph.

**A CRYSTAL RECEIVER FOR HOME-MADE BASKET-COILS**

(Continued from previous page)

must be scraped away to expose the bright surface of the copper.

When the smaller coil is finished the spare cardboard round the edges must be cut away from the former so as to allow the coil to fit easily into the cabinet.

The coils seen in the photographs were actually fixed to home-made mounts, but the mounts sold by most dealers will serve the purpose quite well.

**Preparing the Panel**

Having completed the coils, the receiver can be assembled. The panel is drilled in accordance with the diagram herewith. For the convenience of readers using the components specified, a table is given below showing the sizes of the drills used for the various components:—

Component.	Drill Size.
Condenser ... ..	$\frac{3}{32}$ -in.
Switch ... ..	$\frac{3}{32}$ -in.
Detector ... ..	5/16-in.
Terminals (4.B.A.)	5/32-in.
Screws ... ..	$\frac{1}{8}$ -in.

The panel can now be screwed to the baseboard with two brass screws, and the components mounted on it. Next

the coil holders must be screwed in position. This should be done with the coils plugged in so as to make sure that they will not foul the components on the panel. One holder is screwed down tightly and the other is only fixed with one screw. This provides a means of roughly varying the coup-

**WHAT YOU WILL NEED**

- One ebonite panel measuring 6 in. by 8 in. (Peto-Scott, Ltd.)
- One cabinet, to take the above panel, with a baseboard 9 in. deep. (Peto-Scott, Ltd.)
- One .0005 square-law variable condenser. (Jackson Bros.)
- One P.M. detector (panel mounting). (Radio Instruments, Ltd.)
- One single-pole, two-way, push-pull switch. (Lissen, Ltd.)
- Two "Success" single coil-holders. (Beard and Fitch, Ltd.)
- One packet Glazite connecting wire. (L. E. W. Co.)
- $\frac{1}{2}$  lb. of No. 22 D.C.C. copper wire.
- Two basket-coil mounts.
- Two spring clips.
- Four Terminals.

ling between the two coils. In fixing the movable coil holder enough room must be left for the coil to move as well as its holder.

**Testing the Receiver**

The wiring of the receiver can easily be accomplished with the aid of

the diagram. Readers who find difficulty in soldering will appreciate the fact that no joints were soldered in the original set. When the receiver is finished it should be attached to an aerial, earth and telephones, and tested. The two coils are placed in their respective holders, the primary coil in the movable holder and the secondary coil in the fixed holder. They are then placed at an angle of about 45 degrees and the aerial coil switched into circuit. The crystal clip is then placed on a terminal of the secondary coil holder so that the crystal and telephones are connected across the whole of the secondary inductance. The other clip is left loose. The receiver now employs "aperiodic" coupling. Now the secondary circuit is tuned with the condenser until the signals received are at their loudest. To increase the selectivity of the set, the coils must be moved further apart and the circuit re-tuned. When the coils are placed at right-angles to one another the set will be found to be fairly selective, the signal strength, however, will be found to decrease as the coils are moved further apart.

To test the other circuit, which is one employing auto-coupling, the switch must be moved so that it connects the aerial direct to the clip which has not yet been used. This clip should be attached to the tapping point at the 20th or 30th turn of the

(Continued on page 449)

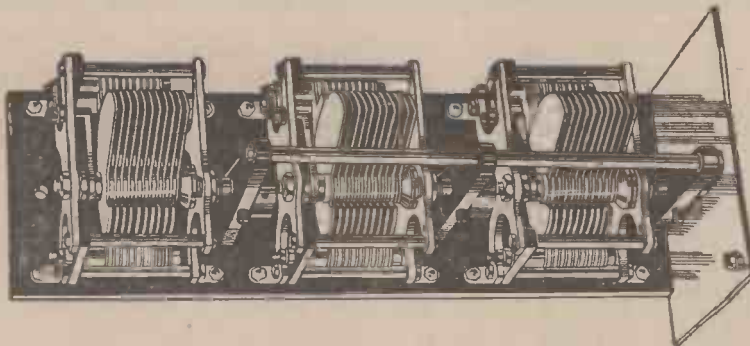

The

**CYLDON**  
(pronounced SIL-DON)

**TRIPLE GANG CONDENSER**

for use in the New Five-Valve "Elstree SOLODYNE."

Price £3 . 10 . 0 (Without Dial)

- 2 Gang Condenser - £2 10s.
- 4 Gang Condenser - £4 10s.

Get full particulars of all Cyldon Products from your dealer or write direct to the makers. Other Cyldon Condensers comprise Square Law, Square Law Dual Pattern, and the S.L.F. 4 in. Knob Dial, supplied free with Square Law and Dual Models, and 2s. extra with S.L.F. or Triple Gang.

**SYDNEY S. BIRD & SONS,**

"Cyldon" Works, Sarnesfield Road, ENFIELD TOWN, MIDDLESEX.

Telephone: Enfield 0672.

**C**ONSTRUCTORS are giving this handsome new model a most enthusiastic welcome because of (1) Its absolute freedom from whip. (2) Independent adjustment of each Condenser by novel means, completely eliminating hand capacity.

**O**THER attractive features are—each Condenser electrically separated. Anti-capacity plate supplied. Operation of all three condensers as "silky" as if only one was used. Whole instrument perfectly rigid. Supplied ready for immediate fitting. Construction and finish are well up to the fine Cyldon standard.

Send for particulars of the Cyldon WAVEMETER—it identifies unknown stations and makes searching and testing out simplicity itself.



**Cyldon TEMPRYTES**

The best means of valve control. British-made and delivered from stock immediately. Can be supplied in correct resistance for any Valve. State resistance (ohms) required, when buying, or be sure to give name of Valve and voltage of Accumulator supplying current to the Valve.

- Cyldon Temprytes ... .. each 2/6
- Holder mountings ... .. each 1/6



# Inventions and Developments



UNDER THIS HEADING MR J.H.REYNER, B.Sc. [Hons], A.C.G.I, D.I.C., AM.I.E.E., OF THE RADIO PRESS LABORATORIES, WILL REVIEW FROM TIME TO TIME THE LATEST DEVELOPMENTS IN THE RADIO WORLD.



IN the present era of simplified control, one of the principal difficulties which is encountered in the design of receiving equipment, particularly high-frequency amplifiers, is the tendency for the circuits to be more lively at one end of the scales than at the other.

In a general type of arrangement the receiver tends to oscillate more readily towards the bottom end of the condenser scale, although this increase may not be continuous, and there is often some point when the capacity is about one-third of the maximum at which the circuit tends to oscillate more readily than at any other point. This is possibly due to the fact that at the very bottom of a condenser scale, when the plates are all out, the loss in the condenser tends to increase somewhat rapidly.

## Additional Adjustments

There are also circuits which tend to oscillate somewhat more readily from the top end of the scale. The "Elstree Six" circuit was a case in point. In any event, however, there is usually some more or less progressive increase in liveliness as the condensers are rotated, and in order to compensate for this, some small reaction or potentiometer control of some sort has to be fitted in order to maintain the receiver in a good sensitive condition. These adjustments, of course, are in addition to such arrangements as may be necessary to stabilise the receiver.

## A Remedy

A patent has recently been taken (No. 253072) which is designed to overcome this difficulty. The grid potential of one of the high-frequency valves in the receiver is controlled by a potentiometer which checks oscilla-

tion by introducing grid damping in the usual manner. Any previous valve

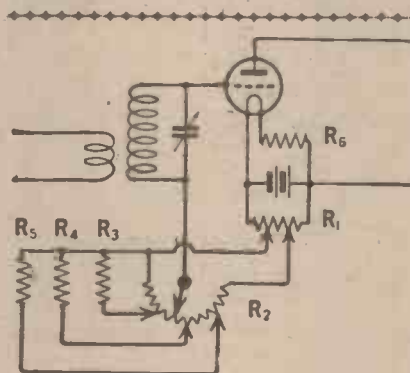

The potentiometer controlling the high-frequency valve is mounted on, or coupled to the spindle of the tuning condenser associated with it.

utilised may be stabilised by an approved means, whether by a neutralising method or not is immaterial.

to the spindle of the tuning condenser associated with it, and is so arranged as to make the receiver more lively towards one end of the scale, and to introduce a corresponding amount of damping at the other end, so that the circuit remains in its state of sensitivity throughout the whole range.

## Special Precautions

A simple potentiometer is not found to give a satisfactory compensation, so that two special connections have to be adopted. In the first place the potentiometer itself ( $R_2$ ) is tapped across a portion of another high resistance ( $R_1$ ), which is connected across the LT battery. This narrows the range of operation of the potentiometer to within any desired amount, so that a full sweep of the slider over the whole potentiometer only varies the potential by the amount necessary to compensate for the loss of sensitivity as the condenser is moved.

## Unequal Variations

In addition to this, it is found necessary in many cases to arrange for an uneven distribution of the potential, so that the variation may be more rapid at one end than at the other. This can be accomplished roughly by shunting portions of the potentiometer by extra fixed resistances, shown in the figure at  $R_3$ ,  $R_4$  and  $R_5$ .

It is, of course, important that the filament potential should remain the same, and, therefore, a fixed resistor should be utilised on the valve or else further correction has to be made. The patent specification in question covers a potentiometer coupled to the filament rheostat to allow for the effect of variations due to the filament potential, but in view of the satisfactory operation of the

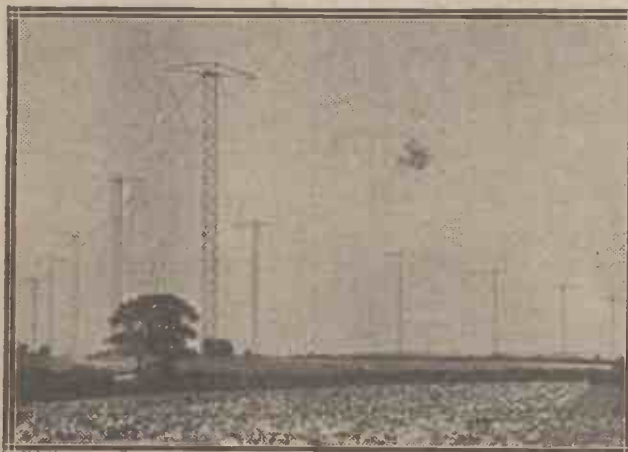

An interesting view of the aerial arrangements at the new Beam station at Bodmin, Cornwall. Notice the angle of the two sets of masts; one set is for Canada (left), and the other for South Africa.

The potentiometer controlling the particular high-frequency valve under consideration is mounted on or coupled

modern valve with a fixed resistance, this further complication is not so important.

~~11/-~~ REDUCED PRICES ~~11/-~~

5/6 OF 11/-  
**VARTA H.T. MONOBLOCKS**



**THE ORIGINAL H.T. MONOBLOCK, and THE ONLY EFFICIENT ONE**

Advt. A.F.A. Accumulators, Ltd., 9A, Diana Place, N.W.1.

**The BRITISH reply to the foreign challenge. prices still lower**



**YOU can now buy a British made Dull Emitter valve for 5/9, and there is no deterioration in quality. The same high standard of Voltron excellence is being maintained—but increased production and the substitution of machinery for expensive hand labour have lowered costs enormously. You get the benefit.**

W. G., of Burnage, Manchester, writes of Voltron Valves:—  
 "I feel I cannot speak too highly of them. My set has been brought to life with them. I thought my results were good enough before, but it was dead compared with my present results." **Close electrode construction, a filament of high emissive value and Voltron special 3 stage pumping ensure absolute uniformity, freedom from microphonic noises and a long life of full clear-toned service. The guarantee is exceptionally generous.**

**VOLTRON**  
 "Buy British and be Sure"

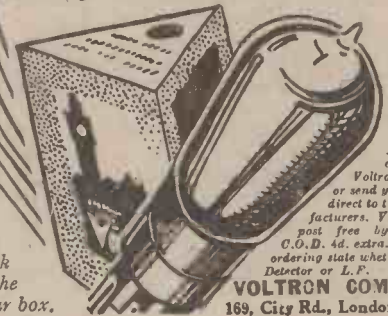

Look for the triangular box.

Ask your dealer for Voltron Valves or send your order direct to the manufacturers. Valves sent post free by return. C.O.D. Ad. extra. When ordering state whether H.F. Detector or L.F.  
**VOLTRON COMPANY**  
 189, City Rd., London, E.C.1

**SUCCESS**  
 RADIO PRODUCTS

*For Perfect Radio Reception*

**SUPER-CONDENSER WITH VERNIER DIAL.**

The Most Perfect Condenser made. Ultra Low Loss S.L.F. Minimum Dielectric Loss. Skeleton End Plates. Grounded Rotor. Spring Pigtail. Ball Bearing. 100 to 1 Slow Motion. Provision for quick searching. No Backlash.

0005 mfd. 18/6 complete.

0003 mfd. 18/- complete.

VERNIER DIAL 5/9

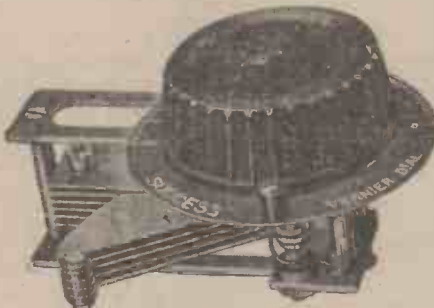

Manufactured by

**BEARD & FITCH LTD.**  
 34-36, Aylesbury Street, LONDON, E.C.1.

'Phone: Clerkenwell 8941.

A UNIQUE FEATURE OF  
**CLIX FITMENTS**

THE PATENT WIRING PRINCIPLE.

EMPLOYED WITH THE HIGHEST EFFICIENCY ON ALL FITMENTS ILLUSTRATED BELOW.



BRIDGE WIRING CHANNELS.  
 BRIDGE WIRING APERTURE.



**CLIX PIN TERMINALS**  
 2d. each.

Nickel-plated. Polished insulator, red or black. The most convenient tag for every purpose.



**CLIX PARALLEL PLUGS**  
 2d. each.  
**SOCKETS** - 1d. each.  
 Nickel-plated. Polished insulator, red or black. A standardized fitment of extraordinary utility.



**CLIX SPADE TERMINALS**  
 2d. each.

Nickel-plated. Polished insulator, red or black. A most efficient fitting for L.T. battery and other leads.



**CLIX WANDER PLUGS**  
 2d. each.  
 Nickel-plated. Polished insulator, red or black. The ideal fitment for all types of H.T. battery.

THE PATENT WIRING PRINCIPLE

Obtainable from your Dealer

**AUTOVEYORS, LIMITED,**  
 84, VICTORIA STREET, WESTMINSTER, S.W.1

'Phone: Victoria 309. Telegrams: "Autoveyors, Sowest, London."

**A CRYSTAL RECEIVER FOR HOME-MADE BASKET-COILS**

(Continued from page 446)

large coil. The set must then be re-tuned. Now the crystal clip can be removed from the terminal and placed on each of the tapping points in turn until the loudest signals are heard with the sharpest tuning.

**Author's Results**

The set was tested on an aerial 90 ft. long and 28 ft. high, situated 14 miles north of 2LO, and was found to give very good results, the signals being received at comfortable strength on the telephones, and the selectivity being such that the signals completely disappeared when the dial was rotated 10 degrees in either direction.

**Long Waves**

To receive Daventry a choice of two methods is available: one can wind two coils with No. 30 double silk-covered wire, with 100 and 250 turns each and use them exactly as for the short waves, except that the crystal and 'phones will always be connected across the whole of the secondary coil, no tapping points being provided. Alternatively, two standard plug-in coils can be bought and used in the same way. A No. 100 and a No. 250 will be needed.

**NEWS IN ADVERTISEMENTS**

Full particulars of the Tudoradio A.C. Mains Unit for the supply of H.T. current will be sent post free to readers upon application.

The Duvoicon and the Duvarileak form the subject of the announcement of Messrs. the Dubilier Condenser Co., Ltd.

In the series of advertisements issued by S.T., Ltd., an offer is made by the manufacturers to advise readers as to the types of the S.T. range most suitable for their receivers.

A complete list of parts for the Monodial are being advertised by Messrs. K. Raymond.

List No. W.4 issued by Messrs. J. J. Eastick will be sent upon application.

The complete range and new prices of Voltron valves, manufactured by Messrs. The Voltron Co., are announced in this firm's advertisement.

"ARJA" Guaranteed 2-Valve Receivers £6:10:0  
 You must not miss this great opportunity of securing a guaranteed two-valve, all-station receiver complete with every accessory. Send at once for your copy of our Illus. Cat., Booklet No. 9 describing this instrument and many others, it is Post Free. You only have to get this book to be convinced. SEND NOW.  
 R. C. JONES, 75, HARGWYNE STREET, STOCKWELL, S.W.9

**MONODIAL BUILT FOR 10/-**  
 We construct any Radio Press set at the price of the components as specified by the designer, plus 2/6 per valve. Marconi Royalty extra. First-class workmanship. Every set guaranteed.  
 LONDON RADIO SUPPLY COMPANY, 11, OAT LANE, LONDON, E.C.2. Phone: City 1977.

**TUNGSTONE 60 VOLT 3 A.H. HIGH TENSION FOR WIRELESS**

NO CRACKLING OR PARASITICAL NOISES ON WIRELESS PHONES OR LOUD SPEAKER. NO FROTHING, FOAMING, HEAT and OTHER TROUBLES

Tungstone (Patented) Tapping-Off Cell-Connector. By means of the Wander Plug supplied free, Tappings can be taken off as required at any two-volt cell, or any varying series of cells.



**TUNGSTONE 60 Volt 3 A.H. is more efficient than a 100 Volt Dry Battery. Will outlive hundreds of Dry Batteries.**

**TUNGSTONE at £5 15s.** includes a Free first partial charge and a Polished Teak Box, also Glass Filler—only 1/11 a volt for a 3 a.h. Inclusive weight 23 lbs. only. Carriage Paid in U.K. SAVES BUYING A SELECTOR SWITCH COSTING £1-17-6. SAVES COST OF FIRST CHARGE

COMPETITORS sell at 3/3 per volt, including a first charge; also a Selector Switch necessary costing £1 17s. 6d. making total cost of £9 15s.

TUNGSTONE creates a World's record for lowest price, minimum weight (only 23 lbs.) portability, accessibility, compactness, perfect rubber insulation, long periods between re-charges, no self-discharge nor sudden drop of voltage. Ideal for Hot Climates, and can be sent Overseas with Free first partial charge, without acid.

Under normal working conditions the calculated plate life is at least Four Years, and for a 3 or 4 valve set estimated to require recharging about every three months. First FREE charge lasts one month.

TUNGSTONE High Tension 60 Volt Battery 3 a.h. is sold in the United Kingdom on Monthly payments over extended period. Apply for particulars. Further interesting information on points of this advertisement are to be found on pages 58, 59, and 67 to 73 of the Illustrated Booklet "Photography tells the Story" which will be sent free on application to the—

**TUNGSTONE ACCUMULATOR CO., LTD.,**  
 St. Bride's House, Salisbury Square, Fleet Street, London, E.C.4.

T.41

**Valves Repaired**  
 AS GOOD AS NEW!!  
 (Except Weco, S.P.'s and low capacity types.) Minimum D.E. Current 0.15 amps when repaired. ALL BRIGHT & DULL EMITTERS Listed at less than 10/-.  
 Minimum charge - 5/-  
 LTD., Dept. W., Tabor Grove, Wimbledon, S.W.

**HALF LIST PRICE**

**EBONITE PANELS**  
 or Strips, etc., described in this issue (or any other) can be obtained immediately through any trader from  
**TRELLEBORGS EBONITE WORKS, LTD.**  
 Audrey House, Ely Place - London, E.C.1

**LITTLE WIRELESS GADGETS**  
**MAP**  
 THE YERNI-NOB, 6d.; Postage, 1jd.  
**MAP Co., 246, Gt. Lister St., Birmingham.**

**£22?** WOULD you like a Multi-Valve Receiver for 40/- down? In our Catalogue 'W' are details whereby many well-known Sets are obtainable on easy terms. Accessories too! Our technical advice is yours without charge. Write to-day to  
**New Times SALES CO.**  
 77, CITY ROAD, E.C.1

# PRACTICAL TOPICS

By G. P. KENDALL, B.Sc.

## A Note on Metal Screens—The Function of a Power Valve.



I HAD a mishap with a screened coil receiver the other day which seems to suggest a moral worth pointing out to other users of these coils. What happened was that I was making certain alterations inside the set, and forgot to disconnect the H.T. battery, and in the course of my proceedings I dropped one of the coil screens amongst the wiring on the baseboard. Naturally, to drop a large metallic object like that amongst the wiring was asking for trouble, and sure enough I got it. Several valves died an untimely death, and I made once more the usual good resolution about using fuses in the H.T. circuit in future. This seems a point worth commending to the notice of those who use screened coils, since I found later that one of my colleagues had had a precisely similar experience a few days later, and it is evidently a thing which one does not need to be particularly clumsy to do.

### Interesting Valves

I had an interesting opportunity recently of trying several of the various newer types of super-power valves, and very fascinating things they proved to be. Now, it is a no uncommon thing to find that it is thought that a power valve is something which enables one to obtain louder signals, and it is much to be desired that before these latest valves come into general use we should all get rid of this idea as completely as possible. The purpose of a power valve is rather to permit strong signals to be handled without distortion, since as a matter of fact it may not produce louder signals than some other type of valve.

In some cases, even, it may produce an actual decrease in signal strength. The crux of the whole matter is that a power valve gives better quality of reproduction, and will handle strong signals without distortion due to overloading.

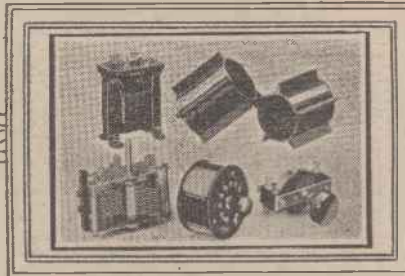

### Better Quality

These latest valves have an exceedingly low impedance, of the order of 3,000 ohms, and are capable of handling really exceedingly powerful signals without a sign of overloading. I noticed that even on signals of reasonable volume for properly filling a good-sized room there was a distinctly perceptible improvement in quality upon

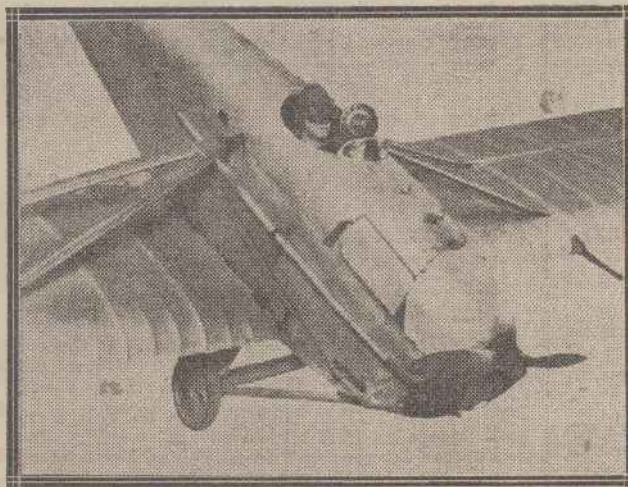

At an aerial pageant held recently at Melbourne, Australia, an aeroplane was fitted with a microphone to enable the pilot to broadcast his impressions via 3LO.

using a super-power valve as against one of the ordinary small power types.

One warning should be given in connection with these valves, that it is absolutely imperative that the makers' instructions as regards grid-bias should be faithfully carried out. Quite a high grid-bias is needed,

The November Issue of  
"MODERN WIRELESS"

Is Now on Sale.

PRICE - - ONE SHILLING.

## Reverse Charging!—Or what happened with an A.C. Rectifier.

some 15 or 18 volts being suitable for anode voltages of 120 or 140, and unless this is provided your H.T. battery will have a short life and a merry one.

### Vibratory Chargers

An A.C. rectifier for battery charging of the vibrating type recently played me a new one, which I hasten to pass on to my readers. These chargers are notoriously erratic, although the particular one which I have been using for some 18 months has so far proved quite reliable. Recently, however, I noticed that a high-tension accumulator seemed to be taking an abnormally long time to charge, although a little more than the normal charging current was passing, as indicated upon a milliammeter which I keep in circuit for checking purposes. What was even more peculiar was that the colour of the positive plates seemed to be becoming lighter instead of darker, and this aroused my suspicions. I inserted a milliammeter of the central zero type in circuit, and discovered that my suspicions were well-founded, and that the charger was passing a current in the reverse direction, and was actually running the battery down instead of charging it!

### The Moral

I noticed that the vibrating reed seemed to be making more noise than usual, and a slight readjustment of this part of the instrument soon put matters right, but the episode seems to convey the moral that one should always keep some sort of indicating instrument in circuit with such a rectifier when charging H.T. accumulators, to show which way the current is really passing. Charging such batteries is always a matter requiring a certain amount of care, since their capacity is so small that they are fairly easily damaged by an episode of this sort, and you may be sure that this is a precaution which I myself shall not omit in future!

## SOME READERS' COMMENTS

### A Short-Wave Alarm

SIR,—I was astonished to notice in several of the daily papers recently that short-waves will probably be used for broadcasting before long. This may be all right for owners of valve sets, but will the crystal user be able to tune in the local station? I think that a certain amount of expert knowledge is necessary to work a short-wave set. Why is the B.B.C. making this sudden move?—Yours faithfully,

B. R. WILKINSON.

[There is no likelihood of the proposed changes being made for a long time. In any case it is improbable that the present broadcasting wavelengths will be dropped.—Ed.]

### Young Blood Wanted

SIR,—I remember reading in *Wireless Weekly* some time ago that the members of the new Broadcasting Commission would probably be considerably older than most of the B.B.C. officials. Three of them are over sixty. Why can we not have more young blood on this Commission? The B.B.C. is at present standing still, and I am very much afraid that next year it will be going back instead of forward!—Yours truly,

M. J. REES.

Swansea.

### Appreciation of the Piccadilly Hotel Broadcasts

SIR,—Can you not use your influence to help the B.B.C. to come to some amicable arrangements with Mr. de Groot and the Piccadilly Orchestra? I, for one, looked forward to the Sunday evening concerts more than to any other broadcast item, and feel that I have really lost something by the breaking-down of the arrangement. I suppose we shall soon hear that Albert Sandler and his orchestra are to broadcast no more. How long will it be before the programmes consist of nothing but talk?—Yours faithfully,

M. K. ROXWELL.

Chatham.

### Dangers of Bureaucracy

SIR,—Your Editorial some time back, with reference to the new Broadcasting Commission, has proved to be true. Already the Chairman's salary is fixed at £4,000. I am afraid it will be tied up with red tape in such a manner that progress will be quite impossible. Can anything be done before the end of the year to save broadcasting from the clutches of Bureaucracy?—Yours faithfully,

ROBERT R. FILNER.

Chester.

## The Popularity Competition

### NAMES OF THE CONSOLATION PRIZE-WINNERS.

Last week we published the names of the winners of the three principal prizes in our great competition, and below we give the names of the 100 winners of consolation prizes.

Arthur Boulton, Barkingside, Ilford; Stephen Hatley, S. Chingford, E.4; R. Robbins, Sandbank, Cheshire; Richard Curd, Walthamstow, E.17; V. R. Grimes, Lower Walton, Felixstowe; F. H. Cone, Stamford Hill, N.16; J. W. Davies, Coulsdon, Surrey; F. C. Marley, Sheffield; E. A. Parkes, Rotton Park, Birmingham; C. A. Jenkins, South Farnborough, Hants; W. H. Judges, St. Albans, Herts; D. G. Parker, Hampstead, N.W.6; E. W. Larmour, Belfast; R. F. Ford, Maida Hill, W.9; H. J. Lewis, Balham, S.W.12; C. P. Davis, Bridgend, Glamorgan; Arthur Watson, Barkingside, Ilford; G. Smith, Upper Parkstone, Dorset; George Webster, Chadwell Heath, Essex; L. H. Ashley, Harlesden, N.W.10; A. Butterfield, Nelson, Lancs; C. J. Channer, London, S.E.5; R. J. Patey, London, W.12; G. L. Pickering, Mount Pleasant, Swansea; C. H. Vines, Small Heath, Birmingham; W. H. Savidge, Nottingham; L. E. Wheeler, West Ealing; Richard Nose, Sydenham, S.E.26; H. G. Brammer, Southsea; A. N. Le Cheminant, Victoria Park, Bristol; C. W. Emley, Sheffield; C. Mullins, Walsall, Staffs.; R. S. Gardener, Surbiton; L. S. Lees, Great Longstone, Derbyshire; J. F. Stone, Liverpool; C. Clough, Levenshulme, Manchester; R. R. Bundy, Wood Green, N.22; B. S. Hayward, Briston, Norfolk; R. C. Jackson, Denmark Hill, S.E.5; T. Davies, Llanelly, Carm.; Reginald Shuffrey, Watford, Herts.; H. Emmett, Ramsbottom, near Manchester; W. Halling, Redditch; W. G. Cooper, Kidderminster; W. Baker, West Ealing; R. A. Dunn, Jnr., Castleford, Yorks.; A. C. Ridger, Earsfield, S.W.18; A. Long, Folkestone; J. F. Terry, East Dulwich; Herbert Marshall, Rochdale; A. F. Smith, Ledgley Park, Prestwick,

Manchester; A. H. Birch, Gillingham, Kent; W. Draper, Liscard, Cheshire; A. W. Combie, Leagrave, Beds.; S. H. Walker, Westhill, Torquay; Reg. Xenaky, Chorlton C. Hardy, Manchester; R. M. Tebbit, Camberwell, S.E.5; A. J. Dodsworth, Watford, Herts; C. Armes, Carshalton, Surrey; J. A. Price, Dowlais, Glam.; W. S. King, Kilburn W.; D. Baker, Croydon; William Openshaw, Bolton; F. C. White, Tottenham, N.; W. R. Flood Thain, Ashton, Northampton; John Cowley, Belfast; H. F. Smith, Colwick Road, Nottingham; M. Wilson, Woodhouse Lane, Leeds; Mrs. N. Cowan, Everton, Liverpool; H. M. Berry, Bury, Lancashire; John Copeland, Parsons Green, S.W.6; Arthur Duckworth, Colne, Lancs.; R. Sanders, Gravesend, Kent; R. Sleep, Newton Abbot, Devon; E. Beer, West Wimbledon; R. Curtis, Harringay, N.4; W. H. Drane, Hayes, Middlesex; John Upton, Lincoln; F. Hines, West Moors, Wimborne, Dorset; F. Dicks, Edmonton, N.18; Robert Porter, Seven Kings, Essex; Robert Camping, Dalston, E.8; John Griffiths, Newport, Mon.; H. Russell Allen, Watford; F. C. Escott, Leigh-on-Sea; George Marland, Firth Park, Sheffield; W. E. Saville, North Kensington; W. Morison, Bo'ness; O. R. Round, Bury, Lancs.; W. Marshall, Barnsley, Yorks.; D. C. Kinmond, Hoylake, Cheshire; H. Clark, Langruth, near Mansfield, Notts.; H. W. Shilback, Maesteg, Glam.; B. Swerdlin, South Hackney, E.9; Thomas Bamford, Hebden-bridge, Yorks.; Reginald Bellamy, West Worthing; J. A. Pangborn, Leytonstone, E.11; Walter Whitehead, Oldham, Lancs.; John Paul, Mossend, Lanarkshire, Scotland; Carey Hargreaves, Bollington, Altrincham.

## EXPERTS IN RADIO

### IS THIS WHAT YOU'RE LOOKING FOR?

Testing the new 2-valve receiver at our Works at Slough, on a standard P.M.G. aerial, we tuned in the two Paris stations, London, Daventry, Bourne-moath, Birmingham and Newcastle on the loudspeaker. This despite bad screening set up by a large power station not more than 50 yards from the vicinity of the laboratory. We were testing on 66 volts only. You can expect even better from the 3-valve Brandeset.



### THE BRANDESET II.

The new Brandes 2-valve set features simplicity of control and ingenious compactness. Condenser dial, filament rheostat, reaction dial and "throw-over" switch for long or short wave tuning complete the panel controls. Straight line frequency condenser tuning and grid-bias is employed. The standard coil is suitable for Daventry and no "plug-in" coils need be purchased. The L.T., H.T., and grid-bias leads are plated into one cable £6 10 from rear of set.

(Exclusive of Marconi Royalty and Accessories.)



### THE BRANDESET III.

The new Brandes 3-valve receiver employs the same ingenious characteristics as the Brandeset II, except that an extra stage of Audio Frequency is employed. It has straight line frequency condenser tuning, grid-bias, and is adapted to long and short wave tuning. Both receivers give most excellent loudspeaker reproduction on a number of stations, and are specially designed for £8 10 this purpose.

(Exclusive of Marconi Royalty and Accessories.)

## Brandes

From any reputable Dealer.

Brandes Limited, 296 Regent Street, London, W.1

ACOUSTICS SINCE 1908

# Rheostat



## Inside

A RHEOSTAT is ingeniously built inside this dial. Only a space of  $2\frac{1}{2}$ " diameter is required in front of the panel and  $7/16$ " at the back. Thus valuable space is saved, wiring is made easier and the appearance of the panel improved.

The movement is extremely smooth and a very fine variation is possible. The dial (made of genuine Bakelite) is marked 0 to 100 and a nickel-plated pointer guides the adjustment. Fixing is by the one-hole method.

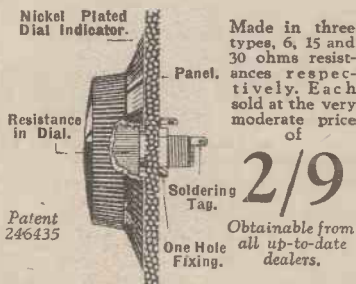

# BENJAMIN

## Self-contained

# RHEOSTAT

Out of sight, out of mind.

THE BENJAMIN ELECTRIC LTD.,  
Brantwood Works, Tottenham, N.17.

The Benjamin Battery Switch gives perfect current control and costs only 1/3.

# I HAVE BEEN ASKED...



I am experiencing irritating trouble with a potentiometer in an H.F. amplifier which I have made up. The potentiometer has fused upon three occasions at the L.T. negative end. I should be glad if you could indicate where the trouble lies.

The fusing of your potentiometer, always at the negative end, indicates that in all probability this component is wrongly connected into circuit. Probably L.T. negative is joined to one end of the resistance element and the slider of the potentiometer is joined to L.T. positive, the filament end of the grid coil being taken to the other end of the potentiometer winding. With these connections the potentiometer will still provide a stabilising effect, as not only is the filament end of the grid coil taken to L.T. positive, but the portion of the resistance winding between the slider and the grid coil is acting as a damping resistance. When the slider of the potentiometer is taken to the negative end of its winding, the amount of resistance wire of potentiometer between L.T. positive and negative is decreased until the resistance is so small as to allow a heavier current than the wire will carry to flow. The wire then fuses. To overcome the difficulty take the wire from the lower end of the grid coil and its attendant tuning condenser to the slider of the potentiometer, whilst taking the ends of the resistance winding to L.T. positive and negative.

Very often when my loud-speaker is connected a noise begins very softly at first but becomes so loud as to destroy all music. It is not a whistle but more like a note produced by a violin. I do not experience this difficulty on head 'phones, so imagine it must be a fault in the loud-speaker, but as this component is an expensive one to change, I should like your advice before purchasing a new one.

The fact that you only experience the trouble you mention when listening on the loud-speaker indicates that in all probability this accessory is responsible. It should not be necessary, however, to purchase a new loud-speaker, and in fact any loud-speaker will give rise to the same difficulty if your valves, which I consider most likely to be responsible, are at fault. The explanation of your trouble probably is that sound waves emitted from

the loud-speaker, or actual mechanical vibrations of this instrument, are communicated to your valves, the electrodes of which begin to vibrate, which in turn causes variations in their anode currents. These variations, taking place at audio frequency, give rise to the note which spoils your reception. The action is, of course, a cumulative one, the note finally building up to a sufficient extent to drown all signals.

If at the present moment the loud-speaker is placed on the same table as your set and facing towards your valves, it is to be advised that it be placed in a remote part of the room when, if the difficulty is not overcome the set should be placed on a felt or rubber pad, or suitable anti-vibratory valve-holders should be fitted.

I have a two-valve receiver with three H.T. terminals, which are marked respectively H.T. negative, H.T. + D.E.T., and H.T. + L.F. Does this mean that I shall require two H.T. batteries and how are the connections made?

From the information you give it is likely that your receiver employs a detector and one note magnifier, and here it is generally to be advised that the maximum H.T. permitted by the maker's specification be employed upon the note magnifier, whilst generally on the detector lower H.T. voltage allows this valve to function at its best. Two H.T. batteries are not necessarily required, and one, preferably of large-cell type and of a voltage of 100 to 120 volts should prove satisfactory. Its H.T. negative terminal should be joined to the H.T. negative terminal on the set, H.T. + D.E.T. should be tapped into a socket between 50 and 70 volts, as determined best by actual experiment, whilst, as previously mentioned, on the note magnifier a high voltage should be employed. This latter is effected by taking a third lead from H.T. + L.F. on the set to a high voltage socket in the H.T. battery

"MODERN WIRELESS"

1/- NOVEMBER ISSUE 1/-  
NOW ON SALE.

Procure Your Copy EARLY.

RECOGNISED WEST END DISTRIBUTOR of the manufacturers of Edison Bell, Jackson's (J.B.) Polar, Igranol, Peerless, Enreka, Ferranti Amplion, Magnam, Burndept, Lotus, Dabulier, Marconi, Dorwood, Sterliah, Success, B.T.H., McMichael, Lissen Utility, E.L. Bowler-Lowe, Formo, Brunet, Ormond, Newey, P. and M., etc., etc.

# K. RAYMOND

27 & 28a, LISLE STREET, LEICESTER SQ., W.C.2.

Hours: 9.15 to 7.45.  
Saturday: 9 to 8.45.  
Sunday: 11 to 1.

Back of Daly's Theatre.  
Nearest Tube, Leicester Square.  
Phone: Gerard 4637.



### All Postage Extra

SCREENED COILS.—B.B.C. 250/550 metres. Tapped Primary Aerial Coils, 6/- H.F. Transformers (Split Primary and Reaction), 10/- Split Secondary H.F. Transformers, 10/- Reinartz Transformers, 10/- 5XX same prices with exception of Reinartz and S. Secondary; these are 14/- each. 6-pin base, with standard spacing and cross-formation, 5/6. Copper Shield, 6/8. Post extra.

MONODIAL RECEIVER ("Wireless")—4 A.P.V. Holders 10/-; R.I. Multi L.F., 25/-; Patent Super L.F., 24/6; H.F. Varley Choke, 9/6; Varley 250,000 ohm Resistance, 9/6; On and Off switch, 1/8; 2 Jacks, 6/-; 4 Fixed Resistors, 10/-; 2 B.B. Neutralizing, 10/-; 1 Franco Midget, 3/9; 2 .002 Fixed, 4/-; 2 H.F. Transformers, with 6-pin base ready for use, 12/6 each; and ORMOND GANG DUAL, 32/- List Total, 28 15s. 9d.

If the complete lot taken I will despatch, carriage paid, for 27 18s. 6d.  
NOTICE.—I can supply handsome American Type solid oak Cabinet, hinged lid for Panel, 14 by 7 by 1. Baseboard 14 in. deep, 25/11 Post, 2/- extra.  
Ebonite Panel, 14 by 7 by 1, 5/- Post, 1/-

SPECIAL! H.F. Transformers for all circuits stocked. Parts for Radio Press Sets a feature. GANG CONDENSERS. DUAL .0005. ORMOND (with dials), 32/- CYLON (no dial) .. 50/- TRIPLE .0005. ORMOND (with dials), 40/- CYLON (no dial) .. 70/- IGRANIC (no dial) .. 75/-

### 2-VALVE SETS



Sets complete with following accessories.

Long distance 2-valve L.F. and Detector Receiver in handsome polished cabinet. Includes set as shown: 1 power, 1 .06 D.E. valve, tuning coils, H.T. 60-v., L.T., Aerial Equipment, H.T. and L.T. Leads, 2 pairs of 4,000 ohm 'phones, or LOUD SPEAKER (Marconi Tax Paid.) 24 19 6 the Lot. Carr. and Pack., 5/-

RADIO MICRO VALVES .05, 3-v., 6/11; .25, 2-v., 8/11; Power 3, 8/8; Power 1, 9/11. (Power are 3-4 volts). Phillips' 4-Electrode, 4-pin for Unidyne, 8/11.

ACCUMULATORS 2-v., .40, 7/11; 2-v., .60, 9/6; 2-v., .80, 12/3; 2-v., 100, 14/6; 4-v., .40, 13/11; 4-v., .60, 17/11; 4-v., .80, 20/6; 6-v., .60, 26/8; 6-v., .80, 35/8; ALSO another good make. 1/6 extra on each of above. Post, 1/-

CALL HERE FOR — IGRANIC — ORMOND — LISSEN Parts we have them and hundreds more!

### S.L.F. CONDENSERS



Latest Model. Now Ready. POST 6D. SET. With knob and dial, Each. .0005 .. 7/11 .0003 .. 9/11 Also with Brass Vanes and 4 in. Dial

OUR NOTED 1-VALVE and CRYSTAL SET, in solid polished cabinet, complete with valves, 'phones, H.T. and L.T. Units, Aerial Equipment, Daventry Coil, Extraordinary valve, 45/11. Car. 2/- ASTOUNDING 2 Valve AM-VALUE in L.F. pillar, 25/11. Amplifiers in COMPLETE handsome with Valves, polished box, H.T. and L.T. 1 valve, 16/11. Units, 44/6. Carriage, 1/6. Carriage, 2/- Grand Value in NON-MICRO- PHONIC VALVE HOLDERS. Board Mounting, 1/6.

CALLERS: SPECIAL PRICES OVER THE COUNTER OUR GOODS AMERICAN Type Oak Cabinets, with baseboard, take 12 by 8 ebonite, 10/8; 12 by 9, 11/8; 16 by 8, 16/11. 18/11. Any size in 3 days. ADICO H.T. has Michesi Trade Test Award. 60-v., 8/11; 100-v., 13/11. Post, 1/6 each.

# A TRANSFORMER WITHOUT A PRECEDENT.



Amplifying every note, every harmonic, every overtone.

Transformer curves may mean little to you, but you know that the real test comes when the transformer is actually working inside your set under ordinary working conditions.

This new LISSEN Transformer will justify its place in the best of receivers—it has had all the LISSEN resources concentrated upon it for many months past—it was only released for sale just in time for the Olympia Exhibition—trade buyers who took away samples from our stand during the first days of the Exhibition came back to us there to praise and to order. Many had tested it against expensive transformers and they talked about its pure tone and powerful volume and wondered at its price. THEY ORDERED AFTER PROVING ITS PERFORMANCE.

Pure, powerful, and economical amplification is now at last within the reach of all. By ourselves distributing direct to the retail trade from factory we cut out all wholesale profits. This new policy has been a deciding factor in enabling us to sell this new LISSEN Part at a remarkably low price. There is no longer any need for you to pay highly for a first grade transformer. So good is this new one that we have unhesitatingly withdrawn all our own previous high priced models in its favour. Compare it against any for tone purity and power—it amplifies every note, every harmonic, every overtone.

7 DAYS' TEST AT HOME. Your dealer will demonstrate, but, better than all, take a LISSENOLA home—put it on your set—put it on your friend's set—try it with the horn of an expensive loud speaker fitted to it—then if you are not satisfied, take it back to your dealer's or send it back to us.

Turns Ratio 3 to 1. RESISTANCE RATIO 4 to 1. Build a Better Amplifier! PRICE 8/6 —and guaranteed for 12 months.

USE IT FOR 1, 2 OR 3 STAGES L.F. Include no postage if you send direct, but please mention dealer's name and address.

LISSEN LIMITED, Lissenium Works, 18-22, FRIARS LANE, RICHMOND, SURREY. Managing Director: T. N. COLE.

## THE "MONODIAL" FOUR

Available as a finished receiver or in parts for home assembly

IF you want an efficient and handsome receiver ready built, you cannot do better than purchase one of these "Star" sets from us. Each one tested on a large number of British and Foreign stations at full loud-speaker strength.

SHOULD you prefer to assemble your own set, you can do so under our famous "Pilot" Service, with every assurance that your efforts will be successful. Write for details of this service, and mention the type of set you want.

FINISHED INSTRUMENT, aerial tested and guaranteed, Royalty-paid .. .. .	£16 17 6
"Pilot" Kit of Components .. .. .	29 4 0
Polished Ebonite Panel, 14" x 7" x 1", drilled .. .. .	0 8 0
Polished Mahogany Cabinet and Baseboard .. .. .	2 5 0

N.B.—When complete set of parts and panels are purchased together a Marconi Royalty of 12s. 6d. per valve must be remitted.

Every finished Receiver sold by us bears the signature of Capt. R. W. TINGEY (late of Radio Press Research Laboratories).

MANY other Radio Press Sets of up-to-date design—the Elstree Solodyne, the Night Hawk, the Distaflex Two, etc., etc.—are available under the unique PILOT Service.

The PILOT MANUAL contains illustrated details of a number of up-to-date sets which we thoroughly recommend. Much useful information on soldering, assembling, testing, etc., is also included. Post free 3d.

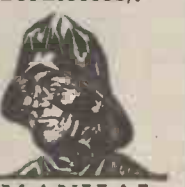

### THE PILOT MANUAL

PETO-SCOTT Co. Ltd., 77, City Rd., E.C.1  
Branches: 62, High Holborn, London, W.C.1. WALTHAMSTOW—230, Wood St. PLYMOUTH—Bank of England Place. LIVERPOOL—4, Manchester St.



Those Accumulators!—The New Beam Stations—Another Loud Loud-Speaker Manchester and the Show — A

I AM glad to see that some of the London "Dailies" have been delivering timely warnings to amateurs whose sole desire is to have their accumulators charged as quickly as possible. Too often the standard by which charging stations are judged is simply the time they take over their charging jobs. Personally, I trust the man who wants a clear 48 hours more than the agent who offers you the battery, back "this time to-morrow." Forty-eight hours at 2 amps. has a much less depressing effect upon the feelings of an accumulator than 12 hours at 8 amps.!

NOW that the Beam transmitters between this country and Canada are actually in working order, the next thing to be done is to speed the service up. So far the regular working speed has rarely exceeded 100 words per minute, but Senatore Marconi hopes to see 1,000 words per minute touched in the future. Another headache for the operator! It certainly seems that hand-operated Morse will die right out in a very short time indeed!

I MYSELF do not quite know what to make of the Queen's Hall affair. Although I can understand that radio is a very fine substitute for the Concert Hall, as far as invalids and cripples are concerned, I cannot imagine any sane person staying at home and listening-in as a substitute for being present at the actual performance. The other complaint of Mr. Boosey (of Chappell's) about the "price-cutting" policy of the B.B.C. on the occasions of their Albert Hall concerts does seem to me much more reasonable, but then I remember reading that the Albert Hall was not half

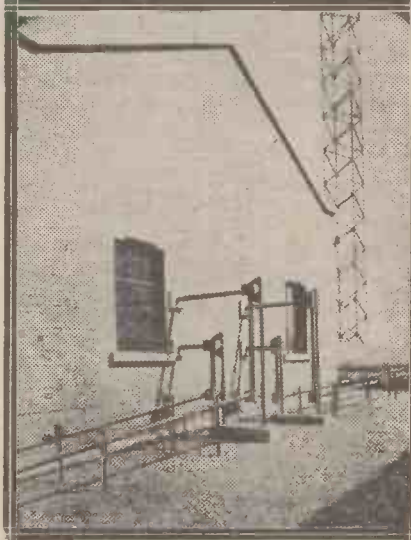

This view of the Bodmin Beam station shows the "feeder" system leading in to the receiving building. The two cables going out to the left are part of the Canadian system, while those going to the right are for use in handling South African messages.

Broadcasting Station for Everyone?—The Manchester Exhibition Progress! —Educational Broadcasting.

I SYMPATHISE with the gentleman in Pimlico who lodged a complaint about the loud-speaker in the hall of the cinema opposite his flat. This instrument of torture (as all these so-called "attractions" generally are) was kept on continuously from five till midnight. It is very curious that the only respectable loud-speakers one seems to hear, with the exception of those used at special demonstrations, are those used quite privately. As soon as they are put forward for advertising purposes they seem to become glaring examples of "how it should not be done."

A STRING band of 32 performers, their ages ranging between 9 and 14, is performing from 2LO on November 16. Loughton, the home of this youthful band of minstrels, is very proud, I understand, of the honour of being allowed to make itself heard in this way. They are to broadcast during the Children's Hour.



This radio-photograph of Queen Marie of Rumania in America was in the hands of the "Wireless" Editorial Department the day after the actual event.

DURING this week the Manchester Evening Chronicle wireless exhibition is being held in the City Exhibition Hall, Manchester. From what I have heard of the arrangements this is to be the biggest show the North has yet seen. All shows of this kind are, of course, to be encouraged. They keep up the public interest when it might tend to grow stagnant; there are too many who think their set is the best in the world, without ever having studied the latest development in radio.

A FEW weeks ago I was greatly amused to hear one of these gentlemen proclaiming loudly that he had "the best set in London." He had "had it six years, and never (Continued on page 456.)

full at either of the first two. Candidly, I think this "unfair broadcast competition" business is being overdone.

men proclaiming loudly that he had "the best set in London." He had "had it six years, and never (Continued on page 456.)



# The TUDORADIO

## JUNIOR A.C. Mains Unit

Output Volts 100

RETAIL PRICE

(Complete)

# 70/-

(Marconi Royalties 12/6 extra)

OVERALL DIMENSIONS :  
6 1/2" x 4 1/4" x 4 1/4" high

Designed to supply H.T. current from Alternating Current mains for small sets only. Output sufficient to supply a 2 or 3 valve set using one small power valve of the B4 or D.E.5 class. Other Models for Other Sets. Ask your dealer for particulars or send direct to:—

**THE TUDORADIO COMPANY, Ltd.**  
Tudor Works, Park Royal, London, N.W.10  
Telephone: Wembley 41.



## Real Efficiency in Tuning

THE NEW



# S. L. F.

Perfectly designed, perfectly constructed, the new J.B. S.L.F. Condenser spreads the stations with scientific precision. Tuning becomes a real pleasure—definiteness coupled with real selectivity marks the new J.B. S.L.F. as the condenser of the future. Its many new features include Special Bearings Top and Bottom, which eliminate springs. The Top Bearing is of large diameter and friction-lined, which ensures an absolutely smooth movement. The brass vanes are supported at tips to ensure accurate spacing. End plates are highly polished and all fittings are heavily nickel-plated.

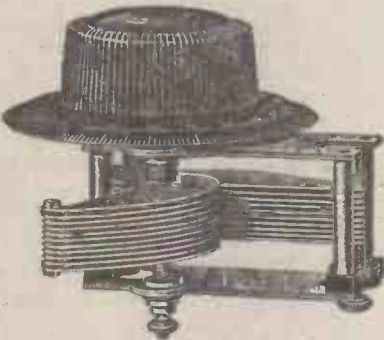

Fitted with 1/2" shaft, sold complete with 4" Dial and is more compact than most S.L.F. Condensers.

	Retail Prices :	
.0005 mfd	.. .. .	11/6
.00035 mfd	.. .. .	10/6
.00025 mfd	.. .. .	10/-

The J.B. .0005 Twin Low Loss Condenser, complete with 4" Bakelite Dial each 21/-  
The new J.B. .0005 Dual Gang Control Condenser for the "Monodial." Complete with 4" Bakelite Dial £1 13 0

**JACKSON BROS.**  
8, POLAND ST-OXFORD ST  
LONDON - W.1  
(First Floor)  
Telephone: GERRARD 7414

**HULLO! EVERYBODY** IS YOUR RECEPTION GOOD?  
ARE YOU GETTING THE MOST FOR YOUR ENERGIES?  
**THE BENNETT COLLEGE**  
WILL SHOW YOU HOW TO INCREASE YOUR EARNING POWER.  
**ADVICE FREE**

**WE TEACH ALL THE FOLLOWING SUBJECTS.**

Having helped thousands of others to achieve success and advancement, it may be possible that we can help YOU. I am assisted by a large and expert staff, and the advice we give is sound. If we cannot help you we will say so; if we can we will tell you how. We have FREE booklets setting out the possibilities in connection with each of the subjects shown in the lists; send for the one in which you are interested, or ask for MY PRIVATE ADVICE, which also is free. You incur no obligation.

**Have You ANY Ambition?**

Most moderate charges, payable monthly. All Text Books free. No extra fees.

**EXPERT TUTORS FOR EVERY DEPARTMENT.**

- COMMERCIAL**
- Accountancy
  - Advert. Writing
  - Salesmanship
  - Army Certif. Courses
  - Auctioneering & Estate Agency
  - Auditing. Banking
  - Book-keeping
  - Commercial Arithmetic
  - Commercial Law
  - Company Law
  - Costing
  - Economics
  - English and French
  - Executorship Law
  - Foreign Exchange
  - General Education
  - Modern Business Methods
  - Police Entrance and Promotion Courses
  - Secretaryship
  - Workshop Organisation



Yours sincerely,

**TECHNICAL—(continued).**

- Concrete and Steel
- Draftsmanship
- Electricity. Engineering
- Engineering Costing
- Quantities & Specifications
- Foundry Work
- Heat Engines
- Internal Combustion Engines
- Marine Eng. B.O.T.
- Mathematics
- Matriculation Metallurgy
- Mining Mine Surveying
- Motor Engineering
- Naval Architecture
- Pattern Making
- Post Office Examinations
- Quantity Surveying
- Sanitation. Shipbuilding
- Structural Engineering
- Surveying and Levelling
- Telegraphy and Telephony
- Town Planning
- Wireless Telegraphy
- Works Managers' Course

*W. Bennett*

**WE SPECIALISE IN PREPARATION FOR ALL EXAMINATIONS. WE GUARANTEE TUITION UNTIL SUCCESSFUL.**

**TEACH BY POST**  
IN ALL PARTS OF THE WORLD

Note Address :  
The BENNETT COLLEGE,  
Dept. 111, Sheffield.

**The Bennett College**  
SHEFFIELD  
Dept. 111.

**FORMO**  
ESTD 1914 P. L. & CO. LTD.

**A MONUMENT IN THE MARCH OF PROGRESS.**  
The Formo Shrouded Transformer is the universal favourite.

10/6 Made in Ratios, 1-1, 1-2, 1-3, 1-4 and 1-5, 1-3 and 1-5 for First and Second Stages.

SEND FOR CATALOGUE AND DESCRIPTIVE LITERATURE OF COMPLETE FORMO RANGE.

**THE FORMO COMPANY,**  
CROWN WORKS, CRICKLEWOOD, N.W.2.  
\*Phone: Hamp. 1787.  
Manchester: Mr. J. B. Leves, 23, Hartley Street, Levenshulme.  
\*Phone: Heaton Moor 475.

"WIRELESS." **COUPON.** Vol. V. No. 12.

**QUESTIONS AND ANSWERS.**

This coupon must be accompanied by a P.O. for 2/6 for each question, and a stamped addressed envelope when sending queries to the Radio Press information Dept. for a postal reply.

## The Week's Diary—Continued from page 454

touched anything except to have the accumulator charged." I wonder what he would think of the Monodial?

I AM inclined to agree, too, with Mr. W. W. Vaughan, Head Master of Rugby, who recently said that "wireless intruded on the private life of the individual." I think, however, that if it does so it is the individual himself who is largely to blame. Mr. Vaughan's argument was that if one continually listens to things that are being listened to by millions, one might suddenly realise how painfully commonplace those things were. What is wanted is a separate broadcasting station for everyone!

ANOTHER celebrity has succumbed to "studio-fright." M. Paderewski has refused an offer made recently by the B.B.C. on the grounds that he is always too nervous when playing before the microphone. Actually, I have heard on quite good authority, the famous pianist may be afraid (quite justifiably) that his reputation might suffer as a result of his performance being heard emanating from the lower type of loud-speaker! One certainly is apt to gather a very wrong impression of an artist's merit when one hears him for the first time by radio.

TO-NIGHT'S International Chamber Concert is not being broadcast from 2LO. The first concert, it will be remembered, was broadcast from London and Daventry. The second will go out from Daventry and the provinces, and the third from London and the provinces. The fact

of the matter is that there are apparently so few people who are thought to listen to chamber music nowadays that the B.B.C. has to give an alternative programme whenever one of these concerts is broadcast!

THE B.B.C. has recently made inquiries of the Kent Education Committee whether the educational possibilities of broadcasting would justify alterations to their transmitting stations and the allocation of a special wavelength for the purpose. The Carnegie trustees have also made

had suddenly removed the grid-bias battery. I have no doubt that the B.B.C. is experimenting in some direction when these little episodes occur, but it would be kinder if they would break the news gently to listeners; I myself have very nearly started a tour of my set to see what has gone wrong!

THERE was a particularly bad burst of this just after the recent excerpt from "The Gondoliers" while a piano solo was being broadcast; the announcement faded right out, and when the actual solo started the general impression was rather similar to that obtained when one listens on a telephone with three or four lines jumbled up! No doubt things will be straightened out soon, but it has been rather alarming once or twice.



A view of part of the power house at the new radio station, showing the generators and switchboard for battery charging.

a grant of £300 for the purpose of a "wireless experiment in Kent," which will probably result in the installation of several receivers in schools.

HAVE you noticed the amount of blasting which seems to go on at 2LO nowadays? Suddenly, in the middle of an item, the loud-speaker will belch forth as if some kind helper

serious losses, which would naturally be undesirable.

WAVE-TRAP.

### NEXT WEEK

All about the Monodial on the longer waves.

ORDER EARLY

### No. 49.

### Making a "Non-Radiating" Receiver!



# S - L - T

## STRAIGHT LINE TUNING CONDENSERS

Separate stations on all wave lengths. Lowest minimum capacity and the most positive slow-motion control—as much as 1,000th of an inch movement can be obtained.

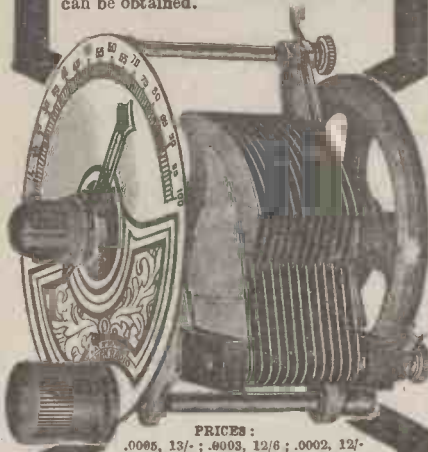

**PRICES:**

.0005, 13/-; .0003, 12/6; .0002, 12/-  
GANG OF THREE, .0005, 50/-

Used by all discriminating amateurs and standardised by many leading set manufacturers.

**S. A. LAMPLUGH LTD.**  
KING'S ROAD, TYSELEY,  
BIRMINGHAM.

Sole Distributors for London and Southern Counties: THE EMPIRE ELECTRIC CO., 303, Euston Road, London, N.W.  
Scottish Dept.: 38, Montrose Street, Glasgow.  
Obtainable from all leading Wireless Dealers.

SEND FOR RADIO LISTS.



This mark is our guarantee.

## LISSENOA & BROWN "A" USERS.

Get the wonderful 14-inch

### CINCINNATI CONE, 1 1/6

Complete with bronze base and support, ready to have Brown reed phone screwed on making it into complete cone speaker, post 1/6. Attachment for Lissenola, 1/6 fully guaranteed.

J. W. MILLER, 68, Farringdon Street, E.C.4.  
Sole British Distributor. Phone, Central 1996.

## H.T. ACCUMULATORS

60 Volts.—Price 32/6

DO YOU REALISE that light weight and low cost may be linked up to high efficiency? The inexpensive 60 volt—3 amp hour ELITE—High Tension Accumulator which actually costs under a 1d. to recharge will do all that the more expensive types will do and are never done.

Therefore look before you leap at our Descriptive Folders, which will be forwarded per return on application.



Type 02. Semi Oil Submerged.

60 volts Complete as illustrated 32/6 or 5/- per 10 volt Unit.

Obtainable only from—

**ACCUMULATORS ELITE,**

32, KING CROSS STREET, HALIFAX.  
Tels.: 1304. Trade Supplied. Telegrams: Elite, Halifax.  
London Distributor:

CECIL POHLMAN, 77, Great Portland Street, London, W.1.

## AMATEUR TRANSMITTING NOTES

### QRA's Wanted

WGHM, SOUU, D6N, APTR, U-AB1, BXY, 9SJ, T-4RB, PAN-RXY, AP4, DLA, LGN, SGL, OHK, PTF, G-2QX, 2ZE, 5ZI, 6GU, 6RT.

G-5WK, G-6MO, G-6GA, G-6TR, F-1AE, I-8AO.

### QRA's Found

K-4YAE (ex K-Y8): Rolf Horkheimer, Rottenburg-a-Neckar.

K-4MCA (ex KPL): Hugo Fagien, Versuchsstation Konigsberg Pr. 12.

C-8WM: W. Machell, s.s. "Rosalind," Red Cross Line, S. John's, Newfoundland.

Y-2JY: C. S. J. Crooks, c/o A. Herbert (India), Ltd., 13, British Indian Street, Calcutta.

BZ-9QA: Paira Collegio Militar, Fortaleza, Ceara, Brazil.

R-2WP: W. N. Paramonov, 14, Neglinney Pr., Moscow.

P-1AY: M. Bontes, Jr., Albufeira, Algarve, Portugal.

P-1AE: Eugenio de Avillez, Costa de Castela 13, Lisbon, Portugal.

G-5DY: (Change of address) Chelmsford Radio Engineering Co., Newhaven, Rainsford Lane, Chelmsford.

SMSP: A. Bertilson, Jarntorget 4, Goteborg, Sweden.

G-2AFG: H. C. Page, 40, Ferme Park Road, Stroud Green, N.4.

G-2AHP: J. Spafford, 15, Priory Road, Blidworth, near Mansfield.

G-2BYN: H. D. Price, 12, Hillcrest Road, Sydenham, S.E.26.

G-2BZC: (Change of address), M. W. Pilpel, 38, Purley Avenue, Cricklewood, N.W.2.

G-5AA: W. A. Read, Westmead, Ashurst Road, N. Finchley, N.12.

BG-1JT: J. Tasker, 61, Hadfield Street, Georgetown, British Guiana.

GH-1FG: Mission Italiana, Sione Street, Aliano, Quito, Ecuador.

LIT-1B: W. Hinentalis, Kaunas (Lithuania), Aukst. Karin, Kursai.

A-2HL: H. F. Lovett, 3, Kahibah Road, Mosman, Sydney, N.S.W.

R-HD6: M. Pedra, Canada Verde, Cordoba, Argentina.

U-5ADG: R. T. Hoffman, 842, Broadway, New Orleans, Louisiana.

U-5GO: R. W. Bush, 438, Oak Avenue, Sulphur Springs, Texas.

U-5MM: A. C. Nott, 4210, Shields Boulevard, Oklahoma City, Oklahoma.

SAD: Swedish Naval Floating Station, Stockholm.

EAR28: J. B. Novo, Patio de Madres 13, Santiago, Spain.

EAR31: A. Estublier, Calle Jaime I, 9, Barcelona.

D-7XU: H. Norgaard, 33 Livjaerggade, Copenhagen.

D-7AF: H. Chr. S. Nielsen, 25 Vendersgade, Copenhagen K.

## THE NEW LOTUS JACKS & PLUGS

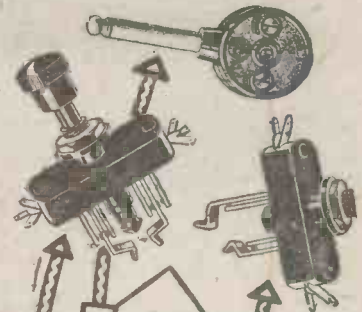

**LOTUS JACK PLUGS**  
Designed for use with Lotus Jacks. Made from moulded brass and nickel. Fits in slots equipped in position by a turn of the screw.  
Price: 2/-

**LOTUS JACK SWITCHES**  
This push pull switch is designed to occupy the minimum space, being only 1 1/2 in. deep. Of the finest Bakelite, it has nickel silver springs and contacts of pure silver. Soldering contacts can be made to suit any wiring.  
Prices:  
No. 9, as illus. 4/-  
Others from ... 2/9

**LOTUS JACKS**  
Designed to take up the least space, the depth of panel being 1 1/2 in. Made from best Bakelite with nickel silver springs and contacts of pure silver. One hole factor can be soldered into any position.  
Prices:  
No. 3 as illus. 2/6  
Others from 2/- to 3/-

The name 'LOTUS' is your guarantee of sound results and solid satisfaction.

From all Radio Dealers

# LOTUS

## JACKS · SWITCHES · PLUGS

Made by the makers of the famed 'LOTUS' Vernier Coil Holders and 'LOTUS' Buoyancy Valve Holders.

**Garnett, Whiteley & Co., Ltd.**  
Lotus Works,  
Broadgreen Road, Liverpool.

# For Every Circuit and Set

there is a guaranteed  
**BRETWOOD  
COMPONENT**



**The Bretwood S.L.F. Condenser.**  
A fine engineering job, quality and accuracy throughout. Reasonable in price and has all the essentials of a true Low Loss, Slow Motion, Straight Line Frequency Condenser.

Prices : .0005 17/6. .0003 14/9.



**Grid Leak de Luxe.**  
The already famous Bretwood Variable Grid Leak has been greatly improved.

Its accuracy is now on a par with S.L.F. Condenser readings. This is secured by the addition of a Syphon Container to fully guarantee even distribution of resistance element. **PRICE 3/6**

**PRICE (with condenser) 4/6**



**The Bretwood Amplifier.**  
Thousands at home and abroad have proved that these give distortionless reproduction.

10 days' Free trial if desired.  
**PRICE 20/-**

GET OUR COMPLETE LIST FREE

**BRETWOOD LTD.,**  
18, London Mews, Maple Street,  
London, W.1.

*Parrs Ad.*

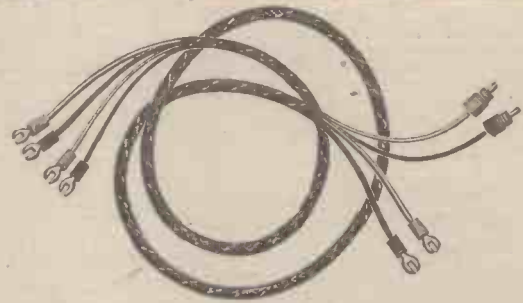

## As used in the **MONODIAL**

One cord only for L.T., H.T. and Grid Bias. Complete with Wander Plugs and Spade Tags, 4-way, 5/6 each; 5-way, 6/6 each; 6-way, 7/6 each; 7-way, 8/6 each.

All Dealers stock or can obtain LEWCOS MULTIWAY BATTERY CORDS for you

THE  
**LONDON ELECTRIC WIRE  
COMPANY & SMITH'S, LTD.**  
PLAYHOUSE YARD, GOLDEN LANE, LONDON, E.C.1

# LEWCOS

Multway Battery Leads

7/6	12 Months' Guarantee. 12 Months' Guarantee	7/6
7/6	<p>Why buy an imported Transformer of unpedigreed stock when you can buy a guaranteed British Transformer for 7/6?</p> <p>The EMPIRE doesn't need a shroud. There is no bad workmanship to cover.</p> <p>75% of total weight is iron core and copper wire. Open to inspection.</p> <p>If your Dealer cannot supply SEND TO US.</p> <p><b>PURITY WITH GOOD AMPLIFICATION</b> Equal to a high-priced British Transformer in performance at the price of a cheap foreigner.</p> <p><b>EMPIRE TRANSFORMER</b></p> <p>THE H.T.C. ELECTRICAL CO., LTD., 4, Boundaries Road, Balham, London, S.W.12. *Phone: Battersea, 0374</p>	7/6
7/6		7/6
7/6		7/6
7/6		7/6
7/6		7/6
7/6		7/6
7/6		7/6
7/6		7/6
7/6		7/6
7/6		7/6

Buy "F.A.R." the Best

THE "F.A.R." LF Transformer (Shrouded) has been proved on actual test to be considerably superior to other types selling at higher prices. Renders high amplification and distortionless speech and music over all frequencies. each

RATIO 1 to 1	} 12/6
" 3 " 1	
" 5 " 1	
" 10 " 1	

FROM ALL DEALERS.

Sole Agent:  
**MAURICE BOBIN**

21, Warwick Lane, London, E.C.4. \*Phone: Central 4872.

## UNPRECEDENTED CLAIMS

Equals Outdoor. Gets More Stations.  
Fixed in 15 Minutes. Practically Invisible. GUARANTEED.

RECEPCO NORMAL INDOOR AERIAL Complete With 150" AERIAL & EARTH WIRE

3/- Complete

Same frequency as 80 ft. Outdoor Aerial.

Experts Amazed. For Crystal or Valve.

Agents everywhere or post free, 3/4.

RADIO RECEPCO CO.  
110, WILTON ROAD,  
VICTORIA, S.W.1.

# From my Armchair

BY EARL RUSSELL.

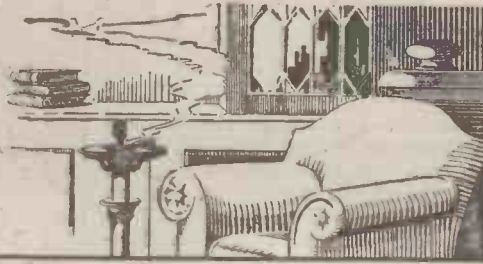

In these columns Lord Russell expresses each week his own personal views on matters of interest to "Wireless" readers.

## The New B.B.C.

The names of the members of the new Broadcasting Commission are being allowed to dribble out one at a time in a rather curious way. I don't know whether the idea is to see what sort of reception they get from the public before the official announcement is made.

Anyway, I am not prepared to comment on these piecemeal revelations, nor to attack Lord Clarendon, for whom everyone in the House of Lords has a great regard. It is not quite the non-political sort of affair that Lord Crawford's Committee suggested; except as to Mr. Reith. He, everyone would agree, has fully earned a seat on the new authority.

## A Valuable Instrument

I have at last acquired an instrument I have been looking for for

years. It calls itself All-Test, and justifies its name. Essentially it consists of a dead-beat, spring-controlled milliammeter reading to 15 milliamperes on a very open and evenly spaced scale. The makers, who are of old repute in the electrical world, guarantee it to 1 per cent. By the addition of shunts or resistance bobbins, neatly arranged to become an integral part of the instrument, one can read up to 30 amperes or 150 volts.

Of course, it can also be used to measure resistances by an easy calculation. I can't think how I have existed without it so long. I have only one grumble; it won't stand up, and I have had to make a little wooden shrine for it.

## Bad Earths

I grow daily more convinced that in our pre-occupation with so many other

matters, elementary things like the earth connection are too much taken for granted. It is not an easy thing to get a good earth: here on my chalk it is very difficult. Gravel, I should have thought, was usually good—in the Thames Valley, for instance, the river runs through the gravel as well as in its bed—but when there is no water the large, loose, dry stones give very poor conductivity.

Then one is airily told to use a counterpoise in difficult cases. A counterpoise should lie fanwise underneath the aerial, either buried a foot, or about four feet above the surface, and insulated. How many lawns or kitchen gardens can be dealt with in this way if one has to consider a wife or a gardener, even if the owner were enthusiastic enough to consent to the disfigurement involved?

Of course, in urban areas there is the main water supply, which is all right if a real contact is made on a large pipe, and not a deceitful blob of solder which has not taken hold on a cold water tap. The earth tube and, better still, the buried bath, with a coke bed around it, are all right in the right soil, but in isolated spots on the wrong kind of soil there is a real difficulty. Many earths that might be good suffer from neglect, and their owners would be surprised if they realised how this neglect spoils their reception.

## SAXON GUIDE TO WIRELESS

This book enables any beginner to construct Wireless Sets which are unequalled in price, quality or efficiency, and the cost is only one-fourth the price charged for a ready-made instrument not half so good. The exact cost of each set is clearly stated.

### FULL INSTRUCTIONS WITH CLEAR WIRING DIAGRAMS

are given for making Super Efficient Crystal Sets, Dual Amplification Receivers, Single Valve Sets, One and Two Valve Amplifiers; Two, Three and Four-Valve Tuned Anode All-Wave Receivers, and the Very Latest Type of Five-Valve Resistance Capacity Receiver.

**NO SOLDERING, NO SPECIAL TOOLS  
NO KNOWLEDGE REQUIRED.**

The chapter on testing wireless components is alone worth the price charged. 176 PAGES. **PRICE 1/3 POST FREE**

### SPECIAL OFFER.

This book will be sent on approval on receipt of your promise to return same post paid or to remit 1/3 within seven days.

SAXON RADIO CO. (Dept. 32), Henry St. Works, BLACKPOOL

## Control the programme without touching your set.

**ELECTONE**  
AUTOMATIC  
PROGRAMME SELECTOR

Selects just the items you want  
AUTOMATICALLY.  
Price 27/6

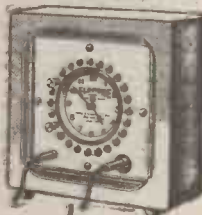

The ELECTONE is one of the most important wireless accessories yet devised. It automatically gives you the items you want, cuts out those you don't want, switches off the set when all is over and saves battery and valve consumption while unwanted items are being broadcasted. Simply plug in at the times when the features you want are scheduled. The one setting is sufficient for any length of programme. The ELECTONE is a handsome and reliable timepiece; the ideal gift. Write for free folder giving name and address of your nearest wireless dealer.

Sole Manufacturers: FREDK. J. GORDON & Co., Ltd., 82, Charlotte St., London. Phone: Museum 5158.

To Set To Accumulator

## As used in the MONODIAL described in "Wireless" Oct. 30.

"THE inductances used have an extremely low self-capacity so that the 200- to 600-metre band is covered by a movement of about 90 degrees on the dial and it is possible to proportion the coils so that the whole of this waveband comes approximately above the critical point on the dial below which there is any risk of the matching not holding good.

Another effect of reducing the size of the inductances is to reduce their H.F. resistance and so produce an increase in efficiency."

## COMPLETE COIL KITS

to standard specification (long wave and short wave coils) are included in the following prices:



- The Monodial .. £2 10 0
- The Elstreflex .. £2 9 0
- The Mewflex .. £4 14 6
- The Distaflex Two .. £4 14 6
- The Magic Five .. £4 7 6
- The Elstree Solodyne £4 9 6
- The Four for Range and Selectivity .. £3 4 0
- The Screened Coil Three .. £2 17 0
- A Three-Valve Trap Receiver .. £1 13 6

Send postcard for full particulars of Colvern Proved Products.

## COLLINSON PRECISION SCREW CO., LTD.,

Provost Works, Macdonald Road, Walthamstow, LONDON, E.17.

Telephone—Walthamstow 532.

ALSO AT 150, KING'S CROSS ROAD, W.C.1

- Copper Screen with Standard 6-pin Base .. 8/6
- Screen complete with Base & unwound Coil .. 12/6
- Former & Base, unwound .. 5/-
- Former only .. 4/-
- Base .. 1/6



**5/6**

**THE SAFETY SWITCH**

Prov. Pat. 20022/26.

Comprises Switch, Lightning Arrestor, Lead-in Tube and weather-proof cover. When off, the set is entirely disconnected from the Aerial and Lightning Conductance is attained *Outside* the house. Safety is ensured should you forget to switch off—by the Permanent Spark Cap provided.

Price - 6-inch Tube - 5/6  
 „ 12-inch Tube - 6/6  
 „ 18-inch Tube - 7/6

Write for List No. W.4, giving full particulars of the Elex Standardised Plugs and Sockets System, recommended and used by all leading Wireless Journals.

**J. J. EASTICK & SONS**  
 Elex House, 115, Bunhill Row, London, E.C.1  
 \*Phone: Clerkenwell 9282-9283.

**CAN WE RUN OUR VALVE FILAMENTS ON A.C.?**  
 (Continued from page 436)

satisfactory reception. The advent of the dull emitter has brought the matter within the region of practical politics. The question is entirely one of heat retentivity. A thick filament will require more heating to bring it to the same temperature, but, at the same time, it will retain its heat for a longer period. Secondly, the higher the temperature the more rapid will be the cooling effect, from which it will readily be seen that a dull-emitting filament, being relatively thicker and cooler than a bright emitter, will tend to retain its heat and remain at a uniform temperature irrespective of any rapid variations of filament current.

Whether this levelling tendency is sufficiently marked with the modern dull-emitter valve is a point which I shall discuss later, when details will be given of some actual tests made on a variety of valves to determine their suitability for use with alternating current filament supply.

**NEXT WEEK.**

In our next issue we shall publish two articles of outstanding interest, one by Captain Round on "What Do We Gain by Low-Loss?" and one by Dame Clara Butt on the topical subject of "Keeping Listeners' Interest: Why Great Artists Cannot Broadcast."

**EVERY LOUDSPEAKER**

**DESERVES MULLARD MASTER VALVES**

— Ask for —  
**Mullard P. M. Power Valves.**

All communications regarding advertisements should be addressed to:

The Advertisement Manager,  
**"WIRELESS,"**  
 Bush House, Strand, London, W.C.2

Telephone: City 9911.

A SENSATION AT OLYMPIA EXHIBITION  
**CHEAPER THAN USING THE MAINS**

Eliminators Eliminated by  
**WESTAM**  
 EVERLASTING  
**H.T. ACCUMULATORS**  
 Requires re-charging twice a year only

**6<sup>d</sup>. a Volt. 2 Amps.**  
 ENTIRELY BRITISH.  
 FULLY GUARANTEED.

60 Volt Model - 30/-  
 also 20, 30, 90, 100 & 120 volts.  
 SCRAP YOUR DRY BATTERY.  
 Catalogue and spare parts list from your dealer, or

**WESTAM ACCUMULATORS,**  
 CLEMENTS ROAD, LONDON, E.6.

Pat. No. 1093626

**Home Entertainment for the Winter Evenings**

The Brightest and most economical is to  
**INSTALL A "SERVICE" RECEIVER.**

THE "SERVICE" LONG RANGE 2-VALVE RECEIVER £10 cash  
 absolutely complete. or £2 deposit and balance monthly

THE "SERVICE" 2-VALVE LOUD SPEAKER RECEIVER £13 cash  
 absolutely complete. or £2 12/- deposit and balance monthly

FREE DEMONSTRATION, INSTALLATION, AND UKKEEP.  
 SEE OUR CATALOGUE FREE ON APPLICATION.

Wireless Specialists. **The Service Company Ltd.** "SERVICE —Our Name and Aim."  
 Wireless Dept.

273-274, HIGH HOLBORN, LONDON, W.C.1

**ETHERPLUS**

**ETHERPLUS GRID LEAK**

1/6 each **ETHERPLUS+ GRID LEAK** 1/6 each

The only efficient medium priced Grid Leak. Guaranteed to be within 5% of the stated resistance. Absolutely reliable under all climatic conditions. Resistances from 25 to 5 Megohms.

From all dealers or from **M. & A. WOLFF,** 9-15, Whitecross St., London, E.C.1

**You can build the MONODIAL for less than £10 even if you have to buy every component.**

The whole of the Components for the Monodial only cost you £9 18s. 0d.

1 Panel, 14 by 7, drilled and engraved ..	£0 7 0	4 Fixed Resistors and Bases	0 10 8
2 Six Pin Transformers, T.B.	1 1 0	1 R.1 Multi Transformer (list Stage) ..	1 5 0
2 Six Leg Bases for same ..	0 5 0	2 Neutralising Condensers ..	0 14 0
1 Second Stage L.F. 6/1 Transformers ..	0 12 6	1 Midget Reaction Condenser	0 3 6
1 R.F. Choke ..	0 8 0	2 Jacks ..	0 3 6
1 Series Condenser and Leak	0 3 0	1 Plug ..	0 1 6
1 Base for same ..	0 1 2	Battery Leads ..	0 3 0
2 Condensers (002) ..	0 4 0	Grid Battery Clips ..	0 1 2
1 2 Gangs Condenser	2 15 0	1 Push- and Pull-Switch ..	0 2 6
1 Micro Dial ..	0 7 6		
4 Buoyancy Valve Holders ..	0 9 0		
		<b>Total</b> ..	<b>£9 18 0</b>

All orders for £2 or over, POST FREE.  
 Full range of literature on Radiax productions, post free, 3d.

**RADIAX LTD.,**  
 14, Accessory House, Palmer Place, London, N.7

**RADIAX**  
 WE SATISFY YOU

Parts Ad.



## Sources of supply

"THE WIRELESS DEALER and Radio Trade Journal" contains two important guides to sources of supply—Index to Advertisers and The Buyer's Guide. The first will refer to advertisements in the issue, while the second will direct you to the manufacturers of any particular product which you may require to order. These two guides compose an important fund of information.

Commence your subscription with the current issue—it is rather an important one for the retail section of the Trade. It contains a detailed "Stand to Stand Review" of the Great Exhibition at Olympia, a comprehensive résumé of the Shows at Belfast, Berlin, New York, and all available information of the Radio Show in one of England's greatest industrial centres—Manchester.

#### SUBSCRIPTION RATES:

7/6 per annum (abroad 10/-). Available to the Trade only. Trade card or business heading should accompany every subscription to the SALES MANAGER, Radio Press, Ltd., Bush House, Strand, London, W.C.2.

**The Wireless Dealer**  
AND  
Radio Trade Journal



## The Tide of the Present

Shouting the slogan "Economy and Simplicity" as the tide of modern progress bears us farther and farther from all that these terms truly represent, we deafen ourselves to their real meaning. In our efforts to reach the state from which we sprang, we merely become involved in further complications and yet we are satisfied that the tide of the present is definitely set for the happy condition of simple and economical existence.

Wireless to-day is perhaps considered, in a broad sense, supreme as an illustration of these two qualities, yet few people have succeeded in reducing its complexities. Only R.I. could produce the Retroactive Tuner, which, for the first time, gave the constructor the means of easy and efficient tuning. Now this unit is universally recognised as the most simple and economical method of tuning. Simple because it ensures that correct aerial reaction is used over the whole range of wave lengths covered, 175-4000 metres, and economical because it supersedes the usual multiplicity of coils, which together with coil holder to cover the same range cost appreciably more than the Retroactive Tuner.

Next time you have difficulty in selecting the station you want, remember the R.I. Retroactive Tuner, the unit that applies the principles of the future to the design of the present.

Price: One Pound Nineteen and Sixpence.

R.I. Ltd., 12 Hyde Street, New Oxford Street, London, W. C. 1





WIRELESS, incorporating 'Wireless Weekly,' NOVEMBER 13, 1926.

# WIRELESS



INCORPORATING  
WIRELESS WEEKLY

2<sup>D</sup>  
WEEKLY



Vol. VII NOVEMBER 13, 1926 [No. 1]

## THE MONODIAL ON THE LONG WAVES

WHAT DO WE GAIN  
BY LOW-LOSS?

By Captain H. J. ROUND, M.C., M.I.E.E.

KEEPING LISTENERS' INTEREST

By Dame CLARA BUTT

[Registered at the G.P.O. as a Newspaper]

# Two interesting receivers published in Issue Now on Sale

**THE "DRAWING ROOM FIVE."** The set described by John Underdown has been designed with the object of giving good all-round results. It will give excellent reproduction from the local station and very good loud-speaker signals on many British and Continental stations. As will be seen from the accompanying illustration, the L.F. Coupling is by the resistance-capacity method. A volume control is provided which enables very loud signals to be adjusted to the strength required.

**A "PUSH-PULL THREE."** This receiver, incorporating the push-pull method of amplification, has been specially designed for those home constructors who, possessing a number of general purpose valves, desire to obtain power valve results without purchasing special L.F. Power Valves. Mr. Stanley G. Rattee is the author.

**BUY YOUR COPY TO-DAY**

**1/-**  
MONTHLY

**MODERN WIRELESS**

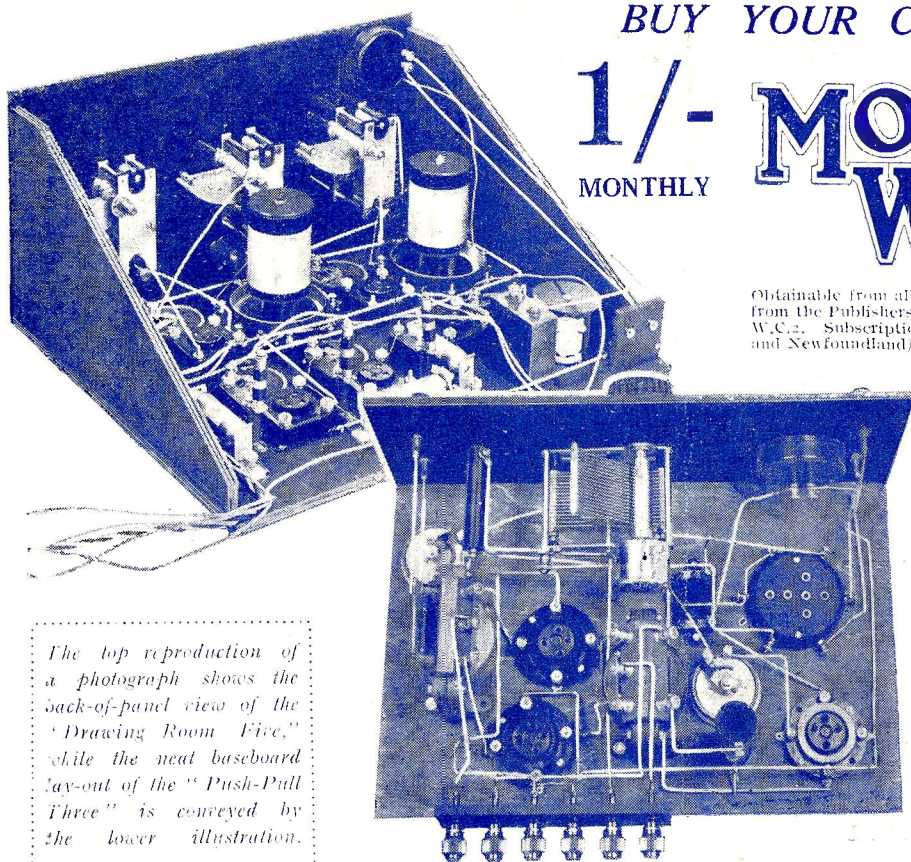

The top reproduction of a photograph shows the back-of-panel view of the "Drawing Room Five," while the neat baseboard lay-out of the "Push-Pull Three" is conveyed by the lower illustration.

Obtainable from all Newsagents, Booksellers or Book-stalls, or direct from the Publishers, Radio Press, Ltd., Bush House, Strand, London, W.C.2. Subscription Rates 15/- per annum (13/6 per annum Canada and Newfoundland). Lesser periods *pro rata*.

*Contents of this issue also include:*

**Some Further Notes on the "Solodyne"**  
**The "Elstree Six" (Further Hints on Operation, etc.)**

**Day and Night Effects**  
*By G. P. Kendall, B.Sc.*

**What Jack Shall I Need?**  
*By A. V. D. Hort, B.A.*

**Neatness and Efficiency (A Crystal Set)**  
*By H. Bramford.*

**Hints for the Short-Wave Novice**  
*By L. H. Thomas (6 QB.)*

**Points about Battery Eliminators**  
*By J. H. Reyner, B.Sc. (Hons.), A.M.I.E.E.*

*This Magazine published "The Elstree Six"*

**Igranic  
Triple Gang  
Condenser**

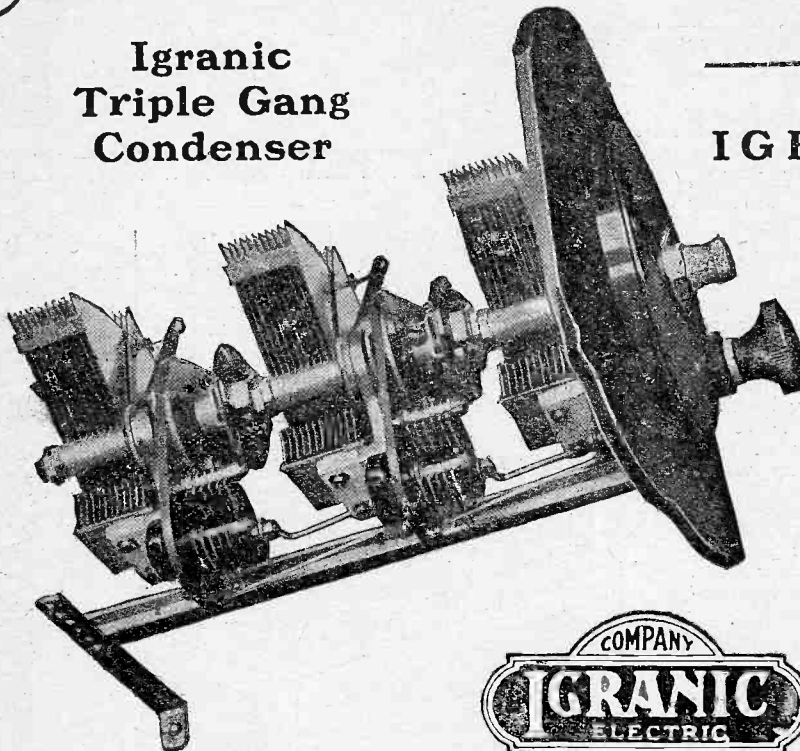

— *and now the*  
**IGRANIC Twin**

**I**GRANIC GANG CONDENSERS successfully solve the problem of single knob control.

Small compensating condensers connected in parallel with the main condensers enable each section to be exactly equalised without the necessity of altering the relative settings of the main condensers.

The Igranic method is simple and practical and preserves the accurate square law tuning of the condensers as a whole.

Twin Gang Pattern... £2 10 0  
Triple Gang Pattern .. £3 15 0

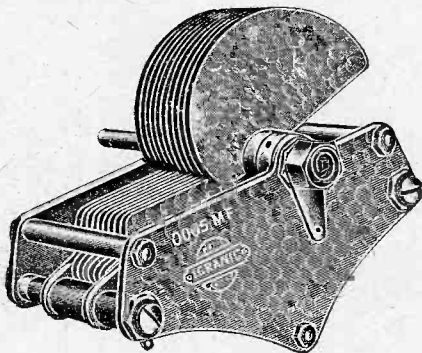

**Low Loss Square Law  
VARIABLE CONDENSERS**

**I**GRANIC VARIABLE CONDENSERS have earned the reputation of being the "choice of experts — and amateurs." Accurate square law tuning, extremely low losses, negligible minimum capacity, smooth ball-bearing movement. Ask your dealer to show you one so that you may see the beautiful workmanship.

Single Pattern.	.00015 mfd.	....	17/-
	.0003	..	18/6
	.0005	..	21/6
	.001	..	25/-

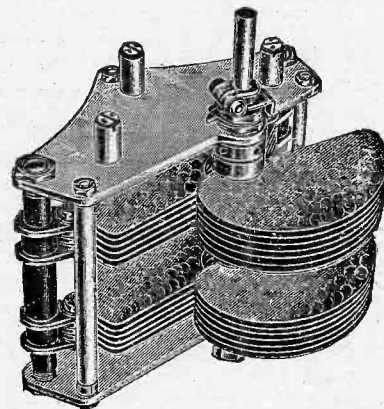

**Low Loss Dual  
VARIABLE CONDENSER**

**I**GRANIC DUAL VARIABLE CONDENSERS are similar in design to the single pattern. The whole construction is particularly rigid, so that there is no risk of the plates getting out of alignment or of the accuracy of tuning being affected.

	.0003 mfd. (Dual)	22/6
	.0005	27/-

SEND FOR  
LIST No. S.38

**IGRANIC ELECTRIC CO LTD**

149 Queen Victoria St., London. Works: Bedford.

Always use the Igranic Indigraph Knob and Dial. Gives smooth slow motion control, entirely free from backlash. Price 7/6

## Ten Reasons why you'll prefer S.T.'s

- (1)—Because they are designed and made by John Scott-Taggart, the best known authority on the valve in this country.
- (2)—Because they have been designed on the only rational basis, namely, that of dynamic characteristic curves, which represent working conditions with an impedance in the anode circuit.
- (3)—Because the performance of a valve (as distinguished from its life) is disclosed entirely by its characteristic curves, and S.T.'s are widely publishing theirs because of their obvious superiority over ordinary valves. *It's their curves that count.*
- (4)—Because S.T.'s are built, like the Pyramids, to last. The torodium filament takes, in practically all types, only 0.1 amp., and gives a copious emission at so low a temperature that no glow can be seen.
- (5)—Because the special alloy of which the filament is made is not brittle, but even after long use remains as flexible and strong as a steel cable.
- (6)—Because the long life and maintained performance is also obtained by the use of the Barget process, which produces in the bulb the highest vacuum which science has yet achieved.
- (7)—Because you save money in upkeep, as the life of the valve is very long and the filament current is exceptionally small. You have only to charge your small accumulator once or twice a year and this also saves you a lot of trouble.
- (8)—Because S.T.'s are not critical to work. Many valves are very critical on filament voltage, but S.T.'s do not need rheostats or even resistors, although both can be used.
- (9)—Because the designer has used every invention (under patent licence) which has advanced the valve and has used the best features of existing valves to obtain the ideal. Every valve is non-microphonic and exceptionally strongly made, though built with the accuracy of a chronometer.
- (10)—Because the valve you are going to buy has a test certificate (see illustration) on its carton, personally initialled by John Scott-Taggart with his own pen to state that he is thoroughly satisfied with that particular valve, which has been rigidly tested electrically and on actual signals under his direct supervision.

**BUY ONE TO-DAY!**

## TYPES and PRICES

2 Volt.		4 Volt.		6 Volt.	
H.F. S.T.21	0.1 amp. 14/-	H.F. S.T.41	0.1 amp. 14/-	H.F. S.T.61	0.1 amp. 18/6
L.F. S.T.22	0.1 amp. 14/-	Power S.T.42	0.1 amp. 18/6	Power S.T.62	0.1 amp. 18/6
Power S.T.23	0.15 amp. 18/6	Super Power S.T.43	0.25 amp. 22/6	Super Power S.T.63	0.25 amp. 22/6

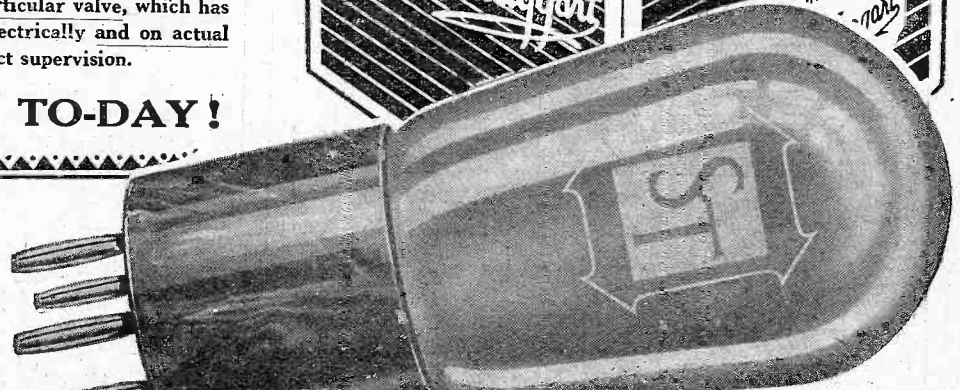

Send for details. If you cannot buy your valve at one of our local dealers, write to us:

Head Office: S.T. Limited, 2, Melburne Place, London, W.C.2.

Works: London. W.1.

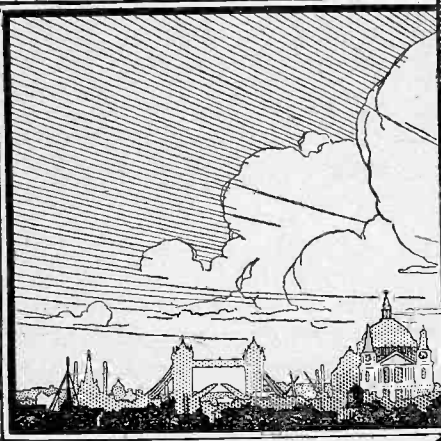

# WIRELESS

INCORPORATING

## WIRELESS WEEKLY

Published by

**RADIO PRESS, LTD.,**  
Bush House, Strand, London, W.C.2.

All communications concerning contributions should be addressed to the Editor and must be accompanied by a stamped addressed envelope if the return of MSS. is desired.

Nothing contained herein is to be regarded as encouragement or permission to infringe any patent rights.

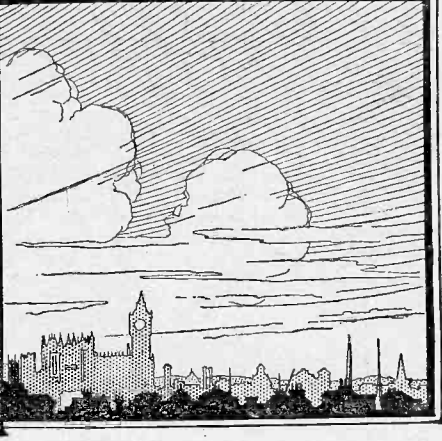

## THIS WEEK'S NOTES AND NEWS

### Manchester's Escape

**2ZY** had quite a narrow escape on October 20. A fire broke out in the offices of an electric lamp firm, just beneath the offices of First National Pictures, Ltd., in Orme Building (also the home of 2ZY). Luckily, it was discovered in good time by a fifteen-year-old office boy, otherwise Manchester listeners might have had to listen to Daventry for some time to come!

### Snobbish!

"**M**AKE your set more select" is the headline of a "Wireless Corner" of one of the provincial papers. How is it done?

### Worse Offenders Still

**M**UCH as some people grumble at the number of talks from 2LO and, in fact, all the B.B.C. stations, I am beginning to think that we are not so badly off as we might be. Personally, my almost infallible method of picking out German stations is to tune in those which have interminable talks going on! The German announcers must have very well-developed tonsils!

### No Wavelength Tests

**I** UNDERSTAND that it has now been decided not to hold a general test of the new wavelengths, when they are brought into use. The relay stations have already carried out several tests, and the B.B.C. state that no trouble is expected in this direction.

### A "Crackling" Tip

**S**EVERAL of my acquaintances have mentioned to me at one time or another that, with the modern valves

which show little sign of glow, they have experienced peculiar cracklings which have been put to the credit of the high-tension battery and subsequently found to be coming from the low-tension accumulator. In the days of bright-emitters, of course, it was generally sufficient to watch the valve filament and see whether any fluctuation took place, but now it is a good plan to keep a filament voltmeter connected across the filament legs of, say,

coloured pansies, elongated caterpillars, attenuated worms are all connected in some mysterious way with the aerial belonging to "the chap next door." We are living in a world of wonders, but I am afraid a good many of them are imaginary!

### Mars

**O**NCE more the experts have failed to produce any convincing signals from the Red Planet. Their efforts have, however, produced many interesting phenomena. I was particularly pleased to note that while a certain gentleman was listening for Mars on 30,000 metres, "the G.P.O. station at Rugby, using a wavelength of 18,740 metres, cut in and drowned the signals!"

### Mass Singing

**O**N November 20 the B.B.C. will probably have to deal with a greater volume of sound than it has ever done before. The date is the occasion of the concert to inaugurate the *Daily Express* National Community Singing Movement, which will be held at the Albert Hall. The broadcast will take place from 9 till 9.30 p.m. and 10.15 to 10.30 p.m. Listeners will also hear the Royal Albert Hall Orchestra and items by Mr. John Goss and Mr. Norman Allin.

### A Record

**S**HORT-WAVE communication has been responsible for the putting up of a remarkable record for "ship-to-shore" telegraphy. The steamship *Jervis Bay* recently established contact with Sydney from a point off Portugal, (Continued on next page.)

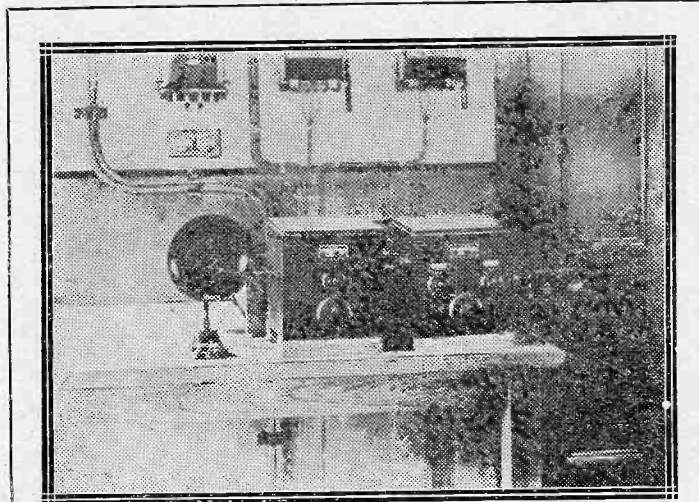

According to reports, the opening day of the new "Beam" service between Bodmin and Canada was marred by an interruption of service, due, it was stated, to "fading." Our picture shows the apparatus which produces an audible note for checking up the constancy of the transmission.

the detector valve. Any "jumps" in the voltage, due to bad connections on the accumulator, are then easily spotted.

### Old Wives' Tales

**T**HERE are still some who believe that wireless has some sort of effect upon their gardens. Giant marrows, shrivelled-up beans, dis-

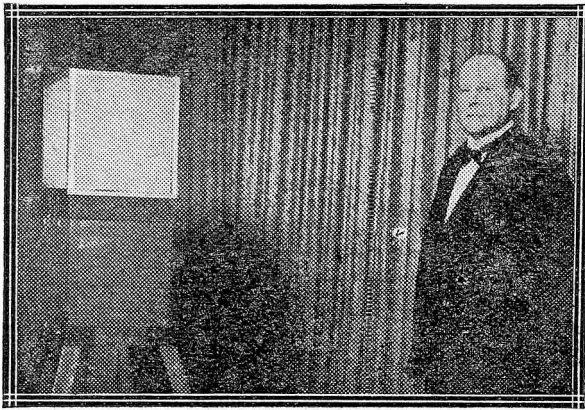

The Editor of "Punch," Sir Owen Seaman, recently gave a broadcast talk from 2LO. Sir Owen is here seen before the microphone at the London station.

over 10,000 miles distant. This is the first time that a ship on this side of Colombo has connected up with Sydney. Using the same power on the usual 600-metre wave, it would have been considered quite creditable to communicate over a distance of about 600 miles!

#### The New Wavemeter

A WEEK or so ago I was shown the new standard wavemeter to be used at 2LO. The wavemeter itself is rigidly made and beautifully finished, and so constructed as to be capable of measuring 2LO's correct wave and the wave of either of 2LO's neighbours—Breslau and Graz. Each European station will have a similar wavemeter adjusted to its own wavelength. Further details of the wavemeter will be found elsewhere in this issue.

#### Radio Week

I AM asked by the Hon. Secretary of the Maidstone and District Radio Society to announce that the Maidstone Radio Week, held under the auspices of the Society, will be held from November 16 to 20 inclusive. The fourth annual Wireless Exhibition is to be held during the week, in the Concert Hall, Corn Exchange, Maidstone. An open competition is also being held. Roll up, Maidstonians, in your thousands!

#### New Dutch Station

THE Dutch Government Telegraph and Telephone authorities are contemplating the erection of a new station to be placed at the disposal of business firms who wish to make announcements at a moderate "advertising rate." From tests that have already been carried out it appears that with 3 kw. in the aerial station at Scheveningen Haven can make itself heard all over Holland. The wavelength used will probably be 1,950 metres.

## THIS WEEK'S NOTES AND NEWS

Continued

#### On Armistice Day

ON Armistice Day special programmes are being broadcast from the Canadian National Railways' fine chain of "CNR" stations, on a wavelength of 434.5 metres. On the following day CNRA will broadcast a special

Armistice Day service from the Central United Church, Moncton.

#### Hands Off!

SIR ARTHUR STANLEY and Professor Low have addressed a letter to Members of Parliament pointing out that the £900,000 accu-

tion is interested in broadcasting, and has made several substantial grants towards the purchase of apparatus.

#### Atmospherics and the Beam

I REMARKED a few weeks ago that no trouble had been experienced by the "Beam" stations on account of atmospherics. Shortly after reports appeared stating that communication had been held up by static disturbances, and, needless to say, I was gently but firmly corrected by some of my readers. I have emerged triumphant, however, since the official report states distinctly that the cause of the delay was *not* atmospherics but fading.

At about the same time as the above occurrence a severe electric storm played havoc with the Transatlantic cables, and very fine displays of the Aurora were seen in America and Scotland.

#### The Birthday Week

WE have some excellent programmes to look forward to during the B.B.C.'s birthday week, mostly of a light nature. The informal "rags" usually forming a feature of the birthday celebrations, providing they are not overdone, are really excellent fun, and always remind me of "P.P.'s" solo efforts, from Writtle—now more than four years ago. This feature will, needless to say, be made the most of this year, since it is the last birthday that the B.B.C. will hold.

#### Welsh Dissatisfaction

WALES is again complaining that it is sadly neglected in radio matters, not only in the matters of language and music, but also as far as the stations themselves are concerned. Cardiff and Swansea are, after all, in the extreme south of Wales, which is a very mountainous country.

#### Do You Agree?

THE following words of wisdom dropped from the lips of Mr. Edison last month: "There isn't 10 per cent. of the interest in radio that there was last year. It's a highly complicated machine in the hands of people who know nothing about it. No dealers have made any money out of it."

CALL-SIGN.

### AT THE SCIENCE MUSEUM

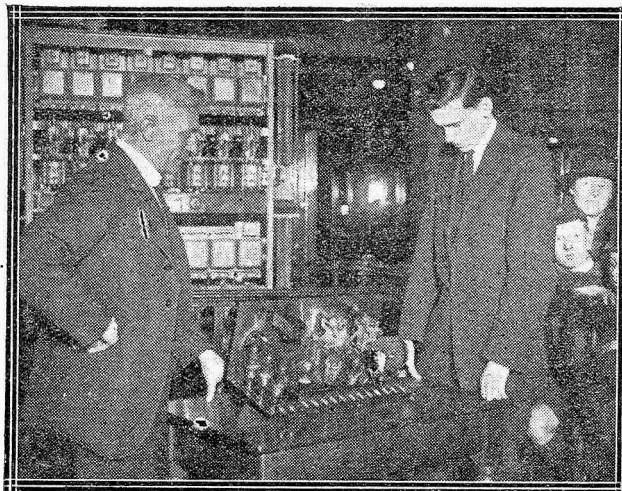

The Government standard seven-valve wireless receiver which is now on view at the South Kensington Science Museum. On certain days of the week this receiver can be heard by visitors to the Exhibition.

mulated by the G.P.O. from licences should not be claimed by the Treasury when the B.B.C. is "handed over," as it is needed for the advance of wireless throughout the Empire.

#### In Czecho-Slovakia

RADIO seems to be in a very flourishing state in the majority of countries which possess a broadcasting service. In Czecho-Slovakia, for instance, a 700 per cent. increase in the number of listeners is reported since the beginning of this year. Several training schools in that country have installed stations, the use of which is shared by other establishments. The Ministry of Educa-

# The "MINIWIRE" SUPERHETERODYNE

By Stanley G. Rattee, M.I.R.E.



Here is a really simple, easy-to-build, easy-to-work "super" using only six valves, which gives very good results on a frame aerial



ANY people who are anxious to build for themselves a multi-valve receiver which will within a reasonable distance of a local station permit them to receive other British or foreign stations will find a ready solution in the superheterodyne. In my own case, though a straight multi-valve set can be made sufficiently selective to cut out the local station for the reception of Bournemouth, local conditions are such that the set will not receive Manchester, though there is no audible interference when the set is adjusted to that station's wavelength.

The reason for this peculiarity is, to my mind, attributed to the close proximity of the Crystal Palace, for not only is Manchester inaudible, but similarly Aberdeen, Glasgow and Newcastle are affected. The aerial used in these circumstances is somewhere about a quarter of a mile from the North Tower of the Crystal Palace, so

placed that the Tower lies between it and the stations given above.

### "Superhet" Advantages

For the reasons given a superheterodyne receiver was tried about a year ago—more out of curiosity to see

tions could be received on a straight set in the circumstances mentioned six valves were needed, three of them being high-frequency amplifiers.

The thought of building a superheterodyne receiver perhaps conjures up in the minds of many home constructors pictures of complicated wiring schemes with possible disappointment following upon several evenings' work with the soldering iron.

To some extent the building of a receiver of the superheterodyne type calls for a certain amount of ability, and in the case of many already published designs the wiring diagram is somewhat awesome, but, notwithstanding these facts, the superheterodyne receiver is not by any means as difficult to build as the average man persuades himself into believing.

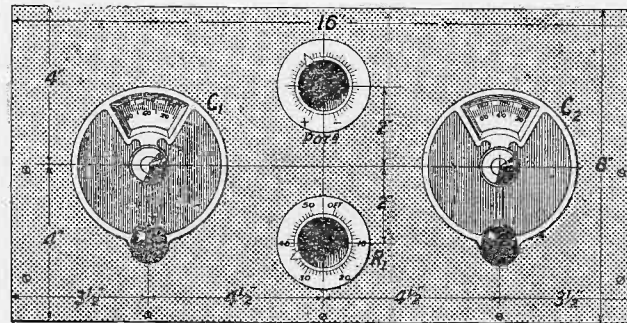

Fig. 1.—Note the simple panel arrangement of the "Miniwire," all dimensions for which can be transferred from this drawing to your panel.

### Simple to Wire

In the case of the "Miniwire" the

### STATIONS RECEIVED

The following list of stations will serve to give some idea of the capabilities of the set, and though numerous others have been heard their origin at the time of writing is somewhat obscure. The stations given were not only identified by the items in their programmes, but confirmation was obtained by actually receiving the announcers' remarks.

The locality where the reception was made was in the Crystal Palace district, S.E. London, and those stations marked with an asterisk were received on the loud-speaker at adequate strength.

- |                     |                 |
|---------------------|-----------------|
| Breslau             | Glasgow         |
| Bournemouth*        | Radio-Milan*    |
| Frankfurt-am-Main*  | Oslo*           |
| Leipzig*            | Newcastle*      |
| Radio-Barcelona*    | Hamburg*        |
| San Sebastian*      | Stuttgart       |
| Cadiz*              | Manchester      |
| Birmingham*         | Radio-Toulouse* |
| Aberdeen (daylight) | Radio-Belgique* |

whether it would receive what the other set could not than anything else—and though the set used was not the one shortly to be described, it is interesting to note that all the main B.B.C. stations could be received in daylight, as against only a few with a straight set. In both cases five valves were used, the straight set being made up of two neutralised H.F. stages, detector, and two note magnifiers, while the superheterodyne was the "Tropadyne" arrangement without any low-frequency amplification.

Further experiment along these lines showed that before all the main B.B.C. sta-

work involved is little more than that called for in the construction of, say, (Continued on next page.)

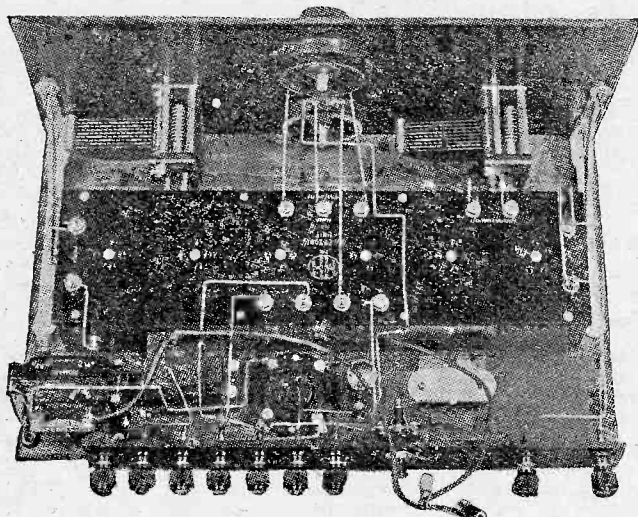

As its name suggests, the great feature of this receiver is the absence of complicated wiring.

# The "Miniwire" Superheterodyne

- Continued

a three-valve receiver, the reason being that the majority of the instrument is already assembled in the form of a unit which may be purchased complete. The various components, such as tuning condensers, potentiometer, and filament resistance, are connected to this unit by means of the terminals provided, while the valves are mounted in holders situated on an ebonite panel forming a lid or covering for the unit itself.

Normally the unit provides for five valves, but in order that a loud-speaker may be used with satisfactory results an extra valve has been added in the form of a transformer-coupled low-frequency amplifier.

## Lay-out

The panel of the receiver carries two variable condensers, a potentiometer and a filament rheostat; the "on-off" switch and all terminals being

fitted to a terminal strip situated at the back of the baseboard. The unit, the low-frequency transformer, the extra valve holder, a fixed resistor and clips for the grid battery are fitted to the baseboard in the conventional manner, and the whole arranged to slide into an American type of cabinet.

## The Circuit

From the circuit diagram which accompanies this article it will be seen that the "Tropadyne" arrangement is employed, which, as has already been pointed out to readers of this journal, utilises a combined oscillator and detector valve, thus economising in the total number of valves used.

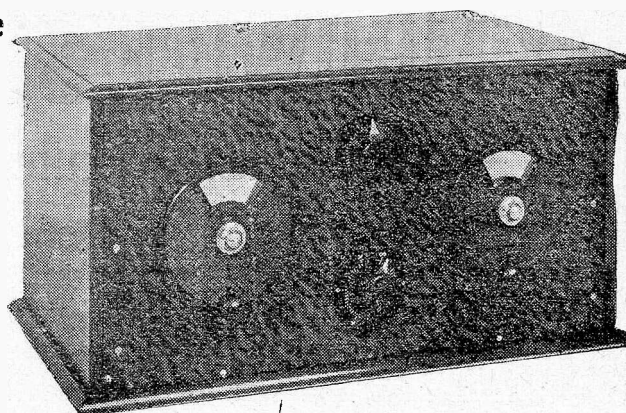

For a receiver employing six valves, the "Miniwire" is remarkably compact.

Since the majority of the circuit is already wired in the unit, the circuit diagram calls for no special discussion, but is given merely from the point of interest to the more advanced reader. The note-magnifier which has been added is, it will be seen, of quite conventional design, and is accommodated with a separate high-tension terminal for, applying voltages higher than that used for the rest of the circuit, to the anode of this last valve.

The two variable condensers, each of .0005 capacity, form the tuning controls, while the potentiometer serves

## WIRING INSTRUCTIONS

Join loop terminals of set to loop terminals of superonic unit and thence, to moving and fixed plates of C1.

Join "Autodyne Condenser" terminals of superonic unit to moving and fixed plates of C2.

Join potentiometer - terminal of unit to one side of potentiometer.

Join potentiometer + terminal of unit to other side of potentiometer.

Join centre potentiometer terminal of unit to slider of potentiometer.

Join phones + terminal of unit to "H.T. +" terminal of transformer T9, T10.

Join phones - terminal of unit to "plate" of T9, T10.

Join "grid" of T9, T10 to G of V6.

Join "grid bias" of T9, T10 to G.B. - wander plug (flex lead).

Join A of V6 to left-hand L.S. terminal.

Join L.S. + terminal to H.T. + 2 and thence to one side of C4.

Join H.T. + of unit to H.T. + 1 of set and to one side of C3.

Join H.T. - of set to remaining sides of C3 and C4, and thence to H.T. - of unit.

Join L.T. - of set to one side of R2 and thence to one side of R1. Join G.B. + flex lead to point on latter wire.

Join other side of R2 to F- of V6.

Join other side of R1 to L.T. - of unit.

Join L.T. + of set to one side of switch S.

Join other side of S to F + of V6 and to L.T. + of unit.

as a stabilising device after the filament resistance has been satisfactorily adjusted.

## Materials

As to components required for building a set to these specifications, these are given in a special manner for quick and easy reference. With regard to the superheterodyne unit, there is, of course, so far as the present set is concerned, no choice but to use the make given, but so far as the

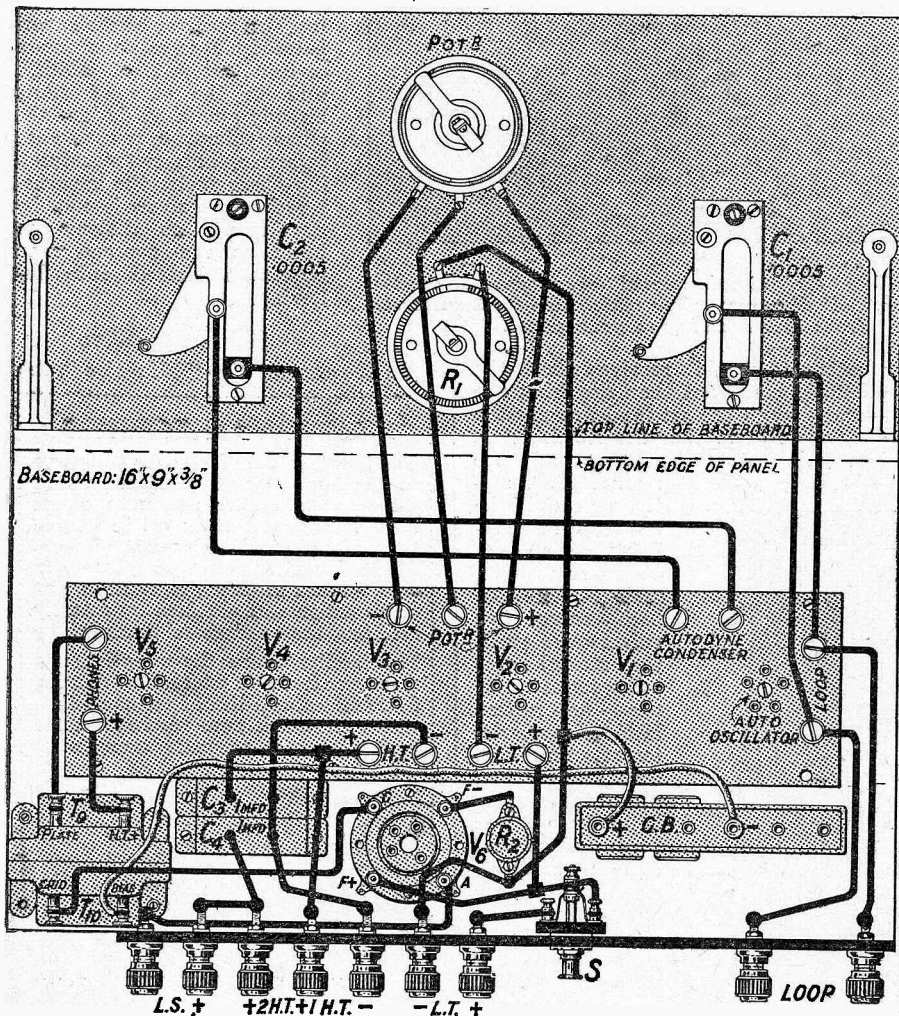
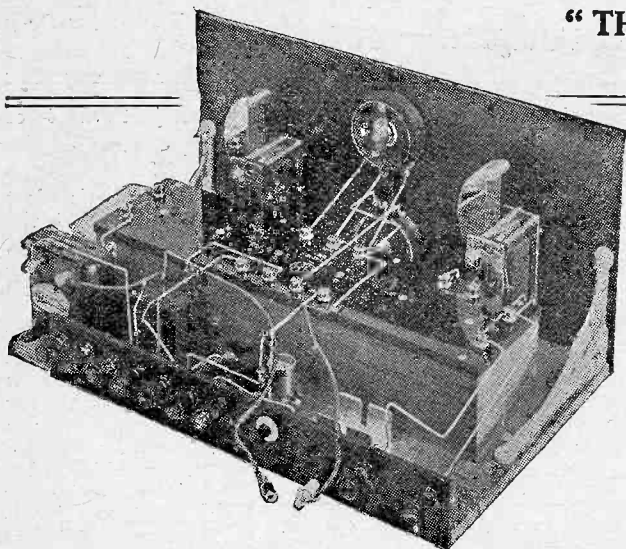

Fig. 2.—The switch marked "S" is brought into use when it is desired to light the filaments.



## "THE SIX-VALVE SET WITH ONE-VALVE WIRING"



The two plugs seen below the switch on the terminal strip make connection to a grid-bias battery.

approaching success though a host of "chirps" may be picked up.

Another point which should be borne in mind is that the filament rheostat should be sufficiently robust and of such a value as to give satisfactory control of the first five valves. This value will, of course, be dependent upon the type of valves it is intended to use, and care therefore must be exercised when buying this component in order

to avoid trouble at some subsequent period.

board by means of the brackets, and before proceeding further, secure the two small flat brackets to the sides of the superheterodyne unit.

Before screwing this latter to the baseboard make the necessary connections with the two condensers on the panel, the unit being in position but by virtue of its not being secured to the baseboard allowing the connections to be more easily made.

Next screw the unit to the baseboard and connect in circuit, that is, to the appropriate terminals on the unit, the filament rheostat and the potentiometer. Place the L.F. transformer, the valve holder, fixed resistor base, and battery clips in position, making sure that sufficient clearance is allowed for the valve and grid battery when these are inserted in the respective positions.

remaining components are concerned, it may be understood that other suitable makes will be found among the many listed in the advertisement

to avoid trouble at some subsequent period.

### WHAT YOU WILL NEED

- "Trolite" panel, 16 in. by 8 in. by 1/4 in. (F. A. Hughes & Co., Ltd.)
- Panel brackets. (Burne-Jones & Co., Ltd.)
- Cabinet and baseboard 9 in. deep. ("Camco.")
- Potentiometer. (Ericsson Telephones, Ltd.)
- Filament rheostat. (Ericsson Telephones, Ltd.)
- Two .0005 S. L. F. Condensers. (Beard & Fitch, Ltd.)

- Two vernier dials. (The Formo Co.)
- Superheterodyne unit, with plug-in Autodyne coil unit. (L. McMichael, Ltd.)
- L. F. Transformer, Type A.F.4. (Ferranti, Ltd.)
- Fixed resistor and base. (Burndept Wireless, Ltd.)
- On-off switch. (A. F. Bulgin & Co.)
- Two 1 mfd. Mansbridge condensers. (T.C.C.)
- Grid battery clip. (A. F. Bulgin & Co.)

- Valve-holder. (Garnett, Whiteley & Co., Ltd.)
- Two Wander plugs.
- Short length rubber covered flexible wire.
- "Glazite" connecting wire.
- Nine terminals marked as per wiring diagram. (Belling & Lee, Ltd.)
- Ebonite strip, 14 in. by 2 in. by 1/4 in. (Burne-Jones & Co., Ltd.)
- Two small flat right-angle brackets.

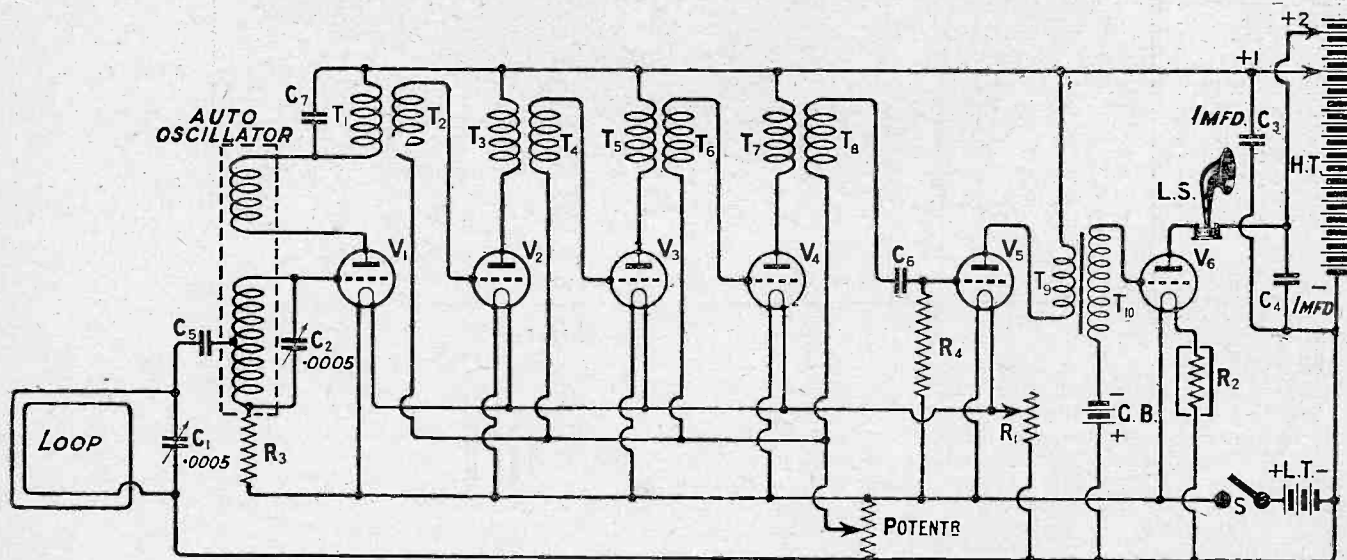

Fig. 3.—For the L.F. amplifying valve a fixed resistor (R2) is used to limit the filament current. The remaining valve filaments are controlled by a variable resistance seen at R1.

pages. In any case, it is recommended that slow-motion dials be used, otherwise it will be found an extremely difficult business to operate the receiver with anything

### Constructional Work

After the panel has been prepared in accordance with the details given in the drawing of the panel layout, this should be secured to the base-

whether or not sufficient room has been allowed for accommodating the stems of the terminals, whereupon all the components, including the terminal strip, may be permanently fixed.

## The "Miniwire" Superheterodyne—continued

### Wiring

The wiring of the receiver will not be found any more complicated than that of an average small receiving set, further, as many of the connections are screwed under terminals, those readers who fight shy of soldering will feel particularly favoured.

Where possible, the general directions for wiring should be followed, as though the connections are clearly given in the wiring diagram, and shown, the constructor is warned against accepting his own interpretation of the arrangement immediately the set is finished, for a single mistake at a point may quite conceivably mean the burning out of all the valves.

Discretion is the better part of valour in these matters, and before connecting any batteries the whole of the wiring should be checked against the diagram. Following upon this, connect the accumulator across the appropriate terminals, place the switch in the off position, turn the filament rheostat to zero and insert the valves. On switching on, the valve situated upon the baseboard should light while the remaining five should show no light until the filament rheostat is turned, whereupon all five will light up together.

### A Safety Test

The negative lead of the H.T. battery can now be connected, and using, say, 3 volts of the H.T. battery, touch the first H.T.+ of the instrument, noting whether or not the valves show any tendency to brighten up, and if nothing untoward happens it may be assumed that so far the circuit is correctly wired. Still using, say, 3 volts H.T., touch the H.T.+2 terminal, making the same observation as before, when if all appears to be correct, connect, say, 60 volts across H.T.— and H.T.+1 and a voltage suitable to the valve chosen for the

last stage to H.T.+2, not forgetting to use suitable grid bias also.

If this last valve is of the power type, then 120 volts will prove a suitable value, while the grid bias voltage may be taken as being somewhere between 6 and 12 volts, according to the make of valve chosen.

### Operating

So far as operating the receiver is concerned, this will be dealt with at some length in next week's issue, but in order that readers may in the meantime learn the preliminary handling of the set the following points should

adjusted to a point just short of oscillation.

### Searching

For the reception of signals first adjust the potentiometer so that the intermediate stages just oscillate, whereupon turn the Autodyne condenser (right-hand side of panel) either one way or the other until a powerful "chirp" is heard. Assuming that no chirp is heard throughout the operation, move the condenser on the left of the panel slightly and try again, whereupon sooner or later a chirp will be heard.

Slowly settle down on this chirp by adjusting both the Autodyne and frame aerial condenser together until the signals, though distorted, are at their loudest, when a slight adjustment of the potentiometer in order to stop oscillation will render the signals clear of distortion.

Further adjustments should now be made to both condensers until the best results are obtained, both with regard to volume and clearness, not forgetting to alter the angle of the frame aerial for possible betterment.

If any difficulty is experienced in finding stations in

this way a rough and ready method may be adopted by first searching on the Autodyne condenser and then adjusting the aerial condenser, keeping the intermediate stages well below self-oscillation the whole time by adjusting the potentiometer to a safe value. The receiver in this way loses much of its sensitiveness, though the method has much to commend it until the operator is proficient in making his adjustments quickly.

Those readers who have never handled a superheterodyne before should bear in mind that signals from a given station can be generally heard at two readings of the Autodyne condenser dial.

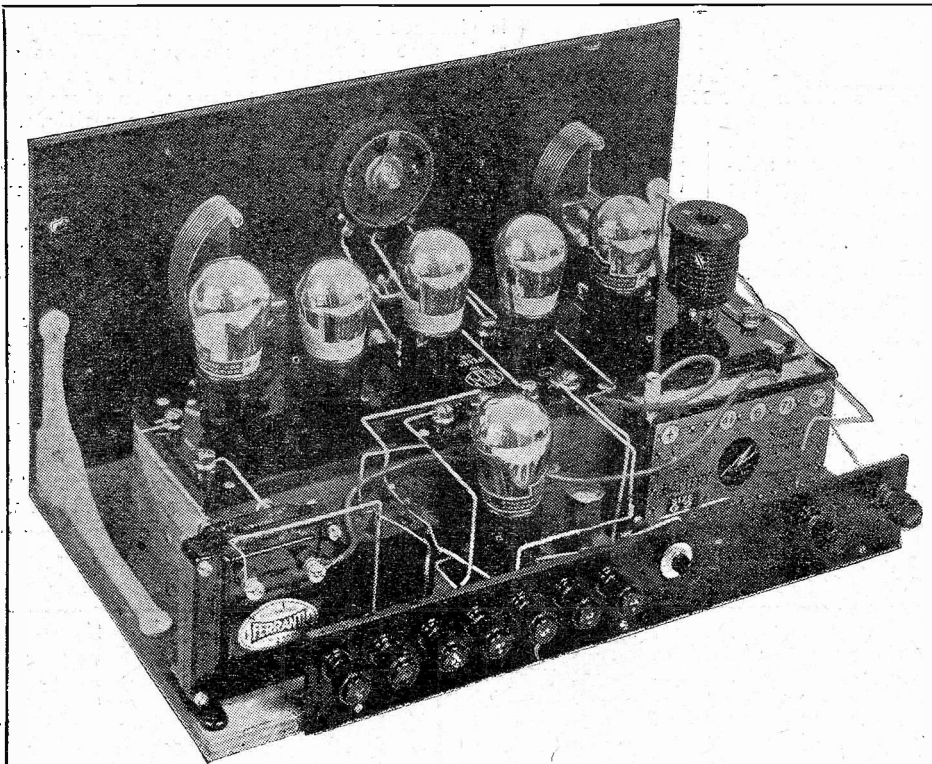

The finished six-valve receiver with coils and valves in position. Note that room is left on the baseboard for the grid-bias battery.

be observed. First connect the frame aerial and loud-speaker (or 'phones) across the appropriate terminals, assuming that the batteries are already connected, insert the Autodyne unit in its five-socket position on the main unit, turn the potentiometer to a mid-scale reading, and light the valves.

By turning the potentiometer either one way or the other a certain point will be reached where a distinct rushing sound is heard. This condition denotes that the intermediate frequency system is oscillating, a condition which is controlled by the potentiometer adjustments; for normal reception the potentiometer should be

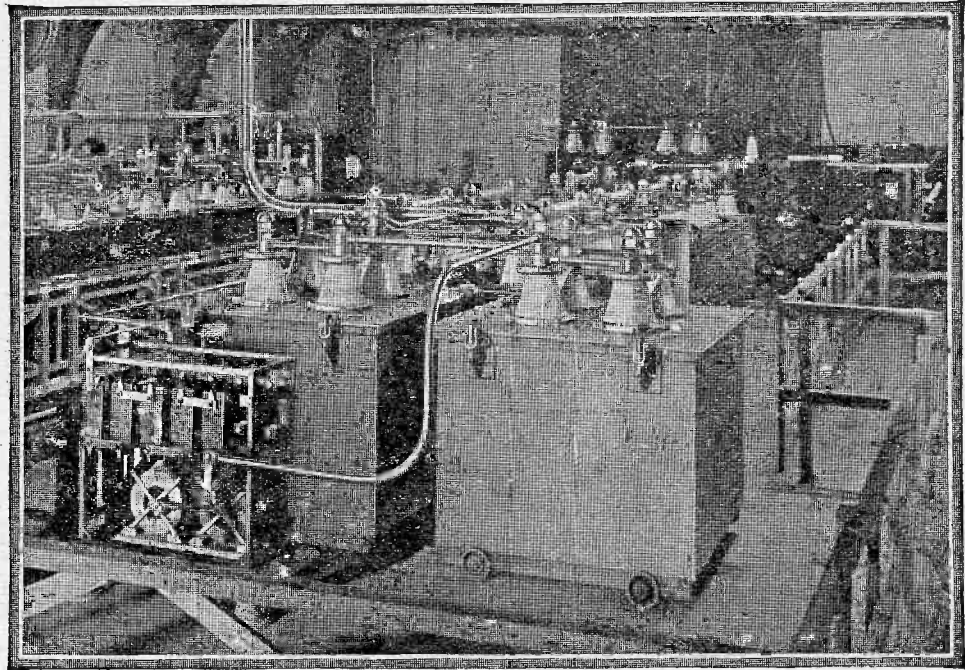

## Specify Dobilier!

Sixteen years ago we commenced manufacturing wireless condensers.

In those days, electrical condensers certainly existed but they were totally unsuitable for wireless purposes. Accordingly we made a minute study of the subject and, as a result of careful observations over long periods, we were enabled to design condensers in which hysteresis losses, insulation leakage and numerous other factors opposed to condenser efficiency were either reduced to the minimum or eliminated completely. The small, meticulously sealed groups of mica and metal plates which form the essential units of the familiar 600 Type condensers are the direct outcome of these observations.

They represent the very high standard of electrical efficiency to which modern science has brought the condenser, and it is interesting to note that the identical units grouped in their tens of thousands, make up the Condenser Banks of the world's principal wireless stations.

In the Condenser equipment of the Government Radio Station at Rugby, of which we show a view above, there

are in each of the large "tanks" over half a million of such mica and metal plates grouped into hundreds of condenser units.

Each of the many millions of plates are individually selected and tested before being collected into groups, and each group was again subjected to frequent and stringent tests during the successive stages of assembly.

This ritual of tests, tests, and more tests is observed in the case of every single product bearing the Dobilier name. Our long experience has taught us that if we are to make condensers which will be satisfactory in service, whether they are designed for High Power Stations or for Broadcast Receivers, we must take precautions to eliminate every possible cause of failure. As Condenser Specialists we know these precautions to be not only desirable but essential. Governments and Manufacturers of Broadcast Receivers all over the world, agreeing with us in this matter, specify Dobilier.

Are there Dobilier Condensers in your set?

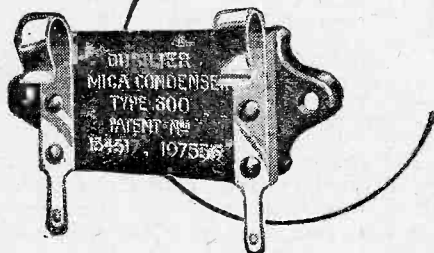

Specify—



ADVERT. OF THE DUBILIER CONDENSER CO. (1925) LTD.,  
DUCON WORKS, VICTORIA ROAD, NORTH ACTON, W.3.  
TELEPHONE: CHISWICK 2341-2-3.

E.P.5; 233

# A.C. FOR VALVE FILAMENTS

## Results of Some Practical Tests

By L. I. LESLIE



In our last issue Mr. Reyner described the possibility of using A.C. mains for filament lighting, and below our contributor describes the results of some actual practical tests at Elstree.



As indicated by Mr. Reyner in his article in last week's *Wireless*, tests have been carried out at the Elstree laboratories with the object of finding out the effects produced when using A.C. for valve filaments. It was shown in the previous article that it was necessary to connect the earth return of the grid circuit to the centre of the secondary of the input transformer, or to the centre point of a potentiometer connected across the filament of the valve in use. By employing this method a large part of the hum caused by the alternating current can be eliminated.

### Another Difficulty

In actual practice, however, there is a further difficulty to be overcome; this is due to the fact that the current passing through the filament is alternating, so that the heating effect is continually varying.

It is well known that two currents, opposite in direction, but of the same magnitude, will each cause the same heating effects in a conductor. With an alternating supply the current changes its direction continuously, starting at a positive value and falling to zero before it becomes negative: this will occur, perhaps, 100 times a second. Although the heating effect on the filament depends on an average value of the current, it is evident that the variations will be perceptible, if the filament is very sensitive to any change of current.

### The Only Remedy

The eye cannot detect fluctuations

in the light produced by an electric lamp working off alternating current: but the ear is much more sensitive in this respect. If the temperature of the valve filament changes with each current fluctuation, the emission will vary, and a hum will be produced in the 'phones connected in the anode circuit of the valve. Therefore the only method of getting over this difficulty is to design a filament which is very insensitive to sudden changes of

power applied to it is to remain constant, the shorter it is the thicker it can be made, and the more desirable it will be for working off alternating current. Finally the co-efficient of heat conductivity of the filament should be as low in value as possible, so that it will not tend to take in or give up its heat too readily. This points to the use of a low-temperature filament, such as is used in modern dull-emitters.

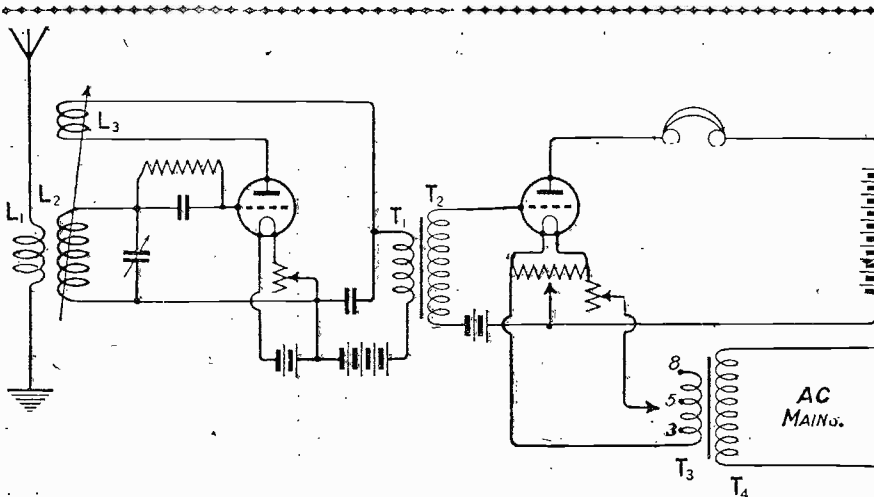

Fig. 1.—The leads from the A.C. mains (240 volts) were taken to the primary of a step-down transformer having a ratio of 30 to 1 for the tests described this week.

current; or, in other words, will always remain at a constant temperature.

The question naturally arises as to what properties such a filament should possess. Length, thickness and co-efficient of heat conductivity must all play an important part in the design. Now, a thin wire will lose its heat much quicker than a thick one; therefore our filament must be thicker than is normally the case. In order to obtain the required emission from a thick filament, a larger current will be necessary, although the voltage may be cut down by a corresponding amount.

It is also evident that, if the emission from the filament and the

### Summarised Requirements

Making a summary of these points, we should expect to get the best results with a filament which is short and thick. This would require a large current at a small voltage. When working off A.C., however, we are mostly concerned with the wattage consumed; therefore we need not worry about the magnitude of the current required provided the voltage is correspondingly reduced.

### Practical Tests

In order to find out if these reasonings were approximately correct, tests were carried out on a large selection of dull-emitter valves. The circuit used is shown in Fig. 1. The leads from the A.C. mains were taken to the primary of a step down transformer, having a turn ratio of 30 to 1. 240 volts were put on the primary, and by means of a tapping from the secondary winding voltages of 8, 5 or 3 could be obtained as desired.

The hum is principally noticeable on L.F. stages, and the actual tests were made on a single-valve amplifier. It was found that grid bias had a noticeable effect on the amount of

## A.C. FOR VALVE FILAMENTS

(Continued from previous page)

hum present, and this was adjusted to the correct operating point for each test. In order to ensure this the amplifier in question was coupled to a simple valve detector, and all the tests were made whilst signals from 2LO were actually being received.

In some cases, using short, heavy-current filaments, the hum was sufficiently reduced to permit the reception of distant stations; but, in any case, the signals from the local station enabled the grid bias to be adjusted to the correct operating point so that no distortion was present.

### Excessive Grid Bias

This precaution proved necessary, because in many instances the hum could be cut down considerably by increasing the grid bias, but in such cases it was found that distortion was being introduced indicating that the grid bias was excessive. The presence of the signals thus acted as a check and ensured the validity of the observations.

In view of the influence of grid bias, it was decided not to run the detector valve off A.C., as if this were done there would be too many variable factors contributing to the final result. Accordingly the detector valve was provided with an accumulator and a separate H.T. battery to confine the observations to the L.F. valve entirely.

### Change-over Arrangements

In order to facilitate the comparison in the hum obtained with various valves, a second valve holder was connected in parallel to the one in use, and by means of a single-pole double-throw knife switch, one valve could be switched on and the other off in a single movement of the switch. It was found necessary to connect the potentiometer across the valve legs (not across the secondary terminals of the transformer), so that its centre point should not be disturbed by alterations of the filament resistance.

A selection of 2-volt valves was first tested; the results obtained were fully in accordance with the theory put forward in this article, the quietest valves being those which took the greatest current. The Marconi Osram D.E.R., which takes a current of 0.35 amps. at 2 volts, gave very little hum, and when listening to the local station, tuned in at moderate strength, it was easy to forget that there was any hum present. The Mullard double green ring, taking 0.3 amps., and the Ediswan A.R.D.E., taking 0.25 amps., were also fairly silent in operation, but the Cossor Point One and the Mullard P.M.1,

taking 0.1 amp., gave a noticeably louder hum.

### Four-Volt Valves

Some 4-volt valves were then tested. As one would expect, the type of valve, taking 0.06 amps. was in general the noisiest, and those taking 0.12 amps. were quieter. A Mullard D.F.A.0 taking 0.35 amps. at 4 volts was then tested and proved to give the loudest hum of any 4-volt valve. Considering its high current consumption, this might appear at first to be in direct contradiction to our theory, but it will be noticed that the filament of this valve is of the loop variety, and therefore about twice the length of those previously tested.

### Tests on Six-Volt Valves

A selection of 6-volt valves were then tried. Most of them, such as the Marconi D.E.5 and D.E. 5B, and the B.T.H. B4 and B7, had long filaments, and all gave a very loud hum. The amount of current taken by these 6-volt valves did not appear to affect the hum produced to any noticeable extent, the length of the filament appearing to over-rule the current factor in this case.

The results quoted are a few selected out of a large number of tests or as indicating the general tendency observed in the experiments. It will be clear that they bear out the theory put forward at the beginning of the article to a large extent, and they serve to emphasise the relative importance of the several factors.

### Importance of Length

Thus the most important factor of all seems to be that of filament length. The 6-volt valves tried, all of which had long filaments, were uniformly unsuitable, and a wide difference in filament current, ranging from 100 milliamperes to .25 amperes, produced no appreciable alteration in the hum. The first essential, therefore, appears to be a short filament.

Here, in order to obtain the necessary emission, a heavy current is required, but this, fortunately, is also the requirement for silent working, the hum becoming appreciably less as the current is increased. In fact, some of the 2-volt valves tried were almost silent in operation. This again bears out the theory.

Two-volt valves are at present limited by the attempt to keep the current within reasonable limits. As has been stated, this objection does not hold in A.C. working, and possibly it is in this direction that future developments may occur.

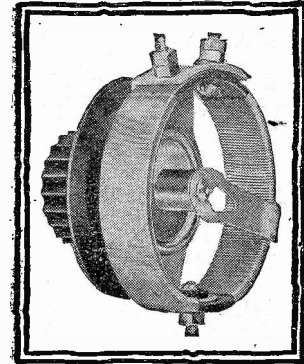
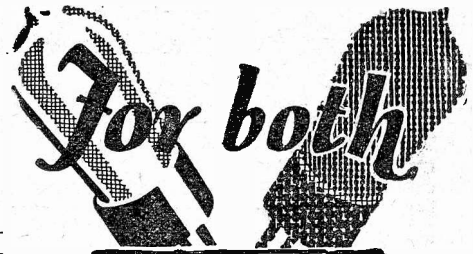

## bright & dull emitter valves

There are two windings on this one Rheostat—one of a resistance of 6 ohms and a combination of this on to a 30 ohm strip winding. This has been specially made to meet the demand for a thoroughly reliable Rheostat covering needs of both bright and dull emitter valves. The resistance wire is wound on hard fibre strip under great tension and is immune from damage. The popular one-hole fixing method is provided and the terminals are conveniently placed. Contact arm has a smooth, silky action. All metal parts nickel-plated. Complete with ebonite combined knob and dial.

**The NATIONAL WIRELESS WEEK**

NOV 7<sup>th</sup> - 13<sup>th</sup>

*Let your Friends Listen*

The  
**'PEERLESS'**  
DUAL RHEOSTAT

PRICE **3/9** EACH.

From all dealers or direct from

**THE BEDFORD ELECTRICAL & RADIO CO., LTD.,**  
22, CAMPBELL ROAD, BEDFORD.

# KEEPING LISTENERS' INTEREST

## WHY GREAT ARTISTS CANNOT BROADCAST

By

DAME CLARA BUTT



FROM the point of view of broadcaster and listener alike, wireless has entered a new era. No longer is it a scientific novelty with which to while away an hour. Probably the vast majority of people in this country have handled wireless sets, and, except for a comparatively small number of enthusiastic experimenters, it no longer holds the same attraction from a mechanical point of view. Even the keenest distant station seeker likes to listen to a good programme from his local station occasionally.

From the listener's point of view broadcasting is beginning to be looked upon primarily as a means of entertainment, and the B.B.C., as the entertainers, will have to see that they keep the interest of their vast audience. Novelties will sooner or later cease to amuse, and entertainment equal in quality to that of the theatres and concert halls will have to be provided.

### The Broadcaster's Viewpoint

The point of view of the broadcaster, too, is changing. Broadcasting was at first treated as a form of privilege, and many famous people were willing to accept it as such. But now that the novelty of singing or playing before a vast unseen audience has worn off, they are no longer willing to broadcast for nothing.

I am not complaining of the present wireless programmes. In their way they are excellent, but I think that, unless concerts by the best artists are given at least once a week, there will shortly be a decrease in the number of licence holders. Music lovers were content to listen to a second-rate violinist or singer when the sound was brought to them by the mysterious ether, but the ether is no longer mysterious, and they are taking broadcasting for granted. Unless it can give them entertainment at least as good as that of the concert halls they will not renew their licences.

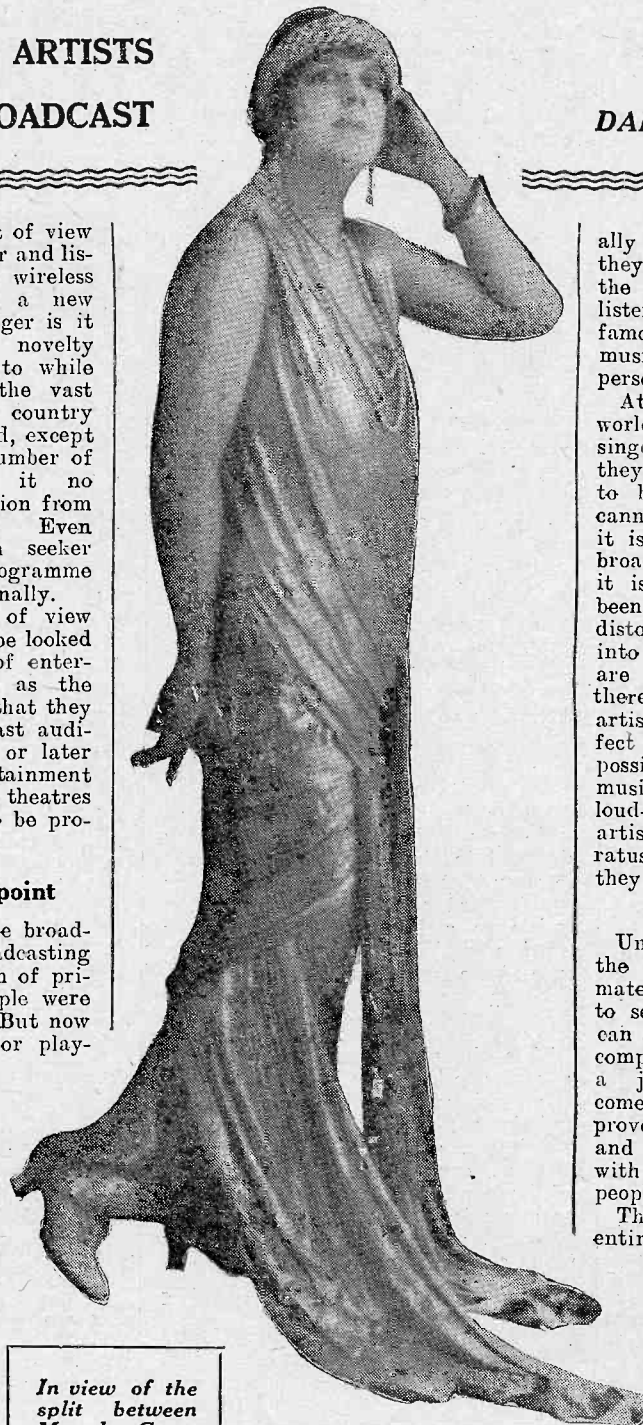

*In view of the split between Mr. de Groot and the B.B.C., this article, from the pen of a famous artist, is of special interest.*

ally famous. Six nights out of seven they provide excellent music, but on the seventh night a large section of listeners will want serious music by a famous musician. They will want the music of someone with a magnetic personality—a Kreisler or a Caruso.

At the moment very few of the world's great instrumentalists or singers will broadcast. It is not that they are not willing, or even anxious, to broadcast, but simply that they cannot afford to do so. Some artists, it is true, still look unfavourably on broadcasting, because they think that it is imperfect. Perhaps they have been unfortunate enough to hear a distorting loud-speaker making music into cacophony. I know that there are distorting receivers—but so are there distorting gramophones, and no artist refuses to make records. Perfect wireless reproduction is not only possible, but the general rule. No musical person would listen to a bad loud-speaker, and I am sure that artists need not fear that faulty apparatus will injure their reputations if they broadcast.

### Broadcasting Beneficial

Unlike other types of broadcaster, the musician does not have his material spoilt when it is distributed to several million people at once. I can sympathise with the comedian who complains that, once he has used a joke on the wireless, it becomes a chestnut. But music improves on a second or third hearing, and I am sure that a great artist, with a magnetic personality, will draw people who have heard him to see him.

The difficulty is, I am aware, almost entirely a question of money. Famous artists cannot afford to broadcast at the fees paid by the B.B.C., and the B.B.C. cannot afford to pay adequate fees, because their income is limited. The matter lies in other hands than those responsible for arranging the programmes, but it is only right that attention should be called to it, and that the money paid by licence holders should be used entirely in providing entertainment for them.

### What We Want

Most B.B.C. artists are good, but few have won their spurs on the concert platform, or become internation-

(Continued on page 14.)

*Who earns your money?  
Who spends it? Who  
chooses your parts for you?*

No set published by any periodical could use only one make of parts or could use the same make of transformer, for instance—it would not be fair to advertisers if they did not all have a share in this kind of mention. **BUT YOU ARE FREE TO CHOOSE YOUR OWN PARTS.**

Your transformer, for instance. Never again pay a high price for your transformer no matter what may be specified—the new LISSEN has revolutionised all previous ideas of transformer price and performance.

So good is it, that all our own high priced models, which have been on the market and largely sold for several years past, have been unhesitatingly withdrawn in favour of this new LISSEN.

*The fine tone and great power of this new LISSEN Transformer have been proved by the trade—they are largely using it for their own built-up sets.*

It Fully Amplifies Every Note—Every Harmonic—Every Overtone.

Choose the New LISSEN. First for its Performance. Secondly for its Price. **ACTUALLY TEST IT FOR 7 DAYS—IF NOT SATISFIED THEN TAKE IT BACK TO YOUR DEALERS OR SEND IT BACK TO US.**

Our new direct to dealer policy of distribution (which cuts out all wholesale profits), aided by our huge production programme and the special plant installed to turn it out have enabled us to sell this new LISSEN Transformer at an unheard-of low price.



**8/6**

AND GUARANTEED FOR 12 MONTHS.

TEST IT FOR 7 DAYS

Turns ratio 3 to 1  
Resistance ratio 4 to 1

Use it for 1, 2 or 3 stages L.F.

*It will suit every circuit and every valve you will want to use.*

**LISSEN LTD., 18-22, FRIARS LANE, RICHMOND, SURREY.**

Managing Director: T. N. Cole.

*Many are using LISSEN Transformers in "N" Circuits.*

**USE LISSEN FIXED CONDENSERS, TOO, Mica and Mansbridge Type**

**LISSEN Mica Type CONDENSERS**

Small energy-conserving condensers—note the new case which enables the condenser to be used upright or flat. At present the new case is available only in the most used capacities, but will quickly become a LISSEN standard.



Capacities—  
.0001 to .001 1/- each (much reduced).  
.002 to .006 1/6 each (much reduced).  
Accurate to 5 per cent.—they never leak—they never vary.

**ADD 10% MORE LIFE TO YOUR H.T. BATTERY**

merely by using a LISSEN 2 mfd. or 1 mfd. (Mansbridge type) condenser across your H.T. battery. It cuts out all the noise from your H.T. battery when the battery is old, and keeps the energy flow steady and quiet in the meantime. One LISSEN condenser will outlast many batteries, and the lengthened life you get out of your battery will pay for the cost of the LISSEN condenser over and over again. Your dealer will tell you how you can easily connect the condenser when buying it. Use either 2 mfd. or 1 mfd. capacity—the larger condenser is more effective.

**LISSEN (Mansbridge Type) CONDENSER**

2 mfd.	.. .. .	4/8
1 mfd.	.. .. .	3/10
Other capacities made are:		
.01	.. .. .	2/4
.025	.. .. .	2/4
.05	.. .. .	2/4
.1	.. .. .	2/6
.25	.. .. .	3/-
.5	.. .. .	3/4
1.0	.. .. .	3/10
2.0	.. .. .	4/8

Instead of a tin case, the LISSEN CONDENSER, unlike all other condensers of the Mansbridge type, has a specially moulded case which in itself is a SOLID INSULATOR. That is why it is impossible for the LISSEN Condenser to short circuit on to its case, an important protection for you when you are using the condensers in any circuit which is connected straight on to the electric light mains.

And due to our new direct-to-dealer policy of distribution THESE LISSEN CONDENSERS COST YOU NO MORE THAN THE ORDINARY KIND.

**LISSEN FIXED GRID LEAKS**

A case of these was left on our factory roof during the summer of 1925, soaked in rain, baked by sun and the resistance value of these leaks never altered.

All capacities, previously 1/8, Now 1/- each.



Improve every circuit by using LISSEN parts wherever you can—save money too—for now you get keen prices as well as fine quality.

## Keeping Listeners' Interest—continued from page 12

Because their income is fixed, regardless of the number of licence holders over about 1,000,000, the B.B.C. do not, perhaps, take the same trouble to keep alive the interest of listeners as they would if they received the whole of the licence fees. Concerts are one of the surest ways of keeping the interest of listeners. If a great artist can pack the Albert Hall to overflowing, surely, when he broadcasts, thousands of listeners will renew their licences simply to hear him.

### What Must Come

Sooner or later the B.B.C. will, I think, have to make contracts with big artists, guaranteeing them a reasonable sum for a certain number of concerts, to be given over a period of, say, two or three years. Sir Harry Lauder and Chaliapino both received large fees for their broadcasts, I believe, but these are but two instances in the course of four or five years!

The broadcasting authorities will have to spend more money when this change takes place. This may mean raising the licence fee (although I think more careful collection of the ordinary fee would meet the case). A pound licence fee would, I know, raise a storm of protest, but, after all, it is not a great sum to pay for the privilege of listening to first-class entertainment every night of the year.

### A Difference

It is sometimes suggested that great artists will no longer be needed on the wireless, because broadcasting will, like the cinema, create its own stars. While it is true that film producers soon gave up looking for talent on the stage, and started training their own stars, I do not think that the same development will take place on the wireless. The arts of the stage and screen are very different, but those of the platform and studio are not dissimilar. A girl with a voice which would not make her world-famous on

the concert platform is hardly likely to become a star because she has learnt the art of broadcasting. On the other hand, I think that the established artist is likely to succeed in the studio, for she has developed personality, and can express it in her voice. I think, also, that listeners will

it is easier for a singer than for a lecturer or comedian to visualise a vast unseen audience. The knowledge that there were millions listening always urged me to give my best.

In addition, I find a certain sentimental enjoyment in broadcasting. It may be true, as Ruskin said, that, if anyone really wants anything, they will find the money to buy it, but I do not doubt that there are many people who never go to big concerts because they cannot afford to do so. It made me very happy to think that there were, perhaps, thousands of these people listening-in.

### Broadcasting and its Opportunities

Often, when I am on tour, a note is slipped into my hand as I go on to the platform. It tells a tale of suffering or bereavement, and begs me to sing "Abide with Me" or "The Lost Chord." Of course, I comply if it is possible, and it makes me very happy to think that my art can help. Broadcasting enables me to reach men and women such as the writers of these notes, and possibly make their troubles easier to bear.

I like singing into a microphone because it is able to "take" my big voice. When I have made gramophone records I have had to stand a long way from the recording apparatus to ensure pure reproduction. But wireless reproduces the "bigness" of my voice without difficulty.

### National Possibilities

Lastly, I am interested in broadcasting because of the wonderful opportunity it is offering to music lovers. It is often said that the English are unmusical, but I think that Englishmen would be as musical as the French, the Germans, or the Italians if they were given the opportunity. Men and women on the Continent are musical because they can hear first-class music for next to nothing.

In England we have no state-aided music, but broadcasting, if it provides first-class concerts, will go a long way to making the Englishman interested in good music.

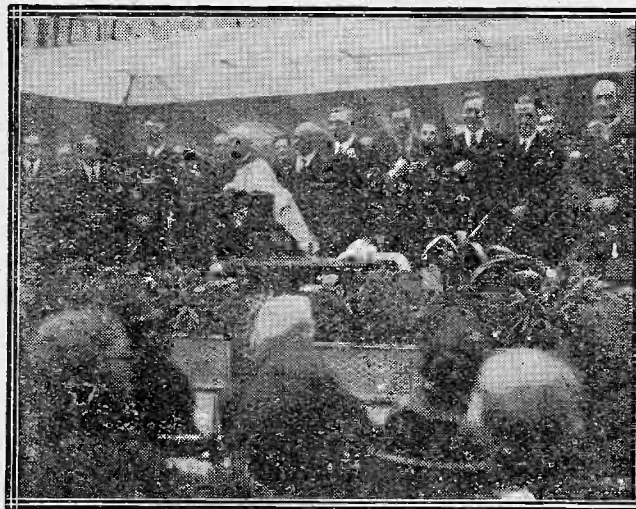

Top.—Sir William Noble, fourth from left in front row, declaring open the Third Manchester Wireless Exhibition, which was held in the City Exhibition Hall at Deansgate. Capt. P. P. Eckersley, Chief Engineer of the B.B.C., is fourth from the right in the front row. Our picture below shows one of the exhibits—a demonstration showing how wireless is used by an army in the field.

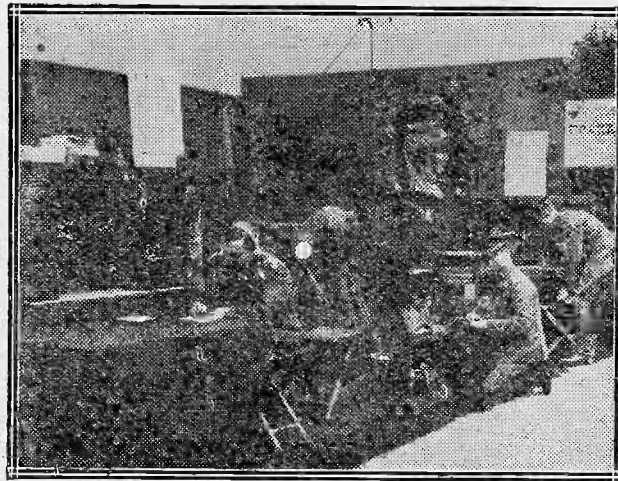

want to hear and see those who broadcast.

### Personal Experiences

This article sounds very commercial, but I hope I have not conveyed the idea that I am interested in broadcasting simply from a financial point of view. On the rare occasions I have appeared before the microphone I have enjoyed myself, and never suffered from "stage fright." Probably



# From my Armchair

BY EARL RUSSELL

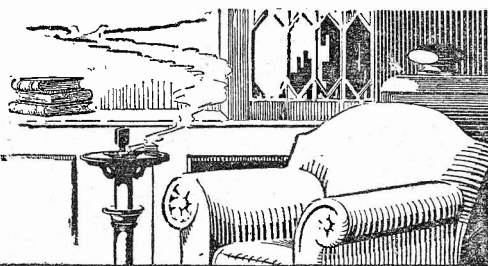

In these columns Lord Russell expresses each week his own personal views on matters of interest to "Wireless" readers.

## How Many Valves?

It is not much more than a year ago that I ventured to commit myself to the view that three valves would probably be the normal limit for receivers. On three valves with the 'phones any station could be audibly picked up with proper tuning; a detector followed by two L.F. amplifiers would give all the loud-speaking required from a local station or Daventry. The use of more valves involved impossible demands for both L.T. and H.T. current. How shortsighted I was in my prophecy! The super-heterodyne came in with its six valves and manufacturers rose to the occasion and produced valves to meet the demand. The dull emitter, which had been an expensive toy, became an article of commerce, not cheap it is true, except in comparison with valve prices of two years ago, but soon earning its keep in accumulator saving.

I am at present running a set with five valves, which together take .6 ampere at 2 volts, as against .7 for each bright emitter at 6 volts. Put into watts it means 1.2 against 21. Moreover, the general public's demand now is for loud-speaking; so, usurping the privileges of Delphi, I now interpret my prophecy to mean that no one in future will use less than five valves.

## Some Curious Views

I have been reading an article lately from a quite competent hand, containing one or two statements which are to say the least open to challenge. For example, it is stated that 12 milliamperes are necessary for ample volume in a loud-speaker. I have a five-valve set which works two loud-speakers quite satisfactorily with  $3\frac{1}{2}$  milliamperes. Crystals are brushed aside as being impossible in sets for the general public. Considering the

vast number of crystal users who have patiently learnt to fiddle with a cat's whisker, and the large number of stable crystal detectors on the market, which will stay put, I do not see why my old friend the crystal should be considered such a hopeless proposition. As a matter of fact, there are two or three reflexing circuits in the air at the present time using crystals which give quite remarkable results.

## Some Construction Points

Amateurs who construct their sets at home will do well to remember that tags are tinned commercially by an acid process which is apt to leave a film of oxide on the tin. This has to be scraped off with a knife or the tag re-tinned if an easy joint is to be made. It is wise to do this in advance rather than to wait until one is about to solder in an inaccessible position.

I have for a long time been in doubt about the best size of wire to use. There was a time when square 16 was the rage, and I still have a preference for that size, but round. I am not at all sure, however, that for a multivalve set on broadcast wavelengths 18 is not quite as good. The use of these modern coil bases and screens make easy leads difficult to find, and 18 Glazite is often the best solution. It would be interesting to have authoritative and quantitative comparisons from Elstree on the point.

# SIEMENS

# "FLUID" LEGLANCHE CELLS

for H.T. purposes

## A novel Feature

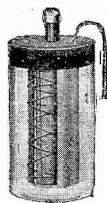

H.T. 1 Size.

The new form of excitant which we supply with these cells renders them as clean and convenient to use as the so-called "dry" cell. "Creeping" of the salts is entirely eliminated and NOISELESS RECEPTION ENSURED.

*It is more economical to purchase the larger size, having regard to the ratio of output in comparison with the price.*

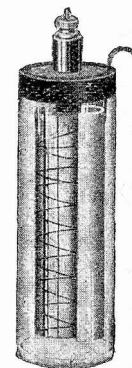

H.T. 3 Size.

Size No.	Nominal E.M.F.	Dimensions overall approximate	Maximum Economical Discharge Rate.	Weight without electrolyte approximate	Ratio of output.	Price per cell complete.
	Volts.	Inches.	Milli-Amps.	ozs.		s. d.
H.T.1	1.55	1 1/4 dia x 3 1/4 high	5	3	1	1 0
H.T.2	1.55	1 1/4 " x 5 "	10	4	2	1 3
H.T.3	1.55	1 1/2 " x 5 1/2 "	20	6	5	1 6

Complete batteries in wood boxes can be supplied for 50 volts (36 cells); 60 volts (44 cells); and 100 volts (72 cells).

Our new catalogue, No. 650, of "Siemens" Radio Batteries contains a large amount of useful information on the CARE, MAINTENANCE and SELECTION of batteries for all radio purposes. It also shows how to obtain the most efficient service at the lowest operating cost. A copy will be sent post free on request.

**SIEMENS BROTHERS & CO., LTD., WOOLWICH, LONDON, S.E.18**

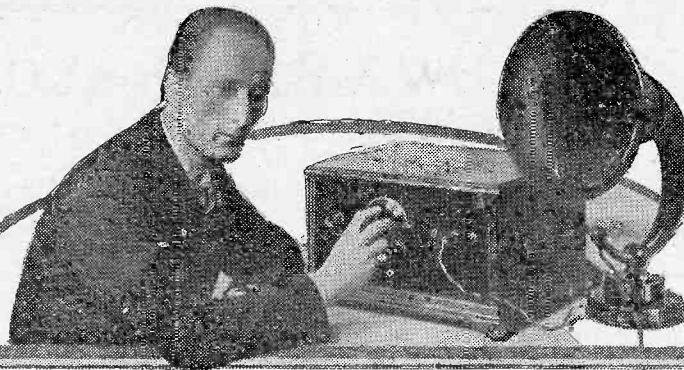

## THE MONODIAL ON LONG WAVES

Some Further Results with our Latest Star Receiver



It has always been the fashion to say "High-frequency amplification on the long waves is easy enough; it is the shorter waves that are so difficult." In the case of the Monodial the reverse has been the case. Little difficulty of any serious nature was found in getting the set to function satisfactorily on the shorter waves, and such troubles as there were did not include parasitic oscillations, or uncontrollable oscillation of any kind.

### A Difficulty

When I first started on the long-wave experiments, however, I found myself up against a serious difficulty. The set went into violent oscillation, which nothing apparently would stop. It was soon found that the trouble did not actually lie in the high-frequency circuit—the trouble was only affecting the detector. On examination, indeed, this almost appeared to be oscillating at several different frequencies.

The detector circuit will be seen in Fig. 2 in the October 30th issue of WIRELESS, in which the constructional details regarding the Monodial were given. As will be noticed, the detector grid circuit consists of an inductance which is tuned by a variable condenser. One side of this circuit is connected to the grid of the valve, while the other goes to the anode through a small variable condenser which is used for reaction. A high-frequency choke is connected in the plate circuit of the detector so as to enable capacity reaction control of

this description to be used, while the L.T. return goes to a point at the centre of the inductance.

### The Reason

It will readily be seen that if it should chance that the choke in the plate circuit were self tuned to the same frequency as that of each half of the coil, each in turn tuned by its self-capacity, the circuit would go into self-oscillation, which nothing would stop—and it does! This is what occurred with several chokes that were

tried, and those with a very small self-capacity were specially found to have this effect owing to the low wavelength to which they are naturally tuned on account of this point.

When at last reaction was induced to behave normally it was found to be extremely fierce, and the expedient of shifting the filament tap further away from the grid end of the inductance had to be resorted to, and although this was a cure for fierce reaction, it might then occur that the choke which was suitable on account of its not giving rise to parasitics with a centre tap would do so with the tapping point shifted down to inductance. A spot had therefore to be chosen which would enable stability to be obtained with the largest number of high-frequency chokes, so that the circuit should not become critical as regards this component.

### Windings

Other points that required investigation were chiefly as regarded the primaries of the two H.F. transformers used, one for the aerial coupling, and one for the intervalve H.F. coupling. The correct proportions of the windings had to be determined, the number of turns and the degree of coupling with the secondary, while, if possible, it was intended that both these inductances should be made the same, so that both coils would be interchangeable.

It was also necessary that the primary winding be connected the right way round, otherwise the receiver would not neutralise correctly, and though the H.F. valve in the Monodial was found to be almost stable on the long waves without being neu-

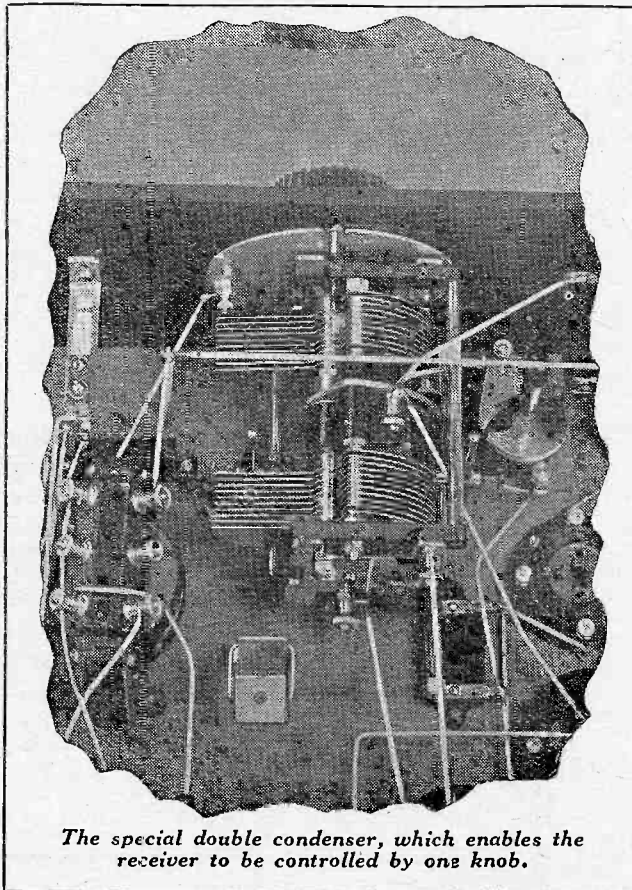

The special double condenser, which enables the receiver to be controlled by one knob.

**THE MONODIAL ON LONG WAVES**

(Continued)

tralised, yet it was necessary to bear in mind that with different valves and under different circumstances this would quite probably not always be the case.

**Results**

Once an indication had been obtained as to the direction in which the solution of the various problems lay, progress was rapidly made, and I soon had the pleasure of listening to a special concert which was being broadcasted from Daventry, unmarred by any form of oscillation from within the set itself. On turning the tuning control and advancing the reaction slightly

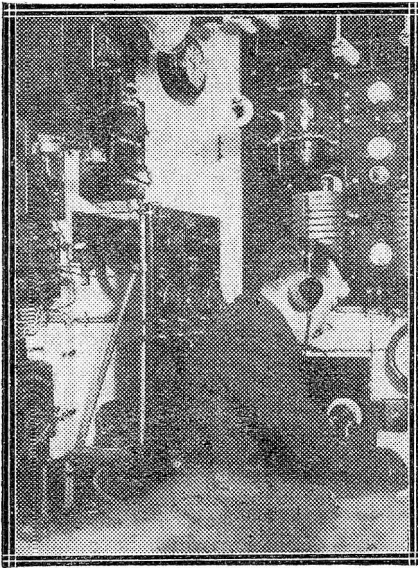

*The wireless cabin of the "Jervis Bay," the chief wireless officer of which vessel is reported to have been in daily communication with Sydney throughout the whole voyage from Australia to Plymouth.*

Radio-Paris was received at medium strength in the loud-speaker.

In view of the fact that a short sercened aerial almost in the heart of town was being used I considered the signal strength to be well up to normal, and, indeed, highly satisfactory for a one-knob control set.

The next station to be picked up in the loud-speaker was Hilversum, who came in at decidedly better strength than did Radio-Paris, while one or two other transmissions round the 1,400-metre mark were heard.

Next week, for the benefit of those who may wish to make their own coils, I will give full details as to the long-wave inductances, together with one or two operating notes specially applicable to long-wave work on the Monodial, and a full test report, since the above results are intended only as a general guide.

C. P. A.

**NOW A Brandes CONDENSER**

**STRAIGHT LINE FREQUENCY SLOW MOTION LOW LOSS.**

It will be obvious from the table given below of new B.B.C. wave-lengths, that a condenser in which the dial reading varies directly as the frequency will give a more uniform separation of stations than one in which the dial reading varies directly as the wave-length. This is particularly apparent in the lower wave-lengths. Brandes Straight Line Frequency Slow

Motion Low Loss Condenser has been specially designed to provide a Straight Line Frequency tuning characteristic and to bring in the B.B.C. Stations well spaced out over the major portion of the dial, whilst, at the same time maintaining the compact form which is so very essential in a back-of-panel instrument.

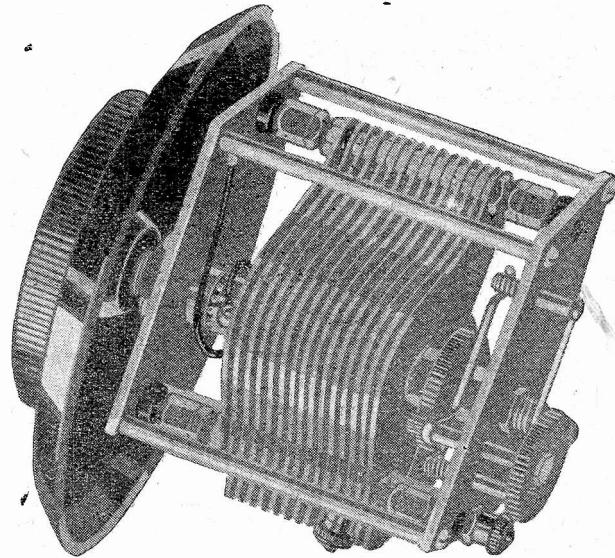

The following table shows the new wave-lengths of the B.B.C. stations with their corresponding frequencies:—

Call Sign.	Station.	Wavelength.	Frequency.
2 BD	Aberdeen	491.8 metres.	610 kc
5 IT	Birmingham		
5 SC	Glasgow	405.4	740 "
2 ZY	Manchester	384.6	780 "
2 LO	London	361.4	830 "
5 WA	Cardiff	353	850 "
2 BE	Belfast	326.1	920 "
5 NO	Newcastle	312.5	960 "
6 BM	Bournemouth	306.1	980 "
2 LS	Leeds	297	1,010 "
	Bradford	294.1	1,020 "
	Other Relays	288.5	1,040 "

With this condenser a positive movement for approximate setting is obtained by turning the 4in. diameter dial which is provided with finger grips for this purpose. The final critical setting is obtained by turning the 2½ in. knob which actuates the slow motion mechanism. Low dielectric losses and the complete absence of backlash are ensured.

**PRICE : ·0005 ... 18/6 ; ·0003 ... 18/-**

(From any good dealer.)

**Numerous Advantages:—**

1. A handsome 4in. dial engraved with clearly marked divisions and provided with finger grip for the approximate setting of the condenser.
2. The large knurled knob 2½ in. diameter operates the patent vernier mechanism for fine or critical tuning.
3. A minimum quantity of highest quality ebonite ensures low dielectric losses.
4. The single hole fixing bush has a knurled face to ensure a firm grip on the panel. Ball bearings fitting into cone-shaped races prevent shake and backlash.
5. A pigtail flexible connection ensures perfect contact between the frame and the moving vane system.
6. Brass vanes and spacing collars chemically cleaned ensure perfect contact.
7. Conical bearings at base prevent shake and backlash.
8. The Slow Motion is transmitted to the moving vanes through a carefully designed friction clutch by means of a train of wheels having a finely knurled surface which ensures a very smooth reduction movement without 'jump or slip.
9. Specially designed spring bearings keep the train of wheels in intimate contact and by exerting a gentle pressure on all the moving parts entirely eliminate backlash. This condenser will provide a Straight-Line-Frequency tuning characteristic with the stations within the B.B.C. frequency range well spaced over the dial. The shape of the moving vane is designed to provide a small compact condenser having a straight-line-frequency tuning characteristic without taking up a large back-of-panel space. Most other S.L.F. Condensers have a long, narrow vane with a very wide swing, taking up a lot of valuable space at the back of the panel.

**BRANDES, Ltd., 296, Regent St., W.1. Works : Slough, Bucks.**

# Secrets of the Low-Frequency Transformer

By J. H. REYNER, B.Sc. (Hons.),  
A.M.I.E.E.

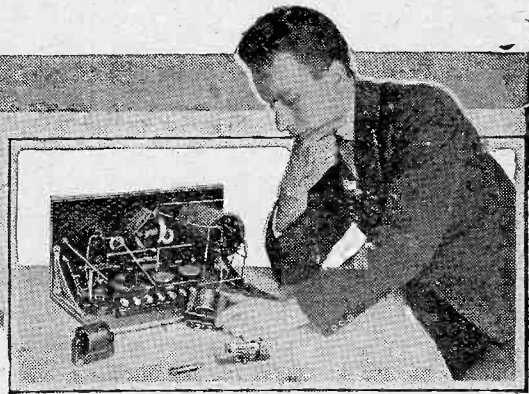

Many people are apt to regard the low-frequency transformer as "a box with four terminals" without paying any attention to its functions and position in circuit. In this special article Mr. Reyner gives some interesting details about this highly-specialised instrument which you should not miss.

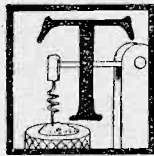

THE modern low-frequency transformer is a highly-specialised instrument. The accumulated results of years of research applied to the problem by some of the best brains in this country have made possible the production of instruments which achieve a high standard of efficiency. It is, indeed, a field of research in which this country is unquestionably the leader, and the methods adopted by British engineers are studied and often copied all over the world.

## The Differences

The average reader must at times wonder what difference there can be between various makes of instruments. The purpose of the low-frequency transformer is to receive the energy from one valve and to pass it on to the succeeding valve, so that it shall be increased in volume, if possible, but at any rate an accurate copy of the signals originally supplied on the input side.

Rival manufacturers claim for their own particular articles various peculiar attributes which assist one or other, or, if possible, both of these two functions. The most important is unquestionably that of faithful reproduction, and the amplification obtained over the whole stage, although of importance, is usually relegated to a second place in the design.

## Strength and Quality

Now there is no doubt that there is a difference between various makes of transformers. Some instruments give markedly better results than others. Two instruments may give an equal amplification, but one may give more natural reproduction than the other. Alternatively, we may have two instruments between which there is little to choose as far as purity is concerned,

and yet one of which will give a quite definite and appreciably greater signal strength than the other. It is proposed in this series of articles to discuss in simple terms the multitude of factors which affect the design

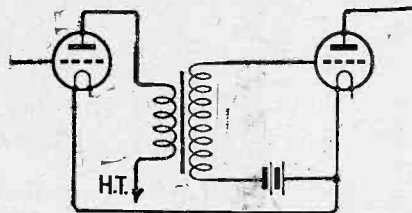

Fig. 1.—A typical low-frequency transformer circuit in its simplest form.

of a low-frequency intervalve transformer.

It is hoped that this will prove of service not only in appreciating the

by which improvements may be effected with existing patterns of transformer which may perhaps have been purchased at a time when the science was not so fully understood as it is to-day. Moreover, as will be seen later, naturalness of reproduction depends to no small extent on the personal factor, and an instrument can often be altered to suit different tastes.

## Fundamentals

Let us consider a low-frequency transformer circuit in its simplest form. In Fig. 1 we have a valve, the anode circuit of which carries the primary of a low-frequency transformer. One end of the secondary winding of this transformer is connected to the grid of the succeeding valve, and the other end to the filament through appropriate grid-bias, in order that the second valve may operate on a suitable part of its characteristic. This latter point is one of considerable importance, and must be assumed to be fulfilled throughout the whole of the discussion which is to follow.

The modern valve, designed for low-frequency work, is so arranged that when it is operating with a suitable transformer in its anode circuit, the variation of current produced in the anode circuit follows faithfully the variation of voltage applied to the grid circuit. In order that this may be the case two effects are necessary. In the first case the grid must never be allowed to become positive, for if this is done grid current will flow, and this immediately absorbs energy from the grid circuit and produces distortion. The second point is that the characteristic must be such as to permit a sufficient grid swing.

As the grid voltage is increased so the anode current increases and vice versa. We therefore have a limiting grid swing. The maximum positive grid voltage is that which, in association with the grid bias provided, (Continued on page 20.)

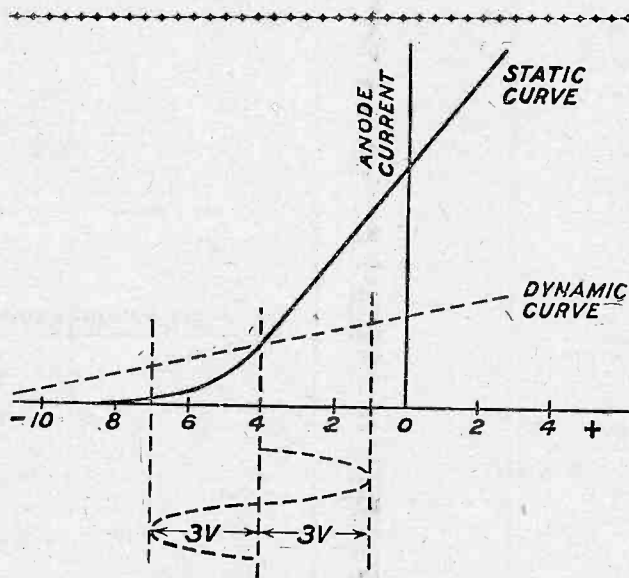



Fig. 2 (a).—This curve is suitable for a grid voltage swing which reaches a maximum of three volts in either direction.

connection between high-quality construction and satisfactory results, but arising out of the discussion of the subject, in indicating possible methods



**REDFERN'S**  
**Ebonart**  
NON-METALLIC SURFACE  
**RADIO PANELS**

are the accepted made-in-England high-grade radio panels with a beautiful surface, making the set de luxe. EBONART is ebonite—the finest; but not all ebonite is Ebonart, which is distinguished by its leak-free surface, brilliantly polished by non-metallic means. *Because of this it needs no scraping.*

3

TAKE no risk in buying the very foundation of your set. You buy your valves on a merited reputation. For the same reason insist on EBONART panels, on which the reputation of Redfern's is staked.

3

MACHINING and tooling qualities of EBONART ensure both ease and accuracy of construction work.

3

EVERY EBONART panel of standard size is sold in a carton, artistic in design, protecting the brilliant surface which is one distinguishing feature of this high-grade ebonite. EBONART is a trade mark, registered for your protection.

3

*Stocked by all reputable radio dealers in the 21 standard sizes in black and mahogany (polished surface) and in fine S.B. matt (black).  
Discriminating buyers of complete radio units always look for the Ebonart tag.*

WRITE FOR FOLDER A 262.

**REDFERN RUBBER WORKS, LTD.**  
HYDE, CHESHIRE.

*London: 75, NEWMAN STREET, W. 1.*

# Louden Valves

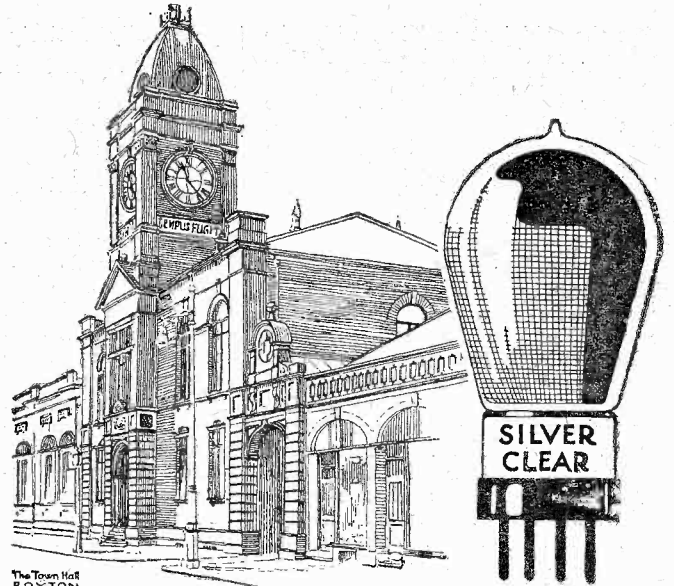

The Town Hall ROYTON

*"I have been running two Loudon Dull Emitters over 18 months . . . at a recent test . . . there was nothing to touch them."*

So writes Mr. O'Neill from Royton, and every post swells the number, now amounting to many thousands, of people who agree with his opinion. Loudon Valves cost less, they last longer, they consume less current, they are famous for "Silver Clear" reception, and they give greater volume. We could write you a treatise on the scientific reasons for all these qualities, but it's Results you want—not Reasons. Write to us for your Loudens to-night. This is Mr. O'Neill's letter:

*"Gentlemen,  
"It might interest you to know that I have been running two Loudon Dull Emitters for over 18 months and they were second-hand when I got them. They also are still going strong."  
"At a recent test of various valves there was none to touch them."  
Please furnish me with a catalogue."  
Yours sincerely,  
"W. O'NEILL (Royton, Nr. Oldham)."*

Louden Valves are made by British labour in a British factory with British capital and can be depended upon for the finest volume, range and silver clearness. They can only be offered at such low prices because of our well-known policy of selling direct to the public and cutting out the middleman's profit. The list below gives prices and full particulars. Order your Loudon Valves from us by post.

<b>4/6</b> Bright Emitters. L.F. Amplifier. F.1. H.F. Amplifier. F.2. Detector. F.3. <b>5.5 volts 0.4 amps.</b>	<b>8/-</b> Dull Emitters. L.F. Amplifier. L.E.R.1. H.F. Amplifier. L.E.R.2. Detector. L.E.R.3. <b>2 volts 0.2 amps.</b>	<b>8/-</b> Dull Emitters. L.F. Amplifier. F.E.R.1. H.F. Amplifier. F.E.R.2. Detector. F.E.R.3. <b>4 volts 0.1 amps.</b>
<b>9/-</b> Dull Emitters. L.F. Amplifier. F.E.R.1. H.F. Amplifier. F.E.R.2. Detector. F.E.R.3. <b>6 volts 0.1 amps.</b>	<b>11/-</b> D.E. Power Valves. Trans. Amplifiers P.E.R.1. Resist. Amplifiers P.E.R.2. <b>4 volts 0.2 amps.</b>	<b>12/-</b> D.E. Power Valves. Trans. Amplifiers P.E.R.1. Resist. Amplifiers P.E.R.2. <b>6 volts 0.2 amps.</b>

Postage and packing: 1 Valve, 4d. 2 or 3 Valves, 6d. 4, 5 or 6 Valves, 9d.

**FELLOWS, PARK ROYAL, N.W.10.**

*Branches:*

- WRITE FOR 48 pp. ILLUSTRATED CATALOGUE No. 34 FREE**
- LONDON: 20, Store St., Tottenham Court Rd., W.C. (Museum 9200).
  - BIRMINGHAM: 248, Corporation Street (Central 435).
  - BRIGHTON: 31, Queen's Road (Brighton 899).
  - CARDIFF: Dominions Arcade, Queen St. (Cardiff 7685).
  - LEEDS: 65, Park Lane (Leeds 21479).
  - NOTTINGHAM: 30, Bridlesmith Gate (Nottingham 5551).
  - TONBRIDGE: 34, Quarry Hill (Tonbridge 172).

**BUY DIRECT AND SAVE MONEY**

# Secrets of the Low-Frequency Transformer—con. from page 18

makes the grid just positive, while the maximum in the opposite direction is that which takes the value down to the lower bend in its curve. If the available voltage range in between these two extremes is less than the signal applied, then we shall get distortion. This point will be clear from the diagram shown in Fig. 2a.

### Dynamic Curves

The actual operating or "dynamic" characteristic of a valve depends on the value of the impedance in the anode circuit. For each particular value of grid bias it is possible therefore to draw a dynamic characteristic. Let us assume that we have a voltage swing which reaches a maximum of three volts in either direction. In Fig. 2 (a) we have a characteristic which is ample to handle such a grid swing. In Fig. 2 (b), however, we have a case where the valve is not adequate for the purpose. We must utilise at least 3 volts grid bias in order to avoid running into grid current, and if we do so we find that we cannot obtain a swing of 3 volts in the opposite direction before the current drops to zero.

This point has been discussed in a fair amount of detail because it is one of paramount importance in the discussion of low-frequency amplifier design. With modern valves it is quite possible to handle a very large volume without running into grid current or "blasting," and we may, therefore, consider the valve as being a faithful reproducing device, the sole purpose of which is to produce an amplification of the signals.

### What We Need

Our problem, therefore, is how to make the fullest possible use of this amplification which is provided by the

practically entirely on this desirable end.

Now the difficulties to be encountered are enormous. The more the problem is examined the more impossible does its achievement appear to be. It has already been mentioned that the characteristics of the valve with which the transformer is associated depend upon the impedance in the anode circuit, and this has a definite effect upon the operation of the whole arrangement in that the amplification over the whole stage is dependent upon the impedance of the transformer primary.

### Variation of Impedance

Now the impedance of the primary winding of a transformer is not a constant property. It depends not only upon the resistance of the winding, but also upon the inductance. This latter property is a measure of the magnetic field produced by the winding, and it is indeed by virtue of this magnetic field that the energy is transferred to the secondary circuit. Unfortunately the effect produced in the anode circuit by the inductance of the transformer is dependent upon the frequency of the current flowing through it.

We are accustomed to speak of choke

an iron core, which tends to oppose the passage of varying currents, although it will have little effect on a direct current. Such choke coils are utilised, for instance, in smoothing out the ripple produced when the electric light mains are used for high-tension supply. They obtain their effect from the

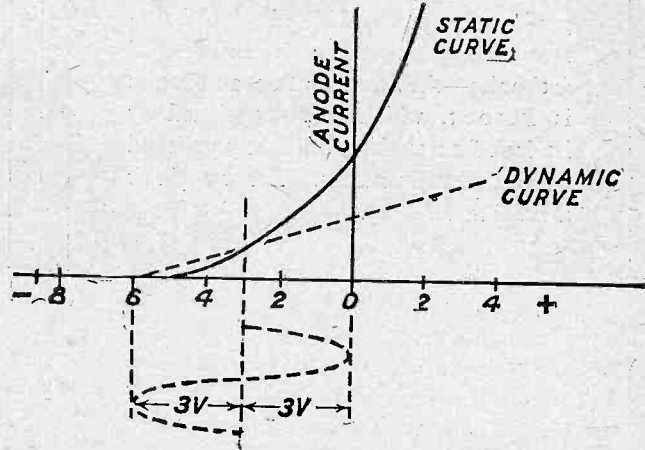

Fig. 2 (b).—At least three volts grid-bias is required in this example to avoid running into grid current, and if this is done, it is not possible to obtain a swing of three volts without distortion.

fact that they oppose any such change in the current, although they do not interfere with any steady flow of current through them. Without going into mathematics in the problem, it will be appreciated that the more rapid the change in current, the greater the choking effect. In other words, the greater the frequency, the more efficient does the choke become, always provided that other effects such as self-capacity do not come into play.

### Effect of Frequency

The primary winding of the transformer, therefore, acts as a choke coil in this manner, and its choking effect or impedance varies as the frequency. For very low frequencies its impedance is quite small, while for higher frequencies of the order of 3,000 or 4,000 its impedance rises to a very high value. Since the amplification of the previous valve depends upon the impedance in the anode circuit it will be clear that the overall amplification, therefore, will vary rapidly with the frequency, which is the exact opposite of the conditions of affairs required.

### The Remedy

To mitigate this disadvantage, therefore, it is necessary to design the transformer so that the primary winding has a high inductance. When the impedance of the anode circuit is about three times that of the valve

(Continued on page 33.)

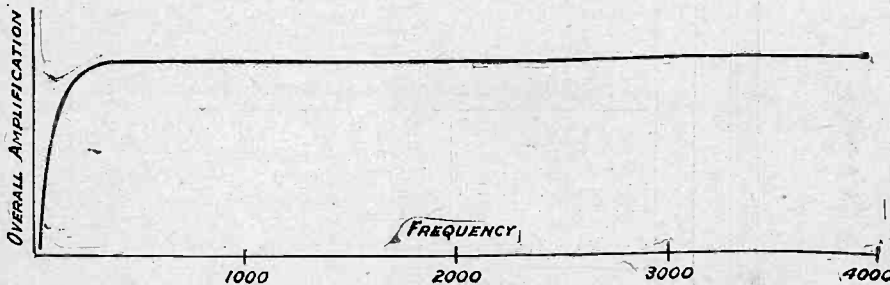

Fig. 3.—When a certain critical point is reached the curve of an L.F. transformer flattens out, and the amplification is practically uniform over the remaining range.

valve without introducing distortion into the circuit, and in order to achieve this result our intervalve coupling should be of such a nature that its response is the same at all frequencies. The research work of the transformer designer is concentrated

coils both in low-frequency and high-frequency circuits, and it should be remembered that the function of such coils is to prevent the passage of varying currents through them. A low-frequency choke is a coil having a large number of turns, often provided with

## SHORT-WAVE NOTES AND NEWS



THROUGHOUT last week all the "G" stations were to be heard working between midnight and 6 a.m. with very fine D.C. notes and rather weaker, but steadier, signals than usual. The explanation of this phenomenon was fairly simple—the T. and R. Section's Low-Power Tests were in progress. Members could be heard repeating five-letter code words and calling stations at distances that instantly branded them as confirmed optimists. Needless to say, much very fine work was done, and a notable feature of the tests was the way in which those who had good aeri-als scored over the others. A really good aerial makes much more difference to low-power work than it does to communications carried out with 500 watts at each end. The maximum power used in these tests was, of course, 5 watts. One well-known transmitter told the writer that his favourite song was "All Through the Night"!

### WIZ

WIZ has actually been heard in communication with other stations, instead of calling the eternal ABC. When the writer heard him he was working GLKY, the s.s. "Carinthia," and saying, in the usual "ham" manner, "Sri, gess n d o.m.!" Obviously an American amateur transmitter had got hold of the key. WIZ, by the way, continues to be a model of steadiness and purity of note. Most of the German commercial stations also leave very little to be desired in this way. Of our own stations,

however, the less said the better. At least two of them sound as if they are working on Ford coils, and a third is a passable imitation of an atmospheric.

### 2XAF

WGY'S transmission under the call

### SEND ALL YOUR QRA QUERIES TO US!

sign of 2XAF, on 32.79 metres, is becoming stronger almost nightly. More than one reader has been moved to write and comment on the obvious

least one person has received this transmission on a crystal and one or two note-magnifiers during the summer, so that it should be quite easy to repeat the feat now.

### Plug-in Coils

The use of standard plug-in coils for short-wave work appears to be on the increase, chiefly on account of the convenience of using one set for all wavelengths. The writer tested out one of these "universal" receivers against a special short-wave receiver a short time ago, and as regards signal-strength there was nothing to choose between them. As far as selectivity went, however, the short-wave set possibly gained a few points. There was certainly very little in it; not enough to justify the use of two separate sets in place of one.

### Short-wave Broadcasting

The possibility of a British broadcasting station on short waves is not so remote, as might be imagined. Such a station would serve the Dominions extremely well, and at the same time would not interfere to any great extent with the amateur enthusiasts in this country, since the "kilocycle accommodation" is so much greater on these waves.

### Expeditions Wanted

There is at present a great dearth of the Expeditions that used to liven up short-wave work. Last winter it seemed that every other day, an amateur in some country effected contact with an unknown expedition with a strange call-sign. This year there does not seem to be nearly so much excitement.

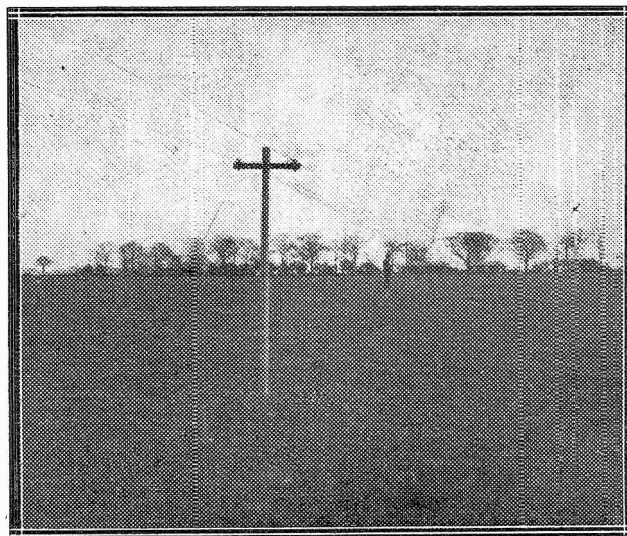

An unusual type of aerial (known as the "Beverage") which is used by B.B.C. engineers at Keston for receiving Hilversum and other long-wave stations, consists of two wires nine feet high and six hundred yards long.

veracity of those who affirm that they received him at loud-speaker strength on two valves, when they had previously been inclined to doubt it. At

# SELLING IN

Everywhere, people are buying S.T. v  
At the Manchester Wireless Ex  
enthusiasm, and some proof of t  
that they were used in an  
the broadcast music

BUY YOUR

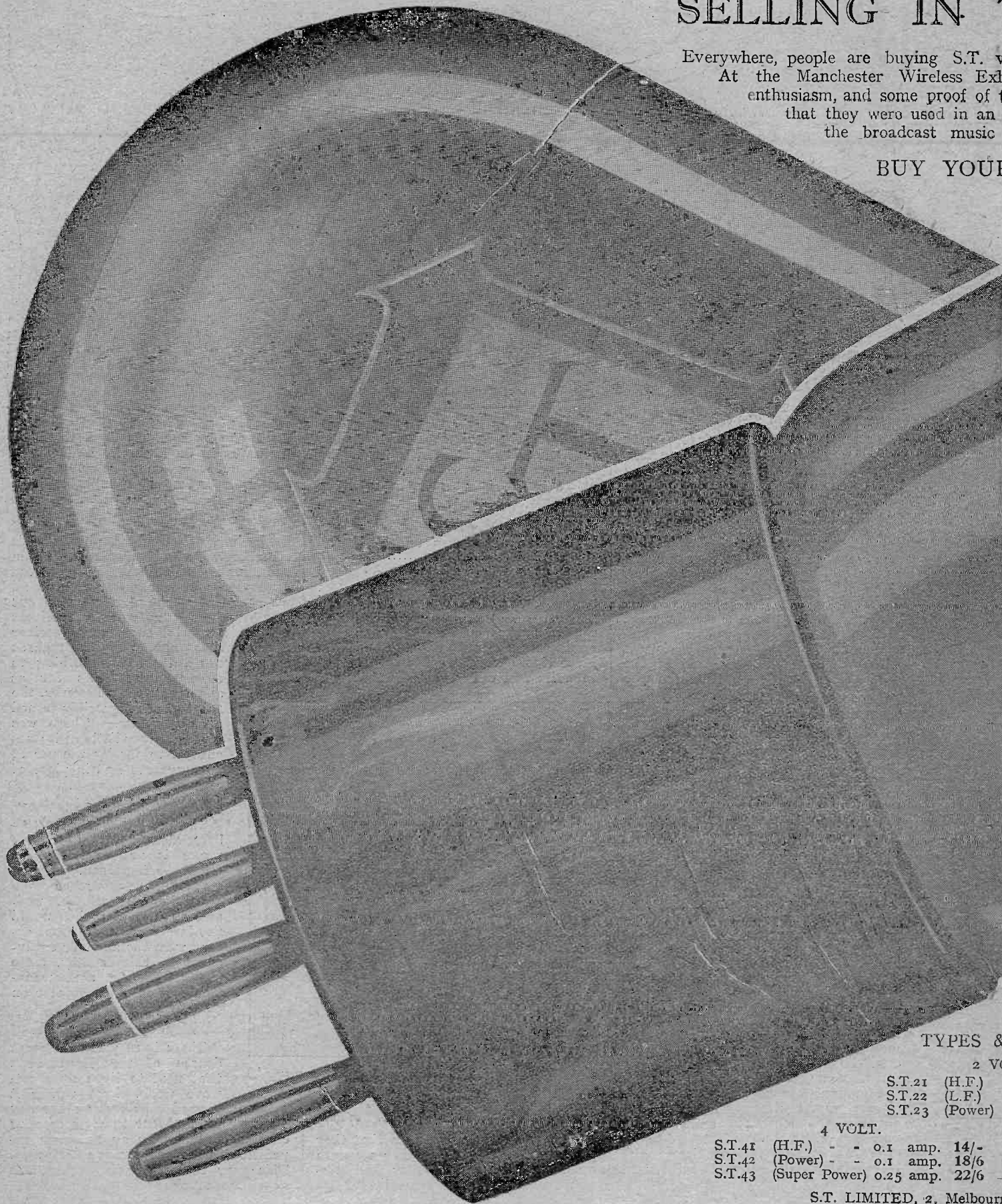

TYPES &

2 V

S.T.21 (H.F.)  
S.T.22 (L.F.)  
S.T.23 (Power)

4 VOLT.

S.T.41 (H.F.) - - 0.1 amp. 14/-  
S.T.42 (Power) - - 0.1 amp. 18/6  
S.T.43 (Super Power) 0.25 amp. 22/6

S.T. LIMITED, 2, Melbourn



# THOUSANDS!

valves and are delighted with them.  
hibition they were received with  
their efficiency lies in the fact  
official receiver supplying  
to the Exhibition.

RS NOW!

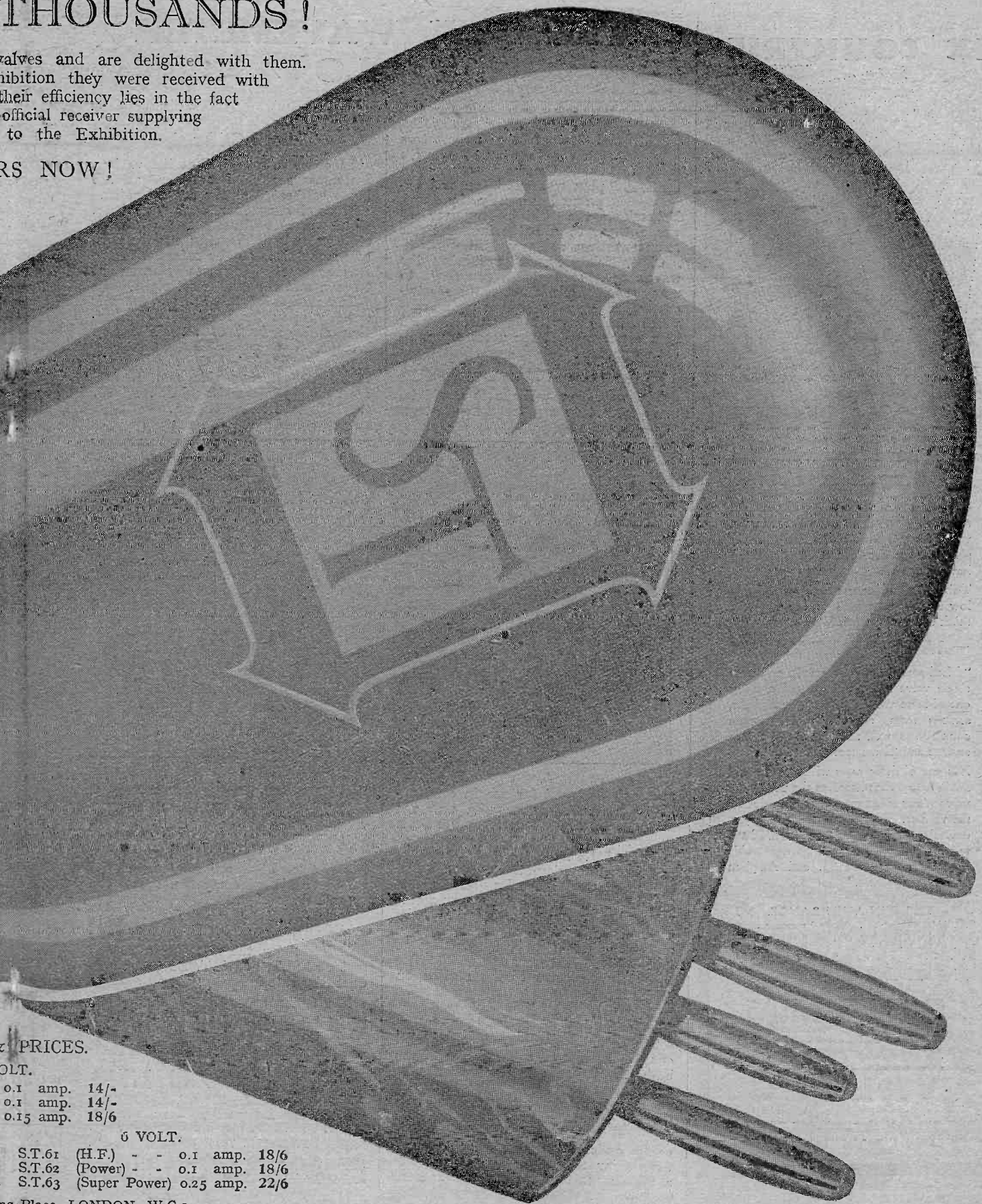

## PRICES.

OLT.

- 0.1 amp. 14/-
- 0.1 amp. 14/-
- 0.15 amp. 18/6

6 VOLT.

- S.T.61 (H.F.) - - 0.1 amp. 18/6
- S.T.62 (Power) - - 0.1 amp. 18/6
- S.T.63 (Super Power) 0.25 amp. 22/6

ne Place, LONDON, W.C.2.

# SIX COUNTRIES

## IN DAYLIGHT

We have received the following testimonial:—

"I do not know whether you know that this particular valve is the finest in the world for use in a reflex set, it easily gives double the volume of any other I have ever used.

This is due of course to the remarkably low impedance, which is the lowest I think of any valve made."

### —AND ON ONE VALVE

"I had some wonderful results on a new single valve reflex unit yesterday, using one of these valves, tuning in, in daylight, stations from six different European countries, as well as a number of British stations and 22 amateur transmitters.

It is one of those cases where one would not believe unless heard, as the use of this valve in any reflex set will at once double the volume. I may add that I am just over three miles from 2 Z.Y. and I have to detune to bring the volume reasonable on a large Brown H.Q. and Amplion Radiolux Speakers."

#### THE BENJAMIN RANGE.

S.P. 18 RED 14/- Fil. Volts 1.6 Amps .3  
 S.P. 18 GREEN 14/- Fil. Volts 1.6 Amps .3  
 S.P. 18 BLUE 14/- Fil. Volts 1.6 Amps .09  
 D.E. 55 18/6. Fil. Volts 5.5 Amps .09  
 S.P. 55 BLUE 18/6. Fil. Volts 5.5 Amps .09  
 S.P. 55 RED 22/6. Fil. Volts 5.5 Amps .25

# BENJAMIN SHORTPATH VALVES

THE BENJAMIN ELECTRIC LIMITED,  
 Brantwood Works, Tottenham, London, N.17.

# THE NEW WAVEMETER AT 2LO

**T**HE first of the wavemeters for use in connection with the Geneva wavelength plan was exhibited and explained recently by Capt. Eckersley, the Chief Engineer of the B.B.C., to a gathering of Press representatives at Savoy Hill.

Capt. Eckersley, in explaining the wavemeter, said that, contrary to many reports, it was not of the crystal-controlled variety, but simply consisted of the usual inductance shunted by a capacity with the necessary indicating devices.

### Small Ranges

The wave-, or perhaps it would be more correct to say frequency-meters,

### Central Calibration

In order to ensure that the various instruments shall not differ, all are being calibrated at one central point.

With instruments such as these, which can be used for checking stations on neighbouring wavelengths, any complaints can be referred to the International Broadcast Bureau at Geneva and the matter set right.

The success of this scheme depends entirely upon the spirit of co-ordination and goodwill of all stations in Europe.

It is expected that the changes will take place during this month, and according to information just received, the 14th is the day chosen.



Representatives of the Press inspecting the new wavemeter, which has just arrived for use at the London station. Captain Eckersley, Chief Engineer of the B.B.C., is fourth from the left.

are each designed for use in conjunction with one station only, and the range covered is 20 k.c. Thus London's new wavemeter, the central reading of which is 361.4 metres or 830,000 cycles, can record any deviation up to 840,000 or down to 820,000 cycles.

Each station will have its own wavemeter permanently secured near the transmitter, explained Capt. Eckersley, and in addition to the checking of their own position stations will be able to check the wave of the station on either side.

### The Indicators

The actual measurements are carried out by means of a small flash-lamp bulb, or, where a greater degree of accuracy is desired, by a device known as a "thermo-couple" which acts upon a galvanometer. The setting on the wavemeter at which the lamp glows corresponds to the frequency at which the station is transmitting, thus it is a simple matter to keep to a fixed wavelength.

## NEWS IN ADVERTISEMENTS

Messrs. County Electrical and Wireless Stores, Ltd., are announcing the complete kit of components for the Monodial Receiver.

Readers are invited to apply to Dept. W.5, Messrs. Hart Accumulator Co., Ltd., for the full details of the series of H.T. and L.T. Batteries produced by this company.

The full range of their products is being advertised by Messrs. Neutron, Ltd.

## GLASS JARS AND ZINGS FOR MAKING WET H.T. BATTERY.

PARTICULARS AND SAMPLES — 3d. STAMPS. FINISH WITH WORRY AND EXPENSE OF DRY H.T. PAPER DIAPHRAGM TYPE SPEAKER PARTS.

**SPENCERS STORES LTD.**  
 4/5, MASON'S AVENUE, COLEMAN STREET,  
 Phone : London Wall 2292. LOTHBURY, E.C.2. (nr. Bank)



## Your Transformer must be right!

**Y**OUR valves may be of the right impedance, your condensers low in loss, your plate voltage right, but if you have a poor transformer you *must* have distortion, poor volume, and worse reproduction.

Put an Ericsson Tested Transformer on your baseboard and the difference will astonish you. Distortion disappears, volume swells and clarity and purity takes the place of discordant muffling and harshness.

Ericsson Tested Transformers are designed along careful tone value lines and are guaranteed distortion free. Replace your present Transformers with Ericsson Tested—you'll transform your set.

Two ratios, one price. 1:2, 1:4

# 17/6

On Sale at all good dealers.  
Write to-day for full particulars.

ERICSSON TELEPHONES LTD.,  
67/73, Kingsway, London, W.C.2.

**Ericsson**  
TESTED  
TRANSFORMERS

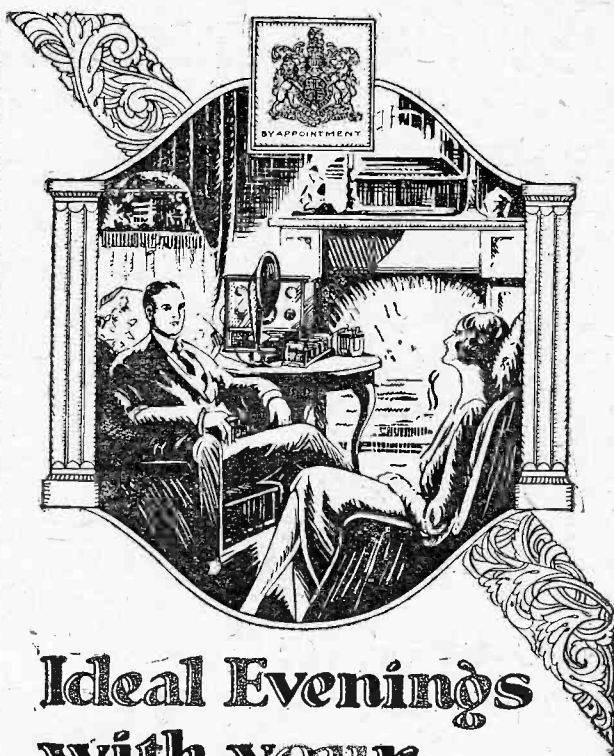

## Ideal Evenings with your Wireless Set

**F**OR real wireless enjoyment—purity of reproduction, freedom from distortion and ample volume of tone are, of course, essential.

Use "HART" BATTERIES with your set for both Low and High Tension supply and "wireless" will reveal new charms to you; their steady voltage, low resistance and exceptional reserve of power ensuring reception at its best.

Discard your dry batteries to-day and substitute the "HART" "RAY" type of High Tension Accumulator (20 volts 14/8, 30 volts 22/-, 60 volts 44/-). The marked improvement in reception will certainly surprise you.

# HART

THE BATTERY OF QUALITY

There are models of "HART" Batteries for all Low and High Tension Circuits. Write to Dept. "W.5" to-day for illustrated lists and full particulars.

HART ACCUMULATOR CO., LTD.,  
STRATFORD, LONDON, E.15

# S.T. VALVES GET 51 STATIONS ON THE MONODIAL

(See WIRELESS, October 30th and November 6th)

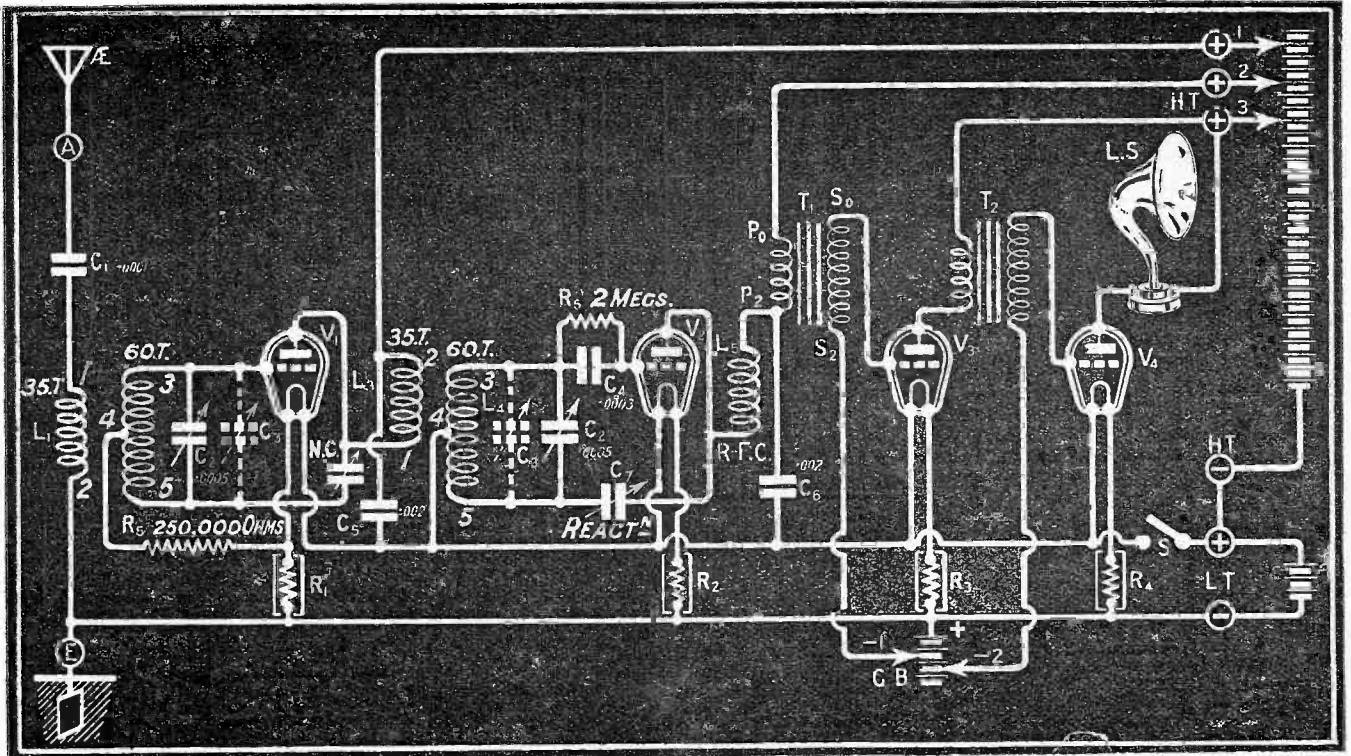

S.T. 21 (1st & 2nd valves).

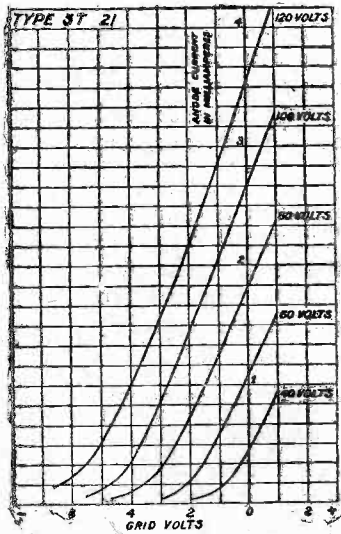

S.T. 21  
H.F.

Filament 1.8 volts.  
0.1 amp.  
Anode 40-120 volts.  
Impedance 26,000 ohms.  
Amplification 16.

An excellent valve for H.F. amplification and resistance capacity coupling. It is also to be recommended as a detector valve.

Price 14/-

S.T. 22 (3rd valve).

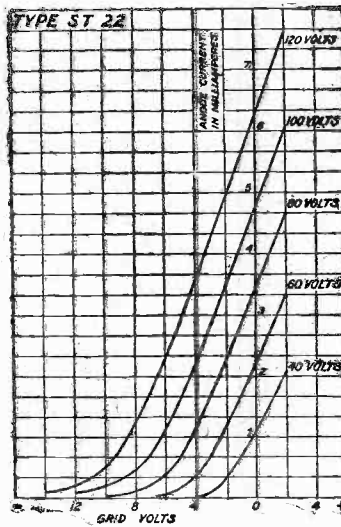

S.T. 22  
L.F.

Filament 1.8 volts.  
0.1 amp.  
Anode 40-120 volts.  
Impedance 16,000 ohms.  
Amplification 10.

This valve is for the first stage of a low frequency amplifier and will give undistorted reproduction. It may also be used for H.F. amplification, especially in neutrodyne circuits, and for detection.

Price 14/-

S.T. 23 (last valve).

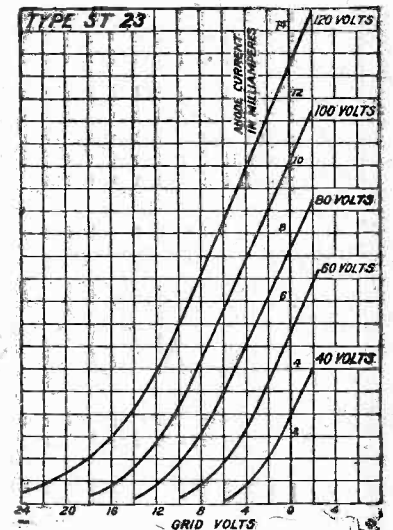

S.T. 23  
POWER

Filament 1.8 volts.  
0.15 amp.  
Anode 80-120 volts.  
Impedance 6,000 ohms.  
Amplification 6.

A magnificent 2 volt. power valve giving superb reproduction when used as the last valve of a set when a loudspeaker is employed. Note its low impedance and the high amplification factor for such a valve.

Price 18/6

Adv. of S. T. Ltd., 2, Melbourne Place, W.C.2.

## Inventions and Developments



**A** PATENT which is of interest principally on account of the possibilities which it suggests is that taken out by the Société d'Etudes pour Liaisons, Telephoniques et Telegraphiques (251,588). It relates to the suppression of certain frequencies or bands of frequencies in a valve amplifier.

### Feed-back Effects

It is well known that the inherent capacity between the anode and grid of a valve produces a feed-back of energy, which may be either positive or negative in character, either producing a tendency to oscillate, or else introducing extra damping into the circuit. In the normal form of amplifier the reaction is positive, and steps have to be taken to check the tendency to oscillation by some suitable means.

### Phase Relations

The question of the sign of the regeneration (i.e., whether the feed-back is positive or negative), depends on the phase of the currents in the various circuits. The currents flowing from anode to grid

of the valve itself, through the inter-electrode capacity, need not pulsate in unison with those in the tuned circuits of the receiver. They may quite conceivably be out of step, or out of phase, as it is called.

For example, we can have two men walking side by side, and both taking equal steps at the same rate, but they can, nevertheless, be out of step. Similarly, we can have currents in different circuits of a valve amplifier out of phase with each other.

If the feed-back current is in phase with the current in the grid circuits, then positive reaction is obtained. If the feed-back is directly opposite in phase we obtain a damping effect. In between the two extremes we have a neutral position, at which no effect is produced.

### The Essential Feature

In the invention in question an additional circuit is connected between the anode and grid, in parallel with the internal capacity. By a suitable

choice of this "network" it is possible to control the phase of the feed-back current so that the reaction effect is either positive, negative, or zero.

With a simple circuit this control is dependent on the frequency. It is possible to arrange for a heavy damping effect to come into play at a certain point so that an almost complete suppression of a given frequency is obtained.

### Possibilities

By the employment of more complex networks, however, similar to band filters, it would be possible to arrange for a circuit to remain stable over the whole working range. It is even conceivable that by some such method a correction could be introduced to allow for the increasing liveliness of the average receiver towards the bottom of the scale.

An aspect of the question which is probably worth investigating is the application to low-frequency work, where the suppression of certain frequencies may be desirable. Possibly also the suppression of certain bands of frequency might assist in the reduction of the effect produced by atmospheric disturbances.

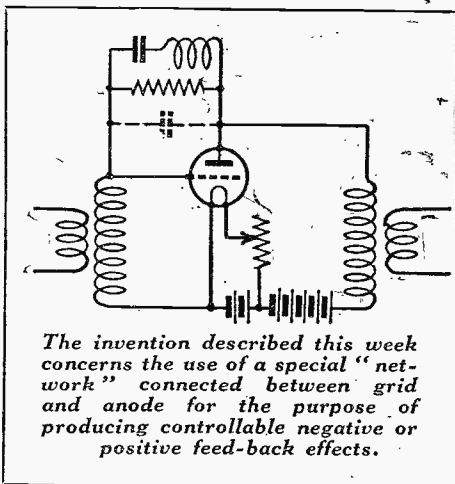

*The invention described this week concerns the use of a special "network" connected between grid and anode for the purpose of producing controllable negative or positive feed-back effects.*

### LATE NEWS

The new B.B.C. wavelengths will come into operation, we are informed, on November 14 and are as follows:—

- Aberdeen and Birmingham, 491.8 metres.
- Glasgow, 405.4 metres.
- Belfast, 326.1 metres.
- London, 361.4 metres.
- Newcastle, 312.5 metres.
- Manchester, 384.6 metres.
- Bournemouth, 306.1 metres.
- Cardiff, 353 metres.
- Leeds, 297 metres.
- Bradford, 294.1 metres.
- Other relays, 288.5 metres.

Listeners are asked not to send in criticisms until the scheme has been in operation for a fortnight or more.

Ashley  
Radio

## JACKS

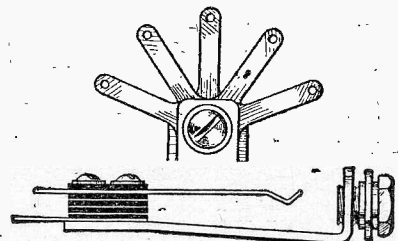

—are made of nickel silver springs, with pure silver contact, and Bakelite insulation throughout. Tags are tinned and spread fan-wise for easy soldering.

JACK No. 1 Single Circuit (open) <b>1/3</b>	JACK No. 2 Single Circuit (closed) <b>1/6</b>
JACK No. 3 Double Circuit <b>1/9</b>	JACK No. 4 Filament Single Control <b>1/9</b>
JACK No. 5 Filament Double Control <b>2/3</b>	

TELEPHONE PLUG, 1/6

### CLARITONE LOUD SPEAKERS

Senior Model, 2,000 ohms, } £5 0 0  
W.265, 120 ohms, W.266 }  
Junior Model, 2,000 ohms, } £2 15 0  
W.267, 120 ohms, W.268 }

### CLARITONE HEADPHONES

W.216 ... 20/-

### ASHLEY WIRELESS TELEPHONE CO., LTD.

17, Finch Place,  
London Road,  
LIVERPOOL



Pat. No. 256833  
Pro. Pat. No. 20339



The Grid Leak is not discernible, being totally enclosed in Bakelite Valve Holder Base.

## Something new and good in component design

The latest LOTUS triumph is a Combination Grid Leak and Valve Holder which eliminates unnecessary wiring and soldering and makes for economy in cost and space.

Guaranteed efficient in construction and design.

From all Radio Dealers

- Combination Grid Leak and Terminal Valve Holder . . . . . 3/9
- Terminal Valve Holder . . . . . 2/6
- Valve Holder without Terminals . . . . . 2/3

All Anti-Microphonic Type.

# LOTUS

Combination

## GRID LEAK AND BUOYANCY VALVE HOLDER

Anti-Microphonic

### Garnett, Whiteley & Co., Ltd.

Lotus Works, Broadgreen Road, Liverpool.

Makers of the famous "Lotus" Vernier Coil Holders

## ACCUMULATOR CHARGING SETS

for Home Service  
NO TECHNICAL KNOWLEDGE OR ATTENTION REQUIRED.

CLEAN, ECONOMICAL, SIMPLE AND EFFICIENT.

Simply plug-in to any Convenient Lampholder. Supplied complete with Adaptor, Flexible Cords and full instructions.

The "ALTERNO." (As illustrated.)

Alternating Current.

Charges the High Tension Accumulator at negligible cost. Price 21/-

The "INDISPENSO." Direct Current.

Charges the High Tension Accumulator at no extra cost when light is in use. Price 6/-

GOLSTONE "PENDLETON." Patent App.

Alternating Current.

Charges the Low Tension 2, 4 or 6 volt Accumulator economically and effectively. No Valves or renewals. Charging Rate approx. 2 Amps. Price £2:12:6

Fitted with Ammeter for ascertaining rate of charge. Price £3:7:6

Please state voltage and frequency of Lighting Mains when ordering.

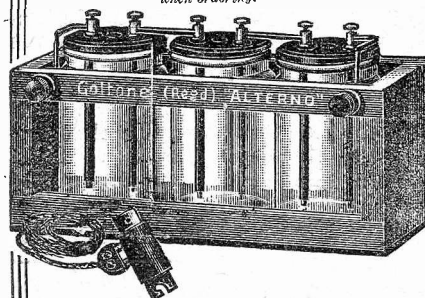

Large fully illustrated Radio Catalogue, No. E/116, on request. Dealers should enclose Business Card for Trade Terms. "Goltone" Products are stocked by the Leading Stores. Refuse substitutes.

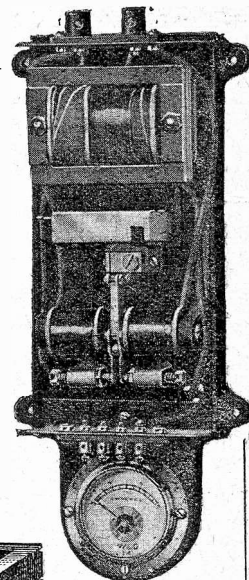

"PENDLETON" CHARGER with Cover Removed.

J.W.D., Ormskirk Road, Aintree, writes:

"I bought an 'Alterno' and was surprised at the results. I think it the most wonderful and simple arrangement I ever saw for so little money."

## Ward & Goldstone

PENDLETON. MANCHESTER

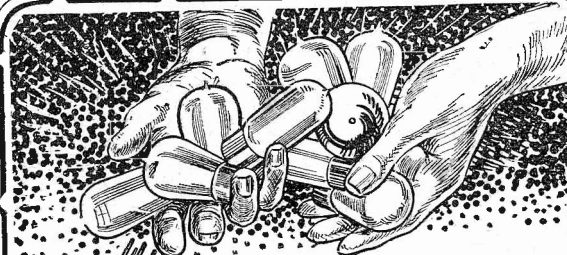

### THE BEST DULL EMITTER MONEY CAN BUY.

Frelat D.E. Valves cost only 4s. 11d. for Detector or Amplifier and they are costed low so that they meet the need of millions in purse and performance. A new addition to the range is the 2-volt power Valve at 8s. 6d., which ensures results that cannot be excelled.

Valves will be sent C.O.D. Type "K" 5/3 post free "D.K.P." 8/10 (New 2-volt power Valve)

4/11 Type K—2 volt .3 amp. 4/11

If your Dealer cannot supply, write to the: CONTINENTAL RADIO IMPORT CO., LTD., SPITAL SQUARE, LONDON, E.1

Frelat

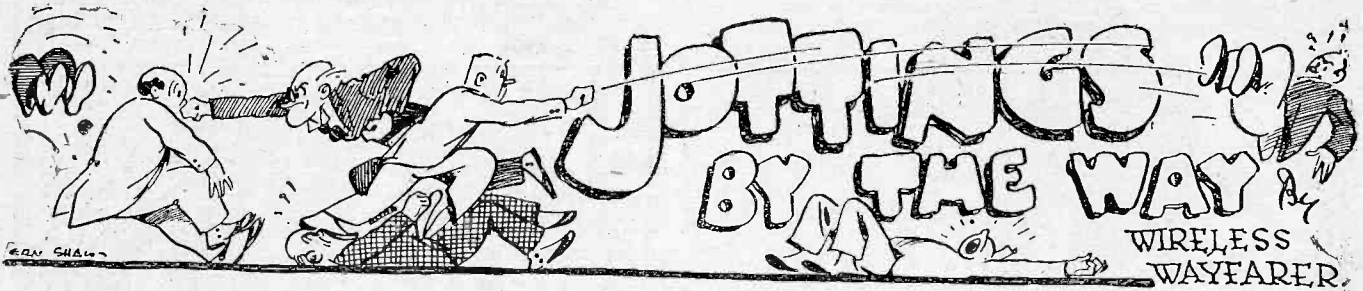

I AM afraid I am a little late," said the General cheerily as he ran into the wireless club the other night. "The fact is I was half the afternoon trying to find why my new set would not work, and I only discovered ten minutes ago that I had forgotten to switch on. Well, as everybody seems to be here let us open the meeting without further delay." We all moved to the table to take our seats. The General sank into his chair with a sigh and a loud pop, only to leap immediately ceiling-wards, the sigh turning into a queer gurgling noise which was apparently an expression of mingled pain and despair. "Encore, encore!" I cried, banging the table like anything. "There is nobody like our chairman for brightening up dull meetings. Encore! Bravo!! Bis!!!"

**Misunderstood**

The General flung me one soul-searing glance and proceeded to turn the fragments of a defunct valve out of his coat-tail pocket into the wastepaper basket. Meantime Poddleby, who is always minding somebody else's business, asked me in a nasty, sneering kind of way to be good enough to behave myself. "Oh, shut up!" I said, "I thought that the General was doing a little comic turn and naturally I applauded." "Your manners," remarked Snaggsby, butting in as usual,

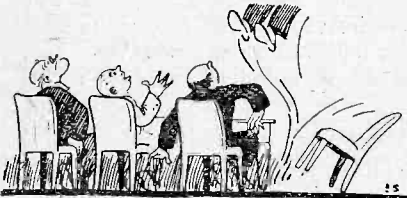

"... Only to leap immediately ceiling-wards ..."

"are simply beyond words." "Then why use words about them," I inquired sweetly. "Because..." Snaggsby began. "Of all the..." shouted Poddleby. They got no further, for if there is one thing I cannot stand it is a display of ill-breeding of this kind. Poddleby was on my right, Snaggsby on my left. Rising suddenly from my chair I seized each

of them by the scruff of his neck and banged their faces together.

**The Fat in the Fire**

"Order!" called the General, looking round from the wastepaper basket. "Order! Order!" shouted Admiral Whiskerton Cuttle, digging his elbow

**A disorderly meeting of the Little Puddleton Wireless Club, followed by a very practical lecture.**

hard into Poddleby's ribs. "Behave, behave," chirped Bumbleby-Brown, applying his elbow to Snaggsby. Some people seem to have no control of themselves. Poddleby simply flew at Admiral Whiskerton Cuttle, whilst Snaggsby turned round and delivered an exceedingly neat left hook on Bumbleby-Brown's third waistcoat button. As Poddleby took the Admiral by surprise he thrust him rather hard against Gubbsworthy, nearly knocking him off his chair. Gubbsworthy naturally retaliated, but in turning round to do so he trod on Dippleswade's toe. In endeavouring to move his feet to a safe place Dippleswade kicked the Editor of the Gazette hard upon the shins, which caused him to start so violently that he upset an inkpot over Breadsnapp's waistcoat.

**Hostilities Spread**

Leaping to his feet Breadsnapp sent a shower of ink all over Professor Goop, who, in a flash, removed one of his elastic-sided boots and smote him with it shrewdly over the head. Unfortunately, the boot slipped from the Professor's grasp, cannoned off Breadsnapp's head and made a bee-line for Winklesworth's left eye. By this time the train of oscillations had travelled right round the table, for Winklesworth, always a bad shot with a boot, missed the Professor clean, but caught Bumbleby-Brown squarely on the briscket. Seldom have I witnessed such a disgraceful scene. As the only two non-combatants, the General and I endeavoured to restore order, but the battle raged for a considerable time, lasting, in fact, until everyone was too exhausted to continue.

**A Point of Order**

"And now," I said, when at last they had desisted from their efforts of annihilating one another, "and now that this exhibition of brotherly love is con-

cluded perhaps we can get on with the meeting." The General, first feeling carefully in his other coat-tail pocket, again took the chair, and at last we got down to real business. What would happen to the club if I were not there to keep them in order I shuddered to think. "I would like..." said the chairman. "I rise to a point of order," said Professor Goop. "Has anybody seen my boot?" The boot was at this moment brought in by young Edward Bugsnip, who had found it in the High Street, whither it had travelled through one of the windows which was not open at the time. The Professor put it absently into his pocket, and the General continued. "I would like," quoth he, "to say that it is high time that the club had an increase in its membership. There are, I know, quite a number of Little Puddletonians who are not members, though they possess wireless sets. An intensive campaign is indicated. Has any member any suggestions to offer?"

**A Brain-wave**

When one or two of the others had given vent to their usual tosh I rose to my feet, but was immediately forced to sit down again by my neighbours, both of whom had some stupid remarks to get off their chests. At the conclusion of these I rose once more, and this time I was not interrupted. "It seems to me," I said, "that what we must do is to get some eminent man down to give a lecture; that we must



"... Through one of the windows which was not open ..."

thoroughly advertise his coming, and that we must invite every Little Puddletonian to attend whether he is a member or not. They will come in their thousands. They will be thrilled. They will enroll as one man. I will stand at the door and collect their subscriptions as they go out." Though my suggestion was accepted with

(Continued on page 31.)



## The Public and the Trade alike acclaim "The ETHOVOX" LOUD-SPEAKERS

They say the results are simply amazing and that our claims have been too modest. They write us to this effect. Have you heard broadcast *via* the "Ethovox." It has to be heard to be believed. Ask your local dealer.



**The "ETHOVOX" LOUD-SPEAKER with Metal Horn.**

The standard full-size "Ethovox," with rubber-covered feet. Finished in Burndept exclusive dust-proof rich mahogany colour. Imitated but unequalled. Height 26 ins. Flair diam. 15 ins. No. 963 "Ethovox" (Type 750), with Metal Horn; for use direct in the plate circuit. Price **£4:10:0**

**The "ETHOVOX" LOUD-SPEAKER with Mahogany Horn**

Similar to above, but the flair is of dark coloured polished mahogany and constructed by a special process which gives it great strength and is particularly neat in appearance. No vibration is possible. No. 966 "Ethovox" (Type 750), with Mahogany Horn; for use **£5:5:0** direct in the plate circuit. Price

Also a "Junior" Model at £2-2-0

BURNDEPT

WIRELESS UNIT 22

*Head Office and Factory:*  
BLACKHEATH, LONDON, S.E.3.  
Telephone: Lee Green 2100.  
*'Grams:* Burndept, Phone, London.

*London Office & Showrooms:*  
15, BEDFORD ST., STRAND, W.C.2.  
Telephone: Gerrard 9072.  
*'Grams:* Burndept, Westrand, London.  
*Agents and Branches everywhere.*

*National Wireless Week—Nov. 7-13.*  
*"Let your friends listen."*

RH

# THIS IS THE VERNI-NOB!

**PRICE**

## 6d.

The Verni-Nob does all the work of a Vernier attachment or Vernier dial and increases the selectivity of your set.

Positive drive—No back-lash, 10 to 1 reduction with 3" dial, 16 to 1 reduction with 4" dial.

Over 8,000 were sold during the Wireless Exhibition at Olympia!

From all dealers.  
By post 7½d.

Fitted in a few moments.



**THE M.A.P. Company**  
246, Great Lister Street,  
BIRMINGHAM

## REDUCED PRICES

of

# LEWCOS

## Inductance Coils

Coil No.	25	35	40	50	60	75	100	150	200	250	300
Old Price	4/6	4/6	4/6	5/-	5/6	5/6	6/9	7/6	8/6	9/-	10/-
NEW PRICE	4/-	4/-	4/-	4/6	4/9	4/9	5/9	6/3	6/9	7/-	7/6

**I**NCREASED DEMAND and new methods of production have made it possible to lower the cost of manufacturing LEWCOS Coils. We have decided to give the public the benefit of this saving immediately.

All enquiries for LEWCOS Radio Products should be made to your local dealer. Descriptive leaflet gladly sent on request to:

The  
**LONDON ELECTRIC WIRE COMPANY & SMITHS, LTD.**  
Playhouse Yard, Golden Lane, London, E.C.1



## Jottings by the Way—continued from page 29

acclamation, it was for some reason decided that the collection of subscriptions should be entrusted to someone with more time on his hands.

### Without a Doubt

The question now arose as to which eminent man should be invited to Little Puddleton. On this point I explained to the assembly there could be no manner of doubt. Positively the only man was Professor S. O. High, the eminent expert in every subject under the sun. Professor High's name is practically a household word. If a walrus arrives in the Thames, Professor High is promptly interviewed by representatives of the entire popular Press, to whom he demonstrates his idea for harpooning walruses from aeroplanes. If somebody invents a new wireless circuit, Professor High is again interviewed and explains exactly why his own is so very much better.

It was Professor High who invented, as I announced exclusively some time ago, a self-rocking cradle with three speeds forward and reverse and a silencer; Professor High has recently described in several acres of print how he makes his alarm clock remove the bedclothes at the right moment by operating a relay, whilst another relay sees to the provision of his early morning tea; it was Professor High who solved the problem of squeaking boots by producing his soleless footwear, and is it not Professor High who keeps on assuring us that wireless is still in its infancy? Need I say more?

### The Subject

My suggestion was agreed to with acclamation, Poddleby being instructed to write forthwith a letter of invitation to Professor High. The Professor accepted by return of post, stating that he would be happy to lecture upon either Paraphlogistic Submodulation, in Brachycymatic Oscillators, or the Ideal Diet for D.X. Enthusiasts. We chose the former subject. Nobody had the slightest idea what it meant, so we all looked wise and pretended that it was just *the* point upon which we had been desiring information for years.

I was fearfully enthusiastic about it, for I suffer at times tortures from day-time and early evening insomnia, and I felt that I should be able to make up for at least a couple of hours of lost sleep. It was arranged that the lecture should take place upon the following Saturday, and since I was

the most presentable of the club's members, being the only one, with the exception of the General, who had escaped unscathed from the scandalous *mêlée* which took place at the meeting at which the suggestion was first made, I was deputed to go to the station to meet the Professor as the club's representative.

### The Arrival

On the great evening I was conveyed

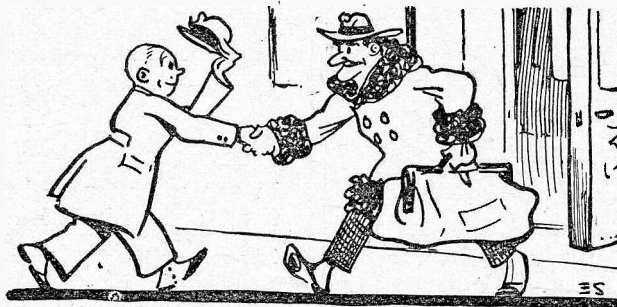

“ . . . Good evening, Professor . . . ”

in state to the station in the *Gazette's* Lizzie, driven by the sub-editor-compositor-reporter-office-boy-chauffeur. As the train came to a standstill a tall figure clad in a fur coat and carrying a gigantic bag stepped from a carriage. “Good-evening, Professor,” I said, advancing and holding out my hand. “I have been deputed by the club to welcome you to Little Puddleton.” “Very kind, I am sure,” answered the Professor, “but I was 'ardly expectin' . . .” “Not a word, not a word, I beg you,” cried I, “you must rest

once. Rising to his feet, he remarked that he would not keep the audience from the feast in store for them by making a speech, and sat down, bowing to the Professor.

### The Demonstration

“Friends,” said the Professor, beaming on his audience, “I scarcely expected to 'ave such a welcome as this on the hoccasion of my first visit to Little Puddleton. (Loud and prolonged applause.) Bein' a man of few words, I would like to give you a himmediate demonstration. Will any gentleman kindly step up on to the platform? Or perhaps the chairman 'ere will kindly hobblige.” Here he stooped down, opened his bag, and took something from it. Moving over to the smiling General, he pressed his head backwards and opened his mouth. His right hand moved so quickly that no eye could follow it.

Next instant the General was stamping round the platform screaming and holding his hand to his face whilst the Professor was displaying to the enraptured audience a gigantic tooth gripped in a pair of forceps. “Instantaneous and completely painless,” he bawled. “You 'ave now seen what Professor Bungo can do for any man, woman or child in this 'ere audience as is sufferin' from a haching tooth.” At this moment a telegraph boy elbowed his way through the throng and handed an orange-coloured envelope to Poddleby. Glancing over his shoulder, I read:—

“Very much regret laid up by sudden attack of influenza.—HIGH.”

It struck me suddenly that I had forgotten to lock the pantry window in my house. I think I can claim on that evening to have broken all records for the distance between the clubhouse and my own. Several people seemed to be inquiring for me, but I could see no point in remaining. After all, I had done my job by meeting the Professor, and the meeting itself was no affair of mine.

WIRELESS WAYFARER.

### A Correction

We are asked by Messrs. S.T. Valves, Ltd., to draw our readers' attention to the fact that a printer's error occurred in their advertisement on page 439. The figures “0.2 to 0.35 amp.” should read “0.2 to 0.25 amp.”



“ . . . The General was stamping round the platform . . . ”

your voice, so that you may be in your very best form.” As we were a little late, I ran him along the platform and through the doors into the *Lizzie*, which, after a succession of back-fires, rattled off to the clubhouse. The meeting was packed to the doors; in fact, I had quite a business to force a way for the Professor to the platform. When I had introduced him to the General, the chairman said that the proceedings might as well start at



*You will—  
when you buy  
NEUTRON  
PRODUCTS*

NEUTRON PRODUCTS are constructed with but one purpose in mind—to give to the user really dependable and lasting service.

NEUTRON VALVES will make a decided improvement in your reception—they are built to give greater volume realistic reproduction of voice and music and to ELIMINATE VIBRATION AND OTHER CONDITIONS THAT IMPAIR RECEPTION. They are positively NON-MICROPHONIC.

Knowing how much vibration impairs the tone quality of reception, enthusiasts everywhere are equipping their sets with Neutron valves. Fit Neutron valves to your set and note the surprising softness and fullness of tone of reception that follows the elimination of vibration.

<i>RED SPOT.</i>	<b>12/6</b>	<i>GREEN SPOT.</i>
H.F. and Detector. 4 volt .06 amps. 2 volt 0.2 amps.	<b>EACH</b>	V.L.F. 4 volt .06 amps. 2 volt 0.2 amps.

**NEUTRON PERMANENT DETECTORS**  
Each Detector is tested on actual Broadcast 130 miles from 5XX  
DE LUXE 5/6; CRYSTASTAT 4/6; PANECTOR 3/5

**NEUTRON  
H.T. Battery**  
Full 60 volt  
**10s. 6d.**

**NEUTRON  
4.5 volt  
Battery**  
Suitable for H.T.  
**5d. each.**

*Advt. of Neutron, Ltd., London.*

**NEUTRON CRYSTAL**  
*The powers of this wonderful crystal are known the world over—no better crystal is or has been made. Of all Radio dealers. Complete with cat's whisker. Price*

**1/6**



Sole Distributors for U.K. and Ireland—  
Neutron Distributors, 144, Theobald's Rd., London, W.C.1.  
All Export enquiries for Continent and Australasia to—  
Fettigrow and Merriman (1925), Ltd.,  
2 and 4, Buckle Street, London.

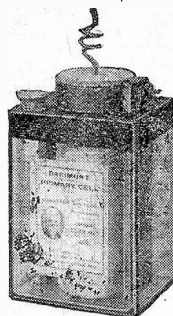

# Comfort

## DO YOU KNOW HOW

you can enjoy your Wireless this winter without the discomfort of carrying heavy accumulators to be charged?

If you use Dull Emitter Valves we can show you how to charge and recharge the

### DARIMONT "HOME-SERVICE" BATTERY

in ten minutes without any electrical connections, and without leaving your home.

*The cost—quite moderate    The current—quite steady*

*ASK YOUR DEALER for particulars of this comfort service, or write for a copy of our Valve Guide and Service Chart to Dept. C,*

### Darimont Electric Batteries Ltd.

ABBEY ROAD, PARK ROYAL, LONDON, N.W.10

Telephone: Wembley 2807.

## The "BULLPHONE" Nightingale

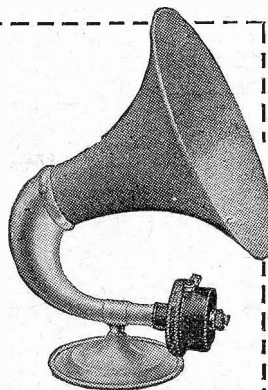

**Will not overload  
from 2 to 10 valves**

**ACCLAIMED THE WONDER  
SPEAKER OF THE WORLD**

The pure rich tone of the Bullphone is true to its name—the "Nightingale."

**5/-** deposit and  
**12 monthly  
payments of  
5/- or 60/-  
cash.**

**CLEAR TONE  
GREAT VOLUME**

**Specification.**

Height 21 ins. Bell Mouth 14 ins. Nickel Arm and Stand. Black crystal bell head, as photo. Also de luxe model, mahogany finish bell, same size, 65/- cash or 10/- deposit. List free.

Individually tested and guaranteed to be superior to any other Loud Speaker, regardless of price, for finish, purity and strength of tone and value. Cash Price 60/-, post free United Kingdom.

*Apply through your local dealer or send direct to us. Deposit returned if not highly satisfactory.*

**W. BULLEN**  
(Dept. W3.)

**38, HOLYWELL LANE,  
LONDON — E.C. 2.**

**SECRETS OF  
THE LOW-FREQUENCY  
TRANSFORMER**

(Continued from page 20)

itself, the amplification obtained from the valve is very nearly equal to that expected from the voltage amplification factor as determined by the characteristics. Any further increase in the impedance beyond this value therefore does not produce any appreciable increase in the amplification obtained over the whole stage.

The obvious method of combating the difficulty which has just been stated, therefore, is to arrange the inductance of the transformer so that its impedance is two or three times that of the valve at a very low frequency. This means that the amplification over the whole stage above this point should remain practically constant, although below his critical frequency it will fall away somewhat rapidly.

**Modern Practice**

Now with a good modern transformer it is possible to arrange that this critical frequency is reached somewhere in the neighbourhood of 200 cycles per second. Since the upper limit of the frequency which has to be handled in the transmission of ordinary speech or music is in the neighbourhood of 4,000 to 6,000, this would appear to be a low frequency. On the other hand, one has only to remember that middle C on the piano corresponds to a frequency of only 256 vibrations per second to realise that the whole of the bass tones in music fall below 200 cycles per second, and that even with the arrangement thus described we amplify these tones to a less extent than the rest of the music. While this will not produce any distortion as such, it will result in a loss of naturalness, and the transformer designer is continually endeavouring to reduce the critical frequency as far as is consistent with the other problems in design.

**Apparent Simplicity**

Now on this simple theory the problem does not appear to be very complicated. We make the impedance of the transformer large compared with that of the valve in use. The effect of this is that for all frequencies below a certain critical point the amplification obtained rises more or less progressively with the frequency. As the critical point is approached, however, the curve flattens out, and beyond this the amplification is practically uniform over the whole range as in Fig. 3.

Unfortunately, however, there are all sorts of other effects which occur, most of the evils being due to the two causes, one the presence of the secondary winding, and the other the magnetic leakage which takes place between the primary and secondary winding. These points will be discussed in the next article of the series.

**High Recommendation by  
"Popular Wireless."**

**TUNGSTONE**  
Pure Lead Grid  
**Accumulator**

Entirely of British Origin and Workmanship.

Editor writes in issue of June 12th, 1926:—

**A**MATEURS who are fortunate enough to own motor-cars need not worry about accumulator charging during the summer. Current can be tapped off from the dashboard to supply portable sets, while, if a "Tungstone" accumulator is used, a cell or two can be removed for running a "household" receiver when the car is in the garage. Better still, extra cells can be purchased and interchanged with those on the "auto." During summer months the car accumulator is not called upon to do much work, so the foregoing is an economical proposition. The "Tungstone" is eminently suitable for the purpose, as its cells can be detached with the greatest of ease. As a matter of fact, the plates themselves can be removed from an individual cell in a few minutes. And this is but one of the many unique features of the Tungstone Accumulator. Its design throughout, from the construction and composition of its plates to its patent "Vislok" terminal locknuts, is a triumph of thoughtful attention to both details as well as essentials.

We have had a 6-volt "Tungstone" in use on a car for a period of about six-months, and six months, moreover, of mainly hard winter work. The self-starter must have been used thousands of times, frequently on very cold mornings, and on one occasion the car was driven a distance of over 100 yards on the starter motor. Additionally, the accumulator has been used for wireless work as well, and yet, when recently we examined its plates, no signs of deterioration were in evidence. Our previous accumulator accumulated a deposit of "mud" half an inch in thickness after a similar period of not quite such hard usage, but the "Tungstone" did not need washing out. It is still in commission, and no doubt will remain at work for many years.

We have not sufficient space at our disposal to describe these products in the detail they deserve.

TUNGSTONE High Tension 60 Volt Battery 3 a.h. is sold in the United Kingdom on monthly payments over extended period. Apply for particulars. Further interesting information on points of this advertisement are to be found on pages 58, 59, and 67 to 73 of the Illustrated Booklet "Photography tells the Story" which will be sent free on application to the—

TUNGSTONE ACCUMULATOR CO., LTD.

St. Bride's House, Salishury Square, Fleet Street, London E.C.4.

**ALL MANUFACTURERS  
GOODS ADVERTISED  
IN THIS PAPER**

Can be obtained C.O.D. or Cash  
with Order, per return, from

**YOUNG'S**

(GLASGOW), LIMITED,

40, STOCKWELL ST., GLASGOW.

Write To-day for Big Free Catalogue.

References: "Wireless."  
Bankers: "North of Scotland Bank," Glasgow.



# What do we gain by Low-Loss

By *Captain H.J. Round M.C., M.I.E.E.*

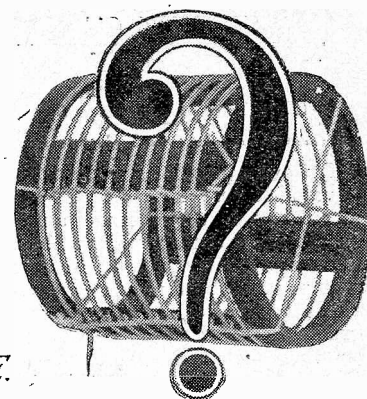

THE real difficulty to the amateur is not whether low-loss is an advantage, but to know when he has got low-loss apparatus.

Let us take a low-loss coil, one of about 200 microhenries is a very normal size. Now, the average old-fashioned coils of this size, wound of solid wire in one layer were of about 12 ohms resistance at 400 metres, and when they were wound in layers this resistance was considerably higher. A more modern coil, wound of stranded wire carefully spaced, can be obtained of 4 ohms resistance—a gain of three to one.

## Inter-action Requirements

Modern receivers, however, usually demand arrangements to prevent induction between the different coils of the receiver, and these arrangements have a habit of increasing this resistance considerably. For instance, an astatic coil system will be at least 6 ohms against the 4 ohms of the normal coil unless more space is allowable. And shielding will add a perfectly indefinite number of ohms, which can only be found by accurate measurement.

## Not Proportional

If these added ohms were proportional to the original ohms then the advantage would still be to the low-loss coil, but unfortunately they are only added. Thus a 4-ohm coil becomes, say, an 8-ohm coil when wound astatically and shielded, and an ordinary coil goes from 12 to 16 ohms, so that the gain of 3/1 becomes only 2/1.

Measurements of resistance are very difficult to do exactly, so that most experimenters will have to resort to trial to find the best arrangements. A few rules can be given which will help to maintain low-loss values in coils.

## Suggested Details

First of all, single-layer cylindrical coils of two to three inches diameter, with preferably a slight spacing be-

A stimulating article which should be read by everyone who takes an interest in modern tendencies in the design of radio circuits.

tween the turns, are as good as any, and if a wire such as enamelled 36/44's is used, with great care taken to connect every strand, no purchasable coil will be better.

Dry cardboard, I think, is as good as any material for winding coils on, but I always prefer to leave my coils

## Advantageous in Multi-Valve Sets

When every care is taken, I think we can assume that shielded astatic low-loss windings are at least as good as old-fashioned coils without the astatic and shielding arrangements, and in many cases can be taken as twice as good, so that from the point of view of multi-valve receivers we have gained considerably.

## On Long Waves

So far I have only spoken about coils of, say, 200 microhenries inductances, but low-loss windings made of stranded wire well spaced, particularly if in layers, are a great gain on the longer waves, the sizes I am referring to chiefly being from 1,500—5,000 microhenries, and it is quite possible now to make windings for these longer waves, which give too fine a tuning for good quality telephony, even without reaction being applied. The same astatic and shielding ideas, of course, apply on these wave-lengths also.

## On Short Waves

On the shorter wave-lengths under 150 metres it is doubtful whether anything will beat coils of solid wire wound rather openly. In this article I will not discuss further the short waves, because measurement of values is rather too difficult altogether for anywhere but a laboratory, and the building of receivers where low-loss matters has not progressed very far.

Low-loss condensers are now very common; in fact, one might say that practically all but the very cheap variety have very little loss.

## Where Do We Gain?

In the normal broadcasting band from 250-600 metres a low-loss coil in the aerial circuit will possibly give a gain of 15 per cent. with an average aerial, and with a very good aerial 30 per cent., by itself a gain hardly worth having, the reason being that the aerial resistance is already so high

(Continued on page 43.)

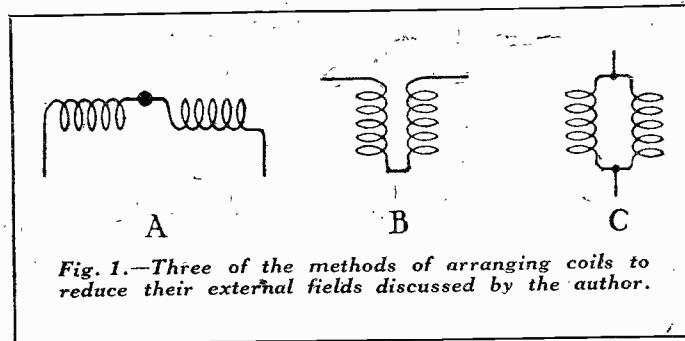

Fig. 1.—Three of the methods of arranging coils to reduce their external fields discussed by the author.

dry, because, unless tests are made of resistance afterwards, the influence of the varnish may be bad; and, of course, there is no simple indication of this.

Coils can be wound astatically in several ways, examples being given in A, B and C in Fig. 1. A has, I think, some advantage in that by making the two halves of the coil movable relatively to one another a small variometer action is possible, enabling circuits to be matched on their condensers.

## Shielding

Shielding is the latest fad, but a very useful one, and one very interesting point is to be noted here. An astatic coil having already a small magnetic external field, will induce smaller currents in the shielding case, so that the losses in the shielding will be less with the astatic coils than with ordinary coils. A series of tests indicate that the total losses on shielded astatic coils are less than in shielded non-astatic coils.

# Have you a gramophone?

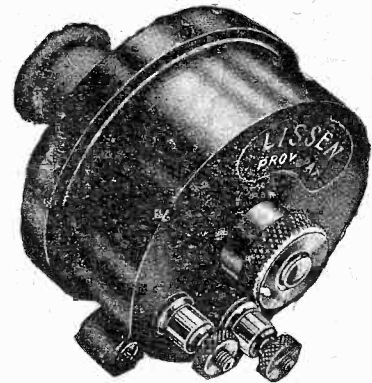

The LISSENOLA can be fitted to it in a second. Never again will you use telephones after hearing what can be done with the LISSENOLA Loud Speaking Unit and a horn made by yourself quickly and easily from materials purchasable anywhere for a few pence, or by fitting the LISSENOLA to your gramophone.

The LISSENOLA Loud Speaking Unit is the essential electro-magnetic sound reproducing mechanism of a loud speaker, concentrated in the most effective manner yet achieved, and produced by large production methods at **A RECORD IN LOW PRICE.** You cannot make it dither or resonate—it will carry high voltages without any sign of overloading—it is not to be confused with any imitations which lack its splendid

magnets, its non-resonant case, its fine tone qualities and tremendous power.

You add your own built horn to the LISSENOLA and you have a big, full-powered, senior-model loud speaker equal to the most expensive you can buy. With each LISSENOLA you are given full size diagrams and clear instructions showing you how to make a big horn. In addition you can also buy the LISSENOLA Reed which adapts the LISSENOLA to take any cone or other diaphragm working on the reed principle. You have in the LISSENOLA therefore the means of trying every known alternative of sound reproduction, an advantage which no other loud speaker gives you.

### 7 DAYS' TEST AT HOME.

Your dealer will demonstrate, but, better than all, take a LISSENOLA home—put it on your set—put it on your friend's set—try it with the horn of an expensive loud speaker fitted to it—then if you are not satisfied take it back to your dealer's or send it back to us.

## THE LISSENOLA

*Made Golden-Toned for your Enjoyment*

# 13/6

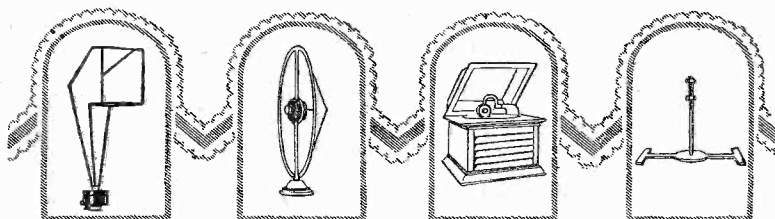

Full directions and full-sized patterns for making this horn are given with every 'LISSENOLA'

A cone diaphragm loud speaker can easily be constructed. The illustration shows one method of mounting.

The 'LISSENOLA' instantly converts any gramophone into a loud speaker.

The 'LISSEN' Reed Attachment (pat. pending) for use with cone diaphragm loud speaker. Price 1/-.

**LISSEN Ltd.,**  
18-22, Friars Lane,  
Richmond,  
Surrey.

Managing Director:  
Thomas N. COLE.

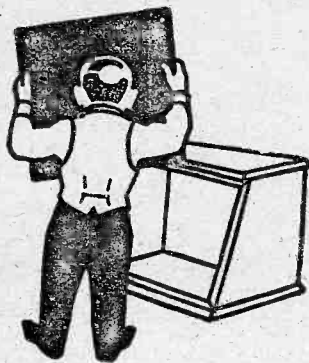

## Saving Space

TWO NEW ideas for saving back pane space—simplifying wiring and mounting, and doing away with all the troubles arising through faulty connections and spacing.

Remember, also, that the BENJAMIN Anti-Microphonic Valve Holder is not only infinitely superior to all its imitators in design and finish, but in actual performance too.

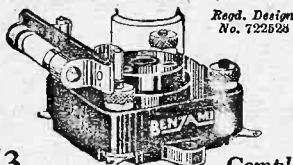

Regd. Design No. 722629

5/3

Complete

**VALVE HOLDER & GRID-LEAK**  
A Dubilier Dume ohm 2 meg. Grid-Leak is fixed on to a rigid insulating bar by means of nickel-plated copper clips.

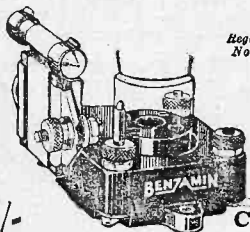

Regd. Design No. 722629

7/-

Complete

**VALVE HOLDER, GRID-LEAK & CONDENSER**

Nickel-plated copper clips carry a Dubilier fixed Condenser (1,0003) in addition to the Grid-Leak. Series or parallel.

**BENJAMIN VALVE HOLDER**

without Leak or Condenser.

Price 2/9

From all good Dealers

# BENJAMIN

BRITISH MADE

Clearer-Tone, Anti-Microphonic  
**VALVE HOLDER**

THE BENJAMIN ELECTRIC LIMITED  
Tottenham, Loncon, N.17.

## COMPONENTS WE HAVE TRIED

### A.C. Rectifier

WE have received from Messrs. Gent & Co. one of their Tangent A.C. rectifiers for H.T. supply. The unit is enclosed in an enamelled metal case. The lid, which is also of metal, completely screens the apparatus contained inside. The leads to and from the unit are brought out through insulated bushes. When the lid is opened the operating panel is exposed to view. Upon this panel is mounted a valve holder and an ebonite insulating strip carrying three terminals, and a knob for controlling one of the H.T. voltages.

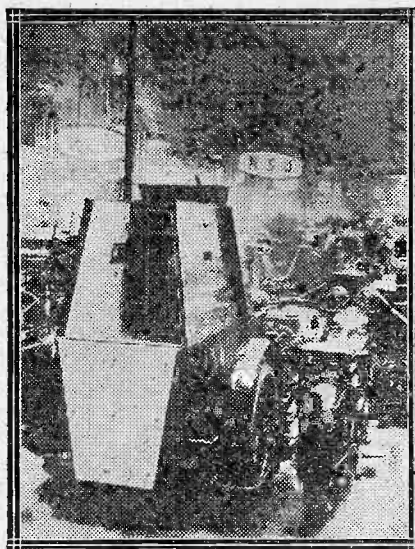

A novelty at the German Automobile Exhibition, a motor-cycle and "side-car" which consists of a complete wireless receiving and transmitting station.

The unit submitted is intended for use with a four-valve receiver, and it was tested upon a combination of two H.F., one rectifier, and one note magnifier. When in use the rectifier was found to be extremely efficient, and no hum could be noticed on the loud-speaker when it was tuned to its most sensitive condition, and even when telephones were used, only a very slight trace of hum was audible. It was found, however, necessary to use the correct grid-bias on the note magnifier valve to obtain the best results.

As previously mentioned, one of the H.T. voltages may be varied, this being done by rotating a small knob inside the cabinet. The three terminals are connected to the receiving set in the usual manner, no further apparatus being necessary. The only criticism we have to make is that the smoothing condensers are of the usual 300-volt type, which hardly gives an adequate factor of safety if the unit is to be used on 240-volt mains.

(Continued on page 41.)

# The latest in Jacks & Plugs

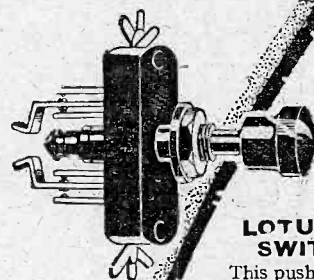

### LOTUS JACK SWITCHES

This push-pull switch is designed to occupy the minimum space, being only 1½ in. deep. Of the finest Bakelite, it has nickel silver springs and contacts of pure silver. Soldering contacts can be made to suit any wiring.

#### PRICES:

No. 9, as illustrated... 4/-  
Others from - 2/9

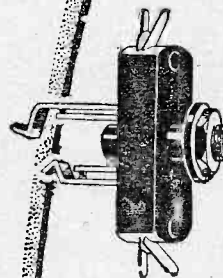

### LOTUS JACK

Designed to take up the least space, the depth back of panel being 1½ in. Made from best Bakelite mouldings with nickel silver springs and pure silver contacts. One-hole fixing. Soldering contacts can be brought into any position.

#### PRICES:

No. 3, as illustrated... 2/6  
Others from 2/- to 3/-

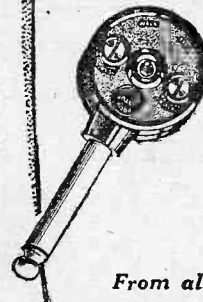

### LOTUS JACK PLUGS

Designed for use with Lotus Jacks. Made from best Bakelite mouldings and nickel-plated brass. To fix, the wires are placed in slots and gripped in position by a turn of the screw cams.

PRICE 2/-

From all Radio Dealers.

# LOTUS

## JACKS·SWITCHES·PLUGS

Garnett, Whiteley & Co., Ltd.

Lotus Works, Broadgreen Road, Liverpool.

**Bowyer-Lowe**  
*This Mark on Wireless Components is your Guarantee*

# PIONEERS of WIRELESS RECEPTION

**B**OWYER-LOWE are amongst the first manufacturers of Wireless Components. Since the days when wireless and its possibilities were but vaguely realised, Bowyer-Lowe have experimented unceasingly, and the components bearing the Bowyer-Lowe nameplate are backed by unlimited knowledge and research.

The "Popular" Condenser has proved the significance of this experience—hundreds of amateurs and experts write their appreciation of its excellent performance.

Design! without freaks or frills the Bowyer-Lowe Popular Condenser is, by its designing, inexpensive to produce, and you may secure the razor-edge tuning this instrument provides, at a trifling cost.

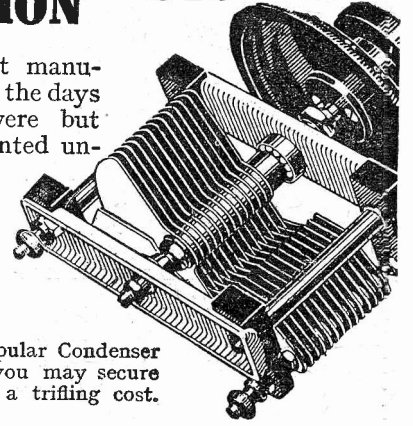

**GUARANTEED for TWELVE MONTHS**

Buy a **POPULAR** To-day—  
 Send your *Congratulations* To-morrow!

0003 M.F. }  
**10'**  
 0005 M.F. }  
**10'6**



ANNOUNCEMENT BY THE BOWYER-LOWE CO. LTD. LEITCHWORTH HERTS

**DON'T** USE A POWER VALVE IN ANY STAGE BUT THE LAST

**BUT**



BRITISH MADE

**TRANSFORMERS**

ARE SUITABLE FOR ALL L.F. STAGES

**TYPE AF3 - 25/-**  
 The "nearly perfect" transformer.

**TYPE AF4 - 17/6**  
 The best transformer at the price.

**FERRANTI LTD.,**  
 HOLLINWOOD,  
 LANCASHIRE.

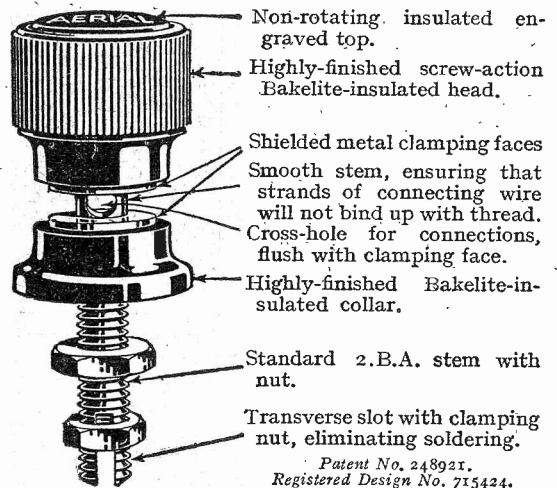
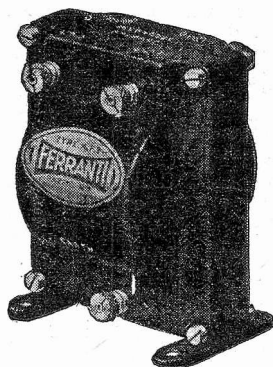

The Belling-Lee Terminal, made with 28 different engravings.  
**STANDARD MODEL** (Bakelite-insulated) (Type B) 9d. each.  
**POPULAR MODEL** (non-insulated) (Type M) 8d. each.

If you cannot get these at your dealers, send your order to us, enclosing his name and address.  
 Illustrated Catalogue free on request.

**BELLING-LEE**  
**PANEL FITTINGS**

BELLING & LEE, Ltd., Queensway Works Ponders End, Middlesex. E.P.S. 13

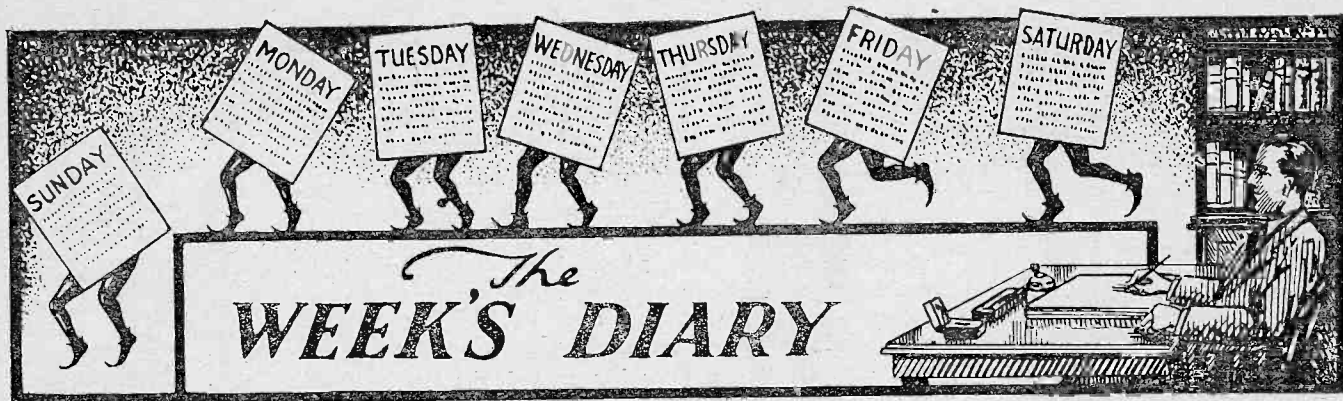

**T**HIS is National Wireless Week. Its slogan is, "Let Your Friends Listen." Perhaps I may be accused of quoting the obvious, but I am doing it for this reason: If you have a set that will not work a loud-speaker without occasioning insulting remarks from your friends, or which is at all prone to burst into oscillation, or to break down, for Heaven's sake *don't* let your friends listen! The object of the week's activities is to increase the numbers of regular listeners, not to repel those who are just on the point of enlisting.

If the week's possibilities are properly exploited it will do a vast amount of good to the progress of wireless in this country. If they are abused they will certainly be harmful.

**A** CONTEMPORARY hints that the sole result of all the recent agitation about listening for signals from Mars is that one worthy gentleman is 4s. 6d. out of pocket. That, perhaps, is the only good that has been done on this earth. But think of the way in which the Martians themselves have been entertained. They have by now a much truer knowledge of the "Earthians" than they ever had before!

**A** PARENTLY not everyone wishes the £900,000 accumulated by the G.P.O. from licences to be devoted to the improvement of the broadcast programmes. One gentleman in Manchester suggests that it would be much better employed by improving the postal service!

**T**HE number of prospective performers rejected by the B.B.C. after auditions have been granted is growing so large that in future it will be necessary to produce specially good recommendations before an audition will be granted. At the Newcastle station, for example, 700 successful artists have been secured as a result of 3,000 auditions.

**I**T is extremely likely now that the new wavelengths for European stations will come into force in the middle of November. The first of the new wavemeters having been delivered safely at 2LO, it really seems that the powers that be intend to "get a move on." Personally, I anticipate very little trouble when the new scheme commences. It seems to me to have been so well worked out that there can be hardly any hitches. Time will prove.

Goldschmidt at Sololo, is now working quite regularly with Belgium, and has maintained perfectly reliable communication for more than a month. The inception of this station was due to the fine performance put up by amateurs at both ends, and when the cable broke down valuable service was rendered by them. Thus there are now two regular links between Belgium and the Congo.

**NOT FROM A 'PLANE**

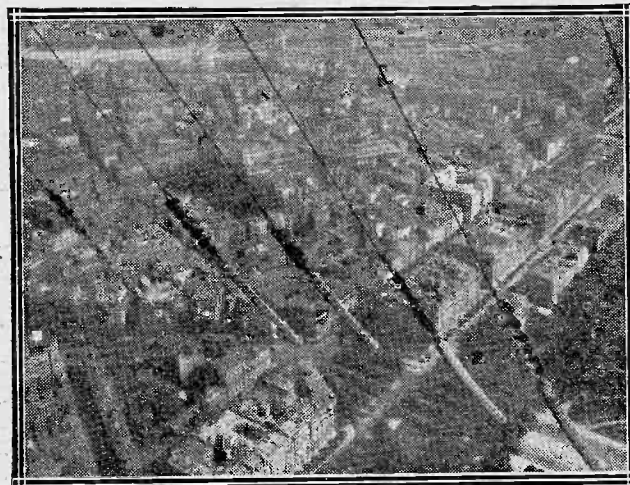

*This rather unusual view from the air was taken from the famous Eiffel Tower in Paris. The insulators, 132 in number, are those supporting the top end of the aerial from which transmissions are well received in this country.*

**T**HE B.B.C. are "going through the mill" generally at the present time on the count of underpaying their artists. Several hitherto well-known performers have made known their intention of refusing to broadcast again, and Mr. C. B. Cochran has now accused the B.B.C. of "buying an artist like a pound of tea." I shall be extremely interested to see their 1927 method of dealing with these little problems.

**T**HERE seem to be several supporters of the idea that the new State B.B.C. is too old. One correspondent says that in his opinion retirement from such a board as this should be compulsory at 50. There are many who agree with him, but I am afraid they are mostly the young ones! Those who are over 50 might very well consider that as a *minimum* age!

**T**HE programme of the Fourth National Concert at the Albert Hall on November 25 strikes me as being even nearer the ideal for such an occasion. Sir Edward Elgar is to conduct the entire concert, which consists of his own compositions. "Call Sign" recently predicted that we might possibly hear an all-British programme from 2LO, and his dream has apparently come true. In addition to this, we are to hear Albert Sammons.

**I**T struck me as rather significant that, on November 2, when the all-Italian Chamber concert was broadcast from 5XX and the provincial stations, there was no transmission from the Rome station. Probably this was nothing more than a coincidence, but at first it might appear that the Italians were rather anxious to see what we were doing to their music!

**NEXT WEEK.  
A SET FOR KDKA.**

**T**HE private station in the Belgian Congo, operated by Mr. Robert



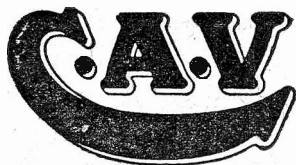

IMPROVED 1927 MODEL  
H.T. ACCUMULATOR

100  
Guineas  
for a  
Name!

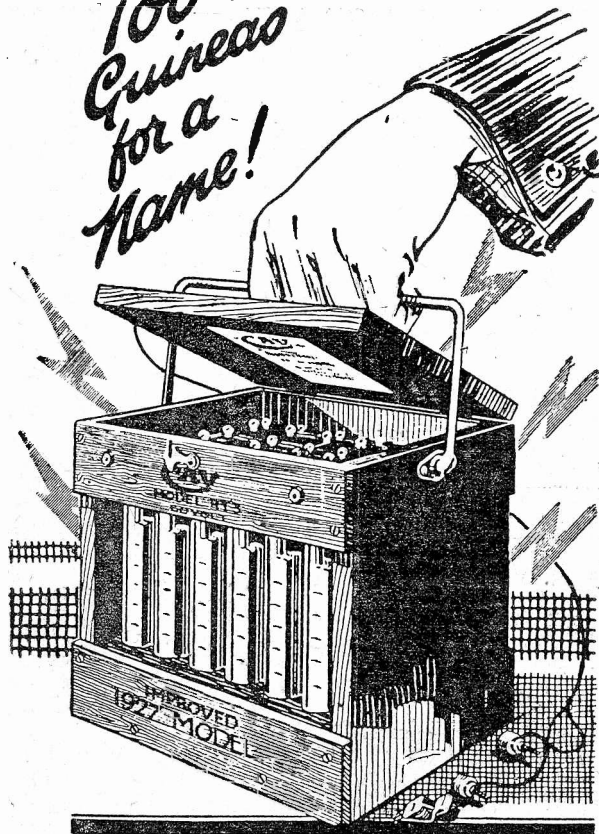

MODEL  
H.T. 3  
(160 VOLTS)

60

SUPPLIED  
READY FOR USE  
NO FILLING,  
WITH ACID.  
NO CHARGING

Dimensions 8 1/2" x 7" x 7 1/2" High  
Weight Charged 16 1/2 lbs Dru 13 1/2 lbs.

Also supplied in 30 or 90 Volts at proportionate prices.

COMPETITION OPEN TO USERS OF THIS ACCUMULATOR.

Full particulars, including conditions of competition, will be forwarded on application. Owing to the various special features of our H.T. Accumulator we desire to give it a distinctive name, and invite suggestions. Prizes will be awarded as follows—

**FIRST PRIZE - 75 GUINEAS**  
to the entrant of name adjudged the best.  
**SECOND PRIZE - 25 GUINEAS**  
to the trader from whom the First Prize  
winner purchased his Accumulator.

**C.A.V. Vandervell & Co., Ltd.**  
ACTON, LONDON, W. 3.

Telephone: Chiswick 3801  
(Private Branch Exchange)

Telegrams:  
"Vanteria-Act-London."

**The NATIONAL WIRELESS WEEK**  
NOV. 7th—13th  
'Let your Friends Listen'

<b>COIL SCREEN &amp; BASE</b>  ONLY 9/-	<b>S.L.F. CONDENSER</b>  4-in. dial. .0003 7/- .0005 7/3	<b>RELIABILITY CONDENSERS</b>  Mansbridge Type. Mids. 1/6 1, 2/6 .25, 1/8 1, 2/6 .5, 1/8 2, 3/6	<b>WIRELESS CABINETS</b>  For Panels 7 in. high Width 8in. Hinged Lid Oak 12 in. 17/- 14 in., 17/6; 18 in., 18/6. Mahogany, 1/- extra.	<b>DEWAR SWITCH</b>  12-Contact. 2/6
---	--	--	--	---

READ THIS LIST AND SAVE MONEY ON COMPONENTS

**ACCUMULATORS**—Exide, D.T.G., 4/6; D.F.G., 8/6; W.J., 20 v. H.T. type, 15/-; Oldham H.T. 16d. per volt, complete; Duros 20 v., 11/-; 10 v., 5/6; Resisting Outfit, 2/6.  
**AERIALS**—200 ft. in copper tape, 1/6; 7/822s Bright, 2/3; Enamelled, 3/3; Electron, 1/8; Superial, 2/6; Mars, 9/6; Ashton Spreaders, 12/- per pair; O.V., complete, 2/6.  
**INSULATORS**—Large Shell, 3d.; Reel or Egg, 1d.; Climax, 6d.; Ditto, with shock absorbers, 3/- pair; Gal. Fulleys, 4d.; 100 ft. Gal. Straining Wire, 1/6; Straining Bolts, 6d.  
**EBONITE**—Any cut, Cleitor brand, 4 in., 1d. sq. in.; 9 in. by 5 in., 2/2; 12 in. by 9 in., 4/6; 15 in. by 9 in., 5/6; 3/16 in., 25 per cent. less. Paragon and Radon, 1d. per sq. in.  
**CONDENSERS**—Low Loss, Square Law, with knob and dial, .0005, 5/-; .0003, 4/6; with Vernier Blade, 1/4 extra; Twin .0005, for Elstree Six, unequalled value, 9/6; Cylon Twin for ditto, 27/6; Ormond, J.B. Utility, Sterling, Polar, Formo, Igranite, G.E.C., Variable in all capacities. Neutrodyne types, Ormond, 2/-; Colvern, 3/6; Gambriel, 5/6.  
**FIXED CONDENSERS**—Dunbar, Edison Bell, Lissen, Watmel, Mullard, McMichael, at advertised prices. Special Reliability Fallon, .0003 mfd., 2 mes. Leak, 1/3; Cases only 4d.  
**TERMINALS AND ACCESSORIES**—Single W. Office N.P. or Pol. Brass with nut and washer, 1d.; Phone and Castle type, 1d.; Double Mark, 3, 2d.; 4-way Phone Connector, 6d.; Pole-binding paper, 3d.; Fluxite, 8d.; Black Tape, 6d. coil; in. Empire Tape, 6d. dozen yards; Insulating tube, 3d. yd.; Glazite, 1/2 10 ft. coil; Shellac Varnish, 6d.; Mica 2" x 1 1/2", 4d. doz.  
**VALVE HOLDERS**—Anti-Phonic Benjamin, 2/3; Lotus, 2/3; with terminals, 2/6; Burndept, 2/9; Harlie, 1/6; Reliability, unequalled, 2/-; all baseboard types, ordinary ditto, 6d.; N.P. Valve Sockets, flush fitting, 1d.; Superior Panel Type, 6d.; All Ebonite, 10/6.  
**HEADPHONES**—B.T.H., 15/-; Brown's "F" Type, 20/-; Reliability, 7/6; Adjustable, 8/-; Dr. Nesper, 12/11; T.M.C., 17/6; Western Electric, 20/-; all 4,000 ohms: Sullivan, 120 ohm Double, Ex-Govt., New, 4/-; 120 ohm Single Phone, 2/6; Long Phone Cord, 1/-.  
**BATTERIES**—Reliability, 90 v., 11/-; 60 v., 7/6; 36 v., 4/6; 15 v., 1/10; Ever Ready, Baby Grand, 18/-; Ormond, 15/-; Royal, 20/-; Success, All Black, 21/-; Silvertown, 21/-; Siemens, Hollesen, 100 v., 21/-; 66 v., 12/8; 36 v., 7/6; Flashlight Battery Cases for 14 Batteries 3/6, 4 v. Batteries, 4d. 60 v., Unequalled, 8/6; Wander Plugs, 1d.; Clix Type, 2d.  
**L.F. TRANSFORMERS**—R.I. Multi-Ratio, 25/-; Marconi Ideal, 25/-; Junior, 18/6; Ferranti A.F.3, 25/-; A.F.4, 17/6; Formo, 10/6; H.T.C. Empire, 7/6; Croix 5 to 1 5/-; Lissen new type, 8/6; Igranite, 10/-; Eureka Concert Grand, 25/-; No. 2, 21/-; Baby Grand, 18/-; Ormond, 15/-; Royal, 20/-; Success, All Black, 21/-; Silvertown, 21/-; G.R.C., 15/-; Brandes, 17/6; Burndept, 16/6; Special Valve, 7/6; Modulation, 7/6.  
**RECENT REDUCTIONS**—Sterling .0005 Square Law Condensers with Vernier, 9/6; Geared 12/-; Miniloss 15/-; .00025, 8/6; Geared, 10/6; Miniloss, 14/-; Marconi Automatic Detector, 2/6; Series Parallel Variometer, 10/6; Eddystone Absorbos feet, set of four, 2/3; Benjamin S.P. Switch, 1/3; N.P. Clix Plug and insulator, 2d.; Adaptor, 1d.; Socket, 2d.  
**LATEST COMPONENTS**—6-Way Coil Stand, 2/9; Colvern Low Loss Inductance Former, 5/6; Formo Straight Line .0005 Condenser, 10/6; Success, 18/6; Eureka, 15/6; Cylon, 15/6; Lissen 60 volt H.T. New Process Battery, 10/6; Valve Vibrating Springs, 6d. set of four.  
**EXPERIMENTERS' PARCELS**. Accessories of Various Types, worth 20/-, post paid, 5/6.

Send for RELIABILITY WIRELESS GUIDE No. 2, Free on Request Trade Supplied

**J.H. TAYLOR & CO.**  
11, RADIO HOUSE,  
MACAULAY ST., HUDDERSFIELD.  
Tel. 341. Grams: THOROUGH HUDDERSFIELD.

Orders 5/6 Value Carriage Paid, Under 5/6 2d. per lb. for Packing, etc.

If coils were this size the Lotus would hold them securely

The Moving Block Cannot Fall

The vernier movement comprises three sets of enclosed precision machine-cut gears, and reduces the speed of the moving block by eight times.

Side plates, coil blocks, and knobs in artistic bakelite mouldings. All metal parts heavily nickel plated. Made for left as well as right hand.

Patent No. 244,251

**PRICES:**  
Two Types:  
For outside panel mounting:  
Two-way ... 7/-  
Three-way ... 10/6  
For inside baseboard mounting, with 6-in. handle:  
Two-way ... 8/-  
Three-way ... 12/6

**LOTUS**  
VERNIER  
COIL HOLDERS

Made by the makers of the famous Lotus Buoyancy Valve Holder.

GARNETT, WHITELEY & CO., Ltd.  
Lotus Works, Broadgreen Rd., LIVERPOOL.

# JUST LIKE JACK-IN-A-BOX

Dutchman, Frenchman, Yank, Spaniard, German . . . . one after another up they come. They can all be tuned into a loud speaker with hardly more trouble than releasing the catch on the jack-in-a-box. They can be—but how often are they?—how often is the experimenter let down just at this point by inferior variable condensers?

Fit "Ormond"—the new Ormond S.L.F. "Slow-Motion Condenser" that the "Geneva Plan" has all but rendered imperative. The marking of the ORMOND dial enables listeners to pick up any station with the minimum of trouble and without any unnecessary calculations. The famous ORMOND SLOW-MOTION FRICTION DRIVE (RATIO 55-1) is incorporated and special ball-bearings give liquid-like movement to every turn of the knob. Easy to mount, having one and three hole fixings with both terminals and soldering tags for connections. Note the extraordinarily low retail prices:—

With 4" Bakelite Knob.  
 .0005 microfarad...20/-  
 .00035 " ...19/6  
 .00025 " ...19/-

**NATIONAL WIRELESS WEEK**  
 November 7th to 13th.  
*"Let your friends listen."*

With Dual Indicator Dial.  
 .0005 microfarad...21/6  
 .00035 " ...21/-  
 .00025 " ...20/6

NEW 1927 Catalogue (42 illustrated pages) gladly sent on request.



199-205 Pentonville Road, King's Cross, London, N.1.  
 Telephone: Clerkenwell 9344-5-6.      Telegrams: "Ormondengl, Kincross."  
 Factories: Whiskin Street and Hardwick Street, Clerkenwell, E.C.1.  
 Continental Agents: Messrs. Pettigrew & Merriman, Ltd., "Phonos House,"  
 2 and 4 Bucknall Street, New Oxford Street, W.C.1.

**DECKOREM**  
BRITISH MADE

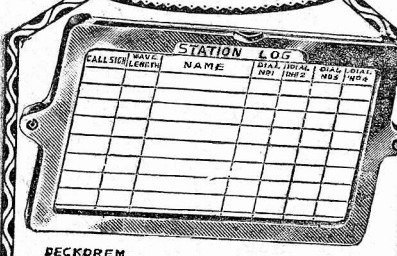

**STATION LOGS**

Make a permanent note of stations received! This handsome accessory is fitted with replaceable cards suitably printed. NICKEL PLATED, OXYDISSED COPPER, or OXYDISSED SILVER FINISH. Complete with cards.

Price **2/-** each.

**RUBY VALVE REFLECTORS**

A sure indication when set is switched "on" or "off," brilliant ruby lens reflects least glow from valves.

Price **9d.** each.

New Catalogues upon application.  
OBTAINABLE FROM ALL DEALERS OR

**A. F. BULGIN & CO.**  
9-10-11, CURSITOR STREET,  
CHANCERY LANE, E.C. 4.



**AERMONIC**  
VALVE HOLDER.

Don't pay more. You can't buy more. New design eliminates losses. New springing system gives better results. List of Aermonic Parts Free

**J. CHRISTIE & SONS, LTD.,**  
246, West Street, Sheffield.

London Agents: A. F. Bulgin & Co., 10, Cursitor St., London, E.C. 4

**BUILD A LOUDSPEAKER**

WITH OUR NEW  
**SEAMLESS MOULDED CONE**  
(Prov. Patent 25089/26)

and a BROWN A. or LISSENO LA. You will obtain PERFECT RESULTS. Successful construction for a minimum outlay is ensured with our Specialties. Illustrated Lists and full particulars for Stamp.

**GOODMAN'S, 27 Farringdon St. E.C. 4**

Also obtainable from Spencer's Stores, 4-5, Mason's Avenue, E.C. 2

**A HOME FOR YOUR WIRELESS SET**

OUR STANDARD  
CABINETS

are DUSTPROOF and house the whole apparatus, leaving no parts to be interfered with. All you do is UNLOCK and TUNE IN Made on mass production lines, hence the low price. Provision is made to take panels from 16x7 up to 30x18 in.

Carriage paid and packed free England and Wales.

Thousand supplied with full satisfaction.

**MAKERIMPORT Co.**

From **£4 15 0** Write for descriptive pamphlet and suggestions for adapting your receiver or panel in our Standard Cabinets. Immediate Delivery. Dept. 4, Maxwell Chambers, 60a, Lord St. LIVERPOOL.

**COMPONENTS WE HAVE TRIED**  
(Continued from page 36)

This unit is extremely simple to work, and we can recommend it to our readers for use with receivers not employing more than four valves.

**"O.C." Transformer**

WE have received from Messrs. Peto-Scott & Co., Ltd.; an improved type of high-frequency transformer, suitable for use with the standard six-pin base. It may be used either in the standard screened coils, or on a six-pin base without the screens.

On actual test we certainly found that the circuit remained stable over a wide band of the neutralising condenser, and that certain circuits which could not be stabilised at all under normal circumstances were quite under control when this new type of transformer was utilised. When tested on the "Solydyne" and the "Mewflex" receivers the stabilising was found to be considerably simplified, and the overall amplification was somewhat increased.

The tuning properties of the circuits remain unimpaired, and the coils are interchangeable with the normal types of H.F. transformer.

We can recommend this interesting unit to our readers.

**EVERY LOUDSPEAKER**

**DESERVES**

**MULLARD**

**MASTER**

**VALVES**

— Ask for —  
**Mullard P. M. Power Valves.**

**VALVES!**

Radio Micro Power	Fama D.E.
3v 1 amp. - - 10/9	2v 2 amp. - - 4/-
3v 3 amp. - - 9/6	M.R., D.E.
Radio Micro D.E.	3v .06 amp. - - 5/6
3v .06 amp. - - 7/-	Fama 60-volt Batteries
Fama D.E.	3-volt Tappings
4v .06 amp. - - 5/9	Guaranteed - - 7/6
Fama Power	
4v 2 amp. - - 8/8	All goods sent post free.

Trade Enquiries Invited. Write for Lists —  
Kindly note change of address —  
**W. SEGAL, 58, RUSSELL ST., LONDON, E.C. 1.**

**"WET" H.T. BATTERIES**

COMPLETE SACK LECLANCHE CELLS. WAXED JAR (1 1/2 by 1 1/2 by 2 1/2). DOUBLE CAPACITY SACK with insulating rings and waxed carbon. ZINC with connecting wire.

PRICE 6/- per doz. CARRIAGE FREE. TRADE SUPPLIED.

**S. E. JONES & CO., Elsecar, Barnsley.**

**2-VALVE AMPLIFIER, 35/-**

1-Valve Amplifier, 20/-, as new; Valves, D.E. .06, 7/-; Headphones, 8/6 pair; new 4-Volt Accumulator, 13/-; new 60-Volt H.T., guaranteed, 7/-; 2-Valve All-Station Set, 24/. Approval willingly. Write for free bargain list.

**R. Taylor, 57, Studley Rd., Stockwell, London.**

**ELECTRADIX**  
**BARGAINS. No. 107**

- ULTRA ONE-METERS.** The famous 58 range Radio Star Instrument 50s. Multipliers 6s. 6d. each.
- SPARK SETS** Sterling Coil, with Contacts. Oscill. adj. Spark Gap. Tapped Helix 25 to 600 metres. H.T. Mica Condenser, Terminals and attachments on ebonite, fine panelled case. These Sets cost £15, and are given away at 15s. 6d. each. Post 1s. 6d.
- 700 G.P.O. 2-RANGE DETECTORS.** Ediswan G.E.C., 750 m/a and 2 1/2 v. etc. Brand new, 5s. 6d. each.
- CELL CHARGERS OFF A.C.** 220 volts 50 cycles to D.C. 6 volts. 6 amps. Fully guaranteed, 70s.
- 1,000 ACCUMULATOR FILLERS,** with suction bulb, celluloid acid chamber and nozzle. For Changing acid and testing Sp. Gr. 1s. 6d.
- WAVEMETER BARGAINS.** Bought from the Admiralty. Gambrell and Heterodyne Wavemeters; neat, but need recalibration. Last few clearing at 10s. each. Post 1s.
- SHORT-WAVE HELIX.** Copper strip on ebonite, with tapping clip, 5s.
- L. F. AMPLIFIERS,** 2-valve in mahogany case, 32s. 6d.
- PORTABLE FRAME AERIALS,** 21s. Indoor Wire 100 ft. 1s.
- DUCONETTE.** Plug in anywhere in lighting circuit, indoor aerial for 2s. 6d.
- 110-v. ELECTRIC IMMERSION HEATERS,** brand new, nickel-plated, with flex and plug. Boils water, eggs, milk, etc., in a few minutes. Two in series for 220 v. Sale price, 5s.
- 220 v. ELECTRIC TOASTERS,** nickelled, brand new, with flex and plug. List 35s. Sale, 7s. 6d.
- HOTPLATES, 100 v. LARGE, 200 v. SMALL SIZE.** Aluminium frame. List, 45s. Sale, 7s. 6d.
- 110-v. ELECTRIC BLOWERS,** or Hair Dryers. Work off 220 v. in series with lamp. Nickel-plated, lightweight, with control switch for hot or cold. Brand new, with flex cord and plug. List 45s. Sale, 12s. 6d.
- 110-v. ELECTRIC MASSAGE VIBRATOR SETS.** Work off 220 v. in series with lamp. Nickel finish with 5 applicators for muscular treatment. In padded case. Brand new. List, £4 5s. Sale 21s. 6d. 110 v. or 220 v. ELECTRIC IRONS, List 21s. Sale 10s. All the above guaranteed for A.C. or D.C., and brand new.
- 300 SURPLUS MARCONI 1-VALVE AND CRYSTAL DET. SETS,** in closed leather pattern case. Straight from the factory of a Leading Wireless Manufacturer, contain ebonite panel with nickel fittings for detector, valve holder, L. and S. wave switch, double spade tuning, two 1,000-w. 200/4,000-metre H.F. chokes, T.C.C. condenser, terminal and plug sockets. All new, fixed and partly wired, with wiring diagram and Osram valve. List price, £7. Sale, 10s. Finished complete, £7 10s. Sets with valve and tested on aerial, 30s.
- MK. III CRYSTAL SET AND TUNER.** Complete with Tapped Tuning Coils and Coupler Combination and Carborundum Detectors, Buzzer, Potentiometer, .001 and .0005 variable Condenser, Tune Stand-by Switch, Crystal or Valve Switch, in mahogany case. Panel engraved. Price 45s.
- EARTH MATS.**—Galv. wave-plate, with Electron wire riveted on, 2s. 6d.; post 9d. Copper Mesh Earth for short waves, 5s. 6d. each. Earth spikes, 1s. 3d.
- G.P.O. PORTABLE TELEPHONES.** Magneto ringing, containing Hand Combination, Phone, Microphone, Receiver, Condenser, Magneto, Bell, Transformer, etc., leather case. Worth £4 each. Price to clear, 22s. 6d.
- TWIN DOUGLAS PETROL ENGINES FOR ELECTRIC COUPLED GENERATION.** In good running order. To clear, £12.

- LABORATORY BRIDGE CONDENSERS,** 5,000 volt mica dielectric, and contain 7 separate condensers. Any condenser can be plugged in separate, and any combination of capacities can be obtained. Condensers all in 3 1/2 in. £2 each.
- M.III SINGLE VALVE TRANSMITTERS,** range 300-1,450 metres, containing Tuning Coil, with Stud Tapping, 2 Variometers, Variometer Reaction and Variometer Tuning, with Ratchet. Low Loss wound on tubular ebonite. Condenser .01. Wound Leak and Condenser. Multiple Switch, Lamp, Heavy Key, Aerial Ammeter, etc., etc., 1/2 in. Ebonite Panel. Cost £25. Price to clear 30s. each. With slight alteration these can be used for receiving. Carriage, 2s. 6d.
- SKINDERVIKEN CRYSTAL LOUD SPEAKER TRANSFORMERS** for Crystal Amplification. List price, 20s. To clear, 10s. each, post 6d.
- LOUD SPEAKERS**—Western Electric, 17s. 6d.; T.M.C., 12s. 6d.; Fuller's Sparta 4 guin., 50s.; Serenada, 30s. Texas Cone, 40s. Magnavox 50s.
- All parts for Paper Loud Speakers. Brown's A. Reed Receivers 12s. 6d. Plated 12 in. Twin Rings, 5s. pair. Stays, 2 for 1s. 9d. Machine Pleat, Parch. Paper for Diaphragms, 2s. 3d.

Personal inspection will convince you of our claim to hold the finest stock of perfect and accurate apparatus for immediate delivery in the City, and your call will be welcomed.

Our 4d. Catalogue containing 600 unique illustrations will save you pounds.

Have you bought your ONE-METER yet?

**ELECTRADIX RADIOS,**  
218, UPPER THAMES STREET.

Blackfriars Stn., Met. Rly. Tel.: City 0191.

## Critical Tuning needs Critical Registration.

The more responsive your set the more critical your tuning.

Can you afford to be without our new **ILLUMINATED TUNING DIAL?** Lights up when in use. Positive hairline tuning.

## ARE YOU BUILDING A MONODIAL OUTFIT?

Once again we are first in the field and have in stock all the components necessary for building the **MONODIAL Set** (full list on application).  
Total Cost - £12 13 0.

Also *Lewcos Coils, Coluenn Coils, Screened Coils, and all components for ALL RADIO PRESS OUTFITS.*

OUR INTERNATIONAL RADIO CATALOGUE (3rd Edition) will be sent to all enthusiasts sending 6d. to cover cost of postage and packing.

# WILL DAY, LTD.,

(DEPT. S),

19, Lisle St., Leicester Sq., London, W.C.2.  
Telephone: Regent 4577. Telegrams: "Titles, Westrand, London."

### HIGH & LOW TENSION ACCUMULATOR HIRE SERVICE

Here's a way of improving reception, saving money, time and trouble for all valve set users who live within 12 miles of Charing Cross. Write now for particulars of this unique service.

**RADIO SERVICE CO.,**  
106, Torrington Avenue, N.W.5.  
\*Phone: North 0623 (3 lines).

**ROTAX** High Tension Accumulators greatly improve Loud-Speaker reception, eliminating the uncanny noises caused by partly run-down dry batteries and may be hired ready for use.

If you add the depreciation in value to the cost of having your own accumulators unskilfully recharged, our Hire Service effects a considerable saving.

## SAXON GUIDE TO WIRELESS

This book enables any beginner to construct Wireless Sets which are unequalled in price, quality or efficiency, and the cost is only one-fourth the price charged for a ready-made instrument not half so good. The exact cost of each set is clearly stated.

### FULL INSTRUCTIONS WITH CLEAR WIRING DIAGRAMS

are given for making Super Efficient Crystal Sets, Dual Amplification Receivers, Single Valve Sets, One and Two Valve Amplifiers; Two, Three and Four-Valve Tuned Anode All-Wave Receivers, and the Very Latest Type of Five-Valve Resistance Capacity Receiver.

**NO SOLDERING, NO SPECIAL TOOLS NO KNOWLEDGE REQUIRED.**

The chapter on testing wireless components is alone worth the price charged. **176 PAGES.** **PRICE 1/3 POST FREE**

**SPECIAL OFFER.**  
This book will be sent on approval on receipt of your promise to return same post paid or to remit 1/3 within seven days.

**SAXON RADIO CO. (Dept. 32), Henry St. Works, BLACKPOOL**

## FORMO

### ULTRA LOW LOSS

#### Straight Line Frequency Condenser.

Cone bearings. Braced Vanes. Positive Collector. A real precision job.

Condenser only—  
0003 μF, 0005 μF ... **9/-**  
Condenser with plain dial. Standard 1/2" dia. Shaft ... **10/6**  
New Vernier Dial ... **6/-**

Reduction Ratio 16-1. No Backlash.

**THE FORMO COMPANY,**  
CROWN WORKS, CRICKLEWOOD, N.W.2.  
Phone: Hamp. 1787.  
Manchester: Mr. J. E. Leary, 29, Hartley Street, Levenshulme.  
Phone: Heaton Moor 475.

## WIRELESS Advertisement Rates

Per page and pro rata

	£	s.	d.
52 consecutive insertions ..	36	0	0
26 consecutive insertions ..	37	0	0
26 alternate insertions ..	38	0	0
13 consecutive insertions ..	38	0	0
13 alternate insertions ..	39	0	0
1 insertion ..	40	0	0

Single column space 30/- per inch

Communications should be addressed to  
The Advertisement Manager,  
**WIRELESS, Bush House, Strand, London, W.C.2**

### SPECIAL ADVERTISING OFFER during Wireless Week and SEVEN DAYS following.

## LOUD SPEAKER GRATIS

to every purchaser of a Three or Four Valve Radiax Receiver.

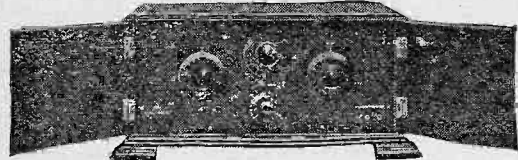

This offer closes on **NOVEMBER 20th.**

3 Valve Set (as illustrated) **£10.5.0** (plus 37/6 Royalty).  
4 Valve Set **£13.10.0** (plus 50/- Royalty).  
Either set obtainable on instalment plan to suit customers' requirements.  
Sets of parts for home assembly from £3.13.0 (2 Valves.)  
Order or enquire now to avoid disappointment.

**RADIAX LTD., 14, Accessory House, Palmer Place, London, N.7**

## NATIONAL WIRELESS WEEK

**Nov. 6th — 13th**

### LET YOUR FRIENDS LISTEN!

## COUPON

**QUESTIONS & ANSWERS**

"WIRELESS," Vol. VI. - No. 1

This coupon must be accompanied by a P.O. for 2/6 for each question, and a stamped addressed envelope when sending queries to the Radio Press information Dept. for a postal reply.

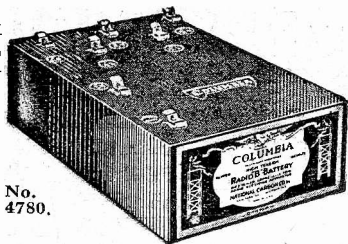

No. 4780.

**"They still read 55-56 volts after 12 months"**

Amateur Experimental Station: G6YR.  
Near Harrogate, Yorks.

DEAR SIRS,

Perhaps the following account of the life of some of your batteries may be of interest to you.

In September, 1925, I purchased 4 of your 4780 dry batteries, totalling, of course, 240 volts. These were obtained because in my present location I have absolutely no other method of obtaining High Tension for my low-power transmitter. I have kept a watchful eye on them and was quite prepared to have another set to buy after about say six months, but I have been amazed at their remarkable life, which so far is 12 months. Each battery still reads about 55 to 56 volts.

They have survived two serious shorts, which would have ruined any ordinary battery; and still continue to give service. My DX may be of interest as, obviously, the h.t. supply plays a big part in results. I have been in two-way communication with Finland, France, Belgium, Holland, Italy, Germany, Denmark, Sweden, Ireland, and Brazil, with an input of 2 (two) Watts, except for Brazil, when I added some more batteries and used 4.8 watts (four point eight). I have also been heard in New York when using 3 1/2 watts, and my telephony signals got out reliably to about 300 miles.

The transmitting circuits are normal ones, a wavelength of 45 metres is used and a Hertz radiator, badly screened, serves as antenna.

—a letter received from a user of Columbia Batteries.

## Columbia Dry Batteries

Ask any good dealer for full particulars or write to us for Columbia literature.

**J. R. MORRIS,**

15, 19, KINGSWAY, LONDON, W.C.2.

Telegrams: Colcarprod, London.

Telephone: Gerrard 3038.

Scottish Representative: John T. Cartwright, 3, Cadogan Street, GLASGOW.

## WHAT DO WE GAIN BY LOW-LOSS?

(Continued from page 34)

that a little more makes very little difference.

On the longer waves a low-loss coil in conjunction with an aerial kept very well away from trees and buildings all along its length will sometimes give a gain of 3 or 4 to 11. On short waves I doubt if there is any marked difference between any ordinary sized coils that can be wound.

### A Really Low-Loss Circuit

By the way, almost the best low-loss circuit I know of is a frame aerial wound of solid wire, each turn spaced from the next one and the framework kept to a minimum. On the Daventry wavelength I find such a frame often requires the insertion of a resistance in series to maintain good quality.

### In Intervale Circuits

Intervale circuits are the places where "low losses" will tell if they are used correctly. A coil of half the loss of another one can give double the magnification if the valves are altered to suit, or 1.4 times the magnification if the transformer ratio is altered, and if we have several such circuits in cascade the total gain can be made large.

### Another Aspect

All the time I have, of course, only considered the resistance as controlling the signal. This is the "in tune" position, but away from this position the reactance takes charge, and as that remains nearly the same, we can say our tuning is improved because we obtain a greater ratio of "in tune" to "out of tune" signals.

### Sometimes Not Desirable

There are one or two cases where low-loss is a disadvantage, chiefly in cascade H.F. amplification. In crudely constructed receivers insufficiently shielded and balanced the tendency to oscillate is greater with such coils, and may be uncontrollable. Then if care is not taken to obtain the right ratio of transformation the tuning curve of each circuit may be too low, with the result of far too sharp a resonance curve, and muffled signals unless mistuning is applied. This muffling is particularly easy to produce on Daventry's wavelength.

### LET US KNOW YOUR RESULTS

How many stations have you heard on the loud-speaker with your Monodial? How near to the wave of the local station can you tune without interference? Remember that the Editor is interested to hear of readers' results in different localities.

IN six Mahogany Cabinets, best components and workmanship, SUPERHET, Convertible One to Three H.F. (Anode or Trans.), and One to Three Stages L.F. (Trans. or Resistance). Too large to take abroad. Accessories as required, cheap. Exceptional opportunity acquiring remarkably efficient set. Trial. Parts alone cost abt. £75. Accept half or near offer. HERBERT DUNK, "The Myrtles," Hawkinge, near Folkestone, Kent.

## EASY PAYMENTS

LOUD-SPEAKERS, HEADPHONES, H.T. ACCUMULATORS. Anything Wireless.

Send a list of the parts you are requiring, and we will send you a quotation on monthly payments.

H. W. HOLMES, 29, FOLEY STREET, Phone: Museum 1414. Gt. Portland St., W.1

## PICKETTS CABINETS

FOR EVERY CONSTRUCTOR.

"Monodial"	.. . . .	from 25/- to 40/-
"Davlow"	.. . . .	.. 35/- to 75/-
"Elstree" Solodyne	.. . . .	.. 45/- to 85/-
"Night Hawk"	.. . . .	.. 25/- to 45/-
"Midget Reflex"	.. . . .	.. 10/6 to 18/6
"Four Valves One Dial"	.. . . .	.. 17/6 to 30/-

GUARANTEED AND SENT ON APPROVAL. Estimates to your own sizes and LISTS FREE.

Picketts—Cabinet (W.L.) Works, Bexleyheath.

## From SCHOOL to PROFESSION via WIRELESS.

No long expensive apprenticeship; just RADIO MARITIME TRAINING, and your son will be placed in a responsible position. Within twelve months the capital invested is returned in his salary as a Wireless Operator. But it must be the TRAINING WITH THE WIRELESS SERVICE BEHIND IT. Write to Radio Maritime, Ltd., 15, Broadway Chambers, Hammersmith, W.6, or to 26-27, St. Mary Street, Cardiff.

### PHONE REPAIR SERVICE

Headphones rewound and Remagnetised 4/6. Loud Speaker rewound 4/6. Transformers rewound 5/-. Remagnetising only 2/-. All work guaranteed. Postage extra. Write for trade terms.—H. R. P. Co., 1, Cottrill Road, Spurstow Terrace, Hackney, E.8.

## LISSENOLA & BROWN "A" USERS.

Get the wonderful 14-inch

## CINCINNATI CONE, 1 1/6

Complete with bronze base and support, ready to have Brown reed phone screwed on making it into complete cone speaker, post 1/6. Attachment for Lissenola, 1/6 fully guaranteed.

J. W. MILLER, 68, Farringdon Street, E.C.4. Sole British Distributor. Phone, Central 1950

## EBONITE PANELS

or Strips, etc., described in this issue (or any other) can be obtained immediately through any trader from

TRELLEBORGS EBONITE WORKS, LTD. Audrey House, Ely Place London, E.C.1

## Valves Repaired

AS GOOD AS NEW!!

(Except Weeco, S.P.'s and low capacity types.) Minimum D.E. Current 0.15 amps when repaired. ALL BRIGHT & DULL EMITTERS Listed at less than 10/-. Minimum charge 5/-. VALCO LTD. Dept. W, Tabor Grove, Wimbledon, S.W.

## REPAIRS

By specialists skilled in every form of accurate and intricate coil winding.

Headphones, Loud Speakers and Transformers rewound, remagnetised, and reconditioned EQUAL TO NEW.

Owing to the rapid growth of business in our REPAIRS Department, we regret that we find it temporarily impossible to maintain our 24 hours service. Pending extension and re-organisation, a delay of a few days may be unavoidable.

VARLEY Magnet Co. Replacements Dept. Woolwich, S.E.18

**VARLEY**

Proprietors: Oliver Pell Control Ltd.



# 5/6

## THE SAFETY SWITCH

Prov. Pat. 20022/26.

Comprises Switch, Lightning Arrestor. Lead-in Tube and weather-proof cover. When off, the set is entirely disconnected from the Aerial and Lightning Conductance is attained *Outside* the house. Safety is ensured should you forget to switch off—by the Permanent Spark Gap provided.

Price - 6-inch Tube - 5/6  
 " 12-inch Tube - 6/6  
 " 18-inch Tube - 7/6

Write for List No. W.4, giving full particulars of the Eelex Standardised Plugs and Sockets System, recommended and used by all leading Wireless Journals.



E. J. EASTICK & SONS  
 Eelex House, 118, Bunhill Row, London, E.C.1.  
 \*Phone: Clerkenwell 9282-9283.

### AMATEUR TRANSMITTING NOTES

#### QRA's Wanted

SK-2NAX, SPR, SPM, PT5, SOUU, BXY, GC-2WL, LGN, OHK, G-5WK, G-6MO, G-6GA, G-6TR, G-6RT.

#### QRA's Found

G-2CB (ex 2BJK): C. A. J. Brookes, 7, Merivale Road, Putney, S.W.15.  
 I-1BS: F. Luise, Piazza Manzi 10, Piacenza, Italy.  
 I-1BF: O. Santini, Viale Cavour, 48, Ferrara, Italy.  
 CVPE: A. Gariso (Div. Hon. Sec., Div. 10), B. M. R. Telegraphs, Villa Pery, Portuguese East Africa.  
 BZ-1AO: F. N. A. Costa, Caixa Postal N. 1587, Rio de Janeiro, Brazil.  
 BZ-1BK: J. C. Roos, 139, Rua Paysandu, Rio de Janeiro, Brazil.  
 D-7AT: A. Lykstoff, 37 Julius Blomsgade, Copenhagen.  
 D-7NR: J. Nissen Rahn, 15, Bispegade, Haderslev, Denmark.

---

**WIRELESS.**—Capable trustworthy men with spare time who wish to substantially increase income required where we are not fully represented. Applicants must have practical knowledge of installation of Set and Aerial, be a householder or live with parents, and be able to give references; state age and experience. Address: Dept. 38, GENERAL RADIO COMPANY, LIMITED, Radio House, Regent Street, London, W.1.

# MICROMAIN

A PERFECT SUBSTITUTE FOR THE H.T. BATTERY, WHERE DIRECT ELECTRIC CURRENT IS AVAILABLE, AT A COST OF A FEW PENCE A YEAR.

SMALLEST



CHEAPEST

Size 3 1/4 x 4 1/4 x 3 1/4 ins.

THESE UNITS ARE SILENT, SAFE AND GUARANTEED FINISHED IN SOLID ALUMINIUM CASES COMPLETE WITH 6 YARDS OF FLEX AND LIGHT ADAPTER.

Model	Tappings	Finish	Price
SUPER	Ten 15-150	Polished	£2- 8-6
SPECIAL	" " " "	Dull Black	£2- 5-0
MARK II	Two 60 and 120	" "	£1-17-6
MARK I	One 90 or 120	" "	£1-10-0

Postage and Packing 1/- per unit extra.

**MICROMAIN UNIT SERVICE,**  
 46, ARTILLERY LANE,  
 LONDON, E.1.

Or Your Wireless Dealer.

**"ARJA" Guaranteed 2-Valve Receivers £6:10:0**  
 You must not miss this great opportunity of securing a guaranteed two-valve, all-station receiver complete with every accessory. Send at once for your copy of our Ultra Cat., Booklet No. 9 describing this instrument and many others. It is Post Free. You only have to get this book to be convinced. SEND NOW.  
 R. C. JONES, 75, HARGWYNE STREET, STOCKWELL, S.W.9

## THE REMARKABLE MONODIAL RECEIVER

Order all, or any, of these Components NOW!  
 IMMEDIATE DELIVERY.

	£ s. d.		£ s. d.
Cabinet (Camco) ..	1 15 0	4 Burndept Fixed Resistors and Holders ..	0 10 8
Ormond Double Condenser ..	1 12 0	2 Baseboard Neutralising Condensers ..	0 10 0
4 Anti Phonic Valve Holders (with terminals) ..	0 10 0	1 P.M. Midget Condenser ..	0 7 6
1 R1 Transformer (multi) ..	1 5 0	1 Varley 250,000 ohm Resistance ..	0 9 6
1 Igranic-Pacnet Transformer ..	1 4 6	2 Dubilier .002 Condensers ..	0 6 0
1 H.F. Varley Choke ..	0 9 6	Grid Battery Clips ..	0 0 6
1 Bulgin "On" and "Off" Switch ..	0 1 6	Battery Leads ..	0 8 6
2 Igranic-Pacnet Jacks ..	0 6 0	3 Pilot Lamps and holders for H.T. Fuses ..	0 4 6
1 Dubilier Condenser and Leak ..	0 5 0		
Ebonart 14in. x 7in. Panel ..	0 7 9		
2 H.F. Transformers and 6-pin Eases ..	1 2 0	Total ..	£11 15 5

Prompt delivery of all parts for "Elstree Six," "Solodyne," etc., etc. Send Cash with Order. Carriage paid on orders value £2 or more.

### County Electrical & Wireless Stores, Ltd.

2 & 3, Norfolk Street, Strand, London, W.C.2.  
 AND AT

1, South Street, Deal.  
 124, Sandgate Road, Folkestone.

5, Yelverton Road, Bournemouth.  
 86, Southgate Street, Gloucester.

**TRADE ALSO SUPPLIED. FULL DISCOUNT TERMS.**

# VACANCIES

APPLICATIONS ARE INVITED FOR TECHNICAL ASSISTANTS WHO HAVE A THOROUGHLY SOUND KNOWLEDGE OF MODERN SETS AND THE RECTIFICATION OF FAULTS. ONLY MEN OF SOUND EDUCATION AND TECHNICAL ABILITIES NEED APPLY.

APPLICATIONS *MUST* BE BY LETTER AND SHOULD GIVE FULLEST DETAILS OF EXPERIENCE AND SHOULD STATE SALARY REQUIRED.

## S.T. LTD., 2, Melbourne Place, London, W.C.2.



## Sources of supply

"THE WIRELESS DEALER and Radio Trade Journal" contains two important guides to sources of supply—Index to Advertisers and The Buyer's Guide. The first will refer to advertisements in the issue, while the second will direct you to the manufacturers of any particular product which you may require to order. These two guides compose an important fund of information.

Commence your subscription with the current issue—it is rather an important one for the retail section of the Trade. It contains a detailed "Stand to Stand Review" of the Great Exhibition at Olympia, a comprehensive résumé of the Shows at Belfast, Berlin, New York, and all available information of the Radio Show in one of England's greatest industrial centres—Manchester.

#### SUBSCRIPTION RATES:

7/6 per annum (abroad 10/-). Available to the Trade only. Trade card or business heading should accompany every subscription to the SALES MANAGER, Radio Press, Ltd., Bush House, Strand, London, W.C.2.

**The Wireless Dealer**  
AND  
Radio Trade Journal

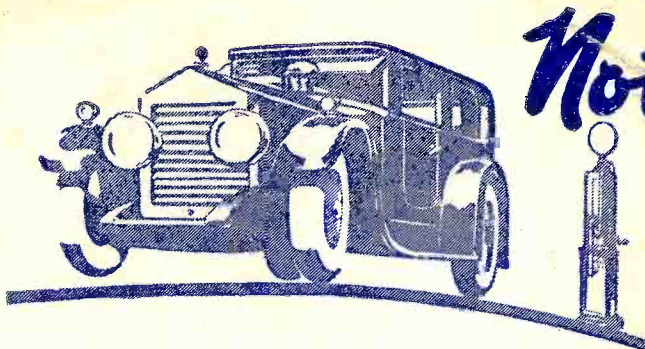

*Not*  
**M.P.G.**

*But*  
**H.P.C.**

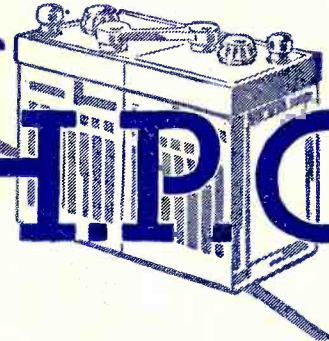

THE history of the radio valve industry is remarkably similar in outline to that of the motor industry.

In both cases the first endeavour was to secure reliable operation. For years the design of cars and valves was improved stage by stage, giving better results and longer service. Then came the question of perfecting that achievement by giving in the case of cars more

**M.P.G.**  
(miles per gallon)

In 1925 Mullard placed on the market the first of a series of valves with qualities far in advance of the old standards and consuming only one-tenth ampere, with the result that the broadcasting public were enabled to secure up to seven times more

**H.P.C.**  
(hours per charge)

from their accumulators.

At the same time these special valves gave them better, purer reception and the danger of loss due to accidents was reduced to a minimum owing to the extreme toughness of the unique Mullard P.M. Filament these valves embodied. In one short year over £200,000 has been saved in reduced upkeep costs by the users of Mullard P.M. Valves, apart from the renewal expenses that have been obviated by the vastly increased life of these valves.

Consider greater economy and greater results when you select your radio valves.

Ask Your Dealer for Mullard P.M. Valves with the Wonderful P.M. Filament.

**Mullard P.M.**  
**Valves will**  
**improve**  
**any receiver.**

- For 4-volt accumulator  
or 3 dry cells
  - THE P.M. 3 (General Purpose) 0'1 amp. 14/-
  - THE P.M. 4 (Power) 0'1 amp. 18/6
  - For 6-volt accumulator  
or 4 dry cells
  - THE P.M. 5 (General Purpose) 0'1 amp. 18/6
  - THE P.M. 6 (Power) 0'1 amp. 18/6
  - For 2-volt accumulator
  - THE P.M. 1 H.F. 0'1 amp. 14/-
  - THE P.M. 1 L.F. 0'1 amp. 14/-
  - THE P.M. 2 (Power) 0'15 amp. 18/6
- These prices do not apply in Irish Free State.*

**British Made**  
in a  
**British Factory**

# Mullard

## THE MASTER VALVE

ADVT. THE MULLARD WIRELESS SERVICE CO. LTD., MULLARD HOUSE, DENMARK STREET, LONDON, W.C.2

Published by RADIO PRESS, LIMITED, Rush House, Strand, London, W.C.2, on Tuesday of each week, and printed for them by THE AVENUE PRESS (L. Upcott Gill & Son, Ltd.), 55-57, Drury Lane, London, W.C.2. Address for subscriptions and Editorial Communications:—Bush House, Strand, London, W.C.2. Address for Advertisements:—Advertisement Manager, WIRELESS, Bush House, Strand, London, W.C.2. Phone: City 9911. Registered as a newspaper and for transmission by Canadian Magazine Post. Subscription rates U.K. and abroad:—13s. per annum, 6s. 6d. for six months, post free. Sole Agents for Australasia:—GORDON & GOTCH (Australasia), LTD. For South Africa:—CENTRAL NEWS AGENCY, LTD. American Agents:—INTERNATIONAL NEWS Co., New York. Canadian Agents:—THE AMERICAN NEWS Co., LTD., also IMPERIAL NEWS Co., LTD.



WIRELESS, incorporating 'Wireless Weekly,' NOVEMBER 20, 1926.

# WIRELESS



INCORPORATING  
WIRELESS WEEKLY

2<sup>D</sup>  
WEEKLY

Vol. VII NOVEMBER 20, 1926 [No. 2]

## PUTTING AMERICA ON THE LOUD-SPEAKER

By A. V. D. HORT, B.A.

## NEED WE NEUTRALISE ?

By J. H. REYNER, B.Sc. (Hons.), A.M.I.E.E.

## HOW TO MAKE THE COILS FOR THE MONODIAL

[Registered at the G.P.O. as a Newspaper]

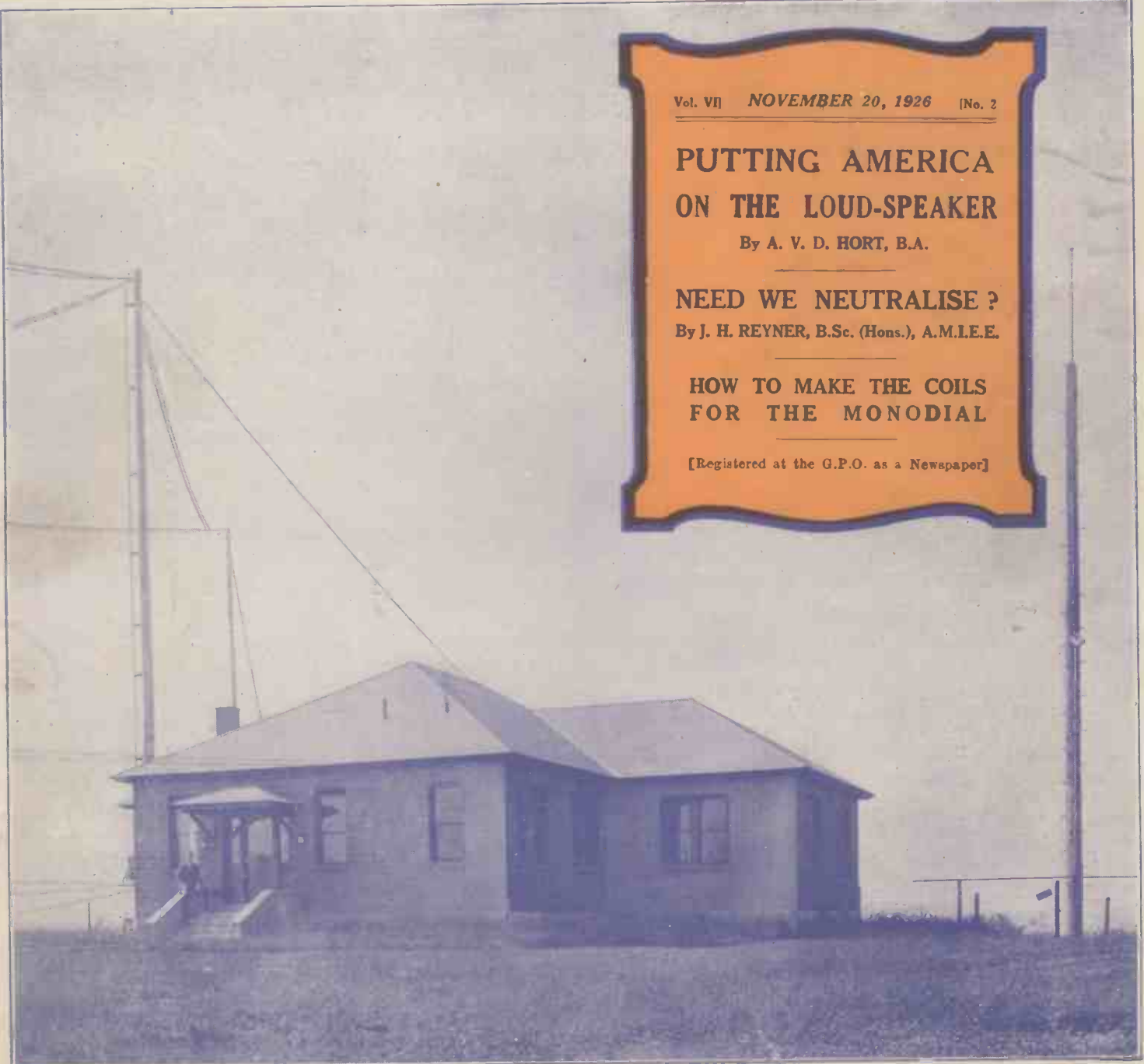

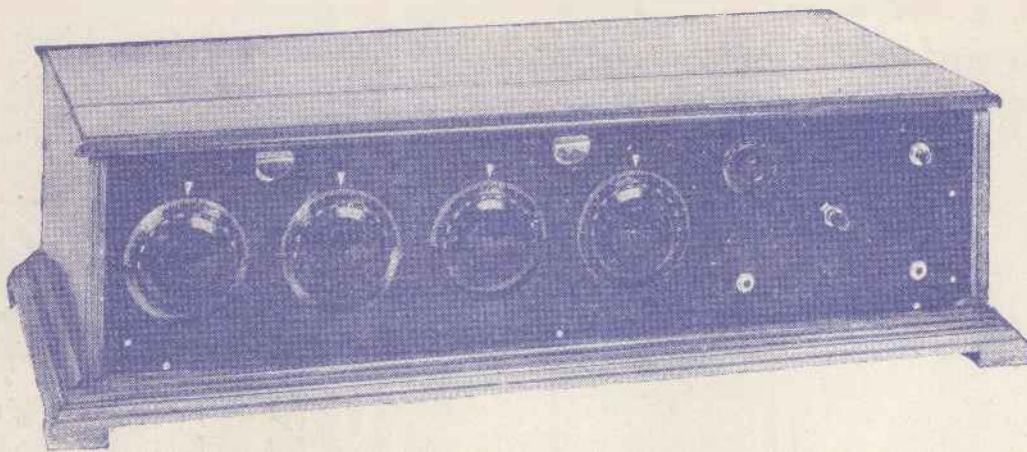

# THE "ALL-BRITISH SIX"

*European Championship Set  
described in the Issue now on sale*

**T**HE "ALL-BRITISH SIX" was entered for competition in the Multi-Valve Class of the International Amateur Set Building Contest at the Radio World's Fair in New York, and was awarded the Third Prize in this Open Competition.

A receiver, to compete successfully in America, needs selectivity of a very high order. Around New York, for example, there are over 65 Broadcasting Stations in operation.

The "All-British Six" uses the circuit of the famous "Elstree Six," modified to allow of the use of screened H.F. Transformers. This modification was made necessary by the extreme selectivity required.

Mr. H. E. Hassall, one of our readers, who constructed and entered the "All-British Six" for the New York Competition, describes in his own words the design and construction of the Set. Full details are given and the usual blueprints may be obtained, so that our readers may make up similar sets, and realise from their own experience the high performance of which the "All-British Six" is capable.

## BUY YOUR COPY TO-DAY

BESIDE THE FULL DESCRIPTION OF THE "ALL-BRITISH SIX," THIS ISSUE ALSO INCLUDES:

**Music Via the Ether**  
By JACK HYLTON.

**Making Use of Your Supply Mains**  
By J. H. REYNER, B.Sc.  
(Hons.), A.M.I.E.E.

**Choice of Programmes Made Easy**  
By STANLEY G. RATTEE,  
M.I.R.E.

**Getting the Best from the "Spanspace Three"**  
By G. P. KENDALL, B.Sc.

**A "Throttle - Controlled" Single-Valve Set**  
By L. H. THOMAS.

**Improving Your Short-Wave Set**  
By A. V. D. HORT, B.A.

**How Wireless Components Are Made**  
By CAPT. JACK FROST,  
M.I.R.E.

**Watch Your Batteries!**  
By A. S. CLARK.

**Do We Need Reaction?**  
By D. J. S. HARTT, B.Sc.

# The Wireless Constructor

SIXPENCE MONTHLY

*December Issue now on Sale*

From all Newsagents, Bookstalls and Booksellers, or direct from the Publishers, Radio Press, Ltd., Bush House, Strand, London, W.C.2.  
Subscription Rates, 8/6 per annum United Kingdom, 7/6 per annum Canada and Newfoundland, and Other Countries 8/6 per annum.  
*Lesser periods pro rata.*

# A Constant High Tension Supply for a Lifetime

## "Goltone" (Regd.) HIGH TENSION BATTERY ELIMINATORS

First cost saved in a short time. Gives increased volume and purity of tone. Simply plug in to any convenient lampholder.  
Complete with Lampholder Adaptor and Flexible Cord, ready for use.

### DIRECT CURRENT MODELS.

Type "D.J." Approx. Tappings, 45 and 100 Volts. Price 32/6

Type "D." Approx. Tappings, 30, 50, 75, 90 and 120 Volts. Price £3

### ALTERNATING CURRENT MODEL.

Approx. Tappings, 30, 60, 90 and 130 Volts. Dual Tappings are taken from each voltage, thus providing 8 separate Tappings.

Price £5 : 10, including valve.

Please state voltage and frequency of Lighting Mains when ordering.  
See List for full details of "Constructional Kits."



### USERS WRITE!

E. J. G., Hillside, Moulscombe, Brighton:—"I find it very satisfactory, and have recommended it to several friends."  
L. A. D., Collinor Road, Edinburgh:—"The Eliminator is working in a highly satisfactory manner."

J. W. G., Atkinson Road, Fulwell, Sunderland:—"I am delighted with the results. I did not think my set could do what it does with the Eliminator instead of dry cells. The increase in volume is great, and no trace of hum whatever."

Mr. H., Market Street, Kirkby Stephen:—"We have had several which have given every satisfaction."

Mr. B., Littleborough:—"Have installed the 'Goltone' A. C. H. T. Battery Eliminator, and must say it has exceeded expectations. It has not the slightest suggestion of hum or distortion of any kind, and is very satisfactory."

Mr. W. F. G., Longsight:—"I was delighted with the result—a beautiful tone, perfectly clear, and no harshness, and at the same time, I may as well tell you, it is a great saving of expense."

G. J. & Co., Church Road, Acton, London:—"The H.T. Eliminator is giving great satisfaction. It is being used within a short distance of an Electricity Station, and the set is perfectly silent, there being not the slightest suspicion of hum to be heard. It is the best we have seen."

Large fully illustrated 48-page Catalogue, No. R. 116, on request. Dealers should enclose Business Card for Trade Terms. Goltone Products are stocked by the Leading Stores. Refuse Substitutes.

### HIGH TENSION WANDER PLUGS



## EASIFIX "COURT"

### RADIO ASSEMBLIES.

Size over all, 8 1/2 ins. Eliminates ugly loose wires and minimises the risk of burning out valves. Each Conductor is distinctively coloured and the whole enclosed within a strong outer braiding. Fitted with Spade Terminals and Wander Plugs.

4 ways, 2/-; 5 ways, 2/3  
6 ways, 2/9; 7 ways, 3/6

Refuse Substitutes

TO HIGH & LOW TENSION PANEL TERMINALS.

### ACCUMULATOR CHARGING SETS for Home Service



### NO TECHNICAL KNOWLEDGE or ATTENTION REQUIRED.

Simple, reliable and convenient. Simply connect to any adjacent lampholder.

Complete with Adaptor, Connecting Cord and full instructions.

"INDISPENSO." (Direct Current.) Charges the High Tension Accumulator at no extra cost when light is in use. Price 6/-

"ALTERNO." (Alternating Current.) Charges the High Tension Accumulator at negligible cost. Price 21/-

Goltone "PENDELTON." Patent App. (Alternating Current.) Charges the Low Tension 2, 4 or 6 volt Accumulator economically and effectively. Charging rate approx. 2 amps. Price £2 : 12 : 6. Fitted with Ammeter, as illus., £3 : 7 : 6

Please state Voltage and Frequency of Lighting Mains when ordering.



"PENDELTON" CHARGER with Cover removed.



CABINETS



CABINETS

## THE MONODIAL

As Specified.

Real Oak - - - 32s. } Complete with Baseboard.  
Solid Mahogany - - 35s. }

WE CAN SUPPLY ANY CABINET REQUIRED.

Send for 20-page Illustrated List FREE.

CARRINGTON MANUFACTURING CO., LTD., Dept. S.W., 18-20, Normans Buildings, Central Street, London, E.C.1.

Telephone—Clerkenwell 5703.

Don't forget to use

# GLAZITE

BRITISH MADE REGD.

## COLOURED CONNECTING WIRE

[ RED YELLOW · BLUE · BLACK · WHITE and GREEN ]

Write for descriptive leaflet to

The LONDON ELECTRIC WIRE CO. & SMITHS LTD. Playhouse Yard, Golden Lane, London, E.C.1.

Makers of Electric Wire



for over 40 years

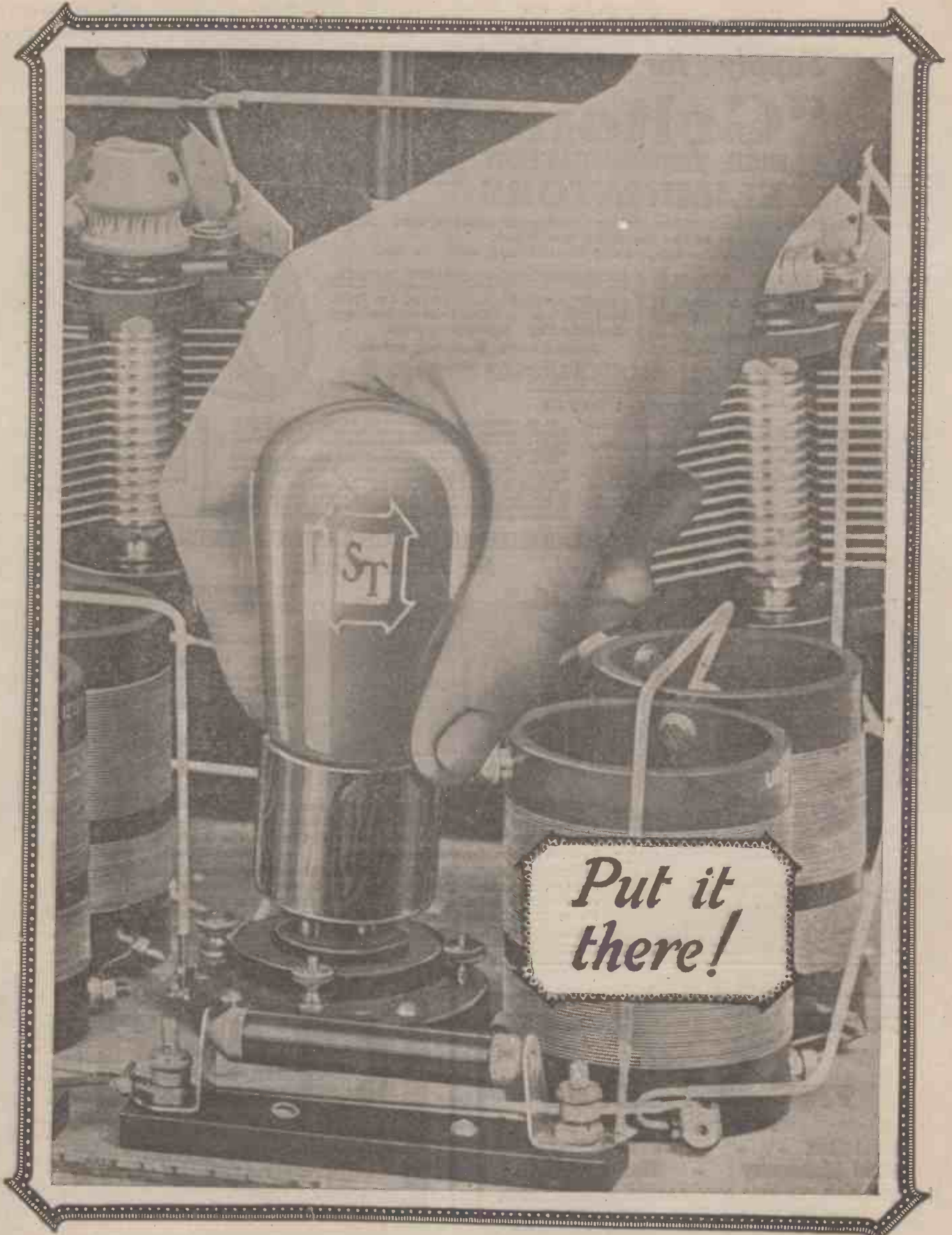

*Advt. of S. T. Ltd., 2, Melbourne Place, Aldwych, W.C.2  
(next to Australia House).*



# WIRELESS

INCORPORATING  
WIRELESS WEEKLY

Published by  
**RADIO PRESS, LTD.,**  
Bush House, Strand, London, W.C.2.

All communications concerning contributions should be addressed to the Editor and must be accompanied by a stamped addressed envelope if the return of MSS. is desired.

Nothing contained herein is to be regarded as encouragement or permission to infringe any patent rights.



## THIS WEEK'S NOTES AND NEWS

### Criticism Invited

**A** WELL-KNOWN B.B.C. official recently took some pains to impress upon me the fact that the B.B.C. wants to receive helpful criticism of its programmes, and wants it badly. What is not needed is the purely destructive criticism that all too often forms a large percentage of the morning postbag. Any letter containing complaints, together with a real and clear reason for putting those complaints forward, is welcomed, but unfortunately is rather a rare specimen.

### Progressive Danzig

**T**HE Post Office at Danzig is in future remitting the licence fee (24s. per annum) in all cases of blind listeners, and, in addition, has organised a fund to provide the blind with sets. Contribution boxes for this fund are installed in all the post offices, and I understand that well over 100 poor people have already received sets. When will this state of affairs be reached in this country?

### Not Wanted

**N**EW YORK has staged the "latest" yet again. A broadcast and a film of a sensational murder trial were both carried out. I may be accused of being narrow-minded, but I must confess that I don't see any object whatever in broadcasting such a sordid business as a murder trial. Still, one never knows how the American public will take it. There may, as a result, be a huge demand for more murder trials in the future. One thing is quite certain: I shall not sit up till 3 a.m. to listen to them on short waves!

### Irish Progress

**M**R. J. WALSH, the Free State Minister for Posts and Telegraphs, considers that within a year or fifteen months every single home in the Irish Free State will be within crystal range of a broadcasting station. He has great plans up his sleeve for the development of broadcasting in the Free State.

### Longer Broadcasting Engagements

**I**T is possible that in the near future the B.B.C. will engage artists in a somewhat similar manner to that in which they are engaged in the music-hall and theatrical world—by the week or fortnight. This is, naturally, the direct result of the recent refusals of well-known artists to give single broadcasts.

Broadcast artists in the States, by the way, have lately taken to the engaging habit of allotting themselves "aeromarks," by which listeners will know them. These aeromarks, or air signatures, serve to help the listener to identify an item when he has missed the announcement. Some of them have even been copyrighted! If you listen, for instance, and hear two rings on a bell, a sound like a carrot growing, and a perfectly enormous explosion, you will know that it is Uncle Jumbo on the air!

### IN THE DUBLIN STUDIO



*The Governor-General of the Irish Free State, Mr. Tim Healy (centre), broadcasting a speech from the Dublin station on the occasion of the Wireless Exhibition held in that city recently.*

### Future Exhibitions

**I**N view of the great success of the Birmingham Radio Exhibition, which ended on October 16, it is probable that Birmingham will in future have an exhibition as a regular annual feature. This suggestion has been made by twenty independent firms, several of whom have expressed themselves willing to take extra space at the next show.

### A New Station

**A** LARGE broadcasting station with an estimated range of 2,000 miles has just been put into operation at Caracas, Venezuela, AYRE, as the newcomer calls itself. (Continued on next page.)

### Ingenious!

**A** WELL-KNOWN telegraph line is showing large placards worded "Messages accepted here for transmission to Mars. Delivery Guaranteed." In brackets, after the word "Mars," in very small letters, is "Pennsylvania." Not many know that that state boasts a town of Mars!

## This Week's Notes and News—continued



The deadlock between Mr. de Groot and the B.B.C. now appears to be complete. This portrait of the well-known conductor shows him with the loud-speaker of a receiving equipment which has been reported to be his only reward for his first eighteen months' broadcasting!

has already been heard all over Venezuela, in spite of the fact that the preliminary tests have only been carried out on low power. It will serve Colombia, Barbados, Trinidad, and some parts of Porto Rico.

### On the Small Scale

THE latest achievement in the realm of broadcasting is that of amplifying the sounds which occur when an atom is split up. Doctor Hans Petterson, of Stockholm, has succeeded not only in making the effects accompanying this experiment visible, but also *audible!* Atoms of silicon, magnesium and carbon have been split. Another device reproduced on a loud-speaker the sounds caused by the collisions of atoms of aluminium with the "debris" of a radium atom; I am told that the sounds resembled "the cannoning of billiard balls."

### A Contrast

MR. GEORGE PALMER PUTNAM, an American publisher, and director of an expedition to Greenland, recently spoke to his wife in New York by Radio from Ellesmereland, in the Arctic, 4,000 miles distant. Mr. Putnam was experiencing the coldest of cold weather, and his wife was in the throes of a heat-wave at the time!

### An Occasion for Television

THE quaint ceremony of the handing over of the King's Keys at the Tower is to be broadcast some time next month, probably on December 9. Unfortunately the sounds associated with the ceremony are not particularly inspiring. We must really hustle up this television business!

### The Premiers at Rugby

PROBABLY one of the most interesting messages transmitted from Rugby was Mr. Bruce's message of greeting to those "back home," on November 6. It was worded as follows:—"From this great wireless station, which communicates with every part of the Empire, near and far, I send to the people of Australia greetings and most sincere wishes for their happiness and prosperity." Twenty-five minutes later the reply was received from Sydney by Imperial Cable, and later word was received from Melbourne that the message had been given out to the Australian Press. It is rather amusing to note that all the distinguished visitors received slight shocks as they grasped the door-handles of their cars at the end of the visit. Rubber tyres form good insulators!

### Judging by Wireless

ON November 20 the Newcastle station will broadcast a brass band contest, which will include the



Reported to be the first such occasion in the history of Spain, the famous Cathedral of Primada has been fitted with a wireless installation. The Dean of the Cathedral is seen in this picture speaking into the newly-fixed microphones.

Beecham would say on the subject of "judging by wireless"!

### Some Coming Events

ON November 28 Mr. Arthur Bourchier will broadcast from 2LO.

The Co-Operators' programme, arranged for a date in July and postponed, is arranged to be broadcast from Kingsway Hall on November 23.

On St. Cecilia's Day, November 22, a special "Blind Programme," arranged by Captain Ian Fraser, M.P., is to be broadcast. Sinclair Logan, Ronald Gourley, and other blind artists, well known to listeners, will participate.

A performance of "Acis and Galatea" will be relayed from the Bishopsgate Institute on December 2.

On the same day Mr. Ramsay Macdonald will give a talk called "Days and Nights in the Sahara."

The principal artists from Felgate King's "Pier Revels of 1926" and "Spa Revels of 1926" will broadcast from 2LO on December 1.

The organiser of "My Programme" on November 29 is described as "A Wireless Pioneer."

"How's That?" is a new radio revue by Mr. C. A. Lewis (Uncle Caractacus), and is being broadcast to-night.

CALL-SIGN.



Interested sightseers at the Manchester Wireless Exhibition inspecting the original television apparatus which Mr. J. L. Baird (extreme left) used in his early experiments.

counties of Northumberland, Durham, Cumberland, and Westmorland. The judge will not see the bands, but will judge them from a special studio in which their performances will be reproduced. I wonder what Sir Thomas



## First Details of a Promising New Type of Circuit

In this article Mr. Reyner gives an account of a promising invention which has just been tested out at Elstree, and which he considers to contain great possibilities for the development of circuits which are inherently stable without neutralising.



**NEUTRALISED** circuits in high-frequency amplifiers have enjoyed a considerable and well-merited popularity. One of the principal troubles arising from the association of efficient tuning circuits with anything approaching a high amplification is the regenerative effect produced by currents flowing through the inter-electrode capacity of the valve or valves in use. As is well known, this may be sufficiently large to cause continuous oscillation over a part or the whole of the tuning band, and it is to overcome this defect that extra circuits are incorporated in a receiver in order to neutralise this internal feed-back through the valve, the result being the neutralised circuit as we know it to-day.

### Great Progress

There is little doubt that the use of this basic principle in one or other of its several forms has enabled radio engineers to produce designs far superior to anything obtainable with the previous methods. Among recent British designs we have multi-valve receivers, such as the "Elstree Six" and the "All-British Six." We can obtain such stability that we can link up several tuning circuits together and so obtain receivers such as the "Solodyne" and the "Monodial." Even the simplest circuits incorporating one or more high-frequency valves can be controlled more easily by the use of a neutralised circuit, and there is a final advantage which is of very consider-

able importance in that the receiver is non-radiating, and any oscillation which may be introduced into the later stages of the receiver does not produce any appreciable oscillation in the aerial with consequent radiation.

### Prejudice!

In passing, reference may be made to the surprising fact that, despite the very large advantages which may be obtained with neutralised circuits, there are many thousands of radio

### Drawbacks

From another point of view, however, this type of circuit suffers from certain disadvantages. In the first place, its adjustment only holds good for a particular valve or type of valve. In the second place, the use of special coils or transformers is necessary. One either has to use some variety of centre-tapped coil or else a special transformer with a neutralising winding in addition to the primary winding, while finally the neutralising circuit suffers from a big disadvantage in that the amplification obtained over the whole of the scale is not uniform. This means that the receiver is more lively and tends to oscillate more easily on the higher frequencies (shorter wavelengths).

### Alternatives

Attempts have been made from time to time to utilise other systems of amplification which did not involve neutralising. One of the most successful circuits in this direction was the parallel-feed arrangement shown in Fig. 1. This was utilised in two very good receivers, the "DX 4" and the "DX 5," which were described by Mr. D. J. S. Hartt some months ago. Here it will be seen that the high-tension supply is taken to the valve through a high-frequency choke coil, while the high-frequency currents themselves are handed on to the next valve through a condenser and a suitable transformer arrangement.

This arrangement gives quite a high degree of amplification, because a full

(Continued on next page.)

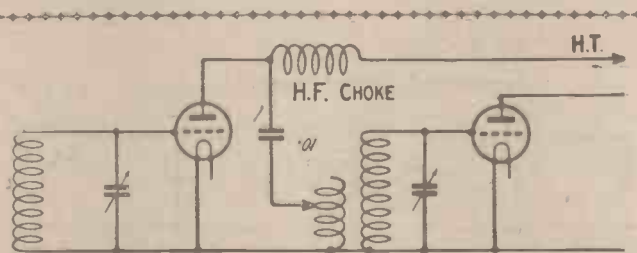

Fig. 1.—One of the successful circuits for H.F. amplification which does not necessarily involve neutralising is the parallel-feed arrangement shown above.

users who still retain their older pattern of receiver. One hears the remark, "Oh, I can't be bothered with neutralising!" and there the matter ends. This attitude may be due to the fact that in the earlier days of neutralising, when the underlying principles were not so fully understood as they are to-day, there was a certain amount of trouble obtained with neutralised receivers owing to the fact that the adjustment did not remain constant over the whole of the tuning band. These difficulties have, of course, been satisfactorily overcome, but prejudice against the neutralised circuit still remains.

## Need We Neutralise?—continued

step-up effect can then be obtained in the transformer, and it has the important advantage that if the constants are correct in proportion, the whole arrangement does not tend to oscillate.

### Importance of Phase

The reason for this is at once simple and straightforward. If an investigation is made of the conditions under which oscillations can be produced by regeneration through the inter-electrode capacity of the valve, it is found that there are certain well-defined limits. In the Inventions and Developments column last week I dealt briefly with this subject, and showed that everything depended upon the relative phase of the reaction currents through the valve and the currents already existing in the grid circuit. It can be shown that the reaction currents are only in the correct phase when the anode circuit of the valve is inductive.

### The Conditions

Thus, if we have a coil in the anode circuit the valve will tend to oscillate. If we have either a resistance or a condenser, oscillation will not result. In the case of a resistance the circuit will be neutral, whereas if the anode circuit is capacitive, then there will not only be no oscillation, but a very definite damping effect. The anode circuit of a valve is very often made up of a network of coils and condensers, but it is easy to calculate the total effective impedance of the network, and according to whether this is inductive, resistive, or capacitive, so we obtain oscillation, pure amplification, or damping.

The parallel feed circuit shown in Fig. 1 can be made by suitable design to be predominantly capacitive, so that the receiver will not tend to oscillate and will be perfectly stable. For a good design, of course, it should be only slightly capacitive, so that there should be only very little damping produced in the circuit, but just sufficient to overcome any stray couplings which may exist between the various coils in the circuit.

### A Defect

A simple circuit such as this, however, suffers from one serious disadvantage, namely, that the effective

impedance of the whole combination varies with the frequency. Thus if it is just capacitive at one frequency it may possibly change completely and become inductive at another frequency. The design must be so arranged, therefore, that it is capacitive at all frequencies over which the circuit is to be worked, and if this is done it means that it will lose efficiency at one end of the scale. If it is only just capacitive at one end of the scale (so that the circuit is just

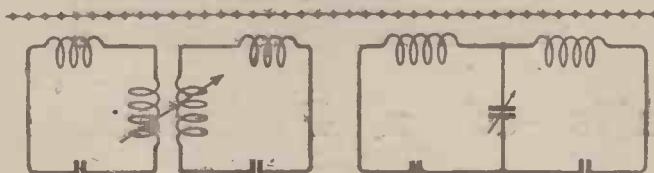

Fig. 2.—The two different kinds of coupling mentioned by Mr. Reyner in his discussions can be reduced to this simple form.

stable), then at the other end of the scale it will of necessity be considerably more capacitive, and an appreciable amount of damping will be introduced into the circuit.

### The Solution Discovered

This problem is similar to that which exists with the ordinary neutralised circuit in which the overall amplification obtained varies with the frequency, and the two problems may be investigated side by side. Recent re-

searches have shown an excellent solution to the problem. Not only is this solution satisfactory, but it opens up a whole field of new circuits for use with high-frequency amplifiers, and, in fact, the development is one which possesses very great possibilities.

### Variation With Frequency

Now electro-magnetic coupling increases with the frequency. Two coils spaced at a given distance apart have a certain mutual inductance between them. If we pass a current through one coil a voltage is produced in the second coil, and the extent of this induced voltage in the secondary is dependent upon the product of the current in the primary, the mutual inductance between the coils, and the frequency of the current. Now under normal conditions the value of the current and the mutual inductance remain constant, but the frequency changes as we go from top to bottom of the broadcast band, and consequently the voltage induced in the secondary, and so the amplification over the whole stage varies over the whole wavelength range.

### Compensation

Capacity coupling, on the other hand, does just the reverse. If we pass a current through a condenser, then the voltage which is produced across that condenser varies with the capacity of the condenser, the value of the current, and inversely as the frequency. Thus if we increase the frequency of the current we reduce the voltage produced across the condenser. Fig. 2 illustrates the two types of coupling.

It will readily be seen that if we can combine these two effects, which are in opposite directions, and if, moreover, we can make the extent of the coupling due to each effect equal in magnitude, then we should obtain a uniform amplification over the whole stage. At the lower frequencies the voltage produced by the capacity coupling would be large, and that produced by the magnetic coupling small. At higher frequencies the position would be reversed, and by a suitable design of the constants of the circuits it is possible to arrange that these two effects balance each other out completely over the whole range.

### Tests at Elstree

Now, experiments which have been conducted at Elstree indicate that this

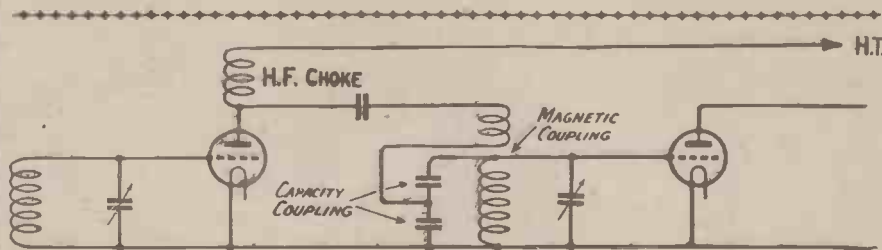

Fig. 3.—In this circuit a combination of magnetic coupling and capacity coupling is used to enable a level amplification curve to be obtained over the whole range of frequencies.

searches have shown an excellent solution to the problem. Not only is this solution satisfactory, but it opens up a whole field of new circuits for use with high-frequency amplifiers, and, in fact, the development is one which possesses very great possibilities.

The overall amplification obtained in a high-frequency stage is dependent upon the coupling in the transformer utilised between the stages. (A tapped coil or tuned-anode arrangement may be considered as a particular kind of transformer.) This coupling may be of two kinds, either magnetic or electrostatic. Magnetic coupling is obtained by direct coupling between two coils or by taking a tap-

(Continued on page 87.)



# Here

R.C. THREESOME  
3-valve resistance  
capacity voltage  
coupled receiver.

# it is!



Ask your dealer about the new **EDISWAN ECONOMY VALVES**

QUARTER-WATT POINT ONE RANGE

*There is an Ediswan Valve for every Wireless Purpose*

**FIT EDISWAN VALVES AND NURSE YOUR SET**

**Free**

**R.C. Threesome**

**3** Coupling

**CHEAP**

3 HOURS TO MAKE

**£3** (or less) FOR P

INSTRUCTION

This book is written in simple non-technical language. Anyone can follow the directions.

## The R.C. Threesome - A wonderful 3 valve set you can build yourself in three hours for £3.0.0. or less

Again, Ediswan leads!—this time with resistance-coupling amplification.

Beautiful, mellow, natural reproduction with an abundance of volume has been made possible by the employment of two New Ediswan Valves—R.C. 2 and P.V. 2—in the new quarter-watt POINT ONE ECONOMY Range.

For the betterment of wireless reproduction, with economy, Ediswan offers FREE, the new R.C. THREESOME Book of simple-to-follow instructions, with a full size blue-print of the wiring diagram. A theoretical diagram is included for experienced experimenters.

If you can use a screwdriver you can make this set in one evening—it's so simple. The necessary components are inexpensive—in fact, the set can be made for £3, or less.

Reception is truly remarkable. Both local and high-power stations come through at full volume—tone is pure and rich without a trace of the throatiness so evident in transformer-coupled sets.

With the R.C. THREESOME you are several steps ahead in radio.

### Fill in the Coupon NOW!

Applications for the FREE blue-print and FREE book of instructions will be dealt with in rotation.

# EDISWAN

F.I.

W. 20/11/26.

To THE EDISON SWAN ELECTRIC CO. LTD.  
123/5 QUEEN VICTORIA STREET - - LONDON. E.C.4.

Please send, post free, presentation copies of the "R.C. Threesome" Instruction Book and Blue-print.

Name .....

Address .....

PLEASE USE BLOCK LETTERS .....

# PUTTING AMERICA ON THE LOUD-SPEAKER

By A. V. D. HORT, B.A.

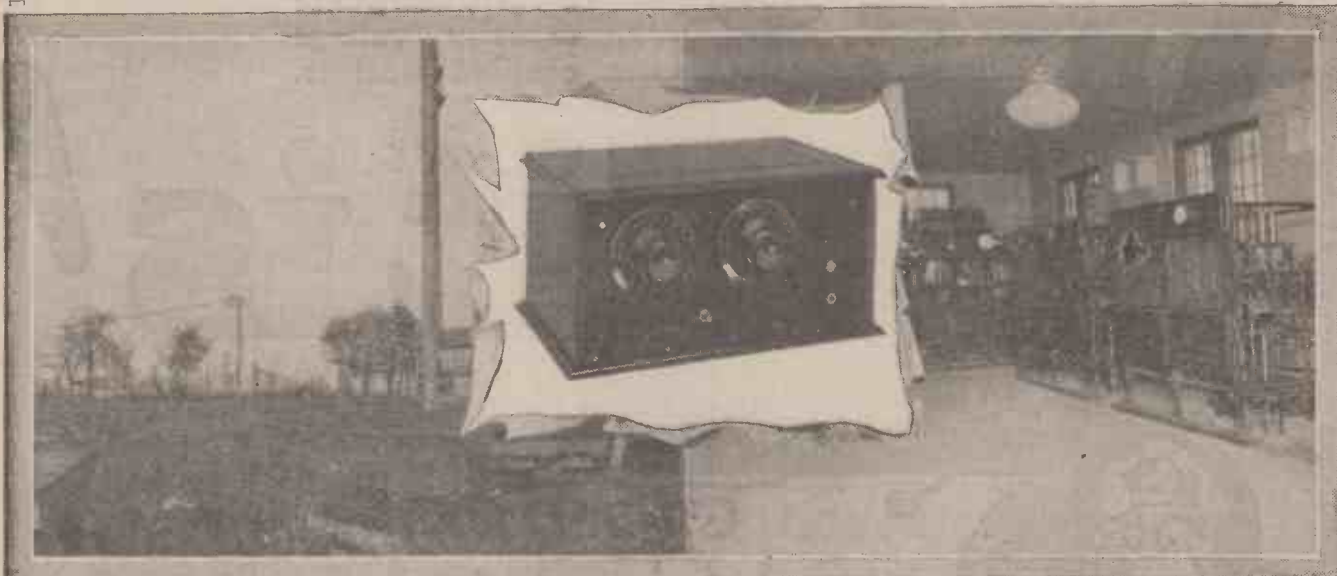

The season of increased short-wave activity is now upon us, and many of our readers will be thinking of entering this fascinating field. This short-wave set, designed by A. V. D. Hort, B.A., uses three valves and can be depended upon to put one or more of the American short-wave broadcasting stations upon the loud-speaker almost any night.



To receive American broadcasting stations at anything approach-loud-speaker strength on the ordinary 300- to 500-metre band of wavelengths usually requires at least a four-valve set. A five-valve set, consisting of two H.F. stages, detector and two L.F. amplifiers, will be needed for average conditions, and even then the reception will be largely dependent on the conditions at the moment.

On the shorter wavelengths good reception is much more certain, at any rate during the winter months. Admittedly, there are fewer stations to choose from, KDKA, East Pittsburgh, and WGY, Schenectady, being the regular performers. On the other hand, these stations can be heard almost any night on a single valve, and the addition of one or more low-frequency amplifiers will enable good volume to be obtained.

## Eliminating Body-Capacity

It was with the idea of securing loud-speaker reception of these stations that the set to be described was designed. The set uses a detector valve, followed by one transformer-coupled and one choke-coupled L.F. stage. There is a certain advantage, among others, which makes the use of a loud-speaker for telephony on these

wavelengths preferable to the wearing of telephones. This is that body-capacity is not easy to eliminate altogether on short waves, and it will often happen that any movement on the part of the operator wearing telephones will upset the tuning of the set. While this body-capacity effect was not

it while tuning. This precaution applied more especially on the shorter wavelengths used by WGY than on KDKA's transmission.

## Results

The set has been used on several occasions for loud-speaker reception from WGY on 32.79 metres, this being the station with the call sign 2XAF. The words of speakers on one occasion (October 13) could be plainly heard in the next room. There was a certain amount of fading, but the signals were never so weak as to make the speaker unintelligible. Both speech and music were received with excellent clarity. With two valves good telephone signals were obtained.

The KDKA transmission on about 63 metres was not heard at such good strength on the loud-speaker, though on telephones ample volume was available. In the writer's experience this station is usually somewhat more difficult to receive at good volume than that on the shorter wavelength.

Amateur and commercial C.W. transmissions came in at great strength on the loud-speaker.

Those who are interested in Morse reception, and who have not tried receiving with a loud-speaker, will find that, especially with strong signals, reading in this way is much less tiring than with telephones.

## Circuit

From the circuit diagram it will be (Continued on page 54.)

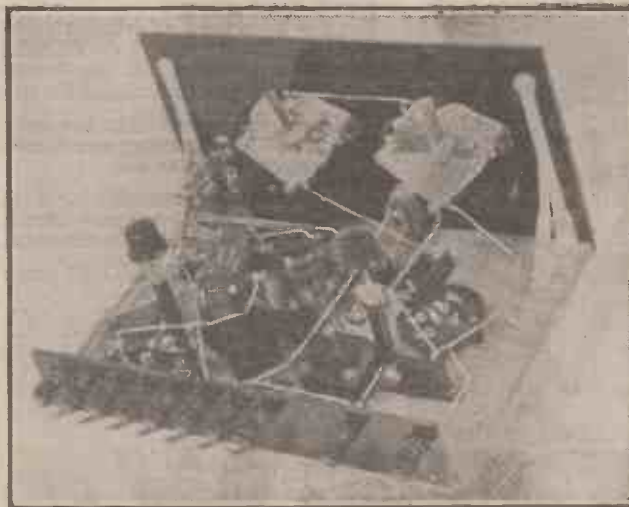

All connections should be made in exactly the order given in the wiring instructions, which have been worked out to make the operation as easy as possible.

found unduly prominent in this set, it was present in sufficient degree to prevent the operator from making any considerable movement while listening to a programme with telephones.

When the loud-speaker was in use the operator could get up and leave the set after it was tuned, provided that care was taken not to sit too close to

# You must have a **LISSENOLA** for this Christmas —only six weeks to go

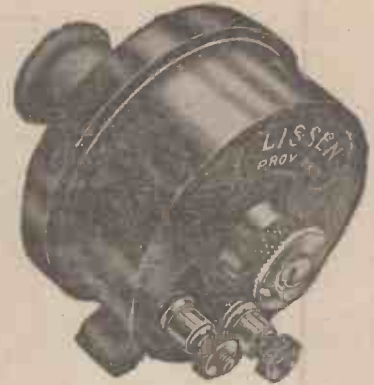

Nights no longer dull, nor long, nor lonely—an entertainer in the LISSENOLA which will bring real radio cheer into every home at Christmas, and before and after it. Ever so easy to get is the LISSENOLA—every good dealer has one ready to supply. Plenty of time now, and not dear either. Everybody at home will welcome it from the minute you bring it in.

Tones more pure you never heard in any speaker, nor volume so powerful and clear.

Never hear the LISSENOLA and you will never know the enjoyment it has brought to tens of thousands who used headphones and other loud speakers which cannot compare with its fine tone qualities.

Hear it, and its natural tones will create a desire to possess it which is not easy to resist. And there is no reason why you should resist it—cost is certainly no obstacle.

## SEVEN DAYS' TEST!

Ask your dealer to let you test it in his shop—tune the set yourself if it needs tuning—turn the adjusting nut on the LISSENOLA if it needs it—compare the LISSENOLA against the most expensive speaker your dealer has—take the horn off and put it on the LISSENOLA,

and try to notice any difference. You will find your dealer friendly, and he will leave the test entirely to you if you ask him to.

### WHAT THE LISSENOLA IS AND WHAT YOU CAN DO WITH IT

It is the essential sound-reproducing mechanism of a loud speaker, concentrated in the most effective manner yet achieved. Put power through it, 220 volts and more. You cannot make it dither or resonate on any voltage you will want to use. Put it on the tone arm of your gramophone instead of the sound box, and your gramophone is instantly a radio loud speaker. Take the LISSENOLA off and slip the sound box back again and you have a gramophone once more. A second's operation either way. OR BUILD A HORN, which is all you need to attach to the LISSENOLA unit to make it a complete senior model powerful loud speaker equal to the most expensive on the market. Or with the LISSENOLA REED (only 1/- extra) you can make a cone or any other loud speaker working on the reed principle.

FULL SIZE PATTERNS AND CLEAR INSTRUCTIONS HOW TO MAKE A HORN FOR A FEW PENCE ARE ENCLOSED WITH EACH LISSENOLA UNIT. You cannot go wrong. This horn when finished will be 24½ ins. high with a flare 9 ins. square. The angles have all been calculated to give reproduction acoustically accurate. This size horn is larger than you would find on a loud speaker selling at many pounds. ITS EFFICIENCY HAS BEEN PROVED—BY TENS OF THOUSANDS OF LISSENOLA USERS.

# THE LISSENOLA

—the Loud Speaker with the Golden Tones

## 13/6

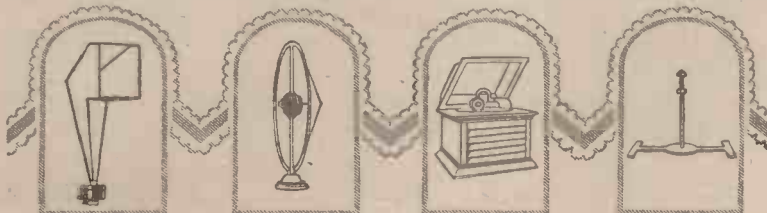

Full directions and full-sized patterns for making this horn are given with every 'LISSENOLA'

A cone diaphragm loud speaker can easily be constructed. The illustration shows one method of mounting.

The 'LISSENOLA' instantly converts any gramophone into a loud speaker.

The 'LISSENOLA' Reed Attachment (pat. pending) for use with cone diaphragm loud speaker. Price 1/-

LISSEN Ltd.,  
18-22, FRIARS LANE,  
RICHMOND, SURREY.

Managing Director:  
THOMAS N. COLE.

# Putting America on the Loud-Speaker—continued from page 52

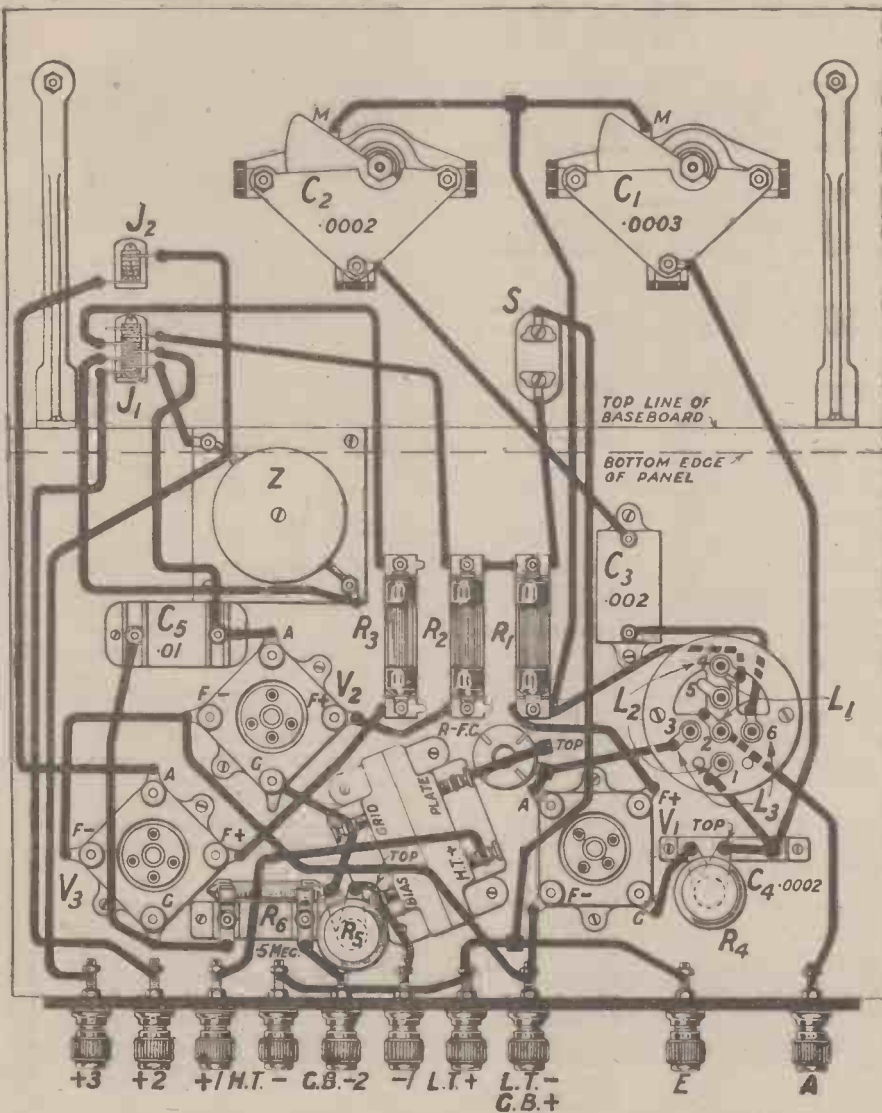

Fig. 1.—The wiring is a little more elaborate than that of most short-wave sets, but the verbal instructions below will make matters quite simple.

### WIRING INSTRUCTIONS

It is recommended that the connections be made in the order given here.

Join aerial terminal to No. 2 socket of coil base.

Join one side of C<sub>1</sub> to G of V<sub>1</sub> and lower end of R<sub>4</sub>.

Join other side of C<sub>4</sub> to top end of R<sub>4</sub> and No. 1 socket of coil base.

Join one filament contact of V<sub>3</sub> to one end of R<sub>3</sub>.

Join one filament contact of V<sub>2</sub> to one end of R<sub>2</sub>.

Join one filament contact of V<sub>1</sub> to one end of R<sub>1</sub>, and also to No. 4 socket of coil base.

Join together remaining filament contacts of V<sub>1</sub>, V<sub>2</sub> and V<sub>3</sub> and continue to L.T. - terminal.

Join No. 3 socket of coil base to A of V<sub>1</sub>, and lower end of R.F. choke.

Join top end of R.F. choke to "PLATE" of T<sub>1</sub>, T<sub>2</sub>.

Join No. 3 socket of coil base to one side of C<sub>3</sub>.

Join A of V<sub>2</sub> to one side of C<sub>5</sub>.

Join other side of C<sub>5</sub> to G of V<sub>3</sub>, and continue to one side of R<sub>6</sub>.

Join other side of R<sub>6</sub> to G.B. - 2 terminal.

Join "GRID BIAS" of T<sub>1</sub>, T<sub>2</sub> to G.B. - 1 terminal, and to top end of R<sub>5</sub>.

Join "GRID" of T<sub>1</sub>, T<sub>2</sub> to G of V<sub>2</sub>, and to lower end of R<sub>5</sub>.

Join "H.T. +" of T<sub>1</sub>, T<sub>2</sub> to H.T. + 1 terminal.

Fix the panel to the baseboard, with leads attached to both terminals of switch S.

Join lower terminal of S to remaining sides of R<sub>1</sub> and R<sub>2</sub>, and continue to contact 2 of Jack 1.

Join together the moving vanes of C<sub>1</sub> and C<sub>2</sub>, and continue to No. 4 socket of coil base.

Join fixed vanes of C<sub>2</sub> to remaining side of C<sub>3</sub>.

Join fixed vanes of C<sub>1</sub> to No. 1 socket of coil base.

Join top terminal of S to L.T. +, H.T. - and Earth terminals.

Join contact 6 of Jack 1 to one side of choke Z.

Join contact 4 of Jack 1 to A of V<sub>2</sub>.

Join contact 5 of Jack 1 to other side of choke Z.

Join contact 3 of Jack 1 to remaining side of R<sub>3</sub>.

Join contact 7 of Jack 1 to H.T. + 2 terminal.

Join A of V<sub>3</sub> to contact 2 of Jack 2.

Join contact 1 of Jack 2 to H.T. + 3 terminal.

seen that the detector valve circuits are of more or less conventional type. The aerial circuit is of the "untuned" type, loosely coupled to the secondary coil L<sub>3</sub>. A combination of magnetic and capacitive reaction is used, C<sub>2</sub> being the reaction control condenser, C<sub>1</sub>, in series with the variable condenser, being merely a safety blocking condenser to prevent noises or damage through partial shorting of C<sub>2</sub> with dust or other foreign matter.

### Low-frequency Stages

The two low-frequency amplifying stages are straightforward. A variable grid-leak is shunted across the secondary of the L.F. transformer, the purpose of which will be explained later in dealing with the operation of the set.

### Switching

Plug and jack switching is employed to make it possible to cut off the last valve, while an on-and-off switch controls the filament supply to all three valves. Insertion of a plug in the first jack, the lower one on the panel, switches off the filament of V<sub>3</sub> and places the telephones in the anode circuit of V<sub>2</sub>. This position is useful for searching. When a station has been located, the loud-speaker plug is put in the second jack, and on removing the telephone plug the third valve is brought into operation.

As few controls as possible are

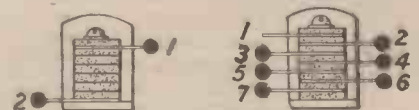

JACK 2 JACK 1

Fig. 2.—This is a key to the reference numbers on the various springs on the jacks.

# A Three-Valve Set for the Short Waves

mounted on the panel. Amperites control the filament current to the valves, only the on-and-off switch appearing on the panel. Of the variable condensers the left dial is for tuning, while the right dial controls reaction. The two variable grid leaks, for the detector valve and across the transformer secondary, are mounted inside the cabinet.

### Components

The list of components used in the set described will be found in the accompanying list. It is important in a set of this type to use components of good quality, and to adhere closely to the layout shown, so that, if any components of makes other than those given are chosen, care should be taken that these are sound in construction, and that their design will not involve any radical departures from the original arrangement.

### Construction

Owing to the compact layout of the set, the details given for its construction should be followed carefully. First of all, drill the panel in accordance with the drilling diagram. Next place the baseboard and panel in the cabinet, and fix the panel with wood-screws through its lower edge. Remove the panel and baseboard from the cabinet, and secure in position the panel brackets, taking care to leave enough room at the sides for the insertion of the set in the cabinet without fouling the fillets. The terminal strip should also be secured to the baseboard with the latter in position in the cabinet. The front panel should now be removed from the baseboard, the brackets being left fixed to the

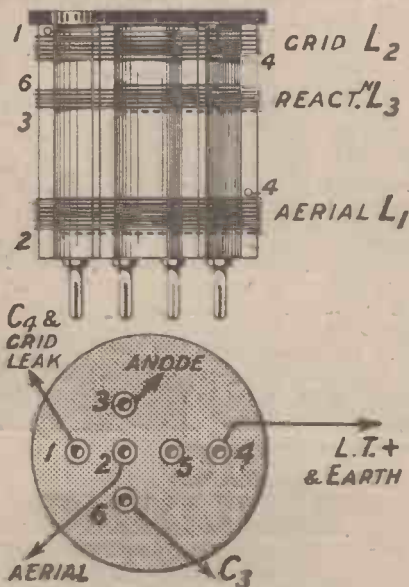

Fig. 4.—The coils are wound upon a standard former of the type used in screened-coil receivers.

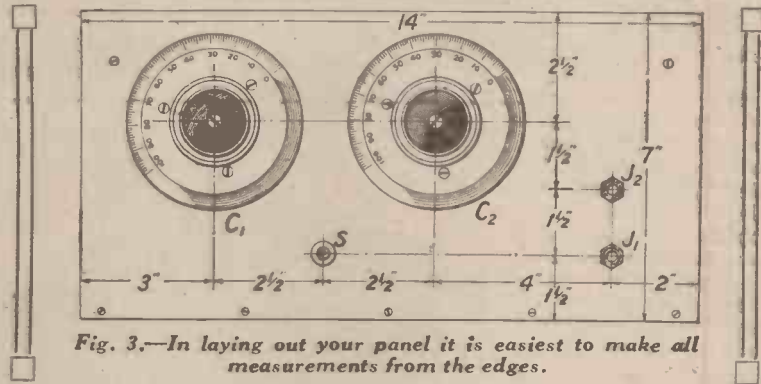
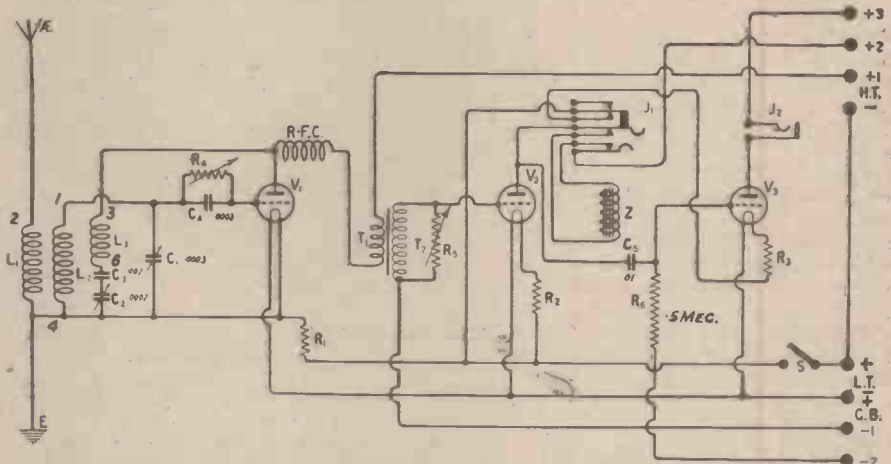

Fig. 3.—In laying out your panel it is easiest to make all measurements from the edges.



The circuit is of quite a simple and straightforward type.

baseboard, and put aside till most of the mounting and wiring of the baseboard components has been completed.

### Follow the Wiring Instructions

Since there is not much space to spare between some of the components, the constructor is recommended to follow carefully the order of operations

detailed in the wiring instructions. If this is not done, difficulty may be experienced in attaching some of the connecting wires.

The details of the coil windings are given in Fig. 4. The grid coil comes at the top of the former, the reaction

(Continued on page 56.)

### WHAT YOU WILL NEED

- One ebonite panel, 14 in. by 7 in. by  $\frac{3}{8}$  in. (Carrington Manufacturing Co., Ltd.)
- One ebonite strip, 13 in. by 2 in. by  $\frac{3}{8}$  in. (Carrington Manufacturing Co., Ltd.)
- One suitable cabinet, with baseboard, 9 in. deep. (Carrington Manufacturing Co., Ltd.)
- One .0003 and one .002 low-loss variable condenser, with "Utility" micro. dials. (Wilkins & Wright, Ltd.)
- One .0002 fixed condenser, type 600A. (Dubilier.)
- One .01 fixed condenser, type 610, and .5 megohm "Dumetohm" leak with mount. (Dubilier.)
- One .002 fixed condenser. (Falk, Stadelmann & Co., Ltd.)
- Two variable grid leaks. (Bretwood, Ltd.)
- One A.F.3 L.F. transformer. (Fer-ranti, Ltd.)

- One "Success" L.F. choke. (Beard and Fitch.)
- One single open, and one double closed filament control jack, and one telephone plug. (Igranic-Pacent.)
- One on-and-off push-pull switch. (Igranic.)
- Three anti-vibratory valve holders. (Benjamin Electric Co.)
- Three Amperites (to suit valves used). (Rothermel Radio Corporation of Great Britain, Ltd.)
- One H.F. choke. (Varley Magnet Co.)
- One coil former and standard 6-pin base. (Collinson Precision Screw Co.)
- Ten terminals—Aerial, earth, H.T. —, H.T. + 1, H.T. + 2, H.T. + 3, L.T. —, L.T. +, G.B. — 1, G.B. — 2. (Belling & Lee, Ltd.)
- Glazite, and a few feet of 24 s.w.g., d.c.c. wire.

APPROXIMATE COST, £8.

coil next, and the aerial coil at the bottom.

**Testing**

When the wiring of the set has been completed, valves should be inserted in the holders and the L.T. battery connected to the appropriate terminals. The switch S and No. 1 jack should then be tested, to see that the valves light properly. In the latter case the third valve should be extinguished when a plug is inserted. A further test with a low value of H.T. connected between H.T. — and the three positive terminals will indicate whether this part of the circuit is in order.

**Valves and Voltages**

General - purpose valves should give fair results in the set, but much better reception may be expected if special valves are used. The combination found most satisfactory by the writer consisted of high-impedance valves of the resistance-capacity type as detector and first L.F. amplifier, with a low-impedance power valve in the second stage. A low-impedance detector valve did not allow of nearly so smooth a control of reaction.

**PUTTING AMERICA ON THE LOUD-SPEAKER**

(Continued)

**Leak Resistances**

A high value of grid-leak was re-

quired for the detector, while to avoid "threshold howling" as the set went into and out of oscillation, the leak across the transformer secondary needed to be of a fairly low value.

This latter resistance is essential if there is any sign of the howling mentioned. It should be set at the highest possible value consistent with smooth reaction control. It will also help to reduce the mush and parasitic noises which are sometimes troublesome on short waves.

Complete details are given on these pages to enable readers to construct the receiver. Further notes on operating the set will follow in a subsequent issue.

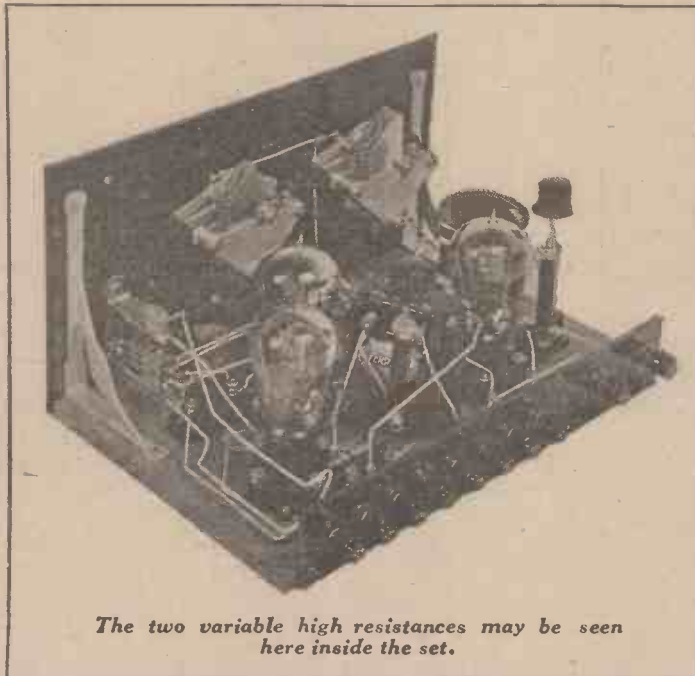

The two variable high resistances may be seen here inside the set.

**HUMOUR AT THE PATENT OFFICE**

Extract from a patent abridgment:  
 "The coupling resistance R may be of the carbon type, but is preferably of wire wound *non-conductively* in several sections having opposed directions of winding."  
 The italics are ours.

You can construct this or this with equal ease

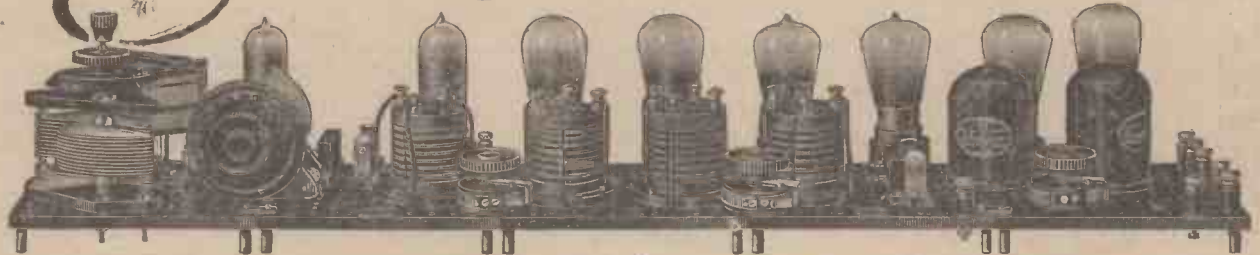
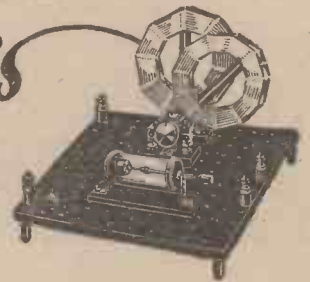

If you adopt  
 No Technical  
 Knowledge Required.

BLACKADDA RADIO CO., LTD,  
 SADLER GATE,  
 DERBY. "Grams : Derby."

Results from Blackadda sets are equal to any on the market. If your local dealer is unable to supply, we will forward direct on receipt of remittance or C.O.D.

**BLACKADDA**

The enthusiast can start with a simple set and gradually build up to the multi-valve receiver without tools, soldering or waste as all parts are interchangeable, he is also enabled to keep up to date with all improvements and developments.  
**FAILURE IMPOSSIBLE**  
 The Blackadda system has revolutionised wireless construction and we publish service sheets describing various new circuits which can be easily understood and followed.

**RADIO BUILDING SYSTEM**

The Blackadda circuit book containing a fund of Wireless information and illustrations and details of over fifty up-to-date circuits is available. Price 1/-.



**A new & better transformer is sweeping the country**

The heart of your amplifier is your transformer. Now LISSEN gives you a transformer which surpasses anything ever before available—users everywhere are learning that it is no longer necessary to pay a high price to get a high-grade transformer. This new LISSEN is being tried and tested under all conceivable conditions everywhere—it is being enthusiastically and largely bought by the trade for their own made-up sets. Throughout the whole range of audible frequencies this new LISSEN amplifies fully every note, every harmonic, every overtone. That means realistic reproduction. In the purity and power of its volume the results are remarkable. You will appreciate at once the clearer tones and greater volume.

Expensively made in all its details, traders at this year's National Exhibition at Olympia, asked to name the price at which they could sell it, invariably named a price close to £1. Many said 25/-, and many even more than that.

**TEST IT FOR 7 DAYS AT HOME.**

If it fails to satisfy you after 7 days' test, take it back to your dealer's or send it back to us. Do this, too, if you are not convinced it is equal to any high-priced transformer you try it against.

**8/6**

GUARANTEED FOR 12 MONTHS.  
7 DAYS' TEST.  
Turns ratio 3 to 1  
Resistance ratio 4 to 1

Suitable for every set and every valve you will want to use.

Use it for 1, 2 or 3 stages L.F.

Compare it against any for tone purity and power. You can get it at your dealer's, but if any difficulty send direct to factory. No postage charged, but please mention dealer's name and address. Or can be sent C.O.D.

N.B.—So good is this new LISSEN that we have unhesitatingly withdrawn all our previous high-priced transformers.

**QUALITY RHEOSTATS**

previously

4/-

**NOW**

**2/6**

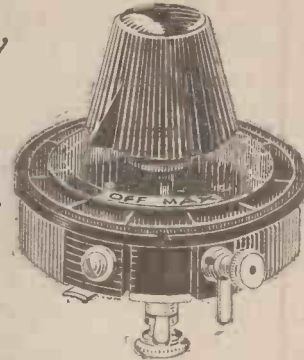

LISSEN quality—look how they are made—the wires cannot move and short circuit—the contact brush rides firmly yet smoothly—the heat-resisting former cannot soften—there are accessible terminals—and the combined knob and pointer will fit flush with the neat photo-engraved dial when mounted. Lastly, note the irresistible appeal of the price, made possible by our big production programme backed by our new direct-to-dealer distribution policy which cuts out all wholesale profits.

	Previously	NOW
LISSEN 7 ohms rheostat, patented	4/-	2/6
" 35 " " "	4/-	2/6
" Dual " " "	6/-	4/6
" Potentiometer, 400 ohms	4/6	2/6

EVERY ONE LISSEN ONE-HOLE FIXING, OF COURSE.

Baseboard mounting type same prices as above.

**A VALVE HOLDER FOR CLEARER, BETTER SIGNALS.**



Because of its low loss and low capacity qualities, the LISSEN Valve Holder plays its part in getting clearer, louder signals. Sent out ready for baseboard mounting, as shown, it can also be used for panel mounting by bending the springs straight.

**LISSEN VALVE HOLDER,**

patented, previously 1/8

**NOW 1/- each.**

IMPORTANT TO THE TRADE.—Retailers who have not already been notified of our new direct-to-dealer policy of distribution should, in their own interests, communicate with us without delay. All orders must now be sent to us at Richmond, and not to usual wholesale factor.

**LISSEN LTD., 18-22, FRIARS LANE, RICHMOND, SURREY.**

Managing Director: Thomas N. Cole.

**BUILD WITH THE BEST PARTS.**

# HAS RADIO KILLED THE CONCERT HALL?

By MARGARET AUSTIN



ALL music lovers must have read with dismay the announcement

that Queen's Hall, Langham Place, may have to close its doors, owing, it is stated, to competition from the B.B.C. According to Messrs. Chappell & Co., the lessees of the Hall, the business of providing concerts for the public has been becoming more and more unprofitable in recent years.

The matter seems to have been brought to a head by the new series of Symphony Concerts organised by the B.B.C. at the Albert Hall. Messrs. Chappell & Co. claim that these concerts are being run at prices with which it is impossible for an ordinary orchestra to compete.

## Departure of Sir Thomas Beecham

On top of this we have the announcement that Sir Thomas Beecham, the famous opera conductor of opera and other classical music, is leaving this country permanently to reside in America. He expresses sheer disgust at the musical taste of this country, and he refers to broadcasting as "the whining and gibbering of goblins and devils."

As one of the depraved multitude who enjoys this apparently Mephistophelian form of amusement, I feel that something is sadly amiss. I am myself a whole-hearted lover of classical music, but at the same time I still experience great pleasure in listening to broadcast programmes from time to time. I wonder whether broadcasting is really to blame for the present situation?

## What Broadcasting Lacks

Queen's Hall was first opened in November, 1893. It rapidly became London's musical centre, and many are the famous musicians who have performed there during its 33 years' history. It is nearly impossible to imagine this wonderful old Hall, full of the most poignant memories, being used for any purpose other than for those brilliant concerts which have so



The recent disputes between the B.B.C. and several well-known artists render this article of interest to everyone. It contains the views of a listener of advanced musical tastes, and we should be interested to hear the opinions of other readers.

long thrilled the music-loving people of London.

Apart from the sentimental associations of the Hall, however, I at any

of the concert hall, despite the laudable attempts of the B.B.C. to introduce this into the transmission. Nevertheless, all the small happenings which go to make one's enjoyment complete are lacking.

## The Personal Touch

The famous promenade concerts which are held nightly for a period of about three months every year would lose most of their charm over the wireless. Half the pleasure is in renewing old acquaintance with the orchestra or well-known members of the audience. There is the old boy in the shabby knickerbockers and silvery hair who is always present on the Wagner nights. You do not know him, but he is one of your friends. Besides, if you do not like a piece you can always sit on the pipes in the corridor outside! You cannot do this in your own drawing room.

To be serious, however, mere broadcast, however good, can never convey the effect of Sir Henry Wood conducting. Who will forget the charm of watching him play on the orchestra, bringing in the different parts as he wants them; and if you know those parts, and when they should come in, the pleasure is increased a hundred times. Think of Mr. Arthur de Greef, with his smiling face and his infectious good nature. All these little personal touches are completely lost in a broadcast programme.

Moreover, at a real concert should anybody even whisper there is immediately a silent uproar, if one may use such an Irishism. Yet, when listening to a broadcast programme, you are quite likely to be interrupted in the middle of your favourite work by a small boy selling tickets for the flower show or some other equally banal matter.

## The Real Reason

No, the truth of the whole matter is that all concerts are having a thin time just at the moment, for the very simple reason that the public have not the money to spend. Broadcasting is pleasant as a substitute, but when funds run to it the true music lover

## A NEW POST OFFICE STATION

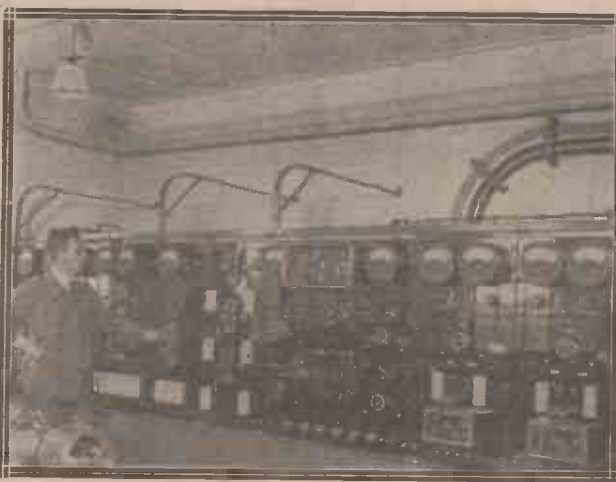

An interesting picture of the main switchboard in the power-room of the new G.P.O. station at St. Albans.

rate do not find listening to wireless concerts anything more than a pleasant reminder of the real thing. One misses completely the atmosphere



**HAS RADIO KILLED THE CONCERT HALL?**

*(Continued)*

makes a bee-line for the Concert Hall. I feel convinced that this is the real reason for the poor attendances, and not any competition from broadcasting: Sir Landon Ronald appears to be of the same opinion, judging by some recent remarks of his in the daily Press, wherein he pointed out that it had been a bad time for musicians generally.

Since the early days of broadcasting, Messrs. Chappell & Co. have taken up a very antagonistic attitude towards the B.B.C. It will be remembered that they banned any artist who had broadcast from appearing at Queen's Hall. This may be excellent as a gesture, but the public wants to hear its favourite artists, and if these artists prefer to broadcast and consequently no longer appear at Queen's Hall, then Messrs. Chappell & Co. have only themselves to blame if the appeal of Queen's Hall is reduced.

**B.B.C. Policy**

The British Broadcasting Co. decided that there was a definite demand for good music. For some time they broadcast the Hallé Concerts from the Free Trade Hall, Manchester, and these proved exceedingly popular; yet they felt something more was necessary, and the result has been the series of Symphony Concerts which were held last year and are being held again this year on a much greater scale at the Albert Hall.

How much more pleasant the position would have been if these great national concerts could have been held with the co-operation of Messrs. Chappell & Co. in the home of English music, Queen's Hall! This, however, apparently was not to be.

At a time when both companies are so anxious to do their best for the musical public in general, it seems most unfortunate that there should be this friction. Whatever the reason, however, it is to be hoped that some satisfactory solution of the difficulty will be found, and that Queen's Hall will still remain the proud old centre of musical life in England.

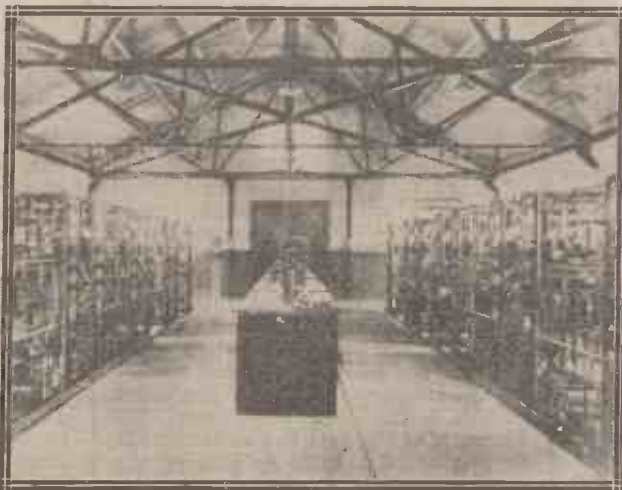

*This photo gives an excellent idea of the general layout of the transmitting room at the Bodmin station. The control tables are situated in the centre of the picture.*

**IN ADVANCE**

Saturday, November 20.

2LO Daily Express concert.

□

5IT Popular programme.

□

5WA "November Night-Lights."

□

2ZY West Country songs.

□

5NO Band Concert.

**Still the Best  
yet reduced in price  
BURNDEPT  
Anti-Phonic  
Valve Holder**

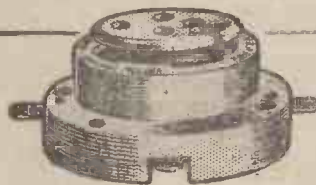

End your valve troubles by fitting Anti-Phonic valve holders to your receiver. They eliminate Microphonic noises, and tend to lengthen the life of any valve by protecting the filament from shock.

The name Anti-Phonic was coined by Burndept, the makers of the first valve holder of this class. In carton, price 2/9.

**BURNDEPT SCORES AGAIN!** Mr. Wm. C. McDougal, of Mosspark, Glasgow, received the Dempsey-Tunney fight on a Burndept Two Valve Set, using Burndept Valves.

*The Burndept range includes everything for efficient radio reception. Guaranteed Super Valves, Components, Loud Speakers and complete installations. Send for the Burndept Literature*



**Head Offices & Factory: Blackheath, London, S.E.3**  
 Telephone: Lee Green 2100. Telegrams: Burnacoil Phonc London.  
**London Offices & Showrooms: 15, Bedford St., Strand, W.C.2**  
 Telephone: Gerrard 9072. Telegrams: Burndept Westrand London.  
**Agents and Branches Everywhere.**

*Don't buy just "wireless" — buy "perfect reproduction." Burndept Receivers, Super Valves and Loud Speakers. The perfect combination*

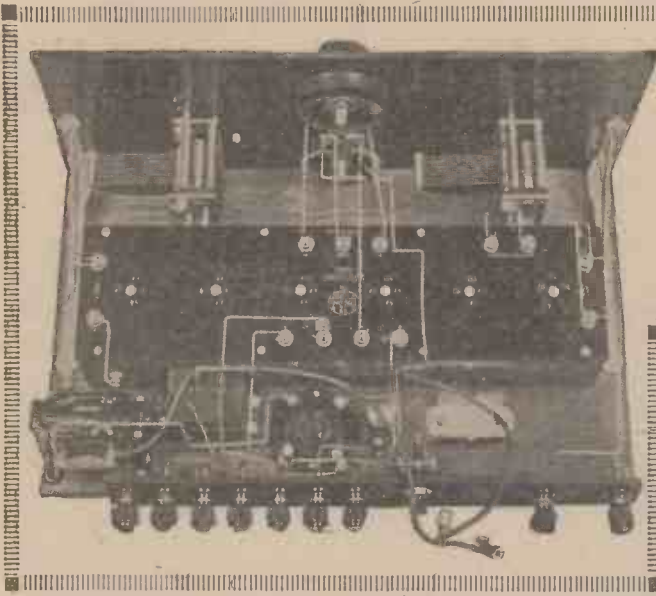

## HOW TO OPERATE THE "MINIWIRE" SUPERHETERODYNE

By **STANLEY G. RATTEE, M.I.R.E.**

Some helpful operating instructions for the six-valve receiver described in detail in our last issue.

dition will obtain when the slider of the potentiometer is somewhere between full negative and

the midscale position, and, though this must not be taken as a definite ruling, it will, nevertheless, serve to show whether the set oscillates too readily on the long-wave side. In the event of this latter being experienced, the filaments of the first five valves should be brightened a little by turning the filament resistance in a clockwise direction; this operation must, of course, be done with due care, otherwise the valves themselves may be harmed.

### Searching for Stations

Adjust the potentiometer, as explained last week, so that the long-wave side is just oscillating (and *only* just!), when, upon turning the dial of the autodyne condenser with the  $C_1$

tive end sufficiently to stop the long-wave side from oscillating. So far the operation is easy; but it must be remembered that operating a superheterodyne for the first time is not so simple a matter as handling, say, an ordinary two-dial receiver, while it must be understood that before any station can be heard the settings of both the condensers must be correct to within a degree or two upon their dial readings. For this reason the method of searching must be one of some system if anything like success is expected.

### How to Start

Probably the best manner in which to start when inexperienced with superheterodynes is to first adjust the potentiometer, so that the intermediate amplifiers are on the edge of self-oscillation, and with the  $C_1$  condenser set to its zero reading, turn the autodyne condenser throughout its full range, then advance  $C_1$  a few degrees in the event of nothing being heard, and again turn the autodyne condenser as before, and so on until the whole of the readings of  $C_1$  have been covered, or until a station is picked up. When a station has been found, move the potentiometer either one way or the other, ever so little, for the loudest results, and re-adjust the autodyne condenser if necessary.

After the station has been tuned in at its loudest strength in this way, it is possible that the quality is none too good, and, since the long-wave side of the receiver is at present on the edge of self-oscillation, this is not altogether a mystery. The slider of the potentiometer should, therefore, be turned slightly away from the point where this self-oscillation occurs, and though signal strength will be slightly reduced, this may be recovered to a very appro-

**U**NLESS one is fortunate enough to be able to charge one's own accumulator, one of the important points to consider when using a receiver employing so many valves is economy in filament current, for, with an extravagant choice of valves, the visits to the charging station are liable to become all too frequent.

The most desirable state of affairs is to use for the first five stages valves which have a filament consumption of .06 or .1 ampere, and, say, a .25 power valve in the last stage.

There is now a sufficient variety of makes with current consumption around these figures that, no matter what the individual preference may be as regards manufacture, no difficulty is likely to be experienced either in the two-volt, four-, or six-volt types.

### H.F. Valves and Potentiometer Control

The high-tension supply for the "Miniwire" may be one of 120 volts, and the wander plugs from the set should be so placed that H.T. + 1 receives about 60 volts and H.T. + 2 the full 120 volts, using suitable grid bias. Assuming that all the batteries have been connected, add the frame aerial and a pair of telephones to the set across the appropriate terminals, and light the valves to their estimated correct brilliance, when, by slowly turning the potentiometer slider from its mid-scale reading to the negative end, a point will be discovered where the intermediate stages break into self-oscillation. When the valve filaments have been correctly adjusted, the con-

denser set to, say, its zero dial reading, several positions will be found upon the dial at which "chirps" may be heard in the telephones, but which disappear when the slider of the potentiometer is turned towards the posi-

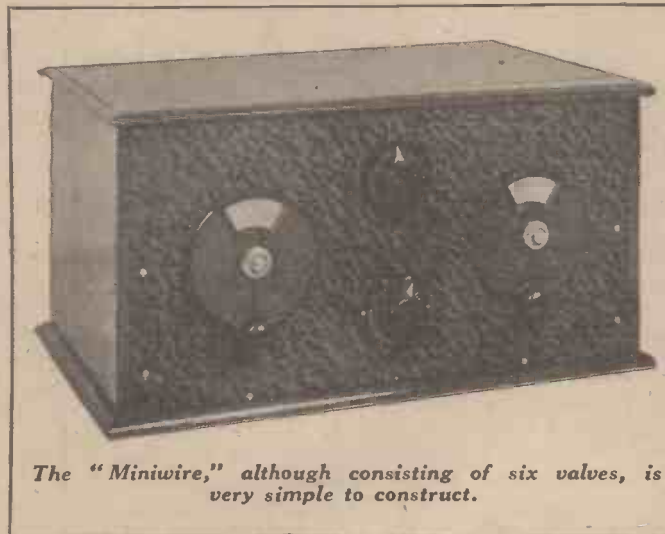

The "Miniwire," although consisting of six valves, is very simple to construct.

## HOW TO OPERATE THE "MINIWIRE" SUPERHETERODYNE

(Continued from previous page)

able extent by adjusting the autodyne condenser, while the quality of reception will be greatly improved.

### Interesting Observations

When the best results have been obtained in this way, the effect of turning the frame aerial should be tried, when in many cases a considerable alteration in signal strength is experienced, though the direction in which one would expect the frame to lie is more often than not—a wrong one!

Another interesting effect which may be observed is the difference in signal strength of a given station when the set is used on different floor levels, and since the "Minewire" is an instrument of relatively small dimensions, it is not difficult to move it about with this experiment in mind. The general observation, when trying different floors, is that the higher one goes the better the result, but on one occasion, when trying a superheterodyne in this way, the reverse was the case, owing, it is presumed, to the presence of an abnormally large water cistern in the loft; the house where this observation was made was in Queen's Gate, London, W., and the effect was most marked. In houses where electric light is used, or where gas pipes are fitted also, many interesting effects can again be observed, particularly with regard to the directional effects of the frame aerial.

### NEWS IN ADVERTISEMENTS

An interesting announcement is being made by Messrs. The Edison Swan Electric Co., Ltd., concerning a new Edison product. This is the R.C. Threesome 3 Valve Resistance Capacity Voltage Coupled Receiver. Readers will note that a coupon is included in the advertisement for their convenience in replying.

A reduction in price of the "Varta" H.T. Battery is being advertised by the manufacturers, A.F.A. Accumulators, Ltd.

A personal note addressed to readers is made the subject of the advertisement of The Bennett College.

Messrs. Jackson Bros. are featuring a new J.B. True Tuning Slow Motion Condenser.

Fully illustrated leaflets on the Magnetic Microphone Bar Amplifier will be sent upon application by Messrs. New Wilson Electrical Manufacturing Co., Ltd.

Cabinets for the Monodial figure in the advertisement of Messrs. Carrington Manufacturing Co., Ltd.

EXPERTS IN RADIO ACOUSTICS SINCE 1908

## IS THIS WHAT YOU'RE LOOKING FOR ?

TESTING the new 2-valve receiver at our Works at Slough, on a standard P.M.G. aerial, we tuned in the two Paris stations, London, Daventry, Bournemouth, Birmingham and Newcastle on the loudspeaker. This despite bad screening set up by a large power station not more than 50 yards from the vicinity of the laboratory. We were testing on 66 volts only. You can expect even better from the 3-valve Brandeset.



### THE BRANDESET II.

The new Brandes 2-valve set features simplicity of control and ingenious compactness. Condenser dial, filament rheostat, reaction dial and "throw-over" switch for long or short wave tuning complete the panel controls. Straight line frequency condenser tuning and grid-bias

is employed. The standard coil is suitable for Daventry and no "plug-in" coils need be purchased. The L.T., H.T., and grid-bias leads are plated into one cable from rear of set.

£6 10

(Exclusive of Marconi Royalty and Accessories.)



### THE BRANDESET III.

The new Brandes 3-valve receiver employs the same ingenious characteristics as the Brandeset II, except that an extra stage of Audio Frequency is employed. It has straight line frequency condenser tuning, grid-bias, and is adapted to long and

short wave tuning. Both receivers give most excellent loudspeaker reproduction on a number of stations, and are specially designed for this purpose.

£8 10

(Exclusive of Marconi Royalty and Accessories.)

# Brandes

From any reputable Dealer.

BRANDES LIMITED • 296 REGENT ST. • W.1

# More Secrets of the Low-Frequency Transformer

By  
**J. H. REYNER,**  
*B.Sc. (Hons.), A.M.I.E.E.*

In our last issue Mr. Reyner disclosed some of the many difficulties associated with the production of a really efficient low-frequency transformer, and below appears a further instalment of his explanation of this highly interesting subject.



**L**AST week we discussed generally the principles underlying the design of the primary impedance of a transformer. It was shown that the amplification obtained from the valve depended essentially upon the value of the impedance in the anode circuit, and that this could be made tolerably constant above a certain critical value of frequency. The designer's aim is to reduce this critical value to as low a frequency as possible in order that the bass tones both in speech and music may be truly reproduced.

## Primary Capacity

Now as far as the primary itself is concerned the problem is not too difficult. It is still a matter of careful design in order to reduce the critical frequency below 200 to 250 cycles per second, principally because after a certain point the self-capacity of the winding comes into play. The effect of this will be to cause a falling off in the amplification towards the high frequencies.

## Use of a By-pass

The practice of placing a small by-pass condenser across the primary of the transformer or choke-coil in order to afford a ready passage for high-frequency currents is well known. The idea is that the small condenser acts practically as a short circuit for the high-frequency currents, whilst offering a very high impedance to the low-frequency currents. It will be appreciated, therefore, that if we increase the value of this condenser unduly, not only will it have a by-pass effect on the radio-frequency currents, but also upon the higher frequencies of the audible range. Thus, in the upper registers, the condenser will exercise a short circuiting effect, and consequently the full amplification will not be developed.

## Balance Needed

The problem, therefore, is one of careful balance between the falling off of amplification at the higher registers



due to capacity, and the increase in the inductance so that the critical frequency may become as low as possible. Practical experience shows that a very good compromise can be arranged between these two, and if this were all

this to the next valve. If we do this by connecting the end of the choke through a condenser to the next grid then we have the coupling known as choke amplification, and owing to the fact just mentioned (that it is possible to design a choke having a good audio characteristic), this method of coupling has found considerable favour.

## Step-up Effects

It has the advantage over resistance amplification in that a high value of high tension is not required, but it suffers from the disadvantage that the amplification obtained is only that of the preceding valve, as a maximum, and in practice something slightly less than this. If, on the other hand, we provide a secondary winding coupled to the primary winding in the anode circuit, and arrange that the number of turns on the secondary is four or five times as large as that on the primary, then we shall obtain a step-up effect, and the amplification obtainable will be the amplification of the valve multiplied by the actual step-up ratio. Such an arrangement constitutes a transformer, but in obtaining this extra amplification we introduce a large number of possibilities of uneven amplification.

## Winding Arrangements

Now, there are various ways of constructing a transformer. We may wind the primary on one section, and place the secondary winding next to it. Then some of the magnetic field produced by the primary would pass through the secondary winding and so induce voltages therein. Such an arrangement would not be very efficient because quite a large proportion of the magnetic field produced by the primary would not pass through the secondary at all. In other words, there would be considerable magnetic leakage. In such cases the effective transformation ratio or step-up ratio of the transformer would not be equal to the ratio of the secondary turns divided by the primary turns, but would be something considerably less.

(Continued on page 64.)

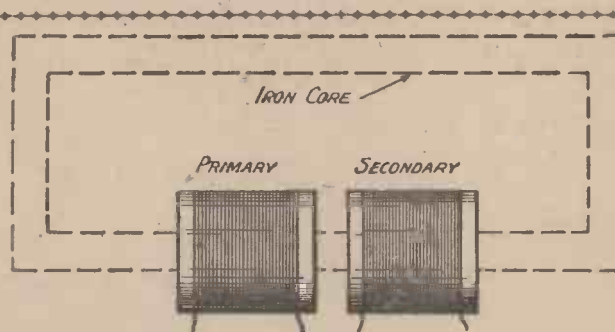

*Fig. 1.—Such an arrangement as placing the primary next to the secondary winding would not be very efficient because a large proportion of the magnetic field produced by the primary would not pass through the secondary at all.*

that had to be overcome the problem would be very much simpler.

At present, however, we have only

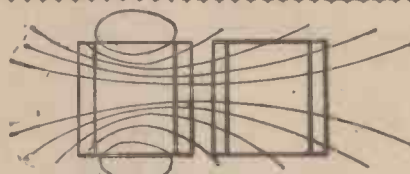

*Fig. 2.—The coupling between two windings placed side by side is not as tight as it might be, there being a tendency for small circulating fields as shown in this figure.*

considered the impedance in the anode circuit. We have a voltage developed across this, and we have to transfer

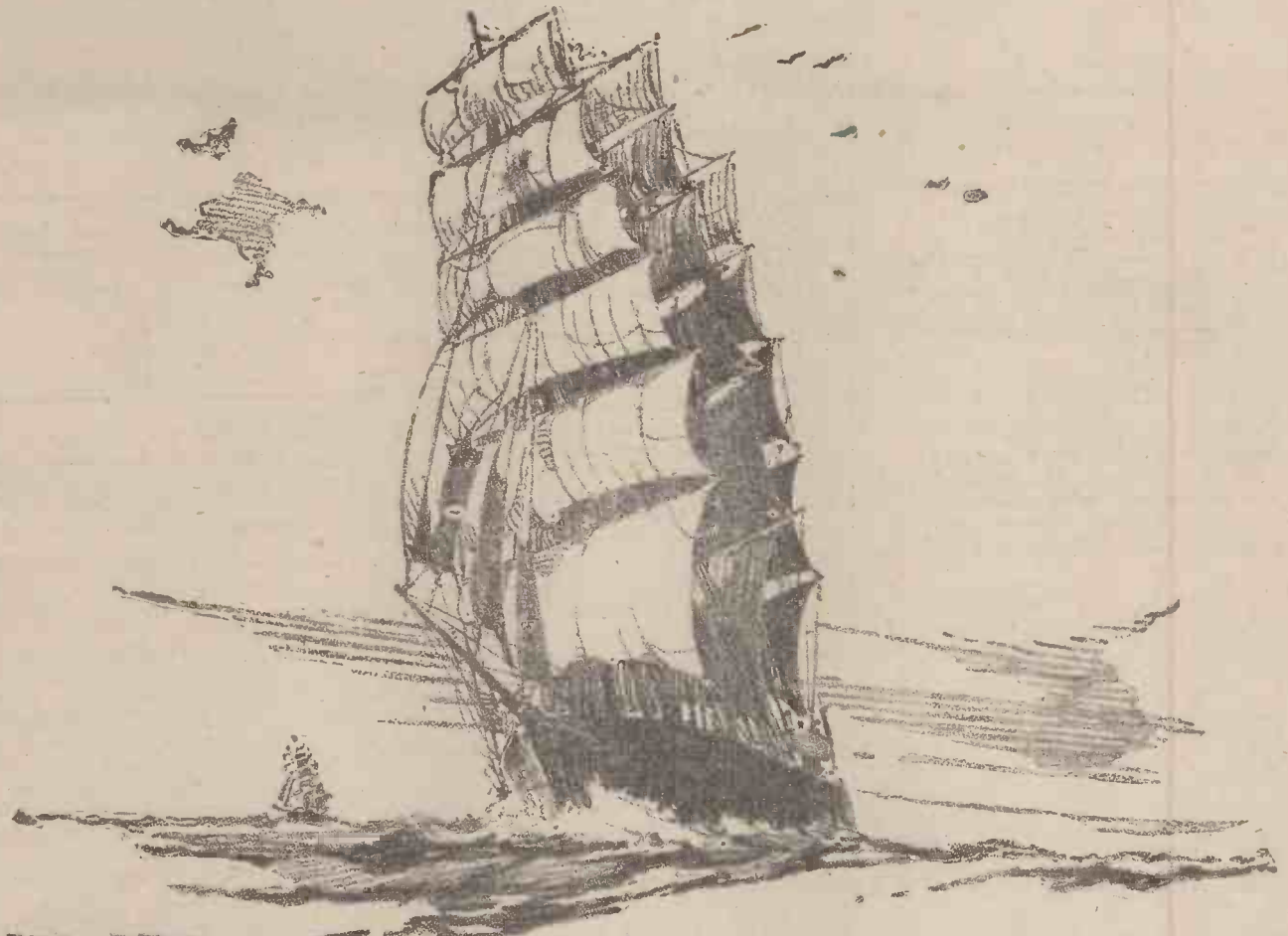

## “WELL FOUND”

When the tall Clippers in all their pride raced for the wool and tea markets of the world, they had to be well found and seaworthy.

And being well found didn't end with having good “sticks, rigging, and running gear,” it implied a tip-top condition from the varnish on the truck down to a clean bottom.

It was attention to details more often than not which decided the issue of these stern chases—the details which, as far as one could see, “didn't matter.”



It is, perhaps, a far cry from Clippers to Condensers, but it is certainly a fact that many people regard Condensers as being a detail that “doesn't matter.”

And still more numerous are the people who say that cheap condensers seem to give just as good results as expensive ones.

The fact is that cheap condensers do *not* give as good results as expensive ones. If they did, we should not be interested from any point of view in making the more expensive variety.

And the second fact—namely that the Dubilier Condensers sold number more than all other makes put together—points to the fact that the great majority of people value a well-found wireless set and insist on seeing that it is equipped with Dubilier Condensers.

Do you?

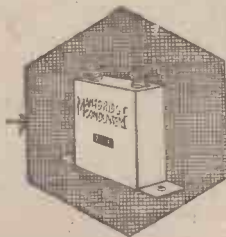

ADVT. OF THE DUBILIER CONDENSER CO. (1925) LTD.  
DUCON WORKS, VICTORIA ROAD, N. ACTON, W-3

# More Secrets of the Low-Frequency Transformer—continued from page 62

## Use of Iron

From a simple point of view of economy of wire and space, this is not desirable, although, as we shall see

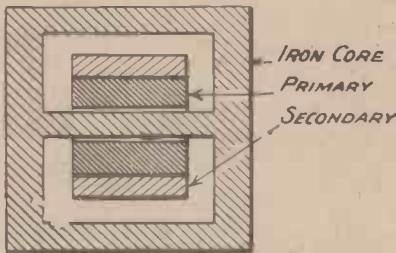

Fig. 3.—Showing the method in which quite a number of modern transformers are arranged.

shortly, there are other considerations which will have to be reviewed. We can increase the magnetic coupling between the two coils, however, by winding them round a completely closed iron core. Iron has a greater permeability, as it is called, than ordinary air, the result being that the magnetic field prefers to flow inside the iron rather than in the outside air. Since the iron core runs through the centre of both coils it follows that we shall obtain an appreciably greater coupling by resorting to this principle.

## Iron Losses

Ordinary iron, however, is subject to certain losses, partly due to small circulating eddy-currents which are induced in the body of the iron itself, and partly due to an effect known as hysteresis, a form of strain set up in the molecules of the iron owing to the rapidly changing magnetisation. For this reason the iron core is made up either of a bundle of soft iron wires, or of thin stampings of magnetic alloy specially designed to minimise these losses. The core is built up of a number of these stampings until the required size has been obtained.

Even with an iron core such as this the coupling between the two windings of the transformers is not as tight as it might be, there being a tendency for small circulating fields, as shown in

Fig. 2. For this reason it is customary either to place one winding over the other—as shown in Fig. 3—or to use the sandwich type of winding, in which both windings are wound in sections, and the transformers are assembled with alternative primary and secondary, as shown in Fig. 4. This sectionalised type of winding also has the advantage that it enables the self-capacity of the windings themselves to be reduced.

By these various means the leakage between the primary and secondary is reduced to a small value, but nevertheless there is a leakage which still remains, and this exercises a considerable effect upon the character of the transformer.

## Remaining Imperfections

If we have a perfect transformer, then anything which is done to the secondary affects the primary to a corresponding extent, and vice versa. Thus if we have a perfect transformer and we short-circuit the secondary,

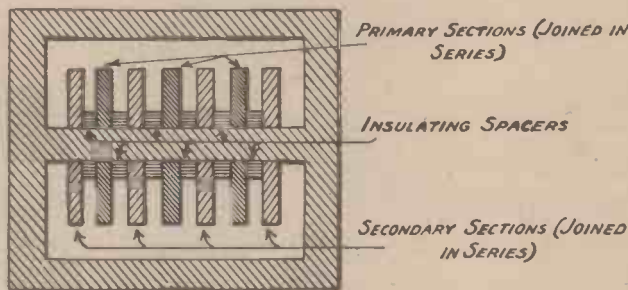

Fig. 4.—The "sandwich" type of L.F. transformer winding consists of alternate primary and secondary sections as shown.

then the primary will behave as if it were short-circuited also. In practice it is found that even when the secondary is short-circuited, the primary still exhibits a very small amount of inductance, this residual

transformer as being made up of two parts. First of all we have the part of the transformer which is perfectly coupled. If we short-circuit the secondary, this portion is also short-

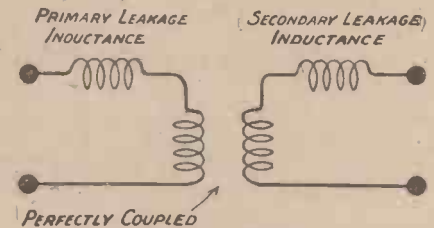

Fig. 6.—If this transformer had a ratio of 1 to 1 then the voltage on the output would be exactly the same as on the input.

circuited. Secondly, we have the small remaining portion which we can regard as the leakage portion of the transformer, and nothing we do to the secondary will ever affect this. This assumption is mathematically sound, and in fact in transformer design this method of splitting up the transformer into two parts is almost universally adopted.

In an exactly similar manner we can consider the secondary winding as being made up of a perfectly-coupled portion and a leakage portion, so that we can take our standard transformer and represent it as shown in Fig. 6, where we have a perfectly-coupled transformer and two small leakage inductances in series with the primary and secondary respectively.

Now in order to simplify the consideration of the problem still further we can remove the transformer altogether. If the transformer in Fig. 6

had a ratio of 1 to 1, then the voltage on the output would be exactly the same as on the input, and to all intents and purposes we could represent the transformer by a choke. If the transformer is not a 1 to 1 ratio, as is more usually the case, then by a suit-

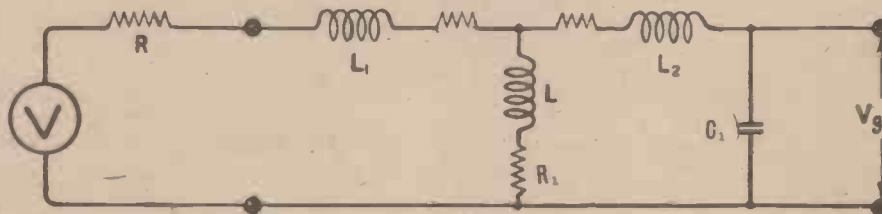

Fig. 5.—How the circuit of an L.F. transformer can be represented.

effect being due to the leakage between the two windings.

## A Helpful Conception

We can, therefore, imagine the

able choice of the values of the equivalent circuits we can still represent it as a single choke, the effect of the step-up ratio reflected in the  
(Continued on page 77.)



## LET ME PUT IT THIS WAY

You fellows will all be wanting valves before long. If you'll take my advice you'll buy S.T.'s. I was wanting some for my super-het when I saw that Scott-Taggart had gone in for the valve business. As you know, I'm a pretty old hand at the game, and I knew he wouldn't have gone in for valves unless he were sure he had something really good.

The results I got were so good that I tried them in my Monodial, using S.T.61's in the first two stages, an S.T.62 in the third, and one of their new super power valves—the S.T.63—in the last holder. I tried them also in the Elstree Six (three S.T.61's, two S.T.62's and an S.T.63) and they do the set more than justice. What do I advise for the Solodyne? My own experience is that three S.T.61's, an S.T. 62 and an S.T.63 are the best. Of course, if you want to use two- or four-volt valves you can get them in the S.T. range.

It's up to you, of course, to choose your own make, but I'd think pretty carefully before making up your mind. Of course, the S.T. curves are extraordinarily good, and some tests I've made myself bear them out. As you've probably seen from their advertisements, every valve is put through a series of stringent tests, so there is no chance of getting one that is not up to standard.

### TYPES and PRICES.

2 VOLT.		4 VOLT.		6 VOLT.	
H.F. S.T.21	0.1 amp. 14/-	H.F. S.T.41	0.1 amp. 14/-	H.F. S.T.61	0.1 amp. 18/6
L.F. S.T.22	0.1 amp. 14/-	Power. S.T.42	0.1 amp. 18/6	Power. S.T.62	0.1 amp. 18/6
Power. S.T.23	0.15 amp. 18/6	Super Power. S.T.43	0.25 amp. 22/6	Super Power. S.T.63	0.25 amp. 22/6

S.T. Limited, 2, Melbourne Place, Aldwych, LONDON, W.C.2.  
(Next Australia House.)



# From my Armchair

BY EARL RUSSELL

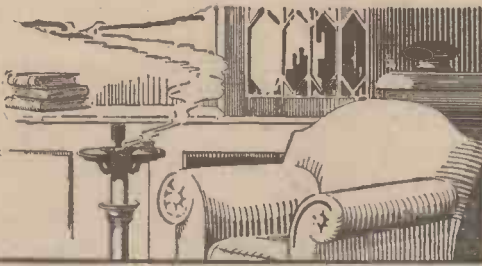

In these columns Lord Russell expresses each week his own personal views on matters of interest to "Wireless" readers.

## Lightning

I am always scared to death of lightning, not so much on account of the personal danger (I don't think any experimenter has been killed since Count Rumford's time) as for fear of the set being destroyed. The other night just after dark was unusual; there was a very brilliant flash of lightning (in a sky that looked all wrong for it) and no thunder. About an hour later when I started my set the ether seemed quite calm. A friend fifty miles away told me he saw two bright flashes the same night, but no thunder. In spite of my fears I am rather careless about earthing my aerials, and hope I shan't suffer for it some day.

## The Little Things

How the little things can bother one at times, particularly when one is in a hurry. I was trying out the "Night Hawk" in a hook-up and, of course, it was rather a mix-up of loose wires

with its five valves, its split-secondary coils, and its heap of fixed condensers and grid-leaks. After careful examination when it wouldn't give tongue, I found two wires off those nasty terminals on little fixed condensers which strip the thread if you try to make them really tight, and a third insulating itself secretly with a little bit of its silk covering. Then the aerial condenser—of first-class make—must needs short in one position because the panel was a little warped. There are few things more maddening than a variable condenser with an intermittent short, and, of course, when it is on the aerial your milliammeter gives no warning. Then one of the valve legs was dirty and wouldn't make good contact on its springy holder. Patience, cleanliness and care; and then again patience, care and a good light are necessary on these occasions. With a multi-valve set it is always a case of the more haste the less speed.

## Reflex Circuits

There are a good many reflex circuits about at this moment, and as a rule they use a crystal for rectification. They are tricky things to handle for more than one reason. First, there is the crystal which has to be adjusted, and if it is the cat-whisker type it generally loses its adjustment when you take your eye off it. Then the valves generally try to rectify instead, and this is very trying. I had this trouble with the old S.T. 100, and I am having it again in an acuter form with the very modern Distaflex. I have coaxed the tiresome thing in every way I can think of; given it unlimited grid-bias, raised and lowered H.T. voltage, and toyed with the ratios of that excellent new multi-ratio transformer of the correct type recommended for the last stage. All in vain; the valves will rectify and the crystal won't.

## Accumulators

A recent experience leads me to utter a word of warning to purchasers of accumulators. Less than three years ago I bought two accumulators of one of the best known makes for £9. They have always been properly cared for and fully charged, but for the last year have failed to hold their charge. So I took them to the makers who, without a word of apology for such bad service, offered to charge me £5 16s. to put them right. My advice is: Never buy an accumulator without a guarantee of its life if properly used.

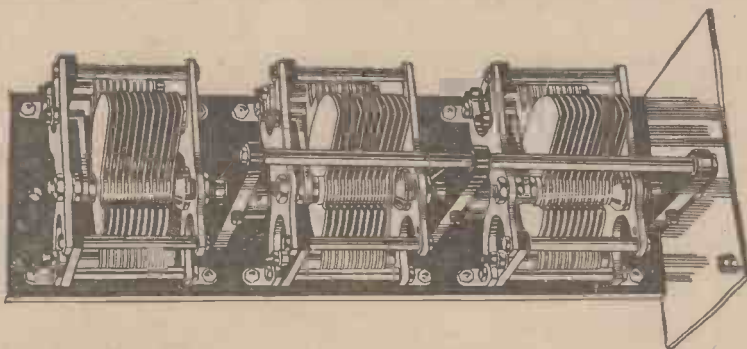

The

# CYLDON

(pronounced SIL-DON)

## TRIPLE GANG CONDENSER

for use in the New Five-Valve "Elstree SOLODYNE."

Price £3 . 10 . 0 (Without Dial)

2 Gang Condenser - £2 10s.     "     "  
4 Gang Condenser - £4 10s.     "     "  
Suitable Vernier Dial for use with above     "     Each 5/-

Other CYLDON Condensers comprise Square Law, Square Law Dual Pattern, and the S.L.F. 4 in. Knob Dial, supplied free with Square Law and Dual Models, and 2s. extra with S.L.F. or Triple Gang.

If unable to obtain CYLDON products from your dealers, send direct to:—

## SYDNEY S. BIRD & SONS,

"Cyldon" Works, Sarnesfield Road, ENFIELD TOWN, MIDDLESEX.

Telephone: Enfield 0672.

**C**ONSTRUCTORS are giving this handsome new model a most enthusiastic welcome because of (1) Its absolute freedom from whip. (2) Independent adjustment of each Condenser by novel means, completely eliminating hand capacity.

**O**ther attractive features are—each Condenser electrically separated. Anti-capacity plate supplied. Operation of all three condensers as "silky" as if only one was used. Whole instrument perfectly rigid. Supplied ready for immediate fitting. Construction and finish are well up to the fine CYLDON standard.

Send for particulars of the CYLDON WAVEMETER—it identifies unknown stations and makes searching and testing out simplicity itself.



## "Cyldon" TEMPRYTES

The best means of valve control. British-made and delivered from stock immediately. Can be supplied in correct resistance for any Valve. State resistance (ohms) required, when buying, or be sure to give name of Valve and voltage of Accumulator supplying current to the Valve.

CYLDON Temprytes ... .. each 2/6  
Holder mountings ... .. each 1/6





## If you had met Scott-Taggart—

**S**UPPOSING a month ago you had been on your way to a dealer to buy a valve and you had met Scott-Taggart. If he had recommended a certain valve as ideal for your purpose, would you have taken his advice? Supposing he had said: "When you get it, I shall be happy to test it out thoroughly and, after I am satisfied it is up to standard, give you a personally signed certificate to that effect," would you have accepted this offer?

You would not consciously have analysed the reputation he has built up as the best-known expert on valves in this country. You probably did not even know that his books on the subject have been a guide to over 500,000 readers of them. It might flash across your mind that he was the head of the great Elstree Laboratories and the keenest of critics of valves and apparatus. How far would his opinion have influenced your judgment? Would you have put his recommended and tested valve in your valve holder with confidence?

*To-day you have actually to answer this question. John Scott-Taggart has relinquished all his former activities to produce the best valve he can. It is available in every type, and the designer personally initials every box to certify that the S.T. valve inside has been tested dynamically (i.e., under actual operating conditions) under his own supervision.*

You are about to buy a new valve. Let it be an S.T.—the valve which, as its dynamic curve shows, gives high amplification and wonderful purity of reproduction. Thanks to the torodium filament and the high constant vacuum, its performance will be maintained, for S.T. valves are built—like the Pyramids—to last.

### TYPES and PRICES

2 VOLT.		4 VOLT.		6 VOLT.	
H.F. S.T.21		H.F. S.T.41		H.F. S.T.61	
0.1 amp.	14/-	0.1 amp.	14/-	0.1 amp.	18/6
L.F. S.T.22		Power. S.T.42		Power. S.T.62	
0.1 amp.	14/-	0.1 amp.	18/6	0.1 amp.	18/6
Power. S.T.23		Super Power. S.T.43		Super Power. S.T.63	
0.15 amp.	18/6	0.25 amp.	22/6	0.25 amp.	22/6

S.T. Ltd., 2, Melbourne Place, Aldwych, London, W.C.2  
(next to Australia House).



EXPERTS IN RADIO



TWO NEW CONES

THE ELLIPTICON

The new Brandes Cone Speaker is of beautiful and distinctive design. It is concealed in a handsome case, which is finely finished in dark walnut. The large vibrating area of the cone, together with a driving unit of special design, bring pleasing and natural tone, with plenty of power. The magnets in the cone unit are very large. There is no diaphragm, but a small armature which, reacting to the faintest impulse, faithfully reproduces extremely low and high tones. Height 13 1/4 ins., depth 7 1/2 ins., width 10 1/2 ins. **£5:10**

THE TABLECONE

The cone is housed in an attractive cabinet of unique design, which has a walnut finish. The circular diaphragm has an extremely sensitive driving unit which brings a wealth of volume with pure and effortless ease. The magnet in the cone unit is unusually large. The instrument is supplied complete with cord connection, and is a proposition of excellent value. It has a genuine claim to be better than any similar instrument at the price. Height 10 ins., depth 11 1/4 ins., **£2:15** (at base), breadth 9 1/2 ins.

Brandes

From any reputable Dealer.

BRANDES LIMITED, 296 REGENT ST., W. 1

ACOUSTICS SINCE 1908

COMPONENTS WE HAVE TRIED  
Conducted by the "Wireless" Laboratories, Elstree

A.C. High-Tension Battery Eliminator

WE have received from Messrs. Phillips & Co. one of their high-tension battery eliminators designed for use on A.C. mains. The unit consists of a metal case approximately 4 1/2 in. by 7 1/2 in. by 5 in. in height. The top of the unit is covered with a lid of moulded composition, upon which is mounted a valve-holder, three terminals, and two control knobs. Connection is made to the lighting circuit by means of the usual plug or adapter, a special plug being provided on the unit for connection at that end.

Two separate voltages of high tension are obtainable, both of which may be varied to suit the conditions under which the unit is used. One terminal is marked detector positive, and three different positions or voltages may be obtained by rotating the knob marked detector. The H.T. terminal is used for the amplifiers, and a continuously variable control is available on this. The other terminal is connected in the usual manner to the H.T. negative of the receiver. The fourth terminal is connected to earth. It was not possible to examine the interior of the unit without destroying it.

The unit was tested with a five-valve receiver having two stages of high-frequency amplification, a rectifier, and two stages of low-frequency amplification. Even when the receiver was tuned to its most sensitive condition, only a very faint hum was discernible on the loud-speaker.

When telephones were used, this hum only caused slight interference on very weak signals. The unit should be removed from the receiver and kept as far away as is practically possible, as the slight radiation from the unit causes the hum to increase if the unit is very near. However, at a distance of 1 ft. from the receiver the hum in the loud-speaker was very small indeed, and would not cause any interference with the reception of moderately weak signals.

S.P.D.T. Knife Switch

A NEAT and well-made single-pole double-throw knife switch has been sent to our laboratories for examination and report by Messrs. A. F. Bulgin & Co., Ltd.

The switch presents a pleasing appearance when mounted, all visible metal parts being nickel-plated. Contact is established by means of three spring sockets, the centre spring of which has the lever arm mounted on it, and the arm simply slips into the other two sockets as required, the sockets of course being fitted one on each side of the centre spring. The box itself is utilised as a drilling template, while a further good point is that soldering tags are provided. When in use a good electrical contact is made, it is simple to mount, and we have no hesitation in recommending it to our readers.

"WIRELESS"

enjoys the LARGEST NET SALE of any Technical British Radio Weekly Journal

PHONE REPAIR SERVICE

Headphones rewound and Remagnetised 4/6. Loud Speaker rewound 4/6, Transformers rewound 5/-. Remagnetising only 2/-. All work guaranteed. Postage extra. Write for trade terms:—H. R. P. Co., 1, Cottrill Road, Sparrow Terrace, Hackney, E.8.



LIFE LONG H.T.

Tromba units are constructed of the finest quality zincs, zincs, jars, etc., and creeping of the electrolyte and the other trouble usual to Leclanche cells eliminated. In units of 60-volt battery in Mahogany and Glass Case, 25 Shillings. Send to-day for descriptive folder, etc.

TROMBA ELECTRICAL CO. 17 WHITE HART LANE, TOTTENHAM, N. 17. OF ALL DEALERS OR DIRECT DEPOSIT 6

GLASS JARS AND ZINGS FOR MAKING WET H.T. BATTERY.

PARTICULARS AND SAMPLES—3d. STAMPS. FINISH WITH WORRY AND EXPENSE OF DRY H.T. PAPER DIAPHRAGM TYPE SPEAKER PARTS.

SPENCERS STORES LTD.

4/5, MASON'S AVENUE, COLEMAN STREET, Phone: London W. 3232. LOTHBURY, E.C.2. (nr. Bank).

K. RAYMOND for Wireless

We stock parts for all circuits and are Distributors of all Leading Manufacturers.

CALL HERE FOR:—LISSEN, BENJAMIN, RADIO MICRO, VOLTRON, COSMOS, MULLARD, EDISWAN, MARCONI, COSSOR, OSRAM, JACKSON (J.B.), DUBLIER, McMICHAEL, SUCCESS, HEARD & PITCH, BOWYER, LOWE, LEWCOO, IGRANIC, EUREKA, ORMOND, UTILITY, FORMO, EDISON BELL, FERRANTI, E.I., POLAR, NEWBY, P & M, MAGNUM. WE HAVE THE GOODS!! CALL AND SEE US. ALL LINES IN DEMAND STOCKED. SPECIAL TERMS TO RADIO CLUBS, GENUINE EXPERIMENTER'S.

BE SURE YOU ARE AT RAYMONDS. Nearest Tube Leicester Square. Phone: Gerard 4637.

WARNING! SEE K. RAYMOND'S NAME ON PREMISES. THIS WILL ASSURE YOU GETTING THE GOODS I ADVERTISE. PLEASE ASK "IS THIS RAYMOND'S?"

K. RAYMOND, 27 & 28a, LISLE STREET, LEICESTER SQ., W.C.2. Back of Daly's Theatre. Hours: 9-15 to 7-45. Saturday: 9 to 8-45. Sunday: 11 to 1.

WIRELESS.—Capable trustworthy men with spare time who wish to substantially increase income required where we are not fully represented. Applicants must have practical knowledge of installation of Set and Aerial, be a householder or live with parents, and be able to give references; state age and experience. Address: Dept. 38, GENERAL RADIO COMPANY, LIMITED, Radio House, Regent Street, London, W.1.



## The brain-made Instrument

A FAMOUS painter when asked with what he mixed his paints replied, "with brains." Just as the finest quality paints cannot make a masterpiece unless brains and vision control the brush, so are the best materials in the world useless, in the making of Loud Speakers, without wisdom, knowledge and experience to guide the hand which designs and makes them. Telephonic experience gained in the days before Broadcasting began—and after; the brain, imagination and

enthusiasm of the pioneer; the skill of the mechanic allied to discernment in the choice of materials—such is the basis of **Brown** success.

When you choose a **Brown**, you buy—not an instrument hastily assembled to conform more or less to an original "pattern," but a Loud Speaker on which has been bestowed all the individual thought, care and attention of a craftsman loving his work. A brain-made instrument!

§ **Brown** Loud Speakers come in nine types, priced 30/- to £15 15s.

# Brown

S. G. Brown, Ltd., Western Avenue  
North Acton, W.3

Retail Showrooms: 19, Mortimer Street, W.1.  
15, Moorfields, Liverpool. 67, High Street, Southampton.

G.A 6262.

# SIEMENS

## H.T. DRY BATTERIES

TALK NO. I

### General Remarks.

Siemens H.T. dry batteries are convenient and simple to use, reliable in service, and they ensure the steady, continuous flow of direct current which is so essential for "noiseless" reception. It is necessary, however, to select the correct size and type of battery to meet the conditions of use, and in order to give some general guidance as to the type of battery most suitable for particular conditions, the following table has been prepared.

Three types of H.T. dry batteries are now available, and practically every kind of Broadcast Receiving apparatus can be provided with H.T. current from dry batteries at a reasonable cost of upkeep.

The recommendations in the table are based upon an average use of 3 hours per day, and it is assumed that where necessary negative grid-bias is provided for the amplifying valves.

Total No. of valves employed	No. of Power Amplifying Valves included	Max. H.T. Voltage applied Volts	Type of Siemens Battery recommended
1 or 2	—	60	Small Capacity
2 or 3	—	60	" "
2	1	60	Large "
2	1	120	" "
2	2	120	" "
3	1 or 2	120	" "
4	—	60	" "
4	1	120	" "
4	2	120	{ Large or extra large capacity.
4	3	120	Extra large capacity.
5	2	120	{ Large or extra large capacity.
5	4	120	Extra large capacity.
7 or 8	2	120	Extra large capacity.

The maximum economical discharge rate for the 3 types of battery is as follows:—

Small Capacity Type	..	..	5 milli-amps.
Large " "	..	..	10 " "
Extra Large Capacity Type	..	..	20 " "

The batteries are quite capable of giving currents of higher values than those stated, but economical service cannot be assured if the rates mentioned above are exceeded.

The above is an extract from our new Cat. No. 650, "Siemens Radio Batteries," which contains a large amount of useful information on the CARE and MAINTENANCE of Radio Batteries, and also full particulars of Sizes, Weights, Prices, etc. A copy of this Catalogue will be sent on application to

SIEMENS BROTHERS & CO., LTD., WOOLWICH. S.E.18

# a remarkable offer!—

Prices Reduced by over 20%

Supplied Direct!

Return if not Completely Satisfied!



PATENT  
No 241383.

"Slektun" Coils are completely enclosed in a case and will not be affected by damp or dust.

We particularly wish to draw your attention to the unique patented method of spacing (as illustrated), which enables us to obtain almost twice as much air-space between the highest potential points or turns of any other plug-in Coil on the market. At the same time we claim the maximum inductance without increasing the size windings, brought about by the use of wedge-shaped Ebonite Separators.

We can only supply Coils in sets, for any other Coil in circuit with "Slektuns" will naturally not produce the same perfection owing to the difference in the direction of the winding.

The following sets are available at once:

**DAVENTRY.**

- A set of 2, viz.: 200 and 250 ... Price 15/-
- .. 3 .. 200, 250 & 300... Price 20/-
- .. 4 .. 150, 200, 250 & 300 Price 25/-

**BROADCASTING.**

- A set of 2, viz.: 35 and 60 ... Price 9/-
- .. 3 .. 35, 60 & 75 ... Price 14/-
- .. 4 .. 35, 50, 60 & 75 Price 17/6

Remember this: The "Slektun" Coil gives the lowest distributed Capacity and Resistance with the highest inductance. (All cases are the same size.) And now forward your order at once to avoid disappointment—Orders taken strictly in rotation.

## The World's finest Coil

We are confident of our claim that "Slektun" Coils are the finest that have ever been produced, and to support our contention give below details of a test made by the National Physical Laboratory. Compare these figures with those of any other Coil:

"Slektun" Coil Inductance: Self Capacity:  
of 200 turns 1770 Micro-Henries 3 Micro-Micro Farads

*These figures constitute a record in the manufacture of Inductance Coils.*

So confident are we that you will obtain unprecedented results that we are prepared to forward "Slektun" Coils direct to you, carriage paid, at the reduced prices and on the condition that if you are not entirely satisfied with them, they can be returned within 7 days and money refunded. Read the details alongside and forward your order at once. This offer is only open for a limited period!

# "Slektun"

THE  
SECRET  
OF  
SELECTIVITY

Registered Trade Mark.

# Coils

The  
**AUTOMATIC COIL WINDING & ELECTRICAL EQUIPMENT Co., Ltd.**

Wellington House, Buckingham Gate, London S.W.1.

## Repairs

Repairs to Transformers, Headphones, Loud Speakers, etc. We have recently equipped an up-to-date workshop on under description of every description. All Repairs done on the "Macadie" Automatic Coil Winding Machine.



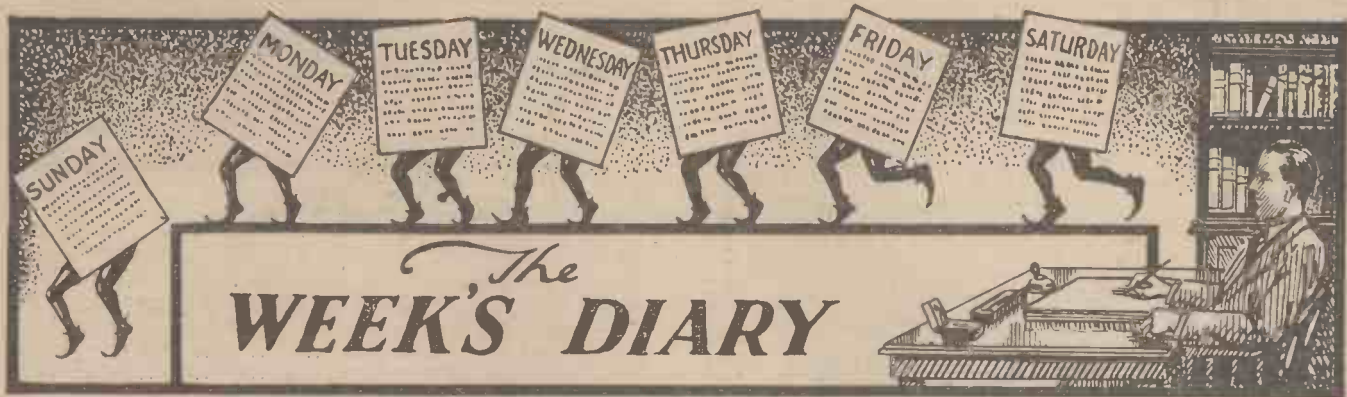

**R**ADIO has rubbed many people up the wrong way during the past year, but none has delivered such a comprehensive curse as Sir Thomas Beecham! He is worth quoting verbatim: "What does music sound like on the wireless? The music of Mozart and Beethoven when broadcast is like the most horrible chattering, gibbering and chortling of devils and goblins, and they call it Beethoven or Wagner! The sound has as much resemblance to Beethoven and Wagner as the singing of Galli-Curci has to the roaring of the Bull of Bashan." Now I must confess that I have heard a wireless set that is very justly described in words of that description. But it was only one set, and I am sure I could not build one like it myself. What strikes me as so peculiar about Sir Thomas's outburst is the fact that he is going to America, of all countries! I am afraid Sir Thomas will find that he has hardly escaped from broadcasting, dance music, films, and other "modern atrocities" when he arrives in New York. On the contrary, I should not be surprised if he returns to England within ten years or so!

**I**T is now practically certain that we shall not hear Mr. de Groot again. It is very difficult indeed to find out who has been at fault in this and other matters; on the one hand is the school that condemns the B.B.C. for paying small fees, and, on the other, the school of sympathisers, pointing out that the B.B.C. cannot afford to provide good programmes unless it receives far more aid from the Government than it does at present. That £900,000 is causing some slight anxiety! Whatever the circumstances, I think it unreasonable of the B.B.C. to consider that any artist can live on the advertisement that he derives from broadcasting. Not that I am hinting that this has been done in the de Groot case, but their attitude seems at times to approach this rather closely.

**B**Y the time this appears in print I fervently hope that the new wavelengths will be in working order. There is no doubt whatever that some percentage of listeners will be inconvenienced by the changes; but, as Captain Eckersley pointed out, whatever is done, someone is bound to grumble. The B.B.C.'s task is thus simply to evolve the scheme that will upset the smallest number of listeners. The only hitch in the new wavelength scheme seems to me to be connected with those who live fairly close to more than one relay station. They may now find that they cannot receive anything

when, to his utter amazement, the words he was reading issued from the loud-speaker. The voice followed him throughout the article, and it was not until he reached the end that the mystery was cleared up. The article was signed "L. G. M.," and Uncle Leslie, who speaks from 2LO on Thursdays, is "L. G. M." of the *Daily Mail*. Uncle Leslie thought part of his article suitable for the Children's Hour, and accordingly read it out. It certainly must be an uncanny experience to sit down in Belgium to read a South African newspaper and, at the same time, to hear an English voice reading the same words!



A facsimile of the "Wireless" card which now graces the walls of many amateur transmitters' "dens." These are sent out from our Elstree laboratories to stations heard on the shorter waves, and the wavelength is stated to a high degree of accuracy.

intelligible on the common wave of 238.5 metres, and will consequently have to transfer their attention to Daventry. On the whole, I have little doubt that the scheme will be quite a success.

**P**ROBABLY no stranger coincidence has ever been known than one reported by Mr. Lewis Wright, who is Trade Commissioner in Belgium for the Government of South Africa. He reached his house near Antwerp rather earlier than usual one day, and settled down, with the loud-speaker switched on, to read a South African newspaper. He had just begun to read an article on "Dragons of To-day"

working until midnight produced the remarkable effect of extracting "confessions" from three gentlemen, each of whom seems certain that he is the one I referred to! One of these is obviously not the gentleman in question, and seems to have considerable justification for objecting to my remarks, which he believed to be addressed to him. His loud-speaker is not raucous, and only one complaint has been received—that a baby is kept awake. In this case the baby's unmusical ear is perhaps to blame. At present it is a dead-heat between the other two.

(Continued on page 73.)

# "VARTA"

**THE ORIGINAL  
AND BEST  
H.T. MONOBLOCK**

~~EX~~ **REDUCED** ~~EX~~  
**PRICES**  
NOW IN  
**5/6 FORCE 11/-**  
BEWARE OF INFERIOR IMITATIONS

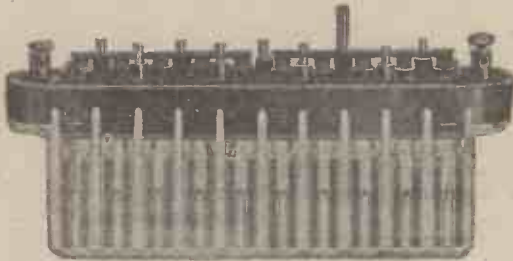

A. F. A. ACCUMULATORS, LTD., 9a, DIANA PLACE, EUSTON RD., N.W.1

## HITCH YOUR AERIAL TO A "STAR"!

We supply all Radio Press "Star" Sets either as finished receivers or in parts for home assembly.

IF you want an efficient and handsome receiver ready built, you cannot do better than purchase one of these "Star" sets from us. Each one tested on a large number of British and Foreign stations at full loud-speaker strength.

SHOULD you prefer to assemble your own set, you can do so under our famous "Pilot" Service, with every assurance that your efforts will be successful. Write for details of this service, and mention the type of set you want.

### THE "MONODIAL" FOUR.

FINISHED INSTRUMENT, aerial tested and guaranteed, Royalty-paid .. **£21 10 0**  
"Pilot" Kit of Components .. **£10 7 3**  
Polished Ebonite Panel, 14" x 7" x 1", drilled .. **0 8 0**  
Polished Mahogany Cabinet and Baseboard .. **2 5 0**

N.B.—When complete set of parts is purchased a Marconi Royalty of 12s. 6d. per valve must be remitted.

Every finished Receiver sold by us bears the signature of Capt. R. W. TINGEY (late of Radio Press Research Laboratories).

MANY other Radio Press Sets of up-to-date design—the M3tree Solodyne, the All British SIX, the Distaflex Two, etc., etc.—are available under the unique PILOT Service.

The PILOT MANUAL contains illustrated details of a number of up-to-date sets which we thoroughly recommend. Much useful information on soldering, assembling, testing, etc., is also included. Post free



### THE PILOT MANUAL

**PETO-SCOTT Co. Ltd., 77, City Rd., E.C.1**

Branches: 62, High Holborn, London, W.C.1. WALTHAMSTOW—230, Wood St. PLYMOUTH—Bank of England Place. LIVERPOOL—4, Manchester St.

G.A. 6396

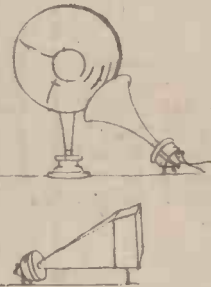
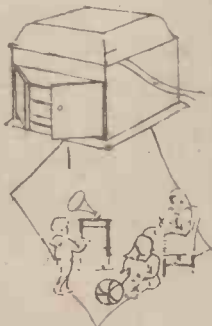

## HEAR THIS GRAMO-SPEAKER

GO to your Dealer and ask him to show you the new, inexpensive T.M.C. Gramo-Speaker. Fit it to your gramophone—it only takes a moment—or to your home-made or purchased horn, and avail yourself of the wealth of entertainment it offers, far below ordinary loud-speaker price. Again, you can easily obtain a cheap loud-speaker extension to

your nursery or domestic quarters by means of this wonderful instrument. Try one with your large loud-speaker for stereoscopic tone experiments. You will be delighted with the reliability, performance and tone of the Gramo-Speaker. It has no equal because like all T.M.C. Radio Products, the Gramo-Speaker is the best of its kind, yet its price is only 13s. 6d.

Ask for the new T.M.C. Catalogue at your local wireless shop, or we will send a copy free on request. Please mention the name of your usual dealer.

Other T.M.C. Radio Specialities.	
<b>LOUD SPEAKERS.</b>	<b>HEADPHONES.</b>
"Concert" .. £5 10 0	No. 3 (Light a. d. weight) in card-board box .. 17 6
"Standard" .. 24 5 0	No. 2A Heavier Model .. 15 0
"Junior" .. £1 10 0	(Flush lined cases 2/6 extra)
"Minor" .. 17 6	

# TMC

Telephone Manufacturing Co. Ltd.  
HOLLINGSWORTH WORKS WEST DULWICH S.E. 21

### Other T.M.C. Radio Specialities.

CRYSTAL SETS from 9/- to £2 7s. 6d.	
<b>LOW CAPACITY KEYS.</b> .. s. d.	
No. 1. 12 Pt., 3 position .. ..	7 0
No. 2. 6 Pt., 2 position .. ..	6 0
No. 3. 24 Pt., 3 position .. ..	15 6

Prices do not apply to the Irish Free State.

**THE WEEK'S DIARY**  
(Continued from page 71)

**S**ERIOUSLY, though, I cannot see any real cause for anyone to object to loud-speakers, provided that they are properly operated—i.e., with as natural a tone as possible, and no louder than the original performance. Speech should be "speech," not bawling.

\* \* \*

**T**HE proposed broadcast of a murder trial in America is another sidelight on the good taste shown by the managers of broadcasting stations in the States. A friend who has just returned from that country assures me that he has heard broadcasts over there which would cause the average Englishman to switch off the set in disgust. The next step, I expect, will be to broadcast the murders.

\* \* \*

**R**ADIO Belgique relayed some gay programmes last week in connection with the Royal Wedding. They were really enjoyable, and

came through remarkably well, both on the main wave of 487 metres and on 265 metres, where Antwerp was relaying them.

\* \* \*

**I** CANNOT say that I was deeply impressed by the Strauss concert at the Albert Hall. The actual broadcast left very little to be desired, but the whole programme that evening seemed to suffer from the "patchi-

ness" which characterises most of the programmes now.

\* \* \*

**D**ID you realise that Dutch listeners to Hilversum do not need a set? They can also hear Paris and Daventry if they are telephone subscribers. The service does not interfere with the ordinary telephone, the music simply being cut off when a private call comes through. By the way, single earpieces are not used!

\* \* \*

**I**T seems likely that when regular relays are desired from the Continental stations, as they certainly will be in time, the numerous Trans-Continental land-lines will be brought into use for the purpose. The "wireless link" idea is certainly more interesting, but even the experts at Keston cannot bring out a Continental programme at respectable strength unless they are given a favourable night, by which I mean one fairly free from atmospheric and fading. To be independent of these two bugbears would be very pleasant, but the old problem arises again: which is to be preferred—the indescribable noises that sometimes occur on a land-line, or the well-known voices of the atmospheric, with occasional heterodyne whistles?

WAVE-TRAP.



The Dominion Premiers, while on their visit to this country, paid a special visit to the Hillmorton Wireless Station at Rugby. They are here seen inspecting some of the control gear.

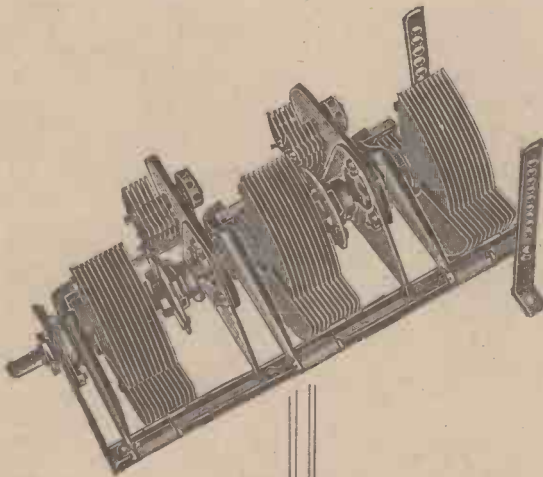

—now comes the  
**Twin Gang!**

**T**HE Igranitic Triple Gang Condenser aroused intense interest—now there is a Twin Gang pattern in which the circuits are equalised in the same manner. Small compensating condenser connected in parallel with the main sections enable

each to be exactly equalised without the necessity of altering the relative settings of the main condensers. The Igranitic method is simple and practical and preserves the accurate square law tuning of the condensers as a whole.

Twin Gang pattern	- - -	£2 10s. 0d.
Triple " "	- - -	£3 15s. 0d.
" " "	without compensating condensers	£3 10s. 0d.

WRITE FOR  
THE NEW  
IGRANIC  
CATALOGUE  
LIST No. S.39.

**An auxiliary for every rheostat**

The Igranitic Auxiliary Rheostat combines the advantages of a fixed resistor and a rheostat. It has a total resistance of 25 ohms., and is variable over its whole range.

**1/-**  
each.



—then "let  
your friend  
listen."

**IGRANIC ELECTRIC CO. LTD**  
149, QUEEN VICTORIA STREET, LONDON.

# The New J.B. TRUE TUNING S.L.F.

is the latest development in SLOW MOTION CONDENSER Design.

The Vanes are designed on a new principle—developed to fall in line with the latest method (Geneva Plan) of allotting wavelengths to transmitting stations—a principle which gives the most even spacing of stations possible, obviating any crowding at the upper end of the scale, and marking the new J.B. TRUE TUNING S.L.F. as the Condenser of the future.

This new model is provided with a Double Reduction friction drive, giving a ratio of 60-1.

The friction surfaces are all metal, and machined to a fine limit of accuracy, preventing any possibility of lost motion.

The use of Ball Bearings cuts down friction to an absolute minimum, permitting a wonderfully smooth control and obviating the disadvantages of "static" friction so usual in the ordinary type of condenser. A noticeable feature is the complete absence of backlash. A coarse and fine movement can be obtained, i.e., the body of the condenser can be moved independently of the friction device for quick search.

One hole fixing, specially designed for rigid mounting, this new model combines all the excellent features of the ordinary J.B., S.L.F.

Retail Prices: .0005 mfd., 16/6; .00035 mfd., 15/6; .00025 mfd., 15/-



2 in. Bakelite Knob for Slow Motion Control Device.

4 in. Bakelite Dial for Coarse Tuning.

(Patented)

JACKS 4-POINT	S.L.F. CONDENSER	RELIABILITY CONDENSERS	WIRELESS CABINETS	DEWAR SWITCH
1-Hole Fixing 1/9	.0008 .0005	With 4-in. dial. Mfd. Mfd. .. 7/- .. 7/8 .. 25, 1/6 1, 2/6 .. 5, 1/9 2, 3/8	For Panels 7 in. High With 5 in. Hinged Lid Oak 12 in. 17/-; 14 in. 17/8; 18 in. 18/6. Mahogany, 1/- extra.	12-Contact. 2/6

## READ THIS LIST AND SAVE MONEY ON COMPONENTS

**CONDENSERS.**—Low Loss, Square Law, with knob and dial. .0005, 5/-; .0003, 4/6; with Vernier Blade, 1/4 extra; Twin .0005, for Elstree Six, unequalled value, 9/6; Cylind Twin for ditto, 27/6; Ormond, J.B. Utility, Sterling, Polar, Formo, Igranic, G.E.C. Variable in all capacities. Neutrodino types, Ormond, 2/-; Colvern, 3/6; Gambriel, 5/6. **FIXED PRICES.**—Dunbrier, Edison Bell, Lissen, Watmel, Mullard, McMichael, at advertised prices. Special Reliability Fallon. .0005 mid. 2 meg. Leak. 1/3; Cases only 4d. **BATTERIES.**—Reliability, 90 v., 11/-; 60 v., 7/6; 36 v., 4/8; 15 v., 1/10; Ever Ready, Siemens, Hellesen, 100 v., 21/-; 86 v., 12/6; 36 v., 7/6; Flashlight Battery Cases for 14 Batteries 3/6, 4 v. Batteries, 4d. 60 v., Unequalled, 6/6; Wander Pings, 11d. Clix Type, 2d. **L.P. TRANSFORMERS.**—B.I. Multi-Radio, 25/-; Marconi Ideal, 25/-; Junior, 18/6; Ferranti A.F.3, 25/-; A.F.4, 17/6; Formo, 10/6; H.T.C. Empire, 7/6; Croix 5 to 1 6/-; Lissen new type, 8/6; Igranic, 16/-; Eureka Concert Grand, 25/-; No. 2, 21/-; Baby Grand, 15/-; Ormond, 15/-; Royal, 20/-; Success, All Black, 21/-; Silvertown, 21/-; G.E.C., 15/-; Brandes, 17/6; Burndept, 16/6; Special Value, 7/8; Modulation, 7/8. **ACCUMULATORS.**—Exide, D.T.G., 4/6; D.F.G., 3/6; W.J., 20 v., H.T. type, 15/-; Oldham H.T. 10d. per volt, complete; Duros 20 v., 11/-; 20 v., 5/6; Repairing Outfit, 2/6. **EBONITE.**—Any size cut, Clayton brand, 3 in., 1d. sq. in.; 9 in. by 6 in., 2/2; 12 in. by 9 in. 4/6; 15 in. by 9 in., 5/6; 3/16 in., 25 per cent. less. Paragon and Radion, 1d. per sq. in. **AERIALS.**—100 ft. 1/2 in. copper tape, 1/6; 7/22s Bright, 2/3; Enamelled, 3/3; Electron, 1/8; Superial, 2/6; Mars, 9/6; Ashton Spreaders, 12/- per pair; O.V., complete, 2/8. **INSULATORS.**—Large Shell, 3d.; Eeol or Egg, 1d.; Climax, 6d.; Ditto, with shock absorbers, 3/- pair; Gal. Pulleys, 4d.; 100 ft. Gal. Straining Wire, 1/6; Straining Bolts, 6d. **TERMINALS AND ACCESSORIES.**—Single W. Office N.P. or Pol. Brass with nut and washer, 11d.; Phone and Castle type, 1d.; Double Mark, 3, 2d.; 4-way Phone Connector, 6d.; Pole-landing paper, 3d.; Fluxite, 8d.; Black Tape, 6d. coil; 1/2 in. Empire Tape, 6d. dozen yards; Insulating tube, 3d. rd.; Glazite, 1/2 10 ft. coil; Shellac Varnish, 6d.; Mica 2" x 1 1/2", 4d. doz. **VALVE HOLDERS.**—Anti-Phonic Benjamin, 2/9; Lotus, 2/3; with terminals, 2/6; Burndept, 2/9; Earle, 1/6; Reliability, unequalled, 2/-; all base-board types, ordinary ditto, 6d.; N.P. Valve Sockets, flush fitting, 1d.; Superior Panel Type, 6d.; All Ebonite, 10d. **HEADPHONES.**—B.T.H., 15/-; Brown's "F" Type, 20/-; Reliability, 7/8; Adjustable, 8/-; Dr. Nesper, 12/11; T.M.C., 17/6; Western Electric, 20/-; all 4,000 ohms; Sullivan, 120 ohm Double, Ex-Govt., New, 4/-; 120 ohm Single Phone, 2/6; Long Phone Cord, 1/- **RECENT REDUCTIONS.**—Sterling .0005 Square Law Condensers with Vernier, 9/6; Geared 12/-; Mifloss 15/-; .00025, 8/6; Geared, 10/6; Mifloss, 14/-; Marconi Automatic Detector, 9/6; Series Parallel Variometer, 10/8; Eddystone Absorbos feet, set of four, 2/3; Benjamin S.P. Switch, 1/3; N.P. Clix Plug and insulator, 21d.; Adaptor, 11d.; Socket, 2d. **LATEST COMPONENTS.**—6-Way Coil Stand 2/9; Colvern Low Loss Inductance Former, 5/-; Formo Straight Line .0005 Condenser, 10/6; Success, 18/6; Eureka, 15/8; Cylind, 15/6; Lissen 60 volt H.T. New Process Battery, 10/8; Valve Vibrating Springs, 6d. set of four. **EXPERIMENTERS' PARCELS.** Accessories of Various Types, worth 20/-, post paid, 5/6

**JACKSON BROS.**  
8, POLAND ST-OXFORD ST  
LONDON - W.1  
(First Floor)  
Telephone -  
GERARD 7414

Send for RELIABILITY WIRELESS GUIDE No. 2. Free on Request Trade Supplied

**J. H. TAYLOR & Co.**  
11, RADIO HOUSE,  
MACAULAY ST., HUDDERSFIELD  
Tel: 341. Grams: THOROUGH HUDDERSFIELD

Orders 5/6 Value Carriage Paid. Under 5/6 2d. per 1/- for Packing, etc.

**100 Guineas for a Name!**

**HAVE YOU ENTERED**

**WRITE FOR FULL PARTICULARS**

**CAV**

**IMPROVED 1927 MODEL H.T. ACCUMULATOR 60 VOLTS 60%**

**SUPPLIED FULLY CHARGED**

Competition open to Users of this Accumulator.

Owing to the various special features of our H.T. Accumulator we desire to give it a distinctive name, and invite suggestions. Prizes will be awarded as follows—

**FIRST PRIZE - - - 75 GUINEAS**  
to the entrant of name adjudged the best.

**SECOND PRIZE - - - 25 GUINEAS**  
to the trader from whom the First Prize winner purchased his Accumulator.

**CAVandervall & Co. Ltd.**  
ACTON, LONDON, W.3





# A CRYSTAL SET TO SUIT ANY CONDITIONS

By H. BRAMFORD

The use of the new six-pin plug-in type of coil renders this receiver quite flexible, and it can be adapted to give the best results under many different conditions.

only are used in place of the more orthodox plug-in type. This unusual feature as regards a crystal set lends itself to adaptability, as will be seen in the subsequent description to be given in this article.

## Constructional Work

The constructional work entailed is quite simple, most of the details being clearly shown in the front and back

on the cabinet itself by means of four countersunk wood screws. The photograph of the open cabinet clearly shows the panel in position. The only component to mount upon the baseboard, which is actually the drop front of the cabinet, is the six-socket base. All is now ready for wiring up.

## Theoretical Circuit

The theoretical circuit given shows the six-socket base numbered to correspond with the actual component. The flex leads and spring clips are indicated by the letters W, X, Y, and Z. The aerial connects in every case to either of the terminals A or A<sub>1</sub>, thus employing or eliminating the series condenser C<sub>2</sub>, as may be desired. This circuit will prove helpful in explaining subsequent connections to be made for various tuning arrangements.

## The Cabinet

Before proceeding with the details of operation, a word relating to the special cabinet may be useful. As it is obvious that various alterations will be made by means of the spring clips from time to time, the cabinet is so arranged that by pulling the front

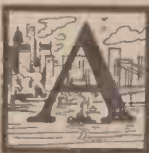

As a crystal receiver, the set to be described in this article has several unique features, which lend themselves principally to work of an experimental nature.

On the other hand, as a tuner, to be used in conjunction with valves, the set should prove extremely useful in a number of ways. Most receivers of an experimental or "multi-purpose" nature are troublesome in some way or other, but it may be safely said in this instance that such is not the case, as the receiver has been particularly designed, even in respect of the cabinet itself, with the object of

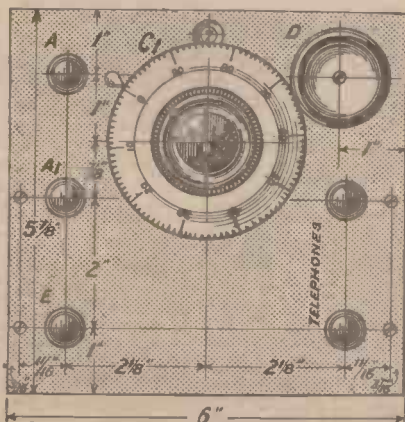
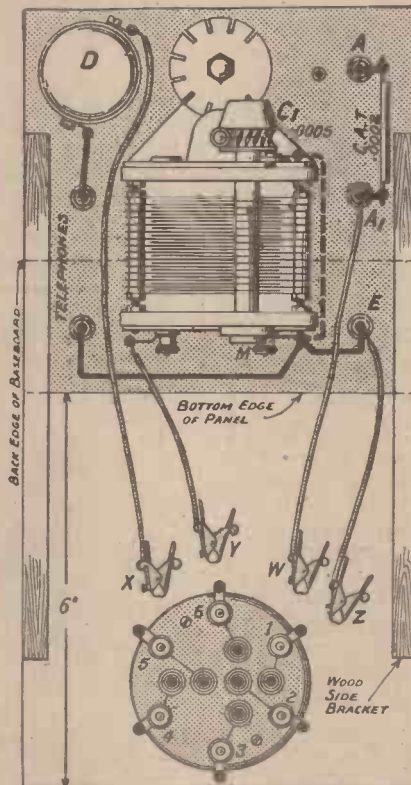

Fig. 1.—In view of the number of components which have to be got in a fairly small space, readers are recommended to follow this panel layout with care.

making such work simple and unconfusing. A number of circuits may easily be tried out, owing to the fact that coils of the six-pin plug-in type



BASEBOARD OR DROP FRONT OF CABINET 8" x 6" x 1/2"

Fig. 2.—The panel is secured to the baseboard by means of wooden supports. The shape of these supports can be seen quite clearly in the photograph at the right of this page.

of panel drawings given. The panel is first prepared in accordance with the dimensions given. When this is done, the five terminals, the crystal detector, and the variable condenser may be mounted upon the panel. The next step is to secure the panel thus equipped to the side brackets provided

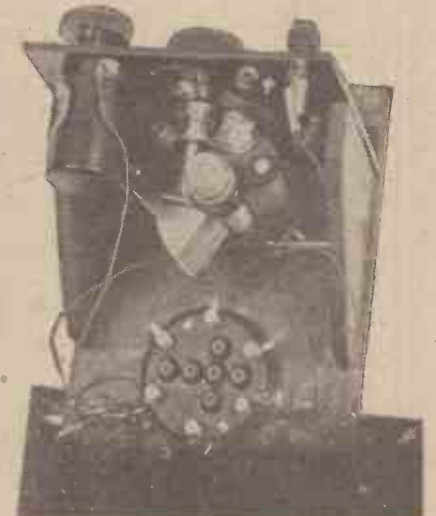

All the necessary connections to the six-pin coil-base are made by means of spring clips.

door down after lifting the top, the whole panel and interior presents itself conveniently for this purpose. The  
(Continued on page 78.)

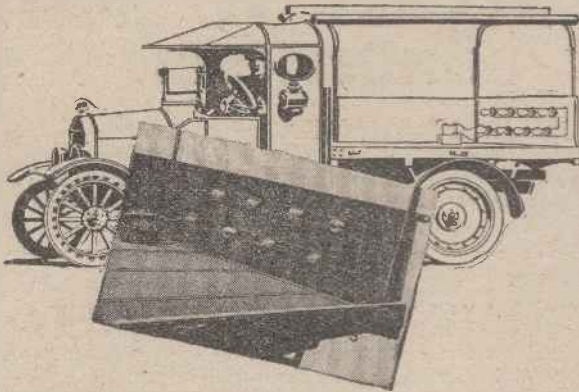

*Here's Proof that  
the 'LOTUS' Survives  
Shock and is  
anti-microphonic*

**E**IGHT 'Lotus' Valve Holders fitted with large power valves and fixed to tailboard of a Ford motor lorry, driven over rough roads for 30 miles, survived the test.

At the finish each spring was as it started—perfect. No damage or looseness at the connection of leg socket and spring—no valve became loose from the holder. Both were electrically perfect all the way.

That is why we guarantee the security of 'Lotus' Valve Holders against shocks and vibration. Fit the 'Lotus' to your set and protect your valves.

*From all Radio Dealers.*

**Prices:**  
Combination Grid Leak and Valve Holder

**3/9**

VALVE HOLDER With Terminals

**2/6**

VALVE HOLDER Without Terminals

**2/3**



Pat. No. 256833.

Made from best bakelite moulding with springs of nickel silver and phosphor bronze valve sockets.

**GARNETT, WHITELEY & CO., LTD.,**  
Lotus Works, Broadgreen Rd., Liverpool.  
*Makers of the famous "Lotus" Vermier Coil Holder*

**A UNIQUE FEATURE OF  
CLIX  
FITMENTS.  
THE PATENT WIRING  
PRINCIPLE**

EMPLOYED WITH  
HIGHEST EFFICIENCY  
ON:—

- CLIX PIN TERMINALS.
- CLIX PARALLEL PLUGS
- CLIX SPADE TERMINALS.
- CLIX WANDER PLUGS.

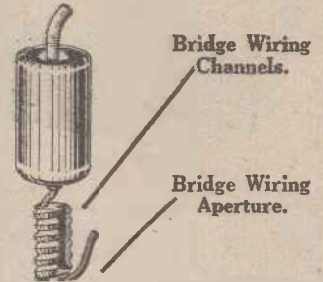

**AUTOVEYORS, LIMITED,**  
84, VICTORIA STREET, WESTMINSTER, S.W.1  
*'Phone; Victoria 309. Telegrams; "Autoveyors, Sowest, London."*

**For Every Circuit and Set**

there is a guaranteed  
**BRETWOOD  
COMPONENT**

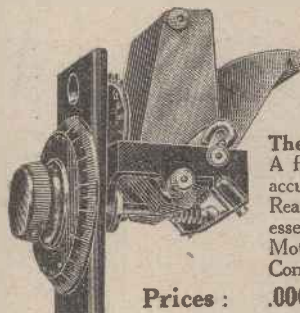

**The Bretwood S.L.F. Condenser.**  
A fine engineering job, quality and accuracy throughout. Reasonable in price and has all the essentials of a true Low Loss, Slow Motion, Straight Line Frequency Condenser.

Prices: .0005 17/6. .0003 14/9.

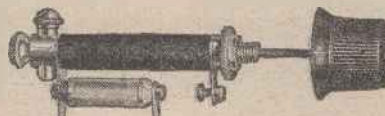

**Grid Leak de Luxe.**  
The already famous Bretwood Variable Grid Leak has been greatly improved.

Its accuracy is now on a par with S.L.F. Condenser readings. This is secured by the addition of a Syphon Container to fully guarantee even distribution of resistance element. **PRICE 3/6**

**PRICE (with condenser) 4/6**

**The Bretwood Amplifier.**  
Thousands at home and abroad have proved that these give distortionless reproduction.

10 days' Free trial if desired.

**PRICE 20/-**

GET OUR COMPLETE LIST FREE



**BRETWOOD LTD.,**  
18, London Mews, Maple Street,  
London, W.1.

*Part Ad.*

**MORE SECRETS OF THE LOW-FREQUENCY TRANSFORMER**

(Continued from page 64)

values of the different parts of the network.

**Effects of Self-Capacity**

Finally we have the self-capacity of the windings, more particularly the secondary. As we increase the number of turns on the secondary so this distributed capacity increases in value, and it plays quite an important part in the calculations. Associated with this is the capacity between the primary and the secondary winding, which is determined by the type of winding adopted, and finally any external capacities which may be connected across the transformer due to the valve, valve holder, wiring, etc. All these capacities may be lumped together to form one equivalent capacity in our equivalent circuit.

**An Equivalent Circuit**

When all these points are taken into consideration we can represent the circuit of our transformers in the simple form shown in Fig. 5. The input from the preceding valve  $V$  causes a current to flow through the circuit. Part of this voltage is lost in the internal resistance of the valve itself, which is shown in the figure as  $R$ . The remainder of the voltage is developed across the transformer and results in the production of a voltage  $V_g$  across the output circuit which is applied to the next valve. As we have just seen, the values of the inductances and capacities in this network are chosen mathematically so that they form an exact representation of the initial transformer.

We need not go into the mathematical problem in any way except to note that the transformer can be represented in this manner. It is then easily possible to observe the various defects which are causing unequal frequency characteristics. Reverting to Fig. 5,  $L_1$  and  $L_2$  are the leakage inductances of the primary and secondary circuits respectively.  $L$  is the equivalent inductance, and  $R_1$  the equivalent resistance of the transformer, these values being so chosen as to duplicate the effect of the transformer allowing for the step-up. Finally, the capacity  $C_1$  across the output represents the combined effect of the distributed capacity in the secondary winding, the mutual capacity between the windings and any stray external capacity.

**Next Week**

The exact effect of these various points we shall discuss next week, but it will be clear from the equivalent network which we have just devised that there are several factors which are not revealed in simple analogies, yet which will have considerable effect on the operation of the transformer.

ALWAYS BUY



HIGH TENSION

**3 a.h. ACTUAL AND GUARANTEED**

otherwise heavy cost constantly recharging. BEWARE of High Tension with Voltage only Stated. Amp. Hour is the Absolute Essential. Absolutely refuse High Tension with Wood Separators between Plates creating filament noises and the primary causes of early destruction of entire Battery.

**LOW TENSION CELLULOID 2-VOLT CONTAINERS (EXCEPT TUNGSTONE) CONTAIN CAMPHOR WHICH THE ACID ATTACKS CREATING CONSTANT FOAMING. ALSO HOLDS THE HEAT.**

Manchester Evening Chronicle.

February 8th, 1929.

**THE TUNGSTONE H.T. BATTERY**

After having one of the above in use for two months, I shall never go back to the dry battery, although I have had excellent reception from the large-sized cells.

After my experience with this battery I can speak with confidence about it. The makers' claims appear rather far-reaching, but each one is fully borne out in practice. The battery is quiet in working, and testing the voltage as the set was working on the Newcastle's transmission last evening the voltage was 60.

My batteries have not an easy time by any means, as on some evenings I have had five valves (three of them power valves) working, and the fact that the battery has stood up speaks well for the units.

The cells are small, but the plates are large, and are prepared in a special manner which the makers claim give them a tremendous holding capacity. The whole sixty volts occupy little more space than a dry battery of the same capacity, so that it can safely be called "the box of stored-up energy."

TUNGSTONE High Tension 60 Volt Battery 3 a.h. is sold in the United Kingdom on monthly payments over an extended period. Apply for particulars. Further interesting information on points of this advertisement are to be found on pages 58, 59 and 67 to 73 of the Illustrated Booklet "Photography tells the Story" which will be sent free on application to the TUNGSTONE ACCUMULATOR CO., LTD., St. Bride's House, Salisbury Square, Fleet Street, London, E.C.4. T.A.42

Birmingham Mail.

February 10th, 1926.

**HIGH TENSION ACCUMULATOR.**

Lately I have been experimenting with a Tungstone H.T. accumulator, 60-volt 3 a.h., and the results have been so satisfactory that I have no hesitation in saying it is worthy of recommendation. The makers claim several advantages for this accumulator, namely its light weight (23 lb.), particularly standardisation and interchangeability of parts, perfect rubber insulation between each cell, etc., but what the average wireless enthusiast will appreciate more than anything else is the perfectly quiet and steady flow of current to the plate, with the result that there is no distracting cackle on the phones or the loud speaker.

Nott. Evening News & Journal.

December 19th, 1925.

**TUNGSTONE H.T. ACCUMULATOR.**

When superlative claims are made concerning the quality of an article we invariably approach it with a caution and a certain amount of diffidence. It was therefore, after thorough tests, a real pleasure to find that in no sense whatever has the Tungstone H.T. accumulator been over-rated.

The accumulator gave an unvarying and reliable discharge at uniform rates over long periods of continuous or intermittent work with no drop in voltage.

**REPAIRS**

Headphones, Loudspeakers and Transformers re-wound and re-conditioned equal to new.

AN UNSOLICITED TESTIMONIAL:

"Thanks to the excellent manner in which it was re-conditioned, the results achieved have been astounding. It is very gratifying to find a firm that really turns out first class job, as I have had very disappointing experiences with firms who have been advertised as experts, and whose workmanship has been very far from good."

Varley Magnet Co. Replacements Dept. Woolwich, S.E.18.

Proprietors: Oliver Fell Control, Ltd.

**EVERY LOUDSPEAKER**

**DESERVES MULLARD MASTER VALVES**

— Ask for —

**Mullard P. M. Power Valves.**

# A Crystal Set to Suit any Conditions—continued from page 75

front of the cabinet itself actually acts as a baseboard to which the panel is secured. When the front of the cabinet, however, is closed up, it presents the usual pleasing appearance, while the panel is at the same time in a most desirable position for operating purposes, with only the top of the cabinet open.

### Operation

The general details of operation as applied to this set are simple. The aerial is connected to terminal A, if the series condenser is employed. Alternatively, the aerial is connected to terminal A<sub>1</sub>. The earth is connected invariably to terminal E. The 'phones are connected to the terminals provided, and the variable condenser set with the moving vanes full out when the dial should read 0°, and the indicating number should also read 0. All that then remains is to arrange a circuit chosen, adjust the detector, and tune in with the variable condenser in the usual manner.

### Using a Six-pin Aerial Coil

A six-pin aerial coil gives us the opportunity of using direct or auto-coupling as shown in the diagrams (a) and (b). The connections for circuit (a) are as follows:—Connect aerial to terminal A or A<sub>1</sub>, and earth to terminal E. Fix clips W, X, and Y to terminal 1 of the base, and clip Z to terminal 2 of the base. In example (b) remove clip W to terminal 3 or 4 of the base, leaving the other connections as before, and transpose the aerial to terminal A if desired.

### Using a Split-secondary Coil

Two examples are shown, (c) and (d), using a split-secondary coil in each case.

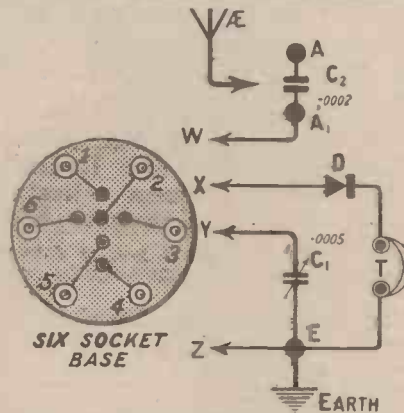
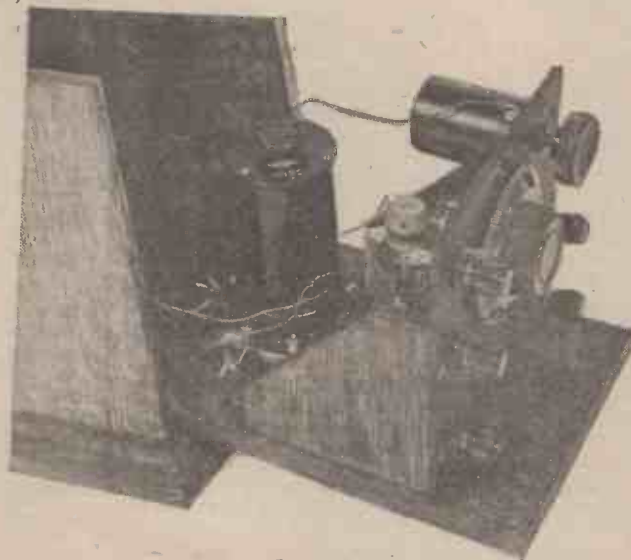

Fig. 3.—The leads shown in this diagram, which terminate in arrow-heads, are equipped with spring clips.



The door seen on the front in the heading photograph is really the baseboard of the set, and in this view it is seen opened out.

The various connections are as follows:—

To use direct-coupling with a centre-tapped crystal (example (c)) connect the aerial to terminal A or A<sub>1</sub>, and earth to terminal E. Join terminals 4 and 5 on the six-socket base. Fix clips W and Y to terminal 3 of the base, and clip Z to terminal 6 of the base. Fix clip X to terminal 4 of the base.

To alter this arrangement to inductive coupling, as in (d), fix clip W to terminal 1 of the base and connect terminals 2 and 6 of the base. This circuit is very selective.

### Other Arrangements

Several other arrangements may, of course, be tried out, the six-pin fieldless coil providing a very interesting source of experiment when valves are used. Also, the split-primary six-pin coil provides further means of taxing one's ingenuity in devising different types of circuit. Using a split-secondary coil, a centre-tapped aerial circuit may also be tried, the number of uses to which this crystal receiver or tuner may be put being considerable.

### Results

Almost all the circuits tried out on a moderate outdoor aerial some 10 miles east of 2LO gave excellent results. Signal strength was in all cases good and operation simple. No difficulty was experienced in receiving Daventry using the larger type of coil. It should be noted that those who wish to wind their own coils may easily do so, full particulars of these coils of each type having been given in the September issue of *Modern Wireless*, to which article reference should be made for (Continued on page 80.)

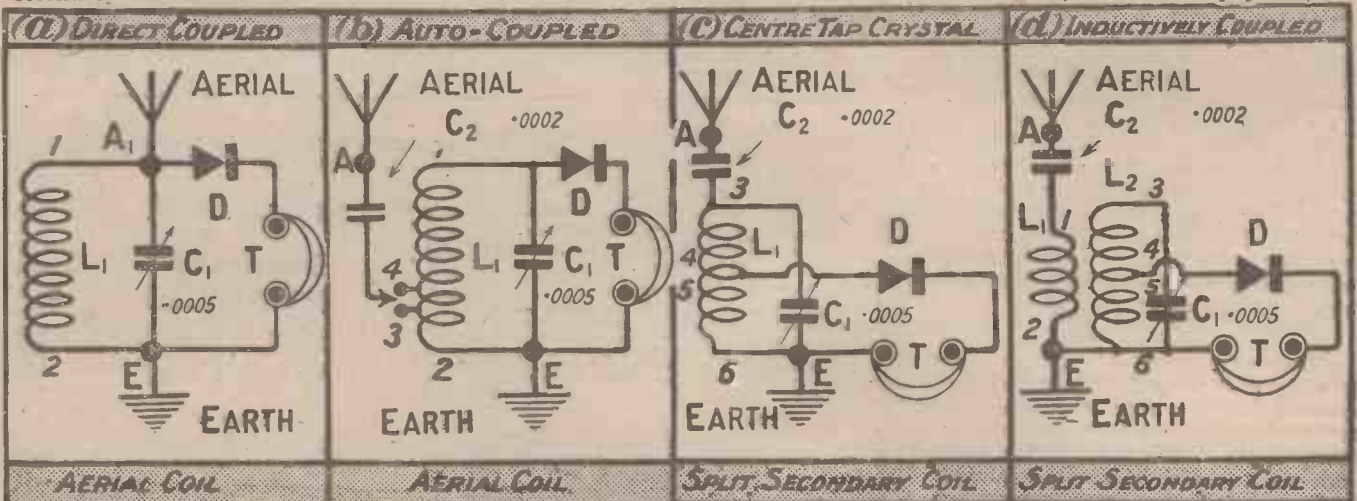

Fig. 4.—All these circuit arrangements are possible on this set, and the numbers accompanying each circuit diagram correspond with those on the coil base shown in Fig. 3.



## THIS H.T. BATTERY

- costs only 13/-,
- is made throughout in London,
- is sent post and packing free,
- reaches you, brim full of energy within a few hours of manufacture owing to the enormous number we sell daily,
- maintains its voltage for the longest possible time owing to the extremely generous "elements" of which it is made,
- will give you a long life of loud, clear reception free from all crackling noises,
- is tapped every 6 volts, enabling you to apply the exact voltage required by your valves for best results,
- is supplied complete with Red and Black wander plugs—no extras to buy,
- is, in short, the **FINEST IN THE WORLD** because no other H.T. Battery made (except other Fellophone batteries) can come anywhere near it in performance or value,

Other Fellophone Batteries are listed below. We can only offer you this astounding value because, by supplying you direct we can save all the middleman's profits and so give you a better battery for less money.

Order from us or from our Branches to-night.

- 54 Volt** (with 3 volt tap for grid bias). Post FREE **6/6**
- 60 Volt** (tapped every 3 volts and supplied complete with Red and Black wander plugs). Post FREE **8/9**
- 108 Volt** (tapped every 6 volts and supplied complete with Red and Black wander plugs). Post FREE **13/-**

**Fellows, Park Royal, N.W. 10**

Branches:

- LONDON: 20, Store Street, Tottenham Court Road, W.C. (Museum 9200).
- BIRMINGHAM: 248, Corporation Street. (Central 435).
- BRIGHTON: 31, Queen's Road. (Brighton 899).
- BRISTOL: 36, Narrow Wine Street.
- CARDIFF: Dominions Arcade, Queen Street. (Cardiff 7685).
- LEEDS: 65, Park Lane. (Leeds 21479.)
- NOTTINGHAM: 30, Bridlesmith Gate. (Nottingham 5551.)
- TONBRIDGE: 34, Quarry Hill. (Tonbridge 172.)

Send for 48-page Catalogue No. 34 FREE

**BUY DIRECT AND SAVE MONEY**

K.P.S. 778



## NOTICE TO BENNETT COLLEGE STUDENTS.

Dear Student,

I am sure you must have a friend who would be only too pleased to hear of our System of Postal Tuition, and as you have had experience of its efficiency you would be doing your friend a good turn and this College also if you were to advise your friend to get in touch with us. He may be engaged in commerce or he may be in a technical trade, or he may wish to get into either one or the other.

No matter what his trade or profession may be it is possible that we may be able to help him forward in it. If he has any ambition at all let him write to me and mention his aspirations; it shall have my personal attention, and if I cannot help him I will say so honestly; if I can help him I will show him the way. My advice is absolutely free; he will incur no obligation whatever; I am only too pleased to give the help that years ago I needed myself.

So successful have our students been these late years, that we have had to add a wing on to the College, and the wing itself is nearly as big as the College. Thousands of people who thought they were in a rut or had come to a dead end have been helped to the front by my advice.

Write to me at this address. (Dept. III), The Bennett College, Sheffield.

Yours faithfully,

F.R.S.A., M.I.Mar.E., A.I.Struct.E., etc.

P.S.—We specialise in preparation for all examinations, commercial or technical.

## An Instrument of Precision

The Etherplus + S. L. Frequency.



The Etherplus + S.L. Frequency Condenser has a low minimum capacity and a self-centring ball race and cone bearing. It gives an even distribution of frequencies over the whole range.

No. W/180-0005 12/- each. (with 4-in. knob dial).

From all dealers or from

M. & A. WOLFF, 9-15, Whitecross St., London, E.C.1

**ETHERPLUS**

"WIRELESS." **COUPON.** Vol. VI. No. 2.

QUESTIONS AND ANSWERS.

This coupon must be accompanied by a P.O. for 2/6 for each question, and a stamped addressed envelope when sending queries to the Radio Press information Dept. for a postal reply.

# ELECTRADIX BARGAINS. No. 111.

**CRYSTAL SETS FOR B.B.C.** 3/6. With Phones, 7/-  
**LOUD SPEAKER BOBBINS.** Silk wound. 1,000 ohms,  
 4d. Phone, unwound, 3d. pair.  
**LOW LOSS RECEIVER INDUCTANCES,** 6 by 2½ in.  
 15 taps to plug sockets on ebonite panel, 200/2,000 metres.  
**H.F. CHOKES,** 5 ohms to 2000 ohms, 2/6. 4/6. Cut-out  
 parasite currents, 2-valve panels, with holders, fitted 4  
 Antipong Springs, 3/6.  
**VARIOMETERS.** B.B.C. on ebonite, 2/6; Polar Cosmos  
 Varso, 8/6.  
**WIRE.** New 22 Gauge Cotton-enamel covered, 1s. 6d. lb.  
 cut price. Two tons all gauges in stock. Navy 7/22  
 Enam. Aerials, Superflex, 3/- 100 ft.; Electronic Aerial,  
 100 ft., 1s. 3d.; 500 ½-oz. reels 28 gauge S.C.C. Wire  
 makes two Broadcast Coils, 4d. each. Vulcanised Twin  
 Flexible Cord, 2/6 doz. yds. 5/36 Silk-covered Flex,  
 12 yds., 9d.  
**R.A.F. 4-WAY SWITCH PLUG AND SOCKET FOR  
 L.T. AND H.T.** 4-pin plug and socket with 4-way  
 cord, with push switch for L.T. The neatest plug and  
 socket device ever made for connecting to Set. Cheap,  
 4s. 6d. pair.  
**PLUGS AND JACKS,** 2s. 6d. Dewar's 1-way, 1s. 6d.;  
 3-way, 2s. 6d. 2-pin Lucas Plug and Sockets, 4d. pair.  
 Panel 2-pin Base and Plug, 8d. Electric Light Adapters,  
 4d.  
**EARTH MATS.** Copper Mesh Good Earth for short  
 waves, 12s. 6d. each. Earth spikes, 1s. 3d., Earth Clips,  
 6d.  
**EARTH WIRE.** Flex rubbered, 1s. dozen yards, 100  
 yard coils, cheap, 6s. 6d.  
**PHONE CORDS.** Brown's Head, Double, new, 1s. 6d.;  
 lightweight, 1s. 3d. Single Cords, 6 ft. with solo plug  
 each end, 9d. Twin L.T. Battery Cords, with spade ends,  
 1s. Single Phone Cords, 7d.  
**LOUD SPEAKER EXTENSION WIRE.** 6s. 100 yards.  
 Transformer Coil Wire, 1s. 3d. lb.  
**VALVES.** Microsix Famous .06 valves, 7s. 6d. Power,  
 12s. 6d. Transmitting Valves, 17s. 6d., all new goods.  
**1,000 INTERVALLE IRONCLAD TRANSFORMERS.**  
 Ratio 5 to 1, Type E. Latest Model at Reduced price of  
 7s. 6d.  
**500 CHOKES FOR SMOOTHING.** We have a few  
 hundred ex-W.D. Marconi, 1,000 or 3,000 ohms. Bargain  
 at 4s. each.  
**2,000 MAGNETS FROM GOVERNMENT LAB.,**  
 for experimenters, 4 in. Bar Steel, 9d.; 10 in. ditto, 1s.;  
 Horse Shoe, 1s.; Magnet Needles, Agate centres, 9d.  
 post extra. Pivot Pillars, 6d.  
**HEADPHONES.** Royal Air Force, 4,000 ohm. Highest  
 Grade Receivers. With special headband, fur-lined for  
 comfort. Worth 25s. per pair. All brand new in boxes,  
 2s. 6d. pair.  
**BROWN'S.** Ex-W.D. 1,500 ohms. "A" need type, 30s.  
 pair. 2,000 ohm single receivers, "A." 12s. 6d. Alumin.  
 Headbands and Swivels, 1s. 9d. Pleated Parchment  
 Paper for Diaphragms, 2s. 6d. MEL Double Head-  
 phones and Cords, 4,000 ohms, 8s. Single L.R. phones,  
 1s. 4d. each, with cord, 1s. 10d. 4,000 ohm Ericsson  
 with Headband and Cords, fine tone, 9s. 6d. Three days'  
 trial. SULLIVAN Double Headphones, L.R. type, new,  
 100 sets, 3s. 6d. pair. B.T.H., 12s. 6d.; Marconi-  
 phones, 11s. 6d.; Magniphones, 11s.; Hexaphones,  
 10s. All first class English, new, with cords.  
**ELECTRIC BELLS,** 1s. 6d. MORSE SOUNDERS,  
 10s. each. MORSE KEYS, with cover, 2s. 6d. Aerial  
 Line Erecting Sets, 2s. 6d. each.  
**INDUCTANCE COIL BLOCKS** for Het., ebonite,  
 enclosing two basket coils, 4s. 6d.  
**600 POTENTIOMETERS.** 350 ohms, 2s. 6d. Panel  
 600 ohm, 4s. 6d. 3,500 ohms, 9s. 6d.  
**PROTRACTORS.** Engraved Double 0-180, in leather  
 case. Taylor, Hobson, Cost £2. Our price, 8s.  
**SWITCHBOXES.** Lucas 3-way Switches, in walnut case,  
 with flush metal cover, 3 levers, 1s. 3d. 8-way, 4s. 6d.  
**GRIDLEAKS.** R.A.F. 2 and 4 meg., 1s.; 10 meg.,  
 1s. 9d.; Marconiphone Sterling, all ranges, 1s. 2d.  
**INSULATORS.** The R.A.F. Light Weight Aerial Insula-  
 tors, brass ring and screwed tension stem. Millions in  
 use, 10,000 in stock. 1s. 6d. a dozen; Bell Porcelain,  
 1s. 3d.; Transmitting Insulators, 1s. 6d.  
**HANLEY PORCELAIN LEAD-IN TUBES.** Straight  
 or drip-proof ends, 6d. and 9d. each. Egg or shell or  
 China reels, 1d. or 10d. per doz. Ballerix Bell Aerial,  
 1s.; large, 1s. 3d.  
**MICA SHEETS.** Best Ruby Mica for Condensers, .002,  
 2 by 2 by .002 thick, 1s. per doz.  
**AEROPLANE AERIALS.** 110 ft. 7-Strand hard drawn  
 H.C. Copper Wire wound on bobbins to run out freely.  
 Sale price, 1s. 3d.; post, 3d.  
**CONDENSERS.** 2 mfd. ex-W.D., 2s. 6d. New 1 mfd.,  
 3s. 8d.; 2 mfd., 4s. 8d.; 4 mfd., 6s. 6d.

Personal inspection will convince you of our claim to hold  
 the finest stock of perfect and accurate apparatus for im-  
 mediate delivery in the City, and your call will be welcomed.

Our 4d. Catalogue containing 600 unique  
 illustrations will save you pounds.

Have you bought your ONE-METER yet?

**ELECTRADIX RADIOS,**  
 218, UPPER THAMES STREET.  
 Blackfriars Stn., Met. Rly. Tel.: Cit 0191.

## A CRYSTAL SET TO SUIT ANY CONDITIONS

(Continued from page 78)

this purpose. It is impossible to give a definite report on each particular circuit, as many will find that one particular arrangement suits their

### WHAT YOU WILL NEED

- One Trolite panel, measuring 6 in. by 5 7/8 in. by 3/16th in.
  - 5 terminals (Aerial, Aerial, Earth, Phones - and Phones+). (Belling Lee.)
  - One variable condenser, .0605. (Collinson Precision.)
  - One crystal detector (Utility). (Wilkins & Wright.)
  - One fixed condenser, .0002.
  - One six socket base. (Lissen.)
- Suitable Coils include:
- Fieldless Coil. (Lissen.)
  - Split Secondary. (Peto-Scott.)
  - Split Primary. (Peto-Scott.)
  - Aerial. (Peto-Scott.)
  - 4 spring clips. (Peto-Scott.)
  - Clazite for wiring. (L.E.W. Co.)
  - Small quantity of insulated flex. (L.E.W. Co.)
  - 4 3/4 in. countersunk wood screws.
  - One Decko dial indicator. (A. F. Bulgin.)
  - Cabinet of special design. (Pickett.)

aerial better than another, but the set will obviously be almost certain to suit everybody who uses it in that the best circuit for their needs may be arrived at by experiment in every case.

### A READER'S VIEW

#### The B.B.C. and Famous Artists

SIR,—I think the manner in which the B.B.C. treats famous artists is nothing short of scandalous, judging from the numbers of them that are falling out. De Groot was one of the few performers really worth listening to, and I am seriously thinking of selling my set and buying a gramophone now that we are to

## NEXT WEEK

An entirely self-contained four-valve "local" receiver.

hear him no longer. I myself have had experience of the B.B.C.'s methods of arranging their programmes, and must confess that I cannot wonder at this latest development.—Yours truly,  
 Musician.  
 Liverpool.

## THE NEW LOTUS JACKS & PLUGS

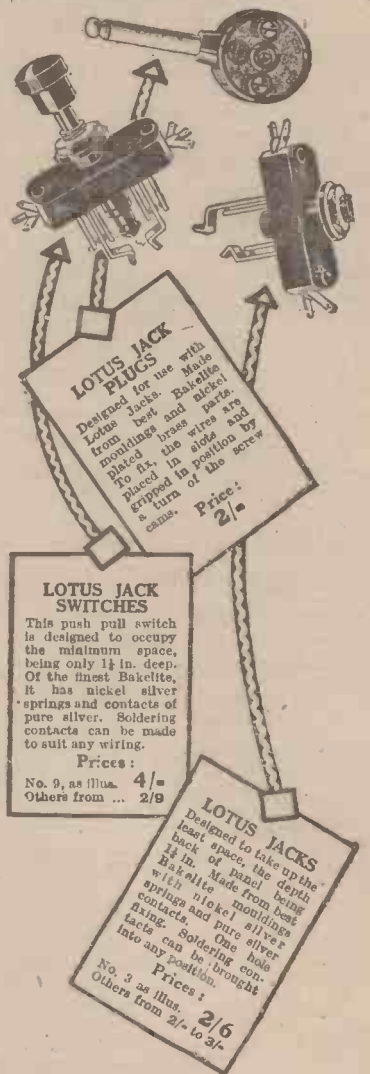

The name 'LOTUS' is your guarantee of sound results and solid satisfaction.

From all Radio Dealers

# LOTUS JACKS-SWITCHES-PLUGS

Made by the makers of the famed 'LOTUS' Vernier Coil Holders and 'LOTUS' Buoyancy Valve Holders.

**Garnett, Whiteley & Co., Ltd.**  
 Lotus Works,  
 Broadgreen Road, Liverpool.

## TAKE YOUR H.T. FROM A. C. MAINS

Having produced and sold large quantities of TRANSFORMERS giving the utmost satisfaction, we are now producing the following lines of POWER TRANSFORMERS suitable for all classes of users.

**SUPER FULL WAVE AUTO-TRANSFORMER**, high wattage type. Outputs up to 300 volts. Milliamps up to 500 **£2**

**MODEL No. 2. FULL WAVE AUTO-TRANSFORMER.** Voltages up to 150. Milliamps up to 100 **30/-**

**HALF WAVE TRANSFORMER**, high wattage type. Outputs up to 300 volts. Milliamps up to 500 **35/-**

**MODEL No. 2. HALF WAVE TRANSFORMER.** Voltages up to 150. Milliamps up to 100 **25/-**

**THE H.T.C. ELECTRICAL CO., LTD.**  
2, Boundaries Road, Balham, S.W.12.

# EFESCA



## "CENTADYNE" Screened Coils FOR NEUTRALISED CIRCUITS

Made to Elstree Laboratories specification and officially approved.

SUITABLE for all star and other circuits described in "Modern Wireless," "Wireless Constructor," and "Wireless," employing 6-pin standard coils.

PRICES OF COILS WITH 6-PIN PLUGS.

	250 to 550 1,000 to 2,000 metres.
Aerial Coils, split primary .. .. .	4/6 4/6 each
H.F. Transformers, split primary and optional reaction ..	7/8 7/8 each
H.F. Transformers, split secondary .. .. .	7/8 7/8 each
Reinartz Coils .. .. .	7/8 15/- each
Copper Screen with 6-pin base .. .. .	15/- each
Unshielded 6-pin base for standard Coils when used without screen .. .. .	4/- each

Ask your retailer, or write for catalogue 573/3 of Efesca Components and circuits employing them.

**FALK STADELMANN & Co. Ltd.**  
83-93, FARRINGDON ROAD, E.C.1  
and at Glasgow, Manchester, Birmingham, Newcastle, and Dublin.

## EFESCA "CONCENTRA"

### Neutralising Condenser

A new departure in design. The moving electrode telescopes into a fixed cylindrical plate, being operated by a wormed spindle with long insulated handle, providing 6 to 1 ratio vernier movement.

While designed for neutralising, it is equally suitable for use as a mixer reaction Condenser, as used in the Monodial Receiver.



Arranged for either baseboard or panel mounting.

PRICE  
**6/-**  
EACH

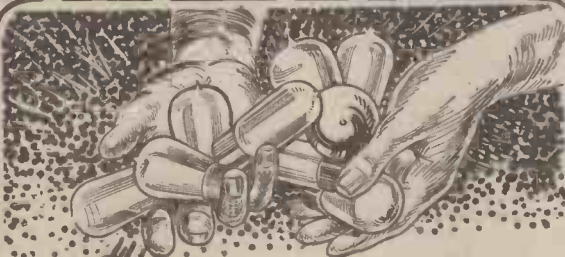

### THE BEST DULL EMITTER MONEY CAN BUY.

Frelat D.E. Valves cost only 4s. 11d. for Detector or Amplifier and they are costed low so that they meet the need of millions in purse and performance. A new addition to the range is the 2-volt power Valve at 8s. 6d., which ensures results that cannot be excelled.

Valves will be sent C.O.D.  
Type "K" 5/3 post free  
" "D.K.P." 8/10  
(New 2-volt power Valve)

**4/11 Type K—2 volt .3 amp. 4/11**

If your Dealer cannot supply, write to the:  
CONTINENTAL RADIO IMPORT CO., LTD., 8, SPITAL SQUARE, LONDON, E.1

*Frelat*



## HOW TO MAKE THE COILS FOR THE MONODIAL

Full details of the special coils for use in our latest Star Receiver



**T**HERE are probably many experimenters who will like to make their own coils for the Monodial, and for their benefit I propose to give some details as to the coils which have been used. I am also going to give some more practical details as to long-wave work further on in this article.

For the short broadcast waveband the two plug-in transformers are both exactly the same. They are wound on formers of the screened-coil type, which are provided with six pins, these being numbered to correspond with the bases as shown in Fig. 1. It will be remembered that the connections employed are:—1 to aerial or anode, 2 to earth or H.T. +, 3 to grid, 4 to the 250,000 ohms resistance or L.T. +, while 5 goes to the neutralising condenser in the H.F. valve circuit and to the midget condenser used for reaction in the detector circuit.

### The Primary

The primary winding is wound in a slot about  $\frac{1}{4}$  in. wide, which is cut in the ribs of the former in the case of Collinson formers, and consists of 35 turns of gauge 30 d.s.c. wire. If wound in a clockwise direction looking at the former from the bottom, the beginning of the winding is connected to Pin No. 1 and the outer end to Pin No. 2. If there is any doubt as to the correct connections to employ, the ends of the windings may be loosely twisted round the pins and afterwards reversed to see which is the correct way round for the primary coil. If the anode coil is connected the wrong way round the receiver will not neutralise correctly.

### Secondary Turns

The secondary consists of 60 turns of the same wire wound in the same direction, starting close to the primary slot. The end nearest this slot is connected to Pin No. 3, a tapping at the

thirtieth turn goes to Pin No. 4, and the far end of the winding is taken to Pin No. 5. Pin No. 6 is left blank. If possible, the secondary or grid wind-

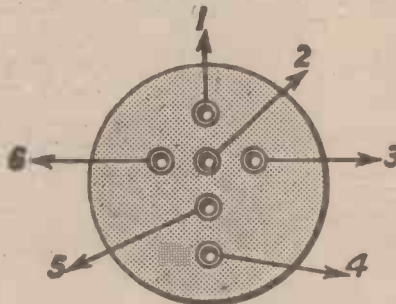

Fig. 1.—The numbering of the standard six-pin bases.

ing should be space wound so as to reduce the high-frequency resistance, and if this is done, a few touches of

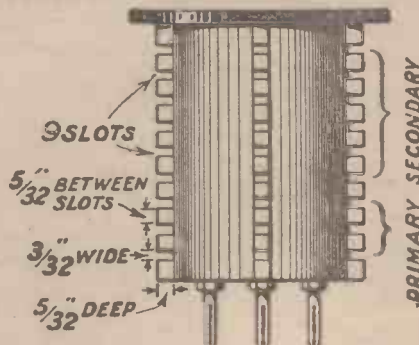

Fig. 2.—Thirty-five turns per slot for the first three slots form the primary, while fifty-five turns in each of the remaining slots form the secondary for long waves.

shellac or dope may be applied to hold the winding in place.

If a slotted former is not available, then the primary may be wound in a

single layer next to the secondary, a space of not more than  $\frac{1}{16}$  inch being left between the two windings. The same number of turns will be required—if anything, a few more may be put on, since the coupling will probably be a little looser. The connections for the primary, if wound in the same direction as the secondary, will be:—Outer end of winding to Pin No. 2 and the inner end—that is, the end which is nearest to that end of the secondary which is connected to Pin No. 3—being taken to Pin No. 1. The primary, it should be noted, is wound at the grid end of the secondary.

### Spacing

The primary winding does not need to be spaced, but as an aid to those who do not possess the means to enable them to do their own space winding I understand that Messrs. Collinson are bringing out one of their ribbed formers with the ribs slotted  $\frac{40}{100}$  to the inch, so that a fine-wire spaced coil can be wound with ease by the voriest beginner.

The greatest care should be taken to see that both coils are wound with the same number of turns. After they are completed and put in the set the gang condenser should carefully be balanced up on a distant station and the difference between the settings of the two halves of the condenser noted. If this difference exceeds about 5 or 6 degrees, then the coil which is tuned by the portion of the condenser, which is further out, is too big, and it should be stripped down a turn at a time till the gang condenser is balanced so that both halves are approximately at the same angle. This balancing should preferably be done on some station which comes in at about 100 degrees on the dial. I found that Dublin was a very suitable station for doing this, since it was not too far up the wavelength scale and yet it could be re-

(Continued on page 85.)



## SAXON GUIDE TO WIRELESS

This book enables any beginner to construct Wireless Sets which are unequalled in price, quality or efficiency, and the cost is only one-fourth the price charged for a ready-made instrument not half so good. The exact cost of each set is clearly stated.

### FULL INSTRUCTIONS WITH CLEAR WIRING DIAGRAMS

are given for making Super Efficient Crystal Sets, Dual Amplification Receivers, Single Valve Sets, One and Two Valve Amplifiers; Two, Three and Four-Valve Tuned Anode All-Wave Receivers, and the Very Latest Type of Five-Valve Resistance Capacity Receiver.

**NO SOLDERING, NO SPECIAL TOOLS  
NO KNOWLEDGE REQUIRED.**

The chapter on testing wireless components is alone worth the price charged. **PRICE 1/3 POST FREE**

### SPECIAL OFFER.

This book will be sent on approval on receipt of your promise to return same post paid or to remit 1/3 within seven days.

SAXON RADIO CO. (Dept. 32), Henry St. Works, BLACKPOOL

USE

# Watmel

## COMPONENTS

THE WATMEL WIRELESS CO., LTD.,

332a, GOSWELL ROAD, LONDON, E.C.1.

Telephone: Clerkenwell 7090.

Representative for Lancs, Yorks and Cheshire:

Mr. J. B. LEVEE, 23, Hartley Street, Levenshulme, Manchester.

A LEADING valve manufacturer reports that "exceptionally good loud-speaker results" were obtained with the Watmel Auto-Choke. "Speech was clear and sharp and music free from distortion."

Get full particulars of Watmel Auto-Choke, Grid Leak, and Combined Fixed Grid Leak and Fixed Condenser from your dealer, or write direct to manufacturers.

# SUPER POWER



**T**HIS is the valve with the golden voice. The very long straight Dynamic curve of the S.T. 65 and its low mean differential A.C. resistance enables it to handle the strongest signals without a trace of distortion. Try it in your last valve holder and this leader of the super power class will give a richness of tone which you have never before achieved.

The S.T. 65 is not merely intended for demonstrations, but also for exquisite reproduction in your own drawing room. The sudden glorious high notes of a soprano or the rich low notes of the organ often cause an increase of 1,000% in the "grid voltage swing" of your valve and the ordinary power valve, perfectly competent to handle music of average strength, falls ignominiously. The S.T. 65, however, cannot "blast," but responds lightly and faithfully to every fluctuation in the music and gives that sense of reality which brings the artist to your own fireside.

Type S.T. 65 Price 22/6. S.T., Ltd., 2, Melbourne Place, W.C.2.

## HIGH & LOW TENSION ACCUMULATOR HIRE SERVICE

Here's a way of improving reception, saving money, time and trouble for all valve set users who live within 12 miles of Charing Cross. Write now for particulars of this unique service.

RADIO SERVICE CO.,  
105, Torrington Avenue, N.W.5.  
Phone: North 0623 (3 lines).

**ROTAX**  
High Tension Accumulators greatly improve Loud-speaker reception, eliminating the uncanny noises caused by partly run-down dry batteries and may be hired ready for use.



If you add the depreciation in value to the cost of having your own accumulators unskilfully recharged, our Hire Service effects a considerable saving.



A MONUMENT IN THE MARCH OF PROGRESS.

The Formo Shrouded Transformer is the universal favourite.

10/6 Made in Ratios, 1-1, 1-2, 1-3, 1-4 and 1-5. 1-3 and 1-5 for First and Second Stages. SEND FOR CATALOGUE AND DESCRIPTIVE LITERATURE OF COMPLETE FORMO RANGE.

THE FORMO COMPANY,

CROWN WORKS, CRICKLEWOOD, N.W.2.  
Phone: Hamp. 1787.

Manchester: Mr. J. B. Levee, 23, Hartley Street, Levenshulme.

Phone: Heaton Moor 476.

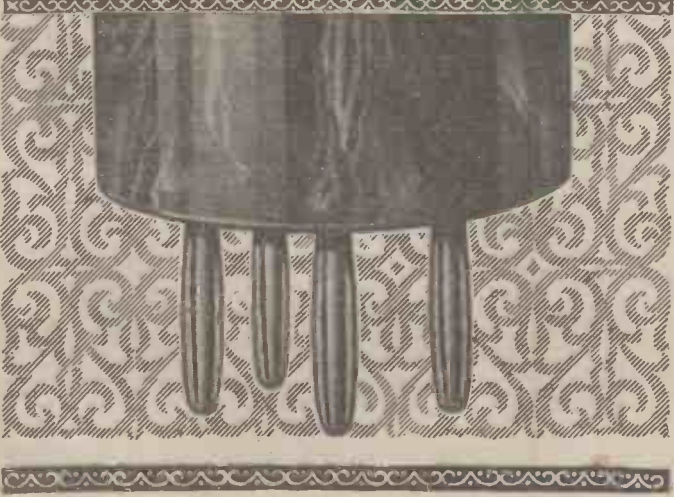

**"NO CRYSTAL SET IS COMPLETE WITHOUT THIS WONDERFUL ATTACHMENT."**

*Extract from an entirely unsolicited testimonial recently received from a customer situated 80 miles from Daventry.*

The **WONDERFUL ATTACHMENT** referred to is the

# MAGNETIC MICROPHONE BAR AMPLIFIER

(Patent No. 248581-25)

Not only will this marvellous device give really good **LOUD-SPEAKER RESULTS** from **CRYSTAL RECEPTION** of average strength, but it is absolutely the **ONLY** means of increasing the strength of weak signals in head-phones without using valves.

**A BOON TO DEAF PERSONS**

**EQUALLY EFFICIENT ON VALVE SETS**

*If your dealer cannot supply order direct from Sole Manufacturers and Patentees*



(Two-thirds actual size.)

**NOT** a Microphone Button.

**NO** Valves, Accumulators, or H.T. Batteries Fragile parts. Distortion.

Nothing to get out of order.

Simple as A B C.

Almost as good as a 2-valve amplifier.

Works perfectly on one or two dry cells.

*Call for demonstrations or write for FULLY ILLUSTRATED LISTS.*

**COMPLETE AMPLIFIER** as shown **PRICE** post free **38/-**  
3-Volt **DRY BATTERY** lasting over three months **4/-** extra.  
No other accessories required.

**NEW WILSON ELECTRICAL MANUFACTURING CO., LTD.,** 18, FITZROY STREET, EUSTON ROAD, LONDON, W.1. Phone: Museum 8974.

## The **BRITISH** reply to the foreign challenge. prices still lower

RENOWNED for reliability, the British bias of quality is the recognised standard of excellence. But to secure this, the once accepted necessity for paying high prices rules exclusively no longer. Instance valves—by the advent of Voltron you can now buy a British Dull Emitter Valve for

Not only British made, the quality of Voltron Valves is British, therefore supreme. But the price is low. **5/9**

Close electrode construction, a filament of high emissive value and Voltron special 3 stage pumping ensure absolute uniformity, freedom from microphonic noises and a long life of full, clear-toned service. The guarantee is exceptionally generous.

W.G., of Burnage, Manchester, writes of Voltron Valves:—"I feel I cannot speak too highly of them. My set has been brought to life with them. I thought my results were good enough before, but it was dead compared with my present results"

# VOLTRON

"Buy British and be Sure"

- TYPE 202  
1.8-2 VOLT  
2 AMP  
PRICE 7/6 5/9
- TYPE LC 2  
1.6-2 VOLT  
0.6 AMP  
PRICE 9/4 7/6
- TYPE LC 4  
3.5-4 VOLT  
0.6 AMP  
PRICE 9/4 7/6
- TYPE LS 2  
2 VOLT D.E.  
POWER VALVE  
PRICE 10/6 9/1
- TYPE P. 6  
6 VOLT D.E.  
POWER VALVE  
PRICE 12/6 12/1
- TYPE P. 4  
4 VOLT D.E.  
POWER VALVE  
PRICE 10/6 10/0

Look for the triangular box.

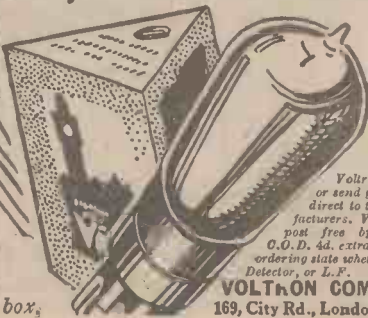

Ask your dealer for Voltron Valves or send your order direct to the manufacturers. Valves sent post free by return. C.O.D. 4d. extra. When ordering state whether H.F., Detector, or L.F.

**VOLTRON COMPANY**  
169, City Rd., London, E.C.1

Every Pair Guaranteed.

## "Phone-Joy"

Only truly experienced when listening-in on Bowerman's Phones. There is a charm, comfort and clarity about these instruments that is beyond praise and beyond rival. Get a pair today—they will amaze and delight you and reveal undreamt-of powers in your sets. Obtainable from Harrods, Selfridges, and all leading wireless dealers or direct under guarantee, P.O. 12/6



12/6 pair pair

For B.B.C. Reception

# Bowerman's

**SUPER POWER HEAD PHONES**

Bowerman's Phones, 10-12, Ludgate Hill, London, Eng.

**WHEN** you are setting out to purchase radio apparatus, first look through the advertisements in your copies of "WIRELESS." You can feel certain of your requirements being suitably and satisfactorily met.

ceived without interference from my local station 2LO.

### On Long Waves

In the same way the long-wave coils should be matched up and the coils should be marked so that, since there is bound to be some difference between them, the larger of the two pairs is always used in the same position, so that under these conditions the matching of the gang condenser will be near enough on the long waves when set on the short.

For the reception of the long waves, I indicated last week that certain modifications in the design of the inductances was required. The first coil is connected to the pins of the former in a similar manner to the short-wave coil, but the second, which couples the H.F. valve to the detector, has to be connected rather differently. The coils are wound on the same former as the short-wave inductances, only these are provided with nine slots equally spaced, as shown in Fig. 2. In the bottom three of these (i.e., those nearest the pins) the primary winding is put, this consisting of 35 turns per slot. The secondary goes into the remaining six slots, 55 turns per slot being put in. The wire used is 34-gauge d.s.c. A tap is taken at the centre of the coil between the third and fourth slots in the case of the aerial coupler, but with the other coil the tap is taken between the fifth and sixth slots, so that it is only one slot away from the end of the

### HOW TO MAKE THE COILS FOR THE MONODIAL

(Continued from page 82)

winding which is connected to Pin No. 5. If this is not done, the reaction control will be found to be extremely fierce, and at the lower readings of the tuning condenser it may be found impossible to stop the set from oscillating.

### The Aerial Condenser

It will be found a decided advantage when working on the long waves to short out the aerial series condenser, and this can easily be done by means of a short length of flex with a spring clip at each end. This is clipped over the two terminals on the series condenser and thus connects the aerial directly to the primary winding.

One other slight alteration is also required, and this is with regard to the high-frequency choke used in the plate circuit of the detector valve. This choke was chosen for its extreme efficiency on the broadcast waves, and I was under the impression that it was also suitable for long-wave work in the Monodial. I now learn, however, that the Varley special split-coil type choke is intended to be used where the reception of both long as well as short wavelengths is desired with such a circuit as this.

### Special Choke

Those, therefore, who wish to listen to Daventry, Radio-Paris and similar long-wave transmissions should exchange their standard chokes for the larger. If this is not done, parasitic oscillations are likely to result owing to the extreme efficiency and low self-capacity of the standard choke as used for short broadcast waves.

Since the new choke is exactly similar in size to the other no trouble need be apprehended as to making the change. This choke will, of course, work satisfactorily on the short waves as well as the long, but those who are not interested in long-wave work need not touch their receivers at all.

### An Important Point.

When listening on the long waves it should not be forgotten that the centre-tap coil goes in the first base, i.e., the one nearest the back edge of the baseboard, while the special detector coil goes in the other socket. If this is not done, not only will it be impossible to stabilise the set on the H.F. side, but the detector too will go into violent oscillation.

To stabilise the set on the long waves the neutralising condenser should be set at the minimum value and the tuning condenser swung over the first 30 or 40 degrees with the reaction condenser set at zero. If it is found that the set oscillates below a certain value (Continued on page 86.)

## Why you can't afford to use Barretors and Fixed Resistors.

THEY are incapable of adjustment and often heat your Filaments unnecessarily. They shorten the life of your Valves through incorrect adjustment. They are expensive to buy and maintain, because a change of Valve necessitates a new Resistor, at an average cost of 2/6. The popular Resistor costs 1/6 for Clips and 2/6 for the Resistance Element.

### The MICROSTAT Variable Fixed Resistor

is attached to your base by two screws, the L.F. switched on, and they are adjusted with Micrometer accuracy to give the exact Filament Emission necessary.

After this they "stay put," and are operated by the pull-push switch like the ordinary Fixed Resistor, or by the "Microstat" Master Rheostat, which gives even wider range of Control.

Should you change your Valve the individual V.F.R. concerned is again adjusted to the correct emission by a slight right or left turn.

They need no renewals, one Resistor suiting any type of Valve, and their initial cost is lower. The complete Microstat V.F.R. costs but 3/- and is **Adjustable for any Valve and LASTS FOREVER.**

Made and guaranteed by the Manufacturers of the World Famous "Microstat."

**LIFFORD ENGINEERING CO.,**  
Lifford Lane, King's Norton, BIRMINGHAM.

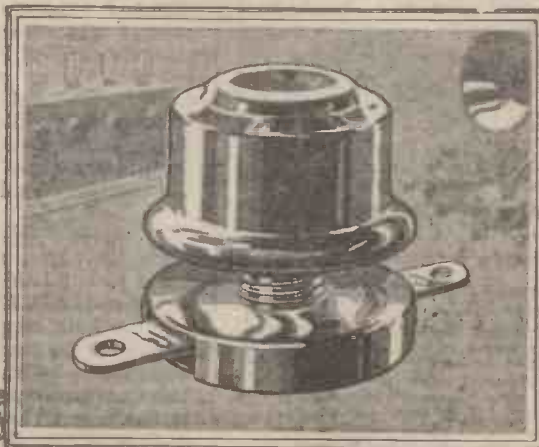

# SPECIAL NOTICE

For the "Monodial"

The Varley Multi-Cellular H.F. Choke SPLIT COIL TYPE

Although the ordinary Varley Multi-Cellular H.F. Choke is suitable in the large majority of cases for the complete Broadcast Wave-band, including Daventry, yet in circuits of the split coil type—among them the Monodial—it has been necessary to introduce a new type to cover the entire wave-band, including Daventry. Like the original model, this new type is remarkably efficient and readers will be glad to know we can make deliveries at once.

PRICE 12/6

Stocked by all the best dealers.



**THE VARLEY MAGNET CO.**  
(Proprietors Oliver Peil Control, Ltd.)  
Granville House, Arundel Street, London, W.C.2.  
Telephone: City 3398.

V. 13

**BUY HYDRA CONDENSERS.**

The fact that they are made by manufacturers of condensers established 28 years ago should be sufficient inducement to use them in your set or eliminator.

Tested on 500 volts and guaranteed not to vary more than 5 or 10 per cent. from rated capacity. Obtainable up to 10 M.F.

Full details and prices from your dealer or direct from

**Louis Holzman**  
109 KINGSWAY LONDON W.C.2. TEL: HOLLBORN 6209

A Small Deposit Buys the Set you want!

How often have you wished for a multi-valve Set, but have been discouraged by the cost? Our Catalogue "W" tells how almost any well-known Receiver can be yours for a small initial payment. Everything is guaranteed. Let us know your requirements and we will advise you. Write to:

New Times Sales Co.,  
77, City Road, E.C.1.

6291

## HOW TO MAKE THE COILS FOR THE MONODIAL

(Continued from page 85)

the neutralising condenser should be increased till complete stability is obtained. No advantage is to be got by turning it further, since the receiver will begin to oscillate again.

The usual method of neutralising with the H.F. valve turned out does not appear to be satisfactory on the long waves, a fact that has been observed by several experimenters.

### Re-balancing

Although there is no real necessity to re-balance the gang condenser, those who are meticulous with regard to such details may do so, and, of course, a slight gain in signal strength on weak stations will result.

With regard to reaction, this was found to be perfectly normal except for the last 20 or 30 degrees on the tuning condenser, when for some reason reaction effects became reversed, so that the set oscillated with the reaction condenser set at zero instead of doing so when it was at its maximum.

### Further Results

The stations received in the course of the test conducted with the long wave coils first tried were:—

Dial reading	Station	Wavelength
48	Probably Geneva	about 750 very weak
72	Hilversum	1050 good loud-speaking
78	Kbely	1110 very weak
82	Soró	1150 weak loud-speaking
94	Berlin	1300 good loud-speaking
106	Moscow (?)	1450 rather weak
117	Daventry	1600 full loud-speaking
128	Radio Paris	1750 full loud-speaking
148	Kosice (?)	2050 very weak

After these stations had been received I turned back on to the short broadcast band to see whether the performance of the set would in any way be affected by the use of the wide-range type H.F. choke which was now being used in the plate circuit of the detector valve. Without even re-balancing the gang condenser, however, I was able to tune in about 10 stations at good loud-speaker strength in the course of nearly as many seconds, the reaction condenser remaining set over quite a wide waveband. Between about 490 and 400 metres, in fact, it was quite unnecessary to touch the reaction at all.

### Hesitation Unnecessary

If, therefore, any reader has hesitated to build this set in case it would not give him a 100 per cent. performance on both long and short waves, he need wait no longer, for the Monodial will give it to him with ease and certainty seven days a week and 52 weeks in the year. The Monodial is the long-distance set with one knob tuning.

C. P. A.

# Ashley Radio JACKS

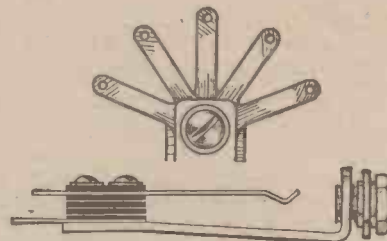

—are made of nickel silver springs, with pure silver contact, and Bakelite insulation throughout. Tags are tinned and spread fan-wise for easy soldering.

JACK No. 1 Single Circuit (open) 1/3

JACK No. 2 Single Circuit (closed) 1/6

JACK No. 3 Double Circuit 1/9

JACK No. 4 Filament Single Control 1/9

JACK No. 5 Filament Double Control 2/3

TELEPHONE PLUG, 1/6

## CLARITONE LOUD SPEAKERS

Senior Model, 2,000 ohms, £5 0 0  
W.265, 120 ohms, W.266 }  
Junior Model, 2,000 ohms, £2 15 0  
W.267, 120 ohms, W.268 }

## CLARITONE HEADPHONES

W.216 .. 20/-

## ASHLEY WIRELESS TELEPHONE CO., LTD.

17, Finch Place,  
London Road,  
LIVERPOOL



## SOLDERING SUPERSEDED

### "KRISCROS" CONNECTORS

SIMPLE, EASILY APPLIED, EFFECTIVE, HEATS, BURNS & YIELD RESULTS



PERFECT JOINTS "A KRISCROS" FOR EVERY CONTACT  
 Prices from 1/- per doz. Send for List.  
 KRISCROS COMPANY, 50, GRAY'S INN ROAD, LONDON, W.C.1

ALL MANUFACTURERS' GOODS  
 ADVERTISED IN THIS PAPER

Can be obtained C.O.D. or Cash  
 with Order, per return, from

**YOUNG'S** (GLASGOW),  
 LIMITED,

40, STOCKWELL STREET, GLASGOW  
 Write to-day for Big Free Catalogue.

## 1/9 AERMONIC

**DON'T PAY MORE**

VALVE HOLDER.  
 Anti-capacity. Anti-Phonic.  
 Don't pay more than 1/9.  
 If hard to get, drop us a line.

J. CHRISTIE & SONS, LTD.,  
 244, West Street, Sheffield.  
 London Agents: A. F. Bulkin & Co.,  
 10, Cursitor Street, London, E.C.4

## BUILD A LOUDSPEAKER

WITH OUR NEW  
**SEAMLESS MOULDED CONE**  
 (Prov. Patent 25069/26)

and a BROWN A. or LISSENOLA. You will obtain  
 PERFECT RESULTS. Successful Construction for  
 a minimum outlay is ensured with our Specialities.  
 Illustrated Lists and full particulars for Stamp.

**GOODMAN'S, 27 Farringdon St. E.C.4**  
 Also obtainable from Spencer's Stores, 4-5, Mason's Avenue, E.C.2

Britain's Best **RADIO** in Radio.

## LAMPLUGH

PRODUCTS

## SILENT VALVE HOLDER

Anti-microphonic.

Fitted with Heavy Terminals & Grip Tags. Price 2/6  
 Obtainable from all leading Wireless Dealers.  
**SEND FOR LISTS.**

**S. A. LAMPLUGH LTD.**  
 King's Road, Tyseley,  
 BIRMINGHAM.

Sole Distributors for London and Southern Counties:  
 The Empire Electric Co., 303, Euston Road,  
 London, N.W.

Scottish Depot: 38, Montrose Street, Glasgow.

## NEED WE NEUTRALISE

(Continued from page 50)

is a practical proposition. A number of circuits have been tried which have given remarkable results. By suitable proportioning of the various parts in the circuit it is possible to obtain a uniform degree of amplification over the whole of the broadcast band. A skeleton circuit showing how this principle may be applied is given in Fig. 3, and it will be seen that here is the required combination of magnetic coupling and capacity coupling, and between the two we obtain a level amplification curve.

### Great Possibilities

This in itself is a most remarkable development, and one which possesses very great possibilities; but the corollary is in many ways more interesting than the basic principle. If the circuit is so designed that its coupling is constant over the whole of the range, then it also follows that its impedance is constant over the whole of the range. If, therefore, we can arrange that this impedance is resistive or just slightly capacitive, we shall obtain a perfectly stable amplifier without any need to neutralise it. Experiments have shown that this is a practical proposition, and stable and uniform amplification over the wide band of frequencies is easily accomplished once the correct proportioning of the circuit is thoroughly understood.

Naturally the principles stated are not quite as simple in their application as one would imagine from this article, wherein everything has been expressed as clearly as possible so that the general principles may be grasped. The experiments which have been conducted, however, have enabled me to obtain all the data necessary, and WIRELESS readers can look forward to a very interesting series of circuits and receivers incorporating new principles.

## THE T. AND R. SECTION LOW-POWER TESTS

The Transmitter and Relay Section of the R.S.G.B. held a special series of low-power tests during the week commencing November 1.

Unfortunately for those who participated in these interesting tests, the week chosen seems to have been the worst week of the year as far as conditions for long-distance working were concerned. Although atmospheric conditions were not greatly in evidence, there was certainly a "blanket" over the London district, and American signals during the hours of the tests were received only with great uncertainty.



## Great New Wireless Offer

**20/- down**

Our wonderful 2-valve set with **loud speaker and headphones** installed **free** in your own home—anywhere—by our own Installation Engineers for £12 cash; or £1 down and 20/- a month for twelve months only. And we guarantee satisfaction.

There is nothing else to buy—the set is complete with all accessories.

When our Engineers have installed the set just switch on and enjoy perfect and powerful loud-speaker reception. You are also entitled to two free calls from our Engineers after the set is working.

The General Radio set is British made, unsurpassed in efficiency and purity of tone. It has no superfluous controls and is as easy to work as turning on the light.

Send a postcard to-day for free illustrated catalogue No. 3 X and full particulars of this offer.

**General Radio** ★

GENERAL RADIO CO. LTD  
 RADIO HOUSE  
 235 Regent Street, W 1

## From SCHOOL to PROFESSION

via WIRELESS.

No long expensive apprenticeship; just RADIO MARITIME TRAINING, and your son will be placed in a responsible position. Within twelve months the capital invested is returned in his salary as a Wireless Operator. But it must be the TRAINING WITH THE WIRELESS SERVICE BEHIND IT. Write to Radio Maritime, Ltd., 15, Broadway Chambers, Hammersmith, W.6, or to 26-27, St. Mary Street, Cardiff.

## Valves Repaired

AS GOOD AS NEW!!

**HALF LIST PRICE**

(Except Weco, S.P.'s and low capacity types.) Minimum D.E. Current 0.15 amps when repaired.  
**ALL BRIGHT & DULL EMITTERS**  
 Listed at less than 10/-.  
 Minimum charge - 5/-  
**VALGO** LTD. Dept. W., Tabor Grove, Wimbledon, S.W.

## RIFANCO-PHONES and PARTS

Cabinets for Wireless or Gramophones, Motors, Tonearms, Soundboxes, Horns, Springs, Needles, Hinges, Knobs, Lidstays, Handles, cheaper than anywhere else. 64 pages, 120 illustrations. Catalogue free telling how to assemble gramophones sent for 3d. 25 types of Motors from 9s. carriage paid. 25 models of Gramophones from 27/6. 4,000 ohm Headphones, 8/6. Accordions 8/6. Violins, 18/- Trade Discount to Regular Dealers.

**REGENT FITTINGS CO.**  
 Dept: "W," 120, Old Street, London, E.C.1.  
 Established 20 years.



**EELEX**

**5/6**

**THE SAFETY SWITCH**

Prov. Pat. 20022/26.

Comprises Switch, Lightning Arrestor, Lead-in Tube and weather-proof cover. When off, the set is entirely disconnected from the Aerial and Lightning Conductance is attained *Outside* the house. Safety is ensured should you forget to switch off—by the Permanent Spark Gap provided.

Price - 6-inch Tube - 5/6  
 „ 12-inch Tube - 6/6  
 „ 18-inch Tube - 7/6

Write for List No. W.4, giving full particulars of the Eelex Standardised Plugs and Sockets System, recommended and used by all leading Wireless Journals.



J. J. EASTICK & SONS  
 Eelex House, 118, Bunhill Row, London, E.C.1.  
 \*Phone: Clerkenwell 9282-9288.

**AMATEUR TRANSMITTING NOTES**

**QRA's Found**

G-2AUL: J. Skidmore, Mill Yard, Park Side, Belper, nr. Derby.  
 G-2BXX: C. Q. Marks, 143, Sinclair Drive, Langside, Glasgow, S.2.  
 C-1AD: G. G. MacKay, Newcastle, New Brunswick, Canada.  
 C-1EI: T. B. Lacey, Loch Lomond Road, Marsh Bridge P.O., St. John, New Brunswick, Canada.  
 U-2CHK: H. Sachs, 170, West 73rd Street, New York City, N.Y., U.S.A.  
 U-2CJE: G. W. Linn, 151, West 231st Street, New York City, N.Y., U.S.A.  
 U-2LI: W. P. Koehel, 301, Belleville Avenue, Bloomfield, N.J., U.S.A.  
 U-3ASA: J. Moore, Madison Avenue, Fort Washington, Pa., U.S.A.  
 SMTU: C. W. Granberg, Lysekil, Sweden.  
 SMRZ: Harald Sjavall, Foreningsg. 41, Goteborg, Sweden.

**QRA's Wanted**

SAB, SMGR, S-2BB, SK-2NAX, SPR, SOUU, LGN, OHK, PT3, G-6GA, G-6MO, WGHM, D6N, APTR, U-AB1, BXY 9SJ, T-4RB, PAN-RXY, AP4, DL4, SGL, PTF, G-2QX, 2ZE, XGRY, XGRQ, U-2NZY, F-1AE, I-8AQ, I-8ZB, BZ-9TS.

**EBONITE PANELS**

or Strips, etc., described in this issue (or any other) can be obtained immediately through any trader from

TRELLEBORGS EBONITE WORKS, LTD.  
 Audrey House, Ely Place - London, E.C.1

**VALVES!**

Radio Micro Power 8v. 1 amp. - 10/6	7 ma D.E. 2v. 2 amp. - 4/-
8v. 3 amp. - 9/6	M.B. D.E. 8v. .06 amp. - 5/6
Radio Micro D.E. 8v. .06 amp. - 7/-	Polo 60-volt Batteries 8-volt Tappings Guaranteed - 7/6
Fama D.E. 4v. .06 amp. - 5/6	
Fama Power 4v. 2 amp. - 8/6	All goods sent post free.

Trade Enquiries Invited. Write for Lists.— Kindly note change of address—  
**W. SEGAL,** 53, RUSSELL ST., LONDON, E.1.

LITTLE WIRELESS GADGETS



THE VERNI-NOB, 6d.; Postage, 11d.

MAP Co., 246, Gt. Lister St., Birmingham.

**LISSENOLA & BROWN "A" USERS. GININNATI CONE, 1 1/6**

Complete with bronze base and support, ready to have Brown reed phone screwed on making it into complete cone speaker, post 1/6. Attachment for Lissenola, 1/6, fully guaranteed. Complete with Lissenola, decorated to match cone, 2/6.

J. W. MILLER, 68, Farrington Street, E.C.4.  
 Sole British Distributor. Phone, Central 1950.

**As used in the MONODIAL described in "Wireless" Oct. 30.**

"THE inductances used have an extremely low self-capacity so that the 200- to 600-metre band is covered by a movement of about 90 degrees on the dial and it is possible to proportion the coils so that the whole of this waveband comes approximately above the critical point on the dial below which there is any risk of the matching not holding good. Another effect of reducing the size of the inductances is to reduce their H.F. resistance and so produce an increase in efficiency."

**COMPLETE COIL KITS**  
 NO EXTRA FOR MATCHED COILS

to standard specification (long wave and short wave coils) are included in the following prices:

	The Monodial ..	£2 10 0
	The Elstreflex ..	£2 9 0
	The Mewflex ..	£4 14 6
	The Distaflex Two ..	£4 14 6
	The Magic Five ..	£3 7 6
	The Elstree Solodyne ..	£4 9 6
	The Four for Range and Selectivity ..	£3 4 0
	The Screened Coil Three ..	£2 17 0
	A Three-Valve Trap Receiver ..	£1 13 6

Send postcard for full particulars of Colvern Proved Products.

Copper Screen with Standard 6-pin Base ..	8/6
Screen complete with Base & unwound Coil ..	12/6
Former & Base, unwound Former only ..	5/-
Base ..	4/-
	1/6

**COLLINSON PRECISION SCREW CO., LTD.,**  
 Provost Works, Macdonald Road, Walthamstow, LONDON, E.17.  
 Telephone—Walthamstow 532.  
 ALSO AT 160, KING'S CROSS ROAD, W.C.1

**CHEAPER THAN USING THE MAINS**

Eliminators Eliminated by

**WESTAM**

EVERLASTING  
**H.T. ACCUMULATORS**  
 Requires re-charging twice a year only

**6<sup>d.</sup> a Volt. 2 Amps.**

ENTIRELY BRITISH.  
 FULLY GUARANTEED.

**60 Volt Model - 30/-**  
 20 v. 10/6, 30 v. 16/-, 90 v. 45/-,  
 100 v. 50/-, 120 v. 60/-.

SCRAP YOUR DRY BATTERY.

All models, catalogues and spare parts from any dealer, or

**WESTAM ACCUMULATORS,**  
 CLEMENTS ROAD, LONDON, E.8.

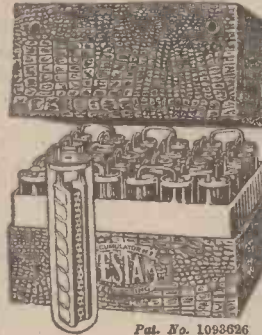

Pat. No. 1098626

**4 STATIONS**

on your Loud Speaker obtainable on

THE GUARANTEED "SERVICE" RECEIVER. **£13 Cash**

A Two-Valve Loud Speaker Set or deposit of **£2 : 12 : 0**

Absolutely Complete. Valves, Coils, H.T. and L.T. Batteries, Aerial and Earth Equipment and Loud Speaker.

For FREE Demonstration, Installation, and Upkeep, see our Catalogue. FREE on application. Also 3 and 4 Valve Receivers and Components.

Wireless Specialists. **The Service Company Ltd.** "SERVICE—Our Name and Aim."  
 Wireless Dept.

**273-274, HIGH HOLBORN, LONDON, W.C.1**



## Sources of supply

"THE WIRELESS DEALER and Radio Trade Journal" contains two important guides to sources of supply—Index to Advertisers and The Buyer's Guide. The first will refer to advertisements in the issue, while the second will direct you to the manufacturers of any particular product which you may require to order. These two guides compose an important fund of information.

Commence your subscription with the November issue—it is rather an important one for the retail section of the Trade.

It contains a detailed and profusely illustrated "Stand to Stand" Review of the Manchester Exhibition, giving special prominence to popular lines. "What the Manufacturers are Doing" and "What the Wireless Journals are Doing"—both widely-read regular features—are of particular interest in this number.

"Fighting the Foreigner" is the title of a powerful article from the pen of one of the leading Sales Managers in the Radio Industry.

Make a note to post your application to-day.

#### SUBSCRIPTION RATES:

7/6 per annum (abroad 10/-). Available to the Trade only. Trade card or business heading should accompany every subscription to the SALES MANAGER, Radio Press, Ltd., Bush House, Strand, London, W.C.2.

*The* **Wireless Dealer**  
AND  
Radio Trade Journal



## THE ODDS ON SUCCESS

That gratification of personal vanity which we call "success" depends not only on our individual ability for its attainment, but to an equally effective degree on the materials which we choose as being of the greatest practical assistance to our effort.

When we build our wireless set, however, this mechanical element assumes the superiority, for we follow certain definite constructional lines and find little scope for our own initiative. Therefore, based on the perfection of the various component parts, the odds are greatly on the side of success.

Theoretically this may be sound but in practice we find that it is not the perfection of any single instrument that counts but also its ability to function correctly in relation to the remaining components with which it is to co-operate.

Designed to fulfil these requirements in every way, the R.I. Multi-Ratio Transformer has almost completely reformed present day audio-frequency amplification as far as quality and power of reproduction are concerned.

Apart from its value as an ordinary transformer, it offers all the advantages of a number of different ratios and impedance values — enough to satisfy the demands of any circuit and any valve.

With its use the odds on successful audio-frequency amplification are decidedly heavy, so much so that the question of odds hardly enters into the matter—The R.I. Multi-Ratio Transformer presents a cast iron certainty. Price 25/-

Write for the R.I. Catalogue—  
R.I. Ltd., 12 Hyde Street,  
New Oxford Street,  
London,  
W.C. 1.



*The mark of  
Better Radio*





WIRELESS, incorporating 'Wireless Weekly,' NOVEMBER 27, 1926.

# WIRELESS



INCORPORATING  
WIRELESS WEEKLY

2<sup>D</sup>  
WEEKLY

Vol. VI. | NOVEMBER 27, 1926 | (No. 3)

**A SELF-CONTAINED  
FOUR-VALVE RECEIVER  
A DE LUXE WAVE-TRAP  
THE SWITCHING BOGY  
MANY SPECIAL FEATURES**

[Registered at the G.P.O. as a Newspaper]

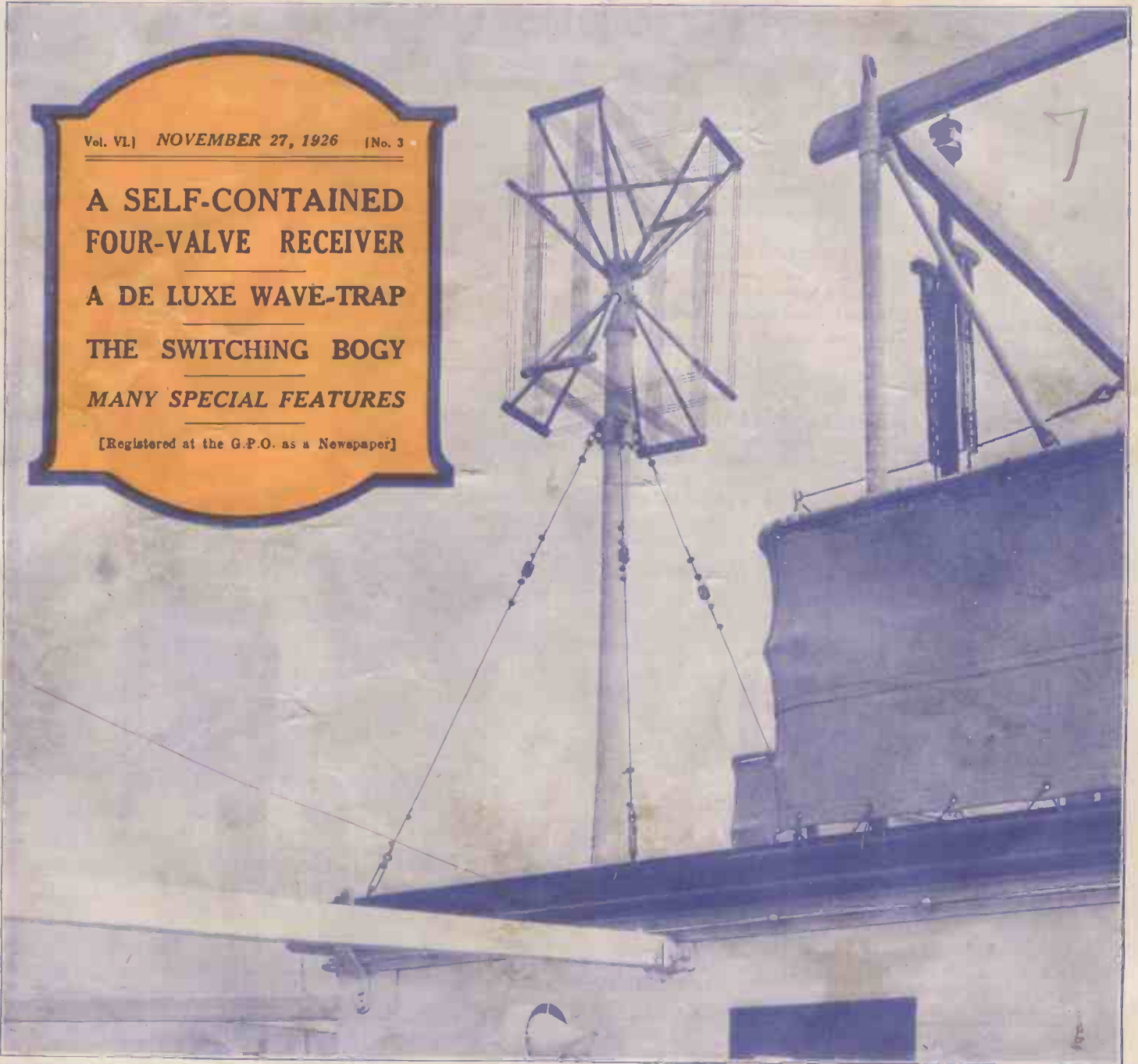



# THE "ALL-BRITISH SIX"

*European Championship Set  
described in the Issue now on sale*

THE "ALL-BRITISH SIX" was entered for competition in the Multi-Valve Class of the International Amateur Set Building Contest at the Radio World's Fair in New York, and was awarded the Third Prize in this Open Competition.

A receiver, to compete successfully in America, needs selectivity of a very high order. Around New York, for example, there are over 65 Broadcasting Stations in operation.

The "All-British Six" uses the circuit of the famous "Elstree Six," modified to allow of the use of screened H.F. Transformers. This modification was made necessary by the extreme selectivity required.

Mr. H. E. Hassall, one of our readers, who constructed and entered the "All-British Six" for the New York Competition, describes in his own words the design and construction of the Set. Full details are given and the usual blueprints may be obtained, so that our readers may make up similar sets, and realise from their own experience the high performance of which the "All-British Six" is capable.

**BUY YOUR COPY TO-DAY**

BESIDE THE FULL DESCRIPTION OF THE "ALL-BRITISH SIX," THIS ISSUE ALSO INCLUDES:

Music Via the Ether  
By JACK HYLTON.

Making Use of Your Supply  
Mains  
By J. H. REYNER, B.Sc.  
(Hons.), A.M.I.E.E.

Choice of Programmes Made  
Easy  
By STANLEY G. RATTEE,  
M.I.R.E.

Getting the Best from the  
"Spanspace Three"  
By G. P. KENDALL, B.Sc.

A "Throttle - Controlled"  
Single-Valve Set  
By L. H. THOMAS.

Improving Your Short-Wave  
Set  
By A. V. D. HORT, B.A.

How Wireless Components  
Are Made  
By CAPT. JACK FROST,  
M.I.R.E.

Watch Your Batteries!  
By A. S. CLARK.

Do We Need Reaction?  
By D. J. S. HARTT, B.Sc.

## The Wireless Constructor

SIXPENCE MONTHLY

*December Issue now on Sale*

From all Newsagents, Bookstalls and Booksellers, or direct from the Publishers, Radio Press, Ltd., Bush House, Strand, London, W.C.2. Subscription Rates, 8/6 per annum United Kingdom, 7/6 per annum Canada and Newfoundland, and Other Countries 8/6 per annum  
*Lesser periods pro rata.*

# The Genie in the Sun-Ray carton



IT was a rare and envied thing in the days of old to be able to conjure up a genie capable of laying the world at your feet. To possess a magic lamp or a magic ring was the ambition of emperors.

To-day we can all have our genie. In every ORMOND Sun-Ray Carton is a genie who at the lightest bidding will place the world at your disposal. A turn of the famous ORMOND Slow Motion Dial—and your wish is gratified. There's no "missing" with an ORMOND Condenser. No tiresome twiddling to and fro until you *almost* get your station. You're there—in a twinkling of an eye.

*There are ORMOND Condensers to suit the needs of everyone.*

## THE ORMOND ENGINEERING CO. LTD.

199-205 Pentonville Rd., King's Cross, London, N.1

Telephone: Clerkenwell 9344-5-8.

Telegrams: "Ormondengi, Kinross."

Factories: Whiskin St. and Hardwick St., Clerkenwell, E.C.1.

Continental Agents: Messrs. Pettigrew & Merriman, Ltd., "Phonos House," 2 and 4 Bucknall Street, New Oxford Street, W.C.1.





Napoleon, the greatest military genius of modern times, believed in hurling the whole might of his armies against the enemy. His success was largely due to decisive crushing blows with forces which were often apparently unnecessarily powerful for the immediate objective.

# POWER

**D**O you ever notice a slightly tinny noise as though your loudspeaker diaphragm were improperly adjusted? Does the quality of reproduction improve as you tone down signal strength? If it does, it is a sure sign that you have been overloading your valves, not your loudspeaker. Up-to-date receivers with modern loudspeakers can give exquisite tone and only 10 per cent. of distortion troubles arise from faulty design. The remaining 90 per cent. comes from the use of wrong valves.

Every S.T. Power Valve takes a remarkably small filament current and has a dead straight dynamic curve of extraordinary length which enables the valve to handle

those sudden glorious and sustained high notes or the rattle of drums which cause momentary increases of sometimes 1,000 per cent. in the amplitude of the voltages applied to the grid. These increases may only come occasionally, but when ordinary valves are used, you know instinctively that the high note will crack or the low notes will blend in a confused roar.

If you use an S.T. Power Valve your signals will be immediately transformed into warm and living music. Buy one to-day, and not only will you get glorious volume, but every note, every inflection of the voice, will be so realistically vivid that you will be startled by the magical change.



## POWER VALVES

2 VOLT  
S.T. 23  
0.15 amp.  
18/6

4 VOLT  
S.T. 42  
0.1 amp.  
18/6

6 VOLT  
S.T. 62  
0.1 amp.  
18/6

S.T. LIMITED, 2, MELBOURNE PLACE, LONDON, W.C.2.

(Next to Australia House.)



## NOTES & NEWS OF THE WEEK

### Opinions Invited

**W**ELL, my readers, what do you think of the new wavelengths? Please write to me with your outspoken opinions on the subject; I always like to read letters containing heated language! Seriously, however, I think the B.B.C. has managed a difficult business extraordinarily well, and, of course, credit is also due to all the smaller Continental stations, which do not possess such elaborate apparatus as our own.

### Searching Made Easy

**M**Y chief impression of the scheme as it is at present is the extreme regularity in the "spacing" of stations round the dial of a straight-line frequency type condenser. Naturally, since all stations are separated by 10 kilo-cycles, you can run round the scale and make a note of those stations that you are unable to receive, simply by watching the size of the "gaps" between stations! With sets like the Monodial about, it is easier to list the stations *not* picked up than to attempt to make out a complete list of those heard!

### A Canadian Boom

**C**ANADA is at present going through a great "radio boom." According to the latest reports from the Department of Commerce at Ottawa, all previous records for the sales of sets and components promise to be broken this season. The Canadians are, of course, excellently placed for radio. In addition to their own stations, they receive many of the more powerful United States stations, at the same time being free from the

The photograph in our heading this week was taken during the visit of a party of blind ex-soldiers to 2LO. Captain Eckersley is seen pointing to the microphone.

interference caused by the enormous number of smaller ones.

### An Expert Opinion

**M**Y remarks some weeks back about the family who never have missed a programme from 2LO, and

very little to grumble about in the programmes, and that he is thinking of starting classes of instruction in "The Art of Listening-In." He can tell which announcer is on duty by the breath he takes before speaking, and whether he is in a good or bad humour.

### An Impossible Ideal

**I**N response to inquiries as to how long we are to wait for the appearance of the ideal set, which will "pick up any station in a moment without interference," I am moved to make the following sad remarks:—

- (i) There will never be a set which *everyone* will consider ideal.
- (ii) It will never be possible to pick up *any* station at a moment's notice.
- (iii) There will always be interference so long as trams, electric railways and spark stations exist.

While on the subject of interference, it may be interesting to some of those who are bothered by mysterious "ticking" and crackling noises to know that a motor-car almost anywhere in one's road is capable of causing quite an audible rattle on the shorter waves. In the road which my aerial beautifies there are generally five cars, and I know each by the noise it makes and the wavelength on which it is strongest. An "Austin Seven" is probably the worst, since its "fundamental" coincides with that of WGY-32.79 metres!

### Fresh Fields to Conquer

**I**F you really want to win the admiration of your radio friends (or

### QUEEN MARIE'S SET



The Radio Corporation of America installed this powerful receiver for the use of Queen Marie of Rumania on the special train prepared for her trip to the West.

my list of "The World's Forgotten Heroes," have brought forth a letter from a hot runner-up for the championship. There is in London a family that has *never* missed listening to 2LO since September, 1925! The writer of this letter tells me that he has found

## Notes and News of the Week—continued

even your acquaintances of the "Liars' Club") the best thing you can do is to tune in to 420 metres and log 1YA, the broadcasting station at Auckland, New Zealand. This station, although the most powerful in New Zealand, uses only 500 watts. There are nine others that work with 50 watts! Three more like 1YA are to be built almost immediately.

### The Stand-by 2LO

**H**AVE you noticed how often the Marconi House transmitter is testing nowadays? Twice lately I have been searching round the Continentals after 2LO has closed down, and the stand-by station has on each occasion wiped things out very efficiently. I don't think that it should be necessary



to put this station "on the air" two or three times a week in order to make sure that it still functions.

### Another "Beam" Benefit

**A**S a result of the almost surprising success of the Beam stations, the Transatlantic Cable rates will probably be reduced very shortly. The President of the Western Union Cable Co. is at present in this country for the purpose of discussing the matter.

### Really Rude!

**S**OME of our contemporaries are really rude! I have before me one that says that "If the B.B.C. has done no other useful work, it has at least rid the country of Sir Thomas Beecham!" I think that has really exceeded the limit in politeness!

### Hilversum's Calls

**I**HAVE just found out that Hilversum is still officially registered under two call-signs—HDO and NSF.

Call-signs, however, show signs of dying out in favour of "pet names," where broadcasting stations are concerned.

### "Wireless" Scores

**I**T was rather peculiar that all the papers (I believe) except WIRELESS last week gave the common wavelength of Aberdeen and Birmingham as 481.8 metres. WIRELESS, of course, gave the correct figure—491.8.

### A G.B.S. Programme?

**T**HE "My Programmes" series has, up to the present, brought forth nothing of particular interest. Rumour has it, however, that Mr. George Bernard Shaw will be asked to draw up a programme. Will it be an evening of silence?

### Changes in India

**I**HEAR that the Calcutta station, 5AF, which used a power of 1½ kilowatts, has been closed down, and

give the effect of an interrupter being ejected.

### An Achievement

**T**HE "Internationalism" of radio has never been more strikingly shown than when the engineers at Keston, listening to WGY on 32.79 metres, picked up the message conveying birthday greetings to the B.B.C. To have been able to broadcast this from the B.B.C. stations at so early an hour as 8.45 p.m. is yet another triumph.

### A Dream?

**R**EGULAR broadcasting of pictures from Radio-Paris and Vienna will commence very soon. Mr. Thorne



## THE ARMISTICE DAY CELEBRATIONS

*The public-address system was used to a greater extent than ever before at this year's Armistice Day celebrations. On the left an engineer may be seen fixing a microphone at the feet of the London Troops' Memorial, and on the right the loud-speakers on the Duke of Wellington's Statue at the Royal Exchange.*

its place will very shortly be filled by a new station which will operate on 12 kilowatts. Whereas 5AF had a daylight range of 200 miles only, it is hoped that the new Calcutta station will be audible regularly in Bombay.

### Rugby Speaks to Australia

**R**UGBY has now succeeded in transmitting telephony direct to Australia, on a wavelength of 5,025 metres; quite a "short wave" compared with its normal 18,000-metre wave. I wonder what an amateur transmitter could do with Rugby's power on 45 metres? Ask Mars!

### That Interruption

**T**HE recent interruption in the B.B.C. debate between Professor Julian Huxley and Mr. Cecil Lewis sounded exactly like an unrehearsed incident to me. A voice screamed, "I protest! This is indecent. I—I—" "Order! Order!" . . . Dead silence! It is announced, however, that the whole thing had been previously arranged and calculated to

Baker, inventor of the "Telectograph" picture receiver, told me that the Telectograph will soon be produced for £10 or so, and he is confident that in the near future every valve set will boast its Telectograph!

### Mistaken Identity

**MAJOR ATKINSON**, of the B.B.C., was the victim of an amusing mistake when he went to Liverpool Street to welcome Dr. Strauss. By the same train from Harwich came Dr. Sthamer, the German Ambassador, who was seen to greet another passenger very warmly. The crowd that had gathered took this to be Dr. Strauss, and followed him to the Embassy car. Eventually Dr. Strauss was found struggling with his luggage and the English language further down the platform!

CALL-SIGN.

# MUSIC AND BROADCASTING

SPECIAL EXCLUSIVE  
ARTICLE BY

SIR THOMAS  
BEECHAM



## CAN BROADCASTING REPRODUCE MUSIC FAITHFULLY?

Sir Thomas explains and qualifies his recent attack in the Press

### “NOT THE ENEMY OF BROADCASTING.”

A great deal of attention has been devoted to the recently published utterances of Sir Thomas Beecham on the subject of the defects of broadcast music, and it is with much pleasure that we are able to present to our readers this exclusive article explaining his true views. It will be observed that Sir Thomas maintains that loud-speaker reproduction is but a travesty of the original, and while it must be admitted that there is unfortunately a good deal of truth in this criticism as far as it concerns the average reproduction with its well-known deficiencies at the bass end of the register, whether or not it is possible to produce something approaching perfection with proper apparatus is another matter. Upon this point we intend to publish the opinions of technical and musical authorities in an early issue.



WHEN I was explaining my reason a short time ago for saying that England was musically going to the devil, someone asked me if I thought broadcasting was responsible, and I gave my opinion on broadcast music. In the reports of the interview which appeared next day I was represented as a monstrous enemy of wireless and a man who thought all licence holders fools. None of my qualifying statements were reported.

Actually, I am not the enemy of broadcasting—let me make that clear at the outset. My attack was launched against wireless only in its capacity of musical criminal. I have said and I will repeat that there is no resemblance between the sound which goes into the microphone at one end and the sound which proceeds from the loud-speaker at the other. The one is music, the other is—well, sound and not always pleasant sound.

#### But Not Music!

I have been accused of making wild statements without full knowledge of the facts. It has even been suggested that I have never listened to a good loud-speaker. Actually I have listened to the best receiving sets and the best

loud-speakers, and I have nothing against them as regards their reproduction of speech and certain other sounds. But they cannot reproduce music.

Here is a fact for my critics. The oboe and the clarinet are wooden instruments which give out sounds produced by the vibration of a reed. The microphone, on the other hand, is

of the oboe, clarinet, flute and piccolo which are transmitted across the ether.

#### A Question of Tone

If I play a passage in the high treble of the piano I am playing the same notes as would be played on the piccolo. The pitch is the same, but there is not the slightest resemblance in tone. It is the same with the microphone and the loud-speaker. They are capable of producing only a very limited range of tones, and it is ridiculous to suppose that you can broadcast the works of Beethoven, Wagner and Strauss, full as they are with the rich glowing tone colour of a big orchestra. I am sure music lovers who heard the broadcast of Strauss' concert from the Albert Hall will agree with me on this point.

#### What is Lost

The works of the great masters were written for instruments and combinations of instruments, all of which have a different and characteristic tone. If the exact sound of these instruments in their integrity is not heard by the listener, then I maintain that he is not hearing the work of that composer. He might as well listen to an arrangement of the piece for pianoforte or, for that matter, accordion or jew's



Sir Thomas Beecham considers that in broadcasting the whole tone value of an orchestral work is lost, and we might as well listen to an arrangement for the pianoforte.

a metal instrument. How can this metal reproduce the exact tone of “wood wind”? In point of fact it cannot, and to the sensitive musical ear it is painful to hear the travesties

## Music and Broadcasting—continued

harp. The thousand and one effects of light and shade of variety and, most important of all, the impulse and vitality of an actual performance are lost when the work is reproduced mechanically. The listener may enjoy what he hears—but he must not deceive himself that it is music or that he would not enjoy hearing what the composer actually wrote in a concert hall.

More unfortunate still is the fact that broadcasting makes bad music sound good. I like to hear a jazz band through a loud-speaker. It muffles its worst noises and makes them tolerable—but I think that dancers will agree that the loud-

I believe that the standard of reproduction has improved amazingly since the inauguration of broadcasting, but even recently I have heard people listening to grating loud-speakers—and the tragedy is that they did not realise they were distorting. Day after day for months they have been listening to distorted music and have become so innoculated with it that they cannot discriminate between good and bad. This surely is the antithesis of musical education!

### A Doubtful Tendency

It is possible that hearing "music" by wireless will encourage people to go to concerts. If that is so, they will certainly never return to wireless, for in the concert hall they can appreciate the personality of the conductor and his orchestra, and they will hear the music as the composer intended they should hear it.

Not least of the dangers of broadcasting music is that it will make us lazy. The Englishman is naturally a lazy fellow—at any rate in his recreation—and during the winter prefers his fireside to the concert hall. Wireless will encourage this attitude. Moreover, wireless is providing cheap entertainments for thousands who used to make their own music in the drawing room. It may have been bad music, but it had more educational value than indiscriminate listening-in. There are even people who have put away their gramophones because wireless provides music with less trouble—there is no changing of needles and records!

### The Attack Defined

Mark this, only in its capacity as a musical criminal do I attack wireless. I recognise that it must be a boon to thousands of sick and infirm, to the blind, and even to the poor. But I want them to realise that it is not music they are hearing. Broadcast music bears as much resemblance to the real thing as the sounds of the Derby did to the race or a broadcast service to a real church service. Any sportsman would rather see the Derby at Epsom than hear it broadcast, and in the same way musical people should prefer being present at a concert to hearing it broadcast.

### Talks

The talks and lectures given by wireless cannot but prove an important educative force. It was perhaps unfortunate that the first two talks I heard were on the domestic habits of the lizard and the dromedary. I do not doubt that serious lectures are given sometimes. For news distribution and time signals wireless is in-

valuable, while from the point of view of the mechanically-minded experimenter I think it admirable. Care and infinite patience must have gone into the making of many sets I have seen, and as a hobby I am sure it will be many years before wireless construction dies out.

### Its True Metier

In time wireless will find its own level. None but the infirm and unmusical will look to it for concerts. The average listener will be interested either as a constructor or in the news and "talking" side of broadcasting. It has been said that wireless is

### IN REMEMBRANCE



*A glimpse of the service which was conducted at the Royal Exchange on Armistice Day. The crowd were able to follow the service from the public address loud-speakers.*

speaker saps the vitality of the performance and damps its fire.

### A Danger ?

We have heard a good deal of talk about musical education by wireless, but sooner or later we shall have to face the facts. Wireless may be giving millions a greater knowledge of music, but it is also ruining their musical taste. If they have to listen night after night to the travesties which are broadcast they will have no musical taste at all in a few years' time. They will have no appreciation of tone colour and probably very little of pitch.

### PREMIERS VISIT RUGBY



*While on their visit to England, the Dominion Premiers paid a visit to the Hilmorton Wireless Station. Headed by Mr. Bruce, they are here seen inspecting the giant aerial masts.*

awakening a new interest in music. Anything that does that in England should be welcome. Only the amazing apathy of the English has enabled the Government to refuse a subsidy for music. Listeners-in have managed to drag a meagre subsidy for broadcast music from them. I hope that this will be the first step towards dragging a subsidy for national concerts and national opera from them. Broadcasting has shown that if music is provided cheaply, Englishmen will listen. It is the duty of the Government to see that the finest music, played under ideal circumstances, is available for all for a small sum.



# A REVOLUTION IN TRANSFORMER VALUE.

—powerful amplifiers now  
within the reach of all.



## Price 8/6

GUARANTEED FOR 12 MONTHS.

Turns ratio 3 to 1.  
Resistance ratio 4 to 1.

*It suits every set and every valve you will want to use.*

Use it for 1, 2, or 3 stages L.F.

Obtainable at all good radio dealers, but if any difficulty send direct to factory. No postage charged, but please mention dealer's name and address. Or can be sent C.O.D.

Ask your dealer's opinion of this new LISSEN.

*Use the new LISSEN Transformer instead of any other Transformer that may be specified in any other published circuit.*

EVERYBODY is wanting to buy this new LISSEN Transformer. Amateurs have them, experimenters have them—the need for paying a high price for a good transformer has gone for ever, for this new LISSEN

AMPLIFIES FULLY EVERY NOTE, EVERY HARMONIC, EVERY OVERTONE.

So good is it that we have unhesitatingly withdrawn all our own previous high-priced models which have been on the market and largely sold for several years past.

Compare this new LISSEN against any for tone purity and power.

### 7 DAYS' TEST AT HOME.

Take one home with you—test it for 7 days, and if it fails to satisfy you, take it back to your dealer's or send it back to us.

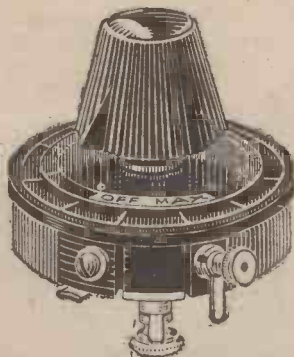

## QUALITY RHEOSTATS

—previously 4/-

NOW 2/6

The LISSEN Range of wire-wound Rheostats and Potentiometers offers the user something from which every discriminating buyer will choose one in preference to all others.

You want in a rheostat a contact brush which gives firm, sure, electrical contact, yet which moves smoothly along and is pleasant to use. This you have in a LISSEN. In addition, the turns of the wire cannot move and short circuit—you cannot get any chattering or arcing. There is no flimsy spring. The photo-engraved dial and combined knob and pointer which, when mounted, fits flush with the dial, gives an extremely neat appearance. These LISSEN rheostats will stand hard use—they are robust as well as good looking.

The reduced prices are the last irresistible appeal that compels you to buy a LISSEN after comparison with all others. These large reductions have been made possible by our new direct to dealer policy of distribution which cuts out all wholesale profits.

	Previously	NOW
LISSEN 7 ohms, patented .. .. .	4/-	2/6
" 35 " " .. .. .	4/-	2/6
" Dual " " .. .. .	6/-	4/6
" Potentiometer, 400 ohms, patented .. .. .	4/6	2/6

EVERY ONE LISSEN ONE-HOLE FIXING. Baseboard type same prices as above.

**IMPORTANT TO THE TRADE!** Orders for LISSEN products must now be sent direct to factory at Richmond and not to usual wholesale factor. Apply for particulars of new trading policy if not already advised. Every dealer in his own interest should be registered with us.

**LISSEN LIMITED, 18-22, Friars Lane, Richmond, Surrey.**

Managing Director: Thomas N. Cole.

LISSEN PARTS, WELL THOUGHT OUT, THEN WELL MADE.



# A TOTALLY-ENCLOSED FOUR-VALVE SET

By *BRIAN ST. CLAIR*

Full constructional details of a four-valve receiver which can be used on a frame or an outside aerial by changing the position of a switch.



**A**FTER careful consideration of the requirements in a domestic receiver I made this set, the construction of which will be found quite straightforward. A frame aerial

wound on one of the hinged sides of the cabinet is employed for the reception of local signals, and a special type of loud-speaker, made by Alfred Graham & Co., is housed in the cabinet itself. Room is also provided for the high-tension, grid-bias, and low-tension batteries, and since valves are recommended which consume 0.1 ampere, the total consumption for the four valves thus being 0.4 ampere, the last-named battery need not be of very large capacity. The small ebonite panel just above the mouth of the loud-speaker contains the one tuning condenser dial, a filament switch, change-over switch, and two terminals.

### Davertry

The frame aerial is wound so that reception from the local station on the ordinary broadcast band is made possible, but by connecting up an outside aerial to the terminals provided and moving over the lever switch, the Daventry station can be tuned in when suitable high-frequency transformers are available. Of course, the local station can also be tuned in on the outside aerial if desired.

### The Circuit

A glance at the theoretical circuit will make clear the arrangement adopted. The circuit is quite a

straightforward one—indeed, simplicity is its recommendation—with two stages of aperiodic H.F. transformer coupling, a rectifier and a transformer-coupled low-frequency amplifier, fixed reaction being applied direct to the frame aerial. The change-over switch  $S_1$  enables either

came in at good loud-speaker strength. With an outside aerial of average size and efficiency connected and a No. 40 coil in the  $L_2$  socket 2LO was very strong while with the H.F. transformers for the higher band of wavelengths and a No. 150 coil the Daventry station was received at good loud-speaker strength. It will be noted that with the outside aerial there is no reaction in use.

### Constructional Points

The complete list of components and material is given for the benefit of those constructors who wish to duplicate the receiver in every detail, but in nearly every case substitutes of good quality can be made without

detriment to the performance. Since the construction of the set is somewhat

(Continued on page 98.)

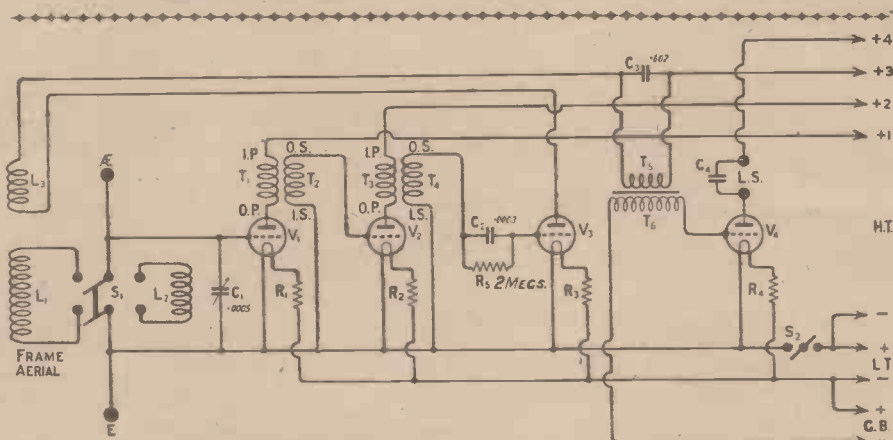

Fig. 1.—The theoretical circuit diagram, showing the connections to the change-over switch.

the frame aerial  $L_1$ , or the loading coil  $L_2$  to be connected across the .0005 condenser  $C_1$  as desired, while  $T_1$ ,  $T_2$  and  $T_3$ ,  $T_4$  represent the aperiodic H.F. transformers covering the band of waves between 300 and 600 metres. While this method of high-frequency amplification is not the most efficient, it has been employed with the express object of keeping controls down to the barest minimum. When used in conjunction with the rectifying valve, in the anode circuit of which is placed a few reaction turns with a fixed coupling to the frame aerial, and a transformer-coupled low-frequency amplifier reception from a main broadcasting station will be sufficient to give loud-speaker results up to a distance of at least 15 miles.

### Some Results

When tested at my own residence, which is situated nearly 10 miles North-West of London, that station



Simplicity is the keynote of the panel layout, as may be gathered from this "dead-on" panel photograph.

**Q** The illustration shows a simple but really effective loud speaker horn—that can be covered with fancy paper or painted so as to resemble a factory article—made for a few pence by following the easy directions supplied with every “Lissenola” Loud Speaking Unit, a Lissen product yielding results equal to the most expensive instrument on the market and sold at the record low price of.. **13/6**



*Christmas in four weeks—  
build a powerful loud speaker*

*that costs less than headphones*

Hardly credible—but true. For less than the price of a pair of phones you can buy the “Lissenola” Loud Speaking Unit, that only needs the addition of a horn to make it a powerful, full-sized instrument, equal in volume, purity and tone to the most costly on the market.

efficient horn for a few pence. Or, by using the “Lissenola” Reed (price 1/- extra), a cone or any other diaphragm working on the reed principle can be quickly made and fitted, yielding results equal to an expensive speaker. By removing the sound-box and substituting the “Lissenola” Unit, any gramophone can instantly be converted into a loud speaker.

**7 DAYS' TEST AT HOME.**

Your dealer will demonstrate, but, better than all, take a “Lissenola” home—put it on your set—put it on your friend's set—try it with the horn of an expensive loud speaker fitted to it—then if you do not prefer the LISSENOLA for tone, quality and power, take it back to your dealer or send it back to us.

*Take no imitations. If an imitation is offered to you come firmly away and send direct to factory—no postage charged, but please mention dealer's name and address.*



The complete Unit with “Lissenola” Reed attached ready to receive a cone—or any other diaphragm working on the reed principle.



The “Lissenola” Reed Attachment (patent pending). Price 1/-.

Any good horn will do. If you have a spare one in the house from a gramophone or a loud speaker it will serve admirably. If not, there are directions with every “Lissenola” Loud Speaking Unit and full-sized patterns, telling you how to make a simple but attractive and really

Full directions and full-sized patterns for making this horn are given with every “Lissenola.”

A cone diaphragm loud speaker can easily be constructed. The illustration shows one method of mounting.

The “Lissenola” instantly converts any gramophone into a loud speaker.

The “Lissenola” Reed Attachment (pat. pending) for use with cone diaphragm loud speaker. Price 1/-.



Showing method of attaching Reed to the “Lissenola” Loud speaking Unit.

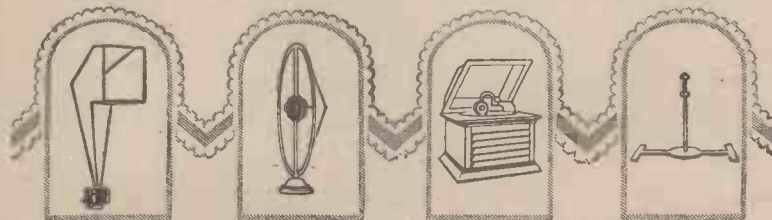

**LISSEN LIMITED, LISSENIUM WORKS, 18-22, FRIARS LANE, RICHMOND, SURREY.**

## A Totally-Enclosed Four-Valve Set—continued from page 96

different from the popular arrangement of baseboard and panel the instructions should be followed carefully and no difficulty will be experienced. Mount the panel on the hinged brackets after drilling the few holes required for fixing the panel components in place and then attach the long baseboard, allowing the panel

away a small rectangular portion of the baseboard in order to secure the filament switch in position. Now screw all the baseboard components into place, following as far as possible

tions it will be necessary to cut out two pieces of ebonite  $2\frac{1}{2}$  in. by  $\frac{1}{2}$  in. by  $\frac{1}{4}$  in., and one piece  $3\frac{3}{8}$  in. by  $\frac{1}{2}$  in. by  $\frac{1}{4}$  in. Mount a pair of terminals on each of the smaller pieces of ebonite, each with a red and black plain top, as shown in Fig. 2, these being for the purpose of connecting to the ends of the frame aerial and

### WHAT YOU WILL NEED

One special cabinet with two side doors and baseboard (Camco).

One ebonite panel 8 in. by  $\frac{1}{2}$  in. (Peto-Scott Co., Ltd.).

One .0005 cam vernier square-law condenser (Radio Communication Co., Ltd.).

Four buoyancy valveholders with terminals (Garnett, Whiteley & Co., Ltd.).

Two aperiodic H.F. transformers (300-600 metres) with bases (Burne-Jones & Co., Ltd.).

One .0003 fixed condenser with grid-leak clips (Dubilier Condenser Co. (1925), Ltd.).

One 2-megohm Dumetohm grid leak (Dubilier Condenser Co. (1925), Ltd.).

Four fixed resistors with bases (Burne-Jones & Co., Ltd.).

One Utility two-way two-pole switch, lever pattern (Wilkins & Wright, Ltd.).

One Decko dial indicator (A. F. Bulgin & Co., Ltd.).

One shrouded L.F. transformer (5 to 1) (The Formo Co.).

One .002 fixed condenser with clips (L. McMichael, Ltd.).

One .002 fixed condenser (Dubilier Condenser Co. (1925), Ltd.).

One baseboard mounting single coil holder (Burne-Jones & Co., Ltd.).

One A.R.61 portable loud-speaker, without container and tripod (Alfred Graham & Co.).

Two engraved terminals (aerial, earth) (Belling & Lee, Ltd.).

Six T.2.L.C. terminals (2 plain red tops, 2 plain black tops and 2 loud-speaker) (J. J. Eastick & Sons).

Thirteen T.14 plugs (assorted colours, including 3 black and 3 red) (J. J. Eastick & Sons).

One pair jointed baseboard brackets (The Formo Co.).

One filament switch (Igranic Electric Co., Ltd.).

Quantity of Glazite for wiring up, rubber covered flex, four small terminals, six spade terminal tags, 4 ozs. No. 20 d.c.c. flexible stranded coil wire, number of ebonite strips  $\frac{1}{4}$  in. thick and sundry screws.

to slope the full amount permitted by the brackets. Cut off the feet of the brackets under the baseboard, since they are not required for supporting purposes. Having made quite sure that the panel and baseboard fit into the cabinet without undue forcing, the panel components can be fixed in position.

It will be found necessary to cut

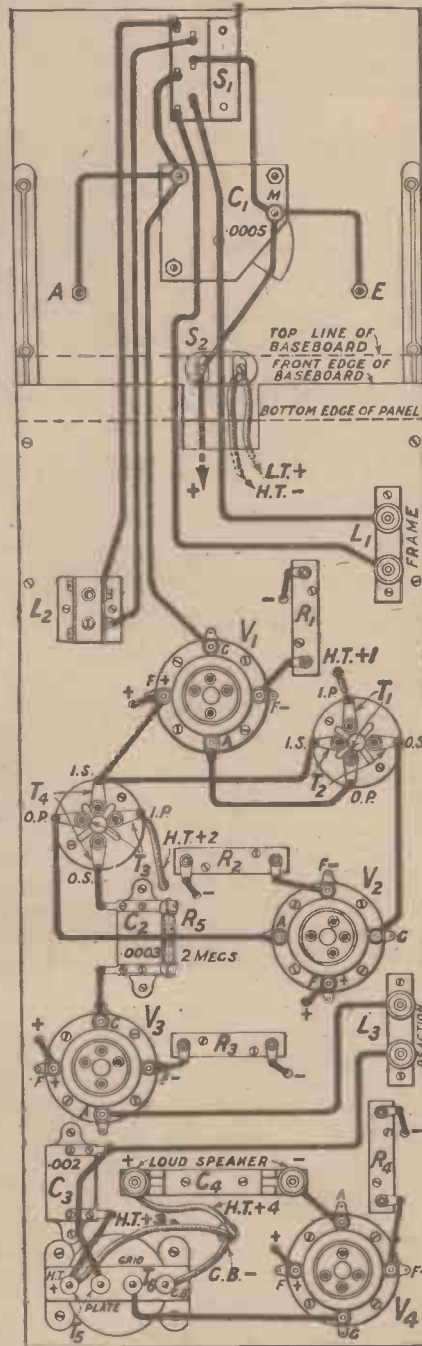

Fig. 2.—This drawing, which shows the panel and baseboard in the same plane, should be used in conjunction with the verbal wiring instructions.

the layout indicated in the wiring diagram.

### Terminals

Before commencing wiring opera-

### WIRING INSTRUCTIONS

Join top left-hand contact of S1 to one side of L2.

Join top right-hand contact of S1 to other side of L2.

Join middle left-hand contact of S1 to fixed plates of C1 and thence to aerial terminal and G of V1.

Join middle right-hand contact of S1 to other side of C1, and thence to earth terminal. Join same side of C1 also to one side of S2 and thence under baseboard to the four holes marked +. Join latter points to the F+ contacts of V1, V2, V3 and V4. Join F+ of V1 also to I.S. of T4 and thence to I.S. of T2.

Join bottom right-hand contact of S1 to L1 terminal nearest panel.

Join bottom left-hand contact of S1 to other L1 terminal.

Join A of V1 to O.P. of T1.

Join I.P. of T1 through baseboard to H.T.+1 plug (flex lead).

Join O.S. of T2 to G of V2.

Join A of V2 to O.P. of T3.

Join I.P. of T3 through baseboard to H.T.+2 (flex lead).

Join O.S. of T4 to one side of C2 and R5.

Join other side of C2 and R5 to G of V3.

Join A of V3 to L3 terminal nearest panel.

Join other L3 terminal to one side of C3 and thence to "plate" of T5.

Join other side of C3 to "H.T.+3" of T5. Join latter point also through baseboard to H.T.+3 (flex lead).

Join "Grid" of T6 to G of V4.

Join G.B. of T6 through baseboard to G.B.— (flex lead).

Join A of V4 to one side of C4 and L.S.— terminal.

Join other side of C4 and L.S.+ terminal through baseboard to H.T.+4 (flex lead).

Join remaining side of S2 to H.T.— and L.T.+ flex leads.

Join one side of R1 to F— of V1, one side of R2 to F— of V2, one side of R3 to F— of V3, and one side of R4 to F— of V4.

Join remaining sides of R1, R2, R3 and R4 together under baseboard (via "minus" holes). Join L.T.— and G.B.+ flex leads to convenient point on latter wiring.

reaction winding. On the larger piece of ebonite mount a pair of terminals marked loud-speaker + and — together with condenser clips.

### Wiring

Having secured these terminal mounts to the baseboard in the positions indicated the wiring may be started. In order to simplify this it

## A "One-Dial" Set for Home Use

was thought advisable to run the filament circuit leads under the baseboard and then pass short leads through holes in the baseboard at the positions where connections must be made. The soldering operations have been kept to a minimum by taking advantage of the terminals which are provided with so many of the wireless components, and it will be found, in practice, that where a receiver has to be constantly moved from place to place the screw connections thus made are liable to stand more shocks than the soldered joints unless extreme care is taken in the soldering operation.

### The Frame

We now come to the frame aerial, and if the arrangement suggested is adopted it will be found that it can be mounted easily on one of the hinged cabinet sides. Obtain or cut out four strips of ebonite  $7\frac{1}{2}$  in. by  $\frac{1}{4}$  in. by  $\frac{3}{8}$  in. thick, and starting  $\frac{1}{8}$  in. from one end cut twenty slots about  $\frac{1}{16}$  in. deep and separated from each other by a distance of  $\frac{3}{16}$  in. Leave a terminal space of  $\frac{7}{16}$  in. and cut a further twelve slots. All these slots can be cut with a coarse hacksaw blade or a ward file, and care must be exercised in the operation in order to prevent the possibility of any of the strips breaking.

### Frame Connections

Mount two small terminals for the beginning and end of the frame aerial, winding 4 in. apart on one strip and  $2\frac{3}{8}$  in. apart on another strip for the start and finish of the reaction winding. Draw two faint pencil lines along the diagonals of the cabinet side and then screw the four strips on to this side. The distance of each corner from the strip edge should be about  $\frac{7}{8}$  in., while it will be necessary to recess the wood slightly where the terminals have been mounted on the strips so that the strips can lay flush.

### Frame Turns

The question of the exact number of turns to be used for the frame aerial is largely a matter of experiment, as owing to the relatively small size of

the frame the largest number of turns should be used for the reception of the local station. Since fixed reaction is employed only a few turns will be

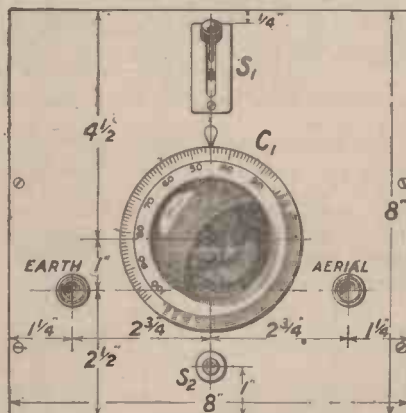

Fig. 3.—To allow the switch S2 to be fitted symmetrically on the panel, a small piece has to be cut out of the baseboard as indicated in Fig. 2.

required for this winding, and after a little experiment it was found that for London the best balance was effected

under the remaining free frame terminal. Wind the reaction coil in a similar manner, starting and finishing at terminals. The wooden side can now be replaced on the cabinet.

### Supporting the Baseboard

In order to keep the baseboard horizontal in the cabinet and to act as a support, a thin strip of ebonite or wood should be screwed to the back of the cabinet, on the inside, at a height of about 7 in. The baseboard and panel can now be inserted in position and the loud-speaker arranged so that the mouth of the horn is just below the panel. Having arranged it centrally it should be screwed down and wedged at the back to keep it in position. A frame constructed from ebonite strips is preferably fitted in front of the loud-speaker mouth, as this will compensate for the reduced dimensions of this mouth when compared with the cabinet and also supports the bottom edge of the front panel.

### Battery Leads

The flexible battery leads pass through holes in the baseboard and terminate in plugs and spade terminals for connecting to the H.T., L.T. and G.B. batteries, which are conveniently accommodated at the back of the cabinet. The two loud-speaker leads terminate in plugs which are inserted in the terminals attached to the condenser clips, the correct value of the paralleling condenser being determined by experiment, but is usually of the order of .002.

### First Tests

We are now ready for testing out the receiver. Insert two high-impedance type

valves in the first two sockets with a general purpose or high-impedance type for the rectifier and a low-impedance type for the L.F. amplifier. Valves should be chosen whose filament current does not exceed 0.1 amp. when worked from either a 2- or 4-volt battery.

Join up the batteries, arranging for a voltage of between 50 and 60 for the two H.F. stages, about 48 volts for the  
(Continued on page 107.)

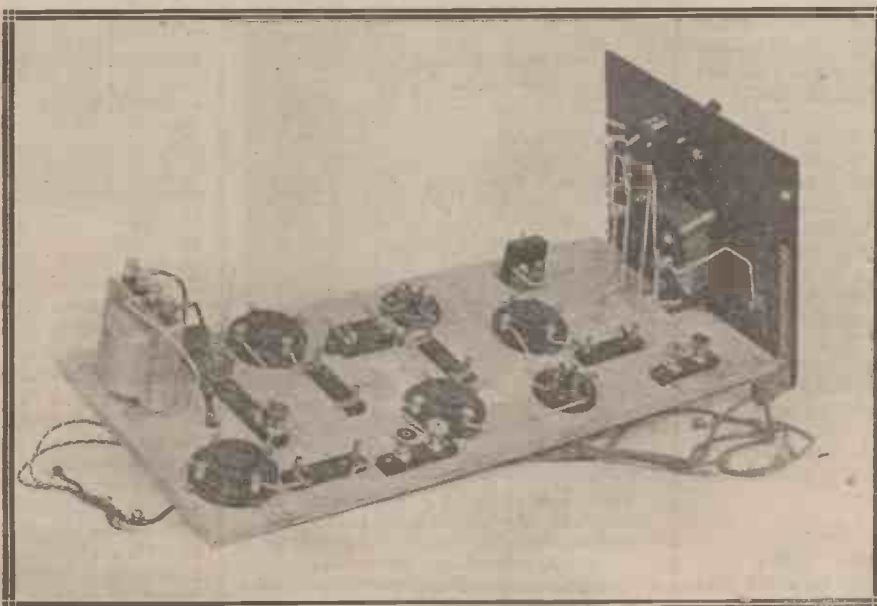

The simple appearance of the set is much enhanced by the fact that a good deal of filament wiring is concealed under the baseboard.



The new Broadcasting Commission, and what our contributor thinks about it!



HERE has been quite a little criticism of the composition of the new Broadcasting Board in Little Puddle-ton, though I cannot say that I agree

with any of it. So far as I can see, the ex-headmaster is just the person to swat the oscillator, the ex-Governor of the Bank of England will simply revel in signing cheques, and the lady member will be able to keep an eye on the Woman's Hour. That none of them, except Lord Gainford, has been what you might call intimately connected with broadcasting in the past, or has any experience of wireless, is a matter of no importance whatever. They will come to their new task with a fine fresh enthusiasm.

**Safe in Britain**

If this had happened in any other country but our own prospects might be rather gloomy, for ex-headmasters are apt to be filled with a desire to educate all with whom they are brought into contact. Since, however, the British nation is what it is, we may be quite sure that the headmaster will be promptly turned on to accounts and will be allowed to have nothing whatever to do with the educational side. In the same way it is all Bush House to a fixed resistor that the ex-Governor of the Bank of England will be sternly banished from the financial department and will probably be turned on to organising concert parties. Luckily, the great palpitating (or should I say oscillating) B.C.L. public has a sense of humour, even if those responsible for the appointments have not.

**An Omission**

To my mind the new Board only lacks perfection in one respect; one name which surely ought to have been there has been omitted from the list. Modesty prevents me from telling you just what that name is, but I may remark that for some months past I had been hoping for a bright and happy New Year, which should provide a certain person which lives at Little Puddle-ton, who is a shining light at the wireless club, who is the right-hand man of Professor Goop, and whose initials are W. W., with a nice fat income, paid regularly on Quarter Day, for doing nothing but to say, "Quite, quite," or "Ah, yes," or "I see," and to present a distinguished

appearance in public, matters which are child's play to me—that is to say, to the unnamed person of whom we have been talking. Without being unduly vain, I have long regarded myself as the ideal member of Boards, committees, and suchlike things.

**A Fine Record**

When after one of the hottest contests on record I was elected a member of the Little Puddle-ton Sewerage Committee, scraping in just one vote ahead of Poddleby (who had only managed to register three votes for himself,

ponents in return. Others made themselves obstreperous by asking awkward questions or interjecting rude remarks at meetings; a search through the files of the *Little Puddle-ton Gazette* will show that only on one occasion did I break silence, though here the reporter was at fault. I was reported to have said, "Hear, hear," in the middle of a speech by General Blood Thunderby, when actually all that I did was to snore. Taking into consideration these facts, and others which are common knowledge, you will, I think, agree that the only reason why the unnamed person of whom we spoke earlier was not elected to the Broadcasting Committee was that he knew something about wireless.

**NOT WIRELESS!**

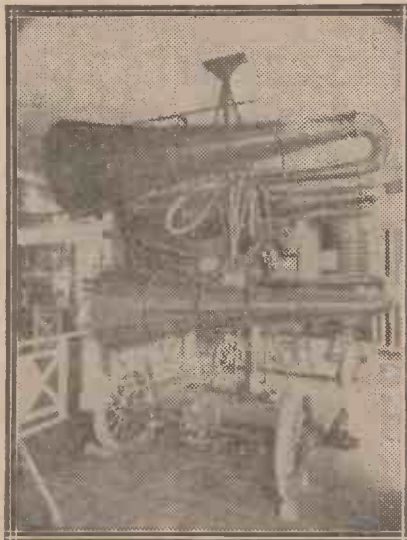

*This weird-looking apparatus is used in the American army for picking up the first faint sounds of approaching aircraft.*

whilst I managed to achieve the feat on four occasions on my own behalf by the exercise of a little sleight of hand), it was universally admitted that I was the model member. Others rose to their hind legs at meetings and spoke at enormous length about nothing in particular; I simply made up for arrears of sleep. Others made the lives of the municipal officials a perfect burden by continually questioning them about the duties which they carried out so efficiently; I simply gave them helpful information about wireless, and borrowed their com-

**And Another**

Apart from this unnamed person there is only one of my countrymen whom I would have liked to see appointed a member of the Committee; this is Professor Goop. A man with a brain so fertile as his might have worked wonders by instilling fresh vitality into broadcasting. It is, of course, highly probable that when meetings of the Committee were called in London Professor Goop would either have forgotten the day altogether, or that if he had turned up he would have insisted upon addressing them on subjects quite above their heads, such as, "What to do when the catwhisker comes uncurled," or "The danger of wearing telephones inside out." But just think how, in his less absent-minded moments, he would put his finger infallibly upon the weak points in broadcasting as we know it to-day.

Had Professor Goop been appointed technical member of the Committee and entrusted with the supervision of the Chief Engineer's Department, we may safely say that things would have begun to happen very shortly after the 1st of January, 1927. Take the valves used at 2, Savoy Hill (I have tried several times to take one, but the engineers have a nasty way of crowding round me when I am going round the building); take, I say, the valves used; practically all of those employed for amplification are of one type. Professor Goop long ago demonstrated that this kind of thing makes for monotony, as well as cramping the style of the engineers, since it means that there are practically no knobs to twiddle. Professor Goop's idea, I

*(Continued on page 102.)*

# MADE IT MYSELF

## This Wonderful 3 valve set in 3 hours for less than 3 pounds



### You too can make this super R.C. Threesome Resistance-Coupling set

IT'S EASY—you can do it in an evening. For local and high-power station work this amazing set will surprise even the most critical of listeners.

Beautiful, mellow, natural reproduction, with an abundance of volume, has been made possible by the employment of two new Ediswan Valves—R.C.2 and P.V.2—in the new quarter-watt POINT ONE ECONOMY Range.

Get this Ediswan FREE Booklet and full-sized blue-print.

### Fill in the Coupon NOW!

Applications for the FREE blue-print and FREE book of instructions will be dealt with in rotation.

Ask your dealer about the new  
**EDISWAN ECONOMY VALVES**  
QUARTER-WATT POINT ONE RANGE  
*There is an Ediswan Valve for every Wireless Purpose*  
**FIT EDISWAN VALVES AND NURSE YOUR SET**

The **R.C. Threesome** Resistance Coupling  
★ PERFECT ★ CHEAP  
★ EASY  
**3 VALVE RECEIVER**  
**3 HOURS TO MAKE**  
(or less) FOR PARTS  
INSTRUCTION BOOK

This book is written in simple, non-technical language. Anyone can follow the directions.

# EDISWAN

To THE EDISON SWAN ELECTRIC CO., LTD.,  
123/5, Queen Victoria St., London, E.C.4

Please send, post free, presentation copies of the "R.C. Threesome" Instruction Book and Blue-print.

Name

Address

PLEASE USE BLOCK LETTERS

W. 24/11/26

## Jottings by the Way—continued from page 100.

know, is to do away with the existing groups of three valves of a similar type in the "A" and "B" amplifiers and to have fresh bunches of miscellaneous valves pushed into the holders at a given hour every day.

### A Great Problem Solved

If this scheme were adopted the unemployment question would be practically solved in this country, for hundreds of thousands of chief knob twiddlers, assistant knob twiddlers, deputy-assistant knob twiddlers, and acting deputy-assistant knob twiddlers would be required at main and relay stations. A little variety, too, would be introduced into the otherwise dull homes of broadcast listeners.

At the present time wireless is not what it was. In its early days broadcasting always gave the ardent listener something to do. At one moment the transmission would be coming in with a roar, which was followed by a delightful fading away until nothing at all was heard. Leaping from his chair, the listener armed himself with screwdriver, pliers, hammer, hacksaw, soldering iron, box spanner, and other tools, to say nothing of a voltmeter and a milliammeter. For the next hour he was thoroughly happy, being engaged in trying to discover what had happened to his set. The result was that he preserved his schoolboy figure, for he was never able to loll for more than a few minutes on end in his armchair.

### A Sad Change

How different things are to-day! The unfortunate enthusiast switches on. Instantly the loud-speaker pours forth perfect reproduction of the local station's programme. He cannot twiddle knobs, for so-called progress has bared his panel of all but one; he cannot try the effect of dimming or brightening his filaments, for up-to-date filaments produce no visible glow, and, even if they did, we do not use rheostats nowadays; he cannot squeak, or chirp, or moan gaily, as was his wont in the good old days, for the neutrodyne circuit has put paid to one of his favourite diversions; his tools grow rusty in their drawer, for he is never called upon to use them; his muscles become flabby, since it never falls to his lot nowadays to prise off a panel with the case-opener or to deal with a recalcitrant nut; he puts on weight, since he can spend the whole evening in awinish ease; he can exercise his slug-

gish brain only by reading Deathel M. Hell or going to the movies; his is truly a parlous state.

### Too Easy

No, wireless has become too easy. The old pastime of trouble-hunting with all its attendant excitements has practically ceased to exist. Gone are the days when we thought that we had traced a queer jarring noise to the effects of a loose screw in a far corner, when we attempted to tighten that screw with a long screwdriver, shortcircuited everything in the process, and afterwards resolved to switch off in future before undertaking similar probing operations into the vitals of the set. Departed are

as in a rash moment we have boasted that it can do. Even the old art of radiolying is almost dead this season; it is quite useless to expect people to believe that you have heard American stations, when they know that you are getting only half a hundredweight a week, just as they are.

### What a Difference

Just think what Professor Goop could, and would, have done to lighten the load of the hard-hit wireless man. One of his most brilliant ideas would certainly have been adopted. This is that the manuscripts of topical talkers should be typed on the backs of sheets of emery cloth, which would have brought, at any rate, one little ray of joy into our homes, for those noises would have had to be traced. Another is that at certain times in the studio the note-oscillator should be set going while a skilled assistant waggles its knobs so that the note runs up and down the scale. This would have revived the dear old days when we *knew* positively that Jones was a howler, cut him dead in the street, and talked darkly of laying low his aerial mast.

Other schemes the Professor has in plenty, each and all of which would have been put into practice had he only been given his chance of bringing about brighter broadcasting. He would have varied the aerial amps of each station several times nightly; he would have been continually messing about with feeders, and earths and things; he would have given back its thrills to simultaneous broadcasting by re-introducing the land-line cross-talk that was sometimes so exciting in the

old days. Do you remember the evening when there was superimposed upon the topical talk an altercation over the telephone between General Blood Thunderby and the operator of the Little Puddleton exchange, who had given him four wrong numbers, "Number engaged," and "Line out of order" inside five minutes?

Nowadays everything is such hopelessly plain sailing that people think nothing of prating about the wonderful purity of their reception, and of asking you to go in and hear it for yourself. And when you turn up the demonstration passes off without a hitch, and you think of how you used to enjoy the impotent wrath and the futile efforts to put things right of Snaggsby or Bumbleby-Brown.

WIRELESS WAYFARER.

## THE TANKS AT CAMBERLEY



*A special feature of the wonderful display of tanks of all sorts and sizes at work, given in honour of the visiting Dominion Premiers, was the use of wireless in controlling certain of the evolutions. The orders were made audible to those watching by means of groups of loud-speakers.*

the joys of digging great holes in the garden at dead of night in pelting rain in order to see whether declining signal strength was due to a worm-eaten earth plate. Lost, perhaps for ever, is the breathless thrill of swarming up the aerial mast at the same time and in similar circumstances to make sure that spiders have not caused a short circuit by spinning their gossamer webs across the insulators.

Improvements in the high-tension battery have robbed wireless of much of its charm, for we no longer have mysterious noises whose cause we must trace; nor, for the same reason, have we still the splendid standby of atmospherics when friends come round to hear the receiving set bring in all Europe in an hour,



# Secrets of the Low-Frequency Transformer

By J. H. REYNER, B.Sc. (Hons.),  
A.M.I.E.E.



Some striking results of tests at Elstree on the effect of the ratio of valve impedance to transformer impedance.



LAST week we considered the various subsidiary effects which occur in a transformer, and we showed that the instrument could be represented by an equivalent circuit such as that shown in Fig. 1. In this equivalent circuit we replaced the perfectly-coupled portion of the transformer by the inductance  $L$  and the resistance  $R_1$ , and in series with the primary and secondary we have the leakage inductances  $L_1$  and  $L_2$ . The capacity associated with the secondary circuit is represented by  $C$ , this capacity being made up, as we saw last week, of three main portions, the self-capacity of the winding, the capacity between the primary and secondary windings, and the external capacity associated with the circuit.

### The Expected Curve

Now we saw that the amplification obtained from the preceding valve

at a frequency of 100 or 200 per second is made several times as large as the valve impedance, then one would expect an amplification curve somewhat similar to that shown in Fig. 2.

### And the Actual

Owing to the fact that the equivalent impedance of the transformer,

resonance occurring in the circuit  $L_1, L_2, C$ , i.e., that obtained by resonance between the two leakage inductances in series and the capacity across the secondary.

### A Compensation Effect

These two effects, therefore, act in opposition, and if they can be arranged to balance each other the amplification is maintained at a steady and constant value. If, on the other hand, they do not correctly balance each other, then we do obtain either a falling off or an increase in the total amplification. Beyond

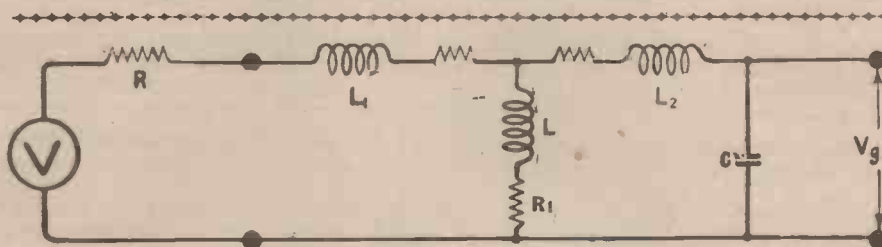

Fig. 1.—This circuit shows how a low-frequency transformer can be split up in imagination into its equivalent constituents.

however, is not a simple inductance, but is a network as shown in Fig. 1, we do not obtain this simple relationship.

As we increase the frequency applied to the transformer, the impedance first of all rises in accordance with the usual laws up to a point at which the inductance of the transformer itself resonates with the capacity  $C$ . Beyond this point the impedance of

this second critical point the impedance of the whole network falls off continuously, and with it the amplification, this being the factor which limits the frequency at which the transformer will amplify in a satisfactory manner.

The actual point at which these resonances occur depends entirely on the design of the transformer. It will be obvious, however, that an increase in the capacity across the

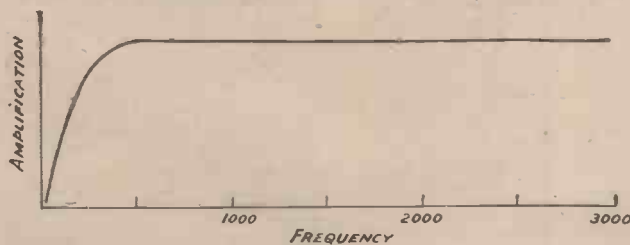

Fig. 2.—From elementary considerations it would be expected that the amplification curve of a transformer would be like this.

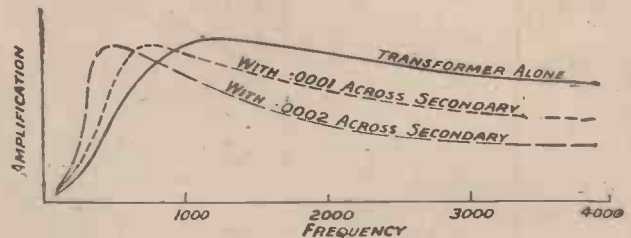

Fig. 3.—The full line is the actual curve obtained in practice with a not particularly good transformer.

depends essentially upon the impedance of the transformer relative to that of the valve. From simple and straightforward considerations one would expect the impedance to rise steadily with the frequency, and if by suitable design the total impedance

the network begins to fall off again, so that there will be a tendency for the amplification to decrease.

At the same time, however, there is another effect which comes into play, tending to increase the impedance once again, and this is due to

secondary will have the effect of reducing the frequency at which the resonances in question occur. For example, the curve shown in Fig. 3 gives the total amplification obtained in a single-valve amplifier using a  
(Continued on next page.)

# Secrets of the Low-Frequency Transformer—continued

general-purpose valve of about 20,000 ohms impedance. The frequency characteristic of this transformer is not particularly good, but it serves to illustrate the purpose.

### Modifying the Curve

The two dotted curves show the frequency characteristic obtained from the same transformer with small capacities of .0001 and .0002 respectively.

that about this point the secondary resonance comes into operation and maintains the amplification at a high value for some 2,000 or 3,000 cycles more.

### Adjustment of the Leakage

In order to achieve this it is necessary deliberately to allow a certain amount of leakage between the

### Shunt Resistances

Another method of varying the characteristics is to connect a comparatively high resistance across one of the windings of the transformer, usually the secondary. For example, a leak of 1 megohm across the secondary will have the effect of flattening out any hump on the curve due to an exaggeration of the resonance point. A

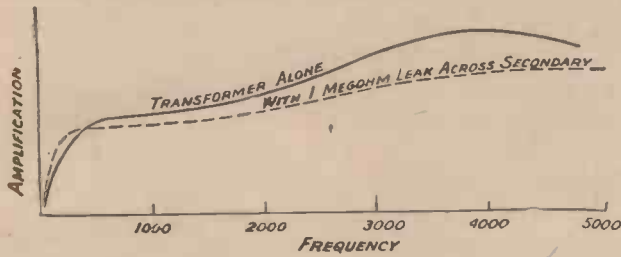

Fig. 4.—Transformer curves can often be modified favourably by the use of shunting resistances across the secondary.

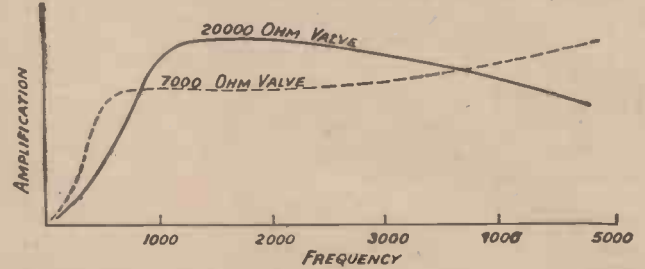

Fig. 5.—This is the sort of effect usually expected when values of different impedances are used with the same transformer.

tively connected across the secondary terminals. The effect of this has been to lower the resonance point. The original transformer over-emphasised the high tones at the expense of the low tones, whereas it will be seen that with the condenser across the secondary the position has been reversed, the amplification on the lower notes being somewhat increased, while that on the higher tones is considerably reduced.

In this way it is very often possible to correct slight defects in one's transformer, and to convert a somewhat thin tone into much more mellow reproduction, though possibly at some small sacrifice of overall amplification.

### Practical Expedients

Let us consider in a little more detail the application of the ideas just outlined in the actual design of transformers. A great deal depends on the two resonance points which are obtained.

The first resonance, namely that of L with C, is usually made fairly low, because this assists considerably in boosting up the amplification on the lower frequencies, and so helping to reproduce the low tones. At the same time, if this is made low, there is a danger that the amplification will fall off somewhere about the middle of the scale, i.e., at a frequency of 2,000 to 3,000 cycles per second only, which would mean that all the upper registers were cut off. In order to overcome this, therefore, it is necessary to arrange the leakage inductances  $L_1$  and  $L_2$ , in such a manner

primary and secondary windings. We do not, therefore, have to obtain as tight a coupling as possible between the two windings, but we have to design in such a manner that there is deliberately a somewhat looser coupling between the two than we could obtain if we wished. The extent of the leakage which is permissible is adjusted such that the leakage resonance exercises the necessary correcting effect on the characteristics.

It will be seen that the matter of the correct design of the transformer is

leak of this kind exercises such an effect principally at or near the actual resonance point, and the damping becomes less marked as the frequency is removed from the actual critical value.

The dotted curve in Fig. 4 shows the improvement obtained in a transformer characteristic by connecting a 1 megohm leak across the secondary. It will be seen that the curve rises more sharply at the lower frequencies, and is maintained at a more constant value over the rest of the frequency band. The actual overall amplification is definitely reduced, but in many cases this can be comfortably afforded in the interests of good quality.

### Effect of Equivalent Resistance

One final point may be mentioned, which is that the actual value of the first resonance point obtained does not only depend on the values of L and C, but also upon the relative values of the equivalent resistance  $R_1$ , and the internal impedance of the valve. Consequently the matching of the transformer impedance to that of the valve becomes of importance from another point of view.

Although from the simple theory of operation of a low-frequency transformer one would imagine that the higher the transformer impedance relative to the valve, the better would be the results, but this is not always the case.

### Striking Examples

Two cases are shown in Figs. 5 and (Continued on next page.)

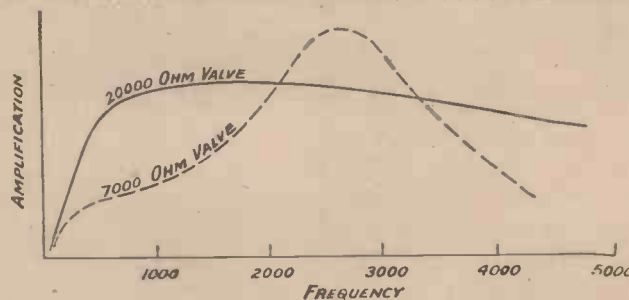

Fig. 6.—Some very surprising departures from the usual assumption as to the effect of valve impedance have been observed at Elstree.

really one of careful balancing of the various resonances. Full advantage is taken of this fact in the modern transformer, but those readers who possess older patterns can conduct for themselves some interesting experiments by connecting small condensers across either the primary or the secondary winding in order to adjust these resonances. In some cases the results will be found undoubtedly beneficial.

**SECRETS OF  
THE LOW-FREQUENCY  
TRANSFORMER**

(Continued)

6. In the first case a transformer was tested with a valve of 20,000 ohms impedance in the preceding stage. This valve was then replaced by one of 7,000 or 8,000 ohms impedance, and, as will be seen, the frequency characteristic is definitely better, the amplification at the lower frequencies being greater in the case of the lower impedance valve.

The curve shown in Fig. 6, however, illustrates the case of another transformer, which was tested under similar circumstances. Here the full curve shows the results obtained with a 20,000 ohms valve, and the dotted curve shows the results obtained with a 7,000 ohm valve. It will be seen in this case that the higher impedance valve gives very definitely superior results. This is due to the fact that the transformer was designed to operate as a first stage transformer following a relatively high impedance valve, and the tests show conclusively that it would be quite unsatisfactory for use in the second stage.

**A Matter of Compromise**

These several points concerning the design and performance of low-frequency amplifiers are often overlooked, and they are certainly of interest. Since the satisfactory reproduction depends upon the balance between so many qualities it is difficult to say definitely that any given effect is bad in a transformer. For example, most people would at first sight condemn a transformer having an apparently high leakage between the primary and secondary, yet as we have just seen, this is very often distinctly beneficial. Thus the design is really a matter of practical research based on theoretical grounds in order to obtain the necessary balance between the several factors.

**"MODERN  
WIRELESS"  
CHRISTMAS NUMBER.**

□ □ □

Two Special Sets,—The Isocoil  
and The Puramasic.

□ □ □

**ORDER EARLY.**

**High Tension TUNGSTONE 60 volt 3 a.h.**

**SIZE OF PURE LEAD PLATES ONLY TWO INCHES SQUARE.  
When fully charged gives the extraordinary and Guaranteed  
Capacity of a 3 a.h. actual.**

**World's record for Lowest Price. Minimum Weight, Portability,  
compactness. Glass Containers individually rubber insulated  
and all stand on a rubber mat. Ideal for Hot Climates and can  
be sent Overseas with first free partial charge without Acid.**

**TUNGSTONE PATENTED CELL CONNECTOR.**

**NOT USING WOOD SEPARATORS  
and having Machine-Pasted Pure lead  
Plates thicker and heavier than usual, it  
produces extraordinary electrical results.  
Negligible internal resistance; no frothing  
or foaming, crackling or parasitical noises  
in Wireless Phones or Loud Speaker. No  
self-discharge. No abrupt voltage drop.  
Tungstone 60 volt is more efficient than  
100 volt Dry Battery. Tungstone Plates  
will last years and can be replaced at small  
cost. Other parts indestructible. The  
perfection of reproduction is confirmed by  
many wireless specialists.**

**Charging High Tension on Low Tension Charging Plant.**

**All H.T. Tungstone Accumulators are fitted with a Patent  
Equipment whereby each series of 12 Volts can be coupled in  
parallel so that these H.T. Batteries of whatever voltage can be  
charged at local Garages and Charging Stations on a 12-16 Volt  
Low Tension Charging Plant.**

**Charging Terminals are provided on the front of the Cabinet  
arranged in two rows, the top row being Positive and the bottom  
row Negative. When in use these charging terminals are  
connected in pairs so that all cells are in Series.**

**TUNGSTONE High Tension 60 Volt Battery 3 a.h. is sold in the United  
Kingdom on monthly payments over extended period. Apply for particulars.  
Further interesting information on points of this advertisement are to be found  
on pages 58, 59, and 67 to 73 of the Illustrated Booklet "Photography tells  
the Story" which will be sent free on application to the—**

T.A.44

**TUNGSTONE ACCUMULATOR CO., LTD.,**

**St. Bride's House, Salisbury Square, Fleet Street, London, E.C.4**



**AERMONIC** cost a shilling less—and they're better. Air-spaced. Anti-phonic. Beautifully sprung. High insulation. Splendid new design. So don't pay more than 1/9  
List of Aermonic Specialities Free.

If your dealer does not stock apply to—  
**JAMES CHRISTIE & SONS, LTD.,**  
246, West Street, SHEFFIELD.

London Agents:  
**A. F. BULGIN & Co., 10, Curlior St., London, E.C.4**

**WIRELESS WAREHOUSE**

The Largest Wireless House outside London.

**PARTS FOR**

Elstree Six Solodyne  
Everyman's 3 & 4 Monodial  
Magic Five Nighthawk  
and all other Popular Circuits.

Do not fail to write for it—it is sure to be in stock.

**"ANSIL" SCREEN AND BASE**  
Copper, 7/6 :: Aluminium, 6/-

Guaranteed and post free over 5/-.  
SEND NOW FOR LIST.

**BUSH HOUSE**

(Established in the Electrical Trade since 1900),  
35, SHUDEHILL, MANCHESTER.

## SHORT-WAVE NOTES AND NEWS



WITH the low-power tests safely behind us, it seems as if long-distance conditions are much improved. It is, at any rate, quite certain that the United States stations are now coming through with much greater strength and regularity than they did during any period of the tests. WIZ continues to be an excellent indication of whether conditions are good or otherwise, and on the few nights when the writer has succeeded in finding him at 8.15 p.m., or soon after, the conditions later (after 11 p.m.) have certainly been abnormally good.

It seems as though the advent of winter will cause the disappearance of signals from South America; the Brazilians are already very weak compared with their strength a few months ago, and the other South American countries seem rather difficult to find at all.

### New Zealand Developments

The New Zealand Association of Radio Transmitters has now been formed with the intention of getting all the New Zealand amateurs together at meetings, which are to be held fairly frequently, and at which practically any matter having a bearing on amateur work will be discussed. Conventions will also be held after a time, and the Association will probably be made a branch of the International Amateur Radio Union.

Two similar organisations have been founded in Japan; one is the Japanese Amateur Radio League, composed of transmitting amateurs, and the other

is a "B.C.L." organisation calling itself the Japanese Amateur Radio Union. Japan is one of the countries where all transmission has to be done "under cover," since it is not yet permitted officially. With the formation of a Transmitters' League the Japanese bid fair to outdo the Dutch transmitters!

### Hours of Liveliness

Without doubt the most "exciting"

often to be heard after 4 a.m. When the writer listened at this time over the band from 18-50 metres recently he heard four new "intermediates" which he was unable to trace, and stations in no fewer than 17 countries, none of them in Europe!

### Improvement on Forty-five.

From the few "chirpy" notes now to be heard, it appears that people are at last "getting the hang" of 45-metre transmission. Most chirps have always been due to an unsuitable method of keying, and once we realise that keying methods that are perfectly efficient on, say, 200 metres may be no good at all on 45 metres, most of our troubles are over. Further, it seems that a keying system that works well on 45 metres is quite suitable for 23 metres, or even shorter wavelengths, from which it appears that a "chirpy" note will in future be the hall-mark of a newcomer who has not yet mastered his circuit properly.

### Swinging Difficulties

Another trouble that is not quite so easy to abolish, however, is the swinging wave caused by the effect of gusty weather upon one's aerial. Unfortunately, even if one's own aerial is reasonably tight, excessive swinging on the part of other aerials close to it will cause unsteadiness on short waves. The writer is situated in this way: a "B.C.L." aerial about fifteen feet from his own swings about two feet in each direction when the weather is really violent, and causes his wave to "creep" badly.



*At the demonstration of some of the latest and most fearsome engines of war to the Dominion Premiers at Camberley, loud-speakers were used to enable them to hear the wireless orders being transmitted to the tanks.*

time to listen on short waves is now between 2 and 6 a.m. The "U" stations literally swamp the ether until about 3.15 or 3.30 a.m., when they begin to "thin out" and the Antipodes gradually make themselves heard. These two sets of signals are, of course, the chief attractions, but all manner of mysterious stations are

## A Totally-Enclosed Four-Valve Set

(Continued from page 99)

rectifier, and 90 volts or more for the L.F. amplifier, with  $4\frac{1}{2}$  or 6 volts grid bias. Flexible leads of adequate lengths and terminating in plugs and spade tags should connect the frame aerial and reaction winding to the appropriate terminals.

outside aerial, the aerial and earth must be joined to the terminals on the front panel, switch S, changed over and a No. 40 coil plugged into L<sub>2</sub>. For Daventry this coil must be replaced by a No. 150 or 200 and H.F. transformers to cover 1,100 to

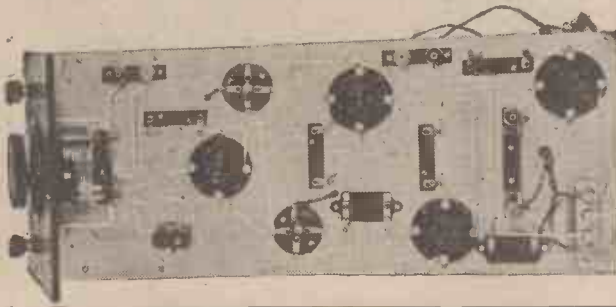

The intending constructor can obtain a good impression of the layout of components on the baseboard from this photograph.

### Tuning In

Switch on the valves and notice whether the receiver oscillates. If so, reduce the H.T. voltages on the first three valves until it is just comfortably clear of the oscillation point. If no oscillation is noticed reverse the connections to the reaction winding or increase the H.T. voltage until the most sensitive condition is obtained. Tune in the local station on C, taking advantage of the directional

3,000 metres substituted for those of the lower waveband.

### Batteries

Before concluding a word should be said about the batteries. The H.T. and G.B. units can be conveniently located in the bottom of the cabinet and straps passed round the batteries and screwed to the wooden base will keep them in place. As far as the accumulator is concerned, the portable non-spill product of Oldhams will be

## ELECTRADIX BARGAINS. No. 110

**BARGAIN ENGLISH PHONES.** 4,000 ohms. Ericsson, Brown's Swivel Headband and cords, fine tone, 9/6; with Fur headband, 6/6. Three days' trial. Sullivan Double Headphones, L.R. type, new, sets, 3/- pair. Single Receivers, new, 1/6 each to 2/6 each. New 4,000 ohm Royal Phones, 9/-, M.E.L. 4,000 ohms: lightweight, 12 months' guarantee. Reduced from 20/- to 8/-. Hesth's, 10/-. Marconiophone, 11/6. B.T.H., 12/6: LOUD SPEAKERS, T.M.C., 14/-. Western Electric, 17/6, cost double. Fuller Sparta 4 guin. model, 50/-; Concert Serenada, with tone control, 30/-; Magnovox Moving Coil, 60/-. Texas Cone, bronze finish, 40/-. Brown's Swivel Headbands, 1/6. Phone Cords, Brown's double new, 1/6; lightweight, 1/3. Single Cords, 6 ft. with solo plug, 3d. Twin L.T. Battery Cords, with spade ends, 1/-. Twin Phone Cords, 7d. Phone Diaphragms, 3d. Single Brown, 12/6. Pleated paper, 2/6.

**SALE 2-VALVE W.D. MARCONI RECEIVERS.**— Portable Set, fitted L.F. Transformer, Condensers, fixed and variable, Rheostat, A.T.I. and Reaction Coil, Ebonite Panel engraved, latest model with geared Dial Condenser. Enclosed mahogany case. Set complete with new .06 Micro Dull-Emitter Valves, 4-volt Accumulator, 60-volt H.T. Battery, English Headphones, etc., Accessories worth £3 10s. Works all B.B.C. and Daventry. Offered for complete outfit as above. Guaranteed. £4 10s. Packing and Carriage, 3/-.  
**2-VALVE TRANSMITTERS.** Trench type in mahogany/canvas covered case. Transmitting Coil with plug tapping, Anode Coil, 6,000 ohms wire leak. Dubilier Condensers. Remote control earth switch, ammeter, etc., £2 10s. Packing and Carriage, 2/6.

**R.A.F. TRANSMITTERS,** with high-class 1 in. Sterling Coil wound 3 lb. fine wire, Oscill. adj. Spark Gap on ebonite. Morse Key. H.T. Mica Condenser. Sets cost £15, and are given away at 14/- each. Post 1/6.  
**H.T. GENERATORS,** 61,000 v., T.V.T. pattern, contain mica condensers, vibrator, plugs, etc., output 30 m/a. Cost £12. Sale price, 25/-; post 1/-. Rectifiers, 2-valve for converting A.C. to D.C., any voltage 250 to 2,000 volts, fitted 1 mfd. H.T. smoothing condenser, switch, valve holders, etc., on ebonite panel. Cost £10. Sale, 20/-; post, 1/3.

**MARCONI D.C. 50 COMBINED TRANSMIT AND RECEIVE.** 300/650 metres, in polished mahogany cabinet, complete and new. Cost £40. £4 each.  
**AMPLIFIERS.** Marconi 3-valve L.F. Transformer, coupled, Selector for one, two, or three valves. Tested and guaranteed, £2 10s. Cost £18. Res. Cap., coupled with switch, £3.

**CHOKES.**—1,000, 1/6. Double, 400 and 1,000 ohms, 6/6; 3,000 ohms, 4/6. Large smoothing chokes, 10/-.  
**INSTRUMENTS.** All ranges at low prices. Small panel for D.E. filaments, 0-250 m/a, 15/-. Central zero, 12-0-12 amps, 8/-; 0-12 amps, 8/-; Voltmeters, 2-range, 0-5 volt and 120 volts, 11/6. M.C. Milliammeters, 0-5 m/a up to 150 m/a, 19/6. Micro-Ammeters for Aerial Current 0-100, 0-200, and 0-500 C.Z., 60/-, 7-range "All In" Test Sets, 60/-. Ev. Edg. Test Sets, 3, 15 and 30 amps., 3, 15 and 150 volts, as used in Army, M.C., 47/6. Thermo-Ammeters from 1 amp. to 200 amps, Mirror Reflecting 0-500 volt or 0-1,000 volt moving coil knife pointer, 55/-; Portable 0-1,500 volt Voltmeter, 60/-. Switchboard Ammeters, 4 in. dials, 32/6.

**ULTRA-ONEMETERS.**—The finest instrument with the widest range ever offered. Every B.C.L. needs one. Instrument, 50/-; Multipliers, 6/6. The Radio Star.  
**GALVANOMETERS.**—Silvertown, 12/6 and 15/-; Reid's Reflect., 21/-. Cambrell's Suspension Moving Coil. Cost £12. Price £3. Electradix ditto, £2 10s.

**BRIDGES, WHEATSTONE.** L.R., 45/-; H.R., G.P.O. type, £7 10s. Paals with galvo, £7 10s. Capacity Bridge for test .0001 mfd. to 10 mfd., £8. Shunt Boxes, 45/-.  
**CONDENSERS.** Variable Marconi's celebrated .01 table pattern. Cost £10. Fine work, 15/6 each. Mark 111, 7/6. Die Cast American Murdoch Table, .001 mfd., 5/-; .0005 mfd., 5/6. Panel type, .001, 7/-; .0005, 4/6. Finston Square Law, 5/6.

**PLUGS AND JACKS,** 2/- pair. Micro. Transformer, 7/6. Micro-Inserts, 1/-. Microphones, 5/-; Hand W.T., 12/6. Electric Bells, 1/6. Morse Keys, Lucas, 2/6. Aerial Line Erecting Sets, 2/6 each. Heterodyne Plug-in Inductance Blocks with two H.F. coils, 4/6.

**CYROSCOPES.** Navy Torpedo in mahogany cases, beautiful workmanship for Television experimenters. Cost £25. Price 15/-.  
**WIRE,** new, 22-gauge cotton-enamel covered, 1/6 lb. Cut price. Two tons all gauges in stock. Navy 7/23 enamel Aerials Superflex, 3/- 100 ft. 500 1/2 oz. reels 28 gauge S.C.C. wire makes two Broadcast coils, 4d. each. Earth Wire. Flex, rubbered, 1/- dozen yards. 100 yards coils cheap. Loud Speaker Extension Wire, 6/- 100 yards. Twin Litz Wire, 6d. yard. Stalls Transformer Wire, 1/3 lb. Stampings, 1/- doz.

**WAVEMETERS.** We have a large stock of all ranges at greatly reduced prices, from Townsends at 35/-.

We stock thousands of Radio and Electrical Bargains. It will Save you Pounds to send for our new illustrated list, price 4d.

## ELECTRADIX RADIOS,

218, UPPER THAMES STREET. E.C.4

Station: Blackfriars (Met. Rly.) Phone: City 0191

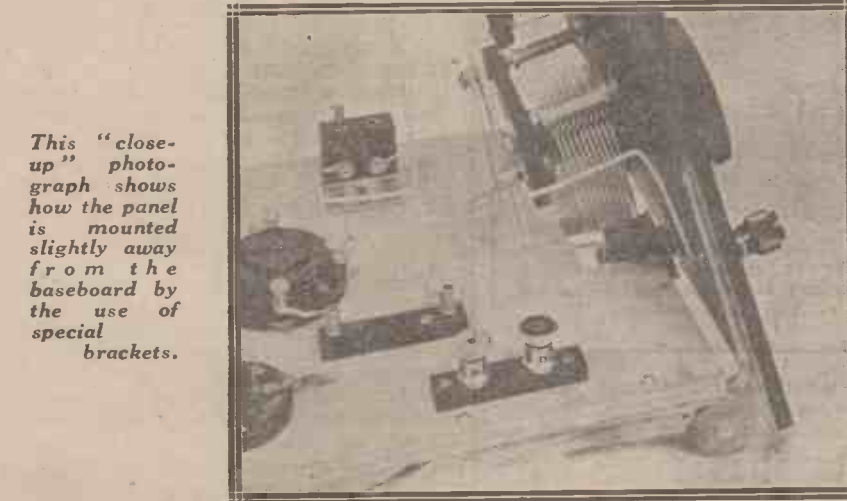

This "close-up" photograph shows how the panel is mounted slightly away from the baseboard by the use of special brackets.

properties of the frame by turning it through 180 deg. and noting when the signals are a maximum. The H.T. voltage may need a slight adjustment as with the fixed reaction it is fairly critical, and the best condition is only determined after a little experiment.

### Using an Aerial

When reception is desired on the

satisfactory, or the DTG and DFG Exide batteries are suitable. Owing to the relatively small space available a large-capacity accumulator is out of the question, and it is suggested that, when possible, leads from the normal large L.T. batteries should be joined to the set leads.

(Further details of the frame, operating notes, etc., next week.)



Full operating instructions are given below for the three-valve, short-wave receiver described in detail in our last issue by Mr. A. V. D. Hort.



**R**EADERS who have made up the three-valve short-wave set described last week, and who are not familiar with the phenomena incidental to the operation of a short-wave set, are most likely to encounter some slight difficulties with the reaction control.

### Choosing a Detector

First of all, the choice of a suitable valve for the detector is of importance. While general-purpose valves may function here, results will be greatly improved by the employment of a valve of the high-impedance type, such as is commonly used for resistance-capacity L.F. amplification. The coil windings given for the receiver were actually designed to function satisfactorily with a valve of this class.

If a valve of lower impedance is used, such as a low-impedance power valve, it will probably be necessary to decrease the size of the reaction winding, or move it further from the grid coil, to avoid excessive overlap. The writer has not found a valve of this class so satisfactory for the purpose as that previously mentioned.

### Testing

Assuming, then, that a suitable valve is available, with a low-impedance valve for the first L.F. stage, the telephones may be plugged into the first jack, and a preliminary test carried out. Leave the aerial disconnected, and set the tuning condenser to the middle of its scale, the reaction condenser being at zero. The detector variable grid leak should be set about  $\frac{3}{4}$  in. out. Apply 40 or 50 volts to the anode of the detector and 60 volts or so to the L.F. valve. Now, on *slowly* increasing the reaction condenser, the set should go smoothly into oscilla-

tion, this condition being indicated by a rushing sound in the telephones as oscillation commences. There should be no sign of a click or plop as oscillation commences, so long as the reaction condenser is moved slowly. If this condenser is turned sharply across the oscillation point, a click will usually be heard, even if the reaction control is working properly.

### Adjusting Reaction

It may be that oscillation does not set in smoothly, however slowly the



*The finished short-wave receiver which is capable of receiving American short-wave stations on the loud-speaker.*

reaction condenser is turned. In this case, vary the value of the detector grid leak till a smooth control is obtained. A slight decrease in H.T. voltage may also be helpful. During this test the leak across the L.F. transformer secondary should be set to a high value.

When a smooth control has been obtained at about the centre of the tuning range, the set should be further tested to see that it oscillates over the whole range of the tuning condenser. The windings specified allow for oscillation to occur most strongly at about the centre of the scale. If, with the aerial still dis-

connected, no oscillation is obtainable at the top of the scale, even with the reaction condenser "all in," the reaction coil should have another turn wound on, or should be pushed up closer to the grid coil; a slight increase in H.T. voltage may also achieve the desired result.

If, on the other hand, the set oscillates easily towards the top of the scale, and will not oscillate at the lower readings, the number of reaction turns should be decreased by a turn at a time, or the two windings separated a little more, till this fault is put right.

### Threshold Howling

A trouble which may be experienced during these tests is howling just as the set goes in and out of oscillation. This is easily cured. Adjust the controls so that the set is howling, and then decrease the value of the leak across the L.F. transformer secondary till the howl just disappears.

### "Dead Spots"

During the tests so far described the aerial should be disconnected from the set, though the earth lead should be in place. The next operation, therefore, is to attach the aerial and test for "dead spots"—that is to say, points on the scale of the tuning condenser at which more than the normal, or even sometimes the available reaction capacity is required to make the set oscillate.

### Aerial Coupling

The coupling of the aerial coil as described was loose enough to eliminate all "dead spots" with the writer's aerial. If any of these occur, however, it will be necessary to remove a turn or two from the aerial coil till the set will oscillate over the

*(Continued on page 112.)*

## REDFERN'S COIL FORMER



Made by the  
Makers of

# Ebonart

In 6-in. lengths.  
2-in. overall diam. 1/6 each  
2 3/4-in. " " 1/9 " "  
3 1/2-in. " " 2/3 " "

**W**ITH this soundly designed low-loss former you can construct any kind of solenoid coil — coils for screening, loose couplers, low loss single-layer coils, H.F. transformers and other types demanded for the most modern circuits. These formers have numerous ribs of such height that the winding is almost circular and the air space unusually big, while the ebonite is of a "horny" consistency which makes working easy and accurate.

Write for Folder A262 to  
REDFERN'S RUBBER WORKS, LTD.,  
Hyde, Cheshire.

## SIEMENS H.T. DRY BATTERIES

FOR  
STEADY  
PERSISTENT  
SERVICE.



SEE THAT  
THEY BEAR  
THIS  
TRADE MARK?

TALK NO. II.

### The Use of Negative Grid Bias

The heaviest drain on the H.T. battery is almost invariably due to valves functioning as low frequency amplifiers, and where a high anode voltage is used it is very necessary to employ a negative grid bias battery, not only to ensure purity in reproduction, but also to reduce the drain on the H.T. battery. The higher the value of negative grid bias the smaller will be the amount of current drawn from the H.T. battery, and therefore as high a value of negative grid bias should be used as is consistent with obtaining a satisfactory volume of reproduction. Should there be any doubt as to the correct amount of negative grid bias to use, reference should be made to the valve manufacturers' data for the particular valves in use. As a general rule, the grid bias battery should be renewed whenever a new H.T. battery is installed, but a test with a suitable voltmeter will determine whether this is necessary or not.

### Allowance for Voltage Drop in H.T. Battery

A point which is not perhaps appreciated sufficiently is the fact that the voltage of a high-tension dry battery steadily falls during its life, and therefore it is desirable to allow for this fall by installing a battery of higher voltage than is normally required by the receiving apparatus. Not only does this ensure the maximum results from the set, but it also effects considerable economy, as the useful life of the battery is thereby extended. Users of multi-valve sets taking a considerable current from the H.T. battery should particularly bear this in mind, as the fall in voltage in their case will probably be relatively greater.

The above is an extract from our new Catalogue No. 650, "Siemens Radio Batteries," which will assist you in the selection of the correct size of battery to be used for any radio purposes. It also contains a large amount of practical information on the CARE and MAINTENANCE of Radio Batteries.

A copy will be sent post free on application to

SIEMENS BROTHERS & CO., LTD., WOOLWICH, S.E.18

# “COME AND TEST

## TESTS

1. The filament current must be right for a given filament voltage.
2. The total emission of electrons from the torodium filament must exceed a certain figure which gives a very big factor of safety.
3. The voltage amplification of the valve must be right.
4. Every valve is tested for mutual conductance, i.e., slope (milliamps per grid volt).
5. The merit of the valve as indicated by  $\frac{M^2}{R}$  must reach the very high standard established by the designer.

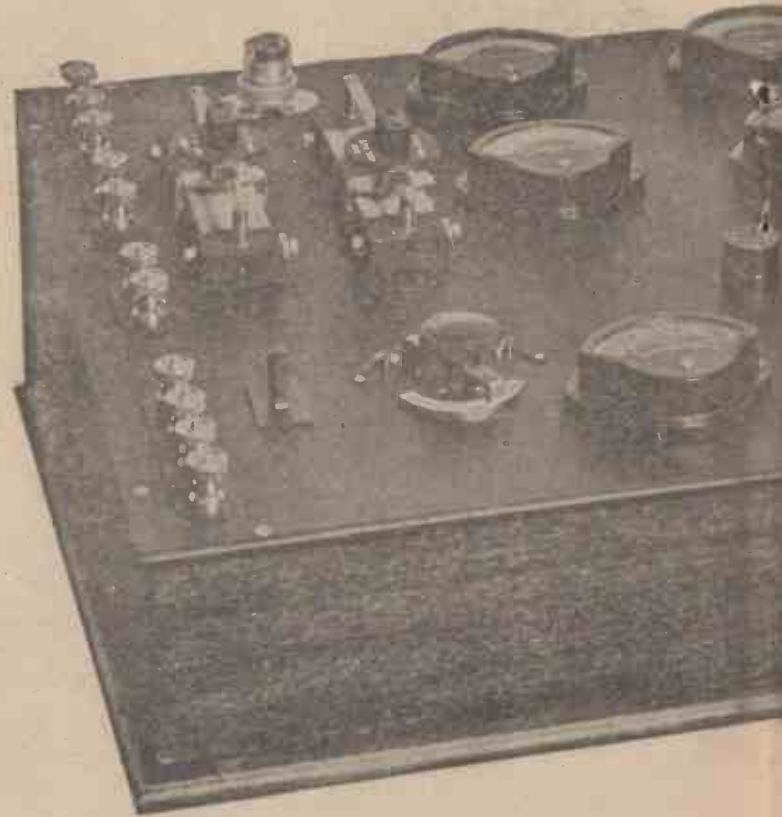

Do you buy your valves “made to measure.” Or are you prepared to put up with any kind of a valve provided it looks all right and the filament is intact?

When you buy an S.T. you know that it has been made to the strictest measure and complies with the specification of John Scott-Taggart, F.Inst.P., A.M.I.E.E. It is not sufficient to test a valve for “emission” and then hope for the best. It is certainly possible to turn out a cheaper valve this way or to make a greater profit, but it is not sound business in the long run. The slightest laxity in testing, the admission of “border line” cases or any other compromise might be a great temptation, but however big the demand may be, the testing staff of S.T. Ltd. proceeds leisurely, critically and conscientiously with its work.

The tests for every S.T. valve include a general factory test, followed by a scientific laboratory test carried out on a panel identical with the one illustrated above. Measurements are taken on seven separate precision meters which indicate filament voltage, filament current, anode voltage, anode current, grid voltage and grid current (in microamperes). Measurements are taken for the tests given above.

A considerable number of valves are rejected on these tests, which to many may seem unnecessarily severe and complicated. Those that pass the tests are tried on actual broadcast signals, the different types being tested in a special set in the actual positions they will occupy, e.g., H.F., detector, power, etc. A dead silent “background” is insisted on here as valve noises would not show up on the previous test. Tests

## TYPES and PRICES.

2 VOLT.		4 VOLT.		6 VOLT.	
H.F. S.T.21	0.1 amp. 14/-	H.F. and Det. S.T.41	0.1 amp. 14/-	H.F. and Det. S.T.61	0.1 amp. 18/6
L.F. and Det. S.T.22	0.1 amp. 14/-	Power. S.T.42	0.1 amp. 18/6	Power. S.T.62	0.1 amp. 18/6
Power. S.T.23	0.15 amp. 18/6	Super Power. S.T.43	0.25 amp. 22/6	Super Power. S.T.63	0.25 amp. 22/6



# THEM YOURSELF!"

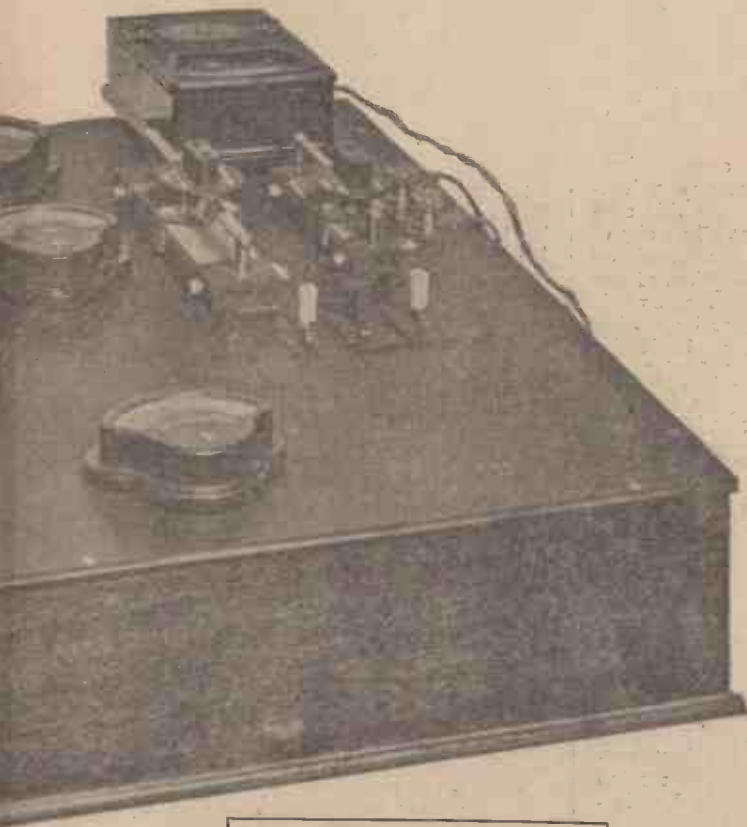

One of the panels on which the electrical tests are made.

## TESTS

6. The impedance of the valve must be within certain limits.
7. The straightness of the dynamic curves is ascertainable from the readings.
8. Uniformity of the valves and correct relative spacing of the electrodes are tested by ascertaining the position of a given characteristic curve relative to the grid zero ordinate.
9. The very high vacuum obtained by the Barguet process is measured by the ionisation system using a special meter which reads to a fraction of a microampere.
10. The perfect insulation, internal and external, of the valve is ensured.

to see whether a valve has any tendency to be microphonic are carried out at this stage. Very few valves are rejected when tested on signals, but the fact that an occasional valve is "found out" makes it necessary, to our mind, to include the test.

The successful valves are now ready for despatch, but before any batch is sent out, they are once more put through their paces on a second panel exactly as before. The ten rather laborious tests are made again by a different test assistant.

The supervision of the final "aerial" and laboratory tests is in the hands of Mr. John Scott-Taggart himself, who initials every carton in which an approved valve is packed.

Every S.T. valve is a picked valve. You can come and pick your own if you like. You can call at 2, Melbourne Place, Aldwych (next to Australia House), and yourself check our measurements on one of our panels. We can afford to make such an offer because it is a matter of personal pride with us that we regard every valve as a separate scientific instrument, in spite of its foolproof and robust construction. Moreover, you can always bring your valve back and have it tested at any time.

Every valve is marked and has a pedigree which we record, and we never lose interest in a valve which has once passed the Scott-Taggart specification. It is hall-marked and we never forget that on its performance and life our reputation depends.

*If you cannot buy a valve from your local dealer, write direct to us or call. All valves will be sent by post insured by us against breakage. C.O.D. orders executed on receipt of postcard. Send for folder containing full description and curves to*

## S.T. LIMITED,

2, Melbourne Place, Aldwych, London, W.C.2.

(Next to Australia House.)

Telegrams: Esteevalve, Estrand, London.

Telephone: City 7269.



## With the 'PEERLESS' Resicon Condenser

(Reg. Trade Mark 457357)

you can tune over a greater range with a given inductance than with many condensers having double the stated capacity. The plates of the "PEERLESS" RESICON CONDENSER are shaped to give uniform tuning over the whole scale, in both aerial and anode circuits—the minimum capacity being very low. A precision instrument. Electrical loss exceedingly low. No side strains. Moving plates revolve freely and without backlash. For Super Heterodyne receivers the "PEERLESS" RESICON CONDENSER is ideal. Operates so finely that vernier is almost unnecessary. One  $\frac{1}{8}$  inch hole only needed for panel fitting.

**Capacity.**

.00025 Complete with Dial. . .	15/-
" (With Dial and Vernier) . . .	17/6
.0003 Complete with Dial. . .	16/6
" (With Dial and Vernier) . . .	19/-
.0005 Complete with Dial. . .	18/-
" (With Dial and Vernier) . . .	20/6



From all Dealers or direct from

**The Bedford Electrical & Radio Co Ltd**

22, Campbell Road, Bedford.

## PUTTING AMERICA ON THE LOUD-SPEAKER

(Continued from page 108)

whole scale. As an alternative a series condenser of about .0001 capacity may be placed in the aerial lead, but the writer prefers the method of adjusting the coil.

It may be that there are no signs of "dead spots" without any adjustment of the aerial coil. In this case a certain improvement in signal strength can usually be effected by slightly tightening the coupling of the aerial coil, either by moving it closer to the other coils, or by adding a few turns. In fact, if it is desired to use the set for 2X.A.F. (32.79 metres) only, for example, the signal strength can be raised to a maximum by tightening the aerial coil coupling till oscillation will only just occur on this wavelength with the maximum setting of the reaction condenser.

### Using the Loud-Speaker

The second L.F. valve should be of the low-impedance power type, like the first. For full volume, an H.T. voltage up to 120 volts may be usefully applied to this valve, with ample grid bias.

When the loud-speaker is to be used on a telephony station, the best procedure is, first, to locate the station with the telephones in Jack 1, with-

THE SPECIAL CHRISTMAS DOUBLE NUMBER OF "MODERN WIRELESS" WILL BE ON SALE ON DECEMBER 1st.

ORDER YOUR COPY EARLY - - PRICE 1/6.

out tuning it in accurately. Then remove the telephones, plug in the loud-speaker to Jack 2, and carry out the final adjustments on the loud-speaker. This procedure will avoid trouble due to a possible slight upsetting of the tuning on changing over from telephones to loud-speaker.

### B.B.C. Stations

It may be of interest to some to note that this receiver makes an excellent loud-speaker receiver for local broadcasting. For this reception another coil former will be required, wound with about 40 or 50 turns of 24 s.w.g. d.c.c. wire, the ends of the winding going to pins 1 and 4, pins 1 and 2 being connected together. This provides a straightforward detector and 2 L.F. receiver without reaction. Reaction may, of course, be provided by means of a suitable winding connected to pins 3 and 6, but the design of this is outside the scope of the present article.



**IT'S WOOD AND GIVES PERFECT TONE TO ANY LOUDSPEAKER**

This Dousona Loud-speaker Horn has solved the problem of perfect Loudspeaker reproduction. It is made entirely of wood of exquisite grain thus obviating all distortion and metallics.

POST  
**30/-**  
FREE

To bring Dousona reproduction within reach of all, the wooden horn will be sold separately. Made to fit all leading loudspeaker units.

Send to-day and know the real pleasure of wireless. Simply send 30/- and mention the make of your loudspeaker base.

*The* **DOUSONA LOUD SPEAKER HORN**

Seven Days' Free Trial. Money back if not satisfied.

DOUSONA MANUFACTURING COMPANY, LTD.,  
170, Fleet Street, London, E.C.4

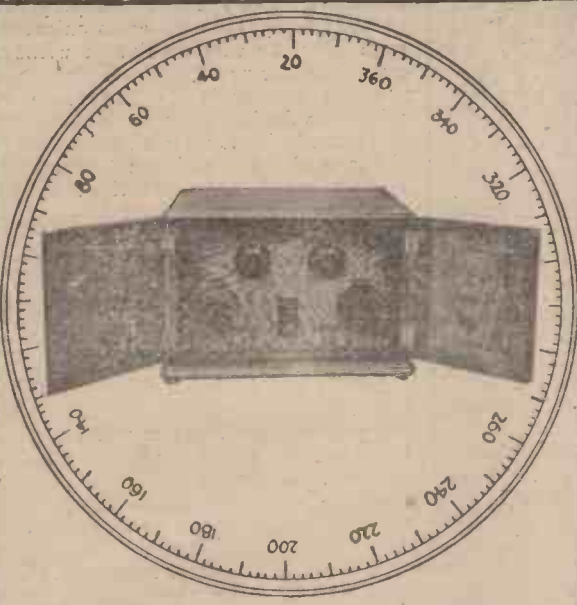

## What gives the Ericsson Family Two its splendid range & purity?

EVERY component in a set, to give lasting satisfaction must pull its full weight—the transformer must do its duty by the valves, the condenser must be smooth and clean moving and possess no “backlash” and the reaction must be gradual and “sweet.”

The close attention paid to these all-important items in the Ericsson “Family Two” has resulted in a set of astonishing range, purity and volume.

There is no straining to receive 5XX up to 150 miles, or any B.B.C. Main Station at 30—at good l.s. strength.

The Ericsson Transformer included gives wonderful clarity of tone. Guaranteed distortion-free.

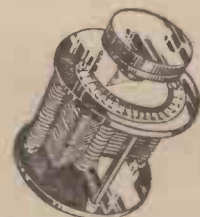

The Ericsson .001 condenser, low in loss and high in efficiency, possesses no backlash and has a lovely movement.



### SPECIFICATION

Sturdy, good-looking oak cabinet. All fittings nickel-plated, all components enclosed free from dirt. Switch for “l.s.” and “telephones.”

**£7:10:0**

Plus 25/- royalty.

At all good dealers. Write 10-day for further particulars.

Ericsson Telephones Ltd.,  
67/73, Kingsway, London,  
W.C.2.

# Ericsson

**FAMILY TWO  
LOUD SPEAKER  
RECEIVER**

## THE DUBILIER “UNIVANE” CONDENSER

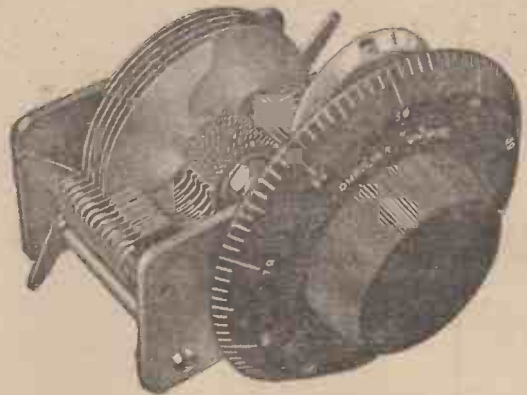

Patent No. 247365

IF YOU VALUE FINE TUNING  
USE A UNIVANE

Did you examine the big working model of the Univane at the Radio Exhibition?

If so you will agree that the problem of ultra-fine tuning has been solved once for all.

The Univane gives the equivalent of a continuous vernier adjustment between minimum capacity and a maximum of 0.0005 mfd.

By a highly ingenious gearing, rotation of the scale moves *one plate at a time*, adding it to or subtracting it from those already in opposition.

Figures appearing on a small auxiliary dial indicate the number of plates in opposition and enable you to make a permanent log of every station heard.

The Univane is in no sense a condenser for “special” circuits; it is intended for use on every occasion where the ordinary variable is employed.

The action is smooth and silken, and the workmanship and finish are of Dubilier standard.

Price  
**25/-**



ADVERT. OF THE DUBILIER CONDENSER CO. (1925), LTD., DUCON WORKS,  
VICTORIA ROAD, N. ACTON, W.3.

E.P.S.231

# From my Armchair

BY EARL RUSSELL.

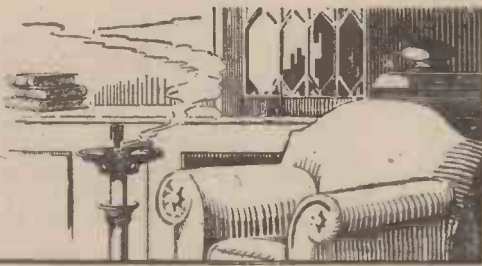

In these columns Lord Russell expresses each week his own personal views on matters of interest to "Wireless" readers.

## Let's Have a Society

The English are rather unique among European nations in their passion for forming voluntary associations on every conceivable subject, and even on any slight differences in the same subject. In religion it leads to that multiplicity of sects which occupies a whole page of Whittaker and fills foreigners with amazement. So it is not surprising to find the same thing in wireless.

On the scientific side we had the proposed Institute of Radio Engineers, now I believe wisely merged into the Wireless Section of the I.E.E. Then there is the Radio Society of Great Britain, by way of being the doyen of amateur bodies, and also fortunately more or less amalgamated with the very powerful organisation of Transmitters. The Wireless League, just amalgamated with a similar body, though the youngest born has the largest membership, which is natural,

as it is by way of representing the ordinary listener. I can imagine circumstances in which its voice would be useful, though I confess I only joined it because I thought 2s. a cheap insurance for my set. Of course, there are also the numerous local Radio Societies, mostly affiliated to the central body, and varying greatly in numbers and activity.

The natural and wise line of future development is continued linking up and amalgamation wherever possible, as this makes for strength and utility. Otherwise we might soon have a crystal users' society, or one vowed to a particular transformer, and become too like that page of Whittaker.

## Talking to Mars

I have never been enamoured of the speculations as to human life on this neighbouring planet. The sensational American reports from Flagstaff Observatory some twenty years ago

were never accepted by serious astronomers. So I am not prepared to credit any idea of communicating with Mars by wireless signals without overwhelming proof.

It is impossible for any man of science to doubt that Mars is composed of elements identical with ours, or that the laws of Nature obtain there. But it does not follow from those admissions that sentient life on Mars, if it exists, is at all similar to ours; or that the inhabitants, if any, of that planet have minds constructed like ours, or even that they have five senses which respond to the same stimuli as ours.

## Text-Books

I have not inquired very minutely, but it seems to me, so far as my knowledge goes, that there is no very good text-book on wireless at the present moment. I mean a book suited to the scientific beginner which summarises up-to-date practice and theory. If one wants this one has to go to the various weeklies and to papers read before the Wireless Section of the I.E.E.

No doubt it is due to the rapid and continuous progress that has been made. In all the books I have examined I find perfectly sound information about inductance, capacity and so on, but no modern tuning circuits, and no modern apparatus. We want someone to do what Sylvanus Thomson did for electricity and magnetism. Of course, such a book would want revision in two years, but that wouldn't matter.

CAV

IMPROVED  
1927 MODEL  
H.T.  
ACCUMULATOR  
60 VOLTS  
60%

SUPPLIED FULLY CHARGED

100  
Guineas  
for a  
Name!

HAVE  
YOU  
ENTERED

WRITE FOR FULL PARTICULARS

**Competition open to Users of this Accumulator.**

Owing to the various special features of our H.T. Accumulator we desire to give it a distinctive name, and invite suggestions. Prizes will be awarded as follows—

CAVanderrell & Co. Ltd.

ACTON, LONDON, W 3

**FIRST PRIZE - - - 75 GUINEAS**  
to the entrant of name adjudged the best.

**SECOND PRIZE - - - 25 GUINEAS**  
to the trader from whom the First Prize winner purchased his Accumulator.



# Using the Monodial on a Frame

By C. P. ALLINSON, A.M.I.R.E.

A severe test of the capabilities of the Monodial



**I** HAVE often been asked in respect of receivers such as the Elstree Six, the Solodyne, etc., "How does it work on a frame?" so last week I decided to use a frame aerial in conjunction with the Monodial and see what kind of results I would obtain.

It may be thought that a four-valve receiver employing only one stage of high-frequency amplification is not capable of giving much of a performance on a frame aerial. Much to my surprise (for I did not think so either), I found that five stations at least were received at quite surprising loud-speaker strength, while on the 'phones a number of transmissions were heard, half of which were not identified. The actual stations heard are given in a list at the end of this article, and this will give an idea of what this receiver is capable of on a frame aerial less than two feet square.

Although I had a number of frames, there was only one which anywhere matched the H.F. coil, and for successful operation of this set on a frame it is, of course, rather important that the inductance of the frame and of the detector grid coil be suitably matched.

## Another Tapping Method

Luckily the frame which fell most suitably on the broadcast band was centre-tapped, so that I could still use the neutralised H.F. circuit. If I had not had a centre-tapped frame I should have had to use the split-condenser method of connecting the filament return to the electrical centre of the frame, as shown in Fig. 1.

A special balancing condenser is employed (Messrs. Peto-Scott make one that will do the job) in which one set of moving vanes goes between two sets of fixed vanes placed opposite each other, so that as the moving spindle is rotated the capacity of one side increases and the other decreases. With the moving vanes centrally placed so that the capacity of each half is the same, we get what is in effect a centre tap to the frame, and

so we can neutralise the high-frequency amplifying valve.

The grid coil of the detector has then to be matched accurately to the frame. In the case of the frame I had the grid coil was a trifle too large, so that I was able to match up by removing turns from it. Should it require more turns, however, then it would need to be rewound entirely, since just putting on the required number of extra turns at one end of the winding would result in the centre tap being shifted, and in some cases this might detract from the performance of the receiver, although in nine cases out of ten it would probably not matter a great deal. The actual shifting of the tap from the centre point does

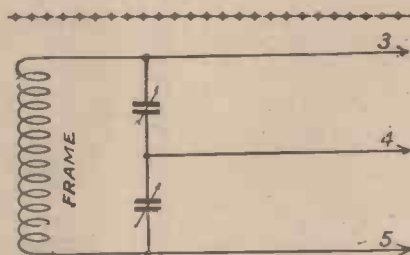

Fig. 1.—The numbered leads in this circuit should be connected to the corresponding numbers on the standard six-pin base.

not matter so much as the fact that putting extra turns on at the free end of the coil would increase the anode winding and thus increase the reaction effects. Under these circumstances it is possible that reaction would be fiercer than convenient for ease of operation.

## Frame Capacity

If you have to strip your coil down, do so a turn at a time from each end, and remember that since the self-capacity of the frame aerial is rather low, it may be necessary to use at least half, if not more, of the balancing condenser when connected across the frame portion of the gang condenser. This may require an extra turn or two of wire to be left on the

detector grid coil if the matching of the gang condenser is to hold satisfactorily over the whole waveband.

I found that quite a fair time had to be spent on experimenting before the right conditions were arrived at, and even then the results obtained fell off rather rapidly below about 300 metres.

On first connecting the frame up I found that it made the set difficult to stabilise unless the frame were placed well away from the receiver. This was owing to coupling with the H.F. transformer which serves to couple the H.F. valve to the detector.

## Frame Connections

I found the simplest way of connecting the frame to the receiver was by means of flex leads ending in valve pins. These fitted into the sockets into which the pins on the coil base are inserted. The correct connections are:—One end of frame to terminal or socket 3, centre of frame to 4, and the other end to 5.

Actually it was not found impossible to stabilise the receiver when the frame was placed close to it, but the difficulty experienced was that every time the frame was moved the coupling with the H.F. transformer was altered and the set had to be re-neutralised. This made it practically impossible to make use of the frame's directional effects, for having swung the frame and re-stabilised one did not remember what the signal strength had been like before swinging the frame, and it therefore became impossible to tell whether any advantage was being gained by altering the direction of the frame.

## Special Transformers

A solution to this difficulty which does not involve placing the frame well away from the set, where it may be difficult to reach and swing, is to make up a special H.F. transformer, using binocular coils.

Since the layout of the Monodial is rather compact, I found it necessary to make up rather smaller ones than I usually use, otherwise the set was

(Continued on page 129.)

# Louden Valves



The Town Hall ROYTON



*"I have been running two Loudon Dull Emitters over 18 months . . . at a recent test . . . there was nothing to touch them."*

So writes Mr. O'Neill from Royton, and every post swells the number, now amounting to many thousands, of people who agree with his opinion.

Louden Valves cost less, they last longer, they consume less current, they are famous for "Silver Clear" reception, and they give greater volume.

We could write you a treatise on the scientific reasons for all these qualities, but it's Results you want—not Reasons. Write to us for your Loudens to-night. This is Mr. O'Neill's letter:

"Gentlemen,  
 "It might interest you to know that I have been running two Loudon Dull Emitters  
 "for over 18 months and they were second-hand when I got them. They also are  
 "still going strong."  
 "At a recent test of various valves there was none to touch them."  
 "Please furnish me with a catalogue."  
 Yours sincerely,  
 "W. O'NEILL (Royton, Nr. Oldham)."

Louden Valves are made by British labour in a British factory with British capital and can be depended upon for the finest volume, range and silver clearness. They can only be offered at such low prices because of our well-known policy of selling direct to the public and cutting out the middleman's profit. The list below gives prices and full particulars. Order your Loudon Valves from us by post.

<b>4/6</b> Bright Emitters. L.F. Amplifier. F.1. H.F. Amplifier. F.2. Detector. F.3. <b>5.5 volts 0.4 amps.</b>	<b>8/-</b> Dull Emitters. L.F. Amplifier. L.E.R.1. H.F. Amplifier. L.E.R.2. Detector. L.E.R.3. <b>2 volts 0.2 amps.</b>	<b>8/-</b> Dull Emitters. L.F. Amplifier. F.E.R.1. H.F. Amplifier. F.E.R.2. Detector. F.E.R.3. <b>4 volts 0.1 amps.</b>
<b>9/-</b> Dull Emitters. L.F. Amplifier. F.E.R.1. H.F. Amplifier. F.E.R.2. Detector. F.E.R.3. <b>6 volts 0.1 amps.</b>	<b>11/-</b> D.E. Power Valves. Trans. Amplifiers P.E.R.1. Resist. Amplifiers P.E.R.2. <b>4 volts 0.2 amps.</b>	<b>12/-</b> D.E. Power Valves. Trans. Amplifiers P.E.R.1. Resist. Amplifiers P.E.R.2. <b>6 volts 0.2 amps.</b>

Postage and packing: 1 Valve, 4d. 2 or 3 Valves, 6d. 4, 5 or 6 Valves, 9d.

**FELLOWS, PARK ROYAL, N.W.10.**

LONDON: 20, Store St., Tottenham Court Rd., W.C. (Museum 9200).  
 BIRMINGHAM: 248, Corporation Street (Central 436).  
 BRIGHTON: 31, Queen's Road (Brighton 899).  
 BRISTOL: 36, Narrow Wine Street.  
 CARDIFF: Dominions Arcade, Queen St. (Cardiff 7685).  
 LEEDS: 65, Park Lane (Leeds 21479).  
 NOTTINGHAM: 30, Bridlesmith Gate (Nottingham 5551).  
 TONBRIDGE: 34, Quarry Hill (Tonbridge 172).

WRITE FOR  
 48-pp.  
 ILLUSTRATED  
 CATALOGUE  
 No. 34  
 FREE

**BUY DIRECT AND SAVE MONEY**

E.P.S. 96.

*The Master Non-Vibratory Valve Holder*

ANTI-  
 -MICROPHONIC  
 -VIBRATION  
 -SHOCK  
 -CAPACITY

SPRUNG-YET  
 THERE ARE NO  
 SPRINGS OR  
 RUBBER  
 SUSPENSION  
 PATENTS.

WORLD

## YOU WOULD LAUGH

If you saw a man using a heap of sand as a spring board. WHY? Because he would not bounce in sand, his bounce is immediately damped out. You cannot eliminate microphonic noises, distortion, and obtain purer and more distant reception by bouncing your Valves on spring boards. WHY? Because springs and rubber accentuate bounce shock and vibration—this is indisputable. The Artic Valve Holder is like the heap of sand, being dead to vibration and shock, a De Luxe Holder which can be obtained at small extra cost. The suspending medium is used by the Admiralty, large Industrial Concerns, etc., for protecting metallic filaments.

**HAVE THE BEST AND ORDER NOW.**

THE ULTRA  
 SENSITIVE  
 VALVE  
 HOLDER

FROM YOUR DEALER  
 OR DIRECT

**3/9**  
 EACH

POST FREE

PURE & ELECTRICAL MFG CO LTD  
 BIRTLEY, Co. Durham

Non-rotating insulated engraved top.

Highly-finished screw-action Bakelite-insulated head.

Shielded metal clamping faces

Smooth stem, ensuring that strands of connecting wire will not bind up with thread. Cross-hole for connections, flush with clamping face.

Highly-finished Bakelite-insulated collar.

Standard 2.B.A. stem with nut.

Transverse slot with clamping nut, eliminating soldering.

Patent No. 248921.  
 Registered Design No. 715424.

The Belling-Lee Terminal, made with 28 different engravings.

STANDARD MODEL (Bakelite-insulated) (Type B) 9d. each.  
 POPULAR MODEL (non-insulated) (Type M) 6d. each.

If you cannot get these at your dealers, send your order to us, enclosing his name and address.  
 Illustrated Catalogue free on request.

## BELLING-LEE PANEL FITTINGS

BELLING & LEE, Ltd., Queensway Works, Ponders End, Middlesex. R.P.B. 13

## The Week's Diary

It is regretted that in consequence of the pressure upon our space resulting from the inclusion of the important topical article by Sir Thomas Beecham it has been necessary to reduce this popular feature to the present dimensions.

**THE** Postmaster - General was flooded with demands for "Brighter Broadcasting" in the first Parliamentary debate ever held on the subject—that of November 15. More money, cheaper licences, more controversial matter, more careful scrutiny of Government control—these were some of the demands pouring in.

**SIR WILLIAM MITCHELL-THOMSON** said, in his speech, that whereas broadcasting was a toy four years ago, it is now a *power*. There is, of course, no doubt about this! The chief part of the debate, however, centred round the contribution made by broadcasting to the revenue. The financial arrangement is to be subject to revision two years hence, because although the new B.B.C. is to receive rather more from the Post Office than the old company, there is no means of forecasting its financial needs.

**THE** news service will undoubtedly be revised very shortly; the Government holds that the restrictions in this direction under which the B.B.C. labours at the present time cannot be maintained. Censorship will also undergo certain changes; in future "controversial" matter will be looked upon only as *propaganda*. We shall, therefore, hear rather more *controversy* in the strict sense of the word.

**I**n general, it appears that the public will have an even greater say in the matter of what is given them by the B.B.C. than they have at present. It is obvious that those who support it must, in the end, have some voice in the way in which it is managed.

**THE** new wavelength scheme is, in my opinion, going decidedly well. The unfortunate heterodyne on 2LO during the early stages of the scheme was due to Leipzig, who changed places with Breslau at the last moment. Now, however, as one has had time to become accustomed to the new dial settings, prospects are much more rosy. Personally, I have found several Continentals that I never had tuned in before coming in at really good strength.

**COUNCILLOR BARKER**, Chairman of the Urban District Council of Lymm, suggests that the acute shortage of gas in that locality is greatly due to the popularity of

broadcasting. He has appealed to local listeners to "deny themselves of half-an-hour of amusement and go to bed at 10.30 p.m. instead of 11 p.m." (The *Manchester Guardian* adds, "Or Listen in the Dark!")

**THE** French Government has recently issued a decree that every commercial aeroplane capable of carrying ten passengers must be equipped with radio apparatus. Further, a special licensed member of the crew, other than the pilot, must be carried as operator. Reception from 800 to 1,850 metres is required, and transmission may be carried out on 600, 850-950, and 1,500-1,550 metres. Regulations of this type are, of course, most important when applied to commercial concerns. They are, in fact, more obviously to be desired than is the case with shipping; the shipping regulations are notably stringent.

**THE** question of the broadcasting of "controversial" speeches is itself leading to a great amount of controversy. The B.B.C. refused to broadcast Mr. George Bernard Shaw, saying that "he might be controversial," and yet broadcast the speeches of the Dominion Premiers, which were at times most highly controversial. Mr. Bernard Shaw himself considers that "nothing that is not controversial could possibly be of the slightest interest to anyone."

**N**EWs has reached me that the gaol in Cork is to be converted into a broadcasting station! A well-known electrical firm has been commissioned by the Irish Post Office to erect a broadcasting station in that town, and the most suitable situation is considered to be the gaol, "now no longer required"! The station will be similar in most respects to 5IT, but will work with a power of 3 kilowatts Geneva rating.

**D**UBLIN is now introducing "those kilocycles" even into the preliminary announcements. The words used are: "This is Dublin 2RN testing with 940 kilocycles, wavelength 319.1 metres." I think it seems extremely likely that the new arrangement of the European stations on a frequency basis will cause a reversion to the "think in kilocycles" idea—the frequencies of the stations are 800 kc., 810 kc., 820 kc., etc. These are surely much easier to remember than 361.4 metres, 288.5 metres, etc.

WAVE-TRAP.

Ashley  
Radio

## JACKS

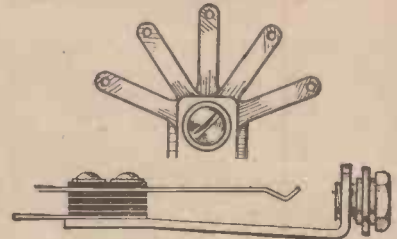

—are made of nickel silver springs, with pure silver contact, and Bakelite insulation throughout. Tags are tinned and spread fan-wise for easy soldering.

JACK No. 1	JACK No. 2
Single Circuit (open)	Single Circuit (closed)
1/3	1/6

JACK No. 3	JACK No. 4
Double Circuit	Filament Single Control
1/9	1/9

JACK No. 5
Filament Double Control
2/3

TELEPHONE PLUG, 1/6

## CLARITONE LOUD SPEAKERS

Senior Model, 2,000 ohms, W.265. 120 ohms, W.266	} £5 0 0
Junior Model, 2,000 ohms, W.267. 120 ohms, W.268	
	} £2 15 0

## CLARITONE HEADPHONES

W.216 .. 20/-

## ASHLEY WIRELESS TELEPHONE CO., LTD.

17, Finch Place,  
London Road,  
LIVERPOOL



*“almost  
the same as  
adding another  
stage of L.F.—”*

**W**HEN you buy LEWCOS you buy more than a coil. “In fact,” writes Mr. Harold F. Grundy, L.R.A.M., of Manchester, “using the LEWCOS Coil amounts to almost the same as adding another stage of L.F. amplification.” Independent National Physical Laboratory figures prove the LEWCOS Coil to have lower H.F. resistance than any other commercial plug-in coil. Try a LEWCOS Coil on your set. Hear the immediate increase in volume. Note the great improvement in selectivity. If you want to get better reception the most economical way is to change to LEWCOS Coils. They make *all* the difference.



All dealers stock or can obtain LEWCOS Coils for you. Write for descriptive leaflet.

*Note new reduced prices*

No.	25	35	40	50	60	75	100	150	200	250	300
Price	4/-	4/-	4/-	4/6	4/9	4/9	5/9	6/3	6/9	7/-	7/6

The  
LONDON ELECTRIC WIRE  
COMPANY & SMITHS, LTD.  
Playhouse Yard, Golden Lane, London, E.C.1.

# LEWCOS

## Inductance Coil

All enquiries for Lewcos Radio  
Products should be made to  
your local dealer.

## DARIMONT “HOME-SERVICE” BATTERIES



enable you to do your own recharging at home in 10 minutes, without any electrical connections.

They are ideal for use  
with Dull Emitter Valves.

The cost—quite moderate. The current—quite steady.

ASK YOUR DEALER for particulars, or write for Valve Guide and Service Chart to Department C.—

DARIMONT ELECTRIC BATTERIES LTD.,  
Abbey Road, Park Royal, N.W.10.  
Phone: Wembley 2807.

## FRELAT D.E. VALVES

**4/11**      **8/6**

**TYPE K.**  
Detector and  
amplifier  
2 volt 3 amp.

**TYPE D.K.P.**  
1½-2v. 3 amp.  
New 2 volt power-valve.



*The best that money can buy*

**H**IGH Cost is the bugbear of Radio. Frelat is the key to economy. Frelat Valves are built to the highest quality standard, then tested by Experts and guaranteed for performance. For tone and volume they are unequalled; for price they stand alone. You should note that the new power valve costs only 8s. 6d. If your dealer cannot supply, send direct. For C.O.D. terms add 4d.—postage free.

CONTINENTAL RADIO IMPORT CO., LTD.,  
8, SPITAL SQUARE, LONDON, E.C.1.



**W**HEN you are setting out to purchase radio apparatus, first look through the advertisements in your copies of “WIRELESS.” You can feel certain of your requirements being suitably and satisfactorily met.



# HOW TO MAKE A DE LUXE WAVE-TRAP

By W. H. FULLER

Full constructional details for making a simple, yet efficient instrument for cutting out your local station.



WAVE-TRAP is a most useful accessory. There are many occasions on which the interposition of a simple trap, such as the one to be described, will nearly double the "test report" of your set by enabling stations to be tuned in which are normally swamped by the local station.

Many people imagine that a trap such as this must necessarily be somewhat large and unwieldy. This is by no means the case, and the particular unit described below has been designed to combine efficiency with handsome appearance. When mounted in its case it may be placed in any desired position in a room (providing that the aerial can be led through it), since it only requires adjusting once in a while.

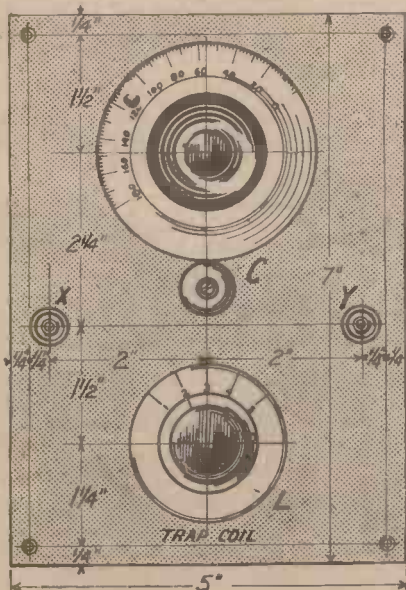

Fig. 1.—A slow-motion type of condenser is used for tuning purposes, the vernier knob being that just below the top dial.

## What is Required

In designing a trap of this sort there are two features to be taken into consideration. In the first place, we have to ensure that the trap itself shall be sharply tuned in order that it shall only affect the station which is to be cut out, i.e., the local station, and shall not seriously reduce the strength of other stations even when they are working on wavelengths quite close to that of the local station.

Secondly, we must have some means of varying the extent to which the trap affects the receiver. This is to a certain degree bound up with the last consideration. We only wish to cut off the local station over a certain number of degrees on the dial. Outside this range the receiver itself is capable of eliminating the interference. The actual setting required depends on the receiver with which the trap is to be used, and we must

## WHAT YOU WILL NEED

- One panel, 7 in. by 5 in. by 1/4 in. (Any good make).
- One slow-motion condenser, .0005. (Jackson Bros.).
- One tapped trap coil. (Burne-Jones & Co.).
- Two terminals.
- One cabinet 4 in. deep. This can be obtained from a cabinet maker, or constructed from three-ply or other suitable wood. The cabinet illustrated was obtained from the Carrington Manufacturing Co.
- One or two lengths of Glazite wire.

therefore make provision for varying degrees of coupling in order that the unit may be suitable for use with any receiver.

## Low-loss Construction

We achieve the first of these ends, that of sharp tuning, by utilising low-loss construction as far as possible. Mr. C. P. Allinson recently carried out an exhaustive series of experiments on wave-traps, and for his final experiments he used a long coil 18 in. in length constructed on the three-step principle devised by Mr. G. P. Kendall.

Such a construction, however, is

satisfactory in the laboratory, but somewhat out of place in the home. Moreover, except where exceptional results are required, quite satisfactory performance can be obtained from a much more compact arrangement. A reasonably low-loss coil can be constructed using a fairly fine gauge of

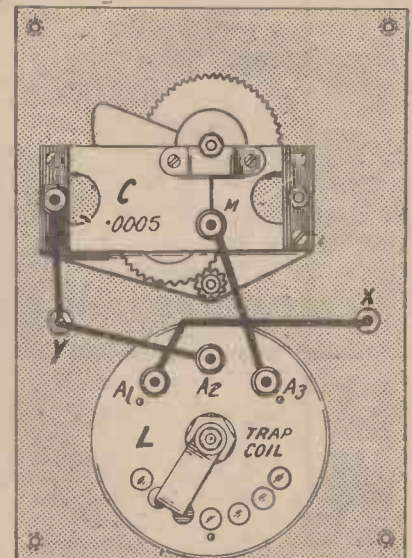

Fig. 2.—No difficulties are likely to be experienced when wiring up the wave-trap!

wire wound on a three-inch diameter former. If a good ratio of length to diameter is chosen, and a spaced winding is used, the resulting coil will have a low resistance.

## The Coil

A tapped trap coil on this principle has been made up by Burne-Jones and Co. It consists of 55 turns of 30 d.s.c. wound on a three-inch former spaced 40 turns to the inch, and tapped at 6, 12, 18 and 24 turns, which makes a convenient unit.

The tuning condenser is a standard type of modern component, one having a slow-motion arrangement being preferable, because of the sharpness of tuning necessary in order to obtain the desired results.

The variable coupling to the set is obtained by a tapping on the coil. This will better be understood by a reference to the circuit diagram which is shown in Fig. 3. The trap is included

(Continued on page 122.)



## A Revolution in Loud Speaker values & prices

**READ THIS DESCRIPTION**  
 The Allhall Loud Speaker stands 21 ins. high and has a depth of 14 ins. from back to front; the base is 8 1/2 ins. overall and is finished in lead black lacquer, relieved by a nickel plated diaphragm control, and supplied complete with long plug-in cords. The neck is of lead black lacquer, and 3 nickel screws secure the horn which is finished in matt black and has a flare of 14 in., ensuring resonance and volume.

A real loud speaker not a "junior" a "baby" or "dinkie." A full size instrument matching in tone the very best money can buy. The secret of this remarkable offer is that we are not controlled in price and we produce and sell in thousands. Don't let high prices stop you getting the best out of Radio—the ALLHALL at 27s. 6d. gives you the very best in tone and volume and we back our assertion with a

**MONEY BACK GUARANTEE**  
 Buy one, try it, and if you are not satisfied send it back within 7 days and your money is returned without any questions being asked.

# 27/6

## L. K. Kremner

Radio Engineers  
 49a, Shudehill, Manchester.

## THE GUARANTEE SLIP

which accompanies every

# FERRANTI TRANSFORMER

### FERRANTI TRANSFORMERS

TYPES AF3 and AF4

are guaranteed to reach you in perfect condition.

They are also guaranteed to be within 5 per cent. of the published curve.

They are further guaranteed against defects in workmanship or material for 12 months from the date of dispatch.

In the unlikely event of any defect developing under proper usage the transformer should be returned, post paid, accompanied by this label with your name and address on the back.

FERRANTI LTD., HOLLINWOOD, LANCS.

Get a Ferranti Transformer for your set

## SAXON GUIDE TO WIRELESS

This book enables any beginner to construct Wireless Sets which are unequalled in price, quality or efficiency, and the cost is only one-fourth the price charged for a ready-made instrument not half so good. The exact cost of each set is clearly stated.

### FULL INSTRUCTIONS WITH CLEAR WIRING DIAGRAMS

are given for making Super Efficient Crystal Sets, Dual Amplification Receivers, Single Valve Sets, One and Two Valve Amplifiers; Two, Three and Four-Valve Tuned Anode All-Wave Receivers, and the Very Latest Type of Five-Valve Resistance Capacity Receiver.

**NO SOLDERING, NO SPECIAL TOOLS  
 NO KNOWLEDGE REQUIRED.**

The chapter on testing wireless components is alone worth the price charged. 176 PAGES. **PRICE 1/3 POST FREE**

### SPECIAL OFFER.

This book will be sent on approval on receipt of your promise to return same post paid or to remit 1/3 within seven days.

SAXON RADIO CO. (Dept. 32), Henry St. Works, BLACKPOOL

### HIGH & LOW TENSION ACCUMULATOR HIRE SERVICE

Here's a way of improving reception, saving money, time and trouble for all valve set users who live within 12 miles of Charing Cross. Write now for particulars of this unique service.

**RADIO SERVICE CO.,**  
 105, Torrington Avenue, N.W.5.  
 Phone: North 0623 (3 lines).

**BOTAX**  
 High Tension Accumulators greatly improve Loud-Speaker reception, eliminating the uncanny noises caused by partly run-down dry batteries and may be hired ready for use.

If you add the depreciation in value to the cost of having your own accumulators unskillfully recharged, our *Intro Service* effects a considerable saving.

## FORMO

ULTRA LOW LOSS

### Straight Line Frequency Condenser.

Cone bearings. Braced Vanes. Positive Collector. A real precision job.

Condenser only—	.0003 μF, .0005 μF	9/-
Condenser with plain dial	Standard 1/2" dia. Shaft	10/6
New Vernier Dial		6/-

Reduction Ratio 10-1. No Backlash.

**THE FORMO COMPANY,**  
 CROWN WORKS, CRICKLEWOOD, N.W.2.  
 14, Moss Lane, Epsom, Surrey, 1927.  
 Manchester: Mr. J. B. Levrq, 25, Hartley Street, Levenshulme.  
 Phone: Heaton Moor 475.

## JUNIT *Wave*

PATENTED

### Needs no Solder

CROSS JOINS

BUTT JOINS

TERMINAL JOINS

**PRICES :** In coils (in cartons), per coil 1/-  
 In 2 feet lengths, per length 2d.

### DON'T SAY WIRE —SAY JUNIT!

**REXO ENGINEERING CO.,**  
 2, RAVENSCOURT SQ., LONDON, W.6.

## How to Wind Coils FOR THE "Elstreflex Two"

For the benefit of readers who are constructing the "Elstreflex Two" and have no copy of the September issue of *Modern Wireless*, in which details of the split-secondary H.F. transformers required are given, we reproduce this data below.

### Split-Secondary H.F. Transformers

This type of transformer is made up in two ranges, one for the lower broadcasting band and one for the Daventry range. The details of the windings are as follows, whilst a diagram showing the numbering of standard six-pin bases is shown in the figure.

#### 250-550 Metres

**Secondary Winding.**—This consists of 130 turns of 28 d.s.c. wire wound unspaced on a 2-in. diameter former. The winding is made up in two portions of 65 turns each, completely isolated from each other, the beginning of the first winding going to 3 and the end to 4. The beginning of the second winding goes to 5 and the end to 6.

**Primary Winding.**—This winding consists of 20 turns of 30-gauge d.s.c. wire wound on a 1½-in. diameter ebonite former placed inside the secondary and mounted centrally. The beginning of this winding goes to 1 and the end to 2.

All windings are wound on in the same direction, and for the simple

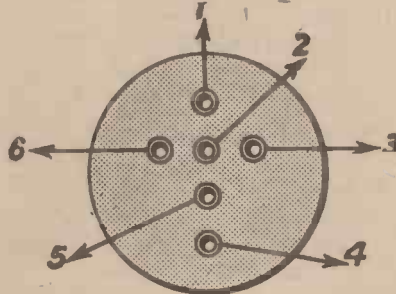

The numbering of the standard six-pin bases.

centre-tapped arrangement 4 and 5 are strapped together.

#### 1,000-2,000 Metres

**Secondary Winding.**—The secondary winding in this case consists of 430 turns of 40 s.w.g. enamelled wire, wound in two equal portions as with the lower broadcast band. An equivalent two-layer winding may be used if this covers the wavelength band.

**Primary Winding.**—This consists of 75 turns of 36 d.s.c. wire.

## NEWS IN ADVERTISEMENTS

A further announcement is made by Messrs. Ediswan Electric Co., Ltd., on the subject of the R.C. Threesome Receiver.

Thousands of radio and electrical bargains are contained in the advertisement of Messrs. Electradix Radios.

An interesting loud-speaker horn is being advertised by Messrs. Dousona.

A new type of Non-vibratory Valve Holder is being marketed by Messrs. Artic Fuse and Electrical Manufacturing Co., Ltd.

A revolution in loud-speaker value and prices is made the subject of an advertisement issued by Messrs. L. Kremner.

It will be observed in the announcement of Messrs. Ferranti, Ltd., that the Ferranti L.F. Transformer is guaranteed to be within 5 per cent. of the published comparative amplification curve.

The Univane Variable Condenser is being featured by Messrs. The Dubilier Condenser Co., Ltd.

A wide range of Lissen Products is covered in the advertisement of Messrs. Lissen, Ltd., and special prominence is given to the Lissenola Unit.

Readers will find more than usual interest in the two-page advertisement issued by Messrs. S.T. Ltd., showing the valve test panel used in the testing of S.T. Valves.



## "Springmore"

"The  
LITTLE Plug  
with the  
BIG grip."



THE IGRANIC "SPRINGMORE" Plug cleans the inner surface of the socket into which it is plugged and grips tightly. H.T. and grid bias battery sockets may vary in size, but the "Springmore" fits them all.

Each "Springmore" Plug is also a socket into which another "Springmore" may be plugged.

In RED, BLACK, or GREEN  
**3d.**  
EACH

WRITE FOR THE NEW IGRANIC CATALOGUE S 40

# IGRANIC ELECTRIC CO. LTD.

149 QUEEN VICTORIA STREET  
LONDON  
WORKS - BEDFORD

<p><b>JACKS 4-POINT</b></p>  <p>1-Hole Fixing 1/9</p>	<p><b>S.L.F. CONDENSER</b></p>  <p>With 4-in. dial. .0003 .. 7/- .0005 .. 7/3</p>	<p><b>RELIABILITY CONDENSERS</b></p>  <p>Manbridge Type. Mtds. 1/8 1, 2/6 3, 1/9 2, 3/6</p>	<p><b>WIRELESS CABINETS</b></p>  <p>For Panels 7 in. high Width 6in. Hinged Lid Oak 12 in. 17/-; 14 in. 17/6; 18 in., 18/6; Mahogany, 1/- extra.</p>	<p><b>DEWAR SWITCH</b></p>  <p>12-Contact. 2/6</p>
--	---	--	---	---

**READ THIS LIST AND SAVE MONEY ON COMPONENTS**

**CONDENSERS.**—Low Loss, Square Law, with knob and dial, .0005, 5/-; .0003, 4/6; with Vernier Blade, 1/4 extra; Twin .0005, for Elstree Six, unequalled value, 9/6; Cylind Twin for ditto, 27/6; Ormond, J.B. Utility, Sterling, Polar, Formo, Igranic, G.E.C. Variable in all capacities. Neutrodyne types, Ormond, 2/-; Colvers, 3/6; Gambriel, 5/6.

**FIXED CONDENSERS.**—Dabiller, Edison Bell, Lissen, Watnet, Mullard, McMichael, at advertised prices. Special Reliability Falcon, 2 nos. Leak, 1/3; Cases only 4d.

**BATTERIES.**—Reliability, 90 v., 11/-; 60 v., 7/6; 36 v., 4/6; 15 v., 1/10; Ever Ready, Siemens, Helleisen, 100 v., 21/-; 66 v., 12/6; 36 v., 7/6; Flashlight Battery Cases for 24 Batteries 3/6, 4 v. Batteries, 4d. 60 v., Unequalled, 5/6; Wander Plugs, 14d.; Clix Type, 2d.

**L.F. TRANSFORMERS.**—E.I. Multi-Ratio, 25/-; Marconi-Ideal, 25/-; Junior, 15/6; Ferranti A.F. 3, 25/-; A.F. 4, 17/6; Formo, 10/6; H.T.C. Empire, 7/6; Crox 5 to 1 6/-; Lissen new type, 8/6; Igranic, 16/-; Eureka Concert Grand, 25/-; No. 2, 21/-; Baby Grand, 15/-; Ormond, 15/-; Royal, 20/-; Success, All Black, 21/-; Silvertown, 21/-; G.R.C., 15/-; Brandes, 17/6; Burndep, 16/6; Special Value, 7/6; Modulation, 7/6.

**ACCUMULATORS.**—Exida, D.T.G., 4/6; D.F.G., 3/6; W.J., 20 v. H.T. type, 15/-; Oldham H.T. 10d. per volt, complete; Duron 20 v., 11/-; 10 v., 5/6; Repairing Outfit, 2/6.

**EBONITE.**—Any size cut, Clifton brand, 1 in., 1d. sq. in.; 8 in. by 8 in., 2/2; 12 in. by 8 in., 4/6; 15 in. by 9 in., 5/6; 3/16 in., 25 per cent. less. Paragon and Radion, 1d. per sq. in.

**AERIALS.**—100 ft. 1 in. copper tape, 1/6; 7/22s Bright, 2/3; Enamelled, 3/3; Electron, 1/8; Superior, 2/6; Mars, 3/6; Ashion Spreaders, 12/- per pair O.V., complete, 2/6.

**INSULATORS.**—Large Shell, 3d.; Reel, Eger, 1d.; Chimax, 6d.; Ditto, with shock absorbers, 3/- pair; Gal. Pullers, 4d.; 100 ft. Gal. Straining Wire, 1/8; Straining Bolts, 6d.

**TERMINALS AND ACCESSORIES.**—Single W. Office N.P. or Pol. Brass with nut and washer, 1d.; Phone and Castle type, 1d.; Double Mark, 3, 2d.; 4-way Phone Connector, 6d.; Pole-Stranding paper, 3d.; Fluxite, 8d.; Black Tape, 6d. coil; 1 in. Emptie Tape, 6d. dozen yards; Insulating tube, 3d. yd.; Glazite, 1/2 10 ft. coil; Shellac Varnish, 6d.; Mica 2" x 1", 4d. doz.

**VALVE HOLDERS.**—Anti-Phonic Benjamin, 2/6; Lotus, 2/3; with terminals, 2/6; Burndep, 2/3; Harlie, 1/6; Reliability, unequalled, 2/-; all baseboard types, ordinary ditto, 6d.; N.P. Valve Sockets, 5d. fitting, 1d.; Superior Panel Type, 6d.; All Ebonite, 10d.

**HEADPHONES.**—B.T.H., 15/-; Brown's "F" Type, 20/-; Reliability, 7/6; Adjustable, 8/-; Dr. Nesper, 12/11; T.M.C., 17/6; Western Electric, 20/-; all 4,000 ohms: Sullivan, 120 ohm Double, Ex-Govt. New, 4/-; 120 ohm Single Phone, 2/6; Long Phone Cord, 1/-.

**RECENT REDUCTIONS.**—Sterling .0005 Square Law Condensers with Vernier, 9/6; Geared 12/-; Minilions 15/-; .00025, 8/6; Geared, 10/6; Minilions, 14/-; Marconi Automatic Detector, 2/6; Series Parallel Variometer, 10/6; Edystone Absorbos feet, set of four, 2/3; Benjamin S.P. Switch, 1/3; N.P. Clix Plug and Insulator, 2d.; Adaptor, 1d.; Socket, 2d.

**LATEST COMPONENTS.**—6-Way Coil Stand 2/3; Colvers Low Loss Inductance Former, 5/-; Formo Straight Line .0005 Condenser, 10/6; Success, 15/6; Eureka, 15/6; Cylind, 15/6; Lissen 90 volt H.T. New Process Battery, 10/6; Valve Vibrating Springs, 6d. set of four.

**EXPERIMENTERS' PARCELS.** Accessories of Various Types, worth 20/-, post paid, 5/6.



## J. H. TAYLOR & CO.

17 RADIO HOUSE,  
MACAULAY ST., HUDDERSFIELD

Send for New RELIABILITY WIRELESS GUIDE No. 8, Freeon Request Trade Supplied

Orders 5/6 Valve Carriage Paid. Under 5/6 2d. per 1/- for Packing, etc.

# How to Make a De Luxe Wave-Trap—continued from page 119

in the aerial lead, between the lead-in and the receiver itself. Only a portion of the coil, however, is actually included in the circuit, and according to the amount of the coil included so the greater or lesser is the trapping effect. This may thus be varied at will to suit different receivers.

### How to Make It

The constructional details are of the simplest, and can easily be carried out.

First of all, mark out the panel as shown in the drilling diagram given, and mount up the trap coil and the tuning condenser. The trap coil is made up as a single-hole-fixing unit, the switch being on the back of the coil. It is operated by a knob which runs through the centre, and is controlled by a knob which is fixed in position after the coil has been mounted on the panel. The two terminals may then be mounted in the positions shown, one on each side of the panel. This completes the constructional work, and the instrument is then ready for wiring up.

### Wiring

Only four wires are required to complete the trap. The left-hand terminal, looking from the front, is joined to the terminal on the coil unit marked A1, which is connected to the tapping switch. The terminal marked A2 is connected to the right-hand terminal, and also to the fixed plates of the condenser. Finally, the terminal marked A3 is connected to the moving plates of the condenser, after which the instrument is complete and ready for use.

The instrument should be mounted in its case and placed in any convenient position between the aerial lead-in and the receiver itself. It should be placed at least six feet away from the receiver, in order to avoid interaction between the trap coil and those in the set itself. This is an important point, and one which is often overlooked in practice, but it will be found to have a marked effect on the efficiency of the trapping action of the unit.

### Connecting Up and Testing

Connect the lead from the aerial to the left-hand terminal and take a second lead

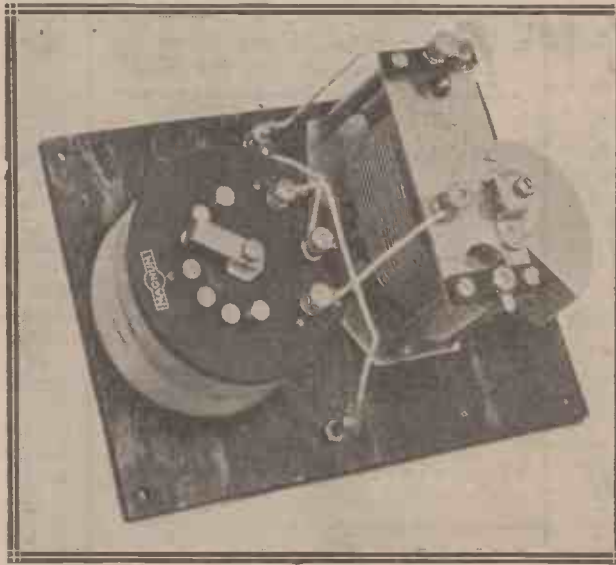

The use of a trap such as the one described will, in all probability, enable you to hear a number of stations which were previously "swamped" by the local.

from the right-hand terminal to the aerial terminal on the receiver. Place the tapping switch in position 1. This cuts the trap out of action altogether. Tune in the receiver to the local station. Now place the trap switch on stud No. 2, which is the first tapping point. In this position six turns of the trap coil are included in the aerial circuit.

Tune the trap condenser carefully. At a certain point the strength of the local station will be found to decrease suddenly. Leave the condenser adjusted to the point at which the strength is a minimum. Now tune the receiver to some distant station in the normal manner, and see whether the interference from the local station is still too strong.

If it is, set the trap tapping to stud No. 3, and repeat the process. If still unsuccessful, try the next stud,

and so on. The larger the tapping on the coil the greater the trapping action, but the wider does the effect become. Consequently, after a certain point the trap begins to affect the distant station which you are tuning to as well as the local station which has to be cut out. After a little experience the best position will readily be found.

### Permanent Adjustment

The trap can then be left adjusted on this position, and will not normally require to be altered again in use. From time to time the wavelength of the local station may vary slightly, in which case it will be necessary to alter the tune of the trap condenser slightly. The tapping, however, will not require to be altered under normal circumstances.

This instrument will be found to be exceedingly convenient to those readers who only have simple sets. A set which is normally quite unselective may be improved out of all recognition by the addition of a simple trap such as this one, and many more hours of enjoyment can be obtained from its use.

### "The Switching Bogey"

It is regretted that the pressure upon our space, consequent upon the inclusion of the important article by Sir Thomas Beecham, has rendered necessary the holding over until next week of the above feature.

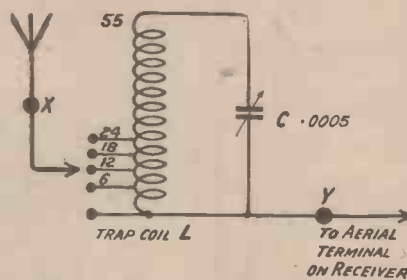

Fig. 3.—The circuit used in the present instrument is of the "series" type.



Quite a popular feature at the Leicester Municipal Library is the "Radio Corner," where books dealing with the subject matter of talks and the score of musical works broadcast each day are displayed.

# CHARGE YOUR ACCUMULATORS AT HOME!

NO TECHNICAL KNOWLEDGE OR ATTENTION REQUIRED. RELIABLE AND EFFICIENT.

Simply plug-in to any convenient lampholder. Each Outfit supplied complete with Adaptor, Connecting Cords and full instructions.

## "Goltone Pendelton" (Patent App.)

(Alternating Current.)

Charges the Low Tension Accumulator economically and effectively at minimum cost. No Renewals. Charging rate approx. 2 Amps. Price complete .. £2 12 6

Fitted with Ammeter, as illustrated, £3 7 6  
When ordering please state voltage and frequency of Lighting Mains.



Fully illustrated Catalogue No. R/1116 Free on request.

## "INDISPENSO" (Direct Current).

Charges the High Tension Accumulator at no extra cost when light is in use. Price complete .. 6/-

## "ALTERNO" (Alternating Current).

Charges the High Tension Accumulator at negligible cost. Price complete .. 21/-  
Stocked by the Leading Stores. Refuse Substitutes.



"Pendelton" Charger with cover removed.



# The Secret of Skilful Condenser Tuning is LATERAL ACTION

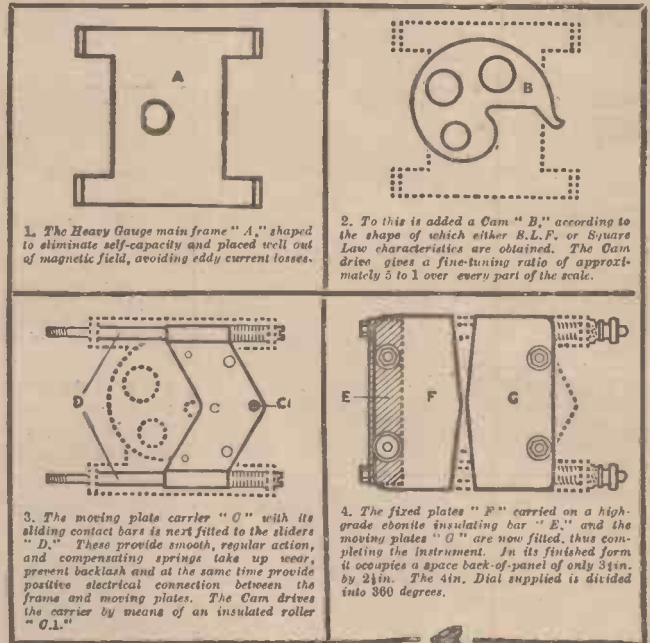

Available in either S.L.F. or Square Law types.

Prices:

.0005 .. 18/6;  
.00025 .. 17/6.

Complete with 4" Knob and Dial.



EVERY part of Ripaults Lateral Action Condenser was designed to achieve sharp, crisp tuning and a greater degree of selectivity than ever before was possible.

This result has been successfully accomplished. Ripaults Lateral Action Condensers put within your reach extraordinarily efficient tuned circuits, while tuning itself is made infinitely easier.

In up-to-date sets *Lateral Action* is the secret of the skilful tuning that brings in Stations "all round the Dial."

# Ripaults

## LATERAL ACTION CONDENSER.

Patent Applied for

Manufactured & Guaranteed by Ripaults Ltd., King's Rd., London, N.W.1

# THIS IS THE VERNI-NOB!

The Verni-Nob does all the work of a Vernier attachment or Vernier dial and increases the selectivity of your set.

PRICE

6d.

Positive drive—No back-lash. 10 to 1 reduction with 3" dial. 16 to 1 reduction with 4" dial.

Over 8,000 were sold during the Wireless Exhibition at Olympia!

From all dealers.

By post 7 1/2d.

Fitted in a few moments.



THE M.A.P. Company

246, Great Lister Street, BIRMINGHAM

### K. RAYMOND for Wireless

We stock parts for all circuits and are Distributors of all Leading Manufacturers.

CALL HERE FOR:—LISSEN, BENJAMIN, RADIO MICRO, VOLTRON, COSMOS, MULLARD, EDISWAN, MARCONI, COSSOR, OSRAM, JACKSON (J.B.), DUBLIER, McMICHAEL, SUCCESS, BEARD & FITCH, BOWYER, LOWE, LEWCOX, IGRANIC, EUREKA, ORMOND, UTILITY, FORMO, EDISON BELL, FERBANTI, R.I., POLAR, NEWBY, P. H. MAGNUM. WE HAVE THE GOODS! CALL AND SEE US. ALL LINES IN DEMAND STOCKED. SPECIAL TERMS TO RADIO CLUBS, GENUINE EXPERIMENTER'S.

BE SURE YOU ARE AT RAYMOND'S.  
Nearest Tube Leicester Square. Phone: Gerrard 4637.

WARNING!  
SEE K. RAYMOND'S NAME ON PREMISES. THIS WILL ASSURE YOU GETTING THE GOODS I ADVERTISE. PLEASE ASK "IS THIS RAYMOND'S?"

**K. RAYMOND,**  
27 28a, LISLE STREET,  
LEICESTER SQ., W.C.2.  
Back of Daly's Theatre.  
Hours: 9-15 to 7-45.  
Saturday: 9 to 8-45.  
Sunday: 11 to 1.

#### 2-VALVE AMPLIFIER, 35/-

1-Valve Amplifier, 20/-, as new; Valves, D.E. 06, 7/-; Headphones, 8/6 pair; new 4-Volt Accumulator, 13/-; new 60-Volt H.T., guaranteed, 7/-; 2-Valve All-Station Set. 24. Approval willingly. Write for free bargain list.

R. Taylor, 57, Studley Rd., Stockwell, London.

#### PHONE REPAIR SERVICE

Headphones rewound and Remagnetised 4/6. Loud Speaker rewound 4/6. Transformers rewound 5/-. Remagnetising only 2/-. All work guaranteed. Postage extra. Write for trade terms.—H. E. P. Co., 1, Cottrill Road, Spurstow Terrace, Hackney, E.8.

### WET H.T. BATTERIES

Sacks, 1/6 per doz. Zincs (connected), 9d. per doz. Glass Jars (waxed), 1/6 per doz.

S. E. JONES & CO., ELSECAR, BARNSELEY.

### JARS, ZINCS, SACS

1/6 DOZ. 1/- DOZ. 1/6 DOZ.

For making Wet H.T. Batteries, post free on 3 doz. or over. - Packed in special carton with division for each cell. This can be used as a container for the battery when made up. Send 6d. for sample complete unit, particulars and instructions.

SPENCER'S STORES, LTD.,

4-5, Masons Avenue, Coleman Street, London, E.C.2  
Phone: London Wall 2202. (Nr. Bank).

### EASY PAYMENTS

LOUD-SPEAKERS, HEADPHONES, H.T. ACCUMULATORS. Anything Wireless.

Send a list of the parts you are requiring, and we will send you a quotation on monthly payments.

H. W. HOLMES, 29, FOLEY STREET, Phone: Museum 1414. Gt. Portland St., W.1

### EVERY LOUDSPEAKER

DESERVES  
MULLARD  
MASTER  
VALVES

— Ask for —

Mullard P. M. Power Valves.

### VALVES!

Radio Micro Power	Fama D.E.
3v 1 amp. - - 10/9	2v 2 amp. - - 4/-
3v 3 amp. - - 9/6	M.R., D.E.
Radio Micro D.E.	2v 60 amp. - - 5/6
3v .06 amp. - - 7/-	Polo 60-volt Batteries
Fama D.E.	3-volt Tappings
4v .06 amp. - - 5/9	Guaranteed - - 7/6
Fama Power	
4v 2 amp. - - 8/6	All goods sent post free.

Trade Enquiries Invited. Write for Lists:—

Kindly note change of address—  
**W. SEGAL, 53, RUSSELL ST., LONDON, E.1.**

# I HAVE BEEN ASKED...



I have a receiver consisting of a detector and two transformer-coupled L.F., and would be glad if you would give me a diagram to add a further note magnifier.

As you already have two transformer-coupled note magnifiers in your set, I would not advise you to attempt to add another valve here, since in practice considerable trouble is often experienced. Your best course would be to add an H.F. valve, and here the "Neutrodapter" described in Vol. 5, Nos. 1 and 2 of this journal should prove satisfactory.

I have ordered fixed resistors for valves of 30,000 ohms impedance, and should be glad if you would tell me whether these resistors will be of use with other valves.

The resistances of fixed resistors required for any valves are determined by the filament characteristics of the valves and bear no definite relation to the impedance. For example, to obtain the fixed resistor for any given valve a very simple calculation is required. The voltage at which the valve should work should be subtracted from the voltage of the accumulator and the figure thus obtained should be divided by the current taken by the valve in amperes. The result is the resistance of the resistor in ohms. The suitability or otherwise of the resistors which you have can be determined by the above simple calculation.

With a receiver which I contemplate constructing there are two transformer-coupled note magnifiers, which receive a common value of high-tension, but have separate grid-bias tappings. Am I correct in assuming, provided I use similar valves here, that I must use more grid bias on the last note magnifier than on the first?

The object of employing grid-bias with any valve is to arrange that the valve works on the correct part of its characteristic curve to perform best the function which it is required to carry out. Incidentally, the higher the value of the negative grid-bias applied to any given valve the lower will be the H.T. current consumption. With two similar valves working on the same H.T. voltage the same value of grid-bias voltage should be employed if the valves are to carry out similar functions. To economise in H.T. current consumption the maximum negative grid bias which will allow the valve to function on the cor-

rect part of its characteristic curve should be used. The working point on the characteristic curve should be so chosen that the voltage swings applied to the grid do not on the one hand cause the valve to function at the lower bend of its characteristic curve, in which case rectification results, and on the other hand do not make the grid positive, as then grid current flows and distortion is thus introduced. In practice, the first note magnifier has to deal with smaller grid swings than has the second, and it therefore follows that in such a case as yours more grid bias may be applied here than to the second valve, without causing rectification and consequent distortion.

I have constructed the "Monodial" and find the set to work excellently upon three valves, but directly the fourth is brought into circuit the set howls and no alteration of the tuning control makes any material difference. At this juncture I will confess that I have altered the layout somewhat, and am using two L.F. transformers, which were incorporated in two separate receivers which I built some time ago. Can you tell me how to overcome the difficulty?

Since the howling only occurs when the second L.F. valve is brought into circuit and is not affected in any way by alteration of the tuning condenser settings, the trouble is due to low-frequency oscillation, which often occurs in a receiver in which two L.F. transformers are used. The first step to take is to reverse the primary connections, that is, the leads to IP and OP, of the second L.F. transformer, coupling V3 and V4. In the event of no cure resulting next connect a resistance of 1/2 or 1/4 megohms across the secondary winding of the same component. This will generally overcome the difficulty, but should it not do so the resistance should be decreased down to the order of 100,000 ohms, in which case an anode resistance will serve. This latter value will probably be found to decrease volume to a noticeable extent, but the increase in purity should be worth while.

If you fail to achieve success from carrying out the experiments mentioned above, one of the L.F. transformers should be changed for another of different type. Attention should also be devoted to the spacing between the transformers, and, if possible, they should be arranged with their axes at right angles.

# RADIO is no longer EXPERIMENTAL

**Y**OUR ear is the final judge of Radio—through it comes your enjoyment—all else is of minor importance. We know, and dealers know, that Bowyer-Lowe Components are far beyond the experimental stage, that a set built with these tested components makes what you hear, the final perfection in Reception.

Bowyer-Lowe Components are sold only on the basis of your being perfectly satisfied. Dealers who stock Bowyer-Lowe products know that these components prove their own supremacy. Profit by their experience—use them in your next set.

*Constant Satisfaction Guaranteed  
—or a free replacement in Twelve Months.*

**13<sup>0</sup> in STAMPS will  
RADIO**

**Bring you the Bowyer-Lowe  
NEWS**

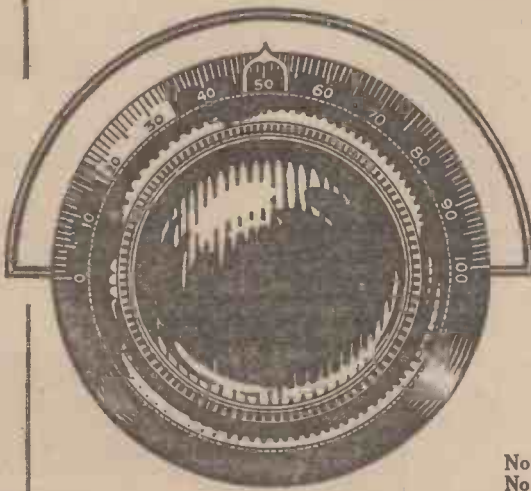

## FIT THIS BURNDEPT ETHOVERNIER DIAL

THOSE elusive stations can be brought in again and again if you fit your receiver with these new Ethovernier Dials and Etholog. The dials are free from backlash, silent, fit practically any type of condenser, and have a high ratio of 18:1. This ratio has been found by experience and trial to be quite high enough, yet not tedious to use.

The Etholog is a unique feature which fits snugly round the dial, being kept in position by the pressure of a spring. It contains a white changeable card, on which you can mark the position of any station or various wavelengths. Its use will obviate the necessity of further reference to the condenser dials once a station has been "logged."

- No. 1151. The Ethovernier, complete with Etholog and card scales . . . 9/-
- No. 1152. Ethovernier without Etholog . . . . . 8/-
- No. 1162. The Etholog only, with spare card scales . . . . . 2/-

*The Burndept range includes everything for Radio reception, from Components to Complete Installations.*

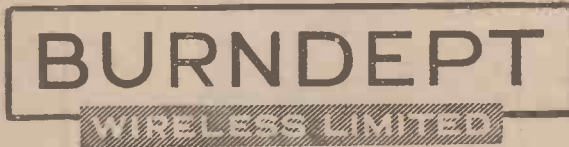

*Send for the Burndept literature, which gives full details of all Burndept Components.*

Head Office and Factory: Blackheath, London, S.E.3. \*Phone: Lee Green 2100. \*Grams: Burnacoll, \*Phone, London.

AGENTS & BRANCHES EVERYWHERE

London Offices and Showrooms: 15, Bedford St., Strand, W.C.2. \*Phone: Gerard 9072. \*Grams: Burndept, Westrand, London.

# The First Night of the New Wavelengths

Some interesting observations at our Elstree Laboratories



THE new wavelengths allotted by the Council of the Office Internationale de Radiophonie came into operation at midnight on Saturday, the 13th instant, and on Sunday many interested listeners throughout the country were raking the ether in order to find what changes had resulted from the alteration.

## Observations at Elstree

Some actual tests were carried out at Elstree during the afternoon and evening of Sunday in order to observe first of all whether the various stations were correctly on their new waves, and secondly how much the change had cleared the ether of the appalling interference with the heterodyning which was prevalent under the old routine.

The careful arrangements which had been made by the authorities to ensure that every station shall have an adequate check on its wavelength appear to have produced satisfactory results in the majority of cases. The following list, which represents a few stations selected at random during the afternoon of Sunday the 14th, shows the discrepancy between the actual wave and the rated wave to be very small, the maximum error being of the order of half a metre.

## A Few Stragglers

It was noted, however, that there were some stations operating in places where they ought not to be. It was rather difficult to identify these stations beyond the fact that they were foreign. For example, Leipzig, operating on a wavelength of about 360.7, started up just before London came on for the evening programme, and was responsible for a continuous heterodyning on London throughout the evening. We say about 360.7, because owing to some over-modulation or similar effect his speech and music were causing his wave to vary the whole of the time. This interference was not serious in the London district although at times it was unpleasant, but from accounts received it caused trouble in more remote districts.

## The Relays

The relay wave-band was extremely amusing. As one would expect, tuning to this band simply resulted in a hopeless jumble. It was also found



that one or two of the stations bearing the common waves had not quite adjusted themselves to the correct wavelength, and were producing heterodyning. Even when this is cleared, however, there can be no doubt that the relay stations will be utterly useless outside a comparatively small radius from the individual transmitting station. Since the purpose of a relay station is primarily to serve the area in its immediate

Station.	Actual.	Official.
British Relays ..	288.9	288.5
Leeds and Hanover ..	296.8	297
Munster ..	303.3	303
Bournemouth ..	306.6	306.1
Newcastle ..	312.5	312.5
Belfast ..	326.4	326.1
Nuremberg ..	330.1	329.7
Cardiff ..	352.3	353
London ..	361.4	361.4
Manchester ..	384.1	384.6
Toulouse ..	399.7	399.6
Berne ..	410.5	411
Frankfort ..	428.5	428.6
Birmingham ..	491.8	491.8
Vienna (Rosenhugel) ..	517.2	517.2
Munich ..	535.7	535.7

vicinity, this state of affairs will not cause great hardship. There will still be plenty of stations for the DX enthusiast to pick up.

## Birmingham and Aberdeen

Birmingham, which shares a common wavelength with Aberdeen, was very good at Elstree, and no trace of any interference from Aberdeen was experienced at any time. During the afternoon it was possible to observe by means of the wavemeter that there were two carriers very slightly different in wavelength, but this cleared itself later on, possibly as the result of slight readjustment of one of the stations in order to bring the two waves exactly in unison. It means, therefore, that Southern listeners will no longer have Aberdeen to listen to, and presumably Northern listeners will lose Birmingham.

## A General Improvement

A general impression during these preliminary days of the change-over was that the conditions were definitely better. There was still a certain amount of heterodyning. Belfast in particular, although quite clear during the afternoon, was completely smothered in the evening by a German station who was producing a very powerful heterodyne.

At the same time, it was possible to run from one end of the scale to the other and receive quite a number of stations absolutely free of interference from other stations. Glasgow was heard, for the first time for many months, at very good strength. Newcastle and Bournemouth in their new positions were both tuned in well, although Bournemouth does not seem to have retained his erstwhile vigour. This, let us hope, is only a temporary matter.

## Co-operation

Generally, all the countries appear to have adopted the new wavelengths willingly and are falling in with the international spirit. It is rumoured that the German stations are not proposing to use the wavemeters with which they have been issued, preferring rather to maintain their own standards. If this is true the action is to be deprecated, since the principal necessity is that the various stations shall all fit into the scheme without interference.

The operation of the plan, at any rate, is very hopeful, and gives one the impression that after a short time to allow the stations to settle down we shall obtain a really satisfactory condition of the ether. At any rate, let us hope so.



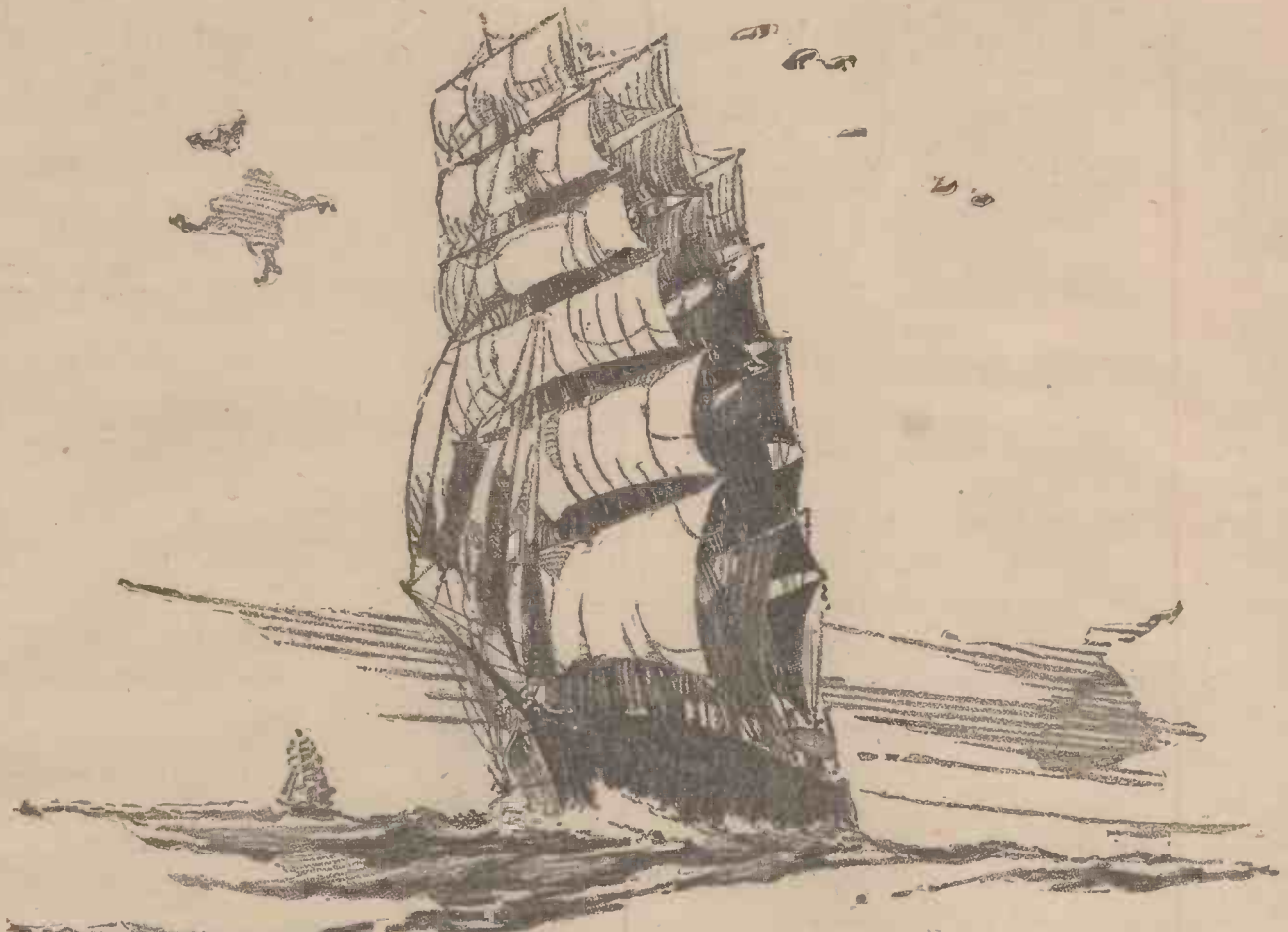

## “WELL FOUND”

When the tall Clippers in all their pride raced for the wool and tea markets of the world, they had to be well found and seaworthy.

And being well found didn't end with having good “sticks, rigging, and running gear,” it implied a tip-top condition from the varnish on the truck down to a clean bottom.

It was attention to details more often than not which decided the issue of these stern chases—the details which, as far as one could see, “didn't matter.”



It is, perhaps, a far cry from Clippers to Condensers, but it is certainly a fact that many people regard Condensers as being a detail that “doesn't matter.”

And still more numerous are the people who say that cheap condensers seem to give just as good results as expensive ones.

The fact is that cheap condensers do *not* give as good results as expensive ones. If they did, we should not be interested from any point of view in making the more expensive variety.

And the second fact—namely that the Dubilier Condensers sold number more than all other makes put together—points to the fact that the great majority of people value a well-found wireless set and insist on seeing that it is equipped with Dubilier Condensers.

Do you?

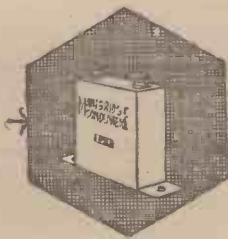

ADVT. OF THE DUBILIER CONDENSER CO. (1925) LTD.  
DUCON WORKS, VICTORIA ROAD, N. ACTON, W.3

Pat. No.  
256833  
Pro. Pat.  
No. 20339



The Grid Leak is not discernible, being totally enclosed in Bakelite Valve Holder Base.

## Something new and good in component design

The latest LOTUS triumph is a Combination Grid Leak and Valve Holder which eliminates unnecessary wiring and soldering and makes for economy in cost and space.

Guaranteed efficient in construction and design.

From all Radio Dealers

Combination Grid Leak and Terminal Valve Holder .. .. .	3/9
Terminal Valve Holder .. .. .	2/6
Valve Holder without Terminals .. .. .	2/3

All Anti-Microphonic Type.

# LOTUS

Combination

GRID LEAK AND BUOYANCY VALVE HOLDER  
Anti-Microphonic

Garnett, Whiteley & Co., Ltd.  
Lotus Works, Broadgreen Road, Liverpool.

Makers of the famous "Lotus" Vernier Coil Holders



# Silvertown

WIRELESS ACCESSORIES

Quality guaranteed by over 50 years' electrical manufacturing experience.

### WINDOW-PANE INSULATOR

Regd. No. 705625.  
(Patent No. 233,880).

Made of best quality enamel coated ebonite, these insulators take advantage of the excellent insulating properties of glass, and at the same time avoid losses by keeping the lead-in well away from walls. Rubber rings form a water-tight joint against the pane. The cone keeps a portion of the insulator dry in wet weather.



PRICE 3/6 each.

A special drill, with instructions for making hole in glass, supplied with each insulator.

### STRAIGHT LINE FREQUENCY CONDENSER (Low Loss)

A precision instrument, the design of which ensures perfect mechanical construction with high electrical efficiency. The rotor plates are earthed, eliminating hand capacity effects. It is also completely silent when adjustments are being made.

Perfect electrical contact is obtained by means of a flexible phosphor bronze pigtail connection.



B.615	0.00025	mfd.	each
B.616	0.0005	mfd.	13/-

### B 601. VERNIOMETER (Patent 253612.)

A most ingenious device for applying slow motion to variable Condensers, coil holders, variometers, etc., consisting of an ebonite dial and knob (0-180°) fitted with worm-wheel bracket and worm-spindle, micrometer barrel and pointer, complete with fixing screws. Gear ratio 240-1. Fitted with instantaneous release. Backlash entirely eliminated. Hand capacity reduced to a minimum. Suitable for the following makes of condensers: Silvertown, Burn-dept, Igranic, Polar, Sterling, Ormond, Jackson, Devicon, Utility, Ashdown, Lamp-lugh, Ediswan, Edison-Bell, Bowyer-Lowe, Atlas, W. & M., A.J.S., etc. Price 6/- each.



AN AID TO ENTHUSIASTS  
We have prepared a logging chart for recording wavelengths, condenser settings, etc., of those stations which require careful calibration to tune in. A copy of this chart, printed on stiff card, with hanger, can be obtained free of charge at any of our Branches or from any high-class dealer.

MAKERS:

THE SILVERTOWN COMPANY,  
106, Cannon St., London, E.C.4. Works: Silvertown, E.16

BELFAST.	DUBLIN.	LONDON.
BIRMINGHAM.	GLASGOW.	MANCHESTER.
BRISTOL.	LEEDS.	NEWCASTLE-ON-TYNE.
CARDIFF.	LIVERPOOL.	PORTSMOUTH.
		SHEFFIELD.



## USING THE MONODIAL ON A FRAME

(Continued from page 115)

rather cramped. Since the number of turns required depends so much on what frame is being used, it is not much good my giving figures for the detector grid coil, but I can indicate roughly the number of turns which will be required for this and the primary winding, which is in the plate circuit of the H.F. valve, together with the correct method of constructing and winding the formers.

The formers consist of two 3 in. lengths of 1½ in. ebonite tubing, which are mounted side by side. Each tube carries two windings, and these windings are wound in the same direction. For each half of the anode coil about 40-60 turns are required, especially if high-impedance high-amplification valves are used. With low-impedance power valves only 25-30 turns will be needed. There should be about ½ in. left between the two windings, and each half of the secondary will consist of about 60 to 80 turns. It is better to wind on too many turns at first, since turns can always be removed if desired. It is not so easy, however, to put extra ones on once the coil is completed.

### Mounting the Transformer

The two tubes carrying the windings are then fixed side by side by two

screws passing right through them, and the various connections made in the standard fashion. It is now necessary to mount the finished coil on a six-pin base to plug into the socket provided in the set.



An extraordinary contrast! The utilitarian loud-speaker is here seen in a strange setting at the famous Cathedral of Primada at Toledo.

Since fieldless coils generally have a higher resistance than plain solenoid inductances, care should be taken over their construction to see that the resistance is kept down as low as possible. This may be done by spacing the windings slightly, making the length to diameter ratio as favourable as possible under the circumstances, and attending to any other details of this description which go to make up the overall efficiency of an inductance.

### The Results

The results to be obtained with a frame on this receiver are really astonishing. On quite an average night, when conditions were nothing out of the way, I was able to receive five stations on the loud-speaker, this including the local. Tuning was certainly critical, and slight hand capacity effects were observed at the lower readings of the tuning condenser. Reaction was quite smooth, however, and this was, of course, an important advantage, since it enabled the utmost to be got from the receiver.

The stations heard on the loud-speaker on another occasion were:—

Birmingham, weak; Aberdeen, very weak; Frankfurt, medium; Radio-Toulouse, clear; Breslau, clear; Hamburg, medium; Bournemouth, fair; Prague, audible.

Other transmissions heard were:—Dublin, Munster, Swansea, Berlin, Rosenhugel, Gratz, and a number of British and German relays.

# The First Essential to Perfect Reception

**B**BROADCASTING brings into your home all that is best in music, drama and education. But to enjoy these to the full, you must use "HART" Batteries on your set for both Low and High Tension Supply "HART" Batteries alone provide that steady power to your valves which enables them to reproduce with maximum power and purity. That is why eminent musicians like De Groot and many others personally use and recommend them.

# HART

## THE BATTERY OF QUALITY

"Ray" Model High Tension Accumulator, 20-volt, 14/8; 30-volt, 22/-.

"Enduro" Low Tension Accumulator, 2-volt, 10 Ampere-Hour Actual, 6/-.

Write Dept. W.6/X for full particulars of all "HART" Models.

HART ACCUMULATOR CO. LTD. STRATFORD, LONDON. E. 15

# The latest in Jacks & Plugs

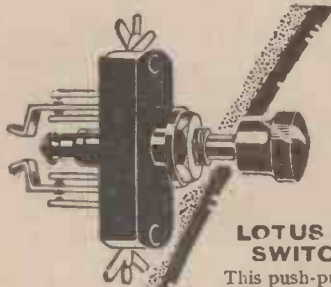

### LOTUS JACK SWITCHES

This push-pull switch is designed to occupy the minimum space, being only  $1\frac{1}{4}$  in. deep. Of the finest Bakelite, it has nickel silver springs and contacts of pure silver. Soldering contacts can be made to suit any wiring.

#### PRICES:

No. 9, as illustrated... 4/-  
Others from - 2/9

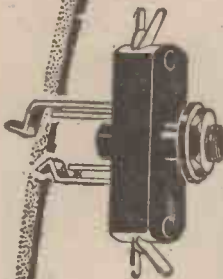

### LOTUS JACK

Designed to take up the least space, the depth back of panel being  $1\frac{1}{4}$  in. Made from best Bakelite mouldings with nickel silver springs and pure silver contacts. One-hole fixing. Soldering contacts can be brought into any position.

#### PRICES:

No. 3, as illustrated... 2/6  
Others from 2/- to 3/-

### LOTUS JACK PLUGS

Designed for use with Lotus Jacks. Made from best Bakelite mouldings and nickel-plated brass. To fix, the wires are placed in slots and gripped in position by a turn of the screw cams.

PRICE 2/-

From all Radio Dealers.

# LOTUS

## JACKS · SWITCHES · PLUGS

Garnett, Whiteley & Co., Ltd.  
Lotus Works, Broadgreen Road, Liverpool.

## COMPONENTS WE HAVE TRIED

(Conducted by the "Wireless" Laboratories)

### Battery Eliminator

WE have received from Messrs. H. Clarke & Co. one of their "Atlas" A.C. high-tension supply units. The unit is enclosed in an enamelled iron case, the lid of which lifts to enable the valves to be inserted in their sockets. On the front of the unit is an ebonite panel containing a strip of terminals, by means of which the required voltages may be obtained and also a stud-switch to enable a variable high-tension tap to be obtained.

High-tension supply may be obtained from two fixedappings giving 60 and 120 volts respectively, or from a third terminal which operates in conjunction with the stud-switch previously mentioned, whereby voltages varying between 20 and 150 are obtained. The unit also supplies grid-bias in steps of 4 volts up to 16.

Provision is made for double wave rectification, the filaments of the valves being lit from a transformer. The circuit, however, is designed so that if desired single wave rectification only may be employed, although the smoothing will not be quite so effective if this is done.

It may be expected that there will be some slight increase in the amount of "hum" heard if this method is used, but this may not be serious.

On test the unit worked very well, there being only a very faint hum when the programmes were not being received and no interference at all could be noticed during the actual items themselves. When used with a set operating off a frame aerial a certain amount of hum was observed unless the negative terminal of the L.T. battery was connected to earth.

It should be observed that the G.B. positive terminal and the H.T. negative terminal are connected together inside the unit. In many modern circuits the H.T. negative terminal is connected to L.T. positive, while the G.B. positive is connected to L.T. negative. When this unit is being used, therefore, care must be taken to avoid any trouble due to this effect. The simplest way out of the difficulty is to connect the negative lead from the H.T. unit direct on the L.T. negative terminal on the receiver.

The unit is neat and compact and extremely convenient; we can recommend it to our readers for use.

### Valve Holder

MESSRS. W. H. TANT & Co. have sent for our inspection one of their "Transant" valve holders. The valve holder consists of a square moulded base into which are fitted the four usual terminals. Four fixing holes are provided.

The valve holder proper consists of a moulded circular barrel, into which are fitted the valve sockets. The anode socket is surrounded by a bright red ring which contrasts greatly with the general black appearance of the holder. The centre holder is supported on a shaped rubber piece which is supported at its extremities on the base of these units.

20/-  
down



## Great New Wireless Offer

Our wonderful 2-valve set with loud speaker and headphones installed free in your own home—anywhere—by our own Installation Engineers for £12 cash; or £1 down and 20/- a month for twelve months only. And we guarantee satisfaction.

There is nothing else to buy—the set is complete with all accessories.

When our Engineers have installed the set just switch on and enjoy perfect and powerful loud-speaker reception. You are also entitled to two free calls from our Engineers after the set is working.

The General Radio set is British made, unsurpassed in efficiency and purity of tone. It has no superfluous controls and is as easy to work as turning on the light.

Send a postcard to-day for free illustrated catalogue No. 4X and full particulars of this offer.

*General Radio*

GENERAL RADIO CO. LTD  
RADIO HOUSE  
235 Regent Street, W1



## BUILD A LOUDSPEAKER

WITH OUR NEW SEAMLESS MOULDED CONE

(Prov. Patent 25089/26) and a BROWN A, or LISSENOLA. You will obtain PERFECT RESULTS. Successful construction for a minimum outlay is ensured with our Specialities. Illustrated Lists and full particulars for Stamp.

GOODMAN'S, 27 Farringdon St. E.C.4

Also obtainable from Spencer's Stores, 4-5, Mason's Avenue, E.O.2.

## PICKETTS CABINETS

FOR EVERY CONSTRUCTOR.

"Monodial"	.. ..	from 25/- to 40/-
"Dawlow"	.. ..	35/- to 75/-
"Elstree" Solodyne	.. ..	45/- to 85/-
"Night Hawk"	.. ..	25/- to 45/-
"Midget Reflex"	.. ..	10/6 to 18/6
"Four Valves One Dial"	.. ..	17/6 to 30/-

GUARANTEED AND SENT ON APPROVAL. Estimates to your own sizes and LISTS FREE.

Picketts—Cabinet (W.L.) Works, Bexleyheath.

## LISSENOLA & BROWN "A" USERS. GINGINNATI CONE, 1 1/6

Complete with bronze base and support, ready to have Brown reed phone screwed on making it into complete cone speaker, post 1/6. Attachment for Lissenola, 1/6, fully guaranteed. Complete with Lissenola, decorated to match cone, 27/6.

J. W. MILLER, 68, Farringdon Street, E.C.4.  
Sole British Distributor. Phone, Central 1950.

# GRAVES

## 2-VALVE LOUD SPEAKER BARGAIN.

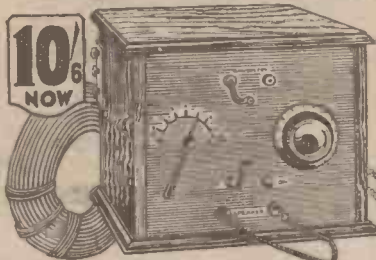

**This highly efficient 2-Valve Loud-Speaker Set is the finest wireless value ever offered.**

It gives a volume and quality of tone unattained by any instrument of a similar price and is the essence of simplicity. Fitted with coils covering all the British wave-lengths, including Daventry.

**THE CABINET** is of beautifully polished Oak, & all components are of the highest quality. Drill Emitter Valves with patent valve holders, 4c.; H.T. Battery, 2-volt accumulator and complete Aerial Outfit. **LOUD SPEAKER** of exclusive design with unique magnetic system and improved mica diaphragm. Price **£7:17:6**

**TERMS:** Our Bargain Price is for deferred payments. Send 10/6 now, & complete purchase in 14 monthly payments of 10/6. If you wish to pay cash, 5 per cent discount is allowed. **Catalogue Post Free.** Up-to-date Crystal & Valve sets at keenest prices.

J. G. Graves Ltd. Sheffield

Fullest Approval

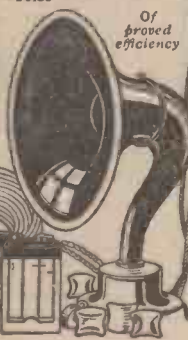

Of proved efficiency

### A HOME FOR YOUR WIRELESS SET

#### OUR STANDARD CABINETS

are **DUSTPROOF** and house the whole apparatus, leaving no parts to be interfered with. Made on mass production lines, hence the low price. Provision is made to take panels from 16x7 up to 30x18 in.

Special Cabinets for the **ELSTREE SOLO-DYNE, NIGHT HAWK, etc.**, now ready.

Write for free particulars.

**MAKERIMPORT CO.**

Dept. 4, 50a, Lord Street, LIVERPOOL.



STOCKED BY ALL THE BEST DEALERS  
TRELLEBORGS EBONITE WORKS Ltd. Audrey House, E.C.1.

### Valves Repaired

AS GOOD AS NEW!!

**HALF PRICE** (Except Weco, S.F.'s and low capacity types.) Minimum D.E. Current 0.15 amps when repaired. **ALL BRIGHT & DULL EMITTERS** Listed at less than 10/-.  
Minimum charge 5/-  
**VALCO** LTD. Dept. W., Tabor Grove, Wimbledon, S.W.

### COMPONENTS WE HAVE TRIED

(Continued from previous page)

Connection is made from the valve socket to the terminals on the base by means of coiled springs. Stops are suitably arranged so that when the valve is inserted or withdrawn no undue tension is placed either on the rubber former or on the connecting spring controls.

The test made for insulating properties indicated that there is a high insulation between the valve legs, and we can recommend this valve holder to our readers.

### True Scale Friction Condenser

**M**ESSRS. The Radio Devices Co., who specialise in the manufacture of condensers, have sent to our laboratories one of their true scale friction condensers for examination.

The component is fitted with a neat ebonite knob and dial, the condenser being driven through a 2 to 1 gear, while a vernier attachment provides an additional slow motion. No end plate is employed at the top of the condenser, a supporting shoulder piece being utilised instead, thus making the instrument considerably stronger.

By means of the knob a friction disc is rotated, and this in turn rotates the friction wheel, a particularly fine even motion being obtained. There is an extra ebonite support for the two terminals, while one-hole fixing is provided for.

The rated capacity of the condenser is .0005, while on test it registered a shade under this value.

The introduction of this instrument will certainly meet with the favour of our readers, and we can recommend it for use.

### Glass Case Accumulator

**A** SAMPLE of their Acton glass case accumulator has been submitted by Messrs. C. A. Vandervell and Co. The unit supplied was a 6-volt 48-ampere hour battery, each of the cells being provided with a glass container in place of the usual celluloid or ebonite. The three cells were mounted in a stout carrying case provided with a leather strap.

No separators were provided between the plates, the glass of the cells being moulded to keep the plates apart. By this construction it is claimed that any undue internal resistance in the battery is completely eliminated, that the battery will maintain its charge even when it is not used for some period, and will stand up to rougher treatment than normal.

We have had the battery in intermittent use now for over two months. During the majority of the time it was used for about two hours a week at the end of which it was put on a steady discharge at a current of 1.5 amperes, and was found in all to give well over its rated capacity.

Despite the extremely irregular use of this unit, therefore, it gave a full discharge, and the plates were in a thoroughly healthy and free condition at the end. There was an entire absence of any sediment at the bottom of the cells, due to disintegration, and as far as can be seen, the battery should give excellent service under rough conditions. We can thoroughly recommend it to our readers.



# Above the snow-line!



dividing that which is from that which might be. Above it, there is a constancy which heeds not time or circumstance, the overwhelming silent strength of snow-clad peaks.

The Mullard Ever-rest wire wound anode resistance is above that standard line which is drawn in your mind whenever a purchase is made, the dividing line between complete satisfaction and dissatisfaction.

A resistance of finely drawn metal, wound on, covered, and interlayered with a strong woven fibrous material, which eliminates all self capacity and also renders the metallic wire free from all mechanical shock. Differing from all others it is not dipped in wax, which allows a perfect distribution of heat.

### Mullard EVER-REST Wire Wound

Anode Resistance (80,000 — 100,000 ohms) .. .. 5/-

Complete with Holder 6/6

(Other Values to Specification.)

Mullard Grid Leaks and Condensers, Type

Grid B 0.5 to 5.0 megohms .. .. 2/6

Type Grid B, combined with .0003 mfd.

Condenser Type MA .. .. 5/-

Type MA Condenser .0002 to .0009 mfd. 2/6

Type MB Condenser .001 to .01 mfd. .. 3/-

Leaflet M.W. free on request.



### WIRE WOUND ANODE RESISTANCE

The MULLARD WIRELESS SERVICE Co., Ltd.  
Mullard House, Denmark St., London, W.C.2

**DECKOREM**  
BRITISH MADE



**One of these**  
**NEUTRALISING CONDENSERS**

was used in the Drawing Room Five described in the Nov. "Modern Wireless."

*The choice of critics.*  
Micrometer precision adjustment is assured and is permanent because you can lock thread screw at neutral point. Minimum Capacity less than 1 m/mfd.



**PRICES** complete with adjusting rods  
No. 1 8 m/mfd. - 3/-  
No. 2 21 m/mfd. - 4/3

**Which is the easiest?**  
To fiddle about with loose wires or to switch in?



**SWITCH** and be safe.  
**ON AND OFF SWITCH** as used in the Monodial  
PRICE 1/6

Send for our latest Catalogues OBTAINABLE FROM BEST DEALERS.

**A.F. BULLOCK**  
9-10-11, CURSITOR STREET  
CHANCERY LANE, E.C.4.

*Parva Ad.*

**AMATEUR TRANSMITTING NOTES**

**QRA's Found**

BN-SK1: J. R. Barnes, Telegraph Dept., Kuching, Sarawak, British North Borneo.  
BN-SK2: H. G. Gray, Kuching, British North Borneo.  
DF-7JO: J. Finsen, Thorshavn, Faroe Islands.  
Y-2AK: J. O. Primavesi, Nueva York 1590, Montevideo, Uruguay.  
G-5SO (change of address): A. M. O. Christian, 19, Parkfield Road, Edgeworth, Bebington, Cheshire.  
G-6JD: O. Jordan, 45, Lower Park, Loughton, Essex.  
G-2AUH: J. Browne, Kenilworth, Beaufort, Ashton-under-Lyne.  
I-IRG: (change of address) Ernestu Montu, Viale Bianca Maria 24, Milan.

**QRA's Wanted**

G-6GB, G-6TV, M-1DJ, PLH, PL5, PTS, PTR, WDW.

**CHRISTMAS DOUBLE NUMBER OF "MODERN WIRELESS"**

1/6 ON SALE 1/6  
DECEMBER 1st.

*Procure Your Copy EARLY.*

**E.E.I.X.**



**TREBLE DUTY TERMINAL**

Made in 26 different lettered tops and six different coloured indications.

Standardised connections, absolutely unique and priced at **4½d.** each.  
Nickel Finish.

Write for List No. W.5, giving full particulars of the E-elex Standardised Plugs and Sockets System, recommended and used by all leading Wireless Journals.

**J. J. EASTICK & SONS**  
E-elex House, 118, Bunhill Row, London, E.C.1.  
\*Phone: Clerkenwell 9282-9283.

**If coils were this size the "Lotus" would hold them securely**



**The Moving Block Cannot Fall**

The vernier movement comprises three sets of enclosed precision machine-cut gears; and reduces the speed of the moving block by eight times.

Side plates, coil blocks, and knobs in artistic bakelite mouldings. All metal parts heavily nickel plated. Made for left as well as right hand.

**LOTUS**  
VERNIER  
**COIL HOLDERS**

**PRICES:**  
**Two Types:**  
For outside panel mounting: Two-way ... 7/-  
Three-way ... 10/6  
For inside baseboard mounting, with 6-in. handle: Two-way ... 8/-  
Three-way ... 12/6

Made by the makers of the famous Lotus Buoyancy Valve Holder.

**GARNETT, WHITELEY & CO., Ltd.**  
Lotus Works, Broadgreen Rd., LIVERPOOL.

**THE RAZOR-SHARP WAVEMETER**

**Indispensable to the long range enthusiast**

This instrument has been designed by Mr. J. H. Reyner, B.Sc. (Hons.). It will assist you to tune in and identify the distant stations. Besides simplifying tuning, this wavemeter will enable you to obtain twice the enjoyment from your receiver.

**Complete Calibration Chart from 180 to 2,000 metres - - Price 1/6 Post Free 1/8**

**RADIO PRESS LTD.**  
BUSH HOUSE, STRAND,  
LONDON—W.C.2



## Sources of supply

"THE WIRELESS DEALER and Radio Trade Journal" contains two important guides to sources of supply—Index to Advertisers and The Buyer's Guide. The first will refer to advertisements in the issue, while the second will direct you to the manufacturers of any particular product which you may require to order. These two guides compose an important fund of information.

Commence your subscription with the November issue—it is rather an important one for the retail section of the Trade.

It contains a detailed and profusely illustrated "Stand to Stand" Review of the Manchester Exhibition, giving special prominence to popular lines. "What the Manufacturers are Doing" and "What the Wireless Journals are Doing"—both widely-read regular features—are of particular interest in this number.

"Fighting the Foreigner" is the title of a powerful article from the pen of one of the leading Sales Managers in the Radio Industry.

Make a note to post your application to-day.

#### SUBSCRIPTION RATES:

7/6 per annum (abroad 10/-). Available to the Trade only. Trade card or business heading should accompany every subscription to the SALES MANAGER, Radio Press, Ltd., Bush House, Strand, London, W.C.2.

*The* **Wireless Dealer**  
AND  
Radio Trade Journal

**WE CALL  
OURS A FILAMENT**



**Sheer honest value**

**Not called by a coined name that means nothing.**

**The first filament made to consume only one-tenth ampere and still unequalled.**

**Its great length and strength give you 3 times more for your money. Can only be obtained in Mullard P.M. Valves.**

**ASK FOR THE VALVES WITH THE WONDERFUL MULLARD P.M. FILAMENT.**

**THE UNBREAKABLE FILAMENT**  
**That defies all but the roughest handling**

# **Mullard**

**THE · MASTER · VALVE**

*Advt. The Mullard Wireless Service Co., Ltd., Mullard House, Denmark Street, London, W.C.2.*

Published by RADIO PRESS, LIMITED, Bush House, Strand, London, W.C.2, on Tuesday of each week, and printed for them by THE AVENUE PRESS (L Upcott Gill & Son, Ltd.), 55-57, Drury Lane, London, W.C.2. Address for Subscriptions and Editorial Communications:—Bush House, Strand, London, W.C.2. Address for Advertisements:—Advertisement Manager, WIRELESS, Bush House, Strand, London, W.C.2. Phone: City 9911. Registered as a newspaper and for transmission by Canadian Magazine Post. Subscription rates: U.K. and abroad:—13s. per annum, 6s. 6d. for six months, post free. Sole Agents for Australasia:—GORDON & GOTCH (Australasia), LTD. For South Africa:—CENTRAL NEWS AGENCY, LTD. American Agents:—INTERNATIONAL NEWS Co., New Ycrk. Canadian Agents:—THE AMERICAN NEWS Co., LTD., also IMPERIAL NEWS Co., LTD.