

WIRELESS, incorporating "Wireless Weekly," August 7, 1926.

WIRELESS



INCORPORATING
WIRELESS WEEKLY

2^D
WEEKLY

Vol. IV.] AUGUST 7, 1926. [No. 11.

IN THIS ISSUE :
**MOLLY-CODDLING
THE B.B.C.**

By PERCY W. HARRIS, M.I.R.E.

A NEW TYPE OF CONDENSER

By J. H. REYNER,
B.Sc. (Hons.), A.C.G.I., D.I.C., A.M.I.E.E.

**SPECIAL ARTICLE
BY CAPTAIN ROUND**

"Cartoonigrafs" Competition

[Registered at the G.P.O. as a Newspaper.]





“The Set that made a village famous”

HAVE you realised the possibilities of this famous set? Can you imagine the joy resulting from the possession of such a magnificent receiver?

Many hundreds have built it and are now enjoying not only pure reception, but are receiving stations with magical ease.

The unbounded possibilities of the “**Elstree Six**” in the number of stations that can be logged have fascinated all.

Their experience is within your reach.

The June and July numbers of **MODERN WIRELESS** give you full details of construction and operation. It is simple to build and easy to handle. It is in fact the receiver of the year.

Build it now: then join the “**Elstree Six**” Club.

One Shilling
MONTHLY

Modern
Wireless

Obtainable from all News-agents, Booksellers, Bookstalls, or direct from the Publishers.
Subscription Rates 15/- per annum (13/6 per annum Canada & Newfoundland).
Lesser periods *pro rata*.

RADIO PRESS LTD., BUSH HOUSE, STRAND, LONDON, W.C.2



Use
THE
CLARITONE
Britain's Best
FROM ALL RADIO DEALERS



*-for H.F.
Amplification*

THE MATCHING AND TESTING of Bowyer-Lowe H.F. Transformers is so carefully executed, that any two transformers can be obtained at any time and from anywhere with the certain knowledge that they will be identical in every detail. Ranges are made covering all wave lengths from 150 to 3,000 and up—as well as a special Neutralising Unit. The Bowyer-Lowe 12 months' guarantee accompanies every transformer.

All are sold at the **9/-** uniform price of

Bowyer-Lowe matched H.F. TRANSFORMERS

ANNOUNCEMENT BY THE
BOWYER-LOWE, CO. LTD LETCHWORTH, HERTS.

OPPOSITE ADAGES, No. 4.

'An ounce of practice is worth a pound of theory'

Specify
DUBILIER
PRODUCTS

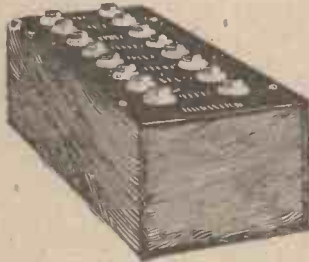

Have you entered for the Dubilicon Competition yet?
If not, write to us now for full particulars.
Cash Prize £200.

REGISTERED  TRADE MARK

DUBILIER
CONDENSER CO (1925) LTD

ADVT. OF THE DUBILIER CONDENSER CO. (1925) LTD., DUCON WORKS, VICTORIA ROAD, N. ACTON, LONDON, W.3. Tel. Chiswick 2341-2-3.

E.P.S. 214

The Big Four

Facts You Must Know

THE WIRELESS CONSTRUCTOR has by far the largest net sale of any technical or semi-technical wireless journal; whether monthly or weekly. During 1925/1926 the advertisement revenue per issue was by far the largest of any wireless journal and reached £3,876.

WIRELESS (incorporating Wireless Weekly) has the largest certified net sale of any *weekly* wireless paper (auditor's certificate for 115,536 copies per week just issued). During 1925/1926 the advertisement revenue achieved the magnificent figure of £1,000 per week.

MODERN WIRELESS comes next to our journal THE WIRELESS CONSTRUCTOR in the monthly field and has a net sale far in excess of any monthly outside the "Big Four" of the Radio Press Limited. During 1925/1926 the advertisement revenue per issue was higher than any other wireless paper (except our own Wireless Constructor) and reached £3,067.

THE WIRELESS DEALER going directly to over 5,000 individual members of the trade has carried during the last year a very large volume of advertising. To give you some idea of this it is sufficient to say that "The Dealer" has carried 56 per cent. more advertising per issue than any weekly wireless trade paper.

From the above facts it is clear that Radio Press papers are pre-eminent in the monthly, weekly and trade fields.

RADIO PRESS LTD., BUSH HOUSE, STRAND, LONDON, W.C.2





WIRELESS

INCORPORATING

WIRELESS WEEKLY

JOINT EDITORS

PERCY W. HARRIS

M.I.R.E.

J. H. REYNER

B.Sc. (Hons.), A.C.G.I., D.I.C., A.M.I.E.E.

ASSISTANT EDITOR

G. P. KENDALL

B.Sc.

TECHNICAL DIRECTOR

JOHN SCOTT-TAGGART

F. Inst. P., A.M.I.E.E.



THIS WEEK'S NOTES AND NEWS

Labour Saving

SAY, bo's and bo'esses, guess I'm jest tickled to death! Here's Tom Blevins, a Utah cowboy, who calls the cows home with a portable wireless set and loud-speaker instead of singing to them! He receives it from station WGES, and wrote to the station telling them that "they sure were saving his voice." If his loud-speaker is anything like the one owned by that neighbour of mine, of whom you hear so much, I shouldn't be surprised if it causes a stampede one of these days.

Local Interference

A FRIEND of mine has recently compiled a list of all the sources of interference with which he has come in contact. It certainly is a formidable affair, and shows how careful one would have to be in choosing a situation which would be free of all "local" interference, without even considering such bug-bears as spark stations and atmospheric. Chief of the nuisances on this list are flashing signs, X-ray machines, vibro-massage machines, tramways, motor commutators, and even the ordinary car magneto.

International Programmes

"UNCLE ARTHUR," though not in Great Britain very often, is, you may be sure, remembering the old folks at home. He is now, I hear, forming a "Commission for Intellectual, Artistic and Social Advancement," which will promote the scheme for international programmes which is to start in the autumn. Under this scheme there will probably be an "English night," when the B.B.C. would relay English programmes, as

sent out from other countries, and, perhaps, a French night, when all the European countries except France would broadcast special French programmes, which would be picked up and relayed by the French stations. This seems to me an extraordinarily interesting scheme, and I am sure those with "DX" sets will look forward to its commencement.



Preparation for the National Radio Exhibition at Olympia from September 4 to 18 are already well-advanced. A preliminary list of exhibitors and stand numbers will be given in our next issue.

Spanish Airways

SPAIN is pushing ahead with the radio equipment of her aircraft, and I now hear that twenty-three Marconi "AD6" type sets (the type used so extensively on British 'planes) have been installed. Further large orders are on hand at present. The ground stations, about ten in number, are very similar to our own "Cr-r-roydon" that we knew so well before the days of broadcasting, but who is now, I am afraid, somewhat neglected.

Portable Sets!

THE Radio Club de France is equipping various refuges for mountaineers with wireless apparatus, both for transmission and reception, in view of the difficulty of fitting them up with the telephone. Specially rugged apparatus is to be used, and the difficulties of getting it up into position are pretty serious, as most of these refuges are higher than any animals can reach; the entire apparatus will have to be carried up on men's backs!

The Swedish "Big Noise"

SINCE I wrote about the erection of a high-power station in Sweden on the lines of Daventry, I have heard officially that it is to "out-5XX 5XX," as 30 kilowatts will be used at first, and possibly 50 kilowatts afterwards. It is to be at Motala, and should be quite a "big noise."

THE latest ships to be equipped with radio are eight whalers. The apparatus will consist of standard Marconi telephony transmitters and receivers.

Strange!

THERE is quite one orchestra in the States that does not play jazz! Stranger still, there is a chance that listeners in this country may hear it. It is the New York Philharmonic orchestra, and it will broadcast from WJZ, the Bound Brook station. If it is at all possible, the indomitable staff at Keston will brave the fury of the X's and "put it through." The broadcasts will not take place just yet, however.

(Continued on next page.)



We are hearing a good deal lately about the use of wireless on trains in America. This view shows three engineers of the Zenith Radio Corporation carrying out experiments on a New York Central train

Perhaps!

A HIGHLY ingenious theory which is said to explain those freak receptions which occur so frequently has just been put forward in all good faith by an unconscious humorist. It is that the Heaviside layer is perforated, and occasionally a wave goes straight through, slides along the top, and falls down again!

Revelations

I SHOULD think, from the advance news of the coming Radio Exhibition that I have received, that the "Attaché - case" receivers which will be on show in large numbers will create quite a sensation among those cynical individuals who think that wireless and weight always go hand-in-hand. Sets are steadily becoming smaller, and results (or, rather, the owners' accounts of results) larger.

A New Service

TELEGRAMS will be sent direct from Nauen, in Germany, to Rio de Janeiro, commencing early in August. The charges will, I hear, be considerably less than those at present in force. Germany is already working direct with North America, Argentina, Java, China and Japan.

Quite Untrue!

A PARTICULARLY bad burst of interference to broadcast receivers on the South Coast was recently traced to a passing liner, which could be quite clearly seen from shore. A Morse reader was able to supply the call-sign of the interfering station, and the owner thereof was looked up in the "book of words," the culprit

THIS WEEK'S NOTES AND NEWS

(Continued)

thus being found. The rumour that coast-dwellers read the Morse by the sparks on the ship's aerial is, however, quite incorrect.

Loud-Speakers Again

FROM all round news is coming a hand of complaints about the raucous loud-speaker and the nuisance it causes. Reading is the first place to take the matter in hand seriously, however, and since the passing of a new by-law it is illegal to operate a loud-speaker in such a manner as to cause annoyance to residents. Bravo, Reading! The loud-speaker hog can make himself a real nuisance, and it is not necessary to use six or seven valves on the local station just in order to show your neighbours what a wonderful set you have. Councillor R. Ellison, of Sidecup, has thought of a scheme for carrying the idea a little further, and hopes to form the S.C.N., or the "Society for Checking Noises"!

I do not advise you, however, to follow the example of the Blackfriars lady, who recently smashed up a set and aerial belonging to someone else in the same house because, like Mac-

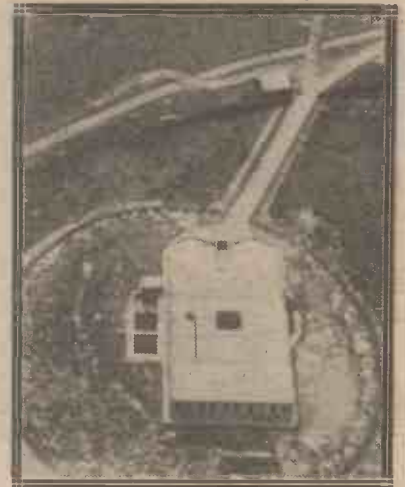

Daventry's "birthday" was celebrated on July 27: A somewhat unusual view of the station buildings appears above.

Firman, will play fairly frequent selections from the older dance repertoire. The Savoy Havana Band is "coming back" on Thursday, August 5, and the Orpheans will be taking a fortnight's holiday from August 15 onwards.

Coming Events

THE first broadcast of Evensong from Westminster Abbey, which was originally announced for July 22, has had to be postponed for a few weeks. It is, however, nothing more than a postponement.

On August 16 "The White Chateau," which was broadcast last Armistice Day, will be repeated. August 16, you will remember, is the anniversary of the landing of the B.E.F. in France in 1914.

The Community Singing in the churchyard of St. Martin-in-the-Fields is, as I predicted, to be broadcast on Thursdays from 1.0 to 1.20 p.m. The usual gramophone transmissions will therefore be postponed till 1.20, and will continue till 2.20.

On August 12 Dover is having a "look-in." The Band of the 2nd Battalion of the Queen's Own Royal West Kent Regiment will broadcast from Granville Gardens Pavilion on that date.

On August 6 the torchlight tattoo at the Depot, Royal Marines, Deal, will also be broadcast. The Depot Royal Voluntary Cadet Corps will also take part.

CALL-SIGN.

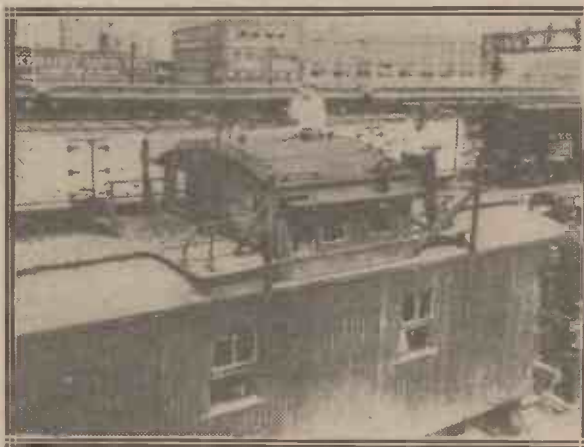

This view shows the aerial being fitted to the train referred to in connection with another photo on this page.

beth, they, with the help of the inevitable loud-speaker, had "murdered sleep." She was fined 1s. I suspect the magistrate of being sympathetic!

A Step Further

THE recent duel between Mr. Jack Hylton and Sir Landon Ronald has encouraged the B.B.C. to carry the "jazz-v.-music" controversy a stage further. For the present, the London dance band, under Mr. Sidney

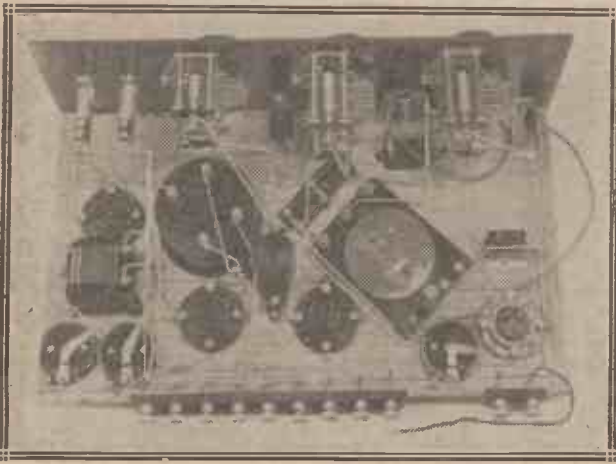

A REINARTZ TUNED-ANODE SET

By W. Q. KAY

This screened-coil four-valve set uses a very simple stabilising scheme, and will be found very easy to operate.



THE system of reaction popularly known as the Reinartz has many advantages, one of the principal being extreme smoothness of operation which can be obtained with its aid. The present

contains a second tuned coil, this coil, however, being provided with an overhanging portion, tapped at various points. The anode of the previous valve is connected to one of theseappings, so that the energy is passed on from one valve to the next by this means.

itself. This has been done accordingly.

L.F. Coupling

Following this valve are two stages of note magnification. The first of these is choke-coupled, a simple choke

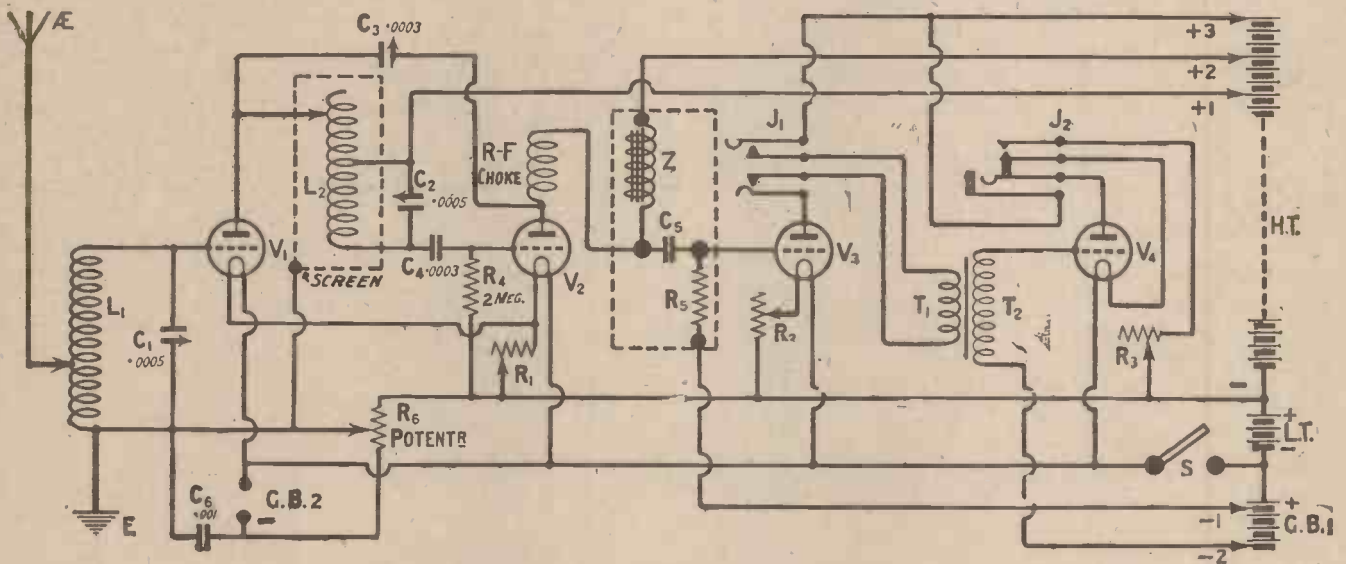

Fig. 1.—The L.F. choke, fixed condenser, and resistance, marked Z, C5 and R5 respectively in this circuit diagram, are all contained in one unit.

receiver is the result of an attempt to apply these principles to a tuned-anode circuit. In many cases to-day a high-frequency amplifying valve is desirable and often essential in order to obtain some special degree of selectivity. If, therefore, we could obtain a receiver in which the Reinartz connection, with its several advantages, could be employed on the high-frequency valve, the resulting combination should be a very good one.

The Circuit

The circuit employed is shown in Fig. 1. The aerial circuit is of the usual type, the aerial circuit proper being connected across a part of the grid coil only in order to improve the selectivity.

The grid circuit of the second valve

Reaction

The anode of the second valve is also connected to the tapping points on the coil, through a variable condenser, in order to provide the necessary reaction effects. The second valve is arranged to act as a detector, for which purpose the usual condenser and leak is incorporated in the grid lead.

As the bottom end of the coil is connected to the high-tension terminal, in order to provide the H.T. voltage for the previous valve, it is necessary to connect the grid leak to the filament and not across the condenser

unit being incorporated for the purpose.

(Continued on next page.)

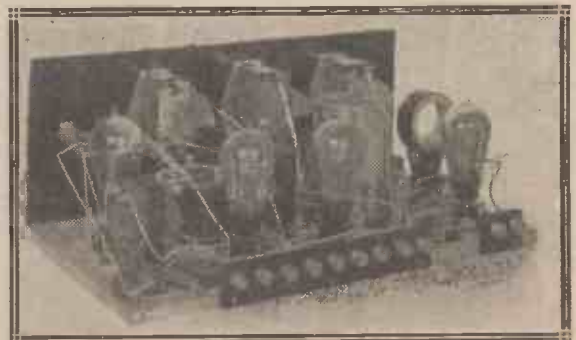

The metal screen seen behind the third valve from the left is connected to earth.

A Reinartz Tuned-Anode Set—continued

In order to prevent the high-frequency currents from passing through the low-frequency paths in the circuit, a high-frequency choke has been incorporated in series with the L.F. choke. This also serves to improve the reaction effect which depends on the H.F. currents flowing through the circuit composed of the condenser C_3 and the coil L_2 .

The second stage is a straightforward transformer-coupled stage. For this purpose a medium-ratio trans-

former is required, assuming that an ordinary L.F. or small-power valve has been employed in the first stage.

I myself have used a B.T.H. instrument in this case having a ratio of 4 to 1, which gives excellent quality.

Switching

Jack switching has been incorporated in order that three or four valves may be employed at will. The last jack is also a filament switching

one, being so arranged that it cuts out the last valve when only three valves are being used. The filament controls are the new Lissen "variable" fixed resistors. These are simply the well-known Lissen rheostats without the knob and dial.

They can thus be fixed on the baseboard, set to the correct position and then left. A simple on-off switch disconnects the L.T. battery when the set is not in use.

A point of particular interest is that

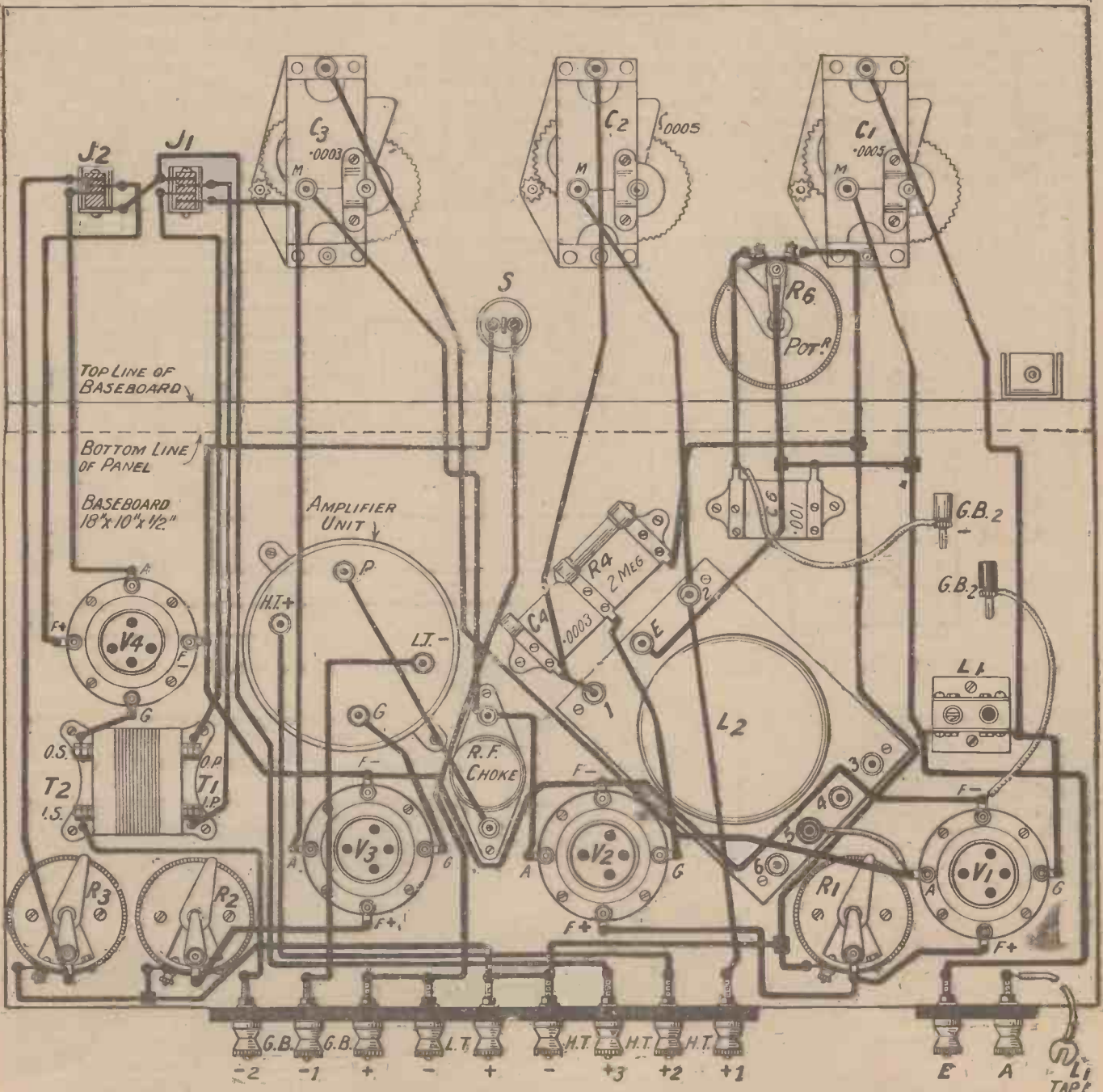

Fig. 2.—The disposition of the coils upon the baseboard should be carefully copied from this wiring diagram.

A Four-Valve Receiver of Special Merit

potentiometer control is used on the first H.F. valve, in place of one of the more usual neutralising methods.

A Screened Coil

The second coil has been enclosed in one of the screened containers developed by Mr. J. H. Reyner, so that all magnetic interaction between the first and second circuits is eliminated. In such circumstances the only tendency to oscillation is that due to the internal capacity of the valve itself, which, though present, is fairly easily controlled.

Potentiometer control has therefore been incorporated, the theory being that the amount of damping required to maintain the circuit in

tance, the results obtained being up to the standard usually obtained with a neutralised H.F. stage. This is pro-

.0003 (reaction) condenser being on the right.

The potentiometer and on-off switch are then mounted in the positions shown, while the two jacks are mounted in the right-hand top corner, as will be seen from the panel diagram and photographs accompanying this article. The panel may now be put on one side, and the remainder of the components laid out on the baseboard.

The single-coil mount is placed on the extreme left of the baseboard, and the screened coil next to it. The position of these two components is not critical, provided that the plug-in coil is more than 1½ in. away from the copper screen.

The H.F. and L.F. chokes and the L.F. transformer may then be laid out, and finally the three fixed re-

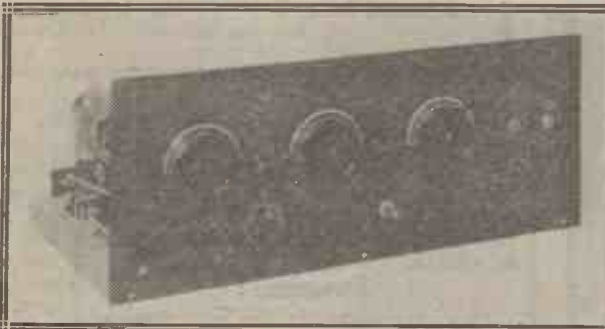

The panel lay-out is a simple one.

bably due to the fact that the first circuit is already damped by the aerial circuit, so that the slight additional damping produced by the potentiometer control is not serious. This argument would not hold for more than one stage of H.F., and only holds in this case because of the use of a shielded coil.

Components

The following components will be required. For convenience the manufacturers' names are given after each component.

One panel, 18 in. x 7 in. x ¼ in. (Trolite).

One cabinet to suit, with baseboard 10 in. deep.

Two .0005 variable condensers, slow-motion type (Jackson Bros.).

One .0003 variable condenser, slow-motion type (Jackson Bros.).

One coil screen (Peto-Scott Co., Ltd.).

One Reinartz coil or, alternatively, one coil blank (Peto-Scott).

One L.F. choke unit complete (Bretwood).

One H.F. choke (Lissen).

One L.F. transformer, 4 to 1 (B.T.H.).

Four valveholders (Lotus).

Three baseboard-mounting resistors to suit valves (Lissen).

One on-off switch (Igranio).

One potentiometer (Lissen).

One single-coil mount (Burne-Jones & Co.).

One double circuit jack, No. 233 (Bowler-Lowe Co.).

One single circuit jack, filament switching type, No. 234 (Bowler-Lowe Co.).

One clip for grid-bias battery (A. F. Bulgin & Co.).

One .0003 fixed condenser with series clip and 2 meg. leak (Dubilier).

One .001 fixed condenser (Dubilier).

Mounting the Components

The construction of the receiver requires a little care owing to the compact layout adopted. The panel components occasion no difficulty. The three condensers are first mounted, the

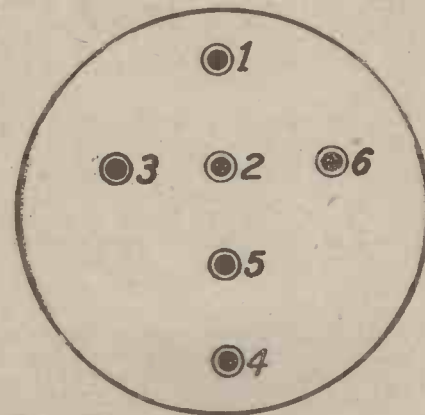
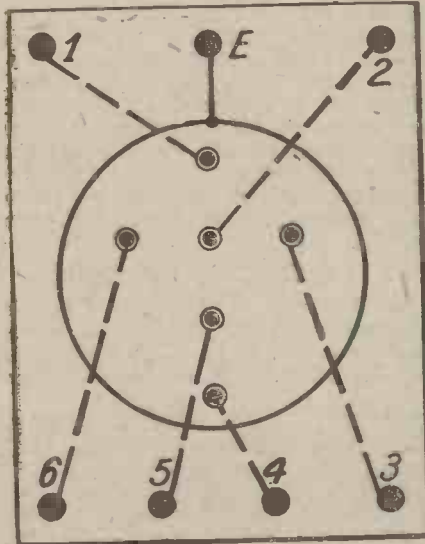

Fig. 3.—The connections between the sockets of the screen and the terminals thereon, and also the numbers of the pins on the coil itself may be gathered from this drawing.

a stable condition would be very small, and would not affect the selectivity of the circuit to any appreciable extent. This proved to be the case in prac-

WIRING INSTRUCTIONS

- Join terminal A to a spade tag (flex lead).
- Join G of V1 to one side of L1 and thence to fixed vanes of C1.
- Join terminal E to other side of L1 and thence to other side of C1. Terminal E also to one side of C6 and thence to slider of R6 and to terminal E of screened coil.
- Join remaining side of C6 to one side of R6 and to black wander plug (flex lead).
- Join A of V1 to fixed vanes of C3 and to spade tag (flex lead).
- Join other side of C3 to one side of R.F. choke and thence to A of V2.
- Join other side of R.F. choke to terminal P of amplifier unit.
- Join H.T.+ of amplifier unit to H.T.+2.
- Join terminal 1 of screened coil to one side of C4 and to fixed vanes of C2.
- Join other side of C4 to G of V2.
- Join terminal 2 of screened coil to other side of C2 and to H.T.+1.
- Join G of amplifier unit to G of V3.
- Join L.T.- of amplifier unit to G.B.-1.
- Join A of V3 to contact 4 of J1 (bottom contact).
- Join contact 1 of J1 to contact 4 of J2 and to H.T.+3.
- Join contact 2 of J1 to I.P. of T1 T2.
- Join contact 3 of J1 to O.P. of T1 T2.
- Join O.S. of T1 T2 to G of V4.
- Join I.S. of T1 T2 to G.B.-2.
- Join A of V4 to contact 3 of J2.
- Join one side of R3 to one side of R2 and thence to L.T.+ , H.T.- , one side of R1, remaining side of R6, and the free side of R4 respectively.
- Join other side of R1 to one filament contact of V1 and V2 respectively.
- Join other side of R2 to one filament contact of V3.
- Join other side of R3 to contact 1 of J2.
- Join contact 2 of J2 to one filament contact of V4.
- Join G.B.+ to L.T.- and thence to one side of S.
- Join other side of S to remaining filament contacts of V4, V3, V2 and V1 respectively. Join latter point to red wander plug (flex lead).

sistors and the four valve holders may be placed in position.

(Continued on page 395.)



A recent portrait of Sir Harry.

IT'S a serious task, ye ken, this bein' unco' funny by wireless! It's so different from the ordinary being funny on the stage that it seems like a new art, which we poor comedians have to learn right from the beginning, like we learnt to be funny in theatres years ago. But there's always something new to learn every time ye broadcast and every time ye listen-in to anyone else.

That Deathly Silence

The difficulties ye meet are all so new and unexpected. I think perhaps it's the absence of applause is the worst obstacle. And the more applause ye're used to on the stage the worse it seems hearing that deathly silence in the studio. Here's a description of the first time I ever broadcast.

I was fair nervous to begin with, I can tell ye! I was thinkin' all the time of how I was tae get all my voice into the microphone without any of it escapin', and wonderin' how on earth I was to get on without being able to depend for a laugh or twa on ma little twirly stick or wee dances. Eventually I decided to dress completely as if I were on the stage, carry out every action and gesture just as exactly, and, in short, behave just as if I were actually facing an audience of millions instead of merely talking to them. It was weird enough, however, and after ma first song I got real microphone-fright.

The Instinctive Pause

Tell ye, it was like this. I paused instinctively to hear the gale of laughter and clapping. But there was never a whisper! The pause seemed ages long, and then ma heart began tae sink, even though I knew the jokes were as guid as ever. Yet this is not enough to satisfy any

BEING FUNNY BY WIRELESS

By SIR HARRY LAUDER

A special article for "Wireless" readers which gives an interesting insight into the difficulties "at the microphone end."

comedian. There is a strange thing about audiences which can never be estimated beforehand, and that is their reception of wee true stories. There's some crowds will laugh uproariously at things which others pass in silence.

Strenuous!

How, therefore, is the unfortunate radio-comedian to judge which will amuse the universal listener-in? Most of us decide it's little use trying, and



Lady Lauder is here seen listening to one of Sir Harry's broadcast performances.

act on this principle. Just those items which get most applause of all on "the boards" are selected, and we hope our very best that something in the programme will please everybody. Still, it's a scaring thing, this performing before an unresponsive audience, for, ye see, in any other place, lack of response tells ye there's something seriously wrong with your work. Oh, it makes ye wipe ye brow, does this broadcasting!

Little Orchestral Help

One thing we funny men always have to remember in sending our fun across the ether. Absolutely the whole effect of our work depends upon what we say and the way we say it. Although the orchestra is helpful, still it is naturally impossible to depend upon it to cover any awkward moment—as it will on the stage—because the conductor can judge no more than yourself just when a wee joke has failed to "get across," and consequently misses the psychological moment to strike up. So what we have to do is this. A sequence has to

be invented, with great care and accuracy, which will lead the listeners-in into the best possible frame of mind to appreciate the jokes. Gradually, ye ken, their minds get "in tune," and they begin to laugh easily. Then one or two of the best of the jokes, a song, and they're all telling one another how fine that little turn was!

The Greatest Difficulty

Our greatest difficulty at present is that it is naturally impossible to hear oneself broadcast. Listening-in to another comedian is not the same thing at all, for you must know that every comedian depends for his appeal on entirely different factors. However, as it seems impossible that an invention could be made to let a pair comedian-laddie listen to his ain jokes (an' perhaps it's as weel!), we must just gang on and be satisfied with the reports of our friends—and our critics.

A Great Opportunity

Still, despite all the worry of it, it's a grand opportunity wireless has given us who can be funny. A new vista has opened to us. Where before we were



The famous comedian before the microphone on the occasion of his broadcast from the Ideal Home Exhibition.

only able to appeal to the limited number of people who can come to theatres and music-halls, now there is the whole

(Continued on page 396.)

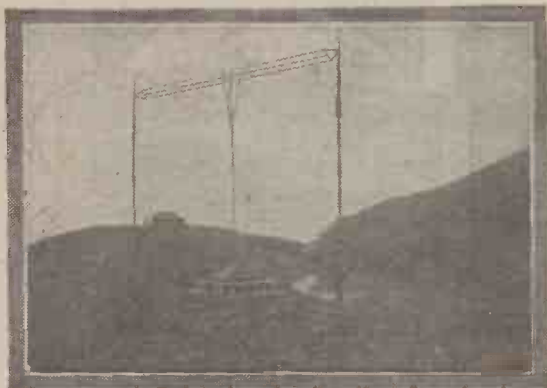

LIGHTNING

By **STANLEY G. RATTEE, M.I.R.E.**

An account of one of the few recorded instances of the striking by lightning of a commercial station.



THE rather severe storm which took place in various parts of the country recently has again raised the old question of "the lightning danger."

From the point of view of interest, the writer, though associated with wireless since his school-days, in most countries of the world, has only experienced one occasion when it could be stated definitely that an aerial was actually struck by lightning.

Other Cases

There have, of course, been several other instances outside my own experience, as, for instance, the description of events at the Elstree Laboratories on April 7, given in Vol. III, No. 10, but from personal contact the following is the only occasion upon which any inconvenience was felt from the direct effects of lightning.

Where It Happened

The incident in question took place in Hongkong, and as readers know this island is not far removed from the tropics. Owing to this fact there are at times most severe storms experienced in and around that part of the world, and though hardly comparable with the more generally less severe storms of Europe, the occasion is, nevertheless, one of interest at this time of the year.

A High Aerial

The aerial, which was suspended between two 220-ft. masts, belonged to a naval station, the installation being the usual transmitters of both spark and C.W. apparatus, with crystal and valve receiver.

During one evening, and without any warning, such as, for instance, the prevalence of atmospherics, a storm suddenly "got up," the very first flash of lightning striking the aerial.

The Flash

At the time the operator on watch

had momentarily removed the 'phones in order to exchange a few remarks with a companion, when suddenly the flash came, accompanied by a deafening report.

The building, which had previously been illuminated by electric light, became totally dark so far as "man-made light" was concerned, but appeared to be quite appreciably lit up by a strong purple glow in the form of tiny sparks creeping all over the walls and windows.

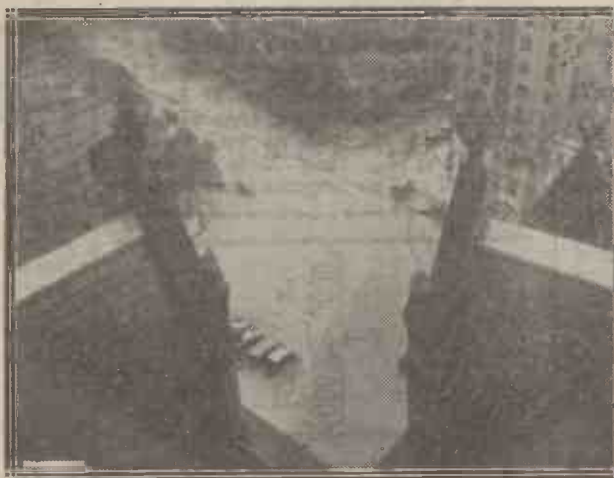

Where a flash of lightning might do real damage: part of the complicated system of aerials at the Central Post Office, New York.

The Main Damage

Upon the cessation of the storm, careful examination of the station revealed the damage done to be mainly confined to the transmitting plant, though the accumulator battery, which formed part of this component, escaped uninjured.

Perhaps one of the most remarkable things is the fact that the receivers were not injured, so far as results were concerned, the only evidence of rough usage appearing on the outside.

The aerial itself was destroyed completely, various pieces of insulators being scattered about on the ground immediately below; the masts, however, were not damaged in any way.

The Earth Switch

Though there were, of course, special switching devices on the station, whereby the aerial could be earthed, there was not an opportunity of taking advantage of this safety switch, on account of the suddenness with which the storm "got up."

It is not usual to experience storms in this country of such severity as those met with in the tropics, but notwithstanding this fact, I am a very strong advocate of that well-known rule, "earth your aerial" and be on the safe side, and as confirmation of the wisdom of this conclusion the photographs we have seen, showing the damaged receiver of an unfortunate listener, are more than sufficient.

AN APPRECIATION

SIR,—I have constructed the WIRELESS transformer-coupled amplifier described by Mr. Stanley G. Rattee in the special amplifier number of WIRELESS, and feel bound to thank him for describing such a splendid little unit. The amplification that can be obtained from it without any trace of distortion is really remarkable, and for stability it is the most satisfactory amplifier I have ever handled.

I have been experimenting with power amplification, using 300 volts on the plate of the last valve (which then requires about 24 volts grid-bias), and find that the transformer and other components, used by Mr. Rattee stand the strain imposed upon them perfectly.

All thanks to WIRELESS and Mr. Rattee.—Yours truly,
ERNEST J. SHERRATT.

Lowestoft.

NEXT WEEK

PORTABLE SETS ON
THE RIVER

YOUR SET AND ITS EARTH

By Captain H. J. ROUND, M.C., M.I.E.E.

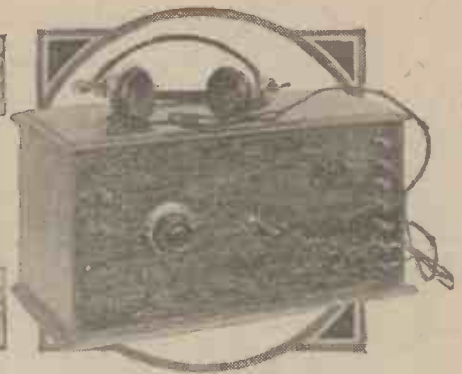

Strange behaviour on the part of many sets, particularly neutralised ones, often means that the earth connection is not doing its duty correctly. Captain Round explains just how the troubles are produced and gives the practical remedies.



IN a recent article I discussed some of the questions involved in the efficiency of aerials, but I entirely neglected certain very practical cases where aerials can be obtained, but earths are

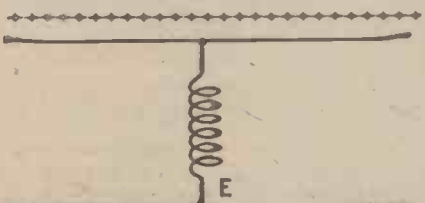

Fig. 1.—If an aerial is connected to earth as in this diagram, the point E is at zero potential.

difficult to get, and as these cases are frequent, and cause trouble with various pieces of apparatus, they are of considerable importance. I shall, of course, not be able actually to deal practically with every case, because there are so many, but in the following notes will be found the general principle to follow in almost every case.

An Important Spot

If an aerial is connected to earth as in Fig. 1, the point E is at zero potential, and in design we try and get all our batteries, etc., connected to this point, so that whatever we do to them there is no effect on signals, but if in the earth lead we put a condenser C

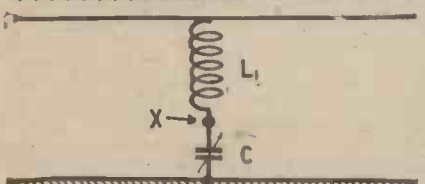

Fig. 2.—The condenser C in the earth lead will bring about a distinct difference of potential between the point X and earth.

(Fig. 2), then there is a distinct difference of potential between the point X and the earth, and if our batteries are connected to X (unless C is a very large condenser), we shall have our

batteries, telephones and our body connected to what should be a sacred point, and as a consequence—aside from variation of tuning as we move about with 'phones on our head—we shall get losses.

The same thing occurs in Fig. 3, where L_1 is the loading coil and L_2 is a long earth lead, X again becomes a sacred point. The case of Fig. 2 occurs where we are using a capacity earth and that of Fig. 3 when using a long earth wire or pipes from the top of a building. The remedy is the same in both cases, and that is to tune the earth connection.

Tuning the Earth Lead

Fig. 4 represents Fig. 2 modified by the addition of a coil L_2 . If L_2 and the earth capacity are in tune with the wave being received as well as the aerial and L_1 , then X is at earth potential and no longer a sacred point.

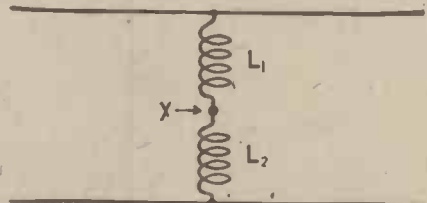

Fig. 3.—In this case L_1 is the loading coil, while L_2 represents a long earth lead.

Fig. 5 is Fig. 3 modified by adding the condenser C to tune the earth, where, if C and L_2 are in tune with the wave being received as well as L_1 and the aerial, then X is again at zero potential.

Practical Methods

And now my difficulty is to give you ways of doing these operations correctly. As a number of other questions are involved, I will take a simple symmetrical case and discuss it in detail, and then build up more difficult cases from that one. Suppose you have a small flat and wish to erect an aerial and you have no satisfactory earth, you want to do two things:—

(1) Get the maximum effective height.

(2) Get the lowest loss aerial and earth system.

Choose your longest room, and across the longest side, 1 ft. from the ceiling

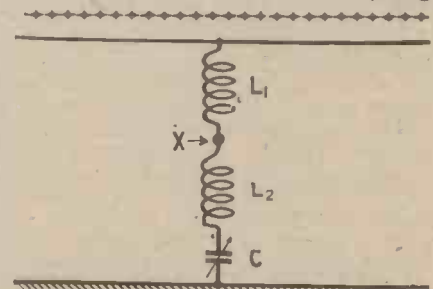

Fig. 4.—If L_2 and the earth capacity C is in tune with the wave being received as well as the aerial and L_1 , then X is at earth potential.

and 1 ft. from the wall, stretch a wire over and insulate it at both ends. If you like to make the one wire into a sausage, well and good; it will increase the capacity, but keep it away from the wall and ceiling. Now across the room underneath the aerial put a similar arrangement 1 ft. from the floor and 1 ft. from the wall.

The Zero Point

The aerial and earth capacities being now roughly equal, your tuning coil should be tapped in the middle for any battery connections, etc., as that point

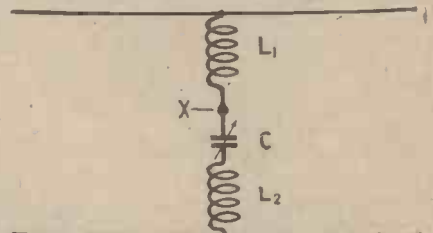

Fig. 5.—This circuit is similar to fig. 3, but has the addition of the variable condenser C to "tune" the earth.

will be at earth potential. A tuning coil for such an arrangement should be built generously, because it will have to consist of a lot of wire. Perhaps

(Continued on page 372.)

1925

CLEARTRON'S POLICY--
"POPULAR PRICES
FOR QUALITY VALVES"

1926

CLEARTRON STANDARD VALVES—C.T.08, C.T.15, C.T.25 and C.T.25B, at 12/6 and 15/- have made CLEARTRON'S name in the Wireless Trade.

CLEARTRON'S new 1926/27 models with NEW filaments, INCREASED electronic emission, HIGHER vacuum and LONGER life.

Give "Last word" satisfaction and are always backed by CLEARTRON'S IRONCLAD GUARANTEE.

Send for new season's catalogue with full technical data, etc.

CLEARTRON RADIO LIMITED

ONE CHARING CROSS, LONDON, S.W.1.
Telephone: Regent 2231-2.

(Works: Birmingham.)
Telegrams: "Cleartron, Westrand, London."

Σ See us at Stands 135, 102, 46

National Radio Exhibition. Σ



CT/54



Low Frequency Transformer.

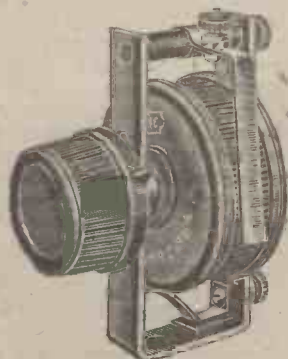

Low Resistance Potentiometer.

Elstree Six

All components required to build the above (with possibly one exception) are made and supplied by Igranic Electric Co., Ltd.

Apply for Price and Particulars.

A set built entirely from "Igranic" parts (with the exception named above) was examined at the Radio Press laboratories, Elstree, on July 6th, 1926, and was found to be equal to any model that had been submitted, even those built entirely from the parts specified in "Modern Wireless."

SEND FOR LIST No. S23



149, QUEEN VICTORIA ST., LONDON
Works: BEDFORD.



"Nonmic" Valve Holder.



Dual Variable Condenser.

Your Set and Its Earth—continued

two coils will be more convenient, and I suggest they should be wooden frames, 9 in. square, wound with No. 20 enamelled wire spaced $\frac{1}{2}$ in., if you do not mind the rather large appearance. The right lengths will have to be found by experiment, but I suggest 200 ft. of wire on each coil, say 70 turns. Tuning can be done by tapping on to the coils. If the same number of turns are used in both aerial and earth leads, then the centre point X (Fig. 6) will be your zero potential place, and you will have an aerial with nearly as good tuning as a frame and with much more induced voltage.

The chief points to aim at here are:—

- (1) To keep bad dielectrics away from both aerial and capacity earth.
- (2) To get high efficiency in the tuning coils.

Any variation from these two points will result in weaker signals and worse tuning.

Alternatives

Having built up this symmetrical arrangement, in which we have made

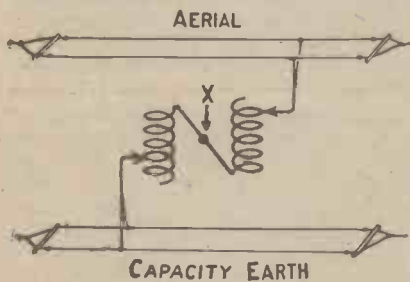

Fig. 6.—By using the same number of turns in this case in both aerial and earth leads, then the centre point X will be at zero potential.

the reasonable assumption that aerial and earth capacities are equal, we can proceed to make variations. For instance, if we have a real earth we can earth X and remove the lower part of the apparatus, and no change of aerial tuning will be necessary, or, leaving the lower part of the arrangement alone below X, we can put an outside aerial on (Fig. 7) and tune it up, and we will know that X is a real zero point; or suppose we tune up the whole arrangement to a station, then connect X to a gas pipe or radiator.

If variation of aerial tuning is required, then a series condenser is required in the earth lead because in this case the earth lead is an inductance and not a capacity like the capacity area (Fig. 8), and this series condenser should be adjusted until the aerial tuning is back at its original value when used with the standard capacity earth. Once this gas pipe arrangement has been adjusted the aerial side can then be replaced by

an outside aerial, so that from the basic system we have constructed a proper aerial system.

Approximation

I do not in all cases suggest this roundabout way of constructing an aerial and earth system, but I give it as an illustration of the method of

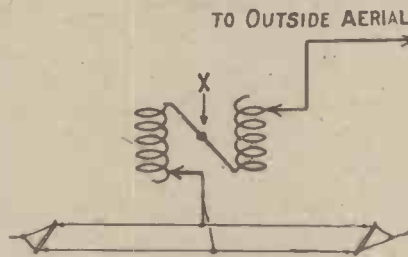

Fig. 7.—Having performed the operations of fig. 6 an outside aerial can be attached and the point X again adjusted to zero potential.

obtaining a correct system if it is required. Great accuracy in getting X to zero potential is not absolutely necessary in many cases—a little inaccuracy is allowable—in fact, it is very difficult to know when X is exactly right. Slight variations from zero potential of the point X are permissible, but too much variation should not be allowed.

In the case of Fig. 8, which I often use for certain multi-valve receivers, I set the earth condenser for about the middle of the wavelength range I am using, and I estimate its value this way: I assume one microhenry per yard of earth wire, then I calculate the condenser in tune with these microhenries at 400 metres and fix it permanently.

With a Neutrodyne

The importance of tuning the earth is mainly from the loss and stability

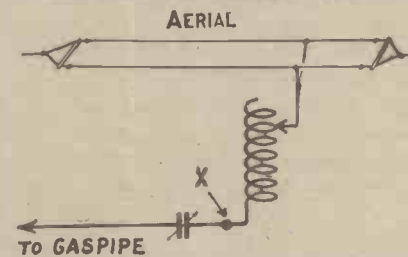

Fig. 8.—If variation of aerial tuning is required, then a series condenser is required in the earth lead.

point of view. One example of the necessity of a good zero potential earth connection is found in the neutrodyne.

The neutralising in a neutrodyne depends upon the ability to pick out some point on the circuit of opposite

potential to that inducing energy back through the valve, and it is obvious that we must be very certain that this point gives us the value of opposite potential we desire at all wavelengths. But if the zero of potential is indefinite, shifting with wavelength as it will do if the earth is capacitive or inductive, the neutrodyne balance will not be maintained, and in that case a partial balancing of the earth capacity or inductance is advisable.

My own 8-valve neutralised receiver (the "Straight Eight") is quite sensitive to a long earth connection, and in this case I balance the earth inductance out for a middle wavelength by the rule I have previously mentioned.

Another Type

The standard capacity earth I have indicated is possibly larger than need be if great care is used in construction. For instance, a large spaced spiral 2 in. long and 10 in. diameter could be used; the rule for getting it

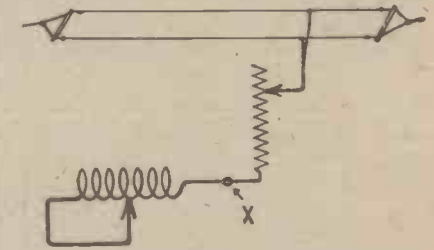

Fig. 9.—The earth inductance and capacity can be replaced by a spiral, which if wound of too many turns will be tunable by tapping the free end back to some point on itself.

into commission being the same as before—that is, to tune up the standard aerial and earth of Fig. 6, then to replace the earth inductance and capacity by the spiral, which, if wound of too many turns to start with, will be tunable by tapping the free end back to some point on itself (Fig. 9), an arrangement which I saw a friend of mine using in 1903 for receiving on 100 metres.

In these capacity earth arrangements, provided the point X has been obtained properly, then it does not matter to which side you connect the crystal or valve grid.

I have indicated a crystal arrangement, the crystal being tapped off either the earth or the aerial tuning coil, and incidentally I may mention such an aerial system is easy to neutrodyne because we have a point of opposite potential on the earth coil to play with, also the arrangement would lend itself to single-valve rectifier and oscillator arrangements for superheterodyne work.

THE FUTURE OF BROADCASTING

By Lt.-Comdr. the Hon. J. M. KENWORTHY, R.N., M.P.

On this page will be found the conclusion of Commander Kenworthy's article, which appeared in our last issue, on the future of the Broadcast Service in Britain.

A Warning

The history of the Road Fund buoys a shoal which we must take steps to avoid, or broadcasting will be run aground in the same way. The Road Fund is the proceeds of the motor-licences. When motor-taxation first came before Parliament for approval it was solemnly promised that the whole of the proceeds of the tax should go to the upkeep and improvement of the roads. In this year of financial stringency the Chancellor of the Exchequer has made a bold raid upon the fund, and is coolly annexing £10,000,000 of money for general revenue purposes. Unless very clear and adequate safeguards are insisted upon by Parliament we shall have a repetition of this sooner or later with regard to the broadcasting funds of the new British Broadcasting Corporation.

Representation of Listeners

Next in importance, I suggest that the views of the listeners must be adequately represented before the Corporation. There should be an Advisory Committee appointed by listeners themselves through their different associations and organisations. This is a necessity in order that the views of listeners should be kept before the Board of Management of the new Corporation. There must be the minimum of Government interference so long as the service is efficiently conducted. Presumably the Postmaster-General will be answerable to Parliament for the efficiency of the service, but that is quite a different thing from Post Office control, which must be avoided at all costs.

No Propaganda!

And lastly, broadcasting must not be used as a means of Government propaganda. We do not want a repetition in this country of what has happened in Russia. In Soviet Russia, broadcasting is a Government monopoly, as it will be in this country in the future. And in Soviet Russia broadcasting is looked upon as the most powerful weapon in the armoury

of the greatest propagandist Government the world has ever seen. In Russia no licences are taken out, and programmes are provided free. From all accounts the programmes are good, particularly excellent music being provided. But loud-speakers abound everywhere in the big cities, and even in the large villages.

All the big cafés and every important place, public squares, etc., have loud-speakers. And from these loud-speakers are given out the news,

A PIONEER'S RETIREMENT

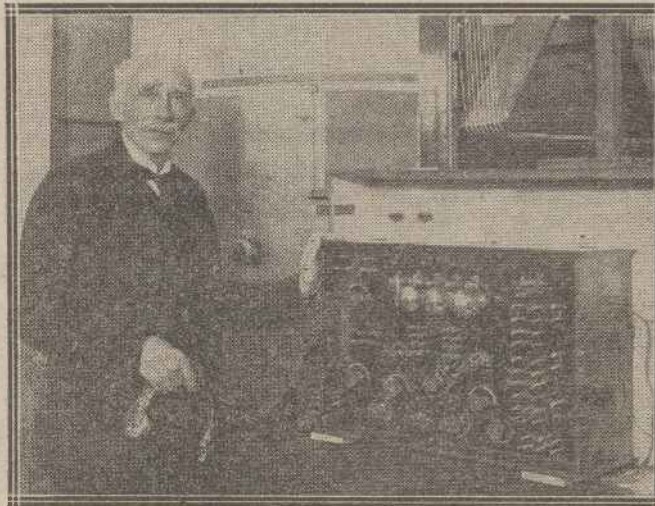

As we announced briefly last week, Dr. John Ambrose Fleming, Professor of Electrical Engineering at University College, London, is retiring after a connection with that institution which has lasted for forty-one years.

speeches of politicians and other matter which the Government wishes the people to hear. This kind of thing may be very good from the point of view of the Government in power, but it is certainly not good for the progress of broadcasting; the temptation will be very great to use broadcasting as a means of placing the views of the Government in power before the people, once the new Corporation has been placed in control for ten years.

Dangers

I believe these are the points on which listeners should concentrate between now and the autumn, as afterwards it will be difficult for mistakes to be rectified. It is all very

well for the Postmaster-General to talk about continuity of programmes. But we are giving up the well-tryed, and, on the whole, successful British Broadcasting Company for an entirely new method of managing and controlling wireless in Great Britain. Let us hope the experiment will be a success.

THE CENTRE PUNCH

The centre punch is absolutely an essential tool if exactness in marking out is required.

The punch is made of specially hardened steel, and has a coned point which is sharp enough to make a small indentation in even hard steel, although it will not pierce or cut to any great depth. This small indentation is sufficiently large to enable a drill to obtain a start in drilling a hole, and to keep the drill in the correct position during the first one or two revolutions.

Mind Your Fingers?

The centre punch is held in the fingers by the milled centre piece, and a sharp tap with a hammer applied to the top. Many bruised fingers have resulted from using centre punches, but an almost infallible method is, instead of looking at the head of the punch, to look at the point. The natural movement of the arms, together with the control exercised by the nerves, will always bring the hammer head in the correct position.

Sharpening

The punch will, of course, sometimes get blunt, and it may be sharpened on an emery wheel or on a hard, very rough stone.

A good centre punch made by any of the well-known tool manufacturers, Brown & Sharpe, Starrett, Goodell-Pratt, etc., will cost about one shilling; the cheaper variety sold at sixpence by unknown makers should be avoided.

pence by
avoided.

□ □ □

Another Satisfied Reader

Sir,—I have been a reader of WIRELESS, from the first number, and even now I cannot repress a certain amount of surprise at the amount of useful matter that you can publish for 2d. every week. What strikes me most is the perfect balance that you manage to preserve week by week; there is never an excess of technical articles or of the more practical articles. For me the balance is just right.—Yours faithfully,

J. L. DAVIDSON,
Cleethorpes.

From my Armchair

BY EARL RUSSELL.

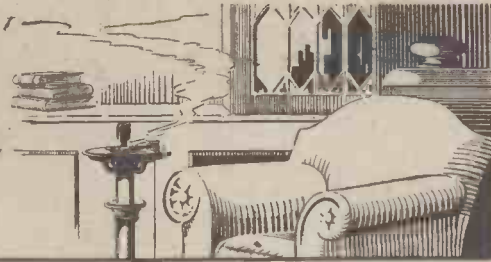

In these columns Lord Russell expresses each week his own personal views on matters of interest to "Wireless" readers.

Great Circles

I have been reading an excellent account of the meaning of great circles and of great circle distances, but in one curious respect the writer uses language that might easily be misunderstood, for he refers to Madras as being due east of London because it happens to be on a great circle passing through London. It is true, as is said in "The Snark,"

"What's the good of Mercator's North Poles and Equators, Tropics, Zones and Meridian Lines?"

So the Bellman would cry: and the crew would reply,

"They are merely conventional signs!"

And so they are, but it is well to use them in accordance with the convention, and by the convention due east and due west we mean places

situated on the same parallel of latitude. There are, of course, an infinite number of great circles passing through London, and any place on the globe is upon one of them.

B.B.C. Experiments

The two-station programme in London seems to have disclosed a good deal of lamentable weakness in crystal tuning; but, of course, a crystal that will receive very satisfactorily is not very selective without a considerable adjunct of coils and condensers. Meanwhile the expiring B.B.C. is getting into trouble all round. One leading article goes for it for constantly changing its policy, so that manufacturers never know where they are, and the wireless trade has to be perpetually scrapping, while another article inquires where the high-power stations are, what the real policy on this matter is, and what the P.M.G. has been doing.

Burnt-Out

Few things are more annoying than a burnt-out transformer in a completed set. Even the generosity of the manufacturer does not make up for the tiresomeness of having to pull inaccessible connections out and put them in again.

What Is It?

In one of our most respected wireless weeklies I read a paragraph of such discretion as to convey nothing to the reader. Let me see if I can do as well: "I am able to state on high authority that the project which was mentioned in a particular paper published in the North, relating to a development that might be expected in the wireless activities of a concern familiar to all of us, was premature and unauthorised. The further statement as to the geographical character of this new development, although representing an arrangement of districts which will at once suggest its origin to the expert amateur, must also be regarded for the present as lacking in complete accuracy or certainty!" Perhaps a wireless reader should not have too keen a sense of humour, for in the same paper I see a reference to oscillating neighbours who were actually "oscillating in step," and it is stated that experienced amateurs will recognise the symptoms at once. It is quite certain that experienced policemen would.

Simple, Accurate, and Easily Adjusted

Don't experiment! Get a "Lotus" and be certain of better results. The vernier movement comprises three sets of enclosed precision machine cut gears and reduces the speed of the moving coil block by eight times. The moving block moves in the same direction as the knob, which prevents confusion. It also becomes absolutely rigid in any position, holding the heaviest coil securely. No screws required to tighten it.

Moving block cannot fall

LOTUS

VERNIER COIL HOLDERS

From all Radio Dealers.

Two Types:

For outside panel mounting:

Two-way 7/-
Three-way 10/8

For inside baseboard mounting, with 6 in. handle:

Two-way 8/-
Three-way 12/6

Garnett, Whiteley & Co., Ltd.,

Lotus Works, Broadgreen Road, Liverpool

Makers of the new improved "LOTUS" Valve Holder.

Bakelite mouldings for the side plates and blocks and knobs; heavy nickel plating for the metal parts.

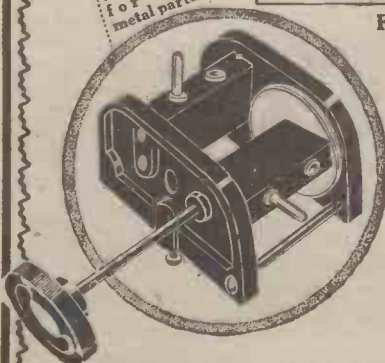

CAXTON 4-VALVE CABINET

Made for Sets "All Concert Receiver," "Fieldless Coil Three Valve Set," "Any Valve Low Frequency Amplifier."

Special Cabinets made to customer's measurements. Prices Quoted.

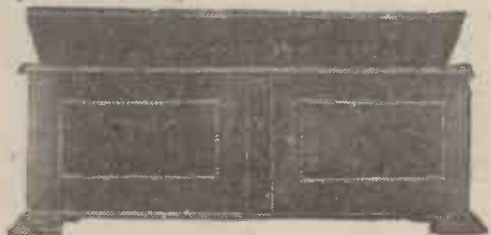

Cash with Order. Fumed Oak ... £1 5 0
Dark or Jacobean Oak £1 10 0
Real Mahogany £1 14 0
Detachable 7" deep Base Board to mount 13" by 8" panel to slide out of Cabinet front.

The two beaded front doors as illustrated, placed 2 ins. in front of the enclosed panel at 10/- extra.

Ebonite or Radion Panels Supplied and perfectly Fitted at low extra cost.

All Polished with the new enamel that gives a glass hard surface that cannot be soiled or scratched. SENT FREE.—Catalogue of standard Wireless Cabinets in various sizes and woods.

Packed and delivered free in U.K.

NO. C2

CAXTON WOOD TURNERY CO., Market Harborough

I HAVE BEEN ASKED....



I have a general purpose 3-valve receiver, consisting of a tuned anode H.F. valve, with reaction on to the anode coil, a detector valve, and one transformer-coupled note magnifier. Although the set tunes in one or two other stations fairly well, the local station, which is five miles away, can be heard practically all round the dial, although maximum signal strength is obtained at one particular setting. Can you advise me how to improve matters?

Where a receiver does not tune sharply on distant stations attention should be paid to the aerial and earth system, the insulation of the former being improved, whilst alternatives should be tried for the latter. An interesting experiment here is to disconnect the normal earth lead from the set and in its place connect a length of

insulated flex, which may be taken throughout the house, on the floor, to act as a temporary counterpoise. If with this latter arrangement tuning is very much sharpened, signal strength is improved and reaction demands are very much lessened, it is probable that your earth is partly responsible for your difficulty.

At any distance less than eight miles from a main broadcasting station, or three miles from a relay station, it is most difficult to decide whether any simple receiver is capable of tuning properly and of receiving the more distant transmissions, since interference is probably so severe that weak signals may be completely drowned. The best procedure to adopt is to employ a wavetrap to eliminate the local programme, and the auto-coupled series

rejector type is suggested as being the most usually effective.

To construct this trap obtain a 2-inch length of 3-inch diameter ebonite tube and wind on it 40 turns of 34-gauge double silk-covered wire, which will take up approximately a winding length of 1 inch. The winding should be tapped at 5, 10, 15 and 20 turns from one end. Across the whole coil a parallel variable condenser of .0005 should be connected. Join the aerial lead-in to one of theappings on the coil, the best being determined by experiment, and join the end of the coil from which the tapping are counted to the aerial terminal of the set, in which latter parallel tuning should be employed.

The method of operating the trap is as follows: First tune in a desired transmission without using the trap, employing ordinary parallel tuning in the set, and then bring the trap into circuit, slowly rotating the trap condenser until signals from the local station disappear completely or are very considerably reduced in strength. Leave the trap condenser set at this position and re-tune the desired transmission on the aerial condenser of the set. This may necessitate slight re-tuning on the trap condenser also, but once this latter has been properly set it should not need alteration. Searching for distant transmissions may then be carried out in the normal way on the controls of the set.

FROM A READER

Why Do We Use Different Ratios?

SIR,—With reference to the article under the above heading in your issue for July 17, whilst the remarks given therein are certainly interesting, yet they do not answer the question asked in the title of the article referred to.

It is, of course, obvious that within certain limits of dimensions the higher the ratio the smaller the primary inductance and consequent impedance at any particular frequency, and *vice versa*.

The article in question does not emphasise, as it should, the relation of frequency to impedance, on which, of course, everything depends, and if one employs transformers in which only 70 per cent. of the maximum amplification is obtained at any particular point it follows that their curves must be of the humped variety, seeing that even the poorest transformer has a very high impedance at its resonant point, at which point almost 100 per cent. of the total available amplification is obtained.

Another point which appears to the writer is that the highest possible inductance and consequent impedances should be used in each stage and whether a transformer with a lower impedance may be used in the second stage depends on the amount of distortion with which one is prepared to put up.

In conclusion, I would ask a question which I have asked on many occasions, namely, why should one use a valve of lower impedance in the first L.F. stage from that used in the detector? My experience is that the best results are to be obtained by using similar valves in both detector and first L.F. positions, provided that one does not employ valves having an impedance greater than about 30,000 ohms.

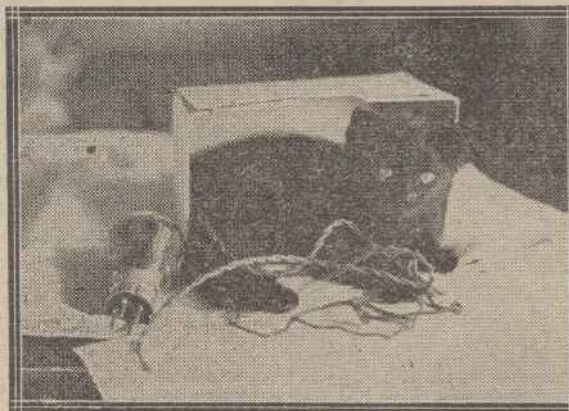

The Elstree night watchman has still an unfortunate penchant for valves, pieces of wire and other unconsidered trifles.

If one uses a lower impedance valve in the first L.F. stages, as a rule one merely loses amplification, which loss it is endeavoured to make up by the employment of a high-ratio transformer, which necessarily has a poor amplification curve.—Yours faithfully,
JOHN BAGGS.

Manchester.

NOTES AND NEWS

ON August 7 Mr. Peter Chaney is presenting "The Shadow Folk" in an entertainment entitled "Piccadilly Circus." This will be performed in the London Studio.

ON August 15 the Rev. F. A. Jarman will give a talk on London's underworld derelicts, including the "down-and-outs" who seek shelter in the crypt of St. Martin's-in-the-Fields at night.

A CONTEMPORARY is asking what our old sets would be saying to one another now if they could talk. What with centre-tapped coils, neutralising condensers, slow-motion dials, screened coils and the like, I don't think they would recognise wireless at all, and, if they could talk, I should not like to hear the language they used!

THE opera "Rigoletto," which was broadcast on July 7, is to be repeated by the B.B.C. on August 20. On this occasion Boosey's version will be employed.

CALL-SIGN.

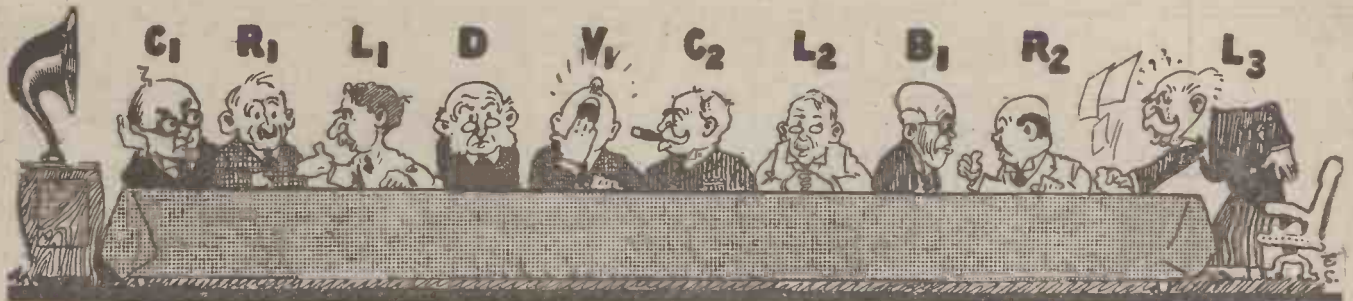

JOTTINGS BY THE WAY By Wireless Wayfarer

AS an earnest student of the advertisement pages of our wireless journals I am reluctantly forced to the conclusion that manufacturers of radio goods are not nearly so open-handed as those who make or deal in articles of other kinds. It is, for example, quite impossible to open a lay magazine or a morning paper without finding announcements from firms who are positively dying to present you with samples of cocoa or tooth paste or aerated breakfast oats or something of that kind. But have you ever come across, say, a loud-speaker manufacturer who is yearning to distribute free samples of his wares? I trow not.

Parsimony

Even those who turn out quite small things like valves and transformers and

rheostats seldom respond in the right spirit if one politely suggests the sending of a free sample. And then again there are delightful little competitions got up by lay advertisers with glorious prizes if you are successful. "Fill in the missing letters of these three well-known English towns," they coo, "and if you are successful you will receive **ABSOLUTELY FREE** as a prize a genuine simulation gold gent.'s watch." The only condition is that you should buy a handsome and inexpensive chain to wear with it. I am still looking for a wireless firm which will ask me to complete L-ND-N, Y-RK, W-G-N, in order to win a five-valve set absolutely free so long as I purchase a pair of genuine flex phone cords for attachment to its terminals.

And Mr. Everyman!

Think, too, of the happy couples who require to furnish the little nests in which they are proposing to settle down. They do not have to go and plank down hard cash. Not a bit of it. They simply trot along to Mr. Savit Sage, choose what they want, and offer to pay two-and-ninence down and one-and-sevenpence-half-

The lamentable lack of faith in human nature of the wireless manufacturer — the same failing among the members of the Little Puddleton Wireless Club.

penny a month. The Smiling Mr. Sage, who winces slightly at the very mention of money, accepts the offer at once, delivers the stuff by aeroplane within the hour, sticks up their wall-papers free of charge, and presents them with a free insurance policy covering all such risks as picture-hanger's thumb and the like. But we poor wireless folk seem to be nobody's children.

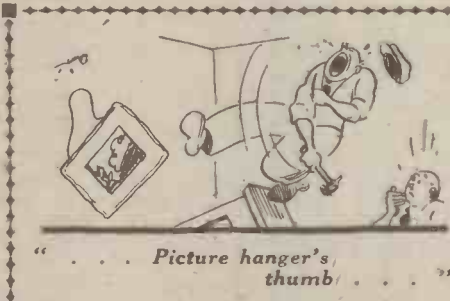

"Picture hanger's thumb"

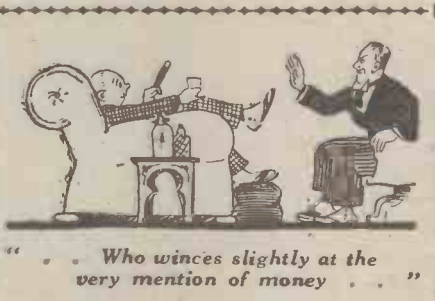

"Who winces slightly at the very mention of money"

So Simple!

How jolly it would be if only we could have interviews like that with Mr. Churn-Bones or Mr. Squito Spot, for instance. Mrs. Wayfarer would say, "We have so enjoyed looking round your beautiful showrooms, Mr. Spot," and Mr. Spot, delighted to hear that we had chosen the biggest set in the place, would be charmed to take simply anything (or even nothing at all) down, and Mr. Spot would tell me not to worry about paying the instalments if they were a bore, and Mrs. Wayfarer would burst into tears of joy, and Mr. Spot would deliver the set in a plain van, and Mr. Spot's men would rig up the aerial mast free of charge, and we should all be jolly and friendly and happy, and that would be that.

Buggy Never Crows!

Think, too, how awfully well off those

racing johnnies are. If ever they want to make a bit of money they just go to see Mr. Bugless Skewheart and ask him if his rules will allow them to wire their wagers ten minutes after the advertised starting time. Mr. Skewheart murmurs, "Why, of course; or the next morning for that matter, if it is more convenient to you," and the thing is done. I sometimes picture myself with shiny topper and beautifully creased nether garments (instead of creased topper and shiny nether garments, as is more usual with me), taking part in a delightful interview:—

"Good morning, Skewheart. My friend, Lord Blotto Bilger, was feeling pretty sick with his agent when I saw him this morning."

"How was that, Sir Wireless?"

"Well, you see, Skewheart, the thought of backing Spavin on the three-thirty yesterday, but forgot to send a wire, and his agent refuses to pay."

"Tut, tut, that is pretty hard lines."

"What would have happened to a client of yours, in such circumstances?"

"In a case like that, Sir Wireless, I always make a point of paying double the odds."

"Your usual fairness! That's why I'm so enthusiastic about Buggy!"

Really, it seems almost a shame to take Mr. Skewheart's money.

The Difference

I should like to have pleasant, friendly interviews of that kind with never a carping word when I go down to the wireless club. The sort of thing that actually does happen to me when I stroll in and find the General and one or two others there is this:

Me: "Evening, General."

The General: "Rrrmph!"

Me: "Evening, you fellows."

Poddleby: "Where's that grid-leak you borrowed a fortnight ago?"

Snaggsby: "Yes, and how about

(Continued on next page.)

Jottings by the Way—continued

the power valve of mine that you did in last week?"

Bumbleby Brown: "And haven't you nearly finished with the headphones that I lent you two years ago?"

Me: "Oh, don't let's bother about trifles like that; I've got some splendid news."

They: ???

Me: "I got WGY on the loud-speaker last night with one valve."

They: "LIAR!"

Though a peaceful person, I naturally seize the heaviest components within reach and hurl them at their unbelieving heads. The club house is instantly turned into a bear garden by these rough fellows and the atmosphere of calm and dignity which should prevail within its walls is gone.

How Beautiful 'Twould Be

How much more beautiful life would be if only one's fellow-members would show a little of the sympathy, the understanding and the Christian charity that distinguish Mr. Skewheart. Sometimes in my imagination I picture



" . . . Fling the heaviest components within reach . . . "

them with changed hearts and see in my fond dreams something like this:

Me (entering the club house): "Evening, General."

The General: "Good evening, my dear fellow. How splendid of you to drop in."

Me: "Evening, you fellows."

Poddleby: "Hullo, Wayfarer. I have been longing to meet you. I have got half a dozen new valves that you simply must try out."

Snaggsby: "Oh, by the way, old chap, I've got a new variable condenser that is much too good for a rotter like me, and I wondered if it would be of any use to you?"

Bumbleby Brown: "That reminds me, I have far more components than I want. Just drop in one evening with a sack, will you, and help yourself."

Me: "Oh, by Jove, I really must return your . . ."

Chorus: "Oh, please, don't bother. Simply delighted for you to have it."

Me: "I am afraid that you will hardly believe me when I tell you that

I had Johannesburg on a crystal at lunch time."

Poddleby: "Just shows what a real expert can do."

The General: "No one would dream of doubting your word."

Bumbleby Brown: "Heartiest congratulations."

Snaggsby: "A real credit to the club."

And then I should look modest, and they would pat me (not too hard) on

ON GUARD!



Mu's ardent desire to scale the new Elstree lattice masts has to be checked. The "night-watchman" is here seen being brought back to the buildings by Mr. Reyner.

the back, instead of swiping me over the ear with an earth tube, as they do in their present unregenerate state.

Oh, Frabjous Day!

Yes, this is the sort of spirit that I want to see permeating wireless. I would like everyone's motto, except my own, to be, "It is more blessed to give than to receive." I make an exception in my own case for two reasons. In the first place, I am perfectly willing to be less blessed by receiving; and in the second, if there were no receivers there could be no

givers, and nobody would be qualified for the major blessing.

It is therefore quite in keeping with the spirit of generosity and self-sacrifice outlined in this striking article that I should be willing to sacrifice the joys of giving from the hardships of receiving. I reserve also the right



" . . . Just drop in with a sack . . . "

to express my disbelief when other people make absurd statements. It has been well said—I forget now by whom; probably I said it myself—that criticism is the foundation of efficiency. If, therefore, there were not one critical voice raised in the club house at times of need, the Little Puddleton Club would soon show a falling off in efficiency, and that naturally would never do.

WIRELESS WAYFARER.

AN INTERESTING LETTER

Radio Contours

SIR,—Upon reading the article by Captain E. A. Anson in the current issue on "Contours in the North-East Sector," it occurred to me that the experiments might be taken a step further to ascertain if reception of broadcast from other stations than 2LO is also of low degree as compared with adjacent areas.

My own experience is that the Marconi House stand-by transmitter gives much better service to this district than does the regular 2LO transmitter. This may be proved by taking the test transmission on Sunday at approx. 10.45 p.m. The B.B.C. explain that any advantage we in the N.E. sector gain by the use of the Marconi House apparatus is so much loss to districts in other directions.

From this it might be inferred that the cause was a directional fault of the transmitting station, but then again the case of "lucky" Braintree remains unsolved, unless it be that elevation gives them the advantage of stronger signals.—Yours faithfully,

A. MITCHELL.

Ilford.

"MODERN WIRELESS"

1/- AUGUST ISSUE NOW ON SALE. 1/-

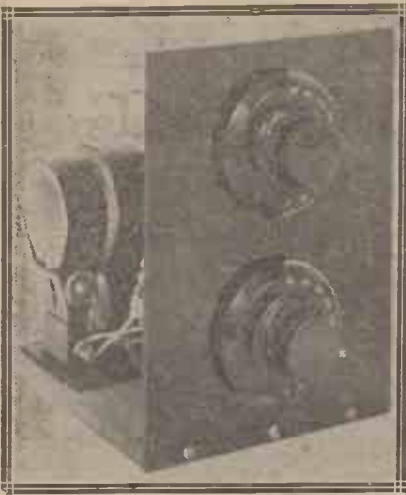

A Tuner Unit for the "Flexible Receiving Equipment"

By H. BRAMFORD

This tuner is specially designed for use in the unit-type receiver described in "Wireless Weekly" for April 7 last, but it will be found a very useful accessory for general experimental work.

unit, Panel E, which took the form of one stage of H.F. amplification.

A Flexible Unit

It is now, therefore, thought by the writer to be advisable to add a further



N extremely simple and effective tuner panel, such as is about to be described, may be put to a varied number of uses and is an acquisition essential to

those who indulge to any degree in experimental work.

The panel is primarily intended for use in conjunction with the "Flexible Receiver," which was first described in *Wireless Weekly*, April 7. It will be remembered that the receiver incorporated four independent panels in the following order:—

Panel A.—Tuner with crystal detector.

Panel B.—Valve detector.

Panel C.—First stage L.F. amplifier.

Panel D.—Second stage L.F. amplifier.

This was followed in a later issue of *WIRELESS*, dated May 29, by the fifth

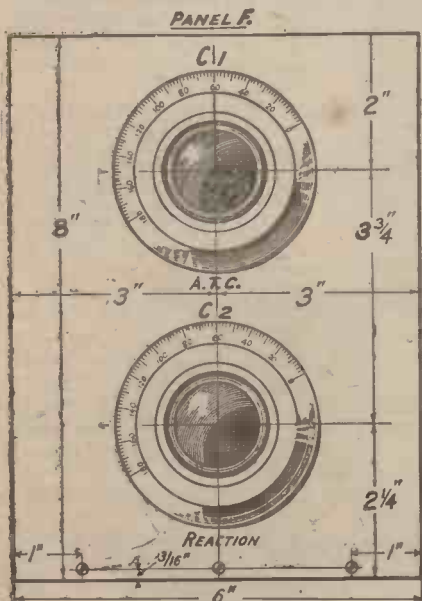

Fig. 1.—Only the two condenser dials appear on the face of the panel.

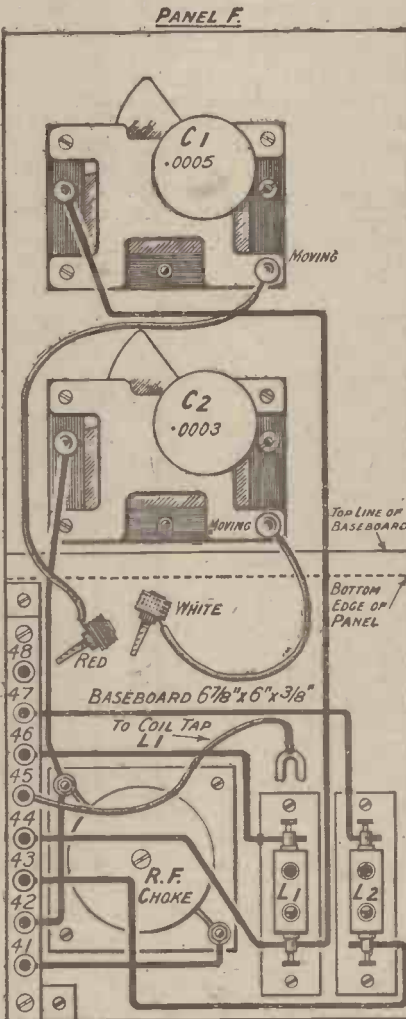

Fig. 2.—A special strip of Clix sockets is provided for inter-connection purposes.

refinement to this receiver in the shape of a special tuner, which gives the advantage of a useful degree of selectivity in addition to a considerable

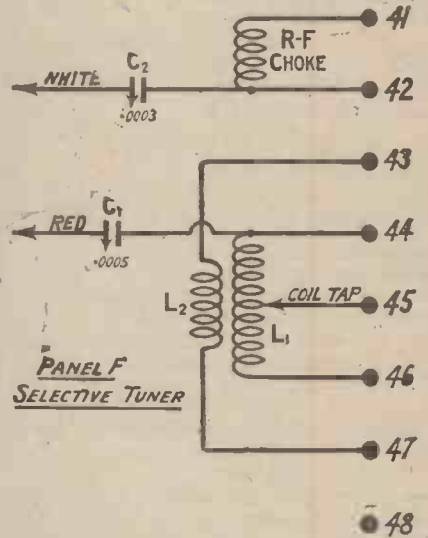

Fig. 3.—The colours indicated in this circuit diagram are those of the Clix plugs.

number of possible tuning arrangements, including various forms of the popular "Reinartz" circuit.

On the other hand, the unit should prove useful in itself as an experimental addition to any form of amplifier panel or for general use. The components which were actually used for

(Continued on page 396.)



The Clix strip is carried on two small brass angle pieces.



MOLLY-CODDLING THE B.B.C.

By **PERCY W. HARRIS, M.I.R.E., Joint Editor**

A strong protest against the grandmotherly supervision exercised by the Post Office over all the topical items broadcast from the B.B.C. stations.



SOME time ago I knew a family which was very proud of its youngest boy. Great pains were being taken to give him a good education—to use the common phrase, “no expense was being spared”; he had a special nurse to look after him, and his parents were particular, *very* particular, of the company he kept.

An Example

A few doors down the road lived another little boy. His parents were proud of him, too, and, for their part, were just as anxious to see him “get on.” I must admit that he was rather a pugnacious little fellow, and when one day in the course of an argument he punched the first little boy on the nose, the indignation expressed by the first little boy’s parents was almost too great for words. On no account must he play with the naughty boy from down the street! The next time they met, an icy stare was returned for the friendly grin, whereupon a second punch on the nose finished the friendship for all time.

And the Result

I saw both the boys the other day (not together, of course), and while the puncher had turned into a manly young fellow, the punchee, carefully guarded from all contaminating influences, is one of the most priggish molly-coddles I have ever met.

At the present time the British Broadcasting Co. is in great danger of being molly-coddled in just the same way by its guardian, the Post Office, who are exercising their censorship rights in keeping from the public a number of “talks,” which, if fairly “strong meat,” are at least fair-minded, intelligent, and, I may say,

much more intelligible than some of the boring talks which are as devoid of interest to the great majority of listeners as they are of harm. Only a week or two ago it was arranged to broadcast a dialogue on the American Debt between Mr. H. D. Henderson, Editor of the *London Nation*, and Mr. Raymond Cran Swing, London correspondent of the *Philadelphia Public Ledger*, a highly-esteemed American newspaper. At the last minute a brief notice in the paper indicated that the dialogue would not be given, the reason being that the

The idea of a dialogue between an intelligent Englishman and an intelligent American, both well versed in the subject was a good idea, and, having read every word of the dialogue which was to have been broadcast, I feel that it would have been one of the biggest broadcast successes we have yet had. Two quite distinct and separate viewpoints would have been put forward, and, in my opinion, nothing but good could have come from the broadcast. I have heard many far more provocative and contentious matters discussed “on the air,” and if this is the kind of talk which is to be suppressed under the new régime, much of the interest of broadcasting may evaporate.

Another Veto

You may think that this is an isolated case, but I can assure you it is not so. Would you have been interested in a debate at the London School of Economics on “Is the House of Commons any Use?” between Mr. J. H. Thomas, M.P., and Mr. G. K. Chesterton, with Mr. Lloyd George in the chair? I am sure a very large number of readers of this journal would have listened to it with pleasure, yet it was turned down by the Post Office.

We have few enough witty speakers in these days, and when their speeches have been broadcast they have proved some of the most amusing items in the programmes. Many people would have given a great deal to have been present at the 70th birthday dinner given to Mr. Bernard Shaw. Why did not the B.B.C. broadcast the speeches at the dinner, you may ask. The necessary gracious permission to do so was not granted by the grandmotherly Post Office.

Wide Powers

So far as I know, the Postmaster-



Every item of the most remotely controversial nature undergoes the censorship of the Post Office.

Post Office had censored it in the good old D.O.R.A. fashion.

An Excellent Idea

Now, there are a whole lot of people in this country who have very definite views on the subject of the British Debt to America. It is not a dry subject if properly treated. It affects us all in so far as taxation is concerned, it has a very real influence in our lives, and, without any doubt whatever, a great number of misconceptions exist on the whole subject.

A Strong Protest Against Post Office Meddling

General is the sole authority (other than the B.B.C., of course) to judge whether or not the matter broadcast is suitable for our consumption. The Postmaster-General himself and his high officials in power at any given time are estimable people, and I have great admiration for them, but the abilities which have raised them to the high positions they hold are not necessarily those which make them fit judges of what the public should hear by broadcast. It is obvious that the Broadcasting Company must be prevented from releasing dangerous matter, but I am sure the public did not realise when broadcasting came into force that such wide censorship powers would be wielded by the Post Office.

A Good Record

The other side of the question is that there are many ways in which the British Broadcasting Co. could have made a complete mess of things, quite apart from the broadcasting of undesirable discussions, but the history of the Company shows that they have used an admirable discretion. It is no small achievement to have successfully conducted programmes for the length of time the present Company has done without causing serious offence in any quarter, for it will be admitted by the biggest critics of the B.B.C. that the few slips have been of quite minor character. After all, is it not worth a few small risks for the sake of maintaining a good, active, virile tone in the service? Or do you prefer the molly-coddle method in which "highly improving" talks on such subjects as the Home Life of the Ant (which will do little Johnny such a lot of good) are preferred to such matters as the witty speeches at the birthday dinner of a great author and dramatist? Possibly the Postmaster-General thought Mr. Bernard Shaw might have used a naughty word which might shock little Johnny's ears.

An Important Selection

You may say, of course, what is the use of discussing all this when we must put up with it? Do not forget that at the end of this year important changes are being made, and it will be necessary to choose the Commissioners for the new broadcasting Commission. The choice of these Commissioners is a very important matter, and not one which we must allow politicians to

"CARTOONIGRAFS" COMPETITION No. 8

FIRST PRIZE

The "Super-Three" Receiver with valves, batteries and loud-speaker

Value - £17 10 0

(Presented by Messrs. Beard & Fitch).

SECOND PRIZE

Set of Five Eureka Coils

(Presented by Messrs. Portable Utilities).

THIRD PRIZE

One "J.B." .0005 Square-Law Low - Loss Condenser with Slow-Motion Drive

(Presented by Messrs. Jackson Bros.)

FIFTY CONSOLATION PRIZES,

Consisting of RADIO PRESS HANDBOOKS

Further particulars and illustrations of these prizes will be given in our next issue.

See page 384

cranks and faddists, and it should be made clear that the great National Service of Broadcasting must be entirely free from the molly-coddle spirit in every shape and form. We must have the best possible broadcast service, a choice of programmes to suit all tastes, and a complete absence of that patronising "We know what's good for them" spirit which animates so many people who put themselves forward in various places as guardians of the public taste. The question of censorship must be considered very carefully by the House of Commons, and the limitations of censorship should be clearly defined in drafting the new arrangement. The public much prefer a boy who is a little man and occasionally naughty, to the meek-and-mild molly-coddle dressed up in a velvet suit and a lace collar, with a Little Lord Fauntleroy hat.

"Cutting"

I have purposely refrained in this article from referring to all of the talks that have been censored, nor have I referred to the number of cases where, in talks which have actually been given, considerable proportions have been deleted by the censor. Those cases to which I have referred above have been of complete censorship, the matter submitted being vetoed as a whole.

Finally, I have more than a suspicion that some of the censoring by the Postmaster-General has been carried out under the impression that anything going out from a broadcasting station will be looked upon as an official pronouncement of the Government's views. Whatever may happen in times of National emergency, in normal times the British Broadcasting Company (and the British Broadcasting Corporation, which is to take its place) must not be looked upon as a Governmental body, and, indeed, the Postmaster-General, in his speech upon the Post Office estimates, was at some pains to impress upon the House that the broadcast service was to be looked upon as something divorced from politics.

DO YOU REMEMBER IT?



One of the first occasions on which wireless was used for controlling a moving object was when this model airship was directed by radio.

A Safeguard

Fortunately, in the House of Commons we have Captain Ian Fraser on the one side and Commander Kenworthy on the other who, I am sure, will do their best to safeguard the new Corporation.

undertake without consulting all interests concerned.

The new Commissioners must be broadminded men and women, not

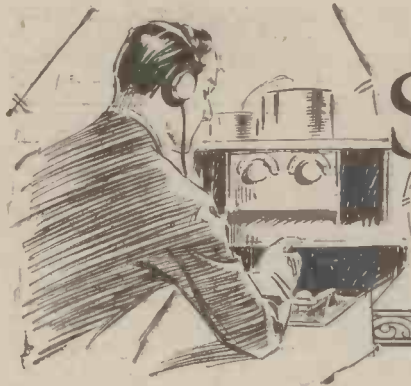

SHORT-WAVE

Notes & News



QNCE again the honours of the fortnight seem to have gone almost completely to the low-power stations. This is not surprising, however, in these days, as the higher-powered stations have already covered all the available "DX," and are turning their attention to reliability tests and schedule work.

The Brazilians continue to come through in large numbers at any time after 10.30 p.m., and various Europeans seem to be able to work them with almost any power, and also to "raise" them with one short call. Apparently the standard of reception in Brazil is high!

A Good Effort

The best report, however, comes from G-60H, who reports two-way work with the U.S.A. with an input of 2.5 watts, *without* a schedule. There are, of course, very few stations who have, as yet, worked America with so low an *initial* power. It is, naturally, much easier to call a station on, say, 20 watts, and then to reduce power to a very low figure without being lost by the other station.

Star Receivers

Apparently there are a few American stations with particularly good receivers, or else they are situated very favourably for the reception of European signals. Most of the British low-power stations who have "got across" at all seem to have worked U-2CVJ, and many others have been in communication with U-1CH and U-1CIB.

GI-6YW, one of the low-power "stars," has now worked Canada and U.S.A., in addition to his famous work with Porto Rico on 2 watts! With 6 watts input he has recently worked C-IED, U-1CIB, GX-6MU (when 850 miles West of Valentia), as well as LA-1A and an Austrian station. Once more, why use more than 6 watts? G-5WV also has worked various

Americans and Z-2AC with inputs varying from 8 to 10 watts.

Telephony Stations

We have received several reports of reception of short-wave telephony from America. Quite a number of the short-wave experimental broadcast stations are working quite regularly, and we hope to be able to publish de-

on 32, 26 and 16 metres, and are easily recognisable by the purity of their telephony. Apparently the crystal control has the effect of eliminating some of the so-called audio-frequency fading, which is often mistaken for "night-distortion"! One correspondent reports receiving the 32-metre transmission on a loud-speaker with a *crystal* and three stages of low-frequency amplification!

Apparently there has been a misunderstanding about the address of 2XG, which is not one of the WGY stations, as previously stated, but the experimental station of the Bell Telephone Laboratories, Ocean Township, N.J., U.S.A.

The Antipodes

The New Zealand and Australian stations have completely disappeared at the time of writing, but it is more than likely that they will be back in full force before this appears in print. In the mornings at about 6 a.m. a large number of "odd" stations are working, including the American commercial stations, NAL, NAW, NKF, and some of the ships in the Pacific waters, such as NEQQ, NAJD, and many others, PI-3AA has also been heard at this time, but none of the Australasian stations have been strong enough to read.

As far as can be foretold from the present weather conditions and the general trend of events lately, it seems that European stations are gradually fading out until late in the evening, and American and other "DX" stations improving steadily. Probably the autumn will be the best time for long-distance work,

though not so good for European communication.



Our cover photograph this week shows one of the frame aerials on the top of Bush House which is used by the U.S. Shipping Board for reception direct from their headquarters in the States. This photograph shows the short-wave transmitter at Bellevue used for despatching some of the traffic to England.

tailed information as to their wavelengths in the near future. WBZ (Springfield, Mass.) is apparently one of the best stations, judging from the number of reports mentioning him. The wavelength used is 49 metres, and another station, most probably 2XG, is on 43 metres rather irregularly. WGY's crystal-controlled transmitters (2XAF, 2XAD and 2XK, etc.) work

Send your
QRA Queries to Us
We have a special department which
deals with them promptly.

Readers' Views and Comments

A Problem

Sir,—I wonder whether any of your readers have experienced a curious difficulty that has been puzzling me for some time. If so, perhaps they will be able to help me to solve it. I have a four-valve receiver built to a design given some time ago in *Wireless Weekly*, which has given me wonderful results for several months. I have been more than pleased with it until about a week ago, when it suddenly began to emit scratchy noises. More by luck than judgment, I found that these noises ceased completely when the aerial was removed. This naturally led me to suspect the aerial, but when I made a single valve set somewhat hastily and attached it to the same aerial, there was no trace of noise whatever. Back went the four-valver, and—back came the noise! I was removing the aerial at the switch, which is close to the point of entry at the window. Can the unpleasant noises have anything to do with the aerial, or are they due to a fault in the four-valver, which only asserts itself when the aerial is in use?

Yours faithfully,
GEO. L. GREEN.
Chessington.

An Appreciation

Sir,—May I be allowed to thank "Wave-Trap" for his interesting and amusing reviews of the week's events in

"The Week's Diary"? I find this one of the best regular features in *WIRELESS*, and I know of many others who turn to these pages first.

Yours faithfully,
H. J. CUDDON.
Ilfracombe, Devon.

"S.L.W." or "S.L.F."?

Sir,—May I be allowed, through the medium of your paper, to voice my appreciation of articles of the type of "S.L.W. or S.L.F." by Mr. J. H. Reyner in your last issue? *WIRELESS* has never neglected the beginner in radio, but he still wants many explanatory articles of that type, and I look forward to reading many of them in the near future.

Yours faithfully,
"OLD-BEGINNER."
Staines, Middx.

A Suggestion

Sir,—Why does not the B.B.C. relay WGY and the American short-wave stations more frequently? These transmissions of theirs have always been very popular, yet when they have one of the best opportunities of doing this (WGY is excellent just now) we hear nothing of them. If I can receive WGY on a large loud-speaker with a two-valve receiver made to one of the last *Wireless Weekly* designs, surely the B.B.C.

should do great things with their elaborate listening-post at Keston.

Is it another question of "Get On With it"?

Yours truly,
W. O. JAMES.
Ludlow, Salop.

AMATEUR TRANSMITTING NOTES

QRA's Wanted

OCTN, SPM, D-7XU, D-7ZG, D6N, L6C.

QRA's Found

G-2BOC: A. C. Porter, 1A, Manor Road, S.E.4.

G-6CQ: G. Souter, Blackfriars Foundry, Elgin.

G-2BAV: A. R. Gardiner, "Ashleigh," Abbots Langley, Watford.

I-1CU: A. Marcello, Via 20 Settembre 89, Rome.

I-1AW: Roberto Nessi, 13, Via Guiseppe, Verdi, Milan.

Cards Held

We shall be glad to receive any information which will help us to trace the owners of the following cards, whose QRAs are at present unknown:

GBZ, R-DD7, X-6XI, G-6CM, X-GB2, BE-1AX, D-PK7, GCA, G-3WK, G-6CR, GBM, A-5KN, PKZ.



FORMO
STRAIGHT LINE & CO. LTD.

ULTRA LOW LOSS
Straight Line Frequency Condenser.
Cone bearings. Braced Vanes. Positive Collector. A real precision job.

Condenser only—
"0003 μF, "0005 μF ... 9/-
Condenser with plain dial.
Standard 1/2" dia. Shaft ... 10/6

Send for Catalogue and Descriptive Literature of Complete Formo Range.

THE FORMO COMPANY,
BROWN WORKS, CRICKLEWOOD, N.W.2.
Phone: Hamp. 1787.

Manchester: Mr. J. B. Levee, 23, Hartley Street,
Levenshulme. Phone: Heaton Moor, 476.
See page 386 for Formo Transformer.

? CHOKE COUPLING ?



FERRANTI

AUDIO FREQUENCY TRANSFORMERS

TYPE AF3

GIVE ALL THE ADVANTAGES CLAIMED FOR CHOKE COUPLING PLUS A STEP-UP OF 3 1/2 TO 1

25/-

Ask your Dealer for Leaflet W-401.
Send us the diagram of your set, and refer to this advertisement and we will suggest improvements.



FERRANTI LTD., HOLLINWOOD, LANCASHIRE.

One Rheostat with two uses!



This "Peerless" Dual Rheostat (as illustrated) covers the needs of both bright and dull emitter valves. It has two windings, one of a resistance of 6 ohms, and a continuation of this on to a 30 ohm winding. The resistance wire is wound on a hard fibre strip under great tension and is immune from damage. The popular one-hole-fixing method is provided, and the terminals are conveniently placed. The contact arm has a perfectly smooth silky action. All the metal parts are nickel-plated. Complete with ebonite combined knob and dial.

THE "PEERLESS" DUAL RHEOSTAT

3/9

From your dealer or direct. Traders requested to apply for Trade Terms.

THE BEDFORD ELECTRICAL & RADIO CO., LTD.
22, Campbell Road, Bedford.

Better than "Cross-words"

CARTOONIGRAFS

(Copyright)

A NEW FASCINATING COMPETITION WHICH WILL APPEAL TO ALL.

By ERN SHAW, the "Wireless" Cartoonist.

The Prizes Offered in Connection with this Competition will be found on page 381.

WHAT TO DO

All you have to do is draw a few lines on the chart and write one line to complete the limerick. If you carefully follow the instructions, given below an amusing picture will appear on the chart. Draw this in ink and then complete the limerick with the wittiest line you can think of and send along to "Cartoonigras," Radio Press, Ltd., Bush House, Strand, to reach here not later than first post Tuesday, August 10. Employees of Radio Press, Ltd., are not eligible. All competitors, by entering, agree to abide by the decision of the Editor, which is final. No correspondence can be entered into regarding this Competition.

FOLLOW THE DIRECTIONS CAREFULLY

Send this whole page complete with your drawing in ink and your last line of the limerick, with your name and address written in ink (block letters), in the spaces provided.

Name

Address

Post to:—"CARTOONIGRAFS,"
RADIO PRESS, LTD., Bush House,
STRAND, W.C.2.
To arrive first post Tuesday, Aug. 10.

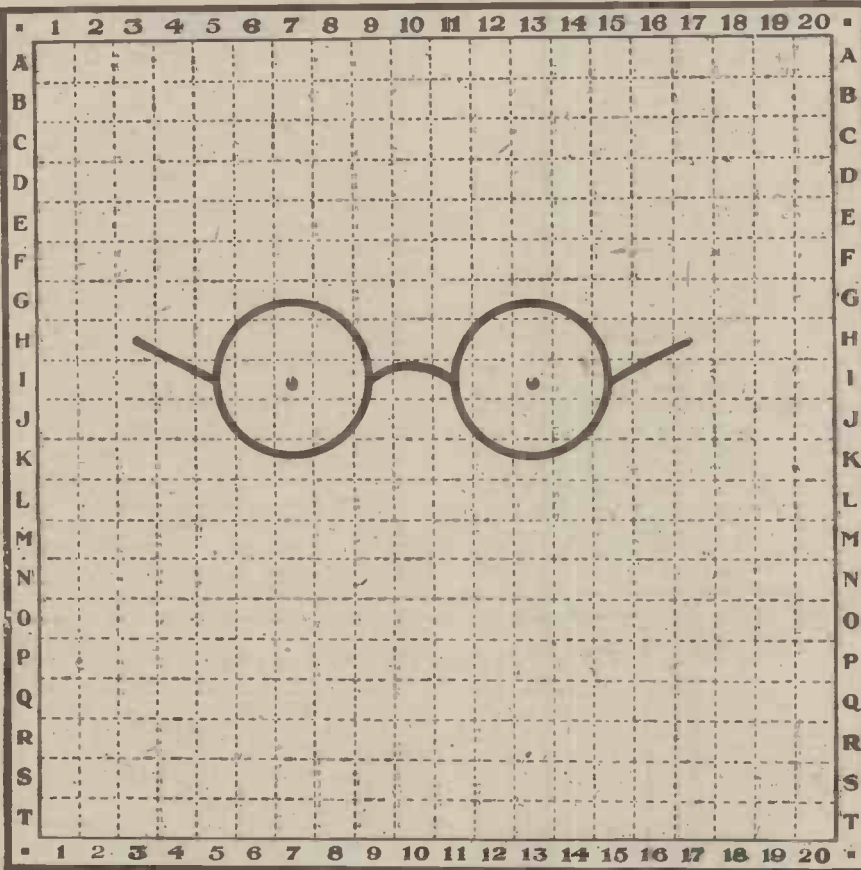

*"Hello! Everybody!" he'll say,
In his humorous broad Yorkshire way.
"You know it's all wrong!
Blossom says before long*

No. 8.—JOHN HENRY.

NOTE.—It is advisable to follow the instructions in pencil first, and then carefully complete the drawing, in ink. Black letters denote new lines. Unless otherwise stated, lines should be drawn to the centre of the square.

Draw a continuous line from M4 to K4
K4 to E3
E3 to C4
C4 to A8
A8 to A13
A13 to D16
D16 to bottom right corner H16
Bottom right corner H16 to G17
G17 to E17
E17 to C16
C16 to B14
B14 to B8
B8 to C5
C5 to bottom left corner H4

Bottom left corner H4 to top left corner H3
Top left corner H3 to I1
I1 to L2
L2 to M3
M3 to M4
M4 to O5
O5 to P6
P6 to R7
R7 to S9
S9 to S11
S11 to R13
R13 to P14
P14 to O15
O15 to M16
M16 to K16
K16 to top right corner I16

Top right corner I16 to top right corner H17
Top right corner H17 to I19
I19 to L18
L18 to M17
M17 to M16
J3 to I3
I3 to top left corner I3
Top left corner I3 to I2
I2 to L3
J17 to I17
I17 to top right corner I17
Top right corner I17 to I18
I18 to L17

E9 to bottom left corner E9
Bottom left corner L9 to M9
M9 to top right corner M9
Top right corner M9 to M10
M10 to top right corner M10
Top right corner M10 to M11
M11 to top right corner M11
Top right corner M11 to L11
From bottom left corner O10 to M10

M10 to bottom right corner O10
O7 to O8
O8 to P9
P9 to P11
P11 to O12
O12 to O13
O8 to bottom right corner O8
Bottom right corner O9 to bottom right corner O10
Bottom right corner O10 to O12
L5 to M6
M6 to N6
N14 to M14
M14 to L15
R7 to bottom right corner T9
Bottom right corner T9 to T6
T6 to top right corner R6
R13 to bottom left corner T11
Bottom left corner T11 to T14
T14 to top left corner R14
From bottom left corner T14 to T14

T14 to O15
O15 to Q16
Q16 to bottom right corner S20
From bottom right corner T6 to centre T6
T6 to O5
O5 to Q4
Q4 to bottom left corner S1
S1 to H7
H7 to I8
I8 to I6
I6 to H13
H13 to H14
H14 to I12

The following lines should be thick:—
G5 to top right corner G6
Top right corner G6 to bottom right corner G8
G15 to top left corner G14
Top left corner G14 to bottom left corner G12
Shade in hair and coat

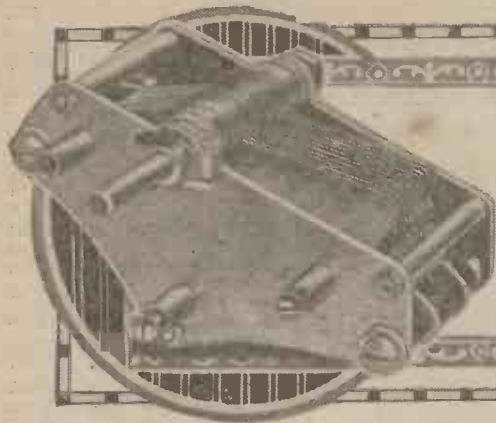

DO WE NEED A NEW CONDENSER ?

By J. H. REYNER,

B.Sc. (Hons.), A.C.G.I., D.I.C., A.M.I.E.E., Joint Editor

IN my last article I discussed the question of special variable condensers giving linear relations between the dial readings and the capacity, wavelength or frequency, as the case might be. I also indicated that there was a fourth type of condenser which, although by no means common, was becoming of increasing importance. This "logarithmic" condenser, as it is called, is of special value in cases where it is desired to match several tuning circuits so that their dial readings are identical. In order to understand this it will be as well to consider what is required in the matching of two tuned circuits.

The Conditions

Let us assume that we have two inductances both approximately equal, and that these are being tuned by two variable condensers. It is desired that the dial readings of the variable condensers shall be the same when the two circuits are in tune, irrespective within limits of the actual position on the condenser. In other words, the two condensers shall rotate both together as the two circuits are tuned to increasing wavelengths.

Let us assume that one inductance is slightly smaller than the other. Then the capacity which is tuning the smaller inductance will have to be slightly larger. Can we compensate for this difference in the condensers by having a small fixed capacity across the other condenser, so bringing the two dial readings equal?

"Balancing" Useless

This arrangement will be quite satisfactory at one particular point on the scale, but it will not apply at any other point. The reason for this can readily be seen. The wavelength to which the circuit tunes is proportional to the product of the inductance and the capacity. If this one inductance is only .9 times as large as the other one, then the capacity with which it is tuned must be approximately 1.1 times as great. We can, if we choose, adjust both condensers to the same value (and consequently the same dial reading) and add a small parallel capacity across one of them, making the total capacity 1.1 times that of the other.

It will easily be seen, however, that the value of this balancing capacity is not fixed. It has to be a certain proportion of the total capacity in use at



The use of double condensers for the simultaneous tuning of two circuits involves many problems concerning the shape of the plates.

any time, so that as we increase the capacity of the condensers we must increase the value of the balancing capacity in order to maintain one condenser at a value of 1.1 times that of the other. Consequently, the method balancing up the circuit by the addition of a small capacity is not a practical one.

Balancing the Dials

Another alternative would be to adjust both condensers to tune to a given point in the middle of the scale, and then to alter the position of the dials until they both gave the same reading. Such an arrangement would give an approximate correction, but would suffer from the same disadvantage as that just discussed.

In such a case we should have

balanced up the circuit by making the value of one condenser 1.1 times that of the other. Obviously, however, it does not necessarily follow that this relationship between the two condensers will hold over the whole of the range. In fact, with a circular plate condenser it would behave in a totally different manner, and would be equivalent to adding a small fixed capacity only, which, as we have seen, is not a practicable solution.

What is Required

With condensers having specially shaped plates to give an "S.L.W." or "S.L.F." law the actual relation would be somewhat complex, but it is obvious that, with plates designed for such a law, no accurate compensation of the character required could be expected.

A little consideration will show that what is really required for an accurate compensation of this type is that the effective proportional change of capacity for a given movement of the condenser shall be the same over the whole scale. This means that if we move the condenser a sufficient number of degrees to make its capacity 1.1 times that of the other, then its capacity will remain 1.1 times as great as the other condenser, at equal dial read-

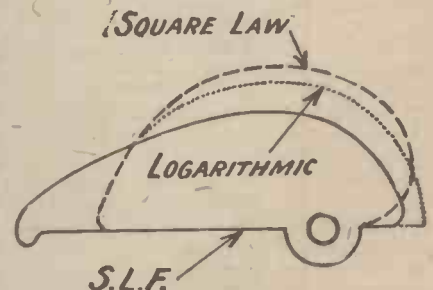

These are the three types of condenser plates discussed by Mr. Reyner. The "logarithmic" type possess important possibilities in cases where it is desired to use "gang control" of a series of similar tuned circuits.

ings, over the whole range of the two. Obviously such a device gives an easy and simple method of correcting any lack of matching in the circuits themselves.

(Continued on next page.)

Do We Need a New Condenser?—continued

An Existing Type

It is quite possible to make up a condenser to obey such a law, and, in fact, instruments of this type have been used in certain special pieces of apparatus for measuring the "decrement" of tuning circuits. The decrement of a circuit is a measure of the ratio of its resistance to its inductance at a given frequency, and instruments can be devised to read this ratio directly. Calculations in such cases are greatly facilitated if a condenser obeying this special logarithmic law is used.

It is not necessary to go deeply into the theory of such a condenser. I propose simply to compare it with the existing types of condenser, from which various conclusions will be drawn. For the benefit of those readers who are interested, however, I will give the formula from which the actual shapes of the plates may be deduced.

The Formula

As the dial reading on the condenser increases, so the radius of the moving plates increases in a certain proportion.

In laying out the shape of the condenser plate we are more concerned with the angle between the zero line and the particular point under consideration. If we call this angle A , then the radius of the condenser plate at that point must be

$$r = \sqrt{2c_0 \epsilon^{AA} + r_1^2}$$

This formula is only given for reference purposes.—The diagram shows the type of plate which is obtained with a condenser of this sort.

There is always a certain capacity in circuit even at the minimum, which is an essential point with this class of condenser, in order that the correct proportional law may be obtained.

The diagram gives an interesting comparison between this type of instrument and the "S.L.W." and "S.L.F." types. It will be observed that the shape of the logarithmic condenser approximates very closely to that of the square-law or "S.L.W." type.

The Difference

The only considerable difference

occurs right at the minimum of the condenser where the square-law plate is curved round to give an almost negligible minimum capacity, while

"C.W." AT SEA

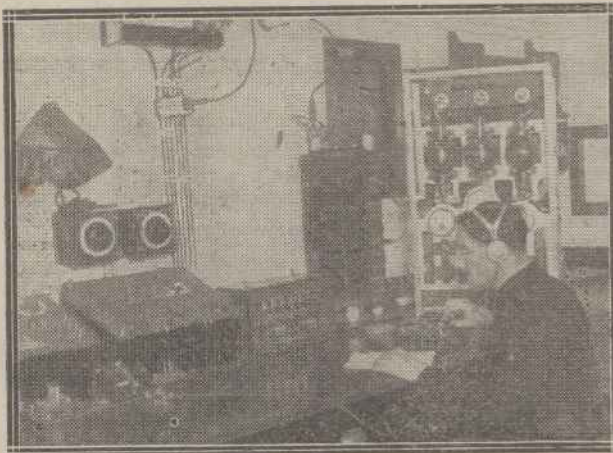

The use of continuous wave transmitters for long-distance maritime work is increasing. This view shows the equipment on a large Italian liner.

the logarithmic plate falls off more gradually to a definite limiting value. Towards the maximum also there is

An Important Point

These differences, however, are comparatively small, and over the working range the curves are very similar.

This is a most important point. It means that the existing type of "S.L.W." condenser is inherently suited for matching a number of tuned circuits.

The usual practice in such cases is to tune in to a station about the middle of the range. If the dial readings are found to disagree slightly, then the dials themselves may be rotated on the spindles until the readings are alike.

A Sound Method

Hitherto such a procedure has been regarded with some suspicion, it being felt that the correction thus obtained was not an accurate one. It now transpires, however, that any errors introduced by this were of minor importance only—at any rate, over the majority of the range.

Reverting to the question of new types of condenser, therefore, we can summarise as follows:—The available condenser giving the best

all-round service, having regard to the spacing of the various stations, and the possibility of matching in tuned circuits, is the square-law or "S.L.W." type.

A Possible Development

The possibility of being able to tune several circuits with one dial only is one which is meriting serious consideration to-day. In such cases the question arises as to whether the square-law plate is sufficiently accurate, or whether a more accurate compensation is desirable.

A Working Compromise

It may be that the logarithmic condenser will ultimately supersede the square-law type. Since the two condensers are similar in general form, the distribution of the various stations around the dial would be little different from that with an "S.L.W." condenser.

On the other hand, the more accurate compensation afforded with the logarithmic type would be of considerable assistance in many cases.

This, however, will remain to be seen, and for the present the existing square-law condenser serves very well.

WIRELESS IN THE FIELD



Rapidly transported wireless sets play a vital part in modern warfare. The photo shows one of these equipments undergoing its final tests. A petrol motor supplies the power.

some difference, the capacity with the logarithmic condenser increasing somewhat more rapidly than with the square-law type.

PRACTICAL TOPICS

By G. P. KENDALL, B.Sc., Assistant Editor

A Puzzling Case—An Old Trouble—Removing Flux Leakages.

I HAVE recently been spending several more or less happy evenings chasing elusive crackles in a six-valve receiver made by a reader from one of my designs in *Modern Wireless*. The fault was one which proved exceedingly difficult to find, all the usual tests failing to give any indication of its whereabouts, and the whole episode was an interesting reminder of the fact that one particular cause of crackling noises has very largely been eliminated by the change in our methods of set construction.

The Exception

I tried all such things as replacing transformers whose windings might be becoming defective, testing valve sockets, and so on, but at no time did I think it worth while to look for that once common cause of noise, namely, an ebonite panel badly splashed with soldering flux.

In the days when we used to build our sets all upon one panel, and when some people made a habit of reversing the set and soldering directly above the panel with a very hot iron and quantities of flux, it was quite a common thing, and indeed it was one of the first to be tested for, to discover that the trouble was purely a matter of surface leakage on the back of the panel.

An Indirect Gain

The present method of arranging sets with only a very few components upon the vertical panel and the great majority of the others in the form of independently insulated units upon a wooden baseboard has practically eliminated this source of trouble. Splashes upon the wooden baseboard do not matter very much as a rule, and such soldering as is done upon the components which are actually mounted on the panel takes place, generally, some little way off the ebonite itself, and moreover is not done directly above it, so that splashes do not fall upon the surface of the panel.

A Dangerous Material

Flux splashes, as a matter of fact, may produce quite low resistance leaks at times, for although some of the commoner soldering pastes are quite good insulators in their original condition, once they have been well singed by the soldering iron they become quite passable conductors.

One does not often come across a set in these days which is entirely built upon one panel, but such instru-

ments are still occasionally constructed, and it may be of interest to remind my readers of the methods to be adopted when it is discovered that flux leakages are taking place upon the ebonite, because unless one knows the special tip, such troubles are rather difficult to remove when the wiring is rather complicated.

The Remedy

The best method which I know of removing such leakages consists in the use of some solvent for the soldering flux, such as petrol, with which the back of the panel should be liberally washed, and at the same time scrubbed with the aid of a stiff paint brush. Such treatment must be really thorough, but no fear need be entertained as to damage to the ebonite, for although the back of the panel will be slightly discoloured by the treatment, its insulating qualities should not be impaired.

Accumulator Tops Again

A reader has been good enough to write to me pointing out that my recent remarks upon the subject of the washing of accumulator tops to remove the accumulation of acid spray, dust, and so on, might well have included a hint which is often given by battery makers for the treatment of such deposits.

The tip in question is simply to use a dilute solution of ammonia for washing the battery, thereby neutralising the acid, and rendering it somewhat easier to wash off. As a matter of fact, however, I do not employ this method myself, because a properly maintained accumulator should not get so dirty as to require the use of a neutralising agent to restore it to a proper condition. If the washing is done with clean water at sufficiently frequent intervals, no very great accumulation of acid should ever be allowed to take place.

A COMMON QUESTION

Can I use an H.F. transformer instead of a neutrodyne unit in an H.F. and detector set?

Yes, provided your H.F. transformer is of barrel type, with suitable coupling between primary and secondary windings. The secondary winding, which is generally larger than the primary, should be employed for the tuned anode coil and the primary winding should be utilised for the neutralising winding.

J. U.

DECKOREM BRITISH MADE
REGD. TRADE MARK. RADIO PRODUCTS

IN A CLASS ALONE

DIAL INDICATORS
ESSENTIAL for fine tuning. Adds appearance and finish.

No. 1 9d. pair
No. 2 3d. each
No. 3 2d. each



MINIATURE PANEL SWITCHES

HIGHLY polished, nickel plated, perfect contact. The acme of perfection.

S.P.D.T. 9d. each. D.P.D.T. 1/6 each.



PANEL DIALITIES
Rgd. No. 717785.

USEFUL where sets are installed in dark corners. Takes standard size bulbs of all voltages. Price 2/6 each.



BATTERY SWITCHES

SMOOTH positive action, one hole fixing, polished knob. A switch of outstanding interest.

Price 1/6 each.



BALANCING CONDENSERS
Rgd. No. 715459.

A Baseboard Unit with exceptionally fine adjustment. Can be locked in position. Highly plated. As used in the "Magic Five" and other circuits. Price 3/- each.



VALVE HOLDERS

A reasonably priced, well-finished article. Baseboard mounting. Price 1/- each.



OBTAINABLE FROM ALL THE BEST DEALERS

SOLE MANUFACTURERS:

A.F. BULGIN & CO.

9-H. CURSITOR STREET
TEL. HOLLORN 2072. CHANCERY LANE, E.C.4. WORKS CHISWICK

TRADE DECKO MARK



OBSERVERS reclining in punts along the shady banks of the River Thames were mildly interested to observe on Saturday, the 24th of July, a steam launch proceeding leisurely up-river with a particularly happy party on board.

"I seem to know that face!" observed a languid youth to his fair companion, referring to a figure on deck.

"Yes, I think I have seen it in the *Mirror* somewhere," came the equally languid answer. "Some music-hall star, I suppose."

As a matter of fact the party in question comprised the majority of the staff of Radio Press, Ltd., including, of course, the highly talented collection of geniuses who are responsible for this journal, who were taking their annual outing to Marlow-on-Thames. After a luncheon which must have left a very small profit for the hotel proprietors considering the quantity that was consumed, the party adjourned to a near-by field, where all kinds of non-technical sports were indulged in with great gusto.

INTERESTED parties who saw Mr. Scott-Taggart excitedly urging the tug-of-war team to still better endeavours and Mr. Harris's frantic attempt to win the sack race remarked that they did not think such wireless people could be so human.

By way of a change, the visitors were given an opportunity of hearing the local loud-speaker at work. After about three seconds' audition, several technical members of the staff disappeared into the building, sought out the set, and promptly remedied several obvious defects in reproduction. Having performed this "daily good deed," they returned and joined the dance which had been organised. Tired out but very happy, the party returned to London, and they have felt very much better for the outing ever since.

Incidentally, I am able to show you

below on this page a photograph of Mr. Harris, who, being a very keen amateur cinematographer, spent a good deal of the time filming all and sundry in and out of the sports. The demonstration of the finished film is eagerly awaited.

THE STALKER STALKED



At the recent Radio Press staff outing Mr. Harris made good use of his kinema camera. He is seen here watching his chance.

SINCE the Zenith Co., in Chicago, with their station WJAZ, defied the edict of Mr. Hoover, the Secretary of Commerce in the United States, and calmly began to broadcast on a wavelength different from that allotted to them, all kinds of things have happened in the American ether. As I have mentioned on a previous occasion, the Government brought an

action against the Zenith people and promptly lost, whereupon the latter, finding that they were at least temporarily freed from restriction, adopted, in common with others, a "go-as-you-please" policy. Until new legislation clears up the

matter, American broadcasting stations are doing just what they like, and chancing to luck as to whether they cause interference. In November, when Congress meets again, one can expect a new measure to be rushed through, giving full authority to the Secretary of Commerce to regulate the stations. Until then the chaos is likely to continue.

I SEE there is an outcrop of complaints regarding annoyance caused by loud-speakers. It is surprising that although it is both cheap and easy to obtain really good-quality reproduction on the loud-speaker, so many people not only put up with inferior reproduction, but actually consider it is the best that can be obtained. Only the other day I met a good lady who announced that she was going to fit a wireless set in her home. "Of course, I shall have to put in a crystal set. Loud-speakers are so horrible, aren't they?" she said.

A few nights before I had met a well-known business man who held just the same views, and I found on investigating that his poor opinion of loud-speaker reproduction had been gained from the awful sounds emitted by a bicycle shop

which he happened to pass every night on his way home from the station.

THE Wireless Societies, which are not usually very active in the summer-time, might well call emergency meetings for the purpose of giving demonstrations to the public of really pure loud-speaker reproduction.

The Week's Diary—continued

Unless this is done all kinds of absurd ideas may be held by local councils. For example, I see that at Sidcup recently a Councillor spoke of "the fearful menace which is overtaking the district by so many residents letting loose those awful loud-speakers." Is there no Sidcup reader of this journal who can give Councillor R. Ellison a demonstration of how excellent and pure reproduction can be with inexpensive apparatus?

THE real trouble comes not from loud-speakers as loud-speakers, but from the absurd attempts of many people to get from them far greater volume than they (and the sets used with them) are designed to give. No person has a right to "show off" his apparatus by seeing how far he can make it heard. A properly controlled loud-speaker need not be an annoyance to anyone.

I HAVE found it again! Here it is, straight from a daily paper:—
"Viscount Wolmer, Assistant Postmaster-General, said the science of wireless telegraphy was still in its infancy." Fancy that now! What wonderful people our legislators are! Remember I am not quoting from a Parliamentary report of twenty years ago, but from the proceedings in the House on the 21st of July.

IN common with many people, I was very disappointed at the Jazz Debate from 2LO. Neither side "made a case" and there was no real argument. Personally, I like some of each kind of music, and the respective good points of classical and jazz music were not made by either side. Incidentally, I did not admire Jack Hylton's choice of what he called "representative" pieces. However, the joke about jazz being described as "jumping from one bar to another" was worth hearing.

THE Elstree Laboratories have been working night and day on, not one but several, remarkable new receivers. Have you ever sighed for an instrument which would enable you to do all your tuning on one dial? The Elstree Laboratories have produced just such an instrument in the

"Elstree Five." Mr. Reyner and I, the other evening, found twenty-seven stations on this instrument between 5 degrees and 90 on the dial. This particular set is only one of the many

ON THE RIVER

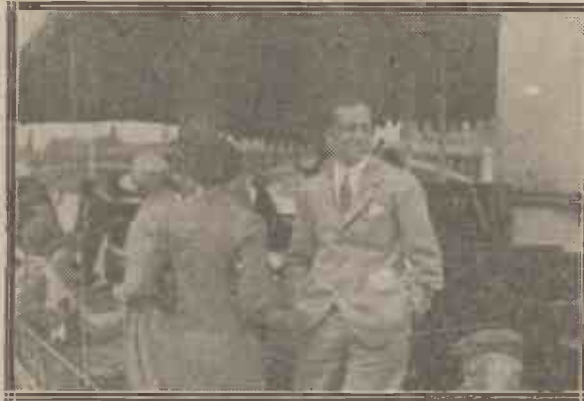

Part of the staff outing referred to by the Diarist was a river trip, on which this snap of Mr. Scott-Taggart was obtained.

special features in the September Double Number of *Modern Wireless*, and the instrument itself will be shown at the Olympia show.

THE "Nighthawk" receiver—Mr. Harris's latest set to which I

you will guess there is something novel about it. But when I tell you that selectivity is far in excess of anything else Mr. Harris has yet produced, and that as for its sensitivity we were able to get full loud-speaker strength from a German station on the earth lead alone, I know you will be still further interested.

Incidentally, it can be built and equipped with all accessories, including valves, accumulator, high-tension battery, and loud-speaker, for £20, and is a handsome addition to any drawing-room. I noticed a large number of ingenious simplifications of constructional work which will be widely welcomed by the home builder. There are, for example, only five holes to be drilled for mounting the components on the front panel. Can you guess what these five holes are? Three are for one-hole fixing variable condensers, the fourth for a one-hole fixing on-and-off switch, and the fifth—well,

I mustn't give all the secrets away! The "Nighthawk" is to be a feature of the *Wireless Constructor*, which will be published on the 15th of September.

FADING



Much work is being done at the U.S. Bureau of Standards on the problem of fading, special recording apparatus being used.

referred in these columns some weeks ago—has now been completed, and I was allowed to hear it working the other night for the first time. When I tell you that it utilises quite a new circuit arrangement, and although it is a five-valve set, uses an ebonite panel measuring only 16 in. x 8 in.,

AMERICANS have not been long in finding out the remarkable new series of receivers produced by Radio Press, Ltd., and one of the leading American wireless journals is already telling its readers about the "Elstree Six" and publishing photographs and wiring diagrams. It is an open secret that in the past British wireless receivers have suffered in comparison with the American, at least so far as selectivity is concerned, but the tables are now being turned, and attention is being concentrated on England.

COMMANDER KEN-WORTHY'S suggestion in the House of Commons that a picture of the Postmaster-General and a hammer should be placed in every public call box, so that callers could find a better outlet for their rage than the instrument itself, is worth adopting in wireless circles. A nice picture of the Programme Board, mounted on cork, and provided with a set of good sharp pins, might afford an outlet for our feelings whenever the programmes do not come up to our own private standard.



INVENTIONS AND DEVELOPMENTS

SOME NEW RESISTANCES

In this feature, conducted by Mr. Reyner, appear from time to time details of some of the latest developments.

IN last week's review I dealt with some special amplifier valves constructed by Dr. Loewe, of Berlin. Two other interesting products have been constructed at the Berlin Laboratories which will be of interest to experimenters in this country. The first of these is a completely enclosed grid leak.

Progress in Resistances

One of the great difficulties with high resistances for use with wireless equipment is the problem of maintaining constant values. The construction of such resistances has improved considerably in the past few years, and the very violent variations which used to be experienced, giving rise to crackling and other unpleasant effects, are now to some extent eliminated. There is still, however, a tendency for high resistances (except those of the wire-wound type which are necessarily more bulky) to vary from their rated value with age.

A New Material

Dr. Loewe has discovered a special compound which he utilises to coat a small glass tube. Connections are made to the resistance material by means of small pieces of wire wrapped round the ends, and coated with a binding material. This end covering is of comparatively low resistance, and it is the space in between the two end connections which is covered with the high-resistance compound.

The whole is mounted inside a small tube from which all gas is exhausted, and practical experience shows that a resistance made up in this manner maintains its value constant under very severe conditions of load.

A Parallel

It is interesting to note that a similar method of construction to this is actually adopted on the Ediswan gridleaks and high-resistances which are now available in this country. It will generally be admitted that if resistances can be produced in the compactness of this type, and still be constant and quiet in operation, we have made considerable strides in the science of resistance manufacture.

The other unit referred to is a completely enclosed Quartz crystal arrangement. The actual method of mounting a Quartz crystal is one re-



The new quartz-control unit invented by Dr. Loewe. The elements are contained in a bulb of gas at reduced pressure.

quiring considerable care, as otherwise minor variations in the frequency of the arrangement may result. Dr. Loewe, therefore, has arranged to mount Quartz crystals in a small en-

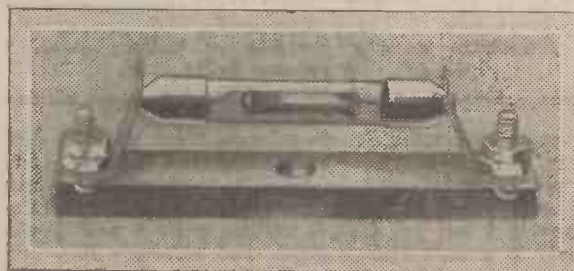

The new resistance elements are contained in evacuated glass tubes.

closed bulb containing gas at a reduced pressure.

The crystal itself is mounted in between the two small plates. If, then, an alternating voltage is applied across the plates, at the resonant frequency of the crystal, the latter will vibrate and will set up a luminous glow inside the tube.

A Resonance Indication

This may obviously be utilised as a definite indication of resonance, and is particularly useful in tuning a radio transmitter to an exact wave. When the wave is exactly that of the crystal, this luminous glow will be present, and any deviation from the specified frequency will cause the bulb to cease glowing.

THE "COCKADAY-HARTLEY" RECEIVER

SIR.—Mr. John W. Barber's "Cockaday-Hartley" three-valve receiver, described in WIRELESS a short time ago, is the best I have yet struck for selectivity combined with simplicity of operation. I have varied the actual components used by Mr. Barber considerably, and yet find that his operating instructions hold good for my own set, on which I have already logged a very large number of the more distant Continental stations. The operation of the set upon a DX station is no more difficult than that of a "straight" one-valver, and the results obtained have astonished most of the so-called "experts" in this neighbourhood.

I should be glad if you could find space to publish this letter, in the hope that it may lead others to construct this set, and obtain equally fine results. I do not think enough research has been carried out with regard to producing really good, selective "DX" receivers without the necessity of using H.F. amplification. The latter, though it undoubtedly is worth while, always introduces more controls. Let us have more of the "D. and note-mag." type.—Yours faithfully,

C. M. DUNN.

E. Dulwich, S.E.22.

A Tuner Unit for the "Flexible Receiving Equipment"

(Continued from page 379)

construction are given, together with the names of the manufacturers. Any departure from the original should only be made with due regard to the size and shape of the different component, lest difficulty be experienced in assembly.

Material Required

- Ebonite panel measuring 8 in. x 6 in. x $\frac{3}{8}$ in. (Cameco).
- Baseboard measuring $6\frac{1}{2}$ in. x 6 in. x $\frac{3}{8}$ in. (Cameco).
- One variable condenser, .0005 geared (Ormond).
- One variable condenser, .0003 geared (Ormond).
- One H.F. choke (Beard & Fitch).
- Two coil holders for baseboard mounting (Peto-Scott).
- One 8-way Clix socket strip (Magnum).
- Two Clix plugs (white and red) (Autoveyors).
- Glazite for wiring (L.E.W. Co.).

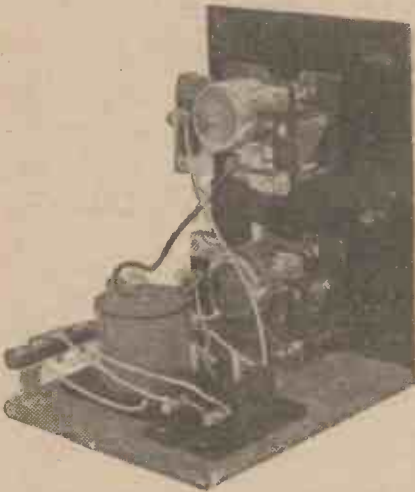

A rear view of the tuner unit removed from the cabinet.

Small length of insulated flex (L.E.W. Co.).

Three $\frac{3}{8}$ in. wood screws (countersunk).

Constructional Work

First drill the ebonite panel in accordance with the details given in the diagram. This operation is completed with five holes only. Next secure the panel to the baseboard by means of three countersunk wood screws. The two variable condensers are then mounted upon the panel in the positions indicated in the diagrams representing the front and back of the panel. The only other components to mount are the choke, the two coil holders, and the Clix socket strip. Details of these strips were given in

Wireless Weekly of the issue mentioned. They may also be obtained ready-made, as mentioned in the component list.

Wiring

Having mounted these remaining components upon the baseboard, the wiring may be proceeded with. This part of the work is, as may be seen from the diagram, extremely simple and straightforward. There are two flexible leads, each of which is equipped at one end with a Clix plug (one white and one red).

One of these leads is connected to the moving element of the variable condenser C_1 and the other to the moving element of the variable condenser C_2 ; a third flex lead is also provided, one end of which is provided with a spade tag for the purpose of making connection to the existing terminals of a standard type of X or other tapped plug-in coil. Little more need be said relating to the construction of this panel, as the diagrams given render the work practically self-explanatory.

The Theoretical Circuit

The theoretical circuit diagram is given in Fig. 3. The flex leads upon the panel are indicated as in the other diagrams, the Clix plug colours being specified in order to facilitate the work of linking up various circuit arrangements with the other panels.

The aerial down lead and the earth lead are also equipped with Clix plugs, which connect direct on to the panel by means of the Clix socket strip. The lead which connects to the tapping of a plug-in coil is also clearly indicated. In order to connect up the various possible tuning arrangements, reference should be made to the other panels which have been described. (Some further notes on the use of this panel, with some circuits to try, will be given in an early issue.)

NEWS IN ADVERTISEMENTS

Messrs. A. F. Bulgin & Co., in their advertisement in this issue, are describing various small components which should prove useful for the constructor who likes to add "gadgets" to a set which is otherwise constructed to a published design.

The Dubilier Condenser Co. are inviting inquiries for full particulars of their "Dubilicon" competition.

The Igranic Electric Company, Ltd., are advertising components suitable for use in the "Elstree Six" receiver recently described in *Modern Wireless*.



This week-end build your own loud speaker!

First of all go to your dealer and satisfy yourself that the "Lissenola," costing only 13/6, really is fully equal in power and tone to any loud speaker on the market. Ask your Dealer to put on the best loud speaker he has in stock—then use the same horn on the "Lissenola" and see if you can notice any difference.

When you get the "Lissenola" home you can build a horn yourself for a few pence, providing you with a powerful instrument which will compare with any expensive loud speaker you have ever heard. Or, if you prefer a cone-principle diaphragm—very simply made—you should get a Lissen Reed as well (1/- extra).

If you have never heard a "Lissenola" there's a surprise in store for you.



Before buying ask your dealer to demonstrate the

LISSENOLA

LISSEN LIMITED,
18-22, Friars Lane,
Richmond, Surrey.

Managing Director: T. N. COLE. L36



Conducted by the "Wireless" Laboratories, Elstree.

Combined Earthing Switch and Lead-in Tube

AS thunderstorms are more frequent at this time of the year some of our readers will be inquiring for some method of overcoming likely dangers from lightning, and in this connection we have received a combined earthing switch and lead-in tube which is manufactured by Messrs. J. Webb, of 35, Claremont Grove, Didsbury, Manchester, costing 4s. to 5s., according to the length of the tube supplied.

The switch is operated from inside the house, a diagram showing the necessary connections being printed on the carton containing the combined instrument. The accessory is fairly simple to fix, it being of course necessary to make a hole in the window frame to lead into the house.

The component submitted to us was of the 12-in. type, and consists of a length of brass rod covered by insulating material. About a quarter of the way down the tube is a round flange of metal, by means of which this tube is screwed into position. One end carries a slate covering as a means of insulation, and under this the arrangement for earthing the aerial is provided for, so that when the knob is pulled outwards the outside aerial is connected direct to earth outside the house. This is done by means of a brass collar fitting into a brass socket, thus making a direct connection to earth, at the same time short-circuiting the brass work carrying the aerial terminal to the set.

The component is well manufactured and can be strongly recommended.

"Atlas" Variable Condenser

MESSRS. H. CLARKE & CO., LTD., have sent us one of their "Atlas" variable condensers for test and report.

This condenser is of low-loss construction, the fixed plates being insulated from the metal end plates by means of short pieces of ebonite, the moving vanes



The Webb lead-in and earthing-switch.

being in electrical connection with the metal end plates, which are cut away in order to reduce the minimum capacity of the condenser. A clearly graduated metal dial is provided, which is graduated from 0 to 180 degrees.

Laboratory Tests.—The rated value of this condenser is .0005 mfd., but when placed on test it was actually found to

be .0006 mfd. The H.F. resistance was of a low order, while the insulation resistance was found to be infinity.

Terminals are provided for making connection to the instrument, which is of the one-hole fixing type. It is strongly constructed and with a degree of efficiency well up to standard.

Cantophone Tuner

MESSRS. THE CANTOPHONE WIRELESS CO. have sent us for test and report one of their tuners. The design of this instrument is novel in that the tuner unit comprises a reaction control in each case, the whole being interchangeable so as to cover

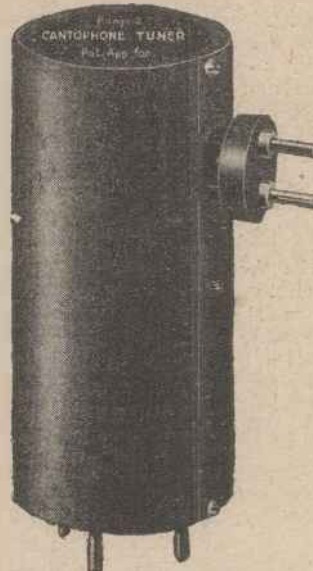

The Cantophone Tuner No. 2 has a tuning range of 220 to 780 metres approximately.

various ranges. Three ranges are supplied, which cover the wavelength bands between 70 and 2,000 metres, the one actually submitted for test being No. 2, which covers 220 to 780 metres. Further, a direct calibration scale is provided for use with a particular make of variable condenser. If a different make is used, of course, the calibration does not quite hold, although it is fairly approximate.

Test Results.—When placed on test in the aerial circuit it was found that the tuning range of this component was approximately from 220 to 750 metres, while the reaction control was found to be perfectly smooth when correct values of H.T. and L.T. were employed. The signal strength from distant stations was found to be normal, while a satisfactory degree of selectivity was obtained in view of the fact that no stage of H.F. was employed.

The instrument is well finished and robustly constructed. It is intended for mounting behind the panel, and it is only necessary to drill one hole for the reaction control. Connections are made to the tuner portion of the instrument by means of soldering tags, while two flexible leads finished with metal eyelets are provided for the connections to the reaction coil. This instrument can be recommended for use.

Accumulator Reviver

MR. SKADDER has submitted to us for test at our Elstree Laboratories a sample of a liquid for reviving accumulators which have sulphated through overloading or other causes.

Manufacturer's Claims.—Two distinct

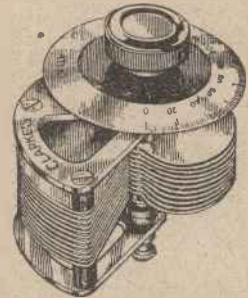

The "Atlas" variable condenser is constructed on low-loss lines.

claims are made for the fluid submitted: (1) That it will revive spoilt accumulators so long as the plates are not badly buckled or shorted, and (2) that it will also serve partly to charge an accumulator in the sense that the charging current need be passed for a much shorter time if the liquid has been used in conjunction with complete replacement of the ordinary acid.

The liquid submitted was transparent and evidently contained acid, but gave no other indication of its nature.

Laboratory Tests.—Two old 2-volt accumulators of 105 ampere-hour capacity were selected which through considerable overload on a motor starter had sulphated badly. Their condition was such that they would gas freely after half-an-hour's charge, and would give a current for about an equal period before becoming completely discharged. After the addition of the liquid under test the voltage of these accumulators rose from almost zero to 0.8 volts and 1.4 volts respectively. After charging for 20 minutes at 6 amps. the voltage rose to 2.1 and 2.2 volts respectively.

On discharge at 6 amps. both accumulators went down in 20 minutes, so that there appeared to be no improvement brought about by the electrolyte.

Both accumulators were then charged at 4 amps. for 7 hours. At the end of that time they were discharged at the rate of 3.8 amps. One accumulator was found to last 5½ hours and the other 6½ hours.

Both accumulators were then given a full charge, and were found to behave as if fully restored. The reduction of the sulphating was also very evident.

General Remarks.—Although the tests we have made do not indicate that the liquid gives a partial charge as claimed, yet it would appear to be very useful as a restorative for accumulators which have been given up as hopeless.

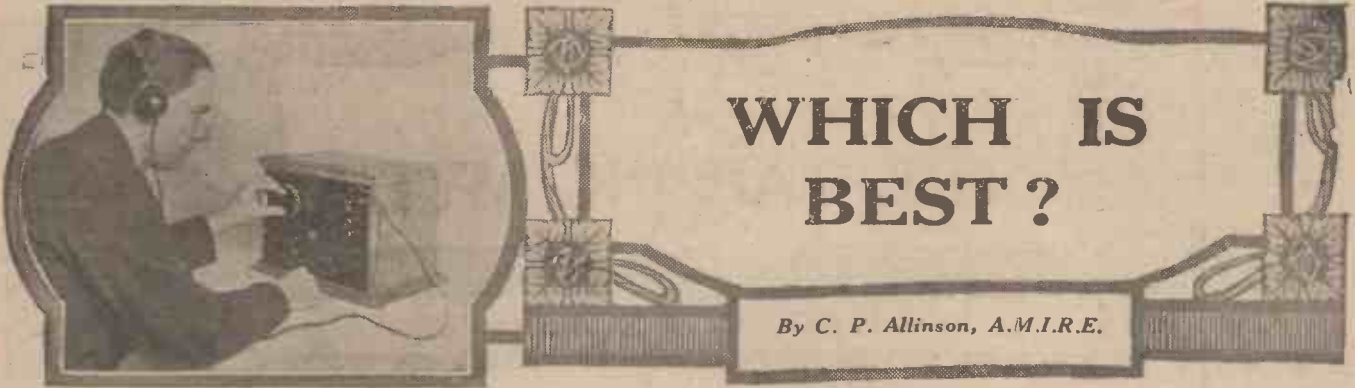

HOW often some amateur friend comes to ask one's advice on a certain point where two different arrangements are possible, asking which of them is best. And in perhaps nine cases out of ten one cannot say definitely, much to his disappointment.

It is strange, however, that so many things occur in wireless that either go against accepted practice or are dead against the (possibly incomplete) theoretical view. With some H.F. circuits where H.F. transformers are used it will be found necessary to employ connections other than those given by the makers, to take just one example.

A "Back-lash" Example

I have always found that when a receiver inclines towards back-lash as regards the control of reaction it is necessary to increase the value of the grid leak. This is a point I have experienced again and again with various types of valve, yet it has been shown theoretically that in most cases the reverse should be the case, and there are no doubt many experimenters who will say that this is correct.

Another point that has been emphasised from time to time is that back-lash may be cured by reducing the H.T. and L.T. voltage applied to the valve. Yet this is not a hard and fast rule. I have found that with

certain types of valve if the filament is run at too low a temperature back-lash will result, and in some cases,



Mr. Lloyd George at the Christian Endeavour Convention at the Crystal Palace. The "Public Address" microphone may be seen in front of him.

too, I have experienced back-lash when the H.T. voltage applied was too small.

Another Case

With regard to back-lash, again, I have invariably found, up to quite recently, that a receiver which was perfectly delightful as regards reaction control would develop this annoying symptom when the grid leak was taken to L.T. — instead of L.T. + as is the usual practice. I constructed a Reinartz receiver recently, however, that suffered from an extraordinarily bad case of this complaint, and nothing could be done to cure it except connecting the grid leak to L.T. —. Incidentally, this gave better signal strength, though it has been shown time and again that the positive connection is the best!

Shortly after this set was built the coil, tuning condensers and H.F. choke were changed, but when re-assembled back-lash was still found to result when the grid return went to L.T. +. What then was the cause of this curious behaviour on the part of this receiver?

Be Wary!

It is cases like these that impress on the amateur even of ten or twelve years' experience the difficulty of giving hard and fast rules on many points regarding the practical application of laws that have been laid down theoretically, and in particular it urges him to caution when asked to give advice on certain phenomena that have been observed under circumstances of which he is unaware.

No. 42.

Appreciation!





THE H.T. TAPPING MYTH

By G. P. KENDALL, B.Sc. Assistant Editor



Do we really need all those tapping points? Mr. Kendall's views take the form of an emphatic negative.



ONCE upon a time we had, for our sins, to use valves which sometimes worked really marvellously, as it seemed then, when tactfully treated, and at other times sulked obstinately and refused to respond to any amount of coaxing on the part of the distracted operator. There was, of course, very little uniformity among the different valves of the same alleged type, but many of them required a very exact adjustment of filament current before they would begin to think about working properly. There was even one remarkable contrivance in which it was possible to adjust the vacuum to the desired degree by holding a lighted match to a little projection formed in the valve and containing a special substance!

Endless Fiddling

Critical adjustments were the order of the day, or at least so it seemed although a lack of understanding on the part of the operator of these new appliances may have had something to do with it. Now, one of the adjustments with which we used to fiddle most painstakingly was that of the plate voltage, for it seemed that often only a few volts alteration would make all the difference in the world to the results.

A Diverting Pastime

Many of the high-tension batteries which I used at that time consisted of large banks of single separate dry cells of considerable size, so that it was possible to tap in at every $1\frac{1}{2}$ volts, and one used to spend much time chasing up and down amongst the cells, seeking for the exact voltage which seemed to give the best results.

A Legacy

I believe it is a legacy from those early days that we now suffer from

what I call the "H.T. tapping myth." Practically every high-tension battery turned out has tapings every three or six volts, or at some similar small intervals, and most beginners spend much good time conscientiously sticking the plugs first in one hole and then in another, observing at the end of it all that there is exceedingly little difference in results at any position within quite wide limits.

The Usual Experience

The high-frequency valves seem to work better with the higher voltages

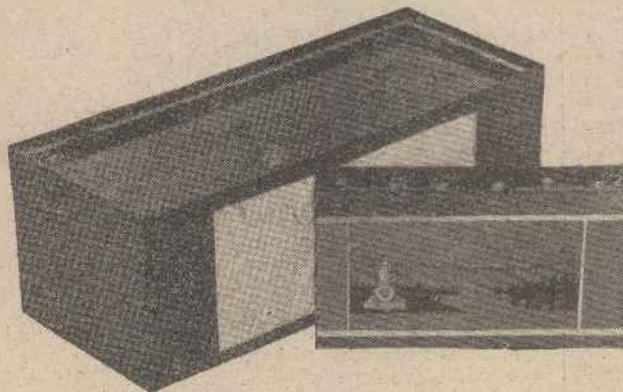

The author urges that about five tapings are ample for general purposes.

up to about 72 or perhaps 80 or 90 in the newer neutralised circuits, the low-frequency valves seem to want all they can get, although there is little improvement with most of the modern types above about 100 volts, while the detector seems perfectly happy with 45 volts; increases above 45 do not appear to improve signals, and may make reaction floppy. These, broadly speaking, are the usual experiences of a beginner, the exact voltages depending, of course, upon the particular valves which he is using; but there is as a rule no very great variation from those which I have given.

General Rules

The fact is that modern valves in the vast majority of circuits are not a

bit critical as to high-tension voltage, the only need for any adjustment at all being usually in the case of a detector valve with reaction, the aim being to secure a smooth adjustment of the oscillation control. As a rule, however, the arbitrary choice of a rather low value, such as 36 or 45 volts, will generally produce the desired result at once. These things being so, one is tempted to ask, "In the name of common sense, why all those tapings?"

Why Not?

Why not drop the use of H.T. batteries simply spotted with tapping points, and use units of reasonable size, say, 120 volts, with the tapping points at the voltages which we *really* use, rather than the multitude of ones which we never use? What we want is a tapping at 36 volts and at 45 volts for the detector valve, others at 72 and perhaps 84 volts for the H.F. valves, and a terminal at the end of the battery for the low-frequency valves.

Do You Agree?

These views, of course, are decidedly personal ones, and I dare say quite a number of readers will disagree with me, in which case I hope they will not hesitate to express *their* views!

□ □ □

Wireless Licence Regulations

Under the G.P.O. regulations, which are of a surprisingly flexible character, you are allowed to take away your wireless set with you when you go on holiday. The licence clause which states that the apparatus is to be used only at a fixed address means, we understand from a G.P.O. official, simply that it must not be stretched to cover two permanent addresses or two permanent sets. The set for which the licence has been taken out may be moved occasionally, provided that it is not used for an unreasonably long period at the second address.

A Reinartz Tuned-Anode Set

(Continued from page 367)

Valves should be inserted in the holders temporarily in order to ensure that ample clearance is provided, and the panel should be placed in its correct position to ensure that none of the panel components foul those on the baseboard.

Wiring

The baseboard components may then be fixed in their positions, the panel placed finally in position and screwed home, when the set is ready for wiring. No difficulty will be experienced here, most of the wiring being at the back of the baseboard. Care should be taken that the connections to the screened coil are correct, and also that the jacks are correctly wired up.

When the receiver has been wired it is ready for test. For this purpose the Reinartz coil must be obtained for

provided that it is reasonably similar, but the particular coil quoted matches the inductance of the screened coil approximately so that the dial readings on the first two condensers are similar.

Now, without connecting the aerial up, test the reaction. Switch on the valves and place the potentiometer towards the positive side. This is to ensure that the first valve shall not oscillate. Now, on increasing the value of the reaction condenser (third condenser on panel), the second valve may be caused to oscillate. This will be observed by a click in the 'phones or loud-speaker, and the value of the H.T. and filament brilliancy should be adjusted until this click is quite soft in character and there is no backlash on the adjustment. That is to say, the reaction starts and stops practically at the same point on the condenser,

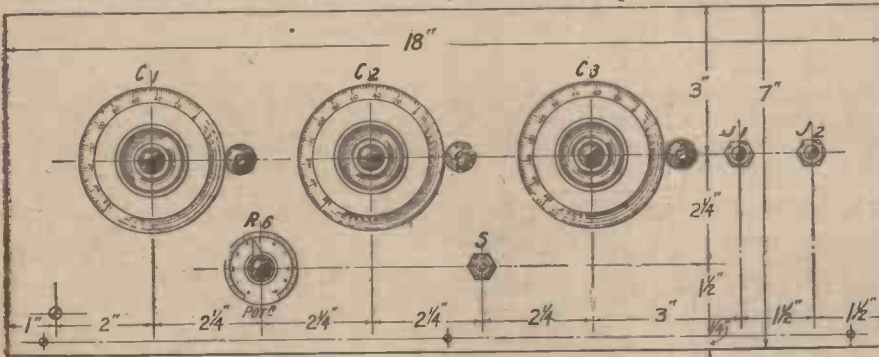

Fig. 4.—All necessary drilling centres can be obtained from this front of panel layout.

insertion in the screen. This may be purchased ready-made with the screening case, or may be wound up by the constructor himself.

The winding is simple. The main coil consists of 80 turns of 28 d.s.c. wire wound on a 2-in. former. This winding is then continued for a further 30 turns, tappings being taken at 15, 20, 25 and 30 turns.

The connections to the coil are as follows: Main coil beginning to No. 1, end to No. 2. Tappings to Nos. 3, 4, 5 and 6 respectively, No. 6 being the 30th turn.

The diagram in Fig. 3 gives the connection between the sockets of the screen and the terminals thereon, and also the numbers of the pins on the coil itself, looking from the bottom.

Testing Out

Having tested the connections in the usual manner to ensure that there are no faults, the receiver may be tested on signals.

Plug a No. 60 X-coil in the first socket. A different value of coil, i.e., a 50 or 75, may be used if desired,

and slides into oscillation without plopping.

Aerial Tests

The aerial may now be connected up and the set tuned in to the local station. When this has been done the potentiometer may be moved towards the negative side a little at a time. As this is done it will be found that the signal strength will increase, and that at one particular point a very marked increase in strength will occur.

If the potentiometer is moved too far towards the negative side, the first valve will burst into oscillation. This must not be permitted, because such oscillation will cause interference to the neighbours. It is not necessary, however, to move the potentiometer so far, a sensitive point being obtainable before the oscillation point is reached. It is advisable to keep the reaction condenser at zero during this portion of the adjustment. It may subsequently be increased, when the signal strength will be considerably improved.

This completes the adjustments, and
(Concluded on next page.)

WIRELESS.—Capable, trustworthy men with spare time who wish to substantially increase income required where we are not fully represented. Applicants must have practical knowledge of installation of Set and Aerial, be a householder or live with parents, and be able to give references; state age and experience. Address: Dept. 38, GENERAL RADIO COMPANY, LIMITED, Radio House, Regent Street, London, W.1.

Build Your Own LOUDSPEAKER WITH A LISSEOLA OR BROWN A and our COMPONENTS. You can construct yourself a handsome CONE type, or PLATED PAPER type LOUDSPEAKER in half an hour for less than it would cost you for the ordinary cheap horn type Loudspeaker. You will obtain VOLUME, CLARITY, and unsurpassed tonal quality. Prices, particulars and Diagrams for stamp. TRADE inquiries invited. Tell your dealer **Goodman's, 27, Farringdon St., E.C.4**
Also obtainable from Spencer's Stores, 4-5, Mason's Ave, E.C.2

EARTH FAULTS ENDED
Entirely new method of Earth-system efficiency. 20 per cent. to 200 per cent. increase guaranteed. Vastly superior to all metal sulphates. Ideal for all outdoor Earths. 2/6 complete, post 6d. Cash on delivery if desired. Particulars free. **J. W. MILLER, 68, Farringdon St., E.C.4.**
Phone: Central 1950. *Approved by Radio Association.*

Valves Repaired
AS GOOD AS NEW!!
(Except Weeco, S.P.'s and low capacity types.) Minimum D.P. Current 0.15 amps when repaired. ALL BRIGET & DULL EMITTERS Listed at less than 10/-. Minimum charge - - - 5/- LTD. Dept. W., Tabor Grove, Wimbledon, S.W.

AGENTS to sell cheapest and safest lamp; good income earned converting paraffin lamps into 150 c.p. Titus Light.
TITUS, Kingston, BRIGHTON.

WET H.T. BATTERIES
British made round or square Leclanche Glass Jars, 24 x 14 x 14, for wet H.T. Units. Waxed, 1/3 doz.; plain, 1/- doz. Carriage and packing extra. 'Phones and Loud Speakers reconditioned, 4/6 & 5/-. The H.R.P. Co., 1, Cottrell Road, Dalston Lane, E.8.

2-VALVE AMPLIFIER, 35/-
1-Valve Amplifier, 20/-, as new; Valves, D.E. .06, 7/- each; smart Headphones, 8/6 pair; new 4-Volt Accumulator, celluloid case, 13/-; new 60-Volt H.T. Battery, guaranteed, 7/-; 2-Valve All-Station Set, 24. Approval willingly.
R. Taylor, 57, Studley Rd., Stockwell, London.

COUPON.
QUESTIONS & ANSWERS.
This coupon must be accompanied by a P.O. for 2/6 for each question and a stamped addressed envelope when sending queries to the Radio Press Information Dept. for a postal reply.
"WIRELESS." Vol. IV. No. 11.

All communications regarding advertisements should be addressed to:
The Advertisement Manager,
"WIRELESS,"
Bush House, Strand, London, W.C.2
Telephone: City 9911.

A REINARTZ-TUNED ANODE SET

(Concluded from page 395)

tuning in may now be carried out in the normal manner. The setting of the potentiometer will not require to be altered much, and need not be touched in normal operation, all tuning being carried out on the two main condensers with the assistance of the reaction control. The sensitive point on the first valve will be found to be slightly different for loud and soft signals, but the variation is only small.

Valves

The first valve should be of the high-impedance type usually quoted as suitable for H.F. work. The second valve may be any suitable detector, of suitable voltage for the accumulator employed. The third valve is the first in the L.F. chain, and should be a low-impedance valve. An ordinary L.F. valve may be employed or a small-power valve. The last valve should be a power valve capable of handling the volume required.

Selectivity

The selectivity is controlled to some extent by the tapping on the screened coil. The smaller this is made, the greater the selectivity, but the signal

strength also falls off somewhat rapidly. A position for best results is easily obtained by trial and error, after which the tapping need not be altered. (Further notes next week.)

BEING FUNNY BY WIRELESS

(Continued from page 368)

world to conquer. Every true artist is unsatisfied so long as there is still any victory to achieve, and here radio offers us untold chances. Every true artist has at some time or another longed to be able to give his art to the little country places, to the inhabitants of those lonely parts where it is impossible to tour—in fact, to share what gifts he or she has universally. Broadcasting has made that into a reality from a dream.

A Great Ambition

Do not think I underestimate my friends of the theatres. You should know how I value them, for they are my oldest friends. But there are hospitals where, perhaps, a song such as "Ah'm Expectin' a Leddy!" and the rest might while away an hour with care and pain forgotten. There are work-tired folks the country through who Harry Lauder longs to coax into merriness and content w' his fooling. Every wireless comedian wants to make

care-weary folk laugh an' increase "goodwill among men."

An International Link

Again, it is universally recognised that nations become more friendly the more they learn about one another, as is the case between English-speaking nations. Wireless, and radio-humour in particular, is going to be a big influence for international friendships among the peoples, for who can be at enmity with a real laughter-maker? Every comedian's biggest ambition is to make real friends with his audiences. I like to think I'm real friends with all mine in the theatres, and now wireless has given us the biggest chance we've ever had yet—nothing less than that of being friends with all the world. An' what can man want more?

A Simple Test

I have a good loud-speaker giving great volume without distortion, but am afraid I might demagnetise it owing to the terminals on it not being marked.

The simplest method to adopt to determine the correct polarity is to connect the loud-speaker in circuit and to so adjust it that it just rattles slightly on strong signals. When so adjusted reverse the leads to it, and if the rattle ceases it was originally connected correctly. If, however, the rattle is accentuated the first connection was not the correct one.—J. U.

Users prove



Frelat

to be the best Dull Emitter Valve.

TYPE K 2 VOLT .3 AMP 4'11

Saves pounds in Battery and valve replacement.

If your Dealer cannot supply, send P.O. for 4/11d., or if C.O.D., send 5d. in stamps.

Read these unsolicited Testimonials

Weymouth.
"I have used two 'Frelat' (4/11d.) Valves for quite a time now and all I can say is that they rival even the most expensive of Valves."

Bury St. Edmunds.
"With the type H. (Detector) Valve recently purchased from you, I have logged the following Stations, using a 'Straightforward One Valve Receiver'—Daventry, London, Bournemouth, Birmingham, Radio Paris, Brussels, Hamburg, Berlin, Dublin, and sixteen other European Stations which have not been identified. The first five have been received in broad daylight, the remainder at dusk."

Continental Radio Import Co., Ltd.
8, SPITAL SQUARE, LONDON, E.1.



FORMO
—THEIR PATENT—

A MONUMENT IN THE MARCH OF PROGRESS.

The Formo Shrouded Transformer is the universal favourite.

10/6 Made in Ratios 1-1, 1-2, 1-3, 1-4 and 1-5. 1-3 and 1-5 for First and Second Stages.

SEND FOR CATALOGUE AND DESCRIPTIVE LITERATURE OF COMPLETE FORMO RANGE.

THE FORMO COMPANY,
CROWN WORKS, CRICKLEWOOD, N.W.2.
*Phone: Hamp. 1787.
Manchester: Mr. J. B. Leves, 23, Hartley Street, Levenshulme. *Phone: Heaton Moor 475.

See page 383 for Formo S.L.F. Condenser.

If you are unable to obtain your favourite Wireless Journals from your Newsagent or Bookseller send a subscription.

WIRELESS INCORPORATING **WIRELESS WEEKLY** Twelve months - 13/- Lesser periods, pro rata

MODERN WIRELESS Twelve months - 15/- Lesser periods, pro rata

THE WIRELESS CONSTRUCTOR Twelve months, 8/6 Lesser periods, pro rata.

Promptly delivered through the Post.

RADIO PRESS, LTD., Bush House, Strand, London, W.C.2



Helps you to stock for public demand

"WHAT the Wireless Journals are Doing"—a prominent feature of THE WIRELESS DEALER—is invaluable to all who sell radio apparatus.

Shelves need no longer be loaded with obsolete goods. This article gives advance information regarding components to be used in forthcoming issues of public wireless journals, and the public demand can now be both closely followed and approximated.

THE WIRELESS DEALER always contains something interesting and informative. It keeps you in close and intimate touch with the personnel of the Industry and with all developments and inventions. Send for a specimen copy now.

SELECTION FROM CONTENTS

Speed up the High-Power Stations!

"The Wireless Dealer" Service and Testing Unit

By Percu W. Harris, M.I.R.E.

There is N Slump!

By A. W agge

Plain Words on Trade Conditions

By Leon A. Sharland

New Components for the Coming Season

By J. H. Reyner, B.Sc. (Hons.), A.C.G.I.,

D.I.C., A.M.I.E.E.

SUBSCRIPTION RATES: 7/6 per annum (abroad 10/-). Available to the Trade only. Trade card or business heading should accompany every subscription to the SALES MANAGER, Radio Press, Ltd., Bush House, Strand, London, W.C.2.

The **Wireless Dealer**
AND MANUFACTURER

All Valves

have constructional features
but only P.M. Valves have the
P.M. Filament—

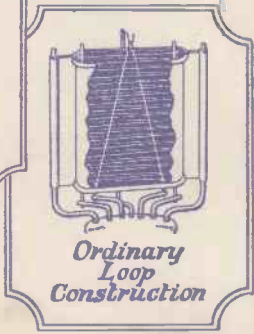
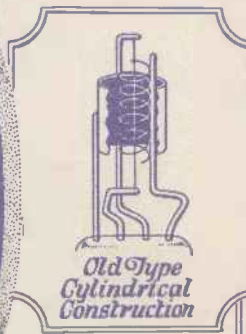
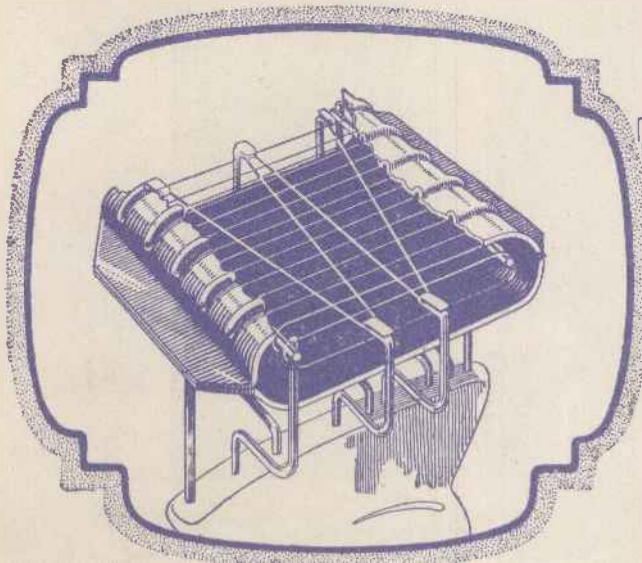

Which valve construction gives you the most for your money

Look at the length, thickness and design of the Mullard P.M. Filament and you will appreciate why those who understand valves place its results 33% higher than any other on the market.

This wonderful P.M. Filament

Is supported by 5 strong but resilient hooks.
Cannot be broken except by the very roughest handling.

Has up to 5½ times greater emission surface.

Requires only one-tenth ampere.

Has the abundant flow of electrons entirely controlled.

Remains ductile even after 1,000 hours life.

Wastes no heat by glowing.

Is free from microphonic noises.

Gives majestic volume.

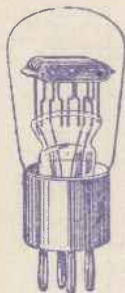

- For 4-volt accumulator or 3 dry cells
THE P.M.3. (General Purpose) 0.1 amp. 16/6
THE P.M.4 (Power) 0.1 amp. 22/6
- For 6-volt accumulator or 4 dry cells
THE P.M.5 (General Purpose) 0.1 amp. 22/6
THE P.M.6 (Power) 0.1 amp. 22/6
- For 2-volt accumulator
THE P.M.1 H.F. 0.1 amp. 15/6
THE P.M.1 L.F. 0.1 amp. 15/6
THE P.M.2 (Power) 0.15 amp. 18/6
- These prices do not apply in Irish Free State

ASK YOUR RADIO DEALER FOR THE VALVES WITH THE P.M. FILAMENT.

Mullard

THE MASTER VALVE

ADVT.. THE MULLARD WIRELESS SERVICE CO., LTD NIGHTINGALE LANE, BALHAM, LONDON. S.W.12.

Published by RADIO PRESS, LTD., Bush House, Strand, London. W.C.2, on Tuesday of each week, and printed for them by THE AVENUE PRESS (L. Upcott Gill & Son, Ltd.), 55-57, Drury Lane, W.C.2. Address for Subscriptions and Editorial Communications:—Bush House, Strand, London, W.C.2. Address for Advertisements:—Advertisement Manager, WIRELESS, Bush House, Strand, London. W.C.2. Registered as a newspaper and for transmission by Canadian Magazine Post. Subscription rates:—13s. per annum, 6s. 6d. for six months, post free. Sole Agents for Australasia:—GORDON & GOTCH (Australasia), LTD. For Canada:—IMPERIAL NEWS, LTD. For South Africa:—CENTRAL NEWS AGENCY, LTD.