

WIRELESS, incorporating "Wireless Weekly," JUNE 26, 1926.

WIRELESS



INCORPORATING
WIRELESS WEEKLY



Vol. IV.] *JUNE 26, 1926* [No. 5

IN THIS ISSUE:

HANDS OFF THE B.B.C.!

SPECIAL ARTICLE

**WILL REFLEX CIRCUITS COME
BACK?** By JOHN SCOTT-TAGGART

**WIN AN EIGHT-VALVE SUPER-
HETERODYNE!**

Easy Competition Within

[Registered at the G.P.O. as a Newspaper.]

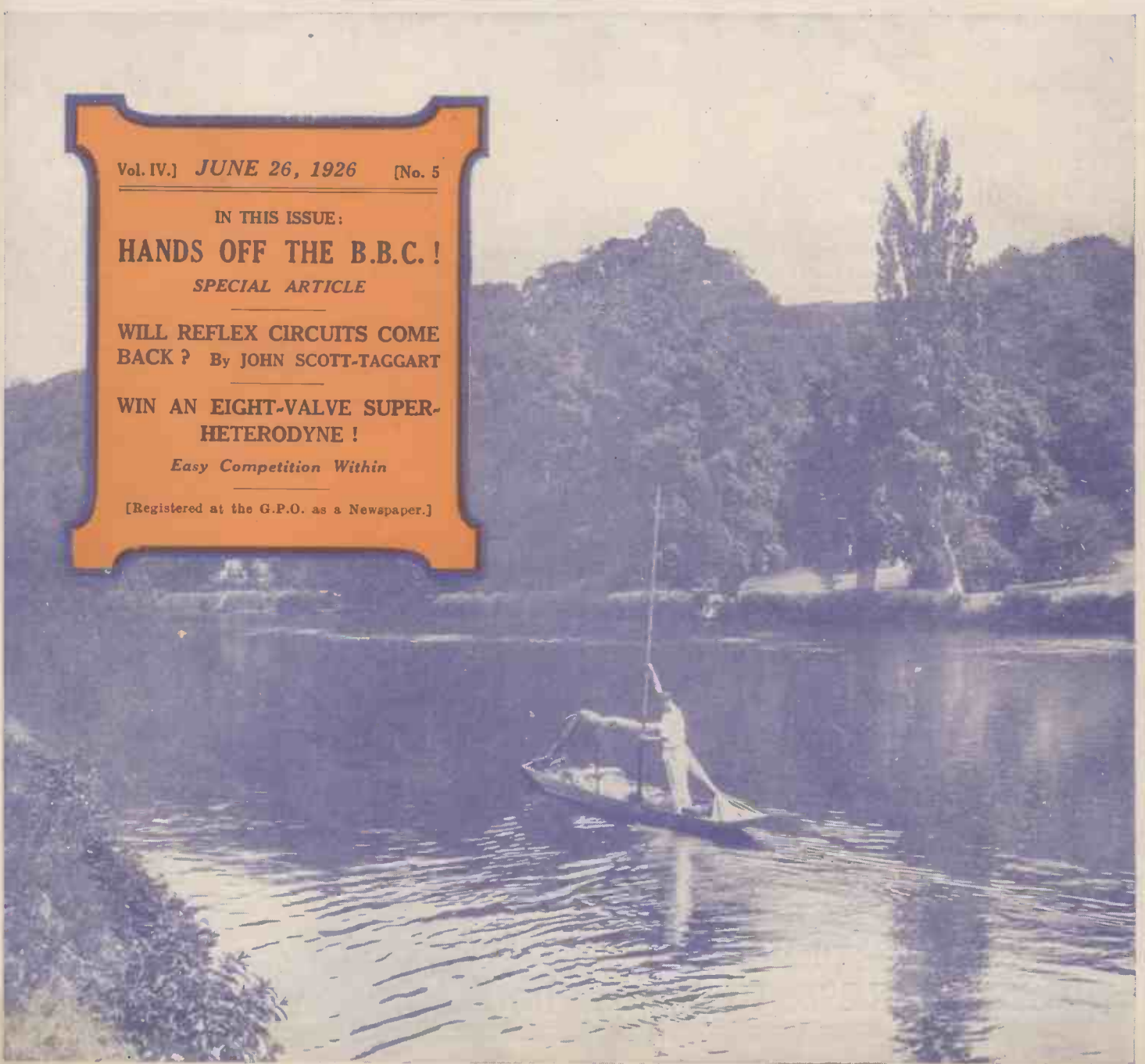

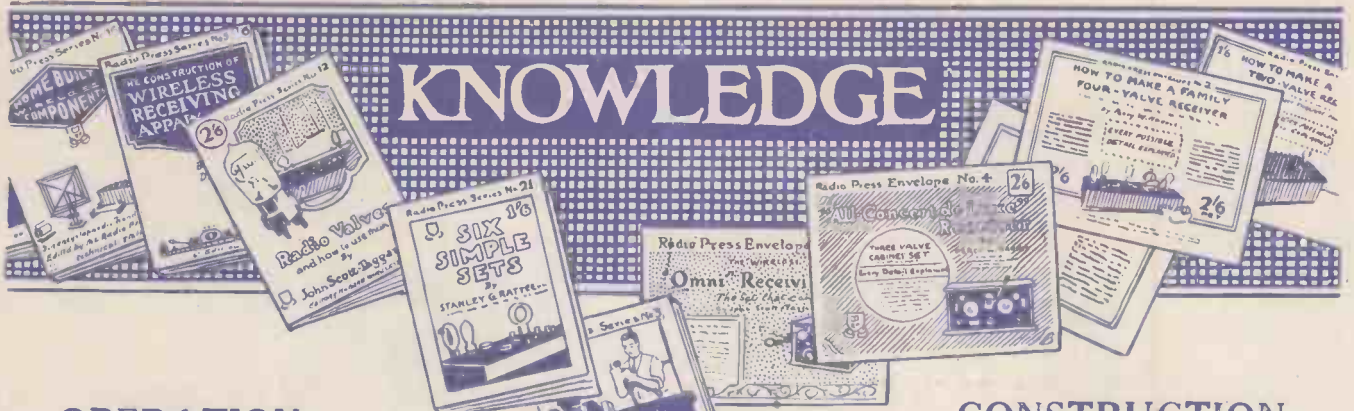

OPERATION

COMPLETE satisfaction from a radio receiver depends upon the operator's knowledge of its fundamentals. The R.P. Books listed here are expressly written for the man who appreciates the convenience of home study.

RADIO PRESS BOOKS

No.		Price	Post Free
1	Wireless for All By John Scott-Taggart, F.Inst.P., A.M.I.E.E.	9d.	11d.
2	Simplified Wireless By John Scott-Taggart, F.Inst.P., A.M.I.E.E.	1/-	1/2
3	How to Make Your Own Broadcast Receiver By John Scott-Taggart, F.Inst.P., A.M.I.E.E.	1/6	1/8
4	How to Erect Your Wireless Aerial By B. E. G. Mittell, A.M.I.E.E.	1/-	1/2
5	The Construction of Wireless Receiving Apparatus By P. D. Tyers.	1/6	1/8
6	The Construction of Crystal Receivers By Alan L. M. Douglas.	1/6	1/8
7	How to Make a "Unit" Wireless Receiver By E. Redpath.	2/6	2/8
8	Pictorial Wireless Circuits By Oswald J. Rankin.	1/6	1/8
9	Wireless Valves Simply Explained By John Scott-Taggart, F.Inst.P., A.M.I.E.E.	2/6	2/8
10	Practical Wireless Valve Circuits By John Scott-Taggart, F.Inst.P., A.M.I.E.E.	2/6	2/8
12	Radio Valves and How to Use Them By John Scott-Taggart, F.Inst.P., A.M.I.E.E.	2/6	2/8
13	500 Wireless Questions Answered By G. P. Kendall, B.Sc., and E. Redpath.	2/6	2/8
14	12 Tested Wireless Sets By Percy W. Harris, M.I.R.E.	2/6	2/8
15	More Practical Valve Circuits By John Scott-Taggart, F.Inst.P., A.M.I.E.E.	3/6	3/10
16	Home-Built Wireless Components By E. Redpath.	2/6	2/8
17	Wireless Sets for Home Constructors By E. Redpath.	2/6	2/8
18	Tuning Coils and How to Wind Them By G. P. Kendall, B.Sc.	1/6	1/8
21	Six Simple Sets By Stanley G. Rattee, M.I.R.E.	1/6	1/8
22	Switches in Wireless Circuits By Oswald J. Rankin.	1/6	1/8
24	Wireless Faults and How to Find Them By R. W. Hallows, M.A.	1/6	1/8
	Elementary Text-Book on Wireless Vacuum Tubes By John Scott-Taggart, F.Inst.P., A.M.I.E.E.	10/-	10/6
	Radio Engineering By J. H. Reyner, B.Sc. (Hons.), A.C.G.I., D.I.C., A.M.I.E.E.	15/-	15/9
	Modern Radio Communication By J. H. Reyner, B.Sc. (Hons.), A.C.G.I., D.I.C., A.M.I.E.E.	5/-	5/6

CONSTRUCTION

THE building of a Radio receiver becomes a most simple job when working from instructions contained in an R.P. Envelope. Every step is explained fully. You cannot go wrong!

RADIO PRESS ENVELOPES

No.		Price	Post Free
1	How to Build an ST100 Receiver By John Scott-Taggart, F.Inst.P., A.M.I.E.E.	1/6	1/9
2	How to Build the "Family" 4-Valve Receiver By Percy W. Harris, M.I.R.E.	2/6	2/8
3	How to Build the "Simplicity" 3-Valve Set By G. P. Kendall, B.Sc.	2/6	2/8
4	How to Build the All-Concert de Luxe Receiver By Percy W. Harris, M.I.R.E.	2/6	2/8
5	How to Build the Omni Receiver By John Scott-Taggart, F.Inst.P., A.M.I.E.E.	2/6	2/9
6	How to Build the ABC Wave Trap By G. P. Kendall, B.Sc.	1/6	1/9
7	How to Build a 2-Valve Amplifier de Luxe By Herbert K. Simpson.	1/6	1/9
8	How to Make a 1-Valve Reflex Receiver By Herbert K. Simpson.	1/6	1/9
9	How to Build an Efficient Single-Valve Set By Herbert K. Simpson.	1/6	1/9
10	How to Make the Twin-Valve Loudspeaker Receiver By John Scott-Taggart, F.Inst.P., A.M.I.E.E.	2/6	2/9
11	An Adaptable Crystal Set and How to Build It By Percy W. Harris, M.I.R.E.	1/6	1/9
12	The Super Seven. An easily built Superheterodyne Receiver By Percy W. Harris, M.I.R.E.	5/-	5/4
13	How to build the Three-Valve Dual Receiver By John Scott-Taggart, F.Inst.P., A.M.I.E.E.	2/6	2/9

"MODERN WIRELESS" COIL TABLE,
For Aerial, Anode and Reaction Coils 6d. 8d.

SIMPLEX WIRING CHARTS.

1	For 2-Valve Set	1/-	1/3
2	For 3-Valve Set	1/-	1/3
3	For 4-Valve Set	1/-	1/3

RADIO PRESS PANEL CARDS.

1	How to Make the W1 Receiver By Herbert K. Simpson.	1/-	1/3
---	---	-----	-----

RADIO PRESS PANEL TRANSFERS.

Large Packet of 80 different Labels	8d.
-------------------------------------	-----

Obtainable from all Newsagents and Bookstalls or direct from the Publishers
RADIO PRESS, LTD., BUSH HOUSE, STRAND, LONDON, W.C.2



You can improve your set by using

**B
T-H**
VALVES

Made in six types, three general purpose and three power amplifying.

General Purpose			
R.	4 volts,	0.7 amps.	8/-
B3.	1.8 "	0.35 "	14/-
B5.	2.8 "	0.06 "	16/6
Power Amplifying			
B4.	6 volts,	0.25 amps.	22/6
B6.	2.8 "	0.12 "	22/6
B7.	6 "	0.06 "	24/6

Ask for the Valve with the monogram



2557 B

Advert. of the British Thomson-Houston Co., Ltd.

APPOSITE ADAGES, No. 1.

"Well begun is half done"

Specify

DUBILIER
PRODUCTS

Have you entered for the Dubilicon Competition yet?

If not, write to us now for full particulars.

Cash Prize £200

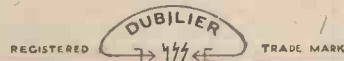

DUBILIER
CONDENSER CO (1925) LTD

ADVT. OF THE DUBILIER CONDENSER CO. (1925) LTD., DUCON WORKS, VICTORIA ROAD, N. ACTON, LONDON, W.3. Tel.: Chiswick 2241-2-3

E.P.S. 198

You need these IGRANIC RADIO DEVICES—NOW

Perhaps you have already felt the need for making certain changes in your receiver. Those distant stations which came in easily during the winter months cannot now be found. It is necessary for you to ensure that the components in your receiver are of the highest efficiency, and possibly the addition of a stage of H.F. amplification will help you to maintain the good all-round reception which is now so difficult to achieve. With the coming of summer, it is more than ever

necessary to guard against lightning by fitting an efficient earthing switch. Then, there is the need for a portable set so that you may gain the fullest pleasure from days in the open air combined with the joys of radio music. Igranic Radio Devices will enable you to fill the foregoing needs—and many others—with perfect satisfaction.

Here are a few of the most interesting Igranic and Igranic-Pacnet components—your dealer will show you the complete range.

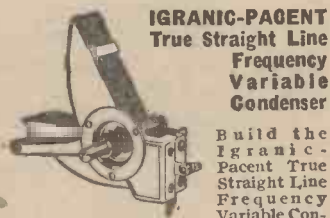

IGRANIC-PACNET True Straight Line Frequency Variable Condenser

Build the Igranic-Pacnet True Straight Line Frequency Variable Condenser into your receiver, and you may feel confident that the energy in your aerial is being utilised to the best possible advantage, thus ensuring maximum signal strength. Further, the perfect ease of tuning afforded by the even distribution of stations over your condenser dial will make reception a real pleasure. Prices: .00035 mfd., 14/6; .0005 mfd., 18/6.



IGRANIC High-Frequency Transformers

Fit these Transformers and be sure that your H.F. amplifier is operating at maximum efficiency. They incorporate the well-known honeycomb duolateral form of winding, and possess electrical features which are conducive to highly satisfactory results. They will enable your set to "reach out" for those distant stations which are now becoming so difficult to receive. Fitted with standard 4-pin mounting and made in four sizes, covering wavelengths from 288 to 3,200 metres when tuned by .0005 mfd. condenser. Prices: 8/- to 12/6.



"XLLOS" (Extra Low Loss) COILS

The new Igranic Coils with real low-loss features. Equally suitable for indoor or outdoor use, because the windings are protected by attractive bakelite covers, which protect them from the harmful effects of dust and damp. Low-capacity mounting, with variable spacing of pin and socket, six sizes—290 to 1,000 metres aerial tuning. Prices: 5/- to 7/-.

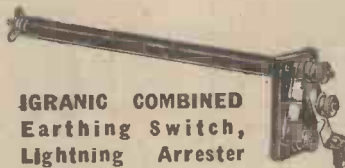

IGRANIC COMBINED Earthing Switch, Lightning Arrester and Lead-in Tube

A highly efficient "lead-in" device, affording perfect protection against lightning and static discharges, and simplifying connections. The ebonite lead-in tube is 10 in. long, and all metal parts are heavily nickel plated. Price 6/6.



IGRANIC-PACNET Jacks and Plugs

A few yards of flex and the appropriate Igranic-Pacnet Jacks and Plugs will enable you to place the loud speaker, or any number of 'phones wherever required in the house or garden. There are ten types of Jacks and various Plugs and Adapters with which you can arrange any combination of connections according to the needs of the moment. They are all robust in construction and reliable in action, and are fully guaranteed.

Prices: 1/6 to 6/6.

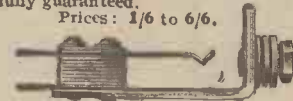

IGRANIC-PACNET Porcelain Rheostats



The Igranic-Pacnet Rheostat affords extremely satisfactory

filament control for any type of valve. Its robust construction and dependability enable it to stand up to hard wear, while its small size renders it very suitable for use in portable sets. Resistances of 6, 10, 20, 30 and 50 ohms are available at the reasonable price of 2/6 each.

All reputable dealers stock them

Write for List S17

Exclusive Manufacturing Licensees



of Pacnet Radio Essentials.

149, QUEEN VICTORIA ST.,

LONDON. Works: BEDFORD



WIRELESS

INCORPORATING

WIRELESS WEEKLY

JOINT EDITORS

PERCY W. HARRIS

M.I.R.E.

J. H. REYNER

B.Sc.(Hons), A.C.G.I., D.I.C., A.M.I.E.E.

ASSISTANT EDITOR

G. P. KENDALL

B.Sc.

TECHNICAL DIRECTOR

JOHN SCOTT-TAGGART

F.Inst.P., A.M.I.E.E.



THIS WEEK'S NOTES AND NEWS

THE terrible power of wireless is being better illustrated every day: at Old Street Police Court recently a woman applied for a summons against several of her neighbours, who were "driving her mad with wireless waves." Does this mean that they were all working loud-speakers on a set with no grid bias? I should think that must be the most effective way of "driving anyone mad with wireless waves"!

The Exhibition

"BUY British Radio Goods" will be the keynote of the "All-In" Radio Exhibition at Olympia in September. Plans for this Exhibition are going ahead well, and we may look forward to the "best show ever."

From Brighton

ON July 17 the B.B.C. is broadcasting the concert from The Dome, Brighton, on the occasion of the Brighton Competitive Musical Festival. We shall hear selections by the winners in each class, and it promises to be an enjoyable evening, complete with "that seaside atmosphere."

A Grumble

I HEAR that the B.B.C. have had quite a number of resentful letters asking why they did not broadcast actual news of the Derby. Some listeners even expected to receive starting prices, a description of the progress of the race, and the results. The arrangement with the Press, of course, precludes the broadcasting of any news before 7 p.m. I must confess that there are times when I would

give almost anything for a "lucky dip" in the B.B.C. postbag.

Some Coming Events

ON June 24 listeners will hear the speech by Mrs. Hubert Barclay, Central President of the Mothers' Union, from the Albert Hall; on

Tribulations of the B.B.C.

THE B.B.C. have been very badly worried lately by correspondents of the type that send in snatches of some programme or other with the query "What station was it?" as often as not without giving the time or date of their reception. As many of these querists as possible are answered in the official organ of the B.B.C., but they can rarely answer them all satisfactorily.

Incidentally, a small child recently heard his first organ recital from the newly-installed set and loud-speaker and at once asked, "Is that the official organ of the B.B.C.?"

From the Abbey

I THINK the new feature, shortly to be inaugurated, of broadcasting evensong from Westminster Abbey every Thursday afternoon, will be distinctly popular among hospital patients and invalids unable to get to church. The Abbey authorities are being very helpful in their co-operation with the B.B.C. with a view to investigating the acoustics of the building. You may rest assured that the transmissions will

be of first-rate quality.

A German Innovation

A NOTHER new use for broadcasting has cropped up at Frankfurt-on-Main, where the Labour Bureau is making arrangements to broadcast reports for the unemployed, stating areas in which they are most likely to find work from day to day.

(Continued on page 148.)

AT MARCONI HOUSE



Much apparatus of historical interest is included in the collection which is kept at Marconi House.

June 26 a new edition of "Winners" will be given, and on June 28 Scala, the Italian banjoist, will give the performance that was previously arranged for July 18.

The Latest

I HEAR that someone has named a motor-boat "2LO." This opens a really excellent field for wags; I think I will call my small dog "Radio-Iberica"!

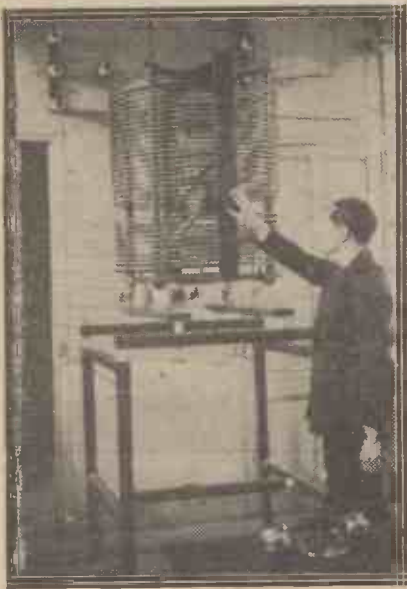

At the long-wave stations the tuning inductances are much more elaborate affairs than those we are accustomed to seeing at such stations as 2LO. These coils are at Radio Paris.

THIS WEEK'S NOTES AND NEWS

(Continued from page 147)

heat waves and dry the clothes on Monday mornings.

Those Breakdowns

THE "breakdown gang" seem to have been kept fairly busy lately, judging by the number of gaps in 2LO's programmes. The general public does not yet realise the enormous amount of complicated apparatus used in connection with a broadcasting station; or they would not be so quick to criticise the B.B.C. when a trivial break occurs. Think of the poor engineers!

In Cologne Cathedral

RADIO apparatus has, I hear, been very successfully used to cure the notoriously poor acoustic qualities of Cologne Cathedral. Microphones and loud-speakers have been installed in various places, and the voice of the preacher now penetrates into every nook and cranny of the Cathedral.

THERE will soon be yet another addition to the list of European transmitting stations, for building operations for the erection of a large broadcasting station have just been commenced in the Free City of Dantzig. The station, it is hoped, will be opened in August.



Our picture shows Mr. J. L. Baird (left), the inventor, erecting his first aerial for television in London. He appears to believe in the twin type of "sky-wire."

The Millennium

A CONTEMPORARY states that the day is fast approaching when all listeners will be able to choose a station that is broadcasting a programme that suits their taste. When this happens, I wonder how many will be discovered listening to the station that is giving a speech on some such controversial subject as "Do Winkles Like Flag-Days?" It seems a pity that the B.B.C. will not be able to tell how many are listening-in to each station.

High Power Again

THE rumour that the B.B.C. are building another station at Daventry, to work on the ordinary broadcast band of wavelength, is, I am told, not a "scare," but quite correct. It will work between 300 and 500 metres, with powers between 10 and 20 kilowatts. The position of Daventry was chosen chiefly because the B.B.C. already have land, water and power there, and a good deal of experimenting will be carried out before the new station is put into regular operation.

Why Not?

A CHEERY writer wants to know why the B.B.C. has not yet broadcast the noise of the weekly wash. A far more practical suggestion (not mine) is that they should broadcast

to the day when "S.B." will mean not only simultaneously broadcast from the B.B.C. stations, but from all stations, in the true sense of the word. Best of luck to "World-Radio"!

"Four Pennies, Please"

SHEFFIELD listeners had a little unrehearsed treat recently. Just at the close of a church service, when the minister had just commenced to pronounce the Benediction, the telephone exchange operator was clearly heard to say, "Four pennies, please," and the four pennies were distinctly heard, followed by a lady's voice "ticking off" an unknown gentleman in no uncertain terms!

More Jazz

IT will be good news to many that, during the summer (for explanation of this word see any dictionary!) 5XX will give dance music every night until midnight. On the other hand, I am not looking forward to having to wait every night until midnight until my next-door neighbour switches off his loud-speaker before I can retire to bed. I am thinking out an efficient way of surreptitiously earthing his aerial.

CALL-SIGN.

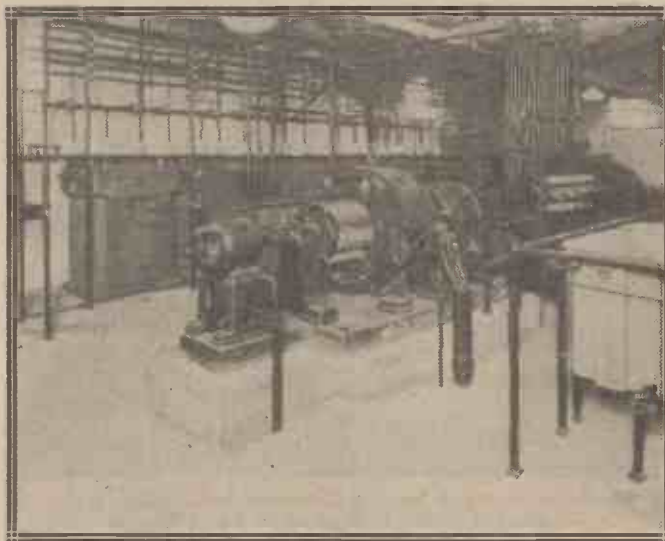

One of the American short-wave telephony stations which is often heard in this country is 2XAR, the high power experimental station of the Radio Corporation of America.

I AM told by a B.B.C. official that the well-known "Radio Supplement" will soon change its name to "World-Radio," which is, I think, a distinctly good omen for the future of broadcasting. I am, perhaps, a trifle optimistic, but I am looking forward

surreptitiously earthing his aerial.

SEND ALL YOUR QRA QUERIES TO US



HANDS OFF THE B. B. C. !

By PERCY W. HARRIS, M.I.R.E., Joint Editor

THREE months ago the Broadcasting Committee issued their Report. It caused quite a little stir at the time, but with the General Strike, the coal situation, and other distractions, the public is in danger of forgetting not only what the Broadcasting Committee said, but that in the very near future the Government is likely to act and to act quickly in putting the report into practical legislative shape.

The Danger

One morning, if we are not all careful, we shall wake up to find in our morning paper a statement that in future the broadcasting organisation will be to all intents and purposes a Government department, and that we must take what we can get, whether we like it or not. And most probably we shall *not*! Although it has had many defects, the present system has served us very well, and anyone who has had experience of how a Government department runs far less delicate matters than entertainment cannot possibly imagine that a nationalised broadcasting organisation would give us anything half so good as we get at present.

Cause for Alarm

You may think I am an alarmist in my views, but listen to a few of the statements contained in the Broadcasting Committee's report—a report which it is likely that the Government will adopt in all those matters which suit its own purpose. After placing on record their "admiration for the work accomplished by the British Broadcasting Company," and stating that "by strenuous application to its duties, aided by the loyalty of its staff," the Company has produced a service which will reflect high credit on British efficiency and enterprise, they state that the organisation laid down by the B.B.C. no longer corresponds to the national requirements or responsibility.

They then continue that they do not recommend a prolongation of the licence of the B.B.C. or the establish-

ment of any similar body composed of persons who represent particular interests. What do they suggest in its place? A new authority with commissioners nominated by the Crown. Here, then, is the first danger. A seat on the commission is to be rewarded by a goodly sum. "We think that the remuneration of the commissioners should be adequate; only thus can it be reasonably expected that the time, energy, enthusiasm, necessary for the efficient discharge of their onerous duties will be constantly forthcoming." In plain

posts with "adequate" salaries and which, if the Committee's report is adopted, would last for ten years without a break, it does not take any great stretch of imagination to see what will happen! As it is there are quite enough people anxious to tell us how to improve ourselves, when they have to give their advice without payment.

posts with "adequate" salaries and which, if the Committee's report is adopted, would last for ten years without a break, it does not take any great stretch of imagination to see what will happen! As it is there are quite enough people anxious to tell us how to improve ourselves, when they have to give their advice without payment.

What Might Happen

The more I think of these Government-appointed commissioners sitting round a table planning our broadcast programmes the more depressed I become. Can you imagine a joke being cracked by this solemn assembly? You may be sure there will be no young people on it—no Government would ever dream of appointing anybody under 50. By this age, if you are pushing enough, you will at last have succeeded in persuading the Government that you have "rendered valuable services" in some particular field. And of course, having "rendered valuable services," you must be rewarded somehow, and a seat on the broadcasting commission will be a most charming and satisfying way of getting rid of you.

Watch Your Pocket!

But a Government-appointed commission is not the only sinister threat contained in the report; in fact, it may be said to fade into insignificance before the prospect of making money out of you. "The present licence fee is 10s., which we do not consider excessive," says the report. "It is, of course, essential that the Postmaster-General should be completely indemnified against the cost of collecting these fees, and against all other expenditures incurred by him in relation to the broadcasting service." Quite! If the Postmaster-General likes to keep their eye on broadcasting, he can have the money to do it. That will be
(Continued on page 150.)



One of the most widely appreciated features of the B.B.C programmes: broadcasts by famous military bands.

English, a good fat salary. "The commission must be self-supporting," says the report, "and can expect no grant from the public funds."

The Result

Now let us see how far we have gone. First of all we are to have a broadcasting organisation run by commissioners appointed by the Crown. Observant persons have noted that when there are any such positions which the Government have the power to fill, all kinds of political busybodies and awkward persons to whom the Government seems to have certain obligations are forthwith thrust into the position, and when under the suggested scheme there are six or seven

HANDS OFF THE B.B.C. ! (continued from page 149)

"one of the other expenditures." And if half-a-dozen high officials like to tour the United States to see what America is doing, that will also be one of "the other expenditures." There are heaps of ways in which the Postmaster-General could use your licence money to cover expenses "incurred by him in relation to the broadcasting service."

A "Surplus"

And "subject thereto," goes on the report, "it will be the duty of the Postmaster-General to pay the commissioners from the licence fees an income thoroughly adequate to enable them to ensure the full and efficient maintenance and development of the service." That sounds very nice, but listen to this paragraph: "On these conditions, and when the adequate service has been assured, but not until then, it is expedient that the surplus should be retained by the State." Did you notice anything there? Of course you did! If you are a motorist and have occasionally thumped over some very vile roads you have perhaps wondered why some of the surplus money in the road fund has not been used to repair them.

Not So !

In your childish innocence you may have thought that the purpose of the road fund was making roads, particularly as we had been told specifically that it was for that purpose alone. When the Government thinks that the broadcasting commission has an income "thoroughly adequate" for a "full and efficient service" they will take the rest. Cannot you imagine some future Chancellor of the Exchequer wrestling with his annual financial problems? "Let me see now," he says to himself, "I must not take any money from the broadcasting funds unless they have a really efficient service! I really think they have! Only last night I heard a most interesting reading from 'The Vicar of Wakefield,' and since the Church Brigade have kindly lent their band we have been able to dispense with several quite expensive orchestras. Yes, I think they could spare a million or so. I need it more than they do!"

Remember !

Notice, too, that it is the Postmaster-General under whom broadcasting in the future will be placed if the Broadcasting Committee's report is adopted. Is the public's memory so

short that they have forgotten the innumerable obstacles placed by this official in the way of the progress of broadcasting? Do they remember the pitiful pleadings of the experimenters to be allowed only a quarter of an hour a week of telephony from Writtle? Have they forgotten that even this small concession was time and again refused and the only regular telephony upon which the experimenter could rely came from Holland, and that only twice a week? Have they forgotten that a licence to receive



How many readers remember the chimes which used to be sounded at 2LO in the early days? "Uncle Arthur" is seen before the simple microphone employed at that time.

from the shackles of democracy are recommended to lose no time in writing to their Member of Parliament and letting him know their views.

Do not forget the Government relies on apathy to get through such a scheme as this, while the average Member of Parliament, unless he is instructed by his constituents to oppose the Bill, is likely to follow the lead of his party whip. Express your views to your Member of Parliament as fully as you can, but whatever you do express them! There is no time to lose.

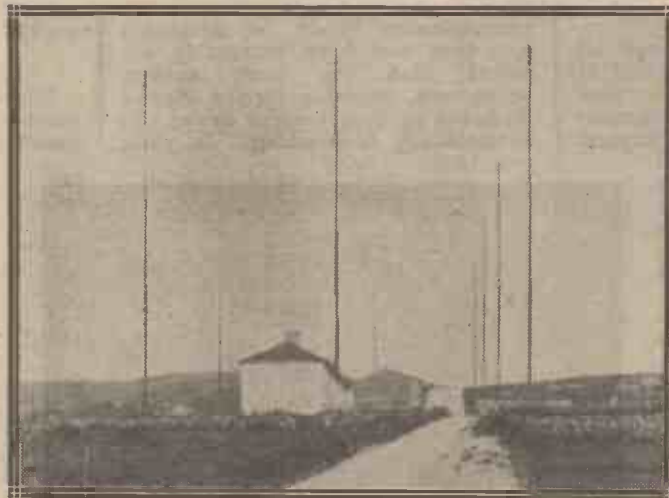

The Post Office regards the erection of high-power stations as its own special prerogative, and does not favour their use for broadcasting.

even this had to be forced out of the Government?

Only pressure of public opinion has made them grant the existing facilities for broadcasting, and it is no secret that the scheme for new high-power stations, by which the listener may be provided with an escape from the programme dilemma, of having to listen to a programme he does not particularly enjoy as there is no alternative, a scheme which is receiving widespread reports throughout the country, is regarded very unfavourably by the Post Office at the present time.

Write to Your M.P. !

There are plenty of other reasons why the lover of broadcasting should view with the greatest apprehension any move to nationalise broadcasting, and readers who want to feel that this vital new public service shall be free

AN INTERESTING QUESTION

My two-valve receiver gave me adequate loud-speaker strength of excellent quality when I lived within eight miles of the local station, but

now that I am 20 miles away, although I obtain the same volume, quality is not so good. My batteries show their correct voltage on load, and I should think the valves are correct also, since the quality of certain distant stations, on telephones, is normal.

The symptoms mentioned are indicative of too much reaction being required to give you loud-speaker strength from the local station, now you have shifted out to 20 miles, and the first steps to be taken should be to increase the size of your aerial to the maximum possible, whilst trying alternative earth connections. If improved quality is not obtained by using less reaction a further note-magnifying valve should be added, and here I would suggest that a resistance-coupled stage be employed. For this purpose a suitable design is given in the June, 1925, issue of *Modern Wireless*.



CONSISTENT RESULTS FROM THE LOCAL STATION— AN ULTRA-SIMPLE SINGLE-VALVER

By H. STANFORD

THOSE who wish to possess a receiver upon which they will be able to obtain really loud signals from the local station, even on a poor aerial, upon the headphones, and also to be capable of receiving other stations with a reasonably efficient aerial, could not do better than construct a simple single-valver such as the one about to be described in this article. Such an instrument may always be relied upon to give good results continuously, which, unfortunately, is not always the case with crystal receivers. In addition to this, the upkeep cost is extremely low. If a .06 valve is used, a 45- or even a 36-volt high-tension battery will give good and efficient service, and will last for many months if of good make. For the low-tension supply two small accumulator cells are suggested as being remarkably economical. Suitable cells, if properly used, give excellent service over a considerable period without recharging.

The receiver itself is particularly

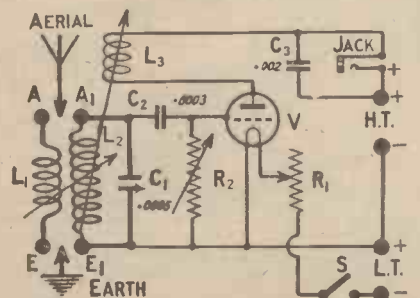

Fig. 1.—The method of aerial coupling can be one of several when using this receiver.

Here is a single-valver which anyone can build. Whilst giving consistent results from the local station, with careful manipulation it can be used for receiving quite a number of those at a distance.

compact and neat, and gives quite a useful degree of selectivity. The material which was actually used for construction is given, together with the names of the manufacturers, for

Six W.O. terminals.
Two small pillar terminals.
Six 3/8-in. countersunk wood screws.
Glazite for wiring (L.E.W. Co.).
One ebonite panel measuring 9 by

5 1/2 by 1/8 (Camco).
Piece of wood measuring 3 by 2 1/2 by 3/8.

Two small angle brackets.

Some insulated flex (L.E.W. Co.).
Cabinet (Camco).

Construction

The ebonite panel should first be drilled in accordance with the details and dimensions given in Fig. 4, which represents the front of the panel. All the components are mounted upon the panel with the exception of the valve holder and the three-way coil holder. The back of panel diagram shows clearly the

wiring and also the best way in which to arrange the components, and this diagram should therefore be carefully followed when this work is being done. The valve holder is mounted upon a piece of wood of the dimensions specified in a drawing herewith. This
(Continued on page 152.)

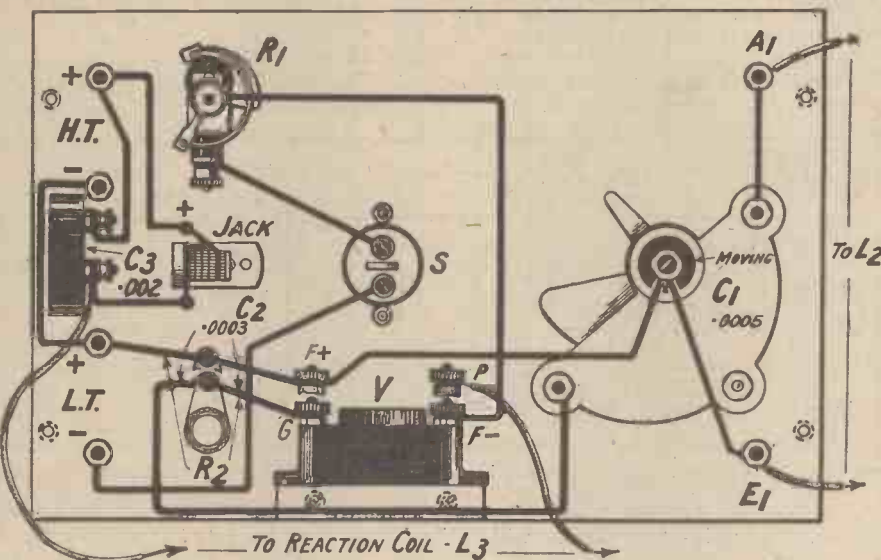
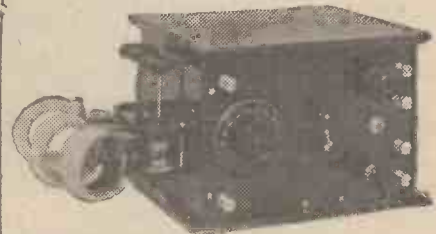

Fig. 2.—No baseboard is employed, but a special fitting is employed by which the valve is kept vertical.

the benefit of those who wish to actually duplicate the original. This course is advised by the writer, as any deviation may lead to unforeseen difficulties, the components mentioned having been chosen in each case for individual reasons.

Material

- One variable condenser .0005 square-law low loss (Utility).
- One filament resistance, 30 ohms (C.A.V.).
- One variable grid leak with condenser .0003 (Bretwood).
- One open circuit plug and jack (Igranic).
- One filament "On-off" switch.
- One "Clearer-Tone" valve holder (Benjamin).
- One three-way coil-holder (short extension handles) (Lotus).
- One fixed condenser .002 (Dubilier).



The three-coil holder is fitted to the side of the cabinet, and the necessary flex leads are brought through the woodwork.

CONSISTENT RESULTS FROM THE LOCAL STATION—(Continued from page 151)

wood base is in turn secured to the back of the panel by means of two 1/2-in. countersunk screws. The three-way coil holder is mounted on the left-hand side of the cabinet as shown in the photograph.

Wiring

A few remarks relating to the wiring may be helpful to the constructor. Firstly, keep all the wires well away from the moving vanes of the variable condenser and the valve. In addition to this, keep the wires as well spaced as possible. If the components are placed as shown, the grid connection to the valve will automatically be an extremely short one.

The four connections which go to the three-way coil holder are made with insulated flex. Each of these leads passes through the side of the cabinet to the external points of connection upon the coil holder itself. It will be noticed that a special attachment is made to each of the connections of one of the moving coil sockets. These attachments take the form in each case of a brass bracket, each of which is provided with a terminal. Details are given in a diagram showing how the coil holder is equipped in this manner.

Theoretical Circuit

It will be seen from the circuit diagram that a choice of tuning arrangements is possible. For instance, direct coupling may be employed by attaching the aerial to ter-

minating the aerial to one of the special attachments upon the moving coil socket L_1 and the earth to the other attachment. Auto-coupling may be employed in each case by merely attaching the aerial to one of the terminal taps upon this style of plug-in coil. Coils of this nature are supplied by Lissen, Ltd.

Coupling Arrangements

Three optional circuit arrangements are shown in Fig. 3. The connections

tion, using ordinary plug-in coils. Arrangement (b) shows auto-coupling using a centre-tapped coil in the fixed coil socket L_2 . Arrangement (c) shows

again auto-coupling using an X coil in the fixed coil holder L_2 . All these arrangements should prove fairly selective. Ordinary direct coupling also may be employed. Reaction is employed in each example given, but this may be eliminated by inserting a shorting link in the moving coil socket L_1 . Other arrangements will occur to the experimenter.

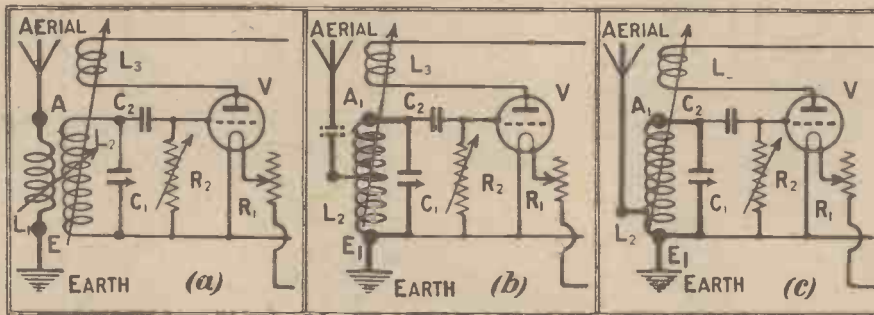
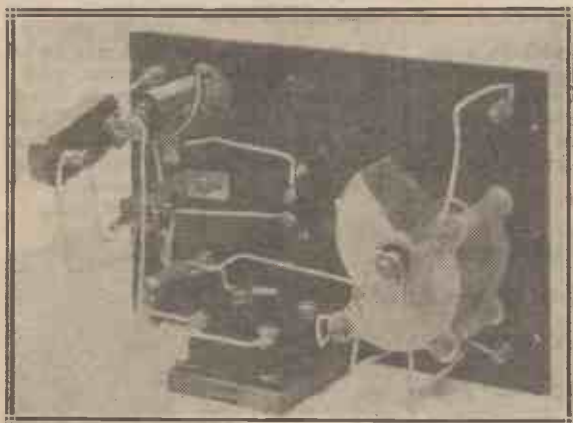

Fig. 3.—Three different methods of coupling the aerial are shown in this drawing.

necessary will easily be followed from this diagram, the terminals for aerial and earth connections being lettered

ing coil socket L_1 . Other arrangements will occur to the experimenter.



The fixed condenser seen on the extreme left is held in position by the stiff wiring.

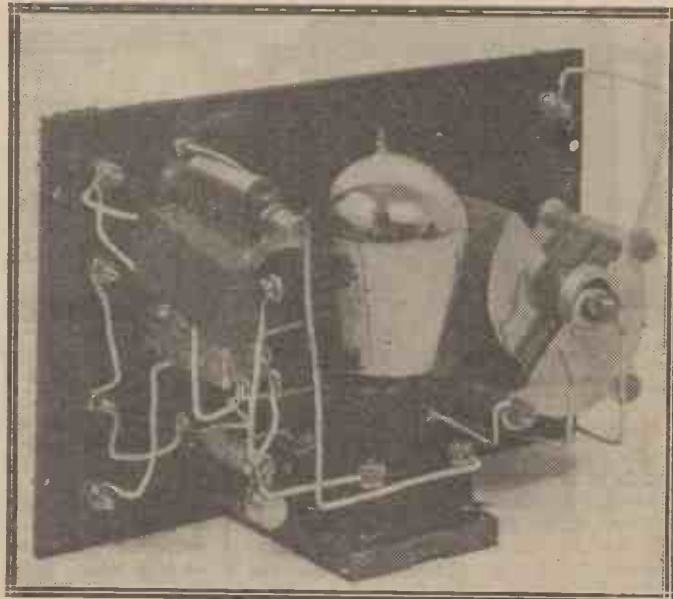

A clearer conception of how the valve holder is fitted will be gathered from this back-of-panel view.

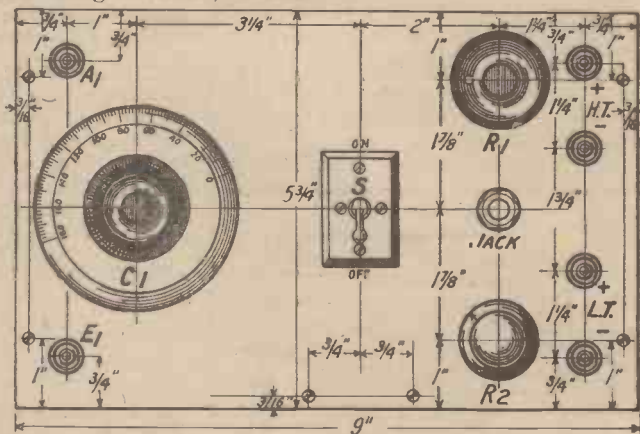

Fig. 4.—When it is desired to switch the receiver off, it is only necessary to place the switch marked S in the off position.

terminal A_1 upon the panel and the earth to terminal E_1 , also upon the panel. Inductive coupling is obtained by con-

to correspond to those given in the other diagrams. Arrangement (a) shows inductive coupling with reac-

Operation

The set should prove quite easy to (Continued on page 174.)

Another great contribution to the Science of Radio by Cossor

Red Top :
For H.F. use.

Plain Top :
For Detector
or L.F. use.

15/6

For 2-volt
Accumulators.

The new Cossor Point One

—the '1 amp. Valve which
utilises Co-axial Mounting

**Cossor
Stentor Two**
Power Valve
Consumption '15 amp

18/6

For 2-volt
Accumulators.

IT was a flash of genius that enabled Simpson eighty years ago to discover chloroform. Genius, too, helped James Watt to read the lesson of the steam engine in the escaping steam from his mother's kettle. Assuredly it was genius that caused Montgolfier to visualise in the floating remnants of a burning paper bag the world's first balloon—the prelude to man's conquest of the air.

And once again a touch of genius has been responsible for an entirely new method of valve construction that bids fair to produce results which, but a year ago, would have been considered impossible.

The new series of Cossor valves employ—for the first time in the history of Radio—a method which, accurately and for all time, ensures perfect alignment for the filament, grid and anode. At the same time it provides a shockproof support for the filament.

Thus throughout the whole life of the valve its working characteristics cannot alter. Age cannot cause filament sag nor can hard wear disturb the exact relative positions of the filament, grid or the anode.

But this is not all. The improved Cossor filament consumes but a moiety of the current required by other Dull Emitters—its consumption at 1.8 volts being barely one-tenth of an ampere. A seven-valve Super Heterodyne, for example, using these new Cossor Point One Valves would not con-

sume as much current as a little one-valve set using a single bright emitter.

As can be imagined, the filament used in this new Cossor is no ordinary filament. Owing to its exceptional length and its scientific method of preparation a great latitude in working voltages is permitted. Satisfactory results are obtainable at a voltage as low as 1.2, so that the valve can, if required, be used with dry cells. Further, its operating temperature is lower than that of any other valve on the market. And everyone knows that low temperature means long life.

The Cossor system of Co-axial Mounting has now finally abolished the last bug-bear of dull emitter valves—microphonic noises. Individual movement of either the grid or the anode in the Cossor Point One is utterly impossible. The seonite insulator holds them both in a vice-like grip which defies the hardest shock.

With its handsome pipless glass bulb, its re-designed low loss moulded base, and its new positive contact pins the introduction of these new valves represents one of the most important events in the progress of the Valve. See your Dealer about them to-day—we can promise you new delights in radio reception. A greater economy, improved sensitivity, a wonderful richness of tone, with a length of life and uniformity of performance which will positively astonish you.

Cossor Valves

—The new Dull Emitters with the long-life '1 amp. filament.

Better than "Cross-words" CARTOONIGRAFS

(Copyright)

A NEW FASCINATING COMPETITION WHICH WILL APPEAL TO ALL.

By ERN SHAW, the "Wireless" Cartoonist.

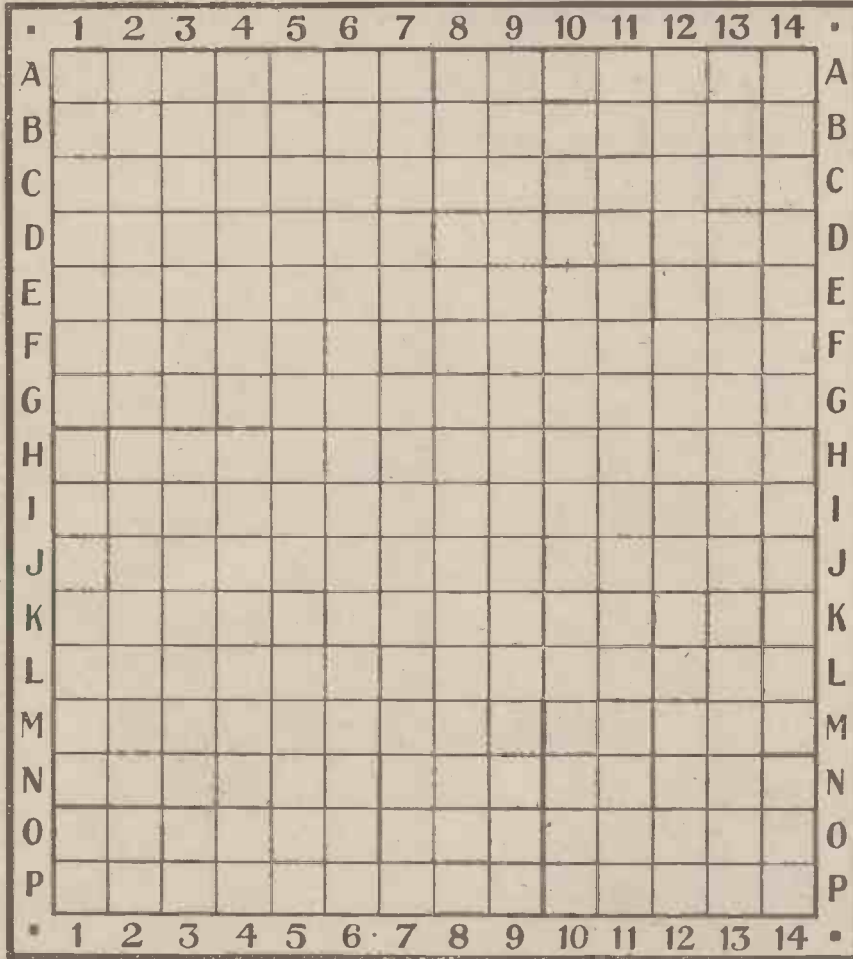

The Prizes Offered in Connection with this Competition will be found on page 178.

WHAT TO DO

All you have to do is draw a few lines on the chart and write one line to complete the limerick. If you carefully follow the instructions given below an amusing picture will appear on the chart. Draw this in ink and then complete the limerick with the wittiest line you can think of and send along to "Cartoonigrafs," Radio Press, Ltd., Bush House, Strand, to reach here not later than first post Tuesday, June 29. Employees of Radio Press, Ltd., are not eligible. All competitors, by entering, agree to abide by the decision of the Editor, which is final. No correspondence can be entered into regarding this Competition.

FOLLOW THE DIRECTIONS - CAREFULLY

Send this whole page complete with your drawing in ink and your last line of the limerick, with your name and address written in ink (block letters) in the spaces provided.

Name

Address

Post to:—"CARTOONIGRAFS,"
7 RADIO PRESS, LTD., Bush House,
STRAND, W.C.2.
To arrive first post Tuesday, June 29.

*When the recent Strike muzzled the Press,
We got the news nevertheless.
Great credit is due
To the B.B.C. who—*

No. 7.—BRAVO! THE B.B.C.

NOTE.—It is advisable to follow the instructions in pencil first, and then carefully complete the drawing in ink. Black letters denote new lines. Unless otherwise stated, lines should be drawn to the centre of the square.

Draw a continuous line from I7 to G8
G6 to D6
D6 to B8
B8 to A10
A10 to A12
A12 to B14
B14 to bottom right corner C14
Bottom right corner C14 to E14
E8 to B11
B11 to C12
C12 to E12
E12 to F13
F13 to E13

E13 to top right corner E13
Top right corner E13 to E14
E14 to bottom left corner G14
Bottom left corner G14 to G13
G7 to G8
G8 to H9
H9 to I8
I8 to H7
H7 to G7
H12 to K12
K12 to top left corner K11

Top left corner K11 to I12
I12 to I13
I13 to top right corner H13
L11 to J13
J13 to I13
J13 to bottom right corner K14
J5 to I4
I4 to I10
I10 to M11
K5 to J4
J4 to J10
J10 to M11
M6 to K4

K4 to K10
K10 to M11
From bottom left corner P4 to P4
P4 to N4
N4 to M5
M5 to M7
M7 to bottom right corner M7
Bottom right corner M7 to O7
O7 to O6
O6 to P6
P6 to bottom left corner P6
P6 to P11

From bottom right corner P11 to P11
P11 to O11
O11 to O10
O10 to top left corner N10
Top left corner N10 to M10
M10 to M12
M12 to bottom right corner M12
Bottom right corner M12 to O13
O13 to P13
P13 to bottom right corner P13
From top left corner H1 to H2
H2 to bottom left corner H1
H2 to O2
O2 to bottom left corner O1
O2 to bottom right corner P2
From top left corner D7 to top right corner D7

Top right corner D7 to D8
D8 to E7
E7 to F7
F7 to F8
F8 to top right corner F8
D8 to C8
C8 to C7
From bottom left corner D10 to D10
D10 to top left corner D10
Top left corner D10 to top left corner D9
Top left corner D9 to C9
C9 to C10
C10 to bottom right corner C10
Place a dot in each of the squares D7 and D9
Shade that portion of the mouth in squares H7, H8, H9 and I8
Shade the hair

WILL REFLEX CIRCUITS COME BACK?

By

JOHN SCOTT-TAGGART

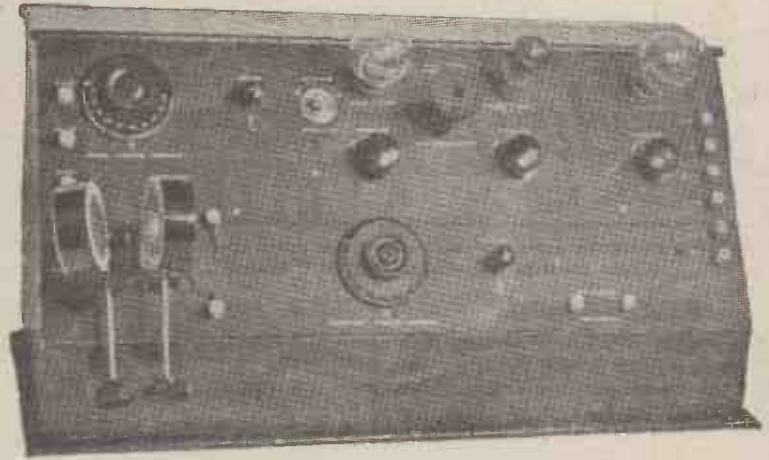

One of the best known reflex receivers—the Three-valve Dual.

No one in this country has a wider experience or has done more to develop reflex circuits than the author of this article. Although reflex circuits have formed only a small part of his contributions to radio yet the extraordinary vogue which some of his reflex designs such as the ST100, 3-valve Dual and others have had, gives a special interest to his views in this article.

loud-speaker signals from the local station. It is true that I have received a very large number of letters from those who have built this receiver protesting against the statement that it is a short-range receiver made in the Envelope describing it, and in the original issue of *Modern Wireless*, which contained the first description of the ST100 circuit.

On the question of range, selectivity and purity of reproduction of wireless receivers, however, I cannot deceive myself. I expect a very high standard, and this standard should be capable of being reached by a novice without any spell-binding adjustments of the receiver.



RATHER more than twelve months ago I wrote an article in *Wireless Weekly* entitled "Are Reflex Circuits Worth While?" This article

- (3) In inexperienced hands buzzing and oscillation are possible.
- (4) The crystal is often a source of nuisance.
- (5) The amount of high-frequency amplification given by the dual valve is far less than that obtainable under the best conditions.

produced the greatest astonishment in all quarters. It was assumed that having been so closely associated with the development of reflex circuits, to decry them in any way would be treachery of the worst kind! I indicated in the article that reflex circuits generally had lost their public appeal, and that people were going to go back to straight circuits. This is very largely what has happened. Although large numbers of people still seem to be building reflex sets, yet even the introduction of permanent detectors has not yet prevented a reversion to more simple forms of circuits.

Drawbacks

My own objections to such a circuit as the ST100, for example, are:—

- (1) It is incapable of getting long-distance stations.
- (2) The selectivity is very inferior.

ST100 Popularity

The ST100 circuit, therefore, became popular because it gave pure and good

Many of the causes of the trouble have been removed by introducing
(Continued on page 173.)

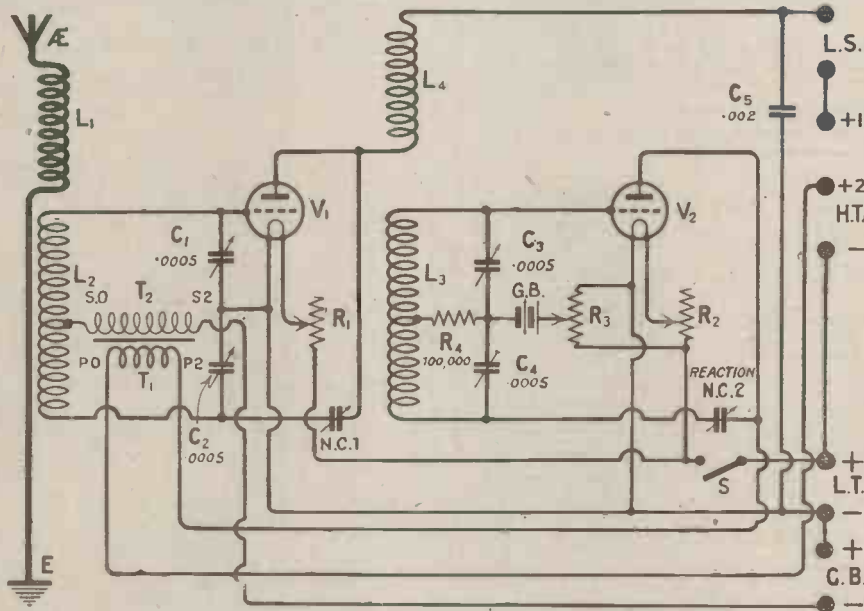

Fig. 1.—One of the circuits developed at our Elstree laboratories which marks an important step towards perfection in reflex circuits. The condensers C1 and C2 are mounted on a single spindle and worked together, and this also applies to the condensers C3 and C4. The valve V2 acts as a rectifier on the anode-current rectification principle and does not use a grid condenser and leak as all previous reflex circuits, using a valve detector, have done.

The "Buzzing" Trouble

In a thorough investigation which I made on reflex circuits in *Modern Wireless* I showed that there were seven or eight different reasons why reflex circuits "buzzed." These reasons varied from the one that the reflex transformer winding with its condenser acted very much like a grid condenser and leak, to the reason that buzzing was very commonly caused by a peculiar reaction chain in which a complicated modulated high-frequency oscillation took part.

From my Armchair

BY EARL RUSSELL.



In these columns Lord Russell expresses each week his own personal views on matters of interest to "Wireless" readers.

B.B.C. Editorials

Some rather acid controversy has taken place in the public Press on the subject of those editorials which we had for three or four days after the General Strike was over. The objection taken was that they were partisan, but frankly I did not think so, and I imagine no one but the coal-owners could have objected to them, for they only expressed, so far as they expressed any opinion at all, what everyone else in the country was thinking.

What, in my opinion, made them so excellent was that they gave the general public some idea of the questions at issue in the coal controversy, about which most people are quite in the dark. The Editor of the *Little Puddleton Gazette* may say that the Government are a cowardly set of knaves, and should be driven from office, but the skilled staff of the

B.B.C. may not impartially marshal a few facts and present them to the public. Is not that rather ridiculous?

Those Battery Plugs

There is a very simple remedy for the ill-fitting H.T. battery plug of which Mr. Kendall complained in a recent issue, which is well worth the small trouble involved. That is to cut upon solid plugs a B.A. thread and to insert the plug with a small right-hand movement, removing it with a left-hand movement. The corresponding thread cuts itself immediately upon the plugs of the battery and a contact can be made solid enough to lift the battery by. Since I adopted this tip I have never had a plug come loose or make a bad contact.

Insulation

An old electrician, like myself, thinks about insulation automatically,

and about its alternative short circuits, but, even so, one may be careless, as two events in one day have taught me. I was using a makeshift spliced-up end to my aerial, and was much bothered by poor strength, until I noticed that the bare splice was making contact with the stay-bar of the window it came through. On the same set I was experimenting in shielding a large home-wound coil with an earthed piece of perforated zinc, and suddenly got a big deflection on the milliammeter, that trusty sentinel which I always keep in circuit when playing tricks. I discovered that the edge of the bit of zinc was touching a bare wire, but by the mercy of providence I did not burn my valves out, and got a lesson cheap.

A Funny Set

I have tried the mystery set. It is a simple enough circuit, except that it works without a gridleak and ought not to tune to the wavelengths it does. Its great point is the cheapness of the coils and the condensers, which are simply discs opening on a threaded spindle. But it does tune with amazing precision and firmness on to its wavelength, and reception is quite loud for two valves. The sensitiveness of the controls is so great that it is rather difficult to work with, but its really interesting point is that it ought not to work at all.

A REAL WIRELESS SERVICE

We have in stock all the Components and Cabinets for the New Marvellous ELSTREE SIX.

Place your orders now.

Have you seen the new DARIMONT CELL? No more carrying heavy accumulators to town. No more worries with damaged Batteries. Instal a Darimont Cell Battery giving a guaranteed life of 100 hours constant discharge of $1\frac{1}{2}$ volts at $\frac{1}{4}$ ampere. Price 5/- each. New charges $1\frac{1}{4}$ each.

Why not secure a copy of our latest Catalogue, which is practically a Guide Book to the Industry, for the cost of postage and packing, viz., 6d.

N.B.—Call and see the ELSTREE SIX at our Showrooms.

WILL DAY, LTD.,
19, Lisle St., Leicester Sq., London, W.C.2
Telephone: Regent 4577. Telegrams: Titles, Westrand, London.

Simple, Accurate, and Easily Adjusted

Don't experiment! Get a "Lotus" and be certain of better results.

The vernier movement comprises three sets of enclosed precision machine cut gears and reduces the speed of the moving coil block by eight times.

The moving block moves in the same direction as the knob, which prevents confusion. It also becomes absolutely rigid in any position, holding the heaviest coil securely. No screws required to tighten it.

LOTUS

VERNIER COIL HOLDERS

From all Radio Dealers.

Two Types:

For outside panel mounting:
Two-way 7/-
Three-way 10/6

For inside baseboard mounting, with 6 in. handle:
Two-way 8/-
Three-way 12/6

Garnett, Whiteley
& Co., Ltd.,

Lotus Works, Broad-
green Road, Liverpool

Makers of the new improved
"LOTUS" Valve Holder.

Moving block
cannot fall

Bakelite mouldings for the side plates, coil blocks, and knobs; heavy nickel plating for the metal parts.

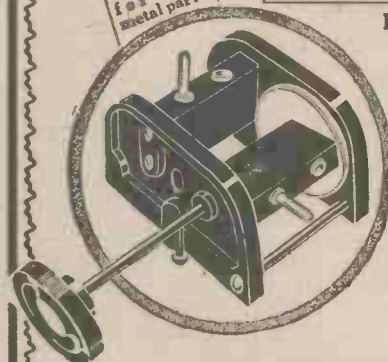



"We arrive. The tea basket is unpacked . . . the portable receiver is put in a position of vantage . . ."

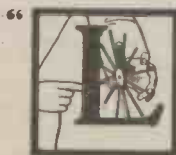

LUCKY blighter," said Carew (that's not his real name but it will pass), "I suppose as soon as you get there you will have tea to the

accompaniment of appropriate music, followed by dancing on the grass. Wish I could afford a nice portable set like yours, but I can't do it just now." (This due to the failure of one Colorado to come up to expectations.)

A Pretty Dream

Carew, you will have guessed, knew little or nothing of wireless. In his imagination he saw us setting off for the afternoon, complete with dog and portable receiver, to our little glade (somewhere in Bucks), there to have tea and disport ourselves to sweet strains from some dance band.

After which the gentle strains of soothing pastoral music should charm our cares away while lazy wreaths of smoke curled upwards through the warm air of a late summer afternoon. (The afternoon was late, not the summer.)

The Reality

Let us examine the reality and compare it with the picture painted by fancy. We arrive. The tea basket is unpacked and all made ready, the portable receiver (a completely self-contained one, carrying all batteries together with the loud-speaker inside the case) is put in a position of vantage, and in order that the greatest volume may be obtained, since we are some 30 miles in a straight line from 2LO, a length of insulated wire is thrown up into the nearest tree with the help of half a brick.

WHERE ARE THOSE SUMMER PROGRAMMES?

By C. P. ALLINSON, A.M.I.R.E.

A body with the public responsibilities of the B.B.C. is always open to criticism from those it serves, and when such criticism is reasonable and constructive it cannot but be wholesome.

The kettle boils, tea is made, and we settle down to enjoy the afternoon's programme. In order that all the elements of novelty should give a spice of surprise to the entertainment that awaited us, no paper has been consulted as to the day's programme. It is therefore with a general expectation of pleasure that we switch into the middle of a talk that appears to deal with "What are Fossils," or may be it was "The Origin of the English Language." It is really immaterial which it was.

No, Thanks !

Having listened to this with earnest attention for at least five seconds we felt that, keen as we all were on the subject, the contrast of bright sunlight and deep leafy green shadows hardly conduced to our devoting our minds to it with the degree of concentration required. We therefore turned the set off again, thinking no doubt at four o'clock a more suitable item would be "on the air."

The afternoon was still warm and a thrush in the thicket vied with a bold blackbird in the bushes in filling the glade with Nature's music. Overhead in the trees a solitary songster trilled his heart to the sky, a blue sky across which drifted a few large clouds looking like etherealised cotton wool.

Up the ride on our right the bolder of the rabbits who had been scared by our arrival ventured forth again to nibble the short sweet grass, and before we knew what had happened a quarter of an hour had passed.

Try Again

We therefore clicked the switch to the "on" position and listened expectantly. As the last notes of Big Ben boomed to a close and the whine of the land line vanished, we waited with hope for the announcement.

It came. "You will now have a talk on 'What it Feels Like to be an Engine Driver,' by one of them."

A vicious click of the switch served to express our feelings more eloquently than words.

On another trial being made we were rewarded with tea-time music from the Piccadero, which, together with the rattle of cups and saucers and the clatter of conversation, continued for an hour. A few attempts were made to dance to some of this but proved unsuccessful, the everchanging



"Nothing could be more enjoyable on a hot summer's afternoon than a talk on 'What is Ectoplasm?' or 'Are Vitamines Catalysts?'"

tempo making it practically impossible to keep in time with the music.

(Continued on page 158.)

WHERE ARE THOSE SUMMER PROGRAMMES ?

(Continued from page 157)

Too Late !

Next came the *children's* hour, during which aunts and uncles disported before the microphone with interludes of songs and stories. Then just as it became time for us to pack up and depart the strains of the Radio Dance Band came from the loud-speaker.

When we got back I thought that I would, purely as a matter of interest, make a comparison of that afternoon's programme with that of six months' ago. The results were enlightening and are here placed next to each other so that those who have not kept copies of the winter's programmes may compare them for themselves.

Time P.M.	January	June
3.15	Transmission to schools. Talk	Transmission to schools. Talk
4.0	Time-signal and a talk	Time-signal and a talk
4.15	Music relayed from Restaurant	Music relayed from Restaurant
5.15	Children's hour	Children's hour
6.0	Dance Music	Dance Music
7.0	Time-signal and news	Time-signal and news
7.25	M—C— playing Chopin's <i>Etudes</i> , Part X	G—B— playing pianoforte sonatas, contd.

This actually takes us past the afternoon performance, as I think it is usually reckoned that the evening's programme commences at 7 p.m.

Where Is It ?

Where, then, is the special summer programme that may reasonably be expected by the listener at this time of the year? Strange it is that out of over four hours' transmission only half was

some really inspiring broadcasts, such as "The Exponential Theorem Illustrated with Advanced Examples" or "What is Ectoplasm?" or again "Are Vitamins Catalysts?"

But joking aside, surely one would anticipate some variation of the programmes (especially as regards reducing the number of talks) to be made in the summer, more particularly as affecting the afternoon's broadcast, even if little or no alteration is made

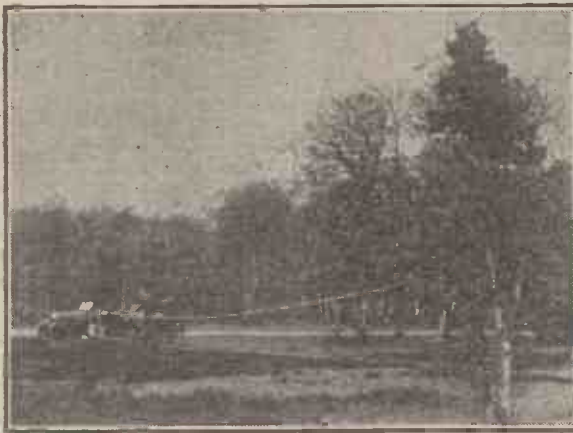

apparently producing any results. Now is surely the time to press the matter, for a revision of the programmes is seriously needed to suit summer-time conditions.

As a matter of fact, in general character there appears to be practically no difference at all either in the afternoon or the evening performances being put out to-day as compared with those given us six months ago. Yet the average listener

occupies himself or herself, as the case may be, far differently now than they did in January.

Changed Conditions

During the week those who do not play tennis or other games up to the last moment that the waning light allows, either spend their time on the road (for what is more delightful than a quiet motor run in the cool of the evening?) or else in the garden. After all, the whole population of London, or any of the large provincial cities for that matter, does not consist of flat dwellers. Experiment would doubtless prove that a certain class of music is far more suited to out-of-door reception than others, a point that does not as yet appear to have received any consideration.

Further, large numbers of sports clubs have installed wireless sets in their club houses for the entertainment of their members, one or more loud-speakers being installed as circumstances may require.

"Echo" Out-of-Doors

The subject of outdoor reception brings me to a subject that has
(Continued on p. 180.)



in the evening programmes.

A difficulty that presents itself, however, is the fact that many listeners are undoubtedly deeply interested in the talks that are broadcast, and though it is the opinion of many people that the number of talks could be cut down and the programmes rearranged more suitably, the talks should be so placed that those who did not care for them could switch their sets off without any material loss of their evening's enjoyment. At the same time, the talks should not come at a time which would be inconvenient for those who wish to listen to

them.

An Opportune Moment

This question of talks is one that recently received a great deal of publicity in the daily Press without

devoted to talk. Surely this is too little! On a fine summer afternoon what is more enjoyable than a series of lectures, talks and educational items on various subjects? Why not cut out the music entirely and give us

A "Two-in-One" Crystal Set

By JOHN PUGH-PRICE

Here is a very handy little instrument which serves two useful purposes; it can be used as a crystal receiver for the local station when your accumulator is away at the charging station, and it can be used as a wavetrap in conjunction with your valve set.

IF your local station seriously interferes with your reception of distant stations, or you are experimentally inclined and occasionally rebuild, or at least try suggested improvements with your set, the instrument to be described will serve a two-fold purpose. In my position, which is about ten miles southwards of ZLO, with my ordinary detector and one note magnifier receiver it is difficult to receive any station below about 400 metres free from interference, and to overcome this difficulty I have experimented with a large number of wavetraps, finally adopting the "auto-coupled series rejector" type, as this seems to be most generally satisfactory on the aerial upon which I have tried it.

Whilst measuring the wavelength covered by the coil, when tuned by a .0005 parallel condenser, using an ordinary buzzer wave-meter and a pair of telephones in series with a crystal detector across the coil, the idea struck me that it would be ad-

out of operation. A both useful and efficient combination resulted.

The Theoretical Circuit

The details of the arrangement will be grasped readily by inspection of

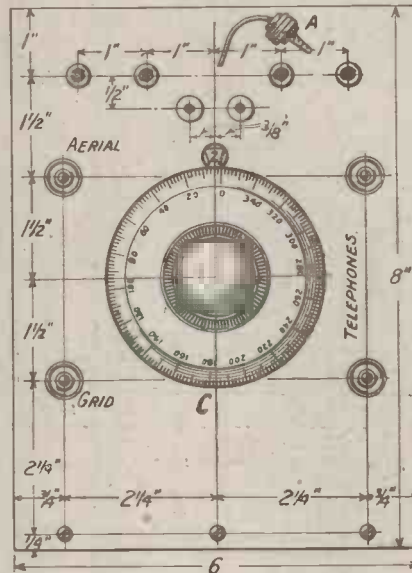
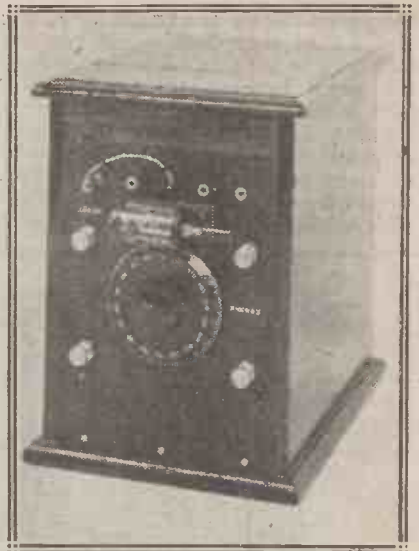

Fig. 1.—When the instrument is to be used as a crystal receiver, the earth should be connected to the terminal marked "grid."

the circuit diagram. L is a fifty-turn coil, wound with 24 gauge d.c.c. wire, on a 3-inch diameter ebonite former, and tapped at ten, fifteen, twenty and twenty-five turns from the lower end of the winding. The whole fifty turns are tuned by the parallel condenser C of .0005, which permits of the lower broadcast wavelengths

being covered when the instrument is functioning either as a wavetrap or as an auto-coupled crystal receiver. For the wavetrap arrangement the aerial is connected to the terminal marked "Aerial," and

that marked "Grid" is joined to the aerial terminal of the set, which latter should be arranged for plain parallel tuning, C.A.T. or series tuning not



Changing the tapping on the coil is effected by altering the position of the plug.

being suitable when the trap is in circuit.

The lead terminating in an arrow head and marked with the letter "A" represents a Clix plug which may be tapped into either of the fourappings to the coil, to which are connected four Clix sockets placed parallel with the upper edge of the panel.

Crystal Set Arrangement

When employed as a crystal receiver the aerial is joined to the aerial terminal and to that marked "Grid" the earth lead is connected. A pair of telephones are joined across the two telephone terminals, and the crystal and phones are tapped across the whole or part of the coil as desired, by means of the flexible lead which will be seen in the wiring diagram, the spring clip being represented by "B" here.

Crystal Damping

By tapping the crystal across part of the coil only, the damping effect which it introduces is minimised, and although only part of the available voltage across the coil is utilised an improvement, both in signal strength and selectivity, may be obtained. To place the crystal across the whole coil "B" is clipped to the lead between the fixed plates of the variable condenser and the upper end of the coil. The four ends of the wires from theappings to the four Clix sockets are bared near the latter, giving four alternative tapping points for the crystal connection.

The General Layout

The neatness of the general arrangement adopted will be appreciated from the photographs and diagrams, an upright panel and an American enclosed type cabinet being employed.

Alteration of the turn numbers in
(Continued on page 160.)

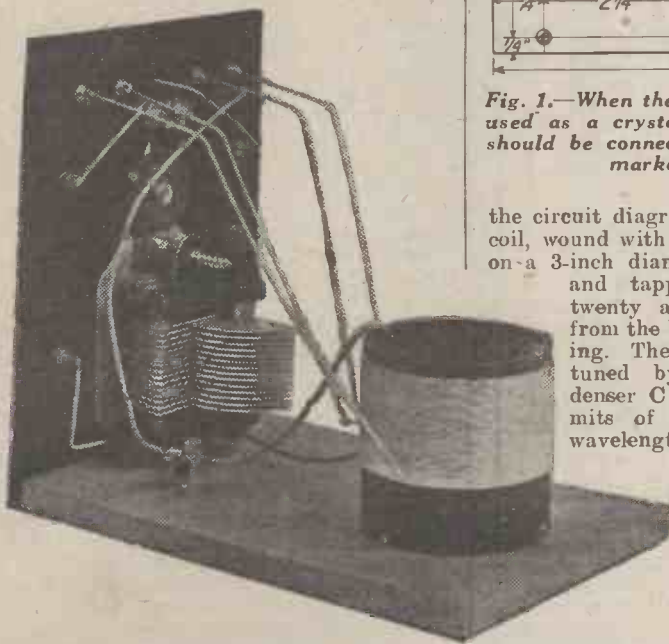

In this photograph the crystal tapping, which may be seen below the variable condenser, is across the whole of the coil.

vantageous to incorporate a crystal detector permanently in order that the wavetrap might be used as a stand-by set, when the valve set was

the aerial circuit is effected by means of the Clix plug, from which the flex lead will be seen to be taken through the panel between the two pairs of Clix sockets. Directly below the Clix tapping sockets is located the crystal detector, which is arranged to plug in and can be removed so as to be preserved from the effects of dust and exposure when the instrument is used as

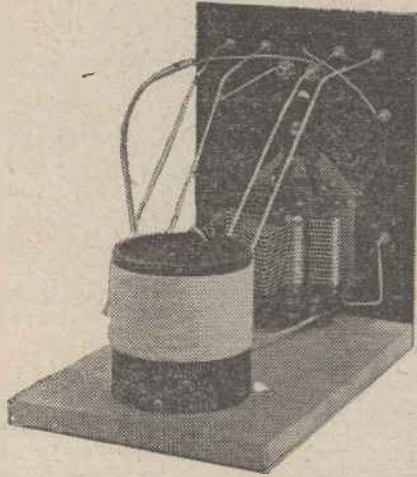

When wiring up, care should be taken to see that sufficient clearance is left for the moving vanes of the condenser.

a wavetrap. The tuning condenser C is placed in the centre of the panel and is of a geared type, allowing of very fine adjustment, since this is necessary when the instrument is employed as a trap.

The Crystal Detector

I have mounted the crystal detector upon the ebonitstrip mentioned in the list of components and have arranged the two valve legs at $\frac{1}{4}$ -in. spacing for insertion into the two valve sockets, which are mounted on the panel. The actual position of the two valve legs should be determined when the valve sockets have been mounted upon the panel, and it should be ascertained that there is ample clearance to allow the Clix plug to be inserted into the coil tapping sockets. The two valve legs are joined respectively to the two side clips holding the crystal detector. Where it is desired to use some other type of crystal detector the dimensions will have to be modified accordingly.

Components

To construct the receiver exactly as shown in the diagrams and photographs, the following components are required, and makers' names are given for the benefit of readers who wish to duplicate the instrument.

One ebonite panel 8 inches by 6 inches by $\frac{1}{4}$ inch thick. (Peto-Scott Co., Ltd.)

One cabinet to take above panel and a 9-inch deep baseboard. This latter dimension should be given when ordering. (Carrington Manufacturing Co., Ltd.)

A "TWO-IN-ONE" CRYSTAL SET

(Continued from page 159)

One .0005 Colvern selector low-loss variable condenser. (Collinson Precision Screw Co., Ltd.)

One panel mounting crystal detector. (Burndept Wireless, Ltd.)

One small piece of ebonite, $2\frac{3}{4}$ in. long by $\frac{3}{4}$ in. wide and $\frac{1}{4}$ or $3/16$ th in. thick.

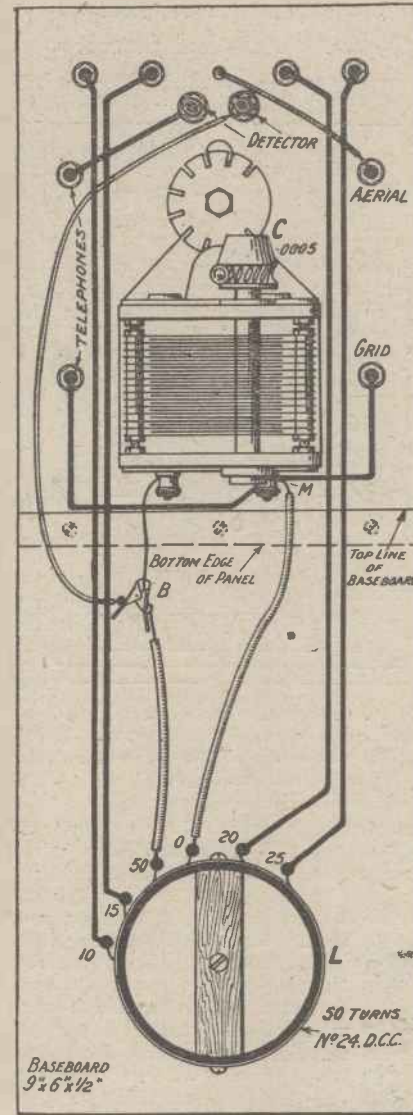

Fig. 2.—The operation of mounting the finished coil upon the baseboard is simple, three screws and a piece of wood being all that is required.

Two valve legs and two valve sockets with nuts or two more Clix sockets. (These may be obtained from any small wireless shop.)

One Clix plug and four Clix sockets. (Autoveyors, Ltd.)

Four type W.O. terminals.

One 3-inch length of 3-inch diameter ebonite tube.

A quantity of 24 gauge d.c.c. wire. A $\frac{1}{4}$ pound reel should be obtained.

A quantity of Glazite and rubber-covered flexible wire.

One spring clip. (Peto-Scott Co., Ltd.)

Radio Press panel transfers.

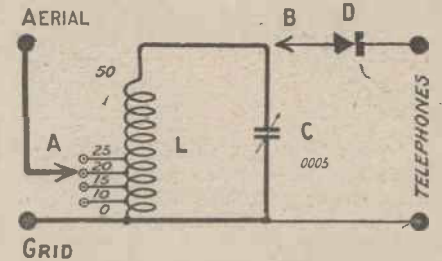

Fig. 3.—Tappings are made at 10, 15, 20 and 25 turns from the grid, or in the case of the crystal set the earth end of the coil.

Construction

From the wiring diagram and photographs no difficulty whatever should be experienced in constructing the instrument, and the only point which calls for real care is winding the coil. The winding should be commenced about a quarter of an inch from one end of the former, the wire being taken through two holes and about 6 inches should be left free. Twenty-five turns should be wound on and a tapping should then be made by baring about an inch of the wire and forming a loop which should be twisted together so as to form a convenient point for soldering to a lead from one of the Clix sockets. Five more turns should be wound on, and another tapping should be made; three tappings at five turns each being required and then the coil is completed by winding on a further ten turns, making fifty turns in all. The winding is finished in a similar manner to the way in which it was started, that is by taking the wire through two holes and by leaving six inches or so to spare. The tappings should be arranged in some staggered formation, permitting a suitable spacing between leads to the Clix sockets to be obtained, but it is immaterial in what order the tappings are taken, since the plug from the "Aerial" terminal can be inserted into any appropriate socket.

Wiring

Before fixing the panel, upon which the condenser, crystal detector, the Clix sockets, etc., have been mounted, to the baseboard, it will be seen that certain of the connections can be made. When these are completed the panel should be fixed into position by means of three No. 4 $\frac{3}{4}$ -inch brass wood screws. The position of the coil on the baseboard can then be determined, and it may be fixed by screwing a piece of wood, which forms a sliding fit inside the tube, to the baseboard.

(Continued on page 166.)



You wouldn't go to sea without a Compass!

JUST as no wise mariner puts to sea without a compass so no real wireless enthusiast should attempt to explore the ether without an equivalent in the "WORLD RADIO," the paper which tells listeners *a week in advance* about Dominion and Foreign programmes. It brings the outside world's broadcasting to Britain and keeps listeners abreast of the times with interesting and up-to-date information about international broadcasting. Another outstanding feature of this companion paper to "Radio Times" is an accurate table of stations abroad in the order of wavelengths, which makes it the essential paper for the enthusiastic listener.

On sale at all Newsagents and Bookstalls; every Friday, 2d., or by post (one year's subscription 13/6) from the Publishers, George Newnes, Ltd., 8-11, Southampton Street, Strand, London, W.C.

WORLD-RADIO

WITH WHICH IS INCORPORATED "RADIO SUPPLEMENT"



FOR
**CRYSTAL - CLEAR
RADIO USE**



L.F. TRANSFORMERS

TYPE AF4, 17/6

TYPE AF3, 25/-

The "Nearly Perfect" Transformer.

Ask for Leaflets Wa401 and Wa402.



FERRANTI LTD., HOLLINWOOD, LANCASHIRE.

CAXTON 4-VALVE CABINET

Made for Sets "All Concert Receiver," "Fieldless Coil Three Valve Set." "Any Valve Low Frequency Amplifier."

Special Cabinets made to customer's measurements. Prices Quoted.



Cash with Order. Fumed Oak ...	£1 5 0
Dark or Jacobean Oak	£1 10 0
Real Mahogany	£1 14 0

Detachable 7" deep Base Board to mount 16" by 8" panel to slide out of Cabinet front.

The two beaded front doors as illustrated, placed 2 ins. in front of the enclosed panel at 10/- extra.

Ebonite or Radion Panels Supplied and perfectly Fitted at low extra cost.

All Polished with the new enamel that gives a glass hard surface that cannot be soiled or scratched. **SENT FREE.**—Catalogue of standard Wireless Cabinets in various sizes and woods.

Packed and delivered free in U.K.

NO. C2

CAXTON WOOD TURNERY CO., Market Harborough

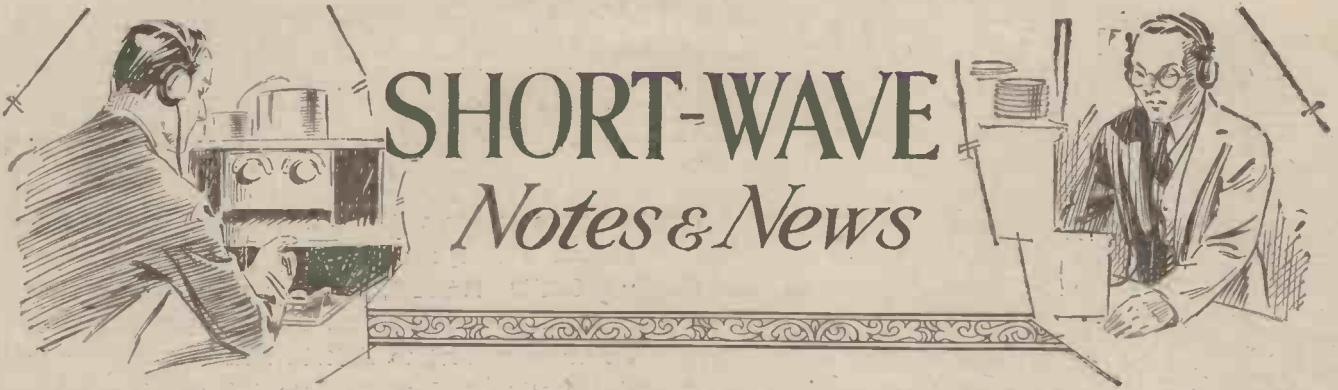

THIS summer seems to be an exact replica of the last, as far as "DX" transmitting conditions are concerned up to the time of writing, and there is every prospect that it will continue to be so. The only difference seems to be in the work with the nearer European countries, which is much easier than it was this time last year. Whether this is on account of the different types of aerial systems now in use or simply a peculiarity of the ether, it is difficult to say at present.

Australia

Australian work in particular is quite lively in the early mornings, particularly from the receiving point of view. GI-6MU received about eighteen Australians between 6 and 8 a.m. on two consecutive mornings, and several British stations with 30 watts or so find no difficulty in communicating with the "A's and Z's" fairly reliably. Our high-power telephony stations, however, do not seem so keen on getting their "fone" through to the Antipodes as they were last year, probably because the novelty has worn off, and they are looking for fresh worlds (literally!) to conquer.

In Ireland

Mr. W. R. Burne (ex G-2KW) is now the managing editor of the *Irish Radio Journal*, and will probably start up some day as a "GW" station. He will be pleased to forward cards to Irish experimenters, if they are addressed to the station, c/o *Irish Radio Journal*, 34, Dame Street, Dublin.

Twenty Metres

Several Americans are now working regularly on 20 metres or thereabouts, and the chief difficulty seems to be the absence of good receivers on that wave; although the signals are getting out quite well, no reports are received. U-9BSK asks us to state that he would

be very glad to receive reports on his Sunday transmissions on 20 metres. These should be addressed to Mr. James Grindle, 1143, Garfield Street, Hammond, Indiana, U.S.A.

Crystal Control

The advantages of crystal control are felt more than ever on 20 metres, where a slight swing in the aerial or, in fact, anywhere in the transmitter, will cause the note to be quite unreadable unless the receiving operator is skilled in the art of chasing a signal

branch of WGY) has started up again on 45 metres and 67.5 metres.

A Trip to the Coast

The writer has spent part of the past week on the South Coast with a short-wave receiver, and has had an interesting chance to compare the conditions with those in London. On the whole, perhaps, signals seem slightly weaker, but surprisingly little interference was experienced from Channel shipping, etc. The general impression was that all the stations that could be received in London could also be heard on the coast, but perhaps a little weaker. Freedom from electric train noises and other atrocities usually associated with large towns was evident immediately the set was switched on!

Scandinavia

Finland and Denmark are showing signs of increased activity nowadays, in the latter case on account of the granting of transmitting licences. About ten Finnish stations are on the air with fair regularity, and probably the same number of Danes. They do not seem to have any use for raw A.C., all the notes that are not pure D.C. being well rectified and smoothed. In Denmark "closed hours" between 7.30 and 10.30 p.m. are enforced for the benefit of the "B.C.L.'s." The Danish stations mostly seem

to start out after DX about 11 p.m., and have been heard working Brazil at that time, although they all use quite low power.

"QSL Bureaux"

The number of "QSL bureaux," through which cards may be sent to foreign amateurs, is now quite large, and in an early issue we will give a complete list of these addresses, together with a new and up-to-date list of "intermediates." These bureaux are extremely useful in the case of countries that have a large proportion of unlicensed transmitters, as cards may be safely sent.

WRONG AGAIN !

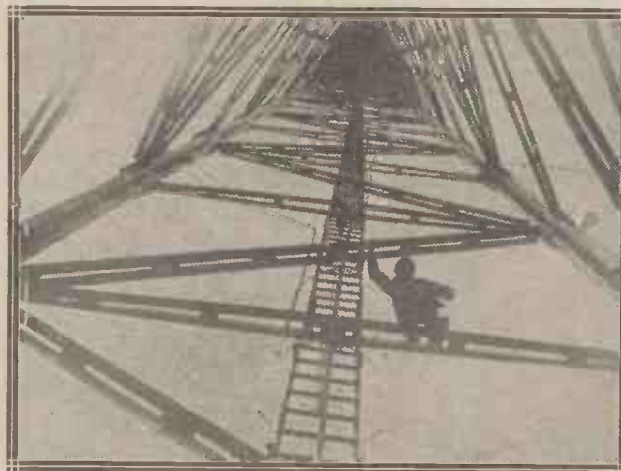

No, this is not another view taken at Rugby, but shows the interior of one of the masts at Nauen.

round the condenser. Unfortunately, quartz crystals already seem to be getting rather scarce. Let us hope a new supply is forthcoming soon.

We have received a number of reports of reception of commercial stations round about 20 metres; but, although Brazilians have also been heard, none of the American amateurs' signals seem to arrive here. Mr. G. L. Brownson (G-2BOW) reports reception of WLL on 18 metres and 2XS (Schenectady) on 14.3 metres, and also one of the Nauen stations (AGK) on 21.4 metres. BZ-1AP and 2AB have been heard on 18 or 19 metres, and he reports that U-2XG (another

ARE YOU IN A DEAD SPOT?

By E. A. ANSON

This week we commence the publication of the results of an important investigation being made on behalf of this journal. Thorough research is being made into the distribution of signal strength from 2LO, and many remarkable facts concerning "dead" areas are coming to light.



If a broadcasting station is situated on a small island and receivers were placed in boats round the station all receivers on a circle with the broadcasting station as centre might receive signals of equal strength. In other words, the signal strength would diminish at equal rates all round the station, and if points of equal signal strength were joined together the result would be a series of circles with the station as the centre point.

Shielding.

If in some way the island shielded the transmitting aerial, perhaps by rising into a tall hill at one place, points of equal signal strength would not lie on a circle. Where the shielding occurred there would be a dent like the one shown in Fig. 1.

Receivers at A and B would receive equally strong signals, but B is nearly twice as far away from the transmitter as A. In actual practice broadcasting does not take place from an islet to listeners in boats. A hundred and one things occur to make these lines of equal signal strength very irregular, particularly when the transmitting station is located in a large town full of iron girders, smoke, etc., such as is the case with 2LO.

The Experiments

This series of articles is essentially practical; it is intended to measure signal strengths all round 2LO at radii of 10, 20, 30, 40, 50 miles, and to join up by interpolation all points of equal signal intensity so that readers may see at a glance what sort of conditions prevail round them. It must be realised that these "radio contours" give a general idea of conditions, but do not attempt to go into details of local irregularities.

The method of making these measurements has been made as simple as possible consistent with obtaining results easily comparable to conditions under which ordinary listeners receive. The single-wire aerial consists of 60 ft. of 12/34s phosphor bronze wire stretched between two 20-ft. masts with a single wire counterpoise

2 ft. 6 in. above the ground. A counterpoise is used in order to avoid varying earth resistances in different localities. The capacity of this aerial is .0001. The H.F. resistance of the aerial-counterpoise system is about normal for a good broadcast aerial and earth.

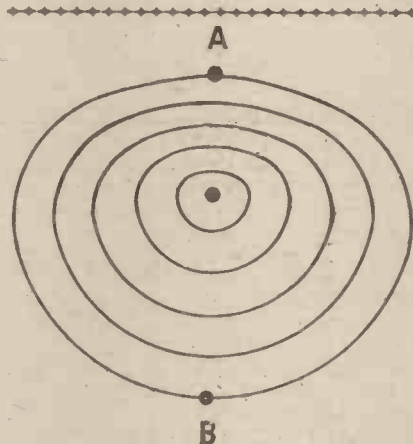

Fig. 1.—These are the imaginary "radio contours" around a station which is shielded in the direction of the point A.

Apparatus

The tuner consists of a McMichael No. 1 Dimic coil and a Sterling Miniloss .001 condenser connected in

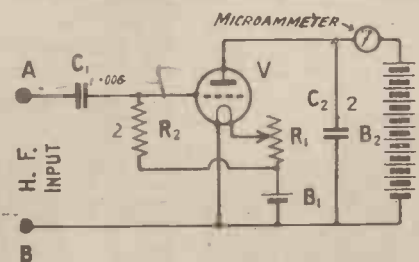

Fig. 2.—This is the measuring circuit used at the shorter distances for determining signal strength. It is connected across a simple receiving circuit.



"Dead spots" are sometimes produced by extremely "local" conditions.

parallel to form a simple receiving circuit. The voltage across the coil when tuned to 2LO is measured by a valve voltmeter of the Moullin type. Put shortly, this voltmeter is merely a calibrated valve such that any H.F. voltage impressed between the grid and filament causes a diminution of plate current which is read on a sensitive microammeter. The circuit is given in Fig. 2.

Valve Details

A DE3b valve is run off a 2-volt accumulator for L.T., and with 40 volts H.T. the filament rheostat is adjusted until the meter indicates 240 microamps. Any H.F. voltage connected between A and B will cause the galvanometer reading to fall in proportion to the H.F. volts impressed. The alteration to the circuit constants which result from connecting up the instrument are very small, about the same or rather less than an ordinary H.F. valve with potentiometer control. It must be pointed out that the instrument measures 2LO's actual H.F. voltage across the coil and ignores the modulated components impressed on the carrier. In other words, it does not matter whether music or speech is being transmitted or not, provided the carrier wave is there.

Practical Ranges

In practice it was found that the simple tuned Dimic coil across the Moullin voltmeter worked admirably up to 20 miles or even 30 miles in places. Beyond this distance it was found necessary to magnify the voltage by means of valves. This was done with a specially constructed valve receiver permitting of fine reaction control by means of a condenser.

This receiver was calibrated to give a magnification of ten. The H.F. voltage was first measured at a suitable distance from 2LO across the tuned coil as already explained. Then the Moullin was put across the tuned

Are You in a Dead Spot?—continued

anode coil of the receiver and reaction adjusted until the signal strength was ten times greater than across the simple tuned coil. Results proved quite satisfactory between the small limits required, about .08 to .01 H.F. volts.

What Contours Mean

Perhaps a word of explanation may assist readers to understand how to make use of these radio contours. All points on the same contour line are at the same signal strength for 2LO. The further apart contours lie the slower the change in signal strength and the better the area. The closer they lie the faster the change in signal strength and the worse the area. Complete closed contours either indicate an abnormally good or bad area according to whether the figures marked against the closed contour are larger or smaller than the neighbouring ones.

The South-eastern Sector

As regards the practical results obtained for the south-east area (the first one investigated), the first obvious thing is that a large part of 2LO's energy is dissipated in the first 20 miles, for the contours lie close together. East of London is very complex, from about Dartford conditions become bad, and patches of bad areas alternate with good areas. In some places 2LO cannot be said to give satisfactory results. A particularly bad area is situated near Boughton Street, whilst a good area compensates for this in the vicinity of

Sittingbourne. Compared to the east, the southern districts would appear to be more fortunate. The contours run evenly at well-spaced intervals culminating in an excellent area between Lewes and Newhaven. There are, however, two bad areas, one at Sevenoaks and the other at Framfield, south of Ashdown Forest.

It is perhaps noteworthy that the forty-mile radius appears to become erratic and uncertain as regards receiving conditions.

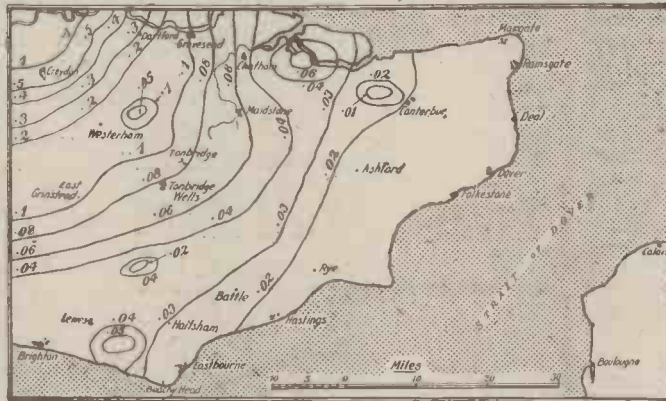

Fig. 3.—These are the results obtained in the south-eastern area. Note the "dead spots" near Westerham and Canterbury, and the area of abnormally good signals between Lewes and Beachy Head.

Comparative Results

The following table may assist the reader to understand what the figures against each contour line mean from his point of view. As already explained, they represent H.F. volts across a simple coil and condenser circuit tuned to 2LO on an aerial 60 ft. long and about 18 ft. above a single wire counterpoise similar to the aerial.

H.F. volts.	Remarks.
.02 - .06	Faint on crystal. Two valves good on 'phones using reaction. Three valves fair on loud-speaker using reaction.
.06 - .1	Crystal fairly clear, and satisfactory in a silent room. One valve good on 'phones using reaction. Two valves comfortably loud on phones. Three valves good on loud-speaker.
.1 - .2	Crystal comfortably clear. One valve loud on 'phones. Two valves uncomfortably loud on 'phones, weak on loud-speaker.
.2 - .5	Crystal quite loud and clear. Any valve set uncomfortably loud on 'phones, weak loud-speaker results even on one valve. Considerable difficulty in cutting out 2LO when trying to receive stations on wave lengths close to that of 2LO. A 3-valve set is considered to be composed of H.F., detector, and one L.F. A 2-valve set is considered to be composed of H.F. and detector.

NEXT WEEK
A THREE-VALVE
REINARTZ RECEIVER

No. 38.

PERHAPS !

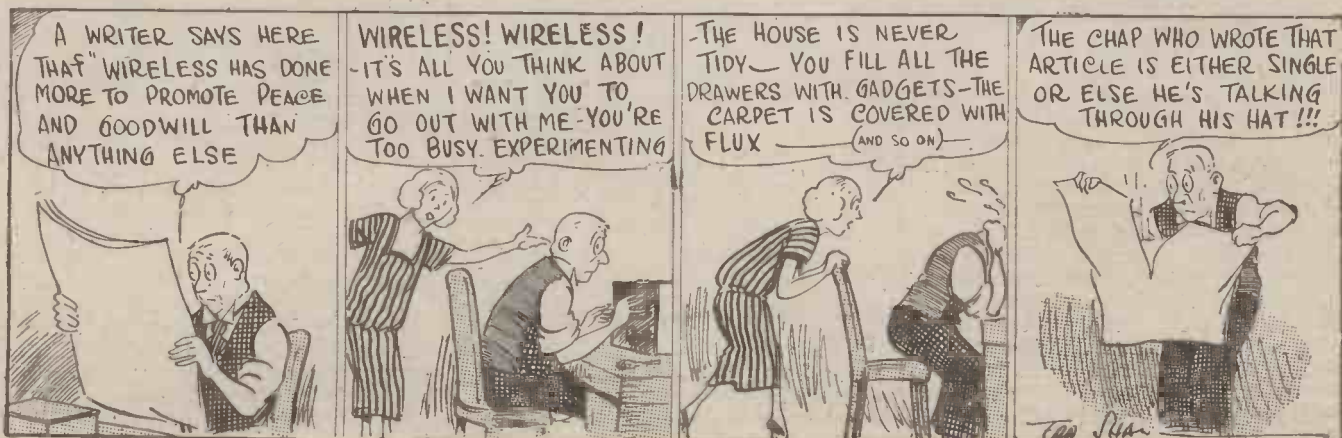

Figures to Remember



The Highwayman

"STAND AND DELIVER!"

—the command of the Highwayman—yes, and the valuables delivered were well worth having. Now, we deliver **SIX-SIXTY VALVES**, and if you value really good reception, they too are well worth having. With these perfectly designed valves the delicate gradations of music are reproduced in all their original beauty, while the remarkably clear reproduction of speech is a proof of the real contribution which 6-60 Valves have made to modern radio science.

Take the S.S.3.L.F. (green disc), for small or medium-sized Loud Speakers. This 3-Volt Valve consumes only .06 amps filament current—which in itself means a big economy in accumulator recharging—and in addition works at such a low temperature that the life of the filament is immeasurably increased. The S.S.3 (red disc) gives excellent results both as an H.F. amplifier and as a detector. Owing to the low current consumption of both types, dry cells may be used.

Then for a real Power Valve—the S.S.7 has no equal. It is absolutely non-microphonic, and when operating at the correct voltage there is no glow whatever from the filament. This valve consumes only .1 amps filament current, and combines remarkable volume with unequalled purity of tone.

Six-Sixty Valves are recommended by all the leading Wireless Journals of to-day. For **PERFECTION OF QUALITY** insist on **SIX-SIXTY VALVES**.



S.S.3 L.F.
(Green Disc).

Voltage - 3 volts.
Consumption .06amps.

PRICE 16/6

Leaflet S.S. 1.7 gives full particulars. Your Dealer will be pleased to order Six-Sixty Valves for you if he is out of stock.



SIX-SIXTY VALVES

Better by Six times Sixty

The Electron Co., Ltd., Triumph House, 189, Regent Street, London, W.1. 10

THE GLORY CORNER

We have **FREE** booklets setting out the possibilities in connection with each of the subjects shown in the lists; send for the one in which you are interested, or ask for **MY PRIVATE ADVICE** which also is free. You incur no obligation.

Have You ANY Ambition?

COMMERCIAL

Most moderate charges, payable monthly. No extra fees.

GOOD REASONS why you should join the Bennett College

1. We give a written guarantee of success
2. We supply all the necessary books **FREE**
3. We have expert tutors for every Department
4. We teach by post—you study in your spare time.

TECHNICAL—Cont.

- Metallurgy Mining
- Mine Surveying
- Motor Engineering
- Naval Architecture
- Pattern Making
- Quantity Surveying
- Sanitation
- Shipbuilding
- Structural Engineering
- Surveying and Levelling
- Telegraphy and Telephony
- Town Planning
- Wireless Telegraphy
- Works Managers' Course

TECHNICAL

- Applied Mechanics
- Architectural Drawing
- Building Construction
- Clerk of Works' Duties
- Boiler Engineering
- Boiler Making
- Chemistry
- Civil Engineering
- Concrete and Steel
- Draughtsmanship
- Electricity
- Engineering
- Foundry Work
- Internal Combustion Engines
- Marine Eng., B.O.T.
- Mathematics
- Matriculation

WE SPECIALISE IN PREPARATION FOR ALL EXAMINATIONS IN CONNECTION WITH THE ABOVE SUBJECTS.

WE TEACH BY POST

Note Address:—
The **BENNETT COLLEGE**,
Dept. 111, Sheffield.

The Bennett College
SHEFFIELD
Dept. 111.

This is the **Glory Corner** at the **Bennett College**. We give it that name because it contains in bundles about **One Hundredweight** of letters which we have received from **Grateful and Successful Students**. We keep all these thousands of unsolicited testimonials as a fountain of inspiration and because we are really proud of them. Having helped thousands of others to achieve success and advancement, it may be possible that we can help **YOU**.

I am assisted by a large and expert staff, and the advice we give is sound. If we cannot help you we will say so; if we can we will tell you how.

Yours sincerely,
J. Bennett

LIGHTNING

WHY RUN RISKS???

No telephone line installed without a similar arrester.

ENSURE PROTECTION BY THE SAME METHOD.

From all reliable dealers or direct from:

"HARMO" PRODUCTS,

4a, Aubrey Rd., Walthamstow, LONDON, E.17.
Telephone: Walthamstow 1193.

3/- ONLY Protects you from Danger. £100 Guarantee given.

COUPON.

QUESTIONS AND ANSWERS.

This coupon must be accompanied by a P.O. for 2/6 for each question, and a stamped addressed envelope when sending queries to the Radio Press Information Dept. for a postal reply. "WIRELESS."

Vol. IV. No. 5.

ANOTHER CLEARTRON PRODUCT

Rotor and Stator, die-cast in one piece, give results hitherto unattainable.

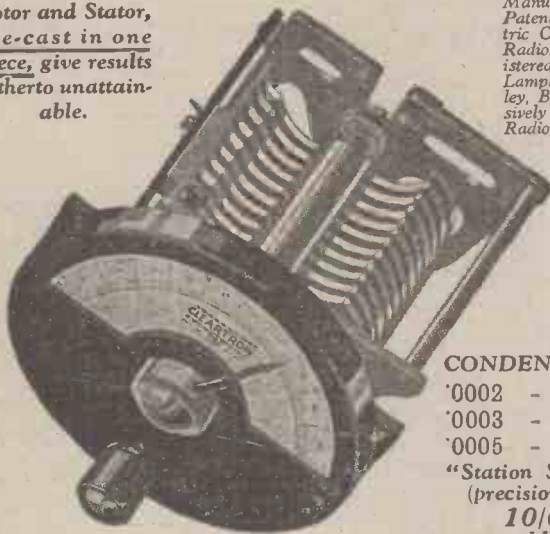

Manufactured, under the Patents of Western Electric Co., and Cleartron Radio, Ltd., and the registered designs of E. A. Lamplugh, Ltd., Tyldesley, Birmingham, exclusively for Cleartron Radio, Ltd. (Sole Proprietors.)

CONDENSERS ONLY:

- '0002 - - - 13/9
- '0003 - - - 14/3
- '0005 - - - 14/9

"Station Selector" Dial (precision movement)
10/6 extra or sold separately.

THE DI-KAST CONDENSER

is a distinct innovation in Condenser design. Avoids the contact resistance losses experienced with separately assembled condensers. Rotor and Stator are die-cast in one, which means positive connexion and perfectly matched characteristics. The specially designed vanes provide straight-line reading, greater range, easy short wave tuning and very low minimum capacity. Another feature of unusual interest is the MICRO STATION SELECTOR, a newly designed dial precision movement, allowing completely selective tuning and ten or more different adjustments between each degree. Play and back-lash entirely eliminated,

Ask your dealer or send for complete explanatory leaflet.

and of course

CLEARTRON VALVES

America's foremost Valve made in Britain's newest factory.



12/6

ALL DULL EMITTERS
Standard Prices

15/-

Full technical data from your Dealer or from us,

CLEARTRON RADIO LTD

ONE CHARING CROSS, LONDON, S.W.1
Regent 2231-2. Cleartron, Westrand, London.

(Works: BIRMINGHAM.)



CT/50

A "TWO-IN-ONE" CRYSTAL SET

(Continued from page 160)

A screw through each side of the tube into this piece of wood then makes a rigid job.

The lower end of the coil is joined to the lead between the two lower terminals on the panel, the moving vanes of the variable condenser, and the brass screen. The upper end of the coil is joined only to the fixed plates of the condenser. The method of completing the remainder of the wiring will be evident from the photographs and wiring diagram.

Testing

To test the receiver as a crystal set join the aerial to the "Aerial" terminal and the earth to that marked "Grid," whilst a pair of telephones should be connected across the two 'phone terminals. The Clix plug "A" is best inserted into the ten or fifteen turn tapping socket. When the above connections have been made rotate the aerial condenser, with the crystal detector plugged in, and when signals are obtained at maximum strength adjust the crystal detector to its best setting.

To utilise the instrument as an auto-coupled series rejector wavetrap the aerial is again joined to the "Aerial" terminal, but the "Grid" terminal is joined to the aerial terminal of the receiver, in which latter plain parallel tuning must be employed. No telephones are connected across the telephone terminals.

The procedure to adopt is as follows. First tune in a desired transmission on the set proper without the trap in circuit and then bring the latter into operation, rotating the trap tuning condenser until the undesired transmission completely disappears or is very much reduced in strength. Retune the aerial condenser of the set, which may necessitate slight readjustment of the trap condenser also. Once these operations have been carried out the trap is adjusted to cut out the local station and can be left set at this position, whilst tuning for other stations is carried out in the normal way on the set controls.

Author's Test Report

Tested on an aerial of average efficiency at 10 miles south of 2LO, when employed as a crystal set, the receiver gave excellent signal strength from that station, and tuning was much sharper than is obtained with a direct-coupled instrument, whilst it was found of advantage to be able to tap the crystal detector across part of the coil only.

Employed as a wavetrap with an ordinary detector and one note-magnifier receiver, with reaction, Bournemouth was obtained completely free from interference from the London station.

COMPONENTS WE HAVE TRIED



Conducted by the "Wireless" Laboratories, Elstree.

"Silverex" Crystal

A "SILVEREX" crystal made by Messrs. Sylvex, Ltd., has been tested with excellent results at our laboratories. The crystal is of medium fine structure, possesses a large number of sensitive spots, and is of convenient size for mounting purposes. A special cat-whisker is provided with it.

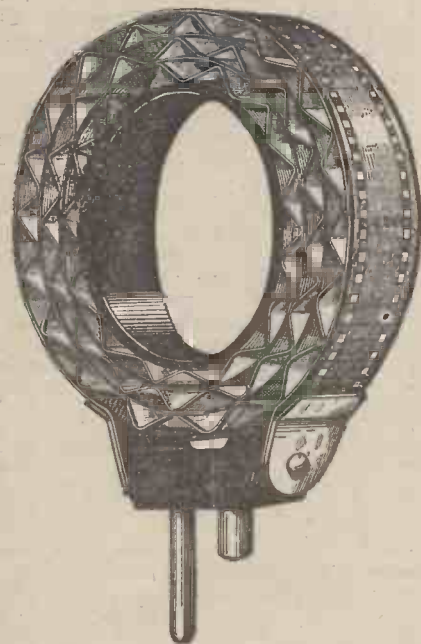

"Lewcos" Coils

FROM Messrs. The London Electric Wire Co. & Smiths, Ltd., we have received several of their new "Lewcos" plug-in coils. These are wound with special Litz wire, the layers being separated by corrugated celluloid and fastened to the standard plug by a celluloid band. The coils were found to be extremely efficient, robust in construction, and pleasingly finished, and can be thoroughly recommended for use.

"Quality" Two-Coil Holder

A "QUALITY" two-coil holder made by Messrs. The Goswell Engineering Co., Ltd., has been tested at our laboratories. Both coarse and fine adjustment are obtainable, the latter by means of an eccentrically mounted bead on an auxiliary spindle, which causes the "fixed" coil block to move through a small arc. A switch which allows the reaction coil to be shortened or its connections reversed at will is also provided. The construction and finish of this coil holder are good, and an adequate vernier control is obtainable.

The "Lewcos" plug-in coils are wound with special wire, the layers being separated by corrugated celluloid.

"Erla" balloon circloid couplers (right hand picture) are robust in construction, and have a satisfactorily low H.F. resistance.

High Resistance Potentiometer

A HIGH resistance potentiometer has been received from Messrs. the Igranic Electric Co., Ltd., for test and report. The resistance element is of graphite, with a sliding carbon brush contact mounted on an insulating moulding. A removable cover and indicating dial are provided. The total resistance of the potentiometer was 50,000 ohms, and it was found to be silent in operation, and well made and finished.

Sterling "Least Loss" Condenser

A STERLING "Least Loss" variable condenser has been submitted by Messrs. the Marconiphone Co., Ltd. It is a brass vanned instrument, the fixed plates being insulated from the aluminium end-plates by means of Pyrex glass. An 8 to 1 reduction is given by special friction gearing. The efficiency was of a high order and the mechanical design excellent, no side or end play being perceptible in the bearings.

"Universal" Rheostat

FROM Messrs. the General Electric Co., Ltd., we have received a "Universal" rheostat. The resistance elements are wound on a square insulating rod bent into a circle, a projection being provided at the junction of the two windings. The total resistance was found to be 30 ohms, the dull- and bright-emitter portions having resistances of 23 and 7 ohms respectively. The rheostat is exceptionally quiet in action and robustly constructed.

"M-L" Transformer

THE "M-L" low-frequency transformer made by Messrs. S. Smith and Sons (M.A.), Ltd., has been tested at the WIRELESS laboratories. A substantial circular core is a feature of this transformer, which is barrel-shaped and partly shrouded. The reproduction was clear and fresh with no sign of roughness and the instrument appears to be stoutly constructed and well finished.

"Erla" Fieldless Coils

TOROIDAL coils have been received from Messrs. C. G. Vokes & Co. They are known as "Erla" Balloon Circloid Couplers, and on test were found to be practically fieldless. One coil was intended for aerial coupling and the others for H.F. stages. It was found that absolute stability was obtained over the whole 200-500 metres band, while a

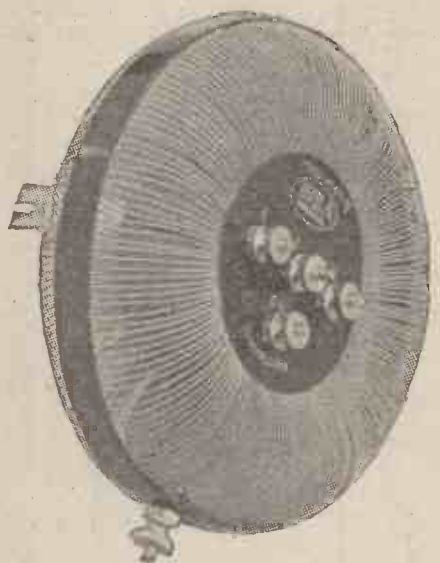

satisfactory degree of H.F. amplification resulted. The coils are robust in construction, have a satisfactorily low H.F. resistance, and are provided with brackets for fixing purposes.

"Camden" Mansbridge Condensers

MESSRS. THE CAMDEN ELECTRICAL CO.'S Mansbridge type fixed condensers are of the usual size and shape and enclosed in grey metal cases. On test their insulator resistance was found to be infinite, while they stood up satisfactorily to a voltage of 500. These condensers are good specimens of their class, and can be recommended.



This week-end build your own loud speaker!

First of all go to your dealer and satisfy yourself that the "Lissenola," costing only 13/6, really is fully equal in power and tone to any loud speaker on the market. Ask your Dealer to put on the best loud speaker he has in stock—then use the same horn on the "Lissenola" and see if you can notice any difference.

When you get the "Lissenola" home you can build a horn yourself for a few pence, providing you with a powerful instrument which will compare with any expensive loud speaker you have ever heard. Or, if you prefer a cone-principle diaphragm—very simply made—you should get a Lissen Reed as well (1/- extra). If you have never heard a "Lissenola" there's a surprise in store for you.

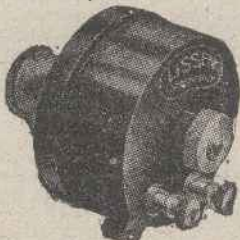

Before buying ask your dealer to demonstrate the **LISSENOLA**

LISSEN LIMITED,
18-22, Friars Lane,
Richmond, Surrey.

Managing Director: T. N. COLE. L36

'Phone Switches in Crystal Sets

In places within a fairly short range of a broadcasting station where signal strength is good there is no reason why a couple of pairs of telephones should not be used with a crystal receiving set so that two people may listen at the same time to the programme. The telephones may be connected either in

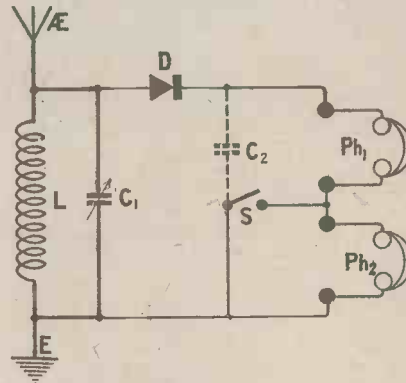

Fig. 1.—Showing how two pairs of 'phones are connected in series.

series as in Fig. 1, or in parallel as in Fig. 2. Which method is the better in any particular case depends largely upon the type of crystal that is in use and the resistance of the telephones. It is best before deciding upon one or the other to experiment with "hook-up" arrangements. Whether the 'phones are in series or

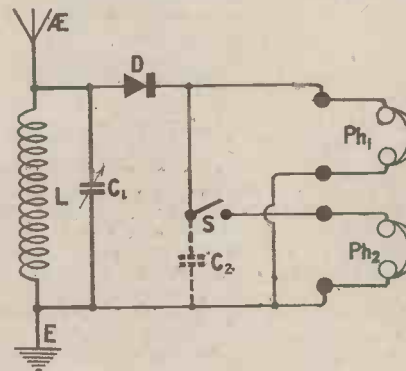

Fig. 2.—In this circuit parallel connections are employed.

in parallel it will usually be found that signal strength is reduced when the second pair is brought into circuit.

A Convenient Switch.

It is therefore very convenient to fit a simple switch which will throw one pair into or out of action, so that nor-

mally the set may be used with a single set of 'phones, the 'second set being brought in when required by a touch of the switch. The diagrams show how this may be done with a simple on and off switch such as can be made in the home workshop or purchased for a few pence. It will be seen that in the series arrangement (Fig. 1) both pairs of telephones are in circuit when the switch is open, but when it is closed the second pair is short-circuited. The telephone condenser C2, if used, should be placed as shown in the drawing, for it is then in circuit whether the switch is open or closed. In the parallel arrangement seen in Fig. 2, closing the switch brings both pairs of 'phones into action, whilst when it is opened the second pair is disconnected. C2 is again in circuit in either position of the switch.

R. W. H.

CORRESPONDENCE

SIRS,—In your issue dated June 5, Mr. Reyner mentions the fact that he heard a harmonic of the Croydon Station on his "Magic Five Receiver."

You may be interested to know that on several occasions recently I have received this harmonic (450 metres) at good loud-speaker strength on a single-valve reflex set at a distance of about two miles from the Croydon Station.—Yours faithfully,

DUDLEY G. BUSTON.

Trinity College, Cambridge.

SIR,—Referring to the question of precaution against the breakage of aerial halyards, I have seen it suggested, among other things, that two pulleys and halyards should be fixed up, so that if one breaks, the other can be brought into use, thus avoiding the necessity of lowering the mast. But this only puts off the evil day till the second one breaks. Perhaps my own plan may be considered interesting. I do not employ a pulley at all, but merely an eyebolt fixed at the masthead, sufficiently large to take not only the halyard, which I find slips through quite freely enough for the once or twice it is necessary to work it, but also and quite independently a length of thin cord tied together into a long loop to lie along and down the mast and secured at the lower end. There is, of course, no strain on this, and until it actually rots, it is always there in the event of the halyard slipping through or breaking, for the purpose of pulling it or a new one up through the eyebolt. I adopted this plan after having "had some." Incidentally, I find the loop of thin cord also useful for hauling up a flag on joy days.—Yours faithfully,

E. J. BARDEN.

Bexley Heath.



The WEEK'S DIARY

I SEE the Post Office is getting busy in prosecuting those who make use of wireless apparatus without paying their license fee. This is as it should be. No intelligent person nowadays can pretend that he does not know a licence is required, but the man who dodges paying the licence is, in my opinion, about as mean as the man who taught his children that the gas meter was a money box for their savings. One of the worst cases I have heard of occurred in a North-East London suburb, where complaints about oscillation drew attention to a particular house in which a Post Office inspector found a single valve set and an amplifier but no licence. Thousands of people will think that the fine of 20s. imposed was not enough, and I have some sympathy with them.

HAVE you noticed how cheap and shoddy wireless apparatus is fast disappearing from even the smaller shops? At one time there was a danger of the market being flooded with cheap Continental productions of very doubtful quality, but home constructors soon had enough of this stuff and were led by bitter experience to make sure that the components they purchased were reliable. The best of the American components reach this country, where they are sold in most cases at a price considerably above that of the similar British production, or when there is no equivalent made in this country, at a price which does not in any way suggest "dumping."

I AM very glad to see that several British manufacturers are introducing really good slow-motion dials, a line in which, up to the present, the Americans have excelled. If sets continue to progress as rapidly as they are doing at present along the lines of selectivity, every set in future will need this kind of dial, and the old three-inch moulded affair will pass right out.

I HAVE thought for some time there has been something missing from the news, and I could not quite make out what it was. I have just realised. What has happened to our annual invention of a wireless receiver no larger than a watch, with which you could hear stations a thousand miles

away? This invention has been a hardy annual for about 20 years, and usually the story (it generally turns up as a paragraph in one of the London dailies) reads something like this:—

"A Jesuit priest in Turin (or Milan or Naples or some other Italian city) has just produced a remarkable invention which takes the form of a wire-

less set no bigger than a watch reminds us that ... " and so on.

A WELL-KNOWN CONTRIBUTOR



Our artist's idea of Lieut.-Commander Kenworthy in a characteristic attitude.

less set no bigger than a watch, with which English, French and German broadcasting can be heard with ease. It is claimed that the new apparatus makes all existing receivers obsolete."

BEFORE broadcasting came in, the invention was reported to be able to receive messages from all parts of the world. Following the appearance of the paragraph in a London

FOR some mysterious reason it is always an Italian priest who invents this set and it is always "no bigger than a watch." The invention is invariably announced as "revolutionary" and just as certainly "will make all existing apparatus obsolete." It is at least 16 years since I personally saw such paragraphs first appearing, and I am sure we are bound to have another one like it in the course of the next week or two. Watch the papers and see!

COMING out of the Club the other day, I ran across a well-known wireless expert who until recently steadfastly refused to try a portable set in his car, taking the line that as a wireless expert he was entitled to relaxation as much as anyone else and did not intend to interrupt the relaxation with "shop." Persuaded at last to break this rule, he took out a portable set made by a friend and was astounded with the results he obtained with it. "What we have most of us overlooked," he said to me, "is that a portable set can be, and nearly always is, used in a location which is far more suitable for wireless reception than that on which the average house is built. The motorist will often stop on a hilltop where there is a view for miles around, and such a spot is usually good for reception, being quite unscreened. I have been astounded with the long-distance work possible with a simple four-valve set, and I think that if the average listener knew how good reception conditions generally are away from town, he would make much more use than he does at present of portable receivers."

SPEAKING of portable sets reminds me that the aerial wire used with them need not be of the
(Continued on page 170.)

The Week's Diary—continued

heavy type used for home aerials, but can be as thin and flexible as you like; braided or flexible wire seems most suitable, as it can be rolled up conveniently without springing out of the hands, as is the habit of the phosphor-bronze variety. Even the thread-like No. 36 S.W.G. has been known to give excellent results, and of this you could put enough on a cotton reel to be sufficient for half-a-dozen aerials, although it requires more than ordinary patience to put it up without breaking it!

THE publication of reports on the new B.B.C. experimental station at Daventry are very promising, and I do not think it will be long before the listener on the 300- to 500-metre band hears some very good signals from that direction. I believe it was first intended to erect this trial station at Chelmsford, but later Daventry was decided upon as a better site, particularly in view of its existing high-power station and supplies of power.

IT is just 27 years since the first wireless station was erected at Chelmsford, although this, of course, was for telegraph and not telephone communication. A month or so later a corresponding station was erected at Dover, communication between the two places being effected in the middle of July. This was quite a considerable distance in those days. I wonder what the engineers of that day would have thought if they had been told that Chelmsford would be the site of a giant station, capable of sending entertainment into a million homes through the medium of apparatus so simple that the proverbial child could work it! Their informant would simply have been called mad and promptly forgotten.

MANY of the early wireless engineers were, contrary to what might be expected, intensely conservative in their methods. There is a story told that Senatore Marconi, having obtained certain results by winding a coil of wire round the leg of a table, insisted on sawing the leg off the table to take it away, in case he could not get such good results with a coil wound on a different former!

HOW many people know that Schenectady (pronounced, by the way, as if it were spelt Skenectady), which is known to British-listeners

only as the location of the famous WGY broadcasting station of the General Electric Co., is one of the oldest towns in America, having been incorporated since the year 1700. Mr.



An interesting application of television is to use the apparatus in the way illustrated here, to permit two persons to see as well as hear one another at a distance.

Harris, who visited the town last year, tells me he was astounded to find, not a thriving modern city with engineering works, factory chimneys, and all



Remarkable as are the results some people seem to obtain, no one has yet claimed reception of 3LO, Melbourne, in this country. The view shows the main transmitting plant and the control table.

other signs of industrial activity, but a sleepy old-world town, long avenues overhung with trees, and practically no indications whatever of commer-

cialism. Practically the only industrial plant in the neighbourhood is the works of the General Electric Co., and this is situated just outside the town and does not disfigure it.

AS one who periodically grumbles at the things he does not like, "Wavetrap" would like to express his appreciation of the "Street Scenes in Old London," which were so admirably broadcast from the London station on Friday the 11th. Such a broadcast seems to adapt itself excellently to the medium, and would keep me at home on any night, whereas the much-advertised talk by a diver from the bed of the river (I wonder what idiot thought of that!) would probably send me out to the nearest place of amusement. After all, the voice of the diver from the bed of the ocean would sound about the same as the voice of the same diver upon the platform of the Oxford Street Tube Station.

THE Wireless Exhibition to be held this year in the smaller hall at Olympia will undoubtedly be the finest show yet. Unlike the previous Exhibition, this year's show will be open to any British wireless manufacturer or distributor, whether or not he belongs to any particular trade association. The British Broadcasting Co. are actively co-operating with the organisers, and I have already heard of two or three special "stunts" being organised which will greatly increase the popularity of the show.

HAVE you ever heard of the use of metal as an insulator? Neither have I, but the wireless correspondent of a well-known daily paper recently headed a paragraph, "Metal Insulation Bad," and then went on to explain that lead-covered cables should not be used for either aerial or earth leads. Some of these daily paper wireless columns are very amusing in reading, and give great joy to the genuine wireless expert.

IT is good news to hear that Senatore Marconi has now quite recovered from his recent serious illness, and is back again in London. Unlike many people whose names have been given to big companies, Senatore Marconi takes an active part in the technical work, and has had a great deal to do with the latest shortwave work. **WAVE-TRAP.**

I HAVE BEEN ASKED



I want to store my L.T. accumulator away for some months. What shall I do?

An accumulator should not be stored, when filled with electrolyte in the normal way, unless provision can be made to recharge it every four to six weeks. Where this cannot be done the battery should be properly charged and the acid should then be withdrawn. The cells should be washed out carefully with distilled water and allowed to drain dry. When this has been effected the battery may be stored without risk of damage resulting.

I have two pairs of telephones of 4,000 ohms and 120 ohms resistance, respectively, and also a telephone transformer. I should like to know whether I can use both pairs of telephones at the same time on my two-valve set, which is a standard detector and one transformer-coupled note magnifier receiver?

It is quite a simple matter to operate the two pairs of telephones upon your receiver and there are two methods by which this may be effected. The simplest method is to connect one side of the input winding of your telephone transformer to one telephone terminal, the other terminal of this winding to one tag of the 4,000 ohms resistance 'phones, and the other side of the same pair of 'phones to the second telephone terminal, whilst the low-resistance telephones will be joined across the output winding of the telephone transformer.

The other method is, leaving the 120 ohm 'phones connected across the output winding of the telephone transformer, to connect the input winding directly across the telephone terminals of the receiver and to join one side of the 4,000 ohms resistance 'phones to the telephone terminal of the set which is joined internally to

H.T. positive whilst connecting a 1 or 2 microfarad Mansbridge-type condenser between the other side of this latter pair of telephones and the other telephone terminal of the set. This latter set of connections is most to be recommended, since neither pair of 'phones carry the direct anode current of the note magnifier.

In the first note magnifying stage of my resistance-coupled-amplifier I employ a general-purpose valve, with an internal resistance of 40,000 ohms and an amplification ratio of 9. I intend to substitute a resistance-coupling type valve, with an internal resistance of 30,000 ohms, and an amplification factor of 20. By effecting this change I understand I shall obtain an amplification of 20 instead of 9 from valve to valve. Is this correct?

With resistance or choke coupling it is impossible to obtain an amplification from valve to valve equal to the amplification ratio of the valve concerned, since to obtain this desirable state of affairs, it would be necessary to employ a choke or a resistance of infinite impedance. This it is impossible to do in practice but by utilising a choke of high inductance or a fairly high value of anode resistance only a small percentage less amplification than that in the ideal case, is obtained.

J. U.



FILAMENT RHEOSTATS AND POTENTIOMETERS.

With the windings carried on a porcelain bobbin and having the contact arm moving on its inner side, the "Cosmos" Filament Rheostat takes up remarkably little space, is strong in construction, and has a very smooth and reliable movement. It is fixed by ONE HOLE, and is provided with a handsome knob and dial. Made in four types, two of which are double wound for Dull OR Bright Valves, and one a Potentiometer, the prices are as follows.

METRO-VICK SUPPLIES, LTD.,

(Proprietors—Metropolitan Vickers Electrical Co., Ltd.)
METRO-VICK HOUSE, 145, CHARING CROSS ROAD, LONDON, W.C.2. R P40

Description	Ohms	Carrying Current	Price.	
			s.	d.
Single Wound	6.0	1.0 amp.	4	6
Double "	18+2	.4-1.5	5	0
Double "	30+4	.2-1.0	5	0
Potentiometer	300	—	6	0

Cosmos

RADIO COMPONENTS

PRACTICAL TOPICS

By G. P. KENDALL, B.Sc., Assistant Editor

H.T. Plugs Again—A Neutralising Scheme—Friction-Drive Dials.

A LITTLE while ago I remarked in these columns that the average wander plug supplied for use with an H.T. battery was a very unsatisfactory affair, and one of my readers has been kind enough to write to me and point out that there does exist a plug which, although perhaps not specifically intended for use with H.T. batteries, nevertheless fits the sockets in question, and has proved in his hands perfectly satisfactory in practice. This is the "Gibson" plug, which is made in several sizes, and is known to me of old as a particularly well-finished and satisfactory little appliance.

Still Not Satisfied

It is made of good hard brass, well-finished, and fitted with an insulating shank of either black or red. As a matter of fact, I had forgotten that Messrs. Gibson had produced one of these plugs in a size to fit H.T. sockets, and I have no doubt that my reader is right in pointing out their suitability, for the material and workmanship are good, and no doubt they would not require that constant opening with the blade of a knife necessary with the cheap and poor variety of plug. Nevertheless, I still feel that something more positive is needed in the way of contact than that which is provided by a split pin, however good

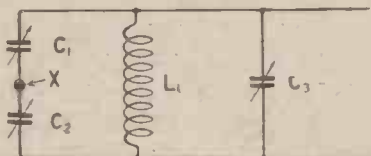

Fig. 1.—An electrical centre-point, X, can be obtained by adjusting C1 and C2.

the latter may be, since it is necessarily very small to fit the standard sockets.

Earl Russell's Method

I see that in another column the Earl Russell describes his method of making sure of a really good and silent contact, and this seems a very promising one. Perhaps we shall see something of the sort fitted as standard to H.T.B.'s ere long.

Another promising device is the special spiral plug now produced by

Messrs. Autoveyors, of Clix fame, a test report of which appeared recently in "Components We Have Tried."

What is Wanted

Although these various devices may, in themselves, be perfectly effective, however, they seem to me merely palliatives. The problem really calls for an approach from the other end, i.e., by the provision by the battery makers of something better than the fiddling little sockets to which we are accustomed.

A Neutralising Tip

I recently described in *Modern Wireless* a circuit modification for the Tropadyne oscillator of my "Open Air" superheterodyne which appears to have aroused a certain amount of interest. It was a method of making a centre tapping upon a circuit by means of an arrangement of con-

AN AERIAL TIP

Is your mast stayed with steel wires? If some of them are of considerable length and run close to the aerial wire itself (or the down-lead, of course), it is quite possible that they may cause trouble, especially in short-wave reception. Try the effect of breaking them up into two or three short lengths with insulators.

densers instead of a direct connection to the middle of a coil, which seems capable of application to various neutralising schemes.

An Application

For example, it answers the needs of various people who have wished to try the type of neutralised circuit used in the "Elstree Six" in an existing set where no double condensers are available. The scheme uses what is, in effect, two small condensers in series across the coil, independently of the tuning condenser. If these two condensers are of equal capacity the common point between them can be regarded as a centre-tap on the circuit, and can be so used.

Fig. 1 shows how the scheme can be arranged with two small separate condensers, C₁ and C₂, in series. Here X is the centre point, and C, the tuning condenser.

A Simplification

Now, this arrangement can be simplified by using a special condenser to combine C₁ and C₂ into one component.

What is required is a condenser with the usual moving plates and two sets of fixed ones, so arranged that the moving set engages more or less with one or the other of the fixed. Such a condenser is represented in Fig. 2, where M denotes the single set of moving plates, F₁ and F₂ the two sets of fixed ones.

Simultaneous Variations

The effect is exactly the same as that of the two separate condensers in Fig. 1, except that movement of a single knob now produces a simultaneous increase in the capacity of one of the series condensers and decrease

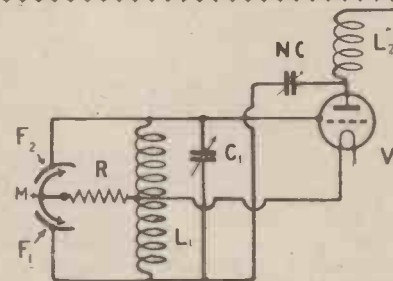

This diagram shows how the neutralising device suggested by Mr. Kendall can be applied to such a circuit as the "Elstree Six."

in that of the other. The diagram Fig. 2, shows how a complete grid circuit and neutralising scheme could be arranged on the lines of the "Elstree Six" circuit, using one of these special condensers, whose size, by the way, need only be quite small.

Friction-Drive Dials

I have just been making up an absorption wavemeter for my own use, and in doing so came across a point about slow-motion dials which seems worth passing on. I had carefully chosen a dial with clear and fine scale divisions, an accurate-reading pointer, and a friction-drive motion which seemed reasonably free from back-lash, and expected to have no difficulties with this part of the instrument.

A Surprise

To my disgust, however, I found when all was finished that the functioning of the slow-motion drive was most erratic—sometimes it would act properly and at others one could turn the knob without producing the slightest movement of the condenser plates. The reason was that the condenser moved somewhat stiffly, and there was not a sufficient grip in the friction mechanism to drive it; the friction surfaces simply slipped. Moral: If your condenser moves stiffly be careful how you choose a slow-motion dial.

NEXT WEEK

SPECIAL ARTICLE BY
Lt.-Comdr. KENWORTHY, R.N., M.P.

WILL REFLEX CIRCUITS COME BACK?

(Continued from page 155)

various important improvements. In spite of these, however, the article of about a year ago which I have referred to was pessimistic in tone, and this was largely due to the fact that we had reached our limit in reflex designs. Moreover, there were such great prospects for the perfectly straight type of circuit that our attention was side-tracked.

A Vital Problem

My great aim recently has been to get the Elstree Laboratories (which serve this journal and *Modern Wireless* and *The Wireless Constructor*) on to the greatest problem of modern times—selectivity plus long range. We can say to-day that we have achieved an entirely new standard in high-frequency amplification by the use of special neutralising means. The "Elstree Six" is merely one type of receiver which is the result of a great deal of experimental work on circuits and designs, and while these two aspects of radio are mentioned, I would like to emphasise the extreme importance of design work as distinct from circuit development. Many of these new sets which will be coming along will be the result of months of experimental work in transforming a given circuit into a complete receiver.

Possible Developments

Having reached such a high degree of efficiency in straight circuits, and there are many very important facts to give our readers in future issues of our journals, I was determined to encourage the fullest investigation as to how we can apply what we have learnt to the production of entirely new reflex sets.

The work already achieved shows that vast improvements are possible in the direction of:—

- (1) Selectivity.
- (2) High-frequency amplification.
- (3) Long range.
- (4) Simplicity of operation.
- (5) The cutting out of radiation from the aerial while using full reaction.
- (6) The development of a reaction adjustment which, while not causing radiation, is easily operated.
- (7) The complete elimination of the tendency of reflex circuits to buzz.

These extraordinary developments in reflex receivers have already been attained, although the actual methods will remain private until published in this journal.

"Elstreflex" Circuits

The final circuits will be called "Elstreflex" receivers. The general opinion hitherto held has been that neutralising methods cannot be applied to reflex circuits properly, and (Concluded on page 178.)

Have you a **CRYSTAL SET?**

Why not exchange it for a Loud Speaker Valve Set? We need not emphasize the advantages—you know them!

Read this:



Absolutely complete, including Loud Speaker, Phones, D.E. Valves, Batteries, Leads, Aerial, etc., etc.

For a few weeks only, to quickly introduce the new, powerful General Radio Broadcast Receivers into various sections of the country, we will accept in part exchange any type of Crystal Set with phones, and allow one pound for same.

Not only that, but—

The balance is payable by twelve monthly instalments of 20/- each only.

And too—

Our Receivers will be installed by our Direct Representatives, anywhere, free!

This offer is limited to a certain number of sets, Full particulars free and without obligation—ask for booklet W. Write NOW to avoid disappointment.

GENERAL RADIO COMPANY, LIMITED, Radio House, 235, Regent St., London, W.1

TRIOTRON VALVES Why pay 14/- for Dull Emmitter Valves? Special 14-day offer of the wonderful Triotron Dull Emmitter Valves. 2 amp 2 volts, 5/6. .06 amp 4 volts, 4/6. Power Valves, 10/6. Post free. Cash refunded if not satisfied. H. E. NICHOLLS, 29-30, Trinity Sq., London, E.C.3

VALVES Repaired Quick
Let our valve making plant repair your broken or burnt out valves efficiently & promptly (most makes). Guaranteed equal to new. Bright emitters 5/-; "D.E."s and 3v types, 7/6. Power valves slightly more, see list. Not repairable: S.P.s WECCO v.34.
RADIONS Ltd., Bollington, Nr. MACCLESFIELD, Ches.
Largest valve-repairing firm in the world. List Free.

EARTH FAULTS ENDED
Entirely new method of Earth-system efficiency. 20 per cent. to 200 per cent. increase guaranteed. Vastly superior to all metal sulphates. Ideal for all outdoor Earths. 2/6 complete, post 6d. Cash on delivery if desired. Particulars free
J. W. MILLER, 68, Farringdon St., E.C.4.
Phone: Central 1950. Approved by Radio Association.

EASY PAYMENTS
We supply ANY MAKE of COMPONENTS by easy payments—ANY MAKE of ACCESSORIES—ANY MAKE of SETS
In fact, everything Wireless that is on the market 10% down. Balance spread over one year.
Send list of requirements to
LONDON RADIO SUPPLY COMPANY, 11, Oat Lane, London, E.C.2
Phone: City 1977.

2-VALVE AMPLIFIER, 35/-
1-Valve Amplifier, 20/-, as new; Valves, D.E., .06, 7/- each; smart Headphones, 5/6 pair; new 4-Volt Accumulator, celluloid case, 13/-; new 60-Volt H.T. Battery, guaranteed, 7/-; 2-Valve All-Station Set, 24. Approval willingly.
R. Taylor, 57, Studley Rd., Stockwell, London.

TRAVELLERS calling upon Wireless Factors wanted to represent good selling wireless novelties. State area covered, and apply to—Box A. 42, c/o WIRELESS, Bush House, Strand, London, W.C.2.

All communications regarding advertisements should be addressed to:

The Advertisement Manager,
"WIRELESS,"
Bush House, Strand, London, W.C.2
Telephone: City 9911.

All Post Free At Callers Prices

S.O.S. BATTERY TESTER. 3-Bead Type, Only 3/6. If full or empty 3/6.	Reliability Condensers Mans. Type. 25. 1/6 1.2/6 1.5/6 2. 3/6	WIRELESS CABINETS For Panels 7" high. With 3" Hinged Lid. Oak 12"; 14/6; 14"; 15"; 16"; 16"; Mahogany. 1/- extra.
SQUARE LAW BRITISH WIRES. VAR. CONDENSER. (Swg. doc. dsc. Matt. 1/2 3/6 1/2 3/6 1/2 3/6 1/2 3/6) With Knob and Dial 18 .. 1/11 3/6 9x6" 2/2 1/10 .001 Panel type 6/8 20 .. 2/2 4/2 12x9" 4/6 3/9 .0005 5/-; .0003 4/6 22 .. 2/6 4/7 12x12" 5/6 6/- Vernier Slide ex 1/4 24 .. 2/11 6/- 15x9" 5/6 4/9 D u b i l l e s, 28 .. 3/4 5/9 15x12" 7/6 5/8 McMichael, Edison 28 .. 3/9 6/6 4x4" 8d. 6d. Bell, Lissen, Mull-30 .. 4/10 7/6 7x5" 1/6 1/2 Lard, Watmel, 32 .. 5/6 8/9 6x6x1" 10d. Igranic - Freshman 38 .. 8/- 13/- Any Size Cut. Usual prices. 40 .. 17/- 20/- Sq. in. 1" 1/4; 1" 1/2.	RELIABILITY WIRELESS GUIDE, No. 2. Free on Request.	RELIABILITY WIRELESS GUIDE, No. 2. Free on Request.

J.H. TAYLOR & Co
11, RADIO HOUSE, MACAULAY ST., HUDDERSFIELD
Tel: 341. Grams: THOROUGH HUDDERSFIELD

LUSTROLOX
WIRELESS VALVES
THE ECONOMICAL COMBINATION.
2V '06 H.F. & L.F. each 9/-
2V '34 P.V. - - - 11/-
Obtainable from LEWIS'S LTD., Liverpool and Manchester, & LUSTROLOX LTD., West Bollington, Nr. Macclesfield.

SPECIAL OFFER OF BLOW-LAMPS
strongly made, size 4 x 3 1/2. Gives powerful flame, removes paint, etc., solkers without iron. Simple, safer economical. Worth 3/6. Satisfaction guaranteed or money back, 1/6 each, 3 for 4/-, post free. Trade Enquiries Invited.
POST FREE 1/6
WILKINSON & SON, 24, North Road, Clapham, S.W.

Valves Repaired AS GOOD AS NEW!!
(Except Weeco, S.P.s and low capacity types.) Minimum D.E. Current 0.15 amps when repaired.
ALL BRIGHT & DULL EMITTERS Listed at less than 10/-.
Minimum charge - - - 5/-
VALCO LTD. Dept. W., Tabor Grove, Wimbledon, S.W.

CONSISTENT RESULTS FROM THE LOCAL STATION
(Continued from page 152)

operate if the following notes are observed. First connect up the aerial and earth in the manner desired, plug in the coils to be used, plug in the valve, and connect up the batteries to the terminals indicated. Put the filament switch "on," having the filament resistance in a suitable position, and the reaction coil at right-angles to the aerial coils. The variable condenser at this stage should read 0 deg. (moving vanes all out): Tune with the variable condenser until signals are heard, and at the same time gradually increase reaction. As soon as a rustle, a click or a howl is heard detune hastily, as this indicates that the set is oscillating.

Get the best results by adjusting the filament resistance and the variable grid leak. The filament switch eliminates the necessity of making repeated adjustments of the filament control, and also of disconnecting the batteries when the set is not in use. Once the best position is found for the variable grid leak, the adjustment may remain fairly constant.

Author's Test Report

The set worked excellently on an indifferent aerial situated some seven

the loud-speaker, speech was plainly audible all over the room. This volume was obtained without any noticeable distortion. If the 'phones were to be used comfortably the set had to be detuned for this purpose. A more detailed report will appear next week, with further operating notes.

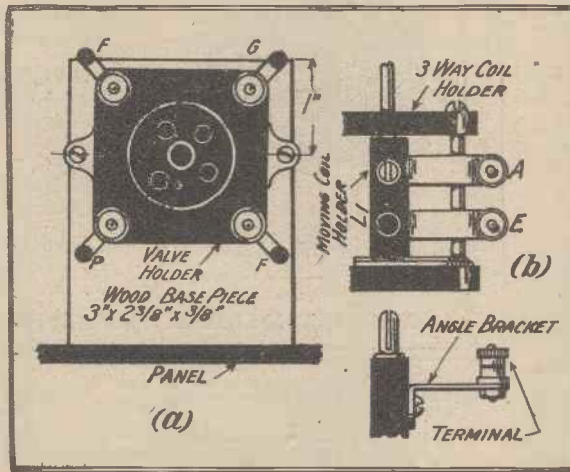

Fig. 5.—This sketch provides the necessary dimension and details for mounting the valve socket and adding the extension pieces to the coil socket.

miles east of 2LO. Signals were overpowering from the local station upon the headphones, and when replaced by

REMARKABLE RESULTS IN FINLAND

SIR,—Since writing you some time ago, giving my results with the "Three Valve Dual" circuit, I have built a low-loss crystal receiver with a "Three-Step" coil described in WIRELESS by Mr. G. P. Kendall, but with 16 threads to the inch, and again feel I must let you know the wonderful results I am obtaining.

Besides the Helsingfors stations, 522 and 440 m. (0.5 kw.), at a distance of 14 miles from Bobäck, I received the following foreign stations at various strengths from R1 to R4: Prague, Münster, Warsaw, Koenigswusterhausen, Oslo, Stockholm, Berlin, Karlsborg, Hamburg, Königsberg, Vienna, Moscow, Sundsvall, Daventry.

Thanking you for your excellent circuits, and wishing you every success.

I remain, yours faithfully,

E. MATSON.

Bobäck, Finland.

2 volt .3 amp.

Try this Valve it's cheaper —but above all much better



The Frelat Valve makes Radio Reception a much less costly thing. The Frelat is listed at the remarkably low price of 4s. 11d. We claim that it is the finest 2-volt Valve on the market and thousands of satisfied users are proving our claim daily. Next time specify Frelat. If your Dealer cannot supply send P.O. 4s. 11d., or request delivery C.O.D. THE CONTINENTAL RADIO IMPORT CO., LTD., 8, SPITAL SQUARE, LONDON, E.1.

4/11



WIRELESS AND THE STRIKE

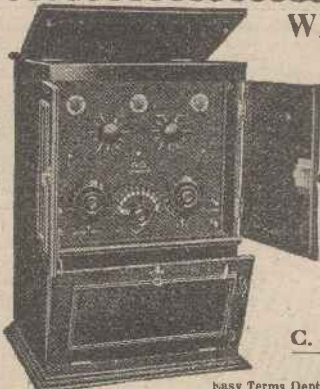

The recent crisis must have proved to everyone that a RELIABLE AND EFFICIENT radio set is a NECESSITY in every home, and DUNHAM'S SETS ARE A VALVE AHEAD OF ANY OTHER MAKES. BUY YOUR DUNHAM RECEIVER TO-DAY ON OUR SPECIALLY EASY REDUCED TERMS. Complete installations from 8/6 monthly. NO DEPOSIT REQUIRED.

Send 2d. stamps for new catalogue of our 14 different models. Your own receiver taken in part exchange if desired.

C. S. DUNHAM, RADIO ENGINEER

(Late of Marconi Sc. Inst. Co.)

Easy Terms Dept., 234-S, Brixton Hill, London, S.W.2

A NEW BOWYER-LOWE PRODUCT EMBODYING ALL BOWYER-LOWE REFINEMENTS & CRAFTSMANSHIP JACKS

The design of Bowyer-Lowe Jacks was evolved to obviate faults usually apparent in Jacks adapted from telephone uses. The following details indicate the superiority of these Components:

1. Girder frame, ensuring rigidity.
2. Hard phosphor bronze springs (tinned).
3. Silver contacts accurately positioned.
4. Ebonite insulation.
5. No loose panel washers.
6. Wide lanial contacts.

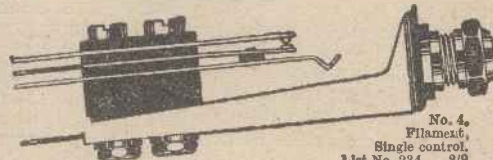

No. 4. Filament, Single control. List No. 234 ... 2/9

PRICES.

- | | |
|--------------------------------|----------------------|
| No. 1—Single circuit, open | List No. 231 ... 2/2 |
| No. 2—Single circuit, closed | List No. 232 ... 2/7 |
| No. 3—Double circuit | List No. 233 ... 3/- |
| No. 4—Filament, single control | List No. 234 ... 2/9 |
| No. 5—Filament, double control | List No. 235 ... 3/3 |

USE BOWYER-LOWE
Tested Components They are Guaranteed

(Announcement by the Bowyer-Lowe Co., Ltd., Letchworth.)



JOTTINGS BY THE WAY By Wireless Wayfarer

This week "Wireless Wayfarer" describes how these pages first came to be illustrated.

Hot Water



THOUGH nearly every-one has been delighted with the illustrations which have decorated these pages, I am sorry to say there are excep-

tions, and you will not be long in guessing that they are to be found amongst the members of the Little Puddleton Wireless Club. It is a curious thing in this world that few people are pleased by their own portraits. Photographers, as you know, make their money by giving a downward-turn to tip-tilted noses, by rounding off those whose hook is too pronounced, or by restraining those

up General, a whittled-down Poddleby, or a hirsute Professor Goop might be things of beauty, but they would not be real; there would not be in them that technical accuracy upon which Radio Press has always prided itself.

First Catch Your Artist

This being so, it was desirable to capture an artist man who would draw things and people as they really were. Having caught him I took him down to Little Puddleton in disguise, and introduced him to the wireless club as a distinguished foreigner unable to speak a word of English. The General, of course, tried him in Hindustani, and the Admiral in both Fijian and Chiuese. Poddleby asked "Kommong

one do with a fellow who does not recognise his own language?

Portraiture

Well, as I was saying, I took the artist man to the meeting, and as he was apparently unable to understand a word of anybody else but myself, no one bothered him and he was able to make faithful sketches from life of all our members. Luckily there happened to be a full house that night, and the heading at the top of this page depicts the scene as he saw it when the General was about half-way through his most enlightening paper, proving that the presence of coiled-up earth worms round the earth plate in winter time increases enormously the natural

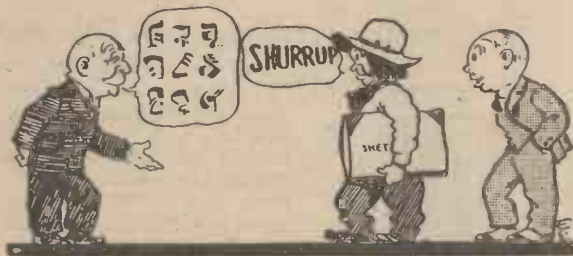

" . . . The admiral tried him in both Fijian and Chinese . . . "



" . . . It is a curious thing in this world that few people are pleased by their own portraits . . . "

which show a tendency to err and stray in all directions over their owners' countenances.

Technical Accuracy

Other tricks of the trade are to remove wrinkles, to whitewash red noses, to cover bald patches with hair and (where the victim is a very young man) to produce a Charlie Chaplin moustache on a virgin upper lip. The resulting portraits are, of course, far less revolting than the sitters themselves, and the fact that there is anything but likeness does not matter in the least. When it was decided to present to your admiring gaze portraits of the Little Puddleton celebrities, it was agreed that mere photographs would not do. A touched-

voo portey voo?" whilst Snaggsby, after taking a few hectic moments to get under way, launched upon him a flood of what he averred to be Russian, though it sounded far more like the remarks of a hen who has just become a proud mamma.

I explained that he was a Czecho-Slovakian, and conversed with him airily in French, which nobody recognised. Honestly, I don't blame them. Not long ago I strolled into a wireless shop in Paris, explaining in fluent French that I wanted a variable condenser. I did quite a lot of talking about plates and capacities and insulation and that sort of thing, and then, if you will believe me, the man said: "Pardon, M'sieu, je ne comprende pas Americain." What can

wavelength of the aerial-earth system owing to the added inductance provided by their convolutions.

Distinction

Owing to the presence of the artist man as my guest I had hardly had an hour's sleep all day, so that you will quite understand the attitude of the distinguished member of the audience shown about half-way down the table. You will admit, I think, that taken as a whole we are not at all a bad looking lot. I do not mean to say that I claim as a body we would carry off many prizes in a seaside beauty competition, but at the same time there is about us a distinct air of character, of purpose, of intel-

(Continued on page 176.)

Jottings by the Way—continued

lectuality and of cerebral force. Anyhow, just take a look round your wireless club the next time you meet and ask yourself candidly whether you, as a crowd, are in the same street. The answer to this question will, I think, be in the interrogative.

Good Intentions

No, I thought that with one exception the portraits made by the artist help, saying that he has hardly done justice to one very modest member of the club, whom it will not be necessary to name. I will only add that in his infancy he was frequently referred to by dear old ladies as a beautiful baby, and that except for one unfortunate accident with a steam-roller his features have undergone no change worth talking about since that time. However, I am not going to kick. I only wish I could say the same of the General and of other members of the club.

When I strolled in two or three nights ago with a bland smile and a strong desire to borrow a couple of valves from somebody, I was aware of a sudden frigidness in the atmosphere. As I entered the buzz of conversation suddenly ceased. There was a moment's pause, and then everybody started talking very hard at the same time. "Twenty past eight," I said. "Funny how these silences always happen at twenty minutes past the hour," I laughed. Nobody else laughed. I stopped laughing. "Evening, General," I said, "how are things with you?" "Grrmph," replied the General. "That's a nasty cold of yours," quoth I with a sympathetic smile. "I should try Sister Susie's soothing syrup if I were you." "Mphgrrmph," was the only answer I got. Imitations of the Zoo animals appeared to be the General's stunt that night, and falling into his vein I gave them first of all the sea lions, then feeding time among the chamois, and finally the laughing jackass. "Thank you very much," said Poddleby, whom I had not observed before, "that last item was most appropriate, in fact one feels that you must have some of the genuine blood in your veins to do it so well." I was about to squash Poddleby when the whole lot turned upon me and asked what the deuce I meant by it.

Base Ingratitude

"Mean by what?" I asked indignantly. "You know well enough," came the chorus. "Who drew those infernal sketches to illustrate the tripe you write?" I explained that

they were done by one of the most distinguished wielders of the pencil, who had actually visited the club in disguise, and had portrayed its members exactly as they were. I added that I thought with the exception of my own they were all jolly flattering portraits, and that there was not a man in the room who ought not to be exceedingly pleased with his picture. I had simply a dreadful time with them.

Even Professor Goop, my colleague

slaughters which they have brought down on their own heads.

Dignity

For the last few days I have given the wireless club rather a cold shoulder. I passed the door of the club house only the other evening when Snaggsby and Gubbeworthy were standing on the step. To show my complete disregard of all of them I simply buttoned up my coat, straightened my tie, and drew a toofer from my gold (rolled) cigar case, lit it, and passed by with an expressive shrug of my Douglas Fairbank's shoulders. Out of the corner of my right eye I saw both of them wilt perceptibly. This strong, square-chinned hero stuff always pays in the end.

I got in rather a nasty one, too, on Winklesworth and Bumbleby Brown in one of our wireless shops the other day. They were there as I walked in, but except for a majestic nod I took no notice of them at all. "Good morning, Mr. Scratchitt," I said, "I want a gridleak of the best quality." This is the first component that I have bought in Little Puddleton, and I could see at once that both of the members of the wireless club were pained that I had not borrowed from them.

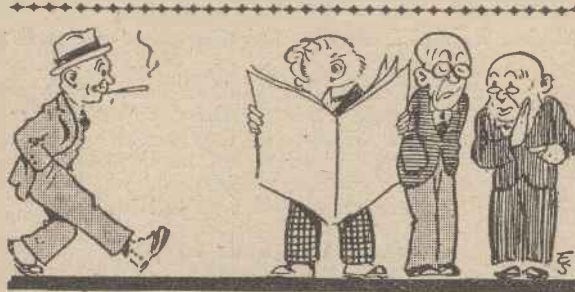

“. . . I stopped laughing . . .”

in designing so many intricate and wonderful circuits, turned upon me and denounced me in the roundest terms as all kinds of dreadful things. Now, I think you will agree that there are times when discretion is the better part of valour. Put me in face of terrible odds and I will show you that I possess a true lion's heart if it is worth while to show my grit. But there is also a very excellent little rhyme which says:—



“. . . Saw both of them wilt perceptibly . . .”

He who jabs and runs away,
Will live to fight another day.

So I jabbed and ran. I just said: "I think you have all been very much flattered, but if you have got a complaint to make you can jolly well make it to the Editors, and not to me." After all, what is the good of having Editors if you do not make proper use of them? Editors simply sit in comfortable chairs, order people about, and draw enormous salaries; there is, so far as I can see, no reason why they should not bear the brunt of on-

International Programmes

On the evening of Wednesday, June 9, a new departure in radio programmes was inaugurated. A programme arranged in Norway, comprising Norwegian music and literature, was "S.B." from eleven countries. 2BD undertook the job for Great Britain. We understand that this plan has found great favour with the International Radio Office at Geneva, which is, of course, aiming to bring about a better understanding between the peoples of Europe by International Programmes of this kind.

**"MODERN
WIRELESS"**

JULY ISSUE

ON SALE JULY 1.

Order Your Copy Early.

HAVE YOU EXPERIENCED

?

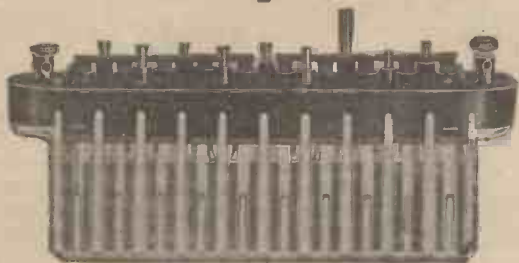

HAVE YOU EXPERIENCED parasitic noises and "mush" marring your reception? Does your loud-speaker whirr and crackle?

Noises such as these are due to fluctuations in the voltage of the H.T. supply, and the slightest variation is magnified enormously.

THE ONLY CURE is the accumulator H.T. battery, and the "DUROS" H.T. ACCUMULATOR IS THE BATTERY BUILT FOR THE JOB.

DON'T SCRAP - RECHARGE!

THE "DUROS" HIGH TENSION ACCUMULATOR UNIT ILLUSTRATED ABOVE IS THE SOLUTION TO THE ANODE CURRENT PROBLEM. 20 VOLT UNIT—12/- 10 VOLT UNIT—6/- A. F. A. ACCUMULATORS, LTD., 9A, DIANA PLACE, EUSTON RD., N.W.1

SUBSCRIPTION RATES

FOR RADIO PRESS JOURNALS.

MODERN WIRELESS

15/- per annum United Kingdom.
13/6 per annum Canada and Newfoundland.
15/- per annum Other Countries.
Lesser periods than 12 months pro rata.

THE WIRELESS

CONSTRUCTOR

8/6 per annum United Kingdom.
7/6 per annum Canada and Newfoundland.
8/6 per annum Other Countries.
Lesser periods than 12 months pro rata.

WIRELESS

(Incorporating Wireless Weekly)

13/- per annum United Kingdom.
13/- per annum Canada and Newfoundland.
13/- per annum Other Countries.
Lesser periods than 12 months pro rata.

THE WIRELESS DEALER

(Available to the Trade only)

7/6 per annum (10/- abroad).

N.B.—Business letter heading or trade card must be sent with subscription.

RADIO PRESS LIMITED,
Bush House, Strand, London, W.C.2

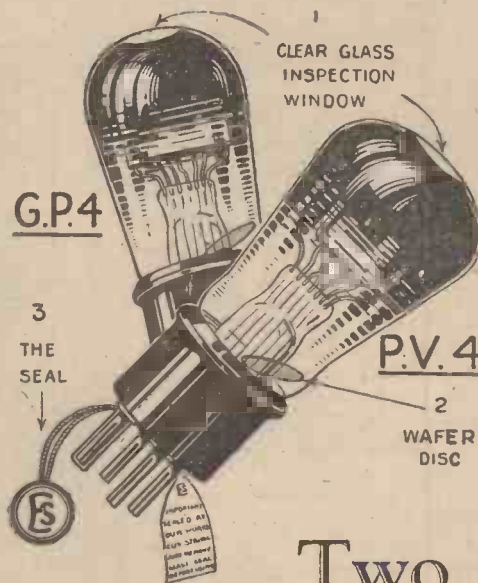

Two New Valves

WHICH ESTABLISH A NEW STANDARD OF EFFICIENCY

EDISWAN—originators of the radio valve—now take reception a definite step forward. Here are two new DULL EMITTER valves—G.P.4 and P.V.4, with characteristics so decidedly superior that a new standard of valve efficiency is established.

You will identify G.P.4 and P.V.4 by these special features: (1) The Clear Glass Inspection Window; (2) The Wafer Disc; and (3) The Seal.

For detailed description and full specification obtain from your Dealer the Ediswan Folder—"Two New Valves."

G.P.4.—General Purpose dull emitter. Low current consumption. Long Life. Powerful amplification. Elimination of objectionable microphonic effects.	P.V.4.—Ideal power valve, companion to G.P.4. When used for Loud Speaker work: powerful, distortionless amplification. No microphonic effects.
--	--

*Both valves work off 4-volt accumulator

EDISWAN VALVES

Will improve any set

THE EDISON SWAN ELECTRIC CO. LTD
123-5, Queen Victoria Street, LONDON, E.C.4

AMATEUR TRANSMITTING NOTES

QRA's Found

SMRG: Gosta Siljeholm, Kristianstad, Sweden.

AI-1CW: (Ex DA-1TA) Capt. Filippini, Governo, Tripoli, Africa.

TUN2: G. Solet, Radio Club de Bizerte, P.O. Box 72, Bizerta, Tunis.

I-ICE: E. Caudiana, Badia, Rovigo.

EAR 23: Juan Portela, Cervantes 10, Cadiz.

O-Z3A: L. Robinson, Box 88, Luderitz, South-West Africa.

SS-2SE: R. E. Earle, Electrical Engineer's Office, Keppel Harbour, Singapore.

ANDIR: Dutch East Indies Military Air Force, Andir, Bandoeng, Java.

D-7MT: E. Poulsen, 6 Virginiavej, Copenhagen, Denmark.

We hear from Mr. A. A. Santos (BZ-6QA) that the call-signs PT1, PT2, PT3, etc., belong to Brazilian Army stations, all working regularly on short waves. The QRA's are as follows:—

- PT1: Rio de Janeiro.
- PT2: Bahia Blanca.
- PT3: Pernambuco.
- PT4: Ceara.
- PT5: S. Luiz do Maranhao.

"CARTOONIGRAFS" COMPETITION No. 7

FIRST PRIZE

The Curtis "Double Circuit Superhet Eight" With Valves

Value - £51 5 0
(Presented by Messrs. Peter Curtis, Ltd.)

SECOND PRIZE

60 Volt "A.F.A." H.T. Accumulator

In Crate
(Presented by A.F.A. Accumulators, Ltd.)

THIRD PRIZE

Three "Voltron" Dull Emitter Valves

(one "LS2" and two "202's")
(Presented by Messrs. The Voltron Company)

FIFTY CONSOLATION PRIZES,

Consisting of **RADIO PRESS HANDBOOKS**

Further particulars and illustrations of these prizes will be given in our next issue.

See page 154

QRA's Wanted

R-FF9, R-FC6, YST, NORB, SQ1Q, NRK, XC51, A-4VS, KEL, MF-8MA, P-RXY, U-NIDK, M-1J, BZ-9QA, B82, G-2CRX, G-6EW.

WILL REFLEX CIRCUITS COME BACK?

(Concluded from page 173)

that a loss of high-frequency amplification immediately results, and an upsetting of the balance so necessary to obtain proper high-frequency amplification. This statement is largely correct when ordinary methods of neutralising are used, but very special solutions of previous troubles are being investigated under my general direction at Elstree, and preliminary results indicate that readers of WIRELESS will find in the "Elstreflex" a great and important development.

"DX RECEPTION MADE EASY"

In the course of its tests at the Elstree Laboratories it was found that the two-valve set described under this title last week gave good telephone signals from Bournemouth, Birmingham and Newcastle. Oscillation proved easy to control, C.A.T. being desirable with the aerial used.

On Guard!

There is no leakage with a "Lotus" Buoyancy Valve Holder on guard.

Immediate and lasting connection made when valve pins enter valve sockets. The leg socket expands and automatically locks.

Absorbs shock, protects the valves and eliminates all microphonic noises.

LOTUS
BUOYANCY
VALVE HOLDER
ANTI-MICROPHONIC

Made from best bakelite moulding with springs of nickel silver and phosphor bronze valve sockets.

Garnett, Whiteley & Co., Ltd.,
Lotus Works, Broadgreen Rd., Liverpool.
Makers of the famous "Lotus" Vernier Coil Holder.

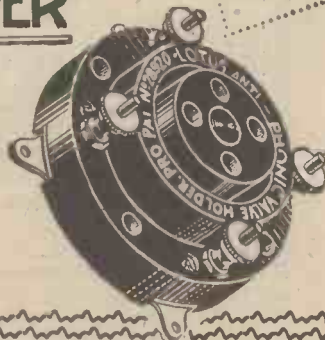

Without Terminals
2/3

With Terminals
2/6



THE "PEERLESS" DUAL RHEOSTAT

3/9

From Dealers or direct.
Trade Terms on request.

THE BEDFORD ELECTRICAL & RADIO CO., LTD.
22, Campbell Road, Bedford.

One Rheostat for both dull & bright emitter valves!

Made specially to meet demand for a rheostat covering needs of both bright and full emitter valves. Two windings, one of a resistance of 6 ohms, and a continuation of this on to a 30 ohm strip winding. Resistance wire wound on hard fibre strip under great tension and immune from damage. One-hole fixing, terminals conveniently placed. Contact arm has smooth silky action. All metal parts nickel-plated. Complete with ebonite combined knob and dial.

TEMPRYTES
(Registered Trade Mark)

The Perfect Control for all Valve Filaments. Manufactured in values to suit all valves. From 3 to 55 ohms.

2/6 Holder Mountings for TEMPRYTES. EACH 1/8 each.

CYLDON
(Pronounced SIL-DON)

GROUND ROTOR CONDENSERS

The absolute pinnacle of Condenser Perfection.

.001 mfd. 21/- each	.0002 mfd. 15/8 each	.0005 mfd. 15/8 each	Large 4 in. Knob Dial.
.0005 " 27/6 "	.0005 Dual 27/6 "	.00035 " 15/- "	as supplied with Square
.0008 " 18/6 "	.0008 " 25/- "	.00025 " 14/6 "	Law Condensers 2/- ea.
.00025 " 18/- "	with 4 in. Knob Dial.		

From your dealer or sent post free from the makers:
SYDNEY S. BIRD & SONS,

"Cylidon Works," Barnesfield Rd., Enfield Town, Middlesex. Telephone: Enfield 672.

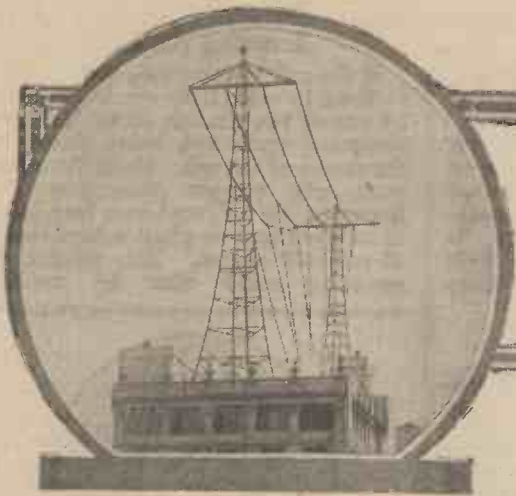

THE LIGHTNING BOGY

By CAPTAIN JACK FROST



H, those atmospherics! They are more prevalent and annoying at this time of the year than they are during the winter time. We notice them more, also, because signals during the long hours of daylight are weaker than during the darker evenings of the winter. But whatever the strength of the signals may be the danger of lightning discharge and its effect on the receiving aerial must be considered and dealt with.

The Warning

The approach of a storm is generally heralded by violent atmospherics which sound like sea waves breaking on a shingly beach. When these sounds are really loud and interfere with reception or when a thunderstorm is in the neighbourhood, it is always best to earth the aerial, which then becomes a protection. To do this the simplest contrivance is an earthing switch which is called a single-pole change-over switch, connected in the way I show in the diagram.

Switch Connections

There are three points of connection upon the porcelain or ebonite block, the centre one having attached to it the knife "blade" which makes contact with the other two connections as it is moved from one to the other.

Connect the lead-in wire from the aerial to the centre or knife-blade screw terminal and the wire from the "aerial" terminal of the receiving set to one of the two end screw connections. Both the earth lead and the wire from the "earth" terminal of the receiving set should be connected to the other end screw connection.

It is preferable to place the whole switch outside the window of the room in which the receiver is standing. Most folk fix it to the wall just outside the window. Never forget, before retiring for the night, to put the switch in the position marked A in the sketch. Likewise, never for-

get before attempting to listen to broadcast to put the switch to position B!

Is the Danger Real?

Electric charges in the atmosphere are spread over sometimes hundreds of square miles of space and they are

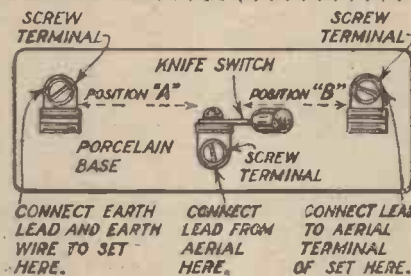

Fig. 1.—If atmospherics are particularly bad, it is only necessary to place the switch arm in position "A," when safety will be assured.

hardly likely to affect a single piece of wire stretched down the centre of someone's garden. Yet there is always an element of chance in it. Your house may be the one in a million which is singled out to be struck by lightning. I maintain that, in such a case, providing that your aerial is properly earthed at the time and that your earth is connected, not through a gas pipe, but through a water pipe or by some other means of direct earth, your aerial will serve rather as a lightning conductor and will tend to protect property rather than damage it. It will certainly not attract lightning which would otherwise not come in your direction.

A Simple Rule

The presence of a storm can always be detected, even when it is not actually overhead: it is quite probable that you know what an atmospheric sounds like. When you hear atmospherics and they sound continuous enough to interfere with reception, and if you are a little nervous of your set being damaged by any charge finding its way to earth through your set, then at that time, why not connect the two leads that run to your set from the aerial and earth respectively, together? Just take the two wires and either bend the two ends together or arrange some method of switching or plugging by which the connection can quickly and safely be made.

Make it a Habit!

A lot of people have an aerial and earth switch of which I have already given you details, together with a sketch. Another useful method is to get into the habit of always connecting your aerial and earth leads together after disconnecting them from the wireless set. Before retiring at



Remote as the chance was, a case of a set being struck by lightning actually occurred and the damage was due entirely to the aerial being used during a storm.

night, even in weather which is not inclined to be at all stormy, it is a good habit to get into because, during the hours of sleep, one never really knows when a storm may arise.

(Continued on page 180.)

THE LIGHTNING BOGY

(Continued from page 179)

Why Trouble?

It may be interesting to note why it is so necessary to take precautions so conscientiously: if you are unfortunate enough to have your aerial struck by lightning whilst it is connected to the instrument, the discharge will naturally go by the most direct route to earth. In other words, via the windings of the coils

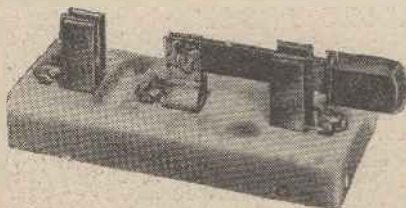

When buying an "earthing" switch, a fairly substantial model should be chosen, and it should be mounted on a porcelain base.

in your set to the earth connection and thence down your earth lead to earth. But what will happen to the windings of your set meantime? Owing to the enormous volume of the electric charge and the "resistance" (speaking rather loosely) of the coils in the wireless set, great heat is generated and the coils fuse—sometimes with a fairly large spark, which might set the inflammable parts of the set alight.

If you take normal precautions you need have no fear. If you find that atmospheric noises are so bad as to interfere with your reception, then just connect your aerial to your earth, either by means of the switch mentioned or by any other method you choose, disconnecting them from the wireless set to do this. This removes the possibility of damage to your set and to anything else. Obviously then, your aerial, connected to your earth will act rather as a safeguard than as a menace.

A "MAGIC FIVE" POINT

A constructor of the "Magic Five" has reported that when he first finished the set he proceeded to test it with the screens removed from the coils, with a view to putting them in place later and noticing whether they made any difference. When he made the test he found that in the case of a weak signal the fitting of the covers caused it to vanish altogether, while a strong signal was very much weakened.

This is perfectly normal; fitting the screens alters the inductance of the coils and necessitates re-tuning on the condensers before the station will be heard properly once more.

MOUNTING BASKET COILS

Various suggestions and ideas for the mounting of ready-wound sets of basket coils have been put forward from time to time, but the undermentioned method may be of interest. It will be found simple to use, few tools being required, and also both cheap and efficient.

The Method

Obtain some 1/16th in. (or thereabouts) celluloid, and cut a strip about 1/2 in. wider than the hole in the centre of the coil to be mounted; the length will be governed by the size of the largest coil in the set. Cut all the strips the same length, allowing 3/8 in. for bending over as a foot, as per sketch.

To bend the celluloid, dip the end into boiling water—for a moment or two, quickly clamp between two pieces of wood, leaving the portion to be bent protruding, and push over the foot-piece at right angles with another piece of wood or something flat. The celluloid will then be found to "stay put."

The Base

This foot is to enable the celluloid to be fastened to a strip of ebonite by two valve pins as sketched, and inserted in the many types of home-made coil-holders previously described in these pages. A celluloid disc is next cut slightly larger than the centre of the coil and pierced in the middle, a corresponding hole being pierced in

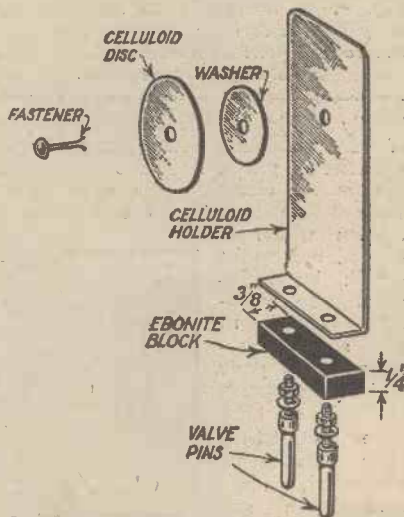

Fig. 1.—Few tools are required in the construction of these simple coil mounts.

the other strip. A paper fastener is then inserted through both pieces of celluloid, clamping the coil between, the ends of the coil being connected in the usual manner.

Securing the Coil

If the coil is not steady enough and inclined to move, this can be obviated by one or two washers of celluloid, or shellacked cardboard, being placed in the centre of the coil. No doubt other ways will suggest themselves for fastening the coil, such as a bent strip of celluloid kept in position by a touch of celluloid cement. This method of mounting could also be readily

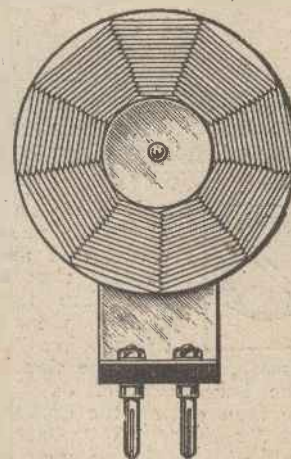

Fig. 2.—The coil is mounted in such a way that no damage is done to the winding.

adapted for use with the standard plug and socket. A glance at the sketches should make all the details clear.

M. H.

WHERE ARE THOSE SUMMER PROGRAMMES?

(Continued from page 158)

already received a fair amount of discussion, that is the question of "echo." It is my personal experience that when a loud-speaker is used in the open music tends to sound flat and dead unless a fair amount of echo is present. The difference between studio and outside broadcasts shows up very markedly on a set being operated in the garden.

There is an old proverb which says that "He who pays the piper calls the tune," or words to that effect. It is the listener who pays for the broadcast service, but the difficulty is to get him to call. Many people to whom I have spoken on the subject are in agreement with the views I have outlined here, but when I say "Why don't you write to the B.B.C. about it?" the reply is almost invariably "Oh! it's too much bother." or else "What is the use of one person writing up?"

"The Wireless Constructor."

Have you got your copy of the July Number?

6d. On Sale Everywhere 6d.

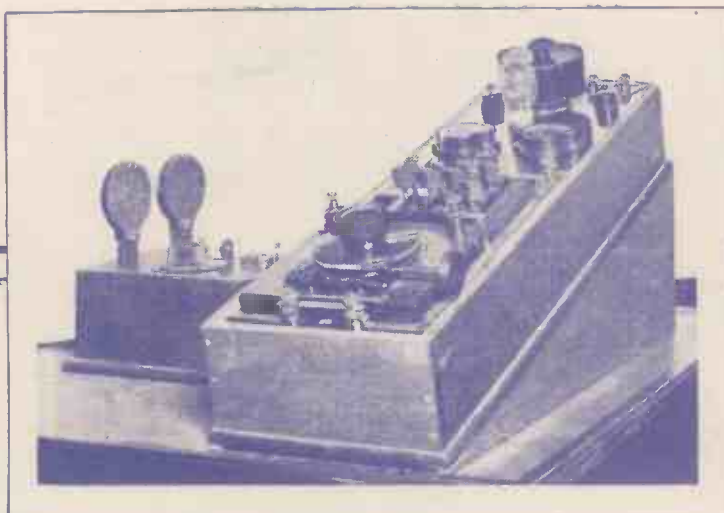

The photograph shows the famous Quartz Crystal Controlled Wave-meter at our Elstree Laboratories, where apparatus sent by manufacturers is tested.

THE NEUTRODYNE

Every dealer should read how vital receiver patents went to America

The universal importance of the inner history of the Neutrodyne—how a British invention, the priority of which has been definitely established, was unknowingly sold to an American Corporation—provides not only reading of extraordinary interest but authentic patent information on the Neutrodyne situation.

This striking article appears in the June issue of THE WIRELESS DEALER which also contains many other important articles on diverse matters of commercial interest.

THE WIRELESS DEALER—the pre-eminent Trade Organ of the Radio Industry—is produced by Radio People for the Radio Trade alone—a subscription will keep you abreast of your competitors.

Use the Advertisement pages of THE WIRELESS DEALER for your business announcements.

All communications regarding "space" should be addressed to The Advertisement Manager, THE WIRELESS DEALER, Bush House, Strand, London, W.C.2.

Subscription rates 7/6 per annum (10/- abroad), post free, available only to bona fide members of the trade. Business letter heading or trade card should accompany every subscription.

WRITE TO THE SALES MANAGER NOW FOR SPECIMEN COPY.

RADIO PRESS LTD.

BUSH HOUSE, STRAND, LONDON, W.C.2



A NEW 2 VOLT VALVE WITH THE WONDERFUL P.M. FILAMENT

Superior to many 6-volt valves and has up to three times greater emission surface.

Gives better results than any other 2-volt valve in all stages of a receiving set.

Makes each accumulator charge last three times as long.

Embodies the special patented P.M. Filament that cannot be broken except by the very roughest handling.

Is so economical that no sign of glow can be discerned.

THE P.M.1 15/6

(For H.F., Detector and L.F. Operation—2 volts One-Tenth Ampere)

GET ONE FROM YOUR RADIO DEALER.

Ask for particulars of the P.M. Series for 2, 4 and 6 Volts.

Mullard

THE • MASTER • VALVE

ADVT. THE MULLARD WIRELESS SERVICE CO., LTD.
NIGHTINGALE LANE, BALHAM, LONDON, S.W.12.

Published by RADIO PRESS, LTD., Bush House, Strand, London, W.C.2, on Tuesday of each week, and printed for them by THE AVENUE PRESS (L. Upcott Gill & Son, Ltd.), 55-57, Drury Lane, W.C.2. Address for Subscriptions and Editorial Communications:—Bush House, Strand, London, W.C.2. Address for Advertisements:—Advertisement Manager, WIRELESS, Bush House, Strand, London, W.C.2. Registered as a newspaper and for transmission by Canadian Magazine Post. Subscription rates:—13s. per annum, 6s. 6d. for six months, post free. Sole Agents for Australasia:—GORDON & GOTCH (Australasia), LTD. For Canada:—IMPERIAL NEWS, LTD. For South Africa:—CENTRAL NEWS AGENCY, LTD.