

Wireless

VOL.2
JUNE

NO.7
1935

AND TELEVISION REVIEW

PRICE

6^D

The

HEXOVERTER

John Scott-Taggart's

first

**SHORT-WAVE
DESIGN**

for

Home Constructors



Our Astounding Book Offer

Your first five volumes of
THE MASTERPIECE LIBRARY OF SHORT STORIES

Are

NOW READY

Send for them without delay

Token No. 2, to complete your first Gift Voucher, appears in this journal to-day. Send in this completed Voucher AT ONCE, and do not forget that to obtain the second set of five volumes (Vols. 6 to 10) you have to collect

ONE MORE TOKEN ONLY

Follow the instructions given on the Gift Voucher carefully, and do not forget to indicate which type of binding you have selected :

BLUE ART. LEATHER or SUPER DE LUXE

Your volumes are waiting. Completed Gift Vouchers and remittances should be sent to:

*The Amalgamated Press Book Dept.
 (G.P.O. Box 184a), Cobb's Court,
 Broadway, London, E.C.4.*

Enclose P.O. for 10/6 for the five volumes in the Art. Leather binding, or £1 for the Super De Luxe edition.

All applications will be dealt with in strict rotation ; the sooner you apply, the sooner will you receive these magnificent volumes, of which you will be justly proud.



The 1000 Best Complete Tales of All Times and All Countries

No fewer than 600 world-famous and gifted authors provide a lifetime's reading entertainment in the 8000 pages of this stupendous work. Everything in it—an inexhaustible wealth of drama, adventure, comedy and humour—has been written to assure you many an hour of absorbing pleasure and a refuge from worries.

There are nearly 800 pages in each volume, and the whole ten weigh nearly 15 lb. Each of the Thousand Short Stories is from 1000 to 8000 words in length, all stories are complete and unabridged, and foreign stories have been translated into English by experts. Only the world's leading authors are represented in its pages. You and your friends will be proud of this wonder collection of the best complete tales of all times and all countries. The volumes themselves will certainly add grace to any, even the richest, library.

The beautiful Edition shown here is bound in lovely lustrous blue art. leather, with blocked decorative design and embellished with 22-carat gold lettering on both spine and front.



CONTENTS OF VOLUMES 1 to 5

EARLY STORIES	FRENCH AND	ENGLISH STORIES
ITALIAN STORIES	FRENCH-BELGIAN	ENGLISH AND
FRENCH STORIES	STORIES	SCOTTISH STORIES

CONTENTS OF VOLUMES 6 to 10

IRISH AND OVER-SEAS STORIES	RUSSIAN AND AMERICAN STORIES	OLD GERMAN STORIES
RUSSIAN STORIES	AMERICAN STORIES	SPANISH AND PORTUGUESE STORIES
SCANDINAVIAN AND DUTCH STORIES.	WAR STORIES: BRITISH, AMERICAN, FRENCH AND ITALIAN.	INDEX TO WHOLE LIBRARY.

CONTENTS



	Page		Page
The Editor's Chat	3	"Jig Prints" for the	
A.V.C. v. Fading	4	"Hexoverter"	22, 24, 36
The "Hexoverter"	5	New Apparatus Tested	23
The "Hexoverter" Rapid		From My Armchair	25
Construction Guide	17	In Lighter Vein	27
Short-Wave Notes	18	Reality in Reproduction	38
B.B.C. News	19	The Grandfathers' Club	40
Practical Hints for All	20	The German Television Service	42
Questions I Am Asked	21	Seeing The Electrons	42
SPECIAL TELEVISION SECTION		Pages 29-35	
Including:			
Sound and Vision on One Wave!	31	Stroboscopes for Time Bases	34
		Some Practical Aerials	35

As some of the arrangements and specialties described in this Journal may be the subjects of Letters Patent the amateur and trader would be well advised to obtain permission of the patentees to use the patents before doing so.



**PUBLISHED BY THE
AMALGAMATED PRESS LTD.
THE FLEETWAY HOUSE
FARRINGDON ST., LONDON, E.C.4**

Make the best
of a
GOOD Job
with

AVO TESTING ACCESSORIES

Add this NEW boxed kit of "AVO" Testing Accessories to your equipment. Every radio test becomes a quicker,

simpler and SAFER job. Finish, once and for all, with those odd links of nondescript wire with which mistakes are so easily made. Wrong connections when testing are annoying and dangerous.

"Avo" Testing Accessories are made by the makers of the famous "Avo" series of testing meters, but can be used with any meters. Bring your equipment to the expert's pitch of efficiency.

If any difficulty in obtaining write us direct.

Automatic Coil Winder & Electrical Equipment Co., Ltd.

Winder House, Douglas St., London, S.W.1.
Telephone: Victoria 3404-7.

POLAR

TYPE 'C' SHORT-WAVE CONDENSER

Specified Solus for the
HEXOVERTER ADAPTOR

Fast and slow-motion. Double Spacing. All-Brass Silent phosphor-bronze ball bearings.

ONE REQUIRED '00015 .. 8/6

Also made in '00025. Price 9/6, and '0001. Price 8/3.

POLAR and POLAR-N.S.F. PRODUCTS also recommended

- | | | |
|-----------------------------------|------|-------|
| Polar Compax '0005 | ... | s. d. |
| Polar Reaction No. 4 '00015 | ... | 2 6 |
| Polar Micro-Drive Arcuate | ... | 3 9 |
| Polar 'N.S.F. Resistors:— | | 7 9 |
| Two 5,000 ohm ½ watt | each | 1 0 |
| One 5,000 ohm 1 watt | ... | 1 0 |
| Two 10,000 ohm 1 watt | each | 1 0 |
| One 100,000 ohm 1 watt | ... | 1 0 |
| One 1 megohm | ... | 1 0 |
| Polar-N.S.F. Tubular Condensers:— | | |
| One '00005-mfd. | ... | 1 0 |
| One '0001-mfd. | ... | 1 0 |
| One 1-mfd. | ... | 1 4 |



WINGROVE & ROGERS LTD.

188/189, STRAND, LONDON, W.C.2

Phone: Temple Bar 2244. Works: Old Swan, Liverpool

Send now for complete catalogue of Polar and Polar-N.S.F. Products.



AVO TESTING ACCESSORIES

Meter Test Prod Kit
Two (+ & -) insulated Test Prod Holders, which can be easily fixed to any meter leads.

Three Pairs (2½", 5", 7") insulated Flexible Test Prods. Two robust nickel-plated Spring clips to fit above holders.

Handy Connector Kit
Two 3" Connecting Leads, each fitted with crocodile clip and spade tag.
One 6" Shorting Link fitted with spade tags.
One 6" Crocodile Clip Connector.
One 12" Crocodile Clip Connector.



"I would never have believed it was possible to produce a DC/AC superhet for 11½ gns. with such good tone and performance *but 'H.M.V.' have certainly done it!*"

SPEAKING as a man who knows something about radio, I must say that this new 'H.M.V.' set is really a splendid bit of work in every way. It's got A.V.C. and all that sort of thing of course—and as for the performance—well, it has certainly made me revise my ideas of what you can get for 11½ gns. in a DC/AC set . . . I know what to recommend when my non-technical friends ask me which set they should buy. You might remind me to write to "His Master's Voice" for a folder about this set. I'd like to keep it by me."



HIS MASTER'S VOICE
UNIVERSAL (DC/AC) SUPERHET FOUR MODEL 340

"HIS MASTER'S VOICE" THE GRAMOPHONE COMPANY LTD., 98-108 CLERKENWELL ROAD, LONDON, E.C.1.

The
Editor's
Chat

Wireless

& TELEVISION REVIEW

About S.T.'s Unique Short-Wave Adaptor for Home Constructors, and the Summer Broadcasts

THIS month we have the privilege of presenting to readers of WIRELESS, John Scott-Taggart's first short-wave design for home constructors.

And our distinguished contributor has taken this opportunity to give his views and impressions of short-wave working generally in some detail. His long article will doubtless be read by every one of our readers with the very greatest of interest.

For many years John Scott-Taggart has consistently produced the most successful and most popular sets, but hitherto he has confined his publication designs to the medium and long waves. This despite the fact that he has been urged time and time again to design short-wave adaptors and receivers.

Great Experience

In view of the considerable public which exists for such apparatus, this might have appeared strange to many, especially were they aware of the fact that John Scott-Taggart's knowledge and experience of short-wave theory and practice is probably greater than that of all but a mere half a dozen or so in this country.

Obviously there were good reasons for his action, and these become quite plain when his engrossingly interesting article on the "Hexoverter" is read. In a nutshell, "S.T." has apparently remained unconvinced that the short waves were able to supply a service to listeners good enough for them to receive the caché of an "S.T." design, in whatever way the available apparatus was used.

Certain developments in

technique, aided by John Scott-Taggart's own fertile brain, have now resulted in a piece of apparatus so greatly superior to any produced by standard practices that he considers he can now invite his vast following to go down to the short waves and enjoy the delights of an entirely new sphere of radio listening.

A Valuable Difference

The "Hexoverter" and its description afford one further proof of the well-known fact that John Scott-Taggart can always be depended upon to be different from all other radio engineers and designers. And different in the valued direction of not being different merely for the sake of difference, but because he remains entirely free from the shackles of accepted convention, and ploughs his own straight, unprejudiced course across both old and completely new

fields, rightly convinced of his own powers and judgment and able to ignore all "red herrings."

Thus it is that his words on short waves are bound to create considerable discussion, though we firmly believe they cannot be disputed in substance and will prove extremely valuable as a sane, reasoned summary of the whole subject.

And thus it is, too, that the "Hexoverter" itself is unlike any previous short-wave adaptor. It is both original in its conception and in its performance.

The B.B.C. and O.B.'s

O. B.'s make summer-time listening an attractive alternative to the more energetic pastimes. Various aspects of the activities of the B.B.C. have occasioned criticism, but we do not remember having seen many published grumbles concerning their O.B.'s.

It is to be hoped that Mr. de Lotbinière who has been appointed director of O.B.'s in place of Mr. Gerald Cock (who is now Director of Television) will manage to maintain the high standard set by his predecessor. He has a hard task, and we extend him our best wishes for as great or even greater success.

The broadcasting of running commentaries on lawn tennis matches, hill-climbing tests, road races etc., require extremely careful handling if they are to hold the full attention of listeners.

The importance of maintaining a high standard of O.B.'s extends beyond that of providing good programme material for a proportion only of listeners.

TELEVISION IN GERMANY



A German television receiver nearing completion in the Telefunken factory. Note the vision end of the cathode-ray tube above the moving-coil speaker.

If you should hear on a friend's new set a foreigner without a sign of fading, do not jump to the conclusion the input signal is necessarily perfectly steady. The chances are all against any such exemplary conduct on the part of the Heaviside layer.

Listen more carefully. You will hear *something* waxing and waning. Not the signal, it is true; but the background—rising and falling with the variations of input signal.

During periods of heavy background noise the signal is fading. At the same time the automatic volume control triggers the high-frequency amplification. It slides back the negative bias, enabling the valves to amplify nearer their maximum.

It Has Won Its Spurs

It is this increased amplification—needed to keep the output volume level when the signal is fading—that puts up the background. Often enough, in modern sets, the only audible sign of fading is an excess of background. Frequently this is missed, because it occurs during loud passages of music.

Automatic volume control, at first looked down upon by some of our technical purists, has definitely won its spurs. I have no patience with those who pretend automatic volume control is not worth while. They cannot have heard the system working at its best, I feel sure.

To me automatic volume control makes all the difference in foreign station reception. Many of the high-power foreign stations have, for me, real programme value, which they never really had in the old days.

How It Works

It is more really important that the average listener should have a good idea of the working of automatic volume control circuits. How can a circuit be so arranged that it almost miraculously overcomes the forces of Nature? As with all great ideas, it is simple. A.V.C. depends, back of everything, on the strength of the incoming signal affecting the rectified current in the detector anode circuit. When

the signal increases so does the rectified current. Likewise, a decrease in signal strength means a decrease in rectified current.

In the variation of this rectified

A.V.C. v. FADING

By

ALAN HUNTER

An explanation of why foreign stations are received so steadily on modern sets, and a description of the various forms of automatic volume control.

current we have, so to speak, a barometer of signal strength. The variations in this current are made to control the high-frequency amplification.

Yet is it not a fact that the whole basis of reception is the variation of the signal by the audible frequency modulations of the carrier wave? And this being so, why does not the A.V.C. cancel out these variations and, indeed, prevent anything being heard at all?

A natural enough question. If automatic volume control worked as *rapidly* as the signal is modulated there certainly would be no signal, no audible sign of it. Things are not arranged that way, actually.

The periods of fading are very

be occurring not more often than once in a second.

The near approach to a conjuring trick produced by a well-acting automatic volume control circuit is made possible by the fact that a condenser's reactance varies with frequency. If we arrange the A.V.C. rectifier in series with a suitable size of condenser we can differentiate quite nicely between fast and slow current changes. With the right capacity we can make the condenser develop voltages only for the relatively slow changes of carrier-wave amplitude—these changes corresponding to modulation.

Then these voltages can be rectified and passed along a resistance to the grids of the high-frequency valves.

The Control in Operation

These, by the way, must be of the variable- μ type, where the amplification is controlled by the amount of negative bias on the control grid. The variable voltage developed across the resistance just mentioned provides the variable negative bias for the variable- μ 's.

A strong signal will cause a considerable rectified current, which will set up across the resistance network a sufficiently high bias voltage to reduce the amplification of the valves. A weak signal, on the other hand, will cause a reduction in the rectified current, providing less of a push-back of amplification.

One of the refinements of the system is known as *quiet* automatic volume control. It is being increasingly used in better class sets. The object is to reduce or cut out interstation noise, which in simple A.V.C. can be more than tiresome.

Preventing Noise

Between stations, where there is no signal current at all, the crude form of A.V.C. will bring the utmost amplification into play. In such a condition the background noise must be high. It will manifest itself as a rushing sound every time the tuning control is moved from one station to another.

The difficulty is got over by biasing the low-frequency valve so much that it is "paralysed" when there is no

(Please turn to page 44.)

FOR USE IN PALESTINE



No matter what is done to the transmitter, fading due to the Heaviside layer cannot be completely eliminated, but A.V.C. in the receiver deals with it most effectively. The Marconi broadcasting transmitter being completed above is for use near Jerusalem.

much slower than the frequency of the modulation changes. The A.V.C. circuit is made to take notice, so to speak, only of those slow changes in carrier strength produced by periodic fading, the assumption being this will



The Hexoverter

SHORT-WAVE ADAPTOR

By *John Scott-Taggart*
M.I.E.E., F. Inst. P., Fel. I.R.E.

WHAT is it that keeps radio men of all ages up at all hours? The short waves.

What is it that gives radio enthusiasts a feeling of contemptuous superiority over their brethren? The short waves.

What branch of radio has maintained the strongest and most lasting hold on its devotees? The short waves.

To professional radio engineers life does not stop at two hundred, nor does enthusiasm wane at two thousand. I myself have worked for years on wavelengths which one would measure with a foot rule as well as on waves ten miles long. But in the case of the general public, interested in radio as a hobby, the waveband which has received almost exclusive attention is that between 200 metres and 2,000 metres; in other words, the "broadcast" waveband as generally understood.

With the "Hams"

There is, of course, that band of brothers, of "old men," of "Hams," who themselves have acquired permission to shake the ether and have carried out such amazingly useful pioneer work on wavelengths which were given to them because the Powers that were thought these frequencies were no earthly or ethereal use to anyone else.

The wavebands which were rejected

by the Government have become the corner stone of the radio firmament.

It is true that some of the short-wave "fans"

have become thoroughly Americanised and enrol themselves in chapters and lodges and other quaint conglomerations of enthusiasm. But this is not a bad thing since short-wave work has always had its spiritual home across the Atlantic.

Adler would no doubt have something to say about walls covered with QSL cards which serve the purpose of wallpaper in many an enthusiasts garret. The semi-mysterious fraternity of young men who talk a jargon of

wavebands. The short waves became a semi-private happy hunting ground, which could be preserved to those who scorned the flesh-pots of the "long" and "medium."

But now all that is being changed. Wavelengths down to 13 metres are riddled with broadcast programmes and the young enthusiast now finds himself suspected of listening to music—an accusation more bitter and riling to the true Ham than a suggestion of embezzlement or forgery.

Welcome Broadcasting

But the average listener delights in this leavening of the short wavelengths with broadcast programmes buttered with intentional entertainment.

But broadcasting on the short wavelengths is not something new, although

This is Mr. John Scott-Taggart's first short-wave design for home constructors. It is an adaptor that can be fitted to practically any broadcast set to enable the short-wave transmissions from all over the world to be heard at astonishing strength. As S.T. himself says, "It is an aristocrat of adaptors—ten times as efficient as any other I have tried—a very real and very serious contribution towards the art of short-wave reception."

their own both amongst themselves and on the ether, may be a trifle self-conscious, but they or their predecessors have led where commerce has followed.

There are hundreds, perhaps thousands, in this country who refuse to admit that they ever listened to broadcasting. Since stations are jammed together like sardines in a tin from 200 to 2,000 metres, escape had to be sought above or below these

it is true that only now is it being seriously developed. Actually, broadcasting has used the short waves for years and home constructors have had a variety of short-wave receivers and adaptors offered to them to encourage them to receive these wavelengths.

Why then have commercial receivers not been fitted with circuits suitable for receiving these short wavelengths? The answer is extremely simple and is two-fold.

(1) Provision for short waves adds considerably to the expense and complication of the receiver.

(2) The results to be obtained have not warranted that expense.

Put in homely phrase: the short waves have not been worth the bother.

This is a terribly audacious thing to say. Thousands of the public and dozens of designers have mesmerised themselves into a state of fanatical admiration of the short waves and for

What is it that keeps radio men of all ages up at all hours? The Short Waves.

What is it that gives radio enthusiasts a feeling of contemptuous superiority over their brethren? The Short Waves.

What branch of radio has maintained the strongest and most lasting hold on its devotees? The Short Waves.

—J. S. T.

a variety of reasons there have been no sober voices to say them nay.

But there are several million receivers all of the latest type and all without short-wave circuits. They tell their story. And yet tremendous efforts have been made to "put over" the short waves. You would be astonished to know how many letters I have received from people who want an all-wave receiver. Most of these know nothing whatever about the short waves or what can be expected from them, but they have seen the flam-

no need to invoke black magic either to design or work a short-wave receiver.

Why do the short waves cast a spell on the listener persuading him that even third-rate reception is fascinating and thrilling? Of course, the allegedly cow-faced British general public cannot be persuaded that whistles, fading, distortion and weak signals can thrill them to the marrow. Only the true initiate can tolerate what the unemotional member of the public would regard as the catsmeat of the ether.

Distance Lends Enchantment

It is, of course, distance that lends enchantment to the programme. A faint, fading, futile phonograph is an excitement and an inspiration if it is scratching a livelihood in Terra del Fuego. Nor does it matter that the garbled warble from one of the Empire stations is mistaken for Brazil. It all helps. If you think it is Brazil you find it awesome; when you find out that it is an Empire station you think it is awful.

The reason is that short-wave enthusiasts apply to short-wave reception standards entirely different from those applicable to medium and long-wave reception. In fact, the average short-wave enthusiast is in the position of the broadcast enthusiast of thirteen years ago who was so thrilled to get anything at all that he put up with the poorest results.

are the lives of hundreds of thousands bound up in the uncertainties of short-wave reception or television technique.

The sober critic has a thankless task. If he points out the truth about

AERIAL INPUT



A CLOSE-UP of the two aerial terminals and the two aerial series condensers—one fixed and the other a .0005-mfd. variable.

television he is thought by some half-developed minds to be "anti-television." Amongst the unthinking masses it is much better to be a stupid optimist or an ignorant enthusiast than a sane critic who refuses to lose his head and prefers to retain his self-respect.

When the science becomes really of practical value as a result perhaps of years of development, those who admired or professed to admire the early crudities cry out to be hailed as pioneers, even though the ultimate results and methods bear not the slightest resemblance to those which evoked no enthusiasm in the breasts of saner people.

Desirable Interest

My own attitude towards the short waves has been consistently the same, and it has been reflected in my published designs. I have always maintained and still maintain that the short waves do not provide entertainment value in any way to be compared with that regularly available on the medium and long waves.

I have avoided rubbing in this viewpoint because there is no doubt that a great deal of interest exists in short-wave reception, and this is altogether to the good. If there were no interest in development until perfection had been reached, progress would be considerably slower.

It is, however, only by frankly recognising the limitations of short-wave reception that this phase of radio can be placed upon a sound basis. It is certainly high time that someone debunked the short waves, so that a



TUNING THE HEXOVERTER for the reception of short waves in conjunction with the S.T.600. The "600" is tuned to a high reading on the long waveband.

boyant claims made for other sets and have been inspired by the promises of world-wide reception.

Why have I then remained so quiet about these short wavelengths. The technique of short-wave reception has been thoroughly understood for many years. There is not the slightest departure from universally comprehended principles as understood by professional radio engineers. There is

In television to-day we have exactly the same non-critical attitude. There are hundreds of television enthusiasts who obviously and deliberately are blinding themselves to the inadequacies of 30-line television. They as fiercely resent criticism as some of the readers of these words will bitterly resent any aspersions on the short-wave band. Just as Mr. Robertson Hare's life is bound up in his moustache, so



A HIGH INDUCTANCE H.F. CHOKES is essential for the anode circuit of the 210 VPT valve in the "Hexoverter." This photograph shows the choke in position, with the lead for the cap terminal of the valve attached to one terminal of the choke.

genuine interest founded on reasonable expectations may be built up and kept up.

It is safe to assume that the best that can be expected in short-wave reception is that provided by the B.B.C. when they relay communications or programmes from America, Canada, Australia and other far distant places. Sometimes the results are very good, sometimes terrible. Whatever the results may be, they are the very best that can be obtained in the given circumstances. The B.B.C. have always the most elaborate technical equipment for short-wave reception. Automatic volume control is used, and a very high degree of sensitivity is available. The combining of different aerials in different positions adds to the success. It is quite obvious that not one in a thousand home constructors is likely to be equipped with the facilities possessed by the B.B.C. If, then, you get fading, distortion, atmospherics, and weak signals from a B.B.C. relay, the outlook is extremely poor for the less ambitious outfit possessed by the home constructor.

The Empire Relays

An excellent test, of course, of short-wave working is the Christmas Empire programme. The average quality of reproduction is much poorer than that radiated by the B.B.C. At times the results are appalling. For example, the singing of the National Anthem in

Australia last Christmas was a pathetic travesty, barely recognisable as either music or song.

Nevertheless, the annual getting-together of the components of the Empire is still a source of wonder and fascination.

The word "fascination" is the favourite one in the quiver of every writer on the short waves. You never hear of a short-wave set giving "amazing" results, as you do in the case of a broadcast

But apparently thousands of wireless constructors come under the hypnotic influence of designers of short-wave apparatus, and spend many happy months being fascinated.

It always surprises me that although poor results are inevitable in practically all cases, very few complaints are received by designers of short-wave apparatus. This shows that, in spite of my own personal cynical attitude, there actually is fascination in receiving the short-wave stations.

Scorning Sentiment

The reason presumably is that huge distances are sometimes covered. Stations in the United States, South America, Australia, are received. So delighted are the listeners at receiving a programme from many thousands of miles away that they do not stop to look the gift programme in the microphone. My own instincts are to exact just as high a standard of quality as that from the B.B.C. I tend to scorn the fascination business and treat the whole question of short wavelengths as a straightforward engineering proposition in which all sentiment and awe are absent.

Nor, now that I offer you a short-wave apparatus, do I intend to repeat the usual selling-talk which has aroused so little enthusiasm in myself. I think the level-headed reader will find my own attitude a reliable one

"I would infinitely prefer one thousand constructors to build the present 'Hexoverter' and obtain real satisfaction than that ten thousand should build a less satisfactory proposition, and become disgusted with the adaptor, short waves generally, and myself in particular."—J. S. T.

receiver. Results are always "fascinating." Personally, I find it even harder to be fascinated than amazed.

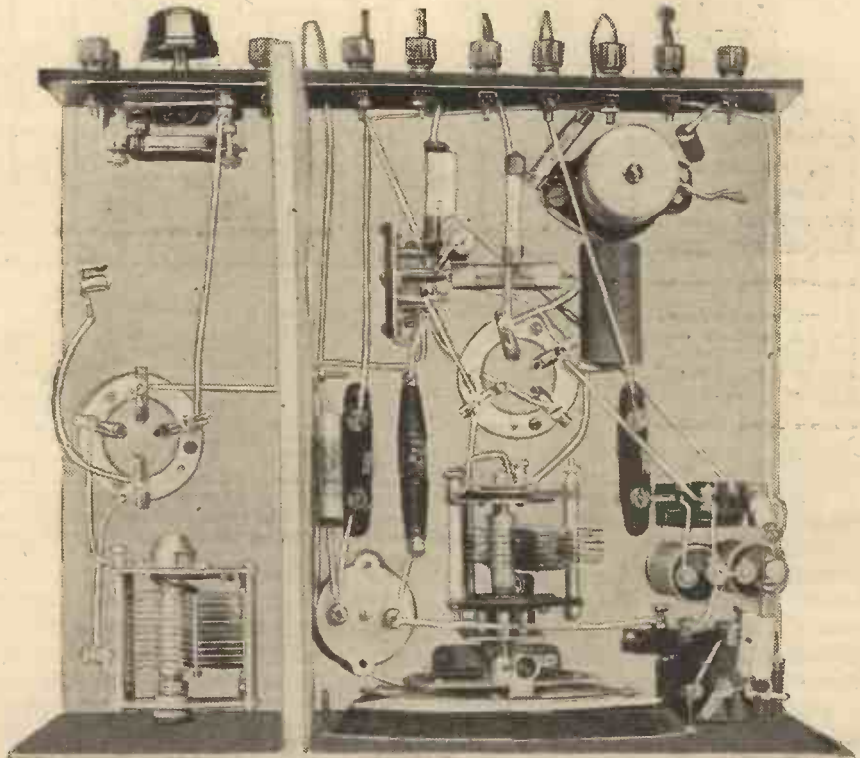

A GENERAL VIEW of the adaptor from which much of the wiring and method of general layout can be understood. Both the valves are fitted horizontally, the holders being mounted edgewise to the baseboard.

The presence of morse stations, however, should not frighten any would-be enthusiast; sandwiched between the morse's strident and intimidating telegraph transmissions will often be found rare and refreshing fruit. But you will have to tune carefully. This is one of the biggest bugbears of short-wave searching. Tuning is as sharp as a knife, and many a station has been missed through the impetuosity of an impatient listener. The trouble has been magnified by the very poor sensitivity of the average short-wave receiver or adaptor. If signals even at the best of times are on the anemic side you will hear next to nothing if slightly off tune.

"The adaptor should be capable of being connected to any kind, or almost any kind, of battery or mains receiver, and give excellent results."—J. S.-T.

The result is that you are often past the tuning point before you have heard anything.

Both these troubles can be overcome by design, and in the "Hexoverter" it is practically impossible to miss a station, because

"All results should be loudspeaker results, and at least a dozen short-wave broadcasting stations should be capable of being received with absolute regularity and reliability and with full entertainment value."—J. S.-T.

you cannot tune rapidly owing to the slow motion provided on the principal condenser, and because the sensitivity is so great that you hear a station as you "approach" it.

Before leaving the black side of the picture, I want you to realise that most short-wave stations not only work on very low power, making reception in this country often a speculative business, but the actual

transmissions sometimes take place only at rare intervals. To read some of the accounts by enthusiastic designers, one would imagine that one could turn on exciting stations with picturesque interval signals (laughing jackasses, cuckoos, the cry of the mongoose, the snarl of the Jabberwock, etc.) like a tap.

Rare Occurrences

You will find that many of these stations work restricted hours and perhaps only between 11 a.m. and noon on the first Thursday in the

Now let us look at the more cheerful aspects of short-wave work. Powers of stations are increasing considerably. More and better programmes are being radiated. Programmes sent out by amateurs for amateurs are now yielding place to commercial or government stations. Countries with colonies, and even those that would like to have some, are sending out broadcast entertainment from the old folks at home. Germany, for example, sends out to South Africa most excellent programmes which are received there by British subjects with great zest and frequently, with greater clarity than is obtained from our own Empire stations.

"The adaptor should be so designed that it could be as easily tuned as any simple broadcast receiver."—J. S.-T.

Stripped of her colonies by the Treaty of Versailles, Germany regales her nationals still in Africa with programmes made—and made very well indeed—in Germany. At 7 p.m. (Greenwich time) Zeesen sends out a strong news bulletin in English which can be very well received in this country as

"The adaptor would be designed not as a toy, but as a very real and very serious contribution towards the art of short-wave reception."—J. S.-T.

well as in South Africa.

There are quite a number of stations which can be well received with little or no fading and with great regularity. Details of these will be given when considering the performance of the "Hexoverter." Precise details of the performance on a short-wave receiver or adaptor have never been given. This I think is a very serious omission. To state that a set has received a

A GUIDE TO THE "JIG-PRINTS"

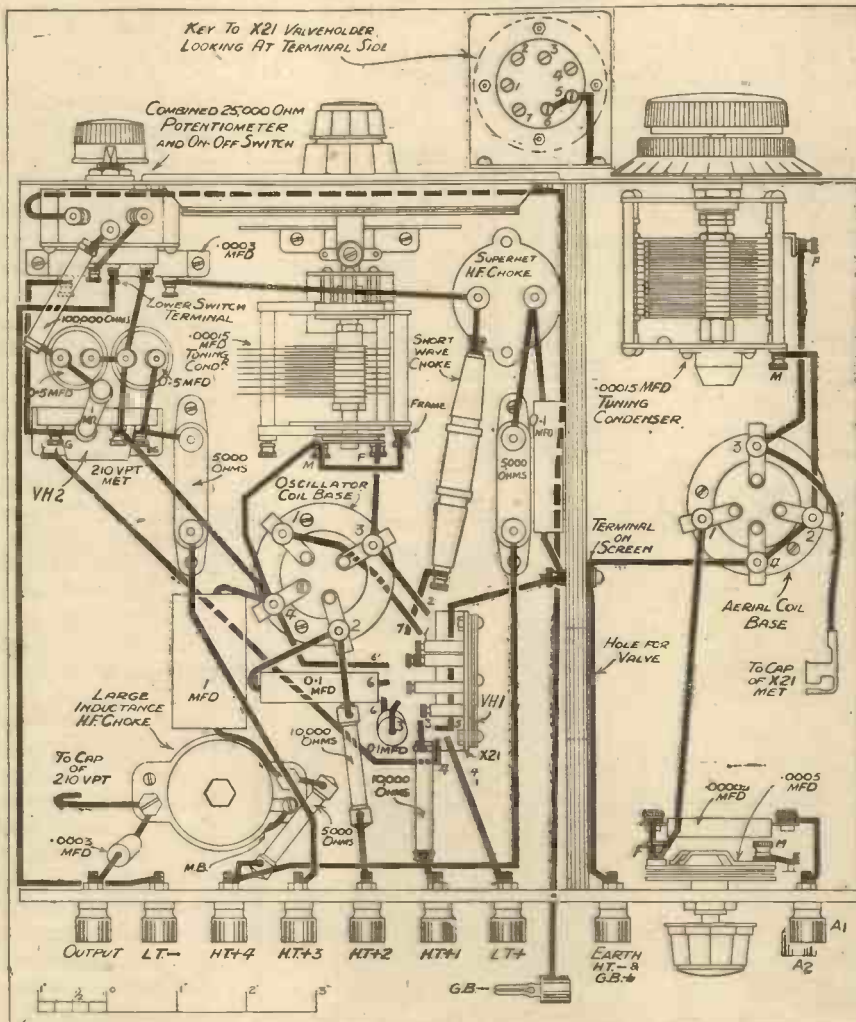

THE "JIG-PRINTS" on other pages of this issue, when assembled will provide a complete, full-size layout and wiring diagram of the "Hexoverter." The reproduction above should be used as a guide when assembling the "Jig-Prints." The small sketch of the valveholder at the top of the diagram is simply to help you wire up and is not a part of the "Jig-Print."

month. Once, however, you have heard such a station you get so genuinely thrilled about it, that its rare appearance is not only not mentioned but not missed. You can live for weeks on it—unlike the ordinary broadcast listener, who expects his cup of experience to be filled to the brim every night with unflinching regularity.

certain station or *should* be able to receive a certain station is almost valueless.

The extreme vagueness which characterises the performance details of short-wave adaptors and receivers may be dictated by necessity, but the ultimate test of a short-wave set is a demonstration. If you suffer from the boasting of a short-wave enthusiast,

**THE "JIG-PRINTS"
FOR THE
"HEXOVERTER"**
are on pages
22, 24 and 36

ask him to give you a demonstration and find out from some list what stations are working at that time.

My aim in designing the "Hexoverter" was to reduce the hazards of short-wave reception to manageable proportions. One may be unable to control the Kennelly-Heaviside layer, but one can and should design for extreme sensitivity, quality of reproduction and ease of tuning. One can also do a little to reduce fading, but this calls for a much more complicated

receiver and one designed from beginning to end for short-wave work, whereas the "Hexoverter" is an adaptor which can be connected to practically any receiver designed for the ordinary "broadcast" wave-band.

The other day I read the opening to a description of a shortwave adaptor. The author said, "The great fascination of the short waves lies in the fact that you never know what you are going to receive." Here we have the vagaries of short-wave working, not criticised but actually exalted to a virtue. The possibility of such a phrase indicates what an entirely different attitude is taken by the short-wave enthusiast. Can you imagine a manufacturer of a broadcast receiver advertising that its chief delight lay in the uncertainty of receiving the Regional B.B.C. programme?

As I have already indicated, I myself take a much more practical view of short-wave reception, and now declare roundly that fiddling, fugitive and fading signals do not fascinate me

SOLVES TWO BIG SHORT-WAVE PROBLEMS

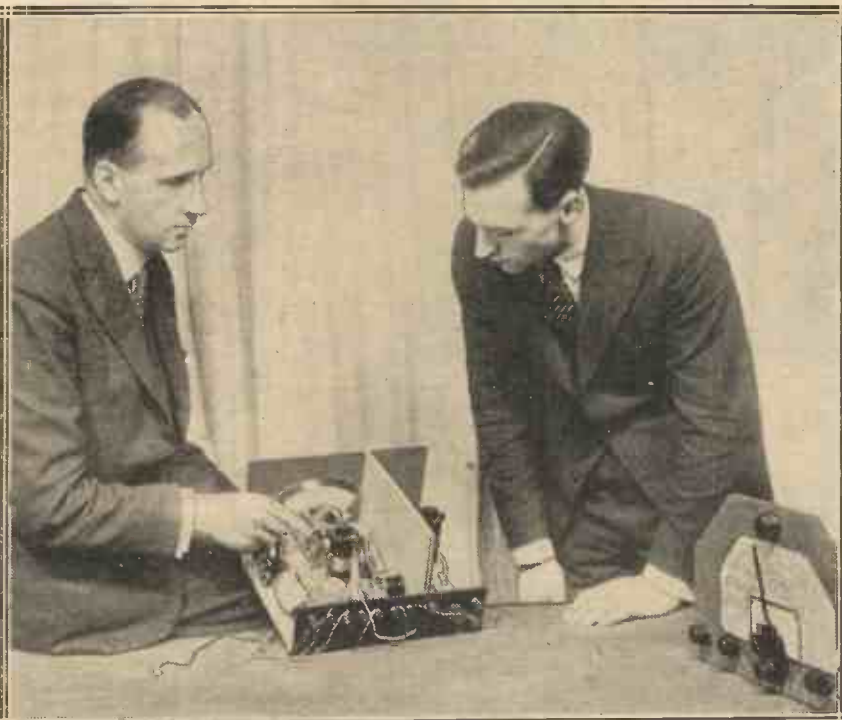

THE HEXOVERTER overcomes two troubles often met on short waves. Missing stations is avoided by the slow-motion drive on the principal condenser, and great sensitivity makes it possible to hear a station without being dead tuned to it.

TEN TIMES BETTER THAN PREVIOUS ADAPTORS

VERTICAL SCREEN DETAILS

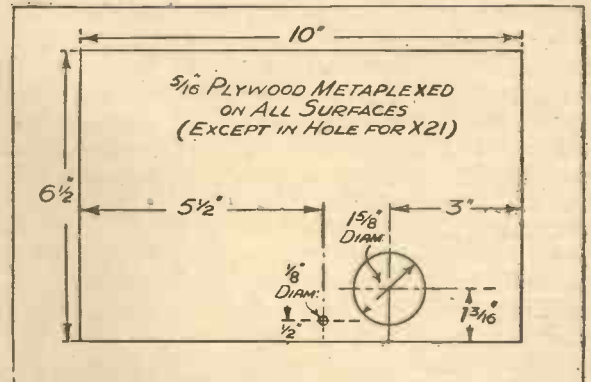

THE METAPLEX SCREEN DIMENSIONS are given in this diagram. Note the two holes, one for the earthing terminal and the other for the valve.

in the slightest. I want signals to be robust, regular and reliable.

It is in this frame of mind that I designed the "Hexoverter," and the following were the requirements I determined to satisfy :

- (1). The adaptor should be capable of being connected to any kind, or almost any kind, of battery or mains receiver, and give excellent results.
- (2). All results should be loudspeaker results, and at least a dozen short-wave broadcasting stations should be capable of being received with absolute regularity and reliability and with full entertainment value.
- (3). The adaptor should be so designed that it could be as easily tuned as any simple broadcast receiver.
- (4). The adaptor would be designed not as a toy, but as a very real and very serious contribution towards the art of short-wave reception.

An Aristocrat

In this latter connection it must be borne in mind that the short-wave broadcasting stations are vital services to far-distant listeners. It may be interesting, and even fascinating, to receive American programmes in this country on the short wavelengths. But there are many thousands of British subjects who have only the Empire stations as a source of entertainment. They want a short-wave receiver or adaptor that is a serious proposition.

The "Hexoverter" is not a cheap adaptor. It is an aristocrat of adaptors, but there is not a penny needlessly spent on its components. It is ten times as efficient as any other adaptor I have ever tried, a tremendous superiority which has only been possible by loosening the purse-strings to some extent.

MOUNTING THE HEPTODE HOLDER

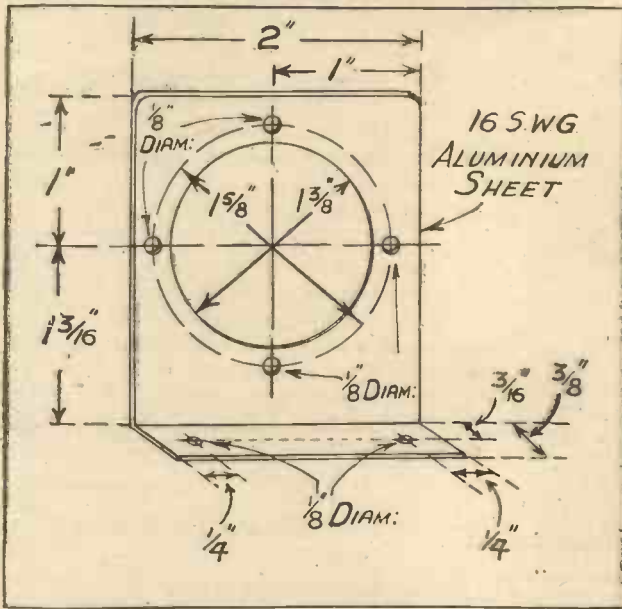

THE HEPTODE VALVE is arranged horizontally, the holder for it being supported by a metal bracket made according to the details in this diagram.

It has been obvious for a number of years that there was an opportunity for me to produce a cheap and highly popular short-wave adaptor which might be made in tens of thousands by those enthusiasts who have built my other receivers. Many of my supporters have wondered why I have never entered this field. The reason is bluntly that I do not think a cheap adaptor is anything but a toy and an infuriating one at that.

Real Satisfaction

I would infinitely prefer one thousand constructors to build the present "Hexoverter" and obtain real satisfaction than that ten thousand should build a less satisfactory proposition, and become disgusted with the adaptor, short waves generally, and myself in particular.

I am perfectly ready to lend out the "Hexoverter" and to publish readers' results with it. I have always been ready to demonstrate my own receivers in public, but I certainly would not do so with anything less effective than the "Hexoverter." Nor have I seen any undue enthusiasm on the part of other designers to demonstrate their short-wave adaptors.

When, therefore, you are reading anything I say about short waves in general, I should like you to bear in mind that I am claiming that the "Hexoverter" will give ten times the efficiency of any other short-wave

adaptor of which I have heard.

Having decided what I wanted to get out of an adaptor, the circuit became the next consideration. Here we have two general kinds of circuits from which to choose. There is the "straight" and the superheterodyne.

The straight circuit suffers from two overwhelming disadvantages. One is that it calls for reaction with its continual adjustment on every station heard. The other is that high-frequency amplification is either im-

possible or of negligible amount. It is usual to use the detector and low-frequency valve or valves of an existing set and to have an adaptor which may consist simply of short-wave tuning arrangements or may consist of a short-wave detector arrangement

complete. Sometimes, screen-grid valves have been used in advance of the detector valve in order to improve reaction and avoid dead spots (points on the tuning range where signals disappear).

Of course, the use of the screen-grid valve for this purpose is really a waste of a valve, and any kind of a short-wave adaptor system using only some of the

**A RAPID CON-
STRUCTION GUIDE FOR
THIS ADAPTOR IS
PROVIDED on
pages 17 and 43**

valves in your main receiver will involve a waste of the other valves.

The straight adaptor is cheap, easy to make and just the kind of thing to attract those who place these factors before performance. My own opinion, however, and I give this in defiance of all the scores of straight short-wave circuits and adaptors that have been offered to and built by the public, is that a superheterodyne circuit followed by adequate intermediate frequency amplification is not only the best but

THE TWO TUNING CONTROLS

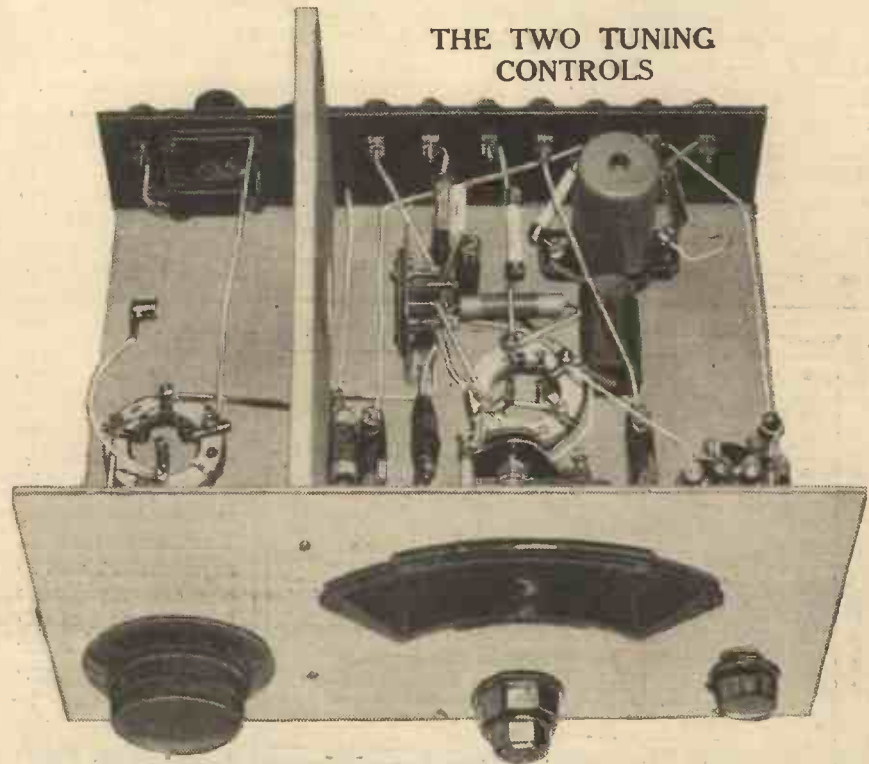

THE AERIAL TUNING, controlled by the left-hand condenser, is much less sharp than the oscillator tuning which is provided with a full-vision scale. The knob on the right of the panel controls volume.

CONSISTENTLY GOOD RESULTS—EXCEPTIONALLY EASY OPERATION

THE THREE PANEL CONTROLS

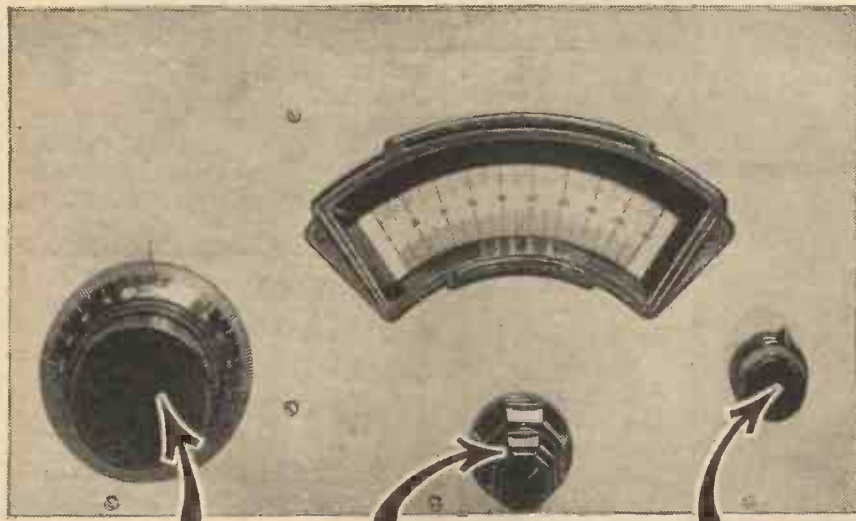

THE AERIAL TUNING.

Comparatively flat tuning will be experienced on this condenser, which tunes the control-grid circuit of the heptode valve. A slow-motion condenser is used but the need for slow movement is not so great in this case as in that of the oscillator tuning control.

THE OSCILLATOR CONDENSER.

A wide vision scale and exceptionally slow-motion tuning control are provided on this condenser for very slow movement of the vanes is essential when searching and tuning short-wave stations on the oscillator circuit. The slow-motion control employed makes it almost impossible to miss a station by going too fast.

TO CONTROL VOLUME.

A multi-mu screen pentode is employed as intermediate frequency amplifier in the "Hexoverter," and the control for this valve is carried out by the knob shown above. A graded potentiometer acts as the volume control, and it is possible to control the volume of the whole outfit by means of this component.

the only satisfactory way of receiving the short waves.

On an ordinary straight circuit there are only three valves often being used, whereas when my "Hexoverter" is used with the S.T.300 there are five valves, while if it is used with the S.T.400, S.T.500, or S.T.600, the whole outfit becomes a six-valve set, and so, on number of valves usefully employed, the "Hexoverter" should and actually

does give overwhelmingly better results. But this is a very important point I wish to make. The results are overwhelmingly better, but not necessarily overwhelming. In other words, I think the ordinary short-wave adaptors and simple receivers are totally inadequate for the job they are meant to perform.

The "Hexoverter" calls for two tuning controls which tune two circuits.

The first one tunes rather flatly, but the second one tunes with great accuracy. It is, however, a very simple matter to tune this second condenser because it has a very good slow motion arrangement. There are no reaction adjustments, and so one can rapidly go from one end of the dial to the other searching for stations without having to titivate them up with reaction. Reaction on a broadcast receiver can be extremely useful, but on a short-wave set or adaptor it will be found that most of

the stations can only be heard when the reaction is coaxed into a critical condition which has to be maintained for every split degree on the dial.

The ordinary broadcast receiver to which the "Hexoverter" is hitched is not altered in the slightest. It is simply tuned to some wavelength which is most conveniently to be found at the top end of the long-wave-band. The "Hexoverter" consists of two valves. The first is a pentagrid, which simply converts the short waves into long waves. For example, the incoming signals may have a wavelength of only 30 metres, but after they have been applied to the pentagrid their wavelengths may be changed to, say, 1,800 metres.

Intermediate Frequencies

Apart from this change in wavelength, the signals exactly resemble the original ones, and are modulated in accordance with the speech or music being sent out from the short-wave broadcasting station. These long-wave station signals are collected from the anode circuit of the pentagrid and are now applied to a variable-mu H.F. pentode.

The long wavelength signals are generally known as the "intermediate frequency" signals because their frequency lies between the incoming very high frequencies and the low frequencies which are applied to the loudspeaker. The second valve of the "Hexoverter" is, therefore, simply an intermediate frequency amplifier. A graded potentiometer acts as a volume control by varying the bias of this H.F. amplifier valve. It is thus possible to control the volume from the whole outfit.

There is a further advantage in having the variable-mu pentode as an H.F. amplifier. The pentagrid takes a

There are quite a number of stations which can be well received with little or no fading and with great regularity.—J. S.-T.

modest current from the high-tension battery, but a screen-grid or H.F. pentode valve might easily take 4 to 5 milliamperes more, which has to be added to the high-tension consumption of the main set if the latter is of the battery-valve type.

By means of the volume control on the H.F. pentode in the "Hexoverter," you never use more high tension current than is absolutely necessary, and so the whole "Hexoverter" is extremely economical as regards H.T. in actual practice.

FOR THE SCREEN MOUNTING

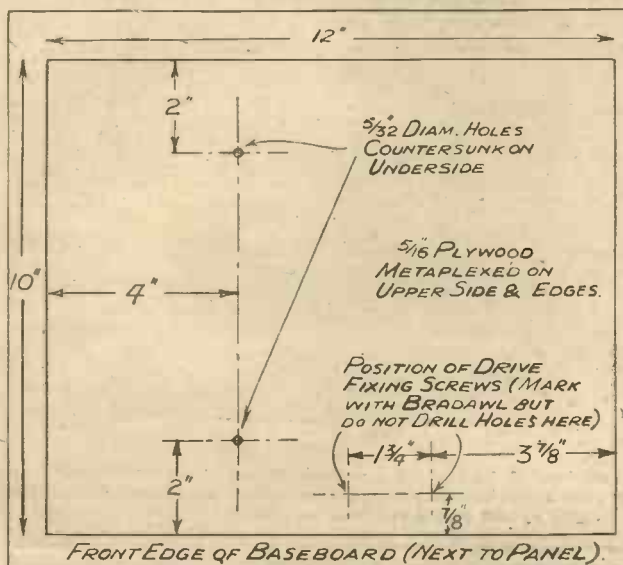

THE BASEBOARD is drilled as shown for the screws holding the screen in position. This diagram shows the upper surface of the baseboard.

The anode circuit of the pentagrid is connected to the control grid of the variable-mu H.F. pentode by means of a superhet choke, so the addition of the extra H.F. pentode does not in the slightest add to the complexity of tuning. This second valve simply has to amplify within a narrow waveband, and there is no need to use tuned amplification which would only involve another tuning control or at least a pre-set adjustment in the anode circuit of the pentagrid.

"Electron Mixing"

The pentagrid valve itself is a valve largely used for superheterodyne reception, and it really consists of a triode oscillator and a screen-grid valve. The two, however, are not separate, but operate on the same stream of electrons. Although this actual valve is of fairly recent origin this principle of electron mixing was incorporated in my

I now declare roundly that fiddling, fugitive and fading signals do not fascinate me in the slightest. I want signals to be robust, regular and reliable.—J. S.-T.

British patent of August, 1919, the first occasion when different frequencies were applied to different grids in a receiving valve. Moreover, in a British patent of 1920, I provided a heterodyne mixing arrangement in which the incoming signals were applied to a control grid while

local oscillations were produced by another grid and anode in the same valve, thus providing "electron mixing," to use a fashionable term.

It is, incidentally, rather typical of some of my more important patents that sixteen years have elapsed before their incorporation into a popular receiver design. So much before their time were many of these valve patents that only now are they coming into their own—when, in fact, the patents have actually lapsed!

The merit of the pentagrid is shown by its wide use in commercial sets for superheterodyne reception, and the circuits used are tied up with the valve and are, therefore, always the same except in small details. There is thus no novelty in the pentagrid circuit.

It will be noticed from the circuit diagram that all the electrodes are extremely well decoupled by resistors

and condensers. This puts up the price considerably, but it ensures that the "Hexoverter" can be used on all receivers without fear of instability or hum.

Most Sets Suitable

The "Hexoverter" would work even on a two-valve set, after a fashion, but one stage of high-frequency amplification in the receiver is desirable if this is of the straight type. The main receiver may, however, be a superheterodyne, and so the "Hexoverter" may be connected to any of the well-known commercial types of mains sets. In this case the "Hexoverter" itself would be connected to an H.T. battery, but if a mains unit is in use you could connect up the various H.T. terminals on the "Hexoverter" to suitable points on the mains unit. In some cases a battery would be needed for the

VIEW FROM BACK OF HEXOVERTER

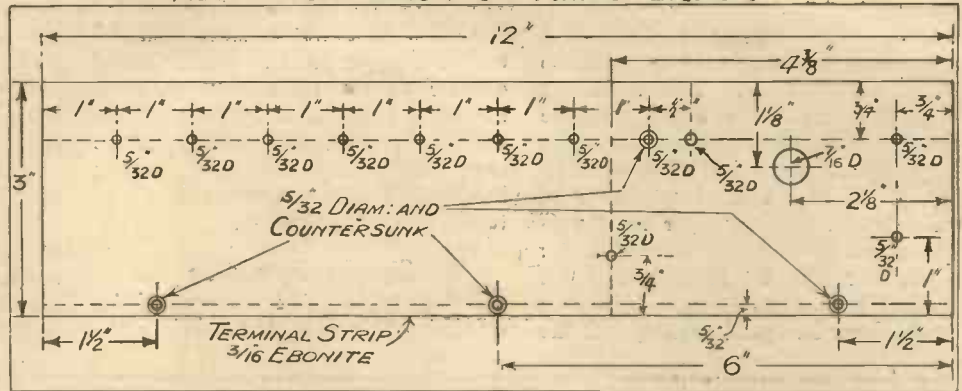

THE TERMINAL STRIP is drilled in accordance with this diagram. Sizes of holes are given so that there should not be the slightest difficulty in preparing the strip.

INSIDE THE ADAPTOR

THE OSCILLATOR COIL.
Two pairs of coils are used for the "Hexoverter," to cover the useful short waveband. The coil unit indicated here is in the oscillator coil-holder and is situated close to the valveholder in which the heptode valve is fixed. Short leads to the valveholder and the oscillator-tuning condenser are important features of the construction.

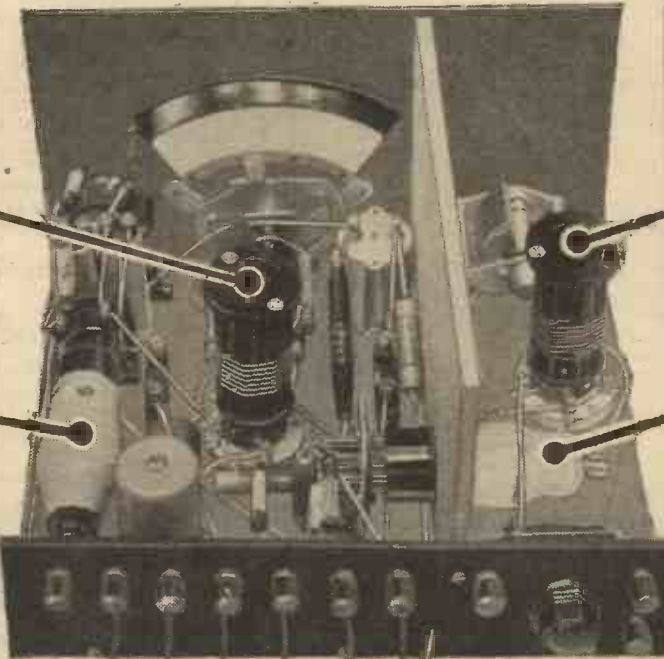

AERIAL AND GRID INDUCTANCES.
Both aerial and grid windings are on this coil former. Fairly fine wire is used for the untuned aerial winding, wound near the base, thick bare wire being used for the grid winding, which is tuned by the variable condenser seen behind the coil unit. Aerial coupling is controlled by the alternative aerial terminals, and the variable solid dielectric condenser.

THE INTERMEDIATE AMPLIFIER.
A screen pentode H.F. valve is used for the amplification of the intermediate frequency, which is provided by the heptode. This valve is fixed in a horizontal position as shown, its anode being connected by a very short lead to the H.F. choke near the terminal strip, and via a fixed condenser to the output terminal of the adaptor.

THE HEPTODE "MIXER."
The valve protruding through the screen is the heptode oscillator-mixer valve which changes the frequency of the incoming impulses and passes them on to the intermediate amplifying valve at a lower frequency. This latter amplifies these impulses and passes them on, out of the adaptor, to the broadcast receiver being used with the adaptor where they are finally detected.

"Hexoverter" even though the main set works off a mains unit.

An aerial coupler condenser of variable type is shown connected to the aerial terminal A₂. This is chiefly for experimental use, and in practice I have found that the aerial coupler capacity has no critical effect at all on reception, and a fixed condenser of .00005-mfd. will serve for most purposes and is connected to terminal A₁.

Anyone with a "Hexoverter" will probably want to try experimenting with short but good aerials, but the

adaptor works perfectly well on the ordinary broadcasting aerial, which should be connected to either the aerial terminal A₁ or to A₂. As the aerial coupler affects calibration to some extent, it is desirable not to vary the aerial coupler too much unless you are experienced at picking up stations; it may be better to connect the aerial to the aerial terminal A₁.

Simple Operation

Details will be given next month for operating this unit, but actually the

instructions are extremely simple, and do not vary in any way from those for tuning any two circuit broadcast receiver. The absence of reaction makes it very much simpler to work the "Hexoverter" than to work any other two-circuit broadcast receiver. The main set requires to be tuned to a wavelength preferably at the top end of the long waveband, and here it is necessary to warn any proposed builders of the "Hexoverter" that unless their receivers are working properly on the long waveband they are

COMPONENTS FOR THE HEXOVERTER

Component.	Make used by Designer.	Suitable Alternative Makes.
2 pairs 4-pin S.W. coils, 16 to 38 metres and 28 to 60 metres	B.T.S. type K	
1 .00015-mfd. Osc. tuning condenser	J.B. "Short-wave Special"	Polar reaction No. 4 .00015-mfd. with Polar micro-drive
1 Dual ratio arcuate drive	J.B.	J.B. Popular Log. slow motion .00015-mfd.
1 .00015-mfd. aerial tuning condenser	Polar short-wave type "C"	Colvern S.T.5C/S with battery 3-pt. switch. (Insulating washers required)
1 25,000-ohm graded volume control with 3-pt. switch	BULGIN G.M. 25. (This is catalogued with insulating washers)	
1 Superhet. screened choke	BULGIN H.F.10 (for anode circuit of heptode)	
1 Super H.F. screened choke	GOLSTONE type S.H.F. (for anode circuit of 210 V.P.T.)	
1 S.W. choke	WEARITE type H.F.3	
1 1-mfd. tubular condenser	T.M.C.-HYDRA	
2 0.5-mfd. condensers	DUBILIER type 9200	
1 .00005-mfd. condenser	DUBILIER type 670	
1 .0003-mfd. condenser	LISSEN Mica L.N.11	Graham Farish, T.M.C.-Hydra, Ferranti, Bulgin, Polar-N.S.F., T.C.C.
1 .0003-mfd. tubular condenser	T.M.C.-Hydra	Graham Farish, Dubilier, Ferranti, T.C.C.
1 .0005-mfd. solid-dielectric variable condenser	GRAHAM FARISH "Litlos" log-mid-line	Polar-N.S.F., Bulgin, Ferranti, Graham Farish, Dubilier, T.C.C.
3 1-mfd. tubular condensers	T.C.C., type 250 350v. D.C. working	Polar, B.T.S., J.B.
2 4-pin coil bases	EDDYSTONE "Frequentite" Cat. No. 949	T.M.C.-Hydra, Polar-N.S.F. Graham Farish, Bulgin, Ferranti, Dubilier
2 5,000-ohms resistances	FERRANTI G.H.5 (½-watt baseboard mounting).	Bulgin "Steatite" type S.W.21
1 5,000-ohms 1-watt metallised resistance	DUBILIER	Graham Farish, with holders or following with terminal blocks — Erie, Dubilier, Polar-N.S.F., Bulgin
1 10,000-ohms 1-watt metallised resistance	DUBILIER	Graham Farish, Polar-N.S.F., Erie, Ferranti, Bulgin
1 10,000-ohms 1-watt resistance	ERIE	Graham Farish, Polar-N.S.F., Erie, Ferranti, Bulgin
1 100,000-ohms 1-watt resistance	ERIE	Dubilier, Graham Farish, Polar-N.S.F., Ferranti, Bulgin
1 1-megohm 1-watt resistance	ERIE	Dubilier, Graham Farish, Polar-N.S.F., Ferranti, Bulgin
1 Universal valveholder	W.B.	Lissen L.N.739
1 7-pin valveholder	CLIX chassis mounting "Air sprung" with terminal screws	
Wander plugs (as required) G.B.—, G.B.+, H.T.—, H.T.+1, H.T.+2, H.T.+3, H.T.+4	CLIX	Belling Lee
2 Accumulator Spade Tags	CLIX	Belling Lee
10 Terminals, A ₁ , A ₂ , E, L.T.—, L.T.+, H.T.+4, H.T.+3, H.T.+2, H.T.+1 Output	BELLING LEE type R.	Clix, Bulgin, Goltone, Eelex
1 Aluminium panel 12 × 7 ins. 16 S.W.G.	PETO-SCOTT	
1 Metaplex screen, 10 × 6½ × ⅜ in. (metallised on all surfaces)	PETO-SCOTT	
1 Metaplex baseboard, 12 × 10 × ⅝ in. (metallised one side)	PETO-SCOTT	
1 Terminal strip 12 × 3 × ⅜ in. ebonite	PETO-SCOTT	
1 Bracket for mounting 7-pin valveholder	PETO-SCOTT	
1 1-in. 6 B.A. round-head bolt (and terminal head) for screen		
1 Cabinet		
Wire and Screws	PETO-SCOTT	

VALVES—MARCONI, OSRAM HEPTODE X.21 metallised. COSSOR 210V.P.T. metallised.

IN THE HEPTODE CIRCUIT

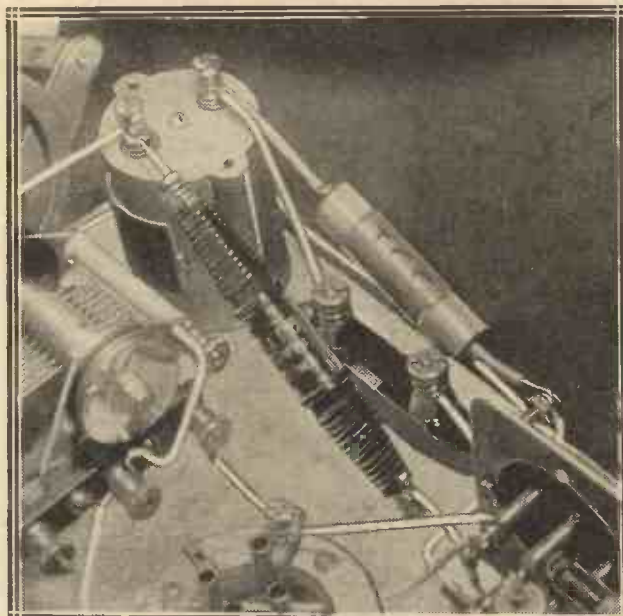

THE SHORT-WAVE H.F. CHOKE which is connected in the anode circuit of the Heptode valve.

not likely to get proper results with the adaptor.

There is a further risk, and this, of course, applies to all superheterodyne adaptors; you may be so positioned in England that Droitwich is picked up on the long waveband so as to swamp everything else. This will only apply on certain sets, and in the case of those who live very near Droitwich. To make a test whether you will be able to work the adaptor, disconnect the aerial completely from your receiver, leaving the earth wire connected to its earth terminal. Keeping any tuning condensers in step, set your receiver to some wavelength on the long waveband. If it is impossible to find a silent or almost silent point on that waveband, the direct pick-up is going to spoil your short-wave results. Such circumstances are not likely to arise except near Droitwich, or very near to a Regional Station. If, however, you cannot obtain a point on the long-waveband where your normal set is silent with the aerial disconnected, then it would be obviously unwise to build any superheterodyne adaptor.

High Efficiency

Adaptors are sometimes criticised on the ground that they are a hotch-potch. This may apply to straight-circuit adaptors, and emphatically so to many all-wave receivers where ordinary broadcast components are used in conjunction with short-wave coils. But in the case of the "Hexo-

verter," except for the absence of automatic volume control, the complete outfit (adaptor and normal set) form a really excellent short-wave receiver which would differ very little indeed from a short-wave receiver specifically designed from end to end for the short waves.

The efficiency throughout is very high, and is probably considerably higher than that of most short-wave sets, since the amount of amplifi-

and receivers. The fact that on occasion you can span the world has given publicists a wonderful opportunity to illustrate articles with waving palms and young men searching for stations on a globe of the world. (Incidentally, I should not be surprised if my own present article were so decorated!)

The absolutely regular stations which you should receive well are:

- Moscow on 50 metres.
- Moscow on 25 metres.
- Jeløy on 31.45 metres.
- Jeløy on 48.94 metres.
- Schenectady (W 2 X A F) on 31.48 metres.
- Rome on 25.4 metres.
- Rome on 31.13 metres.
- Rome on 49.3 metres.
- Vatican City on 19.84 metres.
- Vatican City on 50.26 metres.
- Budapest on 19.52 metres.
- British Empire (G S A) on 49.59 metres (erratic).
- Zeesen (D J C) on 49.83 metres.
- Rio de Janeiro on 31.58 metres.

No Skill Required

Some of these stations require a substantial reduction of volume control and none of them requires any tuning skill.

Remember, the right-hand tuning condenser governs the local oscillations, and that there will normally be two tuning points at which you will

TRY FOR YOURSELF

"I am perfectly ready to lend out the "Hexoverter" and to publish readers' results with it. I have always been ready to demonstrate my own receivers in public, but I certainly would not do so with anything less effective than the "Hexoverter."

—J. S.—T.

cation and the selectivity on the long waveband of the normal set is so good, especially in the case of a straight circuit receiver where use may be made of reaction on the long waves, thus increasing sensitivity and selectivity.

The Question of Performance

My own claim for the "Hexoverter" is that on the wave range 16 metres to 60 metres, you are sure of a dozen stations giving real entertainment on the loudspeaker.

This represents probably less than you may have been led to expect from previous adaptors

IT CONTROLS AMPLIFICATION



A CLOSE-UP VIEW of the volume control which controls the bias of the screen pentode valve, and thereby determines the strength of reception.

hear the desired station; choose the one which gives the clearest results.

The readings on the condensers will never be similar; for one thing, the left-hand condenser has 100 subdivisions, while the right-hand one is marked in 180 degrees.

Here are some sample condenser readings:

Schenectady: Left-hand coil 16/38, left-hand condenser 77°; right-hand coil 16/38, right-hand condenser 132°.

Rio de Janeiro: 16/38, 76½°; 16/38, 132.2°.

Rome (49.3 metres): 28/60, 70°; 28/60, 124°.

Zeesen (49.83 metres): 28/60, 68°; 28/60, 118.1°.

Jelöy (48.94 metres): 28/60, 60°; 28/60, 126°.

Vatican City (50.27 metres): 28/60, 75.5°; 28/60, 119.8°.

Ten Times As Loud

These are taken from my note-book. No attempt was made to keep the aerial coupler the same, or to use the upper or lower oscillator frequency consistently.

If you use the same components as I did—which you should—you will find the stations will come in very near to the right-hand readings.

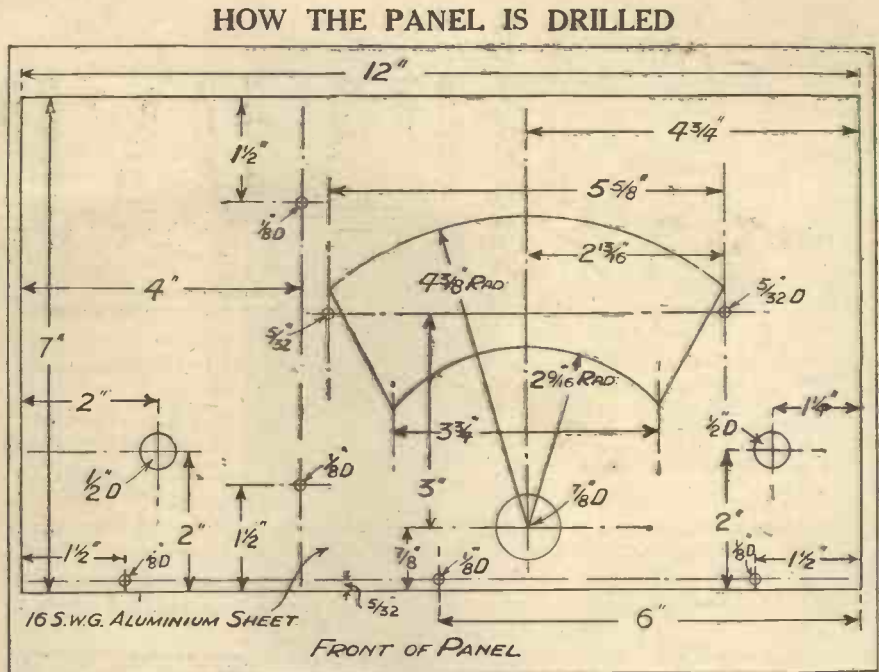

AN ALUMINIUM PANEL is employed in the "Hexoverter," and this shows how the drilling has to be carried out.

The number of stations can be greatly extended if you include those which are erratic. But bear in mind that you have here something ten times as good as anything previously offered—as far as my wide-awake observation goes. Every laughing

jackass will therefore sound ten times as loud, or be ten times as easy to hear.

I am quite confident that the average builder will be indignant over my list of stations reliably heard. Well, let us all compare notes. I shall be pleased to arrange for all results to be published.

Meanwhile, you have my quiet assurance that here is the ideal adaptor suitable for any battery or A.C. mains set.

J. S.-T.

THE ADAPTOR'S EXTERNAL CONNECTIONS

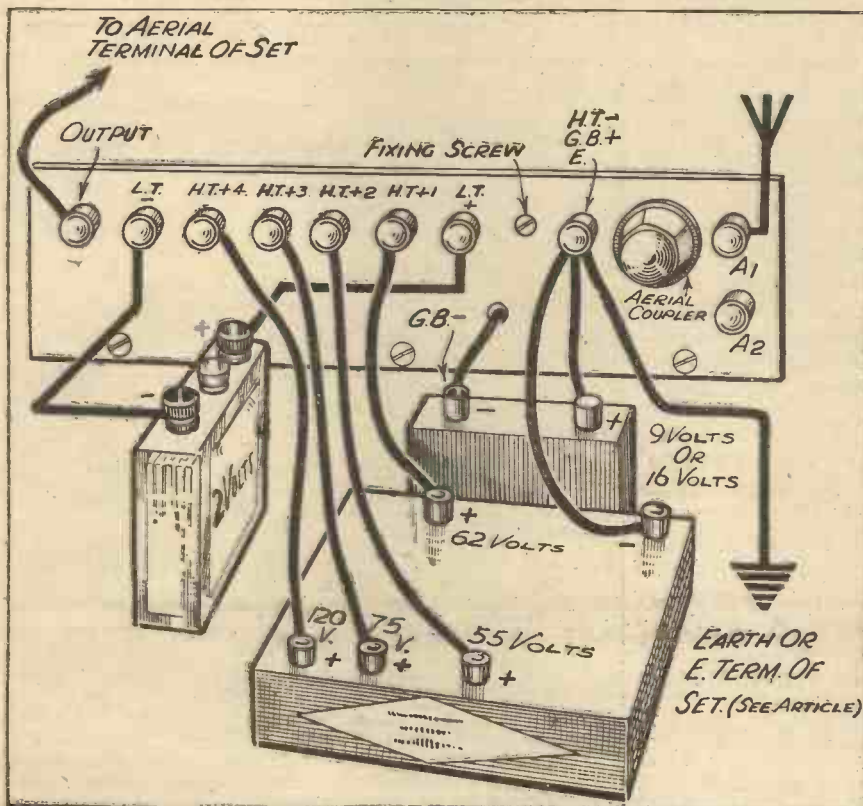

CONNECTING UP THE HEXOVERTER is perfectly straightforward even without a special diagram, but this sketch makes the procedure even easier.

ABOUT THE EARTH TUBE

The correct way of using this popular earthing device.

NINE out of ten earth tubes work inefficiently for the want of human discretion when they are put in the ground. This bald statement can be proved by anyone who cares to inspect a number of tubes which have been in use for any length of time.

Generally, one can pull the average tube out of the ground quite easily, which goes to prove that the earth surrounding the metal is not packed tight to it and forming an efficient contact.

An earth tube should be buried in the ground on the slant so that there is a weight of earth constantly bearing down on it to make a good contact. Also, water should be applied occasionally to prevent the earth caking.

The Hexoverter

Rapid Construction Guide

- (A) Collect and examine required components. Check size of panel, baseboard and screen. If you have the cabinet, see that they will fit it.
- (B) Remove centre socket from W.B. Universal valveholder. Tighten terminal fixing nuts (not terminal heads) on components.
- (C) Lay "jig-print" on Metaplexed surface of baseboard. Keep the "jig-print" steady with a weight. Using a bradawl prick through to baseboard the fixing holes of all baseboard components; if in doubt about any holes, check by laying component over its picture also mark positions for holes for the screen fixing screws.

Remove "jig-print," and with the components themselves check and prepare the fixing holes.

- (D) Drill the two holes in the baseboard for the screen fixing screws. Countersink these two holes on underside (plain wood) of baseboard.
- (E) Using the "jig-print" as a check for their positions, screw down the following in the order given: Aerial coil base, 7-pin valveholder bracket the right way round. (Now fit 7-pin valveholder in bracket with four 6 B.A. nuts and bolts; the two fil. sockets are nearest baseboard edge to which the terminal strip will be attached.) Bulgin super-het choke, two Ferranti 5,000-ohms, two 0.5 mfd. Dubilier type 9200 (cup-base holders only at this stage), W.B. Universal valveholder, oscillator coil base, Goltone Super choke (connecting a wire under the head of the fixing screw which passes through the earthing tag. The other end of this wire is bared and tucked under the Goltone Super choke), Lissen .0003 mica. Fit the double-ratio drive to the .00015 mfd. J.B. and adjust the fixing brackets on the drive to the appropriate level (determined by the condenser mounting bracket). Make sure that the inside end of the slow-motion spindle fits easily into its hole in the latter bracket (and protrudes about $\frac{1}{2}$ in. the other side). Screw with two screws the

drive on to baseboard (see figure on page 12 for position of fixing holes). Secure the condenser mounting bracket with one screw only. The second is not necessary and is practically inaccessible.

- (F) Mark out and drill screen (unless bought ready drilled).
- (G) Mark out and drill terminal strip (unless bought ready drilled).

Use this constructional guide in conjunction with the "Hexoverter" "Jig-Prints" which appear in pages 22, 24 and 36

- (H) Fit terminals to strip with the square nuts; retain the hexagon nuts on one side. Fix strip to baseboard edge, using three countersunk-head brass screws. If the holes are not countersunk do not use countersunk head screws, as they would split strip.
- (J) Mount .0005-mfd. Litlos log-mid-line on strip with the moving vanes terminal next to A2 terminal.
- (K) Mark out (including mark for aerial condenser reading) and drill panel, cutting out the space for the escutcheon unless the panel has been bought drilled and cut.

To cut out the space for escutcheon, lay the panel face upwards on a smooth hard surface and cut along the marks with a steel chisel and hammer.

An alternative method is to drill a chain of small holes, joining the holes with a penknife. Smooth the cut edges with a file. Fit escutcheon on to panel.

- (L) Mount combined volume control and on-off switch on panel, taking care to insulate the spindle bush from the panel by using the two insulating washers provided. This insulation is very important.
- (M) Screw panel to baseboard with three roundhead brass screws.
- (N) Screw screen to baseboard, panel and terminal strip, using roundhead screws through panel and countersunk-head through baseboard and terminal strip.
- (O) Mount the aerial tuning condenser on to panel, inserting the washer provided between the condenser and the inner surface of the panel.
- (P) Carry out the wiring in the following order, using stiffish insulated wire, or any of the proprietary brands. The following abbreviations are used:

A.C.B. = Aerial coil base.

O.C.B. = Oscillator coil base.

A.T.C. = Aerial tuning condenser.

O.T.C. = Oscillator tuning condenser.

V.H.₁ = X21 valveholder.

V.H.₂ = 210 VPT valveholder.

- (1) Goltone choke screen to baseboard (already wired).
- (2) A2 terminal to .0005 Litlos moving vanes.
- (3) A1 terminal to .00005 Dubilier 670 (in mid air).
- (4) .00005 Dubilier 670 to .0005 Litlos fixed vanes.
- (5) Screen to A.C.B.4.
- (6) A.C.B.4 to A.C.B.2.
- (7) A.C.B.2 to A.T.C. moving vanes.

- (8) Heptode grid connector to A.C.B.3. Make sure that this wire makes perfect contact with grid connector (i.e., metal clip which fits on cap at top of heptode).

- (9) A.C.B.3 to A.T.C. fixed vanes.
- (10) E terminal to screen.
- (11) .0005 Litlos (fixed vanes) to A.C.B.1.
- (12) O.T.C. frame (terminal at end of spindle protected with sleeving) to O.T.C. moving vanes (pig-tail terminal).

(Please turn to page 43.)

THE AERIAL END OF THE ADAPTOR

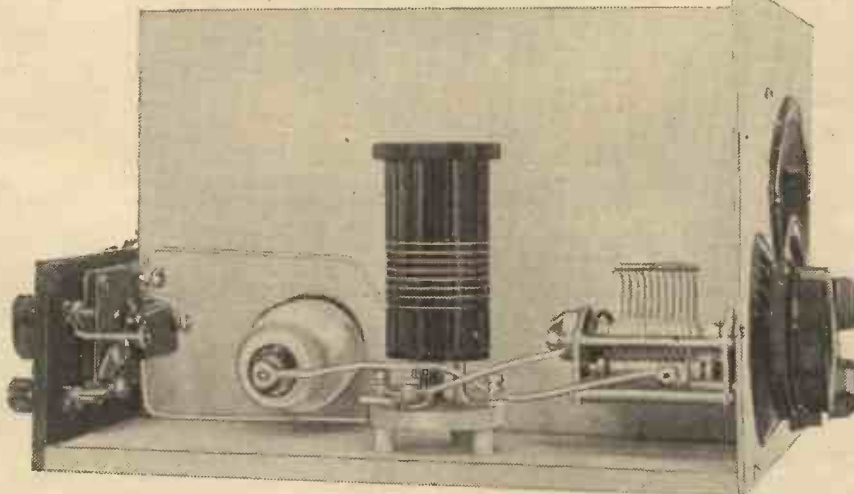

This photograph clearly shows the arrangement of the aerial side of the "Hexoverter." The partition through which the valve is protruding is of 5/16 inch thick plywood metalised on all surfaces and screwed to the baseboard by two screws inserted on the underside.

Short Wave Notes

Did you know that the junk box could be the cause of crackling in a short-wave set? This is but one of the valuable items of information contained in this article by our short-wave expert, W.L.S.

I HAVE often tried to drum in the fact that neatness and good workmanship are essential in a short-wave receiver. Layout, wiring, tight connections—all play a very important part in contributing to the success or failure of the whole outfit.

If you take a pride in your short-wave receiver, and if you really make a hobby of short waves, you should not be content until you have a corner of your den that you can dignify with the title of "short-wave receiving station."

A Typical Instance

Let's examine a few little points first. I called on a friend the other night, and he had his 'phones on, evidently listening to something pretty interesting. "Hullo, old boy," says he; "bring over that other pair of 'phones." I did. I also started on a hunt for crocodile clips, odd lengths of wire, insulating tape and goodness knows what, and, believe me, by the time we had that second pair of 'phones in action the transmission had finished.

That's just a small point. Why not put your receiver on the middle of a clear length of bench or table, and give it all the little luxuries it deserves? Give it a decent lead-in, first of all. If it has to be a long one, let it be run on stand-off insulators—you can get baby ones for twopence a time!

The Battery Leads

Put the batteries down below, by all means, but wire them up tidily. Use spade tags on the accumulator leads and wander-plugs on the H.T.'s. Whenever I see wires poked into an H.T. battery and held in position with match-ends I am inwardly profane.

Next, what's wrong with giving your 'phones a treat in the shape of a couple of plugs and jacks? If you don't want to mount them on the receiver panel (and I prefer not to) just run a flex lead

from the 'phone terminals at the back of the set. Two jacks, wired in parallel, can be fitted on a little strip of ebonite that can be screwed unobtrusively to the front edge of the bench or table.

Personally, I have two little "gadgets" on the front of my bench. One carries two 'phone jacks, with a volume-control (50,000 ohms) across them; the other is a rotary D. P. D. T. switch for changing the 'phones over instantaneously from one receiver to another.

There is, of course, another good reason why you should avoid untidiness like the plague. You simply can't work a short-waver on a bench which carries, a few inches away, an untidy pile of tools, wires and what-nots. You have only to plunge your hand into the heap of junk to start such beautiful crackles as you seldom heard.

AN EFFICIENTLY PLANNED SCHEME

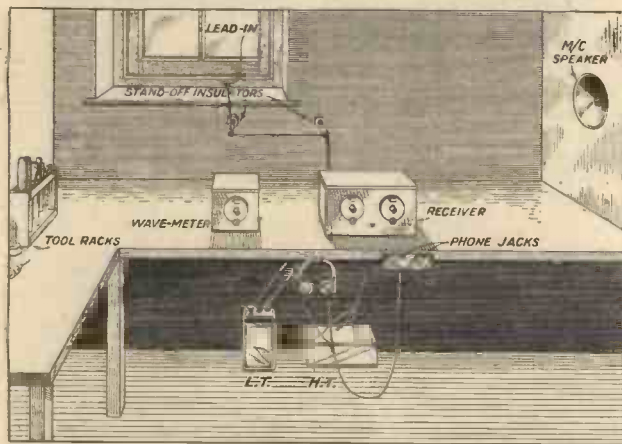

Keep all stray wires and apparatus right away from your short-wave receiver, also see that all wires associated with it are as rigid as possible.

If I stir up my wire-box when it is six feet away from the receiver I can hear the rustling noise in the headphones. What, then, must be the effect of the young scrap-metal yards that some people seem to delight in keeping on their work-benches?

Under the heading of "auxiliary equipment" come the aerial and earth. I don't want to deliver a lecture on aerial systems now. Suffice it to say that it's nice to have the aerial in one

piece—i.e. without a single join, even at the lead-in. Since a spot of both a few years ago I have avoided stranded wire. One strand broke and the two ends, rubbing against the rest of the wire, made a row that nearly drove me mad until I traced it.

No. 14 or 16 enamelled copper is ideal for a receiving aerial, and if you use a glass or ebonite lead-in tube, you can bring the wire straight through into the house, and, possibly, straight to the aerial terminal on the receiver. That is an ideal arrangement, if you can manage it.

That Earth Connection

Now for the earth-lead. If your short-waver happens to be one of those that perform better without an earth, then root up the earth connection quickly, and throw the wire away. There's nothing so likely to cause crackles as an unused earth-lead hanging about, possibly brushing against the wall.

If you do use an earth, keep your lead taut, and support it a few inches away from the wall. Use a good long earth-tube, unless you are old-fashioned enough to solder dozens of connections to a biscuit-tin and bury it at a fabulous depth. I am!

Other little things come to my mind.

That grid-bias battery, for instance. Does it just flop about aimlessly inside the set or have you given it a nice little clip? Avoid anything that's loose or "floppy," even if it has no actual connection with the short-waver itself.

The B.C. Set

Have you a broadcast receiver near by? If so, you should take just as much care not to let it grow "hay-wire" as you do with your short-waver. Just try shaking your battery-leads about on that B.C. set, and see if you can't hear the racket on the short-waver.

Mains wiring, too, should be looked after. Even if you're not running off the mains, you probably have wired up a plug-point for accumulator-charging, soldering-iron, or something of the kind. Your wiring should be done with lead-covered cable, and the covering should not be earthed on to the earth-terminal of your short-waver! If you earth it at all, use a separate lead right down to the ground.

These possibly sound small points, but believe me they are important.



B.B.C. News

Broadcasts by Children—Studio “Boom”—Should the Mike be Faded Out?—Protection of Authors—Summer Talks—An Epidemic of Marriage Proposals!

By Our Special Commissioner

No Coats in Studios

THEY have made a new rule round at the “Big House.” This is that artists must not bring their overcoats into the studios when they are about to perform. It has been found that artists’ coats affect the acoustics of the studios, and have even spoilt transmissions entirely. The only exception that will be made to the new rule will be in St. George’s Hall, and then only in really cold weather.

Children Banned

Children under fourteen may not perform for the B.B.C. The rule was recently tested in the case of Harry Jacobson’s niece, aged seven, who was sought to appear in “In Town To-Night,” before her departure for Hollywood to star in big films. There was nothing doing.

Maida Vale Troubles

The Maida Vale studio is giving a lot of trouble. Orchestral performances are suffering from the “boom” of the place. Definition is bad, and the staccato passages particularly suffer. Conductors are also complaining that they cannot handle their orchestras efficiently under the conditions at Maida Vale. It is hoped that rostrums for the players will solve some of the difficulties.

The Open Microphone

Regular listeners may have noticed that in recent months the B.B.C. has developed the practice of leaving the microphone open between musical items of all kinds. The idea

was to give greater actuality and life to the proceedings, it being felt that the microphone fading out made the whole transmission go dead.

Now the Music Department is complaining that the practice is not good for all items. It seems that in some symphony music, it is really better to fade out the mike between items and movements. So you are likely to see a further change in this presentation method before long.

Author’s Rights

There is some anxiety among authors who write for broadcasting, as well as among composers, about the difficulty of protecting their rights when their work is reproduced in other countries, particularly in Australia.

Mr. Lubbock claims to be a sufferer from unauthorised reproduction of this kind. The B.B.C. is helping the authors by suspending the despatch abroad of original scores and typescripts until satisfactory arrangements are made.

The New “Central Elephant”

The old National Council for Broadcast Adult Education, which was

dissolved last summer after five years service is now replaced by a smaller body, but boasting an equally portentous title: The Central Advisory Committee for Broadcast Adult Education. But there will be at least one important difference between the old “elephant” and the new. I mean there will be a much more definite clash of personalities and opinions. Professor J. H. Nicholson is Chairman and he has with him amongst others, Sir Francis Acland, Sir Charles Cleland, Professor W. Cramp, Principal A. E. Morgan, and Mr. Douglas Jerrold. The last-mentioned has been one of the most outspoken and vigorous critics of the B.B.C. Talks.

The first task, the new “elephant” has tackled is the outline of talks for discussion groups during the Season 1935-1936. The subjects they have approved for series are as follow: Amateur Dramatics, Literature, the Constitution, Problems before the Electorate, Pioneers of Science, Religion and Films.

Holiday Talks

Although the plan of summer talks is a good deal less ambitious than any plan of winter talks, there is still a surprising number of subjects crammed into the limited times available between July and the end of September. I see that Philip Thornton will carry on with the morning talks on music. John Green continues with “The Empire at Work,” on Sunday afternoons. Harold Nicholson returns to the microphone in a short series on Current Literature.

Edith Sitwell will discourse on eccentrics generally in three talks; Algernon Blackwood is down for two talks and Colonel Reitz (author of “Commando”) for one. In addition to these, there may

(Please turn to page 28.)

RELAYED FROM SAN MARCO RESTAURANT



MAURICE WINNICK, who leads the San Marco Restaurant dance orchestra.

LAST month, you will remember, I told you about a special tool that you could buy to assist in fixing up extension wires. And now I want to describe a simple tool which you can make and which will aid you in the same operation.

It is illustrated in one of the two diagrams on this page. The rod may be of brass or any other metal you like, and as long, or perhaps a little longer than the wireman's gimlet to which I referred last month. The diameter should be about the same as the hole which the gimlet makes.

A Simple Expedient

The object of this gadget is to enable the wire to be easily threaded through the holes when they have been made by the gimlet. The trouble with the usual method of poking a piece of stiff wire through first, is that the end may keep catching in small protuberances in the sides of the hole.

This will most likely make the wire bend and prevent it passing through the hole. But the rod just mentioned will go through perfectly easily at the first attempt.

FOR EXTENSION LEADS

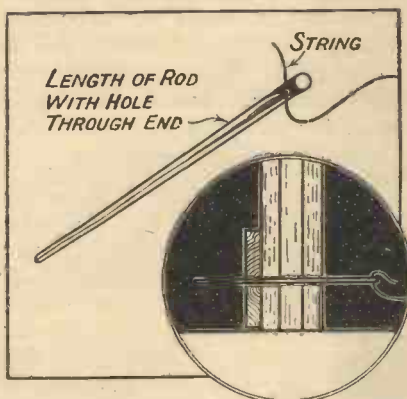

A useful tool which you can make quite easily, and which will assist in the laying down of extension wires.

In one end of the rod, about half an inch from that end, is a small hole through which a piece of thin string is threaded after passing the rod through the hole in the wall or floor. It is now a simple matter to pull the string through by withdrawing the rod. All that remains to do is to attach the wire to the string and pull it through also.

That is a very simple but very effective scheme, and here is another,

Practical HINTS FOR ALL



Some Topical Tips

By

A. S. CLARK

but it concerns something rather different. To be precise it is a method of fixing copper foil to a wooded baseboard or wooden panel.

I think the diagram makes the method perfectly clear really, but all the same, just in case, I'll describe it in detail. The instrument of torture, while looking rather complicated is really quite a common object.

To be precise it is a paper punch of the wire-pin type. It punches a wire staple through the paper and bends the ends over in just the same way as the wire clips which bind this copy of WIRELESS.

When the base, which is seen swinging below the baseboard in the sketch, is out of operation, the ends of the clips do not get turned over. Thus they can be pushed into the wooden baseboard.

Most Efficient Method

Actually they go into the hardest wood with amazing ease, and make a far better job than any brad or tack possibly could. Of course, I quite appreciate that these paper punches are to be found in only a few homes. But when they are available, and don't forget you might be able to borrow one, the idea is of great value.

As a matter of fact, some constructors may find it worth while to purchase one simply for its radio uses. Quite likely you might find it valuable for other radio purposes apart from fixing foils to baseboards.

With the imminence of summer, thoughts will be returning to the good old portable sets. And many of those with portable receivers of the older types will be wishing they had something a bit more modern—chiefly because of the better quality which they give, for in these enlightened days

there are few who do not look askance at tinny, squawky reproduction.

There is a very simple way in which a considerable improvement can be made to some portable

sets of the suitcase type when the quality is on the poor side. First of all, the reason for much of the distortion.

In sets of the suitcase type the frame aerial is in the lid, and the loudspeaker is arranged inside the frame. Therefore, should any H.F. get through to the speaker leads, and it often does with some of the older designs, feedback right through the set via the frame aerial is liable to occur.

Preventing Feed-Back

Not only is this likely to spoil quality, but quite often it upsets volume. And it may take place in spite of the fixed condenser that is usually wired across the loudspeaker leads in a portable.

The method of curing the trouble, which I found amazingly effective in a set I recently doctored, is the simple one of connecting an ordinary H.F. choke in series with the loudspeaker lead that comes from the anode of the power valve.

COVERING BASEBOARDS

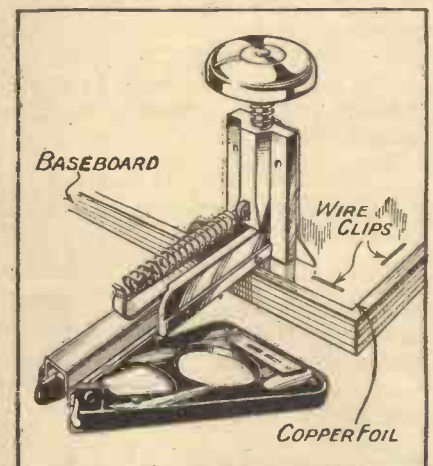

This novel method of fixing foil to a baseboard is one of the best methods ever devised for the job.

Should you find that there is no fixed condenser across the output, you should connect a .001 between the anode of the power valve and its negative filament terminal. Incidentally, mount the H.F. choke as near as you can to the anode socket of the valveholder.

Questions I am Asked

Q. 135. My radiogram is placed about ten feet from where I usually sit in my arm-chair. I am anxious to control volume without having to rise every time. What can you suggest?

A. This depends on how you control the loudspeaker output. The method used on radio sets differs often from that employed in electric gramophone reproduction. The simplest way of controlling volume on a radio set employing some sort of high-frequency amplification is to vary the degree of this amplification. This is usually done by the aid of a variable-mu valve, a potentiometer altering the normal negative bias voltage on the grid of the H.F. valve.

Since this is a voltage control, it is a simple matter to have the potentiometer at your arm-chair, the grid-bias battery remaining in the set, assuming this to be of the battery valve type. In the case of a mains set, the volume control may be a potentiometer associated with or acting as a self-bias resistor.

In both cases it is desirable to "decouple" the volume control at the arm-chair. You do not want high-frequency currents trailing along the wires to the arm-chair. The "bottom end" of the grid circuit is taken through a resistance of, say, 100,000 ohms to the sliding contact on the potentiometer. The bottom end of the grid circuit is also connected to the "earth" or metal chassis through a fixed condenser of, say, 0.1 mfd. The high-frequency currents now pass through this condenser, in preference to the high impedance path to the arm-chair.

Preventing Pick-Up

This decoupling will also prevent troublesome pick-up by the leads to the arm-chair. Such leads are liable to pick up A.C. hum from the wiring system of the house.

Volume control of the gramophone side is much trickier. The potentiometer is now usually across the pick-up, and hum troubles are hard enough to cure on a mains set without adding to the difficulties by providing a low-frequency "aerial," so to speak, only too anxious to pick-up any hum



By
John Scott-Taggart

In this month's answers to questions of general interest Mr. Scott-Taggart discusses the problem of remote volume control, and gives some practical hints on the fitting of this useful feature.

that's going. Sometimes low-frequency pick-up is obtained even on a battery set, due to the proximity of an electric-light system. Cases have also been known where long leads have led to low-frequency oscillation.

These troubles are usually satisfactorily overcome by enclosing the long leads in a lead tube which is connected to earth at the set; lead-covered twin cable is obtainable at any electricians. There is some risk that the metal sheath will so increase the capacity of the leads as to reduce the high-note response.

Q. 136. I am told that the value of resistors is apt to vary. Can you explain the matter? Why are resistors rated in watts?

A. Resistors may alter in value owing to moisture, variations in temperature, the amount of current passing through them, and—in common with human beings and wireless designers—"anno domini."

The temperature changes in a mains set vary with the design, and the position of the resistor with regard to, say, hot mains valves. The tempera-

ture-rise may, obviously, be much greater than in a laboratory. Over-running a resistor by passing too much current through it will probably damage it. It will certainly alter its resistance, either temporarily or permanently. Resistors are rated according to the watts they can safely "dissipate."

Some resistors carry no current, and are thus not subject to change or deterioration of this kind; a wattage of one-quarter or one-half will do in such cases, e.g. grid-bias decoupling resistances or grid resistances. Grid-leaks also carry very little current.

Play for Safety

Anode resistances, however, may carry a good deal of current, and you should play for safety. Five milliamps through 20,000 ohms would produce a voltage drop of 100 volts across the resistor. The wattage is volts multiplied by amperes, so the watts consumed by the resistors equals 100 volts multiplied by five and divided by one thousand. The result is half a watt, so you would be advised to use not less than a 1-watt resistor.

The effect of applying, say, twice the rated load to a resistor is to cause an immediate drop in resistance. This usually increases as the time of overload increases. The temperature of the resistor is, of course, rising meanwhile. The rate of drop of resistance decreases with time.

The change of resistance varies widely with different makes of resistor. Some will drop ten per cent. of their resistance after being "run" at double their rated load for five minutes. A good resistor may only drop two per cent, and a curious effect is sometimes obtained. The variation is greatest after two minutes' overload; after that period the resistance begins to rise in the direction of its former value.

NEXT MONTH

John Scott-Taggart will tell you more about the

"HEXOVERTER,"

his first short-wave home constructor design.

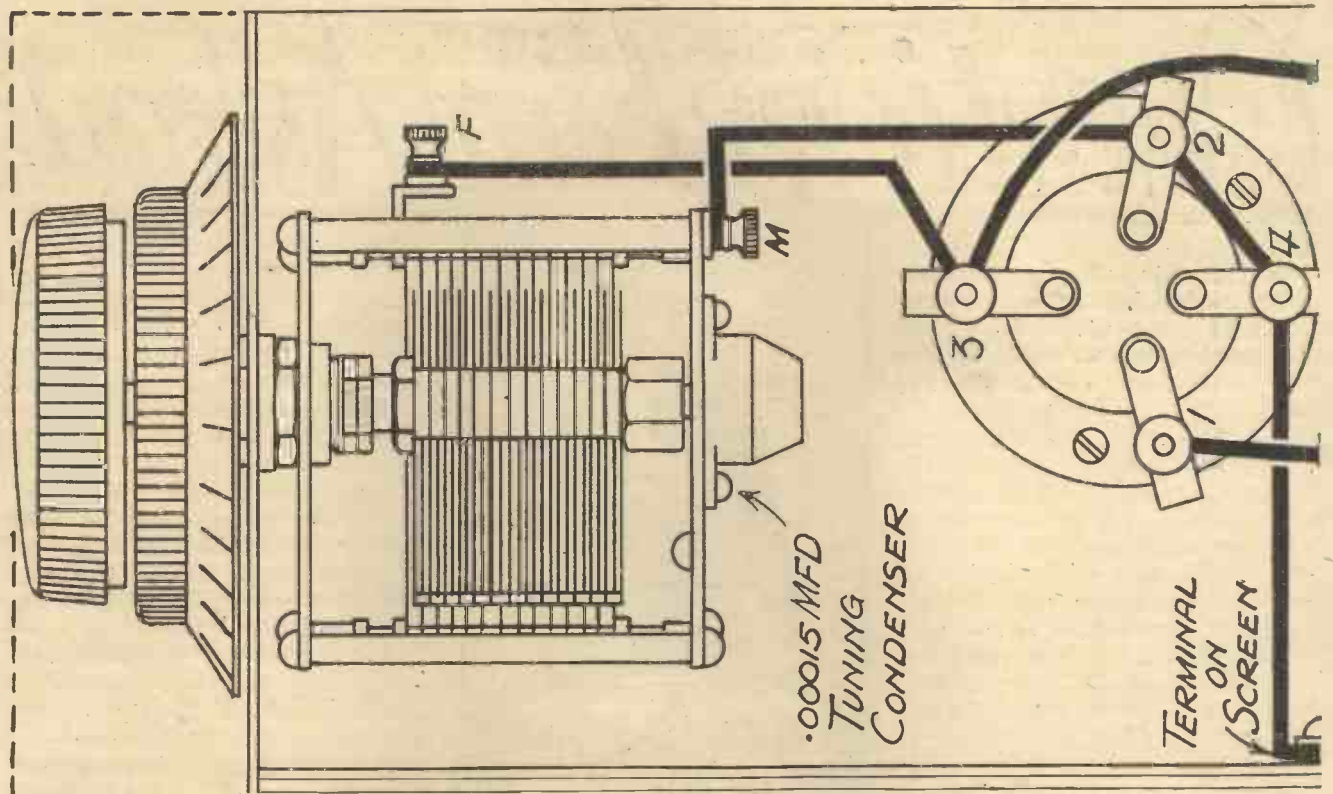

"HEXOVERTER" "JIG-PRINTS"

By cutting out the two drawings on this page together with those on pages 24 and 36 and pasting them together by overlapping at the edges, you obtain a complete full-size wiring chart of the "Hexoverter."

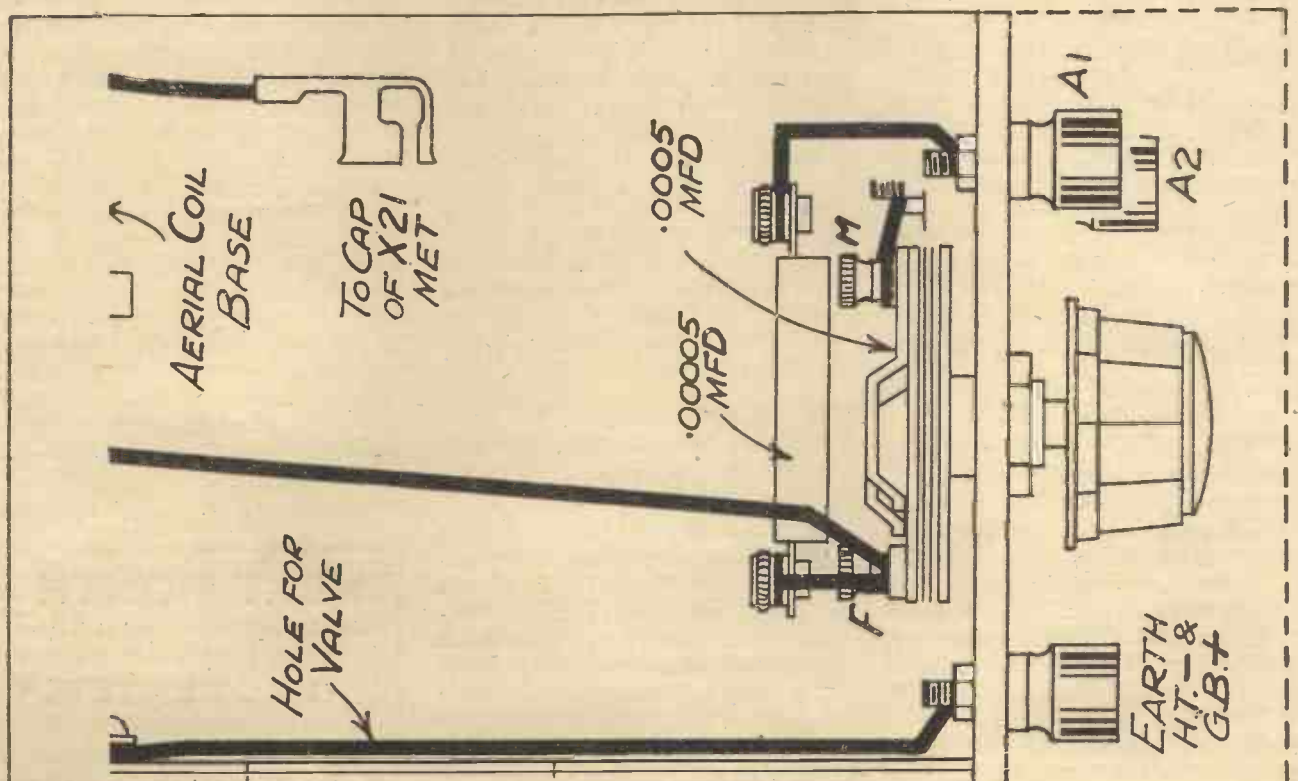

AS WE FIND THEM New apparatus tested

BY THE
"WIRELESS"
RESEARCH DEPT.

Interesting reviews of the latest products submitted by radio manufacturers and traders for examination and test in our laboratories.

Meter Accessories

We have often drawn attention to the practical utility of a good test meter. With one of these invaluable instruments it is the easiest matter in the world to maintain one's set in absolutely first-class order. Moreover, if trouble does occur there is no working in the dark in the effort to trace the fault. The meter enables one to check up voltages, anode and filament currents, resistances, and in fact many sources of trouble quickly and accurately.

But to carry out the various measurements you should have one or two accessories in the form of flexible leads and testing prods. It is true that makeshifts will do the trick after a fashion, but for convenience, quickness, and safety, there is nothing to beat a proper kit designed for the job. Apropos of which the makers of the well-known Avo Minor (The Automatic Coil Winder and Electrical Equipment Co., Ltd., Winder House, Douglas Street, London, S.W.1) are now marketing a particularly useful kit of accessories under their trade name Avo. The kit sells at 2s. 6d., and is worth every penny of it, from the point of view of trouble-saving.

There is, for instance, a set of testing prods of lengths ranging from two and a half to seven inches, each having a definite red or black indication of polarity, so that there can be no possibility of a mistake occurring. The

prod holders can be used with either test prods or crocodile clips. In addition, there are various flexible leads terminating in crocodile clips or spade tags, so that quick connections can be made and the necessary tests carried out expeditiously. It is a very handy little kit.

New Graham Farish Component

It would seem that in a few weeks one of the leading radio firms devises some new gadget or component to facilitate home-construction. The latest set-building aid is the Graham

strengthened with a projecting lug half-way along. On each side of this lug is a terminal. These terminals are essentially practical.

For example, connection is made to the shank by a quick action spring clip which holds the connecting wire firmly in position while permitting instant removal if desired. The terminal head is slotted as well as milled, and, moreover, there is no chance of the connecting lead slipping out or turning. We can recommend "Pop" to all experimenters. It costs only 6d.

Goltone Fuse Plug

A fuse in the right place can save a whole packet of trouble, and there are few radio sets to-day which haven't a fuse somewhere in the circuit. But in mains designs it is also a sound scheme to instal fuses between the mains plug and the mains input to the set.

Then if a short *should* occur, say, across the primary of the mains transformer in the case of an A.C. receiver, or across the mains leads to the smoothing chokes and resistances in a D.C. set, these fuses will blow before those on the house fuseboard. Ward & Goldstone have sent us a well-made double-pole fuse unit designed to plug into the standard 5 amp. socket, the fuse unit taking the place of the ordinary plug.

Each plug contains two 2 amp. cartridge fuses, which cost 4d. each to replace. The plug complete retails at 1s. 4d. (with fuses). Incidentally, these plugs lend themselves to a variety of uses, such as for electric clocks, portable lamps, vacuum cleaner circuits, and so forth.

A HANDY KIT



This is the Avo Kit of useful testing leads and prods for use when fault-finding and making measurements generally.

Farish "Pop"—a snappy name for a snappy component. "Pop" is a neat little terminal strip for baseboard mounting, and will make a special appeal to the experimentally minded.

As the photograph shows, there is a substantial bakelite moulding,

FOR THE EXPERIMENTER

FOR USERS OF MAINS SETS

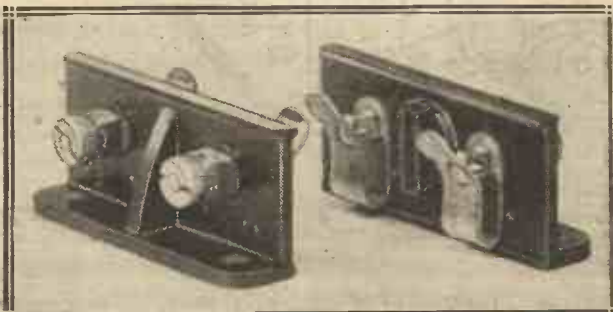

Two views of the Graham Farish "Pop," details of which appear on this page.

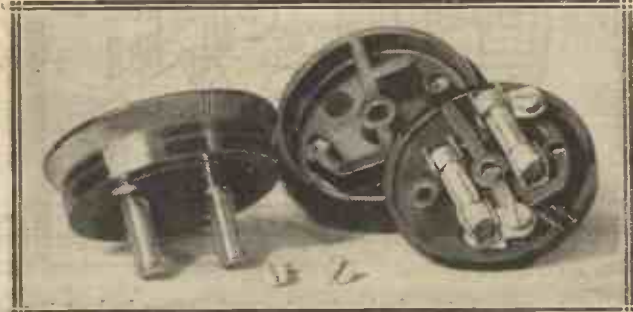

The Goltone double-pole fuse plug fits into the standard 5 amp. wall socket. The fuses blow at 2 amps.

"HEXOVERTER" "JIG-PRINTS" (Contd.)

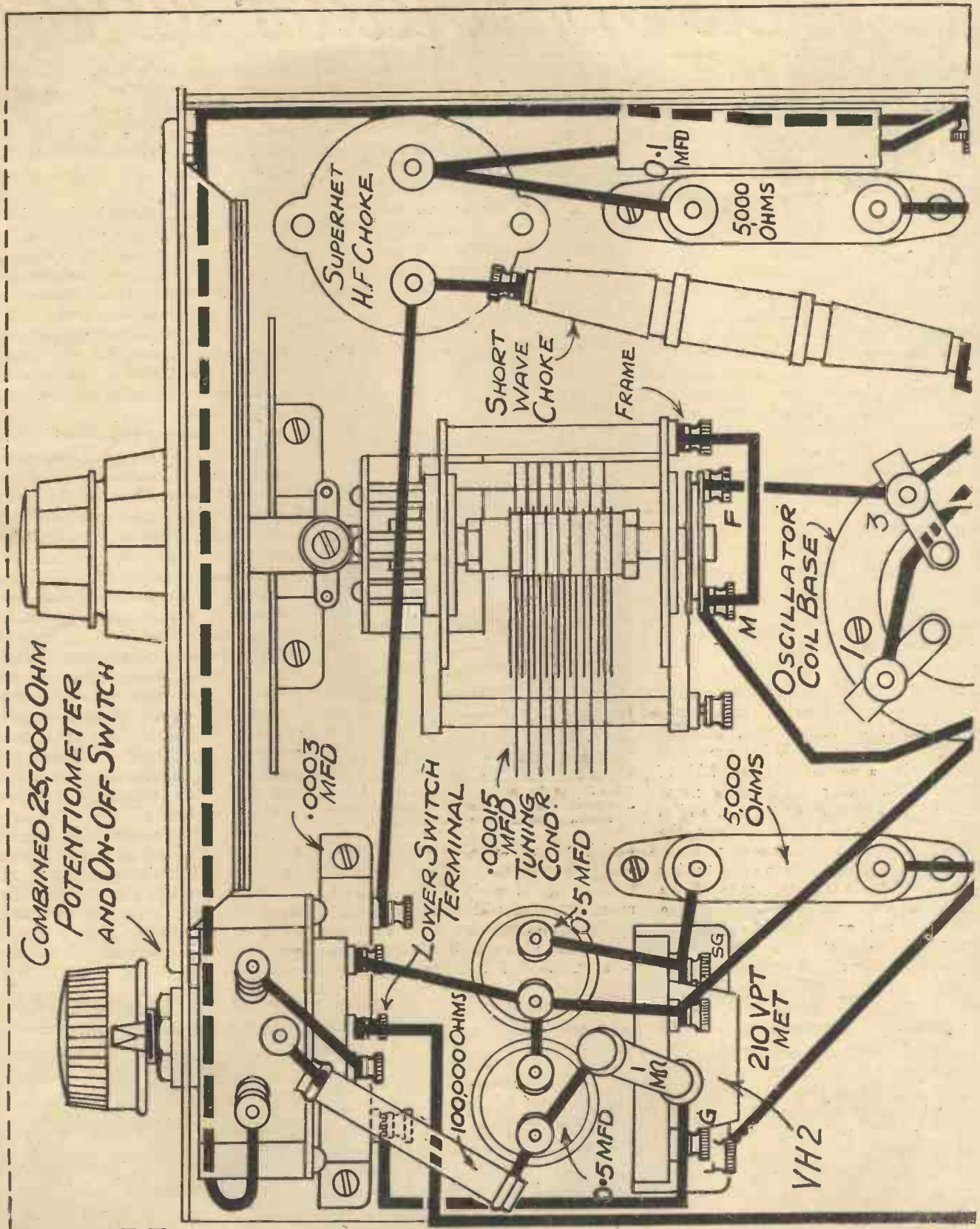

The right-hand side of this drawing as you now look at it should fit over the overlap on the left-hand side of the one on page 36. On the top of the drawing is fitted the upper of the two sections on page 22.

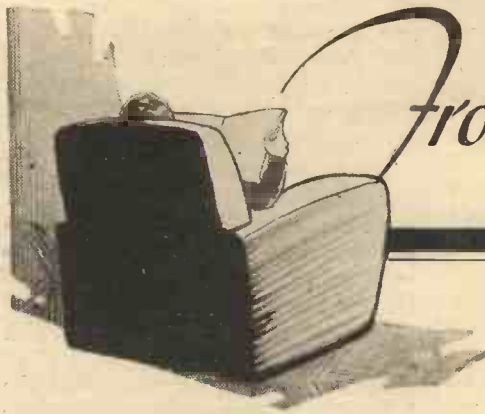

From My Armchair



Youth and its relation to the higher appointments in industry
—Television—The S.T.100—And the “Hexoverter”

How full the air is of Jubilee as I write! The name is bestowed with equal brightness on the newest radio sets and the latest arrival at the Zoo.

When you read this, the fragrance of it will still linger with us. How many readers, I wonder, can look back on twenty-five years of radio?

I started young, but I'm afraid I just miss the round figure of experience. Starting young has its disadvantages. Until the last few years I have been weighed down by the burden of youth. I had to lie about my age to get into the Army and, once in, I needed all the artificial aids of manner and appearance to support the authority that was thrust upon inexperienced shoulders.

Not Old Enough

Coming out of the Army in 1919, I was once more faced with the problem of being too young. As regards employment, I'm afraid I let my Army age stand, but I found that I was barred from all but the lowest grades of membership in learned societies, where truth about age is compulsory and precocity is discouraged. An exception was the Institute of Physics, which placed no age bar to my candidature for their highest diploma. It is not often that a student of the Institution of Electrical Engineers is a Fellow of the Institute of Physics.

These senile recollections are prompted by a combination of the Jubilee spirit and a letter from a young man of twenty-one, who complains bitterly that his age is a bar to promotion, and asks what possible chance he has in a certain company “unless a widespread epidemic removes some

of the mighty from their seats.”

Courage, mon enfant. You say very little about your qualifications; but whatever may be the position in your own company, radio as an industry is a young man's business. Marconi, who started it all, was little more than a lad when he interested the chief engineer of the Post Office in his new-fangled system of communication.

Room for Young Men

And be it said to the credit of our Post Office traditions, Guglielmo Marconi was received with interest and supported by encouragement; although Sir William Preece was no chicken himself. Yet grey hairs in the world of radio, although rare, have never

Eckersley, Maschwitz, Gielgud, are young men—and I don't suppose they ever squealed about being “kept under.”

A great many responsible jobs in the technical world are held by men of thirty. I know one or two chief engineers and dozens of chief research engineers who are that age or thereabouts. Radio and television have a bright future, and age is no bar to success. There is, and will be, enough competition to cause companies to put brains before beards.

* * *

Television, so I am told by our efficient and enterprising Postmaster-General, is “in its infancy.” As this is an official pronouncement, we must

put up with it, but I cannot help wishing he had said:

(a) “Television stands on the threshold of a great future,” or
(b) “Television is still immature,” or
(c) “Television is a young science,” or

(d) “Television is still on the bottle,” or anything that did not remind us of that awful phrase “Television is only in its infancy” which still rings in my shuddering ears. Just when the echoes of it are mercifully dying away, the new catch-phrase is launched with a bright cheerfulness which will encourage every bore in the country to repeat it

CHECKING CRIMINAL ACTIVITIES

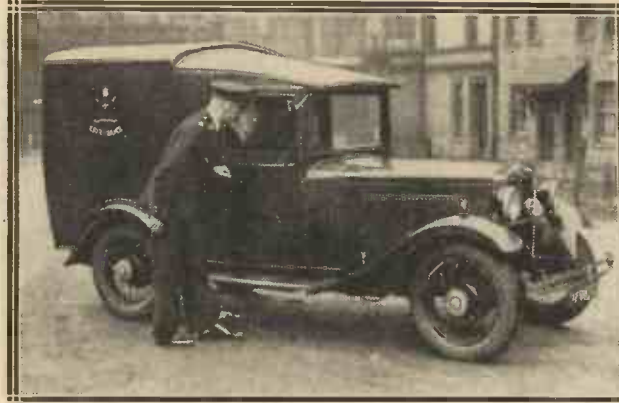

The various police forces all over the country are making full use of radio as an aid to the prevention of crime, and for mobile work generally. Here is one of the latest wireless-equipped motor vans used by the Nottingham City Police.

been the outward and visible sign of prejudice and ignorance.

The head of our whole broadcasting service is a young man. Sir John Reith is only forty-five, a ridiculously youthful age for one who grips in his hands the reins of so vastly important an undertaking. His staff, for the most part, are also young. Roger

for ten years.

“Yes, the picture is a little blurred, but, after all, television is only in its infancy.” “Television has come to stay; at present it may only be in its infancy, but . . .” “The picture is only twelve by eight inches, but T.I.O.I.I.I.” And so on, ad nauseum.

One of our eminent and learned judges recently said: "I thought a cliché was where babies were left." This one is certainly a good home for the infant television.

I suppose every radio engineer just now is being pestered and flattered by people who say: "Television's the coming thing, isn't it? I hope you will invent something wonderful in connection with it. After all, television is only in its—" No, no, a thousand times no; I couldn't bear it again!"

I've had my fill already. Sweet young things lisp brightly: "You're so clever. I hope you make a lot of money out of it." Less sweet, less young things growl less brightly: "I suppose we'll have to read about four hundred, five hundred, six hundred television designs next."

Television research has proved something of a quicksand, an almost bottomless pit into which wealthy corporations with almost illimitable resources have poured money and brains. Let us hope a real foundation has been laid. But let us also wipe a tear for millions of pounds which have been sunk almost without trace.

"I hope you will invent something wonderful—" Very charming, but I am not at all sure that the days of wonderful inventions are not over. Radio has become a kaleidoscope, a mosaic of carefully-fitting parts, each perhaps, a "clever invention," but still only a small part of the whole mosaic.

A "Jig-Saw"

Television, like one of its own pictures, is built up of bits of light and shade, of old stunts and new inspiration—a jig-saw puzzle which at last is coming right.

Many of us have gone broody over a clutch of ideas, hoping to hatch out some that are fertile. My own, by the way, are not all in one basket.

After all, television is the coming thing. It is still only in its—

* * *

Appropriate to the jubilation at present in preparation, a reader sends me a copy of one of the earlier issues of MODERN WIRELESS—to wit, the June, 1923 number, containing details of the

MEMORIES OF THE S.T. 100

S.T.100—the best-known of my earlier circuits.

It is amusing to read some of these articles of mine just to see how my views then compare with later ones.

Early Cynicism

The S.T.100—surely the first of the home-constructed sets to be built on a really large scale—is described in an opening paragraph that surprises me for its early cynicism. I always picture myself then as free from the bitterness that creeps unawares upon the designer as the years roll over him. But listen to this opening paragraph:

"Superlatives have become so common that I hesitate to describe the arrangement either as novel or supersensitive. As regards novelty, we always have the

the exploits of either type. Nevertheless the arrangement about to be described is one which unquestionably gives very good results." Later on: "Such results are quite good as the generality of circuits go."

I seem even then to have been fond of good aeriels. Commenting on the super-regenerative circuit: "The experimenter is, therefore, compelled to work on a much smaller antenna than he could possess. With the S.T.100 the better the aerial the louder the results obtained."

It is interesting to recall that the S.T.100 was a complete failure for the first six months of its life. Readers complained of trouble, and I doubt if we had a single flattering letter. Then everything mysteriously cleared up and results were consistently good.

One reason was that constructors, more experimentally minded, built up circuits with the components on their shelves. As our experience deepened

we had to insist on readers keeping to the original design. Even now, twelve years later, they take liberties with my sets, although I consistently declare that I would rather they left the set alone than "muck it ababt."

An S.T. Talk

Another paragraph from an article: "The set which I am using now was finished twenty minutes before Mr. J. Scott-Taggart was due to give his speech from 2 L O. I was able to receive the speech in S.E. London uncomfortably loud."

What did he mean by that, I wonder? My talk was a technical one and I believe the B.B.C. received five hundred letters next morning asking: "Why did you let him?"

* * *

In this issue you will find a description of my "Hexoverter." In launching this short-wave adaptor I have given tongue to a miscellany of suppressed opinions calculated—if kept submerged any longer—to produce the most fearsome complexes.

Since writing the article I have felt happier than for weeks and have thoroughly enjoyed the good sport obtainable with the "Hexoverter."

(Please turn to page 44.)

RADIO IN THE KING'S HOUSE



One of the H.M.V. loudspeakers shown in the replica of the King's House at the recent Ideal Home Exhibition. This particular model, which is finished in Canadian siltwood, is to be installed in the actual house at Burhill. It will be one of seven operated from an H.M.V. model 800 autoradiogram.

type of person who has been using something like that for years and, as regards supersensitivity, one is competing with the man who hears all the broadcasting stations in the country on one valve on a loop aerial."

As for blushing modesty, how about this: "I have no desire to emulate



THE MUDBURY WALLOW RADIO RELAY COMPANY

FOR a long time I had sat with the Professor in his den at the *Microfarads*, gloomily discussing ways and means. That we had no means was clear, and so far as we could see there were no possible ways. The prospect seemed indeed a grim one. "Never mind about me," murmured the Professor at length. "Let's concentrate on your case and see if we can't find, at any rate, some economies that you might effect. Do you keep any accounts of your expenditure?"

"Why, certainly," I cried, pulling a document from my pocket and handing it to him. "Only this morning I made up my accounts for the year."

The Professor examined the document with some care. It was, he agreed, pretty well a model of the way in which personal accounts should be kept. It read:

	£	s.	d.
Wireless receiving licence		10	0
Stamps, Sundries and things	99	9	11½
Total	£99	19	11½

We agreed that no economy could be effected in the matter of the wireless licence, for the Professor and I are the last people in the world to practise or to preach piracy. The Professor thought that the odd half-penny might have been saved on stamps and sundries and things, but I was rather for spending another one, if only I'd had it, in order to make round figures.

A Brilliant Idea

In the midst of our discussion an idea suddenly occurred to me, one of those brilliant flashes of genius that come only to people like myself.

"Professor," I cried, leaping from my chair, "I have it."

My leap was accompanied by a loud tearing noise and ere I had reached my feet I was conscious of a draught in a place where any such thing is a source of embarrassment to a perfect gentleman. Hastily looking round, I saw that, though I had left my chair, the greater part of the seat of my nether garments had not. I have always maintained that absent-minded people like the Professor should be forbidden by law to use Chatterton's Compound, for they will leave it lying about in most unfortunate places.

DUE TO CHATTERTON'S



Luckily, a coat of Mrs. Goop's that was hanging up in the hall proved an almost exact match to my trousers.

A large square patch was stitched in place by the Professor whilst I lay prone on the hearth-rug.

"Eh, what-what?" gurgled Sir K. N. Pepper, "fancy-dress carnival with funny hats to celebrate the Jubilee?"

When a large square patch had been cut from this, and stitched into position by the Professor, whilst I lay prone on the hearth-rug, it would have taken an eagle eye to discern that any untoward accident had happened.

I mean, of course, as regards my trousers. Mrs. Goop's eye quickly discovered that something had happened to her coat when she returned an hour or so later, but by that time the Professor and I were far away.

"And what," inquired the Professor, putting in the last stitch, "is this big idea of yours?"

He removed himself from the small of my back, where he had been squatting tailor-wise, and I rose to my feet.

"Just this, my dear fellow. We must start a relay company in Mudbury Wallow."

Marvellous Possibilities

"You know," I proceeded, "that in many towns and townlets there are companies which contract to supply two alternative programmes to all subscribers. The said subscribers do not require complete wireless sets; each has merely a simple piece of apparatus, plus a loudspeaker. If the switch is placed so"—my right hand waved gracefully to the right—"the Regional programme comes in. Flicking the switch"—and here my hand flipped to the left—"in the other direction ensures the reception of the National programme. You see? No trouble. No worry. No tuning. Let us start such a service in Mudbury Wallow and subscribers will simply fall over one another to plank down the necessary quota of perfectly good pounds, shillings and pence."

The Professor saw the possibilities in a flash.

"Come on," he cried, and, seizing the first hats that came to hand, we were out of the front door and doubling down the drive before you could say knife.

It was, perhaps, a pity that we had to select our head-gear so hastily. The Professor, I observed, as we ran side by side, was wearing a red pill-box creation belonging to Mrs. Goop, and on removing my own temporary roof for examination, I found rather to my dismay, that it was one of those nautical affairs inscribed "H.M.S. Horrible," and belonging, no doubt, to the Professor's youngest infant; the *Micro-Goop*.

We made straight for Sir K. N.

Pepper's abode, and finding his front door open, dashed into his own particular room.

"We have," I panted, "a terrific idea to put before you."

"What," gurgled Sir K. N. Pepper. "Eh, what—what? Fancy-dress carnival with funny hats to celebrate the Jubilee?"

With a simultaneous gesture of disgust and disclaimer, the Professor and I removed our head-pieces and flung them into the coal-scuttle.

The Company is Formed

"No, no," I said; "something of far greater moment. The Professor and I have a scheme to bring prosperity to Mudbury Wallow. It will solve the unemployment problem." (Here the Professor bowed to me, and I returned his salutation.) "It will ensure that full scope is given to two remarkable men that Mudbury Wallow numbers amongst her sons." Here I bowed low to the Professor, and he reciprocated.

"Further," I continued, "it offers a source of considerable profit to public-minded citizens such as yourself."

I proceeded to outline the relay scheme, and as word followed red-hot word, Sir K. N. grew more and more deeply interested.

Before the evening was out the company had been formed with Sir K. N. Pepper as chairman, and all the necessary capital had been subscribed. What was more to the point, the Professor and I had been appointed joint chief engineers.

Once the scheme had been put before them at a mass meeting in the Town

A GOOD "EARTH"



It was clearly not my fault that one of the drills should go straight into an ascending water main.

Hall, our fellow townfolk fairly fell for it. As I had predicted, subscriptions simply poured in. It was clear from the word go that we were on to a good thing.

If, reader dear, you are ever appointed joint chief engineer or joint anything else, it is just as well to remember that by far the best course is to devise some scheme whereby the other fellow does most of the work (and takes most of the blame if things

INSTALLATION MISHAPS

go wrong), whilst you supervise in a general way and obtain the greater part of the credit if they go without a hitch.

That was roughly how I divided the responsibilities of our most important post with the Professor. Just how wise I was in taking this course was shown less than a week later when we began to run out our first relay line from the central receiving station.

Miss Worple had been the very first of our subscribers, and we were determined to see that she should receive our relay service without a moment's delay. The twin wires had to be taken across the Professor's house to a pair of insulators fixed to a bracket on hers.

Not My Fault

As supervisor I merely indicated to the Professor and his working gang where the bracket should be fixed. It was clearly no fault of mine that one of the drills employed should go straight into an ascending water main. In fact, as I pointed out later when the lady sent in a bill for the damages, it is laid down in all text-books that no other earth connection can approach in efficiency that made to an ascending water main.

At Tootle's house, adventures occurred thick and fast. It is an old building, and the first blow of the hammer driving in a drill at the north-east gable caused a south-west dining-room window to fall out. In fact, before the Professor's stalwarts had done with it, it looked rather as if it had been bombed, then crumpled, and finally struck by lightning.

We were rather luckier with Captain Bucket's little home, for here only some five or six square yards of the roof and a couple of ceilings on the first and second floors required slight repairs when we had done with them, the Professor having fallen through the lot.

A Sudden End

There is no pleasing some people. You may hardly believe it when I tell you that at this juncture the citizens of Mudbury Wallow called a further mass meeting and unanimously resolved that the Mudbury Wallow relay company be required to desist from further devastation. We did our best to bring the town up-to-date, and that is how they treated us. The path of genius is ever a thorny one.

The relay company had to go into liquidation, but all's well that ends well; the Professor and I had been careful to see that a year's salary to the chief engineers was paid in advance before we started operations. Nor is there any question that we had solved the unemployment problem for the time being in Mudbury Wallow.

The slaters, plumbers, glaziers and builders are in fact so delighted with us that they have unanimously elected us honorary vice-presidents of their respective unions.

MORE TROUBLE



The first blow of the hammer driving in a drill at the north-east gable caused a south-west dining-room window to fall out.

B.B.C. NEWS

—continued from page 19.

be a "Survey of Youth" series and some poetry reading thrown in now and again.

P.M.G. and B.B.C.

Relations between the P.M.G., Sir Kingsley Wood, and the B.B.C. are not as smooth as they were. Sir Kingsley is careful to avoid interfering in the internal arrangements and the details of B.B.C. programmes. On the other hand, as the responsible Minister in Parliament he finds it absolutely essential that he should be kept fully informed of B.B.C. policy and plans. Also, there is a growing feeling in political circles that the B.B.C. has become so important that its internal affairs can no longer be regarded as a matter to be settled solely by the B.B.C. Governors. It is more than likely that one of the changes that will be made after the expiry of the B.B.C. Charter and Licence, next year, will be to ensure more publicity and general consideration for the internal organisation and staff appointments of the B.B.C.

Proposals to Announcers

Although this is not Leap Year, there has been recently an almost epidemic outbreak of proposals of marriage to announcers from ardent women listeners. I am told that Mr. Freddie Grisewood heads the list of recipients, Mr. Hibberd is second and Mr. Harmon Grisewood third. All three are already married.

Special TELEVISION Section



Conducted by
**Dr. JOSEPH HARRISON
 ROBERTS, F.Inst.P.**

A NUMBER of readers have asked me whether I think there will be any danger in using a television receiver, owing to the fact that a relatively high voltage is necessary, as much as 2,000 volts or even sometimes more.

It is true that high voltages are required for use with cathode-ray receivers—and incidentally I think it looks as though the cathode-ray type of receiver is likely to be the most popular—but I do not think there is the slightest ground for any fear in regard to the use of such voltages. It is a perfectly simple matter to design the receiver so that the high-voltage components cannot be got at by the user, and to arrange a safety device so that when the set is opened in any way the voltage is automatically switched off in the process.

No Need for Alarm

If it comes to that, you may say the same thing about a radio receiver employing 250 volts A.C.—or even in some cases as much as 450 volts A.C., stepped up by a transformer inside the set. Accidents due to these voltages in a radio set are for all practical purposes unknown, and the Institution of Electrical Engineers have cooperated very effectively with radio manufacturers to maintain a high standard of safety in this particular.

There is really very little required to make a set absolutely safe, and so

long as just that little precaution is taken there is no need for anyone to have the least compunction in buying and operating a set, whether it be a radio set or a television receiver.

As regards the production of these voltages it will, of course, be necessary to obtain them by means of step-up transformers and that rather seems to limit television receivers, operating

★.....★

Among the subjects dealt with by Dr. Roberts this month are television voltages and safety—developments in cathode-ray tubes—television in Germany—screens for television receivers and the retention of the present 30-line system.

★.....★

from the mains, to alternating-current supply.

However, I hope I have answered those readers who have raised this point and have reassured them and all others that really no new situation arises in regard to television from what has already been so effectively dealt with in the case of radio sets.

* * *

With the advent of television (or the impending advent) there has been a good deal of discussion as to what we should call a person who uses a television receiver. I am not trying to be funny or to suggest that he should be called anything but a perfectly serious name. I mean that some term corres-

ponding to “listeners” will have to be found.

In the P.M.G.’s recent Report, the user of the television receiver was referred to as a “looker,” which corresponds exactly to the word “listener.” With regard to the latter term, you may remember that in the early days of broadcasting the B.B.C. and the public used to refer to “listening-in” and the user of a radio set was referred to as a “listener-in.” After a time it dawned on people that the “in” was unnecessary and it was quite sufficient to describe him as “listener” merely. I think the word “listener” is quite a nice and suitable term and it seems a pity that we cannot find, or at any rate have not so far found, a really good corresponding word for television.

All sorts of weird terms have been suggested but, up to now, nothing better has been found than “looker” and, for the verb, “looking-in.”

A Registered Name

The same problem arises with regard to the description of a television set. Some people call it a “televviewer,” which is not a bad effort. One of the best descriptions is the word “televvisor,” but I should mention that this term is a registered trade name, belonging to the Baird Company and so, strictly speaking, cannot be used in regard to television receiving sets except by them.

I suppose when television has been going for a bit some bright idea will occur to someone and we shall get a series of terms which exactly meet the case.

* * *

It is amazing what developments and improvements have been made in cathode-ray tubes since they became so important for television purposes. Some of you may think that the cathode-ray tube has only been recently invented, but in point of fact it dates back to many years ago, I suppose as far back as 30 or 40 or 50 years ago—long before my time, anyway. When I was in Cambridge we used to use cathode-ray tubes for all sorts of experimental purposes, and in those days we had to make our own fluorescent screen—and a nice job it was. It took you about two days continual work, after many shots and failures, to get a really nice even fine-grain fluorescent screen.

Black and White Images

The cathode-ray tube continued to be developed during the war years and, when broadcasting arrived and television was mooted, in however vague a way, people soon realised that the cathode-ray tube was worthwhile. But its development, at any rate for television purposes, has been very largely concentrated into the past year or two.

I was examining some very modern cathode-ray tubes a few days ago and, bearing in mind my own experience with the fluorescent screen in the early days, I marvelled at the uniformity and excellence of the screens which are now being produced. Not only have they this excellent uniformity, but they are even made of a fluorescent material which, instead of giving a ghostly bright-yellow effect—which was all right for scientific purposes but objectionable for television reproduction—can now be made to give a nice soft sepia, or almost black-and-white effect.

The Internal Screen

In addition to all this, the process of making the interior surface of the tube electrically conducting, and at the same time non-reflecting optically, has been brought to a great state of perfection. I dare say you know that, although the cathode beam is projected principally along the geometrical axis of the tube—allowing, of course, for the shift in the process of scanning the screen—quite an appreciable percentage of electrons will wander or be shot off in other direc-

SPECIAL TELEVISION SECTION (Contd.)

tions and will hit the inside surface of the glass.

Since this glass is bone dry it will very easily become electrically charged and you will get all sorts of stray electric fields set up which will disturb the control fields due to the two pairs of control electrodes. It is, therefore, essential to avoid any such stray electrified areas or points on the glass, and this is done by making the surface of the glass conducting. The interior of an ordinary wireless valve is usually conducting by reason of the deposition of the magnesium which is used for gettering the vacuum in the final stages of exhaustion. This type of

it is *black* and has a *mat* surface, and is, therefore, almost completely non-reflecting optically. Perhaps I should explain for those of you who are scientifically curious that a colloidal solution or colloidal suspension (strictly speaking, the word "suspension" is more correct than the word "solution" in this sense) is a mixture of a suitable liquid vehicle with a vast number of extremely fine particles of a substance, so small as to be invisible, but not nearly so small, of course, as *molecules*.

Tubes Will be Cheaper

If the substance is dispersed in the liquid in the form of molecules it is said to be in solution properly speaking, but if it is in very fine particles much larger than molecules, it is referred to as a colloidal suspension.

This has nothing directly to do with television, but I mention it now, having used the word "colloid," because I know from experience that if I do not explain it a good many readers will write to me and ask me what a colloid is.

Cathode-ray tubes can now be obtained at the remarkable price of £8 8s. retail, and there is no doubt that as soon as they begin to be used in large quantities the price will come down. A very few years ago I am sure none of us could have foreseen the amazing developments that have been made in cathode-ray tubes, and certainly those responsible for such improvements deserve the greatest credit.

* * *

Television is going ahead in Germany, and the German Post Office has recently issued a number of official statements on the position, which are designed to clear up conflicting reports that have been made there, as in this [country, so frequently of late.

Television in Germany

Experiments have been made by means of receivers and transmitters located at the summit of the Brocken, in the Harz Mountains, which is about 150 miles from Berlin. From these tests it appears that an ultra-short-wave transmitter located there would be able to serve an area of some 100 miles radius, bringing in towns such as Magdeburg and Hanover. A regular transmitter will be put into operation at the Brocken this summer.

Important experiments are also being made to see whether it is a practical proposition to link towns as

(Please turn to page 41.)

AT THE CRYSTAL PALACE



A Baird ultra-short-wave sound transmitter for use in conjunction with the experimental television programmes.

conducting surface would be quite all right for the cathode-ray tube, but it has the disadvantage that it is a very good optical reflector. Therefore, a process has been evolved for coating the inside of the cathode-ray tube with a graphite preparation, the graphite being deposited from a kind of colloidal suspension in water, or other suitable liquid, several coats being applied until the necessary thickness of graphite has been obtained.

That "Colloidal Suspension"

The graphite has the advantage that, whilst it is electrically conducting,

SPECIAL TELEVISION SECTION

Sound & Vision on One Wave!

by **VICTOR KING**

Our famous contributor discusses some ingenious ideas for the simplifying of television reception and the reduction of the number of radio channels employed.

THERE are three stages in the development of an invention. Theory, laboratory, practice. Television lingered in the theoretical stage for about forty years. And that is without troubling to go very far back along its roots.

Then followed a decade or two of laboratory experiment. And now at long last television is on the eve of becoming a national service. It is also approaching its peak of development. Not, mind you, its peak of perfection.

A POWERFUL SIGNAL

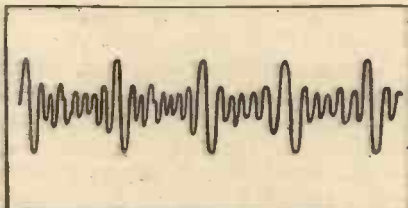

How the synchronising impulses would appear if drawn to the same "scale" as the modulation in the E.M.I. method.

What I mean to say is that never before this year and probably never again will there be so much concentrated research, invention and development of a technical nature in television.

By 1936 television progress will begin to settle down into well-ordered and somewhat less exciting lines, when continued refinement and slow but sure improvement will tend to give way to frenzied expansion.

The examiners of the Patent Office must be having a hectic time. One firm alone, so I have been told, is firing in television patents at the rate of fifty a month!

Achieving Greater Simplicity

The general tendency of invention is in the direction of greater simplicity. At present television necessitates rather elaborate gear. Two ultra-short-wave receivers, one for sound and the other for vision, a cathode-ray tube and its associated time-bases constitute the

simplest practical outfit for high-definition reception.

The time-bases are quite equal in cost and complexity to a complete radio receiver. But there has already been suggested a method for eliminating them. Or, rather, for replacing them for something easier to handle.

The idea is to broadcast two scanning frequencies on a third channel (the other two being, as normally, for sound and vision). These would be picked up on a third receiver, amplified and applied direct to the cathode-ray tube.

These two scanning frequencies would actuate the deflectors of the tube direct and so the problem of synchronisation would also be solved. Synchronisation would be a function only of the transmitter and would not concern the receiver at all.

Sounds very nice, doesn't it? As to its practicability, I should not at this juncture like to make comment. But synchronisation is rather a business. Of the several methods likely to be employed for the forthcoming London transmissions I find the E.M.I. one particularly attractive.

A Patented Method

I say it is likely to be used but I must make it clear that this is purely guesswork on my part. E.M.I. have patented the method but goodness knows what else they have up their sleeves. The proverbial oyster is like a parrot in comparison with E.M.I. in so far as their television activities and plans are concerned!

However the E.M.I. synchronising invention I have in mind is disclosed in a patent specification. Briefly, the idea is that the carrier bearing the modulation of the vision signals has also impressed upon it a frequency for synchronising.

This synchronising frequency is at a greater depth of modulation. That is to say, it is a stronger signal than the vision variations.

Therefore, at the receiver it is a simple matter to arrange things so that the synchronising apparatus (which may be thermionic relays) is affected only by the synchronising impulses, all other current changes leaving it quite unaffected.

I can explain this quite easily by referring you to the second sketch which shows a valve curve. The point marked C is that point on the characteristic of a valve where one endeavours to work in order to obtain undistorted amplification.

Anode Current Changes

If the valve is biased back to the B point, then there will be rectification, for the one-half cycle of the signal will cause a greater anode current change than the other half. But

THE VALVE BIAS

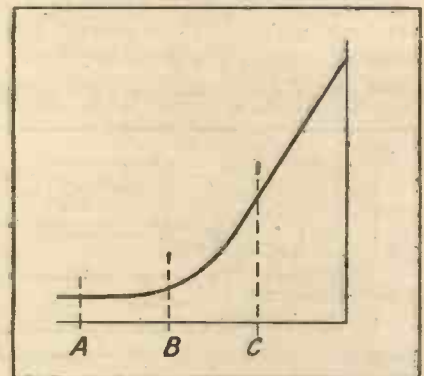

With a valve biased to "A" the ordinary modulation would be ineffectual and only the powerful synchronising impulses would tend to operate the valve.

supposing sufficient grid bias were applied to take the working point right back to A. Then there would be very little, if any, anode current change at all for either half cycle, so long as the positive half did not "swing" beyond the B point.

For normal signals this biasing back would be so drastic that the valve would, in fact, cease to operate. That

is, unless a signal strong enough to cause a swing to beyond the C point occurred. This very roughly is the sort of thing that happens in the E.M.I. synchronising system.

Only the stronger synchronising impulse gets through the biased valve and the relatively weaker vision modulation cannot affect it.

Thinking over this ingenious idea recalled to my mind another television invention which holds even greater possibilities, though I am not so sure about its practicability.

To be quite honest I think it sounds almost too good to be true! However, here it is for your attention, as they say in government offices.

A Suggested Scheme

I should mention, perhaps, that the originator of this invention is my old friend, G. V. Dowding, Technical Editor of this journal. He has worked it out that high-definition television can be accomplished without using any frequencies below 20,000 cycles. That is, for four hundred line, fifty picture stuff.

He bases his argument on the premise that if one whole line occupied only one cycle the bass frequency would be 20,000, therefore, you ought to be able to "chop" anything lower to produce that as your minimum. There may be a fallacy here, but if there is I haven't spotted it yet, and in any case I do see his point that it might well be possible to cut off at that level and still accomplish with the frequencies lying between 20,000 and, say, a million or so all that you want in the way of picture building.

MUCH SIMPLER RECEPTION

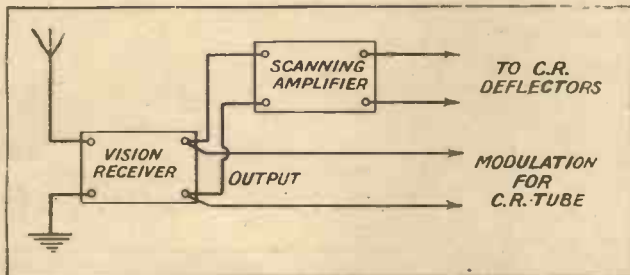

A much simpler method of operation on the receiving side is attained by the use of the transmitted scanning impulses. A schematic sketch of the apparatus required is shown above.

That much sounds perfectly reasonable, doesn't it? Or does it?

Anyway, giving him this first fundamental point, it is clear that we have a carrier on which there are no modulation frequencies below 20,000 cycles.

So he proposes to put his sound in on the same carrier. A first-class sound spectrum with a sharp cut-off at 10,000

which leaves a nice separation gap of from ten to twenty thousand cycles.

If all goes well the television receiver becomes an almost fantastically simple instrument. All you want is the one radio receiver tuned broadly to the one wavelength. Incidentally, an ether channel is saved.

No special filtering would be required to clear away all the vision signals from the sound for any normal loudspeaker ignores all frequencies above—well, let us be charitable, and say ten thousand cycles. Certainly, it would reproduce nothing of the 20,000 upwards vision stuff if it functioned to form. In any case, even if it did the ears would not hear it. Human ears wouldn't, anyway, though an odd squeak or two might get through to a bat!

Sound Filtering

Similarly, filtering the sound stuff away from the vision doesn't sound as hard in theory as it might prove to be in practice. I should have mentioned that the vision signals are supposed to be impressed on the carrier at a considerably greater depth of modulation than the sound. This would have the advantage that there would need to be only about the same degree of amplification for both.

But the real purpose is to enable the sound filtering to be made an easy matter. A cut-off filter allowing only frequencies of 20,000 upwards to get through sounds simple enough. And there is the gap below of ten thousand cycles to allow for residues to attenuate. But in practice it is not always so simple to arrange cut-offs as paper calculations would seem to indicate.

But this is where the greater depth of modulation of the vision signals comes in. A biased valve is proposed working somewhat on the lines of the one I mentioned earlier in this article. This would apply the final knock-out to any sound frequencies that tended to seep in, for it would pass only

the relatively stronger vision signals. Thus, there would be a double filtering effect which ought to prove quite effective.

Recently, I understand that G.V.D. has extended his idea to include scanning frequencies, too, though quite how he does that I do not know, and he is rather secretive about the matter.

ALL ON ONE CHANNEL

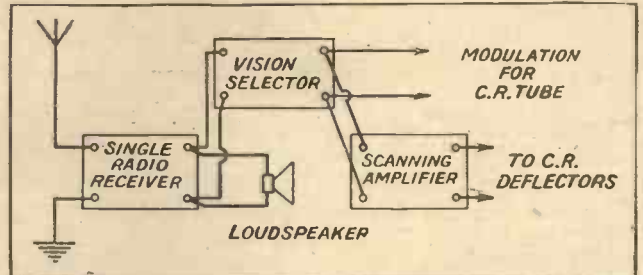

Some idea of the scheme suggested by Mr. G. V. Dowding may be gathered by this diagram.

This would reduce television reception to a single channel. But more, it would mean that all you would want for receiving sound and pictures would be one set with an extra valve or two—which would have on it two sets of output terminals, one for the loudspeaker and one for the cathode-ray tube.

Tuning and operating this outfit would be no more difficult than handling an ordinary sound outfit of to-day. Mind you, although I have said that all this sounds almost too good to be true I have the sneaking feeling that the inventor has at least pointed in a direction of possible future development.

What Is Wanted

Anyway, it seems much more sensible than all this stereoscopic and colour television one continues to hear about. A simplification and cheapening of television is very much wanted. But it seems to me to be almost waste of time at this juncture to worry about colour and stereoscopy.

Television in full natural colours, and with a perfect stereophonic effect is, of course, the ideal, but there is much to be done yet before the foundations are laid of two dimensional television in a single colour. Television has arrived all right. The new high def. stuff is as good as the home-cine, but it will be some time before more than a proportion of listeners will be able to pick it up.

Some won't be able to afford the at-first-rather-expensive gear, and others wouldn't be able to look-in, anyway, because of the transmission-distance limitation.

THE PERFECT PAIR



'00015-mfd.
SHORT WAVE SPECIAL

Cat. No. 2043.

PRICE **5/9**



DUAL RATIO
ARCUATE DRIVE

Cat. No. 2126.

PRICE **6/6**



As yet another instance of J.B. superiority, Mr. John Scott-Taggart has chosen these J.B. Components for his newest short-wave adaptor. The Short Wave Special with silent rotor connection, combined with the Dual Ratio Arcuate Drive make knife-edge tuning simple.

JACKSON BROS. (London), Ltd., 72, St. Thomas Street, S.E.1. Telephone: HOP 1837.

The Game of the CENTURY



Made by the makers of "Lexicon," "Grandfather's Whiskers," and many other novelty pastimes.

3/6

3/6 ONLY

The World's Biggest Jig-Saw and the World's Greatest Travel Game

THRRILLING! Exciting! Enthraling! Instructive! This jolly game is all that and more. It takes you round the world, to lands of romance and mysticism, gives you hours of fun and entertainment and teaches you all sorts of interesting things about the positions of the most important places of the globe. In all there are 500 square inches of Jig-Saw puzzle to be made into a Map of the World. It is an education in itself.

MAPPA-MUNDI

Made by John Waddington Ltd., Makers of the World's Finest Playing Cards. On Sale at all Stationers, Toyshops and Booksellers.

WEARITE

REGD. TRADE MARK

for the "HEXOVERTER" SHORT-WAVE ADAPTOR



The NEW WEARITE SHORT-WAVE COILS

Highly efficient S.W. coils wound on low-loss skeleton Bakelite formers of special design. Pins for standard valve holder mounting. Made in three types as follows:

- Type A (13-28 metres) 3/6
 - Type B (25-50 metres) 3/6
 - Type C (48-100 metres) 3/6
- or set of three Coils. Price 10/6.

SPECIFIED

FILL IN

and post the coupon below for your copy of the Wearite Catalogue of Components with technical data.

The WEARITE SHORT-WAVE CHOKE. Type H.F.3.

A real "standard" amongst S.W. chokes the H.F.3, by reason of the special method of coil winding, etc., has these exceptional characteristics:

Effective induct. 7.5 to 100 metres.
Self Cap. less than 3 m.mfd.
Inductance 4,000 m.h.
D.C. Resist. 50 ohms.



3/6



Here is the famous WEARITE UNIVERSAL COIL, TYPE "A," tunes 180-550 and 750-1,000 metres, is suitable for aerial, anode or bandpass, and of which user writes:

"for selectivity, range and simplicity is all that could be desired. I log more stations than I ever hoped to. PRICE **5/-**"

ASK FOR DETAILS OF THE NEW WEARITE IRON-CORED COILS. Price 7/6.

COUPON

Please send me a copy of Catalogue C.834 together with constructional details, Blue Prints, etc., of Wearite (L.P.) series of receivers, the New Universal Coils and Wave Trap Coils, etc.

Name.....

Address.....

W.6/35.....

TO WRIGHT & WEAIRE, LTD.,
740, High Road, Tottenham, N.7.

★.....SPECIAL TELEVISION SECTION.....★

STROBOSCOPES FOR TIME BASES

Details of a scheme which contains scope for valuable experimentation by readers.

★.....By A. S. CLARK.....★

THE impression that television research and experiment is bound to prove too expensive for the home enthusiast is so strongly embedded in some people's minds that they are inclined to take it as a fact without due consideration. They argue that it is so unlike ordinary reception where little ideas and stunts can be tried out with inexpensive apparatus, often largely home made.

But is this true? Personally, I consider, most certainly not. The trouble is that these people usually have in mind only the major problem of a complete apparatus design for television reception. They forget the multitudinous side issues which simply cry for a little experiment and for the application of a few ingenious ideas.

A Cathode-Ray Snag

It is one of these minor, but nevertheless important considerations that I am going to deal with in this article. And I am going to suggest one line of experiment which may lead one of you to a valuable development, but which certainly offers great interest from an experimental point of view.

The details you must try to work out for yourselves. I have not had

THE DISC MARKINGS

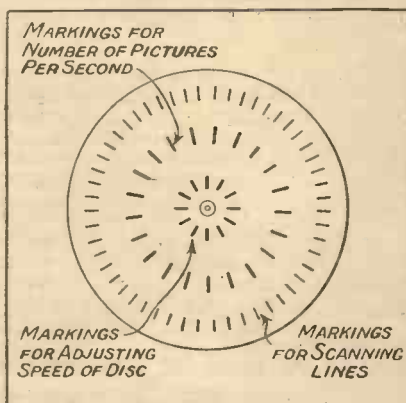

How the three circles of markings might be arranged on the transparent stroboscope disc.

time to get down to them; and if I had, I should be describing a complete design and there would be no researching for you to do!

The matter is one concerning

cathode-ray television receivers. No! Don't turn over, you do not need to possess a cathode-ray tube. That is just where my preliminary point about expense comes in.

But enough of this wandering round the subject. Let's get down to it.

One of the chief difficulties when adjusting the time base of a cathode-ray tube in the endeavour to "tune-in" television pictures is to know when the number of scanning lines and the number of pictures per second are right, or even approximately right. If you are a few lines out or a picture too few per second, you probably will not see anything even remotely resembling an intelligible picture.

Even if you get one of these factors right, and the other is badly out, you will only get a conglomeration of blotches. If you never hit the right combinations you may try all the evening and see nothing!

An Indicator Required

What is wanted is an indicator which will tell you when the two time-bases are operating at the correct speeds. Then you can actually set the television receiver ready for picture reception even before the transmissions begin.

But the thing is how to devise such an indicator. Well, why not develop a special type of stroboscope for the purpose?

Most of you will have seen a stroboscope working on a radiogram, the small marks on it appearing to be stationary when the motor speed is just right. To work it, the stroboscope needs a light which is continually varying in intensity, and this is provided by the electric room-light working off of 50 cycle mains.

In our time base we have the gas-discharge tubes flashing at the same speeds as the cathode ray is scanning the picture screen. So we can use a stroboscope in much the same way as we use one on the radiogram, the difference being that in the case of the time base the varying factor is the light-source and not the speed of the stroboscope.

Of course, we should have very little

light to deal with, but this difficulty could easily be overcome by making the stroboscope of transparent material and viewing the light source direct. I shall refer to this point again in a minute.

Incidentally the gas-discharge tube should give very definite stroboscopic results, because, unlike the electric light filament, its illumination is completely extinguished in between flashes. The electric light remains glowing to a certain brilliancy all the time.

Checking the Motor

The next question is how to ensure that the stroboscope speed, which is in reality our standard, is to be adjusted to exactly the same number of revolutions per minute each time. This is one of the simplest points of all.

PRACTICAL DETAILS

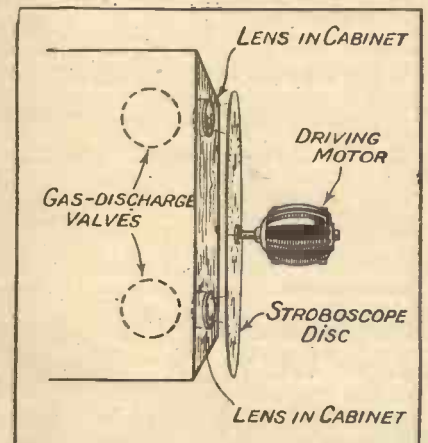

A suggested layout for the motor and disc in relation to the gas-discharge valves.

Either a synchronous motor of the type used for radiograms and which run at a fixed speed, can be used, or a subsidiary stroboscope pattern can be arranged for setting the speed of the motor. In the latter case the procedure would be as follows.

First set the speed of the motor by means of the light from a lamp running on 50 cycle mains. Then switch off the light and proceed to adjust the time-bases by means of the light from the gas-discharge tubes.

A Convenient Design

The number of marks on the stroboscope should be so arranged that they appear to be exactly stationary when the gas-filled valves are flashing, and therefore scanning, at the desired speed. Once the picture was found there would naturally be no point in keeping the stroboscopic device running.

The two diagrams on this page give (Please turn to page 43.)

SPECIAL TELEVISION SECTION

Some Practical Aerials

MUCH has been said about the special ultra-short-wave receivers that will be required for the high-definition television service. Very little, however, seems to have been said about suitable aerials for use with these receivers, and I propose to fill this gap forthwith.

Amateur transmitters, and those who are interested in their doings on the ultra-short waves, have already found out quite a lot about 5-metre aerials. Everything that applies to that wavelength also holds good for the 7-10-metre band, so that much of the initial thinking has already been done for us.

Theory and Practice

The most important thing that the 6-metre enthusiasts have discovered is this: that practice seems to follow theory rather more closely than it does on the "ordinary" short waves. Theory, for instance, tells us that an aerial half a wavelength long, properly fed to the receiver, should give us better results than "any old length," even if quite a lot of height is lost in the shortening process.

In practice this is so. I, for one, can receive 5-metre transmissions on an 8-foot vertical wire inside the "shack" that I can find no trace of on a biggish outdoor aerial.

How nice and convenient the "ultra-shorts" are! For a half-wave aerial is of very convenient dimensions, being roughly 8 feet for 5 metres and 11 feet for 7 metres.

Two Schemes

For reception, two alternative schemes are available. A single wire half a wavelength long may be used, the receiver being fed directly from one end; or a "di-pole" consisting of two

The coming of a television service has brought into prominence the need for special aerials for the reception of the ultra-short-wave broadcasts. Here are some details of simple forms of aerials.

By L. H. THOMAS.

quarter-waves, with feeders of suitable dimensions, may be set up. The latter plan will probably be preferable in many cases, since the aerial itself can be installed on a little mast on the roof, with twin feeders of the "noise-reducing" type coming down into the house.

Fig. 1 shows a folded half-wave type. Since most people won't have rooms 11 feet high, a vertical "end-fed" half-wave aerial is hardly worth considering. We will come, later on, to a way out of that difficulty. Luckily this folded aerial is rather convenient, for 5 ft. 6 in. upwards and another 5 ft. 6 in. across the room can be managed by almost everybody.

I am not claiming that results on this

arrangement will be equal to those obtainable on a straight half-wave; but everything depends upon your locality with regard to the transmitting station.

Fig. 2 shows the genuine di-pole (vertical in this case) with twin feeders. These feeders should, theoretically, run at right-angles to the plane of the aerial for at least a quarter-wave—i.e., 5 ft. 6 in.

The Feeder Length

Separate wires for transposing insulators every few feet will probably be advised "in official circles," but twin flex happens to be quite good, both in theory and practice. The total length of the feeders must be an even number of quarter-waves, which means to say they must be 11 ft., 22 ft., 33 ft., etc. Some people say that they must be an odd number of half-waves, but I can't follow their argument, and, in any case, I find that an even number of half-waves works perfectly on 5 metres.

Now we come to the home end of the aerial. Obviously it's no good installing a perfectly symmetrical di-pole "up in the clear," giving it symmetrical feeders on the way down, and then connecting it across aerial and earth terminals at the bottom! It must remain symmetrical, each feeder being connected on one side of a coupling coil. Possibly this coil may be centre-tapped, the centre being earthed. That doesn't upset the symmetry of the arrangement.

All our coils for these ultra-short waves will be so minute that the aerial coupling coil will only have to consist of four or five turns of about $\frac{3}{4}$ -in. diameter. This should be coupled symmetrically to the input circuit of the receiver, but that is impossible

(Please turn to page 44.)

FOR TELEVISION RECEPTION

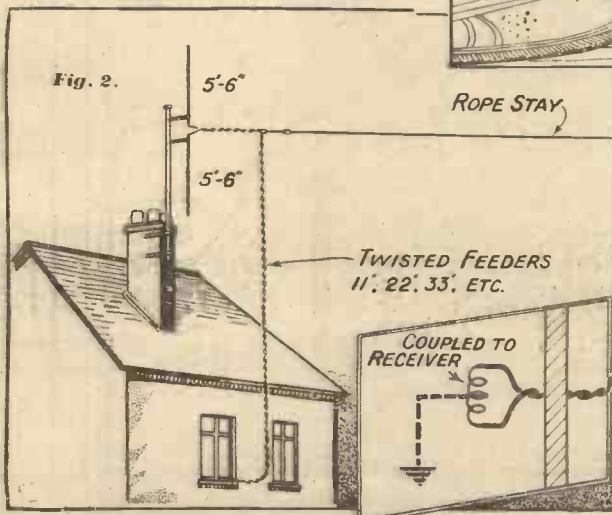
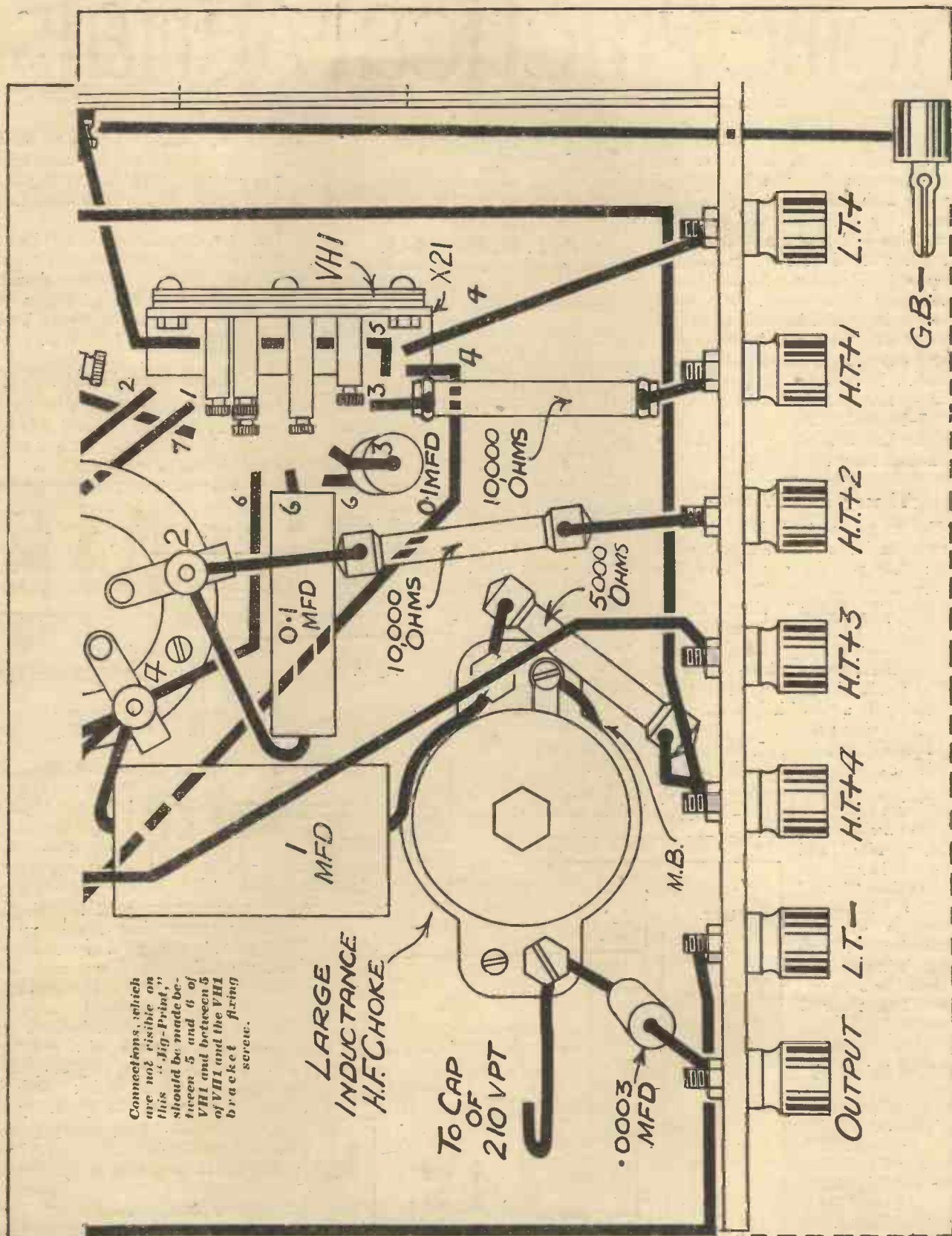

Fig. 1 shows an indoor half-wavelength aerial for short-wave reception, while fig. 2, below it, depicts the use of a di-pole on the chimney stack with a twisted flex feeder running down to the room where the set is situated.

"HEXOVERTER" "JIG-PRINTS" (Contd.)



When this drawing has been linked up with the one on page 24, the lower of the two on page 22 can be joined along its top edge. The complete wiring diagram on page 9 will make quite clear the way in which the sections fit together.

TWO USEFUL HINTS FOR CONSTRUCTORS

If you are getting distortion in your set, one of the most likely causes will be L.F. instability. Naturally, however, there are other sources from which distortion may arise, and while de-coupling will be effective in the first case, it will be pointless to use it if the trouble is due to some other cause.

Any simple method which will enable us to decide whether L.F. reaction is present or not is therefore welcome, and a useful dodge is to connect a resistance, preferably variable, of about 500 ohms in the

TRACKING THE TROUBLE

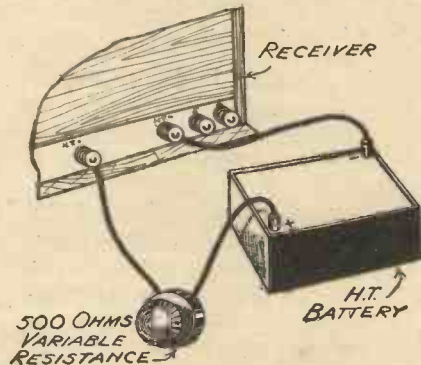

If you have any reason to suspect that distortion in your set is due to lack of decoupling, try this dodge.

H.T. positive lead, or if there is more than one lead, in each of these in turn.

Any tendency towards instability will thus be accentuated. If, however, the resistance makes little difference it is safe to assume that the set is quite stable as regards the L.F. end, and the trouble can be looked for elsewhere.

H. C.

Improvised Indicators

It is no uncommon experience for a constructor when completing a receiver to discover that suitable battery indicating labels are not immediately available.

If the leads are to be passed through the back of the cabinet it is sometimes a difficult matter to trace them, and a good method of preventing any possible risks of connecting the plugs in the wrong sockets is to tie knots in the various leads as an alternative to the indicating tags. One knot can be tied in the H.T. +1 lead, two knots in the H.T. +2 lead, and so on.

In this way the leads can easily be traced and connected in the appropriate H.T. battery sockets.

A. Y.

MR
SCOTT-TAGGART
M.I.E.E. F.Inst.P. Fel.I.R.E.

has **SPECIFIED**

THESE BULGIN COMPONENTS FOR THE

HEXOVERTER S.W. ADAPTOR
FOLLOW HIS EXPERT GUIDANCE!



List No. H.F. 10

4/6
EACH



List No. G.M. 25

5/9
EACH

Left:—**BULGIN SUPER H.F. CHOKE.**

Produced only after intensive research in the laboratories of the House of Bulgin, this H.F. Choke has the astounding inductance of 500,000 μ.H. With its "curve" a straight line from 180 to 2,500 M, this super component is typically "Bulgin" in its performance, quality and reliability.

Below:—**BULGIN GRADED VOLUME CONTROL WITH SWITCH.**

In screened, dustproof case and wound with non-corrodible wire. Rating 250 v. 1 A. with 3-point ON-OFF insulated switch.

Be sure its

SEND FOR 80-PAGE CATALOGUE AND MANUAL NO. 154, "W.T." ENCLOSING 2d. IN STAMPS, TO A. F. BULGIN & CO., LTD., ABBEY ROAD, BARKING, ESSEX.

BULGIN



Specified by the Designer.
"R" Type Terminal
10 at 3d. each



"Bow-Spring"
Wanderplug
1 1/2d. each



Spade
Terminal
2d. each

Use the right Components for the new
"HEXOVERTER"
by Mr. John Scott-Taggart

For a good job well done . . . you can always depend on Belling-Lee Connections . . .

GET THE COMPLETE CATALOGUE NOW--
USE THE COUPON



BELLING & LEE LTD
CAMBRIDGE ARTERIAL ROAD, ENFIELD, MIDDXX

Please send copy of "Radio Connections."

NAME

ADDRESS

W. & T. R. 6/35.

REALITY *in* Reproduction

Do you ever check your reception against the real thing? It is worth doing, as explained in this article by our contributor. He also shows why we do not get complete realism from our radio receivers.

EVERY listener feeling inordinately proud of the realism of his set's reproduction ought to go at least once to, say, the Queen's Hall or equivalent venue of large orchestral combinations.

He ought, moreover, to sit through a varied concert of music played by a magnificently large combination of instrumentalists, preferably on a Wagner night. It is a salutary experience for anyone whose entire enjoyment of orchestral music has come through the loudspeaker. Salutary because it makes you realise how much even the best of radio sets does *not* give you.

The Limits are Enforced

When the concert is over you shake your head, murmuring to yourself that your set has never sounded quite so thrilling as the actual orchestra has done in the hall.

Possibly you search your mind for some clue as to the essential difference between what you heard in the hall and what normally comes through your loudspeaker. Probably you conclude that there is some indefinable adjunct to reality that has so far escaped even the cleverest of radio engineers.

In this you would be rather unfair. Engineers know many ways of adding to radio realism. They cannot put them into practice because it would be uneconomic to do so.

For example, they know what beauty of tone is lost through the guillotining of the higher frequencies of the audible range. They know perfectly well that realism is not possible with a cut-off at, say, 8,000 cycles.

Technical Possibilities

Some of the more enlightened know, too, that by sending out the same programmes through two entirely separate channels, and receiving it on two entirely separate sets—as in stereophonic broadcasting—music takes on a magical bodily presence.

Furthermore, it is known to all engineers that for any given acoustic reception condition the set ought to be provided not merely with a volume control, important though that is in the critical adjustment for realism, but in addition controls for high and low-frequency tone.

Hard economics stop all these aids to realism coming into general use, not ignorance of their advantages. The vexed question of frequency response, of increasing the high note content, involves not merely Governmental but international sanctions of the most difficult kind.

That is to say, before any widespread uplift of the high-frequency response is possible the total number of broadcasting stations must be drastically reduced. Frequencies up to 13,000 cycles definitely add to aesthetic pleasure, as the Bell Laboratories have proved by their historic experiments. Only by reducing the number of stations—or going over wholesale to some form of single side-band working—can this be achieved.

Even supposing that this potent aid to greater realism were allowed, what then? We should come up against a factor all too seldom taken into account. I refer to the restriction by all the broadcasters of the range of sound volumes.

Why Control is Necessary

In the concert hall the intensity range of sound from very soft to very loud may extend over as much as 80 decibels, although perhaps the more normal range in a studio is 60 decibels. It is this difference in sound intensities that makes a visit to a hall or large studio so much more thrilling a way of hearing an orchestra than by wireless.

For now I come to the point. The most that can be broadcast is a sound difference range of 30 decibels. At the B.B.C. the rule is to restrict the audibility range to 24 decibels.

Why this squeezing up of sound? The answer is quite easy to see. Very loud sounds would overload the transmitting valves—not to mention

(Continued on next page.)

CONTROLLING THE VOLUME LEVEL



Mr. Askew at one of the Musical Control desks at Broadcasting House. The modulation meter mentioned in the article can just be seen to the right of the hand.

REALITY IN REPRODUCTION

—continued from preceding page

the average receiver. Very soft sounds would sink down below the "noise level" of transmission and reception.

Control of Loudness

The broadcasting chain has this weakness, then. It cannot cope with the uttermost depths of softness, nor with the uttermost heights of loudness. It is the control engineer's job, knowing the limitations of the apparatus, to see on his meter that the strength of very loud passages is reduced and that the weakness of very soft passages is made good with amplification.

If you peeped, as I did the other day, into the control room at Broadcasting House, you would come upon engineers fingering large black knobs while watching the nervous jerks of the needle of the programme meters.

The Check Meters

These meters have been specially designed by the B.B.C. to keep a check on the programmes, in such a way that they come always within the audibility range imposed by the limitations of the apparatus. It is a clever scheme, I assure you. Equal ratios of sound intensity show as equal differences of scale deflection, so that the check meter provides a direct reading of audible changes of volume.

If you looked closely at the scale you would see its 2½ in. wide dial was divided into seven equal parts. Each division represents 5 decibels, so that the whole scale from 1 to 7 actually covers a range of 30 decibels.

The engineer's job is to keep that meter's needle, which is forever wagging in sympathy with the varying volume of sound being set up at the microphone, within the 1 to 7 limits. Normally they seem to me to juggle with the potentiometers—those large black knobs I mentioned just now—to keep the needle above 1½ and below 7.

Are They Too Zealous?

Indeed, without wishing to cast the slightest aspersion on the good intentions of these engineers, I wonder sometimes if they are not over-zealous with their programme meters. Certain foreign broadcasters appear to me to have a greater contrast in sound volumes. Is it possible we do not enjoy quite the contrast we might?

Perhaps you may imagine I am making an æsthetic mountain out of

a technical molehill. Perhaps I am, and yet I wonder. Anyway, I can quote so great a musical authority as Leopold Stokowski, the famous American conductor, in defence of my thesis.

There is and should be, he says, a very wide range of difference in musical sound volumes if the maximum power is to be gained from the spell of music. One of the greatest joys of music, as he says, is its power to evoke in us moods and states of feeling and being, all of which depend to a large extent on dynamic contrast and gradation—partially lost through the radio medium.

It is just this vital contrast we tend to miss in all broadcast reception of musical programmes. It is just this factor robbing us of the essence of æsthetic pleasure.

Not the Set's Fault

What are we going to do about it? For the moment, nothing. As the other attributes of reality are successively solved we shall have to scrutinise the problem anew. Meanwhile, do not blame your set because it is not utterly real. But perhaps some day, with single side band transmission we shall be able to get at least a better range of frequency response.

PREFERRED and SPECIFIED by

Mr. JOHN SCOTT-TAGGART *for his*

HEXOVERTER

B.T.S.

PLUG-IN SHORT WAVE COILS



PRODUCT of the pioneer manufacturers of popular priced Short Wave Plug-In Coils. Expertly designed and constructed and consistently specified by the leading Radio Journals. Discriminating constructors should refuse all imitations and insist upon *B.T.S.* . . . the choice of Mr. John Scott-Taggart for the Hexoverter Adaptor described in this issue.

TWO PAIRS 16/-
 16-38 metres
 28-60 metres
 4-PIN TYPE K

EXACTLY AS SPECIFIED THE SET

FROM ALL DEALERS. If any difficulty, send direct.

● Send for lists of the famous *B.T.S. Short Wave and Television Kits and S.W. Adaptor . . . everything Short Wave and Television.*

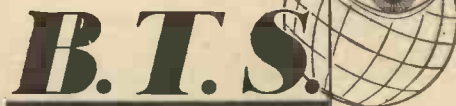

Short Wave and Television Specialists

BRITISH TELEVISION SUPPLIES, LTD. (Dept. W.), BUSH HOUSE, LONDON, W.C.2.
 Telephone: TEMPLE BAR 0134. Telegrams: TELEVIEW, BUSH, LONDON

THE GRANDFATHERS' CLUB

And other interesting radio and record stars are here discussed by our gramophone critic.

It is almost a foregone conclusion nowadays that a person's success in a radio debut will soon be followed by the issue of records of that artist. No matter whether the artist is otherwise well known or is a new arrival to the microphone, if the broadcast is a success, and specially if it has an element of novelty or a story behind it you may be pretty sure that it will not be long before those familiar black discs bear the name of the broadcaster.

One of the latest broadcast novelties that have been subsequently recorded is the singing of members of the Grandfathers' Club. They appeared in an "In Town To-night" programme in February and were soon snapped up by the Regal-Zonophone who have now released a record of 300 of the old fellows.

The Club is certainly unique, and so is the record. The G.C. was founded last October, and all its members are over sixty and are drawn from the same district of North London. Today there are 340 members, and 300 of these are musically inclined and combined to make the record.

The headquarters are at the Holloway Baptist Church, and it was here that the old fellows lifted up their voices for the benefit of gramophone users.

Energetic Singing

These veterans attend the club each day, starting with a service and then continuing with games and practising for musical items—and these grandpas have plenty to occupy them in their musical activities.

In the record four well-known ballads from their repertoire were chosen and sung with great gusto, the solos being taken by George Avery, a youngster of 66, and Tom Harmon, who boasts 77 years. The number of the record is MR1645, and it is certainly one of the novelties of 1935.

A rapidly coming figure in radio is Mantovani, whose Tipica orchestra is a well known combination on the air,—and, of course, at the restaurant at which it plays. Mantovani is of Italian stock, as you would guess from his name, and is 29 years old. It is said that his style of playing represents the dance music of the future; music without blare or extravagance.

Incidentally, Mantovani employs

THE RADIO THREE



Here are the three ladies who have been singing with Maurice Winnick and his orchestra. They are, Kay Cavendish (pianist), Joy Worth, and Ann Canning, the founder of the act.

both his father and his sister in the band, the latter acting as croonette. She is the 24-years-old Stella Nelson, and has been in the show business for some twelve years.

If you are a follower of Guy Lombardo, the famous Canadian leader of the dance band with the particularly sweet saxophone tone, which records for Brunswick, you will have enjoyed the recent broadcasts of Maurice Winnick and his orchestra, which sounds very like Lombardo's band in some ways.

It is now playing at the San Marco Restaurant. You may remember that Maurice Winnick used to record for Papachord while he was playing at Ciro's. Ciro's closed, and for too long this energetic and enterprising band was lost to records and to the West End.

Now the combination is to be heard

on Decca, the latest records being F5505 and 5506, and the saxophone tone is extremely reminiscent of that in Lombardo's band. Maurice Winnick and his band are going to be worth watching, they will go very much further.

A New Vocal Trio

And, finally, a new trio that is to be heard with Winnick and that is meeting with acclaim everywhere, though I have not yet heard a record of them—**The Radio Three**. Here they are on this page—Kay Cavendish, the pianist, Joy Worth, and Ann Canning. And here is their history:

Kay is an athlete, played lacrosse for Surrey and S. England. Fenced for team for England. Golf handicap is six! Has played under the baton of Sir Henry Wood in classical piano compositions.

Joy Worth was born in Java. Sister of R. A. C. Butterworth, the Oxford Blue. Presented at Court in 1928, two portraits of her by different artists "hung" in 1932.

Third member is Ann Canning. Cambridge graduate, and founder and leader of the act. Descendent of Prime Minister Canning.

I like the trio, they sound good, and should go far.

K. D. R.

LISTEN TO THESE

Records from the latest lists that you should hear.

JUBILEE.

Ambrose and His Band have made a special Cavalcade of song hits that cover the years of H.M. the King's reign. (Decca K750.)
Scrapbook for 1910. The first of the Leslie Baily Scrapbook broadcasts recorded in condensed form. Excellent entertainment for the reminiscence. (Col. DX670.)

Twenty-five Years of Musical Comedy. Excellent discs by Gerardo and his Orchestra. (Col. DX679-80.)

VOCAL.

An Old Sacred Lullaby. The Irish tenor, John McCormack, is again heard. Other side is "Candle Light," dedicated to "everybody's mother." (H.M.V. DA1404.)

Born to be a Clown. Our friend Gracie Fields in another of her artistic gems. (H.M.V. B8298.)

Swanee River. The inevitable Bing Crosby. Other side has what is said to be his finest record, "It is Easy to Remember." (Brunswick O1993.)

INSTRUMENTAL.

Majorca. Pipe composition written by H.R.H. Prince of Wales. Played by Scots Guards. (H.M.V. B8292.)

Torch Song Parade. Sidney Torch on cinema organ. Medley of old favourites. Excellent recording. (Col. DX674.)

Beethoven's Eroica Symphony. A superb piece of work played perfectly under the baton of Serge Koussevitsky. (H.M.V. DB2346-51.)

Bolero. Ravel's masterpiece played on—what do you think? The mouth organ. Artist is Larry Adler and the record is Col. DB1516.

DANCE NUMBERS.

I'm Afraid to Open Your Letter. Teddy Joyce and his orchestra. (H.M.V. BD138.)

Oh, Fred! The B.B.C. dance orchestra disports itself in a comedy waltz. (Col. FB1023.)

Blue Moon. Roy Fox and his band. Good record both sides. (Decca F5410.)

SPECIAL TELEVISION SECTION

—continued from page 30.

far apart as, say, Berlin and Munich by means of a "television cable." I understand that two-way television transmission has been effected over relatively short distances, and is believed to be quite practicable over much longer distances, the obstacle being, however, the enormously high cost of the special cable required.

"Delayed" Television

The system of "delayed" television, to which I have referred previously in these notes, is also being rapidly improved, and a service is already being inaugurated whereby a number of "news vans" go around taking short "news reels," these being then used for the purpose of television transmissions after a very short time-interval.

* * *

I said something about cathode-ray screens, but there will, of course, be plenty of mirror-drum and disc receivers in use when television gets going, especially so far as home-constructed sets are concerned. For these it is preferable to have a translucent screen, such as one of "ground glass." The latter material, although very convenient in some ways, is generally too coarse in the grain, with the result that it scatters the light too much, and the observers have to stand as nearly as possible in the path of the light beam if they are to see the picture at its real brightness. If they stand a little to one side—which some of them are more or less bound to do—the brightness and clearness of the image they see are greatly diminished.

A Simple Screen

The drawback can largely be got over by using a translucent screen of much finer optical texture, such as a sheet of waxed paper, or a sheet of draughtsman's tracing paper or tracing cloth (the latter serves the purpose excellently, and is easy to obtain and robust to handle). Care must be taken with any of these screens, however, particularly the waxed paper, not to fold or crease them, otherwise they will develop large white opaque lines across them which will destroy their usefulness for the purpose of a screen.

* * *

It has been suggested by a well-known radio society that when the new high-definition television service begins, the present 30-line system on

broadcast wavelengths should *not* be done away with, but should be retained for the benefit of those who do not wish to go in for short-wave receivers—either on the question of cost or operating—or those who want to experiment first with 30-line reception, and then go further to high-definition reception after a little practice.

Rather Doubtful

This strikes me as having a good deal to recommend it, at any rate so far as the public are concerned, but whether the P.M.G. will consider the expense worth while, when a perfectly efficient high-definition service is in operation, remains to be seen. Personally, I doubt very much whether the suggestion will meet with official approval. I think you will find that when the B.B.C. has been to all the expense and trouble of setting up a full-blooded high-definition service, it won't want to be bothered with an out-of-date system.

Question of Definition

One of the questions which still remains undecided is whether the definition to be adopted in the forthcoming high-definition television service is to be 180-line, 240-line, or a higher figure. It is important that this point should be settled as soon as possible, because it makes it very difficult for manufacturers who are contemplating entering the television market if they do not know the basis on which to base their designs. You will remember that the P.M.G.'s Committee recommended 240 lines, "or even higher," but that was purely a recommendation. Some people maintain that, whereas the practical difficulties are greatly increased in going from 180 lines to 240 lines (especially with mechanical systems) the advantage gained in definition is not in any way comparable and that therefore the higher definition is not justified.

* * *

Many people have asked me whether the "television people" are ready to "send out" television, or whether we are waiting for the P.M.G. or what? I suppose this is a very natural question for members of the public to ask. The fact is, however, that the Baird Company, for one, are "all set" for starting a television transmitting service at this moment. What we are really waiting for now is the settlement of various outstanding points (such as the question of definition), and for the necessary arrangements to be made by the B.B.C. for the actual carrying into effect of the Committee's recommendations and the setting-up of a service, an enormous task.

PETO-SCOTT

IMMEDIATE DELIVERY CASH C.O.D.

Build with a Pilot Author Kit and make a 100 per cent. success certain. Since 1919 the most popular Kits with Home Constructors the whole world over because they are exact to the designer's specifications and are complete down to the last screw.

PILOT AUTHOR KITS HEXOVERTER

AS FIRST SPECIFIED by
Mr. JOHN SCOTT-TAGGART

KIT "A" CASH or C.O.D. £4:14:6
Carriage Paid
Author's Kit of First Specified OR YOURS FOR parts, less Valves and Cabinet and 11 monthly payments of 8/6. **8/6**

KIT "B." As for Kit "A." but including set of 2 specified Valves, less Cabinet. Cash or C.O.D. Carriage Paid, £6/5/6, or 12 monthly payments of 11/6.	KIT "C." As for Kit "A." but including set of 2 specified Valves and Peto-Scott specified Cabinet. Cash or C.O.D. Carriage Paid, £7/3/0, or 12 monthly payments of 13/-.
---	--

PETO-SCOTT CABINET AGAIN SPECIFIED Soundedly constructed with Macassar Ebony Panel Surround, lift-up lid and removable back. Cash or C.O.D. Carriage and Packing 2/6 extra. **17/6**

FINISHED INSTRUMENT
Ready Assembled exactly to Mr. John Scott-Taggart's Specification. Including Valves and Specified Peto-Scott Cabinet. With 4 Coils. Aerial tested on S.W. Telephone. Cash or C.O.D. Carriage Paid, £8/0/0, or 12 monthly payments of 14/9. **14/9**

KIT-BITS You pay the Postman. We pay post charges on all orders over 10/- **GT. BRITAIN ONLY.**

- 1 Peto-Scott Ready Drilled Aluminium Panel, £ 3 0
- 12" X 7"
- 1 Peto-Scott Metaplex Screen, 10" X 6 1/2" X 5/16" with hole for S.G. Valve 1 6
- 1 Peto-Scott Metaplex Baseboard, 12" X 10" X 5/16" (Metallised on one side) 1 6
- 1 Peto-Scott Ready Drilled Ebonite Terminal Strip, 12" X 3" 1 6
- 1 Peto-Scott Bracket for mounting 7-pin Valve Holder 6
- 2 Pts. B.T.S. 4-pin 8 W. coils, 16 to 38 metres, and 28 to 60 metres 16 0
- 1 J.B. "Short-Wave Special" Osc. Tuning Condenser, 00015-mfd. 5 9
- 1 J.B. Dual Ratio Arcuate drive 6 6
- 1 Polar Type "C" Condenser, 00015-mfd. 8 6
- 1 MARCONI-OSRAM X.21. 18/6; 1 COSSOR 210 VPT., Metallised, 13/6 112 0

ONE-POINT-FIVE

KIT "A" CASH or C.O.D. £5. 5. 0
Carriage Paid
Comprising Author's Kit of parts as First Specified and used by Mr. John Scott-Taggart including Ready-drilled ebonite panel, ebonite terminal strip and baseboard ready-fitted with metal foil, less Valves, Cabinet and Speaker. **OR YOURS FOR**

9/6
and 11 monthly payments of 9/6.

KIT "B." As for Kit "A." but with Set of 4 Specified Valves only. Cash or C.O.D. Carriage Paid, £7/9/0, or 12 monthly payments of 13/6.	KIT "C.T." As for Kit "A." but with Valves and PETO-SCOTT One-Point-Five Table Cabinet. Cash or C.O.D. Carriage Paid, £8/8/6, or 12 monthly payments of 15/6.
---	---

KIT "CC" As for Kit "A" but with Valves and PETO SCOTT One-Point-Five Console Cabinet with Shelf and Baffle, less Speaker. Cash or C.O.D. Carriage Paid, £9/18/6, or 12 monthly payments of 16/3.

CONVERSION KIT

S.T.400 to ONE-POINT-FIVE

● All parts required for converting your S.T.400 to the One-Point-Five. Comprising 1 PER-RANTI 300,000 ohms resistance; ERIE 1-watt resistances; 3 CLIX wander plugs; 1 WEARITE type "A" coil; 2 GRAHAM FARISH Litos log.-mid.-line condensers; 1 POLAR Compax 00075-mfd.; 1 ORMOND Extractor condenser; 1 POLYVON S.T.600 Extractor coil; 1 BULGIN 8.36 switch; 1 LISSEN 00005-mfd.; 1 T.C.O. 1-mfd.; 1 DUBILLIER 75,000 ohm.; 1 BELLING-LEE terminal; 1 PETO-SCOTT terminal strip, 16" X 3"; connecting wire, screws, flex. Less Valves and Cabinet. Cash or YOURS FOR C.O.D. Carriage Paid £1/16/0. Or 6 monthly payments of 6/9. **6/9**

PETO-SCOTT CO. LTD.
77(W.7), CITY ROAD LONDON, E.C.1.

Telephone: Clerkenwell 9406/7
West End Showrooms: 62 (W.7), High Holborn, London. EST. 1919
W.C.1. Phone: Holborn 3248

IMPROVING RECEPTION



Now is the time to pay special attention to small but important details such as the efficiency of your Aerial and Earth contacts.

CLIX HEAVY DUTY A.E. CONTACTS

allow Aerial and Earth leads to be taken direct to set sockets or terminals without any breaks or joins; the special metal to metal wiring device takes any insulated wire up to 1/8 in. overall.

3d. each.

CLIX SPECIFIED FOR THE "HEXOVERTER"

- One 7-pin Airsprung Chassis Mounting Valveholder - 1/4
- Five "Master" Wander Plugs - 1d. ea.
- Two Spade Terminals - 1d. ea.



CLIX

Folder "C" Free.

CLIX latest Chassis mounting Strips with terminals and socket contacts. Now available A-E or L-S. Ea. 6d. Solid Plugs for use with above. Ea. 2d.

LECTRO LINX LTD.,

79a, Rochester Row, London, S.W.1

READY in 3 MINUTES



to make **better, cleaner, quicker, cheaper joints SOLDER ELECTRICALLY**

with a



BRITISH THROUGHOUT

7/6

65 WATTS
125 watts 22/6
240 watts 37/6

So simple . . . plug into the nearest lampholder . . . switch on . . . and there you are!

W. T. HENLEY'S TELEGRAPH WORKS Co., Ltd.
Dept. 24 Y.K. Holborn Viaduct, London, E.C.1

THE GERMAN TELEVISION SERVICE

By Dr. Alfred Gradenwitz.

WHEN the new German television service was opened on March 22nd, the event was hailed officially as "a decisive hour in the history of German radio," and discussed over the Television Transmitter by various leaders of radio and post office authorities.

It was pointed out that television would not mean competition, but rather a new stimulus to the film industry. Nor would there be competition between television and the cinema, the adoption of television projectors being an invaluable addition to the resources of a topical picture service.

Mutual Co-operation

While it is thought that firms engaged in television work will try to bring out television receivers manufactured in quantities, though without any price limitations, at the next radio exhibition, a mutual co-operation of firms is suggested, in case the risk of manufacture and marketing should prove prohibitive to individual firms.

It is not thought likely that television receivers should for some time to come be available at prices accessible to the average mortal; in fact, what is anticipated for the near future is a most powerful stimulus to amateur activities.

As stated by the German post office, the "technical account rendered by the British Postmaster-General is mainly identical with the views held by German authorities with regard to the introduction of television," and "they are able in Germany even now to open a television service which practically anticipates what in England is planned for the autumn."

Standards to be Improved

According to an agreement concluded between the German Radio Broadcasting Corporation and the German Post Office, the latter will be relied upon to do the actual development work.

Moreover, it will, as in the past, operate the wireless transmitting stations, whereas the television transmitters (the same as microphones and amplifiers) will be provided and operated by the German Radio Broadcasting Corporation.

While the latter is allowed a free hand in choosing the firms supplying

the necessary apparatus, it will, in conjunction with the Postal Department, draft a Book of Terms, comprising the conditions which the design of any television transmitter will have to comply with. Also, a close co-operation and exchange of working experience between the parties concerned is anticipated and being arranged for.

The present German television standards, viz 180 lines, 25 frames per second, are by no means considered final, but are likely to be further improved in the near future. In the meantime, there will be required a certain choice with regard to pictures to be televised, preferring those with a limited number of persons and close-ups.

While in the case of black-and-white drawings, e.g. in connection with cartoons, normal positive prints can be used, one showing little contrast, will nearly always have to be made of standard films comprising all intermediate shadings between white and black. Present television programmes mainly comprise what is called the Mirror of the Week, viz., an illustrated review of its principal happenings, and amusing as well as instructive pictures.

The new television service has met with general enthusiasm, and has, so far, been working without any hitch.

SEEING THE ELECTRONS

PERHAPS the title of this short article is not quite as accurate as it should be, and "Seeing the path taken by the electron-beam in a cathode-ray tube," would be more strictly correct. But then that would be rather long for a title, and after all, what's in a title?

Anyway, the whole thing concerns an ingenious tube, which has enabled the designers at the Ediswan factory to study the electron beam in its path through the deflectors and various other electrodes in a cathode-ray tube.

As you know, the beam of electrons is quite invisible to the eye, and its presence is only made known by the spot of light that occurs on the fluorescent screen when the beam strikes it, or by the glass of the tube itself going fluorescent when the beam wanders off the screen. The tube shown in the diagram enables the way in which the beam is bent by the deflectors to be seen quite clearly, and the effect of focusing becomes visible together with many other phenomena

connected with the beam's transit through the tube.

The construction is similar to that of an ordinary cathode-ray tube, with the exceptions that the glass does not increase in size at one end, and there is no fluorescent screen. The cathode, accelerator, etc., are all arranged in the normal manner.

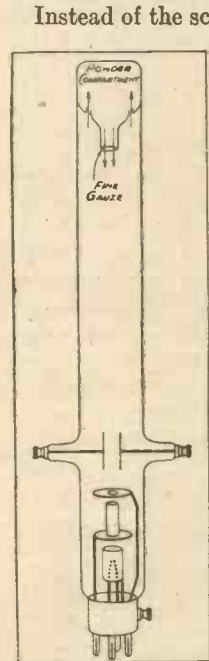

Instead of the screen, this end of the tube is provided with a powder compartment. As the arrows in the diagram indicate, the powder must come out via the tube, which has a

A diagrammatic section of the special cathode-ray tube used for watching the position of the electron stream.

piece of gauze over its end to ensure a fine cloud of powder falling.

When all the powder is out, the tube is simply inverted and the powder shaken back into its compartment via the other holes. It cannot come back out of these holes due to the ridges shaped in the glass.

The powder employed is of a special nature, so that it becomes fluorescent as soon as the electron beam strikes it. Thus the beam becomes visible as the cloud of powder slowly falls.

A. S. C.

STROBOSCOPES FOR TIME BASES

—continued from page 34.

a suggested arrangement which might be adopted for the scheme. The first one shows the stroboscopic disc itself. This could be of glass, or alternatively it could be a thin metal construction with celluloid let in where the two outer circles of marks occur.

In the centre is the circle of markings for the setting speed of the disc. Then come the markings for the number of frames, (a fairly low figure), with the markings for the number of lines on the outside.

The second diagram shows how the disc is mounted in relation to the time base. The latter must be housed in a light-tight cabinet with two small holes, possibly with lenses fitted, arranged to let the light from the gas-

discharge valves fall on the two outer circles of markings.

One hole is arranged on either side of the disc so that the light from one valve does not confuse the issue of the timing for the other. So long as the light covers three or four markings on the disc there should be no difficulty in noting when they are stationary.

THE "HEXOVERTER" RAPID CONSTRUCTION GUIDE

—continued from page 17.

- (13) O.T.C. moving vanes to O.C.B.4.
- (14) O.C.B.4 to metallising terminal of V.H.₁ (6).
- (15) V.H.₁ oscillator anode (1) to O.C.B.1.
- (16) O.T.C. fixed vanes to O.C.B.3.
- (17) O.C.B.3 to V.H.₁ oscillator grid (2).
- (18) V.H.₁ fil. (5) to screen (Metaplexed plywood).
- (19) V.H.₁ anode (7) to S.W. choke in mid air.
- (20) S.W. choke to Bulgin superhet choke. Keep S.W. choke terminal clear of superhet choke case.
- (21) Bulgin choke to '0003 mfd. Lissen.
- (22) V.H.₁ metallising (6) to V.H.₁ fil. (5).
- (23) V.H.₁ fil. (5) to V.H.₁ bracket fixing screw. (22 and 23 are not shown on "jig-print." See diagram on page 9.)
- (24) V.H.₁ screen grid (3) via 0.1 mfd. tubular to V.H.₁ metallising (6).
- (25) Bulgin superhet choke via 0.1 mfd. to screen.
- (26) Bulgin superhet choke to 5,000 ohms Ferranti.
- (27) 5,000 ohms Ferranti to H.T.+4 terminal.
- (28) O.C.B.2 via 0.1 mfd. to V.H.₁ metallising (6).
- (29) V.H.₁ fil. + (4) to V.H.₂ fil. + (lower filament terminal).
- (30) '0003 mfd. Lissen to V.H.₂ control grid. Screw the two 0.5 Dubilier 9200 into their bases.
- (31) 0.5 mfd. Dubilier 9200 to V.H.₂ screen grid.
- (32) V.H.₂ screen grid to 5,000 ohms Ferranti.
- (33) 5,000 ohm Ferranti to H.T.+3 terminal.
- (34) 0.5 Dubilier to 3-point switch.
- (35) 0.5 Dubilier to V.H.₂ fil. — (upper filament terminal).
- (36) V.H.₂ fil. — to O.C.B.4.
- (37) O.C.B.4 via 1 mfd. tubular to Goltone choke.
- (38) Volume control to 3-point switch.
- (39) 0.5 mfd. to 0.5 mfd.
- (40) V.H.₂ control grid via 1 megohm to 0.5 mfd.
- (41) 0.5 mfd. via 100,000 ohms to volume control (middle terminal).
- (42) L.T. — terminal to 3-point switch.
- (43) Goltone choke via 5,000 ohms to H.T.+4 terminal. (Keep bare wires clear of fixing screw on choke).
- (44) V.H.₁ screen grid (3) via 10,000 ohms to H.T.+1.
- (45) O.C.B.2 via 10,000 ohms to H.T.+2.
- (46) Volume control to G.B. — plug. Lead passes along baseboard and through hole in terminal strip.
- (47) Goltone choke to 210 V.P.T. anode cap.
- (48) Goltone choke via '0003 mfd. to output terminal.
- (49) V.H.1 fil. + (4) to L.T. + terminal on strip.
- (Q) Fit knobs to aerial coupler, aerial tuning condenser, volume control and oscillator tuning condenser.

Your short-wave adaptor is now complete.
J. S.-T.



SHORT WAVE
FREQUENCY
CHANGER

for

BATTERY SETS



THE problem of frequency changing

has worried most of us, particularly when dealing with the short waves. It is admitted that electronic methods of coupling are best, but no single valve is entirely satisfactory. An interesting method of employing Marconi X21, 2-volt heptode, has been evolved, and details will be sent to those who are working in this field.

WRITE TO THE VALVE DEPARTMENT, MARCONIPHONE COMPANY LIMITED, 210 TOTTENHAM COURT ROAD, LONDON, W.1, MENTIONING THIS PAPER.

MARCONI
VALVES

THE CHOICE OF THE EXPERTS

SOME PRACTICAL AERIALS

—continued from page 35.

unless the first stage uses push-pull. If it doesn't, one side of the grid coil will be earthed, and the other side "live."

We have to compromise, here, by using quite loose coupling from the aerial. Variable coupling, too, can be quite easily arranged.

Distinct Possibilities

Mr. Victor King, in the April issue, described a scheme for using a short aerial in series with the ordinary broadcast receiving aerial, one being isolated from the other by an ultra-short-wave choke. This scheme has distinct possibilities, its chief advantage being that you can use an end-

fed half-wave (11-ft.) aerial which is out of doors.

Other schemes come to mind—suspending your ultra-short-wave aerial from the guy-wires or halyards of your main aerial, for instance. In passing, I should like to hint that halyards should preferably be of rope, not of wire. With an 11-ft. aerial hanging from a large horizontal length of wire, which possibly earths itself at the far end, you'll never know quite where you are.

There is another point to consider, too—the type of aerial used by the transmitting station. Amateurs on 5 metres invariably find that a station transmitting on a vertical aerial is received best on another vertical. Vertical transmitting aerials seem to be in favour at present with the two firms mainly concerned with television. *Verb. sap!*

I don't think you need worry overmuch about earths. You can't help using an earth on the short and ultra-short waves, even if there's actually no metallic connection. The capacity of the gear to earth, at these tremendous frequencies, provides a path of quite low impedance—probably far lower than that of a long wire.

Try out these aerial schemes on 5 metres, bearing in mind that a quarter-wave is about 4 ft. 2 in. for the amateur band. There's plenty doing on that band in London nowadays.

is another variation. In this system the rectifier is biased so that weak signals do not operate it—the A.V.C. rectifier, that is—and no control is put upon the amplification of the valves. If for some reason very weak signals are wanted, all the available amplification is then helping to make those signals audible. At the same time when the tuning control is switched to a strong signal the A.V.C. will operate, and so save a sudden blare through excessive amplification.

Amplified Control

In really ambitious sets you may find amplified automatic volume control. Here the relatively slight changes of rectified current, developed for A.V.C., are amplified for their work on the control of the high-frequency amplification. A V.C. is certainly an ingenious scheme and those of you not conversant with its operation should try a friend's set that has A.V.C. and handle it a bit—you'll be surprised.

Be guided by
Mr. Scott-Taggart

ERIE RESISTORS

Specified for the
"Hexoverter" Short-Wave Adaptor

Be sure to use Eries. Their quality is a definite step ahead—the perfection of stability! All designers and manufacturers specify Erie Resistors for reliability. Sold at all dealers.

1/- Per Watt in all Values

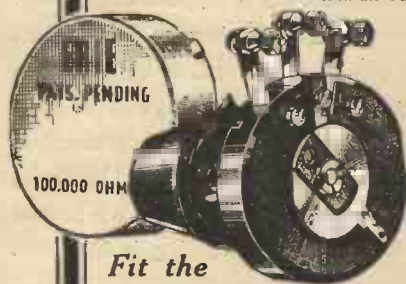

Fit the
ERIE VOLUME CONTROL

The variable resistance that will never develop faults. Permanently noiseless. No hop-off noises. The Erie resistance element and precision construction give smooth and positive contact for a life-time's use. Specified by all leading designers. All sizes 50,000 ohms to 2 megohms.

3/6

or with built-in mains switch 5/-

★ Send for the "Erie Resistor Service Instruction Booklet." Post Free.

The Radio Resistor Co. Ltd., 1, Golden Sq., London, W.1

CABINETS. Write for Free List
GILBERT (cabinet maker), SWINDON.

All communications concerning advertising in "Wireless" must be made to Advertising Department. John Carpenter House, John Carpenter Street, London, E.C.4.

Masterpiece Library of Short Stories. **2**

Printed in Great Britain and published on the 15th of each month by the Proprietors, THE AMALGAMATED PRESS, LTD., The Fleetway House, Farringdon Street, London, E.C.4. Advertisement Offices: John Carpenter House, John Carpenter Street, London, E.C.4. Registered for transmission by Canadian Magazine Post. Subscription Rates: Inland and Abroad, 8/- per annum; Canada only, 7/6 per annum. Sole Agents for South Africa: Central News Agency, Ltd. Sole Agents for Australia and New Zealand: Messrs. Gordon and Gotch, Ltd. S.S.

A.V.C. v. FADING

—continued from page 4.

signal—it does not work at all. As soon as a signal comes along this bias is lifted, and the valve passes signals in the usual way.

Delayed automatic volume control

INDEX TO ADVERTISERS

Alfa-Kubes	Cover iii
Automatic Coil Winder and Electrical Equipment Co., Ltd.	1
Belling & Lee, Ltd.	37
British Television Supplies, Ltd.	39
Bulgin, A. F. & Co., Ltd.	37
Cole, E. K., Ltd.	Cover iv.
Gilbert, J. C. (Cabinets)	44
Gramophone Co., Ltd.	2
Henley's, W. T., Telegraph Works Co., Ltd.	42
Jackson Bros (London), Ltd.	33
Lectro Linx, Ltd.	42
Mappa-Mundi	33
Marconiphone Co., Ltd.	43
Masterpiece Library of Short Stories	Cover ii	
Peto-Scott Co., Ltd.	41
Radio Resistor Co., Ltd.	44
Wingrove & Rogers, Ltd.	1
Wright & Weaire, Ltd.	33

J. S.-T.

FROM MY ARMCHAIR

—continued from page 26.

The article is unconventional in that most designers present only the good features of this department of radio. But I hope all my readers will be sensible and not be "put off" by my restrained attitude. The "Hexoverter" will, I am convinced, give ten times—at least, so my meters tell me—the results from other adaptors.

You may find the article interesting simply as a straight-from-the-shoulder analysis of short-wave reception, but you will find the "Hexoverter" much more so. As a means of exploring what to most listeners is a romantic but hidden band of wavelengths.

The LATEST CRAZE

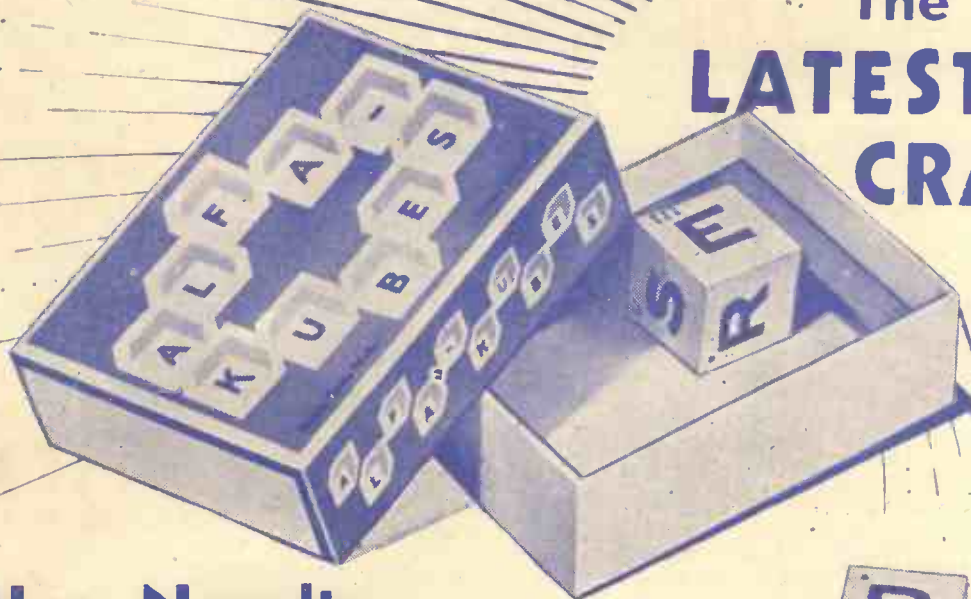

New Novelty Word-Making Dice Game

Fun from A to Z—Witty, Wise and Wheezy—Easy, Too

Can you spell? You don't need to be a first-class speller to enjoy the new and breezy game of making words and scoring points with ALFA-KUBES, but the better you spell—and the more quickly—the bigger will be your score. ALFA-KUBES are six square dice, each with six different letters; and each letter is given a numerical value from one to six. The game is just to throw your ALFA-KUBES as you would ordinary dice, and then make up a word quickly from the letters turned up. You score by adding together the "pips" on each letter of the word you make. That's where skill comes in again. Different words have different value, and those who jump quickest to the highest scoring combination win the game.

Simple, isn't it? And you can see plenty of fun in the offing! What about those bad spellers? What about those who choose a five-letter word thinking that it will count more than one with four? It may not; it's the "pips" that score. See how it goes! Any number can play. It's a game that can be played at any time, both by adults and children. All the family can join in. It costs 1/- only, and the excitement and thrills you can get out of it will be worth that modest sum many times over. ALFA-KUBES will cast its spell on all who play it. Why not invest in a set to-day?



Trade Enquiries to The CHAD VALLEY Co., Ltd., Harborne, Birmingham.

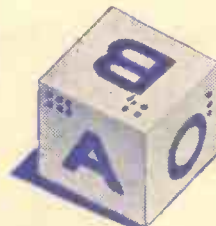

ALFA-KUBES

1/-
Of all Newsagents, Booksellers, Stores and Toyshops.

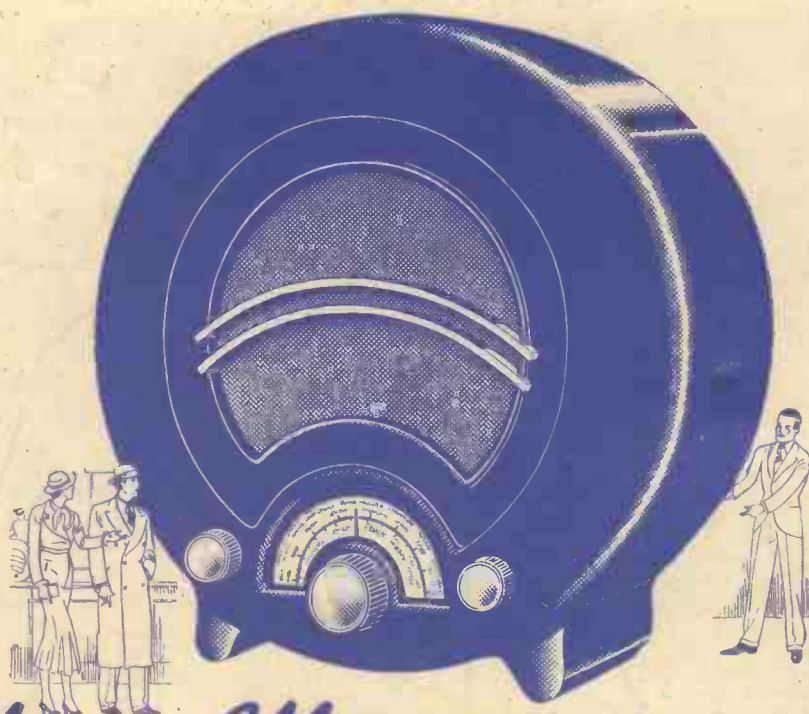

A New Masterpiece — in Price & Performance

Will it operate on A.C. and D.C. mains?

How many valves?

Does it get many foreign stations?

Is it easy to tune?

The cabinet is very handsome!

Has it a moving-coil speaker?

Can one purchase on easy terms?

Certainly. It is a Universal set suitable for mains of 200 to 250 volts

Four, including rectifier

It is an 'All-Europe' receiver, charted by station-name to give 38 stations. Many others should be received

Simplicity itself—just one-knob station-by-name tuning

Yes! It is magnificently moulded, and there are two finishes, figured walnut or black and chromium

Yes, with a natural tone and very generous output

Certainly. Initial payment of 14/6d and 12 monthly payments of the same amount—or approximately 3/6d per week

AND THE PRICE?

8 GNS.

MODEL AD36. Walnut finish 8 gns.
Black and Chromium, as illustrated, 10/6 extra.

Ask your Radio or Motor Dealer for particulars of Ekco Car Radio.

EKCO Radio

TO E. K. COLE LTD., DEPT. D.9. EKCO WORKS, SOUTHBEND-ON-SEA.

Please send me free illustrated literature.

NAME

ADDRESS