

VOL. I.
MAY

NO. 6.
1935

Wireless

AND TELEVISION REVIEW

PRICE

6^D_I

How to Build the

"FERRO-MAINS" THREE



Also a
Special

TELEVISION

Section



OUT TODAY

The Finest of all Jubilee Souvenirs

TWO SUPERB VOLUMES

Bound in Royal Blue Suede Leather Cloth inset with silver panels. A triumph of beautiful printing and binding. Two books of surpassing interest worthy of the great occasion for which they have been specially prepared. These magnificent souvenirs should find a place in every home in the land.

OUR KING & QUEEN

is one of the foremost of Royal Biographies ever published, recording, in a vivid and arresting manner, the most outstanding events in the lives of our beloved Monarchs.

Edited by Sir John Hammerton, it contains nearly FIVE HUNDRED photographic illustrations, a special method of printing being employed to show them on a much larger scale than is usual in a work of this size. In addition, there are—

18 MAGNIFICENT FULL COLOUR PICTURES

It is a book to treasure for all time, no finer souvenir of a great historical occasion could be devised.

WONDERFUL LONDON

presents a living picture of the world's greatest capital as it is to-day, described by its best writers and illustrated by the finest collection of photographic views of London, London life and London ways ever brought within the covers of a single volume. There are over 200 PHOTOGRAPHS reproduced in photogravure.

Contributors to WONDERFUL LONDON include:

- | | |
|------------------|-----------------|
| ALFRED NOYES | E. V. KNOX |
| J. B. PRIESTLEY | |
| H. V. MORTON | ROBERT LYND |
| STEPHEN GRAHAM | |
| SIR PHILIP GIBBS | H. M. TOMLINSON |
| G. K. CHESTERTON | |

Obtainable from all Newsagents, Booksellers, Bookstalls and Leading Stores

6/-
EACH



Each volume measures 11½" x 8½" and is 1½" thick. A limited quantity only has been prepared of each book and they cannot be reprinted. Intending purchasers should secure their copies of these marvellous Jubilee souvenirs without delay.

CONTENTS

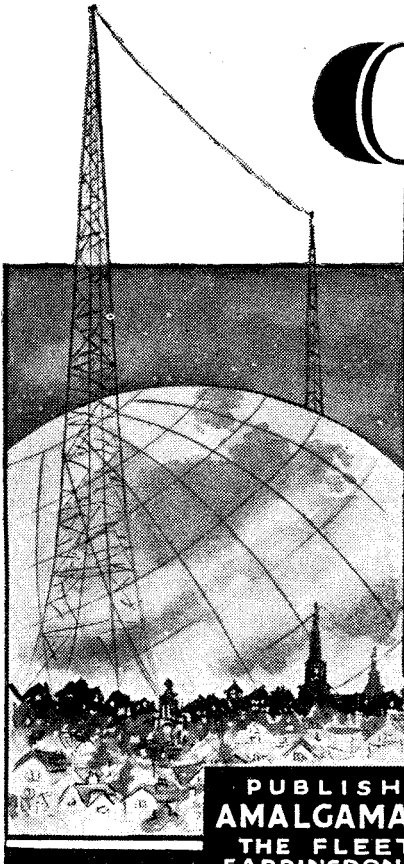

The Editor's Chat	Page 235	The "Ferro-Mains" Three	Page 245
The Tune that Haunts My Memory	236	They Make Your Records	248
The "One-Point-Five"	237	From My Armchair	249
B.B.C. News	239	New Apparatus Tested	251
Practical Hints for All	240	Short Wave Notes	252
How Metal Rectifiers Work	241	Low Capacity Tuning	253
Doctoring a Portable	242	Short Waves in the Tropics	255
Questions I Am Asked	243	In Lighter Vein	264
Push-Push Class B	244	Police Radio	267
		Europe's Announcers	270

SPECIAL TELEVISION SECTION Pages 257-263

Including:

How Television Pictures are Transmitted	Page 259	What Shall Be the "Stuff" of Television?	Page 261
		Receivers for High Definition	263

As some of the arrangements and specialities described in this Journal may be the subjects of Letters Patent the amateur reader would be well advised to obtain permission of the patentees to use the patents before doing so.

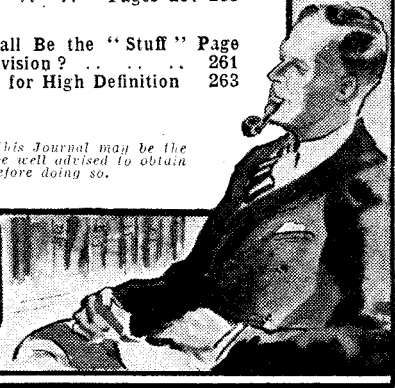
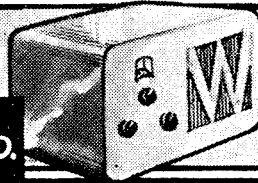

PUBLISHED BY THE AMALGAMATED PRESS LTD. THE FLEETWAY HOUSE FARRINGDON ST., LONDON, E.C.4



Master Fault-Detection WITH EASE

No longer need you covet the world-famous Avometer of the expert radio engineer. From the makers of this, the supreme testing meter, come these two smaller instruments—giving the same accurate and reliable testing facilities to every home constructor. With an AvoMinor you can make any and every test—trace every fault—quickly and easily.

The world-famous D.C.

AVOMINOR

Regd. Trade Mark

is 10 accurate instruments in one. Circuits, valves, components, batteries and power units can all be tested quickly and easily. In handsome case, with leads, interchangeable crocodile clips, testing prods and instruction booklet.

The

UNIVERSAL AVOMINOR

Gives 22 different ranges of readings. The best of A.C. and D.C. meters. 3-inch scale. Total resistance 200,000 ohms. Complete with leads, crocodile clips, testing prods and instruction booklet.

THE AUTOMATIC COIL WINDER AND ELECTRICAL EQUIPMENT CO., LTD.,
Winder House, Douglas Street, London, S.W.1
Telephone: Victoria 3404-7

THE UNIVERSAL AVOMINOR

D.C. VOLTS
0—75 millivolts
0—5 volts
0—25 "
0—100 "
0—250 "
0—500 "

A.C. VOLTS
0—5 volts
0—25 "
0—100 "
0—250 "
0—500 "

MILLIAMPS
0—2.5 milliamps
0—5 "
0—25 "
0—100 "
0—500 "

RESISTANCE
0—20,000 ohms
0—100,000 "
0—500,000 "
0—2 megohms
0—5 "
0—10 "



Deferred Terms if desired.

● Send for fully descriptive folders, post free

"RADIO SERVICING SIMPLIFIED"

Everyone should have this invaluable book. It explains every phase of fault-tracing step by step in non-technical language. The comprehensive information and numerous diagrams render testing and servicing a matter of straightforward procedure.

2/6

Post free 2/9

TELEVISION IS YOUR OPPORTUNITY!

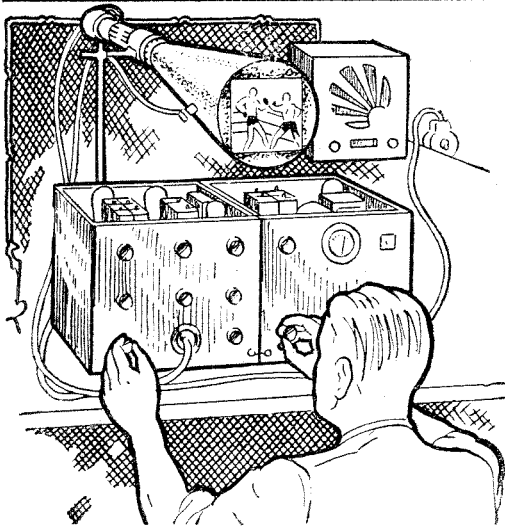

IMPORTANT NEW PART WORK PART 1 Published Today

**COMPREHENSIVE
AUTHORITATIVE
PRACTICAL**

ENGINEERS, research workers, scientists, and manufacturers who have spent years studying the theoretical and practical problems of Television, have placed the results of their knowledge and experience at the disposal of readers of this great new work "Television Today."

No one man to-day can claim to be an expert in every branch of Television practice. Developments in Cathode Ray Tubes, Photo-electric Cells, and other Electron devices such as the Iconoscope, the Farnsworth Electron Camera, the Electron Multiplier, have been so rapid that it was only by enlisting the services of a large number of specialist contributors that we have been able to deal in an adequate manner with the varied aspects of this subject.

If you take a serious interest in Wireless development, make certain of this important new work. The information it contains is reliable, it is up to date and it can easily be understood.

Remember, there will be big opportunities in the near future for men who are familiar with the new technique involved in Television Transmission and Reception. One of these opportunities may come your way. See that you are ready for it. GET PART 1 "TELEVISION TODAY" from your news-agent at once, 1/- . Or direct for 12 post free from George Newnes, Ltd., 8-11, Southampton Street, Strand, London, W.C.2.

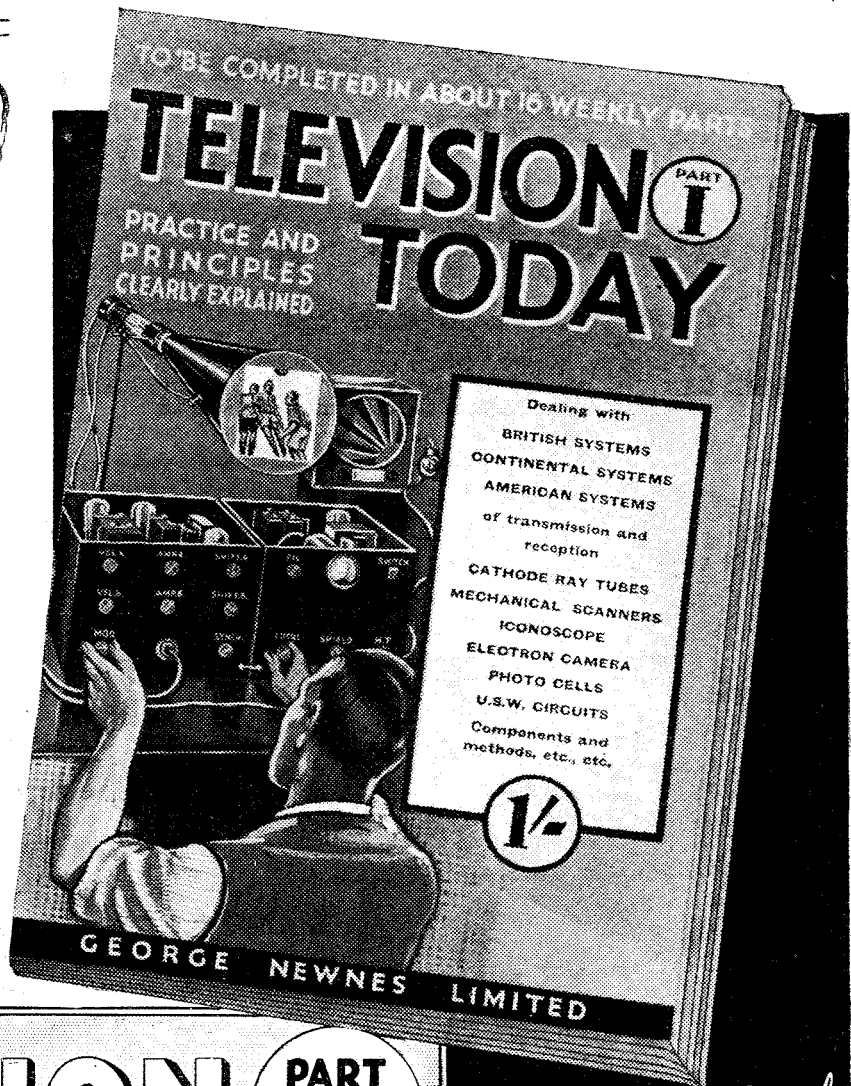

TELEVISION PART 1

PRACTICE AND PRINCIPLES CLEARLY EXPLAINED

TODAY 1/-

To be completed in about 16 Weekly Parts

The
Editor's
Chat

Wireless

& TELEVISION REVIEW

Television Transmissions Present and Future—The "Ferro-Mains" Three

THE publication of the Television Committee's report a month or two ago, and the newspaper comments which followed it, have clearly led a big proportion of the listening public to jump to a wrong conclusion.

They see in their radio programmes that there are regular television broadcasts, and they cannot be blamed for assuming that these transmissions are related to that television which has formed the subject for so much recent discussion.

The result is that many believe that television is actually here now and that at any moment there will be an ample supply of receivers capable of bringing moving pictures of tennis matches, horse races, boat races and other news features into the home, together with televised variety and plays and so on.

Good Entertainment

It is certainly not universally realised that the present transmissions are little if any different from the experimental television broadcasts which have been in progress for some years, and that the television of which the P.M.G. has so glowingly written and spoken is an entirely different proposition.

The existing transmissions on the medium waves do not possess great entertainment value; they are limited in their scope and give crude pictures. Close-ups of faces are, it is true, fairly good, but the "extended" views sadly lack detail.

The new television will demand entirely new apparatus working on a new wavelength (ultra-short). At the time of writing it has not yet been decided where the first station to serve London only will be located.

The P.M.G. has promised that the London television service will commence during the latter half of this

year, and when that happens television can truly be said at least to have made a commencement on a practical basis.

The pictures will be of high definition as against the very low definition of the present experimental system, and the entertainment value of them will be considerable. Make no mistake about that.

We do not know yet exactly what degree of definition will be employed,

ON THE AIR



MANTOVANI, the well-known leader of the *Tipica Orchestra*.

but it will be something above 180 lines as against the present 30 lines; and even a 180-line picture with the dimensions of twelve by nine inches is one which has the power to make the "looker" forget the medium and become enthralled by the subject—so long, of course, as the subject possesses intrinsic entertainment merits.

We recently had occasion to witness

an official demonstration of 180-line television reception, and, although our purpose was technical criticism, we found ourselves laughing at a Mickey Mouse sound cartoon and tending to forget the object of our visit!

But the promise of future television delights and the existence of a reminder of it in the present crude 30-line experimental transmissions ought not to make listeners underrate the importance of sound broadcasting. There is no purpose in delaying the purchase or building of a normal set for the reception of radio programmes, for television on ultra-short waves will not displace these.

The Home Constructor

A special set for ultra-short-wave reception will be additional to this, and adding its cost to that of the viewing apparatus, that £50 to £80 which has been mentioned as the probable price would not seem to be an exaggeration.

Naturally, the home constructor will score on this account, and we shall do our best to enable him to score really heavily!

In the meantime, it is to be hoped that the Television Advisory Committee will soon begin to issue some information regarding the details of the high-definition transmissions. Until these are available, television research is rather at a standstill.

* * *

In this issue will be found full details of an exceptionally efficient A.C. mains set, the "Ferro-Mains" Three. This easy-to-build receiver has proved extraordinarily efficient both in laboratory and home tests. Installed in a locality noted for both the "raggedness" of the mains and poor reception conditions, it has been described as "quite marvellous" by impartial and well-informed critics.

THE TUNE THAT HAUNTS MY MEMORY

Harry Roy, the famous dance orchestra conductor and broadcaster, describes some experiences which he will always remember.

"**H**EAR what they're playing? Do you remember . . . ?"

It has an everlasting fascination for me to know that's what somebody's saying, somewhere, every time I include one of the older numbers in a programme. Tangled up in those jazz tunes I play there are all sorts of stories. I know, because of the letters I get from all over the country every week. Most people have a pet tune which reminds them, every time they hear it, of some incident in their lives. The association may be grave or gay—it may be sentimental or humorous.

A Personal Appeal

There was a man who wrote me once, imploring me to play a certain number at a definite time in my broadcast, in order to help him mend a quarrel with his wife. It was a tune they had danced to the night he proposed to her, and he was relying on the memories it would recall to help them to a reconciliation.

Out of the hundreds of tunes that my band has played, I, too, have one that means more to me than any other. It tickles my memory every time I hear it, and, although it is years old, I nearly always include it in my programmes.

Although I use "Bugle Call Rag" for my signature tune, "Some of These Days" is really the song that has a story for me. It dates back ten years—that story.

"Cut It Out"

For six years, since the end of the war, my brother Syd and I had been working up a band. There had been plenty of ups and downs, but we were definitely beginning to get known in the West End in 1924, and when, one red-letter day, we were asked to go to the Café de Paris, we felt we had really arrived at last.

The first night we were all very nervous. It was a far more sophisticated audience than those we had been playing for. We had been rehearsing night and day to put up a good show, and we were every one of us pretty strung up.

My most vivid recollection, as we played our first number, is the sight of the bare, polished surface of the

empty dancing space. I simply couldn't keep my eyes from it, for I knew if we were going to be a success we must make that glittering crowd of fashionable women, sitting at the little tables with their black and white escorts, want to dance.

The small dance floor yawned before me like a vast Sahara desert. Then, suddenly, the tension broke. A couple were on the floor! I can remember every detail of them even now. The girl was fair and slim. She wore a white gown and her dancing feet were red-shod. In a little while,

BEFORE THE "MIKE"



A recent photograph of Harry Roy singing into the microphone at the May Fair Hotel, London.

the floor was crowded with swaying figures. There was that subtle something in the atmosphere which told that we had made a hit.

"Some of These Days" was the next number we struck up. We were feeling at the top of our form now, and all our nervous exhaustion forgotten. I started to sing, in the same way I do now, when we came to the chorus. I thought it was going down splendidly, when, suddenly a waiter came to me with a note. I opened it while I sang. It was from the management.

"Cut out the singing business," I read, "and stick to the straight

band work. Our clients are too sophisticated for that sort of thing, and it won't go down."

I trailed off in the middle of my singing, feeling as though I could dive through the drums!

After the Tour

So from then on we cut out the singing. We were at the Café de Paris for four years, and every time we played "Some of These Days" I saw again that first night scene. I didn't find the reminder at all amusing then, but now, when I've made a success with just the type of thing they wouldn't let me do ten years ago, I just get a laugh from it every time.

Now this is the second part of the story of "Some of These Days," and it's typical of the irony of life.

After the Café de Paris days we toured half over the world. When we got back to London, talkies had come in, and things were not too good for musicians, since the whole trend of entertainment had changed. We had a pretty up and down time for a while, and then my brother secured a contract for me at the Leicester Square Theatre. I worked up a grand new show in the style that they wouldn't let me try to put over when I was starting to get known in 1924. And I sang several numbers myself.

The Voice That Failed

It went down magnificently. Later I took a new show of the same type to the Pavilion. I included "Some of These Days" in my programme and I made up my mind I was going to sing it this time. The first numbers were an enormous success. The applause was deafening. We were making our biggest triumph yet. Then we started up on "Some of These Days," and I opened my mouth to sing. I got to the second line and couldn't produce a sound!

It was sheer exhaustion from over-work, but it was three weeks before I sang again. In the meantime, the Pavilion management paid me the charming compliment of insuring the voice that I had once been politely told to "shut up," for £5,000!

Now they *ask* me to sing! When I'm conducting the boys at the May Fair, when I'm broadcasting or recording, I'm *expected* to sing. And, incidentally "Some of These Days" is one of my best-seller records.

"Hear what they're playing? Do you remember . . . ?"

Yes. There are hundreds and thousands of real-life stories that the craziest tunes could reveal in this way.

Harry Roy.

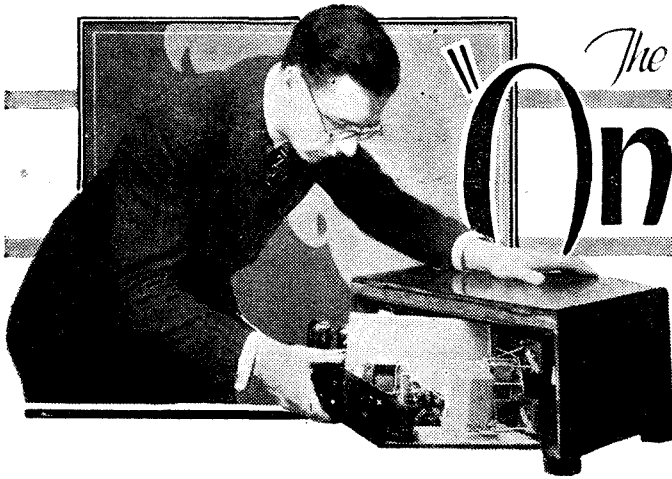

The One-Point-Five

OBTAINING MAXIMUM RESULTS

By JOHN SCOTT-TAGGART,
M.I.E.E., F.Inst. P., Fel.I.R.E.

The "One-Point-Five" should be operated as though it had two separate tuning compartments, and this, and other important aspects of the controls are dealt with in detail in this article by the designer.

To the S.T.400 enthusiasts, tuning the "One-Point-Five" will be child's play. Nevertheless, there are one or two special hints which may be mentioned; actually, they make the new set considerably easier to tune than the "four hundred."

Of Primary Importance

Probably, the most important instruction is: Treat the set as if it were two tuning compartments. The first, or aerial, circuit, as it may be called, has a main tuning condenser (the big left-hand dial). The left-hand push-pull switch governs whether you are on the long or medium waveband. Push in for long waves. The selectivity and signal strength in this circuit is governed by the aerial coupler, which is at the top left-hand corner of the panel. Turn this knob to the left (anti-clockwise), and signals will be weakest and selectivity greatest in this circuit. If you turn the aerial coupler knob to the right (the way the hands of a clock go), selectivity will fall off, but signals will become stronger in the aerial circuit.

The Anode Coupler

In the bottom left-hand corner of the panel you will see the aerial reaction knob. This control can work wonders, but keep the knob turned full left (anti-clockwise) under normal conditions. Only use aerial reaction when signals are too weak otherwise, or when ultra-selectivity is needed. More about this later. Meanwhile, just leave it alone.

Now consider the second, or anode circuit. It is tuned by the right-hand tuning condenser (the large dial on the right). The right-hand push-pull switch governs the waveband on which the anode circuit is working. Push switch in for long waves; pull

out for medium waves. Don't confuse this switch with the on-off toggle switch in the right-hand bottom corner of the panel.

You must always have the two wave-change switches in the same position, you must not have one "in" and the other "out."

The selectivity and signal strength of the anode circuit is controlled by the anode coupler, which is the middle one of the three small knobs along the top of the panel. Turn this knob to the left (anti-clockwise) and you will decrease the strength of signals in the anode circuit, but selectivity of that circuit will be improved; turn

condenser for anode reaction similar to that in my original "One-Point-Five"), it will at once stop if you turn the anode coupler a little to the left. Instead, you may keep the anode coupler full right, and reduce the capacity of the selectivity range-adjuster preset condenser, which, on first wiring up the set, should be at maximum capacity (screwed up). This selectivity range adjuster is a convenience luxury and no one need feel the set is not giving of its best through improper adjustment of this component.

Obtaining Maximum Strength

The top right-hand knob on the panel is the anode reaction control, which applies reaction in the usual way, to the anode circuit.

As there are two tuned circuits in the "One-Point-Five" you can get your signal strength on either or both circuits. Maximum signals will be obtained with aerial coupler at maximum (right), and anode coupler at as near maximum (right) as possible before the set oscillates (if it tends to do this). Selectivity will be poorest under these conditions, but quite possibly you may be working the set under conditions (e.g. in daytime) when high selectivity is not needed.

Controlling Selectivity

If you want high selectivity on both circuits, both aerial and anode couplers should be near their minimum (full left). After a little practice you will find the best positions for the couplers to give you the desired results on any given station. As the signal strength, wavelength, and degree of interference vary with every station, the flexibility given by the "knobs" will be greatly appreciated by those who want the last ounce out of the set.

"SIMPLICITY ITSELF"

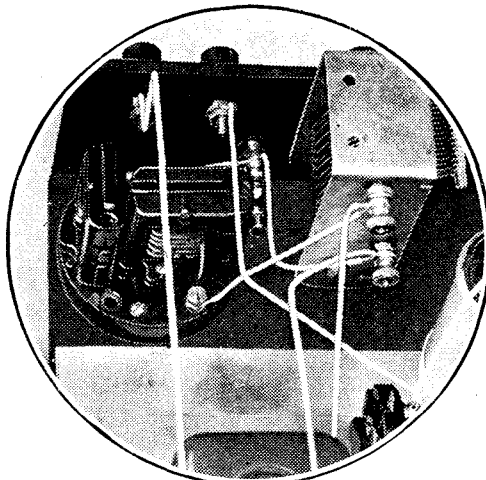

"The process of working the Extractor is simplicity itself," writes Mr. Scott-Taggart, and constructors will agree with him.

the knob to the right (clockwise), and selectivity will be reduced, but signals will be louder. The anode coupler will affect the tuning of the right-hand tuning dial, so a slight readjustment will be necessary on this dial after altering the anode coupler.

If the set oscillates with both reaction knobs at zero (full left, assuming you have used a differential

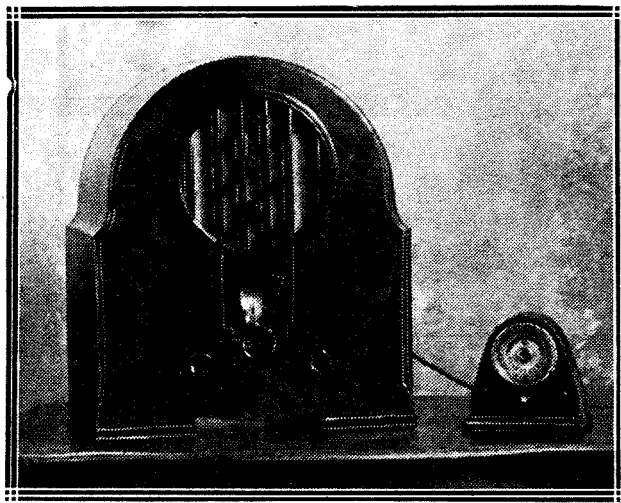

A photograph showing the small size of the clock.

A SWISS watchmaker M. Henri Froidevaux, has designed a particularly compact device by means of which any receiving set can be switched in and out automatically at predetermined times. This self-acting switch enables a choice between interesting items and those not appealing to be made in

advance, and there will no longer be any risk of an interesting transmission being missed by forgetting the proper time, nor will the receiver ever remain switched on beyond the actual transmitting time.

The switch is operated by an eight-day anchor clockwork. The continually rotating hour dial carries at

AUTOMATIC SET SWITCHING

Many set-control devices have been introduced in the past. Here are details of a special clock that automatically turns the receiver on just when it is wanted.

By
ALFRED
GRADENWITZ.

its circumference some readily adjustable small clamps which by means of a screw, can be set to the hour at which the receiver is to be started or stopped. These clamps, through a locking mechanism, transmit an intermittent rotation to a cam comprising a sinuous groove which, by means of a guide running therein, will actuate the interrupter at any given moment.

Prepared in Advance

This apparatus is connected up to the mains and the set by means of a cord and plug.

The owner of such an apparatus will be able to prepare a whole day's programme from a given station in advance, the receiver switching off itself of its own accord at the given moment and not functioning before the next chosen item is due.

THE "ONE-POINT-FIVE"

(Continued from previous page.)

Now about aerial reaction. When it is used it should be used for a definite purpose. Do not use the knob just as a knob to "try." Know exactly what you are doing. The following rules should be observed:

(a) Only apply aerial reaction if you cannot get the same results as regards selectivity or signal strength in other ways—i.e. by the couplers and anode reaction.

(b) See that the anode coupler is between zero and half-way. Aerial reaction is not smooth with too much anode coupler.

Anode Reaction

(c) Under no circumstance apply reaction to the aerial when the anode reaction is critical (very near oscillating point), as extra reaction may well start the set oscillating. By all means have some anode reaction, but not too much.

(d) Never apply aerial reaction to a strong signal. If the station is strong, presumably you propose to use aerial reaction to give greater selectivity. You should weaken the signals in the loudspeaker by reducing the aerial coupler and anode coupler. Then bring up signal strength with the aerial reaction.

(e) Reaction should be cautiously applied in small steps, retuning slightly on the two main dials to give loudest results.

Adjusting the Extractor. The "One-Point-Five," like the S.T.600, works on a principle differing from that adopted in my previous popular sets. The local station is treated as a separate problem and an Extractor circuit is employed. This circuit is tuned by a variable condenser on the terminal strip. A switch is on this strip and it enables you to extract any local station on the medium waves or on the long waves according to the position of the switch.

When you are on the long waves, and desire to cut out Droitwich, you must have the switch in the right position. When switching over to the medium waves don't forget to leave the Extractor circuit on the long waves. It will not affect the set itself much, but you will find you cannot cut out your local regional.

The process of working the Extractor is simplicity itself. You just tune your set to the interfering local, according to the part of the dial you are working on. Do not have the local too loud; cut it down a little with, say, the aerial coupler. Then adjust the Extractor condenser till the local disappears or is extremely weak. You will find that there is a silent point on the Extractor tuning condenser

and that if you tune the Extractor condenser to either side of this point the local will return; therefore leave the condenser at the silent point.

You then forget about the Extractor and tune the set in the ordinary way described. Don't leave the Extractor condenser at any old adjustment because you may find that a particular station you want, say, Copenhagen, just happens to be "extracted." Therefore, leave the Extractor on the local. If you *desire* the local—and we do sometimes!—you can usually bring it up by reaction and "more couplers." It is a fascinating experience, believe me, for the local to be coming in like a weak foreigner. But instead you may prefer to detune the Extractor very slightly off the silent point; you can then bring in the local as loud as you like.

Send in Your Reports

Well, I want you to write and tell me how you get the vastly improved results I have promised you. I shall acknowledge each letter personally, but queries are dealt with (after consultation with me) by the special Query Dept. of this journal.

If you convert to the "One-Point-Five" you will certainly bring your S.T.400 right up-to-date and at very little cost. The improvement is so great that I know you will be delighted.

J. S.-T.



B.B.C. News

Too Much Broadcasting?—The Regional Programmes—
Those Amateur Orchestras—Sir Charles Carpendale's
Future—Accession Day Items

By Our Special Commissioner

SIR JOHN REITH is now taking a direct hand in programme work. He thinks there is too much broadcasting, and has asked that steps be taken to cut down the number of hours of transmission. He also thinks there is not enough repetition of good programmes; he wants more "diagonalisation." Sir John also thinks there are too many alternatives; that it would be a good plan to have much more "S.B." than there is.

If these changes are made the staff could be reduced and the administrative problems simplified generally. But would it be right to settle important programme policies merely to serve convenience of administration? I shall be interested to see to what extent the B.B.C. will go in this retrenchment and economy move.

The Problem of Wales

The B.B.C. does not seem to be able either to satisfy or quieten the Welsh malcontents. The reason is not entirely inability to meet the claims of Wales for a separate station and organisation. It is partly the attitude adopted to Welsh representations.

Great resentment has been expressed by members of a delegation from Wales received at Broadcasting House during the absence of Sir John Reith in South Africa last autumn. It is alleged by several of the Welsh present that the B.B.C. spokesmen were much too peremptory and aggressive. The state of feeling goes from bad to worse. Why is the B.B.C. so ostrich-like in some of its outside contacts and so superbly skilful in others?

The Regional Programmes

There is much satisfaction among staffs of B.B.C. Regions at the stabili-

isation of the number of hours of local programmes that can be taken by each Region. These have varied a good deal in the past, and there has been severe pressure on staff when exceptional commitments have been made. It has now been laid down that each Region will build twenty-five hours a week; staff is to be adapted accordingly. There has been serious overworking of O.B. engineers in the past few years, overworking which no trade union would have tolerated. All this is to stop with the stabilisation being laid down now.

THE CUP FINAL



GEORGE F. ALLISON, the famous radio football commentator, will broadcast a running commentary on the Association Football Cup Final at Wembley Stadium on April 27th.

"Little Man" Out of Favour

The ordinary listener is not to appear in any of the big programmes with which the B.B.C. is to mark the Jubilee. These programmes are to be for those in authority—premiers, governors, and the like. From what I hear, there will be so much pomp and

glitter that human interest will be neglected. Which will be a pity.

Those Amateur Orchestras

The B.B.C. is pondering the problem of the employment for broadcasting of amateur orchestras. There is a good deal of this in the programmes now, and there is a growing feeling that in the present state of unemployment among musicians the practice should be given up entirely. I hope this action is taken. It is obviously wrong for a public corporation like the B.B.C. to lose any opportunity of providing employment to such worthy people as professional British musicians and artists.

Prince's Bagpipe Tune

The B.B.C. was hoping to broadcast the Prince's bagpipe tune, "Majorca"; but it is understood that, by special request from the Prince himself, the proposal was abandoned.

Sir Charles Carpendale's Future

There is a good deal of talk at Broadcasting House about the future of Sir Charles Carpendale, the Controller of Administration, who is now a year over the age limit for normal retention. Sir Charles was recently appointed to the Television Advisory Committee for five years. His active association with the International Broadcasting Union continues.

It is likely, therefore, that before long he will give up his controllership and absorb several advisory functions in addition to the ones he already has. Sir Charles will be considered for an appointment to the new Board of Governors to be set up in 1936.

Sir Landon Ronald and the B.B.C.

I hear that Mr. Roger Eckersley, the Director of Entertainment at Broadcasting House, plans to bring in Sir Landon Ronald as special adviser of musical matters to the Corporation

(Please turn to page 272.)

Practical HINTS FOR ALL

Some Topical Tips

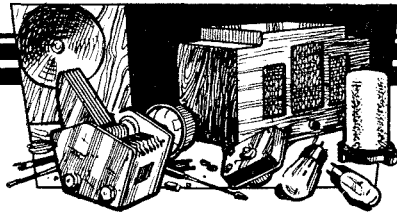

By
A. S. CLARK

LAST month I had a tip concerning the connecting of aerials to mains receivers. This month I want to start with one concerning the connection of mains to a mains receiver.

I am thinking of commercially-built sets at the moment which practically all have some scheme or the other for adjusting for various voltages of mains. Usually the scheme is graduated in 10-volt steps, although sometimes the jumps are a little wider apart.

Check the Voltage

The point is this. If you have the receiver adjusted for mains ten or so volts above or below the voltage of those employed, you will notice but little difference in the results compared with the correct setting.

If the voltage is below that of the setting, no harm can be done, but trouble is almost sure to ensue if the

EASILY MADE SCREENS

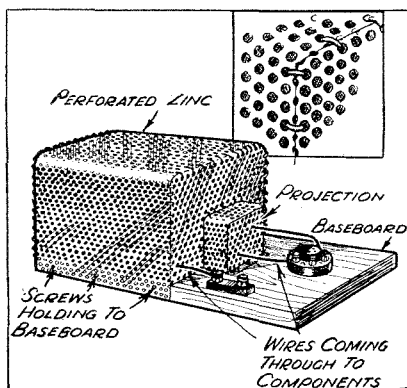

Screens of all shapes and sizes can quickly be made up from perforated zinc as illustrated here.

set is adjusted to too low a tapping. The valve heaters will be overrun, and components will run on the hot side with the result that trouble will come eventually if not immediately.

The significance of this warning will be appreciated when it is stated that

some electric-supply meters are marked, for instance, "200-240 volts." The actual voltage may be 200, 240, or some value in between.

The only way to find out what it is, is to write to the supply company and ask them the exact voltage at your house. In the meantime, you can assume it to be the higher figure, namely 240, and adjust the mains input to the set accordingly. Never assume it to be the lower figure, or take an average and call it 220.

And now for the first diagram on this page. Yes, it does look rather reminiscent of a meat safe! As a matter of fact it is made of the same material as the sides and door of a meat safe, namely perforated zinc.

When one is experimenting, or even when constructing a tried design for that matter, one often finds that screens of the most awkward shapes and sizes are needed. These certainly have no terrors for the expert sheet-metal worker, but most of us would prefer something simpler and quicker to make up.

Well Worth Trying

So I suggest the use of sheets of perforated zinc which can be purchased quite reasonably. To start with, they are easily cut with any old pair of scissors, and are just as easily bent to shape.

Then the presence of the holes makes screwing down to the baseboard an extremely straightforward job, and also enables wires to be brought out to components at any point that happens to be desirable.

The joining together of the various pieces and of the edges, is simply a matter of slipping short pieces of bare copper wire through the holes and twisting the ends together on the inside of the screening "box" (see sketch). Occasionally it may be necessary to twist the ends on the outside, but this does not present any added difficulty.

We all experience terminals coming loose on components from time to time. It is annoying enough when they are on such components as valveholders on which the shank heads can only be got at by disconnecting the component and removing it from the chassis.

A Troublesome Case

But when the trouble occurs in a component in which the head of the terminal shank is sealed up, it is even more "bothersome." Attempts to tighten the securing nut in the ordinary way may prove quite futile, the shank simply turning round with the nut.

In such cases two pairs of pliers, one of the narrow-nosed variety, must be used as in the second illustration. The narrow-nosed pliers are used to hold the shank still while the others perform on the securing nut.

It is most important to see that the

TIGHTENING TERMINALS

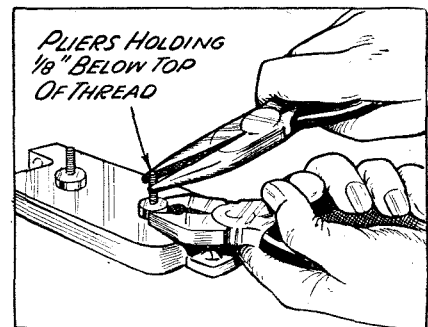

The best way of dealing with terminals which have worked loose, when the heads of the terminal screws are inaccessible.

pliers gripping the shank are an eighth of an inch or so below the end of the shank. Otherwise the beginning of the thread may be damaged, and the terminal head refuse to start, or go on cross-threaded.

Any damaged threads lower down will be put right by the terminal head re-cutting the thread once it has been properly started on the shank.

To finish up with just a word about the running of extension wires. When you have come across particularly awkward corners and walls, you have probably wondered how on earth the professional wireman gets on when he is called in to lay an electric bell.

Well, I'll tell you. His work is made remarkably simple by means of a special tool, and there is no reason why yours should not also.

The instrument is known as a bell-hangers gimlet, and may be purchased at any high-class tool dealers. Types up to about two-foot long are available.

Hole metal rectifiers

Work

The metal rectifier is rather an "inanimate" sort of component after the valve, but its operation and construction is full of interest as is vividly portrayed and explained in this article.

By BERNARD BARNARD.

METAL rectifiers are inevitably associated with the name "Westinghouse" — the firm who have achieved world-wide fame by producing a simple, foolproof and almost everlasting rectifier which can be adapted to a variety of purposes.

The history of the metal rectifier differs considerably from that of its rival, the valve.

For these reasons it has an almost limitless life, is robust and very nearly foolproof.

Many visitors to Radiolympia will remember the Westinghouse exhibit of a rectifier which had been in constant use since, I believe, 1926, and was still giving its normal rated output. Good going, that!

The operation of the rectifier depends upon the little understood but very useful phenomenon that an electric current flows much more freely from copper oxide to copper than in the reverse direction.

Hence, if we interpose a junction of copper and its red oxide in the path of an alternating current it is quite obvious that only the impulses that are travelling in the oxide to copper direction will get through the circuit to any appreciable extent.

familiar vanes are provided for this purpose.

The red copper oxide layers are actually formed on the copper discs themselves by heating to a high temperature in an electric furnace, the copper discs being so arranged that oxide is produced on one side only, the other being kept bright and clean.

Building a Unit

When it comes to assembling a number of these elements so as to form a complete rectifier, each clean side of each copper disc has to make good electrical contact with the oxidised side of its neighbour.

Copper oxide, however, has an uneven surface so it is clamped hard against a soft metal ring, and this ring actually provides the contact between each element.

A diagram of the assembly is shown in Fig. 2 and this will clearly explain the foregoing.

METHOD OF ASSEMBLY

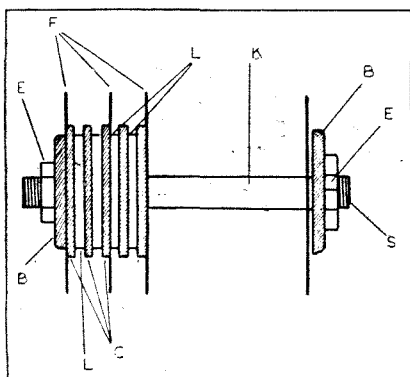

Fig. 2. The copper plates, with oxide on one side, are interspersed with lead rings.

Whereas the valve has grown up hand-in-hand with radio, the metal rectifier started its career in much more mundane surroundings such as in battery charging equipment and railway signalling plants.

As a matter of fact, it was not until it had been thoroughly "weaned" in these departments of engineering that any serious attempt was made to introduce it into mains radio circuits.

Well-Deserved Popularity

However, after it was tried out as a supplier of H.T. for wireless, it went ahead by leaps and bounds and soon gained enormous and well-deserved popularity.

The great advantage of the metal rectifier is that its action depends upon electronic activity and not upon temperature differences or chemical change.

How Discs Are Made

The A.C. will therefore be made unidirectional or, in other words, will be "rectified."

Actually the resistance of the junction in the oxide to copper direction is over 1,000 times less than that in the copper to oxide direction so that rectification is efficient and fairly complete.

A simple combination of these junctions—Fig. 1A— will produce a half-wave rectifier of considerable efficiency.

Full-wave rectification will be obtained with a "bridge" assembly of the junctions as is shown in Fig. 1B, since, no matter which way the input A.C. is flowing, there is always a low resistance oxide to copper path into the D.C. circuit. The arrows in the diagram indicate these alternate paths.

The construction of the rectifier is simple since there are no manufacturing "snags" such as the production of volatile chemicals or high vacua.

However, great care has to be taken to dissipate the heat produced by the slight losses in the rectifier and the

THE TWO TYPES

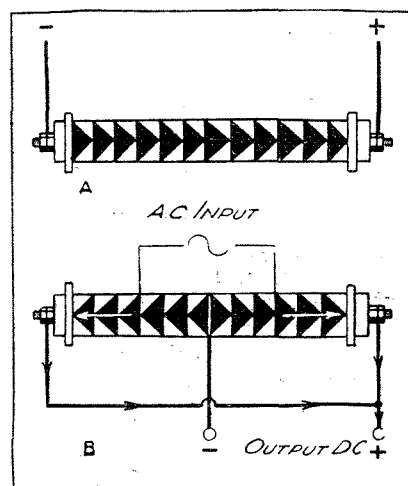

Fig. 1. In this diagram the connections for half-wave and full-wave rectification are shown.

The necessary number of copper discs, C, which are, of course, drilled through their centres, are run on to a spindle, S, which carries an insulating sleeve K. Between each copper disc is a lead ring L, which being soft, conforms under pressure to the rough oxide surface.



Metal rectifiers make up into very compact components. Here is an H.T. rectifier for voltage-doubling circuits.

Cooling fins F, are interspersed along the length of the spindle and serve the dual purpose of dissipating heat and of providing terminal contacts with the elements.

At each end are insulating bushes B and the whole assembly is tightly clamped together along the spindle by the two nuts EE.

Increasing the Pressure

Most mains units which employ metal rectifiers use the popular "voltage-doubling" circuit shown in Fig. 3A.

This arrangement provides a high output voltage at moderate current, which is of course ideal for ordinary radio purposes.

The circuit is a "bridge" arrangement using two metal rectifiers and two large capacity condensers; the operation is shown in Figs. 3B and C.

One half cycle of A.C. is shown in 3B. Only one path is open to the current

in this direction, i.e., through rectifier R1; C1 is therefore charged up.

In 3c—the next half cycle—the current is travelling in the opposite direction and C2 is charged up via R2.

The condensers, which are in series with one another, supply the D.C. circuit according to the momentary direction of the A.C. input.

VOLTAGE-DOUBLING

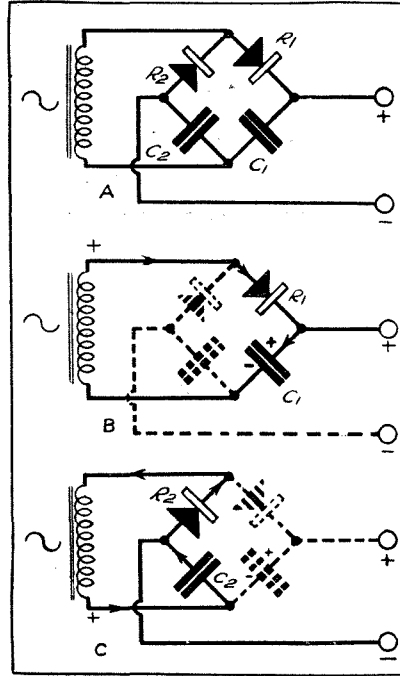

Fig. 3. How the two condensers of a voltage-doubling circuit are alternately charged is explained in the text with the aid of this diagram.

The metal rectifier has undoubtedly as wide a field of application as its valve counterpart.

Apart from such uses as are outside the scope of radio, it can be adapted to supply filament L.T. from A.C. mains for battery valves, and also, as is now well known, to rectify radio frequency currents.

Up to 10 Kilowatts

Since each copper unit is capable of passing only a small current in the conducting direction, it is necessary to connect a number of them in parallel when large currents are required.

This is quite easily arranged and a system giving up to 1 amp. at 2 volts, smoothed by large capacity electrolytic condensers and low resistance L.T. chokes, can be constructed and used in the place of the ordinary 2-volt accumulator.

Similarly, if very high H.T. voltages are required, large numbers of copper elements are connected in series. Since each element will withstand only a small voltage in its non-conducting direction or, to put it another way, the rectified voltage output of one element is small, connecting a number of elements in series will multiply the output voltage of one by the number of elements so connected.

Actually this process of duplication can be carried on until as much as 10 kilowatts of rectified A.C. is available; after this point, however, the bulk and cost become prohibitive.

DOCTORING A PORTABLE

By Eric O'Mahony.

WHEN I saw George heading for the gate with a large parcel under his arm, I knew there was trouble brewing. "It's a wireless," he explained rather unnecessarily. The thing simply shrieked wireless to anyone with the slightest eye for form. "A portable—it's not very loud," he added gloomily.

The outfit was of imposing dimensions, but this proved to be deceptive. On removing the rear panel, the true state of affairs was revealed. Perched, like a small parrot, at one end of the loudspeaker crossbar, was the dinkiest little 2-valve outfit you could wish for.

The Tiny Components

A miniature coil, miniature condensers, and a tiny transformer were dwarfed by the valves into seeming even smaller than they were. Through

a little window at the side, the controls timidly peeped out on the world. Most of the remaining space was occupied by a majestic cone.

To do it bare justice, it gave excellent results for a 2-valver. "Leave it to me, old man." I remarked casually. "I'll stick a third valve on it; it'll be O.K. then." Funny how optimistic one is before tackling these jobs. Make no error, if the set is to remain a true portable, the pathway to success would break the heart of a stone.

A "Peal of Bells"

As a test, an extension platform was built on the loudspeaker crossbar, and a valve and transformer added. The result was amusing, but not unexpected. The detector and 1st L.F. valve immediately became highly microphonic.

Not the ordinary mild ring you can stop by placing a finger on the valve. The mere act of switching on started them off like a peal of bells.

The next step was to bring the set down from the crossbar to the bottom of the cabinet, away from the loudspeaker vibrations. This meant cutting a new window for the operation of the controls, but if you're handy with a fretsaw this need cause little alarm.

Curing the Howl

In this particular case, it proved a blessing in disguise, for the new window was made large enough to take a slow-motion dial, this luxury not being included in the original outfit.

The microphonic howl had vanished, but was replaced by a faint high-pitched whistle. Surprisingly enough, not L.F. instability. The cure was one I had never before either read of or come across in practice. It consisted in earthing the loudspeaker magnet.

A platform screwed to the speaker crossbar to carry the H.T. battery and accumulator added the final touch, and the set then gave highly satisfactory results.

Questions I am Asked

Q. 133. Why has an intervalve transformer to be of a certain ratio? Surely it would be most sensible to increase the step-up effect as much as possible, and so make the receiver as sensitive as it can be made. Is there a catch somewhere?

A. Yes, several catches, and many constructors, beguiled by high ratios, have been caught.

In the first place, ratios are not everything. In fact they tell only half the story and that half is not always true. A ratio of 1 to 3 means that the secondary winding (connected to a valve grid) has three times the number of turns of the primary winding (which is included in the anode circuit of the preceding valve). It says nothing about the actual amount of wire on either winding or the amount of iron or other magnetic material of which the transformer core is made.

You may get a voltage step-up of one to three, but what is the voltage to be stepped up? It is not much good if the voltages developed across the primary are too small through a bad or niggardly design of winding, or a skimmed iron core.

Primary Inductance and Low Notes

One of the essentials for efficiency is an adequate primary inductance. If this inductance is low, the output of the valve will be low also. The output will depend upon the impedance of the primary and this, with a fixed primary, will depend upon the frequency of the alternating current. This frequency is continuously varying when speech or music is being received so the output of the valve will tend to vary. On nearly all transformers there is a tendency for the lowest notes to be inadequately reproduced because the inductance of the primary sets up little reactance (i.e. opposition) to the low-frequency currents and the voltages developed across the primary are stunted. The lower the notes the poorer the reproduction of them.

This is particularly unfortunate, because the human ear responds poorly to the very low notes. To obtain adequate low-note response, the



This month our distinguished contributor gives some very interesting information concerning the effect of L.F. transformer ratio and reaction upon the quality of reproduction.

inductance of the primary must be high and to get this we require many turns of wire. The lowest satisfactory primary inductance is about 40 henries (the henry being the unit of inductance), but a really first-rate transformer may have a primary inductance of 120 henries.

Some of the junk transformers have an inductance of only 20 henries. Their inefficiency and distortion-begetting vices increase rapidly as the notes to be reproduced fall in frequency. (Mention of junk transformers reminds me that a Chinese component manufacturer sent a batch of transformers to England with the trade mark "Junk" on them.)

High-Ratio Difficulties

The cost of a transformer which will do justice to the low notes is necessarily higher and if the ratio of, say, one to three is to be maintained, you will have to increase the secondary turns as well. There are several reasons, apart from expense, why you cannot put a very large number of turns on the secondary, as you would if you aimed at, say, a 1 to 20 ratio. One reason is that the winding would

have a high capacity and the top notes of the upper register would be pruned.

An attempt is sometimes made to give a high ratio, but you will find that the manufacturer has kept down the primary inductance; inadequate low-note response is the result, although what constitutes inadequate is rather a matter of individual opinion.

While on the subject of transformers, it may be said that not only does the response at low frequencies tend to fall off, but the same effect occurs at the higher frequencies. On a poor transformer the performance drops drastically after 3,000 cycles. Money and brains are required to keep up the response at the lower and upper ends.

Q. 134. I have read a score of times that reaction spoils reproduction, but on my set nothing of the kind happens; as reaction is "brought up" the music becomes far more full-bodied and real and far more pleasant to listen to.

A. This is due to better reproduction of the lower notes. Faddists and purists who object to any kind of reaction are inclined to exaggerate the top-note cutting and to ignore any beneficial effects. Reaction on a high-frequency tuned circuit will certainly tend, if increased too far, to reduce the overall top-note response of the set, although it must never be forgotten that the designer may unobtrusively have compensated for this somewhere else in the set; for example, a pentode output valve may tend to exaggerate the high notes so that a reduction earlier in the circuit will be balanced.

Effect of the Side-Frequencies

But what is almost always forgotten is that reaction increases the low notes. The side-frequencies closest to the main carrier wave are those most strengthened by reaction, and it is to these particular side-frequencies that we owe the low notes and much of the "body" and reality of music and speech. They are nearly always poorly reproduced on a battery set, and so reaction often helps greatly to improve the "quality."

PUSH-PUSH CLASS B

Details of an interesting circuit evolved for Class B amplification. The output power obtainable is somewhere in the neighbourhood of 1,500 milliwatts.

By J. H. SLATER

BOTH Q.P.P. and Class B rapidly gained favour among battery users, and soon after their introduction were being employed in countless receivers.

Weighing up the merits of the methods, the odds seem to be about even; Class B has a big advantage in simplicity, while Q.P.P. is slightly more economical.

The Question of H.T.

If the small standing anode current is disregarded in both cases, the drain on the H.T. battery using a Q.P.P. output stage is strictly proportional to the A.C. output, as also is the case of a Class B output valve, but the Class B valve requires energy (about 100 milliwatts) to drive it, supplied by the "driver" valve.

Now the anode current of the "driver" valve is not proportional to the A.C. output it delivers, and may be as high as 3 or 4 milliamps if the maximum output from the Class B valve is required.

It may not have occurred to many that a considerable saving of H.T. current can be made if the Class B valve is fed from a Q.P.P. stage.

Two valves of the P.M.2DX. type can be biased down till the "rest" current is less than $\frac{1}{2}$ milliamp per valve, and the average current for the pair will be about $1\frac{1}{2}$ milliamps. This represents a considerable saving compared with the $3\frac{1}{2}$ milliamps consumed by a small power valve as "driver."

Using a Centre-Tapped Choke

In order to put this system into practice a "driver" transformer with a centre-tapped primary is required, and such a component is not yet available from the ordinary sources.

However, the difficulty is easily overcome by using a centre-tapped

choke with an ordinary "driver" transformer. (See diagram.) Since the transformer primary and choke are in parallel, in order to preserve good reproduction the inductance of the choke should be as high as possible.

One of the 200- or 300-henry centre-tapped chokes on the market is very suitable. Quality will be better with this type of "driver" stage, since in the interests of economy the tendency

plifier using two Class B valves in parallel. A super-power valve would be required to feed them, taking 10-12 milliamps standing current; but adopting the Q.P.P. method this could be cut down to about $4\frac{1}{2}$ milliamps—a very considerable saving.

Such an amplifier could be made to deliver about $4\frac{1}{2}$ watts A.C. output for a total average anode consumption of about 18 milliamps at 120 volts, which is well within the rating of triple-capacity batteries.

A Striking Comparison

Such a feat is nothing short of marvellous when compared with the requirements of a mains amplifier to give the same output—somewhere in the neighbourhood of 80 milliamps at 250 volts using two P.X.A.'s in push-pull.

Another great advantage is that no grid bias is required; thus as the H.T. battery runs down the output valves are always adjusted to their best working points. Even down to 80 volts, $1\frac{1}{2}$ watts could still be obtained with negligible distortion. Of course, the push-pull "driver" valves would require grid bias, but this

PLENTY OF POWER AT SMALL COST

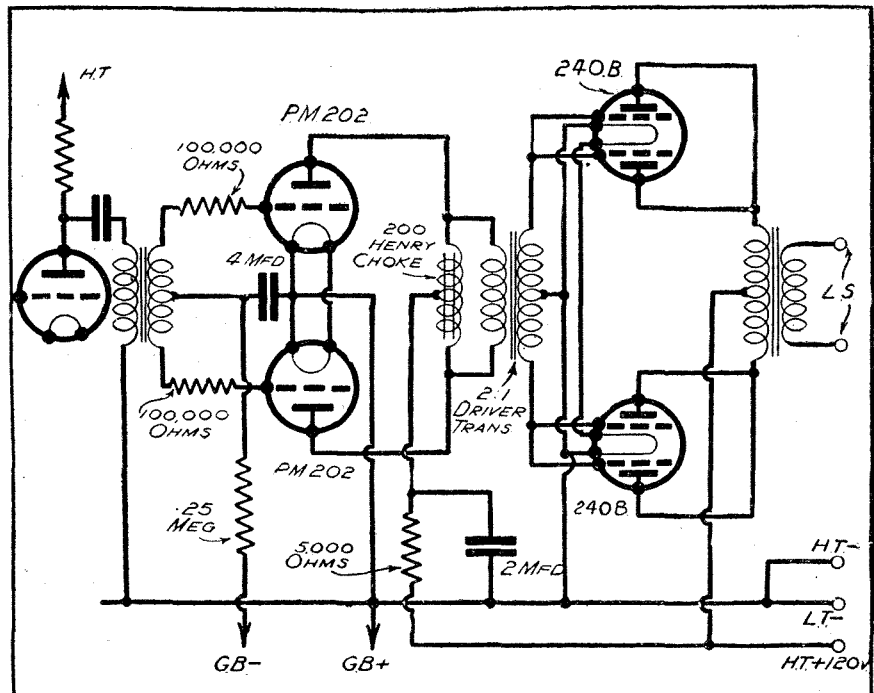

By using a Q.P.P. driver stage, feeding into "push-pushed" Class B valves, a surprising amount of output power is achieved with a remarkably low average anode current consumption.

with a single valve is to bias it so far down that the working point is encroaching on the curved part of the valve slope.

The economy of this type of "driver" stage would be very apparent in a rather more ambitious type of am-

plifier could easily be obtained by a simple automatic method.

In such a manner as described, Class B and Q.P.P., although two very great rivals, can be harnessed to pull together with distinct advantages over a plain system using either method.

The "FERRO-MAINS" Three

THE "Ferro - Mains" Three, which we describe this month, employs what is termed a straight circuit, that is, it is not a super-heterodyne, but a perfectly straightforward H.F. stage, followed by detector and one L.F. amplifying valve. The coils are the well-known Colvern Ferrocart type, and our experience of them, formed over a considerable period, and after practical trial in various types of sets, has proved them to be extraordinarily effective, both from the point of view of station separation and range.

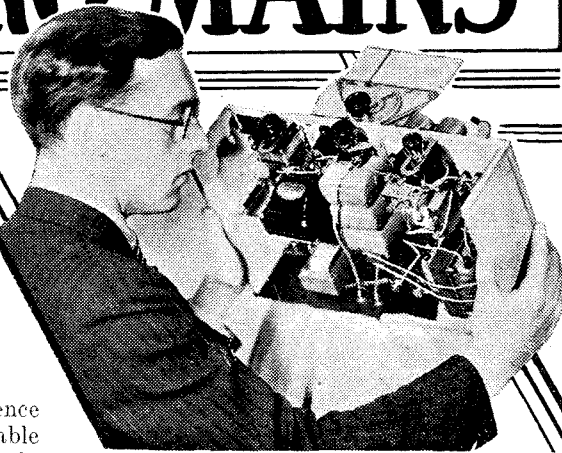

By THE "WIRELESS" RESEARCH DEPT.

A REMARKABLY EFFICIENT "STRAIGHT" THREE FOR A.C. MAINS. INCORPORATING THE MOST UP-TO-DATE DEVELOPMENTS IN RADIO SET DESIGN

A feature of this particular Ferrocart unit which constructors will appreciate is the incorporation of an on-off and radiogram switch in the assembly. These two controls are ganged to the

that the H.F. valve, V1, is a pentode. This arrangement follows the most up-to-date radio practice, and enables the very utmost amplification to be achieved without adding any complications to the circuit as a whole. We may add that there is no fear of instability occurring as the result of this high magnification feature.

The gang tuning condenser and the coil unit are thoroughly screened and, what is more, the tuning condenser is mounted directly above the coil unit, being separated from it by

Band-Pass Coil Unit

The particular unit chosen for the "Ferro-Mains" Three, utilises an inductively coupled band-pass arrangement, in which the aerial and H.F. grid circuits are separately tuned. The unit is, therefore, in three sections, each section being connected in parallel with a .0005-mfd. tuning condenser.

The degree of selectivity given by this scheme is really remarkable in any but the most exceptional conditions—assuming that an outdoor aerial is used.

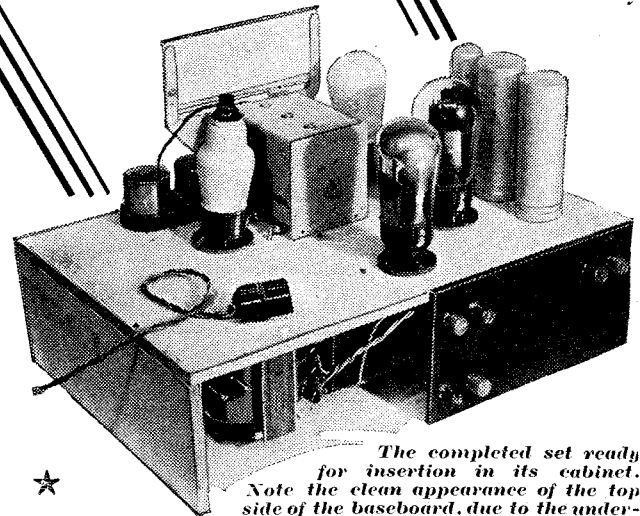

The completed set ready for insertion in its cabinet. Note the clean appearance of the top side of the baseboard, due to the under-chassis wiring employed.

BUILD WITH THESE COMPONENTS

- 1 Colvern Ferrocart 3-gang coil unit, type G1. 2, 3, with mains switch.
- 1 Polar Midget 3-gang tuning condenser, each section .0005 mfd.
- 1 Polar V.P. horizontal drive for above.
- 2 Clix 7-pin chassis mounting valve holders with screw terminals.
- 1 Clix 5-pin chassis mounting valve holder with screw terminals.
- 1 Clix 4 or 5-pin chassis mounting valve holder with screw terminals.
- 1 T.C.C. 4-mfd. fixed condenser, type 80.
- 2 Dubilier 8-mfd. dry electrolytic condensers, type 0281.
- 1 Dubilier 4-mfd. dry electrolytic condenser, type 0283.
- 2 T.C.C. 50-mfd. 12 v. dry electrolytic condensers, type A.W.
- 2 T.M.C. Hydra 1-mfd. fixed condensers, type 25.
- 2 Graham Farish 50,000-ohm "Ohmite" resistances in horizontal holders.
- 1 Graham Farish 20,000-ohm "Ohmite" resistance in horizontal holder.
- 1 Graham Farish 5,000-ohm "Ohmite" resistance in vertical holder.
- 1 Varley 750 ohm "Electronic" resistance, 1-watt type.
- 1 Ferranti A.F.5 L.F. transformer.
- 1 Bulgin smoothing choke, type L.F.14S.
- 1 Wearite mains transformer, type T-21A.
- 1 Bulgin combined fuse-holder and mains connector, F.18.
- 1 Bulgin 2-pin socket for above type, P.29.
- 1 Peto-Scott "Metaplex" (both sides) chassis, 16 in. x 10 in. with 4 in. runners.
- 1 Peto-Scott ebonite terminal panel, 8 in. x 4 3/8 in.
- 6 Clix indicating terminals, type A.
- 1 T.M.C. Hydra .006-mfd. tubular fixed condenser, type T.15 5.
- 1 Dubilier .0002-mfd. fixed condenser, type 610.
- 1 Dubilier .0001-mfd. fixed condenser, type 620.
- 1 T.C.C. .0001-mfd. fixed condenser, type 34.
- 1 Graham Farish screened binocular H.F. choke, type L.M.S.
- 1 Graham Farish screened H.F. choke, type H.M.S.
- 1 Varley 10,000-ohm potentiometer, type G.P.158.
- 1 J.B. .0003-mfd. solid dielectric differential reaction condenser.
- 1 Erie 1-meg. grid leak, 1-watt type.
- 1 Erie 500-ohm resistance, 1-watt type.
- 1 Erie 250-ohm resistance, 1-watt type.
- 1 Erie 100-ohm resistance, 1-watt type.
- 2 Peto-Scott mounting brackets, type 22 1.
- 2 Coils B.R.G. "Quikon" connecting wire.
- 1 Length Goltone screen sleeving.
- Screws, flex, etc.

wave-change switch spindle, and are operated by the one knob. Thus this single knob switches the set on, off, from medium waves to long waves, and vice-versa, and from radio to gramophone.

Turning now to the various other points of interest in the circuit, it will be noticed

the screened "Metaplex" baseboard. This method of mounting provides a logical layout and enables the leads to be kept short.

Preventing Parasitics

Moreover, the pentode is decoupled from the H.T. circuit, and incorporates a volume control potentiometer in accordance with the usual variable-mu practice. Reaction is applied to the detector grid circuit via a differential reaction control and a 500-ohms resistance is inserted between the anode of detector valve and the moving vanes of reaction condenser to prevent parasitic oscillation.

GREAT RANGE WITH HIGH SELECTIVITY

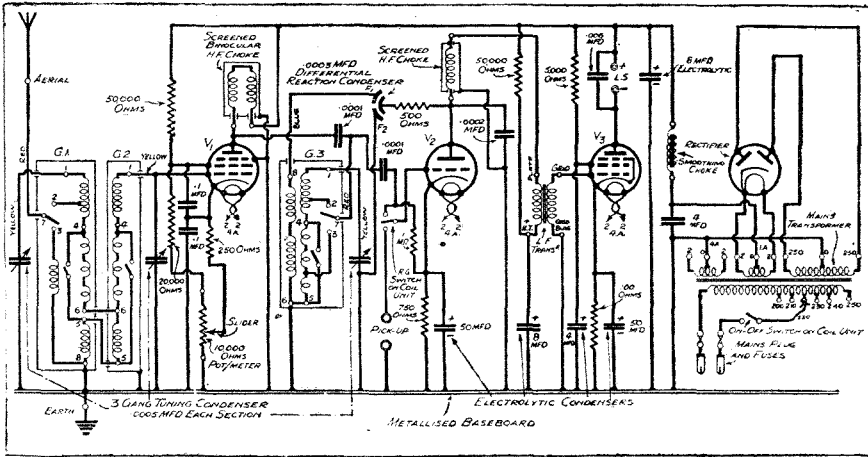

Among the special features of the "Ferro-Mains" Three may be mentioned the use of an H.F. pentode and one of the new Osram N.41 steep slope output pentodes. Band-pass tuning coils of remarkable efficiency are also incorporated in this fine set.

Constructors will also notice that the pick-up is switched into this circuit, so that on "gramophone" the pick-up output is fed through a two-stage L.F. amplifier, the detector valve working as a transformer-coupled L.F. stage.

The detector is very adequately decoupled, an 8-mfd. electrolytic condenser being employed for by-passing.

Another point of interest is a .0002-mfd. fixed condenser, which is joined between the anode of the detector

valve and the earth line, to remove any residual H.F. currents.

The pentode output valve is the latest Osram N.41, and has an extraordinarily steep slope. In practice this means that it will give a very high amplification, and, consequently, excellent results from the weaker distant stations. On the other hand,

RECOMMENDED VALVES AND LOUDSPEAKER

- VALVES**
 S.G.—Cossor M.V.S.—Pen. (7-pin).
 Det.—Cossor 41M.H.L.
 Output.—Osram N.41.
 Rectifier.—Osram M.U.12.
LOUDSPEAKER
 W.B. "Stentorian."

its output wattage of about 3.8 is more than adequate for ordinary domestic requirements on the local B.B.C. programmes.

In short, this combination of high-efficiency H.F. pentode, reaction detector, and steep slope pentode output valve is one that provides the greatest possible efficiency from three valves.

In so far as the power supply is

FOLLOW THIS DIAGRAM CAREFULLY WHEN WIRING UP

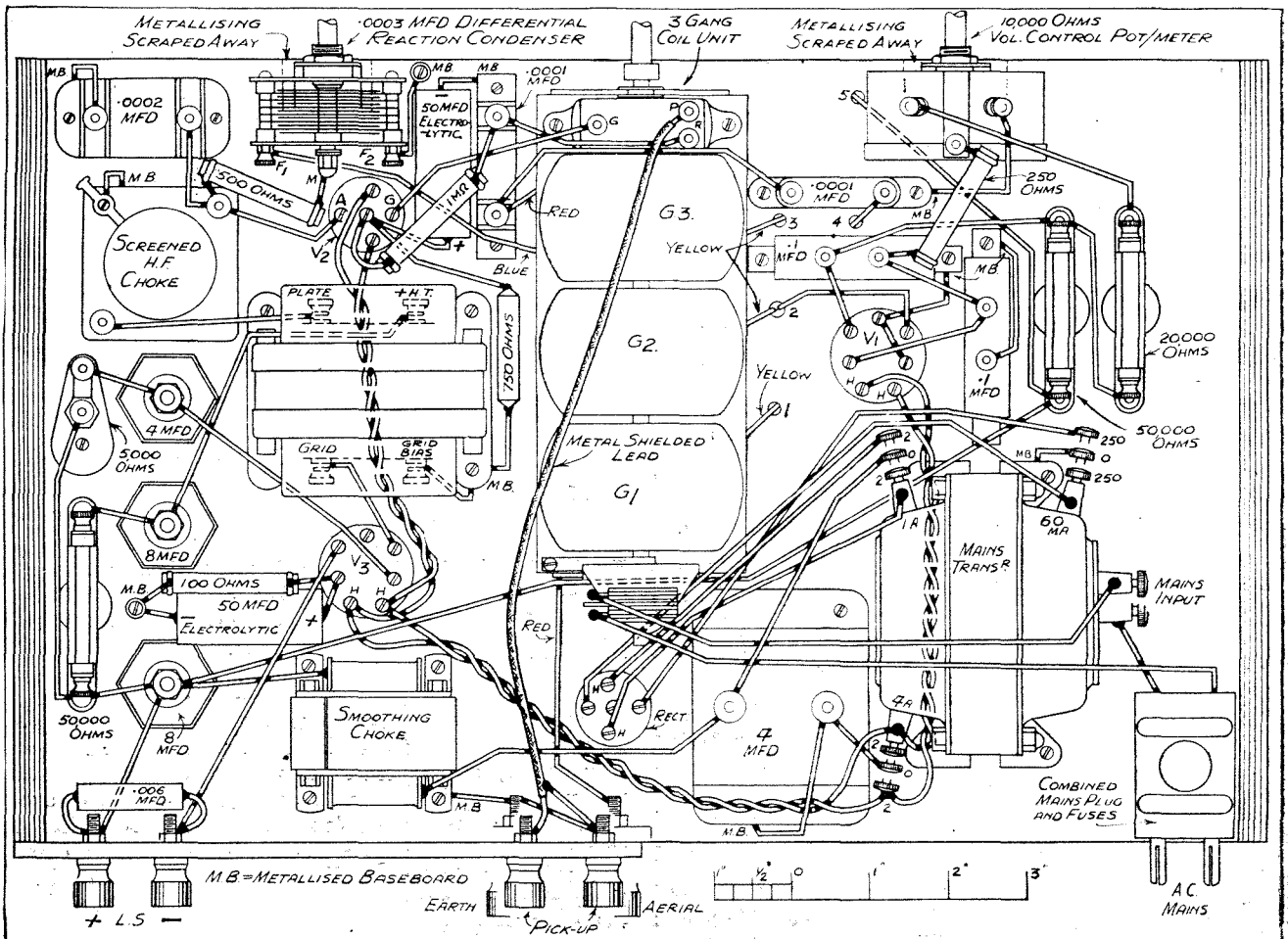

In this diagram of the under-baseboard-wiring it will be noticed that certain leads are taken direct to the "Metaplex" covering. Constructors should make quite sure that these leads make good electrical connection with the metal coating.

concerned, this is looked after by a full-wave indirectly-heated rectifier and efficient smoothing. The circuit is suitable for A.C. mains having voltages of 200-250 at 50 cycles.

The Loudspeaker

A loudspeaker has not been included as part and parcel of the design, and constructors who are purchasing a new one specially for this set should obtain a permanent-magnet type, with a universal input transformer integral with the speaker chassis. They will then have no difficulty in matching up the loudspeaker circuit with the impedance of the output valve.

There are no particular features in the construction that require stressing other than the following: In the first place, the three circular holes for the chassis mounting holders should be cut so as to give adequate clearance between the sockets and the "Metaplex" baseboard.

A SIMPLE ABOVE-BASEBOARD LAYOUT

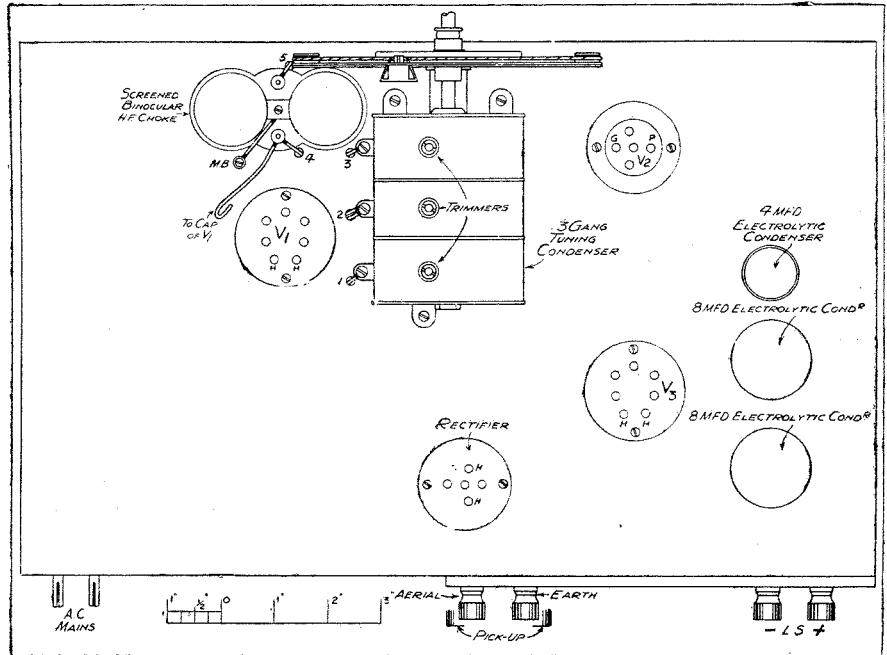

The positions for the various components on the top side of the baseboard can be easily ascertained from this diagram. Note that the two pick-up terminals are immediately below those for aerial and earth.

DRILLING DIMENSIONS

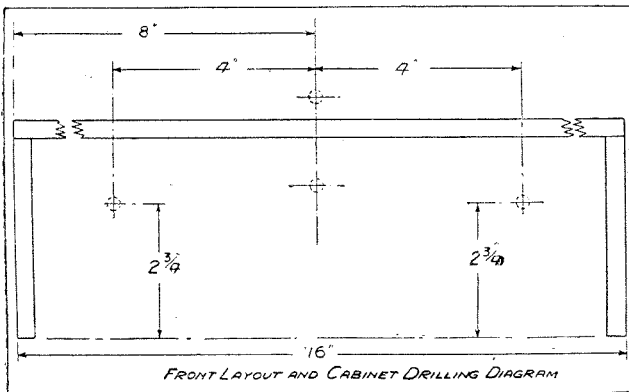

Only four holes have to be drilled in the front of the cabinet for the controls.

There must be no risk of any accidental short circuit on to the metal covering of the baseboard.

Secondly, the three electrolytic condensers are mounted vertically, their holding down nuts being recessed into the underside of the baseboard. This is necessary in order to get sufficient thread through the baseboard to ensure a secure mounting.

The Earth Returns

Next, it will be noticed that certain of the leads are joined straight to the baseboard and care should be taken to see that the connection in every case is good, from the electrical point of view. These connections are, just as important, and have as great a bearing on the efficient working of the set as those of the connections to the terminals of any of the components in the set. They are, of course,

connections to the earth line, and should any of them be below par, trouble is sure to result.

With regard to the mains transformer, this has a dial which is rotated to the voltage of the

mains supply, and should be set on the correct voltage before the component is mounted into position. Full instructions as to how this adjustment is carried out will be found on the leaflet supplied with the transformer.

Notice also that the screens on the 2 H.F. chokes are connected to the earth line. Do not omit these essential connections.

Incidentally, if you make your own

Please turn to page 271.

PERFECTLY STRAIGHTFORWARD WIRING

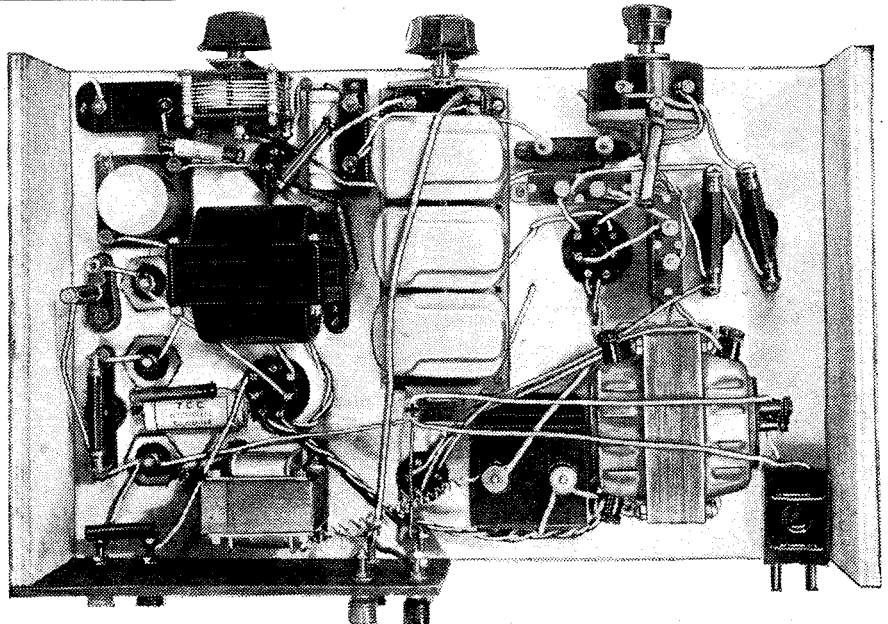

The nuts holding the three vertically-mounted electrolytic condensers in position are recessed into the baseboard. This work is best carried out by cutting the recess for each nut first and then screwing the condenser through from the top of the baseboard.

THEY MAKE YOUR RECORDS

But how have they come to make their names? Here are some interesting facts about the careers of some of our leading gramophone artists.

WE hear so much about film stars and their so-called private lives—how many of them must wish they really were private—that we are rather apt to overlook the older branch of the “canned” entertainment industry, the gramophone.

Perhaps the gramophone stars can hardly be said to possess the glamour of their film cousins, but romance is by no means absent, and the rise to fame of many of the artists forms most interesting reading.

There are millions of people who have never had a singing lesson, but how many of these have become world famous opera stars and gramophone artists? Yet the lovely young Swedish-Russian soprano, **Miliza Korjus**, who has recently been engaged by the Berlin State Opera, has never had a singing lesson in her life.

She has learned all her singing—and she has a glorious voice—from gramophone records made by other great singers. “My father was very fond of music,” she says, “and had a huge collection of records by Galli Curci, Tetrizzini, Frieda Hempel and Selma Kurz, and as a child I learned to imitate them exactly.

A Gramophone Triumph

“Before long I found that I had naturally placed my voice correctly—purely by imitation—and from singing with the gramophone I had learned hundreds of operatic arias.

“At seventeen I went for an audition to a famous German singing teacher, who said, ‘I cannot teach you—you have nothing to learn! So ever since then I have studied, as I did as a child, with the gramophone.’”

A marvellous advertisement for the gramophone, isn't it? But if you will listen to some of the young star's H.M.V. records you will realise how well she has studied and how successful have been her teachers.

* * *

A rapid rise to fame has been the fortune of **Mabel Wayne** successful lady dance number writer, who has given us a whole series of tuneful compositions. And they are particularly tuneful, too, from “Ramona,”

down to the latest, “His Majesty the Baby.”

Mabel Wayne, only writes when she is feeling a bit unhappy, and when she is on top of the world there is a gap in her musical output—or so they say. Anyhow, her recent numbers do not reflect such moods, for “His Majesty the Baby” has no trace of sadness in its composition, though the earlier

HERE IS THE SMILE!



A SMILE, A JOKE AND A PIANO—that is Norman Long's stage slogan, while the smile and the joke are his motto for everyday life. Norman was our first broadcast entertainer, and he is still going strong.

titles, “Ramona,” “It Happened in Monterey,” and “In a Little Spanish Town,” one can imagine were born during times of sadness. How often it is that particularly tuneful music is created in moments of depression or disappointment.

At the time of writing Mabel Wayne is in this country, and Columbia have persuaded her to make a record of her greatest successes, singing and playing her own compositions. It is a surpris-

ing record of tunefulness, and after you have heard it you will realise why it is that this young American has sprung to the top of the tree, and is rightly world-famed. The record is “Some of My Songs,” and is number DX 672. And, naturally, it contains her greatest hit of all, “Little Man You've Had a Busy Day.”

* * *

Another songster at the piano from whom we have just had a Columbia record is **Norman Long**, the first entertainer to broadcast in this country—way back in 1922.

What the War Did

His life is another romance of the stage and microphone, for he started out as a member of the staff of one of the large insurance companies.

With his smile which had been with him almost from birth, and the song and piano which he acquired at the age of ten, Norman Long used to do a little dance-band work before the war, combining music with his less interesting profession.

The war took him away from the latter, but actually advanced his musical career, for he did a great deal of entertaining of troops overseas.

The war over, he set himself to the entertaining business with full energy. He had decided to leave the office stool for the stage just before war broke out, and with the coming of peace he set to work to develop his entertaining faculties.

A Popular Broadcaster

Concert party work gave him much useful experience, and then broadcasting came and put him right on the public map.

He appeared before the microphone many times in the old Marconi House days, and followed the move of the B.B.C. from there to Savoy Hill as one of their most popular broadcasters.

He has recorded many times, first, I believe, with the old Savoy Orpheans, who were under Debroy Somers, and he is the compère in that early record of the Savoy Band Tour of the world.

His Latest Record

And he is still at it, broadcasting and making records between his numerous stage engagements. His latest record is “Come and Join the No-shirt Party,” in which he forms a new party with totally different ideas from those of the numerous organisations who boast various coloured undergarments. The number is DB 1510 and is in the latest Columbia list. **K.D.R.**

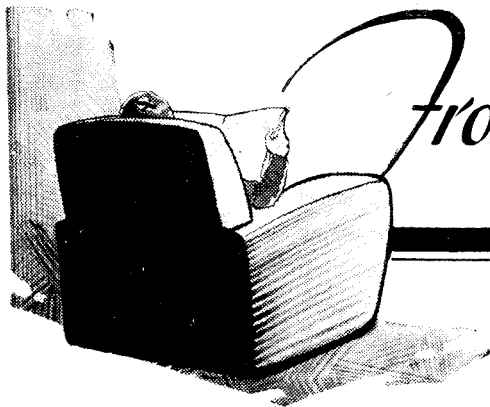

From My Armchair



Mr. Scott-Taggart never minces matters, and this month he has some particularly outspoken remarks to make in connection with receivers which do not work properly.

STRETCHED on one's back for a week, drinking hot lemonade almost literally ad nauseam, periodically inserting between dry lips the tell-tale tube of mercury, one is inclined to take stock.

With nothing else to do, that is what I have been doing.

But perhaps when I say there is nothing else to do, I am in error. Letters from readers come as usual, forwarded with the automatic precision of an editorial office that knows nothing of influenza. For if it did, surely it would sift the grain from the chaff.

High Temperatures

Tears almost flow when one reads the Monday mailbag with a temperature of 102 degrees. The temperature refers to me, not to the mailbag, of course, for the latter is often inclined to be above boiling point.

How I have struggled to put home-construction on a fool-proof basis! But there are undoubtedly offenders on both sides—offenders by no means confined to the constructing public. There are cases where it is clear that the manufacturers are to blame. And the more successful a set, the more complicated the problems arising from it.

Manufacturing Troubles

I can appreciate the difficulties of the manufacturer when a set "catches on" and becomes an enormous success. But I feel that the bigger the demand the more energetic the measures required to cope with it, and the greater the care necessary to guarantee that the components are, like Cæsar's wife, "above suspicion." Testing is the crux of the problem in many cases. Because there is an enormous demand for a certain component, and because production is speeded up, that should not necessarily mean that the tech-

nique of testing should be slackened. On the contrary, it should be tightened up.

If you receive a faulty component, don't blame the set. Once you are convinced the component is faulty, send it back to the manufacturers. Do not be unduly appreciative because the manufacturers send you a new component by return of post. Manufacturers do not get back in practice a fraction of the faulty apparatus which is sometimes allowed to enter the market. Why not? Because the average constructor can only judge overall results and cannot put his finger on the faulty spot in his set. All

the more reason for laying on the complaint with a trowel when the fault is found out.

"But," says a manufacturer, "it is impossible to avoid some faulty apparatus getting through. The human element . . ."

Not Very Expensive

I know something about testing. It costs money—but not nearly as much as some people would have us think.

How often in every field of manufacture does some non-technical director with keen eyes espy a pile of goods and say: "What are all these?" "They're rejects, sir," says someone less mighty. "Rejects?" repeats the director, picking one up. "They look all right to me. We can't afford to scrap all these. We can't deliver fast enough as it is." And the less mighty one says: "Very good, sir," remembering that he has a wife and two children to feed.

The cost of testing is a myth. The real cost is that of the rejected apparatus. Sometimes it can be put right. Sometimes, as in the case of a valve, the ash-can is the only appropriate destiny of a "reject."

The "Human Element"

As for the human element, this can be guarded against. It is true that Polly Peachum, who spends her prosaic working hours checking the inductance of coils may let her mind wander off microhenries and toy with romantic thoughts of an admiring Henry. Not even the Valve Ring can prevent dreams of a diamond ring.

But double or triple checking would prevent all that. Polly may be thinking unduly of Henry while a certain coil test is carried out, but Mary, a check-tester, is not likely to day-dream of Ronald Coleman while checking that particular coil.

NEW B.B.C. STATION

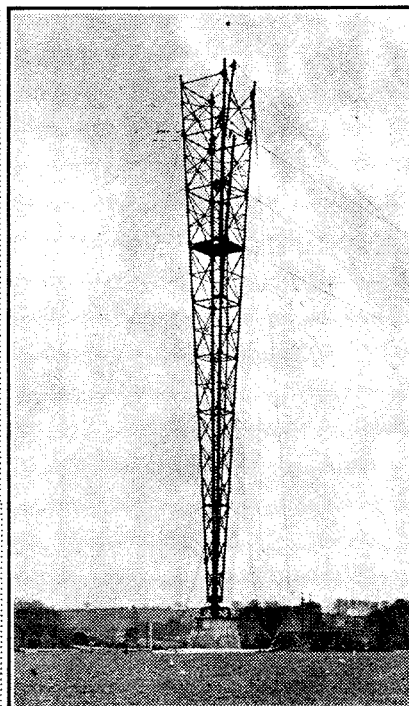

Work on the new B.B.C. station at Lisburn in North Ireland is now well advanced. Here is a photograph of the special anti-fading aerial in the course of erection.

And what if a manufacturer *does* get an unjustifiable complaint now and again? Well, it will keep his conscience in a nice tender sensitive condition. It will keep him on his toes—the only stance any manufacturer has a right to.

And now, while I am all hot and annoyed, let me have a go at the constructor. He believes in giving me "what-for" if his set doesn't work well. He never thinks of pattering little feet and dewy-eyed innocence when he strings together his chains of invective. The trouble is that *sometimes* he blames the wrong person. Let me say at once—to clear the air—that I myself am never wrong!

Whose Fault?

This is very blatant, of course, but look at it this way: I design, say, an S.T.600 and, not relying on my own opinion, I demonstrate it throughout the country. Letters appear from scores who have tried the set in their own homes. Even if you assume that I am a liar and that I have lied with consistent success for twenty years of popularity as a designer, it is probable that at least *some* of those who have attended demonstrations or built the set are reasonably truthful, sincere persons.

If you admit that the S.T.600 is a good set as built by myself, you must inevitably come to the conclusion that a faulty S.T.600 of your own is either different from my S.T.600 or is not properly connected to suitable external apparatus (e.g. batteries), or is not being properly worked.

A Case in Point

If you have departed from my design I, of course, wash my hands of your results and the rudest letters leave me unmoved. It is your design, not mine, and you must cheerfully lump it.

If you have, to save money, built the set from junk (even only one junk component would ruin any set), please keep the fact to yourself; don't blame one who has warned you a hundred times and implored you to build either *my* set or else to leave it absolutely alone.

The other day I saw a set which, because of a technically interesting fault, aroused my curiosity. The owner swore blindly that the set was absolutely the same as my design. Why a thunderbolt has not struck him is a matter of mild wonder as I look up at the ceiling, sucking aspirins. It was an S.T.600, and the Extractor condenser was placed on the panel so that he could tune it conveniently! The result was instability of the first valve and a variety of queer interference effects due to the Extractor circuit feeding its interfering currents (intended to be kept out of the set) into the H.F. circuits.

A NEW PHOTO OF AN OLD FRIEND



Carlos wishes S.T. a merry X-mas & await a straight that I shall excel in performance and quietude! 1934/1935

With careless abandon our friend also ran many of his H.F. wires bang up against the metal work of the coils. Apart from obvious disadvantages, this prevented ganging

The photograph on this page is the portrait of Carlos and his dogs mentioned by Mr. Scott-Taggart last month.

The writing below it is a facsimile of the inscription sent by Carlos with the photograph.—ED.

owing to large "stray capacities." The tone-control condenser was also on the panel, although this perhaps did no harm, although such alterations are very risky.

Of course, if I had **known** of these alterations I would **not** have had anything to do with the set. People who redesign my designs are either fools or experts; I claim to **design** for neither. The fools are a nuisance to everyone, while the experts can do their own designing.

It is astonishing how many utterly inexperienced constructors get perfect results. The reason is simply that they make a Chinese copy of the designer's original set. They are so chary of going wrong that they use exactly the same components and see that every wire connection is bent and placed exactly as in the drawings and photographs. What is more, they read every word written about the set, not only in the original description but in subsequent articles.

The Copyists

Blessed are the Chinese copyists, for they get the author's own results. If they don't, it is due to (a) faulty components or valves, (b) wrong high-tension voltages, (c) faulty operation.

Do not let it be thought that I harden my heart against *any* constructor of one of my sets if he has genuinely attempted *my* design and not his own. But he who says such things as "The S.T.400 is much better than the S.T.600" is simply advertising his ignorance or misfortune.

Streets Ahead

I know what's what about my own sets, and the S.T.600 is streets ahead of any popular set I have designed. I use it daily myself, and its performance is so high that not for two years will it be ap-

proached. If anyone does not agree, there is something wrong with his version of the S.T.600. It will repay him handsomely to find out what it is.

Well, I've just had a look at the thermometer. It's 102.5°—which isn't too bad at all, considering the heat of my opinions. Having got them off my chest, I shall have a better chance of getting this cold off it also. **J.S.-T.**

AS WE FIND THEM New apparatus tested



BY THE
"WIRELESS"
RESEARCH DEPT.

Interesting reviews of the latest products submitted by radio manufacturers and traders for examination and test in our laboratories.

Wearite Components

MOST of the iron-cored tuning coils on the market are of the fully screened type, but there are occasions when screening is not essential. Bearing this in mind, Messrs. Wright & Weaire, of 740, High Road, Tottenham, London, N.17, have added to their already extensive range a par-

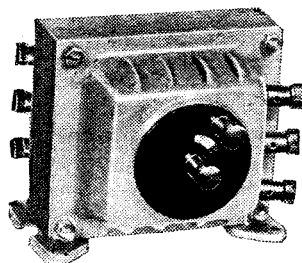

SAFETY FIRST!
The terminals on this Wearite mains transformer are all insulated.

ticularly compact coil of the dual-range type, in which no screening at all is provided.

These particular coils are especially suitable for simple circuits or for portable sets where compactness, combined with high efficiency, is a vital factor. Moreover, the coils lend themselves admirably to the modification of some of the older circuits with a view to bringing them up-to-date to cope with present-day conditions.

The coil under review is termed the I.C.6, is priced at 5s., and has wave-ranges of 190-580 and 850-1950 metres.

In a highly sensitive circuit, utilising an S.G. valve, it is desirable from the point of view of stability to screen one coil, preferably the H.F. unit, and this procedure is, in fact, recommended by the makers. There are cases, of course, where a screen totally enclosing the coil is unnecessary, and the well-known form of vertical screen, combined with a metal-covered base-board will often suffice.

A Good Mains Transformer

Another Wearite component, and one which, we may add, has proved itself highly satisfactory on test, is the T.21A mains power transformer.

sary current for the heaters of three or four A.C. valves as well as 1 ampere for the filament of any "A" type rectifying valve.

A noteworthy point in connection with this particular transformer is the fact that it is absolutely safe to handle, since the terminals are all thoroughly insulated.

Another feature is the method of adjusting the component to suit various mains voltages. On one side of the transformer casing there is a dial, and this is rotated, by removing the outside terminal, until the correct mains voltage appears in the small aperture cut in the circular disc.

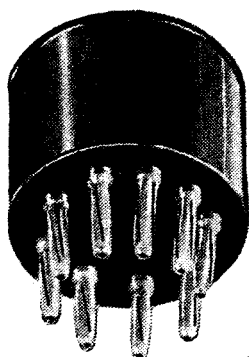

FOR GROUPED LEADS

A very handy Bulgin nine-pin plug designed for use with a standard nine-pin valve holder. It is useful for grouping battery connections and for experimental work generally.

When this point is reached the outside terminal is screwed back into position and the transformer is ready for use. This is a very neat method of voltage adjustment.

The voltage regulation is excellent, and in use the temperature rise is only slight. We can recommend the transformer as a safe, reliable and efficient component.

Bulgin Valve Holders

Constructors are sometimes faced with an elusive crackle which, after many hours of wearisome search, is finally traced to a loose terminal connection, possibly in the valve holder, or, at any rate, in some position which is difficult to get at without partially dismantling the set.

There are, no doubt, many who will say: "Then why not use soldered

joints throughout, so eliminating the possibility of the fault arising from this source?" But the point is that at least 50 per cent of home constructors haven't acquired the art of successful soldering, and therefore rely upon sound terminal design on the part of the manufacturers. After all, a terminal connection, provided it is tight, is as good as any soldered joint.

Messrs. A. F. Bulgin are one firm who appreciate the necessity of providing their components with terminals that cannot possibly work loose. In their new valve holders, for example, they have incorporated special shake-proof washers to all the terminals, so that there cannot possibly be any trouble from this source.

Moreover, the soldering tags (all the valve holders have both terminals and soldering tags) cannot turn because they pass through niches in the base of the valve holder, and in addition are solid extensions of the valve-pin contacts.

These contacts are flat springs, slotted in the centres, and are designed to facilitate the easy insertion and withdrawal of the valve, as well as to ensure an effective connection with each valve pin—qualities not easy to obtain with multi-pin valves.

The valve holders shown in the photographs are of the five- and seven-pin type, and retail at 6d. and 1s. 6d. respectively.

A Handy Plug

The same firm are also marketing a rather fascinating 9-pin plug, designed (Please turn to page 273.)

SHAKE-PROOF TERMINALS

The latest Bulgin valve holders are equipped with terminals which cannot loosen, and so cause imperfect contact. In addition, the soldering tags are solid extensions of the valve-leg connections.

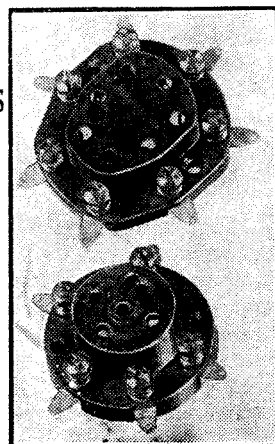

Short Wave Notices

What is the ideal short-waver? That is the difficult question which W. L. S. tackles this month. He handles it with characteristic candour and at the same time gives the reader some most valuable information.

As a result of my recent article on short-wave receiver design, I have received quite a number of letters from readers, and no fewer than ten of them contain the question, "What is your idea of the ideal short-wave receiver?"

Well, allying brevity with candour, I can only say that the ideal short-wave receiver is an impossibility—that's my idea of it. Short-wave reception is such a vast subject that it's fundamentally impossible to design a set that would satisfy everyone.

What do you want—headphone reception of every little upstart short-waver in the world?; loudspeaker reproduction on the "Yanks"?; amateur C.W. reception?; amateur telephony?—probably all of them.

No True "Ideal"

I don't think it's possible to design a set that one could truly term "ideal" on all these points. I think the nearest one could get to it would be a superhet with a really useful H.F. stage in front of the first detector, with provision for plugging in the 'phones instead of the I.F. amplifier. In other words, it would be a superhet for loudspeaker reproduction on strong stations, and a good two-valver of the H.F.-and-detector type for headphone work.

You see, the whole trouble—once more—is background. A short-wave superhet is simply beautiful for filling the house with floods of music from W8XK, W2XAD, or even VK2ME when he's coming over well. But, if you want to receive a 6-watt transmission from, say, VP6AB in Barbados, you will want a very different set to do it with.

So let's split our "ideal" up into several parts, and try and please each group separately. Take Mr. A. first.

He wants to boast, as he takes his corner seat in the 8.35, that he had America on the speaker for an hour last night. He wants good reproduction, too, and doesn't mind spending a bit of money on it.

If he already has a useful broadcast receiver—preferably a superhet—then his easiest way of getting short waves would be to invest in a really good superhet adaptor. If he prefers to leave the B.C. receiver alone, he can make a six-valve short-wave superhet, with S.G. stage, heptode "mixer," two I.F.'s, second detector and pentode output. It'll probably lift the roof clean off his house when he lets it go.

AN AMATEUR-BAND SET

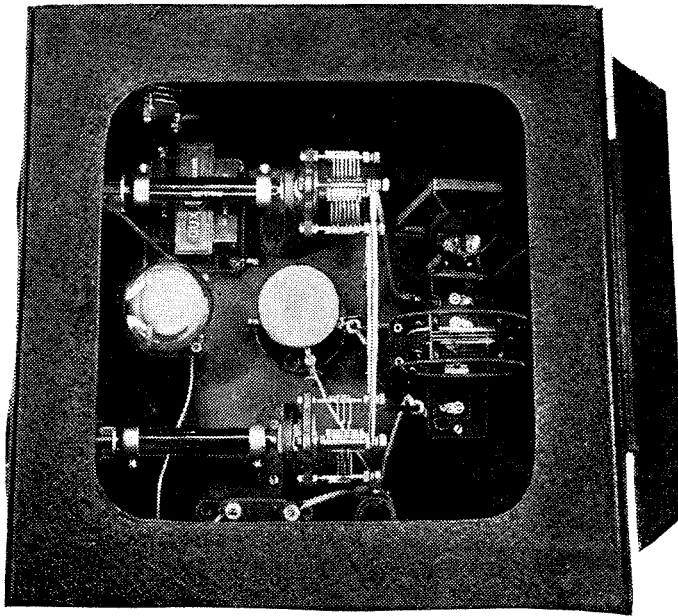

This two-valve short-wave set, used by W. L. S. for reception of amateurs, employs band-spread tuning. The reaction control can be seen at the top of the picture on the left-hand side of the case.

But what of Mr. B.? He knows jolly well that any "mutt" can receive America on the speaker if he uses enough valves, and that just doesn't interest him. No, sir,—what he wants is to be the only man in his suburb who has heard Hong Kong and the Fiji Islands, and he doesn't mind tightening up the 'phones and holding his breath for five minutes to do it.

He wants quite a small set, but essentially a "hot-stuff" one. I prescribe something with a screen-grid detector and a resistance-coupled L.F. stage, with volume control. He will then be able to get that really silent background necessary for the reception of these ultra-weak stations that the average man doesn't bother to listen to.

The Last Two Types

Mr. C, who wants to hear everything that the short waves have to offer, and, if possible, on the speaker, must have a combination of the two sets and it was for him that I suggested the big superhet with facilities for plugging-in 'phones after the first two valves.

There is even a fourth man Mr. D., who hopes, one day, to become an amateur transmitter, and is thrilled to death by listening to them. Anything off the amateur bands just bores him.

I have an amateur-band set of my own which I like to consider the ideal, and it uses two valves, with switching for cutting out the L.F. when things are noisy. It also has band-spread tuning, which is a vital necessity, otherwise all the amateurs will be crammed in a few degrees on the dial, the rest of which will be wasted.

The illustration on this page shows the inside of my own set. The variable condenser near the top is a .0001, and that below it, connected in parallel with it, is of .000015 only. This spreads the amateur bands out beautifully, and whereas they occupy only about 3 degrees on the .0001, they cover 70 or 80 on the other, and tuning is very simple indeed.

Broadcast Bands

This set, with band-spread, should fulfil the requirements of both Mr. B. and Mr. D., since

the band-spread is equally useful on the short-wave broadcast bands.

Followed up by a really fat all-A.C. gramophone amplifier, this set might also be quite near Mr. A.'s ideal, for it will certainly deliver very good loudspeaker volume on most of the stations that it's possible to hear with it. But still I prefer the superhet for the "telephony-only" man—it releases him from the reaction control.



LOW CAPACITY TUNING

ONE of the earliest puzzles that confounds a keen constructor is the problem of choke coupling in a high-frequency stage. The question generally presents itself in this form: if a choke has an inductance of 200,000 micro-henries, compared with the 200 micro-henries of the ordinary tuning coil, why does not the choke provide an efficient coupling between a high-frequency valve and a detector?

Modification Required

Now, in the answer to this question lies one of the most valuable lessons possible to the amateur enthusiast; it gives him an insight into the more complicated aspects of design, and into the subtleties that control the sizes of condensers and other components within fine limits.

The aperiodic stage had a long innings in various forms, and still survives in the by-ways of design. Its last public appearance on a large scale, however, was during the portable craze of three or four years ago.

In spite of the admitted inefficiency of aperiodic coupling when it is compared with a tuned screen-grid stage

AN APERIODIC STAGE

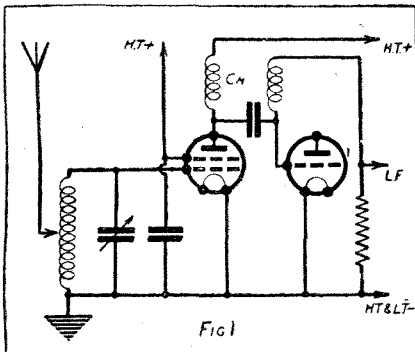

The simplest form of aperiodic H.F. coupling followed by a diode detector.

I am going to suggest that it is still capable of service in a modified form in what I might call the personal type of set.

By this I intend to make a distinction between what is, strictly speaking, an assembly of highly-efficient parts

that have been brought to perfection by the manufacturer; and the construction that embodies at least one component that is the builder's own job.

Further, I think it is essential that this personal contribution by the

Without losing the characteristic simplicity of the aperiodic H.F. stage, the brilliant scheme outlined in this article increases its amplification to an extent which makes it a highly desirable method. The practical application of the system is also discussed

By C. J. DARK

amateur should be the "key" component.

Much of what follows, then, is addressed to those who are primarily interested in the idea behind the set, in doing a bit of work for themselves on the basis of the idea, and not in gluing themselves to a wiring diagram.

The Simple Circuit

The aperiodic stage of high-frequency amplification, in its simple form, is illustrated in Fig. 1. Now it is possible to get a fair measure of magnification from this circuit by a careful choice of valves and components—the amount of amplification, we will say, that would be sufficient to compensate for a very poor aerial or situation, when the listener is within the area of a regional service.

The first point that must be made clear is that success with this circuit depends in only a small degree upon the inductance of the coupling choke, but almost entirely upon the capacities in parallel with it.

"Stray" Capacities

Let us analyse, then, the situation in regard to these capacities: the average H.F. choke will possess a self-capacity of something like 4 micro-microfarads (-000004); the H.F. valve anode to filament capacity will be about 12 m.mfds.; and the grid to

filament capacity of the detector may be 7 m.mfds.

All these capacities are shown as condensers in Fig. 2.

It will be noted that both Fig. 1 and Fig. 2 illustrate a diode detector following the H.F. valve, as the effect of the detector valve capacities is less than with an ordinary grid-leak detector; and for other reasons that will appear later, the diode form is to be preferred both for the theoretical and practical consideration of the matter in hand.

A Large Total

We have, then, a known total of 23 m.mfds. in parallel with the coupling choke; and to this total must be added valve-holder capacities and all the stray incidental capacities due to the wiring—we will ignore, for the moment, the effect of the choke, CH2. Shall we say that all these incidentals make up a total of 30 m.mfds.?

The anode choke, then, we find to be shunted by the alarming figure of 30 m.mfds. (-00003). This combination of inductance and capacity will

INCIDENTAL CAPACITIES

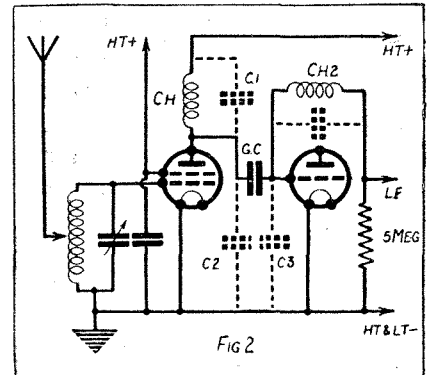

The condensers shown dotted represent unavoidable capacities that affect the working of an aperiodic stage.

obviously form a tuned circuit of very long wavelength, but as we don't usually tune to 5,000 metres or so, we must see what happens lower down the wave scale.

Suppose we wish to tune in at 350

metres, what sort of amplification should we get?

If we could get rid of this stray capacity, and the anode reactance became due to a pure inductance of 200,000 micro-henries, the impedance would be 1,000,000 ohms, and some-

TUNING THE CHOKE

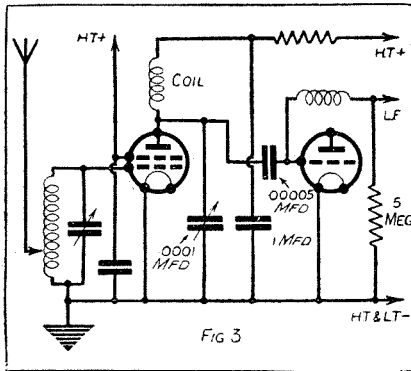

This semi-tuned H.F. choke-coupled stage is suggested in the text as an improvement on the ordinary aperiodic stage.

thing like the theoretical amplification of the valve would be realised in practice.

The question to be answered now is: What is the value of the capacity path of 30 m.mfds.? The answer is 6,000 ohms! As an alternative path, compared with a million ohms, I think 6,000 ohms would take all the traffic!

We have arrived at a point, then, which shows us that, with an average assembly, we can only count upon an impedance of 6,000 ohms in the anode circuit at 350 metres.

Stage Gain

Now we know that the amplification obtained from the screen-grid valve depends, to a large extent, upon the relationship of valve impedance to anode impedance, therefore calculation reveals that we should get a gain of about nine times! Hardly good enough for logging Europe, is it?

Now, it must be remembered that we have secured this amplification figure of nine for conditions of average efficiency, to demonstrate the factors that govern the whole problem.

In other words, we have taken average figures in place of the best possible

figures. Suppose, however, that we pursue this matter to its practical limits in regard to figures, and see how far improvement is possible. To this end, I will take actual capacity values from the catalogues in every case.

In Fig. 2 the dotted condenser C_1 (the self capacity of the H.F. choke) can be reduced to 1.5 m.mfds. by using the "Bulgin Super H.F. Choke." This choke possesses the lowest figure of self-capacity I can discover after quite a long search, and it is certainly abnormally low for this component.

Little Capacity Reduction

The anode-filament capacity of the screen-grid valve, C_2 , is a matter of considerable difficulty, as the figure is very rarely given in the lists. The Mazda people are exceptions in this respect, so we will take the figure of 12.5 m.mfds. for their S.215VM.

Again, the Mazda H.L.210 with a grid to filament capacity of 4 m.mfds, C_3 , will serve as our detector example.

The self-capacity of the choke, Ch_2 , which, as we have seen, can be reduced to 1.5 m.mfds, must now be included—its inclusion has been left to the last moment as its effect is very small, and it was thought desirable to simplify the general impression as far as possible.

This reduction has been brought about by careful search of available figures for chokes, valves, and so on.

It is now obvious from the foregoing that in an aperiodic stage every micro-microfarad of capacity represents so much loss of amplification and, in the

A MODERN CIRCUIT

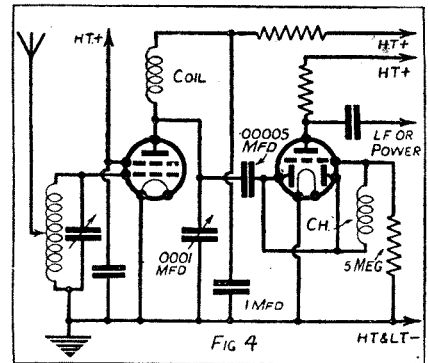

Low-capacity tuning, coupled with the modern double-diode triode, makes an ideal combination.

case of screen-grid valves, the H.F. valve itself is responsible for a large part of the total.

But to revert to our figures: by adding the unavoidable incidental capacities to our figure of 19.5 m.mfds., we cannot calculate for anything lower than 25 m.mfds., against our original rough count of 30 m.mfds.

All that we have succeeded in doing, then, by reducing the effective parallel capacity to the lowest practical limits, is to raise the anode impedance at 350 metres to 7,500 ohms, instead of 6,000 ohms. In terms of amplification, this means from 9 times with average S.G. valve to 15 times with the specified Mazda valve!

An Improvement

Now this order of amplification, as I have suggested earlier, is not to be despised in a local-station receiver—it would give just that extra kick to the detector that would mean the difference between good and bad detection—or good and poor quality. And this without adding the smallest complication to the tuning arrangements.

After reading this short survey of the difficulties inherent in an aperiodic stage of H.F., it might well be thought that they make the whole

Please turn to page 274.

LOOKING AT HIS VOICE

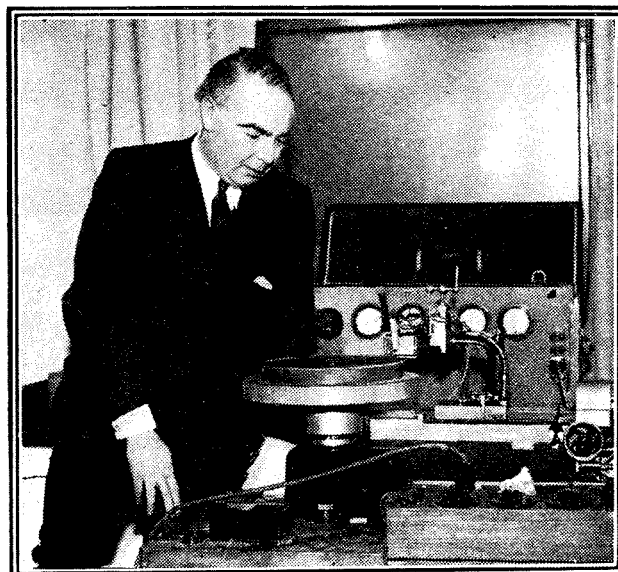

In order to inculcate road sense into children Mr. Hore Belisha made a special record for schools, giving a lesson on the use of road crossings. Here he is seen looking at the imprint of his voice on the wax "blank."

We have, then, exclusive of incidental capacities of wiring, a known total capacity of 19.5 m.mfds. against our first average figure of 23 m.mfds.

Short Waves In The

TROPICS

By
GEORGE F. BROOKS,
B.Sc.

Why is it that the radio which worked so well at "Muddy on the Slush" or Llanfairpwllgwyngyll, etc. (as a change from Wigan), when taken to a hot country, will "act up" or, rather, "lie down" in a most exasperating manner?

It is all a matter of climate and the age-old war in the tropics against heat, damp and insects.

For the past four years I have been living on an island in the West Indies, servicing and manufacturing short-wave radios, especially for use under local conditions.

A Typical Case

From the light of my experiences let me tell you the story of a coffee planter and his radio; it is a typical case, and will well serve to illustrate the pitfalls and how to avoid them.

This planter brought to me, for repairs, a seven valve, all-wave superhet of British make; he had bought it some six months previously, paying about sixty pounds for it.

Knowing that he was a very patriotic Britisher (as most of our colonials are), I did not dare tell him that he could have purchased an equally good American set for about one-third of that price.

Here was the essence of his complaint. At first the radio had operated very well, but after four or five weeks signals had weakened. Thinking that this was due to varying reception conditions, he had put up with this state of affairs until hearing the radio of his neighbour.

The Last Straw

In addition to the weakness, further trouble had developed. The set would operate normally for a few minutes, then, accompanied by a "frying noise," would "stop and start" in a most annoying manner. Finally, a wisp of smoke was noticed coming from "somewhere inside." This was the last straw, and it was decided to bring the radio to me for overhaul.

Before starting the job, I thought it necessary to warn my customer that no spare parts were available for this,



Heat, damp atmosphere, white ants, all take their toll of radio receivers which are used under tropical conditions. Here is the story of just one of many sets that have been subjected to the rigorous climate of the West Indies.

nor any other British-made set, and if any defect should be found in a part which could not be replaced by an approximate American, German or Dutch component, there would be a delay of eight or ten weeks.

The chassis was removed from the cabinet, the latter much too elaborate an affair, and here is suggestion number one. If you are sending or taking a radio to a tropical country, don't waste money on fine cabinet work.

The climate and insects will soon ruin it. The residents in the tropics know this, and consequently use cheap and easily replaced furni-

IN SUNNY CLIMES

Palm trees and abundant vegetation, together with radio's worst enemy, a steaming atmosphere and large temperature changes. A typical scene in the tropics.



ture, so that in any case a handsome cabinet would be out of place with the rest of the household fittings.

The first thing I noticed was that the chassis, an aluminium stamping, was already covered with a grey deposit, not serious yet, but in another eighteen months or so you would be able to pull that chassis apart by hand, rotted away through the chemical action of warm salt atmosphere on that particular metal.

"Whiskers" on the Wiring

From a manufacturer's point of view stainless steel is better, but for the home constructor I recommend "Monelmetal," an alloy of copper and nickel, failing this, ordinary galvanised iron will serve.

Before hooking up the set on the test bench, I glanced over the "innards" and noted that the cotton covered wiring had grown "whiskers."

This is a fungus growth which settles on any damp spot. For example, take off a pair of shoes, slightly moist with perspiration; in a day or so you will find an inch or more of fine grey-green whiskers growing out of them.

Looking a little further, I saw that the rubber covering the filament leads had perished and had become "gummy."

The radio was then cautiously connected to the mains. Immediately a curl of smoke came from the twisted

filament leads. There was a short-circuit where the perished rubber had broken. So much for that. I was glad it was not the mains transformer. That would have meant a delay of weeks, or the difficult task of re-winding.

On with the good work. Check the over-all gain. I might explain here that I did not rely on actual short-wave reception for this test, but used an oscillator with calibrated output and an A.C. meter connected across the speaker.

Complete Break-Down

Gain was very low, so I *carefully* adjusted the trimmers a fraction either way. My experience had taught me that, unless *absolutely* necessary, the trimmers on a super are best left alone. The adjustment, however, brought no improvement, and I was speculating on other possible troubles when the radio "passed out."

A rapid check over the anode to ground voltages showed them to be abnormally low on the 1st I.F. and 1st audio valves, and, even while I tested, there was a "click" from the loudspeaker, and the voltage fell to zero on *all* valves.

This latter development pointed to a probable defect in either the filter choke or the loudspeaker field. It proved the latter. The manufacturer

WHITE ANTS AND VERDIGRIS

over a thousand ohms, considerably more than normal. Removing the shield covering, this unit gave us a shock.

An army of white ants had made "room and board" in and around the transformer windings, the "board" being supplied by the beeswax impregnation of the unit. They had eaten nearly all of the wax, leaving the I.F. winding open to the ravages of the damp atmosphere.

This army routed, I passed on to the audio transformer. Test on the primary showed 6,000 ohms, again too high to be normal, particularly so when a test of the secondary read 5,000 ohms.

Dampness Again

"Unshelling" the unit from its pretty, bakelite case, I found this, also, beeswax covered, fortunately the cover had protected it from the ants, but the wax impregnation had not proved adequate in resisting the attack of dampness which had crept in. At the point where the leads were brought out, there was a tiny green spot of verdigris and unrolling layer after layer showed this defect to be right through the entire primary winding.

The inquiring reader may well ask, at this point, "Why only the primary"? You read a few lines back that it was the primary of the I.F. unit which was defective. Now a similar fault occurs in the audio!

When a direct current is passed through a wire, and that wire exposed to a damp atmosphere, a chemical action takes place, known as "electrolysis" or "electrical decomposition."

Shunt Feeding

This condition may even apply to radio sets used in this country. The first sign of trouble is a "frying" or "crackling" noise, culminating in a complete stoppage, so if you encounter this effect you now know one place where to look for the trouble.

As far as the audio transformer is concerned, the remedy is simple—don't allow any D.C. to flow through the primary winding, use a parallel or "shunt feed" arrangement.

On battery sets, where the H.T. supply is limited, this "shunt feed" system may not work out so well, owing to the excessive voltage drop over the resistance. In such cases I fall back on Ferranti transformers. I really must hand a bouquet to this firm. Mainly due to the good quality of the enamel covering the wire and to the air-spaced method of construction, their transformers stand up very well under tropical conditions.

And this brings us back to the planter's radio. I did parallel feed a

VERY BAD CONDITIONS FOR RADIO RECEPTION

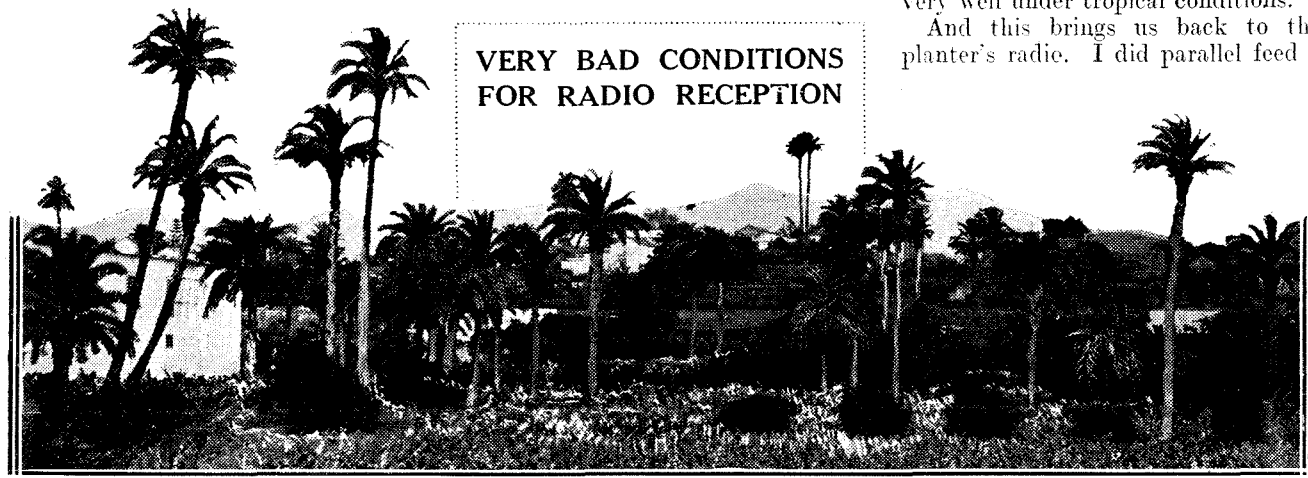

had sealed the end of the winding with adhesive tape, better known as sticking plaster. The linen of the plaster had attracted some fungus, which attacked the joint and caused an open circuit.

This repaired and the end of the field winding stuck down with a blob of sealing wax, I next turned my attention to the I.F. and audio transformers. The primary of one of the former showed a D.C. resistance of

Radio receivers for use in tropical climates need to be built of unusually stout materials, designed to withstand the attacks of white ants, which would gladly nest in I.F. coils, or eat their way through the wax of fixed condensers or L.F. transformers. The humid atmosphere plays havoc with the metal parts of the set, aluminium and thin wires being particularly prone to give trouble due to corrosion, while large changes of temperature test to the full such things as speaker and transformer windings. A set that will stand up to years of use near the Equator is a set indeed.

new audio transformer in this case, but I could not apply this method of protection to the I.F. transformers.

There is, however, a remedy. Air-spaced windings, of good quality enamelled wire, of as large a gauge as you can conveniently use, no impregnation, only a trace of sealing wax to hold the layers in place.

Units of this type were made and the set was again ready for test.

Please turn to page 275.

Special TELEVISION Section



Conducted by
Dr. JOSEPH HARRISON
 ROBERTS, F.Inst.P.

I HEAR from friends in America that the engineers over there are marking time waiting to see what we are going to do in television over here first. One prominent engineer tells me that his company will not go beyond the laboratory stage of television until the try-out period in England has proved successful. They tell me that the biggest problems confronting American broadcasters are: How to raise money to finance television and how to transmit sight and sound frequencies on a chain basis.

Other news from America relates to the transmission of pictures on ultra-short wavelengths—photoradio, they call it. It is sent on a beam which, though weak, can carry the energy as far as a candle light can be seen through a fair telescope. It will carry a transmitted picture from one horizon to the other, a distance of fifty miles or so.

This new method has been tried out between the Empire State Building and Canada, and it is hoped to establish the first commercial station between New York and Philadelphia. Manhattan Island is to become the nucleus of a world-wide system of photoradio.

A Limited Range

At present the range is limited to some 40 or 50 miles, but this limitation has its advantages in communication, for there are no reflections, no double images or "ghosts" as in the case of

short waves. Ordinary short waves go "sky high" only to be reflected from the "radio roof" and thus to produce shadows. Micro-waves (as these ultra-short waves are sometimes called) are also static-free and their messages do not "fade."

(they will be started by the time you read these notes).

The system which is being used is not the same as that used by the B.B.C., and the German director of television, Dr. Kirchstein, claims that it gives better pictures than any other system at present being tried. Its effective range, as with most systems, is limited to about 25 miles.

No doubt many of you know that a 16-kilowatt ultra-short-wave transmitter started broadcasting high-definition television in Germany as far back as August, 1933, a 90-line scan with 25 frames per second

being used. In April 1934 another 16 k.w. transmitter was built for sending out 25 pictures per second on a 180-line scan.

The original transmitter has now been pressed into service for sending out the sound to accompany the pictures from the new transmitter. Vision goes out on 6.7 metres and sound on 6.985 metres.

It is believed in Berlin that high-definition broadcast service of television will be inaugurated in April this year.

The News Van

Topical items will be obtained by means of a daylight television "van" operating on the "delayed" system with a cinema film, this being exposed, developed, fixed and partially dried, all

★.....★
 Dr. Roberts deals first this month with the television positions in America, Germany and Italy. He then has some remarks to make on the possible effect of television on the film industry, and finally discusses some technical aspects of the subject

★.....★
 It is interesting that Mr. David Sarnoff, the well-known President of the Radio Corporation of America, says of the picture transmission (or "facsimile" transmission, as they call it over there). "My faith in the future of radio science is geared to facsimile; the facsimile is going to open the way to television."

* * *
 Television is making rapid strides in Germany. Secret experimental transmissions have been carried out for some time past at the great Rundfunk House, in the "West End" of Berlin, and no announcement of them has been allowed to appear in the German press. I understand, however, that the results obtained have been so promising that there are to be three regular broadcasts each week between 8.30 and 10 p.m.

within the space of 30 seconds. As I have mentioned before, this delayed system seems to me to have tremendous possibilities, as it so greatly simplifies many of the most serious problems of television.

According to news from Italy, Senatore Marconi hopes to perfect means for transmitting television pictures across the Atlantic, and experiments to that end are proceeding at Genoa under the supervision of one of



A TUBE FOR 9-IN. PICTURES

Reginald King, the popular broadcaster, examining one of the new Cosson television cathode-ray tubes.

It will produce high-definition pictures up to 9 inches.

Marconi's best-known research men, M. Matthieu. Senatore Marconi has several times interrupted his work in London for the purpose of journeying to Italy in connection with the tests.

The problem is to find means for transmitting, free from interference, non-fading signals over these long distances. The experiments are being conducted in secrecy between two micro-wave stations installed at similar altitudes and a few miles apart.

The Film Industry

A good deal has been heard lately about the attitude of the film industry towards television. Statements have been freely made that before long television will become so perfect that the film people will be driven out of business. And much more to the same effect. Needless to say, this, like so many other statements about television, is hopelessly exaggerated. It is a great pity that these wild statements should be made, as they do nobody any good and do television a certain amount of harm, by leading the general public to expect far too much at the present time.

Anyway, the film industry has found it necessary to sit up and take notice,

SPECIAL TELEVISION SECTION—*contd.*

and has made a thorough investigation of what it has to fear from television.

There are some 4,000 cinemas in this country, representing about £100,000,000, employing 50,000 people and contributing £6,000,000 a year in entertainment tax alone. The income from radio licences is between three and four millions a year; the income from cinemas is nearer fifty millions a year. These are certain aspects of the case, but they are not the only ones.

I don't think the film business is in need of assistance, but the effect of television will certainly be to its advantage and not otherwise.

People often ask me what is meant by "30-line" television, "180-line" television, "high definition," "low definition," and so on. These terms one constantly sees in the newspapers and perhaps it is a little confusing at first. Actually it is very simple.

Thirty Lines

First of all, "low definition" may be taken as more or less synonymous with "30-line." It means that the spot of light that traverses the receiving screen and builds up the image, moves across the screen in 30 lines in the process of forming the picture—for all the world like 30 lines of type or printing. It is obvious that these lines will be relatively widely spaced apart (as compared with, say, 180 lines or 240 lines), and so the "definition" of the picture will be somewhat coarse or crude, since it will not be possible to bring out the detail clearly.

"High definition" may be taken to mean any number of lines which is considerably greater than the above. For example, 180-lines would be described as "high definition," although the P.M.G.'s Committee recommend that definitions of 240-lines and even much higher should eventually be used. The higher the number of lines the greater the "detail" that can be put into the picture. Of course, the greater the number of lines the faster the light-spot has to fly over the screen and so the greater the difficulties of getting sufficient light into it and of getting a screen material of sufficiently rapid "response." In fact, as the "definition" increases, so the practical difficulties increase very rapidly.

For those of you who have never seen television pictures, I should say, however, that there is no comparison between the detail in a good high-

definition picture (even at only 180-lines) and that in a 30-line picture.

Distortion in Reception

A point that is sometimes overlooked in regard to the amplifiers used in a television receiver, is that any distortion present is bound to affect the received picture, where, in a sound receiver, distortion may be present without making itself very noticeable, owing to the curious "forgiving" property of the ear.

Amplitude distortion is particularly liable to give trouble, and this means that special attention has to be paid to the detector. The grid leak and condenser method of rectification is very efficient when the input amplitude is low, whereas at high amplitudes we usually rely upon the anode-bend system: at about half a volt it is generally reckoned that there is not very much in it either way between the two methods. It is obviously important that there should, if possible, be a linear (that is, straight line) relationship between the input and output signal voltages.

For linear rectification the diode valve is sometimes used, whilst the "Westector" serves the same purpose. A double-diode valve, working in push-pull rectification, is also sometimes used. As a matter of fact, the question of amplifier design and

(Please turn to page 276)

MARIA SANDRA



Special dresses with accented contrasts, such as the Watteau dress Maria Sandra, the television star, is wearing in this picture, will not be vitally essential with the new high-definition transmissions.

Special Television Section

How TELEVISION PICTURES are TRANSMITTED

By Victor King

An Exceptionally Lucid Description of Some of the Latest Developments in Television Transmission

EVEN when the sun is brightly shining on an object or scene the amount of light reflected by it is really quite small.

In television it is made all the smaller because of the necessity of breaking the picture up into tiny fragments and taking extremely rapid glimpses of each fragment, as it were.

The human eye does not suffer from this light limitation because it is able to take in relatively large slices of a scene at once. This is because in the eye there are thousands of nerve cells, each able to act simultaneously with all the others.

Light Greatly Diminished

But in television there is only one light sensitive cell and so this one cell has to be swept rapidly over the

house, that happens to catch the sun rather well—if there is any sun!

You will be able to see only a small part of the picture, although that will be bright enough. But now flash the cardboard backwards and forwards quickly in front of your eye. This will enable you to see a fairly large slice of the object, because of the well-known persistence of vision effect.

But you will find that the scene is now quite dim. That is obviously because of the reduction of light reflected from the object or objects owing to the cardboard screen and its tiny hole being interposed.

But now imagine how dull the scene would be if you had to view all of it in this manner, and not only a slice of it, through a much tinier aperture, which had to be made to travel over a much bigger area.

Actually, about thirty seconds elapse between the time of the movement and its building up in the television receiver. Twenty-nine point something of these seconds are expended in the transmitting apparatus.

THE ICONOSCOPE

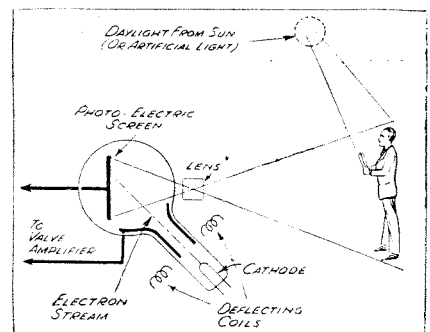

Fig. 2. An "electric eye" developed by Zircorlin to solve the difficulty of transmitting outdoor or other large scenes.

ALL DONE IN THIRTY SECONDS!

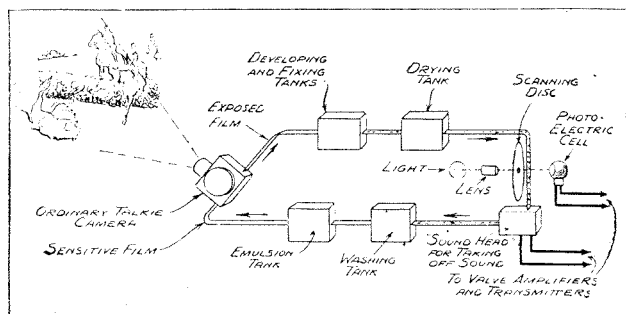

Fig. 1. The sequence of events in the intermediate film process of television transmission. This is a most ingenious and valuable method of which a great deal will probably be heard in the future. The delay in the whole process is only about 30 seconds.

whole picture, giving each point of it only fractional attention.

You can test this effect in a very simple manner. Make a tiny pinhole in the centre of a sheet of cardboard. Look through this pinhole at a brightly illuminated scene, such as a tree or

house, that happens to catch the sun rather well—if there is any sun!

Well, that is the kind of light reduction which confronts the television engineer in attempting to translate scenes into varying electrical currents.

The most successful method I have seen demonstrated so far employs what is known as the Intermediate Film Process. Some of you may think

that this is a wangle; indeed, not a few experts have been heard to declare that it is at best only a makeshift.

But I think it is a very interesting and practical makeshift, and all that can be said against it is that it necessitates heavy gear, and has a time lag.

Which reminds me of Mr. Scott-Taggart's famous television riddle: "How much time must elapse between the movement of the original object and the listener's perception of the movement before television merely becomes picture transmission?" In fact, I think he went further, and queried whether there ever could be true television if this were interpreted as the viewing at a distance of moving objects or persons simultaneously with the original action!

Not Worth Worrying About

I have not put all this as neatly as "S-T." himself did, but I hope you will manage to see what I mean.

However, for practical purposes I don't suppose a thirty second delay amounts to very much, although I can see that many might think it robbed

something of the romance of television.

But let us see what happens in those thirty seconds. Some very cunning processes occur. There is an endless band of film which moves round and round a chain of units, although these separate units are more or less compactly built into the one machine.

There is first a tank which provides the blank film with a sensitive emulsion as it passes through it. Then there is a quite ordinary talking film camera

A RECENT DEVELOPMENT

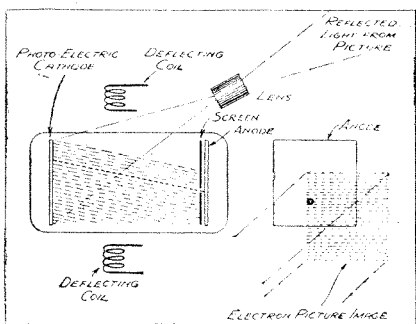

Fig. 3. How the television camera is devised. It is a most interesting method of providing scanning.

which takes pictures of the scene to be televised and plants a sound track for the sounds on the same film.

The film then goes into a developing and fixing tank, then into a drying chamber from which it emerges as positive pictures which you could, if you desired, project on to a screen by means of a standard projector.

But instead of this the film is taken through a scanning unit. There is an extremely bright light condensed by means of a suitable lens into an intense beam. So you see there is none of that dim reflected light to make things difficult, but some really bright, direct light.

Scanning the Film

Now the film is passing through the scanning unit at a steady twenty-five pictures per second, and so, with the aid of a rotating disc pierced with equally spaced holes, it is a simple matter to break the pictures up. In other words the beam of light is made to travel over the whole of each tiny film picture.

The amount of light which passes through the film at any particular point will depend upon the density of the film at that point, and so the photo-electric cell behind the film (see Fig. 1) receives a light varying in intensity in accordance with the position of the light spot.

THE ELECTRON CAMERA

These varying light intensities are changed by the cell into fluctuating electric currents, and in turn these are handed over to a valve amplifier for magnification.

Leaving the scanning unit, the film next comes to the "sound head." This deals with the sound track, and by means of another photo-electric cell electrical impulses of the kind you hand to your loudspeaker are developed.

The film has now completed its work, and so the next process is concerned with a washing tank, which removes the emulsion, pictures and all from the film and leaves it as nothing but a transparent strip of celluloid.

An Outstanding Invention

But next door is the emulsion tank, through which it then passes in order once again to become sensitive film ready for the camera.

A very cunning scheme, I think you will agree, and one which works remarkably well, as I am able to testify, for I have seen it in action dealing with both indoor and outdoor scenes.

There are alternative ideas, and at least one has, I know, been found quite successful. I refer to the Iconoscope. This is a very pretty scheme, and in my opinion it constitutes the most outstandingly original television invention during the past forty years.

Oh, yes, the history of television goes back even farther than that! The Iconoscope is a true television "camera." It is an electrical eye and has no time lag and requires no intermediate-film business.

It comprises a cathode-ray tube in which there is a special photo-electric screen. You can see how it is placed if you look at Fig. 2. This screen is made up

of hundreds of thousands of tiny photo-electric cells.

Sounds a fantastically difficult thing to make, doesn't it? But it isn't, really. A silver-caesium mixture is deposited upon a mica sheet in such a way that it lies in tiny globules, each globule then being a more or less independent cell.

The screen is backed by a metal sheet so that between each cell and this metal sheet is a mica sheet. Each cell is also, therefore, a small condenser.

The Picture Mosaic

The reflected light from the scene to be televised is passed through a lens and focused on to the screen. A voltage is generated by each of the tiny photo-electric cells, and the voltage of each will depend upon the amount of light reflected on to it.

So you have a mosaic composed of tens of thousands of tiny condensers, each holding its own electrical charge.

This mosaic or screen is all the time being scanned by a beam of electrons which is caused to traverse the whole of the screen by means of deflecting coils, in which exist "saw-tooth" voltages derived from the familiar time-bases.

Looked at from another angle, I can say that the electron beam scans the screen of tiny photo-cells-cum condensers in the same kind of way

(Please turn to page 273.)

TELEVISION PIONEER

Mr. J. L. Baird, the famous inventor, standing beside one of his television receivers in his home at Sydenham.



Special Television Section

What shall be the "Stuff" of Television?

TELEVISION has technically arrived. Not exactly the same thing as saying television is here for the man in the street.

Television really presents three main problems. The first has been to make television possible—technically possible, I mean. Various engineers can claim the credit for having helped to solve this first problem. To have made television technically possible.

None has yet completely solved the second problem, although many are engaged in its solution at this very moment. I refer to the problem of making television economically practicable.

A Matter of Price

In various laboratories and between selected points the television technicians have made television—seeing at a distance by wireless—possible. They have produced clear images miles away from their originals, so clear as to have entertainment value.

Between the laboratory and the home is a gap the future scions of the television industry must bridge before the economic problem of making television sets down to a price can be fairly said to be solved. It is a problem, this, of bringing down the price of a specialised product estimated now at anything from £50 to £80 to a figure the man of average means can afford—and that means at least halving the present estimate.

What Should We See?

Let us look ahead, like good televisionaries. Let us assume the second problem is on the way to solution—as it is, without a doubt. We then come up against television's third main problem. And this is the problem I want to speak of here—the problem of finding the "stuff" of television.

Of what, would you say, is the stuff of television to be made? Do not lightly dismiss this as a frivolous question. Do not, I beg of you, superficially argue that the stuff of television must necessarily be the stuff of

present broadcasting—made visual, to aid the aural effect we are beginning to tell ourselves is only a part of entertainment.

I repeat, do not fall into the trap of accepting that line of argument because it can so easily be exposed with a little examination. If you will just think for a moment of a typical day's sound broadcasting you will

Alan Hunter asks a question that is straight to the point. What are we going to see when the new television service begins? The programme side will certainly need careful working out.

realise that a very large proportion of the items simply do not call for any pictorialisation.

Take the average concert of light music. Would that gain so vastly from being televised? Obviously not. Part of its attraction is that it is so light you do not have to concentrate on it—certainly you would not want to be bothered looking at the performers.

Nor would you with what makes up the average evening's entertainment on the wireless; talks, gramophone records, orchestras, sextets, singers, instrumental solos, chamber music, dance bands—I have mentioned practically every form except variety, which is an obvious exception and would palpably gain from being televised.

When, in the old days, I sometimes used to compare the idea of television entertainment with the existing nearest Art form—the cinema—certain touchy-minded people would rise

upon their hind legs and implore me not to be so ridiculous, contending there was no connection at all.

I think I can see a very close connection. After all, you will look at some kind of screen, small perhaps, as far as I can make out from present inquiries. You will look at images in black and white. You will look not always at actualities but often at past events—just as you do at the cinema.

Mr. Baird's View

The moment you remove actuality—surely television's unique attraction?—you do very closely approach the entertainment *form* of the cinema, or perhaps more exactly of the home-ciné outfit.

A digression, please. One summer's afternoon many years ago I was walking up and down a certain seaside esplanade with none other than J. L. Baird. I recall how insistent he was on television's unique advantage over all other forms of entertainment—the simultaneous viewing of something by millions of people instantaneously. He said then that if the actuality of television were removed it was not really television as he understood it.

Yet, as Mr. Baird would be the very first to admit, in practice we have to think of the convenience of those looking millions. If we want millions to see the Derby we shall have to

AT 16
PORTLAND
PLACE



GUSTAVE FERRARI taking the part of a curé in one of the B.B.C. low-definition television programmes. Note the heavy make-up required.

film the event and send it out when those millions are free to see it—that same evening.

In that we should merely be copying the technique of sound broadcasting. Exciting excerpts of running commentaries broadcast to a comparative handful of listeners during the actual event in the daytime are run through the Blattnerphone machine at night, when the listening millions are home from work.

Transmitting News

Even if it were just as easy to televise studio scenes as film—which is not so, of course—the film would have enormous advantages for news events.

Which brings me back to the whole question of the stuff of television. I think we can look ahead to television films of great sporting events, always assuming that vexed questions of copyright can be amicably settled. Perhaps we ought not to take that point too much for granted. There is bound to be a lot of opposition from the organisers of the sporting centres into which the television scanner attempts to gate-crash.

So far, then, I see television pro-

A RIVAL TO THE CINEMA?

viding us with pictures of the day's sporting events; of any great national ceremony, such as the opening of Parliament, of new bridges and buildings, of anything having what is generically dubbed as "news value."

In the cinema news films are always popular. In fact the rapid growth of the cinema exclusively showing news films clearly shows where the public interest lies.

Economic Limitations

But, then, what is television going to do for those mainstays of the entertainment world—the drama and the musical show? Where is its place in relation to variety in all its forms?

At the beginning it is clear that ambitious "direct studio" shows will be limited, partly for technical reasons, and quite as much for economic reasons. Intimate variety shows, where only one or two performers take the scene at a time, offer one aspect of the stuff for television.

In the more elaborate presentations we may expect the film to play a leading part. Whether films made for cinema exhibition will ever come before the scanner is a very moot point, about which the film magnates of this country are naturally silent just at this delicate stage.

Cost Again

As a whole, the film industry must fear television on a large scale. Real home television is such an obvious rival to the cinema, one might say, that it is childish to argue otherwise. And yet there are perfectly sound arguments to back up those who deny any such menace.

For one thing, it is pointed out that the cinema, because of its continuous performances for six

days a week, and its consequently high expectation of custom, can afford to let the public in for prices that rule out competition from any other kind of entertainment.

One cinema manager whom I was chatting to recently asked me to do a rapid calculation as to the cost of going into the best seat in his house once a week for a whole year. I found it came to much less than ten pounds. He smiled, quoting then the estimated price of a home televiewer—£80.

I thought I saw another even more potent reason for suggesting that the cinema need not fear television—the gregarious nature of human beings. Ordinary mortals really do not like being alone. On the contrary, they are never so happy as when with a crowd. There is certainly a great deal to be gained in sheer entertainment by enjoying it with others.

A Psychological Error

When wireless began there was plenty of talk about the menace of it. Existing forms of public entertainment were seriously threatened, it was contended. People would stay at home instead of going out to the theatre or cinema.

A grave psychological error. People like gathering together in crowds. Above the normal enjoyment of any entertainer is the added pleasure of laughing with the crowd.

Part of the failure of broadcast entertainment—variety and vaudeville, I mean—is that it attempts to make people laugh when alone, without the magic of mass suggestion.

Why worry over what seems an academic argument, you say? Because it is important that the television broadcasters should come to an understanding with the film industry as soon as possible. If it can be logically argued—only experience can provide a proof, of course—that television in the home is but a complementary form of entertainment, in no way ousting the attraction of the cinema, why then, we might hope for some of the precious material at the disposal of the established industry.

The Main Problem

For I cannot help feeling that a great deal of the stuff of this television ought to be made up of the artistic resources of the cinema industry. The direct studio material and talent seems a meagre alternative in contrast.

Television's biggest problem is to find the right stuff. And then, as the Americans would say, television can do its stuff.

A STUDY IN BLACK AND WHITE



SPECIAL TECHNIQUE in television scenery and the staging of small plays and sketches is needed for the low-definition system. What will be required for the far better high-definition transmissions remains to be seen.

Special Television Section

RECEIVERS for HIGH DEFINITION

THE new television service is going to be intensely interesting from the home-constructor's point of view. One reason for this is that he is going to have two completely different fields to explore. One concerns the cathode-ray tube time-base circuits, or, for that matter, any other means of scanning that proves satisfactory.

The other concerns the whole question of ultra-short-wave receivers, and is, in itself, a wide enough field to keep anyone interested for a very long time.

Quite Logical Development

The one thing that must be avoided is a suggestion that these receivers are freaky affairs, making use of a completely new technique. They won't be anything of the kind. A good 7-metre receiver is just a logical development of a good 70-metre receiver, which, in its turn, can be evolved from a good 700-metre receiver.

Common sense has always been the backbone of radio research, and it will be needed in large quantities when we all become television enthusiasts. It seems to be agreed that the simplest type of receiver that will be practicable is a superhet. When you consider the requirements, it is fairly easy to see why.

First Requirement

We want, first, a detector that is efficient enough on 7 metres to pick up the television signal. We then have to amplify this signal, doing our best to retain all the modulation, which will extend in frequency right up to at least a million cycles.

An L.F. amplifier that will do this isn't a very simple thing to construct. On the other hand, if we "superhet it," an I.F. amplifier suitable for the job is a relatively easy matter to arrange.

Then, again, H.F. amplification on that wavelength is extremely tricky, and is even regarded by some as impossible. If we can't use H.F., and we are bent on a straight set, we mustn't use reaction on the detector, or it will

sharpen up the tuning to such an extent that we shall cut off our high-frequencies.

If, therefore, we cannot receive the transmissions on a detector *without reaction* and an L.F. amplifier, we shall

=====

The principles which will have to be adopted in planning receivers for the new high-definition picture transmissions are explained in this contribution.

=====

By L. H. THOMAS

have to fall back on the superhet. And why not? It is in accordance with everyday practice in broadcast reception—it is well understood—and it is simple.

Here, then, will be a practicable receiver. We shall want a 7-metre detector circuit fed from a specially-designed aerial system. We shall want a beat-frequency generated by a separate valve that will convert our

the transmission is on 7.5 metres—40,000 kilocycles. We will make our I.F. amplifier work on 37.5 metres—8,000 kilocycles. What we want, then, is a first detector on 40,000 k.c. and a local oscillator tuned to 32,000 (or 48,000) k.c. Either setting will give us our beat-frequency of 8,000 k.c., which will be amplified in the I.F. stages.

Instead of using one efficient, sharply-tuned I.F. stage, we shall have to start introducing inefficiency and flat tuning. The two go together, and you can't design a flat-tuned circuit without inefficiency. To compensate for this, we shall have to use a number of stages, probably three.

An I.F. amplifier with three stages can make use of six flatly-tuned circuits, and at 37.5 metres (8,000 k.c.) one can easily provide a band-width of 800 k.c. by this means. That will probably be sufficient to enable our very high modulation frequencies to survive their passage through the amplifier.

At the far end of the latter, then, we shall have a 37.5-metre wave carrying modulation frequencies up to nearly a million, and we must detect it with our second detector, still without losing that "super-top." Furthermore, we may have to give it one stage of L.F., but that does not present any tremendous difficulty.

A Simple Plan

The diagram on this page shows a hypothetical layout of such a receiver. The first detector and oscillator circuits are screened from each other and ganged. The I.F. stages are all "fixed-tuned"

and require no adjustment after the initial lining-up. The second detector might complete the picture, any L.F. required being mounted with the cathode-ray gear, but I have shown one stage in the actual receiver.

Possibly the actual signal will be passed to the tube straight from the second detector, the L.F. only being

(Please turn to page 276.)

A. SUGGESTED LAYOUT

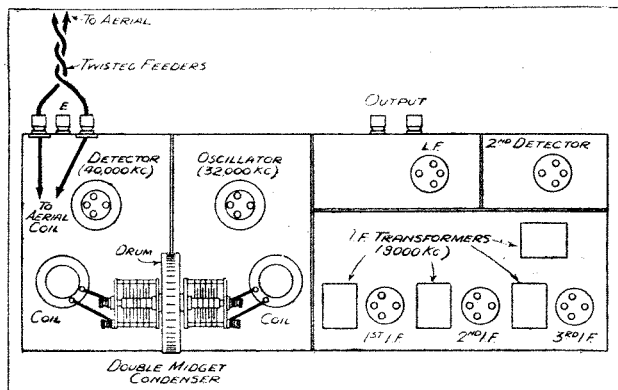

This diagram shows a suitable layout for a short-wave superhet to receive the television broadcasts.

7-metre signal into something like a 40-metre signal.

We shall have a specially flatly-tuned I.F. amplifier that will give us all the amplification that we want, on 40 metres, without cutting off our high-frequencies, and then we shall come to the second detector.

Now let us talk in frequencies. To make it easier, we will assume that

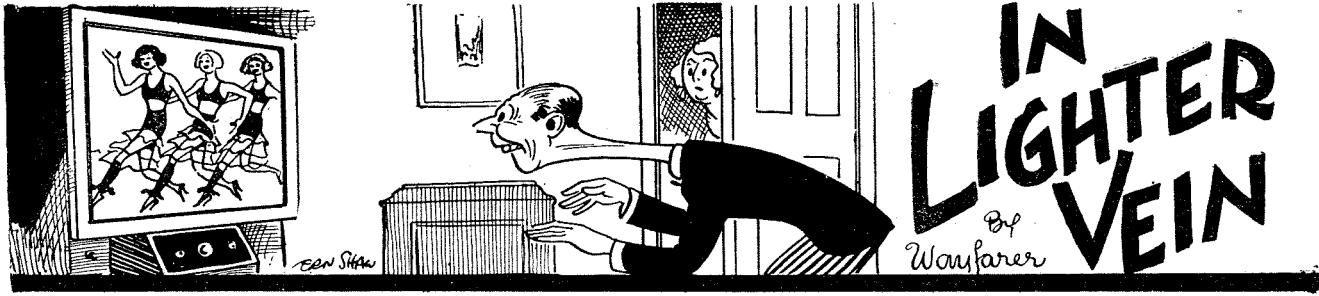

ONE of those wobbly contraltos who always sound to me as if they had swallowed a pulsating suet pudding had apparently just opened her throat and her ruby lips and let the tremolo rip.

Quick as I am, the Professor beat me to the switch, and one of the most welcome silences ever broadcast ensued.

"What says the poet," mused he, "Before they die swans sing.

Ah! me, t'were no bad thing
Could some birds die before they sing."

"The bird," I remarked, "that we have just heard may die unwept and unhonoured, but not, regrettably, unsung. But what about it now that we are on the verge of television?"

"We Must Jump"

"Tum-tum, tum-tum, tum-tum, tum-tum," crooned the Professor, marking the beat with waving hands and nodding head.

"When television's here I ween
Some birds will flicker on the screen.

To hear them
made one feel quite green,
But far, far better heard
than seen."

"Beautiful lines," I said; "and they remind me, my dear fellow, that you and I must forthwith jump into this television business with both feet. How quaint these expressions are!" I continued. "How anyone capable of executing a leap could arrive with less than two feet completely escapes me! Which recalls to me, *pace* the Western Brothers, an episode of my old school days."

"I take it," cooed the Professor, "that they were bipeds at Borstal?"

My subsequent gesture with the poker was so eloquent that the Professor relapsed into silence.

"It reminds me," I mused, "of one fellow who, as the result of strenuous physical development, had acquired

swelling muscles of steel and a head of the purest bone. When he had performed in the gym one day all sorts of queer antics on the horizontal bar and things, one small boy offered to bet him a level two bob that he couldn't climb right up the rope without his feet.

A Home-Constructor's Set

"The roof was a lofty one, but with much strenuous effort he touched the top beam. 'Two bob from you, young fellow!' he cried, looking down.

AUTOMATIC HORROR CONTROL

WITH THE IMMINENCE OF TELEVISION PROFESSOR GOOP FEELS IT INCUMBENT ON HIM TO PRODUCE A DEVICE WHICH AUTOMATICALLY FADES THE PICTURE WHEN UGLY ITEMS ARE BROADCAST—UNFORTUNATELY IT WORKS ALL TOO WELL

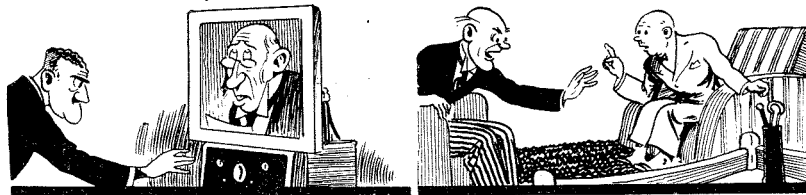

A talk on "Do Shrimps Make Good Mothers?"

"Goop-Wayfarer" I cooed, reaching for the poker.

'No,' piped the small boy; 'you've got your feet with you!' But to return to the subject of television."

"Don't you think," inquired the Professor, "that readers of WIRELESS will rather expect us to design a home-constructor's television receiver?"

The Automatic Control

"Why, of course!" I cried. "Let's get to work at once. Now, clearly this receiver must have some very special features. What in your view is the most desirable?"

"A quick-action on-and-off switch,"

replied the Professor, "the accent being on the off."

"If I take your meaning rightly it is that when some lop-eared old codger with a face like a boot settles down for a topical talk on 'Do Shrimps Make Good Mothers'? the looker-in should be able to put an end as quickly as possible to the painful business of seeing as well as of hearing him open and shut his head."

"Precisely," agreed the Professor. "In fact, I think that we might go even better in the Eagle-Eye Television Receiver that we are about to design."

"Better?"

"Yes. I am rather thinking of introducing my new system of Automatic Horror Control.

A De-Awfulliser Circuit

"In the broadcast wireless receiver the automatic volume control's purpose is to keep the sound level more or less constant; it thus prevents shocks to the ears. For the television receiver we require something which will prevent shocks to the eyes, and that is where my A. H. C. comes in."

"And how do you propose to work it?"

"It has been proved," said the Professor, "that any pleasant sound consists of pure sine

waves or of combinations of them. Working on these lines, I deduce that any pleasant sight must be conveyed only by waves of similar form. In sound, any departure from the sine wave produces mere ear-shattering noise. It is only logical to suppose that in vision a horrible sight is the product of waves shaped all anyhow."

"Go on," I begged. "your tale interests me strangely."

"By means of the special Goop De-Awfulliser circuit . . ."

"Goop-Wayfarer," I cooed, reaching once more for the poker.

" . . . Goop-Wayfarer De-Awfulliser circuit I should have said,

FERRANTI

**VALVES
FOR
EVERY RADIO
PURPOSE**



Illustrated is
VALVE EP4
SUPER POWER VALVE
PRICE
16/6

Write for
booklet to
FERRANTI LTD.
HOLLINWOOD
LANCS.

**MANY HAVE BEEN
DISAPPOINTED IN THE PAST**

*—Unable to obtain a copy of
WIRELESS, because they left it
too late.*

DON'T MISS YOUR COPY

of

WIRELESS AND TELEVISION REVIEW

*Place a regular order with your
newsagent to supply it every month
and*

KEEP UP-TO-DATE

by reading regularly

**BRITAIN'S LEADING RADIO
MAGAZINE**

MODERNISE

with these

WEARITE

REGD. TRADE MARK

COMPONENTS

SPECIFIED

By Mr. John Scott-Taggart
for the

ONE POINT FIVE

He used this WEARITE
UNIVERSAL "A" Coil
to modernize an earlier
circuit. Whatever your
present set bring it up to
date with these "A" Coils.
They are UNIVERSAL
in that one type is suitable
for H.F. Aerial or Band
Pass Tuning.

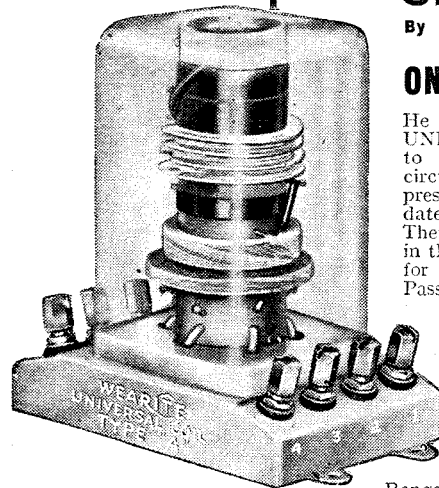

**PRICE
PER COIL**

5/-

Range 180-550 and 850-1950
metres.

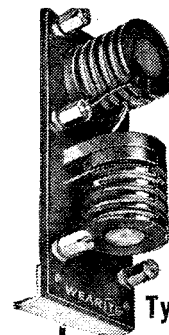

The
**WEARITE
IRON
CORED
COIL**

Type I.C.6.

A small general pur-
pose coil (iron cored)
standard for all uses
in average 2, 3 or
4 valve Set. The
ideal coil for your
PORTABLE.

Range 190-580 and
850-1950
metres as
shown. **5/-**

With screen
(Type
I.C.S.6.) **7/6**

**The WEARITE
IRON CORED
WAVE TRAP
COIL**

Here is the biggest
step forward yet
made in Wave Trap
design. With a 0005
Variable Condenser
and switch, it is
fitted in your aerial
lead and operates
on both wave-
bands. Send for
full de-
tails. Price **7/6**
See editorial review on
page 79, "Popular
Wireless", of March
30th, 1935.

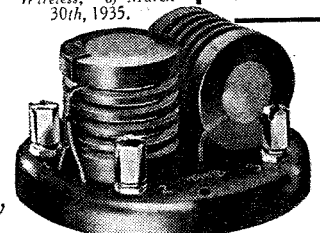
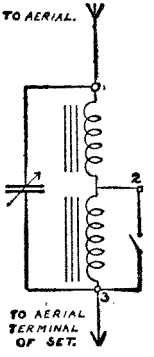

Send This Coupon To-day

COUPON

To Messrs. Wright & Weaire, Ltd.,
740, High Road, Tottenham, N.17.

Please send me a copy
of your latest Booklet
P834 containing full
technical data on Coils,
Chokes, Transformers,
etc., and also Blue
Prints of "Teamster"
Receivers.

Name.....

Address.....

W.5/35.....

incorporating a squish valve, it is possible to ensure that the illumination of the image varies according to its being easy to look at or the reverse. If, for instance, we have in the television studio the B.B.C.'s super beauty chorus their sine wave curves will ensure the fullest illumination. But when other less pleasing eye-fuls appear the illumination of the screen will be suitably dimmed, thus easing the pain of the looker-in. If, for example, we are dealing with a fat, bandy-legged tenor who sings from one corner of a mouth like a gash in a melon, the A. H. C. will ensure a complete black-out."

How It Works

This was clearly a noble idea, and, fired with enthusiasm, I insisted that experimental work should start forthwith. It will be appreciated that the working out of our amazing De-Awfulliser circuit involved an immense amount of work. But the Professor and I are not frightened of that kind of thing. Once we commit ourselves to a task we stick to it like flies to a fly-paper.

Every morning I was up with the lark*, and seldom could I snatch more than three hours apiece for the four

A BANDY-LEGGED TENOR

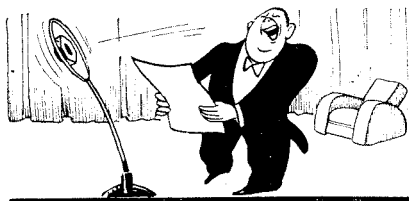

* Who sings from one corner of a mouth like a gash in a melon."

daily meals that are essential if my constitution is to be kept up. The Professor was equally active. You will see that our days were pretty full. That I wore myself to a shadow† is of no moment so long as I can be of service to readers of WIRELESS.

The principle of the Goop-Wayfarer De-Awfulliser circuit presents little difficulty to the meanest intelligence, so you, reader dear, should be quite all right if you make a special effort. It is best expressed by a straightforward formula in which the first half of the Greek Alphabet squared is divided by the cube root of the co-tangent of the second half.

Really Quite Simple

From this it follows, as a moment's thought will show, that concrete-cored coils wound with Splitz wire are essential, the ratio of length to diameter being given immediately by the simple

TESTING THE "DE-AWFULLISER"

formula in which the entire Hebrew alphabet is multiplied by its complete Arabic counterpart and then integrated by the application of the square root of -1. To us mathematicians (this again means you, in case you are feeling a little sore) the thing is just child's play, is it not? Or isn't it? Anyhow, you see what I mean? Or don't you?

We decided to give our first demonstration of this epoch-making circuit at Mudbury Wallow. A transmitter was rigged up at Captain Buckett's house, and by means of two Goop-Wayfarer televiewers things were so arranged that (a) the members of the Mudbury Wallow Wireless Club could see and hear the performance in the Clubhouse, whilst (b) the artist in the studio could see exactly how he or she was coming over.

The Automatic Horror Control amply demonstrated its wonderful properties during the early part of the programme. Owing to the gentle dimming of the image Tootle was quite bearable when he gave his flute solo, and even Sir K. N. Pepper's reminiscences of his career in the East hurt neither eyes nor ears. It was, in fact, clear that the Automatic Horror Control was working perfectly. All would, I think, have gone well had not Miss Worple simpered up to the microphone and electric eye to give her poignant little poem "The Hideous Beauty Of Mud."

The Terrible Climax

The electric eye took one squint at Miss Worple and, to our horror, we at the clubhouse realised that the De-Awfulliser circuit wasn't having any. The viewing screen went completely dark and at the same instant the warning klaxon horn, which is part and parcel of the Goop-Wayfarer television receiver, hooted loud and long. The same effects were, of course, produced by the repeating apparatus in

* Professor Sloschpiller, the eminent ornithologist, mentions in his monumental work, "The Avian Fauna Of Britain," that in the neighbourhood of Mudbury Wallow the lark never leaves his watery nest before midday.—Ed.

† The slimming effect of these labours will be appreciated when it is mentioned that on the day when he handed in his manuscript Mr. Wayfarer tipped the beam of the office scales at a mere 17 st. 4½ lb. Last month, on the same scales, his weight was 17 st. 4½ lb. Can we say more?—Ed.

Captain Buckett's studio, and the results were nothing short of lamentable.

In about three strides Miss Worple was down in Captain Buckett's kitchen, where instinctively her hand found the rolling-pin. With this she dealt faithfully with the apparatus in the captain's home. She then proceeded at the gallop to the wireless clubhouse, arriving before the Professor had had time to realise what was happening or to make a timely get-away.

POOR PROFESSOR GOOP

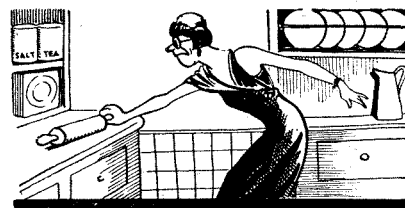

"Instinctively her hand found the rolling-pin."

The Professor hopes to be able to get about on crutches in three weeks' time or so. Meanwhile, he is seriously considering whether knitting does not offer better opportunities than television as a line for scientific research.

L.F. INSTABILITY

Have You Tried These Remedies?

IF we were all radio engineers, life would be simpler but perhaps less exciting. For we humbler folk, after doing up an old set, the question is not "Does it conform to specification?" but "Just what will happen?"

Most of the troubles of those living far from any station are due to high-stage gain. To get selectivity, volume must sometimes be sacrificed, and one is tempted to use L.F. transformers to pep things up again. Result—L.F. instability.

A High-Pitched Whistle

The symptoms of this malady are a high-pitched whistle or a piercing howl. In the latter case, a hurried reversal of a transformer secondary is indicated. This strategical move will at least reduce matters to a mild whistle. Here the real problem begins, for although the symptoms are practically identical in every case, there is no universal remedy. The most generally useful are an output choke, 100,000 ohms across the secondary and decoupling.

E. O'M.

Police Radio

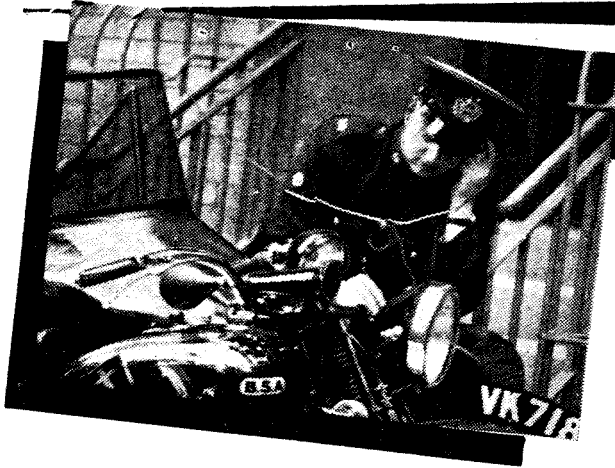

A police radio network is rapidly spreading over the country with powerful transmitters installed at headquarters for communication with the car patrols.

By a Special Correspondent.

“**C**ALLING all cars . . . calling all cars . . .” is no longer an Americanism, or a *cliche* of gangster films.

Crystal-controlled broadcasters are being fitted at police headquarters all over the country, and enterprising provincial Chief Constables are competing in a friendly race with Scotland Yard to install the best radio gear.

The chief electrical firms in the country are, under contract, making various sections of the police radio apparatus. It is all British made. Marconi experts have designed new transmitters for the job, and when the helmeted radio operators drive hard through crowded streets they are in constant touch with headquarters' transmitters putting a powerful code signal on the air.

“Robot” Transmitters

Many central police stations are fitted with “robot” police transmitters of the TP2A. type. This gives an output of 150 watts carrier to the aerial. Quartz crystal control is provided for any wavelength between 100 and 150 metres, with alternative valve drive over the whole band.

When you examine one of these police transmitters you discover that the component parts are mounted in a metal structure with screening compartments and removable side-screens and hinged front, the whole being finished in grey enamel. Safety switches are fitted so that opening the doors or side screens automatically disconnects the power supply, thus making the transmitter safe to touch.

inserted through the front. After the set has been tuned to the required wavelength and the circuits adjusted, these rods are withdrawn and the circuits locked so that the adjustments cannot be interfered with by anybody other than the police officer in charge.

Circuit Details

The stages and circuits, complete with meters and tuning and operating controls, comprise the quartz unit, crystal drive valve, isolator and frequency changer, drive amplifier, intermediate magnifiers, together with modulator and sub-modulator valves. A tone generator, with L.F. oscillating valve, provides for tonic train transmission for calling.

The intermediate magnifier can be used as an alternative simple valve drive if required, on any wave between 100 and 150 metres. Speech is carried out by the choke control method.

The sub modulator or input amplifier stage provides sufficient magnification to enable remote telephone operation to be effected over a short line, as is sometimes required when the transmitter is situated at a distance from the central police station.

The operating gear fitted on the

police operators' bench comprises a small control unit with switchgear, sockets, a microphone on a desk stand, headphones, loudspeaker and morse key.

The Power Supply

The exact arrangement of the power supply (using either rectifier or motor generator sets) depends on the nature of the mains supply. If a suitable alternating current supply is available, the supplies for the main and auxiliary circuits of the transmitter are provided by a group of rectifiers; no running machinery being required.

These rectifiers are of the valve or metal oxide type. The units are mounted in enclosed metal structures, complete with the transformers,

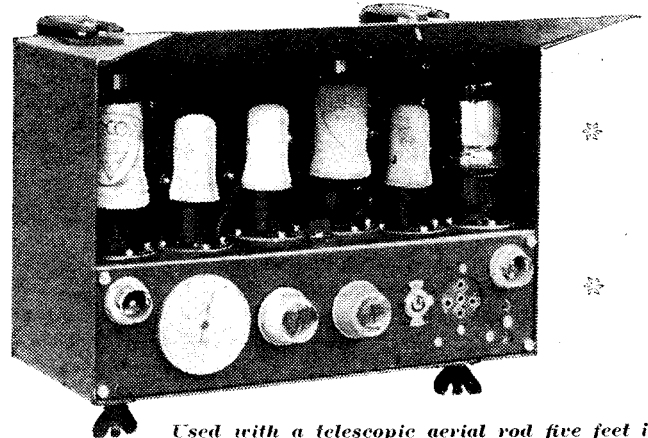

Used with a telescopic aerial rod five feet in length, this Marconi five-valve superhet fits in the police car in special quick release brackets, so that it can readily be removed for servicing or replacement.

smoothing circuits, controls and meters. All filament supplies are taken from the alternating current supply via transformers and regulators.

The police radio officer can talk to the radio-equipped patrol cars, but most of the messages are broadcast in code.

As most of the operators in the cars (in the Scotland Yard area) are

NUMBER OF POLICE CARS RAPIDLY INCREASING

ex-Naval radio men, the code traffic is rapid. The apparatus in the radio cars is easily handled so that the men have only to wear earphones and make notes. Some of the cars are fitted with transmitters such as the Marconi TP5A., so that the patrol men can talk back to headquarters.

A test car has been tried out with one of these combined receivers and transmitters. Briefly, it comprises transmitter, receiver with loudspeaker, switch unit for control of apparatus, rotary converter unit for receiver, rotary converter unit for transmitter, aerial change-over, telegraph key, microphone aerial and 12-volt battery.

Mounted Beneath the Dashboard

The transmitter and receiver are separate units and can be mounted in the most convenient positions; in general the best place is beneath the dashboard. The rotary converter units can, in most cases, be mounted beneath the bonnet. On both converter units are mounted the fuses protecting the equipment—they are thus easily accessible when necessary. The transmitter converter unit contains two relays, one for the valve filaments, the other for starting the converter, and also the necessary smoothing for the supplies. The receiver converter unit also contains the relay and smoothing.

The units comprising the equipment are connected together wherever practicable by means of cables fitted with plugs and sockets. Replacement in the event of any unit breaking down is thus easily carried out.

The receiver is mounted in special quick release brackets so that it may be removed for servicing and replaced by another. All that is necessary for its removal is to take out the aerial, loudspeaker and supply plugs, and slack-off the quick release thumb screws. The receiver complete in its case may then be removed and another put in its place.

Easy Replacement

By removing the plugs and sockets from the transmitter panel and undoing four screws the transmitter may be withdrawn from its case for replacement by another, if necessary.

The relays in the two converter units are operated by small tumbler switches on the switch unit, which is mounted on the dashboard. Also on this unit are two small red lights which indicate when the filaments of the transmitter and receiver are on. This safeguards against the possibility of the filaments being left on. An

aerial change-over relay is mounted on the side of the car in a convenient position for changing the aerial from the transmitter to the receiver.

The aerial consists of a 5-ft. telescopic metal rod extending to 9-ft. when required for extreme ranges with the car stationary. In the unextended position it is rigid enough for travelling at high speeds. An alternative aerial (grid type) can be used, if desired, which is supported to the roof of the car on the inside.

A cover fits over the front of the transmitter to protect it. This is quickly removed by means of two snap catches when it is desired to tune up. Once this is done, provided the same aerial is used, there is no need to touch the transmitter adjust-

TO CALL POLICE

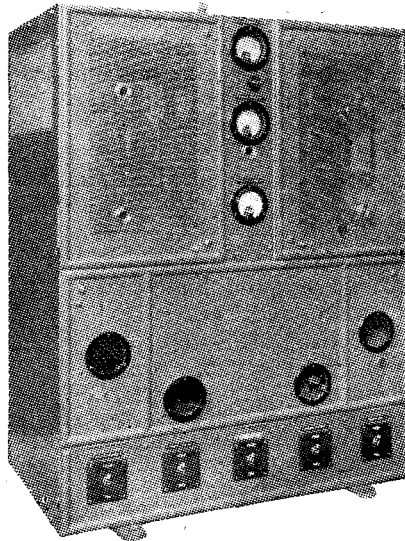

A typical Marconi police transmitter such as is installed at the various headquarters of the mobile radio squads.

ments. By undoing four screws and unplugging the supply and aerial leads, the transmitter can be withdrawn complete from its container for servicing.

The key and microphone plug into the switch unit on the dashboard. The key can be mounted behind the dashboard with the handle projecting through to the front or alternative positions for plugging in the key and microphone may be provided for operation from any convenient position in the car.

The receiver is a super-heterodyne which, in addition to giving very great sensitivity on a small aerial, has the advantage that only one tuning control is required. It covers a frequency

band of 2,030–2,070 kilocycles, or any band of similar ratio within the transmitter wave-range, and is capable of receiving morse or telephony. Six Pigmy valves are employed, and the receiver will deliver an undistorted output of 500 milli-watts.

A very efficient automatic volume control system is embodied which maintains a constant level of speech.

Panel Controls

The only controls mounted on the front panel are: That for tuning, a combined "on-off" switch and manual volume control and morse-telephone switch. The tuning adjustment and the combined "on-off" and volume control can, if desired, be operated through a remote control unit.

The police network over the country using this type of gear is rapidly spreading, and soon there may be many transmitter-equipped patrol cars on the road.

Using Bead Hydrometers

A BEAD hydrometer is a most useful accessory. With two plate accumulators, where ample room is available, the bead hydrometer can often be lowered into the filling hole and jammed in place. Or the beads can simply be removed and dropped into the accumulator where they will find their own level. If the accumulator is exhausted they will lie on the bottom.

As the accumulator is charged the acid becomes capable of supporting a greater weight and the beads commence to rise. When the final bead rises to the surface the accumulator is practically fully charged and charging should be discontinued after an hour or two.

A Point to Note

It is important to find out that the gravity of the acid is suitable for the particular beads used. If the acid in your battery is too weak the final bead will never rise however much the accumulator is charged. Alternatively some large batteries use acid with a maximum gravity of 1,300. The beads sold in shops would be quite unsuitable in this case, as at least one bead would continue to float when the accumulator was exhausted. Reference to the printed instructions or a test with a reliable hydrometer at full charge will show whether your accumulator is suitable.

J. L.

How to use

WESTINGHOUSE
METAL RECTIFIERS

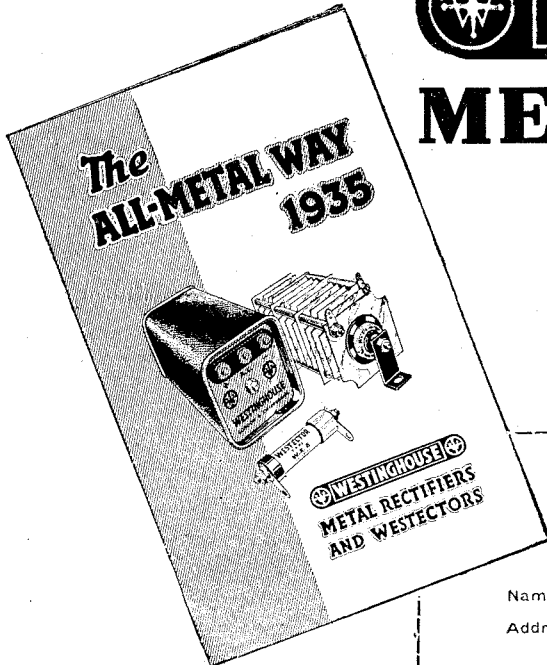

This booklet tells you how to build your own H.T. eliminator or L.T. trickle charger, how to run your moving coil loud-speaker from the mains, how to secure all the advantages offered by A.C. Mains by the most satisfactory method—reliable All-Metal Rectification. The coupon and 3d. in stamps will bring you a copy.

COUPON

WESTINGHOUSE BRAKE & SAXBY SIGNAL CO. LTD.,
82, York Road, King's Cross, London, N.1.

Please send me "The All-Metal Way, 1935" for which I enclose 3d. in stamps.

Name
Address

POLAR
SPECIFIED for the
'FERRO-MAINS THREE'

The POLAR
MIDGET
THREE - GANG
with
V.P. HORIZONTAL
DRIVE

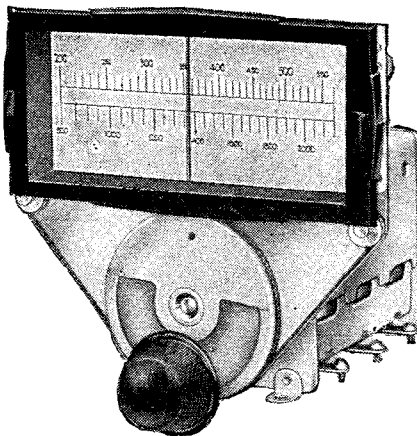

Steel frame and cover. Ball-bearing shaft. Small overall dimensions. Trimmers operated from top. Matched to within 1/2 per cent or 1 mmfd. whichever is the greater. Three-Gang as shown with V.P. Horizontal Drive - - - **23/-**

Condensers Only
2-gang - - - 11/-
3-gang and super-het type - - - 16/6

Polar Tuning graphs available 3d. each post free.

Send for POLAR Catalogue

WINGROVE & ROGERS LTD.

188/9 Strand, London, W.C.2.

Telephone :
Temple Bar 2244.

Works :
Old Swan, Liverpool.

6694

SPECIFIED ALONE
For the **"FERRO-MAINS-3"**

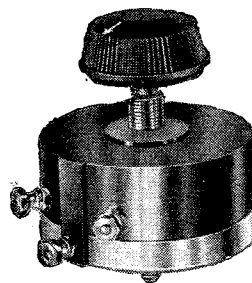

Solus specification has been given by the designer to the two following Varley components—a 10,000 Ohm Volume Control and 750 Ohm "Electronic" Resistance. Be sure of the best results from your "Ferro-Mains-3" by using these two fine Varley Components. Write to-day for our **FREE** Illustrated Catalogue containing information about all Varley components.

(ABOVE)
VOLUME CONTROL (10,000 Ohms, 15 m.a.), List No. C.P.158 - - - **5/6**

(ON RIGHT)
ELECTRONIC RESISTANCE (750 Ohms, 3 watt, 62 m.a.), List No. C.P.203 - **2/6**

Varley

Bloomfield Road, Woolwich, S.E. 18.

Tel. WOOLwich 2345





EUROPE'S ANNOUNCERS

M. Edin Ben Danout, of Radio Paris.



Léon Moulin, whom we hear from Luxembourg.

Well-known voices of the air! What do their owners look like, what are the stories behind these people we hear so often from the Continental stations? In this article our special correspondent gives a vivid pen picture of a number of Europe's most popular announcers.

"LONDON without Stuart Hibberd would not be London," I have heard friends say, and in the same way Rome without "Marilou" (Signorina Maria Louisa Boncompagni) might be any Italian station, but not the capital. Can you visualise Radio Toulouse without Jean Roy, the man who claims that since the French station first came on the air he has carried out his duties for over 28,000 hours?

The First Lady

At any time when listening to radio broadcasts, we hear the voices of a number of announcers of different nationality; with some, in the course of time, we have become so familiar that on hearing them we can tell at once to which station the receiver is tuned.

It is not an easy task to select the most popular announcers on the Continent, and the work is rendered more difficult by the fact that daily more women — or shall we say ladies? — are taking over the studio duties hitherto so capably carried out by the male sex.

However, "Marilou" holds the record for being the first announceress in Europe. Without

doubt much of the popularity of the Rome programmes is due to her personality; she possesses a deep soprano voice, and is peculiarly suited to her work as for many years she studied the art of elocution. In Signorina Maria Rosa Corsini she has an able assistant.

Italy, generally, specialises in women studio announcers, for we find them at Genoa, Bari, Bolzano, Florence, and Milan.

Another female voice which is heard nightly is that of Madame Janini

Sztompa-Grabowska, of Warsaw. She started to broadcast in 1926, after acting for some time as secretary to the station music director. When the Warsaw high-power station was launched her "fan" mail assumed vast proportions, and her fame as an announcer was so widespread that in Norway her portrait was given away with a certain brand of chocolates.

Whilst dealing with the fair sex, I must not fail to mention Mademoiselle Lola Robert, who, following a recent plebiscite organised in the French capital, was declared by Paris listeners

at Radio Luxembourg, the former in German—and sometimes English—the latter in French, not forgetting a new arrival, Senhora Maria de Rezende, whom you may hear nightly reading out the news bulletin or giving out details of programmes at the Lisbon studio of the Barcarena station.

Among the Men

Having thus gallantly given the ladies the first place, may I now refer to mere man? Jean Roy of Radio Toulouse, notwithstanding his claim, is not, I believe, the doyen of the French announcers. This title is held, if I am not mistaken, by Marcel Laporte, the original *Radiolo* of Radio Paris, and now at the Poste Parisien.

Assuredly, he taught the Frenchman to speak before the "mike," and created the unconventional and more homely type of studio official. Similar to Leopold Bracony, his colleague at Brussels No. 1, he started his career by being an actor, and this experience, in their opinion, is one of absolute necessity for the carrying out of their tasks.

José Torres (Toresky) whose ventriloquial dialogues form such a distinctive feature of the Barcelona (E A J I) announcements and publicity "puffs," has also, in the course of a

thirty-five years' career on the stage, played drama, comedy and operetta. Hence, doubtless, his remarkable versatility.

Carl F. Schionning, of Copenhagen, was equally a student of the histrionic art at *Det Kongelige Teater* (The Royal Theatre) in the Danish capital; he has acted as announcer since 1926. He is now 44 years old, although he looks much younger.

Léon Moulin, whose photograph is published here, is the man who gives

(Continued on next page.)

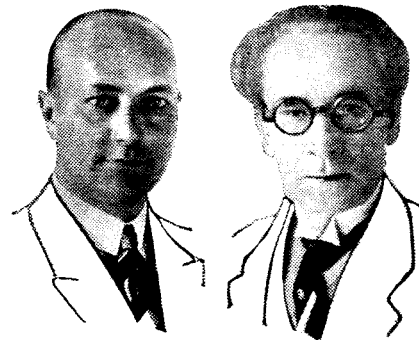

Four more personalities of the European ether. On the left is José Torres, the ventriloquial announcer at Barcelona; top left is the owner of the Copenhagen voice, Carl F. Schionning; top right shows Frantisek Havel, actor, and announcer of Prague; and the remaining photo is of L. Bracony, of Brussels.



to own the most melodious voice in France, surely a very high distinction, or Signorina Nini, of the Monte Ceneri (Switzerland) station, said to be the most youthful of these officials in the world. Born at Alexandria (Egypt) where she learned English, she also speaks Italian, German, French, and is fluent in the local dialect.

At Radio Luxembourg

Then again, there are Fraulein Eva Siewert and Mademoiselle Annette Cornevin, who are regular "speakers"

EUROPE'S ANNOUNCERS

—continued from previous page.

cut the programme items at Radio Luxembourg in dialect for local listeners; you may have heard his call: *Hai Radio Leutzelburg*. Léon Moulin has the gift of the gab, for he was formerly a commercial traveller, and acquired the mike habits when he acted as announcer for a small Luxembourg station some years ago.

The Prague Station

When, by chance, you pick up the call *Hallo Praha*, you will not fail to notice the deep, sonorous voice of Frantisek Havel, of the Prague studio. Neither will you be surprised to learn, judging its tone and clearness of enunciation, that its owner for over twenty-five years played important parts in productions presented at the main Czech theatres. In 1913 Havel abandoned the boards for the screen, and has featured in many Continental silent films. He also maintains that the true announcer should have had an education in the dramatic art.

Finally, notwithstanding the fact that Radio Paris now boasts of some half-dozen announcers, Edin Ben Danou still remains a strong favourite. As his name shows, he is of Arab descent, but educated in both Algeria and France, he made his reputation both as singer and musician. It is Ben Danou who on most days organises and *compères* the programmes of "canned music" broadcast by France's National transmitter Radio Paris.

AN EXTENSION VOLUME CONTROL

THIS extension volume control is intended for battery-fed variable-mu screened-grid receivers. The extension control consists of a 50,000-ohm variable resistance and an ordinary jack plug which is inserted in a special jack on the set when it is required to make use of the control.

The special jack is a closed circuit jack, that is, the contacts of the jack are shorted together until a plug is inserted. The wiring of this jack is very simple. The lead that runs from one end on the volume-control winding to G.B. + (or earth) is broken and the two spare ends attached to the two terminals on the jack.

As the jack is automatically shorted the volume control is not affected until

the extension control plug is inserted. When it is inserted the shorting contacts are broken and the 50,000-ohm resistance is placed in series with the volume-control winding. Increasing the value of this resistance has the same effect as turning the main control towards its minimum position.

IT JUST PLUGS IN

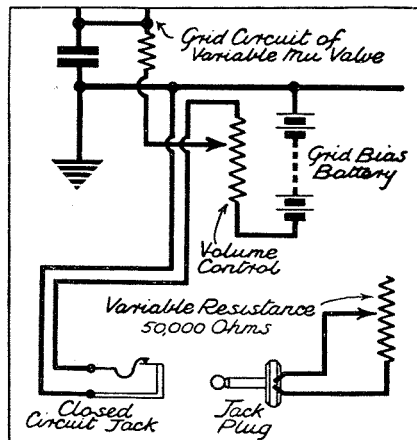

The extension volume control plugs into a two-contact jack on the set.

To obtain full control on the extension control the main volume control should be turned to its maximum position. The extension resistance may be mounted in any suitable position, or it can be mounted in a suitable wooden or metal case; some cigarette presentation boxes are very suitable. The Bulgin jack J.7 and the Bulgin plug P.15 are very suitable on account of their small size.

H. E. P.

THE "FERRO-MAINS" THREE

—continued from page 247.

chassis from "Metaplex" sheets instead of buying it complete, don't forget to bond the different surfaces together. You can easily do this by joining a connecting wire between each of the surfaces, clamping the ends of the wire firmly beneath washers held down by wood screws.

The Coil Wiring

Here is an important point in wiring up the coil unit. Turn the unit upside down before you attempt to connect it up and you will find a black lead joined to tag No. 8 on the coil G1. Connect this lead to a soldering tag which you will find close to tag No. 8.

There is one more connection. Look under coil G3 and you will see a lead connected to tag No. 5. This should be joined to tag No. 6, which is already connected to the coil chassis.

(Continued on next page.)

PETO-SCOTT

IMMEDIATE DELIVERY CASH C.O.D.

PILOT AUTHOR KITS

FERRO-MAINS 3

Described in this month's issue

KIT "A" CASH or C.O.D. £10. 8. 6

Author's Kit of First Specified parts, including Peto-Scott ready-drilled "Metaplex" Chassis and Ebonite Terminal Panel, less Valves and Speaker.

OR YOURS FOR 19/-

and 11 monthly payments of 19/-

KIT-BITS You pay the Postman. We pay post charges on all orders over 10/-.

	£	s.	d.
1 Peto-Scott ready-drilled Metaplex (both sides) chassis, 16" x 10", with 4" runners	4	6	
1 Peto-Scott ready-drilled ebonite terminal panel	1	3	
1 Colvern Ferrocart 3-gang coil unit, with mains switch	1	19	0
1 Polar Midget 3-gang condenser, with v.l. horizontal drive	1	3	0
1 Wearite mains transformer, Type T.21a	1	5	0
1 Ferranti L.F. transformer, type A.F.5	1	10	0
1 Set of 4 Specified Valves	3	4	6
1 W.B. Sentionian standard speaker	1	12	6

ONE-POINT-FIVE

KIT "A" CASH or C.O.D. £5. 5. 0

Comprising Author's Kit of parts as First Specified and used by Mr. John Scott-Taggart including Ready-drilled ebonite panel, ebonite terminal strip and baseboard ready-fitted with metal foil, less Valves, Cabinet and Speaker.

OR YOURS FOR 9/6

and 11 monthly payments of 9/6.

KIT "E." As for Kit "A" but with Set of 4 Specified Valves only. Cash or C.O.D. Carriage Paid, £7/9/0. or 12 monthly payments of 13/6.	KIT "C." As for Kit "A" but with Valves and PETO-SCOTT One-Point-Five Table Cabinet. Cash or C.O.D. Carriage Paid, £8/8/6. or 12 monthly payments of 15/6.
--	--

KIT "CC" As for Kit "A" but with Valves and Peto-Scott One-Point-Five Console Cabinet with Shelf and Baffle, less Speaker. Cash or C.O.D. Carriage Paid, £8/18/6. or 12 monthly payments of 16/3.

FINISHED INSTRUMENTS. In Peto-Scott Cabinets. Table Model with valves, less batteries. Cash or C.O.D. Carr. Pd. £9/15/0. or 12 monthly payments of 17/8.

Console Model, with valves and Peto-Scott S.1 P.M. speaker, less batteries. Cash or C.O.D. Carr. Pd. £11/11/0. or 12 monthly payments of 21/3.

CONVERSION KIT

S.T.400 to ONE-POINT-FIVE

All parts required for converting your S.T.400 to the One-Point-Five. Comprising 1 FER-RANT 300,000 ohms resistance; 2 ERLE 1-watt resistances; 3 CLIX plugs; 1 WEARITE type "A" coil; 2 GRAHAM FARISH Litos log-mid-line condensers; 1 POLAR Compax-00075-mfd.; 1 ORMOND Extractor condenser; 1 COLVERN S.T.600 Extractor coil; 1 BULGIN S.56 switch; 1 LISSEN-00005-mfd.; 1 T.C.C. 1-mfd.; 1 DUBILIER 75,000 ohm.; 1 BELLING-LEE terminal; 1 PETO-SCOTT terminal strip, 16" x 3"; connecting wire, screws, flux, less Valves and Cabinet. Cash or C.O.D. Carriage Paid £1/16/0. Or 6 monthly payments of 6/9.

YOURS FOR 6/9

B.T.S. 1935 SHORT WAVE ADAPTOR

Make your Set an All-Wave Set. receive America direct! Simply plug into your present Set. With 2 plug-in coils, 15-52 metres. Send only 7/6; balance in 10 monthly payments of 5/-.

Cash or C.O.D. Carriage Paid, £2 12/6. Extra Coils 46-96 and 90-190 metres, 4/6 each. Send for descriptive leaflet.

PETO-SCOTT CO. LTD.

77 (W.6), CITY ROAD LONDON, E.C.1.

Telephone: Clerkenwell 9406/7 West End Showrooms: 62 (W.6), High Holborn, London, E.S.T. 1919 W.C.1. Phone: Holborn 3248

THE "FERRO-MAINS" THREE

—continued from previous page.

Do not forget to make these connections.

You will notice that the set isn't shown in a cabinet. Many constructors prefer to have the cabinet made to their own ideas, and there is plenty of scope in this direction in the case of the "Ferro-Mains" Three. If you decide to buy a kit of parts you can get a special cabinet for the set from Messrs. Peto-Scott Co. Ltd.

There are 4 main controls on the

panel. These are as follow: In the centre, the tuning control operating the three sections of the gang condenser; immediately underneath is the knob which operates the wave-change switch, mains on and off, and radiogram switching; on the extreme right is the reaction control, and on the left of the panel the volume control.

Generally speaking, reaction will not be required, except for the reception of the more distant stations.

Trimming The Receiver

When the set is completed the only operation which has to be carried out is that of trimming. The tuning

condenser is provided with independent trimmers to each section. These can be adjusted by inserting the blade of a screwdriver, or a piece of wood, shaped at one end, after the fashion of a screwdriver blade, in the slots of the trimmer adjusters. The trimmers should be screwed right up, and then unscrewed equally about 2½ times. A fairly weak station should then be tuned in on the loudspeaker. It is advisable to choose a station whose wavelength is somewhere at the lower end of the tuning range, medium waveband, and a certain amount of reaction should be used.

The two trimmers nearer the front of the panel should then be adjusted very gradually one at a time, until the maximum volume is obtained from the station tuned in. A final adjustment should then be carried out on the aerial trimmer, i.e. the one farthest from the panel. The whole idea is to obtain a trimming adjustment with as little added capacity as possible.

It will be appreciated that a clockwise movement of the trimming adjusters produces a large effect in wavelength round about 200 metres, and if too much is used it has the effect of reducing the wavelength range of the set.

B.B.C. NEWS

—continued from page 239.

for the next five years. Sir Landon has always been a great friend of broadcasting, and obviously has some right to first consideration for a job such as this when it is going. The idea is to get B.B.C. music policy lined up more definitely with outside musical opinion during the time when the new constitution of the B.B.C. is being considered.

Accession Day Items

After the King's broadcast at eight o'clock on Accession Day, Monday, May 6th, there will be a five minutes' interval of silence, a variety O.B. from Brighton, a speech by Rudyard Kipling from the dinner of the Royal Society of St. George; then at 9.20 the B.B.C. Chorus will provide half an hour of community singing. The news will follow at 9.45; then at 10.15 the Poet Laureate will read an ode specially composed by himself for the occasion; from 10.20 to 11.30 Henry Hall and his Orchestra will have the air, with Brighton dance music closing the programmes from eleven-thirty to one in the following morning.



**Service your own Radio
IT'S CHEAPER!**

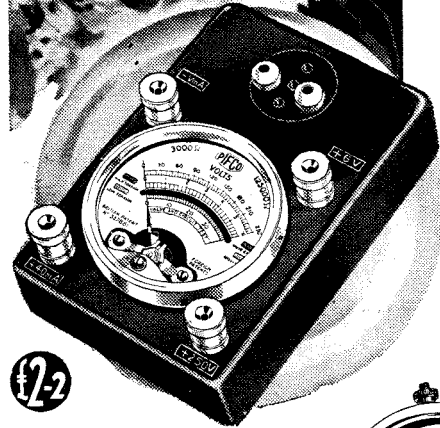

GAINING knowledge from other people is apt to be expensive. You owe it to yourself to find out what is wrong with your radio receiver with absolute certainty before running up expensive service bills. Any kind of radio fault is easily traced with a Pifco Radiometer. The possession of a Pifco Radiometer is the finest insurance against expensive repair bills and disappointments. There is a model for both mains or battery sets.

£2.2

DE LUXE MODEL.
'All-in-One' RADIOMETER.
This moving-coil instrument tests everything—all-mains units, electric and battery radio, D.C. or Rectified A.C. Diameter of dial, 2½ ins. Finished in mottled bakelite. Hundreds of thousands are in use all over the world. Price £2.2.0. A case can be supplied at 2/6 extra.

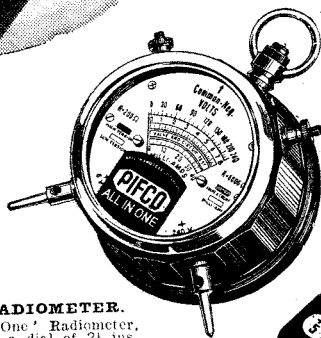

Ask your dealer to-day to show you one or write for Pifco Testmeter Folder, post free, from **PIFCO LTD., SHUDEHILL, MAN-CHESTER** or 150, Charing Cross Road, London, W.C.2.

ALL-IN-ONE RADIOMETER.

This popular 'All-in-One' Radiometer, for battery sets, has a dial of 2½ ins. diameter and is finished in mottled bakelite. Hundreds of thousands are in use all over the world. Price 12/6. A case can be supplied at 2/6 extra.

12/6

PIFCO ELECTROMETER.

The Pifco **ELECTROMETER** is indispensable to electricians, radio engineers, etc. Encased in black bakelite, preventing external shorts, and supplied with two 22-in. long rubber-covered cables. Double range, 0.5j volts and 0.250 volts. For voltage and circuit testing on D.C. or A.C. mains of any frequency. Complete with cables. Price 12/6.

12/6

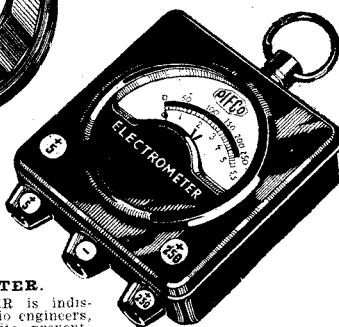

PIFCO

ROTAMETERS and RADIOMETERS
PIFCO ON THE SPOT WILL TRACE YOUR TROUBLES LIKE A SHOT

NEW APPARATUS TESTED

—continued from page 251.

for use in conjunction with a standard 9-pin valve holder. The idea of the plug is to enable the experimenter to group his connections together, as an alternative to a haphazard arrangement of terminals, such as might often be the case in an experimental hook-up.

The advantage of grouping in this way is that it makes for interchangeability. For instance, it might be possible to arrange the connection of, say, a standard amplifier in this way so that it can be rapidly joined up to bench layout for testing purposes.

There is naturally no need to use all the nine pins—three or four can be employed if desired, but it is certainly an advantage to have nine available.

The plug is very well made, and costs 2s. 3d.

High-Fidelity Needles

Radiogram enthusiasts will learn with interest that the H.M.V. Company has recently produced a needle specially designed to do full justice to the high-note reproduction given by the modern high-quality radiogram.

These "High Fidelity" needles, as they are styled, are sold in packets of ten for 1s., and will play 30 to 60 record sides without causing serious high-note loss. The needles are made of exceptionally hard steel, and have a minute film of chromium plating on their tips.

The tip of each needle is magnified 400 times before and after plating to ensure that all the needles are of standard dimensions and that the points are perfectly formed. On no account should the number of playings per needle exceed 60, otherwise quality of reproduction will suffer. And an interesting point in connection with this is the fact that 60 playings is equivalent to a record track length of about five miles. When you remember that every time a record is played the needle point has to resist a friction equivalent to a pressure of nearly 5 tons per square inch, you will appreciate something of the research and experimental work necessary to produce a really efficient needle, and one, moreover, which will not cause excessive wear on the record.

"Telestat" Cable

The Television Committee's report has given prominence to the increasing value of the short waves and the forthcoming high-definition television ser-

vice will bring into being many thousands of special short-wave receivers all over the country.

One of the difficulties that owners of these receivers may have to contend with is that of interference from car ignition systems and similar sources. Messrs. Ward and Goldstone, Ltd., of Frederick Road, Salford 6, Lanes., who have made a special study of the

VERY COMPACT

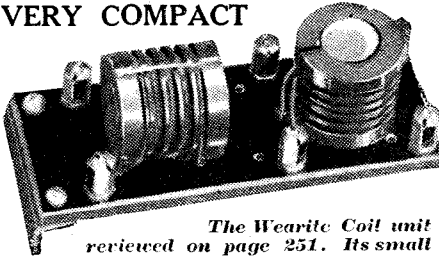

The Wearite Coil unit reviewed on page 251. Its small size can be judged from this illustration.

elimination of this type of interference, have brought out a new cable which they call the "Telestat."

It is a twin cable intended for dipole and other special short-wave aerials. Short-wave enthusiasts who wish to obtain further details of the method of using this "Telestat" cable, and of the various static elimination circuits, should get into touch with the above firm, who will supply them with the necessary particulars.

HOW TELEVISION PICTURES ARE TRANSMITTED

—continued from page 260.

as does the electron beam in an ordinary cathode-ray tube scan the reception screen in order to build up a picture at the receiving end.

But in the Iconoscope, as the beam touches each of the tiny cells, so it neutralises its electric charge. In consequence there will be a voltage difference of a varying nature set up between the metal plate behind the cells (for this plate is the "other" plate to every one of the tiny condensers) and the metal lining of the tube which forms the direct link for the cathode "return" of the electrons.

The voltage difference varies as with the varying electric charges set up in the tiny cell condensers, and so once again we have our electrical picture pattern in a stretched-out form, as it were, all ready for transmission.

Talking about electrical patterns reminds me of another electron-television-camera idea which also is very ingenious, though I frankly admit I know less of its potentialities in practice.

(Continued on next page.)

AND NOW EXCLUSIVELY SPECIFIED FOR THE 'FERRO-MAINS III'



Model PMS1

- Stentorian Senior (PMS1) 42/-
100 per cent. dust protection. Oversize cone.
- Stentorian Standard (PMS2) 32/6
- Stentorian Baby (PMS6) 22/6



STENTORIAN

PERMANENT MAGNET MOVING-COIL SPEAKER

Whiteley Electrical Radio Co., Ltd., Radio Works (Electrical Department), Mansfield, Notts.

FOR BETTER RADIO

solder your contacts electrically

Plug in your Solon Electric Soldering Iron to the nearest lampholder and you know it'll be ready to make good jobs in three minutes.

**IT'S QUICKER
BETTER · MORE
ECONOMICAL
AND EFFICIENT**

7'6
65 WATTS
125 watts 22'6
240 watts 37'6

SOLON
ELECTRIC
SOLDERING IRON

BRITISH THROUGHOUT

W. T. HENLEY'S TELEGRAPH WORKS CO., LTD.
DEPT. 22Y.K., HOLBORN VIADUCT, LONDON, E.C.1

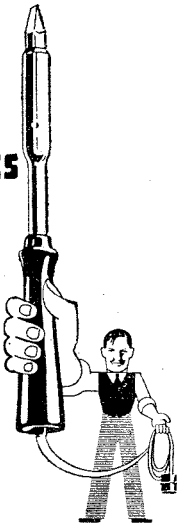

Prevent two most prevalent faults

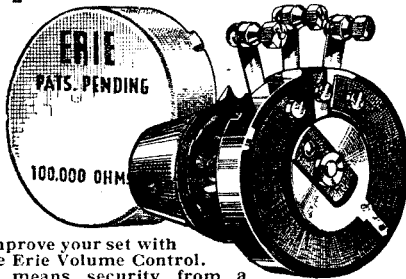

Improve your set with the Erie Volume Control. It means security from a most frequent source of trouble. The Erie resistance element and Erie precision construction give smooth and positive contact—with freedom from hop-off noises—for a life-time's use. All the leading set designers specify this better potentiometer. Made in all sizes 50,000 ohms to 2 megohms

3'6
or with built-in mains switch
5 -

ERIE

VOLUME CONTROL

FREE

Send for the helpful "Erie Resistor Service Instruction Booklet." Post Free.

ERIE RESISTORS SPECIFIED for the "Ferro-Mains Three"

Make absolutely sure that you are using Eries. Faulty resistors are the chief cause of trouble. That's why designers and manufacturers all specify Eries for reliability.

The Radio Resistor Co. Ltd., 1, Golden Sq., London, W.1

HOW TELEVISION PICTURES ARE TRANSMITTED

—continued from previous page.

This, too, takes the form of a cathode-ray tube of sorts. You will find a sketch of it at Fig. 3. The reflected light is in this case brought to bear upon a cathode of a photo-electric nature which emits electrons in accordance with the intensity of the light. More light, more electrons; less light, less electrons.

By means of very carefully arranged regulating potentials the picture pattern of these emitted electrons is exactly preserved so that, if they encountered a screen of fluorescent material such as is in an ordinary cathode-ray tube, the picture would be reproduced.

But they do not meet such a screen, instead, they strike a quite plain intercepting screen in which there is a very small hole.

A Simple Analogy

The whole beam is moved horizontally and vertically by means of deflecting coils to make each part in turn of the electron picture come opposite the small hole. The electrons which get through form a tiny current of electricity which is passed to an external circuit for amplification.

Perhaps some of you haven't quite got the idea. Think of the rays from a magic lantern or cinema projector being so deflected that each part of the picture they carry is in turn brought opposite a small hole in a solid wall. Obviously, the amount of light getting through that hole would vary as with the different intensities of light and shade of the picture.

Now imagine the light rays to be electrons and the wall with a tiny hole in it to be the screening partition in Fig. 3, and I think all of you should be able to understand how this particular "television camera" works.

LOW CAPACITY TUNING

—continued from page 254.

thing impracticable or, at least, that it has such a limited use as to be hardly worth revival at this stage of the game.

However, I have not yet said my last word on the subject, for there is

something better that can be done while retaining practically all the simplicity—perhaps I should say the primitive simplicity—of the pure aperiodic stage.

It might be called by two or three names, such as semi-aperiodic tuning, broad tuning or, as I prefer it, "low capacity tuning."

Now all the capacities with which we have been concerned in our examination of aperiodic coupling form part of the tuning capacity of a tuned-anode circuit.

Incidentally, it may be noted that while we arrived at an irreducible minimum figure of 25 m.mfds., the ordinary tuned coupling is generally based upon a minimum capacity of about 75 m.mfds.!

Using a Tuned Coil

If, then, in place of the choke we substitute a coil of suitable inductance, and tune it with a small variable condenser—which should possess a very low minimum value—the coil will tune over any required band of wavelengths.

For instance, suppose we confine reception to the medium band only, our tuned-anode circuit will show little variation of impedance over quite wide bands of wavelengths. A rough setting at approximately 300 metres will serve at the bottom end of the scale, with further advances to the middle and upper parts of the dial at higher wavelengths.

Our tuned circuit may be of high resistance, but it must be of low self-capacity; the coil may be wound with any fine wire, say, No. 40 enamelled, on a 1½-inch former—about 150-200 turns, or thereabouts, will be about correct.

Keep Capacity Down

The turns should be spaced to ensure a low self-capacity. This coil will have a quite surprising inductance compared with the ordinary coil—something like 600 microhenries in place of the more common 150-200 microhenries!

The tuning condenser needs rather careful choice, as most ordinary types have a high minimum value—and this would upset our calculations badly. If a correct balance is obtained between coil and condenser—that is, with a coil of maximum inductance so that a wavelength of 250 metres is brought in at the bottom of the condenser—the maximum value of capacity need not exceed .0001 mfd. (Fig. 3).

Finally, to complete the elaboration from the primitive to the ultra-modern, in Fig. 4 the "low capacity tuned coupling" is shown adapted for use with a double-diode triode valve, a very interesting circuit combination.

CABINETS. Write for Free List
GILBERT (cabinet maker), SWINDON.

SHORT WAVES IN THE TROPICS

—continued from page 256.

Still rather weak. I was stumped for a while, until I began brushing away the "whiskers" of fungus from the wiring. Gain rose appreciably, and this gave me a clue. All the cotton covered hook-up was removed and replaced with that having a glazed cover. On the completion of this the radio operated normally, and my customer was satisfied. Apparently

the public in this country, if possible even simpler, for the climate in the tropics is not conducive to patient "diddling" around with tricky sets.

So ends the story of the coffee planter's radio, but there are a few other components in a receiver which should be purchased with care if they are to be used between the tropics of Cancer and Capricorn.

Design of Components

Mains transformers, providing they are of ample proportions, and well designed to withstand the notorious fluctuating lines, need no special treatment. They should be mounted so

PRAISE FOR THE "ONE-POINT-FIVE"

Read what these constructors say.

SELECTIVITY REALLY MARVELLOUS

Dear Sir,—I feel I must write and congratulate you on your wonderful set, the S.T. "One-Point-Five." I have converted my S.T.300 Star into it, and—Gee! What a conversion it is! I have always wanted a set with a kick in it. I've got it. Selectivity with the help of the Extractor is really marvellous; in fact, the Extractor is an eye-opener.

I might have been a "Chorlton-cum-Hardy" if I hadn't known the worth of S.T. in front of the name of a set. When I first switched on I couldn't get a sound out of it; an extremely unfortunate coincidence had happened—the loudspeaker leads chose to give out during the conversion!

Thanking you again for a wonderful set.

J. H. E. Dunsford,
Beaufort House, Marshfield,
Chippenham, Wilts.

8 MILES FROM DROITWICH

Dear Sir,—You ask for reports on the S.T.1-5.

Well, mine is as follows:

1. Set O.K.
2. 100 per cent better than the good S.T.400.
3. Cut out Droitwich 8 miles away from the address below.
4. Tone and volume envied by all visitors to the same address.

I must say that I am glad I converted, and thus saved myself going into debt for a commercial receiver.

Fred Gilbert,
1, Skinner Road, St. John's,
Worcester.

EDINBURGH DEMONSTRATIONS

Dear Sir,—May I offer my congratulations on your 1-5 set. It is the nicest of all your sets that I have built; these do not include your S.T.600.

At Edinburgh in the day-time the Scottish National is so loud that it has to be detuned.

In the evening Radio Normandy can be heard, using the lead-in wire, which is about 3 feet long.

Also Toulouse can be separated from Hamburg, and Radio Paris from Breslau, using a full-size aerial.

Rome is difficult to get at good strength. The Extractor is essential. I should be pleased to demonstrate the set to anyone.

L. Hammond, Eng. Capt., R.N. (Retd.),
1, Merchiston Bank Gardens,
Edinburgh.

there had been some H.F. leakage over the fungus-covered wiring.

Personally, I thought the set too difficult to handle, too many controls and very critical in tuning; and here I would like to raise another point. I do wish designers would realise that listeners in the tropics are not necessarily short-wave enthusiasts. They consider the transmissions more from the entertainment point of view than the stunt of distant reception.

The non-technical Tea Planter, Coffee Grower or Citrus man, and his even less technical wife, are the type of people who use short-wave receivers. Consequently such apparatus must be just as easy to handle as those sold to

that there is adequate ventilation. Due to the heat generated in operation, they are not, as a rule, affected by dampness.

Condensers and resistors are quite a problem. The former, when of the cardboard tube type, with paraffin-wax-sealed end, are particularly vulnerable to attack, both from heat and insects. Those little pests, the white ants, assisted by the giant cockroaches, will make short work of such units. I always found it advisable to use the bakelite encased type for small values, with the metal container, sealed with pitch of a high-melting point, or sealing wax, where higher values were required.

COLVERN FERROCART COILS...

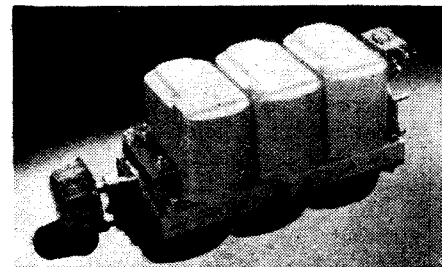

Specified for the FERRO-MAINS THREE

1 Colvern Ferrocart 3-Gang Coil Unit type G1, G2, G3, with Mains Switch - - - Per Set **39/-**

The most accurate coils yet designed. Be wise in your choice... choose COLVERN

COLVERN LTD., Romford, Essex
London Office: 150, King's Cross Road, W.C.1.

Wireless

AND TELEVISION REVIEW

JAN. issue.

The Roberts Three

CLIX Valveholders—Wander Plugs—Panel and Spade Terminals.

FEB. issue.

The "Ferrogang" Four

CLIX Valveholders—Wander Plugs—Panel and Spade Terminals.

MARCH issue.

The "One-Point-Five"

CLIX Wander Plugs and Terminals.

APRIL issue.

The "Sensitune"

CLIX Panel and Spade Terminals—Wander Plugs.

MAY issue.

The "Ferro-Mains" Three

CLIX ONCE AGAIN SPECIFIED

This time for their famous Chassis Mounting Valveholders. 4-pin 8d. 5-pin 9d. 7-pin 1/-.

FIT CLIX FOR PERFECT CONTACT

LECTRO LINX, LTD.,
79a, Rochester Row, London, S.W.1

Wireless Magazine

Published about the 25th of the month 1/-

58/61 FETTER LANE,
LONDON, E.C. 4.

NOTE—This reply is sent by post in advance of publication. Both text and illustrations (if any) are the copyright of the Proprietors of the above Journal, and may NOT be republished without their written permission.

In addressing to "The Wireless Magazine" any question arising out of this reply, please quote No..... 2883

Mr. F. Jackson

Dear Sir,

It is quite a simple matter to combine the output circuit, as described by Mr. Noel Bonavia Hunt, with the A.P.A. and we have shown on the attached sheet a diagram of the connections between the two.

The 200-volt supply for the electrostatic speaker through the 3 to 5-henry choke can be obtained from the 200-volt supply for the set, as we have shown by the dotted line.

Yours faithfully,

W.M. TECHNICAL STAFF.

Our Astounding Book Offer to Regular Readers

£10.10.0
Set of
VOLUMES
for **21/-**

The 1,000 Best Complete Tales of all Times and all Countries

Special arrangements have been made whereby regular readers of this journal can secure, at a tenth of the value, the few remaining sets of the famous MASTERPIECE LIBRARY OF SHORT STORIES. The supply is limited, and immediate steps must be taken to reserve a set by those intending to take advantage of this unprecedented bargain offer.

No fewer than 600 world-famous and gifted authors provide a lifetime's reading entertainment in the 8,000 pages of this stupendous work. Everything in it—an inexhaustible wealth of drama, adventure, comedy and humour—has been written to assure you many an hour of absorbing pleasure and a refuge from worries

There are nearly 800 pages in each volume, and the whole ten weigh nearly 15 lb. Each of the Thousand Short Stories is from 1,000 to 8,000 words in length, all stories are complete and unabridged, and foreign stories have been translated into English by experts. Only the world's leading authors are represented in its pages. You and your friends will be proud of this wonder collection of the best complete tales of all times and all countries. The volumes themselves will certainly add grace to any, even the richest, library.

The beautiful Edition shown below is bound in lovely lustrous blue art leather, with blocked decorative design and embellished with 22-carat gold lettering on both spine and front.

Make sure of your set before it is too late.

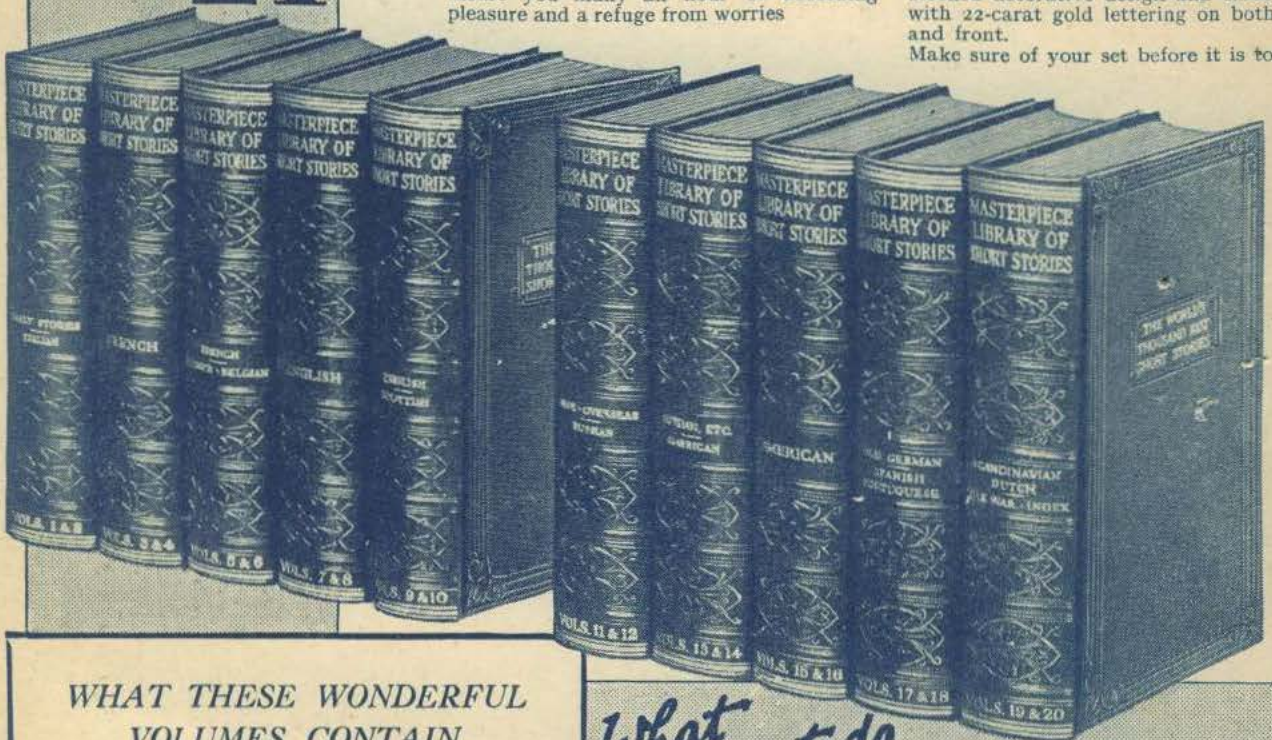

WHAT THESE WONDERFUL VOLUMES CONTAIN

- | | |
|--|--------------------------------|
| Early Stories | Irish and Overseas Stories |
| Italian Stories | Russian Stories |
| French Stories | Russian and American Stories |
| French and French-Belgian Stories | American Stories |
| English Stories | Old German Stories |
| English and Scottish Stories | Spanish and Portuguese Stories |
| Scandinavian and Dutch Stories. War Stories: British American, French and Italian. Index to whole Library. | |

What you have to do

TO SECURE THE BIGGEST BOOK BARGAIN EVER KNOWN

First of all you must send a postcard to The Amalgamated Press Book Dept (G.P.O. Box No. 184a), Cobbs Court, Broadway, E.C.4, applying for your Gift Vouchers for the Masterpiece Library of Short Stories. There are two vouchers in all. The first Gift Voucher contains two spaces on which you have to stick two consecutive tokens cut from the bottom left-hand corner of the last page of reading matter of WIRELESS and TELEVISION REVIEW. The second Gift Voucher has only one space on which you must attach ONE Gift Token. When complete, send in your first Gift Voucher together with a cheque or P.O. for 10/6 to cover cost of carriage and delivery to your door, cardboard container for packing, insurance, etc., and

your first five volumes will be despatched. Follow exactly the same course to obtain the second five volumes. You have to collect three tokens only before you can make this wonderful ten-volume Masterpiece Library of Short Stories completely yours; 10/6 must be sent with each completed Gift Voucher for each set of five volumes, and the Masterpiece Library of Short Stories can only be supplied to readers who complete the necessary Vouchers. As these volumes are only available to regular readers, if you have not placed a regular order for WIRELESS and TELEVISION REVIEW you must do so at once. Irish Free State readers are not eligible.

