

BBC ENGINEERING TRAINING MANUAL

TELEVISION ENGINEERING

Principles and Practice

VOLUME TWO

VIDEO-FREQUENCY AMPLIFICATION

S. W. AMOS, B.Sc. (RADIO), A.S.C.E.E. and D. C. BIRKINSHAW, SER. MAJ. RETD.

A 'WIRELESS WORLD' PUBLICATION

About This Book

THIS is the second volume of a textbook on television engineering written by members of the BBC Engineering Division, primarily for the instruction of the Corporation's own staff. The work is intended to provide a comprehensive survey of modern television principles and practice.

This volume describes the fundamental principles of video-frequency amplifiers and examines the factors which limit their performance at the extremes of the pass-band. A wide variety of circuits is described and particular attention is paid to the use of feedback. There is a section dealing with the special problems of camera-head amplifiers.

Because of the nature of the subject, the text is necessarily more mathematical than that of Volume I, but whenever possible self-contained mathematical derivations have been included as appendices at the ends of chapters.

Volume I of this book deals with fundamental television principles, camera tubes, television optics and electron optics. Volumes III and IV are now in the course of preparation. Volume III will deal with waveform generation and Volume IV with a wide range of circuit techniques. These volumes will complete the work.

272 pages. 156 illustrations
including art plates.

35s. net

BBC ENGINEERING TRAINING MANUALS

TELEVISION ENGINEERING
Principles and Practice

VOLUME TWO
VIDEO-FREQUENCY AMPLIFICATION

By
S. W. AMOS, B.Sc. (Hons.), A.M.I.E.E.
and
D. C. BIRKINSHAW, M.B.E., M.A., M.I.E.E.

With 156 illustrations

LONDON : ILIFFE & SONS, LTD.
NEW YORK : PHILOSOPHICAL LIBRARY

First published in this series, 1956

*Published, by arrangement with the BBC, for "Wireless World" by
Ilfiffe & Sons, Ltd., Dorset House, Stamford Street, London, S.E.1*

*Published in the U.S.A. by Philosophical Library, Inc., 15, East
40th Street, New York, 16, N.Y.*

Made and printed in England at The Chapel River Press, Andover, Hants

BKS 2506

TELEVISION ENGINEERING
Principles and Practice

VOLUME TWO

IN THIS SERIES

MICROPHONES

Staff of the BBC Engineering
Training Department

SOUND RECORDING AND REPRODUCTION

J. W. Godfrey and S. W. Amos, B.Sc., A.M.I.E.E.

STUDIO ENGINEERING FOR SOUND BROADCASTING

Members of the BBC Engineering Division
Ed.: J. W. Godfrey

ACKNOWLEDGMENT

By permission of the Television Society, Fig. 122 (One Circuit for Optimal Voltage Feedback), Fig. 123 (A More Convenient Circuit for Optimal Feedback), Fig. 127 (A Video-frequency Amplifier with Maximal Feedback) and Fig. 128 (A Video-frequency Amplifier with Maximal and Optimal Feedback) are based on illustrations in “ Negative Feedback Amplifiers with Desired Amplitude-Frequency Characteristics ”, by V. J. Cooper, *Journal of the Television Society*, Vol. 6, No. 6, April–June, 1951. The feedback classification and some of the calculations in Part 4 of this volume are based on this Paper.

CONTENTS

<i>Chapter</i>	<i>Page</i>
PREFACE	11
PRINCIPAL SYMBOLS USED	13
 <i>PART I: FUNDAMENTAL PRINCIPLES OF VIDEO-FREQUENCY AMPLIFICATION</i>	
1 AMPLITUDE AND PHASE CHARACTERISTICS	17
Introduction—Frequency Range of Video Signal—Relationship between Phase and Time—Attenuation and Phase Distortion at High Frequencies—Attenuation and Phase Distortion at Middle Frequencies—Attenuation and Phase Distortion at Low Frequencies—Signal Inversion—Group Delay—Appendix A: Test Card C	
 <i>PART II: VIDEO-FREQUENCY AMPLIFICATION: HIGH-FREQUENCY CONSIDERATIONS</i>	
2 SIMPLE RC-COUPLED CIRCUIT	37
Introduction—Sources of Shunt Capacitance—Effect of Shunt Capacitance on Frequency Response—Effect of Shunt Capacitance on Phase Response—Gain—Frequency Response—Phase Response—Group Delay—Response to Voltage Step—Appendix B: Charge and Discharge of a Capacitor in a Resistive Circuit	
3 SHUNT-INDUCTANCE CIRCUIT	55
Introduction—Gain—Frequency Response—Maximal Flatness—Conditions for Maximal Flatness of Frequency Response—Phase Response—Group Delay—Conditions for Maximal Flatness of Group Delay Curve—Response to Voltage Step—Design of Shunt-inductance Circuit—4-element Shunt-inductance Circuit—5-element Shunt-inductance Circuit—Appendix C: Conditions for Maximal Flatness	
4 SERIES-INDUCTANCE CIRCUIT	75
Introduction—Gain—Frequency Response—Comparison with Shunt-inductance Circuit—Conditions for Maximal Flatness of Frequency Response—Phase Response—Group Delay—Conditions for Maximal Flatness of Group Delay Curve—Response to Voltage Step—Design of Series-inductance Circuit—Combined Shunt- and Series-inductance Circuit	

CONTENTS

<i>Chapter</i>		<i>Page</i>
5	CIRCUITS EMPLOYING CATHODE COMPONENTS	94
	Introduction—Effect of Current Feedback—Conditions for Maximal Flatness of Frequency Response—Adjustment of Feedback Independently of Bias—3-element Current Feedback Circuit—Appendix D: Reduction in Gain due to Current Negative Feedback	
6	RELATIONSHIP BETWEEN PASSBAND AND GAIN	105
	Simple RC-coupled Amplifier—Shunt-inductance Amplifier—Series-inductance Amplifier—Figure of Merit for a Valve—Limiting Values of Gain—Limiting Values of Frequency	
7	AMPLIFYING STAGES CONNECTED IN CASCADE	112
	Introduction—Addition of Frequency Responses and Delay Times—Addition of Rise Times—Use of Complementary Characteristics—Decrease in Stage Gain to give Constant Passband—Design of a Multi-valve Amplifier—Amplifier with Alternate Gain Stages and Cathode Followers	
8	DISTRIBUTED AMPLIFIERS	121
	Introduction—Fundamental Considerations—Superiority over Conventional Cascaded Amplifiers—Frequency and Phase Characteristics of Distributed Amplifiers	
9	PHASE EQUALISERS	126
	Introduction—Frequency Response of Symmetrical Lattice Network—Simple Lattice Network—More Complex Phase Equalisers—Derivative Equaliser—Appendix E: Frequency Response of Lattice Network—Appendix F: Derivation of Expressions for Phase Angle and Group Delay of More Complex Phase Equaliser—Appendix G: Equivalence of Lattice and Bridged-T Networks	
 <i>PART III: VIDEO-FREQUENCY AMPLIFICATION: LOW-FREQUENCY CONSIDERATIONS</i>		
10	INTER-VALVE COUPLING CIRCUIT	158
	Introduction—Simple RC-coupled Amplifier at Low Frequencies—Effect of Inter-valve Coupling Components illustrated Vectorially—Low-frequency Frequency Response of Simple RC-coupled Amplifier—Phase Response—Charge and Discharge of a Capacitor in a Resistive Circuit—Effects of Series and Parallel RC Circuits on a Square Wave—Relationship between Sag and Time Constant—Relationship	

CONTENTS

<i>Chapter</i>		<i>Page</i>
	between Sag and Frequency Response—Relationship between Sag and Phase Response—Effective Increase in Grid Resistor by Current Feedback—Appendix H: Relationship between Sag and Frequency Response—Appendix J: Increase in Effective Grid Resistor by Current Feedback	
11	ANODE-DECOUPLING CIRCUIT Introduction—Effect of Anode-decoupling Circuit illustrated Vectorially—Design of Anode-decoupling Circuit—Frequency Response of Decoupled Circuit—Phase Response of Decoupled Circuit—Alternative Circuit	177
12	CATHODE-DECOUPLING CIRCUIT Introduction—Distortion due to Cathode Circuit illustrated Vectorially—Frequency Response—Phase Response—Use of External Source of Grid Bias—Use of Resistive Cathode Circuit—Cancelling Distortion due to Cathode Circuit by Anode-decoupling Circuit	188
13	SCREEN-DECOUPLING CIRCUIT Introduction—Effect of Screen-decoupling Circuit illustrated Vectorially—Calculation of Distortion due to Screen-decoupling Circuit—Pentode without Screen-decoupling Resistor—Use of Cathode Follower to feed Screen—Appendix K: Phase and Frequency Response due to Finite Screen Impedance	200
14	D.C. COUPLING Introduction—Design of d.c. coupled Circuit	209
<i>PART IV: FEEDBACK IN VIDEO-FREQUENCY AMPLIFIERS</i>		
15	BASIC PRINCIPLES OF FEEDBACK Introduction—Fundamental Considerations—Voltage and Current Feedback—Series- and Parallel-connected Feedback—Frequency-discriminating Feedback	213
16	FEEDBACK IN A SINGLE-STAGE RC-COUPLED AMPLIFIER Introduction—Aperiodic Voltage Feedback—Aperiodic Current Feedback—Critical Voltage Feedback—Critical Current Feedback—Maximal Voltage and Current Feedback—Optimal Voltage Feedback—Optimal Current Feedback—Negative Feedback at Low Frequencies	223

CONTENTS

<i>Chapter</i>		<i>Page</i>
17	FEEDBACK IN MULTI-STAGE AMPLIFIERS	244
	Introduction—Maximal Feedback in a Two-stage Amplifier— Instability in Multi-stage Feedback Amplifiers—Overloading of Feedback Amplifiers—Video-frequency Amplifier with Maximal Feedback—Video-Frequency Amplifier with Maximal and Optimal Feedback	
<i>PART V: NOISE IN VIDEO-FREQUENCY AMPLIFIERS</i>		
18	SOURCES OF NOISE	256
	Introduction—Thermal or Johnson Noise—Shot Noise— Equivalent Noise Resistance—Partition Noise	
19	NOISE IN CAMERA HEAD AMPLIFIERS	260
	Introduction—Noise Sources—Camera Tube Output Coupling	
	INDEX	269

PREFACE

THIS is the second volume of a textbook on television engineering written primarily for the engineering staff of the British Broadcasting Corporation and intended to provide a comprehensive survey of modern television principles.

This volume describes the fundamental principles of video-frequency amplifiers and examines the factors which limit their performance at the extremes of the passband. A wide variety of circuits is described and particular attention is paid to the use of feedback. There is a section dealing with the special problems of camera-head amplifiers.

Because of the nature of the subject, the text is necessarily more mathematical than in Volume 1 but, whenever possible, self-contained mathematical derivations have been included as appendices at the ends of the chapters.

The text of the present volume was written by S. W. Amos, B.Sc., A.M.I.E.E., of the Engineering Training Department, in collaboration with D. C. Birkinshaw, M.B.E., M.A., M.I.E.E., Superintendent Engineer, Television, and is based on an internal BBC manual written by the same authors in collaboration with J. L. Bliss, A.M.I.E.E., of the Designs Department. This volume was edited by L. F. Ostler, Assoc. I.E.E., of the Engineering Training Department.

PRINCIPAL SYMBOLS USED

A	(i) In general, gain of an amplifier (ii) Internal gain of a feedback amplifier
A'	External gain of a feedback amplifier
A_{hf}, A_{mf}, A_{lf}	Gain of an amplifier at high, medium and low frequencies respectively
$A_{hf}', A_{mf}', A_{lf}'$	External gain of a feedback amplifier at high, medium and low frequencies respectively
A_{max}	Maximum value of gain
C	Capacitance
C_b	Capacitance decoupling bias resistor
C_f	Anode-decoupling capacitance
C_{fb}	Capacitance in feedback circuit
C_g	Grid-coupling capacitance
C_i	Input capacitance of a valve
C_k	Capacitance in cathode circuit
C_o	Output capacitance of a valve
C_{sg}	Screen-grid decoupling capacitance
C_t	Total shunt capacitance at anode of a valve
C_t'	Effective value of C_t when feedback is applied
D	Delay
F	Passband of an amplifier
G_m	Change in screen-grid current per volt change in control-grid voltage
G_{sg}	Change in screen-grid current per volt change in screen-grid voltage
I	Current
I_a	Anode current
I_{ns}	Current due to shot effect
I_g	Screen-grid current
K	Ratio of C_i to C_t
L	(i) In general, inductance (ii) Number of lines per picture
L_a	Inductance values used in anode line of a distributed amplifier
L_g	Inductance values used in grid line of a distributed amplifier
R	Resistance
R_a	Anode load resistance
R_a'	Resistance of R_a and R_f in parallel
R_b	Bias resistance
R_c	(i) Terminating resistance of network or line (ii) Resistance in parallel with C_g in d.c.-coupled circuit
R_f	Anode-decoupling resistance
R_{fb}	Resistance in feedback circuit
R_g	Grid resistance
R_k	Cathode resistance
R_k'	Resistance of R_k and r_k in parallel

PRINCIPAL SYMBOLS USED

R_l	Load resistance for camera tube
R_n	(i) Equivalent noise resistance of a valve (ii) Reduced value of anode load resistance in a multi-valve amplifier to keep the bandwidth the same as that of a single stage
R_{sg}	External resistance in screen-grid circuit of a valve
R_{sg}'	Resistance of R_{sg} and r_{sg} in parallel
T	Periodic time of an oscillation
V	Voltage
V_{ak}	Anode-cathode voltage
V_{fb}	Feedback voltage
V_{gk}	Grid-cathode voltage
V_{in}	Input voltage
V_n	Noise voltage
V_o	Initial voltage
V_{out}	Output voltage
V_{sgk}	Screen grid-cathode voltage
V_t	Voltage after a time t
Z	Impedance
Z_a	Impedance in anode circuit of a valve
Z_{fb}	Impedance in feedback circuit
Z_k	Impedance in cathode circuit of a valve
Z_L	Load impedance
Z_{oc}	Input impedance of a network when the output is open-circuited
Z_{sc}	Input impedance of a network when the output is short-circuited
Z_{sg}	Impedance of the screen-grid circuit of a valve
a	Factor expressing the magnitude of the inductance in a shunt-inductance amplifier
c	Factor expressing the magnitude of the inductance in a series-inductance amplifier
f	Frequency
f_c	Cut-off frequency
f_g	Frequency at which the reactance of C_g equals R_g
f_k	Frequency at which the reactance of C_k equals R_k'
f_o	Turnover frequency, i.e. frequency at which the reactance of C_t equals R_a
f_{max}	(i) In general, maximum frequency (ii) Frequency at which the gain of a valve falls to unity
f_r	Resonance frequency of series and parallel LC circuits in phase equaliser
f_{sg}	Frequency at which the reactance of C_{sg} equals R_{sg}'
g_m	Mutual conductance of a valve, i.e. change in anode current per volt change in grid voltage
g_m'	Effective value of g_m when feedback is applied
g_s	Change in anode current per volt change in screen-grid voltage
m	Ratio of the two inductance values in phase equaliser
n	Number of stages in multi-valve video-frequency amplifier

PRINCIPAL SYMBOLS USED

ρ	Factor equal to R_f/R_a or $g_m R_k$
r_a	Anode a.c. resistance of a valve
r_k	Internal cathode resistance of a valve ($= 1/g_m$)
r_{sg}	Screen-grid a.c. resistance of a valve
t	(i) Time in general (ii) Rise time of a pulse
x	Normalised frequency in amplifiers, i.e. variable directly proportional to frequency ($=f/f_0$)
y	Variable inversely proportional to frequency ($=f_0/f$)
z	Normalised frequency in phase equalisers, i.e. variable directly proportional to frequency ($=f/f_T$)
α	Real part of feedback fraction
β	Fraction of output voltage fed back ($=V_{fb}/V_{out}$)
γ	Imaginary part of feedback fraction
μ	Amplification factor of a valve
ϕ	Phase shift
ω	Angular frequency ($=2\pi f$)
ω_g	Angular frequency at which the reactance of C_g equals R_g
ω_k	Angular frequency at which the reactance of C_k equals R_k'
ω_n	Angular turnover frequency, i.e. frequency at which the reactance of C_t equals R_a
ω_r	Angular resonance frequency of series and parallel LC circuits in phase equaliser
ω_{sg}	Angular frequency at which the reactance of C_{sg} equals R_{sg}'

PART I: FUNDAMENTAL PRINCIPLES OF VIDEO-FREQUENCY AMPLIFICATION

CHAPTER 1

AMPLITUDE AND PHASE CHARACTERISTICS

1.1 INTRODUCTION

IN Volume 1 the fundamental nature of the television waveform is described and it is shown to contain a number of frequencies which, in the British system, occupy the range from zero to 3 Mc/s. We shall now consider the problem of amplifying television signals and will show that the amplifiers used for this purpose (termed video-frequency amplifiers) must have a level amplitude-frequency response over this band and, in addition, must have a phase-frequency response which satisfies certain stringent requirements.

1.2 FREQUENCY RANGE OCCUPIED BY VIDEO SIGNAL

Although the frequency components of a picture signal occupy a wide frequency band, the spectrum is not continuous, the components being spaced at intervals as shown in Fig. 1, which represents the spectrum of a stationary picture.

As indicated, there is a strong component at line frequency (taken as 10 kc/s) and components at multiples of this frequency. There is also a strong component at frame frequency (50 c/s) and components at multiples of this frequency. If there are details which are scanned in one frame but not in the next there is, in addition, a component at the picture frequency (25 c/s). Finally there is a zero-frequency component representing the average brightness of the picture. The amplitudes of the various components depend on the composition of the picture, and if there are a number of large areas of substantially uniform tonal value, the low-frequency harmonics are pronounced but if there is a wealth of fine detail the high-frequency harmonics are pronounced.

If the picture contains movement, the spectrum becomes more complex due to the addition of further components. In effect,

some of the components corresponding to the stationary picture develop systems of sidebands symmetrically disposed about the frequency of the component.

Although theoretically the harmonics of the line and frame frequencies extend to an infinite frequency, it is impossible to transmit such a wide spectrum and no signals are transmitted above a certain

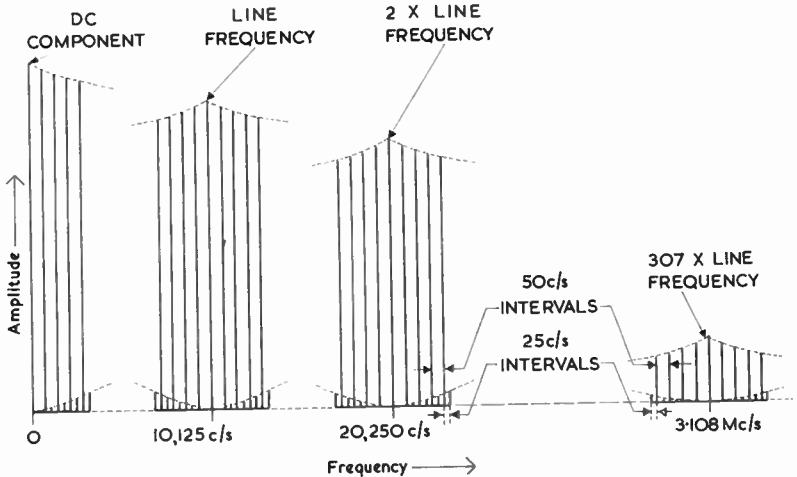

Fig. 1—Typical spectrum of the picture signal of a stationary scene

upper-frequency limit. In Volume 1 it was shown that a practical upper limit for the video-frequency bandwidth of a television system is given by the expression

$$f_{max} = \frac{a(L - S_p)}{2(T_l - S_l)} \dots \dots \dots (1)$$

- in which a = observed aspect ratio,
- L = number of lines per picture,
- S_p = total number of lines per picture suppressed by the frame-suppression periods,
- T_l = time of one line,
- S_l = line-suppression period.

The derivation of expression (1) is given on p. 25 of Volume 1. In the British television system $a = 4/3$, $L = 405$, $S_p = 28$, $T_l = 98.7 \mu\text{sec}$ and $S_l = 18 \mu\text{sec}$, giving an upper frequency limit of 3.11 Mc/s. This implies that the highest harmonic of the line frequency

AMPLITUDE AND PHASE CHARACTERISTICS

(10·125 kc/s) present in the video signal is the 307th corresponding to a frequency of 3·108 Mc/s.

The video waveform contains sync signals in addition to picture signals and these also occupy a certain frequency band. The spectrum of the sync signals is similar to that of a picture signal; in fact the waveform of the line-sync signal is such that if it were applied to the input of a cathode-ray tube during the normal scanning period it would produce on the screen a vertical black bar with sharply defined edges. Similarly the waveform of the frame-sync signal is such as to produce a horizontal black bar. It follows that the sync signals also have frequency components which are multiples of the frame and line frequencies and theoretically extend to an infinite frequency. In practice the harmonics need only extend to a certain upper frequency limit, the value of which can be assessed by considering the purpose of these signals. They are required to synchronise pulse generators and for this purpose the most important property of the sync signals is the time of rise of the leading edge which should be short to ensure precise operation of the generators.

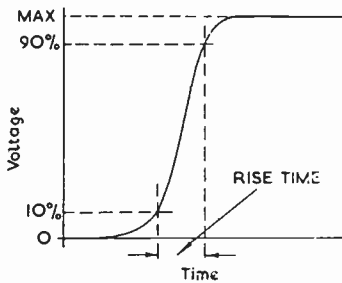

Fig. 2—Rise time of a pulse

The meaning of *rise time* is illustrated in Fig. 2; it is defined as the time taken for the amplitude of a pulse to rise from 10 per cent to 90 per cent of its final value and it is related to the frequency range according to the expression.

$$f = \frac{1}{2t} \dots \dots \dots (2)$$

in which f = uppermost frequency
 t = rise time of the pulse.

If the pulses were truly rectangular, the rise time would be zero and the frequency range occupied by the pulse spectrum would extend to infinity. In practice rise times must be finite because of the limited passband and in the line-sync pulses in the British television system the rise time is 0·2 μ sec which, from (2), corresponds to a frequency limit of 2·5 Mc/s.

Summarising the previous few paragraphs, we may say that an amplifier to reproduce the picture signal without distortion must have a satisfactory frequency response extending from zero frequency to 3 Mc/s, approximately. Any amplifier with such a response is also capable of amplifying sync signals without distortion.

1.3 RELATIONSHIP BETWEEN PHASE AND TIME

The phase response of a video-frequency amplifier is quite as important as its frequency response because deficiencies in either can cause distortion of the picture. In the circuits normally used in amplifiers, attenuation and phase distortion usually occur together but there are certain types of circuit in which phase distortion alone occurs.

Any deficiencies in frequency response can be made good by the use of compensating networks in the amplifier but these inevitably introduce phase distortion. The latter can be reduced by the inclusion of some of the specialised networks mentioned above; these, if properly designed, do not affect the frequency response but give phase distortion offsetting that introduced by the amplifier; such networks, known as *phase equalisers*, are extensively employed.

The concept of phase is important in television engineering because it is a method of stating time. It is essential, to avoid distortion, that details should be displayed at the right *places* in a reproduced picture and this necessitates the arrival of the video signals representing details at the right *time* to enable the details to take up their correct positions in each horizontal and vertical scan.

If a signal of frequency f is applied to an amplifier, the output has the same frequency but is not, in general, in phase with the input. This is because the signal takes a finite time, usually termed *delay*, to pass through the amplifier. It is immaterial whether this phenomenon is expressed in terms of the phase lag of the output relative to the input signal or as a time delay because these two quantities are related by the following simple expression.

If the output signal lags on the input signal by ϕ_a^0 , the phase lag is $\phi_a/360$ of a cycle equivalent to

$$\frac{\phi_a T}{360} \text{ sec}$$

where T is the time of one cycle. The periodic time T is given by $1/f$, f being the frequency of the signal. Thus

$$\text{delay} = D = \frac{\phi_a}{360f} \text{ sec}$$

If the phase shift is ϕ_r radians, the delay is $\phi_r/2\pi$ of a cycle equivalent to

AMPLITUDE AND PHASE CHARACTERISTICS

$$\frac{\phi_r T}{2\pi} \text{ sec}$$

Substituting $T = 1/f$ we have

$$\begin{aligned} \text{delay} = D &= \frac{\phi_r}{2\pi f} \\ &= \frac{\phi_r}{\omega} \text{ sec} \end{aligned}$$

Combining these two expressions for delay

$$D = \frac{\phi_r}{\omega} = \frac{\phi_d}{360f} * \dots \dots \dots (3)$$

- in which D = delay in seconds,
- ϕ_r = phase lag in radians,
- ϕ_d = phase lag in degrees,
- ω = angular frequency in radians per second,
- and f = frequency in cycles per second.

For a single-frequency signal the delay is of no particular significance but video signals have a large number of harmonics all of which should take the same time to pass through the amplifier, i.e., delay should be independent of frequency. From (3) this requires that the phase lag in the amplifier should be proportional to frequency.

Any departure from strict proportionality between phase angle and frequency implies a variation of delay with frequency and causes distortion known as *phase distortion* or *delay distortion*. Delay in itself does not imply distortion.

Summarising, to avoid distortion a video-frequency amplifier should have a level frequency response and phase shift proportional to frequency over the entire video band.

In general, when the scanning agent in a television system moves along a scanning line it encounters a number of picture details each with its particular value of brightness. The picture signal generated as a result of this scan has a number of different levels corresponding to the tonal values of the elements as shown in Fig. 3.

If two neighbouring elements have markedly different brightnesses, corresponding to a sharp vertical edge in the picture, the video signal

* In this expression the phase lag ϕ must be positive to give a positive delay because f is necessarily a positive quantity. It is unfortunate that this does not agree with the convention usually adopted in vector diagrams. In such diagrams vectors are assumed to rotate in an anticlockwise direction and lagging phase angles have a negative sign. This sign should be ignored in calculations of delay.

TELEVISION ENGINEERING PRINCIPLES AND PRACTICE

contains a large and sudden change of level as shown in Fig. 4. Such a step signal is a *transient* and its frequency components extend over the whole frequency band from zero to infinity. For this reason such a signal is useful for test purposes, any short-comings in the frequency or the phase response of an amplifier causing dis-

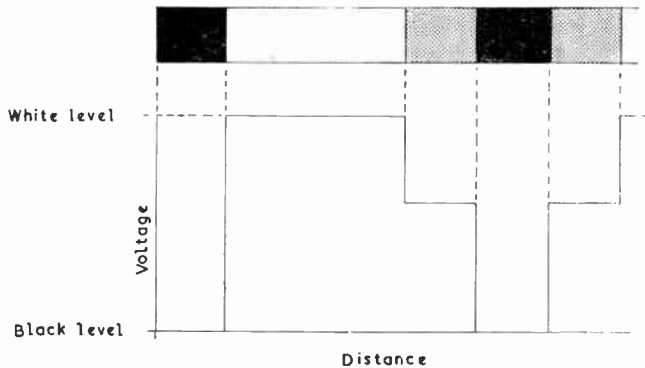

Fig. 3—Part of a line of a television picture and the corresponding video signal

tortion of the signal. In general, deficiencies in the response at frequencies well above the line frequency (say above approximately 100 kc/s) cause distortion of the vertical edge of the waveform whereas deficiencies at frequencies well below the line frequency (say about the frame frequency) cause distortion of the horizontal sections of

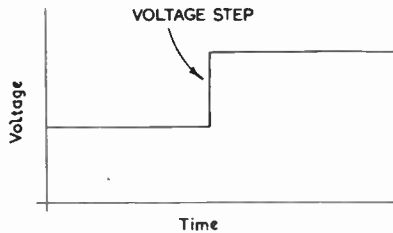

Fig. 4—An infinitely-steep transient

the waveform before and after the transition (see Fig. 5). Attenuation and phase distortion will now be considered in more detail.

1.4 ATTENUATION AND PHASE DISTORTION AT HIGH FREQUENCIES

If a transient such as that shown in Fig. 4 is applied to an amplifier having a level frequency response and zero phase shift over an infinite frequency band, there is no delay and the output transient

AMPLITUDE AND PHASE CHARACTERISTICS

is a perfect copy of the input, occurring coincidentally with it as shown in Fig. 6.

If the amplifier has a perfect frequency response and phase shift is proportional to frequency over an infinite bandwidth, the step

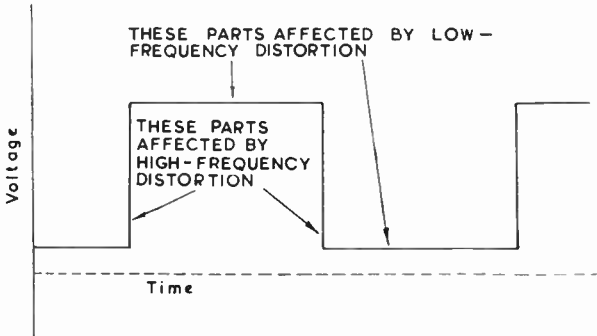
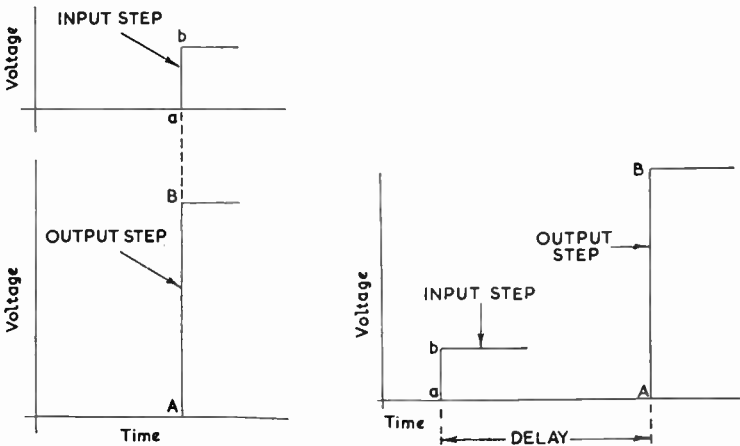

Fig. 5—Portions of a step waveform affected by attenuation and phase distortion at high and low frequencies



(Left) Fig. 6—Voltage step as reproduced by an amplifier with a level frequency response and zero phase shift over an infinite frequency range. (Right) Fig. 7—Voltage step as reproduced by an amplifier with a level frequency response and phase shift proportional to frequency over an infinite frequency range

waveform is reproduced as shown in Fig. 7; there is no distortion but the output is delayed by a time D after the input, D being related to the phase shift according to equation (3).

Figs. 6 and 7 both represent the performance of amplifiers with responses extending to an infinite frequency. This is an unattainable

ideal and in practical amplifiers attempts are made to secure a level frequency response and phase shift proportional to frequency up to the limit of the video band.

1.4.1 Rise Time

Fig. 8 illustrates the effect of passing the step wave of Fig. 4 through an amplifier with such a limited passband; it is assumed that the frequency response is perfect and that phase shift is strictly proportional to frequency over this band. The output pulse is delayed by an interval D , related to the phase shift as indicated in expression (3), and has a finite rise time (t), dependent upon the passband as indicated in expression (2).

If the passband of the amplifier includes the whole of the video-frequency band, the finite rise time of the output waveform will not

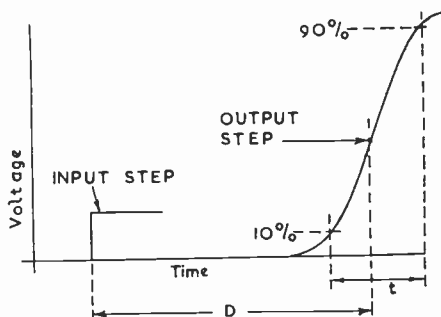

Fig. 8—A voltage step as reproduced by an amplifier with a level frequency response and phase shift proportional to frequency over a limited frequency range

obviously degrade the quality of reproduced pictures. Sometimes, however, the passband of the amplifier is not adequate and at the upper end of the video-frequency range the response falls off and proportionality between phase shift and frequency is no longer maintained. As a result picture components above, say 2 Mc/s. may be delayed with respect to those around 100 kc/s. A step wave reproduced by such an amplifier has an appearance similar to that shown in Fig. 8. Because of the restricted passband the rise time is now long enough to have an appreciable effect on picture quality. This is illustrated in Fig. 9 which should be compared with Fig. 10 which shows a substantially undistorted reproduction of the same test card. In Fig. 9 there is a loss of fine detail and a lack of sharpness of vertical edges, the overall effect being that of a blurred picture.

1.4.4 Ringing

If the correction circuits included in an amplifier to extend the frequency response give a sharp cut-off at the upper-frequency limit of the passband, the effect shown in Fig. 15, known as *ringing*, may

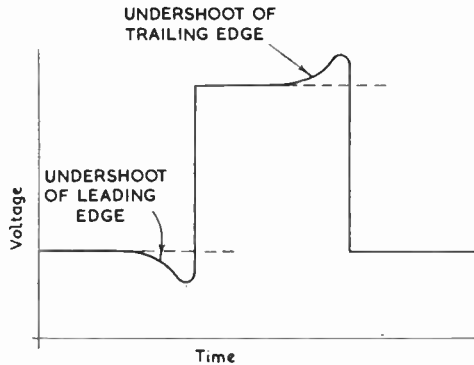

Fig. 14—Waveform of a pulse with undershoot of the leading and trailing edges

be produced. This may be regarded as an extreme form of overshoot in which the transient overshwing persists as a damped oscillation. Alternatively overshoot may be regarded as ringing in which the oscillation is critically damped.

The effect of ringing on a picture is illustrated in Fig. 16. Vertical edges are reproduced with vertical black and white bars to the right, the bars becoming fainter as their distance from the edge increases.

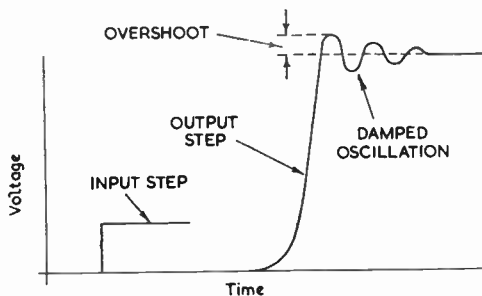

Fig. 15—Input and output waveforms for an amplifier giving transient oscillations after transition

The effect of ringing on a reproduced image can be made negligible if the frequency of the transient oscillations is made so high and their amplitude so small that they cannot be properly reproduced

AMPLITUDE AND PHASE CHARACTERISTICS

1.4.2 *Overshoot*

The performance of the amplifier can be improved by including in it certain circuits, described later, which have the effect of levelling the frequency response at the upper end of the video band. Although these have the beneficial effect of decreasing the rise time, thus improving definition, the consequent disturbance of the phase relationships frequently causes the phenomenon of *overshoot* illustrated in Fig. 11. This is an effect which can be compared with that of inertia in mechanical systems and causes the voltage, after executing the transient, to exceed momentarily the final steady value.

The effect of overshoot on a reproduced picture is illustrated in Fig. 12. Although the definition is better than that in Fig. 9, the

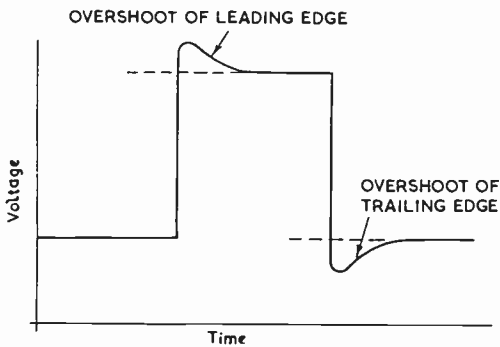

Fig. 13—Waveform of a pulse with overshoot of the leading and trailing edges

picture is marred by white borders on the right-hand side of black vertical lines and black borders following white lines.

Overshoot may be defined as a momentary exaggeration of the amplitude of a step signal in which the exaggeration is in the same direction as the step. When it occurs on the leading and trailing edges of a pulse, the reproduced signal has the form shown in Fig. 13.

1.4.3 *Undershoot*

Sometimes in the reproduction of a step signal, there is a momentary exaggeration of the amplitude in which the increase in amplitude is in the opposite direction to the step and occurs before it. This is known as *undershoot* and is illustrated in Fig. 14 which shows undershoot of the leading and trailing edges of a pulse.

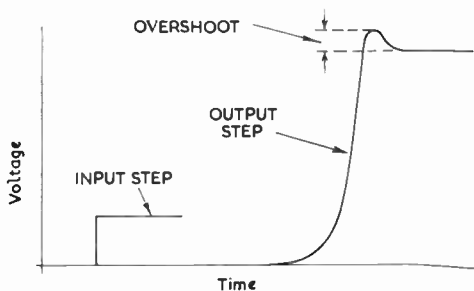

Fig. 11—Step voltage as reproduced by an amplifier with overshoot

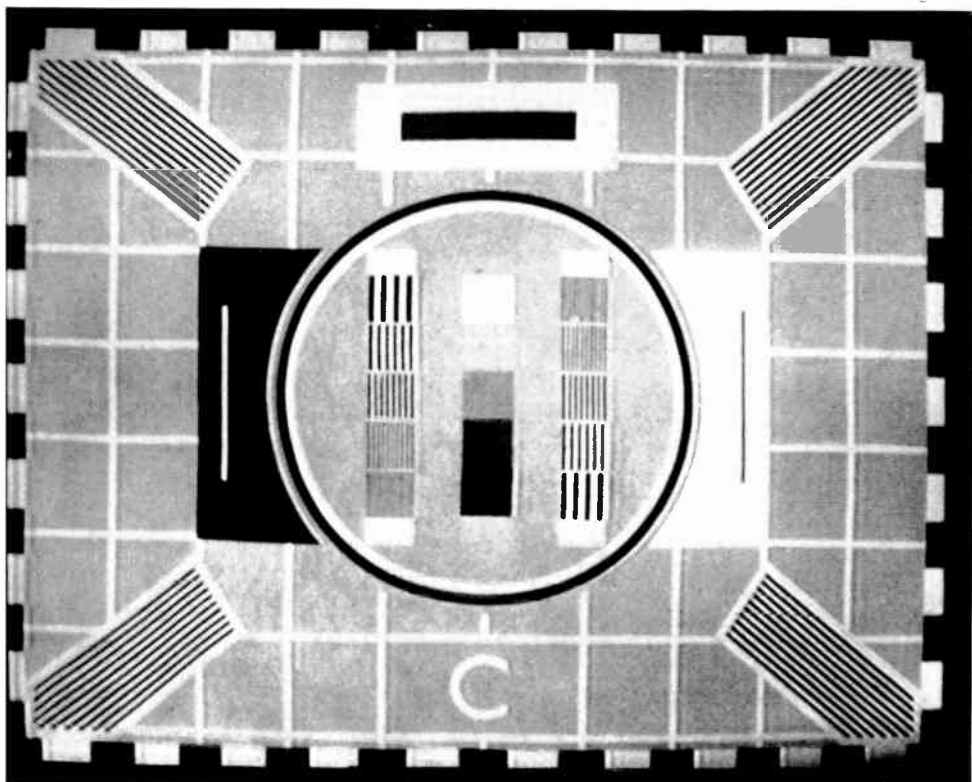
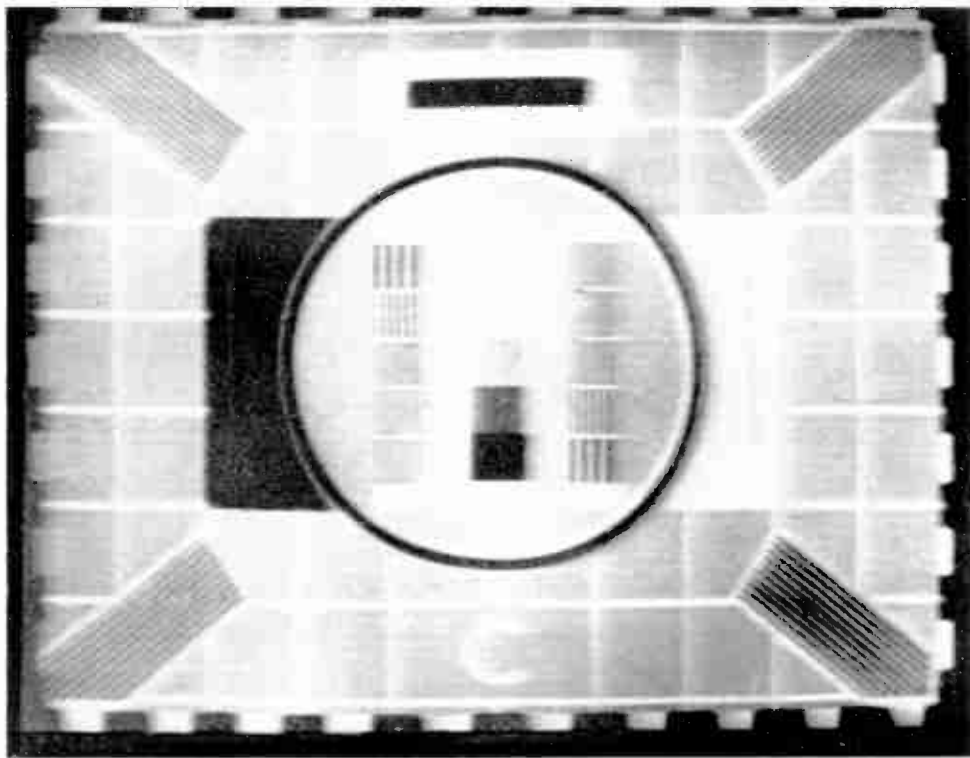
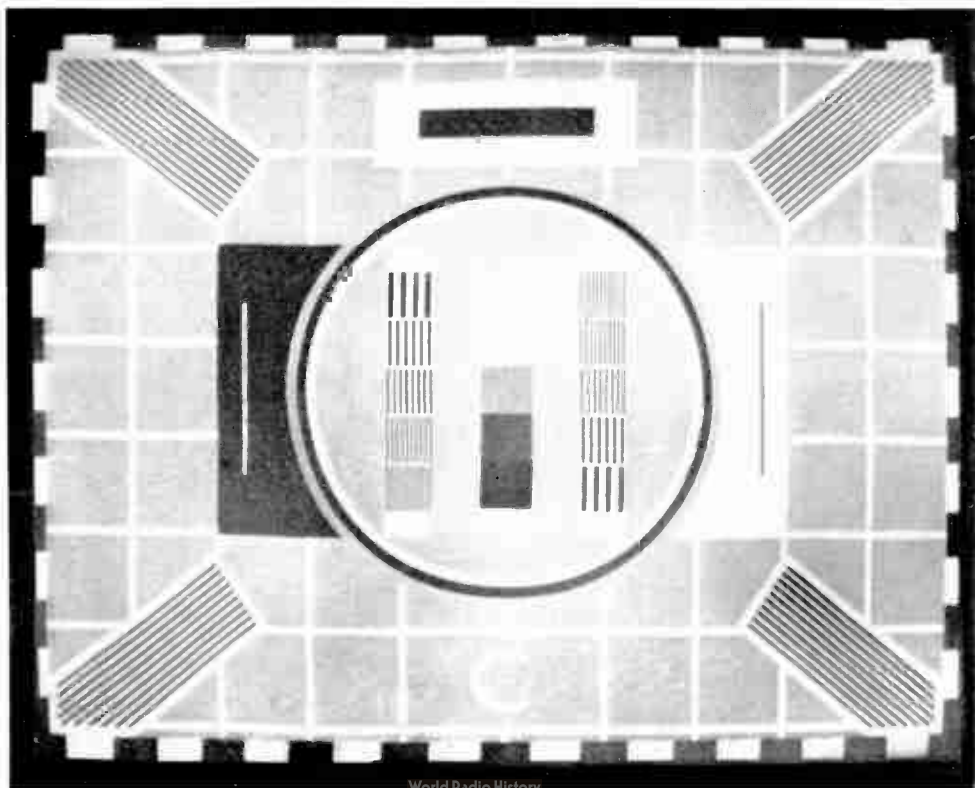

Fig. 12—Image of test card C as reproduced by a video-frequency amplifier giving overshoot at high frequencies



(Above) Fig. 9—An image of test card C as reproduced by a video-frequency amplifier with phase lag and amplitude loss at high frequencies. (Below) Fig. 10—An image of test card C as reproduced by a video-frequency amplifier which is reasonably free from distortion



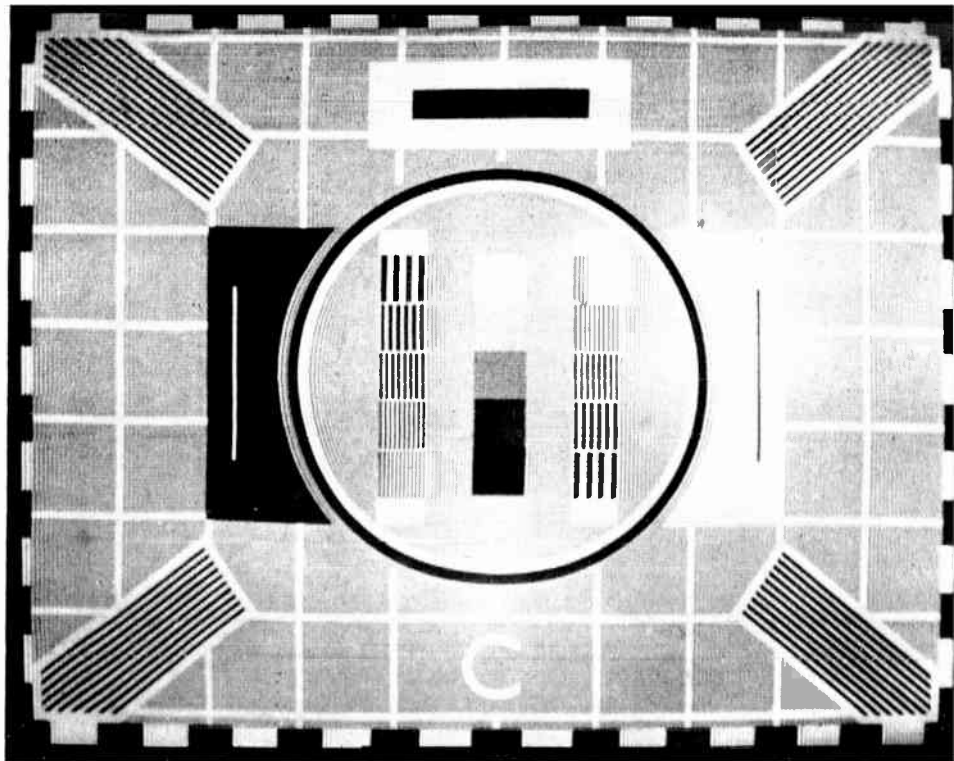

Fig. 16—An image of test card C as reproduced by a video-frequency amplifier in which there is "ringing"

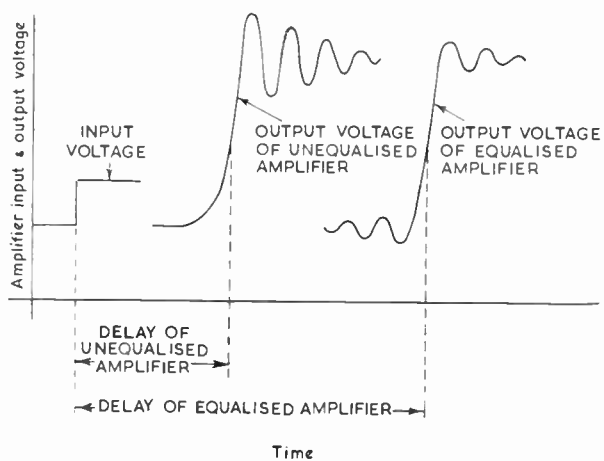
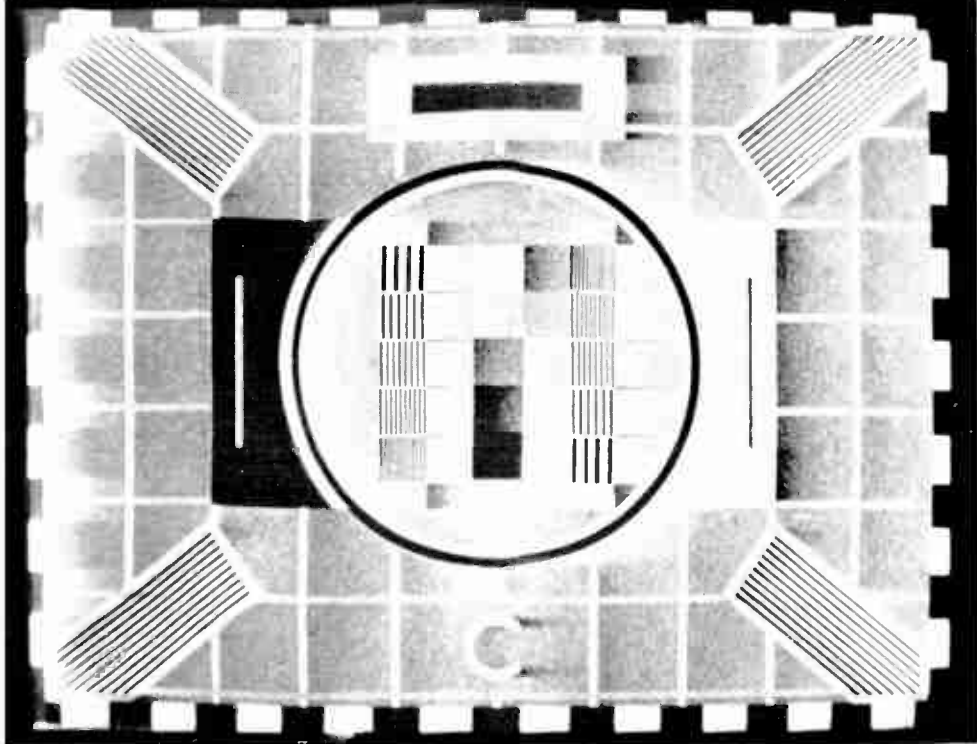
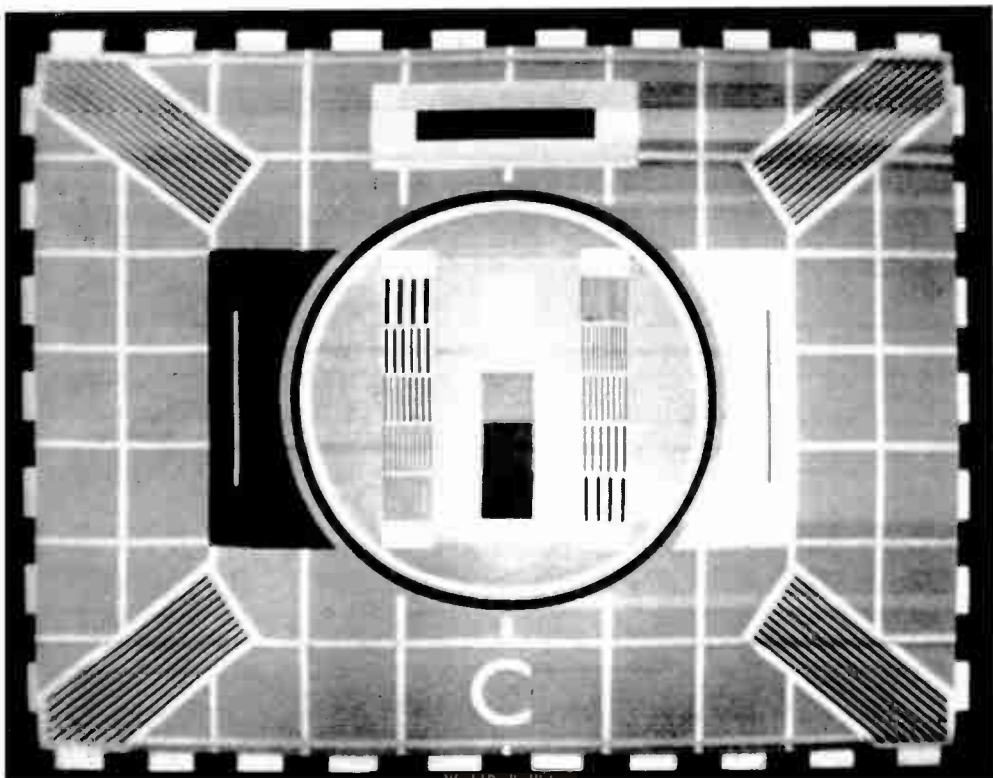

Fig. 17—Effect of phase equalisation on the response of amplifier to a voltage step input



(Above) Fig. 18—An image of test card C as reproduced by a video-frequency amplifier giving short-term streaking. (Below) Fig. 19—Image of test card C as reproduced by a video-frequency amplifier giving long-term streaking



AMPLITUDE AND PHASE CHARACTERISTICS

because of the aperture distortion of the scanning beam; the initial overshoot may even improve reproduction by exaggerating the contrast of the step signal.

The phase disturbance caused by a correcting circuit in an amplifier may be reduced by use of a phase equaliser and Fig. 17 illustrates the effect of such an equaliser. The overall delay of the amplifier is increased but the amplitude of the transient oscillations after the transition, and the rise time, are both reduced. The equaliser also has the effect of introducing transient oscillations *before* the transition.

1.5 ATTENUATION AND PHASE DISTORTION AT MIDDLE FREQUENCIES

1.5.1 *Streaking*

Attenuation and phase distortion can also occur at much lower frequencies, e.g. of the order of the line frequency. Signals at such frequencies have an appreciable variation in value during the line period and the effect of distortion is to cause irregularities in background tone along the scanning lines. Such distortion causes incorrect illumination of elements immediately following details in the scene. Fig. 18 illustrates the effect of overshoot at such frequencies; every important black area is followed by a white streak and every white area by a black streak. In Fig. 18 the streaks are of relatively short duration, lasting for a fraction of a line length, but it is possible for the streaks to last longer than this. They may equal or exceed the line length, giving streaks right across the picture, as shown in Fig. 19.

The streaks illustrated in Figs. 18 and 19 were produced by attenuation and phase distortion in an amplifier but similar effects can be produced by other causes. Streaks can be obtained, for example, from overloading of amplifiers and as a result of the afterglow in a flying-spot scanner.

1.6 ATTENUATION AND PHASE DISTORTION AT LOW FREQUENCIES

Attenuation and phase distortion commonly occur at frame frequency or below, picture components being advanced or retarded in phase with respect to signals at say 100 kc/s. The line period represents such a small fraction of a cycle at such low frequencies that there is practically no change in tonal value during a period. Low-frequency components thus have little effect on picture definition and can only affect the tonal value of the picture over a ~~line~~ ^{frame} of several lines. In other words these components control the background tone of the picture and when distorted they cause irregularities of shading from the top to the bottom of the picture.

Since low-frequency components are not concerned with details of the picture, the type of distortion caused by low-frequency deficiencies in an amplifier can most easily be appreciated by considering the reproduction of a scene without detail, for example a uniform white area. The video-frequency signal generated by scanning such a scene has a uniform level which is interrupted by the sync signals as shown in Fig. 20 (a). This illustrates a sample of the signal taken over a period of a few lines.

1.6.1 Sag

If the amplifier has a falling frequency response and a leading phase angle at low frequencies (as frequently occurs) such a video signal is reproduced as shown in Fig. 20 (b). Although the signal level does not change appreciably during the period of any particular line, there is a gradual drift towards black over the duration of a

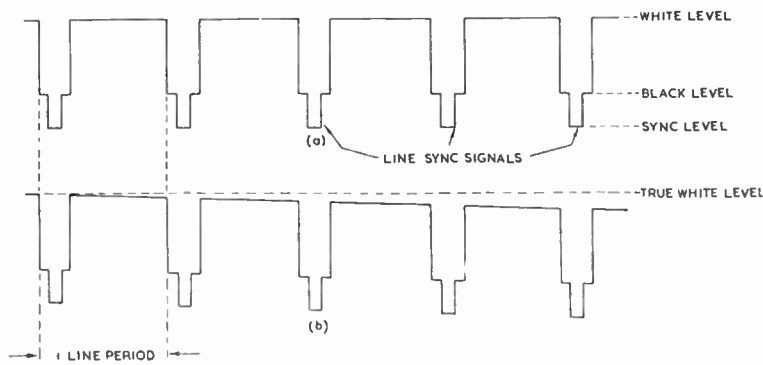
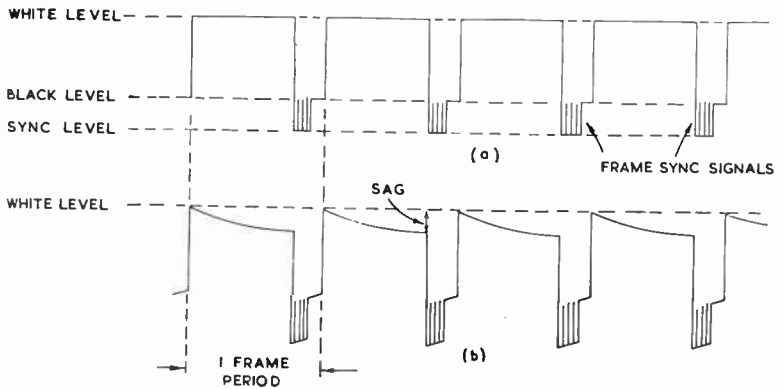

Fig. 20—Video signal corresponding to a uniform white scene over several line periods (a) undistorted and (b) after distortion in an amplifier with amplitude loss and a leading phase angle at low frequencies

number of lines. The precise form of the distorted waveform is perhaps better illustrated in Fig. 21. The wave shown at (a) is that corresponding to a uniform white scene over a period of several frames; line-sync signals are omitted for sake of clarity and the frame-sync signals and frame-suppression periods are shown in diagrammatic form only. After distortion by the amplifier the wave has the form shown at (b).

It is assumed that the high-frequency response of the amplifier is perfect and thus the vertical edges of the wave are perfectly reproduced. There is a *sag* in those parts of the wave which should be horizontal, these curves being, in fact, exponential. The picture corresponding to the waveform of Fig. 21 (b) is white at the top but



(Above) Fig. 21—Video signal corresponding to a uniform white scene over several frame periods (a) undistorted and (b) after distortion in an amplifier with amplitude loss and a leading phase angle at low frequencies

(Below) Fig. 22—Image of test card C as reproduced by a video-frequency amplifier with distortion at frame frequency

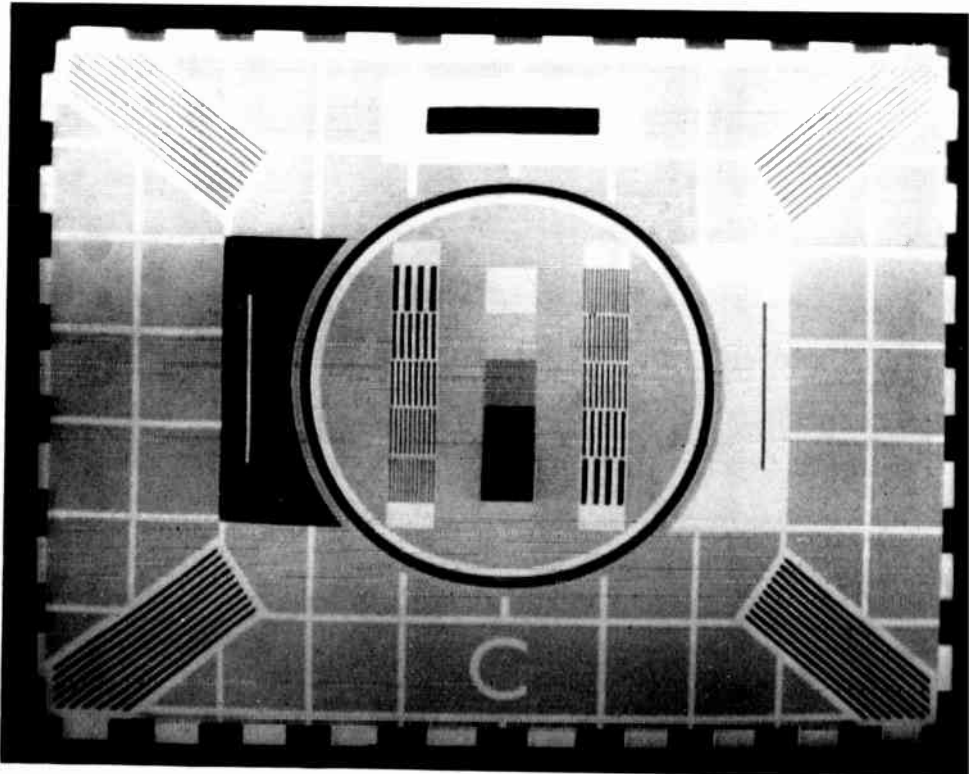

AMPLITUDE AND PHASE CHARACTERISTICS

gradually shades to grey at the bottom. Although this effect has been described in respect of a uniform white scene, it occurs no matter what the nature of the scene and the variation in background shading is superimposed on any details the picture contains. This is illustrated in Fig. 22.

1.7 SIGNAL INVERSION

When a signal is applied to the grid of an amplifying valve with a resistive load, the signal generated at the anode is inverted with respect to the input signal as shown in Fig. 23. This process has

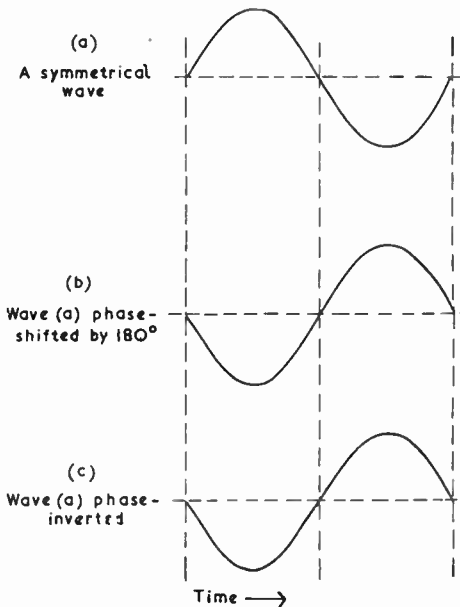

Fig. 23—A sine wave is shown at (a), the effect of phase-shifting it by 180° at (b), and inverting it at (c)

been described as phase-shifting the signal by 180° . This expression arose because, in the particular case of a sine wave, the processes of inversion and phase-shifting by 180° yield waveforms of the same shape, as illustrated in Fig. 23. The valve does not, in fact, introduce any phase shift; it cannot do so because, in an ideal valve, there is no inductance or capacitance to cause such phase shift. Moreover the action of a valve, at the frequencies with which we are concerned, may be considered as instantaneous; the output is not delayed to an extent equivalent to 180° phase shift.

These points are also illustrated in the waveforms of Fig. 24.

The wave shown at (a) is unsymmetrical and is of the general form of a video signal. At (b) is shown the effect of putting wave (a) through a device having phase shift proportional to frequency (to avoid distortion), the phase shift at the fundamental frequency of the wave being 180° . Wave (c) shows the output of a valve amplifier when input (a) is applied to the grid. The difference between (b) and (c) confirms the point made above that the valve cannot be regarded as a source of phase shift; its effect is simply to invert the wave without introducing time delay.

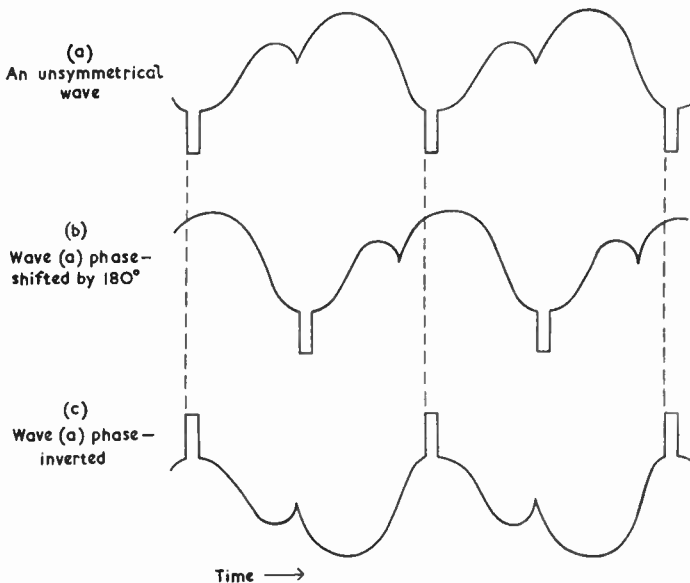

Fig. 24—An unsymmetrical wave is shown at (a), the effect of phase-shifting the fundamental component by 180° at (b), and of inverting it at (c)

The effect of adding a second valve amplifier is, of course, to restore the signal to its original (upright) form and, in general, we can say that the output signal of an amplifier with n amplifying stages of the conventional earthed-cathode type is inverted when n is odd and upright when n is even.

1.8 GROUP DELAY

To avoid distortion in a video-frequency amplifier, the phase shift must be proportional to frequency, this being the condition for constant delay at all frequencies, as described in 1.3. If the relationship between phase shift and frequency for such an amplifier

AMPLITUDE AND PHASE CHARACTERISTICS

is displayed graphically, it has the form of a straight line passing through the origin (Fig. 25). A feature of such a straight line is that its slope is constant at all points, being related to the delay thus

$$\tan \alpha = \frac{\phi}{\omega} = D \quad \dots \quad (4)$$

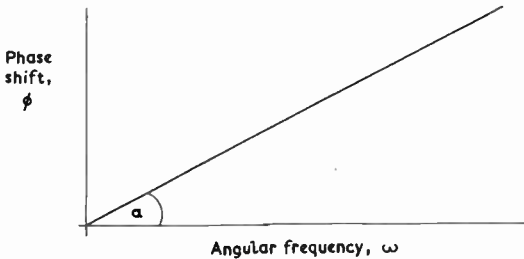

Fig. 25—Phase-frequency characteristic of an ideal amplifier

The phase-frequency curve for a real amplifier may take the form shown in Fig. 26. This is approximately linear for frequencies up to a certain value, indicating nearly constant delay and low distortion at such frequencies. Towards the upper end of the passband, however, the curve falls short of the ideal (shown dotted). A curve of this shape is typical of an amplifier having undesirably long rise times (Fig. 2) in its step response.

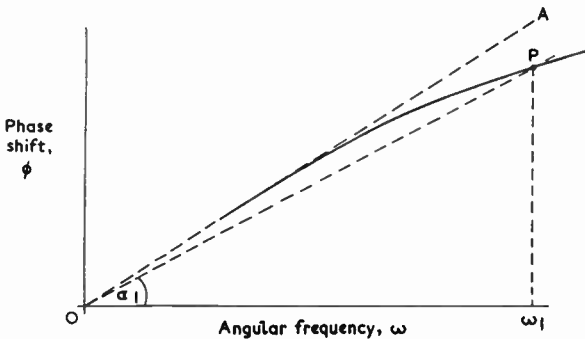

Fig. 26—One possible form for the phase-frequency characteristic of a practical amplifier

The delay of the amplifier is still given by expression (4), in which α is the slope of the chord from the origin to the curve which corresponds to the frequency in question (not the slope of the curve itself). For example, the delay at the angular frequency ω_1 in Fig. 26 is given by $\tan \alpha_1$ where α_1 is the slope of the chord OP. At high frequencies the slope of this chord is less than that of the

ideal straight line OA indicating that the delay is less at these than at lower frequencies, this implying distortion.

Another form the phase-frequency curve may take is that shown in Fig. 27; this is approximately linear up to a certain frequency but then departs from linearity, the curvature being of opposite

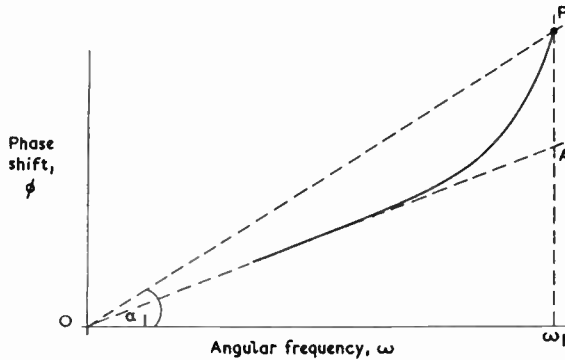

Fig. 27—Another form of a practical phase-frequency curve

sign to that of Fig. 26. A curve of this shape usually implies that the amplifier has overshoot (Fig. 11) in its step response. The delay at a high angular frequency ω_1 is given by $\tan \alpha_1$ where α_1 is the slope of the chord OP and this is greater than the delay at lower frequencies, implying the presence of distortion.

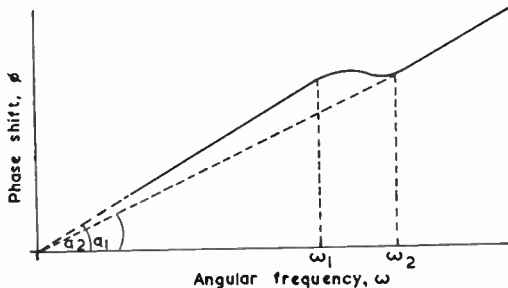

Fig. 28—Phase-frequency relationship of a type giving serious distortion but little variation in delay over the passband

If the amplifier introduces delay which varies over the passband, it inevitably distorts the waveform of complex signals passing through it. The variations in delay are not, however, a very sensitive indication of the seriousness of the distortion. For example, Fig. 28 shows a phase-frequency relationship which departs from strict proportionality quite markedly between the angular frequencies

AMPLITUDE AND PHASE CHARACTERISTICS

ω_1 and ω_2 . An amplifier with such a characteristic would give serious distortion even though the departure from linearity is confined to a small frequency range. There is, however, very little difference between the slopes α_1 and α_2 of the two chords which measure the time delay at the two frequencies. Even a small change in delay may indicate considerable distortion.

A more sensitive indication of the seriousness of any phase distortion is given by the slope of the curve itself, usually measured by the slope of the tangent to the curve at the point representing the frequency in question. In general, for a given non-linear curve, the slope of the tangent shows greater variations than the slope of the chord, particularly when the observations are taken over a restricted frequency range. In confirmation of this point, the slope of the chord in Fig. 28 varies from 1.2 at ω_1 to 1.0 at ω_2 , a change of 1 part in 5. The slope of the tangent is 1.2 at ω_1 and -0.35 at ω_2 , a much greater change.

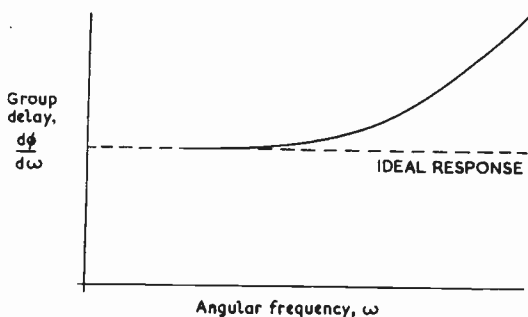

Fig. 29—Group-delay-frequency characteristic of an amplifier tending to give overshoot in its step response

The slope of the tangent is the *envelope delay* or *group delay* and is given by $d\phi/d\omega$. This should be compared with the delay D (known as the *absolute delay* or *total delay*) which, as already shown, is given by ϕ/ω . Group delay is so-called because it represents the delay of a small group of frequencies relative to that of frequencies immediately below the group.

For an ideal amplifier, group delay is constant, i.e. independent of frequency, as shown in the dotted lines in Figs. 29 and 30, the numerical value of the group delay being of no particular significance. If, however, the amplifier is imperfect, group delay departs from a constant value and the shape of the group-delay-frequency curve indicates the type of distortion introduced by the amplifier.

For example, if the group delay varies with frequency as in Fig. 29,

c 33

this indicates that the slope of the phase-frequency curve increases with frequency; the phase-frequency curve has the form shown in Fig. 27, which is that of an amplifier tending to produce overshoot in its response to a step input. If, on the other hand, the group delay-frequency curve has the form shown in Fig. 30, this indicates that the slope of the phase-frequency curve decreases with frequency.

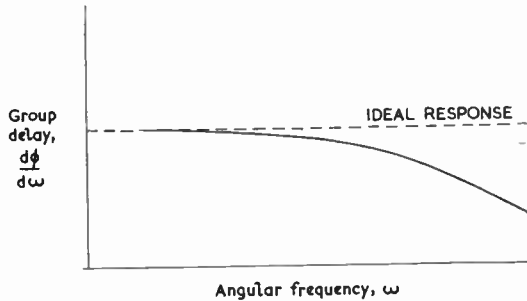

Fig. 30—Group-delay-frequency characteristic for an amplifier tending to give appreciable rise times in its step response

The shape of the corresponding phase-frequency curve is as shown in Fig. 26, which is that of an amplifier giving a slow build-up, i.e. appreciable rise time in its step response.

It is not impossible for a phase-frequency curve to have a region of negative slope; a characteristic with such a region is shown in Fig. 31. For such a curve the group delay has a negative value

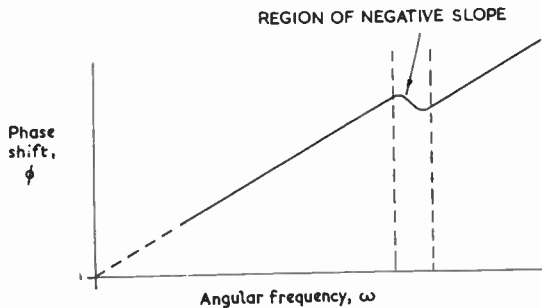

Fig. 31—A phase-frequency characteristic with a region of negative slope

over a limited frequency range. This does not imply that there is an absolute phase advance or that the output occurs before the input but that the delay for the band of frequencies for which $d\phi/d\omega$ is negative is less than for the frequencies immediately below.

AMPLITUDE AND PHASE CHARACTERISTICS

Measurements of phase response are not usually made at frequencies below a certain middle frequency such as 100 kc/s because the performance of an amplifier at such low frequencies is more easily assessed in other ways (e.g. by stating the sag in a reproduced square-wave testing signal). For this reason the phase-frequency characteristics in Figs. 26 to 31 are shown dotted over the low-frequency range.

Summarising the previous few pages, we may say that the conditions for distortionless video-frequency amplification are that the amplitude-frequency and the group delay-frequency curves should both be level over the video-frequency range.

In general, video-frequency amplifiers consist of two or more valves coupled by circuits containing inductance, capacitance and resistance. Some of these components control the frequency and phase response of the amplifier at the high-frequency end of the band whilst others control the low-frequency response. These two groups of components function to a large extent independently and it is possible to describe them separately. In Chapters 2-9 the various circuit techniques used to obtain the desired high-frequency response are described; those used to give the required low-frequency performance are considered in Chapters 10-14. An amplifying stage can incorporate any one of the high-frequency circuits together with any one of the low-frequency circuits, making possible a large number of different arrangements for each of the stages of a video-frequency amplifier.

APPENDIX A

TEST CARD C

The BBC test card C (Fig. 10) has been designed to give an indication of the performance of a television chain and includes the following patterns each intended to assess a particular characteristic of the system. Although the card serves as a good check on the performance of video-frequency amplifiers in the chain, many of the patterns are of course intended to test other aspects of the system.

1. *Aspect Ratio.* The concentric black and white circles surrounding the five-frequency gratings appear circular when the width and height of the picture are adjusted to give the standard aspect ratio of 4 : 3.

2. *Resolution and Bandwidth.* Within the circles there are two groups of frequency gratings each consisting of five gratings with vertical black and white stripes corresponding to fundamental frequencies of 1·0, 1·5, 2·0, 2·5 and 3·0 Mc/s. In the left-hand group the 1·0 Mc/s grating is at the top, the frequency increasing towards the bottom and in the right-hand group the order is reversed.
3. *Contrast.* At the centre of the card is a 5-step contrast wedge of which the top square is white and the lowest black. The three intermediate squares should be reproduced as pale, medium and dark grey.
4. *Scanning Linearity.* The background of the card is a middle grey and has a network of white lines. The areas enclosed between the lines should be reproduced as equal squares.
5. *Separation of Picture and Sync Signals.* The border of the test card consists of alternate black and white rectangles. If the reproducing equipment does not separate picture and sync signals properly, this chequer board will show up the defect.
6. *Low-frequency Response.* At the top centre of the card is a black rectangle within a white rectangle; in a perfect system this is reproduced as a rectangle of uniform black on a clean background. Any streaking in the system will show up against this white ground.
7. *Reflections.* Reflections may occur in propagation or in the receiving installation and are indicated by two single vertical bars, one white on a black ground and the other black on a white ground which should be reproduced without images on the right-hand sides. These bars also show up overshoot or undershoot.
8. *Uniformity of Focus.* In the corners of the card are sets of diagonally-disposed black and white stripes corresponding to a frequency of approximately 1 Mc/s. All four sets should be uniformly resolved.

PART II: VIDEO-FREQUENCY AMPLIFICATION: HIGH-FREQUENCY CONSIDERATIONS

CHAPTER 2

SIMPLE RC-COUPLED CIRCUIT

2.1 INTRODUCTION

THE simplest type of amplifier which can be used for video amplification is the simple RC-coupled amplifier, the circuit of which is given in Fig. 32. This diagram illustrates the principal components required in such an amplifier but does not indicate all the components that exist in the circuit and which can affect the high-frequency performance. For example, Fig. 32 does not show the capacitance between the anode of the valve and h.t. negative:

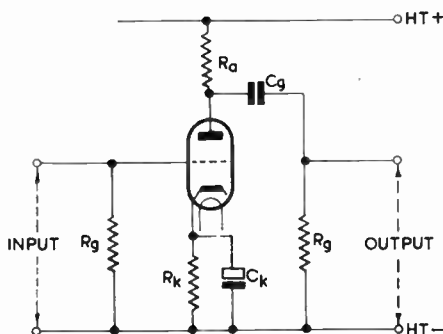

Fig. 32—Fundamental circuit of RC-coupled amplifier

this capacitance is important because it is effectively in parallel with the anode-load resistor R_a and controls the frequency and phase response of the amplifier at high frequencies.

2.2 SOURCES OF SHUNT CAPACITANCE

The total capacitance C_t in parallel with R_a has a number of sources but the principal ones are indicated by the dotted lines in Fig. 33 (in which the valves may be pentodes). These are:

- (a) The output capacitance C_o of valve V1. This is composed

of the anode-cathode, anode-suppressor grid and anode-earth capacitances of the valve but the valve-holder and associated wiring also make a contribution.

- (b) The input capacitance C_i of valve V2. For a pentode of the type commonly used in video amplifiers this is chiefly the grid-cathode capacitance c_{gk} and control grid-screen grid capacitance c_{g1g2} of the valve. For a triode valve, however, the input capacitance can be many times the physical grid-cathode capacitance because of feedback, known as *Miller effect*, from the anode circuit to the grid circuit via the anode-grid capacitance c_{ag} . For a pentode c_{ag} is commonly 1/1,000th of that for a triode and Miller effect need not usually be taken into account in video amplifiers employing pentodes.

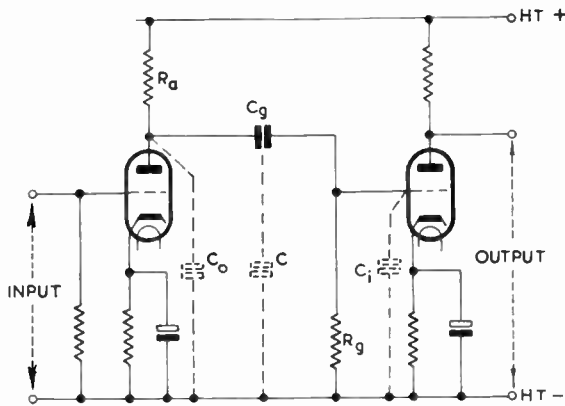

Fig. 33—Chief sources of capacitance shunting the anode resistor of an RC-coupled amplifier

- (c) The capacitance C of the coupling capacitor C_g to h.t. negative. C_g is commonly $0.1 \mu\text{F}$ but is sometimes as large as $1 \mu\text{F}$. Such capacitors must generally be rated to stand 350 volts and are large enough physically to have a capacitance of several picofarads to h.t. negative.

The total shunt capacitance C_t can therefore be expressed as the sum of the above sources thus:

$$C_t = C_o + C_i + C \dots \dots \dots (5)$$

2.3 EFFECT OF SHUNT CAPACITANCE ON FREQUENCY RESPONSE

Fig. 34 shows the complete circuit of a stage of RC-coupled amplification which employs a pentode valve. At middle frequencies

SIMPLE RC-COUPLED CIRCUIT

such as 100 kc/s the reactance of the anode-decoupling capacitor C_f (which is in series with R_a) is negligible compared with R_a . Moreover, the reactance of C_t , which is in parallel with R_a , is very large compared with R_a . Thus R_a is the effective anode load and the gain is approximately $g_m R_a$. As frequency is increased the reactance of C_t falls and becomes comparable with R_a , reducing the effective value of anode load and the gain. At still higher frequencies the reactance of C_t becomes small compared with R_a , and $1/\omega C_t$ becomes the effective load. Since the load is now inversely proportional to frequency, the gain is also inversely proportional to frequency and the frequency-response curve at high frequencies falls at the rate of 6 db per octave. The ideal frequency response is, of course, a level one and the effect of shunt capacitance is

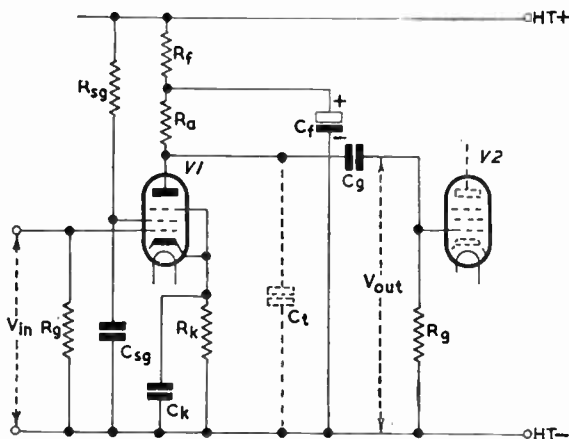

Fig. 34—RC-coupled amplifier with all decoupling components

undesirable. The circuits described subsequently are for the most part designed to offset the shunting effect of C_t and thus to extend the high-frequency response.

2.4 EFFECT OF SHUNT CAPACITANCE ON PHASE RESPONSE

The way in which the shunt capacitance affects the phase response is best illustrated by vector diagrams. At middle frequencies, where C_f and C_t both have negligible effects, the load is predominantly resistive and the phase relationship between grid potential, anode current and anode potential is as illustrated in Fig. 35. The alternating component of the anode current I_a is in phase with the grid-cathode voltage V_{gk} ; the alternating anode potential V_{ak} is in antiphase to the anode current and the grid voltage.

At high frequencies the reactance of C_t is comparable with R_a and the load is appreciably capacitive. The voltage generated across such a parallel RC network lags on the current passing through it and thus the output voltage of the RC-coupled amplifier at high frequencies lags relative to its phase for a resistive load. The vector diagram now has the form shown in Fig. 36. The dotted line represents the phase of the output voltage for a resistive load and V_{ak} indicates the phase for a capacitive load. The angle of lag is ϕ which varies from zero at middle frequencies to a maximum of 90° at very high frequencies.

If ϕ is proportional to frequency, this variation of phase angle is not important because it indicates delay, but not distortion, of

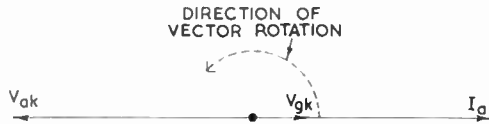

Fig. 35—Vector diagram illustrating the phase relationships in an RC-coupled amplifying stage at middle frequencies

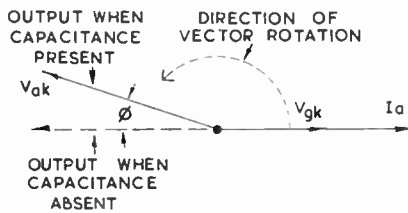

Fig. 36—Vector diagram illustrating the phase relationships in an RC-coupled amplifying stage at high frequencies

the signal. If, however, the relationship departs from proportionality, distortion is inevitable. The initial part of the ϕ - f curve for a simple RC-coupled amplifier is, in fact, a good approximation to the ideal straight line as shown in the following description.

2.5 GAIN

If the valve in Fig. 34 is replaced by its equivalent generator, the circuit has the form shown in Fig. 37(a) at high frequencies. The effective anode load is composed of R_a and C_t in parallel and is given by

$$Z_a = \frac{jR_a X_{ct}}{R_a + jX_{ct}}$$

SIMPLE RC-COUPLED CIRCUIT

where X_{ct} is the reactance of C_t . Replacing X_{ct} by $-1/\omega C_t$ and rearranging we have

$$Z_a = \frac{R_a}{1 + j\omega C_t R_a} \dots \dots \dots (6)$$

From Fig. 37(a) we have

$$I = \frac{\mu V_{gk}}{r_a + Z_a} \dots \dots \dots (7)$$

in which μ and r_a are, respectively, the amplification factor and anode a.c. resistance of the valve, and I is the alternating component of the anode current. Fig. 37(a) also shows that the output voltage V_{out} is given by

$$V_{out} = I Z_a \dots \dots \dots (8)$$

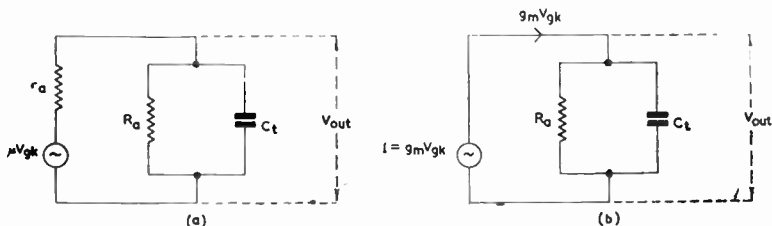

Fig. 37—The equivalent circuit of an RC-coupled stage with the valve regarded (a) as a constant-voltage generator and (b) as a constant-current generator

Combining (7) and (8) to obtain the gain A of the valve, we have

$$A = \frac{V_{out}}{V_{gk}} = \frac{\mu Z_a}{r_a + Z_a} \dots \dots \dots (9)$$

At low frequencies the shunting effect of the reactance of C_t is negligible and expression (9) becomes

$$\frac{V_{out}}{V_{gk}} = \frac{\mu R_a}{r_a + R_a} \dots \dots \dots (10)$$

Since μ , R_a and r_a are all essentially positive quantities, V_{out}/V_{gk} must also be positive. This implies that V_{out} and V_{gk} are in phase whereas in fact they are in antiphase. A minus sign is generally introduced into expressions such as (9) to indicate the phase

relationship between V_{out} and V_{gk} . The expression we shall use is thus

$$A = \frac{V_{out}}{V_{gk}} = - \frac{\mu Z_a}{r_a + Z_a} \dots \dots \dots (11)$$

In video-frequency amplifiers the impedance Z_a of the anode load is usually small compared with the anode a.c. resistance of the valve and expression (11) may be rewritten

$$A \simeq - \frac{\mu}{r_a} \cdot Z_a = - g_m Z_a \dots \dots \dots (12)$$

where g_m is the mutual conductance of the valve. Substituting for Z_a from (6) we have

$$A = \frac{V_{out}}{V_{gk}} = - \frac{g_m R_a}{1 + j\omega C_t R_a} \dots \dots (13)$$

Because Z_a is small compared with r_a , the valve can be represented as a constant-current generator as in Fig. 37(b). Expression (12) follows directly from consideration of this equivalent circuit. Expression (13) may be rewritten

$$A = \frac{V_{out}}{V_{gk}} = - \frac{g_m R_a}{1 + j\omega/\omega_0} \dots \dots \dots (14)$$

in which $\omega_0 = 1/R_a C_t$, i.e. ω_0 is the angular frequency at which the reactance of C_t equals R_a .

2.6 FREQUENCY RESPONSE

Expression (14) gives the gain of the amplifier at any frequency. In order to assess the shunting effect of C_t , we shall compare the gain at frequencies for which C_t has an effect with the gain at low frequencies when the effect of C_t is negligible. The effect of C_t is usually negligible at frequencies below approximately 100 kc/s and we shall take this medium frequency as a reference frequency. The gain at medium frequencies A_{mf} is equal to the gain at low

SIMPLE RC-COUPLED CIRCUIT

frequencies and can be obtained by putting ω equal to zero in expression (14); this gives

$$A_{mf} = -g_m R_a \quad \dots \quad \dots \quad \dots \quad (15)$$

Expression (14) gives the gain at high frequencies (A_{hf}) and combining this with expression (15) we have

$$\frac{A_{hf}}{A_{mf}} = \frac{1}{1 + jx} \quad \dots \quad \dots \quad \dots \quad (16)$$

in which $x = \omega/\omega_0$ and is directly proportional to frequency. In (16) A_{hf}/A_{mf} is a complex quantity, the numerical value of which is given by

$$\frac{A_{hf}}{A_{mf}} = \frac{1}{\sqrt{(1 + x^2)}} \quad \dots \quad \dots \quad (17)$$

Thus the frequency response of the amplifier may be calculated from the expression

$$\begin{aligned} \text{response in db} &= 20 \log_{10} \frac{A_{hf}}{A_{mf}} \\ &= 20 \log_{10} \frac{1}{\sqrt{(1 + x^2)}} \\ &= -20 \log_{10} \sqrt{(1 + x^2)} \\ &= -10 \log_{10} (1 + x^2) \quad \dots \quad \dots \quad \dots \quad (18) \end{aligned}$$

If $x = 1$ the high-frequency response is -3 db relative to the medium-frequency response. The frequency at which $x = 1$ is easily obtained from the relationship $x = \omega/\omega_0$. We have

$$\begin{aligned} \frac{\omega}{\omega_0} &= 1 \\ \therefore \omega &= \omega_0 \\ &= \frac{1}{R_a C_t} \\ \therefore f &= \frac{1}{2\pi R_a C_t} \quad \dots \quad \dots \quad \dots \quad (19) \end{aligned}$$

At the frequency given by this expression the frequency response is 3 db down; this frequency is sometimes known as the *turnover* frequency. Expression (19) can be made the basis of a method for measuring the total shunt capacitance of an amplifying stage. A reasonably low value of R_a is chosen (say 2 k Ω) and the output voltage is noted for a certain input at a low frequency (say 1 kc/s). The frequency is then determined for which, with the same input amplitude, the response falls to 71 per cent (corresponding to 3 db

loss). The total stray capacitance can then be determined from the expression

$$C_t = \frac{1}{\omega R_a} \quad \dots \quad \dots \quad \dots \quad (20)$$

For example if the turnover frequency is measured as 5 Mc/s with R_a equal to 2 k Ω , the total shunt capacitance is given by

$$\begin{aligned} C_t &= \frac{1}{6.284 \times 5 \times 10^6 \times 2 \times 10^3} \text{ F} \\ &= 15.9 \text{ pF} \end{aligned}$$

Expression (18) is plotted in Fig. 38; this is a universal frequency-response curve applicable to all RC-coupled stages provided ω_0 is taken as the turnover frequency, i.e. the angular frequency for which the reactance of C_t equals R_a . As already shown mathematically the loss of the circuit is 3 db when $x = 1$ (i.e., at the turnover frequency); the loss is 7 db one octave higher at $x = 2$ and is 10 db when $x = 3$. For higher values of x the curve tends to become linear with a slope of 6 db per octave. In fact at high frequencies the curve becomes asymptotic to the line (shown dotted in Fig. 38) having a slope of 6 db per octave and passing through zero loss at the turnover frequency.

Numerical Example

A numerical example will make clear the use of the curve. Suppose an RC-coupled stage is required to have a frequency response level within 1 db up to 3 Mc/s. The total shunt capacitance is 25 pF and the valve has a g_m of 8 mA/V. What value of anode load must be used and what is the stage gain?

From Fig. 38 the response is -1 db when $x = \omega/\omega_0 = 0.5$. But $\omega = 2\pi f = 2\pi \times 3 \times 10^6$ rad/sec.

$$\therefore \omega_0 = 2\pi \times 6 \times 10^6 \text{ rad/sec}$$

i.e., the turnover frequency for this circuit is 6 Mc/s.

Since $\omega_0 = 1/R_a C_t$

$$\begin{aligned} R_a &= \frac{1}{\omega_0 C_t} \\ &= \frac{1}{2\pi \times 6 \times 10^6 \times 25 \times 10^{-12}} \Omega \\ &= 1,060 \Omega \end{aligned}$$

SIMPLE RC-COUPLED CIRCUIT

The stage gain is given by

$$\begin{aligned}
 A &= g_m R_a \\
 &= 8 \times 10^{-3} \times 1,060 \\
 &= 8.5 \text{ approximately}
 \end{aligned}$$

This is the greatest gain possible with the given valve and for the required frequency response. If a greater value of R_a is used, the gain at low frequencies is higher but the loss exceeds 1 db at 3 Mc/s; if a lower value of R_a is used the loss is less than 1 db at 3 Mc/s but the gain is less generally.

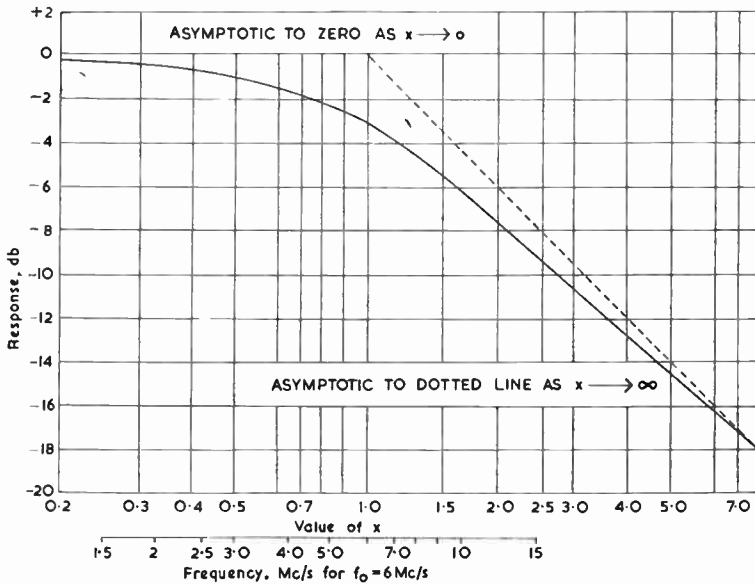

Fig. 38—Universal frequency-response curve for simple RC-coupled amplifier

Fig. 38 can be used to give the frequency response directly for any values of C_t and R_a by placing a logarithmic frequency scale along the horizontal axis. The length of one cycle, i.e., the interval corresponding to a 10 : 1 change in frequency on this scale must equal that for 1 cycle on the original graph and the turnover frequency on the new scale must coincide with the point where $x = 1$ on the original graph.

In Fig. 38 the logarithmic frequency scale for the numerical example has been included. On this scale 3 Mc/s locates with

$x = 0.5$ and 6 Mc/s with $x = 1$. From the curve the response can be seen to be -3 db at 6 Mc/s and -9 db at 15 Mc/s .

2.7 PHASE RESPONSE

Expression (14) can be written in the form

$$V_{out} = - \frac{g_m V_{gk} R_a}{1 + jx} \dots \dots \dots (21)$$

and, from the concept of the constant-current generator, $g_m V_{gk}$ is equal to I , the alternating component of the anode current

$$\therefore V_{out} = - \frac{I R_a}{1 + jx} \dots \dots \dots (22)$$

Rationalising this we have

$$\frac{V_{out}}{I} = - \frac{R_a}{1 + x^2} + \frac{jxR_a}{1 + x^2} \dots \dots \dots (23)$$

This is of the form $(R + jX)$ and the phase difference between V_{out} and I is given by $\tan^{-1} X/R$, i.e.

$$\begin{aligned} \phi &= \tan^{-1} -x \\ &= -\tan^{-1}x \dots \dots \dots (24) \end{aligned}$$

The negative value of ϕ implies that the phase angle between V_{out} and I is between 90° and 180° when the angle is measured in an anti-clockwise direction; the vectors thus have the same relative positions as V_{ak} and I_a in Fig. 36 and this indicates that V_{out} lags on the anode current by a phase angle which is larger than for a purely resistive load. Thus a negative value of ϕ implies a lagging phase angle.

Expression (24) is plotted in the form of a curve in Fig. 39. This shows that the relationship between phase shift and frequency is substantially linear up to a value of x of approximately 0.5 . This was the frequency limit chosen in the numerical example and the constants evaluated for that example would therefore give a reasonable performance in a video-frequency amplifier. For values of x above 0.5 the $\phi - x$ curve shows curvature of the form which indicates appreciable rise time in a simple circuit.

The slope of the curve in Fig. 39 can be determined in the following way: If the negative sign of ϕ is ignored, the equation to the curve is given by

$$\phi = \tan^{-1}x \dots \dots \dots (25)$$

SIMPLE RC-COUPLED CIRCUIT

which may be written

$$x = \tan \phi \quad \dots \quad \dots \quad \dots \quad (26)$$

From this

$$\begin{aligned} \frac{dx}{d\phi} &= \sec^2 \phi \\ &= 1 + \tan^2 \phi \\ &= 1 + x^2 \end{aligned}$$

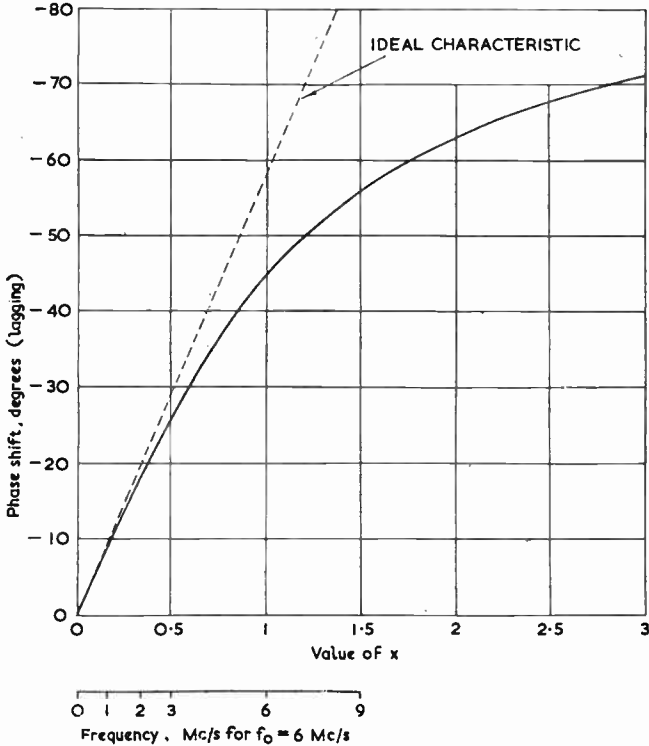

Fig. 39—Universal phase shift-frequency curve for simple RC-coupled amplifier

The slope of the curve is thus given by

$$\frac{d\phi}{dx} = \frac{1}{1 + x^2} \quad \dots \quad \dots \quad \dots \quad (27)$$

At the origin ($\omega = 0$) the slope is equal to unity if ϕ is expressed in radians but 57.3 if, as in Fig. 39, ϕ is expressed in degrees. If

this slope had been maintained for all values of x , the curve would, of course, be a straight line passing through the origin. Phase shift would then be directly proportional to frequency, which is one of the ideals aimed at in video-frequency amplifier design. Thus a straight line passing through the origin with a slope of 57.3 may be regarded as the ideal phase-frequency characteristic for a simple RC-coupled amplifier and any imperfections in the phase response can be measured by the deviations of the practical $\phi-f$ curve from this straight line. The practical $\phi-f$ curve agrees well with the straight line at low frequencies (small value of x) but departs from it more and more as frequency increases.

Numerical Example

At $x = 0.5$ the practical characteristic differs from the ideal by $28.65 - 26.57 = 2.08^\circ$. If, as in the numerical example quoted earlier, the upper passband limit is 3 Mc/s, this phase shift corresponds to a variation in delay given by

$$D = \frac{\phi}{360f}$$

from expression (3). Substituting for ϕ and f

$$\begin{aligned} D &= \frac{2.08}{360 \times 3 \times 10^6} \text{ sec} \\ &= \frac{2.08}{360 \times 3} \mu\text{sec} \\ &= 0.002 \mu\text{sec approximately} \end{aligned}$$

A variation in delay as small as this will have negligible effect on the quality of the reproduced picture. In fact the variation can approach $0.1 \mu\text{sec}$ before the quality of a picture becomes noticeably affected. Thus approximately 50 such RC-coupled stages can be used in cascade before the overall variation in delay approaches the limiting value. The gain per stage is, however, quite low (8.5 approximately).

2.8 GROUP DELAY

The group delay $d\phi/d\omega$ of a circuit gives a more sensitive indication of phase distortion than the phase-frequency characteristic itself. A generalised group delay curve for a simple RC-coupled stage is given in Fig. 40. This shows the variation in $d\phi/dx$ with x and thus does not give values of group delay directly; the ordinates are, however, directly proportional to group delay because $d\phi/dx$ is

SIMPLE RC-COUPLED CIRCUIT

equal to $\omega_0 \cdot d\phi/d\omega$. To obtain group delay, the ordinates should be divided by ω_0 . Gouriet* has termed $d\phi/dx$, *normalised group delay*. Since a negative phase angle implies a positive time delay, $d\phi/d\omega$ and $d\phi/dx$ are positive quantities.

The normalised delay is 1 at $x = 0$, 0.8 at $x = 0.5$ and 0.5 at $x = 1$. Ideally, group delay should be constant and a good approximation to constancy can be obtained by making the upper frequency of the passband correspond to a small value of x . Since $x = \omega/\omega_0$ and ω is fixed by the passband limit, this can only be done by choosing a high value of ω_0 . As $\omega_0 = 1/R_a C_t$ and C_t is

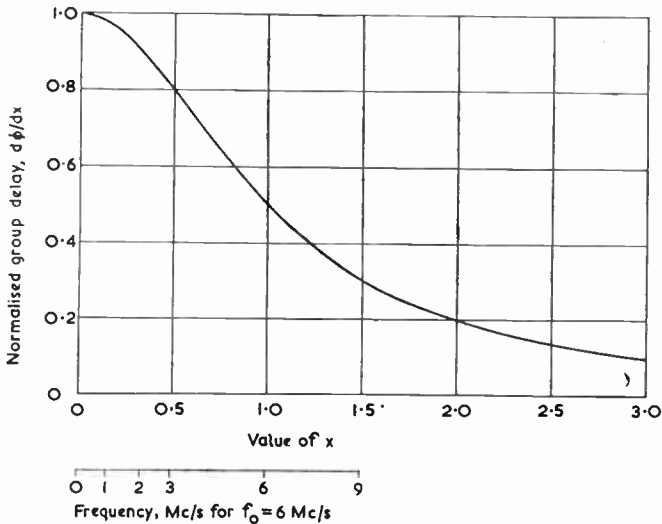

Fig. 40—Universal normalised group delay-frequency curve for simple RC-coupled amplifier

fixed for a given valve, a larger value of ω_0 implies a low value of R_a and hence low gain. Thus for a given valve the phase response can only be improved by sacrificing gain.

Numerical Example

As already shown, if an RC-coupled stage is required to operate up to 3 Mc/s, a satisfactory performance in respect of phase shift can be obtained by making ω_0 correspond to 6 Mc/s. The upper frequency limit then occurs at a value of x of 0.5, for which the normalised group delay is 0.8 compared with 1 at $x = 0$.

* G. G. Gouriet, "V.F. Amplifier Couplings." *Wireless Engineer*, October–November 1950.

As examples of the calculation of group delay we will calculate the value of $d\phi/d\omega$ for this particular amplifier at two frequencies. In general

$$\frac{d\phi}{d\omega} = \frac{1}{\omega_0} \cdot \frac{d\phi}{dx} \quad \dots \quad \dots \quad \dots \quad (28)$$

If ω_0 corresponds to 6 Mc/s, the group delay at zero frequency is given by

$$\begin{aligned} \frac{d\phi}{d\omega} &= \frac{1}{6.284 \times 6 \times 10^6} \text{ sec} \\ &= 0.0265 \times 10^{-6} \text{ sec} \\ &= 0.0265 \text{ } \mu\text{sec} \end{aligned}$$

At 3 Mc/s ($x = 0.5$) the group delay is given by

$$\begin{aligned} \frac{d\phi}{d\omega} &= \frac{0.8}{6.284 \times 6 \times 10^6} \text{ sec} \\ &= 0.0212 \text{ } \mu\text{sec} \end{aligned}$$

The difference in group delay at the two extremes of the band is thus 0.005 μsec , representing a very small departure from constancy.

2.9 RESPONSE TO VOLTAGE STEP

The performance of a video-frequency amplifier has so far been expressed in terms of the steady-state amplitude-frequency response (e.g., Fig. 38), and the steady-state phase-frequency response (e.g., Fig. 39); both curves can be obtained from the results of tests using sinusoidal input signals. From the information contained in these curves the response of an amplifier to a step signal can be deduced.

There is, however, an alternative method of investigating the performance of a video-frequency amplifier and that is by observing the waveform of the output when a square-wave input is applied to the amplifier. A recurring square-wave signal can be regarded as a succession of alternate positive and negative step signals.

When a voltage step is applied to the grid of a valve, a corresponding current step is applied to its anode load. If the load has the form of an RC circuit as in Fig. 34, the voltage developed across the load has an exponential rise given by the expression

$$V_{out} = IR_a(1 - e^{-t/R_a C_r}) \quad \dots \quad \dots \quad (29)$$

in which I is the amplitude of the anode-current step. This expression is derived in Appendix B, page 52.

SIMPLE RC-COUPLED CIRCUIT

As t increases, the term in e decreases and ultimately reaches zero. Thus the final amplitude is IR_a and (29) may be rewritten

$$\frac{\text{amplitude at time } t}{\text{final amplitude}} = 1 - e^{-t/R_a C_t} \quad \dots (30)$$

From this expression a generalised curve can be prepared to illustrate the output waveform for all simple RC-coupled amplifiers.

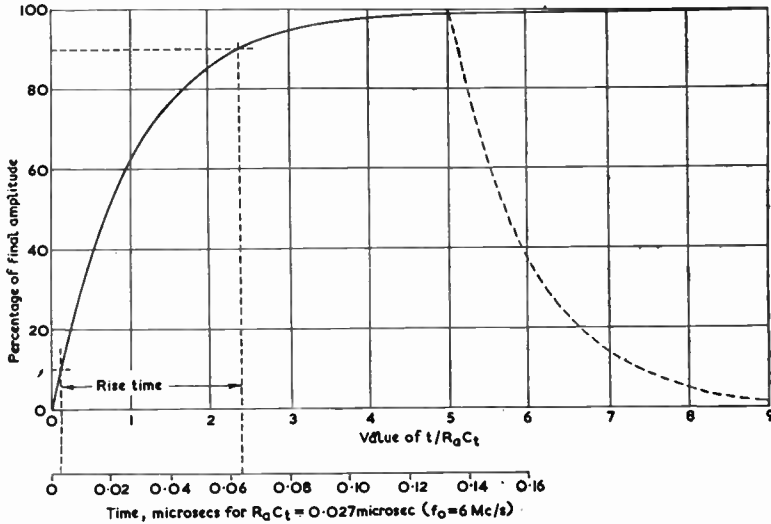

Fig. 41—Universal curve showing step response of a simple RC-coupled amplifier

In this curve, given in Fig. 41, t is expressed in terms of $R_a C_t$, the time constant of the anode load. When $t = R_a C_t$ (30) gives

$$\begin{aligned} \frac{\text{amplitude at time } t}{\text{final amplitude}} &= 1 - e^{-1} \\ &= 1 - 1/e \\ &= 1 - 0.37 \\ &= 0.63 \end{aligned}$$

i.e., the output amplitude is equal to 63 per cent of the final amplitude at a time equal to the anode time constant after the application of the input step; this, of course, is one of the ways in which the term *time constant* can be defined. This simple relationship is very useful, for it can often be used to give a quick guide to the performance of a circuit.

Numerical Example

Fig. 41 shows that the rise time, i.e., the time taken for the output to increase from 10 per cent to 90 per cent of its final amplitude is approximately $2.2R_aC_t$; in the numerical example mentioned earlier this is equal to $2.2 \times 1,080 \times 25 \times 10^{-12} \text{ sec} = 0.06 \mu\text{sec}$. As shown in Fig. 41 the curve can be made to apply to the numerical example by placing a time scale along the horizontal axis so that the time constant ($R_aC_t = 1,080 \times 25 \times 10^{-12} \text{ sec} = 0.027 \mu\text{sec}$) coincides with $t/R_aC_t = 1$.

The dotted curve in Fig. 41 shows how the anode potential falls when a positive voltage step is applied to the grid; the curve is similar in shape to the solid one but is inverted. The negative voltage step is assumed applied at a time given by $t = 5/R_aC_t$ and fall times should therefore be measured from this point. The combination of the two curves gives the response of the amplifier to a single square input pulse.

Fig. 41 thus illustrates the step response of a simple RC-coupled amplifier for an infinitely-steep transient input. In practice, input transients are not infinitely steep but have a finite rise time. The output of a simple RC-coupled amplifier for an input pulse with a finite rise time is similar in form to that illustrated in Fig. 41 but, of course, the rise time of the output depends on the rise time of the input signal and that of the amplifier (for an infinitely steep transient).

APPENDIX B

CHARGE AND DISCHARGE OF A CAPACITOR IN A RESISTIVE CIRCUIT

THE circuit in Fig. B.1 shows a capacitor C and a resistor R connected in series. When such a circuit is connected to a source of steady e.m.f. as illustrated, the capacitor acquires a charge and the voltage across C rises until it equals the source e.m.f. It is the purpose of this appendix to deduce the law connecting the voltage across C and time when the e.m.f. is suddenly applied. If the e.m.f. is short-circuited when C is fully charged, the capacitor discharges through R and the voltage across it falls; the law of this fall in voltage is also deduced in this appendix. The problems are most easily solved if q (the charge on the capacitor plates) is treated as the variable.

If the charge on the capacitor plates is q , the voltage across C

SIMPLE RC-COUPLED CIRCUIT

is q/C . The voltage across R is given by $R.i$ where $i = dq/dt$. Thus equating voltages in the circuit

$$V = R \cdot \frac{dq}{dt} + \frac{q}{C}$$

from which

$$\frac{dq}{dt} + \frac{q}{CR} = \frac{V}{R}$$

This equation is most readily solved by multiplying by $e^{t/RC}$ i.e., $e^{t/RC}$. We have

$$\frac{dq}{dt} \cdot e^{t/RC} + \frac{q}{CR} \cdot e^{t/RC} = \frac{V}{R} \cdot e^{t/RC}$$

which may be written

$$\frac{d}{dt} (q \cdot e^{t/RC}) = \frac{V}{R} \cdot e^{t/RC}$$

Fig. B.1—Circuit of capacitance and resistance connected to a source of e.m.f.

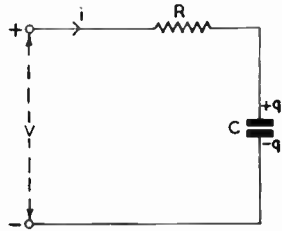

Integrating

$$q \cdot e^{t/RC} = CV e^{t/RC} + A$$

where A is the constant of integration. Thus

$$q = CV + Ae^{-t/RC} \quad \dots \quad (1)$$

Let $V = V_0$ and suppose $q = 0$ when $t = 0$. This is true when the capacitor is initially discharged and when a steady voltage V_0 is suddenly applied to the circuit. Putting $V = V_0$ in equation (1)

$$q = CV_0 + Ae^{-t/RC}$$

Substituting $q = 0$ and $t = 0$ gives

$$0 = CV_0 + A$$

$$\therefore A = -CV_0$$

Substituting for A in (1)

$$q = CV_0(1 - e^{-t/RC}) \quad \dots \quad (2)$$

This equation shows that q approaches CV_0 as t approaches infinity. Thus CV_0 is the limiting value q_0 of the charge on the plates.

The voltage across C at any instant t is given by q/C and from expression (2) is given by

$$V = \frac{q}{C} = V_0(1 - e^{-t/RC}) \quad \dots \quad (3)$$

This equation shows that the voltage V approaches the applied value V_0 as t approaches infinity.

If the source of external voltage is short-circuited when the capacitor has finally acquired the applied voltage, the ensuing relationship between q and t can be obtained by putting $V = 0$ in expression (1). We have

$$q = Ae^{-t/RC} \quad \dots \quad (4)$$

Moreover suppose the charge on the capacitor is CV_0 when $t = 0$. Substituting in (4)

$$CV_0 = A$$

Thus the final solution is given by

$$q = CV_0e^{-t/RC}$$

and the variation of the voltage across the capacitor is obtained by dividing by C thus

$$V = \frac{q}{C} = V_0e^{-t/RC}$$

CHAPTER 3

SHUNT-INDUCTANCE CIRCUIT

3.1 INTRODUCTION

IN the previous chapter we have shown that a simple RC-coupled circuit can be used as a video-frequency amplifier but, to obtain satisfactory amplitude-frequency and phase-frequency characteristics, the anode load and hence the gain must be kept low. It is possible to design circuits to give higher gain for the same frequency response or, alternatively, a better frequency response for the same gain; the first of these circuits to be described is that shown in Fig. 42 (a), known as the *shunt-inductance* circuit.

The circuit is similar to that of a simple RC-coupled circuit (Fig. 34) but has an inductor L_1 connected in series with the anode load resistor R_a . Although in series with the valve and anode resistor, this inductor forms part of the shunt arm of the equivalent network (Fig. 42b) coupling the valve to the next stage and this fact gives this circuit its name.

At low frequencies the circuit of Fig. 42 (a) behaves as a simple RC-coupled amplifier having a gain of $g_m R_a$, the reactance of L_1 being negligible at these frequencies.

The value of L_1 is so chosen that its reactance is appreciable (thus maintaining gain) at those frequencies where the simple RC-circuit begins to show a fall in gain.

In the equivalent circuit given in Fig. 42(b), the valve is represented as a constant-current generator.

3.2 GAIN

The gain of a shunt-inductance stage may be expressed by the general formula

$$\begin{aligned} A &= \frac{V_{out}}{V_{gk}} \\ &= -g_m Z_a \quad \dots \quad \dots \quad \dots \quad (31) \end{aligned}$$

in which Z_a is the impedance of the network $L_1 R_a C_t$ and is given by

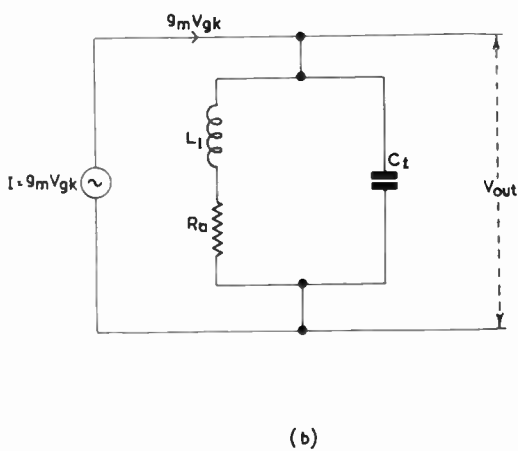
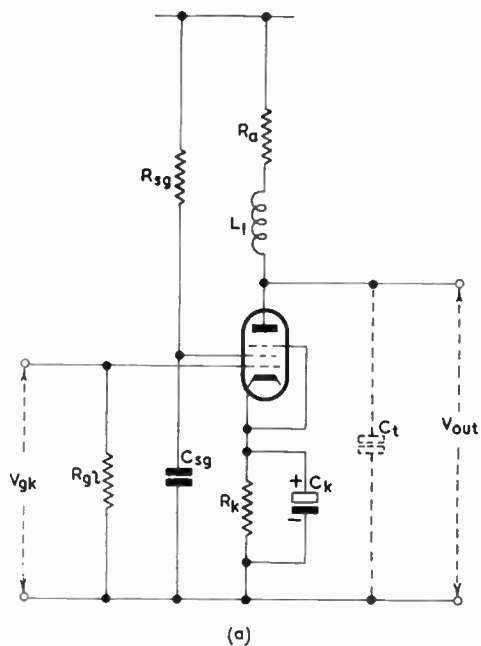

Fig. 42—Shunt-inductance circuit (a) and its electrical equivalent (b)

SHUNT-INDUCTANCE CIRCUIT

$$\begin{aligned}
 Z_a &= \frac{(R_a + j\omega L_1) \cdot \frac{1}{j\omega C_t}}{R_a + j\omega L_1 + \frac{1}{j\omega C_t}} \\
 &= \frac{R_a + j\omega L_1}{j\omega C_t R_a - \omega^2 L_1 C_t + 1} \quad \dots \quad (32)
 \end{aligned}$$

Combining (31) and (32)

$$\begin{aligned}
 A &= \frac{V_{out}}{V_{gk}} \\
 &= - \frac{g_m(R_a + j\omega L_1)}{j\omega C_t R_a - \omega^2 L_1 C_t + 1} \quad \dots \quad (33)
 \end{aligned}$$

This can be more conveniently expressed by making the following substitutions:—

$$\omega_0 = 1/R_a C_t \quad \dots \quad \dots \quad (34)$$

$$x = \omega/\omega_0 \quad \dots \quad \dots \quad (35)$$

$$L_1 = a R_a^2 C_t \quad \dots \quad \dots \quad (36)$$

Substitutions (34) and (35) were also used in the analysis of the simple RC-coupled circuit. From substitution (36) we can deduce that a is a numerical factor which expresses the magnitude of the inductance in terms of the anode resistor and the shunt capacitance. Making these substitutions in (33) we have

$$\begin{aligned}
 A &= \frac{V_{out}}{V_{gk}} \\
 &= - \frac{g_m R_a (1 + jax)}{1 + jx - ax^2}
 \end{aligned}$$

3.3 FREQUENCY RESPONSE

The gain of the circuit at medium frequencies (A_{mf}) is given by $-g_m R_a$ and we can thus say

$$\frac{A_{hf}}{A_{mf}} = \frac{1 + jax}{1 + jx - ax^2} \quad \dots \quad \dots \quad (37)$$

from which

$$\frac{A_{hf}}{A_{mf}} = \sqrt{\frac{1 + a^2 x^2}{(1 - ax^2)^2 + x^2}} \quad \dots \quad (38)$$

which gives the relative frequency response in terms of x (directly

proportional to frequency) and a , the size of the inductor. The response may be expressed in decibels thus:

$$\begin{aligned} \text{response in decibels} &= 20 \log_{10} \frac{A_{hf}}{A_{mf}} \\ &= 20 \log_{10} \sqrt{\left(\frac{1 + a^2x^2}{(1 - ax^2)^2 + x^2} \right)} \\ &= 10 \log_{10} \frac{1 + a^2x^2}{(1 - ax^2)^2 + x^2} \dots \dots (39) \end{aligned}$$

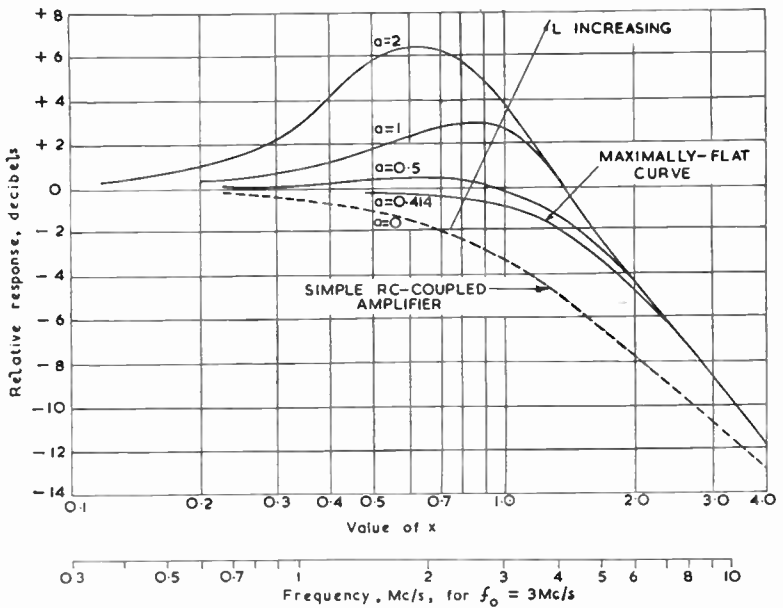

Fig. 43—Universal frequency response curves for shunt-inductance amplifier

The response for various values of a is given in Fig. 43 in which for comparison the response of a simple RC-coupled circuit is shown in dotted lines. This curve is labelled $a = 0$, for if a is put equal to 0 in expression (36) it follows that $L_1 = 0$; if a is put equal to 0 in expression (37) it reduces to the corresponding expression (16) for a simple RC-coupled circuit.

Fig. 43 shows that increase in the value of a , i.e., increase in L_1 gives an increase in the relative response at frequencies near the value for which $x = 1$, i.e., near the frequency at which the reactance

SHUNT-INDUCTANCE CIRCUIT

of C_t equals R_a , the turnover frequency for the simple RC-coupled amplifier. For values of a greater than approximately 0.5, the response has a peak which becomes more marked as a increases. When a is very large, the inductance is large and its reactance is great compared with the anode-load resistance over a wide frequency band. Thus the circuit tends to take the form of a valve working into a parallel-tuned circuit, and has a sharp peak at the resonance frequency of the load. Such a response is necessary in a tuned amplifier but is undesirable in a video-frequency amplifier. By using a low value of L_1 , the reactance/resistance ratio (i.e., the Q -factor) in the anode circuit is made very low and a substantially aperiodic response is obtained. Generally the value of a in video-frequency amplifiers is less than 0.5.

Numerical Example

We will calculate the values of R_a , L_1 and the gain for a stage of amplification in which $g_m = 8$ mA/V and $C_t = 25$ pF. The frequency response is required to be level up to 3 Mc/s. The design is based on $a = 0.5$ and $x = 1$ at 3 Mc/s.

Since $x = \omega/\omega_0$, $\omega = \omega_0 = 2\pi f$ where $f = 3$ Mc/s

$$\therefore \omega_0 = 2\pi \times 3 \times 10^6 \text{ rad/sec}$$

$$R_a = \frac{1}{\omega_0 C_t}$$

$$= \frac{1}{2\pi \times 3 \times 10^6 \times 25 \times 10^{-12}} \Omega$$

$$= 2,120 \Omega$$

$$L_1 = aR_a^2 C_t$$

$$= 0.5 \times (2.12 \times 10^3)^2 \times 25 \times 10^{-12} \text{ H}$$

$$= 56.2 \mu\text{H}$$

$$A = g_m R_a$$

$$= 8 \times 10^{-3} \times 2.12 \times 10^3$$

$$= 17 \text{ approximately}$$

The gain is thus 17 up to 3 Mc/s and from Fig. 43 the response is 1 db down when $x = 1.2$, i.e., at 3.6 Mc/s. This is a marked improvement over the simple RC-coupled stage, the parameters of which were calculated in the numerical example on page 44; the simple RC circuit had half the gain and was 1 db down at 3 Mc/s.

3.4 MAXIMAL FLATNESS

3.4.1 Introduction

The response curve for a simple RC-coupled amplifier is given by expression (17) which can be written in the form

$$\frac{A_{hf}^2}{A_{mf}^2} = \frac{1}{1 + x^2} \dots \dots \dots \dots \dots \quad (40)$$

The corresponding expression for the shunt-inductance circuit is, expanding the denominator of (38),

$$\frac{A_{hf}^2}{A_{mf}^2} = \frac{1 + a^2x^2}{1 + (1 - 2a)x^2 + a^2x^4} \dots \dots \dots \quad (41)$$

Expressions (40), (41), and the corresponding expressions for other circuits not yet encountered, are all of the type

$$\frac{A_{hf}^2}{A_{mf}^2} = \frac{\alpha_0 + \alpha_1x^2 + \alpha_2x^4 + \dots + \alpha_nx^{2n}}{\beta_0 + \beta_1x^2 + \beta_2x^4 + \dots + \beta_mx^{2m}} \dots \quad (42)$$

in which x is a variable directly proportional to frequency, $\alpha_0, \alpha_1, \alpha_2$, etc., and $\beta_0, \beta_1, \beta_2$, etc., being constants dependent on component values and independent of frequency.

These constants generally become smaller with ascending powers of x and are often zero beyond a certain power. The numerator usually has the same number of terms as the denominator or one less, i.e., $m = n$ or $m = n + 1$. The constants can be expressed in terms of component values by equating the coefficients of like powers of x in expression (42) and the expression for the circuit in question. For example, comparison of expressions (40) and (42) shows that for the simple RC-coupled amplifier

$$\left. \begin{aligned} \alpha_0 &= 1 \\ \alpha_1, \alpha_2, \alpha_3, \text{ etc.} &= 0 \\ \beta_0 &= 1 \\ \beta_1 &= 1 \\ \beta_2, \beta_3, \beta_4, \text{ etc.} &= 0 \end{aligned} \right\} \dots \dots \dots \quad (43)$$

Similarly, by comparing expressions (41) and (42) we can show, for the shunt-inductance circuit:—

$$\left. \begin{aligned} \alpha_0 &= 1 \\ \alpha_1 &= a^2 \\ \alpha_2, \alpha_3, \alpha_4, \text{ etc.} &= 0 \\ \beta_0 &= 1 \\ \beta_1 &= (1 - 2a) \\ \beta_2 &= a^2 \\ \beta_3, \beta_4, \beta_5, \text{ etc.} &= 0 \end{aligned} \right\} \dots \dots \quad (44)$$

SHUNT-INDUCTANCE CIRCUIT

The curve of expression (42) may have a number of maxima and minima and may thus show large departures from the ideal response which is a straight line parallel to the frequency axis and having the equation

$$\frac{A_{hf}}{A_{mf}} = \text{a constant} \quad \dots \quad \dots \quad \dots \quad \dots \quad (45)$$

It was shown by Landon* that if the constants $\alpha_0, \alpha_1, \text{etc.}$, and $\beta_0, \beta_1, \text{etc.}$, satisfy a certain relationship, the expression (42) reduces to the form

$$\frac{A_{hf}}{A_{mf}} = \text{a constant} + x^p \quad \dots \quad \dots \quad \dots \quad (46)$$

where p is a constant. The significant feature of expression (46) is that it contains only a single term in frequency. The curve of expression (46) has no maxima or minima and, for small values of x , approximates to the ideal straight line. This curve is said to have maximal flatness* and the conditions necessary to achieve it are as follows. They are deduced in Appendix C.

$$\frac{\alpha_0}{\beta_0} = \frac{\alpha_1}{\beta_1} = \frac{\alpha_2}{\beta_2} = \dots = \frac{\alpha_n}{\beta_n} \quad \dots \quad \dots \quad (47)$$

If the constants in expression (47) are replaced by their equivalents in terms of the circuit constants, a relationship between the circuit parameters is obtained; if the circuit parameters are adjusted to this relationship a maximally-flat frequency-response curve is obtained.

Though it is a useful guide to choice of component values, the condition of maximal flatness does not necessarily give a curve with least deviations from the ideal response. Up to a given frequency limit a curve with one maximum may have less deviations from the ideal than the maximally flat curve. An example of this is provided by Fig. 54 in which the curve labelled $K = 0.6$ is a nearer approach to the ideal than the maximally-flat curve which is also shown.

3.4.2 Conditions for Maximal Flatness of Frequency Response

For maximal flatness we have, from expression (47)

$$\frac{\alpha_0}{\beta_0} = \frac{\alpha_1}{\beta_1} = \frac{\alpha_2}{\beta_2}$$

The values of these constants for the shunt-inductance circuit are

* V. D. Landon, "Cascade Amplifiers with Maximal Flatness." *R.C.A. Review*, January and April 1941.

given in expression (44). Substituting these in (47) we have

$$\frac{1}{1} = \frac{a^2}{1 - 2a}$$

which may be written

$$a^2 + 2a - 1 = 0 \quad \dots \quad \dots \quad \dots \quad (48)$$

The positive root of this quadratic equation is

$$\begin{aligned} a &= \sqrt{2} - 1 \\ &= 0.414 \end{aligned}$$

The frequency response for $a = 0.414$ is given in Fig. 43 and represents a close approximation to the ideal response, which is a straight line parallel to the frequency axis.

We will now calculate the value of inductance required to give a maximally-flat frequency response over the video band. We must first decide what loss is tolerable at the upper frequency limit, 3 Mc/s. If a loss of 1 db can be accepted, the maximally-flat curve can be used up to $x = 1$ as shown in Fig. 43. The same limit was used in the previous numerical example and from this we have that

$$\omega_0 = 2\pi \times 3 \times 10^6 \text{ rad/sec}$$

From (34)

$$R_a = \frac{1}{\omega_0 C_t}$$

and if C_t is 30 pF

$$\begin{aligned} R_a &= \frac{1}{6.284 \times 3 \times 10^6 \times 30 \times 10^{-12} \Omega} \\ &= 1770 \Omega \end{aligned}$$

The value of L_1 for maximal flatness is given by (36), putting $a = 0.414$. We thus have

$$\begin{aligned} L_1 &= aR_a^2 C_t \\ &= 0.414 \times 1770^2 \times 30 \times 10^{-12} \text{ H} \\ &= 38.8 \mu\text{H} \end{aligned}$$

The stage gain depends on the mutual conductance and, if this is taken as 8 mA/V, is given by

$$\begin{aligned} A &= g_m R_a \\ &= 8 \times 10^{-3} \times 1770 \\ &= 14.2 \end{aligned}$$

SHUNT-INDUCTANCE CIRCUIT

If a level amplitude-frequency response were the only criterion to be satisfied in a video-frequency amplifier, the design could be based on the conditions for maximal flatness, although, as pointed out above, a slight deviation from the component values for maximal flatness may sometimes be desirable to give a nearer approach to the ideal response. Unfortunately an amplifier with a satisfactory amplitude-frequency characteristic may have a poor phase characteristic or an unsatisfactory step response and as much attention must be paid to these properties as to frequency response.

3.5 PHASE RESPONSE

The phase response can be deduced in a manner similar to that used for the simple RC-coupled amplifier. From expression (33) we have

$$\begin{aligned} A &= \frac{V_{out}}{V_{gk}} \\ &= - \frac{g_m(R_a + j\omega L_1)}{j\omega C_t R_a - \omega^2 L_1 C_t + 1} \end{aligned}$$

from which

$$V_{out} = - \frac{g_m V_{gk} (R_a + j\omega L_1)}{j\omega C_t R_a - \omega^2 L_1 C_t + 1}$$

But $g_m V_{gk} = I$, the alternating component of the anode current

$$\begin{aligned} \therefore \frac{V_{out}}{I} &= - \frac{R_a + j\omega L_1}{j\omega C_t R_a - \omega^2 L_1 C_t + 1} \quad \dots \quad \dots \quad \dots \quad (49) \\ &= - \frac{R_a(1 + j\omega L_1/R_a)}{1 + j\omega C_t R_a - \omega^2 L_1 C_t} \end{aligned}$$

Putting $\omega_0 = 1/R_a C_t$, $x = \omega/\omega_0$ and $L_1 = a R_a^2 C_t$ as before, we have

$$\frac{V_{out}}{I} = - \frac{R_a(1 + jax)}{1 + jx - ax^2} \quad \dots \quad \dots \quad \dots \quad (50)$$

Rationalising this expression

$$\frac{V_{out}}{I} = - \frac{R_a}{(1 - ax^2)^2 + x^2} - \frac{jxR_a(a - 1 - a^2x^2)}{(1 - ax^2)^2 + x^2} \quad \dots \quad (51)$$

which is of the form $(R + jX)$. The phase difference between V_{out} and I is given by $\tan^{-1}X/R$, i.e.,

$$\phi = \tan^{-1}x(a - 1 - a^2x^2) \quad \dots \quad \dots \quad \dots \quad (52)$$

This expression is plotted in Fig. 44 for the same values of a as in Fig. 43; the dotted curve shows the response of a simple RC-coupled amplifier. Low values of a give the best approximations to the ideal linear response and the curve for $a = 0.5$ (chosen for the numerical example) gives quite a reasonable approximation. The delay distortion of an amplifier having $a = 0.5$ can be assessed in the following way:—

Expression (52) may be written

$$\begin{aligned}\tan \phi &= x(a - 1 - a^2x^2) \quad \dots \quad \dots \quad (53) \\ &= ax - x - a^2x^3\end{aligned}$$

Differentiating with respect to x

$$\sec^2\phi \frac{d\phi}{dx} = a - 1 - 3a^2x^2$$

Substituting $(1 + \tan^2\phi)$ for $\sec^2\phi$

$$(1 + \tan^2\phi) \frac{d\phi}{dx} = a - 1 - 3a^2x^2$$

Substituting for $\tan \phi$ from (53)

$$[1 + x^2(a - 1 - a^2x^2)^2] \frac{d\phi}{dx} = a - 1 - 3a^2x^2$$

from which

$$\frac{d\phi}{dx} = \frac{a - 1 - 3a^2x^2}{1 + x^2(a - 1 - a^2x^2)^2} \quad \dots \quad (54)$$

This is a general expression for the slope of the curves in Fig. 44. The slope at the origin is obtained by putting $x = 0$ and gives

$$\frac{d\phi}{dx} = a - 1$$

when $a = 0.5$ the slope is -0.5 . If the sign of this slope is neglected, the slope of the $a = 0.5$ curve is 0.5 at the origin provided ϕ is plotted in radians; when ϕ is in degrees as in Fig. 44, the slope is $57.3/2$, i.e., 28.65 . If this slope had been maintained for all values of x the curve would, of course, be a straight line passing through the origin. For such a curve, phase shift is proportional to frequency which is one of the ideals aimed at in video-frequency amplifier design. Thus a straight line passing through the origin with a slope of 28.65 may be regarded as the ideal phase-frequency

SHUNT-INDUCTANCE CIRCUIT

characteristic for a shunt-inductance amplifier having $a = 0.5$ and any imperfections in the phase response of such a circuit can be measured by the deviation of the practical $\phi - f$ curve from this straight line. The practical curve agrees well with the straight line at low frequencies (small value of x) but departs from it more and more as frequency increases.

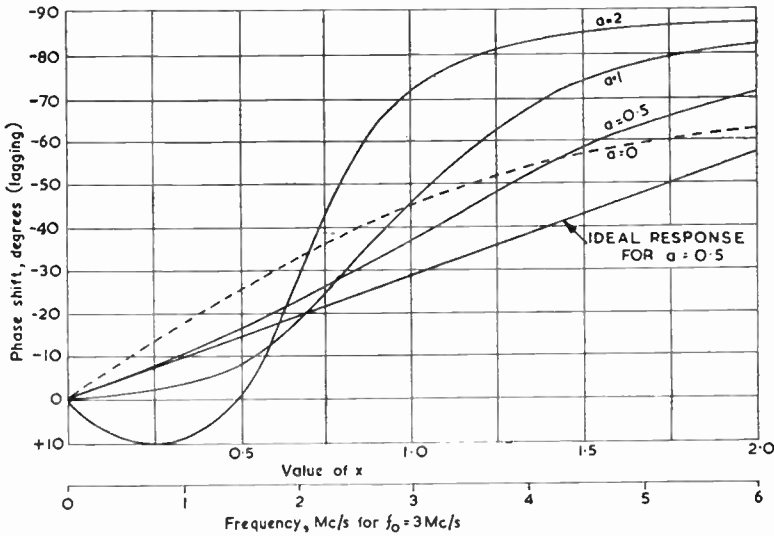

Fig. 44—Universal phase shift-frequency curves for shunt-inductance amplifier

Numerical Example

At $x = 1$ the practical characteristic differs from the ideal by $37 - 28.65 = 8.35^\circ$. If, as in the numerical example, quoted earlier, the upper passband limit is 3 Mc/s, this phase shift corresponds to a delay given by

$$D = \frac{\phi}{360f}$$

from expression (3). Substituting for ϕ and f

$$\begin{aligned} D &= \frac{8.35}{360 \times 3 \times 10^6} \text{ sec} \\ &= \frac{8.35}{360 \times 3} \mu\text{sec} \\ &= 0.008 \mu\text{sec approximately.} \end{aligned}$$

This is approximately 4 times the variation in delay obtained with the simple RC-coupled stage of the previous example but the gain is double due to the use of the characteristics up to $x = 1$. This can be shown as follows:—In the previous example the passband limit, 3 Mc/s, corresponds to a value of x of 0.5; thus ω_0 corresponds to 6 Mc/s. In this example the same passband limit corresponds to a value of x of 1; thus ω_0 corresponds to 3 Mc/s. The value of ω_0 for the shunt-inductance circuit is half that for the simple RC-coupled circuit; since $\omega_0 = 1/R_a C_t$, provided C_t is the same for both circuits, R_a for the shunt-inductance circuit is twice that for the simple RC-coupled circuit.

If the deviations of the two circuits from the ideal phase response are compared for the same values of x , it will be found that the LCR circuit gives a better performance. This is illustrated in the following table.

x	Deviations from ideal response (degrees)	
	RC circuit	LCR circuit ($a = 0.5$)
0.5	2.08	1.40
1.0	12.30	8.35
1.5	29.65	14.80

For a given upper frequency limit, the deviations are directly proportional to the variation in delay and are compared for the same values of x which, for a given value of C_t , implies the same values of R_a and hence the same gain.

The comparison applies when $a = 0.5$ but this is not the value of a which gives the nearest approach to the ideal phase-frequency characteristic; this particular value of a can be calculated as shown below.

3.6 GROUP DELAY

Group delay, $d\phi/d\omega$ can be written as

$$\frac{d\phi}{d\omega} = \frac{1}{\omega_0} \cdot \frac{d\phi}{dx}$$

and, substituting for $d\phi/dx$ from expression (54)

$$\frac{d\phi}{d\omega} = \frac{1}{\omega_0} \cdot \frac{(a-1) - 3a^2x^2}{1 + x^2(a-1 - a^2x^2)^2} \quad (55)$$

SHUNT-INDUCTANCE CIRCUIT

The variation with frequency of the normalised group delay $d\phi/dx$ for a shunt-inductance circuit is illustrated in Fig. 45 for values of a of 0, 0.32, 0.5 and 1. The curves were plotted from expression (54) the value of which is taken as positive, since negative phase angles imply positive delay. To obtain group delay from the curves, the ordinates must be divided by ω_0 . Ideally the group delay should be independent of frequency and the ideal characteristic is a horizontal straight line. To obtain a reasonable approximation to such a performance, the value of a must clearly be less than approximately 0.5; the curves of $a = 1$ and above represent most unsatisfactory phase responses.

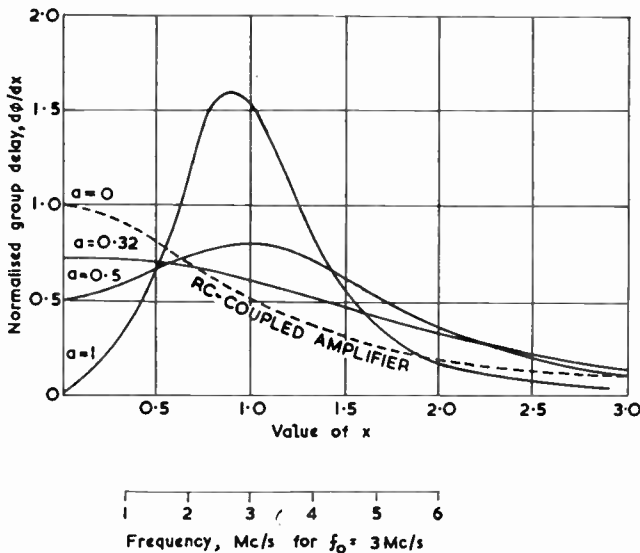

Fig. 45—Universal normalised group delay-frequency curves for a shunt-inductance amplifier

3.7 CONDITIONS FOR MAXIMAL FLATNESS OF GROUP DELAY CURVE

Expanding the denominator of expression (54) we have

$$\frac{d\phi}{dx} = \frac{(a-1) - 3a^2x^2}{1 + (a-1)^2x^2 - 2a^2(a-1)x^4 + a^4x^6} \quad \dots (56)$$

This expression is of the same type as expression (42), that is to say it has the same form as the expressions previously derived for the square of the frequency response (see for example expressions 40 and 41). The concept of maximal flatness can be applied also to

expressions for group delay and by use of the condition of expression (47) a relationship between the circuit parameters can be obtained for which the group delay-frequency curve is maximally flat; for these circuit parameters the phase-frequency curve will be a close approximation to the ideal linear response.

For maximal flatness of group delay characteristic we have, applying the rules set out on pages 60 *et seq.*

$$\frac{a - 1}{1} = \frac{-3a^2}{(a - 1)^2}$$

Cross-multiplying we obtain the cubic equation

$$(a - 1)^3 = -3a^2$$

which simplifies to

$$a^3 + 3a - 1 = 0$$

This equation has, of course, three roots but the only one which interests us is $a = 0.32$, and this is the value of a which gives maximal flatness of the group-delay characteristic.

As Fig. 45 shows, the phase response of a maximally-flat shunt-inductance circuit is better than that of a simple RC-coupled circuit ($a = 0$). For example, the group delay of the shunt-inductance circuit varies from 0.75 to 0.65 between $x = 0$ and $x = 1$; over the same frequency range the group delay of the simple RC-coupled amplifier varies from 1.0 to 0.5, a much larger variation. This bears out the results in the table on page 66.

3.8 RESPONSE TO VOLTAGE STEP

The response of a video-frequency amplifier to a voltage step is perhaps the most useful criterion of its performance. As already shown, both frequency and phase characteristics must be good in order to obtain good reproduction of such a signal. When a voltage step is applied to the grid of a shunt-inductance amplifier, a corresponding current step is applied to the LCR anode circuit and the voltage across this circuit grows according to the curves given in Fig. 46. The expression from which these curves were plotted is somewhat complex and is not given here; although it can be obtained by methods similar to those used in the appendix to Chapter 2, this expression is more conveniently derived by Heaviside's operational calculus. Some books giving details of these methods are listed in the bibliography at the end of this book.

For comparison, the dotted curve shows the response of a simple RC-coupled amplifier: $a = 0$ implies that $L_1 = 0$. The curves show that the addition of the shunt inductance to the simple RC

SHUNT-INDUCTANCE CIRCUIT

circuit improves the transient response by decreasing the rise time; in fact the rise time for $a = 0.5$ is approximately $1.1R_aC_t$ compared with $2.2R_aC_t$ for the simple RC-coupled amplifier. Unfortunately the addition of inductance causes pronounced overshoot if carried too far and the largest value of inductance which can be used without causing overshoot corresponds to $a = 0.25$. When $a = 0.5$ the overshoot amplitude is approximately 7 per cent of the final pulse amplitude and when $a = 1$, it is nearly 30 per cent.

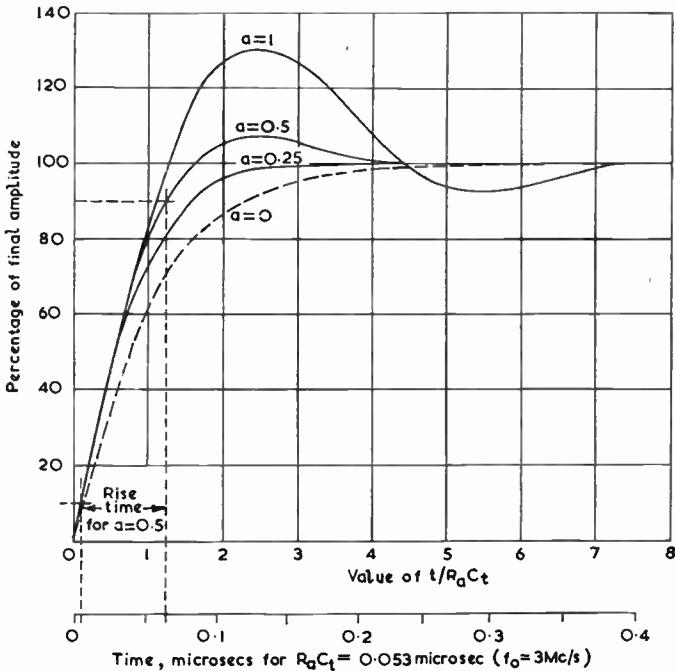

Fig. 46—Universal curves showing step response for shunt-inductance amplifier

In certain circumstances a small percentage of overshoot may be tolerable; for example, when only one or a small number of stages are used in cascade or when the interpreting device (usually a cathode-ray beam) is unable to reproduce the overshoot because of aperture distortion. But even a small percentage of overshoot can be very troublesome when a large number of stages are used in cascade; the amplitude of overshoot increases with each successive stage and may become intolerable at the final stage even though the overshoot per stage is very small.

The frequency of the ripple constituting the overshoot is approximately the resonance frequency of L_1 and C_t .

Numerical Example

The time scale in Fig. 46 applies to the numerical example given earlier. For this particular circuit ω_0 corresponds to 3 Mc/s and $R_a C_t$ is therefore given by

$$\begin{aligned} R_a C_t &= \frac{1}{\omega_0} \\ &= \frac{1}{2\pi \times 3 \times 10^6} \text{ sec} \\ &= 0.053 \mu\text{sec.} \end{aligned}$$

The rise time for this value of $R_a C_t$ is approximately 0.06 μsec as shown in Fig. 46; this is the same as for the simple RC-coupled circuit used earlier as a numerical example but the shunt-inductance circuit gives double the gain. On the other hand the shunt-inductance circuit gives overshoot and the RC-coupled circuit does not.

3.9 DESIGN OF SHUNT-INDUCTANCE CIRCUIT

A shunt-inductance circuit cannot be designed to give maximally-flat frequency and group-delay responses at the same time; maximal flatness of frequency response is obtained when $a = 0.414$ and maximal flatness of group delay when $a = 0.32$. Provided an overshoot of the order of 3 per cent can be tolerated, a compromise value of a such as 0.37 can be adopted; if no overshoot can be accepted, the value of a must not exceed 0.25.

The value ascribed to ω_0 determines the gain of the stage and depends on the degree to which departures from the ideal response can be tolerated. If the response must be near the ideal, as when a large number of stages are to be used in cascade, ω_0 must correspond to a high frequency, say 2 or 3 times the desired upper limit of the amplifier. The amplifier response is then given by the initial portions of the curves in Figs. 44 to 46; for example, if ω_0 corresponds to 6 Mc/s and the amplifier limit is 3 Mc/s, the response extends up to $x = \omega/\omega_0 = 0.5$. For a given value of C_t , R_a is inversely proportional to ω_0 ; high values of ω_0 thus imply low values of R_a and hence low gain. If the response need not be so close to the ideal, as when only a few stages are used in cascade, ω_0 can be made lower, possibly below the desired amplifier upper limit, and higher gain per stage is possible. In practice values of x up to 0.85 or 1 are commonly used.

SHUNT-INDUCTANCE CIRCUIT

3.10 4-ELEMENT SHUNT-INDUCTANCE CIRCUIT

We have shown that the frequency response of a simple RC-coupled circuit can be extended by use of shunt inductance and, to a first degree of approximation, the extension is greater as the inductance is increased. Unfortunately a large inductance causes a peak in the frequency-response curve, a poor phase response and excessive overshoot. To give a reasonable performance in these respects the inductance must be limited and the maximum extension of frequency response is not obtained.

The performance can be improved by use of a circuit with an effective inductance which increases with frequency. One circuit with such a property is that shown in Fig. 47, provided the resonance frequency of L_1C_1 occurs above the video-frequency band. The effective reactance of L_1 in parallel with C_1 is given by

$$j\omega L_1 + \frac{1}{j\omega C_1} = \frac{j\omega L_1}{1 - \omega^2 L_1 C_1} \quad \dots \quad (58)$$

When C_1 is omitted, the reactance is, of course, $j\omega L_1$ as can be shown by putting $C_1 = 0$ in expression (58).

At very low frequencies $\omega^2 L_1 C_1$ is very small compared with unity and the reactance is approximately $j\omega L_1$, that of L_1 alone; at low frequencies therefore the effect of the added capacitor is negligible. At high frequencies, however, $\omega L_1 C_1$ becomes appreciable compared with unity and the effective reactance is greater than $j\omega L_1$; the circuit thus behaves as though the inductance increases with the frequency. C_1 cannot be made too large otherwise the resonance frequency of $L_1 C_1$ will occur within the band it is desired to amplify; the voltage developed across a parallel-tuned circuit shows rapid

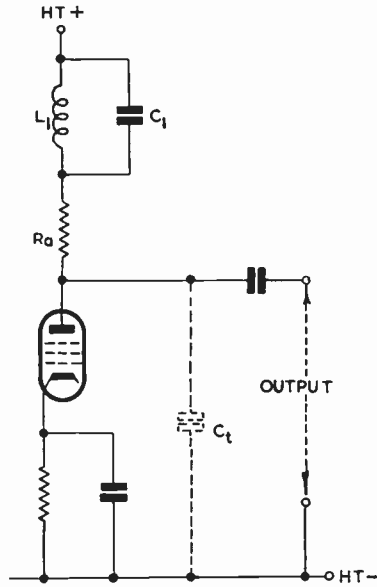

Fig. 47—Four-element shunt-inductance circuit

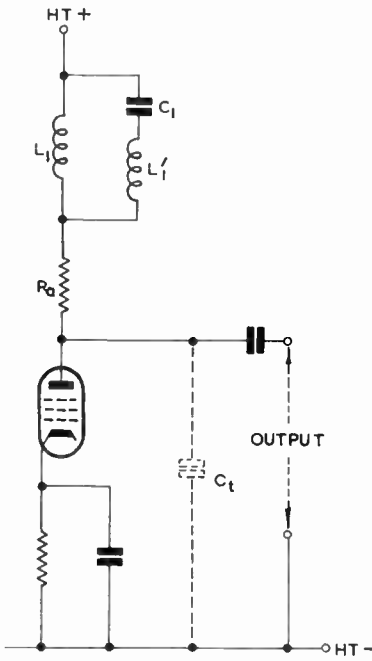

Fig. 48—Five-element shunt-inductance circuit

changes in phase as the frequency of the current fed to it is swung through the resonance value. Such phase changes would cause serious mutilation of pulse shape and C_1 is therefore made small to keep the resonance frequency high. The optimum value of C_1 can be calculated as follows:—

In expression (33) for the gain of the shunt-inductance circuit, the inductance L_1 is replaced by $L_1/(1 - \omega^2 L_1 C_1)$, the effective inductance of L_1 and C_1 in parallel. It is convenient to express C_1 as a fraction of C_t , and C_1 is accordingly replaced by bC_t where b is a numerical factor expressing the capacitance of C_1 . Thus L_1 is replaced by

$$L_1/(1 - \omega^2 b L_1 C_t)$$

and the resulting expression is arranged as in expression (42).

The conditions for maximal flatness (expression 47) can then be applied; the result is that $a = 0.414$ (as for the simple shunt-inductance circuit) and $b = 0.354$. C_t is commonly about 30 pF and C_1 should thus be approximately 10 pF to give maximal flatness of frequency response. This is a small capacitance which can be obtained without using a physical component. For example, the capacitance can be provided by the self-capacitance of L_1 by winding the coil in a suitable manner. Alternatively the capacitance can be obtained by mounting the coil near or within a conducting sheet.

The 4-element shunt-inductance circuit has a better frequency response than the shunt-inductance circuit but the step response shows more ripple for a steep transient input. The ripple is, however, at a higher frequency than for the shunt-inductance circuit and may not be visible on a cathode-ray tube screen.

3.11 5-ELEMENT SHUNT-INDUCTANCE CIRCUIT

A further improvement in the shunt-inductance circuit can be

SHUNT-INDUCTANCE CIRCUIT

obtained by connecting an additional inductor L'_1 in series with C_1 as shown in Fig. 48.

The process of compensation can be continued to higher orders; the next step (6-element circuit) is to connect a fixed capacitor in parallel with L'_1 . By continuing compensation the frequency, phase and transient responses can be made as close as we please to the ideal; the process is, in fact, one of successive approximation. In practice it is difficult to carry the process beyond the 6-element circuit because of the difficulty of making and adjusting the small values of inductance and capacitance which are necessary.

APPENDIX C

CONDITIONS FOR MAXIMAL FLATNESS

Equation (17) in Chapter 2 gives the high-frequency response of a simple RC-coupled amplifier as

$$\frac{A_{hf}{}^2}{A_{mf}{}^2} = \frac{1}{1 + x^2}$$

in which x is a variable directly proportional to frequency. The corresponding expression (41) for a shunt-inductance circuit is

$$\frac{A_{hf}{}^2}{A_{mf}{}^2} = \frac{1 + a^2x^2}{1 + (1 - 2a)x^2 + a^2x^4}$$

in which a is a factor expressing the magnitude of the inductor. These, and the corresponding expressions for other circuits not yet encountered, have the form of a fraction in which the numerator and the denominator are series containing even powers of x ; usually the denominator has more terms than the numerator. The expressions for the group delay of the circuits are also of this type. In general such expressions can be represented thus

$$\frac{a_0 + a_1x^2 + a_2x^4 + \dots + a_nx^{2n}}{\beta_0 + \beta_1x^2 + \beta_2x^4 + \dots + \beta_mx^{2m}} \quad \dots \quad (1)$$

in which a_0, a_1, \dots, a_n and $\beta_0, \beta_1, \dots, \beta_m$ are all constants and m normally exceeds n . When x is zero expression (1) has the value a_0/β_0 but when x increases from zero the value of the expression differs from a_0/β_0 the extent of the difference depending on the magnitude of the coefficients in the numerator and denominator.

It is the purpose of this appendix to derive the relationship between the coefficients which must be satisfied in order that expression (1) shall give a maximally-flat curve, i.e., a curve the equation to which has only a single term in frequency.

Dividing the numerator by the denominator in expression (1) we have

$$\frac{\alpha_0}{\beta_0} + \frac{(\alpha_1 - \alpha_0\beta_1/\beta_0)x^2 + (\alpha_2 - \alpha_0\beta_2/\beta_0)x^4 + \dots + (\alpha_n - \alpha_0\beta_n/\beta_0)x^{2n} - \alpha_0\beta_mx^{2m}/\beta_0}{\beta_0 + \beta_1x^2 + \beta_2x^4 + \dots + \beta_mx^{2m}} \quad (2)$$

in which it is assumed for convenience that $m = (n + 1)$, a condition found in practice. This expression can be made less dependent on frequency by equating the coefficient of x^2 in the numerator to zero.

We have then

$$\alpha_1 - \alpha_0\beta_1/\beta_0 = 0$$

giving

$$\frac{\alpha_1}{\beta_1} = \frac{\alpha_0}{\beta_0} \quad \dots \quad \dots \quad \dots \quad (3)$$

The expression can be made even less dependent on frequency by equating the coefficient of x^4 to zero; this gives

$$\alpha_2 - \alpha_0\beta_2/\beta_0 = 0$$

from which

$$\frac{\alpha_2}{\beta_2} = \frac{\alpha_0}{\beta_0} \quad \dots \quad \dots \quad \dots \quad (4)$$

This process can be continued for all the coefficients in the numerator up to that of x^{2n} for which

$$\frac{\alpha_n}{\beta_n} = \frac{\alpha_0}{\beta_0} \quad \dots \quad \dots \quad \dots \quad (5)$$

Combining equations (3), (4) and (5)

$$\frac{\alpha_0}{\beta_0} = \frac{\alpha_1}{\beta_1} = \frac{\alpha_2}{\beta_2} = \dots = \frac{\alpha_n}{\beta_n} \quad \dots \quad \dots \quad (6)$$

When these conditions are obeyed expression (1) becomes

$$\frac{\alpha_0}{\beta_0} - \frac{\alpha_0\beta_mx^{2m}/\beta_0}{\beta_0 + \beta_1x^2 + \beta_2x^4 + \dots + \beta_mx^{2m}} \quad \dots \quad (7)$$

in which there is only one term in x in the numerator. A curve having an equation of this type is said to have maximal flatness and to obtain this condition the coefficients of x must satisfy the condition of equation (6).

CHAPTER 4

SERIES-INDUCTANCE CIRCUIT

4.1 INTRODUCTION

IN the circuits described in the previous chapter the inductor L_1 , though in series with the anode resistor, forms part of the shunt arm of the network connecting the valve to the succeeding stage. In the alternative circuit shown in Fig. 49 (a) the inductor L_2 is a series element in the network between the anode of V1 and the grid of V2. The inductor thus separates the output capacitance C_o of V1 from the input capacitance C_i of V2 (Fig. 49a) and makes this circuit capable of a better performance than the shunt-inductance type. In the equivalent circuit of Fig. 49 (b) the coupling capacitor C_g is omitted because its reactance is negligible at high frequencies.

A significant feature of the series-inductance circuit is that the signal-frequency potential at the grid of V2 differs from that at the anode of V1; in the shunt-inductance circuit of Fig. 42 (a) the potentials at these two points are equal, the impedance between the points being negligible at high frequencies. In other words, Fig. 49 is an example of a 4-terminal network and Fig. 42 of a 2-terminal network; this point is illustrated in Fig. 50.

As illustrated in Fig. 50 (b) the series-inductance circuit has the form of a low-pass filter section and the practical values of C_o , L_2 and C_i are usually such that the source impedance (R_a) is of the same order as the iterative impedance of the 4-terminal network. As illustrated in Fig. 50 (b) the circuit is an example of a network which is terminated at the sending end but it can alternatively be terminated at the receiving end as shown in Fig. 52.

4.2 GAIN

The circuit of Fig. 49 (a) may be redrawn as shown in Fig. 51 in which

$$Z_1 = \frac{R_a + \frac{1}{j\omega C_o}}{R_a + \frac{1}{j\omega C_o}} = \frac{R_a}{1 + j\omega C_o R_a} \quad \dots \quad (59)$$

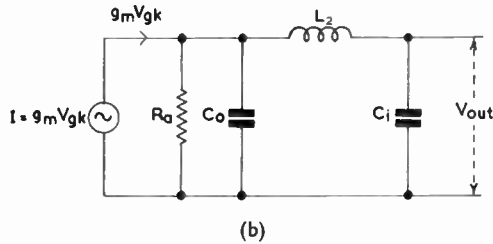
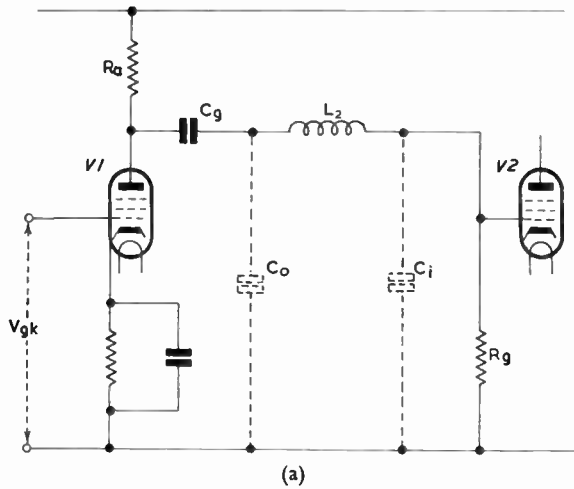

Fig. 49—Series-inductance circuit (a) and its electrical equivalent at high frequencies (b)

SERIES-INDUCTANCE CIRCUIT

$$Z_2 = j\omega L_2 \quad \dots \quad (60)$$

$$Z_3 = \frac{1}{j\omega C_i} \quad \dots \quad (61)$$

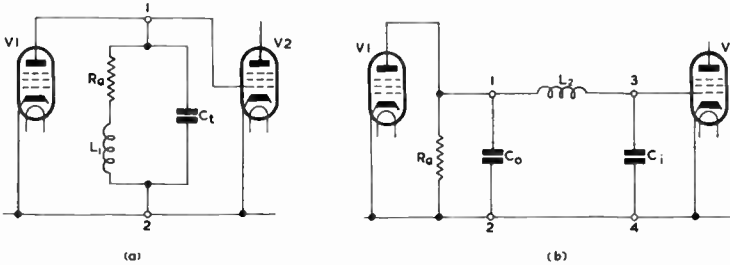

Fig. 50—Basic circuits of (a) shunt-inductance and (b) series-inductance amplifiers

From Fig. 51

$$V = -I \cdot \frac{Z_1(Z_2 + Z_3)}{Z_1 + Z_2 + Z_3}$$

in which I is the alternating component of the anode current. The negative sign indicates the antiphase relationship between V and I .

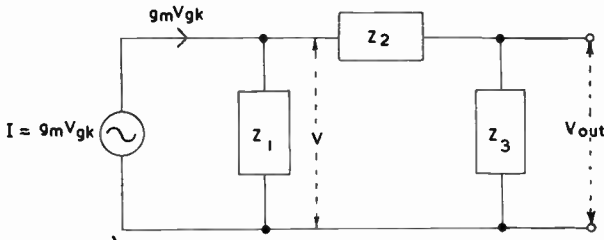

Fig. 51—Equivalent circuit of Fig. 49 (b)

But $I = g_m V_{gk}$

$$\therefore V = -g_m V_{gk} \cdot \frac{Z_1(Z_2 + Z_3)}{Z_1 + Z_2 + Z_3} \quad \dots \quad (62)$$

Moreover

$$V_{out} = V \cdot \frac{Z_3}{Z_2 + Z_3}$$

Substituting for V from (62)

$$V_{out} = -g_m V_{gk} \cdot \frac{Z_1 Z_3}{Z_1 + Z_2 + Z_3}$$

from which

$$A_{hf} = \frac{V_{out}}{V_{gk}} = - \frac{g_m Z_1 Z_3}{Z_1 + Z_2 + Z_3} \dots \dots \quad (63)$$

This expression shows that Z_1 and Z_3 may be interchanged without affecting the result; in other words the gain of the circuit is the same no matter whether the anode resistor is situated on the input side of the network as in Fig. 49 or on the output side as in Fig. 52. If C_o and C_i are equal, a given value of R_a gives the same performance at either end of the filter; if, as is usual in practice, C_o and C_i are not equal, when R_a is transferred from one end of the filter to the other, its value must be changed to give the same performance.

Substituting in (63) for Z_1 , Z_2 and Z_3 from (59), (60) and (61) respectively

$$A_{hf} = \frac{V_{out}}{V_{gk}} = - \frac{g_m \cdot \frac{R_a}{1 + j\omega C_o R_a} \cdot \frac{1}{j\omega C_i}}{\frac{R_a}{1 + j\omega C_o R_a} + j\omega L_2 + \frac{1}{j\omega C_i}}$$

4.3 FREQUENCY RESPONSE

Multiplying numerator and denominator by $j\omega C_i(1 + j\omega C_o R_a)$ and re-arranging we have

$$A_{hf} = - \frac{g_m R_a}{1 + j\omega(C_o + C_i)R_a - \omega^2 L_2 C_i - j\omega^3 L_2 R_a C_o C_i}$$

but $-g_m R_a = A_{mf}$ the gain at medium frequencies. Making this substitution we have

$$\frac{A_{hf}}{A_{mf}} = \frac{1}{1 + j\omega(C_o + C_i)R_a - \omega^2 L_2 C_i - j\omega^3 L_2 R_a C_o C_i} \dots \quad (64)$$

This expression can be put into a more convenient form by three substitutions similar to those used in the analysis of the shunt-inductance circuit (expressions (34), (35) and (36)). The first substitution is

$$\omega_0 = \frac{1}{R_a C_t}$$

and since $C_t = (C_o + C_i)$

$$\omega_0 = \frac{1}{R_a(C_o + C_i)} \dots \dots \dots \quad (65)$$

SERIES-INDUCTANCE CIRCUIT

which corresponds to expression (34). The second substitution is

$$x = \frac{\omega}{\omega_0}$$

and the third

$$L_2 = cR_a^2 C_t$$

Substituting $(C_o + C_i)$ for C_t

$$L_2 = cR_a^2(C_o + C_i) \dots \dots \dots (66)$$

which corresponds to expression (36).

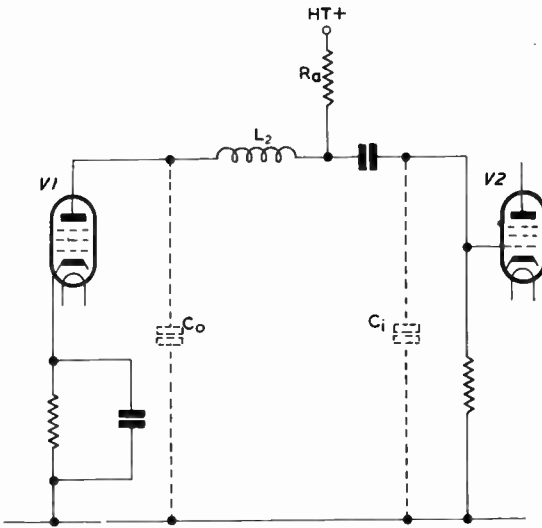

Fig. 52—Alternative series-inductance circuit

For a given pair of valves C_o and C_i are fixed. Thus, from (65) R_a is fixed by the chosen value of ω_0 ; the gain of the circuit is, of course, given by $g_m R_a$. Expression (65) defines the value of R_a connected across C_o , the input to the filter. If the anode resistor is connected across C_i , the output of the filter, its value R_a' should be $R_a C_o / C_i$ to give the same performance. Thus R_a' is given by

$$\begin{aligned} R_a' &= R_a \cdot \frac{C_o}{C_i} \\ &= R_a \cdot \frac{C_o \cdot C_t}{C_t \cdot C_i} \dots \dots \dots (67) \end{aligned}$$

This expression can be put into a neater form by the two substitutions

$$\frac{C_i}{C_t} = K \quad \dots \quad \dots \quad \dots \quad (68)$$

and

$$\frac{C_o}{C_t} = (1 - K) \dots \quad \dots \quad \dots \quad \dots \quad (69)$$

which follows from (68). K is a constant dependent on the valves used. Substituting for C_o/C_t and C_i/C_t in (67) gives the value of R_a' as

$$R_a' = R_a \cdot \frac{(1 - K)}{K} \quad \dots \quad \dots \quad \dots \quad (70)$$

This value of resistor connected across the filter output gives the same performance as a resistor R_a connected across the filter input.

Once R_a is determined, the value of L_2 is fixed by the chosen value of c according to equation (66).

Expression (64) can be put into a simpler form by substituting for R_a from (65), L_2 from (66), C_i/C_t from (68) and C_o/C_t from (69). The final form for the expression is

$$\frac{A_{hf}}{A_{mf}} = \frac{1}{1 + jx - cx^2K - jxc^3K(1 - K)} \quad \dots \quad \dots \quad (71)$$

Expression (71) may be written

$$\begin{aligned} \frac{A_{hf}}{A_{mf}} &= \frac{1}{\sqrt{\{(1 - cx^2K)^2 + [x - cx^3K(1 - K)]^2\}}} \\ \therefore \frac{A_{hf}^2}{A_{mf}^2} &= \frac{1}{(1 - cx^2K)^2 + [x - cx^3K(1 - K)]^2} \quad \dots \quad (72) \end{aligned}$$

The frequency response of the circuit is thus given by $20 \log_{10} \frac{A_{hf}}{A_{mf}}$

$$\begin{aligned} &= 10 \log_{10} \frac{A_{hf}^2}{A_{mf}^2} \\ &= -10 \log_{10} \frac{A_{mf}^2}{A_{hf}^2} \\ &= -10 \log_{10} \left\{ (1 - cx^2K)^2 + [x - cx^3K(1 - K)]^2 \right\} \quad (73) \end{aligned}$$

At a given frequency, i.e., for a given value of x , the response depends on c which measures the inductance L_2 and on K (which

80

SERIES-INDUCTANCE CIRCUIT

measures the ratio of the filter output capacitance to total filter capacitance). For the type of valve which is commonly used for video-frequency amplification C_i is approximately double C_o , corresponding to a value of K of 0.67, and we shall first plot curves of expression (73) for this value of K . The curves are shown in Fig. 53 for various values of c . The dotted curve ($c = 0$) gives the response of a simple RC-coupled stage. The curves show that the effect of increasing c from zero is first to extend and improve

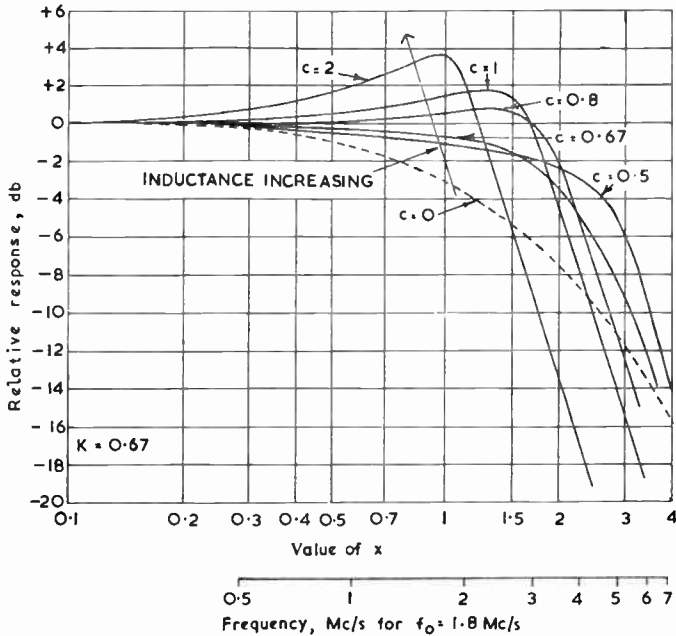

Fig. 53—Universal frequency-response curves for series-inductance circuit showing effect of varying the inductance

the frequency response. If the useful frequency response is taken as extending to the frequency at which the response is 3 db down, a stage with $c = 0.67$ covers approximately double the passband of a simple RC-coupled stage. If c is increased beyond 0.67, however, the response becomes more peaked and the passband smaller.

The curves in Fig. 54 illustrate the effect on the frequency response of varying K , keeping c constant; in other words these curves illustrate the performance of a circuit with a fixed inductor when the ratio of C_i to C_o is varied, the total capacitance ($C_o + C_i$) remaining constant. The chosen fixed value of c is 0.67 because,

as will be shown later, this value gives maximal flatness of frequency response. The response is shown for $K = 0.5, 0.6, 0.67$ and 0.75 . The curves show that the response at high frequencies can be considerably modified by alteration of K and in general the high-frequency response is increased by decreasing K ; for example when $K = 0.75$ the response is -9 db when $x = 2.5$ but decreasing K to 0.67 reduces the loss at this frequency to 6 db and when $K = 0.6$ the curve is level at $x = 2.5$. These curves illustrate one disadvantage of this circuit, namely that the high-frequency response is sensitive to small variations in the value of C_o or C_i .

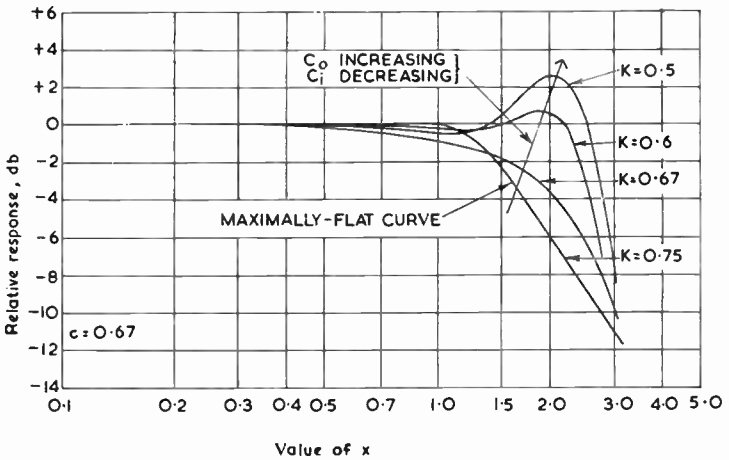

Fig. 54—Universal frequency-response curves for series-inductance amplifier showing effect of varying capacitance ratio

4.4 COMPARISON WITH SHUNT-INDUCTANCE CIRCUIT

If the curves of Fig. 54 are compared with the corresponding ones for the shunt-inductance circuit (Fig. 43) we can see that the series-inductance circuit can be used to give a substantially level frequency response up to higher values of x (i.e., higher frequencies) than the shunt-inductance circuit. We can illustrate this statement by comparing the useful extent of a certain frequency-response curve of the series-inductance circuit with that of a similarly-shaped curve for the shunt-inductance circuit. Suitable curves to compare are those for $c = 0.67$ and $K = 0.6$ for the series-inductance circuit and $a = 0.5$ for the shunt-inductance circuit, the curves representing possibly the best frequency responses of which these circuits are capable.

SERIES-INDUCTANCE CIRCUIT

The series-inductance circuit is 3 db down at $x = 2.5$ whereas the shunt-inductance circuit is 3 db down at $x = 1.7$. This means that if both circuits are designed to be 3 db down at the same frequency the series-inductance circuit will give a higher gain. This can easily be shown in the following way: For the series-inductance circuit the response is -3 db when $x = \omega/\omega_0' = 2.5$ where $\omega_0' = 1/R_a'C_t$. The shunt-inductance circuit is 3 db down when $x = \omega/\omega_0 = 1.7$ where $\omega_0 = 1/R_aC_t$. Equating the expressions for ω , which is the same for both circuits, we have

$$\begin{aligned} 2.5 \omega_0' &= 1.7 \omega_0 \\ \therefore \frac{2.5}{R_a'C_t} &= \frac{1.7}{R_aC_t} \\ \therefore R_a' &= \frac{2.5}{1.7} R_a \end{aligned}$$

Thus R_a' is greater than R_a in the ratio $2.5/1.7$ and the gain of the series-inductance circuit is greater by $20 \log_{10} 2.5/1.7 = 3.35$ db. The shunt-inductance circuit may, however, have a superior phase characteristic.

Numerical Example

A series-inductance stage has $C_o = 10$ pF, $C_i = 20$ pF and $g_m = 8$ mA/V. Find the values of R_a and L_2 to give a response level up to 3 Mc/s.

For this particular example $K = C_i/(C_i + C_o) = 20/30 = 0.67$ and the response curves are as shown in Fig. 53. From this diagram $c = 0.8$ gives a reasonably level response up to $x = 1.8$ and the design will be based on this value of c .

The frequency is 3 Mc/s when $x = 1.8$ and we have

$$\begin{aligned} x &= \frac{\omega}{\omega_0} \\ &= \frac{f}{f_0} \\ &= \frac{3}{f_0} \\ &= 1.8 \\ \therefore f_0 &= 1.67 \text{ Mc/s.} \end{aligned}$$

From equation (65)

$$\begin{aligned} R_a &= \frac{1}{\omega_0 C_t} \\ &= \frac{1}{6.284 \times 1.67 \times 10^6 \times 30 \times 10^{-12}} \Omega \\ &= 3,180 \Omega \end{aligned}$$

From equation (66)

$$\begin{aligned} L_2 &= cR_a^2 C_t \\ &= 0.8 \times (3.18 \times 10^3)^2 \times 30 \times 10^{-12} \text{ H} \\ &= 242 \mu\text{H} \end{aligned}$$

The stage gain = $g_m R_a$

$$\begin{aligned} &= 8 \times 10^{-3} \times 3,180 \\ &= 25 \text{ approximately} \end{aligned}$$

The frequency-response curve for these values of R_a , C_t and L_2 can be exhibited by locating a logarithmic scale on Fig. 53 with 1.67 Mc/s coinciding with $x = 1$ as shown.

4.5 CONDITIONS FOR MAXIMAL FLATNESS OF FREQUENCY RESPONSE

Expanding the denominator of expression (72), we find that the frequency response of the series-inductance circuit is given by

$$\frac{A_{hf}}{A_{mf}} = \frac{1}{1 + (1 - 2cK)x^2 + [c^2K^2 - 2cK(1 - K)]x^4 + c^2K^2(1 - K)^2x^6} \quad (74)$$

The conditions for maximal flatness of this expression can be obtained, as for the shunt-inductance circuit, by comparing expression (74) with expression (42) to find expressions for the constants α_0 , α_1 , β_0 , β_1 , etc., which are then substituted in the general expression for maximal flatness (47). Since $\alpha_1 = 0$ and $\alpha_2 = 0$ this yields the results

$$\begin{aligned} 1 - 2cK &= 0 \\ c^2K^2 - 2cK(1 - K) &= 0 \end{aligned}$$

But for expressions similar to (74) which have a numerator of unity, the conditions for maximal flatness can be derived directly by inspection. The condition is that the expression should contain only a single frequency-dependent term. Expression (74) contains three such terms and two must be equated to zero to give the conditions for maximal flatness. It is usual to leave the term

SERIES-INDUCTANCE CIRCUIT

with the highest power of the variable and thus the coefficients of x^2 and x^4 are made zero. We thus have, as before,

$$(1 - 2cK) = 0 \quad \dots \dots \dots (75)$$

and

$$c^2K^2 - 2cK(1 - K) = 0 \quad \dots \dots (76)$$

Expression (76) simplifies to

$$cK - 2(1 - K) = 0 \quad \dots \dots (77)$$

From (75)

$$c = \frac{1}{2K} \quad \dots \dots \dots (78)$$

Substituting for c in (77)

$$\begin{aligned} 0.5 - 2(1 - K) &= 0 \\ \therefore K &= 0.75 \quad \dots \dots \dots (79) \end{aligned}$$

Substituting for K in (78)

$$c = \frac{1}{1.5} = 0.67 \quad \dots \dots \dots (80)$$

The frequency response for $c = 0.67$ and $K = 0.75$ is shown in Fig. 54. The curve is 6 db down when $x = 2$ and a much better approximation to the ideal frequency response is obtained with smaller values of K . For example, when $c = 0.67$ and $K = 0.6$ the response is maintained level within less than 1 db up to $x = 2.3$. This illustrates a point made earlier, that the frequency response can sometimes be improved by choosing values slightly different from those giving maximal flatness. This can also be inferred from equation (75). For maximal flatness the terms in x^2 and x^4 vanish, leaving the term in x^6 , but it is possible to find values of c and K for which the net value of the terms in x^2 , x^4 and x^6 is less than the value of the x^6 term for maximal flatness. This condition is obtained when $c = 0.67$ and $K = 0.6$.

4.6 PHASE RESPONSE

If we substitute $-g_m R_a$ for A_{mf} in expression (71) we have

$$A_{hf} = \frac{V_{out}}{V_{gk}} = \frac{-g_m R_a}{1 + jx - cx^2K - jcx^3K(1 - K)} \quad \dots \dots (81)$$

But $g_m V_{gk} = I$, the alternating component of the anode current

$$\therefore \frac{V_{out}}{I} = \frac{-R_a}{1 - cx^2K + j[x - cx^3K(1 - K)]} \quad \dots \dots (82)$$

When this is rationalised we have

$$\frac{V_{out}}{I} = -R_a \cdot \frac{(1 - cx^2K) - j[x - cx^3K(1 - K)]}{(1 - cx^2K)^2 + [x - cx^3K(1 - K)]^2} \quad (83)$$

which is of the form $(R + jX)$. The phase difference ϕ between V_{out} and I is given by $\tan^{-1}X/R$, i.e.,

$$\phi = \tan^{-1} \frac{x - cx^3K(1 - K)}{cx^2K - 1} \quad \dots \quad (84)$$

This expression is plotted in Fig. 55 for $c = 0.8$ and $K = 0.67$, the values chosen in the numerical example. The second curve is for $c = 0.48$ and $K = 0.833$; as shown later these values give maximal flatness of group delay-frequency characteristic. The angles are all negative; as explained earlier this indicates a lagging phase.

The delay of an amplifier using this circuit can be estimated in the following way. Expression (84) may be written

$$\tan \phi = \frac{x - cx^3K(1 - K)}{cx^2K - 1} \quad \dots \quad (85)$$

Differentiating this with respect to x we have

$$\sec^2 \phi \cdot \frac{d\phi}{dx} = - \frac{1 + x^2cK[1 - 3(1 - K)] + x^4c^2K^2(1 - K)}{(cx^2K - 1)^2} \quad (86)$$

Now

$$\sec^2 \phi = 1 + \tan^2 \phi$$

and substituting for $\tan \phi$ from (85)

$$\sec^2 \phi = 1 + \left[\frac{x - cx^3K(1 - K)}{cx^2K - 1} \right]^2$$

Substituting for $\sec^2 \phi$ in (86)

$$\frac{d\phi}{dx} = - \frac{1 + x^2cK[1 - 3(1 - K)] + x^4c^2K^2(1 - K)}{(cx^2K - 1)^2 + [x - cx^3K(1 - K)]^2} \quad \dots \quad (87)$$

This is a general expression for the slope of the characteristics in Fig. 55. The slope at the origin is obtained by putting $x = 0$ which gives

$$\frac{d\phi}{dx} = -1 \quad \dots \quad (88)$$

The slope of the characteristics is thus -1 and is independent of

SERIES-INDUCTANCE CIRCUIT

the value of c and of K . All curves thus have the same slope at the origin and if they continued with this same slope as frequency increases to the limit of the video-frequency band, the phase characteristic would be ideal. The ideal characteristic is thus a straight line passing through the origin and having a slope (expressed in radians) of unity. If the negative sign is ignored the slope expressed in degrees is 57.3 and the straight line with this slope is shown in Fig. 55.

It can be seen that the two practical $\phi - x$ curves depart from the ideal at high values of x although the agreement between the ideal curve and the curve for $c = 0.48$ and $K = 0.833$ is very good; the latter curve represents the performance of a circuit with a maximally-flat group delay characteristic.

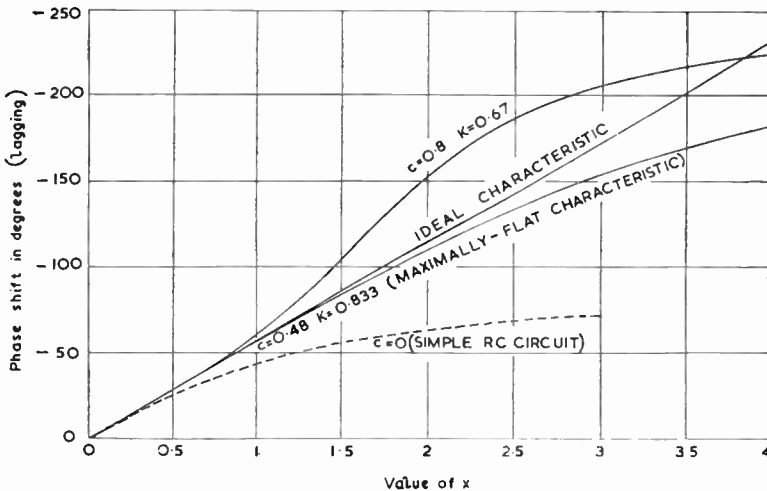

Fig. 55—Universal phase shift-frequency curves for series-inductance amplifier

Numerical Example

The values $c = 0.8$ and $K = 0.67$ are those adopted in the earlier numerical example and from Fig. 55 it is possible to calculate the variation in delay of such a circuit.

In this example the upper frequency limit occurred at $x = 1.8$ and from Fig. 55 the phase angle at this frequency is 136° . Ideally it should be $1.8 \times 57.3 = 103^\circ$; the departure is thus 33° which, at a frequency of 3 Mc/s, corresponds to a variation in delay given by expression (3) namely

$$\begin{aligned}
 D &= \frac{\phi_d}{360f} \\
 &= \frac{33}{360 \times 3 \times 10^6} \text{ sec} \\
 &= \frac{11}{360} \mu\text{sec} \\
 &= 0.03 \mu\text{sec}
 \end{aligned}$$

Thus only 3 such stages could be used in cascade before the overall variation in delay approaches the value 0.1 μsec quoted earlier as the maximum tolerable before obvious distortion occurs.

For the maximally-flat characteristic the deviation from the ideal at $x = 1.8$ is only approximately 1° , representing a very much better performance.

4.7 GROUP DELAY

An expression for the group delay of the series-inductance circuit can be obtained from expression (87)

$$\begin{aligned}
 \text{group delay} &= \frac{d\phi}{d\omega} \\
 &= \frac{1}{\omega_0} \cdot \frac{d\phi}{dx} \\
 &= - \frac{1}{\omega_0} \cdot \frac{1 + x^2cK[1 - 3(1 - K)] + x^4c^2K^2(1 - K)}{(cx^2K - 1)^2 + [x - cx^3K(1 - K)]^2} \quad \dots \quad (89)
 \end{aligned}$$

The negative sign prefacing this expression is a consequence of the negative (lagging) phase angle but since a negative phase angle implies positive time delay, expression (89) is assumed to give a positive result and is so plotted in Fig. 56. As in previous circuits it is more convenient to plot values of $d\phi/dx$ (normalised group delay) than $d\phi/d\omega$ and the curves of Fig. 56 show the variation of $d\phi/dx$ for $c = 0.8$, $K = 0.67$ (values chosen for the numerical example) and $c = 0.48$, $K = 0.833$ (values giving maximal flatness of group-delay characteristic). To obtain group delay from Fig. 56 the ordinates should be divided by ω_0 . These curves show more convincingly than those of Fig. 56 the superiority of the phase response for the circuit having $c = 0.48$ and $K = 0.833$. The curve for $c = 0.8$ and $K = 0.67$ has a marked departure from a level response around $x = 1.7$ showing the phase response to be unsatisfactory at such frequencies. This departure from linearity

SERIES-INDUCTANCE CIRCUIT

of the phase characteristic is associated with the sharp cut-off of the frequency response curve shown in Fig. 53.

4.8 CONDITIONS FOR MAXIMAL FLATNESS OF GROUP DELAY

Expression (89) can be rewritten in ascending powers of x thus

$$\frac{d\phi}{d\omega} = -\frac{1}{\omega_0} \cdot \frac{1 + x^2 cK[1 - 3(1 - K)] + x^4 c^2 K^2(1 - K) + x^6 c^3 K^2(1 - K)^2}{1 + x^2(1 - 2cK) + x^4[c^2 K^2 - 2cK(1 - K)]} \dots (90)$$

Applying the conditions of expression (47)

$$\frac{-1}{1} = \frac{-cK[1 - 3(1 - K)]}{1 - 2cK} = \frac{-c^2 K^2(1 - K)}{c^2 K^2 - 2cK(1 - K)} \dots (91)$$

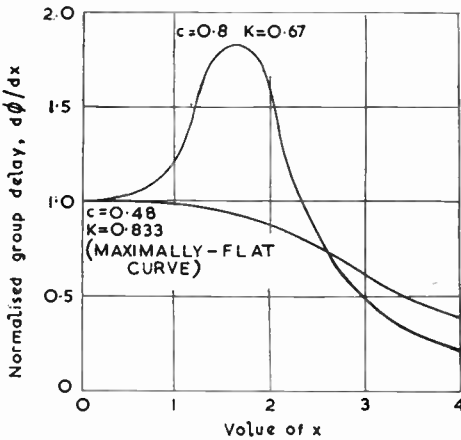

Fig. 56—Universal normalised group delay-frequency curves for a series-inductance amplifier

Cross-multiplying the first and second fractions

$$1 - 2cK = cK[1 - 3(1 - K)] \dots \dots (92)$$

$$\therefore 3cK^2 = 1$$

$$\therefore cK^2 = \frac{1}{3} \dots \dots \dots (93)$$

Cross-multiplying the first and third fractions in expression (91)

$$c^2 K^2(1 - K) = c^2 K^2 - 2cK(1 - K)$$

$$\therefore cK^2 = 2(1 - K)$$

Substituting for cK^2 from (93)

$$\frac{1}{3} = 2(1 - K)$$

$$\therefore K = \frac{5}{6} = 0.833$$

Substituting for K in (93) gives

$$c = 0.48$$

The conditions for maximal flatness of group delay-frequency characteristic are thus

$$\begin{aligned} K &= 0.833 \\ c &= 0.48 \end{aligned} \quad \dots \quad \dots \quad \dots \quad \dots \quad (94)$$

4.9 RESPONSE TO VOLTAGE STEP

The response of an amplifier to a voltage step is a most useful test of its performance as video-frequency amplifier. When such a step is applied to the grid of a series-inductance amplifier, a corresponding current step is applied to the anode circuit. The voltage generated across the anode resistor, R_a , is not directly applied to the grid of the next valve (as in a shunt-inductance circuit) but is applied to the series circuit of L_2 and C_i , the voltage across C_i being the input to the next valve. The series inductance delays the start of the output voltage as shown in Fig. 57; for comparison, curves for a simple RC-coupled circuit and a shunt-inductance circuit are included on the same diagram.

The rise time for the series-inductance circuit is approximately $1.5 R_a C_i$ compared with $1.1 R_a C_i$ for the shunt-inductance circuit and $2.2 R_a C_i$ for the simple RC-coupled circuit.

4.10 DESIGN OF A SERIES-INDUCTANCE CIRCUIT

The conditions for maximally-flat frequency response are $K = 0.75$ and $c = 0.67$; for a maximally-flat group-delay characteristic $K = 0.833$ and $c = 0.48$. The circuit cannot, therefore, be designed to give maximal flatness in both respects simultaneously. A compromise solution is commonly adopted such as $K = 0.8$ and $c = 0.6$. To make $K = 0.8$, C_i must equal $4 C_o$ and normally the input capacitance of valves of the type likely to be used in a video-frequency amplifier is approximately double the output capacitance (corresponding to $K = 0.67$). The required value of K can sometimes be obtained by placing the coupling capacitor

SERIES-INDUCTANCE CIRCUIT

(which has appreciable capacitance to earth) on the grid side of the inductor (where increased capacitance is wanted). It is undesirable to add fixed capacitors to the filter output to increase K because this increases C_t , necessitating a reduction in R_a and gain to maintain a given frequency response.

The value of c must be kept low to avoid excessive overshoot. As explained for the shunt-inductance circuit, a small amount of overshoot may be acceptable when a small number of cascaded stages is to be used or when the interpreting device does not register the oscillations.

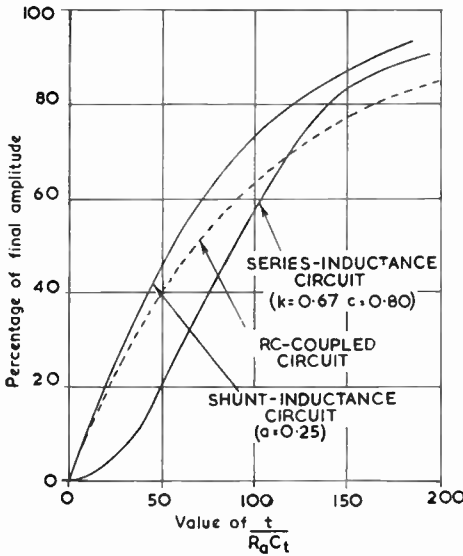

Fig. 57—Universal curves showing step responses of series-inductance, shunt-inductance and simple RC-coupled circuits

The tendency towards ringing can be reduced by connecting a resistor in parallel with L_2 . The value of the resistor must be chosen with care; if it is too high, its effect will be negligible whereas if it is too low, it will degrade the performance of the circuit. A typical practical value of such a damping resistor is $5R_a$, i.e., of the order of 15 k Ω .

4.11 COMBINED SHUNT- AND SERIES-INDUCTANCE CIRCUIT

Shunt- and series-inductance circuits can be combined as shown in Fig. 58; this circuit gives a performance slightly superior to that of the series-inductance circuit. Some indication of the order of

component values required can be obtained by determining L_1 , L_2 and K for maximal flatness of frequency response and group delay. The method of determining these values has already been shown for the shunt and series-inductance circuits and will not be

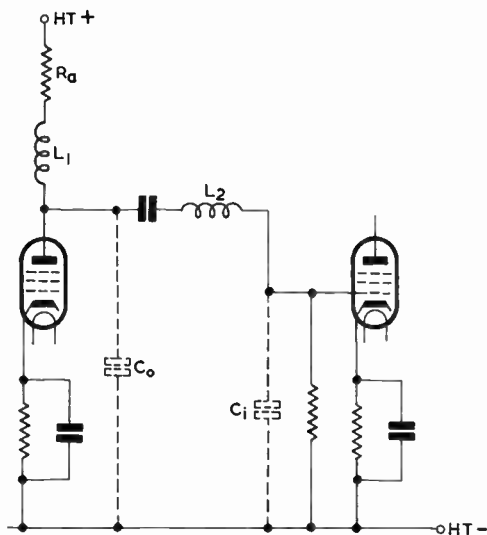

Fig. 58—Combined shunt- and series-inductance circuit

repeated for the combined circuits because the expressions involved are somewhat unwieldy. The results are, however, set out below.

Condition	L_1	L_2	$K (= C_0/C_1)$
Maximal flatness of frequency response ..	$0.14 R_a^2 C_l$	$0.60 R_a^2 C_l$	0.6
Maximal flatness of group delay characteristic ..	$0.10 R_a^2 C_l$	$0.458 R_a^2 C_l$	0.72

The value of K likely to be obtained in practice is approximately 0.67; this value lies between the two quoted above and is a suitable value to use. Values of L_1 and L_2 may differ slightly from the values listed above; as shown for the shunt- and series-inductance circuits, it is often possible to effect an improvement by slight departure from the values for maximal flatness. Moreover, the component values for maximal flatness sometimes lead to slight

SERIES-INDUCTANCE CIRCUIT

overshoot which, though acceptable in a single stage, may be intolerable in a multi-stage amplifier.

The superiority of the combined shunt- and series-inductance amplifier over the simple series-inductance type can be explained in the following way: The series inductance together with the capacitors C_o and C_i constitute a low-pass π -section network. The iterative impedance of such a network is substantially constant at low frequencies but rises rapidly as frequency approaches the cut-off value. To obtain a good approximation to a level frequency response the terminating impedance of the network should similarly rise with frequency, to maintain matched conditions over as large a frequency range as possible. In a simple series-inductance amplifier the terminating impedance is R_a which is constant and matching is good only over a restricted frequency range. In the combined circuit of Fig. 58, the terminating impedance is that of R_a and L_1 in series. This rises with increase in frequency and by correct design can be made to match the variations of iterative impedance, thus maintaining good voltage gain over a wide frequency band.

CHAPTER 5

CIRCUITS EMPLOYING CATHODE COMPONENTS

5.1 INTRODUCTION

IN the three circuits described in the previous chapters, a satisfactory performance is obtained from a video-frequency stage by arranging for the shunt capacitance at the anode to form an essential component of the load impedance into which the valve works. There is, however, an alternative method of design in which the disadvantages associated with the anode shunt capacitance are offset by including a corrective network in the cathode circuit. Such a cathode circuit gives frequency-discriminating current feedback which, by suitable design, can be arranged to give the necessary level frequency response and desired phase characteristics over the video band.

5.2 EFFECT OF CURRENT FEEDBACK

The simplest circuit employing such feedback is that shown in Fig. 59. At medium and low frequencies the reactance of C_t is large compared with R_a and that of C_k is large compared with R_k ; thus the amplifier effectively performs as one with an anode load of R_a and an unbypassed cathode resistance of R_k . There is thus some current feedback due to R_k and the gain is less at these frequencies than if R_k were decoupled. At high frequencies, when the shunting effect of C_t on R_a is appreciable, the reactance of C_k is comparable with R_k and reduces feedback to improve gain, and maintain the frequency response.

5.3 CONDITIONS FOR MAXIMAL FLATNESS OF FREQUENCY RESPONSE

If the cathode circuit impedance is Z_k , the effect of the current feedback is to reduce the mutual conductance from g_m to g_m' where

$$g_m' = \frac{g_m}{1 + g_m Z_k} \quad \dots \quad \dots \quad \dots \quad (95)$$

This is proved in Appendix D. The gain of the valve thus becomes

$$A_{hf} = -g_m' Z_a$$

CIRCUITS EMPLOYING CATHODE COMPONENTS

in which Z_a is the impedance of R_a and C_t in parallel. Substituting for g_m' from (95) and putting Z_a equal to $R_a/(1 + j\omega C_t R_a)$ we have

$$A_{hf} = - \frac{g_m R_a / (1 + j\omega C_t R_a)}{1 + g_m R_k / (1 + j\omega C_k R_k)} \quad \dots \quad (96)$$

Since $A_{mf} = -g_m R_a$, this may be written

$$\frac{A_{mf}}{A_{hf}} = 1 + j\omega C_t R_a + g_m R_k \cdot \frac{1 + j\omega C_t R_a}{1 + j\omega C_k R_k} \quad \dots \quad (97)$$

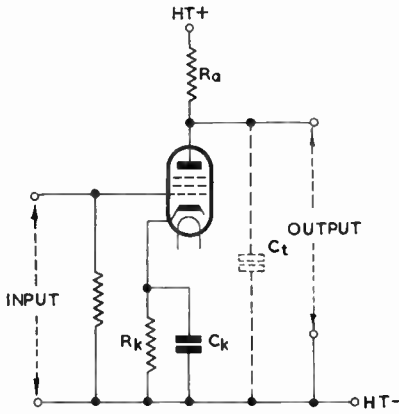

Fig. 59—Use of cathode capacitance to improve high-frequency response

The condition for maximal flatness is that the expression for the frequency response should contain only a single term in frequency. As it stands, expression (97) has two terms in ω but the third term can be made independent of frequency by making $R_a C_t$ equal to $R_k C_k$. We then have

$$\frac{A_{mf}}{A_{hf}} = (1 + g_m R_k) + j\omega C_t R_a$$

from which

$$\frac{A_{mf}^2}{A_{hf}^2} = (1 + g_m R_k)^2 + \omega^2 C_t^2 R_a^2$$

which is the equation to a maximally-flat curve. The condition for maximal flatness is thus

$$R_a C_t = R_k C_k \quad \dots \quad (98)$$

Putting $R_k C_k = R_a C_t$ in (96) gives

$$\begin{aligned}
 A_{hf} &= - \frac{g_m R_a}{1 + g_m R_k + j\omega C_t R_a} \\
 &= - \frac{g_m R_a}{1 + \frac{g_m R_a}{j\omega C_t R_a} + g_m R_k} \dots \dots (99)
 \end{aligned}$$

It is instructive to compare this expression with that for an amplifier without feedback, i.e., an amplifier without R_k and C_k (Fig. 59) or one in which R_k and C_k are present but C_k is so large that its reactance is small compared with associated impedances at the frequencies under consideration. As shown in expression (13) the high-frequency gain of such an amplifier is given by

$$A_{hf} = - \frac{g_m R_a}{1 + j\omega C_t R_a}$$

Comparison of this with expression (99) shows that the current feedback has two effects:

- (1) It reduces the effective g_m of the valve to $g_m/(1 + g_m R_k)$;

$$\therefore g_m' = \frac{g_m}{1 + g_m R_k}$$

- (2) It reduces the effective output capacitance C_t in the same ratio, i.e., to $C_t/(1 + g_m R_k)$; this improves the gain at high frequencies relative to that at medium frequencies (though both are less than without feedback because of the reduction in effective mutual conductance). Thus

$$C_t' = \frac{C_t}{1 + g_m R_k}$$

where C_t' represents the effective anode-earth capacitance.

These two points are illustrated in Fig. 60 which gives the response curves of an RC-coupled amplifier with and without maximal current feedback. The application of feedback reduces the gain at all frequencies but improves the frequency response. Without feedback the amplifier is 10 db down at the frequency f_1 whereas with feedback it is only 3 db down at the same frequency.

Numerical Example

As a numerical example, suppose that an amplifier of the type

CIRCUITS EMPLOYING CATHODE COMPONENTS

shown in Fig. 59 is required to have a frequency response flat within 1 db up to 3 Mc/s. To give the correct grid bias the cathode resistor R_k is 200 Ω ; C_t is 30 pF and g_m is 8 mA/V. The values of R_a and C_k and the stage gain are required.

From Fig. 38 the frequency response of a simple RC-coupled amplifier is 1 db down when $x = 0.5$. Thus $\omega/\omega_0 = 0.5$ and ω corresponds to 3 Mc/s; ω_0 therefore corresponds to 6 Mc/s.

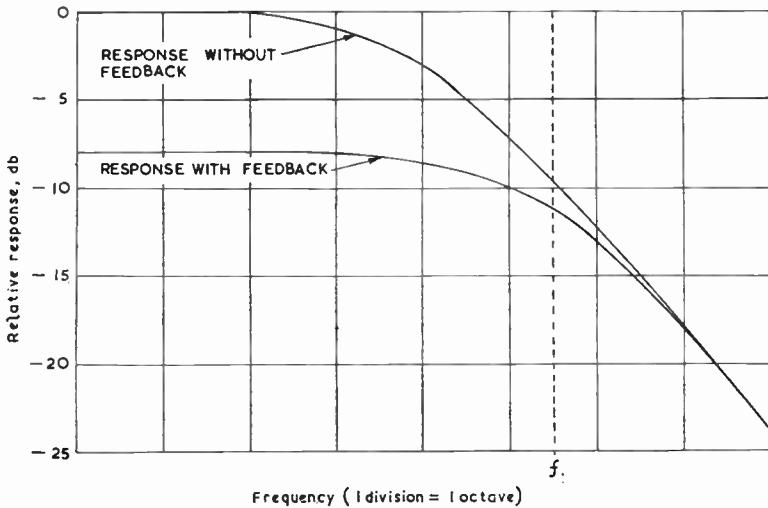

Fig. 60—Effect of maximal current feedback on the frequency response of a single-stage RC-coupled amplifier

From (99) the effective anode shunt capacitance is given by

$$\begin{aligned}
 C_t' &= \frac{C_t}{1 + g_m R_k} \\
 &= \frac{30}{1 + 8 \times 10^{-3} \times 200} \text{ pF} \\
 &= \frac{30}{2.6} \text{ pF} \\
 &= 11.5 \text{ pF}
 \end{aligned}$$

The current feedback has effectively reduced the anode-shunt capacitance to 1/2.6 of its real value. The valve behaves as though it had an output capacitance of 11.5 pF and the value of the anode resistor to give the desired frequency response can be obtained

from the value of ω_0 and C_t' thus

$$\begin{aligned} R_a &= \frac{1}{\omega_0 C_t'} \\ &= \frac{1}{6.284 \times 6 \times 10^6 \times 11.5 \times 10^{-12} \Omega} \\ &= 2.3 \text{ k}\Omega \end{aligned}$$

The effective mutual conductance of the valve is reduced by feedback in the same ratio as the effective output capacitance and is thus given by $8/2.6 = 3.08$ mA/V giving the stage gain as

$$\begin{aligned} A &= g_m R_a \\ &= 3.08 \times 10^{-3} \times 2.3 \times 10^3 \\ &= 7 \text{ only} \end{aligned}$$

The value of C_k necessary to give this performance can be determined by equating the time constants of anode and cathode components.

$$\begin{aligned} R_k C_k &= R_a C_t \\ \therefore C_k &= \frac{R_a C_t}{R_k} \\ &= \frac{2,300 \times 30}{200} \text{ pF} \\ &= 345 \text{ pF} \end{aligned}$$

The gain is approximately 0.4 times that available from a shunt-inductance circuit with the same frequency response (and thus the same rise time) and is equal to that obtained from the same valve with an anode resistor of $2,300/2.6 = 890 \Omega$ and a decoupled cathode circuit. To offset this disadvantage, the feedback circuit has better linearity at low frequencies and greater output signal-handling capacity.

The latter advantage arises in the following manner: Because of the effective reduction in output capacitance, a valve with feedback can be operated with a higher value of anode-load resistor than the same valve without feedback yet giving the same frequency response. This increased value of anode load enables the valve to deliver a bigger output-voltage swing for a given anode-current swing than without feedback. Thus feedback of this type may be used to obtain a larger undistorted output from a given valve, or alternatively, if no increase in output is required, enables a valve to be

CIRCUITS EMPLOYING CATHODE COMPONENTS

replaced by a smaller-current type which can deliver the required signal by virtue of feedback.

5.4 ADJUSTMENT OF FEEDBACK INDEPENDENTLY OF BIAS

In particular circumstances it may happen that the value of cathode resistor required for grid bias purposes is also suitable for providing current feedback, and a single cathode resistor can

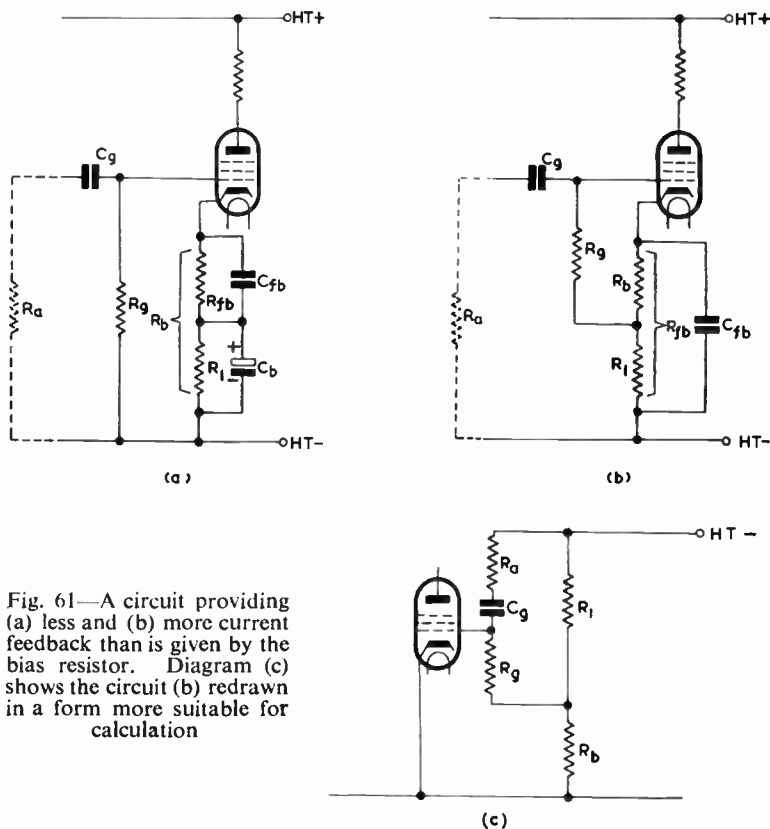

Fig. 61—A circuit providing (a) less and (b) more current feedback than is given by the bias resistor. Diagram (c) shows the circuit (b) redrawn in a form more suitable for calculation

be used. In general, however, feedback requirements necessitate a value of resistor which differs from that required to supply grid bias and Fig. 61(a) gives a circuit diagram in which the degree of feedback is less than that provided by an unbypassed bias resistor. The bias resistance R_b comprises two resistors, R_{fb} and R_1 , in series but of these only one, R_{fb} , is required to give current feedback. The other, R_1 , is therefore shunted by a large-value capacitor C_b ,

the reactance of which is so small that the video signals generated across it by the alternating component of valve anode current are negligible. The feedback voltage is developed across R_{fb} only and this is shunted by a small capacitor C_{fb} which has the effect of reducing the feedback as frequency rises, thus maintaining the frequency response as explained above.

In the circuit of Fig. 61(b) the degree of feedback is greater than that provided by the cathode bias resistor. To make the cathode resistance larger than R_b , an additional resistor R_1 is introduced in series with it. Neither of the two resistors is decoupled and both are effective in providing feedback. The feedback is made to vary with frequency by inclusion of the capacitor C_{fb} . The grid leak R_g is returned to the junction of R_1 and R_b in order to give the correct bias, i.e., in order that the steady voltage between grid and cathode shall be due to the steady component of anode current flowing in R_b .

Calculation of the degree of feedback in circuits such as those illustrated in Fig. 61(a) and (b) is not always as straightforward as might be imagined because the feedback is dependent on the impedance of the signal source and on the point of the cathode circuit to which the grid leak is returned. The signal source impedance is often approximately equal to the anode-load resistor R_a of the previous valve and is indicated as such in Fig. 61. The dependence of feedback on these factors can be more easily visualised by drawing the circuit diagram in an unconventional form. Fig. 61(c) gives the circuit of Fig. 61(b) redrawn thus.

Fig. 61(c) shows that the grid of the valve is connected to the junction of a potential divider composed of R_a and R_g and that this divider is connected across part (R_1) of the cathode load. Because of this, the voltage generated across the cathode load by the alternating component of anode current is not applied between grid and cathode in full, and thus the whole of the cathode circuit is not fully effective in providing current feedback. The voltage across R_b is fully effective but that generated across R_1 is reduced in the ratio $R_g/(R_a + R_g)$ before application to the grid. If R_a is small compared with R_g (which is often true in practice) this reduction is negligible and R_b and R_1 are both fully effective in providing feedback. If, however, R_a and R_g are comparable, the reduction is considerable and must be taken into account in calculating feedback.

5.5 THREE-ELEMENT CURRENT-FEEDBACK CIRCUIT

It has already been shown that a shunt-inductance circuit can be made to give a closer approximation to the ideal response by

CIRCUITS EMPLOYING CATHODE COMPONENTS

the inclusion of further capacitors or inductors of suitable value. A similar process can be applied to the cathode circuit and a 3-element current-feedback circuit is illustrated in Fig. 62. The circuit is basically that of Fig. 59 but an inductor is connected in series with the cathode capacitor C_k . White* suggests that a value for L_k is $0.5eC_k/g_m^2$ where $e = R_a/R_k = C_k C_t$.

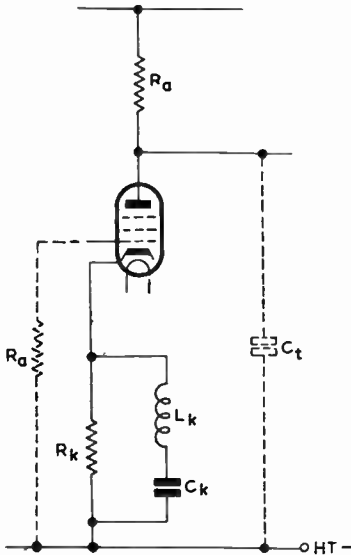

Fig. 62—Three-element current-feedback circuit

Numerical Example

Suppose $g_m = 8 \text{ mA/V}$, $R_a = 2 \text{ k}\Omega$, $C_t = 25 \text{ pF}$ and $R_k = 150 \Omega$. The values of C_k and L_k are required. We have

$$\begin{aligned}
 e &= \frac{R_a}{R_k} \\
 &= \frac{2,000}{150} \\
 &= 13.33
 \end{aligned}$$

* E. L. C. White, "Design of a Television Camera Channel for a C.P.S. Emitron." *I.E.E. Journal*, November 1950.

and

$$\begin{aligned} C_k &= eC_t \\ &= 13.33 \times 25 \text{ pF} \\ &= 333 \text{ pF} \end{aligned}$$

The value of the cathode inductor is therefore given by

$$\begin{aligned} L_k &= \frac{0.5eC_k}{g_m^2} \\ &= \frac{0.5 \times 13.33 \times 333 \times 10^{-12}}{8^2 \times 10^{-6}} \text{ H} \\ &= 34.7 \text{ } \mu\text{H} \end{aligned}$$

A circuit such as that shown in Fig. 62 gives about half the gain of a four-element shunt-inductance circuit with the same bandwidth but as already pointed out the feedback circuit is capable of a larger undistorted output and at low frequencies has better linearity.

APPENDIX D

DECREASE IN GAIN DUE TO CURRENT NEGATIVE FEEDBACK

FIG. D.1 gives the basic circuit of an amplifying stage which has an anode-load impedance Z_a and a cathode impedance Z_k . The alternating component of anode current I_a in flowing through Z_a produces the output voltage V_{out}

$$V_{out} = I_a Z_a \quad \dots \dots \dots (1)$$

In flowing through Z_k this current gives rise to the feedback voltage V_{fb}

$$V_{fb} = I_a Z_k \quad \dots \dots \dots (2)$$

Moreover if Z_a and Z_k are both small in comparison with the anode a.c. resistance of the valve we have

$$I_a = g_m V_{gk}$$

and, substituting for I_a in (1)

$$V_{out} = g_m V_{gk} Z_a$$

CIRCUITS EMPLOYING CATHODE COMPONENTS

giving the internal gain A of the amplifier, i.e., the gain measured with respect to a grid-cathode input signal as

$$A = \frac{V_{out}}{V_{gk}} = g_m Z_a \dots \dots \dots (3)$$

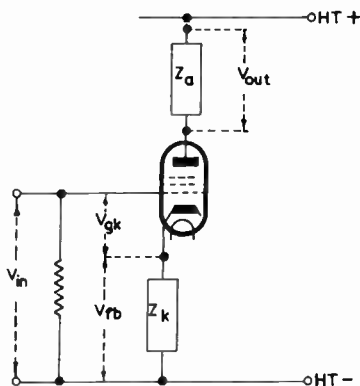

Fig. D.1—Basic circuit for current negative feedback

The external gain A' of the amplifier, i.e., the gain measured with respect to an input signal V_{in} is similarly given by

$$A' = \frac{V_{out}}{V_{in}} = g_m' Z_a \dots \dots \dots (4)$$

where g_m' is the effective value of mutual conductance. An expression for g_m' can be obtained as follows:

Substituting $g_m V_{gk}$ for I_a in (2) we have

$$V_{fb} = g_m V_{gk} Z_k$$

From Fig. D.1

$$\begin{aligned} V_{in} &= V_{gk} + V_{fb} \\ &= V_{gk} + g_m V_{gk} Z_k \\ &= V_{gk}(1 + g_m Z_k) \end{aligned}$$

From which

$$V_{gk} = \frac{V_{in}}{1 + g_m Z_k}$$

Thus

$$\frac{V_{out}}{V_{in}} = \frac{g_m Z_a}{1 + g_m Z_k}$$

Comparison of this with expression (4) shows that

$$g_m' = \frac{g_m}{1 + g_m Z_k}$$

The effect of current feedback on the gain of an amplifier is thus equivalent to a reduction in effective mutual conductance from g_m to $g_m/(1 + g_m Z_k)$.

CHAPTER 6

RELATIONSHIP BETWEEN PASSBAND AND GAIN

6.1 SIMPLE RC-COUPLED AMPLIFIER

IN a simple RC-coupled amplifier the gain is 3 db down at the turnover frequency, i.e., the frequency for which $\omega = \omega_0 = 1/R_a C_t$. If this frequency is regarded as the upper limit of the passband F we have

$$\text{passband} = F = \frac{1}{2\pi R_a C_t} \quad \dots \quad (100)$$

The gain A of the amplifier is equal to $g_m R_a$ and substituting for R_a in (100) we have

$$AF = \frac{g_m}{2\pi C_t} \quad \dots \quad (101)$$

This expression shows that the product of gain and bandwidth depends only on the mutual conductance and the sum of the input and output capacitances. It is therefore a constant for a given type of valve used as a simple RC-coupled amplifier. To give some indication of the magnitude of this constant let $g_m = 8 \text{ mA/V}$, $C_o = 10 \text{ pF}$ and $C_i = 20 \text{ pF}$. For a valve with such parameters the gain-bandwidth product is from (101) given by

$$\begin{aligned} AF &= \frac{8 \times 10^{-3}}{2 \times 3.142 \times 30 \times 10^{-12}} \text{ c/s} \\ &= 42.3 \text{ Mc/s} \end{aligned}$$

From a knowledge of this constant, a number of calculations can be performed. For example if a 5-Mc/s bandwidth (measured to the 3 db-loss point) is required from an RC-coupled amplifier employing this particular type of valve, the maximum gain obtainable is given by

$$\begin{aligned} A &= \frac{42.3}{F} \\ &= \frac{42.3}{5} \\ &= 8.46 \end{aligned}$$

To give this gain and bandwidth, a particular value of anode-load resistor is necessary. Its value can be obtained from the relationship

$$A = g_m R_a$$

Rearranging this we have

$$R_a = \frac{A}{g_m}$$

Substituting the numerical values for A and g_m

$$\begin{aligned} R_a &= \frac{8.46}{8 \times 10^{-3}} \Omega \\ &= 1060 \Omega \end{aligned}$$

As a second calculation, suppose the problem is to obtain the greatest bandwidth consistent with a particular value of gain. If the gain is, for example, 25, the maximum bandwidth obtainable from a simple RC-coupled amplifier using the particular type of valve described above is given by

$$\begin{aligned} F &= \frac{42.3}{A} \\ &= \frac{42.3}{25} \text{ Mc/s} \\ &= 1.7 \text{ Mc/s} \end{aligned}$$

and the value of anode-load resistor required is given by

$$\begin{aligned} R_a &= \frac{A}{g_m} \\ &= \frac{25}{8 \times 10^{-3}} \Omega \\ &= 3125 \Omega \end{aligned}$$

As a third numerical calculation, suppose an amplifying stage is required to have a gain of 15 and a bandwidth of 4 Mc/s. Substituting in (101) we have

$$\begin{aligned} \frac{g_m}{C_t} &= 2\pi AF \\ &= 6.284 \times 15 \times 4 \times 10^6 \\ &= 377 \times 10^6 \end{aligned}$$

RELATIONSHIP BETWEEN PASSBAND AND GAIN

The problem now is to find a valve with such a value of g_m/C_t . If g_m is 8 mA/V, the value of C_t must not exceed

$$\begin{aligned} C_t &= \frac{g_m}{377 \times 10^6} \\ &= \frac{8 \times 10^{-3}}{377 \times 10^6} \text{ F} \\ &= 21 \text{ pF} \end{aligned}$$

Alternatively if C_t is 25 pF, g_m must be greater than

$$\begin{aligned} g_m &= 377 \times 10^6 \times C_t \\ &= 377 \times 10^6 \times 25 \times 10^{-12} \text{ A/V} \\ &= 9.4 \text{ mA/V} \end{aligned}$$

to give the required performance. If it is impossible to find a valve for which g_m/C_t is equal to or exceeds 377×10^6 , the required performance cannot be obtained without using an additional amplifying stage or a different type of circuit. The connection of two or more valves in parallel does not help: although this increases the effective mutual conductance, it also increases the capacitance in the same ratio and the performance is identical with that of a single valve.

6.2 SHUNT-INDUCTANCE AMPLIFIER

One way of achieving a greater gain-bandwidth product than is obtainable from a simple RC-coupled amplifier is to employ a shunt-inductance circuit. It was shown in Chapter 3 that such an amplifier can give approximately twice the gain of the RC-coupled amplifier for a given bandwidth. Thus the gain-bandwidth product for the shunt-inductance amplifier is given by

$$\begin{aligned} AF &= 2 \times \frac{g_m}{2\pi C_t} \\ &= \frac{g_m}{\pi C_t} \quad \dots \quad \dots \quad \dots \quad \dots \quad (102) \end{aligned}$$

This product is again constant for a given valve but its value differs from that for the simple RC-coupled amplifier.

6.3 SERIES-INDUCTANCE AMPLIFIER

It was shown in Chapter 4 that a series-inductance amplifier can give a gain of approximately three times that of a simple RC-coupled

amplifier for the same bandwidth. Thus the gain-bandwidth product for such an amplifier is given by

$$AF = 3 \times \frac{g_m}{2\pi C_t}$$

$$= \frac{3g_m}{2\pi C_t} \dots \dots \dots (103)$$

This product is constant for a given valve but its value differs from that for the simple RC-coupled and shunt-inductance amplifiers.

6.4 FIGURE OF MERIT FOR A VALVE

Expressions (101), (102) and (103) for the gain-bandwidth products of various types of video amplifier all contain the common factor g_m/C_t , the ratio of mutual conductance to the sum of the input and output capacitances. This ratio is a measure of the utility of the valve in video-frequency amplifiers and is known as the *figure of merit* or *merit factor* for the valve.

The relationship between the gain-bandwidth product and the figure of merit depends on the type of circuit used and expressions (101), (102) and (103) apply to three circuits used for video-frequency amplification. These circuits have one feature in common, namely that the bandwidth is determined by both the output capacitance C_o and the input capacitance C_i . The bandwidth can be extended if C_o or C_i can be eliminated or reduced. Such an extension is possible by using a cathode follower after a gain stage; the input capacitance of a properly-designed cathode follower stage is very small and the major capacitance limiting the bandwidth of the previous gain stage is its own output capacitance C_o .

As an example of the improvement in bandwidth brought about by the use of a cathode follower let us consider a simple RC-coupled amplifier with $g_m = 8 \text{ mA/V}$ and $C_o = 10 \text{ pF}$ preceding the cathode follower. From expression (101) we have

$$AF = \frac{g_m}{2\pi C_t}$$

for a simple RC-coupled amplifier in which $C_t = C_o + C_i$. When the effect of C_i is eliminated by the cathode follower, this expression becomes

$$AF = \frac{g_m}{2\pi C_o}$$

RELATIONSHIP BETWEEN PASSBAND AND GAIN

Substituting numerical values

$$\begin{aligned} AF &= \frac{8 \times 10^{-3}}{6.284 \times 10^{-7} \times 10^{-12}} \text{ c/s} \\ &= 127.3 \text{ Mc/s} \end{aligned}$$

Since $C_t = 3C_o$ this is three times the gain-bandwidth product available when no cathode follower is used and gives a gain of 42 for 3 Mc/s bandwidth and 12.7 for 10 Mc/s bandwidth.

Similar improvements are possible using other forms of gain stage before cathode followers.

6.5 LIMITING VALUES OF GAIN

Expressions (101), (102) and (103) show how the gain of a simple RC-coupled amplifier can be improved, without sacrificing bandwidth, by adopting first the shunt-inductance and second the series-inductance circuits. This process of improvement by the addition of further components cannot be continued indefinitely. For a given valve and a given bandwidth, there is a limiting value of gain which cannot be exceeded no matter how complex the circuit is made. For a valve for which C_o is in parallel with the input capacitance C_t of the following stage this limiting gain is given by

$$A_{max} = \frac{2g_m}{\omega C_t}$$

From this we can calculate what fraction of the theoretical maximum gain is obtained in practice from the circuits which are described in earlier chapters and contain a limited number of components. We shall make the comparison at the turnover frequency. At this frequency $\omega = 1/R_a C_t$ and substituting for ω in the above expression gives the theoretical maximum gain as $2g_m R_a$.

Consider first the simple RC-coupled amplifier. This has a gain of $g_m R_a$ at low frequencies but this falls at high frequencies and is equal to $0.707g_m R_a$ (corresponding to 3 db loss) at the turnover frequency. The theoretical maximum gain is $2g_m R_a$ and thus an RC-coupled amplifier gives only $0.707/2 = 0.35$ of the maximum gain at the turnover frequency.

The shunt-inductance amplifier gives approximately double the gain of the RC-coupled amplifier at the turnover frequency and thus gives 0.71 of the maximum possible gain.

If the valve input and output capacitances are separated by an impedance, as in the series-inductance circuit, the theoretical

maximum gain is given by

$$A_{max} = \frac{2g_m}{\omega\sqrt{C_o C_i}} *$$

In practice C_o is often approximately 1/3rd of C_i and C_i is 2/3rds of C_t . Substituting for C_o and C_i in the above expression we have

$$A_{max} = \frac{3\sqrt{2}g_m}{\omega C_t}$$

From this we can estimate the fraction of the theoretical maximum gain which is obtained in practice from a series-inductance amplifier. We shall make the comparison at the turnover frequency for which $\omega = 1/R_a C_t$. Substituting for ω in the above expression we have

$$\begin{aligned} A_{max} &= 3\sqrt{2}g_m R_a \\ &= 4.242g_m R_a \end{aligned}$$

It was shown in Chapter 4 that a series-inductance amplifier can be designed to give a gain of approximately three times that of a simple RC-coupled amplifier for the same bandwidth. The gain of the series-inductance amplifier at the turnover frequency is thus given by

$$\begin{aligned} A &= 3 \times 0.707g_m R_a \\ &= \frac{3g_m R_a}{\sqrt{2}} \end{aligned}$$

Comparing this with the theoretical maximum gain available we see that the fraction of the maximum gain realised in practice is given by

$$\begin{aligned} \frac{A}{A_{max}} &= \frac{3g_m R_a}{\sqrt{2}} \cdot \frac{1}{3\sqrt{2}g_m R_a} \\ &= \frac{1}{2} \end{aligned}$$

Thus series-inductance amplifiers can give higher gain than shunt-inductance types even though their gain is only 50 per cent of the theoretical maximum whereas that of the shunt-inductance amplifier is 70 per cent of the maximum.

* H. A. Wheeler, "Wideband Amplifiers for Television." *Proc. I.R.E.*, July 1939, Vol. 27, No. 7.

6.6 LIMITING VALUES OF FREQUENCY

Expression (101) gives the gain-bandwidth product for an RC-coupled amplifier as

$$AF = \frac{g_m}{2\pi C_t}$$

and, as shown earlier in this chapter, if $g_m = 8 \text{ mA/V}$ and $C_t = 25 \text{ pF}$

$$AF = 42.3 \text{ Mc/s}$$

If we put $f = 42.3 \text{ Mc/s}$ we find $A = 1$; i.e., if the passband is to extend to 42.3 Mc/s , the anode load resistor must be made so small ($= 1/g_m$) that the stage gain is only unity. This value of frequency is the highest that can be achieved with this type of valve and particular form of coupling circuit; any attempt to extend the passband by further reduction of load resistor results in less than unity gain. For an RC-coupled amplifying stage therefore the upper frequency limit (f_{max}) is given by

$$f_{max} = \frac{g_m}{2\pi C_t}$$

There are similar expressions for the maximum frequencies obtainable with shunt- and series-inductance amplifiers. These can be obtained from expressions (102) and (103) and are as follows: for the shunt-inductance amplifier

$$f_{max} = \frac{g_m}{\pi C_t}$$

for the series-inductance amplifier

$$f_{max} = \frac{3g_m}{2\pi C_t}$$

This limitation on upper frequency cannot be overcome by connecting valves in parallel because this increases shunt capacitance in the same ratio as mutual conductance and leaves the frequency response unaffected. Nor can it be overcome by connecting valves in cascade. As shown in the next chapter when stages are cascaded, it is necessary to decrease the anode-load resistors to preserve the bandwidth of the individual stages. If the gain is already unity, any reduction in load value results in less than unity gain for the stages and hence for the amplifier as a whole.

The only way this frequency limitation can be avoided is to use a valve with a better merit factor (larger ratio of g_m to C_t) or to use a distributed amplifier (see Chapter 8).

CHAPTER 7

AMPLIFYING STAGES CONNECTED IN CASCADE

7.1 INTRODUCTION

WE have so far considered the performance of typical single stages of amplification. These are important because video-frequency amplifiers usually contain a number of stages in cascade and the characteristics of each stage contribute to the overall characteristic of the amplifier.

7.2 ADDITION OF FREQUENCY RESPONSES AND DELAY TIMES

If the frequency response of the stages are expressed in decibels, the overall amplifier response can be determined by adding those of the individual stages. Similarly the overall group delay can be obtained by adding the group delays of the individual stages. The step responses are, however, not arithmetically additive; when a number of stages are cascaded, the chief effect on step response is an increase in apparent time delay, an increase in rise time and (if the stages have overshoot) an increase in amplitude and duration of overshoot. The increase in apparent time delay is indicated by the development of a *foot* on the step response, the length of the foot increasing as the number of stages is increased. The reason for the increased delay can be explained as follows: the first valve in the amplifier is fed with an abrupt voltage step but, because of the finite rise time of the first stage, the second stage receives a voltage which takes an appreciable time to build up to its final value. The input to the third stage is even slower in reaching its final value and the apparent delay thus increases as the number of stages is increased. This is illustrated in Fig. 63 which shows the step response for 1, 2, 4 and 8 identical shunt-inductance stages with $a = 0.5$.

7.3 ADDITION OF RISE TIMES

When two or more amplifier stages, each with the same rise time, are cascaded, the overall rise time is increased. As shown by Kallmann, Spencer and Singer* the overall rise time is related to the value for an individual stage by a law depending on the shape

* H. E. Kallmann, R. E. Spencer and C. P. Singer, "Transient Response." *Proc. I.R.E.*, March 1945, Vol. 33, No. 3.

AMPLIFYING STAGES CONNECTED IN CASCADE

of the transition curve. For example when shunt-inductance stages with $a = 0.6$ are cascaded, the rise time is increased to 1.4 times its original value every time the number of stages is doubled. The multiplication factor is 1.3 when $a = 0.7$ and 1.25 when $a = 1.0$. There is however considerable overshoot for large values of a and small values, such as $a = 0.4$, are used in practice. Provided overshoot is not excessive, the multiplication factor is approximately 1.41 for shunt-inductance and series-inductance amplifiers. This particular value of multiplication factor is equivalent to addition by squaring the individual rise times, adding them and finding the

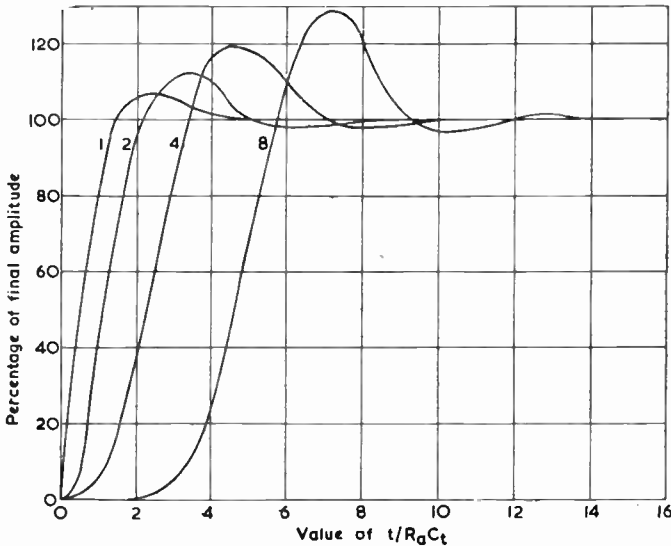

Fig. 63—Step response of amplifiers consisting of 1, 2, 4 and 8 identical shunt-inductance stages

square root of the sum. This can be shown in the following way in which t_1 is the rise time per stage and t_n the overall rise time. It is assumed that there are n stages in cascade

$$\begin{aligned} t_n &= \sqrt{(t_1^2 + t_1^2 + t_1^2 \dots n \text{ terms})} \\ &= \sqrt{(n t_1^2)} \\ &= \sqrt{n} \cdot t_1 \end{aligned}$$

Thus when $n = 2$

$$\begin{aligned} t_n &= \sqrt{2} t_1 \\ &= 1.41 t_1 \end{aligned}$$

When $n = 4$

$$t_n = 2t_1$$

and when $n = 8$

$$\begin{aligned} t_n &= \sqrt{8}t_1 \\ &= 2\sqrt{2}t_1 \\ &= 2.83t_1 \end{aligned}$$

7.4 USE OF COMPLEMENTARY CHARACTERISTICS

If the individual stages had ideal frequency- and group-delay characteristics, any number of stages could be cascaded without effect on the frequency response, group-delay response or the rise time. In practice, however, individual stages are not ideal and as the number of stages cascaded increases, the passband becomes narrower and the group-delay curve departs more and more from a level response.

Although the previous statement is true in general, it is sometimes possible to select a stage which will equalise the frequency response and the group-delay curve of a second stage, the overall characteristics of the combination thus being nearer the ideal than those of either stage alone.

For example, a simple RC-coupled stage has a frequency response which is 3 db down at the frequency for which $x = 1$ and a shunt-inductance stage with $a = 0.7$ has a response approximately 2 db up at this same value of x , as can be seen by interpolation from Fig. 43. If both circuits have the same value of ω_0 , the ordinates at $x = 1$ can be added to show that the combination of both circuits has a response which is 1 db down at $x = 1$.

The group delay-frequency characteristics for these two circuits can both be estimated from Fig. 45, they are of opposite curvature up to $x = 1$ giving an overall characteristic which is better approximation to the ideal than that of either circuit alone.

7.5 DECREASE IN STAGE GAIN TO GIVE CONSTANT PASSBAND WHEN CASCADING

When a number of identical amplifying stages are connected in cascade the passband is decreased. This can be illustrated by reference to an amplifier consisting of two similar RC-coupled stages. Each stage alone has a passband extending to the frequency for which $x = 1$ as shown in Fig. 38, the response at this frequency being 3 db down.

AMPLIFYING STAGES CONNECTED IN CASCADE

The frequency response of two circuits in cascade is 6 db down at $x = 1$ and is 3 db down at that frequency for which each individual stage is 1.5 db down. From Fig. 38 this frequency is given by $x = 0.65$; thus the passband of the two-stage amplifier is approximately two-thirds that of the individual stages. This implies, of course, that the rise time for the amplifier is approximately 1.5 times that of the individual stages. If the passband of the two-stage amplifier is required to extend to $x = 1$, i.e., if the response is to be 3 db down at $x = 1$, the individual stages must be designed to be 1.5 db down at $x = 1$. This can only be done by increasing the value of ω_0 for the stages and, to obtain the desired response, ω_0 must be increased to 1.5 times its original value; as C_t is fixed, ω_0 can only be increased by decreasing R_a and this decreases the gain per stage in the same ratio. The stage gain is thus $1/1.5 = 0.67$ of its original value and the overall gain is $(1/1.5)^2 = 4/9$, i.e., just under half of what it would have been if the anode resistors had not been reduced.

The reduction in individual stage gain necessary to preserve a given passband becomes very marked as the number of stages is increased and, in fact, ultimately sets a limit to the number of stages which can profitably be used. This can be shown in the following way, in which for simplicity, simple RC-coupled amplifiers are assumed. The result, however, is of general application.

From expression (13) the gain of a simple RC-coupled amplifier at high frequencies is given by

$$|A| = \frac{g_m R_a}{\sqrt{(1 + \omega^2 C_t^2 R_a^2)}} \dots \dots \dots \quad (104)$$

If n similar stages, each with an anode resistor of value R_n , are connected in cascade the overall gain A_n is given by

$$A_n = A^n = \frac{(g_m R_n)^n}{(1 + \omega^2 C_t^2 R_n^2)^{n/2}} \dots \dots \quad (105)$$

The passband limit occurs where the gain falls to $1/\sqrt{2}$ of its value $(g_m R_n)^n$ at medium frequencies and at this frequency

$$\begin{aligned} \frac{1}{(1 + \omega^2 C_t^2 R_n^2)^{n/2}} &= \frac{1}{\sqrt{2}} \\ \therefore (1 + \omega^2 C_t^2 R_n^2)^n &= 2 \\ \therefore \omega^2 C_t^2 R_n^2 &= 2^{1/n} - 1 \\ \omega C_t R_n &= \sqrt{(2^{1/n} - 1)} \dots \dots \quad (106) \end{aligned}$$

If the passband limit ω is to equal that of a single stage with an anode resistor of R_a we have

$$\omega = 1/R_a C_t$$

and substituting for ω in (106)

$$\frac{R_n}{R_a} = \sqrt{(2^{1/n} - 1)} \quad \dots \quad (107)$$

This expresses the relationship between R_n and R_a which must be satisfied in order that an amplifier having n stages each with an anode resistor of R_n should have the same passband as a single stage employing an anode resistor of R_a . For example if $n = 2$ we have

$$\begin{aligned} \frac{R_n}{R_a} &= \sqrt{(\sqrt{2} - 1)} \\ &= \sqrt{0.41} \\ &= 0.64 \end{aligned}$$

This shows that the anode-load resistors in a two-stage amplifier should each be 0.64 of the anode-load resistor of a single-stage amplifier for both amplifiers to have the same passband. This confirms the result deduced from frequency-response curves above.

The relationship between R_n/R_a and n is illustrated in the following table.

n	$\frac{R_n}{R_a}$
2	0.64
4	0.436
6	0.35
8	0.30
10	0.2682

This table shows how the value of the anode resistors must be progressively reduced (to maintain the passband) as the number of stages in an amplifier is increased. This reduction ultimately sets a limit to the number of stages which can profitably be cascaded.

As the number of cascaded stages is increased, this limit is reached when the additional gain due to a further stage is just neutralised by the loss occasioned by the reduction in value of the anode-load resistors (necessary to preserve the bandwidth). If the number of stages is increased beyond this point, the overall gain of the amplifier begins to fall and ultimately reaches unity if the number of stages is increased sufficiently. Thus the gain of an amplifier rises to a

AMPLIFYING STAGES CONNECTED IN CASCADE

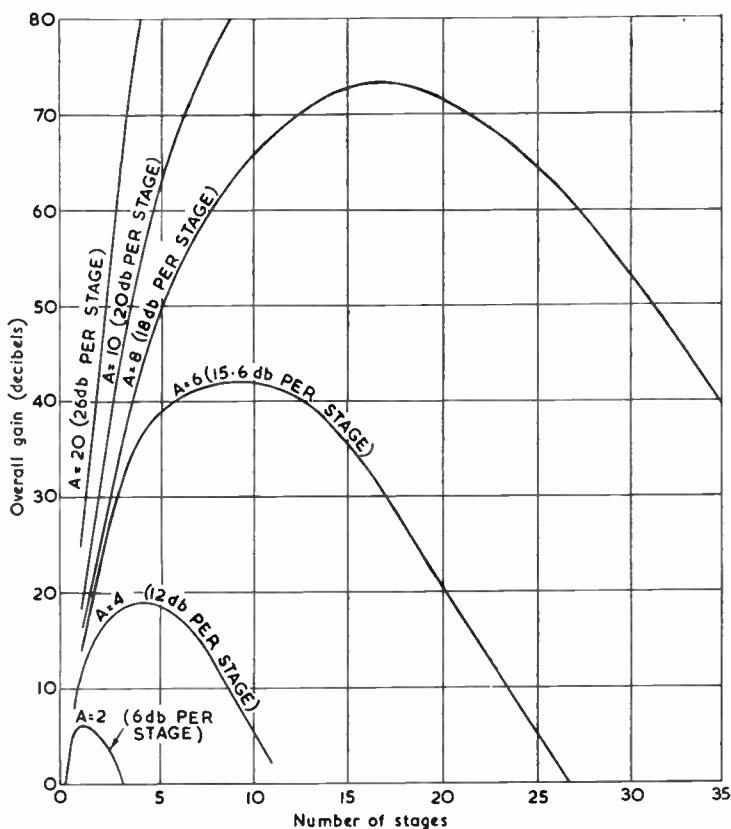

Fig. 64—Curves illustrating the relationship between overall amplifier gain and number of stages for a number of values of stage gain. It is assumed that the value of the anode-load resistors is always adjusted to give the same passband

maximum and then falls as the number of stages is increased, provided the value of the anode resistors is at all times adjusted to maintain a constant passband.

This is illustrated in Fig. 64 which shows the relationship between overall gain and number of stages for a number of individual values of stage gain. For convenience overall and stage gains are expressed in db. The curves show that if the stage gain is low, the number of stages which can profitably be cascaded is extremely small. For example if the stage gain is 4, the optimum number of stages is also 4 giving an overall gain of 8 (18 db). If the number of stages is increased or decreased from 4, the overall gain falls. If the gain

per stage is high, the number of stages which can be profitably cascaded is also high. For example when the stage gain is 10, an overall gain of nearly 1,000 (60 db) can be obtained with 4 stages and 10,000 (80 db) with 8 stages, both numbers being well below the optimum number of stages which can be cascaded for this value of stage gain.

The curves of Fig. 64 were calculated in the following way. The gain of a multi-stage amplifier is given by

$$A_n = (g_m R_n)^n \quad \dots \quad (108)$$

Substituting for R_n from (107)

$$\begin{aligned} A_n &= g_m^n R_a^n (2^{1/n} - 1)^{n/2} \\ &= A^n (2^{1/n} - 1)^{n/2} \quad \dots \quad (109) \end{aligned}$$

where A is the gain of a single-stage amplifier with an anode resistor of R_a .

As a numerical example suppose the stage gain is 6 (15.6 db) and we require to know the gain of a 6-stage amplifier with the same bandwidth. Substituting for A and n in (109)

$$\begin{aligned} A_n &= 6^6 (2^{1/6} - 1)^3 \\ &= 6^6 (0.1225)^3 \\ &= 86 \end{aligned}$$

i.e., nearly 39 db.

The considerations discussed above apply whether the stages connected in cascade belong to one or a number of amplifiers. If an amplifier with a gain of, say, 45 db is connected in cascade with a similar amplifier, the overall gain is 90 db, but the bandwidth is reduced by the introduction of the second amplifier and this is true whether the amplifiers are close physically or separated by other equipment such as lines.

7.6 DESIGN OF A MULTI-VALVE AMPLIFIER

The minimum number of similar stages necessary in an amplifier can be determined in the following manner.

1. The maximum permissible drop in gain at the upper-frequency limit of the amplifier is known (it does not usually exceed 2 db) and this should be divided by a number n which is a rough estimate of the number of stages required. In this way the maximum permissible drop in gain per stage is obtained.
2. Knowing this and the upper-frequency limit of the amplifier,

AMPLIFYING STAGES CONNECTED IN CASCADE

the value of ω_0 for the stages can be found from the universal frequency-response curves. R_a can be determined from the relationship $R_a = 1/\omega_0 C_t$ and the stage gain from $A = g_m R_a$.

3. The overall gain of the amplifier can be obtained from the expression $(g_m R_a)^n$. If this is less than the required overall gain, the calculation must be repeated for a larger value of n ; if $(g_m R_a)$ exceeds the wanted overall gain, the calculation must be repeated for a smaller value of n .

7.7 AMPLIFIERS WITH ALTERNATE GAIN STAGES AND CATHODE FOLLOWERS

Video-frequency amplifiers are sometimes constructed of alternate gain stages and cathode followers as shown in Fig. 65. Although the cathode followers have each a gain of slightly less than unity,

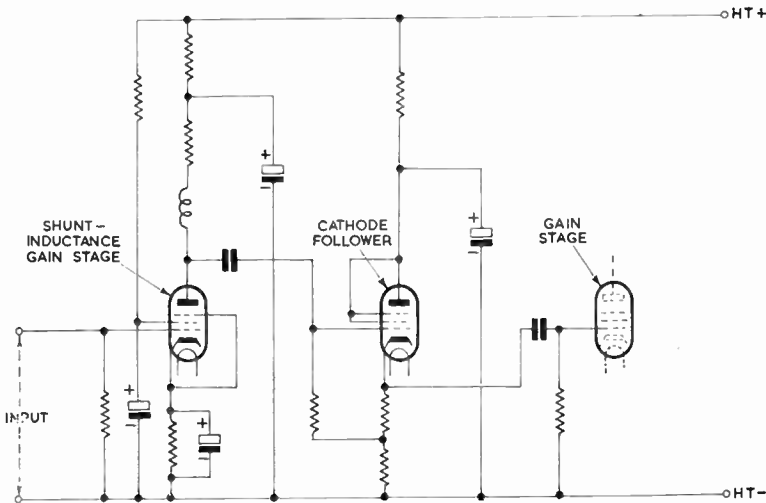

Fig. 65—Section of a video amplifier consisting of alternate gain stages and cathode followers

their inclusion results in a considerable improvement in amplifier performance. The reason for this was mentioned in Chapter 6; the cathode followers act as buffers and prevent the input capacitance C_i of the gain stages appearing in parallel with the output capacitance C_o of the previous gain stage. In other words the input capacitance of the cathode followers is very small and the total shunt capacitance at the anode of each gain stage only slightly exceeds its own output capacitance. Each gain stage may thus have higher

values of anode-load resistor (implying higher gain) than would be possible in the absence of the cathode followers.

The input capacitance of a cathode follower is small only if the output load is high. For successful operation of this circuit, therefore, the cathode-follower load must be high at all frequencies in the video band. This load consists essentially of the cathode resistor in parallel with the input capacitance of the following gain stage. There is no difficulty in making the resistor value sufficiently high but the shunt capacitance can become a limiting factor. The circuit will operate successfully provided the shunt reactance is large compared with the output impedance of the cathode follower at the highest video frequency. If the cathode follower has a mutual conductance of 5 mA/V, its output impedance ($1/g_m$) is approximately $1/(5 \times 10^{-3}) = 200 \Omega$. If the input capacitance of the following stage is 20 pF, its reactance at 3 Mc/s is given by

$$\begin{aligned} X &= \frac{1}{\omega C} \\ &= \frac{1}{6.284 \times 3 \times 10^6 \times 20 \times 10^{-12}} \Omega \\ &= 2,650 \Omega \end{aligned}$$

which satisfies the required condition because it is large compared with 200 Ω . In fact the frequency has to be raised to 40 Mc/s before the shunt reactance equals 200 Ω .

CHAPTER 8

DISTRIBUTED AMPLIFIERS

8.1 INTRODUCTION

IN Chapter 6 it is explained that there is no point in connecting similar valves in parallel in an effort to improve high-frequency response. The factor which determines the utility of a valve in a video-frequency amplifier is g_m/C_t and, by a parallel connection, g_m and C_t are both increased in the same ratio, leaving the frequency response unaffected.

If, however, an amplifier could be built in which valves are connected in parallel in such a way that their mutual conductances are additive whilst their capacitances are not, such an amplifier would not be subject to the upper frequency limitations discussed in Chapter 6 and very wide-band passbands would be possible. Such a method of paralleling is possible by using delay lines as inter-valve coupling elements and amplifiers employing this technique are termed distributed amplifiers.

8.2 FUNDAMENTAL CONSIDERATIONS

The basic circuit of a distributed amplifier is given in Fig. 66. The grids of a number of valves are connected together via inductors L_g in such a way that these, together with the input capacitances C_i of the valves (shown dotted), form a delay line. The input signal is applied to one end of this line and the other end is terminated in a resistor equal to the characteristic impedance $\sqrt{(L_g/C_i)}$ of the line. The anodes of the valves are similarly connected via inductors L_a which, together with the output capacitances C_o (shown dotted), also form a delay line. This line is terminated in its characteristic impedance $\sqrt{(L_a/C_o)}$ at the left-hand end, the output load being connected to the right-hand end.

A signal applied to the input of the grid line sets up a wave which travels to the right at a velocity given by $1/\sqrt{(L_g C_i)}$. On reaching the right-hand end of the line, this wave is absorbed in the terminating resistance and, provided this resistance is of the right value, there is no reflection. As the wave travels along the line it excites each of the valves in turn and each valve develops a corresponding current waveform in the anode circuit. The output of each valve

divides into two, half being transmitted to the left to be absorbed in the terminating resistance and the other half being transmitted to the right to form the output signal of the amplifier. Provided the anode-line terminating resistance is of the right value, the backwards-travelling wave is completely absorbed in the terminating resistance and there is no reflected wave to interfere with the forwards-travelling wave. The useful outputs from all the valves are additive, provided the velocity of propagation along the anode line $1/\sqrt{L_a C_o}$ is equal to that along the grid line.

The current flowing into the output load from each valve is one half that due to the same number of valves connected directly in parallel and the gain of the amplifier is thus given by

$$A = \frac{ng_m R_a}{2} \dots \dots \dots (110)$$

where n is the number of valves,

g_m is the mutual conductance of the valves

R_a is the anode load resistance.

This expression shows that each valve behaves as though it had half its nominal mutual conductance, half the output power being wasted in the anode-line terminating resistor. In spite of this loss, however, the distributed amplifier is capable of a performance not possible with conventional cascaded amplifiers.

The gain of a distributed amplifier is directly proportional to the number of valves and any desired gain can be obtained by using enough valves. Provided the anode and grid lines are properly terminated, the addition of further valves to a distributed amplifier does not affect the input or output impedance but merely increases the number of sections in the grid and anode lines.

8.3 SUPERIORITY OVER CONVENTIONAL CASCADED AMPLIFIERS

It was shown in Chapters 6 and 7 that a conventional cascaded amplifier has an upper frequency limit beyond which it is impossible to amplify; this limit arises when the anode-load resistor is reduced to such a low value (to extend the passband) that the stage gain falls to unity.

This limitation does not apply to distributed amplifiers; even when R_a is so low that $g_m R_a$ is less than unity, the overall amplifier gain can be made to exceed unity by using sufficient stages. This is because every valve added to a distributed amplifier contributes its quota to the output and it is not necessary to reduce the anode loads to maintain the bandwidth as in cascaded amplifiers. A distributed amplifier with a gain of several decibels up to a frequency

DISTRIBUTED AMPLIFIERS

of, say, 200 Mc/s can be built using valves which, in conventional circuits, have an upper frequency limit of, say, 50 Mc/s.

Such an amplifier might require a large number of valves if they were all connected in parallel as in the basic circuit of Fig. 66. It is, however, possible to reduce the number of valves necessary to give a required gain and passband, by using a cascade arrangement of distributed amplifiers. In other words, it may be more economical to use, say, 2 distributed amplifiers in cascade, each containing 4 valves, than to build a single distributed amplifier to give the same performance, which may require say 12 valves. When distributed amplifiers are connected in cascade, there is an effective reduction in passband and to avoid this the effective anode loads must be reduced by choice of values of L_a and L_g . There

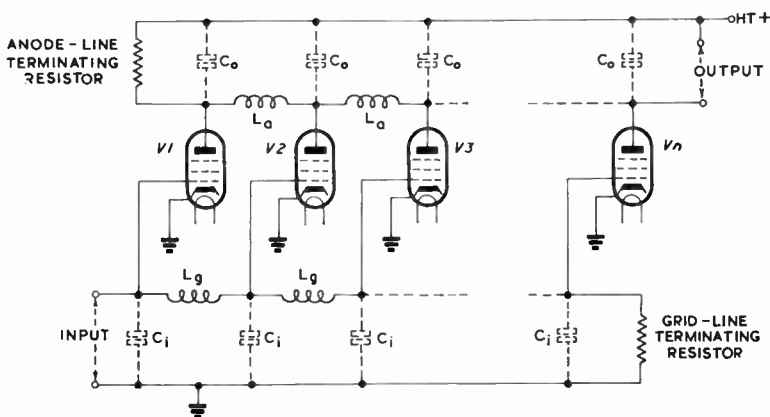

Fig. 66—Basic features of a distributed amplifier

are, of course, a large number of possible arrangements in which a given type of valve can be employed to produce a required gain and passband but there is one optimum arrangement which requires the least number of valves.

8.4 FREQUENCY AND PHASE CHARACTERISTICS OF DISTRIBUTED AMPLIFIERS

The grid and anode delay lines are of the form of low-pass filters. One of the properties of such networks is that the impedance measured across the shunt capacitors is substantially constant at low frequencies but rises as frequency approaches the cut-off value for the network, given by $1/\pi\sqrt{LC}$. These impedances constitute the anode loads into which the valves work; thus the overall frequency response of the amplifier rises as frequency approaches

the cut-off value. The phase-frequency characteristic also shows divergences from the ideal as this frequency is approached.

There are a number of ways in which these variations in frequency and phase response can be reduced. One method is to introduce mutual inductance between successive sections of the grid and anode lines. Practically this may be achieved by connecting the grids and anodes of the valves to the centre points of the inductors as shown in Fig. 67. There is an optimum value of mutual inductance,

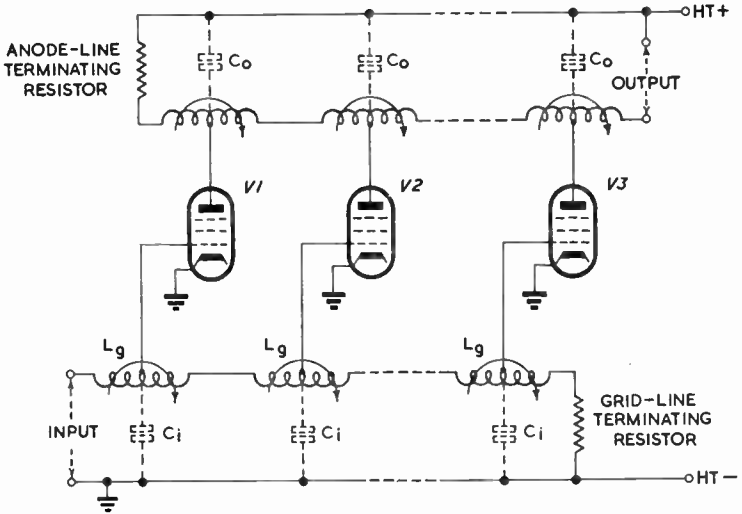

Fig. 67—Basic circuit of alternative form of distributed amplifier

which depends on the valves and passband required, and for this value the frequency and phase characteristics are satisfactory up to 0.8 of the cut-off frequency.

Numerical Example

To give some indication of the order of component values required, we will consider the design of a distributed amplifier using valves with $g_m = 8 \text{ mA/V}$, $C_i = 20 \text{ pF}$ and $C_o = 10 \text{ pF}$ and required to have a passband extending to 50 Mc/s.

If 50 Mc/s represents 0.8 of the cut-off frequency, f_c , we have

$$f_c = \frac{50}{0.8} \text{ Mc/s}$$

$$= 62.5 \text{ Mc/s}$$

DISTRIBUTED AMPLIFIERS

This is the cut-off frequency for both lines. Hence

$$f_c = \frac{1}{\pi\sqrt{L_g C_i}} = \frac{1}{\pi\sqrt{L_a C_o}}$$

from which

$$L_g C_i = L_a C_o = \frac{1}{\pi^2 f_c^2}$$

giving

$$L_g = \frac{1}{\pi^2 f_c^2 C_i}$$

$$\text{and } L_a = \frac{1}{\pi^2 f_c^2 C_o}$$

Substituting for π, f_c and C_i

$$\begin{aligned} L_g &= 3 \cdot 142^2 \times (62 \cdot 5 \times 10^6)^2 \times 20 \times 10^{-12} \text{ H} \\ &= 1 \cdot 3 \mu\text{H} \end{aligned}$$

Since $C_o = C_i/2, L_a = 2L_g = 2 \cdot 6 \mu\text{H}$.

The grid-line terminating resistance is equal to the characteristic impedance of the grid line and is given by

$$\begin{aligned} \sqrt{\frac{L_g}{C_i}} &= \sqrt{\left(\frac{1 \cdot 3 \times 10^{-6}}{20 \times 10^{-12}}\right)} \\ &= 127 \cdot 5 \Omega \end{aligned}$$

This is also the input resistance of the amplifier.

Since $C_o = C_i/2$ and $L_a = 2L_g$ the characteristic impedance of the anode line is four times that of the grid line and is thus $4 \times 127 \cdot 5 = 510 \Omega$. This is also the effective anode load of each of the valves. The gain of each stage is given by

$$\begin{aligned} A &= \frac{g_m R_a}{2} \\ &= \frac{8 \times 10^{-3} \times 800}{2} \\ &= 2 \cdot 04 \end{aligned}$$

the factor of 2 being necessary because only half the anode current of each valve is useful. A gain of 10 (20 db) can thus be obtained by using five valves in the distributed amplifier.

The passband of this amplifier extends to 50 Mc/s whereas the maximum frequency at which valves of this type can give worthwhile gain in conventional circuit is 42·3 Mc/s as shown on p. 111.

CHAPTER 9

PHASE EQUALISERS

9.1 INTRODUCTION

CERTAIN types of network, notably lattice structures, have a level frequency response and a phase-frequency characteristic with curvature opposite in form to that obtained from video-frequency gain stages such as shunt- and series-inductance amplifiers. If such a network is used in conjunction with a gain stage, it has no effect on the frequency response of the amplifier but can, by suitable design, reduce the phase distortion.

Networks used for this purpose are termed *phase equalisers* and amplifiers intended for use with them can be designed to give higher gain than if no phase equalisation is intended; the reason is that the form of the phase-frequency characteristic of the amplifier is no longer a limiting factor in design.

9.2 FREQUENCY RESPONSE OF SYMMETRICAL LATTICE NETWORK

In general a lattice network has two series and two shunt elements as shown in Fig. 68; this particular network is a symmetrical one in which both series elements are equal to Z_1 and both shunt

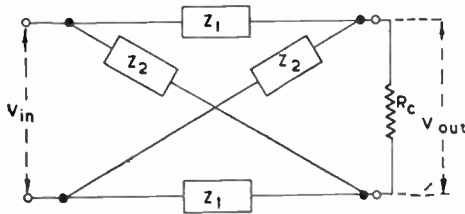

Fig. 68—General form of symmetrical lattice network

elements are equal to Z_2 . The network is shown terminated in a resistance R_c . For purposes of calculation it is often more convenient to redraw the network in the form of a bridge circuit as shown in Fig. 69. If R_c is made equal to the iterative impedance of the network, the ratio of the output to the input voltage is given by

$$\frac{V_{out}}{V_{in}} = \frac{1 - \sqrt{(Z_1/Z_2)}}{1 + \sqrt{(Z_1/Z_2)}} \quad \dots \quad (111)$$

PHASE EQUALISERS

This expression is derived in Appendix E at the end of this chapter. The frequency response of the network is thus given by

$$20 \log_{10} \frac{V_{out}}{V_{in}} = 20 \log_{10} \frac{1 - \sqrt{Z_1/Z_2}}{1 + \sqrt{Z_1/Z_2}} \quad \dots (112)$$

9.3 SIMPLE LATTICE NETWORK

In the simplest type of lattice network which can be used for phase equalisation, the series elements are equal inductors and the shunt elements equal capacitors. The network thus has the circuit shown in Fig. 70.

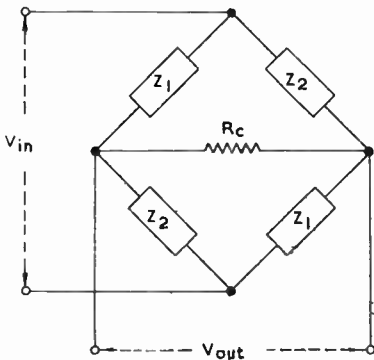

Fig. 69—Network of Fig. 68 redrawn in bridge form

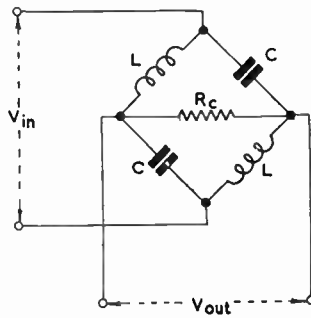

Fig. 70—Simple lattice network composed of two inductors and two capacitors

9.3.1 Frequency Response of Simple LC Lattice Network

Comparing the circuits of Figs. 69 and 70 we have

$$\begin{aligned} Z_1 &= j\omega L \\ \text{and } Z_2 &= 1/j\omega C \\ \therefore \frac{Z_1}{Z_2} &= -\omega^2 LC \end{aligned}$$

Let ω_r be the resonant angular frequency of LC . Then

$$\omega_r = \frac{1}{\sqrt{LC}} \quad \dots \dots \dots (113)$$

and Z_1/Z_2 may be written

$$\begin{aligned} \frac{Z_1}{Z_2} &= -\frac{\omega^2}{\omega_r^2} \\ &= -z^2 \quad \dots \dots \dots (114) \end{aligned}$$

where $z = \omega/\omega_r$ and is a variable directly proportional to frequency. Substituting for Z_1/Z_2 from (114) in (111)

$$\begin{aligned} V_{out} &= 1 - \sqrt{(-z^2)} \\ V_{in} &= 1 + \sqrt{(-z^2)} \end{aligned}$$

Since $j = \sqrt{-1}$ this may be written

$$\frac{V_{out}}{V_{in}} = \frac{1 - jz}{1 + jz} \quad \dots \quad \dots \quad \dots \quad (115)$$

from which

$$\begin{aligned} \frac{V_{out}}{V_{in}} &= \sqrt{\left(\frac{1 + z^2}{1 + z^2}\right)} \\ &= 1 \end{aligned}$$

Thus the output voltage is equal to the input voltage at all frequencies. The network introduces no loss and may be inserted in a video-amplifying chain without effect on the gain or frequency response of the chain.

9.3.2 Phase Response of Simple LC Lattice Network

This characteristic can be deduced by rationalising expression (115) thus

$$\begin{aligned} \frac{V_{out}}{V_{in}} &= \frac{1 - jz}{1 + jz} \times \frac{1 - jz}{1 - jz} \\ &= \frac{1 - 2jz - z^2}{1 + z^2} \end{aligned}$$

This expression is of the form $(R + jX)$ and the phase angle ϕ between V_{out} and V_{in} is given by $\tan^{-1} X/R$, i.e.,

$$\phi = \tan^{-1} \frac{-2z}{1 - z^2} \quad \dots \quad \dots \quad \dots \quad (116)$$

which, for values of z of less than unity, gives a negative phase angle, i.e., a lagging phase. Differentiating to obtain an expression for the normalised group delay we have

$$\frac{d\phi}{dz} = \frac{-2}{1 + z^2} \quad \dots \quad \dots \quad \dots \quad (117)$$

a result also deduced in Appendix E. In expression (117) the negative sign can be neglected, since a negative phase angle implies

PHASE EQUALISERS

positive delay. The group delay is thus given by

$$\begin{aligned} \frac{d\phi}{d\omega} &= \frac{1}{\omega_r} \cdot \frac{d\phi}{dz} \\ &= \frac{1}{\omega_r} \cdot \frac{-2}{1+z^2} \dots \dots \dots (118) \end{aligned}$$

The variation of ϕ and $d\phi/dz$ with z is illustrated in Fig. 71; the curvature of these characteristics is such that if they are added to those of some of the amplifier circuits described earlier, the overall phase shift (or group delay) shows less departure from the ideal

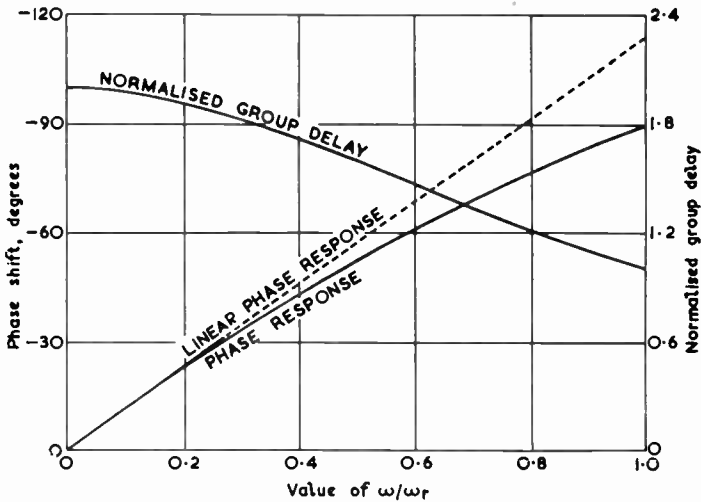

Fig. 71—Variation with frequency of phase angle and normalised group delay of a simple lattice network

characteristic than that of the amplifier alone. The phase-compensating stage increases the overall phase shift or group delay but decreases the rise time and improves reproduction of transients.

9.3.3 Design of a Simple Phase Equaliser

The component values required in a network to phase equalise an amplifier are usually determined empirically. The amplifier is phase corrected by means of a variable phase equaliser, the controls of which are adjusted to give the best possible pulse response. The equaliser can then be prepared from the information given by the readings on the dials of the variable equaliser.

However, to give some indication of the order of component values required in phase equalisers, the constants of a simple lattice

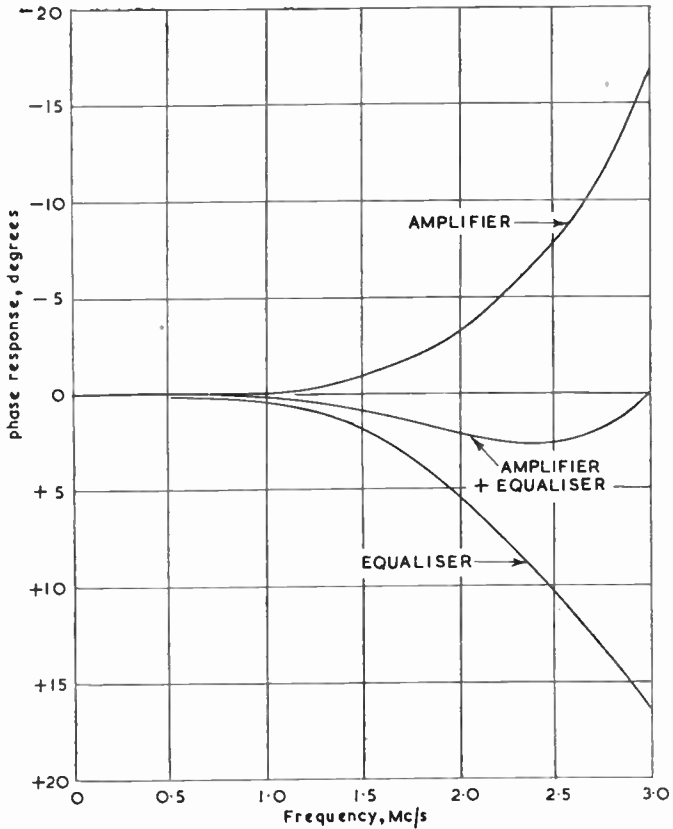

Fig. 72—Phase response for an amplifier, its equaliser and the combination

network required to equalise a particular amplifier, will be evaluated analytically. This method cannot usually be employed in practice because the phase characteristics of the amplifier are seldom known with sufficient accuracy. We shall assume that the amplifier to be equalised is a series-inductance type with $c = 0.8$ and $K = 0.67$, the passband extending to $x = 1.5$ which corresponds to 3 Mc/s. Since $\omega/\omega_0 = 1.5$ when ω is equivalent to 3 Mc/s, ω_0 is equivalent to 2 Mc/s.

The phase-frequency curve for such an amplifier is given in Fig. 55; it shows that the deviations from the ideal linear response are considerable, particularly near the upper limit of the passband. When $x = 1.5$ the phase angle lags 16.5° on the ideal value but the deviations are less at lower frequencies; this is illustrated in Fig. 72

PHASE EQUALISERS

in which the difference between the real and ideal response is plotted as a function of frequency expressed in Mc/s.

To phase compensate such an amplifier, the equaliser must have a phase response which also deviates from linearity by 16.5° at 3 Mc/s, the deviation being of opposite sign to that of the amplifier. Examination of the phase response of the simple *LC* equaliser (Fig. 71) shows that the deviation is of the necessary amount and in the desired sense when $z = 0.875$. Thus $\omega/\omega_r = 0.875$ when ω is equivalent to 3 Mc/s and ω_r is therefore equivalent to $3/0.875 = 3.43$ Mc/s. The lower curve of Fig. 72 gives the phase response of the equaliser plotted against frequency.

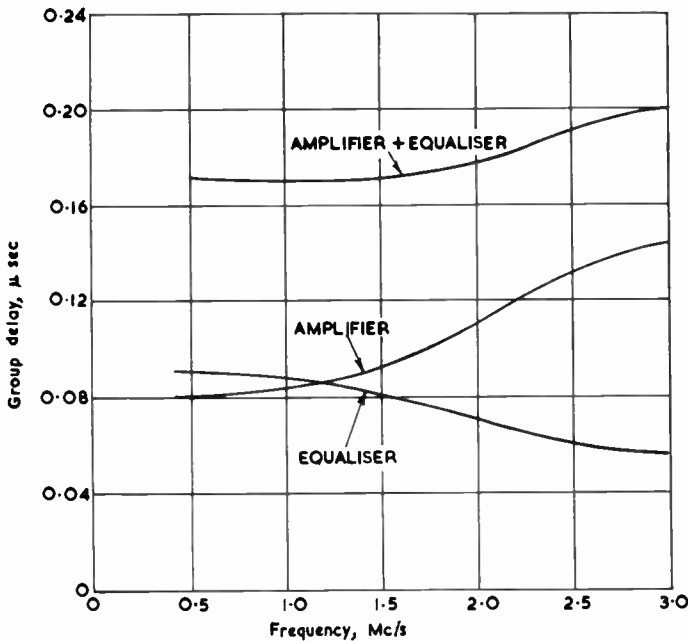

Fig. 73—Variation with frequency of group delay for amplifier, equaliser and the combination

By adding the curves for amplifier and equaliser in Fig. 72 we obtain a third curve illustrating the overall phase response of the amplifier and equaliser. This shows that there is a small residual phase error at frequencies between 2.0 Mc/s and 2.5 Mc/s.

To assess the significance of these phase errors the group delay-frequency curves for amplifier, equaliser and the combination are given in Fig. 73. The curve for the amplifier was obtained from

Fig. 56 in the following way. The value of x corresponding to any given frequency is obtained from the relationship

$$x = \frac{\omega}{\omega_0}$$

in which ω_0 corresponds to 2 Mc/s. The normalised group delay corresponding to this value of x is determined by interpolation from Fig. 56. Finally, the group delay is obtained by dividing the normalised group delay by ω_0 .

The curve for the equaliser was obtained from Fig. 71 by a similar method. First the value of z for any given frequency is determined from the relationship

$$z = \frac{\omega}{\omega_r}$$

in which ω_r corresponds to 3.43 Mc/s. The normalised group delay for this value of z is obtained by interpolation from Fig. 71 and finally the group delay is determined by dividing the normalised group delay by ω_r .

The overall group delay curve in Fig. 73 was obtained by simple addition of the other two. Before equalisation the group delay for the amplifier varied from 0.08 μ sec to 0.14 μ sec, a change of 0.06 μ sec; after equalisation the variation is from 0.17 μ sec to 0.20 μ sec, a change of 0.03 μ sec. Although the total group delay is increased by phase equalisation, the variation of group delay with frequency is reduced.

9.3.4 Calculation of Equaliser Component Values

The value of ω_r for the phase equaliser determines the product LC according to expression (113)

$$\omega_r = \frac{1}{\sqrt{LC}}$$

The iterative impedance of the equaliser determines the quotient L/C as shown in general terms in expression (3) of Appendix E.

$$R_c = \sqrt{\left(\frac{L}{C}\right)}$$

These two expressions together determine L and C . Multiplying the expressions we have

$$\omega_r R_c = \frac{1}{C}$$

PHASE EQUALISERS

$$\therefore C = \frac{1}{\omega_r R_c} \quad \dots \quad \dots \quad \dots \quad \dots \quad (119)$$

Substituting for C in (113)

$$L = \frac{R_c}{\omega_r} \quad \dots \quad \dots \quad \dots \quad \dots \quad (120)$$

In the equaliser discussed above $\omega_r = 3.43$ Mc/s. Suppose R_c is required to be 300Ω . Substituting in (119)

$$C = \frac{1}{6.284 \times 3.4 \times 10^6 \times 300} \text{ F}$$

$$= 156 \text{ pF}$$

Substituting in (120)

$$L = \frac{300}{6.284 \times 3.4 \times 10^6} \text{ H}$$

$$= 14 \mu\text{H}$$

The characteristics of an equaliser of this type can be varied, to suit the phase response of the amplifier requiring compensation, by alteration of the value of ω_r . This is best achieved by increasing or decreasing L and C in the same ratio, keeping the quotient L/C , and hence the iterative impedance of the equaliser, constant. The shape of the phase characteristic of the equaliser is, however, unaffected by variation of ω_r and this type of equaliser is therefore not so flexible as those in which the shape of the phase characteristic can also be varied.

9.4 MORE COMPLEX PHASE EQUALISERS

9.4.1 Introduction

If the amplifier to be phase equalised has a number of stages it may happen that the characteristics of a simple LC phase equaliser is inadequate to effect the necessary correction. Two or more simple LC equalisers may then be used in cascade and, to obtain the calculated performance, each section must be terminated in a resistance equal to the iterative impedance of the section. It is best to design each section to have the same value of iterative impedance because all sections can then be correctly terminated by a single resistor of the correct value connected at the end of the equaliser chain.

Sometimes, however, even a multi-section equaliser of this type is incapable of providing the required degree of correction and a

more complex type of equaliser is employed. One of the disadvantages of the simple LC equaliser is that the shape of the phase characteristic (Fig. 71) is fixed and does not always fit the characteristic of the amplifier to be equalised and in the more complex type it is desirable to have some control over the characteristic shape. This facility can be achieved by the introduction of

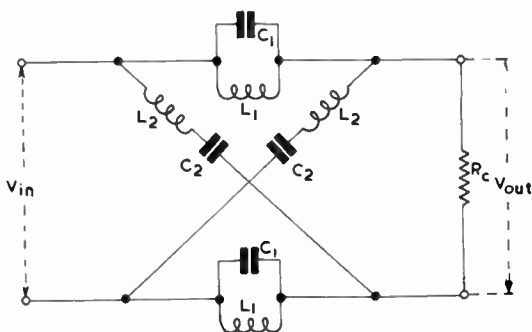

Fig. 74—More complex phase equaliser

further circuit elements into the equaliser; for example, the symmetrical lattice form can be retained and the required facility obtained by using a parallel LC circuit for each series element and a series LC circuit for each shunt element, as shown in Fig. 74.

9.4.2 Frequency Response

In an equaliser of the type shown in Fig. 74 it is usual to arrange for the resonance frequencies of all four LC circuits to be equal. Thus

$$\omega_r^2 = \frac{1}{L_1 C_1} = \frac{1}{L_2 C_2}$$

from which

$$L_1 C_1 = L_2 C_2 \quad \dots \quad \dots \quad \dots \quad \dots \quad (121)$$

Let

$$L_2 = m L_1 \quad \dots \quad \dots \quad \dots \quad \dots \quad (122)$$

As we shall see later m is the factor which controls the shape of the group delay-frequency characteristic. From (121) and (122)

$$C_1 = m C_2 \quad \dots \quad \dots \quad \dots \quad \dots \quad (123)$$

As shown in Appendix F the impedance of the series arm Z_1 is given by

$$Z_1 = \frac{j\omega L_1}{1 - z^2} \quad \dots \quad \dots \quad \dots \quad \dots \quad (124)$$

PHASE EQUALISERS

and that of the shunt arm is given by

$$Z_2 = \frac{1 - z^2}{j\omega C_2} \dots \dots \dots (125)$$

where $z = \omega/\omega_r$. Appendix F also deduces the result

$$\sqrt{\left(\frac{Z_1}{Z_2}\right)} = \frac{jz}{jm(1 - z^2)} \dots \dots \dots (126)$$

By substituting for $\sqrt{(Z_1/Z_2)}$ in expression (115) the ratio of V_{out}/V_{in} can be deduced as

$$\begin{aligned} \frac{V_{out}}{V_{in}} &= \frac{1 - \sqrt{(Z_1/Z_2)}}{1 + \sqrt{(Z_1/Z_2)}} \\ &= \frac{1 - jz/\sqrt{m(1 - z^2)}}{1 + jz/\sqrt{m(1 - z^2)}} \dots \dots (127) \\ \therefore \left| \frac{V_{out}}{V_{in}} \right| &= \sqrt{\left[\frac{1 + z^2/m(1 - z^2)^2}{1 + z^2/m(1 - z^2)^2} \right]} \\ &= 1 \end{aligned}$$

i.e., the network has unity gain at all frequencies, as for the simple lattice network.

9.4.3 Phase Response

The phase characteristics for the network can be deduced by rationalising expression (127) and is expressed by the equation

$$\phi = 2 \tan^{-1} \sqrt{m(1 - z^2)}/z \dots \dots (128)$$

a result which is deduced in Appendix F. Two further results which are also derived in this appendix are the expressions for group delay and normalised group delay given below

$$\frac{d\phi}{dz} = \frac{2\sqrt{m(z^2 + 1)}}{z^2 + m(1 - z^2)^2} \dots \dots (129)$$

$$\frac{d\phi}{d\omega} = \frac{1}{\omega_r} \cdot \frac{2\sqrt{m(z^2 + 1)}}{z^2 + m(1 - z^2)^2} \dots \dots (130)$$

The variation of $d\phi/dz$ with z for various values of m is illustrated in Fig. 75. This shows that the shape of the group delay-frequency characteristic varies considerably with the value of m ; it is, for example, negative when $m = 0.1$ and positive when $m = 1$ for values of z up to approximately 0.7. The value of m of 0.33 is commonly used in phase equalisers because this value gives

maximal flatness of group delay-frequency characteristic and therefore has minimum effect on the delay at low and medium frequencies. The condition for maximal flatness can be deduced as follows. Re-arranging (129) in ascending powers of z , we have

$$\frac{d\phi}{dz} = \frac{2\sqrt{m} + 2\sqrt{mz^2}}{m + (1 - 2m)z^2 + mz^4} \quad \dots (131)$$

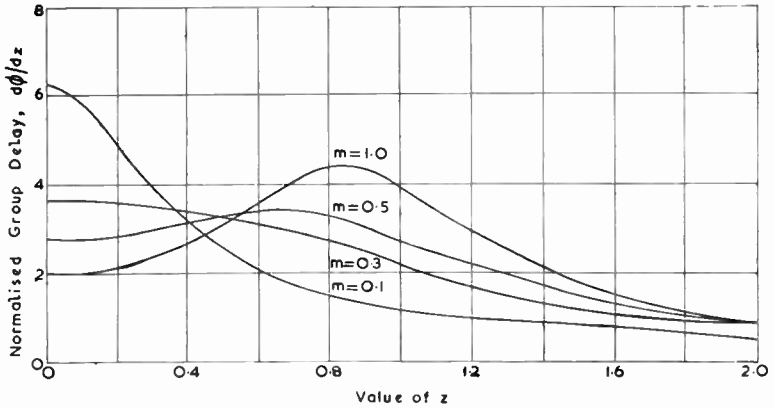

Fig. 75—Variation of normalised group delay with frequency for the equaliser of Fig. 74

Applying the conditions for maximal flatness

$$\frac{2\sqrt{m}}{m} = \frac{2\sqrt{m}}{1 - 2m}$$

Thus $1 - 2m = m$

giving $m = 0.33$

Equalisers of this type are usually placed at the input or output of an amplifier where they can be given relatively low values of iterative impedance such as 75Ω . Such low values of impedance necessitate small-value inductors which can be constructed with negligible self-capacitance.

9.4.4 Equivalent T-section

The circuit arrangement of Fig. 74 is convenient if the equaliser is used for coupling a balanced line to the amplifier but is not suitable for use with an unbalanced feeder such as a co-axial cable because of the absence of a terminal common to input and output connections. The lattice structure can, however, be transformed

PHASE EQUALISERS

into an equivalent bridged-T network as shown in Appendix G. The form of this network is given in Fig. 76.

The iterative impedance of an equaliser of a symmetrical lattice or equivalent type is given by

$$R_c = \sqrt{(Z_1 Z_2)} \quad \dots \quad \dots \quad \dots \quad (132)$$

as shown in Appendix E. Substituting for Z_1 and Z_2 from (124) and (125) respectively we have

$$R_c = \sqrt{(L_1/C_2)} \quad \dots \quad \dots \quad \dots \quad (133)$$

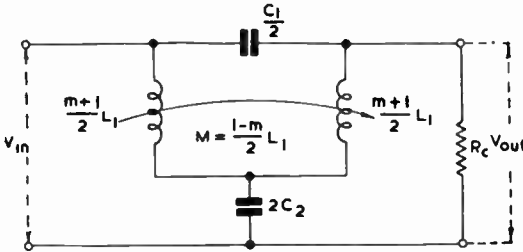

Fig. 76—Bridged-T network equivalent to the lattice structure of Fig. 74

From (133) and the relationships $L_1 C_1 = L_2 C_2$ (expression 121), $L_2 = m L_1$ (expression 122) and $C_1 = m C_2$ (expression 123) we can express C_1 , C_2 , L_1 and L_2 in terms of ω_r , R_c and m as follows:

$$C_2 = \frac{1}{\sqrt{m \omega_r R_c}} \quad \dots \quad \dots \quad \dots \quad (134)$$

$$\begin{aligned} C_1 &= m C_2 \\ &= \frac{\sqrt{m}}{\omega_r R_c} \quad \dots \quad \dots \quad \dots \quad (135) \end{aligned}$$

$$L_2 = \frac{\sqrt{m R_c}}{\omega_r} \quad \dots \quad \dots \quad \dots \quad (136)$$

$$\begin{aligned} L_1 &= \frac{L_2}{m} \\ &= \frac{R_c}{\sqrt{m \omega_r}} \quad \dots \quad \dots \quad \dots \quad (137) \end{aligned}$$

The equaliser is usually situated at the input or output of the amplifier and the value of R_c is made equal to the impedance at this point; a common value is 75 Ω . The values of ω_r and m are determined by the shape of phase characteristic required for amplifier

compensation. Frequently, however, m is fixed at approximately the value (0.33) for maximal flatness of group delay characteristic, leaving ω_r as the only parameter which can be varied to "match" the equaliser characteristic to that of the amplifier. On the other hand it might be possible to obtain more perfect equalisation by suitably choosing m and ω_r .

9.4.5 Design of a Bridged-T Equaliser

We shall assume that the amplifier to be phase equalised consists of 6 similar shunt-inductance stages with $a = 0.5$, the upper frequency limit of 3 Mc/s corresponding to $x = 1$. The normalised group delay-frequency curve for one such stage is given in Fig. 45; for 6 stages the normalised group delay will, of course, be 6 times that indicated in the diagram. The equaliser is of the type shown in Figs. 74 or 76 and is to have an iterative impedance of 75 Ω .

It is not possible to add the normalised group delay-frequency curves for amplifier and equaliser directly unless ω_0 for the amplifier is equal to ω_r for the equaliser. Although ω_0 may equal ω_r for a particular amplifier and equaliser it is, in general, unlikely to be so and the first step in designing the equaliser is to redraw the characteristic for the amplifier as a group delay-frequency curve. This can be done by dividing the normalised group delay-frequency curve labelled $a = 0.5$ in Fig. 45 by ω_0 . For the amplifier in question $\omega/\omega_0 = 1$ when ω is equivalent to 3 Mc/s; thus it follows that ω_0 is equivalent to 3 Mc/s. The ordinates in Fig. 45 must be divided by $\omega_0 = 2\pi f_0 = 6.284 \times 3 \times 10^6$ to obtain the group delay for one stage. For example, the normalised group delay at $x = 0$ is, from Fig. 45, 0.5 for a single stage. For 6 such stages it will thus be 3.0 and the group delay is given by

$$\begin{aligned} & 3.0 \\ & 6.284 \times 3 \times 10^6 \text{ sec} \\ & = \frac{1}{6.284} \mu\text{sec} \\ & = 0.16 \mu\text{sec} \end{aligned}$$

By calculating the group delay at other values of x , the curve labelled "amplifier" in Fig. 77 was obtained. For convenience the frequency axis is calibrated in Mc/s. The total variation in group delay is from 0.16 μsec at zero frequency to nearly 0.26 μsec at 3 Mc/s, a change of approximately 0.1 μsec .

The equaliser must be designed to eliminate this variation by adding to the characteristic of the amplifier a complementary curve

PHASE EQUALISERS

also having a total variation of nearly $0.1 \mu\text{sec}$ but of opposite sign. We shall use the characteristic for $m = 0.3$ (Fig. 75). The value of ω_r for the equaliser can be found by trial and error or can be calculated from the expression for the characteristic but this method involves the solution of a complex equation and it is usually quicker to use the alternative (trial and error) method illustrated below.

As a first attempt let ω_r correspond to 3 Mc/s . The passband of the amplifier then extends to $z = 1$ and the change in normalised group delay over the passband is, from the curve labelled $m = 0.3$ in Fig. 75, 1.4 . This corresponds to a change in group delay of $1.4/\omega_r = 1.4/(6.284 \times 3 \times 10^6) = 0.074 \mu\text{sec}$ which is insufficient

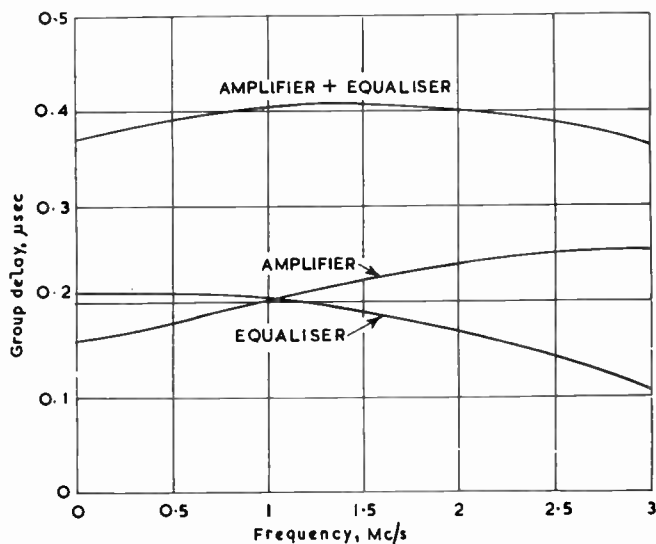

Fig. 77—Addition of group delay-frequency curves for amplifier and equaliser

to offset the change in group delay in the amplifier. A smaller value of ω_r is necessary and as a next step, let ω_r correspond to 2.5 Mc/s . The passband then extends to $z = 3/2.5 = 1.2$ for which the variation in normalised group delay is 2.0 . This corresponds to a change in group delay of $2/(6.284 \times 2.5 \times 10^6) = 0.127 \mu\text{sec}$, which exceeds the required value. The value of ω_r chosen for this example corresponds to 2.75 Mc/s for which the passband extends to $z = 1.1$. The variation in normalised group delay over this band is 1.75 corresponding to a change in group delay of $1.75/(6.284 \times 2.75 \times 10^6) = 0.101 \mu\text{sec}$, nearly equal to the required value.

The group delay-frequency curve for the equaliser can now be prepared by dividing the ordinates for $m = 0.3$ in Fig. 75 by ω_r ($6.284 \times 2.75 \times 10^6$). For example, at $z = 0$ the normalised group delay is 3.6 and the group delay is thus

$$\begin{aligned} & \frac{3.6}{6.284 \times 2.75 \times 10^6} \text{ sec} \\ &= \frac{3.6}{6.284 \times 2.75} \mu\text{sec} \\ &= 0.21 \mu\text{sec} \end{aligned}$$

The curve is that labelled "equaliser" in Fig. 77, in which the frequency axis is calibrated in Mc/s (3 Mc/s corresponding to $z = 1.1$). The variation in group delay is from 0.21 μsec at zero frequency to 0.11 μsec at 3 Mc/s, a change of 0.1 μsec as for the amplifier characteristic.

By adding the curves for amplifier and equaliser, the composite characteristic is obtained. As shown in Fig. 77 this has a much smaller variation in group delay (approximately 0.04 μsec) than the uncompensated amplifier (0.1 μsec) and thus the addition of the equaliser improves the pulse response. The total delay is, however, increased by the addition of the phase equaliser.

We can now calculate the component values required in the equaliser. From (134)

$$\begin{aligned} C_2 &= \frac{1}{\sqrt{m\omega_r R_c}} \\ &= \frac{1}{\sqrt{0.3 \times 6.284 \times 2.75 \times 10^6 \times 75}} \text{ F} \\ &= 0.0014 \mu\text{F} \end{aligned}$$

From (135) $C_1 = mC_2$
 $= 420 \text{ pF}$

From (136) $L_2 = \frac{\sqrt{mR_c}}{\omega_r}$
 $= \frac{\sqrt{(0.3) \times 75}}{6.284 \times 2.75 \times 10^6} \text{ H}$
 $= 2.38 \mu\text{H}$

From (137) $L_1 = \frac{L_2}{m}$
 $= 7.9 \mu\text{H}$

PHASE EQUALISERS

Thus a symmetrical lattice structure to effect the desired equalisation should have the component values shown in Fig. 78.

If the equaliser has the form of Fig. 76, the series capacitor is given by

$$\begin{aligned} \frac{C_1}{2} &= \frac{420}{2} \text{ pF} \\ &= 210 \text{ pF} \end{aligned}$$

The shunt capacitor has the value

$$\begin{aligned} 2C_2 &= 2 \times 0.0014 \text{ } \mu\text{F} \\ &= 0.0028 \text{ } \mu\text{F} \end{aligned}$$

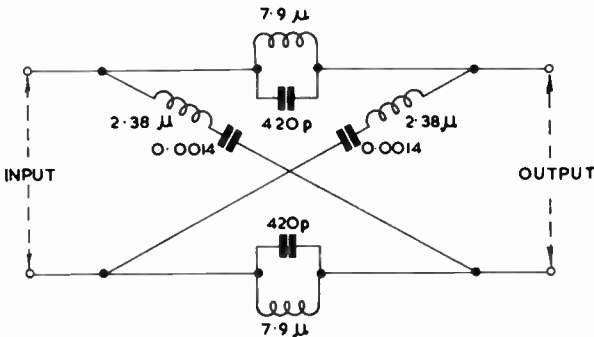

Fig. 78—Component values required in a symmetrical lattice equaliser

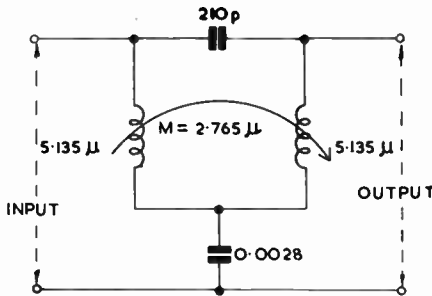

Fig. 79—Component values required in a bridged-T equaliser

The shunt inductors are given by

$$\begin{aligned} \frac{(m+1)L_1}{2} &= \frac{0.3+1}{2} \times 7.9 \text{ } \mu\text{H} \\ &= 5.135 \text{ } \mu\text{H} \end{aligned}$$

The mutual inductance is given by

$$\begin{aligned} \frac{(m-1)L_1}{2} &= \frac{0.3-1}{2} \times 7.9 \mu\text{H} \\ &= -2.765 \mu\text{H} \end{aligned}$$

The component values required in a bridged-T equaliser are therefore as shown in Fig. 79.

9.5 DERIVATIVE EQUALISER

9.5.1 Introduction

The equalisers just described employ networks of inductance and capacitance which reduce the phase distortion of a video-frequency amplifier or chain without affecting the frequency response.

Derivative equalisers differ from phase equalisers in that they employ valves in addition to LC networks and can be used to reduce phase distortion, attenuation distortion or both in one operation. The principles of this type of equaliser can be approached in the following way.

9.5.2 Principles of Operation

A simple RC-coupled amplifier has limited application as a video-frequency amplifier because the frequency and phase responses are satisfactory only up to approximately half the turnover frequency. As pointed out in Chapter 3, by the inclusion of an inductor of suitable value in series with the anode resistor the frequency range for satisfactory performance can be extended by one octave, the amplifier being now useful up to the turnover frequency. The inclusion of such an inductor can be regarded as the first step towards equalisation of the frequency and phase response of the basic amplifier. The effect of the inductor is to add to the output of the RC-coupled amplifier an additional voltage, given by Ldi/dt , which is proportional to the inductance and to the rate of change, i.e., the first derivative of the current in it.

The equalisation so achieved is not perfect. The high-frequency response of the RC-coupled amplifier is given by expression (13) which can be written in the form

$$\frac{A_{hf}}{A_{mf}} = \frac{1}{1 + j\omega C_t R_a}$$

which is modified by the inclusion of the inductor to

$$\frac{A_{hf}}{A_{mf}} = \frac{1 + j\omega L_1/R_a}{1 + j\omega C_t R_a - \omega^2 L_1 C_t}$$

PHASE EQUALISERS

which can be derived from expression (33). As shown by the latter expression, the response of the shunt-inductance amplifier is still dependent on frequency, although by suitable choice of inductance it can be made a better approximation to the ideal than that of the RC-coupled amplifier.

The equalisation due to an inductor can be made far more effective if it is made the anode load (L_3) of a second valve, the grid of which is fed from the anode of the RC-coupled amplifier, the anode signals of the two valves being combined to form the output. The gain of the second valve is given by $j\omega L_3 g_m$ and thus the combined output is given by

$$\begin{aligned} \frac{A_{hf}}{A_{mf}} &= \frac{1}{1 + j\omega C_t R_a} + \frac{j\omega L_3 g_m}{1 + j\omega C_t R_a} \\ &= \frac{1 + j\omega L_3 g_m}{1 + j\omega C_t R_a} \end{aligned}$$

Inspection of this formula shows that if $g_m L_3$ is made equal to $R_a C_t$, the right-hand side reduces to unity, implying that the gain at high frequencies is equal to the gain at medium no matter what these

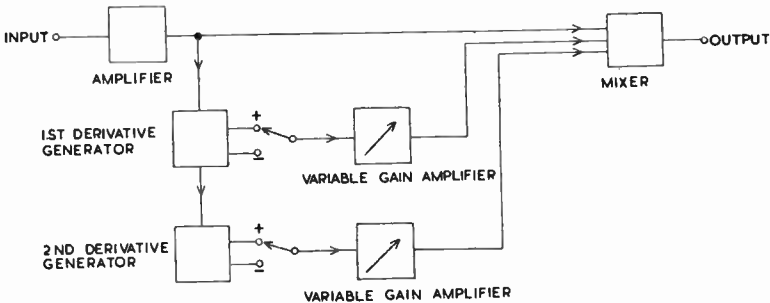

Fig. 80—Block schematic diagram of a derivative equaliser

frequencies are. Moreover there is no phase distortion and equalisation is therefore perfect. The value of $g_m L_3$ can be made equal to $R_a C_t$ by varying the gain of the second valve or of an additional amplifier introduced between the second valve and the mixing point. The second valve and its anode inductor have the effect of producing an output signal with the form of the first derivative of the input signal, and such gain variation can alternatively be regarded as controlling the amplitude of the first-derivative signal which is mixed with the original.

In practice the amplifier requiring equalisation is unlikely to contain a single RC-coupled stage but will contain a number of

stages of a more complex type. Nevertheless the addition of a certain amplitude of first-derivative signal usually brings about a considerable improvement in phase and frequency response. Further improvement can be obtained by use of an additional valve and anode inductor to derive a voltage proportional to the second derivative of the input signal, which can be mixed in suitable proportions with the first derivative and original input signals.

Thus a derivative equaliser may consist of two stages of differentiation (each consisting essentially of a valve and anode inductor) and provision for mixing the original signals with any proportion (within certain practical limits) of first- and second-derivative signals. Usually there is provision for reversing the polarity as well as adjusting the amplitude of the derivative signals. A block schematic diagram of such an equaliser is shown in Fig. 80.

APPENDIX E

FREQUENCY RESPONSE OF A LATTICE NETWORK

FIG. E.1 gives the circuit of a symmetrical lattice network and in Fig. E.2 it is redrawn in the form of a bridge circuit. In Fig. E.2 the terminating resistance R_c is shown and we shall assume that this is equal to the iterative impedance of the lattice network. It is the purpose of this appendix to deduce the frequency characteristic of a symmetrical lattice network terminated in its iterative impedance.

The iterative impedance of any 4-terminal network is given by $\sqrt{(Z_{oc}Z_{sc})}$ where Z_{oc} is the input impedance of the network when the output terminals are open-circuited, and Z_{sc} is the input impedance of the network when the output terminals are short-circuited. When the network is terminated in its iterative impedance as in Fig. E.1 the input impedance is also equal to the iterative impedance.

From Fig. E.1

$$Z_{sc} = \frac{2Z_1Z_2}{Z_1 + Z_2} \quad \dots \quad \dots \quad \dots \quad \dots \quad (1)$$

$$Z_{oc} = \frac{1}{2}(Z_1 + Z_2) \quad \dots \quad \dots \quad \dots \quad \dots \quad (2)$$

$$R_c = \sqrt{(Z_{oc}Z_{sc})}$$

Substituting for Z_{sc} and Z_{oc} from (1) and (2) respectively

$$R_c = \sqrt{(Z_1Z_2)} \quad \dots \quad \dots \quad \dots \quad \dots \quad (3)$$

PHASE EQUALISERS

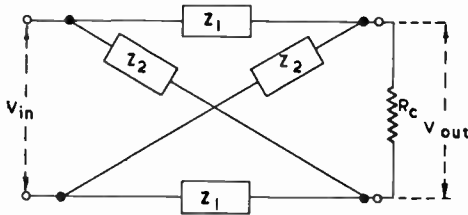

Fig. E.1—Symmetrical lattice network

From Fig. E.2

$$i_{in} = i_1 + i_2$$

$$i_{out} = i_1 - i_2$$

$$\therefore \frac{i_{out}}{i_{in}} = \frac{i_1 - i_2}{i_1 + i_2} \quad \dots \quad \dots \quad \dots \quad (4)$$

Equating voltages round one of the meshes of Fig. E.2

$$i_1 Z_1 + (i_1 - i_2) R_c = i_2 Z_2$$

from which

$$\frac{i_1}{i_2} = \frac{Z_2 + R_c}{Z_1 + R_c}$$

Subtracting 1 from both sides of this equation

$$\frac{i_1 - i_2}{i_2} = \frac{Z_2 - Z_1}{Z_1 + R_c} \quad \dots \quad \dots \quad \dots \quad (5)$$

Adding 1 to both sides

$$\frac{i_1 + i_2}{i_2} = \frac{Z_1 + Z_2 + 2R_c}{Z_1 + R_c} \quad \dots \quad \dots \quad \dots \quad (6)$$

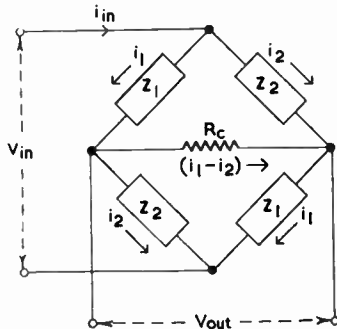

Fig. E.2—Symmetrical lattice network redrawn as bridge circuit

Dividing (5) by (6)

$$\frac{i_1 - i_2}{i_1 + i_2} = \frac{Z_2 - Z_1}{Z_1 + Z_2 + 2R_c}$$

Substituting for R_c from (3)

$$\begin{aligned} \frac{i_1 - i_2}{i_1 + i_2} &= \frac{Z_2 - Z_1}{Z_1 + Z_2 + 2\sqrt{(Z_1 Z_2)}} \\ &= \frac{(\sqrt{Z_2} - \sqrt{Z_1})(\sqrt{Z_2} + \sqrt{Z_1})}{(\sqrt{Z_1} + \sqrt{Z_2})^2} \\ &= \frac{\sqrt{Z_2} - \sqrt{Z_1}}{\sqrt{Z_1} + \sqrt{Z_2}} \\ &= \frac{1 - \sqrt{(Z_1/Z_2)}}{1 + \sqrt{(Z_1/Z_2)}} \end{aligned}$$

Substituting for $(i_1 - i_2)/(i_1 + i_2)$ from (4)

$$\frac{i_{out}}{i_{in}} = \frac{1 - \sqrt{(Z_1/Z_2)}}{1 + \sqrt{(Z_1/Z_2)}}$$

Since the input impedance of the network is equal to its output load the ratio V_{out}/V_{in} is equal to i_{out}/i_{in}

$$\therefore \frac{V_{out}}{V_{in}} = \frac{1 - \sqrt{(Z_1/Z_2)}}{1 + \sqrt{(Z_1/Z_2)}}$$

Another expression of which use is made in the text is (117) for the normalised group delay $d\phi/dz$ of a simple lattice structure. This can be derived in the following way.

It is shown in the text that

$$\phi = \tan^{-1} \frac{-2z}{1 - z^2}$$

$$\therefore \tan \phi = \frac{-2z}{1 - z^2}$$

Differentiating

$$\sec^2 \phi \frac{d\phi}{dz} = -\frac{2(1 + z^2)}{(1 - z^2)^2}$$

$$\therefore (1 + \tan^2 \phi) \frac{d\phi}{dz} = -\frac{2(1 + z^2)}{(1 - z^2)^2}$$

PHASE EQUALISERS

Substituting for $\tan \phi$

$$\left[1 + \frac{4z^2}{(1 - z^2)^2} \right] \frac{d\phi}{dz} = - \frac{2(1 + z^2)}{(1 - z^2)^2}$$

Rearranging

$$\begin{aligned} \frac{d\phi}{dz} &= \frac{-2(1 + z^2)}{(1 - z^2)^2 + 4z^2} \\ &= \frac{-2(1 + z^2)}{(1 + z^2)^2} \\ &= - \frac{2}{1 + z^2} \end{aligned}$$

APPENDIX F

DERIVATION OF EXPRESSIONS FOR THE PHASE ANGLE AND GROUP DELAY OF MORE COMPLEX PHASE EQUALISERS

THIS appendix is devoted to the derivation of expressions for the phase angle and normalised group delay for a network of the form shown in Fig. F.1. It also deduces another expression which is required in the text.

The impedance of the series arm Z_1 is given by

$$\begin{aligned} Z_1 &= \frac{j\omega L_1 / j\omega C_1}{j\omega L_1 + 1 / j\omega C_1} \\ &= \frac{j\omega L_1}{1 - \omega^2 L_1 C_1} \end{aligned}$$

But $\omega_r^2 = 1 / L_1 C_1$

$$\begin{aligned} \therefore Z_1 &= \frac{j\omega L_1}{1 - \omega^2 / \omega_r^2} \\ &= \frac{j\omega L_1}{1 - z^2} \quad \dots \quad \dots \quad \dots \quad (1) \end{aligned}$$

where $z = \omega / \omega_r$. The impedance of the shunt arm Z_2 is given by

$$\begin{aligned} Z_2 &= j\omega L_2 + 1/j\omega C_2 \\ &= \frac{1}{j\omega C_2} (1 - \omega^2 L_2 C_2) \end{aligned}$$

But $\omega_r^2 = 1/L_2 C_2$

$$\begin{aligned} \therefore Z_2 &= \frac{1}{j\omega C_2} (1 - \omega^2/\omega_r^2) \\ &= \frac{1 - z^2}{j\omega C_2} \quad \dots \quad \dots \quad \dots \quad (2) \end{aligned}$$

From (1) and (2) the value of $\sqrt{(Z_1/Z_2)}$ which is required in expression (112) for V_{out}/V_{in} is given by

$$\begin{aligned} \sqrt{\left(\frac{Z_1}{Z_2}\right)} &= \sqrt{\left(\frac{j\omega L_1}{1 - z^2} \cdot \frac{j\omega C_2}{1 - z^2}\right)} \\ &= \frac{j\omega}{1 - z^2} \sqrt{(L_1 C_2)} \end{aligned}$$

But $L_1 = L_2/m$

$$\begin{aligned} \therefore \sqrt{\left(\frac{Z_1}{Z_2}\right)} &= \frac{j\omega}{1 - z^2} \sqrt{\left(\frac{L_2 C_2}{m}\right)} \\ &= \frac{j\omega}{1 - z^2} \cdot \frac{1}{\omega_r \sqrt{m}} \\ &= \frac{jz}{\sqrt{m}(1 - z^2)} \end{aligned}$$

The text shows that the relationship between V_{in} and V_{out} is given by

$$\begin{aligned} \frac{V_{out}}{V_{in}} &= \frac{1 - \sqrt{(Z_1/Z_2)}}{1 + \sqrt{(Z_1/Z_2)}} \\ &= \frac{1 - jz/\sqrt{m}(1 - z^2)}{1 + jz/\sqrt{m}(1 - z^2)} \\ &= \frac{\sqrt{m}(1 - z^2) - jz}{\sqrt{m}(1 - z^2) + jz} \end{aligned}$$

Rationalising we have

$$\frac{V_{out}}{V_{in}} = \frac{m(1 - z^2)^2 - 2\sqrt{m}jz(1 - z^2) - z^2}{m(1 - z^2)^2 + z^2}$$

This is of the form $(R + jX)$ and the phase angle ϕ between V_{out} and V_{in} is given by $\tan^{-1}X/R$, i.e.,

PHASE EQUALISERS

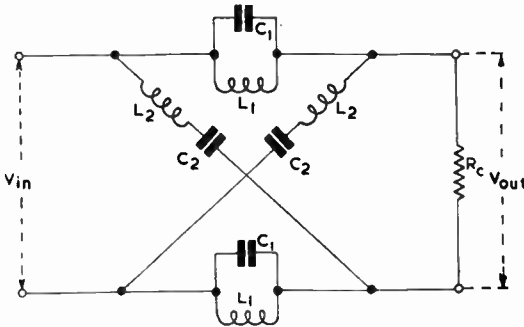

Fig. F.1—Circuit of more complex phase equaliser

$$\begin{aligned}\phi &= \tan^{-1} \frac{-2\sqrt{m(1-z^2)}z}{m(1-z^2)^2 - z^2} \\ &= \tan^{-1} \frac{-2\sqrt{m(1-z^2)}/z}{m(1-z^2)^2/z^2 - 1}\end{aligned}$$

Let $\sqrt{m(1-z^2)}/z = y$

$$\begin{aligned}\therefore \phi &= \tan^{-1} \frac{-2y}{y^2 - 1} \\ &= \tan^{-1} \frac{2y}{1 - y^2}\end{aligned}$$

From the identity

$$\tan 2\phi = 2 \tan \phi / (1 - \tan^2 \phi)$$

this may be written

$$\begin{aligned}\phi &= 2 \tan^{-1} y \\ &= 2 \tan^{-1} \sqrt{m(1-z^2)}/z\end{aligned}$$

which defines the phase response of the network. The expression may be written

$$\tan \frac{\phi}{2} = \frac{\sqrt{m(1-z^2)}}{z}$$

Differentiating

$$\frac{1}{2} \sec^2 \frac{\phi}{2} \cdot \frac{d\phi}{dz} = - \frac{\sqrt{m(z^2 + 1)}}{z^2}$$

$$\therefore \frac{1}{2} (1 + \tan^2 \frac{\phi}{2}) \cdot \frac{d\phi}{dz} = - \frac{\sqrt{m(z^2 + 1)}}{z^2}$$

Substituting for $\tan \frac{\phi}{2}$ and re-arranging

$$\frac{d\phi}{dz} = - \frac{2\sqrt{m(z^2 + 1)}}{z^2 + m(1 - z^2)^2}$$

which expresses the normalised group delay of the network.

APPENDIX G

EQUIVALENCE OF LATTICE AND T-SECTION NETWORKS

A lattice network (Fig. G.1) can be used to equalise amplifiers having a balanced input or output circuit in which neither terminal is earthed. Frequently, however, the circuit to which the equaliser must be connected, is unbalanced, having one terminal earthed and for this purpose an unbalanced equaliser is required. There is no unbalanced lattice network which satisfies these requirements but it is possible to derive a different form of unbalanced network, a T-network (Fig. G.2), which has properties identical to the symmetrical lattice structure, from which it was derived. The input and output circuits of such a T-network have a common terminal which may be earthed and such networks are well suited for inclusion in unbalanced input or output circuits of amplifiers.

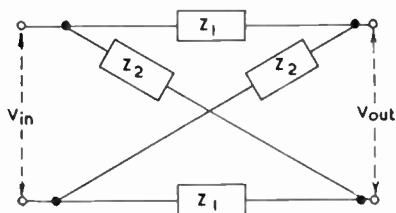

Fig. G.1—Symmetrical form of lattice network

It is the purpose of this appendix to derive relationships between the impedances Z_1 and Z_2 of a symmetrical lattice network and the impedances Z_a and Z_b of an unbalanced T-network which must be satisfied for the networks to be equivalent, i.e., have identical properties.

PHASE EQUALISERS

There are four important parameters of any 3- or 4-terminal networks. These are:—

- (a) the input impedance when the output is open-circuited (i.e., unterminated);
- (b) the input impedance when the output is short-circuited;
- (c) the output impedance when the input is open-circuited;
- (d) the output impedance when the input is short-circuited;

and for two networks to be equivalent it is necessary that the four impedances of one network should equal the corresponding impedances of the other. For symmetrical networks impedance (a) is equal to impedance (c) and impedance (b) to impedance (d); thus to obtain the conditions for equivalence it is necessary only to equate the input impedances when the output terminals are open-circuited Z_{oc} and also the input impedances when the output terminals are short-circuited Z_{sc} .

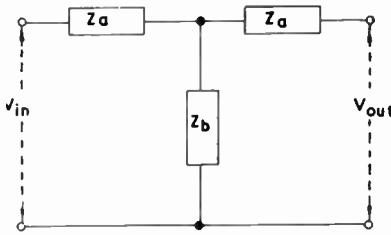

Fig. G.2—Symmetrical form of T-section network

For the lattice network (Fig. G.1)

$$Z_{oc} = \frac{Z_1 + Z_2}{2}$$

For the T-network (Fig. G.2)

$$Z_{oc} = Z_a + Z_b$$

Equating these

$$Z_a + Z_b = \frac{Z_1 + Z_2}{2} \quad \dots \quad \dots \quad \dots \quad (1)$$

For the lattice network

$$Z_{sc} = \frac{2Z_1Z_2}{Z_1 + Z_2}$$

For the T-network

$$Z_{sc} = Z_a + \frac{Z_a Z_b}{Z_a + Z_b}$$

$$= \frac{Z_a(Z_a + 2Z_b)}{Z_a + Z_b}$$

Equating these

$$\frac{Z_a(Z_a + 2Z_b)}{Z_a + Z_b} = \frac{2Z_1 Z_2}{Z_1 + Z_2} \quad \dots \quad \dots \quad \dots \quad (2)$$

Multiplying (1) by (2)

$$Z_a^2 + 2Z_a Z_b = Z_1 Z_2 \quad \dots \quad \dots \quad \dots \quad (3)$$

Squaring (1)

$$Z_a^2 + 2Z_a Z_b + Z_b^2 = \frac{1}{4}(Z_1 + Z_2)^2 \quad \dots \quad \dots \quad \dots \quad (4)$$

Subtracting (3) from (4)

$$Z_b^2 = \frac{1}{4}(Z_1 + Z_2)^2 - Z_1 Z_2$$

$$= \frac{1}{4}(Z_2 - Z_1)^2$$

$$\therefore Z_b = \frac{Z_2 - Z_1}{2} \quad \dots \quad \dots \quad \dots \quad (5)$$

Substituting for Z_b in (1)

$$Z_a + \frac{Z_2 - Z_1}{2} = \frac{Z_1 + Z_2}{2}$$

$$\therefore Z_a = Z_1 \quad \dots \quad \dots \quad \dots \quad (6)$$

Thus the equivalent T-section has series arms each consisting of an impedance Z_1 and a shunt arm consisting of an impedance of $(Z_2 - Z_1)/2$ as shown in Fig. G.3.

The lattice network used in phase equalisers of the more complex

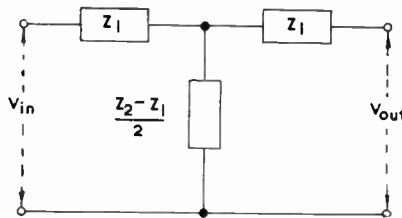

Fig. G.3—T-section network equivalent to the lattice structure of Fig. G.1

PHASE EQUALISERS

type has the form shown in Fig. G.4. The process of deducing the constants for the equivalent T-section can be simplified by temporarily ignoring either the two inductors L_1 or the two capacitors C_1 . This is permissible because these components connect the input to the output terminals and can be regarded as external to the network. After the form of the equivalent T-section has been deduced, these components must be re-introduced to give the final form of the equivalent network.

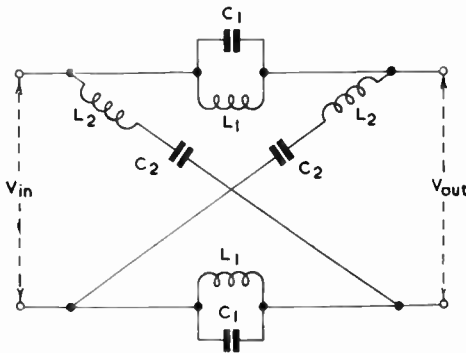

Fig. G.4—Lattice network used in complex phase equalisers

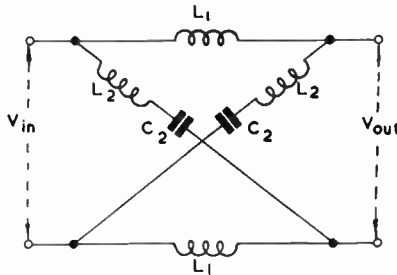

Fig. G.5—The network of Fig. G.4 after removal of series capacitors

When the capacitors C_1 are omitted, the lattice has the form shown in Fig. G.5 and comparison of this with Fig. G.1 shows that

$$Z_1 = j\omega L_1$$

$$Z_2 = j\omega L_2 + 1/j\omega C_2$$

From equations (5) and (6) the impedances in the equivalent T-section

are given by

$$\begin{aligned}
 Z_a &= Z_1 \\
 &= j\omega L_1 \\
 Z_b &= \frac{Z_2 - Z_1}{2} \\
 &= \frac{j\omega L_2}{2} + \frac{1}{2j\omega C_2} - \frac{j\omega L_1}{2} \\
 &= j\omega(L_2 - L_1)/2 + 1/2j\omega C_2
 \end{aligned}$$

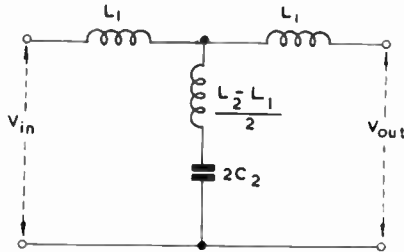

Fig. G.6—T-section equivalent to the lattice structure of Fig. G.5

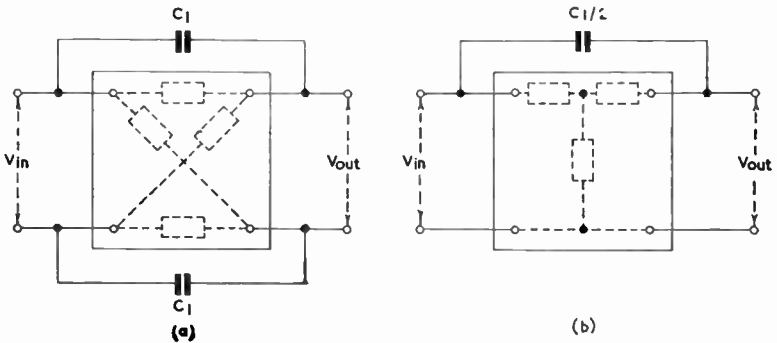

Fig. G.7—Series capacitors in (a) balanced and (b) unbalanced network

Thus the series arms each consist of an inductor of L_1 and the shunt arm consists of an inductor of value $(L_2 - L_1)/2$ in series with a capacitor of $2C_2$, giving a T-section of the form shown in Fig. G.6.

We must now re-introduce the capacitance which was originally ignored to simplify the above calculation. In doing this we must bear in mind that the original lattice network was balanced and had therefore two capacitors arranged as shown in Fig. G.7(a) whereas the equivalent network (Fig. G.7(b)) is unbalanced and has only

PHASE EQUALISERS

one capacitor. To make the networks of Fig. G.7 equivalent, the series capacitor in (b) must be equal to the two capacitors of (a) in series. If the capacitors in (a) are both equal to C_1 , that in (b) must be equal to $C_1/2$. Thus the bridged-T network equivalent to Fig. G.4 has the form and component values indicated in Fig. G.8.

This network includes an inductor of $(L_2 - L_1)/2$ in the shunt arm. Since $L_2 = mL_1$ this inductance is equal to $(m - 1)L_1/2$ as shown in Fig. G.9. The values of m used in phase equalisers are less than unity and this shunt inductance is negative, implying that the network is not physically realisable. It can, however, be modified into a network with the same performance and which is physically realisable. To do this the shunt inductor is replaced by a transformer as shown in Fig. G.10. Such a circuit can give the equivalent

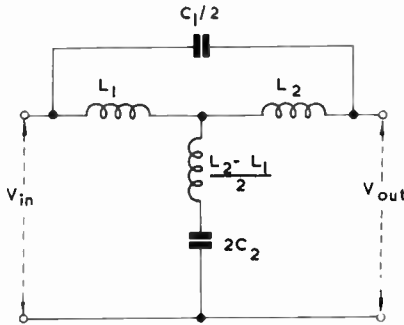

Fig. G.8—Bridged-T network equivalent to lattice structure of Fig. G.4

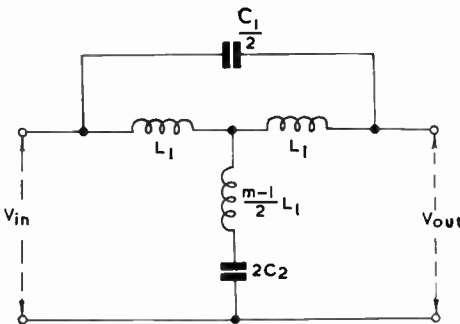

Fig. G.9—Bridged-T network equivalent to Fig. G.8

of negative mutual inductance because the sign of the mutual inductance can be effectively reversed by interchanging the connections to the primary or the secondary winding.

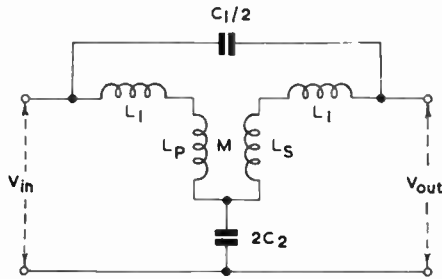

Fig. G.10—Network of Fig. G.9 with the shunt inductor replaced by a transformer

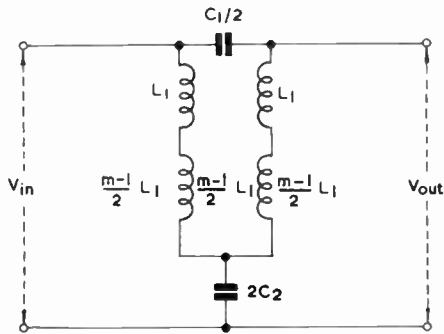

Fig. G.11—Values of L_p , L_s and M required to make the network of Fig. G.10 equivalent to that of Fig. G.8

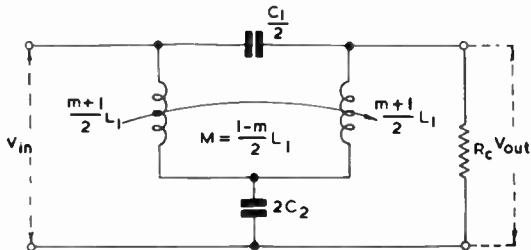

Fig. G.12—The bridged-T network finally derived

PHASE EQUALISERS

We have now to determine the values of L_p , L_s and M necessary to make the networks of Figs. G.9 and G.10 equivalent. There is no reason why L_p and L_s should not be equal and the transformer thus becomes of unity turns ratio. The value of M required is $(m - 1)L_1/2$ from Fig. G.9. The value of L_p (and L_s) depends on the degree of coupling between the transformer windings; if the coupling is less than unity, L_p and L_s will be greater than M . If the coupling is equal to unity, L_p and L_s are equal to M namely $(m - 1)L_1/2$ and for this value of coupling the equivalent circuit has the form shown in Fig. G.11.

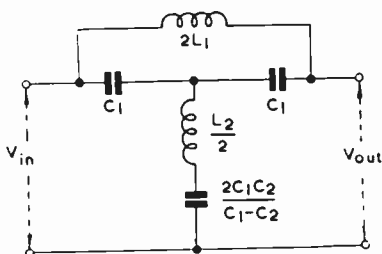

Fig. G.13—Alternative form of T-section equivalent to the lattice structure of Fig. G.4

The primary winding L_p can now be combined with the inductor L_1 , to which it is connected to form an inductor of value

$$L_p + L_1 = \frac{(m - 1)}{2} \cdot L_1 + L_1$$

$$= \frac{m + 1}{2} L_1$$

The secondary winding can similarly be combined with the inductor to which it is connected to form another inductor of $(m + 1)L_1/2$. Provided the mutual inductance remains at the value $(m - 1)L_1/2$, these changes do not affect the properties of the network. The network finally derived, shown in Fig. G.12, is physically realisable and is identical in its properties to the networks of Figs. G.4, G.8 and G.11.

If in the derivation of the T-section equivalent to the original lattice network the inductors L_1 had been omitted instead of the capacitors, a different form of equivalent T-section is obtained; it is shown in Fig. G.13. If C_1 is less than C_2 a negative capacitance is required in the shunt arm; thus this network is physically realisable only if C_1 exceeds C_2 .

PART III: VIDEO-FREQUENCY AMPLIFICATION: LOW-FREQUENCY CONSIDERATIONS

CHAPTER 10

INTER-VALVE COUPLING CIRCUIT

10.1 INTRODUCTION

THE requirements of the low-frequency performance of a video-frequency amplifier were briefly stated in Chapter 1: in short they are that the amplifier should be capable of amplifying the frame- and picture-frequency components of the signal without appreciable distortion. Furthermore, there should be a response at zero frequency to enable the mean picture brightness to be transmitted and (this amounts to the same thing) to ensure that the black level remains constant. If the amplifier satisfies these requirements, it will also be capable of amplifying the frame-sync signal without introducing excessive sag.

The necessity for a zero-frequency response suggests that the entire video chain from camera tube to picture tube should be d.c. coupled. Such an arrangement would be very difficult to achieve technically but fortunately is not necessary. Capacitance-coupled amplifiers can be used and the low-frequency components introduced artificially, whenever required, by d.c. restoration or d.c. clamping. There are a number of points in the chain where this is necessary; for example, d.c. clamping of the picture signal is essential at early links in the chain when suppression and sync signals are inserted to form the video signal. It is also necessary at later points whenever the video-frequency waveform is monitored or displayed. In particular it is desirable in high-power video-frequency stages of a television transmitter. Here clamping results in economy of operation because it has the effect of reducing the effective absolute excursion of the signal, implying that the valves can be smaller, or that more efficient use can be made of existing valves than is possible in the absence of clamping. The entire video chain could be capacitance-coupled but this would require a large number of d.c. clamps; the number of clamps should be kept

INTER-VALVE COUPLING CIRCUIT

low to economise in cost and because they tend to introduce spurious signals into the video-frequency waveforms. The number of clamps is therefore kept small by use of d.c. coupling in some of the links of the chain; for example, d.c. coupling is generally employed in the video-frequency amplifier between the detector and cathode-ray tube in television receivers.

Sometimes d.c. coupling is employed for reasons unconnected with the provision of a zero-frequency response; for example, it may be used to prevent low-frequency instability in a feedback amplifier or to ensure a good response at very low frequencies.

In general the low-frequency response of a video-frequency amplifier is satisfactory if the frame-sync waveform (effectively a rectangular wave) can be amplified without introducing excessive

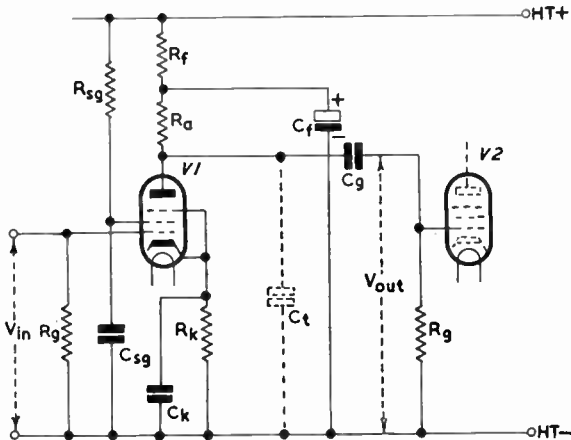

Fig. 81—Basic circuit of RC-coupled amplifier employing a pentode

sag (2 per cent is often quoted as the maximum permissible tolerable). To obtain such a performance at a frame frequency of 50 c/s requires a good phase and frequency response extending to frequencies of less than 1 c/s. Moreover, there are certain points in the video chain where two or more stages must be d.c. coupled. The following chapters describe the circuits which can be used to achieve such results.

10.2 SIMPLE RC-COUPLED AMPLIFIER AT LOW FREQUENCIES

The performance at low frequencies of a simple RC-coupled amplifier such as that shown in Fig. 81 is in general not up to the standard required in a video-frequency amplifier because of the numerous sources of phase and attenuation distortion. The chief

sources of distortion are as follows:

- (a) inter-valve coupling components $R_g C_g$,
- (b) cathode-decoupling components $R_k C_k$,
- (c) screen-decoupling components $R_{sg} C_{sg}$,
- (d) anode-decoupling components $R_f C_f$.

Of these the coupling components $R_g C_g$ are the most important because it is often possible to eliminate the effects of the decoupling components: some of the methods which can be used for this purpose are described in later chapters. In this chapter, therefore, we shall assume that the low-frequency performance is determined solely by the coupling components. Thus the circuit under consideration is that shown in Fig. 82 from which all decoupling

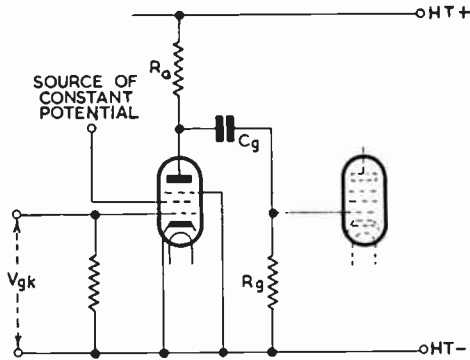

Fig. 82—A simple RC-coupled amplifier with all decoupling components removed

components have been eliminated. The effect of R_g and C_g on the frequency and phase response is shown first by vector diagrams.

10.3 EFFECT OF INTER-VALVE COUPLING COMPONENTS ILLUSTRATED VECTORIALLY

The coupling components $R_g C_g$ are usually so chosen that the reactance of C_g is small compared with R_g at low frequencies. There are, however, upper limits to the values of R_g and C_g which can be used and at very low frequencies the reactance of C_g inevitably becomes comparable with R_g . At these frequencies the impedance of the circuit $R_g C_g$ is reactive and the current in the circuit leads the applied voltage (V_1 output) as shown in Fig. 83. The input to V_2 is developed across R_g and is in phase with the current; it

INTER-VALVE COUPLING CIRCUIT

therefore leads the output of V1 by a phase angle of ϕ° as shown. The increase in impedance of $R_g C_g$ at low frequencies also causes the voltage across R_g to fall with decrease in frequency. Thus the phase lead is accompanied by a fall in amplitude.

The magnitude of the amplitude loss and the leading phase angle can be calculated by the following method.

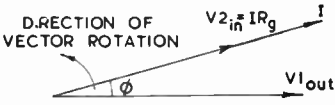

Fig. 83—Vector diagram illustrating the phase lead introduced by a coupling capacitor-grid leak combination at low frequencies

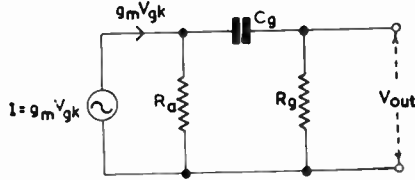

Fig. 84—Equivalent circuit for Fig. 80

10.4 LOW-FREQUENCY RESPONSE OF SIMPLE RC-COUPLED AMPLIFIER

The equivalent circuit of Fig. 82 is given in Fig. 84. Normally R_g is large compared with R_a and the current I in Fig. 84 may be assumed to flow in R_a only. The voltage V_a developed across R_a is thus given by

$$V_a = -g_m V_{gk} R_a \quad \dots \quad (138)$$

the negative sign indicating the phase reversal between anode and grid potentials. R_g and C_g form a potential divider across R_a and V_{out} is given by

$$V_{out} = \frac{R_g}{R_g + 1/j\omega C_g} \cdot V_a$$

Substituting for V_a from (138)

$$V_{out} = -g_m V_{gk} R_a \cdot \frac{R_g}{R_g + 1/j\omega C_g}$$

giving

$$\begin{aligned} A_{lf} &= \frac{V_{out}}{V_{gk}} \\ &= -\frac{g_m R_a R_g}{R_g + 1/j\omega C_g} \dots \dots \dots (139) \end{aligned}$$

But

$$\begin{aligned} A_{mf} &= -g_m R_a \\ \therefore \frac{A_{lf}}{A_{mf}} &= \frac{R_g}{R_g + 1/j\omega C_g} \end{aligned}$$

Let $\omega_g = 1/R_g C_g$ and $x = \omega/\omega_g$. As in the analyses of circuits

used at high frequencies, x is a variable directly proportional to frequency.

$$\begin{aligned} \therefore \frac{A_{if}}{A_{mf}} &= \frac{1}{1 + 1/jx} \\ &= \frac{jx}{1 + jx} \quad \dots \quad \dots \quad \dots \quad \dots \quad (140) \end{aligned}$$

From this

$$\left| \frac{A_{if}}{A_{mf}} \right| = \frac{x}{\sqrt{1 + x^2}} \quad \dots \quad \dots \quad \dots \quad (141)$$

and the frequency response is given by

$$\begin{aligned} \text{response in decibels} &= 20 \log_{10} \left| \frac{A_{if}}{A_{mf}} \right| \\ &= 20 \log_{10} \frac{x}{\sqrt{1 + x^2}} \quad \dots \quad \dots \quad (142) \end{aligned}$$

The curve of this expression is plotted in Fig. 85 and this shows that the loss is 3 db when $x = 1$; this occurs when $\omega/\omega_g = 1$, that is when $\omega R_g C_g = 1$ or when $R_g = 1/\omega C_g$. The loss is thus 3 db at the frequency for which the reactance of the coupling capacitor equals the grid resistor. If this frequency is calculated for given coupling components, the response curve for the combination can be obtained directly from Fig. 85 by locating a logarithmic frequency scale along the horizontal axis so that the calculated frequency coincides with $x = 1$. This has been done in Fig. 85 for coupling components having a product (time constant) of 0.01 sec, e.g., 0.01 μF and 1 $\text{M}\Omega$; for this combination $x = 1$ corresponds to 16 c/s.

From the frequency response curve of Fig. 85, the loss is 7 db at $x = 0.5$, one octave below the frequency for which $1/\omega C_g = R_g$ and as the frequency decreases the rate of loss increases to 6 db per octave and remains constant at that value. This can be seen from expression (142) for when x is small compared with unity the response in db becomes $20 \log_{10} x$, i.e., every doubling (or halving) of x gives a 6 db change in response. Thus as frequency decreases the response curve becomes a straight line; if this line is produced it meets the ordinate at $x = 1$ at a point corresponding to zero loss. A similar result holds for the high-frequency response of a simple RC-coupled amplifier as shown in Fig. 38.

10.5 PHASE RESPONSE

The phase response of the simple RC-coupled circuit can be

INTER-VALVE COUPLING CIRCUIT

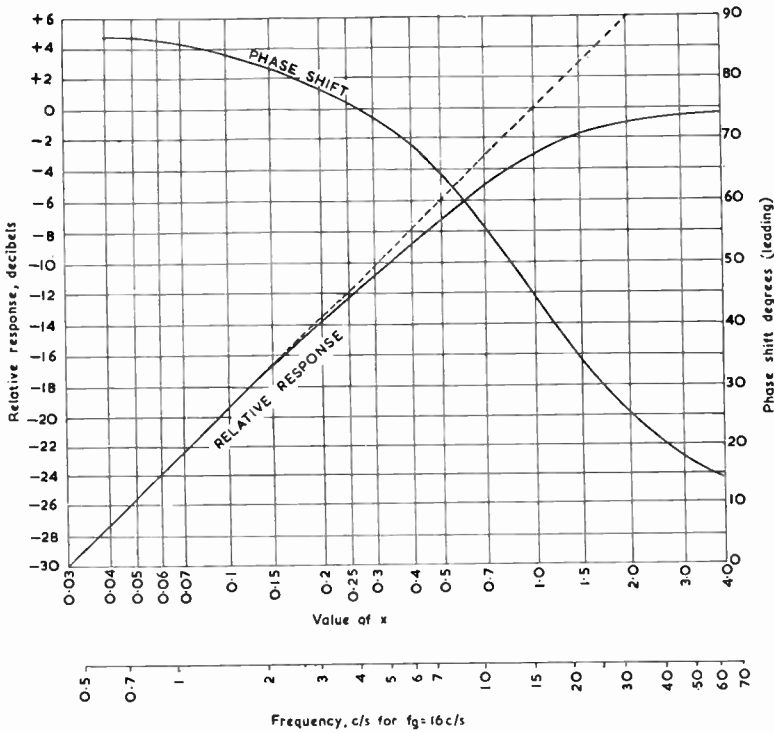

Fig. 85—Universal frequency-response and phase-response curves for simple RC-coupled circuit at low frequencies

deduced from expression (139). Since $I = g_m V_{gk}$ this can be written

$$V_{out} = - \frac{I R_a R_g}{R_g + 1/j\omega C_g}$$

$$\therefore \frac{V_{out}}{I} = - \frac{jx R_a}{1 + jx} \quad \dots \quad (143)$$

Rationalising

$$\frac{V_{out}}{I} = - R_a \cdot \frac{jx + x^2}{1 + x^2}$$

which is of the form $(R + jX)$. The phase angle between V_{out} and I , the alternating component of the anode current, is given by $\tan^{-1} X/R$, i.e.,

$$\phi = \tan^{-1} \frac{1}{x} \quad \dots \quad (144)$$

This expression is also plotted in Fig. 85. This diagram shows that the phase angle is 45° (leading) at the frequency for which $x = 1$, i.e., at the frequency for which the reactance of the coupling capacitor equals the grid resistor.

In a simple RC-coupled amplifier, the phase angle is lagging at high frequencies due to shunt capacitance and leading at low frequencies due to series capacitance. At a certain medium frequency, therefore, there is zero phase shift, and, as we have seen, to minimise distortion in reproducing detail in pictures it is essential to make phase shift proportional to frequency above this medium frequency. There is, in practice, no need for such strict proportionality below the frequency of zero phase shift but to minimise variation in background shading from the top to the bottom of the picture, the phase response at low frequencies of the entire television system must be so controlled that a square-wave at frame frequency is reproduced with less than, say, 2 per cent sag.

Such a test signal provides a realistic criterion of response because the video signal corresponding to a picture consisting of a white half separated from a black half by a horizontal line is a square wave at frame frequency (50 c/s in the British system). Moreover the frame-sync signal approximates in form to a rectangular wave at frame frequency.

10.6 CHARGE AND DISCHARGE OF A CAPACITOR IN A RESISTIVE CIRCUIT

In order to understand the process of amplifying a low-frequency square wave in an RC-coupled amplifier, it is instructive to consider the operation of a simple circuit such as that shown in Fig. 86.

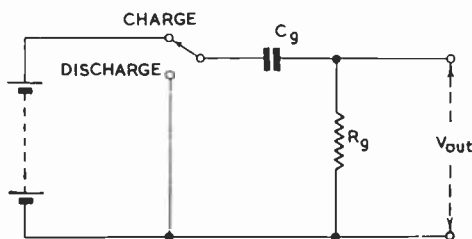

Fig. 86—Circuit for the charge and discharge of a capacitor

In this a capacitor may be charged from a battery via a series resistor and, by operating the switch, may be discharged through the same resistor. If the switch is repeatedly reversed, the waveform developed across the resistor has the same shape as the output of an RC-coupled amplifier with a square-wave input.

INTER-VALVE COUPLING CIRCUIT

10.6.1 Large Time Constant

To begin with, suppose the capacitor is uncharged when the switch is operated to the *charge* position. At this instant the current is large because there is no *back e.m.f.* from the capacitor and the current is limited only by the resistance in the circuit. As current flows into the capacitor, the latter begins to acquire charge and the voltage between the plates rises exponentially towards the battery value; this voltage is in opposition to that of the battery and thus the current falls exponentially as charging proceeds.

To simulate the behaviour of an amplifier with a square wave input, the switch is reversed after a certain interval of time. If the time constant $R_g C_g$ is large compared with this period, the capacitor has acquired only a small fraction of its total charge when the battery voltage is removed. Current flows through R_g throughout the whole period of the applied voltage, although it falls exponentially from the moment the battery is applied. Provided $R_g C_g$ is very large, however, the fall is small during the period of application and the current is only slightly less than its initial value when the battery voltage is removed.

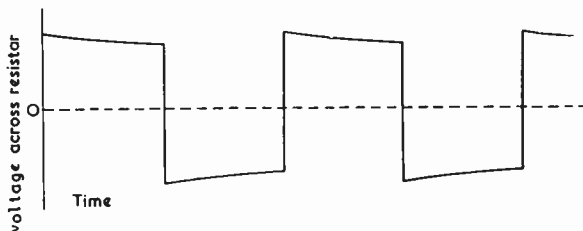

Fig. 87—Output of RC circuit for a square-wave input when the time constant is large compared with the period of the input

When the switch is operated to the *discharge* position, the capacitor begins to discharge through the resistor and there is an instantaneous reversal in the direction of the current through R_g . The current is initially high, being limited only by the value of the resistor R_g , but again falls exponentially as discharging proceeds. If the discharge period is of the same duration as the charge period, the current is only slightly less than its initial value when the battery voltage is restored by the next operation of the switch. At this moment the current again reverses in direction and C_g begins to charge again as already described. Thus the current in R_g reverses when the switch is reversed but is otherwise substantially constant. Thus, provided $R_g C_g$ is large enough, the voltage across R_g is a reasonably faithful copy of the applied voltage (Fig. 87).

10.6.2 Small Time Constant

If the time constant $R_g C_g$ is small compared with the period of the applied voltage, the output waveform has a different shape. When the switch is first operated to the *charge* position, the current jumps to a large value and the capacitor begins to acquire charge as before. But because of the small time constant the charging process is practically completed and the current in R_g falls almost to zero before the switch is operated to the *discharge* position. At this instant, the capacitor begins to discharge through the resistor (the current being opposite in direction to that which

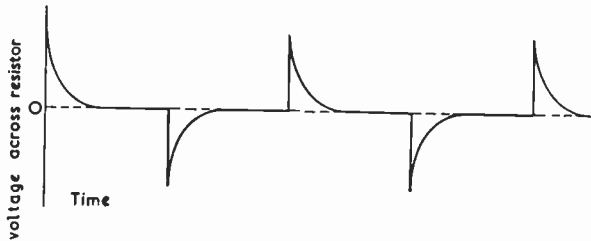

Fig. 88—Output of RC circuit for a square-wave input when the time constant is small compared with the period of the input

flowed during charging) and the discharge is virtually complete before the battery is restored. The voltage across R_g has, of course, the same waveform as the current and is illustrated in Fig. 88; it represents a very distorted version of the input signal. The waveform is, in fact, an approximation to the first differential co-efficient of the square-wave signal and such an RC combination with a small time constant is sometimes referred to as a *differentiating circuit*.

10.7 EFFECTS OF SERIES AND PARALLEL RC CIRCUITS ON A SQUARE WAVE

The preceding pages show that the effect of passing a square wave through a series RC circuit, such as the coupling components of an amplifier, is to introduce a slope (known as sag) in the horizontal sections of the wave, the vertical sections being reproduced without distortion. This can be contrasted with the effect of a parallel RC circuit (such as the anode resistor and anode shunt capacitance) on a square wave: this circuit distorts the vertical edges by introducing a rise time, but the horizontal sections remain unaffected. Just as there is a simple relationship between the rise time and the time constant of the parallel RC circuit which produces

INTER-VALVE COUPLING CIRCUIT

it, so is there a simple expression connecting the sag and the time constant of the series RC circuit: it may be deduced as shown below.

10.8 RELATIONSHIP BETWEEN SAG AND TIME CONSTANT

As proved in Appendix B, the discharge curve of an RC combination obeys the law:

$$V_t = V_0 e^{-t/R_g C_g} \quad \dots \quad (145)$$

where V_0 = initial voltage across the resistor

V_t = voltage across the resistor after a time t (Fig. 89)

This equation may be rewritten

$$V_0 - V_t = V_0(1 - e^{-t/R_g C_g})$$

The left-hand side of this equation ($V_0 - V_t$) is the difference between the initial voltage and the value after a time t ; it is, in

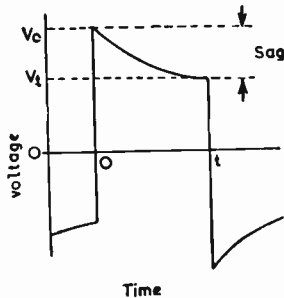

Fig. 89—Distortion of square wave due to small time constant

fact, the sag as shown in Fig. 89. Thus expression (145) may be rewritten

$$\frac{\text{sag}}{V_0} = 1 - e^{-t/R_g C_g} \quad \dots \quad (146)$$

The left-hand side of this expression (sag/V_0) may be termed the *relative sag* but it is more usual to multiply this by 100 to obtain the *percentage sag* which is thus given by

$$\begin{aligned} \text{percentage sag} &= 100 \cdot \frac{\text{sag}}{V_0} \\ &= 100(1 - e^{-t/R_g C_g}) \end{aligned}$$

A sag of 2 per cent means that the fall in voltage during half a

cycle of a square wave is $\frac{1}{50}$ th of the initial voltage. Expanding $e^{-t/R_g C_g}$ we have

$$\text{percentage sag} = 100 \left(\frac{t}{R_g C_g} - \frac{t^2}{2! R_g^2 C_g^2} + \frac{t^3}{3! R_g^3 C_g^3} - \dots \right) \quad (147)$$

Provided $R_g C_g$ is large compared with t the second and later terms can be neglected in comparison with the first. Thus we have

$$\text{percentage sag} = \frac{100t}{R_g C_g} \quad \dots \quad \dots \quad \dots \quad (148)$$

This simplification is equivalent to assuming that the decay curve is linear.

If we decide that the sag for a 50 c/s square wave shall be 1 per cent (representing an extremely high standard of performance) we have

$$\frac{100t}{R_g C_g} = 1$$

The duration t of half a cycle is 0.01 sec; substituting for t in the above expression

$$\frac{1}{R_g C_g} = 1$$

$$\therefore R_g C_g = 1 \text{ sec}$$

Any combination of grid capacitor and grid leak having this time constant will give the desired performance. Two possible combinations are 1 μF and 1 $\text{M}\Omega$ or 0.1 μF and 10 $\text{M}\Omega$. These are, however, inconvenient combinations, the first because a capacitor of 1 μF is large physically and its shunt capacitance to earth degrades the high-frequency response; the second because a grid leak of 10 $\text{M}\Omega$ is too high for the type of valve commonly used for video-frequency amplification. A time constant of 1 sec is thus impractically high.

To keep shunt capacitance to a reasonable value the coupling capacitor is usually kept below 0.1 μF and to avoid any possibility of grid emission the grid leak should not exceed 1 $\text{M}\Omega$. For these values the time constant is 0.1 sec and substitution in equation (148) shows that the sag, for a 50 c/s square wave, is 10 per cent. This is too much to be tolerated even in a single stage and further stages will, of course, introduce additional sag.

It is obvious that a simple RC-coupled stage, if left uncorrected, would produce intolerable distortion at low frequencies and some form of correction is essential. Some of the methods which can be

INTER-VALVE COUPLING CIRCUIT

used to effect this compensation are described later but before describing these we shall deduce the relationship between sag, frequency response and phase response.

10.9 RELATIONSHIP BETWEEN SAG AND FREQUENCY RESPONSE

Sag is related to frequency response according to the following expression which is deduced in Appendix H

$$\text{percentage sag} = 100\pi \sqrt{\left[\frac{2(V_{in} - V_{out})}{V_{in}} \right]} \dots \dots (149)$$

In this V_{in} and V_{out} are the input and output amplitudes of a sinusoidal signal having the same frequency as the square wave used in sag determinations.

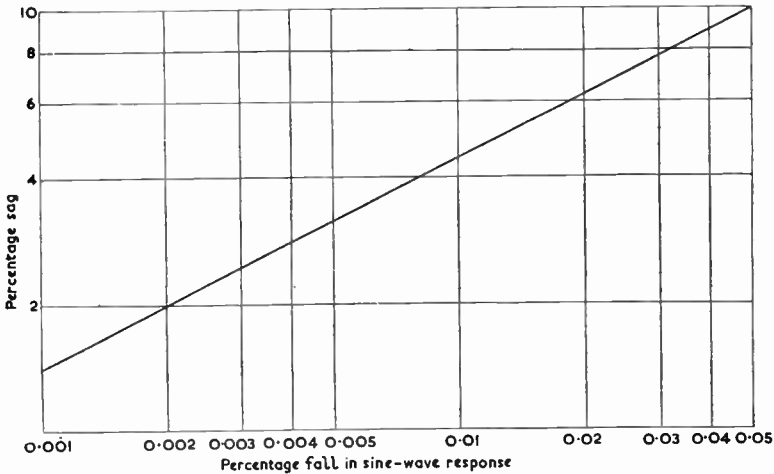

Fig. 90—Relationship between sag and frequency response for a simple RC circuit

This expression is plotted in Fig. 90 and shows that even if the loss of sine-wave amplitude is as low as 0.05 per cent, there is a 10 per cent sag when square waves of the same frequency are reproduced. In order to keep the sag less than 2 per cent the loss in sine-wave amplitude must be less than 0.0025 per cent. This implies that if the square wave has a frequency of 50 c/s, the response must be less than 0.00025 db down at 50 c/s and less than 3 db down at 0.3 c/s. This latter result is perhaps easier to deduce from expression (148); this shows that $R_g C_g$ must be at least 0.5 sec

to keep the sag less than 2 per cent. Now

$$\begin{aligned}\omega_g &= \frac{1}{R_g C_g} \\ &= \frac{1}{0.5} \\ &= 2\end{aligned}$$

The loss is 3 db at the frequency for which $\omega = \omega_g$, i.e., when

$$\begin{aligned}f &= \frac{\omega_g}{2\pi} \\ &= \frac{2}{2\pi} \\ &= \frac{1}{\pi} \\ &= 0.3 \text{ c/s approximately}\end{aligned}$$

10.10 RELATIONSHIP BETWEEN SAG AND PHASE RESPONSE

Sag is related very simply to the phase shift at the fundamental frequency of the square wave. The relationship may be deduced in the following way.

From (144)

$$\frac{1}{x} = \tan \phi$$

But $x = \omega/\omega_g = \omega C_g R_g = 2\pi f R_g C_g$

$$\therefore 2\pi f R_g C_g = 1/\tan \phi \quad \dots \quad \dots \quad \dots \quad (150)$$

In expression (148) t represents the time of one half-cycle, i.e., $\frac{1}{2}f$. Substituting this for t gives

$$\text{percentage sag} = \frac{100}{2f R_g C_g} \quad \dots \quad \dots \quad \dots \quad (151)$$

Eliminating $2f R_g C_g$ between (150) and (151) gives

$$\text{percentage sag} = 100 \pi \tan \phi \quad \dots \quad \dots \quad \dots \quad (152)$$

This expression is plotted in Fig. 91; the curve shows that a phase shift of as little as 1° corresponds to a sag of 5.5 per cent.

INTER-VALVE COUPLING CIRCUIT

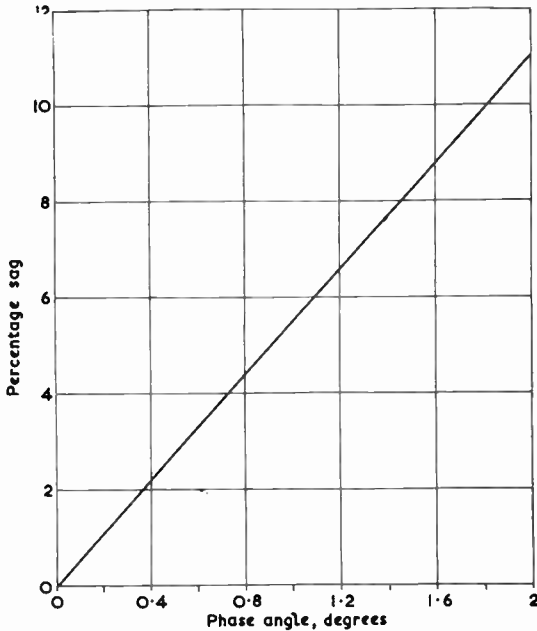

Fig. 91—Relationship between phase shift and sag for a simple RC circuit

10.11 EFFECTIVE INCREASE IN GRID RESISTOR BY CURRENT FEEDBACK

One way of extending the low-frequency of an RC-coupled amplifier without resorting to the use of prohibitively large coupling capacitors or grid resistors is by use of negative feedback. A simple method of applying such feedback is illustrated in Fig. 92 which shows the grid resistor returned to a tapping point on the cathode circuit of V2. Due to current feedback in R_k , the effective value of R_g is several times greater than its physical value; in fact it is shown in Appendix J at the end of this chapter that the effective grid resistor of valve V2 is equal to $(1 + g_m R_k) R_g$ where g_m is the working mutual conductance of V2 and R_g is the ohmic value of the grid resistor. This is greater by the factor $(1 + g_m R_k)$ than when R_g is returned to h.t. negative. Thus the effective time constant in the grid circuit is $R_g C_g (1 + g_m R_k)$.

As a numerical example consider a circuit in which $g_m = 8 \text{ mA/V}$, $R_k = 1 \text{ k}\Omega$, $C_g = 0.1 \text{ }\mu\text{F}$ and $R_g = 1 \text{ M}\Omega$. The factor by which

the value of the grid resistor is effectively multiplied is given by

$$(1 + g_m R_k) = (1 + 8 \times 10^{-3} \times 10^3) \\ = 9$$

The circuit thus behaves as though the grid resistor had a value of 9 MΩ and the effective time constant in the grid circuit is equal to

$$9R_g C_g = 9 \times 10^6 \times 0.1 \times 10^{-6} \text{ sec} \\ = 0.9 \text{ sec}$$

which is nearly equal to the value of 1 sec deduced above as necessary to keep the sag in a 50 c/s square wave to less than 1 per cent.

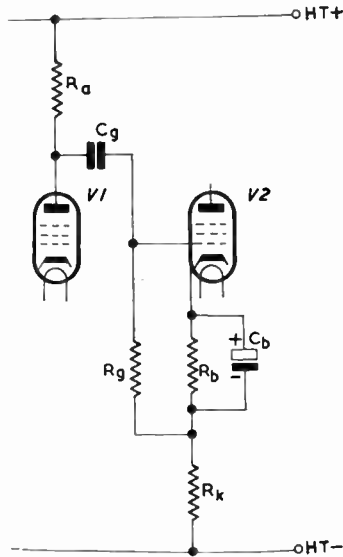

Fig. 92—Extension of low-frequency response by current feedback

The effective multiplication in the value of the grid resistor is equivalent to an extension in low-frequency response. In fact we can say that if the response is 3 db down at a frequency f_1 without feedback (e.g. with $R_k = 0$) it will be 3 db down at a frequency $f_1/(p + 1)$ with feedback, where $p = g_m R_k$. The frequency and phase response of a circuit such as that illustrated in Fig. 92 are given, in terms of p , in Figs. 96 and 97.

The extension of low-frequency response is obtained at the expense of a reduction in gain in the valve V2. Because of the current feedback, the gain of this stage is reduced in the ratio

INTER-VALVE COUPLING CIRCUIT

$1/(1 + g_m R_k)$, the same ratio in which the time constant is increased.

As shown on p. 94 a circuit similar to that in Fig. 92 can in addition be used to extend high-frequency response by shunting R_k with a capacitor which effectively removes the current feedback at the upper video frequencies. This capacitor has negligible effect at low frequencies and thus by means of such a circuit the frequency response can be extended at both ends.

APPENDIX H

RELATIONSHIP BETWEEN SAG AND FREQUENCY RESPONSE OF AN RC CIRCUIT

FIG. H.1 illustrates a simple RC circuit which is frequently encountered in amplifiers, particularly in inter-valve coupling circuits. If the input to this circuit is a sinusoidal signal of constant amplitude but falling frequency, the output is also sinusoidal but its amplitude falls because of the rising reactance of the capacitor. The output is of the same frequency as the input but is advanced in phase, the phase difference increasing asymptotically to 90° as frequency approaches zero. Fig. H.2 represents the relative amplitudes and phases of the input and output signals at one particular frequency; the output has half the amplitude of the input and the phase difference is 30° .

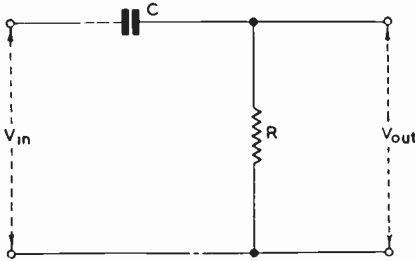
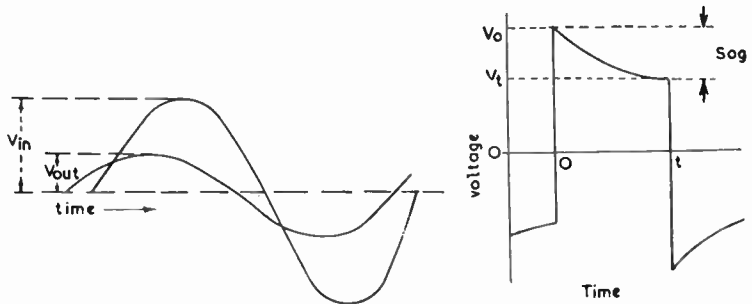

Fig. H.1—Simple RC circuit as used in coupling the output of one valve to the input of the next

Suppose now a square wave is applied to the input of the circuit. This is equivalent to the simultaneous application of a large number of sinusoidal components of harmonically-related frequencies. Each is subjected to an amplitude loss and a phase advance in passing through the circuit and all combine at the output to produce



(Left) Fig. H.2—Illustrating the fall in amplitude and phase advance of a sinusoidal signal when applied to the circuit of Fig. H.1
 (Right) Fig. H.3—Illustrating the sag introduced into a square-wave signal when applied to the circuit of Fig. H.1

a square wave with sag as shown in Fig. H.3. The sag is usually expressed as a percentage and is equal to $100(V_o - V_t)/V_o$ where V_o is the initial voltage and V_t the voltage after a time t .

There is a relationship between the value of $(V_{in} - V_{out})/V_{in}$ for a sinusoidal signal and $(V_o - V_t)/V_o$ for a square-wave signal and it is the purpose of this appendix to deduce it.

Fig. H.4 represents the relative phases and magnitudes of the current and voltages in the circuit of Fig. H.1. The vector OX represents the phase of the current and OA represents, to some chosen scale, the voltage developed across R ; this voltage is in phase with the current. OB represents in magnitude and direction the amplitude and phase of the voltage developed across C ; this voltage lags the current by 90° . The vector sum OC of OA and OB represents the applied voltage in magnitude and direction and ϕ is the angle of lead between the voltage across R and the applied voltage. From this diagram

$$\tan \phi = \frac{AC}{OA}$$

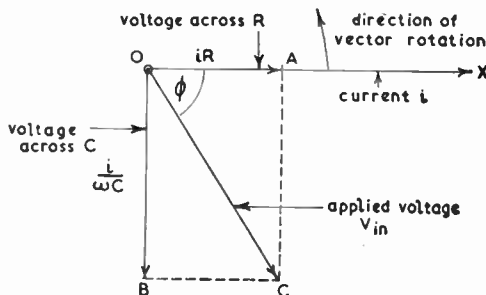

Fig. H.4—Vector diagram of voltages in RC circuit with sinusoidal input

INTER-VALVE COUPLING CIRCUIT

and if the angle ϕ is very small OA is practically equal to OC and we may say

$$\tan \phi \simeq \frac{AC}{OC}$$

This, of course, is tantamount to saying that the tangent of a small angle is approximately equal to its sine. From Pythagoras

$$AC = \sqrt{OC^2 - OA^2}$$

and hence

$$\begin{aligned} \tan \phi &= \frac{\sqrt{OC^2 - OA^2}}{OC} \\ &= \frac{\sqrt{V_{in}^2 - V_{out}^2}}{V_{in}} \\ &= \sqrt{\left[\frac{(V_{in} - V_{out})}{V_{in}^2} (V_{in} + V_{out}) \right]} \end{aligned}$$

When ϕ is very small V_{in} and V_{out} are approximately equal and $(V_{in} + V_{out})$ can be replaced by $2V_{in}$ giving

$$\tan \phi = \sqrt{\left[\frac{2(V_{in} - V_{out})}{V_{in}} \right]}$$

From expression (152) in the text

$$\begin{aligned} \text{percentage sag} &= 100 \pi \tan \phi \\ &= 100 \pi \sqrt{\left[\frac{2(V_{in} - V_{out})}{V_{in}} \right]} \end{aligned}$$

APPENDIX J

INCREASE IN EFFECTIVE VALUE OF GRID RESISTOR BY SERIES-CONNECTED CURRENT FEEDBACK

It was explained in the text that the value of the grid resistor of a valve can be effectively increased by returning the resistor to a point on the cathode circuit of the valve as shown in Fig. J.1, this point not being decoupled to h.t. negative at signal frequency. It is the purpose of this appendix to derive an expression for the effective value of the grid resistor in such a circuit.

The resistor R_b provides grid bias but not current feedback, for

it is decoupled by the capacitor C_b assumed to have negligible reactance at the signal frequency. R_k is not decoupled, however, and gives rise to a feedback voltage V_{fb} equal to $I_a R_k$ where I_a is the alternating component of anode current. This may be written

$$\begin{aligned} V_{fb} &= I_a R_k \\ &= g_m V_{gk} R_k \end{aligned}$$

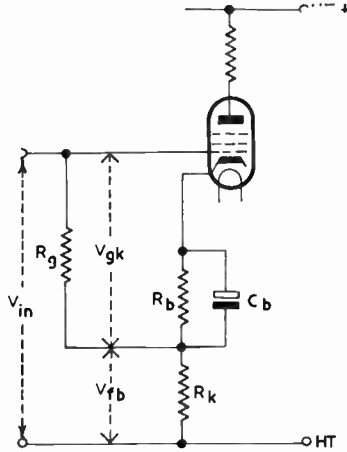

Fig. J.1—Current feedback circuit for increasing effective value of grid resistor

From the diagram

$$\begin{aligned} V_{in} &= V_{gk} + V_{fb} \\ &= V_{gk} + g_m V_{gk} R_k \\ &= V_{gk}(1 + g_m R_k) \end{aligned}$$

The effective value of the grid resistor is given by V_{in}/I where I is the current flowing through the input terminals; this current in flowing through R_g sets up the valve input signal V_{gk} and is thus given by V_{gk}/R_g . The effective resistance in the grid circuit is thus given by

$$\begin{aligned} \frac{V_{in}}{V_{gk}/R_g} &= \frac{V_{in}}{V_{gk}} \cdot R_g \\ &= R_g(1 + g_m R_k) \end{aligned}$$

CHAPTER 11

ANODE-DECOUPLING CIRCUIT

11.1 INTRODUCTION

WE have so far examined the effects of the inter-valve coupling components ($R_g C_g$ in Fig. 93) on the low-frequency response of an amplifier. In a practical amplifier, however, there are a number of other RC circuits which can affect the low-frequency response, namely the anode-, screen- and cathode-decoupling components. Here we describe the effect of the anode-decoupling components ($R_f C_f$) and the circuit with which we deal is that shown in Fig. 93.

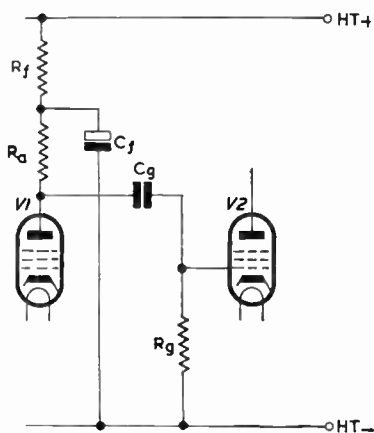

Fig. 93—An RC-coupled amplifier containing inter-valve coupling and anode-decoupling components

Anode-decoupling components were originally used in multi-valve amplifiers to minimise positive feedback (and possible motor-boating) due to the impedance of the h.t. supply (which is common to all stages) and to provide additional smoothing of the h.t. supply to early stages. Such networks are often unnecessary for these purposes in video-frequency amplifiers because these are fed from well-smoothed h.t. units of very low impedance. Nevertheless anode-decoupling components are often included in video-frequency amplifiers because of a third effect, namely that

they can, by suitable choice of component values, give a useful extension of the low-frequency response. The term *decoupling* is perhaps inappropriate to describe components introduced into an amplifier purely to extend the low-frequency response but this term will nevertheless be retained.

The extension of the low-frequency response arises in the following way. At middle and high video frequencies, R_f is short-circuited by C_f and the effective anode load consists principally of R_a . At low frequencies where the reactance of C_f is high, the effective load is greater, consisting of R_a in series with the parallel combination of R_f and C_f ; at zero frequency the load is simply R_a and R_f in series. The components R_f and C_f also introduce a lagging phase angle which increases as frequency is reduced. This effect is opposite to that of the coupling circuit R_gC_g and, by suitable choice of component values, it is possible to arrange for the effect of one network to cancel that due to the other. The compensation thus achieved cannot be perfect down to zero frequency but it is possible by this means to extend the low-frequency response of an amplifier by two or three octaves.

11.2 EFFECT OF ANODE-DECOUPLING COMPONENTS ILLUSTRATED VECTORIALLY

The effect of the anode-decoupling circuit can be illustrated by means of a vector diagram such as that given in Fig. 94. At middle frequencies for which the anode load is purely resistive, the vector diagram has the form shown at (a); the anode current I_a is in phase with the input signal V_{gk} and the anode-cathode potential is in antiphase with I_a .

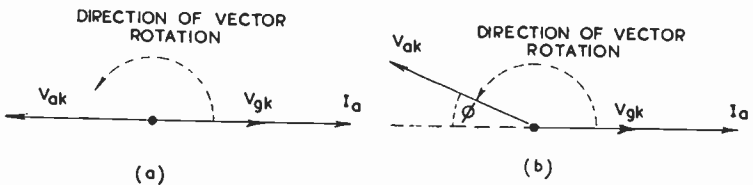

Fig. 94—Vector diagram illustrating the effect of anode-decoupling components

At low frequencies for which the reactance of C_f is appreciable, the effective anode load has a capacitive component and the voltage developed across the anode load lags relative to the voltage for a purely resistive load (Fig. 94b). The angle between the vector V_{gk} and V_{ak} (measured anti-clockwise) is less than in (a) indicating the phase lag caused by the anode-decoupling circuit.

ANODE-DECOUPLING CIRCUIT

11.3 DESIGN OF ANODE-DECOUPLING CIRCUIT

There is little point in deducing the frequency and phase response of the anode-decoupling circuit alone because it is generally proportioned to offset the distortion introduced by the inter-valve coupling circuit. We shall therefore deduce the frequency response of an amplifying stage which includes both anode-decoupling and inter-valve coupling circuits (Fig. 93). To obtain maximum extension of frequency response the values of coupling and decoupling components must satisfy certain simple mathematical relationships which can be deduced in the following way.

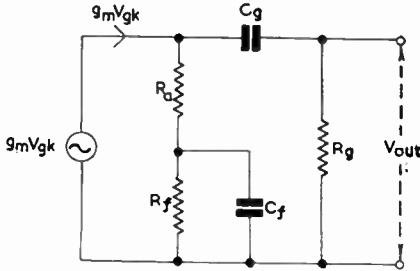

Fig. 95—Equivalent of the circuit shown in Fig. 93

We shall assume that R_g is very much greater than $(R_a + R_f)$; the anode load of valve V1 is thus composed effectively of R_a in series with the parallel combination $R_f C_f$ as shown in the equivalent circuit of Fig. 95. The impedance of R_f and C_f in parallel is given by

$$\begin{aligned}
 Z_f &= \frac{R_f | j\omega C_f}{R_f + 1/j\omega C_f} \\
 &= \frac{R_f}{1 + j\omega C_f R_f} \quad \dots \quad \dots \quad \dots \quad (153)
 \end{aligned}$$

The anode load is given by

$$R_a + Z_f = R_a + \frac{R_f}{1 + j\omega C_f R_f}$$

and the voltage developed across the anode load by the current $g_m V_{gk}$ flowing in it is given by

$$- g_m V_{gk} \left(R_a + \frac{R_f}{1 + j\omega C_f R_f} \right)$$

the negative sign indicating the phase inversion between anode and grid potentials.

The voltage delivered at the grid of V2 is developed across R_g

and is less than that developed across the anode load because R_g and C_g behave as a potential divider connected across the anode circuit. The ratio in which R_g and C_g step down the anode potential is given by

$$\frac{R_g}{R_g + 1/j\omega C_g} = \frac{j\omega C_g R_g}{1 + j\omega C_g R_g}$$

Thus V_{out} , the grid voltage for V2, is given by

$$V_{out} = -g_m V_g \left(R_a + \frac{R_f}{1 + j\omega C_f R_f} \right) \cdot \left(\frac{j\omega C_g R_g}{1 + j\omega C_g R_g} \right)$$

and the stage gain A_{1f} is expressed by

$$\begin{aligned} A_{1f} &= \frac{V_{out}}{V_g} \\ &= -g_m \left(R_a + \frac{R_f}{1 + j\omega C_f R_f} \right) \cdot \left(\frac{j\omega C_g R_g}{1 + j\omega C_g R_g} \right) \\ &= -g_m j\omega C_g R_g (R_a + R_f) \cdot \frac{1 + j\omega C_f R_a'}{(1 + j\omega C_f R_f)(1 + j\omega C_g R_g)} \end{aligned} \quad (154)$$

where R_a' is the resistance of R_a and R_f in parallel and is given by

$$R_a' = \frac{R_a R_f}{R_a + R_f} \quad \dots \quad \dots \quad \dots \quad (155)$$

Expression (154) may be written

$$A_{1f} = -g_m j\omega C_g R_g \left(\frac{1 + j\omega C_f R_a'}{R_a + R_f + j\omega \frac{R_f C_f}{R_a + R_f}} \right) (1 + j\omega C_g R_g) \quad \dots \quad (156)$$

Now as shown in expression (155) if R_f is large compared with R_a , R_a' is approximately equal to R_a and the first bracketed term in the denominator of the above expression simplifies to $j\omega C_f$.

The stage gain of the circuit (Fig. 93) as a whole is then given by

$$A_{1f} = -g_m \frac{R_g C_g}{C_f} \cdot \frac{1 + j\omega C_f R_a'}{1 + j\omega C_g R_g} \quad \dots \quad \dots \quad \dots \quad (157)$$

This expression is independent of frequency if

$$R_a' C_f = R_g C_g \quad \dots \quad \dots \quad \dots \quad (158)$$

This shows that the design of the anode-decoupling circuit is intimately bound up with that of the inter-valve coupling circuit.

ANODE-DECOUPLING CIRCUIT

Applying the conditions of expression (158) to (157) we have

$$A_{1f} = -g_m \cdot \frac{R_g C_g}{C_f} \\ = -g_m R_a' \dots \dots \dots (159)$$

Since there is now no term in j in the expression for A_{1f} the circuit gives no phase shift at any frequency. From the foregoing the conditions to be observed to maintain this performance are:—

1. R_f should be large compared with R_a
2. The time constant $R_a' C_f$ should equal $R_g C_g$. If the previous condition is observed, R_a' is approximately equal to R_a and this second condition implies that the product of anode resistor and decoupling capacitor should equal that of grid resistor and coupling capacitor.

The second of these conditions can usually be observed without introducing any practical circuit difficulties but if the first were strictly maintained the h.t. voltage on the anode of V1 might be reduced to too low a value; R_f is therefore sometimes made no more than 2 or 3 times R_a to keep the anode voltage at a reasonable value. This means that the compensation cannot be perfect down to zero frequency. Even so, the effect of the decoupling circuit is to bring about a great improvement in low-frequency performance. To show this we must derive an expression for the frequency response of a circuit with inter-valve-coupling and anode-decoupling components. This may be done in the following way.

11.4 FREQUENCY RESPONSE OF DECOUPLED CIRCUIT

When the second of the above conditions is observed expression (154) may be written

$$A_{1f} = - \frac{g_m j \omega C_g R_g (R_a + R_f)}{1 + j \omega C_f R_f} \dots \dots (160)$$

Eliminating R_a' between (155) and (158) we have

$$\frac{R_a R_f}{R_a + R_f} = \frac{R_g C_g}{C_f}$$

from which

$$R_f C_f = R_g C_g \cdot \frac{R_a + R_f}{R_a} \dots \dots (161)$$

Substituting for $R_f C_f$ in (160)

$$A_{1f} = - \frac{g_m j \omega C_g R_g (R_a + R_f)}{1 + j \omega C_g R_g (R_a + R_f) / R_a} \\ = - g_m R_a \cdot \frac{j \omega C_g R_g (R_a + R_f) / R_a}{1 + j \omega C_g R_g (R_a + R_f) / R_a} (162)$$

But $-g_m R_a = A_{mf}$, the gain at medium frequencies.

$$\therefore \frac{A_{if}}{A_{mf}} = \frac{j\omega C_g R_g (R_a + R_f) / R_a}{1 + j\omega C_g R_g (R_a + R_f) / R_a} \quad \dots (163)$$

Putting $p = R_f / R_a$, $\omega_g = 1 / R_g C_g$ and $x = \omega / \omega_g$ we have

$$\frac{A_{if}}{A_{mf}} = \frac{jx(p + 1)}{1 + jx(p + 1)} \quad \dots \dots (164)$$

The frequency response of the circuit is thus given by

$$\left| \frac{A_{if}}{A_{mf}} \right| = \frac{(p + 1)x}{\sqrt{1 + (p + 1)^2 x^2}} \quad \dots \dots (165)$$

and the response in decibels by

$$\begin{aligned} \text{response} &= 20 \log_{10} \left| \frac{A_{if}}{A_{mf}} \right| \text{ db} \\ &= 10 \log_{10} \frac{(p + 1)^2 x^2}{1 + (p + 1)^2 x^2} \text{ db} \quad \dots (166) \end{aligned}$$

This expression is plotted in Fig. 96.

The dotted curve labelled $p = 0$ gives the response of an RC-coupled amplifier with no anode decoupling ($R_f = 0$), and is 3 db down at the frequency for which the reactance of the coupling capacitor equals the grid resistor. The effect of increasing p (i.e. increasing R_f) is to move the characteristic bodily to the left, without change of shape, thus extending the low-frequency response. When $p = 5$ the frequency at which the response is 3 db down is at $x = 0.17$ compared with $x = 1$ for the circuit without decoupling.

The effect of the decoupling circuit is to reduce the frequency for a given fall in response in the ratio $1/(p + 1)$. This can be deduced in the following way. Let f_1 be the frequency at which an RC-coupled amplifier without decoupling has a certain loss and let f_2 be the frequency at which the circuit when decoupled has the same loss.

Let x_1 be the normalised frequency corresponding to f_1 . Then

$$\begin{aligned} x_1 &= \frac{\omega_1}{\omega_g} \\ &= \frac{f_1}{f_g} \end{aligned}$$

ANODE-DECOUPLING CIRCUIT

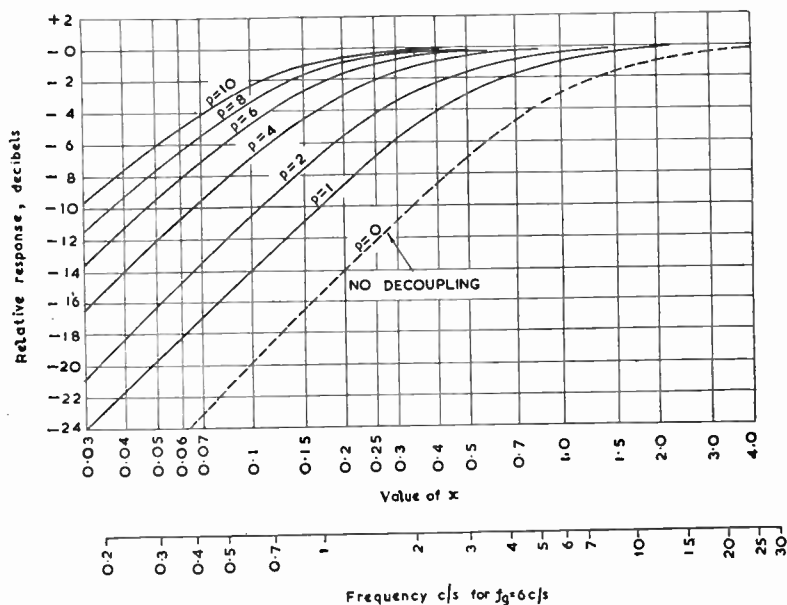

Fig. 96—Universal frequency-response curves for simple RC-coupled circuit with anode decoupling

where f_g is the frequency at which the reactance of the coupling capacitor is equal to the value of the grid resistor. Similarly

$$x_2 = \frac{f_2}{f_g}$$

where x_2 is the normalised frequency corresponding to f_2 .

For the circuit without decoupling, at the frequency f_1 , we have

$$\begin{aligned} \frac{A_{1f}}{A_{mf}} &= \frac{jx_1}{1 + jx_1} \\ &= \frac{1}{1 + 1/jx_1} \dots \dots \dots (167) \end{aligned}$$

and for the decoupled circuit at the frequency f_2

$$\begin{aligned} \frac{A_{1f}}{A_{mf}} &= \frac{jx_2(p + 1)}{1 + jx_2(p + 1)} \\ &= \frac{1}{1 + 1/jx_2(p + 1)} \dots \dots \dots (168) \end{aligned}$$

For the same fall in response expressions (167) and (168) are equal

$$\therefore 1 + \frac{1}{j\omega x_2(p+1)} = 1 + \frac{1}{j\omega x_1}$$

giving $x_2(p+1) = x_1$

$$x_2 = \frac{x_1}{p+1}$$

from which $f_2 = \frac{f_1}{p+1}$ (169)

which shows that the addition of decoupling has lowered the frequency, for a given loss, in the ratio $1/(p+1)$.

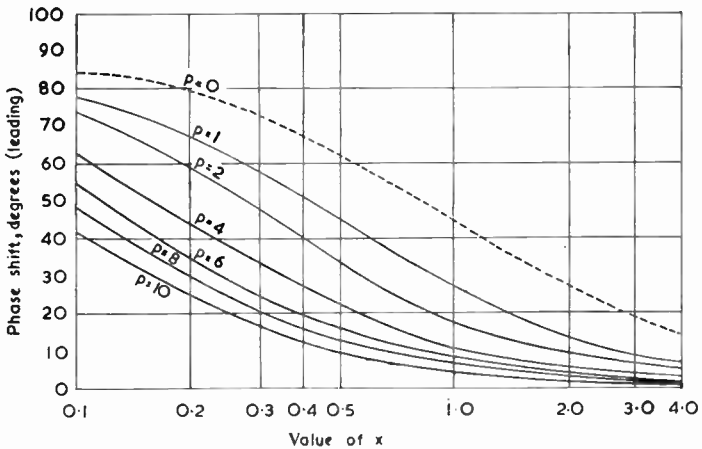

Fig. 97—Universal phase-response curves for simple RC-coupled circuit with anode decoupling

This extension of low-frequency response can be regarded as due to an effective increase in the time constant of the inter-valve coupling components, such as is brought about by the use of current feedback, and in fact the curves of Figs. 96 and 97 apply equally to the anode-decoupling and feedback circuits.

Numerical Example

As a numerical example of the design of a video-frequency stage with low-frequency compensation by means of the anode-decoupling circuit, consider a valve in which the value of R_a has been fixed by high-frequency considerations at $2,000 \Omega$. R_f is given the highest value compatible with adequate h.t. voltage on the valve anode.

ANODE-DECOUPLING CIRCUIT

If the valve consumes, say, 10 mA from an h.t. supply of 250 V, R_f can usually be 10 k Ω (leaving 130 V on the anode). An arbitrary value is chosen for C_f —say 16 μ F.

The time constant $R_a'C_f$ can now be evaluated from expression (155), the value of R_a' being given by

$$\begin{aligned} R_a' &= \frac{R_a R_f}{R_a + R_f} \\ &= \frac{2 \times 10 \times 10^6}{12 \times 10^3} \Omega \\ &= 1.7 \text{ k}\Omega \text{ approximately} \end{aligned}$$

$$\begin{aligned} \therefore R_a' C_f &= 1.7 \times 10^3 \times 16 \times 10^{-6} \text{ sec} \\ &= 0.027 \text{ sec} \end{aligned}$$

For maximum extension of low-frequency response the grid circuit time constant $R_g C_g$ must equal this value. Suitable component values are 1 M Ω and 0.03 μ F or 270 k Ω and 0.1 μ F or, of course, any other combination of resistance and capacitance which has this value of product.

In order to calculate the frequency response of the circuit so designed we must first determine the response in the absence of decoupling components. This is most conveniently expressed in terms of the parameter ω_g , the angular frequency at which the reactance of the coupling capacitor is equal to the grid resistor. This frequency is given by

$$\begin{aligned} \omega_g &= \frac{1}{R_g C_g} \\ &= \frac{1}{0.027} \end{aligned}$$

from which

$$\begin{aligned} f_g &= \frac{\omega_g}{2\pi} \\ &= \frac{1}{6.284 \times 0.027} \text{ c/s} \\ &= 5.9 \text{ c/s} \end{aligned}$$

At this frequency the response of the circuit without decoupling is 3 db down and if a logarithmic frequency scale is placed along the horizontal axis of Fig. 96 so that 5.9 c/s coincides with $x = 1$, the response curve for the undecoupled circuit is given by the curve labelled $p = 0$.

For the decoupled circuit $R_f = 5R_a$, giving $p = 5$ and the frequency response with decoupling is given by the curve labelled $p = 5$ in Fig. 96. As shown by this curve, the response is 3 db down at approximately 1 c/s, one-sixth of the frequency at which the undecoupled circuit is 3 db down. This confirms that the addition of decoupling has the effect of increasing the time constant of the coupling circuit by $(p + 1)$, i.e. 6 times, to the value $6 \times 0.027 = 0.162$ sec. From expression (148) the sag introduced by this circuit in reproduction of a square wave is given by

$$\text{percentage sag} = \frac{100t}{R_g C_g}$$

If the frequency is 50 c/s, t , the time of half a cycle, is 0.01 sec and we have

$$\begin{aligned} \text{percentage sag} &= \frac{1}{R_g C_g} \\ &= 1 \\ &= 0.162 \\ &= 6 \text{ approximately} \end{aligned}$$

11.5 PHASE RESPONSE OF DECOUPLED CIRCUIT

Although the percentage sag introduced by a particular circuit can be determined from steady-state frequency-response considerations and the design can be carried out on the basis of such response curves, it is nevertheless useful to know the phase response of the circuit. For the circuit of Fig. 93 this can be determined in the following way. Putting $A_{mf} = -g_m R_a$ in expression (164) we have

$$\begin{aligned} A_{lf} &= \frac{V_{out}}{V_{gk}} \\ &= \frac{g_m R_a jx(p + 1)}{1 + jx(p + 1)} \end{aligned}$$

But $g_m V_{gk} = I$, the alternating component of the anode current. Substituting I for $g_m V_{gk}$ gives

$$\frac{V_{out}}{I} = - \frac{R_a jx(p + 1)}{1 + jx(p + 1)} \dots \dots \dots (170)$$

Rationalising

$$\frac{V_{out}}{I} = - R_a \frac{jx(p + 1) + x^2(p + 1)^2}{1 + x^2(p + 1)^2}$$

ANODE-DECOUPLING CIRCUIT

This is of the form $(R + jX)$ and the phase angle ϕ between V_{out} and I is given by $\tan^{-1}X/R$, i.e.

$$\begin{aligned} \phi &= \tan^{-1} \frac{x(p + 1)}{x^2(p + 1)^2} \\ &= \tan^{-1} \frac{1}{x(p + 1)} \dots \dots \dots (171) \end{aligned}$$

This expression shows that the phase angle is positive, i.e. V_{out} leads I .

This expression is plotted in Fig. 97 which shows that at a given frequency x , the phase shift is reduced by increasing p , that is by increasing the value of the decoupling resistor R_f . The curves in this diagram have the same shape but are progressively displaced to the left as the value of p is increased. Thus increase of p decreases phase shift and renders the amplifier more suitable for amplification of video signals.

Expression (171) shows that the effect of adding the decoupling network is to reduce the phase shift ϕ at a given frequency equivalent to $1/(p + 1)$ of its former value (provided, of course, that $R_a' C_f$ is equal to $R_g C_g$). This reduction in phase shift is, from expression (151), equivalent to an equal reduction in sag during the reproduction of square waves. This confirms the deduction made from consideration of the frequency response.

Alternative Circuit

Fig. 98 shows an alternative circuit giving substantially the same performance as Fig. 93. At high frequencies the effective anode load is R_a because the reactance of C_f is negligible; at low frequencies when the reactance of C_f is high, the anode load tends to the value R_f . The circuit of Fig. 93 is probably better because $R_f C_f$ provide anode decoupling and smoothing in addition to extending the low-frequency response.

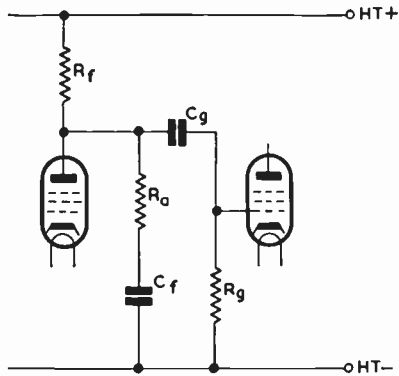

Fig. 98—An alternative circuit for extending low-frequency response

CHAPTER 12

CATHODE-DECOUPLING CIRCUIT

12.1 INTRODUCTION

WE have so far discussed the effects on the low-frequency response of an amplifier of the inter-valve coupling and anode-decoupling components and have shown that these can be arranged to cancel over a limited frequency range. We shall now describe the effects of a third RC circuit, namely the cathode-decoupling components ($R_k C_k$ in Fig. 99). These components are similar to the inter-valve coupling components in their effect on frequency and phase response; in other words they produce a falling amplitude response and an

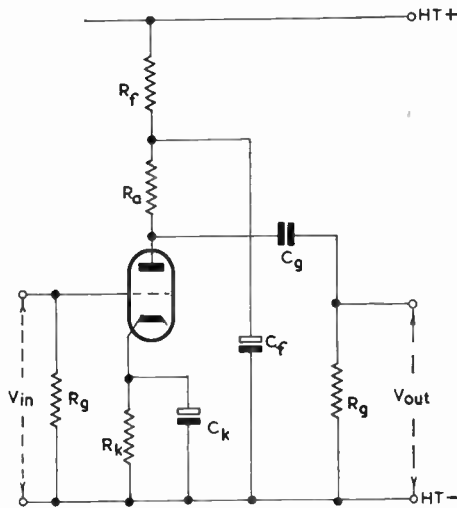

Fig. 99—RC-coupled amplifier including inter-valve coupling, anode decoupling and cathode-decoupling components

increasing (leading) phase angle as frequency is reduced. This suggests that it should be possible to arrange for the anode-decoupling components to cancel the effects of the cathode-decoupling components. As shown here, this can be done and the frequency and phase response at the anode of the valve can be made perfect down to zero frequency. It is not possible, however, to arrange

188

CATHODE-DECOUPLING CIRCUIT

for the anode-decoupling components to neutralise the effects of inter-valve and cathode-decoupling components simultaneously.

12.2 DISTORTION DUE TO CATHODE COMPONENTS ILLUSTRATED BY VECTORS

The resistor R_k is included in the cathode circuit to provide the valve with grid bias. It also gives current feedback and an attendant loss in amplitude response which is normally undesirable and C_k is included to eliminate feedback. The capacitor is effective in doing this at all frequencies for which the reactance is small but unless a prohibitively large capacitor is used, feedback is present at very low frequencies. This causes a fall in output, and a phase shift in the output of V1 at frequencies near the value for which the reactance of C_k equals R_k . The phase shift can be illustrated in a vector diagram such as that shown in Fig. 100. This shows the anode

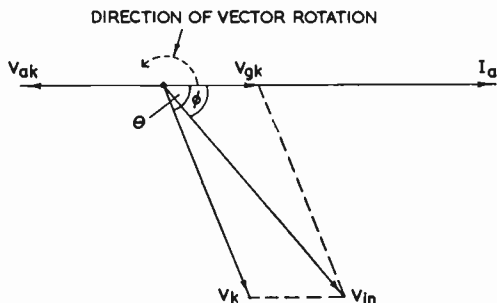

Fig. 100—Illustrating the phase lead of an RC-cathode circuit

voltage V_{ak} in antiphase with the grid-cathode signal V_{gk} and the anode current I_a . At the frequencies for which the reactance of C_k is comparable with R_k , the potential V_k developed across the cathode components lags the anode current by an angle ϕ of less than 90° , as shown in the diagram. The input voltage V_{in} to the valve is made up of V_{gk} and V_k and its phase and magnitude can be determined by completing the vector parallelogram as shown.

At frequencies for which the cathode circuit is of negligible impedance, the anode potential is in antiphase with the grid potential and the vectors representing these voltages therefore have the relative positions of V_{ak} and V_{gk} in Fig. 100. At low frequencies an input signal V_{in} gives an output signal V_{ak} . The angle between V_{in} and V_{ak} , measured in an anticlockwise direction (the conventional direction for vector diagrams), is $(180 + \phi)^\circ$ which exceeds the angle between V_{gk} and V_{ak} by ϕ° . Thus it may be said that the cathode components cause a phase lead of ϕ° .

12.3 FREQUENCY RESPONSE

The magnitude of the attenuation and phase distortion introduced by an RC cathode-decoupling circuit can be calculated in the following way.

The impedance Z_k of R_k and C_k in parallel is given by

$$\begin{aligned} Z_k &= \frac{R_k \cdot \frac{1}{j\omega C_k}}{R_k + \frac{1}{j\omega C_k}} \\ &= \frac{R_k}{1 + j\omega C_k R_k} \quad \dots \quad \dots \quad \dots \quad (177) \end{aligned}$$

In flowing through this impedance, the valve cathode current I sets up a voltage V_k given by

$$V_k = IZ_k \quad \dots \quad \dots \quad \dots \quad (178)$$

If the valve is a pentode we can neglect the screen current and assume that the anode and cathode currents are equal. The input signal V_{in} is equal to the sum of the grid-cathode signal, V_{gk} , and the cathode-earth signal, V_k . Thus

$$\begin{aligned} V_{in} &= V_{gk} + V_k \\ &= V_{gk} + IZ_k \end{aligned}$$

But $I = g_m V_{gk}$

$$\therefore V_{in} = V_{gk}(1 + g_m Z_k)$$

from which

$$V_{gk} = \frac{V_{in}}{1 + g_m Z_k} \quad \dots \quad \dots \quad \dots \quad (179)$$

The output signal, V_{out} , is given by $-IR_a$ and substituting $g_m V_{gk}$ for I ,

$$V_{out} = -g_m V_{gk} R_a$$

Substituting for V_{gk} from (179)

$$\begin{aligned} V_{out} &= -g_m R_a \frac{V_{in}}{1 + g_m Z_k} \\ \therefore A_{lf} &= \frac{V_{out}}{V_{in}} \\ &= -\frac{g_m R_a}{1 + g_m Z_k} \quad \dots \quad \dots \quad \dots \quad (180) \end{aligned}$$

CATHODE-DECOUPLING CIRCUIT

This can be simplified by putting A_{mf} for $-g_m R_a$

$$\frac{A_{if}}{A_{mf}} = \frac{1}{1 + g_m Z_k} \quad \dots \quad \dots \quad \dots \quad (181)$$

Substituting for Z_k from (177) and re-arranging

$$\frac{A_{if}}{A_{mf}} = \frac{1 + j\omega C_k R_k}{1 + j\omega C_k R_k + g_m R_k} \quad \dots \quad \dots \quad (182)$$

Now $g_m = 1/r_k$ where r_k is the ratio of a small change in cathode potential to the corresponding change in cathode current. Substituting $1/r_k$ for g_m in (182) and re-arranging we have

$$\frac{A_{if}}{A_{mf}} = \frac{r_k + j\omega C_k R_k r_k}{r_k + R_k + j\omega C_k R_k r_k}$$

Dividing numerator and denominator by $(r_k + R_k)$

$$\frac{A_{if}}{A_{mf}} = \frac{r_k/(r_k + R_k) + j\omega C_k R_k r_k'}{1 + j\omega C_k R_k r_k'} \quad \dots \quad (183)$$

where

$$R_k' = \frac{r_k R_k}{r_k + R_k} \quad \dots \quad \dots \quad (184)$$

R_k' is the resistance of the external cathode resistor R_k and the internal cathode resistance r_k in parallel. It is the resistance which would be measured by an a.c. bridge connected between cathode and h.t. negative.

Expression (183) can be arranged in a simpler form by the substitutions

$$\omega_k = 1/R_k' C_k \quad \dots \quad \dots \quad (185)$$

$$x = \omega/\omega_k \quad \dots \quad \dots \quad (186)$$

ω_k is thus the angular frequency at which the reactance of the cathode capacitance equals the external cathode resistance R_k and the internal cathode resistance ($r_k = 1/g_m$) in parallel. As before x is a variable directly proportional to frequency. Making these substitutions we have

$$\frac{A_{if}}{A_{mf}} = \frac{r_k/(r_k + R_k) + jx}{1 + jx} \quad \dots \quad \dots \quad (187)$$

From which

$$\left| \frac{A_{if}}{A_{mf}} \right| = \sqrt{\left[\frac{r_k^2/(r_k + R_k)^2 + x^2}{1 + x^2} \right]} \quad \dots \quad (188)$$

The response in decibels is thus given by

$$20 \log_{10} \frac{A_{if}}{A_{mf}} = 10 \log_{10} \left[\frac{r_k^2 / (r_k + R_k)^2 + x^2}{1 + x^2} \right]$$

$$= 10 \log_{10} \left[\frac{1 / (1 + g_m R_k)^2 + x^2}{1 + x^2} \right] \dots (189)$$

This expression is plotted in Fig. 101 for values of $g_m R_k$ between 0 and infinity. The diagram shows that there is a step in the frequency response which may be regarded as beginning below a frequency corresponding to $x = 1$, i.e., at the frequency for which the reactance of C_k equals R_k and r_k in parallel. The curves are all

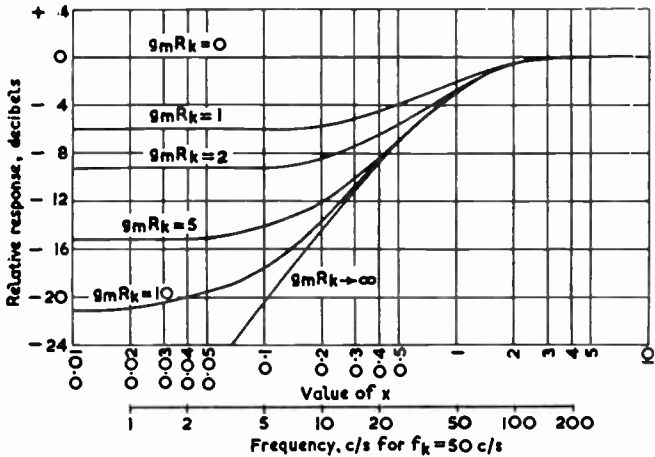

Fig. 101—Effect of finite cathode impedance on frequency response of an amplifier

asymptotic to the line $g_m R_k = 0$ representing zero loss at high frequencies and to the loss $-20 \log_{10} (1 + g_m R_k)$ at low frequencies. This loss can be evaluated very simply by putting $x = 0$ in expression (189). The low-frequency loss is thus 6 db when $g_m R_k = 1$; this occurs when $R_k = 1/g_m$, i.e., when the external cathode resistance equals the internal resistance ($1/g_m$). In most practical amplifiers the value of the cathode bias resistance is approximately equal to $1/g_m$ and the curve for $g_m R_k = 1$ is thus of great importance.

12.4 PHASE RESPONSE

The phase characteristic may be deduced from expression (187).

CATHODE-DECOUPLING CIRCUIT

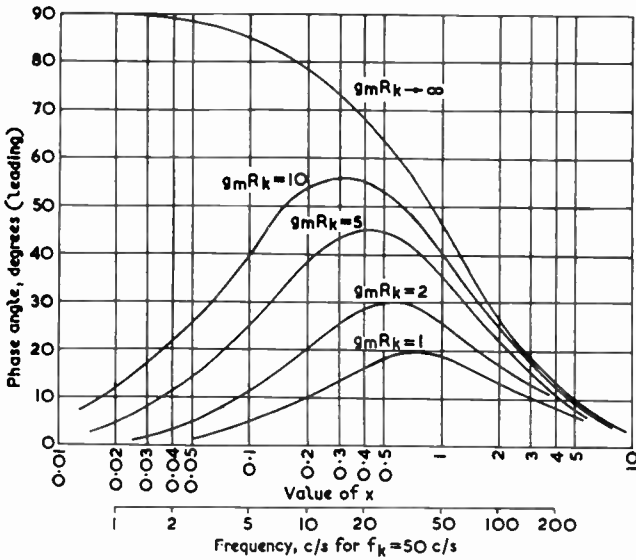

Fig. 102—Effect of finite cathode impedance on phase characteristic of an amplifier

This may be restated thus

$$A_{lf} = \frac{V_{out}}{V_{in}} = -g_m R_a \cdot \frac{r_k / (r_k + R_k) + jx}{1 + jx}$$

Rationalising

$$\frac{V_{out}}{V_{in}} = -g_m R_a \frac{r_k / (r_k + R_k) + jx - jxr_k / (r_k + R_k) + x^2}{1 + x^2}$$

This is of the form $(R + jX)$ and the phase angle ϕ between V_{out} and V_{in} is given by $\tan^{-1} X/R$, i.e.,

$$\begin{aligned} \phi &= \tan^{-1} \frac{x - xr_k / (r_k + R_k)}{r_k / (r_k + R_k) + x^2} \\ &= \tan^{-1} \frac{xR_k}{x^2(r_k + R_k) + r_k} \\ &= \tan^{-1} \frac{xg_m R_k}{x^2(1 + g_m R_k) + 1} \quad \dots \quad (190) \end{aligned}$$

Since x , g_m and R_k are all essentially positive quantities ϕ is also positive implying a phase lead. This expression is plotted in Fig. 102 for the values of $g_m R_k$ used in Fig. 101. It can be seen

that the phase angle rises to a maximum as frequency is lowered and, except when $g_m R_k$ is infinite, returns to zero again.

Numerical Examples

From the universal curves of Figs. 101 and 102 it is possible to deduce the frequency and phase response for a particular valve and cathode circuit or alternatively to determine what component values are necessary to give a desired response.

For example consider an amplifier stage in which g_m is 8 mA/V, R_k is 125 Ω and C_k is 50 μF . The frequency and phase responses are required.

We have

$$\begin{aligned} r_k &= \frac{1}{g_m} \\ &= \frac{1}{8 \times 10^{-3}} \Omega \\ &= 125 \Omega \\ R_k' &= \frac{r_k R_k}{r_k + R_k} \\ &= \frac{125 \times 125}{250} \Omega \\ &= 62.5 \Omega \end{aligned}$$

The reactance of C_k is equal to R_k' at the frequency for which

$$\begin{aligned} \omega &= \frac{1}{R_k' C_k} \\ \therefore f &= \frac{1}{2\pi R_k' C_k} \\ &= \frac{1}{6.284 \times 62.5 \times 50 \times 10^{-6}} \text{ c/s} \\ &= 50 \text{ c/s approximately} \end{aligned}$$

The frequency response of the amplifier can be obtained by locating a frequency scale along the horizontal axis in Fig. 101 so that $x = 1$ corresponds with 50 c/s. This has been done in this diagram and the response of the amplifier (given by the curve labelled $g_m R_k = 1$) shows that the loss is 2 db at 50 c/s, 4 db at 25 c/s and 6 db below approximately 10 c/s. The phase response of the amplifier can be

CATHODE-DECOUPLING CIRCUIT

obtained in a similar manner from the curve labelled $g_m R_k = 1$ in Fig. 102. As shown the phase shift is nearly 20° at 50 c/s; this would cause prohibitive sag in the reproduction of a 50 c/s square wave.

The phase shift can be decreased by increasing the value of C_k but what value of C_k is necessary to limit the sag to, say, 5 per cent at 50 c/s? This can be calculated from Fig. 102 in the following way. From Fig. 91, 5 per cent sag corresponds to a phase shift of 1° approximately at the fundamental frequency of the square wave. Substituting $g_m R_k = 1$ and $\phi = 1^\circ$ in expression (190) we have that x is approximately 28.5. Hence

$$\frac{\omega}{\omega_k} = 28.5$$

at 50 c/s. Now $\omega_k = 1/R_k' C_k$. Hence

$$\begin{aligned} C_k &= \frac{28.5}{\omega R_k'} \\ &= \frac{28.5}{6.284 \times 50 \times 62.5} \text{ F} \\ &= 1450 \mu\text{F} \end{aligned}$$

This is a large value of capacitance and even though only a low value of voltage rating is necessary, the component is bulky and inconvenient to use. The necessity for it can be avoided by some of the alternative methods of design now to be described.

12.5 USE OF EXTERNAL SOURCE OF GRID BIAS

From expression (182) for the effect of an RC circuit on the frequency response of an amplifying stage it is clear that the loss in low-frequency response (and the phase distortion) can be eliminated by putting $R_k = 0$, i.e., by omitting the RC combination and connecting the cathode directly to h.t. negative. This is permissible, provided the negative grid bias required is obtained from an external source as shown in Fig. 103.

12.6 USE OF RESISTIVE CATHODE CIRCUIT

If it is essential to obtain grid bias by a resistor in the cathode circuit, the loss in low-frequency response and the accompanying phase distortion can be avoided by omitting the decoupling capacitor C_k , leaving the cathode circuit as shown in Fig. 104. This eliminates

the j -term in expression (182) but introduces a loss at all frequencies given by

$$20 \log_{10}(1 + g_m R_k) \text{ db}$$

and if $g_m = 8 \text{ mA/V}$ and $R_k = 150 \Omega$,

$$\begin{aligned} \text{loss} &= 20 \log_{10}(1 + g_m R_k) \\ &= 20 \log_{10} 2.2 \\ &= 6.85 \text{ db} \end{aligned}$$

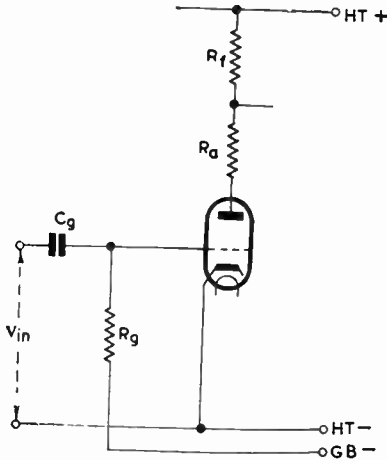

Fig. 103—By using an external bias source, distortion due to cathode components can be eliminated

If the anode resistor R_a is $2,000 \Omega$, the gain in the absence of feedback is given by

$$\begin{aligned} A &= g_m R_a \\ &= 8 \times 10^{-3} \times 2 \times 10^3 \\ &= 16 \end{aligned}$$

and with feedback the gain is reduced to

$$\begin{aligned} A' &= \frac{g_m R_a}{1 + g_m R_k} \\ &= \frac{16}{1 + (8 \times 10^{-3} \times 150)} \\ &= \frac{16}{2.2} \\ &= 7.6 \end{aligned}$$

CATHODE-DECOUPLING CIRCUIT

The loss is serious but there are circumstances where it can be afforded. The loss can be reduced, of course, by decreasing the value of R_k ; this can sometimes be done when the input signal for the valve is very small (as, for instance, in a camera head amplifier)

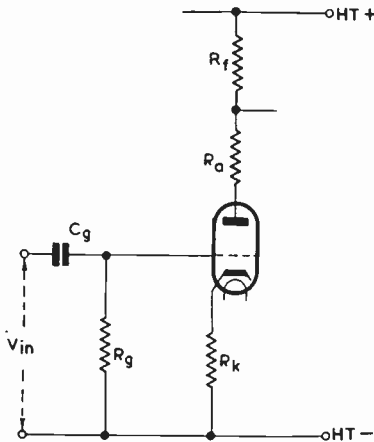

Fig. 104—Distortion due to cathode components can also be eliminated by omission of the decoupling capacitor

where there is little likelihood of the valve taking grid current. In such circumstances it might be possible to reduce R_k to, say, 80Ω , which gives a grid bias of nearly 1 V with 12 mA cathode current, and the gain reduction due to feedback is 4.3 db.

12.7 CANCELLING DISTORTION DUE TO CATHODE COMPONENTS BY ANODE-DECOUPLING COMPONENTS

If neither of the above methods can be used and an RC-cathode circuit is essential, the distortion introduced by the cathode-decoupling components can be eliminated by arranging for it to cancel that produced by the anode-decoupling circuit. (This is only possible, however, if the anode-decoupling circuit is not already being used to offset the distortion due to the inter-valve coupling components.) To effect this neutralisation the anode-decoupling and cathode-decoupling components must satisfy certain conditions which can be deduced in the following way.

The gain A of a valve with anode decoupling and cathode decoupling (Fig. 105) is given by

$$A = \frac{-g_m Z_a}{1 + g_m Z_k} \quad \dots \quad (191)$$

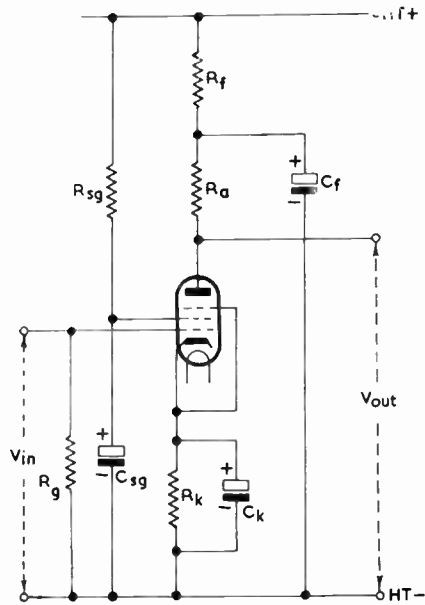

Fig. 105—Compensating distortion due to cathode components by anode decoupling

where Z_a is the impedance of the anode circuit and Z_k is the impedance of the cathode circuit. The anode load Z_a is made up of R_a in series with the parallel combination of C_f and R_f and is thus given by

$$Z_a = R_a + \frac{R_f}{1 + j\omega C_f R_f}$$

The cathode circuit impedance is simply composed of C_k and R_k in parallel. Thus

$$Z_k = \frac{R_k}{1 + j\omega C_k R_k}$$

Substituting for Z_a and Z_k in (191)

$$A_{1f} = \frac{-g_m \left(R_a + \frac{R_f}{1 + j\omega C_f R_f} \right)}{1 + \frac{g_m R_k}{1 + j\omega C_k R_k}}$$

Multiplying numerator and denominator by $(1 + j\omega C_k R_k) (1 + j\omega C_f R_f)$

CATHODE-DECOUPLING CIRCUIT

we have

$$A_{1f} = -g_m R_a \frac{(1+j\omega C_k R_k)(1+j\omega C_f R_f) + \frac{R_f}{R_a}(1+j\omega C_k R_k)}{(1+j\omega C_k R_k)(1+j\omega C_f R_f) + g_m R_k(1+j\omega C_f R_f)} \quad (192)$$

This expression can be made independent of frequency and equal to $-g_m R_a$ by so choosing component values that the following two equations are satisfied

$$R_f C_f = R_k C_k \quad \dots \quad (193)$$

$$R_f = g_m R_k R_a \quad \dots \quad (194)$$

Dividing (193) by (194) we have

$$C_f = C_k / g_m R_a \quad \dots \quad (195)$$

Expressions (194) and (195) give the values of R_f and C_f necessary to achieve this compensation.

As an illustration of the magnitudes of R_f and C_f required in a practical amplifier, suppose the valve has an anode-load resistor of 2,000 Ω , a mutual conductance of 8 mA/V and that the cathode components are 150 Ω and 50 μ F. From (194) we have

$$\begin{aligned} R_f &= g_m R_k R_a \\ &= 8 \times 10^{-3} \times 150 \times 2 \times 10^3 \Omega \\ &= 2,400 \Omega \end{aligned}$$

and from (195)

$$\begin{aligned} C_f &= C_k / g_m R_a \\ &= 50 \times 10^{-6} / (8 \times 10^{-3} \times 2 \times 10^3) \text{ F} \\ &= 3 \mu\text{F approximately} \end{aligned}$$

These are easily-realisable component values and thus the compensation can be made perfect and independent of frequency, implying that the response curve of the amplifier, measured at the valve anode, is level down to zero frequency. The zero-frequency response will, of course, be lost if the anode is capacitance-coupled to the grid of the succeeding valve.

In the previous chapter the anode-decoupling circuit was used to offset distortion occurring in the inter-valve coupling circuits and it was not possible in such a circuit to make the compensation independent of frequency because this necessitated an infinite value of R_f . Thus practical values of R_f , though they appreciably extend the low-frequency response, cannot give a zero-frequency response.

CHAPTER 13

SCREEN-DECOUPLING CIRCUIT

13.1 INTRODUCTION

THE last of the four RC circuits which can affect the low-frequency response of an RC-coupled amplifier is the screen-decoupling circuit $R_{sg}C_{sg}$ in Fig. 106.

This has an effect similar to that of the cathode circuit, namely that it gives a fall in amplitude response and a leading phase angle, both of which increase as frequency is reduced. The process by which this occurs can be described in the following way. The value of R_{sg} is initially chosen to give the desired steady screen voltage; if C_{sg} is not included, this resistor also behaves as a screen load, causing the screen potential to vary in antiphase with the grid signal. The variations in screen potential modulate the anode electron stream in antiphase to the grid potential causing a negative feedback effect and consequent loss of signal output. C_{sg} is included to prevent this effect; it presents the screen with a low value of load, reducing the signal amplitude at the screen, and the feedback effect. The capacitor is effective in reducing feedback at all frequencies for which the reactance is small but unless a very large capacitor is used, feedback is still present at very low frequencies and causes a fall in output. At frequencies for which there is an appreciable signal amplitude at the screen the feedback causes phase shift.

We shall first illustrate qualitatively by means of vector diagrams the production of this distortion by a finite screen load and will then show how the magnitude of the distortion can be calculated.

13.2 EFFECT OF SCREEN-DECOUPLING CIRCUIT ILLUSTRATED VECTORIALLY

Fig. 107 (a) illustrates the relationship between the electrode potentials and anode current when the screen load is purely resistive. The grid-cathode potential V_{gk} gives rise to an anode current I_a which is in phase with V_{gk} ; the anode potential V_{ak} and the screen potential V_{sgk} are both in antiphase to the anode current.

If the screen load is made purely capacitive, the screen potential lags 90° on the phase indicated in Fig. 107 (b); that is to say the screen potential now leads the anode current by 90° . The relative

SCREEN-DECOUPLING CIRCUIT

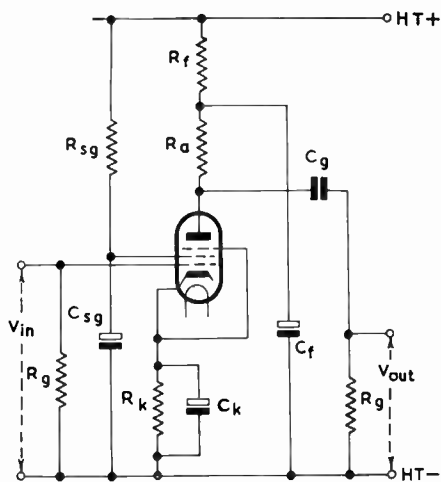

Fig. 106—Complete circuit diagram of an RC-coupled amplifier using a pentode

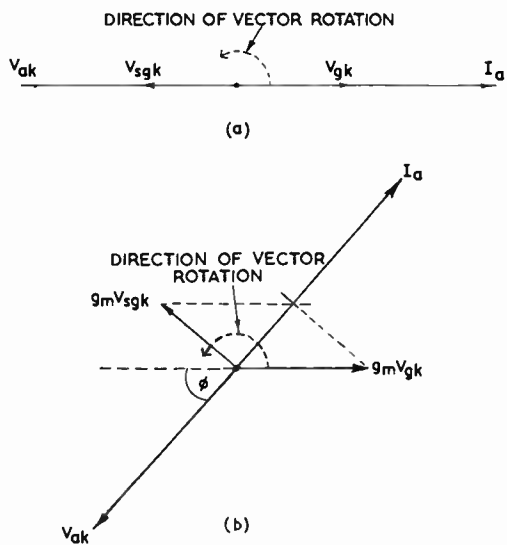

Fig. 107—Vector diagram illustrating the distortion produced by the screen-decoupling circuit at low frequencies

phases of grid potential, screen potential and anode current for a capacitive screen load are illustrated in Fig. 107 (b). The phase of the anode current relative to the grid potential differs from that in Fig. 107 (a) because the anode current is primarily determined by control-grid and screen-grid potentials (the influence of the anode potential being negligible). In constructing the vector parallelogram to illustrate the relationship between grid potential, screen potential and anode current, due allowance must be made for the fact that the anode current is not equally affected by a given change in control-grid and screen potential; the control-grid potential is much more effective than the screen potential in changing the anode current. The effects of these potentials are measured by the conductances of the respective electrodes; the change in anode current per volt change in control-grid potential is the mutual conductance g_m of the valve whereas the change in anode current per volt change in screen potential is the screen conductance g_s which, in a typical valve, may be, say, 1/20th of g_m . If the lengths of the potential vectors in Fig. 107 (b) are made to represent the product of conductance and potential (the directions of the vectors still representing the phase of the potentials) the relationship between anode current and electrode potentials can be illustrated by a parallelogram as shown dotted. The anode potential V_{ak} is still in antiphase to the anode current and, in Fig. 107 (b), is advanced in phase by ϕ° compared with Fig. 107 (a). This is the phase advance caused by the capacitive screen load.

13.3 CALCULATION OF DISTORTION DUE TO SCREEN-DECOUPLING CIRCUIT

The effect of the screen-grid impedance is calculated in Appendix K where it is shown that

$$\frac{A_{1f}}{A_{mf}} = \frac{1}{1 + G_s Z_{sg}} \quad \dots \quad (196)$$

in which G_s is the conductance of the screen circuit, i.e., the change in screen current per volt change in screen potential and Z_{sg} is the impedance of the external screen circuit. This expression is of the same form as (181) for the effect of the cathode circuit impedance with G_s substituted for g_m and Z_{sg} substituted for Z_k . If, as is usual, the external screen circuit consists of a dropping resistor R_{sg} and a decoupling capacitor C_{sg} in parallel, we have

$$Z_{sg} = \frac{R_{sg}}{1 + j\omega C_{sg} R_{sg}}$$

SCREEN-DECOUPLING CIRCUIT

Substituting for Z_{sg} in (191)

$$\begin{aligned} A_{lf} &= \frac{1 + j\omega C_{sg} R_{sg}}{1 + j\omega C_{sg} R_{sg} + G_s R_{sg}} \quad \dots \quad (197) \\ A_{mf} & \end{aligned}$$

which can be re-arranged to give

$$\begin{aligned} A_{lf} &= \frac{r_{sg}(r_{sg} + R_{sg}) + jx}{1 + jx} \quad \dots \quad (198) \\ A_{mf} & \end{aligned}$$

in which r_{sg} is the screen a.c. resistance, i.e., the ratio of a small change in screen potential to the resulting change in screen current. r_{sg} is the reciprocal of G_s . x is given by ω/ω_{sg} where

$$\omega_{sg} = 1/R'_{sg} C_{sg} \quad \dots \quad (199)$$

and

$$R'_{sg} = R_{sg} r_{sg} / (r_{sg} + R_{sg})$$

Expression (198) is identical in form with (187) for the cathode circuit. Thus the curves of Figs. 101 and 102 apply equally to the loss and phase shift due to the screen grid circuit provided G_s is substituted for g_m (or r_{sg} for r_k), R_{sg} for R_k and C_{sg} for C_k . For the screen circuit $x = 1$ corresponds to the frequency for which the reactance of the screen decoupling capacitor equals R'_{sg} , the resistance of the external screen resistor R_{sg} and the screen a.c. resistance r_{sg} in parallel.

The curves of Figs. 101 and 102 can be used to determine the frequency and phase response for a given valve and screen-decoupling components or to determine the component values necessary to give desired responses.

As an example of the former use, consider a pentode amplifying stage in which $G_s = 0.04 \text{ mA/V}$, $R_{sg} = 25 \text{ k}\Omega$ and $C_{sg} = 8 \text{ }\mu\text{F}$.

$$\begin{aligned} G_s R_{sg} &= 0.04 \times 10^{-3} \times 25 \times 10^3 \\ &= 1 \end{aligned}$$

and thus the frequency and phase responses of this particular amplifier are given by the curves labelled $g_m R_k = 1$ in Figs. 101 and 102. To calibrate the frequency axis, however, we must determine the frequency for which $x = 1$.

$$\begin{aligned} r_{sg} &= \frac{1}{G_s} \\ &= \frac{1}{0.04 \times 10^{-3} \text{ }\Omega} \\ &= 25 \text{ k}\Omega \end{aligned}$$

$$\begin{aligned}
 R_{sg}' &= \frac{r_{sg}R_{sg}}{r_{sg} + R_{sg}} \\
 &= \frac{25 \times 10^3 \times 25 \times 10^3}{50 \times 10^3} \Omega \\
 &= 12.5 \text{ k}\Omega \\
 f_{sg}' &= \frac{\omega_{sg}}{2\pi} \\
 &= \frac{1}{2\pi R_{sg}' C_{sg}} \\
 &= \frac{1}{6.284 \times 12.5 \times 10^3 \times 8 \times 10^{-6}} \text{ c/s} \\
 &= 1.6 \text{ c/s}
 \end{aligned}$$

Thus $x = 1$ in Figs. 101 and 102 corresponds to 1.6 c/s for this circuit. Fig. 101 shows that the response is 2 db down at 1.6 c/s, 4 db at 0.8 c/s and 6 db at 0.3 c/s. Fig. 102 shows that the phase shift is approximately 20° at 1 c/s, 5° at 10 c/s and 2° at 50 c/s. A phase shift of 2° represents a sag of 11 per cent in reproducing a 50 c/s square wave.

As an example of the second type of calculation we will determine the value of C_{sg} necessary to keep the sag at 50 c/s below 2 per cent in an amplifier in which R_{sg} must be 25 k Ω to give the required screen potential. As before G_s is taken as 0.04 mA/V.

From Fig. 91, to keep the sag within the prescribed limit, the phase shift at 50 c/s must be less than 0.35° . The value of x can be calculated from expression (190) by putting $g_m R_k = 1$ and $\phi = 0.35$; this gives the result $x = 83$.

The required value of C_{sg} can now be calculated in the following way.

$$\begin{aligned}
 x &= \frac{f}{f_{sg}} \\
 &= 83 \text{ when } f = 50 \text{ c/s} \\
 \therefore f_{sg} &= \frac{f}{x} \\
 &= \frac{50}{83} \text{ c/s} \\
 &= 0.6 \text{ c/s}
 \end{aligned}$$

SCREEN-DECOUPLING CIRCUIT

Now
$$f_{sg} = \frac{1}{2\pi R_{sg}' C_{sg}}$$

from which
$$C_{sg} = \frac{1}{2\pi f_{sg} R_{sg}'}$$

$$= 6.284 \times 0.6 \times 12.5 \times 10^3 \text{ F}$$

$$= 21.2 \mu\text{F}$$

This capacitor requires a high voltage rating and is hence a rather bulky component. It is sometimes possible to avoid the necessity for such components by use of the techniques now to be described.

13.4 PENTODE WITHOUT SCREEN-DECOUPLING RESISTOR

From expression (197) we can see that if R_{sg} is omitted, the low-frequency gain becomes independent of frequency and equal to the medium-frequency gain. All terms in ω disappear which implies that there is now no phase distortion. R_{sg} and C_{sg} can be omitted by choosing a pentode which will operate satisfactorily

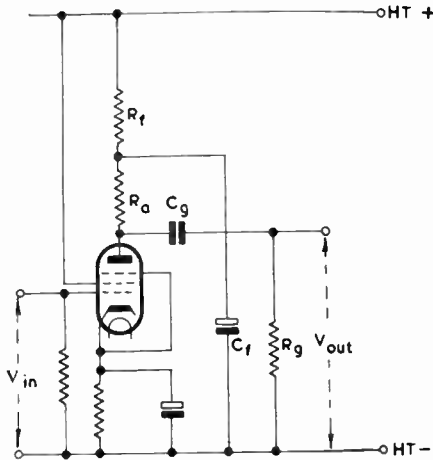

Fig. 108—Pentode RC-coupled amplifier with screen grid fed directly from the h.t. line

without exceeding the maximum safe dissipation with the screen fed directly from the h.t. supply, say 250 V, as shown in Fig. 108. The screen load thus becomes the internal impedance of the h.t. supply unit which is usually very low in units designed to feed television amplifiers.

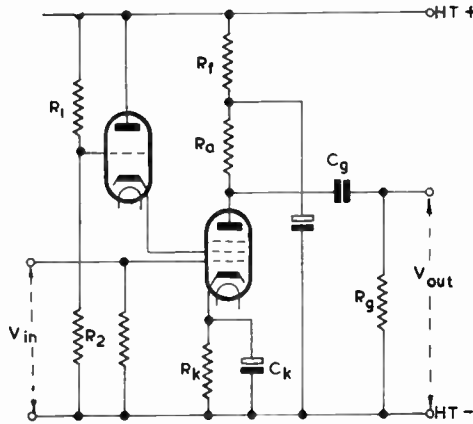

Fig. 109—Pentode RC-coupled amplifier with screen grid fed from a cathode follower

13.5 USE OF CATHODE FOLLOWER TO FEED SCREEN

Alternatively, if the screen potential must be considerably lower than the h.t. supply voltage, it is possible to feed the screen from a cathode follower situated in the amplifier or in the h.t. unit as shown in Fig. 109. The screen load is the output impedance of the cathode follower which is, of course, very low and gives negligible degeneration.

APPENDIX K

PHASE AND FREQUENCY RESPONSE DUE TO FINITE SCREEN IMPEDANCE

If the external screen impedance of a pentode valve is not zero, the screen impedance will vary at signal frequency when a signal is applied to the control grid. This variation of screen potential affects the anode current, reducing the anode voltage and causing phase shift by a process somewhat similar to that by which the external cathode impedance affects the anode output. The magnitude of the effect can be calculated as follows.

The alternating component I_a of the anode current of a pentode is given by

$$I_a = g_m V_{gk} + g_s V_{sgk} + g_a V_{ak} \dots \dots (1)$$

SCREEN-DECOUPLING CIRCUIT

- in which g_m = mutual conductance, defined by $\Delta I_a / \Delta V_{gk}$,
 V_{gk} = grid-cathode voltage,
 g_s = anode-screen transconductance, defined by $\Delta I_a / \Delta V_{sgk}$,
 V_{sgk} = screen-cathode voltage,
 g_a = anode conductance, defined by $\Delta I_a / \Delta V_{ak}$, i.e., it is the reciprocal of the anode a.c. resistance, r_a ,
 V_{ak} = anode-cathode voltage.

For the type of pentode valve commonly used in video-frequency amplifiers, g_a is very small, the anode current being almost unaffected by changes in anode voltage. We may thus take g_a as being negligible and expression (1) then becomes

$$I_a = g_m V_{gk} + g_s V_{sgk} \dots \dots \dots (2)$$

The alternating component I_s of the screen current is given by a similar expression

$$I_s = G_m V_{gk} + G_s V_{sgk} \dots \dots \dots (3)$$

- in which G_m = the mutual conductance defined by $\Delta I_s / \Delta V_{gk}$
and G_s = the mutual conductance defined by $\Delta I_s / \Delta V_{sgk}$.

When a pentode valve is used as an amplifier and the external screen impedance is finite, the anode current is determined by the control-grid and screen-grid voltages; the latter is the product of screen current and screen impedance and is opposite in phase to the control grid potential. Thus

$$V_{sgk} = - I_s Z_{sg} \dots \dots \dots (4)$$

where Z_{sg} is the impedance of the external screen-grid circuit. Substituting for V_{sgk} in (2)

$$I_a = g_m V_{gk} - g_s I_s Z_{sg} \dots \dots \dots (5)$$

Substituting for V_{sgk} in (3)

$$I_s = G_m V_{gk} - G_s I_s Z_{sg}$$

from which

$$I_s = \frac{G_m V_{gk}}{1 + G_s Z_{sg}} \dots \dots \dots (6)$$

Substituting for I_s in (5)

$$I_a = g_m V_{gk} - \frac{g_s Z_{sg} G_m V_{gk}}{1 + G_s Z_{sg}}$$

$$= g_m V_{gk} \left[1 - \frac{g_s G_m Z_{sg}}{g_m (1 + G_s Z_{sg})} \right] \dots \dots (7)$$

Now

$$\begin{aligned} g_s G_m &= \frac{\Delta I_a}{\Delta V_{sgk}} \cdot \frac{\Delta I_s}{\Delta V_{gk}} \cdot \frac{\Delta V_{gk}}{\Delta I_a} \\ &= \frac{\Delta I_s}{\Delta V_{sgk}} \\ &= G_s \end{aligned}$$

Substituting for $g_s G_m/g_m$ in (7)

$$\begin{aligned} \therefore I_a &= g_m V_{gk} \left[1 - \frac{G_s Z_{sg}}{1 + G_s Z_{sg}} \right] \\ &= g_m V_{gk} \cdot \frac{1}{1 + G_s Z_{sg}} \end{aligned}$$

The output voltage, V_{out} , is given by

$$\begin{aligned} V_{out} &= -I_a R_a \\ &= -g_m V_{gk} R_a \cdot \frac{1}{1 + G_s Z_{sg}} \\ \therefore A_{lf} &= \frac{V_{out}}{V_{gk}} \\ &= -g_m R_a \cdot \frac{1}{1 + G_s Z_{sg}} \end{aligned}$$

Substituting A_{mf} for $-g_m R_a$

$$\frac{A_{lf}}{A_{mf}} = \frac{1}{1 + G_s Z_{sg}}$$

G_s is the reciprocal of the screen a.c. resistance r_{sg} and this expression may thus be written

$$\frac{A_{lf}}{A_{mf}} = \frac{1}{1 + Z_{sg}/r_{sg}}$$

which is similar to the expression due to the impedance in the external cathode circuit namely

$$\frac{A_{lf}}{A_{mf}} = \frac{1}{1 + Z_k/r_k}$$

CHAPTER 14

D.C. COUPLING

14.1 INTRODUCTION

WE have now discussed the influence of the inter-valve and decoupling circuits on the frequency and phase response of video-frequency amplifiers and have shown that correct choice of component values in these circuits can extend the low-frequency response by several octaves down to frequencies of the order of 1 c/s. If, however, RC-coupling is used between successive stages it is not possible to extend the response down to zero frequency and such a response is needed in video-frequency amplifiers for certain applications. We shall now describe a circuit, known as *d.c. coupling*, which can be used to achieve this result. When correctly designed, a d.c.-coupled amplifier has a frequency response which is level down to zero frequency. Such amplifiers are often used, however, in applications where a good response is wanted at very low frequencies such as 0.01 c/s and where a response at zero frequency is no disadvantage.

14.2 DESIGN OF D.C.-COUPLED CIRCUIT

In its simplest form d.c. coupling is achieved as shown in Fig. 110, by connecting the anode of one valve directly to the grid of the succeeding stage, without using the usual coupling capacitor and grid resistor. Provided effects due to anode-, screen- and cathode-decoupling circuits can be overcome, this simple circuit gives a response down to zero frequency but it has a number of practical inconveniences associated with the steady voltages it is necessary to maintain on the various electrodes. For example the grid of V2 carries the steady voltage on V1 anode, necessitating a high cathode voltage for V2 in order that V2 shall have the correct value of grid bias. To offset the effects of this voltage and give a reasonable value of anode-cathode voltage for V2, the h.t. voltage applied to this valve must be considerably higher than normal. This difficulty is aggravated in a multi-valve direct-coupled amplifier of this type and necessitates an inconveniently-high value of h.t. voltage. Moreover component values must be adhered to very precisely because valve bias voltages depend on them; thus close

tolerance components are required. Further, any change in the steady electrode potentials in an early stage (due, for example, to an ageing component or valve) may become large enough, after amplification by subsequent stages, to prevent normal operation of a later stage. For example, as a result of the voltage change, the steady potential on the grid of the final stage may become sufficiently negative to bias the valve beyond anode-current cut-off. This can be prevented by a system of zero-frequency feedback described later.

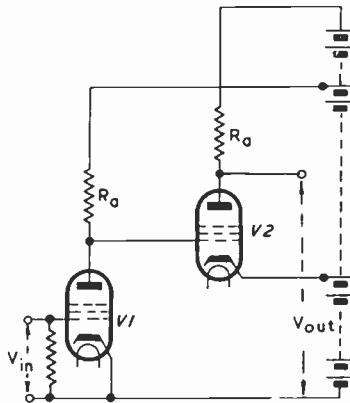

Fig. 110—Basic form of d.c.-coupled circuit

These difficulties can be reduced by modifications to the basic circuit and Fig. 111 shows the form most commonly used. This may be regarded as a conventional RC-coupled circuit with an anode-decoupling circuit and with an additional resistor R_c connected in parallel with the coupling capacitor to provide the zero-frequency response. The value of R_c is chosen in the following way.

Because of the presence of the anode-decoupling circuit, the zero-frequency gain measured at the anode of V1 is greater in the ratio $(R_a + R_f)/R_a$ than at medium frequencies when R_f is effectively short-circuited by C_f . However, signals being transferred from the anode of V1 to the grid of V2 are attenuated by the network $R_c C_g R_g$; the attenuation is very small at medium frequencies and above because C_g effectively short-circuits R_c but increases as frequency is reduced and is equal to $R_g/(R_c + R_g)$ at zero frequency. Thus the decoupling components give a rising low-frequency characteristic and the coupling components give a falling characteristic. These characteristics are both produced by

D.C. COUPLING

RC circuits of the same form, consisting of a parallel resistance-capacitance combination in series with a resistor. By suitable choice of component values the frequency characteristics of these two networks can be made exactly complementary and the overall response is then level down to zero frequency. To achieve this compensation two conditions must be satisfied. Firstly the ratio of the two resistances in each network must be the same. Thus

$$\frac{R_c}{R_g} = \frac{R_f}{R_a} \dots \dots \dots (200)$$

Secondly the product of capacitance and resistance in one network must equal that in the other, i.e. both must have the same time constant. This equality may be written

$$R_f C_f = R_c C_g \dots \dots \dots (201)$$

The design of a circuit of this type can be carried out in the following way. There are six component values to be decided,

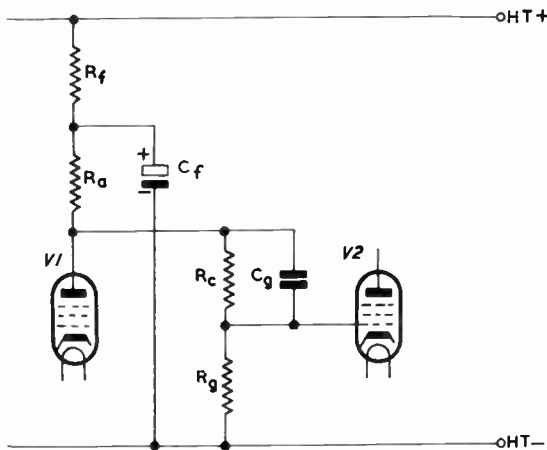

Fig. 111—Practical form of circuit giving a response level down to zero frequency

namely R_a , R_f , R_c , R_g , C_f and C_g . The value of R_a is determined by high-frequency considerations and a typical value is 2,000 Ω . The decoupling resistor R_f is usually made 5 or 6 times R_a , e.g. 12 k Ω . R_g is given a large value which will not, however, encourage grid emission; a common-used value is 470 k Ω . The value of R_c can

now be calculated from the first of the two relationships given above. We have

$$\begin{aligned} R_c &= \frac{R_f R_g}{R_a} \\ &= \frac{12 \times 10^3 \times 470 \times 10^3}{2 \times 10^3} \Omega \\ &= 3 \text{ M}\Omega \text{ approximately} \end{aligned}$$

We now have to determine suitable values for C_f and C_g . These capacitances are related according to the second of the above two relationships and if the numerical values are substituted for R_c and R_f in this, we find that C_f must be 250 times C_g to give a response level down to zero frequency. It would appear, therefore, that the absolute values of C_f and C_g do not matter provided $C_f = 250 C_g$. There are, however, practical limits to the values of capacitance which can be used; for example if C_g is made too large its shunt capacitance to earth is considerable and the high-frequency performance of the amplifier is affected. For this reason C_g should preferably not exceed $0.1 \mu\text{F}$. On the other hand if C_f is made too small it becomes ineffective as a decoupling and smoothing component. C_f should ideally not be less than, say, $16 \mu\text{F}$. Using this value we have that $C_g = C_f/250 = 0.07 \mu\text{F}$.

Thus suitable component values for the circuit are

$$\begin{aligned} R_a &= 2 \text{ k}\Omega \\ R_f &= 12 \text{ k}\Omega \\ R_g &= 470 \text{ k}\Omega \\ R_c &= 3.3 \text{ M}\Omega \\ C_f &= 16 \mu\text{F} \\ C_g &= 0.07 \mu\text{F} \end{aligned}$$

R_c is 6 times R_g and the steady potential applied to the grid of V2 is $\frac{1}{7}$ th of the anode potential of V1. The latter is approximately 110 V and the steady voltage on V2 grid is only $110/7$, nearly 16 V, which can readily be offset by appropriate choice of cathode potential. This circuit does not, therefore, necessitate the provision of an inconveniently-high h.t. supply voltage.

PART IV: FEEDBACK IN VIDEO-FREQUENCY AMPLIFIERS

CHAPTER 15

BASIC PRINCIPLES OF FEEDBACK

15.1 INTRODUCTION

THE principle of feedback, i.e. that of taking a voltage from one stage of an amplifier and returning it to an earlier stage to aid or oppose in phase the input there, is extensively employed in video-frequency amplifiers. Such feedback has numerous advantages: it can be used to extend the frequency range; to decrease harmonic and phase distortion and to improve the signal-handling capacity of valves (an example of this is given in Chapter 5). Feedback also makes the characteristics of the amplifier less dependent on valve parameters, enabling valves to be changed without significant alteration in amplifier performance.

Feedback may also have an effect on the input and output impedances of the amplifier, and can increase or decrease either according to the feedback connections used; this change in amplifier characteristics is sometimes desirable, sometimes not.

The advantages of feedback are not obtained without cost; the gain of an amplifier is reduced by the application of negative feedback. Moreover when considerable feedback is used there is a risk of instability.

In this chapter we shall discuss the fundamental principles which govern the use of feedback in video-frequency amplifiers, and subsequent chapters will describe the various types of circuit which can be used to apply feedback.

15.2 FUNDAMENTAL CONSIDERATIONS

There are many different ways of deriving the feedback voltage from an amplifying stage and as many methods of reintroducing it at an earlier stage. Three typical circuits are shown in Fig. 112.

In Fig. 112 (a) feedback is obtained from the resistor R_k which

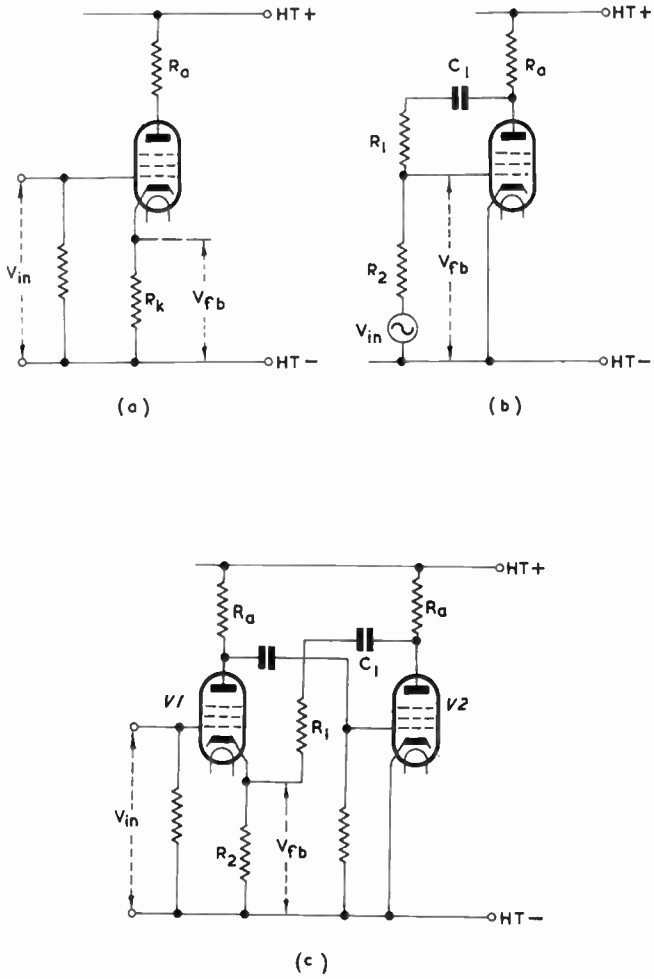

Fig. 112—Three circuits providing negative feedback

BASIC PRINCIPLES OF FEEDBACK

may also function as an automatic bias component. The alternating component of the cathode current sets up a signal-frequency feedback voltage across R_k and the grid-cathode signal of the valve consists of this voltage and the external input signal connected in series. These two voltages are in phase opposition; this may be deduced in the following way. A positive-going signal applied to the grid causes an increase in anode current and a positive-going cathode voltage. The latter is equivalent, in its effect on anode current, to a negative-going signal on the control grid. Thus the input signal and feedback voltage are in phase opposition and this circuit is an example of *negative* feedback.

In Fig. 112 (b) the two resistors R_1 and R_2 form a potential divider across the anode load resistor R_a and the voltage across R_2 is applied to the valve grid as a feedback voltage. C_1 is a low-reactance capacitor necessary to avoid direct current flowing through R_1R_2 from the h.t. supply. A positive-going signal applied from an external source to the valve grid causes a negative-going (amplified) signal at the valve anode and a negative-going feedback voltage. The feedback voltage thus opposes the input signal in phase; this circuit is, therefore, an example of *negative* feedback.

Fig. 112 (c) illustrates the elements of a 2-stage amplifier and feedback is again applied by a potential divider R_1R_2 connected in parallel with the anode resistor R_a of the second stage. In this circuit R_2 also functions as bias resistor for V1. This is again an example of negative feedback as shown in the following argument: a positive-going signal applied to V1 grid causes a negative-going signal at V1 anode and hence at V2 grid. This, in turn, gives rise to a positive-going signal at V2 anode and a positive-going feedback voltage at V1 cathode. A positive-going signal at V1 cathode has the same effect on V1 anode current as a negative-going signal on V1 grid. The external signal which brought about this feedback voltage was positive-going and thus this circuit gives *negative* feedback.

The foregoing paragraphs may be summarised in the following way. The signal at the anode of an amplifying valve is phase inverted with respect to the grid signal which produced it. To obtain negative feedback in a single-stage amplifier it is necessary to use a feedback circuit without phase shift such as a resistive potentiometer between V1 anode and grid. If a second amplifying stage is added, an additional phase inversion is introduced and to obtain negative feedback now the resistive potentiometer should be connected between V2 anode and V1 cathode. In negative feedback circuits, allowance can be made for the sign or polarity of the

output signal by introducing the feedback voltage into the grid or cathode of the chosen valve. There is hence no need to preface expressions for stage gain by a sign to indicate the presence of a phase reversal and, to simplify the subsequent algebra, all stage gains are regarded as positive.

The effect of feedback on the gain of an amplifier can be illustrated by block schematic diagrams as shown in Fig. 113. The upper diagram (a) shows an amplifier of gain A . If a signal of 1 volt amplitude is applied to the input terminals of this amplifier, the output signal is of A volts amplitude.

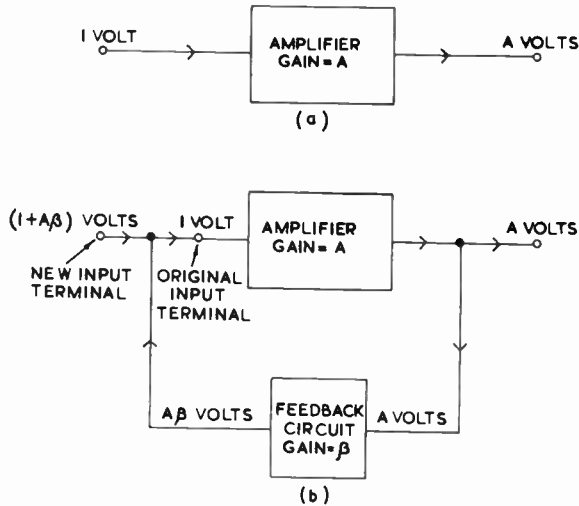

Fig. 113—Illustrating the principle of feedback

The lower diagram (b) represents the same amplifier with a feedback circuit added. The feedback circuit has the effect of abstracting a fraction β of the output of the amplifier and returning it to the input. If the input to the original amplifier terminals is of 1 volt, the output is still of A volts amplitude. This output is the input to the feedback circuit and the output of this circuit is $A\beta$ volts. The phase of this voltage is such that it is necessary to apply $(1 + A\beta)$ volts to the new input terminals to produce A volts output. The gain of the amplifier with feedback is

$$A' = \frac{A}{1 + A\beta} \quad \dots \quad \dots \quad \dots \quad (202)$$

A' is known as the *external gain* of the amplifier and A is the

BASIC PRINCIPLES OF FEEDBACK

internal gain. For negative feedback A and β are both positive quantities and, from (202), the external gain is less than the internal gain.

Expression (202) can be written in the form

$$A' = \frac{1}{1/A + \beta}$$

from which it follows that if $1/A$ is small compared with β , the external gain is approximately equal to $1/\beta$. This is a convenient result to remember; the value of β in a circuit can often be stated from an inspection of the component values in the feedback chain enabling the gain to be assessed approximately on inspection.

If the feedback is positive the product $A\beta$ has the opposite sign from that in expression (202) and we have

$$A' = \frac{A}{1 - A\beta} \quad \dots \quad \dots \quad \dots \quad \dots \quad (203)$$

showing that the external gain is greater than in the internal gain. When $A\beta = 1$ the external gain becomes infinite; for this value of $A\beta$ the amplifier becomes unstable and if $A\beta$ is greater than 1 the amplifier becomes capable of supplying its own input, i.e. it becomes an oscillator.

The factor $(1 + A\beta)$ which occurs in the denominator of expression (198) is known as the *feedback factor*; it always exceeds unity for negative feedback.

15.3 VOLTAGE AND CURRENT FEEDBACK

The performance of a feedback amplifier is dependent on the value of β and this can be determined by inspection of the circuit. For example in a circuit of the type shown in Fig. 112 (b) and (c) in which feedback is applied by means of a potential divider the value of β is given by

$$\beta = \frac{R_2}{R_1 + R_2}$$

Fig. 114 (a) shows the general form of a circuit of this type in which the load and the potentiometer arms are all impedances. We thus have

$$\beta = \frac{Z_2}{Z_1 + Z_2}$$

The impedance $(Z_1 + Z_2)$ is generally made large compared with Z_L in order that the addition of the feedback potentiometer shall have no significant effect on the output load of the amplifier. In

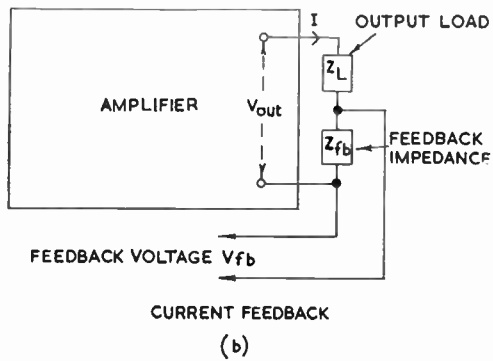
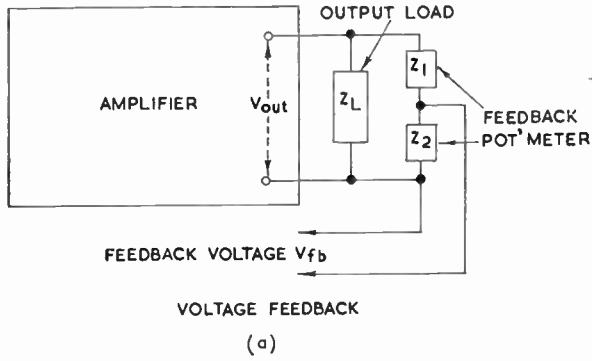

Fig. 114—Distinction between voltage and current feedback

a circuit of this type the feedback voltage V_{fb} is proportional to the output voltage V_{out} and the circuit is often said to provide *voltage feedback*.

A circuit such as that shown in Fig. 112 (a) belongs to the general type shown in Fig. 114 (b) in which the impedance Z_L is equivalent to the anode load resistor R_a and the impedance Z_{fb} is equivalent to R_k . In such circuits Z_{fb} is usually made small compared with Z_L in order that the insertion of the feedback component does not affect the output load significantly. The feedback voltage is equal to $I Z_{fb}$ and is thus proportional to the current in the load circuit; such circuits are said to have *current feedback*.

Examination of Fig. 114 (b) shows that the feedback voltage V_{fb} can be expressed as a fraction of V_{out} just as in the voltage feedback circuit of Fig. 114 (a). In fact we have, for the current feedback circuit,

$$\beta = \frac{Z_{fb}}{Z_{fb} + Z_L}$$

which compares directly with the expression for β given above for the voltage feedback circuit. The concept of feedback fraction is thus common to voltage and current feedback circuits and if, in the mathematical treatment of feedback, all expressions are given in terms of β , it becomes unnecessary to draw a distinction between these two types of circuit. This simplified approach to the subject is used in the following text.

It will be noticed that the value of β for a voltage feedback circuit does not involve the load impedance Z_L . In the current feedback circuit, however, the load impedance forms the upper arm of the feedback potentiometer; β is then dependent on the value of Z_L . This has important practical consequences, because the load impedance Z_L is not always an independent variable; frequently its value and nature are determined by design requirements other than those involving feedback. Thus in a current feedback circuit Z_{fb} may be the only parameter which can be chosen to give the desired performance. In a voltage feedback circuit both Z_1 and Z_2 can be given any value we please to obtain the required performance. Thus in general current feedback circuits are less flexible than their voltage feedback equivalents.

15.4 SERIES AND PARALLEL-CONNECTED FEEDBACK

Feedback is used to extend frequency response and improve linearity but in addition it has an effect on the input and output impedances of the amplifier. The effect on output impedance depends on the type of feedback used: voltage feedback decreases

output impedance and current feedback increases it. The effect on input impedance is independent of the type of feedback and is determined by the nature of the circuit used to introduce the feedback voltage into the amplifier. In general this circuit can be designed to inject the feedback voltage in series with the external input signal or in parallel with it. The distinction between series- and parallel-connected feedback is illustrated in Fig. 115. In (a) the grid-cathode signal V_{gk} of the valve consists of the input signal V_{in} and the feedback voltage V_{fb} connected in series. This is an example of series-connected feedback and the input impedance is greater than the value of R_g ; such a circuit was in fact used in

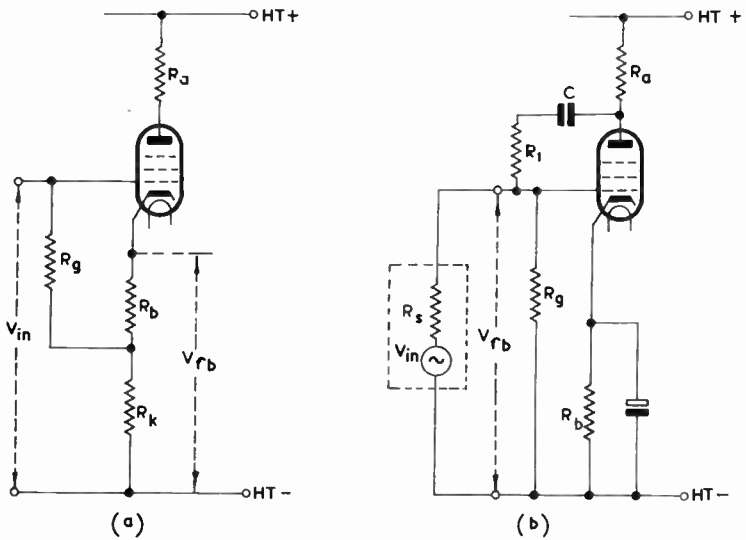

Fig. 115—A circuit providing series-connected feedback is shown at (a) and parallel-connected feedback at (b)

Chapter 10 to increase the effective time constant $R_g C_g$ in the grid circuit of a valve. Since R_k provides current feedback, this circuit also has the effect of increasing the output impedance. In (b) it is assumed that R_s , the internal resistance of the signal source V_{in} , is very small compared with R_g . The input signal therefore appears in full between the grid and cathode of the valve. R_s also behaves, however, as the lower arm of the feedback potentiometer, the upper arm being R_1 . The feedback voltage also appears across R_s and between the grid and cathode. This is an example of parallel-connected feedback and has the effect of decreasing the input

BASIC PRINCIPLES OF FEEDBACK

impedance which is therefore smaller than R_g . This circuit provides voltage feedback and the *output impedance* is also reduced.

The conclusions of the preceding paragraphs may be summarised thus: the effect of feedback on *output impedance* is determined by the *type of feedback*; the effect on *input impedance* is determined by the type of *connection*. A more precise summary of these effects is given in the following table:

<i>Impedance</i>	<i>Type of feedback</i>	<i>Type of connection</i>	<i>Effect</i>
Input	Voltage or current	Series	Increased
Input	Voltage or current	Parallel	Decreased
Output	Voltage	Series or parallel	Decreased
Output	Current	Series or parallel	Increased

15.5 FREQUENCY-DISCRIMINATING FEEDBACK

Negative feedback extends the frequency response of an amplifier even if the feedback fraction β is independent of frequency, as when a purely resistive potential divider is used. However, greater control of the overall frequency response of a feedback amplifier is possible if the feedback fraction is made to vary with frequency. By appropriate choice of the nature and magnitude of Z_1 , Z_2 (Fig. 114 (a)) and Z_{fb} (Fig. 114 (b)) it is possible to make β constant or frequency-dependent at will and by altering the degree of frequency-dependence of β , a variety of different shapes of overall frequency response is possible.

For example, it may happen that an amplifier has a satisfactory frequency response but feedback is needed to improve linearity or signal-handling capacity. In such circumstances the circuit must be designed to have no effect on frequency response. This is possible by correct choice of components for the feedback potentiometer, such feedback being termed *aperiodic*.

Alternatively it may be desirable to design the feedback circuit to give critical damping of the transient oscillation which occurs during reproduction of a steep transient. Such feedback is termed *critical* and it leaves the shape of the frequency-response curve unaltered but increases the frequency coverage; in other words the equation to the curve is still of the same form (e.g., still cubic) but the values of the coefficients are changed by critical feedback.

As a third possibility, feedback may be used to obtain a maximally-flat frequency response, i.e., a response with an equation containing only a single term in frequency. Such feedback is termed *maximal* and in certain simple circuits, such as a single-stage RC-coupled amplifier, maximal feedback requires the same type of feedback circuit as critical feedback.

Fourthly, the constants of a feedback circuit can be proportioned to give an optimally-flat response, i.e., one with an equation having no terms in frequency. Such feedback is termed *optimal* and gives the widest possible frequency coverage.

In the majority of video-frequency amplifiers employing feedback the circuits are designed to give maximal or optimal feedback and in the following pages emphasis is mainly on these forms of feedback.

CHAPTER 16

FEEDBACK IN A SINGLE-STAGE RC-COUPLED AMPLIFIER

16.1 INTRODUCTION

THE advantages of feedback in a video-frequency amplifier were described in general in the previous chapter; it was shown that one of its most useful effects is that on frequency response. By extending the high-frequency response, feedback can reduce rise time and by extending the low-frequency response it can reduce sag. Although the same feedback components can be used to extend high- and low-frequency response simultaneously, the effects on the two extremes can be considered separately and we shall first consider the design of feedback circuits to give a desired shape of high-frequency response; the effect on low-frequency response is considered later. For the sake of simplicity this chapter deals with the application of feedback to single-stage RC-coupled amplifiers. Later chapters describe the design of multi-stage feedback amplifiers.

16.2 APERIODIC VOLTAGE FEEDBACK

It will be recalled that this form of feedback improves linearity and signal-handling capacity but leaves frequency response (and hence rise time) unaffected. With feedback of this nature the external high-frequency gain A_{hf}' is related to the internal high-frequency gain according to the relationship

$$A_{hf}' = \frac{A_{hf}}{K} \quad \dots \quad (204)$$

where K is a real constant, the value of which is determined by the degree of feedback. The type of voltage- and current-feedback circuit required to give a performance of this nature can be determined in the following way.

From expression (202) the external gain is given by

$$A_{hf}' = \frac{A_{hf}}{1 + A_{hf}\beta} \quad \dots \quad (205)$$

where β is the feedback fraction. A_{hf} is related to the medium-

frequency gain A_{mf} according to expression (16), namely

$$A_{hf} = \frac{A_{mf}}{1 + jx}$$

and substituting for A_{hf} in the denominator of (205) we have

$$A_{hf}' = 1 + \frac{A_{mf}}{A_{mf}\beta(1 + jx)}$$

Equating this with expression (204)

$$K = 1 + \frac{A_{mf}\beta}{1 + jx}$$

which gives the value of β as

$$\beta = \frac{K - 1}{A_{mf}} \cdot (1 + jx)$$

In this expression for β , K and A_{mf} are both real numbers with no imaginary components. Thus β must be a simple multiple of $(1 + jx)$, i.e., must be of the form

$$\beta = K_1(1 + jx)$$

where K_1 is another real constant. To determine the form of β more precisely it is desirable to expand x thus

$$\begin{aligned} \beta &= K_1(1 + jx) \\ &= K_1(1 + j\omega/\omega_0) \\ &= K_1(1 + j\omega C_t R_a) \quad \dots \quad \dots \quad (207) \end{aligned}$$

A feedback fraction of this type can be obtained by correct choice of components in the feedback circuit and we shall first determine the component values required in a voltage-feedback circuit of the type shown in Fig. 114 (a). β is given by

$$\beta = \frac{Z_2}{Z_1 + Z_2}$$

Z_2 is often small compared with Z_1 and the feedback fraction is given approximately by

$$\beta = \frac{Z_2}{Z_1} \quad \dots \quad \dots \quad (208)$$

Now Z_1 and Z_2 can both have resistive and reactive components if necessary and in general β has real and imaginary components. By choosing the nature of Z_1 and Z_2 appropriately β can be made of the form as in expression (207). This can be done in two ways.

FEEDBACK IN A SINGLE-STAGE RC-COUPLED AMPLIFIER

(1). By making Z_1 purely resistive and Z_2 resistive and inductive as shown in Fig. 116. Here Z_1 consists simply of a resistor R_1 and Z_2 of a resistor R_2 in series with an inductor L_2 . We thus have

$$Z_1 = R_1$$

and

$$Z_2 = R_2 + j\omega L_2$$

Substituting in (208)

$$\begin{aligned} \beta &= \frac{Z_2}{Z_1} \\ &= \frac{R_2 + j\omega L_2}{R_1} \\ &= \frac{R_2}{R_1} + j\omega \frac{L_2}{R_1} \dots \dots \dots (209) \end{aligned}$$

This is of the form of expression (207). These two expressions can be equivalent only if their real and imaginary parts are equal.

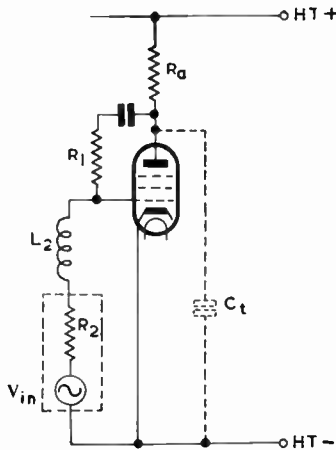

Fig. 116—One circuit for aperiodic voltage feedback

Equating real parts we have

$$K_1 = \frac{R_2}{R_1} \dots \dots \dots (210)$$

Equating imaginary parts

$$K_1 C_t R_a = L_2 / R_1$$

Substituting for K_1 from (210) gives the required value of inductor as

$$L_2 = R_2 C_t R_a \dots \dots \dots (211)$$

Provided expressions (210) and (211) are satisfied, the feedback is aperiodic.

As a numerical example suppose $R_a = 2 \text{ k}\Omega$, $C_t = 25 \text{ pF}$ and $g_m = 8 \text{ mA/V}$. The internal gain of the amplifier at medium frequencies is given by

$$\begin{aligned} A_{mf} &= g_m R_a \\ &= 8 \times 10^{-3} \times 2 \times 10^3 \\ &= 16 \end{aligned}$$

Suppose now aperiodic voltage feedback is to be applied to this amplifier, sufficient to reduce the gain to 8 at medium frequencies. From expression (202) the required value of β is given by

$$\begin{aligned} \beta &= \frac{A - A'}{AA'} \\ &= \frac{16 - 8}{16 \times 8} \\ &= \frac{1}{16} \end{aligned}$$

This gives us the ratio of R_2 to R_1 because as shown in (209) the value of β approximates to R_2/R_1 at medium frequencies. Now R_2 is the resistance of the signal source and if we take this as being $2 \text{ k}\Omega$, R_1 is given by

$$\begin{aligned} R_1 &= \frac{R_2}{\beta} \\ &= 16 \times 2 \times 10^3 \Omega \\ &= 32 \text{ k}\Omega \end{aligned}$$

The required value of inductance is given by

$$\begin{aligned} L_2 &= R_2 C_t R_a \\ &= 2 \times 10^3 \times 25 \times 10^{-12} \times 2 \times 10^3 \text{ H} \\ &= 100 \mu\text{H} \end{aligned}$$

- (2). By making Z_2 purely resistive and Z_1 a parallel network of resistance and capacitance as shown in Fig. 117. For this circuit we have

$$\begin{aligned} Z_2 &= R_2 \\ Z_1 &= \frac{R_1}{1 + j\omega C_1 R_1} \end{aligned}$$

FEEDBACK IN A SINGLE-STAGE RC-COUPLED AMPLIFIER

The feedback fraction is thus given by

$$\begin{aligned} \beta &= \frac{Z_2}{Z_1} \\ &= \frac{R_2}{R_1} (1 + j\omega C_1 R_1) \\ &= \frac{R_2}{R_1} + j\omega C_1 R_2 \dots \dots \dots (212) \end{aligned}$$

which is of the same form as expression (207). Comparing the real parts of these expressions we have

$$K_1 = \frac{R_2}{R_1} \dots \dots \dots (213)$$

and comparing the imaginary parts

$$R_1 C_1 = R_a C_t$$

from which

$$C_1 = \frac{R_a C_t}{R_1} \dots \dots \dots (214)$$

Provided the component values satisfy expressions (212) and (214), the feedback is aperiodic.

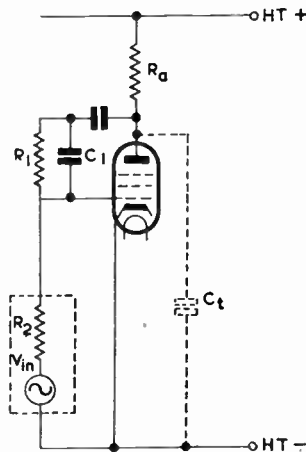

Fig. 117—Another circuit for aperiodic voltage feedback

If this form of feedback is applied to the amplifier of the previous numerical example we have $R_a = 2 \text{ k}\Omega$ and $C_t = 25 \text{ pF}$. As before, we will assume R_2 to be the internal resistance of the signal source which has a value of $2 \text{ k}\Omega$.

We will assume the same degree of feedback is to be applied, as before, and hence $K_1 = 1/16$. Thus

$$\begin{aligned} R_1 &= \frac{R_2}{K_1} \\ &= 16 \times 2 \times 10^3 \Omega \\ &= 32 \text{ k}\Omega \end{aligned}$$

Substituting in expression (214)

$$\begin{aligned} C_1 &= \frac{2 \times 10^3 \times 25 \times 10^{-12}}{32 \times 10^3} \text{ F} \\ &= 1.5 \text{ pF} \end{aligned}$$

16.3 APERIODIC CURRENT FEEDBACK

We will now determine the nature of a current-feedback circuit to give this same performance. For current feedback the feedback fraction is given by

$$\beta = \frac{Z_k}{Z_L}$$

where Z_L is the impedance of the anode load which, for the single-stage amplifier under consideration, is composed of R_a and C_t in parallel. Thus

$$Z_L = \frac{R_a}{1 + j\omega C_t R_a}$$

giving

$$\beta = \frac{Z_k}{R_a} (1 + j\omega C_t R_a) \quad \dots \quad (215)$$

Comparing this with the value of β required for aperiodic feedback we have

$$K_1 = \frac{Z_k}{R_a}$$

which shows that the only condition to be satisfied is that Z_k should be purely resistive. Thus if the valve is given an undecoupled cathode resistor R_k as shown in Fig. 118 the feedback is aperiodic. The value of the cathode resistor is given by

$$R_k = K_1 R_a \quad \dots \quad (216)$$

As a numerical example we will calculate the value of R_k necessary to apply aperiodic current feedback to the single-stage amplifier of the previous two examples.

FEEDBACK IN A SINGLE-STAGE RC-COUPLED AMPLIFIER

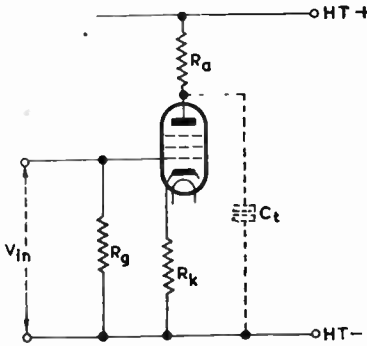

Fig. 118—A circuit for applying aperiodic current feedback to a single-stage amplifier

It has already been established that $K_1 = 1/16$ and from (216) we have

$$\begin{aligned}
 R_k &= K_1 R_a \\
 &= \frac{2 \times 10^3}{16} \Omega \\
 &= 125 \Omega
 \end{aligned}$$

16.4 CRITICAL VOLTAGE FEEDBACK

This type of feedback extends the frequency response of the amplifier but does not change the form of the equation to the response. For example, the high-frequency response of a single-stage RC-coupled amplifier obeys the equation

$$A_{hf} = \frac{A_{mf}}{1 + jx}$$

and by the application of critical feedback, the response is modified according to the equation

$$A_{hf}' = \frac{A_{mf}/K_2}{1 + jx/K_2} \quad \dots \quad (217)$$

where K_2 is a real constant. Comparing these two equations we see that one effect of the feedback is to divide the numerator by K_2 ; this, of course, expresses the reduction in gain due to feedback. In the denominator we note that x is divided by K_2 ; this expresses the improvement in frequency response due to feedback because it is the coefficient of x which determines the rate of fall of the high-frequency response.

We shall now determine what type of circuit is necessary to apply critical feedback to a single-stage amplifier.

From (205) the high-frequency gain is given by

$$A_{hf}' = \frac{A_{hf}}{1 + A_{hf}\beta}$$

Substituting $A_{mf}/(1 + jx)$ for A_{hf} we have

$$\begin{aligned} A_{hf}' &= \frac{A_{mf}/(1 + jx)}{1 + A_{mf}\beta/(1 + jx)} \\ &= \frac{A_{mf}}{1 + jx + A_{mf}\beta} \\ &= \frac{A_{mf}(1 + A_{mf}\beta)}{1 + jx/(1 + A_{mf}\beta)} \quad \dots \quad \dots \quad (218) \end{aligned}$$

Comparing this with expression (217) we see that the condition for critical feedback is that

$$K_2 = 1 + A_{mf}\beta$$

which gives

$$\beta = \frac{K_2 - 1}{A_{mf}} \quad \dots \quad \dots \quad (219)$$

K_2 and A_{mf} are both real terms and hence β must also be real. In a voltage feedback circuit this can be obtained by use of a purely resistive feedback potentiometer as shown in Fig. 119.

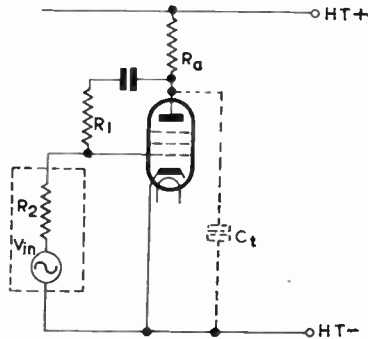

Fig. 119—One circuit for critical voltage feedback in a single-stage amplifier

FEEDBACK IN A SINGLE-STAGE RC-COUPLED AMPLIFIER

In this circuit we have

$$\begin{aligned}\beta &= \frac{Z_2}{Z_1} \\ &= \frac{R_2}{R_1}\end{aligned}$$

and in the amplifier discussed earlier, in which $R_a = 2 \text{ k}\Omega$, $C_t = 25 \text{ pF}$ and $g_m = 8 \text{ mA/V}$ we have that

$$\frac{R_2}{R_1} = 16$$

to give sufficient feedback to reduce the gain to 8. If, as assumed before, R_2 is the internal resistance of the signal source and is equal to $2 \text{ k}\Omega$, R_1 is given by

$$\begin{aligned}R_1 &= 16 R_2 \\ &= 16 \times 2 \times 10^3 \Omega \\ &= 32 \text{ k}\Omega\end{aligned}$$

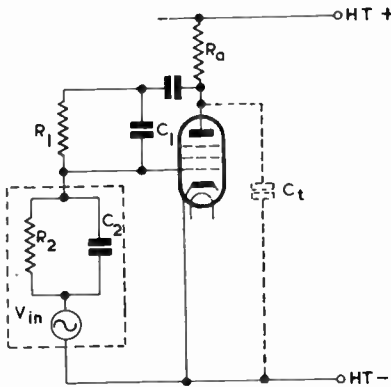

Fig. 120—Circuit for critical voltage feedback when the impedance of the signal source has a capacitive component

If the source is a previous amplifying stage, its impedance is likely to consist of resistance in parallel with capacitance as indicated in Fig. 120. It is still possible, however, to obtain critical feedback by using a parallel RC network for the upper arm of the feedback potentiometer. In such a circuit the feedback fraction is given by

$$\beta = \frac{Z_2}{Z_1}$$

where

$$Z_1 = R_1 / (1 + j\omega C_1 R_1)$$

and

$$Z_2 = R_2 / (1 + j\omega C_2 R_2)$$

Thus

$$\beta = \frac{R_2(1 + j\omega C_1 R_1)}{R_1(1 + j\omega C_2 R_2)} \quad \dots \quad \dots \quad (220)$$

This expression for β can only be real provided the complex quantities in numerator and denominator are equal. This gives

$$R_1 C_1 = R_2 C_2 \quad \dots \quad \dots \quad \dots \quad (221)$$

and this is therefore the condition for critical voltage feedback.

To give some indication of the practical magnitudes of the feedback components suppose $R_2 = 2 \text{ k}\Omega$ and $C_2 = 25 \text{ pF}$, the remaining parameters having the values quoted for previous numerical examples. The feedback fraction at low frequencies is given by

$$\beta = \frac{R_2}{R_1}$$

and as shown earlier this ratio must equal 1/16 to give a stage gain of 8, this corresponding to 6 db feedback. We thus have

$$\begin{aligned} R_1 &= 16 R_2 \\ &= 16 \times 2 \times 10^3 \ \Omega \\ &= 32 \text{ k}\Omega \end{aligned}$$

From (221)

$$C_1 = \frac{R_2 C_2}{R_1}$$

Substituting for C_2 , R_2 and R_1

$$\begin{aligned} C_1 &= \frac{2 \times 10^3 \times 25 \times 10^{-12}}{32 \times 10^3} \text{ F} \\ &= 1.5 \text{ pF} \end{aligned}$$

16.5 CRITICAL CURRENT FEEDBACK

For critical current feedback we have

$$\beta = \frac{Z_k}{Z_L}$$

where Z_L is the load impedance and is given by $R_a / (1 + j\omega C_t R_a)$. The feedback fraction can only be real provided Z_k is also made up of resistance and capacitance in parallel as in Fig. 121. If Z_k consists of R_k and C_k in parallel we have $Z_k = R_k / (1 + j\omega C_k R_k)$ and

FEEDBACK IN A SINGLE-STAGE RC-COUPLED AMPLIFIER

$$\beta = \frac{R_k(1 + j\omega C_t R_a)}{R_a(1 + j\omega C_k R_k)} \quad \dots \quad (222)$$

This expression is of the same form as (220) and the condition for β to be real is that

$$R_k C_k = R_a C_t \quad \dots \quad (223)$$

i.e., the time constant of the cathode circuit should equal that of the anode circuit.

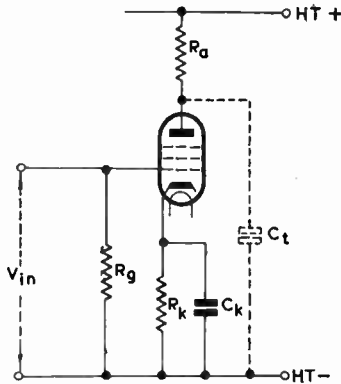

Fig. 121—Circuit for critical current feedback

We will determine the values of R_k and C_k required to give critical feedback in the single-stage amplifier of earlier examples. The feedback fraction at low frequencies is $1/16$ to give a gain of 8 and hence

$$\frac{R_k}{R_a} = \frac{1}{16}$$

from which

$$\begin{aligned} R_k &= \frac{R_a}{16} \\ &= \frac{2,000}{16} \text{ } \Omega \\ &= 125 \text{ } \Omega \end{aligned}$$

From (223)

$$\begin{aligned} C_k &= \frac{R_a C_t}{R_k} \\ &= \frac{2 \times 10^3 \times 25 \times 10^{-12}}{125} \text{ F} \\ &= 400 \text{ pF} \end{aligned}$$

16.6 MAXIMAL VOLTAGE AND CURRENT FEEDBACK

This form of feedback gives a maximally-flat frequency response, i.e., one having an equation with only a single term in frequency. Now the frequency response of a single-stage RC-coupled amplifier is maximally flat without feedback. This follows from expression (17) which may be written in the form

$$\left| \frac{A_{mf}}{A_{hf}} \right|^2 = 1 + x^2 \quad \dots \quad \dots \quad \dots \quad (224)$$

which contains only one frequency-dependent term.

It does not follow from this that there is no point in applying maximal feedback to such an amplifier. Such feedback is still worth while because it can be designed to reduce the coefficient of x^2 in expression (224) which improves the frequency response. This can be shown in the following way. From expression (217) the external high-frequency gain of a single-stage RC-coupled amplifier with feedback is given by

$$A_{hf}' = \frac{A_{mf}K}{1 + jx/K}$$

where $K = (1 + A_{mf}\beta)$. Now $A_{mf}/K = A_{mf}'$, the medium-frequency external gain, and thus we have

$$\frac{A_{mf}'}{A_{hf}'} = 1 + \frac{jx}{K}$$

from which

$$\left| \frac{A_{mf}'}{A_{hf}'} \right|^2 = 1 + \frac{x^2}{K^2} \quad \dots \quad \dots \quad \dots \quad (225)$$

Provided K is real, this is the equation to a maximally-flat curve. For K to be real, β must be real and this is the condition required for critical feedback. This can also be inferred from examination of expressions (224) and (225); both are of the same (maximally-flat) form differing only in the value of the coefficient of x^2 . Application of maximal feedback has not then changed the form of the equation to the response and this is, by definition, critical feedback. For a single-stage RC-coupled amplifier therefore the conditions for maximal feedback are also those for critical feedback; this is not true, however, for an amplifier with more than one RC-coupled stage.

16.7 OPTIMAL VOLTAGE FEEDBACK

This form of feedback extends the frequency response to the

FEEDBACK IN A SINGLE-STAGE RC-COUPLED AMPLIFIER

maximum degree and gives a response with an equation having no frequency-dependent terms.

Under the section on critical feedback it is shown that

$$A_{hf}' = \frac{A_{mf}}{1 + jx + A_{mf}\beta} \quad \dots \quad (226)$$

for a single-stage RC-coupled amplifier with feedback. To obtain optimal feedback it may be necessary to employ a complex value of β and thus we may put

$$\beta = \alpha + j\gamma$$

where α is the real component and γ the frequency-dependent component of the feedback fraction. Substituting for β in (226) and rearranging

$$\begin{aligned} \frac{A_{mf}}{A_{hf}'} &= 1 + jx + A_{mf}(\alpha + j\gamma) \\ &= (1 + A_{mf}\alpha) + j(x + A_{mf}\gamma) \\ \therefore \frac{A_{mf}^2}{A_{hf}'^2} &= (1 + A_{mf}\alpha)^2 + (x + A_{mf}\gamma)^2 \end{aligned}$$

in which the first term is real and the second term frequency-dependent. The condition for optimal flatness is that the second term should be zero, i.e.,

$$x + A_{mf}\gamma = 0$$

giving

$$\gamma = - \frac{x}{A_{mf}}$$

Substituting for x and A_{mf}

$$\gamma = - \frac{\omega C_t}{g_m} \quad \dots \quad (227)$$

Thus the feedback fraction required for optimal flatness is of the type

$$\beta = (\alpha - j\omega C_t/g_m) \quad \dots \quad (228)$$

in which α determines the medium-frequency gain according to the expression

$$A_{mf}' = \frac{A_{mf}}{1 + \alpha A_{mf}}$$

It is clear from this that if α is put equal to zero, the external gain becomes equal to the internal gain, i.e., feedback of this type does

not reduce the gain of the amplifier. Putting $a = 0$ in (228)

$$\beta = \frac{-j\omega C_t}{g_m} \dots \dots \dots (229)$$

and if this form of feedback is applied to an amplifier, there will be no effect on medium-frequency gain which remains at $g_m R_a$ and the high-frequency gain is also made equal to $g_m R_a$ up to (theoretically) an infinite frequency.

To apply optimal voltage feedback we must so choose the nature of Z_1 and Z_2 in Fig. 114 (a) that the feedback fraction Z_2/Z_1 is of the form of expression (228). This can only be achieved by using a negative capacitance for Z_1 (Z_2 being resistive) or a negative inductance for Z_2 (Z_1 being resistive). It may be thought that an

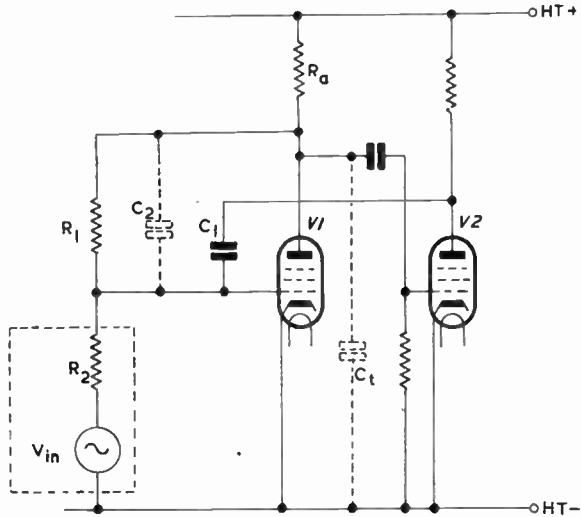

Fig. 122—One circuit for optimal voltage feedback

inductor behaves as a negative capacitor but this is not true because the reactance of an inductor is proportional to frequency whereas that of a negative capacitor is inversely proportional to frequency. For a similar reason a capacitor cannot be used as a negative inductor.

The effect of a negative capacitor can, however, be obtained if the feedback voltage is derived not from the anode of the RC-coupled amplifier itself but from some point in the following stage where the signal voltage is in antiphase to that at the anode. One suitable circuit is that shown in Fig. 122. In this R_1 and R_2

FEEDBACK IN A SINGLE-STAGE RC-COUPLED AMPLIFIER

constitute the feedback potentiometer, and C_2 (shown dotted) is the required negative capacitance connected between anode and grid of V1. The effect of C_2 is, in fact, provided by the capacitor C_1 connected between the anode of V2 and the grid of V1, the signal at V2 anode being in antiphase to that at V1 anode.

If in Fig. 122 C_1 is made equal to the required negative capacitance (C_2), the gain of V2 need only be slightly greater than unity to give the required feedback; the frequency response of V2 then hardly affects the overall performance of the amplifier. If, however, C_1 is made smaller than C_2 , V2 must have appreciable gain to give the desired performance and the high-frequency response of V2 begins to have an effect on the overall response.

The required values of R_1 , R_2 and C_1 can be determined in the following manner. From Fig. 122 the value of β is given by

$$\beta = \frac{Z_2}{Z_1}$$

in which Z_1 is composed of R_1 and C_2 in parallel and Z_2 consists simply of R_2

$$\begin{aligned} \therefore \beta &= \frac{R_2(1 + j\omega C_2 R_1)}{R_1} \\ &= \frac{R_2}{R_1} + j\omega C_2 R_2 \quad \dots \quad \dots \quad \dots \quad (230) \end{aligned}$$

Comparing this with expression (228) we have

$$\alpha = \frac{R_2}{R_1} \dots \dots \dots \dots \dots \dots (231)$$

$$C_2 = -\frac{C_1}{g_m R_2} \dots \dots \dots (232)$$

As a numerical example we will calculate the values of R_1 , R_2 and C_1 necessary to apply optimal feedback to the single-stage amplifier of earlier examples. To reduce the gain to 8, it has been established that $\alpha = 1/16$. Hence from (231)

$$R_1 = \frac{R_2}{\alpha}$$

If R_2 is taken as 2 k Ω

$$\begin{aligned} R_1 &= 16 \times 2 \times 10^3 \Omega \\ &= 32 \text{ k}\Omega \end{aligned}$$

Putting $g_m = 8 \text{ mA/V}$ and $C_t = 25 \text{ pF}$ in (232)

$$\begin{aligned} C_2 &= - \frac{25 \times 10^{-12}}{8 \times 10^{-3} \times 2 \times 10^3} \text{ F} \\ &= - 1.5 \text{ pF} \end{aligned}$$

If V2 has a gain of unity, therefore, C_1 should be approximately 1.5 pF.

If the feedback is required to have no effect on the medium-frequency gain it is necessary to make $\alpha = 0$. As shown in expression (231) this can be achieved by omission of R_1 , which is equivalent to making R_1 infinite. This does not affect the value of C_1 required for optimal flatness.

The feedback provided by R_1 and R_2 is negative because it is derived from the anode of V1 where signal voltages are in antiphase with those at the grid. The feedback provided by C_1 at high frequencies is positive, because the signal voltage at V2 anode is in phase with that at V1 grid. It is therefore necessary to guard against the possibility of continuous oscillation if C_1 is greater than the value necessary for optimal flatness. If R_1 is omitted, this circuit is identical with that of an anode-coupled multivibrator (see Volume III) in which the degree of regeneration is insufficient to cause oscillation.

As shown by the calculation above, the value of C_1 for optimal flatness is very small and is difficult to manufacture with accuracy; thus the danger of instability is a very real one. The risk can be reduced, however, by use of the alternative circuit shown in Fig. 123. In this circuit the resistive potential divider is connected, as before, between anode and grid of V1. C_2 , shown dotted, is the negative capacitance required between anode and grid to give optimal feedback. In this circuit the positive feedback voltage is applied to the cathode circuit of V1 and must hence be obtained from a voltage source in phase with V1 anode potential. It cannot be obtained by connecting a capacitor between anode and cathode of V1 for such a capacitor would behave as a capacitive load on the valve; it is obtained instead from a cathode follower fed from V1 anode. There is no need to introduce a cathode follower purely for the purpose of providing feedback. It is customary to use a cathode follower as the final stage of a video-frequency amplifier in order to give the amplifier a low output impedance which matches the characteristic impedance of a cable; this follower can be used to supply feedback in addition. Although the positive feedback voltage is generated across a resistor in the cathode circuit of V2, this is not an example of current feedback. In effect V2 provides

FEEDBACK IN A SINGLE-STAGE RC-COUPLED AMPLIFIER

at its cathode a copy of the voltage at V1 anode (but with a low source resistance) and the circuit thus provides voltage feedback.

The advantage of this circuit over that illustrated in Fig. 122 is that the value of C_1 required to give optimal feedback is larger and can therefore be more accurately adjusted to the desired value. The capacitance value required can be calculated in the following way.

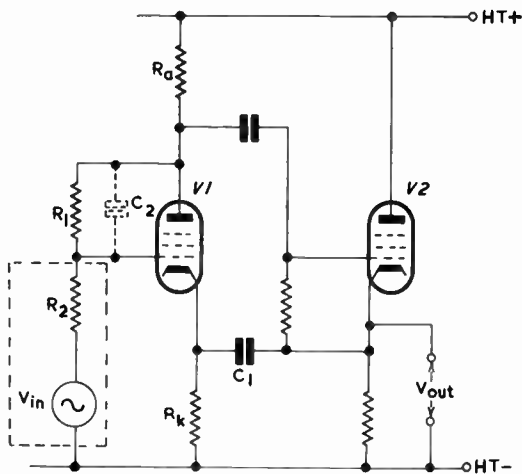

Fig. 123—A more convenient circuit for optimal voltage feedback

Fig. 123 contains two separate feedback potentiometers, namely R_1R_2 and C_1R_k . The first-mentioned provides negative feedback according to the expression

$$\alpha = \frac{R_2}{R_1}$$

and the second positive feedback according to the expression

$$\gamma = - \frac{R_k}{R_k + 1/j\omega C_1}$$

R_k is generally small compared with $1/j\omega C_1$ and this may be simplified to

$$\gamma = -j\omega C_1 R_k$$

Thus the feedback fraction is given by

$$\beta = \frac{R_2}{R_1} - j\omega C_1 R_k \quad \dots \quad \dots \quad \dots \quad (233)$$

which corresponds with expression (228) for optimal feedback.

Equating the coefficients of the j -terms in these two expressions we have

$$R_k C_1 = \frac{C_t}{g_m}$$

giving

$$C_1 = \frac{C_t}{g_m R_k}$$

If $C_t = 25 \text{ pF}$, $g_m = 8 \text{ mA/V}$ and $R_k = 150 \text{ } \Omega$, the value of C_1 is given by

$$\begin{aligned} C_1 &= \frac{25 \times 10^{-12}}{8 \times 10^{-3} \times 150} \text{ F} \\ &= 21 \text{ pF} \end{aligned}$$

a more convenient value than the 1.5 pF required for the previous circuit. In practice C_1 is variable and is adjusted on test to give the desired frequency response.

16.8 OPTIMAL CURRENT FEEDBACK

To obtain optimal flatness by means of current feedback in a single-stage amplifier, the feedback fraction Z_k/Z_L must be of the form given in expression (228).

Thus

$$\frac{Z_k}{Z_L} = \alpha - \frac{j\omega C_t}{g_m}$$

But Z_L is composed of R_a and C_t in parallel

$$\therefore Z_k = \frac{R_a}{1 + j\omega C_t R_a} \cdot \left(\alpha - \frac{j\omega C_t}{g_m} \right)$$

This expression is of the general type $(A - j\omega B)/(C + j\omega D)$ where A , B , C and D are constants and it is extremely difficult to devise a network with an impedance of this form. Optimal flatness is therefore normally obtained by use of voltage feedback.

16.9 NEGATIVE FEEDBACK AT LOW FREQUENCIES

We shall now deduce the conditions necessary to give various types of feedback at low frequencies in a single-stage RC-coupled video-frequency amplifier. It is assumed that the low-frequency response is controlled entirely by the grid capacitor C_g and grid leak R_g , a practical assumption because losses at low frequencies due to cathode and screen circuits can be minimised by the methods discussed earlier.

FEEDBACK IN A SINGLE-STAGE RC-COUPLED AMPLIFIER

From expression (139) the internal gain A_{If} of the amplifier at low frequencies can be written

$$A_{If} = \frac{g_m R_a R_g}{R_g + 1/j\omega C_g} = \frac{A_{mf}}{1 + 1/j\omega C_g R_g} \dots \dots \dots (234)$$

in which the negative sign indicating phase reversal between grid and anode circuits has been omitted for the reasons given at the beginning of Chapter 15. If $\omega_g = 1/R_g C_g$ expression (234) may be written

$$A_{If} = \frac{A_{mf}}{1 + \omega_g/j\omega}$$

and if y is substituted for $\omega_g/j\omega$ we have

$$\therefore A_{If} = \frac{A_{mf}}{1 - jy} \dots \dots \dots (235)$$

Since ω_g is constant for given values of R_g and C_g , the variable y is inversely proportional to frequency.

Expression (235) is similar to expression (16) for the high-frequency performance with $-y$ substituted for $+x$ and, subject to this substitution, the conditions deduced for feedback at high frequencies also hold for low frequencies. For this reason the subject of feedback at low frequencies will not be treated here in detail; the necessary calculations can be made using the basic principles already described. We shall, however, give one example of such a calculation, and this is the determination of the form of feedback circuit needed to give maximal feedback in a single-stage amplifier.

The circuit required to give maximal feedback also gives critical feedback in a single-stage amplifier and both have the effect of producing an external gain defined by

$$A_{If}' = \frac{A_{mf}/K}{1 - jy/K} \dots \dots \dots (236)$$

(see expression 217). The internal gain is given by

$$A_{If} = \frac{A_{mf}}{1 - jy}$$

In general the external gain of any amplifier is given by expression (205), i.e.

$$A_{If}' = \frac{A_{If}}{1 + A_{If}\beta}$$

Substituting for A_{if} from (235)

$$\begin{aligned} A_{if}' &= \frac{A_{mf}(1 - j\nu')}{1 + A_{mf}\beta(1 - j\nu')} \\ &= \frac{A_{mf}}{1 - j\nu' + A_{mf}\beta} \\ &= \frac{A_{mf}(1 + A_{mf}\beta)}{1 - j\nu'(1 + A_{mf}\beta)} \end{aligned}$$

Comparing this with (236) we see that the condition for maximal feedback is that

$$K = 1 + A_{mf}\beta$$

which gives

$$\beta = \frac{K - 1}{A_{mf}}$$

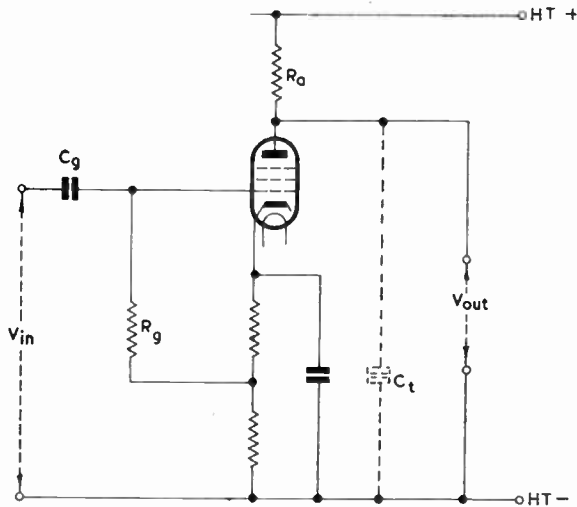

Fig. 124—A critical-feedback circuit which increases input and output impedances

K and A_{mf} are both real terms and hence β must also be real. This derivation follows precisely that given on p. 229 for feedback at high frequencies. Such a value of β can be obtained in a voltage feedback circuit by use of a purely resistive feedback potentiometer. In a current-feedback circuit β is given by Z_{fb}/Z_L and at low frequencies Z_L is equal to R_a , the shunting effect of C_t being negligible.

FEEDBACK IN A SINGLE-STAGE RC-COUPLED AMPLIFIER

Thus maximal feedback at low frequencies is obtained with a purely-resistive cathode circuit.

Maximal feedback at low frequencies requires a real value of β . This is also the condition required to give maximal feedback at high frequencies and thus a purely-resistive feedback potentiometer will give maximal feedback at both extremes of the band.

Some of the circuits described in this chapter employ parallel-connected feedback and others series-connected feedback. For example Fig. 119 shows a circuit with parallel-connected critical feedback; such feedback has the effect of decreasing the input and the output impedances. If this decrease is undesirable, critical feedback can be alternatively obtained by series-connected current feedback which has the effect of increasing both input and output impedances. The circuit is given in Fig. 124 which differs from that shown in Fig. 121 in that the grid resistor is returned to a tapping point on the cathode resistor.

CHAPTER 17

FEEDBACK IN MULTI-STAGE AMPLIFIERS

17.1 INTRODUCTION

FEEDBACK is more effective in improving linearity and extending frequency response as the internal gain of the amplifier is increased. Thus feedback applied over a multi-stage amplifier is more useful than that applied to a single-stage amplifier. We shall now discuss the nature of the feedback circuit required to give maximal and optimal flatness of frequency response in multi-stage amplifiers, using the methods of the previous chapter. For simplicity we shall deal first with a 2-stage amplifier, and will deduce the nature of the feedback circuit required to give the required response at high frequencies. As we have seen, such a circuit will, in general, also produce maximal flatness at low frequencies.

17.2 MAXIMAL FEEDBACK IN A 2-STAGE AMPLIFIER

Consider an amplifier containing two similar RC-coupled stages. The internal gain A_{hf1} of each stage is given by

$$A_{hf1} = \frac{A_{mf1}}{1 + jx} \quad \dots \quad \dots \quad \dots \quad \dots \quad (237)$$

in which A_{mf1} is the medium-frequency internal gain and x is equal to $\omega C_t R_a$ as before. The internal gain A_{hf2} of the complete amplifier is thus given by

$$\begin{aligned} A_{hf2} &= \frac{(A_{mf1})^2}{(1 + jx)^2} \\ &= \frac{A_{mf2}}{(1 + jx)^2} \quad \dots \quad \dots \quad \dots \quad \dots \quad (238) \end{aligned}$$

where A_{mf2} is the medium-frequency internal gain of the amplifier. The external high-frequency gain is given by the general expression (205) namely

$$A_{hf2}' = \frac{A_{hf2}}{1 + A_{hf2}\beta}$$

In this A_{hf2} is defined by (238) and β , the feedback fraction, will probably need to be complex and can thus be replaced by $(\alpha + j\gamma)$.

Making these substitutions we have

$$\begin{aligned}
 A_{hf_2}' &= \frac{A_{mf_2}(1 + jx)^2}{1 + A_{mf_2}(\alpha + j\gamma)/(1 + jx)^2} \\
 \therefore \frac{A_{mf_2}'}{A_{hf_2}'} &= (1 + jx)^2 + A_{mf_2}(\alpha + j\gamma) \\
 &= 1 - x^2 + A_{mf_2}\alpha + j(2x + \gamma A_{mf_2}) \\
 \therefore \frac{A_{mf_2}'}{A_{hf_2}'}^2 &= (1 - x^2 + A_{mf_2}\alpha)^2 + (2x + \gamma A_{mf_2})^2 \\
 &= (1 + A_{mf_2}\alpha)^2 + 4x\gamma A_{mf_2} + 2x^2(1 - A_{mf_2}\alpha) + \gamma^2 A_{mf_2}^2 + x^4 \dots (239)
 \end{aligned}$$

Of these five terms all except the first are frequency-dependent, i.e., contain x or γ . The condition for maximal flatness of frequency response is that there should be only a single term in frequency. This is usually chosen to be the term containing the highest power of frequency, the last term in expression (239). Maximal flatness is thus obtained by arranging for the second, third and fourth terms to cancel and the relationship to be satisfied is

$$A_{mf_2}^2\gamma^2 + 4x\gamma A_{mf_2} + 2x^2(1 - \alpha A_{mf_2}) = 0 \quad \dots (240)$$

Solving this quadratic equation for γ we have

$$\gamma = \frac{-2x \pm x\sqrt{2(1 + \alpha A_{mf_2})}}{A_{mf_2}} \quad \dots (241)$$

The feedback factor, for maximal flatness, is thus given by

$$\beta = \alpha + j \frac{x\sqrt{2(1 + \alpha A_{mf_2})} - 2x}{A_{mf_2}} \quad \dots (242)$$

A feedback fraction of this nature is obtained with a potential divider, the upper arm of which consists of resistance (R_1) and capacitance (C_1) in parallel, the lower arm consisting of resistance (R_2) only. Fig. 125 shows such a potential divider used in a 2-stage RC-coupled amplifier.

Unless R_1 is of a high value it will be necessary to include a blocking capacitor C_2 to avoid d.c. flowing in R_1 from the h.t. supply. Such a capacitor is no disadvantage at high frequencies because it can be made large enough for its reactance to be negligible in comparison with R_1 . It is, however, impossible to make the reactance of C_2 negligible at low frequencies without using a prohibitively large capacitance. This difficulty is usually solved by omitting C_2 and obtaining feedback from a cathode-follower output stage; the circuit is given later.

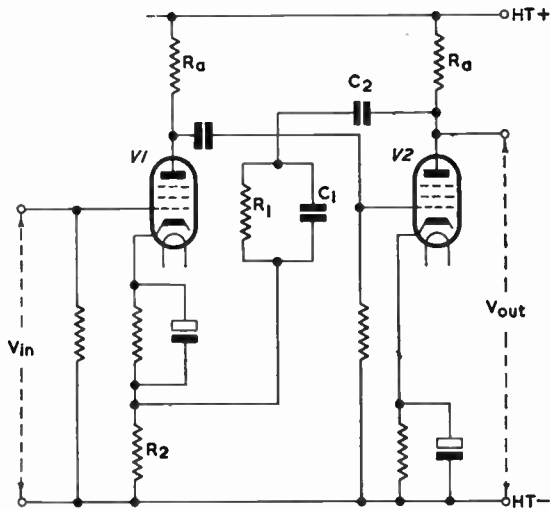

Fig. 125—Two-stage video-frequency amplifier with maximal voltage feedback

For the circuit of Fig. 125 we have

$$\beta = \frac{R_2}{R_2 + 1 + j\omega C_1 R_1} R_1$$

But R_2 is in general small compared with $R_1/(1 + j\omega C_1 R_1)$ and thus we have

$$\beta = \frac{R_2}{R_1} (1 + j\omega C_1 R_1) \dots \dots \dots (243)$$

which is of the same form as (242). Equating real parts we have

$$\alpha = \frac{R_2}{R_1} \dots \dots \dots (244)$$

Equating imaginary parts

$$\omega C_1 R_2 = \frac{x \sqrt{2(1 + \alpha A_{mf2})} - 2x}{A_{mf2}}$$

Substituting $\omega C_1 R_a$ for x , R_2/R_1 for α and $g_m^2 R_a^2$ for A_{mf2} we have

$$C_1 = C_t \frac{\sqrt{2(1 + g_m^2 R_a^2 R_2/R_1)} - 2}{g_m^2 R_a R_2} \dots \dots (245)$$

which gives the value of C_1 necessary for maximal flatness.

FEEDBACK IN MULTI-STAGE AMPLIFIERS

The circuit of Fig. 125 sometimes requires an inconveniently-small value of C_1 . This is an indirect consequence of the fact that R_1 is effectively in parallel with R_a , the anode load resistor of V2. R_1 cannot be less than the optimum load of V2, say 2 k Ω and to give a reasonable degree of feedback the ratio R_2/R_1 may be of the order of 1/20 giving R_2 as 200 Ω . Substitution in (245) shows that C_1 should be approximately 2 pF for maximal flatness.

This difficulty, as well as that of the blocking capacitor C_2 , can be avoided by connecting the feedback potential divider across the output of a cathode follower stage V3 which is fed from V2 anode. Such a stage is often used to give a video-frequency amplifier a low output impedance and it has the advantage of isolating the feedback circuit from V2 anode, thus permitting the use of reasonable values

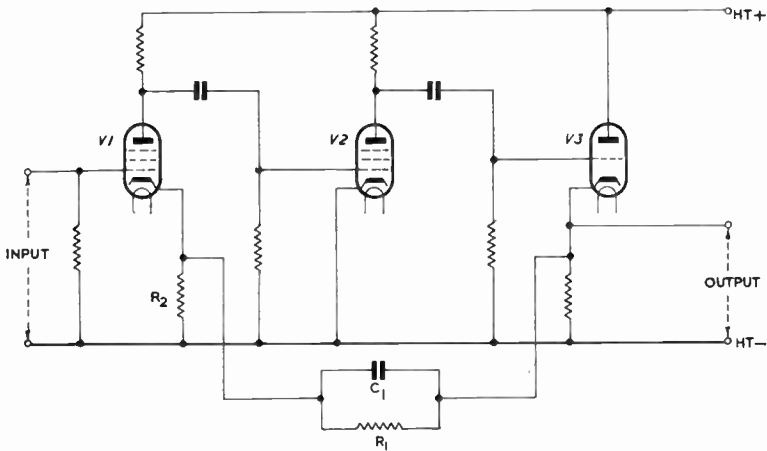

Fig. 126—Two-stage RC-coupled amplifier with output and feedback from a cathode-follower stage

of capacitance in the feedback network. Typical practical component values are calculated in the following numerical example.

Suppose $g_m = 8$ mA/V, $R_a = 2$ k Ω and $C_t = 25$ pF. The internal stage gain is 16 and the overall internal gain approximately 250. We will calculate the component values required to give an external gain of 10, in the circuit of Fig. 126.

The required external gain is small compared with the internal gain and is given approximately by $1/\beta$. Thus $1/\beta = 10$ giving β as 1/10; and the arms of the feedback potentiometer are related by

$$R_1 \simeq 10R_2$$

In such a circuit R_1 can be as low as 300 Ω , making R_2 30 Ω . The

value of C_1 can be calculated from expression (245) by substituting for g_m , R_a , R_1 , R_2 and C_t . We have

$$\begin{aligned} C_1 &= 25 \sqrt{\frac{2(1 + 250/10)}{10^{-4} \times 2 \times 10^3 \times 30}} - 2 \text{ pF} \\ &= 25 \sqrt{\frac{52}{6}} - 2 \text{ pF} \\ &= 25 \times \frac{5.2}{6} \text{ pF} \\ &= 21.6 \text{ pF} \end{aligned}$$

17.3 INSTABILITY IN MULTI-STAGE FEEDBACK AMPLIFIERS

The methods used to calculate the component values in single- and two-stage feedback amplifiers could be applied to amplifiers with more than two stages but the calculation is somewhat tedious. Moreover when two or more stages are included within a feedback loop there is a tendency for oscillation to occur at a frequency outside the passband. Even if oscillation can be avoided, the response curve may have an undesirable rise towards one or both ends of the passband. These effects usually occur at the low-frequency end of the passband because there are more sources of phase shift at such frequencies than at the high-frequency end. To reduce these effects, feedback is not usually applied over more than two stages and, in an amplifier containing numerous stages, feedback is applied in a number of separate loops, each embracing only two stages. This method has the advantage that the component values required for, say, maximal feedback can be readily calculated; it also simplifies the detection of faults in the amplifier.

Even in a two-stage amplifier, however, the possibility of oscillation due to feedback still exists and must be minimised. The instability can arise whenever there are three or more RC or RL circuits in the chain comprising amplifier and feedback circuit. For example, there may be one RC-coupling circuit between V1 anode and V2 grid, a second in V2 cathode circuit and a third (constituting the feedback circuit) between V2 anode and V1 cathode. Although phase shift may be very small over the passband, at frequencies much lower than the picture frequency these circuits all introduce phase shift, and, if this totals 180° , the feedback voltage is in phase with the signal at the point of introduction of the feedback voltage. Such feedback is *positive* and increases the gain of the amplifier, causing oscillation if the feedback voltage is large enough. Whether oscillation occurs depends on the overall gain of amplifier and feed-

back circuit (known as the *loop gain* $A\beta$). It will occur if the loop gain exceeds unity at the frequency of 180° phase shift. Such oscillation is likely to occur if the RC circuits have approximately the same time constant, because in such circumstances 180° phase shift is obtained for a small value of attenuation. The attenuation can be increased, thus decreasing the likelihood of oscillation, by making the time constants of the RC circuits as different as possible. For example an RC circuit giving 60° phase shift has an attenuation of 6 db (as shown in Fig. 85); three such circuits thus give 180° phase shift and 18 db attenuation. If the time constants can be so adjusted that, at this same frequency, one circuit has 35° phase shift, the second 60° and the third 85° , the overall phase shift is still 180° but the attenuations are now 2 db, 6 db and 21 db respectively making a total of 29 db, 11 db greater than before. Thus by choosing the time constants appropriately it is possible to avoid instability due to feedback; the condition required is that 180° phase shift occurs at a frequency for which the RC circuit with the shortest time constant gives enough attenuation to reduce the loop gain to less than unity.

This emphasises the need for elimination of RC circuits whenever this is possible and preceding chapters give some of the methods used for this purpose in amplifiers. In addition, however, it is desirable to eliminate time-constant circuits from the feedback network. This is usually achieved by use of direct coupling from a cathode-follower output; an example is given in Fig. 126. Although there is an RC circuit in the feedback network of Fig. 126 the values are chosen to have no effect at low frequencies; the capacitor C_1 is in fact included to give maximal feedback at high frequencies. By use of this direct coupling phase shift is avoided at low frequencies and in fact feedback is effective down to zero frequency.

Instability may also occur at high frequencies when feedback is applied to a video-frequency amplifier and may be avoided by methods similar to those used at low frequencies. The RC circuits controlling the phase shift of the amplifier at high frequencies are, of course, those formed by the anode-load resistors and the associated shunt capacitance. These time constants should be dissimilar to minimise the risk of instability: thus in a two-stage amplifier it is preferable to use anode load resistors of $1\text{ k}\Omega$ and $4\text{ k}\Omega$ rather than equal resistors of $2\text{ k}\Omega$. As suggested in the next few paragraphs, it is preferable to make the high-value resistor the anode load of the first valve rather than that of the second.

17.4 OVERLOADING OF FEEDBACK AMPLIFIERS

One of the properties of feedback amplifiers which must be

allowed for during design is that the largest input signal which can be accepted without overloading is smaller when the rise time is small than when it is large. To quote typical figures, an amplifier may accept a 2 V signal with a rise time of $0.5 \mu\text{sec}$ but only 1 V when the rise time is $0.1 \mu\text{sec}$. This happens because the feedback voltage, having travelled through the amplifier and the feedback circuit, has a rise time appreciably longer than that of the initial input signal and cannot arrive in time to limit the input to the first valve to a value acceptable by this valve without overloading. If under steady-state conditions the external input is, say, 10 V amplitude and the feedback voltage 9 V, the grid-cathode signal of the first valve is of 1 V amplitude. If the 10 V signal builds up to its final amplitude very rapidly, the feedback voltage may be unable to keep up with it and for a brief period following every input-voltage change, the valve may receive an abnormally large input. This momentary signal may be large enough to cause grid current or anode current cut off, either of which cause severe distortion of the output signal.

This effect disappears if the external input signal is reduced to 1 V amplitude because the valve can handle this even in the absence of feedback. It also disappears if the rise time of the input signal is increased until the feedback voltage can follow the input signal fairly closely, because the difference between them is never large enough to overload the valve. If the input signal has a rise time short compared with that of the amplifier and feedback circuit, the magnitude of the largest amplitude which can be accepted without distortion decreases as the rise time is reduced.

In the preceding argument it was assumed that overloading occurred in the valve to which the feedback voltage is applied. These are the conditions in a single-stage feedback amplifier but there are additional factors to be taken into account in a two-stage amplifier. In such an amplifier, as in any multi-stage amplifier, overloading usually occurs in the later stages because of the greater amplitude of the signals there. Thus in a two-stage amplifier the second stage is likely to overload before the first; this is true in the absence of feedback and irrespective of the time constants used.

When feedback is applied, the relative size of the anode time constants affects the overloading characteristics. If the rise time of the amplifier and feedback circuit is larger than that of the input signal, V1 will receive momentary abnormally-large signals as explained above and these will tend to overload V2. Whether V2 does overload or not depends on the allocation of time constants between V1 and V2 anode circuits. If V1 anode has a short time constant and V2 anode a large one, signals at V1 anode have a

rapid build up and V2 anode potential will have difficulty in following them; V2 is thus likely to overload. On the other hand if V1 anode has a large time constant and V2 anode a short one, signals at V1 anode are comparatively slow in build-up and V2 anode potential is able to follow them; V2 is thus unlikely to overload. To minimise overloading difficulties therefore, it is preferable to have the larger time constant in the anode circuit of the first valve.

To conclude this chapter we shall give two circuits of video-frequency amplifiers with feedback and will point out the methods adopted in their design to obtain the desired performance.

17.5 VIDEO-FREQUENCY AMPLIFIER WITH MAXIMAL FEEDBACK

The circuit of the first of these amplifiers is given in Fig. 127; it has two RC-coupled amplifying stages V1 and V2 preceding a cathode-follower output stage. There are no series or shunt inductors in the amplifier but the response is made level up to 10 Mc/s by maximal feedback. This is applied by the components R_5 , R_6 , R_{12} , R_{13} , and C_4 which form a potential divider of the type required for maximal feedback. The feedback fraction is given by

$$\beta = \frac{R_5 + R_6}{R_5 + R_6 + R_{12} + R_{13}}$$

Substituting component values

$$\begin{aligned} \beta &= \frac{10 + 22}{10 + 22 + 82 + 220} \\ &= \frac{32}{334} \\ &= \frac{1}{10} \text{ approximately} \end{aligned}$$

The internal gain of this amplifier at medium frequencies is probably of the order of 250, i.e., approximately 16 per stage and this value of β represents a large degree of feedback. The danger of low-frequency oscillation is prevented by eliminating as far as possible RC networks with large time constants and by making the time constants of those which remain markedly different. For example there are no RC networks in the screen-grid circuits of any of the valves, the screen grids being connected to h.t. positive via 47 Ω resistors (included to suppress parasitic oscillation). Similarly there are no RC networks in any of the cathode circuits. The cathode circuits of V1 and V3 are purely resistive and the cathode of V2 is bonded

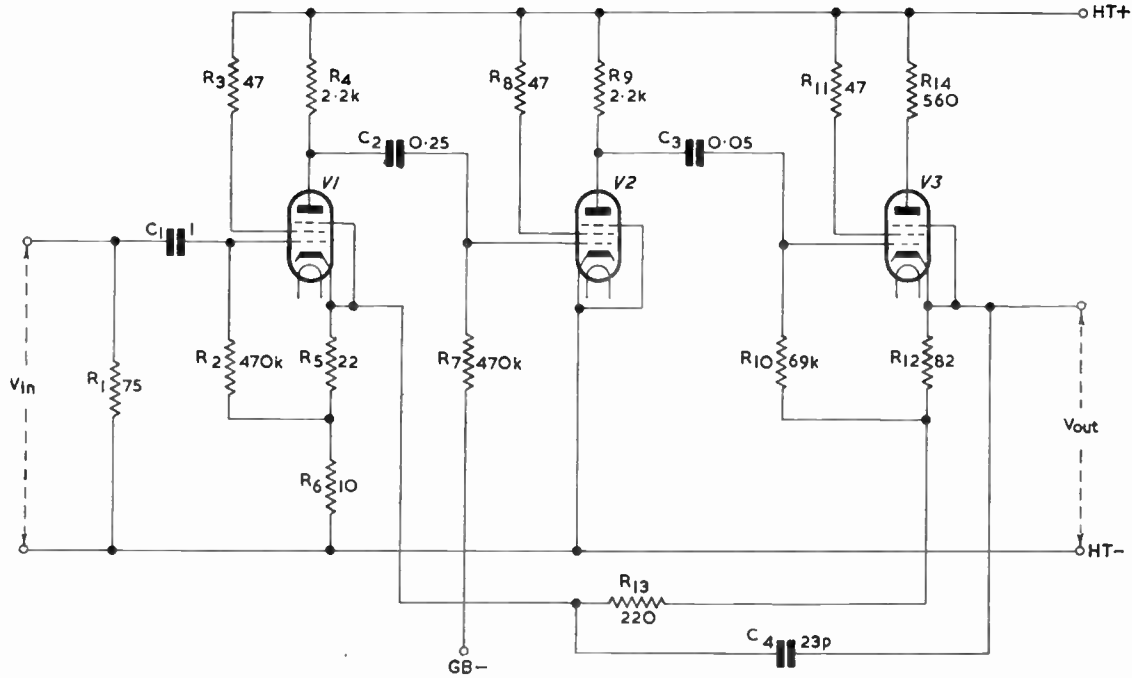

Fig. 127—A video-frequency amplifier with maximal feedback

FEEDBACK IN MULTI-STAGE AMPLIFIERS

directly to h.t. negative, grid bias being supplied from an external source. Only two RC circuits are present, namely the inter-valve coupling circuits R_7C_2 and $R_{10}C_3$. The first of these has a time constant given by

$$\begin{aligned}R_7C_2 &= 470 \times 10^3 \times 0.25 \times 10^{-6} \text{ sec} \\ &= 120 \text{ millisecc approximately}\end{aligned}$$

and the second has a time constant given by

$$\begin{aligned}R_{10}C_3 &= 69 \times 10^3 \times 0.05 \times 10^{-6} \text{ sec} \\ &= 3.5 \text{ millisecc}\end{aligned}$$

These are in the ratio 34 : 1, sufficient to avoid low-frequency oscillation.

The large degree of feedback ensures a good low-frequency response but there is an RC network (R_2C_1) at the input of the amplifier, apparently outside the feedback loop, and it is interesting to consider the effect of this on the amplifier performance. In fact the feedback does have an effect on the time constant of this network, because R_2 is returned to a tapping point on V1 cathode circuit. R_2 thus behaves as a component with many times its real resistance and the effective time constant is larger than its apparent value of 0.47 second ($C_1 = 1 \mu\text{F}$; $R_2 = 470 \text{ k}\Omega$). This effective multiplication of the value of R_2 is, of course, another method of expressing the increase in input resistance of V1 caused by the series-connected voltage feedback of the amplifier.

The value of C_4 required to give maximal feedback can be calculated as illustrated on p. 247, where a value of 21.6 pF was obtained for an amplifier very similar to that under examination. The value of C_4 used in this amplifier is 23 pF.

This amplifier has so much feedback that it is possible to state its gain by inspection of the component values of the feedback circuit. These components give β as approximately 1/10 and thus the gain is 10.

17.6 VIDEO-FREQUENCY AMPLIFIER WITH MAXIMAL AND OPTIMAL FEEDBACK

Fig. 128 gives the circuit of a four-stage video-frequency amplifier with two feedback circuits, one giving maximal feedback and the other optimal feedback. The circuit is basically similar to that of Fig. 127 with maximal feedback derived from V3 cathode and applied to V1 cathode; this feedback is in effect derived from V2 anode, V3 behaving as a cathode follower and giving a copy at its

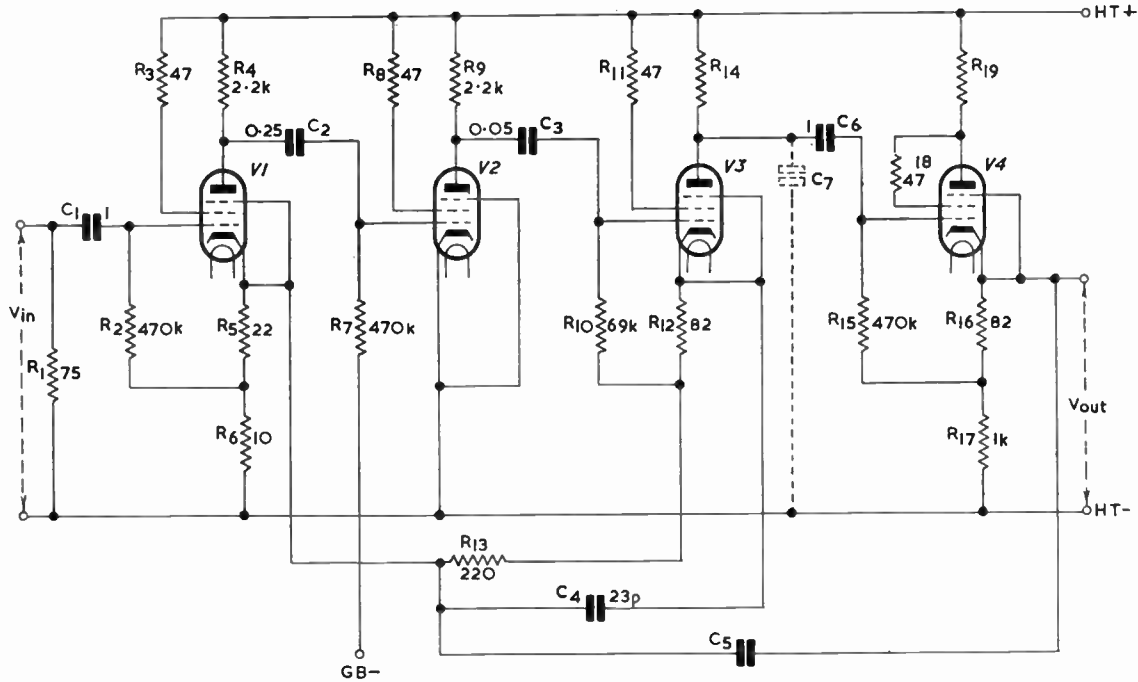

Fig. 128—A video-frequency amplifier with maximal and optimal feedback

cathode of the voltage applied to its grid. In addition, however, V3 is used as a gain stage having an anode load resistor R_{14} which feeds the output cathode follower V4. The feedback from V3 cathode circuit does not, of course, compensate for the falling high-frequency response due to R_{14} and the associated stray capacitance C_7 (shown dotted) or the falling low-frequency response due to the coupling components R_{15} and C_6 .

The high-frequency response is corrected by optimal feedback applied by means of the capacitor C_5 from the cathode of V4 to the cathode of V1. The signal at V4 cathode is of the same phase as that at V3 anode which is phase-reversed with respect to that at V3 cathode. Thus the signal at V4 cathode is in the right phase to provide optimal feedback via C_5 . The capacitance of C_5 depends on the value of R_{14} , decreasing as R_{14} is increased. By correct choice of the value of C_5 the frequency response of V3 and of the whole amplifier can be maintained level up to 10 Mc/s for values of R_{14} up to 1 k Ω and to 5 Mc/s for values of R_{14} up to 3.3 k Ω .

The low-frequency response of C_6 and R_{15} is made good by using a large time constant ($C_6R_{15} = 0.47$ sec) which is effectively multiplied to a much greater value by feedback due to the undecoupled cathode resistor R_{17} . If we assume V4 to have a mutual conductance of 8 mA/V and R_{17} is 1 k Ω , the time constant is effectively increased 9 times to over 4 sec, as shown by the expression derived in Appendix J of Chapter 10.

PART V: NOISE IN VIDEO-FREQUENCY AMPLIFIERS

CHAPTER 18

SOURCES OF NOISE

18.1 INTRODUCTION

IN the preceding sections of this book we have taken no account of the noise which is always present in video-frequency amplifiers. We have, in fact, assumed that the video signal is large compared with noise in all stages of the amplifier. This is true of the video-frequency amplifiers used in the later links of the television chain but does not apply to amplifiers at the beginning of the chain. Amplifiers fed from the output of a camera tube, for example, have a small input voltage which may not be large compared with the noise introduced in the early stages of the amplifier and by the components coupling the tube to the amplifier. Very careful design is necessary to preserve a good signal-noise ratio in these and other amplifiers which have small inputs. In this section we shall illustrate some of the methods used to minimise the effects of noise but will first show how the magnitude of noise voltages and currents may be calculated.

Noise may arise from numerous sources; it can occur as a result of induction from leads or heaters carrying mains-frequency currents and from valve microphony when the amplifier is moved. Noise from these sources can, however, be practically eliminated by careful design and choice of valves. Far more troublesome is the noise due to thermal agitation in conductors (Johnson noise) and to electron streams in valves and camera tubes (shot effect).

18.2 THERMAL OR JOHNSON NOISE

The free electrons in a conductor are in constant movement and the rapidity of movement increases as temperature is raised. If there is no voltage to cause a drift of electrons in a particular direction, the number of electrons passing any given point in a conductor in any direction equals the number passing the point in the opposite

SOURCES OF NOISE

direction. Although this is true in general there can be momentary surfeits or deficits of electrons at particular points in a conductor. This implies that there are varying voltages in the conductor and these, if amplified and reproduced by a loudspeaker, have the sound of a smooth hiss. If such noise voltages occur in a video-frequency amplifier and are reproduced together with a picture on a cathode-ray tube they give rise to spurious items of detail on the screen. As suggested by the previous few paragraphs, thermal noise increases with temperature. This is indicated in the following expression for the r.m.s. noise voltage in a conductor.

$$V_n^2 = 4RkT\Delta f \quad \dots \quad (246)$$

where R is the resistance of the conductor,
 k is Boltzmann's constant = 1.374×10^{-23} Joule per °C,
 T is the temperature of the conductor in degrees absolute, and
 Δf is the passband over which the noise is measured.

Substituting for k and putting T equal to 290° (equivalent to 17° C or approximately 63° F, i.e., average room temperature) we have, taking the square root of expression (246),

$$V_n = 1.25 \times 10^{-10} \sqrt{R\Delta f} \text{ volts} \quad \dots \quad (247)$$

showing that the noise voltage for a given bandwidth is proportional to the square root of the resistance.

Thus the noise voltage developed between the ends of a 10 kΩ resistor over a passband of 3 Mc/s is from (247) given by

$$\begin{aligned} V_n &= 1.25 \times 10^{-10} \times \sqrt{(10^4 \times 3 \times 10^6)} \\ &= 2.165 \times 10^{-5} \text{ V} \\ &= 21.65 \mu\text{V} \end{aligned}$$

18.3 SHOT NOISE

In an electronic tube or valve the number of electrons passing a given point in the emission or beam from the cathode varies slightly from instant to instant although the current, averaged over an appreciable period, may be constant. These minute variations constitute a noise current of magnitude

$$I_{ns}^2 = 2I_a e \Delta f \quad \dots \quad (248)$$

where I_{ns} is the r.m.s. noise current,
 I_a is the average value of the electron stream,
 e is the charge on an electron,
 and Δf is the bandwidth over which the noise is measured.

Substituting the value for e gives the noise as

$$I_{ns} = 5.45 \times 10^{-4} \sqrt{(I_a \Delta f)} \mu\text{A} \quad \dots \quad (249)$$

This expression holds only for a saturated valve, i.e., one in which all the electrons liberated from the cathode are collected by the anode. For a triode as commonly used for amplification, the anode current is limited by space charge and the noise current is approximately 2/3rds that given by expression (249).

As an example the noise produced by a space-charge limited triode consuming 10 mA and within a 3 Mc/s bandwidth is from (249) given approximately by

$$\begin{aligned} I_{ns} &= 0.67 \times 5.45 \times 10^{-4} \times \sqrt{(10 \times 10^{-3} \times 3 \times 10^6)} \text{A} \\ &= 0.063 \mu\text{A} \end{aligned}$$

and if the valve has an anode load of 2 kΩ, the noise due to shot effect, developed across it is given by $2,000 \times 0.063 = 126 \mu\text{V}$.

18.4 EQUIVALENT NOISE RESISTANCE

From expression (249) the shot-noise current is proportional to the square root of the current and the bandwidth; thus the noise voltage produced across the anode load Z_a due to shot effect in a

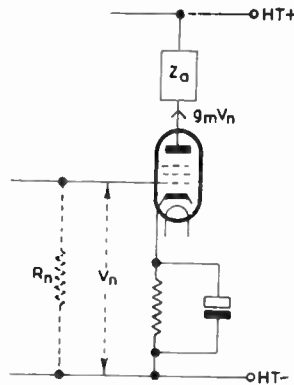

Fig. 129—Equivalent noise resistance of a valve

valve is proportional to $Z_a \sqrt{(I_a \Delta f)}$. It is convenient to regard this noise as due to thermal agitation in a fictitious resistor connected between the grid and cathode as shown in Fig. 129; this resistor is known as the equivalent noise resistance, R_n .

SOURCES OF NOISE

From (247) the Johnson noise voltage produced by such a resistor is proportional to $\sqrt{(R_n \Delta f)}$ and, if the valve gain is $g_m Z_a$, the amplified noise appearing in the anode circuit is proportional to $g_m Z_a \sqrt{(R_n \Delta f)}$. Thus

$$g_m Z_a \sqrt{(R_n \Delta f)} \propto Z_a \sqrt{(I_a \Delta f)}$$

from which R_n is proportional to I_a/g_m^2 . Thus to obtain a low value of shot noise, that is a low value of equivalent noise resistance, a valve is required to have a low value of anode current and high mutual conductance. Special triodes with such properties have been developed for use in amplifiers where the signals are of very low amplitude.

18.5 PARTITION NOISE

In general, triodes give less shot noise than tetrodes or pentodes with the same gain and for this reason are often used instead of pentodes in the first stage of a camera head amplifier. The superiority of the triode in signal-noise ratio is due to the division of current between anode and screen which occurs in tetrodes and more complex valves. The fraction of the cathode current which reaches these two electrodes does not remain precisely constant from moment to moment. Minute variations occur and these cause effects of a similar nature to thermal-agitation and shot noise. Because of this partition effect, the noise of a pentode is from three to five times that of a triode.

CHAPTER 19

NOISE IN CAMERA HEAD AMPLIFIERS

19.1 INTRODUCTION

THERMAL-AGITATION and shot noise is particularly troublesome in the early stages of video-frequency amplifiers fed from the output of camera tubes as the output of these tubes is in general very small.

Shot noise can arise in the camera tube itself, and in subsequent valves, but it is generally necessary to take account of the noise of the first two valves of the head amplifier. The signal amplitude in later stages is usually so large that the additional noise introduced by these stages is negligible in comparison with it. In assessing the effects of noise due to thermal agitation it is usually necessary to consider that produced by the signal resistor and the anode load of the first valve; the noise in resistors later in the chain is swamped by the signal.

The relative magnitude of the noise from these sources depends on the type of camera tube. In an iconoscope, or one of its derivatives, or an orthicon (i.e., in any tube having a signal plate) the noise in the camera-tube beam is small and the chief sources of noise are shot effect in the first valve and thermal agitation in the signal resistor. For a camera tube such as the image orthicon, there is an important additional source of noise, namely the electron beam of the tube; this noise is present whether there is a signal output from the tube or not. As explained in Volume I, the beam current in these tubes is kept to a minimum to reduce noise as far as possible.

19.2 NOISE SOURCES

In confirmation of the statement that shot effect in the first valve and thermal noise in the signal resistor are the chief sources of noise in an orthicon head amplifier, we will calculate the noise voltage at the anode of the second stage due to the following sources—

1. Shot effect in camera-tube beam current.
2. Shot effect in first valve.
3. Shot effect in second valve.
4. Thermal noise in signal resistor.
5. Thermal noise in first valve anode resistor.

The essential features of the circuit are shown in Fig. 130.

NOISE IN CAMERA HEAD AMPLIFIERS

1. Shot Effect in Camera-tube Beam Current

If the beam current is $1 \mu\text{A}$, the noise current is, from (249)

$$\begin{aligned} I_{ns} &= 5.45 \times 10^{-4} \times \sqrt{(10^{-6} \times 3 \times 10^6)} \text{ A} \\ &= 0.001 \mu\text{A} \end{aligned}$$

and if the signal resistor is $2 \text{ k}\Omega$, the noise at the first valve grid is $0.001 \times 10^{-6} \times 2 \times 10^3 \text{ V} = 2 \mu\text{V}$. The gains of V1 and V2 will be taken as 10 and thus the noise at the anode of V2, due to shot effect in the camera tube beam, is $2 \times 10 \times 10 \mu\text{V} = 200 \mu\text{V}$.

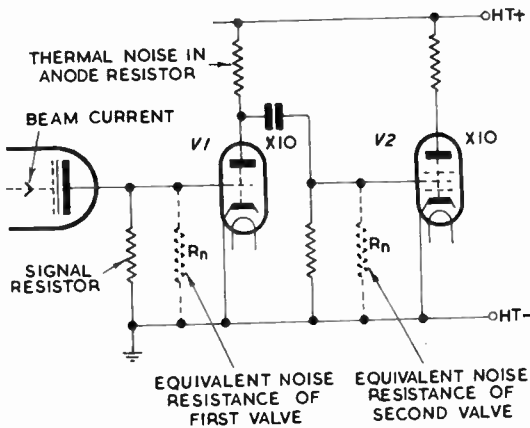

Fig. 130—Essential features of early stages of a camera head amplifier illustrating sources of noise

2. Shot Effect in First Valve

This calculation is made on page 258 and the noise voltage at the anode of V2 is $126 \mu\text{V}$. After amplification by V2, the noise due to shot effect in V1 is $126 \times 10 \text{ V} = 1,260 \mu\text{V}$.

3. Shot Effect in Second Valve

The noise at the anode of V2 is, of course, $126 \mu\text{V}$.

4. Thermal Noise in Signal Resistor

If the signal resistor is $2 \text{ k}\Omega$, the voltage across it due to thermal agitation is given, from (247) by

$$\begin{aligned} V_n &= 1.25 \times 10^{-10} \sqrt{(2 \times 10^3 \times 3 \times 10^6)} \text{ V} \\ &= 10 \mu\text{V}. \end{aligned}$$

The gain from the grid of V1 to the anode of V2 is 100, and thus the voltage at the anode of V2 due to thermal agitation in the load resistor is $10 \times 100 \mu\text{V} = 1,000 \mu\text{V}$.

5. *Thermal Noise in First Valve Anode Resistor*

The voltage at the grid of V2 due to thermal agitation in the anode load of V1 (assumed to be $2 \text{ k}\Omega$) is, from the previous calculation, $10 \mu\text{V}$ and after amplification by V2, this becomes $100 \mu\text{V}$.

Examination of the results of these calculations shows that the chief sources of noise are shot effect in V1 ($1,260 \mu\text{V}$) and thermal agitation in the signal resistor ($1,000 \mu\text{V}$), which are of the same order. The noise due to shot effect in the first valve is kept at a minimum by use of a low-noise valve such as the special triodes which have been developed for use in such positions; thermal agitation noise is kept low by choice of the value of signal resistor. The choice of signal-resistor value is, however, complicated because the frequency response of the camera-tube output circuit is dependent on it. We will now consider this point in greater detail.

19.3 CAMERA-TUBE OUTPUT COUPLING

The simplest type of camera-tube output-coupling circuit is that shown in Fig. 131. A load resistor R_l is connected directly in the

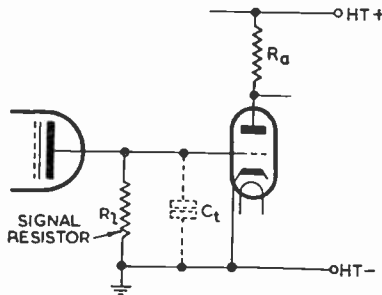

Fig. 131—Basic output coupling circuit for camera tube

output circuit of the tube and the voltage developed across this is directly connected to the input terminals of the head amplifier.

Camera tubes of the iconoscope, image-iconoscope and orthicon type have a very high output impedance, being mainly the reactance of the signal plate-earth capacitance. This impedance is normally very large compared with likely values of load impedance R_l . The tube thus behaves as a constant-current source and the output voltage is directly proportional to the value of the load resistance.

Thermal agitation noise is proportional to the square root of the resistance as shown by expression (247). Thus the signal-noise ratio is proportional to the square root of the resistance and increases as the resistance is increased. It is advantageous, therefore, to use as high a value of signal resistor as possible, but an upper limit is set by the shunt capacitance C_t across the load. If the load is high, the capacitive reactance is an appreciable shunt at high video frequencies and reduces the effective load, causing the output voltage to fall at the upper end of the video range. To enable high values of load resistance to be used, it is essential to minimise stray capacitance. To this end the head amplifier is located as close to the tube as possible, but even so the capacitance cannot be reduced much below approximately 25 pF. This value is made up of the capacitance of the signal plate itself, the lead to the first valve grid and the input capacitance of the first valve. To avoid partition noise the first valve is almost certain to be a triode and its input capacitance may considerably exceed the value of the grid-cathode capacitance because of Miller effect.

A capacitance of 25 pF has a reactance of $2,000 \Omega$ at 3 Mc/s and, to minimise the shunting effects of this on the load resistance, the latter cannot be more than $2,000 \Omega$. Such a low value of load resistance gives a poor signal/noise ratio and it is essential to find methods of reducing the shunt capacitance still further.

One method which can be employed is to reduce the Miller effect in the first valve of the head amplifier. The increase in input capacitance due to Miller effect is given by $C_{ag}(A + 1)$ where C_{ag} is the grid-anode capacitance and A is the stage gain. This capacitance can thus be reduced by decreasing A , i.e., by decreasing R_a the anode load of V1. This load resistance is sometimes reduced to a value less than that required for frequency-response considerations in order to reduce input capacitance.

Even by adopting measures of this nature it is not possible to use tube load resistances much higher than a few thousands of ohms without losing gain at the upper end of the video-frequency band due to capacitive shunting. With such low load values the signal-noise ratio is poor unless a prohibitively large light input is used. Thus it would appear to be very difficult to reduce the shunt capacitance to an acceptably low value.

There is, however, an alternative solution to this problem which is commonly adopted. The shunt capacitance is made as small as practicable and a large value of tube load resistance is used. This results in an acceptable signal-noise ratio but the frequency response of the tube output circuit falls as frequency rises. The frequency response is corrected in subsequent stages of the head amplifier by

designing this section to have a rising high-frequency response. The noise voltage across the tube load resistance has equal-amplitude components at all frequencies in the video-band and, because of the frequency response of the amplifier, the high-frequency components are subjected to a greater amplification than the low-frequencies. Thus the signal-noise ratio at the amplifier output is better at low frequencies than at high ones; this is sometimes referred to as a triangular noise spectrum. By arranging for the signal-noise ratio to vary in this way, more noise can be tolerated than if the signal-noise ratio were made constant and independent of frequency. By confining the noise to the upper end of the video band, the noise is seen as a fine grain superimposed on the picture; this is more acceptable than the larger grain which is obtained when the noise components are spread uniformly over the spectrum.

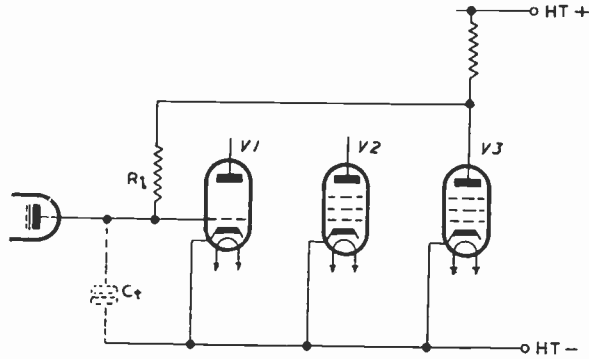

Fig. 132—Basic features of a circuit used for camera-tube output coupling

By using this technique it is possible to use tube load resistances as high as $1\text{ M}\Omega$. This is large compared with the reactance of the shunt capacitance and the frequency response of the tube output circuit is very nearly inversely proportional to frequency, i.e., the response falls at the rate of 6 db per octave throughout the video band. To correct this, the head amplifier must have a response which rises at the rate of 6 db per octave throughout the spectrum.

Fig. 132 illustrates the basic features of a circuit arrangement which can be used to give such a performance. The rising frequency characteristic is obtained by use of frequency-discriminating feedback applied from output to input of a 3-stage video-frequency amplifier. The feedback circuit consists simply of a potential divider with a resistive upper arm, and a capacitive lower arm; such a circuit makes β inversely proportional to frequency and gain

NOISE IN CAMERA HEAD AMPLIFIERS

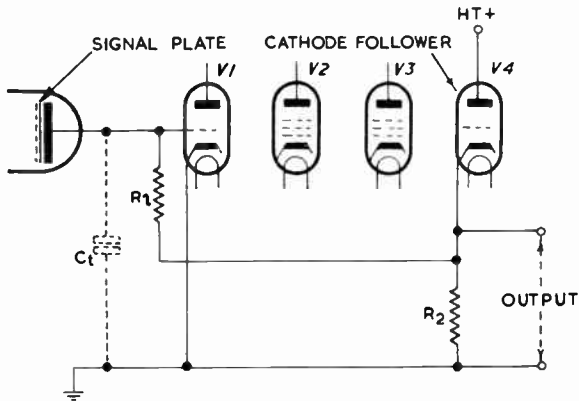

Fig. 133—Circuit of Fig. 132 with feedback derived from a cathode follower

directly proportional to frequency. The most interesting feature of the circuit is that the upper potential divider arm is the tube load resistance and the lower arm is the capacitance shunting the tube output circuit. This circuit may alternatively be regarded as an example of parallel-connected feedback; the parallel connection makes the effective input impedance of the amplifier very much less than R_l the value of the load resistor, thereby eliminating the effect of the shunt capacitance and the high-frequency loss.

In practice the load resistor is not returned to the anode of V3 but to the output of a cathode follower fed from V3 anode, the circuit having the basic form illustrated in Fig. 133.

BIBLIOGRAPHY

- R. G. Shiffenbauer: "Phase Distortion in Television," *Wireless Engineer*, January 1936.
- R. L. Freeman and J. D. Schantz: "Video Amplifier Design," *Electronics*, August and November 1937.
- S. W. Seeley and C. N. Kimball: "Analysis and Design of Video Amplifiers," *R.C.A. Review*, October 1937.
- E. W. Herold: "High-frequency Correction in R.C. Amplifiers," *Communications*, August 1938.
- A. Preisman: "Some Notes on Video Amplifier Design," *R.C.A. Review*, April, 1938.
- A. V. Bedford and G. L. Fredenhall: "Transient Response of Multi-stage Video Amplifiers," *Proc. I.R.E.*, April 1939.
- S. W. Seeley and C. N. Kimball: "Analysis and Design of Video Amplifiers," *R.C.A. Review*, January 1939.
- H. A. Wheeler: "Wideband Amplifiers for Television," *Proc. I.R.E.*, July 1939.
- V. D. Landon: "Cascade Amplifiers with Maximal Flatness," *R.C.A. Review*, January 1941.
- H. E. Kallman, R. E. Spencer and C. P. Singer: "Transient Response," *Proc. I.R.E.*, March 1945.
- J. M. Miller: "Cathode Neutralisation of Video Amplifiers," *Proc. I.R.E.*, September 1949.
- R. C. Palmer and L. Mautner: "Figure of Merit for Transient Response of Video Amplifiers," *Proc. I.R.E.*, September 1949.
- C. F. Brockelsby: "Negative Feedback Amplifiers," *Wireless Engineer*, February 1949.
- H. Mayr: "Feedback Amplifier Design," *Wireless Engineer*, September 1949.
- J. E. Flood: "Negative Feedback Amplifiers," *Wireless Engineer*, July 1950.

TELEVISION ENGINEERING PRINCIPLES AND PRACTICE

- G. G. Gouriet: "V. F. Amplifier Couplings," *Wireless Engineer*, October–November 1950.
- E. L. C. White: "Design of a Television Camera Channel for use with the C.P.S. Emitron," *I.E.E. Journal*, November 1950.
- V. J. Cooper: "Negative Feedback Amplifiers," *Journal of the Television Society*, April–June 1951.
- J. D. McGee: "A Review of some Television Pick-up Tubes," *Journal of the I.E.E.*, November 1950.
- O. H. Schade: "Electro-optical Characteristics of Television Systems," *R.C.A. Review*, March 1948.
- E. L. Ginzton, W. R. Hewlett, J. H. Jasberg and J. D. Noe: "Distributed Amplification," *Proc. I.R.E.*, August 1948, Vol. 36, No. 8.
- W. H. Horton, J. H. Jasberg and J. D. Noe: "Distributed Amplifiers; Practical Considerations and Experimental Results," *Proc. I.R.E.*, July 1950, Vol. 38, No. 7.
- B. Murphy: "Distributed Amplifiers," *Wireless Engineer*, February 1953, Vol. 30, No. 2.
- G. G. Gouriet: "Spectrum Equalisation," *Wireless Engineer*, May 1953, Vol. 30, No. 5.

INDEX

- AMPLIFIER:**
Camera Head, 197, 260
Distributed, 121
Feedback, 223
Series-inductance, 75
Shunt-inductance, 55
Simple RC-coupled, 37, 159
Amplitude and Phase Characteristics, General, 17
Aperiodic Feedback, Definition, 221
Aperiodic Current Feedback, Single-stage Amplifier, 228
Aperiodic Voltage Feedback, Single-stage Amplifier, 223
Attenuation and Phase Distortion:
High Frequencies, 22
Low Frequencies, 27
Middle Frequencies, 27
- CATHODE FOLLOWER,** 119, 206, 251, 253
Characteristic Impedance, 121
Critical Current Feedback, Single-stage Amplifier, 232
Critical Feedback, Definition, 221
Critical Voltage Feedback, Single-stage Amplifier, 229
Current Feedback, 94, 102, 171, 175, 189, 217 et seq
- DELAY,** 20, 31, 48, 65, 87, 112
Delay Line, 121
Derivative Equaliser, 142
Design:
Bridged-T Equaliser, 138
Multi-valve Amplifier, 118
Series-inductance Amplifier, 90
Shunt-inductance Amplifier, 70
Simple Phase Equaliser, 129
Differentiating Circuit, 166
- ENVELOPE DELAY,** (See Group Delay)
External Gain, 216
- FIGURE OF MERIT,** 108
Frequency Response:
Anode-decoupled Circuit, 181
Cathode-decoupling Circuit, 190
Distributed Amplifier, 123
Lattice Network, 126, 144
Screen-decoupling Circuit, 202, 206
Series-inductance Amplifier, 78
Shunt-inductance Amplifier, 57
Simple RC-coupled Amplifier, 42, 161, 169, 173
- GAIN:**
Multi-valve Amplifier, 114
Series-inductance Amplifier, 75
Shunt-inductance Amplifier, 55
Simple RC-coupled Amplifier, 40
Group Delay, 30, 33, 48, 66, 88, 112, 128, 135
- INSTABILITY,** 248
Internal Gain, 216
Inversion of Signal, 29
Iterative Impedance, 75, 93, 126, 133, 136, 144
- JOHNSON NOISE,** 256
- LATTICE NETWORK,** 126, 144, 150
Limiting Values:
Frequency, 111
Gain, 109
- MAXIMAL CURRENT FEEDBACK:**
Single-stage Amplifier, 234, 242
2-stage Amplifier, 244

INDEX

- Maximal Feedback, Definition, 221
- Maximal Flatness of Frequency Response:
 - Cathode Components, Circuits employing, 94
 - Feedback Circuits, 221
 - Series-inductance Amplifier, 84
 - Shunt-inductance Amplifier, 61
- Maximal Flatness of Group Delay Curve:
 - Phase Equaliser, 136
 - Series-inductance Amplifier, 89
 - Shunt-inductance Amplifier, 67
- Maximal Voltage Feedback, 234, 242, 245, 251, 253
- Merit Factor, 108
- Miller Effect, 38, 263

- NEGATIVE FEEDBACK, 94, 189, 200, 213 et seq
- Noise Resistance, 258

- OPTIMAL CURRENT FEEDBACK, 240
- Optimal Feedback, Definition, 221
- Optimal Flatness of Frequency Response, 221, 234, 240, 253
- Optimal Voltage Feedback:
 - Single-stage Amplifier, 234
 - Multi-stage Amplifier, 253
- Overshoot, 25, 32, 69, 91, 93, 113

- PARTITION NOISE, 259
- Phase Equalisers:
 - Design, 129, 138
 - Frequency Response, 126, 134
 - General, 27
 - Phase Response, 128, 135
- Phase Response:
 - Anode-decoupled Circuit, 186
 - Cathode-decoupling Circuit, 192
 - Distributed Amplifier, 123
 - Phase Equaliser, 128, 135
 - Series-inductance Amplifier, 85
 - Shunt-inductance Amplifier, 63
 - Simple RC-coupled Amplifier, 39, 46, 162, 170
- Positive Feedback, 177, 238, 248

- RESPONSE TO VOLTAGE STEP:
 - Multi-valve Amplifier, 112
 - Series-inductance Amplifier, 90
 - Shunt-inductance Amplifier, 68
 - Simple RC-coupled Amplifier, 50
- Ringing, 26, 91
- Rise Time, 19, 24, 31, 46, 52, 69, 90, 98, 112, 115, 129, 166, 223, 250

- SAG, 28, 35, 158, 164, 166, 173, 186, 195, 223
- Shot Noise, 257
- Signal Inversion, 29
- Stage Gain of Cascaded Amplifier, 114
- Streaking, 27

- TEST CARD C, 35
- Thermal Noise, 256
- Time Constant, 51, 98, 162, 165, 184, 211, 233, 249, 253
- T-section Phase Equaliser, 136, 150
- Turnover Frequency, 43, 59, 105, 109, 142

- UNDERSHOOT, 25