

ELECTRONICS WORLD

+ WIRELESS WORLD

JANUARY 1990 £1.95

21 DAY 8 PROGRAMME

Denmark Dkr. 63.00
Germany DM 12.00
Greece Dra. 680
Holland Dfl. 12.50
Italy L 6500
R £2.97
Spain Ptas. 700.00
Singapore S\$ 11.25
USA \$5.95

HYPOTHESIS

Inertia's riddle

ENGINEERING

**Surrounded
by sound**

REVIEW

**PC add-in spectrum
analyser**

SPECIAL
FEATURE

**CONSUMER
ELECTRONICS**



The Programmer that fits your Pocket - £495

S3 is a product which has shaken the industry. It is in all the big-name catalogues. It is used by all the big-name companies. That's because S3 has an elegance and fitness-for-purpose that puts it in a different league from old fashioned bench programmers. But you don't have take our word for it. You can get an S3 on NO-RISK APPROVAL and find out for yourself.

S3 doesn't only program EPROMS

S3 programs any (E)EPROM you can put in the socket. Choose manufacturer and device from a menu and S3 will select one of 80-odd algorithms. But programming memory devices is only a part of S3's repertoire. It's not the be-all and end-all. If you need to program EPLDs, CMOS PALS, NOVRAMS, SINGLE-CHIP MICROS and the like, S3 is still the best tool for the job. Dataman provides dedicated modules and software, which are much cheaper than any other solution because the S3 you already own acts as a "mainframe". These products don't just exist in our imagination. We have them on the shelf, ready to ship.

Software upgrades are FREE

When new programmable parts are released, Dataman provides new software to program them. This software is FREE. It is also easy to install. The original program comes in a ROM. You place it in the socket (see picture) and press the HELP button. It loads in a few seconds. And you only have to do it once. S3 retains its program - and your data - in non-volatile memory, even when switched off. We post the new program on our Bulletin Board. If you have a modem, you can download it. There are lots of other useful programs available too. Give our BB a call on 0305-251786.

Terminal Program with S3 Driver

We offer a TERMINAL PROGRAM which supports four COM ports simultaneously at speeds up the 115,200 baud. This program is useful in its own right. It also has a FRONT-END DRIVER for S3, with MENUS and HELP screens. This gives you Remote Control of all S3's functions. You can Upload and Download files, change configuration and do everything remotely that you can do with S3's keyboard. Some companies make a song-and-dance about their software drivers, - and charge you at least £100. Ours is free. Not 'free' when you buy something, but FREE to any Company requesting literature.



Universal Assembler & Editor

S3 is also a MEMORY-EMULATOR. Use it with an Assembler and you have a complete Microprocessor Development System. It happens that Dataman sells a fast full-featured Editor/Assembler, called SDE, for use with S3 (or without).

RS232 socket (DB25) on the back, for remote control.

Emulator lead (supplied) plugs in beneath.

S3 programs and emulates 25 and 27 series EPROMS up to 27512.

The 80 character LCD shows ASCII and HEX.

Quality keyboard for fast data entry.

S3 will program hundreds of PROMS without recharging.

Charger unit (supplied) recharges S3 in 3 hours.

A single keypress will Assemble and Link the source file(s), download to S3 and start the program running on your target system. SDE has some amazing features. If it finds an error when assembling, it puts you back in the source-file at the error line. It will tell you the absolute address of any line of source code. That saves the chore of printing listings when debugging. SDE comes in single or multiple processor versions. Do try it. You will like it.

Specifications and Price List

S3 has a 64 kbytes CMOS RAM buffer for storing USER programs and ROM/RAM EMULATION - access time is about 120ns. There are also 8K bytes of program RAM, a serial interface at 300, 600, 1200, 2400 4800 and 9600 baud for remote control and uploading and downloading files. S3 comes complete with Manual, Mains-charger unit, ROM emulator lead, write-lead and software to program and emulate (E)EPROMS and FLASH EPROMS. Re-charging takes 3 hours and does not prevent normal use. Typically one charge per week is enough. S3 measures

7.3 x 4.4 x 1.8 ins and weighs just over 1 lb. **£495.00**
 SDE Editor/Assembler/Comms single-processor **£195.00**
 SDE Editor/Assembler/Comms multi-processor **£395.00**
 S3 Developer's Package Reveals all S3's secrets.
 Contains Circuit Diagrams, Source Code, BIOS calls and Editor/Assembler (as SDE above) for NEC78C06 processor in S3. Lets you write your own custom software - even make S3 into a something completely different. **£195.00**
 MCS48 module for 8741/42/48/49 **£125.00**
 MCS51 module for 8751/52/53 **£125.00**
 32 pin module for EPROMS (inc FLASH) over 1m **£75.00**
 40 pin module for EPROMS over 1meg **£75.00**
 EPLD (CMOS PAL) modules (set of 2) for Erasable Programmable Logic Devices. Works with manufacturer's compilers to provide self-contained system. Receives, translates, creates and transmits JEDEC files. Loads, burns and copies parts such as 22V10, 20G10, 16R4, 16R6, 16L8, 16L8, PEEL18CV8, EP300 to EP900, 50C30 to 50C90 from Cypress. AMD, AMI, Altera, Gould, Texas, Intel, ICT **£295.00**

S3 IS GUARANTEED FOR 3 YRS. OTHER PRODUCTS 1 YR. BOTH PARTS AND LABOUR. VAT MUST BE ADDED TO ALL PRICES. IN UK ONLY BUT POSTAGE IS FREE. SPECIAL OR FOREIGN DELIVERY COSTS EXTRA

Socket is used to program PROMS and load software.

Money-back Guarantee

Our aim is to get a product into your hands. Our products sell themselves. We promise to hand your money back without question if you're not mightily pleased. Dataman products are so well thought out and downright useful - and such good value for money - that we hardly ever get any returns.

What to do next

Send your business-card or letterhead quoting where you saw this ad. That gets you LITERATURE and YOUR FREE TERMINAL PROGRAM (not just a demo - it really works!) If you're in a hurry, phone and speak to Debbie, Emma, Chris or Nigel. Some formalities are necessary, but we will waste no time in getting the goods to you. Tomorrow morning is quite possible.



Lombard House, Cornwall Rd,
 DORCHESTER, Dorset DT1 1RX,
 Phone 0305-268066
 Fax 0305-264997 Telex 418442
 Bulletin Board 0305 251786
 300/1200/2400,N.8,1 (24hr)

CONTENTS

FEATURES

RFI, LOGIC AND BOARD DESIGN10

Peter Turner analyses three logic families for RFI emission by comparison on a standard layout.

SOLID STATE AUDIO POWER16

John Linsley Hood considers gain stages, power supplies and the vexed question of test parameters.

SPECIAL FEATURE CONSUMER ELECTRONICS.....33

THE GREAT VIDEO RACE.....33

Thirteen years on with JVC and Sony still locked in a standards battle for home video. Barry Fox reports.

SURROUNDED BY SOUND.....35

Multi-channel sound tracks recorded for the big title feature films are finding their way into the home.

INSIDE TRACK TO DOLBY S.....45

The latest noise reduction system from Dolby pushes the performance of the analogue audio cassette medium into the realm of CD.

UP IN THE AIR.....47

Events of the previous year have not clarified the muddle within satellite television broadcasting.

SILICON LIFESTYLE51

Consumer electronics could replace military applications as the technology driver for semiconductor technology. Leon Clifford reports.

JAPAN ON SHOW53

The Japan Electronics show provides the world's fashion indicator for consumer electronics. Peter Wall rides the latest wave of high tech non-essentials.

STANDARD HDTV?54

Most unlikely, says Geoff Lewis. Japan and the USA may go in several directions at once but, wherever they eventually end up, it won't be the same place as Europe.

HEARING IS BELIEVING?57

The hi-fi business seems particularly vulnerable to fraudsters, charlatans and pre-owned car salesmen. The equipment reviewers are particularly susceptible to this kind of nonsense says Barry Fox.

INERTIA'S RIDDLE60

Inertia has been misunderstood ever since the time of Galileo says Dr Peter Graneau.

REVIEW - PC BASED SPECTRUM ANALYSER..... 71

Mike Tooley reviews a new PC based card + software package which converts a PC into a storage oscilloscope and spectrum analyser.

In next month's issue. The Establishment firmly maintains that non-ionizing radiation has no pathological consequences beyond those attributed to the heating effect arising at high intensities.

Most researchers now disagree. Almost every serious study - including biochemical experiments conducted on living tissue - indicates that non-ionising fields have a significant and occasionally profound effect at levels much lower than we previously thought of as safe. The stray magnetic field from the scanning coils in the VDU which you may be sitting in front of are almost certainly breaking out calcium ions from the cell membranes of your brain (W Ross Adey *et al*). This contrasts with the popular notion that VDUs cause damage by X-radiation.

We feel that people should be allowed to make up their own minds. The February issue will bring together the available evidence.



REGULARS

COMMENT 3

Killing fields. From the VDU which you may be sitting in front of.

RESEARCH NOTES 5

Chess robotics, the dangers of low level microwaves, two cheers for Phobos and RF for ozone protection.

PIONEERS 12

Karl Ferdinand Braun, father of the oscilloscope, never patented his invention. He wished it to be freely available for the benefit of all researchers.

UPDATE23

News from around the industry and Comconic 89.

CIRCUIT IDEAS.....28

Control systems simulator, wideband VCO and a medical freezer alarm are included in this month's circuit suggestions.

LETTERS..... 64

Elf reception, nonsense, crossed field antennas, laser vibration measurement and cyclic redundancy checks are fed back.

APPLICATIONS..... 76

Low cost DFM, compact telephone, high voltage Schottky and LED smoke detection.

RF CONNECTIONS.....78

Speaking in digits and stabilising LC oscillators.

PROFESSIONAL LOGIC ANALYSIS FOR UNDER £400

In recent years, the personal computer has become an integral part of the modern electronics laboratory. The Logic Analyser is now as necessary to design, development, test and maintenance departments as a multimeter or an oscilloscope.

Flight Electronics' range of PC based Logic Analysers offers the advantages of low cost and high specification while saving the bench space normally occupied by stand alone alternatives.

Being PC based allows great flexibility in permanent storage of data and set ups, either to disk for recall at a later date, or for hard copy.

The Flight Electronics range of Logic Analyser cards has internal clock speeds of up to 200MHz and are suitable for use with XT, AT, monochrome and colour PCs.

Data acquisition can be displayed in both timing and state formats. Presentation of information is clear and uncluttered. The soft key controls mean simplicity of operation, making the products particularly suitable for both industrial and educational use.

Flight Electronics offers a choice of five models, ranging from a unit suitable for the first time student user to the complex requirements of the design and development laboratory.

We also supply a range of PAL/EPROM programmers for your PC. Call our sales office for a free copy of the Flight Electronics catalogue.

FEATURES

- Wide choice of specifications
- High specification at low cost
- Up to 200MHz internal clock
- Up to 3 independent clocks with 12 qualifiers
- 24 signal input channels
- Up to 16K memory depth
- 16 level sequential triggering (models 27200 & 27100)
- Pre and post triggering
- State listing in Binary, Hex and ASCII
- Timing display of all channels simultaneously
- User specified channel labelling
- Auto and conditional repeat
- Data save to and load from disc

NEW
from **£399**

We can even supply suitable PCs. Call our sales office for a quote.



Model	Frequency	Channel	Memory	Impedance	Threshold Voltage	External Clock	Trigger	Qualify	Max Input	Max Input Bandwidth
CLK-27200	200MHz 250Hz to 50MHz	Channel 0-5 Channel 0-23	16K 4K	1M Ω ≤ 5 pF	2 Independent settings -8 to 14V	3 Channels 0-50MHz	16 Levels "0", "1", "x"	12 Channels "0", "1", "x"	= 150V	100MHz
CLK-27100	250Hz to 100MHz 250Hz to 50MHz	Channel 0-5 Channel 0-23	16K 4K	1M Ω ≤ 5 pF	2 Independent settings -8 to 14V	3 Channels 0-50MHz	16 Levels "0", "1", "x"	12 Channels "0", "1", "x"	= 150V	100MHz
CLK-2400	100MHz 25KHz to 25MHz	Channel 0-5 Channel 0-23	4K 1K	12K Ω ≤ 15 pF	1 Setting -10V to 10V	1 Channels 0-25MHz	1 Level "0", "1", "x" 100MHz "0", "1" only	1 Channel "1"	= 25V	25MHz
CLK-12100	100MHz 25KHz to 50MHz	Channel 0-11 Channel 0-23	2K 1K	1M Ω ≤ 5 pF	TTL	0-50MHz	1 Level "0", "1", "x"	NO	= 10V	50MHz
CLK-2450	25KHz to 50MHz	Channel 0-23	1K	1M Ω	TTL	0-50MHz	1 Level "0", "1", "x"	NO	= 10V	50MHz



Flight Electronics Ltd.
Flight House, Ascupart Street
Southampton SO1 1LU, U.K.
Telephone: Southampton
(0703) 227721 (6 lines)
Telex: 477389 FLIGHT G
Fax: (0703) 330039

ORDERING INFORMATION (Excl. VAT. P&P £7.00)

Description	Part No	Price £
CLK-2450 PC Logic Analyser	655-001	399.00
CLK-12100 PC Logic Analyser	655-002	499.00
CLK-2400 PC Logic Analyser	655-003	799.00
CLK-27100 PC Logic Analyser	655-004	999.00
CLK-27200 PC Logic Analyser	655-005	1599.00

CALL US NOW ON 0703-227721

CIRCLE NO. 134 ON REPLY CARD

Killing fields

CONSULTING EDITOR

Philip Darrington
01-661 8632

EDITOR

Frank Ogden
01-661 3128

ILLUSTRATION

Roger Goodman

DESIGN & PRODUCTION

Alan Kerr

EDITORIAL ADMINISTRATION

Lindsay Gardner
01-661 3614

ADVERTISEMENT MANAGER

Paul Kitchen
01-661 3130

DISPLAY SALES MANAGER

Shona Finnie
01-661 8640

ADVERTISING PRODUCTION

Una Russ
01-661 8649

PUBLISHER

Susan Downey
01-661 8452

FACSIMILE

01-661 8939



Electronics World + Wireless World is published monthly (USPS 687540). By post, current issue £2.25. Back issues (if available) £2.80. Order and payments to 301 *Electronics and Wireless World*, Quadrant House, The Quadrant, Sutton, Surrey SM2 7AS. Cheques should be payable to Reed Business Publishing Ltd. Editorial & Advertising offices: 110W, Quadrant House, The Quadrant, Sutton, Surrey SM2 7AS. **Telephones:** Editorial 01 661 3611, Advertising 01 661 3130, 01 661 8469. **Telex:** 892084 REED BP G (E L P). **Facsimile:** 01 661 8939 (Groups II & III). **Beeline:** 01 661 8975 or 01 661 8986. 300 baud, 7 data bits, even parity, one stop bit. Send all DJ, then FAX, to start. **ANSIS** to sign off. **Newstrade:** Quadrant Publishing Services, No. 01-661 3301. **Subscription rates:** 1 year (normal rate) £30 UK and £35 outside UK. **Subscriptions:** Quadrant Subscription Services, Oakfield House, Perry Mount Road, Haywards Heath, Sussex RH16 3DH. Telephone 0444 441212. Please notify a change of address. **USA:** \$16.00/annual. Reed Business Publishing (USA), Subscriptions Office, 301 E. 42nd Street, NY, 10017. **Overseas advertising agents:** France and Belgium: Pierre Müssard, 18-20 Place de la Madeleine, Paris 75008. **United States of America:** Jay Feinman, Reed Business Publishing Ltd, 301 E. 42nd Street, New York, NY 10017. Telephone (212) 867 2080. Telex 23827. **USA mailing agents:** Mercury Airfreight International Ltd, Inc, 100 Byrnedale Ave., Avenel, NJ 07001. 2nd class postage paid at Rahway, NJ. Postmaster: send address to the above.

©Reed Business Publishing Ltd 1989. ISSN 0266-3744

In the spring of 1974, a 47 year old experimental psychologist, Dr Nancy Wertheimer, began spending a couple of days each week driving through the residential suburbs of Denver, Colorado. Occasionally she would stop the car at one of the addresses on her list, get out and start making notes on what she found. Which was rarely, if ever, anything out of the ordinary.

The list from which Dr Wertheimer drew her itinerary comprised the home addresses at birth of every child in the Greater Denver area who had died of leukemia between the years 1950 and 1969. Dr Wertheimer was an epidemiologist looking for environmental links to this predominantly childhood cancer.

The addresses on the list were unremarkable, not revealing clusters of anything in particular at first. After a while, she did begin to notice pole mounted transformers, the last leg of the local power distribution system, taking the 7600 volts area feed down to 115 volts for the house feeds. The associated wiring straggle, so common to the rooflines of American towns and cities, also began to leap out at her, along with the cylindrical transformers. More addresses brought more pole mounted transformers and heavy service feed wiring stitched from pole to pole.

But there could be nothing out of the ordinary here, she decided, having consulted with her physicist friend, Ed Leeper. Leeper agreed that, while all houses carry AC mains, stray magnetic fields from the steel clad transformers dwindle to nothing after a few feet.

Being open minded people, the two decided to check stray magnetic powerline fields for certain elimination. The physicist built the psychologist a simple inductive loop detector coupled to a sensitive amplifier. So armed, Dr Wertheimer revisited some of the addresses on the list. The device hummed loudly when located at the base of a transformer pole, just as expected. More surprisingly, it continued to hum loudly when the psychologist walked away from the pole, along the block, under the wires. The hum only reduced after several service drops to nearby houses.

Dr Wertheimer repeated the observation at other addresses from the childhood leukemia list. She also noted on further examination that leukemia excesses tended to occur in clusters along the wiring span between transformer poles and up to their third service drop: this corresponded to the highest current levels flowing in the line associated with the greatest low frequency AC line fields.

Such were the origins of suspicion that power lines can kill in more ways than by simple electrocution. Given this clue, other epidemiologists studied further disease clusters, returning similar findings. For instance, an analysis of US radio amateur deaths determined a myeloid leukemia excess of three times, presumably because radio amateurs expose themselves to low frequency electric fields, either occupationally, or in pursuit of their hobby.

Some 17 death surveys of electrical and electronic workers had been undertaken by 1986. Fifteen of them demonstrated a possible link between electric/magnetic fields and the development of cancer.

You won't find many champions for the hypothesis among governments and utilities; the official reticence is disturbing. The Establishment firmly maintains that non-ionizing radiation has no pathological consequences beyond those attributed to heating effect arising at high intensities.

Most researchers now disagree.

Almost every serious study – including biochemical experiments conducted on living tissue – indicates that non-ionizing fields have a significant and occasionally profound effect at levels much lower than we previously thought of as safe. The stray magnetic field from the scanning coils in the VDU which you may be sitting in front of are almost certainly breaking out calcium ions from the cell membranes of your brain (W. Ross Adey *et al*). This contrasts with the popular notion that VDUs cause damage by X-radiation.

We feel that people should be allowed to make up their own minds. With this in view the February issue of *Electronics World + Wireless World* will bring together the available evidence: epidemiological, biophysical, old and new. You may then decide for yourself.

Frank Ogden

Low Cost RS-232 Analysis

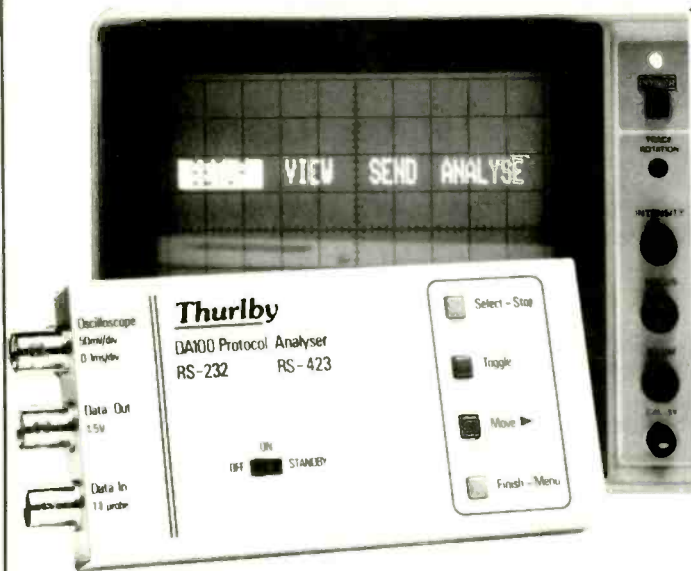

Serial Data Protocol Analyser £79 plus vat

The Thurlby DA100 is a very low cost protocol analyser for problem solving on asynchronous serial data systems, particularly RS-232.

It provides baud rate analysis, data word format analysis, data monitoring (ASCII or Hex), triggered data capturing, and test data generation.

The DA100 uses an oscilloscope as its display device. It connects to any standard 'scope via a single cable and displays 32 characters of text. Alternatively an optional LCD display unit can be fitted. An optional RS-232 breakout-box is also available.

Contact us now for full technical details.

Thurlby

Thurlby-Thander Ltd., Glebe Road, Huntingdon,
Cambs. PE18 7DX
Fax: 0480 450409 Tel: 0480 412451

CIRCLE NO. 104 ON REPLY CARD

METEX & TEST LAB INSTRUMENTS YOU PAY TRADE PRICES!

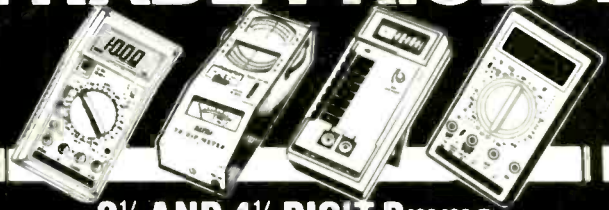

3 1/2 AND 4 1/2 DIGIT Dmms

ALL WITH CONTINUITY TEST (★ With Capacitance + With Hfe ○ With Freq.)

PRO SERIES METEX

3 1/2 & 4 1/2 DIGIT
All With Case. 20A AC/DC
17mm Display (3800 12mm)
3800 32 Range 0.5% (-) £31.50
3610 30 Range 0.3% (-) £39.53
3630 30 Range 0.3% (+) £47.57
3650 30 Range 0.3% (+/-) £52.93
3650B as 3650 with Bargraph £58.96
4630 4 1/2 Digit 30 Range Data Hold 0.05% (+/-) £71.00
4650 as 4630 Plus 2 Freq. Ranges £76.38

STANDARD SERIES

3 1/2 DIGIT 12 mm DISPLAYS
2315B 17 Range 10 ADC £20.00
2318B 23 Range 10ADC (-) £23.72
2335 31 Range 10A AC/DC (-) £22.74
2325 32 Range 10A AC/DC (+/-) £30.42
2355 32 Range 10A AC/DC (+/-) £34.57
2365 38 Range 10A AC/DC (+/-) £37.25
Plus Logic Probe

METEX AUTORANGE

3 1/2 DIGIT With Datahold & Freq Counter
M80 21mm display £50.92
M818 17mm display, true RMS £56.28
M818b with bargraph £64.32

TEST INSTRUMENTS

3000 LCR AC Bridge	£102.30	TE220 1 MHz Audio Generator	£81.75
M3002A AC Millivolt Meter 1MHZ	£85.80	3300 Autorange Digital Cap. Meter	£64.00
2020 500 KHZ Function Generator	£96.50	6100 Signal Tracer/Injector	£52.30
4162AD 150 MHZ Fr Gen. Plus 6 Digit Counter	£172.86	5250 150 MHZ 7 Digit Frequency Counter	£64.50
2603AD 1 MHz Af Gen. plus 6 Digit Counter	£166.16	DST5M 5 MHz Bench Scope	£168.00
TE200 150 MHZ Rt Gen. (350 MHZ Harmonic)	£80.00	243 0/24V 0/3A Variable PSU	£56.00
		245 0/24V 0/5A Variable PSU	£69.55
		154 4/15V 0/4A Variable PSU	£40.00

"POCKET" TEST INSTRUMENTS

YF20 Dual Scale Sound Level Meter 120dB	£32.85	3900TD LCD Dmm With Dwell And Tach Ranges	£49.58
225V VHS Video Head Tester	£30.69	KT50 LCD 8 Range Capacitance Meter	£36.20
1065 Digital Lux Meter - 3 Ranges	£46.83	8060 LCD Digital True Power Meter 6KW 19	£64.00
07 Logic Probe	£7.63	2070 19 Range Multimeter 10ADC + Buzz	£12.00
M625 Logic Probe/Pulsar	£14.74	2030ET 27 Range 10A AC/DC. Cap. Hfe Temp. Buzz	£35.30
300 AC Clamp Meter 600A/300V/Resis	£33.50	S050E 41 Range FET mm	£26.77
M265 Add on AC Clamp Probe for Dmm's	£16.48	DMS Wallet Autorange Dmm	£17.35
501 Electronic Insulation Tester 500V	£53.25	921 Pen Type Autorange Dmm	£24.78
504 Electronic Insulation Tester 1000V	£70.88	850 Mains Phase Tester	£21.20
K0M6 TR Dip Meter 1.5 to 250 MHZ	£41.88	260 1000A AC Digital clamp meter	£40.25
1062 LCD Temperature & data hold	£36.72	261 Add on Insulation tester for 260	£29.35
302K LCD Temperature Two 1/P	£32.00		

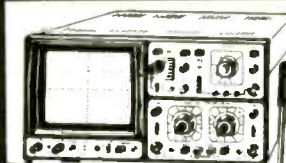

AUDIO-ELECTRONICS ARE ALSO INSTRUMENT DISTRIBUTORS FOR HAMEG • FLIGHT • BLACKSTAR • ALTAI • THURLBY • THANDAR • CROTECH • LEADER AND HITACHI PHONE FOR BEST PRICES.

(Prices correct at 17.10.89)
TELEPHONE YOUR ORDER WITH VISA/ACCESS
OPEN 6 DAYS A WEEK FOR CALLERS

ADD 15% VAT
(UK ONLY)

AUDIO ELECTRONICS

301 Edgware Road, London W2 1BN
Tel: 01-724 3564 Fax: 01-724 0322
Sales office 01-258 1831

TRADE/EDUCATION ORDERS ACCEPTED.
EDUCATION AND QUANTITY PRICES AVAILABLE

INSTRUMENT CATALOGUE WITH DISCOUNT VOUCHERS
Send A4 SAE
£1.00 stamp UK
or £2.00 stamp for full catalogue.

CIRCLE NO. 139 ON REPLY CARD

Man versus machine

Ever since the 1930s, when Alan Turing described his universal calculating machine, scientists and others have been predicting the eventual arrival of a computer with human-type consciousness. Partly, of course, this stems from a fear that such machines, like aberrant genetically-engineered creatures, would subjugate and enslave their creators. On a less emotive level it's not unreasonable to conclude that today's increasingly intelligent machines will one day outperform our frequently illogical and befuddled brains. Certainly the view popular among artificial intelligence researchers today is that machines will eventually be developed that (who?) think in a way qualitatively indistinguishable from human thought.

Whether or not that will happen is a question so overlaid with philosophical and moral overtones that no instant appraisal would do more than invite opinionated correspondence. What could be emerging, however, is a hint that conscious and intuitive machines will need operating systems very different from those in use today.

One hint of this comes from a much-publicized chess match staged in New York at the end of October. Gary Kasparov, the reigning world champion (human), took on Deep Thought, the reigning world champion (machine) and won. The crowds (human) raised a cheer for their compatriot and the issue seemed settled; man had triumphed over machine. The press were jubilant in their revelations that the computer had stubbornly gone on playing when any fool could see the outcome.

The point they surely missed (though Kasparov, to his credit, didn't) was that, given enough processing power, a machine will eventually be able to play chess better than any human. Kasparov expects to be beaten when Carnegie-Mellon University scientists introduce Deep Thought II some time in 1994. He's philosophical though because, unlike the crowds who affirmed human supremacy by cheering him to victory in October, Kasparov doesn't see eventual defeat as signalling the demise of human intelligence.

For one thing, although the Russian champion may not have been aware of it, he was using his mental processing powers much more efficiently than Deep Thought. No human chess player

would ever waste time calculating 760,000 options before making a move! So even if he had lost the latest game, his whole approach would have been infinitely more intelligent than the brute-force algorithms of the computer.

To be fair to the inventors of Deep Thought, their approach wasn't entirely that of a number-crunching tour de force. Chess represents an interesting intellectual challenge which is too complex to be cracked simply by brute force. Someone with a better number cruncher than mine calculated that a brute-force algorithm to trace out a decision tree for all possible games would need to perform sums more numerous than all the atoms in the universe.

Chess programs therefore have to

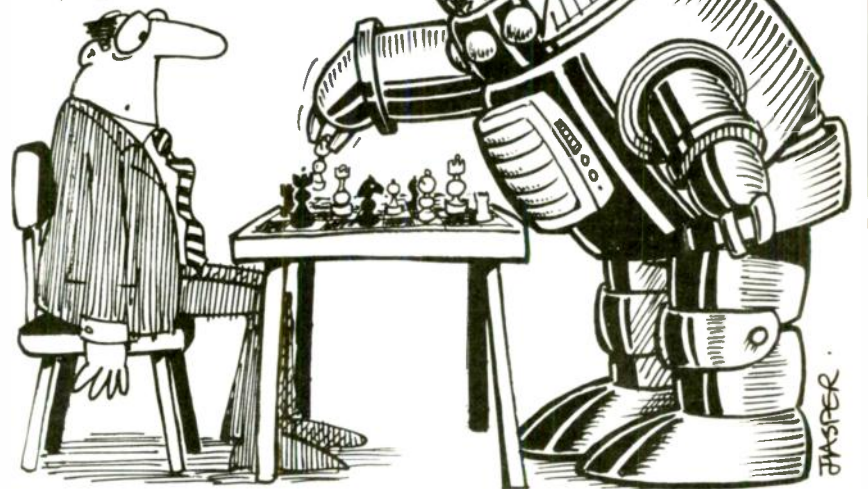

take short cuts or introduce some measure of chance or randomness if they are to achieve anything at all. That, of course, is also why they can sometimes be beaten by players such as Kasparov.

Chance isn't, however, a weakness. In chess programs as in human behaviour it's a necessary ingredient. Randomness in a perverse sort of way can actually be a catalyst for creating order and progress. Without it we'd still be sitting in our caves doggedly doing the billions of calculations necessary to decide the desirability of lighting a fire or even of procreating . . . which leads to my second bit of tentative evidence that there's more to life than even the most complex logic. It comes in the form of a newly-published book *The Emperor's New Mind* by Roger Penrose (OUP).

Among other things, Penrose questions the popular view that all nature

can be expressed in terms of mathematical rules which in turn can be run on a computer. He argues that some truths – even those that are theoretically computable – are beyond a practical solution, at least by conventional logic. The example of a chess game, as we saw earlier, represents more or less the practical limits of today's machines . . . which seems to imply that we'll never have computer systems that can do

better than tell us what to do with our king's pawn.

As I suggested earlier, the real breakthrough may eventually come with radically new operating systems. Penrose hints that progress towards consciously intelligent machines may lie in a new generation of quantum computers working in the mystery world of particles that don't seem to obey the rules of everyday commonsense. It's all very futuristic and thought-provoking and perhaps also a challenge to our traditional mechanistic and reductionist thinking. For me, however, it's a pleasant reminder (chess games notwithstanding) that we're more than just a collection of advanced neural networks. How else could a bowl of cold porridge (as Alan Turing put it) compose symphonies and perceive the beauty of truth?

NOW YOU CAN LEARN ABOUT THE TRANSPUTER...

The most powerful microprocessor in the world using concurrent processing.



■ State of the art technology!

With major computer companies "designing-in" the Transputer, it is imperative that today's technology does not remain a mystery.

In short, the Transputer Training System gives you a unique low-cost method of obtaining practical experience – fast!

■ Saves your time

Unpack, plug in and start learning. Everything you need including self teach manuals in one package.

■ Saves your money

The complete system costs just £995.00 + VAT and uses any IBM Compatible PC with 640K RAM and hard disk as the host computer.

■ Now with 1/2 price course option

Attend our special 3 day course for just £200 extra if order with the system. Normal price of course is £400.

The unique Transputer Training System has been designed specifically for education and is therefore ideal for use in colleges and universities. The excellent self-teach manuals, included with the package, mean that it can also be used by engineers to rapidly evaluate the transputer and utilise its amazing power in real time applications.

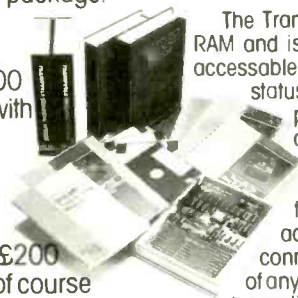

The system is supplied with everything you need including:

- **Interface card** – takes a 'short slot' in the PC and provides link in/out and control lines.
- **Cable** – links the interface card to the Transputer Module.
- **Transputer Module** – complete T414 based subsystem, supplied in its own sturdy case.
- **Power supply** – independent power to transputer if required.
- **Development Software** – folding editor, OCCAM compiler, downloader, terminal emulator and utilities, hosted on the PC.
- **Example programs** – no less than 28 fully worked examples.
- **On Screen Tutorials** – learn how to use the system 'on-screen'.
- **Hardware Manual** – full circuit diagrams, timing diagrams and circuit descriptions.
- **TDS User Guide** – self contained tutorial guide to using the development software.
- **TDS User Manual** – the reference manual for the development software.
- **Introduction to OCCAM** – a complete self-teach course in OCCAM.
- **OCCAM Programming Manual** – the definitive guide to OCCAM.
- **T414 Engineering Data** – full specifications for the Transputer.
- **C012 Engineering Data** – full specifications for the Link Adapter.

The Transputer Module houses a 15 MHz T414 with 256K RAM and is external to the PC, so that the hardware is fully accessible. The module includes a wealth of test points, 14 status LEDs, 16 I/O lines, EVENT input, independent power supply, prototyping area and four 15 way D connectors, which allow access to the 10 M bits/sec links and control signals.

Full hardware and software support is provided for multi-transputer applications. Simply plug additional Transputer Modules into the spare link connectors using the cables supplied. In this way networks of any configuration using any number of transputers may be realised! Each module can run one or more concurrent processes and has access to its own local 1/4 Mb RAM and I/O system.

The I/O connector links directly to our Applications Board, which enables the Transputer to control DC motor speed, temperature, analog input/output, and much more!

CIRCLE NO. 117 ON REPLY CARD

FLIGHT ELECTRONICS LTD.

Flight House, Ascupart St, Southampton, SO1 1LU.
Telex: 477389 FLIGHT G Fax: 0703 330039

Call 0703 227721 today
for a free full colour
catalogue.

**AVAILABLE NOW
FROM STOCK!**

Ultimate truth in three flavours

After years of intense rivalry, the Stanford Linear Collider (SLC) in California and the recently-opened CERN Large Electron Positron facility (LEP) near Geneva are now producing significant numbers of so-called Z-particles. These are formed when electrons and their oppositely charged counterparts crash head-on and destroy themselves in a blaze of energy.

SLC did much of the pioneering work, including estimates of the mass of the Z; LEP has the clear lead though in terms of the number of particles it can produce in its 27km circular tunnel.

What is now exciting physicists is not the sheer number of recorded subatomic collisions but the figures now emerging for the average lifetime of the Z-particle. Measurements taken from around 11,000 observed collisions show it can exist for around 10^{-25} s. This short lifetime is good news for physicists because it places finite limits on the number of even smaller particles into which it can decay.

Measurements of the energy spectrum of the observed Z-particle suggest that all matter is comprised of three, and only three, families of fundamental particles. Everyday matter is the first family, comprising electrons, neutrinos, 'up' and 'down' quarks. Then there's a family including muons (heavy, short-lived electrons), 'strange' and 'charmed' quarks. Finally there's a group consisting of tauons, 'bottom' and 'top' quarks.

Convenient though this finding is for standard models of particle theory, it doesn't explain why there are only three families. Burton Richter, director of SLC, regards it as a complete mystery why God chose three rather than one, nine or even forty-seven.

One must be thankful He did; more particles would lead to untidy complexities, while fewer would lead to a Universe containing substantial amounts of anti-matter – violent and uncomfortable!

New study into low-level microwave radiation

Can long-term exposure to low-level microwave radiation from sources like air traffic control radars cause cancer in humans? And if cancers begin through other causes, can exposure to microwave radiation accelerate their growth?

Researchers from the US Air Force School of Aerospace Medicine and the Georgia Institute of Technology hope to find answers over a period of 18 months as they complete one of the largest studies ever conducted of long-term exposure to low-level microwave radiation. The work could help establish standards for safe human exposure to radiation of all kinds, but particularly the upper radio frequencies that are becoming increasingly widespread in the environment. The US Air Force in particular wants to be certain that people exposed for long periods to low-level electromagnetic radiation from its radar installations are not adversely affected.

In February, Georgia Tech began exposing a population of 200 mice to low-level, pulsed, microwave radiation. Over the next 18 months, the animals – a cancer-prone strain commonly used in research – will be carefully studied and compared to a control group of equal size that are maintained under identical conditions. Jim Toler, co-director of the Tech's Bioengineering Centre, will be looking at whether the microwave environment in any way either triggers development of abnormal cells or promotes the growth of abnormal cells once the development of such cells has been triggered by other processes.

The mice will be exposed to a level of microwaves similar to that encountered by persons working around radar installations or living nearby. The levels are within accepted standards for human exposure and the frequency – 435MHz – has been chosen because it is a military radar frequency and because few biological experiments have been conducted in this part of the spectrum.

The effects of electromagnetic radiation on biological systems depend on four variables: the frequency of emissions, the type of pulse used, the energy

level and the exposure time. For that reason, the results will not necessarily apply directly to other types of electromagnetic energy, since the coupling of



Georgia Tech's microwave exposure facility, testing animals' susceptibility to radiation

radiation to a biological system is highly dependent on frequency.

The study uses Georgia Tech's microwave exposure facility, one of the only two in the United States equipped to study long-term exposure on large populations of animals, and follows earlier research into the levels of stress which might be created by microwave fields. That study, reported in the *Journal of Microwave Power and Electromagnetic Energy* [vol. 23, no 2, 1988] found no increase in levels of stress-sensitive blood hormones within a population of 100 mice.

MICROWAVE



CIRCLE NO. 144 ON REPLY CARD

MONITORS



CIRCLE NO. 145 ON REPLY CARD

ANALYZERS

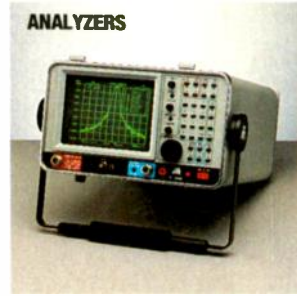

CIRCLE NO. 146 ON REPLY CARD

ANTENNAS



CIRCLE NO. 147 ON REPLY CARD

OSCILLOSCOPES



CIRCLE NO. 148 ON REPLY CARD

AUDIO

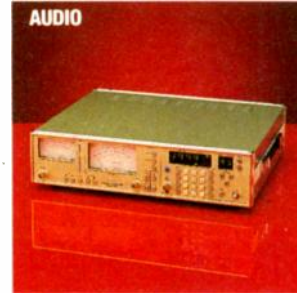

CIRCLE NO. 149 ON REPLY CARD

RF POWER

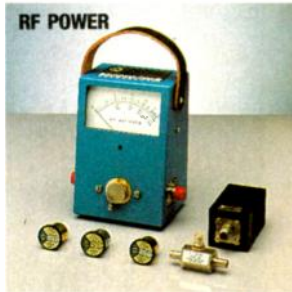

CIRCLE NO. 150 ON REPLY CARD

DSO'S



CIRCLE NO. 151 ON REPLY CARD

COUNTERS

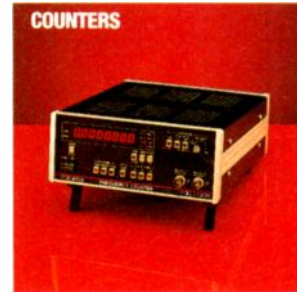

CIRCLE NO. 152 ON REPLY CARD

Fieldtech

TEST & MEASUREMENT

Fieldtech is one of the UK's leading suppliers of high quality test and measurement equipment. Now in its 25th year, Fieldtech continues to grow by providing a problem solving approach that ensures customers keep coming back. To find out how we can help you contact one of our applications engineers today. Fieldtech is a member of Hunting Plc.

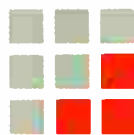

Fieldtech

CIRCLE NO. 153 ON REPLY CARD

Fieldtech Heathrow Limited, Huntavia House, 420 Bath Road, Longford, West Drayton, Middlesex UB7 0LL, England. Tel: 01 897 6446 Fax: (Gil/III) 01 759 3740. Telex: 23734 FLDTEC G



Two cheers for Phobos

We all (mea culpa) assumed that the premature demise of the two Russian Phobos probes would result in little or no new scientific data from Mars and its two moons. Yet in spite of failing to take the hoped-for close-up pictures, Phobos-2 did in fact orbit the planet about a hundred times before being lost forever as the result of an onboard computer malfunction.

Perhaps because of the danger of being eclipsed by the outstanding success of the US Voyager-2 spaceprobe, the Russians have only now published full details of this their most recent interplanetary mission (*Nature* vol. 341 no 6243). Far from being a total failure, Phobos-2 has sent back some pictures

and field measurements that have been hailed as spectacular.

Before contact was lost, Phobos-2 sent back 37 pictures of the potato-shaped moon Phobos against a background of Mars. These were taken with three CCD cameras with different focal length lenses and different spectral sensitivities. Video processing was done by a 1.5Gbit computer system developed jointly by Bulgaria, East Germany and the USSR. Further analysis of the videospectrometric (*sic*) data is now in hand to produce a detailed three-dimensional model of Phobos and to gain more insight into the strange craters and grooves on its surface.

All in all, fifteen papers are pub-

lished, covering optical imaging, thermal and gamma ray imaging, analysis of Martian rocks and atmospheric studies. From an engineering viewpoint, however, perhaps the most interesting Soviet discoveries have been those concerning the electric and magnetic environment of Mars.

Unlike the Earth whose strong magnetic field deflects away the solar wind (a stream of charged particles flowing out from the Sun), Mars has little to protect it from this constant bombardment. The solar wind therefore interacts with the Martian ionosphere and the gaseous ions that comprise it. The dynamic pressure is so strong that it squeezes this ionospheric plasma around the planet, tearing it away on the 'downwind' side away from the Sun. This tailwind escape of the Martian upper atmosphere has been estimated by one of the research teams to be around 1-2kg/s. It may not seem much, but at this rate the whole Martian atmosphere would disappear within 10⁹y. There is probably some small

Radio waves to protect the ozone?

Research at the University of California, Los Angeles and Clemson University, South Carolina has led to an intriguing possibility for protecting the Earth's ozone layer, which is currently being destroyed by aerosol propellants.

Alfred Wong *et al* (comments *Plasma Phys. Controlled Fusion*, 1989 vol. 12 no 5) base their ideas on the fact that ozone is destroyed by neutral chlorine atoms released when chlorofluorocarbons (CFCs) are broken down chemically by the action of the Sun's UV radiation. One chlorine atom is believed to be capable of catalyzing the decomposition of around 10⁵ ozone molecules.

Wong believes that such chlorine atoms could be rendered harmless to the ozone by giving them a negative charge and converting them into chloride ions. Chloride ions react only weakly with ozone molecules, which have a strong electron affinity and therefore tend to be electrostatically repelled.

What is interesting about Wong's proposal is the means he suggests for ionizing the chlorine atoms. If a high power beam of HF radio energy could be directed up at the ionosphere, then electron heating would occur, leading to ionization of this neutral chlorine. Experiments are now planned in which radio beams at a frequency of 1.5MHz and powers of several hundred mega-

watts will be blasted upwards to interact with electrons at heights of 50-80km.

Initially, the idea will be just to monitor the effectiveness of ionization and also the extent to which the ions can be distributed beyond the immediate confines of the radio beam, thus spreading their beneficial effects. As a long-term solution to our ozone-damaging activities, Wong acknowledges that radio beams would be far too expensive. Indeed, if a few hundred megawatts were all that were needed, then today's commercial HF traffic would have put the ozone layer to rights long ago.

Nevertheless, if this pilot study supports the theory, then alternative ways could be considered for ionizing the chlorine. One idea Wong proposes is to place a large metal screen in orbit to trap the Sun's energy and release huge numbers of electrons as a result. Photoelectric emission on the grand scale!

All this may seem a massive flight of fancy until you realize that no-one has yet come up with a better way of putting a quick end to the destruction of the ozone layer. If unchecked, this destruction is likely to continue for decades to come. More knowledge about atmospheric dynamics may, one hopes, render Wong's suggestion unnecessary, but until it does there's a lot to be said for keeping this seemingly crazy idea in reserve.

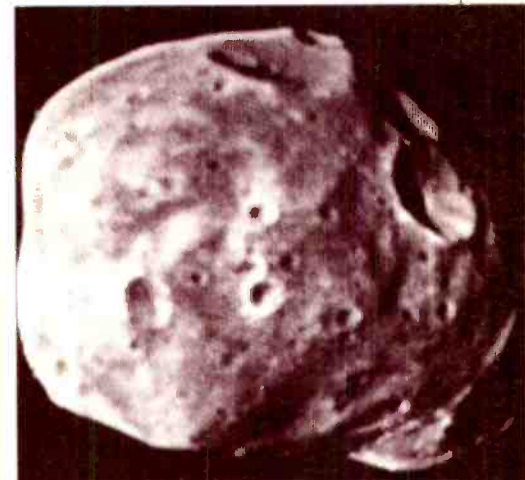

Phobos seen from the Russian Phobos-2 probe, the picture being taken by a CCD camera. Reprinted by permission from Nature, vol. 341, p.586 C. MacMillan Magazines Ltd.

degree of replenishment from surface rocks, but the present tenuous atmosphere does indicate what might have happened to the Earth but for our magnetic field – yet another example of the intriguingly delicate balance necessary for life to evolve.

Research Notes are by John Wilson of the BBC World Service science unit.

In the October 1988 issue of *EW*, I described a circuit developed at the University of York to demonstrate some of the basic concepts of waveforms in the frequency domain, as well as touching on some of the problems of electromagnetic compatibility (EMC) and radio-frequency interference (RFI). Since then, the demonstration has undergone several stages of development.

If you remember, I originally produced what could be regarded as a "typical" electronic circuit, paying little attention to the layout in the hope that it would radiate a good range of frequencies, which it did! Logically, the next step was to attempt a better design of the same circuit. At the university we have now produced a set of circuit boards which clearly illustrates the advantages, from an EMC point of view, of good circuit-board design.

Figure 1 shows a block diagram of the circuit, which was described in detail in October 1988.

Improving the layout

The original circuit board is 22×10 cm, giving a chip density of one per 18cm^2 . The tracks are long, analogue and digital grounds are mixed, there is minimum decoupling of the power lines and no ground plane – a thoroughly bad design.

To improve on this I made the board as small as I thought possible without making the layout too difficult and time consuming. The MkII circuit board (from exactly the same circuit diagram) is a mere 11×9 cm, giving a chip density of one per 8.25cm^2 . The tracks are shorter, which means they are not efficient radiators at 'problem' frequencies in the hundreds of megahertz range. In addition, each IC has a decoupling capacitor on each of its power-supply pins, sited close to the IC where possible. Also analogue and digital ground tracks are as widely separated as possible to stop the fast rising edges of the digital signals coupling to and corrupting the analogue signal – always good practice when analogue and digital signals are present on the same board.

The MkIII circuit board is identical to the MkII except that it has a ground plane to provide a short circuit for high-speed glitches and noise components due to capacitance between tracks on one side of the circuit board and the ground plane on the other – the circuit board material itself acts as the dielectric. Ground planes are a very effective method of reducing RFI from circuit boards, as we will see.

RFI and printed boards

Peter Turner illustrates the beneficial effect of intelligent board layout on the amount of interference generated

Performance

The performance of the three circuit boards was assessed on a 3m test site using a biconical aerial and an Anritsu MS2601A spectrum analyser. The aerial has a flat response over the band 30-300MHz.

Figure 2 shows the background radiation on the 3m test site, the peaks around 100MHz being national and local broadcast radio and those at around 150MHz either radio amateurs or the emergency services and public utilities.

In Figure 3, the spectrum of radiation from the poorly laid out MkI circuit board shows a considerable amount of radiation up to 300MHz. Some peaks at around 120MHz actually exceed the levels of broadcast radio! There was still significant radiation up to about 600MHz from this board.

Figure 4 is the MkII board; the large peak at 137.6MHz is the local water board telemetry signal. Apart from this, the radiation is very much reduced – say 10-15dB down on average.

The MkIII board (with ground plane is shown in Figure 5; it is very difficult to see any difference between this and the background reading of Figure 2 (apart from the water board).

In addition to investigating the three circuit boards described, I examined the

Good circuit board design will be more or less compulsory from the 1st January, 1992 – the proposed date for compliance with a directive on electromagnetic compatibility (EMC) being drawn up by the European Commission. The directive will lay down the maximum amount of electromagnetic radiation which electronic equipment will be allowed to radiate and manufacturers will have to provide a statement that their equipment complies with the objectives of the directive.

There is concern that many companies in this country will not be aware of the implications of the directive. Clearly, the design-test-modify cycle could become very costly if repeated too many times; it is therefore important that engineers and even undergraduates take the ideas of EMC to heart right at the start of the design process. In other words, it is far better to design a good circuit board than to design a bad one which will require enclosing in an expensive screened box to comply with the directive.

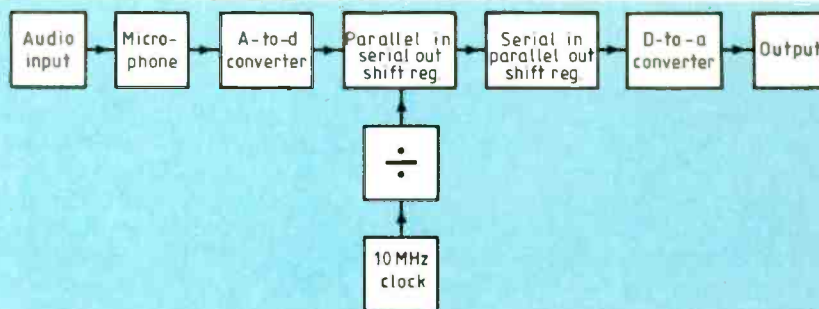

Fig. 1. Block diagram of circuit used for the tests. A full circuit diagram was given in February, 1989.

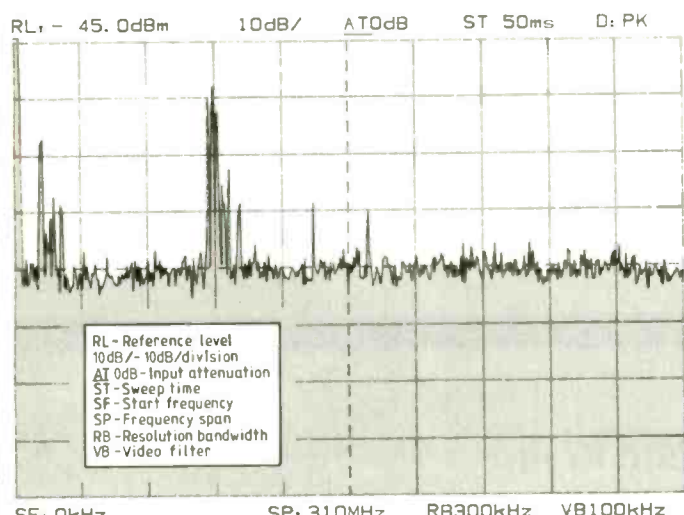

Fig. 2. Background radiation on the site. Largest peaks are broadcast radio. Crystal clock frequency is 10MHz.

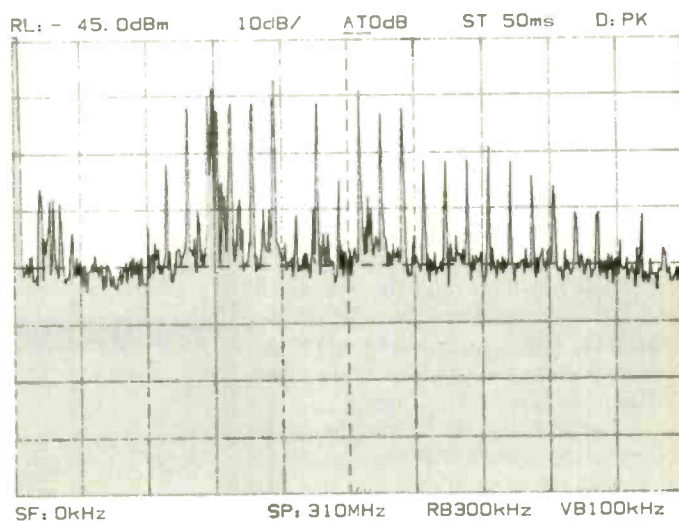

Fig. 3. Radiated spectrum from badly laid out MkI board. Peaks are visible up to 300MHz - mainly harmonics of the 10MHz crystal.

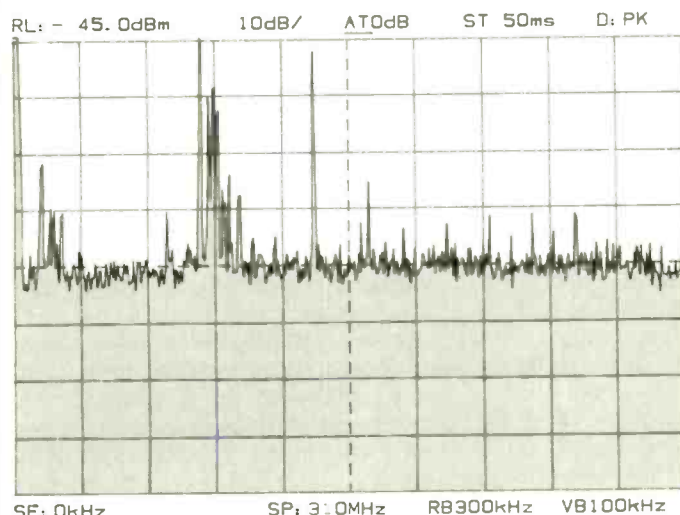

Fig. 4. Better laid out MkII board, showing reduced radiation. Peak at about 140MHz is water board telemetry.

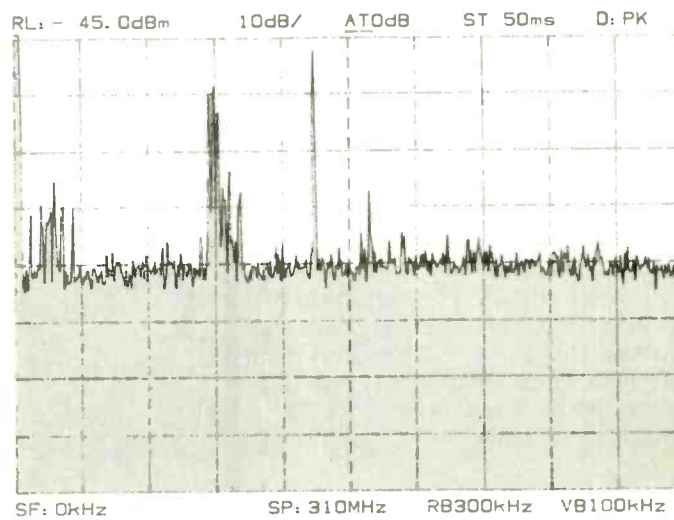

Fig. 5. MkII board with ground plane. Radiation reduced almost to background level.

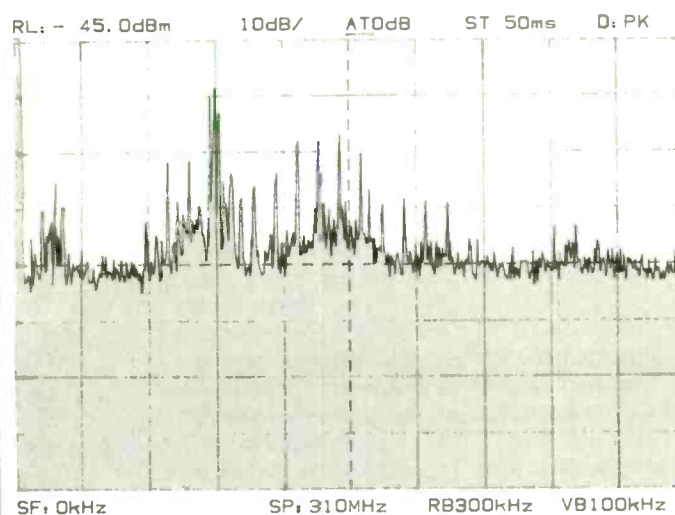

Fig. 6. Radiation from MkI board but with lower-speed and lower-power 74HCT logic devices.

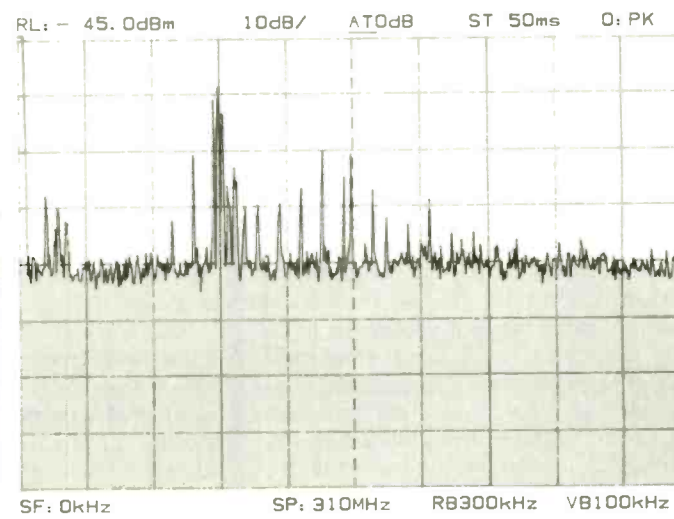

Fig. 7. MkI board with lower-speed 74LS devices.

RFI properties of the different 74-series logical families. I made two more boards in the MkI layout using 74HCT family and 74LS family chips, as opposed to the 74F series for the first three boards.

Figure 6 shows the emission from the 74HCT circuit board. There is still a good deal around the 120-200MHz region, but nowhere near the amount of the 74F series and not much at all over 200MHz. This is as expected due to the lower power and slightly slower performance of the 74HCT family.

In Figure 7, the 74LS board has some output in the 120-200MHz range associated with the poor layout, but this falls off more quickly than the 74HCT board due to the lower speed and hence more slowly rising edges of the 74LS family.

EC directive and BS6527

The details of the directive on EMC is still being thrashed out but, for guidance, we can look at BS6527: the British Standard specification for "Limits and methods of measurement of radio interference characteristics of information technology equipment". This is also a European standard EN55022 and, as such, will be quoted in the EC Directive.

BS6527 divides IT equipment into two classes. Class B equipment must fall within the limits of radiated field strength in the frequency range 30 - 1000MHz at a test distance of 3m as shown by the table.

Frequency range (MHz)	Limits [dB(μ V/m)]
30-230	100
230-1000	123

All the circuit boards are within the Class B limits of BS6527 and should, I believe, comply with the EC directive when it is announced. However, the MkI circuit board does show the effects of a bad layout when compared to the MkII and MkIII layouts. An improvement of 30dB was achieved merely by altering the layout of the circuit board. If the clock frequency were several times higher, then the MkI board could easily exceed the limits since the higher the frequency, the better it would radiate. Figures 6 and 7 showed the benefit of using the lower-specified logic families when speed or low power consumption is not important: the faster the chip, the more it radiates. 1992 is just round the corner and manufacturers would be well advised to have EMC in mind right at the start of the design process. ■

PIONEERS

Karl Ferdinand Braun (1850-1918): inventor of the oscilloscope

W.A. ATHERTON

Ferdinand Braun invented the oscilloscope and discovered the rectification effect, two truly major contributions to the art of electronics. But when he shared the Nobel Prize for physics in 1909 with Marconi it was for his work on radio telegraphy. Of all the early radio pioneers he probably understood the science of radio better than any.

From humble beginnings, this gentle and modest man developed a brilliant academic career and was one of the great scientists of his day. In 1914 he travelled from his native Germany to the USA to defend his patents in court. World War I prevented his return and he became an enemy alien, but his age and reputation saved him from any embarrassment. On the 20th April, 1918 he died, aged 67, in an enemy but friendly country. Another seven months would have seen the war at an end and the old man able to return home.

Braun was born at Fulda, about 60 miles north-east of Frankfurt, on the 6th June 1850. His father, Johann Conrad, was a civil servant and a protestant; his mother, Franziska Göhring, was a catholic. They agreed to raise their four sons, of whom Ferdinand was the fourth, as protestants and their two daughters as catholics. Though they were not well off, by hard work and

careful housekeeping they managed to educate their boys and provide dowries for their girls.

While at Fulda's high school, Ferdinand came to love crystallography. At 15 he wrote a textbook on the subject, complete with 200 hand-drawn illustrations, but it was never published. He also published a scientific article (on water) in a teachers' journal. He, and a friend who had done likewise, were reprimanded for "unauthorized publication". Not deterred, Braun published another which was translated into Russian. At 16 he published his third; truly a boy wonder.

On entering the University of Marburg as a 17-year old, he studied physics, chemistry and mathematics. The latter was not to his liking and he always found mental arithmetic difficult. Years later, colleagues joked that the only time he got his calculations right was when two errors cancelled out. One (invented) tale had him multiplying 25 by 2 during a lecture, rounding the 25 to 30 for simplicity to give 60, then commenting that 60 was too high so the answer was probably nearer 50. A popular article about him, years after his death, was headlined "Wizard Hated Mathematics". It was not true. He was just bad at mental arithmetic.

Still, he disliked the maths lectures at Marburg. Of one lecturer he wrote, "His lectures are completely indigestible. All he does is to dictate notes that only a stenographer could take down." Not surprisingly Braun soon switched to Berlin, the major science university in Germany. There he made a good impression and was one of only four students allowed access to one private laboratory.

In December 1869, Professor G.H. Quincke offered him a laboratory assistantship with a salary sufficient to make him partially independent of his father, who was trying to steer him into a secure career as a qualified school teacher. For now the salary on offer was enough to

overcome his father's reserve about a career in science.

In 1872, Braun submitted for his doctoral examination, for which his examiner, Hermann Helmholtz, passed him *cum laude*. "On the whole it went quite well," he wrote to his parents, though he was shocked at the cost of printing his thesis.

Soon afterwards, Quincke moved to Würzburg to take the chair of physics and Braun went as his assistant. His low salary still did not make him financially secure so, pleasing his father, he qualified as a school teacher and earned extra income from writing. His gift for sarcasm got him published under pseudonyms in major magazines – he always aimed high.

Rectification

After two years, a full university post still eluded him and he settled for teaching at a high school in Leipzig; father had been right. A university was still his aim, but meanwhile teaching gave some time for scientific research.

At 15, he published a textbook on crystallography complete with 200 hand-drawn illustrations.

Braun had already experimented with electrical conduction through electrolytes and salts and he now studied earlier work on conduction through mineral crystals. He solved the vexing problem of making contacts to the crystals by an example of what was to become his elegant experimental style. He simply bent two silver wires. One became a ring which supported the crystal, the other became a spring whose point pressed onto the crystal. It was a near-perfect set-up for the discovery of the point-contact crystal rectifier.

Just when he discovered rectification is not known, but he announced it on the 23rd November, 1874; "the resistance varies according to current direction, intensity, and duration," he wrote. At first the discovery did not make a big

impact in scientific circles, though Arthur Schuster repeated the results at Cambridge with clean and oxidized copper wires.

Two years later, Braun expressed his work as departures from Ohm's Law. He recognised that the effect took place at the surface of the crystal, that a point contact was needed, and that it happened very rapidly (in less than 1/500th second). It was 30 years before an important application was found, as a crystal detector for radio receivers.

The word rectification now has implications which go beyond the original discovery. What Braun discovered was that there are experimental set ups in which a direct flow of electricity is conducted better in one direction than the other. When he made his fourth and last publication on the rectifier effect in 1883 he was able to refute every accusation of experimental error and to extend the observations to alternating current. His last observation showed that the effect held true even for very short pulses of current.

The latter experiments took place at Strasbourg University, which he joined as an associate professor in the Spring of 1880, having held a similar position for three years at Marburg after leaving his teaching job in Leipzig. For a number of years he played musical academic chairs as he strode along the path of success from university to university. The next move was to a full professorship at the Technical University of Karlsruhe (1883), then to Tübingen (1885), and back to Strasbourg (1895).

It was at the time of the move to Tübingen that he got married. He and his wife, Amalie, set up house in the castle that was the physics institute. Unlike the domestic quarters the laboratory was in the unheated castle tower and subject to the vagaries of the weather; in winter the temperature hovered for weeks at -1°C . Braun's replacement at Karlsruhe was fortunate in inheriting a spacious lab in which, three years later, he performed the most famous experiments ever carried out there: his name – Heinrich Hertz. Braun meanwhile set about getting a new lab.

Oscilloscope

Braun the inventor was initially sceptic-



Karl Ferdinand Braun aged 36, inventor of the oscilloscope, discoverer of rectification and one of the founding fathers of radio. Photo – Tuesday Society, Tübingen.

The oscilloscope was not patented; Braun wanted it to be freely available to benefit all researchers

al about two great scientific discoveries. Hertz's discovery of electromagnetic waves was one, the other was Roentgen's discovery of rays which passed through matter – X-rays. "Roentgen has otherwise always been a sensible man," he said, "and it isn't even carnival time yet." However, he soon caught the "radiation fever" that followed the

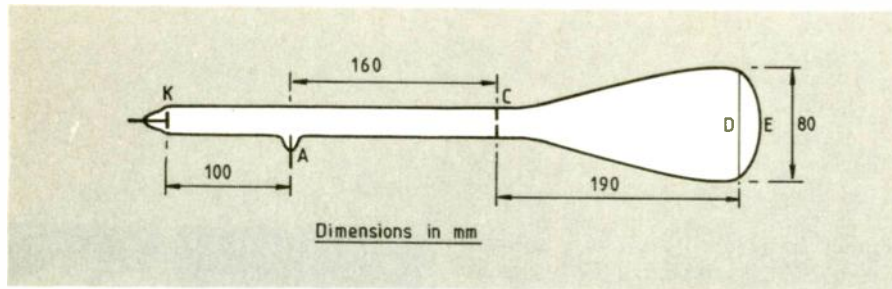

Fig. 1 Braun's cathode-ray tube. K is the cathode, from aluminium sheet; A the anode; C an aluminium diaphragm with a 2mm hole to narrow the beam; D the fluorescent screen; and E the glass tube.

announcement, but instead of X-rays he chose to re-examine cathode rays.

It was known that cathode rays could illuminate a fluorescent screen in an evacuated tube, that they could be formed into a beam, cast shadows, and be deflected by a magnet. But it was Braun who conceived an application for the phenomena. Gradually he arrived at a satisfactory design for a new tube. When a magnetic-field coil was placed close to the body of his tube and the alternating mains current applied to it, the traditional spot of light on the screen became a wobbly, vertical line. When the line was viewed through a rotating mirror in front of the screen an apparent horizontal motion was added and the sine wave of the current could be seen. Braun invited his associates to meet the alternating current from the Strasbourg generating station "in person".

He announced his invention of the 15th February 1897 in a paper, "On a Method of Demonstrating and Studying the Time Dependence of Variable Currents." It was also reported that the output of the Strasbourg station was a good sinewave, whereas that from an induction coil generator was awful, an epic demonstration of the value of the primitive oscilloscope. For the first time researchers could see what was happening in electrical circuits. Two years later, horizontal beam deflection was introduced by Braun's assistant

Of all the radio pioneers, Braun was probably the one who best understood the science of radio

Jonathan Zenneck to replace the rotating mirror.

The oscilloscope was not patented; Braun wanted it to be freely available to benefit all researchers. A bigger prize awaited him, the Nobel, awarded for his later work on radio telegraphy.

Radio

Braun was introduced to wireless telegraphy when he joined a group perfecting a telegraph which operated by conduction through water, a bid to avoid Marconi's patents. He then invented a new radio spark transmitter (loosely based on improvements he had made to the "water" transmitter) which not only broke Marconi's patent monopoly but gave an improved performance as well. After a demonstration in September 1898 the water telegraph was scuttled in favour of a radio telegraph using the new transmitter. A company was formed and became known as Telebraun. It was one of the forerunners of Telefunken.

By the turn of the century, a distance of 35 kilometres had been achieved and crystal rectifiers had been tested as detectors. By October 1900, the port of Cuxhaven had radiotelegraphic communication with lightships and pilot boats, and Heligoland was linked to the shore. Enquiries arrived from around the world.

However, Telebraun was broke and a rival German company, supported by AEG and based on Adolf Slaby's work, was well publicized. Braun's business colleagues finally allowed him to speak out on behalf of his inventions and publicity was gained which helped to secure financial backing. In December 1900, Telebraun became a subsidiary of Siemens.

Of all the radio pioneers, Braun was probably the one who best understood the science of radio. Marconi, by comparison, was an improver and inventor. Yet it was Marconi who grabbed the

headlines and the impressive firsts. In 1902, a merger between the rival German groups was discussed but foundered, and patent suits began. The rivalry became of national concern. Even the Kaiser worried that, through Marconi, the British were gaining a stranglehold.

As a result of government pressure, the merger finally took place on the 15th May 1903. Germany's four main radio pioneers, Braun, Siemens, Slaby and Arco pooled their resources. The new company took its name from the first syllables of the merging companies: the Braun/Siemens Telebraun and the Slaby/Arco Funkentelegraphie - Telefunken. There were 33 employees.

Braun then turned to other problems: the effect of gravity on the growth of plant cells for example, but his reputation is founded on his three supreme

Braun invited his associates to meet the alternating current from Strasbourg in person

contributions to our profession: the discovery of rectification, the invention of the primitive oscilloscope, and his contributions to radio telegraphy. It was this reputation that ensured him a respectful reception in the USA when he was trapped there, and died there, as an enemy alien. His wish to be buried in his native country was eventually honoured in 1921, when his ashes were interred in his parents' grave in his home town of Fulda. His wife, who had died during the war, was buried in Strasbourg which, by then, was once again French territory. They were survived by their four children. ■

References

This account is largely based on the biography by F. Kurylo & C. Süßkind, "Ferdinand Braun", MIT Press, 1981.

Tony Atherton is a Principal Lecturer at the IBA Harman Engineering Training College, Seaton, Devon.

COLOURCEL

NPQ*
INK JET
PRINTER

262,143 MORE COLOURS THAN THE MODEL 'T'

£2995 exc.
VAT

Addressable to
262,144 colours:
per pixel, 160 pixels per
inch, both axes.
1280 pixels per line.
A4 width internal paper
roll and cutter.
Compatible with Integrex
Fast Frame Grabber.
Centronics Interface.



IMAGES BY
MIKE KING
CITY POLY

* Near Photographic Quality



CIRCLE NO. 125 ON REPLY CARD

INTEGREX LTD., CHURCH GRESLEY, BURTON-ON-TRENT, STAFFS. DE11 9PT, ENGLAND
TEL: (0283) 215432 TELEX: 341727 FAX: (0283) 550325

 PUBLIC SECTOR CUSTOMERS:
FOR SPECIAL PRICING
CALL 0603 695051

Since it is preferable to achieve a high degree of linearity in the transfer characteristics of the amplifier without having to use large amounts of negative feedback to straighten out the kinks, designers have paid much attention to the design of those stages which provide the bulk of the voltage gain within the power amplifier.

Gain stage design

The principal techniques at the disposal of the circuit designer in his pursuit of greater linearity are the use of long-tailed pair gain stages, since these tend to lessen the generation of even-order distortion components; the cascode connection of the devices in the various ways shown in Fig. 1, because this isolates the amplifying device from the output voltage swings; and the use of highly symmetrical driver stage layouts, which can lessen problems due to slew-rate limiting. All of these methods are exploited, in various combinations, in contemporary circuit designs.

It is practicable to obtain high gain with wide bandwidth simply by cascading a series of amplifier stages, as in the relatively early design due to Lohstroh and Ojala¹ shown in outline in Fig. 2, but the cumulative phase errors of succeeding stages make overall loop stability more difficult to achieve.

Nevertheless, this approach has been adopted commercially; a design employed by Pioneer in their M-90 power amplifier, shown schematically in Fig. 3, shows strong similarities to the Lohstroh/Ojala layout. This Pioneer design also shows a trend, which is increasingly favoured in Japan, of using cascode-connected (monolithic) dual-junction fet inputs stages, because of the ease of matching the DC offset characteristics in a monolithic pair, and the greater input linearity of fets in comparison with bipolar transistors.

The bipolar cascode devices, Tr_2 and Tr_3 , which can be high-voltage working types, then allow the supply line voltages to be chosen without the constraints imposed by the relatively low gate/drain breakdown voltages of the fets.

SOLID-STATE AUDIO POWER

In this final part, John Linsley Hood considers gain stages and power supplies, and takes a quizzical look at testing and specifications.



The use of high-voltage, small-signal mosfets in place of cascode isolated junction fets as the input devices, as adopted in a recent design of my own² shown in Fig. 4, allows a simpler layout without loss of performance, provided that some initial set-up adjustment is made to compensate for possible bias-voltage differences between the two input devices.

The performance of the gain stage is enhanced by cascode connecting the driver stage preceding the output emitter followers, as shown in the two designs of Figs. 5 and 6 due to Borbely^{3,4}, since this stage will be required to handle a large signal-voltage swing.

Cascode connection, in this case, improves the effective linearity of the input device, particularly in respect of collector voltage modulation of the current gain (Early effect), and also eliminates unwanted effects due to the collector/base feedback capacitance.

Figure 7 shows an elaboration of this layout used in the Technics SE-A100 amplifier, in which the combination of the emitter-follower group $Tr_{8,9}$ and the current mirror formed by $Tr_{10,11,15}$ is used to achieve a symmetrical drive system from a less complex single-ended input stage, which makes it easier to control the output stage quiescent current than with a fully symmetrical driver layout, even though this may be theoretically superior.

Although the availability of high-

Fig. 1. Fet/bipolar cascode combinations, giving good input/output isolation. Circuit at (a) gives high gain, high output impedance and high-voltage operation; (b) gives very high Z_{in} , high Z_o and high voltage; (c) very high Z_{in} and Z_o and low/medium voltage; (d) high gain, very high Z_o and low/medium voltage.

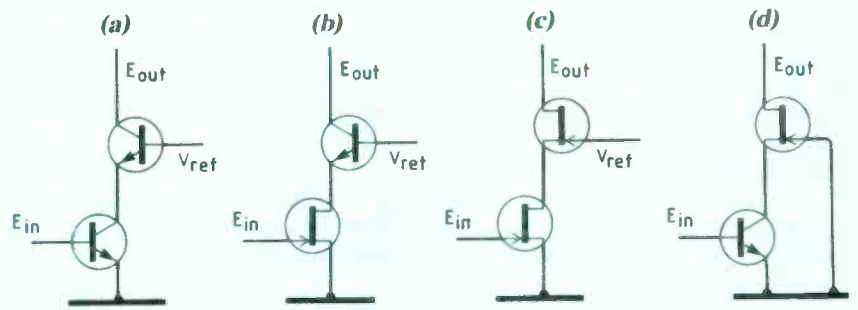
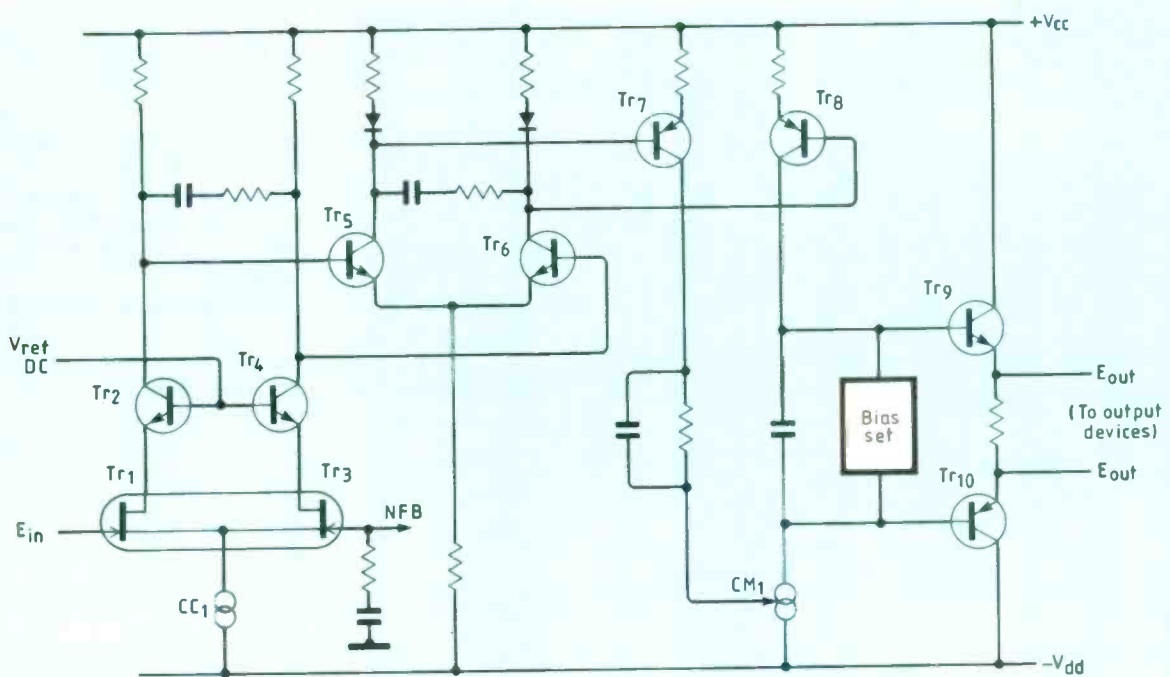
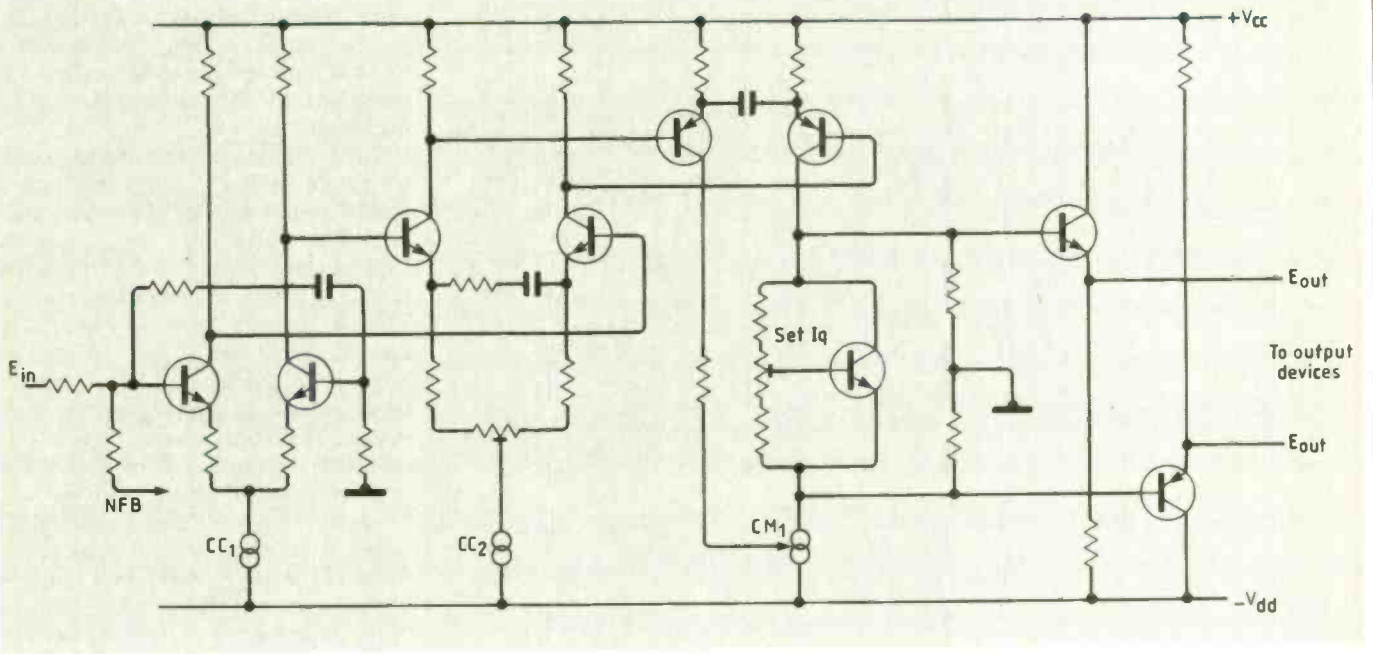

Fig. 2. High-quality amplifier design by Lohstroh and Otala, giving high gain and wide bandwidth by the use of several gain stages.

Fig. 3. Pioneer's M-90 amplifier, a commercial embodiment of the Fig. 2 circuit.



EVOLUTIONARY AUDIO

voltage devices has led to the increasing use of linear ICs in driver gain stages, those designs aimed at the upper end of the market appear to rely almost exclusively on discrete-component circuit constructions.

An exception to this is the use, as in the Quad 405, 510, 520 and 606 amplifiers, of an IC op-amp as a DC comparator, (Fig. 8), to ensure that the

no-signal DC voltage at the loudspeaker output terminals remains close to the desired zero level. This is a worthwhile and increasingly widely adopted stratagem.

Fig. 4. High-voltage mosfets allow a simpler design at the expense of freedom from setting up.

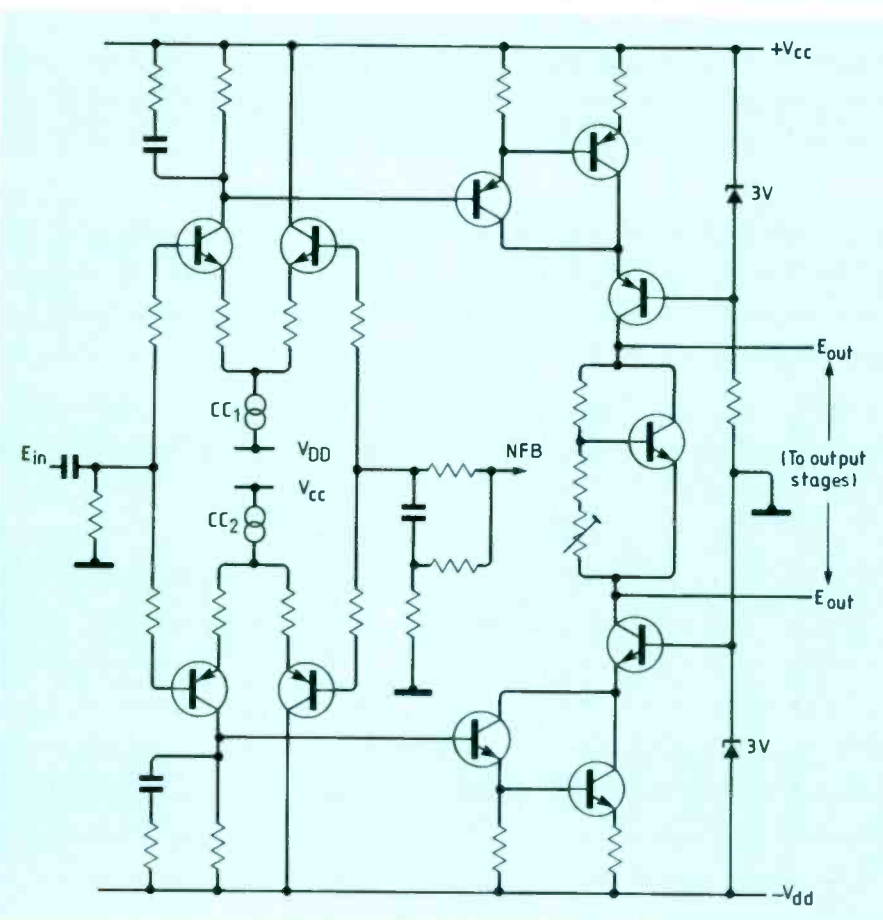
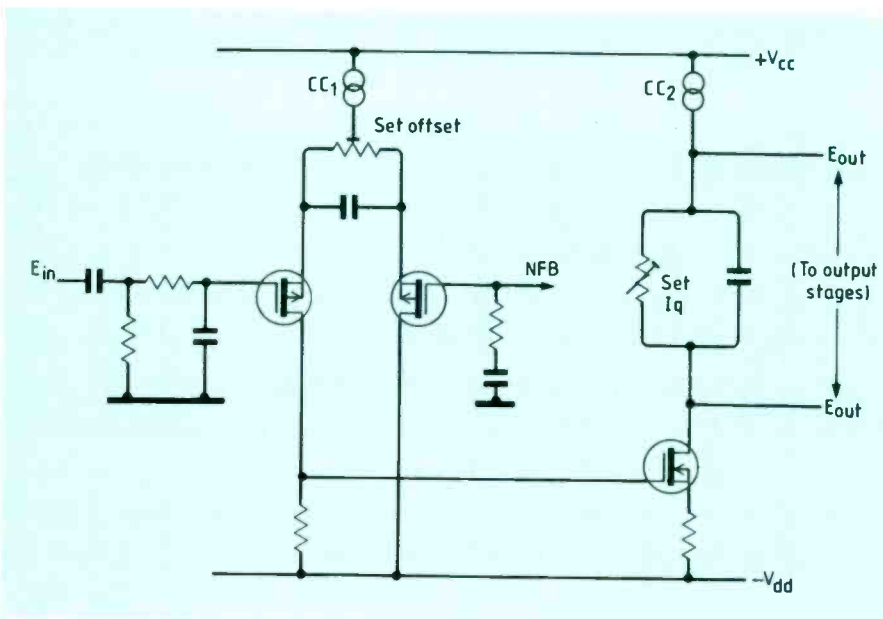

Power supplies

From the point of view of the purist, there is no substitute for an electronically stabilized supply as the DC source for the power amplifier, since this will provide rails of known and precisely controlled potential, largely free from noise and ripple and having a low source impedance.

It also confers the advantage, in the case of a power amplifier, that the output power available can be precisely specified and unaffected by short-term changes in the mains supply voltage. Instantaneous power-supply clamping or shut-down can also be brought about in the event of an abnormal load-current demand or a DC-offset fault condition at the loudspeaker output terminals.

Such a stabilized power supply offers many advantages, including that of better sound quality from the power amplifier, particularly where separate supplies are provided for the output devices and the preceding driver stages. This is due to the very low source impedance of the supply lines, which appears to confer both a more 'solid' bass, as well as a more precise stereo image. Suitable designs tend to be complex, however, as in a published twin DC supply design of my own⁵.

From low-voltage preamplifier supplies, stabilized supply lines derived from IC voltage regulators are now almost universally used but, in the case of power amplifiers, a rigidly controlled DC supply would not meet some specific user requirements.

This is because a significant part of the market consists of enthusiasts for rock and similar music, for whom the physical impact of the sound is an important part to the enjoyment of the music. In this use, the equipment is operated at as high a sound output level as circumstances allow, and freedom from noticeable clipping is a substantial advantage.

Since many peak power demands are of relatively brief duration, an unstabilized power supply, having a relatively high off-load supply line voltage with large-value reservoir capacitors, will allow the amplifier to sound appreciably 'louder' than a similar design with a more rigidly controlled but lower-voltage DC supply. This is an aspect few manufacturers can afford to ignore.

Fig. 5. Linear high-gain stage due to Borbely, using symmetrical configuration.

Figure 9 shows a typical modern power supply, with entirely separate supplies for each channel, and very large-value reservoir capacitors. Clearly, the output current from such a supply could be highly destructive of the loudspeaker system in the event of a component failure and various protection systems are used, ranging from simple fuses in the output lines to elaborate relay protection systems, such as that shown in Fig. 10.

However, with all of these electromechanical components included within the loudspeaker output line, there remains the real possibility of poor electrical connections through mechanical wear or contact corrosion, which can lead to high resistance junctions. There is also the possibility of rectifying effects, which are of much greater audible significance than any benefits thought to be conferred by ultra-low resistance speaker cables.

Amplifier testing

In an ideal world, there would be some clearly understood and universally agreed set of standards by which the performance of an amplifier – or any other component in the sound reproduction chain – could be assessed.

Some of the design errors which arose in the early days of transistor amplifiers disclosed inadequacies in the test

Fig. 6. Another Borbely cascode design, with source-followers.

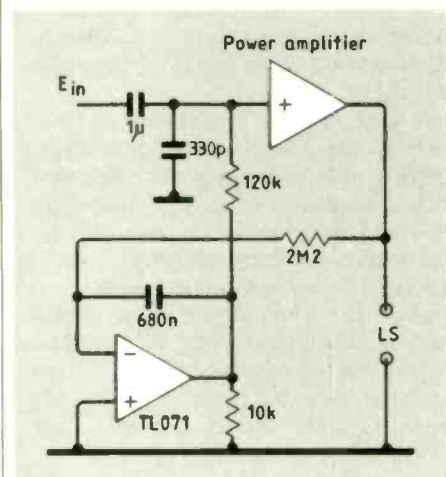
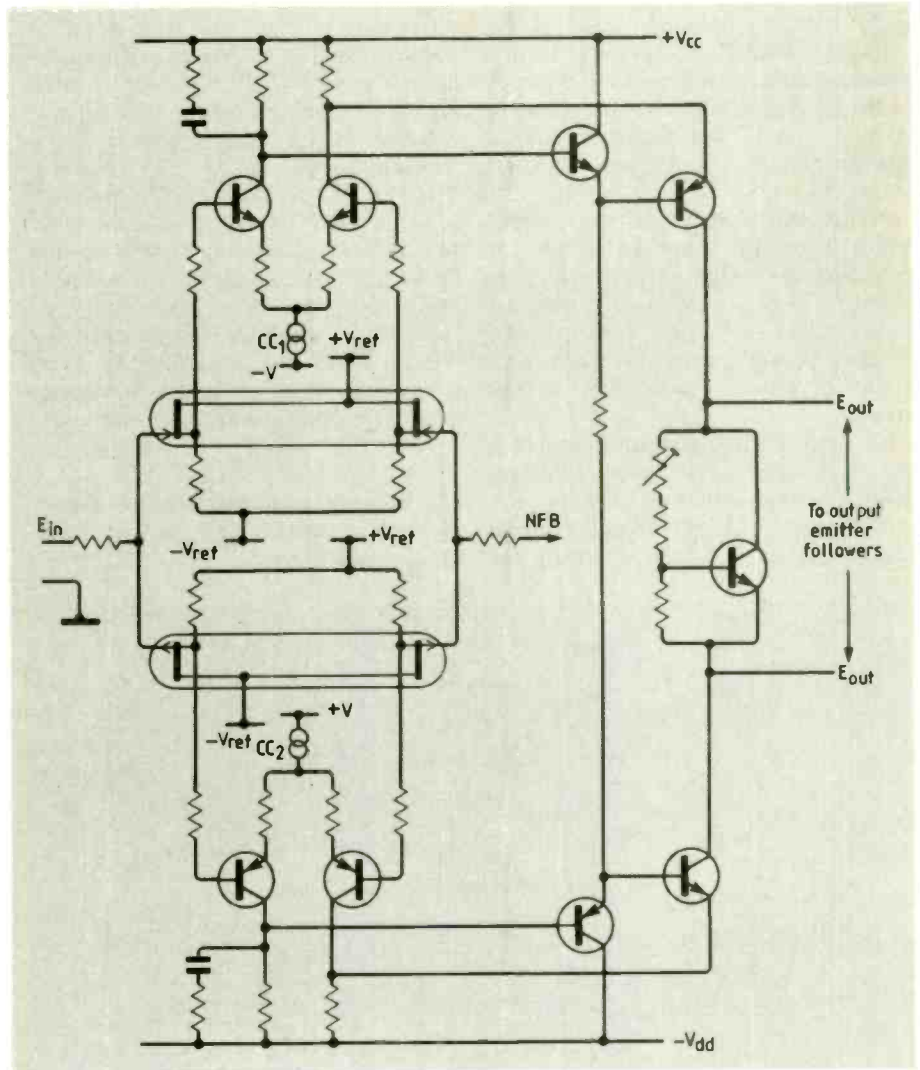
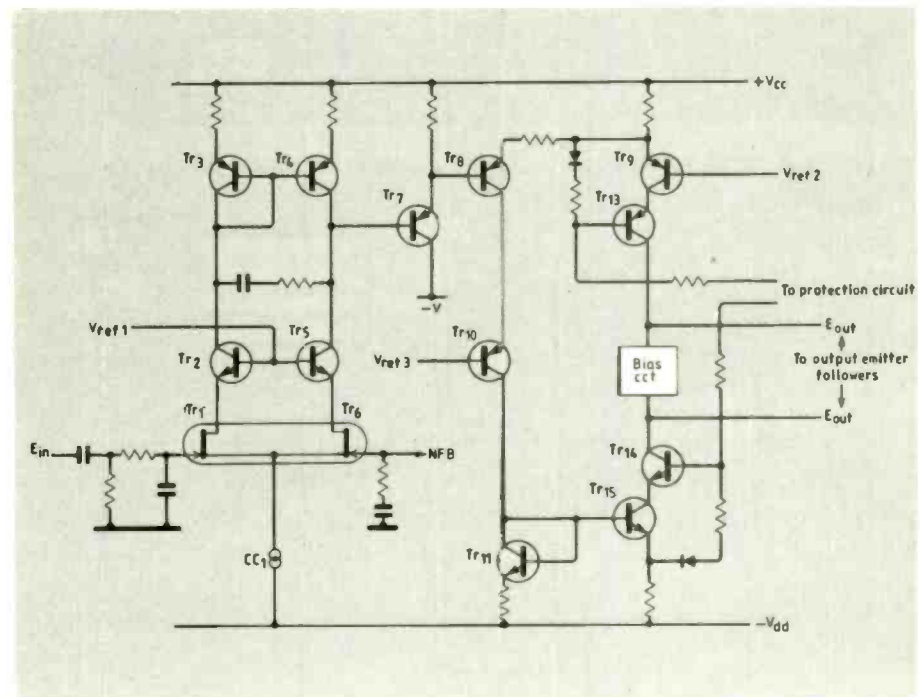

Fig. 8. Output DC level correction used by Quad in which the op-amp maintains the no-signal direct voltage near zero.

Fig. 7. Single-ended cascode input stage by Technics makes for ease of quiescent current adjustment.



EVOLUTIONARY AUDIO

methods then employed. Sadly, thirty years later, we are still some way from a complete understanding of the types of technical specification we should seek to meet, or of the relative acoustic significance of the known residual errors.

Part of this problem is due to clear differences in their response to instrumental evaluation between the three groups of customers; the classical music devotee, the rock music enthusiast and the relatively naive, and musically uninterested 'man in the street'.

In classical music and traditional jazz played on acoustic instruments, a direct comparison is possible between the sound of the original performance and that of the reproduction, allowing for

differences in the acoustic ambience of the settings; the importance of residual defects in reproduction, so far as these are identifiable, can be quantified.

Some of the early public demonstrations staged by G. A. Briggs of Wharfedale and P. J. Walker of Quad, in which live and reproduced music were directly compared in a side-by-side demonstration, showed that even in those days the differences could be surprisingly small and encouraged the belief that the performance tests employed were adequate to assure satisfactory performance, as they could

Fig. 9. Simple unstabilized power supply for output stages used even in high-quality amplifiers.

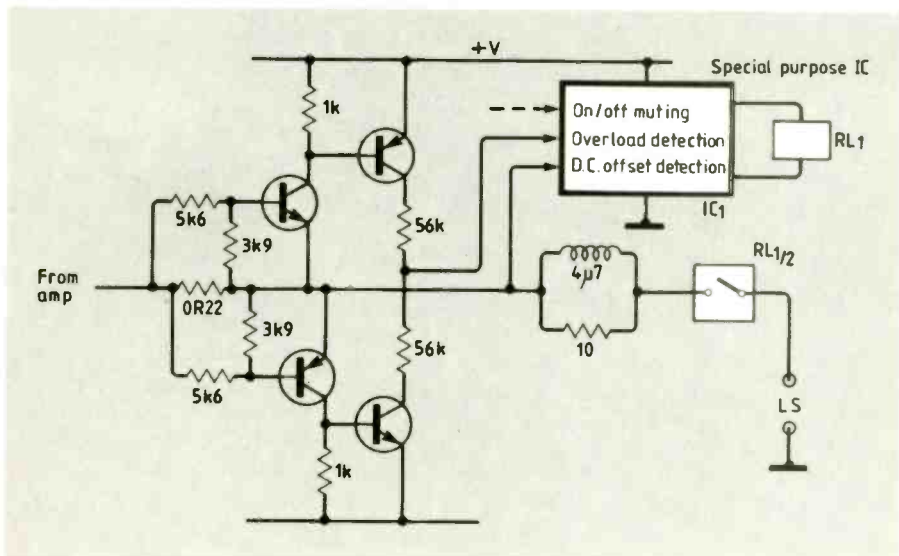
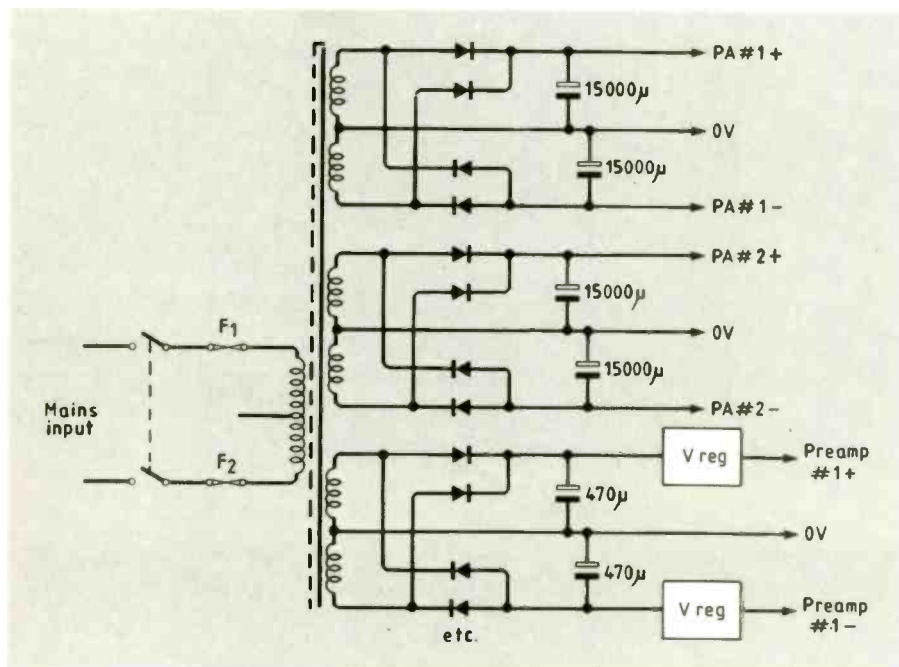

well have been for the equipment then being used.

For the relatively unsophisticated buyer of equipment, the important factors are physical appearance, the number of facilities it offers, its apparent value for money and its numerical performance specifications, such as power output, bandwidth, and steady-state harmonic and intermodulation distortion factors.

The fact that very highly specified power amplifiers may not sound any better, and perhaps even worse than systems which are less well specified, has cast some doubt on the value of many performance measurements. This doubt is encouraged by the growing use of up-market equipment for the reproduction of music originating mainly from electronic or electronically assisted instruments - which definition must also include the human voice, where this is augmented by a microphone and amplifier - and fed directly on to tape.

This music is also likely to have been extensively modified during the recording process, so that the performance is heard for the first time when the disc or tape is replayed. The judgment of the listener will therefore be based less upon whether the reproduced sound is accurate than on whether it is pleasing to the ear.

Whether it is warranted or not, enthusiasts insist that there are differences in the listener appeal of the various available units and that these differences may not be measurable by any of the normally specified performance parameters. Guidance, when needed, must therefore be sought elsewhere.

A wide range of periodicals exists to cater for this need and also, perhaps, to reinforce the belief that the respective merits of various brands of equipment can only be assessed by comparative listening trials carried out by (their own) skilled and experienced reviewers.

Clearly, the absence of valid numerical or instrumental standards for defining subjective amplifier performance is a matter of wide concern, and various attempts have been made to set matters straight.

To involve the ear of the listener in the assessment of performance, Colloms⁶ and Baxandall⁷ almost simultaneously proposed the substitution of the amplifier under test

Fig. 10. Typical commercial speaker protection and switch-on/off muting circuit.

for a nominal (phase-corrected) straight wire, using a circuit layout of the kind shown in Fig. 11. Perhaps predictably, the conclusions reached by these two authors differed, with Colloms claiming that there were significant differences which could be detected by this method and Baxandall asserting that all competently designed units, operated within their limits, will sound identical.

An early observation of audio enthusiasts was that, in spite of their generally poorer specifications, valve amplifiers "sounded better" than transistor amplifiers. This was probably because the valve amplifiers had a more gradual overload characteristic than their transistor equivalents, especially since most solid-state amplifiers would use output-transistor protection circuitry, which would impose a rigid limit on the permissible output current into a short circuit or low-impedance load. Valve amplifiers did not impose this output current limitation and for both of these reasons could sound significantly 'louder' than notionally more powerful transistor operated systems.

In an attempt to test the validity of these claims for the audible superiority of valve amplifiers, the Acoustical Manufacturing Company (Quad) commissioned a series of double-blind group listening trials, reported by Moir⁸, in which the panel was selected to include people who had published their beliefs that there were significant differences between amplifier types and that valve amplifiers were superior. In the event, the conclusions of this trial were that there was no statistical significance in the group preferences, individually or collectively, between the Quad 303 and 405 transistor amplifiers, or between either of these and the Quad II operated amplifiers.

However, a possibly important factor was that the output signals from the amplifiers were monitored with an oscilloscope to ensure that at no time were the output levels high enough to cause clipping, however briefly.

As an extension to this valve versus transistor debate, Hiraga⁹ tried to relate the claimed sound differences between the two amplifier types to test results derived from wide-band spectrum analysis. In general, his findings confirmed that the listener did not necessarily prefer undistorted signals.

A further attempt to provide a test method to give better correlation with the subjective assessment than simple THD or bandwidth measurements was evolved by the BBC and described by

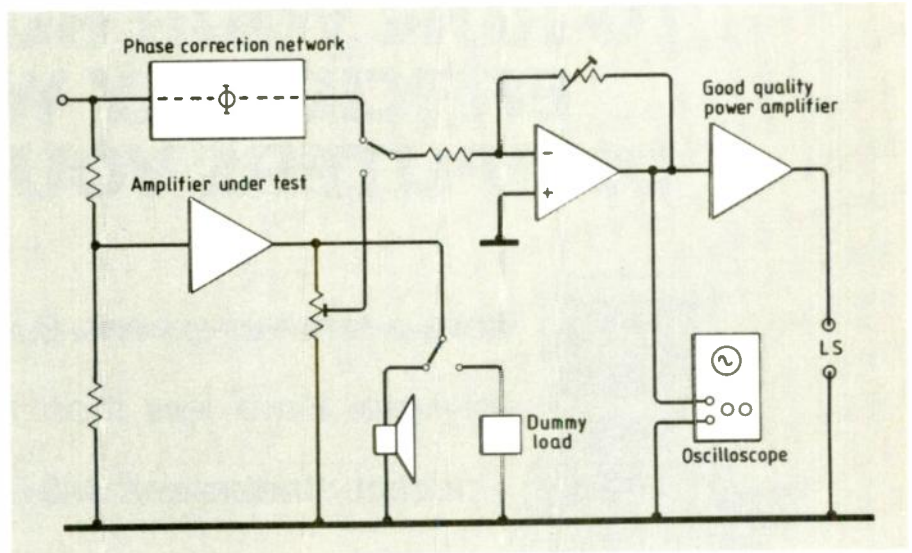

Fig. 11. Circuit for "straight-wire" substitution test on audio amplifiers.

Belcher¹⁰, using weighted pseudo-random noise signals followed by a comb-filter rejection network.

This gave very good correlation with a listening-panel assessment of sound quality impairment through various causes, which showed that the nature and linearity of the transfer characteristic of the system was important. This conclusion was corroborated by Hirata¹¹, who evolved a test method based on an asymmetrical pulse waveform input, in an attempt to discover why it was possible to hear and identify the audible defects of an amplifier in the presence of much larger defects introduced by the loudspeaker.

Unfortunately, the gulf between engineers and the subjective-sound fraternity still remains, one side claiming that any differences between well designed amplifiers will be vanishingly small, and the other asserting that dramatic changes in performance can be made by such unlikely actions as replacing the standard mains cable with a more expensive one.

The absurdity of some of these claims provoked Self¹² into a defence of engineering standards against the metaphysical assertions of the 'add-on' fraternity. As I indicated in a subsequent letter¹³, I feel that we may still have things to learn, outside the comfortable realms of the steady state.

As engineers, we have made mistakes in the past through the lack of stringency in the tests we applied. This experience must make us more cautious in claiming perfection as a result of favourable responses to a limited number of possibly inappropriate test

measurements; we may still have overlooked something.

For myself, I believe that some audible differences do remain between apparently impeccably specified amplifiers, particularly where these are based on dissimilar design philosophies and I think some of these audible differences are related to quite clearly visible, and measurable, differences in their step-function response characteristics. There are certainly other things which also have an effect on sound quality which we could measure, if only we knew where to look. ■

References

1. Lohstroh, J., and Otala, M., AES 44th Convention, Rotterdam, 1973, Re1, H6
2. Linsley Hood, J. L., *Electronics and Wireless World*, March 1989, pp. 261-264.
3. Borbely, E., *Wireless World*, March 1983, pp. 69-75.
4. Borbely, E., *Audio Amateur*, February 1984, pp. 13-24.
5. Linsley Hood, J. L., *Electronics and Wireless World*, May 1989, pp. 524-527.
6. Colloms, M., *Hi-Fi News and Record Review*, October 1977, pp. 83-85.
7. Baxandall, P. J., *Wireless World*, November 1977, pp. 63-66.
8. Moir, J., *Wireless World*, July 1978, pp. 55-58.
9. Hiraga, J., *Hi-Fi News and Record Review*, March 1977, pp. 41-45.
10. Belcher, R. A., *Wireless World*, May 1978, pp. 36-41.
11. Hirata, Y., *Wireless World*, October 1981, pp. 49-52.
12. Self, D.R.G., *Electronics and Wireless World*, July 1988, pp. 692-696.
13. Linsley Hood, J. L., *Electronics and Wireless World*, September 1988, pp. 860-861.

Corrections

In part 2 of this article in the November issue two small errors appeared. In Fig. 18, a 47k feedback resistor between the output and Tr₄ base is missing. It should be shown between the 1k and 32k resistors. The capacitor at the earthy end of the 8.2k resistor is 0.1µF.

TO RUN YOUR BUSINESS EFFICIENTLY WITH COMPUTERS YOU MUST:

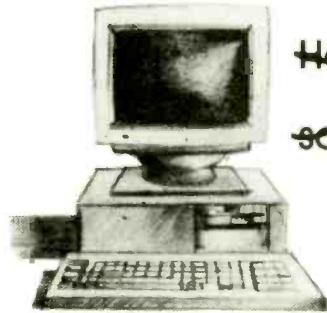

~~Have a team of experts. Buy new hardware and software. Have less than two pounds in your pocket. Understand MS-DOS, SQL and OS/2, know how many pixels are available on a VGA screen (What is a VGA screen?). Be near a good newsagent. Appreciate operating system~~



~~differences between Apples and Apricots.~~
Really want to get the best out of information technology for your business.

PRACTICAL **COMPUTING**

**THE MONTHLY MAGAZINE
FOR BOFFINS, EXPERTS, BUSINESS PEOPLE.
OUT NOW!**

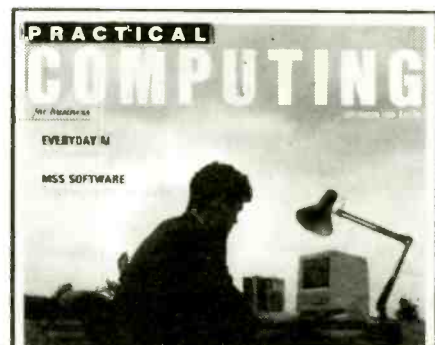

CIRCLE NO. 137 ON REPLY CARD

Jovian witnesses

Jupiter will be having a busy time shortly, in terrestrial terms, when the Ulysses and Galileo spacecraft buzz the planet in February 1992 and December 1995 respectively.

While Ulysses, a joint European Space Agency/NASA project will be using Jupiter purely for the slingshot effect needed to pull it onto a trajectory over the solar poles, NASA's Galileo will send a probe directly into the planet's atmosphere where it will have a brief 60-75 minutes of glory.

Galileo's successful launch last October on the shuttle Atlantis means that both orbiter and probe craft, after 2.4 billion miles, will be sending back details of Jupiter and its moons, as well as the short descent into the hydrogen/helium atmosphere, almost four years after Ulysses has performed its acrobatics around the planet.

Ulysses has been in development since 1984, when it was planned to fill the gap left by cancellation of a two-spacecraft mission which would have given simultaneous data on the Sun's north and south poles. NASA's financial difficulties put paid to the grander

scheme, but Ulysses will still orbit the Sun to obtain both north and south pole data, albeit a year apart, when conditions may have changed with respect to each other.

The spacecraft will be the fastest man-made object in the universe after launch with an escape velocity of 11.4km/s and its instrumentation will be powered by a radioisotope thermoelectric generator.

The Jupiter slingshot is intended to impart enough energy to the spacecraft to propel it out of the plane of the ecliptic (the plane containing the earth and other planets orbiting around the sun) and swing it back over the southern pole of the Sun at an altitude of about 300 million km.

The Sun's magnetic field, solar winds and atmosphere are radically different at the poles, being less affected by the Sun's rotation and interactivity between high and low-speed solar winds.

Apart from direct solar interest, the position of Ulysses in relation to earth orbiting craft will be used to investigate phenomena such as cosmic gamma bursts and gravitational wave bursts.



Speaking advert

Not a lot of people want to hear this, but Dallas is going to tell them anyway. Texas Instruments's Dallas labs have been working overtime to produce the first talking ad.

In conjunction with LA-based Inter-visual Communications, which worked on the electronic module and its assembly in Hong Kong via subsidiary Varsity Electronics and ad. agency McCann Erickson Dallas, the intrepid TI has

taken its aural message into the pages of Business Week in the form of a voice synthesised electronic advert.

Forty two words tell it as it is when the reader removes a label covering the switch. The credit card sized device, containing speech synthesizer chip, three tablet sized batteries, and 25mm piezoelectric speaker pushes the corporate message around 650 times and costs, in bulk, around US\$4 a throw.

Insurance premium

The first 486 processor upgrade in Europe for the IBM PS/2 70/A21 went to the lucky Norwich Union Insurance Group only three months after Intel's initial announcement.

The i486 PS/2 processor upgrade promises up to 80 per cent higher performance in business applications and up to three times the performance in numeric-intensive applications. It offers a 32-bit, 25MHz processor, internal

cache memory controller, internal cache memory and an internal floating-point maths coprocessor.

Norwich Union says the i486 provides it with the power needed to exploit fully its future IBM OS/2 based Token Ring network services. The installation, by IBM Systems Centre, Computer Marketing, is reported to have gone smoothly.

Satellite confusion

BT Vision, the visual telecommunications arm of British Telecom, seems set to add to the 'power tower' of satellite receiving equipment which is piling up on top of TV sets.

The company is introducing an 'over-air authorization' system, which authorizes particular TV sets to receive signals by sending codes with the TV programmes. But the system uses the D2MAC transmission standard and Eurocrypt 'M' for scrambling the signals, neither of which are used by the Sky or BSB companies.

However, BT is negotiating with France Telecom, the driving force behind the French TDF direct broadcast satellite, to agree common standards for transmission and encryption. This move might reduce the power tower.

BT Vision claims that its new system will allow customers to buy extra channels or single programmes in minutes, with a 'phone call to their local retailer. The retailer will then notify the controlling computer, which will send authorization via the satellite. Blackouts could be applied both to subscribers late with payments and to geographical regions.

LCD better than CRT?

Conventional CRT displays for computers and television could be designed out of video equipment within the next five years if LCD development maintains its present pace.

Both Toshiba and Hitachi used Com-ponic 89 – the Paris components show – to demonstrate 10in flat-screen technology working in full colour with pixel definition equivalent to IBM's latest VGA standard. Decently sized flat screen colour TVs are now a distinct possibility.

Liquid-crystal screens have been around for a long time: assemblies incorporating nearly a million pixels haven't. Colour VGA display requires three 640×480 pixel screens to display simultaneously each of the primary colours. If this isn't achievement enough, Hitachi claimed a contrast ratio of 80:1 for its screen, better than most CRTs when operated with viewing conditions of normal ambient light.

The show prototypes were backlit by

cold-cathode fluorescent tubes in both cases, the likely choice for production units. This produced a picture subjectively as bright as a typical CRT, but on a completely flat surface, as one would expect from this type of display. The perfect registration coupled with the absence of defocus on highlights gave the image a sharper quality than its conventional equivalent.

Hitachi appears to have moved further than Toshiba through the use of TFT (thin-film transistor), techniques rather than simple matrix technology. Hitachi's screen had no perceptible lag when changing from image to image, a problem which afflicts the current generation of mono LCD computer screens. Tosh's prototype displayed a single image which made it impossible to judge the speed of the screen. Neither company was prepared to put a price tag on the displays although Hitachi expected to be selling its product by the end of 1990.

The same company also demonstrated a high definition mono screen with a 10in diagonal, made up from 1120×780 pixels. This is intended for cad and graphics usage.

Computer applications have provided the launch impetus for LCD displays but TV and video promises the largest volume of business. The size limit for production LCD television screens is currently 6.5in, corresponding to a pixel count of about 158 000 for each of the three colours. Toshiba's show demonstration used a Sony 8mm video source coupled to both 6.5 and 4in TFT screens. The picture quality was good, although the viewing angle was rather narrow in comparison to a conventional display. Improvements in the viewing angle will need to be achieved for LCD to gain market share from CRT in domestic TV usage.

The new advances have been made possible by better silicon-on-glass deposition techniques. Current genera-



Talytherm

TALYTHERM. REAL TIME THERMOGRAPHIC IMAGING FOR INDUSTRY

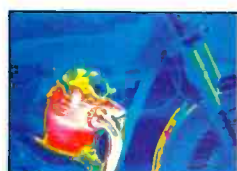
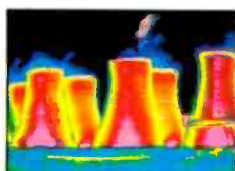
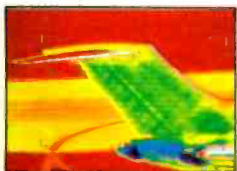

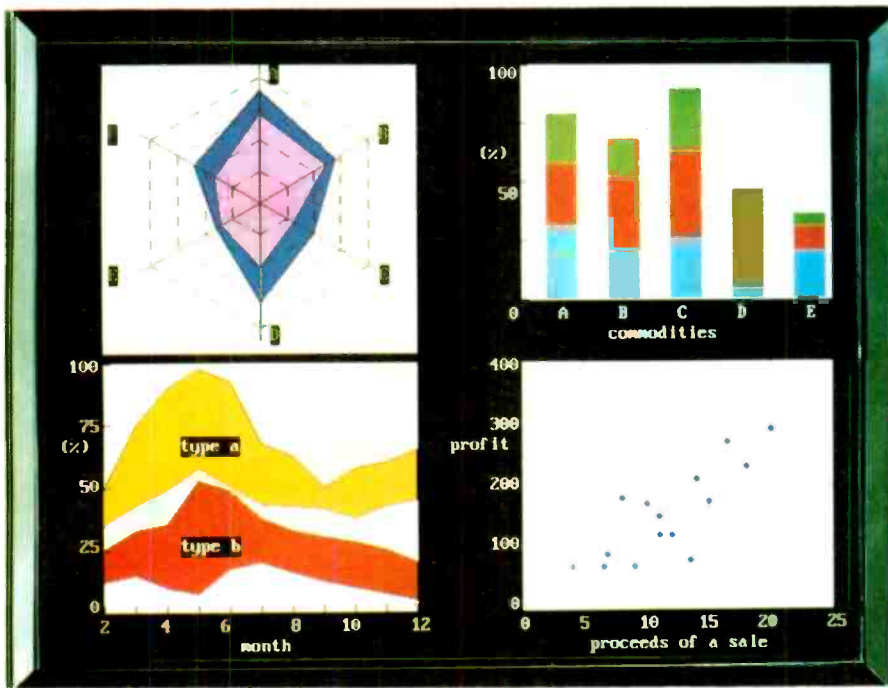

Hitachi's 10in thin-film-transistor display, which has no perceptible lag.

tion displays mostly use a matrix of translucent metallic stripes printed directly onto a glass substrate; the LCD pixels are formed at the intersections. The matrix of relatively thick stripes has high capacitance, resulting in low switching speeds and a sluggish screen. New panels incorporate a layer of either amorphous or polycrystalline silicon, integrating a single switching transistor for each pixel.

These use much thinner, lower capacitance stripes for faster operation. The transistor switches the pixel element, a rectangular translucent plate connected to its drain circuit, the plate normally floating unless switched by the transistor. This allows the pixel to remain "on" or "off" without being continually addressed, in the same way that a d-ram cell stores charge. As well as being faster, it offers precise control of individual mark/space ratio which means wider greyscales and more colours.

THERMOGRAPHY IS FULLY ESTABLISHED IN YOUR INDUSTRY AS AN IMPORTANT TOOL FOR RESEARCH, OBSERVATION AND MEASUREMENT. ALTHOUGH THE CHOICE IS WIDE, SERIOUS CONSIDERATION HAS TO BE GIVEN TO THE SELECTION OF THE MOST SUITABLE EQUIPMENT.

CONSIDER CALIBRATION STABILITY OVER LONG PERIODS, AND STATE OF THE ART WINDOW DRIVEN SOFTWARE WITH A FULL RANGE OF IMAGE PROCESSING FUNCTIONS. NOW YOU HAVE DEFINED TALYTHERM FROM RANK TAYLOR HOBSON.

EVERY PICTURE TELLS A STORY

CONSIDER A SYSTEM TO MEET THE FULL REQUIREMENTS OF THE SERIOUS USER, AND COMBINE THE BEST OF ALL ASPECTS OF PERFORMANCE. CONSIDER A THERMOGRAPHY SYSTEM WHICH SCANS THE SCENE AT FULL STANDARD TV RATES, 50HZ FIELD RATE AND 15KHZ INFRARED LINE RATE. CONSIDER A SENSITIVITY OF 0.03°C DETECTABLE TEMPERATURE DIFFERENCE. CONSIDER A SYSTEM THAT OFFERS 512 SCANNED INFRARED LINES WITH 780 SAMPLES PER LINE, AND IMAGE PROCESSING IN A 512 X 512 IMAGE ARRAY.

IN YOUR INDUSTRY TALYTHERM COULD BE THE SOLUTION TO PROBLEMS IN:

- HIGH VOLTAGE TRANSMISSION LINE AND INSULATOR INSPECTION.
- INSPECTION OF TRANSFORMERS.
- TRANSIENT HEAT GENERATION IN INTEGRATED CIRCUITS AND SEMI-CONDUCTORS.
- INSPECTION OF PRINTED CIRCUIT BOARDS UNDER LOAD CONDITION.

FOR FURTHER DETAILS ABOUT REAL-TIME THERMOGRAPHIC IMAGING EQUIPMENT FOR YOUR INDUSTRY, CONTACT AN EXPERT AT RANK TAYLOR HOBSON, WHO WILL BE PLEASED TO PUT YOU IN THE PICTURE ... WHICH IS BETTER THAN A THOUSAND WORDS.



RANK TAYLOR HOBSON, PO Box 36, NEW STAR ROAD, LEICESTER LE4 7JQ, UK. TEL: 0533 763771. FAX: 0533 460543. TELEX: 34411

CIRCLE NO. 121 ON REPLY CARD

BSB "nearly there"

British Satellite Broadcasting claims to have working prototypes of its Squarial flat-plate antennas. This follows an order placed with the Japanese firm Matsushita for 70,000 of the dishes.

The aim is to get the dishes made in volume in time for the satellite service's spring launch.

Nick Hart from BSB denied rumours that the delay in production was because of difficulty in designing a true antenna array. Instead he put the blame on the 2285 descrambler chip from ITT. He said "the chip gave us problems. It was new technology and was hard to get 100% right first time. There are still some failures but we are nearly there."

The Squarial, though, will be bigger than originally planned. The firm claims it went up from a 30cm unit to a 40cm one because of the extra two channels that the IBA awarded to BSB in June.

BSB plans to launch a second satellite half way through next year. But it wants all five channels available in the Spring. This means that some of the five channels will be operating on half power and a 30cm Squarial would not have given satisfactory reception.

A 35cm parabolic dish is also planned and more manufacturers for that and the Squarial will be announced soon. In a survey done by BSB, some consumers said they preferred a parabolic dish.

Cool millions

Matching other countries' efforts in developing superconductivity needs at least 35-40 per cent extra government funding, according to Oxford Instruments' deputy chairman, Sir Martin Wood.

Sir Martin's company leads the field in the UK, and in an address to the Royal Society in London, he said that senior industrialists have too little understanding of superconductivity and there is a shortage of graduates and postdoctoral researchers in the field.

In addition, he called for education of investing shareholders so that they could see the importance of long term R&D.

Transputer megacell

Low(ish) priced hi-tech is one option being discussed for the Inmos transputer, in applications such as parallel processing PCs, although Inmos says that it will be at least a year before it has available standard cell devices incorporating transputer cores.

First device to be used in this way will

be the \$20 T400.

Inmos does not see the move to use the transputer for standard cell purposes as a move away from the transputer as a stand-alone micro.

Since buying Inmos, SGS-Thomson has slashed prices on other versions of the transputer.

ECL Mips

An ECL version of Mips Computer systems 32-bit risc micro has been developed, designated R6000 and capable of 50-60 mips. The three-chip set is being made by Bipolar Integrated Technology, which is also giving the rival Sun Microsystems SPARC risc micro the bipolar treatment.

NEC is also reported to be working on an ECL implementation, and Siemens has the option to do so.

Tasty technologies

There are two top flavours this month and one of them, the Intel 486 processor, will probably stay at the top for the next year or so. The other is the Extended Industry Standard Architecture (EISA).

Several PC makers, such as Tandon, Compaq, Hewlett Packard and Olivetti, have jumped in and launched systems based on these two developments. Others are set to follow almost immediately.

The new machines have price tags that start well over the £5000 mark. They are therefore not something that the average punter will expect to see in the local Dixons for a while yet, even if they could then afford them. It does, however, give a good indication of the trend that will dominate systems design in a couple of years.

In this context, EISA is an interesting debating point. Its tenets are well-known - develop an extension of the standard PC/AT expansion bus architecture that can cope with the I/O demands of high-speed 32bit processors running a multitasking

operating system such as OS/2 or Unix

Its one idiosyncrasy remains its attachment to the old AT architecture and the use of this by its supporters to promote it as having 'thousands' of add-in boards available already.

But these are old AT boards, most of which offer expansion facilities or additional functionality which is now an integral part of the system motherboard in the new 386 and upcoming 486-based machines. It is even arguable to what extent new machines will require any expansion capabilities except for those users who want to add esoteric peripherals or facilities.

And even here the fast-emerging crop of 486-based machines is incorporating facilities which, it is hoped, might attract the users' eye. Tandon, for example, has a desktop system coming which includes an integral 600Mbyte read-write optical disk as back up to a 760Mbyte hard disk.

Olivetti's EISA machine, a floor-standing tower system primarily aimed at being a network server, comes with

Intel i860 64bit risc chip as a math coprocessor. To say that this will do maths with a device like that on-board is going to be putting it mildly.

Compaq has multiple 486s in its EISA machine, or at least the facility to equip one of its new range with more than one 486 processor.

All of this power, of course, has yet to find a real, standard operating system that can exploit it. OS/2 is talked about at great length, but there are still few applications available off the shelf, though many in intangible hyperbole. The system itself is arguably deficient because it has been designed specifically for the old 286 processor and does not exploit the capabilities of the 386 or 486. A new version, which does, is coming - 'soon'.

Unix, on the other hand, is here. But the downside of that is that there are still many different versions of it.

So, the chances are you will all be using 486-based mega-PCs to run your old dos applications by the time all this high-tech power descends to high-street pricing levels.

Martin Banks

R.S.T.

LANGREX SUPPLIES LTD

R.S.T.

One of the largest stockists and distributors of electronic valves, tubes and semiconductors in this country.

Over 5 million items in stock covering more than 6,000 different types, including CRT's, camera tubes, diodes, ignitrons, image intensifiers, IC's, klystrons, magnetrons, microwave devices, opto electronics, photomultipliers, receiving tubes, rectifiers, tetrodes, thyratons, transistors, transmitting tubes, triodes, vidicons.

All from major UK & USA manufacturers.

Where still available.

Obsolete items a speciality. Quotations by return. Telephone/telex or fax despatch within 24 hours on stock items. Accounts to approved customers. Mail order service available.

LANGREX SUPPLIES LTD

1 Mayo Road, Croydon, Surrey CR0 2QP.

Tel: 01-684 1166

Telex: 946708

Fax: 01-684 3056

CIRCLE NO. 129 ON REPLY CARD



FIGHTING TALK...

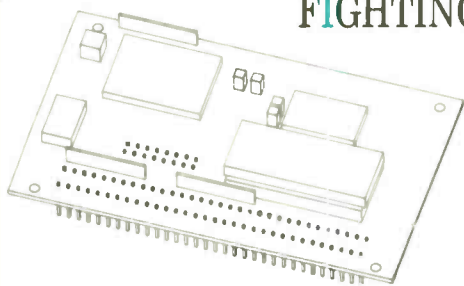

TDS
9090

Weighing in at 60g and only 100 x 72mm this card packs a punch with 2 x RS232 and 35 parallel I/O lines. Up to 16K of compiled user program and 30K of data RAM gives it a long reach. The on card Forth multitasking gives you talkback even when the Hitachi processor has something going on in background. Friendly, using +6 to +16V, the watchdog timer won't let it go crazy and the standard EEPROM means the TDS9090 need not forget those important details.

1 off £194.95 including manual and non volatile RAM 

Triangle Digital Services Ltd

100a Wood Street, London E17 3HX

Telephone 01-520 0442 Telex 262284 (quote MO775) Fax 01-509 3263

CIRCLE NO. 123 ON REPLY CARD

IBM-PC I/O Cards

There has never been a better time to start using your IBM compatible PC for data acquisition and control

The new selection from Fairchild offers an exceptionally wide range so you can get nearer than ever to your precise requirements

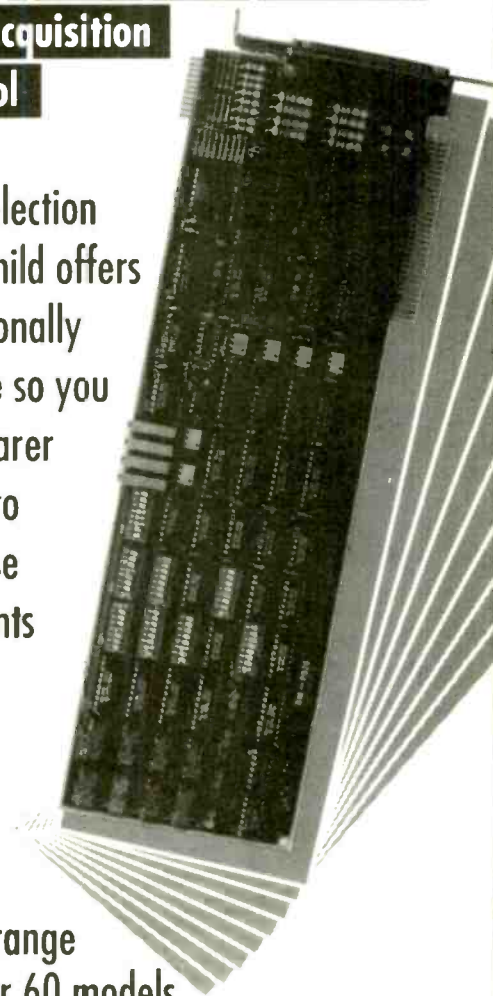

- wide range — over 60 models
- high quality
- software support in 7 programming languages
- IBM-PC/XT/AT compatible

Call us today on **042121 6527** for a free full colour product selector chart

Fairchild

Fairchild Ltd Eastpoint Burgoyne Road Thornhill Southampton SO2 6PB
Tel:042121 6527 Fax:042121 6583

CIRCLE NO. 140 ON REPLY CARD

Control system simulator

It is a common practice to test the dynamic performance of any control system with certain known and standard inputs and then evaluate the error pattern to determine the health of the system. A simulator capable of generating very low-frequency simple harmonic motion (SHM), constant-velocity ramps and step functions is used for this, but the equipment has draw backs because of its gear trains, cams, friction drives and governor controls. Even though these are time tested, they tend to drift from their initial settings, resulting in poor accuracy and non-repeatability.

Featured here is a simple electronic simulator configured around the popular 8085 CPU and some of its supporting ICs. The SHM test is considered the

toughest test for most of the control systems as it contains acceleration, deceleration, change of sign and constant velocity. To synthesise SHM, a complete cycle of a sine function is sampled into 16K words with 16bit resolution. However, you can see that, with the data of the first quarter (0 to 90°), the entire waveform can be constructed by appropriately manipulating the sign and amplitude at the sampling instants. Thus, $4K \times 16$ samples of the first quarter of the sine wave only need to be stored, addressed at certain rate and then scaled up or down corresponding to the period and pitch selections.

The 8155's 14bit timer generates the terminal count indicating the rate at which the samples are latched out. Two eight bit ports are programmed to out-

put the 16bit sampled data and the six-bit port to input the pitch and period. The 256byte ram in the 8155 forms a scratch pad.

The step function can be created by selectively inverting one of the output bits according to the bit weight. Bit weight can be decided in conjunction with its interface to the digital-to-synchro or resolver converters. An hardware HALT can also be of some use where the output waveform needs to be stopped at any desired phase (position) before applying the step function. In addition, a simple program to count up and count down can generate the constant speed slow or fast ramps.

George Varkey
Kerala
India

Wide-band VCO for UHF

My main considerations when designing this circuit were wide tuning band-width, low phase noise and low cost.

Decoupling of the base of Tr_2 should be made as close to the package of the device as possible preferably using a chip capacitor.

Capacitor C_6 is selected to give the widest tuning band width and highest power output and will vary according to PCB layout. Again, this should be a chip capacitor and should be connected as close to the

transistor terminals as possible.

Transistor Tr_1 forms the basis of an active bias circuit to provide the oscillator with good frequency stability with temperature.

With the right PCB layout and a ground plane the circuit is capable of a tuning range of 310 to 680MHz, a minimum power output of 50mW into 50Ω and a phase noise better than 85dBc/Hz at 10kHz.

Malcolm Holmes
Bedford

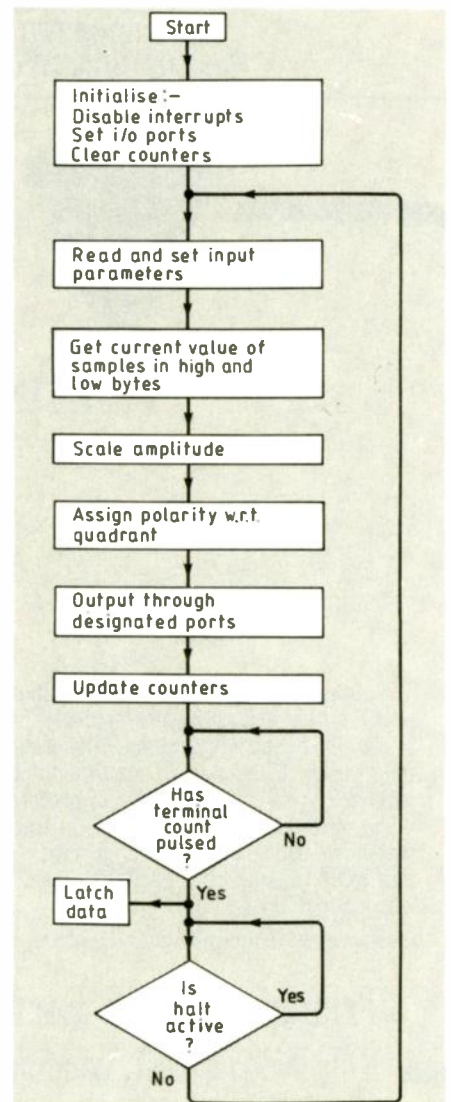
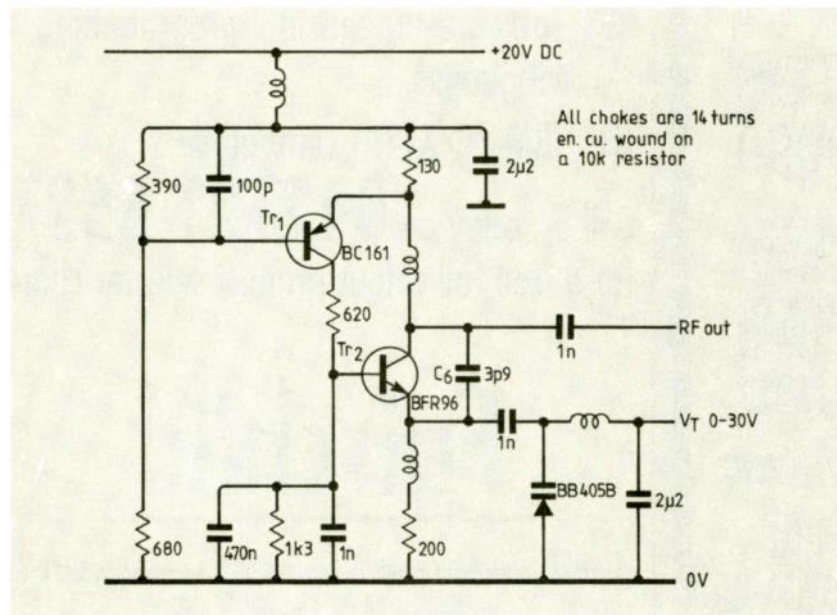

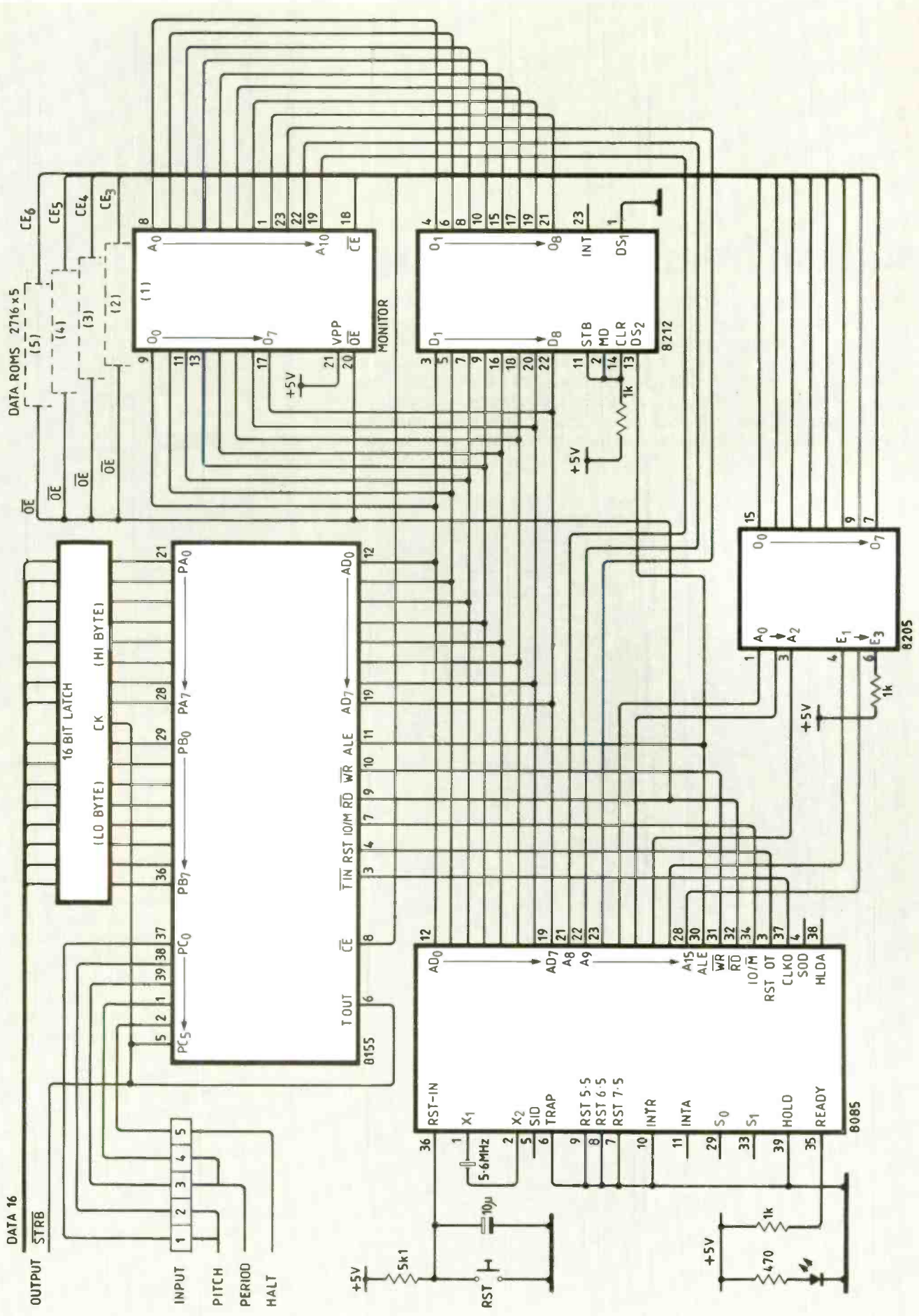

Medical freezer alarm system

In medical research, clinical trials can require the freezing of large numbers of blood samples for years and accidental thawing of the samples can be a very expensive business. We have used this thaw-warning system successfully over a number of years; it is not exotic but it has proved reliable and it is inexpensive.

Several independent local sensors, operating from their own mains supplies in groups, trigger both a local audible group alarm and a remote shared warning lamp. Provision is also made for triggering an intercom or, after a delay, say, a radio alarm leased from a security company who then page an operator. The delay, of about 18 minutes, pre-

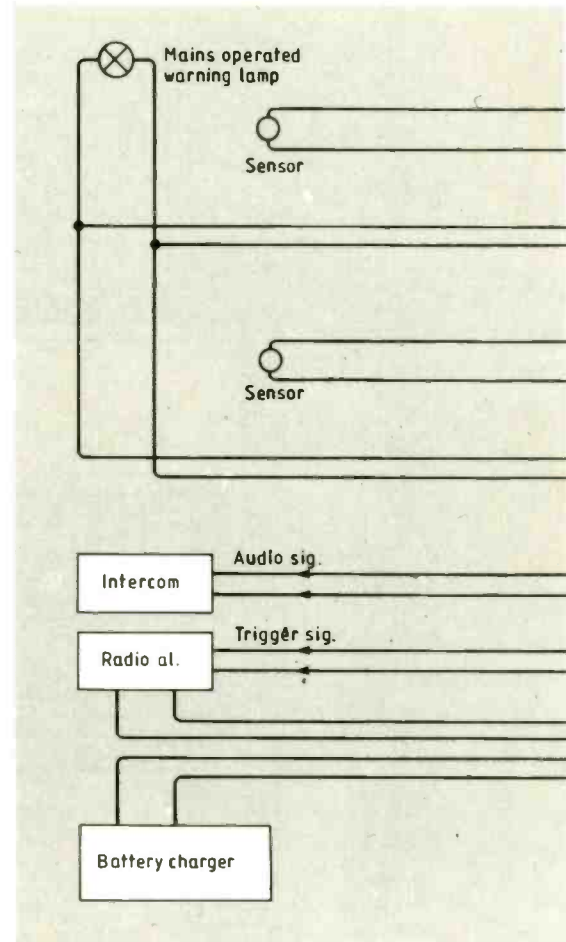
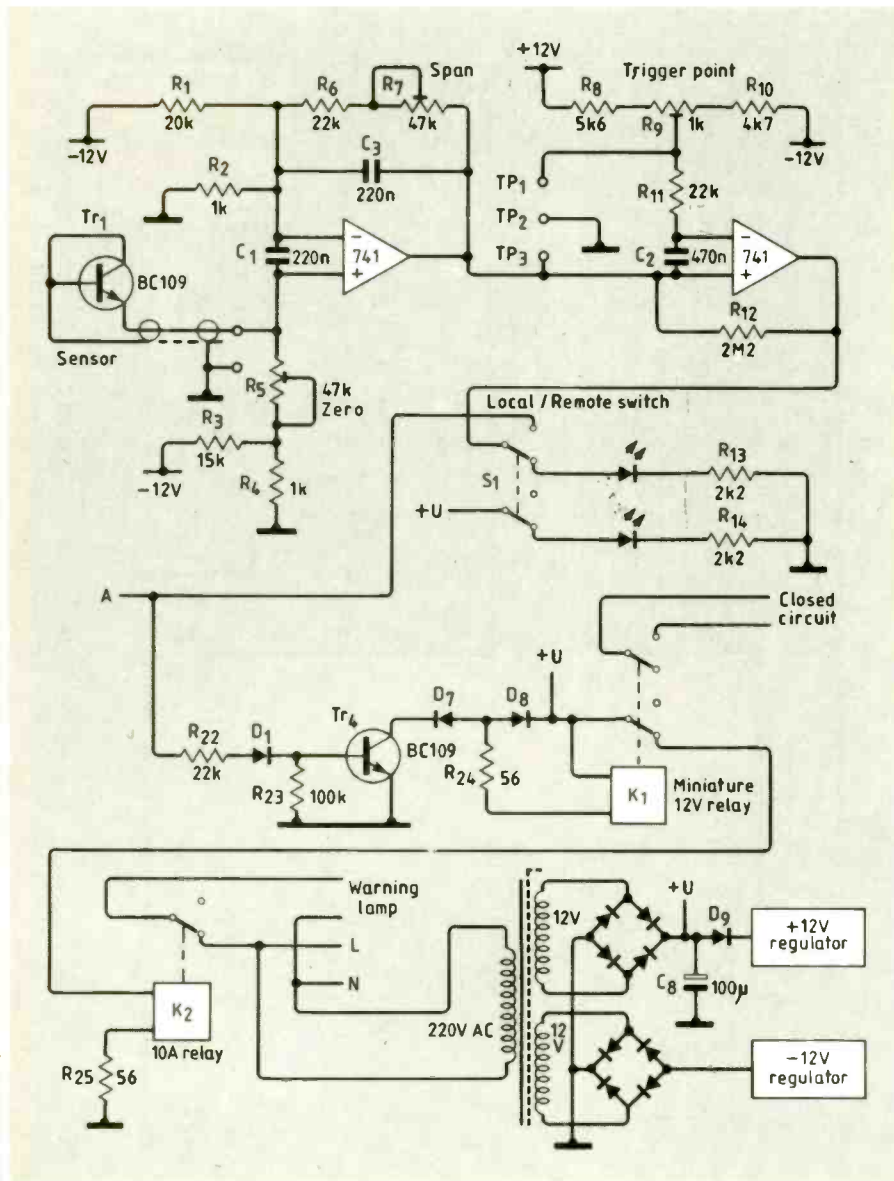

vents triggering from spurious signals and short interruptions of the mains supply.

Of two leds in the sensor unit, one indicates when the unit is not ready to be switched into the common circuit and the other reminds the operator to do so.

In order to isolate the BC109 temperature sensor from its environment, it is immersed in silicone oil in a sealed test tube. When setting up for a refrigerator instead of a freezer (+10°C instead of -10°C), R₈ and R₁₀ are interchanged; R_{1,3} may need adjusting slightly to compensate for differences in op-amps.

In the control unit, Delay and Isolation switches S_{3,4} are only used during servicing. Normally, the delay switch is left on; switching to intercom mode automatically switches the delay off. In this way, problems can be picked up immediately during the daytime with the switch in intercom mode, and after 18 minutes at night with the switch set for radio mode. When either a sensing unit is switched into the common closed circuit, or the central control unit is operating normally and switched to radio alarm mode, all leds will be unlit.

J. Malherbe
Pharmacology Department
University of the Orange Free State

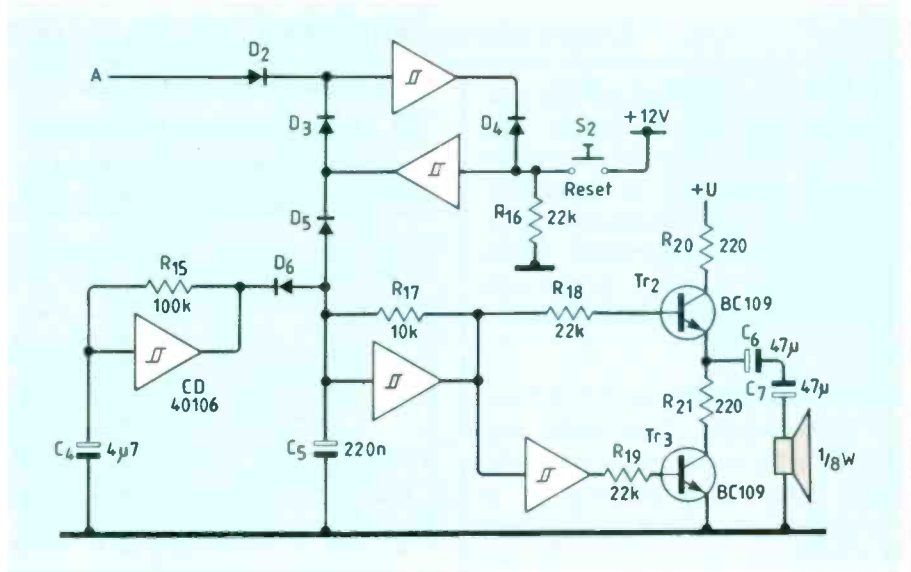
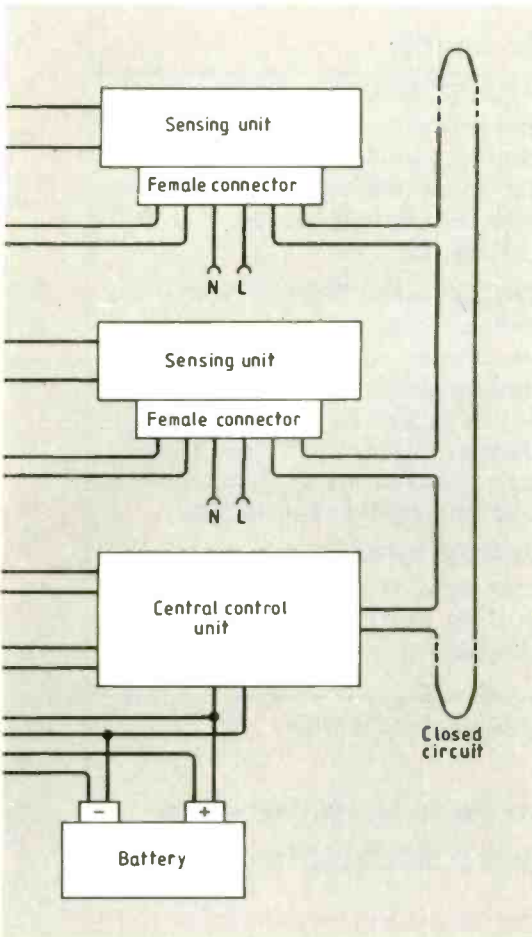

From above, clockwise; overall block diagram; sensing unit audible alarm section and latch; control unit; power supply and sensing unit.

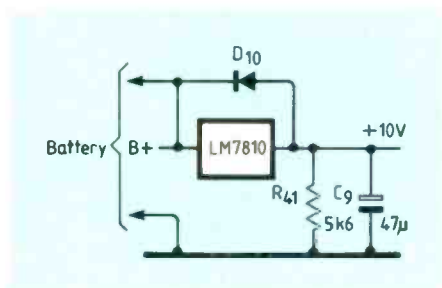
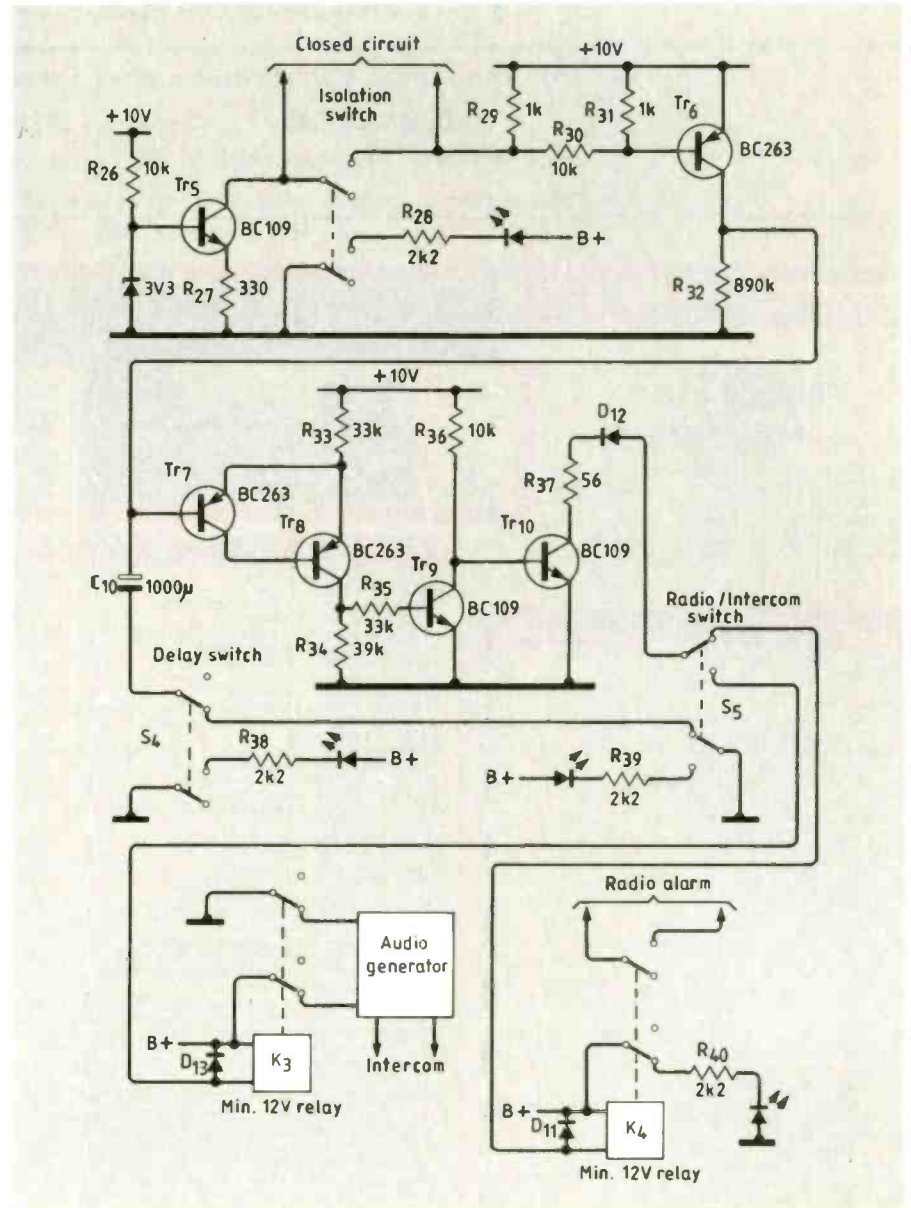

PROTEL PCB CAD SYSTEMS

Professional high quality PCB CAD SYSTEMS at a Price you can afford.

Conventional and SMD on both sides of the board.

PROTEL AUTOTRAX at £999.00 is an affordable, precision design tool that improves productivity for occasional and expert users alike. It streamlines the PCB layout processes while providing powerful interactive design automation, and generates professionally accurate PCB artwork.

PROTEL TRAXSTAR at £807.50* is a grid based, costed maze autorouter with full rip-up and re-route capability. The router incorporates a user-definable cost structure and allows separate cost structures for the route, rip-up and smoothing passes. Works with Protel Autotrax files.

All Protel Users Contact J.A.V.

For Technical Support & Upgrades

Version 3 Schematic users contact us now for free upgrade to Version 3.30

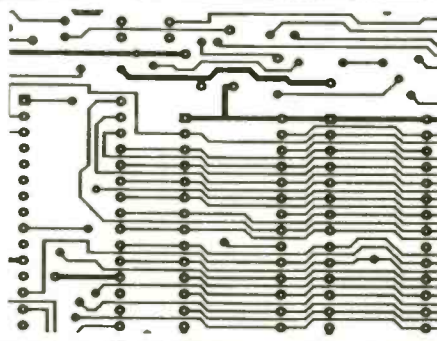

RANGE NOW INCLUDES
COSTED RIP-UP AND RE-ROUTER

PROTEL SCHEMATIC at £498.75* streamlines drafting operations, improving productivity, design practice and documentation. Used on its own or with Autotrax to form a powerful PCB CAD system.

PROTEL EASYTRAX at £299.00 is a low cost entry level easy to use precision tool that generates professionally accurate PCB artwork, with support for a wide range of displays, photoplotters, pen plotters, laser and dot matrix printers all as standard. (NOW UNPROTECTED)

PROTEL TRAXVIEW at £430.00 is a new utility program for viewing and editing Gerber files. Includes Panelization

J.A.V. Electronics Limited, Unit 12a Heaton Street, Denton, Manchester, M34 3RG

Tel : 061 320 7210

Fax : 061 335 0119

The UK Distributor for the PROTEL CAD Software. Main Dealers for ROLAND Plotters. Dealers for Sage, Brother, OKI, Amstrad & Epson.

Evaluation Disk Available on Request. All Prices Exclude VAT. *Price Includes 5% Discount if Bought With Autotrax.

CIRCLE NO. 115 ON REPLY CARD

OSCILLOSCOPES



PHILIPS PM3256 75MHz ruggedised portable £650
PHILIPS PM3267 100MHz dual-trace oscilloscope £500
TEKTRONIX 2213A 60MHz dual-trace £375
TEKTRONIX T922 15MHz dual-trace £175
GOULD OS3300B 50MHz dual-trace dual-timebase £175
(Fast turnover of oscilloscopes, please phone for up-date)

£325

MARCONI INSTRUMENTS

TF1152A/1 RF power meter 0.25W-250MHz £75
TF1245/1246 O-Meter and oscillator £500
TF2015/2171 UHF AM/FM signal generator with synchroniser £750
TF2162 MF attenuator 0-111db in 0.1db steps £100
TF2300A as above with deviation to 1.5KHz fsd £350
TF2300B modulation meter as above £450
TF2356 level oscillator 20MHz £400
TF2501 power meter 0.3W fsd DC-1GHz £150
TF2600 millivoltmeter AF 1mV-300V fsd £75
TF2600B video voltmeter 1mV-300V fsd £175
TF2604 electronic multi-meter £150
TF2807A PCM multiplex tester £400
2828A/2829 digital simulator/analyser £1,500
2833 digital in-line monitor £275
TF2908 blanking & sync mixer £250
6460 RF power meter £350
6460/6420 power meter/microwave head £495
TF893A audio power meter 1mW-10W fsd £75
TK2374 zero-loss probe £300
TF2304 automatic modulation meter £450
2092C noise receiver, many filters available £500
2091/2092A noise gen/receiver & filters £750
6600A/6646 sweeper 8-12 4GHz £750
2018 synthesized signal generator 80kHz-520MHz £2,250
6056B signal source 2-4GHz £850
TF1313A 0.1% universal LCR bridge £250
TF2011 FM signal generator 130-180MHz £195
TF2012 FM signal generator 400-520MHz £195
2438 (303J) 520MHz universal counter-timer £500
TF2303 modulation meter £325
2019 synthesized signal generator 0.08-1040MHz £2,500
TF2700 RCL component bridge £250
TF2163S UHF attenuator 0-142db £325
TF2905/8 sine squared pulse and bar generator £450
TF2370 spectrum analyser 110MHz £3,500

RALFE · ELECTRONICS

36 EASTCOTE LANE, S. HARROW, MIDDLESEX HA2 8DB
TEL: 01-422 3593, FAX: 01-423 4009



EST. 35 YEARS

TEST & MEASUREMENT EQUIPMENT

AVO B151 LCR universal bridge £250
AVO RM160/3 megohmmeter £150
STOLTZ A.G. prom programmer M2 Maestro £250
RACAL 9083 2-tone signal source £300
RACAL 9084 104MHz synthesized sig. gen. GPIB £1,000
WAVETEK 1503 sweeper 450-950MHz £450
WAYNE KERR B642 Auto Balance bridge £295
VALPAID Inverters 24V DC-230V AC from £75
RIKADENKI 3 pen chart recorder £450
SCHLUMBERGER SRTC-GA63 selective call test set £1,750
TEKTRONIX 7D12M/2 A/D converter plug-in £350
TEK 2901 time-mark gen £250
TEKTRONIX 178 IC fixture £250 Tek 606 XY monitor £250
TEXSCAN WB713 0-950 sweep generator £950
TEXSCAN 9900 300MHz sweeper/display £350
PHILIPS PM2554 AF mill-volt meters £125
PHILIPS PM5324 RF generator 0.1-1.10MHz AM/FM £450
PHILIPS PM8043 XYT Plotter A4 £750
PHILIPS PM8220 single pen chart recorder £195
E.N.I. 503L amplifier 40db, 510MHz, 3W £295
FLUKE 5100B instrument calibrator £5,950
FLUKE binary programmable power supply £500
GEN RAD 1607A transfer function bridge £500
IWA TZU SM2100 dual-channel audio spectrum analyser £2,950
KEITHLEY 175 digital multi-meter £200
TEKTRONIX 548A PAL TV waveform monitor £500
TEKTRONIX SG503 signal generator/TM501 frame £1,250
TEKTRONIX 496P 1kHz-1800MHz spectrum analyser with tracking generator and counter £8,500
WAYNE KERR 4210 RCL component bridge GPIB £500

WANTED: Top quality 'high-end' test equipment for stock or will sell on commission. Please call, post of Fax list, any quantity. Signal generators, spectrum analysers etc urgently required for waiting customers.

ALL OUR EQUIPMENT IS SOLD IN EXCELLENT, FULLY FUNCTIONAL CONDITION AND GUARANTEED FOR 90 DAYS. MAIL ORDERS AND EXPORT ENQUIRIES WELCOMED. PLEASE TELEPHONE FOR CARRIAGE QUOTE. ALL INSTRUMENTS ARE AVAILABLE EX-STOCK AS AT COPY DATE. GOOD QUALITY TEST EQUIPMENT ALWAYS WANTED FOR STOCK. PRICES QUOTED ARE SUBJECT TO ADDITIONAL VAT.

HEWLETT-PACKARD

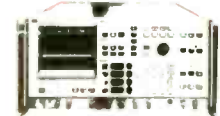

1122A power unit for Iet probes £195
11602B transistor fixture £395
8733A pin modulator £250
629A Logic comparator £275
10529A/10526T Logic troubleshooter £295
382A(P) P-band attenuator 0-50db £250
415E swr meter £295
6516A power supplies 0-3KV 6mA £250
7046B(07) 2-pen XY plotter high-speed £1,000
8018A(01) serial data generator £1,000
5011T logic troubleshooting kit complete £500
400FL mV-meter £325
8165A function 1MHz-50MHz £1,950
435A/8481A RF power meter & head.
(Other heads available) £750
3581A AF wave analyser £1,250
3575A gain/phase meter 1Hz-13MHz £1,250
432A/478A microwave RF power meter £375
8553B 110MHz spectrum analyser plug-in £950
7563A log voltmeter/amplifier £250
11683A range calibrator for power meters £250
3582A dual-channel audio spectrum analyser £3,500
5505A laser interferometer £5,000
5423A structural dynamics analyser £3,000
8405A vector voltmeter £1,000
8556A/001 L.F. spectrum analyser plug-in £750
8559A/181R 21GHz spectrum analyser £4,950
8565A 40GHz spectrum analyser £8,500
8640B/001 phase-locked signal generator £2,250

ADDITIONAL EX-STOCK T & M KIT

VARIACS (Claude Lyons) 0-270V, 20A £100, 15A £75, 8A £45
GOULD DSA600 digital synthesizer analyser £250
PM5534 standard TV pattern generator, NTSC £2,500
PM5545 PAL 625 colour encoder £1,000
PM6302 RCL component bridge £250
PM2120 universal switches for syst '21' £500
PM5580 IF modulators Systems B, G & M £1,000
PM5597 TV VHF modulators. Rack of 5. System 'G' £1,000
FLUKE 8060A digital multi-meter £225
ELECTROVISUALS TV waveform monitor and vectorscope EV4010/EV4020 19" rackmounting 3U £950
ROHDE & SCHWARZ SWOF III videoskop c/w sideband adaptor POA
PHILIPS PM5190 synthesized function gen 1MHz-2MHz £950
PHILIPS PM8235 multi-point pen recorder £395
TEXSCAN AL61 4-1000MHz spectrum analyser, battery portable £1,250
WAVETEK 2000 sweep generator 0-1400MHz £950
WAVETEK 157 synthesizer 100uHz-1MHz £250

CIRCLE NO. 132 ON REPLY CARD

THE GREAT VIDEO RACE



CONSUMER ELECTRONICS



After thirteen years of video recording, JVC and Sony are still locked in a standards battle that shows no sign of subsiding. Barry Fox comments on the state of play.

The VHS system, unveiled in Japan in 1976, changed the course of history by offering two hours of recording time from a cassette which at the time looked astonishingly small.

Sony had offered the Beta system a year earlier, but it could manage only one hour. At the time, Akio Morita, Sony's charismatic boss, argued that because most television programmes ran for less than an hour, two-hour recording time was not important. Later, of course, Sony extended Beta playing time and JVC's parent, Matsushita, doubled VHS recording time to four hours by halving tape speed. All these pioneering developments were in the NTSC format for the US and Japan.

The PAL versions of VHS and Beta were launched in Europe in the spring of 1978. Their technical parameters steered a middle course between the extreme playing times offered in NTSC format.

Beta pushed the boundaries of tape and head technology to offer a high writing speed (5.0m/s) from narrow tracks (33 microns) and low tape speed (1.87m/s); VHS played safer with a lower writing speed (4.85m/s), wider tracks (49 microns) and higher tape speed (2.34cm/s). As a result, provided the tape was of good quality, Beta gave better pictures than VHS. But purely for commercial reasons VHS became the de facto

standard. JVC's negotiator Shizuo Takano played a clever game by licensing the format to anyone who wanted it, whereas Akio Morita kept a tighter grip on the technology. There are now over 230 million VHS recorders in use around the world.

The VHS cassette was clearly too large to be used in a camcorder which met the industry's target size – a Super 8 home movie film camera. In March 1983, 122 companies from all around the world agreed on a standard for 8mm video, based on a much smaller cassette with longer playing time.

VHS family

The VHS family was originally party to the agreement, but opted out in favour of miniaturizing the VHS cassette. The compatible C, Compact, cassette was announced in 1982. Sony went ahead with Video 8 in Europe in 1985. The camcorder market is now roughly split 50/50 between VHS and Video 8.

VHS picture quality was improved by the HQ (high-quality) system, actually a clutch of minor modifications to the recording format. These preserved compatibility with pre-HQ VHS, and for this very reason could offer only relatively minor improvements in resolution.

In 1987, JVC bit the bullet and

announced Super VHS (with a European version following the year after). This improved picture quality, but at the cost of full compatibility. S-VHS uses a signal coding system which is a halfway house between component coding (as used by professional MII and Betacam systems) and composite coding (as used for broadcast television, U-Matic and domestic video recorders, such as standard VHS).

The S-VHS recorder records a composite 'S' signal but puts out a Y/C signal. In this the luma (Y) and chroma (C) are kept separate (hence 'S'). But the chroma is a composite mix of the two colour difference signals; and this composite mix is either in PAL/SECAM or NTSC format, depending on the country and local television line standard.

By keeping the Y and C signals separate there is less risk of colour interference and picture degradation. But the benefit is only seen when tapes that are replayed through a television set with an S terminal, which also keeps the Y and C signals separate.

S-VHS picture quality is also improved because the luma carrier is higher above the chroma, so that there can be wider FM deviation with

Above: S-VHS VCR with stereo sound

less chance of mutual interference. For Europe, the S-VHS chroma frequency remains the same as standard VHS (627kHz) but the luma spreads over 1.6MHz (between 5.4MHz and 7MHz) instead of 1MHz (between 3.8MHz and 4.8MHz) for standard VHS. This lifts resolution to over 400 lines, compared with 250 lines or less for standard VHS.

The debit is that, although an S-VHS recorder will play back either standard or S recordings, a standard VHS deck will not play back S-VHS recordings. This means that the software industry must embark on double inventory duplication and stocking if it is to service S-VHS deck owners. So far, the software companies have not thought that the population of S-VHS decks warrant this. In chicken and egg fashion, the lack of software deters people from paying £1000 for an S-VHS deck.

What looks like a useful selling feature, the routine incorporation of a Nicam stereo sound decoder in S-VHS decks, has also failed to attract customers. This is quite simply because the BBC took a financial decision to delay the start of Nicam broadcasting until 1991. And although Channel 4, Thames, LWT and Yorkshire TV all officially began Nicam broadcasting on September 11 this year, neither they nor the IBA did anything – not even a press conference was held – to tell the trade, press and public about it.

The result is that S-VHS is

currently of most interest to serious home-movie buffs who uses S-VHS camcorders to shoot tapes of high enough quality to sustain multi-generation copy editing. Although broadcasters and professional users like S-VHS picture quality, they are unhappy with the sound. Being analogue, it cannot withstand the three generations of copying which they regard as the minimum for editing. The same problem arises if attempts are made to record time-code pulses on the S-VHS soundtrack.

Hi-8

Rising to the S-VHS challenge, Sony developed an improved high-band version of Video 8; Hi-8 was launched in Europe at the end of August. Like S-VHS, Hi-8 raises the frequency of the luma carrier and widens the FM deviation from 1.2MHz to 2MHz. As with S-VHS, the Y/C signals are kept separate for feeding to an S terminal television set. And, like S-VHS, resolution is better than 400 lines.

But whereas S-VHS still relies on ferric oxide tape (albeit of higher coercivity than standard VHS oxide) the 8mm formats have moved on and up the coercivity scale to pure metal; metal powder for standard Video 8

Hi-8: Sony's first machine

S-VHS: Panasonic's NV-MS50 camcorder

and metal evaporated for Hi-8. This is the first use of ME tape for video. As with S-VHS, there is limited compatibility. Hi-8 recordings will not play back on standard Video 8 hardware.

Sound

Although there is little to choose between S-VHS and Hi-8 picture quality, both the 8mm formats offer one very important advantage which will attract professional users. Although the option is not implemented on the first Hi-8 camcorder, there is room for a burst of PCM sound at the end of each helical video track. This is quite separate from the picture signal and thus can be independently dubbed.

So far, VHS and Super VHS have been able to offer only analogue sound; mid-fi linear audio from edge tracks and high-quality FM stereo which is depth-multiplexed with the picture signal. There are two possible ways of recording PCM sound along with the VHS picture signal. But each is a compromise.

One option is to bury the PCM in a triple-depth multiplex recording sandwich, along with the video and FM analogue stereo. The other is to sacrifice the linear tracks down the edge of the tape and switch the video heads to record bursts of PCM in the tape area thereby released.

The multiplexed approach locks the sound and vision signals together, thereby restricting dubbing; sacrificing the linear tracks compromises compatibility.

"We are still studying the options" says JVC's head office in Japan. "Whatever system is adopted, compatibility is our major concern. Although past history shows that compatibility is not a big issue for broadcasters, for domestic users compatibility is the major concern. It has always been our policy to preserve compatibility."

Fine words. But when the need arose, JVC was prepared to compromise compatibility with S-VHS. The big surprise, and lost opportunity, was that PCM sound was not built into the S-VHS format at the time of its launch. While JVC was ditching picture compatibility between new recordings and old machines, the company should surely have gone the whole hog and ditched audio compatibility too. Behind the scenes, Panasonic advised this, but was over-ruled.

This may prove to have been a serious tactical error by JVC and the rest of VHS family. It gives Sony and Hi-8 a leading edge with their target market of what the advertising industry has quaintly christened "Prosumers".



SURROUNDED BY SOUND

The latest sound surround systems can stimulate the parts of the soundfield that others can't reach, says Peter Dolman

Successfully implementing surround-sound techniques can make listening more enjoyable by adding acoustic detail to give a more concise perceived sound. Naturally occurring directional cues, abundant in real life – for example ambience from wave reflections in a concert hall – can merely be inferred by conventional twin channel arrangements. Spatial techniques give the creative association of imagery outside the listener's normal field of vision; by using stimuli which activate natural human responses, sensations from the subtle to the fantastic can be invoked.

The surround sound system was conceived in the 1970s for the film industry. Known as Dolby Stereo it has up to six audio channels. With the more recent licenced Dolby decoders for domestic use, it is possible to emulate the overall cinematic experience in the home.

The use of surround sound in the cinema and home involves appreciating the effect of interplay between visual and aural stimuli: thus such a system differs considerably to that of a sound image only system.

An isolated aural stimulus will not be perceived unless that stimulus is adequately sustained for about 10 to 20ms. This gives the possibility of concealing distortion by taking steps to ensure that that duration of such noise is below this threshold. The principle is exploited in detecting and controlling optical clash referred to later.

Rhythm method

At any instant, attention is directed to a relatively small portion of auditory space. With two or more sounds in different spatial locations, they are perceived (in the absence of visual confirmation) as either separate, attention stepping from one to the other, or spatially related, depending on the extent to which the sounds exhibit any recognised common ground such as rhythm content.

Whatever the perceived image, its localisation is believed to involve

binaural detection, based on relative values of arrival time, the ensuing phase relationships and intensity levels. These provide directional cues, identifying on which side of the head the stimulus is located. Yet, given these specifics, unambiguous localisation in the absence of supplementary information is not readily achieved (see Fig.1).

If a sound source, X, radiates a tone which impinges on the ears according to the criteria so far discussed, the ambiguity may be represented by constructing a hyperbola, focussed at the ear, such that the ratio $d_1:d_2$ remains constant, irrespective of where X is on that hyperbola.

Yet it is possible to localise accurately in terms of azimuth and elevation, without supplementary visual or reverberant information. One method is interpreting successive measurements taken during intuitive movements of the head. But localisation is also possible without head movement. Relative wave composition corresponding to the actual source location is a function of multiple delay paths set up by the outer ear. Although this will set up complex wave patterns in each ear, it has been shown that precise localisation is possible with one ear only, implying the option of comparison to some reference data.

Where head movement is instinctively used to localise, tones exhibiting slow sweeps in terms of amplitude or frequency equate to a confusing array of readings. This helps explain why emergency vehicle sirens are more difficult to pinpoint than the old-fashioned two-horn or fire bell.

Neurophysically, a functional division of the auditory pathway exists, such that localisation and identification subsystems provide separate analysis of the dimensional and tonal qualities of the perceived soundfield. The selective attention to such interrelated elements in physiological terms has a counterpart in the treatment of audio signals in a surround system.



CONSUMER ELECTRONICS



With Dolby Stereo, you could have this character in your sitting room, should that thought appeal to you. The system of surround sound is used in the Warner Brothers' BATMAN film.

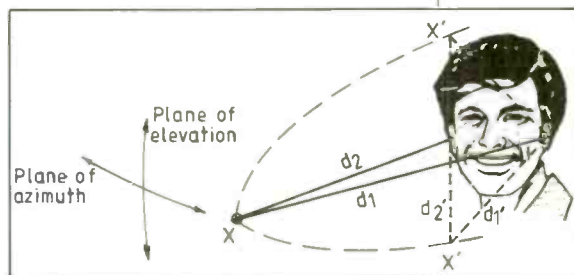

Fig.1. Generation of a pure tone anywhere on the hyperbola produces similar relative binaural values of intensity, arrival time and phase.



CONSUMER ELECTRONICS

A phenomenon which can be exploited is the Precedence Effect. If a click is emitted simultaneously by two matching, well-spaced loudspeakers, an observer will perceive the closest speaker to be the sound source. The crucial factor is the relative arrival time of like components. Providing there is a difference of several milliseconds, the subsequent source can be louder than the prior source, yet the second click will not be perceived.

Work by Haas in 1951 suggests that the delayed signal is not merely suppressed. In an experiment with speech, the level of the prior signal is adjusted to lie below the intelligibility threshold, while the relatively delayed signal source is set to exceed this level. The result is that intelligible speech is observed — apparently sourced by the nearer loudspeaker. It seems probable that this highly specific mechanism has evolved to help counteract everyday perceptual interference, for example misleading directional cues from strong sound reflections.

When an aural stimulus is detected, not only is tonal character and location expressed, but so too is a measure of its size. If one listens to a distant barely audible tone of around 1kHz, the subjective size of the emitting surface seems to correspond to a few square centimetres, in sharp focus; as intensity increases the image appears to enlarge. If the frequency of the tone is reduced, the image expands further still, while its border becomes less clearly defined. Interpreting this suggests that such ambient variability in a reproduced soundfield may be controlled by careful definition of signal composition and processing. A distant feel can thus be imparted to selected regions of the spatial image and to the corresponding radiators.

In film and television, account is taken of the need for correlation between the visual image and the

perceived bulk of the attendant sound elements.

Walt Disney

For several decades multichannel audio techniques have assigned dimensional qualities to cinema soundtracks. As far back as the early 1940s, cinema-goers experienced stereophonic presentations with Disney's classic animation *Fantasia*, which used an audio effect known as *Fantasound*. With widescreen film developed in the 1950s came the need for a more explicitly expressed sound field which reinforces the on-screen action, or perhaps generates on or off-screen directional cues. Of the various multichannel soundtrack concepts to appear during the 1950s and 1960s it is the 70mm (six track) and 35mm (two track) wide-screen formats which have prevailed. By the late 1970s the name Dolby had become synonymous with the issue of cinema surround-sound, and more than 2000 titles have been produced bearing the Dolby Stereo logo.

The large-screen 70mm format carries six discrete magnetic audio tracks of 18kHz bandwidth. Before Dolby, these tracks drove an array of five loudspeakers behind an acoustically transparent cinema screen, plus a sixth driving an array of surround loudspeakers around the sides and rear of the theatre. The assignment of these channels has altered slightly since the introduction of Dolby Stereo, giving the cinema-goer a visceral and dynamic experience by a sub-woofer channel (known as *Baby Boom*) and *Split-Surround* separation of the surround effect. Both enhancements are derived by filtering information from channels two and four.

The 70mm system is principally for premier releases and can be shown only in suitably equipped theatres. Due to its discrete multichannel form, it is impractical to incorporate it in a domestic set-up.

In the 35mm Dolby Stereo format, matrixed LCRS (left, centre, right, surround) audio signal components are conveyed by two variable area optical tracks. This is easier to manufacture than a magnetic medium. In operation, the optical system proves to be the most robust choice — its magnetic counterpart may suffer from soundtrack flaking, ageing and replay head wear.

A parameter of the optical system which must be considered is its behaviour when handling material with a wide dynamic range. Unlike magnetic tape, which saturates gently, optical clips hard — the result is called optical clash.

Three stereo DME (dialogue, music, effects) stems represent the premixed common source material from which the mix down to 35mm and up to 70mm is derived. In view of different characteristics of the two recording mediums, it is vital that signal levels be carefully controlled if multiple release is envisaged. To help, an optical process monitoring function is used, which the recording engineer can select to simulate the response of the 35mm optical format. In the optical process, frequency response is restricted to 25Hz to 13kHz and a clash simulator provides an aural approximation of the effect of exceeding 100% modulation. Interpreting perceptual latency of auditory detection indicates that distortion which occurs for less than 10ms will not be perceived; thus twin clash indicators are used, one which responds to a clash duration of less than 10ms, the second to indicate a clash of greater than 100ms.

Matrix monitoring

The DME stems comprise LCRS signals which are matrixed on a two-track Lt-Rt (left total, right total) printing master. This will be transferred 1:1 to an optical negative for generating 35mm stereo optical prints; this mix is in Dolby Stereo material for home video release or stereo television transmission.

To ensure the dynamics of the Lt-Rt pair are technically and aesthetically appropriate to reproduce in various listening situations, the film mix is monitored using the 4:2:4 technique. The LCRS input signal is matrix encoded according to established Dolby MP (Motion Picture) coefficients. Intermediate Lt-Rt signals are generated and these feed directly to a MP matrix decoder, the output of which is monitored during the record process (see Fig. 2).

This back to back configuration produces an effective feedback loop which takes account of the combined action of the encode/decode

Fig.2. The 4:2:4 matrix monitoring principle.

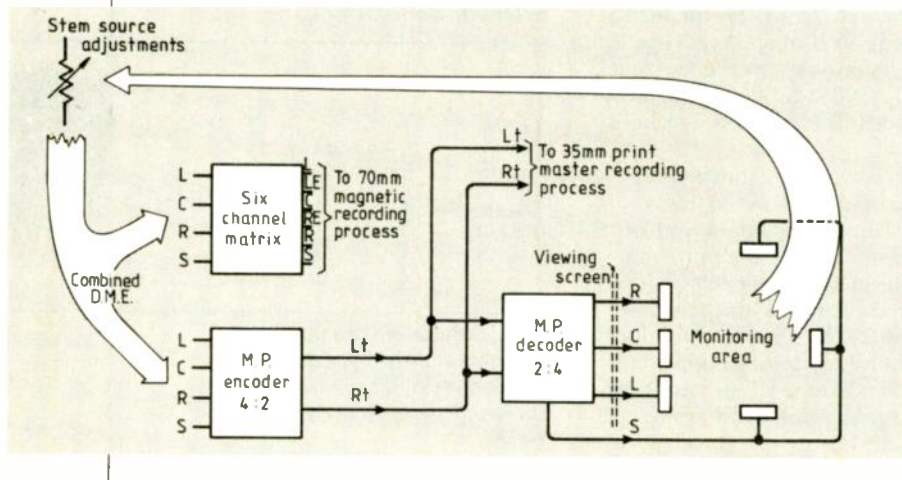

arrangement. Although the final mix will produce the desired spatially defined soundfield when reproduced by an LCRS surround decoding system, measures are taken to ensure good results in less sophisticated systems. Using 4:2:4 monitoring, mixers can ensure that stereo (Lt, Rt) and mono (Lt+Rt) compatibility targets are not compromised by extra processing.

In most cases, two-channel stereo reproduction is enhanced due to the production of a diffuse out-of-phase phantom surround image when an effect is panned from front to back. Mono compatibility problems will be resolved during four channel monitoring, the required in-phase components being reproduced as a hard centre. Out-of-phase material appears as a hard surround.

The use of the 4:2:4 system lets creative judgement, anticipating the combined action of the encode/decode process, be made with confidence. Such monitoring is essential as, unlike a quadrophonic system, this form of surround sound must confirm and reinforce the visual stimulus.

Putting the phantom in its place...

In a domestic audio set-up, stereo has become synonymous with two loudspeakers, while in theory a larger number of channels could be used. In conventional stereo, common elements produced by the two loudspeakers generate phantom images, the perceived locations of which will be determined by the relative proportions of like components contributed by each channel, and by the position of the listener relative to the speakers (see Fig. 3a). To convey a central phantom image P to an observer central to the soundfield, as at (a), necessitates the perception of correlated signal components of equal value. Although this may be achieved in a well designed listening room, it is unlikely to be practical in any audio-visual environment, due to the requirement for a wide range of seating positions. Thus a listener off-axis, such as at (b) will observe a disconcerting error in the position of the sound image relative to the visual presentation (pb). This causes disorientation.

For most visual presentations, the main dialogue is central. Thus the third audio channel of the MP matrix conveys central image information, anchoring the on-screen dialogue and permitting off-axis seating

arrangements, as shown in Fig. 3b.

To complement this, the remaining channel provides a broadly distributed rear or surround sound contributions. This single channel does not create a point source behind the listener, but this should not be considered to be a limitation — indeed, such sounds can cause disquieting unconformity.

However, atmospheres (such as applause, distant sounds, thunder and ambience) all create the feeling of being in the action without the need for extreme precision. Acoustic detail such as this can be ideally attained by a single-channel multispeaker array at the sides and rear of the listener.

Domestic theatre

The television industry is poised to deliver what it calls home theatre, including large CRTs, improved aspect ratio, 100in LCD projection systems and high-definition flicker-free displays, complemented by high quality audio.

The technology behind Dolby Stereo aural cinema presentations can provide the same spatial resolution in the home. Termed Dolby Surround, the system keeps the capabilities of Dolby Stereo without the standardisation of specialist reproduction in the cinema.

Providing an ultra-large television display is not considered to be imperative. In many cases, the size of the decoded sound image will far exceed that of the visual counterpart, an effect common in real life. Subjective tests indicate that an expansive and spatial soundfield has

the psychological effect of increasing the perceived picture size.

Compared with quadrophonic systems, the economics of owning a Dolby Surround System are more palatable; there is no requirement for dedicated transcription equipment — the stereo signal source will, by definition produce the Lt-Rt signal pair necessary to drive the 2:4 surround decoder, providing Dolby Stereo encoding was used originally. This applies to many film releases already available from video libraries, frequently with both linear and hi-fi sound tracks encoded.

The same facilities are available on suitably encoded CDV (compact disc video), where full 16bit digital audio quality will translate to the LCRS channels, accompanying the off-disc visual presentation with a correspondingly explicit high-fidelity soundfield. Whenever a Dolby Stereo release is televised, decoding is made easier, providing the receiver can receive stereo broadcasts. Many surround television presentations are broadcast and there are more than 3 000 000 domestic Dolby Surround decoders in use worldwide.

By careful choice of encoding coefficients, the optimum degree of decoding compatibility may be achieved (see Fig. 4). The Lt-Rt distribution signals contain the original aspects of the soundfield so that compatibility is maintained should two-channel stereo, or mono reproduction be desired.

The encoder accepts the four input signals, LCRS, and subsequently

continued on page 40



CONSUMER ELECTRONICS

Fig.3. Dialogue anchorage using a central speaker stops listener disorientation.

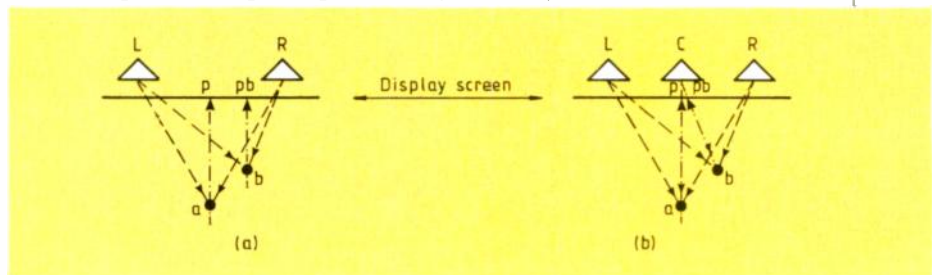
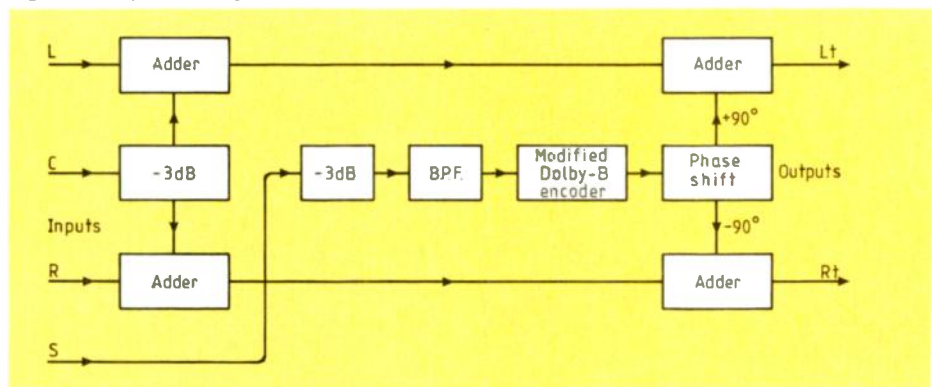

Fig.4. Conceptual Dolby stereo or surround encoder.



On special offer: Hz, μF and $^{\circ}\text{C}$

All digital multimeters offer V, A and Ω . Instruments from ELECTRONICS WORLD + WIRELESS WORLD can also give you Hz, μF and $^{\circ}\text{C}$ on selected models with up to 4½ digits of precision. At prices you wouldn't believe.

DM 7333

- ◆ capacitance to 20 μF
- ◆ frequency to 200kHz (10Hz resolution)
- ◆ transistor h_{FE} test
- ◆ extra large 3½ digit display
- ◆ £67.87

Our special reader offer, negotiated with South Korea's technology driver, GoldStar, brings you a choice of four top quality digital multimeters. Each instrument has specific facilities to match your needs. Simply choose the model which suits you and fill in the coupon below. Alternatively, use your credit card to order the model of your choice by phone.

DM 6133

- ◆ 3½ digit display
- ◆ 0.3% accuracy
- ◆ £46





CONSUMER ELECTRONICS

continued from page 37

generates composites Lt and Rt. The L and R input channels are carried by the Lt-Rt pair without alteration. The C input is first reduced by 3dB to maintain constant acoustic power, then divided equally into Lt and Rt. A correct phantom centre will be reproduced if the two channels are not decoded as the two centre signal elements are balanced and in phase.

The S input signal is similarly reduced by 3dB and undergoes band-pass filtering and a modified form of Dolby-B encoding. Plus and minus 90° phase shifting is then applied to create a 180° phase relationship between the components which are added to the Lt and Rt channels.

Separation is maintained between the L and R signals as they remain independent throughout the encoding process. Isolation between the C and S channels will also be maintained providing the amplitude and phase characteristics of the Rt-Lt transmission channels are accurately balanced.

Installing a typical unit involves adjusting for optimum S/N performance, with a minimum of dialogue leakage in the left and right channels, by metered input level and balance presetting. Subjective equalisation of loudspeaker outputs is made easier by incorporating a calibrating generator, gated to

deliver band-limited noise bursts, centred on 1kHz, in an ordered sequence, sustained for around two seconds per channel.

Power output stage options vary from one decoder to another. Various configurations are possible including the use of separate, dedicated four-channel power amplifiers, use of an existing stereo system to handle left and right channels and self-powered active loudspeakers for the surrounds.

Surround channel delay time may be fixed at 20ms, but some units permit adaptation for many domestic settings by providing adjustment from 15 to 30ms. This lets the perception of leakage in the surrounds be minimised by trimming to provide optimum effectiveness of the Precedence Effect for a given layout.

Many decoders have non-correlative spatial effect modes as well as Dolby Surround or Pro Logic, thereby using multichannel capability for non-encoded source signals.

Dolby Surround or Pro Logic decoding can be implemented by analogue or digital techniques; frequently a combination of the two will be encountered. For example, the customer IC discussed earlier uses analogue processing to achieve adaptive matrixing, while in the surround channel a digital delay is

becoming favoured.

Sensory experience

In emulating a sensory experience, where visual and aural stimuli can be perceived to correlate naturally, the generation of a spatial soundfield involves the development of a record/replay system that can fulfil exacting technical demands in terms of definition, stability and capability by appropriate signal processing.

The characteristics of the Dolby MP matrix have proved to be effective in using a twin channel format to achieve this; once exclusive to the cinema, the development of the Dolby Surround and Pro Logic decoder provides the means to extract the dimensional properties of encoded software in the home.

With the arrival of four-channel sound processors with a host of control or treatment options, specific to listening material, as well as Dolby Surround or Pro Logic decoding, the discrete components of domestic stereo and Home Theatre equipment may well evolve into an integrated audio-visual entertainment system.

Surround decoder

Figure 5 shows the principle of operation. The Lt and Rt signals pass unmodified (except for level and channel balance correction) to appear as L output and R output. As Lt and Rt carry the centre signal

TAKING PRECEDENCE

The ability of the surround channel to effectively project its sonic image into the theatre or lounge does not rely on perfect signal isolation. Many signals assigned to the surround track convey atmospheres which realistically would be expected to manifest themselves both in and out of the field of vision (such as rain, wind and thunder). This does not mean that crosstalk between front and rear channels can be permitted to exist unimpeded; indeed it is the impingement of inappropriate aural stimuli from outside the viewer's established area of apprehension which has the greatest potential for detracting from the presentation.

To mitigate this, a signal processing technique is used which elegantly exploits the Precedence Effect. This incorporates a delay (fixed or adjustable) in the surround channel only, the action of which causes the surround signal — including the unwanted leakage effect described — to impinge on the ear of the observer some 15 to 30ms

after the arrival of aural stimuli in the field of view. So any common crosstalk element will be perceived as non-existent. Loudspeaker placement relative to the seating arrangement is a factor which must be considered carefully for this technique to be effective.

Small signal processing errors will arise in the complex path which conveys the original audio production to the replay environment; phase disturbances become increasingly significant at higher frequencies and, when these occur in the absence of any countermeasure, they give rise to unacceptable activity in the surround channel. For example, the result of a given azimuth error between the Lt and Rt channels will be to produce frequency-dependent centre-channel leakage effects, making separation particularly difficult at higher frequencies. To overcome the problem, a limited bandwidth of 7kHz is used for the surround channel; while this might appear to

impose a restriction, this measure equates to an appropriate form of spectral modification conducive to the material.

The spectrum of distant atmosphere and ambience tends to favour the mid to low audio frequencies — high-frequency elements, being most easily impaired by local propagation conditions, are seldom prevalent. Those which are perceived tend to define point sources. Therefore the absence of high-frequency components in the surrounds imparts a distant quality, impairing one's ability to localise and reflecting a real-life phenomenon.

The spatial uniformity achieved also allows for a good deal of flexibility in arranging seating positions relative to the surround loudspeakers; this particularly benefits individuals near the speakers. The third method used to optimise surround channel performance is a dedicated noise reduction technique.

element, the sound mix will convey a correct perspective of the stereo soundstage by phantom imaging. However, there is an option of realising the centre channel in discrete form: thus a summing stage combines the in-phase components to produce an optional centre channel output.

The surround signal is detected by the Lt-Rt difference amplifier that passes through a 7kHz low-pass filter, delay line and modified Dolby-B decoder to reduce centre channel crosstalk. A proportion of the surround signal will appear at the terminals of the left and right loudspeakers, but its antiphase relationship will tend to diffuse the image generated.

In practice, the LCR loudspeakers will be physically grouped, which has the beneficial effect of compressing a lot of spatial detail across the field of view, and spreading out the effect of the surrounds to the rear.

In the LRS passive decoder, a high degree of separation is achieved; a centre-only signal will produce equal left and right outputs, defining a phantom central image, similar to that ideally attained in a carefully arranged listening room with two-channel stereo. Left or right only will produce an output from the appropriate loudspeaker, plus a measurable contribution 3dB down from the surrounds. The listener's awareness of this unwanted crosstalk is far less than implied here.

Surround-only signals generate a unified surround output, plus an out of phase left/right contribution, diffused according to the acoustic properties of the environment. This arrangement is the preferred one for passive type domestic decoders, but it does not provide anchorage of on-screen dialogue nor is it conducive to off-axis seating arrangements. If required, the centre channel drive in Fig. 5 can be implemented, but at the expense of L/R separation. Because the centre channel is obtained by summing Lt and Rt, a solitary L or R source signal will generate a corresponding centre channel output which will have the effect of reducing the perceived width of the sound stage.

Figure 4 shows that, prior to matrixing, the surround channel S is treated by a modified form of Dolby-B encoding; following dematrixing the signal undergoes a complementary process in the surround decoder. The purpose of this is twofold.

First, the S/N performance of the surround channel is improved while the desired frequency response is maintained. Secondly, the decoding action brings about a dynamic

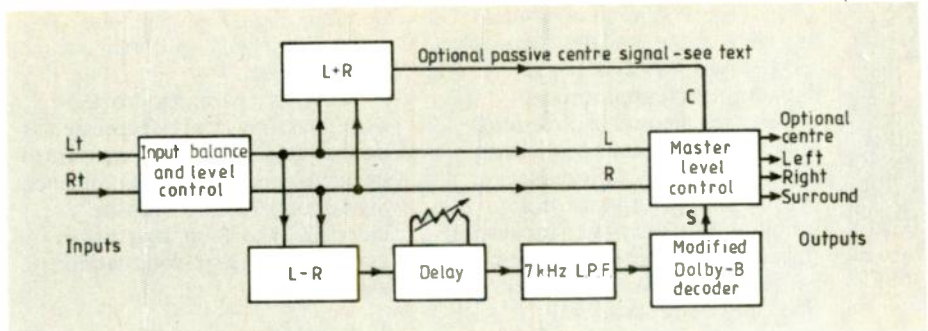

Fig. 5. Passive surround decoder.

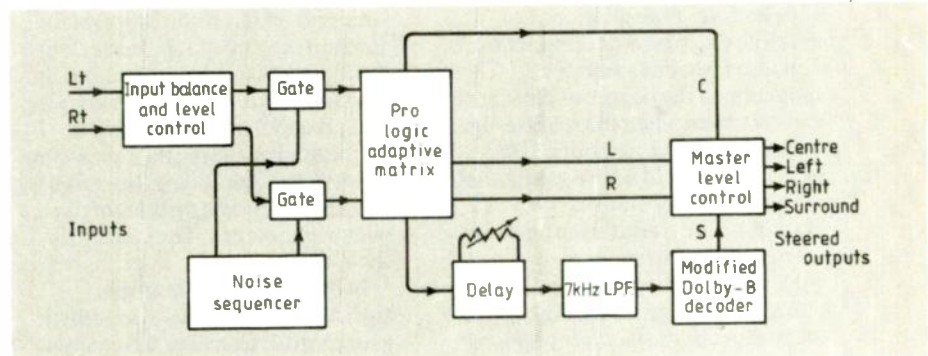

Fig. 6. Dolby Pro-Logic decoder.

reduction in the amount of HF leakage permeated in the surround channel (particularly effective on sibilants) because the LCR channels are not previously encoded. The degree of B-type encoding has been relaxed from 10 to 5dB to prevent the encoded surround signal components from conspicuously affecting the nature of the left and right channel signals.

The perceived front-to-back separation is subjectively improved by implementing techniques based on the Precedence Effect and spectral modification.

The passive or Dolby Surround decoder combines the circuit simplicity with the ability to produce an impressive spatial soundfield. This makes its inclusion in domestic stereo video systems an attractive proposition, implemented either as a stand-alone unit or by means of additional circuitry inside associated audio/visual products.

A limitation of the passive decoder is the restricted soundstage width across the observer's field of vision if a centre channel loudspeaker is used for dialogue anchorage. In large-screen cinema applications, this would result in an imprecise correlation of aural and visual stimuli, and impose seating limitations. Thus cinema processors have an active version of the surround decoder, which achieves improved channel separation, provides a discrete centre channel and maintains a uniform and expansive soundfield. Recently a

direct descendant of the active cinema processor, the Dolby Pro-Logic surround decoder has become available.

The technique for recovering detailed sound placement is directional enhancement (see Fig. 6). In this, the Lt-Rt signals are applied to an adaptive matrix which continually analyses the incoming soundfield information in terms of magnitude and associated direction of dominant signal components. This leads to the production of a steering vector to control the variable matrix which delivers appropriately weighted LCRS drive signals at its output.

Comparing Fig. 6 with Fig. 5 shows that the adaptive matrix has replaced the L-R and L+R stages of the passive variety.

Prominent signal components in the mix contribute vital directional cues to the reproduced soundfield. Their detection lets the adaptive matrix assign a quality of discreteness by appropriate soundtrack separation and allocation. Undesirable adjacent-channel leakage in the passive decoder will be most apparent when it is presented with a solitary point source signal, in an otherwise quiet soundfield. Although this is a somewhat extreme situation, it is a condition in which the outcome of directional enhancement in the Dolby Pro-Logic decoder is most effective.

At the other extreme, a soundfield composed of signals with similar intensities such as average loudness



CONSUMER ELECTRONICS

will not convey directional cues to any great extent, and therefore only a modest degree of directional enhancement is appropriate.

Thus, the amount of directional enhancement must be proficiently and automatically adjusted to provide a rapid response on an instantaneous basis when processing signals which represent two or more encoded positions, that is where the signal peaks are sufficiently prominent to be perceived as occupying separate spatial locations. This involves time division multiplexing of the steering action.

It also provides a suitable reduction of the degree of directional enhancement when the relative signal dominances of the soundfield fall below a threshold where substantial decoder action would be inappropriate, resulting in an audibly 'nervous' spatial image.

Detection of soundtrack dominance is achieved by taking the logarithm of orthogonally opposed signals and subtracting one from the other. This is analogous to taking the ratio of the signal levels ignoring absolute values, a process which closely mirrors the way loudness is perceived in real life. The resultant control voltages facilitate steering of the adaptive matrix to provide that degree of LCRS separation necessary to prevent audible crosstalk, while exploiting the masking effect of the

dominant signal on the spatial redistribution of non-dominant components.

The spatial parameters of the dominant signal can be expressed as the encoded angle with a measure of its relative magnitude of dominance. Signal contributions from the independent orthogonal pair can assign any given spatial location within 360°.

Gain riding

Steering is facilitated by four control voltages, under the direction of the dominance vector. It is their relative combination which manipulates the adaptive matrix, producing discrete L, C, R and S outputs. A simple method of regulating the separation process uses gain riding, favoured by some SQ decoding systems of the quadrophonic era. The concept is shown in Fig. 7.

In this system, undesirable crosstalk is reduced by sympathetic gain control. Consider the example of an isolated centre signal where $L_t = R_t$. To counter the unwanted contributions of the left and right outputs, the control stage responds by implementing reciprocal VCA action. In principle, it is possible to achieve complete separation in a 360° soundfield resolving the four channels in their discrete form.

In reality, dominant and non-dominant signals will occupy a spread

in the soundfield. Thus it can be seen that the occurrence of a dominant sound will cause non-dominant components in the other channels to suffer amplitude modulation according to its duration. The result is that of audible pumping and spatial instability due to spontaneous and insular level variations across the soundfield.

As an alternative to gain riding, Dolby Pro Logic decoders use a cancellation concept which maintains a constant signal power for all components of the soundtrack, irrespective of the degree of directional enhancement applied.

Figure 8 introduces a means of eliminating undesirable centre channel leakage in the left output. This is achieved by blending a controlled proportion of inverted R_t signal into the left channel. The equal, antiphase centre signal components will thus cancel, eliminating dialogue leakage.

It will be apparent that the left channel now carries an inverted right signal element. This form of spatial redistribution is the unavoidable result of such cross-mixing, but the effect is not detrimental to system performance. Steering has been achieved without compromising the stability of the overall power levels associated with the reproduced soundfield.

This example defines conditions of a maximum difference in the signal levels being handled by the left and centre channels, thus corresponding to maximum steering action and consequent spatial redistribution. In most cases, the comparative range of levels is not likely to be as great. As the levels in the soundfield become similar, each begins to mask the cross-talk of the other, a natural form of crosstalk concealment, requiring less in terms of directional enhancement for proper localisation, and hence reducing redistribution of the non-dominant signal components.

In the adaptive matrix block diagram in Fig. 9 two main paths are present; a relatively straightforward signal path involving a minimum of processing; and a complex path which conditions and analyses the input signals for control purposes.

In the control path, the L_t - R_t signals are band-pass filtered to remove LF components which do not provide directional information, and to attenuate HF signals which may contain uncertain phase or amplitude characteristics.

The L_t - R_t signals are converted to their cardinal elements and, after

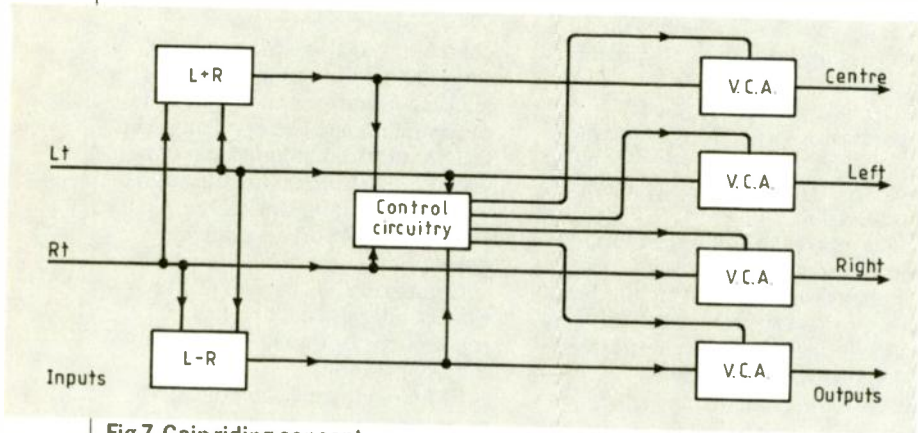

Fig.7. Gain riding concept.

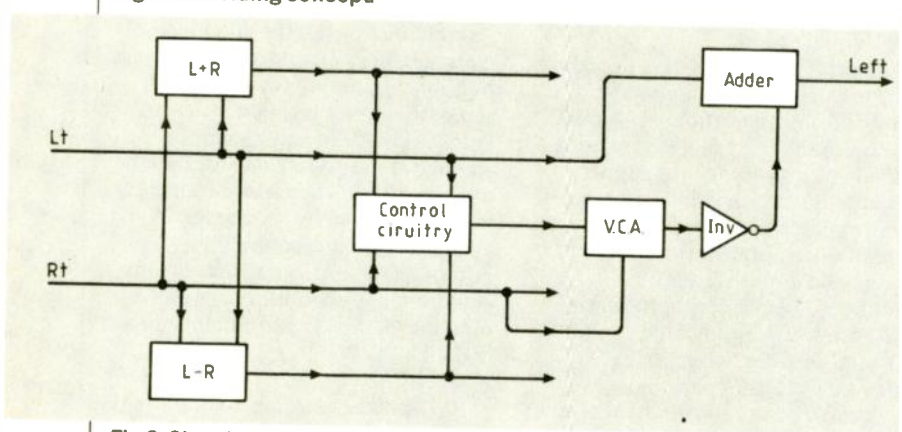

Fig.8. Signal cancellation concept.



A FREE I.Q. FOR AN I.D...

GET SHARP

Earn the chance to win a Sharp Personal Organiser in our Prize draw when you introduce a new reader to Electronics World.

Add your name and address to the coupon, then invite colleagues to complete it by taking out a subscription to Electronics World. If we receive their subscription before 30th March 1990 they will qualify for over 25% discount off the normal price:

Uk £22 for a year. Overseas £26.00 for a year.

As soon as we've received their subscription, your card will be entered in our prize draw.

Draw Rules

1. The prize in the draw must be won. The winning name will be selected at random out of a box by the Publisher of Electronics World.
2. The closing date for entries is 30th March 1990 and the draw will be conducted on 15th April 1990.
3. We reserve the right to publish the winner's name.
4. Employees of Reed Business Publishing Group or any of its associated companies are ineligible, as are members of their immediate families and all persons under the age of 18.
5. The draw and prize allocation will be witnessed independently by a Commissioner of Oaths. No correspondence will be entered into concerning the result of the draw and no liability can be accepted for entries lost or rendered unrecognisable in the post.

Please enter your name and address here and ask your colleague to complete the rest:

NAME _____

ADDRESS _____

POSTCODE _____

I accept your invitation to subscribe for only _____ per year. Please send Electronics World + Wireless World every month to my work/home address.

NAME _____

JOB/TITLE _____

COMPANY _____

ADDRESS _____

POSTCODE _____

Please invoice me/my Company

I enclose payment for !£..... by cheque/money order, made payable to REED BUSINESS PUBLISHING GROUP

Please charge my Access/Visa/American Express Card/Diners Club

Please send this coupon Freepost to Iain McGrath, Electronic World + Wireless World, FREEPOST, CN 2297 Room H315, Quadrant House, The Quadrant, Sution, Surrey SM2 5BR

EXPIRY DATE _____

SIGNATURE _____

DATE _____



CONSUMER ELECTRONICS

full-wave rectification, orthogonal pairs are log, converted and their difference taken. Signals at this point are bipolar in nature; for example, when the L/R voltage changes in a positive direction, dominance is to the left and a negative shift indicates dominance to the right. No voltage shift is indicative of zero dominance along the L-R axis.

The control voltages are monitored continuously to determine the value of their relative dominances with respect to a pre-determined threshold. Should either exceed this, the control circuit shifts to the fast operating mode.

The bipolar dominance information is converted to four unipolar control voltages. These express soundtrack dominance as perceived by the individual, and are applied to a bank of VCA stages with the input channels Lt-Rt, thus generating eight sub-terms. These in turn feed the four-channel combining network, accompanied by the input Lt-Rt signal feeds, according to a predetermined weighting factor; the ten terms give rise to forty summed components, the signs and magnitudes of which produce the required LCRS outputs, featuring the appropriate degree of directional enhancement with the optimum non-dominant signal redistribution.

Since its introduction in 1987, the Dolby Pro Logic decoder has gained favour with the videophile. The recent development of a custom integrated circuit, the LA2770, which embodies the entire process of Fig.9 has facilitated a significant reduction in manufacturing costs, making ownership of a decoder as attractive in economic terms as it is sonically.

As digital audio can achieve channel separation of about 90dB it is instructive to consider the significance of this in terms of the surround system. With a transmission path over which multilingual signals are to be carried, a maximum degree of crosstalk rejection is clearly desirable because the signals are unrelated. The impact of such an effect will represent a considerable distraction. The MP matrix process does not handle incongruent information, rather it conveys sound elements which unite a defined soundfield. This is a very different requirement.

Surround sound correlated to a visual presentation is intended to envelop, drawing the individual into a setting where the interplay of aural and visual stimuli can impart the original creative intentions of the producer. It follows that crosstalk must, by definition, bear relation to the main signal of interest — subjectively this will minimise its perception.

Crosstalk-related displacement of sonic location becomes less perceptible between adjacent loudspeakers when their spacing is reduced; this corresponds to the recommended arrangement in the home. Soundfield resolution is such that spatial definition is optimised across the field of vision, with the LCR channels producing augmentation of the presentation. The critical surround channel is treated by additional psychoacoustic-based processing, which confers improved separation, thus maintaining the forward focussed soundfield.

For various reasons it may be

Taking bass in small doses

desirable to assign certain portions of the reproduced audio spectrum to alternative speakers or locations. This can be achieved without detriment. For example, it is improbable that the need will occur for the surrounds to deliver isolated heavy bass signals. Such information will be distributed throughout the soundfield by the front channels. Also signals above 7kHz are attenuated. Thus small loudspeakers with a limited frequency range are considered suitable for surround reproduction.

Another popular arrangement lets a relatively small and inconspicuous centre channel loudspeaker be used by diverting the centre bass component to the full-range left and right speakers. Termed bass splitting, this is a feature included in all Pro Logic decoders. In surround and Pro Logic systems the overall timbre of the selected loudspeaker arrangement should be discerned as uniform. For example, the centre speaker contribution must be perceived to match those of the left and right to prevent undesirable variations in tonal character of a panned soundfield component. ■

Fig.9. Dolby Pro-Logic adaptive matrix.

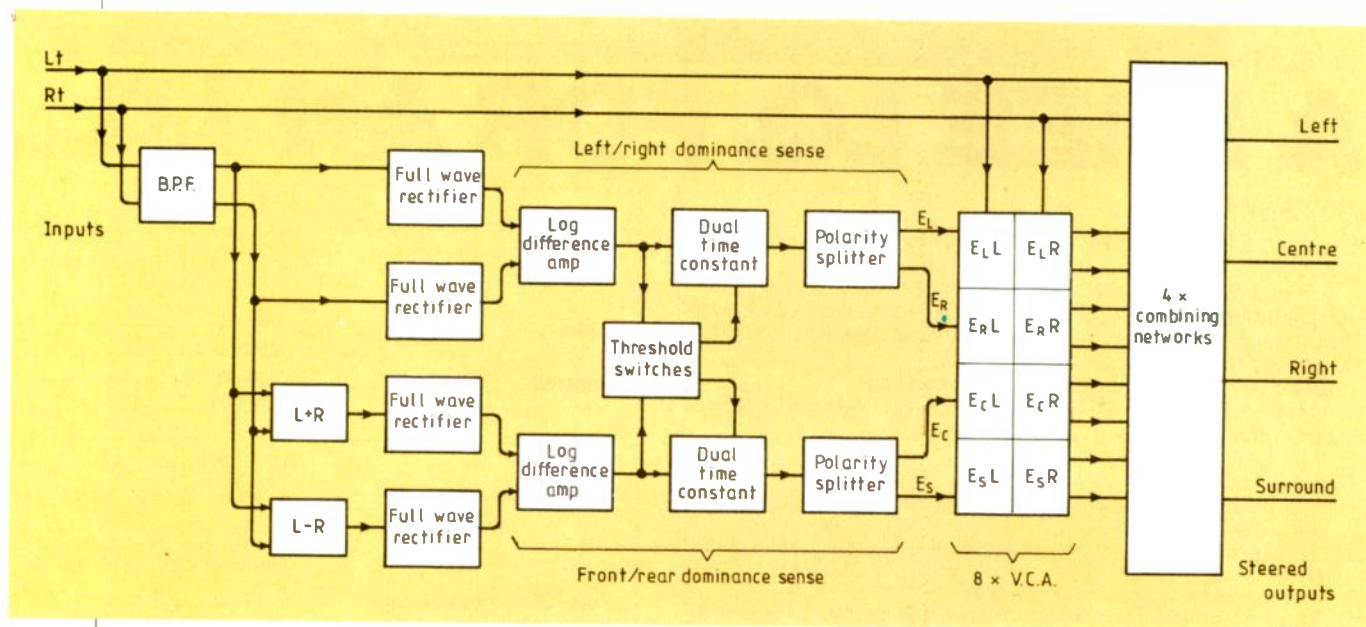

INSIDE TRACK TO DOLBY S



CONSUMER ELECTRONICS

Dr Ray Dolby's name has been synonymous with audio tape noise-reduction systems for nearly 20 years. The latest version, Dolby S, pushes the performance of the analogue audio cassette into the realm of CD.

Dolby S-type, like other Dolby systems, is a noise reduction circuit for cassette machines which encodes tapes as they are recorded and decodes them on playback. It offers 10dB of noise reduction at low frequencies, and 24dB at the higher frequencies where most cassette noise lies. Moreover, cassette recordings encoded with Dolby S-type, but played back with Dolby B-type or no decoding, are subjectively free of pumping effects.

S-type is based on Dolby SR, the professional Spectral Recording system introduced in 1986. Among the SR techniques used is the combination of both fixed and sliding bands. Although S-type has many similarities with the professional version, it has about half the complexity.

Complementary noise-reduction systems work by boosting low-level signals during recording, then reducing them – along with added tape noise – during playback. High-level signals are not boosted, to prevent tape overload. To prevent audible side effects such as noise modulation, the ideal NR system would apply constant gain wherever there are no high-level signals during recording, even in the presence of such signals elsewhere in the spectrum. Dolby refers to this as *the principal of least treatment*. Dolby S-type adheres more closely to the principle than Dolby B.

As a result, high-level signals have little effect on low-level signals, which contributes to freedom from audible side effects and reduces susceptibility to decoding errors.

Sliding band

At higher frequencies where cassette noise predominates, Dolby S-type combines both fixed and sliding bands; at low frequencies, where noise is far less significant, a fixed band is used.

The system minimises the

reduction in record compression which occurs at frequencies above higher-level signals when a fixed band alone is used, and at frequencies below higher-level signals when a sliding band alone is used. The effect of higher-level signals on low-level signals is thereby minimized within the noise reduction band.

Where the action minimizes the effect of moderately high-level signals within a noise reduction band, modulation control minimizes the effects of very high-level signals outside the NR bands on the bands themselves. For example, without modulation control, the stronger a signal in the midrange, the further away from that signal a sliding high-frequency band wants to move, thereby reducing the audible NR effect. Modulation control prevents high-level signals above a certain threshold from causing the sliding band to move any further than necessary. Therefore, in keeping with the principle of least treatment, modulation control helps to keep low-level signals more consistently compressed.

Staggered-action compression

Dolby S-type provides more than 20dB of noise reduction at higher frequencies. Providing so much noise reduction by conventional techniques would subject low-level signals to an unduly high compression ratio. Therefore, with Dolby S-type, compression is provided by two staggered stages operating at different signal levels with comparatively gentle compression ratios. This technique was pioneered in Dolby C and refined in Dolby SR.

Spectral skewing and anti-saturation techniques are frequency-shaping networks which, in the case of spectral skewing desensitize the system to frequency response errors, and in the case of anti-saturation "load" the tape more effectively. Anti-saturation provides increased



headroom and lower distortion. In Dolby S-type anti-saturation is applied at low frequencies as well as high; unlike Dolby C-type. This helps to reduce the low-frequency distortion which results from the low-frequency boost from cassette record equalization.

The cassette medium differs substantially from 15 or 30in/s open reel tape recording. The spectral content of the noise is different, the lower cassette operating speed minimizes print-through, and home listening levels are typically lower than studio monitoring levels.

Because cassette tape noise is concentrated at higher frequencies, and because of comparatively low print-through, with Dolby S-type only a single-stage, fixed NR band at low frequencies is necessary. By contrast, Dolby SR provides two staggered stages of both fixed and sliding band low-frequency NR. At higher frequencies, where Dolby S-type provides two staggered stages of both fixed and sliding band NR, Dolby SR has three. This virtually eliminates the possibility of audible noise modulation at listening levels. Therefore, although there are others, a major difference between Dolby SR and Dolby S-type is that the



CONSUMER
ELECTRONICS

former requires ten active NR elements and the latter only five.

S-Type circuit operation

Like all other Dolby noise reduction systems, S-type is complementary, that is signals are encoded before being recorded, then decoded in a complementary manner during playback. The following discussion describes the operation of an encoder, but it should be noted that an encoder can be switched to the decode mode in the same manner as an A-type, B-type, C-type, or SR processor.

As with C-type NR, an S-type encoder has two staggered-action compressors, each having a passive main path which is summed with an active side chain, and each of which operates over a different signal level range. The high-level stage has three compressors in its sidechain, which are known as the high-frequency fixed band (HF/FB), the high-frequency sliding band (HF/SB), and the low-frequency fixed band (LF/FB). The low-level stage has a high-frequency sliding band and a high-frequency fixed band. Fixed bands are band limited to provide more compression at frequencies below dominant signals above 6kHz, which gives less signal modulation in the encoder and less overall noise modulation. The fixed and sliding bands operate together in a technique known as action substitution.

The encoder output is filtered and then fed back to the control paths of each compressor to control compressor action using modulation control.

The low-frequency spectral skewing network is at the encoder input, while high-frequency attenuation is provided by two high-frequency spectral skewing circuits which are distributed between the low and high-level stages to reduce compression ratios at high

frequencies. Two stages of ant saturation circuitry provide high frequency attenuation at high-levels to reduce tape overload.

An S-type encoder adapts its characteristics to the input signal in such a way as to provide the maximum amount of boost at all times, especially at frequencies which are lower or higher than the dominant signal. The overshoot suppression (OS) circuits used are also designed to allow maximum boost from the compressor. Thus, the least treatment is given to the signal at all times, resulting in a very stable output with little dynamic action.

When the signal is decoded, the maximum amount of noise reduction is obtained in the presence of signals, ensuring low noise modulation and a high degree of tolerance to errors in the transmission chain. Up to 24dB of noise reduction at high frequencies and 10dB at low frequencies is provided.

High-level stage. The high-level stage is active for signal levels in the range from -25dB to Dolby level, and provides up to 12dB of boost at frequencies above 400Hz and 10dB of boost at frequencies below 200Hz.

The LF/FB is basically a passive low-pass filter followed by a variable attenuator, with the amount of attenuation increasing with signal level. The HF/FB is similar, although the variable attenuator follows a high-pass filter. The HF/SB is a variable-frequency high-pass filter, whose corner frequency rises with increasing signal level or frequency (as in B and C-type processors). The input of the sliding band is connected in such a way as to provide an output which is the sum of the fixed band output and a signal which is the difference of the HF/FB output and the input signal (action substitution).

The control signals are derived from the compressor output, which is

filtered, rectified, and averaged to produce a smooth control signal. An alternate path is provided to quickly charge the control path under high-level transient conditions to suppress overshoots. Modulation control signals are subtracted from the control path to reduce the control signal and the resultant attenuation under conditions where extra attenuation is not necessary. The final signal is then fed to a nonlinear control-law stage which provides the required attenuation versus control voltage characteristics.

Low-level stage. The low level stage is active for signal levels from -50 to -25dB. No low-frequency signal processing is provided, but in all other respects it is quite similar to the high-level stage.

Modulation control. Modulation control is used to prevent unnecessary modulation of the compressors in the presence of high-level signals. It is inactive at low levels. The encoder output is fed to the input of the modulation control circuit, where it is split into three frequency bands. The MC1 signal goes through a 3kHz high-pass filter to a full-wave rectifier, and is then fed in opposition to the HF/SB control signals. MC2 is created by smoothing the MC1 signal, using a 2ms time constant. This signal is then applied in opposition to the HF/SB overshoot suppression signal. MC3 is low-pass filtered at 200 and 400Hz, full-wave rectified, and then fed in opposition to the HF/FB control signals. The LF/FB is controlled by MC4, which first passes through 200 and 400Hz high-pass filters and a full-wave rectifier.

Testbed for Dolby S:
the Pioneer CT-91A



SATELLITE TELEVISION BROADCASTING

Confusion may be the epitaph for satellite broadcasting, reports Tom Ivall

When the neatly-packaged 60cm dishes for Astra reception appeared in the shops one might have expected the sales of satellite television receivers to take off rapidly. Being fixed and having offset feeds, these antennas are simple and unobtrusive compared with the larger and often steerable TVRO dishes needed for receiving the lower power comsat transmissions. Prices for the total extra equipment settled in the region of £300 to £400, very much in line with other domestic electrical products such as hi-fi sets and washing machines.

But the response from the British public has been much slower than the equipment manufacturers and programme providers had hoped for. This is borne out by simply observing the number of houses fitted with dishes and unofficial estimates from industry sources. At the beginning of 1990 there will probably be about 350,000 satellite tv receivers in UK homes, including the few tens of thousands of TVRO systems already installed before Astra transmissions started.

If you think Neighbours is bad, read on...

The reasons for this lack of enthusiasm, in a country otherwise so addicted to television viewing, are not far to seek. Satellite tv programmes so far transmitted are of lower quality and appeal than those available at less expense from the terrestrial broadcasters. Sky Television, described by one critic as "orbital garbage disposal", expects to lose about £120 million in its first year. There is also much competition from VCR films. And the current high interest rates have reduced disposable income.

The public is confused by the technical situation. Many know that the British Satellite Broadcasting (BSB) satellite is due to come into service in spring. This means that the viewer will need additional equipment to receive the programmes, from a different orbital

position, in a different frequency band, with different polarization, signal coding and scrambling/encryption method. To receive all the scrambled channels on the Astra and BSB satellites people will have to buy or rent three different descrambling systems.

Add to this BSB's premature advertising of its Squarial antenna, its postponement of service launch because receivers with ITT chips (see August 1988 issue, p. 778) were not ready and press speculation about a possible merger between Sky Television and BSB, and it's not hard to understand why many viewers are adopting a wait-and-see policy.

Nothing in space

This cautious response from the public must be aggravating the financial position of the satellite tv broadcasters. There is already a number of unused transponders in orbit, representing idle capital investment. Beaming down on Europe are 29 medium- and high-power transponders (carried by the

Astra, BSB, Olympus, TDF-1 and TV-SAT 2 spacecraft).

At the time of writing fewer than half are transmitting regular programmes. SES (the Astra owner-operator) and BSB each intend to launch an additional satellite in a matter of months. As already reported in this journal, there is likely to be a glut of channels available to Europe in a year or two, some 140, and according to one expert: "there will be a lot of hardware up there doing nothing."

The table shows the present position. The Astra satellite operates at medium power in the Fixed Satellite Service frequency allocation while the remainder operate at high power in the DBS allocation resulting from the WARC 1977 plan. Astra signals have linear polarization and the others circular polarization. The Sky TV transmissions from Astra are composite coded in PAL while the WHSTV (W. H. Smith) transmissions from the same spacecraft are being changed from PAL to D-MAC component coding. Olympus-1, TDF-1 and TV-SAT 2, all owned by agencies of governments, have to deliver signals to Continental cable tv distribution systems as well as directly to homes. They therefore use D2-MAC component coding, adapted to the limited bandwidth cable systems.

Olympus-1 is a European Space Agency multipurpose test satellite

A BSB publicity picture showing the original 25cm Squarial intended for manufacture in the UK. Manufacturing difficulties have forced a size increase to 40cm, with manufacture taking place in Japan.

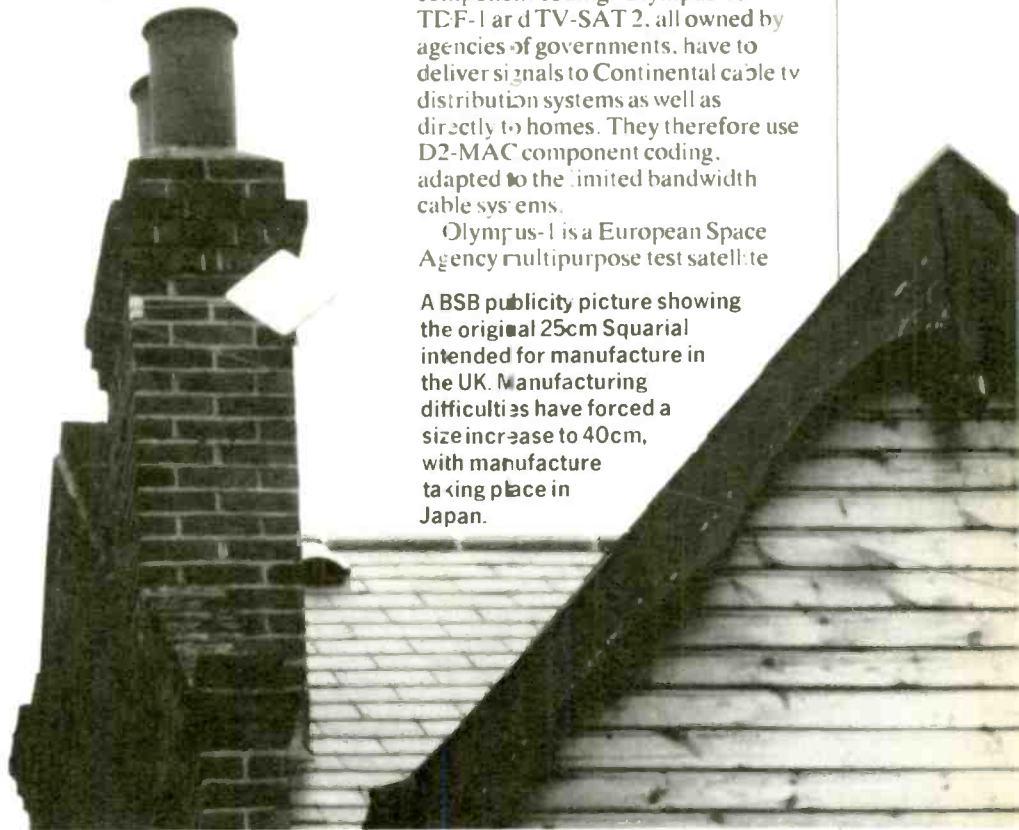

CONSUMER ELECTRONICS



CONSUMER ELECTRONICS

with four different communications payloads for experimental projects. One of these is specifically for DBS. It has two transponders, each with a steerable beam giving the very high EIRP of 63dBW at beam centre.

One Olympus transponder provides the European Channel, and its beam gives a circular footprint centred on Europe. Among other transmissions this will broadcast BBC programming every evening. Originated by BBC Enterprises and starting early in 1990, these programmes will be uplinked to Olympus from a 4-metre transportable earth station in London.

Initially the BBC transmissions will be test programmes assembled from existing sources, but Olympus should eventually have its own programming, probably a mixture of entertainment, specialist material and news. The general idea is to explore what can be achieved with satellite broadcasting to very large (European-wide) audiences on the public service principle. A BBC European tv service has already been going out, since March 1989, on the Intelsat-VA F11 comsat.

The second Olympus DBS transponder is being used for a pre-operational broadcasting service by Radiotelevisione Italiana (RAI). Here the spacecraft's steerable antenna has an elliptical reflector to give optimum coverage of Italy. Its boresight is kept pointing accurately at the required location in Italy by a closed-loop positioning system working from a beacon signal transmitted from the ground. On-board processing achieves a pointing accuracy of within 0.2°.

Radiated powers, of course, determine the size of receiving dishes needed for a given c/n ratio. With the BSB satellite Marcopolo-1 there is some uncertainty, at the time of writing, about its service EIRP.

Originally this Hughes spacecraft was intended to transmit four programmes on three channels, using three of the six separate chains of equipment in the payload and so operating with full redundancy. Each of the three transponders was to provide an EIRP of 61 to 62dBW in the centre of the UK coverage area and guarantee a specified minimum of 59dBW at the periphery.

Problems at BSB

But meanwhile the company has found itself in a beleaguered position. The early start of Sky and WHSTV broadcasts has provided ready-made competition. There have been difficulties in financing the project (so far £424 million has been raised but as much again is still needed). Delay in the production of special BSB conditional-access receivers has caused the launch of the service to be postponed from autumn 1988 to spring 1990. Not to mention all the public embarrassment over the mysterious Squarial - more of which later.

As a result BSB has decided that it wants to improve its position in the market place by starting with a bang - namely with five simultaneous programmes instead of three. These would be on channels 4, 8, 12, 16 and 20 in the DBS plan. But since the total RF power available in the spacecraft is limited by the solar power supply and payload design, this increase in the number of channels would mean a reduction of EIRP by about 3dB (a half) in each channel.

Such a reduction, however, is not permitted in the terms of the contract

between BSB and the IBA. The IBA is responsible for the transmissions and the technical quality of the received pictures. Officially it should not allow any reduction below the specified 59dBW mentioned above. And it can prevent transmission because it owns and operates the uplink earth station at Chilworth, Hampshire.

In practice the IBA would probably be willing to allow the five simultaneous transmissions to go ahead if BSB could demonstrate that the received picture quality would be adequate on half power. But at the time of writing production models of the special BSB receivers have not emerged from the four licensed manufacturers and consequently the company has not yet satisfied the IBA that the half-power pictures would be satisfactory.

As the reduced-power BSB transmissions would still have a higher EIRP than those from Astra, and as the noise performance of receivers is now extremely good (for example, transistor noise figures as low as 1.6dB), it seems probable that all will be well. One possibility is that BSB could transmit one programme on a transponder at full power (say the Movie Channel) and the remaining four programmes at half power. In total radiated power this would be equivalent to each of the original three channels operating at full EIRP.

BSB hopes to launch its second satellite in a matter of months. If and when Marcopolo-2 goes into orbit, the five programmes can be distributed between the doubled number of transponders and so broadcast on full power.

Fig. 1. Outline of the VideoCrypt scrambling system based on public key cryptography and using smart cards.

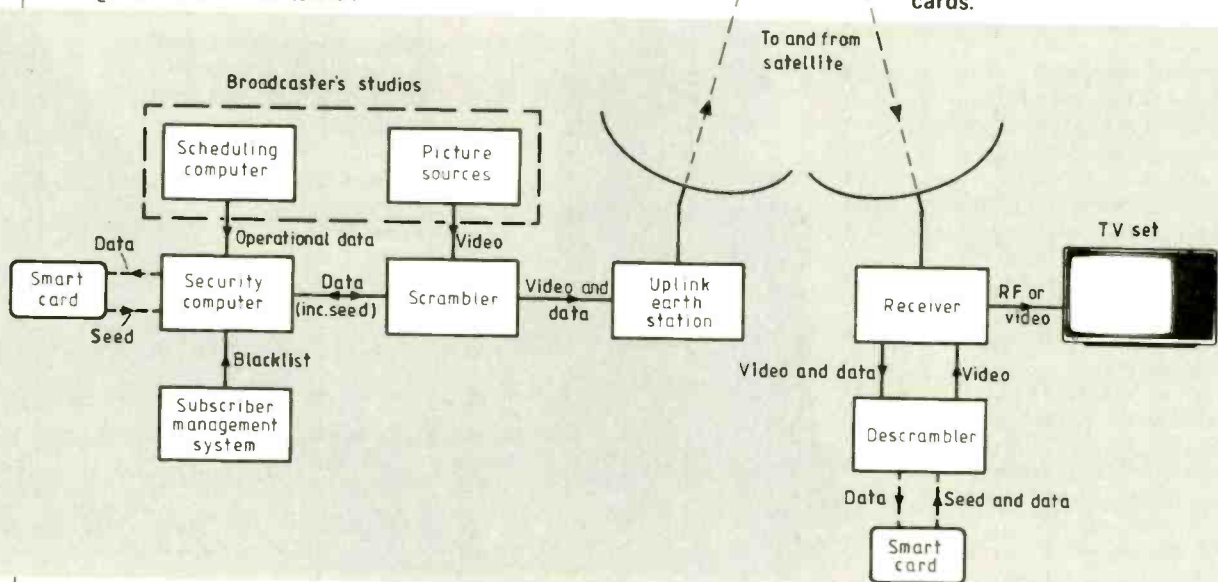

TELECOMMUNICATION TRAINING EQUIPMENT

Full range of Training Equipment including:

- ANALOGUE & DIGITAL COMMUNICATION CIRCUIT & SYSTEMS
- FIBRE OPTICS
- MICROWAVE
- TELEPHONY
- RADAR **NEW**

For more information contact:

LAB-VOLT (UK) LTD.

4A Harding Way,
St. Ives Industrial Estate
Huntingdon,
Cambridgeshire
PE17 4WR
Tel: (0480) 300695. Fax: 0480 61654

Lab-Volt®

CIRCLE NO. 110 ON REPLY CARD

SMC

South Midlands Communications

RADIO

TRANSCIVERS/RECEIVERS

SMC the leading European specialist in general radio communications have developed modular systems for rapid delivery, particularly useful for emergencies, disasters, political unrest and aid concerns. This can consist of rugged, simple to use, HF transceivers i.e. the FT80C with a frequency range of 1.5-30MHz used with either one of the SMC basic wide band antennas, or more efficient, the multi spot frequency antennas complete with transportable masts. More powerful and complex transceivers are also available.

Where monitoring or reception is required then either the FRG8800 HF receiver with VHF option or the FRG9600 VHF, UHF all mode scanning receiver are available with proven quality, sensitivity and reliability, at realistic prices.

ANTENNAS

The TWB2530 and TEB3 are just two samples of the large range HF, VHF and UHF antennas available from SMC. Both have been specifically designed for users with very different requirements showing the breadth of our capability. The rugged transportable TWB2530 is a full self-contained extremely lightweight, yet tough enough to withstand rough handling and quick assembly in adverse terrain.

The TEB series of spot frequency HF beam antennas give excellent forward gain, rugged construction for long life, at a cost effective price.

If you require further information on the 300 various support mounts, HF, VHF or UHF antennas, simply call for our new shortform catalogue.

Both can be supplied with the most efficient antennas and desirable accessories.



TWB2530



TEB3

SMC LTD, SM HOUSE, SCHOOL CLOSE, CHANOLERS FORD INDUSTRIAL ESTATE, EASTLEIGH, HANTS SO5 3BY.
Tel: (0703) 255111. Telex: 477351 SMCMM G. Fax: 0703 263507

CIRCLE NO. 130 ON REPLY CARD

PINEAPPLE SOFTWARE

New New New SERIAL DATA PROBLEMS? New New New

A brand new program for IBM's and compatibles allows complete monitoring of two way data flow down any RS232 serial data line. DATACAP will capture and store data from 110 to 9600 BAUD and display it on screen or print it in such a way that it's direction as well as it's position in the data stream, is indicated.

Applications include diagnosis of both hardware and software faults, and investigation of any problems encountered with handshaking protocols. It is also ideal as a teaching aid to demonstrate the ways in which computers communicate.

DATACAP £25.00 p & p free

BBC PCB Software

PCB is a powerful Rom based printed circuit board design program suitable for all BBC computers. A second eeprom is optionally available to add a powerful auto track routing facility to the program. This utilises a 'rats-nest' input routine and allows any component to be 'picked up' and moved around the board without having to re-specify component interconnections. The full autoroute facilities are available even on a standard unexpanded model B.

'PCB auto-route is remarkable. No similar software comes near the price.' ACORN USER Aug 88.
PCB manual track routing £85.00 PCB auto-routing £185.00
PCB plotter driver £35.00 P & P free

IBM PCB Software

EASY-PC EASY-PC is a powerful PCB design program combined with a schematic drawing package. Up to 8 board layers plus upper and lower silk screens. Board size up to 17" x 17". Powerful zoom and pan features. Suitable for IBM PC/XT/AT & compatibles with 512k Ram. — £98.00 P & P free

MARCONI TRACKERBALLS

We now have an adapter available to link the trackerball to the Archimedes, to enable it to directly replace the Archimedes mouse.

Bare Trackerball (No software) £45.00
BBC Model with software £59.00
Adapters to drive BBC Mouse software £8.00
Archimedes Adapter £19.95
IBM model (serial interface) £99.50

P & P on
Trackerballs
£1.75

Trackerballs also available for other computers, please phone for details.

MITEYSPICE, SPICE.AGE and ECA-2

Three very powerful circuit analysis packages. Miteyspice is available for the BBC range of computers, and Spice Age and ECA-2 for the IBM and compatibles.

Spice Age is a new product for the IBM range which provides facilities for transient and Fourier analysis as well as D.C. and freq. response performance.

Miteyspice (For BBC and Archimedes) £119.00
Spice Age (IBM PC/XT/AT 512k Ram) from £70.00 P & P free
ECA-2 (IBM PC/XT/AT 256k Ram) £675.00
LCA-1 (Logic Analyser for IBM's) £450.00



Pineapple Software, Dept. WW, 39, Brownlea Gardens, Seven Kings, Ilford, Essex, IG3 9NL. Telephone 01-599 1476.

Add 15% VAT to all prices.



CIRCLE NO. 108 ON REPLY CARD



CONSUMER ELECTRONICS

The BSB Squarial receiving antenna remains something of a mystery, with the manufacturer unknown at the time of writing, though the company says prototypes are being tested around the country. It is a flat plate array made up of many paralleled radiating elements. One model measures 35cm square and another 40cm square. An early version developed by ERA Technology was a 16 x 16 array of shallow, square microwave horns with a signal probe in each and a combining network at the back of the plate. Later it was found that greater antenna efficiency could be obtained by replacing the probes with a half-height waveguide linking into a combiner.

Of course, there are other kinds of flat-plate arrays with different forms of radiating elements. Marconi Space Systems, for example, has developed a printed patch technology to produce direct radiating phased arrays. Whatever structure has been adopted by BSB, the attraction of the flat plate array is, of course, the compactness of the design (no reflector dish and no feedhorn stuck out in front).

But the overriding problem is how to mass-produce such a multi-element array with sufficient mechanical accuracy and repeatability at low cost for a consumer market. The microwave structure is quite complex – for example it has to convert the incoming circular polarization into linear polarization – and demands fine manufacturing tolerances. Meanwhile the first viewers of BSB's satellite broadcasts may well find themselves using conventional dishes to start with.

Scrambling systems

Commercial satellite television is moving towards a more hermetic way of running its services. The reason is the hope of eventually breaking even, making a profit and getting a return on shareholders' investment. Sky Channel started broadcasting to all Europe from a communications spacecraft in the early 1980s but made

losses year after year because its revenues came only from advertising.

Although the potential audience was huge, the company couldn't tell advertisers to what extent the programmes were actually being received and viewed. And many advertisers were not distributing their wares throughout Europe anyway. So advertising revenue proved completely inadequate. This experience has convinced the commercial broadcasters that subscription television with conditional access is the only sure way of getting income from their transmissions, though advertising may help.

Conditional access is provided by scrambling the baseband signals to exclude pirate viewers. The subscription paying viewer has a descrambler unit which is controlled by an encrypted key, either built in by the manufacturer or originated by the broadcaster. Some of the Astra satellite channels, like Filmnet and TV3, are scrambled already. Sky Movies intends to scramble in February 1990. The pop music channel MTV will probably do so when it can. WHISTV will be scrambling when it changes its transmission standard from PAL to D-MAC.

BSB is even more hermetic in its way of permitting conditional access to the broadcasts. Apart from scrambling, it controls the technology used in the satellite receivers as well, by allowing only a chosen number of manufacturers (Ferguson, Philips, Salora, Tatung) to make the sets under licence to a BSB specification. In particular BSB has controlled the design and supply of the vital D-MAC decoder and descrambler ICs by ordering these chips directly from ITT semiconductors. Thus no other set makers are available to manufacture and supply receivers for BSB transmissions in a general way.

Soft and hard

Scrambling techniques can be roughly divided into two kinds, so-called 'soft' and 'hard'. In the soft kind the key to the scrambling is wired into the descrambling unit.

This method is used, for example, by the Filmnet channel on Astra. Consequently almost any electronics engineer can discover the key and make descramblers (confusingly called decoders in advertisements) for general sale. About a dozen firms are doing this in the UK.

Hard scrambling, which is much more difficult to crack, uses highly complex digital coding and additional keys. For both the PAL and D-MAC standards the cut-and-rotate method of scrambling is used. Television lines are cut at pseudo-random intervals and transposed. The key to this process is transmitted as digital data along with the main signal but in an encrypted form which can only be deciphered at the receiver by means of another key.

An outline of the Eurocrypt system to be used on BSB's D-MAC transmissions appeared in the December 1988 issue, p. 1207. In general, receivers will be individually addressed over-air through the D-MAC data multiplex. All five channels will be scrambled. The 'free' channels will be automatically descrambled in the receivers for all viewers but the subscription channel (for films) will only be descrambled, by transmission of authorization data, for those viewers paying the appropriate monthly fees.

WHISTV will be using the Eurocrypt system, developed in France, on their Astra channels. This is broadly similar to Eurocrypt in principle (though not interchangeable) but the company has not yet decided which of two slightly different versions, called 'S' and 'M', to adopt.

A third scrambling/encryption system, called VideoCrypt (originally Palerypt) is to be used by Sky Movies. Fig. 1 is an outline of the scheme. A key to the scrambling sequence is transmitted during the vertical blanking interval but the descrambling is only authorized when the viewer inserts an additional key in the form of a smart card (like a credit card containing a microprocessor) into the descrambling unit.

The basic principle is public key cryptography. This entails several algorithms which are 'public knowledge' in the sense that the hardware can be examined, but two different secret keys, one at the transmitter and one at the receiver. A characteristic of this cryptographic method is the use of a 'seed' or starting key, which is used with the algorithms to derive the main two keys for the scrambling-descrambling process. The smart cards are sent to subscribers and changed every few months to make pirate code breaking very difficult. ■

Table 1: European medium- and high-power television broadcasting satellites

Satellite	Owner	Coverage Area	Orbital Position	EIRP (dBW)	Frequency Band (GHz)	Polarization	Signal Coding	Scrambling
Astra	SES	W. Europe	19.2°E	52	11.2-11.45	L.H & V	PAL	VideoCrypt Eurocrypt
Marcopolo-1	BSB	UK	31°W	58	11.7-12.1	C.R.H.	D-MAC	Eurocrypt
Olympus-1	ESA	1-Europe 2-Italy	19°W	63	11.7-12.5 12.1-12.5	C. ? C.L.H.	D2-MAC D2-MAC	Eurocrypt Eurocrypt
TDF-1	TDF (France)	France	19°W	63.5	11.7-12.1	C.R.H.	D2-MAC	Eurocrypt
TV-SAT2	W. German Post Office	W. Germany	19°W	63.5	11.7-12.1	C.L.H.	D2-MAC	Eurocrypt

*Estimated provisional figure. See text for clarification

SILICON LIFESTYLE

It was claimed at a recent TI technology conference that consumer electronics would be at the front of advancing semiconductor technology. Optical mirror chips to replace LCD displays and night vision systems for car drivers are just a couple of the more likely developments. By Leon Clifford.

Among all the markets for electronic components, it will be consumer electronics which will be most affected by fast changing semiconductor technology. This was the clear message coming out of a recent seminar organized by US electronics giant Texas Instruments.

One of the most exciting developments is a possible successor to LCD screens for televisions: "mirror" chip technology.

Mirror chips were originally developed by TI as a device for switching optical-fibre signals. The chip itself is made up of an array of tiny mirrors, no more than a few microns across, attached to a silicon substrate. By passing currents through control electrodes in the silicon, the mirrors could be made to move, directing optical signals from fibre to fibre, and creating a cheap and compact light switch.

But now the company is working on a scheme, backed by the Pentagon's Defense Advanced Research Project Agency (DARPA), to develop high definition television (HDTV) displays for military equipment and computers, and mirror chip technology could well fit the requirements.

In high definition displays, the chips could form the heart of an extremely bright projection system for projecting pictures on large flat screens. Current projection television systems cannot be used in daylight or in well-lit rooms because they are too dim.

But mirror chips allow the picture information to be added to a bright projection beam. The beam is directed onto the array of mirror elements where each tiny mirror, representing a single pixel, can either reflect the beam out onto the screen or deflect it away to produce a dark spot. Suitable filtering produces colour.

High-definition televisions will use a number of other leading-edge technologies too, according to TI. Fast-access, high-capacity memory

chips for large video frame storage will be needed, while fast digital signal processors will have to incorporate very powerful parallel processing to deal with different parts of the screen at the same time. Large 100 000 gate asics (application specific integrated circuits) will keep everything under control.

Early high-definition systems will run off analogue broadcast signals so HDTV sets can be expected to stimulate the market for high performance analogue-to-digital converters. These will feed the memory-based digital HDTV chassis.

Meanwhile, outside the house, developments in electronics are going to change the family car. The electronics content of cars is already rising fast, and complex asics, digital signal processors, flash memory, smart-power devices, analogue-to-digital converters and digital-to-analogue converters will all be put to work on the road.

Electronic fuel control and engine management are commonplace and the real-time adaptive suspension fitted to last year's Lotus racing cars will be standard issue on most of the private cars bought in the mid-1990s. The proportion of cars with engine transmission control and computerised anti-lock braking will grow, while more applications for electronics within the car will be found: from enhanced radios to "climate" control and navigation aids.

High clock-rates associated with fast processors mean it is important to keep core elements near each other. To meet this demand TI's solution is to make use of multi-chip packaging techniques, combining its Sun Microsystems' Sparc risc chip with a floating point co-processor in the same package. Eventually, as more gets crammed onto smaller areas of silicon, TI plans to incorporate fast sram memory and memory controllers into the same package.

Shrinking transistors, complex asic technology and multi-chip packages



Lotus 1988 sports cars without (top) and with (bottom) real-time adaptive suspension.

will enable chip companies to field full personal computer and workstation chip sets in one single package. The 100M transistor chips that will become available towards the end of the 1990s will put multiple execution units, parallel processing and lots of memory all on the same piece of silicon, capable of delivering around 2,000 million instructions per second.

Much of this power will be thrown at the human/computer interface and into fast realistic graphics, touch screen operations, voice recognition and speech synthesis. Not only will this make the ubiquitous PC easier to use, but it will inevitably trickle through to the human/machine interface in other equipment.

For the modern consumer, who is increasingly likely to be relying on electronics in daily life, that has to be good news. ■



CONSUMER ELECTRONICS

THE ORIGINAL SURPLUS WONDERLAND!

THIS MONTH'S SPECIAL!

Very high resolution, fully cased 14" green or amber screen monitor with non-glare screen and swivel/tilt base. The very latest technology at the very lowest price! Fully compatible and plug compatible with all IBM PCs and clones fitted with a high res Hercules or equivalent card! Enables superb graphics and resolution, all at a give away price. Has many extra features including aux +5 & 12v DC outputs to power at least 2 disk drives, If your PC power supply is getting hot! Supplied BRAND NEW and boxed. State whether amber or green screen required.

Amber£79 Green£69 (E)

COMPUTER SYSTEMS

TATUNG PC2000. Big brother of the famous Einstein. The TPC2000 Professional 3 piece system comprises: Quality high resolution Green 12" monitor. Sculptured 92 key keyboard and plinth unit containing Z80A CPU and all control circuits. PLUS 2 Integral TEAC 5.25 80 track double sided disk drives. Generous other features include dual 8" IBM format disk drive support. Serial and parallel outputs, full expansion port, 64K ram and ready to run software. Supplied complete with CPM, Wordstar and Basic. Brand new and covered by our famous 90 day guarantee and backup. Normal price of this unit is over £1400!

Our price ... only£299 (E)

PC-AT 286 CLONE Lowest ever priced 8 mhz PC-AT clone complete with a 20mhz hard drive, a 5.25" 360k floppy, 640k of RAM plus Hercules card compatibility. The keyboard is NCR with 85 keys in an attractive beige, grey and cream finish to match the computer. The monitor is very high resolution 14" non-glare, with your choice of amber or green screen. A very nice package at a super price!

Our price ... only£799 (E)

SPECIAL PURCHASE V22 1200 baud modems

We got a tremendous buy on further stocks of this popular Master Systems 2/12 microprocessor controlled V22 full duplex 1200 baud modem - we can now bring them to you at **half last advertised price!** Fully BT approved unit, provides standard V22 high speed data comm, which at 120 cps, can save your phone bill and connect time by a staggering 75%! Ultra slim 45 mm high. Full featured with LED status indicators and remote error diagnostics. Sync or Async use; speech or data switching; built in 240v mains supply and 2 wire connection to BT. Units are in used but good condition. Fully tested prior despatch, with data and a full 90 day guarantee. What more can you ask for - and at this price!

ONLY £69 (D)

Write to us today and get your name on our mailing list for our FREE eight weekly bargain flyer *The Display* with thousands of unadvertised special offers.

MONITORS

COLOUR MONITORS

Decca 16" 80 series budget range colour monitors. Features include PIL tube, housed in a beautiful teak style case and guaranteed 80 column resolution, features which are only normally seen on colour monitors costing 3 times our price! It is absolutely ready to connect to a host of computer or video outputs. Manufacturers fully tested surplus, sold in little or hardly used condition with 90 day full RTB guarantee. Decca 80 COMPO 75 ohm composite video input with integral audio amp & speaker. Ideal for use with video recorder or our Telexbox ST, or any other audio visual use.

Only £99.00 (E)

HI-DEFINITION COLOUR MONITORS

Brand new Centronic 14" monitor for IBM PC and compatibles at a lower than ever price! Completely CGA equivalent. Hi-res Mitsubishi 0.42 dot pitch giving 669 x 507 pixels. Big 28 Mhz bandwidth. A super monitor in attractive style moulded case. Full 90 day guarantee.

Only £149 (E)

20" 22" and 26" AV SPECIALS

Superbly made UK manufacture. PIL all solid state colour monitors, complete with composite video & sound inputs. Attractive teak style case. Perfect for Schools, Shops, Disco, Clubs. In EXCELLENT little used condition with full 90 day guarantee.

20".....£155 22".....£170 26".....£185 (F)

MONOCHROME MONITORS

Wang green screen 12" chassis monitor with composite video input. Adjustable for tilt. Requires 12 vdc. Brand new and boxed in perfect condition.

Only £39 each or 2 for £75 (F)

Motorola M1000-100 5" black & white compact chassis measuring only 11.6H x 12W x 22D. Ideal for CCTV or computer applications. Accepts standard composite or individual H & V syncs. Needs 12vdc at only 0.8a. Some units may have minor screen blemishes. Fully tested with 30 day guarantee and full data.

£29.00(C)

Fully cased as above in attractive moulded desk standing swivel. Dim 12 x 14.5 x 26cm.

£39.00(C)

JVC 751 ultra compact chassis monitor for 12vdc 0.7a. Dim 11 x 14 x 18cm. Simple DIY data included to convert to composite video input. Full data. BRAND NEW

£65.00(B)

20" Black & white monitors by Aztek, Cotron & National. All solid state, fully cased monitors ideal for all types of AV or CCTV applications. Standard composite video inputs with integral audio amp and speaker. Sold in good used condition - fully tested with 90 day guarantee.

£85.00(F)

FLOPPY DISK DRIVES BARGAINS GALORE!

NEW 5 1/4 inch from £29.95!

Massive purchases of standard 5 1/4" drives enables us to present prime product at industry beating low prices! All units (unless stated) are removed from often brand new equipment and are fully tested, aligned and shipped to you with a 90 day guarantee and operate from +5 & +12vdc, are of standard size and accept the standard 34 way connector.

SHUGART SA406. BRAND NEW £29.95(B)
TANDON TM100-2A IBM compatible DS £39.95(B)
TANDON TM101-4 80 Track DS £49.95(B)
CANON, TEC etc. DS half height. State 40 or 80T £75.00(B)
TEAC FD-55-F. 40-80 DS half height. BRAND NEW £99.00(B)

3 1/2 INCH BRAND NEW AT £19.95!!

Never before seen price for a 3 1/2" drive. Standard size believed to be by Canon. Brand new and packaged - mint condition! 40 track SS, run from +5 & +12vdc with standard power connector. Only £19.95 or 2 for £34.50(B)

CHOOSE YOUR 8 INCH!

Shugart 800/801 SS refurbished & tested £125.00(E)
Shugart 851 double sided refurbished & tested £195.00(E)
Mitsubishi M2804-63 double sided switchable hard or soft sectors - BRAND NEW £250.00(E)

SPECIAL OFFERS!!

Dual 8" drives with 2 megabyte capacity housed in a smart case with built in power supply! Only £499.00 (F)
Ideal as exterior drive!

End of line purchase scoop! Brand new NEC D2246 8" 85 megabyte of hard disk storage! Full CPU control and industry standard SMD Interface. Ultra hi speed transfer and access time leaves the good old ST506 interface standing. In mint condition and comes complete with manual. Only.....£399(E)

MAINS SUPPRESSORS & FILTERS

The "Flitan" from Cotran is a British made high current mains spike suppressor and Rf filter in one, capable of handling up to 10 amps! The attractive case has an integral 13 amp socket for your equipment plug and a flying lead terminates in a quality plug (to BS 1363A standard) to go to the mains socket. There is an internal fuse plus one in the plug. Two LED indicators, one for power on and the other lights if the internal fuse fails. Dims: 6" x 3" x 2". Brand new. Distributor's price - £65.00! Continental plug version Flit-C. Either only £15.95 each or 2 for £29.95 (B)
Beiling-Lee type L2127 mains RFI filters rated at 250 volts 3 amps maximum. Comes complete with a built in mains cable (English coding), and a three pin miniature non-reversible socket and a mating plug, to go to the equipment. Ideal for those who are bugged by RFI interference. Very compact. Dims 3-1/8" x 2.5" x 1.5".....£3.95 each or 3 for £10 (A)

COOLING FANS

Please specify 110 or 240 volts for AC fans.

3 Inch	AC. 1 1/2" thick	£ 8.50(B)
3 1/2 Inch	AC ETRI slimline. Only 1" thick.	£ 9.95(B)
4 Inch	AC 110/240v 1 1/2" thick.	£10.85(B)
4 Inch	AC 1 1/2" thick	£ 9.95(B)
10 Inch	Round. 3 1/2 thick. Rotron 110v	£10.95(B)
62 mm	DC 1" thick. No. 812 for 6/12v. 814 24v.	£15.95(A)
92 mm	DC 12v. 18 mm thick.	£14.95(A)
4 Inch	DC 12v. 12w 1 1/2" thick.	£12.50(B)
4 Inch	DC 24v 8w. 1" thick.	£14.50(B)

RECHARGEABLE BATTERIES

LEAD ACID

Maintenance free sealed long life. Type A300.

12 volts	12 volts 3 amp/hours	£13.95(A)
6 volts	6 volts 3 amp/hours	£ 9.95(A)
12 volts	Centre tapped 1.8 amp hours	£ 5.95(A)
12 volts	12 volts 24 amp hours. A200. RFE.	£29.00(B)

SPECIAL OFFER!

100 amp/hours at 6 volt! Brand new Chloride Powersafe 3VB11. Leakproof with additional snap-on security lid. Perfect for uninterruptible power supplies, portable power source, caravans etc. Normally costs £80!
£39 (E)

NICKEL CADMIUM

Quality 12v 4ah cell pack. Originally made for the Technicolor video company. Contains 10 GE top quality D nicad cells in a smart robust case with a DC output connector. Ideal for portable equipment. Brand new.

£19.95(B)

Ex-equipment NICAD cells by GE. Removed from equipment and in good, used condition: D size 4ah

4 for £5(B)

F size 7ah

6 for £8(B)

SPECIAL INTEREST

Racal-Redac real time colour drafting PCB layout system. Includes furniture and huge monitor. Complete ready to go! £3950
DEC VAX11/750 Inc. 2 Meg Ram DZ and full documentation, in brand new condition! £3900
Calcomp 1036 large drum 3 pen plotter £ 650
Thurby LA 180A logic analyser £ 275
1.5kw 115v 60hz power source £ 950
Wayne Kerr RA200 audio real time freq. res. analyser. £3000
VG Electronics 1033 Teletext Bridge £3750
Tektronics R140 NTSC TV test signal standard. £ 875
Sony KTX 1000 Videotex system - brand new £ 790
DEC LS11/02 CPU board £ 150
ADDS 2020 VDU terminals - brand new £ 225



Made for the US military to the highest possible spec, these units were originally designed as a highly rugged portable point to point distance measuring set. Inbuilt in the unit is a full duplex speech link which may be used as is, or adapted for use as a data link. Many features include 50 km point to point range, approx 10.5 GHz operation for max security, low power consumption (typ. 2 amps at 12 vdc), and small physical size 14w, 15h x 13d including built in dish, fully portable weatherproof case. Supplied in used but tested condition complete with instructions and accessories.

Only £295 per pair (E)

Optional 12v integral nicad pack

(3 hours approximate duration)£22
Limited quantity - don't miss out this time!!!

May require licence for UK use

POWER SUPPLIES

All PSUs 220-240vac input and are BRAND NEW unless stated. Many types ranging from 3v to 10kv always in stock.

Fine OP-8619 20 watts switch mode. +5v @ 2a. +12v @ 1a. -12v @ 0.1a. 5" x 3" x 1-1/2". £15.95(B)
Atec AC-8151 40 watts. Switch mode. +5v @ 2.5a. +12v @ 2a. -12v @ 0.1a. 6-1/4" x 4" x 1-3/4". £19.95(B)
Greendale 19AB0E 60 watts switch mode. +5v @ 6a. +12v @ 1a. +15v @ 1a. RFE and fully tested. 11 x 20 x 5.5cms. £24.95(C)
Conver AC130. 130 watt hi-grade VDE spec. Switch mode. +5v @ 15a. -5v @ 1a. +12v @ 6a. 27 x 12.5 x 6.5cms £49.95(C)
Boehler 13090. Switch mode. Ideal for drives & system. +5v @ 6a. +12v @ 2.5a. -12v @ 0.5a. -5v @ 0.5a. £29.95(B)
Farnell G6/40A. Switch mode. 5v @ 40a. Encased £95.00(C)
Farnell G24/5S. As above but 24v @ 5a. £65.00(C)

IBM KEYBOARD DEAL

A replacement or backup keyboard, switchable for IBM PC, PC-XT or PC-AT. LED's for Caps, Scroll & Num Locks. Standard 85 keyboard layout. Made by NCR for the English & US markets. Absolutely standard. Brand new & boxed with manual and key template for user slogans on the function keys. Attractive beige, grey and cream finish, with the usual retractable legs underneath. A generous length of curly cord, terminating in the standard 5 pin DIN plug. A beautiful clean piece of manufacturer's surplus. What a deal!

BRAND NEW AND BOXED ONLY..... £49 (B)

THE AMAZING TELEBOX!

Converts your colour monitor into a QUALITY COLOUR TV!!



TV SOUND & VIDEO TUNER!

Brand new high quality, fully cased, 7 channel UHF PAL TV tuner system. Unit simply connects to your TV aerial socket and colour video monitor turning same into a fabulous colour TV. Don't worry if your monitor does not have sound, the TELEBOX even has an integral audio amp for driving a speaker plus an auxiliary output for headphones or Hi Fi system etc. Many other features: LED Status Indicator, Smart moulded case, Mains powered, Built to BS safety specs. Many other uses for TV sound or video etc. Supplied BRAND NEW with full 1 year guarantee.

Telexbox ST for composite video input monitors.....£29.95(B)
Telexbox STL as ST but with integral speaker.....£34.95(B)
Telexbox RGB for analogue RGB monitors.....£65.95(B)

NOT suitable for IBM or Clone type colour monitors. PAL overseas version please call. SECAM not available.

BRAND NEW PRINTERS

Epson MX-80 F/T One of the most popular printers around! Bi-directional printing with full logic seeking. 9 x 9 dot matrix for enlarged, bold, condensed etc. Standard parallel interface. Brand label removed from front. Handles tractor, fanfold and individual paper. OK with IBM PC and most others. A tremendous buy! FOR A LIMITED TIME ONLY.....£129.00 (E)
Hazelton Esprint small desktop. 100 cps with RS232 and standard parallel. Full pin addressable and 6 user selectable fonts. Up to 9.5" paper. Sheet & tractor feed. SPECIAL SALE £99.00(E)
Centronics 150 series. Always known for their reliability in continuous use - real workhorses in any environment. Fast 150 cps with 4 fonts and choice of interfaces.
150-SN up to 9.5" paper..... £155.00(E)
150-SW up to 14.5" paper..... £199.00(E)
Specify whether serial or parallel required.

CALL FOR THE MANY OTHERS IN STOCK INCLUDING DAISY WHEELS.

Visit our Shop - Technical help always on hand plus many un-advertised specials. You can buy a colour television for as little as £29! Come and join the gang at 215 Whitehorse Lane!

LARGE QUANTITIES OF OSCILLOSCOPES AND TEST GEAR ALWAYS AVAILABLE - CALL NOW!

DISPLAY

-Electronics-

MAIL ORDER & OFFICES
Open Mon-Fri 9.00-5.30
Dept WW, 32 Bliggin Way,
Upper Norwood,
London SE19 3XF.

LONDON SHOP
100's of bargains!
Open Mon-Sat 9-5.30
215 Whitehorse Lane,
South Norwood,
London, SE25 6RB.

DISTEL © The Original.
Free dial-up database!
1000's of Items into On Line
300 bd 01-679-1888,
1200/75 bd 01-679-6183,
1200/1200 bd 01-679-8769

ALL ENQUIRIES
01-679-4414
Fax- 01-679-1927
Telex- 894502



All prices for UK Mainland. UK customers add 15% VAT to TOTAL order amount. Minimum order £10. PO orders from Government, Universities, Schools & Local Authorities welcome - minimum account order £25. Carriage charges (A)=£2.00, (B)=£4.50, (C)=£8.50, (D)=£10.00, (E)=£12.00, (F)=£17.00, (G)=Call. All goods supplied subject to our standard Conditions of Sale and unless otherwise stated guaranteed for 90 days. All guarantees on a return to base basis. We reserve the right to change prices & specifications without prior notice. Orders accepted subject to stock. Quotations willingly given for higher quantities than those stated. Bulk surplus always required for cash.

JAPAN ON SHOW

The Japan Electronic Show provides the best fashion indicator to consumer electronics. Peter Wall rides the latest wave of high tech non-essentials.

The first signs that Japan is taking seriously the agreement over DAT between the software and hardware companies was PIONEER's D-700 DAT player with SCMS (serial copy management system), pioneered by Philips. Release date and price are not yet decided, which is not surprising as it will take several months to fully implement the necessary chips. Be prepared, however, for revised DAT players for sale in Europe appearing in late 1990. Significantly I was not aware of any recordable CD players at the exhibition. This type of CD looks better than DAT because access time by dodging across tracks on a disc must always be much faster than going up and down tape. The technology for recordable CD exists but problems remain in achieving adequate life time for recordings, at prices consumers will pay.

A second significant trend is a large surge of interest in Dolby Pro-Logic by many companies, notably JVC (Theatone System), Kenwood (KA-V700), NEC and Mitsubishi. This more advanced decoding system for Dolby Stereo encoding on films has now become practicable with the availability of dedicated chips. The system provides the option to use a centre front speaker (the TV set speaker for instance) to give greater stability of sound image off axis from the centre and much closer to the sound system in the cinema. Films used in the cinema with Dolby Stereo sound tracks retain all the audio data when converted to video cassettes.

Although companies seem to be using on-screen display for the viewer to control system settings, I saw no evidence of memory storage facilities. You can become hooked on this system, making simple stereo on films seem very dull.

Panasonic have a competitive system called THX, employed by George Lucas for theatre use, but intended for the consumer.

Video displays

Many manufacturers had prototype colour LCD panels, in which the quality of colour and definition is improving. They are getting bigger

and can be viewed from an acute angle. Companies like Matsushita, Sharp and Epson are spending a lot of money. Prices of sets containing LCD, eg. Epson E-2000 with a 4in x 3in screen at £440, indicates that there is still a long way to go before colour LCD panels replace CRTs in popular size TV sets, if they ever do.

One way forward is to use LCD panels as part of a video projector, and several products were in evidence such as the Selko-Epson VPS-700 at about £2,000.

One set used projection technology as part of the TV set. A product seen with about a 49in screen could be considered favourably against a 51in CRT type next to it. It is shorter from front to back and probably lighter. For the largest sets, this begins to look an attractive alternative. LCD technology may squeeze the CRT from both ends of the size spectrum.

VCRs

S-VHS was the dominant theme but, for industrial use, Mitsubishi's Hi-Vision HD-10 uses a cassette similar to VHS but with 1/2in metal tape. The 20MHz bandwidth is obtained by speeding up the tape to 100mm/s. This approaches the bandwidth necessary to handle HDTV signals which Japan views as having many medical database, training and industrial uses as well as use for broadcasting.

There is always the possibility of VHS and S-VHS eventually being replaced by true digital recording on the tape. The advantage would be similar to that of DAT—perfect copies—assuming copyright problems could be sorted out. Although some companies are known to be studying digital recording for eventual consumer application, I saw no sign of such techniques for consumer use at Osaka.

The ratio price of the cheapest S-VHS recorder seen (Toshiba A-E51 at 135,000 Yen) and the cheapest VHS recorder (Hitachi M230 at 65,000 Yen) is 2.07; one could expect S-VHS recorders to drift down to £600 in the UK market over the next two to three years.



Videomaster S-VHS video recorder, with extensive editing functions, by Panasonic

Lap top AV units

Video 8 has the advantage of size but offers limited prerecorded software. Sony's 8mm video players are about one quarter the volume of the full VHS versions on offer from Panasonic, Hitachi and Sharp but at 30 per cent lower prices.

Japanese industry now offers the complement to camcorders, the video printer. Costs of a print are around 40p for 4 x 3in. A typical product price in Japan is £650 for a unit with a resolution of 260 000 pixels.

Camcorders

The format battle Video 8/VHS/VHSC continues, but the designs are beginning to take into account the photographers' needs. A top line machine typically provides seven modes: everything automatically set; shutter speeds restricted to 1/60 to 1/250 but exposure auto; fixed at 1/500, exposure auto; longer exposure time so good for focus depth, (people in front of a mountain, both in focus); fixed shutter speed down to 1/10 000, ideal for sports; exposure fixed, speed auto for controlled focus depth; fully manual.

The new VHS-C tape with 45/90 minutes on SP/LP and the new generation of VCRs capable of handling VHS-C without adaptors, will significantly shift market preferences towards VHS-C camcorders. ■



CONSUMER ELECTRONICS



CONSUMER ELECTRONICS

STANDARD HDTV?

Geoff Lewis surveys the proposed standards for high-definition television, which are beset by political considerations.

Three families of high-definition television systems to take us into the next century are now under consideration for adoption as a world standard.

Japan, the USA and Europe all have their own systems, although the only system commercially available is the Japanese HiVision (MUSE) system which, they say, will go ahead as a transmission medium regardless of other developments elsewhere. Indeed, there is evidence of an attempt to force its introduction into the USA as a *de facto* standard. The table shows how limited is the extent of current agreement on standards.

	NHK	HDMAC	HDNTSC
lines/field	1125	1250	1050
fields/sec	60	50	59.94
interlace	2:1	2:1	2:1
aspect ratio	16:9	16:9	16:9

The following short descriptions might help to dispel some of the fog that surrounds the choices, which are rapidly turning into political and commercial, rather than technical arguments.

MUSE

At the time of writing, this is the only system that is commercially available. As developed by Sony Broadcast as a production facility, it is known as the High Definition Video System (HDVS). As developed for transmission over satellite and cable links, the system is commonly known as MUSE (Multiple Sub-Nyquist Sampling Encoding) or HiVision.

The basic principle of bandwidth reduction and transmission encoding is to take the wideband video signal in RGB, component form and matrix it to provide luminance (Y) and chrominance (C_R & C_B) colour-difference signal components, which are then sampled at 64.8MHz, to produce 1920 samples per line. The chroma components are then time compressed by a factor of four, arranged in line-sequential order and multiplexed into the line-blanking interval.

This bandwidth reduction technique recognises that there is considerable redundant or unchanging information between image frames. With the aid of a four-field store, the image pixels are separated into stationary and moving areas using intra and inter-field filtering. To cater for the camera motions of pan and tilt,

Fig.1 HD-MAC bandwidth reduction, using static and moving-area filters, selected as image content requires.

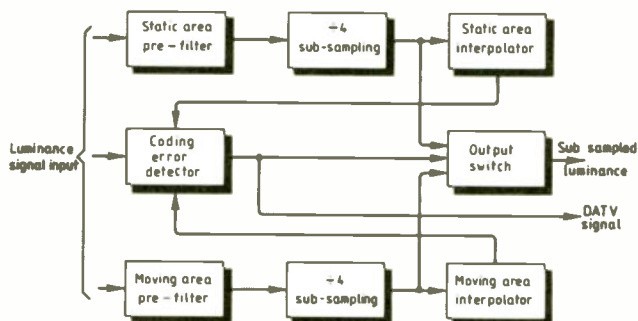

a motion-compensation vector is calculated for each field, which is multiplexed into the vertical blanking interval as a control signal. A further sub-sampling that selects every fourth pixel data reduces the bandwidth to 16.2MHz.

The sound channel uses near-instantaneous companding in a manner similar to that of compact disc, but with different parameters. Using compression, time is provided for either two or four audio channels, either in stereo or dual language. The compressed-audio digital signal is then time shifted and, together with synchronizing pulses, multiplexed into the vertical blanking interval, the complex digital signal then being converted into analogue format before being used to frequency modulate the radiated carrier.

Complementary-motion compensation at the receiver interpolates by taking corresponding pixel samples from all four fields to regenerate the stationary areas. For the moving areas, the reconstruction interpolates from samples in the same field, the motion vector being added to the pixel addresses of the previous field in the memory to provide for the appropriate movement.

During its development, MUSE has spawned several variants. MUSE-T is intended for the transmission of high-quality signals that are ultimately intended to be re-broadcast or networked. This has a bandwidth of 16.2MHz and occupies 54MHz of satellite transponder bandwidth. MUSE-E is intended for direct reception and, with a bandwidth of 8.1MHz, can be accommodated in 27MHz of RF bandwidth. Narrow-MUSE has the number of scanning lines reduced to 750 during encoding, to reduce bandwidth; the missing lines are interpolated at the receiver. MUSE-6 and MUSE-9 are designed to be NTSC-compatible, using 1 or 1/2 channels.

European HD-MAC

This system is a result of European cooperation within the Eureka 95 (EU 95) Project and the basic work of the IBA on the MAC concept. In this case, each line is sampled 1296 times per 64µs to provide a digital signal for processing and time compression. The luminance component is compressed by a factor of 3:2 and chrominance by 3:1, which increases the video signal base bandwidth from 5.7MHz to 8.5MHz. The U and V colour-difference signals are time multiplexed on a line-sequential basis with the luminance component and converted back into an analogue format for transmission. The digital sound and data signal are included in the line blanking interval. There are three members of this group in use: B-MAC, D-MAC and D2-MAC, differing chiefly in the way in which the sound and data components are multiplexed. D-MAC uses duobinary signalling for sound and data at a rate of 20.25Mbits, whilst D2-MAC has half the capacity with a bit rate of 10.125Mbits.

As modified for high definition, HD-MAC is based on 1250 lines with 50Hz fields, 16:9 aspect ratio and 2:1 interlace or progressive scan. Such parameters result in a video bandwidth in excess of 30MHz; time compression is achieved using 1920 samples per line. Because the high-definition image contains about four times the information of the basic MAC image, the bandwidth-reduction techniques required would suggest that three-

dimensional filtering and sampling would be necessary at the encoder. This would require the use of a complementary three-dimensional interpolating decoder at the receiver, with a considerable increase in the cost to the viewer.

The technique adopted uses a combination of horizontal, vertical and temporal filtering paths that can be selected on an adaptive basis according to the image content. The filter path used is selected to produce the smallest coding error for each area of the image. The basic principle of operation is shown in Fig. 1.

The digital assistance signal is multiplexed into the vertical blanking interval as a duobinary component at 20.25Mbits, signalling to the receiver decoder which coding path has been used, so that the decoder can follow the encoder. The high cost of the encoding section is thus included in a few production areas, leaving the viewer to bear a relatively low cost. Motion compensation information is also included in the DATV (Digital Assisted Television) signal as a vector, to indicate to the receiver which of three channels have been used to portray either static, slow moving or fast moving areas of the image. Figure 2 shows, in principle, how the DATV signal is used to ensure that the high-definition signal can be transmitted over a standard MAC channel and provide an input to a standard 625-line MAC receiver.

Wide MAC or HDB-MAC

Whilst not European, this system owes its origins to the IBA work on MAC. The variant has been developed by Scientific Atlanta (USA) and Digital Video Systems Corp (Canada) for use in the 525-line regions of operation. The system generates a 1050-line wide-screen display by using a line differencing and interpolating technique to double the line rate and considerably improve the vertical resolution of the image. The concept is not considered as a contestant for a world standard and is currently being sold into the corporate video distribution networks.

NORTH AMERICAN CONTESTANTS

It is only possible to describe a few of the competing proposals here. These have been chosen, not for any particular merit, but to give an insight into the techniques that can be used to introduce HDTV into the very large installed NTSC customer base.

Advanced Compatible Television (ACTV)

This system, invented by the David Sarnoff Research Centre (GE, NBC, and RCA) to fit within a 6MHz NTSC channel, has basic parameters of 1050 lines 59.94Hz fields, 12.4MHz luminance bandwidth, with 3.75MHz and 1.25MHz for the L and Q channels respectively. Wide-screen source material is digitized, filtered and converted into 525-line interlaced format. Four signal components are then generated as follows:

- A 4:3 aspect-ratio signal is taken from the central portion and time expanded to fill all but 2µs of the active line period. Low frequencies from the two remaining side panels are then time compressed to be added before and after the central component.
- The high frequencies from the side panels are then time expanded to fill the active line period. This results in bandwidth reduction to about 1MHz.
- A signal is derived from the video frequencies between 5MHz and 6.2MHz, which are down-converted to 0 to 1.2MHz.
- A helper signal is generated by filtering and band limiting the vertical luminance detail to 750kHz. This is used in the wide-screen receiver to help regenerate the missing lines and improve the vertical resolution.

Figure 3 shows the multiplexing process that is used to

generate the transmission signal. Components 2 and 3 are quadrature modulated on to a 3.1MHz sub-carrier and then added to signal 1. This complex signal, along with component 4, is used to quadrature modulate the final RF carrier. A standard NTSC receiver processes only the central portion of the image, the auxiliary signals being lost in the overscan.

Super NTSC

This concept, developed by Faroudja Laboratories, is more an attempt to improve the images from NTSC through a standard 6MHz channel, rather than to generate an HDTV system, although the results achieved are most impressive. Non-linear high frequency detail processing at the transmitter and



CONSUMER ELECTRONICS

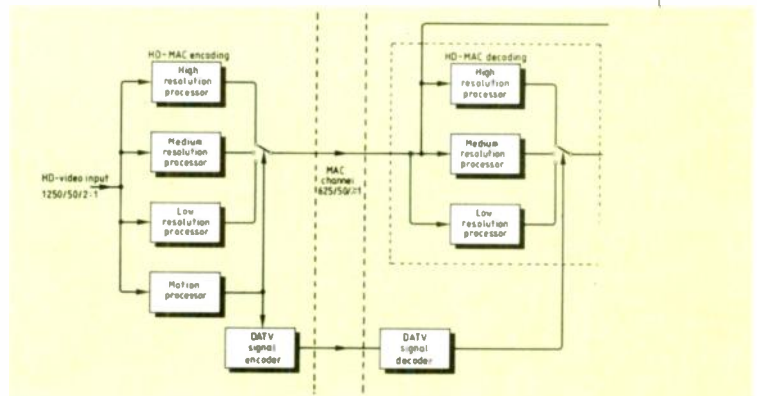

Fig.2. DATV codecs allow HDTV signal to be transmitted on a MAC channel and used by MAC receiver.

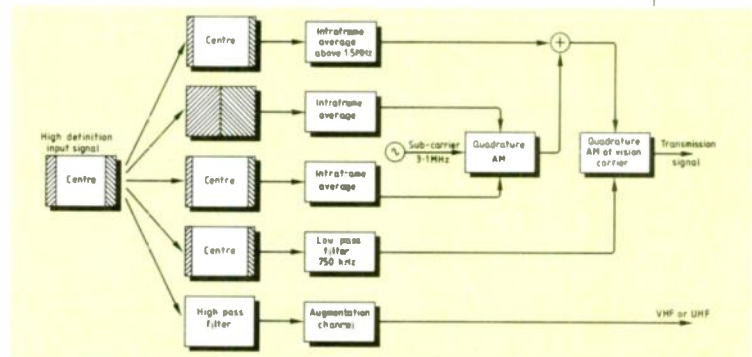

Fig.3. Sarnoff ACTV multiplexing to produce transmitted signal.

complementary post-processing in a modified receiver are used to produce images of HDTV standard. This is achieved by the use of a field store to provide line doubling with motion interpolation. NTSC-type artefacts are removed by the use of accurate adaptive comb filters in both the encoder and decoder.

Why one standard?

Any world standard that is selected now will have to last at least for the next 20 years to recover the massive costs. In that time, rapid developments in digital and computer technology, which could give birth to a smart receiver, could well drive such a system into early obsolescence. Recent developments in telecine and electron-beam recording introduced by Rank Cintel and Sony for tape-to-film and film-to-tape transfers have produced machines capable of working to HDTV standards. Since the quality aimed at is that of 35mm film, why not allow the development of two or even three electronic standards for HDTV and leave film to act as a world conversion standard? This would have the additional advantage of releasing high-cost programmes into television and the cinema simultaneously. ■

THE COMPLETE 68000 TRAINING SYSTEM



- 68000 — LATEST 16-BIT TECHNOLOGY
- SUPERB DOCUMENTATION — COMPLETE WITH USERS MANUAL
- SOURCE LISTING AND 3 TECHNICAL MANUALS
- COMPLETE PACKAGE — START LEARNING IMMEDIATELY
- BUILT-IN ASSEMBLER
- POWERFUL DEBUGGING FACILITIES
- POWERFUL INPUT/OUTPUT
- 2 × RS 232 ● 24 I/O LINES
- G64 EXPANSION BUS ● 24 BIT COUNTER/TIMER
- EXPANSION MEMORY SOCKETS
- ACCEPTS EPROMS, EEPROMS OR RAM TO 128KB

Flight Electronics Limited lead the field in microprocessor training systems. The **NEW FLIGHT-68K**... designed and built in the U.K., has been designed specifically for education.

The hardware is designed to be easily understood, yet is comprehensive enough for many advanced control applications. The board features a full specification 68000, versatile memory system, 68681 dual UART linked to two full specification RS232 ports, 68230 Parallel Interface/Timer plus a G64 bus connector which enables a wide range of low cost interface boards to be utilised.

The firmware is simplicity itself to use. All commands are self explanatory and will prompt the user for information where required, which means that users will be able to start learning about the 68000 in a matter of minutes!

A set of 53 monitor commands offer full program generation, debugging and system control facilities enabling the FLIGHT-68K to be used in a 'stand-alone' configuration using a terminal as the system console. For more advanced applications, the FLIGHT-68K may be used as a target for 68000 object code files.

Also available from Flight Electronics is a powerful macro cross-assembler for use with the BBC computer, enabling a full 68000 development system to be realised at very little extra cost!

The documentation provided with the system is a model of clarity and comprehensiveness, providing concise, easily accessible information on all aspects of the 68000 and the FLIGHT-68K.

Much of the manual is written in a tutorial format, with a wealth of practical example programs.

Each system is supplied complete with protective case, power supply, User Manual, Monitor Source Listing and the original technical manuals for the 68000 and peripheral I.C.s.

ONLY £395
+ P&P & VAT
FLIGHT ELECTRONICS LTD.

Flight Electronics Ltd. Flight House, Ascupart St., Southampton SO1 1LU. Telex: 477389 FLIGHT G. (0703) 227721-6 LINES
TELEPHONE NOW FOR FULL DETAILS!

CIRCLE NO. 118 ON REPLY CARD

Hearing is believing?

The hi-fi business seems peculiarly vulnerable to fraudsters, charlatans and pre-owned car salesmen. The industry's golden ears are distorted by a mixture of flattery and auto-suggestion, says Barry Fox.

Where did all the snake oil salesmen go when the Wild West was tamed?

Into hi-fi, of course.

A few years ago a jaded audio engineer told me his secret master plan. He was going to create a market for "hi-fi solder".

His solder would contain a secret ingredient that eliminated the distortion created by conventional solder joints.

No matter that no-one had previously measured, or heard, any distortion created by factory soldering. A clever campaign by word of mouth, and demonstrating to selected journalists, would do the trick.

"Now listen to this", he would say to a golden-eared pundit. "Can you really say there's no difference between the sound from these two amplifiers, one factory-fresh and the other re-made with hi-fi solder?"

Never underestimate the powers of auto-suggestion. Tell someone that they are listening to something special, while inferring that their keen hearing is famous the world over, and you immediately have a convert with religious fervour to convert others.

Don't fudge the issue with blind and double-blind testing. Just tell people what to hear, and they will

Tell someone they are listening to something special and that their keen hearing is famous and you have a convert with religious fervour

obediently hear it. Better still, get them to pay through the nose for a sprinkle of electronic magic dust. It takes a brave man or woman to admit that they have been conned and wasted their money.

I don't doubt for a moment that if the man with the hi-fi solder plan had followed through, tortured souls all round the world would soon have been re-soldering every joint in their hi-fi, or paying specialist treatment centres to do the job for them. They would have gladly ignored the residual hum and intermittent crackle that would surely have resulted from the amateur reconstruction of joints that soon "went dry". All they would have heard was the absence of solder distortion. And who could have proved that they were not hearing an absence of something which never existed?

As far as I know, the hi-fi solder plan was never put into action. But I often wonder how many of the other hi-fi crazes began with a similar over-a-drink fantasy and ended up as a solid commercial venture. As the late Lenny Bruce so succinctly put it. "If they'll give, I'll grab".

At the Tokyo Audio Fair recently, I watched a roomful of head-nodding Japanese super-ears listening to what they obviously thought was the obvious difference in sound between different cables – all virginally pure of oxygen contamination and with stringy copper crystals neatly aligned in applie pie order. I don't doubt that they all heard how much better the more expensive cables sounded.

But at the same time I wondered why they were ignoring the far more significant effect on the sound caused by cramming at least two dozen different loudspeaker pairs into the same room, without any apparent attempt at shorting the voice coils to stop them flapping in sympathetic distortion.

Of course there is an obvious benefit from using gold- and silver-plated plugs and sockets. As any schoolboy will tell you, they do not

There is no doubt that most people who pay hard-earned cash for mumbo-jumbo witchcraft will rather hear the difference than admit they were taken for a ride

corrode and so will not introduce crackles and semiconductor junctions which rectify the sound of passing radio taxis.

Likewise no-one disputes that the use of thin, high-resistance cables will affect the sound from loudspeakers, if only by reducing gain. By the same token, nice thick cables with plenty of heavy copper will do a better job.

I don't doubt the sincerity of those who truly believe that the sound is better if the copper has linear crystals and is oxygen-free. What I, and other cloth-eared pragmatists like me, object to is the quite shocking disregard for scientific methodology in some of the "proving" tests.

We have recently seen a fatal fascination for the "neutralization" treatment of everything from metalwork to paper-back books in rooms dedicated to super-fi listening. Again, there is no doubt that most people who pay hard-earned cash for mumbo-jumbo witchcraft will rather hear the difference than acknowledge that they were taken for a ride. That's fair enough. If they want to invest in neutralization, rather than going to concerts or buying gramophone records or beer



CONSUMER ELECTRONICS



CONSUMER ELECTRONICS

in the pub, good luck to them and those who sell the treatment.

But please don't anyone preach the gospel, and expect others to play the same stupid game, without first running blind tests in which no-one knows what they are hearing.

In fact, even blind tests can be fudged – as all those tests on the difference between valves, transistors, analogue waves and digital pulses proved. It only takes one strong character on the panel to influence the rest with a pained grunt or a sigh of satisfaction.

Any logged result can always be excused. You just blame the stress of the test procedure, inadequacy of the source material or, if all else fails, some unspecified weak link in the chain, such as the contacts of the switch used for the A/B test transition.

Hi-fi magicians, as opposed to serious reviewers who listen and measure and try to reconcile the two, abhor rational explanations as rabidly as Nature abhors a vacuum.

Of course not all amplifiers sound the same; of course there are differences between analogue and digital recordings; and of course different digital-to-analogue decoders create different audible

Hi-fi magicians, as opposed to serious reviewers who listen and measure..., abhor rational explanations as rabidly as Nature abhors a vacuum

effects. Early transistor amplifiers sounded downright nasty, because their designers were still "thinking valves". The master tapes from which digital CDs are pressed will often have been equalized to compensate for the physical deficiencies of a vinyl LP. If the record company cuts costs and uses the same tape as a master for "flat" CDs, you end up with something that sounds very nasty indeed.

Until recently, the electronics companies were vying with each other to offer DACs with as many bits of resolution as possible. Now the world has gone mad for one-bit

coding.

The Japanese had developed this technology two years ago but, by their own admission, held back on an announcement for the simple reason that they could not see how to explain to the public that suddenly multiple bits were out, and single bits were in. When Philips went with Bitstream, the Japanese rode on the back of the confusion caused. But because many companies will not have single-bit hardware available until next year, Philips' premature announcement successfully shot the industry in the foot for the Christmas market. Punters are now waiting to buy for fear of being left with obsolete DACs. Not of course that the average punter has any idea what a DAC is – just that what was previously held to be good is now held to be not so good as that which is not yet available.

Little birds tell me that the next round of nonsense will centre on the theory that some optical-fibre cables are better at carrying digits than others. So fibres sound different. Doubtless the more expensive ones will sound better. The sales possibilities for this one are endless.

The absurdity is that while all this is going on the audio industry still has not got round to doing what the professional sound recording industry did years ago. In a recording studio, the cables from different microphones are colour coded, to make connections at the mixing desk fast, easy and unambiguous. But hi-fi buffs still grovel on the ground with a spaghetti cobweb of indistinguishable leads, connecting innumerable different audio and video sources. Who will be first to forget about the minor benefits of grossly over-priced hi-fi cabling, and offer the public the real benefit of colour coded connecting cables?

And who will be first to offer a video cassette with both linear and hi-fi stereo which identifies the left and right and rear surround channels, and their phase, to help set up an audio-video system?

For my money, straightforward questions like these sum up the status quo in hi-fi. (status quo is, after all, only Latin for the mess we are in). The hi-fi industry has never been able to see the wood for the trees. Minor improvements are endlessly debated while the real and significant benefits (like the glorious convenience of CD) are taken for granted. The wrong channels are connected, out of phase, by miracle cables.

Which makes me fear that it will only be a question of time, before someone makes the hi-fi solder joke a deadly serious business venture. ■



IN VIEW OF THE EXTREMELY RAPID CHANGE TAKING PLACE IN THE ELECTRONICS INDUSTRY, LARGE QUANTITIES OF COMPONENTS BECOME REDUNDANT. WE ARE CASH PURCHASERS OF SUCH MATERIALS AND WOULD ACCEPT A TELEPHONE CALL OR A LIST IF AVAILABLE. WE PAY TOP PRICES AND COLLECT.

R. Henson Ltd.

21 Lodge Lane, N. Finchley, London, N12 8JG.

5 mins. from Tally Ho Corner

**Telephone:
01-445 2713/0749**

CIRCLE NO. 109 ON REPLY CARD

WE HAVE THE WIDEST CHOICE OF USED OSCILLOSCOPES IN THE COUNTRY

TEKTRONIX 4454A Four Trace 150MHz Dual TB As new. Manufacturer's guarantee till Feb 91. **£1700**
 TEKTRONIX 225 Dual Trace 50MHz Delay Sweep **£575**
 TEKTRONIX 2215 Dual Trace 60MHz Delay Sweep Dual TB **£505**
 TEKTRONIX 475 Dual Trace 50MHz Delay Sweep **£650**
 TEKTRONIX 465 Dual Trace 100MHz Delay Sweep **£500**
 TEKTRONIX 7403 Four Trace 50MHz Delay Sweep **£400**
 TEKTRONIX 454 Dual Trace 150MHz Delay Sweep **£400**
 TRO CS1100 Dual Trace 100MHz Delay Sweep **£500**
 HITACHI V1050F Dual Trace 100MHz Delay Sweep **£550**
 PHILIPS PM3262 Dual Trace 100MHz Delay Sweep **£475**
 TELEQUIPMENT D83 Dual Trace 50MHz Delay Sweep **£300**
 TELEQUIPMENT D755 Dual Trace 50MHz Delay Sweep **£275**
 GOULD 250R Dual Trace 35MHz **£250**
 GOULD 250R Dual Trace 10MHz TV Trig **£140**
 HP 170A Dual Trace 100MHz Delay Sweep Trig **£500**
 HP 1720A Dual Trace 15MHz **£200**
 GOULD ADVANCE DS1100 Dual Trace 30MHz **£210**
 GOULD ADVANCE DS255 Dual Trace 15MHz **£210**
 COSSOR CDU150 Dual Trace 35MHz Delay **£180**
 SE LABS SM111 Dual Trace 18MHz **£130**
 TEKTRONIX 647A Dual Trace 100MHz Delay Sweep **£300**
 GOULD ADVANCE OS3000A Dual Trace 40MHz Delay Sweep **£250**
 TRO CS1100 Digital Storage Dual Trace 10MHz **£350**
 This is just a sample - many others available.

MARCONI Mobile Radio Test Set TF2950 **£650**
 RACAL DANA 6002 Microprocessor Digital Multimeter 6 1/2 Digit **£850**
 BOCON 210A Power Amp 10-500MHz, Output 4.5W plus. **£500**
 MARCONI/SANDERS Sig Source 60588 B 12.5MHz **£650**
 MARCONI TF2008 AM/FM 10MHz/510MHz Sig Gen **£375**
 MARCONI TF2015 AM/FM 10-520MHz Sig Gen with Synchroniser TF2171 **£450**
 MARCONI TF2015 without Synchroniser TF2171 **£300**
 MARCONI TF2016 AM/FM 10MHz/170MHz with Synchroniser **£400**
 MARCONI TF2016 without Synchroniser TF173 **£300**
 MARCONI MOD METERS TF2300, TF2300B, TF2300B from DYMAR 1525 AM/FM 0.1-184MHz Sig Gen **£200**
 RACAL 9084A AM/FM 10MHz/104MHz Sig Gen Synthesised **£600**
 HP 620B Signal Generator 7.1GHz **£400**
 HP 618C Signal Generator 3.8-7.6GHz **£400**
 HP 616B Signal Generator 1.8-4.2GHz **£400**
 LEADER SC216 Sig Gen AM/FM 0.1-300MHz, 75-115MHz, Built-in FM Stereo Modulation. **£575**
 WAVEGEN 157 Programmable Waveform Synthesiser 100 MicroHz-1MHz Sine/Sqr/Tri 0.1% Acc **£300**
 FEEDBACK F6601 Sig Gen 0.01Hz-1MHz, Sine/Sqr/Tri **£150**
 MARCONI Automatic Distortion Meter TF2337A 400Hz or 1kHz, Measurement from 0.01% **£100**
 PHILIPS 333 Functions Gen 0.1Hz-28MHz **£450**

AVO MULTIMETERS (P&P £10 all Units)
 Avo 8s, 9s and Ministry Versions. With Batteries & Leads from TEST LEADS for Avo's Red & Black with 2 croc Clips & 2 probes **£50**
 Black EVER READY Case for Avo's. Un used (P&P £4) **£15**
 BATTERIES 15volts £3 each 10 for £25 (P&P extra)

AVO TRANSISTOR ANALYSER Mk2 CT446 substrate style. With Batteries & operating instructions. ONLY £25 (P&P £3)
 MARCONI AF Power Meter TF893A 20Hz-35kHz, 20mV-10W, 9dB Manual. **ONLY £25 (P&P £2)**
 MARCONI RF Power Meter TF1152A/1 DC: 500MHz/0.5-25W, 50 ohm With Manual. **ONLY £30 (P&P £2)**
 FARWELL Oscillator LFM3 10Hz-10MHz Sine/Square **£200**
 RACAL 9915 Freq Counter 1MHz-50MHz (Crystal Oven) **£150**
 RACAL 9900 Series Universal Counter Timers from **£150**

This is a very small sample of stock. SAE or telephone for LIST of OVER 700 ITEMS. Please check availability before ordering. CARRIAGE all units £16 VAT to be added to total of goods and carriage.

HP SPECTRUM ANALYSER R-8590A 10KHz-1.5GHz IEEE £4,750

TEKTRONIX OSCILLOSCOPE 2235 Dual Trace 100MHz Delay Sweep **£750**
 PHILIPS OSCILLOSCOPE PM3217 Dual Trace 50MHz Delay Sweep **£500**
 GOULD OS 300 Oscilloscope Dual Trace 20MHz **£250**
 GOULD 1421 Digital Storage Dual Trace 20MHz **£750**
 THANDARTA 2080 Logic Analyser 20MHz Channel **£375**
 THURLEY PL3200MD 0-30V 2A Twice Quad Meas Digital Meters **£200**
 FEEDBACK F5606 Sweep Function Gen 0.01Hz-1MHz (P&P £7) **£200**
 SOLARTRON 7045 Multimeter 4 1/2 digit LED 30 ranges Auto/Manual (P&P £7) **£125**
 LOGIC PROBE type 3300A TTL/Cmos (P&P £3) **£18**
 TEKTRONIX 1M501 with SG503 Leveled Sinewave Gen 250kHz-25MHz **£1,000**
 RAS MOBILE RADIO TEST SET SMFP 0 4.520MHz **£2,000**
 WAYNE KERR B605 AutoComponent Bridge LCD **£450**
 WAYNE KERR B623 Component Meter with CAD LCD **£125**
 SCHAFFNER NSG200K with Interference Gen NSG222 and NSG223 **£1,200**
 ELECTRO METRICS Interference Analyser EMC10 20Hz-50MHz **£900**
 AVO VALVE CHARACTERISTIC METER CVM163 **£350**
 HP 6255A PSU 0.40V-1.5A 1amp **£175**

HAMEG MODULAR SYSTEM

HMB011 Main Frame with HMR012 Saw Wave Generator 20Hz-20MHz, HMB010 Full Wave Generator 0.1-1MHz, Sine/Sqr/Tri, and HMR011 2 Digital Multimeter 4 1/2 digit **ONLY £375**
 RHODE & SCHWARZ Voltmeter 3 SW01 with Sideband Adaptor P.O.A. **£100**
 FERROGRAPH RS2 Recorder Test Set **£275**
 WOELKE Wow & Flutter Meter ME108 **£100**
 LEADER LMV196A Two Channel Millivoltmeter 5Hz-500kHz 100uV **£100**
 TRO SG402 AM Sig Gen 100kHz-30MHz Un used. **£50**
 LEVELL OSCILLATORS TG152/TG200 Series from MARCONI ATTENUATORS TF2162 DC 1MHz/600 ohm 0.1-111dB (P&P £7) **£75**
 HATFIELD ATTENUATORS 50ohm DC-250MHz/2-100dB/600 ohm DC 1MHz (New Price £135) (P&P £4) **ONLY £50**
 TELEQUIPMENT GUIDE TRACER 471 **£290**

NEW EQUIPMENT

HAMEG OSCILLOSCOPE HM1805 Triple Trace 100MHz Delay Timebase **£726**
 HAMEG OSCILLOSCOPE HM604 Dual Trace 60MHz Delay Sweep **£575**
 HAMEG OSCILLOSCOPE HM203 6 Dual Trace 20MHz Component Test Set **£314**
 HAMEG OSCILLOSCOPE HM205 2 Dual Trace 20MHz Digital Storage. All other models available. All prices inclusive supplied with 2 probes **£527**
 BLACK STAR EQUIPMENT (P&P all units £5)
 APOLLO 10 100MHz Ratio Period/Time interval etc **£222**
 APOLLO 100 100MHz (As above with more functions) **£296**
 METEOR 100 FREQUENCY COUNTER 100MHz **£99**
 METEOR 600 FREQUENCY COUNTER 600MHz **£125**
 METEOR 1000 FREQUENCY COUNTER 1GHz **£178**
 JUPITER ORSON FUNCTION GEN 0.1Hz-500kHz Sine/Sqr/Tri **£110**
 DYNACOLOR R&B GENERATOR R&B TV Video **£209**
 All other Black Star Equipment available
 HUNLI CHANG DMM 7030 1 1/2 digit. Hand held 28 ranges including 10 Amp AC DC 0.1% Acc (P&P £4) **£39.50**
 As above DMM H010 0.25% **£33.50**
 Carrying case for above **£3.00 ea**
 OSCILLOSCOPES PROBE S Switched X1, X10 (p&P £1) **£11**

Those Engineers Ltd

Electronic CAD, control systems circuit simulation software

Product	Functionality	M/c	O/S	Recommendation	Price
ECA-2 NEW VERSION MULTIPLE SCREEN PLOTS	Analogue circuit simulator. Allows effects of different components to be investigated - more effectively than by bench testing. Very high specification program includes Monte Carlo & Worst Case tolerancing. Fourier analysis of transients. Non-linear components characterised by breakpoints or polynomial functions.	PC XT AT 386 256k RAM Mac	DOS 2.0 or later	Believed to be the most powerful PC-based analogue simulator available. Regularly upgraded. Integrates fully with VUTRAX for schematic entry of circuits.	£675 (special terms for education - ask for ECA-2S)
LCA-1	Logic Circuit Analyser; a new sister program to ECA-2. Produces logic analyser-style output traces (up to 68 signal traces) and incorporates delay and nestable macros.	As ECA	As ECA	This digital program simulates minmax propagation delay and integrates fully with VUTRAX schematic entry.	£450 (special terms for education)
MITEY SPICE	Analogue circuit simulator incorporates non-linear quiescent handling and small-circuit AC analysis. Full Ebers-Moll bipolar transistor representation, new transformer model and graphics display - up to 26 parameters.	BBC- Archimedes (ext. spec.)	DFS ADFS Native OS	Established teaching standard. Mitey Spice is starting 200+ node capacity, almost instant calculation; immediate development of complex circuits.	£119 (special terms for education - please ask us)
SPICE-AGE NEW VERSION FOURIER HARMING WINDOW	Analogue circuit simulator in GEM environment. Available in modular form covering: 1 - Frequency response 2 - DC quiescent analysis 3 - Transient analysis 4 - Fourier analysis	PC XT AT 386 512k RAM mouse desirable	DOS 2.0 or later	Licensed GEM supplied at no extra cost. Module 1 Additional modules Full program Multi user pro version a remarkable program	£70 £70 £245 Please ask us
PCS	Process control simulator for 3-term control. Quantization effects and saturation modelled.	AS CODAS	AS CODAS	Digitising cursor, on-line help, plant noise all available.	£100 (special terms for education)
CODAS II	Single-input control system simulator represents non-linearities and transport delays. Transient response, root locus, Nyquist, Nichols and Bode plots all available.	BBC Arch. PC XT AT	DFS emul DOS 2.0 or later	Ideal for control engineers. 4 domains; time, frequency, root locus & interactive.	£475 (special terms for education)
PCBAR	Auto-routed printed circuit board drawing program output to a plotter (driver extra) or to Epson FX compatible printer. Very easy to use.	BBC Arch	DFS ADFS emul	Ideal for prototyping, hobbyists, and teaching. Excellent quality prints (double size) from dot-matrix printer.	£85 (manual) £185 (auto route)
VUTRAX & A NEW VERSION 4x FASTER	A multi-sheet schematic drawing system with special features for drawing validation. Integrates fully with optional PCB layout and technical drawing modules.	PC XT AT 640k 8087/80287	DOS 2.0 or later	An important cornerstone for electronic design. Highly recommended enhancement for ECA-2 and LCA-1.	£499 (special terms for education)

Another first - SAUNA - 3D THERMAL ANALYSIS

Put your heat sources (calculated by ECA-2) on your heatsinks or circuit board and discover the local temperature distributions and inside the 3D of your enclosure. This menu-driven and highly graphic finite element program will guide you through revealing analyses that could not possibly be attempted by any other means. This program is so easy to use, you will never get overheated again! Stay cool for just £945!

Those Engineers have been providing circuit designers with micro-based simulation and pcb layout software since 1983. We now have a broad range of packages covering many applications and running on machines from the BBC Micro to 386-based PCs. The chances are, if you want computer based analysis software or a layout system, we have a cost-effective CAD package to suit your needs. When you telephone Those Engineers, you will be speaking to an engineer who will see it as his duty to advise you - our reputation is built on service and not opportunistic sales. Access payment accepted - please add VAT to above prices.

Those Engineers Ltd

100, KENYON ROAD, READING, BERKS RG6 1PL
 Tel 01 435 2771 Fax 01 435 3757

CIRCLE NO. 116 ON REPLY CARD

STEWART OF READING

110 WYKEHAM ROAD, READING, BERKS RG6 1PL
 Callers welcome 9am to 5.30pm. MON-FRI. (UNTIL 8pm. THURS)



CIRCLE NO. 124 ON REPLY CARD

THE RIDDLE OF INERTIA

Peter Graneau gives an account of Professor A.K.T. Assis' work on inertia, which confirms Newton's belief in instantaneous action at a distance.

In the 'Dialogues concerning two new sciences'¹ Galileo (1564-1642) wrote: "I, Simplicio, who have made the test can assure you that a cannon ball weighing one or two hundred pounds, or even more, will not reach the ground by as much as a span ahead of a musket ball weighing only half a pound." Whether or not this experiment was performed before the doubting professors of the University of Pisa by dropping weights from the Leaning Tower is still being discussed by historians. The debate takes away nothing from the stunning discovery made by Galileo which will forever remain a landmark of science. What kind of force counteracted the force of gravitational attraction to the centre of the earth by just the right amount to make the heavy object fall no faster than the light object?

Newton (1642-1727) called it 'vis insitas', a force which lay dormant in matter until the body was accelerated. This force gauged itself to be proportional to the mass of the body and its acceleration. It also directed itself to be precisely in opposition to the direction of acceleration. This was Newton's second law of motion and it has remained the definition of the inertial force. Generations of scientists have wondered why the same quantity, which we call the mass of the object, plays a part in the force of gravitation and in the force of inertia. Their surprise could immediately be dispelled if it was shown that the force of inertia was actually a force of gravitational attraction. Precisely this feat was accomplished recently by the Brazilian physicist Assis². He published his theory in the prestigious American journal 'Foundations of Physics'. Before explaining Assis' achievement, it may be helpful to consider a second riddle of inertia and the attempts which have been made since Newton's time to discover the origin of inertia.

Newton gave us three fundamental force laws. Perhaps the most important of them is known as 'the third law of motion'. It asserts that all forces of nature are paired forces of the simultaneous mutual interaction of two entities of matter, be they particles, bodies or stars. As an example of paired forces Newton developed his universal law of gravitation. The collision of two billiard balls involves a pair of forces. Tension in a metal is due to forces between pairs of atoms. In addition to the contact forces just mentioned, we have the far-action (action at a distance) forces between gravitating masses, magnets and electric charges. Only one force of nature stands alone and unpaired. This is the force of inertia (force = mass × acceleration). It openly violates the third law of action and reaction. This fact was covered up by Newton and all who followed him. But it was clearly

Only one force of Nature stands alone and unpaired. This is the force of inertia.

brought to the fore by Aspiden³ in a recent *E&W* article.

To complete his theory of mechanics, Newton ascribed the force of inertia to the acceleration of a particle relative to 'absolute space'. This was a desperate move because, as he admitted later in his life, there was no way of detecting absolute space. Two hundred years later, the Austrian mathematician, physicist and philosopher Mach (1838-1916) pointed out that Newton might as well have attributed the force of inertia to acceleration relative to the fixed stars. Mach went further and argued that the force of inertia must be due to an interaction with the fixed stars. This removed the conflict with the third law and made inertia conform with the principle of relativity which had been formulated by Berkeley late in Newton's lifetime. At the end of the 19th century Mach knew little about our galaxy, the Milky Way, to which all the visible fixed stars belonged. With today's astronomical knowledge, Mach's Principle - as Einstein would call it - should read:

"The inertia of particles and bodies on earth and in the solar system is due to their acceleration relative to all matter outside the solar system."

The cautious Mach did not specify the kind of interaction which might take

place between the particle on earth and another in the distant universe. Einstein (1879-1955) had no such hesitations. In his principle of the equivalence of gravitational and inertial mass, he coupled inertia directly to forces of gravitation. This principle became the basis of his general theory of relativity. Einstein was strongly influenced by Mach's writings on relativity in the latter's book dealing with the science of mechanics⁴. But ultimately Einstein admitted that his theory of gravitation and inertia did not comply with Mach's principle. One of his thought experiments served as the test. If the universe consisted of only one particle, he asked, would this particle be endowed with inertia? Mach's answer would have been "no", because the isolated particle had no matter with which it could interact. In Einstein's world it was space that acted on matter and therefore the lonely particle would still have to respond to acceleration with a force of inertia.

Einstein's resolute insistence on the local interaction of matter with the free energy residing in the field could not

Retarded action disconnects a body from the rest of the universe and makes it impossible to satisfy Mach's Principle

possibly be reconciled with Newton's instantaneous action at a distance on which Mach's principle squarely rested. This very same fact foiled the attempts of others who tried to unravel the mysteries of inertia without abandoning field theory. A noble effort in this direction was made by the Cambridge astrophysicist Sciama⁵ in the middle of the present century. He coined the remark "... matter has inertia only in the presence of other matter". The process of imbuing matter with inertia Sciama called 'induction': he borrowed the term from electromagnetism. As he adhered to the rules of field theory, he had to make the matter which caused



the induction of inertia send out energy at the velocity of light. This process virtually disconnected the bodies on earth from the distant matter in the universe by millions of years. There was no hope in Sciama's theory of producing simultaneous reaction forces far away in the universe. Hence inertia remained an isolated unpaired force, just as in Newton's theory. Sciama failed to follow up with a second paper, as he had promised in the first publication. It seems he became disillusioned with his idea of the induction of inertia.

Dicke⁶ of Princeton University and a number of other physicists also attempted to explain inertia. They lost themselves in the mathematical labyrinth of field physics and were unable to locate the remote and simultaneous reaction forces required by Mach's principle.

A new approach to the problem was proposed by Moon and Spencer⁷; it led to success at the hands of others. The American husband and wife team of the Massachusetts Institute of Technology and the University of Connecticut dispensed with the field and its resident free energy. They assumed instead that the forces of gravitation were transmitted by the retarded action at a distance. Then they modified Newton's law of gravitation by adding an 'inertia-gravity' term. Like gravity itself, inertia-gravity depended on the two masses of the interacting bodies. To appreciate the remaining aspects of the Moon and Spencer theory we will con-

sider a body A on earth and a body B in the distant universe.

The gravity force is an attraction between A and B and decreases with the inverse square of the distance between the bodies. In contrast to this position-dependent force, the inertia-gravity force depends on the acceleration of A relative to what Moon and Spencer called the substratum of the universe. The latter interaction is neither an attraction nor a repulsion. It acts on A in the direction opposite to the acceleration. The direction of the force on B was left undefined. The magnitude of the interaction force depends in a complicated way on the distance between A and B. Finally we have to assume the inertia-gravity force decreases with the velocity of A relative to the substratum in such a way that it tends to zero as the velocity of light is approached.

When the equally directed inertia-gravity forces on A (due to all bodies in the universe) are summed, the result gives the inertia force on A. It becomes zero when the acceleration of A ceases. An assumption of the integration is that the matter in the universe is distributed isotropically with respect to the earth. The theory has two weaknesses. It leaves the direction of the distant reaction force undefined and is therefore likely to violate Newton's third law. More important, as in field theory, the retarded action disconnects A from the rest of the universe and makes it impossible to satisfy Mach's principle. The

lasting value of the Moon and Spencer theory was that it pointed the way to a modification of Newton's law of gravitation which might eventually resolve the mystery of inertia.

In 1982 the British physicist Burniston Brown⁸ refined the Moon and Spencer theory by what would have been a thoroughly Newtonian technique, if it had avoided the retardation aspect. He made the inertia-gravity force a force of attraction depending on the relative acceleration between A and B. This eliminated the cosmic substratum (absolute space?) and fixed the direction of the reaction force in the distant universe. Surprisingly, all the inertia-gravity forces on A summed vectorially to a single force which opposed the acceleration of A relative to the reference frame provided by the distant galaxies. However, to achieve this result, the galaxies had to be distributed isotropically around the earth. A disturbing implication of this was that it placed the earth at the centre of the universe. Nevertheless, the isotropic distribution of galaxies is in general agreement with prevailing astronomical speculations.

Strangely, Burniston Brown paid only lip-service to the concept of retarded actions. All his calculations ignored the retardation. They equally well reflected the situation that would have arisen in a Newtonian model with simultaneous far-actions.

It was Phipps⁹ who claimed that Mach once stated his principle in the following way:

"When the subway jerks, it is the fixed stars that throw you down."

Phipps goes on to explain: "Note the irreconcilable conflict of Mach's thinking with causal (retarded action) thinking. After the subway jerks, there is no time for the fixed stars to accomplish our observed downfall, if those stars must act at speed c (velocity of light) in a causally retarded fashion – as modern physics teaches of all fundamental distant actions." Phipps also stressed that, if we believe Mach, the universe we feel in having to overcome inertia is the present universe, while the universe we see with our eyes is of course very ancient.

Finally we come to the Assis paper² published in 1989. He defined his objective as follows:

"The goal of the present work is to give a relational theory for gravitation and from it arrive at Mach's idea that inertial forces come from the gravitational interactions of any body with the rest of the universe."

Both Brown and Assis proposed a law of gravitation which actually consisted of three contributions. One varied with the distance between the interacting particles. This was Newton's term. The second term varied with the relative velocity and the third term with the relative acceleration of the attracting particles. The velocity term could be ignored because it made no contribution either to the normal forces of gravitation or the forces of inertia. A major difference between Brown and Assis was that the latter accepted Newton's simultaneous far-actions, and the former did not. Referring once more to a body A on earth, Assis observes:

"We can divide the forces acting on body A into two parts. The first part is the interaction with local bodies and with anisotropic distributions of bodies surrounding it. The second part is the interaction with isotropic distributions of bodies which surround it."

"When the subway jerks, it is the fixed stars that throw you down."

This was an ingenious idea because, whatever the distribution of matter in the universe relative to the earth, we can always divide it into an isotropic distribution superimposed on an anisotropic distribution. Then the earth does not have to be positioned in the centre of the cosmos. With his law of gravitation Assis proceeded to calculate the net force on body A due to all bodies B in the isotropic and anisotropic parts of the universe. The anisotropic universe (mainly the matter in the solar system) then gave the normal forces of gravitation which make the apple fall to the ground and cause the tides. The isotropic part of the universe produced the force of inertia in accordance with Newton's second law.

It boils down to this. The moon and the earth attract each other due to the common gravitational pull contained in Newton's and Assis' theories. Newton went on to claim that the inertia force on the moon, which keeps it in orbit around the earth, is caused by the moon's relative acceleration to absolute space. Against this, Assis maintains that the very same force is called forth by the relative acceleration-dependent attractions of the moon to the isotropically

distributed matter in the cosmos.

What are the practical consequences of the Assis theory? First of all, it gives us the 'sky-hook' on which we can hang the mystifying forces of gyroscopes⁵. For example, take a top spinning about an axis which is inclined at 45 degrees to the vertical, and precesses about the vertical axis. An upwardly directed force of inertia prevents this top from falling over to the ground. Assis says that this upward force pulls on the distant universe. Cousins¹⁰ wrote a 500-page report on gyroscopic devices and reproduced many patents and discussions which will be better understood with instantaneous reaction forces distributed throughout the cosmos.

The Assis theory gives us no answer to Laithwaite's question¹¹: can the inertial force be made stronger than the gravitational pull of the earth? But it gives us legitimate reasons for undertaking research on so called 'anti-gravity' devices. Above all, with Assis' concept we can explore the distant universe by laboratory experiment. ■

Dr Peter Graneau is with the Center for Electromagnetics Research of Northeastern University, Boston MA 02115, U.S.A. The article is based on a lecture he delivered at the University of Perugia, Italy, in September 1989. Leonhard Holihan, Director of the Advanced Energy

Research Institute in London, suggested the publication of the article and helped with its preparation.

- Galileo Galelei, Dialogues concerning two new sciences, Northwestern University, Evanstone IL (1939).
- A.K.T. Assis, "On Mach's principle", *Foundations of Physics Letters*, vol. 2, p. 301 (1989).
- H. Aspden, "Anti-gravity electronics", *Electronics & Wireless World*, Jan. 89, p.29.
- E. Mach, The science of mechanics, Open Court, London (1942).
- D.W. Sciama, "On the origin of inertia", *Royal Astronomical Society, Monthly Notes*, vol. 113, p.34 (1953).
- R.H. Dicke, The theoretical significance of experimental relativity, Blackie, London (1964).
- P. Moon, D.E. Spencer, "Mach's principle", *Philosophy of Science*, vol. 26, p.125 (1959).
- G. Burniston Brown, Retarded action-at-a-distance, Cortney Publications, Luton England (1982).
- T.E. Phipps, Heretical verities: Mathematical themes in physical description, Classic Non-Fiction Library, Urbana IL (1987).
- F.W. Cousins, Gyroscopic inertial devices, A report for the Advanced Energy Research Institute, London, (April 1988).
- R. Walgate, "Eric Laithwaite defies Newton", *New Scientist*, 14 Nov. 1974, p. 470.

MAKING ELECTRONICS C.A.D. AFFORDABLE

TINY-PC

PCB CAD, FOR THE PC/XT/AT

EASY-PC

- Are you still using tapes and a light box?
- Have you been putting off buying PCB CAD software?
- Have you access to an IBM PC/XT/AT or clone?
- Would you like to be able to produce PCB layouts up to 17" square?
- With up to 8 track layers and 2 silk screen layers?
- Plus drill template and solder resist?
- With up to eight different track widths anywhere in the range .002 to .531"?
- With up to 16 different pad sizes from the same range?
- With pad shapes including round, oval, square, with or without hole and edge connector fingers?
- With up to 1500 IC's per board, from up to 100 different outlines?
- With auto repeat on tracks or other features - ideal for memory planes?
- That can be used for surface mount components?
- With the ability to locate components and pads on grid or to .002" resolution?
- With an optional auto via facility for multilayer boards?
- With the ability to create and save your own symbols?
- That can be used with either cursor keys or mouse?
- That is as good at circuit diagrams as it is at PCB's?
- Which outputs to dot matrix printer, pen-plotter or photo-plotter (via bureaux)?
- Where you can learn how to use it in around an hour?

**BRITISH
DESIGN
AWARD
1989**

FROM
£49
inc VAT

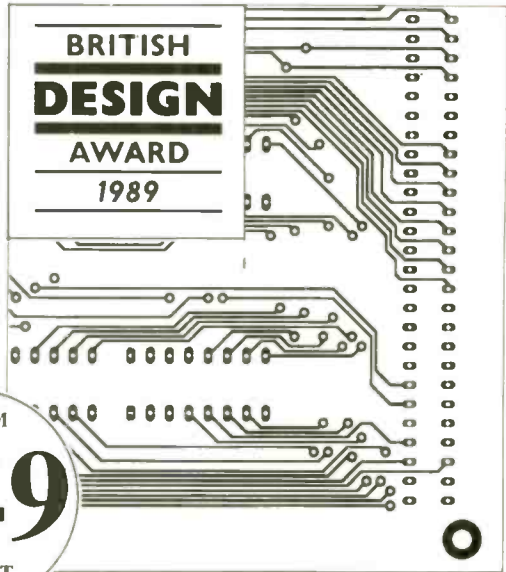

SMITH CHART PROGRAM —

Z MATCH

CIRCUIT ANALYSIS BY COMPUTER

ANALYSER II

For IBM, PC/XT/AT and clones inc. Amstrad 1512 and 1640 and BBC B, B+ and Master.

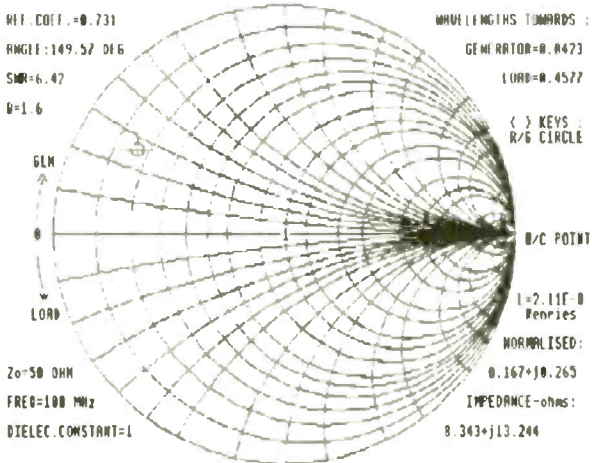

Z-MATCH - Takes the drudgery out of R.F. matching problems. Includes many more features than the standard Smith Chart.

Provides solutions to problems such as TRANSMISSION LINE MATCHING for AERIALS and RF AMPLIFIERS with TRANSMISSION LINE, TRANSFORMER and STUB MATCHING methods using COAXIAL LINES MICROSTRIP, STRIPLINE and WAVEGUIDES. The program takes account of TRANSMISSION LINE LOSS, DIELECTRIC CONSTANT, VELOCITY FACTOR and FREQUENCY.

Z-MATCH is supplied with a COMPREHENSIVE USER MANUAL which contains a range of WORKED EXAMPLES

£130 ex VAT for PC/XT/AT etc.
£65.00 ex VAT for BBC B, B+ and Master

For IBM PC/XT/AT and clones inc. Amstrad 1512, 1640, R.M. NIMBUS, and BBC B, B+, and Master.

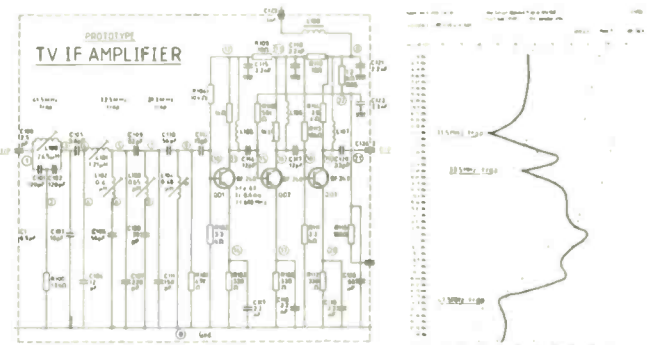

"ANALYSER II" — Analyses complex circuits for GAIN, PHASE, INPUT IMPEDANCE, OUTPUT IMPEDANCE and GROUP DELAY over a very wide frequency range.

Ideal for the analysis of ACTIVE and PASSIVE FILTER CIRCUITS, AUDIO AMPLIFIERS, LOUDSPEAKER CROSS-OVER NETWORKS, WIDE BAND AMPLIFIERS, TUNED R.F. AMPLIFIERS, AERIAL MATCHING NETWORKS, TV I.F. and CHROMA FILTER CIRCUITS, LINEAR INTEGRATED CIRCUITS etc.

STABILITY CRITERIA AND OSCILLATOR CIRCUITS can be evaluated by "breaking the loop".

Can save days breadboarding and thousands of pounds worth of equipment.

£195 ex VAT for PC/XT/AT etc.
£130 ex VAT for BBC, B, B+ and Master

All major credit cards accepted

WRITE OR PHONE FOR FULL DETAILS:- REF WW

Number One Systems Ltd



Harding Way, St Ives, Huntingdon Cambs, PE17 4WR
Tel: St Ives (0480) 61778 (4 lines)

We provide full after-sales support with free telephone 'hotline help' service.

Software updates are free within 6 months of purchase date.

CIRCLE NO. 112 ON REPLY CARD

de Sitter and the ether

After reading the letter by C.C. Busby and C.J. Busby (*EW+EW*, November 1989 p. 1084) one begins to wonder how much more experimental evidence is needed before Einstein's postulate about the constancy of light speed is overturned.

Can it be that the discovery of the de Sitter phantoms was what was behind a recent Leningrad conference on "The Problem of Space and Time in Modern Science" sponsored by the Academy of Science of the USSR? A report by one US participant in this event, published in the *Commercial Dispatch*, Columbus, Mississippi on April 6, 1989, indicated that it had been learned that earlier two scientists had been dismissed from the Pulkovo Observatory because they had discovered facts which contradicted Einstein. However, perestroika had opened doors and this conference had become a forum for expressing disagreement with Einstein's theory. Quoting from the report, "At least four of the representatives from Novosibirsk, Russia's 'atomic city', were stressing the idea of

going back to a more classic belief regarding relativity. During the conference the burning question was: Why did the scientific world decide to go with Einstein's theory?"

To add a third element to this de Sitter revolution against Einstein, I draw attention to some words at the end of a paper Binary stars from Three Viewpoints by P. Moon, D.E. Spencer and E.E. Moon, which has appeared in the latest issue of *Physics Essays* (vol. 2, pp. 275-287).

"This paper makes no attempt to analyse all the experiments that are generally regarded by physicists to be verifications of special and general relativity. It deals with a relatively modest question: Should all thought concerning the postulates on the velocity of light have ended with de Sitter's 1913 publications? Many experiments do exist that are not consistent with the special and general theories of relativity. It is because of these experiments that the authors feel it is still worthwhile to investigate the postulates of currently accepted physics with an open mind."

The authors declare that the object of this latter paper is to prepare the way for a new interpretation or postulate on

the velocity of light which is consistent with the existence of 'universal time', something that is anathema to the relativist.

The institutional addresses of the authors raising these issues are Massachusetts Institute of Technology and the University of Connecticut in the USA, Kings College, Cambridge in the UK and Pulkovo Observatory, Leningrad, USSR. In the light of views expressed from such a background, I suspect we are now witnessing the crumbling foundations of Einstein's theory and cannot continue much longer to regard those who challenge the Einstein doctrine as ill-informed 'cranks'.
H. Aspden,
Department of Electrical Engineering,
University of Southampton.

ELF reception

Mr McGregor's letter describing a novel satellite antenna using gnomes' hats (November, 1989) reminded me of an idea I had a while ago. I was going to file a patent application, but I have not got around to it, and may as well share the information.

The central 'stick' on a sundial is called a gnomon (hence the connection with gnomes). For a given orientation of a sundial, the tip of the shadow traces out a path such that each unique position of the sun in the sky corresponds to a unique position of the shadow. By inscribing sets of orthogonal lines on the base of the sundial it would be possible to read off the sun's elevation and azimuth. Alternatively, if the sun's position is known in advance (from nautical tables for example), then the orientation of the sundial can be worked out.

A sundial could be constructed from a satellite dish. The dish is moved to a point in the required direction by watching the position of the shadow cast by the gnomon, taking into account the time of day, time of year and latitude. This information could be inscribed on the dish, but the system would be more versatile if the information was kept in a set of tables.

Those who can think in three-dimensional geometry will

realise that a 'degree of freedom' has to be constrained. The easiest way to do this is to fix the dial vertically (or for a dish, fix the elevation) and then to rotate the dial about a vertical axis. Another possibility may be for the dish to be on a polar mount.

Anyone embarking on such a design is warned that, although the three-dimensional geometry is not difficult, it is an onerous task to calculate the position of the sun accurately. It is done by iterative methods from knowledge of the earth's orbit. The best method, however, is to use someone else's tables!

This method is an extension to the practice of observing the sun at a certain time and date when it is eclipsed by the satellite, in order to see if you have a line-of-sight path to the satellite.

David Gibson
Broadstone
Dorset

Crossed-field antenna

As a final-year electrical engineering student at the University of Sydney doing my thesis on antennae, I was fascinated by your article on the crossed-field antenna. The idea of an antenna whose radiated wavelength is independent of physical size would be, as the authors suggested, unprecedented. Thus I spent several months on experimentation and theoretical study of the concept of the CFA.

At the end of this examination the conclusion I arrived at was that this antenna would not produce efficient radiation at a wavelength independent of physical size. The major problems associated with this design are as follows.

1. In Fig. 6 of the article, the wires connecting to the upper E-plate and upper D-plate from the splitter and phasing unit would interact with the other 'open' wires as well as the other capacitor plates. This would lead to the generation of both E and H fields, thus significantly distorting the 'synthesis' of the Poynting vector $S = E \times H$.
2. This running of the coax.

Nonsense – but which nonsense?

As I survey the disordered criss-cross of narrow-gauge automatons, what do I find? A contents page containing a descriptive summary of Letters including the word "Nonsense".

Could this be a Freudian slip? To a metaphysicist who actually understands causation, all other explanations of what goes on in the "real" world of apparency, below it, are nonsensical.

Thus, Sir, before you label sense as nonsense, pray consider doing better than a certain professor of physics, with whom I have corresponded, who muttered blithely about answering all my points when he would have done better to demonstrate a mental ability to

integrate rather than demonstrate that he could not see the Garden for all the other dead slugs*.

It is in fact refreshing to read the print-out of a better-programmed computer like Mr Whiston (November), and that is why I grant you the benefit of the doubt as to why you published it if it is nonsense: or were you really referring to the object of his critique?

**Slug: a solid line of type cast by linotype process, largely defunct.*

James A. MacHarg
Wooler
Northumberland

I refuse to print this arrant nonsense – Ed.

Maximum IEEE-488 Performance for Your High-Speed AT Computer



The National Instruments AT-GPIB . . . the new standard for IEEE-488 interfaces

At last, a low-cost IEEE-488 PC/AT controller board can transfer data continuously at the maximum specified rate of 1 Mbytes/sec. The key to this high performance is the state-of-the-art FIFO buffering and special last-byte handling circuitry of our custom gate array, Turbo488™. The Turbo488 also conserves valuable computer bus bandwidth by packing 8-bit IEEE-488 data bytes into 16-bit words.

By moving time consuming software functions into hardware, the Turbo488 significantly reduces the overhead of a software driver too. The combination of the AT-GPIB and our streamlined software driver gives you the power needed for today's high speed digitisers.

The AT-GPIB is controlled by the *de facto* industry standard NI-488 software. NI-488 has high-level routines that transparently handle IEEE-488 protocol and buffered DMA transfers. These routines can be used with any popular language and are the perfect match for the structured, hierarchical programming style preferred by users of high-speed, compiled languages such as C and Pascal.

If you are familiar with dedicated controllers, NI-488 gives you the option of using our Universal Language Interface driver with any DOS language to programme with Hewlett-Packard style commands. The speed of this driver is best suited for interpretive languages like BASIC.

Your investment in National Instruments is a sound one. You can still run your existing NI-488 programs yet automatically take full advantage of the Turbo488. If you're just getting started, our interactive instrument control and menu-driven configuration utilities will get you up and running in no time.

Your relationship with National Instruments does not end when you purchase our products. A staff of applications engineers is always a free phone call away.

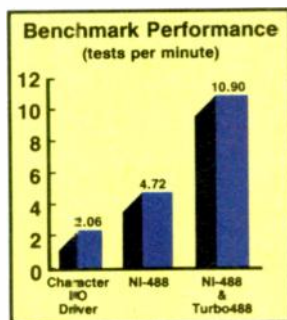

Turbo488 technology is standard on our boards for Micro Channel and Macintosh computers

 **NATIONAL INSTRUMENTS**
The Software is the Instrument™
National Instruments UK Corp.
21 Kingfisher Court
Hambridge Road, Newbury
Berks RG14 5SJ
Tel: 0635 523545
Fax: 0635 523154

**Call FREEPHONE 0800 289 877
for a catalogue and details of our
FREE 'Hands On' Roadshows.**

CIRCLE NO. 141 ON REPLY CARD

inner cable through open space will also lead to a very significant change in the antennae terminal impedance – one which is highly sensitive to any frequency changes: this was verified experimentally. Hence any power output of the antenna would be significantly reduced as the input matching network would no longer provide correct matching for maximum power transfer from the input.

3. This antenna would look like a highly capacitive load, which is undesirable in antennas since, for good power radiation, a good terminal impedance matching is required. This is difficult to achieve with a highly capacitive load – particularly over a broad frequency range.

4. Maxwell's equations show that when an RF voltage source is set up across any set of parallel plates – regardless of their thickness – both **E** and **H** fields are created. These fields will additionally interact with each other. Hence the statement that "The Poynting vector $S = E \times H$ is directly synthesised by separate **E** and **H** field stimulus" does not appear correct – particularly over the claimed bandwidth of 30%.

However, despite these reservations, it appears from the article that the authors have produced an antenna which exhibits the stated properties. If they could provide some further results and procedures it would

greatly assist in further research on the CFA.

— How far from the antenna were the measurements taken? That is to say, in the near or far field.

— What is the radiation resistance of the antenna? Or, how efficient was the CFA?

— What is the input impedance of the antenna over a broad frequency range?

— What is the comparative gain of the antenna?

In conclusion, the CFA would indeed be a revolutionary new antenna design and I personally would be interested in seeing it further developed as there are numerous applications for such an antenna – even with a poor efficiency: for example, hand-held radar over moderate distances.

Stefan J. Jackson
Air Navigation Dept. of
Electrical Engineering
University of Sydney
N.S.W.
Australia

Laser vibration measurement

Lee Tracy's interesting and informative article on electronic surveillance in the October issue mentions Decca's laser vibration system but fails to give credit to the inventors. May I be permitted to fill in the background?

The original project was

undertaken by Miss Helen Avsec working for a Ph.D. under my supervision at Surrey University. It was part of a programme to study vibration of turbine blades using laser Doppler and was initially funded by the Science Research Council. Collaboration subsequently developed with Mr S. Botcherby at Decca who was able to help with equipment. The result was a startlingly original instrument: the clever part lay in its ability to sense direction of motion in a laser homodyne system without an offset local oscillator. Its sensitivity was also quite extraordinary; on a specular reflector it was able to detect movements as small as 10^{-20} cm, but less on an ordinary scattering target.

The principles of the instrument were reported at the Conference on Laser Engineering and Applications in Washington in May 1969, under the authorship of Botcherby, Avsec (later Mrs Botcherby) and myself.

When it became apparent what the real application of the instrument would be, we at Surrey moved on to other laser Doppler work, taking the view that electronic surveillance was an inappropriate topic for a university. Owing to the security interest, subsequent developments elsewhere have been shielded under security wraps.

Quintin Davis
Martin, Davis & Partners
Leatherhead
Surrey

Test-card tapes

Two years ago I bought an ex-BBC studio tape machine: the very machine which was used to play the tapes of BBC test-card music between the late 1950s and early 1960s.

It is my ambition to own tape recordings of all the tapes of music played with the test card between 1958 and 1965 so that once again they can be played on the same machine that played them during that period of time.

The BBC cannot help, since the tapes no longer exist, so I'm writing to you in the hope that your readers can help.

If any readers can assist in any way, perhaps they would contact me.

Norman D. Cooper
71 Newcoln Road
Edgehill
Scarborough
North Yorkshire
YO12 4BL

Untangling the magnetic knot

Mr Ove Tedenstig has supplied us with a mathematical summary of his views concerning Colin White's September 1989 article on magnetic units. We would be pleased to supply a copy of the summary on receipt of a stamped, addressed envelope. Ed.

Cyclic redundancy checks

I read with interest Graham Stephens' article on CRC's in September's issue as I have used them for some time in my work of reading 'alien' format disks onto an IBM PC using central point bitcopy cards. During this work, it was necessary to develop from scratch a number of CRC routines which work in the opposite direction (disk data goes msb first) to those of Mr Stephens, but which have been optimised significantly.

I have applied these techniques to the 6502 routine you published. The routines are primarily concerned with speed, which can be quite significant when dealing with 10k of track data. If you take the xor logic further you can iterate the data xor and related bit shifts completely out of the loop.

My assertion is that you only need to xor the data with remis once at the beginning and in the loop merely shift the remainder and xor with the polynomial when a '1' bit falls off the end.

This method I call fast serial and is more efficient in space and speed than the one published.

The next step is to realise that for each piece of 'data xor remis' there are only 256 possible ways that the polynomial can be xor'ed with the remainder and

Anti-gravity

Philip Lonsdale's letter in the July *W&W* describing the "Dean Drive" was most interesting. Presumably it consisted of two dumb-bell weights shuttled across a rotating shaft at twice the rotational frequency; or two contra-rotating devices, more likely. A less developed type of Dean Drive seems to be known to many 1½ to 3 year old toddlers as they persuade tricycles and trolleys to move, albeit slowly, in one direction on level surfaces by undulating their bodies and not using their feet at all. Anyone

who has laid a concrete floor with a vibrating screed will also know that there is a definite preferred direction of travel for these devices.

I have always assumed that the horizontal force resulted from asymmetrical frictional forces but perhaps someone more expert in the conversion of angular momentum into linear momentum could give me the real reason. Did I hear someone shout "conservation laws!"

M. Hamer
Ullingswick
Hereford

SMALL SELECTION ONLY LISTED – EXPORT TRADE AND QUANTITY DISCOUNTS

RING US FOR YOUR REQUIREMENTS WHICH MAY BE IN STOCK

Cossor Oscilloscopes CDU150(CT531/3) £150 only. Solid state general purpose bandwidth DC to 35MHz at 5MV/cm – Dual Channel – delayed time base – illuminated graticule – Beam finder – Calibrator – power 200V – 250 volts AC – protection cover containing polarized viewer and camera adaptor plate – probe (1) – mains lead. Tested in fair condition with operating instructions. FEW AVAILABLE – NO PROTECTIVE COVER BUT MAINS LEAD + 1 PROBE – £125 – TESTED – Manual £15 extra.

Tektronix 475 – 200Mc/s Oscilloscopes – tested from £400 less attachments to £700 as new c/w manual, probes etc.

Tequipment D755 – 50Mc/s Oscilloscopes – Tested c/w 2 Probes – £250. Manual £5 extra.

Marconi TF2002AS – AM-FM Signal Generator – 10Kc/s to 72Mc/s – £85. Tested + probe kit – Manual £10 extra.

Marconi TF2002B – AM-FM Signal Generator – 10Kc/s-88Mc/s. – £100 Tested to £150 as new + Probe kit – Manual £10 extra.

Marconi TF2008 – AM-FM Signal Generator – Also Sweeper – 10Kc/s-510Mc/s – from £350 Tested to £500 as new with manual – Probe kit in wooden carrying box – £50 extra. (Few available with small faults £300).

Don 10 Telephone Cable – ½ mile canvas containers or wooden drum new from £20.

Infra-red Binoculars in fibre-glass carrying case – tested – £100 each also infra-red AFV sights – £100 each S.A.E. for details.

Army Whip Aerials screw type F sections and bases large qty available P.O.R.

Test Equipment we hold a large stock of modern and old equipment – RF and AF Signal Generators – Spectrum Analysers – Counters – Power Supplies – Scopes – Chart Recorders all speeds single to multiplex – XY Plotters A4-A3.

Racal Modern Encryption Equipment – Racal Modern Morse Readers and Senders – Clark Air Operated Heavy Duty Masts – P.O.R.

All items are bought direct from H M Government being surplus equipment; price is ex-works. S.A.E. for enquiries. Phone for appointment for demonstration of any items, also availability or price change V.A.T. and carriage extra.

**JOHNS RADIO, WHITEHALL WORKS,
84 WHITEHALL ROAD EAST, BIRKENSHAW,
BRADFORD BD11 2ER. TEL NO. (0274) 684007. FAX: 651160**

WANTED: REDUNDANT TEST EQUIPMENT – VALVES – PLUGS – SOCKETS – SYNCHROS ETC. RECEIVING AND TRANSMITTING EQUIPMENT – GENERAL ELECTRONIC EQUIPMENT

CIRCLE NO. 131 ON REPLY CARD

Field Electric Ltd. Tel: 01-953 6009. 3 Shenley Road, Borehamwood, Herts WD6 1AA. Fax: 01-207 6375, 0836 640328

SPECIAL OFFERS

NEC 9" Green Screen Monitors 75 Comp Video Input.
Plastic case with handle. 240 VAC input 20 MHz bandwidth. £24.95 c/p 6.00
12 VDC TTL input black and white monitors new ex/equipment 9" high resolution cased jdg height feet. £36.00 c/p 4.00
Norton Communications 1640 Modems. No guarantee. £10.95c/p 4.00
NEC 12" Green Screen Monitors 240 Vac Comp Video Input 20 MHz band with cased £34.90 c/p 6.00
Mitsubishi M4054-4 new 1/2 height disk drives 80 track d/sided d/density 360 rpm no info. £40.00 c/p 3.75
Tabor 3" disk drive some info new & boxed £10.90 c/p 2.25
MPI full height floppy disk drives 40 track single sided £10.90 c/p 1.50
Ashtabua Pro headphones. 6mm mono jack fitted new & boxed 200 ohm imp. £15.00 c/p 2.50
Ashtabua Pro headphones. jack plug fitted with built in boom mic ideal for communications £30.00 c/p 2.50
Landberg series 5000 reel to reel tape recorder. chassis £15.90 c/p 6.00

5.25" Winchester (half height) hard disk drive by Tandem TM 252 unformatted 12.8 Mb New ex/equipment £57.90 c/p 5.50 Peripheral comms controller BX MC68661 BXMC14891 BXMC1488P 13 various chips all in holders new ex/equipment £9.95
Power supplies switch mode units all 240 vac input. 5V 20A £18.90 5V 40A £18.00 5V 60A £23.00 Farnell Fan Cooled + 5V 10A - 5V 1A - 12V 3A - 12V 1A £35.00 Gould 379 5V 40A - 12V 4A - 15V 11A £30.00 c/p 4.90; Farnell 200W + 15V 4A - 15V 4A - 5V 30A £27.75 5V 1A PC Card £7.50
Winchester hard disk drive new model 02020 20mb £144.00 c/p 12.00
Lambda 12 VDC set 65A linear psu £345.00 c/p ring for quote
240V primary 11V Sec. 80A £45.00 c/p ring for quote
Portable isolating transformers 240 VAC/110 VAC 500VA cont. rating 1/2 hr rating 750 VA 1/4 hr is spotted within a yellow splash proof case £45.00 c/p 6.50

HEWLETT PACKARD/TEKTRONIX EQUIPMENT

Please ring for quote on c/p

HP693D Sweep Oscillator 4/8 GHz £475.00
HP606B Sig Gen 50 MHz to 65 MHz £275.00
HP486A Thermistor Mount £115.00
HP651B Test Oscillator 10 MHz £200.00
HP3450B Multi-Function Meter £200.00
HP2605M DC PSU 5Vdc 100A £60.00
HP Voltage Divider Probe 10004D New £85.00
HPC34/431C power meter 10 MHz 40GHz £40.00
HP3330B Auto/Synthesizer 0.13 MHz £750.00
HP86A Personal Computer New/boxed £195.00
HP82901S 2 x 5.25" d/drives new cased £200.00
HP616B Sig Gen. 1.8 to 4.2 GHz £275.00
HP12A Sig Gen 450 to 1230 MHz £275.00
HP180A Rackmount O Scope c/w 1801A 1821A No guarantee £100.00
HP872A 4 pen plotter (damaged electrostatic cover) £350.00
HP1900 A Pulse Generator c/w 908A delay gen 1005A rate gen 1915A variable transition time output option 004 25 MHz £375.00
TER 7403N Mainframe 100MHz no guarantee (needs attention working) £100

TER 535A 25 MHz c/w 1A1 plug in (needs attention working) £65.00
TER 564B storage manframe portable £65.00
TER 7403N 100 MHz manframe portable c/w 7A18 7B53N £575.00
TER 561 Mainframe c/w 2B67 & type 63 off amp 10 MHz single beam blue trace (mtr) £95.00
TER 502A 100kHz dual beam (mtr) £40.00
TER 453 50 MHz O Scope £425.00
TER 465 100 MHz O Scope in cal £586.90
TER Plug in type 7853M £225.00
TER Plug in type 7892 £225.00
TER Plug in type 7870 No guarantee £100.00
TER Plug in type 7001 logic analyzer £425.00
TER Plug in type 0F1 display formatter £425.00
TER power module 509 £275.00
TER LA 501W logic analyzer £450.00
TER WR 501 word recognizer £450.00
TER 00 501 digital delay £190.00
TER 286 Sampling head multiplex unit £75.00
TER 178 linear IC test fixture £120.00
TER 6045 let probe £75.00
TER S3A sampling head £100.00

GENERAL TEST AND MEASUREMENT EQUIPMENT

Please ring for quote on c/p

Marconi Inst 1 Universal Bridge 1313A £200.00
Datron 103A RMS Voltmeter
Fluke AC/DC Differential V/Meter £100.00
Datron 1030 RMS digital voltmeter £125.00
Exact 337 digital phase gen/100MHz £175.00
Solortron Frequency res/analyzer 1310 £225.00
Feedback variable phase OSC 100kHz £100.00
HML 411 capacitor charger 20kV new £1000.00
Devices instantaneous calibrator 2751 £40.00
Bell & Howell dataset cal unit for FM £120.00
Dawe type 1290D transistor strobe £80.00
Singer Gertsch phase angle v/meter £200.00
Advance INST/PC52A pulse gen/ £100.00
Farnell 200 30V D-1A metered psu £190.00

SE Labco O Scope EM102 15MHz D/Trace £180.00
AMF Verner digital counter 737A £55.00
Wayne Kerr B224 Universal Bridge £250.00
AVO Universal Bridge D1 50 £160.00
Ampex VR7003H Video Recorder £150.00
EM BTR Recorder 2 Ch/VMTR £150.00
KEPCO PSU 0/2000V 0/10MA PSU 0FS/2000 £60.00
Farnell DAV1 30 AC voltmeter 1/2
Gould OS3000A O Scope 40 MHz delay £325.00
Sanders Fleaguide £25.00
Dynamico O Scope 25 MHz dual trace £115.00
Bryans XY Plotters from £75.00

COMPUTER EQUIPMENT

Altos Computer Systems DMA8002E £120.00
DEC Rambow 100A £120.00
DEC PC350 Model WF 3252B £200.00

Ferrari F100A Digital Micro £150.00
Level RC Oscillator TG200 DM
Please ring for quote on c/p rates

We would like the opportunity to tender for surplus equipment

Official Orders/Overseas Enquiries Welcome. Order by phone or post. Open 6 days. Postal rates apply U.K. mainland only. All test equipment carries warranty. All prices include 15% VAT unless stated. Please your order for quick delivery. Access, Ames, Demers, Visa accepted. We can supply telephone and some audio equipment, electrical and aerial equipment, much more than is shown in our ad. Please ring

CIRCLE NO. 105 ON REPLY CARD

M & B RADIO (LEEDS) THE NORTH'S LEADING USED TEST-EQUIPMENT DEALER

Oscilloscopes		Lynce SQ10 Sine/Square Audio Osc	£75
Tektronix 475 20MHz Dual Trace Delayed T/B	£599	Radford L004 Distortion Osc	£400
Tektronix 2445 150MHz Four Trace	£1250	Radio Receivers	
Tektronix 2465A 350MHz Four Trae	£1695	Racal RA217 10MHz to 30 MHz Digital	£450
Tektronix 7603 Main Frame 7B53/7A18/7A18 (Offer Price)	£599	Racal RA17	£150
		Eddystone 830/7	£225
Tektronix 468 Digital Storage Scope	£1250	Special Offers	
Tektronix T935A 35MHz Dual Trace	£245	Avo B Reconditioned Testmeters Case w/ Leads Inc	£65
Tektronix T912 Portable Storage	£275	Avo EA113 Electronic Multimeters	£40
Tektronix T915 15MHz 2 Dual Trace	£195	GEC Selectest Super 50 Testmeters	£60
Tektronix 212 500KHz Dual Trace Miniscope	£375	Philips PM2403 Electronic Multimeters	£40
Tektronix 221 5MHz Single Trace Miniscope	£350	Philips PM2412A Electronic Multimeters	£55
Tektronix 453 60MHz Dual Trace	£295	Leader LMV181A AC Milivoltmeter	£85
H/P 1703A Dual Trace Storage Scope	£400	Leader LMV186A 2 Channel AC Milivoltmeters	£125
H/P 1715A 200MHz Dual Trace with DVM Opt	£750	Brandenburg 470 Power Supply (2.5kV)	£75
H/P 1740A 100MHz 2 Dual Trace	£450	Exact 121 Function Generators 2Hz-2MHz - Sweep	£85
Kikusui 5060 60MHz Dual Trace (New)	£450	Philips PM5501 PAL Colour Bar Generators Isolation Transformers 500VA in yellow moulded cases	£35
Philips 3232 True Dual Trace	£195	Trio AG203 CR Oscillator Sine/Square	£85
Philips 3234 Dual Trace Storage	£250	Trio PF810 SWR/Power Meters	£85
Philips 3217 50MHz Dual Trace Dual T/B (As New)	£495	Isolation 240V to 24V 60VA for Weller Irons	£5
Tequipment D755 50MHz Dual Trace Delayed T/B	£275	Test Equipment	
Tequipment D83 50MHz Dual Trace Large Display	£285	Marconi 2955/2958 Tacs Cellular Test Set	£4950
Tequipment D61 15MHz Dual Trace	£100	Marconi 2950 PHR Radio Test Set	£450
Cossor CDU150 35MHz Dual Trace Delayed T/B	£155	Marconi TF2331 Distortion Meter	£250
Gould 051100 30MHz Dual Trace	£200	Marconi TF2000 AF Oscillator - ATT	£250
Scopes 4D25 25MHz Dual Trace	£140	Marconi TF2005/R Dual AF Oscillator - ATT	£295
Scopes 4D10 10MHz Dual Trace	£110	Marconi TF2160 Monitored Alt	£100
Philips 3110 Dual Trace 10MHz	£110	Marconi TF1313 1% LCR Bridge	£140
Tektronix 647 100MHz Dual Trace Delayed T/B	£175	Marconi TF2120 Function Generator	£225
H/P 180 Oscilloscope with 50MHz Plugins	£200	Marconi TF2300 Mod Meter (1GHZ)	£150
Signal Generators		Marconi TF2303 Mod Meter As New	£275
Marconi TF2015 10MHz-520MHz AM/FM	£375	Marconi TF2500 Valve Voltmeters	£30
Marconi TF2015 with TF2171 Synchronizer	£500	Marconi TF2604 RF Millivoltmeters	£85
Marconi TF2016A 10KHz-120MHz AM/FM Rev Power Trip	£375	Marconi TF2650 Fet Multimeters	£75
Marconi TF2008 10KHz-520MHz AM/FM - Sweep	£400	Marconi TF1065 RT Test Set (Mod - RF Power - Dev)	£40
Marconi TF995 1 5MHz-220MHz AM/FM (Special Offer)	£85	Marconi TF6460 RF Power Meter (10MHz 40GHZ)	£200
Racal 3092 1 5MHz-520MHz Sig-Gen	£750	Adret Codasync 10Hz-10MHz	£100
Racal 3061/3062 10MHz Synthesizer	£350	Dymar Modulation Meter 3 to 480MHz	£250
Philips PM5234 100KHz 110 MHz AM/FM - Sweep	£175	Marconi TF1245/1247/1248 O Meter	£55
H/P 8640B Signal Generator Opt 001	£225	Bradley 156 Oscilloscope Calibrator	£175
H/P 3200B VHF OSC 10MHz-500MHz AM/CW	£175	H/P Logic Trouble Shooting Kit	£75
Fluke 6160A 1Hz-30MHz Syn Signal Source	£175	Wayne Kerr B424 LCR Bridge	£175
Philips PM6456 FM Stereo Generator	£150	Am 401 LCR Comparator Data Bridge	£225
Farnell LFM2 1Hz 1000KHz Audio Osc Sine/Square	£65	Racal VHF/UHF RT Calibrator	£275
		H/P 3456A Digital Multimeter	£150
		Iwatsu SC7103 10Hz-1 GHz Freq Counter (New)	£375
		Gen/Rad 1390B Random Noise Generator	£195
		H/P 4271B 1MHz Digital LCR Meter	£1000

**ALL PRICES PLUS VAT AND CARRIAGE
86 Bishopgate Street, Leeds LS1 4BB.
Tel: 0532 435649. Fax: (0532) 426881**

CIRCLE NO. 113 ON REPLY CARD

FULL SPECTRUM MONITORING



The world is at your fingertips with ICOM's new IC-R9000 radio communications receiver with continuous all mode, super wideband range of 100KHz to 1999.8MHz and a unique CRT display that shows frequencies, modes, memory contents, operator-entered notes and function menus. The revolutionary IC-R9000 features IF Shift, IF Notch, a fully adjustable noise blanker and more. The Direct Digital Synthesiser assures the widest range, lowest noise and rapid scanning. 1000 multi-function memories store frequencies, modes, tuning steps and operator notes. Eight scanning modes include programmable limits, automatic frequency and time-mark storage of scanned signals, full, restricted or mode-selected memory scanning priority channel watch, voice-sense scanning and a selectable width around your tuned frequency.

ICOM Icom (UK) Ltd. Tel: 0227 363859. Telex: 965179 ICOM G N.B. For Wales and the West contact: M.R.S. Communications Ltd. Cardiff. Tel: 0222 224167.

Please send information on Icom products & my nearest Icom dealer.

Name/address/postcode:

.....

.....

Job Title: Tel:

Post to Icom (UK) Ltd Dept. WW, FREEPOST, Herne Bay, Kent CT6 8BR

CIRCLE NO. 120 ON REPLY CARD

hence I can create a 512 byte table of all the possible 16bit xor patterns. This method I call Fast Parallel.

As I wanted the routine to be as flexible as the others, you have to run the 'buildcrc' routine each time you change the polynomial, so that a new table can be created.

C. Turvey
Xth Planet Software
Southampton

Faster than light

With regard to the article by Pappas and Obolensky in the December 1988 issue of *E&WW*, I would ask that the oscilloscope itself be examined.

I have been looking at the light output from a fast spark, (rise time 2-3ns, duration 20ns) using a Tektronix 7104 oscilloscope and observed the trace looping the loop. It turned out that the

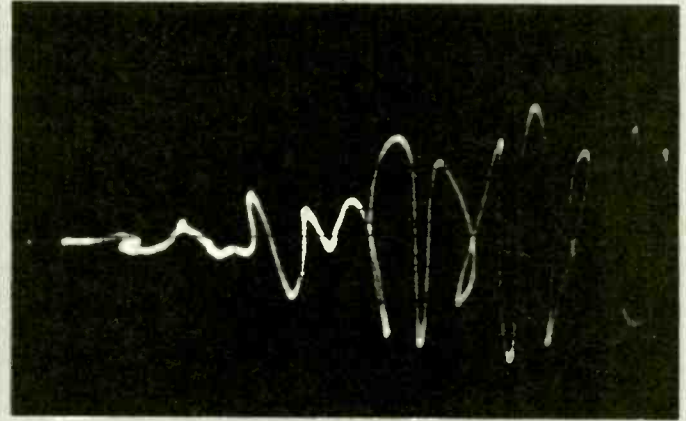

trace was being deflected by direct radiation of electromagnetic signals acting either on the electron beam or being picked up by the deflection plates in the CRT. The vertical component appeared before the signal, since the direct radiation had not been delayed internally. I found that the two side panels of the oscilloscope were not earthed, and acted as antennae for the radiation. Earthed side panels are, apparently, an optical extra from Tektronix, who possibly generate sales for the option by isolating the panels.
Keith Wood
West Derby
Liverpool

The reported measurement of superluminal velocities of electrical signals (A.G. Obolensky and P.T. Pappas: *EWW*, December 1988) and the subsequent correspondence (*EWW* March, April, 1989) raise an exciting issue if what is suggested can really be sustained.

I would like to draw attention to my description of the initiation of current flow in an electrical circuit presented in *Electromagnetic Fields in Electrical Engineering* (Plenum, New York, 1988). Quoting from my article 'A contribution to the theory of skin-effect', which appeared in that work:

"At the moment of closing switch S the conductors of the circuit receive two signals:

i) A voltage signal U which determines the direction of the movement of electrons,

ii) An independent current signal di/dt ."

In considering this, I did not raise the question about the velocities of these two signals. The current signal, which is the power pulse, creates a magnetic field in and around the conductors. The transformation of energy needs time and is connected with power losses. This process proceeds with a Maxwellian velocity.

The voltage signal, however, prepares the way for the current. It is a precursor signal, so named by Dr Aspden. The precursor signal sets up an electrical order in the conductors. Without the voltage signal the electrons compensating the nuclear charge in atoms constituting the conductor, have a chaotic motion, not oriented according to the current direction.

I believe that the precursor signal orientates the orbital electron motion at the atomic level and thus prepares the current path. Its action should be quicker than the Maxwellian velocity usually regarded as the speed of light. I hope that these remarks will be of interest to *EWW* readers.

Dr Jan Nasilowski,
Instytut Elektrotechniki,
Warsaw,
Poland.

Which Mips?

Rupert Baines article "Who's who in RISC" (November 1989 *EW+WW*) credits the Intel 860 co-processor with "150 Mips performance, more than seven times as fast as its nearest

Fast serial CRC routine for the 6502

```
.crc      LDY    #&08      ;Bit counter
          LDA    data     ;The xor has been moved outside the loop
          EOR    remls    ;and the bit shifts on the data removed
.crcouter LSR    remms      ;shift right the high byte of remainder
          ROR    A        ;the low byte is still in A
          BCC   crcinner  ;Was the bit falling off the end '1'
          EOR    polyls   ;Xor the low byte with the polynomial
          TAX    remms    ;A about to be trashed, so move remls to X
          LDA    remms    ;Xor the high byte with the polynomial
          EOR    polyms
          STA    remms
.crcinner TXA          ;Recover low byte of remainder
          DEY          ;Repeat for all 8 bits
          BNE   crcouter
          STA    remls   ;Save the low byte of remainder
          RTS
```

Parallel CRC routine for the 6502

```
.crc      LDA    data     ;Xor the data to the current low byte
          EOR    remls
          TAX    remls
          LDA    remms    ;Change to a table reference
          EOR    crcls,X  ;Get high byte of remainder
          STA    remls    ;Xor with the table value for low CRC because
          LDA    crcms,X  ;after 8 shifts it becomes the remainder low byte
          STA    remms    ;Now get the new remainder high byte from
          RTS            ;the high CRC table.

.buildcrc LDX    #&00      ;Builds a CRC table for all values of X 0 to 255
.buildouter STX   remls   ;Just put the X byte in the remainder
          LDA    #&00
          STA    remms
          LDY    *#&08
          LSR   remms
          ROR   remls
          BCC   buildinner
          LDA   remls
          EOR   polyls
          STA   remls
          LDA   remms
          EOR   polyms
          STA   remms
.buildinner DEY          ;Repeat for all 8 bits
          BNE   buildmid
          LDA   remls    ;Move the new low remainder to the low CRC
          STA   crcls,X  ;table
          LDA   remms    ;Move the new high remainder to the high CRC
          STA   crcms,X  ;table
          INX          ;Repeat for all values of X
          BNE   buildouter
          RTS

.crcls    :256 bytes of storage
.crcms    :256 bytes of storage
```

competitor". Absolute nonsense! For a company with no history of developing advanced architectures (best not to mention the iAPX 432!), the 860 is a very commendable product. However, its performance running real programs is virtually the same as the IDT/MIPS 79R3000, which Baines correctly acknowledges as the highest performance risc architecture in production today.

Such contrary positions arise because people have differing interpretations of a Mip, ranging from millions of instructions per second at one extreme (or native Mips), to machine relative Mips such as VAX-Mips. To make an audio analogy, sustained VAX-Mips could be said to be the continuous power per channel of an amplifier in watts. By contrast, peak native Mips equate to those words beloved by advertisers, total peak music power!

Promulgation in the media of performance numbers such as peak native Mips is one of the primary reasons for confusion in the risc market. Potential users are unable to relate such units of performance to actual system performance they might realise in their particular design.

A telling observation one could make about the various risc architectures is that, despite having the R2000/3000 architecture as a "role model" for several years, the best other designs have achieved is to equal the R3000 performance, as the 860 does. Most don't come close. The 860 achieves its performance by the brute-force technique of massive parallelism and very wide internal busses (around a million transistors). The R3000, by contrast, uses elegant architecture (115 000 transistors) and sophisticated optimizing compilers. Those who think the 860 is as truly wonderful as Baines claims should ask Intel why they are redesigning it.

Most semiconductor market analysts are predicting that the R3000 and the Sun Sparc processor will share equally about 70% of the risc market by the mid 1990s. All other risc

suppliers will have to fight over the remaining 30%. The 35% of the market prediction for Sparc results almost entirely from vertical integration within Sun Microsystems. By contrast, R3000 is used by DEC, CDC, Sony, Bull, Siemens, Nixdorf, Prime, Ardent and many other blue chip corporations.
Steve Bennett
Manager European Applications
IDT Europe Ltd.
Leatherhead

No integers for $a^n + b^n = c^n$

My previous notes, neatly and faithfully reproduced in the January issue, assume that it would be absurd to expect a solution simply by replacing the common exponent 2 in Pythagorean equations with a greater integer. This is an opinion, not a proof.

Regarding any applicable set of integers, or P triple as some would call it, c is one of the odd numbers and a is usually the even one. Let this be the case at present.

If $c^2 - b^2 = a^2$ then a^2 would, like $c^2 - b^2$, be divisible by $c - b$. So also would a^n because this is a multiple of a^2 . Then $a^n / (c - b) = a^{n-2} (c + b)$ which is the product of two even numbers.

However, when n is odd, the other side, now $(c^n - b^n) / (c - b)$, equals the sum of an odd number of odd numbers.

In a different way it can also be shown that when n is even, the supposition is again unquestionably absurd. Fellow-readers might like to amuse themselves with this one while I tidy up the explanation. Of course, if this were anything more than a diversion, scientists would have sorted it out.

Incidentally, a more revealing way of expressing the division of $x^n - y^n$ by $x - y$ is by saying that it equals the sum of n terms, the first and greatest of which is x^{n-1} with each succeeding term y/x times its antecedent. This changes the order used in the January examples which seemed easier to memorise.
Name and address supplied.

Audio power

I was very interested to read the article in November *EW+WW* by J. Linsley-Hood on the history of audio amplifiers, since it triggered fond memories of his original article in *Wireless World* on his class-A amplifier, which became my first foray into audio construction and hence analogue design. Following its success, much heat and several happy years were spent in the early 1970s on various audio projects, developing better and better technical 'performance'. (Just how many readers built a 'Nelson-Jones' FM tuner?)

By around the end of the 1970s, though, it became more and more difficult to ignore the price of ready-made equipment, its improving performance and also its appearance relative to that obtainable with home-built items. Thus began the drift into purchasing ready-made equipment, which if nothing else, had at least some resale value, a story that is all too familiar within amateur radio. The result is, of course, that fewer and fewer people are motivated to experiment with circuitry and their knowledge of analogue design and

development becomes limited only to any industrial experience that they might gain.

The purpose of this letter is to issue a rallying-cry to those who are still active with such analogue circuitry, whether audio or RF, since the personal experience that results from such activity is far more wide-ranging than simply a working piece of hardware. (This can sometimes be seen when looking at some designers' prototypes, the circuit layout and number of decoupling capacitors - if any). As time goes by it is inevitable that the need to create such circuitry will diminish as other, probably more digital areas open up for attention. In the meantime, when you buy that piece of foreign equipment, remember whose circuitry they developed it from and never forget that the results of the mega-corporations can always be improved upon with thoughtful design and innovation!

Brian J. Frost
Dorset Design and
Developments
Ferndown
Dorset

Wien oscillator amplitude

Having a toothache which seemed to be influenced by cold, I decided to stay in the warm, instead of working, and have a look at Peter F. Vaughan's little problem (*EW+WW*, November, 1989, p. 1083). It turned out to be soluble by the old CD method, where $D = d/dt$. As, unfortunately, Peter took R_1 and R_2 for two feedback resistors, one cannot use 1 and 2 as suffixes for the main Wien oscillator components without treading on his toes. However, if one uses T_1 for the time constant of the series CR circuit considered by itself, T_2 for that of the parallel CR circuit by itself and T_3 for that of a CR circuit formed by the capacitor of the series circuit with the resistor of the parallel circuit, with m for feedback ratio, one gets an equation for

output voltage V_0 leading to:-

$$[T_1 T_2 D^2 + (T_1 + T_2 + T_3 - m T_3) D + 1] V_0 = 0 \quad (1)$$

Assuming a solution $V_0 = e^{pt} \sin \omega t$ where $\omega \gg p$. Differentiating to suit (1), and equating sine and cosine terms to 0, we obtain $\omega \approx 1 / (T_1 T_2)^{1/2}$ with a correction term in p, and $p = 1/2 \cdot (m - 1) T_3 - T_1 - T_2$. This result implies that the critical condition between decay and build-up arises at $m = 1 + (T_1 + T_2) / T_3$ and permits calculation of the build-up and decay rates for appropriate values of m.
George Lewin
Samtronix
South Ascot
Berkshire

KESTREL ELECTRONIC COMPONENTS LTD.

- * All items guaranteed to manufacturers spec.
 - * Many other items available.
- 'Exclusive of V.A.T. and post and package'

	1+	100+		1+	100+
Z8530	2.00	1.00	2732A	2.20	1.85
Z8536A	2.00	1.00	2764A-25	2.20	1.65
Z80B CPU	1.20	0.65	27C64-25	2.20	1.50
Z80B CTC	1.20	0.65	27128A-25	2.40	1.75
Z80B (CMOS) CPU	1.40	1.00	27256-25	2.60	1.70
Z80B (CMOS) CTC	1.40	1.00	27C256-25	2.60	1.75
74LS00	0.13	0.07	27C512-25	4.80	3.30
74LS125	0.14	0.11	6116LP-150	1.20	1.00
74LS138	0.14	0.09	6264LP-150	2.60	1.95
74LS175	0.14	0.11	8251A	1.30	0.95
74LS240	0.28	0.22	8156D-2	1.60	1.00
74HC02	0.12	0.08	8255-5	1.30	1.05
74HC147	0.20	0.10	82C55	1.30	1.00
74HC373	0.22	0.18	8085A	1.00	0.70
74HCT00	0.12	0.07	8259AC-2	1.00	0.60
74HCT153	0.27	0.22	6845P	1.70	1.25
74HCT373	0.22	0.15	6850P	1.00	0.60
74HCT574	0.22	0.20	8250AN	4.60	3.00
1.8432MHz Crystal	0.82	0.68	Z80A CPU	0.80	0.65
4 meg crystal	0.60	0.27	Z80A CTC	0.80	0.45
6 meg crystal	0.60	0.27	Z80A P10	0.80	0.50

All memory prices are fluctuating daily, please phone to confirm prices.

178 Brighton Road,
Purley, Surrey CR2 4HA
Tel: 01-668 7522. Fax: 01-668 4190

CIRCLE NO. 122 ON REPLY CARD

NEARLY 10,000 READERS HAVE REQUESTED SERVICEMAN SINCE IT'S LAUNCH. SHOULDN'T YOU BE READING IT TOO?

Written by service engineers for service engineers involved in repair and service of all categories of Brown and White consumer products.

Regular coverage of news, views and new products together with equipment reviews and informative articles have established **Serviceman** as essential reading for all service engineers.

To obtain your **FREE** copies just complete the coupon below and we will send you an application card.

Please send completed coupon to: 'Serviceman', Reed Business Publishing Group, Room 1520, Quadrant House, The Quadrant, Sutton, Surrey SM2 5AS.

NAME

COMPANY ADDRESS

.....

POSTCODE

TELEPHONE

Please include Remove my name for Business Direct Mail. Registered Number 151537 England.

CIRCLE NO. 128 ON REPLY CARD

BENCH POWER SUPPLIES

Indispensable to any R&D or service department, educational establishment or laboratory is a reliable and rugged bench power supply unit. Without one, work can literally grind to a halt.

Flight Electronics can offer power supply solutions to meet all your requirements.

High specifications, superior safety standards and durable unit construction ensure that every unit will give many years of problem-free service.

Budget-priced units offer the same basic features as more advanced models, including:

- Overload and short circuit protection
- Independent or dual tracking
- Push button range selection
- Fully floating outputs

Want to know more?

Flight Electronics Limited,
Flight House, Ascupart Street,
Southampton SO1 1LU.
Telephone: (0703) 227721
Telex: 477 389 FLIGHT G
Fax: (0703) 330039

Telephone Flight's sales office for friendly, qualified advice.

CIRCLE NO. 155 ON REPLY CARD

SIGNAL ANALYSIS ON A PC

Most electronic engineers and technicians know how to make good use of the range of facilities offered by a budget-priced oscilloscope, but there is an increasing need for measurements which go beyond the simple real-time display of waveforms. To this end, digital storage facilities (which permit the capture of transient events for subsequent display and analysis) are now commonplace in more expensive equipment.

The spectral analysis of a waveform can yield a great deal of information which cannot easily be gleaned from a conventional time related display. In this case, an instrument which can display signal amplitude against frequency is needed.

Clearly, most of us will require access, at some time or other, to both a spectrum analyser and a storage oscilloscope. This is, of course, fine for those working on an unrestricted budget; most of us, however, need to count the cost of even the most modest items of test equipment and thus may not be able to justify the considerable investment in items such as spectrum analysers and oscilloscopes which incorporate digital storage.

Enter the PC

Happily, the solution to this (and many other instrumentation problems) is readily to hand and takes the form of the ubiquitous PC microcomputer (and compatible types), operating in conjunction with an adapter card and appropriate software.

PC-based solutions to instrumentation problems are becoming increasingly cost-effective. Not only can they provide a highly flexible alternative to traditional methods (based on stand-alone items of test equipment) but PC-based systems can be easily configured to cope with the changing requirements

Mike Tooley reports on a new software/hardware package which converts a PC into a storage oscilloscope and spectrum analyser

of the user. Furthermore, due to its almost universal availability, a measurement facility can normally be based on an available PC, thereby reducing capital outlay.

SCOPE

The Radioplan SCOPE package is an excellent example of the use of a PC microcomputer in the field of waveform analysis. The package was originally developed for use on baseband communications systems, but has a wide range of applications in the fields of noise, strain and vibration analysis, as well as in medical instrumentation, physiology, audio and sonar signal processing.

SCOPE offers an impressive specification, with sampling rates of up to 500kHz (maximum display frequency 250kHz), four-channel operation, and five operational modes (including quasi-real-time oscilloscope and spectrum analyser).

Waveform analysis

Before explaining how the package operates, it is worth summarizing the principal techniques available to those engaged in signal analysis.

Electrical signals can be characterized in three ways: amplitude, frequency, and time. Conventional two-dimensional screen displays relate amplitude and time (i.e. a time-domain display), or amplitude and frequency (i.e. a frequency-domain display). A time-domain display is the type normally associated with an oscilloscope (see Fig. 1), while a frequency-domain display is that which is conventionally produced by a spectrum analyser, as seen in Fig. 2.

In some cases, it may be desirable to display all three parameters (amplitude, frequency and time) simultaneously, which requires a three-dimensional "landscape" or "waterfall" display. Figure 3 shows a representative three-

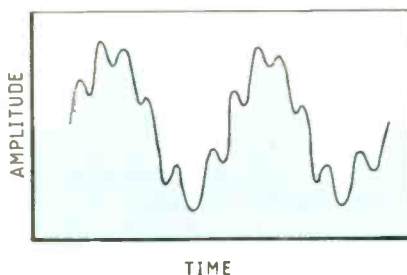

Fig. 1. Time domain display (conventional oscilloscope)

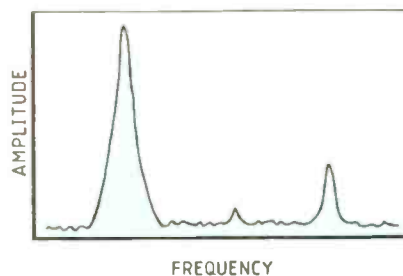

Fig. 2. Frequency domain display (spectrum analyser)

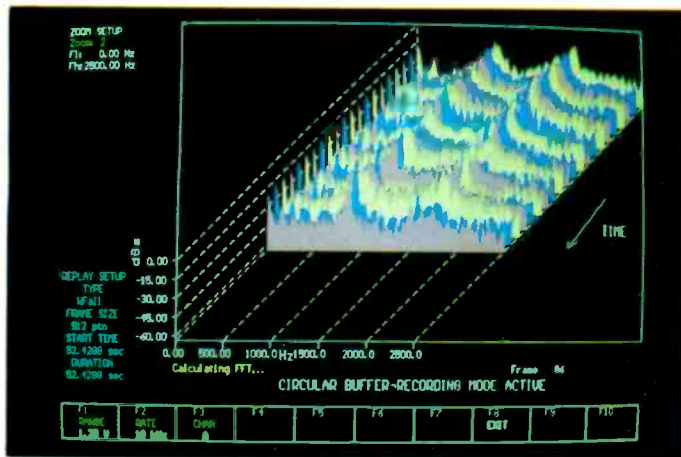

Fig. 3. Waterfall display of FSK signal in noisy HF channel (13.8MHz) 10kHz sampling rate, 2x zoom.

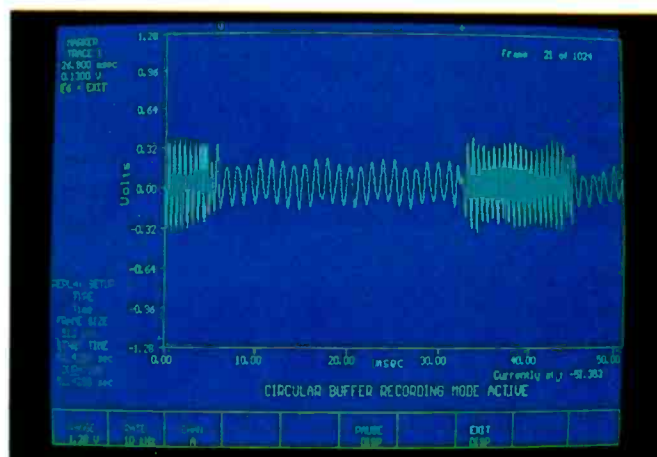

Fig. 4. Time display of FSK signal showing tone burst 26.8ms (from buffer replay).

dimensional display based on axes of amplitude, frequency and time. This form normally comprises a sequence of amplitude/frequency plots and provides a spectral history of a signal under investigation.

Numerical methods based on the Fourier series may be used to resolve a complex waveform into components at different frequencies. Modern digital methods of waveform analysis involve regular sampling of the amplitude of a signal, converting it to digital form and storage of data in semiconductor random access memories. A fast Fourier transform (FFT) algorithm may be used to convert data acquired in the time domain to corresponding frequency-domain data.

SCOPE provides the user with the following facilities:

- digital signal recorder and analyser.
- digital storage oscilloscope.
- spectrum analyser.

The hardware is based on a single full-sized PC adapter card. Apart from the usual bus interface, this card contains 512Kbyte of ram, a fast A-to-D converter (ADC0820) and two c-mos analogue multiplexers. The software package is supplied on a single 5.25in or

3.5in disk, which contains two files: SCOPE_EG (the functional software) and SCOPE_DE (a demonstration program).

User interface

The user interface is based on a series of screens, which are related in a tree structure of up to three levels. Movement up and down between the levels is achieved by use of the function keys. To aid the user, the definitions of these keys are clearly displayed in the lower portion of the screen.

The use of the function keys is largely self evident and, in this respect, the package is reasonably intuitive. At other times (e.g. in REPLAY mode) parameters are altered by the arrow keys and the page keys. Here again, operation is quite straightforward.

The initial (Level 1) screen is displayed as soon as the program is run. This screen is used to select the main operational modes and, in the case of the data recording modes, the data capture parameters must be set up from this screen, which is divided into three main areas, the largest of which (in the upper right quadrant) is devoted to the graphic display. This region is bounded by a vertical axis (calibrated in voltage or dB) and a horizontal axis (calibrated in time or frequency). A small area to the left of the display area is used for trace and cursor information and a strip at the bottom of the screen is reserved for displaying the function keys and their current settings.

Five function keys are operational from the Level 1 screen. F1 is used to select the voltage range (1.29V, 2.56V, 6.4V, 12.8V, 25.6V, 64V, 128V or 256V) and F2 sets the sampling rate (200Hz, 500Hz, 1kHz, 2kHz, 5kHz, 10kHz, 20kHz, 50kHz, 100kHz,

200kHz, or 500kHz). The default settings on start-up are 128V and 20kHz respectively.

I found the initial voltage setting to be consistently too large since and had to resort to changing the setting each time the equipment was used. Some mechanism for allowing the user to change (and store) the default settings would have been a useful addition to the package.

While in oscilloscope or spectrum analyser modes, the function keys F1 to F3 remain operational, but their values are frozen in the other modes while data is being recorded in the data buffer for later analysis and display.

Record mode is entered from the initial (Level 1) screen by using function keys F1 to F3 to set up the recording parameters, selecting the RECORD function using F5 and finally pressing the EXECUTE key, F10. Fortunately, this is somewhat less cumbersome than it sounds!

During recording, data is stored in a cyclic 512Kbyte buffer on the adapter card. Acquisition may be halted at any time and restarted from the same point in the buffer. Once the buffer is full, the oldest data is overwritten.

REPLAY mode is entered from RECORD mode by pressing F9 followed by F10. The replay mode enables data previously stored in the 512Kbyte buffer to be analysed and displayed in various ways. TIME allows signal amplitude to be plotted against time and in FREQUENCY, signal amplitude is plotted against frequency. WATERFALL presents a series of frequency plots against time in a three-dimensional "landscape" display. Finally, the SPECTROGRAPH display shows a consecutive series of frequency plots using a two-dimensional format with colour coding to represent signal amplitude. This last

The SCOPE hardware and software costs £1800. For those who may be contemplating purchase of the package, Radioplan can supply the demonstration program on a 5.25in floppy disk. It simulates all the features of the real program (with the exception of triggered signal capture). The simulation illustrates a 1kHz CW signal and a chirped 2-4kHz signal within the receiver passband.

The disk is available free, but readers should be aware that, as with the fully functional version, the software requires that the PC on which it is run is fitted with a numeric coprocessor.

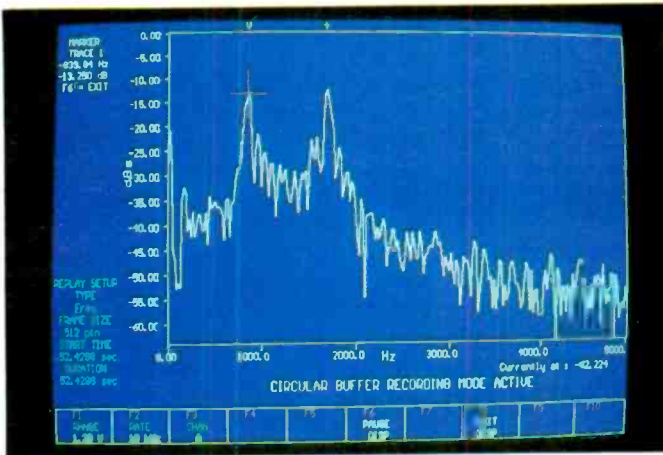

Fig. 5. Spectrum display of FSK signal showing frequency shift of 839.84Hz and 13.250dB amplitude difference.

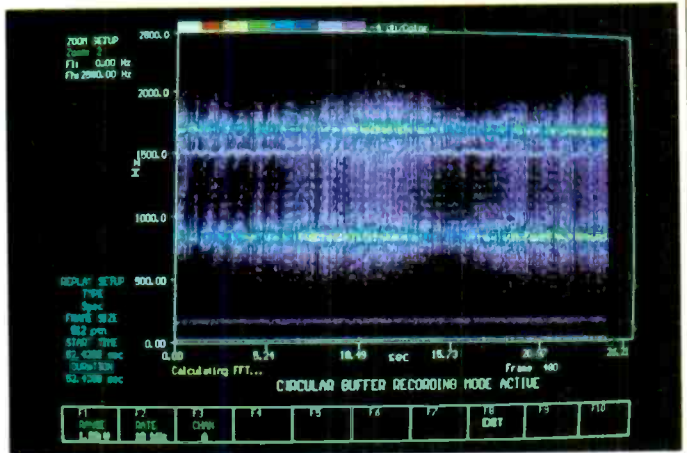

Fig. 6. Spectrogram display of FSK signal showing pulsed fading and differential fading between tones.

method of display requires some considerable time!

Once in replay mode a menu of parameters appears at the bottom left of the screen. A menu allows the following parameters to be displayed: type of display (time-domain, frequency domain, waterfall, or spectrograph), size of frame (either 512, 1024, 2048 or 4096 points), start time, and duration.

In the case of time and frequency displays, F6 may be used to pause the current frame for further measurements to be made. As soon as the frame is frozen, a cursor in the form of a V, and a reference cross, appear on the top line of the screen. A cross-hair also appears on the trace of the waveform at a point vertically below the cursor. By moving the cursor and the reference cross it is possible to make relative readings of amplitude or time between any two points on the displayed waveform. Fine and coarse control of the cursor and reference cross is provided by means of the HOME, INSERT, and arrow keys. In the case of a multi-trace display, the

PAGE UP and PAGE DOWN keys may be used to move the cursor between traces and the DELETE key can be used to ZOOM the designated trace so that it fills the entire screen.

Single-shot and triggered modes

Single-shot mode is similar to RECORD, except that recording stops as soon as 512Kbyte of data has been captured. At this point, the REPLAY menu is entered automatically. Triggered mode is also entered from Level 1 and the operator is presented with a menu from which to select a number of parameters, including trigger voltage, trigger polarity, and pre-trigger time. The pre-trigger time may be altered in increments equivalent to 2Kbyte of stored data (which is equivalent to an increment of 2048/Fs seconds, where Fs is the Fourier sample rate).

Having set the trigger parameters, F10 enables triggering and the display shows elapsed time while waiting for the trigger to occur. At this point F8 may be

used to abort to Level 1. Once triggering has occurred, capture is halted after 512Kbyte of data has been stored.

Oscilloscope and spectrum analyser modes

In oscilloscope mode, the voltage range, timebase, input channel, and number of points plotted (512, 1024, 2048 or 4096) are all selectable by means of appropriate function keys. Altering the number of points plotted causes a proportionately longer time period to be displayed. However, since the display is limited to 512 horizontal points, this is achieved by missing out every second, fourth or eighth point of the waveform.

Operating environment

The minimum system requirement for the Radioplan SCOPE package is an IBM PC-AT-compatible fitted with an EGA graphics adapter, numeric coprocessor (80287), and a Radioplan 0.5Mbyte DSR board.

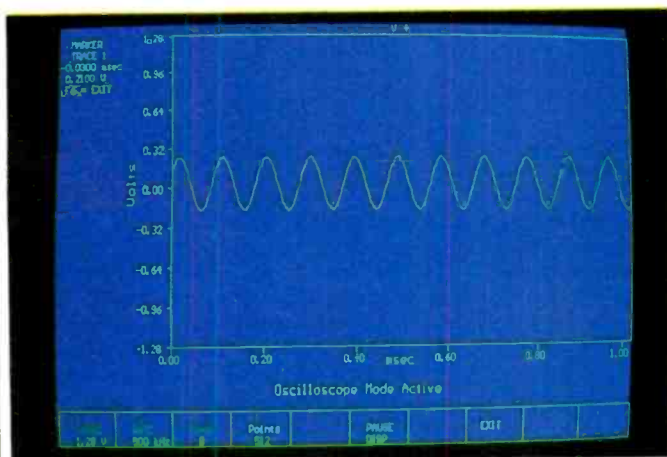

Fig. 7. Signal generator output, with cross-hairs positioned at discontinuity.

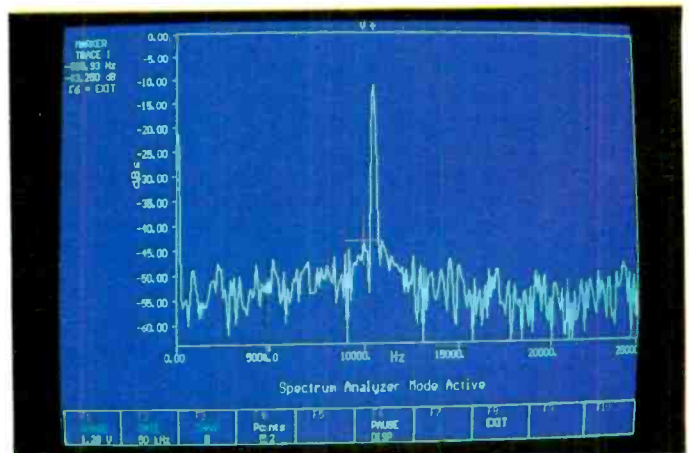

Fig. 8. Spectrum of signal shown in Fig. 7

When the display is paused, a cursor and cross appear (as in the case of the REPLAY mode described earlier). This facility permits extremely accurate measurements of time and voltage.

In spectrum analyser mode, the controls operate in the same manner as in the oscilloscope mode except that, when the number of points is increased, the additional data is displayed by increasing the number of traces on the screen. In order to examine one of a number of multiple traces displayed on the screen, a ZOOM facility is provided (as in REPLAY mode).

Operation

I put the package through its paces by analysing a variety of different signals. These included the output of a low-distortion oscillator, a fast rise-time pulse derived from a high-voltage pulse generator, and a noisy FSK signal received using a modern VHF CW-SSB transceiver. The results of these investigations are displayed in Figs 4 to 8. At all times, SCOPE proved to be powerful yet easy to use.

The software is, however, lacking in two particular areas. The first of these is the fact that there is no means of preserving the recorded data on disk for future display and analysis. In many

applications this would be an extremely useful facility and, while one could make use of a TSR program simply to capture screen displays, this is not quite the same thing as being able to store the captured data and later reload, making full use of the range of options available.

The other notable omission is that of a dos shell facility. Many of today's software applications allow users to exit to a dos shell to execute dos commands. Such a facility would be almost mandatory if the software were to be enhanced to permit savings and loading data.

One further small niggle concerns the procedure for returning to the initial Level 1 screen, which is only possible to reach by returning through all the previously accessed levels. This is done by pressing F8, setting the screen mode to QUIT or pressing any key, depending upon the screen currently being displayed. All this is very well but a single "escape" key would have been preferable.

The SCOPE package is competitive with several others. Its nearest competition (which has a somewhat inferior specification) is the SNAPSHOT STORAGE SCOPE package from HEM. When running in conjunction with MetraByte's hardware (a DAS-

16F analogue interface card) this package will operate at 100,000 samples per second with DMA transfer. The combined price of a DAS-16F and HEM software amounts to about £1650, but the lack of an on-board memory buffer must be considered as something of a shortcoming. SNAPSHOT STORAGE SCOPE software does, however, allow users to store data in Lotus 1-2-3 compatible format and also contains a mathematical package which incorporates correlation and statistical functions (among others). My preference, however, remains with the Radioplan offering.

The Radioplan package will find a place in education as well as in industry. Furthermore, when one considers the facilities offered by the package and the cost of equivalent stand-alone instruments (i.e. an oscilloscope with digital storage oscilloscopes and a spectrum analyser), its package must be considered remarkable value. ■

Radioplan Ltd are at Unit 14, Cheltenham Trade Park, Arle Road, Cheltenham, Gloucestershire, GL50 8LZ. Telephone: (0242) 224304

BOOKS

A Twentieth Century Professional

Institution: the story of the I. E. R. E. 1925-1988, by Graham D. Clifford and Frank W. Sharp. Having started life as the Institute of Radio Engineers, a title which was changed almost immediately to the Institute of Wireless Technology to avoid confusion with its American cousin, the radio engineers' body continued in independent existence until October 1 last year. This official history, which deals with administrative matters and the development of the organization rather than its influence on the progress of radio technology, marks its absorption into the IEF. Published by Peter Peregrinus Ltd on behalf of the Institution of Electrical Engineers, 331 pages, hard back, £15.

The Art of Electronics by Paul Horowitz and Winfield Hill, second edition. Wide-ranging reference work covering circuit elements and techniques of all types, including topics the book describes as important but

neglected. Its 15 sections main deal with subjects ranging from the basic principles of electronics to design, construction and measurement techniques, taking in such matters as filters, microcomputers, high frequencies and micropower design on the way. The authors' text is unfailingly direct and approachable, always coming straight to the point with solid information of practical value. Besides the theory is a generous amount of detailed advice and designers' lore which individuals might otherwise have to learn the hard way; examples are the troublesome quirks of c-mos and TTL devices. Very recommendable. Cambridge University Press, 1125 pages, hard covers, £29.95.

The Compact Disc, a handbook of theory and use, by Ken C. Pohlmann. Chatty yet systematic and comprehensive treatment of the little silver miracles. As the author puts it in his preface, a good teacher is like a good nurse with a hypodermic needle - you never

feel the pain. Among his subject headings are fundamentals of digital audio, the CD system, player design principles, practical concerns (concerns for the audiophile, that is), disc formats (including CD-rom, CD-Video, erasable CDs and others) and manufacturing processes; and at the end is a glossary of technical terms. Each chapter ends with a useful reading list. Coding methods are explained in detail, but circuit descriptions are kept to block diagram level. The author's approach will appeal to engineers who want to know how their domestic hi-fi works but do not want to plough through an academic text. The information is well up to date and covers techniques such as piezoelectric embossing used in Teldec's DMM mastering process for CDs, and the 18-bit converters used in certain Japanese consumer CD players; though the exotic D-to-A conversion methods used in the latest players look as if they could change that. Oxford University Press, 288 pages, hard covers, £30.

The Archer Z80 SBC

The SDS ARCHER – The Z80 based single board computer chosen by professionals and OEM users.

- ★ Top quality board with 4 parallel and 2 serial ports, counter-timers, power-fail interrupt, watchdog timer, EPROM & battery backed RAM.
- ★ **OPTIONS:** on board power supply, smart case, ROMable BASIC, Debug Monitor, wide range of I/O & memory extension cards.

CIRCLE NO. 127 ON REPLY CARD

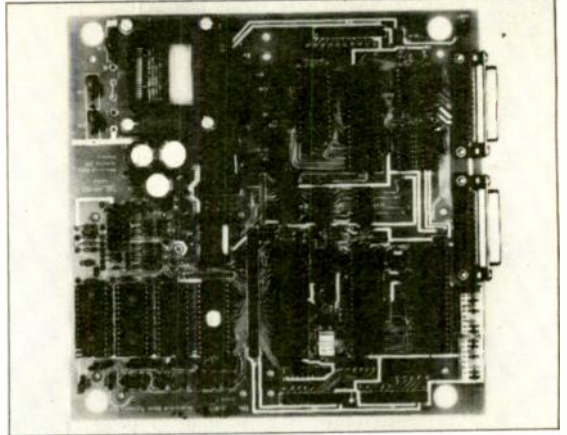

The Bowman 68000 SBC

The SDS BOWMAN – The 68000 based single board computer for advanced high speed applications.

- ★ Extended double Eurocard with 2 parallel & 2 serial ports, battery backed CMOS RAM, EPROM, 2 counter-timers, watchdog timer, powerfail interrupt, & an optional zero wait state half megabyte D-RAM.
- ★ Extended width versions with on board power supply and case.

CIRCLE NO. 143 ON REPLY CARD



Sherwood Data Systems Ltd

Unit 6, York Way, Cressex Industrial Estate, High Wycombe, Bucks HP12 3PY. Tel: (0494) 464264

COMPUTER PERIPHERALS

HP 432A Power Meter & Head	£	Sekosha SL-80 24 Pin D/M Printer (New)	225
HP 4951C + 1817GA Protocol Analyser	200	Altos 986 40M Computer	1200
HP 612C 1250MHZ Generator	2250	Zenith Turbosport Laptop Computer	2200
Wavetek 1503 950MHZ Sweeper	50		
HP 9816S Technical Computer	295		
Marconi 6550 Power Meter (Asic)	1350		
Racal 9081A 512MHZ Sig Gen	50		
Telequipment D75 50MHZ Scope	575		
Leader Loc-7000 Scope Calibrator	225		
HP 6521A 0-1000V DC Power Supply	400		
Fluke 761A Meter Calibrator	250		
HP 7475A Plotter RS232	500		
HP 7221C Plotter RS232	750		
HP 7440 Plotter RS232	250		
HP 7650A Plotter RS232/HP-1B	450		
HP Laserjet II Printer	1750		
Kyocera F1010 Laser Printer	995		
Canon LPB 8-A1 Laser Printer	1250		
	750		
		NEW DISK DRIVES £ SEAGATE ST-225 20MB 65MS H/H 180 ST-251-1 40MB 28MS H/H 295 ST-138-0 30MB 40MS 3.5in 235 ST-138-1 30MB 28MS 3.5in 245 ST-4053 40MB 28MS F/H 375 ST-4096 80MB 28MS F/H 450 RLL ST-225R 20MB 65MS H/H 150 ST-277R-1 60MB 28MS H/H 310 ST-4144R 122MB 28MS F/H 525	
		ALL DRIVES NEW AND SEALED ALL OTHER ITEMS SECOND USER BUT FULLY FUNCTIONAL WITH 30 DAY WARRANTY MANY OTHER ITEMS AVAILABLE SUITABLE EQUIPMENT PURCHASED PLEASE CALL	

ALL PRICES ARE EXCLUSIVE OF VAT AND CARRIAGE & SUBJECT TO AVAILABILITY

ENGTECH LTD.

The Little House
Shepherds Hill
Merstham
Redhill RH1 3AD
Tel: 07374 5131 Fax: 07374 5161

CIRCLE NO. 119 ON REPLY CARD

SIGNAL ANALYSIS on a PC

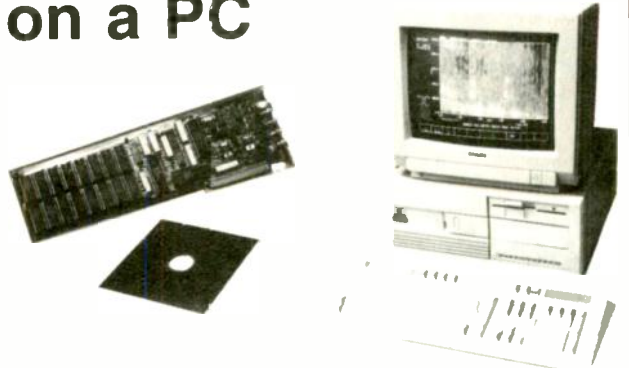

A plug-in card and software from Radioplan give your PC AT/XT these capabilities:

- Oscilloscope
- FFT Spectrum Analysis up to 4096 points
- Digital recording up to 500 kBytes
- Sampling rates up to 500 kHz
- Waterfall display of Spectrum frames
- Spectrograph with colour-coded amplitude

Applications include:

- Speech & acoustic signal analysis
- Radio signal modulation analysis
- Vibration analysis
- Impulse testing

Send for your brochure or demonstration disk to:

Radioplan Limited

Unit 14, Cheltenham Trade Park, Arle Road, Cheltenham, Gloucestershire GL50 8LZ
Telephone (0242) 224304; Telefax (0242) 227154;
Telex: 437244 CMINTL

CIRCLE NO. 133 ON REPLY CARD

APPLICATIONS SUMMARY

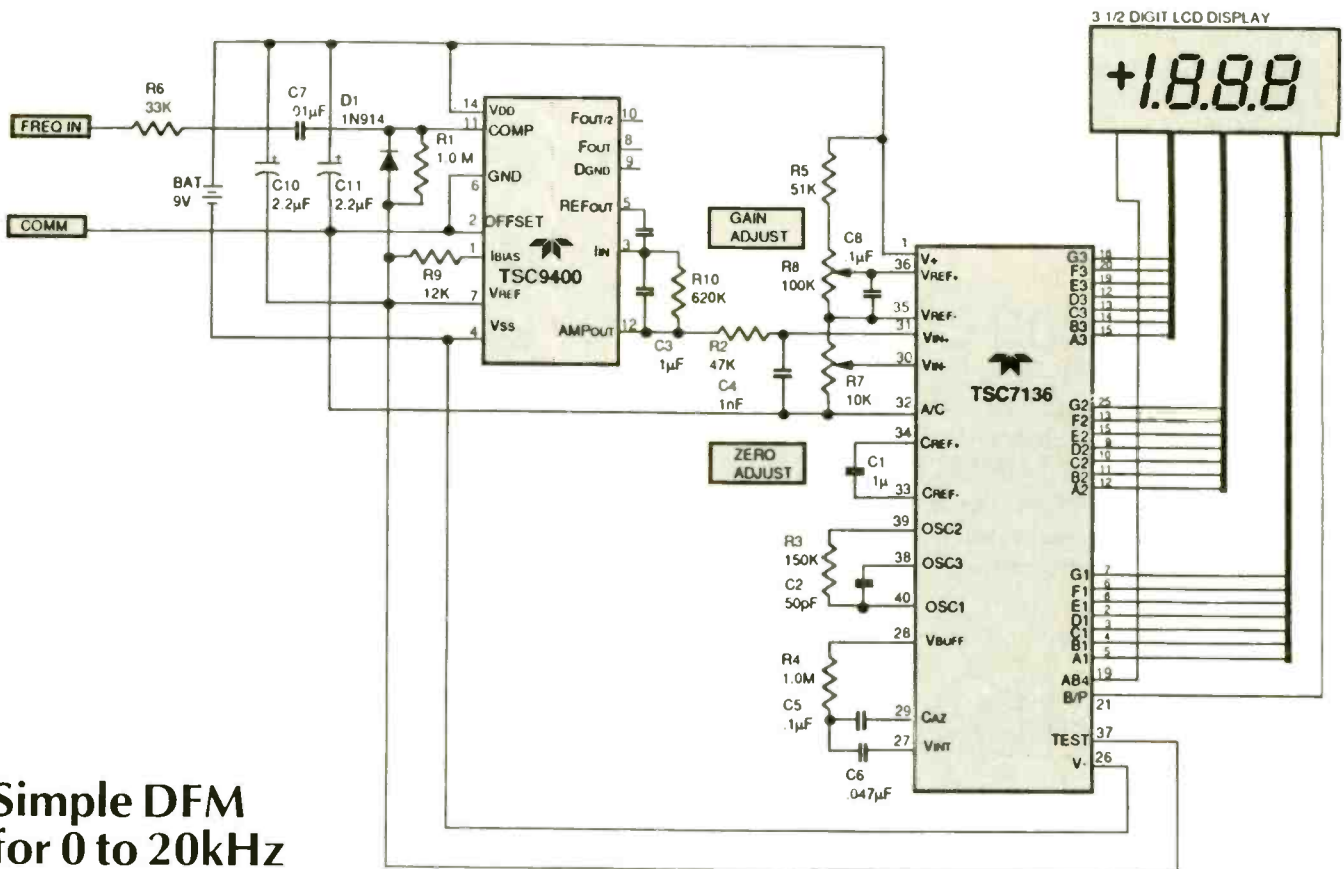

Simple DFM for 0 to 20kHz

Two chips from Teledyne Semiconductor provide a means of constructing a low-cost digital frequency meter suitable for audio frequencies. Application Note 37 details a battery-powered (single 9V) frequency meter running at three

conversions per second, using an oscillator frequency of 48kHz for maximum rejection of stray AC pick up.

The TSC7136 dual-slope analogue-to-digital converter directly drives a 3 1/2 digit non-multiplexed LCD display, so

no digital conversion is required. It derives its input from the TSC9400 frequency-to-voltage converter.

Semiconductor Supplies International Ltd, Dawson House, 128-130 Carshalton Road, Sutton, Surrey. SM1 4RS

Compact telephone construction

Motorola's MC34114 is a monolithic, integrated, telephone speech network intended to replace the bulky magnetic

hybrid circuit of a telephone set. It incorporates the necessary functions of transmit and receive amplification plus

sidetone control, each with externally adjustable gain. To reduce RFI problems, the microphone amplifier has a balanced differential input stage.

The data sheet for this device contains several circuits, including a basic pulse/tone telephone, shown here, together with a fully featured telephone with selectable handset/speakerphone operation, ten-number memory, tone ringer and privacy functions. More information on these telephones is contained in Application Notes 1002/1004. *Motorola Ltd, 88 Tanners Drive, Blake-lands, Milton Keynes. MK14 5BP*

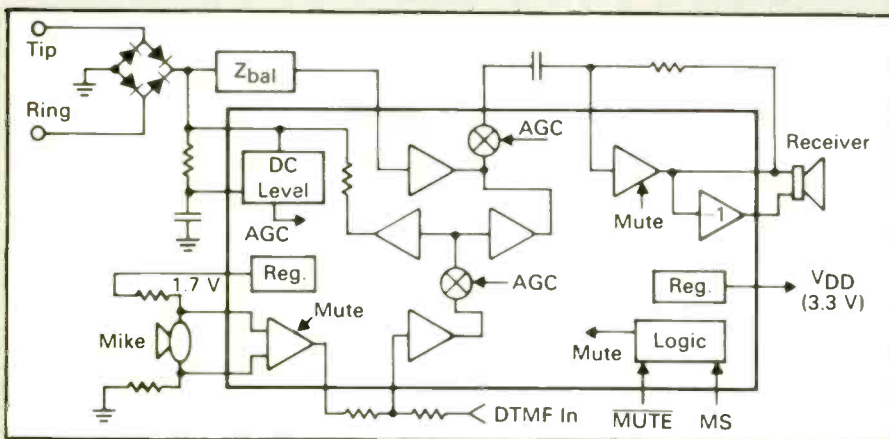

High voltage Schottky efficiency

Although the low forward voltage drop of Schottky rectifiers has long been exploited to improve efficiency in converters rated at up to 15 volts, their use in converters in the 15-36 volt region has been limited by the lack of higher voltage devices.

Motorola's application note AR322/D outlines a multi-output converter operating at high frequencies from a preregulated 120V DC supply. Using MBR1060/MBR10100 devices, it provides $\pm 36V$ at 2A max and $\pm 15V$ at 3A max. If conventional p-n junctions are used as rectifiers in the same output stages, a trade-off between output voltage and efficiency exists.

While p-n-junction devices may be selected which meet the reverse voltage requirements, the forward voltage drop is high over a range of currents and, as a result, so too are the rectifier losses. However, if the peak reverse voltage requirements fall within ratings, Schottky rectifiers can reduce rectifier losses.

In this example, 100V Schottky rectifiers are adequate for the 36V outputs while 60V devices suffice for 15V.

Motorola Ltd, 88 Tanners Drive, Blakelands, Milton Keynes MK145BP. Tel. 0296 395252

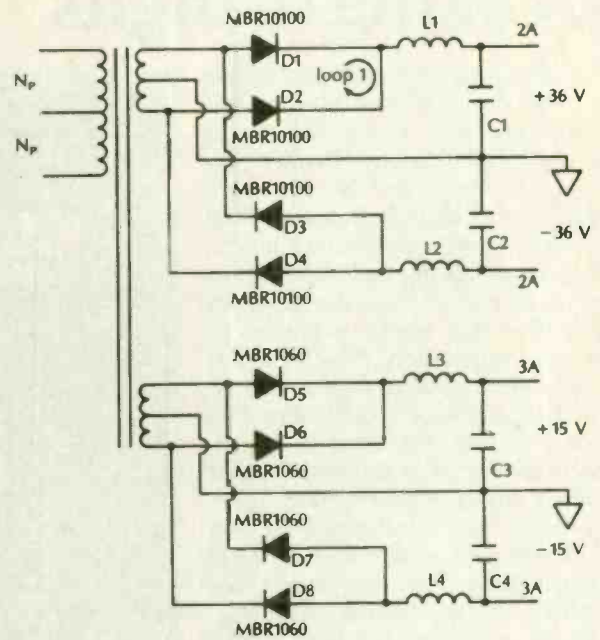

LED smoke detection

A smoke detector based on the CS-235 chip from Cherry Semiconductor uses a pulsed infrared led as the light source and a silicon photodiode as the light detector. The CS-235, along with passive external components, controls the system timing and signal processing.

Low average current is attained by pulsing the system once every 10s for 20ms. Bias is applied to the signal processing circuitry for this time inter-

val. During the second half of the pulse (the last 10ms) the IR led is pulsed and the unit samples for an alarm level smoke condition.

After the first alarm, the sampling rate increases to two seconds. Finally,

after three consecutive alarms, the logic drives the output latch to activate the alarm. This latch can sink 100mA maximum and will clamp the V_{cc} pin to 5V. Clere Electronics Ltd, Kingsclere, Newbury, Berks.

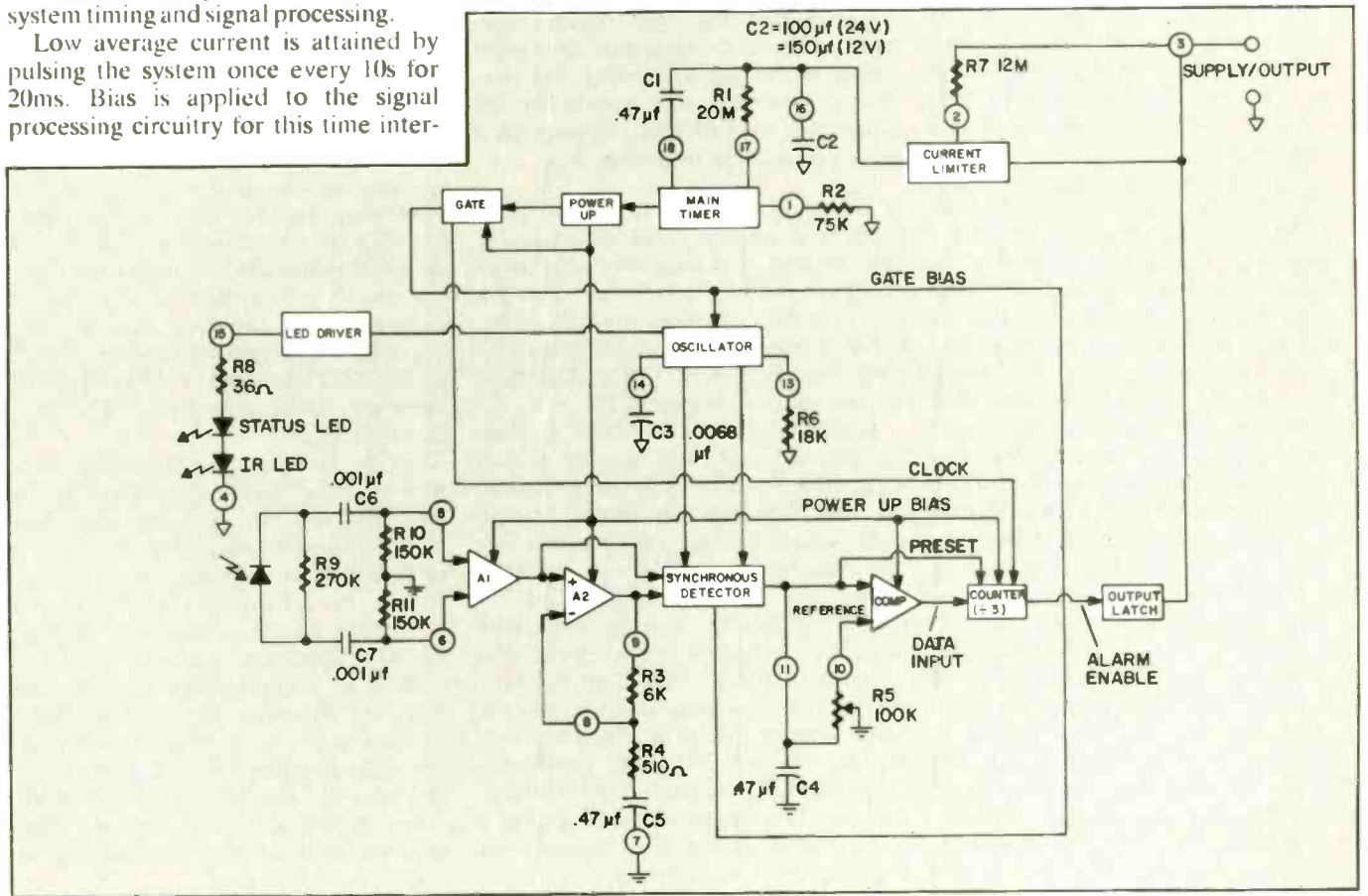

Speaking in digits

At a recent IEE colloquium, Professor C. Xydeas (University of Manchester) and speakers from the Universities of Surrey and Southampton, Queen's University of Belfast, and BT Research Laboratories at Mendlesham described progress in speech coding techniques, claiming that coding techniques have come a long way since the days of direct quantization into linear or non-linear pulse code modulation (PCM). Present day algorithms seek to exploit the intrinsic properties of speech signals to achieve better compression/speech-quality characteristics and hence higher efficiency. Study of novel coding algorithms have been encouraged by new applications such as satellite-to-mobile communications, the proposed Pan-European digital cellular-radio networks and voice store-and-forward systems, as well as by rapid advances in VLSI digital signal processing which have enabled complex coding algorithms to be implemented on a single chip. The aim in such work is to provide digitized speech of required quality and robustness while using the minimum number of bits at the lowest possible cost. Compression can be achieved by exploiting the intrinsic properties of speech, including redundancy. Factors involved include quality of recovered speech; output bit rate; complexity/cost; resistance to transmission errors and noisy source environments; and coding delay.

Requirements range from broadcast-quality speech (50 to 7000Hz, S:R well over 35dB); "toll quality" speech for long-distance communications (200 to 3400Hz, S:R over 35dB); to "communications" and "military" quality where the emphasis is on intelligibility. For some military applications, "synthetic" quality, where the recovered speech has lost its naturalness and speaker-recognition characteristics and with intelligibility degraded, can be based on high-cost vocoder with hybrid speech coding to permit a digital bit-rate of 2.4Kbit/s for use over HF circuits with linear predictive coding (LPC). Currently the main interest is for systems of "toll" quality, or a little less, with systems based on sub-multiples of the 64Kbit/s ISDN basic subscriber telephone rate. Such work is producing an alphabetical soup of coding techniques. Those in the frequency domain include adaptive transform coding; sub-band coding; harmonic coding; and sinusoidal transform coding (STC), while those

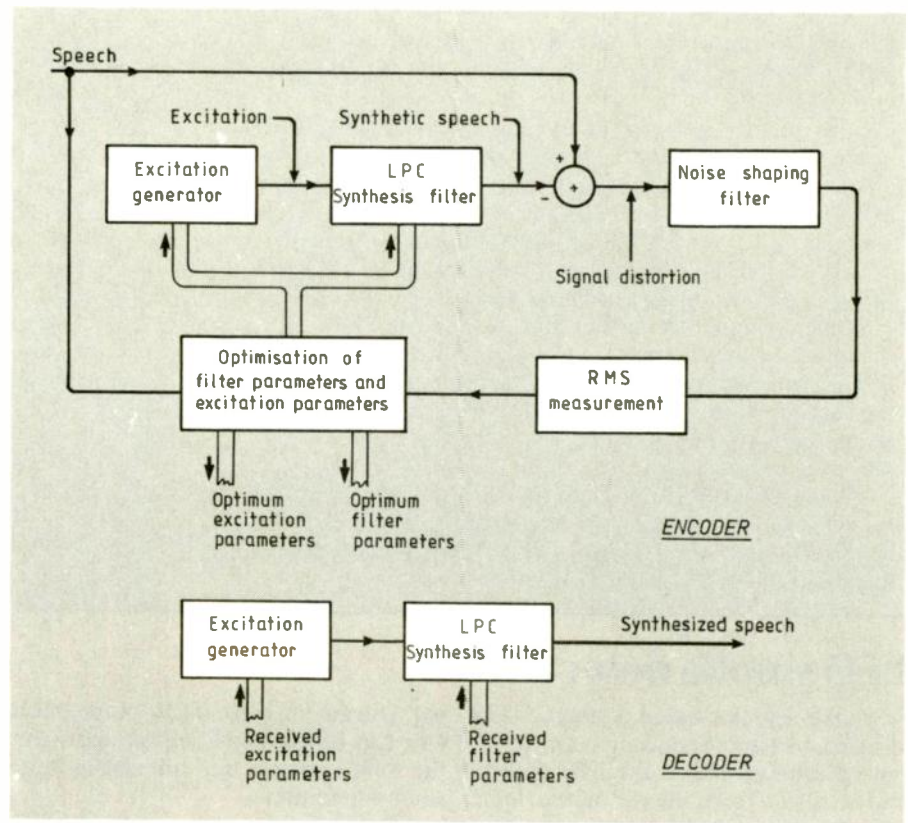

Encoder and decoder of an analysis-by-synthesis predictive coder, which represent a recent development in speech coding technology and which can provide improved-quality speech in the range 9.6 to 4.8Kbit/s, implemented using existing DSP technology.

in the time domain include adaptive predictive coding; residual predictive LPC coding; and analysis-by-synthesis predictive coding which, in turn, includes multipulse excitation LPC in the form of regular pulse excitation LPC; codebook excitation LPC; and backward excitation recovery LPC.

Currently 32 and 16Kbit/s systems can provide near "toll" quality, with a lot of effort to extend this downwards to 9.6 and 4.8Kbit/s. Professor Xydeas noted that harmonic coding with adaptive transform coding can produce reasonable communications quality speech at 8Kbit/s and modifications have been proposed to improve results at 6 and 4.8Kbit/s. STC can produce good communications quality speech at 8Kbit/s which can be modified to operate at 4.8 and 2.4Kbit/s. Codebook excitation LPC vocoders (CELP) forming speech-synthesis filters based on a codebook of random vectors can result in good communications speech quality

at 4.8 Kbit/s, comparable to 32Kbit/s continuously variable slope delta coding.

D. Freeman (BTRL) also reviewed some of the standards adopted or proposed for low bit-rate speech coders, including the 9.6Kbit/s standard for aeronautical-satellite communications. Following international competition, the BTRL 9.6Kbit/s speech coder based on a multipulse LPC technique has been chosen. Two competing systems, proposed by AT&T and the Voicecraft consortium, are currently being considered for a CCITT low-delay 16Kbit/s coder standard. Both algorithms are variations of CELP.

At the University of Southampton a new coding strategy, based on a transformed-binary vector-excited-LPC 7.5Kbit/s coder, with embedded error-correction, is claimed to provide a robust overall transmission rate of 11.4Kbit/s at an economic cost that would be applicable to mobile radio.

W.T.K. Wong (BTR&T) described work in conjunction with the University of Liverpool on a robust LSP (line spectral pair) quantizer which can work satisfactorily with a bit error of 1 in 40, more robust to channel errors than conventionally error-protected digital transmission schemes.

Affordable, stand alone, PCB fault- diagnosis equipment.

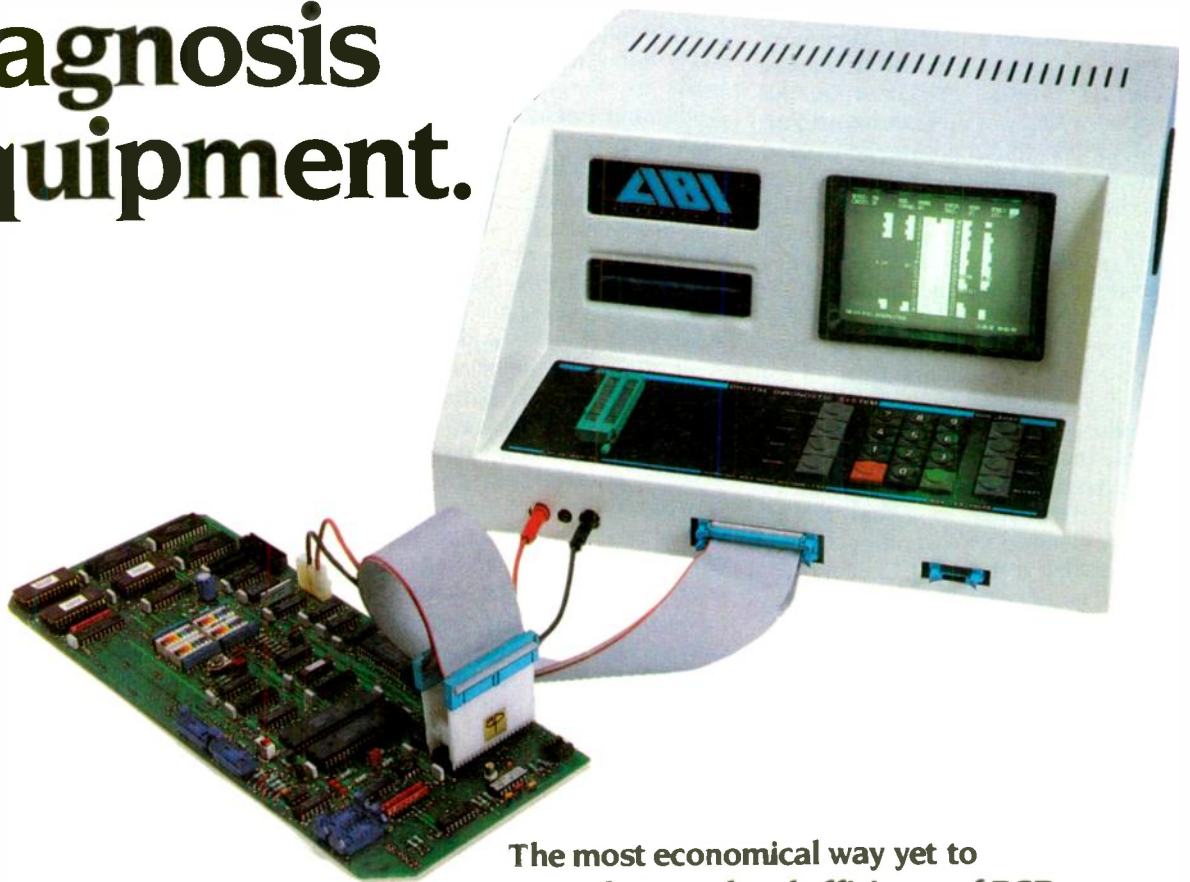

The most economical way yet to
improve the speed and efficiency of PCB
servicing and manufacturing defects analysis.

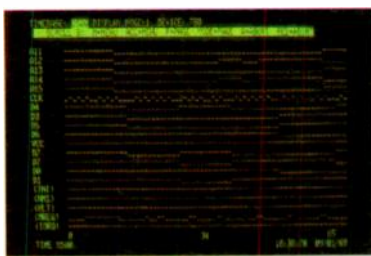

A Z80 logic trace,
showing part of the test
sequence

- **24 and 40 pin Variants.** Providing a host of features for rapidly testing digital IC's in circuit.
- **Save and Compare.** Data from a known good PCB can be saved enabling a suspect board to be compared in minutes without circuit documentation.
- **Automatic Circuit Compensation.** An IC is tested in the way it is connected. No need to program each test.
- **SearchMode.** To identify unmarked IC's and give an equivalent for replacement.
- **Manufacturing Defects Analysis.** Rapid access to circuit information to locate production faults.
- **Out of Circuit Testing.** ZIF sockets make the units ideal for goods inward inspection and checking a device is functional before soldering.

Phone for your free data and
information pack now!



0226 350145

ABI
E · L · E · C · T · R · O · N · I · C · S

ABI Electronics Ltd Mason Way Platts Common Industrial Park Barnsley South Yorkshire S74 9TG
Tel: 0226 350145 Telex: 547938 EXPERT G Fax: 0226 350483

CIRCLE NO. 156 ON REPLY CARD

Stabilizing the LC oscillator

Rather over 20 years ago, I recall Keith Thrower of Racal patiently attempting to explain to me a novel frequency stabilizing system, marketed as the Racalator. This was an external add-on digital system that could be connected to the variable-frequency oscillator of any receiver, transceiver or transmitter having a free-running LC oscillator in the days before the built-in frequency synthesizer had become firmly established. The Racalator, described in IEE Conference Publication No 31, 1967 Frequency Generation and Control for Radio Systems, allowed the LC VFO to be manually tuned to any desired frequency; the Racalator would then be switched into circuit and hold the mean oscillator frequency to within $\pm 2\text{Hz}$, and was capable of correcting an unlocked oscillator drift of ± 1 part in 10^4 . It could cope with a 50Hz transient change in less than five seconds without any apparent increase in VFO noise and no measurable degradation in cross-modulation performance.

About five years later, Dr Michael Underhill (Philips ex-Mullard Research Laboratories) described a new HF/VHF tunable oscillator, covering 3 to 6MHz, using a PAL-type (D14) delay line as a stabilizing element for an LC oscillator. In his original system the delay line provided a comb of equally spaced locking frequencies (15.625kHz apart for a 64 μs delay line) with continuous tuning of the oscillator provided by a voltage control and phase detector arrangement, later simplified by a goniometer phasing technique. The stability of such arrangements is deter-

mined by the phase delay of the delay line. Good spectral purity was obtained when the oscillator was locked, since feedback reduced the FM noise sidebands within a band of ± 2 and 3Hz. I had the opportunity of testing a form of delay-line-stabilized variable oscillator built by Brian Rose, without the continuous-tuning facility, and found that it gave a very high degree of short-term stability (within 1Hz for periods of five minutes or so) but had a disconcerting habit of suddenly jumping to the adjacent locking point.

In the mid-1970s, the Dutch amateur Klaas Spaargaren, PA0KSB, developed a much simplified stabilizer somewhat along the lines of the Racalator and a number of British and American amateurs successfully implemented his system. One of them, Joe Cropper, G3BY, pointed out that when he viewed the action of the control voltage pulses on an oscilloscope he was reminded of the old "hit and miss" gas-engine governor which, when lifting the valves to reduce speed, would emit as it did so a series of "thump, thump, gasp, thump, gasp" sounds in varying rhythms. This led me to propose the name "huff and puff" for the Dutch system and the name stuck. The original stabilizer used TTL devices (74191, 7474) with a counted-down timing signal from a crystal oscillator using 7490

Outline of the stable, continuously tunable oscillator based on two voltage-controlled oscillators, one of which is a crystal variable type which can be "pulled" by about 10kHz from its nominal 16MHz. The oscillator, as implemented by Klaas Spaargaren, uses both c-mos and TTL devices, together with a number of discrete transistors and diodes.

dividers. A 1977 version used c-mos devices. In effect the "huff and puff stabilizer" converts a free-running VFO into an oscillator which can be tuned manually in the usual way but is then held to the nearest of a series of small predetermined incremental steps with minimal drift. Unlike simple, low-cost PLL synthesizers, it does not introduce spurious products or FM noise on to the oscillator output.

Now Klaas Spaargaren has developed a new stable variable oscillator capable of providing a pure, stable and accurately adjustable frequency which takes advantage of the ability to "pull" the frequency of a crystal oscillator over a small range of frequencies without significantly degrading its performance. He then uses this as a reference signal for an LC oscillator used, for example, as the local oscillator of an HF communications receiver. His new system is based on two voltage-controlled oscillators: a wide-band VCO with, for example, a range of 23 to 23.5MHz and a narrow-band voltage-controlled "variable crystal oscillator (VXO)" covering 16,000 to 16,010kHz, with a sample-and-hold phase detector driven by a signal between 10,000 and about 10,000.5kHz counted-down from the VXO. When the VXO is tuned from 16,000 to 16,014kHz the VCO follows and tunes for example from 23,000 to 23,014kHz, the multiplication factor of the phase detector reference being 2300.

But the VCO will also stabilize for other high multiples such as 2301, 2302 etc. In the locked situation with drift correction the VCO is very stable as the effective multiplication factor of the VXO frequency is only 1.4 and, as the loop bandwidth of the PLL can be made relatively large, low-frequency noise and any mains-frequency modulation are attenuated. The basic stability of the crystal oscillator is degraded very little in a VXO that tunes over a narrow range using only a single pulling capacitor. Klaas Spaargaren has used the 23MHz output as the injection signal for a 14MHz amateur-band receiver with a balanced mixer and had "found it one of the best oscillators that I have ever used for that purpose. It has excellent stability with a minimum of unwanted effects. The tuning rate can easily be adjusted between just a few and many kilohertz per knob revolution. There are many options for the basic system. I hope that many experimenters will become just as enthusiastic as I am. ■

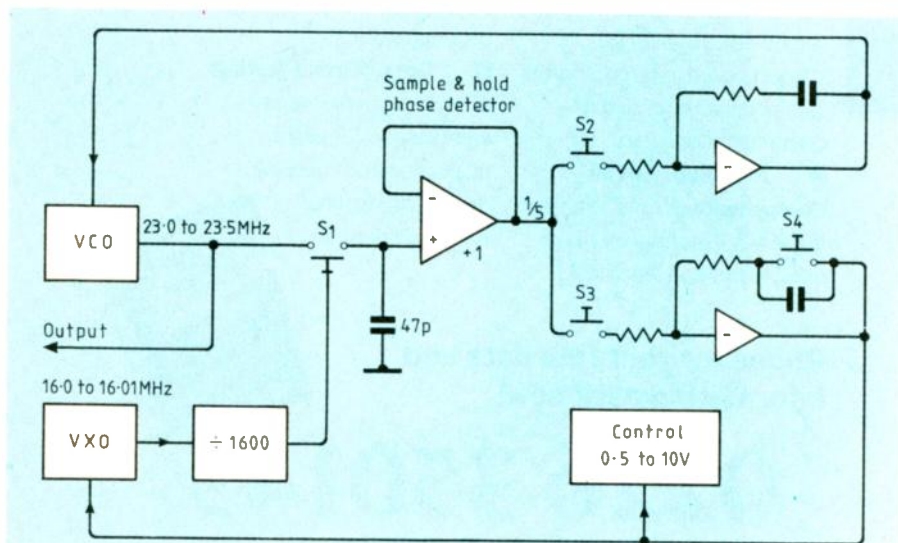

RF Connections are by Pat Hawker

TAYLOR RF/VIDEO MEASUREMENT INSTRUMENTS

MEASUREMENTS MADE EASY



UNAOHM EP741FMS FIELD STRENGTH METER/SPECTRUM ANALYZER

- Frequency Range:** 38.9MHz to 860MHz, continuously adjustable via a geared-down vernier
- Frequency Reading:** TV Bands - 4 digit counter with 100KHz resolution
FM Band - 5 digit counter with 10KHz resolution
Reading Accuracy: reference Xtal +/- 1 digit
- Function:** NORMAL picture only
ZOOM 2 to 1 horizontal magnification of picture
- TV Monitor:**  picture + line sync pulse (with chromaburst if TV signal is coded for colour)
- Panorama:** Panoramic display of the frequency spectrum within the selected band and of tuning marker.
- Panorama Expansion:** Adjustable expansion of a portion of the spectrum around the tuned frequency.
- Analogue Measurement:** 20 to 40dB. Static measurement of received signal. Scale calibrated in dBuV (at top of picture tube) to rms value of signal level.
- DC/AC Voltmeter:** 5 to 50V.
- Measurement Range:** 20 to 130dBuV in ten 10dB attenuation steps for all bands. -60 to 130dBuV in nine 10dB steps for I.F.
- Measurement Indication:** ANALOGUE: brightness; stripe against calibrated scale superimposed on picture tube. The stripe length is proportional to the sync peak of the video signal.
- Video Output:** BNC connector. 1Vpp maximum on 75Ω
- DC Output:** +12V/50mA maximum. Power supply source for boosters and converters.
- TV Receiver:** Tunes in and displays CCIR system I TV signals. Other standards upon request.
- Additional Features:** (1) Video input 75Ω. (2) 12V input for external car battery. (3) Output connector for stereo earphones.

PRICE: £1344.00 nett. excluding V.A.T. and Carriage



UNAOHM EP742 FIELD STRENGTH METER/SPECTRUM ANALYZER

Specification as EP741 + Synthesized Tuning 99 channels, Programme Storage.
(EP815 Satellite Converter can be added as illustrated)

PRICE: £1498.00 nett. excluding V.A.T. and Carriage



UNAOHM EP760 COLOUR TV FIELD STRENGTH METER

- INPUT**
- Sensitivity:** 20 to 130dBuV in ten 10-dB steps for TV and FM bands. 60 to 130dBuV in eight 10-dB steps for I.F.
- Readout:** Digital: input signal level provided directly in dB.
- FREQUENCY**
- Range:** 38.9MHz to 860MHz
- Selection:** -99 channel frequency synthesis within bands I-III-IV/V. -30 program storage capabilities. -manual tuning with sharp-tune control.
- Readout:** Two LCD displays: the first for channel or program; the latter for frequency in MHz with 100KHz resolution for TV bands and 10KHz for FM.
- SPECTRUM ANALYSIS**
- Frequency Range:** The entire TV and FM range. It is possible to display a portion of the selected band.
- Marker:** Two markers are available in different colours and with digital frequency reading. In addition to locating frequencies, they are used to define frequency intervals.
- Video Filter:** A switchable video filter is provided to improve measurement accuracy in connection with Unaohm noise generator NG750.
- SYNC PULSE DISPLAY**
- Display:** The entire horizontal blanking time, sync pulse and burst included, is displayed on the left side of the picture tube.
- AUDIO**
- Mono:** TV and FM audio can be heard through a loudspeaker. 0.5W maximum power.
- Stereo:** TV and FM audio can be heard through a pair of earpieces (2 equal to or higher than 8Ω).
- VIDEO**
- External video Input/output:** Approx 1Vpp on 75Ω, positive polarity. Pin pair 19-20 of SCART.
- RGB output:** Approx 1Vpp on 75Ω. Pins 7-11-15 of SCART.
- Teletext decoder:** All teletext pages broadcast can be recalled by means of the front keyboard of the unit.

PRICE: £2465.40 nett. excluding V.A.T. and Carriage

TAYLOR BROS (OLDHAM) LTD.
BISLEY STREET WORKS, LEE STREET,
OLDHAM, ENGLAND. OL8 1EE
TEL: 061-652-3221 TELEX: 669911 FAX: 061 626 1736

Versatower:

A range of telescopic towers in static and mobile models from 7.5 to 36 metres with tilt-over facility enabling all maintenance to be at ground level.

Designed in accordance with CP3 Chapter V, part 2, 1972 for a minimum wind speed of 140 kph in conditions of maximum exposure and specified by professionals world-wide where hostile environments demand the ultimate in design, quality and reliability. Suitable for mounting equipment in the fields of:

- Communications
- Security surveillance - CCTV
- Meteorology
- Environmental monitoring
- Geographical survey
- Defence range-finding
- Marine and aero navigation
- Floodlighting
- Airport approach lighting

Further details available on request.



STRUMECH ENGINEERING LIMITED

Portland House, Coppice Side, Brownhills
Walsall, West Midlands WS8 7EX, England
Telephone: Brownhills (0543) 452321
Telex: 335243 SEL.G
Fax: 0543 361050



CIRCLE NO. 107 ON REPLY CARD

EPROM PROGRAMMER 100 (E)EPROM and MICRO-CONTROLLER types...

1 2508/10ms	24 27+12	47 87256	70 GR27256	93 80C51*
2 2508/50ms	25 27+12/QP	48 87C257	71 GR27512	94 8052*
3 2518/10ms	26 27513	49 8755	72 GR27513	95 8044*
4 2518/50ms	27 27513/QP	50 8755A	73 8748	96 NMC27C16B
5 2532/10ms	28 27811/QP	51 8355*	74 8749	97 NMC27C32B
6 2532/50ms	29 27D10/QP	52 63701V	75 8750	98 NMC27C64
7 2564/10ms	30 HN27C101G	53 63701X	76 8748H	99 NMC27CP128
8 2564/50ms	31 NMC27C1023	54 63705V	77 8749H	100 NMC27CP256(B)
9 2758	32 uP027C10010	55 63705Z	78 8750H	101 NMC27C512
10 2718	33 TC5710000	56 63701Y	79 8741	
11 2732	34 TMS27C010	57 75P54	80 8742	
12 2732A/10ms	35 HN27C301P	58 75P64	81 8041*	
13 2732A/50ms	36 MSM27C100K	59 2816A	82 8042*	
14 2764/50ms	37 uPD27C1000D	60 2817A	83 8048*	
15 2764	38 TC5710010	61 2864A	84 8049*	
16 2764A	39 HN27C1024G	62 EMULATOR 2716	85 8050*	
17 2764A/QP	40 NMC27C1024	63 EMULATOR 2732	86 8751	
18 27128	41 uPD27C1024D	64 EMULATOR 2764	87 8752	
19 27128A	42 27210	65 EMULATOR 27128	88 87C51	
20 27128A/QP	43 TMD27210	66 EMULATOR 27256	89 87C51FA	
21 27256	44 MS427C102K	67 EMULATOR 27512	90 8752	
22 27256/QP	45 TC-71024D	68 GR2764	91 8744	
23 27256	46 87C84	69 GR27128	92 8051*	

New
Devices
continually
being
introduced

*read only
QP = Quick Pulse

... what more could you ask!

THE MODEL 18 PROM PROGRAMMER

- All 1 Mbit EPROMS, Greenwich Instruments Emulators, 27C parts and EEPROMs now programmable!
- Upgradable for future types.
- Designed, manufactured and supported by MQP in England.
- Comprehensive User Manual.
- 32 and 40 pin devices require low cost socket adapter.
- Supports our new EPROM Emulator as 27-6 to 27512 EPROM
- Mains powered unit external to your computer, without speed penalty.
- Fast interactive algorithms automatically selected as appropriate.
- Two independent communications protocols built in. Use with:
 - any host computer with RS232 port and terminal emulator.
 - our PROMDRIVER Advanced Features User Interface Package available for all MS-DOS and PC-DOS computers. NEW FAST COMMS - 1 Mbit PROMS programmed in about 2 1/2 mins.
- Quick Pulse programming now available for suitable EPROMS - e.g. 2764s in 10 secs!
- Limited version also available for CP/M computers.

Still only
£189.95
+ VAT



Hundreds of satisfied customers. As supplied to: BT Mercury, UKAEA, British Aerospace, Thorn EMI, Mitel, Cosworth Engineering, British Gas, Kodak, Lucas, Ferranti, Smiths Industries, Telecom Technology and major Universities and Colleges of Further Education.

Please enquire about our other products:

EPROM EMULATOR CROSS ASSEMBLERS
EPROM ERASER BIPOLAR PROM PROGRAMMER
PAL PROGRAMMER GANG EPROM PROGRAMMER
EPLD PROGRAMMER EPROM & PAL DESIGN & PROGRAMMING SERVICE

Telephone ACCESS orders welcome.



Phone for free information pack and price list - 0666 825146
ELECTRONICS, UNIT 2, PARK ROAD CENTRE, MALMESBURY,
WILTSHIRE, ENGLAND SN16 0BX.

CIRCLE NO. 111 ON REPLY CARD

COMPUTER APPRECIATION,

The Penny Theatre, 30/31 Northgate,
Canterbury, Kent, CT1 1BL.
Tel: (0227) 470512

HEWLETT PACKARD MODEL 5501A LASER TRANSDUCER. With Piezoelectric tuning for precise control of wavelength in measuring applications. With various mirrors and accessories. £250.00

KRATOS MS30 DOUBLE BEAM MASS SPECTROMETER. Approximately 8 years old with negative ion capability & fast atom bombardment (FAB). With gas & direct introduction sample probes & with gas chromatograph inlet system. Output spectra are available directly via a HEWLETT PACKARD storage display & a UV RECORDER. An on-line DATA GENERAL DS60 computer system, which includes a graphics printer & two TEKTRONIX 4014 terminals, analyses output. The various sections of the instrument may be available separately. A new high flux magnet was fitted shortly before the instrument was decommissioned. P.O.A.

SPECTRA PHYSICS MODEL 164A 30mW HELIUM NEON LASER with power supply. A powerful Helium Neon laser ideally suited for holography. £350.00.

LUMONICS SYSTEM 2000 RUBY LASER with Q-switch, temperature controlled KDP frequency doubler, output monitor. 0.3 Joule per pulse, Q-switched output, 6 ppm. Suitable for holography involving moving objects. A low power He/He laser for mirror alignment and all manuals are included. Current new price of equivalent model exceeds £15000.00. £3500.00.

ITT PERFECTOR TELEX MACHINE. With 32k memory, screen with slow scrolling, keyboard etc., together with operators and service manuals. £99.50.

BIOMATION Model 810D LOGIC ANALYSER. Combines with any oscilloscope to provide 8 channel logic analyser. Size and colour to match Tektronix 400 series portables. £75.00.

DIGITAL Q-BUS, box, power supply, and 8 x dual slot backplane, all brand new. Needs easy modification (14 wirewrap connections) to update. £75.00.

TEKTRONIX Model 4051 intelligent graphics display with BASIC in ROM and RCA tape cartridge drive. Good tube and useful for maintenance purposes. £99.50.

COMPUTER APPRECIATION IS FOR SALE

The successful business established in 1973 is for sale due to the present proprietor moving overseas. The stock in hand, trading name & knowhow are all available for a lot less than you'd imagine.

CIRCLE NO. 138 ON REPLY CARD

REPRINTS

IF YOU ARE INTERESTED IN A PARTICULAR ARTICLE SPECIAL FEATURE OR ADVERTISEMENT IN OUR JOURNAL WHY NOT TAKE ADVANTAGE OF OUR REPRINT SERVICE.

REPRINTS CAN BE OBTAINED AT A REASONABLE COST, TO YOUR OWN INDIVIDUAL SPECIFICATIONS PROVIDING AN ATTRACTIVE AND VALUABLE ADDITION TO YOUR OWN PROMOTIONAL MATERIAL.

FOR EXAMPLE, A TWO PAGE ARTICLE CAN BE REPRODUCED AS A FOUR PAGE FOLDER WITH ADDITIONAL WORDING ON THE FRONT PAGE AS AN INTRODUCTION.

FOR FURTHER DETAILS CONTACT:

**CLARE HAMPTON ON
01-661 8672**

CIRCLE NO. 136 ON REPLY CARD

18th-century resistors

The squire of Seaton Delaval invented the metal-oxide resistor in 1759. With his experimental method, he was lucky to survive to tell the tale.

LEONID N. KHRYZHANOVSKY

The invention of the resistor does not seem to have ever been considered by historians, which is in contrast with the case of the capacitor, the literature on the history of the Leyden jar abounding! My purpose is to trace the invention of the resistor back to the 18th century and it is appropriate to start with some scientific developments in eighteenth century Russia.

RICHMANN'S POWDERS

Although systematic research into electricity in Russia had begun a century and a half later than in Western Europe, Russia's first electrician, Georg-Wilhelm Richmann (1711-1753), of German descent, built in 1745 the world's first electric measuring instrument, a quadrant-scale electrometer based on a linen thread fixed to the top of an insulated vertical metal bar, the deflection angle of the thread being a measure of the 'electric virtue' communicated to the bar². Richmann's electrometer, called by him *index electricus* and known in Europe as the electrical gnomon³, allowed important experiments.

Richmann was a colleague and friend of Mikhail Lomonosov (1711-1765), Russia's greatest scientist of the 18th century. Richmann began his report at the conference of the Imperial Academy of Sciences of St Petersburg, held on 30th April 1753, with the following words:

Lomonosov passed me three portions of crushed glass differing in the degree of comminution and expressed a wish for me to investigate what would occur if an electrified mass

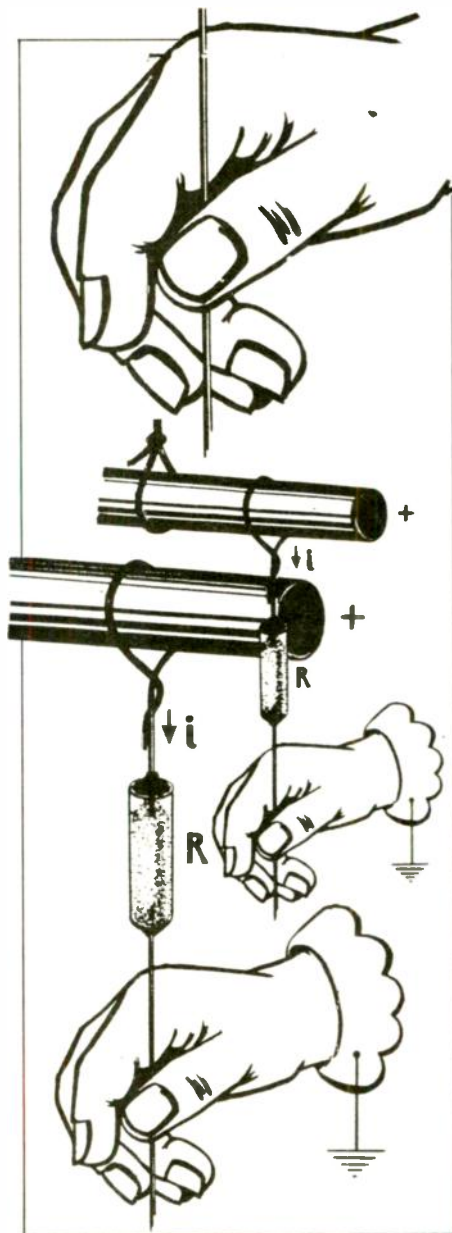

rested on the powders, thus giving me an opportunity to discover truths of no small importance⁴.

Richmann performed the following experiment on each powder. He poured some powder into a metal vessel connected somehow to the earth. Dipped into the powder was a wire suspended from a prime conductor with Richmann's electrometer connected to it. He found that the higher the humidity was, the faster would be the leakage of the charge on the prime conductor as indicated by the electrometer. He reported:

Starting from this indication, it is possible to apprehend the state of the air in different places and at different times⁵.

Here we see the idea of a humidity sensor of the resistor type. Richmann also found that 'a fine powder entraps moisture stronger than a coarser one does', pointing to the feasibility of humidity sensors with different sensitivities, to use modern terms.

Thus, an intrinsically insulating substance such as glass could be made to exhibit electrical conduction in the St. Petersburg experiments. An inverse problem was solved in Britain several years later, using a similar experimental arrangement.

DELAVAL'S CALCES

Edward Hussey Delaval (1729-1814) showed in his letter dated 15th March 1759 to Benjamin Wilson, Fellow of the Royal Society of London, that although the metals are conductors, their calces offer 'resistance to the passage of the electric fluid', i.e. constitute *resisters* (Delaval's spelling)⁶. The term 'resist-

ance' already existed⁷. He implied that different resistors might have different resistances.

Delaval reports on the design and construction of his resistors:

I have filled several small glass tubes with the dry powders and calcined metals, viz. ceruse, lead ashes, minium, calx of antimony, etc. Into each end of every tube I put a piece of iron wire, which communicated with the calx, and fastened them with wax: so that the electric fluid, not being able to escape by means of the glass, must either pass thro' the calx, or not at all. Upon hanging one of the wires, bent for the purpose, to the electrified bar, and holding the other in my hand...

He estimated the resistance by his sensation of the 'passage of the electric fluid' and sparks.

Here he modestly observes in a footnote: 'Since I wrote this letter, I have been informed that part of this first experiment, relating to metallic calces, has been made before by Dr. Watson', reference being made to a well-known paper of William Watson (1707-1787)⁸. But there is no evidence that Watson had fabricated any devices similar to Delaval's resistors. Watson does state that 'the calces of metals...prevent in a great degree the quick propagation of electrical power' and that ceruse, i.e. the calx of lead, red lead, litharge, lunar caustic, the calx of silver or rusted iron filings are unsuitable for the electrodes, either inside or outside of a Leyden jar. However, it was Delaval who has introduced the term 'resistor', made real resistors and conducted a thorough research into their nature.

Delaval goes on:

That this change (in resistance), in metals particularly, is not owing to, or promoted by, the circumstances of mere pulverization, is evident... because the finest filings or powders of metals conduct as readily as the intire substances do. I have glass tubes armed as above, and filled with the preparations called powder of tin, etc. which conduct as well as a wire when it is not discontinued.

Delaval addressed himself to the effect of temperature ('a moderate heat, not the intense one that calcines') on resistance and found that temperature affects resistance in a complicated manner.

Now a forgotten electrician of the 18th century, Delaval had paved the way with the above experiments for Henry Cavendish (1731-1810) who, more than a decade later, used his own

body as an ammeter in discharge circuits of Leyden jars to estimate various resistances, also in series or parallel connections.

Delaval's resistors might have served as a model for Branly's coherer, the importance of which to the development of wireless communication cannot be overestimated.

As for the materials of his resistors, Delaval has anticipated a future technological development in electronics, metal-oxide resistors being nowadays very popular electronics components.

The inventor of the resistor bore the title of Esquire of Seaton Delaval, Northumberland, and Dodington, Lincolnshire, and was not a prolific author. He left several papers on optics and only two known papers on electricity, of which the first has been discussed here. He did not become Fellow of the Royal Society until 1814⁹. ■

References

1. J.L. Heilbron. "Electricity in the 17th and 18th Centuries: A Study of Early Modern Physics". Berkeley and Los Angeles: University of California Press, 1979, p.314 ff.
2. G.-W. Rickmann. "Works on Physics". Moscow 1956, p.338 ff. The book (in Russian) contains Richmann's complete works in physics, both published and unpublished, translated from the Latin or German.
3. W. Watson. An Answer to Dr. Lining's Query relating to the Death of Professor Richmann. *Phil. Trans.*, 1754, vol. 48, Pt.II, p.768-772.
4. Richmann. *Op.cit.*, p.322.
5. *Ibid.*, p.323.
6. B. Wilson. A letter from...to the Rev. Tho. Birch, D.D. Secret. R.S., *Phil. Trans.*, 1759, vol. 51, Pt.I, p.83-88.
7. L-G. le Monnier. Recherches sur la communication de l'électricité. *Histoire de l'Académie...Paris*, 1746, p.447-464.
8. W. Watson. A Collection of the Electrical Experiments... *Phil. Trans.*, 1748, vol.45, p.49-120.
9. J.C. Poggendorff (Editor). "Bibliographisch-literarisches Handwörterbuch zur Geschichte der exacten Wissenschaften", in 2 vols., Leipzig: Bart, 1863, vol. 1, columns 540-541.

The author is with the A.S. Popov Central Museum of Telecommunications, Leningrad

Computer Integrated Testing, by Allen Buckroyd. Computer integrated manufacture (CIM), which would ultimately use a central controller to co-ordinate the whole process of design and production, is not yet common, although it is developing fairly rapidly. To achieve the ideal, all the separate computer-controlled processes must be brought together under one controller; one such is test.

Automatic testing is, of course, well established, but for the maximum benefit ATE has to be integrated in the CIM concept, in which role it is termed computer integrated testing (CIT). This extensive book is intended for engineers who are already familiar with the ATE environment but who need to know how to incorporate it into the overall system. A complete section on computer-aided design is included and there are five case studies, including one on asics. BSB Professional Books, hard covers, 394 pages, £45.

Electronic Engineer's Reference Book, sixth edition, edited by F.F. Mazda. A massive work of reference which contains contributions from nearly ninety authors. It is impossible to do justice to such a book in this amount of space, but perhaps it can be said that there is not a great deal of electronic engineering left uncovered, in greater or lesser detail. It is organized in five sections: techniques, which is concerned with mathematics, statistics and electric circuit theory; physical phenomena; materials and components, from simple passive devices to VLSI integrated circuits; electronic design, instrumentation and broadcasting; and applications such as communications satellites, radar and the Integrated Services Digital Network. As befits a work of this size, the index is extensive and well organized. Butterworth Scientific, hard covers, about two inches thick (no page numbers!), £85.

Newnes Computer Engineer's Pocket Book, second edition, by Michael Tooley. An extremely comprehensive storehouse of well organized information on computer hardware and software, intended for those who fall into the somewhat hazy category of "software engineer". It contains notes of varying length on the whole spectrum of practical computer-related topics, from Boolean algebra to microprocessor architecture, all in considerable detail and clearly indexed. Heinemann Professional Publishing, 222 pages, hard covers, £9.95

Servicing TV and Video Equipment, by Eugene Trundle. This is a well produced and illustrated, practical text on the fault-finding and repair of equipment, including video cameras, both modern and slightly longer in the tooth. It is general in nature, but uses commercial circuitry to illustrate the points made in the text. As the author points out, the complexity of domestic electronics has reached the point where "seat-of-the-pants" servicing is no longer feasible and where repair by substitution is by no means as easy as it was. There is a useful chapter on the use of modern test equipment and, wherever necessary, the mechanical aspects of servicing are well covered. Heinemann Professional Publishing, hard covers, 209 pages, £25.

APPOINTMENTS

01-661 8640

DISPLAY APPOINTMENTS
£29 per single col. centimetre (min. 3cm).
1/2 page £1271
Full colour £400

Full page £2311

1/4 page £693
2nd colour £275

Cheques and Postal Orders payable to REED BUSINESS PUBLISHING GROUP LTD and crossed.

UNIVERSITY OF YORK DEPARTMENT OF COMPUTER SCIENCE

Experimental Officer (Computer Hardware Design)

You should normally possess a degree in Computer Science or Engineering, or Electronic Engineering, or an equivalent qualification, and have experience of digital circuit design. Experience of CAD techniques for p.c.b. layout would be an advantage. The work involved will be in support of the Department's research and teaching activities in computer science and engineering.

The post is available immediately and the salary will be within the range: £10,458-£16,665 per annum.

Informal enquiries may be made by telephone to Mr Peter Burgess (0904) 432724.

Six copies of applications, with full curriculum vitae and naming three referees, should be sent by Friday, 5 January 1990 to the Personnel Office, University of York, Heslington, York YO1 5DD. Further particulars are available. Please quote reference number 4/8111.

Magazine journalism?

ELECTRONICS WORLD + WIRELESS WORLD

ASSISTANT EDITOR,

Electronics World + Wireless World

We're looking for a genuine all-rounder to help us produce the magazine that you're now reading.

This full-time job, based at Sutton, Surrey, involves the running of outside contributors together with the commissioning and preparation of feature material. You will also find yourself reporting and writing on technology matters.

Your responsibilities will require a fair degree of personal order. However, the rewards are £15k negotiable and the promotion prospects endless.

Interested? Please write to me with a few details about yourself and your ambitions.

Frank Ogden, editor,

Electronics World + Wireless World,
Room L301,
Reed Business Publishing Group,
Quadrant House, The Quadrant,
Sutton, Surrey SM2 5AS.

*Please mark the envelope
"confidential."*

AUDIOLAB

DESIGN ENGINEERS

Our design team has recently moved to St. John's Innovation Centre, Cambridge. We now wish to recruit two graduate Electronics Engineers with experience in RF, Digital, Broadcast and Audio equipment design, to work on exciting and innovative new projects.

Please write to Philip Swift, or telephone for an informal discussion.

Cambridge Systems Technology Ltd
26 Roman Way Industrial Estate
Godmanchester, Huntingdon
Cambs PE18 8LN. Tel. 0480 52521

**TO ADVERTISE IN THE CLASSIFIED
SECTION PLEASE PHONE
01-661 8640**

CLIVEDEN

Technical Recruitment

Field Service Engineer South East

Radio Communications
Kent based engineer to install and maintain paging intercom systems. RF and logic electronics experience essential. preferably with microprocessor knowledge. ONC or equivalent in electronic engineering. To provide a prompt and efficient technical support service and liaise with customers.
Up to 12K - Car - Benefits

T.V. Engineers Berkshire

2-3 years experience of audio video TV servicing. Previous experience of involvement with dealer or rental retailers an advantage. HNC Electronics or City and Guilds (224).
£10,000-£12,000

Test Technician Berkshire

Repairing mobile telephones down to component level. Experience of a modern testing environment essential. Knowledge of signal generators, audio analysers, modulation analysers, RF and signals experience beneficial. ONC electronics. To deal with day to day problems in production area and test repair centre.
£10,500-£11,000K

Field Service Engineer Middlesex

City and Guilds Qualified Engineer with component level repair experience required. Must have radio and television knowledge. Excellent career prospects in small expanding company.
£11,000 -

Field Service Engineer South East

Engineer with IBM PC - Compatibles experience required. Must have at least 18 months similar experience and be prepared to cover south-east area.
£11,500 - Car

Roger Howard, C.Eng., M.I.E.E., M.J.E.R.E.
CLIVEDEN TECHNICAL RECRUITMENT
92 The Broadway, Bracknell, Berks RG12 1AR
Tel: 0344 489489 (24 hour)



'ENGINEERING' CAREERS in 1990

Let CADMUS eliminate the stress. If you are an electronics engineer and qualify for coverage in our monthly register it will give you discrete access to over 3000 UK companies. You don't even need a 20p stamp, phone 0603 761220 (24hrs) for a registration form or send your CV and details of your career objectives to:—



Freepost, Sackville Place
44-48 Magdalen Street
Norwich NR3 1BR



Cellular Radio

M3/M4 Corridor

£10-20K

Career prospects in Radio and Telecommunications are exceptional in the Hampshire, Berkshire, Surrey area. Expansion for a number of our clients who are leaders in this field, has resulted in career opportunities in the following areas:

- Electronics Design
- Electro-Mechanical Design
- Software Design
- Product Support
- Manufacturing/Production Engineering
- Purchasing/Materials Control
- Installation/Commissioning

I am particularly interested in talking to individuals with experience in:

- RF/Microwave
- Analogue/Digital/DSP
- C/Pascal/Assembler
- Electronics Packaging
- ASIC/VLSI Design
- Test/ATE
- Quality/Service

Excellent benefits packages are available along with plenty of scope for personal development within a commercial electronics environment.



For further information please contact
Celia Paterson, Professional & Technical
Appointments, Unit 9b, Intec 2, Wade
Road, Basingstoke, Hants RG24 0NE.
(0256) 470704.

Wanted urgently Practical people for the Third World.

Many people want to help the Third World. But relatively few can offer the kind of help wanted most: the handing on of skills and professions which lead to self-reliance.

You could make this priceless contribution by working with VSO.

Current requests include:

- | | | | |
|---|--------------------------|---|--------------------------|
| Refrigeration/
Radio/
TV Engineers | <input type="checkbox"/> | Electrical
Engineers
for instruction/
installation | <input type="checkbox"/> |
| Hospital
Electronics
Engineers | <input type="checkbox"/> | Electronics
Instructors | <input type="checkbox"/> |
| Audiology
Technician | <input type="checkbox"/> | Maintenance
and repair
Technician | <input type="checkbox"/> |

For more details, please complete and return to: Enquiries Unit, VSO, 317 Putney Bridge Road, London, SW15 2PN. Tel. 01-780 1331.

Conditions of work: • Pay based on local rates • Posts are for a minimum of 2 years • Many employers will grant leave of absence.

I'm interested. I have the following training/experience.

Name _____

Address _____

EWW/1/90

VSO

Helping the Third World help itself.

20p stamp appreciated.

Charity no. 313757.

TO ADVERTISE
IN THE CLASSIFIED SECTION
PLEASE PHONE
01-661 8640



**TECHNICAL ENGINEERING
AND DEVELOPMENT**

DESIGN, TEST, SERVICE Q.A. & PRODUCTION ENGS. IN ELECTRONICS

Permanent jobs throughout the UK including Jr. Technicians, new graduates & managers to 25K.

Please send c.v. to 3, Heathmans Road,
London SW6 4TJ or phone 01-736 9857

RECRUITMENT AGENCY

barnet

EDUCATIONAL SERVICES

AUDIO VISUAL AIDS TECHNICIAN

£9,879-£10,935 pa inc.

- + qualification allowance
- + essential car user allowance

Required at Barnet Schools Technical Support workshops situated at Manorside School, Squires Lane, N3. Responsible for maintaining video cassette recorders and televisions to component level as well as maintaining and repairing a wide range of other audio visual equipment including radio cassette recorders, slide projectors and music centres.

A current driving licence is essential.

Ref: ADM/E/608.

Closing date: 5th January 1990.

For more information contact Mr R. Drayson at Barnet School Technical Support Workshops, Manorside School, Squires Lane, N3. Tel: 01-349 2775.

Application forms available from the Recruitment Office, London Borough of Barnet, 16/17 Sentinel Square, Brent Street, Hendon, NW4 2EN. Tel: 01-202 8282 ext 2372 (01-202 6602 outside office hours).

AN AUTHORITY COMMITTED TO EQUAL OPPORTUNITIES



LONDON BOROUGH

barnet

NORTHAMPTONSHIRE COUNTY COUNCIL COUNTY SUPPLIES

MAINTENANCE OF RADIO EQUIPMENT FOR POLICE AUTHORITY

Contractors are invited to submit an application for inclusion on an ad hoc selected list of tenderers for the provision of radio maintenance of equipment used throughout the Northamptonshire Police Authority, as indicated.

- I UHF hand held radios
- II UHF base stations
- III VHF/UHF & VHF mobile radios for a) maintenance and b) installation
- IV VHF hilltop sites
- V Radio control systems
- VI Miscellaneous radio and audio equipment

Applicants should provide the following information

- I Full details of the company – company registration, type of company, plc, partnership etc
- II Financial statements covering the last 3 years
- III Details of similar contracts undertaken in the private and public sector, giving details of customers and nature and size of contract
- IV Details of any experience working with the emergency services and in particular with Police Forces
- V Summary of company's experience in UHF/VHF radio systems

All requests must be submitted in writing by 29 January 1990 and addressed to:

**The County Supplies Officer
County Hall
Gulldhall Road
Northampton
NN1 1DN**

marked 'Maintenance of Radio Equipment' (attn: Mr J Overton – Contracts Section).

CLASSIFIED

01-661 8640

CLASSIFIED DISPLAY: £29 per single column centimetre (min 3cm).
LINE ADVERTISEMENTS (run on): £6.00 per line, minimum £48 (pre payable).
(Please add on 15% V.A.T. for prepaid advertisements).

BOX NUMBERS: £15.00 extra. (Replies should be addressed to the box number in the advertisement, c/o Quadrant House, The Quadrant, Sutton, Surrey SM2 5AS).

Cheques and Postal Orders payable to REED BUSINESS PUBLISHING GROUP LTD and crossed.

ARTICLES FOR SALE



Cooke International

HAVE SCOPES, SIGNAL GENERATORS, POWER SUPPLIES, POWER METERS, DVM'S, OSCILLATORS, ATTENUATORS TEST INSTRUMENTS

FOR SALE AND WANTED

Contact: Cooke International, Unit Four, Fordingbridge Site, Main Road, Barnham, Bognor Regis, West Sussex PO22 0EB. Tel: 0243 545111. Fax: 0243 542457
Wide range of items available. Send for lists

UNIVERSITY OF READING

ELECTRONICS TECHNICIAN (*Grade D*) in Speech Research Laboratory, Department of Linguistic Science to assist in design and construction of specialised instrumentation. Candidates should have experience in electronics and a knowledge of IBM personal computers would be an advantage. Informal enquiries to: Mr. W. Jones (0734 875123 ext. 7468). Salary scale £8,645 to £10,632 p.a. T 72A.

Application forms available from:

Personnel Office,
University of Reading,
Whiteknights,
P.O. Box 217,
Reading RG6 2AH

031662

WE BUY AND SELL TOP QUALITY TEST AND MEASUREMENT EQUIPMENT W

J
L
A
U
Q

RALFE ELECTRONICS

36 Eastcote Lane,
S.HARROW, Middlesex HA2 8DB
Tel: 01-422 3593. Fax: 01-423 4009.

Please contact us for our latest stock list of top-quality re-calibrated, test equipment. Good equipment also WANTED for stock and waiting customers for 'high-end' equipment.

Stock examples: TAKEDA RIKEN 1GHz analyser £2950, MARCONI TF2370 analyser £3000, B&K 1023 £2000, FERRO RTS2's £250 etc etc etc.

P
O
T

LLS DNA YUB EW TNEMPIUQE TNEMERUSAEM DNA TSET YTILAUQ POT LLES

B
U
Y

A
N
D

ANCHOR SURPLUS LTD

OSCILLOSCOPES & GENERAL TEST EQUIPMENT

All items supplied in tested and working condition.
Calibration verified at no extra cost.

TEK 475 200MHz - D. Beam - DT. Base	£485
TEK 7603 c/w 7D01 Logic anal. DFI Disp. for matter	£999
TEK 7603 c/w 7A16, 7A18, 7A26, 7B53A p/ins	£999
Gould OS1 100-S1 30MHz Dual Beam	£155
Philips PM3217 50MHz	£325
Cossor CDU150 35MHz	£149
SE LABS SM111 18MHz	£145

SPECIAL

BRAND NEW & BOXED AVO MODEL 8 MK5 MULTIMETERS
WITH AVO EVEREADY CASE PROBES LEADS.

£50

Also

AVO Model 9S (Mil. version of model 8) c/w case probes leads	£50
Tequipment CT17 curve tracer - mint	£200
Marconi TF2008 Sig Gen's 10MHz - 510MHz AM-FM	£375
Marconi TF2002AS Sig Gen's 10KHz - 72MHz AM-FM	£80
Marconi TF2603 RF Millivolt 10 1.5GHz	£75

Accessory kits available

MANY, MANY more items in stock and arriving daily at our three acre depot in Nottingham. We are open to callers 9am-6pm weekdays - 8pm-4pm Saturday
PLENTY OF FREE PARKING

**Anchor Surplus Ltd., The Cattle Market Dept.,
off London Road, Nottingham NG2 3GY**

Telephone: (0602) 864041 or 864902

Fax: (0602) 864667

Shaun Pollard (Electronics Manager)

ALL PRICES EXCLUDE VAT & CARRIAGE

TO MANUFACTURERS, WHOLESALERS, BULK BUYERS, ETC.

LARGE QUANTITIES OF RADIO, TV AND ELECTRONIC COMPONENTS FOR DISPOSAL

SEMICONDUCTORS, all types, INTEGRATED CIRCUITS, TRANSISTORS, DIODES, RECTIFIERS, THYRISTORS, etc RESISTORS, C/F, M/F, W/W, etc CAPACITORS, SILVER MICA, POLYSTYRENE, C280, C296 DISC CERAMICS, PLATE CERAMICS etc ELECTROLYTIC CONDENSERS, SPEAKERS, CONNECTING WIRE, CABLES, SCREENED WIRE, SCREWS, CHOKES, TRANSFORMERS etc ALL AT KNOCKOUT PRICES
- Come and pay us a visit ALADDIN'S CAVE

TELEPHONE: 445 0749/445 2713

R. HENSON LTD

21 Lodge Lane, North Finchley, London N12.

(5 minutes from Tally Ho Corner)

1613

GOLLEDGE

ELECTRONICS

QUARTZ CRYSTALS OSCILLATORS AND FILTERS of all types. Large stocks of standard items. Specials supplied to order. Personal and export orders welcomed - SAE for lists please. OEM support thru: design advice, prototype quantities, production schedules. Golledge Electronics, Merriott, Somerset TA16 5NS. Tel: 0450 73718. (24721)

RF & MICROWAVE!

Design & Test Engineers seeking top positions, from satcomms to CT2 should contact the specialists

GARIBALDI RECRUITMENT
0494 773918

160 Bellington Road Chesham HP5 2HF

VALVES FOR AUDIO, industry, receiving, transmitting - wholesale, export, retail. Phone/fax for immediate quote. Billington Valves, 39 Highlands Road, Horsham RH13 5LS, England. Phone 0403 210729. Fax 0403 40214. Callers by appointment only Mon-Fri 9.00am - 5.30pm.

SERVICES

SHORT-RUN
ELECTROMECHANICAL AND
ELECTRONIC REPAIR AND
MAINTENANCE WORK
UNDERTAKEN BY
EXPERIENCED ENGINEERS.
WRITE TO BOX NO: 2606

ARTICLES WANTED

STEWART OF READING
110 WYKEHAM ROAD,
READING RG6 1PL.
TEL: 0734 68041.
FAX: 0734 351696

**TOP PRICES PAID FOR ALL
TYPES OF SURPLUS TEST
EQUIPMENT, COMPUTER
EQUIPMENT, COMPONENTS
etc. ANY QUANTITY.**

103

720K 3.5 INCH DRIVE £34.50 + VAT NEW LOW PRICE TO CLEAR WAREHOUSE

Japanese made, modern, low component, cast chassis drive. Surface mount design with industry standard interface. Removed from almost new systems, these are top quality drives in excellent condition. Boxed and with a full six month guarantee. 80 track double sided 1 megabyte unformatted; **£34.50** (carr. £3); **£30** ten or more. Cradle to fit drive in a 5.25" slot e.g. IBM PC **£4.95** (carr. £1.00; free with drive). Power and data connectors to suit £0.99p (carr. free). Box of 10 3.5" discs **£9.95** (carr. £1).

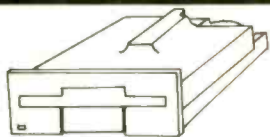

N.B. Drives work with virtually all computers but we have not yet succeeded in getting them to work with the Atari ST.

EPSON 12" TTL MONO MONITOR (GREEN)

High resolution, IBM and Hercules compatible. Supplied complete with leads for direct connection to any PC. **£46.50** (carr. £5.50)



RACAL V22 MODEM MPS1222

Microprocessor based modem providing full duplex communication at 1200, 600 and 300 baud to the CCITT V22 standard. Features include: ★ Can be used on standard phone line (PSTN) and private circuit (PC) ★ Auto answer but needs telephone to dial ★ 1200, 600 and 300 baud ★ Very high quality construction ★ BT approved ★ Self and loop tests (V54) ★ Comprehensive manual included. Uncased card **£19.95** seven cards in rack **£195** (carr. one £3.50; seven £15)

HARD DISC DRIVES

Rodime R0352 3.5" 10M byte. Standard MFM ST 506 interface **£55** (carr. £3.50)
As above, but with SCSI interface, **£75** (carr. £0.50)
CDC Wren 80 M byte ST 506 28ms MFM **£349.00** last few! (carr. £5)
Rodime 26 M byte ST 506 MFM **£89.50** (carr. £4)
CDC Wren 35 M byte non-standard NRZ interface **£49.00** (carr. £3.50)

5.25 INCH FLOPPY DISC DRIVES

Panasonic (720K IBM) 80 track double-sided **£34.95** (carr. £3.50)
Teac 1.2 M byte IBM AT style drive **£49.95** (carr. £3.50)

POWER SUPPLIES

Farnell N180 cased 180 Watt PSU + 5V at 20A, + 12V at 2A, - 12V at 2A, +24V at 5A and - 5V at 1A. Very high quality British unit. **£26.95** (carr. £3). ASTEC AC9231 cased 50 Watt PSU + 5V at 6A, + 12V at 2.5A, 5V at 0.5A (float) and 12V at 0.5A **£15.95** (carr. £3).



Visa & Access
accepted 24 hour
phone service

matmos

DAISYWHEEL PRINTER

Olivetti DY200. Modern, office quality, bidirectional daisywheel printer. Complete with manual, daisywheel, ribbon and standard Centronics interface. Prints at 25 cps, variable pitch; 132 characters in 12 pitch, proportional spacing. Sprocket and sheet feed options, p.o.a. Full IBM and Diablo emulations. **£99.50** (carr. £6.50).

FACIT ULTRA FAST DOT MATRIX PRINTER

Prints at up to a maximum of 500 CPS. Made to a very high standard for heavy duty use. Compact slimline desktop model (only 26 inches wide). Ideal for Universities, large mailing lists, central printer in department or any other serious application **£349.00** (carr. £25).

WANG PM005 12" COLOUR MONITORS

15KHz analogue RGB input, high definition, suitable for Amiga, Atari, BBC etc. **£99.50** (carr. £6.50).

HITACHI COLOUR MONITORS

CM1473ME 14" MULTISYNC suits all standards. Latest technology high spec. monitor **£279** (carr. £12.50).
CM1474 12" as above but fixed on the VGA standard frequency **£239** (carr. £10).

QUALITY VGA CARD

Up to 800 x 600.
Fully compatible **£129** (carr. £3).

HITACHI PROFESSIONAL CAD MONITORS

CM2086 20" the ultimate monitors available in 48KHz CAD frequencies **£494** (carr. £35).
CM1686A 16" ultra high resolution also in two CAD frequencies: 48 KHz **£325** (carr. £25), 64 KHz **£395** (carr. £25).

HITACHI CDR2500 CD ROM DRIVE

Full height 5.25", high sierra spec., including IBM controller card and MS-DOS extension **£285** (carr. £4).

STC SCRIBE KEYBOARDS

Keyboards as supplied with Scribe wordprocessors. These are serial units but no data is available. **£5.95** (carr. £3).

SOUND EQUIPMENT all second-hand.

Hill DX140 140 watt per channel stereo amplifier. 19" rack mounting very high quality **£119** (carr. £5).
Speakers, amps, mikes etc. regularly in stock — please ring for current details.

* VAT and carriage must be added to all items.

* Everything new unless stated otherwise.

* Access and Visa telephone service.

Matmos Ltd., Unit 11, The Enterprise Park, Lewes Road, Lindfield,
West Sussex RH16 2LX.
Telephone: (04447) 2091 or 3830 Fax: (04447) 4258

CIRCLE NO. 106 ON REPLY CARD

INDEX TO ADVERTISERS

Appointments Vacant Advertisements appear on pages 85 – 87

	PAGE		PAGE		PAGE
ABI Electronics	79	Johns Radio	67	Raedek Electronics Co	942
Audio Electronics	4	Kestrel Electronic		Radioplan	75
Computer Appreciation	82	Components	70	Ralfe Electronics	32
Dataman Designs	IFC	Lab-Volt (UK)	49/OBC	Rank Taylor Hobson	24 & 25
Display Electronics	52	Langrex Supplies	27	Sherwood Data Systems	75
Electrical & Radio Trading	70	M & B Radio (Leeds)	67	South Midlands	
Engineering Technologies	75	M Q P Electronics	82	Communications	49
Fairchild	27	Matmos	88	Stewart of Reading	81
Field Electric	67	National Instruments	65	Strumech Engineering	82
Flight Tech Heathrow	8	Number One Systems	63	Taylor Bros. (Oldham)	59/IBC
Flight Electronics	2/6/56/70	Pineapple Software	49	Those Engineers	81
Icom (UK)	67	Practical Computer	22	Thurlby Thandar	4
Integrex	15	R. Henson	81	Triangle Digital Services	27
J A V Electronics	32				

OVERSEAS ADVERTISEMENT AGENTS

France and Belgium: Pierre Mussard, 18-20 Place de la Madelaine, Paris 75008.

United States of America: Jay Feinman, Reed Business Ltd., 205 East 42nd Street, New York, NY 10017 - Telephone (212) 867 2080 - Telex 23827.

Printed in Great Britain by Carlisle Web Offset, Caxton Road, Newtown Trading Estate, Carlisle, Cumbria CA2 7NR, and typeset by Graphac Typesetting, 181 191 Garth Road, Morden, Surrey SM4 4LL, for the proprietors, Reed Business Publishing Ltd, Quadrant House, The Quadrant, Sutton, Surrey SM2 5AS. © Reed Business Publishing Ltd 1989. *Electronics and Wireless World* can be obtained from the following: AUSTRALIA and NEW ZEALAND: Gordon & Gotch Ltd, INDIA: A. H. Wheeler & Co. CANADA: The Wm Dawson Subscription Service Ltd., Gordon & Gotch Ltd. SOUTH AFRICA: Central News Agency Ltd; William Dawson & Sons (S.A.) Ltd. UNITED STATES: Worldwide Media Services Inc., 115 East 23rd Street, NEW YORK, N.Y. 10010. USA. *Electronic & Wireless World* \$5.95 (74513).

TAYLOR

R.F. EQUIPMENT MANUFACTURERS

PERFORMANCE & QUALITY

19" RACK MOUNT CRYSTAL CONTROLLED VESTIGIAL SIDEBAND TELEVISION MODULATOR

PRICES FROM £214.13 (excluding VAT & carriage)
Prices CCIR/3 £214.13
CCIR/3-1 £273.67



19" RACK MOUNT VHF/UHF TELEVISION DEMODULATOR

PRICE AT ONLY £198.45 (excluding VAT & carriage)

WALLMOUNT DOUBLE SIDEBAND TELEVISION MODULATOR

PRICES FROM ONLY £109.76 (excluding VAT & carriage)



Prices
CCIR/5-1 1 Modulator £109.76
CCIR/5-2 2 Modulators £167.99
CCIR/5-3 3 Modulators £237.59
CCIR/5-4 4 Modulators £307.19
CCIR/5-5 5 Modulators £376.79

CCIR/3 SPECIFICATION	
Power requirement	- 240V 8 Watt (available other voltages)
Video Input	- 1V Pk-Pk 75 Ohm
Audio Input	- 8V 600 Ohm
FM Sound Sub-Carrier	- 6MHz (available 5.5MHz)
Modulation	- Negative
IF Vision	- 38.9MHz
IF Sound	- 32.9MHz (available 33.4MHz)
Sound Pre-Emphasis	- 50us
Ripple on IF Saw Filter	- 6dB
Output (any channel 47-86MHz)	- +6dBmV (2mV) 75 Ohm
Vision to Sound Power Ratio	- 10 to 1
Intermodulation	- Equal or less than 60dB
Spurious Harmonic Output	- -40dB (80dB if fitted with TCFL1 filter or combined via TCFL4 Combiner/Leveller)

CCIR/3-1	- Specification as above but output level 60dBmV 1000mV Intermodulation 54dB
----------	--

Other Options Available	- I.F. Loop/Stereo Sound/Higher Power Output
-------------------------	--

Alternative Applications	- CCTV Surveillance up to 100 TV channels down one coax. telemetry camera control signals, transmitted in the same coax in the reverse direction.
--------------------------	---

802 DEMODULATOR SPECIFICATION	
Frequency Range	- 45-290MHz, 470-860MHz
A.F.C. Control	- +/- 1.8 MHz
Video Output	- 1V 75 Ohm
Audio Output	- .75V 600 Ohm unbalanced
Audio Monitor Output	- 4 Ohms
Tunable by internal preset Available for PAL System I or BG	

Options	- Channel selection via remote switching. Crystal Controlled Tuner. Stereo Sound.
---------	---

CCIR/5 MODULATOR SPECIFICATION	
Power Requirement	- 240V
Video Input	- 1V Pk-Pk 75 Ohms
Audio Input	- 1V rms 30K Ohms Adjustable .4 to 1.2
Vision to Sound Power Ratio	- 10 to 1
Output	- 6dBmV (2mV) 470-860MHz
Modulation	- Negative
Audio Sub-Carrier	- 6MHz or 5.5MHz
Frequency Stability	- 25 Deg temperature change 150KHz
Intermodulation	- less than 60dB
Sound Pre-Emphasis	- 50us
Double Sideband Modulator (unwanted sideband can be suppressed using TCFL4 Combiner/Leveller)	

CHANNEL COMBINER/FILTER/LEVELLER to combine outputs of modulators	
TCFL2	2 Channel Filter/Combiner/Leveller. Insertion loss 3.5dB
TCFL4	4 Channel Filter/Combiner/Leveller. Insertion loss 3.5dB
TSRO	Enables up to 4 x TCFL4 or TCFL2 to be combined.

TAYLOR BROS (OLDHAM) LTD.
BISLEY STREET WORKS, LEE STREET,
OLDHAM, ENGLAND.

CIRCLE NO. 102 ON REPLY CARD

TEL: 061-652 3221 TELEX: 669911 FAX: 061-626 1736

Telecommunications Training

from fundamentals to state-of-the-art technology

Lab-Volt offers a comprehensive range of telecommunications training equipment that covers basic electronics, analogue and digital communications circuits and systems, fibre optics, and microwave and radar technologies.

Our equipment is:

- modular and easy to upgrade
- industry relevant
- engineered for educational purposes.

Lab-Volt closely relates its telecommunications training equipment to operational systems found in industry, with educational enhancements such as fault insertion switches in many of the modules, labelled and easily-accessible test points, short-circuit protection, silk-screened component identification, and full signal compatibility for system-level modules. We supply student and instructor manuals that are written specifically for the equipment; they provide practical hands-on technical training with step-by-step exercises, laboratory experiments, and troubleshooting activities.

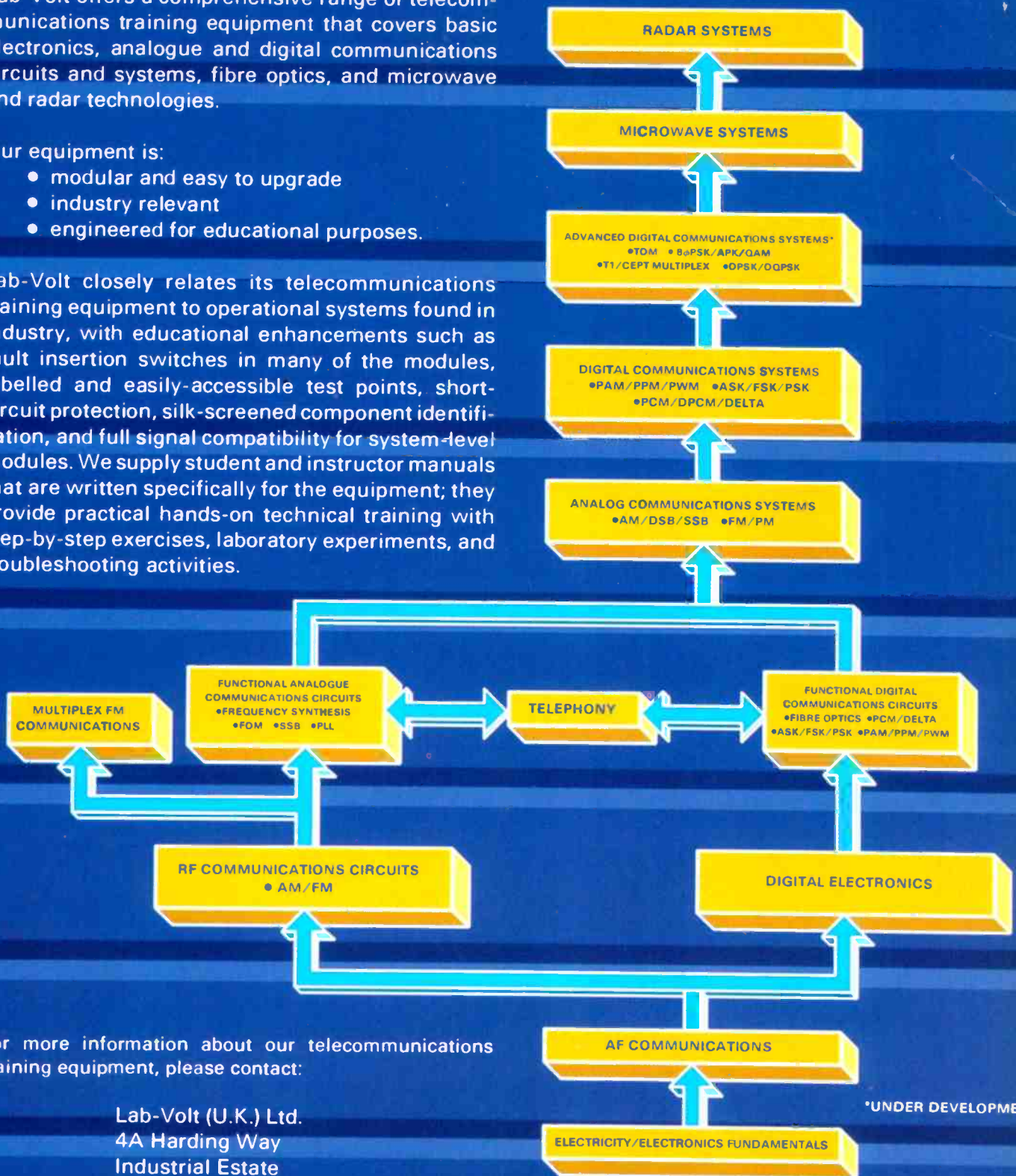

For more information about our telecommunications training equipment, please contact:

Lab-Volt (U.K.) Ltd.
 4A Harding Way
 Industrial Estate
 St. Ives
 Cambridgeshire
 PE17 4WR
 Or Call: 0480 300695

Lab-Volt®