

PIC developer – 20% reader discount

ELECTRONICS WORLD

Austria Asch. 66.00
Denmark DKr. 67.00
Germany DM 15.00
Greece Dra. 1100.00
Holland Dfl. 11.75
Italy L. 8800.00
Malta Lm. 1.55
IR £3.30
Singapore S\$7.50
Spain Pts. 850
USA \$5.95

INCORPORATING WIRELESS WORLD

A REED BUSINESS PUBLICATION
SOR DISTRIBUTION

April 1997 £2.35

ULTRA-FAST AUDIO POWER

**Battery-low
warning**

**Resistor
calculator in c**

**Doug Self on
balanced i/o**

**Fessenden's
heterodyne**

**Programmable
LSI**

**Monitoring
mains**

**PIC-based
message
beacon**



Extra circuit ideas in this issue



9 770959 833035

Small PROBLEMS? BIG Awkward No Time SOLUTION!

PIC based TOOLS to help you realise your project:
from single applications to full scale production

BASIC STAMPS[®]

PIC based BASIC Stamps are perfect for one-off and low volume applications. Their easy to learn but powerful BASIC syntax (with familiar instructions such as GOTO, FOR ... NEXT, and IF ... THEN as well as instructions for serial I/O, pulse measurement, button debounce, DTMF, X-10 etc) will get your application up and running in hours. Once programmed, the Stamp runs independently of your PC and programs are stored in non-volatile EEPROM so they can be changed at will. Detailed manuals cover many commonly needed routines and the Stamp is well supported by a growing list of custom application kits to cut development time even further. Available in two formats:

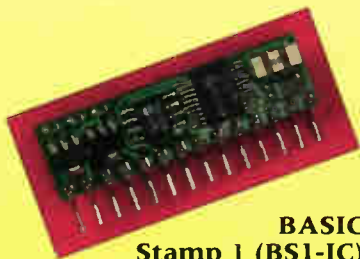

BASIC Stamp 1 (BS1-IC)
8 I/O Lines
up to 80 program lines
Comms to 2400 baud
35x10mm size
£29 single price

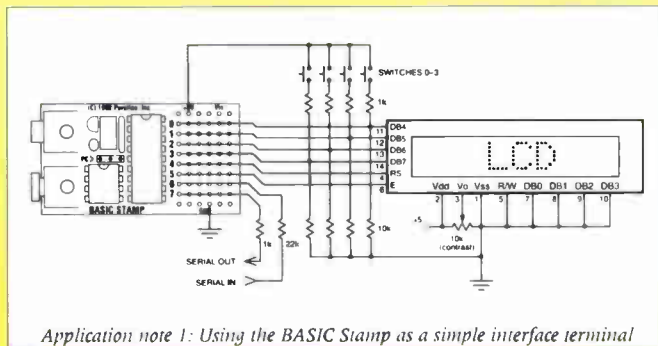

Application note 1: Using the BASIC Stamp as a simple interface terminal

Typical Application

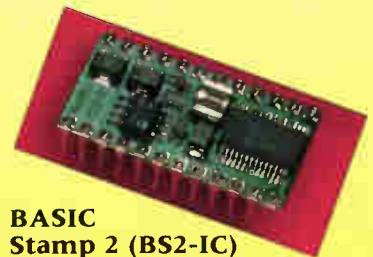

BASIC Stamp 2 (BS2-IC)
16 I/O Lines
up to 500 program lines
Comms to 50 kbaud
24pin DIP package
£49 single price

BASIC Stamp Development Kits including PC software, manuals, 24+application notes, downloader cables, Stamp (BS1-IC or BS2-IC) and corresponding Project Board - £99 / £119

PIC16Cxx DEVELOPMENT TOOLS

For medium to large volumes and high speed requirements, the popular range of PICs is hard to beat. We offer an extensive range of programmers, emulators and associated hardware to support the following PICs: 52 54 55 56 57 58 620 621 622 61 62 63 64 65 71 72 73 74 84

PIC16Cxx Programmer



- Also stocked
- * ZIF sockets
 - * SOIC/SSOP/PLCC adapters
 - * Prototyping boards
 - * Compilers/Simulator

OVER
5000
SOLD

In Circuit Emulators

- * True hardware emulation of program memory, registers and I/O
- * Unlimited breakpoints.
- * Single stepping
- * Software-programmable oscillator
- * Windows Environment
- * Runs from 32Khz to 10Mhz ('xx) and 20Mhz ('5x)
- * Source level debugging for PASM(X), MPASM and MPC
- * Optional trace facility

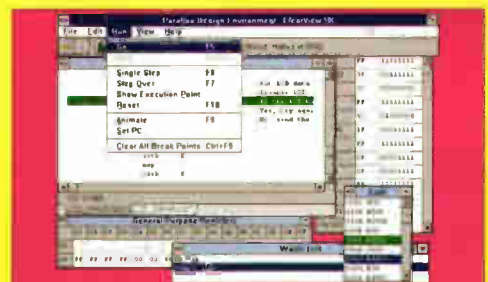

Milford Instruments
Milford House, 120 High Street,
SOUTH MILFORD LS25 5AQ
01977 683665 Fax 01977 681465

Please call or fax to receive
our catalogue and price list.
All prices exclude VAT
and £3 shipping.

BASIC Stamp and the Parallax logo are
registered trademarks of Parallax, Inc.

PARALLAX

3805 Atherton Road, #102
Rocklin, CA 95765 USA
916-624-8333, Fax 916-624-8303
<http://www.parallaxinc.com>

Contents

Cover - Jamel Akib



278 STOCHINO

Not only is Giovanni Stochino's power amplifier ultra fast, slewing at over 300V/ μ s, it is also pure, with a thd of 0.002% when driving 100W at 1kHz.

285 BATTERY LOW WARNING

To be re-used successfully, alkaline cells need to be recharged when two-thirds full. But how do you know when you've used a third of the charge? Rod Cooper explains.

291 MONITORING MAINS

Using a DIY transformer backwards provides a convenient and safe means of monitoring mains current. By Nick Wheeler.

293 HETERODYNE

John Belrose and George Elliott set the record straight as to who invented the heterodyne.

298 MESSAGE BEACON

Bill Francis' beacon sends messages from a central transmitter to a number of remote stations - all under PIC control.

306 A BALANCED VIEW

Douglas Self explains how to get signals from A to B with the best possible integrity using balanced line inputs and outputs.

330 SOUND FROM PICTURES

Richard Ball reports on a new flat-panel loudspeaker technology.

332 I/O THROUGH WINDOWS

Windows was not intended for control applications, but you can write your own DLLs, as Colin Attenborough explains.

340 RESISTORS IN C

Calculate parallel and series resistor combinations quickly and precisely using John Lavender's c program.

343 PROGRAMMABLE LOGIC

In this month's extract, Geoff Bostock investigates more powerful programmable devices produced using large-scale integration.

Regulars

267 COMMENT

Modem mayhem

268 NEWS

3D acceleration sensor, New 23GHz transistors, 0.18 μ m chip geometries, 2Gbit/s static ram, Network computers.

274 RESEARCH NOTES

Steel advances flat-panel displays, Sun-burned satellite? Atom-firing laser, High sensitivity on-chip microphone.

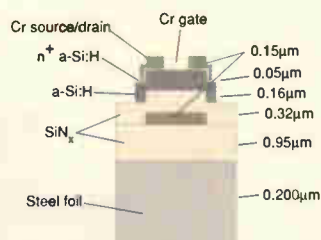

Could steel outperform glass and polymers as a substrate for flat-panel displays? See page 274.

313 LETTERS

Simpler outphasing, Cable debate, Marconi sell-out, Crossover design, Error cancelling.

335 NEW PRODUCTS

Pick of the month - classified for convenience.

322 CIRCUIT IDEAS EXTRA

- RMS-to-dc converter reads in dB,
- Active 0.1V drop 3-phase rectifier,
- Low-power liquid detector
- Voltage controlled common-mode
- Manually loading serial data
- 20Hz to 22kHz in one sweep
- Locking an LC oscillator
- I²C driver for lcd modules
- Noisy supply for radio testing

Special offers



Develop your own PIC microcontroller systems. Vann Draper is offering 20% discount on a PIC development system with in-circuit emulation options - see page 304.

Reader offer

0.02Hz to 2MHz function generator with built-in frequency meter for £179 - see page 314.



A new technology allows you to hide your loudspeakers in picture frames; but will it catch on? Richard Ball reports on page 330.

**MAY ISSUE
ON SALE 3 APRIL**



The Coolest ICE

For the complete range of development tools including assemblers, C compilers and simulators, call Ashling.

- Real-time non-intrusive emulation
- Exceptional Windows® Debugging interface
- All derivatives supported
- Performance analysis and code coverage
- 50Mhz clock speed and low voltage support
- Up to 16Mb shadow RAM and 512K trace
- Integrated Windows® Development Environment

SUPPORTED PROCESSORS

- 80C51
- 680C11
- 80C51XA
- MCS®251
- 68HC05
- MELPS 7700
- SAB-C500
- Z80/Z180



Ashling Microsystems Ltd. Intec 2, Wade Road, Basingstoke, Hants. RG24 8NE, UK
Tel: 01256 811998 Fax: 01256 811761 e-mail: sales@ash-uk.demon.co.uk

CIRCLE NO. 106 ON REPLY CARD

MARCONI 2370 Spectrum analyser



- 30Hz – 110MHz Frequency range
- 1Hz Resolution/phase lock tuning
- Digital storage with dual display
- Built-in tracking generator
- 9 digit frequency counter

£850 + carriage/vat

Includes 30 day unconditional warranty

M&B Radio, 86 Bishopgate Street, Leeds LS1 4BB

Tel: (+44) 0113 2435649

Fax: (+44) 0113 2426881

CIRCLE NO. 107 ON REPLY CARD

New: Windows software for TiePieSCOPE HS508 and TP508

This powerful windows software gives you new possibilities and intuitive control of the five integrated devices (Oscilloscope, Voltmeter, Transient recorder, Spectrum analyzer and Square wave generator) to perform all your advanced measurements.

Oscilloscope:

- Number of samples settable between 10 and 32760
- Up to 32K samples on screen
- Free settable pretrigger between 0 and 100%
- Easy time axis zoom: scaleable scrollbar slider
- Free settable sample frequency from 0.01 Hz to 50MHz
- Graphical adjustment of vertical offset and gain
- WYSIWYG trigger level, -hysteresis and -slope-adjustment with one control
- Place the mouse over a control, press the right button and adjust all properties of that control using the popup menu
- Cursor measurements
- Storing and recalling reference signals
- Match channel available
- Speedbutton toolbar
- Colour printing supported

Voltmeter:

- Up to six clear, fully configurable displays
- 10 math operations, like true RMS, mean, peak to peak, frequency etc
- 16 display functions like Ch1+Ch2, Ch2-Ch1, Ch1*Ch2, log(Ch1/Ch2) etc.
- Data logging to disk and printer
- Speedbutton toolbar

Fax or E-mail for a free demo disk



TiePieSCOPE HS508

- interface parallel printer port
- resolution 8 bits
- input range 200mV - 80V full scale
- price £597.00 incl. software, manual and 2 probes (1:1/1:10 switchable)

TP508

- interface PC-XT/AT ISA slot
- resolute 8 bits
- input range 20mV - 80V full scale
- price £630.00 incl. software, manual and 2 probes (1:1/1:10 switchable)

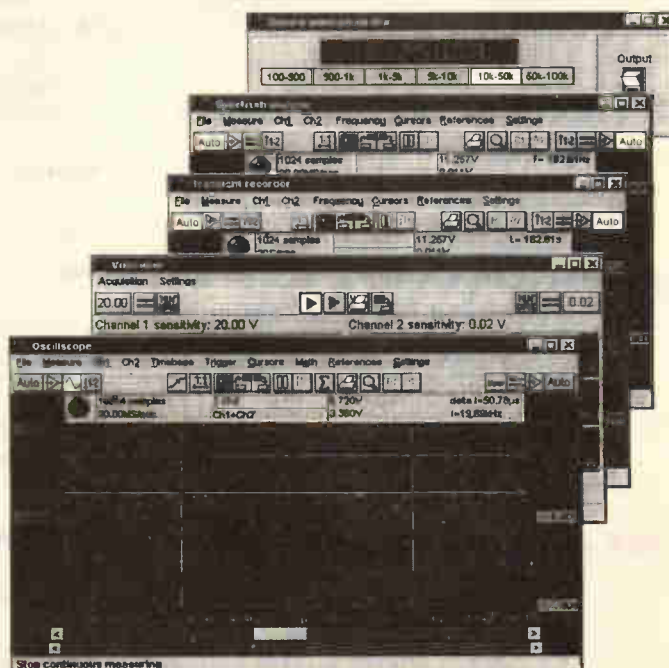

Minimum system requirements: Window 3.1 or higher, 386 processor, 4MB RAM, 4MB free disk space

Prices are excluding VAT

TiePie engineering (NL)

P.O. Box 290
8600 WL SNEEK
The Netherlands
Tel.: +31 515 415 416

E-mail: tiepie@tiepie.nl
Site: http://www.tiepie.nl
Fax: +31 515 418 819



TiePie engineering (UK)

28, Stephenson Road, Industrial Estate,
St. Ives, Cambs, PE17 4WJ,
United Kingdom
Tel: +44 1480 460028 Fax: +44 1480 460340

CIRCLE NO. 108 ON REPLY CARD

Modem mayhem

EDITOR

Martin Eccles
0181 652 3128

CONSULTANTS

Jonathan Campbell
Philip Darrington
Frank Ogden

DESIGN

Alan Kerr

EDITORIAL

ADMINISTRATION

Jackie Lowe
0181-652 3614

E-MAIL ORDERS

jackie.lowe@rbp.co.uk

ADVERTISEMENT MANAGER

Richard Napier
0181-652 3620

DISPLAY SALES EXECUTIVE

Malcolm Wells
0181-652 3620

ADVERTISING PRODUCTION

0181-652 3620

PUBLISHER

Mick Elliott

EDITORIAL FAX

0181-652 8956

CLASSIFIED FAX

0181-652 8956

SUBSCRIPTION HOTLINE

01622 778000

SUBSCRIPTION QUERIES

01444 445566
FAX 01444 445447

ISSN 0959-8332

NEWSTRADE ENQUIRIES

0171 261 7704

For a full listing of
RBI magazines:
<http://www.reedbusiness.com>

 REED
BUSINESS
INFORMATION

Just as you have forked out £200 for the latest 33.6kbit/s data modem – or probably twice as much to go ISDN – you're told you have got it wrong. You should have waited for the new 56kbit/s modem.

Or should you? All is not what it seems and this proposal for a new 56kbit/s modem 'standard' looks distinctly shaky. For a start, it's not a standard, more like two proprietary and mutually incompatible contentions for a standard. What is more, it is debatable whether it is truly the advance it claims to be. It could even become one of those glorious side-alleys, like PAL-Plus, DCC and the Sony Elcaset – technically ingenious but ignored by most users.

Ingenuous these modems certainly are, achieving higher speed (in one direction) by eliminating one digital-to-analogue conversion process. What is not so clear is whether most users will actually benefit thereby. And if not, why upgrade to the new 'standard'?

Two competing developers have announced modems that achieve line speeds of up to 56kbit/s, but in the downstream direction only. The data that you transmit has a maximum transfer rate of 28.8 or 33.6kbit/s. Moreover, the two protocols, x2 from US Robotics and K56Flex being developed by Lucent and Rockwell are not mutually interoperable. While each vendor is attempt to grab market share – and sell their expensive equipment to Internet service provider hosts – the fact remains that they are not mutually compatible. If your host does not support the new standard your transmission will drop back to your previous standard speed, probably 28.8kbit/s.

The speed increase applies only for connections made to host modems equipped with the same 'flavour' of 56kbit/s as your own, which more or less restricts it to Internet connections. Point-to-point data transfer and connections to bulletin boards or your friends' PC parented on analogue lines will be restricted to 28.8 or 33.6kbit/s.

In many situations, too, any speed increase is illusory. On Internet connections at least, there is little to be gained from a lightning-speed connection to your nearest point of presence if the real log-jams prevail the other side. For the average user slow downloads will remain a fact of life until extra bandwidth is installed along the main arteries of the Internet.

For some users upgrading to 56kbit/s will involve minimal expense and might even be worthwhile. This is because US Robotics says that all of its products that currently support software downloads can be easily upgraded to x2. This does not apply to its older products, though.

Whether the upgrade turns out to be worthwhile or

Electronics World is published monthly. By post, current issue £2.35, back issues (if available) £2.50. Orders, payments and general correspondence to **L333, Electronics World, Quadrant House, The Quadrant, Sutton, Surrey SM2 5AS**. Tlx:892984 REED BP G. Cheques should be made payable to Reed Business Information Ltd
Newstrade: Distributed by Marketforce (UK) Ltd, 247 Tottenham Court Road London W1P 0AU 0171 261-5108.

Subscriptions: Quadrant Subscription Services, Oakfield House Perrymount Road, Haywards Heath, Sussex RH16 3DH. Telephone 01444 445566. Please notify change of address. Subscription rates 1 year £32 UK 2 years £43.00 3 years £75.00. Surface mail 1 year £37.00 2 years £60.00 3 years £86.00 Air mail Europe/Eu 1 year £46.00 2 years £73.00 ROW 1 year £56.00 2 years £89.00



The notion that the new 56kbit/s modems represent an ISDN-killer is entirely false.

not really depends on take-up of the x2 protocol by Internet service providers. It remains to be seen whether they opt to support x2; currently K56Flex counts more companies – but not necessarily more market share – on its side.

Meanwhile, don't hold your breath waiting for either new standard to be ratified. In fact they may even be defeated on purely regulatory grounds. A report in the *Los Angeles Times* of 24th January suggests the 28.8kbit/s modem standard may well remain the norm for some while longer. The USA's regulatory body, the Federal Communications Commission, currently has a regulation that limits the amount of power used to send data through a telephone line – which could compromise the legality of faster modems.

The report argues that because newer, faster modems will require more power for data transmission than the existing rules allow, the FCC must grant a waiver before 56k modems can be released. Whichever viewpoint prevails, it is clear that asymmetrical 56kbit/s modems are an interesting way-station along the route to high-speed data transfer – but not the ultimate end-station. The notion that these new modems represent an ISDN-killer is entirely false.

Andrew Emmerson

Overseas advertising agents: France and Belgium: Pierre Mussard, 18-20 Place de la Madeleine, Paris 75008. United States of America: Ray Barnes, Reed Business Publishing Ltd, 475 Park Avenue South, 2nd Fl New York, NY 10016 Tel: (212) 679 8888 Fax: (212) 679 9455

USA mailing agents: Mercury Airfreight International Ltd Inc, 10(b) Englehard Ave, Avenel NJ 07001. 2nd class postage paid at Rahway NJ Postmaster. Send address changes to above.

Printed by BPPC Magazines (Carlisle) Ltd, Newtown Trading Estate Carlisle. Cumbria, CA2 7NR

Typeset by Marlin Imaging 2-4 Powerscott Road, Sidcup, Kent DA1 4 SDT.

© Reed Business Information Ltd 1997 ISSN 0959 8332

Europe too slow on ISDN technology

Hardy telecommunications network operators are delaying the potential of networked computing by their slow implementation of ISDN and successor digital subscriber line (xDSL) technologies.

That was the message coming from the chairman and CEO of Intel, Dr Andy Grove, at a London seminar recently. "Technically there's nothing on the way to move us to higher bandwidth better than ISDN," said Grove. However, except for

Germany, the implementation of ISDN is "very slow", he said.

Driving networked computing forward was the fact that up to 200m people across the world have PCs that can be connected to the communications networks. But hobbling its progress is the limitation of the network. "We need improving bandwidth and declining prices and neither trend is being served sufficiently," said Grove.

"The computer industry does its stuff in delivering increased

performance and reducing prices because it's a competitive and open industry", said Grove, "but the telecommunications industry has a government monopoly legacy which is not used to delivering its services in a competitive economy."

America is far in advance of Europe in using PCs for communications – 40m Americans have e-mail access, only 8m Europeans. A continuation of that gap could lead to a 'technology deficit' for Europe, said Grove.

However, he quoted a survey suggesting that the UK was far ahead of Continental Europe in plans to add Internet access to its business computers – 30 per cent of UK IT managers are intending to add it, compared to 12 per cent in Germany and only 6 per cent in France.

Grove reiterated Intel's commitment to keep its microprocessors compatible with all past software written for them. "Backwards compatibility is an immutable definer of our road map", said Grove, "it has been for fifteen years and it's going to be for a long, long time".

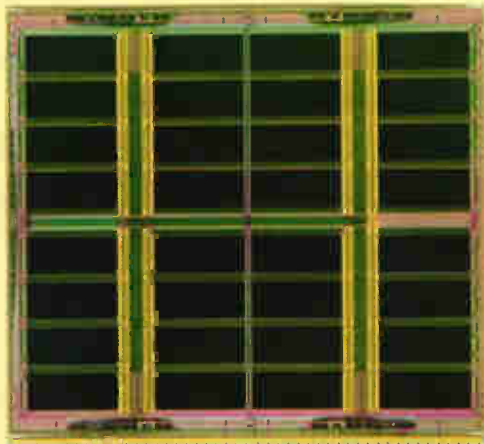

2Gbyte/s static ram holds 4Mbit

NEC has developed a 4Mbit, 500MHz static ram capable of a 2Gbyte/s data transfer rate. Designed for use as level two cache for microprocessors, the ram has a pipeline-burst architecture where data is transferred as a sequence of four, 32-bit words. The 12x11mm chip is fabricated in 0.25µm c-mos. Its current consumption is 270mA. An additional 40mA is needed to drive the 4cm path to the processor.

LSI's G11 process uses five metal layers. Layers one to three are 0.85µm wide, while four and five have twice the width.

New process delivers 0.18µm geometries

LSI Logic launched its latest semiconductor process for ASIC and c-mos devices this week. The G11 process uses transistors with

an effective gate length (Leff) of 0.18µm, or 0.25µm drawn.

G11 devices will be able to integrate over eight million logic gates and 8Mbytes of s-ram on the same die, says the company. This corresponds to dies containing 64m transistors. Three-transistor d-ram and mixed signal circuits are also available.

Logic gate count has increased by 60 per cent over the previous G10 process. Speed is up by a claimed 30 per cent while power dissipation is a quarter of G10's.

Ronnie Vasishta, marketing manager for G11, said: "We see market needs separated into three distinct areas." These are low power, battery applications such as mobile phones; the high

performance area including workstations and the 'balanced' market such as consumer goods.

LSI is providing two different libraries for G11: one for high performance, and the other tailored to high density and low power. The third market area would use a mixture of the libraries depending on a product's specific needs.

Initial G11 production is expected this year. Full production at LSI's 8in Gresham, Oregon fab is due in 1998.

LSI has joined a growing list of manufacturers offering 0.18µm devices. Texas Instruments and IBM have both announced a 0.18µm Leff process. NEC is believed to be waiting until March to release details of its process.



ANCHOR SUPPLIES Ltd

The Cattle Market Depot
Nottingham NG2 3GY. UK

Telephone: +44 (0115) 986 4902/
+44 (0115) 986 4041 24hr answerphone
Fax: +44 (0115) 986 4667



NEW LOWER PRICES

Micro Video Cameras

NEW LOWER PRICES

Following our recent Readers Offer for the 721-S Micro Camera many readers have contacted us asking about



other items in our range of Micro Cameras and Security Surveillance equipment.

We are SOLE AUTHORISED IMPORTERS of the entire range of Cameras and Video Surveillance equipment produced by the world's leading manufacturer. ALL items in the range carry a full 12 Months Guarantee.



If you would like to receive our comprehensive catalogue of Cameras and associated equipment please send a large SAE with 48p postage, marked "Camera Catalogue"

Here is a sample of the available stock.

- A-721-S Micro Camera 32mm x 32mm ... £85 A-721-P Micro PIN-HOLE Camera ... 32mm x 32mm ... £85
A-921-S Camera with AUDIO ... 30mm x 30mm ... £95
A-1211 C/CS Mount Camera ... 110mm x 60mm x 60mm ... £110
A-521 Micro Cased Camera 43mm x 48mm x 58mm ... metal cased ... £120
6001-A High Resolution COLOUR Cameras (420 lines) ... 0.45 lux ... £210
Outdoor Camera Housings ... Aluminium ... £35 Camera Mounting Brackets ... Universal Mounting ... £5.95
Camera Switchers ... for up to 8 Cameras ... £75

NEW MODEL Auto Record Controllers ... Infra Red Controller using "One For All" technology controls your STANDARD VHS Video, and allows you to make unattended recordings of intruders etc. Accepts Normally open or Normally Closed contact inputs. Self contained unit ... Turns your VHS recorder into a professional Security Recorder ONLY ... £85

QUAD-1 B/W Multivision Processor ... 4 pictures on one screen/video ... Including 4 channel switcher ... NOW ONLY £249

QUAD-2 COLOUR Multi Vision processor, REAL TIME ... including 4 channel switcher ... 4 Pictures on one screen/video ... NOW ONLY £575.

QUAD-3 COLOUR Multi Vision Processor. REAL TIME ... with On screen Titles and Time/Date information ... Including 4 channel switcher ... 4 Pictures on one screen/video ... NOW ONLY £695.

SCI ... SCANNER ... 350° PAN ... Automatic / Manual ... £105

IRI-1 Infra Red Illuminator ... 12V operation ... 60 degree illumination angle to 20m. For "Total Darkness Surveillance" ... NOW ONLY £85.

VMS-1 .. Video Motion Sensor ... replaced alarm sensors with totally electronic video monitoring system that detects changes in the video signal .. £175

C/CS Format lenses ... Premium 3.6mm = £22.50 Superior 8mm = £27.50

PLEASE NOTE:

SPECIAL OFFER

New and Boxed 14" COLOUR MONITORS...Models 1412 24V DC operation @ 2.2A..Twin Composite Video Inputs (75ohm BNC) Black steel case...Supplied with a pair of trailing leads for DC connections. Very easy to convert to 240V operation by adding a 240V / 24V supply either internally or externally. 30 Day Warranty.

NEW CONDITION

Circuit Diagram available...request at time of ordering

NOW ONLY £99.00 INCL VAT

Courier delivery to UK addresses = £12.25)

VHS Video Players...Front Loading VHS Decks..12V operation. Rear Panel 2.6mm DC socket for power. Play..FF..RW..Stop Controls with the addition of REPEAT facility which allows the tape to be rewound and replayed time and time again. Video / Audio Outputs via Phono Sockets

AS-NEW Condition..

NOW ONLY £50.00 INCL VAT

(Courier delivery to UK addresses = £8.75)

OPEN 6 DAYS A WEEK

Mon-Fri 9am-6pm Sat 8am-4pm

NO APPOINTMENTS NEEDED. CALLERS ALWAYS WELCOME
NATIONAL AND INTERNATIONAL MAIL ORDER A SPECIALITY

ALL PRICES INCLUDE VAT (AT 17.5%) and COURIER DELIVERY UNLESS OTHERWISE STATED



CIRCLE NO. 109 ON REPLY CARD

Sensor detects acceleration in 3D

The University of California, Berkeley and Sandia National laboratories have described their three-axis micromachined accelerometer that includes on-chip servo and signal conditioning circuitry.

Both Analog Devices and Motorola already produce single-axis devices and Analog's has on-chip circuitry, so what is remarkable about this design?

"Apart from sensing all three axes, not just one or two, our accelerometer is different because it has fully differential signal conditioning throughout," said Mark

Lemkin of Berkeley's team: "This increases its noise immunity to the point where a microprocessor could be placed on the same chip without disrupting the accelerometer's operation." The noise immunity requirement is bought into focus by the sensors output voltage of $7\mu\text{V/mg}$ (g is gravitational acceleration).

X and Y axes are sensed using two comb finger arrays similar to Analog's and Z-axis (out of the plane of the chip) measurements are made using a moving flat plate mass above a fixed plate. In this sense it is less sophisticated than Motorola's which has fixed plates above and below the moving mass, but simplifying the structure has allowed the use of a single polysilicon layer process. A capacitor with two fixed plates provides compensation.

Acceleration is measured by determining how much force is required to keep the moving masses in a fixed position relative to the substrate. The same capacitive electrodes are used both to sense the mass position and provide a restraining force. To separate the functions, the tasks are performed

sequentially, the inertia of the plate integrating the force pulses.

The control loops use noise shaping. Lemkin said: "This idea is not new, but noise shaping, using a $\Sigma\Delta$ loop, provides a direct digital output. This kind of loop can be difficult to stabilise and we have included forward path compensation using a discrete time FIR lead filter."

Sandia built the device using its buried micromachine technology where the micro-accelerometer is built in a trench on the wafer and covered with SiO_2 while the c-mos circuitry is fabricated.

James Smith of the Sandia team said: "The etch resist for the c-mos circuitry is spun out onto the wafer. Unless the wafer surface is completely flat, and micromachines are too high at around $6\mu\text{m}$, it does not flow to a consistent thickness. Unfortunately, the c-mos cannot be made first because it is damaged by the temperature needed to anneal the micromachine."

Annealing the machine first, then burying it, leaves a flat surface for c-mos fabrication and the SiO_2 is etched away at the end to uncover the machine and free its working parts.

Sticky problem with subscribers

Sincere apologies to UK subscribers who did not receive their cover mount gift of a pack of Resintech adhesive. At the eleventh hour, the Post Office decided that the cover mount was unsuitable to travel through the post. Apologies to Resintech too, who pulled out all the stops to manufacture the packs. Would any subscriber wishing to obtain their gift please write to Electronics World Glue Offer, Simmonds, 82-84 Peckham Rye, London SE15 4HB. Please include your name, address, subscriber number and telephone number if possible.

23GHz transistors promise to reduce phone costs

Philips Semiconductors has developed a way to make bipolar junction transistors (bjts) for the mobile phone market.

Operating at up to 23GHz, these fifth-generation silicon devices are claimed to be faster than the previous process. Being easier to make, they also promise to reduce the cost of the rf portion of cellular and cordless phones.

Wout Bijker, product marketing manager at Philips, said: "To enable the mobile phone market, handset manufacturers need to offer low cost, smaller and lighter phones."

Much of the recent research in mobile phones has focused on their shift to the higher 1.8 and 1.9GHz operating frequencies. Receiver and transmitter stages need

transistors for amplifiers working at these frequencies.

Gallium arsenide (GaAs) devices have the appropriate speed, low noise and power characteristics, but are expensive. Philips claims its bjts have the right gain, noise and power characteristics, and are cheaper than their GaAs counterparts.

Richard Ball, *Electronics Weekly*

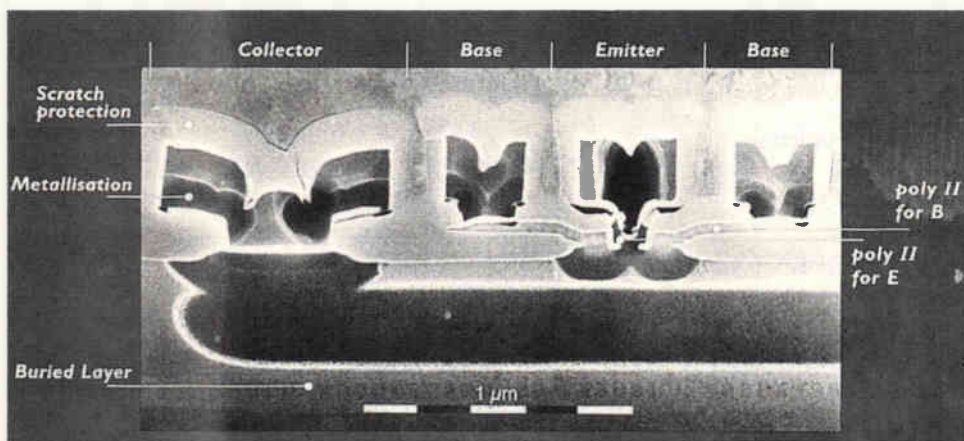

Mobile transistors... The double poly process has all connections to the top layer of metal. In older processes, the emitter and base were on one side of the substrate, the collector on the other. The active region of the device is grown epitaxially using chemical vapour deposition. Base and emitter connections are made via two layers of polysilicon. In the earlier process, the base metal lines and pad formed a capacitor with the collector on the opposite side of the substrate. Now the base-collector capacitance is reduced, speeding up the bjt.

Important Announcement



E II R

Due to policy changes at the **Ministry of Defence**, Miscellaneous Government Surplus will no longer be sold via open auctions. The Disposal Sales Agency has appointed **MGS (UK) Ltd** as agents to act on their behalf to market and sell Genuine Ministry of Defence Surplus equipment.

The categories include:

Canteen & Catering . . . Gymnasium . . . Photographic & Surveying
. . . Tools & Engineering (General) . . . Tools & Engineering
(Electrical) . . . Communications . . . Miscellaneous Electrical . . .
Household Electrical . . . Hi-Tech Electrical . . . Camping &
Survival . . . And Much Much More.

For anything from
Amplifiers, CCTV and Spectrum Analysers, through to Frequency
Counters, Oscilloscopes & Mainframes (the list is massive and
being constantly updated), customers can contact MGS (UK) Ltd
direct at:

MGS (UK) Ltd

TELEPHONE: (01530) 810000

The Oaks Industrial Estate,

FAX: (01530) 830730

Ravenstone Rd,

WEB: <http://www.MGS.ltd.uk>

COALVILLE,

e-mail: sales@mgs.ltd.uk

Leics. LE67 3NB

MGS (UK) Ltd Contractors To The Ministry Of Defence

CIRCLE NO. 110 ON REPLY CARD

Terabit memory chips produced using quantum wells

Single electron memories are frequently talked about among the storage literati, but Professor Hans Ludwig Hartnagel of the Technical Institute of Darmstadt, Germany points out a flaw in these devices: "The time taken to transfer, and therefore to read, an electron is non-deterministic, it cannot be predicted. It is like radioactive decay, it could happen after a picosecond or only after a whole second." The consequence, if Hartnagel is to be believed, is that a single electron per bit memory is not a practical proposition.

"The time distribution of a single-electron transfer event makes using Boolean logic impossible. Instead, some kind of statistical, fuzzy logic is required," said Hartnagel: "However, if a reasonable number of

electrons is transferred, say 100, the time distribution of electron transfers is statistically far more certain. The time of peak electron flow is almost entirely predictable."

His argument is, that single electron storage cells have to be surrounded by a statistical decision making logic, wasting their size advantage. Far more sensible, he claims, to use around 100 electrons and be sure that the bit exists and can be manipulated with certainty.

Hartnagel proposes a quantum well charge coupled approach analogous to that used in charge-coupled device (ccd) cameras.

His device uses quantum wells, made of GaAs, in a AlGaAs substrate. Electrons in the GaAs do not have enough energy to escape into

the AlGaAs, even with the additional thermal excitation that room temperature gives them. They are therefore trapped, or stored.

By placing a potential difference across two electrodes, one at each end of the cell, an energy gradient can be created to 'tip' the electrons into an adjacent cell. Once the gradient is removed the electrons are stored in the adjacent cell.

In his memory, the quantum wells are placed in a square matrix with X electrodes running in one direction between the cells and Y electrodes in the other.

While maintaining all other electrodes at a 'hold' potential, operating a pair of X electrodes tips a whole column of cells into their neighbours. Operating a pair of Y electrodes tips a whole row. By manipulating both X and Y electrodes, a single cell can be tipped into its diagonal neighbour. The plan is to use diagonal tipping to turn the whole matrix into a single serially-addressed storage cell chain.

Hartnagel has high hopes for quantum memories: "Conventional 1Gbit memories will be with us in two to three, perhaps five, years. Quantum terabit memories should around in 10."

His team has so far made larger cells transfer successfully and has modelled the 100 electron cells.

Steve Bush, *Electronics Weekly*

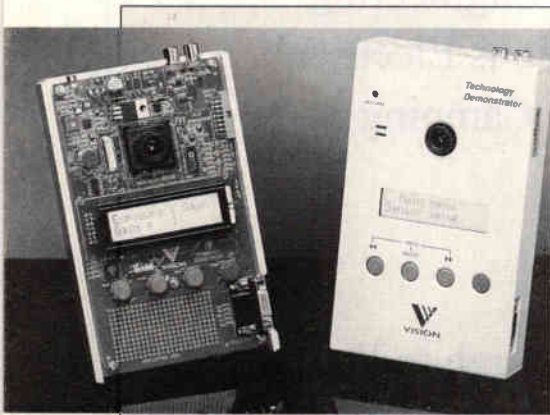

Smile please... Edinburgh camera-on-a-chip company, Vision, has developed a technology demonstrator based on its medium resolution 5400 monochrome image sensor. Potential customers can evaluate the sensors and use the design as a basis for their own systems. The unit includes the sensor, lens, a-to-d converter, audio circuit, microcontroller and RS232 port for pc connection. The mode of operation is controlled through panel buttons and the lcd. Vision's 5400 devices use a c-mos process to integrate the image sensor and processing circuitry on the same die. The 384 by 287 image can be output directly as an EIA or CCIR composite video signal.

Will network computers overtake pcs?

Half the UK's large companies believe that network computers (NCs) will replace pcs as the choice for corporate desktop computing within the next five years, according to City market analysts, Durlacher Multimedia.

Meanwhile, IT industry analyst Robin Bloor says that enthusiasm for the NC is

mounting in the UK. "The 'buy in' for this is very strong," he told *EW*, adding that "there are a number of beta sites where NCs are being used which have already noticed significant reductions in administration costs."

The Durlacher Intranet Report 1997, which is based on interviews with 100 IT

directors and managers from top 1000 UK companies, cites that corporate Intranets will help to drive the change to NCs.

But Bloor argues that the savings in PC software and hardware upgrade costs will be the key driver. "In the business environment you want the tools to do the job," he said. "The last thing you want is the tools to keep changing for you."

This claim is backed by BT, which was the first European company to deploy Sun Microsystems' JavaStation NC. Terry Carlin, head of systems at BT Customer Service said: "We believe that with NCs the support costs can be reduced quite considerably."

Bloor maintains that NCs will be the obvious choice for business in years to come, while PCs will be mainly used in the home. "The home pc market and the corporate market have been provided with the same product for years. It's wrong," he said.

Jon Mainwaring, *Electronics Weekly*

MGS wins MOD contract to supply surplus equipment

Distributor MGS (UK) Ltd has won a contract to trade Ministry of Defence surplus electronics equipment that has been traditionally been sold via auction and tender.

Part of the MOD's 'Partners in Enterprise' initiative, the contract is a new concept, giving MGS access to almost all surplus electronics equipment becoming available from the UK's most important military bases.

In the past, dealers in surplus equipment have been forced to bid at auctions. From March this year, they will be able to buy their requirements from MGS. This will make it possible for dealers to update their stocks as they deplete, rather than having to take their chances at auction.

According to MGS's Director, Tommy Hedges, "This means that surplus dealers, who have previously had to pay varying, and sometimes inflated, prices at auction can now buy from us at standardised prices - giving the customer a better deal. And because MGS will be holding large stocks in its warehouse, it will be easier for dealers to provide their customers with more continuity in product ranges."

NEW!

Electronics Workbench Version 5.0

Electronics Workbench Version 5 with analog, digital and mixed A/D SPICE simulation, a full suite of analyses and over 4,000 devices. Still the standard for power and ease of use. Now ten times faster. Still the same low price.

Join over 75,000 customers and find out why more engineers and hobbyists buy Electronics Workbench than any other SPICE simulator. You'll be working productively in 20 minutes, and creating better designs faster. We guarantee it!

£199

SAME GREAT PRICE!

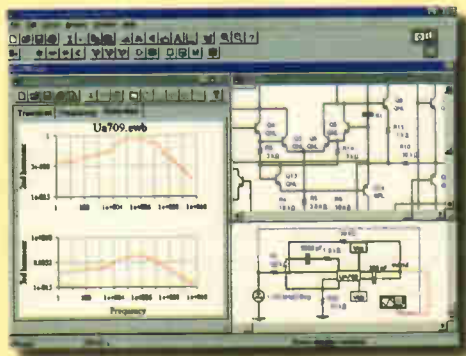

High-End Features

TRUE MIXED ANALOG/DIGITAL	YES
FULLY INTERACTIVE SIMULATION	YES
ANALOG ENGINE	SPICE 3F5, 32-BIT
DIGITAL ENGINE	NATIVE, 32-BIT
TEMPERATURE CONTROL	EACH DEVICE
PRO SCHEMATIC EDITOR	YES
HIERARCHICAL CIRCUITS	YES
VIRTUAL INSTRUMENTS	YES
ON-SCREEN GRAPHS	YES
ANALOG COMPONENTS	OVER 100
DIGITAL COMPONENTS	OVER 200
DEVICE MODELS	OVER 4,000
MONEY-BACK GUARANTEE	30-DAY
TECHNICAL SUPPORT	FREE

Powerful Analyses

DC OPERATING POINT	YES
AC FREQUENCY	YES
TRANSIENT	YES
FOURIER	YES
NOISE	YES
DISTORTION	YES

30-DAY MONEY-BACK GUARANTEE
VERSION 5.0 FOR WINDOWS 95/NT/3.1.

CIRCLE NO. 111 ON REPLY CARD

44 (0)1203 233 216

Fax: 44 (0)1203 233 210 E-mail: sales@rme.co.uk

FEATURES OF ELECTRONICS WORKBENCH VERSION 5 WHAT'S NEW

... (small text describing features) ...

GENERAL

... (small text describing general features) ...

COMPONENTS

... (small text describing components) ...

VIRTUAL TEST INSTRUMENTS

... (small text describing virtual test instruments) ...

... (small text describing virtual test instruments) ...

POWERFUL NEW VERSION!

Electronics Workbench[®]

VERSION 5

Exclusive Distributor

Robinson Marshall (Europe) Plc
Nadella Building, Progress Close, Leofric Business Park,
Coventry, UK CV3 2TF.

Shipping Charges UK £7.99. All prices are plus VAT. Electronics Workbench is a trademark of Interactive Image Technologies Ltd, Toronto, Canada. All other trademarks are the property of their respective owners.



RESEARCH NOTES

Jonathan Campbell

How too much Sun killed a satellite

Earlier this year, AT&T's Telestar 401 satellite suddenly stopped sending signals to Earth. Scientists are still not exactly sure why this happened, but they believe the event was just one effect of a massive solar storm. However the difference to previous odd events connected with solar activity is that this time researchers had in place a fleet of satellites that was able to observe the storm – the biggest ever documented – as it blew around the Earth.

In fact the storm is one of the best-documented space weather events ever. It began when, on 6 January, the Soho satellite took a picture of the Sun that showed the edge of a

huge eruption called a coronal mass ejection (cme). Four days later, the disturbance was recorded as it sped by another satellite, called Wind, that is designed to monitor the solar wind just up-stream from Earth. Then, hours later, the Polar satellite recorded the effects on energetic particles in Earth's radiation belts. Over the next several days, the intensity of the radiation belts increased more than 100 times over their previous levels.

The three satellites – Soho, Wind, and Polar are part of the International Solar-Terrestrial Physics program, a collaboration of NASA, the European Space Agency and the Japanese

Institute of Space and Aeronautical Science. From ground observatories, satellites, spacecraft and computer simulations and models, ISTP is building a comprehensive picture of Earth's magnetosphere and how it interacts with the sun.

"We compiled the most complete data available on conditions in the magnetosphere during the event," says Geoff Reeves, project leader for Polar's energetic particle instrument at Los Alamos National Laboratory.

"Combined with information from the other satellites, now we can better understand why and how these solar events sometimes produce big effects."

Could steel replace glass in flat panel displays?

Dramatic improvements in the durability and lightness of flat panel displays could be on the horizon following announcement of successful devices built on a steel foil substrate instead of glass. The development has been announced by two researchers at Princeton University, who have fabricated high-quality thin film transistors (tfts) on 200µm-thick stainless steel.

Rigorous mechanical stressing of the devices – including dropping

from a height of 16m onto a hard surface, and flexing the substrate in multiple orientations – are reported to have produced no change in the characteristics of the tft ('Amorphous silicon thin-film transistors on steel foil substrates', *IEEE Electron Device Letters*, Vol. 17, No 12, pp. 578-560).

The advantages of steel foil in terms of durability are pretty clear. But although stainless foil has been used in photovoltaic devices, its use as a substrate in display electronics has not been attempted before.

However, as the researchers point out, while the opacity of metal foils limits tft circuit applications to reflective or emissive displays, metal surfaces can be modified by coatings to achieve a wide range of optical properties. Moreover, the thermal coefficient of steel is a much better match to that of silicon. By adjusting the alloy, complete matching is possible.

This is a far more preferable situation than exists with the other great hope for more durable

devices – plastics. Thermal coefficients of polymers are around 20-50 times that of silicon, and there are several other engineering problems that have to be overcome before plastics can be seriously considered.

But the current research shows that stainless-steel substrates could be the breakthrough needed in the fabrication of non-breakable tft backplanes, and would greatly reduce the substrate thickness and weight in comparison to traditional glass substrates.

So far, though the devices have shown a relatively high quality, no attempt has been made by the Princeton engineers to optimise substrate or film parameters. This leads to optimism that the metal-foil alternative has the potential to offer a very robust process, easily transferable to industrial applications.

More information contact: SD Theiss, Department of Electrical Engineering, Princeton University, Princeton, NJ 08544, USA.

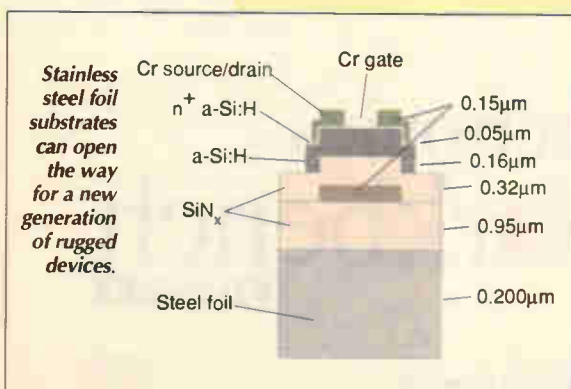

Coincidentally, at the time of the solar event scientists and satellite operators from across the country were meeting to discuss ways better to forecast the 'weather' in space that affects satellites.

Over phone lines, fax machines and the world wide web, scientists with space weather data frantically downloaded the information onto their laptops. The result is that researchers were able to build up a preliminary but remarkably complete picture of what happened on the sun. It showed how the disturbance travelled to Earth, what it did to the magnetosphere when it got here, "and how that might have killed a \$200 million satellite," adds Reeves.

More information contact: Gary Kliewer, Los Alamos National Laboratory, Los Alamos, New Mexico 87545, USA.

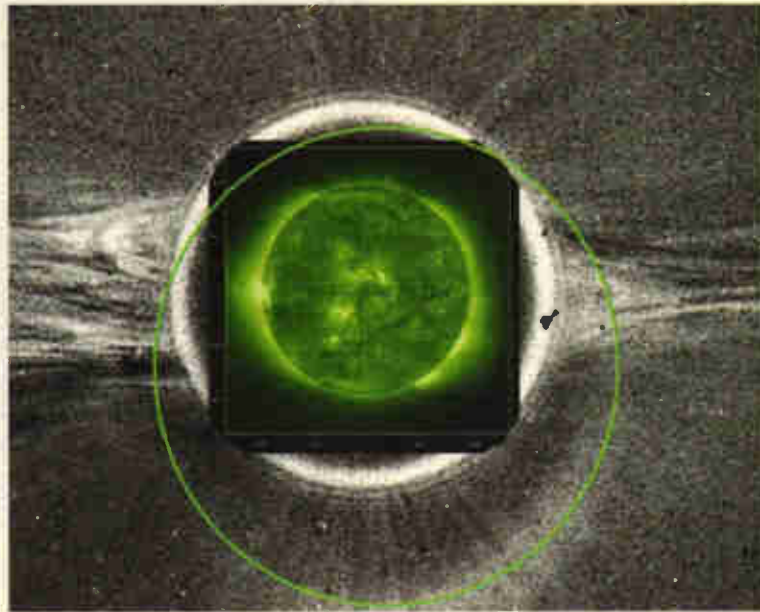

Start of the storm that killed a satellite: The cme, or coronal mass ejection, observed by the large angle spectrometric coronagraph aboard Soho, at the start of its journey Earth-wards at speeds between 400 and 500km/s. The image is a projection of the cme halo onto an extreme ultraviolet telescope image of the sun.

Putting the μ back into microphone

University of California engineers have produced an on-chip microphone that demonstrates greater sensitivity than any previous similar device and can also double as a loudspeaker. Key to design of the microfabricated device is a cantilever diaphragm that produces less residual stress than previous diaphragm microphones, while the relatively large deflections of the free end can produce a significant acoustic output ('Piezoelectric cantilever microphone and microspeaker,' SS Lee *et al*, *Journal of Microelectromechanical Systems*, Vol. 5 No 4, pp. 238-242).

Microphones are basically pressure sensors that detect airborne sound pressures that are ten orders of magnitude lower than ambient pressure. So the microphone needs an extremely compliant diaphragm to have an acceptable sensitivity.

This latest development reflects growing interest in the micromachining of microphones. Among the advantages of micromachining over conventional fabrication are improved control, extreme miniaturisation, the ability to integrate with on-chip circuitry, and potential low-cost as a result of batch processing.

The 2000 by 2000 by 4.5 μ m California cantilever diaphragm has a zinc-oxide piezoelectric thin film on a supporting layer of low-pressure chemical-vapour-deposited low stress silicon nitride. By controlling

distribution of residual stress, out-of-plane deflections were typically no more than 35 μ m.

Measured sensitivity of the microphone is around 3mV/ μ bar in the low frequency range, rising to 20mV/ μ bar at the lowest resonant frequency of 890Hz.

Using the device as a loudspeaker produced a sound pressure level (spl) of 75dB at 890Hz, increasing to approximately 100dB at 4.8kHz.

The researchers say that the technique used to manufacture a flat, multilayer cantilever, involving patterning different thicknesses of ZnO film, could also hold relevance to production of other micromachined structures.

More information contact: Seung Lee, Berkeley Sensor & Actuator Center, Department of Mechanical Engineering, University of California, Berkeley, CA 94720, USA.

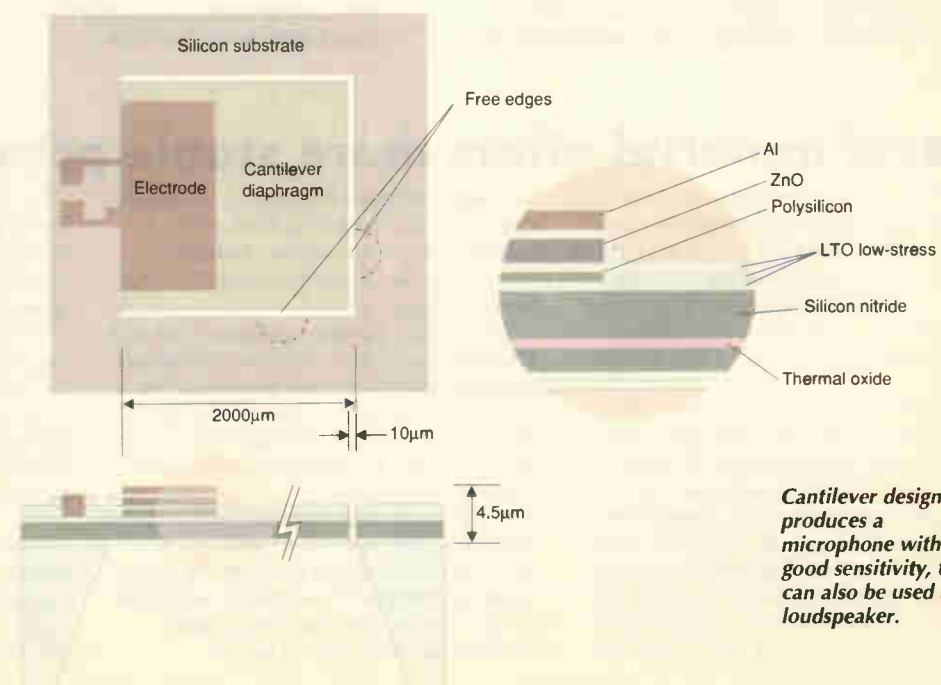

Cantilever design produces a microphone with very good sensitivity, that can also be used as loudspeaker.

New laser knocks atoms into line



The new atom laser emits pulses of coherent atoms. Each pulse contains 100,000 to several million coherent atoms and is accelerated downward by gravity. The curved shape of the pulses was caused by gravity and forces between the atoms. (Field of view 2.5 mm x 5.0 mm.)

Physicists at MIT have created the first atom laser, a device that resembles an optical laser but emits atoms instead of light. The atoms have the remarkable property of coherency – moving in phase to form a single giant matter wave – and the resulting beam can be focused to a pin-point or made to travel large distances with minimal spreading. Already, researchers are speculating how the laser might be used to deposit atoms onto computer chips, creating much finer patterns than currently possible.

The atom laser has been a long-sought goal in physics, but there were many doubts whether it could be realised. An important intermediate step towards its development was the creation of a Bose-Einstein condensate (bec). This was achieved by chilling a gas of atoms to such a low temperature that the atomic matter waves overlap, and the atoms lose their individual identities.

The MIT group cooled the gas in two stages. In the first stage, laser cooling, the atoms were bombarded with optical-laser light. Frequencies and polarisations of the laser beams were chosen in such a way that photons emitted by the gas atoms were slightly more energetic than photons absorbed by the atoms. The energy difference is responsible for the cooling effect. After absorbing and emitting about 100,000 photons, the atoms reached a temperature of about 100 microkelvin.

The atoms were then cooled using evaporative cooling. In this technique, the hottest atoms are



Michael Andrews, Marc-Oliver Mewes, and Wolfgang Ketterle gather around the machine they and their MIT collaborators used to demonstrate the first atom laser.

removed from the atomic sample, thus reducing the average energy – and therefore the temperature – of the remaining atoms. In addition to being cooled, the atoms also had to be very well insulated from the room-temperature environment. This was accomplished by confining the atoms in a special magnetic trap inside an ultra-high vacuum chamber.

Once the bec has been formed, the beam of Bose-condensed atoms is extracted from it by applying an oscillating magnetic field. In this way, the new laser emits multiple pulses of Bose-condensed droplets, each 'droplet' containing 100,000 to several million coherent atoms.

The last remaining obstacle was to demonstrate coherence. For this, the group applied a standard method used to show the wave nature of particles or radiation. In this technique, two samples are overlapped. If the photons or atoms in the separate samples are indeed coherent, each sample behaving as a giant wave, then the samples will interfere with each other, in the same way that happens when two waves meet in a pond. The result: a periodic pattern, or standing wave, that can be photographed.

To their jubilation – and after 20 hours of aligning and focusing their instruments – this is exactly what the MIT team found.

Novel material offers more stable pcbs

Zirconium tungstate, the wonder material that contracts instead of expands when heated, could be used in a composite form to produce circuit boards that expand at the same rate as the silicon devices it contains. This is just one of the many applications currently being considered for this peculiar material.

Since the discovery of zirconium tungstate's odd behaviour last year in the Center for Advanced Materials Research at Oregon State University, scientists have been rushing to find out more about it and to look for potential applications. So far, more than 40 private companies are said to have requested material samples from OSU, and Arthur Sleight, the Milton Harris Professor of Materials Science at the University says

that applications are now being considered across a whole range of technologies, including electronics, optics, fuel cells, oxygen sensors, thermostats, and even new dental filling products.

The negative thermal expansion, from near absolute zero to about 800°C of zirconium tungstate has never before been observed. It's now known to be caused by oxygen atoms in the material 'vibrating' when heated, pulling the zirconium and tungsten atoms closer together.

The latest reported advance that has caused surprise is its behaviour under pressure. At near 1000bar its crystal structure collapses, forming molecular 'cross braces' and losing much of the negative thermal expansion characteristic that makes it unique.

But when heated moderately, the material then regains its property of shrinking when heated, leading Sleight to suggest a possible use in some type of composite that could serve as a 'shock absorber.'

The material also offers unusually high oxygen mobility, suggesting possible uses in fuel cells or oxygen sensors.

As yet, all future applications are still on the experimental drawing board. But Sleight says he is "more optimistic than ever" about the potential for real world uses.

Contact: Arthur Sleight, Milton Harris Professor of Materials Science, Center for Advanced Materials Research, Oregon State University, Corvallis, Oregon, USA. Tel 00 1 541 737 6749.



For all your Power Distribution
Olson offer a varied choice

OLSON Distribution Units

OLSON ELECTRONICS LIMITED

OLSON DISTRIBUTION PANELS FUSED, WITH R.F. FILTER AND R.C.D. PROTECTION

OLSON ELECTRONICS LIMITED

OLSON The Rack Range

OLSON ELECTRONICS LIMITED

OLSON 'The Rack Range' mains distribution panels for 19" rack mounting

OLSON ELECTRONICS LIMITED

OLSON Office Furniture Cable Management
 Manufactured to BS 6396

OLSON ELECTRONICS LIMITED

OLSON Mains Distribution Panels with Non Standard Sockets

OLSON ELECTRONICS LIMITED

OLSON

OLSON ELECTRONICS LIMITED

OLSON Earth Leakage Distribution Units

PORTABLE UNIT Type PBL 3
 WALL MOUNTED UNIT Type BWS 2
 BENCH UNIT Type BBL 500

OLSON ELECTRONICS LIMITED

OLSON Distribution Units

OLSON ELECTRONICS LIMITED

OLSON PANELS with 10AMP CEE22/IEC SHUTTER SOCKETS
 FUSED DOUBLE PUSSED WITH BLANK FILTER AND RCD PROTECTION

OLSON ELECTRONICS LIMITED

OLSON

OLSON ELECTRONICS LIMITED

OLSON Mains Distribution Panels INTERNATIONAL RANGE

OLSON ELECTRONICS LIMITED

OLSON FUSED SUPER SLIM

OLSON ELECTRONICS LIMITED

OLSON DATA PROTECTOR

OLSON ELECTRONICS LIMITED

OLSON INDUSTRIAL RANGE
 16 AMP 110V AND 240V TO BS 4343/IEC 309

OLSON ELECTRONICS LIMITED

OLSON Distribution Units

OLSON ELECTRONICS LIMITED

OLSON 19" FAN TRAYS

OLSON ELECTRONICS LIMITED

OLSON The Rack Range

OLSON ELECTRONICS LIMITED

OLSON SERVICE PILLAR FOR THE OPEN-PLAN OFFICE

OLSON ELECTRONICS LIMITED

OLSON Distribution Units
 16 AMP 110V AND 240V

OLSON ELECTRONICS LIMITED

Building on his earlier fast driver amplifier work, **Giovanni Stochino** has now developed what is possibly the fastest high-power audio amplifier of its type. More impressively, he has done so without sacrificing audio purity.



Jemel Akib

300V/ μ s power

In my previous article¹ I described how the basic architecture of high-speed voltage feedback amplifiers can be applied to the design of high-performance audio-power equipment. Detailed design information for a non-slewing 100 watt into 8 Ω mosfet power amplifier was given. It featured a linear output speed of $\pm 170\text{V}/\mu\text{s}$ and its rated output power total harmonic distortion figures were 0.004% and 0.045% at 1kHz and 20kHz, respectively.

Subsequent investigations have shown that further evolution of the basic architecture can provide higher speed and better thd figures – comparable with top-class hi-fi amplifiers – relative to the basic configurations.

This article reports the results of my recent investigations and experiments and provides design details for a new low-distortion, very high speed 100W into 8 Ω audio power amplifier, which features a slew rate higher than $\pm 300\text{V}/\mu\text{s}$ and rated power thd figures of less than 0.002% and 0.020% at 1kHz and 20kHz, respectively.

Improved high-speed architectures

In my last article, I demonstrated that the thd and speed performances of the basic high speed voltage-feedback architectures appear to be influenced by the low, i.e. unity to two, current gain of the intermediate stage. This implies that a substantial improvement of both thd and speed figures can be obtained when a higher current gain class AB intermediate

stage is incorporated in the original schemes¹.

The problem here is that this change has to be done without degrading the other performances and, more importantly, the robustness of the basic design.

With this requirement in mind, my investigations have focused on the topologies shown in Figs 1 and 2.

The input stages are designed to provide class AB operation and the simultaneous availability of large push-pull currents, I_R and I_L , with the appropriate phase, at nodes A and B, Fig. 2. I have already shown² that this feature is very important to avoid the dangerous simultaneous conduction of the upper and lower half of the intermediate stage. During simultaneous conduction there is a risk of driving intermediate stage transistors out of the dynamic safe operating area.

Avoiding simultaneous conduction contributes to the robustness of the amplifier. It is particularly important in very fast high-power amplifiers, where the feedback loop forces the intermediate stage to provide high peak currents during large/fast input transients.

Another key feature of these schemes is the use of common-base transistors $Tr_{10,11}$. These play a twofold role:

- to allow the use of low voltage high current gain transistors Tr_9 and Tr_{12} , which increases the available gain and peak current of the intermediate stage;

- to improve amplifier linearity.

Relative to Fig. 2, the configuration of Fig. 1 potentially provides higher input stage large signal transconductance and less power consumption. As is well known, large signal transconductance in both schemes is determined mainly by cross coupling resistor R . However, while in Fig. 2 the value of R is mainly governed by the need to provide the level shifting voltage with reasonable power consumption, in Fig. 1 this limitation does not apply. As a result, R can be set as low as convenient.

Because of the above, Fig. 1 promises better speed and lower power consumption than Fig. 2, although at the expense of offset and noise precision and distortion performance. Differences in the two schemes are only in the input stage. Intermediate and output stages are exactly the same for both designs.

Compared with the simplified circuit diagram presented in my March '96 article, the clamping network at the output of the input stage in these designs shows one additional diode, which has been introduced to increase the intermediate stage peak output current to about 80mA. Accordingly, higher maximum output rates of change are to be expected. In order to produce comparable results, the two amplifiers are designed with as close as possible phase margins and unity gain frequencies under closed-loop conditions.

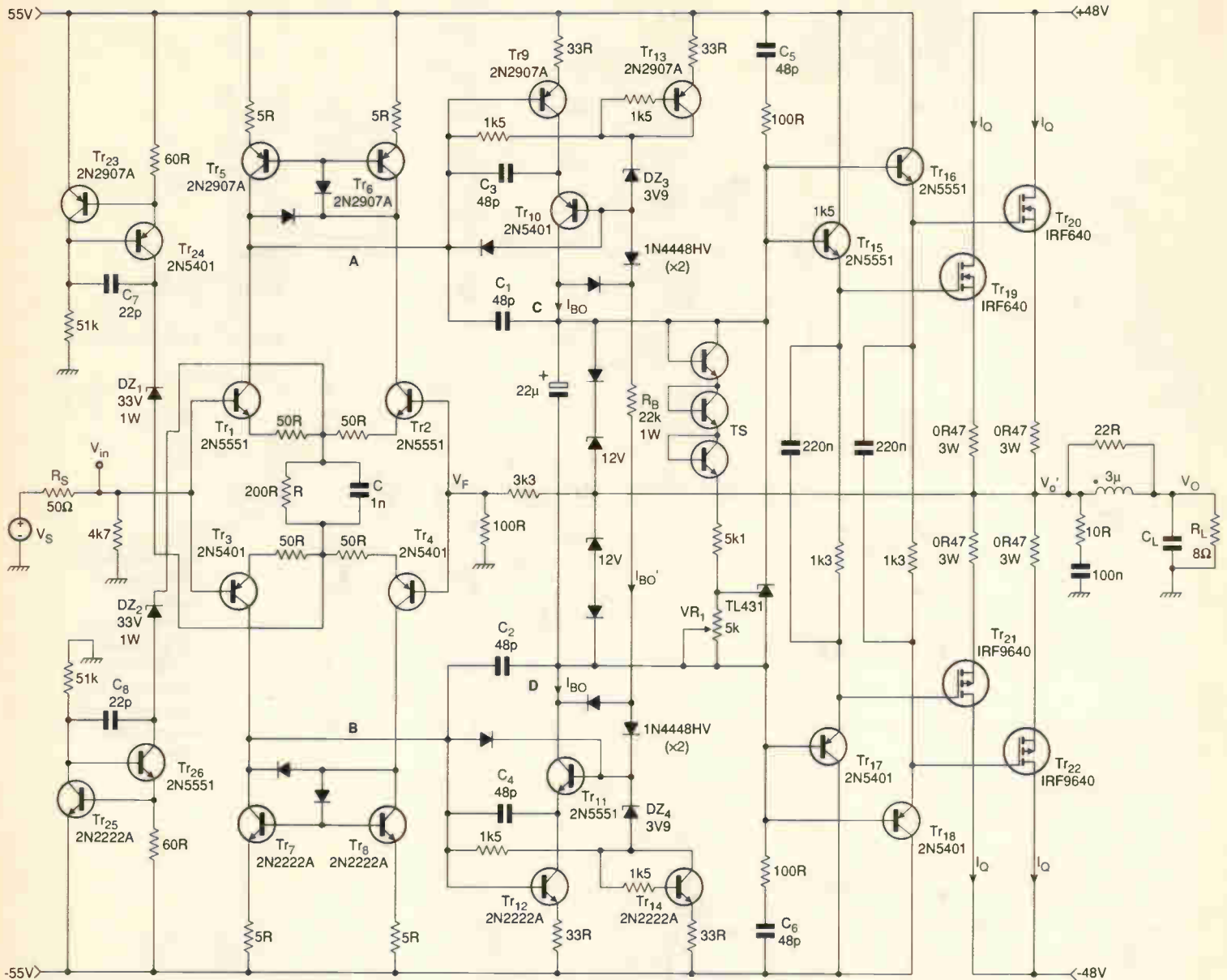

Fig. 3a). Detailed circuit diagram of the final 100W/8Ω audio-power amplifier, featuring a speed higher than ±300V/μs, and a rated power thd of 0.002% at 1kHz and 0.018% at 20kHz. Note that all diodes are 1N4448 Diodes 1N4448HV are 1N4448 selected for a reverse voltage higher than 120V. Add 100μF/100nF decoupling to each 55V rail and 1000μF/2×100nF to each 48V rail.

Some Spice simulation results are reported in Tables 1 and 2. Here, the main characteristics of the two new amplifier configurations are compared with the basic non-slewing architecture, with similar characteristics.

It is clear that the new implementations provide better speed and thd performances than the basic non-slewing architecture design, confirming the theoretical predictions.

Figure 1 and 2 have very similar closed-loop performances. However, due to the reduced

number of transistors in the input stage, Fig. 2 offers better open-loop performance, in terms of frequency response and phase margin, as well as less noise.

In the light of the above, Fig. 2 seems to represent the best candidate for the design of a high-performance audio power amplifier, although power consumption is higher due to the level shifting current needed to bias the input stage. Moreover, this topology can be expected to provide reduced sensitivity to layout and parasitics, as well as load impedance variations. Consequently it will simplify design and implementation.

Implementing the power amplifier

Design has been optimised through intensive simulation work and verification tests on the experimental prototype. Measurements have substantially confirmed simulation results.

Discrepancies only occur when simulation data are close to or below the limits of available test equipment, the readings from which include noise, as well as thd. This is the case

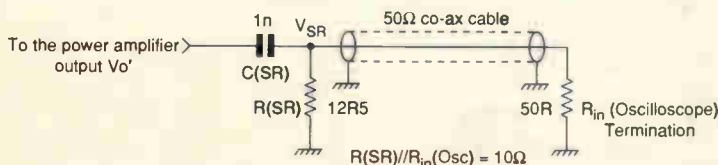

Fig. 3b). Slew rate test circuit from D. Self³. Component values and circuit have been adapted to high-speed measurement. Slew rate, SR, can be determined by the following; $SR = V_{SR(max)} / (C_{SR} R_P) = 100 \times V_{SR(max)}$ in V/μs, where $R_P = R_{(SR)} / R_{IN(OSC)} = 10\Omega$. Oscilloscope bandwidth is higher than 200MHz.

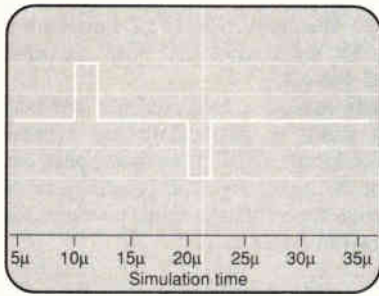

Fig. 4. Input stimulus type used for verifying the amplifier's speed, during simulation and experiments. Vertical scale is 3V/div. Maximum speed measurements were made using both standard and Self methods.

for thd at 1kHz. The differences at 20kHz can be explained by layout problems in the experimental prototype and/or by the influence of component mismatches.

Final design

Figure 3a shows the complete circuit diagram of the final low thd, high speed 100W, 8Ω audio power amplifier.

Compared with Fig. 2, extra capacitors C₃ to C₈ are introduced in the assembled prototype. These components compensate for layout parasitics and achieve a clean step response in all operating conditions, Figs 4, 5 and 6.

The diode clamping network on the collectors of the input stage transistor has been simplified. Two diodes connected to zener diodes DZ₃ and DZ₄ perform the same task of the original circuit. Here, positive and negative peak currents of the intermediate stage are slightly higher and symmetrical than in Fig. 2.

The biasing network of the intermediate stage is made from Tr₁₃, Tr₁₄, DZ₃ and DZ₄, in addition to current setting resistor R_E. Nominal bias current, given by,

$$I_{BO} \approx I_{BO'} = (V_{CC} + V_{EE} - 2V_Z - 4V_{BE(on)}) / R_B$$

and is about 6mA.

Bias setting and stabilisation of output power mosfets is achieved by means of the TL431 shunt regulator and temperature sensing network TS in Fig. 3a. This network con-

Table 1. Characteristics of Fig. 1 and Fig. 2 fast audio-power amplifiers. Test conditions are I_Q=120mA, R_s=50, Load=8Ω//0.5µF.

Characteristic	Basic nsa ¹	Fig. 1	Fig. 2
Best input offset voltage ²	350µV	180µV	170µV
DC gain, open loop	80dB	110dB	111dB
Unity-gain frequency	22.5MHz	19MHz	22MHz
Open-loop gain at 20kHz	64.5dB	67dB	68dB
Open-loop amplifier phase margin ³	-81°	-127°	-93°
Closed-loop amplifier phase margin ⁴	+82°	+79°	+76°
Slew rate, 10V pp square wave input	±160V/µs	±210V/µs	±185V/µs
Output noise, bandwidth 80kHz	34µV rms	50µV rms	31µV rms

Table 2. THD of amplifiers in Fig 1 and Fig 2 with same test conditions as Table 1.

V _{out} (Vpp)	Basic nsa ¹ design		Fig. 1		Fig. 2	
	1kHz	20kHz	1kHz	20kHz	1kHz	20kHz
20	0.0018 %	0.0240%	0.0008 %	0.0140%	0.0006%	0.012 0 %
80	0.0090 %	0.0380%	0.0005%	0.0100%	0.0004%	0.0080 %

Notes

1. Non-slewing amplifier
2. In the simulation phase, devices and components have been considered perfectly matched.
3. Amplifier only, i.e. without the feedback network.
4. Amplifier plus feedback network. Closed loop gain is 30.6dB.

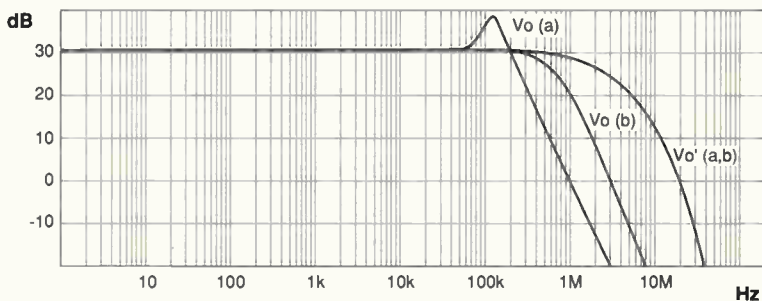

Fig. 5. Simulated frequency response - i.e. magnitude - of the power amplifier in Fig. 3. Test conditions are V_o(a) load=8Ω//0.5µF, V_o(b) load=8Ω//0.05µF, vertical scale is 10dB/div and frequency range is 1Hz to 100MHz.

sists of three diode-connected 2N5551s and is mounted very close to the output mosfets on the same heatsink to provide thermal coupling.

This scheme provides a stable working point for the temperature sensor TS, which is insensitive to I_{BO} variations. This is because current I_{TS} is kept constant by the TL431's 2.5V internal reference, through the relationship

$$I_{TS} = V_{ref} / R(T_1)$$

Since, as is well known, each transistor provides a ΔV_{be}/ΔT of about -2 mV/°C, TS yields a total ΔV_{TS}/ΔT of -6 mV/°C. This has been found adequate to compensate for the intrinsic I_Q changes with temperature of power devices.

Bias current I_Q of each mosfet is set at 120mA via trimmer VR₁, after a reasonable

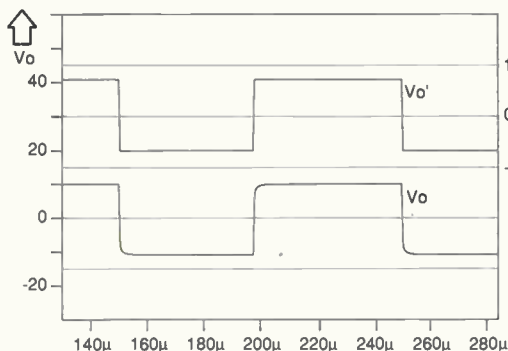

Fig. 6a). Simulated voltage step response of the power amplifier in Fig. 3. Test conditions are V_{o'}=20V peak-peak, load=8Ω//0.005µF, vertical scale is 15V/div and frequency is 10kHz.

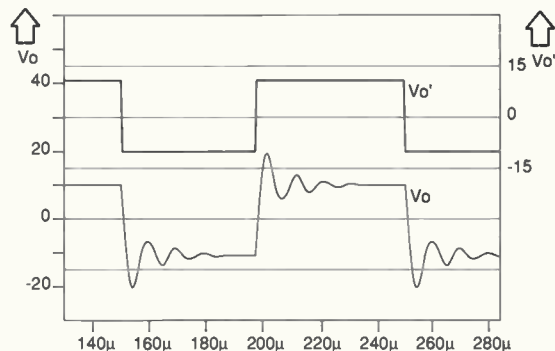

Fig. 6b). Simulated voltage step response of the power amplifier in Fig. 3. Test conditions in this case are the same as for 6a), except for the load, which is 8Ω//0.5µF.

amplifier warm-up time. Make sure to set this trimmer to its highest value before applying power to the amplifier. Measured I_Q variations during operation are less than 20%.

Supplying power

To increase the amplifier's efficiency, separate unregulated $\pm 48V$ supply rails are used for the output power devices, which are IRF640 and IRF9640 types from International Rectifier. The rest of the amplifier is powered by two regulated +55 and -55 V supply rails.

Tables 3 and 4 demonstrate the notable improvement of harmonic distortion figures. At 1kHz, measured thd is mainly limited by the available instrumentation, as illustrated by the fact that it remains virtually unchanged when load impedance reduces to 4 Ω .

The maximum rate of change of the output voltage results in excess of 300V/ μ s, confirming that the new architecture is viable for reliable high-speed power amplification. Measurements of slew-rate were made both in the traditional way, and in accordance with the practical method suggested by Douglas Self,³ with appropriate adaptations.

The test circuit is shown in Fig. 3b. Assuming $V_O \gg V_{SR}$, the maximum rate of change SR is determined by,

$$SR \approx \frac{V_{SR(max)}}{C_{SR} R_p} = 100 \times V_{SR(max)} \text{ V}/\mu\text{s}$$

where $R_p = R_{SR} // R_{IN(osc)} = 10\Omega$.

To the best of my knowledge, this speed is the highest ever reported for a high power audio amplifier, which makes use of voltage-feedback.

The theory behind the speed performance of this architecture can be basically explained as follows. The maximum current available at

nodes A and B depends on the maximum input voltage, V_{max} , which can be safely applied to the input of the amplifier. This is given by equation 4 of my March '96 article,

$$I_{A(max)} = \frac{V_{(max)} - 2V_{be(on)}}{2R_c + R} = \frac{V_{EBO} - V_{be(on)}}{2R_c + R}$$

This current amounts to about 18mA for the component value and active device types used in Fig. 3a.

Since capacitance at nodes A and B in Fig. 3a is about 50pF, the maximum slew rate across C_1 and C_2 is $SR_{A,B} = 360V/\mu$ s. Capacitors C_3 and C_4 do not play a major role in this context because the voltage variation across them is limited to a few volts.

On the other hand, the current available at the output of the intermediate stage, nodes C and D, is about 80mA. Total node capacitance, including the reflected capacitance of the output power devices, is less than 230pF. Slew rate at the input of the output stage will therefore exceed $SR_{C,D(min)} = 350V/\mu$ s.

Bias current considerations

It is worth pointing out that this high value of slew rate can be sustained by the amplifier only if biasing current I_{BO} is large enough to charge/discharge at the same rate the base-collector capacitances C_{bc} of Tr_{10} and Tr_{11} , which equal 5-8 pF. This means that $I_{BO} \geq SR_{CD(min)} C_{bc}$ has to be set at 2.8mA.

A safety margin is recommended for taking into account parasitics and base drive requirements, which equals,

$$I_{B(peak)} / \beta_{(min)} = 80mA / 30 = 2.7 \text{ mA.}$$

The minimum output slew rate $SR_{(min)}$ will be slightly less than $SR_{CD(min)}$, due to the gate driving requirements of the output power

devices. The above theoretical values are in line with simulation, and with measured results, Table 4.

In this design, a 1nF capacitor has been added across R to increase the dynamic transconductance and the available peak current of the input stage corresponding to the maximum expected input signal transients, say 3V peak. In such a case,

$$I_{A(peak)} = \frac{V_{in(peak)} - 2V_{be(on)}}{2R_c} \leq 18mA$$

This results in a slight increase of speed for input signals within the linear dynamic range of the amplifier and in a further reduction of the already low residue of dynamic intermodulation distortion.

Cross-coupling capacitor C needs to be treated very carefully. In fact input transistors Tr_1 to Tr_4 , under large signal conditions, behave like a full wave rectifier of the voltage difference $V_{IN} - V_F$. Current flowing in C is thus unidirectional. This results in a dynamic charge build-up across C, which is particularly important at high frequencies and during transients, when $V_{IN} - V_F$ is usually larger.

The charge build-up could end by producing undesirable bias and gain modulation of the input stage, and, consequently, increased high frequency thd and intermodulation distortion. This effect is also evident from the fact that while C can truly help to boost the linear speed of the amplifier during occasional transients, it does not produce the corresponding improvement of the linear power bandwidth and of the dynamic intermodulation distortion.

Minimising charge build-up

In order to minimise the above side effects, a low value of capacitance should be chosen. Definition of the right value of C is not an easy task, since its influence on the circuit performance is both amplitude and frequency dependent. The following rule of thumb has proved effective in many applications,

$$C \leq \frac{1}{10(2\pi R F_M)}$$

where F_M is the maximum input frequency, which is 20kHz for audio applications. This implies that the zero introduced by R/C in the large signal frequency response of the amplifier has to be located far above the audio frequency range. According to the above empirical inequality, C should be lower than 3.9nF. As a matter of fact, the value employed in this design, 1nF, has not produced measurable effects on thd performance. ■

References

1. Stochino, G., "Non-slewing Audio Power Amplifier", *Electronics World*, March 1996, pp. 256-259.
2. Stochino, G., "Ultra-fast Amplifier", *EW*, October 1995, pp.835-841.
3. Self, D., "High Speed Audio Power", *EW+WW*, September 1994, pp.760-764.

Table 3. Total harmonic distortion of final amplifier in Fig. 3a, with $R_s=50\Omega$, $I_Q=120mA$ and 80kHz bandwidth.

V_{out} (V _{pp})	Spice simulation		Measured 8 Ω load*		Measured 4 Ω load*	
	8 Ω load	20kHz	1kHz	20kHz	1kHz	20kHz
5	0.00010%	0.0040%	0.0031%	0.005%	0.0035%	0.007%
10	0.00025%	0.0140%	0.0024%	0.008%	0.0029%	0.010%
20	0.00070%	0.0190%	0.0020%	0.011%	0.0023%	0.013%
40	0.00060%	0.0145%	0.0023%	0.015%	0.0023%	0.018%
80	0.00060%	0.0110%	0.0021%	0.018%	0.0023%	0.026%

*Instrumentation limit, thd+noise): 0.002% at 1kHz; 0.003% at 20kHz.

Table 4. Further characteristics of Fig. 3a amplifier, $R_s=50\Omega$, load=8 Ω , $I_Q=120mA$

Characteristic	Spice simulation	Measurement results
Input offset voltage	1.6 mV
Slew rate†, C=0pF	+336/-297V/ μ s	+310/-360V/ μ s
Slew rate†, C=1nF	+360/-304V/ μ s	+360/-370V/ μ s
Output noise, bw=80kHz	31 μ V (rms)	39 μ V (rms)

† $\pm 6V$ peak pulse input, as in Fig. 4.

Transform your PC

into a digital oscilloscope, spectrum analyser, frequency meter, voltmeter, data logger .. for as little as £49.00

Pico Technology specialises only in the development of PC based data acquisition instrumentation. **Call for your guide on 'Virtual Instrumentation'.**

The ADC-10 supplied with PicoScope gives your computer a single channel of analog input.

ADC-10 £49 with PicoLog £59

Virtual Instrumentation

Pico's PC based oscilloscopes simply plug into the parallel port turning your PC into a fully featured oscilloscope, spectrum analyser and meter. Windows and DOS software supplied.

ADC-100 Dual Channel 12 bit resolution

The ADC-100 offers both a high sampling rate 100kHz and a high resolution. Flexible input ranges ($\pm 50\text{mV}$ to $\pm 20\text{V}$) make the unit ideal for audio, automotive and education use.

ADC-100 £199 ADC-100 with PicoLog £219

ADC-200 Digital Storage Oscilloscope

- 50 MSPS Dual Channel Digital Storage Scope
- 25 MHz Spectrum Analyser
- Windows or DOS environment
- $\pm 50\text{mV}$ to $\pm 20\text{V}$
- Multimeter
- 20 MSPS also available

ADC 200-20 £359.00

ADC 200-50 £499.00

Both units are supplied with cables, power supply & manuals.



Data Logging

Pico's range of PC based data logging products enable you to easily measure, display and record temperature, pressure and voltage signals.

TC-08 Thermocouple to PC Converter

- Supplied with PicoLog software for advanced temperature processing, min/max detection and alarm.
- 8 Thermocouple inputs
- No power supply required.

TC-08 £199

TC-08 £224 with cal. Cert.

complete with serial cable & adaptor. Thermocouple probes available.



Call for free demo disk and product range catalogue

Post & Packing UK £3.50, Export customers add £9 for carriage & insurance.

Pico Technology Ltd. Broadway House, 149-151 St Neets Rd, Hardwick, Cambridge. CB3 7QJ UK
Tel: + 44 (0)1954 211716 Fax: + 44 (0)1954 211880 E-mail: post@picotech.co.uk Web: http://www.picotech.co.uk/

Phone or FAX for sales, ordering information, data sheets, technical support. All prices exclusive of VAT

CIRCLE NO. 113 ON REPLY CARD

Halcyon Electronics Off-Air Frequency Products



We manufacture a range of Off-Air Frequency products including frequency standards, sources and disciplined standards including GPS. Customised units also available

Precision Frequency Source

1kHz to 16MHz sinewave output, 0.0001Hz resolution,
Easily settable via decade switches,
VCXO backup as standard

Off-Air Frequency Standard

1MHz, 5MHz and 10MHz, outputs,
Options include Sinewave, Signal inhibit and Audio Warning

CIRCLE NO. 114 ON REPLY CARD

We are well known for our quality new and used test equipment. Our list is extensive, ranging through most disciplines. Call for details

CIRCLE NO. 115 ON REPLY CARD

Halcyon Electronics

423 Kingston Road, Wimbledon Chase, London SW20 8JR
Phone: 0181 542 6381 Fax: 0181 542 0340

CIRCLE NO. 116 ON REPLY CARD



CHELMER VALVE COMPANY

*If you need Valves/Tubes or RF Power
Transistors e.t.c. ... then try us!*

We have vast stocks, widespread sources and 33 years specialist experience in meeting our customers requirements.

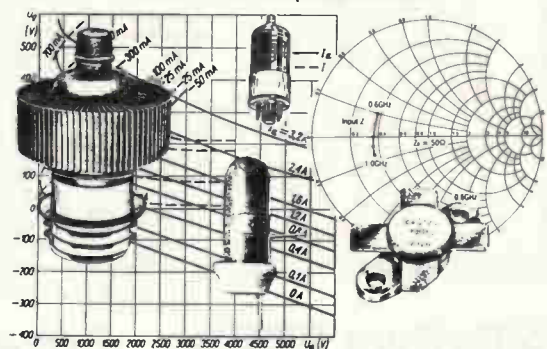

Tuned to the needs of the Professional User

Chelmer Valve Company, 130 New London Road,
Chelmsford, Essex CM2 0RG, England

☎ 44-01245-355296/265865

Fax: 44-01245-490064

CIRCLE NO. 116 ON REPLY CARD

CHART AUDIO LEVELS

In-vision colour display or hard copy printout

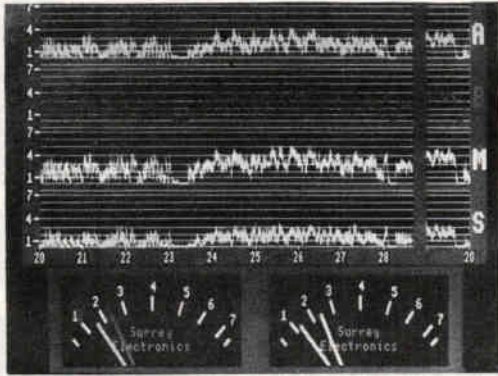

PPM10 In-Vision PPM and Chart Recorder generates a display emulating the well known coaxial TWIN movements for monitoring stereo audio levels and mono compatibility. Also: STEREO TWIN METER BOX comprising PPM9 board, featuring inherent stability with law under microprocessor control. A free standing mains powered box frequently used for final stereo monitoring when working to broadcast standards. Manufactured under licence from the BBC.



★ Advanced Active Aerial 4kHz-30MHz ★ Stabilizer frequency shift units for howl reduction ★ 10 Outlet Distribution Amplifier ★ Stereo Variable Emphasis Limiter ★ PPM9, PPM5 hybrid and PPM8 IEC/DIN -50/+6dB drives and movements ★ Broadcast Stereo Coders ★ Broadcast Monitor Receiver 150kHz-30MHz ★

SURREY ELECTRONICS LTD
The Forge, Lucks Green, Cranleigh
Surrey GU6 7BG
Telephone: 01483 275997 Fax: 276477

New Special Offers

New mini waterproof TV camera 40x40x15mm requires 10 to 20 volts at 120mA with composite video output (to feed into a video or a TV with a SCART plug) it has a high resolution of 450 TV lines Vertical and 380 TV lines horizontal, electronic auto iris for nearly dark (1 LUX) to bright sunlight operation and a pinhole lens with a 92 degree field of view, it focuses down to a few CM. It is fitted with a 5 wire lead (12v in gnd and video out)..... £95.57 + VAT = £109.95 or 10 + £89.32 + VAT = £104.95	Used 8748 Microcontroller.....£3.50
High quality stepping motor kits (all including stepping motors) 'Comstep' independent control of 2 stepping motors by PC (Via the parallel port) with 2 motors and software..... Kit £67.60 Ready built £99.00	SL952 UHF Limiting amplifier LC 16 surface mounting package with data sheet.....£1.95
Software support and 4 digital inputs kit.....£27.00	DC-DC converter Reliability motor V112PS 12v in 5v 200ma out 500v input to output isolation with data..... £4.95 each or pack of 10 £39.50
Power interface 4A kit.....£36.00	Hour counter used 7 digit 240v AC 50Hz.....£1.45
Stepper kit 4 (manual control) includes 200 step stepping motor and control circuit.....£23.00	QW ERY keyboard 58 key good quality switches new.....£6.00
Hand held transistor analyser it tells you which lead is the base, the collector and emitter and if it is NPN or PNP of faulty.....£33.45	Airpax AB2903-C large stepping motor 14v 7.5' step 27ohm 68mm dia body 6.3mm shaft.....£8.95
spare 6v battery.....£1.20	or £200.00 for a box of 50
LEDs 3mm or 5mm red or green... 7p each yellow 11p each cable ties 1p each £5.95 per 1000, £49.50 per 10,000	Polyester capacitors box type 22.5mm lead pitch 0.9uF 250vdc..... 18p each
Rechargeable Batteries	14p...100+ 9p...1000+..... 20p each
AA (HP7) 500mAH.....£0.99	13p...100+ 10p...1000+..... 15p each
AA 700mAH.....£1.75	1uf 50v bipolar electrolytic axial leads..... 7.5p 1000+ 15p each
C2AH with solder tags.....£3.60	0.22uf 250v polyester axial leads..... 7.5p 100+ 15p 100+
D 4AH with solder tags.....£4.95	Polypropylene 1uf 400vdc (Wima MKP10) 27.5mm pitch 32x29x17mm case..... 7.5p each 60p 100+
1/2AA with solder tags.....£1.55	27.5mm pitch 32x29x17mm case..... 7.5p each 60p 100+
AAA (HP16) 180mAH.....£1.75	Philips 128 series solid aluminium axial leads - 33uf 10v & 2.2uf 40v..... 40p each 25p 100+
Standard charger charges 4 AA cells in 5 hours or 4Cs or Ds in 12-14 hours + 1xPP3 (1, 2, 3 or 4 cells may be charged at a time).....£5.95	Philips 108 series long life 22uf 83v axial..... 25p 100+ 30p each
High power charger as above but charges the Cs and Ds in 5 hours. AAs, Cs and Ds must be charged in 2s or 4s.....£10.95	Multilayer AVX ceramic capacitors all 5mm pitch 100v 100pf, 150pf, 220pf, 10,000pf (10n)..... 10p each 5p...100+ 3.5p...1000+ 500pf compression trimmer..... £5.95 or £49.50 for 10
Nickel Metal Hydride AA cells high capacity with no memory, if charged at 100ma and discharged at 250ma or less 1100mAH capacity (lower capacity for high discharge rates).....£3.75	40 uf 370vac motor start capacitor (dialectro type containing no pcbs)..... £5.95 or £49.50 for 10
Special offers, please check for availability.	Solid carbon resistors very low inductance ideal for RF circuits - 27ohm 2W, 68ohm 2W..... 25p each 100+
Stick of 4 42x18mm Nicad batteries 171x16mm dia with red & black leads 4.8v.....£5.95	We have a range of 0.25w, 0.5w, 1w and 2w solid carbon resistors, please send 5A£ for list.
5 button cell 6V 280mAH battery with wires (Varta 5x250DK).....£2.45	P.C. 400W PSU (inter part 201035-001) with standard motherboard and 5 disk drive connectors, fan and mains inlet/outlet connectors on back and switch on the side (top for tower case) dims 212x149x145mm excluding switch.....£85.00 each
Shaded pole motor 240V ac 50mm x 20mm shaft.....£4.95 each	MX180 Digital multimeter 17 ranges 1000vdc 750vac 200mhz 200mA transistor Hfe 9v and 1.5v battery test..... £9.95
115v AC 80v DC motor 4x22mm shaft 50mm dia x 60 long body (excluding the shaft) it has a replaceable thermal fuse and brushes.....£3.95 (100+)	AMD 27256-3 Eproms..... £2.00 each £1.25 100+ DIP switch 3PCU 12 pin (ERG SDC-3-029)..... 60p each
7 segment common anode led display 12mm.....£0.45	Disk drive boxes for 5.25 disk drive with room for a power supply, light grey plastic, 67x268x247mm..... £7.95 or £49.50 for 10
LM337K TO3 case variable regulator.....£1.95	Hand held ultrasonic remote control.....£3.95
GAAs FET low leakage current S887S..... £1.44 100+ £1.95 each	CV2486 gas relay, 30x10mm dia with 5 wire terminals, will also work as a neon light..... 20p each
B5250 P channel mosfet..... £0.45	Verbatim R300NH Streamer tape commonly used on nc machines and printing presses etc. it looks like a normal cassette with a slot cut out of the top..... £4.95 ea. £3.75 100+
BC359 transistor..... £3.95 per 100	HVS-2405-E5 5.24v 50mA regulator ic 18-264vac input 8 pin DIL package..... £3.49 each (100 + £2.25)
BC347A transistor..... 20 for £1.00	LM 555 timer ic 16p..... 8 pin DIL socket 6p
74LS05 hex inverter..... £10.00 per 100	

All products advertised are new and unused unless otherwise stated. Wide range of CMOS TTL 74HC 74F Linear Transistors kits. Rechargeable batteries, capacitors, tools etc always in stock. Please add £1.95 towards p&p. VAT included in all prices.

JPG Electronics, 276-278 Chatsworth Road, Chesterfield S40 2BH
Access/Visa Orders (01246) 211202 Fax: 550959
callers welcome 9.30am to 5.30pm Monday to Saturday

CIRCLE NO. 117 ON REPLY CARD

EASY-PC Schematic and PCB CAD

From Super Schematics

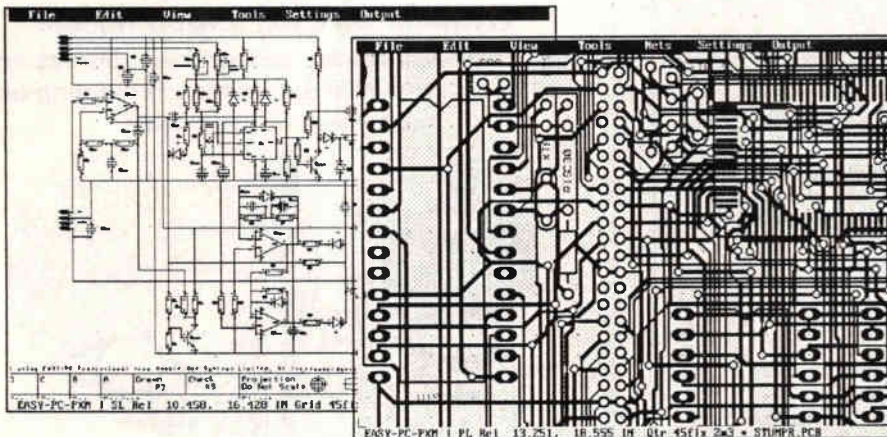

- Runs on:- PC/ 386/ 486 with VGA display
- Links to PULSAR (logic), ANALYSER III (analogue) & LAYAN (electromagnetic) simulators (Pro' versions)
- Design:- Single sided, Double sided and Multi-layer boards.
- Provides full Surface Mount support.
- Standard output includes Dot Matrix / Laser / Ink-jet Printer, Pen Plotter, Photo-plotter and N.C. Drill.
- Optional, powerful, 32 bit, Multi-pass, Shape based, Shove Aside, Rip-up and Re-try Autorouter (XM only).

To Perfect PCB's Prices From £75/\$135
Number One Systems

Please contact us for a demonstration disc and full information

UK/EEC: Ref: WW, Harding Way, St.Ives, Cambridgeshire, ENGLAND, PE17 4WR. e-mail: sales@numberone.com
Telephone UK: 01480 461778 (7 lines) Fax: 01480 494042 International +44 1480 461778
USA: Ref: WW, 126 Smith Creek Drive, Los Gatos, CA 95030
Telephone/Fax: (408) 395-0249

http://www.numberone.com



adifpro2

CIRCLE NO. 118 ON REPLY CARD

To successfully re-use alkaline cells, recharging is best done while the cell is still has about two-thirds capacity. But how do you know when the cell is ready for recharging? **Rod Cooper** explains how, and expands on the charger circuit presented last month.



Hashim Akib

Battery-low warning

Warning

Never attempt to recharge alkaline cells with anything other than a charger that is specifically designed to recharge alkaline-cells. Such a charger was described in last month's issue.

The question most frequently asked is how many times an alkaline-manganese cell can be recharged? On the bench, I have achieved ten times original capacity – that is over 30 recharge/discharge cycles at 30% discharge, plus any remaining charge. But these tests used consecutive discharge/charge cycles, so they do not represent everyday use.

In practice, without a timer to tell you when to recharge, you can expect to get ten recharges at 30% discharge, but this depends a lot on the type of usage. Considering that mains electricity costs 7p per kWh and alkaline-manganese cells cost about £55 per kWh this is still very good economics.

With a timer, you could reasonably expect double this figure, but a lot depends on the ageing effect that all electrochemical storage is

subject to. If there are numerous charge/discharge cycles in a short period the results are better. For this reason, is it not a good idea to recharge clock batteries for example.

Implementing the charger

Readily available AB range aluminium cases are ideal for housing the charger described in last month's issue. The lid can be easily arranged to swing open to insert cells. Being all-metal, the enclosure gives a fair degree of shielding from electromagnetic interference which my article last month showed could trigger the comparator prematurely.

With this type of aluminium case it is possible to use the base as a heat-sink for the output transistor, T_{r2} . Not a lot of heat is generated, so the point of using a generous area of

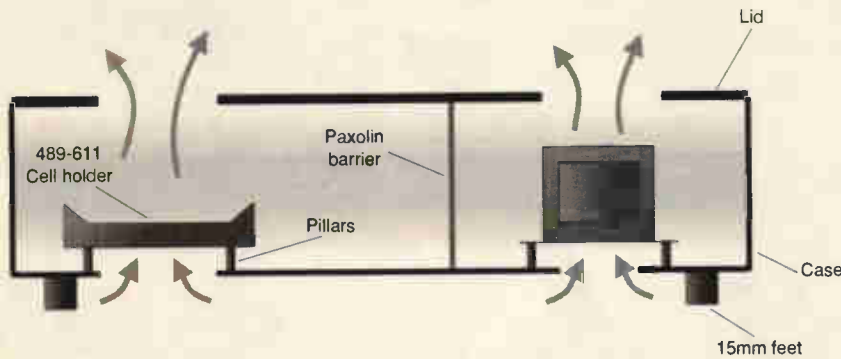

Fig. 1. Cross section of a housing suggested for the alkaline-cell charger described last month.

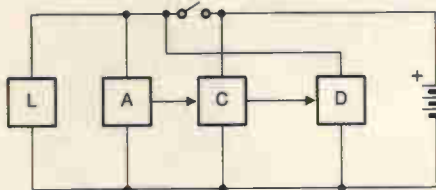

Fig. 2. Elements of the timer circuit for helping determine when a cell is 1/3 depleted.

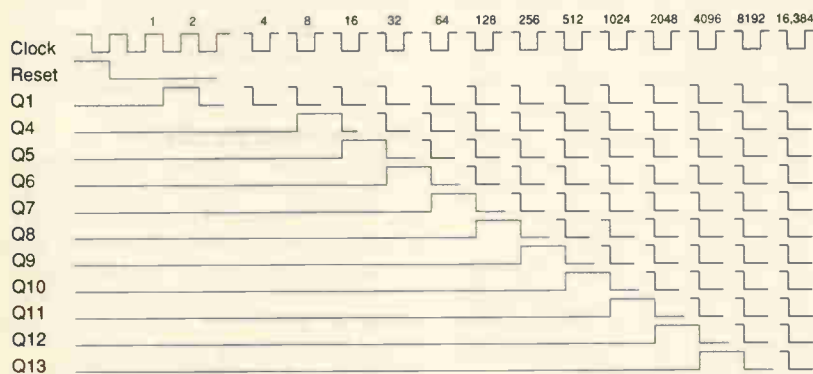
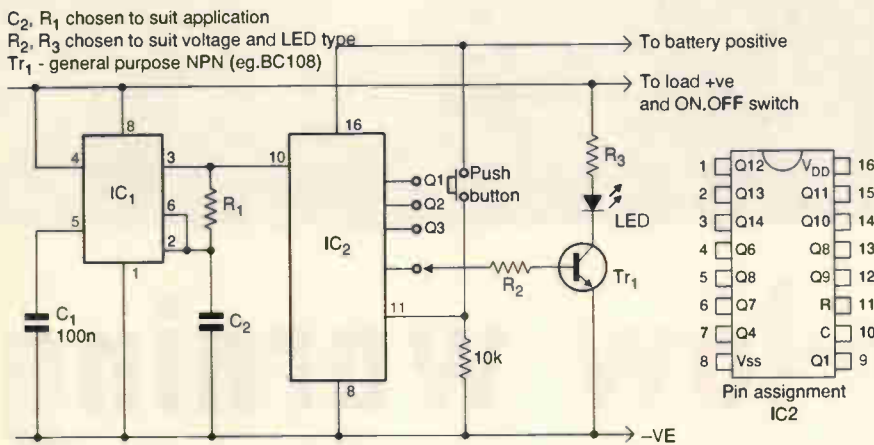

Fig. 3. While the battery-operated appliance is switched on, the counter counts. Once the timer is tailored to suit the current drain of the appliance and capacity of the cell, this method gives an accurate indication of when the cell needs recharging – extending its useful life.

metal like the case is to keep the inevitable small amount of dc drift due to temperature change to a minimum.

The 7805 regulator was chosen so that it too could be clamped to the metal case. It is deliberately over-rated; However, I have used a 78L05 regulator with a metal clip-on heat sink as an alternative and this gives comparable results.

It is best to put a thermal barrier between the mains transformer and the rest of the circuit and to give this section its own ventilation path. A piece of Paxolin is satisfactory, as shown in Fig. 1. Some transformers on the market, of third world manufacture, get quite hot even when not under load, so plenty of ventilation slots are needed. When the lid is down, the heat from the transformer will not then warm up the rest of the charger.

Efficient ventilation can be achieved by mounting the transformer and cell holders on pillars and putting some ventilation slots directly underneath and above them. The holders must be of an open-frame design, such as RS 489-611, not the enclosed type like the Bulgin cylindrical series. I must emphasise that good ventilation is essential.

Although not mentioned in the first part of the article, the indicator led should be a low-current variety such as RS 826-515. If any difficulty is experienced getting Tr_4 to remain hard on, this indicator led can be removed and transferred to an emitter-follower attached to the comparator output. In addition, when charging D cells, with some low-gain specimens of ZTX450 the value of R_9 may need to be reduced to keep Tr_4 hard on. Although it doesn't dissipate much power, this transistor should also have a clip-on heat sink to reduce the effects of thermal drift.

Also not shown in the first article, resistors R_3 and R_{10} both need a trimming resistor in parallel to get a reasonable position on the preset pots for the balance point. To put the wiper within a reasonably central position, try values around 56k Ω . This method compensates for component tolerances and also avoids having to buy precise values for the resistive divider.

To make the preset pots more sensitive, you could try dropping the value to 470 Ω and adjusting these trimmer resistors to suit.

If you use a tungsten lamp, as suggested, for showing how much current is passing, then the filament must be in direct view. It is no good covering it with a diffuser lens – you will not see any glow at low current. If the lamp holder has such a lens, remove it.

Discharge timer – the missing link

Fitting a discharge timer to the battery-powered appliances is the key to successful alkaline-manganese recharging. The lack of a simple, cheap timer which can be easily fitted to appliances has held back the progress of commercially-available chargers. Results have

been reported as generally disappointing. The reason is that in many cases the 30% limit cannot be easily estimated by the average member of the battery-using public.

It is not difficult to add a timer to appliances, where there is sufficient space. Although it is easy to find a small space in things like hand lanterns and portable radios, items such as battery shavers and the smaller hand-torches pose a problem.

The timer described here can be miniaturised if necessary by using an smd design. I have tried designing odd-shaped pcbs to fit around corners and into circular spaces. But what is really needed for use in small or densely-packed appliances is a purpose-built timer - a thick-film hybrid or ASIC.

The principle of the timer is very simple, Fig. 2. Oscillator A is driven in parallel with the load L - i.e. it only runs when the switch is on. It drives a multi-stage ripple counter C from which various outputs can be tapped to give a range of times. When the chosen output changes state, warning device D is turned on.

Note that, like the oscillator, D is powered

only when the switch is on. It would most likely go unobserved if powered when the appliance is not switched on, possibly taking the battery beyond the 30% limit.

Counter C is maintained by being permanently connected to the battery during the time the batteries are in the appliance, but as it is a CMOS device the drain is tiny - typical quiescent current is 5nA at 5V for the i.c. shown. For the vast majority of applications this can be ignored.

A practical version of this circuit is shown in Fig. 3. Timer IC₁ is a 555 which supplies a rough square-wave to IC₂, a 4020 binary ripple counter. There are 14 stages to IC₂, so the output from one of these is picked off to give a time suit the cell type and load current. At the end of the chosen time period the output goes high, Tr1 turns on, which powers the led.

The choice of timing components R₁ and C₂ for the 555 is dictated by the type of application so specific values are not shown, but this timer can be set for a few hours or up to a day or so. For longer periods, a second counter could be added or alternatively there are single

Charging NiCd cells

Because the charge currents for alkaline-manganese are by coincidence near the C/10 rate used for the equivalent sizes of NiCd cells, the charger described in last month's issue will also recharge these. As it uses periodic current reversal, the charger will do this job better than some commercially available chargers. Note that the end-of-charge cut-off will not operate if you charge NiCd cells.

ics available with even more stages.

Whenever the cells are replaced after charging, the reset button should be pressed to zero the count.

The 4020 works down to 3V. There are 555-type timers which will work down to 2V, such as the ICM75551PA.

M&B RADIO (LEEDS)

THE NORTH'S LEADING USED TEST EQUIPMENT DEALER

OSCILLOSCOPES

HP 5411D 500 MHz digitizing scope (colour display)	£3800
HP 5411D 100 MHz 4 channel digitizing scope (colour display)	£2250
HP 54201D 300 MHz 4 channel digitizing (27 channels logic state triggering)	£1900
TEKTRONIX 2465ADM 350 MHz 4 channel (digital multimeter, GPIB) (new)	£2500
TEKTRONIX 2465A 350 MHz 4 channel	£2000
TEKTRONIX 2230 100 MHz 2 channel digital storage	£2000
TEKTRONIX 2220 60 MHz 2 channel digital storage	£1500
TEKTRONIX 2445 150 MHz 4 channel GPIB	£1400
TEKTRONIX 2246 100 MHz 4 channel auto	£1400
TEKTRONIX 7844/7824/7197/7928/75B0 (600 MHz/2x 400 MHz)	£1200
TEKTRONIX 485 350 MHz 2 channel scope	£600
TEKTRONIX 475A 250 MHz 2 channel	£650
TEKTRONIX 475 200 MHz 2 channel	£400
TEKTRONIX 466 100 MHz 2 channel	£475
TEKTRONIX 465B 100 MHz 2 channel	£400
TEKTRONIX 465 100 MHz 2 channel	£475
TEKTRONIX SC504 THS02HS01 80 MHz + DVM	£300
TEKTRONIX 434 25 MHz channel storage	£300
TEKTRONIX 314 10 MHz 2 channel storage	£400
TEKTRONIX 2225 50 MHz 2 channel	£450
TEKTRONIX 2236 100 MHz 2 channel timer/counter	£750
TEKTRONIX 5113 storage mainframe (new)	£275
TEKTRONIX 212 500 KHz 2 channel handheld battery portable	£1650
PHILIPS PM 3375 100 MHz 250MS/GP-IB	£1650
PHILIPS PM 3055 50 MHz 2 channel	£625
PHILIPS PM 3057 50 MHz 2 channel	£475
PHILIPS PM 3217 50 MHz 2 channel	£400
IWATSU SS 6122 100 MHz 4 channel with cursors	£800
IWATSU SS 5710 60 MHz 4 channel	£400
LEADER LB0524L 40 MHz 2 channel	£300
HITACHI V110 100 MHz 2 channel with cursors	£750
GOULD 420 100 MHz DSO 2 channel 4 colour hardcopy	£1400
GOULD OS300 20 MHz 2 channel	£200
GOULD OS2508 15 MHz 2 channel	£145
UNAOMH G508 DT 20 MHz 2 channel (compact)	£160
BALLANTINE 1022B 25 MHz 2 channel portable	£225
SPECTRUM ANALYSERS	
TEKTRONIX 492 50 KHz-21 GHz OPT 001/002	£5500
TEKTRONIX 494P 10 KHz-21 GHz	£9000
TEKTRONIX 2710 10 KHz-2 GHz	£4000
TEKTRONIX 7112 10 KHz-1.8 GHz + mainframe	£1000
TEKTRONIX 715 + L2 OPT 25 tracking gen. + mainframe	£1750
HP 8755A 4 MHz-1300 MHz network analyser	£2000
HP 84100A 11A network analyser 110 MHz-12.4 GHz	£800
HP 8550B 100 KHz-1500 MHz + mainframe	£1750
HP 8559B 10 MHz-22 GHz OPT 003/004/043	£4950
HP 3582A 0.02 Hz-25.5 KHz dual channel signal analyser	£1800
HP 3562A 64 uHz-100 KHz dynamic signal analyser + 1 year HP Cal	£6000
HP 14078552B/8553B 1 KHz-110 MHz	£450
HP 14178552B/8554B 100 KHz-1250 MHz	£1000
HP 14178552B/8555A 10 MHz-18GHz	£1500
MARCONI TF2370 30 MHz-110 MHz digital storage	£850
BRUEL & KJAER 2033 20 Hz-20 kHz audio	£1000
SIGNAL GENERATORS	
HP 8442A 100 KHz-1050 MHz signal generator	£10000
HP 8904A DC-600 KHz multifunction synthesizer	£2500
HP 8657A 100 KHz-1040 MHz signal generator	£3000
HP 3314A 0.001 Hz-19.99 MHz function/waveform monitor	£2750
HP 3304C 10 Hz-32.5 MHz selective level meter	£1750
HP 8683D 2.3 GHz-13 GHz OPT 001/003 solid state generator (as new)	£2300
HP 8620C/86230B 1.8 GHz-4.2 GHz sweeper	£1000
HP 8620C sweeper mainframes (as new)	£250
HP 8654B 10 MHz-500 MHz RF generator	£495
HP 3300B 10 MHz-100 MHz RF generator	£2000
HP 3336B 10 Hz-21 MHz synthesizer/level meter	£600
HP 3320A frequency synthesizer 0.1 Hz-13 MHz	£450

HP 3312A 0.1 Hz-13 MHz function generator	£400
HP 3308 0.005 Hz-5 MHz function generator	£200
HP 8005B 0.3 Hz-20 MHz pulse generator	£375
TEKTRONIX 2901 time mark generator	£250
MARCONI TF230 10 KHz-20 MHz synthesizer	£2000
MARCONI TF2015/2171 10 MHz-520 MHz with synchronizer	£495
MARCONI TF2015 10 MHz-520 MHz	£350
MARCONI TF2016 10 KHz-210 MHz RF generator	£300
MARCONI TF2016 10 KHz-100 MHz (250) TF2016A	£295
PTS Inc. PTS 160 100 KHz-160 MHz frequency source	£200
FLUKE 6011A 10 Hz-11 MHz 12 synthesized signal generator	£1000
ROHDE & SCHWARTZ AP642 0.1 Hz-260 KHz LF gen (new)	£2000
SAYTOS MA 30 10 Hz-100 KHz	£175
WILTRON 610D/501 1 MHz-1500 MHz sweeper + log meter	£750
GIGA GR101A 12 GHz-18 GHz pulse generator	£600
PHILIPS PM537A 100 KHz-125 MHz RF generator	£400
ADRE 2230A 200 Hz-1 MHz synthesized source	£450
WAYTEK 193 20 MHz sweep/modulation generator	£400
WAYTEK 171 2 MHz synthesized function generator	£450
WAYTEK 182 0.002 Hz-2 MHz function generator	£175
THANDAR TG503 0.005 Hz-5 MHz pulse/function generator	£225
SAITOH MA 30 10 Hz-100 KHz	£175

TEST EQUIPMENT

ELECTRO-METRICS EMC-25 MkIII interference analyser 10 KHz-1 GHz	£995
BALL EFRATRON MRT-4H rubidium frequency standard	£4000
HP 4954A 1275 frequency difference meter	£1800
WAYTEK 1031A log lin RF peak power meter DC-26 GHz	£1500
ANRITSU M565A 2 GHz error detector	£1250
TEKTRONIX 1141PSG11/7SG11 pal video generator	£1500
TEKTRONIX 145 pal gen lock test signal generator	£1500
TEKTRONIX 521A vector scopes	£350
TEKTRONIX A6902A isolator	£450
DRANET 454 impedance analyser	£1000
PHILIPS PM8252A dual pen recorder	£225
SCHLUMBERGER 7702 digital transmission analyser (new)	£600
SCHLUMBERGER 4900 A/R/F measuring unit	£400
SCHLUMBERGER AF405 3 tone generator/modulator	£195
FERROGRAPH RTS 2 audio test set	£400
APBER 4400A audio test set	£600
WANDEL & GOLTERMAN P5519 level generator	£500
MARCONI TF2305 mod meter 50 KHz-2.3 GHz	£2000
MARCONI TF2610 true RMS voltmeter	£695
MARCONI 4950/910 10 Hz-20 GHz RF power meter	£850
MARCONI 4959A VSWR indicator	£495
MARCONI 6440/6421 10 MHz-12.4 GHz RF power meter	£250
MARCONI TF2306 programmable interface unit	£400
MARCONI TF2432A 10 Hz-560 MHz frequency counter	£125
EIP 535 10 Hz-18 GHz microwave frequency meter 12 digit	£850
HP 4954A potokil analyser + HP 181 USA pod	£4000
HP 7000A mainframe + 2x 7020SA graphic displays	£4000
HP 5342A 500 MHz-18 GHz microwave frequency meter	£900
HP 5335A universal systems counter	£1200
HP 5345A 1.5 MHz-26.5 GHz counter/5355A/5356A+B sensors	£2000
HP 4358B/481A/4844A/1708A 10 Hz-18 GHz (new/HP case/manuals)	£1100
HP 4358B/481A 10 Hz-18 GHz RF power meter	£800
HP 4358B/481A/100 KHz-4.2 GHz RF power meter	£550
HP 432A/478A 10 MHz-10 GHz RF power meter	£275
HP 436A RF power meter	£650
HP 4367A RF power meter	£425
HP 5087A distribution amplifier (new)	£175
HP 3488A switch controller	£550
HP 11710A 15 Hz-50 KHz selective voltmeters as new	£400
HP 3779A primary multiplex analyser	£250
HP 333A distortion analyser	£295
HP 11710A down converter	£250
HP 3710B/714H down converter/oscillator	£495
HP 400E 10 Hz-21 MHz AC voltmeter	£123
HP 3403C true RMS voltmeter (digital)	£195

HP 3406A 10 KHz-1200 MHz RF sampling voltmeter with probes	£200
HP 3466A 4.5 digit multimeter	£125
HP 3466A 4.5 digit auto-ranging multimeter	£200
HP 3437A 3.5 digit high speed system voltmeter	£200
HP 3455A 6.5 digit bench multimeter	£495
HP 3468A 5.5 digit multimeter/auto cal (LCD)	£400
HP 5004A signature analyser	£150
HP 5005A signature multimeter	£200
HP 6448A DC power supply 0-400V/0.1-5 amp	£750
HP 6255A dual DC power supply 2x 0-20V/0-3 amp	£185
HP 6253A dual DC power supply 2x 0-20V/0-3 amp	£200
HP 6825A power supply/amplifier -20v to +20v/0.2 amp	£350
HP 6268B DC power supply 0-40V/0-20 amp OPT 005/010/040	£500
HP 11645B 150 MHz-18 GHz modulator	£250
HP 355C RF step attenuators 0-12 dB DC-1 GHz (NEW)	£195
HP 355D RF step attenuators 0-120 dB DC-1 GHz (NEW)	£195
BIRD 43 RF wattmeters	£45
BIRD 8323 30 db coaxial attenuator 100V	£300
BALLANTINE 6125C prog time/amplitude test set	£300
HALCYON 500B/51A universal test system	£150
BROADLEY 192 oscilloscope calibrator	£500
KEMO DP1 1 Hz-100 KHz phase meter (new)	£150
WAYNE KERR CT94A LCR meter battery portable	£275
AVO 215-1J2 AC/DC breakdown ionisation tester	£400
FARNELL RB1030/35 electronic load	£495
FARNELL TH10 KHz-1000 MHz true RMS sampling voltmeter	£350
FARNELL CDD3502 dual power supply 0-35v 2 amp	£450
FARNELL TSW70 power supply 0-70v 0.1 amp	£
SIEMENS U2233 psychrometer (new)	£
SIEMENS O1108 200 KHz-30 MHz level meter	£350
SIEMENS W2108 200 KHz-30 MHz level oscillator	£350
NARDA 3001 450 MHz-950 MHz directional coupler 20db	£100
NARDA 3041-20 500 MHz-1000 MHz directional coupler 20db	£125
NARDA 3044B-20 3.7 GHz-8.3 GHz 20db directional coupler	£150
NARDA 3004-10 4 GHz-10 GHz 10db directional coupler	£175
NARDA 60132 solid state amplifier 8 GHz-12 GHz	£100
SAYTOS AMH 1.5 MHz-2 GHz automatic modulation meters	£175
ROHDE & SCHWARTZ NKS RF power meter	£600
WATKINS-JOHNSON receivers various types in stock phone for details	£450
RACAL RA1018 30 MHz-30 MHz receivers	£200
RACAL RA17 30 MHz receiver	£200
RACAL RA1218 30 MHz receiver	£350
RACAL RA1772 30 MHz receiver	£650
RACAL 2309/2329/2352/294 20 MHz-1000 MHz receivers	£1000
RACAL RA 6793A 30 MHz receiver (as new)	£1250
RACAL RA1779/MA 1107 30 MHz receiver	£1500
RACAL 9023 saw tone oscillator	£200
RACAL 9008 1.5 MHz-2000 MHz automatic modulation timer	£350
RACAL DANA 9004M 50 MHz universal counter timer	£95
RACAL DANA 9914 10 Hz-200 MHz frequency counter	£100
RACAL DANA 9915 10 Hz-530 MHz frequency counter	£100
RACAL DANA 9916 10 Hz-520 MHz frequency counter	£150
RACAL DANA 9919 10 Hz-1100 MHz frequency counter	£295
RACAL DANA 9908 10 Hz-1100 MHz universal counter timer	£400
RACAL DANA 9921 10 Hz-3000 MHz frequency counter	£400
RACAL DANA 9991 10 Hz-160 MHz universal counter timer 9 digit	£395
RACAL DANA 9992 10 Hz-1300 MHz nanosecond counter timer	£600
RACAL DANA 9300 RMS voltmeter	£350
RACAL DANA 9301A true RMS RF millivoltmeter	£400
RACAL DANA 6000 microprocessing digital voltmeter	£250
BRUEL & KJAER 971 phase meter	£400
DATRON 1071 autocal digital multimeters	£400
FLUKE 8505A digital multimeter	£750
FLUKE 8505A thermal RMS multimeter	£1000
FLUKE 103A frequency comparator	£250
FLUKE 3330B prog constant current/voltage calibrator	£450
FLUKE 3100B calibrator	£2950
FLUKE 3200A programmable AC calibrator + 3205A precision power amp	£4000
FLUKE 5440B direct volts calibrator	£4950
FLUKE MICROSYSTEMS INC. AN/TRC-176 VHF/UHF K&L filters	£400
SPECIAL OFFERS	
SOLARTRON 7045 4.5 digit bench multimeter (battery/ma)ms	£60
FLUKE 25 high spec digital multimeters with manual and probes (as new)	£70
SMITHS 3" diameter altimeters	£65
SIEMENS PDRM62 portable LCD radiation meters (new)	£50

ALL PRICES PLUS VAT AND CARRIAGE • ALL EQUIPMENT SUPPLIED WITH 30 DAYS WARRANTY

86 Bishopgate Street, Leeds LS1 4BB
Tel: (0113) 2435649 Fax: (0113) 2426811

PROTEUS

For DOS and Windows 3.1, 95 & NT

The Complete Electronics Design System - Now With RIP-UP & RETRY!

NEW LOW PRICE OPTIONS AVAILABLE
Level 1 (500 pins) from £250
Level 2 (1000 pins) from £495
Level 3 (unlimited) from £995

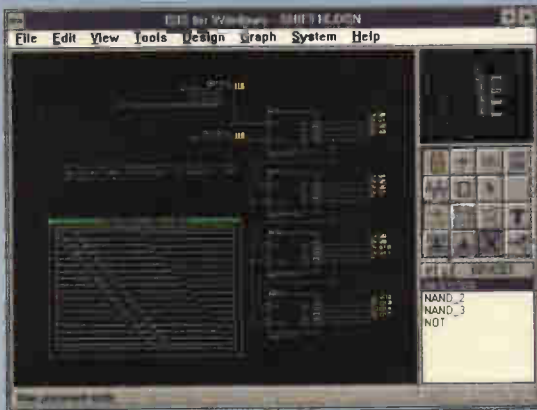

Schematic Capture

- Easy to Use Graphical Interface under both DOS and Windows.
- Netlist, Parts List & ERC reports.
- Hierarchical Design.
- Extensive component/model libraries.
- Advanced Property Management.
- Seamless integration with simulation and



Simulation

- Non-Linear & Linear Analogue Simulation.
- Event driven Digital Simulation with modelling language.
- Partitioned simulation of large designs with multiple analogue & digital sections.
- Graphs displayed directly on the schematic.

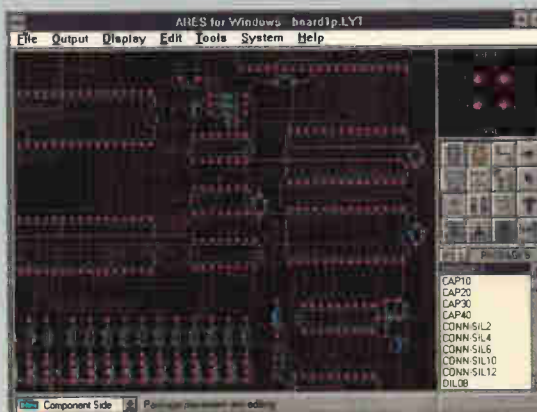

PCB Design

- 32 bit high resolution database.
- Multi-Layer and SMT support.
- Full DRC and Connectivity Checking.
- RIP-UP & RETRY Autorouter.
- Shape based gridless power planes.
- Output to printers, plotters, Postscript, Gerber, DXF and clipboard.
- Gerber and DXF Import capability.

labcenter
Electronics

Call now for your free demo disk
or ask about the full evaluation kit.
Tel: 01756 753440. Fax: 01756 752857.
53-55 Main St, Grassington. BD23 5AA.

Fully interactive demo versions available for download from our WWW site.
Call for educational, multi-user and dealer pricing - new dealers always wanted.
Prices exclude VAT and delivery. All manufacturer's trademarks acknowledged.

EMAIL: info@labcenter.co.uk
WWW: <http://www.labcenter.co.uk>

ELECTRONICS WORLD

+ WIRELESS WORLD

Electronics World+ Wireless world is applied electronic design. We'll show you how to use the latest silicon technology plus...

- ✓ CAE software
- ✓ New product reviews
- ✓ Technology reports
- ✓ Detailed circuit diagrams
- ✓ Innovations
- ✓ Explanations of complex technology
- ✓ Comment and much more in your issue.

So whether you are designing your own system or curious about your competitors Electronics World + Wireless World will help you keep the leading edge.

Money back Guarantee.

Receive a full refund on your subscription within the first 90 days if you are not completely satisfied. Thereafter, we'll refund the unused portion of your subscription should you wish to cancel.



SAVE UP TO 10%

Interfacing with C

**ELECTRONICS
WORLD**
• WIRELESS WORLD

Interfacing



Howard Hutchings



Without an engineering degree, a pile of money, or an infinite amount of time, the revised 289-page **Interfacing With C** is worth serious consideration by anyone interested in controlling equipment via the PC. Featuring extra chapters on Z transforms, audio processing and standard programming structures, the new **Interfacing with C** will be especially useful to students and engineers interested in ports, transducer interfacing, analogue-to-digital conversion, convolution, digital filters, Fourier transforms and Kalman filtering. Full of tried and tested interfacing routines.
Price £14.99.

Listings on disk – over 50k of C source code dedicated to interfacing. This 3.5in PC format disk includes all the listings mentioned in the book **Interfacing with C**. Note that this is an upgraded disk containing the original **Interfacing With C** routines rewritten for Turbo C++ Ver. 3. Price £15, or £7.50 when purchased with the above book.

Especially useful for students, the original **Interfacing with C**, written for Microsoft C Version 5.1, is still available at the special price of £7.50.
Phone 0181 652 3614 for bulk purchase price.



Use this coupon to order

Please send me:

Title	Price	Qty	Total
Enhanced Interfacing with C book @	£14.99	£.....
Enh. Interfacing with C book + disk @	£22.49	£.....
Interfacing with C disk @	£15	£.....
Original Interfacing with C book @	£7.50	£.....
Postage + packing per order UK	£3.50	£.....
Postage + packing per order Eur	£7	£.....
Postage + packing per order ROW	£12	£.....
Total			£.....

Name

Address

Phone number/fax

Make cheques payable to Reed Business Publishing Group Ltd
Or, please debit my Master, Visa or Access card.

Card type (Access/Visa)

Card No

Expiry date

Mail this coupon to Electronics World Editorial, Quadrant House, The Quadrant, Sutton, Surrey, SM2 5AS, together with payment. Alternatively fax full credit card details with order on 0181 652 8956 or e-mail them to jackie.lowe@rbp.co.uk. Orders will be dispatched as quickly as possible, but please allow 28 days for delivery.

KENWOOD

CS-5270 100Mhz 3 Channel

Oscilloscope Combining

Accuracy with Simple Operation

8 traces with digital read-outs and cursor functions



★ 3 Channel, 8 Trace Scope for a Variety of Waveform Displays ★ Synchronisation with Composite Video Signals (NTSC, PAL and MUSE) ★ High-precision Digital Measurement with Cursors ★ Three-channel Readout ★ Operation Panel Laid Out For Easy Operation ★ Kenwood's Original Hybrid ICs ★ High Sensitivity of 1mV/div ★ Automatic Triggering (FIX) to Solve Complicated Triggering Problems ★ Delay Sweep for Expanded Waveforms ★ Three Signals can be Exactly Synchronized in the V mode ★ 150-mm Rectangular CRT with Internal Graticule and Illuminated Scales ★ Maximum Sweep Time 5 ns/div (at 10 X Mag) ★ Single Sweep for the Measurement of Transient Events ★ Special Video Signal Clamp Eliminates Triggering Adjustments ★ Variable hold-off to Observe complex sync waveforms ★ With vertical axis signal terminals ★ High-Precision of +/- 3% for measurements with greater accuracy.

Price £1195-00 + VAT (£1404-12) Carriage Free

Over 100 Quality Instruments Available In The Kenwood Range

Order by Credit card or Cheque with order



B.K. ELECTRONICS

Unit 1 Comet Way,
SOUTHEND-ON-SEA,
Essex, SS2 6TR.
Tel.: 01702-527572
Fax: 01702-420243

Official orders welcome From Colleges, PLC's etc



CIRCLE NO. 121 ON REPLY CARD

The Balance Box

Microphone or line level amplifier for balanced or unbalanced signal lines

Professional portable units operating from an internal PP3 battery or external mains adaptor



- ★ Precision true floating transformerless balanced input and output at microphone or line level
- ★ Simple interfacing and conversion between balanced and unbalanced signal lines
- ★ Low noise and distortion
- ★ High common mode rejection
- ★ Switchable gain selection
- ★ Extensive RFI protection

The Phantom Power Box – The Headphone Amplifier Box - The OneStop

DIN rail mounting radio frequency interference filter and voltage transient protector for voltage and current loop process signal lines

Conford Electronics Conford Liphook Hants GU30 7QW

Information line: 01428 751469 Fax: 751223

E-mail contact@confordelec.co.uk

Web <http://www.confordelec.co.uk/catalogue/>

CIRCLE NO. 122 ON REPLY CARD

Radio Receiver Trainer

An Invaluable Learning and Design Tool for all Experimenters

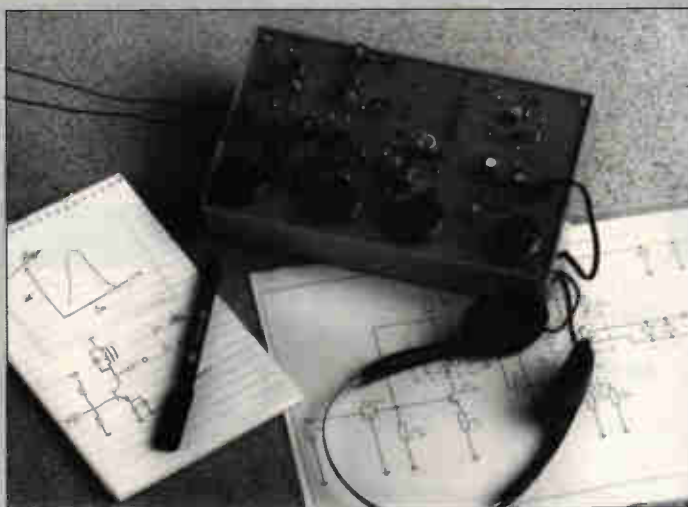

The Radio Receiver Trainer contains eight receiver building blocks and a comprehensive training manual.

Simply connect the building blocks to build AM, SW, Superhet and Direct Conversion receivers. Decode SSB and CW. Use proven building blocks to develop and test your own designs.

Pricing:	Complete	£129.00
	Kit	£89.00
	(Excludes case & headphones)	



P&P is £5 (UK), £8 (EC), £12 (World)
Add Vat to Total Price

Mail Order To: **Pyramid Electronics LTD.**
204 Ferndale Road,
Brixton,
London SW9 8AG
Phone (0171) 738 4044 Fax (0171) 274 7997
(Out of office hours ordering by answering machine)

Building Blocks:	Bandspread Tuner
	RF Oscillator
	Mixer
	IF Amplifier
	AM Detector
	Beat Frequency Oscillator
	Audio Filter
	Audio Amplifier

Monitoring MAINS

Nick Wheeler shows how to monitor mains current using a simply made current transformer.

The traditional method of current measurement is to measure the voltage drop across a suitable series resistor. This is no good for monitoring the mains current, as a resistor giving reasonable sensitivity for the small always-on loads, such as timers and answering machines, would be far too large to cope with heavy, intermittent, heating loads, refrigerators and so on. The latter can come on at any time unless switched off, which would make measurements very tedious.

The current transformer

Traditionally, current transformers comprise a secondary winding of many turns wound on a toroidal core. The primary is the conductor being monitored, which is passed through the central hole.

For increased sensitivity, the primary conductor can be threaded through the hole two or more times. This arrangement is fine for original installations, such as for motor control, but is unsuitable for retrospective domestic installation, as it means breaking the circuit, which stops all the clocks, etc., around the house.

There are 'clamp' meters, in which the core can be broken open against a powerful spring. With these the conductor can be encircled without disconnecting it. They are, however, costly. In any case I was also interested in current waveforms.

Implementation

I used one of the small do-it-yourself transformer kits, which are available from many sources. These have a fully insulated mains winding, usually consisting of two 120V windings which can be connected in series or parallel. This forms the secondary of the current transformer.

The window provided for the d-i-y secondary in normal application is large enough to accommodate a single pass of the thick cable connecting the meter to the fuse box, usually easily accessible. The clamping plates which carry the mounting lugs will have to be sawn open at a suitable point and threaded over the cable, if required. I did not do this as provided the assembly bolts are applied after the laminations have been assembled the transformer can be reused for another purpose subsequently. The laminations are of the E & I form in all examples I have seen, and can be put in in

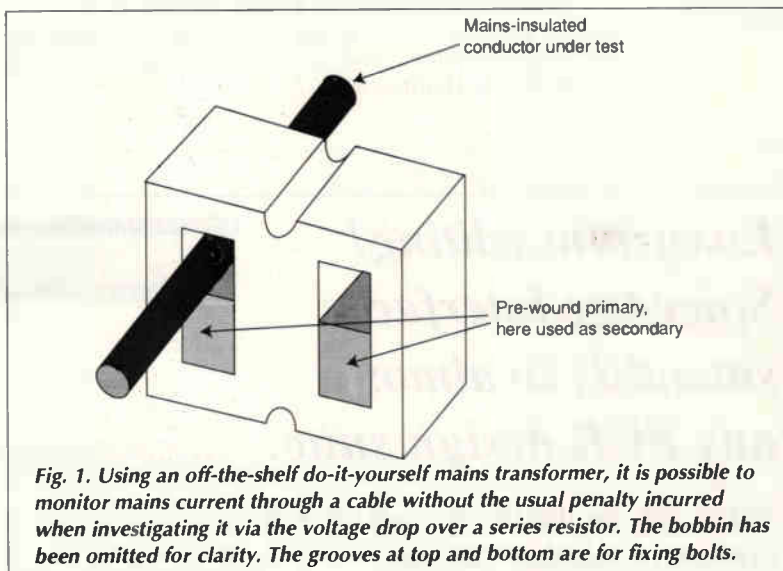

Fig. 1. Using an off-the-shelf do-it-yourself mains transformer, it is possible to monitor mains current through a cable without the usual penalty incurred when investigating it via the voltage drop over a series resistor. The bobbin has been omitted for clarity. The grooves at top and bottom are for fixing bolts.

stacks of five alternately.

Figure 1 is a sketch of the assembly.

Making measurements

A current transformer must always be operated with a secondary load. Otherwise a heavy current surge in the monitored conductor can induce very high voltages in the secondary – possibly leading to flashover and breakdown.

Calibration is carried out by connecting a heavy resistive load, such as a heater, via a shunt lead threading the core, as in Fig. 1. The current can be measured with a digital multimeter, and the secondary load adjusted to give a convenient voltage. The meter should be shorted until the heater is at operating temperature. Otherwise the cold surge may blow the meter fuse.

Values in the region of $1k\Omega$ are suitable and will yield secondary voltages of the order of ten. Ordinary low-wattage resistors should be adequate.

Calibration is most conveniently done in the laboratory, even though this involves disassembling the transformer before final use.

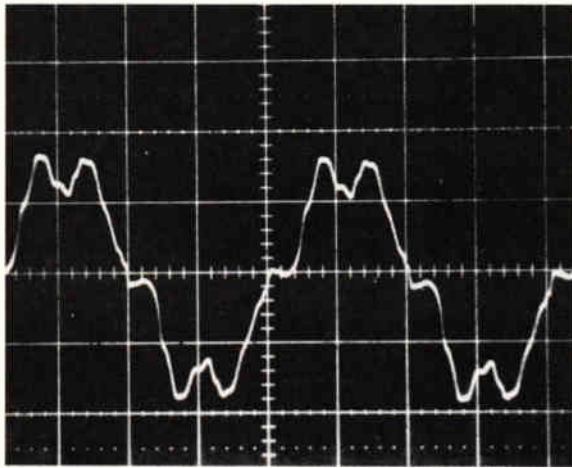

Fig. 2. Mains current waveform resulting from 125 μ F across 240V mains. Current observed on a moving-coil meter was 9.7A.

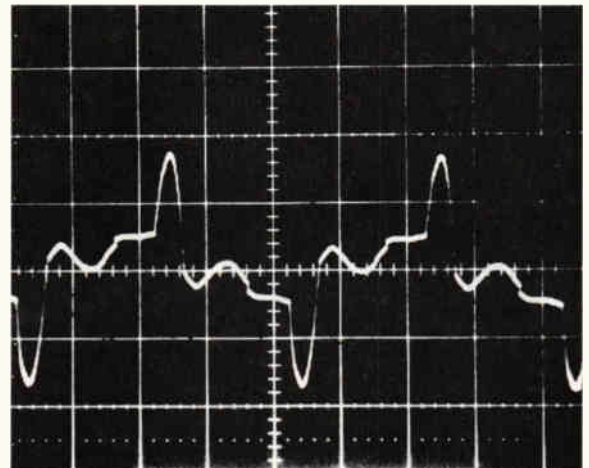

Fig. 3. Current waveform resulting from a load of about 100VA in the form of two switch-mode power supplies.

Waveforms

Because the transformer is operated at far below the usual flux levels the observed waveforms across the load resistor can be assumed to be accurate. The voltage waveform across my mains is apparently a good sinusoid, with occasional transients. The current waveform through 125 μ F indicates that it is actually quite rich in harmonics, Fig. 2.

Figure 3 was observed when my pc and my oscilloscope, both of which use switch-mode power supplies, were the main load. Horrible, isn't it?

In summary

This article has shown that useful information about the quality of the mains signal, and current being drawn, can be obtained with little trouble or expense.

There is a small penalty, however. The secondary load of the current transformer appears as a tiny resistance in series with the power line. It is tiny, since it equates to the load resistance divided by the square of the transformer ratio. For 1k Ω and a ratio of 1000:1, values which are quite typical, insert a resistance of 1m Ω .

**Luxuriant editing!
SpiceAge interfaces smoothly to almost any PCB design suite.**

Although we would like you to use our own excellent Geswin schematic capture program which is purpose built for SpiceAge, if you already have a schematic program, there is a good chance that SpiceAge will work with it better than any other circuit simulator.

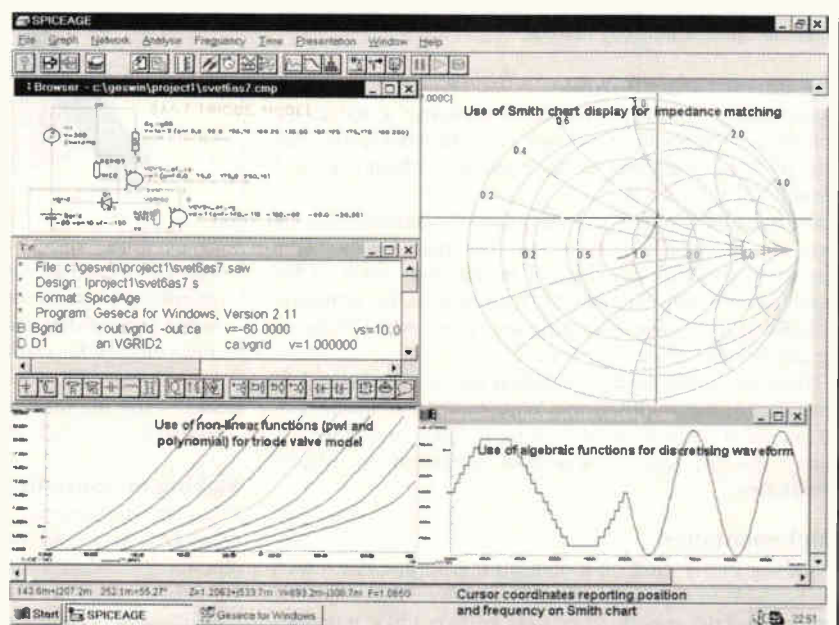

When you iterate between a schematic and a SPICE-like simulation environment while refining your circuits, the simulation settings and precious details such as polynomial functions on components can be lost. So without Geswin, it was sometimes easier to write the simulation netlist directly. However, SpiceAge's **circuit update** button only affects *changes* in the circuit built by the schematic and, because it retains all the previous information, you can spontaneously iterate between schematic and circuit.

To hear more about this and other nice touches in SpiceAge, please contact:

Those Engineers Ltd, 31 Birkbeck Road, LONDON NW7 4BP.

Tel 0181 906 0155 FAX 0181 906 0969 Email 100550.2455@compuserve.com

Whose heterodyne?

John Belrose and George Elliott set the record straight as to who invented the heterodyne.



Professor Reginald Aubrey Fessenden

Tom O'Dell¹ recently surveyed the archives to find out where the real credit belongs for the birth of the heterodyne principle, which is the basis of nearly all radio receivers today. He attributes the coining of the word heterodyne to John Erskine-Murray. Tom's reference is the Oxford English Dictionary.

But Erskine-Murray is only a source reference. In the Appendix of his translation of Ernst Ruhmer's book on 'Radio Telephony', in a section detailing Fessenden's work, he states that "one of the most interesting of Professor Fessenden's many inventions is what he (Fessenden) calls the 'heterodyne' receiver..."²

Continuing, O'Dell concludes that while Fessenden's original patents (1050441 and 1050728 which we discuss below) describe the idea of producing a beat frequency, it is unlikely that his device(s) ever worked at radio frequencies. O'Dell attributes the "first successful" heterodyne receiver to Rudolf Goldschmidt, who devised a curious mechanical type of synchronous detection and heterodyning receiver in 1913.

In our view O'Dell does not attribute proper credit to Reginald Aubrey Fessenden, the radio pioneer who invented radio as we know it today. He did indeed devise the heterodyne principle, as well as coining the word heterodyne. Below is our survey of Fessenden's contributions to the birth of the heterodyne principle.

Fessenden's heterodyne principle

The Canadian/American radio pioneer and inventor Reginald Aubrey Fessenden (1866-1932) was granted almost 300 United States patents – most of them in telecommunications. His most notable invention was the heterodyne principle, which is fundamental to all radio today. Being trained in the classical languages, he coined the term —heterodyne— from two Greek words inferring the mixing of two forces.

The Fessendens were an old-line North American family having emigrated from Germany to Cambridge, Massachusetts Bay Colony, in about 1628. Reginald's family branch moved from the USA to what is now Quebec Province about the year 1800.

Born and educated in Canada, he moved permanently to the United States just prior to his 21st birthday, becoming an immediate US citizen. In 1921 he was awarded the Medal of

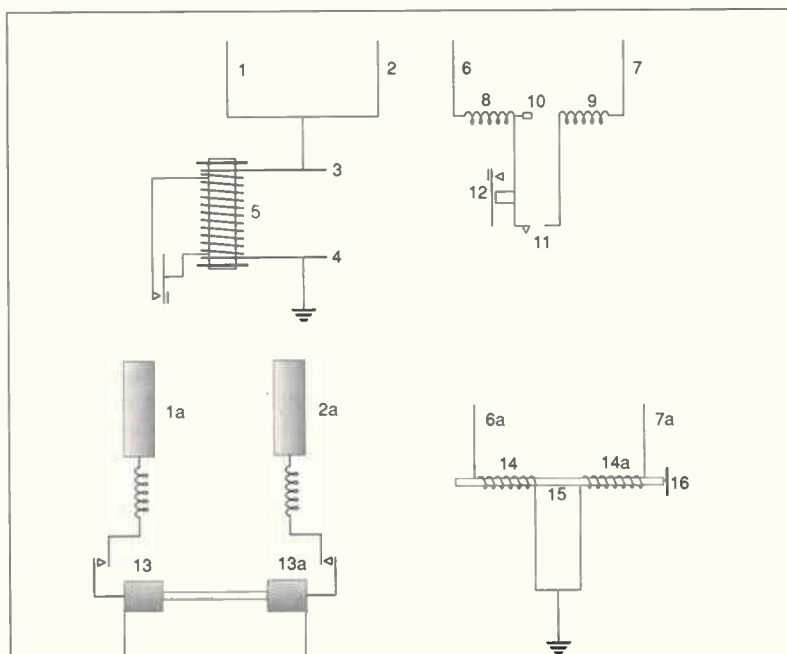

Figs 1, 2. Copy of Fessenden's heterodyne principle patent, filed 28 September 1901, granted 12 August 1902.



Fig. 3. The solid sine waves illustrate phase relationship between incoming signals of different frequencies. Grey sine wave shows resulting beat frequency.

Fig. 4. Sketch of Fessenden's advanced heterodyne receiver system.

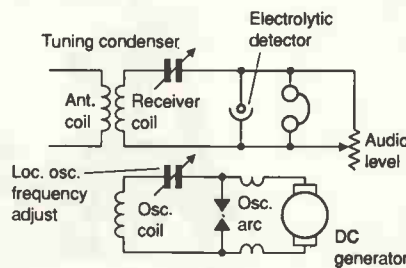

Honor of the Institute of Radio Engineers for his discovery of the heterodyne principle.

During the 1890's Fessenden considered the then standard wireless detector, the coherer, to be a severe obstacle to radio's long-term future. In effect he was saying the spark transmitter/coherer-detector communication system then in use must succumb to the efficiencies apparent in the continuous wave, or cw, method of wireless communication.

No such system was in sight in 1900, so Fessenden came up with methods to generate and receive cw. He devised a new type of detector – an electrolytic detector for rectifying and detecting cw signals; and the 'heterodyne principle', which led to cw wireless telegraphy, radio telephony and the many modes of telecommunications which we enjoy today.

The patent covering Fessenden's heterodyne principle was US No 706740, filed 28 September 1901 and granted 12 August 1902. Further related heterodyne method patents were US No 1050441, filed 27 July 1905 and granted 14 January 1913, and US No. 1050728.

The specification applicable to US No 706740 includes a continuous wave transmitting station emitting two different frequencies at the same time. The system also includes a receiver which combines the rf signals into a usable, single, audio-range frequency tone, suitable for the ear of the listener.

Figures 1 and 2 – close likenesses of diagrams from Fessenden's original patent, granted 12 August 1902 – show his heterodyne transmitter and receiver. In Fig. 2, two high-frequency alternators, 13 and 13a are shown connected by a common drive shaft to permit rotation by a common drive source.

The alternators that Fessenden anticipated were to be in accordance with those specified in his patent application US No 62301, filed 29 May 1901. Alternator 13a was to be adjusted for a frequency output about 3% greater than alternator 13. The two transmitting antennas are shown as 1a and 2a, with 2a being tuned to a frequency about 3% greater than 1a.

In Fig. 2, the two receiving antennas 6a and 7a of the heterodyne receiver are tuned to the same frequencies as were transmitting antennas 1a and 2a. Detail 16 is an earphone diaphragm with a common iron-core 15. The received signals of different frequencies appear as voltages across earphone coils 14 and 14a. The result is a 'beat' frequency in the audible range, actuating diaphragm 16.

This is the arrangement that has been critically commented on by O'Dell. Whether this crude method worked efficiently is unimportant. Figure 2 represents Fessenden's cw transmitting and receiving system in its simplest form.

In Fig. 3, the solid sine waves illustrate the phase relationship between two incoming signals of different frequencies. The grey sine wave is meant to show the resultant beat frequency. Fessenden's 'heterodyne principle' was a brilliant conceptual discovery earning him a place in radio history even without his notable other inventions.

Fessenden's heterodyne method

Remarkably, Fessenden was able to conceive the heterodyne principle without the wonders of the vacuum tube. He had to work with what was available at the turn of the century – in further development with the arc oscillator, the primitive detectors, the hf alternator, etc.

During 1902, Fessenden improved his heterodyne receiver by placing the second-frequency transmitter right at the location of the receiver site. The second signal was now under the control of the receiver operator, making the system easier to manage, Fig. 4. This led to his advanced heterodyne patent No 1050441.

The advanced heterodyne system was easily adjusted by the receiving site operator and did not involve the sending transmitter operator as did the initial version. Fessenden produced the locally generated frequency with an oscillating arc, or an alternator. Both these methods were in use until 1914/15 when the triode took over, but the arc was preferred.

In the words of Dr Sam Kintner³, a member of the original Fessenden team, "This (the heterodyne principle) was another bold stroke of Fessenden, in which he departed from methods practiced by others. Like other great inventions, it was made before he had suitable equipment with which to practice it. He required a source of local oscillations of adjustable frequency, and an hf alternator or oscillating arc was all that was available.

"The term heterodyne was coined by (Prof.) Fessenden and has a technical meaning which may in general be explained as follows:

If currents of two different frequencies 'beat' in the same circuit they will produce a new frequency and are said to heterodyne (from the Greek words, heteros – other or different, and dynamis – power) and the new frequency is called the heterodyne frequency. Further to simplify the matter: if frequencies being received are of such rapidity as to be beyond the human ear, such as 300kHz, in order to hear the 'heterodyne' one would generate in the receiving apparatus a frequency of 301kHz. The result of combining the two would be that the 'beat' note would equal the difference between the two or 1kHz which could easily be transformed into tones suitable for the ear of the listener. Mysterious and magical no doubt but scientific fact nevertheless.

"Fessenden, who devised and named, the heterodyne system applied for a letters patent in 1905. His triumph was more theoretical than real for he was years ahead of the industry. His own cw apparatus was the only system capable of using the heterodyne system. Not until 1912 when the triode tube of DeForest became practicable for the general public did Fessenden's heterodyne invention assume its true importance in radio technology".

But others used heterodyning too...

As radio moved onward after 1915, Fessenden's heterodyne patents became essential for all forms of wireless communications. Numerous lawsuits were fought in the US courts during the 1920's over the heterodyne patent rights.

Unfortunately, Fessenden did not receive any significant financial benefit from his patents. He lost control of the patents prior to 1911, through a series of legal manoeuvres by his partners and his lawyer. He was a first-class scientist, but an unwary business-man.

The following is a summation of one of these classic heterodyne US lawsuits. It was fought during 1924-25 and the plaintiff was the National Electric Signaling Company (NESCO) and the US Government was the defendant. The plaintiff, NESCO, sought to recover compensation for the unlicensed use of the Fessenden's heterodyne patents, by the

NOW THE BATTLE IS REALLY OVER



After 10 years and with more than 20,000 users, ULTimate Technology now introduces the ULTiboard Wizard. This system is highly praised for its very powerful placement and routing algorithms by both the less experienced users and by the experts. The technology applied in the ULTiboard Wizard used to be available only as options on the more powerful and expensive Workstations. The PCB design depicted below illustrates the capability of the Wizard, its 4-layer version was employed in the ULTiboard Professional Design Contest at the Electronics'95 Exhibition. The same design was now executed in a 2-layer version with the ULTiboard Wizard in less than 2 hours.

ULTIBOARD WIZARD

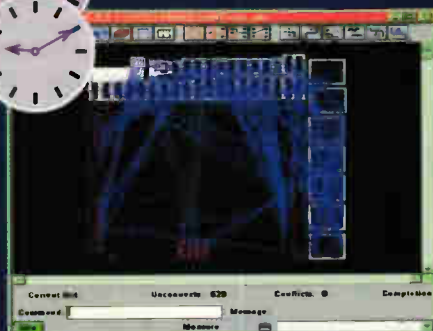

The schematic is ready, the board outline established and all components are imported. The components with a fixed location are placed interactively. (10 min.)



AutoPlace rapidly and conveniently places the remaining components with algorithms that approach the interactive method of expert designers. On-line changes are possible. (5 min.)



Power and Ground are routed semi-automatically (under the management of the designer). The (EMC) critical connections are also layed interactively. (15 min.)



Now the SPECTRA Autorouter is employed to finish the routing of the design at high speed and with high-grade quality. All design rules

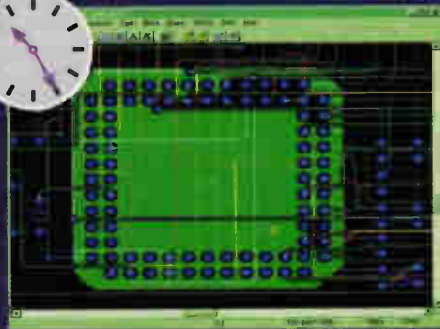

All adjustments are done quickly and efficiently with the interactive autorouter. All the corners of the traces are chamfered and polygons are placed. (10 min.)

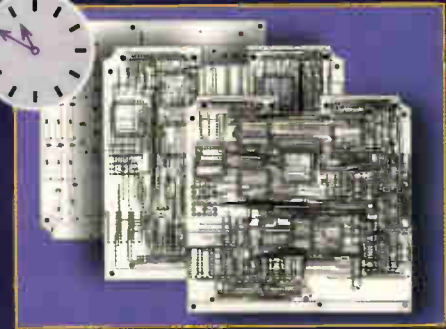

Following the connectivity- and design rule checks, the output on matrix or laser printers, pen or photo plotters can be run. Back-Annotation automatically updates the schematic. (25 min.)

ULTimate Technology now makes the best PCB Design tools available at very competitive prices from UK £ 2,675,- (Excl. VAT, 1400 pins version with 4 signal layers). We imagine you will want to see for yourself whether you too can achieve such fantastic results with the ULTiboard Wizard. Please come to our stand J135 at ICAT 97 at NEC (Birmingham) and convince yourself. A demo-CD is available.

CIRCLE NO. 138 ON REPLY CARD

ULTIMATE
TECHNOLOGY

E-mail: sales @ ultiboard.com
Internet: http://www.ultiboard.com

UK/Ireland Sales-Office:
1 Viney Woodside • Lydney
Gloucestershire • GL15 4LU • U.K.
tel. : (+44) 1594 - 516647
fax : (+44) 1594 - 516659

Corporate Headquarters:
Energistraat 36 • 1411 AT Naarden
The Netherlands
tel. : (+31) 35 - 6944444
fax : (+31) 35 - 6943345



4-6 MARCH 1997
NEC BIRMINGHAM
STANDNR. J135

US government. Fessenden was a co-founder and an officer of NESCO but had been ejected from this firm by his partners, prior to 1911.

The plaintiff, NESCO, engaged the services of a number of expert witnesses, who became legends in the history of early American radio, to appear on their behalf. One of these witnesses was Haraden Pratt who was born in California in 1891. In his teens became an amateur radio operator. Before he was 21 years old he was employed by the United Wireless Telegraph Co. and the Marconi Company.

Pratt graduated from the University of California in 1914 as an electrical engineer. At various times during his years at the University he served as radio operator on a number of ships in the Pacific and at the Marconi port station at San Francisco. After graduation, Pratt was appointed 'assistant-engineer-for-construction' for Marconi Wireless at their Pacific high-power stations.

In 1915 he was placed in charge of the US Navy Radio Laboratory at Mare Island, California. In 1917, when the US

entered WW 1, the US Navy assumed control of the US west coast commercial wireless stations and placed the maintenance of them under Pratt's laboratory. In 1918 he was transferred to Washington DC and placed in charge of the US Navy's high power radio stations.

In December 1919, Pratt left the Navy and became Chief Engineer of the Federal Telegraph Company of California. This company operated commercial radio stations on the US west coast and in the Hawaiian Islands as well as designing and constructing high-power radio stations for the US Navy. Pratt's deposition in the NESCO vs US Government heterodyne lawsuit, is dated 7 April 1924 and was heard in a Pittsburgh PA courthouse.

Pratt testified he operated with a heterodyne receiver for the USN at Mare Island, California, copying traffic mainly from the Panama Canal Zone during the summer of 1915. This particular receiver had been made by Lee DeForest for the USN. He said he understood, in 1915, Fessenden's heterodyne principle to be – a "method of reception involving the generation locally at the receiver of a source of continuous electrical oscillations with such a frequency that an interaction will occur with the received high frequency current of the radio signal, due to association of local oscillatory means with the receiving set, which will produce beats which can be adjusted to be audible to the human ear".

Pratt testified he became aware of the existence of Fessenden's heterodyne principle following the USS SALEM heterodyne tests at sea in 1913. He said the use of the heterodyne system greatly extended the range of communication over that which would have been possible by the use of other means.

Pratt said Fig. 5 was a fair, simplified representation of the Fessenden heterodyne receiving circuit used by the US Navy in the years 1917-18-19. This was a self-heterodyne set. Pratt was asked to explain the cause of the local oscillations, and how are they caused interaction with the received signal oscillating currents. His reply follows:

"The vacuum tube with its associated circuit generates an hf current in a coil, which is associated with the antenna circuit, so that this coil not only carries these hf currents but also those impressed upon it by the virtue of the current in the antenna system, due to the presence of the latter in the distant electrical field of the transmitting station being received. The two currents so impressed in this coil, being in the same circuit, combine when the adjustments are properly made, into an electrical current of which these two electrical currents are components. This new current has the necessary characteristics, which when rectified by a rectifying device, would produce an audible sound in the telephone receiver properly connected. The rectifying device in Figure 5 was incorporated in the same vacuum tube as was used to generate the local hf current, which is one of the other functions performed by this tube".

The heterodyne receiver comes into use

By mid 1913, the US Navy was convinced it had a unique cw communications system at hand with Fessenden's heterodyne receiver and the Federal oscillating arc transmitter. The USN's plan to dispense with the British Marconi, and the German Telefunken and Arco-Slaby systems was successful.

By March 1914 the vacuum tube method had been incorporated in Fessenden's reception method using the self-heterodyne circuit in which the detector and local oscillator are in the same tube envelope. In mid-1914, orders for these sets were placed by the USN with DeForest, Marconi, Wireless Specialties, etc. Fessenden and NESCO were not on the bidders list.

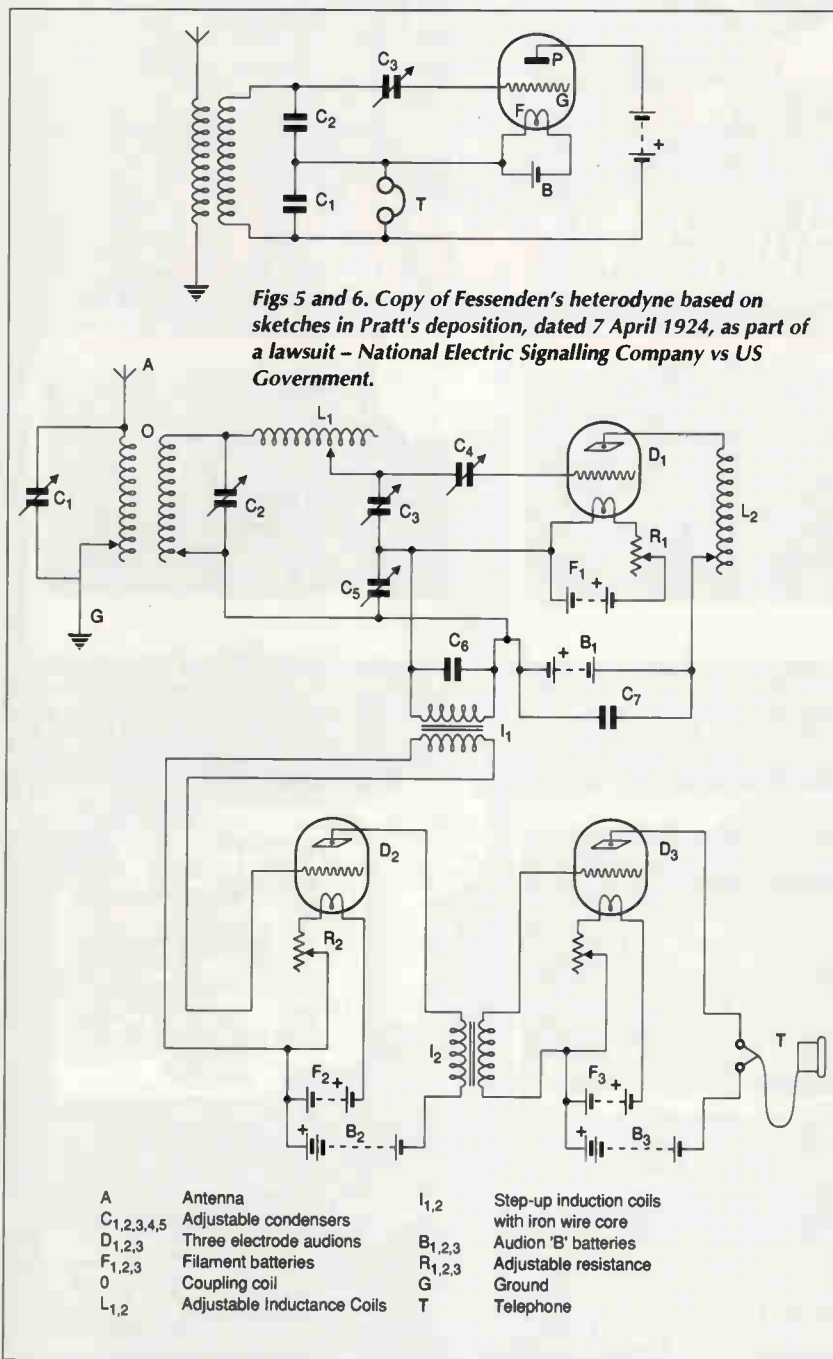

Figs 5 and 6. Copy of Fessenden's heterodyne based on sketches in Pratt's deposition, dated 7 April 1924, as part of a lawsuit - National Electric Signalling Company vs US Government.

When the United States entered WW 1 the USN seized the huge German-owned commercial transmitting station at Sayville, NJ, where the USN immediately installed a Fessenden heterodyne principle receiver. It was a single-tube self-heterodyne set with two stages of audio amplification, Fig. 6.

The wisdom of the US Navy to move from 'spark' to cw wireless systems beginning in 1912-13 was significant. By 1918, high-power Navy stations were in service at Annapolis, MD, Panama Canal, Philippines, Hawaii, France, San Diego, etc. These cw stations had Federal oscillating arc transmitters with power outputs from 100 to 1000kW, and employed Fessenden's heterodyne principle receivers.

The system was awe-inspiring, allowing the USN to communicate with its ships at any location on the high seas. This 1918 wireless cw communication network far surpassed what Britain, Germany, France or any other country could claim. Built in a relatively short five-year period, the US Navy system was much superior to the Marconi's 'spark' system.

In summary

The Fessenden heterodyne patents, US Nos 706740, 1050441 and 1050729, cover a basic radio invention that is fundamental to signal reception. Some historians consider that Fessenden's heterodyne principle is his greatest contribution to radio science. It has been argued that both Armstrong (US) and DeForest (US) based their feedback regenerative detector patents on these Fessenden heterodyne patents. It is without question that both Armstrong and Levy (Fr.) incorporated Fessenden's heterodyne principle in their superheterodyne circuits, which are used today in all forms of telecommunications.

Through a series of corporate transactions, these Fessenden heterodyne patents came to be controlled by the Radio Corporation of America/General Electric Company. For years, those companies would not licence them for use by others. Fessenden did not receive any payment or fee from this 'radio trust'.

As the 1920's came to a close, this restraint-of-trade business method was judged illegal. As a side issue, Fessenden was awarded a relatively small compensatory sum by the US courts almost 30 years after filing his first heterodyne invention. After this legal settlement he left the United States forever, taking up residence in Bermuda where he passed away in 1932 at the age of 66 years.

Fessenden – a genius, and a mathematician – was the inventor of radio communications as we know it today^{4,5}.

References

1. O'Dell, T., 'Whose Heterodyne?', *Electronics World + Wireless World*, June 1995, pp. 495-498.
2. Ruhmer, E., 'Wireless Telephony', translated from German by J. Erskine-Murfay, Crosby Lockwood and Son, London, 1908, pp. 173, 201-202.
3. Kintner, S.M., 'Pittsburgh's Contribution to Radio', Joint meeting of the IRE and AIEE, at Pittsburgh, 7 April, 1932 (abstracted in *QST*, July 1932, pp. 31-33 and 90).
4. Belrose, J.S., 'Fessenden and the Early History of Radio Science', *URSI Radioscientist & Bulletin*, September 1994, pp. 94-110.
5. Belrose, J.S., 'Fessenden and Marconi: Their Differing Technologies and Transatlantic Experiments during the First Decade of this Century', IEE Conference Publication No. 411, September 1995, pp. 32-43.

Eight year EW index Hard copy or disk

Includes over 600 circuit idea references

Whether as a PC data base or as hard copy, SoftCopy can supply a complete index of *Electronics World* articles going back over the past eight years.

The computerised index of *Electronics World* magazine covers the eight years from 1987 to 1995 – volumes 94 to 101 inclusive – and is available now. It contains almost 2000 references to articles, circuit ideas and applications – including a synopsis for each.

The EW index data base is easy to use and very fast. It runs on any IBM or compatible PC with 512k ram and a hard disk.

Even though the disk-based index has been expanded significantly from five years to eight, its price is still only £20 inclusive. Please specify whether you need 5 1/4 in, 3.5 in DD or 3.5 in HD format. Existing users can obtain an upgrade for £15 by quoting their serial number with their order.

Hard copy *Electronics World* index

Indexes on paper for volumes 100 and 101 are available at £2 each, excluding postage.

The image shows two overlapping screenshots of a computer database interface. The top window, titled 'Circuit Ideas', lists various electronic projects such as 'Remote motor control', 'Resistance multiplier', 'SCR Inverter', and 'Simultaneous insertion & return loss'. The bottom window, titled 'Design: RF', lists references to articles on topics like 'Directional couplers, hybrid', 'Gigahertz Systems on a Chip', and 'Microwaves, New wave'. A sidebar on the right of the bottom window lists specific articles with their dates and page numbers, such as '#1 Concepts, circuits & devices' from April 1994.

Photo copies of

Electronics World articles

Photo copies from back issues of *Electronics World* are available at a flat rate of £3 per article or 50p per circuit idea, both excluding postage.

Ordering details

The EW index data base price of £20 includes UK postage and VAT. Add an extra £1 for overseas EC orders or £5 for non-EC overseas orders.

Postal charges on hard copy indexes and on photocopies are 50p UK, £1 for the rest of the EC or £2 worldwide.

For enquiries about photocopies, etc,

please send an sae to SoftCopy Ltd at the address below.

Send your order to SoftCopy Ltd., 1 Vineries Close, Cheltenham GL53 0NU, tel 01242 241455, or e-mail at 100556.112@compuserv.com. Please make cheques payable to SoftCopy Ltd – not EW or Reed Business Publishing. Please allow up to 28 days for delivery.

Message beacon

Bill Francis' PIC-based wireless message system is kept simple by having pre-determined messages in eeprom at the receiving end.

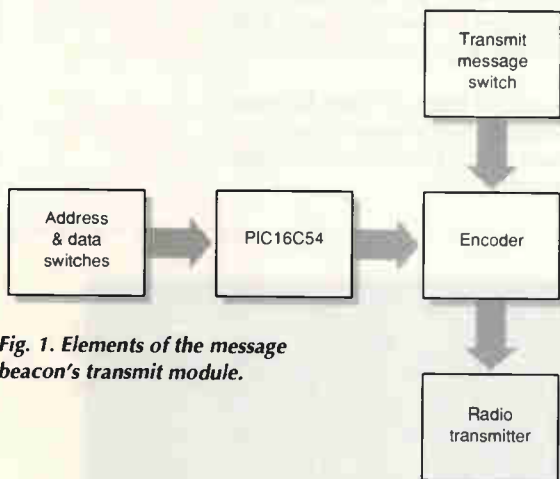

Fig. 1. Elements of the message beacon's transmit module.

On occasions, it is useful to have information conveyed to a number of display stations throughout a given area. In an office block, for example, it may be necessary to have a message display showing pricing information, periodically updated, in every room in the building.

The solution described here simplifies the task by storing pre-written messages in eeprom within each remote display unit. It incorporates existing remote control ICs – namely the *M145026* and *27* – to translate receiver and message information.

The requirement here is for a message display system capable of displaying predetermined messages on one of several display units, all controlled from a central transmitter via a wireless link. The link is achieved using a uhf transmitter module and matching receiver, namely the *TXM-418-A* and *SILRX-418-A* respectively.

Transmitting messages

Circuitry for the transmitter is relatively simple. Figure 1 shows its block diagram. Control is carried out by a *16C54* PIC, programmed to read two switches connected to port B bits *PB₅* and *PB₆*. Switch *SW₁* is the 'address count'. When this switch is made, the PIC increments the address input to the *M145026* encoder up to a maximum of 31. Further increments cause the address count to 'roll over' to zero. The address identifies one of 31 receiver units.

In a similar way, *SW₂* operates the 'data count' corresponding to the message to be displayed. The maximum value for the data count is 15. Again, any further increment causes the data count to roll over to zero.

The address and data values are output on the PIC port B bits *PB₀* to *PB₄* and port A respectively. These values are connected to the corresponding inputs of the *M145026* encoder and leds via inverters indicating the address and data values to the user. Passive components around the encoder set the IC's clock frequency to a relatively slow 8.53kHz.

Switch *SW₃* is the transmit switch. When this switch is made, the IC outputs the code on its data out pin 15. Data output connects to the input of the radio transmitter module via comparator, *IC₅*, which provides a 12V logic level to the transmitter. Code is then transmitted.

A number of options are available in the choice of antenna. The one used here is a helical type, constructed from 34 turns of 0.5mm diameter enamelled copper wire close wound on a 2.5mm former. This gives the best compromise in terms of performance, ease of use and immunity to de-tuning. Figure 2 is the circuit diagram.

The number of functions available on the transmitter is dictated by the software for the PIC microcontroller,

PIC emulation on a shoe string

Developing a microcontroller-based system can be very expensive. For this design, a new PIC development system called *PIC-DATS* was used. This allowed the development investment, excluding that for the host pc, to be kept below £300 – and that price includes in-circuit emulation.

Capable of handling Microchip's *16C54*, *55*, *56*, *57* and *84* microcontrollers, the unit interfaces to any pc compatible via the serial port. Interface software provided with the unit carries out a number of functions, all operating seamlessly. Programs are written via the user's own editor, such as MS-DOS EDIT. They are then assembled using Microchip's cross-assembler and debugged – all from within the same environment.

An add-on provides the facility to program the microcontroller when program development is complete. This add-on can also program the *16C71* and erase the *16C84* since it has electrically-erasable prom for both program and data.

One of the features of *PIC-DATS* is that PIC programs are simulated on the pc, but when the programs make reference to input and output, data is read and written to and from a 40-way connector on the development unit. This means that programs can be developed and debugged with real i/o.

Taking this a stage further, it is possible to connect the 40-way connector to a chip header that can be plugged into the PIC IC socket on a pcb under development. This means that the only difference between the *PIC-DATS* and a true in-circuit emulator is that the *PIC-DATS* cannot operate at true speed. Since the programs are simulated on the pc, the speed at which the program runs depends on the standard of pc being used.

Fig. 2. Transmitter circuit diagram.

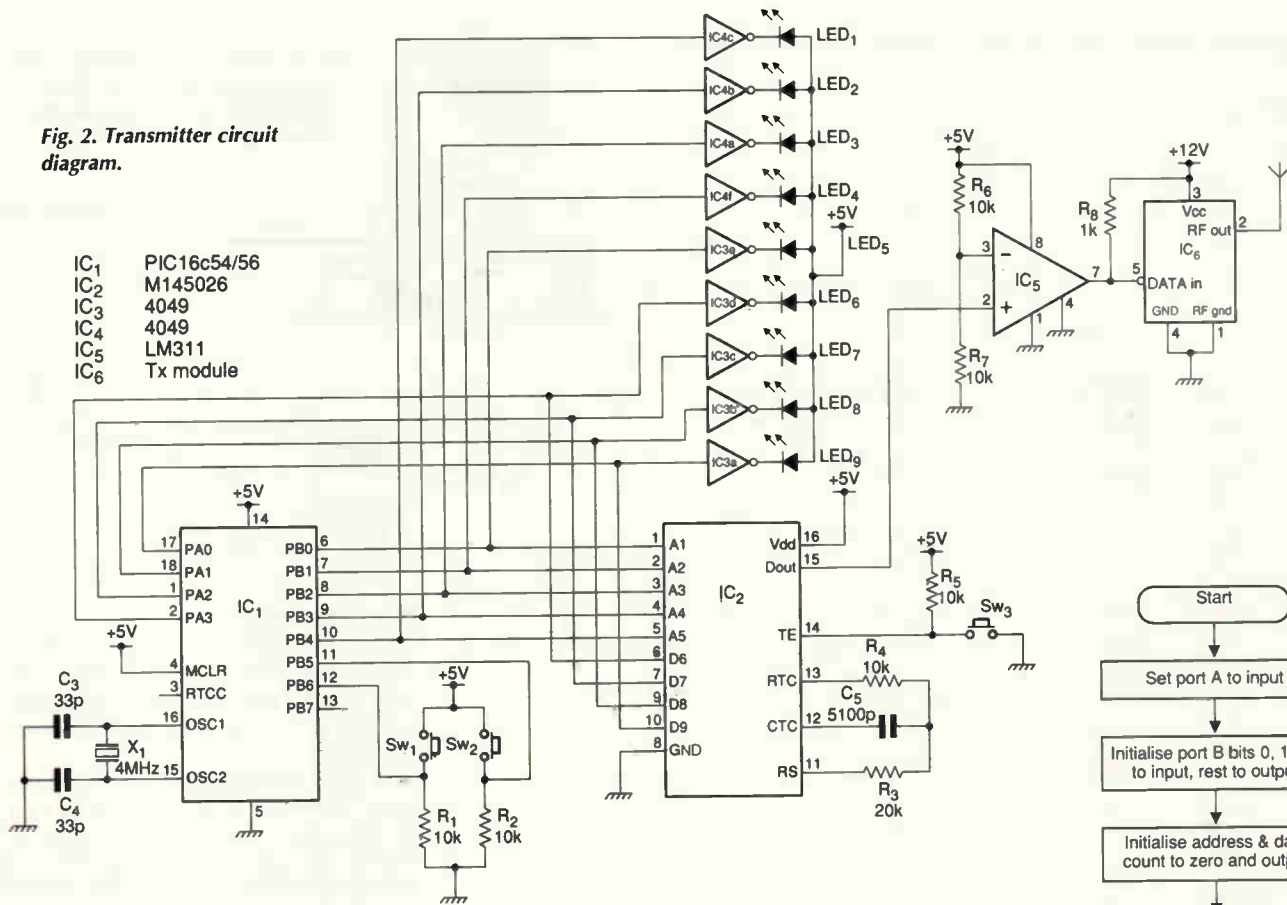

- IC₁ PIC16c54/56
- IC₂ M145026
- IC₃ 4049
- IC₄ 4049
- IC₅ LM311
- IC₆ Tx module

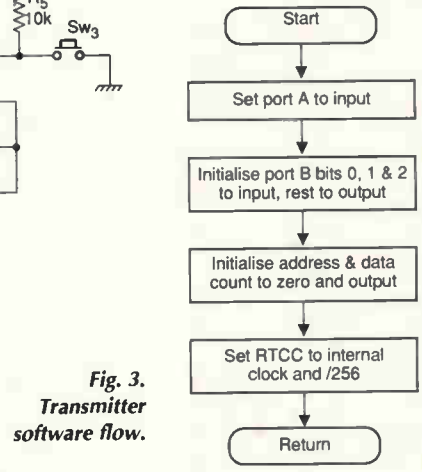

Fig. 3. Transmitter software flow.

which is relatively simple. The program has two main functions. One is to read the address count switch, SW₁. If the switch is made, the address counter is incremented and the value is output on the appropriate port. The other is to read the data count switch, SW₂. If this switch is made, the data counter is incremented and the value is output on the appropriate port.

Using a PIC for the control functions reduces the chip count to one. If standard logic were used, the chip count could easily be four or five. This microcontroller approach makes pcb design much simpler and puts less demand on the power supply. It also gives more flexibility since the software can easily be modified.

Transmitter software

Even the relatively simple program for the transmitter microcontroller requires some thought before coding is attempted. First, the individual functional blocks must be isolated. The functional blocks described here are:

- Microcontroller and variable initialisation
- Switch de-bounce
- Increment address count and output
- Increment data count and output

You may not need all of the blocks depending on your application. Remember that these are subroutines. A main control program is also required to coordinate the routines.

Initialisation. Usually, the microcontroller requires initialising only once. This is normally the first operation to be performed on power up.

The ports have to be set to input or output, or a combination of both, and the option register has to be initialised to set the real-time-clock, or rtc. In this case, the rtc is used on the internal clock and has the pre-scaler assigned to divide-by-256. This division is used in a delay routine for de-bouncing the switches.

Finally, the outputs will need to be set to their initial values and any variables, or file registers, initialised. The flow chart is shown in Fig. 3 and the corresponding code is shown in the full listing under the label INTP.

Switch de-bounce. A simple delay routine debounces the switches. This delay is derived from the rtc, which is set to increment via its internal clock through a 256 pre-scaler. The rtc register is cleared then the program loops until bit 7 of the rtc is set. Further flow charts are not shown here, but the complete program listing is given in Fig. 3.

Increment address counter. When the increment address switch, SW₁, is made the UP_ADDRESS routine is called. The delay routine is called immediately, in order to de-bounce the switch. On return from the delay routine the switch is tested again. If it is not still made, the routine returns taking no action. This guards against spurious noise and spikes.

If the switch is still made, the address counter is incremented if the present value is less than 31, otherwise it is set to zero. The routine then waits until the switch is released and again is de-bounced by calling the delay routine. The address value is then output on the appropriate port.

Increment data counter. Operation of this routine is identical to that of the increment address counter with three exceptions: it reads increment data switch, SW₂, whose maximum value is 15, and the data is output to a different port.

The control program

To begin with, the main or control calls the initialisation routine then enters a never ending loop, continually testing the two switches. If one of the switches is pressed, the program is directed to the appropriate routine as can be seen in the program listing.

When the program is complete, it requires testing. Using the PIC-DATS programmer (detailed later) allows each routine to be tested individually, first in simulation only, then, when necessary, using the in-circuit emulator cable in order to reflect real input and output.

Once the PIC-DATS is connected to the pc, and the associated software started, the user is presented with an information screen on the pc. The in-circuit emulator cable is then connected between the PIC-DATS unit and the PIC IC socket on the circuit board, Fig. 4. The assembled program is then loaded onto the programmer system allowing the user to run, trace or single step any part or all of the program.

List 1. Transmit control subroutines. Routines are called when a switch is pressed.

```

;***** EXP1.ASM *****
;FILE SAVED AS TXMOD.ASM
;FOR PIC 16C55 18 PIN DEVICE
;RESONATOR 4Mhz
;INSTRUCTION CLOCK 1.00 Mhz T= 1uS
;WATCHDOG DISABLED
;CODE PROTECTION OFF
PROCESSOR 16C54
TITLE "Transmitter module program"
INCLUDE EQUATES.ASM
DATA EQU 10H ;IC DATA WORD
ADDRESS EQU 11H ;IC ADDRESS WORD
ORG 1FFH ;CHANGE ADDRESS DEPENDING ON PIC TYPE
;SEE RESET VECTOR SECTION
;THE PROGRAM STARTS HERE
RESET START
GOTO START ;***** THE ROUTINES START HERE *****
ORG 00
START CALL INITP ;INITIALISE PORTS
REPEAT BTFSB PORTB,6 ;TEST FOR UP ADDRESS
CALL UP_ADDRESS ;IF ON INCREMENT ADDRESS
BTFSB PORTB,5 ;TEST FOR UP DATA
CALL UP_DATA ;IF ON INCREMENT DATA
GOTO REPEAT ;DO FOREVER
DELAY CLRF RTCC ;SET DELAY
DEL_LOOP BTFSB RTCC,6 ;TEST BIT 6
GOTO NEXT ;IF SET JUMP TO MEXT
GOTO DEL_LOOP ;ELSE JUMP TO DEL_LOOP
NEXT RETLW 0 ;RETURN
UP_ADDRESS CALL DELAY ;DEBOUNCE SWITCH
BTFSB PORTB,6 ;TEST IF STILL PRESSED
GOTO END_UP_ADDRESS ;IF NOT PRESSED THEN DO NOTHING
WAIT_AS BTFSB PORTB,6 ;WAIT TILL SWITCH RELEASED
GOTO WAIT_AS ;WAIT ADDRESS SWITCH
CALL DELAY ;DEBOUNCE SWITCH RELEASE
MOVLW 1 ;SET W=1 FOR ADD
ADDWF ADDRESS ;ADDRESS:=ADDRESS+1
BTFSB ADDRESS,5 ;TEST IF > 31
GOTO ADDRESS_ZERO ;IF > 31 SET TO ZERO
CONT_ADDRESS MOVF ADDRESS,W ;GET ADDRESS
MOVWF PORTB ;AND OUTPUT
END_UP_ADDRESS RETLW 0 ;RETURN
ADDRESS_ZERO CLRF ADDRESS ;SET ADDRESS TO 0
GOTO CONT_ADDRESS ;AND CONTINUE
UP_DATA CALL DELAY ;DEBOUNCE SWITCH
BTFSB PORTB,5 ;TEST IF STILL PRESSED
GOTO END_UP_DATA ;IF NOT PRESSED THEN DO NOTHING
WAIT_DS BTFSB PORTB,5 ;WAIT TILL SWITCH RELEASED
GOTO WAIT_DS ;WAIT DATA SWITCH
CALL DELAY ;DEBOUNCE SWITCH RELEASE
MOVLW 1 ;SET W=1 FOR ADD
ADDWF DATA ;DATA:=DATA+1
BTFSB DATA,4 ;TEST IF > 15
GOTO CONT_DATA ;IF > 15 SET TO ZERO
CONT_DATA MOVF DATA,W ;GET DATA
MOVWF PORTA ;AND OUTPUT
END_UP_DATA RETLW 0 ;RETURN
DATA_ZERO CLRF DATA ;SET DATA TO 0
GOTO CONT_DATA ;AND CONTINUE
INITP RETLW 0 ;RETURN
MOVLW 0 ;MAKE PORT A OUTPUT
TRIS PORTA ;DO IT
MOVLW #0E0H ;PORT B BITS 7, 6 & 5 INPUT, REST OUT
TRIS PORTB ;DO IT
MOVLW 0 ;CLEAR W
MOVWF DATA ;DATA = 0
MOVWF ADDRESS ;ADDRESS = 0
MOVWF PORTA
MOVWF PORTB
MOVLW 7 ;SET RTCC PRE-SCALER = 256
OPTION ;DO IT
RETLW 0 ;RETURN
END
    
```

The PIC-DATS system is menu driven so operation is largely intuitive. For example, to single-step the main program, simply select the 'debug' pull down menu using the keyboard or mouse, select single step and press enter. The user is then prompted for a start address, 'R' specifies the reset address, and reset condition.

Subsequent single steps are then executed by pressing the return or 'S' key. This continues until any other key is pressed. The last line

of code executed is shown on the user screen and the next line to be executed is shown in the top right-hand corner of the user screen.

As single stepping continues, the values read from the switches are 'real' values and can be seen in the appropriate file register. In the PIC-DATS system, if the program is found to perform incorrectly, it can be edited, cross-assembled and reloaded, all from within the programmer system. This allows rapid program development.

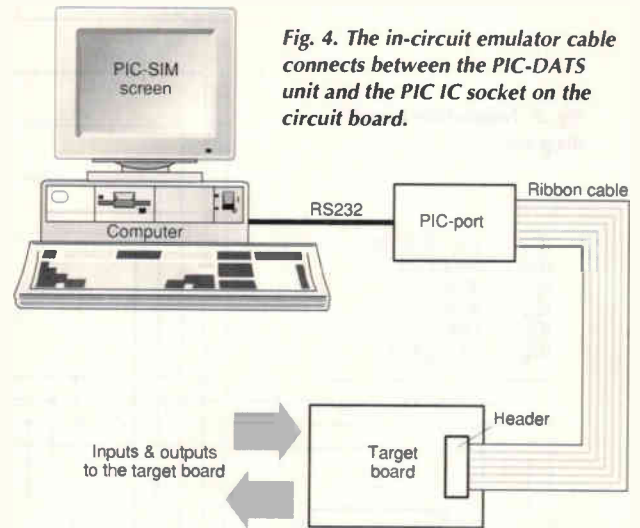

Fig. 4. The in-circuit emulator cable connects between the PIC-DATS unit and the PIC IC socket on the circuit board.

Receiver details

Messages for displaying by the receiver are stored in an eeprom. The content of the actual messages will vary depending on the particular application. Programming of the eeprom is up to you.

As a guide, the messages for the eeprom used in the development unit were written on a microprocessor cross-assembler using the 'define message' assembler directive. The eeprom was then programmed. The maximum length of the message in this application is 127 characters, which is adequate for most liquid-crystal display modules.

The PIC is not designed for interfacing to external memory, but an eeprom can be interfaced using the PIC's i/o ports. This approach does, however, require that data transfers are performed under program control. Addressing the eeprom and retrieving the data involves 8 data lines and 11 address lines.

The PIC used in the receiver is the 16C55 which has 20 programmable i/o pins. Clearly, some sharing of i/o resources is needed. To accomplish this, part of the eeprom address is latched using a 74LS374 octal data latch. In effect, a bus system is created. This bus uses port C of the PIC to transfer data and bits 0-2 and 4-7 of port B to control the data transfers, Fig. 5. A block diagram of the receive and decode section is shown in Fig. 6.

Software and circuit operation

The radio receiver module receives the encoded transmission and passes the digital data to the input of the M145027 decoder. If the transmitted address matches the address set up on the address select switches, the decoder issues a valid transmission, VT, signal and outputs the transmitted code.

This allows up to 32 receiver modules to be used individually with one transmitter unit. The VT signal connects to port B bit 3 of the PIC which, under program control, waits till the VT signal goes active low.

When the PIC receives an active VT, again under program control, the PIC reads the code from the decoder via port A. This code is then used as the upper four bits of the eeprom

address thus forming the 'base address' of the message to be displayed. In order to display the message the PIC must perform the following actions:

- The base address – the code received – must be output on address lines A₇₋₁₀ (A₈₋₁₀ via port B bits 0-2, and A₇ latched from port C, bit 7).
- Lower order address lines are set to zero and latched on to A₀₋₆ of the eeprom. Data is read from the eeprom. If the data is zero, the processes is ended (null terminating string).
- The data is written to the lcd module.
- The address is incremented.
- Go to step 2.

As mentioned in the description of the transmitter, each operation must be isolated and coded individually. The receiver module is more complex than the transmitter unit so great care must be exercised in isolating and developing each operation, or sub-routine.

When a particular solution is developed, it is important that its operation is tested as much as possible before moving to the next task. This can be achieved using the PIC-DATS unit since it is possible to run each subroutine using the in-cable and monitor the various signals on the receiver unit as the routine is stepped through. Here, the following individual requirements were isolated:

- Initialise PIC
- Delay
- Wait for 'not busy' from lcd module
- Write data to lcd module
- Clear lcd module
- Initialise lcd module
- Clock address latch
- Read eeprom
- Main control routine

The program listing shows that each one of the above operations corresponds to a subroutine. As the programs are developed, each subroutine is tested as a self-contained item. When the routine operation is acceptable, that routine is used as required within a program. This is the best way to develop.

Initialising the PIC. Initialisation of the PIC divides in to two parts – the operation of the ports and the OPTION register. The ports are set to input or output and assigned an initial value as indicated in Table 1.

In this case, the OPTION register is used to set the prescaler to 256 and assign it to the rtc with internal clock. The routine performing these operations can be seen in the program listing under the name INITP.

Delay. The delay routine is a general purpose delay for use by other routines. It is similar to that described in the transmitter section of this project and therefore will not be further described here.

Wait for not busy from lcd module. The lcd module control signals are interfaced as indicated in Table 1. Port C is used as the data bus while the three control bit are derived from port B and have functions as shown in Table 2.

The lcd module carries out commands internally following a command instruction. While the command is being executed, no further commands or data may be written to the module. The display module uses the 'Busy' signal to indicate the current status of the device and is accessed by performing a read cycle and examin-

List 2. Routines for the PIC-controlled message receiver module.

```

;***** RXMOD.ASM *****
;FOR PIC 16C55          28 PIN DEVICE
;RESONATOR            4MHZ
;INSTRUCTION CLOCK    4.00 MHZ T= 1uS
;WATCHDOG              DISABLED
;CODE PROTECTION      OFF
PROCESSOR 16C55
TITLE "Receiver module program"
INCLUDE EQUATES.ASM
LCD_EN EQU 7H ;LCD ENABLE BIT
LCD_WR EQU 6 ;LCD W/notW BIT
LCD_RS EQU 5 ;LCD REG SEL BIT (SAME AS LATCH EN)
LATCH_EN EQU 5 ;LATCH ENABLE ACTIVE HIGH
EPROM_OE EQU 4 ;EPROM OUTPUT ENABLE ACTIVE LOW
VT EQU 3 ;VALID TRANSMIT BIT
EPROM_DATA EQU 11H ;STORE FOR EPROM DATA
MESSAGE_CODE EQU 12H ;STORE FOR RECEIVED CODE
ADDRESS EQU 13H ;STORE FOR ADDRESS
ORG 1FFH ;RESET ADDRESS
;RESET VECTOR
;PROGRAM START

RESET
GOTO START ;PROGRAM START
;***** THE ROUTINES START HERE *****
ORG 00
START CALL INITP ;INITIALISE PORTS
CALL DELAY ;ALLOW POWER UP TIME
CALL INIT_LCD ;RESET LCD MODULE
REPEAT BTFSF PORTB,VT ;TEST VALID TRANSMIT BIT
GOTO REPEAT ;AND WAIT TILL NOT VALID
WAIT_VT_VALID
BTFSF PORTB,VT ;TEST VALID TRANSMIT BIT
GOTO VALID_TX ;RECEIVED A TRANSMISSION!
GOTO WAIT_VT_VALID ;WAIT FOR VALID TRAN
;*****SUBROUTINES*****
;*****DELAY*****
DELAY CLRF RTCC ;SET DELAY
DEL_LOOP BTFSF RTCC,7 ;TEST BIT 7
GOTO NEXT ;IF SET JUMP TO MEXT
GOTO DEL_LOOP ;ELSE JUMP TO DEL_LOOP
NEXT RETLW 0 ;RETURN
;*****WAIT FOR NOT BUSY BIT*****
WAIT_BF MOVLW #0FFH ;SET PORT C TO INPUT
TRIS PORTC ;DO IT
BSF PORTB,LCD_WR ;SET READ
BSF PORTB,LCD_EN ;ENABLE LCD
WAIT_BF1 BTFSF PORTC,PB7 ;TEST BF
GOTO BF_GONE ;IF 0, LCD MOD NOT BUSY
GOTO WAIT_BF1 ;ELSE TRY AGAIN
BF_GONE BCF PORTB,LCD_EN ;DISABLE LCD MOD
BCF PORTB,LCD_WR ;PUT BACK TO WRITE
MOVLW #0 ;SET PORT C BACK TO OUTPUT
TRIS PORTC ;DO IT
RETLW 0 ;RETURN
;*****WRITE CHARACTER TO LCD MODULE FROM LOC'N EPROM_DATA *****
WRITE_LCD CALL WAIT_BF ;WAIT TILL FREE (ALSO SET C TO O/P)
MOVF EPROM_DATA,W ;GET DATA
MOVWF PORTC ;AND O/P
BSF PORTB,LCD_RS ;SELECT DATA REG
BSF PORTB,LCD_EN ;ENABLE LCD MOD
BCF PORTB,LCD_EN ;& CLOCK
BCF PORTB,LCD_RS ;RESTORE INIT COND
MOVLW #0FFH ;SET PORT C BACK TO I/P
TRIS PORTC ;DO IT
RETLW 0 ;& RETURN
;*****INIT LCD MODULE*****
INIT_LCD MOVLW 0 ;SET PORT C TO O/P
TRIS PORTC ;DO IT
MOVLW #38H ;SET COMMAND
MOVWF PORTC ;& OUTPUT TO PORT C
BSF PORTB,LCD_EN ;ENABLE LCD MOD
BCF PORTB,LCD_EN ;& CLOCK
CALL DELAY ;WAIT
BSF PORTB,LCD_EN ;ENABLE LCD MOD 2ND TIME
BCF PORTB,LCD_EN ;& CLOCK
CALL DELAY ;WAIT
BSF PORTB,LCD_EN ;ENABLE LCD MOD 3RD TIME
BCF PORTB,LCD_EN ;& CLOCK
CALL DELAY ;WAIT
MOVLW #38H ;FUNCTION SET
MOVWF PORTC ;O/P IT
BSF PORTB,LCD_EN ;ENABLE LCD MOD
BCF PORTB,LCD_EN ;& CLOCK
CALL DELAY ;WAIT
MOVLW #8 ;DISPLAY OFF
MOVWF PORTC ;O/P IT
BSF PORTB,LCD_EN ;ENABLE LCD MOD
BCF PORTB,LCD_EN ;& CLOCK
CALL WAIT_BF
MOVLW #1 ;DISPLAY ON & CLEAR
MOVWF PORTC ;O/P IT
BSF PORTB,LCD_EN ;ENABLE LCD
BCF PORTB,LCD_EN ;& CLOCK
CALL WAIT_BF
MOVLW 06H ;ENTRY MODE
BSF PORTB,LCD_EN ;ENABLE LCD
BCF PORTB,LCD_EN ;& CLOCK
CALL WAIT_BF
SET_LCD MOVLW 0 ;SET PORT C TO O/P
TRIS PORTC ;DO IT
MOVLW #38H ;FUNCTION
SET

```

Continued over page

```

MOVWF PORTC ;O/P IT
BSF PORTB,LCD_EN ;ENABLE LCD MOD
BCF PORTB,LCD_EN ;& CLOCK
CALL WAIT_BF
MOVLW #0EH ;DISPLAY ON
MOVWF PORTC ;O/P IT
BSF PORTB,LCD_EN ;ENABLE LCD MOD
BCF PORTB,LCD_EN ;& CLOCK
CALL WAIT_BF
MOVLW #6H ;ENTRY MODE SET
MOVWF PORTC ;O/P IT
BSF PORTB,LCD_EN ;ENABLE LCD MOD
BCF PORTB,LCD_EN ;& CLOCK
CALL WAIT_BF
MOVLW #1H ;CLEAR DISPLAY
MOVWF PORTC ;O/P IT
BSF PORTB,LCD_EN ;ENABLE LCD MOD
BCF PORTB,LCD_EN ;& CLOCK
CALL WAIT_BF
MOVLW #0H ;
MOVWF PORTC ;O/P IT
BSF PORTB,LCD_EN ;ENABLE LCD MOD
BCF PORTB,LCD_EN ;& CLOCK
MOVLW #0FFH ;SET PORT C BACK TO
INPUT
TRIS PORTC ;DO IT
RETLW 0 ;RETURN
;*****GO TO HEXTE LINE (LINE 2)*****
LINE_2 CALL WAIT_BF ;WAIT FOR NOT BUSY,(SET
C TO O/P)
2) MOVLW #0C0H ;SET DD RAM TO 40 (LINE
MOVWF PORTC ;O/P IT
BSF PORTB,LCD_EN ;ENABLE LCD MOD
BCF PORTB,LCD_EN ;& CLOCK
MOVLW #0FF ;SET PORT C TO INPUT
TRIS PORTC ;DO IT
RETLW 0 ;RETURN
;*****CLOCK LATCH DATA TO EPROM LATCH*****
CLOCK_LATCH_DATA
CLRWF PORTC ;SET PORT C TO OUTPUT
TRIS PORTC ;DO IT
MOVF ADDRESS,W ;GET DATA TO LATCH
MOVWF PORTC ;AND OUTPUT
BSF PORTB,LATCH_EN ;CLOCK LATCH
BCF PORTB,LATCH_EN ;
MOVLW #0FFH ;SET PORT C TO INPUT
TRIS PORTC ;DO IT
RETLW 0 ;RETURN
;*****READ EPROM AND STORE DATA*****
READ_EPROM BCF PORTB,EPROM_OE ;EPROM OUTPUT ENABLE
NOP ;WAIT
MOVF PORTC,W ;READ DATA
MOVWF EPROM_DATA ;AND STORE
BSF PORTB,EPROM_OE ;DISABLE EPROM OUTPUT
RETLW 0 ;AND RETURN
;*****INITIALISE I/O*****
INITP CLRWF PORTC ;PORT C = 0
CLRWF PORTA ;PORT A = 0
CLRWF PORTB ;PORT B = 0
MOVLW #0FFH ;MAKE PORT A INPUT
TRIS PORTA ;DO IT
MOVLW #08H ;PORT B BIT 3 INPUT,REST OUT
TRIS PORTB ;DO IT
MOVLW #10H ;INIT PORT B
MOVWF PORTB ;DO IT
MOVLW #0FFH ;SET PORT C TO INPUT
TRIS PORTC ;DO IT
MOVLW #7 ;SET RTCC DIVIDE FACTOR
OPTION ;DO IT
RETLW 0 ;RETURN
;*****MAIN CONTROL ROUTINES
VALID_TX CALL SET_LCD ;GOT A TRANSMISSION
MOVF PORTA,W ;INITIALISE LCD MODULE
MOVWF MESSAGE_CODE ;READ MESSAGE CODE
;AND STORE
;SET UP ADDRESS
CLRWF ADDRESS ;SET ADDRESS TO ZERO
BTFSC PORTA,W ;TEST LSB OF CODE
BSF ADDRESS,7 ;IF SET, SET MSB OF ADDRESS
RRF MESSAGE_CODE ;MOVE CODE 1 TO RIGHT
NEXT_CHAR CALL CLOCK_LATCH_DATA ;LATCH ADDRESS ONTO EPROM
MOVLW #0F8 ;CLEAR BASE ADDRESS BITS
ANDWF PORTB ;DO IT
MOVF MESSAGE_CODE,W ;GET BASE ADDRESS
IORWF PORTB ;SET UP 3 LSB'S LEAVING OTHER BITS
CALL READ_EPROM ;READ EPROM DATA..DATA IN EPROM_DATA
;TEST FOR ZERO (EOL)
MOVF EPROM_DATA,W ;RETRIEVE DATA
IORLW #0 ;TEST FOR ZERO
BTFSC STATUS,ZERO ;IF NOT ZERO CARRY ON
GOTO REPEAT ;ELSE END
MOVLW #1 ;SET UP INCREMENT
ADDWF ADDRESS ;INCREMENT ADDRESS
MOVLW #10H ;TEST FOR END OF LINE 1
SUBWF EPROM_DATA,W ;
BTFSC STATUS,ZERO ;IF NOT LINE TO SKIP
GOTO NEW_LINE ;ELSE NEW LINE
CALL WRITE_LCD ;ELSE WRITE DATA TO LCD
GOTO NEXT_CHAR ;DO NEXT
NEW_LINE CALL LINE_2 ;GO TO LINE 2
GOTO NEXT_CHAR ;AND CONTINUE
END

```

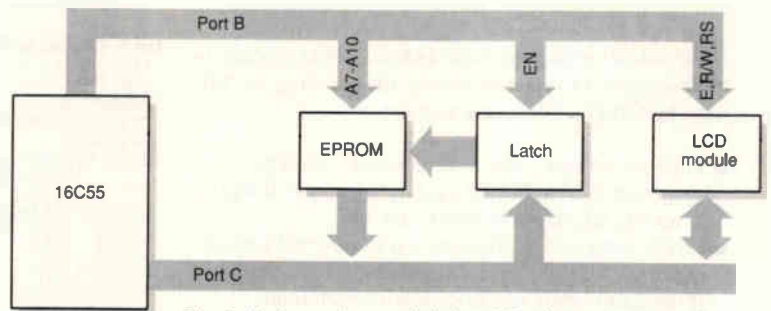

Fig. 5. Each receiver module has PIC whose ports B and C are used as control, address and data buses for the message eprom and display. The latch allows the eprom address range to be extended.

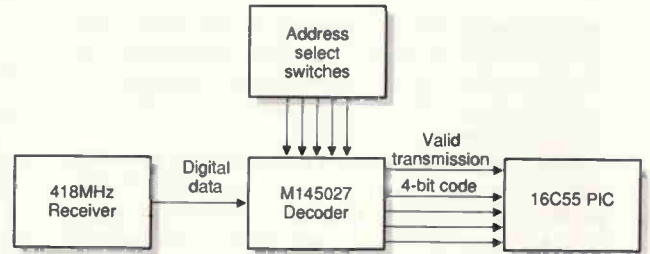

Fig. 6. Overall system diagram of the receiver module shows how the low-power radio receiver feeds the decoder module, which in turn sends the received information to the PIC.

ing the state of bit 7 – the busy signal. If the busy signal is high, then an internal operation is in progress and no further information may be written to the device.

Wait for not busy. This routine performs the following sequence:

Port C is made input.

The lcd module is set to 'read' by setting the R/W bit and enabled by setting the enable bit.

The data bus – port C of the PIC – is then read and bit 7 tested.

If Bit 7 is a logic 1, step 3 is repeated.

The read and enable bits are cleared.

Port C put back to output.

The routine associated with this process can be seen in the program listing under the label 'WAIT_BF'. As it's name suggests, this subroutine cycles waiting till the lcd module is not busy before a return is executed.

Write data to lcd module. This routine writes data held in a file register, named EPROM_DATA, to the lcd module. In this application, the data is the data previously retrieved from the eprom and stored by the READ_EPROM routine, described later. The write operation is accomplished by performing the following steps:

Call the WAIT_BF routine. This makes sure that the lcd module is ready to receive data. Note also that port C is left as output.

Data held in register file EPROM_DATA is retrieved, placed it in the W register, and output it to port C, which is connected to the data pins of the lcd module. Set the RS bit of the lcd module to logic 1 to select data, and enable the lcd module by placing a logic zero on the enable pin.

Clock data into the lcd module by clearing the enable bit followed by disabling the lcd module. Set port C to input.

applied to the address lines, this is achieved by latching the address into the address latch. The required sequence is as follows:

- Set port C to output.
- Retrieve current address and send to port C.
- Set then clear latch enable bit to clock latch.
- This bit is port B bit 5, called LATCH_EN.
- Restore port C to input.

In the program listing, this subroutine is called 'CLOCK_LATCH_DATA'.

Read eeprom data. In normal operation data is read from eeprom automatically when a microprocessor performs a read operation. All the control signals are provided by the microprocessor. In this case the data transfer must be performed under program control by producing the following sequence:

- Enable the eeprom outputs by clearing the output enable which is connected to port B bit 4, labelled LATCH_EN.
- Read port C which now has the EPROM data applied.

Disable the EPROM outputs by setting the output enable high.

This sequence is carried out by the READ_EPROM routine in the program listing. The main program simply calls each subroutine as required. One facility not mentioned so far is the ability to include a new line control within the stored message. The line-feed code 10₁₀ is used to indicate that the cursor on the lcd module should be moved to the start of line two. As each code is read from the eeprom, it is tested for a new line. If a new line is required the subroutine LINE_2 is called.

Circuit details

The complete circuit diagram is shown in Fig. 7. Note the way port C of the PIC is used as a bus system. Each device on the bus is capable of being tri-state which allows each device to be selected under program control. It should be apparent that it is very important that programmer is especially careful to enable only one device at a time to avoid bus conflict.

The receiver is tested using the same approach as the transmitter, each routine test-

ed and proved individually using the PIC-DATS with or without the in-circuit emulator cable, then the program is tested as a whole.

As the program is traced – or run – and with the optional in-circuit emulator cable fitted, each character of the message can be seen as it is transferred from the eeprom to the lcd module. The process is complete by programming the PIC, probably a one-time programmable version, using a PIC programmer, then inserting the chip in the socket on the circuit board.

One transmitter is capable of controlling up to 32 receiver units. The transmitter and receiver were designed to be 'stand alone' so the system can be used in almost any environment. ■

The low-power transmitter and receiver mentioned in this article are available from Radiometrix at a 50% discount to readers mentioning this article – until 30 May. Call Radiometrix on 0181 4281220 or fax on 4281221. Further information, including full data, can be found on <http://www.radiometrix.co.uk>.

Develop PIC microcontroller systems for just £239

Vann Draper is launching a PIC development system called PIC-DATS that sells for under £300 – including development module, simulation and software design tools, power supply, COM port cable and manual.

As a bonus, the company is making the system available exclusively to EW readers at a 20% discount, so you can buy the development system, with software, for just £239 – fully inclusive.

Connecting via a serial port, the PIC-DATS development system handles 16C5x, 16C85 and 16C71 PIC controllers. The development system includes PIC-SIM – a software package that simulates the PIC on your pc compatible.

Programs under development are written

and run on the pc, but when program instructions refer to peripherals, the operation is reflected on the PIC's i/o lines. In this way, you get the benefits of simulation – single-stepping and easy debugging – combined

with the advantages of emulating the system in the real world. Emulation cables for a wide variety of PIC microcontrollers are available as optional extras. Ring Vann Draper for more details on 0116 2771400, fax 2773945.



PIC-PORT hardware features

- 16C55 microcontroller running at 4MHz.
- 16C55 input/output and control lines accessed via 40 IDC connector.
- RS232 port using the 16C55 on board serial communications.
- PIC and serial driver/receiver socketed.
- Unregulated 8-18V dc or regulated +5V dc supply.
- 5V supply sourced from the i/o connector.

PIC-SIM simulation software features

- Line-by-line assembler
- Assembly code assembled direct into memory.
- Disassembler.
- PIC code programs may be entered directly into the simulator
- Intel hex merged format files may be loaded from the user's assembler
- PIC cross assembler MPASM supplied as standard
- Register operations – registers are displayed on host pc
- Contents of any file may be modified.
- User programs run in real time
- Programs continue until sleep instruction, watch-dog time-out or manual halt
- In trace mode, instructions are detailed on the host as the program runs
- PIC watch dog timer fully supported
- Break point program development tool
- Single stepping possible via a single key press

PIC-SIM is an integrated environment. User's cross-assembler, editor and DOS commands are directly accessible via the PIC-SIM communication software providing the totally integrated environment.

Please send me

..... PIC-DATS(s) PIC development systems at £239 each (fully inclusive) for which I enclose a total of £.....

Name

Company (if any)

Address

Phone number/fax

Make cheques payable to Vann Draper Electronics Ltd
Or, please debit my Master, Visa or Access card.

Card type (Access/Visa)

Card No

Expiry date

Please mail this coupon to Vann Draper Electronics, together with payment. Alternatively fax credit card details with order on 0116 2773945 or telephone on 0116 2771400. Address orders and all correspondence relating to this order to Vann Draper Electronics at Unit 5, Premier Works, Canal Street, South Wigston, Leicester LE18 2PL.

*Overseas readers can also obtain this discount but details vary according to country. Please ring, write or fax to Vann Draper Electronics.

ANTRIM TRANSFORMERS LTD

TOROIDAL TRANSFORMERS



Large standard range from 15VA to 1kVA approved to EN60742 & AS3108



Custom designs to most international standards from 10VA to 3kVA



Rapid quotation, design and prototype service Any size production run catered for



All transformers manufactured at UK factory allowing fast lead times at no extra cost



70V / 100V Line, valve output & low noise audio designs available



Medical designs to IEC601/BS5724 & UL544

AGENTS / DISTRIBUTORS REQUIRED WORLDWIDE

Technical Sales Department, 30 Bramley Avenue
Canterbury, Kent, CT1 3XW, England

Tel: +44 (0)1227 450810 Fax: +44 (0)1227 764609

BRITISH MADE & BUILT TO LAST

CIRCLE NO. 126 ON REPLY CARD

Working Partners

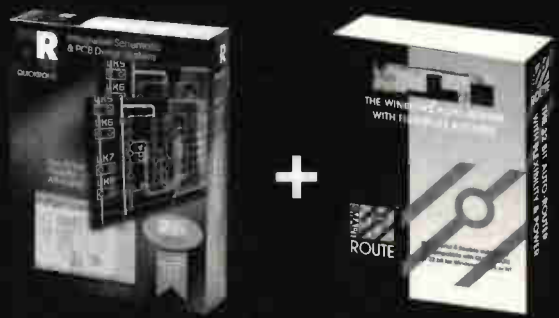

SMARTRoute's Power Quickroute's Ease of Use

Phone now and find out how
Quickroute & SMARTRoute can work for you

Tel 0161 476 0202 Fax 0161 476 0505

WWW: www.quickroute.co.uk EMail: info@quicksys.demon.co.uk

Quickroute Systems Ltd. Regent House
Heaton Lane Stockport SK4 1BS U.K.

Phone for a FREE information pack

CIRCLE NO. 127 ON REPLY CARD

8 CAVANS WAY, BINLAY INDUSTRIAL ESTATE, COVENTRY CV3 2SF

Tel: 01203 650705

Fax: 01203 650773

Mobile: 0860 400683

(Premises situated close to Eastern-by-pass in Coventry with easy access to M1, M6, M40, M42, M45 and M69)

MISCELLANEOUS

Adrat 740A - 100kHz-1120MHz Synth. signal generator	£2000
Anritsu ME462B - DS-3 transmission analyser	£3000
Anritsu MG642A - Pulse pattern generator	£1500
Barr & Stroud - EF3 variable filter (0.1Hz-100kHz)	£150
Dynapart TP20 - Intellipace tape peel tester, immac. cond.	£1750
E.I.P. 331 - 18GHz frequency counter	£850
Fuke 5100A - Calibrator	£4500
Fuke 5101B - Calibrator	£5000
Fuke 5205A - Precision power amplifier	EP O.J.L.
Fuke 7105A - Calibration system (As new)	EP O.J.L.
Guidline 9152 - T12 Battery standard cell	£55
Heiden 1107 - 30v-10A Programmable power supply (IEEE)	£850
Hewlett Packard 331A - Distortion analyser	£300
Hewlett Packard 339A - distortion measuring set	£1500
Hewlett Packard 432A - Power Meter (with 478A Sensor)	£275
Hewlett Packard 435A or B - Power Meter (with 8481A/8484A)	from £750
Hewlett Packard 16300 - Logic Analyser (43 channels)	£1950
Hewlett Packard 16500A - Fitted with 16510A/16515A/16530A/16531A Logic analyser	£4000
Hewlett Packard 3325A - 21MHz synthesiser/function gen.	£1500
Hewlett Packard 3336A - Synthesised, signal generator (10Hz-21MHz)	£1000
Hewlett Packard 3437A - System voltmeter	£350
Hewlett Packard 3438A - Digital multimeter	£200
Hewlett Packard 3455A - 8 1/2 digit multimeter (autoscal)	£750
Hewlett Packard 3456A - Digital voltmeter	£750
Hewlett Packard 3478A - Multimeter (5 1/2 digit) HPB	£550
Hewlett Packard 3488A - HP-IB switch/control unit (various plug-ins available)	£650
Hewlett Packard 3711A/3712A/3791B/3793B - Microwave link analyser Sensor	£2485
Hewlett Packard 3776A - PCM Terminal test set	£2000
Hewlett Packard 3779 A/C - Primary mux analyser	£600/£500
Hewlett Packard 4271B - LCR meter (digital)	£900
Hewlett Packard 4275A - Multi-frequency LCR meter	£3950
Hewlett Packard 4279A - 1MHz, C-V meter	£650
Hewlett Packard 4338A - Milliohmeter (as new)	£2000
Hewlett Packard 4342A - Q meter	£995
Hewlett Packard 4948A - transmission impairment measuring set	£2000
Hewlett Packard 4953A - Protocol analyser	£1995
Hewlett Packard 4954A - Protocol analyser	£2250
Hewlett Packard 4972A - LAN protocol analyser	£2000
Hewlett Packard 5314A - new 100MHz universal counter	£250
Hewlett Packard 5328A - 100MHz universal frequency counter	£2500
Hewlett Packard 5342A - Microwave freq. counter (18GHz)	£1500
Hewlett Packard 5385A - Frequency counter 1GHz (HP1B) with Opts 001/003/004/005	£995
Hewlett Packard 6034A - System P.S.U. 0-60v/10a	£1150
Hewlett Packard 6181C - D.C. current source	£150
Hewlett Packard 6261B - Power supply 20V-50A	£450

DISCOUNT FOR QUANTITIES

Hewlett Packard 8011A - Pulse gen. 0.1Hz-20MHz	£500
Hewlett Packard 8152A - Optical average power meter	£1250
Hewlett Packard 8158B - Optical attenuator with opt's 002 & 001	£1100
Hewlett Packard 8185A - 50MHz programmable signal source	£1850

TELNET

Hewlett Packard 8349B - Microwave broadband Amp (as new) 2-20MHz	£3250
Hewlett Packard 8350B - Sweep oscillator mainframe (plug-ins avail)	£2500
Hewlett Packard 8403A - modulator	£500
Hewlett Packard 8405A - Vector voltmeter	£500
Hewlett Packard 8620C - Sweep oscillator mainframe	£400
Hewlett Packard 8683A - Microwave signal gen. (2.3-6.5GHz)	£2500
Hewlett Packard 8684A - S-4GHz to 12.5GHz Sig Gen	£2500
Hewlett Packard 8750A - Storage normaliser	£375
Hewlett Packard 8901A - Modulation Analyser	£2500
Hewlett Packard 8903A - Audio analyser (20Hz-100kHz)	£1995
Hewlett Packard 8958A - Cellular radio interface	£3500
Hewlett Packard 11729B - Carrier noise test set	£2000
Marconi 8938 - A/F power meter	£295
Marconi 2018 - 80kHz-520MHz synth signal generator	£850
Marconi 2019 - 80kHz-1040MHz synth signal generator	£1750
Marconi 2019A - 80kHz-1040MHz synthesised sig. gen	£1950
Marconi 2022A - 10kHz-1GHz - AM/FM signal generator	£2000
Marconi 2610 - True RMS voltmeter	£850
Marconi 2850BS - Digital Transmission analyser (as new)	£2250
Marconi 2871 - data communications analyser	£1500
Marconi 2955 + 2956 - Radio Comms test set + tacs adaptor	£3500
Marconi 6500 - automatic amplitude analyser	£1500
Philips PM 5187 - 10MHz function gen	£400
Philips PM 5190 - LF synthesiser with GPIB	£800
Philips PM 5193 - 50MHz synthesised function generator	£1500
Philips PM 6673 - 120MHz high resolution universal counter	£350
Philips PM 6670 - 120MHz high resolution timer/counter	£350
Philips PM 6662 - 1.5 GHz programmable high resolution timer/counter	£900
Racal Dana 1992 - 130MHz frequency counter opts 4B/55	£750
Racal Dana 3100 40 - 130MHz synthesiser	£450
Racal Dana 9084 - Synth. sig. gen. 104MHz	£300
Racal Dana 9301A - True RMS R/F millivoltmeter	£950
Racal Dana 9303 - True RMS R/F level meter	£450
Racal Dana 9921 - 3GHz frequency counter	£450
Schaffner NSG 2034 - Line voltage variation simulator	£995
Schaffner NSG 222A - Interference simulator	£995
Schaffner NSG 223 - Interference generator	£750
Schlumberger 2720 - 1250MHz Freq. Counter	£600
Schlumberger 4015 - 1GHz radio comms test set	£6000
Schlumberger 4031 - 1GHz radio comms test set	£8250
Schlumberger 4031A - Radio Comms Test Set	£5000
Schlumberger 4923 - Radio Code Test Set	£900
Syston Donner 1980B - Microwave Sweeper (12-18GHz)	£2500
7777 & Schwarz MFP22 - 1GHz radio comms test set + options	£2500
7777 & Schwarz URE - RMS Voltmeter DC 10Hz to 25MHz	£580
Tektronix 577 - Curve Tracer	£1150
Tektronix 580 - Many available such as PG508, FG504, SC504, SW503, SG502 etc	
Tektronix TMS003 - AFG5101 - Arbitrary Function Gen.	£1750
Tektronix 1240 - Logic Analyser	£750
Tektronix AM503 + TM501 + P6302 - current probe amplifier	£995
Tektronix AA5001 + TM5006 - Mainframe programmable distortion analyser	£1995
Tektronix PG506 + TG501 + SG503 TM503 - Oscilloscope calibrator	£1995
Time 9814 - Voltage calibrator	£750
Wavetek 1728 - Programmable sig. source (0.001Hz-13MHz)	£450
Wayne Kerr 8905 - Precision LCR meter	£850
Wayne Kerr 8245 - Precision inductance analyser	£3250
Wayne Kerr 8425 - Precision component analyser	£2750
Wayne Kerr 4210 - LCR meter	£500
Wiltron 6626S - Programmable sweep gen. (3.6-6.5GHz)	£650

OSCILLOSCOPES

Cossor 3102 - 60MHz dual channel	£250
Could OS255 - 15MHz dual channel	£150
Gould OS3000 - 40MHz dual channel	£250
Gould OS3351 - 40MHz dual channel	£225

Gould OS4000 - 10MHz Digital storage	£200
Gould 5110 - 100MHz Intelligent oscilloscope	£750
Hewlett Packard 1800 - 100MHz 4 channel	£300
Hewlett Packard 182C - 100MHz 4 channel	£350
Hewlett Packard 1740A, 1741A, 1744, - 100MHz dual ch	from £350
Hewlett Packard 541000 - 1GHz digitizing	£2995
Hewlett Packard 54200A - 50MHz 2 channel digitizing	£1000
Hewlett Packard 54201A - 380MHz digitizing	£1750
Hewlett Packard 54501A - 100MHz digitizing 4 channel	£1950
Hitachi V212 - 20MHz dual channel	£180
Hitachi V222 - 20MHz dual channel	£200
Hitachi V650F - 60MHz dual channel	£350
Hitachi VC6265 - 100MHz digital storage (as new)	£2000
Intron 2020 - 120MHz digital storage (as new)	£750
Meguro MSO 1270A - 120MHz digital storage (as new)	£1750
Kikusui COS 6100 - 100MHz 5 channel 12 trace	£475
Nicolet 3091 - Low freq D.S.O.	£1100
Philips 3217 - 50MHz dual channel	from £250
Philips 3219 - 50MHz with analogue storage, Dual CH	£400
Philips 3263 - 100MHz dual channel with microprocessor cont. timing	£1500
Philips 3295 - 350MHz dual ch	£1750
Philips PM3295A - 400MHz dual channel	£1750
Tektronix 2445 - 150MHz - 4 channel	£1250
Tektronix 2445A - 150MHz - 4 channel	£1500
Tektronix 455 - 50MHz dual channel	£350
Tektronix 2221 - 60MHz digital storage	£1500
Tektronix 7854 - 400MHz Waveform processing oscilloscope	£1500
Tektronix 464/466 - 100MHz storage	from £250
Tektronix 465/465B - 100MHz dual ch.	from £350
Tektronix 468 - 100MHz D.S.O.	£750
Tektronix 475/475A - 200/250 MHz dual channel	from £475
Tektronix 434 - 25MHz 2 channel + analogue storage	£250
Tektronix 454 - 150MHz 2 channel	£400
Tektronix 2215 - 60MHz dual ch.	£425
Tektronix 2215 - 60MHz dual ch.	£450
Tektronix 2225 - 50MHz dual trace	£450
Tektronix 2235 - 100MHz Dual channel	£800
Tektronix 2236 - 100MHz Dual Trace with Counter/Timer/Dmm	£995
Tektronix 2235 - 5100MHz dual ch. (portable)	£750
Tektronix 7131, 7603, 7613, 7623, 7633, - 100MHz 4 ch.	from £300
Tektronix 7904 - 500MHz 4 ch.	from £850
Tektronix 7934 - 500MHz with storage	from £1000
Tequipment D83 - 50MHz dual channel	£200
Tequipment DM63 - 20MHz 4 channel	£150

Other scopes available too

Alltech 757 - 10kHz-22GHz	£2750
Hewlett Packard 141T + 8552B + 8555A - (10MHz-18GHz)	£1600
Hewlett Packard 182T with 8559B - (10MHz-21GHz)	£3750
Hewlett Packard 853A with 8559B - (0.01-21GHz)	£4250
Hewlett Packard 3580A - dynamic signal analyser, dual channel	£7500
Hewlett Packard 3580A - 5Hz-50kHz	£995
Hewlett Packard 3582A - 25kHz analyser, dual channel	£2500
Hewlett Packard 3709B - Constellation Analyser with 15709A High Impedance interface (as new)	£6750
Hewlett Packard 8505A - Network analyser (500kHz-1.3GHz)	£4000
Hewlett Packard 8519E - 1.5GHz spec analyser	£8500
Marconi 2370 - 110MHz spec analyser	£750

MANY MORE ITEMS AVAILABLE - SEND
LARGE S.A.E. FOR LIST OF EQUIPMENT ALL
EQUIPMENT IS USED - WITH 30 DAYS
GUARANTEE, PLEASE CHECK FOR AVAILABILITY
BEFORE ORDERING - CARRIAGE
& VAT TO BE ADDED TO ALL GOODS



A balanced view

Douglas Self explains how to get signals from A to B with the best possible integrity using balanced line input and output techniques

Balanced inputs and outputs have been used for many years in professional audio, but profound misconceptions about their operation and effectiveness still survive. Balanced operation is also making a slow but steady advance into top-end hi-fi, where its unfamiliarity can lead to further misunderstandings. As with most topics in audio technology, the conventional wisdom is often wrong.

A practical balanced interconnect is not always wholly straightforward. Some new variations on input and output stages have emerged relatively recently. For example, a

'ground-cancelling' output is not balanced at all, but actually has one output terminal configured as an input. This can come as a surprise to the unwary.

Despite its non-balanced nature, such a ground-cancelling output can render a ground loop innocuous even when driving an unbalanced input. But even an audio professional could be forgiven for being unsure if it still works when it is driving a balanced input. The answer – which in fact is yes – is explained in a second article on this subject, details of which are given later.

Electronic versus transformer balancing

Electronic balancing has many advantages. These include low cost, low size and weight, superior frequency and transient response, and no problems with low-frequency linearity. While it is sometimes regarded as a second-best, it is more than adequate for hi-fi and most professional applications.

Transformer balancing has some advantages of its own – particularly for work in very hostile rf/emc environments – but many serious drawbacks. The advantages are that transformers are electrically bullet-proof, retain their common-mode rejection ratio performance forever, and consume no power even at high signal levels. Unfortunately they also generate low-frequency distortion, have high-frequency response problems due to leakage reactance and distributed capacitance. Transformers are also heavy and expensive.

The first two objections can be surmounted – given enough extra electronic circuitry – but the last two cannot. Transformer balancing is therefore rare, even in professional audio, and is only dealt with briefly here.

To balance...

Balancing offers the following advantages

- Discriminates against noise and crosstalk.
- A balanced interconnect – with a true balanced output – allows 6dB more signal level on the line.
- Breaks ground-loops, so that people are not tempted to start 'lifting grounds'. This is only acceptable if the equipment has a dedicated ground-lift switch, that leaves the metalwork firmly connected to mains safety earth. In the absence of this facility, the optimistic will remove the mains earth – which is not quite so easy now that moulded plugs are standard – and this practice must be roundly condemned as dangerous.

...or not to balance

Balancing also brings with it the following disadvantages.

- Balanced connections are unlikely to provide much protection against rf ingress. Both sides of the balanced input would have to demodulate the rf with exactly the same effectiveness for common-mode cancellation to occur. This is not very likely.
- There are more possibilities for error when wiring up. For example, it is easy to introduce an unwanted phase inversion by confusing hot and cold in a connector. This can go undiscovered for some time. The same mistake on an unbalanced system interrupts the audio completely.

Balancing basics

Balanced connections in an audio system are designed to reject both external noise, from power wiring etc, and also internal crosstalk from adjacent signal cables.

The basic principle of balanced interconnection is to get the signal you want by subtraction, using a three-wire connection. In many cases, one signal wire – the hot or in-phase conductor – senses the actual output of the sending unit. The other, the cold or phase-inverted, senses the unit's output-socket ground, and the difference between them gives the wanted signal.

Any noise voltages that appear identically on both lines, ie common-mode signals, are in theory completely cancelled by the subtraction. In real life, the subtraction falls short of perfection, as the gains via the hot and cold inputs will not be precisely the same. The degree of discrimination actually achieved is called the common-mode rejection ratio, or cmrr.

The terms hot and cold, for in-phase and out-of-phase respectively, are used throughout this article for brevity.

While two wires carry the signal, the third is the ground wire which has the dual duty of both joining the grounds of the interconnected equipment, and electrostatically screening the two signal wires by being in some way wrapped around them. The 'wrapping around' can mean:

- A lapped screen, with wires laid parallel to the central signal conductor. The screening coverage is not perfect, and can be badly degraded as it tends to open up on the outside of cable bends.

- A braided screen around the central signal wires. This is more expensive, but opens up less when the wire is bent. Screening is not 100%, but certainly better than lapped screen.

- An overlapping foil screen, with the ground wire – called the drain wire in this context for some reason – running down the inside of the foil and in electrical contact with it. This is usually the most effective as the foil cannot open up on the outside of bends, and should give perfect electrostatic screening. However, the higher resistance of aluminium foil compared with copper braid means that rf screening may be worse.

Electrical noise

Noise gets into signal cables in three major ways.

Electrostatic coupling. An interfering signal with significant voltage amplitude couples directly to the inner signal line, through stray capacitance. The situation is shown in Fig. 1, with C,C representing the stray capacitance

between imperfectly-screened conductors; this will be a fraction of a picofarad in most circumstances. This coupling is unlikely to be a problem in hi-fi systems, but can be serious in studio installations with unrelated signals going down the same ducting.

The two main lines of defence against electrostatic coupling are effective screening and low-impedance drive. An overlapping foil screen – such as used on Belden microphone cable – provides complete protection. Driving the line from a low impedance, of the order of 100Ω or less, means that the interfering signal, having passed through a very small capacitance, is a very small current and cannot develop much voltage across such a low impedance.

For the best results, the impedance must remain low up to as high a frequency as possible; this can be a problem as op-amps invariably have a feedback factor that begins to fall

List 1. Line output arrangements.

- Unbalanced output
- Impedance-balanced output
- Ground-cancelling output, or ground-compensated output.
- Balanced output
- Quasi-floating output
- True floating transformer output

from a low, and possibly sub-audio frequency, and this makes the output impedance rise with frequency.

From the point of view of electrostatic screening alone, the screen does not need to be grounded at both ends, or form part of a circuit.¹ It must of course be grounded at some point.

Electrostatic coupling falls off with the

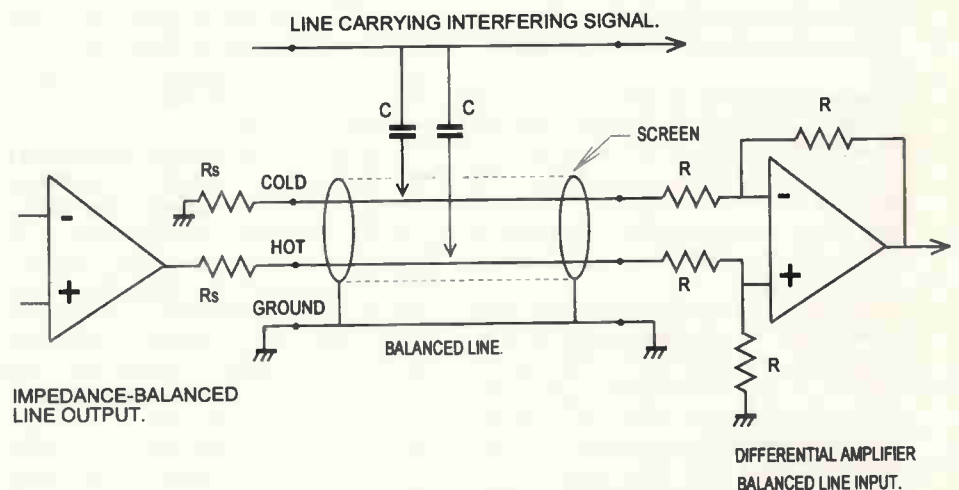

Fig. 1. Electrostatic coupling into a signal cable. R_s is 100Ω and R is 10kΩ. The second R_s to ground in the cold output line makes it an impedance balanced output.

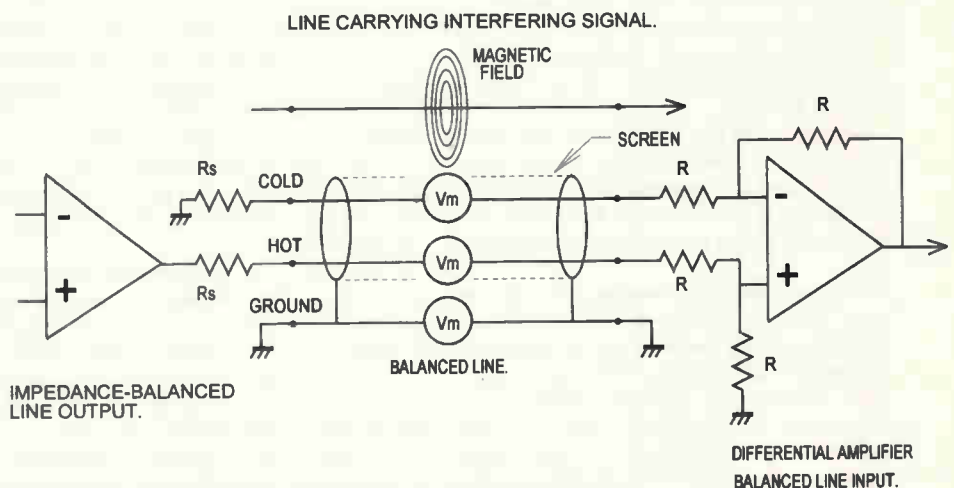

Fig. 2. Magnetic coupling into a signal cable, represented by notional voltage-sources V_m .

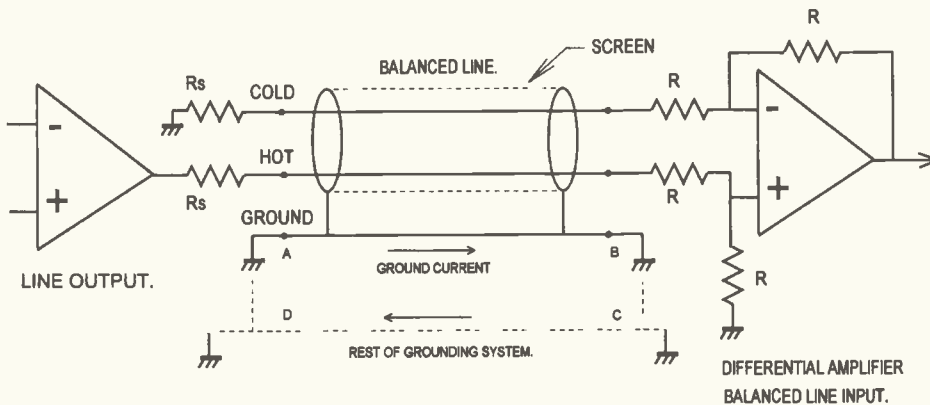

Fig. 3. Ground-voltages coupling into a signal cable. The ground voltage between A and B is due to ground currents flowing around ABCD.

square of distance. Rearranging the cable-run away from the source of interference is more practical and more effective than trying to rely on very good common-mode rejection.

Magnetic coupling. An emf, V_m , is induced in both signal conductors and the screen, Fig 2. According to some writers, the screen current must be allowed to flow freely, or its magnetic field will not cancel out the field acting on the signal conductors. Therefore the screen should be grounded at both ends, to form a circuit.²

In practice, the field cancellation will be far from perfect. Most reliance is placed on the common-mode rejection of the balanced system, to cancel out the hopefully equal voltages V_m induced in the two signal wires. The need to ground both ends for magnetic rejection is not a restriction, as it will emerge that there are other good reasons why the screens should be grounded at both ends of a cable.

In critical situations, the equality of these voltages is maximised by minimising the loop area between the two signal wires, usually by twisting them tightly together. In practice most audio cables have parallel rather than twisted signal conductors, and this seems adequate most of the time.

Magnetic coupling falls off with the square of distance, so rearranging the cable-run away from the source of magnetic field is usually all that is required. It is unusual for it to present serious difficulties in a domestic environment.

Common-impedance coupling. Ground voltages coupled in through the common ground impedance; often called 'common-impedance coupling' in the literature.³ This is the root of most ground loop problems. In Fig. 3 the equipment safety grounds cause a loop ABCD; the mere existence of a loop in itself does no harm, but it is invariably immersed in a 50Hz magnetic field that will induce mains-frequency current plus odd harmonics into it.

This current produces a voltage drop down the non-negligible ground-wire resistance, and this once again effectively appears as a voltage source in each of the two signal lines. Since the cmrr is finite a proportion of this voltage will appear to be differential signal, and will be reproduced as such.

A common source of ground-loop current is the connection of a system to two different 'grounds' that are not actually at the same ac potential. The classic example of this is the addition of a 'technical ground' such as a buried copper rod to a grounding system which is already connected to 'mains ground' at the power distribution board. In most countries this 'mains ground' is actually the neutral conductor, which is only grounded at the remote transformer substation. The voltage-drop down the neutral therefore appears between 'technical ground' and 'mains ground' causing large currents to flow through ground wires.

A similar situation can occur when water-pipes are connected to 'mains ground' except that interference is not usually by a common ground impedance; however the unwanted currents flowing in the pipework generate magnetic fields that may either create ground loops by induction, or interfere directly with equipment such as mixing consoles.

In practice, ground voltages cause a far greater number of noise problems than the other mechanisms, in both hi-fi and professional situations.

Even there is no common-impedance coupling, ground currents may still enter the signal circuit by transformer action. An example of such a situation is where the balanced line is fully floating and not galvanically connected to ground – which is only possible with a transformer-to-transformer connection.

The shield wire or foil acts as a transformer primary while the signal lines act as secondaries; if the magnetic field from the shield wire is not exactly uniform, then a differential

noise voltage appears across the signal pair and is amplified as if it were a genuine signal. This effect is often called shield-current-induced-noise, or SCIN, and cables vary in their susceptibility to it according to the details of their construction.⁴

Fortunately the level of this effect is below the noise-floor in most circumstances and with most cables, for once a differential-mode signal has been induced in the signal lines, there is no way to discriminate against it.

From this summary I deduce there are two principle effects to guard against; electrostatic coupling, and the intrusion of unwanted voltages from either magnetic coupling or ground-loop currents.

Electrostatic interference can be represented by notional current-sources connected to both signal lines; these will only be effectively cancelled if the line impedances to ground are the same, as well as the basic cmrr being high. The likely levels of electrostatic interference current in practice are difficult to guess, so the figures I give in the second article are calculated from applying 1mA to each line; this would be very severe crosstalk, but it does allow convenient relative judgements to be made.

Magnetic and ground-voltage interference can be represented by notional voltage-sources inserted in both signal lines and the ground wire; these are not line-impedance sensitive and their rejection depends only on the basic cmrr, as measured with low-impedance drive to each input. Similarly ground-voltage interference can be represented by a voltage-source in the ground wire only.

Both input and output are voltages so the cmrr can be quoted simply as a ratio in decibels, without specifying any level.

Line outputs

A line output is expected to be able to drive significant loads, partly because of a purely historical requirement to drive 600Ω, and partly to allow the parallel feed of several destinations. Another requirement is a low source impedance – 100Ω or less – to make the signal robust against capacitive crosstalk, etc.

There are many line output and input arrangements possible, and the results of the various permutations of connection are not always entirely obvious. An examination of the output types in use yields List 1.

Unbalanced output. There are only two physical output terminals – signal and ground, Fig. 4a). A third terminal is implied in Fig 4a, emphasising that it is always possible to connect the cold wire in the cable to the ground at the transmitting (output) end.

The output amplifier is almost always buffered from the line shunt-capacitance by a resistor R_s in the range 33 to 100Ω, to ensure stability. This unbalances the line impedances. If the output resistance is taken as 100Ω

worst-case, and the cold line is simply grounded as in Fig 4a, then the presence of R_s degrades the common-mode rejection ratio to -46dB, even if the balanced input at the other end of the cable has perfectly matched resistors.

Impedance balanced output. There are now three physical terminals, hot, cold, and ground, Fig. 4b). The cold terminal is neither an input nor an output, but a resistive termination with the same resistance R_s as the hot terminal output impedance. This type of output is intended for use with receiving equipment having balanced inputs. The presence of the second R_s terminated to output ground makes the impedance on each signal line almost exactly the same – apart from op-amp output impedance limitations – so that good rejection is achieved for both common-mode ground voltages and electrostatic interference.

If an unbalanced input is being driven, the cold terminal on the transmitting (output) equipment can be either shorted to ground locally or left open-circuit without serious consequences. Either way all the benefits of balancing are lost.

The use of the word 'balanced' is unfortunate as this implies anti-phase outputs, which are not present.

Ground-cancelling output. Also called a ground-compensated output, this arrangement is shown in Fig. 5a.

This allows ground voltages to be cancelled out even if the receiving equipment has an unbalanced input. It prevents any possibility of creating a phase error by miswiring. It separates the wanted signal from the unwanted by addition at the output end of the link, rather than by subtraction at the input end.

If the receiving equipment ground differs in voltage from the sending ground, then this difference is added to the output so that the signal reaching the receiving equipment has the same voltage superimposed upon it. Input and ground therefore move together and there is no net input signal, subject to the usual resistor tolerances.

The cold pin of the output socket is now an input, and must have a unity-gain path summing into the main signal output going to the hot output pin. It usually has a very low input impedance equal to the hot terminal output impedance.

It is unfamiliar to most people to have the cold pin of an output socket as a low impedance input, and this can cause problems. Shorting it locally to ground merely converts the output to a standard unbalanced type. If the cold input is left unconnected then there should be only a very small noise degradation due to the very low input impedance of R_s .

Ground-cancelling outputs would appear to be very suitable for hi-fi use, as they are an

economical way of making ground-loops innocuous. However, I am not aware that they have ever been used in this field.

Balanced output. The cold terminal is now an active output, producing the same signal as the

hot terminal but phase-inverted, Fig. 5b. This can be simply done by using an op-amp stage with a gain of minus one to invert the normal in-phase output. Phase spikes are shown on the diagram to emphasise these phase relationships.

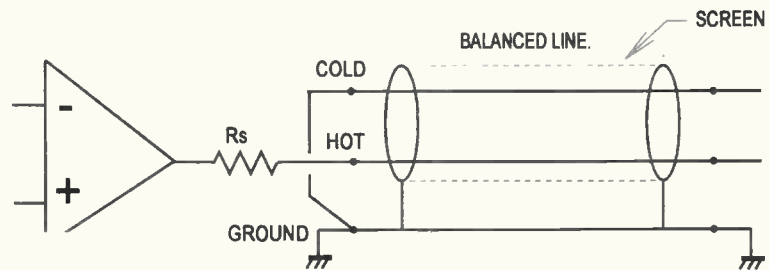

Fig. 4a. An unbalanced line output. The cold output – if it exists at all – is connected directly to ground.

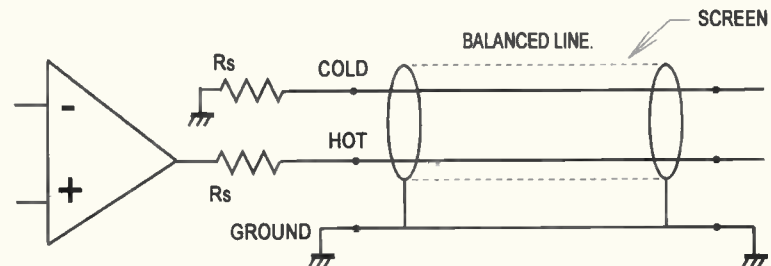

Fig. 4b. An impedance balanced output. The cold output is connected to ground through a second R_s of identical value.

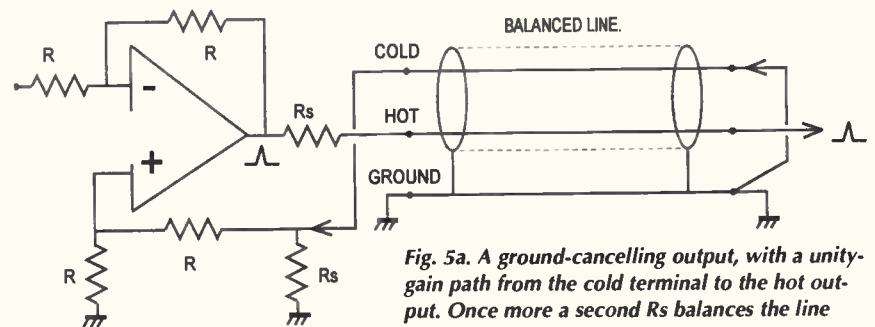

Fig. 5a. A ground-cancelling output, with a unity-gain path from the cold terminal to the hot output. Once more a second R_s balances the line impedances.

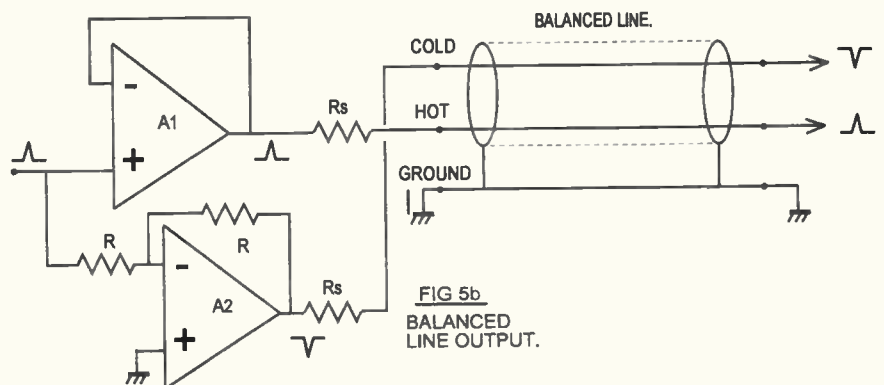

Fig. 5b. A balanced output. A2 is a unity-gain inverter driving the cold output. Line impedances are balanced.

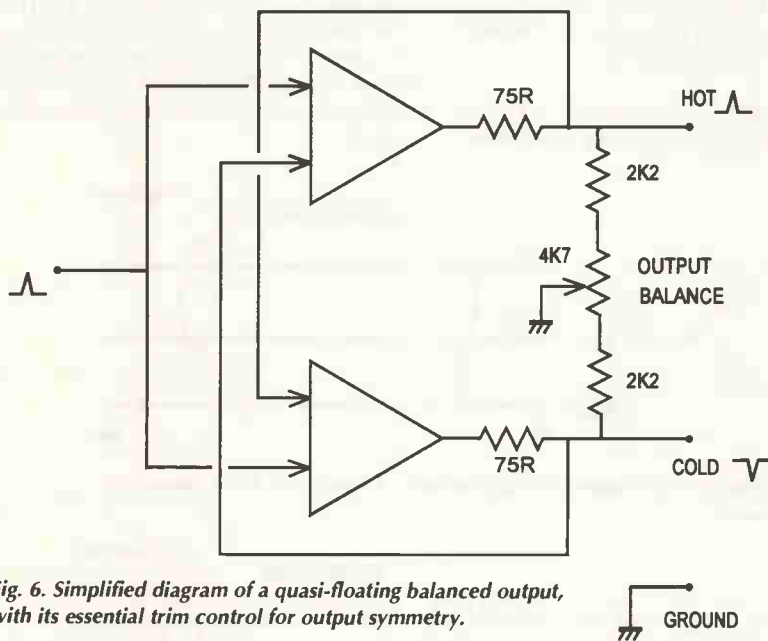

Fig. 6. Simplified diagram of a quasi-floating balanced output, with its essential trim control for output symmetry.

The in-phase signal itself is not degraded by passing through an extra stage and this can be important in quality-critical designs. The inverting output must not be grounded; if not required it can simply be ignored.

Unlike quasi-floating outputs, it is not necessary to ground the cold pin to get the correct gain for unbalanced operation, and it must not be grounded by mistake, because the inverting op-amp will then spend most of its time in current-limiting, probably injecting unpleasant distortion into the preamp grounding system, and possibly suffering unreliability. Both hot and cold outputs must have the same output impedance R_s to keep the line impedances balanced.

A balanced output has the advantage that it is unlikely to crosstalk to other lines, even if they are unbalanced. This is because the current injected via the stray capacitance from each crosstalking line cancels at the receiving end.

Another advantage is that the total signal level on the line is increased by 6dB, which can be valuable in difficult noise situations. All balanced outputs give the facility of correcting phase errors by deliberately swapping hot and cold outputs. This tactic is however a double-edged sword, because it is probably how the phase became wrong in the first place.

This form of balanced output is the norm in hi-fi balanced interconnection, but is less common in professional audio, where the quasi-floating output gives more flexibility.

Quasi-floating output. This kind of output, Fig. 6, approximately simulates a floating transformer winding; if both hot and cold out-

puts are driving signal lines, then the outputs are balanced, as if a centre-tapped output transformer were being used.

If, however, the cold output is grounded, the hot output doubles in amplitude so the total level is unchanged. This condition is detected by the current-sensing feedback taken from the outside of the 75Ω output resistors. Current driven into the shorted cold output is automatically reduced to a low level that will not cause problems.

Similarly, if the hot output is grounded, the cold output doubles in amplitude and remains out of phase; the total hot-cold signal level is once more unchanged. This system has the advantage that it can give the same level into either a balanced or unbalanced input without rewiring connectors. 6dB of headroom is however lost.

When an unbalanced input is being driven, the quasi-floating output can be wired to work as a ground-cancelling connection, with rejection of ground noise no less effective than the true balanced mode. This requires the cold output to be grounded at the remote (input) end of the cable. Under adverse conditions this might cause hf instability, but in general the approach is sound. If you are using exceptionally long cable, then it is wise to check that all is well.

If the cold output is grounded locally, ie at the sending end of the cable, then it works as a simple unbalanced output, with no noise rejection. When a quasi-floating output is used unbalanced, the cold leg must be grounded, or common-mode noise will degrade the noise floor by at least 10dB, and there may be other problems. In both of the unbalanced cases the maximum signal possible on the line is

reduced by 6dB.

Quasi-floating outputs use a rather subtle circuit with an intimate mixture of positive and negative feedback of current and voltage. This performs the required function admirably; its only drawback is a tendency to accentuate circuit tolerances, and so a preset resistor is normally required to set the outputs for equal amplitude; the usual arrangement is shown in Fig. 6.

If the balance preset is not correctly adjusted one side of the output will clip before the other and reduce the total output headroom. After factory setting this preset should not need to be touched unless the resistors in the circuit are replaced; changing the op-amp should make no difference.

The balancing network consists of a loading resistor to ground on each output; in this respect the output characteristics diverge from a true floating output, which would be completely isolated from ground. These loading resistors are lower than the input impedance of typical amplifiers are used with unequal input impedances, (see the section on line inputs, below) the output balance is not significantly disturbed and clipping remains symmetrical on the hot and cold outputs.

Quasi-floating outputs are often simply referred to as 'balanced' or 'electronically-balanced', but this risks serious confusion as the true balanced output described earlier must be handled in a completely different way from quasi-floating.

True floating transformer output. This can be implemented with a transformer if galvanic isolation from ground is required. The technique is rarely used.

The second article in this pair looks at line inputs in detail, examines what happens when the different kinds of input and output are connected together, and deals with the philosophy of audio system wiring. ■

References

1. Williams, T., 'EMC for Product Designers,' Newnes (Butterworth-Heinemann), pub 1992 ISBN 0 7506 1264 9, p. 176.
2. Williams, T., As reference 1 above, p. 173.
3. Muncy, N., 'Noise Susceptibility in Analog and Digital Signal Processing Systems,' JAES Vol. 3 No 6, June 1995, p.447
4. Muncy, N., As reference 3 above, p. 441.



SOLUTIONS FOR **STICKY** PROBLEMS

ResinTech Adhesive Experts

A complete range of resin based products with a choice of packaging options

Adhesives
Sealants
Encapsulants

Cable system adhesives
Repair systems for hose and pipe
Retail pack for hobbies and DIY

PACKAGING OPTIONS

TwinPack
Clip separated sachet

- Safe sealed unit to time of application
- Quick, clean, easy to use.
- Ideal for small batch operations, repairs etc.
- No liquid waste
- Sizes 5, 10, 15ml

For easy spread adhesives

DuoSyringe
Side-by-side double syringe

- Accurate application and placement from bead to stripes
- Mixing nozzles and applicator guns
- Ideal for larger batch, and industrial use
- Cylinder contents can be reused
- Sizes 50, 200ml

For medium viscosity and non-sag sealants

Contact us for solutions to your sticky problems:
Resintech Limited, Horcott, Fairford GL7 4BX.
Tel 01285 712755, fax 01285 713036

Q. WHY SIMULATE?

A. Because It Really Works...

...when you have the right software tools. With ICAP/4, The Virtual Circuit Design Lab, you can simulate the toughest System, IC, and Board-level designs.

You said you would do more simulation if the tools were easier to use. Well here you go!

→ Ease of Use for The Beginner, Power For The Professional

With ICAP/4Windows you can sweep ANY circuit variable from the schematic and instantly view the results. Seamless schematic-simulator integration makes it easy to see the effects of design changes.

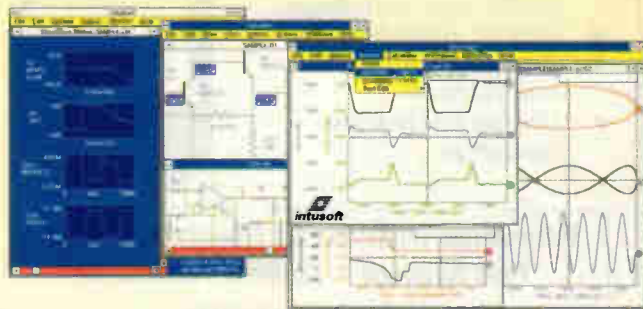

→ Unmatched SPICE Power

Interactive Native Mixed Mode SPICE 3F and XSPICE based simulator with unlimited circuit size

Simulate all types of designs: Power, ASIC, RF, Analog, Digital, Electro-Mechanical

Advanced Features: AHDL Modelling, Latest BSIM3 MOS model, Simulation Alarms, Scripting Language

State-of-the-Art Convergence Algorithms

Powerful Behavioural Modelling Enhancements

New.. Interface Your Simulation with Test Hardware

→ Bigger SPICE libraries than ANY other vendor

8000+ models with more model types than any other vendor! Special RF and Power Libraries!

→ Integration With OrCAD® Capture™ or Protel® Schematic³™

We are the first to bring you real integration with other schematic packages using OLE2 techniques. You can run IsSpice directly from other schematics and cross-probe the results. All simulation functions are available from dialogues and little or no typing is required.

→ Software That Meets Your Needs

New Network Version (No Protection Key Required)
Unmatched Free Support
No maintenance fees
Windows, 95, NT, DOS, Macintosh, Power Mac

→ Upgrade path:

ICAP/4Lite £450 → ICAP/4Lite Xtra £1300 → ICAP/4Windows £2300
three complete design and simulation systems, with increasing functionality.

Simply The Best SPICE At An Unbeatable Price!

Download Your **FREE SPICE**
Simulation Kit, App Notes, and
FREE Model Libraries!

Web site: <http://www.softsim.com>

email: info@softsim.com

Technology Sources, Falmouth Avenue, Newmarket,
Suffolk CB8 0LZ, trading as:

Phone: 01638-561460
Fax: 01638-561721

SoftSim

Now!
Magnetics
Designer
Even
Newer!
Test Designer
Demos Available

CIRCLE NO. 129 ON REPLY CARD

LETTERS

Letters to "Electronics World"
Quadrant House, The Quadrant,
Sutton, Surrey, SM2 5AS

Simpler outphasing

In the April 1996 issue of *Electronics World*, David Gibson describes the use of all-pass filters in the outphasing methods used for ssb generation. He describes the use of a cascade of two first order all-pass filters in one leg – producing the in-phase output, and another two in the other leg, producing the quadrature output.

A letter published subsequently mentioned a simpler method using fewer op-amps, but I cannot recall the exact details. I think he may have been referring to Shirley's work*. Published as long ago as 1970, this article gives a full design with component values, for a quadrature network covering five octaves, with a peak deviation from 90° of ±3.8°. The values given are for a design covering 70Hz to 2.1kHz, but adjusting it for the communications bandwidth of 200Hz to 3kHz is only a matter of scaling the capacitor values. Allowing for an equal (geometric) overlap at each end, the range becomes 168Hz to 5.366kHz. This is $N=1.79$ times up on 3kHz and N times down on 300Hz, since N squared times ten equals two to the power five. One could select a range not of five octaves but only 3.33 octaves (300Hz to 3kHz). But the extra range at each end is useful to provide a little leeway for rolling off the response outside the three-decibel points of 300Hz and 3kHz. Otherwise brickwall filtering of the baseband signal will be needed, to prevent frequencies outside that

range reappearing in the other – supposedly – suppressed sideband.

Shirley's article gives a graph showing the peak deviation from quadrature for an outphaser using two all-pass filter sections in each leg, against the desired span, e.g. 3.8° for five octaves as already mentioned. If the speech baseband is however known to be already band-limited to 300Hz to 3kHz, the graph shows that for a design covering just a 10:1 frequency ratio, the peak deviation from quadrature becomes just ±1.1°. The article also gives a Basic program listing which will calculate the required component values for any given bandwidth, returning in addition the resultant peak phase deviation from quadrature.

Using two first order all-pass filter sections per leg as in David Gibson's design, the component requirement runs to a total of twelve resistors, four capacitors and four op-amps. The circuit mentioned Shirley's article, which uses second order all-pass filter sections, needs the same tally of passives, but only two op-amps. As dual op-amps have a smaller footprint than quads, there is a minor advantage where space is at a premium.

In ssb speech communication links, measures such as vogads, IF clipping etc. are used to try and increase 'talk power', by increasing the mean to peak power ratio of the transmission.

A further useful method is to 'brighten' the speech with a 'blue' filter – one where the response increases by 6dB per octave as the frequency rises. This emphasises the

lower level unvoiced sounds such as sibilants, fricatives, plosives and the like (ess, elf, pea, tea), which are crucial to intelligibility. Such a filter will of course shift the relative phase of the higher and lower frequencies of the baseband signal.

Fortunately, the relative phases are unimportant and indeed not perceived at all by the ear. However, such a blue filter, and indeed the all-pass filters used in outphasing methods, will have a very pronounced effect on any digital traffic that one sends over the link.

Ian Hickman
Waterlooville
Hants

*Shirley, F. R., 'Shift phase independent of frequency', *Electronic Design* No 18, Sept. 1 1970.

On the wire

I read Cyril Bateman's article regarding loudspeaker cables with great concern. Despite his request, I have no interest in, "shooting these findings down in flames". There is little doubt that what Mr Bateman measured was repeatable.

However, there is a great step between making a repeatable measurement – however unsurprising – and giving a coherent theory which explains the measured results. My concern is that Mr Bateman has not made that step. His arguments are so flawed and his misuses of technical terms are so frequent that I have difficulty knowing where to begin putting

them right. There is no justification whatsoever for treating loudspeaker cables as transmission lines and they do not have a characteristic impedance at audio frequencies.

Mr Bateman's use of the term transmission line is at variance with the accepted definition employed by the great body of electronic engineers. If technical definitions can be varied at will in this way it will not be long before communication is rendered impossible.

Existing circuit theory predicts the error due to loudspeaker cable very well, but even if it did not there would not be a problem. Loudspeaker design has moved on and the traditional passive loudspeaker fed by cable from a remote wideband amplifier is a bit of a dinosaur. Passive crossovers simply cannot meet modern performance criteria. With modern active designs there is no loudspeaker cable at all and it is difficult to see how Mr Bateman's findings advance the art.

The editor cannot be blamed for printing the articles in question. If *Wireless World* – for we still call it that – had been a peer review journal, many valuable articles would never have been printed. The down side of this freedom is that occasionally something regrettable is printed. *Wireless World* has a long standing tradition of doing the peer review in the letters page after publication.

As the author of some tens of *WW* articles I am acutely aware that one's work is well scrutinised and erroneous statements are usually set right by readers. If one is humble enough to heed readers comments, one can learn a great deal and I would commend this course to Mr Bateman.

John Watkinson BSc MSc FAES
Reading,
Berkshire

Cyril replies

May I thank John Watkinson for agreeing with my conclusion that the best speaker cable is to avoid using one i.e. to have no cable at all. Perhaps this is no surprise since these words were in fact used by Nelson Pass in his 1980 *Speaker Builder* article I referenced.

However, I must disagree with John in that the vast majority of hi-fi listeners do in fact listen to two or

Electricity without magnetism

Your July 1992 issue included an article entitled 'Electricity without Magnetism'. That article prompted me to write a somewhat disparaging letter in September of 1994. As I had hoped, the letter resulted in a response in the November 1994 issue from one of the co-inventors, Dr. Harold Aspen, in which he advised that the invention/discovery was being further investigated by a group at MIT, USA.

We are just entering 1997 but to date no further information appears to have trickled out regarding where the invention now stands. Is it a non-starter? Many years ago I was deeply involved with both thermocouples and low-power ultrasonics, in totally separate applications. The ultrasonics work used thermionic valves because transistors had not then

been invented. Since the device in question appears to take advantage of both technologies it is of considerable interest to me. I have endeavoured to obtain a small quantity of the PVDF material referred to in the article but have failed. That has prevented me from trying to duplicate the co-inventors work.

So, I will be delighted if someone is willing to bring me up to date with the present position. If Dr Aspen reads this letter, then perhaps he will now appreciate that my letter of July 1992 to *EW* was written with the sole intention of provoking a reply from one of the inventors – which it did. I had earlier written direct to his co-inventor, Mr. J. S. Strachan, Edinburgh University, but that proved to be abortive.

R I Tufft
Thirsk
North Yorkshire

25% reader discount



MX2020 function generator with int/ext sweep; spans 0.02Hz to 2MHz and is available to readers for just £179 – fully inclusive of VAT and postage

Function generator for just £179

Featuring a bright 4-digit LED frequency counter which is externally accessible, the MX2020 function generator covers the range 0.02Hz to 2MHz, making it suitable for both audio and low-end RF work. Selectable output waveforms are sine, square, triangle, skewed sine, pulse and ttl. Amplitudes are 2V pk-pk to 20V pk-pk unloaded, while output impedance is 600Ω (to 100kHz) or 50Ω. Output is offsettable to ±10V. Further features are:

- 4-ranges, 1Hz-9999kHz *f* meter, 15mV sens.
- 20dB attenuator
- 100/120/220/240V mains operation
- Frequency is 100:1 variable
- Symmetry is variable between 10:1 and 1:10
- Sine wave distortion <1% at 100kHz
- Squarewave rise time 100ns or 20ns for ttl
- Log/lin sweep, 20ms to 2s, 1:1 to 100:1
- VCF i/p 0-10V, range 100:1
- 5.24288MHz timebase, 20ppm stability

Normally, the MX2020 sells at £199, excluding 17.5% VAT and delivery costs. But *Television* readers can obtain this instrument for just £179 – fully inclusive of VAT and delivery. This represents a saving of well over 25%.

To receive your function generator, simply fill in the coupon on the right and send it, together with a cheque or postal order for £179, to Vann Draper Electronics at Unit 5, Premier Works, Canal Street, South Wigston, Leicester LE18 2PL.

*Overseas readers can also obtain this discount but details vary according to country. Please ring, write or fax to Vann Draper Electronics.

Alternatively fax credit card details with order on 0116 2773945 or telephone on 0116 2771400. Please direct all queries relating to this offer to Vann Draper Electronics

Use this coupon to order your MX2020

Please send me.....MX2020(s) function generators at the fully inclusive special offer price of £179 each.

Name

Company (if any)

Address

Phone number/fax

Total amount £.....

Make cheques payable to Vann Draper Electronics Ltd
Or, please debit my Master, Visa or Access card.

Card No

Expiry date

Please mail this coupon to Vann Draper Electronics, together with payment. Alternatively fax credit card details with order on 0116 2773945 or telephone 0116 2771400. Address orders and all correspondence relating to this order to Vann Draper Electronics at Unit 5, Premier Works, Canal Street, South Wigston, Leicester, LE18 2PL. Overseas readers can also obtain this discount but details vary according to country. Please ring, write or fax to Vann Draper Electronics

three way passive crossover speaker systems driven via several metres of cable. This indeed was the basic assumption used for all three of my recent articles, consequently his comments regarding active designs are not relevant to this series.

It seems my use of the transmission line equation at audio frequencies causes him discomfort. Perhaps it is worth recalling this equation was originally called the 'Telegrapher's' equation and was developed to quantify audio frequency transmission along telegraph lines. It was mathematically defined by Kennelly and Steinmetz in 1893, and while neither I nor the contents of my library are quite that old, I believe this predated its use for radio-frequency transmission. It is also perhaps worth recalling this mathematical derivation results from considerations of extremely short lengths of line.

Obviously, as stated in the articles, the commonly used rf simplification of $(L/C)^{1/2}$, which assumes that the ac resistive portion is negligibly small, is not applicable at audio frequencies since regardless of cable lengths, this resistive term dominates.

I didn't originally set out to prove cable impedance was relevant. Having performed the various measurements, which John accepts are repeatable, and using the accepted dogma of series resistance and inductance, I was totally unable to explain the voltage changes with frequency from 1kHz to 10kHz and change of cable, for the mosfet amplifier, Fig. 1, January 1987 issue, p. 55. These measurements for both amplifiers have recently been repeated over the extended frequency range 1kHz to 1MHz,

Marconi sell out

Does it matter when we disperse at auction a major archive of scientific and technical papers, photographs and historic artefacts, encapsulating the very origins of a major science-led industry?

Some might think not, but that is exactly what GEC will shortly do with the complete archive and museum of the Marconi Company – at Christie's in London, on April 24 and 25.

It is clear from Christie's press release that this material is an unparalleled record of the origins and development of 'wire-less' communications, world-wide, and as such would be of first importance to maritime, military and general historians – as well as a source of inspiration to radio and electronic engineers. Part of the tragedy is that this collection has been so little studied, and that no attempt was made to display it during the Marconi Centenary Year. Nor has any worthwhile

monograph seen recent publication.

International interest in this auction will be very great; and in the absence of intervention, dispersal abroad is likely. The Royal Commission on Historic Manuscripts, National Heritage Memorial Fund and Heritage Lottery Fund should consider this case as a matter of urgency.

Meanwhile, where are our national museums and professional institutions who should surely be exercising a watching brief? And if this sale goes through – what other major institutions, some also concerned with broadcasting and telephony, will see fit to follow in taking the car boot sale approach to their – and our – historical inheritances?

Dr Thomas Going
Southend
Essex

with exactly the same results.

If John can offer an alternative more acceptable explanation as to how amplifier/cable/speaker damping performance can increase with frequency, when both the series impedance of the cable and the amplifier output impedance increase with frequency, I and I'm sure many other readers, would be more than pleased to be so informed.

If John also has access to better supporting evidence as to the behaviour of speaker cables, again it would be beneficial if other readers could be so updated. For my part, I shall continue to rely on my copy of 'Reference Data for Radio Engineers', published by Sams & Co, which states the full transmission line equation $((R+j\omega L)/(G+j\omega C))^{1/2}$, as quoted in my articles, is an 'accurate equation applicable from dc up to such frequency when higher modes appear'.

Irate communication over cable

I knew it! The March issue of *EW* has the now inevitable crop of letters which endlessly discuss the pros and cons of loud speaker cable construction; a subject whose boredom is only exceeded by that of a general election campaign:

While I appreciate that your editorial staff cannot influence the quality and quantity of letters submitted on any particular subject, you surely could draw a line under this one now and say 'enough is enough'

I realise that there just may be quite incredibly sensitive individuals in the population who can detect aurally the minutiae of distortion in their hi-fi systems; the difference for example between 0.001 and 0.01% of thd. However, since the signals subject to the minuscule distortion,

if any, of loud speaker cables are also subject to the passage through innumerable acoustic, electric, electronic, modulation, demodulation and conversion processes on their way from source to loud speaker, one is tempted to dismiss as trivial the effect of speaker cables which are constructed from anything less sophisticated than multistranded bus-bars made from ultra pure, oxygen-free electrolytic platinum.

Do you remember the days gone by when your letter pages resounded with discussions on gravity, relativity, cosmology, the speed of light, Michelson and Morley, the Catt anomaly, Silvertooth, Aspden and the ether and so on and so on? Oh dear, what has gone wrong with *EW*? Or is it that something has gone wrong with your readers?,
M G T Hewlett
Midhurst
W Sussex

Q&A

90° phase shift made easy

A In the February issue of *Electronics World*, a reader searches for a method of producing 90° phase shift. A QBasic program published in the 13 September 1976 issue of *Electronic Design* does exactly that.
Dave Hayes

Led backwards

Q Why do light-emitting diodes have such a low reverse voltage? Often, only a few volts is specified. Many circuits would be simplified if the rating was 15V or so. Is the restriction to do with the manufacturing process?

P Gascoyne
Wantage
Oxfordshire

Sound-driven car?

Q Does one of your more mature readers remember reading a constructional article, circa 1936, which appeared, I think, in *Car Mechanics* or *Car Illustrated*, both American publications (an English publication would at

that time have used 'supersonic' not 'ultrasonic'). It used a mechanical ultrasonic generator, which was basically a close pair of perforated metal discs one being rotated at high speed, to generate high powered ultrasonics. These ultrasonics vapourised water contained in a sealed tank, which in turn, so it was claimed, developed sufficient pressure to operate a small steam engine with which to propel a car.

No doubt such a system could set up cavitation and vapourise water, but how to cope with the attendant noise of what was essentially a crude siren is difficult to understand. Perhaps one of your readers – probably deaf since 1936 – having built the contraption, might have some information.

Magnetostriction technology using frequencies above audibility might be a means of designing a modern equivalent for an ancient proposal. Who knows? Perhaps we might be able to discover from where many politicians get their 'hot air'.

R L Tufft
Thirsk North Yorkshire

Wireless Service Manual?

Q Does anyone have a copy of the *Wireless Service Manual*, published by Iliffe around 1950? I am interested in details of an oscilloscope that incorporated an indicator unit known as a 'plan-position indicator'.

C M Lindars
Providence Cottage
Unity Lane
Misterton
Crewkerne
Somerset TA18 8NA

Circuits for j-fets please

Q Does anyone know where I can get hold of application circuits for *MPF102* or similar j-fets please?

W D Nicholson
13 Devanham Road
Handforth
Cheshire SK9 3QE

Cross over crossover

Bill Teleki's article 'Crossover Networks Made Simple' on pp. 548-550 in the July/August 1996 issue includes simulated responses for various orders of passive crossover networks computed on the basis of a purely resistive load. However, Bill has omitted to mention that the impedance of typical loudspeaker drive units is usually reactive in nature. This can significantly affect the performance of any filter networks that have been designed on the assumption that the impedance of a loudspeaker driver behaves like a pure resistor.

Here I will give an example of the effects of impedance mistreatment on the response of a two-way third-order Butterworth crossover. Crossover frequency is chosen to be 3000Hz, and component values are computed using the assumption that the low-frequency and high-frequency drivers are each 8Ω resistive loads.

For the purpose of this discussion, the sound-pressure response of these drivers is assumed to be ideal, in the sense that it is completely flat from dc to infinite frequency.

Resulting low and high-pass filter response functions, together with the summed response, are shown in Fig. 1. The -3dB crossover point at

3000Hz is clear, as is the $\pm 135^\circ$ phase shift of the low and high-pass filtered responses, respectively.

Figure 2 shows impedance response curves of two typical loudspeaker drivers, where one curve is for a woofer and the other is for a tweeter. The woofer's impedance response rises at high frequencies because of the inductance of the voice-coil and eddy current losses in the magnetic motor.

Note that the phase shift of the woofer impedance asymptotes to a value slightly greater than 45° at high frequencies. This impedance behaviour cannot be modelled by a simple inductance, as many people assume, as this would lead to an asymptotic phase shift of 90° . Because the lower limit of the plotted frequency range is 100Hz, the peak in the woofer impedance at the free air resonance frequency of the woofer is not displayed. The tweeter's impedance curve shows a peak at this driver's free air resonance frequency, while staying relatively constant elsewhere in the frequency range.

When the lowpass and highpass sections of the third-order Butterworth crossover network are terminated by the actual woofer and tweeter impedances, a number of interactions occur, and the results are shown in Fig. 3. Filtered and

summed responses are quite different from those obtained when the drivers were assumed to be simple resistive loads, and the overall result can only be judged as being unacceptable. It is clearly evident that the lowpass filtered response no longer follows the desired response characteristic of a third-order Butterworth filter frequency response function.

A large peak at about 2500 Hz is evident, and the roll-off rate between 10kHz and 20kHz is only 13 dB/octave instead of the expected 18 dB/octave. The high-pass filtered response is much less affected,

although it does show minor response anomalies, such as approximately 1dB of boost in the 12kHz frequency region. As a result, the magnitude of the summed response is far from flat, which is not the desired result.

This simple example illustrates that it is not a good idea to assume that a crossover network designed on the basis of constant resistive loads will perform adequately when the true driver impedances are connected to the filter network.

In this instance, the problems occurring with the woofer can be greatly reduced by the use of an RC

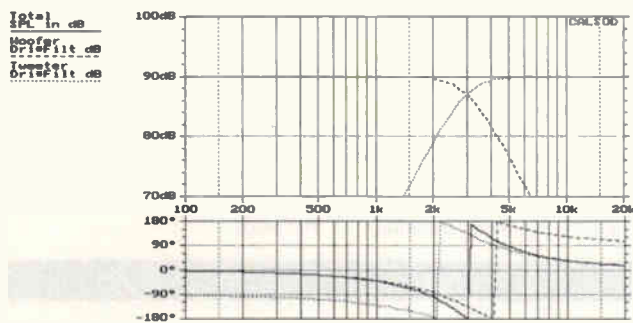

Fig. 1. Simulated response for ideal purely resistive 8Ω drivers using a two-way third-order Butterworth crossover plotted over the frequency range from 100Hz to 20kHz.

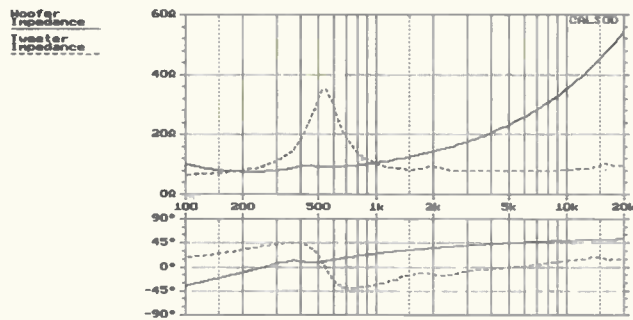

Fig. 2. Typical impedance response curves for a woofer (solid line) and tweeter (dashed line).

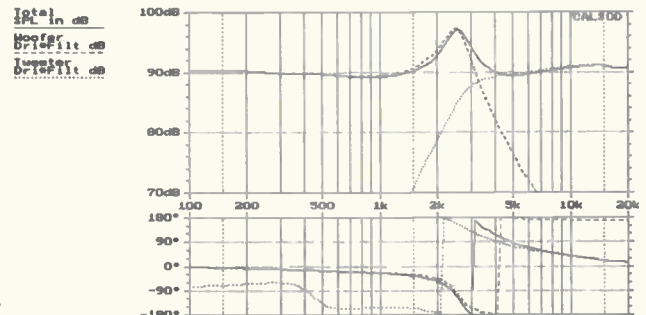

Fig. 3. Low-pass (dashed line), high-pass (dotted line) and summed (solid line) frequency response functions obtained when the theoretical filter design is terminated with typical woofer and tweeter impedances.

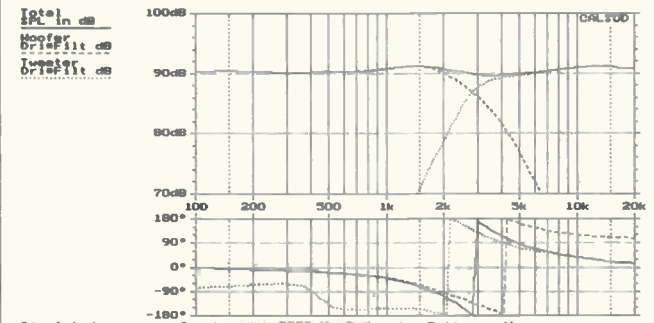

Fig. 4. Low-pass, high-pass, and summed responses obtained when a Zobel network is added to equalise the woofer impedance.

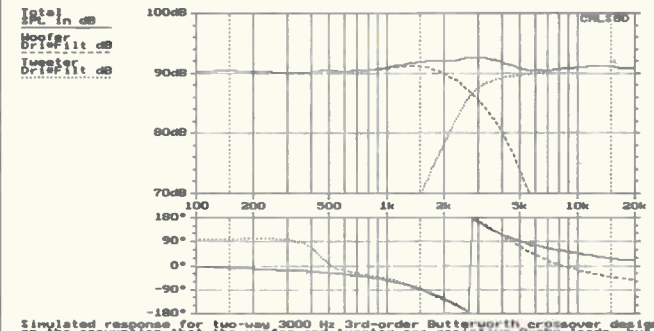

Fig. 5. Low-pass, high-pass, and summed responses obtained when driver natural roll-offs are added to the model for the crossover with the Zobel network.

SMALL SELECTION ONLY LISTED - EXPORT TRADE AND QUANTITY DISCOUNTS - RING US FOR YOUR REQUIREMENTS WHICH MAY BE IN STOCK

- HP New Colour Spectrum Analysers
 HP141T + 8552B IF + 8553B RF - 1KHz-110Mc/s - £700.
 HP141T + 8552B IF + 8554B RF - 100KHz-1250Mc/s - £900.
 HP141T + 8552B IF + 8556A RF - 20Hz-300KHz - £700.
 Special Offer just in from MOD Qty 40 HP8555A RF Units 10Mc/s - 18GHzS.
 HP141T + 8552B IF + 8555A 10Mc/s-18GHzS - £1200.
 HP ANZ Units Available separately - New Colours - Tested
 HP141T Mainframe - £350.
 HP8552B IF - £300.
 HP8553B RF 1KHz to 110Mc/s - £200.
 HP8554B RF 100KHz to 1250Mc/s - £500.
 HP8555A RF 10Mc/s to 18GHzS - £800.
 HP8556A RF 20Hz to 300KHzS - £250.
 HP8443A Tracking Generator Counter 100KHz-110Mc/s - £300.
 HP8445B Tracking Preselector DC to 18GHz - £350.
 HP3580A 5Hz - 50KHz ANZ - £750 - £1000.
 HP3582A 0.2Hz to 25.6KHz - £2k.
 HP8568A 100Hz-1500Mc/s ANZ - £6k.
 HP8569B 10Mc/s-22GHz ANZ - £6k.
 HP Mixers are available for the above ANZ's to 40GHz
 TEK 492 - 50KHz - 18GHz Opt 1+2 - £4k-£4.2k.
 TEK 492 - 50KHz - 18GHz Opt 1+2+3 - £4.5k.
 TEK 492P - 50KHz - 21 GHz Opt 1+2+3 - £5k.
 TEK 494AP 1Kc/s - 21GHz - £7k.
 TEK 496P 1KHz-1.8GHz - £4k.
 TEK 5L4N 0-100KHz - £400.
 TEK 7L5 + L1 - 20Hz-5Mc/s - £700.
 TEK 7L5 + L3 - Opt 25 Tracking Gen - £900.
 TEK 7L12 - 100KHz-1800Mc/s - £1000.
 TEK 7L18 - 1.5-60GHz - £1500.
 TEK 491 10Mc/s-12.4GHz-40GHz - £750. 12.4GHz-40GHz with Mixers.
 Tektronix Mixers are available for above ANZ to 60GHzs
 Systron Donner 763 Spectrum ANZ + 4745B Preselector .01-18GHz + Two Mixers 18-40GHz in Transit Case - £3k.
 HP8673D Signal Generator .05-26.5GHz - £20k.
 Systron Donner 1618B Microwave AM FM Synthesizer 50Mc/s 2-18GHzs
 R&S SWP Sweep Generator Synthesizer AM FM 4-2500Mc/s - £3.5k.
 ADRET 3310A FX Synthesizer 300Hz-60Mc/s - £600.
 HP8640A Signal Generators - 1024Mc/s - AM FM - £800.
 HP3717A 70Mc/s Modulator - Demodulator - £500.
 HP8651A RF Oscillator 22Kc/s - 22Mc/s.
 HP5316B Universal Counter A - B.
 HP6002A Power Unit 0-5V 0-10A 200W.
 HP6825A Bipolar Power Supply Amplifier.
 HP461A-465A-467A Amplifiers.
 HP81519A Optical Receiver DC-400Mc/s.
 HP Plotters 7470A-7475A.
 HP3770A Amplitude Delay Distortion ANZ.
 HP3770B Telephone Line Analyser.
 HP8182A Data Analyser.
 HP59401A Bus System Analyser.
 HP6260B Power Unit 0-10V 0-100 Amps.
 HP3782A Error Detector.
 HP3781A Pattern Generator.
 HP3730A + 3737A Down Converter Oscillator 3.5-6.5GHz.
 HP Microwave Amps 491-492-493-494-495-1GHz-12.4GHz - £250.
 HP105B Quartz Oscillator - £400.
 HP5087A Distribution Amplifier.
 HP6034A System Power Supply 0-60V 0-10A-200W - £500.
 HP6131C Digital Voltage Source + - 100V 1/2 Amp.
 HP4275A Multi Frequency L.C.R. Meter.
 HP3779A Primary Multiplex Analyser.
 HP3779C Primary Multiplex Analyser.
 HP8150A Optical Signal Source.
 HP1630G Logic Analyser.
 HP5316A Universal Counter A+B.
 HP5335A Universal Counter A+B+C.
 HP59501B Isolated Power Supply Programmer.
 HP8901A Modulation Meter AM - FM - also 8901B.
 HP5370A Universal Time Interval Counter.
 Marconi TF2370 - 30Hz-110Mc/s 750HM Output (2 BNC Sockets+Resistor for 500HM MOD with Marconi MOD Sheet supplied - £650.
 Marconi TF2370 30Hz-110Mc/s 50 ohm Output - £750.
 Marconi TF2370 as above but late type - £850.
 Marconi TF2370 as above but late type Brown Case - £1000.
 Marconi TF2374 Zero Loss Probe - £200.
 Marconi TF2440 Microwave Counter - 20GHz - £1500.
 Marconi TF2442 Microwave Counter - 26.5GHz - £2k.
 Marconi TF2305 Modulation Meter - £2.3k.
 Rascal/Dana 2101 Microwave Counter - 10Hz-20GHz - £2k.
 Rascal/Dana 1250-1261 Universal Switch Controller + 200Mc/s PI Cards.
 Rascal/Dana 9303 True RMS Levelmeter + Head - £450. IFFE - £500.
 TEKA6902A also A6902B Isolator - £300-£400.
 TEK 1240 Logic Analyser - £400.
 TEK FG5010 Programmable Function Generator 20Mc/s - £600.
 TEK2465A 350Mc/s Oscilloscope - £2.5k + probes - £150 each.
 TEK CT-5 High Current Transformer Probe - £250.
 TEK J16 Digital Photometer + J6523-2 Luminance Probe - £300.
 TEK J16 Digital Photometer + J6503 Luminance Probe - £250.
 ROTEK 320 Calibrator + 350 High Current Adaptor AC-DC - £500.
 FLUKE 5102B AC-DC Calibrator - £4k.
 FLUKE 1120A IEEE - 48B Translator - £250.
 Tinsley Standard Cell Battery 5644B - £500.
 Tinsley Transportable Voltage Reference - £500.
 FLUKE Y5020 Current Shunt - £150.
 HP745A + 746A AC Calibrator - £600.
 HP8080A MF + 8091A 1GHz Rate Generator + 8092A Delay Generator + Two 8093A 1GHz Amps - 15400A - £800.
 HP54200A Digitizing Oscilloscope.
 HP11729B Carrier Noise Test Set .01-18GHz - LEF - £2000.
 HP3311A Function Generator - £300.
 Marconi TF2008 - AM-FM signal generator - also sweeper - 10Kc/s - 510Mc/s - from £250 - tested to £400 as new with manual - probe kit in wooden carrying box.
 HP Frequency comb generator type 8406 - £400.
 HP Vector Voltmeter type 8405A - £400 new colour.
 HP Sweep Oscillators type 8690 A & B + plug-ins from 10Mc/s to 18GHz also 18-40GHz. P.O.R..
 HP Network Analyzer type 8407A + 8412A + 8501A - 100Kc/s - 110Mc/s - £500 - £1000.
 HP Amplifier type 8447A - 1-400Mc/s £200 - HP8447A Dual - £300.
 HP Frequency Counter type 5340A - 18GHz £1000 - rear output £800.
 HP 8410 - A - B - C Network Analyzer 110Mc/s to 12GHz or 18GHz - plus most other units and displays used in this set-up - 8411a - 8412 - 8413 - 8414 - 8418 - 8740 - 8741 - 8742 - 8743 - 8746 - 8650. From £1000.
 Rascal/Dana 9301A - 9302 RF Millivoltmeter - 1.5-2GHz - £250-£400.
 Rascal/Dana Modulation Meter type 9009 - 8Mc/s - 1.5GHz - £250.
 Marconi RCL Bridge type TF2700 - £150.
 Marconi/Saunders Signal Sources type - 6058B - 6070A - 6055A - 6059A - 6057A - 6056 - £250-£350. 400Mc/s to 18GHz.
 Marconi TF1245 Circuit Magnification meter + 1246 & 1247 Oscillators - £100-£300.
 Marconi microwave 6600A sweep osc., mainframe with 6650 PI - 18-26.5GHz or 6651 PI - 26.5-40GHz - £1000 or PI only £600. MF only £250.
 Marconi distortion meter type TF2331 - £150. TF2331A - £200.
- Tektronix Plug-Ins 7A13 - 7A14 - 7A18 - 7A24 - 7A26 - 7A11 - 7M11 - 7S11 - 7D10 - 7S12 - S1 - S2 - S6 - S52 - PG506 - SC504 - SG502 - SG503 - SG504 - DC505A - FG504 - 7B80 + 85-7B92A - WR501 - DM501A - FG501A - TG501 - PG502 - DC505A - FG504 - 7B80 + 85-7B92A
 Gould J3B test oscilloscope manual - £150.
 Tektronix Mainframes - 7603 - 7623A - 7613 - 7704A - 7844 - 7904 - TM501 - TM503 - TM506 - 7904A - 7834 - 7623 - 7633.
 Marconi 6155A Signal Source - 1 to 2GHz - LED readout - £400.
 Barr & Stroud Variable filter EF3.0.1Hz - 100Kc/s + high pass + low pass - £150.
 Marconi TF2163S attenuator - 1GHz. £200.
 Farnell power unit H6050 - £400 tested. H6025 - £250.
 Rascal/Dana 9300 RMS voltmeter - £250.
 HP 8750A storage normalizer - £400 with lead + S.A or N.A Interface.
 Marconi TF2330 or TF2330A wave analysers - £100-£150.
 Tektronix - 7514 - 7T11 - 7S11 - 7S12 - S1 - S2 - S39 - S47 - S51 - S52 - S53 - 7M11.
 Marconi mod meters type TF2304 - £250.
 HP 5065A rubidium vapour FX standard - £1.5k.
 Systron Donner counter type 6054B - 20Mc/s - 24GHz - LED readout - £1k.
 Rascal/Dana 9083 signal source - two tone - £250.
 Systron Donner - signal generator 1702 - synthesized to 1GHz - AM/FM - £600.
 Tektronix TM515 mainframe + TM5006 mainframe - £450 - £850.
 Farnell electronic load type RB1030-35 - £350.
 Rascal/Dana counters - 9904 - 9905 - 9906 - 9915 - 9916 - 9917 - 9921 - 50Mc/s - 3GHz - £100-£450 - all fitted with FX standards.
 HP4815A RF vector impedance meter c/w probe - £500-£600.
 Marconi TF2092 noise receiver. A, B or C plus filters - £100-£350.
 Marconi TF2091 noise generator. A, B or C plus filters - £100-£350.
 Marconi 2017 S/G 10KHz - 1024MHz.
 HP180TR, HP182T mainframes £300-£500.
 Philips panoramic receiver type PM7900 - 1 to 20GHz - £400.
 Marconi 6700A sweep oscillator + 18GHz PI's available.
 HP8505A network ANZ + 8503A S parameter test set + 8501A normalizer - £4k.
 HP8505 network ANZ 8505 + 8501A + 8503A.
 Rascal/Dana VLF frequency standard equipment. Tracer receiver type 900A + difference meter type 527E + rubidium standard type 9475 - £2750.
 HP signal generators type 626 - 628 - frequency 10GHz - 21GHz.
 HP 432A - 435A or B - 436A - power meters + powerheads - Mc/s - 40GHz - £200-£1000.
 Bradley oscilloscope calibrator type 192 - £600.
 HP8614A signal generator 800Mc/s - 2.4GHz. new colour £400.
 HP8616A signal gen 1.8GHz - 4.5GHz. new colour £400.
 HP 3325A syn function gen 20Mc/s - £1500.
 HP 3336A or B syn level generator - £500-£600.
 HP 3586B or C selective level meter - £750-£1000.
 HP 3575A gain phase meter 1Hz - 13Mc/s - £400.
 HP 8683D S/G microwave 2.3 - 13GHz - opt 001 - 003 - £4.5k.
 HP 8660 A B C syn S/G. AM + FM + 10Kc/s to 110Mc/s PI - 1Mc/s to 1300Mc/s - 1Mc/s to 2600Mc/s - £500-£2000.
 HP 8640B S/G AM-FM 512Mc/s or 1024Mc/s. Opt 001 or 002 or 003 - £800-£1250.
 HP 8622BX Sweep PI - 01 - 2.4GHz + ATT - £1750.
 HP 8623B Sweep PI - 2 - 18GHz - £1000.
 HP 86230B Sweep PI - 2 - 18GHz - £1250.
 HP 86 Series PI's in stock - split from 10Mc/s - 18.6GHz - £250-£1k.
 HP 8620C Mainframe - £250. IEEE - £500.
 HP 8615A Programmable signal source - 1MHz - 50Mc/s - opt 002 - £1k.
 HP 8601A Sweep generator. 1 - 110Mc/s - £300.
 HP 3488A HP - IB switch control unit - £500 + control modules various - £175 each.
 HP 8160A 50Mc/s programmable pulse generator - £1000.
 HP 853A MF ANZ - £1.5k.
 HP 8349A Microwave Amp 2 - 20GHz Solid state - £1500
 HP 3585A Analyser 20Hz - 40Mc/s - £4k.
 HP 8569B Analyser .01 - 22GHz - £5k.
 HP 3580A Analyser 5Hz - 50KHz - £1k.
 HP 1980B Oscilloscope measurement system - £600.
 HP 3455A Digital voltmeter - £500.
 HP 3437A System voltmeter - £300.
 HP 3581C Selective voltmeter - £250.
 HP 5370A Universal time interval counter - £450.
 HP 5335A Universal counter - 200Mc/s - £500.
 HP 5328A Universal counter - 500Mc/s - £250.
 HP 6034A System power supply - 0 - 60V - 0 - 10 amps - £500.
 HP 5150A Thermal printer - £250.
 HP 164A Data error analyser - £150.
 HP 4437A Attenuator - £150.
 HP 3717A 70Mc/s modulator - £400.
 HP 3710A - 3715A - 3716A - 3702B - 3703B - 3705A - 3711A - 3791B - 3712A - 3793B - microwave link analyser - P.O.R.
 HP 3730A + B RF down converter - P.O.R.
 HP 3552A Transmission test set - £400.
 HP 3763A Error detector - £500.
 HP 3764A Digital transmission analyser - £600.
 HP 3770A Amp delay distortion analyser - £400.
 HP 3780A Pattern generator detector - £400.
 HP 3781A Pattern generator - £400.
 HP 3781B Pattern generator (bell) - £300.
 HP 3782A Error detector - £400.
 HP 3782B Error detector (bell) - £300.
 HP 3785A Jitter generator + receiver - £750-£1k.
 HP 8006A Word generator - £100-£150.
 HP 8016A Word generator - £250.
 HP 8170A Logic pattern generator - £500.
 HP 59401A Bus system analyser - £350.
 HP 59500A Multiprogrammer HP - IB - £300.
 Philips PM5390 RF syn - 0.1 - 1GHz - AM + FM - £1000.
 S.A. Spectral Dynamics SD345 spectroscope 111 - LF ANZ - £1500.
 Tektronix R7912 Transient waveform digitizer - programmable - £400.
 Tektronix TR503 + TM503 tracking generator 0.1 - 1.8GHz - £1k - or TR502.
 Tektronix 576 Curve tracer + adaptors - £300.
 Tektronix 577 Curve tracer + adaptors - £300.
 Tektronix 1502/1503 TDR cable test set - £1000.
 Tektronix AM503 Current probe + TM501 m/frame - £1000.
 Tektronix SC501 - SC502 - SC503 - SC504 oscilloscopes - £75-£350.
 Tektronix 465 - 465B - 475 - 2213A - 2215 - 2225 - 2235 - 2245 - 2246 - £250-£1000.
 Kikusui 100Mc/s Oscilloscope COS6100M - £350.
 Nicolet 3091 LF oscilloscope - £400.
 Rascal 1991 - 1992 - 1988 - 1300Mc/s counters - £500-£900.
 Fluke 80K-40 High voltage probe in case - BN - £100.
 Rascal Recorders - Store 4 - 4D - 7 - 14 channels in stock - £250-£500.
 Rascal Store Horse Recorder & control - £400-£750 Tested.
 EIP 545 microwave 18GHz counter - £1200.
 Fluke 510A AC ref standard - 400Hz - £200.
 Fluke 355A DC voltage standard - £300.
 Wiltron 610D Sweep Generator + 6124C PI - 4 - 8GHz - £400.
 Wiltron 610D Sweep Generator + 61084D PI - 1Mc/s - 1500Mc/s - £500.
 Time Electronics 9814 Voltage calibrator - £750.
 Time Electronics 9811 Programmable resistance - £600.
 Time Electronics 2004 D.C. voltage standard - £1000.
 HP 8699B Sweep PI YIG oscillator. 01 - 4GHz - £300. 8690B MF - £250. Both £500.
 Dumburger 1250 Frequency response ANZ - £1500.
 Dumby Loads & power att up to 2.5 kilowatts FX up to 18GHz - microwave parts new and ex equipment - relays - attenuators - switches - waveguides - Yigs - SMA - APC7 plugs - adaptors. B&K items in stock - ask for list.
 W&G items in stock - ask for list.
 Power Supplies Heavy duty + bench in stock - Farnell - HP - Weir - Thurlby - Rascal etc. Ask for list.

ITEMS BOUGHT FROM HM GOVERNMENT BEING SURPLUS. PRICE IS EX WORKS. SAE FOR ENQUIRIES. PHONE FOR APPOINTMENT OR FOR DEMONSTRATION OF ANY ITEMS, AVAILABILITY OR PRICE CHANGE. VAT AND CARRIAGE EXTRA

ITEMS MARKED TESTED HAVE 30 DAY WARRANTY. WANTED: TEST EQUIPMENT-VALVES-PLUGS AND SOCKETS-SYNCRS-TRANSMITTING AND RECEIVING EQUIPMENT ETC.

Johns Radio, Whitehall Works, 84 Whitehall Road East, Birkenshaw, Bradford BD11 2ER. Tel. No: (01274) 684007. Fax: 651160

CIRCLE NO. 134 ON REPLY CARD

impedance equalisation network connected across the terminals of the woofer. This serves to flatten the woofer's impedance at high frequencies, making it behave much more like a constant resistance. Such a network is referred to as a Zobel network, and is often used by designers of crossover networks.

Figure 4 shows the results that can be achieved when a Zobel network comprising $R=8\Omega$, $C=10\mu F$ is connected across the terminals of the woofer. It is evident that the results are much better than those that were achieved without the use of the Zobel network. The low-pass response is now much smoother and closer in shape to the ideal third-order Butterworth response, and combines relatively well with the high-pass response to produce a reasonably flat summed response.

Another factor that was not mentioned in Bill's article that also needs to be accounted for in any crossover design is the natural response of each of the drivers. For example, the woofer might have a high-frequency roll-off that could typically be modelled by a second-order Butterworth response with a -3dB cut-off at 5kHz, while the tweeter's low-frequency roll-off might be simulated using a second-order Butterworth response with a -3dB point of 1.2kHz. Figure 5 shows the responses obtained when these natural driver roll-offs are added to the simulations involving

the crossover network with the Zobel network.

In this particular case, a slight boost in summed response in the crossover region is introduced. This results mainly from the fact that the lowpass and highpass responses shown in Fig. 5 are now acting in phase through the crossover region, whereas in Fig. 4 there is a phase difference of about 90° .

You should also remember that inter-driver time delays between the output from the woofer and tweeter also affect the summed response of the loudspeaker system. These time delays are caused by the physical offsets in the locations of the driver acoustic centres.

Depending on the actual loudspeaker system, the inter-driver time delays may improve or adversely affect the initial crossover design. Because of this, they should be understood to be an important factor affecting the performance of the completed loudspeaker system. For example, at 3kHz the wavelength of sound is 0.115m. A horizontal offset between the acoustic centres of the drivers of $1/4$ of this, 0.029m, will lead to an additional phase shift of 90° between the outputs from woofer and tweeter.

Depending on the crossover topology chosen, this can have serious consequences for the quality of summed response. If a third-order acoustic Butterworth crossover

topology is chosen, an additional 90° of phase shift will lead to a significant dip in the summed response at the crossover frequency.

I hope that these examples help to make it clear to you that there is no simple method of crossover design that will produce good results. Indeed, many different factors need to be taken into account if the selected crossover filter is to perform to the desired specification. This is the reason why it is unlikely that prebuilt crossover networks will produce worthwhile results when used with drivers for which they have not been designed.

All of the above simulations were performed using the Calsod loudspeaker design program developed by me in my spare time. It comes in two editions. Calsod 1.40 is the 'budget' edition (retail price AUD\$119), while version 3.10 is the full featured edition (retail price AUD\$449 with printed manual, AUD\$379 with on-disk manual). When purchased from Audiosoft, all prices include air mail postage and handling. Both versions of the programme are capable of carrying out the simulations described in the text of my letter, and the program has many other useful features that would be of assistance to crossover network designers, including a network optimiser.

The package is available from Audiosoft, Melbourne, Australia,

fax: +61 3 9497 4441 or e-mail: audiosoft@netwide.com.au, or from Marton Music in the UK on 01282 773198, fax 01282 773198.

Witold Waldman
Melbourne
Australia

Preamp design thoughts

I have read with interest recent articles on low noise audio preamplifiers. This shift of emphasis away from what seems near obsessive examination of audio power amplifier distortion to the subtleties of small signal manipulations is welcome. My tin ears will tolerate modest distortion in listening at sociable levels, but are perhaps as sensitive to hum and noise levels as any auric articles, so any improvement in these parameters should be welcomed. I make the following observations on two particular pieces.

Simon Bateson's design in the May Issue is headlined as the ultimate microphone preamp, and the purpose designed late eighties SSM2016 IC at its heart is undoubtedly excellent at its job. How unfortunate it is then that the apparent obsolescence (letters July/August) of the IC has meant an early revision of Mr Bateson's 'final microphone preamp'. Perhaps surprisingly the revised design employs the SSM2017, which has a much lower specification than the 2016, and this with an undesirable and improperly polarised electrolytic. This latter inclusion apparently makes no audible difference, but I suspect that this component now becomes the most critical in respect of noise (and distortion?) performance in the amplifier.

The INA103, whose use he rejects in his letter, actually exhibits greatly superior dc precision to both 2016 and 2017. It certainly would not require capacitor coupling. The noise figure of the SSM devices, as in most instrumentation amplifiers, is a function of gain and falls to around 2.5dB at a gain of 100 from 1dB at a gain of 1000.

The INA103 would give a 1.5dB noise figure with 150Ω input ($1\text{ nV}/\sqrt{\text{Hz}}$) at $G=1000$, 3dB at $G=100$; ie only marginally poorer. Actual noise performance of the amplifier will be highly dependent on the impedance spectrum of the microphone. Are these important curves readily available? They need to be to make proper objective design decisions.

The 'no-compromise' disc preamp by Douglas Self in the July/August issue purports to use the latest of op-amps, but resigns itself to being a revision of his earlier 1983 design. The rather complex moving coil

Pioneers of broadcasting

In their interesting article 'Making Continuous Waves', Tom Ivall and Peter Willis mention the early work of Canadian-born Professor Reginald Fessenden who broadcast speech and music in an historic 'first broadcast' on Christmas Eve 1906 using a steam-driven high-frequency alternator at Brant Rock, Massachusetts, USA. They also mention the start of regular programmes by KDKA in 1920 and "in the same year" regular broadcasts began in Europe from The Hague.

This seems a little unfair to the Dutch engineer Kanso Henricus Schotanus à Steringa Idzerda who in fact began his Hague Concerts from his PCGG valve transmitter almost a year before KDKA launched its service.

I will summarise briefly what I wrote in an article 'The Hague Concerts from PCGG - the bitter-sweet story of Hanso Idzerda' published in Radio Bygones, April/May 1990.

There are several claims and counter-claims surrounding the birth of radio broadcasting but there can be no doubt that for British listeners full credit belongs to Hanso Idzerda who launched the first of his 'musical evenings' on Thursday, 6 November 1919, with broadcasts specifically intended for British enthusiasts from April 1920. His broadcasts preceded the experimental radiotelephony 'broadcasts' from Chelmsford by the Marconi Company from February 1920.

On a wavelength of 670 metres, PCGG began almost a year before KDKA Pittsburgh (27 October 1920) and is often credited with being the world's first

broadcasting station.

There were earlier experimental transmissions of speech and music - Fessenden, in 1906, was almost certainly the first. De Forest and his Radio Telephone Company made experimental transmissions from about 1908-12 and again in 1916-17.

An authenticated claim can also be advanced on behalf of a group of Belgian experimenters including Raymond Braillard and Robert Goldschmidt who set up a transmitter in the grounds of the Royal Castle at Laeken and broadcast programmes of music for public reception every Saturday from 28 March 1914. This continued until August 1914, when their transmitter was hurriedly destroyed shortly before the Germans entered Brussels.

Idzerda, however, seems to have been the first to build a transmitter specifically for broadcasting on a semi-commercial basis with the firm intention of expanding the sale of the crystal sets, valved amplifiers and components made or marketed by his own firm (Ned Radio-Industrie, or N R-I).

It seldom pays to be a pioneer. Hanso Idzerda and PCGG were gradually squeezed out as the popularity of wireless grew. From about 1924 PCGG broadcasts virtually ended and he drifted out of the public eye.

Twenty years later, during WW2, he was found trespassing on a prohibited area, apparently searching for fragments of an exploded V2. He was arrested by the Germans on suspicion of espionage or possibly held purely as a hostage. He was executed by shooting during the night of 3/4 November 1944.

Pat Hawker, G3VA
London SE22

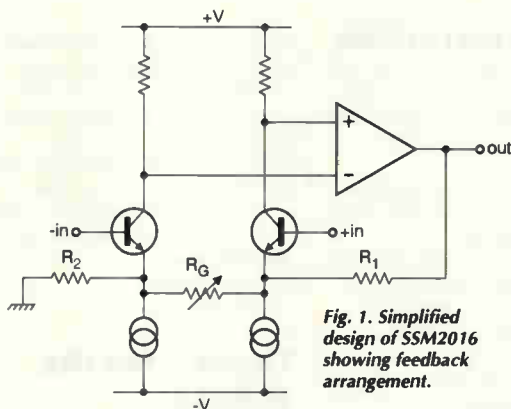

Fig. 1. Simplified design of SSM2016 showing feedback arrangement.

stage as shown resists full analysis as the negative rail voltage is omitted and therefore the transistor operating point is uncertain. Assuming $70\mu\text{A}$ as shown in Table 2, the three 2SB737 devices in parallel should give approximately $1\text{nV}/\sqrt{\text{Hz}}$ ($1.7/\sqrt{3}$) voltage noise density. This figure can be slightly bettered using the LT1028 op-amp ($0.85\text{nV}/\sqrt{\text{Hz}}$) or the AD797 ($0.9\text{nV}/\sqrt{\text{Hz}}$) with a much simpler circuit. The excellent dc characteristics of these modern devices obviates the need for capacitor coupling and their power supply rejection ratio recommend their use in this role. The LT1028 can drive a 100Ω load while maintaining $1\text{V}/\mu\text{V}$ open-loop gain. As a result, it should maintain very low distortion.

In the presented design, some of the available gain is thrown away, and distortion increased from the lower resultant feedback presumably due to the inability of the 5532 to drive less than 600Ω – the total feedback resistance. Additional device cost (circa £7; 1 off) would be offset by reduced associated component cost and pcb surface area. It is practically negligible compared with the cost of top-rate pickup cartridges. I wonder if these recent devices have been considered and/or tested and rejected?

The topologies of the two preamplifiers are actually identical except that the 2016 device offers balanced operation. The 2017 is, I believe, similar internally. Figs 1 and 2 show the essentials with an n-p-n in the Self case for reader comparison.

Figure 1 is actually simpler in its practical implementation due to its precision dc balance, and offers a very desirable advantage from a common-mode rejection angle where the cartridge can be suitably connected.

Similarly the INA103 should again prove ideal here. I am sure Robert Pease (Letters, Jul/Aug 1996) would be interested in any improvement to (perceived) sound quality of using these relatively exotic but affordable and available devices.

Finally, a couple of general

queries. Can Mr Self provide references or the measured data on capacitor induced distortion in filter circuitry to which he refers? Secondly, perhaps he can explain why it is advantageous to follow the RIAA curve to within $\pm 0.05\text{dB}$? It is practically a truism to state that loudspeaker and room colouration show response flatness at least an order of magnitude poorer. Vacuuming the carpet would likely give as insubstantial a difference. I look forward to further preamplifier articles in *EW* to remain abreast of the state-of-the-art in this esoteric field.

Michael Hutchings
Fareham
Hampshire

Douglas replies

Anyone who publishes a design in *Electronics World* must expect a bracing shower of criticism, and so I was not surprised to read Mr Hutchings' unenthusiastic assessment of my preamp in the April Letters column. I was sorry though that there appeared to be nothing at all he liked about it. I also regret he finds my studies of power amplifier distortion "obsessive". For my own part I rather dislike the current trend for labelling anyone who shows any interest in anything as "obsessed".

Where Mr Hutchings got the idea that my preamplifier purported to use the latest of op-amps I do not know. I said explicitly in the article that the 5534 might be a relatively ancient design, but the laws of physics have not decayed over the years, and neither has its superb audio performance. It is used almost to the exclusion of anything else in professional audio all round the world, so clearly there is a good reason. It is simply not possible to buy anything better at anything like the price.

As for noise, if Mr Hutchings had examined my article more closely he would have seen that an I_c of $70\mu\text{A}$ for the 2SB737 transistor is for the moving magnet case. The I_c for the moving-coil stage is 1mA per device, which is a bit different. This

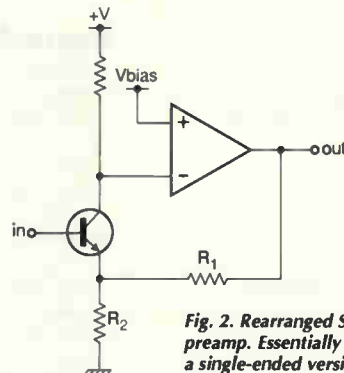

Fig. 2. Rearranged Self preamp. Essentially this is a single-ended version of Fig. 1.

gives a voltage noise density, e_n , of $0.29\text{nV}/\sqrt{\text{Hz}}$ and a current noise density, i_n , of $2.5\text{pA}/\sqrt{\text{Hz}}$ – much less than his figures, and voiding most of his argument. The LT1028 now calculates as at least 7dB noisier than my version.

Mr Hutchings also seems to have based his calculations solely on e_n ; this can lead you grievously astray. It is essential to add the effects of i_n , which is high for the op-amps Mr Hutchings prefers. The i_n is just as important as e_n in a moving-magnet stage, due to the high source impedance at high frequencies of the cartridge inductance.

The LT1028 calculates as 0.7dB noisier than the 5532 in an RIAA stage, allowing for both e_n and i_n . However, its worse than that, Jim. The application of op-amps to audio is even less straightforward than it appears.

Take the OP27, which on paper (adding in both e_n and i_n) is 2.3dB quieter in an RIAA stage with a real cartridge load. If you measure it, you will find it is actually 2dB noisier than the despised 5532 it replaces. The resolution of this paradox is that most op-amps are optimised for dc performance rather than audio. The OP27 is no exception, and so it has a bias-current cancellation system strapped to the inputs. This generates extra common-mode noise, and if the impedances at the two inputs are not the same – and they are very different in an RIAA stage – the extra noise is not cancelled. The LT1028 incorporates a similar bias-cancel structure.

From the data sheet, the LT1028 seems to generate significant ($>0.01\%$) distortion, and I suspect it will be a lot worse into 100Ω – even at modest levels.

I agree entirely that the AD797 is a superb op-amp, and it was in fact my original intention to use it in the preamp. However, I found that hf stabilisation, particularly with high negative feedback factors, could be very tricky, and placing such a design in front of the public would be to open a veritable oil-drum of worms.

In view of Mr Hutchings' lack of

enthusiasm for distortion reduction, as expressed at the start of his letter, I was surprised that he feels the sub- 0.002% thd of the moving-coil stage is too high. I agree that it looks wrong 'to throw' away gain and hence negative feedback factor, but the vital point is that my circuit has a discrete input stage. This has gain of its own, and when added to that of the op-amp, open-loop gain is not lacking.

The alternative approach Mr Hutchings suggests – which I assume has not actually been built and tested – apparently costs seven times as much as my solution. There is no way you are going to get that back by saving a square inch of pcb area. As for equalling the performance – well, I will be interested to see if it can be done.

Finally, what is the advantage of an RIAA curve accurate to $\pm 0.05\text{dB}$, when scratching your nose causes a bigger change in room response? Well, what is the point in trying to do anything better? I wasn't designing a living-room, I was designing a preamp.

My philosophy is to get the best possible performance without spending significantly more money. The RIAA scheme gives remarkable accuracy for a modest outlay, and does it in a way that I thought would be interesting to readers.

A purely electronic system jolly well ought to be orders of magnitude better than a complicated electro-mechanical-acoustic system, because the problems are so much easier to solve.

One rationale for designing better and better amplifiers is to spur the loudspeaker community into designing better speakers. I detect that this trend has already begun, as I see more and more technical papers about the measurement and simulation of speaker non-linearities in *JAES*, etc.

As for non-electrolytic capacitor distortion, I do have a few nuggets of data to offer. If my third-order subsonic filter is tested at 8V rms in isolation, the thd above 100Hz is below 0.0004% . At 20Hz , third-harmonic distortion rises sharply to 0.004% , corresponding to the -3dB point of the filter. It continues to rise as frequency falls – despite the roll-off in output level. This is with standard 63V polyester capacitors.

Changing all three to 100V polyester (as per prototype) reduces the 20Hz thd to 0.0006% , though there is still a steep rise below this frequency. I think this proves, a) that the distortion originates in the

15Hz subwoofer – missing resistor

In the phase splitter of Fig. 1b, resistor R_3 has no annotation on the diagram. It is $10\text{k}\Omega$.

capacitors, and, b) that it depends on the capacitor dielectric. As is usual with third-harmonic distortion, the thd is proportional to voltage squared. There is no such effect in the RIAA stage, so I can only

assume that polystyrene is better from this point of view.

I am grateful to Marcel van de Gevel for pointing this out.
Doug Self
 London

Error cancelling in audio

In last December's Letters column, p. 688, K.H. Ellis shows the 'Hawksford' error cancellation technique for power amplifiers. The following analysis shows that 'error cancellation' is too optimistic a description.

According to this technique the error of an output-stage (B) is subtracted from the input signal:

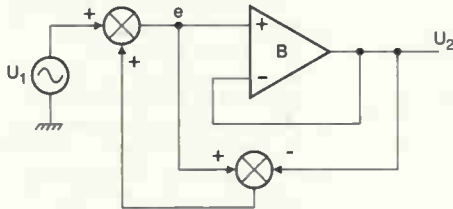

This can be simplified to,

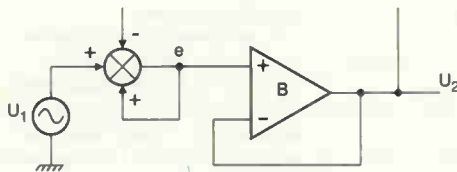

Physical realisation of the summing device can be modelled as,

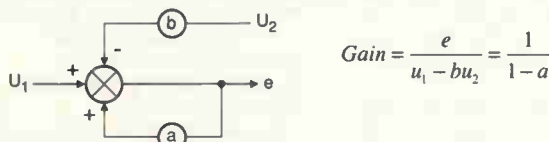

$$Gain = \frac{e}{u_1 - bu_2} = \frac{1}{1 - a}$$

where elements 'a' and 'b' represent the non-ideal behaviour of the summing action (a,b=0.9... to 1).

For 'a' approaching 1, the gain approaches infinity so the summing device acts like an open-loop op-amp. This can also be seen with a realistic implementation, such as:

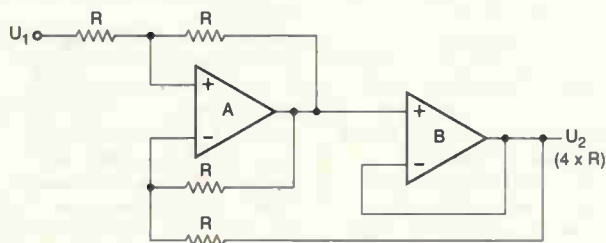

Due to cancellation of the negative and positive feedback around amplifier 'A', this circuit simplifies to:

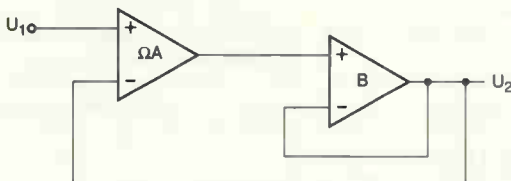

Thus the proposed system behaves like an ordinary feedback amplifier.

Nanno Herder
 University Groningen
 The Netherlands

Sounds incredible

There are some questions that arise from the interesting article by Reg Miles 'Sonics from Ultrasonics' on pp 14-15 in the January 1997 issue.

It is a very old misconception to imagine that the simple sum of two sinusoidal variations such as $\sin(2\pi f_1 t) + \sin(2\pi f_2 t)$ will produce a pair of new 'sum and difference' signals of frequency $(f_1 + f_2)$ and $(f_1 - f_2)$. In fact these 'sidebands' appear only when subsequent non-linear or multiplicative signal processing is effected.

The misconception is encouraged both by the fact that many systems spuriously contain sufficient non-linearity to supply some processing and also by misinterpretation of a bit of mathematics (often published in early textbooks) describing the purely notional envelope of the waveform of the simple sum.

In practice, the ear can supply the non-linearity, but even then, you would not wish to rely upon this oddity to reproduce high quality sound, and certainly not to apply high intensity ultrasonic stimulation to such a sensitive and valuable human sense organ.

The report that "...polyurethane filters had to be hung between the people and the (loud)speakers to selectively absorb the ultrasound..." to prevent 140dB levels from damaging people, demonstrates what a bad idea it is. If the ultrasound is at a high level it is dangerous. If it is reduced before reaching the ear, it will not work and there was no point in producing such high power - unless there is some curious nonlinear effect taking place in the absorbent curtains.

Bob Pearson
 Bourne
 Lincolnshire

CAD inadequacies

May I thank Ralph Giegler for his complimentary comments on the "Route to pcb-CAD" series of articles?

The via problem he mentions is a common one. No-one likes vias, so most autorouters have a via minimiser strategy. The Ares level II autorouter from Propak has such a minimiser, so has the Ares III from Proteus. You can choose a hole size and via pad size to suit yourself, but if you pick a size which is too large you will make it more difficult for the autorouter, as the obstruction will then restrict its choice of routes.

I have tried miniature eyelets and conductive epoxy paste for vias, as well as Veropins, short wires and the plating-through

process. For making vias on one-offs, none of them is very good. I use link-pins (RS part no. 435-383) which are designed for this job and can be very rapidly inserted. They come in sticks of 50 pins and, at only £10 per box of 1000, are not too expensive. Using them saves a lot of time and effort.
Rod Cooper
 Sutton Coldfield
 West Midlands

Thanks for the debate

Cyril Bateman appears to say that an increase in conductor separation changes the voltage drop in a cable from about 40mV pk-pk to nearer 50mV - the drop due to the amplifier output impedance appears to increase as well, which is suspicious, but I'll let that pass.

How many volts are being produced by the driving amplifier? Far more than a few millivolts, I'll wager, though he does not actually say. In reality a change of a few millivolts is irrelevant when the voltage across the speaker terminals is measured in volts.

Secondly, Cyril does a PSpice analysis using an exponentially damped sine wave. The sharp change in slew rate at the start of the waveform introduces high frequency components which stimulate ringing at 50kHz and upwards. This only lasts 100µs at most. There is a much higher level and longer lasting 10kHz signal present at the same time. The idea that the quieter, shorter, and ultrasonic component should be "clearly audible" is laughable. More importantly however, his claim that the waveform used is representative of audio transients is quite wrong. Real sounds recorded on real recording equipment do not contain components at 50kHz and above to stimulate such ringing.

In the third article, Geoff Williams tells us that putting things near speaker cable seriously affects sound quality, bare wire outperforms insulated wire, and the only real answer is Litz wire, and cable ratings may well need to be of the order of 50A... Heaven help us! It never ceases to amaze me that people can seriously write such twaddle.

Still, it all makes for a very entertaining read, so I thank you for printing it all. I would especially like to thank Eric Forth for pointing out that taking a blowtorch to lawnmower cable improves its high frequency performance.

Alan Robinson
 Holgate
 York

For more information about any of the products or services in this issue of **ELECTRONICS WORLD**, simply ring the relevant enquiry number. Enquiry numbers may be found at the bottom of each individual advertisement.

- 101 102 103 104 105 106 107 108 109
- 110 111 112 113 114 115 116 117 118
- 119 120 121 122 123 124 125 126 127
- 128 129 130 131 132 133 134 135 136
- 137 138 139 140 141 142 143 144 145
- 146 147 148 149 150 151 152 153 154
- 155 156 157 158 159 160 161 162 163
- 164 165 166 167 168 169 170 171 172
- 173 174 175 176 177 178 179 180 181

Name _____
Job title _____
Company Address _____ _____ _____
Telephone _____ MAY
Only tick here if you do not wish to receive direct marketing promotions from other companies. <input type="checkbox"/>

Newsagent order form

Pass this order form to your newsagent to ensure you don't miss the next issue of *EW*.

To
(name of Newsagent)

Please reserve me the May issue of *Electronics World* - on sale 3rd April - and continue to order every month's issue until further notice

Name.....

Address.....
.....
.....
.....

Thank you

Subscribe today!

Guarantee your own personal copy each month

Save on a 2 year subscription

Subscribe today!

Guarantee your own personal copy each month

Save on a 2 year subscription

CIRCUIT IDEAS

Do you have an original circuit idea for publication? We are giving **£100** cash for the month's top design. Additional authors will receive **£35** cash for each circuit idea published. We are looking for ingenuity in the use of modern components.

WIN A TTI PROGRAMMABLE BENCH MULTIMETER

"High accuracy, resolution and bandwidth - performance beyond the capability of hand-helds"

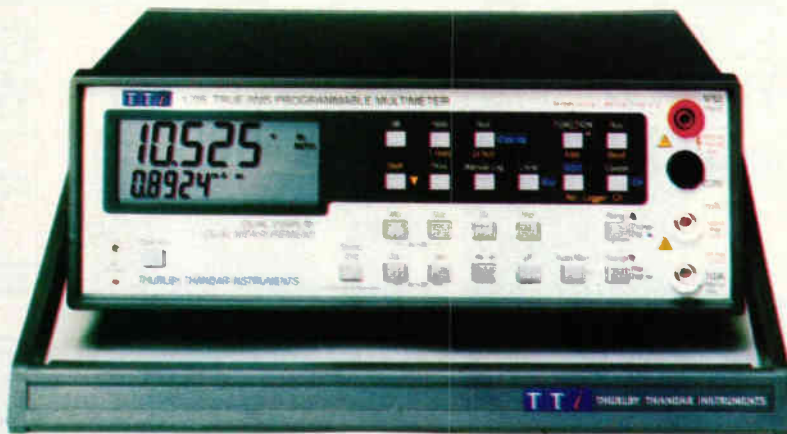

This high-performance bench multimeter could be yours in exchange for a good idea. Featuring a dual display, the 4.5-digit 1705 multimeter resolves down to 10µV, 10mΩ and 0.1µA and has a basic dc accuracy of 0.04%. Frequency measured is 10Hz to 120kHz with an accuracy of 0.01% and resolution to 0.01Hz. Capacitor and true rms measurements are also featured.

Recognising the importance of a good idea, Thurlby Thandar Instruments will be giving away one of these excellent instruments once every six months. This incentive is in addition to our monthly £100 'best circuit idea' award and £35 awards for each circuit published.

Rms-to-dc converter reads in decibels

Analog Devices's data sheet for the AD536 shows an rms-to-dc converter with a decibel output. I have experienced difficulty in obtaining proper logarithmic conformance over the full dynamic range and also the Q81 or PT16 temperature-compensating resistors specified.

Reference current for the converter is usually produced by a

resistor to the supply rail from the decibel output on pin 5, the resulting current being $I_{ref} = (V - \Delta V_{be}) / R$, since ΔV_{be} is the subject of the measurement, there is now a little non-linearity as I_{ref} varies with V_{be} . My solution is to use a constant-current source: an LT1004 diode and the uncommitted, unity-gain buffer in the AD536. Logarithmic

conformance is improved and I_{ref} is independent of supply variations. Potentiometer VR_1 sets zero so that 1V rms is equivalent to 0dB, and VR_2 sets the output to +100mV/dB.

My temperature sensing resistor is the TG2103G by VTM Ltd, obtained from Farnell.

Alex Birkett
London SE22

Offering improved performance over the Analog Devices suggested circuit, this conforms well to a log. law and, as a bonus, reduces the effect of supply variation.

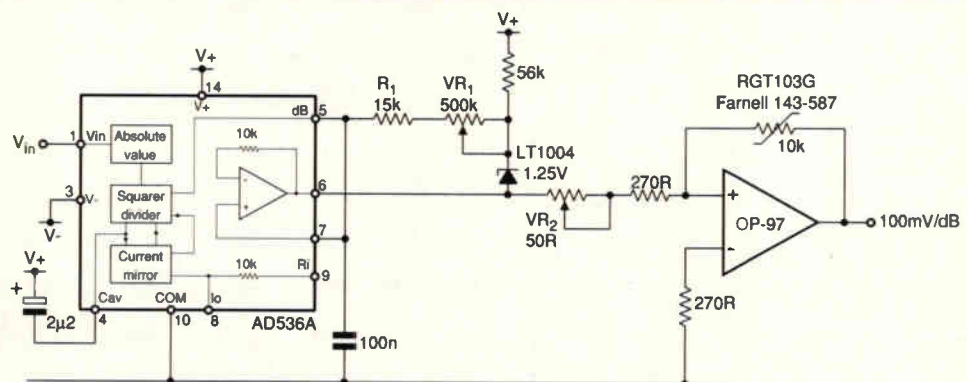

Active three phase rectifier features 0.1V drop

This circuit reduces the normal 1.2V forward voltage drop of a bridge rectifier to around 0.1V. It makes use of the little known fact that power fets work backwards as well as forwards, allowing the inherent reverse biased diode in their structure to be shorted by turning the transistor on.

With all the transistors off, the source-drain diodes in the fets rectify the incoming three phases, providing dc at the output which is subject to the diode drops.

When the output reaches about 4V the op-amps, wired as comparators, begin to operate.

Taking IC_{1a} and p-channel Tr_1 as an example, the comparator senses the voltage across the fet. While the phase voltage is lower than the positive rail, the output of the comparator will be high because the voltage at the non-inverting input of the comparator is higher than that at the inverting input.

As the phase voltage increases above the rail voltage, the inverting input becomes the more positive and the output goes low. This causes the transistor to turn on, shorting out its diode. Current flowing through the on-resistance of the fet creates a voltage drop that maintains the comparator output low, keeping the transistor on.

When the phase voltage drops below the output rail, current begins to flow back through the fet. This reverses the voltage drop across the fet which causes the output of the comparator to swing high, turning the fet off. Positive feedback ensues, ensuring that only a brief pulse of reverse current flows.

All the positive side switches are the same and the negative side switches are similar, but use n-

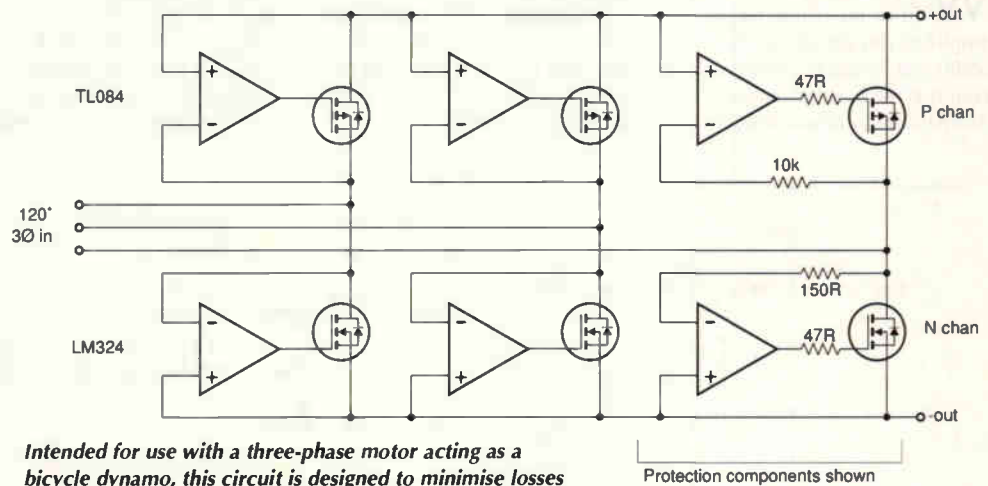

Intended for use with a three-phase motor acting as a bicycle dynamo, this circuit is designed to minimise losses due to rectifier voltage drop.

channel fets.

The op-amps have to work with their inputs outside their supply voltages, so they are chosen specifically. The LM324 input voltage range includes the negative rail and its output defaults low when its inputs are pulled above the positive rail. The TL084 input range includes the positive rail and its output defaults high when its inputs are pulled below the negative rail. The minimum working voltage of TL084s varies from maker to maker. Motorola's seem to work at 4V.

The op-amp output series resistors are there to suppress oscillation in the unlikely event that it should occur because of fet gate capacitance.

Once the rectifier is working actively, the op-amp inputs do not stray far outside the voltage rails, but at voltages below active operation, or if a fet fails, they can be pulled more than a volt to the wrong side.

£100 WINNER

The LM324 is adequately protected by limiting its current to less than 50mA using a resistor. The TL084 is more difficult. If an input is drawn more than 0.3V below the negative rail damage can be done whatever the series resistance is. Including a diode from the positive rail catches the non-inverting input 0.6V below the positive rail and the 10kΩ resistor limits the diode current.

Transistor turn-off depends on the op-amps detecting the reverse voltage across the transistors in the on state. To guarantee this, the op-amp input offset voltage must be less than the $R_{DS(on)}$ of the fet multiplied by the maximum desired amplitude of the reverse current pulses.

Steve Tree
Epsom
Surrey

Simple, economical and low power water detector

Existing water detectors possess several drawbacks. If direct voltage is used on the probes, they oxidise. If alternating voltage is applied at 5-10kHz, the current drawn is high and the accompanying diode pump and comparator increase the component count. There are dedicated ics for the purpose, but they also draw high currents – even when water is not present.

The circuit shown uses three gates, three resistors and a capacitor. It operates from 5V to 15V dc and does not oxidise its probes.

One gate from the 4093BE works as an oscillator, the frequency of which

is 0.1Hz by virtue of the 66MΩ feedback resistance and 0.1μF capacitor; you can hear a click from the piezo sounder every few seconds, which is useful in confirming operation.

However, when the probes touch water, the reduced resistance across the feedback chain causes an increased oscillation frequency and an audible tone from the sounder.

Two of the remaining gates are buffers for the signal to the sounder and R_3 prevents shorts between gate input and output if the probes become shorted.

The circuit draws about 75μA in

standby; 1.5mA when it finds water.

Philip Male
Drake's Broughton
Pershore
Worcestershire

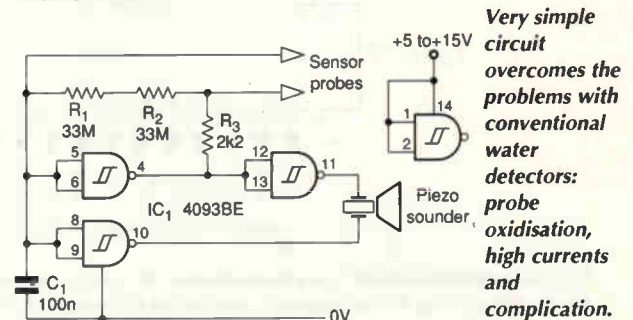

Very simple circuit overcomes the problems with conventional water detectors: probe oxidation, high currents and complication.

Voltage-controlled output common-mode

While behaving as a normal differential input/output amplifier, this circuit has the additional feature of controllable common mode at the output; it is independent of input common-

mode voltage.

For example, if the control input voltage V_{cm} is 0.9V and V_{do} 0V, then both V_{out+} and V_{out-} will be 0.9V; for a V_{do} of 1V, V_{out+} will be 1.4V and V_{out-} 0.4V.

Differential gain is

$$V_{do}/V_{di} = 2 + (2 \times R_x/R_1);$$

$$V_{out+} = V_{cm} + V_{di} \times (1 + R_x/R_1);$$

$$V_{out-} = V_{cm} - V_{di} \times (1 + R_x/R_1)$$

where $R_x = R_2 = R_3 = R_4 = R_5$.

In comparison with a normal

differential amplifier, input impedance is reduced by the effect of $R_{8,9}$. If this poses a problem and if a precise setting of output common mode is unnecessary, then eliminate $R_{8,9}$ and take the positive A_1 input to either of the inputs, which will apply a small offset to the output. Otherwise, for a low-frequency input, again eliminate $R_{8,9}$ and take A_1 input from half-way down R_1 ; the input is across R_1 , so the effect is the same. The only slight problem is possible instability, which can be cured by a capacitor across R_6 .

One can envisage several applications for this circuit; it does, of course, provide absolute values of output signals. It could also, perhaps, be used in a pulse-width modulator.

Albert Pijuan
Girona
Catalonia

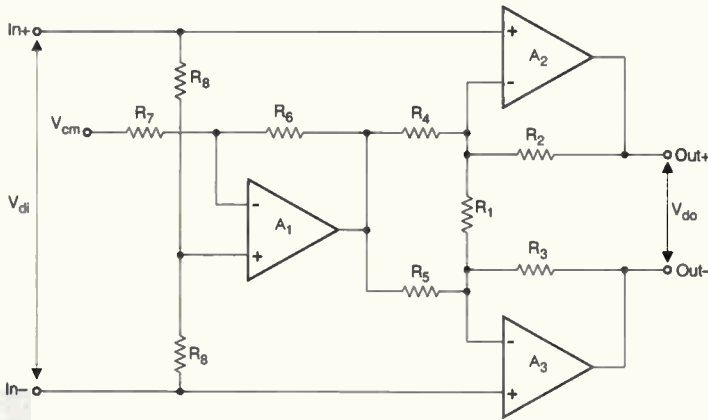

$$R_2 = R_3 = R_4 = R_5 = R_x$$

$$R_6 = R_7$$

$$R_8 = R_9$$

$$V_{do} = Out+ - Out-$$

$$V_{di} = In+ - In-$$

$$\text{Differential gain} = \frac{V_{do}}{V_{di}} = 2 + \frac{2R_x}{R_1}$$

$$Out+ = V_{cm} + V_{di} \left(1 + \frac{R_x}{R_1}\right)$$

$$Out- = V_{cm} - V_{di} \left(1 + \frac{R_x}{R_1}\right)$$

This differential amplifier has its output common-mode voltage defined by a voltage input. Output excursions are independent of the input common-mode level.

Manually loading serial data

Figure 1 shows a method of manually programming a 16-bit word and transmitting it on an SPI or QSPI serial interface. In this way, serial data peripherals such as data converters, memory and display drivers may be exercised before the system is complete. It serves write-only peripherals updating on the rising edge of /CS.

The HC193, IC₁, is a synchronous up/down counter, IC₂ an HC74 D-type flip-flop and the HC4514, IC₄, a 4-to-16 line decoder – all common CMOS devices also in the 4000 series. Microprocessor monitor IC₃ is a MAX1232 that gives a low-frequency, two-phase clock inhibited at logic level at the /MR input, and two

speeds set by the switch on the TD pin.

Depressing switch S_{16} starts a count down by pulsing /LOAD on IC₁, the count starting at 16 or 8 depending on the position of S_{17} , and Led₂ flashes. Each output of IC₄ pulses high in turn, the resulting serial data output depending on which of the S_{0-15} switches are made; a closed switch produces a 1 output.

Data is set up on the rising RES output of IC₃ and clocked out on the rising edge of

/RES. When the count on the ABCD inputs of IC₄ reaches zero, IC₁'s /BORROW output produces a negative pulse to send the /Q output of IC₂ low, which stops the clock by the manual reset input of IC₃. Led₂ stops flashing to indicate the end of the cycle; it is normally on, but flashes when this circuit or another bus master is active. Led₁ lights when this circuit transmits.

Data output is compatible with CMOS inputs of most SPI peripherals and a simple buffer makes it ttl-compatible. IC₄ is only enabled by IC₂ Q output during writing, the bus therefore being otherwise free for use by other interface controllers, which will override /CS and clock outputs.

Kevin Bilke
Maxim Integrated
Products, Reading

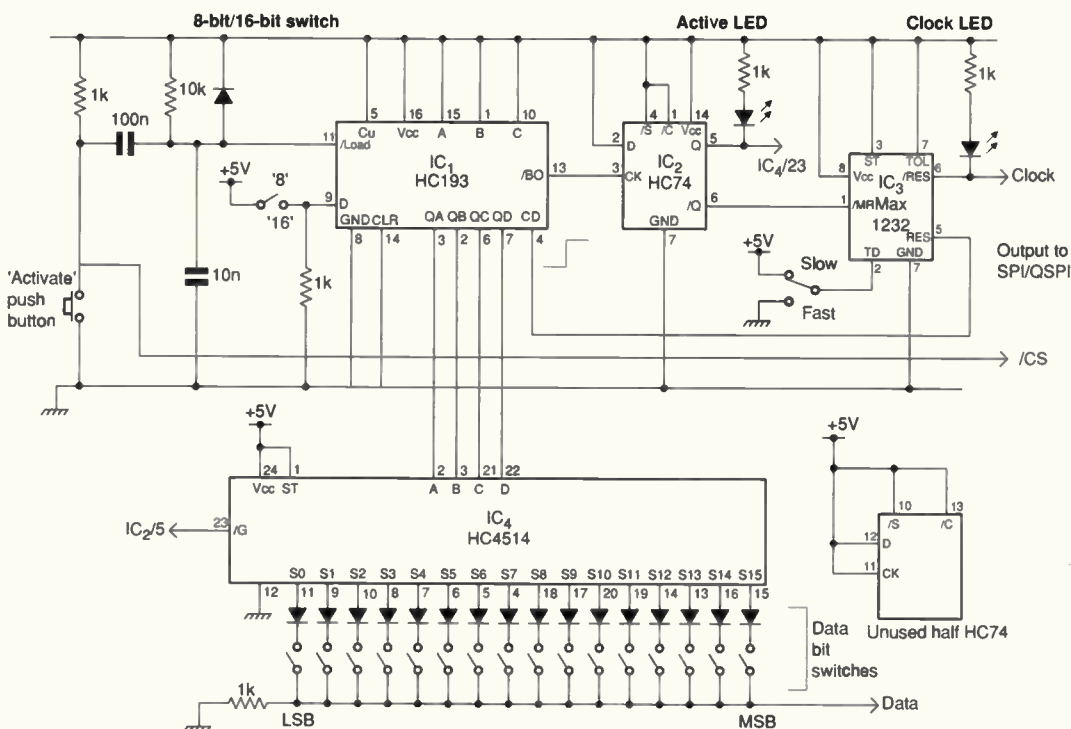

To load serial data into SPI peripherals before the system microcontroller or software are working, this circuit allows a 16-bit word to be manually entered and transmitted along the SPI bus.

Locking an LC oscillator

You can lock an LC oscillator parametrically by periodically varying the damping of the tuned circuit. In this circuit, frequency f_1 may be synchronised by an external signal at the same frequency or by a sub-multiple of it.

Behaviour is similar to that shown when an oscillator is locked by injecting an external signal: as the tuning point is approached a beat appears and the system locks near zero beat, locking over a small range of tuning.

Operation is at its best when f_2 is a square wave having a short rise time. Differentiator C_3R_2 produces spikes to turn Tr_1 on, current pulses then flowing from the tuned circuit into C_2 , charging it and

periodically damping the tuned circuit. In the circuit shown, this happens during positive half cycles across the tuned circuit.

Output appears across R_1 , as does a direct voltage which goes through a minimum near the middle of the locking

Positively locking an LC oscillator by using the locking signal to damp the tuned circuit. Values shown are suitable for frequencies up to a few tens of kilohertz.

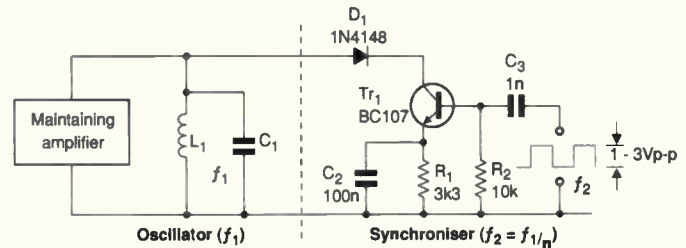

range; at this point, there is only a small disturbance of the tuned circuit by locking pulses. The circuit locks, in the short term, for f_1/f_2 up to about 100.

Component values are not critical, but R_1 should be about equal to the tuned circuit dynamic resistance.

George Short
Brighton

Voltage-controlled oscillator

Inspiration for this circuit came from an article by Ayers in 1994, in which the properties of operational transconductance amplifiers were discussed. In this case, otas are used in a controllable sinewave generator to cover the audio band, 20Hz-22kHz, in one sweep.

Two operational transconductance amplifiers, $IC_{5a,b}$, form a state-variable filter whose frequency response is made

variable by means of the input from P_1 . Output from the filter goes back to its input via IC_3 and the limiter, so that the circuit oscillates at the filter frequency.

Since the feedback signal is limited, the output voltage of the filter is virtually constant with frequency and no level control is needed. Buffer IC_6 gives 10Vpk-pk of sinusoid, which is not entirely distortion-free; my application could

tolerate a little distortion, but the circuit had to be simple.

Bernard Van den Abeele
Evergem
Belgium

Reference

I. Ayers, D. 'The Versatile world of OTAs'.
Electronics World + Wireless World,
March 1994, p197.

State-variable filter is voltage controlled to form a single-sweep 20Hz-22kHz oscillator with constant output voltage.

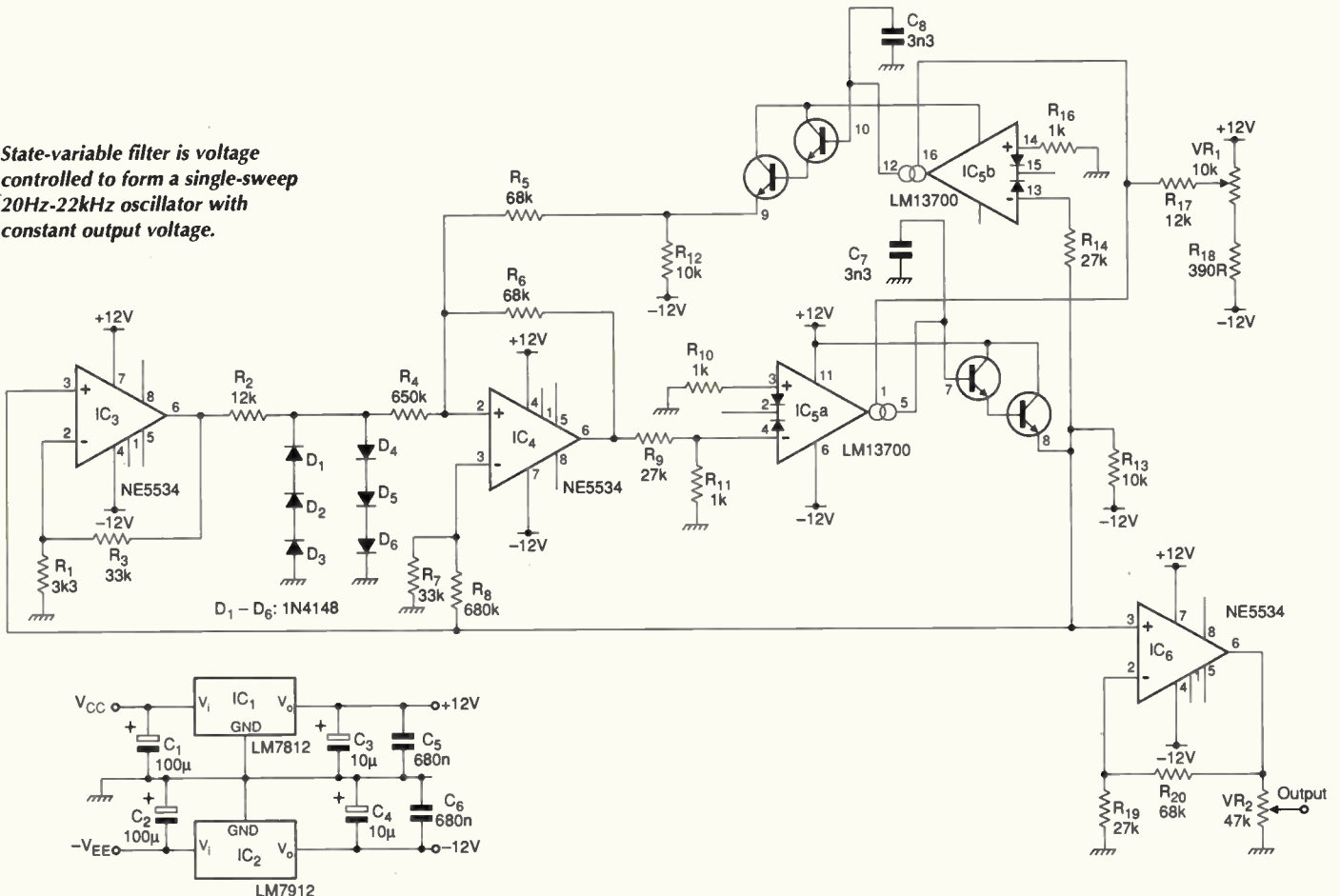

Simple I²C-to-lcd interface

For small Ic displays, driving can hardly be simpler than this method, which uses one PCF8574 8-bit i/o port with interrupts and five passive components to drive a four-bit display

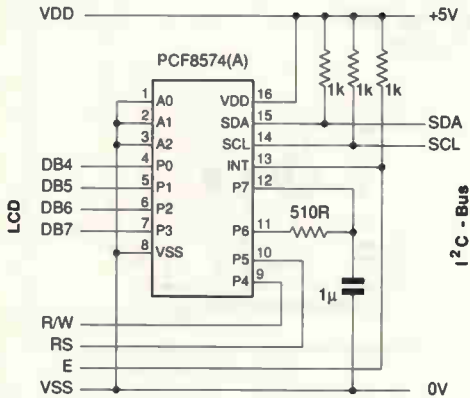

Simple and frugal I²C interface for liquid-crystal display modules.

module, freeing four port lines for control.

Writing to the port when /INT is set resets /INT high, any change of state on any input setting /INT low again, the change occurring after data is transferred so that the data is recognised. An RC network between output P₆ and input P₇ effects this timing, shifting the output signal past the end of data transfer. Toggling P₆ on every input causes this interrupt S/R sequence to form an E signal for the display.

Two consecutive calls to the I²C port effects a complete data transfer of eight data bits; data, msb first, in the lower nibble and control bits in the upper, E being generated automatically, as above, if P₆ changes state in succession. Observing the timing of the display instruction cycles means that there is no need to read the BUSY flag, but set E high by not toggling P₆, set the device for input, read from the display and toggle E low again, twice. Make sure to track the state of P₆.

The bus address of the PCF8574 is 0100xxxw and for the 8574A 0111xxxw, xxx being set by hardware and w being the write bit. To initialise the display for four-bit working on two lines, with cursor shift rightwards and visible, send the following hex sequence to the I²C device:

C3 83 C3 83 C2 82 C8 80 CE 80 C1 80 C6,
the first five being for external and internal sync. followed by byte pairs for function set, display on, clear display and entry mode set.

The word 'wireless' results from:
A7 E7 A6 E9 A7 E2 A6 E5 A6 EC A6 E5 A7 E3 A7 E3.

80 C₁ clears the display.

Dipl. Ph. Detlef Mahr
Freiburg
Germany

Noisy supply for aircraft radio testing

Electronic equipment in aircraft running on 12V dc must work in the presence of supply noise of 2V pk-pk; this circuit is meant to test aircraft radio.

Essentially, the tester takes the form of an oscillator applied to the adjustment pin of an LM317 voltage regulator. Since the 'noise' waveform did not have to be

anything too wonderful, I used an oscillator consisting of two gates from a 4811 drive a 4817 counter with weighted outputs to produce a sinusoid in the 30-3500Hz range. This output goes to a 741, which also sets the output direct voltage level between 5V and 15V, to modulate the supply.

Aside from radio testing, the circuit

can be used to test the equivalent series resistance of an electrolytic capacitor by setting the dc bias and modulating the source, the series resistor being steel wire, measured by length.

J D Ingram
Gawler
South Australia

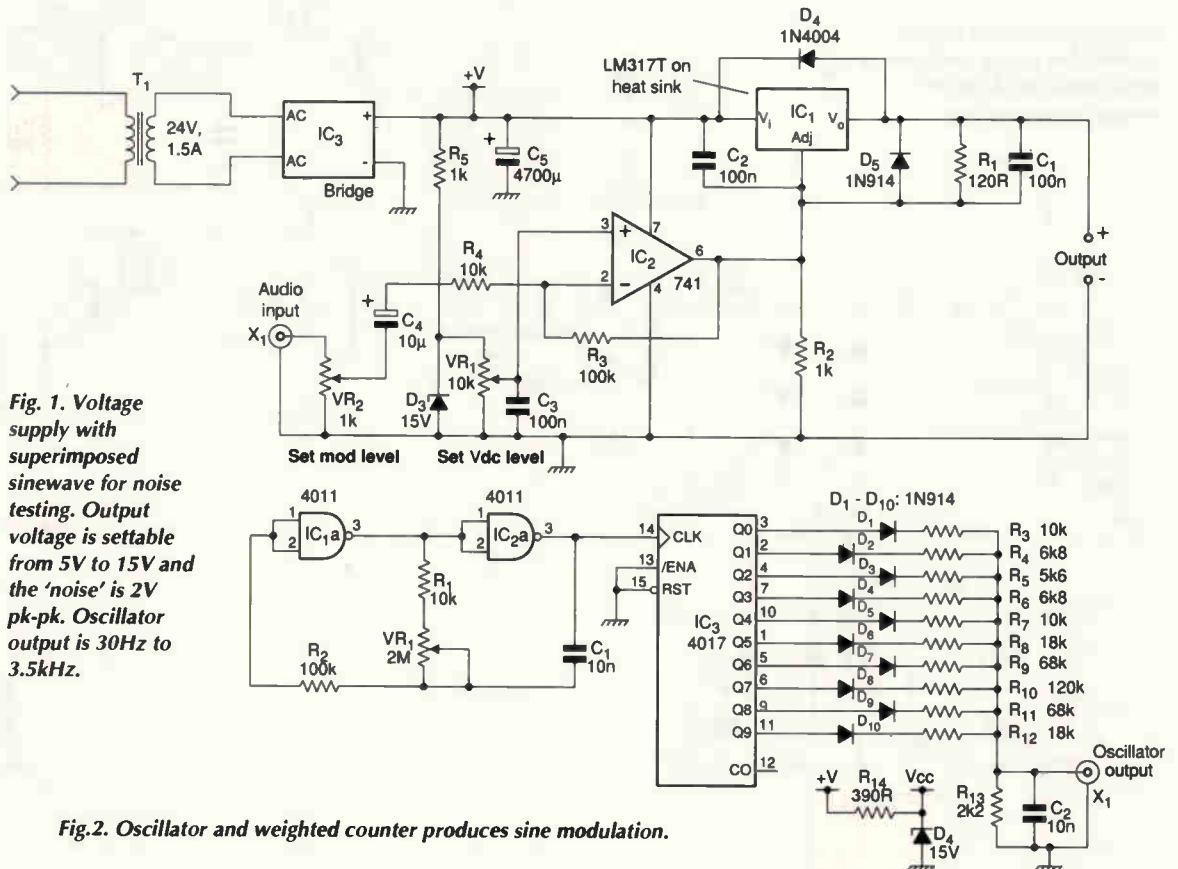

Fig. 1. Voltage supply with superimposed sinewave for noise testing. Output voltage is settable from 5V to 15V and the 'noise' is 2V pk-pk. Oscillator output is 30Hz to 3.5kHz.

Fig.2. Oscillator and weighted counter produces sine modulation.

ADVERTISERS PLEASE NOTE

For all your
future enquiries
on advertising
rates

Please contact
Malcolm Wells on

Tel: 0181-652 3620
Fax: 0181-652 8956

YOUR
Ideal Partner
in UHF and VHF
COMMUNICATION



One stop solutions
for all your radio
telemetry module needs.

When the success of your products depends on radio telemetry modules, you need a business partner you can trust. A skilled and experienced manufacturer that can offer modules of the highest quality, operating over a wide range of frequencies.

In other words, a partner like Wood & Douglas. Founded on technical excellence, Wood & Douglas is a British company that specialises in the design, development and production of radio-based products. With over 30 staff dedicated to meeting your requirements, the company is able to provide true one-stop purchasing - whatever your RTM needs.

All radio modules are highly functional, capable of meeting a wide range of requirements. Designed to offer efficient, easy-to-use radio telemetry components for system designers, they can open up a whole new world of product possibilities.

From portable bar-code readers to earthquake monitors, Wood & Douglas can help you make the most of the opportunities in radio telemetry.

To find out more about the possibilities, contact...



WOOD & DOUGLAS

Lattice House, Baughurst, Tadley, Hampshire RG26 5LP, England
Telephone: 0118 981 1444 Fax: 0118 981 1567
email: info@woodanddouglas.co.uk
web site: http://www.woodanddouglas.co.uk

Field Electric Ltd.

Tel: 01438-353781 Fax: 01438 359397

Mobile: 0836-640328

Unit 12b, Parsons Green Ind. Est.
Stevenage, Herts SG1 4QG

12" Colour VGA-SVGA 800x600 Monitors	£52.50
14" Colour VGA Monitors various 1st brand makes	£80.00
17" Colour VGA-SVGA Monitors 1st brand makes	£285.00
Sony 9" RGB Colour Monitors (Trinitron)	£39.00
Compaq Docking Stations for laptop & notebooks	£24.95
Tseng Dual Port VGA-SVGA ISA 16 Bit Card 1mb to run 2 monitors from 1 pc	£29.95
Hauppauge Win/TV Card 16 bit ISA card	£40.00
Roland DXY 1300 8 Pen Plotter	£135.00
Roland DXY 1100 8 Pen Plotter	£120.00
Hewlett Packard 7470A Plotter RS232 8 Pen	£75.00
Hewlett Packard Colour Pro Plotter RS232 8 Pen	£75.00
Hewlett Packard 7475A Plotter RS232 6 Pen	£70.00
Hewlett Packard 7550A Plotter HP-IB RS232 etc	£155.00
Hewlett Packard Laserjet 11D Printer	£180.00
Hewlett Packard Scanjet	£95.00
Sony Lasermax Videodisk Player LDP 1500P	£165.00
Racal Inst. 9915 UHF Freq. Meter 500 MHz	£90.00
Racal Inst. 9916 UHF Freq. Counter 500 MHz	£130.00
Leader LMV 181A AC Millivoltmeter	£130.00
Blackstar Multimeter 3225	£50.00
Siemens Data Line Analyser K1190 with manual	£280.00
Farnell PSU 0-70VDC 0-5A/0-30 VDC 0-10A	£225.00
Marconi Inst. Data Comms Tester 2870	£295.00
Marconi Inst. Digital Line Monitor 2833	£270.00
Marconi Inst. Digital Analyser 2829	£270.00
Philips PM3233 10 MHz D/trace Scope	£50.00
Tektronix DAS9100 Digital Analysis System	£145.00
Iswatsu SS5702 20 MHz D/trace Scope	£140.00
Hewlett Packard 415E SWR Meter	£75.00
Hewlett Packard 3551A Transmission Test Set	£180.00
Hewlett Packard 5004A Signature Analyzer	£75.00
Philips PM 6611 Universal Counter 80 MHz	£90.00
Hewlett Packard 5300B Measuring System with 5312A HP-IB Interface 1.3 GHz	£300.00
PLOTTERS • COMPUTERS • COMMUNICATIONS • PSU • VDU's • VIDEO	
• FANS • TEST • CABLE • NETWORK • PRINTERS •	
DISK DRIVES ALWAYS IN STOCK. OVERSEAS ENQ. WELCOME	
TELEPHONE ORDERS ACCEPTED	
C/P DETAILS PLEASE RING. ALL PRICES PLUS 17.5% VAT	

CIRCLE NO. 135 ON REPLY CARD

CIRCLE NO. 136 ON REPLY CARD

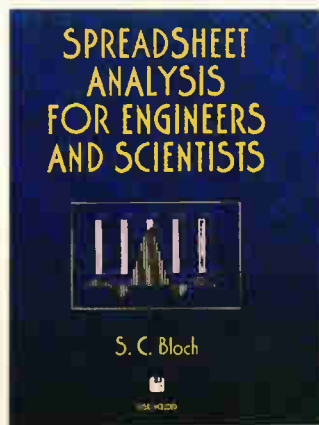

Spreadsheet Analysis for Engineers and Scientists

With this practical, hands-on guide, engineers and researchers learn, quickly and easily, the latest and most useful electronic spreadsheet methods. Using a variety of interactive techniques, including worksheets, self-test and practical programs on the included disk, *Spreadsheet Analysis for Engineers and Scientists* show you how to harness the power and versatility of spreadsheet programs, including those that contain the fast Fourier transform, complex operations and Bessel functions, and how to customise your own applications.

Includes disk

0471 126837, 336pp
UK £37.50, Europe £39.50, ROW £49.50

Electronic Component Reliability

Fundamentals, Modelling, Evaluation and Assurance

This text approaches the quality and reliability of electronic components from a unique standpoint. Traditionally the twin subjects of reliability physics and reliability statistics have been treated as separate entities. Here, the author examines both areas and reveals how components fail and how failures develop over a period of time.

0471 952966, 374pp
UK £50.50, Europe £53.50, ROW £66.50

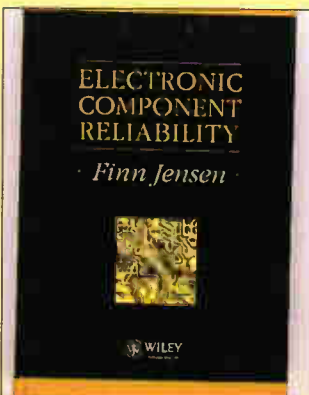

Fuzzy Logic

Implementations and Applications

Offering a new perspective on a growing field, this text explores the many hardware implications of fuzzy logic based circuits. As use of AI increases, so the VLSI area of circuits is becoming a growth subject. Opening with an overview of fuzzy sets and fuzzy logic the book moves on to cover a range of non-standard solutions for fuzzy logic VLSI circuits. Future trends, new concepts and ideas are all examined and supported with practical examples from the author's research.

ISBN 0471 950599, approx 346pp,
UK £50.50, Europe £53.50, ROW £66.50

Microelectronic Switched-Capacitor Filters

Switched-capacitor filters and associated MOS integrated circuits are now an established technology finding applications in the telecommunications and instrumentation fields. With unrivalled breadth of coverage, this book surveys the design techniques of an important class of analogue signal processing systems. An accompanying diskette containing a comprehensive computer-aided design package (ISICAP) enables readers to gain a greater depth of understanding of the described techniques. Containing both source code



files and an executable version of the main design package, this alone will be an indispensable tool for many circuit designers.

Includes disk

0471 954047 384pp
UK £75.50, Europe £79.00, ROW £92.00

The I²C Bus

From theory to Practice

With a special emphasis on the I²C Bus, this guidebook through the world of micro controller-managed serial buses presents comprehensive coverage of the theory necessary to design the best possible communications bus for any particular application. The book examines typical industrial and consumer applications and enables the reader to design effectively in a real-world environment. A disk containing software for the I²C bus is also included.

Includes disk

0471 96268 6, 314pp
UK £54.50, Europe £56.50, ROW £65.00

High Frequency Analog Integrated Circuits

As one of the first textbooks to discuss integrated circuit design considerations and

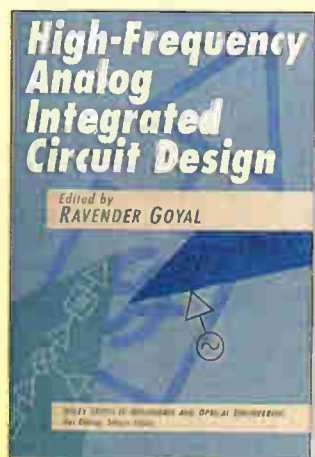

actual designs from the basic concepts, this title provides a solid background in designing basic circuits, advanced circuits and synthesis techniques.

0471 530433 424pp
UK £80.00, Europe £83.00, ROW £95.00

Speech Coding

A Computing Laboratory Textbook

This is one of the first lab manuals with software dedicated exclusively to speech processing and coding. It takes advantage of the development of the personal computer by making this technology accessible to a wider audience. The manual and Dos based software together create a user-friendly digital signal processing lab which allows the user to

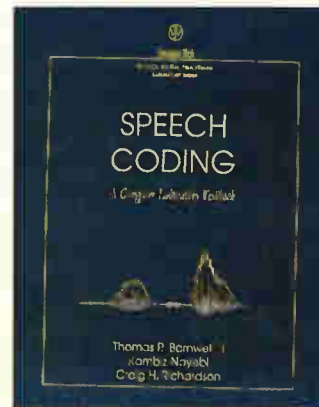

perform a wide variety of speech coding and speech processing experiments. The text presents and explains a set of basic speech coders analytically and in terms of the specific parameters controlling each coder. The manual leads the student through the experimental process of understanding how speech coders work and sound via over 70 exercises and projects. The class-tested menu-driven, Dos-based software can be operated by students with little or no training.

Includes disks

0471 516929, 194pp,
UK £28.95, Europe £30.95, ROW £36.95

Solar Cells and their Applications

The past decade has witnessed numerous important breakthroughs in solar cell technology, many of which have occurred in just the past few years. Far cheaper to produce and maintain, exhibiting a longer lifetime, and considerably more efficient than ever before, solar cells are, at last, in a position to compete with traditional technologies for both small and large-scale energy conversion applications. Including contributions from some of the world's leading experts in the field, this book reports the most important recent advances in solar cell technology. From in-depth discussions of breakthroughs in cell, module, and system technologies to a probing look at important environmental, health, and safety issues in the photovoltaic industry, it covers a broad range of topics of vital interest to solar cell researchers, power systems designers, and all those with professional interest in current and future capabilities of this important technology. Offers a detailed look at cutting-edge solar technology from an international team

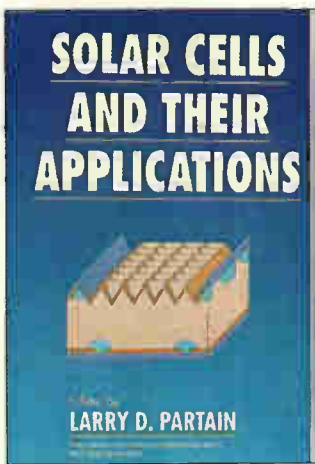

of researchers. Covers silicon, GaAs, InP, CdTe, a-Si:H, CuInSe₂ and GaSb solar cells, cells, concentrators, multijunction cell configurations, space cells, and more. Describes a wide range of applications – from space cells to terrestrial systems Provides an informal look ahead at the future of solar cell technology. 0471 574201, 596pp, UK £71.50, Europe £75.00, ROW £92.00

Introduction to High-Speed Electronics and Optoelectronics

Lasers, fibre optics, and high-speed optical systems share many concepts with microwave devices. Furthermore, semiconductor-based optoelectronics and microwave integrated circuits share evolving process technologies. It is only natural, therefore, that students of optoelectronics be introduced to high-speed concepts in a unified manner. This highly practical intensive introduction enables electrical engineers, applied physicists, and students to develop and identify tools for understanding, analysis, design, and characterisation of high speed components. Broad in scope, this unique



text/reference examines the complementary nature of electronics and optics and emphasizes high-speed technology in which the two fields are less differentiated. Beginning with an overview that develops a perspective and appreciation of analog high-speed technology in general, the book goes on to cover devices and circuits used at microwave and millimeter-wave frequencies, optical components, and optoelectronic integrated circuits and subsystems. Particular attention is paid to applications in the area of high levels of interest in this area and because many of the concepts are applicable in other fields. The book concludes with important coverage of the often-overlooked area of measurement and characterization of high-speed devices. Fully referenced and supplemented with hundreds of helpful illustrations, *Introduction to High-Speed Electronics and Optoelectronics* is equally useful as a professional reference or a textbook for senior undergraduate and first-year graduate courses. 0471 015822, 312pp, UK £65.00, Europe £67.00, ROW £77.00

Risc Systems and Applications

Professor Daniel Tabak has completely revised and updated his two previous books on Reduced Instruction Set Computer architecture to produce this new book, RISC Systems and Applications. The text is a unique, concentrated, detailed description of the architecture and implementation of most recent high-performance RISC systems, such as DEC Alpha AXP21164, IBM/Motorola/Apple PowerPC 620, Sun Microsystems and Texas Instruments UltraSPARC and SuperSPARC, MIPS technologies R10000, Intel i860 XP, Motorola MC88110, Hewlett-Packard PA-7100/8000 and the transputer. It also includes details of pioneering devices such as Berkley's RISC II and Stanford's MIPS and multiprocessor, real-time and workstation systems. ISBN 0863 801889, 452pp, UK £50.50, Europe £54.00, ROW £67.00

All prices are fully inclusive of packing and delivery

Return to Jackie Lowe, Room L333, Quadrant House, The Quadrant, Sutton, Surrey, SM2 5AS

Please supply the following titles:

Qty	Title or ISBN	Price

** All prices on these pages include delivery and package **

Total _____

Name _____

Address _____

Postcode _____ Telephone _____

Method of payment (please circle)

Access/Mastercard/Visa/Cheque/PO

Cheques should be made payable to Reed Business Publishing

Credit card no _____

Card expiry date _____

Signed _____

Please allow up to 28 days for delivery

One of the most useful attributes of flat panel speakers is their ability to be disguised, in this case as a picture.

Sound from pictures

Richard Ball reports on a further new flat-panel loudspeaker technology, this time involving piezo-electric drivers.



Noise Cancellation Technology, also known as NCT, is one of two companies proving the popular bus theory – wait for years and then two come along at the same time. In this case the ‘bus’ is flat panel loudspeaker technology which NCT has developed along similar lines to another company, NXT, a subsidiary of Verity (see *EW*, January 1997, p. 33).

Although the technologies may at first appear to be remarkably similar, the final products have been arrived at through apparently different research.

Malcolm McDonald, managing director of NCT in the UK, said: “We started with car headliners about two years ago.”

The headliner is the material covering the inside of the roof of the car. This is a much better place to site loudspeakers than down by the passengers’ ankles or behind the rear passengers’ heads. For proof of this, sit in the back seat of the average 18 year old’s car. Asking for a bit more bass could result in serious haemorrhaging.

Low-frequency response

However, NCT had a problem with low-frequency response. To solve its problem, the company went to the State College in Pennsylvania, and a US company called Oxford Speakers, experts in active noise control. Between them, McDonald says, “they managed to work out how to couple piezos [piezo-electric transducers] to panels to create low frequency sound.”

The low frequency crossover point is around 180Hz, so a subwoofer is used to fill out the bass below this frequency. The flat speakers

were placed in the car headlining. Because the subwoofer is non-directional, it can be placed in any convenient position.

But McDonald says: “Psychologically, all the sound coming from the top is not what you are used to.” For this reason the best results come from some speakers being placed near the floor.

A speaker set up like this can reduce weight and cost while saving space the company claims. To prove its point, in the UK, NCT has fitted out a Vauxhall Vectra and a Ford Mondeo with the flat speaker setup for demonstration purposes.

Much of the car headlining work has been carried out in conjunction with Johnson Controls, one of the world’s largest manufacturers of car fittings.

The same principles of coupling piezo transducers to panels has been applied in other areas including ceiling tiles and pictures. The ceiling tiles are aimed at exhibitions, factories and offices. Pictures can be used in just about any conceivable environment, but they are most suited towards home entertainment.

A baffling problem

With the pictures, there were initial problems placing them close to the wall. Any closer than a few inches and the sound from the rear interfered destructively with that from the front. This was solved by framing the active panel, and using a heavy back panel to reduce sound from the rear. In this way, the destructive interference is avoided.

It is interesting to note that this out-of-phase sound leading to destructive interference from the rear is the opposite of the claims from

NXT, the other flat speaker company. In NXT’s case, sound from the rear is claimed to be in-phase with sound from front.

For both car headliners and pictures, finding the right panel material was an experimental process. Lots of different materials were tried, but the best in terms of sound quality and cost was to use standard poster board fixed in a frame. This is rather convenient as poster board is one of the cheapest materials available, although its long term resistance to the constant vibration has yet to be established.

The next problem was that of coupling power from the piezo-electric transducer into the panel. With a single piezo transducer, McDonald says an insufficient amount of power is transferred to the panel.

“We use multiple actuators to control the modal response,” says McDonald. “Several transducers help to smooth the low frequency modes” and to provide the power.

To decide exactly how many piezo actuators to use and where to site them, the company used a mixture of mathematical modelling and experimentation.

The behaviour of the panel is “very hard to model at high frequencies”, says McDonald. This is because the fixing of the panel in a frame leads to complex boundary conditions which preclude modelling.

Therefore, the panels are modelled at low frequencies and experimented on at higher frequencies.

The result is a panel with a flat frequency response from 180Hz to 20kHz – the company claims within ± 1.34 dB. For home theatre, in the same way as the car headliner example, a subwoofer is used for very low frequencies.

The polar plots, taken with a microphone at two metres, show sound pressure levels at two frequencies, 500Hz and 8kHz. The relatively constant level at all angles is in marked contrast to polar plots of older flat panel speakers, particularly the electrostatic type, and of conventional cone loudspeakers. These tended to be highly directional in nature. The directivity of conventional cone units is especially bad at high frequencies.

These plots from NCT are very similar to those from NXT - the other recent designer of flat panel loudspeakers.

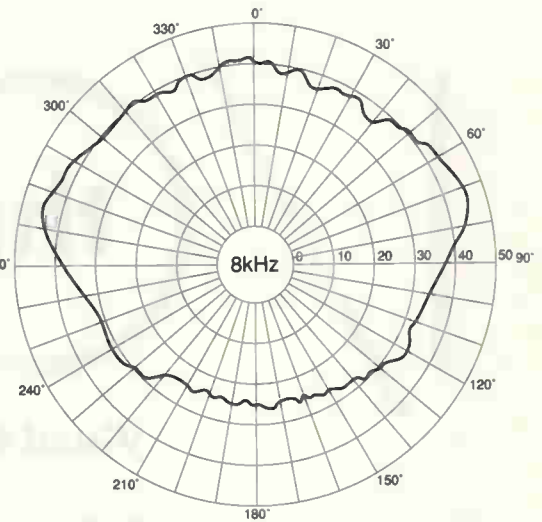
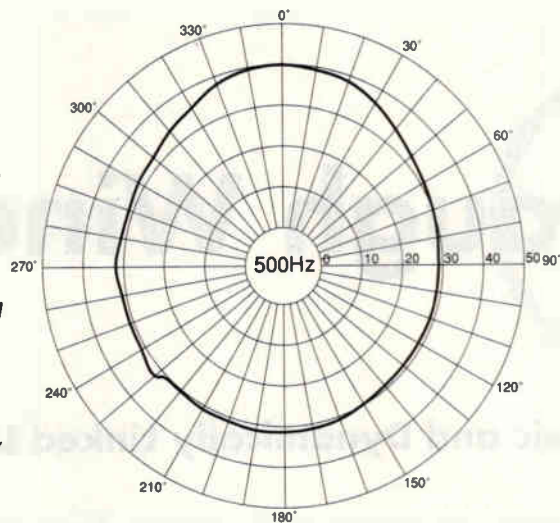

For pictures, the final product typically measures 600 by 650mm, and is driven by eight actuators.

So why use multiple transducers?

Piezo-electric transducers have a high impedance, the opposite of most amplifier outputs. They can be modelled as capacitors, so their low frequency impedance is high, making them inefficient at coupling power from the amplifier to the panel at audio frequencies. Therefore, several transducers are distributed around the panel to provide enough energy. At

high frequencies the modal density increases so more actuators are needed here to control the modes.

NCT claims the speakers are approximately ten per cent efficient. This may not appear brilliant, but it is better than conventional moving coil loudspeakers. These typically have efficiencies of a few per cent.

"We use transformer coupling in cars to cover the impedance mismatch," said McDonald. And the company is designing a direct drive amplifier to suit a capacitive load.

The use of piezo-electric devices as the actu-

ators for the panels has led to good high frequency performance. This is opposite to electromagnetic transducers which roll off at higher audio frequencies.

The company claims to have measured up to 50kHz from the panels in an anechoic chamber. This is limited to 20kHz in products.

McDonald says this means there is no phase change at the higher frequencies. Because of this, he says, "the mid range transient response is very fast. If anything we have to calm it down at high frequencies."

SEETRAX CAE RANGER PCB DESIGN

WITH COOPER & CHYAN AUTOROUTER

RANGER3 - DOS £2500
- Windows\NT £2900

Hierarchical or flat schematic linked to artwork.
 Unlimited design size, 1 micron resolution
 Any shaped pad, definable outline library
 Pin, gate & outline swapping - auto back annotation
 Split power planes, switchable on - line DRC

COOPER & CHYAN SPECCTRA
 autorouter (SP2)

Inputs: OrCAD, Cadstar,
 PCAD, AutoCAD DXF

Outputs: Postscript, Windows bit map

R2 & R3 Outputs: 8/9 & 24 pin printers, HP
 Desk & Laser Jet, Cannon Bubble Jet,
 HP-GL, Gerber,
 NC Drill, AutoCAD DXF

RANGER2 £150

Upto 8 pages of schematic linked to artwork
 Gate & pin swapping - automatic back annotation
 Copper flood fill, Power planes, Track necking,
 Curved tracks, Clearance checking,
 Simultaneous multi-layer auto-router

RANGER2 UTILITIES £250

COOPER & CHYAN SPECCTRA auto-router (SP1)
 Gerber-in viewer, AutoCAD DXF in & out

**UPGRADE YOUR PCB PACKAGE
 TO RANGER2 £60**

TRADE IN YOUR EXISTING PACKAGE TODAY

Seetrax CAE, Hinton Daubnay House, Broadway Lane, Lovedean, Hants, PO8 0SG
 Call 01705 591037 or Fax 01705 599036 + VAT & P.P

All Trademarks Acknowledged

through Windows

Visual Basic and Dynamically Linked Libraries

Windows was not designed with control engineering in mind, but it is possible to perform i/o tasks by writing your own Dynamically Linked Libraries, as Colin Attenborough explains.

Visual Basic lets you write a program with a Windows graphical user interface with minimum effort. The usual Windows paraphernalia of buttons, check boxes, list boxes and radio buttons – and more – are available by drawing them onto a background 'form'.

What happens when, say, button1 is clicked, is determined by what you put in the 'Button1-Click()' subroutine, which becomes available when the Button1 is added to the form. All 'controls' offer subroutines for all the possible events that can happen to them. And the remainder of the language is comprehensive, too.

Visual Basic weakness

A problem with Visual Basic is that it cannot access

hardware directly; there is no equivalent to QuickBasic's INP and OUT functions, no PEEKs, POKEs or the like.

This is a disappointment. Hanging peripherals on the printer port is an honourable pastime, but doing it with Visual Basic needs an intermediate step – which is the subject of this article. The intermediate step is, in its simplest form, a dynamically linked library, or dll, which can be written in C and called from Visual Basic.

DLL for LPT read/write

The simplest useful dll is generated from a .def file and a '.c' file, List 1.

A dll generated from these files is on the article disk detailed later; it is used in Visual

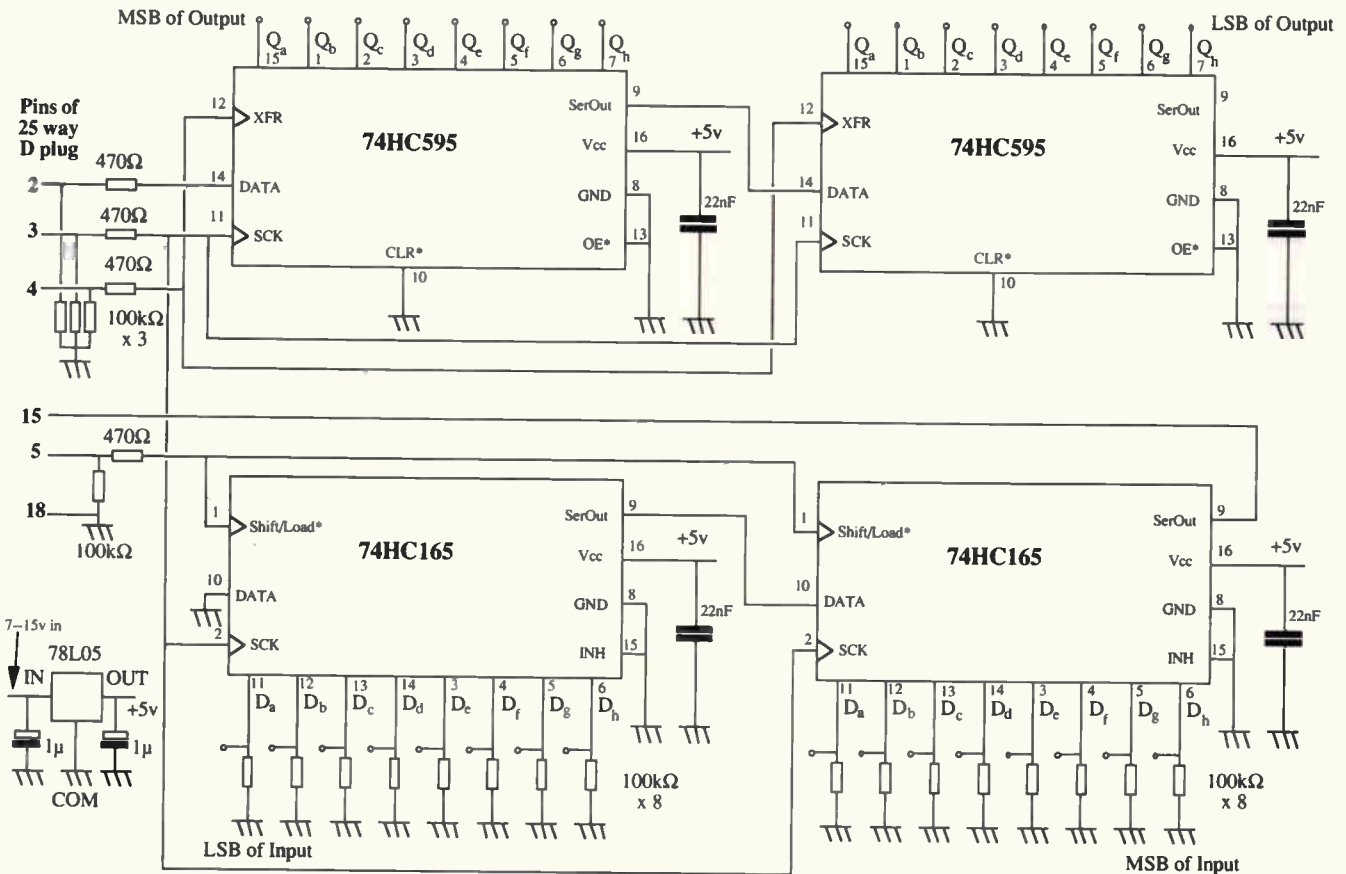

Connected to a pc's LPT port, this interface can be used to clock 16-bit parallel words in both directions.

Basic by including the line,

```
Declare i_o Lib "<full path
name>\IO8.dll" (ByVal ip As
Integer, ByVal op As Integer,
ByVal Written) As Integer
```

in the "general [declarations]" section of the forms where it is to be used, and is called by

```
Rval%=i_o(&H379, &H378, <value
to write to &H378>)
```

List 1. The simplest useful dll is generated from a .def file and a .c file.
IO8.c

```
#include <windows.h>
#include <stdio.h>
#include <stdlib.h>
#include <conio.h>

int FAR PASCAL LibMain (HANDLE hInstance,
WORD wDataSeg, WORD cbHeapSize, LPSTR
lpCmdLine)
{
    return 1;
}

/* the function made available to the user */

int FAR PASCAL _export i_o(int inport,int out-
port,int poked)
{
    int data;
    /* here are the C outp() and inp() functions */
    /* at the heart of the dll */
    /* write the value 'poked' to the address 'outport'*/
    outp (outport,poked);
    /*assign the value read from the address 'inport' to
    the variable 'data'
    data=inp(inport);
    return(data);
    }

IO8.def

LIBRARY      mylib
```

List 2. Producing your own dll using Turbo C++ for Windows.

To generate a dll called 'my_dll' in directory 'c:\my_dir'

Project/New Project
Select Target type Dynamic Library .DLL
Under "Project Name and Path" enter
c:\my_dir\my_dll.ide
Under "Standard Libraries" select "Static" and Runtime
Open Advanced: deselect .rc; select .c or .cpp as desired.
Close Advanced
Click "OK"
Now enter the code needed for the dll you want to write in the file my_dll.c or my_dll.cpp.

16-bit input and output

The virtue of the dll in List 1 is that it allows writing of eight bits, (or twelve bits including the port at base address+2, see the appendix) and reading five bits, from the printer port with no added hardware. For a wider i/o port, you need to use serial techniques and external circuitry, as in the diagram.

Output data are shifted into two cascaded 74HC595 dual-rank shift registers; when the data are in place, a transfer pulse moves them to the output pins, thus avoiding transient changes as the data are clocked in.

Data for input are loaded into two cascaded 74HC165 parallel in/serial out shift registers, and then clocked into the pc. A total of five signals to and from the pc are needed - namely clock, data, data output strobe and data input strobe from the pc, and data input to the pc.

Writing your own dlls

No C compiler is needed to use the dlls on the disk available. Those of you with Windows C compilers may want to write your own dlls, however. Here's a brief outline of how to do so using Turbo C++ for Windows.

List 2 shows how to generate the dll which is placed in a specific directory. By default the .def and .c files will be named my_dll. The trivial example already given will serve as a .def file. To add further source files, right click the mouse on the dot to the left of the .dll icon in the Project window. Select Project/Build All to generate the dll.

You can safely ignore the warnings about the variables hInstance, wDataSeg, cbHeapSize and lpCmdLine being unused. Alternatively, you can add #pragma argsused just after the #includes. The _export keyword is of course not needed for functions internal to the dll which are not visible to the dll user.

If you're using C++ rather than C, you'll need to add extern 'C' to the start of the definitions of exported functions, eg,

```
extern "C" int FAR PASCAL
_export i_o(int inport,int
outport,int poked)
```

Printer port address and connections

The printer port's address can be found using the MSD.EXE utility found in the MSDOS 6 folder. Address 378₁₆ is the usual base address, where there's an eight bit output port. A five bit input port is at base address+1, and a four bit output port at base address+2. Table 1 gives the connections to the 25-way printer socket. ■

I am grateful to Cambridge Consultants for permission to publish this article - in particular to Paul Cox for help in the generation of dlls.

Table 1. Printer port pins together with addresses
These numbers correspond to those on the left-hand side of the circuit diagram.

Pin	Address	Bit	I/O
1	0x37A	0	Out
2	0x378	0	Out
3	0x378	1	Out
4	0x378	2	Out
5	0x378	3	Out
6	0x378	4	Out
7	0x378	5	Out
8	0x378	6	Out
9	0x378	7	Out
10	0x379	6	In
11	0x379	7	In(inverted)
12	0x379	5	In
13	0x379	4	In
14	0x37A	1	Out
15	0x379	3	In
16	0x37A	2	Out
17	0x37A	3	Out
18	Earth		
19	Earth		
20	Earth		
21	Earth		
22	Earth		
23	Earth		
24	Earth		
25	Earth		

Software on disk

A disk supporting this article is available. It contains two directories, one for the 8-bit, no-added-hardware port and one for the 16-bit port using added circuitry as shown in the diagrams. Each of these directories is further split into two directories: C_bits containing the dll and the source files needed to make it, and VB_bits, containing the Visual Basic program to use the dll.

The Visual Basic programs are the simplest ones that will demonstrate the dll's abilities. Both use an array of check boxes to define the state of the output lines: both include a software timer. In the 8-bit version, the inputs are read, and the outputs written, at the end of each timer period; the 16-bit version writes the outputs when the boxes change state, and reads inputs at the end of each timer period.

Send a postal order or cheque for £15 (£17 overseas) payable to Reed Business Publishing to DLL, Electronics World Editorial, Quadrant House, The Quadrant, Sutton, Surrey SM2 5AS. Don't forget to send your address.

HART

The Home of *Hi-Finesse*. Its not what you do,
its **HOW** you do it that counts!.

VISATON® SPEAKER KITS & DRIVE UNITS

New to the UK, VISATON offer a range of speaker kits and drive units that give the home builder access to units and designs that are unrivalled for quality, performance and value. Their designs are very well known in Germany, where they are based, and over 25 years they have built up an enviable reputation for high quality sound. All their designs come from a solid background of the best in design and research and their factory contains one of the largest anechoic chambers in the World, backed up by the very latest in computerised test equipment. This quality of research facility, added to design collaboration with major universities and their high end magazines, produces products of impeccable performance and value that are the best available to the home speaker builder. Their range of products covers the whole spectrum of sound reproduction and includes speaker kits for home cinema, hi-fi and car use. There is also a vast range of drive units from 15" woofers to ribbon tweeters. Speaker design software and database are available for the home user who wants to try his hand, or for commercial manufacture. A small selection follows, our lists will give you more!

Hart Audio Kits and factory assembled units use the unique combination of circuit designs by the renowned John Linsley Hood, the very best audiophile components, and our own engineering expertise, to give you unbeatable performance and unbelievable value for money.

We have always led the field for easy home construction to professional standards, even in the sixties we were using easily assembled printed circuits when Heathkit in America were still using tagboards! Many years of experience and innovation, going back to the early Dinsdale and Bailey classics gives us incomparable design background in the needs of the home constructor. This simply means that building a Hart kit is a real pleasure, resulting in a piece of equipment that not only saves you money but you will be proud to own.

Why not buy the reprints and construction manual for the kit you are interested in to see how easy it is to build your own equipment the HART way. The FULL cost can be credited against your subsequent kit purchase.

'AUDIO DESIGN' 80 WATT POWER AMPLIFIER.



This fantastic John Linsley Hood designed amplifier is the flagship of our range, and the ideal powerhouse for your ultimate hi fi system. This kit is your way to get 2K performance at bargain basement prices. Unique design features such as fully FET stabilised power supplies give this amplifier World Class performance with startling clarity and transparency of sound, allied to the famous HART quality components and ease of construction. Standard model comes with a versatile passive front-end giving switched inputs, with ALPS precision "Blue Velvet" low-noise volume and balance controls, no need for an external preamp.

Construction is very simple and enjoyable with all the difficult work done for you, even the wiring is pre-terminated, ready for instant use! All versions are available with Standard components or specially selected Super Audiophile components and Gold Plated speaker terminals and all are also available factory assembled.

K1100 Complete STANDARD Stereo Amplifier Kit,	£415.21
K1100S Complete SLAVE Amplifier Kit,	£353.62
K1100M Complete MONOBLOC Amplifier Kit,	£271.20
RLH11 Reprints of latest Amplifier articles,	£1.80
K1100CM Construction Manual with full parts lists,	£5.50

ALPS "Blue Velvet" PRECISION AUDIO CONTROLS.



Now you can throw out those noisy ill-matched carbon pots and replace with the famous Hart exclusive ALPS 'Blue Velvet' range components only used selectively in the very top flight of World class amplifiers. The improvement in track accuracy and matching really is incredible giving better tonal balance between channels and rock solid image stability. Motorised versions have 5v DC motor.

MANUAL POTENTIOMETERS

2-Gang 100K Lin.	£15.67
2-Gang 10K, 50K or 100K Log.	£16.40
2-Gang 10K Special Balance, zero crosstalk & centre loss.	£17.48

MOTORISED POTENTIOMETERS

2-Gang 20K Log Volume Control	£26.20
2-Gang 10K RD Special Balance, zero crosstalk and less than 10% loss in centre position.	£26.98

32W VALVE AMP TRANSFORMERS

Special set of toroidal transformers, 2 output & 1 mains for the "Hot Audio Power" valve amplifier design described in the Oct. 1995 issue of "Wireless World". Total Wt 4.8Kg. Special price for the set. £99, Post £8. Photocopies of Article by Jeff Macaulay. £2.00

JOHN LINSLEY HOOD SINGLE ENDED CLASS 'A' POWER AMPLIFIER

A new concept in amplifier design to meet the needs of modern users who want the warmth and purity of sound given by valve amplifiers from the vintage years, without the problems of cost, deterioration and danger associated with trying to use valves today. It employs the newly re-discovered single-ended circuit configuration to give total freedom from crossover artifacts and to give a sound that is indistinguishable from the famous "Williamson" design, the undisputed leader of the field, with its triode connected KT66s and all-triode drivers. Described in the September 1996 issue of EWW the new version retains the basic simplicity and purity of the original but with modern components and an increased power rating of 15W RMS per channel.

Full Kit in 3u high Rackmount Case,	£388.25
Set of 3 PCBs only,	£60.50

ASM100 ACTIVE SUBWOOFER MODULE



This attractive module consists of a low pass filter and power amplifier ready for you to mount in a suitable sub-woofer cabinet. The combined unit can then be combined with any new or existing hi fi or home cinema speaker system to add in the real bass punch missing from most setups.

The ASM 100 module comes as a ready-to-mount unit on a solid diecast aluminium frame/heatsink. Input signal can be at line or speaker level for easy system integration. There are three separate stereo inputs at line level and the unit will use any signal presented or mix all inputs to add bass to any signal. The speaker level inputs are used by simply wiring the unit in parallel with the existing speakers to provide them with strong bass support. Crossover frequency can be selected to 50, 100 or 200Hz and the bass level can be adjusted by a front panel control. The 'Green' power supply switches the unit to standby if no signal is present. Drawings are included free for the compact 418 x 380 x 303mm cabinet. With its powerful 125 watt output and versatile filtering the ASM 100 is the ideal universal active driver module for all subwoofer requirements.

ASM 100 Module, complete with IEC mains lead, instructions and ASM - W20 cabinet drawings. Pt. No. V7000. £185.29
W 200 S 20cm Long Throw Drive unit for use in ASM - W20 cabinet. £36.68

FIESTA 30 LOUDSPEAKER KIT

An Ultra High Efficiency speaker, specially suitable for Valve Amplifiers.

Specially selected as the ideal partner for the new John Linsley Hood 15W Valve Sound Amplifier, or indeed any actual valve amplifier, the FIESTA 30 features the astonishing efficiency and sensitivity needed to achieve a satisfying sound level from amplifiers of limited power output.

To complement the sound purity of such amplifiers a full three speaker system is used with a 300mm (12") woofer, 200mm (8") mid-range and high quality horn tweeter in a vented bass reflex enclosure.

All these drive units have been carefully selected for their individual virtues, and collective excellence, the tweeter for instance being a high end unit with exceptional pulse response as a result of its combination of Kapton former, aluminium diaphragm and aluminium voice coil.

Nominal Power Rating is 150W, Max. Music Power 250W, Impedance 8 ohm, Mean Sound Pressure 91dB. Speaker kit comes with all parts to make a pair of speakers, but not the cabinet parts. Crossover units are factory assembled, ready to fit.

Kit No.LK5963 Per Pair,	£424.93
-------------------------------	---------

HOME CINEMA SPEAKERS.

The VISATON range of speaker kits includes all you will ever need for your surround sound home cinema setup. The Hi-Tower Kit is ideal as a super luxury pair of stereo main speakers. The "Centre 80" uses special magnetically screened drivers to avoid picture disturbance and a pair of "Effect 80's" are used as rear speakers. Any of a range of sub-woofers then adds weight to the sound of the robot feet. Centre 80 Kits include drive units, crossover, terminals and grille. (You make the box) Price each, £64.08
Effect 80, Rear Speaker Kits, per pair, £39.00

DRIVE UNITS.



BG30NG 30cm. (12") Woofer. High efficiency, (95db) for sealed or vented cabinets. Peak power handling 250watts. 8 ohm. £69.61

W200S 20cm. (8") Woofer. Long throw unit with rubber surround and extended rear pole to give no less than 20mm cone displacement. Ideal for compact sub-woofers such as ASM-W20. 8ohm. £36.68
NG8 Protective Metal Grille. £5.66



W100S 10cm (4") Low/Midrange. Coated paper cone, rubber surround, high temperature voice coil. Suitable as woofer in mini enclosures or midrange in 3-way systems. 4ohm. £18.06
NG4 Protective Metal Grille. £3.20

FRS8 8cm.(3.3") Fullrange driver. Linear frequency response between 200 and 20KHz. Large Magnet, 20mm voice coil and rubber surround. 8ohm. £8.36



DT2.5 10mm Polycarbonate Tweeter. High efficiency ferrofluid tweeter for use over 4,500Hz. Very good price/performance ratio. 8ohm. £8.77

SC5 10mm. Magnetically shielded Tweeter for use in surround sound centre speakers. 8ohm. £9.24

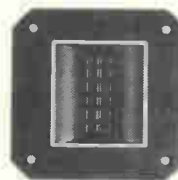

RHT12S High End Ribbon Tweeter. Superior double magnet construction gives an exceptionally low distortion and linear response from 4,000 to 30,000Hz. Cabinet cutout diameter 95mm. 8ohm. £87.77

DHT9AW-NG Hi-Tech, Hi-Fi, horn type tweeter. Frequency response from 3,500 to 38,000Hz and very good pulse response due to aluminium cone, Kapton voice coil and aluminium wire. Peak power handling 150W. 8ohm. £31.99

ASM100 and our 80 watt power amplifier are on demonstration at Wilmslow Audio's new premises at Broughton Astley near Leicester. Tel 01455 286603.

POSTAGE on UK orders is £2 up to £20, £4.50 over £20.

Overseas please enquire.

Our LISTS are FREE on request.

Send for Your **FREE** copy of our LISTS

24 Hr. ORDERLINE 01691 652894
Fax. 01691 662864

All Prices include UK/EC VAT.

CIRCLE NO. 138 ON REPLY CARD

HART
HART ELECTRONIC KITS LTD.
1 Penylan Mill, OSWESTRY,
Shropshire, SY10 9AF,
UK

NEW PRODUCTS CLASSIFIED

Please quote "Electronics World" when seeking further information

ACTIVE

Discrete active devices

Pin-diode switches. KDI SWX Series miniature, high-isolation pin diode switch modules are for use in cellular and PCS base stations, providing up to 60dB of isolation to guard against lightning strikes and switching spikes. The range covers the 200-2400MHz range, isolations being from 24.5dB to 51dB at 2GHz, according to type, with insertion losses of 0.6dB and 0.9dB respectively. Power handling lies between 20dBm and 35dBm, depending on reverse bias. Packages have a full ground plane underneath, so that board space there can be used for other things. Anglia Microwaves Ltd. Tel., 01277 630000; fax, 01277 631111.

Miniature flash cards. Flash Miniature Cards by Smart come in 2Mbyte and 4Mbyte form in the size supported by the Miniature Card Implementers' Forum. They are essentially matchbook-sized flash memories to store voice, images or data that fit into an adapter to go into a pc or notebook card drive slot, complying with MCIF specifications and working from 3.3V and 5V supplies. Access time is 100ns at 5V. One application envisaged is storage in digital still cameras. Smart Modular Technologies. Tel., 01908 234030; fax, 01908 234191.

Microprocessors and controllers

Metering controller. Using 400 μ A (active) and 1.6 μ A (standby), TI's MSP430 metering microcontroller family has several low-power modes down to 0.1 μ A. The device contains a 16-bit risc cpu, a range of programming and memory options, a 14-bit a-to-d converter and an lcd driver. There are 51 instructions with seven address modes and the structure allows register-to-register instructions to be carried out in 300ns at 3.3MHz clock speed, each instruction being usable with each address mode. Memory options include rom, eprom and otp versions from 4K to 16K capacity, and either 256 or 512byte of ram. MSP430x310 is designed for use with resistive sensors, providing dual-slope conversion, and the 320 version includes a full, six-input successive-approximation converter. Arrow-

Jermyn. Tel., 01234 270027; fax, 01234 214674/791501.

8-bit microcontroller. An 8-bit microcontroller by Toshiba, the TMP87PM29U has 32Kbyte of one-time-programmable memory and 1Kbyte of ram. It works on 2.7V at low power and is therefore well suited to battery equipment using lcd screens. It has an lcd driver, a uart, an a-to-d converter, an 8-bit timer, four 8-bit timers and interval and watchdog timers and is also available in masked-rom versions with 16, 24 and 32Kbyte of rom. Toshiba Electronics UK Ltd. Tel., 01276 694600; fax, 01276 694800.

Power semiconductors

Fast, 7A/600V igbts. Unusually, Harris's HGTP7N60C3 insulated-gate field-effect transistor is happy working in the frequency range 50-100kHz, with losses down to 600 μ J. It is rated at 7A, 600V at 110°C (14A at 25°C) and fall time when switching 7A at 480V at 150°C is 275ns. Harris Semiconductor UK. Tel., 01276 686886; fax, 01276 682323.

PASSIVE

Passive components

Multi-gang pots. ECO 16mm conductive-polymer potentiometers, made with recyclable plastic, are now available in multi-gang versions. Compared with the company's metal-cased models, the plastic construction confers the advantages of compactness, the provision of a locating spigot for angular alignment, better sealing and lower cost. A notched backplate accepts a spring clip to replace the normal nut and washer fixing. Dual-gang units can have matched tolerances for stereo or have different values and laws, the range of values being 1k Ω to 1M Ω , 0.25W for linear types and 4.7k Ω to 470k Ω , 0.12W for the non-linear variety. All can be fitted with rotary switches. Omeg Ltd. Tel., 01342 410420; fax, 01342 316253.

Precision resistors. Rhopoint offers a range of conformally coated metal-foil resistors that exhibit a temperature coefficient of ± 2.5 ppm/ $^{\circ}$ C. Alpha FL components have a thickness of 6.2mm and possess a long-term stability of ± 0.0005 per 1000h over a temperature range of -25° C to

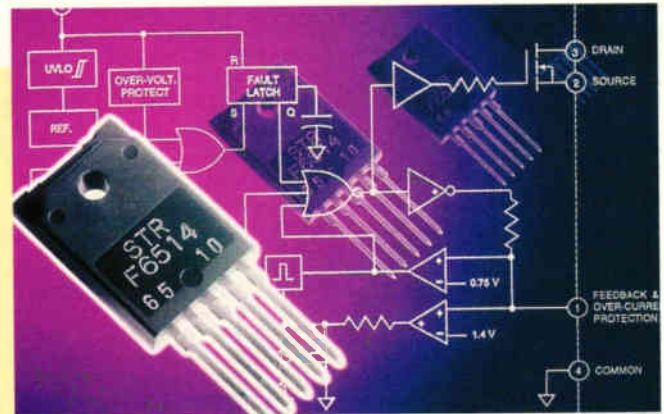

Mixed-signal ics

Switched-mode ic. Allegro's STR-F6500 is a switched-mode power-supply ic for requirements in the 30-300W range. It contains an off-line mosfet power switch and controller in a 5-pin package forming, with few external components, a complete supply module. This is a flyback converter with quasi-resonant soft switching to reduce switching losses and conducted and radiated interference. Protection is undervoltage lockout with hysteresis, overvoltage shutdown and thermal shutdown to protect the ic and following components. Switching frequency is reduced during startup to control dissipation, all startup components being included. Allegro Microsystems Inc. Tel., 01932 253355; fax, 01932 246622.

155°C. Power ratings are 0.125W for the FLA and FLC types, while the FLB is rated at 0.25W. Values are 5 Ω to 150k Ω in tolerances down to $\pm 0/02\%$ can be supplied, but for off-the-shelf ordering, the range is 50 Ω to 100k Ω at $\pm 0.1\%$. Rhopoint Components Ltd. Tel., 01883 717988; fax, 01883 712938.

Resistor networks. MiniNet silicon-based resistor networks are said to be the smallest such devices currently available, being some 25-30% smaller than ordinary ones. They are made in ic-type packages and consist of a thin film of tantalum nitride on a silicon substrate. Values range from 10 Ω to 100k Ω in tolerances from $\pm 5\%$ to $\pm 1\%$ and temperature coefficients of ± 250 ppm to ± 50 ppm. Maximum voltage is 50V dc and power rating 0.1W-0.9W at 70°C. Arrow-Jermyn. Tel., 01234 270027; fax, 01234 214674/791501.

Miniature capacitors. CapXon miniature electrolytics are now available in the UK. There are seven voltage ratings between 4V dc and 50V dc in values between 0.2 μ F to 220 μ F and in sizes from 3mm diameter by 5mm long to 6.3mm diameter by 5mm long, the latter being for a 220 μ F, 4V type. Europa Components & Equipment plc. Tel., 0181 953 2379; fax, 0181 207 6646.

Displays

Backlighting leds. From Dialight, the 553-22xx-100 led indicator, which is optimised for backlighting use, being space-saving in that two leds are mounted in one assembly. To reduce stray light from the assembly to other positions and to obtain maximum output on the viewing axis, the housing is extended and the leds fitted with tinted, non-diffused lenses. Leds in red, yellow or green produce 12mCd at 10mA. Gothic Crellon Ltd. Tel., 01734 788878; fax, 01734 776095.

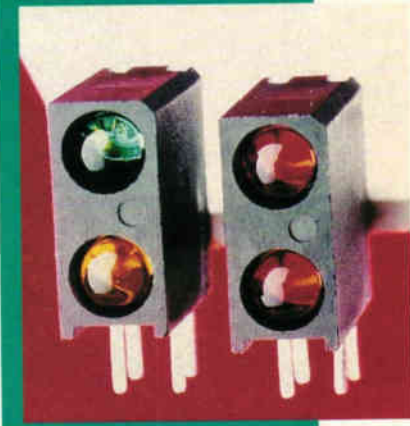

Please quote "Electronics World" when seeking further information

Connectors and cabling

Optical connectors. Framatome has a new series of lightweight connectors for lans, fibre cable management and distribution, ATM and premise installation. They incorporate a dome-shaped zirconia ferrule and exhibit low insertion loss, simple connection and nickel-plated zamack bayonet coupling. Cable diameters accepted are 0.9mm-2.8mm with a fibre diameter of

Power connectors. Rendar has a full range of power connectors meeting EN60 320 and rated at 10A, 250V ac, with variants for the US being rated at 15A, 125V ac. Connectors in the range are approved to UL, CSA, VDE and BSI and any not covered by international safety regulations are tested to BS 5733. In the range is a variety of inlets with choices of mountings, rewirable plugs and connectors and outlets. There are also the *Twinbloc* and *Quadbloc* multi-outlet blocks and the *Stripbloc*, which carries power and signal lines. Rendar Ltd. Tel., 01243 866741; fax, 01243 841486.

126µm, variability after connection being under 0.2dB after 1000 test cycles. Cable retention is 15.9kg and temperature stability ±0.1dB between -40°C and 80°C. Assemblies are available. Framatome Connectors UK Ltd. Tel., 01582 475757; fax, 01582 476203.

Cable screen clamps. Emc requirements have made for an increase in the usage of screened cables, and focused attention on the need for a reliable and simple method of making connection to the screen. Wieland Electric now has three sizes of clamps to a busbar fixing rail for use with cable of 7-16.5mm in diameter, the clamps having stainless steel contact springs to avoid damage to the screen and to provide corrosion resistance. The rails are insulated and can be fixed directly to a panel and can also be used as pure screen connectors remotely from the terminals. Wieland Electric Ltd. Tel., 01483 31213; fax, 01483 505029.

VME backplane. Vero has started production of backplanes to the latest draft of the VME64 Extensions standard. Twelve-layer stripline backplanes come in widths of 7-20 slots with smt terminations for lower crosstalk. J1 and J2 slots have the new 160-pin, 5-row DIN connectors, which are compatible with existing 3-row, 96-pin connectors, and an optional 2mm J0 connector has an extra user-defined 95 pins; a further

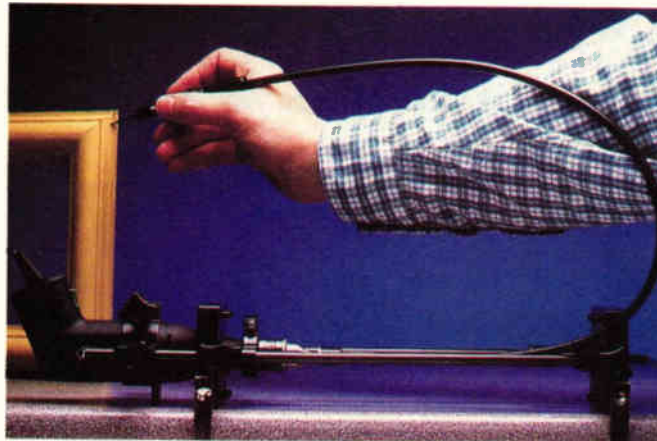

35 ground returns are available. There are a 3.3V and two user-defined ±V1 and ±V2 rails, which can be used together to give 48V telecomms supply. Total power is about 2kW. Vero Electronics Ltd. Tel., 01489 780078; fax, 01489 780978.

400 contacts on double Eurocard. Emi has an interconnection method that provides up to 400 contacts on a double-width Eurocard using the standard DIN format. This is done by combining two *Emi E160* connectors, which each have five rows of 32 pins, with an *Emi E80* of five rows with 16 pins a row to give a continuous 2.54mm pitch for a standard layout. Features include early make/last break of 0.8mm for male contacts, precentring for male connectors; press-fit termination; and wave soldering. Radiatron Components Ltd. Tel., 01784 439393; fax, 01784 477333.

Cordsets. Clarke Cable's mains cordsets are available from Roxburgh. These are 100% tested, 2m cables with a range of UK and European standard connectors, various cable colours and other terminations being supplies as needed. Roxburgh Electronics Ltd. Tel., 01724 281770; fax, 01724 281650.

Filters

Solder-in emi filters. New emi filters by Syfer are suitable for soldering directly to a panel, are smaller than threaded equivalents and are shorter. The type for soldering into a 3.5mm hole has capacitance values to 33nF, while the 5.8mm type goes to 470nF. Voltage rating is 500V dc and current rating 10A. Syfer Technology Ltd. Tel., 01493 440047; fax, 01493 440048.

Emi filters. These bidirectional chip filters from Murata, the *EMIFIL NFMM839R* series, are for use on clock or interface lines and possess a smooth change of impedance with frequency, reducing waveform distortion and reflection. There are two cut-off frequencies: 20MHz and 50MHz, insertion loss being typically 8dB at 100MHz and 20dB at 500MHz for the 20MHz device. Minimum insulation resistance is

Drill/lathe/drive-shaft kit.

Minicraft's lathe and drill kit, the *MB6001*, is now sold with a free flexible drive shaft, the *MB720*, until the end of April. The whole kit, which costs £139.99, consists of the 100W drill; a variable-speed transformer which is usable with all Minicraft 12V tools; a lathe attachment, three chisels and cutting, polishing, grinding accessories; and the drive shaft. Minicraft. Tel., 01388 420535; fax, 01388 817182.

1GΩ and the filters are rated at 50V dc, 25mA. Murata Electronics (UK) Ltd. Tel., 01252 811666; fax, 01252 811777.

Hardware

Fan. Miniature radial fans from Papst in the *RE38 Series* mount straight onto a pcb and are meant for localised cooling. They operate from 12V dc at temperatures between 40°C and 90°C, supplying 1.5 or 3.5ft³/minute, depending on the model. Challenger Components Ltd. Tel., 01795 477255; fax, 01795 477259.

Test and measurement

Portable dsos. *TDS200 Series* oscilloscopes from Tektronix are low-cost, portable digital storage oscilloscopes with backlit lc displays, the reason for a back-to-front dimension of 11cm. Tek's Digital Real-time technology provides a response similar to that of an analogue instrument. Bandwidths are in the 60-100MHz range, sampling being at 1Gsamples/s simultaneously on both channels. The user interface (controls) are similar to those of analogue types, but with a collection of automatic measurement features, storage and instrument setups; automatic peak detection reduces the possibility of aliasing. There is provision for optical communication to give hard copy output or via GPIB/RS232 to a pc. Thurlby Thandar Instruments Ltd. Tel., 01480 412451; fax, 01480 450409.



Please quote "Electronics World" when seeking further information

Function generator. In seven ranges, the *GX245* portable function generator by Metrix covers 0.5Hz-5MHz and contains a frequency counter to measure up to 120MHz. Both internal and external sweeps are available with start/stop control in linear, log., dc level and single-shot modes. Square-wave rise time is under 40ns and less than 12ns for ttl loads. Frequency resolution is 0.001Hz at the lower frequencies, output frequency being shown by a 5-digit lcd. Metrix Electronics plc. Tel., 01384 402731; fax, 01384 402732.

40GHz spectrum analysis. Rohde & Schwarz announces two new spectrum analysers: the 26.5GHz *FSEM* and the *FSEK* for 40GHz, both being modular in form to allow customisation for a number of uses, although all models in the *FSE* range include as standard functions for work on digital radio and television measurements in development, production and service. Synchronised tuning up to the 5ms

Four-channel temperature monitor. *Tempscan T100*, intended for small temperature-controlled stores, incorporates variable high and low alarm limits for each channel, defrost and door-open inputs and selectable recording intervals from 15m to 1h, operation being controlled by a lockable function switch. An internal tally-roll printer provides reports and functions are selected by either front-panel keypad or, optionally, by an RS-232 interface to a computer using software supplied or users' own. Danesbury Data Systems. Tel., 01438 712041; fax, 01438 712900.

full span sweep ensures high accuracy at every point and the gap sweep function and 200ns/division resolution at zero span allows pulse rise and fall time measurement simultaneously. Phase noise is typically -128dBc/Hz at 10kHz offset. Rohde & Schwarz UK Ltd. Tel., 01252 811377; fax, 01252 811447.

Rail-mounted kWh meter. *RM303* from Northern Design mounts on a DIN rail, six modules wide, and provides a readout on a large backlit lcd to better than IEC 1036 Class 1 for both single and three phase inputs, also offering an optional pulse output, as required for building energy management applications. It is a single-function instrument with standard current-transformer inputs for connection to loads from a few watts to several hundred kilowatts, readings being stored in the event of a power failure. Northern Design (Electronics) Ltd. Tel., 01274 729533; fax, 01274 721074.

Optical preamplifier. EG&G Instruments has a new optical-input preamplifier, the *Model 5188*, designed for use as a light-to-voltage converter. Two versions exist: the *5188A*, with an InGaAs input detector for near-infrared radiation, and the *5188B*, which uses a silicon device for the visible part of the spectrum. Sensitivity extends to fractions of a picowatt with no noise degradation, to 18mW without overload. Ac and dc signal components are processed separately and give independent outputs. Input is by way of an FC/PC connector. EG&G Instruments Ltd. Tel., 01734 773003; fax, 01734 773493.

Interfaces

Laptop-to-Fieldbus. From National, the *PCMCIA-FBUS*, which is a Foundation Fieldbus interface for

pcs running Windows NT and having PCMCIA slots; the interface includes NI-FBUS driver software for Win NT. There is also a network 'configurator' – a 32-bit Windows application to deal with the configuration of fieldbus segments. National Instruments UK. Tel., 01635 523545; fax, 01635 523154.

Literature

Microcontroller design guides. Toshiba's three new design guides cover 1-bit, 8-bit and 16-bit microcontroller families, providing application examples and lists of available development software. Toshiba Electronics UK Ltd. Tel., 01276 694600; fax, 01276 694800.

Virtual instruments. National Instruments has a new catalogue, the 1997 Instrumentation Reference and Catalogue, which contains nearly 700 pages and is free. National is well known for its range of pc-based instruments and the publication offers tutorials on data acquisition, GPIB, VXI and automation in industry, in addition to the normal functions of a catalogue. National Instruments UK. Tel., 01635 523545; fax, 01635 523154.

Materials

Emc kit. A kit of materials from Vacuumschmelze, the EMC KIT, consists of 17 toroidal cores and 22 common-mode chokes using high-permeability, nano-crystalline *Vitoperm 500 F*, to assist engineers to design small, flat mains filters for the 1-25A (single-phase) or 3-40A (three-phase) ranges. The kit also contains a disk with Excel Work Sheet VACSIM 3.0 to help with dimensioning chokes and simulating insertion loss in a 50Ω system between 10kHz and 100MHz. Vacuumschmelze GmbH. Tel., 0049 61 81/38-26 29; fax, 0049 61 81/38-28 60.

Power supplies

Switching regulators. Micrel Semiconductor has two new regulators, the *MIC2570/1* one and two cell boost regulators, both being constant duty-cycle, gated-oscillator types. The *2570* is for two-cell working from 1.3V to 15V input, the *2571* being for single-cell use and works on inputs down to 0.9V. This one is in a new 8-lead Mini8 package, which is less than half the size of SO-8s. Both devices have selectable output of 2.85V, 3.3V or 5V or adjustable output up to 36V. An n-p-n switch in the unit avoids the need for a series-pass component for peak inductor currents to 800mA. Micrel Semiconductor Europe. Tel., 01635 524455; fax, 01635 524466.



Earth tester. PIDA members can now supply the Norma *Handy Geo*, a compact, handheld, battery-powered tester for two-pole and three-pole earth resistance and noise voltage measurement. Its large lcd provides legends and an analogue scale, backlighting being switchable. The instrument will detect external ac and dc volts, will define probes and has an adjustable limit. PIDA. Tel. and fax., 0756 799737.

15 and 30W dc-to-dc converters. Improved versions of Vero's *DC15100* and *DC30100* converters exhibit input tolerance of -25% to 50% about nominal inputs of 12V, 24V or 48V. Single and dual regulated outputs of 5V, 12V, $\pm 12\text{V}$ and $\pm 15\text{V}$ are available at efficiencies of around 85%, with cmos/ttl compatibility and full rfi screening. Both types meet the ETSI for telecomms. Vero Electronics Ltd. Tel., 01489 780078; fax, 01489 780978.

Programmable supply. TTI's *TSP3222H* is a GPIB-controlled supply giving dual independent 0-32V, 0-2A outputs. Rapid response to output demand, regardless of load current, is provided by active circuitry that sinks current when required. All functions, including output configuration, overvoltage trips and meter damping are bus-controlled and outputs are readable via the bus to a 12-bit resolution. Each output operates in constant-V or constant-I mode with auto crossover and mode indication; serial or parallel combination is programmable. There is also keyboard setting for all functions with memory to save up to 25 settings. Thurlby Thandar Instruments Ltd. Tel., 01480 412451; fax, 01480 450409.

Rechargeable batteries. Thirteen models of *Eleckson* batteries cover the range 6V, 1.3Ah to 12V, 44Ah and 0.33kg to 14kg, most popular



Please quote "Electronics World" when seeking further information

sizes being included. Lower-power types use standard push-on terminations, with heavier nut-and-bolt fastening for the larger batteries. There is no corrosive gas discharge and the batteries are suitable for constant, float charge or cyclic use. Camden Electronics Ltd. Tel., 01727 864437; fax, 01727 855400.

Radio communications products

Superhets at superegen prices. Low Power Radio Solutions has introduced the *SuperReceiver* - a superhet for low-power links using the Plessey *KESRX-01* chip. It meets the 2nW emc limit under RES0908 and is made in the same sil package used by the earlier superegen. receiver. Frequency is either the pan-European 433.92MHz or the UK 418MHz, both crystal-controlled. There is a received signal-strength indicator pin and the unit is meant for use in battery-powered systems, taking 2.5mA when active. Data rate is 10kb/s and sensitivity better than -103dB. Low Power Radio Solutions Ltd. Tel., 01993 709418; fax, 01993 708575.

Protection devices

Resettable fuses. *PolySwitch* resettable fuses from Raychem come in five ratings from 3A to 11A, each with a 16V, 100A surge rating. They are conductive polymer devices with metal electrodes, the polymer increasing its resistance in the presence of overload and

latching in this state until the fault is removed, when the device resets after cooling down. Raychem Ltd. Tel., 01793 572692; fax, 01793 572209.

Switches and relays

Relay module. Matsushita has a DIN-rail-mounted safety relay module that is provided with quick-connect terminals, power indication and the choice of a range of operating voltages. These are rotating-armature *SF2/4* relays for safe switching in the presence of malfunction or contact problems. Each module has two or four sets of mechanically interlocked normally open or normally closed contacts in a sealed package, contacts being rated to break 1500VA at up to 44V, 6A. Matsushita Automation Controls Ltd. Tel., 01908 231555; fax, 01908 231599.

Load-break switches. Crompton Greave has a new series of load-break switches with a new handle having a positive stop to prevent the switch overthrowing. These UL/CSA-approved switches have isolated double-break contacts with seals to IP65. Thirty variants offer three, four or five poles and current handling from 25A to 63A. Front and base mounting is available, with locking facilities, and there is a front-panel marking system for accurate alignment of door interlock handles. D S Hodgson Ltd. Tel., 01923 859191; fax, 01923 859794.

GPIB-controlled relay module. ICS Electronics has produced the *Model 4864* GPIB-to-relay interface for the ATE market, offering different combinations of contacts and isolated inputs to control external devices from a GPIB bus. There are 16 outputs, all of which can be controlled individually, run as a single or multiple scanner or all switched at the same time. Eight isolated inputs are usable to sense signals or contact closures or to verify an external response to a control output. Three types are produced: the *4864-11* has 0.5A contacts; *4864-12* 1A types; and



4864-14 solenoid/relay driver outputs to connect larger relays. Amplicon Liveline Ltd. Tel., 0800 525 335 (free); fax, 01273 570215.

Miniature snap switch. Cherry *Hirose* snap switches take up 10% of the space normally needed for a switch of this type, measuring 12.8 by 13.8 by 5.8mm. The range includes versions for 50mA to 3A, with silver alloy, silver or gold contacts. A variety of actuators is available and straight, left or right terminations. Cherry Electrical Products Ltd. Tel., 01582 763100; fax, 01582 768883.

Transducers and sensors

Pressure sensors. Schaevitz *P3000* pressure sensors from Lucas are meant for use in the measurement of very low vented gauge, absolute or wet/dry differential pressures in a variety of fluids, the lowest range being 0-5mbar and the highest 0-5bar. The pressure-sensing element includes an all-welded Ni-Span C capsule for low hysteresis and constant scale factor with temperature, a linear variable differential transformer measuring the displacement of the capsule. Lucas Control Systems Products. Tel., 01753 537622; fax, 01753 823563.

Led shaft encoder. Using red, green or orange 31-led arrays, the 20mm diameter, low-profile shaft encoder from ALPS provides 15 pulses per revolution for each phase (two click, one pulse), having an expected life of 15,000 revolutions at 500rev/hour. Operating current is 10mA. Roxburgh Electronics Ltd. Tel., 01724 281770; fax, 01724 281650.

Vision systems

Cctv Rx/Tx. *VideoWave* video transmitter and receiver are low-power, single-band components that may now be used without licensing. The system provides a real-time, secure radio link using a unique, scrambled, monochrome closed-circuit tv output at a fraction of the cost of other methods. Units are for fixed or mobile use from 12V dc,

Computers

Fireproof computer. Well, perhaps not, but the *TMI Hardbody* is a lightweight, handheld pc that will take the kind of punishment development engineers have nightmares about. It has a splash-resistant case, a pen-based interface (you use a pointer instead of a keyboard) and a long-life battery. It will survive a 20g shock for 6ms, 2g vibration between 5Hz and 200Hz and 0-95% non-condensing relative humidity. Temperature range is -10°C to 50°C. Insides consist of a 66MHz 486DX, 32Mbyte of ram, a 260Mbyte hard disk and a VGA lcd with a 2048 by 2048 touch screen. There are two PCMCIA slots, two RS-232 ports and comms ports for peripherals, rf lan and wan connection is via optional adaptors. Crellon Microsystems. Tel., 01734 776161; fax, 01734 776095.

using one-to-one, multiplexed or broadcast video transmission. Both units measure only 160mm by 90mm by 60mm. Radio Data Technology Ltd. Tel., 01376 501255; fax, 01376 501312.

COMPUTER

Data acquisition

96-channel analogue VME input. Newest member of Pentland Systems' *VGX* family is the *VGDA*, which consists of 96 12-bit analogue-to-digital converters in two VME slots to give high channel-density simultaneous sampling, accuracy being maintained by a calibration rom. Data transfer can be by VME or VSB or straight to dsp modules by way of *TMS320C4X* comms ports or front-panel data ports. Pentland Systems Ltd. Tel., 01506 464666; fax, 01506 463030.

Data communications

Lan/wan transceiver. Developed by Triquint in the US, the *TQ8105*

Ferrite cores. Murata cores for emi suppression provide 'excellent noise suppression' which is effective at frequencies up to 500MHz. Data lines may be passed through the cores or wound round them several times. Surtech Interconnection Ltd. Tel., 01256 51221; fax, 01256 471180.



Sonet/SDH atm transceiver runs at 622Mb/s, dissipates 2.3W and is contained in an 100-pin JEDEC quad flatpack. Its claim to fame stems from the provision of three alarm signals which indicate imminent loss of data before it happens. Flags are waved if there is a loss of local reference signal; at a loss of received signal after 128 zero transitions; or if the data has started to drift because of trouble at the other end. It is compatible with ecl, pecl or ttl clocks running at between 19.44MHz and 155.2MHz and it holds its end up in temperatures between -40°C and 125°C. Pronto Electronic Systems Ltd. Tel., 0181 554 5700; fax, 0181 554 6222.

Software

Datataker programmer. Data Electronics' *Datataker* series of data loggers is now augmented by the introduction of a Windows programmer and supervisor to retrieve and present its results. *Delogger Pro* offers the choice of a gui or text window for entering commands, data being shown as charts or in text form. Programming requires little use of the keyboard, most being carried out by clicking on icons, all without the presence of loggers. The program has its own relational database with up to eight filter parameters to create reports and will work with other databases such as Foxpro and Microsoft Access for more complicated work. Charting functions show data in real

time and the package also supports a modem manager for remote data collection. Data Electronics. Tel., 01462 481291; fax, 01462 481375.

Datcomms analyser. *COM-Watch 2000* allows a user to visualise and analyse data communication simultaneously on up to 16 channels and will communicate with a device to test its data; test programs may be written in the Script command language. The facility is used to start, debug and service links and in software development. In its passive mode, *COM-Watch* uses the RS-232 adaptor to see data communication, trigger functions determining which data to monitor, subsequent analysis being concerned with crc calculation, checksums and searching for patterns, strings and signal errors. Amplicon Liveline Ltd. Tel., 0800 525 335 (free); fax, 01273 570215.

Analogue circuit simulator. *SiMetrix*, from Newbury Technology, is a Windows-based circuit simulation package costing £245. Features include an integrated circuit editor with multi-level undo, waveform analysis and real-time waveform display. It is based on Spice 3 and supports transient, dc, dc sweep, ac, noise and transfer function analysis and recognises lossy transmission lines, arbitrary sources and GaAs fets. The model library contains 1300 devices, a new mosfet model being designed for vertical devices with non-linear gate/drain capacitance. Newbury Technology Ltd. Tel., 01635 966395; fax, 01635 868322. ■



Development and evaluation PIC emulation. *ICEPIC2* from RF Solutions is a modular in-circuit, real-time emulator, Windows-based, for all types of Microchip's PIC microcontrollers at up to 25MHz. Code can be debugged at source level in assembler or C, a 4K (expandable to 8K) hardware trace buffer being provided. There are unlimited hardware trigger break points on any address or range of addresses and the emulator performs single steps or procedure steps. Standard 8K of *PIC16CXX* emulation memory is expandable to 16K. Units are complete with power supply, RS232 interface and software. RF Solutions Ltd. Tel., 01273 488880; fax, 01273 480661.

ADVERTISE FREE OF CHARGE

Subscribers* to *Electronics World* can advertise their electronics and electrical equipment completely free of charge

Simply write your ad in the form below, using one word per box, up to a maximum of twenty words. Remember to include your telephone number as one word. You must include your latest mailing label with your form.

* This free offer applies to private subscribers only. Your ad will be placed in the first available issue.

This offer applies to private sales of electrical and electronic equipment only.

Trade advertisers - call Malcolm Wells on 0181-652 3620

All adverts will be placed as soon as possible. However, we are unable to guarantee insertion dates. We regret that we are unable to enter into correspondence with readers using this service, we also reserve the right to reject adverts which do not fulfil the terms of this offer.

Please send your completed forms to:

Free Classified Offer: Electronics World, L333, Quadrant House, The Quadrant, Sutton, Surrey SM2 5AS

Resistors in

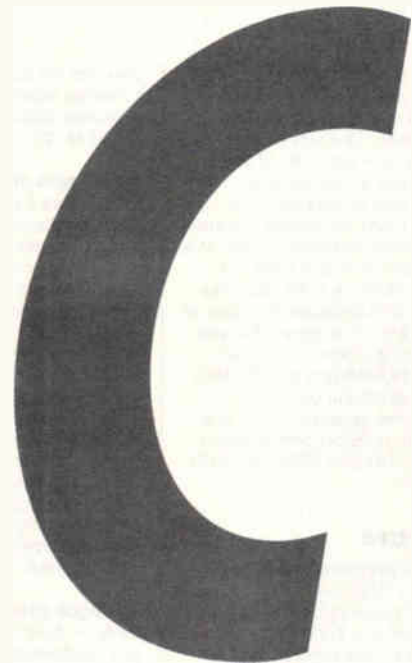

Calculating the value of parallel resistors normally involves a chart-type calculator or an electronic calculator and time-consuming equations. John Lavender describes an alternative solution offering convenience, speed and – above all – accuracy.

Written in 'C', this short program calculates series and parallel combinations of standard value resistors for any required value with an accuracy of less than 0.25%.

There are many reasons for using series or parallel resistor combinations. Achieving voltage and power ratings are not the least of these. But when a non-standard value is required, or the required standard value is not to hand, parallel or series resistor combinations are the only solution.

Whereas series pairs can usually be worked out using mental arithmetic, for most people, parallel pairs require at least a pen and paper. There are some helpful rules of thumb, but if you don't know them, or can't remember them, the only resort is lots of calculations.

The two better known formulae used to calculate parallel resistance are, for two resistors,

$$R_1 = (R_1 \times R_2) / (R_1 + R_2)$$

and for multiple resistors,

$$1/R_1 = 1/R_1 + 1/R_2 + 1/R_3 + \dots + 1/R_n$$

The first formula may be transposed to give,

$$R_1 = (R_2 \times R_1) / (R_2 - R_1)$$

when the value of one resistor and the total resistance is known.

The second formula may also be transposed to,

$$R_1 = (R_1 \times R_2 \times R_3 \dots R_n) / ((R_1 \times R_2) + (R_1 \times R_3) + (R_2 \times R_3) \dots + (R_1 \times R_n) + (R_2 \times R_n) + R_3 \times R_n), \text{ etc}$$

for calculators without a reciprocal function.

Having for many years used the above formulae and a parallel resistance calculator chart¹, I found that I required greater accuracy and flexibility when calculating resistor combinations. It was to this end that a short 'C' program was written that displayed a range of parallel-pair combinations within predetermined limits of the required value.

These limits are referred to as the accuracy range – or perhaps more precisely the 'inaccuracy range'. This is the degree of variation from the required value; the larger the variation, the greater the number of combinations displayed.

The reason I decided to display a range of combinations rather than simply the most accurate is that it gives you the opportunity of selecting,

- The most accurate combination,
- A pair with close values for current sharing – or voltage sharing, in the case of series pairs,
- A high/low value combination for applications where trimming may be required, or,
- The values of resistors on hand.

The program was found to be invaluable, saving many hours of manual calculations. Over a period of time the original program has been modified, added to, and generally improved, both series and parallel combination pairs being calculated.

Any EIA range can be selected...

Any EIA range from E6 to E96 can be selected, and the calculation parameters of resistor

Fig. 1. Simulation of a screen produced using the c resistor calculation program.

```

Enter EIA range - 96, 48, 24, 12, 6, 96
Enter resistors percentage tolerance. (e.g. 1) .1
Enter accuracy range. (e.g. .25) .025
Enter value of required resistor in ohms or 0 (ZERO) for change. 4440

121R + 4k32 = 4441.0000 0.023%, 4436.56 to 4445.44 -0.077 to 0.123% error
221R + 4k22 = 4441.0000 0.023%, 4436.56 to 4445.44 -0.078 to 0.123% error
1k43 + 3k01 = 4440.0000 0.000%, 4435.56 to 4444.44 -0.100 to 0.100% error
1k5 + 2k94 = 4440.0000 0.000%, 4435.56 to 4444.44 -0.100 to 0.100% error
4k53 || 221k = 4439.0103 -0.022%, 4434.57 to 4443.45 -0.122 to 0.078% error
4k53 || 226k = 4440.9839 0.022%, 4436.54 to 4445.42 -0.078 to 0.122% error
4k75 || 68k1 = 4440.2881 0.006%, 4435.85 to 4444.73 -0.094 to 0.106% error
4k99 || 40k2 = 4438.9907 -0.023%, 4434.55 to 4443.43 -0.123 to 0.077% error
5k49 || 23k2 = 4439.4561 -0.012%, 4435.02 to 4443.90 -0.112 to 0.088% error

Enter value of required resistor in ohms or 0 (ZERO) for change.
    
```

tolerance and accuracy range may be varied. Maximum and minimum resistance, due to resistor tolerance, is displayed both in ohms and as a percentage difference from the required value.

Another feature that has been added is that the resistor values are displayed in the generally accepted form of 0R22, 6R8, 10R, 560R, 1k2, 47k, 330k, 1M0, etc., which makes for easier reading. Figure 1 shows a typical screen display from this program. The listing for this program is beyond the scope of this article, but the program is available, as detailed later.

List 1 is a modified version of the original program. It is easy to use, and calculates series pairs as well as the parallel combinations. The range of resistor values used in the calculations are the E24 values from 0.01Ω to 91MΩ, which covers the majority of the readily available resistor values.

The accuracy range is pre-set by the 'percentage=0.25' declaration at the end of line 7 of the listing. This value can be changed to suit your requirements, but I have found 0.25% to give the best range of results.

In use, the program could not be simpler. Load the program, enter the required resistor value, in ohms, hit the enter key and the results appear on screen. Other values are entered as required, then, when finished, press the zero key to exit the program.

If more than 24 combinations are found, "MORE -" is displayed at the bottom of the screen. Hit a key and the next screen of combinations is displayed.

Series combinations are displayed in the form of,

3300.00+6800.00=10100.0000 0.0000% error.

and for parallel combinations:

3300.00||6800.00=2221.7822 -0.0098% error.

Although this program will run on any pc compatible, it is advisable to use at least a 486DX. This is because the program makes some 57,600 sets of calculations for each required value.

Calculations are made for every resistor value, paired with every value for both series and parallel combinations. A lesser pc will take several minutes to run through this number of calculations.

For those of you who do not have access to a 'C' compiler, a disk with a DOS-executable program (E24.EXE) is available. The disk also contains an E96 version of the program (E96.EXE) and the 'C' listings of both ver-

sions. As a special offer, the executable file for the more comprehensive program referred to in the text is included on the disk for the all-inclusive price of £15. Send your request to: J. E. Lavender, 5 Shackleton Avenue, Yate BS17 4NW, enclosing a cheque or money order for £20 ■

References

1. Hammond, M. A., Parallel resistance calculator, p45, *Electronics World* April 1962 (This is an American magazine, not related to *Wireless World*). (EIA 24 values and improved version of the 'Resistors in parallel' chart, by the same author, published on p339 of the July/August 1959 issue of *Wireless World*.)

List 1. Calculate parallel resistances in C with speed and accuracy.

```

1  #include <stdio.h>
2  #include <conio.h>
3  main()
4  {
5      float mult*10*={0.01,0.1,1.0,10,100,1000,10000,100000L,1000000L,10000000L},
6      value*24*={1.0,1.1,1.2,1.3,1.5,1.6,1.8,2.0,2.2,2.4,2.7,3.0,3.3,3.6,3.9,4.3,
7      4.7,5.1,5.6,6.2,6.8,7.5,8.2,9.1}, r1, r2, rc, rs, rt, e, percent=.25;
8      int ra, ma, rb, mb, ctr;
9      printf("\nEnter the required value of resistor in ohms\n");
10     scanf(" %f",&rc);
11     do
12     {
13         ctr = 0;
14         for (ma = 0; ma < 10; ma++)
15         {
16             for (ra = 0; ra < 24; ra++)
17             {
18                 for (mb = 0; mb < 10; mb++)
19                 {
20                     for (rb = 0; rb < 24; rb++)
21                     {
22                         r1 = (value*ra * mult*ma*);
23                         r2 = (value*rb * mult*mb*);
24                         rs = r1 + r2;
25                         if (r1<=r2&&rc<=rs+(rs*percent/100)&&rc>=rs(rs*percent/100))
26                         {
27                             if (rc != r1 && rc != r2)
28                             {
29                                 e = ((rs - rc)/rc) * 100;
30                                 printf ("\n%.3f + %.3f = %.4f %.4f %% error.",r1,r2,rs,e);
31                                 ctr++;
32                             }
33                         }
34                         rt = ((r1 * r2)/(r1 + r2));
35                         if (r1<=r2&&rc<=rt+(rt*percent/100)&&rc>=rt-(rt*percent/100))
36                         {
37                             if (rc != r1 && rc != r2)
38                             {
39                                 e = ((rt - rc)/rc) * 100;
40                                 printf ("\n%.3f || %.3f = %.4f %.4f %% error",r1,r2,rt,e);
41                                 ctr++;
42                             }
43                         }
44                     }
45                 }
46             }
47         }
48     }
49     printf ("\n\nENTER ANOTHER VALUE OR ENTER '0' (ZERO) TO EXIT\n");
50     scanf (" %f",&rc);
51 }
52 while (rc != 0);
53 return 0;
54 }

```

Surplus always wanted for cash!

THE ORIGINAL SURPLUS WONDERLAND!

THIS MONTH'S SELECTION FROM OUR VAST EVER CHANGING STOCKS

Surplus always wanted for cash!

LOW COST PC's -

SPECIAL BUY 'AT 286'

40Mb HD + 3Mb Ram



LIMITED QUANTITY only of these 12Mhz HI GRADE 286 systems Made in the USA to an industrial specification, the system was designed for total reliability. The compact case houses the motherboard, PSU and EGA video card with single 5 1/4" 1.2 Mb floppy disk drive & integral 40Mb hard disk drive to the front. Real time clock with battery backup is provided as standard. Supplied in good used condition complete with enhanced keyboard, 640k + 2Mb RAM, DOS 4.01 and 90 DAY Full Guarantee. Ready to Run!

Order as HIGRADE 286 **ONLY £129.00 (E)**

Optional Fitted extras: VGA graphics card	£29.00
1.4Mb 3 1/4" floppy disk drive (instead of 1.2 Mb)	£19.95
Wordperfect 6.0 for Dos - when 3 1/4" FDD option ordered	£22.50
NE2000 Ethernet (thick, thin or twisted) network card	£29.00

LOW COST 486DX-33 SYSTEM

Limited quantity of this 2nd user, superb small size desktop unit. Fully featured with standard simm connectors 30 & 72 pin. Supplied with keyboard, 4 Mb of RAM, SVGA monitor output, 256k cache and integral 120 Mb IDE drive with single 1.44 Mb 3.5" floppy disk drive. Fully tested and guaranteed. Fully expandable.

Many other options available - call for details. **£399.00 (E)**

FLOPPY DISK DRIVES 3 1/2" - 8"

5 1/4" or 3 1/2" from only £18.95!

Massive purchases of standard 5 1/4" and 3 1/2" drives enables us to present prime product at industry beating low prices! All units (unless stated) are BRAND NEW or removed from other brand new equipment and are fully tested, aligned and shipped to you with a 90 day guarantee and operate from standard voltages and are of standard size. All are IBM-PC compatible (if 3 1/2" supported on your PC).

3 1/2" Panasonic JU363/4 720K or equivalent RFE	£24.95(B)
3 1/2" Mitsubishi MF355C-L 1.4 Meg. Laptops only	£25.95(B)
3 1/2" Mitsubishi MF355C-D 1.4 Meg. Non laptop	£18.95(B)
5 1/4" Teac FD-55GFR 1.2 Meg (for IBM pc's) RFE	£18.95(B)
5 1/4" Teac FD-55F-03-U 720K 40/80 (for BBC's etc) RFE	£29.95(B)
5 1/4" BRAND NEW Mitsubishi MF501B 360K	£22.95(B)
Table top case with integral PSU for HH 5 1/4" Floppy or HD	£29.95(B)
8" Shugart 800/801 B* SS refurbished & tested	£195.00(E)
8" Shugart 810 B* SS HH Brand New	£195.00(E)
8" Shugart 851 B* double sided refurbished & tested	£250.00(E)
Mitsubishi M2894-63 B* double sided NEW	£275.00(E)
Mitsubishi M2896-63-02U B* DS slimline NEW	£285.00(E)
Dual 8" cased drives with integral power supply 2 Mb	£499.00(E)

HARD DISK DRIVES

End of line purchase scoop! Brand new NEC D2246 8" 85 Mbyte drive with industry standard SMD Interface, replaces Fujitsu equivalent model. Full manual. Only £299.00 or 2 for £525.00 (E)

3 1/2" FUJI FK-309-26 20mb MFM I/F RFE	£59.95(C)
3 1/2" CONNER CP3024 20 mb IDE I/F (or equiv) RFE	£59.95(C)
3 1/2" CONNER CP3044 40mb IDE I/F (or equiv) RFE	£69.00(C)
3 1/2" RODIME R03057S 45mb SCSI I/F (Mac & Acorn)	£69.00(C)
3 1/2" WESTERN DIGITAL 850mb IDE I/F Brand New	£185.00(C)
5 1/4" MINISCRIBE 3425 20mb MFM I/F (or equiv.) RFE	£49.95(C)
5 1/4" SEAGATE ST-238R 30 mb RLL I/F Refurb	£69.95(C)
5 1/4" CDC 94205 41 40mb HH MFM I/F RFE tested	£69.95(C)
5 1/4" HP 9754B 850 Mb SCSI RFE tested	£89.00(C)
5 1/4" HP C3010 2 Gbyte SCSI differential RFE tested	£195.00(C)
8" FUJITSU M2322K 160Mb SMD I/F RFE tested	£195.00(E)
Hard disc controllers for MFM, IDE, SCSI, RLL etc. from	£16.95

THE AMAZING TELEBOX

Converts your colour monitor into a QUALITY COLOUR TV!!



TV SOUND & VIDEO TUNER
CABLE COMPATIBLE

The TELEBOX is an attractive fully cased mains powered unit, containing all electronics ready to plug into a host of video monitors made by makers such as MICROVITEC, ATARI, SANYO, SONY, COMMODORE, PHILIPS, TATUNG, AMSTRAD etc. The composite video output will also plug directly into most video recorders, allowing reception of TV channels not normally receivable on most television receivers* (TELEBOX MB). Push button controls on the front panel allow reception of 8 fully tuneable 'off air' UHF colour television channels. TELEBOX MB covers virtually all television frequencies VHF and UHF including the HYPERBAND as used by most cable TV operators. A composite video output is located on the rear panel for direct connection to most makes of monitor or desktop computer video systems. For complete compatibility - even for monitors without sound - an integral 4 watt audio amplifier and low level Hi Fi audio output are provided as standard.

TELEBOX ST for composite video input type monitors	£36.95
TELEBOX ST as ST but fitted with integral speaker	£39.50
TELEBOX MB Multiband VHF/UHF/Cable/Hyperband tuner	£69.95

For overseas PAL versions state 5.5 or 6 MHz sound specification. *For cable / hyperband reception Telebox MB should be connected to a cable type service. Shipping code on all Telebox's is (B)

DC POWER SUPPLIES

Virtually every type of power supply you can imagine. Over 10,000 Power Supplies Ex Stock Call for info / list.

Issue 13 of Display News now available - send large SAE - PACKED with bargains!

DISPLAY ELECTRONICS

ALL MAIL & OFFICES
Open Mon-Fri 9.00-5.30
Dept WW. 32 Biggin Way
Upper Norwood
LONDON SE19 3XF

LONDON SHOP
Open Mon - Sat 9:00 - 5:30
215 Whitehorse Lane
South Norwood
On 68A Bus Route
Between Heath & Selhurst Park SR Rail Stations

NEW DISTELCO
The Original
FREE On line Database
Info on 20,000 + stock items!
RETURNING 50%!

ALL ENQUIRIES
0181 679 4414
FAX 0181 679 1927



All prices for UK Mainland. UK customers add 17.5% VAT to TOTAL order amount. Minimum order £10. Bona Fide account orders accepted from Government, Schools, Universities and Local Authorities - minimum account order £50. Cheques over £100 are subject to 10 working days clearance. Carriage charges (A)=£3.00, (A1)=£4.00, (B)=£5.50, (C)=£8.50, (D)=£12.00, (E)=£15.00, (F)=£18.00, (G)=CALL. Allow approx 6 days for shipping - faster CALL. Scotland surcharge CALL. All goods supplied to our Standard Conditions of Sale and unless stated guaranteed for 90 days. All guarantees on a return to base basis. All rights reserved to change prices / specifications without prior notice. Orders subject to stock. Discounts for volume. Top CASH prices paid for surplus goods. All trademarks etc acknowledged. © Display Electronics 1986. E & O E. 06/6

IC's - TRANSISTORS - DIODES

OBSOLETE - SHORT SUPPLY - BULK

6,000,000 items EX STOCK

For MAJOR SAVINGS - CALL FOR SEMICONDUCTOR HOTLIST

VIDEO MONITOR SPECIALS

One of the highest specification monitors you will ever see - At this price - Don't miss it!!

Mitsubishi FA3415ETKL 14" SVGA Multisync colour monitor with fine 0.28 dot pitch tube and resolution of 1024 x 768. A variety of inputs allows connection to a host of computers including IBM PC's in CGA, EGA, VGA & SVGA modes. BBC, COMMODORE (including Amiga 1200), ARCHIMIDES and APPLE. Many features: Etched faceplate, test switching and LOW RADIATION MPPR specification. Fully guaranteed, supplied in EXCEL-

LENT little used condition. **Only £119 (E)** Order as MITS-SVGA
Tilt & Swivel Base £4.75
VGA cable for IBM PC included.
External cables for other types of computers CALL

As New - Used on film set for 1 week only!!
15" 0.28 SVGA 1024 x 768 res. colour monitors.
Swivel & tilt etc. Full 90 day guarantee. £145.00 (E)

Just In - Microvitec 20" VGA (800 x 600 res.) colour monitors.
Good SH condition - from £299 - CALL for info

PHILIPS HCS35 (same style as CM8833) attractively styled 14" colour monitor with both RGB and standard composite 15.625 KHz video inputs via SCART socket and separate phono jacks. Integral audio power amp and speaker for all audio visual uses. Will connect direct to Amiga and Atari BBC computers. Ideal for all video monitoring / security applications with direct connection to most colour cameras. High quality with many features such as front concealed flap controls, VCR correction button etc. Good used condition - fully tested - guaranteed
Dimensions: W14" x H12 3/4" x 15 1/2" D.
Only £95 (E)

PHILIPS HCS31 Ultra compact 9" colour video monitor with standard composite 15.625 KHz video input via SCART socket. Ideal for all monitoring / security applications. High quality, ex-equipment fully tested & guaranteed (possible minor scuff marks). In attractive square black plastic case measuring W10" x H10" x 1 1/2" D. 240 V AC mains powered.
Only £79.00 (D)

KME 10" 15M10009 high definition colour monitors with 0.28" dot pitch. Superb clarity and modern styling. Operates from any 15.625 khz sync RGB video source, with RGB analog and composite sync such as Atari, Commodore Amiga, Acorn Archimedes & BBC. Measures only 13 1/2" x 12" x 11". Good used condition.
Only £125 (E)

20" 22" and 26" AV SPECIALS

Superbly made UK manufacture. PIL all solid state colour monitors, complete with composite video & optional sound input. Attractive teak style case. Perfect for Schools, Shops, Disco, Clubs, etc. In EXCELLENT little used condition with full 90 day guarantee.

20"....£135 22"....£155 26"....£185 (F)

SPECIAL INTEREST ITEMS

MITS. FA3445ETKL 14" Industrial spec SVGA monitors 2Kw to 400 Kw - 400 Hz 3 phase power sources - ex stock	£245
IBM 8230 Type 1, Token ring base unit driver	£950
IBM 53F5501 Token Ring ICS 20 port lobe modules	£750
IBM MAU Token ring distribution panel 8228-23-5050N	£95
AIM 501 Low distortion Oscillator 9Hz to 320KHz, IEEE	£550
Trend Data 274 Data Analyser with G703(2M) 64 i/o	£POA
Marconi 6310 Programmable 2 to 22 GHz sweep generator	£6500
HP1650B Logic Analyser	£3750
HP3781A Pattern generator & HP3782A Error Detector	£POA
HP APOLLO RX700 system units	£950
HP6621A Dual Programmable GPIB PSU 0-7 V 160 watts	£1800
HP3081A Industrial workstation clw Barcode swipe reader	£175
HP6264 Rack mount variable 0-20V @ 20A metered PSU	£675
HP54121A DC to 22 GHz four channel test set	£POA
HP7580A A1 8 pen HPGL high speed drum plotter	£1850
EG-G Brookdale 95035C Precision lock in amp	£650
Veng Eng. Mod 1200 computerised inspection system	£POA
Ling Dynamics 2kW programmable vibration test system	£POA
Computer controlled 1056 x 560 mm X Y table & controller	£1425
Keithley 590 CV capacitor / voltage analyser	£POA
Racal ICR40 dual 40 channel video recorder system	£3750
Fiskers 45KVA 3 ph On Line UPS - New batts Dec.1995	£9500
ICI R5030UV34 Cleanline ultrasonic cleaning system	£POA
Mann Tally MT645 High speed line printer	£2200
Intel SBC 486/133SE Multibus 486 system, 8Mb Ram	£1200
Zeta 3220-05 A0 4 pen HPGL fast drum plotters	£1150
Nikon HF-X-11 (Ephiphot) exposure control unit	£1450
Motorola VME Bus Boards & Components List. SAE / CALL	£POA
Trio 0-18 vdc linear, metered 30 amp bench PSU. New	£550
Fujitsu M3041R 600 LPM band printer	£1950
Fujitsu M3041D 600 LPM printer with network interface	£1250
Perkin Elmer 2998 Infrared spectrophotometer	£POA
VG Electronics 1035 TELETEXT Decoding Margin Meter	£3750
Andrews LARGE 3.1 m Satellite Dish + mount (For Voyager!)	£950
Sekonic SD 150H 18 channel digital Hybrid chart recorder	£1995
TAYLOR HOBSON Tallysurf amplifier / recorder	£750
System Video 1152 PAL waveform monitor	£485
Test Lab - 2 mtr square quietised acoustic test cabinets	£300
Kenwood 9801 PAL Vectroscope - NEW	£650

Please call for further details on the above items

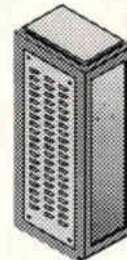

19" RACK CABINETS

Superb quality 6 foot 40U
Virtually New, Ultra Smart
Less than Half Price!

Top quality 19" rack cabinets made in UK by Optime Enclosures Ltd. Units feature designer, smoked acrylic lockable front door, full height lockable half louvered back door and louvered removable side panels. Fully adjustable internal fixing struts, ready punched for any configuration of equipment mounting plus ready mounted integral 12 way 13 amp socket switched mains distribution strip make these racks some of the most versatile we have ever sold. Racks may be stacked side by side and therefore require only two side panels to stand singly or in multiple bays. Overall dimensions are: 77 1/2" H x 32 1/2" D x 22" W. Order as:

OPT Rack 1 Complete with removable side panels	£335.00 (G)
OPT Rack 2 Rack, Less side panels	£225.00 (G)

32U - High Quality - All steel RakCab

Made by Eurocraft Enclosures Ltd to the highest possible spec, rack features all steel construction with removable side, front and back doors. Front and back doors are hinged for easy access and all are lockable with five secure 5 lever barrel locks. The front door is constructed of double walled steel with a 'designer style' smoked acrylic front panel to enable status indicators to be seen through the panel, yet remain unobtrusive. Internally the rack features fully slotted reinforced vertical fixing members to take the heaviest of 19" rack equipment. The two movable vertical fixing struts (extras available) are pre punched for standard 'cage nuts'. A mains distribution panel internally mounted to the bottom rear, provides 8 x IEC 3 pin Euro sockets and 1 x 13 amp 3 pin switched utility socket. Overall ventilation is provided by fully louvered back door and double skinned top section with top and side louvers. The top panel may be removed for fitting of integral fans to the sub plate etc. Other features include: fitted castors and floor levelers, prepunched utility panel at lower rear for cable / connector access etc. Supplied in excellent, slightly used condition with keys. Colour: Royal blue. External dimensions mm=1625H x 635D x 603 W. (64" H x 25" D x 23 3/4" W)

Sold at LESS than a third of makers price!!

A superb buy at only £195.00 (G)

Over 1000 racks - 19" 22" & 24" wide
3 to 44 U high. Available from stock!!
Call with your requirements.

TOUCH SCREEN SYSTEM

The ultimate in 'Touch Screen Technology' made by the experts - MicroTouch - but sold at a price below cost!! System consists of a flat translucent glass laminated panel measuring 29.5 x 23.5 cm connected to an electronic controller PCB. The controller produces a standard serial RS232 or TTL output which continuously gives simple serial data containing positional X & Y co-ordinates as to where a finger is touching the panel - as the finger moves, the data instantly changes. The X & Y information is given at an incredible matrix resolution of 1024 x 1024 positions over the entire screen size!! A host of available translation software enables direct connection to a PC for a myriad of applications including: control panels, pointing devices, POS systems, controllers for the disabled or computer un-trained etc etc. Imagine using your finger with 'Windows', instead of a mouse!! (A driver is indeed available!) The applications for this amazing product are only limited by your imagination!! Complete system including Controller, Power Supply and Data supplied at an incredible price of only: **£145.00 (B)**

Full MICROTOUCH software support pack and manuals for IBM compatible PC's £29.95 RFE - Tested

LOW COST RAM & CPU'S

INTEL 'ABOVE' Memory Expansion Board. Full length PC-XT and PC-AT compatible card with 2 Mbytes of memory on board. Card is fully selectable for Expanded or Extended (286 processor and above) memory. Full data and driver disks supplied. RFE. Fully tested and guaranteed. Windows compatible. **£59.95(A1)**
Half length 8 bit memory upgrade card for PC AT XT expands memory either 256k or 512k in 64k steps. May also be used to fill in RAM above 640k DOS limit. Complete with data.
Order as: XT RAM UG. 256k. £34.95 or 512k £39.95 (A1)

SIMM SPECIALS

1 MB x 9 SIMM 9 chip 120ns	Only £16.50 (A1)
1 MB x 9 SIMM 9 chip 80ns £19.50 or 70ns £22.95 (A1)	
1 MB x 9 SIMM 9 chip 80ns £21.50 or 70ns £23.75 (A1)	
4 MB 70 ns 72 pin SIMM - with parity - Only £95.00 (A1)	
INTEL 486-DX3 CPU £55.00 INTEL 486-DX6 CPU £69.00 (A1)	

FANS & BLOWERS

EPSON DO412 40x40x20 mm 12v DC	£7.95 10 / £65
PAPST TYPE 612 60x60x25 mm 12v DC	£8.95 10 / £75
MITSUBISHI MMF-D6D12DL 60x60x25 mm 12v DC	£4.95 10 / £42
MITSUBISHI MMF-08C12DM 80x80x25 mm 12v DC	£5.25 10 / £49
MITSUBISHI MMF-09B12DH 92x92x25 mm 12v DC	£5.95 10 / £53
PANCAKE 12-3.5 92x92x18 mm 12v DC	£7.95 10 / £69
EX-EQUIP AC fans. ALL TESTED 120 x 120 x 38 mm specify 110 or 240 V £6.95. 80 x 80 x 38 mm - specify 110 or 240 V £5.95	
IMHOF B28 1900 rack mnt 3U x 19" Blower 110/240v NEW	£79.95

Shipping on all fans (A). Blowers (B). 50,000 Fans Ex Stock CALL

Programmable logic

Building on his earlier articles, **Geoff Bostock** now looks at more complex programmable logic devices involving large-scale integration.

One approach to making programmable logic devices with a higher logic content is to integrate several small programmable-array logic ICs into one package. Different manufacturers may differ in detail in the way they do this, but they all have certain features in common. Figure 1 shows the basic structure of a large-scale integration programmable-array logic device, or PAL. Such devices are also called complex PLDs, or CPLDs.

There are four blocks to consider in each device. These are the input cells, an interconnection matrix, the logic blocks and the i/o cells.

Input cells and i/o cells may be taken together as some families have no, or only a few, separate inputs and use i/o cells for this function. In general, an i/o cell connects the logic blocks to the outside world and features a ttl or c-mos

interface. Most devices operate with 0.4V and 2.4V output logic levels. This means that they need level conversion if they are to drive true c-mos logic; they have high impedance inputs and can be driven by c-mos without any problem.

The outputs always have a tri-state capability which can be permanently enabled or disabled, or controlled by internal logic. They can function as dedicated inputs, dedicated outputs with optional feedback or as bussable outputs. The advantage of being able to choose the function of all inputs and outputs is that the input and output sites are not pre-determined and this gives extra flexibility to the pcb layout.

In small PLDs, every input to the device may be connected to every product term. Even a quite large PAL, such as the 22V10, will have a manageable number of fuses with this universal connectivity. The 22V10 has 132 product terms

This article is derived from Geoff Bostock's new book 'FPGAs and programmable LSI – a designer's handbook'. The work covers designing FPGAs, large PAL structures, RAM and antifuse-based FPGAs and FPGA selection. Comprising 215 pages, this book is available by sending a postal order or cheque with a request for the book to Electronics World, Quadrant House, The Quadrant, Sutton, Surrey SM2 5AS. The fully-inclusive price is £27.50 UK, £30 Europe or £33 rest of world. Alternatively, fax your full credit card details and address on 0181 652 8956 or e-mail jackie.lowe@rbp.co.uk.

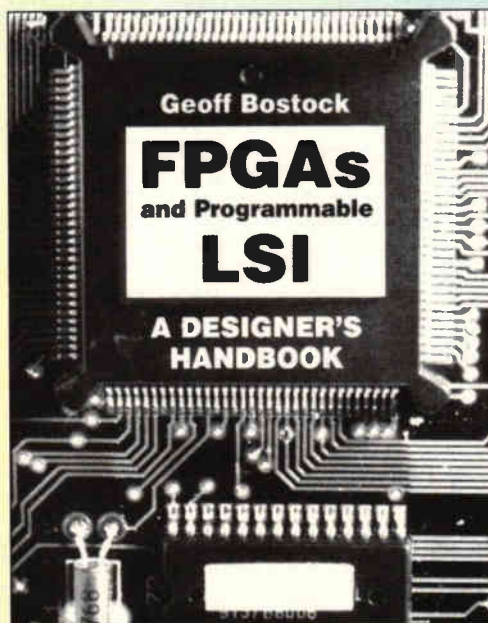

Geoff Bostock runs his own FPGA/PLD Design Consultancy, and may be contacted on 01380 828241, or by e-mail at geoff.bostock@zetnet.co.uk

with 44 potential connections to each, giving a total of 5808 fuses not counting configuration sites.

A PLD in a PLCC84 package may have 72 input/outputs; if each i/o has an average of just four product terms there will be 4 by 72 by 144, or 41472, programmable cells. This does not allow for any buried logic cells. If each i/o has a buried macrocell associated with it the total number of fuses is quadrupled.

While such a total is not outside the possibilities of technology, there are performance penalties with this approach. The more fuses there are, the more expensive the chip, and the longer it takes to program. The solution is an interconnection matrix which selects a reduced number of inputs to feed each logic block. It is best, therefore, to consider each logic block as an individual PAL within the larger PLD, each PAL being connected to the others via the interconnection matrix.

Looking at each logic block as an individual PAL simplifies the description of the architecture. Discrete PALs contain at least eight, and up to sixteen, product terms per output. Very often, only two or three terms are actually used in many applications.

This variability gives the PLD manufacturer a problem; how many product terms need to be provided with each macrocell? In many cases the answer is to incorporate some method where terms may be shared between macrocells within each logic block. In this way, if a function does not need all its available terms, they can be used by one of its neighbours.

Another area where product terms are wasted in discrete

PALs is the i/o macrocell used as a dedicated input. In many CPLDs, there are two feedback paths to the interconnection matrix; one goes from the i/o pin and the other from the macrocell output. In this case, if an i/o pin is used as a dedicated input the logic terms can still be used as a buried macrocell which cannot be accessed directly from the outside. Some PLDs also include macrocells which are always buried as a way of increasing the logic capability without increasing the i/o count.

Performance criteria

The two principal measures of performance affecting selection of a logic device are speed and power consumption, but the balance between them varies according to the application. Clearly, in a fast computer, speed is the most important factor. In a portable telephone on the other hand, power would be the controlling consideration. In many cases a compromise can be achieved, as 'it must be faster than 15ns but the less power it takes the cheaper we can make the power supply'.

Propagation delay, the most common measure of speed, is almost entirely determined by the time taken to charge and discharge the capacitance associated with the components and interconnections used to build the device. Once again, you can split a PLD into sections to see which areas are critical and reliant on the design of the chip rather than just processing.

Starting with the input, this is probably the simplest part of the PLD as its function is just to buffer external logic levels to the internal levels. Delay time will be largely process-

Generic PLDs, FPLAs and FPLSs

It is a drawback to the range of PALs described in the previous article that the designer is restricted to fixed architectures with eight, six, four or no flip-flops. The introduction of generic macrocells made PLDs more flexible architecturally. The diagram top right shows a typical macrocell; the flexibility is achieved by the use of programmable multiplexers to route the output signal through different paths.

The design of the macrocell varies slightly from device to device; this example is actually used in the 22V10 device. There are four possible sources for the output signal. These are combinational, combinational but inverted, registered and registered/inverted. The same programmable bit that selects the registered or combinational signal for the output also routes it back to the AND array, but always inverted.

Generic PLDs can cover most programmable logic applications in a given package size, simply because of the range of input/output configurations which can be programmed into each device. The GAL16V8 (generic array logic with versatile outputs) can perform the same function as the PALs 16L8, 16R4, 16R6 and 16R8 plus innumerable other i/o combinations which are not found as

standard PALs. The GAL16V8 is a 20-pin device and there is a 24-pin GAL20V8 which has similar features, but with four more inputs.

The most likely problem with fitting a logic circuit into a GAL16V8 or GAL20V8 is the number of product terms available. Combinational outputs have seven terms and registered outputs eight terms each and, if the function requires more terms, a different solution will have to be found.

The first approach would be to try logic minimisation, but most logic compilers incorporate a minimiser anyway. It might be worth trying to invert the output sense and minimise, but there is no guarantee that would be successful either.

The 24-pin GAL22V10 has more product terms, a variable number from eight to sixteen depending on which output is being used, and this will cope with most logic designs.

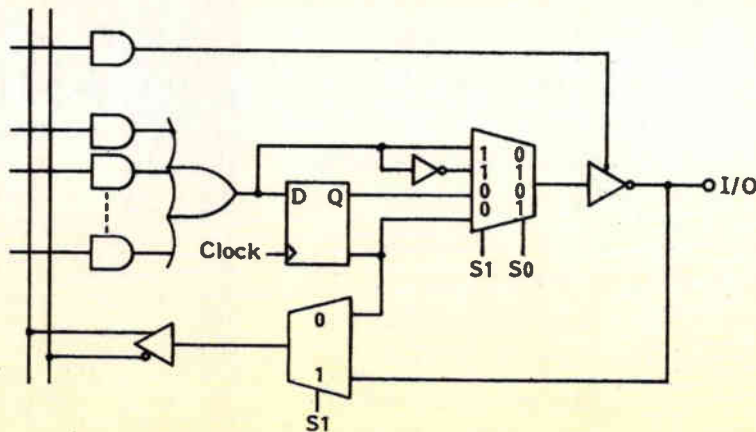

Macrocell for the PALCE22V10. Here, flexibility is achieved by using programmable multiplexers.

dependent as the input buffer will be designed to the minimum geometry allowed by the process. No heavy drive is needed to interface to the internal logic.

Some devices do feature input latches or registers, which will be optional and, therefore, add no delay when by-passed. When they are being used it is, again, most likely that they will be a minimum geometry design and their time penalty be entirely process-dependent.

Outputs determine the drive available for interfacing to external circuitry and, in this way, are no different from any other logic device. The drive capability of an output stage is usually characterised by the output short-circuit current.

One section of a CPLD whose performance can be affected by the way in which the chip is designed is the interconnect matrix. This matrix is an array of switches with as many inputs as there are device inputs, i/os and macrocell feedbacks. There are outputs to each of the logic blocks.

Each switch is like a small capacitor hanging on the input line, whether it is connected to a logic block, or not. As a result, the number of inputs to all the blocks determines the capacitance of the interconnect matrix.

The time taken to charge and discharge a capacitor is determined by the current which is used for this, so one way to speed up the matrix would be to increase the current driving each of the block inputs. This would also have the effect of increasing the power consumption of the whole chip. There are two consequences of doing this; firstly it increases the size, and hence cost, of the power supplies in the overall system. Secondly it increases the heat produced by the chip and, therefore, its running temperature. It may also have implications in the cooling needed for the system in which it is being used.

An alternative approach is to limit the number of signals which are switched into each of the logic blocks. This will reduce the total capacitance loading each AND term and hence the delay time for a given level of current drive. It also means that some of the input and feedback signals are not available for use by some of the AND terms.

The logic block itself offers only a little scope for performance optimisation. Limiting the number of terms in each block will save power, or allow more power to be used for each term, but this also limits the complexity of the logic function which can be implemented. At the heart of the block is, usually, a flip-flop with surrounding switches to mute the logic signal, as in the 22V10.

Many large-scale-integration PAL devices also include product term switching which can allocate some or all of the product terms to adjacent logic blocks. This reduces the waste when blocks are only partially used, or used as direct inputs.

Although the product terms consume power in normal operation, some devices contain a 'turbo' switch. In non-turbo mode, the logic array is only powered when input signals are changing, the output signals being latched. An activity detector switches on the array power and enables the output latches when a change is detected at any input. Because this causes extra delay through the device, setting the turbo on keeps power applied permanently giving high speed at the expense of high dissipation, Fig. 2.

The features characterising CPLDs, then, are logic blocks with wide input gating, a central switch matrix, one-to-one correspondence between logic blocks and i/o pins and a compromise between speed, power and internal connectivity.

Logic cell arrays

Although the term 'logic-cell array' is strictly applicable to one manufacturer's product, it does describe the second

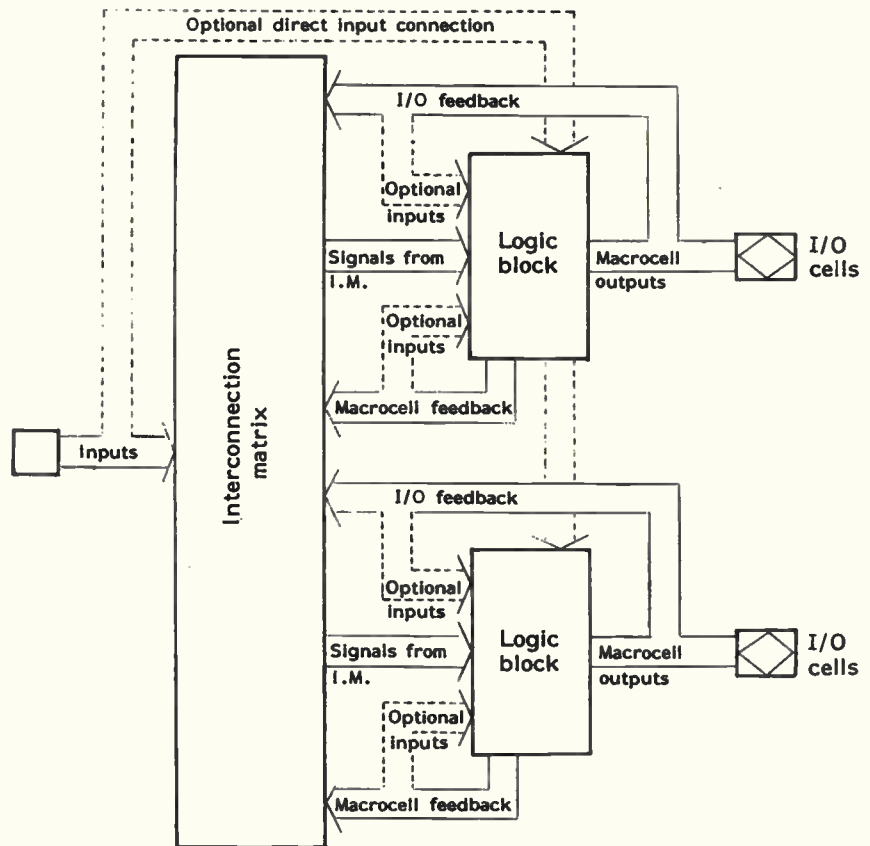

Fig. 1. Basic structure of a large-scale integration PAL, also called a complex PLD or CPLD.

generic programmable LSI structure quite accurately. The layout of a typical LCA is shown in Fig. 3, and contains three basic elements, i/o cells, logic cells and routing channels. Most devices in this class use ram cells for configuration and signal routing.

Signals enter and leave the device through i/o cells with connections to the busses in the routing channels. The logic cells also have programmable connections to the routing lines which run past them. In this way, the signals are propagated round the chip. The logic blocks themselves are usually more complex than a typical PAL-type macrocell, but with far fewer inputs, typically only four or five. Thus, the logic structures can be fabricated from pure c-mos.

Unlike CPLDs, whose i/o pins are usually associated with a particular logic block, LCA i/os are independent of the internal logic. Any pin can be an input and an output and all the i/o cells are identical, although they may share their function with the signals needed to set the device up in the configuration phase. Complexity of the i/o cell varies according to device family, but they will normally have the usual function such as tri-state capability on outputs and the possibility of hitching or registering input signals.

As mentioned earlier, the logic cells themselves tend to have the possibility of implementing quite complex functions but with no more than six inputs. Implementing wide gating functions may require cascading over two or more levels of logic.

A CPLD can usually cope with a width of twenty or more signals in a single level of gating. An LCA design will, therefore, look more like a discrete logic design than a PAL, and logic minimisation may be performed more profitably with this in mind.

The routing channels in an LCA owe more to masked ASICs than PALs also. Most LCAs include different lengths of muting within a device for, as we shall see, many of the

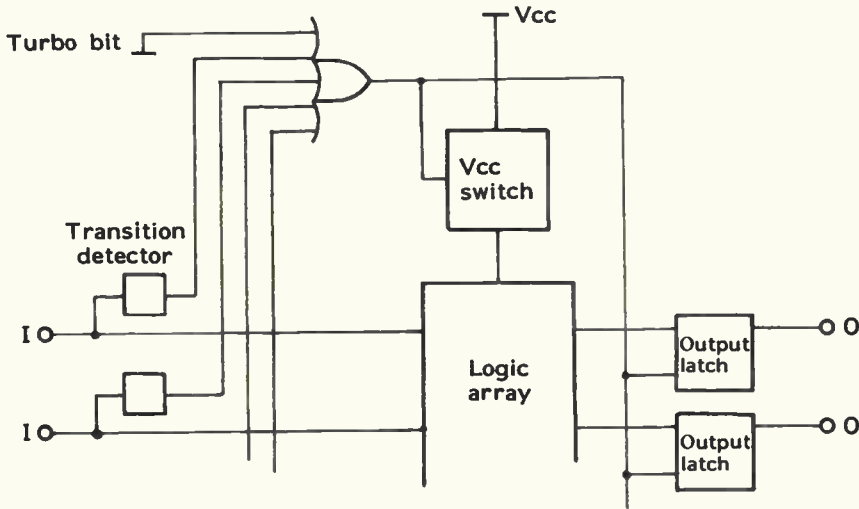

Fig. 2. Turbo switch circuit. In turbo mode, the device is permanently powered but in non-turbo mode, it is only powered while an input signal is present.

factors which determine device performance are connected with routing. Short tracks are usually available for routing signals between adjacent cells while longer tracks may be needed for carrying signals across larger areas of the chip. One or more additional tucks may be provided for clocks and other global signals, which may need a high fan-out.

The longer a routing track the higher its capacitance so performance is optimised by keeping track lengths as low as possible, which is helped by placing cells close together when their logic functions are closely associated in the circuit schematic. Often, repeaters or drivers are inserted along long tracks to help improve the delay due to track capacitance. Where horizontal and vertical muting channels cross they may be connected by programmable switches in order to divert signals to other rows or columns.

Performance factors

As before, I will focus on speed and power consumption as the most important measures of performance. In practice, propagation delays between the different elements in an LCA can only be inferred from measurements made with different circuit configuration. For example, the difference in delay time between a single-level logic circuit and a two-level logic circuit should give the delay through a logic cell. The problem in making a judgement between two different circuits lies in other factors, such as the interconnect delay. Performance will depend as much on the way in which circuits are laid out as on the delay through circuit elements.

Furthermore, different arrays have logic cells of different

Fig. 3. Logic-cell array contains three basic elements - i/o cells, logic cells and routing channels.

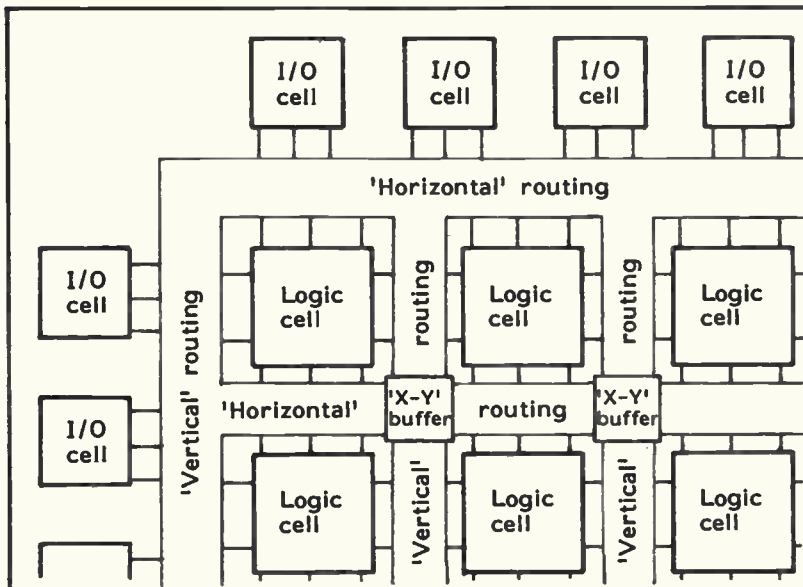

complexity, so performance can also depend on the appropriateness of the logic function and the logic capability of the target device. At a simple level, a six-input gate may need two stages of gating in one array but only one in another, making the second appear faster irrespective of the intrinsic delay of the two devices. One good measure of the true speed of the internal logic is the maximum frequency at which a flip-flop will operate. This can be gauged by configuring a cell as a divider and finding the frequency at which the output disappears.

Because the internal logic cells in most LCA devices use relatively narrow gating, true c-mos circuitry is used in building the internal logic cells. Stand-by power is therefore comparable, in most cases, to that of the same circuit built in discrete c-mos logic. The only factor which usually causes a problem is any level shifting needed to interface the inputs to ttl levels.

As with discrete c-mos logic, power consumption starts to rise as soon as signals in the circuit start to change, and internal and external nodes need charging and discharging. Because the capacitance involved with internal connections is significantly lower than that of external connections, an LCA will usually dissipate less power during docked operation than the equivalent discrete circuit.

Actual power will depend on the number of nodes which are switching at any one time and will need some complex analysis to make an accurate prediction of power. It is often possible to calculate the predicted power consumption from within the design environment.

Device configuration

The devices in this class of FPGA usually hold their configuration data in a shadow ram. Every interconnection site and every logic configuration bit is defined by one bit of this ram. Because static ram is a volatile storage medium, on power-up, an LCA will not be configured at all. The configuration data must be stored in some non-volatile device, such as an eprom, or it may be booted from disk in the same way as a computer operating system.

Some devices can use standard components, such as 27Cxxx eproms, while others are tailored to a specific memory. A typical configuration set-up is shown in Fig. 4.

There are two issues raised by the use of external memory components to configure LCAs. Firstly there is the problem of security; one of the attractions of programmable logic devices is the ability of most of them to read-protect the data after programming, making it difficult to copy the function programmed into the PLD. If the programming data has to be read in each time the system is powered up, this principle is defeated at the outset. Even if the data in the external store is protected somehow, a logic analyser will soon decipher the bit stream used to program the LCA.

A less contentious issue is the use of two devices to perform a logic function which, in other families, is contained within a single device. This may be overcome by combining the data for LCA configuration with some other data, such as the operating program for a microprocessor. But it still leads to complications in the hardware design for the overall system. If several LCAs are used in one system they can share a single eprom, in most cases, which reduces the hardware overhead to a fraction of a device.

The upside of this arrangement is that reconfiguration of a system can be managed by software even, in many cases, while the system is actually operating. This may be a simple change, such as redefining a memory map to re-allocate resources, or a partial or complete change of logic function. In Atmel devices, part of the device can be reconfigured while the rest is still functioning; the name *Cache Logic* has been coined to describe this function, by association with

cache memory, which buffers and speeds up data exchanges in computer systems.

Antifuse FPGA technology

The architecture of antifuse FPGAs is practically identical to LCAs. Uncommitted i/o cells surrounding logic cells and routing channels. Any differences are due mainly to the two different technologies involved. The main difference is in the resistance of the transmission elements. LCAs use a mos transistor, which has a relatively high on-resistance compared with an antifuse, once it has been blown.

Whenever a signal passes through a fuse element, it must charge up the capacitance of the component to which it is connected. The capacitance of tracks and gate inputs will not differ significantly between the two technologies. As a result, the series resistance of the fuse makes a significant difference to device performance. Antifuse devices can, therefore, use an architecture which has longer connecting tracks than LCAs.

In practice they are often supplied with tracks of differing lengths within a single routing channel. The actual track length required for any specific connection can be optimised by choosing an appropriate path in the routing channel. By minimising interconnect capacitance and series resistance, in this way, the interconnect delays are minimised and there is no need for repeaters or drivers within the connection structure.

Another trade-off is the size of the logic cell and the amount of interconnection. In a practical device it must be possible to connect the logic cells together even when approaching 100% utilisation. One way to improve connectivity is to make the logic modules quite complex; by incorporating more logic in each module, fewer connections between modules are needed. This is the trend in LCAs.

If track delays are less significant, the logic modules may be made simpler, and complex functions built by using short lengths of track to connect them. Module usage is likely to be improved in this way, with less wasted logic functions and silicon area. Antifuse FPGAs are, therefore, able to use a smaller grained structure than LCAs and, usually, offer a less wasteful solution to most logic circuits.

Although this approach may need more interconnects, the antifuse technology helps to reduce the cost impact of the on-chip area. Antifuses occupy about a square micrometre and fit inside the aluminium tracks, thereby taking up no extra space in the array. Ram-based FPGAs need a ram cell and mos transistor at each crossing point, and these add to the area occupied by the interconnect.

Granularity is an important feature of ASICs as it determines the efficiency with which logic functions can be implemented. Mask-programmed ASICs, for example, are usually fine grained as they have low resistance vias to connect logic blocks to the tracks. A logic cell is just a small gate and more complex functions are easily built without incurring much speed penalty from the interconnect.

Antifuse FPGAs have a more complex basic cell; a flip-flop with some universal gating is quite common. A typical LCA logic block has two flip-flops driven by some fairly complex combinatorial logic.

By way of example, a 4000-gate LCA, namely the Xilinx XC4004A, has 144 logic blocks while a 4000-gate antifuse FPGA like the Actel A1240A, has 684 modules. In order to achieve 4000 routable gates, a sea-of-gates gate array may need 7000 gates in its basic array, where one gate in the array corresponds to a single cell but also has to act as part of the routing resource.

Performance of antifuse FPGAs

Most of the remarks about LCA devices also apply to

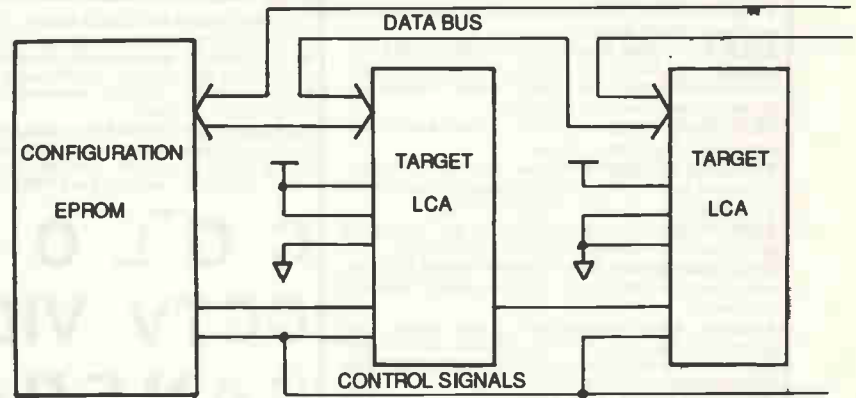

Fig. 4. Typical LCA configuration circuit. Some arrays take standard eeproms while others are tailored to a specific type.

antifuse FPGAs. The logic cells are true c-mos and consume 'zero power' at zero frequency. Logic circuits are not very useful at zero frequency and as soon as signals begin to switch, power is dissipated by the charging currents for the parasitic capacitances. In practice, this current is negligible below 1 MHz but becomes significant above this frequency.

Within an FPGA there are two sources of power dissipation, the active circuit elements and the interconnects. For a given feature size, capacitance of circuit elements will be practically the same, irrespective of architecture. Any difference in consumption will be due largely to the interconnect capacitance.

Antifuse FPGAs tend to use more tracks than LCAs, as the LCA logic cells can perform more complex functions. On the other hand, LCAs may use longer tracks and higher capacitance connections between tracks, so the comparison may well depend on the actual logic being implemented.

The same arguments also apply to dynamic performance, with the added factor of the resistance of the two types of programmable connection. Logic requiring the connection of large numbers of gates will usually perform better in antifuse FPGAs, because of the superior performance of the antifuse.

Where logic function can be concentrated into the more complex LCA cells, antifuse devices will probably use more interconnects and show a poorer dynamic performance. If we extend the argument to include CPLD structures, the trend is more pronounced. They will perform well in highly structured circuits, where the macrocells can implement a whole logic function, but deteriorate badly as soon as repetitive feedback has to be introduced in more fragmented circuits.

Using antifuse FPGAs

The main drawback with antifuse FPGAs centres on the programming situation. Even a small circuit can take three minutes to programme while the larger devices may take ten minutes. This compares with a few seconds for most CPLDs structures and no time at all for LCAs, which are programmed in-circuit each time they are powered up. A single programming station, with four sockets, is limited to between 200 and 600 circuits a day and, therefore, adds a significant overhead to the basic cost of the device.

The upside to this limitation on production throughput and increased cost is a double benefit. A circuit using an FPGA will start working the instant it is switched on, and requires no overhead in program storage or extra design work in arranging for the device configuration function.

The other advantage is security. It is difficult to read back some FPGAs, but they also contain security fuses to prevent this from being done. Complex PLDs also contain security cells to prevent direct reading, although sophisticated analysis may defeat device security. LCAs are much more difficult to keep secret. ■

MOONSHINE BIBLE 270 page book covering the production of alcohol from potatoes, rice, grains etc. Drawings of simple home made stills right through to commercial systems. £12 ref MS3
NEW HIGH POWER MINI BUG With a range of 800 metres or more and up to 100 hours use from a PP3 this will be popular! Bug measures less than 1" square! £28 Ref LOT102.

SINCLAIR C6 MOTORS We have a new one available without gearboxes at £50 ref LOT25

BUILD YOU OWN WINDFARM FROM SCRAP New publication gives step by step guide to building wind generators. Armed with this publication and a good local scrap yard could make you self sufficient in electricity! £12 ref LOT81

PC KEYBOARDS PS2 connector, top quality suitable for all 286/386/486 etc £10 ref PCKB. 10 for £55.

TRACKING TRANSMITTER range 1.5-5 miles, 5,000 hours on AA batteries, also transmits info on car direction and motion! Works with any FM radio. 1.5" square! £65 ref LOT101

ELECTRIC DOOR LOCKS Complete lock with both Yale lock and 12v operated deadlock (keys included) £10 ref LOT99

GALLIUM ARSENIDE FISHEYE PHOTO DIODES Complete with suggested circuits for long range communications/switching £12 complete.

SURVEILLANCE TELESCOPE Superb Russian zoom telescope adjustable from 15x to 60x! complete with metal tripod (impossible to use without this on the higher settings) 66mm lens, leather carrying case £149 ref BAR69

WIRELESS VIDEO BUG KIT Transmits video and audio signals from a miniature CCTV camera (included) to any standard television! All the components including a PP3 battery will fit into a cigarette packet with the lens requiring a hole about 3mm diameter. Supplied with telescopic aerial but a piece of wire about 4" long will still give a range of up to 100 metres. A single PP3 will probably give less than 1 hours use. £99 REF EP79. (probably not licensable)

CCTV CAMERA MODULES 46X70X29mm, 30 grams, 12v 100mA, auto electronic shutter, 3.6mm F2 lens, CCI/IR 512x492 pixels, video output is 1v p-p (75 ohm). Works directly into a scart or video input on a tv or video. IR sensitive. £79.95 ref EF137.

IR LAMP KIT Suitable for the above camera, enables the camera to be used in total darkness! £5.99 ref EF138

INFRA RED POWERBEAM Handheld battery powered lamp, 4 inch reflector, krypton bulb, gives out powerful infrared light! 4 D cells required. £39 ref PB1.

MONO VGA MONITORS, Perfect condition, Compaq, 14", 3 months warranty £29 ref MVGA

SOLAR COOKER GUIDE Comprehensive plans

9 WATT CHIEFTAN TANK LASERS

Double beam units designed to fit in the gun barrel of a tank, each unit has two semi conductor lasers and motor drive units for alignment. 7 mile range, full circuit diagrams, new price £50,000? us? £349. Each unit has two gallium Arsenide injection lasers, 1 x 9 watt, 1 x 3 watt, 900nm wavelength, 28vdc, 600Hz pulse frequency. The units also contain an electronic receiver to detect reflected signals from targets, five or more units £299 ea. £349 for one. Ref LOT4.

TWOWAY MIRROR KIT Includes special adhesive film to make two way mirror(s) up to 60"x20". (glass not included) gives full instructions. £12 ref TW1.

NEW LOW PRICED COMPUTER WORKSHOP/HI-FIRCB UNITS Complete protection from faulty equipment for everybody! Inline units fit in standard IEC lead (extends it by 750mm), fitted in less than 10 seconds, reset/test button, 10A rating. £6.99 each ref LOT5. Or a pack of 10 at £49.90 ref LOT6. If you want a box of 100 you can have one for £250!

RADIO CONTROLLED CARS FROM £6 EACH!!! All returns from famous manufacturer, 3 types available, single channel (left, right, forwards, backwards) £6 ref LOT1. Two channel with more features £12 ref LOT2.

THOUSANDS AVAILABLE RING/FAX FOR DETAILS!

MAGNETIC CARD READERS (Swipes) £9.95 Cased with flyleads, designed to read standard credit cards! they have 3 wires coming out of the head so they may write as well? complete with control electronics PCB, just £9.95 ref BAR31

WANT TO MAKE SOME MONEY? STUCK FOR AN IDEA? We have collated 140 business manuals that give you information on setting up different businesses, you peruse these at your leisure using the text editor on your PC. Also included is the certificate enabling you to reproduce (and sell) the manuals as much as you like! £14 ref EP74

PANORAMIC CAMERA OFFER Takes double width photographs using standard 35mm film. Use in horizontal or vertical mode. Complete with strap £7.99 ref BAR1

COIN OPERATED TIMER KIT Complete with coin slot mechanism, adjustable time delay, relay output, put a coin on anything you like! TV's, videos, fridges, drinks cupboards, HiFi, takes 50p's and £1 coins. DC operated, price just £7.99 ref BAR27.

ZENITH 900 X MAGNIFICATION MICROSCOPE Zoom, metal construction, built in light, shmp farm, group viewing screen, lots of accessories. £29 ref ANAYLT.

AA NICAD PACK Pack of 4 tagged AA nicads £2.99 ref BAR34

PLASMA SCREENS 22x310mm, no data hence £4.99 ref BAR67

NIGHTSIGHTS Model TZS4 with infra red illuminator, views up to 75 metres in full darkness in infrared mode, 150m range, 45mm lens, 13 deg angle of view, focussing range 1.5m to infinity. 2 AA batteries required. 950g weight. £199 ref BAR61. 1 years warranty

LIQUID CRYSTAL DISPLAYS Bargain prices,
 16 character 2 line, 99x24mm £2.99 ref SM1623A
 20 character 2 line, 83x19mm £3.99 ref SM2020A
 16 character 4 line, 62x25mm £5.99 ref SMC1640A

TAL-1 110MM NEWTONIAN REFLECTOR TELESCOPE Russian, Superb astronomical 'scope, everything you need for some serious star gazing! up to 169x magnification. Send or fax for further information ref TAL-1, £249

SOLAR ENERGY/GENERATOR PLANS For your home, loads of info on designing systems etc £7 ref PV1

SOLAR COOKERS Comprehensive guide to building solar powered cookers. Includes plans, recipes, cooking times etc £7 ref SBC1

WOLVERHAMPTON BRANCH NOW OPEN AT WORCESTER ST W'HAMPTON TEL 01902 22039

CENTRAL POINT PC TOOLS Award winning software, 1,300 virus checker, memory optimiser, disc optimiser, file compression, low level formatting, backup scheduler, disk defragmenter, undelete, 4 calculators, DBase, disc editor, over 40 viewers, remote computing, password protection, encryption, comprehensive manual supplied etc £8 ref LOT 97 3.5" disks.

GOT AN EXPENSIVE BIKE? You need one of our bottle alarms, they look like a standard water bottle, but open the top, insert a key to activate a motion sensor alarm built inside. Fits all standard bottle carriers, supplied with two keys. SALE PRICE £7.99 REF SA32.

COLOUR CCTV VIDEO CAMERAS, BRAND NEW, CASED, £119.

PERFECT FOR
 SURVEILLANCE
 INTERNET
 VIDEO CONFERENCING
 SECURITY
 DOMESTIC VIDEO

Works with most modern video's, TV's, Composite monitors, video grabber cards etc Pal, 1v P-P, composite, 75ohm, 1/3" CCD, 4mm F2.8, 600x582, 12vdc, mounting bracket, auto shutter, 100x60x180mm, 3 months warranty, 10 or more £99 ea.



Check out our
WEB SITE

<http://www.pavillon.co.uk/bull-electrical>

GOT AN EXPENSIVE ANYTHING? You need one of our cased vibration alarms, keyswitch operated, fully cased just fit it to anything from videos to caravans, provides a years protection from 1 PP3 battery, UK made. SALE PRICE £4.99 REF SA33.

DAMAGED ANSWER PHONES These are probably beyond repair so just £4.99 each. BT response 200 machines. REF SA30.

IBM PS2 MODEL 160Z CASE AND POWER SUPPLY Complete with fan etc and 200 watt power supply. £8.95 ref EP67

DELL PC POWER SUPPLIES 145 watt, +5, -5, +12, -12, 150x150x85mm complete with switch, flyleads and IEC socket. SALE PRICE £8.99 ref EP55

1.44 DISC DRIVES Standard PC 3.5" drives but returns so they will need attention SALE PRICE £4.99 ref EP68

1.2 DISC DRIVES Standard 5.25" drives but returns so they will need attention SALE PRICE NOW ONLY £3.50 ref EP69

PP3 NICADS Unused but some storage marks. £4.99 ref EP52

DELL PC POWER SUPPLIES (Customer returns) Standard PC psu's complete with fly leads, case and fan. +12v, -12v, +5v, -5v SALE PRICE £1.99 EACH worth it for the bits alone! ref DL1. TRADE PACK OF 20 £29.95 ref DL2.

GAS HOBS AND OVENS Brand new gas appliances, perfect for small flats etc. Basic 3 burner hob SALE PRICE £24.99 ref EP72. Basic small built in oven SALE PRICE £79 ref EP73

ENERGY BANK KIT 100 6x6" 6v 100mA panels. 100 diodes, connection details etc. £69.95 ref EF112.

PASTEL ACCOUNTS SOFTWARE, does everything for all sizes of businesses, includes wordprocessor, report writer, windowing, networkable up to 10 stations, multiple cash books etc. 200 page comprehensive manual. 90 days free technical support (01342-

*SOME OF OUR PRODUCTS MAY BE UNLICENSABLE IN THE UK

BULL ELECTRICAL

250 PORTLAND ROAD, HOVE, SUSSEX.

BN3 5QT. (ESTABLISHED 50 YEARS).

MAIL ORDER TERMS: CASH, PO OR CHEQUE

WITH ORDER PLUS £3 P&P PLUS VAT.

PLEASE ALLOW 7-10 DAYS FOR DELIVERY PHONE ORDERS WELCOME (ACCESS, VISA, SWITCH, AMERICAN EXPRESS)

TEL: 01273 203500
 FAX 01273 323077
 E-mail bull@pavillon.co.uk

326009 try before you buy! Current retail price is £129, SALE PRICE £9.95 ref SA12. SAVE £120!!!

RACAL MODEM BONANZA! 1 Racal MPS1223 1200/75 modem, telephone lead, mains lead, manual and comms software. the cheapest way onto the net! all this for just £13 ref DEC13.

BULL TENS UNIT Fully built and tested TENS (Transcutaneous Electrical Nerve Stimulation) unit, complete with electrodes and full instructions. TENS is used for the relief of pain etc in up to 70% of sufferers. Drug free pain relief, safe and easy to use, can be used in conjunction with analgesics etc. £49 REF TEN1

PC PAL VGA TO TV CONVERTER Converts a colour TV into a basic VGA screen. Complete with built in psu, lead and s/ware. Ideal for laptops or a cheap upgrade. Supplied in kit form for home assembly. SALE PRICE £25 REF SA34

EMERGENCY LIGHTING UNIT Complete unit with 2 double bulb floodlights, built in charger and auto switch. Fully cased, 6v BAH lead acid req'd. (secondhand) £4 ref MAG4P11.

YUASHA SEALED LEAD ACID BATTERIES Two sizes currently available this month. 12v 15AH at £18 ref LOT8 and 6v 10AH (suitable for emergency lights above) at just £6 ref LOT7.

ELECTRIC CAR WINDOW DE-ICERS Complete with cable, plug etc. SALE PRICE JUST £4.99 REF SA28

AUTO SUNCHARGER 155x300mm solar panel with diode and 3 metre lead fitted with a cigar plug. 12v 2watt. £8.99 REF SA25.

MICRODRIVE STRIPPERS Small cased tape drives ideal for stripping, lots of useful goodies including a smart case, and lots of components. SALE PRICE JUST £4.99 FOR FIVE REF SA26

SOLAR POWER LAB SPECIAL You get TWO 6"x6" 6v 130mA solar cells, 4 LEDs, wire, buzzer, switch plus 1 relay or motor. Superb value kit SALE PRICE JUST £4.99 REF SA27

RGB/CGA/EGA/TL COLOUR MONITORS 12" in good condition. Back anodised metal case. SALE PRICE £49 REF SA16B

PLUG IN ACORN PSU 19v AC 14w, £2.99 REF MAG3P10

13.8V 1.9A PSU cased with leads. Just £9.99 REF MAG10P3

UNIVERSAL SPEED CONTROLLER KIT Designed by us for the C5 motor but ok for any 12v motor up to 30A. Complete with PCB etc. A heat sink may be required. £17.00 REF: MAG17

PHONE CABLE AND COMPUTER COMMUNICATIONS PACK Kit contains 100m of 6 core cable, 100 cable clips, 2 line drivers with RS232 interfaces and all connectors etc. Ideal low cost method of communicating between PCs over a long distance utilizing the serial ports. Complete kit £8.99. Ref comp1.

VIEWDATA SYSTEMS made by Phillips, complete with internal 1200/75 modem, keyboard, psu etc RGB and composite outputs, menu driven, auto dialler etc. SALE PRICE £12.99 REF SA18

AIR RIFLES 22As used by the Chinese army for training purposes, so there is a lot about! £39.95 Ref EF78. 500 pellets £4.50 ref EF80.

VIDEO SENDER UNIT. Transmits both audio and video signals from either a video camera, videorecorder, TV or Computer etc to any standard TV set in a 100' range! (tune TV to a spare channel) 12v DC op. Price is £25 REF: MAG15 12v psu is £5 extra REF: MAG5P2

***MINIATURE RADIO TRANSCENVERS** A pair of walkie talkies with a range up to 2km in open country. Units measure 22x52x155mm. Including cases and earpieces. 2xPP3 req'd. £30.00 REF: MAG30

***FM TRANSMITTER KIT** housed in a standard working 13A adapter!! the bug runs directly off the mains so lasts forever why pay £700? or price is £15 REF: EF62 (kit) Transmits to any FM radio.

***FM BUG BUILT AND TESTED** superior design to kit. Supplied to detective agencies. 9v battery req'd. £14 REF: MAG14

GAT AIR PISTOL PACK Complete with pistol, darts and pellets £12.95 Ref EF82B extra pellets (500) £4.50 ref EF80.

6"x12" AMORPHOUS SOLAR PANEL 12v 155x310mm 130mA. SALE PRICE £4.99 REF SA24.

FIBRE OPTIC CABLE BUMPER PACK 10 metres for £4.99 ref MAG5P13 ideal for experimenters! 30 m for £12.99 ref MAG13P1

**MIXED GOODIES BOX OF
 MIXED COMPONENTS WEIGHING 2 KILOS
 YOURS FOR JUST £6.99**

4X28 TELESCOPIC SIGHTS Suitable for all air rifles, ground lenses, good light gathering properties. £19.95 ref R7.

GYROSCOPES Remember these? well we have found a company that still manufactures these popular scientific toys, perfect gift for your educational use. £6 ref EP70

HYPOTHERMIA SPACE BLANKET 215x150cm aluminised foil blanket, reflects more than 90% of body heat. Also suitable for the construction of two way mirrors! £3.99 each ref O/L041.

LENSTATIC RANGER COMPASS Oil filled capsule, strong metal case, large luminous points. Sight line with magnifying viewer. 50mm dia, 866gm. £10.99 ref O/K604.

RECHARGE ORDINARY BATTERIES UP TO 10 TIMES! With the Battery Wizard! Uses the latest pulse wave charge system to charge all popular brands of ordinary batteries AAA, AA, C, D, four at a time! Led systems show when batteries are charged, automatically rejects unsuitable cells, complete with mains adaptor. BS approved. Price is £21.95 ref EP31.

TALKING WATCH Yes, it actually tells you the time at the press of a button. Also features a voice alarm that wakes you up and tells you what the time is! Lithium cell included. £7.99 ref EP26.

PHOTOGRAPHIC RADAR TRAPS CAN COST YOU YOUR LICENCE! The new multiband 2000 radar detector can prevent even the most responsible of drivers from losing their licence! Adjustable audible alarm with 8 flashing leds gives instant warning of radar zones. Detects X, K, and Ka bands, 3 mile range, 'over the hill' 'around bends' and 'rear trap' facilities, micro size just 4.25x2.5x.75". Can pay for itself in just one day! £79.95 ref EP3.

3" DISCS As used on older Amstrad machines, Spectrum plus 3's etc £3 each ref BAR400.

STEREO MICROSCOPES BACK IN STOCK Russian, 200x complete with lenses, lights, filters etc very comprehensive microscope that would normally be around the £700 mark. our price is just £299 (full money back guarantee) full details in catalogue.

WE BUY SURPLUS STOCK

FOR CASH

BUYERS DIRECT LINE 0802 660377

DC TO DC CONVERTERS

DRM58 input 10-40vdc output 5v 8A £15
DRM128 input 17-40vdc output 12v 8A £50
DRM158 input 20-40vdc output 15v 8A £50
DRM248 input 29-40vdc output 24v 8A £40
DRS123 input 17-40vdc output 12v 3A £20
DRS153 input 20-40vdc output 15v 3A £20
DRS243 input 29-40vdc output 24v 3A £15

SOLID STATE RELAYS

CMP-DC-200P 3-32vdc operation, 0-200vdc 1A £2.50
SMT20000/3 3-24vdc operation, 28-280vac 3A £4.50
SMT20000/4 3-24vdc operation, 28-280vac 4A £5.00
ZRA6025F 28-280vac operation, 28-280vac 25A £7.00

200 WATT INVERTERS Nicely cased units 12v input 240v output 150watt continuous, 200 max. £49 ref LOT62

6.8MW HELIUM NEON LASERS New units, £65 ref LOT33
COIN SLOT TOKENS You may have a use for these? mixed bag of 100 tokens £10 ref LOT20.

PORTABLE X RAY MACHINE PLANS Easy to construct plans on a simple and cheap way to build a home X-ray machine! Effective device, X-ray sealed assemblies, can be used for experimental purposes. Not a toy or for minors! £6/5et. Ref F/XP1.

TELEKINETIC ENHANCER PLANS Mystify and amaze your friends by creating motion with no known apparent means or cause. Uses no electrical or mechanical connections, no special gimmicks yet produces positive motion and effect. Excellent for science projects, magic shows, party demonstrations or serious research & development of this strange and amazing psychic phenomenon. £4/5et Ref F/TK1.

ELECTRONIC HYPNOSIS PLANS & DATA This data shows several ways to put subjects under your control. Included is a full volume reference text and several construction plans that when assembled can produce highly effective stimuli. This material must be used cautiously. It is for use as entertainment at parties etc only, by those experienced in its use. £15/5et. Ref F/EH2.

GRAVITY GENERATOR PLANS This unique plan demonstrates a simple electrical phenomena that produces an anti-gravity effect. You can actually build a small mock spaceship out of simple materials and without any visible means- cause it to levitate. £10/5et Ref F/GRA1.

WORLDS SMALLEST TESLA COIL/LIGHTENING DISPLAY GLOBE PLANS Produces up to 750,000 volts of discharge, experiment with extraordinary HV effects, 'Plasma in a jar', St Elmo's fire, Corona, excellent science project or conversation piece. £5/5et Ref F/BTC1/LG5.

COPPER VAPOUR LASER PLANS Produces 100mw of visible green light. High coherency and spectral quality similar to Argon laser but easier and less costly to build yet far more efficient. This particular design was developed at the Atomic Energy Commission of NEGEV in Israel. £10/5et Ref F/CVL1.

VOICE SCRAMBLER PLANS Miniature solid state system turns speech sound into indecipherable noise that cannot be understood without a second matching unit. Use on telephone to prevent third party listening and bugging. £6/5et Ref F/V59.

PULSED TV JOKER PLANS Little hand held device utilises pulse techniques that will completely disrupt TV picture and sound works on FM too! DISCRETION ADVISED. £8/5et Ref F/TJ5.

BODYHEAT TELESCOPE PLANS Highly directional long range device uses recent technology to detect the presence of living bodies, warm and hot spots, heat leaks etc. Intended for security, law enforcement, research and development etc. Excellent security device or very interesting science project. £8/5et Ref F/BHT1.

BURNING, CUTTING CO2 LASER PLANS Projects an invisible beam of heat capable of burning and melting materials over a considerable distance. This laser is one of the most efficient, converting 10% input power into useful output. Not only is this device a workhorse in welding, cutting and heat processing materials but it is also a likely candidate as an effective directed energy beam weapon against missiles, aircraft, ground-to-ground, etc. Particle beams may very well utilize a laser of this type to blast a channel in the atmosphere for a high energy stream of neutrons or other particles. The device is easily applicable to burning and etching wood, cutting, plastics, textiles etc £12/5et Ref F/LC7.

MYSTERY ANTI GRAVITY DEVICE PLANS Uses simple concept. Objects float in air and move to the touch. Defies gravity, amazing gift, conversation piece, magic trick or science project. £6/5et Ref F/ANT1K.

ULTRASONIC BLASTER PLANS Laboratory source of sonic shock waves. Blow holes in metal, produce 'cold' steam, atomize liquids. Many cleaning uses for PC boards, jewellery, coins, small parts etc. £6/5et Ref F/ULB1.

ULTRA HIGH GAIN AMP/STETHOSCOPIC MIKE/SOUND AND VIBRATION DETECTOR PLANS Ultrasensitive device enables one to hear a whole new world of sounds. Listen through walls, windows, floors etc. Many applications shown, from law enforcement, nature listening, medical heartbeat, to mechanical devices. £6/5et Ref F/HGA7.

ANTI DOG FORCE FIELD PLANS Highly effective circuit produces time variable pulses of acoustical energy that dogs cannot tolerate £6/5et Ref F/DOG2.

LASER BOUNCE LISTENER SYSTEM PLANS Allows you to hear sounds from a premises without gaining access. £12/5et Ref F/LLIST1.

LASER LIGHT SHOW PLANS Do it yourself plans show three methods. £6 Ref F/LLS1.

PHASOR BLAST WAVE PISTOL SERIES PLANS Handheld, has large transducer and battery capacity with external controls. £6/5et Ref F/PSP4.

INFINITY TRANSMITTER PLANS Telephone line grabber/room monitor. The ultimate in home/office security and safety! simple to use! Call your home or office phone, push a secret tone on your telephone to access either: A) On premises sound and voices or B) Existing conversation with break-in capability for emergency messages. £7 Ref F/TELEGRAB.

BUG DETECTOR PLANS Is that someone getting the goods on you? Easy to construct device locates any hidden source of radio energy! Sniffs out and finds bugs and other sources of bothersome

WOLVERHAMPTON BRANCH NOW OPEN AT WORCESTER ST W'HAMPTON TEL 01902 22039

interference. Detects low, high and UHF frequencies £5/5et Ref F/BD1.

ELECTROMAGNETIC GUN PLANS Projects a metal object a considerable distance-requires adult supervision £5 ref F/EMJ2.

ELECTRIC MAN PLANS, SHOCK PEOPLE WITH THE TOUCH OF YOUR HAND! £5/5et Ref F/EMA1.

PARABOLIC DISH MICROPHONE PLANS Listen to distant sounds and voices, open windows, sound sources in 'hard to get' or hostile premises. Uses satellite technology to gather distant sounds and focus them to your ultra sensitive electronics. Plans also show an optional wireless link system. £8/5et Ref F/PM5.

2 FOR 1 MULTIFUNCTIONAL HIGH FREQUENCY AND HIGH DC VOLTAGE, SOLID STATE TESLA COIL AND VARIABLE 100,000VDC OUTPUT GENERATOR PLANS Operates on 9-12vdc, many possible experiments. £10 Ref F/HVM7/TCL4.

INFINITY TRANSMITTERS The ultimate 'bug' fits to any phone or line, undetectable. Listen to the conversations in the room from anywhere in the world! 24 hours a day 7 days a week! Just call the number and press a button on the mini controller (supplied) and you can hear everything! Monitor conversations for as long as you choose £249 each, complete with leads and mini controller Ref LOT9. Undetectable with normal RF detectors, fitted in seconds, no batteries required, lasts forever!

SWITCHED MODE PSU'S 244 watt, +5 32A, +12 6A, -5 0.2A, -12 0.2A There is also an optional 3.3v 25A rail available. 120/240v I/P. Cased, 175x90x145mm. IEC Inlet Suitable for PC use (6 d/drive connectors 1 m/board). £10 ref PSU1.

VIDEO PROCESSOR UNITS/6v 10AH BATT/12V 8A

TX Not too sure what the function of these units is but they certainly make good stippers! Measures 390X320X120mm, on the front are controls for scan speed, scan delay, scan mode, loads of connections on the rear. Inside 2x 6v 10AH sealed lead acid batts, pcb's and a 8A? 12v toroidal transformer (mains in). Condition not known, may have one or two broken knobs due to poor storage. £17.50 ref VP2.

RETRONIGHT SIGHT Recognition of a standing man at 300m in 1/4 moonlight, hermetically sealed, runs on 2 AA batteries, 80mm F1.5 lens, 20mw infrared laser included. £325 ref RETRON.

MINI FM TRANSMITTER KIT Very high gain preamp, supplied complete with FET electret microphone. Designed to cover 88-108 Mhz but easily changed to cover 63-130 Mhz. Works with a common 9v (PP3) battery, 0.2W RF. £7 Ref 1001.

3-30V POWER SUPPLY KIT Variable, stabilized power supply for lab use. Short circuit protected, suitable for professional or amateur use 24v 3A transformer is needed to complete the kit. £14 Ref 1007.

1 WATT FM TRANSMITTER KIT Supplied with piezo electric mic. 8-30vdc. At 25-30v you will get nearly 2 watts! £12 ref 1009.

FM/AM SCANNER KIT Well not quite, you have to turn the knob your self but you will hear things on this radio that you would not hear on an ordinary radio (even TV). Covers 50-160mhz on both AM and FM. Built in 5 watt amplifier, inc speaker. £15 ref 1013.

3 CHANNEL SOUND TO LIGHT KIT Wireless system, mains operated, separate sensitivity adjustment for each channel, 1.200 w power handling, microphone included. £14 Ref 1014.

4 WATT FM TRANSMITTER KIT Small but powerful FM transmitter, 3 RF stages, microphone and audio preamp included. £20 Ref 1028.

STROBE LIGHT KIT Adjustable from 1-60 hz (a lot faster than conventional strobes). Mains operated. £16 Ref 1037.

COMBINATION LOCK KIT 9key, programmable, complete with keypad, will switch 2A mains 9v dc operation. £10 ref 1114.

PHONE BUG DETECTOR KIT This device will warn you if somebody is eavesdropping on your line. £6 ref 1130.

ROBOT VOICE KIT Interesting circuit that distorts your voice adjustable, answer the phone with a different voice! 12vdc £9 ref 1131

TELEPHONE BUG KIT Small bug powered by the phone line, starts transmitting as soon as the phone is picked up! £8 Ref 1135.

3 CHANNEL LIGHT CHASER KIT 800 watts per channel, speed and direction controls supplied with 12 LEDs (you can fit traces instead to make kit mains, not supplied) 9-12vdc £17 ref 1026.

12V FLOURESCENT LAMP DRIVER KIT Light up 4 foot tubes from your car battery! 9v 2a transformer also required. £8 ref 1069.

VOX SWITCH KIT Sound activated switch ideal for making bugging tape recorders etc, adjustable sensitivity. £8 ref 1073.



Check out our
WEB SITE

<http://www.pavillon.co.uk/bull-electrical>

PREAMP MIXER KIT 3 input mono mixer, sep bass and treble controls plus individual level controls, 18vdc, input sens 100mA. £15 ref 1052.

*SOME OF OUR PRODUCTS MAY BE UNLICENSEABLE IN THE UK

BULL ELECTRICAL
250 PORTLAND ROAD, HOVE, SUSSEX.

BN3 5QT. (ESTABLISHED 50 YEARS).

MAIL ORDER TERMS: CASH, PO OR CHEQUE

WITH ORDER PLUS £3 P&P PLUS VAT.

PLEASE ALLOW 7-10 DAYS FOR DELIVERY PHONE ORDERS

WELCOME (ACCESS VISA, SWITCH, AMERICAN EXPRESS)

TEL: 01273 203500

FAX 01273 323077

E-mail bull@pavillon.co.uk

SOUNDEFFECTS GENERATOR KIT Produces sounds ranging from bird chips to sirens. Complete with speaker, add sound effects to your projects for just £9 ref 1045.

16 WATT FM TRANSMITTER (BUILT) 4 stage high power, preamp required 12-18vdc. can use ground plane, yagi or open dipole. £69 ref 1021.

HUMIDITY METER KIT Builds into a precision LCD humidity meter, 9ic design, pcb, lcd display and all components included. £29

PC TIMER KIT Four channel output controlled by your PC, will switch high current mains with relays (supplied). Software supplied so you can program the channels to do what you want whenever you want. Minimum system configuration is 286, VGA, 4.1.640k, serial port, hard drive with min 100k free. £24.99

FM CORDLESS MICROPHONE This unit is an FM broadcasting station in miniature, 3 transistor transmitter with electret condenser mic+fetamp design result in maximum sensitivity and broad frequency response. 90-105mhz, 50-1500hz, 500 foot range in open country! PP3 battery required. £15.00 ref 15P42A

MAGNETIC MARBLES They have been around for a number of years but still give rise to curiosity and amazement. A pack of 12 is just £3.99 ref GI/R20

NICKEL PLATING KIT Professional electroplating kit that will transform rusting parts into showpieces in 3 hours! Will plate onto steel, iron, bronze, gunmetal, copper, welded, silver soldered or brazed joints. Kit includes enough to plate 1,000 sq inches. You will also need a 12v supply, a container and 2 12v light bulbs. £39.99 ref NIK39.

Miniature adjustable timers, 4 pole c/o output 3A 240v, HY1230S, 12VDC adjustable from 0-30 secs. £4.99

HY1260M, 12VDC adjustable from 0-60 mins. £4.99

HY2405S, 240v adjustable from 0-5 secs. £4.99

HY24060m, 240v adjustable from 0-60 mins. £6.99

BUGGING TAPE RECORDER Small voice activated recorder, uses micro cassette complete with headphones. £28.99 ref MAR29P1.

POWER SUPPLY fully cased with mains and o/p leads 17v DC 900mA output. Bargain price £5.99 ref MAC6P9

9v DC POWER SUPPLY Standard plug in type 150ma 9v DC with lead and DC power plug, price for two is £2.99 ref AUG3P4.

COMPOSITE VIDEO KIT, Converts composite video into separate H sync, V sync, and video. 12V DC. £8.00 REF: MAG8P2.

FUTURE PC POWER SUPPLIES These are 295x135x60mm, 4 drive connectors 1 mother board connector. 150watt, 12v fan, iec inlet and on/off switch. £12 Ref EF6.

VENUS FLYTRAP KIT Grow your own carnivorous plant with this simple kit £3 ref EF34.

6"X12" AMORPHOUS SOLAR PANEL 12v 155x310mm 130mA. Bargain price just £5.99 ea REF MAG6P12.

FIBRE OPTIC CABLE BUMPER PACK 10 metres for £4.99 ref MAG5P13 ideal for experimenters! 30m for £12.99 ref MAG13P1

ROCK LIGHTS Unusual things these, two pieces of rock that glow when rubbed together! belived to cause rain! £3 a pair REF EF29.

3' by 1' AMORPHOUS SOLAR PANELS 14.5v, 700mA 10 watts, aluminium frame, screw terminals, £44.95 ref MAG45.

ELECTRONIC ACCUPUNCTURE KIT Builds into an electronic version instead of needles! good to experiment with. £7 ref 7P30

SHOCKING COIL KIT Build this little battery operated device into all sorts of things, also gets worms out of the ground! £7 ref 7P36.

FLYING PARROTS Easily assembled kit that builds a parrot that actually flaps its wings and flies! 50 m range £6 ref EF2.

HIGH POWER CATAPULTS Hinged arm brace for stability, tempered steel yoke, super strength latex power bands. Departure speed of ammunition is in excess of 200 miles per hour! Range of over 200 metres! £7.99 ref R/9.

BALLON MANUFACTURING KIT British made, small blob blow into a large, longlasting balloon, hours of fun! £3.99 ref GI/E99R

9-0-9V 4A TRANSFORMERS, chassis mount. £7 ref LOT19A.

2.6 KILOWATT INVERTERS, Packed with batteries etc but as they weigh about 100kg CALLERS ONLY! £120.

MEGA LED DISPLAYS Build your self a clock or something with these mega 7 seg displays 55mm high, 38mm wide. 5 on a pcb for just £4.99 ref LOT16 or a bumper pack of 50 displays for just £29 ref LOT17.

CLEARANCE SECTION, MINIMUM ORDER

£15, NO TECHNICAL DETAILS AVAILABLE, NO RETURNS, TRADE WELCOME.

2000 RESISTORS ON A REEL (SAME VALUE) 99P REF BAR340

AT LEAST 200 CAPACITORS (SAME VALUE) 99P REF BAR342

INFRA RED REMOTE CONTROLS JUST 99P REF BAR333

CIRCUIT BREAKERS, OUR CHOICE TO CLEAR 99P REF BAR335

MICROWAVE CONTROL PANELS TO CLEAR £2 REF BAR 329

2 TUBES OF CHIPS (2 TYPES OUR CHOICE) 90P REF BAR305

LOTTERY PREDICTOR MACHINE! JUST £1.50 REF BAR313

HELLA/ROVER ELECTRIC LAMP LEVELLER £2 REF BAR311

SINCLAIR C5 16" TYRES TO CLEAR AT JUST 75P REF BAR318

LARGE MAINS MOTORS (NEW) TO CLEAR AT 75P REF BAR310

MODEMS ETC FOR STRIPPING £2.50 EACH REF BAR324

110V LARGE MOTORS (NEW) TO CLEAR AT 50P REF BAR332

MODULATOR UNITS UNKNOWN SPEC JUST 50P REF BAR323

GX4000 GAMES COINLESS JUST £4 REF BAR320

SMART CASED MEMORY STORAGE DEVICE, LOADS OF BITS

INSIDE, PCB, MOTOR, CASE ETC. BUMPER PACK OF 5

COMPLETE UNITS TO CLEAR AT £2.50 (FOR 5) REF BAR 330.

2 CORE MAINS CABLE 2M LENGTHS PACK OF 4 £1 REF BAR337

PC USER/BASIC MANUALS, LOADS OF INFO. £1 REF BAR304

PCB STRIPPERS TO CLEAR AT 2 FOR 99P REF BAR341

3 M 3CORE MAINS CABLE AND 13A PLUG, 60P REF BAR325

WE BUY SURPLUS STOCK

FOR CASH

BUYERS DIRECT LINE 0802 660377

FREE CATALOGUE

100 PAGE CATALOGUE NOW AVAILABLE, 45P STAMPS.

CLASSIFIED

TEL 0181 652 3620

FAX 0181 652 8956

ARTICLES FOR SALE



SUPPLIER OF QUALITY USED TEST INSTRUMENTS



CONTACT

Cooke International

ELECTRONIC TEST & MEASURING INSTRUMENTS
Unit Four, Fordingbridge Site, Main Road, Barnham,
Bognor Regis, West Sussex, PO22 0HD, U.K.
Tel: (+44)01243 545111/2 Fax: (+44)01243 542457

CIRCLE NO. 137 ON REPLY CARD



OPERATING & SERVICE MANUALS

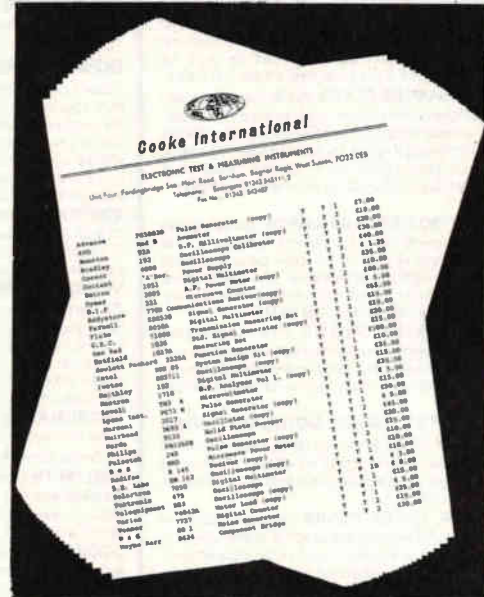

CONTACT

Cooke International

Unit Four, Fordingbridge Site, Main Road, Barnham,
Bognor Regis, West Sussex, PO22 0EB, U.K.
Tel: (+44)01243 545111/2 Fax: (+44)01243 542457
NOW AVAILABLE CATALOGUE ON DISC

CIRCLE NO. 138 ON REPLY CARD

ADVERTISERS' INDEX

Anchor Supplies	269	Niche Software	312
Antrim Transformers	304	Number One Systems	284
Ashling Microsystems	266	Olson Electronics	277
B K Electronics	290	Pico	283
Bull Electrical	342 & 349	Pyramid	290
CMS	283	Quickroute Systems	304
Conford Electronics	290	Ralfe Electronics	352
Dataman	OBC	Robinson Marshall	273
Display Electronics	314	Seetrex	331
Equinox Technologies	IBC	Stewart of Reading	312
Field Electric	327	Surrey	284
Halcyon Electronics	283	Technology Sources	311
Hart Electronic Kits	334	Telnet	304
Johns Radio	317	Those Engineers	292
JPG Electronics	284	Tie Pie	266
Labcentre	288	Ultimate Technology	295
M & B Radio	266 & 287	Warwick Industrial	312
MGS	271	Wood & Douglas	327
Milford Instruments	IFC		

ARTICLES WANTED

WE WANT TO BUY!!
IN VIEW OF THE EXTREMELY
RAPID CHANGE TAKING PLACE
IN THE ELECTRONICS
INDUSTRY, LARGE QUANTITIES
OF COMPONENTS BECOME
REDUNDANT. WE ARE CASH
PURCHASERS OF SUCH
MATERIALS AND WOULD
APPRECIATE A TELEPHONE
CALL OR A LIST IF AVAILABLE.
WE PAY TOP PRICES AND
COLLECT.

R. HENSON LTD.
21 Lodge Lane, N.Finchley,
London N12 8JG.
5 Mins, from Tally Ho Corner.
TELEPHONE
0181-445-2713/0749
FAX 0181-445-5702

Consider

Your costs to continue to stock
UNWANTED SURPLUS . . . EXCESS . . . OBSOLETE
STOCKS OF:-
ELECTRONIC-ELECTRICAL COMPONENTS &
ACCESSORIES

RELEASE
 for
PAYMENT IN ADVANCE
OF COLLECTION
 contact

K.B. Components,
21 Playle Chase, Gt. Totham, Maldon, Essex, CM9 8UT
 Tel:- 01621 893204 Fax:- 01621 893180 Mobile:- 0802 392745
 REGISTER TO RECEIVE MONTHLY PUBLISHED STOCK LISTS AT NO CHARGE OF
 ALL EXISTING NEW, UNUSED, STOCKS OF ALL COMPONENTS AND ACCESSORIES.

TOP PRICES PAID

For all your valves, tubes, semi
 conductors and IC's.
Langrex Supplies Limited
1 Mayo Road, Croydon
Surrey CR0 2QP
TEL: 0181-684 1166
FAX: 0181-684 3056

★★WANTED★★

Test equipment, Electronic Scrap,
 Valves, Transmitters/Receivers,
 Factory & Warehouse Clearance.
 Confidentiality Assured.

TELFORD ELECTRONICS
Phone: 01952 605451
Fax: 01952 677978

WANTED

TOP PRICES PAID

For all your Test Equipment,
 Receivers, Transmitters etc.
 Factory Clearance, Prompt
 Service and Payment.

HTB ELEKTRONIK

Alter Apeler Weg 5
 27619 Schiffdorf, Germany
Tel: 0049 4706 7044
Fax: 0049 4706 7049

40 YEARS WIRELESS WORLD '52-'75
 bound, '76-'92 unbound. Offers Telephone
 01276 65529.
 TEK 576 (577) Curve Tracers, Phone 01460
 73557.

Small selection of Aircraft
 Starter motors, DC
 generators and rotary
 converters. Possibly suit
 Electric vehicles etc.
 £10 to £50 depending on
 condition and type.

Tel: Bristol 0117 9793883

Wandel Goltermann

PRA.1, 2mbit Frame
Mux Analyzer superb
instrument.
£3,500 o.n.o.

Tel: 01566 781680

HEWLETT PACKARD

TEKTRONIX MARCONI TEST EQUIPMENT WANTED!

M&B RADIO
86 Bishopgate Street, Leeds LS1 4BB
Tel: (+44) 0113 2435649
Fax: (+44) 0113 2426881

SMALL SELECTION of Aircraft Starter
 motors, DC generators and rotary converters.
 Possibly suit electric vehicles etc. £10 to £50
 depending on condition and type. Tel: Bristol
 01179 793883.

MICROCHIP 'MICROMASTER' develop-
 ment system £1.150. Multicone 'Vaporette' sol-
 dering machine £500. Both unused. Icelab
 8051/2 Emulator £400. Tel: 01295 810859.

RF DESIGN SERVICES

All aspects of RF hardware
 development considered from
 concept to production.

WATERBEACH ELECTRONICS

TEL: 01223 862550
FAX: 01223 440853

Complete surface mount
 assembly kit. Handles up to
 Eurocard size boards. Little
 used. £950 + VAT.

A3 Pen Plotter, Graphtec
 MP4200 and Ringdale Printer
 Buffer. Excellent condition.
 £400.

Telephone: 01256 54786

VALVES, and CRTs AVAILABLE

ONE MILLION VALVES stocked for Audio, Receiving, Transmit-
 ting & RF Heating. Rare brands such as Mullard & GEC available.
 Also MAGNETRONS, KLYSTRONS, CRTs and SOCKETS.

Large stocks of Russian & Sovtek items.

Please ask for our free catalogues of valves or CRTs.

VALVES, etc. WANTED

Most types considered but especially KT88 (£48), PX4/PX25
 (£50), KT66 (£35), KT77 (£15), EL34 (£10), EL37 (£9), ECC83 (£3).
 Valves must be UK manufacture to achieve prices mentioned.
 Also various valve-era equipment e.g. Garrard 301, (up to) £80.
 Ask for a free copy of our wanted List.

BILLINGTON EXPORT LTD., Billingshurst, Sussex RH14 9EZ.
Tel: 01403 784961 Fax: 01403 783519

VISITORS STRICTLY BY APPOINTMENT.

MINIMUM ORDER £50 plus VAT

ARTICLES FOR SALE



Protect Your Microchips
from STATIC DISCHARGE !



Use an SSE grounding kit.

Kit includes:

- static dissipative solder resistant rubber mat.
- wrist strap
- ground lead
- earth plug

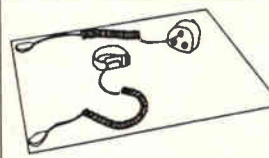

Mat size 70 x 30 cm - offer price £16.55 per kit + VAT - Ref: AGK1
 Mat size 25 x 20 cm - offer price £12.55 per kit + VAT - Ref: AGK2

STATIC SAFE ENVIRONMENTS
 127 Hagley Road, Birmingham B16 8XU
Tel: 0121 454 8238 Fax: 0121 625 2275

Payment by CHEQUE / ACCESS
 VISA / MASTERCARD
 Catalogue available

SPECTRUM ANALYSERS



ANRITSU MS420J 10Hz-30MHz network/spectrum analyser £5000
AVCOM - portable, battery operated, to 1000MHz £2000

TEKTRONIX 492 21GHz portable spectrum analyser, with options 1, 2 and 3 £6500 or £7500 with multiplexer and mixers to 40GHz
HP8711A 300kHz-1.3GHz network analyser £4000
HP8753A vector network analyser, 3GHz £7500
HP8702B lightwave component analyser (options 006/011) 6GHz £10000
HP8559A/182T 21GHz £4500
HP8557A/182T 350MHz £1500
HP8590A 1.8GHz portable, RS232 option £4250

MARCONI INSTRUMENTS



2018 synthesized AM/FM signal generator 80kHz-520MHz £1250
2019 synthesized AM/FM signal gen 80kHz-1040MHz 2305 modulation meter £2000
2828A/2829 digital simulator/analyser £2500
2955 radio communications test set £500
6460/6421 power meter & sensor 10MHz-12.4GHz £3250
65xx waveguide detector for use with 6501/2-scalar analysers £350
TF2910 TV interval timer £250

ralfe electronics exclusively professional T&M ©
• 36 Eastcote Lane • South Harrow • Middx HA2 8DB • England •
TEL (+44) 0181-422 3593 • FAX (+44) 0181-423 4009

EST
41
YRS



DISTRIBUZIONE E ASSISTENZA, ITALY: TLC RADIO, ROMA (06) 871 90254

TEST EQUIPMENT

ADRET 740A synthesized signal generator 0.1-1120MHz £2500
ANRITSU MS420J network/spectrum analyser 10Hz-30MHz £500
BRUEL & KJAER 2307 level recorder £1000
BRUEL & KJAER 2308 analogue X-Y pen recorder £750
CHASE LFR1000 interference measuring receiver 9kHz-150kHz £1000
DATRON 1061 & 1061A - various, digital multimeter & 1065 - call from £500
DATRON 1065 digital multimeter all ranges plus IEEE £500
FARNELL SSG2000 synthesized signal generator 10Hz-2000MHz £2500



ISO9002 ACCREDITED STOCKIST MEASUREMENT & TEST EQUIPMENT

PHILIPS PM5167 1mHz-10MHz function generator £275
RACAL-DANA 9300 milli-voltmeter £400
RACAL-DANA 9301A true RMS RF milli-voltmeter £350
SCHLUMBERGER 7081 precision voltmeter 8.5 digits £2750
TEKTRONIX P6201 FET PROBE £350
WANDEL & GOLTERMANN WM30 level tracer £500
WANDEL & GOLTERMANN PJM-4S jitter meter for SONET & SDH £5500
WAVETEK 23 synthesized function generator 0.01Hz-12MHz £1250
WAVETEK 1067 opt 522 1-500MHz sweep generator £500
WAYNE KERR 3220 20A bias unit (for 3245 inductance analyser) £1250
TEKTRONIX AM503/P6303 current probe £1500

HEWLETT PACKARD



1640B serial data generator £500
3764A digital transmission analyser £1500
3335A synthesizer/level generator £2000
3235A switch/test unit £1000
3324A synthesized function generator £2000
33320G/33322G programmable attenuators 4GHz, with driver 11713A £1000
As above but 18GHz set £1500
3581C selective voltmeter £1250
3779D primary multiplex analyser £5000
37900D signalling test set with 2 x 37915A interface cards £5500
4140B pA/meter, DC voltage source £4000
4272A multi-frequency lcr meter £3500
435B microwave power meter, analogue £400
5386A 3GHz frequency counter £1500
54100A 1GHz digitizing oscilloscope, now inc 2 x 1GHz active probes £2000
54502A digital oscilloscope 400MHz 400MSa/s £2500
8007B pulse generator 100MHz £950
8018A serial data generator £1000
8082A pulse generator 250MHz £2000
8111A pulse generator 20MHz £1250
8146A optical tdr, with options 2/3/plug-in 81465SH (single-mode) £8500
816A slotted line 1.8-18GHz with 809C & 447B probe £500
8444A tracking generator with option 059 £1000
8622A/8620C 10MHz-2.4GHz sweep generator £2000
87510A gain-phase analyser 100kHz-300MHz £6500
8753A 3GHz vector network analyser £7500
J2215A FDOI portable multimode test set £1500
J2219A 486-based, colour option main-frame £1000
J2219A/J2171A 486-based colour screen option network advisor £3000

SEND FOR LATEST STOCK LIST. WE FAX LISTS AND SHIP WORLDWIDE. ALL FULLY LAB-TESTED AND NO-QUIBBLE GUARANTEED

CIRCLE NO. 142 ON REPLY CARD

ELECTRONIC UPDATE

Contact Malcolm Wells on
0181-652 3620

A regular advertising feature enabling
readers to obtain more information
on companies' products or services.

A world of colour LCD

The widest range of colour LCDs, LCD monitors and plug and play kits available in the UK, all in one easy to use brochure, is now available FREE!



Comprehensive new LCD brochure

The widest range of colour LCDs, LCD monitors and plug and play kits available in the UK, all in one easy to use brochure, is now available FREE!

It includes products ranging from 2.9" monitors to 16.1" colour LCD screens, mono/colour STN TFTs and touch screen technology from the worlds leading manufacturers.

Phone Trident today for your free copy.

Tel.: 01737 765900
Fax: 01737 771908

CIRCLE NO. 143 ON REPLY CARD

New 1997 Instrumentation and Reference Catalogue

The new 1997 Reference and Catalogue from National Instruments features 50 new products for virtual instrumentation including new solutions for data acquisition and visualisation, MMI/SCADA and computer based image capture and analysis. Not merely a catalogue, it includes many useful tutorials and is invaluable for any engineer or scientist.

Call National Instruments for your FREE copy on:
01635 523545

CIRCLE NO. 144 ON REPLY CARD

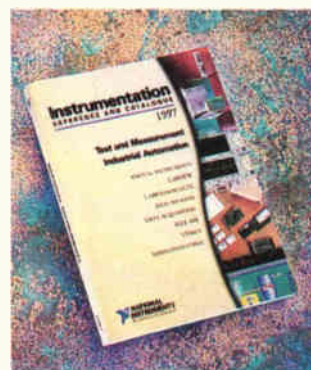

NEW Feedback T&M Catalogue

The latest edition of the Feedback Test & Measurement catalogue is now available. Over 60 pages packed with more than 800 products divided into over 20 sections. The catalogue is indexed for both product and manufacturer and is fully illustrated. Whether you are looking for an individual product, a complete workstation, or a solution to a particular Test & Measurement need the NEW Feedback catalogue will solve your problems, send for a copy NOW!

CIRCLE NO. 145 ON REPLY CARD

NEW JENSEN TOOLS CATALOGUE

Colourful new Catalogue, hot off the press from Jensen Tools, presents unique new tool kits for service/support of communications equipment. Also latest test equipment from many major manufacturers. Includes hard-to-find tools, PC/LAN diagnostics, bench accessories, static control, technical manuals and more.

Ring 0800 833246 or Fax 01604 785573 for a free copy.

Jensen Tools, 10-12 Ravens Way, Northampton NN3 9UD

CIRCLE NO. 146 ON REPLY CARD

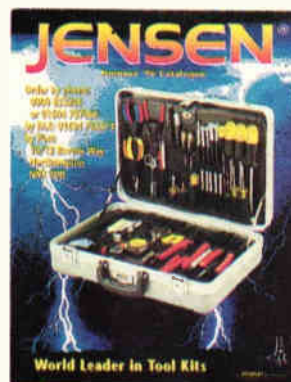

Feedback TEST & MEASUREMENT

over 800 products from the worlds leading manufacturers

For friendly service & fast delivery phone Feedback 148 on 01800 653222

8051 MICROCONTROLLERS + FLASH

MICRO-PRO 51

State-of-the-art programmer for the 8051 family

- Programming support for the entire Atmel 89C and 89S microcontroller families
- Also supports many Philips, Intel, Dallas & Siemens 8051 derivatives
- Field programmable hardware ensures future device support

Order code: MP51-SYS £125.00

Products are now available from Farnell Components

Microcontroller in-circuit re-programming adaptor

Now you can re-program the entire Atmel microcontroller family in-circuit!

No more re-moving chips - ideal for 8051 single-chip project development.

Supplied with AT89C2051 and AT89C52 + 11.0592 MHz Crystal.

(Requires Micro-Pro 51 programmer to operate - see above)

Order code: AD-MICRO-ICR £125.00

Package Adaptors

PLCC 44-pin adaptor

Suitable for most 8051 derivatives

Order code: AD-PLCC44-A
£65.00



SOIC 20-pin adaptor

Suitable for Atmel AT89C1051 & AT89C2051

Order code: AD-SOIC20-A £75.00

Please enquire for our full range of adaptors

The **Atmel** 8051 FLASH microcontroller family

Atmel Part Code	89C51	89LV51	89C52	89LV52	89C55	89S8252	89C2051	89C1051
Flash Code ROM (bytes)	4K	4K	8K	8K	20K	8K	2K	1K
EEPROM	-	-	-	-	-	2K	-	-
I/O Pins	32	32	32	32	32	32	15	15
Watchdog timer	-	-	-	-	-	YES	-	-
Serial UART (full duplex)	YES	YES	YES	YES	YES	YES	YES	-
Analogue comparator	-	-	-	-	-	-	YES	YES
Package Pins (DIL)	40	40	40	40	40	40	20	20

- Atmel microcontrollers feature on-chip re-programmable FLASH code memory
- FLASH is electrically erasable in under 15ms (no need for UV eraser)
- 89C51/89C52 are drop-in FLASH replacements for the generic 87C51/87C52 devices
- 89C2051 is a single-chip 8051 in a 20 pin package...even retaining the serial port

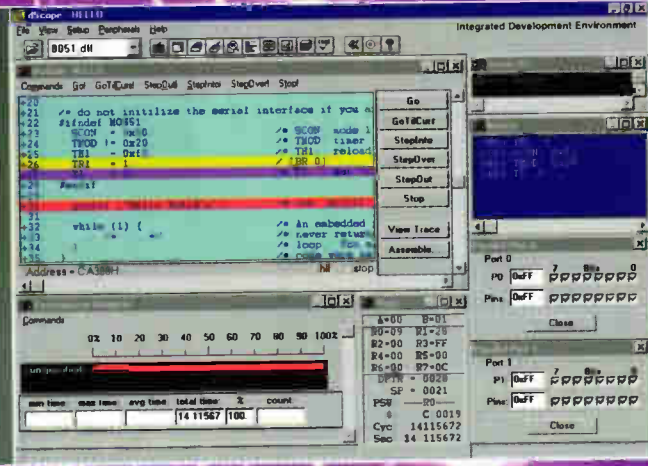

8051 STARTER SYSTEM

- ✓ Optimising C Compiler
- ✓ Macro Assembler
- ✓ Software Simulator
- ✓ Device Programmer
- ✓ Sample Devices
- ✓ Hardware/Software Documentation

Only £199.00

Plus
FREE Atmel CD ROM data book
* System supplied with 1 x Atmel AT89C1051 and 1 x AT89C2051 Microcontrollers
* C-compiler + Assembler output restricted to 2k total program code.

Order code: AT-89CX051-ST

UPGRADE TO 8K VERSION NOW AVAILABLE

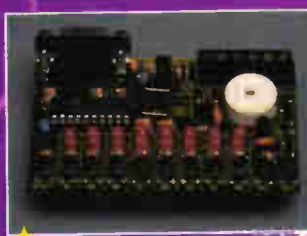

89C-1051/2051 Microcontroller Demo Module
A feature packed evaluation module for the Atmel 8051 derivatives. LED/WATCH array, RS-232, A/D, Lightmeter, Piezo sounder

Order code: AT-89CX051-DEMO
£58.00



89C-1051/2051 Microcontroller OEM Module
An ideal OEM module which can be used for evaluation or can be designed into custom products. RS-232/485, 1K EEPROM, A/D, I/O Header

Order code: AT-89CX051-OEM £29.00



The Embedded Solutions Company

Visit our web page at: www.equinox-tech.com

Email: sales@equinox-tech.com

229 Greenmount Lane, Bolton BL1 5JB UK



SALES: 01204 492010 TECHNICAL: 01204 491110 FAX: 01204 494883 (INTERNATIONAL DIALLING CODE +44 1204)

Equinox reserves the right to change prices & specifications of any of the above products without prior notice. E&OE. All prices are exclusive of VAT and carriage

THE WORLD'S MOST POWERFUL, PORTABLE PROGRAMMERS

£495 + VAT

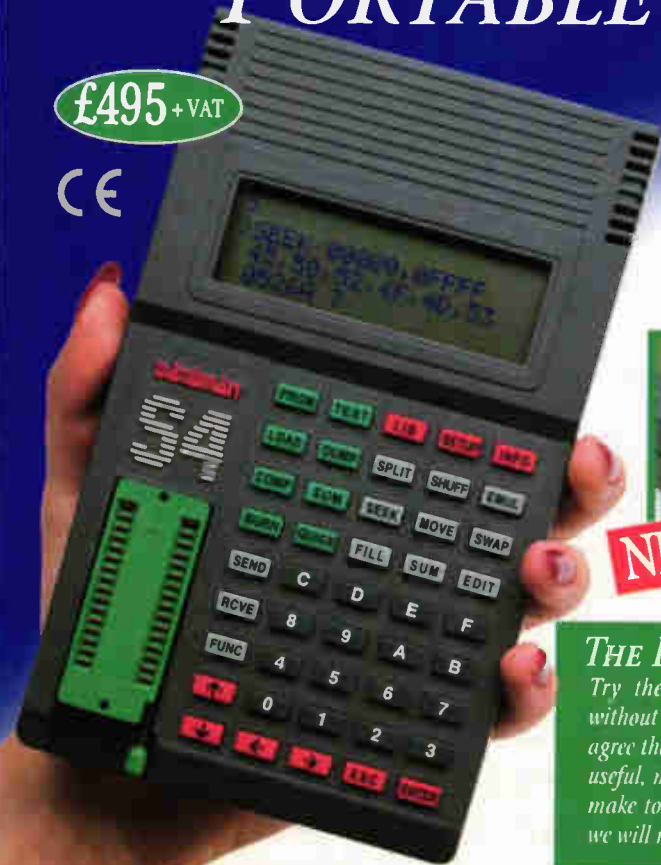

S4 GAL module

Programs a wide range of 20 and 24 pin logic devices from the major GAL vendors. Supports JEDEC files from all popular logic compilers.



The current device library contains over 1800 of the most popular logic and memory devices including GALs, PALs, CEPALs, RALs, 8 and 16-bit EPROMs, EEPROMs, PEROMs, FLASH, BOOT-BLOCK, BIPOLAR, MACH, FPGAs, PICs and many other Microcontrollers. We even include a 44-pin universal PLCC adaptor.

If you need to program different packaging styles, we stock adaptors for SOP, TSOP, QFP and SDIP. The Dataman-48 is also capable of emulation when used with memory emulation pods.

Order your Dataman programming solution today via our credit card hotline and receive it tomorrow. For more detailed information on these and other market leading programming products, call now and request your free copy of our new colour brochure.

THE DATAMAN CHALLENGE

Try the Dataman S4 or Dataman-48 without obligation for 30 days. If you do not agree that these are the most effective, most useful, most versatile additions you can make to your programming toolbox, we will refund your money in full.

Dataman S4

Compare the Dataman S4 with any other programmer and you'll see why it's the world's undisputed number one.

S4 is capable of programming 8 and 16-bit EPROMs, EEPROMs, PEROMs, 5 and 12V FLASH, Boot-Block FLASH, PICs, 8751 Microcontrollers and more. S4 also emulates ROM and RAM as standard!

S4 is the only truly hand held programmer that ships complete with all emulation leads, organiser-style manual, AC charger, spare library ROM, both DOS and Windows terminal software, and arrives fully charged and ready to go! Who else offers you all this plus a three year guarantee?

Customer support is second to none. The very latest programming library is always available free on the Internet, and on our dedicated bulletin boards. Customers NEVER pay for upgrades or technical support.

Dataman-48

Our new Dataman-48 programmer adds PinSmart® technology to provide true no-adaptor programming right up to 48-pin DIL devices. Dataman-48 connects straight to your PC's parallel port and works great with laptops. Coming complete with an integral world standard PSU, you can take this one-stop programming solution anywhere!

As with S4, you get free software upgrades and technical support for life, so now you don't need to keep paying just to keep programming.



hotline
01300 320719



Orders received by 4pm will normally be despatched same day.
Order today, get it tomorrow!

DATAMAN

Dataman Programmers Ltd, Station Road, Maiden Newton, Dorset DT2 0AE. UK
Telephone +44/0 1300 320719 Fax +44/0 1300 321012 BBS +44/0 1300 321095 (24hr)
Modem V.34/V.FC/V.32bis Home page: <http://www.dataman.com>
FTP: <ftp.dataman.com> Email: sales@dataman.com