

wireless world

APRIL 1978 40p

Australia SA1.25
Canada \$1.75
Denmark Kr. 11.00
Germany DM. 4.50
Greece Dr. 47.00
Holland Dfl. 4.50
Italy L. 1100
New Zealand SNZ1.50
Norway Kr. 11.00 incl. posts
Singapore M \$3.25
Spain Ptas. 80.00
U.S.A. \$1.65

**Russian white-light
holography**

Cassette-programmed calculator
Viewdata computer



The Versatile Fet Multimeter

Eight optional accessories including an r.f. probe, a peak-to-peak probe, a temperature probe, and a coaxial T-connector, make the TF 2650 Solid State FET Multimeter one of the most comprehensive general purpose multimeters available. Such versatility makes the TF 2650 ideal for use in servicing, production, technical education, research, design and many other applications, while the battery/mains option makes it equally suitable for field, laboratory or workshop.

Accuracy is $\pm 1.5\%$ on most ranges and the f.e.t. input amplifier gives an output resistance of typically 100 M Ω with good overload protection. Scales cover from

1.5 mV and 0.15 mA f.s. to 1500 V and 1.5 A a.c. and d.c. The accessories extend the ranges up to 30 kV and 150 A, r.f. up to 1 GHz and temperatures up to 500°C. Resistances can be measured from 100 Ω to 100 M Ω mid-scale with a facility to make in-circuit measurements on solid-state devices. A centre-zero facility is available on most ranges.

The basic instrument is supplied complete with co-axial leads, crocodile grips, test prods and a leather carrying case.

For further information write or phone:

mi MARCONI INSTRUMENTS

Marconi Instruments Limited · Longacres · St. Albans · Hertfordshire · England AL4 0JN · Tel: (0727) 59292 · Telex 23350
 Marconi Electronics Inc · 100 Stonehurst Court · Northvale · New Jersey 07647 USA · Tel: (201) 767-7250 · Twx: 710-991-9752
 Marconi Instruments · 32 avenue des Ecoles · 91600 Savigny-Sur-Orge · France · Tel: 996.03.86 · Telex: 600541.F
 Marconi Messtechnik GmbH · 8000 Munchen 21 Jorgstrasse 74 · West Germany · Tel: (089) 58 20 41 · Telex: 5 212642

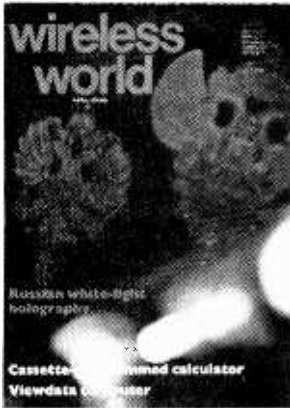

An example of white-light holography which uses incoherent light to create a three dimensional image. For further details see page 68. Photograph by Paul Brierley

IN OUR NEXT ISSUE

Loudspeaker system with a common bass enclosure, active crossovers, electronic delay compensation and equalization. Articles discuss choice of drivers, enclosure design and positioning in room.

New distortion measurement using pseudo-random binary test signal gives much better correlation between subjective and objective measurement than does t.h.d.

Liquid crystals. A summary of the techniques used in this, the newest type of display, and the advantages and drawbacks to each technique.

Current issue price 40p, back issue (if available) 50p. at Retail and Trade Counter, Paris Garden, London SE1.

By post, current issue 55p, back issues (if available) 50p, order and payments to Room 11, Dorset House, London SE1 9LU.

Editorial & Advertising offices: Dorset House, Stamford Street, London SE1 9LU.

Telephones: Editorial 01-261 8620. Advertising 01-261 8339.

Telegrams / Telex: Wiworld Bispres 25137 BISPRES G. Cables: Ethaworld, London SE1.

Subscription rates: 1 year £7.00 UK and £9.00 overseas (\$24 USA and Canada).

Student rate: 1 year, £3.50 UK and £4.50 overseas (\$11.70 USA and Canada).

Distribution: 40 Bowling Green Lane, London EC1R 0NE. Telephone 01-837 3636.

Subscriptions: Oakfield House, Perrymount Road, Haywards Heath, Sussex, RH16 3DH. Telephone 0444 59188. Subscribers are requested to notify a change of address.

USA mailing agents: Expeditors of the Printed Word Ltd, 527 Madison Avenue, Suite 1217, New York, NY 10022. 2nd-class postage paid at New York.

IPC Business Press Ltd, 1978
ISSN 0043 6062

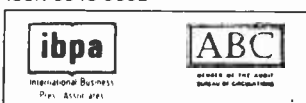

wireless world

ELECTRONICS / TELEVISION / RADIO / AUDIO

APRIL 1978 VOL 84 NO 1508

37 Speakers cornered

38 Radio landing systems
by P. R. Darrington

44 The Viewdata computer
by S. Fedida

49 News of the month
Solar cells
Frequencies in the 'third world' Public Viewdata

53 Integrated-circuit memories-2
by John Dwyer

57 Cassette tape programmer
by Evert Olsson

61 Circuit ideas
Adjustable tracking voltage regulator
Simple noise generator

63 Pickup arm design techniques-2
by Tejinder Singh Randhawa

71 Some tests on extended response cartridges
by David Heller

73 Logic design-12
by B. Holdsworth and D. Zissos

76 Improved stereo decoder i.c.
by Michael J. Gay

81 Circards

82 World of amateur radio

83 Electronic systems-8

85 Letters to the Editor
Questions about fuses
Audio equipment reviews Mysteries of Sporadic E

88 Communications '78

90 New products

92 Sidebands
by Mixer

F.M. TUNERS, MODULES & UNITS by *Icon Design*

T3 Six touch tuned pre-set stations plus manual tune, with digital frequency readout, combined with 1.8 micro-volt sensitivity and anti-birdy stereo make this one of the finest tuners available. Intelligent tuning indicator, a.f.c. and interstation mute included for easy operation by all the family. Two tone gold and brown front panel with teak veneer cabinet will blend with any surroundings. **£149.00**



M1 This module is the heart of the above tuner, giving a mono output with a.f.c., mute, and tuning indicator functions. Drift free tuning by 10 turn pot over the range 88 to 108 MHz. This module will not let you hear out-of-tune stations, and the fine tuning lamp is extinguished unless a station is received. The ideal basis for any High quality F.M. system. **£29.95**



M2 The ideal choice for adding stereo to the M1 module or any suitable mono receiver, this module has anti-birdy filters and pilot tone output filters, together with a phase-locked decoder for stable performance. **£8.36**



M4 An integrated circuit regulator supplies all the power for the M1, M2 and M5, in addition to being short circuit proof and having automatic thermal shut-down, and ensuring hum free reception. **£6.93**

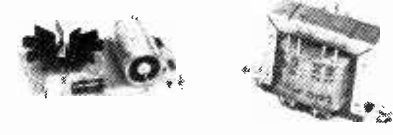

M5 The M5(mk2) touch module adds 6 touch selected pre-set stations to the manual tuning already provided by the M1 module. Illuminated buttons indicate the channel selected, while remote control using a single contact push button steps the channels in an endless loop, including the manual control channel. Auto power-up channel selection may be set to any of the seven available channels. Remote inhibit and a lamp test facility are provided. **£17.54**

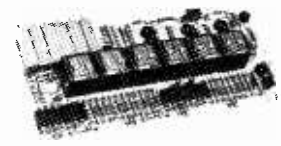

M6 Using the optimum selection of discrete, E.C.L., T.T.L. and C-MOS technologies, this module will add the luxury of digital readout to the M1 module above, or any other LP1186 based receiver. The small (95 x 103mm) board contains all the logic, displays, and regulated power supply. Range is 60 to 99.9MHz, resolution 0.1KHz, and stability better than 40 p.p.m. per deg. C. It comes complete with mains transformer, polarised filter, and list of station frequencies. **£44.40**

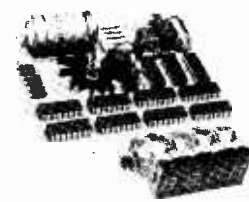

★★ PLUS TWO NEW ONES ★★

M7 This new module is a 4 way touch select switch having illuminated touch buttons, and C-MOS logic level outputs. Features pre-set power-up selection, and remote step facility. Multiple units may be cascaded to give 8, 12 or more channels of switching, and two modules may be paralleled to give full remote control from two or more locations. The outputs may be used to control logic etc., or to drive the new M8 channel selector opposite. **£6.95**

M8 Controlled from single pole switches, or the M7 module, this unit will switch 4 mono or two stereo audio channels. Two M8 modules will therefore switch 4 stereo signals driven by one M7 touch switch, or other combinations may be controlled by multiple touch switches, providing a flexible system of audio selection and control. The ideal module for pre-amplifier source selection, avoiding long signal wires to and from control panels, and their associated hum and cross-talk problems. **£4.95**

ORDERING INFORMATION

Small orders <£5.00 plus 50p handling charge.
 U.K. Orders post free, plus 12.5% V.A.T.
 Overseas, send for Pro-forma invoice first, or send £3.00 air mail for small items
 SEND FOR ILLUSTRATED DATA PACK
 (Reply coupons please overseas)
 ACCESS MASTERCHARGE BARCLAYCARD VISA
 CREDIT CARDS TAKEN
 (Just quote number when ordering)

KITS AND COMPONENTS

SL301	£1.67	BC184	£0.15	Cermet pre-sets	£1.20
SL3046	£0.94	BC214	£0.15	Transformers: 120/240v	
TBA750	£1.71	1N4001	£0.06	6VA 4.5v	£2.33
SL1310	£2.15	1N4148	£0.04	6VA 20v	£2.33
TBA625C	£1.65	P.C.B. M1	£2.64	Kit K14 (M1)	£27.95
UA78M20	£1.65	P.C.B. M2	£1.65	K57 (M2)	£6.84
UA78M05	£1.65	P.C.B. M3	£1.65	K112 (T3)	£137.80
SFJ10-7MA	£1.71	P.C.B. M4	£1.65	Descriptive booklet	50p
LP1186	£8.53	Coil ass.	£0.55	Overseas	£1.50
2N3904	£0.20	10t 50K pot	£3.89		

TO ICON DESIGN

33 Restrop View
 Purton, Wilts., SN5 9DG

Please supply data on (Circle as required)

M1 M2 M4 M5 Mk 2 M6 M7 M8 ALL

Address label Block letters

.....

LOW COST VOLTMETERS

from the
range
of

LEVELL
PORTABLE INSTRUMENTS

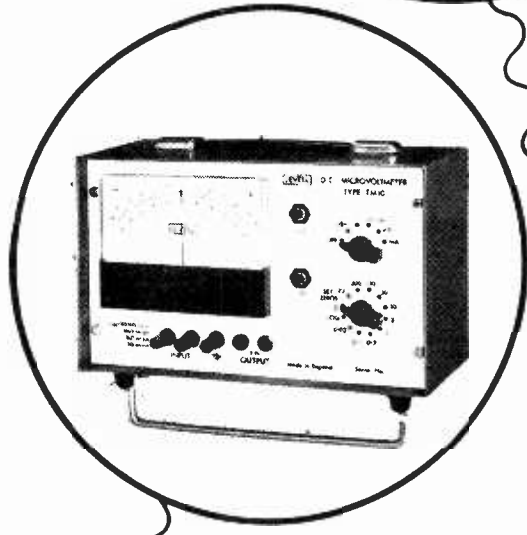
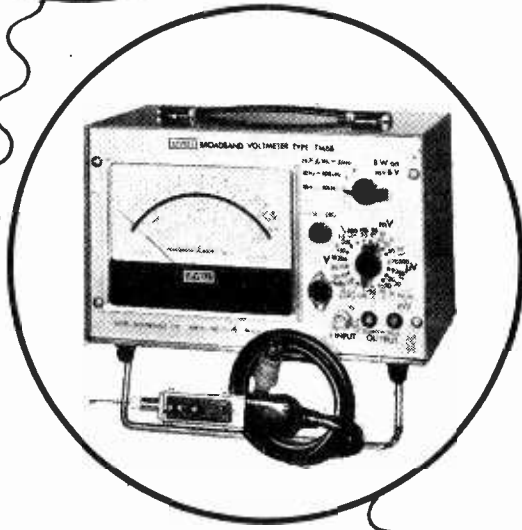
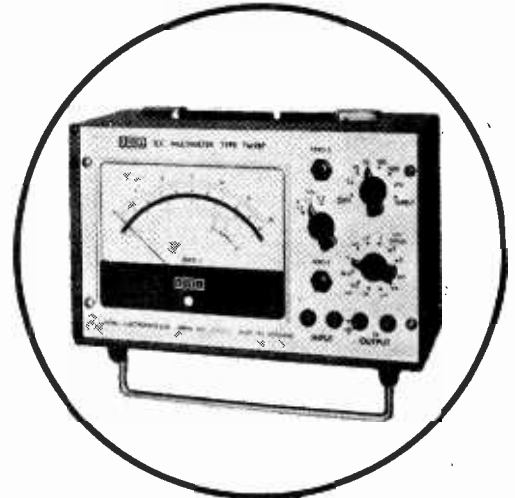
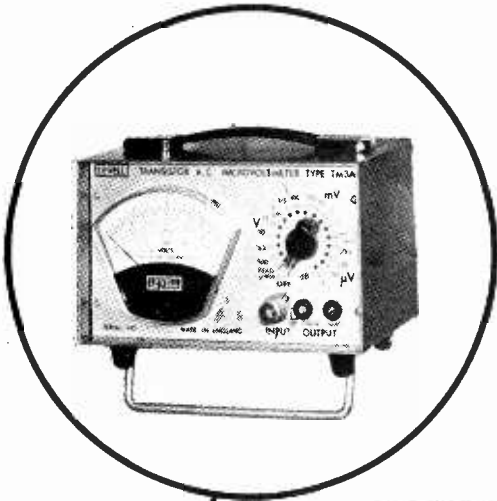

A.C. MICROVOLTMETERS
VOLTAGE & dB RANGES: 15µV, 50µV, 150µV ... 500V.
 Acc. ± 1% ± 1% f.s.d. ± 1µV at 1kHz - 100, - 90 ... +50dB
 Scale - 20dB/ + 6dB rel. to 1mW/600Ω.
RESPONSE: ± 3dB from 1 Hz to 3MHz, ± 0.3dB from 4Hz to 1MHz above 500µV. Type TM3B can be set to a restricted B.W. of 10Hz to 10kHz or 100 kHz.
INPUT IMPEDANCE: Above 50mV > 4 3MΩ < 20pf. On 50µV to 50mV: > 5MΩ < 50pf.
AMPLIFIER OUTPUT: 150mV at f.s.d.
 type **£89** type **£99**
 TM3A TM3B

D.C. MULTIMETERS
VOLTAGE RANGES: 3µV, 10µV, 30µV ... 1kV.
 Acc. ± 1% ± 1% f.s.d. ± 0.1µV. LZ & CZ scales.
CURRENT RANGES: 3pA, 10pA, 30pA ... 1mA (1A for TM9BP).
 Acc. ± 2% ± 1% f.s.d. ± 0.3pA. LZ & CZ scales.
RESISTANCE RANGES: 3Ω, 10Ω, 30Ω ... 1 GΩ linear Acc. ± 1% ± 1% f.s.d. up to 100MΩ.
RECORDER OUTPUT: 1V at f.s.d. into > 1kΩ on LZ ranges.
 type **£130** type **£140**
 TM9A TM9BP

BROADBAND VOLTMETERS
H.F. VOLTAGE & dB RANGES: 1mV, 3mV, 10mV ... 3V.
 Acc. ± 4% ± 1% f.s.d. at 30MHz - 50dB, - 40dB, - 30dB to + 20dB. Scale - 10dB/ + 3dB rel. to 1mW/50 Ω ± 0.7dB from 1MHz to 50MHz, ± 3dB from 300kHz to 400MHz.
L.F. RANGES: As TM3 except for the omission of 15µV and 150µV.
AMPLIFIER OUTPUT: Square wave at 20Hz on H.F. with amplitude proportional to square of input. As TM3 on L.F.
 type **£140** type **£150**
 TM6A TM6B

D.C. MICROVOLTMETERS
VOLTAGE RANGES: 30µV, 100µV, 300µV ... 300V.
 Acc. ± 1%, ± 2% f.s.d., ± 1µV. CZ scale.
CURRENT RANGES: 30pA, 100pA, 300pA ... 300mA.
 Acc. ± 2%, ± 2% f.s.d., ± 2pA. CZ scale.
LOGARITHMIC RANGE: ± 5µV at ± 10% f.s.d., ± 5mV at ± 50% f.s.d., ± 500mV at f.s.d.
RECORDER OUTPUT: ± 1V at f.s.d. into > 1kΩ.
 type **£77**
 TM10

These highly accurate instruments incorporate many useful features, including long battery life. All A type models have 83mm scale meters, and case sizes 185x110x130mm. B types have 127mm mirror scale meters and case sizes 260x125x180mm.

LEVELL ELECTRONICS LTD.
 Moxon Street, High Barnet, Herts. EN5 5SD
 Tel: 01-449 5028/440 8686

Prices are ex works with batteries. Carriage and packing extra. VAT extra in U.K. Optional extras are leather cases and mains power units. Send for data covering our range of portable instruments.

SEE US ON STAND 111, AT THE SCOTTISH ELECTRONICS EXHIBITION
 WW-058 FOR FURTHER DETAILS

The competition's days are numbered

The AVO DA 116 is the latest digital multimeter to come on the market. It may not be the first, but it's certainly the best. Why? Because it's from AVO. We've taken time to get everything right. The size, the shape, the performance, the lot. After all, it's taken us many years to establish our reputation for quality and we're not prepared to throw it away for the sake of being first into the market place. These features prove our point.

Built to last For a start, we've avoided building a pocket-sized multimeter. They can slip out of a pocket or just as simply be 'lost'. We've also worked hard on the casing. It's designed to take all the knocks and still come back for more.

Easy to read We've used a 3½ digit liquid crystal display which gives large easy-to-read numbers (in any light) and decimal placement as well as automatic polarity indication on d.c. ranges.

Wide ranges Measurements may be made up to 1000V and 10A on both a.c. and d.c. ranges. There are six resistance ranges measuring up to 20 MΩ. Added to this, the AVO DA116 also incorporates a special Junction Test range for the testing of diodes or transistors in circuit.

High Speed Ohms We've incorporated a Fast Ohms range for continuity testing, with a normal response time of about one-tenth of normal resistance ranges.

Long battery life There's not a digital multimeter to beat it for long battery life. Four ordinary zinc carbon 1.5V batteries should last you more than 500 hours. And when the batteries need replacing, you get immediate visual indication.

Handy protective cover It doesn't only protect the instrument, but it also houses the test leads and provides a ready made support stand when you're using the instrument on a bench.

Value for money The AVO DA116 is really competitively priced. After all, what's the point of building a great multimeter if nobody can afford it? We think we've done a great job on the AVO DA116. Once you've tried it we think you'll agree. Get in touch with us today and we'll let you have the full facts. Or better still, call your usual supplier for a demonstration.

**AVO LTD., Archcliffe Road, Dover, Kent. CT17 9EN.
Tel: (0304) 202620 Telex: 96283.**



Thorn Measurement & Components Division

**You'll never meet
a better meter**

AVO



H5Ω Avometer DA116

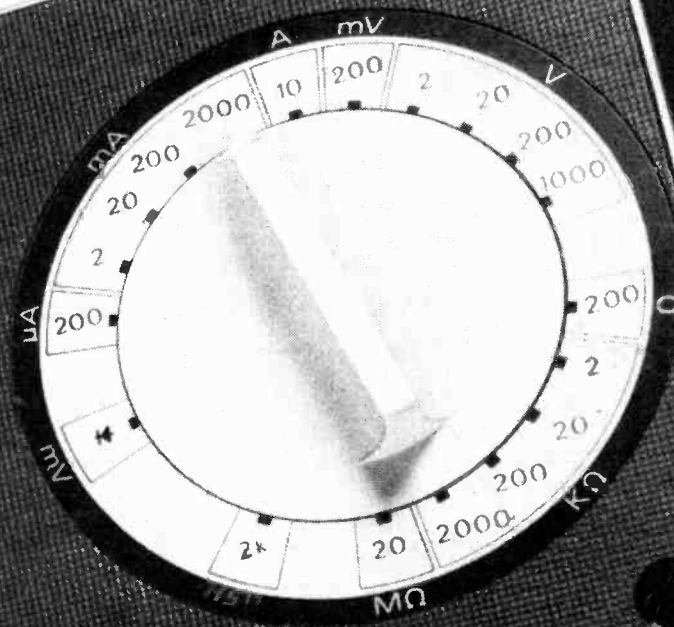
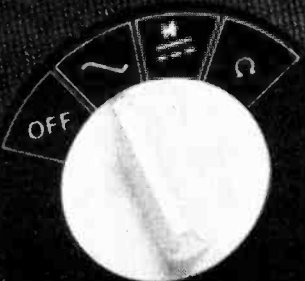

+10A Δ

DA116

WW-050 FOR FURTHER DETAILS

GenRad's Top Trio...

... a low cost/high performance range of μP -based bridges

GenRad's new range of μP -based bridges make full use of advanced technology to meet tomorrow's testing needs today. Check the list of features, and contact us for further information, price and delivery.

1658 RLC Digibridge

- * Automatically measures R, L, C, D and Q
- * 0.1% Basic accuracy
- * 10 Bins for sorting
 - * Autoranging
- * IEEE 488 bus/handler interface option
 - * Three test speeds
- * Selectable continuous, average or single component measurements
 - * Three types of display programmed bin limits, measured values or bin number
- * Five-digit display for R, L and C
- * Four-digit display for D and Q
- * Selectable test frequencies of 1 kHz and 120 Hz (100 Hz)
- * Series or parallel measurement mode selection
- * Built-in Kelvin test fixture tests radial and axial lead components

1658 RLC Digibridge™

* Under £2,000

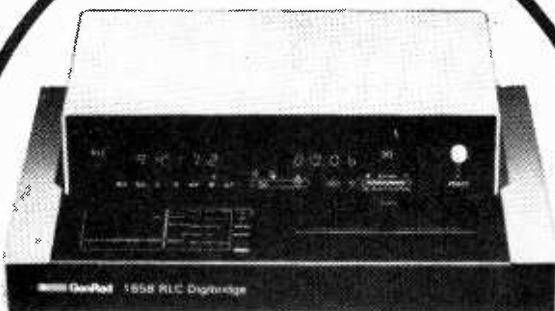

The 1657 Digibridge

- * Automatically measures R, L, C, D and Q
- * 0.2% Basic accuracy
- * Five-digit display for R, L and C
- * Four-digit display for D and Q
- * Microprocessor-directed ranging
- * Selectable test frequencies of 1 kHz and 120 Hz (100 Hz)
- * Series or parallel measurement mode selection
- * Built-in Kelvin test fixture tests radial and axial lead components

1687 Megahertz LC Digibridge

- * Automatically measures Ls & Q, Cs & D, Cs & Rs, Cp & Gp
- * 0.1% basic accuracy for C
- * 0.2% basic accuracy for L
- * Automatic limit-comparison (10 bins)
- * Autoranging
- * IEEE 488 bus/handler interface option
- * Two test speeds
- * Selectable continuous, average or single component measurements
- * Four types of display - programmed bin limits, measured values, deviation measurement (ΔL or ΔC), or bin number
- * Five-digit display for L and C
- * Four-digit display for Q, D, R and G
- * Optional Kelvin test fixture tests radial and axial lead components

1687 Megahertz

LC Digibridge™

* Under £2,500

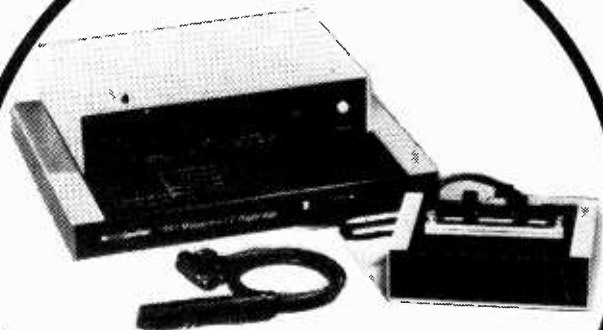

1657 Digibridge™

* Under £1,000

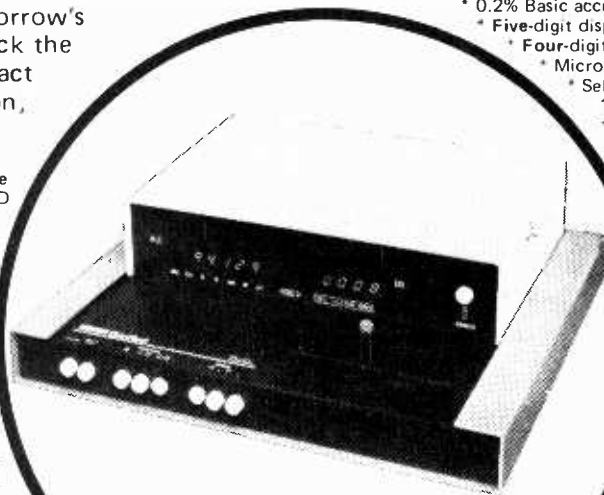

GenRad Ltd.
Bourne End, Bucks. SL8 5AT
Phone (06285) 2 66 11, Telex 848321

 **GenRad**

WW-085 FOR FURTHER DETAILS

BIMCONSOLES BIMBOXES BIMBOARDS BIMDRILLS BIMDICATORS

ABS & DIECAST BIMBOXES

5 sizes, in either ABS or Diecast Aluminium
ABS moulded in Orange, Blue, Grey or Black
Diecast Aluminium available in Grey Hammettone
or Natural

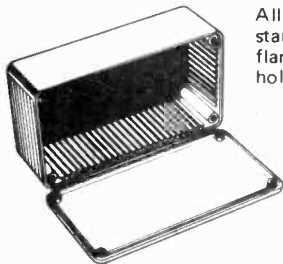

All boxes incorporate guides on all sides for holding 1.5mm thick pcb's and stand-off bosses in base for supporting small sub-assemblies etc. Close fitting flanged lids held by screws running into integral brass bushes (ABS) or tapped holes (Diecast).

	ABS	Diecast	Hammettone	Natural
(100x50x25mm)	BIM2002/12	£0.87*	BIM5002/12	£1.20*
(112x62x31mm)	BIM2003/13	£0.97*	BIM5003/13	£1.50*
(120x65x40mm)	BIM2004/14	£1.05*	BIM5004/14	£1.86*
(150x80x50mm)	BIM2005/15	£1.18*	BIM5005/15	£2.38*
(190x110x60mm)	BIM2006/16	£1.84*	BIM5006/16	£3.41*

Also available in Grey Polystyrene (112x61x31mm) with no slots and self tapping screws BIM2007/17 £0.82*

MINI DESK BIMCONSOLES

Moulded in Orange, Blue, Black or Grey
ABS and incorporating guides on all sides
for holding 1.5mm thick pcb's. 1mm Grey
Aluminium panel sits recessed into front of
console and held by screws running into
integral brass bushes. Stand-off bosses in
base for supporting small sub-assemblies
etc. 4 self adhesive
rubber feet also in-
cluded.

BIM1005
(161x96x58mm)
£1.97*
BIM1006
(215x130x75mm)
£2.70*



LOW PROFILE BIMCONSOLES

1mm Grey Aluminium panel sits
recessed into front
of console base,
which is moulded in
Orange, Blue, Black
or Grey ABS and
sits on 4 self adhe-
sive rubber feet. Incorporating guides
for holding 1.5mm thick pcb, the base also
has stand-off bosses for supporting small
sub-assemblies etc. and ventilation slots.
Front panel is held by 4 screws which run
into integral brass bushes.

BIM6005 (143x105x55.5[31.5] mm) £2.14*
BIM6006 (143x170x55.5[31.5] mm) £2.73*
BIM6007 (214x170x82[31.5] mm) £3.75*

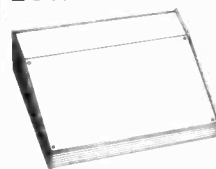

MULTI-PURPOSE BIMBOXES

Moulded in Orange, Blue, Black or Grey
ABS with 1mm thick Grey aluminium
recessed front cover which is retained by
4 screws running into integral brass bushes.
1.5mm pcb guides are incorporated on all
sides and as with all ABS boxes they are
85°C rated. 4 self adhesive rubber feet
also included.

BIM 4003 (85x56x28.5mm) £1.13*
BIM 4004 (111x71x41.5mm) £1.42*
BIM 4005 (161x96x52.5mm) £1.87*

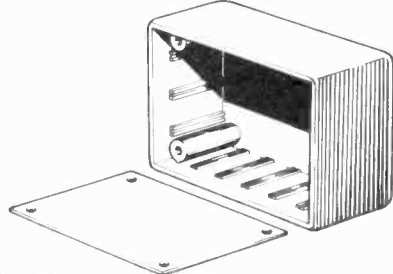

All aluminium, 2 piece desk consoles with either 15° or 30° sloping fronts, sit on
4 self-adhesive non slip rubber feet. Ventilation slots in base and rear panels permit
efficient cooling.

Colour Code	Top Panel	Base	15° Sloping Panel	
A	Off White	Blue	BIM7151 (102x140x51[28] mm)	£ 9.43
B	Sand	Green	BIM7152 (165x140x51[28] mm)	£10.43
C	Satin Black	Gold	BIM7153 (165x216x51[28] mm)	£11.42

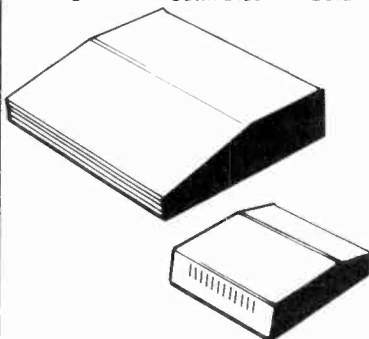

BIM7154 (165x211x76[33] mm)	£12.39
BIM7155 (254x211x76[33] mm)	£13.66
BIM7156 (254x287x76[33] mm)	£14.65
BIM7157 (356x211x76[33] mm)	£15.80
BIM7158 (356x287x76[33] mm)	£16.78

30° Sloping Panel	
BIM7301 (102x140x76[28] mm)	£ 9.43
BIM7302 (165x140x76[28] mm)	£10.43
BIM7303 (165x183x102[28] mm)	£11.42
BIM7304 (254x140x76[28] mm)	£12.39
BIM7305 (254x183x102[28] mm)	£13.66
BIM7306 (254x259x102[28] mm)	£14.65
BIM7307 (356x183x102[28] mm)	£15.80
BIM7308 (356x259x102[28] mm)	£16.78

MAINS BIMDRILL

Operates directly
from 220-240Vac
and supplied with
2 metres long cable
fitted with 2 pin
DIN plug. Will
drill brass, steel and

aluminium as well as pcb's etc. Has integral
biased-off switch and accepts tools with 1,2
and 3.2mm dia shanks £9.72*

Accessory Kit including 1mm, 2mm, .125"
twist drills, 5 burs and 2.4mm collet £2.20*

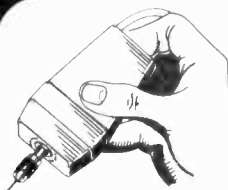

12 VOLT BIMDRILLS

2 small but powerful 12V dc drills, easily
held in hand or used with lathe/stand
adaptor. Both drills have integral on/off
switches and 1 metre long cable.

Mini Bimdrill with 2 collets up to 2.4mm
capacity £7.56*

Major Bimdrill with 3
collets up to 3mm
capacity £12.96*

Mains to 12 Volts
adaptor, lathe, stand
and accessory kits also
available, details on
request.

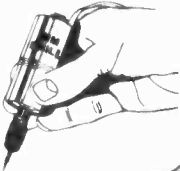

DIL COMPATIBLE BIMBOARDS

Bimboards accept all sizes of DIL packages
as well as resistors, diodes, capacitors and
LED's etc. They have integral Bus Strips
running up each side for carrying Vcc and
ground as well as Component Support
Brackets for holding lamps, fuses and
switches etc. Available as either single or
multiple units, the latter mounted on
1.5mm thick, matt black aluminium back
plates which stand on non slip rubber feet
and have 4 screw terminals for incoming
power.

Bimboard 1 contains 500 individual sockets
whereas the multiple units containing 2,
3 or 4 Bimboards incorporate 1,100, 1,650
or 2,200 individual sockets, all arranged
on a 2.5mm(0.1") matrix.

Bimboard 1 £ 9.72* Bimboard 2 £22.68*
Bimboard 3 £32.40* Bimboard 4 £42.12*

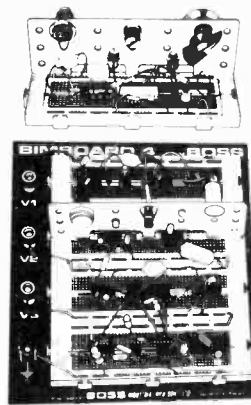

BIMDICATORS



Remember we are
also one of Europe's
largest manufacturers
of Filament, Neon
and LED indicators.
Send for our
BIMDIATOR DATA

BOSS

INDUSTRIAL MOULDINGS LIMITED

2 Herne Hill Road, London SE24 0AU

Telephone: 01-737 2383

Telex: 919693 Answer Back 'LITZEN G'

Cables & Telegrams: 'LITZEN LONDON SE24'

*All quoted prices are 1 off
and include Postage,
Packing and VAT. Terms
are strictly cash with
order unless you have
authorised BOSS account.
For individual data sheets
on all BOSS products
send stamped, self
addressed envelope

The new, comprehensive JVC 3/4" video cassette range

See-and believe



A pioneering electronics organisation with 51 years' experience of high-technology engineering, JVC has been developing and introducing new and better video products for 21 years.

Now, for the first time in Britain, you can choose from a new and comprehensive range of JVC 3/4" U-format colour-plus-monochrome video cassette units, up to 38% smaller than directly competitive equipment.

From the compact portable CR-4400E for location work to the versatile CR-8300E for production studios, these easy-to-use models meet every video cassette recorder demand. They give you exactly the same top-quality recording and playback throughout the range. Price differences simply reflect the number of facilities available, not the performance.

The range. For those needing NTSC as well as PAL playback (perhaps for shipboard entertainment), JVC has the new CR-5060ED.

If you're looking for stop-action playback and PAL record-playback facilities, the new CR-6060E with its specially engineered still-frame system is the one for you. (Optional remote control available.)

PAL recording, plus PAL and NTSC playback, come together in the new CR-6060ED. Again, with optional remote control.

Full electronic editing facilities are built into the superb new CR-8300E, a PAL record/playback unit. For even more flexible editing, add the JVC RM83 editing suite.

Where you must have portable video equipment, able to record cassettes that can also be replayed by a mains cassette unit without an adaptor, it's got to be the new assembly-edit CR-4400E. This comes complete with built-in video/RF replay facilities. And, of course, there's a colour camera to match.

Use the inquiry service to get the literature from Bell & Howell. Test for yourself the versatility of these new JVC units. Admire the outstanding picture quality each provides. Seeing is believing. You'll believe, as we do, that JVC U-format equipment is the best in the world.

WW-061 FOR FURTHER DETAILS

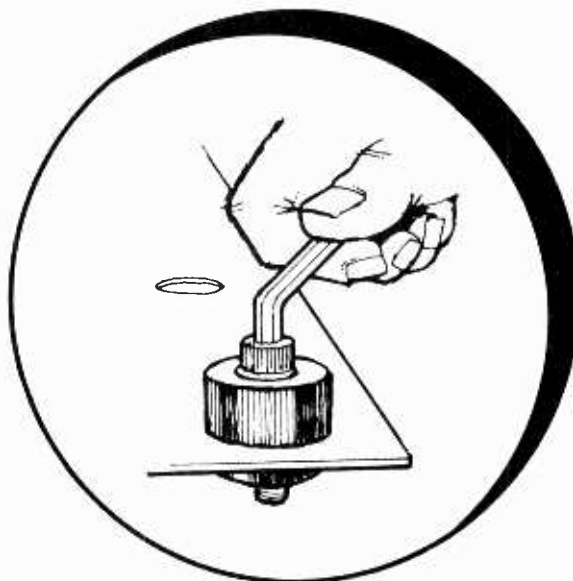

FOR CLEAN HOLES FAST!

- Easiest and quickest way of punching holes in sheet metal (up to 1.625mm mild steel)
- Q-MAX stands for quality and reliability
- Holes are punched cleanly and no filing is necessary
- Continuous even load during punching
No jagged edges. Burr freehole
- Specially heat treated to maintain keen cutting edge
- Used for years all over the world
- Simple operation, saving time and energy

57 METRIC & LINEAR SIZES



SHEET METAL PUNCHES

Q-Max (Electronics) Ltd ^(R)

40-41 Furnival Street
London EC4A 1JQ
Telephone: 01-242 7400

Fuji tape. To get the optimum results from any U-format equipment use Fuji Beridox tape. *Provably* superior to conventional CrO₂ tape, it's now available from every Bell & Howell dealer.

Bell & Howell A-V Ltd.
Alperton House,
Bridgewater Road,
Wembley, Middlesex, HA0 1EG.

 **BELL & HOWELL**

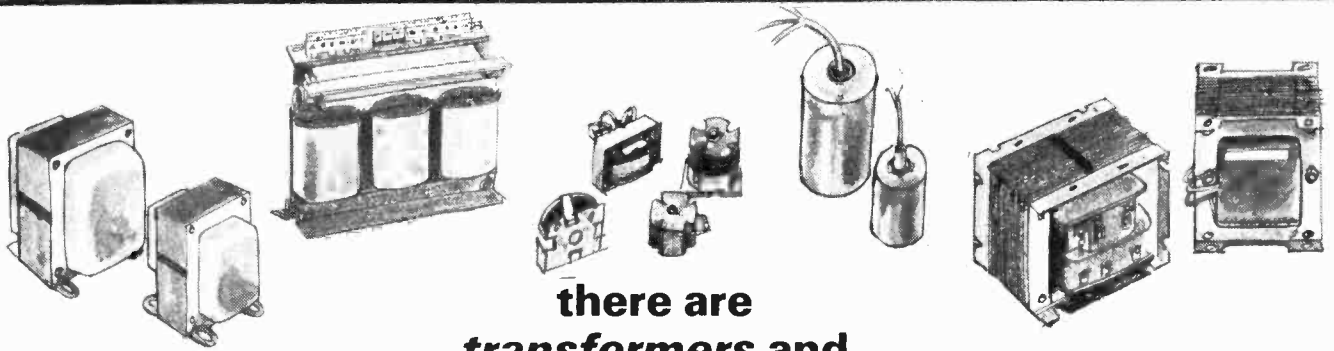

there are
transformers and

Drake Transformers

A wide range of transformers
manufactured in production
quantities to customers' own
requirements; prompt design
and prototype service.

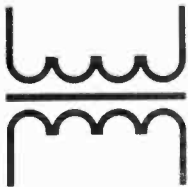
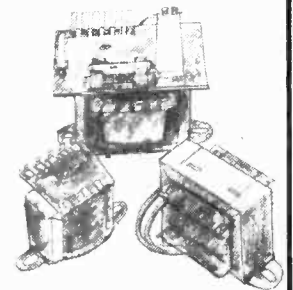
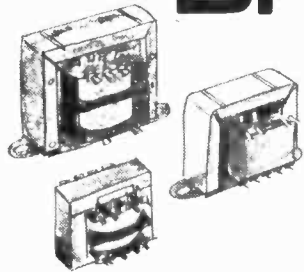

Drake Transformers Limited

South Green Works, Kennel Lane, Billericay, Essex CM11 2SP
Telephone: Billericay 51155. Telex: 99426

WW-051 FOR FURTHER DETAILS

Total Capability
in soldering

LITESOLD

ETC/2A SYSTEM Adjustable and transient free electronic temperature control



Send TODAY for FREE Catalogue with full details of this and other equipment

ETC/2B SYSTEM Tamper-proof adjustable electronic temperature control



12

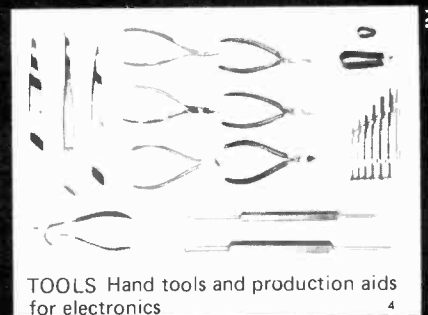

TOOLS Hand tools and production aids for electronics

4

8

SOLDER POTS

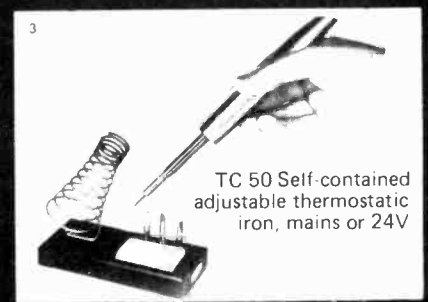

TC 50 Self-contained adjustable thermostatic iron, mains or 24V

LIGHT SOLDERING DEVELOPMENTS LTD

97-99 Gloucester Road, Croydon, Surrey CRO 2DN Telephone 01-689 0574, Telex 8811945

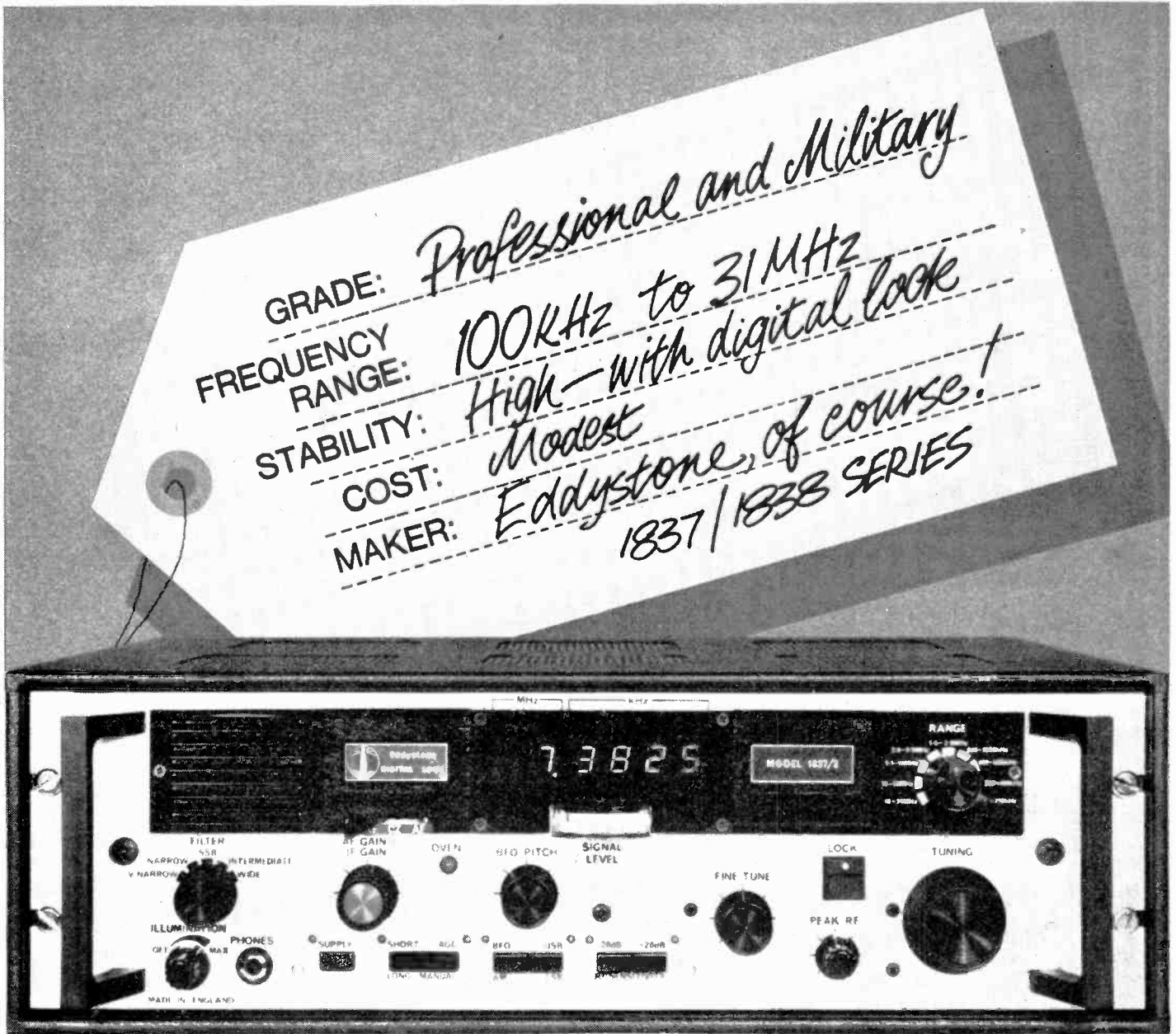

Eddystone's new 1837/1838 series of high-grade h.f. communications receivers covers most general-purpose applications in professional and military communication, including marine use where speech, telegraphy or f.s.k. teleprinter signals are employed. A particular feature of the new receivers is the unique method used for frequency stabilization, which provides the convenience of manual tuning with the facility for locking the frequency to a high degree of accuracy.

The 1837/1838 series has been approved by the British Ministry of Posts and Telegraphs as complying fully with specifications MPT 1201, 1216, 1217, 1204. Reliability is an outstanding feature, and the performance is maintained under severe environmental conditions of climate and location.

Please ask for full details: 1837/1 Ship's Main and Reserve Receiver; 1837/2 General-Purpose High Stability Receiver; 1838 Series General-Purpose Telephony Receiver.

Eddystone Radio Limited

Member of Marconi Communication Systems Limited

Alvechurch Road, Birmingham B31 3PP, England

Telephone: 021-475 2231 Telex: 337081

A GEC-Marconi Electronics Company



WW-068 FOR FURTHER DETAILS

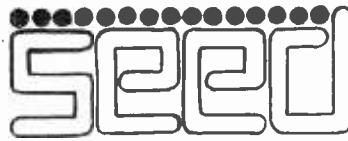

PORTLAND HOUSE, COPPICE SIDE, BROWNHILLS

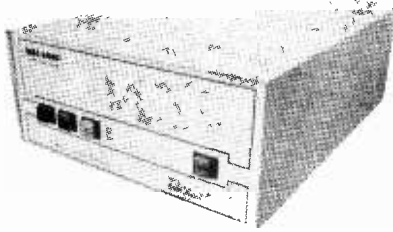

MSI 6800
with 8K Ram. Runs at 2MHZ
KIT £375



SWTPC 6800
with 4K Ram. Runs at 1MHZ
KIT £275

FD8 FLOPPY DISC £935. BFD68 MINI FLOPPY £522
SOROC 1Q120 TERMINAL £699 ASS.
CASSETTE INTERFACE KIT £18.95

Send S.A.E. for full brochure

STRUMECH ENG. ELECTRONICS DIV. BROWNHILLS 4321

WW 036 FOR FURTHER DETAILS

KGM TV CAMERAS

the big choice



Type 130 is a compact $\frac{2}{3}$ inch camera with an unusually high specification for a camera of this size. It is a sturdy, reliable camera of great versatility.

Type 113 is an extremely rugged camera designed for critical applications of a very wide nature. Resolution is better than 800 lines.

Type 118 is a day and night camera based on Type 113 but with many unique features to enhance its performance in difficult light conditions.

KGM cameras and monitors are backed by KGM's many years' experience of designing and building CCTV equipment for large industrial users and leading public authorities. *Send for your data sheets now.*

KGM ELECTRONICS
LIMITED

Clock Tower Road, Isleworth, Middlesex TW7 6DU
Tel: 01-568 0151. Telex: 934120

WW—025 FOR FURTHER DETAILS

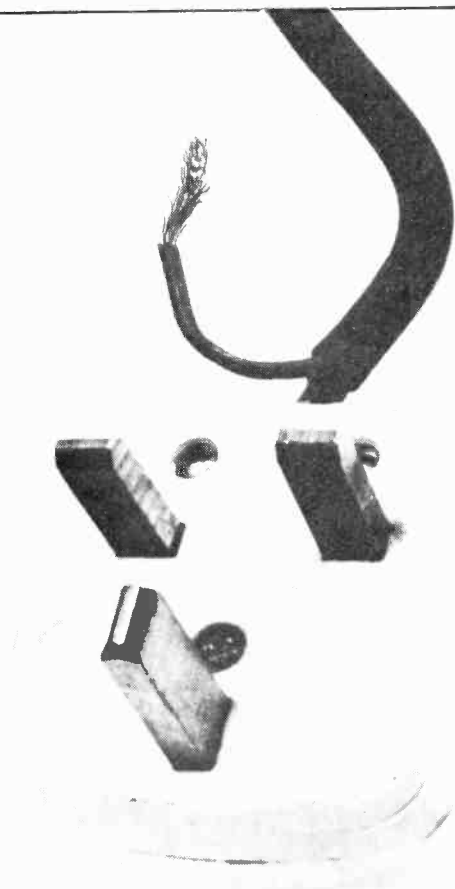

It's easy enough checking this end, but what about the other?

...and that's where NEAL FERROGRAPH test sets come in. All of the professional measuring equipment necessary to test and calibrate a wide range of audio apparatus; compactly combined, and designed to function with minimum effort.

The RTS 2, a unique concept. Simplifies measurements of gain, noise, frequency response, input sensitivity, output power, distortion and the parameters relating to recording equipment, such as wow and flutter, crosstalk, drift and crasure. Its range of measurements can be extended even further by the addition of the Auxiliary Test Unit **ATU1**.

Send today for full technical information relating to these instruments, and other high quality products in the combined NEAL FERROGRAPH range.

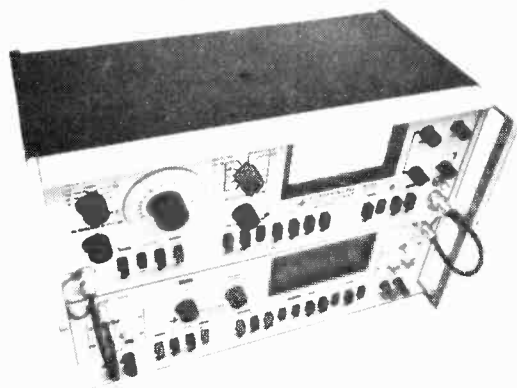

NEAL FERROGRAPH
TOTAL TAPE TECHNOLOGY

SIMONSIDE WORKS · SOUTH SHIELDS · TYNE & WEAR NE34 9NX
Telephone SOUTH SHIELDS (0632) 566321 Telex 537227

WW — 006 FOR FURTHER DETAILS

Introducing the new Quick Charge Cordless Soldering Iron

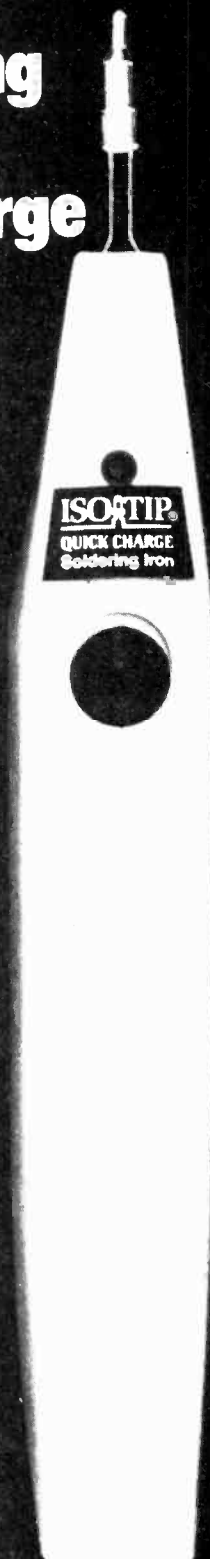

- Solder heat in five seconds
- No wires to restrict use
- Completely recharges in only 4 hours!
- No need for earthing
- Capacity to solder up to 125 joints

This new rechargeable soldering iron from Greenwood brings added freedom to professional soldering. The Quick Charge recharges so fast that completely dead battery cells can be brought to full charge in about 4 hours — three times faster than before. In its stand the Quick Charge is, of course, being continually charged. A wide range of tips and now also a P.C. Drill attachment make this the most 'versatile' professional soldering iron available.



Illustration actual size.

Greenwood Electronics

Greenwood Electronics, Portman Road, Reading RG1 1NE
Telephone 0734-595844 Telex 848659

WW—054 FOR FURTHER DETAILS

HIGH POWER DC-COUPLED AMPLIFIER

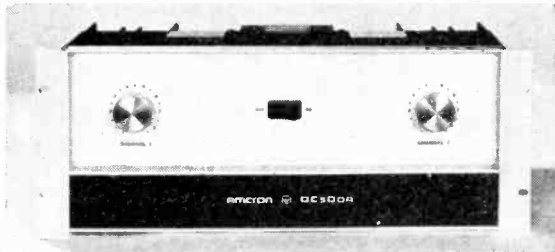

- ★ UP TO 500 WATTS RMS FROM ONE CHANNEL
- ★ DC-COUPLED THROUGHOUT
- ★ OPERATES INTO LOADS AS LOW AS 1 OHM
- ★ FULLY PROTECTED AGAINST SHORT CCT, MISMATCH, ETC.
- ★ 3 YEAR WARRANTY ON PARTS AND LABOUR

The DC300A Power Amplifier is the successor to the world famous DC300 which is so widely used in Industrial, and Research applications in this country. It is DC-coupled throughout so providing a power bandwidth from DC to over 20,000Hz. The ability of the DC300A to operate without fuss into totally reactive loads while delivering its full power, and maintaining its faithful reproduction of Pulse or complex waveforms has established the DC300A as the world's leading power amplifier. Each of the two channels will operate into loads as low as 1 ohm, and the amplifier can be rapidly connected as a single ended amplifier providing over 650 watts RMS into a 4 ohms load, and still providing a bandwidth down to DC. Below is a brief specification of the DC300A, but if you require a data sheet, or a demonstration of this fine equipment please let us know.

Power Bandwidth	DC 20kHz @ 150 watts + 1db. 0db.	Slewing Rate	8 volts per microsecond
Power at clip point (1 chan)	500 watts rms into 2.5 ohms	Load impedance	1 ohm to infinity
Phase Response	+0. -15 DC to 20kHz, 1 watt &Ω	Input sensitivity	1.75 V for 150 watts into &Ω
Harmonic Distortion	Below 0.05% DC to 20kHz	Input Impedance	10K ohms to 100K ohms
Intermod. Distortion	Below 0.05% 0.01 watt to 150 watts	Protection	Short mismatch & open cct. protection
Damping Factor	Greater than 200 DC to 1kHz at &Ω	Power supply	120-256V 50-400Hz
Hum & Noise (20-20kHz)	At least 110db below 150 watts	Dimensions	19" Rackmount, 7" High, 9 1/2" Deep
Other models in the range: D60 — 60 watts per channel		D150A — 150 watts per channel	

Other models available from 100 watts to 3000 watts



MACINNES LABORATORIES LTD.

MacInnes House, Carlton Park Industrial Estate
Saxmundham, Suffolk IP17 2NL. Tel: (0728) 2262 2615

MACINNES FRANCE

18 Rue Botzaris
Paris 75019, France
Tel: 206-60-80 or 206-83-61

WW-030 FOR FURTHER DETAILS

How to generate confidence



G5
£76.14
inc. VAT
and P.&P.

M2B
£76.14
inc. VAT
and P.&P.

Produce instruments with a high specification at a low price — put them in steel cases for rugged reliability and guarantee the results. The G5 is a low distortion 10Hz to 1 MHz, sine/square signal generator with a 600 ohm switched attenuator and a low impedance output of up to 3 watts. Coupled with the M2B millivoltmeter, with its 1.2 mV full scale maximum sensitivity, you have the ideal test set. Calibrated in true RMS on the a.c. ranges it will measure up to 400 volts ac or dc and has a db range from — 70 db to +54 db.

Send your Order now to Linstead Manufacturing Co. Ltd., Roslyn Road, London N15 5JB.

Linstead

Telephone: 01-802 5144

WW-053 FOR FURTHER DETAILS

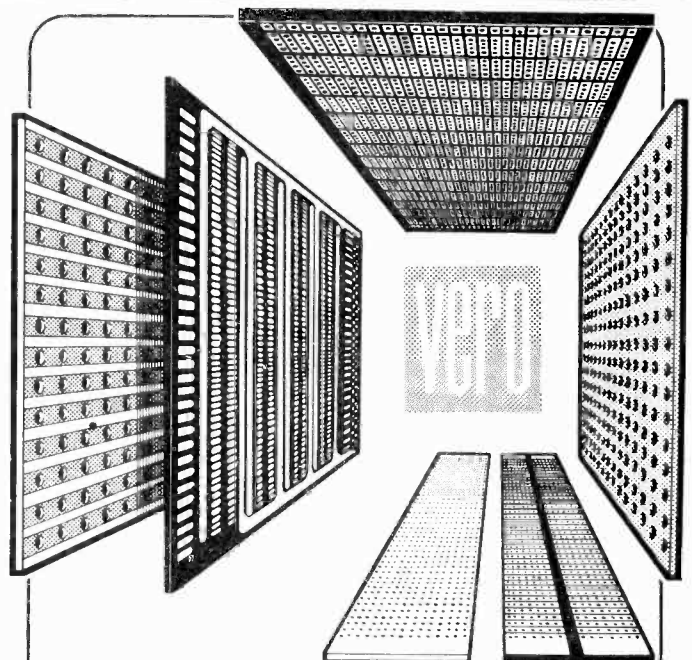

Our new 1978 catalogue lists circuit boards for all your projects, from good old Veroboard through to specialised boards for ICs. And we've got accessories, module systems, cases and boxes — everything you need to give your equipment the quality you demand. Send 25p to cover post and packing, and the catalogue's yours.

VERO ELECTRONICS LTD. RETAIL DEPT.
Industrial Estate, Chandlers Ford, Hants. SO5 3ZR
Telephone Chandlers Ford (04215) 2956

WW-043 FOR FURTHER DETAILS

IF YOU NEED JACKFIELDS WHY NOT TALK TO THE SPECIALISTS?

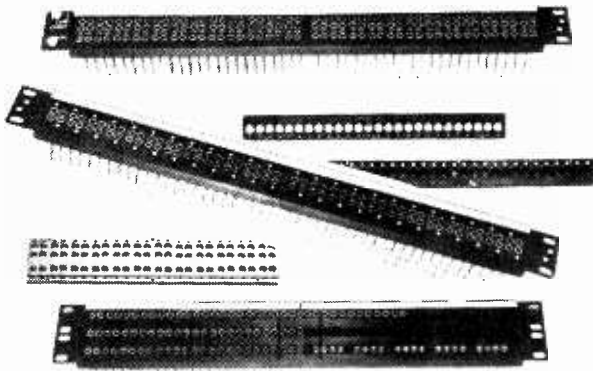

PANELS AND ASSEMBLIES

No supplier offers a wider range of panels, inserts and accessories for just about any configuration. And you can get them in any stage of assembly . . . individual components, sub-assemblies, or complete pre-wired and connectorised assemblies ready to install. Our Bantam range gives a space saving of up to 50 per cent.

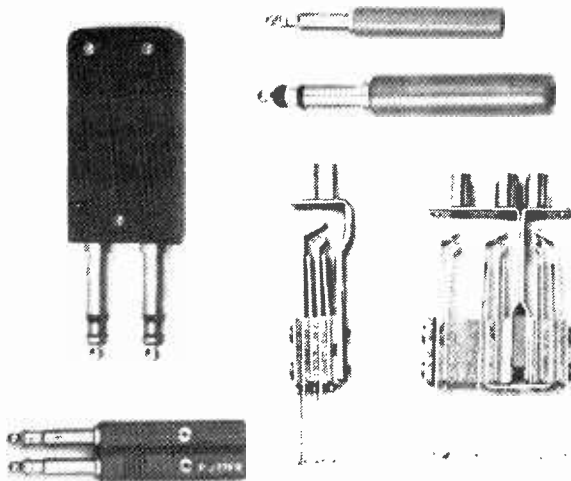

JACKS AND PLUGS

Singles . . . twins . . . back-to-back . . . 2+1 . . . patch and switchboard cords . . . in long frame and Bantam . . . and our new Printed Circuit Board Jacks . . . most standard types are available for immediate off-the-shelf delivery.

For further information on these and our range of B.P.O. type components telephone or send the attached below to:

C.A.E. LIMITED

70/82 Akeman Street
Tring, Herts. HP23 6AJ
Tel. (044-282) 4011

Telex: 82362 BATECO G

Please visit us on Stand 4332 at Communications '78 Exhibition

Please send us copy of current catalogue.

NAME
COMPANY
POSITION
ADDRESS

Tel

Design

Development

Prototype or quantity production

Wound components sub-assemblies

Professional or consumer applications

Design on our capability

Probably the best-equipped — and most experienced coil-windings specialists in Europe, Plessey Windings invites enquiries for all types of wound components and sub-assemblies.



Vicarage Lane, Ilford, Essex, England IG1 4AQ.
Telephone. (01) 478 3040. Telex: 23166.

More information, please, about coil winding

Name _____

Company _____

Position _____

Telephone _____

Please call me

A. D. BAYLISS & SON LTD.

Behind this name there's a lot of real POWER!

Illustrated right is a **TITAN DRILL**

Mounted in a multi-purpose stand. This drill is a powerful tool running on 12v DC at approx. 9000 rpm with a torque of 350 gm. cm. Chuck capacity 3.00 m/m.

The multi-purpose stand is robustly constructed of steel and aluminium. The base and bracket are finished in hammer blue.

Also available for use in the stand is the **RELIANT DRILL** which is a smaller version of the Titan. Approx. speed 9000 rpm, 12v DC, torque 35 gm. cm. Capacity 2.4 m/m.

TITAN DRILL & STAND

£19.50

+ 8% VAT = £21.06 + £1 P&P

TITAN DRILL ONLY

£8.90 + 8% VAT = £9.61 + 35p P&P

RELIANT DRILL & STAND

£16.37

+ 8% VAT = £17.68 + £1 P&P

RELIANT DRILL ONLY

£5.22 + 8% VAT = £5.64 + 35p P&P

TITAN MINI KIT DRILL

£14.78

Plus 20 Tools

+ 8% VAT = £15.93 + 50p P&P

RELIANT MINI KIT DRILL

£12.00

Plus 20 Tools

+ 8% VAT = £13.08 + 50p P&P

TRANSFORMER UNIT

£8.55

+ 8% VAT = £9.23 + 75p P&P

These are examples of the extensive range of power tools designed to meet the needs of development engineers, laboratory workers, model makers and others requiring small precision production aids.

To back up the power tools, Expo offer a comprehensive selection of Drills, Grinding Points and other tools.

SEND STAMP for full details to main distributors

A. D. BAYLISS & SON LTD., Pfera Works, Redmarley, Glos. GL19 3JU

Stockists: Richards Electric, Worcester and Gloucester; Hoopers of Ledbury; Hobbs of Ledbury; D&D Models, Hereford; Bertella, Gloucester
J. Power Services & Co. Ltd., Worcester

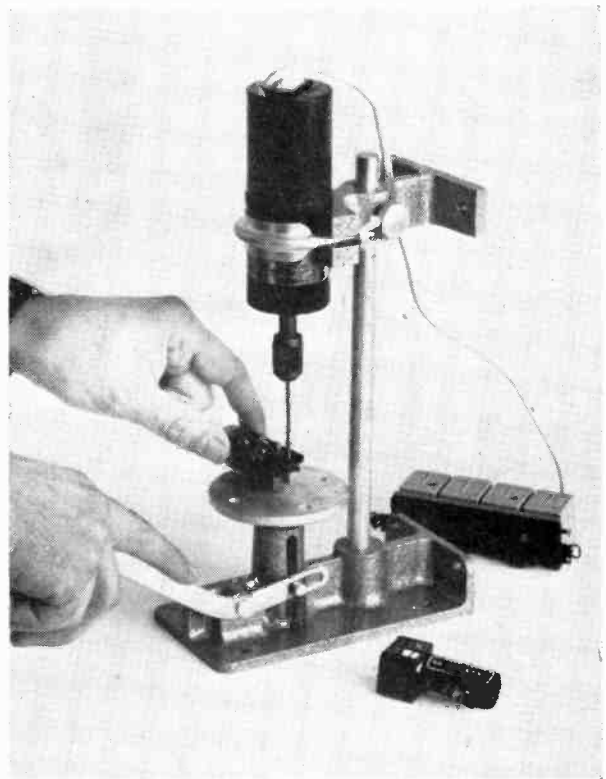

WW — 010 FOR FURTHER DETAILS

Get your copy of the Proline Professional tape recorder leaflet.

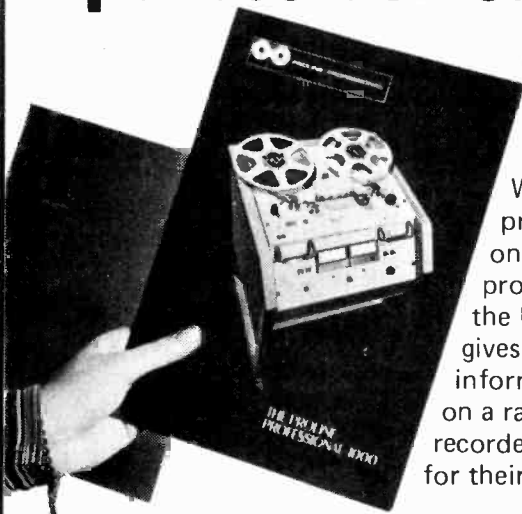

Written by professionals only for the professional, the leaflet gives full information on a range of recorders, noted for their

SOPHISTICATION WITHOUT COMPLICATION

Fill in the reader enquiry card or write to:
TONY COSTELLO OR JOHN ROBINSON
LEEVEES-RICH EQUIPMENT LTD
319 TRINITY ROAD LONDON SW18 3SL
01-874 9054

WW—029 FOR FURTHER DETAILS

Tools that fit the job

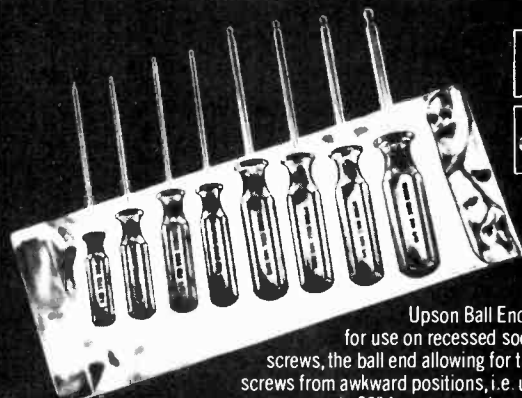

Upson Ball Ended Drivers — for use on recessed socket head hex screws, the ball end allowing for the removal of screws from awkward positions, i.e. up to approximately 30° from any angle — as illustrated.

Upson Hold-E-Zee Screwdrivers have a spring clip which fits over the screw head holding the screw in position on the driver so that it can be positioned without difficulty in awkwardly placed positions. When the screw is started, the blade can be slipped off the screwhead, the spring holder retracted and the screw tightened in the usual way.

These screwdrivers have a patented Lok-Block Handle which makes it virtually impossible, in any circumstances, for the blade to turn independently within the handle.

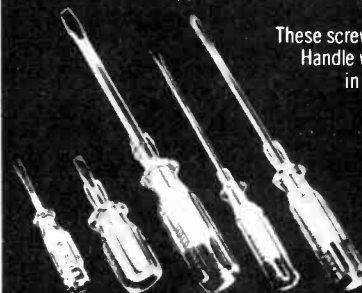

UPSON

For All Those Nasty "17"-17" Screws
In Awkward Places...

SPECIAL PRODUCT DISTRIBUTORS LTD 81 Piccadilly London W1V 0HL. Tel: 01-629 9556

WW—037 FOR FURTHER DETAILS

METER PROBLEMS?

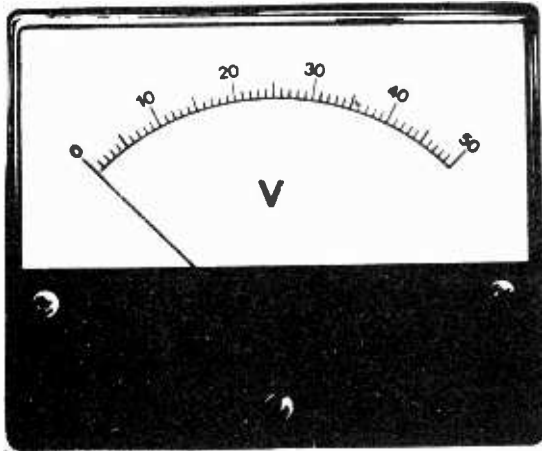

137 Standard Ranges in a variety of sizes and stylings available for 10-14 days delivery. Other Ranges and special scales can be made to order

Full Information from:

HARRIS ELECTRONICS (London)

138 GRAYS INN ROAD, W.C.1 Phone: 01/837/7937

WW-083 FOR FURTHER DETAILS

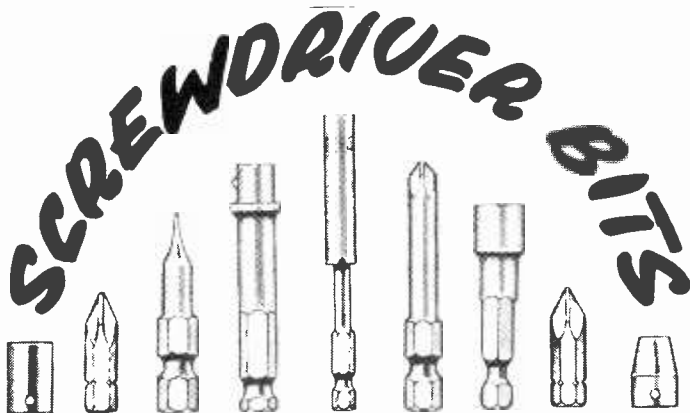

FOR POWER & HAND DRIVING

For Pozidriv, Phillips, Slotted, Torx, Hexagon, Tri-Wing, and other recess and head forms.

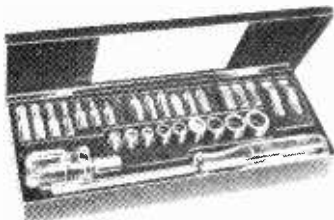

A range of Hand Screwdriving Kits is now available

Catalogue and Price List on request

HARMSWORTH

HARMSWORTH, TOWNLEY & CO. LTD.
HAREHILL TODMORDEN LANCS OL14 5JY
Phone 070-681 2601 & 070-681 5246

WW-017 FOR FURTHER DETAILS

Join the Digital Revolution

Understand the latest developments in calculators, computers, watches, telephones, television, automotive instrumentation . . .

Each of the 6 volumes of this self-instruction course measures 11 1/4" x 8 1/4" and contains 60 pages packed with information, diagrams and questions designed to lead you step-by-step through number systems and Boolean algebra to memories, counters and simple arithmetic circuits and on to a complete understanding of the design and operation of calculators and computers

Design of Digital Systems



£7.10

plus 90p packing and surface post anywhere in the world. Overseas customers should send for Proforma invoice. Payment by credit cards accepted

Also available -- a more elementary course assuming no prior knowledge except simple arithmetic
Digital Computer Logic and Electronics

In 4 volumes

£4.60

plus 90p P. & P.

- 1 Basic Computer Logic
- 2 Logical Circuit Elements
- 3 Designing Circuits to Carry Out Logical Functions
- 4 Flipflops and Registers

Offer Order both courses for the bargain price £11.10 plus 90p P. & P. A saving of £1.50.

**Designer
Manager
Enthusiast
Scientist
Engineer
Student**

These courses were written so that you could teach yourself the theory and application of digital logic. Learning by self instruction has the advantages of being quicker and more thorough than classroom learning. You work at your own speed and must respond by answering questions on each new piece of information before proceeding to the next.

FLOW CHARTS & ALGORITHMS — The Algorithm Writer's Guide — Construction, content, form, use, layout of, algorithms and flow charts. Vital for computing, training, wall charts, etc. Size A5, 130 pages. **£2.95** plus 45p p&p

Guarantee—If you are not entirely satisfied your money will be refunded.

CAMBRIDGE LEARNING ENTERPRISES, Unit 3, Freepost, RIVERMILL LODGE, ST. IVES, HUNTINGDON, CAMBS, PE17 4BR, ENGLAND. TELEPHONE ST. IVES (0480) 67446. PROPRIETORS DRAYRIDGE LTD. REG. OFFICE RIVERMILL LODGE, ST. IVES, GYRO AC. No. 278 9815 REGD IN ENGLAND NO 1328762.

Cambridge Learning Enterprises, Unit 3, Freepost
Rivermill Lodge, St. Ives, Huntingdon, Cambs, PE17 4BR, England
Please send me the following books

- sets Digital Computer Logic & Electronics @ £5 50 p&p included
- sets Design of Digital Systems @ £8 00 p&p included
- Combined sets @ £12 00 p&p included
- The Algorithm Writer's Guide @ £3.40 p&p included

Name _____
Address _____

I enclose a cheque / PO payable to Cambridge Learning Enterprises for £

Please charge my Access / Barclaycard / Visa / Eurocard / Mastercharge / Interbank account number _____

Signature _____ delete as appropriate

Telephone orders from credit holders accepted on 0480-67446 (Ansafoone). Overseas customers should send a bank draft in sterling drawn on a London Bank.

WW4

After the introduction of the CQ 110 E and CQ 301, NEC have completed their CQ-Line with the CQ 201 Digital VFO, the SP 110 Speaker and the M110 SSB Microphone. The NEC CQ-Line represents highest technical standard, with regard to design, quality, reliability and price which is available to the modern radio communicator today.

NEC CQ 110 E, 300 watts Digital transceiver Modes: FSK/USB/LSB/CW/AM, 100-240V AC/13.5DC hand mike, Control speaker, VOX Sidetone, 3 Xtal filters, Blower, RCA 7360 RX Mixer, 22 fix-channels, 60 Page Manual, 160-10 meter, 11 Ranges of 500 Khz.

NEC CQ 301 2-3 KW SSB/AM Linear Amplifier 160-10 meter, 2 EIMAC 3-500Z. Handbook, 100-240 V AC, High Speed Blower, incorp. Power Supply.

NEC CQ 201 Digital Additional VFO for Split-Frequency Operation, containing 3 VFO systems, usable as frequency counter, 100-240 V AC/13.5VDC, Handbook.

NEC SP 110 Communication Speaker with Electronical Digital Clock, timer, etc. handbook 100-240 VAC.

NEC M 110 SSB Communications Microphone, designed for CQ - Line.

Colour of CQ line brown military sand-touch.

- ★ Dealer inquiries welcome
- ★ ASK ABOUT OUR UP TO 120 DAYS FINANCING FACILITIES
- ★ ASK FOR OUR COLOUR CATALOGUE against payment of SFR 16 — or any other equivalent currency.
- ★ Shipments to EVERYWHERE



Sole distributor in Europe:

CEC Corp., Via Valdani 1 — CH 6830 CHIASSO—SWITZERLAND
Phone: (091) 44 26 51. Telex: 79959 CH

WW—011 FOR FURTHER DETAILS

Gas filled indicator tubes always available

character heights 8 -135 mm.

KGM ELECTRONICS LIMITED

Clock Tower Road, Isleworth, Middlesex TW7 6DU

Tel: 01-568 0151. Telex: 934120

WW—024 FOR FURTHER DETAILS



carbon film RESISTORS

ON BANDOLIERS OR PREFORMED 12.5mm AT NO EXTRA COST

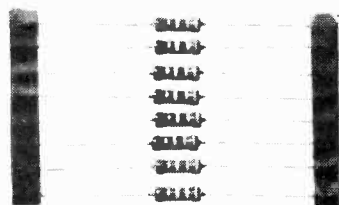

Z & I

AERO SERVICES LTD.

42-44A-46 Westbourne Grove London W2 5SF
Tel 01-727 5641 Telex 261306

WW—071 FOR FURTHER DETAILS

Keep holes neat or stop them up.

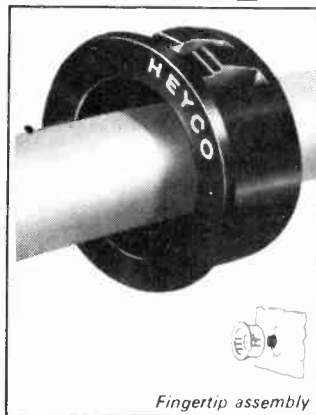

Fingertip assembly

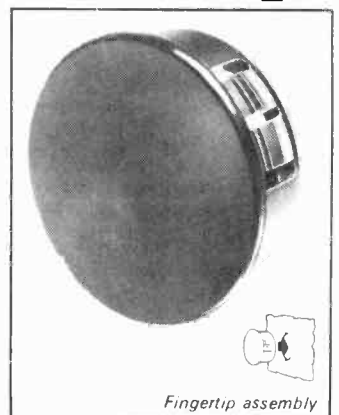

Fingertip assembly

HEYCO NYLON SNAP BUSHINGS convert sharp edges to smooth, insulated holes, quickly and easily. Snap lock into panels. 56 sizes to fit holes from $\frac{3}{16}$ " to 3" diameter.

HEYCO NYLON HOLE PLUGS seal unwanted holes neatly, quickly and easily. Low cost. Rattle-free fit. 25 sizes to fit holes from $\frac{3}{16}$ " to 2" diameter.

FREE SAMPLES

and catalogue showing our full range of bushings on request.

Heyco Manufacturing Co. Ltd.

Uddens Trading Estate, Nr. Wimborne, Dorset BH21 7NL
Tel: Ferndown (STD: 0202) 871411/2/3

© Telegrams: HEYCOMAN Wimborne. Telex: 41408

WW—084 FOR FURTHER DETAILS



WHY SETTLE FOR LESS— THAN A 6800 SYSTEM

MEMORY—

All static memory with selected 2102 IC's allows processor to run at its maximum speed at all times. No refresh system is needed and no time is lost in memory refresh cycles. Each board holds 4,096 words of this proven reliable and trouble free memory. Cost—only £80.00 for each full 4K memory.

INTERFACE—

Serial control interface connects to any RS-232, or 20 Ma. TTY control terminal. Connectors provided for expansion of up to eight interfaces. Unique programmable interface circuits allow you to match the interface to almost any possible combination of polarity and control signal arrangements. Baud rate selection can be made on each individual interface. All this at a sensible cost of only £30.00 for either serial, or parallel type

PROCESSOR—

"Motorola" M6800 processor with Mikbug[®] ROM operating system. Automatic reset and loading, plus full compatibility with Motorola evaluation set software. Crystal controlled oscillator provides the clock signal for the processor and is divided down by the MC14411 to provide the various Baud rate outputs for the interface circuits. Full buffering on all data and address busses insures "glitch" free operation with full expansion of memory and interfaces.

POWER SUPPLY—

Heavy duty 10.0 Amp power supply capable of powering a fully expanded system of memory and interface boards. Note 25 Amp rectifier bridge and 91,000 mfd computer grade filter capacitor.

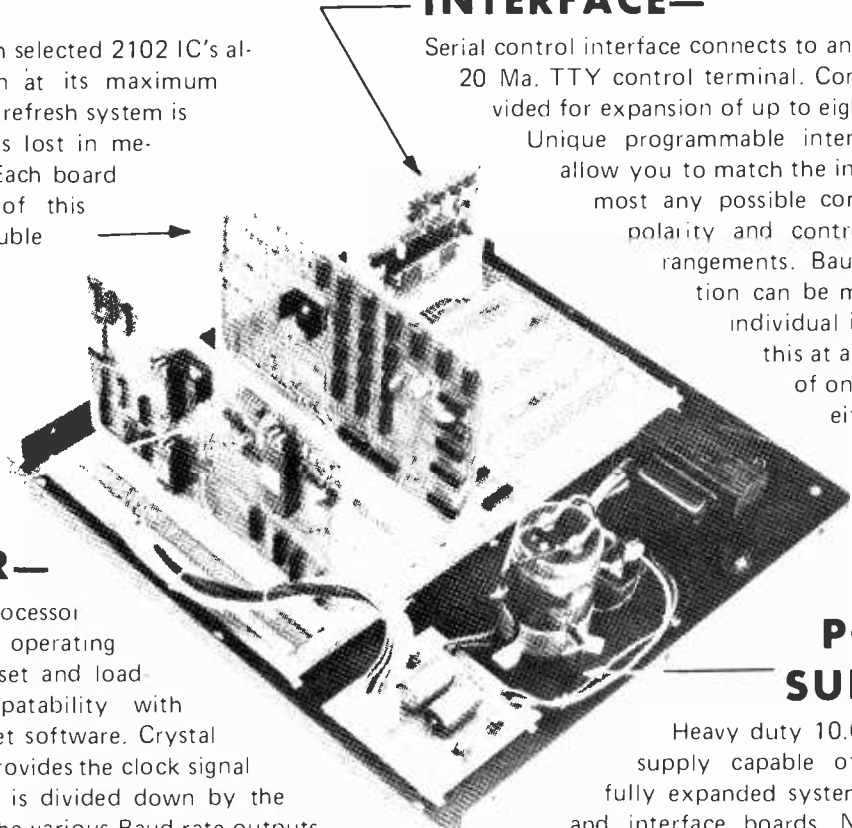

DOCUMENTATION—

Probably the most extensive and complete set of data available for any microprocessor system is supplied with our 6800 computer. This includes the Motorola programming manual, our own very complete assembly instructions, plus a notebook full of information that we have compiled on the system hardware and programming. This includes diagnostic programs, sample programs and even a Tic Tac Toe listing.

Mikbug[®] is a registered trademark of Motorola Inc.

STP 6800
Computer System

with serial interface and 4,096 words of memory. **£275.00**
(Kit form only)

PRICE EFFECTIVE 1st OCTOBER, 1977



Prices quoted do not include VAT

Please send me details of your full range of computer equipment and software.

Name

Address

.....

.....

Southwest Technical Products Co.
174 Ifield Road, London, SW10

THE **baker** QUALITY



150 watt mixer amplifier

- All purpose Bass, Lead, Rhythm Guitars, Discotheque, Vocal, Public Address, etc.
- Amplifier "Mains switch" for instant sound or muting.
- Three loudspeaker outlets for 4, 8 or 16 ohms operation.
- Four high gain inputs, each 28 mv, 50K ohm for full output.
- Individual volume controls with "Four channel" mixing facilities.
- 150 watts into 8 ohms. R.M.S. Music Power.
- Distortion less than 1% at full output.
- Slave output 500 M.V. 25 K.ohm.
- Accepts loudspeakers from 4 ohms upwards. Standard jack sockets.
- Frequency Response 25 Hz — 20kHz ± 3dB integral Hi Fi preamp
- 32dB. Variation on wide range separate Bass & Treble controls.
- Fully Short and Open circuit proof. electronic and fused.
- Compact — 16" x 8" x 5 1/2" approximately.
- Lightweight — Only 14lb. — approximately. Blue wording on Black facia.
- Made in England. 12 months' guarantee. 200/250v A.C. mains or 120V to order.
- All transistor and solid state devices.

Distributors required in certain countries and parts of UK.

Baker Loudspeakers Limited

NEW! Star sound

A high power full range quality loudspeaker produced to give exceptional reproduction. Ideal for electronic guitars, organs, public address or discotheques. This loudspeaker is recommended where high power handling is required with quality results. The high flux ceramic magnet assembly ensures clear treble response so necessary for today's musician.



GROUP 50/12 inch

Voice Coil Impedance	4 or 8 or 16 ohms
Maximum Power	60 watts (120 watts U.S.A.)
Bass Resonance	55 c.p.s.
Useful Response	30-16,000 c.p.s.
Flux Density	15,000 lines
Voice coil	1 1/2" / 38 mm
Overall diameter	12 1/2" / 310 mm
Overall depth	4 3/4" / 120 mm
Fixing holes diagonal	13" / 330 mm
Baffle aperture	11" / 280 mm
Nett weight	10 lbs / 4.5 kg

GROUP 25 12 inch

Voice Coil Impedance	4 or 8 or 16 ohms
Maximum Power	30 watts (60 watts U.S.A.)
Bass resonance	55 c.p.s.
Useful Response	30-13,000 c.p.s.
Flux density	12,000 lines
Voice coil	1 1/2" / 38 mm
Overall diameter	12 1/4" / 310 mm
Overall depth	4 3/4" / 120 mm
Fixing holes diagonal	13" / 330 mm
Baffle aperture	11" / 280 mm
Nett weight	5 lbs / 2.3 kg

GROUP 35 12 inch

Voice Coil Impedance	4 or 8 or 16 ohms
Maximum Power	40 watts (80 watts U.S.A.)
Bass Resonance	55 c.p.s.
Useful Response	30-13,000 c.p.s.
Flux Density	14,000 lines
Voice coil	1 1/2" / 38 mm
Overall diameter	12 1/4" / 310 mm
Overall depth	4 3/4" / 120 mm
Fixing holes diagonal	13" / 330 mm
Baffle aperture	11" / 280 mm
Nett weight	6 lbs / 2.7 kg

GROUP 50 15 inch

Voice Coil Impedance	8 or 16 ohms
Maximum Power	75 watts (150 watts U.S.A.)
Bass Resonance	45 c.p.s.
Useful Response	30-13,000 c.p.s.
Flux Density	15,000 lines
Voice coil	2" / 51 mm
Overall diameter	15 1/2" / 390 mm
Overall depth	6" / 153 mm
Fixing holes diagonal	16 3/8" / 417 mm
Baffle aperture	11" / 280 mm
Nett weight	15 lbs / 6.8 kg

337 Whitehorse Road, Croydon, Surrey, England

Telephone: 01-684 1665

FAST RESPONSE STRIP CHART RECORDERS

Made in USSR

Series H3020

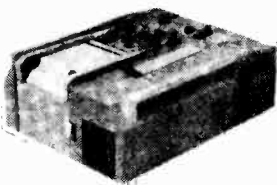

Basic error: 2.5%
Sensitivity: 8mA F.S.D.
Response: 0.2 sec.
Width of each channel:
Single and three-pen recorders: 80mm
Five-pen recorders: 50mm

Chart speeds, selected by push buttons: 0.1-0.2-0.5-1.0-2.5-5.0-12.5-25 mm/sec.
Chart drive: 200-250V 50Hz
Recording: Syphon pen directly attached to moving coil frames. Curvilinear co-ordinates.
Equipment: Marker pen, timer pen, paper footage indicator, 10 rolls of paper, connectors, etc.

- H3020-1 (Single pen):** 285mm wide x 384mm deep x 165mm high **PRICE £108.00**
- H3020-3 (Three pen):** 475mm wide x 384mm deep x 165mm high **PRICE £160.00**
- H3020-5 (Five pen):** 475mm wide x 384mm deep x 185mm high **PRICE £295.00**

Series H327

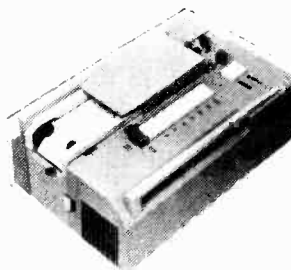

Polarized moving iron movements with syphon pens directly attached. Built-in solid state amplifier (one per channel) provides 8 calibrated sensitivity steps. Two marker pens are provided.
Basic error 4%. Frequency response from DC to 100Hz 2dB.

Sensitivity: 0.02 - 0.05 - 0.1 - 0.2 - 0.5 - 1 - 2 - 5 volts/cm
Width of each recording channel: 40mm
Chart drive: 220-250V 50Hz
Chart speeds: 1-2.5-10-50-125-250mm/sec.

- Type H327-1. Single pen:** Dimensions: 259 x 384 x 165mm
Weight 15 kilos **PRICE £265.00**
- Type H327-3. Three pen:** Dimensions 335 x 384 x 165mm
Weight 20 kilos **PRICE £520.00**
- Type H327-5. Five pen.** Dimensions: 425 x 385 x 165mm.
Weight 25 kilos **PRICE £770.00.**

Note: Prices are exclusive of VAT

Available for immediate delivery

Z & I AERO SERVICES LTD.

44A WESTBOURNE GROVE, LONDON W2 5SF

Tel. 01-727 5641

Telex: 261306

WW-072 FOR FURTHER DETAILS

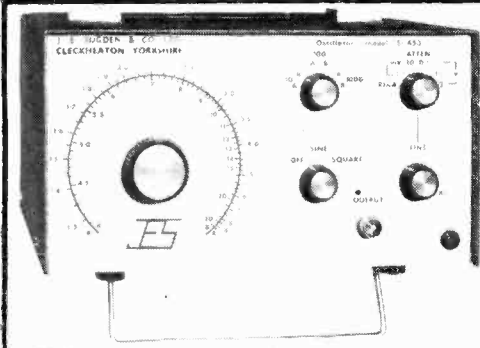

JES AUDIO INSTRUMENTATION

Illustrated the Si453 Audio Oscillator

SPECIAL FEATURES:

- ★ very low distortion content—less than 0.03%
- ★ an output conforming to RIAA recording characteristic
- ★ battery operation for no ripple or hum loop
- ★ square wave output of fast rise time

£60.00

also available

Si451 Millivoltmeter

- ★ 20 ranges also with variable control permitting easy reading of relative frequency response

£60.00

Si452 Distortion Measuring Unit

- ★ low cost distortion measurement down to 0.01% with comprehensive facilities including L.F. cut switch, etc

£48.00

ALL PRICES PLUS VAT

J. E. SUGDEN & CO. LTD., CARR STREET, CLECKHEATON, W. YORKS. BD19 5LA.

Tel. 0274-872501

WW—065 FOR FURTHER DETAILS

TWO NEW SUPERMODULES: 170W INTO 4 OR 8 OHMS

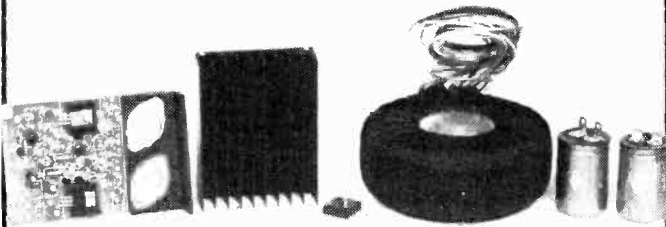

By popular demand we have designed higher powered versions of our well known modules. The CE 1704 which gives 170W into 4 ohms and the CE 1708 which gives 170W into 8 ohms are physically similar to the original types and have the same combination of compatible performance features which makes CRIMSON amplification audibly superior to the competition and the only choice if you have an ear for music. We have also produced suitable power supplies which again use our superb TOROIDAL TRANSFORMERS only 50mm high, with a 120-240 primary and single bolt fixing. Write or phone for more information and biased opinions.

POWER AMPLIFIER MODULES

	Home	Europe
CE 608 60W/8 ohms 35-0-35V	£16.30	£16.60
CE 1004 100W/4 ohms 35-0-35V	£19.22	£19.30
CE 1008 100W/8 ohms 45-0-45V	£23.22	£23.30
CE 1704 170W/4 ohms 45-0-45V	£29.12	£28.46
CE 1708 170W/8 ohms 60-0-60V	£31.90	£31.04

TOROIDAL POWER SUPPLIES

CPS 1 for 2xCE or 1xCE 1008	£14.47	£18.40
CPS 2 for 2xCE 1004 or 2xCE 608	£16.82	£20.57
CPS 3 for 2xCE 1008 or 1xCE 1704	£17.66	£21.35
CPS 4 for 1xCE 1008	£15.31	£19.18
CPS 5 for 1 x CE 1708	£22.68	£26.50
CPS 6 for 2 x CE 1704 or 2 x CE 1708	£23.98	£27.70

HEATSINKS

Light Duty 50mm 2 C/W	£0.90	£1.30
Medium Power 100mm 1.4 C/W	£1.60	£2.40
Osco/Group 150mm 1.1 C/W	£2.30	£3.65

THERMAL CUT-OUTS

Recommended for improved reliability		
70°C for use with free air heatsink	£1.60	£1.90
40°C for use with fan cooled heatsink	£1.60	£1.90

T.H.O. : Typically < .02 any power. 1kHz. 8 ohms
 T.J.D. : insignificant
 Slew rate limit : 20V/μS
 S/N ratio : 110dB
 Freq. response : 10Hz-35kHz, -3dB
 Stability : Unconditional
 Protection : Drives any load safely
 Sensitivity : 775mV (250mV or 100mV on request)
 Size : 120 x 80 x 25mm

CRIMSON ELEKTRIK

Please note our new address and telephone number:
**Stamford House, 1A Stamford Street,
 Leicester LE1 6NL. Telephone: (0533) 537722**

Home prices include V.A.T. & postage. C.O.D. 90p extra. £100 limit. Export no problem. European prices include carriage, insurance and handling, payment in Sterling by bank draft. P.O. International Giro or Money Order. Outside Europe please write for specific quote by return. Send SAE or two International Reply Coupons for full literature. Favourable trade quantity price list on request. High quality pre-amp circuit 20p.

WW 047—FOR FURTHER DETAILS

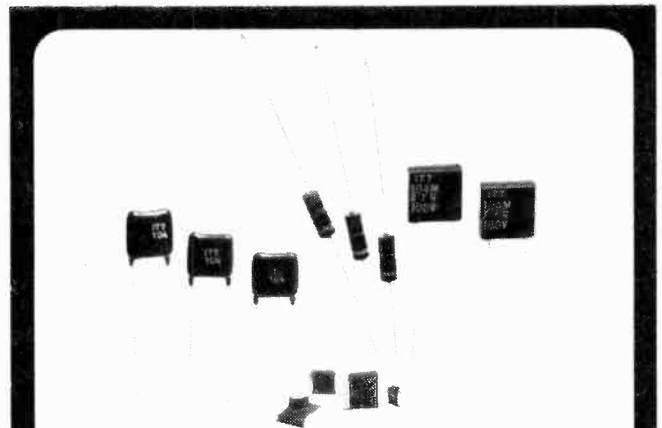

MULTILAYER CERAMIC CAPACITORS

- ★ STYLES - Chips: 12 rectangular 4 discoidal - Radial Lead: 3 moulded 9 dipped - Axial Lead: 2 moulded 2 glass encased
- ★ DIELECTRICS - COG, X7R, Z5U
- ★ VOLTAGES - 200, 100, 50
- ★ APPROVALS - BS 9075 N023, N024, N025 BS 9075 F005, F022

- ★ NEW CATALOGUE AVAILABLE
- Send for your copy now

UK DISTRIBUTORS:
 ITT Electronic Services: 0279 26777
 Intel Electronics Ltd: 0462 812 505
 Compstock: 0268 27722

ITT Components Group Europe
MULTILAYER CERAMICS DIVISION
 South Denes, Great Yarmouth, Norfolk NR30 3PX.
 Tel: 0493 56122. Telex: 97421. Cables: Resistor.

Components **ITT**

WW—074 FOR FURTHER DETAILS

Decade Boxes

Professional Quality Instruments
 at a price you can afford



CHOOSE FROM OVER 60 MODELS MADE BY BRITAIN'S BEST SELLING MANUFACTURER OF DECADA BOXES

TYPICAL MONEY SAVING MODELS:—

Cat. Ref.	Average Accuracy 0.4%	
J70	Seven Decade 0 to 11,111,110 by 1 ohm steps	£54.50
J60	Six Decade 0 to 1,111,110 by 1 ohm steps	£46.40
J2	Five Decade 0 to 111,110 by 1 ohm steps	£38.10
J4	Four Decade 0 to 11,110 by 1 ohm steps	£31.00
J6	Three Decade 0 to 1,110 by 1 ohm steps	£25.60

CAPACITANCE DECADA BOXES (Accuracy 1% 500 Vdc.)

JC2	Three Decade 30 - 11,140 pF infinite resolution	£29.10
-----	---	--------

Prices subject to V.A.T. ex-works

J.J. LLOYD INSTRUMENTS LIMITED
 Brook Avenue · Warsash · Southampton SO3 6HP England
 INSTRUMENTS Tel: Locks Heath 4221 Telex: 477042 JAY JAY - SOTON

WW—027 FOR FURTHER DETAILS

EUROTECH

MISCELLANEOUS

Grubb Parsons Type IRG A20 Analyser	£480
6v 25 Amp. Power Supply Units	£25
D.M. Digital Voltmeter, Type 2022S	£240
Electro Scientific Industries Portametric PVB 300	£180
Stanley Lab. Counter Timer SL111	£100

OSCILLOSCOPES

TEKTRONIX

Type 551 with Power Supply	£300
Type 545A with 1A2 Dual Trace Amp	£485
Type 585 with Type 82 Dual Trace	£550
Type 581A with Type 82 Dual Trace	£550
Plug in Modules	
Type CA, G, H, L, K	£80 each
Type 3A75 Amp. 4MHZ	£80
3A8 Operational Amp	£75
3T77 and 3S76 Sampling	£250
82 Dual Trace Amp	£135

FLUKE EQUIPMENT

883 Differential Voltmeter	£1340	540B Thermal Transfer Standard	£1425
895 Differential Voltmeter	£1485	6011 Synthesiser 10HZ-10MHZ	£3045
931B Differential Voltmeter	£1260	6160B 180 MHZ Synthesiser	£4735
8375 D.V.M	£1620	2240Data Logger with Options 05, 06, 07, 08	P.O.A.
1900/01 Battery Operated Counter	£210	2240AData Logger with Options 05, 06, 07, 08	P.O.A.
1920/06 520 MHZ Counter	£604		
1953B 520 MHZ Counter Timer	£585		
1953/10 Counter plus HF Option	£862		
1953/7 and /10 Counter H.F. with prescaler	£937		

Virtually brand new

THE TEST EQUIPMENT BROKERS
EQUIPMENT SOLD, PURCHASED, RENTED, LEASED
ALL PRICES EXCLUDE VAT AND CARRIAGE
TEL. NEWPORT 0633 211243.

EUROTECH
25 CHEPSTOW ROAD
NEWPORT, GWENT, U.K.

WW-013 FOR FURTHER DETAILS

Wilkinsons RELAYS

B.P.O. TYPE 3000 AND 600

Built to your specification. Highest quality at competitive prices with quick delivery service. Quotations by return home and overseas. Ask us first for Telecommunication Components. Now available JACK-IN RELAY MOUNTINGS these jack-in and strip mountings are used primarily to house relays and associated components. The mountings are drilled to accept the B.P.O. type 3000 relay or any other equipment using similar drawings. They are available with up to 32 relay positions and the price range is from £5 each. We are suppliers of Single and Double Pole High Speed Relays B.P.O. No. 9 and 12 Resistor Coils to B.P.O. Standards.

We can also supply your requirements in stock quantity orders for a wide range of components including 2000 and 4000 type two motion selector mechanisms complete. Contact us today for all your parts needs.

APPARATUS RACKS highest quality steel Post Office standard open type 7H, or 9H, available, drilled for 19 inch panels with base and cable fixing clamps. £25 each.

B.P.O. No. 2 Unselectors 10 Bank 5 Pole 50 Way all non-bridging wipers 50 volts £10 each.

HIGH SPEED COUNTER 10 counts per second with four digits size 3 1/4" x 3 1/4" available in the following DC voltages 6, 12, 24, 50 or 100 volts £1.75 each, also available with five digits £2.75 each.

In stock now, immediate delivery Transformers TR3 215A/216A £5 ea., 480A £4 ea., Rectifiers 1/12A2 etc. 35p ea., u Plug No. 1506 25p ea., Plugger Key P.O. 308 35p ea., Lamp Jack P.O. type for labular bulbs 35p ea.

L. WILKINSON (CROYDON) LTD., LONGLEY HOUSE, LONGLEY ROAD, CROYDON, CR0 3LH
Phone: 01-684 0236. Grams: WILCO CROYDON

WW-005 FOR FURTHER DETAILS

QUARTZ CRYSTALS - FAST!



AEL

AEL CRYSTALS LIMITED
 Gatwick House, Horley, Surrey, England RH6 9SU
 Telephone: Horley (02934) 5353 Telex: 87116 (Aerocon Horley)
 Cables: Aerocon Telex Horley

WW - 008 FOR FURTHER DETAILS

INSTANT CIRCUIT CONSTRUCTION

SOLDERLESS BREADBOARDING

THE SK 10 BREADBOARDING SOCKET OFFERS THESE ADVANTAGES:

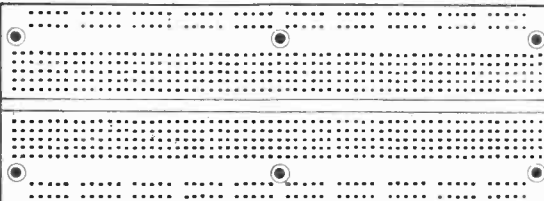

- Multi-power busses
- 64 pairs of nickel silver contact
- 5 milliohm standard contact resistance
- 20-26 gauge wire

All SK 10 sockets carry a lifetime guarantee. If a unit ever fails in normal usage,

return it to us for a free replacement.

No questions asked. Ask for full catalogue of E & L digital learning products.



Special offer to cash with order customers

£12.50

inc VAT & P&P

E & L INSTRUMENTS UK.

62, Queen Anne St, London W1M 9LA. Tel: 01-486-3589.

WW - 014 FOR FURTHER DETAILS

www.americanradiohistory.com

WILMSLOW AUDIO

The firm for Speakers

HI-FI DRIVE UNITS



PA GROUP & DISCO UNITS



WILMSLOW AUDIO

KITS FOR MAGAZINE DESIGNS etc.



SPEAKER KITS

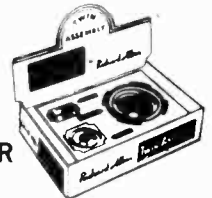

Audax HD12 9 D25	£7.50
Audax HD13 D34H	£12.50
Audax HD20 B25H4	£14.65
Audax HD20B25J4	£10.95
Audax HD11 P25EBC	£6.95
Baker Superb	£22.50
Castle BRS/DD	£11.95
Chartwell CE205 8" bass, matched pairs only	pairs 59.00
Coles 4001	£5.90
Coles 3000	£6.25
Celestion HF1300 II	£7.50
Celestion HF2000	£9.75
Dalesford D20/105 4"	£10.95
Dalesford D30/110 5"	£10.95
Dalesford D50/513 6 1/2"	£11.15
Dalesford D50/200 8"	£11.95
Dalesford D70/250 10"	£24.95
Dalesford D100/310 12"	£34.95
Decca London	£37.25
Decca CO/1000/8	£7.95
Decca DK30	£24.50
E.M.I. type 350 4 ohm	£9.25
E.M.I. 14A/770 14" x 9"	£12.50
E.M.I. 8" x 5" d/c 10 watt	£3.95
Goodmans Axent 100	£8.50
Isophon KK10 8	£8.25
Isophon KK8/8	£7.50
Jordan Watts Module	£17.95
Jordan 50mm Unit	£22.50
Jordan CB Crossover	£22.50
KEF T27	£8.50
KEF T15	£10.75
KEF B110	£10.95
KEF B200	£11.95
KEF B139	£24.95
KEF DN13	£4.95
KEF DN12	£7.25
Lowther PM6	£43.95
Lowther PM6 MKI	£45.90
Lowther PM7	£78.95
Peerless DT10HFC	£9.50
Peerless K010D1	£8.25
Peerless K040MRF	£10.50
Radford BD25 II	£26.95
Radford MD9	£14.50
Radford MD6	£17.95
Radford FN8/FN831	£19.95
Richard Allan CG81	£8.95
Richard Allan CG121 Super	£19.50
Richard Allan HP88	£13.50
Richard Allan LP88	£9.25
Richard Allan HP12B	£21.50
Richard Allan DT20	£6.25
Richard Allan DT30	£6.95
Shackman Electrostatic c/c polar network & x o	pair £99.90
Tannoy HPD 295A	£83.00
Tannoy HPD 315A	£93.00
Tannoy HPD 385A	£110.00

Baker Group 25	£13.00
Baker Group 35	£14.50
Baker Group 50/12	£21.00
Baker Group 50/15	£25.75
Celestion G12M	£12.95
Celestion G12H	£16.95
Celestion G15C	£27.95
Celestion G18C	£41.95
Celestion G12/75	
(alum. dome)	£22.50
Celestion G12/75 (d/cone)	£24.50
Celestion G12M/50	
(cambric edge)	£16.95
Celestion G15/100	
(alum. dome)	£33.75
Celestion MH1000	£13.50
Celestion Powercell 12"/100	£45.95
Celestion Powercell 15"/100	£48.95
Celestion Powercell 15"/125	£51.95

Fane Pop 3:1	£10.95
Fane Pop 50	£12.50
Fane Pop 55	£16.95
Fane Pop 60	£19.95
Fane Pop 70	£21.95
Fane Pop 100	£35.95
Fane J44 horn	£6.50
Fane J104 horn	£13.75
Fane J73 horn	£9.75
Fane Guitar 80L	£19.75
Fane Guitar 80B	£19.95
Fane Disco 80	£21.50
Fane PA80	£19.50
Fane Bass 85	£29.95
Fane Crescendo 12A	£42.95
Fane Crescendo 12B	£44.95
Fane Crescendo 15/100	£54.95
Fane Crescendo 15/125	£64.95
Fane Crescendo 18	£75.95
Fane 920 II Horn	£45.95
Fane HPX1/HPX2	£2.50
Fane PH50	£7.50

Goodmans 8PA	£3.95
Goodmans 10P	£6.95
Goodmans 12P	£16.95
Goodmans 12PD	£18.95
Goodmans 12PG	£18.25
Goodmans 18P	£39.95
Goodmans 50HX	£18.95

Motorola Piezo Horn	£8.50
Richard Allan HD8T	£12.95
Richard Allan HD10T	£13.25
Richard Allan HD12T	£18.75
Richard Allan HD15	£29.95
Richard Allan HD15T	£30.50

Kits include drive units, crossovers, BAF/Long fibre wool, etc. for pair of speakers. Carriage £3 50

Practical HiFi & Audio PRO9-TL (Rogers) £118.00

Felt panels for PRO9-TL £5.50 + £1 50 p&p

HiFi Answers Monitor (Rogers) £129.00

HiFi News State of the Art (Atkinson) £161.00

HiFi News No Compromise (Frisby) £126.00

Popular HiFi Mini Monitor (Colloms) £63.00

Practical HiFi & Audio Monitor (Giles) £119.00

Practical HiFi & Audio Triangle (Giles) £76.00

Practical HiFi & Audio BSC3 (Rogers) £60.00

HiFi News Tabor (Jones) £57.75

HiFi News Tabor (with H4 bass units) £65.00

Wireless World Bookshelf (Wilkinson) £56.50

Wireless World T L / KEF (Bailey) £112.00

Wireless World T L / Radford (Bailey) £154.00

Send 3 x 7p stamps for reprints/construction details of any of above designs.

Prices per pair Carriage £2 50

Dalesford System 1 £52.90

Dalesford System 2 £55.75

Dalesford System 3 £101.75

Dalesford System 4 £108.00

Dalesford System 5 £139.00

Dalesford System 6 £93.00

Eagle SK210 £13.90

Eagle SK215 £23.50

Eagle SK320 £33.50

Eagle SK325 £57.00

Eagle SK335 £70.90

Goodmans DIN20 £31.50

Goodmans Mezzo Twinkit £51.95

Lowther PM6 Kit £91.75

Lowther PM6 MKI Kit £96.50

Peerless 1060 £61.50

Peerless 1070 £109.90

Peerless 1120 £123.00

Peerless 2050 £43.95

Peerless 2060 £58.50

Radford Studio 90 £154.00

Radford Monitor 270 £208.00

Radford Studio 270 £275.00

Radford Studio 360 £390.00

Richard Allan Twin £29.90

Richard Allan Triple 8 £45.50

Richard Allan Triple 12 £55.90

Richard Allan Super Triple £65.90

Richard Allan RAB £42.75

Richard Allan RAB2 £67.75

Richard Allan RAB2L £73.50

Seas Mini £21.95

Seas 203 £35.50

Seas 302 £43.90

Seas 303 £73.90

Seas 503 £111.90

Wharfedale Denton 2XP £26.95

Wharfedale Linton 3XP £41.95

Wharfedale Glendale 3XP £56.95

Everything in stock for the speaker constructor!

BAF, long fibre wool, foam, crossovers, felt panels, components, etc.

Large selection of grille fabrics (Send 15p in stamps for fabric samples)

(Prices correct at 1/1/78)

CARRIAGE & INSURANCE

Tweeters, Crossovers 40p each

Speakers up to 10" 75p each

Speakers 12" £1.25 each

Speakers 15" £2.00 each

Speakers 18" £2.95 each

Speaker Kits £2.50 pair

Mag. design kits £3.50 pair

SWIFT
OF WILMSLOW
The firm for Hi-Fi
5 Swan Street,
Wilmslow, Cheshire.

Send 15p stamp for free 38 page catalogue 'Choosing a Speaker'

Telephone: Speakers, Mail Order and Export:
Wilmslow 29599 Hi-Fi: Wilmslow 26213

Lightning service on telephoned credit card orders!

WILMSLOW
AUDIO
The firm for Speakers
Swan Works, Bank Square,
Wilmslow, Cheshire.

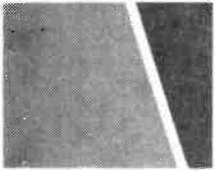

fact:
the IV does more...
much more!



new! Shure V15 Type IV
SUPER TRACK IV™
 Stereo Dynetic® Pickup Cartridge

Era IV begins! The new Shure V15 Type IV cartridge is an altogether new pickup system that exceeds previous cartridge performance levels by a significant degree. It systematically solves not one, but several problems prevalent in modern disc sound reproduction.

Demonstrably improved trackability across the audible and subaudible range at ultra-light tracking forces

The V15 Type IV has a new stylus assembly design for dramatically increased trackability. The effective stylus mass has been lowered significantly by utilizing a telescoped shank structure and a new lightweight high-energy magnet. The reduced effective mass of the new structure helps improve trackability in the critical mid and high frequencies. A newly designed two-function bearing system has been independently optimized for low frequencies and for high frequencies so that trackability is enhanced across the audio spectrum.

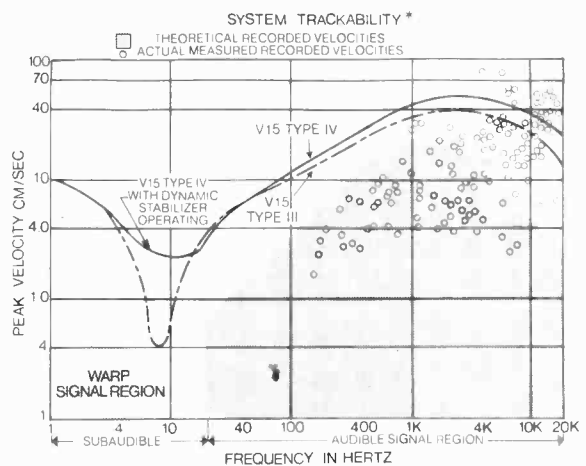

*Cartridge-tone arm system trackability as mounted in SME 3009 tone arm at 1 gram tracking force.

See top of next page

WW-064 FOR FURTHER DETAILS

The shaded area at right in the Trackability chart on preceding page represents recommended theoretical limits of record cutting velocities. However, the scattered points are the "hottest" recorded velocities actually measured on today's difficult-to-track records. The new V15 Type IV tracks far more of the "hottest" points at a low stylus force than any other existing cartridge! (The curve shown is for 1 gram tracking force. By increasing this to 1¼ grams, even more of these points—which encompass virtually all records produced thus far—will be tracked.)

Dynamically stabilized tracking that overcomes record warp problems
Our war on warp...

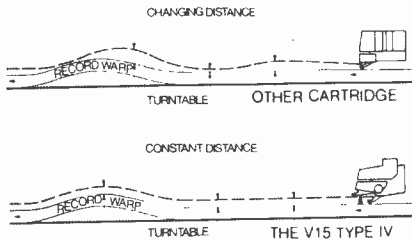

The warp problem

Note the shaded area (at bottom left of the Trackability chart at left) which represents actual warp signals found on records, and the revolutionary subaudible warp trackability characteristics of the SUPER TRACK IV. Reactions of the playback system to these very low frequency warps (between 0.5 and 8 Hz) existing on virtually all recordings can result in gross changes in the distance between the cartridge and the record. This distance change alters the stylus tracking force and the vertical tracking angle and can result in groove skipping, cartridge bottoming, signal wow, and even amplifier and/or speaker overload. Trackability at all frequencies is diminished by these warp-caused changes in tracking force!

Also, at some very low frequency (from 5 to 15 Hz), the tone arm-cartridge combination has a resonance frequency. When this resonance frequency is excited by the warp, all the above symptoms are intensified.

The Super Track IV® total design solution:

A viscous-damped Dynamic Stabilizer on the V15 Type IV combines with a new stylus assembly to minimize or completely eliminate warp-related problems. It raises the arm-cartridge resonance frequency and attenuates the arm-cartridge system resonance effect.

An electrostatically-neutralized record surface

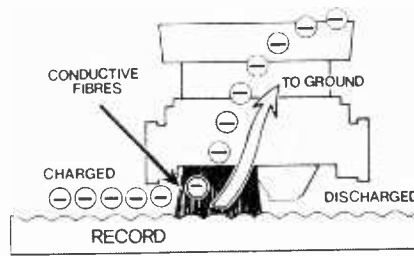

The static problem:

Static charges are omnipresent and unevenly distributed on all records. These charges can attract the cartridge unevenly and change the arm-to-record distance, the vertical tracking angle, and stylus tracking force. The result is wow and flutter. Also, static discharge through the stylus and amplifying system can be a cause of annoying pops and clicks.

The Super Track IV total design solution:

Electrically conductive fibres in the Dynamic Stabilizer of the V15 Type IV ride on the surface of the record and continuously sweep the grooves just ahead of the stylus. This picks up the static electricity and discharges it to ground, much like a miniature lightning rod. The record surface is thus electrically neutralized. The static charge is prevented from affecting the arm-to-record distance, or from causing static noise in the system. Discharging the static stabilizes tracking force during the entire record playing process and does away with the electrostatic attraction of dust to the record surface.

In addition, the conductive fibres effectively sweep the record surface to remove loose dust and lint.

Ultra-flat response

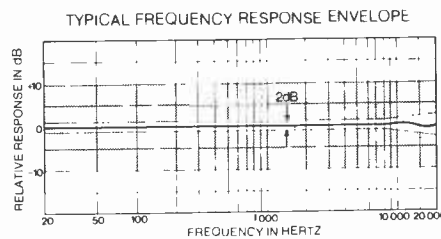

Each V15 Type IV cartridge is individually tested for frequency response that is well within the 2 dB envelope shown here.

Dramatically reduced distortion

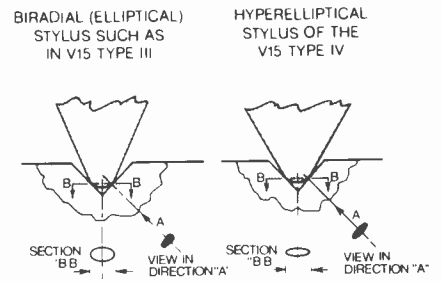

The Hyperelliptical nude diamond tip configuration of the V15 Type IV represents a significant advance in tip design for stereo sound reproduction. As the above figures show, its "footprint" (represented by the black oval) is longer and narrower than the traditional Biradial (Elliptical) and narrower than long-contact shapes (such as the Hyperbolic). This results in an optimized tip-groove contact area and dramatically reduces both harmonic distortion (white bars in graph) and intermodulation distortion (black bars).

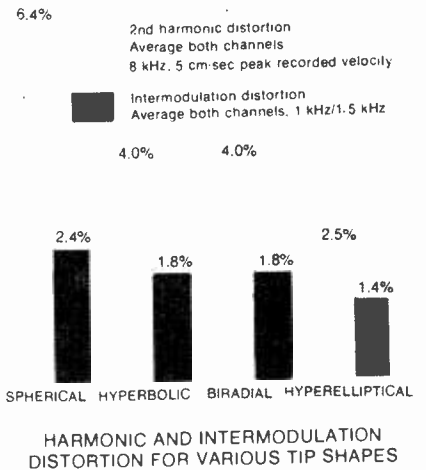

HARMONIC AND INTERMODULATION DISTORTION FOR VARIOUS TIP SHAPES

Hear this singularly musical, technically unsurpassed, and supremely uniform new pickup system at your high fidelity dealer's showroom, or write for the complete story.



Shure Electronics Limited, Eccleston Road, Maidstone ME15 6AU
Telephone: Maidstone (0622) 59881

THE JAMES SCOTT INDUSTRIAL MICROWAVE RANGE OF EQUIPMENT

The James Scott range of Microwave equipment offers industrial users a greater choice of alternative systems in robust, industrial, cast aluminium housings, for a wide variety of applications.

The range is made up of standard sub-assemblies which can be permuted to suit individual application requirements. Here are some suggested applications for these units.

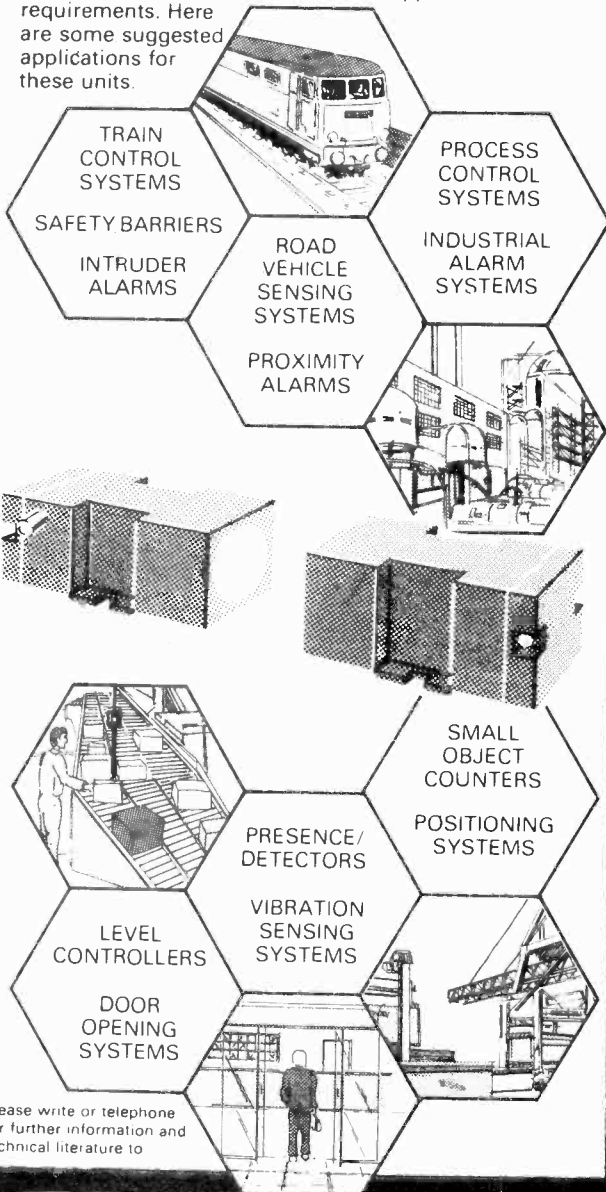

Please write or telephone for further information and technical literature to

JAMES SCOTT
(Electronic Engineering) Ltd
 CARNTYNE INDUSTRIAL ESTATE
 GLASGOW G32 6AB Tel: 041-778 4206 Telex 778286

WW-079 FOR FURTHER DETAILS

LOWE ELECTRONICS LTD.

119 CAVENDISH ROAD, MATLOCK, DERBYSHIRE

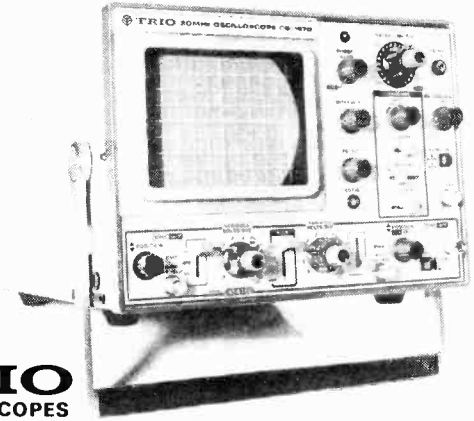

TRIO OSCILLOSCOPES

The Trio CS1500 series oscilloscopes offer top performance at moderate cost. The specifications show the performance features that have made these oscilloscopes firm favourites in all parts of the world, with a selection of bandwidths to 30 MHz and sensitivities down to 5mV/cm on a 130 mm screen. Prices are very realistic and more so when you learn that the price includes two full bandwidth X10/X1 dual purpose probes — normally offered as expensive options. Delivery is even better — ex stock and we intend to keep it that way.

CS-1570 130mm DUAL TRACE TRIGGERED SWEEP OSCILLOSCOPE

£430 + 8% VAT
 including two X10 Full Bandwidth Probes

- 130mm mesh PDA
- DC 30MHz / 5mV
- Delay line
- Auto level triggering
- Display modes (CH1 CH2 DUAL ADD)
- Trigger modes (AC LF Rej HF Rej DC)

SPECIFICATION	
Bandwidth	DC to 30MHz (—3dB)
Deflection factor	5mV/div to 5V/div
Input R.C	1MΩ 24pF
Risetime	11.7nsec
Overshoot	Better than 3%
Signal delay	160nsec
Polarity	CH2 can be inverted
Sweep time	0.2μs/div to 0.5s/div
Magnifier	x 5
Linearity	Better than 3%
Calibrator	0.5Vpp (1kHz square wave)
Intensity modulation	More than 5Vpp
Phosphor	P31
Power	AC 100 / 120 / 220 / 240V
Dimensions	50/60Hz 25W
Weight	W260 x H190 x D375 (mm)
	8.5kg

Also available
 CS1560A 15MHz
 CS1562 10MHz

£300 And many more items of Trio Equipment
£250 55p for full catalogue and price list

TEL. 0629 2430 OR 2817. TELEX 377482 LOWLEC G

WW-045 FOR FURTHER DETAILS

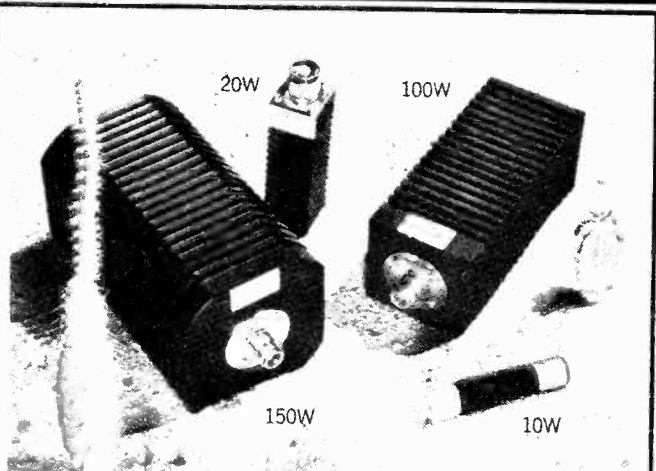

PAY LESS FOR LOADS?

With nearly 3 decades of experience built into every TERMINALINE® Coaxial Load Resistor, buying BIRD will often cost no more or save you money. BIRD QC Quick-Change Connectors on any models offer a choice of any common RF connector, eliminating the need for performance-degrading adapters. Twenty aircooled (1W to 2.25W), thirteen aircooled liquid loads (2DW to 5kW) and nineteen watercooled TERMINALINE® models (1kW to 50kW) are listed in our 1978 Catalogue.

UK REPRESENTATIVE FOR BIRD ELECTRONIC

aspen
 electronics limited

2 KILDARE CLOSE EASTCOTE MIDDLESEX HA4 9UR
 Tel: 01-868 1188 Telex 8812727

WW-076 FOR FURTHER DETAILS

CHROMASONIC electronics

56A Fortis Green Road
Muswell Hill London N10 3HN
Telephone 01-883 3705

C-MOS

4000	.18*	4049	.58*	7442	.52*
4001	.18*	4050	.58*	7445	.70*
4002	.18*	4051	.86*	7447	.59*
4006	1.09*	4052	.86*	7448	.65*
4007	.19*	4060	1.16*	7451	.16*
4009	.62*	4068	.22*	7470	.27*
4010	.62*	4070	.22*	7472	.22*
4011	.18*	4071	.22*	7473	.27*
4012	.21*	4081	.22*	7474	.27*
4013	.53*	4082	.22*	7475	.40*
4014	1.00*	4510	1.24*	7476	.30*
4015	.97*	4511	1.54*	7485	.76*
4016	.58*			7486	.27*
4017	.97*			7489	2.32*
4018	.97*			7490	.38*
4019	.58*			7492	.41*
4020	1.08*	7400	.16*	7493	.41*
4021	.97*	7401	.16*	74107	.27*
4022	.88*	7402	.16*	74121	.27*
4023	.19*	7403	.16*	74123	.49*
4024	.78*	7404	.17*	74141	.65*
4025	.19*	7408	.19*	74145	.65*
4026	1.76*	7410	.16*	74151	.49*
4027	.58*	7413	.27*	74154	.85*
4028	.87*	7420	.16*	74174	.72*
4029	1.18*	7427	.28*	74192	.86*
4040	1.08*	7430	.16*	74193	.86*
4042	.93*	7441	.56*	74196	.97*

TTL

You can combine C-MOS & TTL for quantity discounts.
25 plus less 5%. 100 plus less 10%.

SEVEN SEGMENT DISPLAYS

LIGHT EMITTING DIODES

9.125" (inc. clip)

TIL209 Red	15p*	10+	100+
TIL212 Yellow (H.B.)	27p*	22p*	17p*
TIL216 Red (H.B.)	27p*	22p*	17p*
TIL232 Green (H.B.)	27p*	22p*	17p*

0.2" (inc. clip)

TIL220 Red	15p*	13p*	11p*
TIL224 Yellow (H.B.)	30p*	26p*	20p*
TIL228 Red (H.B.)	30p*	26p*	20p*
TIL234 Green (H.B.)	30p*	26p*	20p*

(H.B.)—High Brightness

LITRONIX All Red

DL701 Com A 0.30" R/H dec. pt	1.72*
DL704 Com C 0.30" R/H dec. pt	1.72*
DL721 Com A 0.51" R/H Dec. dt	3.04*
DL746 Com A 6.30" R/H dec. pt	2.43*
DL747 Com A 6.30" L/H dec. pt	2.43*

MONSANTO Green

MAN51 Com A 0.30" R/H dec. pt	2.34*
MAN52 Com A 0.30" L/H dec. pt	2.34*
MAN53 Com A 0.30" R/H dec. pt	2.34*
MAN54 Com C 0.30" R/H dec. pt	2.34*

Red

MAN71 Com A 0.30" R/H dec. pt	1.52*
MAN72 Com A 0.30" L/H dec. pt	1.52*
MAN73 Com A 0.30" R/H dec. pt	1.52*
MAN74 Com C 0.30" R/H dec. pt	1.52*

KCITON

XAN362 C A R 0.30" L/H dec. pt	1.81*
XAN352 C A G 0.30" L/H dec. pt	2.21*
XAN82 C A Y 0.30" L/H dec. pt	2.43*

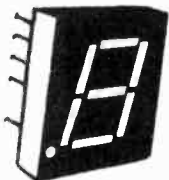

★ **555 Timer** ★
4 for £1.00
★ **28p* each** ★

OUR NEW A4 E.C. BOOKLET
Supplied FREE with orders of any I.C.s worth £4.00 or more. Contains Circuits, pin connections & Data. (35p inc. P&P if sold alone)

I.C. SOCKETS

8 pin	10p*	16 pin	14p*	28 pin	30p*
14 pin	12p*	24 pin	26p*	40 pin	40p*
I.C. pins 100	54p*	1 000	£3.78*		

LINEAR I.C.s AUDIO I.C.s

μA703 (TO99)	1.00	μA711 (14 pin DIL)	.90
μA709 (8 pin DIL)	.41	μA711 (TO99)	.98
μA709 (14 pin DIL)	.41	μA741 (8 pin DIL)	.25
μA709 (TO99)	.50	μA741 (14 pin DIL)	.42
μA709 (8 pin DIL)	.50	μA741 (TO99)	.45
μA710 (14 pin DIL)	.55	μA847 (14 pin DIL)	.90
μA710 (TO99)	.60	μA748 (8 pin DIL)	.42

LINEAR I.C.s AUDIO I.C.s LINEAR I.C.s AUDIO I.C.s

μA748 (14 pin DIL)	.60	CA3089/TDA1200	2.30	LM372N	1.75
μA748 (TO99)	.65	CA3090Q	4.25	LM373N	2.99
μA753 (8 pin DIL)	1.95	CA3123E/LM1820	1.50	LM377N	1.95
AY-1-0212	6.50	CA3097E	1.75	LM380N-8	1.00
AY-1-5051	1.95	CA3130S	.99	LM381N	1.75
AY-5-1224A	3.39*	CA3140S	.99	LM380N	.99
AY-5-3507	5.99*	CA3160S	1.60	LM382N	1.35
AY-5-4007	7.99*	CA3600E	1.75	LM3900N	.65
CA3045	1.50	LM301AN (8 pin)	.40	LM3905N	1.50*
CA3046	.89	LM301AT (TO99)	.50	LM3809N	.70*
CA3053	.85	LM308N (8 pin)	.90	MC1303/LM1303N	1.10
CA3075	2.00	LM308T (8 pin)	1.40	MC1310P	1.80
CA5080	.80	LM339N	1.00	MC1312P	2.15
CA3081	1.50	LM370N	2.75	MC1314P	3.50
CA3082	1.50	LM371	1.75	MC1315P	6.10

VAT INCLUSIVE PRICES

Items followed by a ★ include V.A.T. @ 8% all others include 12.5% ALWAYS PLEASED TO SEE PERSONAL CALLERS
TRADE AND EXPORT CUSTOMERS MOST WELCOME Overseas Customers deduct 2/27 from items marked with a ★ 1/9 from others

WW — 032 FOR FURTHER DETAILS

When it comes to DIL and SIL

12 IS THE MOST SIGNIFICANT FIGURE

That's right. We have 12 years' experience in the design, development and production of thick film circuits. All this experience has been built into our DIL and SIL resistor networks, to give you some of the most cost effective units available anywhere.

There's an extremely wide choice of standard circuit configurations available in 14-pin and 16-pin DIL Ceramic Sandwich packages, as well as a superb selection of standard SIL components with 2 to 14 elements.

If the precise resistor network you need is not in the standard range, for a nominal tooling charge we will custom-design it for you. Either way, you'll reap the benefits in reduced component handling, higher packaging density, and the possibility of automatic insertion techniques. For more information, contact:

ITT Components Group Europe
RESISTOR DIVISION,
South Dunes, Great Yarmouth, Norfolk NR30 3PX
Tel: 0493 56122. Telex: 97421. Cables: Resistor

WW—078 FOR FURTHER DETAILS

AVAILABLE NOW

UNION CARBIDE TANTS
PLESSEY MINIBOX
BLUE MAX CERAMICS

CAPACITORS FROM VEROSPEED

Now you can get our new range of capacitors ex stock. And when we say now, we don't mean in two or three weeks. Phone us your order by 3 p.m. and we'll promise to post them today! That's what Verospeed means.

Verospeed
10 Barton Park Industrial Estate,
Eastleigh, Hampshire SO5 5RR
Tel: (0703) 618525

WW—059 FOR FURTHER DETAILS

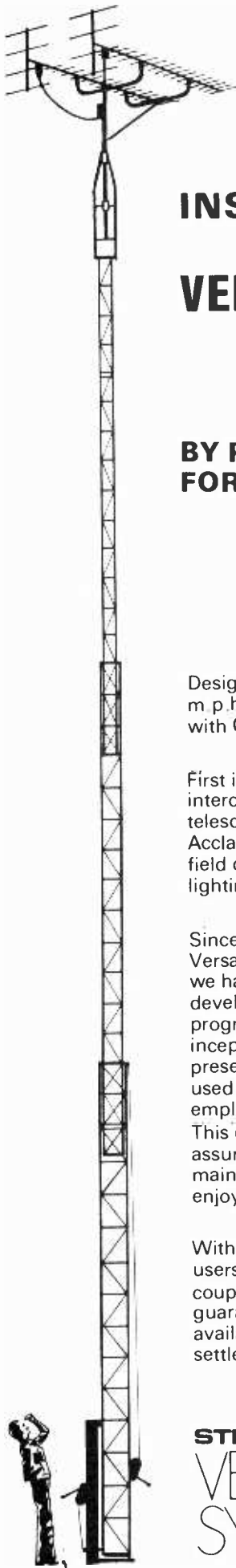

INSIST ON VERSATOWER

**BY PROFESSIONALS—
FOR PROFESSIONALS**

Designed for Wind Speeds from 85 m.p.h. to 117 m.p.h., conforming with CP3 Chapter V, part II.

First in the field with a fully interchangeable (versatile) telescopic, tilt over, tower system. Acclaimed as the world leader in the field of communications and lighting, both static and mobile.

Since the launching of the Versatower system early in 1968 we have operated a continuous development and applications programme. Consequently from inception right through to the present day, detail design, materials used and production techniques employed are continually updated. This coupled with our quality assurance scheme ensures that we maintain the leader position we enjoy today.

With many thousands of satisfied users throughout the world, coupled with our no nonsense guarantee and immediate spares availability, it makes little sense to settle for an alternative product.

STRUMECH
VERSATOWER
SYSTEM

WW-081 FOR FURTHER DETAILS

ELECTRONIC INDUSTRIAL THERMOMETER

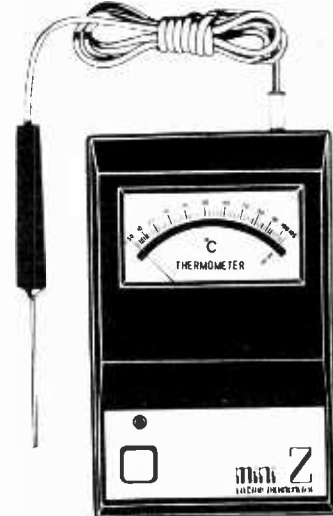

THE MODERN WAY TO MEASURE TEMPERATURE

A Thermometer designed to operate as an Electronic Test Meter. Will measure temperature of Air, Metals, Liquids, Machinery, etc., etc. Just plug-in the Probe, and read the temperature on the large open scale meter. Supplied with carrying case, Probe and internal 1 1/2 volt standard size battery.

Model "Mini-Z 1" measures from -40° C to + 70° C. Price £25.00
 Model "Mini-Z 2" measures from -5° C to + 105° C. Price £25.00
 Model "Mini-Z Hi" measures from + 100° C to + 500° C £27.50
 (VAT 8% EXTRA)

Write for further details to

HARRIS ELECTRONICS (LONDON)
 138 GRAY'S INN ROAD, LONDON, WC1X 8AX
 (Phone 01-837 7937)

WW-018 FOR FURTHER DETAILS

TIME PEACE £9.45*

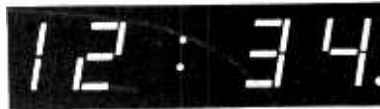

Not a spelling mistake, but another descriptive term for the National MA1012 complete clock & display module.

Featuring sleep and snooze timers, 24 hour alarm format, fast and slow setting, alarm output switch.

Display area 76 x 20 mm. Total size 3 1/2 x 8 x 2 cm.

The MA1012 is non-strobed, with direct drive to the display LEDs, thus causing none of wideband RF noise associated with earlier clock IC designs. It is suitable for any tuner or radio timing applications, plus all the usual clock applications. Help reduce noise pollution with our MA1012 clock module! The module requires only switches and mains transformer. A suitable 240v AC input transformer is available for £1.50 + 8%vat. Two modules, with two transformers, for £20.00 + 8% VAT.

REFERENCE SERIES TUNER MODULES

- EF5803 2 MOSFET AGC RF stages, with low noise selected MOSFETs, MOS mixer, Buffered local oscillator output for counter and synthesizer purposes, 6 tracked tuned circuits, IF and image <100dB down. £19.75
- Ref. FMIF Selectable 2 or 3, 6 pole linear phase IF filters, two MOS IF preamps, twin detector coil for 0.07% THD Δf 22.5kHz. Noise mute, deviation mute, adjustable range AFC, meter output. £16.25
- Ref. MPX With the incomparable HA1196 PLL low noise, wide range decoder IC, preamp and LC low pass filter on input, twin LC pilot and base-bandpass filters on the output. With 2 x LM380N ICs for monitor amp purposes available on the board. £16.45

Our other ranges of FM and AM tuner modules available as before

EF5801	17.45	EF5600	12.95	7252	26.50	7122	13.22
7030	10.95	EC3302U	7.50	7253	26.50	Most also available in kits:	
91196	12.99	8319	11.45	91197	11.35	details in catalogue & price list	

COILS FOR LW, MW, SW 1,2, and 3 now listed in catalogue 30 & 33p ea
 TOKO 10k series coils now for 1.5 to 30MHz, giving a total coverage in osc and rf coils

Low cost meters: Internally illuminated edgewise meters 200uA, and back lit flat face meters 200uA. A wide choice of scales - or material to DIY.

Equipment boxes: These must be the best value in ABS (black) equipment boxes with close fitting (flanged) lids. 8x6x4 (cms) 54p ea*, 10x7.5x4 (cms) 66p ea*, and 12x10x4.5 (cms) 76p ea*. Also new stackable component storage boxes and trays.

DETECKNOWLEDGEY: theory and practise of metal locator principles including BFD IB, phase angle, pulse induction. A unique reference for users and constructors. £1.00

Our usual unique range of coils, filters etc for radio: from TOKO; 350,000 in stock. The best in linear ICs for RF, HA1137:£2.20; HA1196:£4.20; HA1197:£1.40, plus all common radio and multiplex devices, audio ICs (TBA810AS £1.09), MOSFETs, a unique line in varicap diodes for AM tuning :: see the latest catalogue for details. 45p

Postage 25p per order, VAT 12.5% except where otherwise indicated (*8%). Send to: 2 Gresham Road, Brentwood, Essex. tel (0277) 216029. Only 200m from station!

ambit international

WW - 009 FOR FURTHER DETAILS

WE KNOW OF ONLY ONE OTHER POWER AMPLIFIER MODULE SUPERIOR TO OUR JPS 100 — The JPS 150

For starters, JPS Power Amplifier Modules are designed, manufactured and tested in England, yet sold throughout the world.

Incorporating comprehensive protection circuits including mismatch, short and open circuits, impedance and thermal protection, these Modules will ensure a high standard of both reliability and top performance.

Unlike other models, they offer an indefinite life-span! Should they ever require any attention or repair, all components on both Modules are easily replaceable. And, what's more, they both also carry a full two-year guarantee. That's confidence for you!

Power Output
Frequency Response
Power Bandwidth
Slew Rate
Total Harmonic Distortion
Hum and Noise
Damping Factor
***Input Sensitivity**
***Input Impedance**
Power Requirements
Transistor Complement
Module Dimensions
Guarantee

JPS 100 £28.50
170 watts RMS ohms
10-22kHz — 02dB
10-22kHz — 02dB
8.4 Volts per microsecond
0.04% @ 1kHz
115dB below 100 watts
Greater than 300 to 1kHz
0dB (0.775 Volts) 100 watts
47k
— 45 Volts
12 transistors, 1 integrated circuit
4" H x 5" W x 2" D
Full 2 year

JPS 150 £33.30
170 watts RMS 8 ohms
10-30kHz + 0dB — 02dB
10-22kHz + 0dB — 02dB
9.00 Volts per microsecond
0.04 @ 1kHz
115dB below 150 watts
Greater than 400 to 1kHz
0dB (0.775 volts) 150 watts
47k
— 55 Volts
12 transistors, 1 integrated circuit
6" H x 5" W x 2" D
Full 2 year

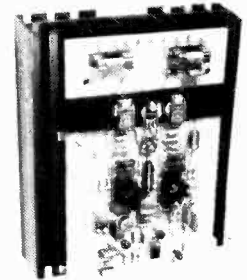

PS3 powers 2 JPS 150 £31.50

JPS Associates

BELMONT HOUSE STEELE ROAD PARK ROYAL LONDON NW10 7AR
TELEPHONE 01-961 1274 TELEX: TITTS 016226

* These parameters may be changed to suit particular requirements.

For industrial usage frequency response can be extended DC to 30kHz + 0dB — 0.2dB (150 only)

POWER SUPPLIES

PS1 Powers 1 JPS 60 price £15.50
PS2 Powers 1 JPS 100
Powers JPS 100
Powers 1 JPS 150 Price £21.50

All prices are subject to 8% VAT

All module drive cards are based on industry standard Eurocard system (100 x 15 mm)

A 60-watt version is also available with a similar specification. Price £23.30 + VAT

WW—021 FOR FURTHER DETAILS

NB THE NEWBEAR COMPUTING STORE



Software & Literature Section

SOFTWARE GAMES (with paper tape)
FOR THE 6800
The Bear Game £2.00
The Well, Tempered Microprocessor £2.00
3K Basic £5.00
8K Basic £10.00
Coreident Editor & Assembler £10.00
Plus range of 780 software

BOOKS
P & P 50p per book unless otherwise stated
Computer designs, 77-68 a 6800 Microcomputer £7.50
Spare diagram set for 77-68 £1.50
WB-1 a TTL Microcomputer £8.50
Spare diagram set for WB-1 £1.00
Zilog, Z80 Technical Manual £3.75
Z80 PIO Technical Manual £2.25
Motorola, Understanding Microprocessors (30p p&p) £2.75
M6800 Microprocessor Programming Manual £4.50
M6800 Microprocessor Applications Manual (£1 p&p) £9.50
M. O. S. Technology, KIM 1-User Manual £5.00
6500 Programming Manual £5.00
6500 Hardware Manual £5.00

Adam Osborne, Introduction to Microcomputers Vol. D Beginners Book £5.95
Vol. 1 Basic Concepts £5.95
Vol. 2 Some Real Products £11.95
8080 Programming for Logic Design £6.95
6800 Programming for Logic Design £5.95
Z80 Programming for Logic Design £5.95
Some Common Basic Programs £9.95
Payroll with Cost Accounting in Basic £9.95
General Ledger System £9.95
Accounts payable and Accounts receivable £9.95
Sybx, Microprocessors, from chips to systems. Rodney Zaks £8.00
Microprocessor Interfacing Techniques, C207 £8.00
Some Common Basic Programs P. 10 £7.25
Scalbi, '8080' Software Gourmet Guide Cookbook £7.25
'8080' Software Gourmet Guide Cookbook £7.25
What to Do After your Hit Return £7.00
(PCC First book of Computer Games)
PCC Reference on Home Computers £4.95
Dr Dobbs Volume 1 £10.00
Instant Basic £4.95
Your Home Computer £1.95
My Computer Likes Me £1.75
Games with a Pocket calculator £2.45
Games, Tricks & Puzzles for a hand calculator £8.95
Best of Creative Computing Vol. 1 £6.95
Best of Creative Computing Vol. 2 £3.99
Hobby Computers are here £3.99

Our range of books is constantly expanding. Please write for latest list

Hardware Components Section

MEMORIES
2102-1 £1.50 4027 (250ns) £6.00
2102L-1 £1.60 2114 (450ns) £10.00
2112 £3.04 4116 (250ns) t.b.a.
2708 (450ns) £10.50

Please enquire for 16K dynamic and 100 up prices.

MOTOROLA MICROCOMPUTING IC's
MC6800P £14.00 MC6830L7 £11.33
MC6820P £8.20 MC6802P £2.88
MC6850P £6.74 MC14536P £3.69
MC6810AP £3.61 MC3459 £2.53

ZILOG MICROCOMPUTING IC's
Z80 CPU 2.5MHz £15.50 Z80 PIO PS £10.00
Z80 CTC PS £10.00

MICROPROCESSORS
8080A t.b.a. 6502 £14.93
SC/MP Mk II t.b.a. F-8 t.b.a.
2650 t.b.a.

INTERFACING ICs
MC1488P £1.40
MC1489P £1.40
75150P £1.30
75150N £1.20
75154 £2.50
4895 £1.95

BUFFERS
81LS95 £1.43
81LS96 £1.43
81LS97 £1.43
81LS98 £1.43
81LS99 £1.43
BT26 £1.84
BT95 £1.60
BT97 £1.60
74367 £1.30

LOW POWER SCHOTTKY TTL PRICE LIST

74LS00	—18	74LS30	—29	74LS107	—38
74LS01	—21	74LS32	—24	74LS109	—38
74LS02	—21	74LS33	—40	74LS112	—38
74LS03	—21	74LS37	—30	74LS113	—38
74LS04	—26	74LS38	—30	74LS114	—38
74LS05	—26	74LS40	—27	74LS125	—56
74LS08	—21	74LS42	—88	74LS126	—56
74LS09	—21	74LS47	—96	74LS132	—90
74LS10	—21	74LS48	—96	74LS138	—38
74LS11	—26	74LS51	—21	74LS158	£1.05
74LS12	—21	74LS54	—21	74LS159	£1.05
74LS13	—55	74LS55	—21	74LS151	—96
74LS14	£1.26	74LS73	—34	74LS153	—96
74LS15	—21	74LS74	—38	74LS154	£1.98
74LS16	—21	74LS75	—34	74LS155	£1.05
74LS17	—21	74LS76	—34	74LS156	£1.05
74LS21	—26	74LS76	—34	74LS157	—96
74LS22	—21	74LS78	—34	74LS157	—96
74LS26	—31	74LS83	£1.05	74LS158	—88
74LS27	—21	74LS86	—38	74LS160	£1.22
74LS28	—40				

CONNECTORS & SOCKETS
Subminiature D Type
9 way plug .58 25 way plug .92
9 way socket .88 25 way socket £1.50
9 way cover .74 25 way cover .85
15 way plug .74 37 way plug £2.10
15 way socket £1.09 37 way socket £3.11
15 way cover .83 37 way cover £1.19

EDGE CONNECTORS
80 way 0.1" single sided £1.80
45 way 0.1" single sided £1.30
43 way 0.156" double sided £4.20
(for Motorola excorisor, D1, D2 kit bus)
64 way plug for Eurocard to DIN 41612 £1.55
64 way socket for Eurocard to DIN 41612 £2.99
10 way plug Molex for S-50 bus (SWT PC 6.800) .30
10 way socket Molex for S-50 bus (SWT PC 6.800) .32

D-I-L SOCKETS
(low profile gold plated)
14 pin .24 24 pin .36 16 pin .60
16 pin .25 40 pin .66 24 pin £1.20

SCOTCHFLEX CONNECTORS
40 way plug £2.40 40 way socket £2.62

PRINTED CIRCUIT BOARDS
For 77-68 (8" x 8" 0.1" edge 78 way)
CPU board £10.00
4K RAM board £10.00
Bootstrap loader board £10.00
Prototyping p.c.b. £9.95
(low pack density)
Prototyping p.c.b. £10.91
(high pack density)
4K RAM board For E-77 (double Eurocard) £6.25
Prototyping p.c.b. £7.52
(low pack density)
For 3U 43 way systems (4 1/2" x 8")
2K RAM board £8.50
Back plane (Vero) board approx 10" x 4" £1.47
For S-50 bus (SWT PC 6.800)
4K RAM board £15.00
For S-100 bus
4K RAM board £15.00
4k RAM board For Excorisor bus (D1, D2, MT) £10.00

Goods are normally shipped within 24 hours, subject to availability. Barclaycard & Access. VAT at 8% for Hardware Components. 30p postage and packing unless otherwise stated. Cheques to be made out to 'The Newbear Computing Store'. Send for an up-to-date catalogue to The Newbear Computing Store, 7 Bone Lane, Newbury, Tel. 0635-46898. Callers welcome Monday to Saturday 9.00 a.m. - 5.30 p.m. The Newbear Computing Store is a division of Newbury Laboratories Ltd.

FREQUENCY COUNTERS

1 / 10 Hz to 1.2GHz. Sensitivity 10mV
5 parts 10¹⁰



FREQUENCY COUNTER
TYPE 801B

FREQUENCY STANDARDS

CRYSTAL 1 Meg, 100Kcs, 10Kcs
5 parts 10¹⁰
OFF/AIR 10 Meg, 1 Meg, 1 part 10⁸

310M	32MHz 5 Digit £98	401A	32MHz 6 Digit £138
501	32MHz 8 Digit £192	701A	80MHz 8 Digit £210
801B/M	250MHz 8 Digit £280	901M	520MHz 8 Digit £395
Memory versions available if not suffixed M	£30 extra	1001M	1.2GHz 8 Digit £670

Start/Stop versions plus £18

Type 101 1MHz 10 KHz Crystal Standard £98
Type 103 Off/Air Standard £98
Type 203 Low Frequency Generator £78

FREQUENCY GENERATORS

DISTORTION 0.3%
Amplitude Stability 0.1%
10Hz to 100kHz

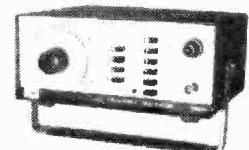

LOW FREQUENCY GENERATOR TYPE 203



R. C. S. ELECTRONICS, 6 WOLSLEY ROAD, ASHFORD, MIDD. ASHFORD (69) 53661

SUPPLIERS TO: Ministry of Defence, G.P.O., B.B.C., Government Depts., Crystal Manufacturers and Electronic Laboratories world-wide

WW—046 FOR FURTHER DETAILS

PISTONCAP™
Precision Trimmers

From Sprague - Goodman are designed for critical applications and are approved to Mil - C-14409D and Stanag - 4093.
Choice of three types of glass/quartz dielectrics and wide range of mounting styles. Capacitance range (max) up to 120pF. Environmentally sealed versions available.

DAU-UK LIMITED
Church House, 94 Felpham Road, Felpham
Bognor Regis, West Sussex PO22 7PG
Bognor Regis (02433) 28122
Telex 877285

WW-082 FOR FURTHER DETAILS

LEADER Electronic Kits

Digital Clock Kits

Available in 24 hour version (Kit No. LCK101) or 12 hour version (Kit No. LCK201)
0.5" High brightness Red LED display. Teak case with optional grade red perspex front.
Fast & slow reset. 240v 50 Hz. Modular construction.
Full instruction booklet.
Ret. Retail **£13.99** inc. VAT/P&P (Ex. VAT **£12.95**)

Bench Power Supply LPU102

Variable voltage power supply kit with 5 - 30v DC at 1 Amp. Featuring unique Fairchild regulator chip. (as featured in E.T.I. Magazine)
Fully drilled & painted case/chassis. Meter, all parts.
Full instruction booklet.
Ret. Retail **£18.75** inc. VAT/P&P (Ex. VAT **£17.36**)

Laboratory Power Supply LPU103

Excellent power supply design featuring exceptional regulation. Zero to 30 volt and Zero to 1 Amp variable output with variable limiting in two ranges 0 - 100mA & 0 - 1A. Output meter reads both current & voltage. System can stand up to 2 hours in full short circuit condition.
Fully punched, plated & painted case/chassis. front panel detail. Building manual/circuits etc.
Ret. Retail **£29.99** inc. VAT/P&P (Ex. VAT **£27.77**)

Test Bench Oscillator LTO104

Sine wave test oscillator featuring Output variable 0 - 1 volt between 15 Hz to 30 kHz in four ranges 600 Ohm output impedance. Max. 1% distortion at 1 kHz.
Fully portable. fuses 2 x PP3 batteries - extra!
Ret. Retail **£7.99** inc. VAT/P&P (Ex. VAT **£7.40**)

"LEADER" Electronic Kits enable even the inexperienced constructor to produce equipment of excellent appearance through our policy of providing Comprehensive manual of building instructions. Fully finished cases/chassis including all necessary drilling, punching, plating, painting.
Screen printed front panel decals with all lettering etc. Matching instrument knobs
And most of all - ALL PARTS to the last nut & bolt.
"LEADER" Electronic kits are distributed by Arrow Electronics Limited, Leader House, Coptfold Road, Brentwood, Essex. Tel. 0277 219435 Telex 99443

WW-092 FOR FURTHER DETAILS

FOR COMPUTER PEOPLE WHO WANT ABSOLUTELY EVERYTHING

If you've anything to do with computers, it pays to know what's going on right across the industry.

It could affect where you work and for how much - not just now but a year or two into the future.

That's why you need to read Computer Weekly. It's the only paper that covers every aspect of the computer industry, from hardware to software to sales to jobs. Especially jobs.

It's expert, enquiring - and highly entertaining. But not just anybody can receive a free copy of Computer Weekly. First, you must work in one of the categories itemised below. And second, you actually have to ask to receive your initial copy.

If you would like to join the 74,329* computer professionals who are requested readers of the one newspaper of interest to the whole computer community, fill in the coupon below.

*ABC July-Dec 77.

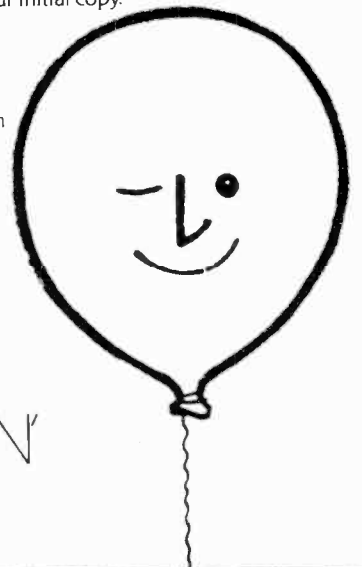

YOU AIN'T SEEN NOTHIN' YET

COMPUTER WEEKLY

Simply complete and return the coupon - and leave the rest to us. Computer Weekly is sent free of charge to the following categories in the UK and Eire only:
Company directors, Company secretaries, Management services executives, Civil servants responsible for computing, Management/computer consultants, Lecturers and teachers, DP manager/supervisors, Systems analysts/O&M officers, Programmers, Operators, Computer salesmen, Field engineers.

To: Controlled Circulation Department, IPC Business Press (Sales & Distribution) Ltd., 40 Bowling Green Lane, London EC1R 0NE.
Tel: 01-837 3636.
Yes, I would like to become a requested reader of Computer Weekly.

NAME _____

OCCUPATION _____

COMPANY _____

ADDRESS _____



S500-D

It is unique. Meet the new leader from H.H.

- * High Power capability, up to 500 watts per channel output.
- * Two channel stereo, or bridged output.
- * Superb audition performance, ultra low intermodulation and T.I.M. distortion.
- * Modular construction, integral force cooled dissipators (FCD).
- * High efficiency Toroidal Power Supply.
- * Compact size, only 3½" high x 19" rack mounting.

Send for detailed information:
H.H. ELECTRONIC,
 Viking Way, Bar Hill,
 Cambridge, CB3 8EL.
 Telephone: Crafts Hill (0954) 81140
 Telex: 817515 HH ELEC G

WW—052 FOR FURTHER DETAILS

Audio Connectors

Broadcast pattern jackfields, jackcords, plugs and jacks.

Quick disconnect microphone connectors. Amphenol (Tuchel) miniature connectors with coupling nut.

Hirschmann Banana plugs and test probes, XLR compatible in-line attenuators and reversers.

Low cost slider faders by Ruf.

Future Film Developments Ltd.
 36-38 Lexington Street
 London W1R 3HR
 01-437 1892/3

WW—015 FOR FURTHER DETAILS

DATEST 1 TRANSISTOR AND OP. AMP. TESTER

**Simplifies semiconductor testing
Saves time and errors**

- * Tests are automatic and unambiguous
- * Tests devices in and out of circuit
- * Handles bipolars, FETs (all types), LEDs, diodes, op. amps. (out of circuit only)
- * Automatically displays device polarity and, for devices out of circuit, device type
- * Checks for gain, leakage, input offset

Price: including test probes, full instructions and delivery (UK only): £49 plus VAT (8%). Data sheet on request.

DATONG ELECTRONICS LIMITED
 Spence Mills, Mill Lane, Bramley, Leeds LS13 3HE
 Telephone: Pudsey (0532) 552461

WW—012 FOR FURTHER DETAILS

The new 3002 pocket digital thermometer with increased resolution to 0.1°C.

The successful 3001 pocket digital thermometer has been joined by another model of equally high design and style standards, but offering an improved resolution of 0.1°C.

It's called the 3002. And it's specially for those applications requiring a thermometer of extra sensitivity.

So now, Comark offer a choice of pocket digitals with sensitivities to match your needs. There's the 3001 with its 0.5°C resolution or the new, 3002. Both operate in the temperature range—50°C to +1000°C.

Either way you'll get a unit incorporating the reliability of custom MOS, and the big clear readout of a 10 mm green fluorescent display.

Our new colour data sheet gives all the facts. Please request your copy now.

Comark

WW—093 FOR FURTHER DETAILS

Making temperature measurement easy.

Comark Electronics Limited,
 Brookside Avenue, Rustington, West Sussex BN16 3LF, England.
 Telephone: (09062) 71911. Telex: 877317.

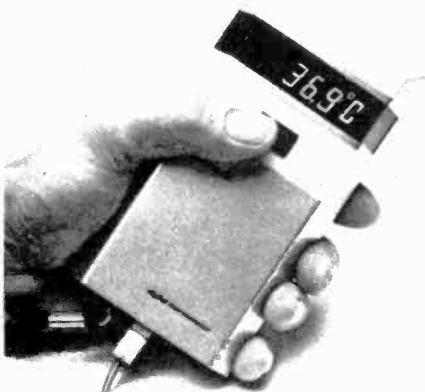

TRUE PROFESSIONALS

Including: EMI, Decca (UK), BBC, Pink Floyd, Hawker Sidley, Metropolitan Police, The Who, Queen, Thames TV, ITN, Capital Radio, Decca (France), Ministry of Defence, Birds Eye, Rolls Royce, Crown Agents, Madame Tussaud's, Island Music, Chappells, Dick James Music, Neve, Alice, Israel Defence Ministry, Yes Music, University of Bucharest, Pye TVT, Avon Health Authority, Government of Seychelles, Philippines Radio, London Broadcasting, Rolling Stones, Thin Lizzie, British Railways, Natural History Museum, Virgin Records, Kirilo Savic Institute of Belgrade, all British Universities, London Weekend TV, BOC, Wings, IBM, every Local Radio Station, Post Office Research, Rank Organisation, and many others.

ACKNOWLEDGE

That ITA has more to offer:

- **Location.** In Central London - easy parking.
- **Delivery.** Large stockholding covering 500 versions for immediate delivery.
- **Servicing** By ITA factory trained staff. Quickest turnaround time. Machines supplied or rebuilt for special requirements.
- **Pricing.** Check our prices - you will find them lowest ALWAYS.

ITA'S ADVANTAGES



REVOX

A wide range of two channel recorders from this famous manufacturer, with tape speeds from 15/16 ips to 30 ips. Options include variable speed and sel-sync. Models include A77, B77 and 377 with 3 speeds and editing (designed and modified by ITA specifically for professional applications).

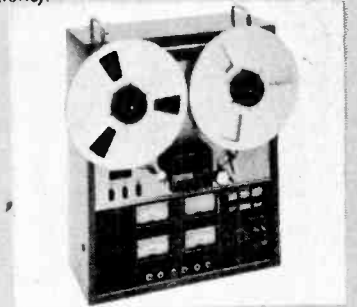

TEAC

Recorders for logging and studio use - tape speeds from 1 1/2 to 15 ips. 2, 4 or 8 channel. A range of mixers is also available.



ITAM

4 and 8 channel recorders for studio use. Any tape speed from 1 1/2 ips for logging and data recording.



OTARI

Duplicating equipment for high speed cassette copying, including the DP4050 model - the world's finest in-cassette copier, with 6 slave units.

ITA

1-7 Harewood Avenue, Marylebone Road, London NW1. Tel: 01-724 2497.
Telex: 21879.

WW-089 FOR FURTHER DETAILS

www.americanradiohistory.com



Test Equipment

Here's a brand new multimeter from Eagle: 100,000 opv, 3-colour scale anti-parallax mirror, taut band movement, electronic protection, reversible polarity, 15 amps AC range. Complete with real leather carrying case, shoulder strap and probes.

And all that for a retail list price of under £47.00!

But that's not all - we've got a range of other meters to cover every possible need of the electrical or electronic engineer from about £6.50 upwards. Send the coupon now for the complete catalogue.

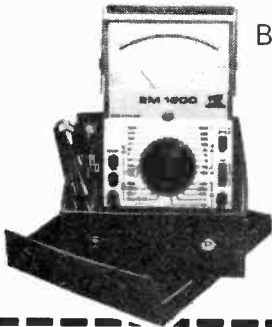

Please send me your catalogue with full details of all your test equipment.

Name

Address

Eagle International, Precision Centre, Heather Park Drive, Wembley HA0 1SU Middlesex Tel: (01)-902 8832



WW—070 FOR FURTHER DETAILS

HAVE YOU DONE IT LATELY!

Fit a new tape head and transform the performance of your tape recorder

MONOLITH
THE MONOLITH ELECTRONICS CO. LTD

QUALITY
REEL TO REEL
AND CASSETTE TAPE HEADS

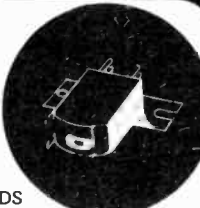

Full Catalogue 25p

Please enclose
20p P&P with order

B24—RP stereo cassette glass/ferrite record/playback £9.84
B12—01 mono cass. playbk. £1.60 B24—01 stereo cass. playbk. £2.80
A28—05 stereo 8tk cartridge £1.80 E12—09 stereo/mono cass. erase £1.80

5/7 Church St, Crewkerne, Som. Tel. (0460) 74321

WW—056 FOR FURTHER DETAILS

THERMOSTATIC SOLDERING IRONS

A FULL RANGE FROM 50 TO 500 WATT

VariStat irons incorporate a robust, reliable differential expansion thermostat which combined with a high wattage element gives rapid heat-up and close temperature control, adjustable over a wide range.

MODEL 'D' 50 WATT MINIATURE IRON

Weight 2 oz.
Bit Size 1/16", 3/32", 1/8", 3/16", 1/4"
Voltage 250 to 12 volts

MODEL 'M' 50 WATT MINIATURE IRON

Weight 1 1/4 oz.
Bit Size .04", 1/16", 3/32"
Voltage 250 to 12 volts

MODEL 'B' 70 WATT

Weight 4 3/4 oz.
Bit Size 11/64"
Voltage 250-24 volts

MODEL 'H' 150 WATT HIGH PRODUCTION INSTRUMENT

Weight 6 oz.
Bit Size 3/16", 1/4", 3/8", 7/16"
Voltage 250-24 volts

MODEL 'I' 500 WATT INDUSTRIAL

Weight 1 3/4" lb.
Bit Size 7/8" tapered to 1/2"
Voltage 250 and 110 volts

Model 'H' Instrument Iron
Approx. third-size

Manufactured by:

CARDROSS ENGINEERING CO. LTD.

Woodyard Road, Dumbarton
Phone: Dumbarton 62655

WW—077 FOR FURTHER DETAILS

QUARTZ CHRONOMETERS



and

TIMERS

from

ELECTRO SYSTEMS and TIMING CO.

Outstanding features of the Series 400 Chronometers and Timers:

- ★ One second per month accuracy at 20° C
- ★ Desk and 19 inch panel versions available
- ★ Rechargeable Ni-Cad battery available
- ★ Easy to read LED display, 12 or 24 hour modes available
- ★ 12 month guarantee
- ★ 220/240V mains operation. 110V Models available
- ★ Range of options include one pulse per second, one pulse per 30 seconds and one pulse per minute output. Latched BCD output. Master/Slave drive. Decoded time/control pulses. Magnetic tape interface.

ELECTRO SYSTEMS & TIMING CO.

18 Southdown Road, Portslade, Sussex BN4 2HN
Tel. Brighton 415763

WW—060 FOR FURTHER DETAILS

SOUND SAVINGS ON DORAM KITS.

save **£20.00** on each unit when bought in kit form

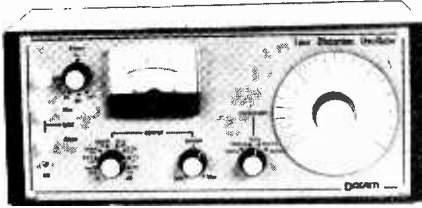

Low distortion audio oscillator kit
KEY DATA 0.005% THD min: 10Hz-100kHz
ONLY £79.95 Also available ready-built

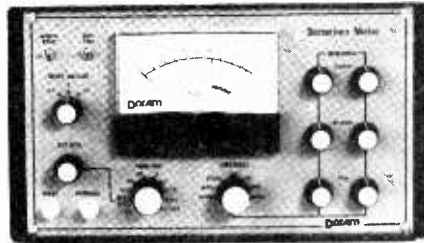

Harmonic Distortion meter kit
KEY DATA range 20Hz-40kHz THD down to 0.003%
ONLY £79.95 Also available ready-built

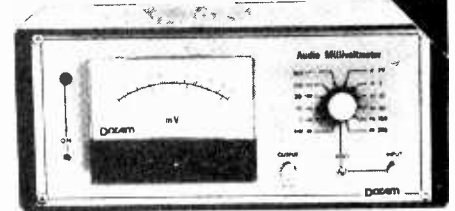

Audio millivoltmeter kit
KEY DATA 1M Ω /p impedance or 600 Ω , 15Hz-100kHz $\pm 1/2$ dB
ONLY £69.95 Also available ready-built
Available from 23rd March—order now.

Complete the coupon and post today! Doram, PO Box TR8, Leeds LS12 2UF, West Yorkshire

Please send me the following. I enclose cheque/PO made payable to Doram Electronics value £ _____

Order Code

60-610-7WW
74-710-7WW

LOW DISTORTION AUDIO OSCILLATOR
Kit form : £79.95
Ready built : £99.95

60-612-1WW
74-720-0WW

HARMONIC DISTORTION METER
Kit form : £79.95
Ready built : £99.95

60-614-5WW
74-730-3WW

AUDIO MILLIVOLTMETER
Kit form : £69.95
Ready built : £89.95

All prices subject to 8% VAT

NAME _____

ADDRESS _____

TOWN _____

COUNTY _____

DORAM Department W W, PO Box TR8, Leeds LS12 2UF, West Yorkshire

WW-095 FOR FURTHER DETAILS

RADFORD HD250 High Definition Stereo Amplifier

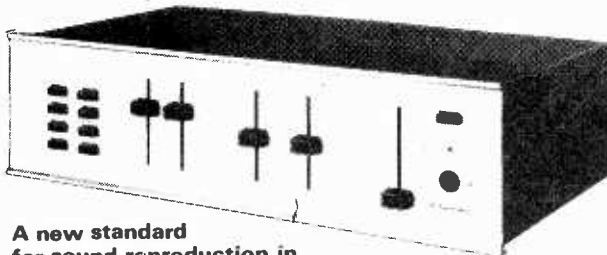

A new standard for sound reproduction in the home! We believe that no other amplifier in the world can match the overall specification of the HD250.

Rated power output: 50 watts av. continuous per channel into any impedance from 4 to 8 ohms, both channels driven.

Maximum power output: 90 watts av. per channel into 5 ohms.

Distortion, preamplifier: Virtually zero (cannot be identified or measured as it is below inherent circuit noise.)

Distortion, power amplifier: Typically 0.006% at 25 watts, less than 0.02% at rated output (Typically 0.01% at 1 KHz)

Hum and noise: Disc.—83dBV measured flat with noise band width 23 KHz (ref 5mV); —88dBV "A" weighted (ref. 5mv)

Line —85 dBV measured flat (ref 100v)
—88dBV "A" weighted (ref 100v)

Hear the HD250 at

SWIFT OF WILMSLOW

Dept. WW, 5 Swan Street, Wilmslow, Cheshire
(Tel: 26213)

Mail Order and Personal Export enquiries: Wilmslow Audio, Swan Works, Bank Square, Wilmslow (Tel. 29599)

Now available ZD100 power amplifier and ZD22 pre-amplifier

WW-039 FOR FURTHER DETAILS

£100 off
this super Hi-Fi system the
MATSI TFS60



from the

Lion House

BUDGET HI-FI DEPARTMENT

You can now purchase this fantastic Hi-Fi system complete for only £152.00 at what must be a fraction of its value today.

System consists of:—the famous MATSI TFS60 Tuner/AMP; a really top quality receiver from one of Japan's leading manufacturers, 15 watts per channel FM/MW/LW, two LH6 speakers fitted with AR units and a Goldring belt-drive turntable with magnetic cartridge complete with an attractive plinth & cover of ultra modern design. Leads, etc. supplied free.

LION PRICE: Complete MATSI System £152.00
or purchased individually:

TF60 Receiver: £69.90. LH6 Twin Speakers £55.

Goldring Turntable (cartridge Plinth & Cover) £29.95

Leading suppliers of TELEVISIONS, RADIOS, TAPE RECORDERS, BUDGET HI-FI CASSETTE RECORDERS, SPEAKERS, AMPLIFIERS, TUNER/AMPS, VIDEO and MUSIC CENTRES and ACCESSORIES. EXPORT TELEVISIONS and MUSICAL INSTRUMENTS. ALL AT KEEN PRICES

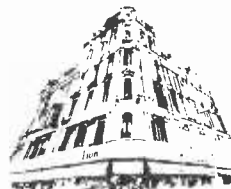

Lion House

Stockists for the world's major Hi-Fi manufacturers

LONDON'S HI-FI SUPERSTORE
277 TOFTENHAM COURT ROAD, LONDON W1
Tel: 01 580 7383 and 01 637 1601
Telex: 28394 LION G

(Open 9 am to 6 pm Monday to Saturday (Thursday until 7 pm))



WW-028 FOR FURTHER DETAILS

THE BENEFITS OF A TEST SET

— for the price of a signal generator!

If you're servicing or manufacturing mobile communications receivers then look closely at Farnell's new synthesized 10 to 520MHz signal generator, the SSG520. It outperforms other units in many respects, and, with its remarkable ease of setting, repeatability and SINAD facility gives you most of the advantages of a receiver test set costing much more.

Typical tests the SSG520 does with speed and simplicity are:—
 checking and aligning channel frequency and bandwidth
 i.f. and filter alignment
 sensitivity tests (so easy with SINAD)
 mute/squelch performance
 adjacent channel rejection (using two units) and
 signal to noise and a.f. distortion tests are made easier using the SSG520.

R.F. leakage is remarkably low, permitting totally unambiguous sensitivity measurements down to $0.2\mu\text{V}$ ($0.05\mu\text{V}$ if you like, using a 20dB pad). There's no leakage from counter display holes—there isn't one; you don't need a counter with our thumbwheel setting/readout. The SSG520 can be tuned in 100Hz steps under locked conditions with maximum stability over the entire frequency range.

Contrast this with competitive instruments which have either a mere 2% tuning range before re-lock or will only fast synthesize in 100kHz steps! Stability and accuracy are excellent and an optional ovened crystal version is available. Sideband phase noise is better than $-100\text{dB}/\text{Hz}$ and harmonics better than -25dB . Any combination of a.m. and f.m. modulation, internal or external is possible. Output is calibrated and automatically levelled over the whole frequency range and the attenuator is set by adjacent 10 and 1dB click stop controls giving direct reading of dBm and volts—quicker to operate and enabling accurate mute/squelch settings.



Farnell

So if you want to improve service or production throughput of mobile radio telephones, fixed receivers, handportables, public correspondence radiophone and paging systems without spending as much as you would have thought, use this magazine's reply system now to obtain full details and price.

You will also receive, with our compliments, a free copy of our pocket card of useful Telecommunications Data.

wireless world

Speakers cornered

Editor:

TOM IVALL, M.I.E.R.E.

Deputy Editor:

 PHILIP DARRINGTON
 Phone 01-261 8435

Technical Editor:

 GEOFFREY SHORTER, B.Sc.
 Phone 01-261 8443

Projects Editor:

 MIKE SAGIN
 Phone: 01-261 8429

Communications Editor:

 RAY ASHMORE, B.Sc., G8KYY
 Phone 01-261 8043

News Editor:

 JOHN DWYER
 Phone 01-261 8620

Drawing Office Manager:

ROGER GOODMAN

Production:

D. R. BRAY

Advertisement Controller:

G. BENTON ROWELL

Advertisement Manager:

 BOB NIBBS
 Phone 01-261 8622

CHRIS PRIER

Phone 01-261 8037

Classified Manager:

 BRIAN DURRANT
 Phone 01-261 8508 or 01-261 8423

 EDDIE FARRELL (*Classified Advertisements*)
 Phone 01-261 8508

 JOHN GIBBON (*Make-up and copy*)
 Phone 01-261 8353

Publishing Director:

GORDON HENDERSON

It seems that some of the loudspeaker manufacturers are unwilling to help audio magazine equipment reviewers test their products, their disapproval extending to a refusal to lend the reviewers samples of their speakers. This is a curiously ineffective method of protest — perhaps magazines should, as a matter of principle, buy the products anonymously to fend off criticisms of having tested “tweaked” equipment, but that apart, one finds oneself to some extent in sympathy with the makers. It must be galling in the extreme to put in the work, time and money to develop and launch a new loudspeaker, investing heavily in highly-advanced test instrumentation only to find that some “popular” reviewer (no disrespect: popular — of the people) who may, or may not, have sufficient knowledge or facilities for proper testing, decides that he doesn't like it much and proceeds to say so in print. It could be very damaging to the new speaker's chances in the market and, perhaps, for no good reason.

On the other hand, there appears to be no very good reason why speaker manufacturers should be protected from this kind of publicity, any more than washing-machine makers or supermarket operators. So long as a writer stays within the law of Injurious Falsehood, it must be wrong to attempt to prevent him from putting forward his opinion, however ill-founded it may be.

Bearing in mind that the room in which the loudspeaker is to be used is as much a part of the system as is the enclosure itself, and also remembering that the majority of readers of “high-fidelity” magazines are not trained to understand acoustic measurements made in highly artificial anechoic conditions, it could reasonably be said that the popular

reviewing of loudspeakers is simply not possible. But until every retailer can be persuaded to allow customers to hear speakers in their homes, it is difficult to see how any guidance can be given except in the form which is currently seen.

The use of anechoic chambers to test speakers is often criticised because the conditions bear little relation to those experienced in a room. Well, of course they do, but which room? The use of such a chamber removes the unknown variables from a test and gives each unit the same conditions. To be of value to the average untrained reader of reviews, the results of such tests would have to be viewed in conjunction with results of acoustic measurements on his listening room, with a view to reducing the acoustic deficiencies of one by a judicious selection of the other. A set of loudspeaker types heard by a panel and listed in order of preference in a particular room can be listed in a completely different order in another room — a test carried out fairly light-heartedly by *Wireless World* staff some time ago. Perhaps a British Standard Room should be specified.

While the above state of affairs remains impractical, the methods of testing and reporting currently adopted by reviewers will probably remain. Adjectives, selected by reviewers to mean something to themselves, will still be used because a subjective experience is difficult to describe in other than subjective terms. Manufacturers have no chance whatever of putting a stop to reviews of any standard of competence; they must be prepared, like any other maker of equipment which is expensive and complicated enough to be difficult to assess by the customer, to take the rough with the smooth.

Radio landing systems



Background to radio blind landing aids and the choice of i.l.s. replacement.

by P. R. Darrington

EVERYTHING that goes up, barring the more exotic space machinery, eventually comes down again and, so far as aeroplanes are concerned, they start trying to get back the instant the wheels clear the runway. Flying, as someone must have said, is a controlled fall — a concept which can be successfully concealed from airline passengers while they cruise at 20,000ft. During the landing phase, particularly in fog or at night, pilots earn their salaries and nervous passengers recall the relevant statistic — 75% of all flying accidents occur during approach and landing or during take-off.

Radio assistance to pilots engaged in locating runways and landing on them began in earnest during the '30s and experienced a tremendous spurt in development during the war, when thousands of hurriedly-trained pilots had to be rounded up. The assistance offered took two forms, with responsibility in the air or on the ground. MIT developed a system known as Ground Controlled Approach (GCA), in which the aircraft is tracked on radar. A wide-ranging p.p.i. surveillance radar locates the aircraft many miles away from the runway and, using a v.h.f. link, the operator guides the aircraft into the purview of a short-range, more precise radar, with which the pilot can be 'talked down' in azimuth and elevation on to the runway. All the aircraft needs is a v.h.f.

A technical battle, with political and commercial undertones, has been grinding on between US and UK aviation organizations for some four years, with the microwave landing system of the future as the prize. Allegations and counter-allegations are launched with reckless abandon and, less than two months before ICAO (the International Civil Aviation Organization) is due to make its choice of system, a US Congressional committee is investigating British charges of deception brought against the Federal Aviation Agency. The FAA, not to be outdone, is retaliating with assertions that the British are trying to palm the world off with an under-developed system.

receiver. This type of system is still used, although the short-range radar is now given the name precision approach radar (p.a.r.). Synthetic displays, generated by computer, are used to give bright displays and to handle multiple targets with little or no clutter from precipitation or static returns. The aircraft must now carry a transponder, triggered from the ground, which supplies pulses for range and angle of approach determination.

The second approach, in which information is derived in the air from ground transmitters, is the basis of many modern systems and is at the centre of

both leading systems of microwave landing assistance, of which more later.

Probably the first attempt at this was the Lorenz design¹, later known as Standard Beam Approach. This was based on an idea by P. von Händel and worked out by the German Lorenz company — later to become part of ITT. The Lorenz system used a single transmitter, working at 36MHz, to provide azimuth and glide path indication. Some idea of contemporary practice can be obtained from the preamble to the article referred to: "In the best modern altimeters . . . error does not exceed about 75 feet. Now, with no more detailed height information than is provided by such means as this, it is actually possible on a large aerodrome to land an aeroplane in safety, by throttling the engine down and awaiting contact with the ground".

Guidance was obtained in azimuth by switching a mildly directional beam from side to side of the runway as shown in Fig.1, the range being claimed as 40 miles at 3000 ft. The beam was switched by keying reflectors spaced half a wavelength away from the vertical dipole, the time spent on each side of the landing path being different — 'dots' and 'dashes' were formed in this way. The dots were equal in length to the spacing between dashes, so that on the centre line they merged to form a continuous tone. The pilot listened to the

signals and was able to keep within a "few degrees" of the ideal landing path.

Range was determined roughly by signal strength, but also by outer and middle markers radiated on 7.9m. These markers took the form of low-power transmitters, feeding horizontal dipoles, located 0.5 and 3km from the downwind end of the runway. Visual contact with the ground was necessary, although Denman said that a "completely blind landing (could) perhaps be made, if necessary".

Glide path information was dependent on an assessment of signal strength: the pilot would read the beacon signal strength from a meter on the display when passing the outer marker and try to maintain the same reading until touch down, as in Fig. 2. Indication of directions to the pilot was by means of headphones (dots, dashes for azimuth and superimposed tones for the markers) and by meter for field strength. Later the system was modified to use a similar system for elevation as for azimuth.

Lorenz was used, in SBA form, until the '50s, with improved display and beam-forming aerials. It was the basis of the Knickebein and X-Gerät bombing aids used by the Germans during World War II, in which applications nothing needed modification save the receiver, which required enough sensitivity to work at a range of several hundred miles.

This method of identifying on which side of the ideal flight path the aircraft was flying was to remain and to be used for many different systems. In 1935, three separate Lorenz-type systems were under test at Croydon airport, made by S.T.C., Plessey and Marconi.

A radar system developed during the war to assist a lot of very confused bomber crews to limp home was BABS—Beam Approach Beacon System. This was a secondary system in that a bea-

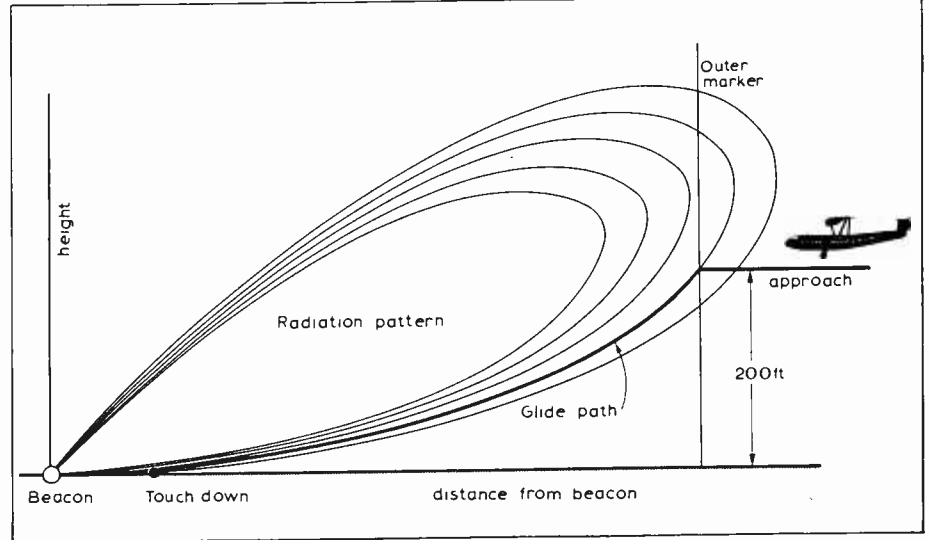

Fig.2. Lorenz glide-path guidance. On passing the outer marker, the pilot tries to keep the signal level constant until near touchdown.

con would radiate two beams, overlapping on the runway in the approved manner, but only when triggered by an airborne Rebecca equipment from up to 20m away. One advantage was that distance-to-go information determined from go-and-return timing of the pulses, was continuously available and no distance markers were needed. Presentation was by c.r.t., which required the assistance of a second crew member to interpret the display and to direct the pilot.

Several other schemes of landing

Fig.1. Elements of the Lorenz landing aid. The diagram is based on one which appeared in Wireless World for April 5, 1935, and the field diagrams may appear a little strange; though the principle remains.

guidance were proposed. For example, in 1963 F. G. Miles proposed and developed a television system² whereby the pilot was presented with a picture of the airfield. A scale model was scanned by a television camera, the picture being transmitted to the aircraft by normal television methods. The position of the camera was directed in azimuth, elevation and range by a locked-on radar, while roll, pitch and height information were derived from the aircraft's flight instruments and telemetered to the ground control. Both air and ground-derived sets of information were used by a computer to adjust the attitude, position and movement of the camera. In the report referred to in reference 2, the system was said to have reached a breadboard stage, but to have been used successfully by the Army in tank training.

C.S.F. in France³ developed a system in 1953 which again used the principle of overlapping beams, but on a single transmission frequency. The scheme was to use a time-multiplexed switch to launch the signal from four aerials, arranged as upper and lower for elevation and laterally for azimuth. As the beam was switched round the aerials by a 600Hz mechanical rotary switch, the modulation frequency was changed at each one to give the effect of four beams. A gap between sets of transmissions was used to interrogate an airborne transponder which gave a range measurement. Presentation of localizer and glide-path information was by means of the usual crossed-pointer instrument, and accuracy of the localizer was within $\pm 0.5^\circ$ at 1.5m from the transmitter; distance was measured to within 150 yd at 5 miles.

I.I.s.

All the systems so far described suffered from one or more defects. Perhaps accuracy was poor, or they did not fail safe or they presented the pilot with too great a work load at precisely the time when he needed all his faculties to be free to fly the aircraft.

Instrument landing systems (i.l.s.) surmounted most of these drawbacks. It

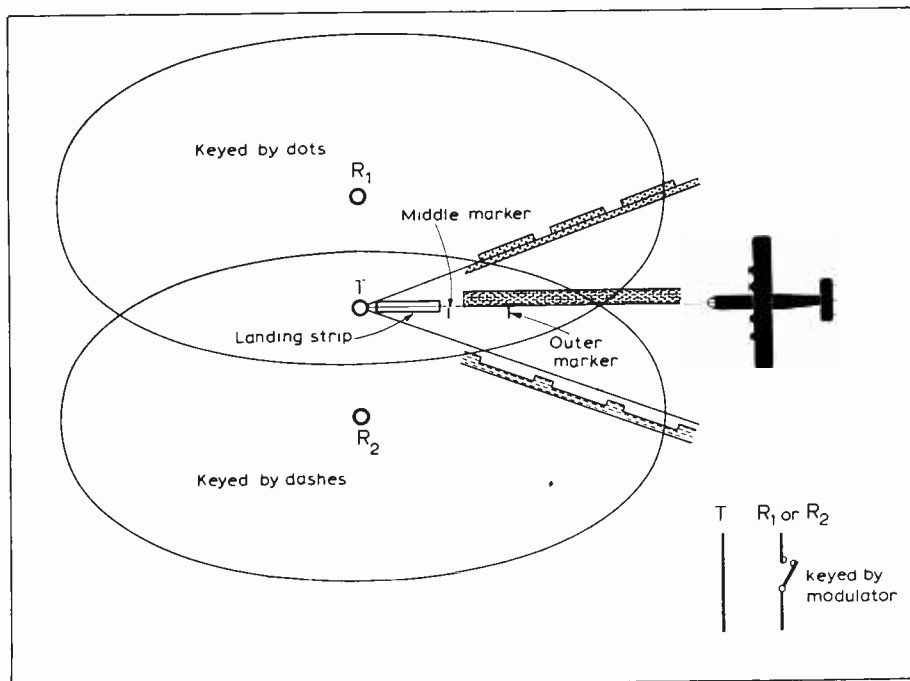

was developed in America before the war and was first demonstrated by the Federal Aviation Agency (then the CAA) at Indianapolis in 1939. The International Civil Aviation Organization adopted it in 1946 in an attempt to obtain a world standard system.

The system adopted was chosen from five possible approaches, one of which was a microwave localizer and glide path. It was decided to go for a v.h.f. equi-signal localizer and u.h.f. glide-path indicator, the CAA system being the final choice. It was itself a development by the CAA of a military aid, the SCS51, which had seen much service and was well proven. I.l.s. works on higher frequencies than the earlier systems (110MHz localizer, 330MHz glide path) and it was thought the anomalous propagation would be reduced.

Figure 4 shows the system in broad outline. Horizontal guidance is obtained from a large aerial sited at the upwind end of the runway, working at around 110MHz, and radiating two beams modulated at 90Hz and 150Hz. The two beams overlap and give an equal modulation on the runway centre-line. Efficient a.g.c. is provided in the airborne receiver to avoid the effects of variations in transmitter power. The receiver produces an output proportional to the difference between 90Hz and 150Hz modulations, with which is driven a centre-zero meter, zero being vertical. A voice channel can be provided and the localizer is identified by morse signals every 10s.

A similar system to that used in the localizer is used to give glide-path information, the array being sited at the

approach end of the runway. Frequencies lie in the band 328.6 to 335.4MHz and the required beam shape to give an overlap at the glide-path angle is achieved by a combination of direct and ground-reflected waves. Two aeriels are used, the effect being to produce a set of lobes, a large central 90Hz one and several smaller 150Hz ones. The effect is that the overlap between the large lobe and the smaller gives an asymmetrical fly up/fly down signal.

Outer and middle markers are provided, as shown in Fig. 4. These are transmitted on 75MHz with modulations of 400Hz for the outer and 1300Hz at the inner marker, which sometimes tends to be ignored by pilots, since at a distance of 3500 ft from touch-down they rely more on altimeter readings. Marker signals are made to switch on warning lamps and provide a tone warning.

I.l.s. has been the standard system since the late '40s and is to continue in service at least until 1985. It has been extremely successful in service and is almost mandatory all over the world. The system has been used for automatic landing⁴ with either a highly accurate version of the localizer or a Murphy leader-cable layout. Radio altimeter data plus that from i.l.s. was used in an autopilot computer to provide "hands-

off" landings, although an element of blind faith was invoked in the interval between 150ft and 60ft, in which interval the aircraft would probably be flying over rough ground. The radio altimeter would not give a good height indication relative to the level of the runway and was therefore switched out, the autopilot maintaining the aircraft in an attitude based on a stored history of its behaviour from 2000ft until the 60ft level was reached. Radio altimeter assistance was again called upon in the expectation that the runway was now below, whereupon rate of descent was made proportional to height, a process which was intended to produce an exponential flare-out.

In 1967, however, it was becoming apparent that i.l.s. was not the complete answer. A paper read by Benjamin⁶ at an a.t.c. conference indicated that i.l.s. was just not good enough for regular automatic landing because of reflections of radiated energy, noise, and overflying aircraft causing anomalous signals at the receiver. In addition, the signal level dropped by up to 20dB just before touchdown due to the beam directing much of its energy above the aircraft. The author proposed a method of overcoming these drawbacks, giving it the name. Correlation Protected I.L.S. (CPILS). The principle was that transmitters would be placed halfway along the runway at each side, their transmissions being cross-correlated. The noise would then be 'cancelled out', leaving the pristine i.l.s. signal. A similar system was proposed for the glide-path plane.

The initiative for further work came from the U.S. In 1967, the Radio Technical Commission for Aeronautics formed its Special Committee SC-117 to develop a new system. Two systems were proposed—Doppler and a frequency reference scanning beam method. Meanwhile, the British Department of Industry, the Civil Aviation Authority (CAA), Ministry of Defence and Plessey came up with the British proposal, which was a Doppler system (DMLS). Australia put forward a time referenced scanning beam and Germany a distance-measuring equipment (d.m.e.) based landing system (DLS), all of the proposals using microwaves. France proposed AGDLS (Air-to-Ground Data Link System). The All Weather Operations Panel of ICAO proposed, in 1971, a development and testing period for the submissions and the final agreement on the choice of a future system was to be taken in 1976. For one reason or another, minds have been changed, systems have been dropped or discounted, one country has effectively "taken over" another's proposal and the three systems now being considered are:

- Doppler Microwave Landing System (UK) — DMLS
- Time-Referenced Scanning Beam (USA and Australia) — TRSB

Fig.3. Crossed-pointer type of indicator, used in many landing systems. The centre dot represents the aircraft, the pointer crossing the centre of the approach path.

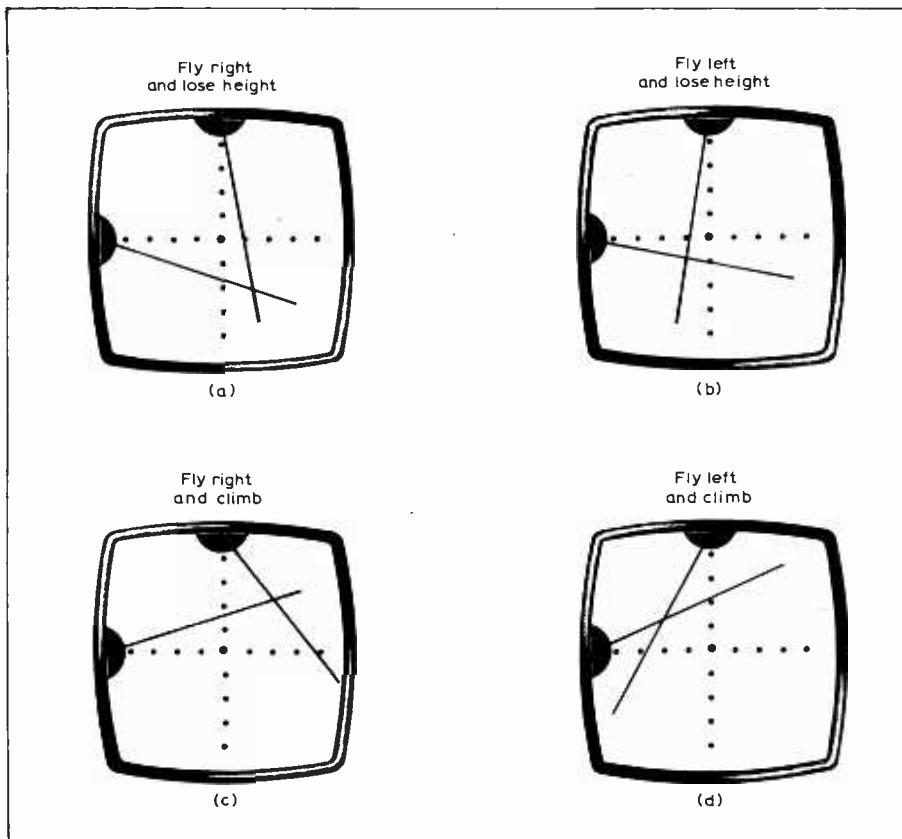

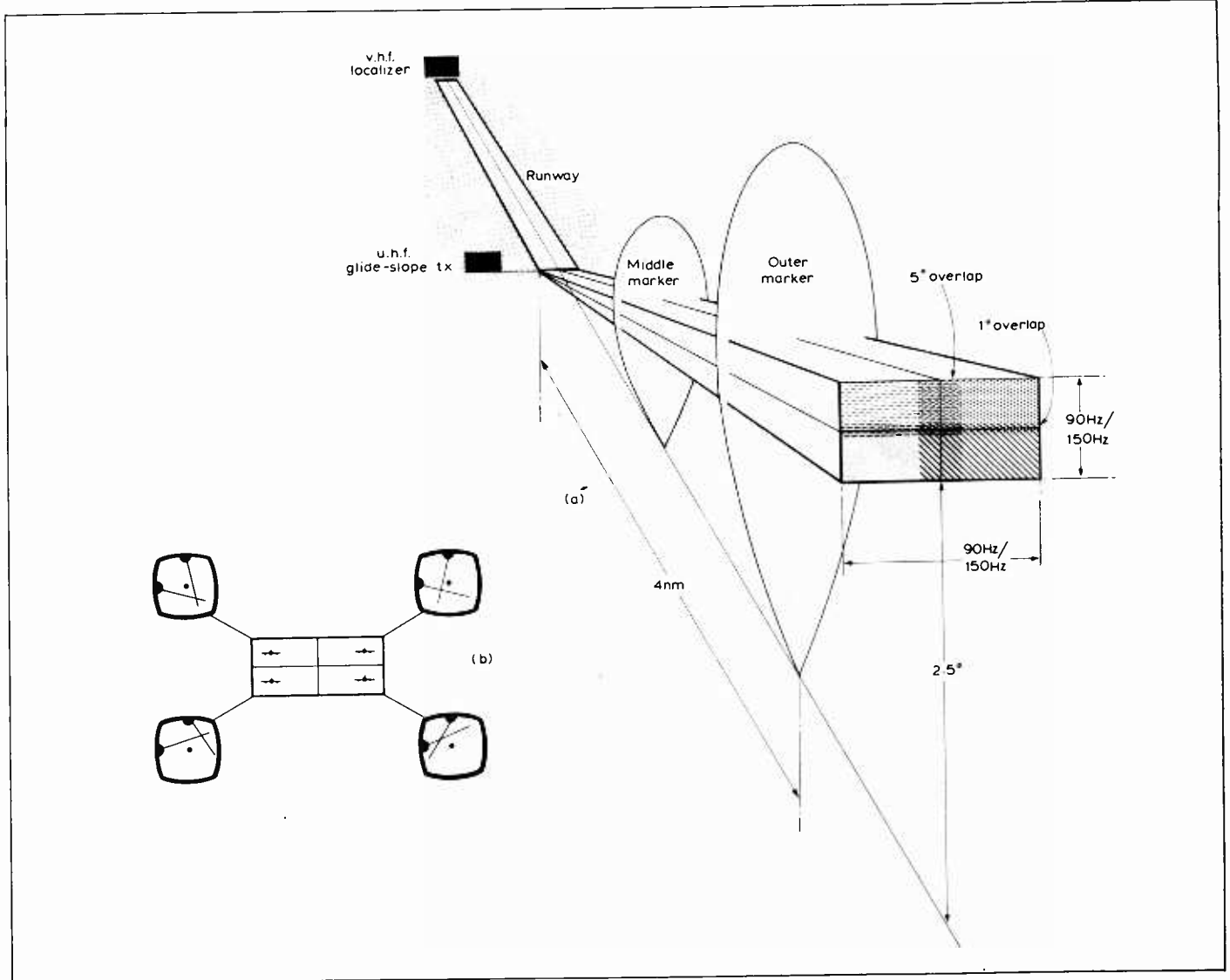

● D.m.e.-based Landing System (West Germany) — DLS

A decision is due to be taken in April 1978 on the system to be adopted.

Requirements

The facilities required by ICAO in the system to be adopted internationally are

- Azimuth guidance up to $\pm 40^\circ$ relative to the centre line and up to at least 15° .
- Azimuth guidance in overshoot to $\pm 40^\circ$.
- Elevation guidance to 20° .
- Flare guidance from -2° to 8° .
- Range by d.m.e.

Doppler

Early work on effects eventually to be used to advantage in DMLS was done by Dr H. G. Busignies⁷ and C. E. Strong and C. W. Earp⁸. Busignies had worked on propagation from a commutated linear array of aerials and found that such an array produced "a transmitted wave characterized by having a spectrum of frequencies, the frequencies varying with different directions of propagation". Earp's work was con-

Fig.4. V.h.f. instrument landing system (i.l.s.) The aircraft recognizes the 90 or 150Hz tone and determines its position in the beam in vertical (u.h.f. transmitter) and lateral (v.h.f. transmitter) directions, as shown at (a). The resulting indication is as seen in (b).

cerned with the relationship of the aperture of an array and its site error suppression characteristics.

The basic Doppler principle is seen in Fig. 5. A linear array of radiators is successively energized by a commutating switch, all having been energized in turn after around lms. The microwave frequency is about 5GHz. When the radiated energy is observed from a position normal to the line of the array, the frequency received is f_0 , but if the observer is to one side, as in Fig. 5a the commutation gives the effect of a moving source and a Doppler shift is experienced, positive or negative, depending on the observer's direction of offset. The amount of shift is $f_D = \frac{V}{\lambda} \sin \theta$, where V is the speed of commutation, and λ is the wavelength of the source. The angle of the observer relative to the

array can be calculated. In fact, the airborne receiver sees a phase progression which can be said to be a frequency.

To make use of the principle, the azimuth array is placed at the upwind end of the runway and a similar array placed vertically at the approach end to provide glide-path guidance. The error which would be produced by the aircraft's own movement is eliminated by radiating a fixed reference frequency from one element in the array, offset by a small amount from the swept frequency. The aircraft detects the beat between the two signals and all processing is therefore carried out at the low beat frequency.

The short array of elements, together with the commutation, produces a spectrum whose envelope shows a peak, which defines the angle of the receiver with respect to the array normal. The width of the peak is inversely proportional to the aperture of the array. In the aircraft, a tracking filter, feeding a counter, measures the frequency of the peak in the spectrum. Range is determined by an ordinary d.m.e. beacon and interrogator.

A time-division multiplex format is adopted for the DMLS system which contains time-slots for azimuth and

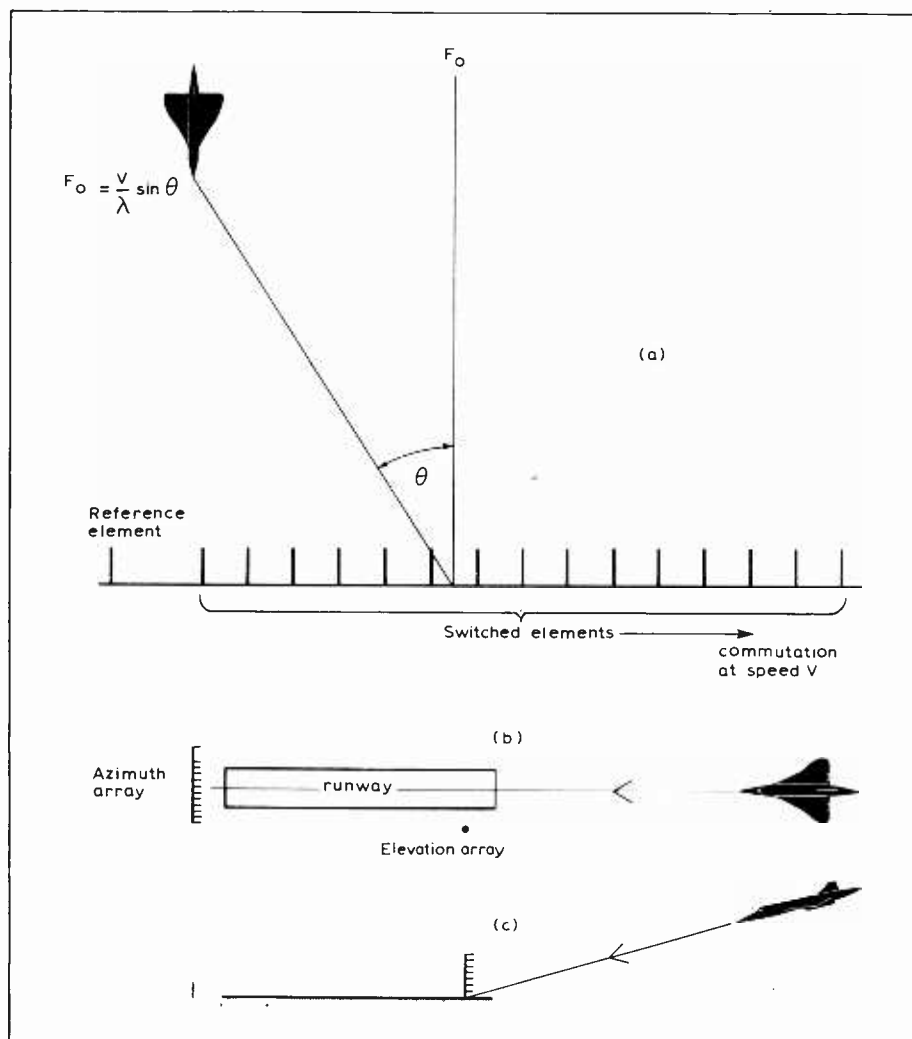

elevation and also for flare. Before each azimuth or elevation slot, a preamble is transmitted which contains

- unmodulated carrier for a.g.c. reference.
- a 5-bit framing code.
- function (azimuth or elevation) identification.
- Morse signal for runway identification.
- 32-bit word to give the airborne processor data on runway length, etc.
- a signal to determine whether the aircraft is outside the system coverage.

The resulting field pattern gives coverage to 20 nm, azimuth angle of 80° up to 20,000ft and back guidance for missed approach or take-off of 40° azimuth up to 5,000ft.

During trials of Doppler m.l.s. in automatic landing it has been found that no 'gap' between the 150ft and 60ft levels, as was needed by i.l.s. is required, since the glide-path indication is sufficiently improved to offer accurate guidance down to the altitude where a radio altimeter takes over.

TRSB

The Australian Interscan proposal and American time referenced scanning beam system⁶ are essentially identical in principle. Differences lie in the aerial designs—an area in which most of the

Fig.5. Principle of Doppler m.l.s. in its basic form. A full-capability system would have two azimuth and elevation aeriels for missed-approach guidance. The elevation transmitter and aerial are shown in the heading photograph

problems experienced with TRSB seem to have been experienced.

The principle is simple and is seen in Fig. 6. In azimuth a 5GHz beam, narrow laterally and wide vertically, is scanned to and fro over the entire coverage of the system. The aircraft has a receiver and processor which determines the time taken for the beam to pass the aircraft in one direction, go to the limit of its sweep and pass the aircraft again on its return sweep. From this time interval, the processor determines the position of the aircraft in azimuth relative to the centre of the sweep. A similar beam performs the same process for the elevation plane. The position of the aircraft in azimuth and elevation, relative to the runway centre line, is uniquely determined by the two time intervals.

The signal format is in the synchronized time-division multiplex mode, in which auxiliary data can be transmitted using differential phase-shift keying at 15kb/s. The azimuth sector of the time-multiplexed signal consists of an identification block fol-

lowed by up to three pulses used for the suppression of beam side lobes outside the required coverage volume, if required — a scanning-beam system is more vulnerable to side lobes, since the beam is used as a timing signal. After the pulses comes the time allotted for the scan and the pulses used for test purposes. The rate of angle data refreshment is 13.5 readings per second for azimuth and 40 per second in elevation.

The auxiliary data, transmitted in blocks immediately before the angle measurement period, is concerned with airport identification, deviation sensitivity scaling factors, the operational status of the ground equipment, data on the glide-slope for the airfield and which function is about to be measured.

DLS

Both Germans (Standard Elektrik Lorenz) and French (Service Technique de la Navigation Aérienne) have considered microwave landing as only part of a wider scheme of integrated air traffic control and en-route navigation. Both use existing L-band d.m.e. beacons at around 1GHz and, in azimuth and elevation, are ground-derived systems, which means that the information is obtained in ground equipment and transmitted to the aircraft. The data is, therefore, available on the ground for use in other systems or in emergency.

Distance measuring equipment (d.m.e.) is, essentially, a ground transponder. The aircraft transmits a pair of pulses to trigger the beacon, which replies by transmitting a pair of pulses back to the aircraft (pulse pairs are used to avoid spurious beacon triggering). The delay between transmission and reception is a measure of the distance. Much additional circuitry is needed to obtain reliability, security and lack of ambiguity, but this does not affect the landing system.

The sequence of events is that the airborne d.m.e. interrogator emits a train of pulses to the two aeriels—DLS-E for elevation and DLS-A for azimuth, shown in Fig. 7. The direction of the incident radiation is determined by each aerial, the elevation data being added to that from the azimuth aerial. The DLS-A station is also the d.m.e. transponder and, after a fixed delay, the station transmits a pulse pair for distance in the ordinary d.m.e. manner, followed by two other pulse pairs for azimuth and elevation information. The time between reception of the original pulse and each pulse pair is an indication of the relevant quantity.

The aeriels consist of vertical staggered dipole interferometers (up to 40) each with its own receiver. The outputs from the receivers give amplitude and phase data which is fed to a processor, which calculates the angle of incidence of the radiation.

The coverage of the system is almost hemispherical, but accuracy is greatest

in the ICAO-required azimuth of $\pm 40^\circ$ out to 30n.m. Only a small addition to airborne equipment is required and indication is by numerical reading of range and cross-pointer meter. Flare guidance is provided by triangulation of DLS-A and E stations.

AGDLS

The name of the French system (Air/ Ground Data Link System) is almost the whole story. As in the German DLS, AGDL is part of a wide-ranging rationalization of aircraft navigation and guidance, which is currently being undertaken by the Service Technique de la Navigation Aérienne.

Again, this is an L-band ground-derived system, using interferometer aerials to determine azimuth and elevation, but the most important point is that the system is basically a two-way, full-duplex data link, operating in the 1500-1600MHz band.

Ground-to-air communication is a continuous data stream, which allows the aircraft clock generator to lock. The down-link is solely for responses to interrogation. As the aircraft is addressed by ground control, it transmits data for other purposes, the incident angle of which can be determined by the aerials. The time for the round trip again provides distance. Data on elevation, azimuth and distance are processed by a ground computer and sent to the aircraft as part of the data stream in numerical form.

The reasons for the development of m.l.s. have been aired at length, but a reiteration may help to put the present situation into perspective.

One of the main advantages of any of the proposed systems is the possibility of incoming aircraft adopting curved approaches, rather than being constrained to follow the straight and narrow i.l.s. beam. Where the i.l.s. takes noisy aircraft over densely-populated areas, for example Hounslow, the change to m.l.s. should be of great help. Many aircraft can be handled simultaneously, all of them coming in from different directions, if necessary. An aircraft could also retain its altitude until very near the runway.

I.l.s. suffers from anomalous v.h.f. propagation, the beam being deformed by terrain, buildings and aircraft flying over the localizer. M.l.s. offers reduced vulnerability to these effects—the beams can be tailored to suit particular situations and the frequencies used and beamwidths employed avoid trouble of this kind, although those interested in denigrating any particular system seem to seize on this aspect as being the least easily proven.

It is said that m.l.s. will need less maintenance than i.l.s. equipment, leading to lower life-cycle costs. Doppler has certainly been shown to require very little installation and setting up—3 days is about the current par, against 3 months for i.l.s.

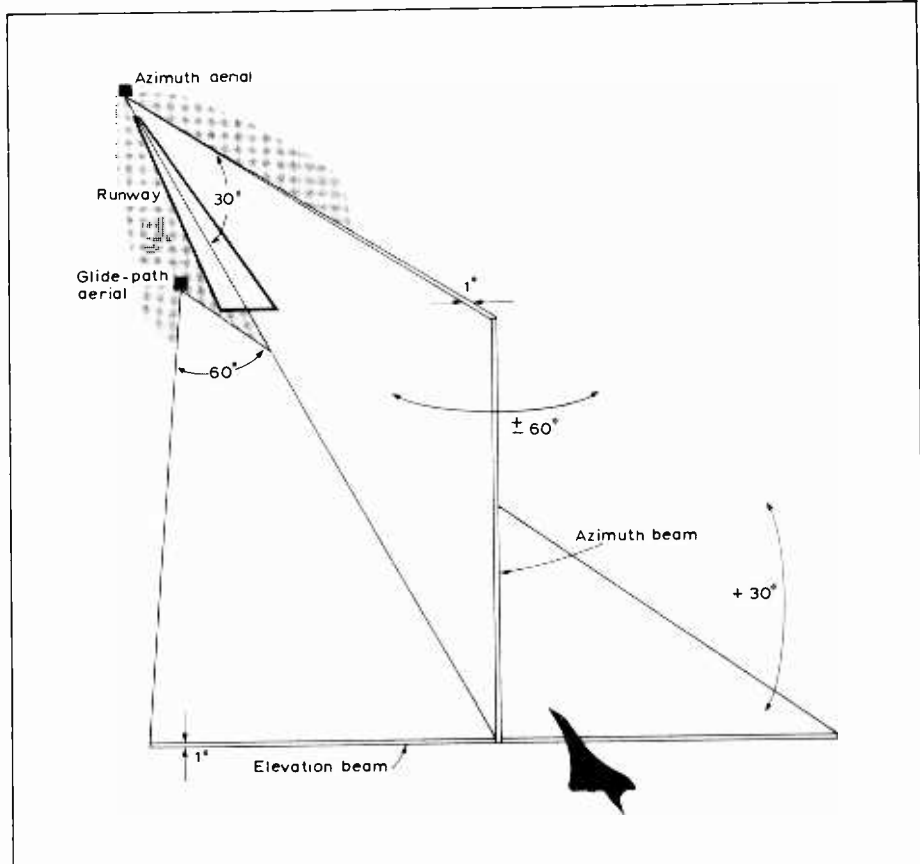

Fig.6. Basic TRSB system of microwave landing aid. The two beams scan to produce time / position data. Vertical beams widths down to 1° are used for 15000ft runway, up to 3° for 5000ft runways.

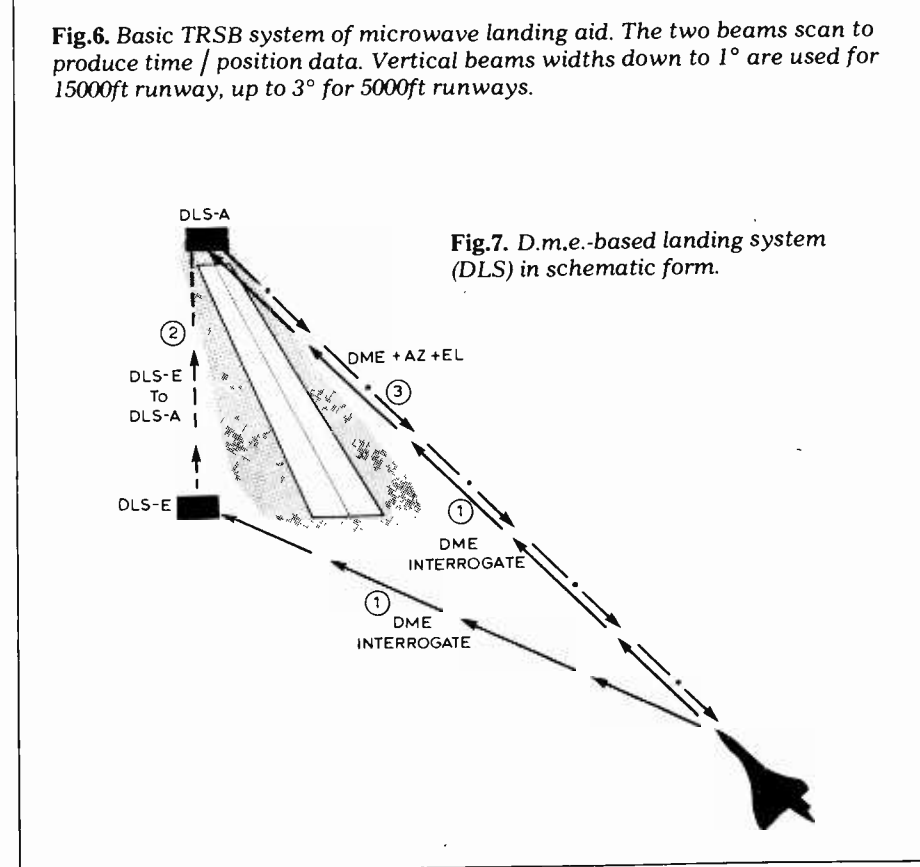

Fig.7. D.m.e.-based landing system (DLS) in schematic form.

Finally, the reduction of m.l.s. beam deformation by terrain (particularly in the elevation beam of i.l.s.) means that landing guidance can be provided at airports such as Berne (Belp) where i.l.s. is simply not possible at all.

Pros and cons

There has been an unedifying scramble between the US, UK and

Australian candidates to have their systems adopted. If the writings emanating from each camp are examined in isolation it is as though no other system had ever been mooted, so completely has competitor's work been ignored. The Australian work was the basis for the American TRSB, but one looks in vain for any acknowledgement of the fact. Americans do their best to

continued on page 56

The Viewdata computer

How information is retrieved at the command of the subscriber

by **S. Fedida** B.Sc.(Eng.) M.Sc., F.I.E.E., A.C.G.I. Post Office Research Centre

Concluding our series on Viewdata, the Post Office's information retrieval system (February, March, April, May issues, 1977), this article explains how information is held in the data base and controlled by a digital computer so that it can be made available on demand to distant subscribers equipped with Viewdata terminals.

IN THE initial studies on Viewdata four important assumptions were made about the system. First, the data base had to be very large in order to satisfy the information needs of modern society and to ensure that the range was broad enough to attract a sufficiently large body of users and thus establish a low-cost mass market. Also we did not want to duplicate the fairly costly services already available to meet the needs of the specialists. Secondly, the communications medium between users and data bank was to be the existing telephone network, which is essentially narrow band but so well developed and established as to provide an ideal medium for this service. Thirdly, the time taken for information retrieval had to be very short, a maximum of two seconds to ensure satisfactory quality. And fourthly, the Viewdata system potentially had to be capable of supporting a host of communications and other facilities, such as person to person messages (including communication with and between the deaf), educational services and simple computational work for the student and small business.

Given these four assumptions it followed inevitably that the information provided had to be based on a distributed network of computers, each of which would be capable of storing the data in a random access device. A wideband communications medium such as cable tv could have been used to provide a similar service, including the interactive ability, with the scope and speed of response of Viewdata, but the cost of establishing such a network on a nation-wide basis is very high indeed (estimates vary between £1000 million and £5000 million). This choice was eliminated from the start because of cost, but had it been pursued it might have operated on a frame grabbing basis, like broadcast teletext, with a minimal computer used for convenience.

The choice of a computer for Viewdata was based primarily on the need to support on each machine as many simultaneous users as possible, in order to reduce the cost per user per unit time. A rugged, reliable machine capable of running continuously for long periods of time without supervision, and not requiring a special environment such as

air conditioning and a false floor, was wanted for the same reason. Since in the information retrieval mode it was obvious that the processing time required to service enquiries could be made very small indeed, the need was for a data concentration and communications switching system rather than a data processing or computation machine. Thus the choice was for a real-time control and automation type of computer, rather than a number cruncher. Of the machines existing on

The GEC4080 digital computer used for Viewdata.

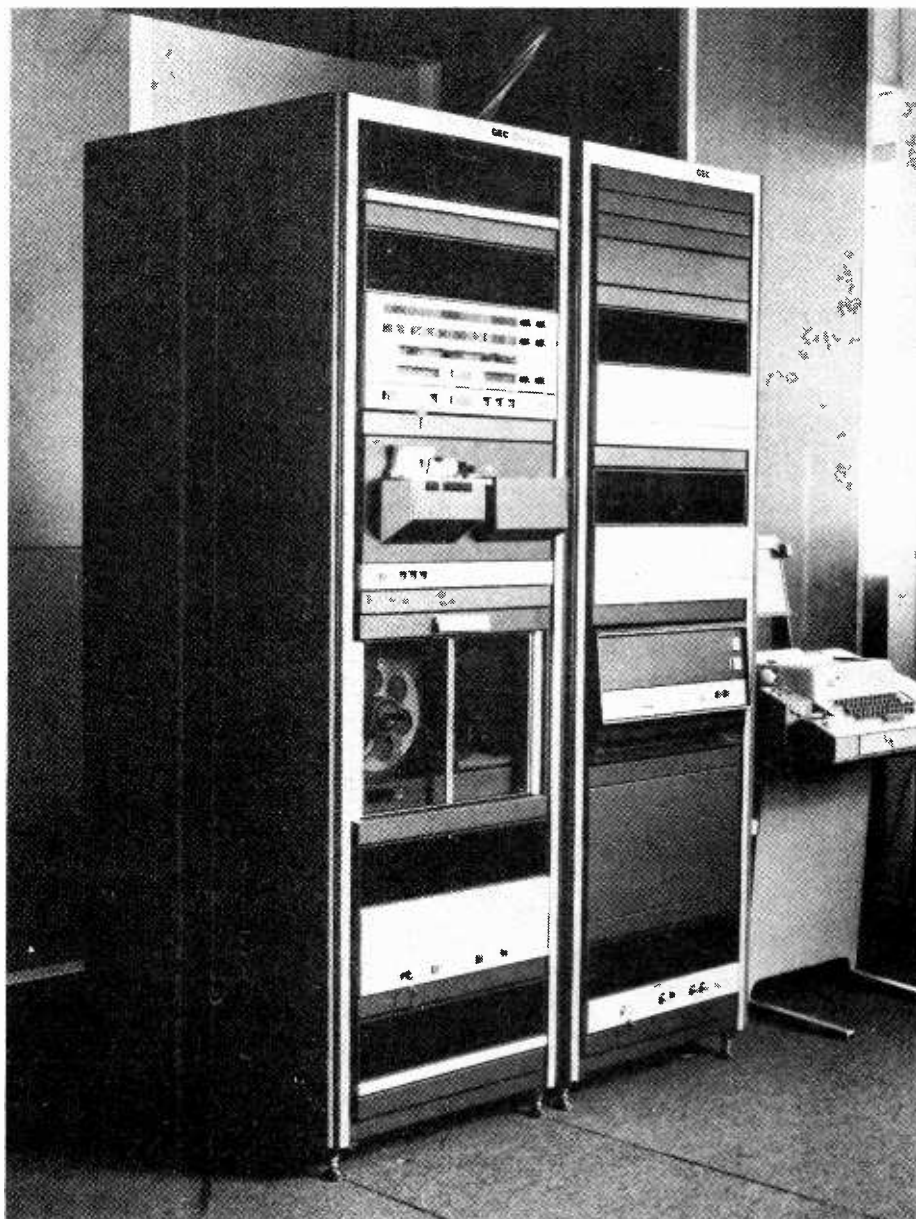

the UK market at the time the GEC4080 was selected as the most suitable for this purpose. One advantage of this machine is a hardware micro-programme, the nucleus which gives it added speed in the scheduling operation in addition to ensuring a high degree of software security and protection when handling a large number of users.

The GEC4080 is a medium scale processor designed for use in real-time applications. The main parts of the machine are shown in Fig 1. First there is the central processor unit (c.p.u.) with its associated main store modules. An integral part of the c.p.u. is a multiplexer unit, which controls communication between the c.p.u. store and the peripherals. A range of input/output processors is used optionally to increase data throughput to the peripherals. These may vary in design and some special ones may be connected to the c.p.u. as required. The range of peripherals includes paper tape readers, a paper tape punch, a line printer, a card reader, magnetic tape units and exchangeable disc stores. Data flows to the outside world are controlled by single channel and multichannel "communications controllers." Further details of the machine are given in the appendix.

Disc store

A most important part of the whole computer is of course the store which holds the data available to the Viewdata users. This is in fact the disc store shown in Fig 1, and a great deal of the overall performance and economics of the system depends on it. Two models of disc store have been used in the experimental system, a 9.6Mbyte disc and a 70Mbyte disc, the latter having arrived rather later on the scene. Indeed the emphasis is now shifting towards disc stores of even larger storage capacities as economies of scale are becoming very significant in this particular component.

The 9.6Mbyte store comprises one fixed disc and one exchangeable disc, both of 14in diameter on one spindle rotating at 2400 r.p.m. There are four data recording surfaces, with 408 tracks to the inch. Maximum bit densities along the track are 1500 to 2200 per inch according to the track position, thus giving a maximum bit rate of 2.5Mb/s. The machine has a set of four read/write heads on a single moving arm, each head "flying" at a distance of about 80 microinches from the surfaces. The significant parameters of the drive are the "latency" (average time to find the required record on the track = 1/2 revolution time) of 12.5ms, and the "seek time" (or time to position the moving head onto the required track) which is 8ms for a one-track movement or 70ms for traversing the complete range of track. In this store the magnetic recording method is double

Table 1 — characteristics of disc drives

	9.6Mbyte	70Mbyte
No. of data surfaces	4	5
Disc diameter	14in	14in
R p.m.	2400	3600
Track density	200 per in	384 per in
Total no. of tracks per surface (cylinders)	408 (8 spare)	823
Bit densities (bits/in)	1500/2200	4038/6038
Data transfer rate	2.5MHz	9.677MHz
Average latency	12.5ms	8.33ms
Seek timing		
track to track	8ms	7ms
average	41ms	30ms
maximum stroke	70ms	55ms
Capacity (sectored)		
No. of sectors per track	24	64
Bytes per sector	256	256
Bytes per track	6,144	16,384
Bytes per cylinder	24,500	81,970
Bytes per drive	9.83 × 10 ⁶ (400 tracks)	66.19 × 10 ⁶ (808 tracks)
Capacities (unsectored)		
Bytes per track	7,812	20,160
Bytes per cylinder	31,250 (4 tracks)	100,800 (5 tracks)
Bytes per drive	12.75 × 10 ⁶	82.9 × 10 ⁶
Modulation method	double frequency	Modified frequency modulation
Drives per controller	4	16

frequency. A flux reversal is recorded at regular clock rate intervals, the space between reversals defining a bit cell. A "1" is recorded by an additional flux reversal between two consecutive clock time reversals.

The 70Mbyte store is essentially a similar to the 9.6Mbyte one, but with five recording surfaces, a nearly doubled track density and a more than doubled bit density, thus providing almost seven times the storage

capacity. The increased bit density along a track results from the improved recording method used called "modified frequency modulation" which, while still using the same bit cell definition between two consecutive clock pulses, only requires flux transitions at data "1", and between consecutive "0"s, but not between the bits of a "10" or "01" combination or at clock pulse instants, i.e., at cell boundaries. Because of the higher speed of revolution and faster moving head actuators, both latency and seek times are substantially reduced.

A comparison between the parameters of the two drives is given in Table 1. We shall see later that the

Fig. 1. Main units of the GEC4080 digital computer used for Viewdata. See appendix for detailed description.

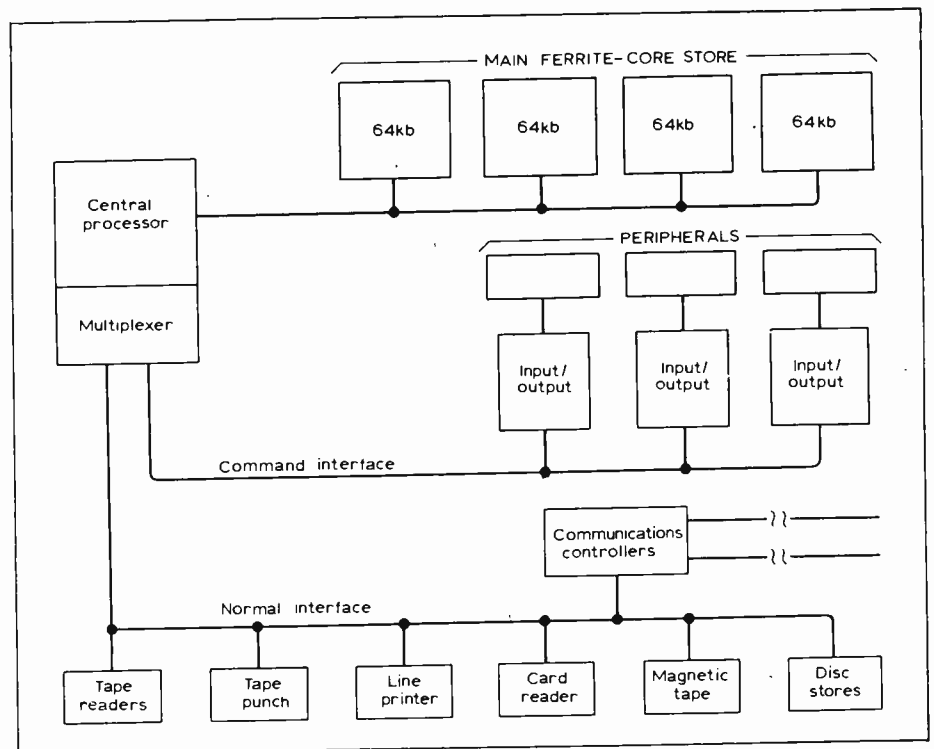

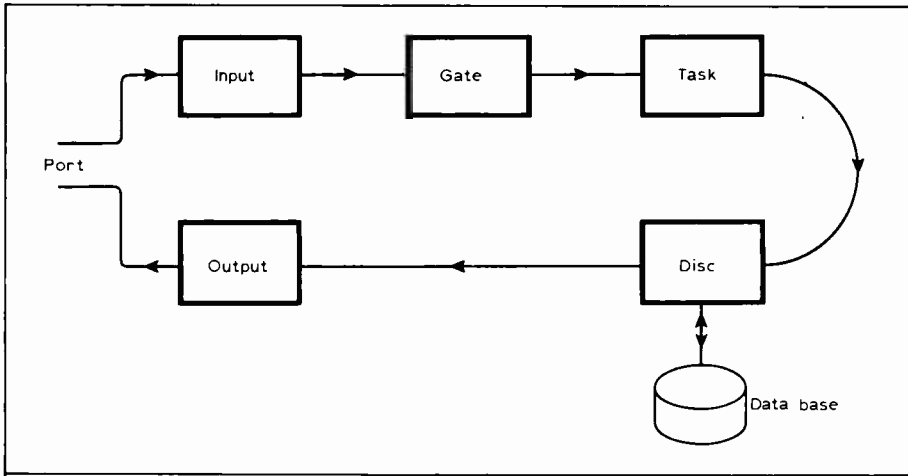

Fig. 2. The five main processes in Viewdata.

improved performance of the 70Mbyte disc has a significant impact on the performance and hence the economics of the overall system.

Viewdata software

The programmes run on the Viewdata computer contain a number of independent processes (or logical computer routines), each executing a well defined task, as we shall see later, and invoked by all the users in turn. Communication between processes — the links which ensure that a whole sequence of operations each implemented by a separate process may be carried out *in toto* — is accomplished by messages and by shared segments of store defined by these messages, which contain all the relevant data enabling a process to take over where a previously operating process has left off. The situation is illustrated graphically in Fig 2.

There are five main processes involved in the operation of the computer system as follows:

Input. This accepts a character from one of the computer ports and assembles a message in which it deposits the character received. The message is identified by the port number.

Gate. This process accepts the message from **input**, identifies the task to be performed on the character just received and places the message in a queue awaiting processing by **task**.

Task. This process uses the input character and other data in the message, identifies the next frame to be output in response to the user's request and sends the message on to **disc**.

Disc. This process retrieves the required frame from disc storage, as indicated by **Task**, adds it to the message and passes it on to **output**.

Output. This process extracts the information from the message and transmits it to the originating port. When this is completed **output** returns the message to **gate** to await the next instruction from the same port.

We have seen that the Viewdata software is based on the principle of dividing programmes into a number of modules or processes, which are substantially independent of each other,

not only in their function but also in the timing — they can run in an asynchronous way. The main requirements which have to be met in this situation are as follows:

Store protection. To prevent different programmes or processes from interfering with one another in accessing each others' store areas for data or code.

Communication between processes. This has to be organised in a controlled manner to ensure that only previously defined and allowable communications modes between processes take place.

Fast and simple scheduling. To ensure that should a process need to pass control to one or more other processes, the scheduling needed to implement this operation can take place safely and fast.

Fast response to peripheral interrupts. In a multi-user environment events which take place outside the computer, e.g. a user response or command, must be able to evoke a fast response by raising interrupts on the current processes whenever necessary.

Protection of shared data areas and codes. This is to ensure that several

Fig. 3. Viewdata software: control of operation of processes by the "Nucleus" programme.

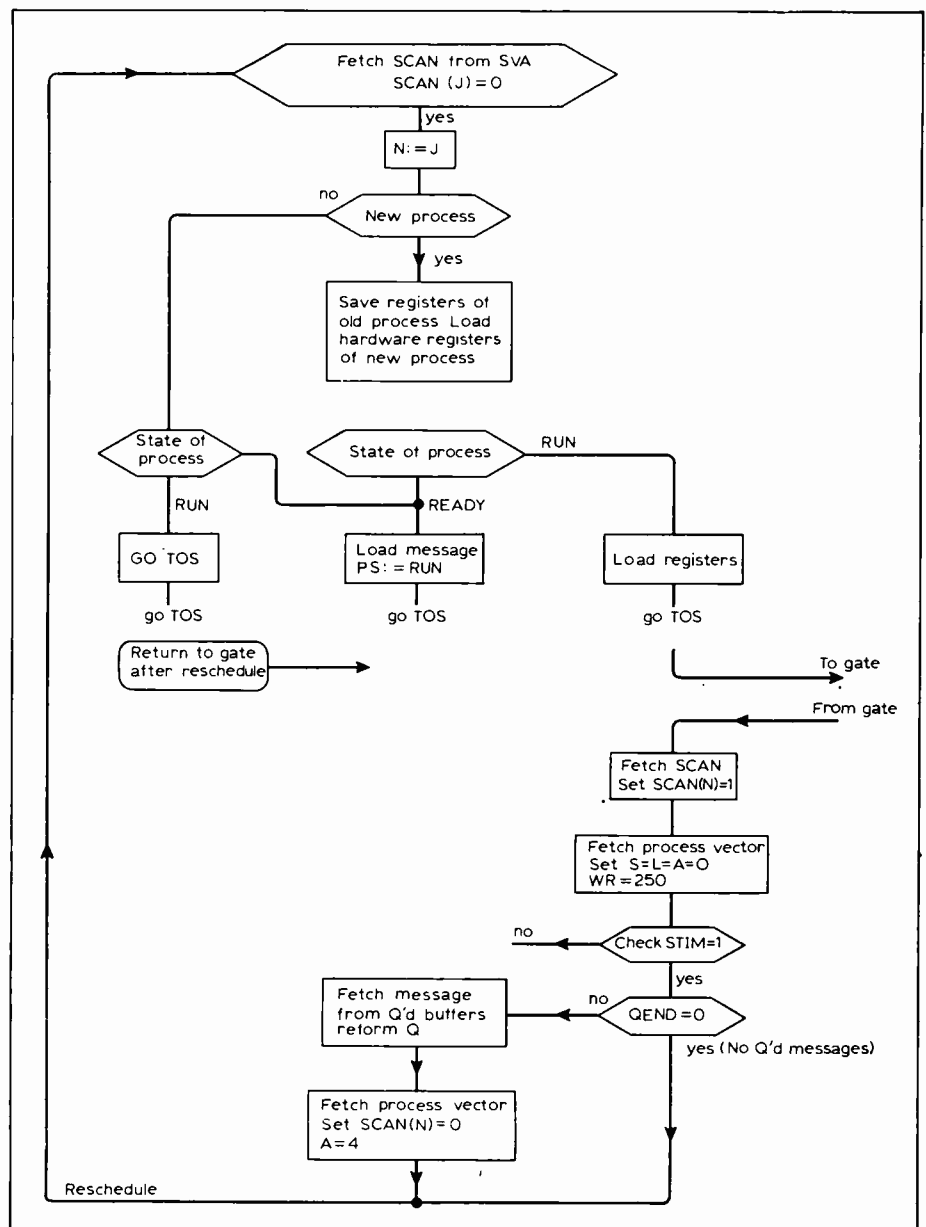

processes can share data areas and codes without mutual interference. The semaphore system ensures this.

Error detection. This is to ensure that errors in processes are quickly detected before they are propagated throughout the system and cause "crashes".

These functions are normally performed by the executive software of a multi-user system, and tend to create time-consuming overheads in terms of c.p.u. processing time. In the machine selected for Viewdata these functions are performed by a programme called "Nucleus," which provides a substantial increase in speed and substantial freedom from corruption by virtue of its being implemented by a hardware microprogramme (hardware logic).

Control by "Nucleus"

The way in which Nucleus supervises and controls the interrelation between processes and ensures adequate protection of data and code areas in store is explained briefly below in the context of the Viewdata software, as illustrated in Fig. 3.

Process selection. Beginning from the initial programme loading procedure which starts the software system, Nucleus examines a 32-byte area of main store which extends from location 0 called the SCAN area, Fig. 4, in order to find out which process is due to be run next. The SCAN area is one component of the "system variable area" (SVA) in which are stored a number of parameters essential for running Nucleus. To each declared process in the system there corresponds one bit (a SCAN bit) in the SCAN area; SCAN bit (J) which corresponds to process number J, is set to 0 if the process is in the READY state or the RUN state and set to 1 if the process is in the FREE, WAIT or STOPPED state (more about these later).

A process is placed in the READY state, when a message for that process is received; it implies that the process should now be run. A process is in the RUN state either when it is actually running or when it is transferred from the READY state in order to start running. The other states will be explained later. When Nucleus finds a SCAN bit J

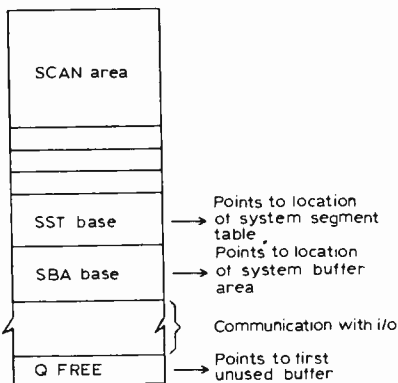

Fig. 4. The system variable area of the main store.

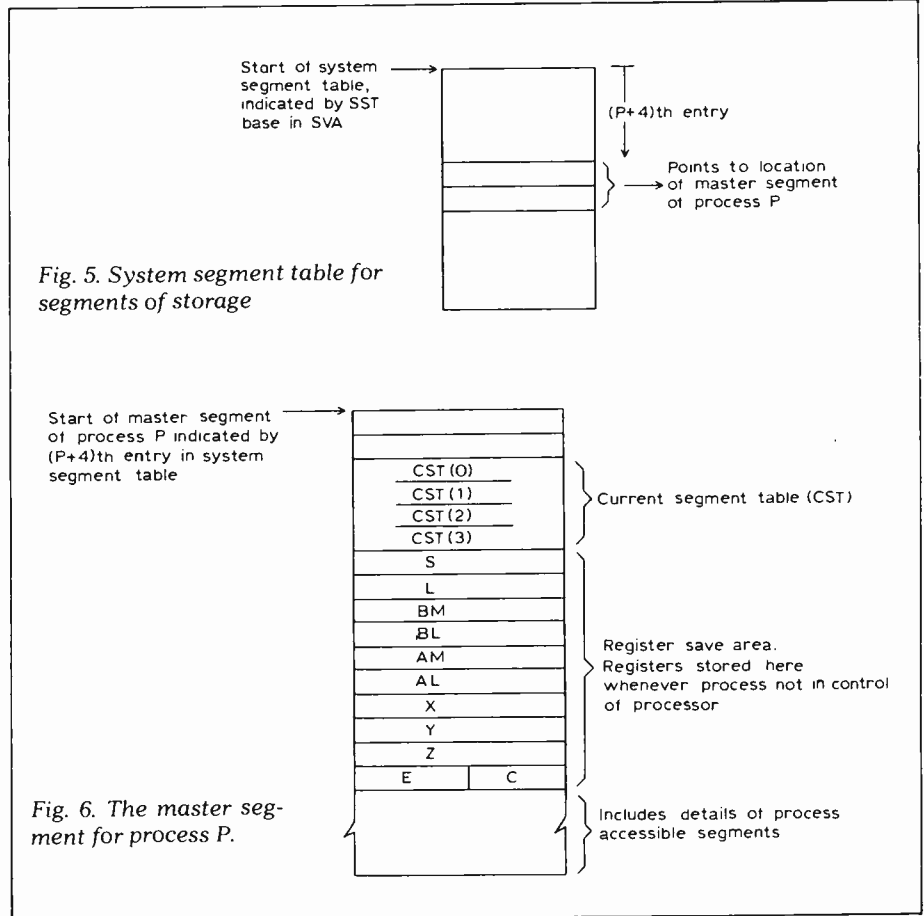

Fig. 5. System segment table for segments of storage

Fig. 6. The master segment for process P.

in the READY or RUN state, it has to decide whether the corresponding process is the current process which has just completed a run or another one. This it does by comparing the SCAN bit J with the number N of the process currently in control of the processor.

The process change. If a new process is to be run, i.e. $N \neq J$ (we shall see later how Nucleus knows which process is currently in control of the processor) the following procedure is followed:

(a) *Save working registers of old process:* The working registers of the old process are saved in the "register save" area of its master segment as explained below:

The segmentation system. The storage used by the Viewdata computer is divided into a number of segments, each of which is identified by a number and consists of a multiple of 64 bytes of storage each, up to a maximum of 64 kbytes. Segments may be in non-contiguous locations in the main store or in a backing store.

Each process may have at any time access to four segments known as its current segments. It also owns a fifth segment known as its master segment, which is accessed normally only by Nucleus, but certain other privileged systems processes may also have access to it.

A process is not normally given access to its master segment. A process may also "own" other segments, but these are not accessible at the same time as the current and master seg-

ments. A table kept in main store called the system segment table (SST) Fig. 5 contains for each segment an entry which specifies the location and size of the segment in main store. The entry for segment number N is found in location $4N$ of the system segment table. The entry for the master segment of a process is the $(P+4)$ th entry in the system segment table.

The master segment of a process P contains amongst other details the following:

- (i) A register save area in which the contents of working registers are stored whenever the process is not in control of the processor.
- (ii) Entries giving details of the current segments.
- (iii) Entries giving details of all programme accessible segments.
- (iv) Entries specifying communication channels between processes, i.e. defining the possible destination for inter-process and i/o messages generated by the process.
- (v) Entries regarding error traps and recoveries. The layout of a master segment table is given in Fig 6.

Thus, given the process number P, it is possible for Nucleus to locate the address of its master segment through the $(P+4)$ th entry in the system segment table and of all the process's other segments by reference to the master segment. □

(To be continued)

Appendix: the GEC4080 computer

Details of the GEC4080 digital computer outlined at the beginning of the article and in Fig. 1 are as follows:

The central processor unit comprises three sub-units: the central processor, which provides the arithmetic, logic and programming capability of the system; the basic multiplexer channel (b.m.c.) which provides the basic input and output capability to the peripherals; and the control and monitoring unit (c.m.u.) which provides for the overall control of the system and a range of maintenance facilities.

The central processor has a repertoire of about 180 16-bit long instructions, 8 programme accessible registers and a main-store capacity of 32kb to 256kb. Store protection is provided by means of 4 hardware segment registers. A hardware microprogramming element, Nucleus, provides facilities for protection, communications, scheduling and input/output. Although the c.p.u. is essentially a 16-bit machine, arithmetic and logical operations may be performed on 8-bit, 16-bit and 32-bit operands, while logical operations may be performed on 1-bit operands, and floating point arithmetic may be carried out on 32- and 64-bit numbers.

Typical operating times, with a 550 nanoseconds store, are as follows:

Add (single precision)		1.1µs
Multiply	16 × 16	3.6µs
	16 × 32	5.85µs
Divide	32 ÷ 16	20.35 µs
Register to register		2.35 µs

The main store. The maximum internal addressable store of the 4080 is 256 kilobytes, which is partitioned in 64 kbyte modules, each with its own power supplies. It is a ferrite core store in a 2½D organisation, with a cycle time of 550ns nominal and width of 16 bits + 2 parity bits. Data may be read out or written in as 8-bit bytes or 16-bit half-words. During a write operation, parity bits are formed for each byte and during a read operation the parity of each byte is checked, parity failure being indicated to the c.p.u. The c.p.u. may access any one of the store modules, by way of a store access director, connected to the c.p.u. via the primary store interface. Each store module may also be directly accessed, independently of the c.p.u., by any of the i/o's and by the b.m.c.

The basic multiplexer channel. The b.m.c. is one of the input/output processors, associated with the c.p.u. and integral with it. The b.m.c. and the c.p.u. share a common interface with the main store, Fig. 7. The b.m.c. executes or controls all data transfers to and from the main store, and while sharing with the c.p.u. a common interface (or channel of communication) with the main store, it has priority over the c.p.u. in the event of simultaneous requests for data transfers.

Data transfers between the b.m.c. and a peripheral dependent on it are carried out via the normal interface (n.i.), while the overall control of input/output facilities is exercised by the c.p.u., using the command interface (c.i.).

The b.m.c. performs two types of data transfer: programme transfers and autonomous transfers. In a programme transfer a single byte or halfword of data is transferred between the c.p.u. registers and a peripheral, while in an autonomous transfer a block of data, which may consist of one or more bytes or halfwords, is transferred between the main store and a peripheral independently of the c.p.u.

Thus the b.m.c. executes all programme transfers, over the normal interface at the instigation of the c.p.u. via the command interface. However, it only controls the transfer of data, over the normal interface, between peripherals and main store. Finally, the b.m.c. executes the transfer of data between main storage and control and monitor unit. Autonomous transfers are originated by the peripheral controller, associated with one or more peripherals, which alerts the b.m.c., whereupon the latter allocates the necessary autonomous transfer cycles. The b.m.c. can handle up to 256 concurrent autonomous transfers on up to 256 ways.

The control and monitoring unit. This unit, as the name indicates, provides sets of switches and indicators for the control and monitoring of the c.p.u. and associated

peripherals. There are basic controls for the operation of the equipment, controls for commissioning and maintenance purposes, displays of data available on a number of highways selected by rotary switches and means for keying in data into selected registers in the central processor.

The c.m.u. provides facilities for the control of the c.p. and b.m.c., and facilities for the monitoring of registers and data highways within the c.p. and b.m.c. for maintenance purposes. The c.m.u. controls comprise: (a) the display of register contents and data highways, selected by a rotary switches; (b) the setting-up on switches of data patterns which may be written into hardware registers and may also be read, for engineering purposes, by programmed instructions; and (c) control switches and indication lamps to reset, run or initial programme load the c.p., and display the c.p.u. run state.

In particular it is possible to read or write to store, to initiate autonomous transfer of the b.m.c., to insert instructions or operands from data switches and to initiate microstep and instruction steps.

Input output processors. Up to three input/output processors may be attached to the c.p.u. — although more may be also connected by way of extension units. The standard i.o.p. is called the external multiplexer unit. This is used when the b.m.c. throughput is not sufficient to serve the number of peripheral controllers supported by the system. The e.m.c. is capable of performing autonomous data transfers up to a maximum rate of 1.5 × 10⁶ bytes/half-words per second, the actual maximum depending on peripheral and interface design. The e.m.c. is connected to the c.p.u. via the command interface, to one or more store modules via the store interface and to the appropriate peripheral via the normal interface.

Communications controllers. These units provide the interface for transferring data between the c.p.u./b.m.c. and telephone lines.

A single channel asynchronous controller is capable of directly controlling P.O. Datel services using standard modems at speeds between 50 and 9600 bauds, in a half duplex mode. It accepts parallel data from the normal interface, converts it to serial data and adds start and stop bits. In the receive mode it looks for a start bit and strobes-in the following data bits which it offers in parallel to the normal interface. In addition the controller is capable of operating the automatic answering facility provided by the P.O. Data Control Equipment No 2A (DCE2A). Data transfer between modem and normal interface take place in 8-bit bytes in autonomous input/output cycles.

A multichannel asynchronous communications controller is capable of handling 16 half duplex channels, in a way similar to that indicated above for the single channel unit. Data transfer rates are, however, limited to 4800 bauds or 2400 bauds when the unit is extended to handle 32 channels.

A single channel synchronous communications controller controls the flow of data in a half duplex mode between the normal interface and modem lines in autonomous input/output cycles, and converts data from 6- or 8-bit binary to serial and vice-versa. Character synchronisation is achieved by generating on transmission two 6- or 8-bit synchronising characters, and on reception by looking for two 6- or 8-bit synchronising characters. The controller is capable of handling data transfers at rates up to 50kbauds. □

Fig. 7. Basic systems configuration. The GEC4080 digital computer used for Viewdata.

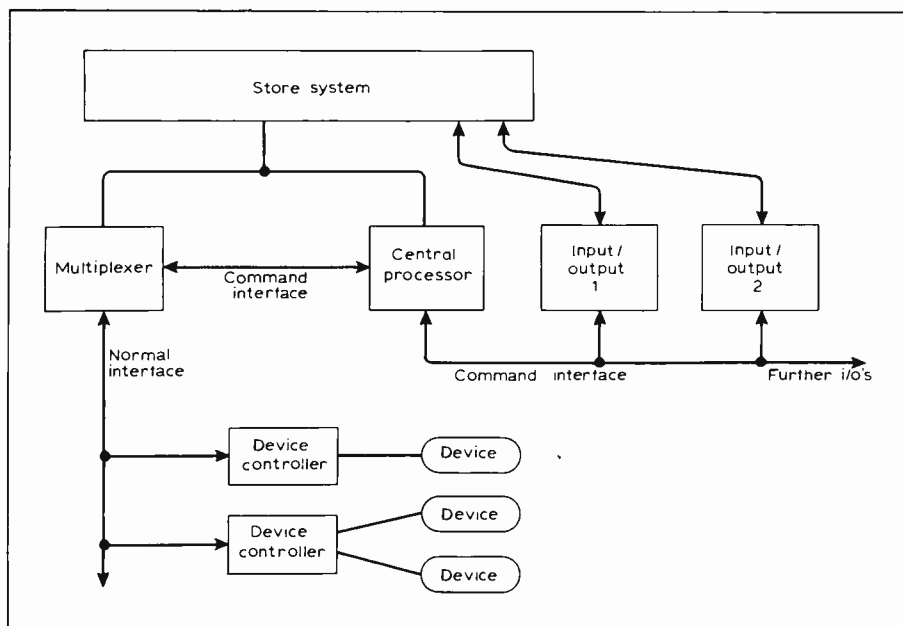

Viewdata to go public

THE POST Office intends to start Viewdata as a full public service early in 1979, without waiting for the results of the market trial due to start this June. The launching date of the new service will be at least a year earlier than was originally intended because of the "tremendous support for Viewdata from the organizations providing the information and from the television and electronics industry" the Post Office says. More than £20 million will be spent in the next twelve months to start the public service. Of this £5 million will be spent immediately to set up ten Viewdata centres in London and at least two other cities. Centres are planned for Birmingham, Cardiff, Edinburgh, Leeds, Manchester and Norwich. By 1985 it is expected that about £100 million will have been invested in Viewdata. (See article in this issue on the Viewdata computer; also February, March, April, May 1977 issues).

Wireless World's call for Viewdata services to be run by independent operators in competition with the Post Office (February, p25) has been publicly supported by the leader of the British radio and television dealers. Gerry Plowright, national president of the Radio, Electrical and Television Retailers' Association told York Centre members at their annual dinner in Leeds: "I feel it will be helpful — to gain wider experience — if some parts of the Post Office trials could be placed with independent operators who will no doubt be a major part of the market promotion when the system eventually comes into overall public service". Mr Plowright was referring to the market trials of Viewdata starting this June.

After the clear statement by Dr Alex Reid, the Post Office's project manager for Viewdata, that the system is not a PO monopoly and that completion would be welcome (Letters, March issue), there is now a pretty strong invitation for commercial organizations to take part. We wait, in particular, for member firms of the National Association of Radio Communication Services to come forward with schemes, for it was this organization in its recent manifesto (February, p25) which claimed that the necessary computers, data bases, software and domestic terminals could be provided by private enterprise. "There could be competing systems, there could be alternative computer services, there could be a number of software organizations all providing similar, stimulating and competitive services to the public. All would use the telephone network".

A leading campaigner for NARCS is Mr John Stanley, chairman of Air Call Ltd, the message handling company. So what about it, Mr Stanley? Air Call has already had experience in using its own computer for information handling.

In another part of his speech, reported in *Electrical and Electronic Trader*, Mr Plowright delivered a message to the television set makers that RETRA will fight to keep independent dealers in the market for Viewdata receivers. He said it was evident that manufacturers are concentrating their efforts towards the multiple rental companies, but "there is no way in which this association can stand by and see a domination of this area by the multiple rental industry. My message to the set makers is therefore that they must recognise this area of the market and provide equipment to the independents — both for the market trial and the subsequent public service".



EBU condemns Geneva m.f./l.f. plan

THE EBU technical centre hopes that the Geneva medium and long wave frequency plan agreed in 1975 "will never be fully implemented since this would lead, as is generally known, to an intolerable congestion of these bands."

The EBU's analysis of the plan points out that the total carrier power provided for in the Copenhagen plan was 20MW, that this had risen to 82MW by 1974, and that the latest Geneva plan might push the figure up to 214MHz. Apart from low-power channels there are about 500 new stations in the plan.

In the l.f. band the projected increases are from 9MW to 23MW, and from 35MW to 83MW on medium wave. Yet these massive increases, around 150%, will only result in a 30% increase in ground-wave coverage. "With the low absolute coverage at night in the m.f. band, this seems to indicate that the possible investments for the transmitters (modification of the aerial systems or power increases) hardly seem to be justified in general."

Coverage might be increased during the day by increasing power "but this would lead to even more pronounced differences between day and night time service ranges than at present. From the programme angle this seems to be really undesirable."

As to the provision of a sky-wave service, the analysis says the prospects are "not encouraging". There would, strictly speaking, be no sky wave reception unless listeners accepted lower-quality standards of service. "However, due to the excessive power increases in the Geneva plan ionospheric cross-modulation would naturally cause higher interference."

The EBU's rejection of the plan is based on the belief that it does not amount to a plan at all. The 1975 conference ended by more or less agreeing that there could be no agreement, and that everyone could have what they asked for. The results are bound to be chaotic, though it is some comfort that the plan only lasts for 11 years.

It became clear at the end of the conference that the British delegation's strategy, mapped out largely by the Home Office, had been mistaken. Their approach had been that the British Isles, having done pretty well at the previous conference in Copenhagen in 1948, would do well if they merely held on to what they had got, so they adopted very limited objectives. On their return from

C.c.d. colour tv camera

NEXT YEAR RCA hope to start selling a hand-held tubeless colour tv camera. Although the camera will not be of broadcast quality, it represents a further promise of even greater reductions in size and weight for cameras used in electronic news gathering.

The 3.6lb camera has three c.c.d. image sensors, one each for red, blue, green. The sensor is made from a silicon wafer with 512 to 320 elements on it, and the image diagonal is 13mm, corresponding to a 7/8in vidicon tube. After processing, say RCA, the image is compatible with 525 line video displays.

Geneva, BBC delegates were furious at what had happened, and blamed the Home Office and the Government for trying to restrict the British demands.

This partly explains the wavelength changes due to be made in November. Had the BBC not made these changes the interference would be intolerable, particularly for Radio 3 since Albania may build a 450 kW station on 464m, now used by Radio 3. But it remains that these are internal changes made to make the best of a bad job, rather than changes which are clearly stated in the plan itself.

There were other changes that have been made because the BBC wanted to rearrange the national frequencies, and because it was felt in some quarters that we ought to have a national station covering the whole of the UK. One reason for that is that everyone could be reached in the event of some unspecified national emergency. The BBC and the Home Office appear to have worked closely on the plan, and the initial differences appear to have been patched up.

Channels increase

From an engineering point of view it might have been easier and cheaper to make all the changes gradually, but the difficulty of educating the public to a series of continual changes outweighed that, and all of the changes were hung on the 1975 conference peg.

The EBU document, prepared by the Technical Centre in Brussels, shows that UK transmitter power will go up overall by only 15%, but the number of channels goes up from 25 to 42, and the number of transmitters from 83 to 126 (night-time) or 127 (day-time). That does not mean that the number of frequency assignments to the UK has increased by 17, since, as always, there is provision for the use of non-assigned frequencies, provided there are certain safeguards against interference in the country to which the frequency has been assigned, and that the extra user puts up with interference on that channel. The only extra frequency that the BBC got was the 227 kHz needed to obtain fully national coverage on Radio 4, including the Scottish borders. Bearing in mind the low increase in power, the table indicates that the extra 17 medium wave frequencies are being used mainly for low-power local radio stations. □

Revived interest in solar energy

RECENT STUDIES appear to have dismissed solar energy as an alternative to dwindling oil supplies, largely on the grounds that the greatest energy is always falling on those parts of the earth where the energy is not needed. The energy needs of big cities will have to be met by nuclear energy.

Yet a clear pattern is emerging in the uses to which solar energy is being put so far. The Post Office is experimenting with solar powered telephones at the Blakeney Point, Norfolk, bird sanctuary and plan to provide a similar installation on the remote Scottish island of Soay which, off the south coast of Skye, should give valuable information about the energy obtainable in areas not noted for long periods of sunshine.

At a seminar held in London on February 7, Motorola described the work they had been doing on solar cells since 1974. Their conclusion was that, at least in the short term, solar cells would be used for what they described as "remote site power", where there were no power lines, and which were difficult for maintenance engineers to reach.

At a secret laboratory in Phoenix, Arizona, Motorola are developing a great many solar devices, largely photovoltaic. The emphasis on photovoltaics arises largely from investment in solar research by the US government, some \$110 million in photovoltaics of a total \$150 million budget. That \$110 million, comments Hammond, represents only one-tenth of the investment in nuclear energy sources.

Until now solar cells have been inefficient and expensive. At the moment the price is about \$15 to \$25 per watt, while the economic price has to come down to \$0.5/W. According to Motorola's solar operations marketing manager, Mr Bob Hammond, this will not happen until at least 1990. The future of solar energy lies in photovoltaic cells of silicon. Silicon is abundant, and the production of silicon wafers is a fairly well-understood technology. Most of the savings, says Hammond, down to about \$2/W, will be gained by cutting down the waste in cutting slices from the silicon ingot. At the moment the diamond saw, which has been used to cut silicon wafers for the last 20 years, wastes a great

deal of material between slices, and the swarf, being mixed with cutting oil, has been thrown away. Once the slice gets down to 4 to 5 mils it shatters. Motorola have developed a new technique which uses a wire saw to get thinner slices with only 3 mils of swarf loss.

The theoretical maximum efficiency of a photovoltaic silicon cell is about 22%, and arises from the difference between the energy distribution pattern of sunlight, and the corresponding output obtainable from a cell throughout the spectrum. Motorola's new cell, shown in the picture, can produce 500W from an array six by eight feet. The operating point for each cell in the array is 0.44V at 1.3A. The cell acts as a constant current source, with output directly proportional to light intensity. Each cell has six contacts on the cell surface, and the two modules on offer from next year, one of 36 and another of 48 cells, can be supplied with a variety of interconnections to meet various voltage and current needs.

The cell surface is made up of tiny pyramids which Motorola say allows the cell to absorb up to 99% of the incident light since reflections from the first contact with the silicon will bounce into an adjacent surface. A coating of silver nitride reduces reflections further.

An energy source for a typical medium-sized radio repeater would be about \$3,000, including regulators, batteries and so on.

Other applications include oil rigs, cathodic anticorrosion protection systems for pipelines, and navigation beacons. It seems likely, however, that Motorola has its eye less on the supply of solar cells than the supply of complete repeater, navigational and other systems, with a solar energy option.

As to the future they think that the \$2/W barrier can be broken with their ribbon technique, replacing the silicon wafer with a 100m long, 7.6mm wide and 125 micron thick ribbon made of polycrystalline silicon deposited on a substrate. A swept laser beam moves down the ribbon, melting it as it goes and forming more efficient monocrystalline silicon.

They believe the market will rise to \$1,000 million by the end of the 1980s, when solar cells will be used for other remote sites. By 1983 solar cells will be used on farms, and rural electrification will begin three years later. By 1988 solar energy may power houses, they say.

Perhaps. Meanwhile the European Space Agency has awarded our own British Aerospace with a contract worth £311,000 to develop a lightweight solar array to power a direct broadcast tv satellite in the mid-1980s. BA have already built such arrays for Intelsat IV and IVA, the Ariel series and many more. The biggest contract was a £6 million order to build the solar array for NASA's space telescope. The sites don't come any remoter. □

Games chip confusion

THE VIDEO games market is growing at a rate which outstrips its supply. One distributor has been so caught up in the scramble that he appears to have been misled.

A recent issue of *Practical Wireless* carried an article about video games in which they named as a supplier A. Marshall (London) Ltd.

Marshall's were inundated with requests for a GI tank battle game chip, AY3 8700, and they accordingly started searching high and low for them. At the beginning of February they issued a press release saying they had "finally succeeded in obtaining supplies of the tank battle games chips AY3 8700 and are offering these at £21.95 each, inclusive of VAT plus 40p postage and packing."

When a member of the *Wireless World* staff called on Marshall's a day or so later, however, he was told that the chip would not be available for four weeks. Worse, GI in London told us that the 8700 was an obsolete device which had not been available for some time and which was not pin-compatible with GI's new range of dedicated games chips. Neither was it available in a 625 line version.

When we phoned Marshall's they said the type number "had been changed to 8710," and that a telex had arrived at their office saying that a plane-load of 8710s were on their way. The 8710 is in fact a new device which is available in a 625 line version, and is pin-compatible with GI's new line, but GI in New York told us that, far from being on a plane to Marshall's, the device was not even available in America yet. When we told GI in New York that Marshall's had obtained a plane-load they told us "that can't be."

Marshall's had ordered the chips through an American factor called JSH, with whom they had done business before. When we

phoned Marshall's again to tell them what GI, the only makers of the chips, had said, they expressed concern and said they would ring the US and report back to us.

In the face of our information JSH's plane-load of 8710s vanished, we presume in the Bermuda triangle, and JSH told Marshall's they would deliver in mid-March, but the experience has made Marshall's a little sceptical even about that.

The distributor's life is not a happy one, it seems, even when he does his best to keep supplies running, which is why *Wireless World* has decided to look into the supply scene. Our report will appear in the next few months.

Economic and electronic market prospects

THE UK semiconductor market will grow by 19%, 7% more than its nearest rival, in 1978, according to Piero Martinotti, European marketing director of Motorola. Sweden will have the lowest growth at 5%, 7% below the average for Europe. In addition, the market in 1979, previously predicted as a slump for Western Europe, and indeed the world, will merely be a period of no growth.

Martinotti predicts real growth in the British economy at 3% a year. Investment will go up 12%, he estimates. One sign of the times is that much of this growth will arise through increased government intervention, leading to increased growth in military and telecommunications, but the consumer electronics sector will suffer further in Europe as a whole, and hence in Britain. It will form 35% of the European market in 1978, a drop of 2% this year, and fall to 32% in 1979. □

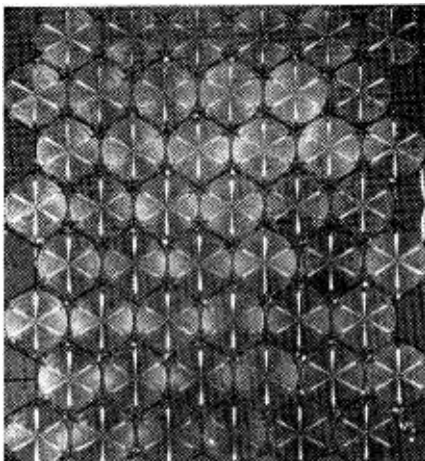

A 48 cell Motorola panel. Each 3in cell has six contacts and 16 thin metal rings to collect the charge without masking the cell from sunlight. This array is rated at 26W. These arrays are counting traffic in Arizona, powering a police radio repeater in Idaho, and protecting buried pipes in Texas.

In brief

Surrey University are to hold an introduction to programmable automation from April 10 to 20.

Bleasdale are running various courses on computer systems design using the Motorola 6800 microprocessor, for advanced students.

Chelsea college's 1978 digital system design course will run from May 15 to 19.

Essex University will hold their teachers' electronics summer school from July 10 to 14, covering both linear and digital design.

AES at the IEE: April 11, Hearing and noise by Peter Wilkins BMEch Eng, MSc; May 9, Underwater acoustics and seabed studies by Professor W. D. Chesterman of Bath University; June 13, Multidimensional audio by Henning Möller of B & K, all at 7 pm.

The **ERA** and the **Institute of Physics** are to hold the first international science and security conference and exhibition at Brighton from September 12 to 14, to be opened by Sir Harold Wilson.

BASF have introduced a cassette tape whose bias point has been chosen to coincide with that of the greatest number of high-bias Japanese machines. Ferro-Super LHI needs a setting such that there is 1.75dB overdrop from maximum output, about mid-way between the typical variations on Japanese machines.

Dr C. Kao and D. G. Hockham of **STC**, who developed the basis of optical fibre communications, have been awarded the £25,000 Rank Prize for important developments in the future of world telecommunications.

The first **fibre optic** and communications exhibition and conference is to be held on September 6 to 8 in Chicago's Hyatt Regency Hotel.

Cambridge Consultants have developed a fibre optic tee coupler for use in single fibre data highways.

General Instrument Microelectronics have moved their London office to Regency House, 1-4 Warwick Street, W1. Telephone 01-439 1891.

Racal have taken over Fairley Electronics, of Barnstaple, Devon, part of the Fairley Group, for £700,000. Racal have also delivered 100 s.s.b. two way mobile radios to the Nigerian highway patrol. Eastern Gas's customer credit records, enquiries, billing and stock control is to go onto two ICL 1904S mainframe computers, connected to 100 remote v.d.us at ten sites, and another 50 v.d.us based at Enfield. The system was designed by Computer Automation.

The Gulf of Suez Petroleum Company have ordered a 24-channel communication system to run between Cairo and the Gulf of Suez oil terminal at Ras Shukair from Plessey EAE. The order is worth £1.8m.

The **FCC** has rejected the idea of an undersea cable to link Europe and North America on the grounds that it is not needed. Extra capacity would be provided by satellites. ITT World com, which wants to build the TAT7 cable, is to ask for a review of the decision. In January the "world's largest capacity undersea cable, between Roma and Palermo, Sicily, carried colour tv signals alongside 8000 phone channels. The 250 mile cable was installed by ITT subsidiary STC.

The Public Broadcasting Association of Australia has called for Australian delegates to the **WARC** to re-think their policy.

Developing countries "deplore" Western retention of frequencies

THE NEEDS and allocation of spectrum space "are at variance between the developing and the more developed countries," says a recent editorial in the journal of the Asian Broadcasting Union. "In countries with poor or meagre communications, the need for extensive broadcasting coverage is essential for social and economic growth." The education and unification of a community can be efficiently achieved by radio and tv, but other telecommunications services are yet to be developed "and progress can be frustratingly slow. Although there are over 358 million telephones in the world, only 65 million of them are in Asia, Africa, Central and South America. Radio and television are vital to these areas and [results] can often be obtained faster through these services than by other means. Consequently their demand for spectrum has become acute."

The editorial, in the January 1978 issue, is written in the context of the prospects for the 1979 World Administrative Radio Conference, and it will add weight to the arguments of those who believe that there will be great pressure from the developing countries for a more favourable distribution of the spectrum in those countries.

The journal notes that broadcasting coverage in the developed countries has reached saturation. Of the world's 25,500 radio broadcast transmitters 75% are in the developed countries, and America has 1,790 receivers per 1,000 inhabitants, while the developing countries have only 76 per 1,000. Radio use in the developed countries has become so extensive that technology is aimed at developing methods to remove certain services from radio altogether and put them on cables and wires, "making room for the expansion of new and existing services which can only exist by means of radio propagation." Yet some users "tenaciously maintain their hold over [their previous allocations] for variously described 'back-up' or 'stand-by' purposes. . . . In today's overcrowded spectrum where space is at a premium this selfish dog-in-the-manger policy can only be deplored."

The editorial presses for the WARC to dispense with the "artificial ITU geographical zones" and the adoption of new zones based on development, economics and need. It goes on to add that, on these grounds, the developing countries are more deserving of the l.f., m.f. and h.f. bands, since these "pro-

vide the only economical and direct means of reaching a large audience. . . . The h.f. bands provide the only presently available method for world-wide broadcasting, without any apparent alternative, as well as providing the most economical means for internal coverage of the larger developing nations."

Single-sideband modulation would mean the re-equipping of a large audience with new receivers, and satellite broadcasting will take many years to develop and will be limited to national coverage.

Short waves are the only alternative for world-wide broadcasting. To alleviate overcrowding in this band elbow room in the allotted spectrum will have to be found, and this will be had at the expense of the fixed services. This would involve only expenditure on the part of the sender and the recipient of the point-to-point fixed services, as opposed to prohibitive expenditure in equipping the world's population with new receivers.

An article elsewhere in the journal points up the greater emphasis in the developing countries on frequencies below 30MHz. In the lobbying for WARC it has been mentioned that the broadcasters have 60% of the usable space above 30MHz, while Mr Irfanullah of the Pakistan Broadcasting Corporation notes that broadcasting claims 9.5% of the spectrum in his region, while fixed and mobile services together have 85% of the allocations. Totals like that convey the reasons for the editorial's impatience to cut the fixed portion (49%) down to size. But there is little indication of the way the proportions allocated to each use within the h.f. band have been worked out.

The emphasis on short wave for worldwide broadcasting arises from the desire to convey cultural and political ideals to the rest of the world. This sensitivity to the way the West sees the developing world was also reflected in the suggestion last year that there should be alternatives to the news reporting of the international news agencies, such as Reuters, UPI and AP. In addition, a conference of the non-aligned nations' broadcasting organisations was held in Sarajevo last October "to consider the ways and means by which broadcasting organisations could co-ordinate to project the image of member countries to each other and to the world at large." There is no doubt that all eyes were fixed on WARC 79. □

Batching by microprocessor

THE USE of a microprocessor in Pye Ether's electronic weighing equipment, demonstrated in mid-February, shows many of the benefits of automation and the results that will flow from it: the need to save costs by reducing wastage of raw materials, the need to save energy, and the desire to cut down on costly labour. In addition, quality control is made easier, and the processes themselves more safe.

The PR1654 will control the amounts of up to 14 ingredients and the time of their arrival. It will also operate heaters and stirring equipment at the appropriate parts of the cycle. Should weights or timings depart from

the pre-set tolerances the whole process is stopped. Pye Ether, part of Philips automation, claim accuracies of 0.1% for a machine which they say combines batching techniques in a single instrument which were previously available only in separate packages at many times the price.

It takes its information from up to eight load cells, and can be programmed from a computer or punched card reader.

Pye also showed an eight channel contactless transmission system which uses low frequency multiplexed f.m. radio to measure the temperature, pressure, acceleration or torque of fast-rotating objects. The transmitter on the object, six to eight inches from its stationary receiver, can stand accelerations up to 3,000G, say Pye. □

"Authorities can be made to concede frequency space"

HOME OFFICE and Ministry of Defence secrecy about the radio spectrum prevents potential users from making a proper assessment of the conflicting demands for frequencies, according to a book just published by the Consumers' Association. "Many observers suspect," says its author, Peter Lewis, "that the amount of the spectrum held on to for 'defence purposes' is as unwarranted as was the post-war retention of land commandeered for the duration of hostilities."

"The cause for concern," he writes, "is not that the defence services should have frequency space — obviously they have need of it, but that behind the mists of secrecy they are holding on to more than they need."

On the 1979 World Administrative Radio Conference, the book says this will decide "how the radio-frequency spectrum is to be allocated as between broadcasting and the many and growing claimants for non-broadcast use. There will," it continues, "be intense struggle on the part of individual countries to at least hold on to the share of frequencies each already possesses, but it is also to be expected that the Third World will press its claim to receive a fairer share than it has had so far. This apparently remote bureaucratic and technical wrangle will affect us all."

Lewis reminds us that the Post Office and the then Ministry of Posts and Telecommunications (whose officials now work at the radio regulatory department of the Home Office) "based their case against the North Sea pirates in part on the interference they said would be caused to existing broadcasters and to maritime communications — a view which later re-arrangements of radio channels showed to be unduly pessimistic."

Similar obstacles were placed in the way of the establishment of local commercial radio, but these were overcome by reallocating two BBC frequencies (194m and 261m) and developing directional m.f. transmitters. In addition, the Post Office, the Ministry and the BBC were forced to concede that frequencies not assigned to the UK could be used in certain circumstances, "arrangements whose existence [they] had not publicly admitted before."

Further, the Annan committee had been misled into believing that the shortage of frequencies was greater than it was. This only emerged, however, when the shortage of frequencies was adduced as a reason for depriving the BBC of its local radio stations and putting them in the charge of the proposed Local Radio Authority. Back-peddalling furiously, the BBC protested that Annan had got it wrong.

"From these examples it does appear that under pressure the authorities can be made to concede frequency space." The battles still to be fought were

- Faster clearance of Band 11. At the moment frequencies from 97.6 to 100 MHz are used by the Home Office for police and ambulance services. The BBC is pressing for broadcasting use up to 108MHz at the 1979 WARC. The Annan report said the clearance would take several years, and that the frequencies should eventually be used for a national channel. Lewis asks: "Should we not, however, be pressing for speedier withdrawal by non-broadcast

users, for use of 100 to 108MHz as well, and public discussion on the merits of another national channel as opposed to more local stations?"

- Hoarding of u.h.f. frequencies. These are needed if small, isolated communities are to receive tv signals. Four government committees since 1967, including Annan, have urged that these frequencies, above 854MHz, be released, to no effect. "There has been no public response to this by the Home Office explaining the reason for its stand, which some observers think is due to the presence in this area of the spectrum of a large NATO communications system."

- Citizens' band. The Annan committee acquiesced in the conservative attitude to c.b. saying that 27MHz c.b. would cause interference — in fact the proposal had been for a service on some other frequency. At the back of the Home Office's objection to c.b. is the Calvinistic assumption that such a use would be frivolous.

- Duplication of services on v.h.f. and medium wave. At night there are sometimes five different places on the dial where one can receive Radio 2.

Even more serious than the hoarding of frequencies is "the secretiveness with which the Home Office makes decisions without public accountability, even if there is liaison with many of the bigger users of frequency space. There is no way the Home Office approach to frequency spectrum management can be questioned and two unsatisfactory consequences follow: "one is that in a 'lobbying' type of situation users take what they can get and often keep quiet for fear of losing even what they have.

"The second, much more serious consequence is that the Home Office negotiates on our behalf internationally without public knowledge of its intentions. The World Administrative Radio Conference (WARC) in 1979 is the next occasion for a thorough appraisal of frequency allocation, at which decisions must be taken in order to accommodate the likely increase in the number of different services throughout the world during the rest of the century. The American FCC has made known its intended position at WARC, but attempts, for example by the Community Communications Group (Comcom), to find out what the Home Office are proposing on behalf of the UK have been met with refusal on the grounds that the information is classified."

For the rest *Whose Media?* is concerned mainly with the content and organisation of broadcasting. There is hardly a mention of mobile radio, and just a little on citizens' band. The book is intended as a fairly intelligent discussion of the consequences of the Annan report, which it describes in detail. There is at least one minor technical error, where the frequencies above 1MHz are described as microwaves, where it should be 1GHz.

- Talks with the Home Office have elicited their view that to open the discussion wider would be unconstitutional. They believe that they are answerable, through the Minister in Parliament. There has never been, and there is unlikely to be, a full scale debate

on radio frequencies in the Commons, however. Neither do they intend, even by pulling the strings of their minister in the Commons, to submit their proposals to Parliament before the WARC; the "classified" label serves to relieve them of that obligation.

Peter Lewis is a leading activist in the Community Communications Group (Comcom), formed early last year. It has attracted a considerable support from cable broadcasting companies and some local authorities, as well as a Gulbenkian Foundation grant.

Peter M. Lewis, *Whose Media? The Annan report and after: a citizens' guide to radio and television.* Consumers' Association. £3.95.

Feedforward limiting and compression

THE LEVEL of sounds which must pass through noisy signal channels has to be controlled so that the signal is always above the level of the system noise but is not so high as to overload the channel. The gain of the channel is increased below a certain threshold, and reduced progressively above another threshold, depending on the instantaneous level of the sound.

The effect on the signal is often noticeable and intrusive. Since the gain cannot immediately be returned to its former value, the effect on signals which have continually varying periods of low and high intensity sound is to cause breathing as the system noise increases during the recovery periods, and drops sharply as the next loud sound arrives. The effect is well demonstrated during long periods of applause on a.m. radio.

An alternative approach, developed by Dr L. Philips and Mr L. Thomas of Swansea University, has won backing from the National Research & Development Corporation.

The new method uses a delay and feedforward technique. Each half-cycle of the waveform is scaled up to a maximum level by adjusting the channel gain of the delayed signal at the zero-crossing point. The amount of adjustment is obtained by sampling the maximum level of the non-delayed half cycle and feeding the scale factor forward. The delay must be greater than a half cycle of the lowest frequency to be transmitted. The scale factor is determined by sampling the maximum level between two consecutive zero-crossings.

A noise threshold prevents any change in gain below that level. With an eight bit companding analogue-to-digital converter and a noise-free sinusoidal input the output is constant through a 70dB change in input, and the peak to r.m.s. ratio of speech is reduced from 12dB to 6dB.

The inventors say that one change in the quality of speech is to make sibilants more noticeable, and the description of the device stresses its use for speech and not musical sounds, but they add that each sample's scaling factor could be transmitted along with the processed signal to restore it to the original quality. A demonstration model has been made using an Intel 8080 microprocessor, and manufacturers interested in making the device should contact Mr Roy Easson of NRDC in London. □

Integrated-circuit memories — 2

A summary of techniques developed in the last ten years

by John Dwyer

This concluding article outlines the prospects for new types of device designed to supplement the rapidly developing random-access memory. It describes the different types of read-only memory available, and examples of how they are used.

RANDOM ACCESS memory access times and prices are such that the core is being replaced by m.o.s. r.a.m. and the fixed head disc, at 10ms and around 8 bits/cent, is giving way to bubble and charged couple device (c.c.d.) memories. They are not yet cheaper but their access times are lower than disc.

The bubble memory is generally regarded as one of the brightest stars on the memory horizon, which is ironic since it is not a semiconductor but a magnetic device. Magnetic devices do, after all, have an inherent binary characteristic and are non-volatile. They are quickly readable at high speed and low power. They are also capable of packing great amounts of information in a small space.

The first magnetic bubble devices, available last year, are easier to make than semiconductor devices and have ten times the information density. The way they store information, as a stack of circulating loops, makes them very similar to the magnetic drums they are likely to replace.

The principle is that in some magnetic films the plane of magnetisation is either up or down in the crystal. The material normally used is a magnetic garnet film on a non-magnetic garnet substrate. When no external field is applied half the area of the film will be magnetised upward to the surface and the other half downward, the areas having common magnetisation joining up to form long, thin strings of common polarity.

If an external magnetic field is applied in the up direction, the domains of the opposite polarity will shrink until they form round cylinders which, under the microscope, look like bubbles. The stronger the field the smaller they become until a critical field is reached where, at about 1/3 of their original diameter, they disappear, suddenly and irreversibly.

The bubbles can be created in the crystal by placing above it a single 'hairpin' conductor through which a

current is passed. The bubble will form at the sharp elbow of the conductor.

The bubbles are highly mobile in two dimensions and can be moved around at will. They also repel one another. The normal method of propagation is to rotate the magnetic field which produced them. This induces local changes in the polarity of permalloy T or chevron shapes on the surface of the crystal. These changes in polarity move the series of bubbles along a predetermined path. In memory applications the bit of information is stored by the presence or absence of a bubble, though bubble memories are being developed in which the 0 or 1 are determined by two different types of bubble.

The bubbles are detected in three ways. As a bubble passes under the sense wire it induces a voltage. This was a satisfactory method until bubbles became so small the voltage they induced became too difficult to detect.

National Semiconductor's 65,536 bit r.o.m. the MM5235. Made with a triple ion-implant metal gate m.o.s. process the 28 pin array has a typical access time of 450ns.

A more satisfactory method is to measure the change in resistance of permalloy as the bubble passes underneath it. The third method is to use an indium antimonide detector and measure the Hall voltage the bubble produces. These two methods give signals of a millivolt or so.

Bubbles are coming into general use. In 1975 Hitachi delivered a 2Mbit memory to the Japanese government for a special project. The stores were made up of 32 64K chips each 6 by 6.5mm and with an average access time of 5ms. They have now made 256K chips.

Around the same time NASA announced that they had contracted Rockwell to produce a bubble storage system, and that Rockwell had produced what they called "the largest integrated circuit memory element ever fabricated." It held 102,400 bits, and was designed for a 100 Mbit solid-state recorder. The recorder they had produced was one third the size, half the weight and took half the power of its conventional equivalent.

The final 100Mbit store is due for delivery this year. In February last year the Bell telephone company, whose associate, Bell Labs, first developed

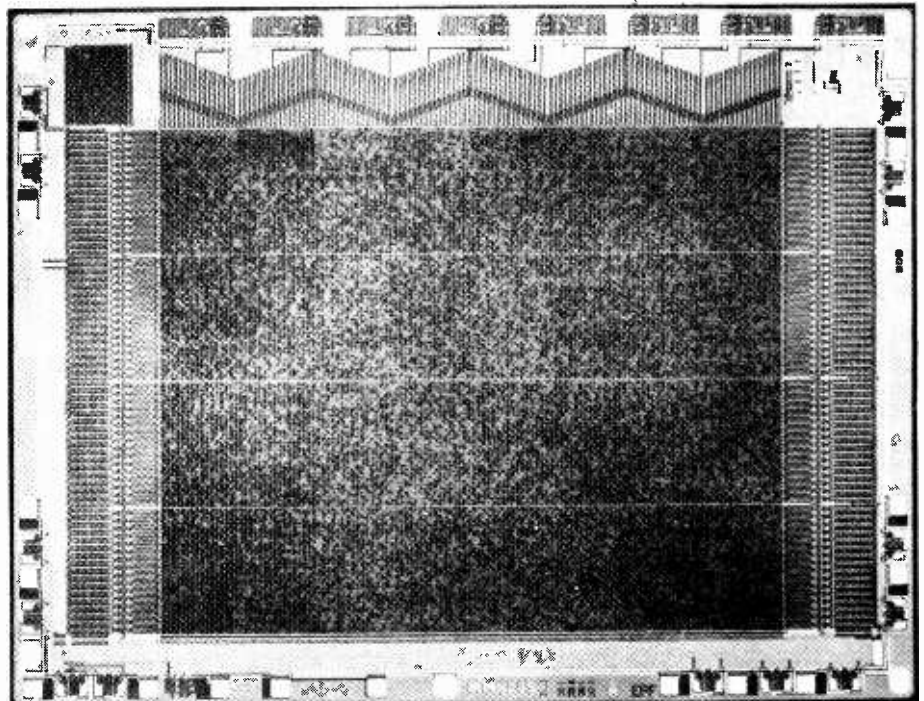

magnetic bubbles ten years ago, installed a recorded-message machine, the 13A, which used bubble memories to store a 12s, 272,000 bit message. Each chip held 68,000 bits.

A couple of months later, in April 1977, Texas Instruments launched two portable computer terminals which used bubble storage to store 20Kbytes, expandable to 80Kbytes. This represents a typical application of bubble memories, since these terminals have used ordinary audio tape cassettes as a cheap storage medium until now. An indexed item might take seconds or even minutes to find on the cassette, but the access time using the bubbles is less than 15ms.

However, two notes of caution were struck last year by independent marketing consultants. Venture Development Corporation announced in June that it would be at least five years before floppy disc makers need worry about bubbles or c.c.d, and in November Creative Strategies Inc said bubbles would not be "a reality" until 1980, when its market would expand with the arrival of a 1Mbit chip.

C.c.d. has even less to look forward to, according to CSI. "The charge coupled device, once regarded as the answer to large memory array problems, will not match earlier sales predictions due to its failure to become price-competitive. Caught between the large dynamic n.m.o.s. arrays and bubble memory technology, c.c.d.s will be squeezed into a small market niche, capturing 2% of total memory sales."

Other interpretations of the way the market is going include the view that c.c.d. has a good future for at least the next five years since it is a semiconductor technology and therefore the ability to use it is already present. After that floppy discs will begin to disappear, and their going will coincide with the appearance of bubble memories large enough (1Mbit) to offer a low cost/bit. During that five years, c.c.d. technology will have advanced by an amount we can only guess at.

Essentially the c.c.d. memory is a very long shift register, with diffusions at either end of the register, corresponding to source and drain, and a series of electrodes in between. The application of a clock voltage to successive electrodes causes the silicon layer beneath to become depleted, and minority carrier charges can be injected into this depletion well. If successive clocks are applied to successive electrodes the minority charge is moved along the silicon surface. The clock signals have to be overlapped, which means that successive electrodes are supplied with signals which are lagging by $360^\circ/n$, where n is the number of separate, isolated but interleaved, electrodes. Early systems used four-phase clocks, where every fourth electrode was commoned, but devices with three and two phase clocks have been produced. C.c.d.s can store analogue as well as digital quantities.

The memories are organised so that a 0 or 1 corresponds to the presence or absence of minority carriers in the depletion well. Operation can be serial-parallel-serial, recirculating loops, or line-addressed.

In the first the bits enter the memory horizontally, one bit at a time. When the row has been filled a column pulse (with a frequency of F/m, where F is the serial clocking frequency into the row and m is the number of bits the row can hold) moves the whole input row down a row, leaving the next set of row clock pulses to fill the input register again. When all the rows are filled the information is clocked out at the bottom at row-input speed. The access time is high and the device requires both fast and slow clocks, but according to Plessey Memories, who are working on c.c.d.s "it is almost certain that this will be the most commonly-used configuration for low cost computer memories.

In the recirculating loop method the end of each successive row is connected to the beginning of the one below it and the information simply zig-zags its way to the bottom. In line addressing each row has its own clock and can work independently of the others. Information is read into empty registers and left there until it is needed.

Last spring Texas Instruments introduced a 64K c.c.d. chip, and Plessey have just announced a device compatible with Intel's IN65 c.c.d. memory. National are to second-source Intel's 2464 64K (65,536 bit) c.c.d. serial memory, a device organised as 256 short recirculating loops of 256 bits. The access time for a c.c.d. device is about $1\mu s$ but it is volatile.

Read-only memories have a great many uses, apart from conversions, say from one alphabet to another or from one programme language to another. Indeed, most future systems are likely to contain many times as much r.o.m. as they are r.a.m, especially as the r.o.m. is non-volatile. A r.o.m. can store waveforms if its input is applied cyclically, as in electronic music. It can also serve as a code convertor, as when a series of inputs can give a predetermined and perhaps different number of outputs. The example we have shown is the simple conversion of a series of binary numbers into signals suitable for application to a seven segment display.

Read-only memories (r.o.m.) have achieved 64Kbits on an m.o.s. chip, and t.t.l. r.o.ms are available up to 8K. Access times vary between 500ns, and 50ns for a 1K t.t.l. r.o.m. There are a number of types available. Manufacturers may make a standard r.o.m. for which the final connections programming the r.o.m. are added at the last stage and are different for each user. The user supplies a tape which is used to programme the memory at the factory. This method is only suited to very large-scale production.

Field-programmable read-only memories are more popular for smaller runs. The user programmes these by putting them on a commercially available machine, and addressing the places where he wants 1s and 0s. A field-programmable r.o.m. is programmable only once. P.r.o.ms are usually bipolar, and are more expensive than mask-programmable r.o.ms.

A third, more recent type of memory is the erasable programmable read-only memory. Developed by Intel, these became available in 1970. They use a floating-gate m.o.s. process. Each cell is a p-channel silicon-gate m.o.s. transistor in which the gate is an island of silicon

Fig. 8. Converting a four-bit number to operate a seven-segment display.

TRUTH TABLE												
Input				Decoder	r.o.m.							Output
A	B	C	D	a	b	c	d	e	f	g		
0	0	0	0	1	1	1	1	1	1	0	0	
0	0	0	1	0	1	1	0	0	0	0	1	
0	0	1	0	1	1	0	1	1	0	1	2	
0	0	1	1	1	1	1	1	0	0	1	3	
0	1	0	0	0	1	1	0	0	1	1	4	
0	1	0	1	1	0	1	1	0	1	1	5	
0	1	1	0	1	0	1	1	1	1	1	6	
0	1	1	1	1	1	1	0	0	0	0	7	
1	0	0	0	1	1	1	1	1	1	1	8	
1	0	0	1	1	1	1	0	0	1	1	9	

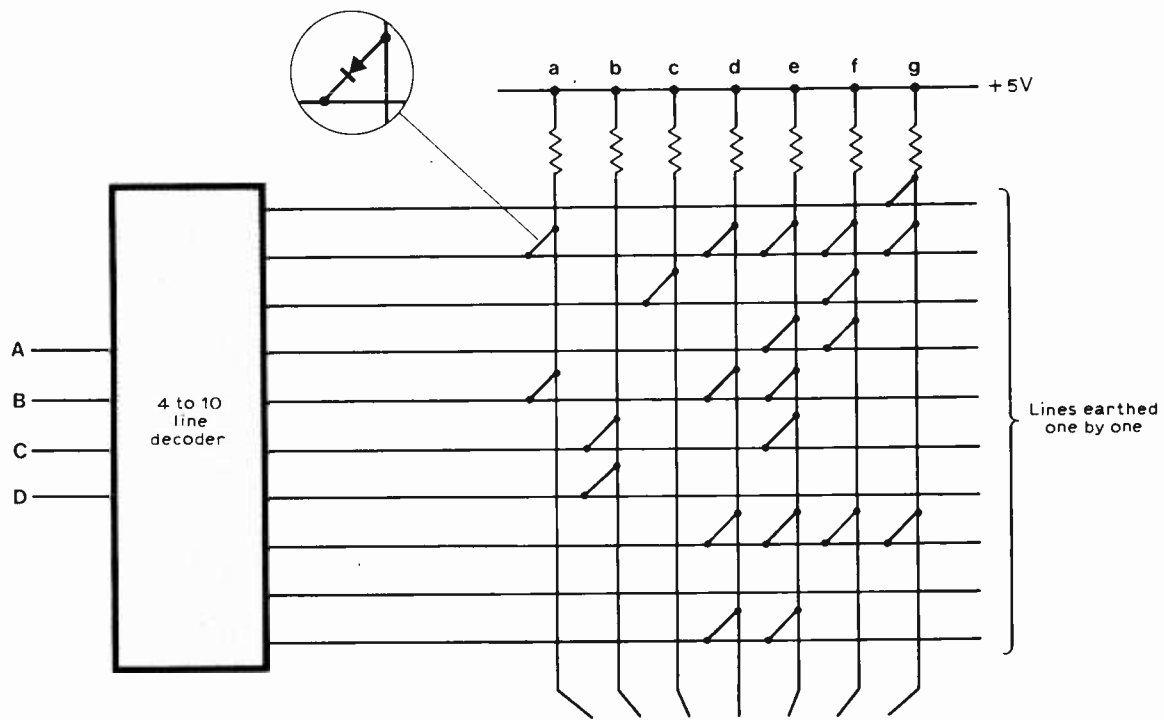
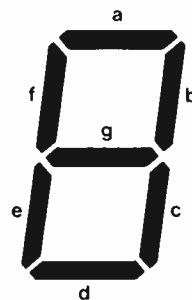

Fig. 9. The connections are programmed on the r.o.m. and are essentially diode arrays with the diodes removed (where there is a 1 in the truth table) or left in circuit (0).



surrounded by silicon oxide between the aluminium source and drain terminals. No electrical contact is made to the gate, but electrons can be injected into it by avalanche injection from either the source or the drain p-n junctions. The presence or absence of charge can be sensed by measuring the conductance between the source and drain regions. The array is programmed by applying a reverse bias of 30V or so to the gate or drain p-n junctions in particular cells.

The programme is erasable by shining ultra-violet light on the chip, which allows electrons to return to the silicon substrate via a photocurrent.

Last year Intel produced a 16K n-channel version with a single 5V power supply, an access time of 400 to 1,000ns and a programming time of 30 to 100s. National now have a 64K 450ns r.o.m. and are working in 128K and 256K additions to this triple-layer, ion-implanted family.

Newer devices are electrically alterable memories (e.a.r.o.m.). In programming voltages are applied which are well outside the memory's working range and which define the memory's operation until those large voltages are reapplied in a different way. In some

applications the distinction between r.o.ms and r.a.ms is beginning to blur. Some e.a.r.o.ms use a modification of the floating gate principle, others use nitride storage (m.n.o.s.). Eight kilobit e.a.r.o.ms of around 0.5 to 1µs are now available.

One point worth bearing in mind on p.r.o.ms is the length of time they are able to retain their programmes. If nichrome fuse links are used, for example, and selected fuse links on the matrix are blown, some of the fuses may re-form themselves within a few hours of programming. Certain e.p.r.o.ms, it is reported, lose their programmes within a year. The normal guarantee is about ten years, and it may be one hundred, but with avalanche-injected charges it is not forever, especially if the device is operating in high temperatures.

Several other storage techniques have surfaced over the last few years, such as holography, domain tip memories and others. Many of them have no advantage over the techniques already described and, though in some cases as good, therefore offer no reason for a transfer to them. Some once seemed promising but have fallen from favour. A couple of years ago the electron-beam

addressed memory (e.b.a.m.) was hailed as a future winner. At the end of last year, however, it was believed that only Micro-Bit of Massachusetts was still pursuing the idea, and General Electric were trying to sell their technology, having stopped the project.

Over the last five years around fifty companies have been involved in memory development in Europe, the US and Japan. The following list gives the names of the most important manufacturers and those who have agencies in the UK.

AEG-Telefunken, Postfach 1109, Heilbronn, Germany. Telephone 01 131-8821.

American Microsystems Inc, 108A Commercial Road, Swindon Wilts. (0793) 31345. Agents: Ritro, see Solid State Scientific.

Advanced Micro Devices, c/o Quarndon Electronics Ltd, Slack Lane, Derby DE3 3ED. Derby 32651.

Electronic Arrays Inc, 550 E Middlefield Rd, Mountain View, California.

Fairchild Semiconductor, Kingmaker House, Station Road, New Barnet, Herts. 01-440 7311.

Ferranti Semiconductors, Gem Mill, Fields New Road, Chadderton, Oldham OL9 8NP.

General Instrument Corporation, 57/61 Mortimer Street, London W1N 7TD. 01-636 2022.

Harris Semiconductor, Memec Ltd, The Firs, Whitchurch, near Aylesbury, Bucks. Whitchurch (029 664) 366/7/8.

Honeywell Ltd, Charles Square, Bracknell, Berks. Bracknell 24555.

Hitachi (UK) Ltd, Hitachi House, Station Road, Hayes, Middlesex UB3 4DR. 01-848 8787.

Intersil Inc (including AMS), 8 Tessa Rd, Reading, Berks RG1 8NS. Agents: Macro Marketing.

Intel Corporation (UK) Ltd, Broadfield House, 4 Between Towns Road, Cowley, Oxford OX4 3NB.

Matsushita Electronics Corporation, 1 Kotari-Yakemachie, Nagaokakyo, Kyoto 617, Japan.

ITT Semiconductors, Maidstone Road, Footscray, Sidcup, Kent. Harlow 26777.

Monolithic Memories Inc, 1165 E Arques Ave, Sunnyvale, California. Agents: Ritro, see Solid State Scientific.

Mostek Corporation, 240 Upper St, London N1. 01-359 6271.

Motorola Semiconductor, York House, Empire Way, Wembley HA9 0PR. 01-903 0944.

Mullard/Philips/Signetcs, Mullard House, Torrington Place, London WC1E 7HD. 01-580 6633.

Nitron, 10420 Bubb Road, Cupertino, California.

National Semiconductor (UK) Ltd, 19 Goldington Street, Bedford MK40 3LF. 0234 211262.

Nippon Electric Company (NEC), 43 Civic Square, Motherwell ML1 1TH. (0698) 69121. Agents: Celdis, Macro Marketing.

Philips: see Mullard.
Plessey Semiconductors Ltd, Cheney Manor, Swindon, Wilts. (0793) 6251.

RCA Ltd, Lincoln Way, Windmill Road, Sunbury-on-Thames, Middlesex. Sunbury-on-Thames 85511.

SGS-ATES (UK) Ltd, Walton Street, Aylesbury, Bucks. (0296) 5977.

Siemens Ltd, Great West House, Great West Road, Brentford, TW8 9DG. 01-568 9133.

EMM-Semi, Semi, Electronic Memories, 3883 No. 28th Ave, Phoenix, Arizona. Agents: Memec Ltd.

Signetics, see Mullard.

Thompson CSF, Ringway House, Daneshill, Basingstoke RG24 0QG. Basingstoke 29155.

Texas Instruments Ltd, Manton Lane, Bedford MK41 7PA. Bedford 67466.

Solid State Scientific (SSS), agents: Ritro Electronics (UK) Ltd, Grenfell Place, Maidenhead, Berks. (0628) 36227.

Toshiba (UK) Ltd, Toshiba House, Greater South West Road, Feltham, Middlesex. 01-751 1281.

Zilog, Nicholson House, Maidenhead, Berks. Maidenhead 36131.

Fairchild, Mostek, NEC and Motorola are also sold by Celdis Ltd, 37-39 Loverock Road, Reading RG3 1ED.

Most of the products made by the manufacturers listed above are available through a number of distributors, and the British suppliers are not necessarily the sole agents or the only suppliers of those products. In other cases, British subsidiaries may refer inquiries to head office. □

continued from page 43

ignore the British Doppler in the face of highly successful practical tests of the system and rumours of skulduggery are rife. On the other hand, the French and Germans do not see the ICAO choice of a system as final, since their own systems are of a more far-seeing nature and are intended to form part of a total air navigation system in the future. Whether TRSB or DMLS is chosen by ICAO, it seems possible that it will all have to be examined again in ten year's time.

As seen by their proposers, the points for (very few against) their systems are, looking on from the outside, fairly contrived, and are to do mainly with aeriels and propagation.

It has been shown that all systems proposed, with the exception of the m.l.s. part of AGDLS, have satisfied most of ICAO's requirements in all major particulars. (AGDLS is still a 'paper' proposal, although it has successfully performed in tests at Brétigny).

However, the arguments will not be stilled until after the April ICAO meeting. Proponents of Doppler strenuously deny that their system suffers from 'scalping'—a type of signal deformation by reflection from objects—and can point to many successful trials at 'difficult' airports, after each of which they have distributed their tracking results. In contrast TRSB had, until recently, only been tested at Atlantic City, and results from the tests have been very difficult indeed to come by. Now, the UK camp have coerced the Americans into tests at the same airports as Doppler and the first results, from Kristiansand and Brussels, show that there is little difference in performance. The Doppler men say that their system is easier to monitor, needing only a one-point field monitor, whereas TRSB needs monitors in several parts of the coverage volume. They also say that the Americans have had continual trouble with aerial design, although it appears that they have at least one which performs well now—probably an Australian design. Plessey say that over 10% of the elements in a Doppler array can fail before any deterioration in performance is seen—they call this a 'fail-soft' characteristic. In contrast, TRSB needs all elements in the array to be energized, with a well-graded amplitude and phase at each. (Doppler elements are fed with the same signal in turn). It is said that a 'thinned' Doppler array, with elements 'missing' will work well, with acceptable side lobes. With a shifting reference frequency, a vernier-like effect can be employed to restore the Doppler signal. A scanning beam with side-lobes (the result of missing elements) cannot, say the British, be acceptable and cost cannot be reduced by 'thinning' the array, although Cox and Sebring⁸ have said that 20% of a phased array can be failed without destroying the characteristics.

Doppler men point to the high cost of

development (really rather irrelevant now), high maintenance costs and lack of flexibility of TRSB. They also point out that the high sampling rate of Doppler, whose beams exist continuously, unlike those of TRSB, mean better 'smoothing' of aircraft motion.

Those interested in the adoption of TRSB appear to pin most of their faith on allegations that Doppler will suffer from multipath propagation errors. The fact that UK workers have shown little confidence in Lincoln Laboratories computer simulation, preferring to fly the tests and see what happens in practice, is seen by some Americans as a failing, even though practice has shown that multipath trouble predicted by the computer is conspicuous by its absence. Both Doppler and scanning beam proposers claim one disadvantage for DLS. It is said that, since it is 'open' continuously, interference can be more of a problem when compared with TRSB, which gates the information and Doppler, which has its tracking filter.

In retaliation, the German and French companies point out the fact that the use of L-band techniques affords a considerable saving in spectrum allocations—a factor which may not be of prime importance at this time, but which could assume greater significance in the future. DLS has the advantage that it uses existing L-band d.m.e. airborne equipment with comparatively small attachments which can be fitted at any time, and can use this equipment for navigation as well as landing. Flare is also provided by triangulation of DLS aerial signals.

Tests at John F. Kennedy airport are to take place as this is being written and further tests at Montreal will be undertaken in a few weeks. In April, ICAO makes its choice, which seems a pity. There is absolutely no reason why the decision must be made now—the deadline has been postponed once already and could be put back again.

It could well be that, given a month or two to cool down, the French AGDLS or German DLS integrated systems would appear more attractive. A complete new look at air navigation methods must surely make more sense than another piecemeal alteration. □

References

1. Denman, R. The Lorenz blind landing system, *Wireless World*, April 5, 1935, p.332.
2. Full visibility landing system, *Wireless World*, May 1963, p.209.
3. New navigational aids, *Wireless World*, August 1953, p.375.
4. No hands blind landing, *Wireless World*, December 1958, p.579.
5. Benjamin, J. Correlation-protected i.l.s., IEE/IERE Conference on Air Traffic Control Systems Engineering and Design, 1967.
6. U.S. Patent 2411518, November 26, 1946.
7. British Patent 549530, August 4, 1944.
8. Cox, R. M. and Sebring, J. R., M.l.s.—a practical application of microwave technology, *IEEE Trans. Microwave Theory and Techniques*, Vol. MTT-24, No. 12, December 1976.

Cassette tape programmer — 1

A simple interface for calculators

by Evert Olsson

The interface described in this article was the winning entry in a designer's contest arranged by the Swedish electronics journal *Radio & Television*. It is an add-on unit which makes a simple calculator programmable by using an ordinary cassette tape recorder as a programme storage medium. No modifications are required on the recorder, but the calculator must be provided with two connectors to make programming possible. The original article was first published in the above mentioned journal.

Although modifications are described for the Sinclair Cambridge, almost any calculator can be adapted. The programming unit is not intended to compete with commercial units, particularly in terms of speed, but it is an interesting project for people who want to gain experience in programming and interfacing. The complete circuit can be hard-wired on two boards measuring about 10 × 16cm and the only test equipment necessary is a d.c. coupled oscilloscope with triggered time-base, and a voltmeter. A quiz machine is also described which uses the same principle and almost the same hardware as the programming unit. Details are given for the construction of both or either one of the circuits.

Basic principles

The block diagram in Fig. 1 shows the operations for recording a programme. Signals from the 18 calculator keys are converted into a five-bit code by the diode matrix. A pulse from the detector circuit loads the code into a shift register which converts it to serial form. The detector also enables the RS flip-flop which drives the tape recorder via a buffer stage. After a delay of about two seconds, which allows the recorder's motor speed to stabilize, a clock generator is started. Output pulses from this circuit are gated with counter outputs and used to shift the code out of the register. This serial code is shown in Fig. 2 and is basically a five-bit telex format with the time element altered to suit the calculator de-bounce logic. On the last counter pulse the start flip-flop, shift register, and counter are reset. The serial code is amplitude modulated on a carrier of about 5kHz so that when the carrier is off no code is being processed. Each key depression runs the tape for

about three seconds which allows 600 programme steps per side of a C60 cassette. Speech signals from a microphone can be mixed with the modulated carrier but the tape runs for as long as the remote-button on the microphone is pressed. Therefore, fewer programme steps can be recorded. Although the serial code could be

packed much more densely onto the tape, a lower density was chosen so that single programme steps can be edited. In addition to the 18 calculator keys there is a pause switch which is used to make programmed stops on the tape.

The execution of a programme is shown in Fig. 3. The tape is started by the same RS flip-flop and buffer stage

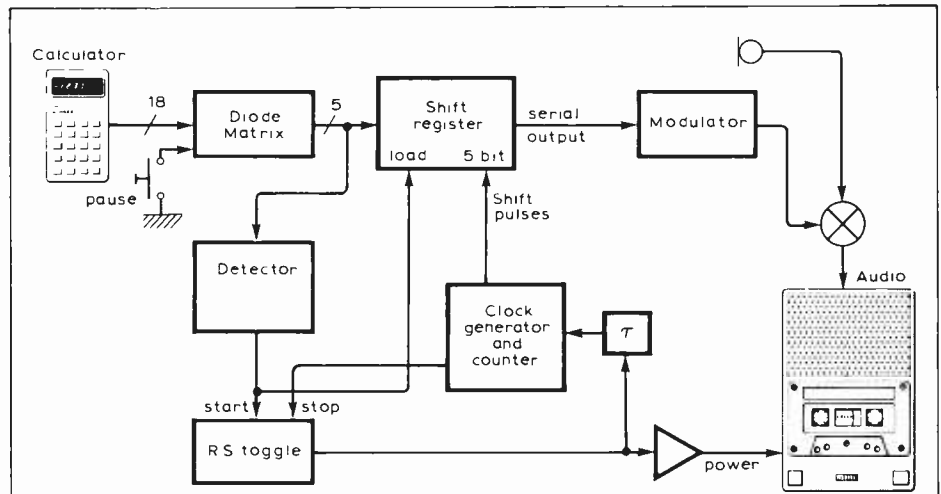

Fig. 1. Circuit operations for the record mode where the logic acts as a parallel-to-serial converter.

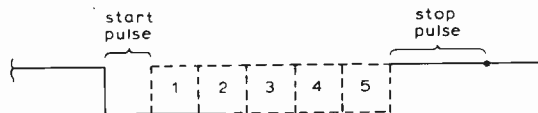

Fig. 2. Serial five-bit code.

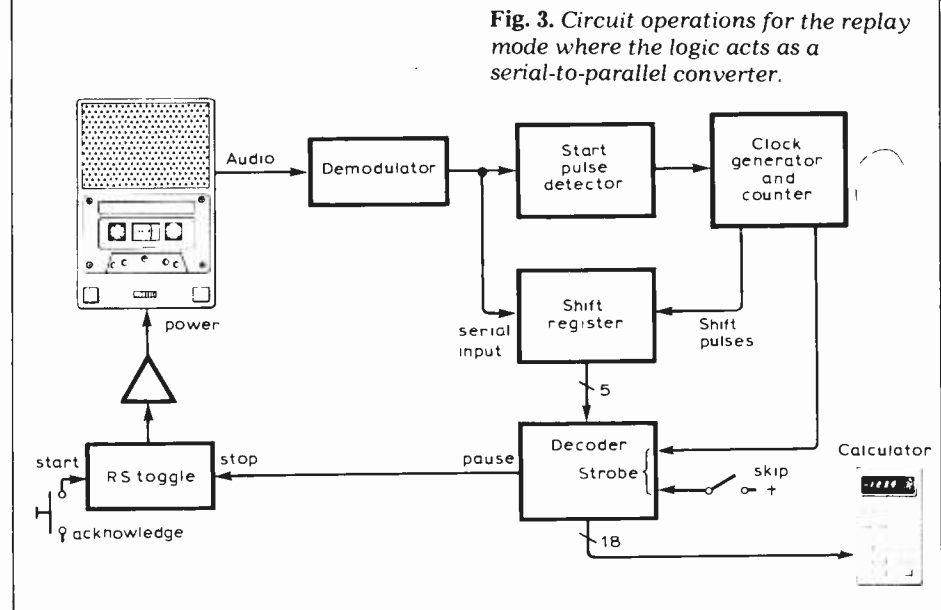
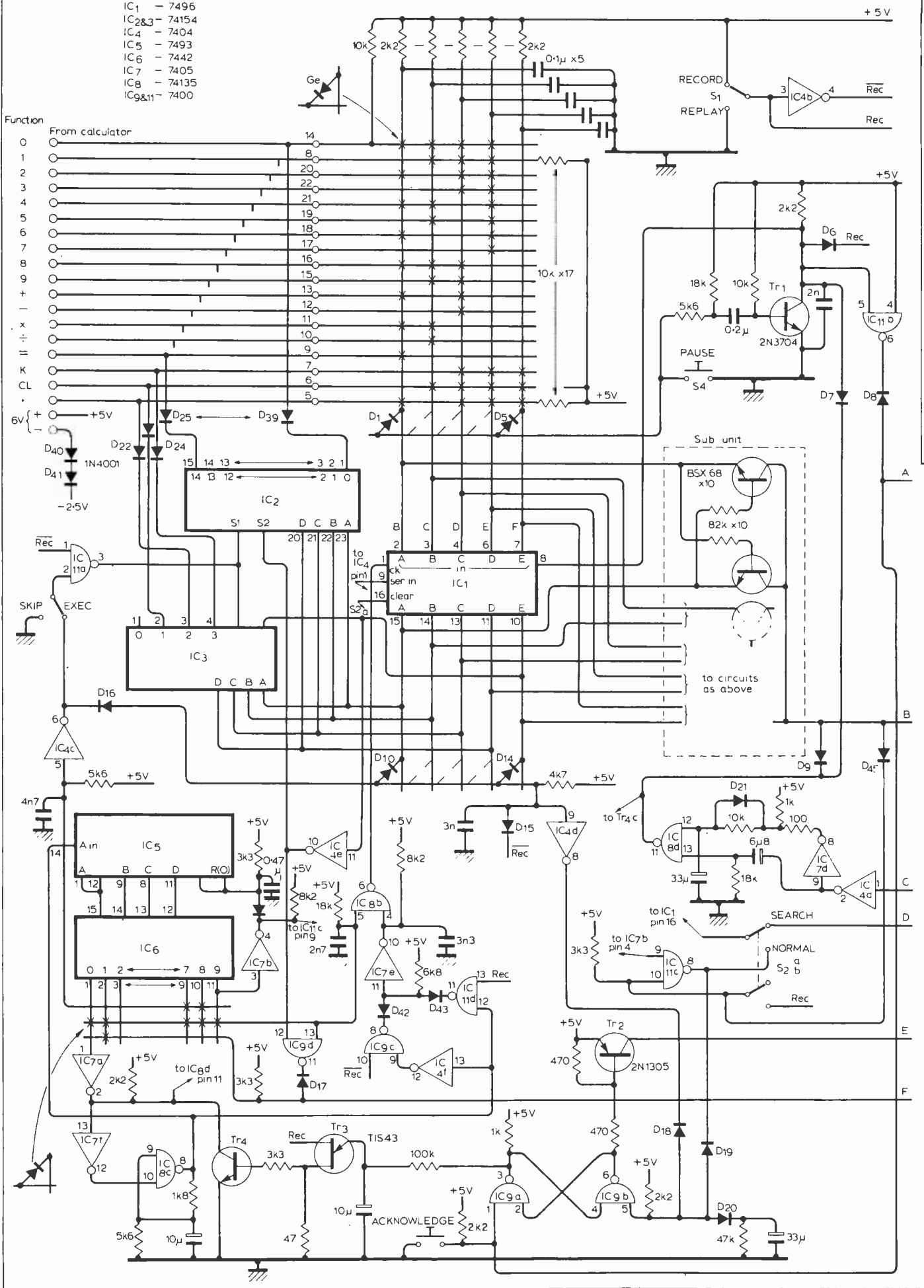

Fig. 3. Circuit operations for the replay mode where the logic acts as a serial-to-parallel converter.

- IC1 - 7496
- IC2&3 - 74154
- IC4 - 7404
- IC5 - 7493
- IC6 - 7442
- IC7 - 7405
- IC8 - 74135
- IC9&11 - 7400

Function

- 0 From calculator
- 1
- 2
- 3
- 4
- 5
- 6
- 7
- 8
- 9
- +
-
- x
- ÷
- =
- K
- CL
- .



when the acknowledge switch is pressed, and runs continuously until a pause code is encountered. The acknowledge switch is also used to restart the tape after a programmed halt. When a carrier signal is detected on the tape a tuned demodulator recreates the pulse train in Fig. 2.

The start pulse of this pulse train activates the clock generator and its associated counter which in turn loads the pulse train into a serial-in-parallel-out shift register. When the complete pulse train is loaded the parallel outputs are decoded back to 18 lines which are wired-OR with the calculator keys. A 19th output from the decoder, which corresponds to the pause switch, activates the RS flip-flop to stop the tape. The pause facility allows the calculator keys to enter numerical values between programme steps without rushing.

All of the decoder outputs except pause can be turned off by a skip switch which is used to make jumps forward in the programme. Because the record and replay modes operate in a similar way, much of the circuitry is common. The

complete circuit is shown in Fig. 4. Switching between record and replay takes place at several points in the logic, so normal and inverted signals are used for the two modes.

Circuit operation

As described earlier, the recording cycle is started by pressing any calculator key. Because germanium diodes are used in the matrix, and the calculator adaptation circuits, to be described later, are very sensitive, pull up resistors have to be used in the code and key lines. Diodes D₁ to D₅ detect when a key is pressed and turn off Tr₁ momentarily. The short pulse on the collector of Tr₁ loads the contents of the code lines into shift register IC₁. Because the pause switch turns Tr₁ off without passing through

the diode matrix its code is 11111. To eliminate contact bounce the relevant code lines are held low for about 20μs by five 0.1μF capacitors. The load pulse starts flip-flop IC_{9ab} via IC_{11b} and further loading of the shift register is prevented by D₇. The flip-flop turns Tr₂ on which supplies current to the recorder, and also starts a unijunction-transistor timer. After about two seconds this timer enables the Schmitt trigger oscillator IC_{8c} via Tr₄ and IC_{7f}. The oscillator output is connected to the input of counter IC₅ which always starts with a negative-going edge. The counter outputs are decoded by IC₆ and a small diode matrix. When the counter leaves its zero state IC_{7f} is held low by IC_{7a}, and IC_{8c} continues to oscillate until the counter is again reset by decoder output 9. The 0.47μF capacitor is used to extend the reset pulse which makes trouble-shooting easier. In the record mode the oscillator output is gated by IC_{11d}, IC_{7e} and IC_{8b}. This output is used as a clock pulse for the shift register. Shifting occurs on the negative-going edge. The shift-pulse input must be

Fig. 4. Full circuit diagram of the tape programmer. All diodes in the matrix of IC₁ should be gold bonded germanium types. Two clock phases are used and are shown as REC and REC̄. To improve clarity connections between these signals are not drawn.

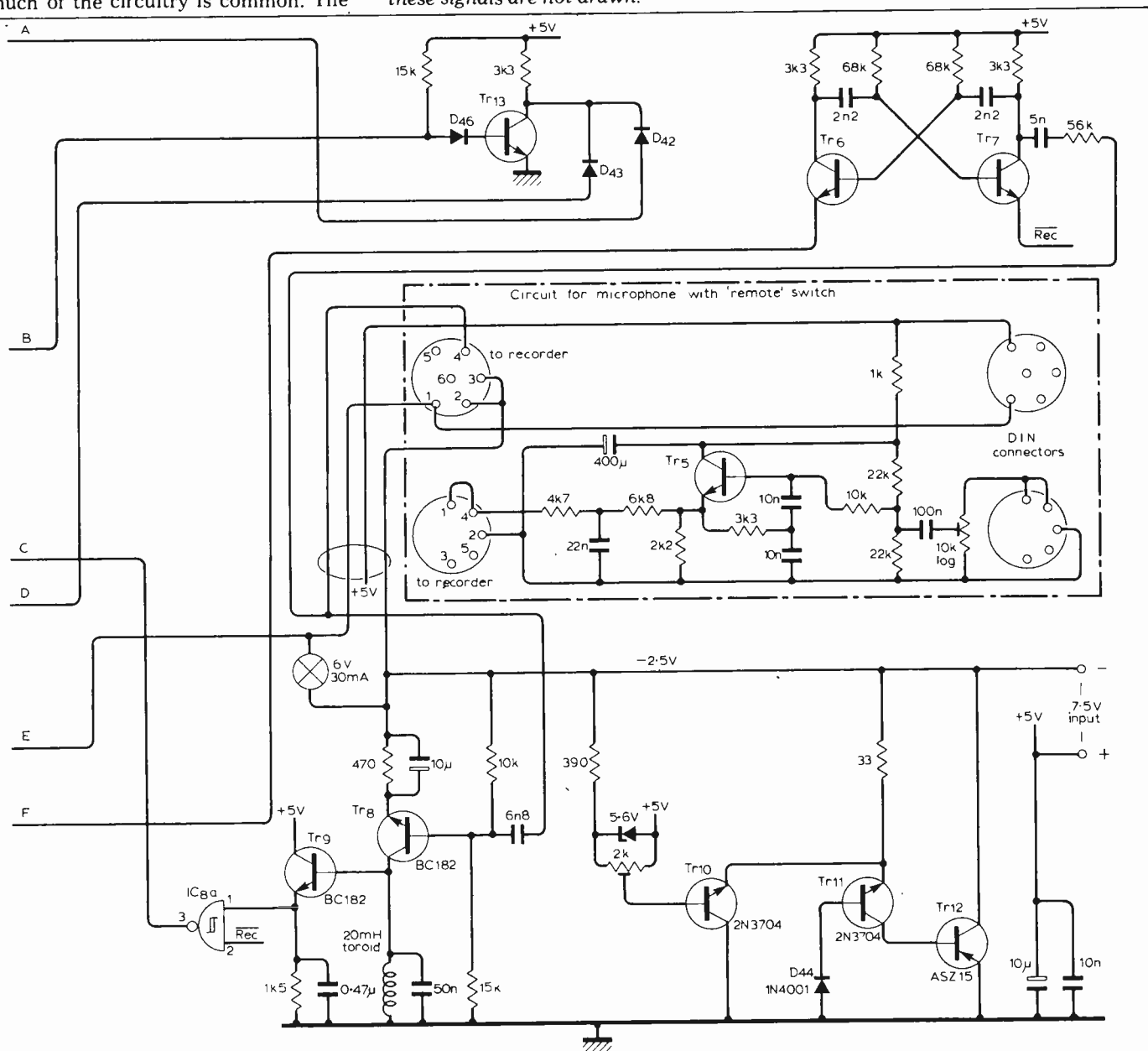

high when the register is loaded. Clock pulses reach the register during counter states 2 to 6. The register's serial output is also gated via IC_{9d}. Diode D₁₇ allows wired-OR connection with the decoders output. Counter state 1 corresponds to the start pulse, and state 7/8 to the stop pulse. At state 9 the counter, shift register, and flip-flop are reset to complete the recording cycle.

During this cycle the waveform in Fig. 2, which appears at the anode of D₁₇, turns on the astable flip-flop Tr₆ Tr₇ to produce the carrier. The carrier level is set by a 56kΩ resistor together with the input impedance of the replay amplifier Tr₈. Speech signals from the microphone are first filtered by Tr₅ and its associated components, before being fed into the tape recorder. This filter, which prevents normal speech from disturbing the pulse decoding during replay, is provided with a separate volume control for speech signals. The cassette machine's record level control is set to maximum which is around 100mV into 1MΩ.

In the prototype the author used a Philips EL3302 recorder which uses the same pin for record and replay.

Change-over occurs in the recorder, and the output level is unaltered by the volume control which can be used to adjust the level of speech without affecting the replay logic.

Replay mode

In the replay mode the recorder is started by its mechanical switch and the acknowledge switch in the logic. When a carrier is encountered on the tape the signal is amplified by Tr₈ and band-pass filtered by an LC network which is tuned as closely as possible to the astable multivibrator. Transistor Tr₉ is a high-impedance emitter-follower detector which produces about 2V on its emitter when the carrier is present. Because the pulse edges are quite slow at this point due to the LC filter, a Schmitt trigger IC_{8a} is used to improve the pulse shape. Pin 3 of IC₈ exhibits the waveform shown in Fig. 2. This pulse train is fed to the shift register's serial input and a start pulse detector consisting of IC_{4a}, IC_{7d} and IC_{8d}. The clock generator IC_{8c} is started synchronously with the start pulse's leading edge and stays on for 9 cycles. The clock phase

used for IC₁ shifts in the middle of each data pulse in the train to prevent any small tape speed errors from destroying the reproduced code. When the complete pulse train has been shifted into the register, decoders IC₂ and IC₃ are enabled via IC₆, IC_{4c}, switch S₃ and IC_{11a} unless S₃ is in the skip position. However, the pause code 11111, will still be operating so it is decoded by the diode gate D₁₀ to D₁₆. Diodes D₂₂ to D₃₉ are included to enable wired-OR-connection to the calculator keys but these do not need to be gold-bonded germanium types.

Switch S₂ is used when single instructions in a programme are to be changed. When the tape is replayed with S₂ in the search position the tape stops after every instruction. Restart is achieved with the acknowledge key. Therefore, when the instruction before the one to be changed is found, S₁ is switched to record, S₂ to normal and the old instruction is replaced with a new one. □

to be continued

Electronics, computers and the industrial strategy

IMPATIENCE WITH the government's industrial strategy, which is based on the Government's 1975 white paper, is growing. The Hitachi debacle (WW Jan and Feb) has reinforced the view that the NEDO sector working parties through which the strategy is supposed to work are little more than lobbying groups, and there is less planning than merely pleading for lumps of government cash.

On few of the economic sectors does so much depend as on the electronics, computers, components and telecommunications sectors. A spate of reports has appeared in the national and specialist press in the last few weeks outlining the massive tasks these sectors face if Britain is to survive to the 1990s and beyond. Yet all that is officially available from the NEDO is a long series of anodyne memoranda marking the end of the industrial strategy's second year, and the oft-intoned remark that the job of the sector working parties so far has been "analytical", to produce reports.

"They have had to collect and analyse complicated sectoral data, reach conclusions about constraints and opportunities, propose targets and begin the formulation of sectoral strategies," says a memo from Denis Healey and Eric Varley to the NEDO. "They have made impressive progress over the past two years."

Yet the chairman of the Industrial Strategy Staff Group, second permanent secretary to the Treasury, Mr Lawrence Airey, says in another memo that "Any attempt to add together the figures produced by different SWPs is hazardous since it relies on material which was never intended for that purpose; the SWPs did not use uniform methods, assumptions or presentation; The SWPs cover only part of manufacturing industry . . .; SWP's proposals for action are often novel."

The memo also notes that the firms in each industrial sector have very little to do with the work of the SWPs; "Feedback, evidence of discussion and reaction in the firms are often slight."

Not encouraging when you consider that the whole point of the industrial strategy is to arrive at "an agreed approach by feeding information upwards from the various sectors of industry into macro-economic planning."

Elsewhere a report published by the computer SWP says that little is being done to quantify the impact that microprocessors will have on the office and the shop floor: "The bulk of the expansion of cheap computing into machine tools, telecommunications and office equipment is still to come."

The working party is also concerned at the effects on computing of the weakness of the home-based semiconductor industry, particularly in mainstream products based on advanced technology.

But another report, this time from the Department of Industry to the NEDO, suggests that it is pointless putting money into strengthening the mainstream semiconductor industry since this would require £400 million, and the home market would, unlike that for the Americans, be too small. Neither is there any point trying to engineer a merger between our three biggest companies, GEC, Ferranti and Plessey, since they would still be much smaller than any of the 15 giants.

The report notes that British expertise has been concentrated largely in the special systems market, where there is a large requirement for custom-built equipment, at low volume. £60 million should be found over the next five years to build an industry on which its future customers can rely, and another £20 million should be found to promote that special expertise abroad. Half of

this total of £80 million should come from the government and half from the industry itself, though the government would put more in.

As to the non-home-based UK companies such as Mullard (Philips) or ITT, these should be encouraged to invest in standards manufacturing plants in the UK, with the benefit of Government or EEC financial encouragement.

The report notes the massive amounts of investment going into very large scale integration (v.l.s.i.) microelectronics in other countries: \$500m a year in the USA, £500m in Japan, and £50m to £60m in France and Germany, with heavy government involvement. So far the British industry has been promised £30m, and another £25m at least is under discussion.

This explains why, when we spoke to Jack Akerman, managing director of Mullard and deeply involved in the industrial strategy, before Christmas, he was evidently satisfied with the prospects for government help: "Before long there will be further support in the solid state area," he had said. But he added that none of these schemes would work "if there are too many strings." Thus the government's hopes for some kind of planning agreements with the various sectors would seem to be optimistic, even though Akerman later said he was in favour of planning. He added that he was also optimistic about the prospect of aid from Brussels.

Akerman believes that, wherever the investment comes from, we have to make it in order to have a stake in an electronic future that he describes as mind-boggling: "With electronics the blind can see and the dumb can talk and the deaf can hear. We can do so much with electronics." And if we missed the boat? "We can't even contemplate that we miss it." □

CIRCUIT IDEAS

Adjustable tracking voltage regulator

BOTH OUTPUTS of this regulator can be adjusted simultaneously by one potentiometer. Diodes D_1 and D_2 act as a reference, where the positive temperature coefficient of D_1 is cancelled by the negative temperature coefficient of D_2 . Amplifier A_1 regulates $-V_0$ so that the output of A_2 is always at the reference voltage. Amplifier A_3 has its non-inverting input connected to 0V and the point between R_9 and R_{10} is also at 0V. Because $-V_0$ is fixed, $+V_0$ has to be regulated at the same voltage as $-V_0$. Resistor R_9 equals R_{10} . R_4 and R_5 are scaled to give a constant K so that $-V_0$

$$= V_{ref} \cdot \frac{R_{adj}}{R_3 + R_{adj}} \cdot K.$$

R_{11} acts as a current sense resistor, and provides a current limit of approximately $\frac{0.68 A}{R_{11}}$.
S. Choudhari,
Trondhiem,
Norway.

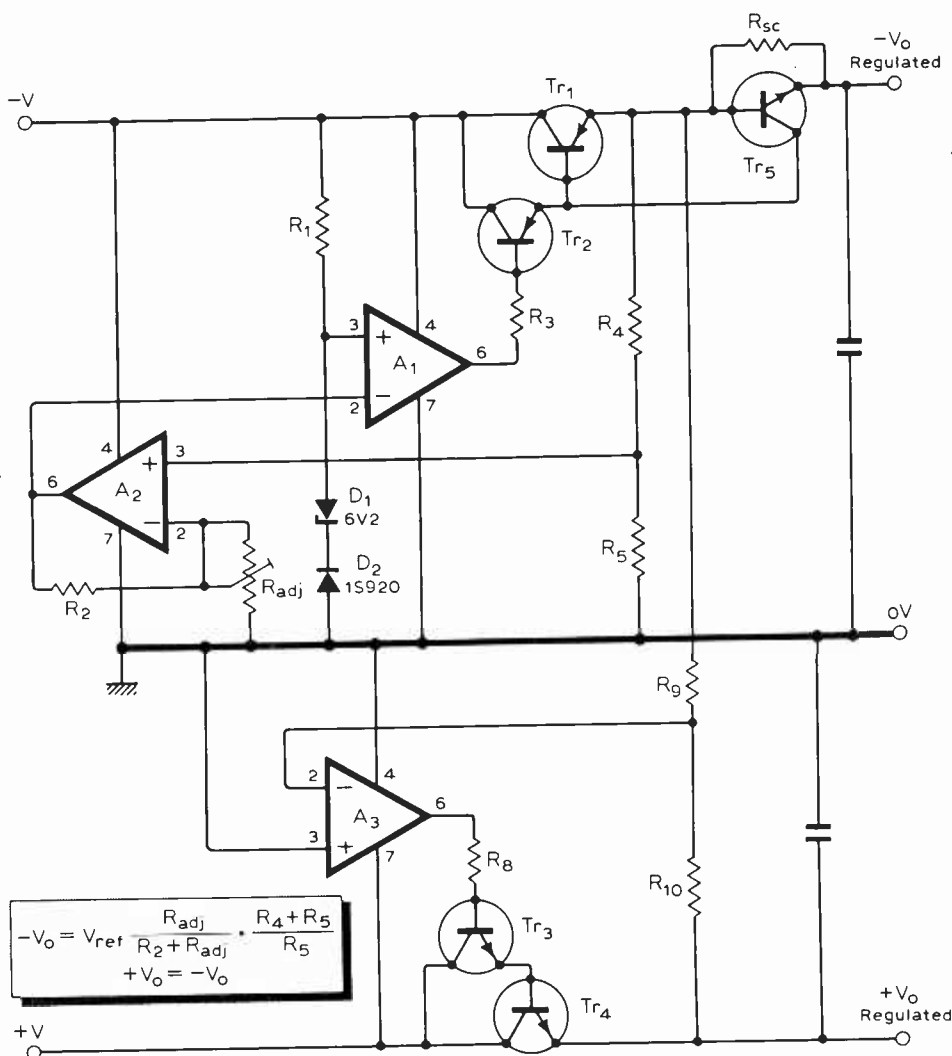

$$-V_0 = V_{ref} \cdot \frac{R_{adj}}{R_2 + R_{adj}} \cdot \frac{R_4 + R_5}{R_5}$$

$$+V_0 = -V_0$$

Negative supply for op-amps

A SINGLE TIMER i.c. used as an astable multivibrator can provide a 200mA negative supply from a positive rail voltage. The square-wave output drives a diode-clamp consisting of C_1 and D_1 . Components C_2 and D_2 smooth the squarewave to give a negative d.c. output. With the component values shown the oscillator frequency is about 2kHz, but any value between 1kHz and 4kHz is satisfactory.

A. Pongsupaht,
Dept. of Electronic Engineering,
University of Birmingham.

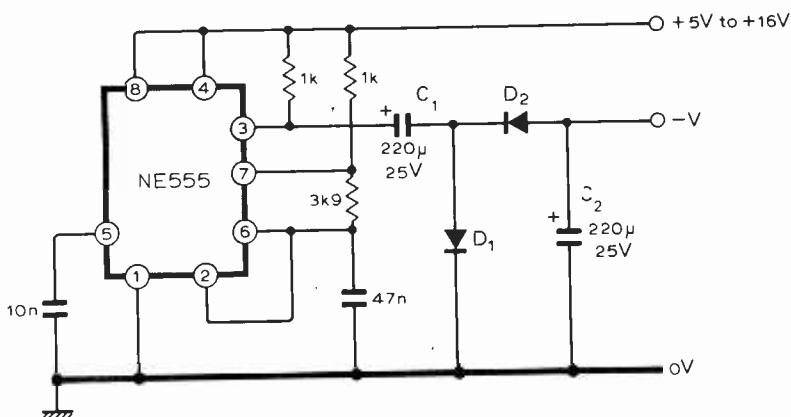

I Ching

THIS CIRCUIT is the electronic equivalent of I Ching, a form of divination originally from China. In its classic form a response is obtained by the manipulation of 50 sticks or by the combination three coins. A book on the subject is then required to interpret the result. The whole process must be repeated six times to have a complete response. The electronic version consists of an oscillator running at 4 kHz, a double counter which produces a 2 kHz waveform with a 50% duty cycle, and a 500 Hz waveform with a 25% duty cycle. This is the correct relationship which reflects the combinations obtainable from I Ching in its original form. When reset is pressed the oscillator runs, i.e.d. 1 is on and all other i.e.d. are off. When set is pressed the oscillator stops, i.e.d. 1 goes off, i.e.ds 2, 3 and 4 are enabled and the information in the double counter is displayed. Either i.e.d. 2 or 3 will always light up representing a Yin and Yang line respectively. In those cases when i.e.d. 4 also lights, it means that the Yin or Yang line is also a moving line. The circuit is then reset and is ready for a new reading until all 6 have been taken. The circuit is not critical and will operate from a supply between 3 and 12V.

D. Di Mario,
Johannesburg,
S. Africa

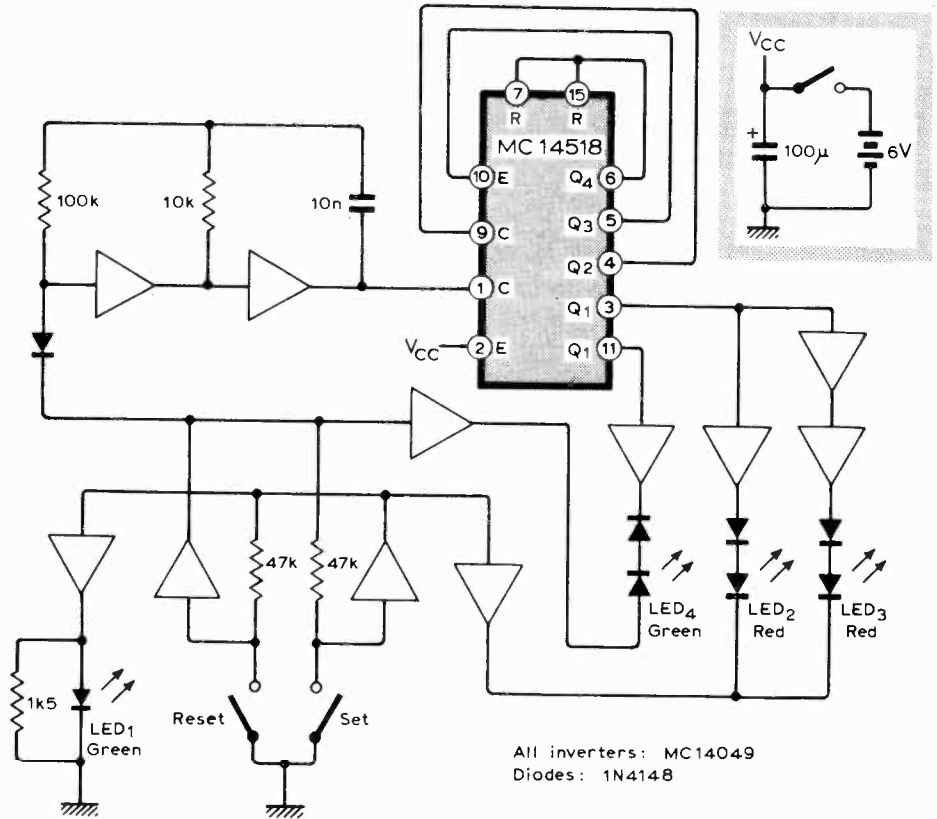

All inverters: MC14049
Diodes: 1N4148

Low current 555 timer

IN THE OFF STATE the supply current to a 555 timer is about 3mA. For battery powered circuits where this is too high the modified circuit shown can be used. This reduces the current to about 2µA although the on state current rises to about 3.5mA. Other properties of the timer remain practically unaltered. When the circuit is off, pin 2 is disconnected from ground so Tr₁ and Tr₃ are turned off. Because the 555 has no sup-

ply voltage Tr₂ is also off. When a negative trigger pulse is applied to pin 2, Tr₁ and Tr₃ are turned on and connect the timer to the supply rail. A positive pulse from pin 3 of the timer turns Tr₂ on which keeps Tr₃ on. After the delay period has elapsed the timer returns to the off state. Connections 4, 5, 6 and 7 of the i.c. are still used but pins 1, 2, 3 and 8 are replaced by the new connections. Dr O. B. Hellman,
Turku,
Finland.

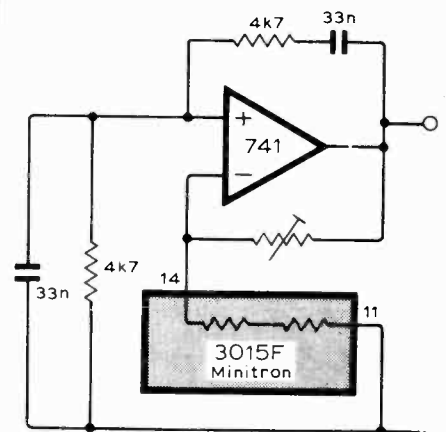
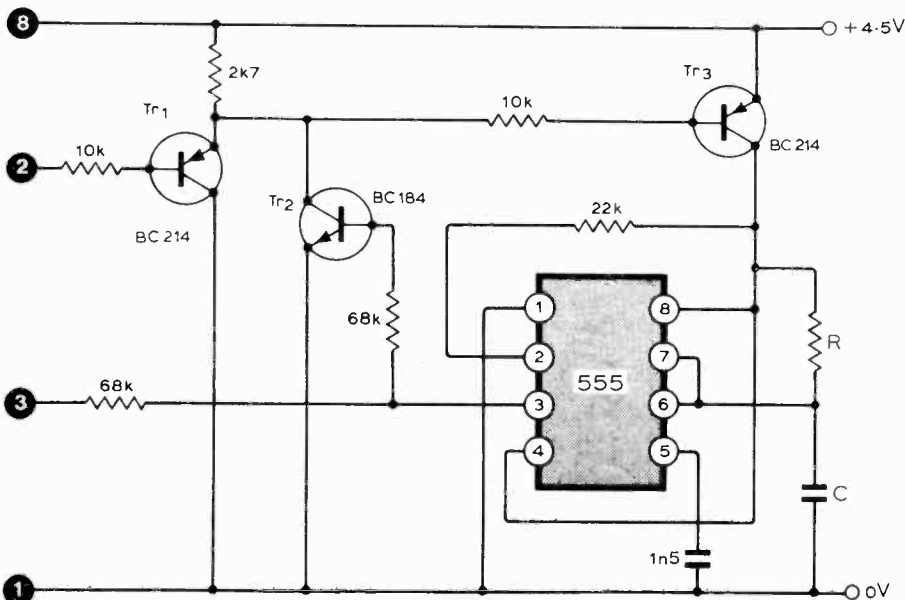

Minitron replaces thermistor

IN CONVENTIONAL Wien bridge oscillators an expensive and delicate thermistor is used to stabilize the amplitude. This circuit uses segments of a minitron display whose resistances increase from about 100Ω at one volt, to about 700Ω at six volts. Various combinations of the seven segments can be used and one minitron can be used in several circuits.

The design shown operates at around 1kHz and produces one volt r.m.s. For setting up, a 10kΩ variable resistor to give one volt output.

R. Gough,
Shenstone,
Staffs.

Pickup arm design techniques — 2

Continuing the story of the pickup arm and the factors influencing its design

by Tejinder Singh Randhawa VU2TSR

In its account of the historical development of the pickup arm, Part 1 described how the problems of tracking error could be countered by clever design. This second part introduces additional factors to be considered in pickup arm design, beginning with tracing error distortion, and describes how they influenced the author in the design of his own pickup arm.

A serious form of distortion introduced by a finite-radius spherical stylus reproducing a cut record is tracing error distortion. This problem, illustrated in Fig. 4, was first recognized in 1932 by H. A. Frederick¹², and the present name was given to the problem by M. J. D. Toro¹³ in 1937.

The first rigorous analysis of tracing error distortion was done in 1938 by J. A. Pierce and F. V. Hunt¹⁴. The topic has since attracted considerable attention and further analyses have been carried out^{15,16,17}. Tracing error distortion, which consists mainly of odd harmonics, and tracking error distortion, are the two major causes of distortion in record reproduction. Tracing error distortion, which is a problem relating to the transducer, is considered in this article on pickup arm design because it is instructive to compare the two.

Using the formulae for tracing error distortion with typical figures (a spherical stylus with a tip radii of 0.0006 inch), and using a relatively small arm, one finds that, after correcting for recording characteristics, the break frequency between tracking error distortion and tracing error distortion occurs at about 2,000Hz. In other words, for the recorded signal below 2,000Hz

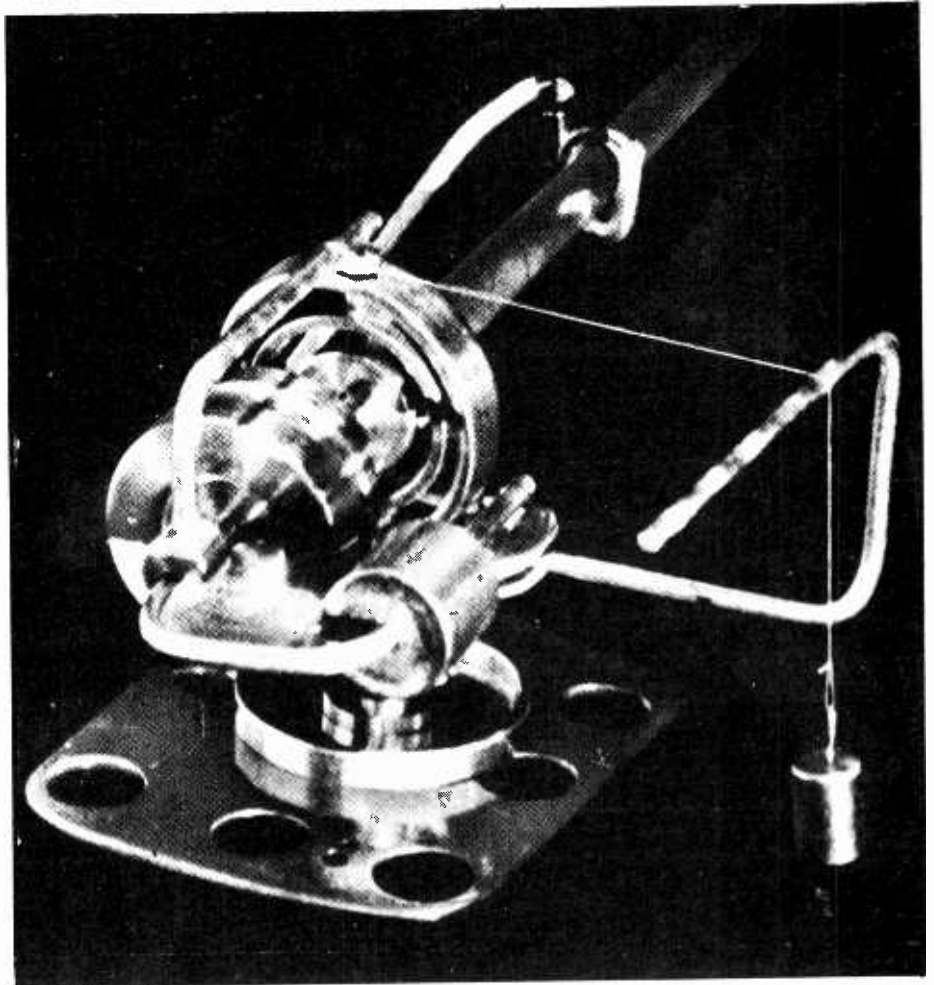

Rear view of mounting post and weighting arrangements for author's pickup arm.

Fig. 4. Graphical representation of how a recorded pure sinewave becomes a distorted sinewave when played back by the stylus.

tracking error dominates, while above this figure, tracing error distortion takes over. However, with the coming of elliptical styli, the break frequency is shifted to between about 4,000 and 6,000Hz because the effective stylus radius (the portion of the stylus that traces the groove modulations) is reduced to about one-half or one-third that of spherical styli, and the tracing error distortion is proportional to the square of the effective radius and the frequency.

Since tracing error consists mainly of odd harmonics, the harmonic distortion components will lie above 12,000Hz. However, in practice the actual tracing error distortion produced is less than the theoretically-calculated figure because of the deformation of the groove. To further reduce tracing error distortion, papers have been published^{11,18,19} describing equipment that has been

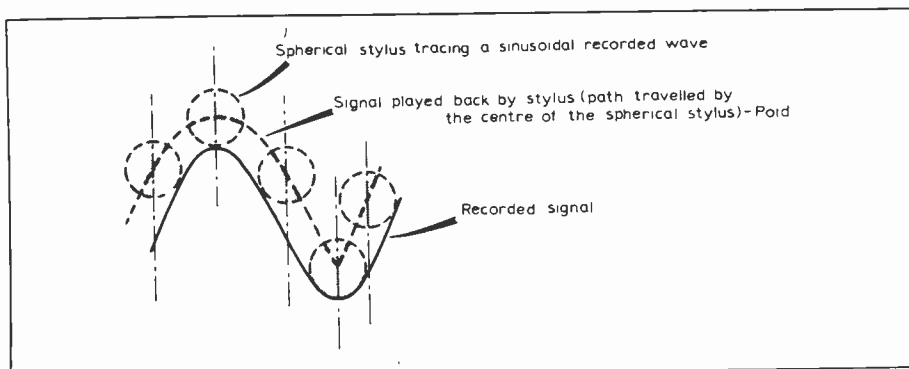

designed to compensate for tracing error in the recording process itself. One method that was suggested (and used briefly for vertical recordings, in the earlier days) was to reproduce the distorted traced signal and re-record it in reversed phase. The main disadvantage with this method is that it would require strict standardization of reproducing styli on all domestic cartridges.

If one considers that tracing error distortion is comparable to tracking error distortion, and that a properly mounted 9in (effective length) arm will give second-harmonic tracking-error distortion figures of less than 1% (see table), it might seem pointless to reduce tracking error distortion by articulating arms, pivoted heads and associated gadgetry, which only increase the inertia of the pickup arm and its effective mass. This is undesirable, as will be explained later. An earlier device, the Burne Jones arm, which had a pivoted head, was claimed to have a maximum tracking error of 1 degree. The Ortho-Vox arm corrected for tracking error by varying the effective length of the arm and the overhang as the arm moved across the record. The resulting reduction in tracking error was claimed to be equivalent to extending the arm length to 8 feet. Perhaps the ultimate, accurate application of the pivoted head method has been achieved by the Garrard Zero 100 arm. This arm has a maximum tracking error of 0.022 degrees at the record radius of 3.25in. For a detailed computer analysis of the linkage of this arm, see reference 20.

For minimum tracking error distortion, it is important to set the offset angle and overhang accurately. Different cartridges have varying positions for the stylus relative to the mounting screws. To overcome this problem, in some pickup arms, the cartridge can be moved within the shell to place the stylus at the correct position, while in others the entire pickup arm can be moved to or away from the turntable centre to vary the overhang. The former method has its advantages because, when the stylus position changes considerably, both the overhang and the effective stylus-pivot length of the arm change. Consequently, a new effective length would require a recalculation of the offset angle, overhang and the zero tracking error points. Now, as seen from the table, a change in the effective length of the arm does not significantly change the zero tracking error points. However, this assumes that the offset angle is the optimum one for the length. In the above case the offset angle is fixed and will differ from the optimum. Fortunately, it will be corrected automatically to some extent because an increase or decrease in the effective length will correspondingly decrease or increase the offset angle. This can be verified from the geometry of a pickup arm. Also, from the formula it can be seen that, as the arm length increases the offset angle required decreases, and

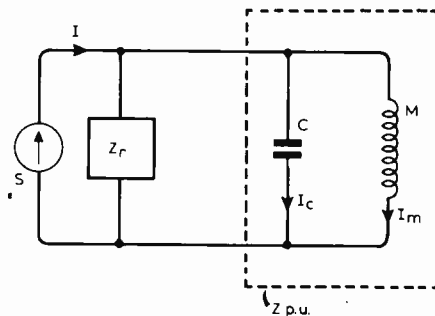

Since $Z_r \gg Z_{p.u.}$, S acts as a constant current source and Z_r can be neglected from the analysis, then for the parallel resonant frequency $(f_0) = \frac{1}{2\pi\sqrt{MC}}$

Fig. 5. Equivalent circuit of a pickup arm and cartridge. S is the current (velocity) source, C is the stylus compliance, I is the current (modulation velocity), I_c represents the velocity of the stylus tip relative to the arm (transducer velocity), and I_m represents the arm velocity. Z_r is the mechanical impedance of the turntable as seen by the stylus and is a function of the compliance and resistance of the record material and supporting means. M is the mass of the arm referred to the stylus point ($M = I_h/R^2$) where I_h is the total inertia of the arm about the pivot and R is the pivot-to-stylus length.

vice-versa. On the other hand, the latter method has the advantage that the shell can be made smaller and lighter.

An accurate iterative procedure for setting the arm optimally has been suggested by Stevenson. This procedure requires the use of an alignment protractor. At the first zero tracking error radius R_1 , Fig. 1(b), the overhang should be adjusted until the tracking error is zero (with the offset angle set to approximately the optimum value). At R_2 , the second zero tracking error point, one should observe whether the tracking error is positive or negative. A positive tracking error will be obtained at radii greater than R_2 . If it is positive, it indicates that both the offset angle and the overhang are less than the optimum value and should be increased slightly. If the tracking error at R_2 is negative, it indicates that the offset angle and the overhang are larger than the optimum value and should be decreased slightly. The above steps should be repeated until minimum tracking error at R_1 and R_2 is obtained.

Pickup arm-cartridge resonance

The electrical equivalent circuit of the arm and cartridge combination is illustrated in Fig. 5 and, as can be seen, the stylus compliance and effective mass of the pickup arm form a parallel resonant circuit. This will create problems if the resonance frequency coincides with an audio frequency or any other annoying frequency. For various M and C com-

binations, the range of f_0 lies in the lower end of the audio spectrum – below about 40Hz. There was a time when f_0 used to lie at about 60Hz because of the extremely low compliance of the styli of the available cartridges, and attempts were made to lower it. Nowadays, it is the opposite; with high compliance cartridges available, f_0 tends to go down to below 10Hz and manufacturers are desperately attempting to lower the value of M for their arms, making small improvements wherever possible, even to the extent of doing away with headshell collar nuts. This is justified.

To have a low value of M , a light gauge aluminium tube should be used in a way that employs the shortest length of the tube (as in Fig. 6(b)). Why bends are still used despite this disadvantage can be appreciated only when one tries to design a turntable oneself. With the bend, the arm in Fig. 6(a) will have a smaller angular motion from the rest position (parallel to the side edge of the record player unit) to the end of the record than the straight tube arm. Further, a heavier counterweight near the pivot, rather than a lighter one at a correspondingly greater distance, decreases M . All this trouble to decrease M and raise f_0 has to be taken because the region 0 to 10Hz can be full of troublesome frequencies due to eccentric centre holes in records, warps, ripples, turntable platter excitation, and so on. Even though the inherent response of the cartridge at these very low frequencies might be extremely small, resonance effectively magnifies the response, and if these frequency signals reach the speaker, a Doppler effect will result. Given a choice M should be smaller in the vertical direction than in the horizontal direction to raise the vertical f_0 component, since rumble is greater in the vertical direction than in the lateral direction. Also, less vertical inertia helps the arm in coping with record warps.

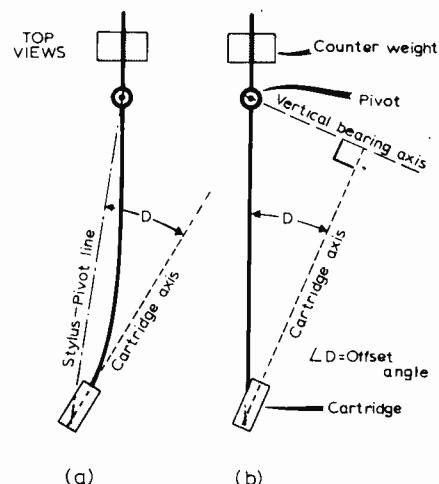
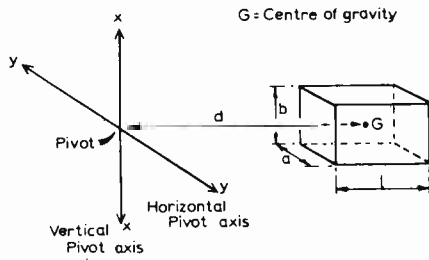

Fig. 6. Two methods of setting a cartridge at an angle to the pickup arm. Employing a short tube, as in (b), helps to reduce the effective mass of the arm.



Inertia about vertical pivot = $I_{xx} = \frac{1}{12} M(b^2 + l^2) + Md^2$

Inertia about horizontal pivot = $I_{yy} = \frac{1}{12} M(a^2 + l^2) + Md^2$

Fig. 7. Optimum design of a rectangular parallelepiped counterweight (M is the mass of the counterweight).

Fig. 7 gives the optimum design for a rectangular parallelepiped counterweight and the inertia formulae relating to it. Unfortunately, some designers use counterweights of this kind but with b much greater than a. As can be seen from the equations, this results in a condition where the vertical inertia is greater than the horizontal inertia. This is undesirable because it results in a lower vertical resonance frequency (with respect to horizontal resonance frequency) and this decreases the arm's ability to track warped records. In fact, for a lower vertical inertia (with respect to horizontal inertia) both b and l should be made smaller, however unconventional the counterweight might look.

Damping

The pickup-arm cartridge resonance can be damped by mechanical resistance damping in the stylus and the pivot, or by dynamic damping. Figure 8(a) shows the equivalent circuit for the first method. This method of damping the pickup arm-cartridge resonance was dropped when it was pointed out in 1951²¹ by W. S. Bachman that large tracking weights will be required if R is selected for effective damping. For effective damping $R = \sqrt{4M/C}$ = 2000Ω assuming M = 16gms (H) and C = 16μF. Now $F = RV/\sqrt{2}$ = 20,000 dynes, approximately 20gms (where V is the peak recorded velocity) for a recorded velocity of 10cm/s r.m.s.

Figure 8(b) shows the equivalent

circuit of the popular pivot damping method, which Bachman recommended. An efficient way of applying this method of damping was to have a pivot in the form of a hemisphere and a complementary cup or mandrel and sleeve arrangement. The distance between the two was variable, and the volume in between was filled with a viscous fluid. In this way, knowing the dimensions of the arrangement and the fluid viscosity, a value of R could be calculated. (For details of the 'Gray', viscous damped arms 108C and 212, see reference 22.) This method was suitable for the high-tracking-weight, low-compliance cartridges of 20 years ago, but not for the low-tracking-weight, high-compliance cartridges of today. Indeed, the arms were damped so much that manufacturers used to boast that, with their viscous damped arm, a record could not be damaged due to the arm being accidentally dropped over the record, because it would simply fall down very gently.

As can be seen from the equivalent circuit, at low frequencies, the insertion of a resistance in the M branch tends to reduce the current in that branch and divert more to the C branch. Physically, this means that the low frequency response of the cartridge would be increased. This may be a disadvantage if the cartridge already has a good low frequency response characteristic because it would increase its response in the danger zone 0 to 15Hz. It is worth mentioning that in the older designs R was calculated and applied meticulously. These days we sometimes come across the deplorable quack tendency of applying a dash of oil or a spot of grease to effectively damp all resonances.

In the third method, dynamic damping, the arm mass is divided into two separate parts and joined through a visco-elastic coupling, as shown in Fig. 9. Fig. 8(c) shows the equivalent circuit for this method. B. Bauer²³ has experimentally determined that, for this method to be effective, the ratio of the mass associated with the rest of the arm (M₂), should be at the most 3:7 (ideally it should be 0:10 which of course is impossible). To obtain this, the cartridge and shell portion of the arm should be as light as possible and the visco-elastic coupling should be immediately behind the shell. It is unfortunate that manufacturers place the

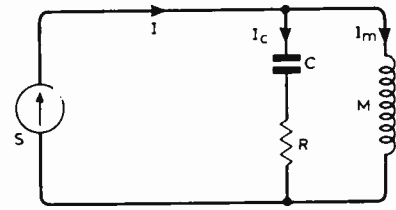

R = Resistance introduced in stylus mounting

(a)

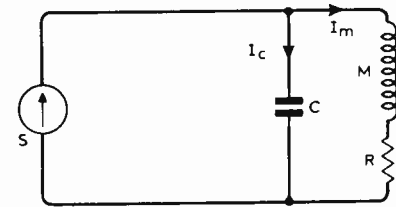

Below the recorded audio frequencies S represents the slow motion of the arm from the outer to the inner part of the record—due to the stylus following the groove

R = Resistance introduced in arm mounting

(b)

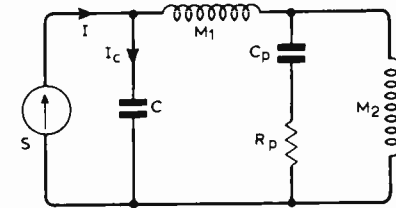

Cp and Rp are the Compliance and Resistance, respectively, of the coupling

(c)

Fig. 8. Equivalent electrical circuits for (a) stylus resistance damping, (b) mechanical resistance damping in arm pivot, and (c) dynamic damping.

coupling way behind the shell, just in front of the counterweight, as this makes the damping less effective.

All the above methods work optimally, only within certain restrictions. Resonance problems were mainly associated with audio frequencies on the older units, but today rumble pickup, which is greater in the vertical direction, and warps and ripples on the record, are the main cause. Keeping these points in mind the author tried to use mechanical resistance damping in the vertical pivot only, keeping the horizontal pivot resistance free so that it did not oppose the slow motion of the arm from the outer to the inner portion of the record. In this design, the resistance applied to the vertical pivot was not of the constant-resistance fluid type. Instead, a static value of resistance was applied when the arm was stationary in the vertical plane, but when a warp moved the arm upward a dynamic value came into effect (which

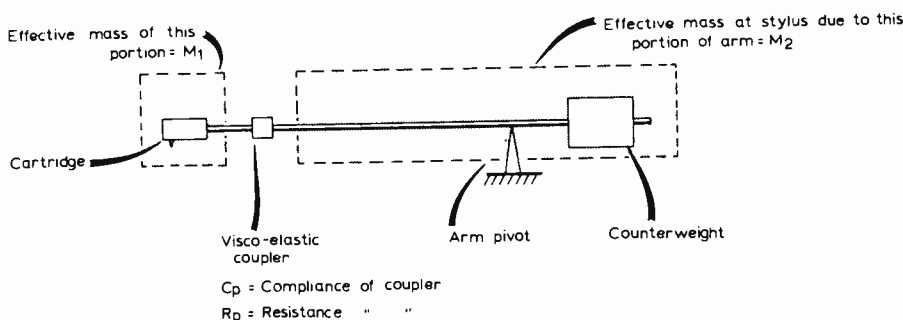

Fig. 9. Physical arrangement of dynamic damping parameters.

was less than the static value), which made it easier for the arm to cope with the warp. However, the author dropped this method because even the smaller dynamic value resulted in an audible wow when a high compliance cartridge went over a warp.

Another feature that the author had in his older arm was adjustable inertia. It is perfectly alright to design an arm with a minimum M but sometimes the M and C values combine to place f_0 where it coincides with an annoying frequency (assuming inefficient damping). Since M cannot be decreased further, the only way out would be to change C — the cartridge. However, when M can be increased it can help in decreasing the pickup of the annoying frequency, as explained in Fig. 10(a). To vary the inertia while keeping the tracking weight fixed, the author made a counterweight in three parts such that M could be increased by moving the outer parts of the counterweight outwards, as shown in Fig. 10(b). He did not use this counterweight in his latest arm because it required a heavy counterweight as near to the pivot as possible. Nonetheless, the author still strongly advocates the use of adjustable inertia since, if one is troubled by the pickup of a troublesome frequency, M can be increased by adding external weights to the arm to see if it helps.

Skating force

Skating force, or sidethrust force, is perhaps the most debated topic in pickup arm design. Points raised by audio enthusiasts include, whether skating compensation is necessary, what kind of compensation is the best and the best way to calibrate it, whether it stays constant across the record radius or increases or decreases. It is something like the Yagi versus Quad controversy among radio amateurs. Different arguments, with certain qualifications, can be put forward both for and against the necessity of skating compensation.

At the outset, the author would like to stress that the total sidethrust force is not that component of the tangential frictional force that is directed to the

record centre, as is popularly but erroneously thought. The true skating force is that component of the tangential frictional force which acts at right angles to the pivot-stylus line. The former is less than the latter. This restatement is necessary because, often in articles the formula for the former is derived and it is said that it is this force that the antiskating mechanism has to counter. The formula for skating force and the force diagrams are given in Fig. 1(b). A look at this figure also points out another fallacy that exists regarding skating force. It is said that the skating force arises because of the offset angle and the overhang. This is wrong. Even if there were no offset angle and overhang in an arm, skating force would exist because of the large tracking error.

The stylus position for a straight arm passing through the centre of the record is also shown in Fig. 1(b). The tracking error of such an arm at the start of a 12 inch record will be 18.6° for an effective arm length of 9in. (This is obtained by putting C and D equal to zero in the tracking error equation — Equation 4). The skating force for this case would therefore be equal to $F\sin(18.6)$ which is slightly less than the skating force for an arm of the same effective length having the optimum offset angle and overhang ($F\sin(25)$). In fact, offset angle and overhang help in reducing drastically the variation of the skating

force across the record, since, in the former straight-arm, zero overhang case, the skating force at the minimum recorded radius would equal $F\sin(7)$ — an enormous variation compared to the value at the start of the record. The variation in skating force for a 9in optimum design is shown in Fig. 2(c), which follows from Fig. 1(b). It is maximum at the start of play, decreases and then increases.

For a blank disc, providing the disc speed is constant, the skating force should remain constant, because it depends on the dynamic friction coefficient. In practice, when playing a modulated disc, the skating force is increased and made slightly dependent on the groove speed because of the modulations. This dependence on record speed is insignificant and so different calibrations are not necessary for $33\frac{1}{2}$ rev/min and 45 rev/min records. Elliptical stylii require negligibly greater skating compensation than spherical stylii. Different arm lengths have different offset values and tracking error angles, and therefore the skating force, will vary, its value being smaller for longer arms. In other words, there is no fixed value for it.

Experiments have proved that skating force does give rise to considerable distortion²⁴ and so it is desirable to counter it. Various bias adjusters or sidethrust compensators may be used to counter this force. These include magnetic repulsion, levers and the 'weight on a nylon thread' method, which was suggested by John Crabbe in 1960 and till today remains a popular, simple method to oppose the skating tendency. One cartridge manufacturer even claims that a brush attached permanently to the front of the cartridge (primarily to clean the record) is sufficient to counter the skating force.

Lateral balancing

The most misused and misunderstood feature on modern pickup arms is the lateral (or angular) balance adjustment control. It comforts the user, assuring him that all forces are balanced, leaving the cartridge to turn angles. The basic reason why the lateral force arises when the mounting is tilted is because the entire arm turns angularly around the arm tube axis. This is illustrated in Fig. 11(a). Due to the bend in the arm the centre of gravity (c.g.) of the arm section in front of the mountings will lie somewhere in the triangle ABC in the horizontal plane of motion of the arm. If the mounting is vertical, then at the second position of the arm the plane of the triangle ABC will remain horizontal. Now, suppose that the mounting is tilted forward, as in Fig. 11(b). Observe that the arm is still perfectly horizontal. (The following example is valid only for a gymbal mounted as shown in Fig. 11(c). That is, one with a vertical bearing in the inner ring, a knife edge mounting for vertical motion and a

Fig. 10(a). Diagram shows that an increase in the effective mass of the pickup arm helps to reduce the pickup of an annoying frequency which coincides with the resonance frequency. When the arm inertia is increased the effective mass referred to the stylus tip increases and the resonant peak (assuming insufficient damping) shifts to the left.

Fig. 10(b). Physical implementation of Fig. 10(a). By moving the outer parts of the three-part counterweight outwards, the inertia will be increased without affecting the tracking weight.

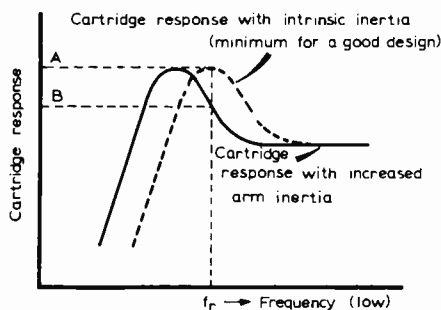

f_r = Rumble frequency
 A = Rumble pickup for minimum inertia case
 B = Rumble pickup when M is increased — resonance frequency decreases

(a)

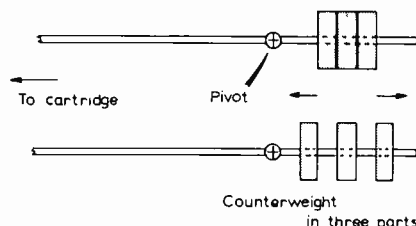

(b)

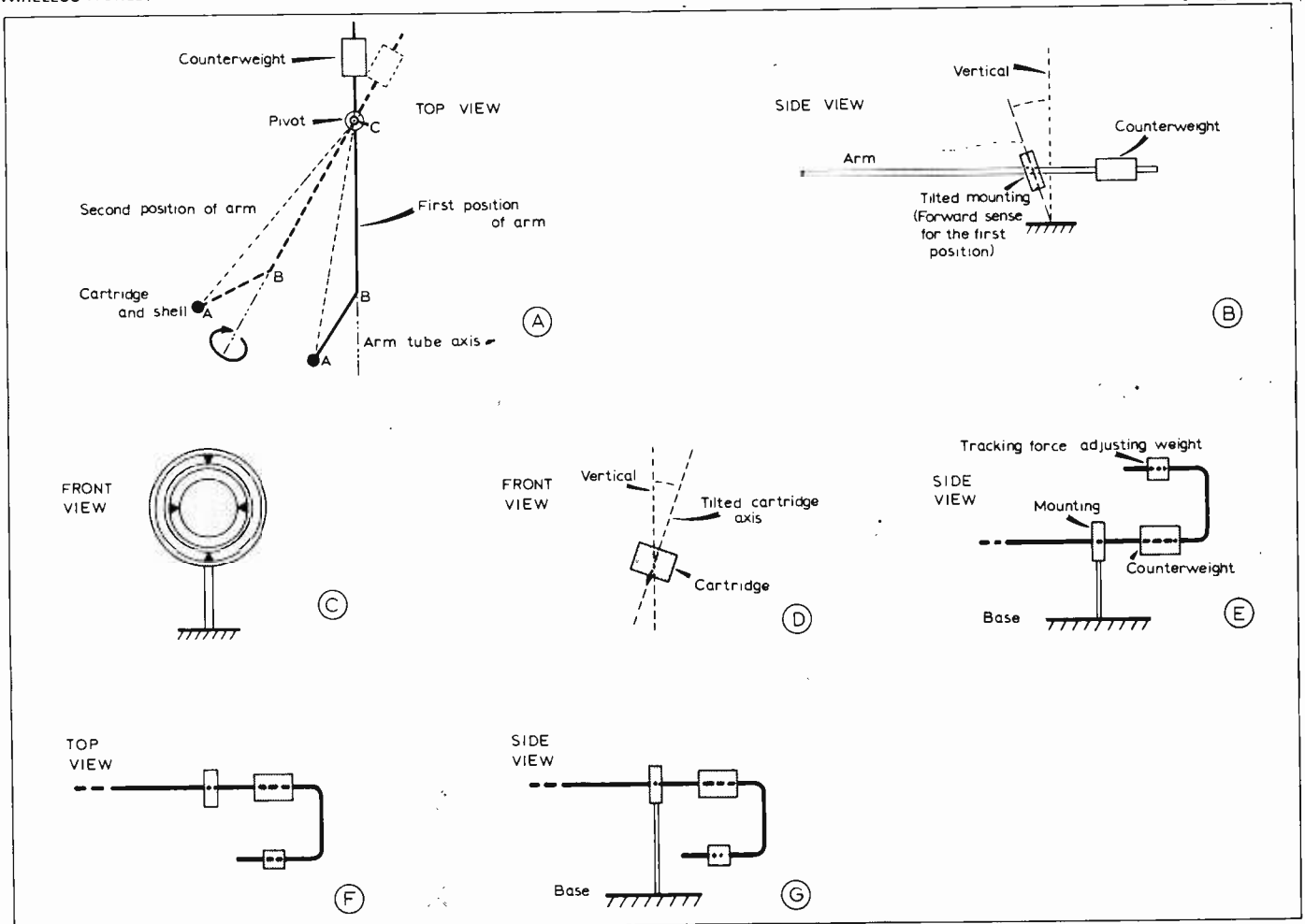

bearing for horizontal motion). In this case, when the arm moves to the second arm position, the arm and hence the triangle ABC, will tend to turn around the arm axis in the direction indicated. As this would entail the raising of the centre of gravity of ABC, such a movement will be opposed. In simple words, an anti-clockwise torque will result. In the conventional lateral balancing arrangement, a weight (which can be the tracking force adjustment weight itself) is placed in the lateral plane on the side opposite to the bend (Fig. 11(f)). Then, for the above case, an anti-clockwise movement would tend to raise the weight and give rise to a clockwise torque. The distance of this weight from the arm in the lateral plane is adjusted so that the two torques are equally opposed. An eccentric counterweight is sometimes used for this purpose.

This method successfully counters the lateral force but the arm mounting is still not vertical. Consequently, when the arm moves to the second position, the cartridge axis will not be vertical but will be at an angle to the vertical (Fig. 11(d)). Clearly, this is to be avoided. In effect, the lateral balancing control is a solution to one of the outcomes of the problem and not a solution to the basic problem itself. The author believes that a few extra minutes spent while mounting the arm, to ensure that the mounting is vertical, would be a better solu-

Fig. 11. Tilted mountings. If a mounting, of the gymbal type as in 'c' or the 'knife-edge and bearing' type, is tilted forward as in 'b', the arm will tend to turn about the tube axis. In a bent-arm construction, this results in a torque in the anticlockwise direction because the c.g. of the triangle ABC will tend to occupy the lowest possible position. (Observe that the arm is horizontal in 'b'.) Tendency of arm to rotate as in 'a' results in axis of cartridge tilting as in 'd'. Anticlockwise force can be countered using tracking-force adjusting weight in horizontal plane of the arm on side of counterweight opposite the offset, as in 'f'. 'e' illustrates an unstable arrangement for the weight, and 'g' illustrates the stable arrangement.

tion and would be time well spent. In the author's latest arm design, lateral force adjustment is possible because the U-shaped rod carrying the counterweight and the tracking-force adjusting weight can be rotated around the arm tube axis enabling the perpendicular distance (in the horizontal plane) between the tracking weight and the axis to be varied. This can be used to apply a variable lateral force to both sides of the arm. However, it is better to ensure that the gymbal is mounted absolutely vertical in the first place. In any case, the straight tube design obviates the need

for lateral balancing since the so called lateral force for tilts will be negligible. It might seem odd, therefore, that the author has chosen to mount the tracking force weight in the horizontal plane of the arm and not the vertical plane, thereby deliberately off-balancing the arm laterally, in the conventional sense. The reason is that the term lateral balance is a misnomer and a more appropriate term would be 'angular balance.' For example, consider Fig. 11(e), where all the mass elements of the pickup arm lie in the vertical plane of motion of the arm. It might be construed that, in this case, the arm would be inherently laterally balanced. This is not so, and a little thinking (and the reader is urged to experiment himself) shows that if the mounting is tilted forward, a slight displacement of the arm in the clockwise sense will result in a clockwise torque. A small displacement of the arm in the anticlockwise direction will result in a torque in the anti-clockwise direction (that is, relative to the centre position).

The tracking force weight can be placed in three positions. It can be placed in the horizontal plane of the arm on the side of the counterweight (Fig. 11(f)), in the vertical plane of the arm above the counterweight (Fig. 11(e)), or below the counterweight (Fig. 11(g)). A little thought (and experimentation) will show that Fig. 11(f) corresponds to 'neutral equilibrium', Fig. 11(e) corres-

ponds to unstable equilibrium and Fig. 11(g) corresponds to stable equilibrium. Physically, it means that in the last two cases, for a fixed setting of the tracking force weight, the tracking force at the stylus will vary for different levels of the arm (for record changer arms). In general, to measure the vertical friction and stiction of the arm at the stylus position, the arm should be balanced and a small weight placed on the shell. The value of this weight, which is sufficient to move the arm appreciably, gives the required figure. Clearly, there is going to be a difference, for the 'stable' and the 'unstable' position (the value for the former will be more than the latter). So, to appreciate the friction figures of an arm, a knowledge of the equilibrium condition of the arm will be in order.

Pickup arm length

After discussing the essential features of pickup arms, it is now possible to decide the optimum length of a pickup arm. The various points that are affected by pickup arm length are: tracking error distortion, record wear due to tracking error, elliptical-stylii lag effect due to tracking error, effective mass of the arm, the inertia of the arm, skating force, and friction and stiction measured at the stylus point. A 12in arm gives less tracking error distortion than a 9in arm (see table) but a properly mounted 9in arm gives less than 1% harmonic distortion. Since tracing error distortion is comparable to tracking error distortion, it would seem pointless to increase the length beyond 9in to further decrease tracking error distortion. Since a 12in arm has less maximum tracking error than a 9in arm (0.58 degrees less) it might be construed that it will wear records less. However, with the high compliance cartridges available nowadays, this will be insignificant.

It is said that elliptical stylii can reduce tracing distortion at the expense of increasing error by causing a lag effect (reproduction delay) between the two channels of a stereo record⁹. This arises because, due to tracking error, the elliptical stylus does not trace the groove exactly as it was recorded since one point of contact will be slightly delayed or advanced relative to the other. Calculations show that a 12in arm does not improve matters considerably over a 9in arm, in this respect. In any case, it should be noted that tracing error is itself a form of delay (or lag and lead) distortion. This is illustrated in Fig. 4. Calculations show that the effective mass M for a 9in arm is smaller than for a 12in arm. As stated earlier, a smaller value of M is desirable. To be able to play a warped record properly, the term $I_H\omega$ (angular momentum) has to be a minimum for a particular arm. For a given warp amplitude, the angular velocity imparted to the 12in arm will be 9/12th of the angular velocity imparted to the 9in arm, but, because there is also

an increase in the inertia, the beneficial effect of using the longer arm is cancelled. Since a smaller offset angle is required for a 12in arm than for a 9in arm, the former will have a smaller skating force. Compensation will still be required for the longer arm and so this advantage does not really help matters, unless the user is averse to using sidethrust compensation. For given friction and stiction figures for a mounting, a smaller force will be required to move the arm at the stylus position 12 inches from the pivot, than at 9 inches from the pivot. A good mounting has a low enough inherent friction and stiction, so this is of negligible advantage in favour of the longer arm.

From the above points it is evident that a smaller 9in arm has a clear advantage over a longer 12in arm. Not surprisingly, the trend these days is towards smaller arms and some manufacturers have even stopped production of their longer models. □

References

- 12 Frederick, H. A., Vertical Sound Records, *J. Soc. Motion Picture Engrs.*, Vol. 18, p141, Feb. 1932.
- 13 Toro, M. J. D., Distortion in Sound Reproduction, *J. Soc. Motion Picture Engrs.*, Vol. 29, p493, 1937.
- 14 Pierce J. A. & Hunt, F. V., Distortion in Sound Reproduction from Phonograph Records, *J. Soc. Motion Picture Engrs.*, Vol. 31, p157, Aug. 1938.
- 15 Lewis W. D. & Hunt, F. V., A Theory of Tracing Distortion in Sound Reproduction from Phono Records, *J. Acoustic Soc. Amer.*, Vol. 12, p348, Jan. 1941.
- 16 Roys, H. E., Analysis by the Two Frequency Intermodulation Method of Tracing Distortion Encountered in Phonograph Reproduction, *R.C.A. Review*, Vol. 10, p254, June 1949. See also Sept. 1953.
- 17 Corrington, M. S., Tracing Distortion in Phonograph Records, *R.C.A. Review*, Vol. 10, p241, June 1949.
- 18 Fox E. C. & Woodward, J. G., Tracing Distortion - It's Cause and Correction in Stereodisk Recording Systems, *J. Audio Engg. Soc.*, Vol. 11, p294, Oct. 1963.
- 19 Washizawa, S. et. al., Development of Skew Sampling Compensator for Tracing Error, *J. Audio Engg. Soc.*, Vol. 21, p630, Oct. 1973.
- 20 Freudenstein F. & Soylemez, E., Kinematic Design of Tone Arm Articulation for Minimum Tracking Error in Automatic Turntables, *Mechanism & Machine Theory*, Vol. 8, p517, Winter 1973.
- 21 Bachman, W. S., The Application of Damping to Phonograph Reproduction Arms, *Proc. I.R.E.*, Vol. 40, p133, Feb. 1952.
- 22 Snow, C. A., A New Viscous Damped Tone Arm Development, *J. Audio Engg. Soc.*, Vol. 6, No. 3, p197, July 1958.
- 23 Bauer, B. B., Damping of Pickup Arms, *J. Audio Engg. Soc.*, Vol. 11, p207, July 1963.
- 24 Woodward J. G. & Werner, R. E., High Frequency Intermodulation Testing of Stereo Phonograph Records, Vol. 15, p130, April 1967.

White-light holography

Our front cover shows the gold keys of the city of Leningrad (formerly St Petersburg) recreated by one of the finest reflective white-light holograms ever produced. The holographic plate was made in a similar way to conventional types using the coherent light from an argon laser. Instead of splitting the laser light into an incident and reference beam, a single beam is passed through the plate onto the object. Part of the light is reflected back onto the rear of the light is reflected back onto the rear of the plate where it creates an interference pattern with the original beam. This pattern is then recorded on the emulsion. The main differences, however, are in the type of emulsion, a fine-grain thick layer type, and the process used to "develop" the plate. This allows the image to be seen in incoherent white light from a point source such as a filament lamp.

During the developing process the emulsion and hence the interference pattern shrinks. Because this interference pattern acts like a diffraction grating when white light is directed onto it, the image is seen in one particular colour. By expanding the emulsion the plate can be "tuned" for the natural colour, gold in the case of the keys.

The ability to optimise a single colour helps to make the image look very solid and sharp. In Russia the pioneer of white light holography Yu. N. Denisjuk has developed the technique of white-light holography to the point where it is intended to replace certain treasures on display by holographic replicas. Unfortunately information concerning the emulsion and developing process is limited, but as can be seen from our photograph the image of the keys is very convincing.

We would like to thank Laser Light Controls Ltd whose photographic assistance during their recent Science Museum exhibition was appreciated.

KEEP YOUR COOL

WITH ANTEX SOLDERING IRONS...

THIS UNIQUE SAFETY STAND-PART OF THE ANTEX SOLDERING KITS SK3 and SK4

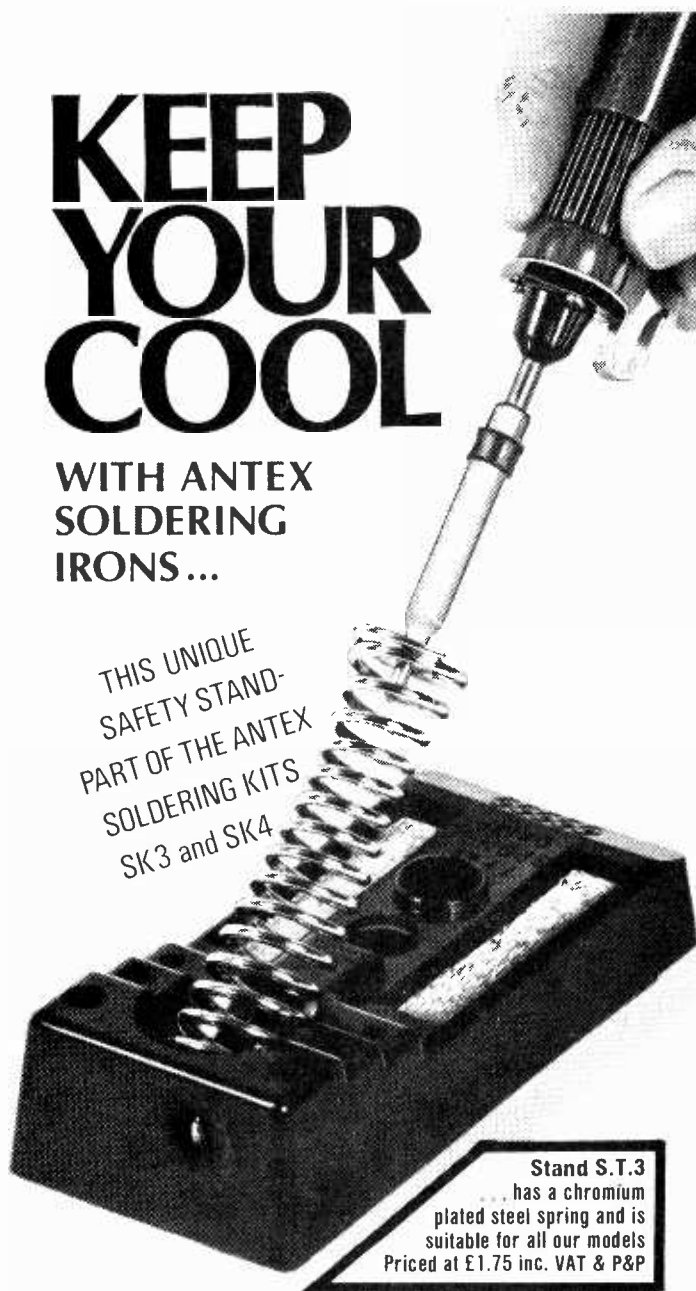

Stand S.T.3 has a chromium plated steel spring and is suitable for all our models Priced at £1.75 inc. VAT & P&P

With the new Antex soldering stand you have the assurance that with the iron tucked neatly into the strong angled spring coil you have maximum safety when preparing or waiting for the iron to heat. Moulded into this stand is provision for six alternative bits, and two small sponges for cleaning bits.

This sturdy plastic stand is a useful addition to any household or workshop. The SK3 and SK4 kits comprise of a full instruction card mounted with either the CX miniature soldering iron or the larger X25 general purpose iron. Included in both of these kits is the safety stand.

All the range of Antex soldering irons are made on the principle of putting the heating element inside a shaft, then the desired bit is eased over the shaft, giving maximum heat transference, this is why so often a small Antex iron can do the job of a larger conventional iron. The precision made slide on bits are slit to make them easily interchangeable.

Our comprehensive range is sure to meet your need.

Model CX-17
watts



A miniature iron with the element enclosed first in a ceramic shaft, then in stainless steel. Virtually leak-free. Only 7 1/2" long. Fitted with a 3/32" bit. £3.91 inc VAT & P&P. Range of 5 other bits available from 1/4" down to 3/64"

Model X25-25 watts



A general purpose iron also with a ceramic and steel shaft to give you toughness combined with near-perfect insulation. Fitted with 1/8" bit and priced at £3.91 inc VAT & P&P. Range of 4 other bits available. **B.E.A.B. APPROVED**

Model SK3 KIT



Contains both the model CX soldering iron and the stand S.T.3. Priced at £5.62 it makes an excellent present for the radio amateur, model-maker or hobbyist.

Model SK4 KIT



With the model X25 general purpose iron and the S.T.3 stand and its B.E.A.B. safety label, this kit is a must for every tool-kit in the home.

Model SK1 KIT

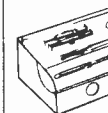

This kit contains a 15-watt miniature soldering iron, complete with 2 spare bits, a coil of solder, a heat sink and a booklet. "How to solder". Price £6.18 inc VAT & P&P.

Model MLX KIT



The soldering iron in this kit can be operated from any ordinary car battery. It is fitted with 15 feet flexible cable and battery clips. Packed in a strong plastic envelope it can be left in a car, a boat or a caravan ready for soldering in the field. Price £4.59 inc VAT & P&P.

Stocked by most of the well known wholesalers and many retailers. Order direct from us for a complete catalogue.



Please send the following I enclose cheque P.O. Giro No258 1000

..... Name

Please send the ANTEX colour brochure Address

.....

ANTEX LTD. FREEPOST, PLYMOUTH PL1 1BR TEL. 0752 67377 ww 4 78

WW-075 FOR FURTHER DETAILS

Stay ahead-follow this sign

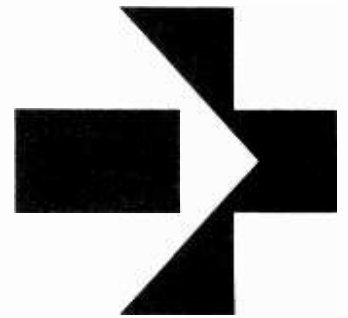

GOULD ADVANCE INSTRUMENTS HAVE A WORLDWIDE REPUTATION. BUT THEY NEED NOT COST YOU THE EARTH.

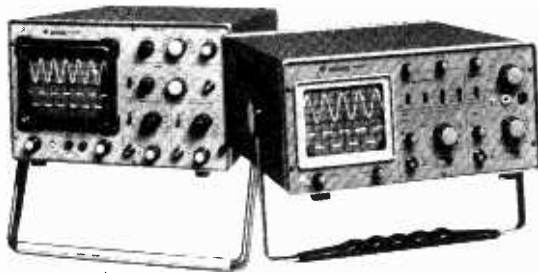

OS245A AND OS250B OSCILLOSCOPES

Two dual trace oscilloscopes, with sensitivity of 5mV/div., and 2mV/cm respectively. The OS250B offers variable trigger level with or without bright line. The OS245A has a bandwidth of 10MHz, the OS250B offers 15MHz. Fully portable, these are the ideal instruments for servicing, educational and general purpose applications.

ALPHA III DIGITAL MULTIMETER

A tough, attractive, 3½ digit multimeter with 25 ranges and a basic accuracy of $\pm 0.2\%$. A bright red LED display gives a clear reading even in high ambient light conditions, and yet power consumption is low enough for extensive field applications.

A purpose built CMOS chip incorporates all analogue and digital circuitry, giving a low component count and increased reliability.



TC 320 TIMER COUNTER

This new, tough, 5-digit unit has an operating frequency of 35MHz. Plated through hole PCB construction keeps the component count down, for exceptional reliability. Frequency measurements up to at least 35MHz can be easily read from the clear 7-segment display. The TC320 offers outstanding performance – including "disciplined" triggering – at a remarkably modest price.

BETA DIGITAL MULTIMETER

A general-purpose multimeter, offering 29 ranges, including temperature (optional), and a basic accuracy figure of $\pm 0.2\%$. A clear, 3½ digit Liquid Crystal Display, 0.5" high, gives a high-contrast read-out. Fully portable, with a minimum of 300 hours' battery life, the Beta has already established a reputation for accuracy and reliability.

For details of any of these instruments and the Gould Advance 2 year guarantee, write or phone today.

Gould Instruments Division,
Roebuck Road, Hainault, Essex IG6 3UE.
Telephone: 01-500 1000 Telex: 263785.



GOULD

WW-055 FOR FURTHER DETAILS

Some tests on extended response cartridges

Tests complement those of July 1976 issue

by David Heller, B.Sc.(Eng)

Earlier tests on nine extended-response cartridges with white noise record, demodulator and spectrum analyser are augmented with results for six further pickups.

In addition, damping properties are investigated and stereo compatibility assessed. Within the limitations of the tests the moving-coil pickups appear to be superior to the moving-magnet types.

APPEARANCE OF EARLY extended frequency response (e.f.r.) cartridges on the market highlighted the fact that while cartridge manufacturers placed much importance on extending the amplitude response of cartridges, few paid much attention to high frequency separation or phase response and delay properties of these cartridges. This initial oversight was a major contributing factor in the poor quality of recovered audio from CD-4 discs and only over the past few years have a new generation of extended-response cartridges appeared which display much superior characteristics in this regard.

Criteria which I believe e.f.r. cartridges should fulfil are as follows.

Amplitude response. When equalized through the required circuitry (normally RIAA) the frequency response should be flat to about 18kHz. In the range 18kHz to 45kHz the cartridge should be able to track such frequency bands with high output (0.5mV or greater) but a flat response over this range is not essential, because the signal is frequency modulated.

Crosstalk. High channel separation should exist over the frequency range to 45kHz, otherwise frequency beats occur in the carrier range which leads to distortion and degradation of the recovered audio signal. This phenomenon was apparent with earlier e.f.r. cartridges and data issued seldom gave reference to crosstalk characteristics in the carrier region. Crosstalk figures in excess of 15dB in the carrier region should be the minimum obtainable.

Phase response and delay. Two-channel matrix systems use amplitude and phase relationships for encoding and decoding so that phase differences between the left- and right-hand channels of the cartridge may affect performance. In the carrier region, phase imbalance may result in crosstalk. De-

lays between baseband and demodulated carrier signals should be determinable and constant over the required frequency band. (Early e.f.r. cartridges displayed delays of about 25 μ s at 30kHz and which varied over the frequency band. The latest type have cut this delay to about half this figure and are also less frequency dependent.)

In addition to these criteria I believe it is important that the cartridges should

reproduce mono and stereo discs with the same quality as high-grade conventional cartridges, so listening tests were also carried out with reference to a good quality stereo pickup.

For the white noise tests a Rotel RP3000 turntable fitted with an SME Series II Improved arm with detachable headshell was used. Each cartridge was separately aligned according to SME instructions.

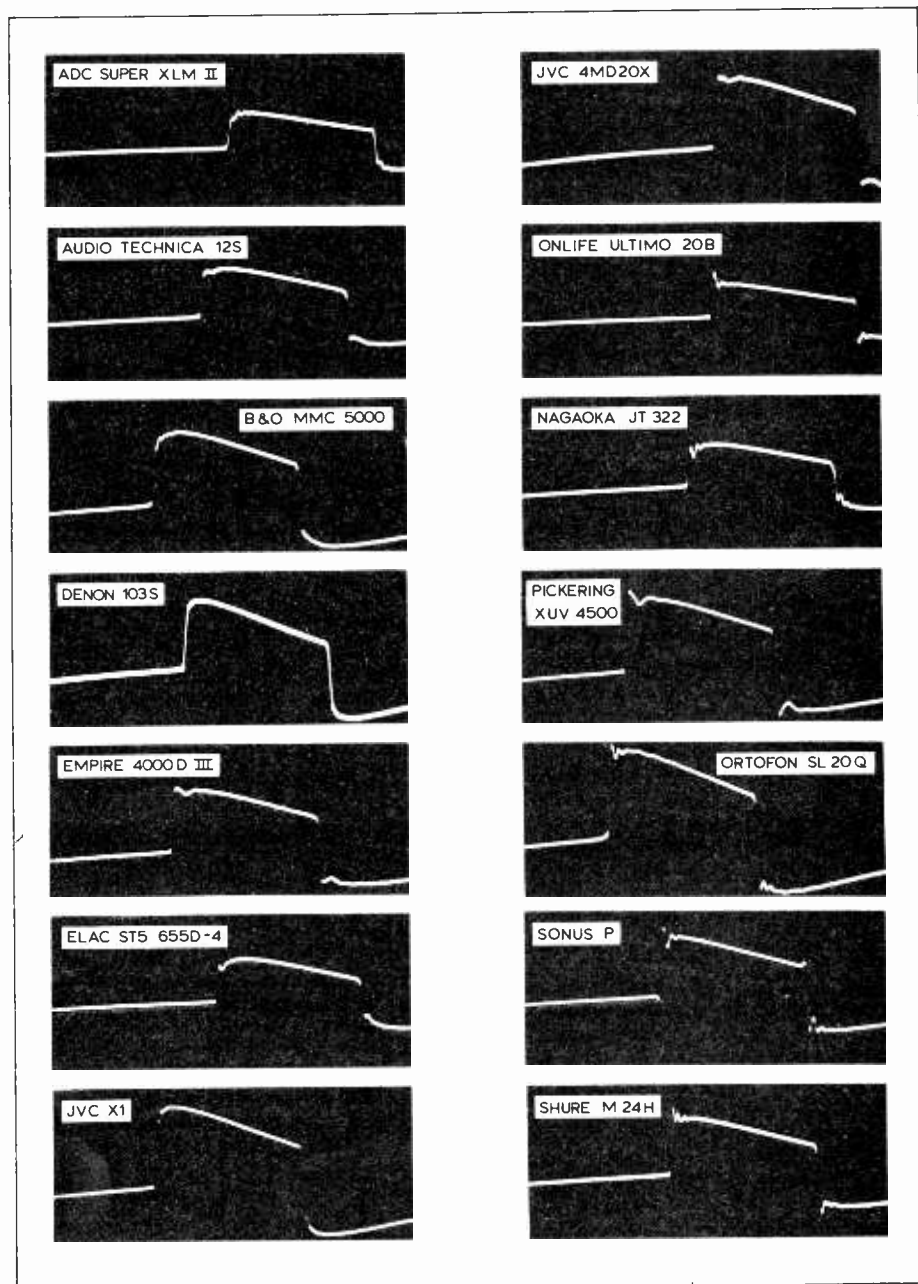

A CD-4 test record distributed by Sutton-Miller and produced by Louis Dorren and James Yabbert together with the aid of a Hewlett Packard audio spectrum analyser proved an invaluable tool. The record, whose pressing quality is not all that I would have liked, has a band of white noise which when passed through the cartridge and demodulator is used to maximize separation of the demodulator. The spectrum analyser then draws out the amplitude response for the front and back channels. The shape and distance between these two responses gives a good indication of amplitude response and delay characteristics.

The results of these tests are shown in the accompanying photographs. The top trace is the front channel response, the bottom trace is the rear channel and the difference between the two is the separation between front and back. In all cases only right-channel measurements were made. Each horizontal division is 1kHz while each vertical division accounts for 10dB separation.

The demodulator used (*Wireless World* June and July issues, 1976) had extremely linear phase, i.e. constant delay, through both the baseband and carrier signal paths. Therefore any variation in the delay of the cartridge would show up in the separation characteristics. Crosstalk would not do so because the white noise is played on one side of the groove only, the other side having no baseband or carrier modulation.

Examination of the various curves shows that the Denon 103S produced by far the best results with a consistent 18dB front/back separation over the range to 13kHz (only 10kHz shown here).

The JVC X1, ELAC ST5655D-4, Ortofon SL20Q and Onlife Ultimo 20B produced roughly equivalent results with peak separation of 18dB falling to 10dB at 7kHz and little separation at 10kHz.

The Pickering XUV4500 showed maximum separation of 10dB, but this

was constant over the 10kHz bandwidth. This cartridge therefore has a constant delay over the desired frequency band, but its value is significantly different from the other cartridges tested in the group.

The B & O MMC5000 had slightly better separation (about 14dB) more or less maintained over the 13kHz band, again illustrating the constant delay characteristics of the cartridge.

The Audio Technica AT12S and the JVC 4MD20X (a selected version of the AT12S) produced peak separation of about 18dB, decreasing to 5dB at 8kHz and remaining at such to 13kHz.

The Nagaoka JT322 showed peak separation of 15dB, but no separation was apparent after 9kHz.

The Shure M24H showed peak separation of 15dB, dropping to 10dB at 6kHz and disappearing at 9.5kHz, with the Empire 4000DIII following much the same pattern, but only displaying peak separation of 12dB.

Finally the ADC Super XLM/II and the Sonus P failed completely to show any separation for the white noise test. On closer examination, this did not prove that either of these cartridges could not track the carrier, only that they were incapable of doing so effectively during high and rapid baseband modulations. This was later borne out in listening tests with CD-4 discs.

With the aid of a JVC test record which had 300Hz square-wave tracks, it was possible to test the various damping properties of the test cartridges. No RIAA equalization was used. Page 71 shows the results.

Again the Denon 103S proved superior with the B & O MMC5000 and JVC X1 showing very similar results to the Denon. Although the remaining cartridges exhibited some overshoot, this was rapidly damped in all cases. The Ortofon SL20Q would probably have exhibited better results in another arm with heavier damping as the SME/Ortofon combination is not believed to be particularly good.

Listening tests

The test disc already mentioned has a track with music coming from the four speakers in sequence. This track is used to set the demodulator for maximum separation and this is achieved by turning the front channel gain down and adjusting a separation control for a null in the back channels. As both left and right channels are done independently, one can listen for crosstalk between left and right. In only one case (the Shure M24H) did this prove noticeable and not annoyingly so, but it was higher than with the other cartridges.

A second disc used was a CD-4 pressing of Mandigo which had a severe warp. All the cartridges, except the Ortofon SL20Q, tracked the worst track with no audible loss of carrier. I believe that the Ortofon problem relates to its combination with the SME arm and headshell and SME have themselves recognised this and intend releasing an attachment which may be added to the SME arm to improve performance of such cartridges in their arms.

A third disc was a fairly early CD-4 pressing which had some noticeable carrier loss, but which was not warped. Here the JVC X1, the Pickering XUV4500, Ortofon SL2Q, Elac ST5 655D-4 and Denon 103S proved best. Next the AT12S, Empire 4000DIII, JVC 4MD20X, and Ultimo 20B gave very acceptable results. The Shure M24H was not as good but proved superior to the Nagaoka JT322. The B & O MMC5000, ADC Super XLM/II and the Sonus P displayed frequent carrier loss especially when high baseband modulation was present.

Finally informal subjective listening test were carried out by a small panel using the Shure V15III as a reference. It is difficult to choose a standard for such comparative tests, but the V15III was chosen because of its relative popularity and well-known tracking ability. The first result was surprise at the very high standard of reproduction when used on conventional discs. Secondly, the major default of most cartridges tested was their susceptibility in picking up noise from dirty or scratched discs. And a final point was the consistently good results achieved by the moving-coil cartridges.

Conclusion

The cartridges which tracked well and exhibited large carrier outputs so that so-called "carrier breakup" was less apparent on bad records were the JVC X1, Pickering XUV4500, Shure M24H, Elac ST5 655D-4, Denon 103S, AT12S, Empire 4000DIII, Ortofon SL20Q, Ultimo 20B and JVC 4MD20X. Of these the only one whose tonal quality I found disturbing was the Empire 4000D which seemed very "brittle". As regards playback of conventional two-channel or mono discs the best were undoubtedly the moving-coil types, with the Denon 103S being superior and the Ortofon

continued on page 75

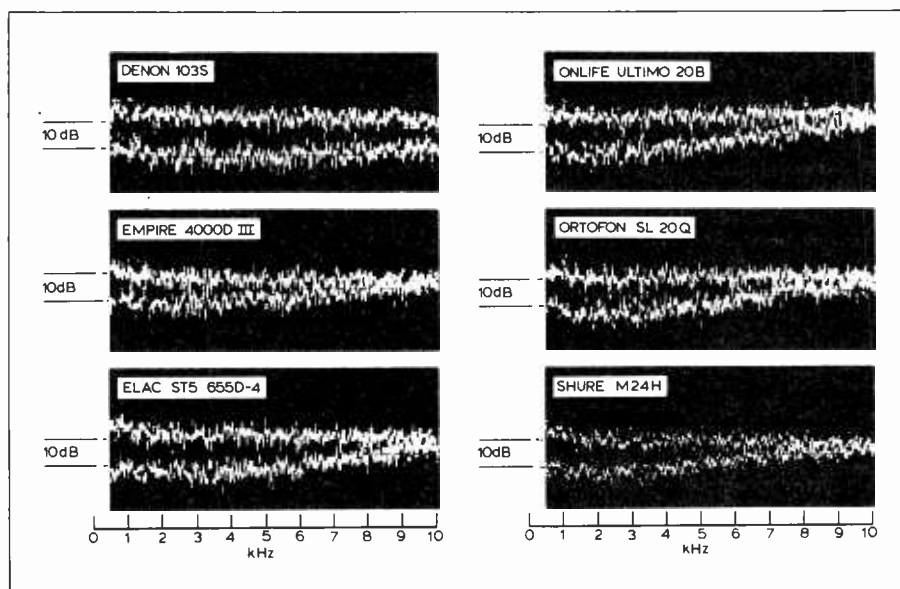

Logic design — 12

M.s.i. — applications of read-only memories

by **B. Holdsworth*** and **D. Zissos†** *Chelsea College, University of London

†Dept. of Computing Science, University of Calgary, Canada

This is the second part of the article on applications of medium-scale integrated logic circuits. The first part was a discussion of the use of multiplexers and decoders, and the article now continues with a look at the use of read-only memories as function generators.

Read only memories

THE CIRCUIT shown in Fig. 11 is that of a 64-bit r.o.m. organised as 8 words of 8 bits each. It consists of a 3-bit address decoder, a 64-bit memory, and 8 output buffers. An enable input, when at logical 0, enables all the gates in the address decoder. The vertical lines in the memory section are called word lines and the horizontal ones bit lines.

Words are programmed into the r.o.m. at each address and the output on the bit line depends on whether it is connected to the addressed word line or not, the connexion being made by the presence of an m.o.s. or bipolar transistor, depending upon which technology is used. If connected, the bit line is raised to a logical 1 and if not it remains at logical 0. In this way the word programmed at the selected address is transferred to the output.

A schematic way of representing a programmed 64-bit r.o.m. is shown in Fig. 12, where at those intersections of bit lines and word lines marked by a dot there is an OR input for the output function. For example, the output at Z_8 is $P_0 + P_5 + P_7$. Hence the r.o.m. shown in Fig. 12 is being used to generate eight 3-variable functions, each of which is expressed in canonical form.

If a customer wishes to realise the functions shown in Fig. 12 he must supply the manufacturer with either a connexion matrix, such as the one shown in that diagram, or a truth table, as shown in Table 1. Alternatively, the customer may have his own programming facilities and in those circumstances he would purchase a programmable read only memory (p.r.o.m.).

Addressing. The connexion matrix shown in Fig. 13(a) is for a two 8-bit word r.o.m. addressed in one dimension only. The total capacity of the r.o.m. is 16 bits and the Boolean functions generated by it are:

$$Z_1 = P_2 + P_5 + P_7$$

$$\text{and } Z_2 = P_0 + P_4 + P_5 + P_7$$

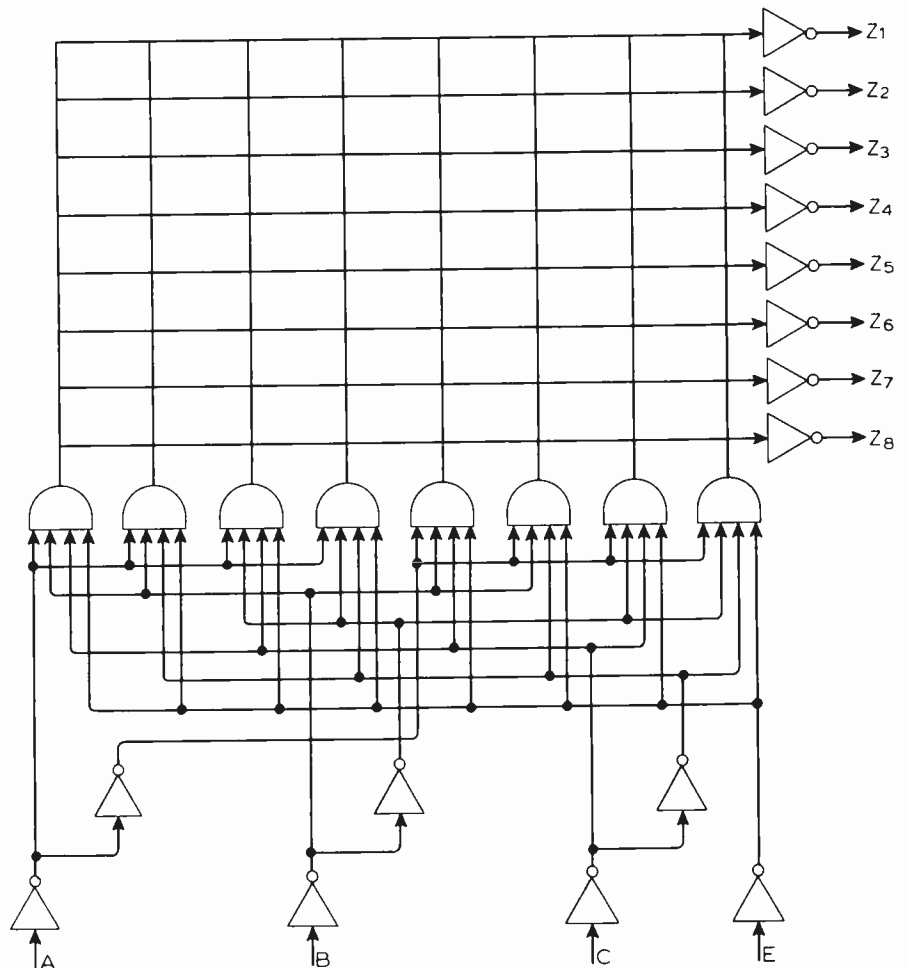

Fig. 11. 64-bit r.o.m. with address decoder and enable input. No intersections are programmed.

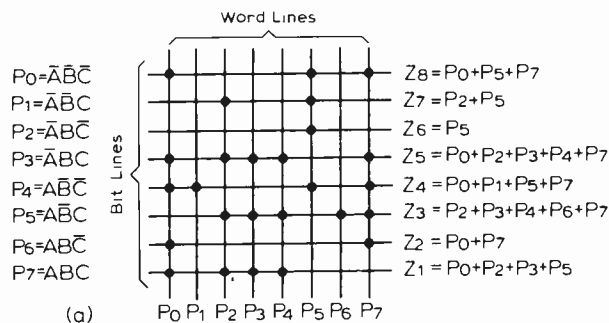

Fig. 12. Connexion matrix for a 64-bit r.o.m. at and the equivalent truth table in Table 1.

Table 1

Address			Output functions							
A	B	C	Z ₁	Z ₂	Z ₃	Z ₄	Z ₅	Z ₆	Z ₇	Z ₈
0	0	0	1	1	0	1	1	0	0	1
0	0	1	0	0	0	1	0	0	0	0
0	1	0	1	0	1	0	1	0	1	0
0	1	1	1	0	1	0	1	0	0	0
1	0	0	0	0	1	0	1	0	0	0
1	0	1	1	0	0	1	0	1	1	1
1	1	0	0	0	1	0	0	0	0	0
1	1	1	0	1	1	1	1	0	0	1

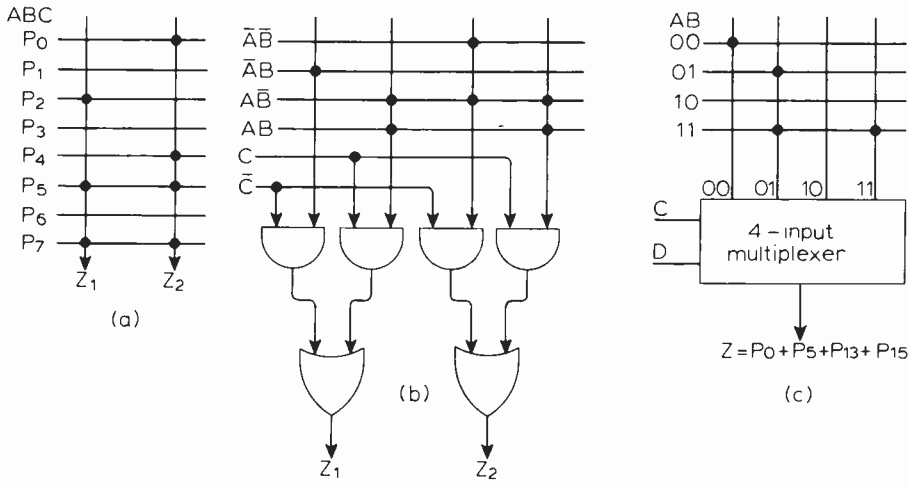

Fig. 13. A 2x8-bit word r.o.m. addressed in one dimension is shown at (a), while at (b) is the two-dimensional method. Generation of one 4-variable function using two-dimensional scheme is seen at (c).

Table 2.

Present State				Output Word				Present State				Output Word				
A	B	C	X	A	B	C	Z	A	B	C	X	A	B	C	Z	
0	0	0	0	1	0	0	0	0	0	0	1	0	0	1	1	0
0	0	0	1	0	0	0	1	0	0	0	1	1	1	0	1	0
0	1	0	0	1	1	0	0	0	1	1	0	0	1	0	0	0
0	1	0	1	1	1	0	0	0	1	1	0	0	1	1	0	0
1	0	0	0	1	1	0	0	0	1	1	1	1	1	1	1	0
1	0	0	1	1	1	0	0	0	1	1	1	1	1	1	1	0
1	1	0	0	1	0	0	1	0	1	0	1	0	1	1	1	0
1	1	0	1	0	1	0	0	1	0	1	1	1	1	1	1	0
0	1	0	0	0	0	0	0	1	1	1	0	0	0	0	0	1
0	1	0	1	0	0	0	0	1	1	1	1	0	0	0	0	1

Table 3

Present State				Output Word										
A	B	C	X	P	A	B	C	g ₁	a ₁	r ₁	g ₂	a ₂	r ₂	
0	0	0	0	d	0	1	0	0	1	0	0	0	0	1
0	0	0	1	d	0	0	0	1	0	0	0	0	0	1
0	1	0	0	d	0	1	0	0	1	0	0	0	0	1
0	1	0	1	d	1	1	0	0	0	1	0	0	0	1
1	1	0	0	0	1	1	0	0	0	1	0	0	0	1
1	1	0	1	1	1	1	0	0	0	1	1	0	0	0
1	1	1	0	d	1	1	1	0	0	1	1	0	0	0
1	1	1	1	0	0	1	1	0	0	1	0	1	0	0
1	1	1	1	1	1	1	1	0	0	1	1	1	0	0
0	1	1	0	d	0	0	1	0	0	1	0	0	0	1
0	1	1	1	d	0	1	1	0	0	1	0	0	1	0
0	0	1	0	d	0	0	1	0	0	1	0	0	0	1
0	0	1	1	d	0	0	0	1	0	0	0	0	0	1
1	0	0	d	d	1	0	1	0	0	1	0	0	0	1
1	0	1	0	0	1	0	1	0	0	1	0	0	0	1
1	0	1	0	1	1	1	1	0	0	1	1	0	0	0
1	0	1	1	d	1	0	1	0	0	1	0	0	0	1

Fig. 15. Block diagram from problem of Example 5 at (a) and state diagram at (b). State table is in Table 2 and connexion matrix for 64-bit r.o.m. is at (c). R.o.m. implementation is shown in (d).

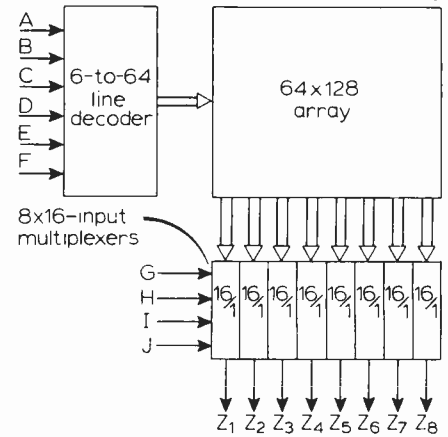
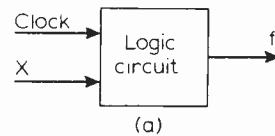
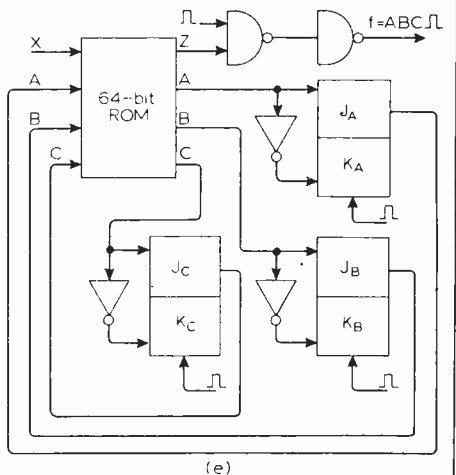
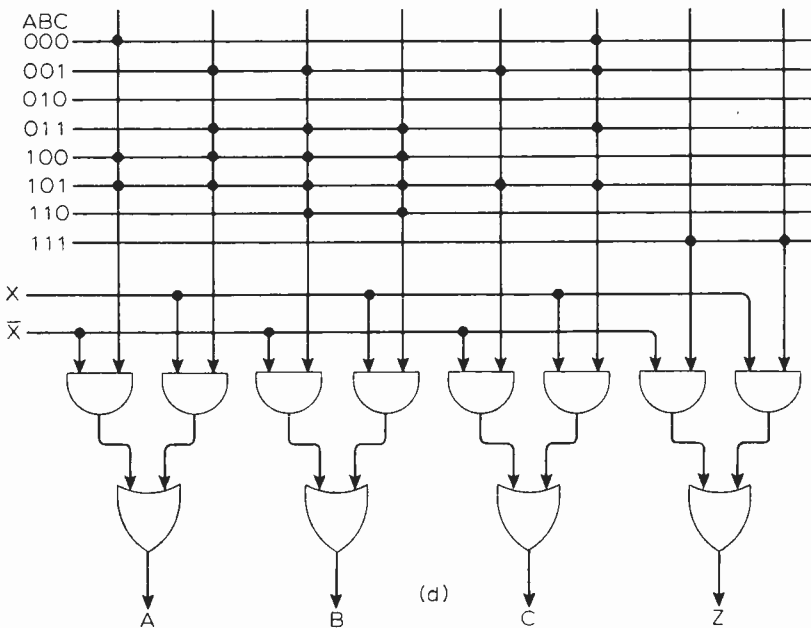
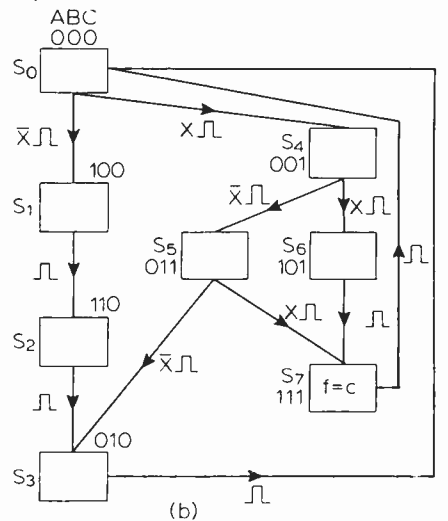

Fig. 14. Reduction of number of lines to and from r.o.m. by two-dimensional addressing.



An alternative two-dimensional method of addressing a 16-bit r.o.m. is illustrated in Fig. 13(b), in which examination of the connexion matrix shows that the same Boolean functions are generated as in the previous case. Using this technique there is a reduction in the number of address lines required, but additional gating is needed.

The same r.o.m. in conjunction with one 4-input multiplexer can be used to generate one 4-variable function as shown in Fig. 13(c), where six address lines only are needed as compared to the sixteen address lines required with one-dimensional addressing.

Clearly, large capacity r.o.ms can be similarly addressed in two dimensions. For example, a 1024-word by 8-bit r.o.m., using single dimensional addressing, would require 1024 address lines for the 10 input variables. On the other hand, a two dimensional addressing scheme such as the one shown in Fig. 14 can be used, in which the numbering of lines entering and leaving the 64×128 array has been reduced from 1032 to 192. For this particular r.o.m. a 1 or a 0 can be specified in any of 8192 locations and the number of possible stored combinations is, therefore, 2^{8192} .

Sequential circuits using r.o.m.

R.o.ms are suitable devices for the implementation of clock driven and event driven logic circuits and their use in this application will be illustrated with the aid of two examples.

Example 5. Serial b.c.d. messages arrive on line X, most significant digit first. Each data bit is synchronised with a clock pulse. Design a circuit using a r.o.m. that generates a fault signal on terminal f each time an invalid code is received.

Step 1. I/O characteristics. These are described in the statement of the problem and are summarised in the block diagram Fig. 15(a).

Step 2. Internal characteristics. A suitable state diagram is shown in Fig. 15(b)

Step 3. State table. This is shown in Table 2 and is displayed in a suitable form for r.o.m. implementation.

Step 4. Connexion matrix. This is shown in Fig. 15(c) for a two dimensionally addressed 64-bit r.o.m.

Step 5. Circuit implementation. This is shown in Fig. 15(d). Besides the 64-bit r.o.m. additional logic is required to produce the output signal $f = ABC\bar{L}$. Additionally three D-type flip-flops are required in each feedback line to synchronise the operation of the circuit to the clock.

The next example illustrates the implementation of an event-driven logic circuit with a r.o.m.

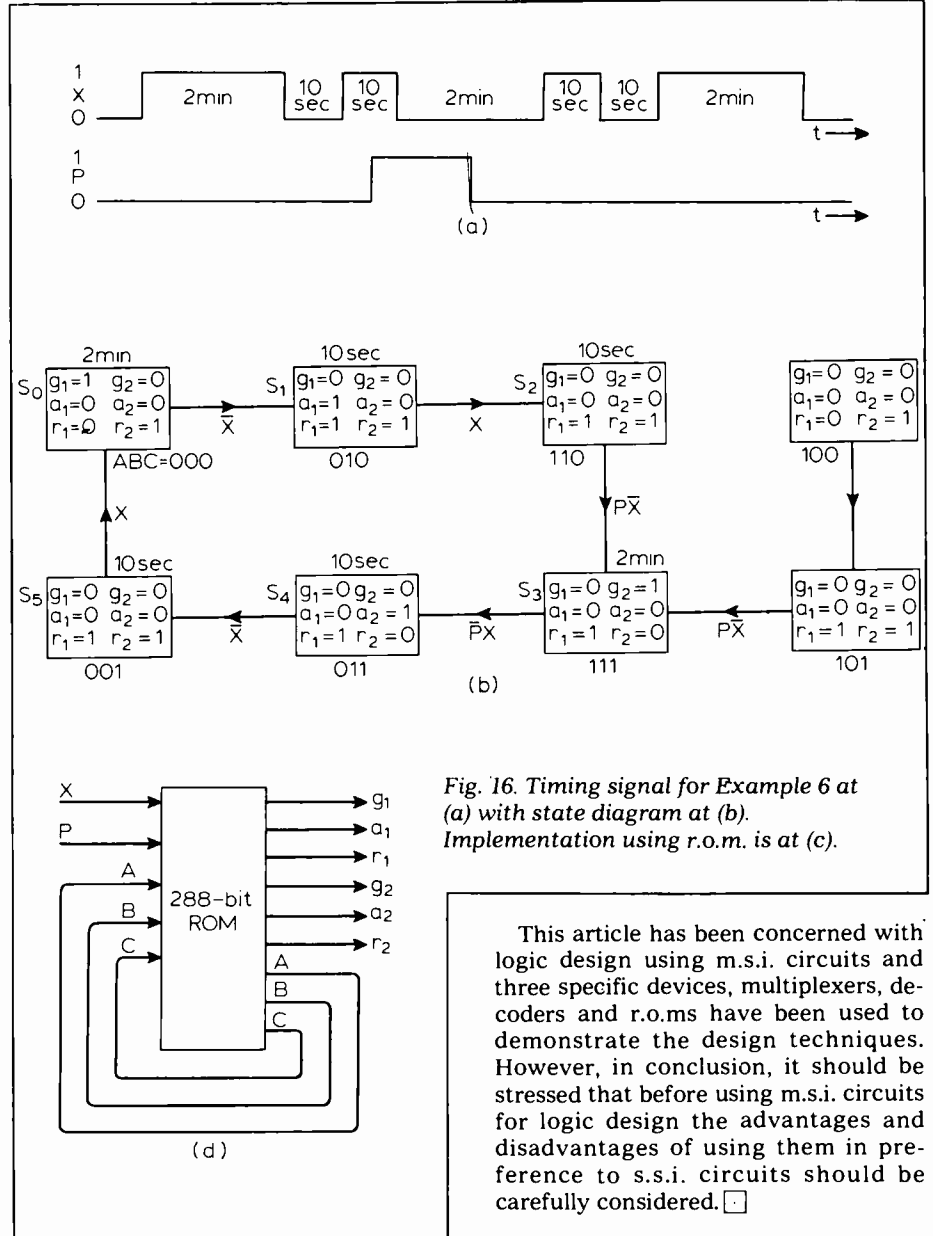

Fig. 16. Timing signal for Example 6 at (a) with state diagram at (b). Implementation using r.o.m. is at (c).

Example 6. A road intersection is controlled by a set of traffic lights. For each road the light sequences are tabulated below:

Road 1—green amber red red red red

Road 2—red red red green amber red

The lights are driven by a timing signal X and a synchronisation signal P as shown in Fig. 16(a).

Step 1. I/O characteristics. These are described in the statement of the problem.

Step 2. Internal characteristics. A suitable state diagram is shown in Fig. 16(b).

Step 3. State table. This is shown in Table 3 and is displayed in a suitable form for r.o.m. implementation.

Step 4. Circuit implementation. This is shown in Fig. 16(c). In practice, r.o.ms are manufactured in standard sizes and a suitable r.o.m. or combination of r.o.ms would have to be chosen from those available.

continued from page 72

SL20Q a close runner-up. The JVC X1, B & O MMC500 ADC Super XLM, Nagaoka JT322, Elac and Sonus P gave a very good account of themselves.

My choice overall would be the Denon 103S followed by the Ortofon SL20Q which is about a third of the price of the former and gave a really good account of itself. It would probably do even better in another arm. The best of the non-moving coil types would be the JVC X1. The best of the cheaper type is undoubtedly the AT12S which still gives very good value for money.

Acknowledgment. Thanks to Hewlett Packard, Telfor Cameras and Sansui Audio Europe for the loan of equipment.

Improved stereo decoder i.c.

Phase-locked loop decoder with variable blend is insensitive to interference at 57 and 114kHz

Michael J. Gay, Motorola Semiconductor Inc

In the TCA4500 stereo decoder digitally generated waveforms eliminate a previously troublesome sensitivity to interference at 114kHz, the third harmonic of the subcarrier. But the introduction of the ARI road traffic information system in Germany means that f.m. transmitters carrying this service have an a.m. subcarrier at 57kHz which interferes with the regeneration circuits of stereo decoders. The TCA4500A overcomes this with a three-state switching function; it also includes a variable blend facility that gives a smooth change from mono to stereo reception.

THE TCA4500A differs from its predecessors^{1,2} essentially in the development and use of special modulating functions to avoid certain interference problems, and in the introduction of the variable separation control.

The performance of the modulators in the phase-locked loop and decoder sections is critical to the performance of the whole circuit. The first-mentioned must provide a correction signal derived from the pilot-tone while handling a composite signal ten times larger, without introducing any significant spurious low frequency components.

The last-mentioned must provide a demodulated channel difference signal of precisely controlled level, uncontaminated by sum signal.

To achieve the necessary performance the modulators must be switching types, in which the modulating function contains only the levels +1, -1 or 0. Such modulators have been used in previous decoders driven with accurate, digitally generated square waves to yield square-wave modulating functions of levels +1 and -1, and which provide precise fundamental components, zero mean level, and no even harmonics. Their characteristics suffice for treating the composite stereo signal alone or, in the U.S.A., a stereo signal to which an SCA signal has been added. They become inadequate, however, if the signal is contaminated by interference at the third harmonics of either the pilot-tone (57kHz), or of the subcarrier (114kHz).

Interference at 114kHz can be translated into the audio band, by multiplication with the third harmonic component of the decoder modulating

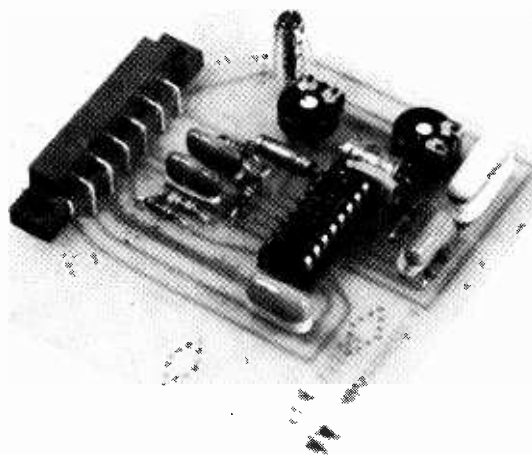

Basic decoder operation

The composite stereo input signal is applied to a preamplifier which provides two outputs, one passed via a phase lead network to the p.l.l. and stereo switch sections, and one fed directly to the decoder section.

The loop employs an RC oscillator operating at six times the subcarrier frequency (228kHz) from which waveforms at the subcarrier and pilot frequencies are developed by a digital divider. One pair of 19kHz waveforms is returned to the loop phase detector (modulator) where they develop a modulating function, which operates on the pilot component of the incoming signal and develops the loop error signal. The error signal after filtering and amplifying is applied to the v.c.o. which consequently becomes phase-locked to the pilot tone. As the loop error is nominally zero, it follows that the 19kHz waveforms applied to the loop phase detector will be in quadrature with the pilot tone when the loop is locked. To obtain a signal proportional to the pilot-tone amplitude a second pair of 19kHz waveforms is derived, in quadrature with the first pair, and these are multiplied with the composite signal in the stereo switch modulator. The

output of this modulator is filtered and applied to a trigger circuit which permits or inhibits the application of the 38kHz waveforms to the decoder section. The trigger circuit also operates the stereo indicator lamp.

When applied to the decoder section modulator, the 38kHz waveforms develop a modulating function which, operating on the composite signal, translates the difference signal into audio while translating the other components into the supersonic range. The modulator provides anti-phase outputs which pass through a blend circuit and are then added, individually, to the unmodified composite signal. Assuming that the relative signal levels are correct, the blend circuit being set for full separation, the addition will in one case cancel the left channel audio components, leaving only the right channel signal, and in the other case cancel the right channel components leaving the left channel. The separated signals are applied to the output amplifiers which provide gain and de-emphasis, the last-mentioned serving also to reduce the spurious high frequency components present.

function, while interference at 57kHz can multiply with the third harmonic component of the phase-locked loop modulating function, producing low frequency outputs which phase modulate the v.c.o., and all the waveforms derived from it, thus causing intermodulation distortion. With European channel spacing the sidebands of adjacent transmitters can fall in the 114kHz region – too close to be eliminated by the i.f. filter – and the ARI system has now added a signal at 57kHz.

To eliminate the adjacent channel interference European receivers have commonly used a 114kHz notch filter preceding the decoder, although this is not entirely satisfactory as rejection is really required over the band 99-129kHz. To eliminate the ARI system interference a second notch filter at 57kHz would be required.

The two forms of interference could be better eliminated by using modulating functions from which the third harmonic has been removed, as well as the second. The necessary functions are three-state forms (1, 0, -1) but they can be obtained by applying two-state waveforms to an appropriate modulator, such as the common chopper type, as shown in Fig. 1. The desired modulating function contains no second nor third harmonic terms nor any multiples thereof.

The driving signals can be produced from a three-stage shift register connected as a Johnson counter, operating at 114kHz. The shift register in Fig. 2 is formed of six bistable circuits, coupled by transmission gates, and driven by 114kHz C and \bar{C} signals from a binary divider which is fed by the 228kHz v.c.o. The shift register provides six pairs of antiphase 50% duty-cycle square waves spaced at 30° intervals. Two NAND gates provide the desired 19kHz 66% duty-cycle square waves, while two exclusive-OR gates provide the same forms at 38kHz. A pair of shift register outputs are used directly to drive the modulator in the quadrature-correlator section of the circuit.

The system has a slight drawback in that the 38kHz modulating function lags the 19kHz p.l.l. modulating function by one half period of the oscillator. The loop and correlator-section modulators are, however, necessarily a.c.-coupled to the preamplifier to eliminate d.c. offset problems. By using an appropriate coupling capacitor, a 15° phase lead at 19kHz can be obtained to cancel the error.

Variable separation and decoder section

A major difference between the TCA4500A and earlier decoders is the addition of the variable blend control. Intended to allow a receiver to change continuously between mono and stereo operation, it avoids abrupt changes in sound energy distribution. It is intended

Characteristics for circuit of Fig. 4 with Vcc 12V and 2.5V pk-pk L or R-channel stereo signal.

	Min.	Typ.	Max.
Stereo channel separation: unadjusted	30dB		
optimized on other channel	40dB		
Mono voltage gain	0.8	1	1.2
Harmonic distortion			
2.5V pk-pk composite input			0.3%
1.5V pk-pk composite input		0.1%	
Signal to noise ratio		90dB	
Capture range		± 5%	
Ultrasonic frequency rejection			
19kHz		31dB	
38kHz		50dB	
Stereo switch levels			
19kHz input for lamp "on" hysteresis	12mV	16mV	20mV
Quiescent output voltage change with mono/stereo switching		5mV	20mV
Stereo blend control voltage (pin 11)			
3dB separation		0.7V	
30dB separation		1.7V	
Minimum separation (pin 11 at 0V)			1dB
Blend control current		100µA	
Mono channel imbalance (pilot off)			0.3dB
Pilot tone harmonic rejection 57kHz		45dB	
Subcarrier harmonic rejection			
76kHz		45dB	
114kHz		50dB	
152kHz		50dB	
Supply ripple rejection		55dB	
Input impedance		50kΩ	
Output impedance		100Ω	
Operating supply voltage	8V		16V
Current drain (lamp off)		35mA	

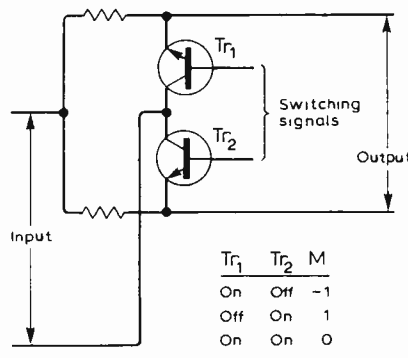

Fig. 1. Instead of using filter to prevent distortion due to interference at 57 & 114kHz, the decoder switching function is arranged to have no second or third harmonics. The three-state function is obtained from a chopper as shown.

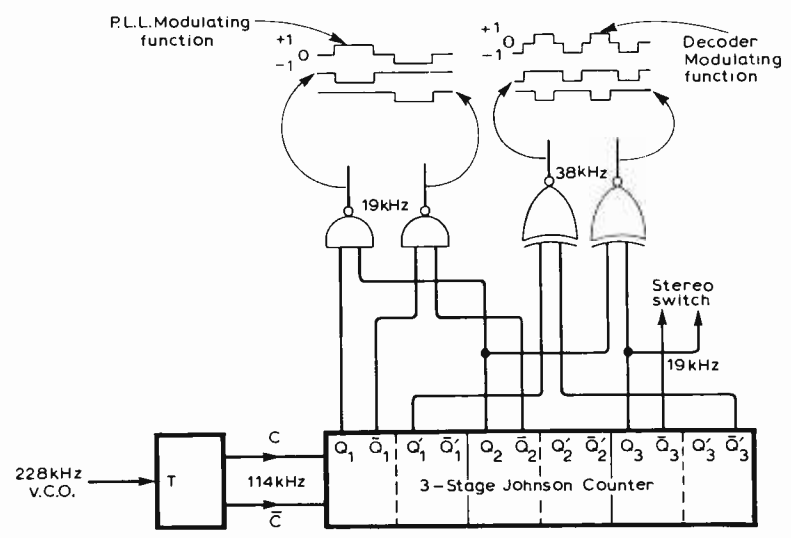

Fig. 2. Driving signals for the modulators are formed from six bistable circuits arranged as a Johnson counter, providing six pairs of antiphase square waves at 30° intervals.

that the separation be controlled by an external signal derived from the receiver's S-meter or a.g.c. system, although a user control is obviously possible as well. The control is additional to the normal mono-stereo switch, activated by the pilot-tone level at the decoder input.

The operation of the variable separation control can best be explained by reference to the complete circuit of the decoder section³, Fig. 3. Biasing arrangements have been omitted for simplicity. The composite stereo signal is applied to the modulator R_1, R_2, Tr_1, Tr_2 and to the amplifier $Tr_3, Tr_4, R_4, R_5, R_6$. The amplifier output currents contain the sum signal as the sole audio components, while the modulator output

contains the difference signal as the sole audio component. The collector currents of the transistors Tr_5, Tr_6 thus contain antiphase difference signals which after passing through the blend circuit $Tr_7, Tr_8, Tr_9, Tr_{10}$ are added to the currents from Tr_3, Tr_4 for matrixing. The blend circuit acts by partially combining, and thus mutually attenuating, the antiphase difference signals according to the control voltage applied. Full cancellation, and hence mono operation occurs with equal conduction in the blend transistors, while full separation is obtained when Tr_8, Tr_9 are taken out of conduction. A particular advantage of this method of obtaining variable separation is that, provided the blend transistors are matched, neither their

base resistances, nor the biasing resistors R_9, R_{10} cause distortion. The distortion components cancel due to the signal currents being in antiphase.

The decoder section is followed by the output amplifiers Tr_{11}, Tr_{12} (only one is shown in Fig. 3) which provide gain and de-emphasis defined by the external components R_{12}, C_2 . Stability is assured by R_{11}, C_1 .

The recommended application circuit is shown in Fig. 4 and the main characteristics are given in the table. Of particular interest are the residual levels of third harmonic in the p.l.l. and decoder section modulating functions, which have been reduced to 40 to 50dB below the fundamental components.

continued on page 81

Fig. 3. Blend circuit acts by partially combining antiphase difference signals according to control signal derived from a.g.c. or S-meter circuit.

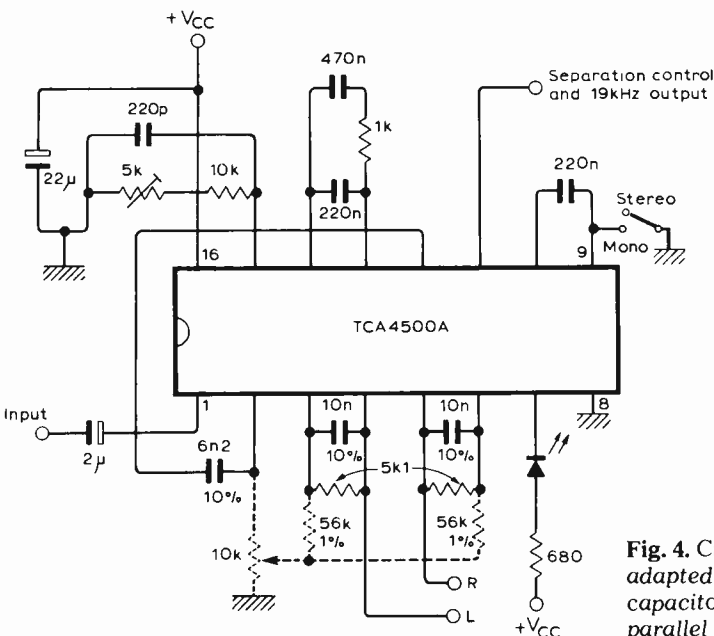
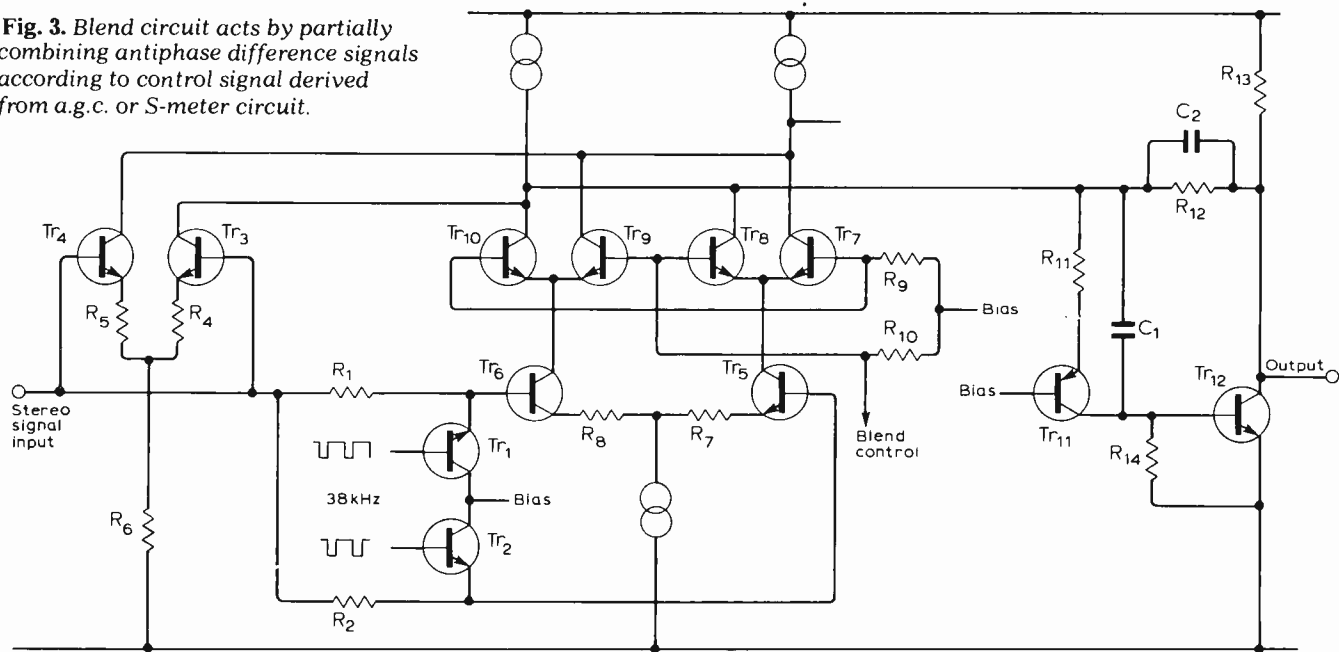

Fig. 4. Circuit giving unity gain can be adapted to give 6dB gain by changing capacitor at pins 4 & 5 to 4.7nF, their parallel resistors to 10kΩ and adding 27kΩ resistors from pins 3 & 6 to earth. Broken lines indicate optional wiring for pre-set separation control.

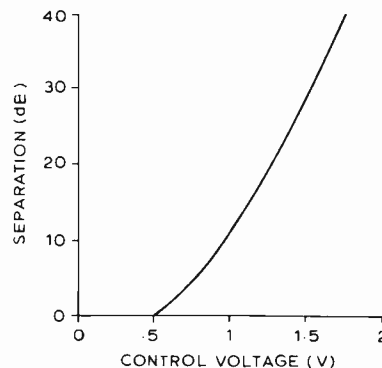

Fig. 5. Separation is $4.3qV/kT$ where V is the control voltage applied across the blend transistor bases.

The most economical, compact and convenient breadboards on the market!

They are the PROTO-BOARD[®] PB-6 and PB-100 solderless breadboard kits.

Buy them, and you are only minutes away from the first circuit.

Contacts are made from non-corrosive nickel-silver alloy, and are reliable for more than 10,000 insertions.

Contact resistance is a mere 0.4 mΩ, insertion force is typically 3ozs per lead, and interterminal capacitance is typically less than 5 pF.

The kits are a must for experimental and development work in digital, audio, RF, video and beyond.

Resistors, capacitors, transistors, DIP's, LED's, transformers, pots, jumpers and any other component with leads between 0.015" and 0.032" will fit the contacts.

You can run circuits well beyond the recommended ambient operating temperature (100°C) if you wish, because the plastic used in the PROTO-BOARD is rated to over 200°C.

The kits come complete with instruction manual, assembly hardware, binding posts, non-scratch feet and the appropriate number of preassembled sockets and bus strips.

The sooner you order, the sooner you'll have that first circuit operating.

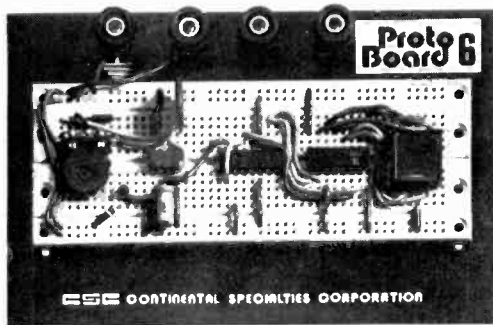
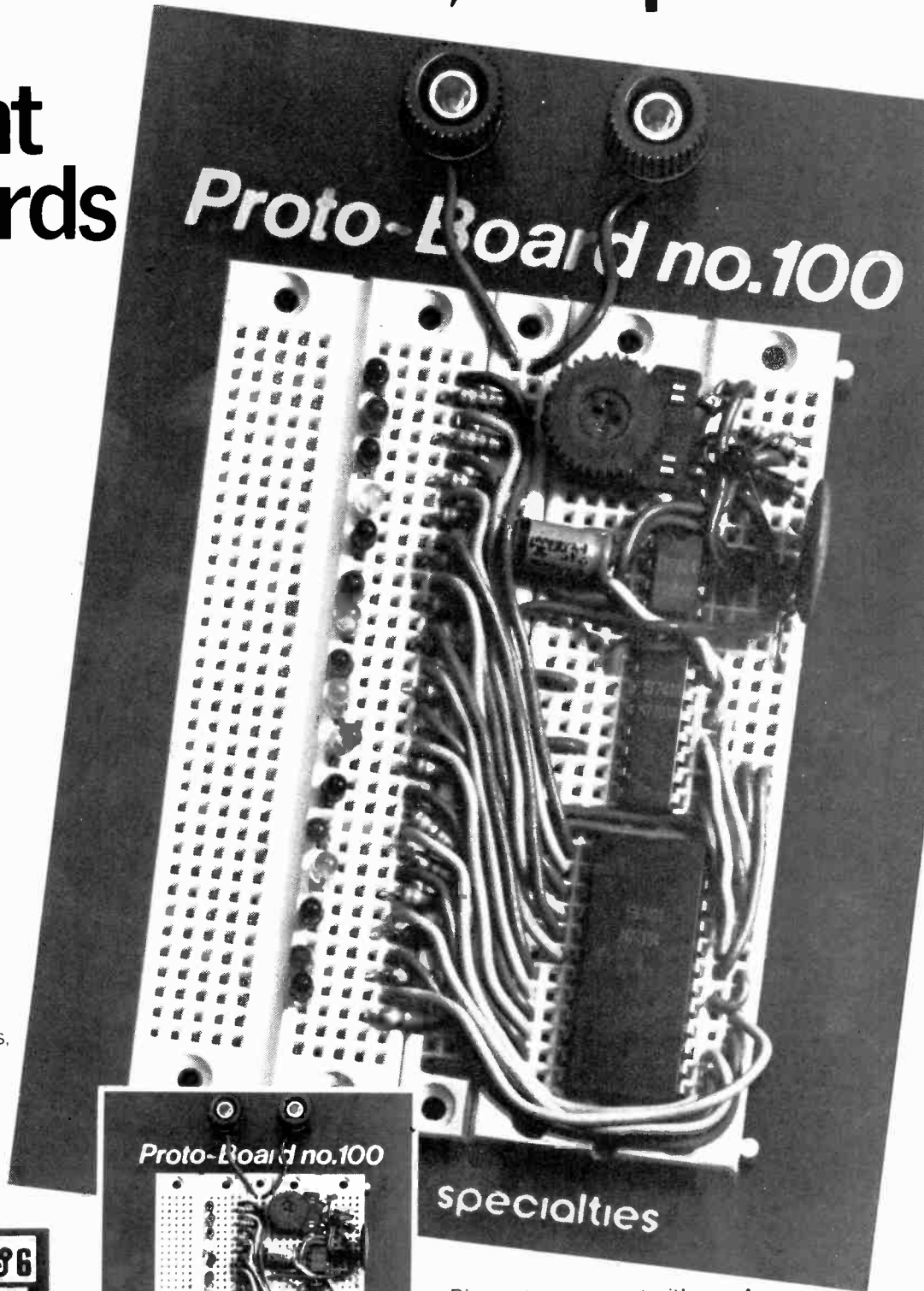

THE PB-6 630 SOLDERLESS CONTACTS. TAKES UP TO SIX 14-PIN DIP'S OR EQUIVALENT IN LARGER AND SMALLER IC'S. FOUR 5-WAY BINDING POSTS. 6" x 4"
ONLY COSTS £11.01

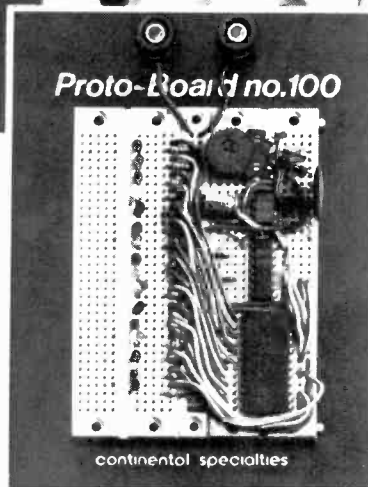

THE PB-100 760 SOLDERLESS CONTACTS. TAKES UP TO TEN 14-PIN DIP'S OR EQUIVALENT IN LARGER AND SMALLER IC'S. TWO 5-WAY BINDING POSTS. 6" x 4.5"
ONLY COSTS £13.82

Ring us (01-890 0782) with your Access, Barclaycard or American Express number and your order will be in the post that night. Alternatively, send a cheque, or postal order (don't send credit cards!) and it still only takes a few days. Otherwise ask for our complete catalogue. Our prices include VAT (8%) and postage. All prices and specifications correct at the time of going to press.



'Wenden' range modular amplifiers

A range of communications amplifiers having power ratings from 15 to 200 watts, plug-in input facilities ensure individual requirements can be provided.

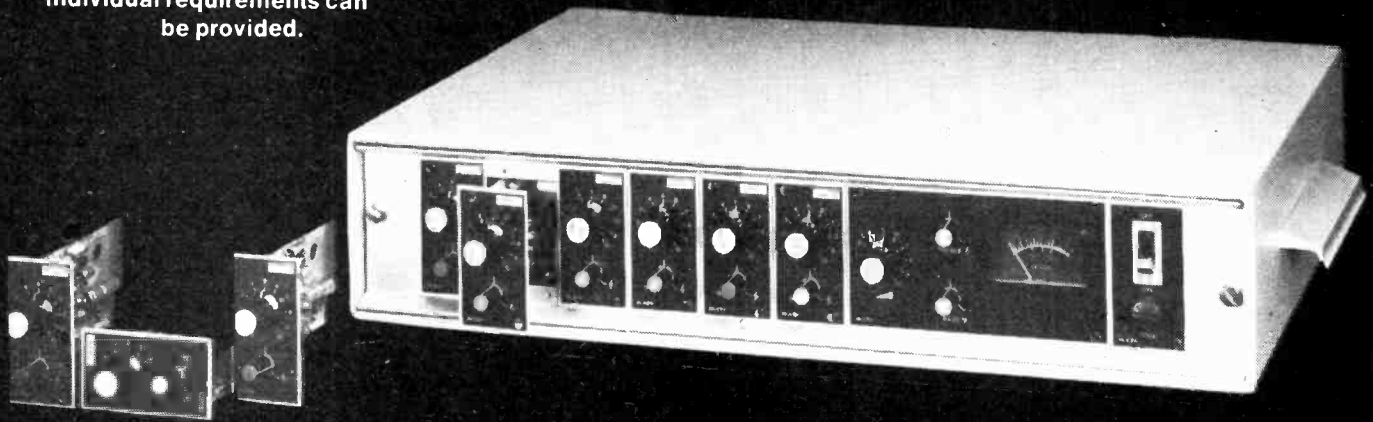

Manufacturers of
sound systems
and electronics

Station Road, Wenden
Saffron Walden
Essex CB11 4LG
Saffron Walden
(0799) 40888

audix



Model 178

Now . . . the next generation of bench DMMs!

Two New Keithley Models offer uncompromising performance and outstanding value!

- Accuracy 3½'s can't match: 0.4% + 1 digit on dc volts and ohms
- Large, bright, 20,000-count LED display that's quick and easy to read.
- Convenient bench size that won't get "lost" yet doesn't crowd.
- Exceptional reliability.

Model 178 offers functions and ranges for most measurement needs 100 μ V to 1200V dc, 100 μ V to 1000V ac, 0.1 Ω to 20M Ω .

Model 179 is a full-function, multi-feature model offering the same advantages as the 178. Plus TRMS AC; 10 μ V Sensitivity; Hi and Lo Ohms; AC and DC Current Yet it's still half the price you'd expect. Only £199.

Both models feature designed-in reliability. Rugged circuits use a minimum of parts — high quality, off-the-shelf parts — carefully assembled and tested by Keithley. Outstanding overload protection and rugged mechanical design keep both units going even after severe abuse. One-year accuracy specifications minimise recalibration costs. A battery option, user installable, gets you off "line" for critical measurements or for field use.

For complete specifications on the 178 and 179, call Keithley Instruments, 1 Boulton Road, Reading. Phone 0734 861287

KEITHLEY

The measurement engineers.

WW-026 FOR FURTHER DETAILS

continued from page 78

The control voltage applied to the blend transistors is derived from a resistor-transistor network, designed to provide a convenient control characteristic. To retain a 16-pin package the blend control terminal has been combined with a terminal which provides a 19kHz output, derived from the v.c.o. for alignment. The blend control operates over a 0 to 2V range, giving full separation at 2V, Fig. 5. If the terminal is left open-circuit, the 19kHz signal appears about a mean level of 4V.

Acknowledgment. I am indebted to H. Maeder of Motorola Semiconductor Inc., Geneva for many useful discussions concerning the digital parts of the circuit.

References

1. Gay, M. J. Monolithic phase-lock loop stereo decoder, *IEEE Trans on Broadcast and Television Receivers*, vol. BTR-17 no. 4 Nov. 1971.
2. Gay, M. J., U.S. patent 3962551. Methods and Systems for Providing Stereo Decoding Signals.
3. Gay, M. J., U.S. patent 3916109. Stereo Demodulating Circuits and Method of Demodulation. □

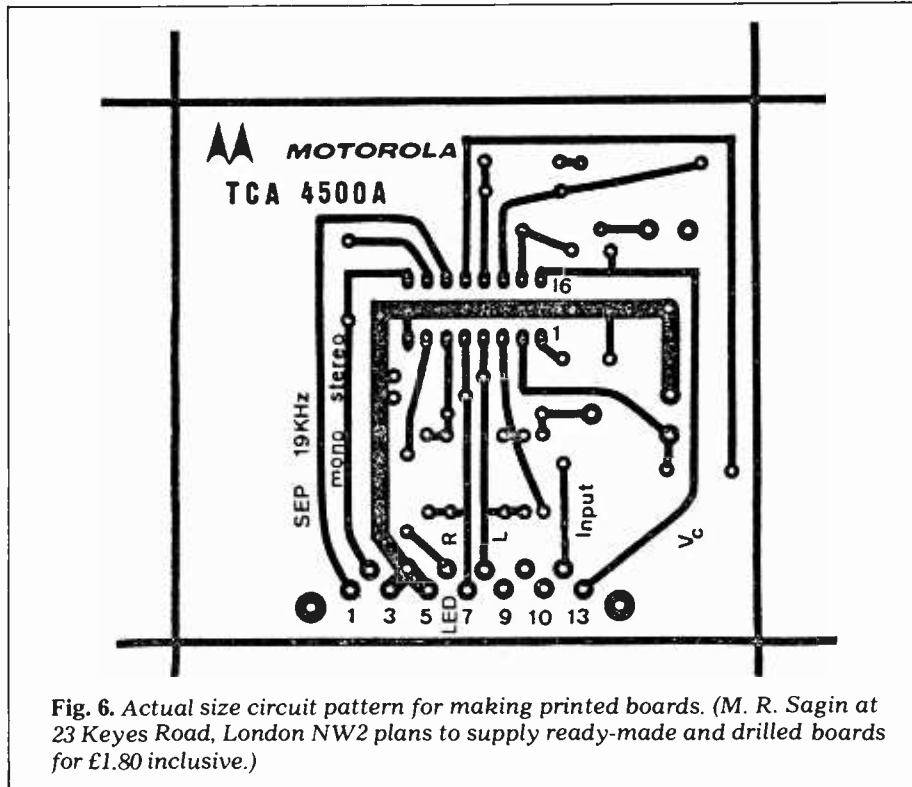

Fig. 6. Actual size circuit pattern for making printed boards. (M. R. Sagin at 23 Keyes Road, London NW2 plans to supply ready-made and drilled boards for £1.80 inclusive.)

Circuit design

by J. Carruthers, J. H. Evans, J. Kinsler and P. Williams

THERE ARE TWO EXTREME WAYS of designing a circuit: most of us use each without depending totally on either. We can look up a standard circuit in a reference book, in an article from a technical journal or in some manufacturer's application note. We should look these up – there is no advantage in foregoing the accumulated experience of others. A good designer is one who pinches the best ideas; it is what he does with those ideas that is important.

The other extreme is the creation of a novel circuit. When we achieve this, rarely enough to be memorable, the results are long-term as well as short. It lights up the mind and the idea can be transmitted and transmuted into useful variants for months or even years afterwards. These gems cannot be planned for or relied on but like Humpty Dumpty's words they have to earn their living. At a lower level we can encourage the appearance of good ideas in our own thinking by exposing ourselves to as many good ideas of others as possible. We should question all assumptions – lateral thinking, the leap-in-the-dark, serendipity are different aspects of this viewpoint.

A frustrating but valuable experience in point was that provided by a chief engineer at a R & D establishment. Most of the projects were long-term with few of the variables quantified at the point where the designs had to start. An outline design would be prepared and a

prototype finished amazingly close to 5 o'clock on a Friday evening. On bursting through the door on the following Monday the first words the chief would spring on his minions were "what happens if...?". It left a lasting impression on those who worked in that department: that even when the prototype was "out-the-door" it was not the end of the idea, that there was still meat on the bones.

It is the experience of circuit designers that the same idea can be worked over time and again, each time yielding fresh insight. Once the grammar of circuit design has been grasped then even a limited vocabulary of particular circuits can cover a wide range of problems.

The argument can be extended. By exposing ourselves to the greatest variety of influences, we increase the chance of spotting relationships between apparently unrelated topics.

This all suggests three interrelated ways of improving our performance: read voraciously; be ready to accept and start operating on any new idea as it appears; worry at each basic idea until it can be fitted into as many other familiar ideas as possible. It was with these feelings that Circards was started some five years ago. To find information on a particular circuit was not too difficult; to find information on the practical implementation of a class of circuits was much harder. The hope was that by collating as many variants as possible

on a given circuit type, that this search could be circumvented or at least shortened for the reader. By including as many suggestions as possible for varying the circuit operation and for adapting it to other purposes, the user could get started faster on his real function than of making the circuit do something for him. Thirdly, as many novel ideas as possible were included; often those appearing in the less familiar journals, sometimes those of the authors or their colleagues. The value of these lie not so much in the particular solutions but in the way they might act as triggers for the user's own insight.

Over these five years the range of circuits touched on has been very wide – arguably too wide in that with necks stuck out that far we were liable to have them chopped-off pretty frequently. There have been innumerable close shaves but we have survived, just. We are immensely grateful for all the encouragement we received. In the process of writing these cards and articles, we have un-muddled much of our thinking on circuits, acquired experience in design that would have come in no other way, and exposed in ourselves further and deeper levels of ignorance than we dreamed possible! It has been mixed pain and pleasure all the way, and to anyone else who feels like tackling a project as big as this (380 cards with 600 graphs and 1200 diagrams and well over 200,000 words) we would say: you'd have to be daft to try. But in this daft world you have to be daft to survive. □

We hope to publish a full list of card titles; meanwhile a copy is available from WW.

Topical techniques

The American Radio Relay League has begun promoting a novel form of speech processing that is claimed to be applicable to all the usual speech modes, including s.s.b., n.b.f.m. and a.m., and capable of reducing spectrum bandwidth by one half. Called "narrow-band-voice-modulation" (n.b.v.m.), the system has been developed by Dr R. W. Harris, University of the Pacific, in conjunction with J. F. Cleveland, WB6CZX and T. Lott, VE2AGF/W6. It was first tested on the 14MHz band in May, 1977. The system exploits the fact that while consonants provide much of the intelligence in speech, the vowel sounds normally dominate by some 20-25dB. In n.b.v.m. transmissions the consonants are emphasized and the signal spectrum folded to occupy only half the normal bandwidth. It is stated that the signal can be resolved on conventional s.s.b. receivers using the lower sideband mode, tuning the receiver 3kHz higher in frequency and adjusting the b.f.o. to give maximum intelligibility. In an introductory article in QST only an outline of the system was given with few specific details.

The Yagi aerial is over 50 years old, although the contribution made in 1937 by Dr George Brown of RCA in emphasising the value of close-spaced elements should not be forgotten. But surprisingly, even today, many designs are developed as much by trial and error as by theoretical calculation. A valuable, although not unchallenged, treatise on practical design was published about a year ago by the US National Bureau of Standards in NBS Technical Note 688 "Yagi Antenna Design" as the result of extremely detailed investigations by Peter Viezbicke. This attempts to present in graphical form the effect of many different aerial parameters on realizable gain, based on measurements made on 400MHz at a model aerial range.

However, Leslie Moxon, G6XN, has pointed out a number of oddities that appear to resurrect some old controversies, including the maximum gain (reference dipole) that can be achieved with two elements, and also the question of optimum length of directors. Peter Viezbicke, in assessing the effect of reflector spacing on measured gain, maximises this to 2.6dB with a single-element reflector, plus an extra 0.75dB with three reflecting elements. Yet there is plenty of reliable evidence to show that a two-element Yagi aerial can provide a realizable gain of 4 to 5dB. Further, the NBS publication puts the maximum realizable gain of a three-element array as high as 7.1dB although again there is much solid evidence suggesting that some 6dB is about as much as one can achieve in practice. Despite its age, the Yagi aerial clearly does not readily yield up all of its design secrets!

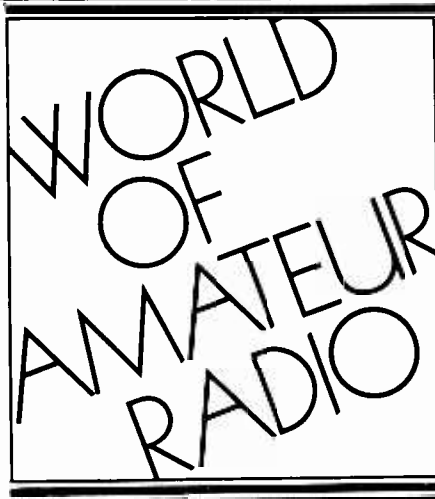

The market place

In virtually every country except the USSR and some (but not all) the Eastern European countries, the amateur market is now dominated by Japanese products. One of the few exceptions to the general rule is, paradoxically enough, in the field of antennas where the Japanese-originated Yagi beams as well as multi-band vertical rods have come in the majority from two American firms: Hy-Gain Electronics and Mosley Electronics. But recently, according to *Time* magazine, Hy-Gain has filed bankruptcy papers and sent its 1,000 employees home, although still fighting to reorganize and stay in business.

The firm's problems seem to stem largely from its involvement with Citizens' Band equipment. In 1977 CB became in the United States a major loss-maker when the FCC authorized 40-channels at a time when stocks of 23-channel equipment were very high. Distributors slashed prices until 23-channel models were being offered at rock-bottom prices on a saturated market, and in the outcome Hy-Gain may not be the only casualty.

Meanwhile ARRL continues to bemoan the drying up of the one-off component suppliers, except at prices that reflect the distributors' view that the paper-work costs more than the profit margin. Disappearance from stockists' lists of the slower-moving items is proving a problem for US publishers, with "component lists" outdated almost before they appear in print. To get on the air at low cost, newcomers are increasingly having to turn to the second-hand market, as hardening rates of exchange continue to raise the price of Japanese equipment in many countries.

In the air

According to *IARU Region 1 News* there are now over 120 beacon stations in Region 1, of which over 20 operate above 1GHz. The use of these beacons for propagation studies is underlined by S. Canivenc, F8SH, the v.h.f. sporadic-E

co-ordinator for IARU Region 1. On June 7 and 11, 1977, the French 50MHz beacon FX3VHF was heard by A. McClellan, VE1ASJ, at St John, Nova Scotia in Eastern Canada. Trans-equatorial reception of the beacon was reported on October 27 by Ray Crac-knell, ZE2JV, at Salisbury, Rhodesia. Transmissions from FX3VHF are continuing in a southerly direction until May 15, 1978 when transatlantic tests are to be restarted. The beacon, on 50.104MHz, has a transistorized power amplifier providing 70 watts r.f. power and about 1kW e.r.p. During the summer of 1977 there were a number of 50MHz contacts over the 8500km path between Japan and California, and F8SH suggests these may have been due to three- or four-hop sporadic-E propagation.

The RSGB has stated that the authorities possess complete information on the "vandals" abusing GB3LO and that most of them are licensed amateurs. The society however emphasises that at some 70 other repeaters, now operational, virtually no problems are experienced.

A 50-yen postage stamp featuring an old horn loudspeaker and a Morse key was issued in Japan last autumn to commemorate the 50th anniversary of the first Japanese private experimental licence in September 1927. There are now over 465,000 licensed amateurs in Japan, although not all represent active stations.

In brief

A change of venue has been announced for the annual convention of the British Amateur Radio Teleprinter Group. It is to be held on Saturday, July 15, at Harpenden Public Hall, Harpenden, Herts, a venue chosen for easy access by rail or motorway. There will be trade stalls, picture tape factory, demonstrations, lectures, etc, and non-members of BARTG are welcome; from 1100 to 1700 hours The Welsh Amateur Mobile Rally is on Sunday, May 21 at the Barry Rugby Football Club, Myneth Duffan, Barry, South Glamorgan with more trade stalls than usual At the turn of the year there were a number of 1.8MHz two-way contacts between the UK and Japan with about ten Japanese stations logged between 1907.5 and 1912.5kHz The rising sun-spot number has brought good openings on 21 and 28MHz bands this winter A satellite ground station is being built at 4UITU, the amateur station located at the ITU Headquarters in Geneva Auroral openings appear to have been more frequent than usual this winter with a number of successful predictions The AMSAT Oscar D satellite tests in December were successful and (as Oscar 8) is due to have been launched in early March.

PAT HAWKER, G3VA

Electronic systems — 8

The transmission and reception of pictures

In previous articles we have seen how audio information may be communicated over vast distances. We are now going to consider the mechanisms for transmitting and receiving visual data, typically in the form of pictures. This important area is manifested in the many forms of television, and also in facsimile — for the transmission of press photographs and pictures from satellites showing weather situations.

WHILE this article is particularly relevant to television, it is perhaps more correct to use the term video to describe the graphic data and signals. Theoretically, a visual scene (picture) is composed of an infinite amount of detail. However, by using artificial aids such as the microscope and the telescope, more of this detail can be seen.

To represent this theoretical picture in all its detail would require an infinite number of picture elements, each capable of varying through a very wide range of intensities. In practice, the number of picture elements and the range of brightness of each element may be quite severely limited and yet still provide sufficient detail to give a satisfactory presentation of the original scene.

If the picture is to be transmitted, one way of doing it is to subdivide it into a grid pattern comprising a finite number of picture elements, as in Fig. 1. The average brightness of each element can be individually measured by a photo-sensor (light cell) and the output of each sensor connected to a receiver which produces a light output corresponding in position and intensity to that element in the original scene. To transmit a picture, a large number of sensors and

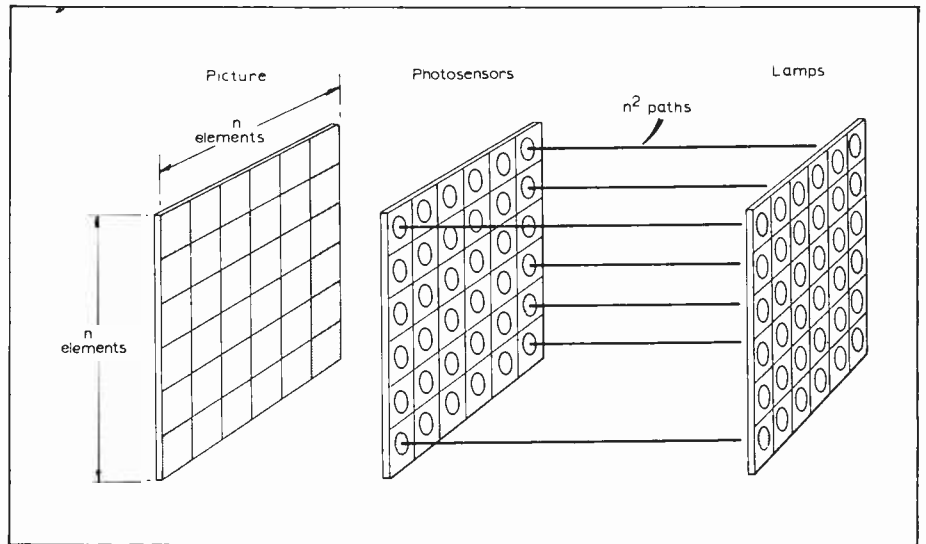

FIG. 1. Representation of parallel video transmission. Each element is independently sensed, transmitted and recreated.

receivers (each with their own transmission connection) would be needed, requiring a large number of parallel transmission paths. Consequently, this system is readily rejected at least on the grounds of the physical bulk of the equipment and its sheer cost.

In practical visual systems, the picture elements are transmitted sequentially over a single intercommunication between transmitter and receiver by using a method called scanning. A simple illustration of this is given in Fig. 2. During a scan, the sensors for each picture element are interrogated one after the other in a regular manner which is typically of the form used with the written word, i.e. from left-to-right and top-to-bottom. At the end of each horizontal line there is a jump to the start of the next and at the end of the picture (bottom, right) the scan jumps back to the top left-hand corner to restart. The zig-zag path traced out during the scan is called a raster. The picture is reconstituted at the receiving end of the link by presenting the sequential brightness signal to an array of light generators in synchronism with the scan at the transmitting end.

One disadvantage of this transmission system is that it takes a considerable length of time to transmit a full picture and if a succession of pictures are required to convey the impression of motion, as in cine, it cannot be transmitted faster than a certain rate.

Television and cine rely on an important feature of the human eye,

FIG. 2. Simple illustrations of raster scanning. (a) shows the raster scan on a display. Dotted lines indicate a rapid jump. (b) shows the vertical scanning of a sequential video-transmission system. Switches on the sensors and lamps run in synchronism. Similar switches are required for the horizontal scan.

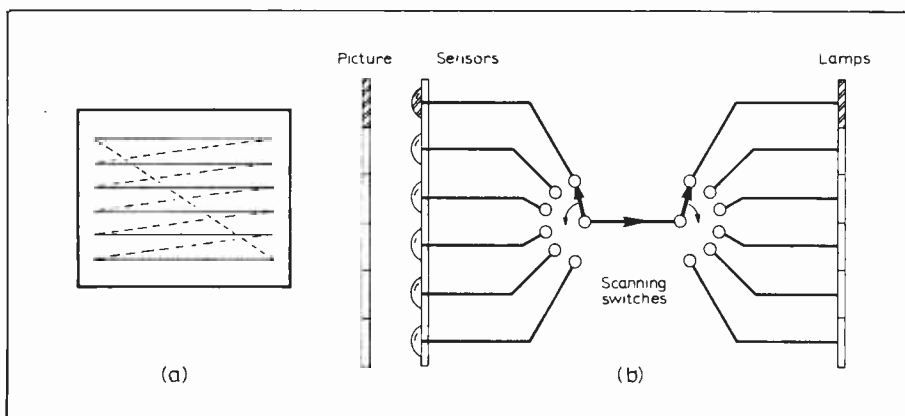

namely, persistence of vision. This permits the impression of continuous motion without jerks or flicker when a section of pictures are presented in rapid succession to the eye. Indeed, each picture may be in a scanned form, as in television, such that even though the line structure traced by the scan may be clearly visible, the sequential addressing of the picture elements will be quite undetectable, providing the scan is sufficiently rapid.

Spatial resolution

If a picture is made up of ten horizontal lines, each containing ten elements, the resultant 100-element picture would have a very low resolution. For good results, a figure of at least 500 lines, with an equivalent horizontal definition, is considered necessary, but it is important to remember that the picture resolution required is a function of viewing distance and the screen size. It is only at and beyond a certain distance from the picture that the individual elements are unresolved and appear to give a continuous effect. Likewise, it is unnecessary and uneconomic to provide a higher definition than prescribed by a situation where a fixed or minimum viewing distance is dictated.

Scanning rate

Associated with the phenomenon of persistence of vision, there is a certain frequency at which a light may be flashed below which the light is seen to blink or flicker, and above which the light appears to be of constant intensity. This frequency is called the flicker-fusion frequency. Although its value depends on the intensity of the light source and varies from person to person, it is usually within the range 30 to 35Hz under normal television viewing conditions. See previous article, Part 7. Its relevance to visual systems lies in the fact that a scan must be performed at a rate above the flicker-fusion frequency to avoid a flickering image, which can be most irritating to the viewer. For this reason, a scanning rate of greater than 40 scans per second—often written as “scanning at 40Hz”—is ideal.

Although in Part 7 it was stated that the flicker-fusion frequency is approximately 70Hz, this figure is the worst case achieved under the conditions of intensity and ambient illumination which yield the highest figure. Visual presentation of information is highly subjective and a scanning rate of 40Hz does, under normal viewing conditions, prove to be acceptable.

Interlacing

We therefore have two requirements for the raster scan. It must comprise at least 500 scanning lines, and the total scan should be completed at least 40 times per second. The current European standards are in fact 625 lines at a scanning rate of 50Hz.

Here the use of the 50Hz mains frequency is intentional since the effect

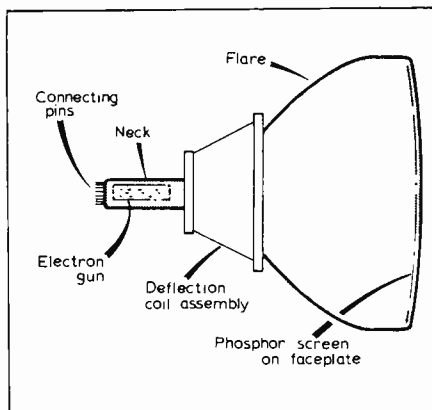

FIG. 3. Structure of cathode-ray tube.

of any mains-borne interference such as hum tends to be minimised.

Although the bandwidth requirements of television signals are considered later in this section, it is necessary at this stage to point out that the bandwidth of a tv signal characterised by 625 lines at 50Hz is approximately 12MHz. This high figure obviously limits the number of broadcast television channels and places severe performance requirements on the electronic circuitry. It would be advantageous on these counts to be able to reduce the bandwidth by, for example, reducing the scanning rate—provided that problems regarding flicker were not encountered. This may be achieved by a process called interlacing.

In an interlaced presentation the complete raster is produced by two successive scans, each providing half of the total number of picture lines. In a 2:1 interlaced scan, the scanning lines of one field interlace in the spaces between the lines of the other field. Each vertical scan of half the total number of lines is called a field, while each full picture, consisting of two fields, is called a frame. The field frequency is retained at 50Hz (in Europe) while the frame frequency, the total picture repetition rate, is now 25Hz. As a result the bandwidth of the video signal is halved to a figure of approximately 6MHz.

Interlacing allows the transmission and reception of good quality pictures within a practical bandwidth at an effectively flicker-free scanning rate. Although only half the picture information is presented at a 50Hz rate by interlacing, this 50Hz figure represents the flicker frequency in spite of the fact that the full frames are produced at the lower rate of 25Hz. Persistence of vision is such that each field is sustained for a short interval before totally decaying and the two fields are seen simultaneously in spite of the fact that they occur at intervals of 20 ms.

Visual display

The requirements for a display for a visual system are as follows. The display surface should ideally consist of a flat screen and, for most applications,

should have a rectangular format. An exception is the radar display, of course. The screen should be capable of resolving a large number of picture elements (typically 500×500), addressable by horizontal and vertical scanning signals. Since the individual elements need not be defined, the active screen surface may be continuous. The light output from each element should be controllable by an intensity signal through a brightness range from total extinction to a maximum intensity appropriate to the application. If the visual system is to be commercially viable, the display, and its associated components, should be inexpensive and reliable.

The Cathode-ray tube

The cathode-ray tube (c.r.t.) satisfies the above requirements and has been recognised as the established visual display over the last few decades. A c.r.t. assembly consists of three integral parts: the screen, neck and flare, as shown in Fig. 3.

The screen, which is nearly rectangular, is coated on its inner surface with phosphor, a compound which emits light when it is bombarded by high velocity electrons. A narrow beam of electrons is generated in the electron gun housed in the tube neck and are accelerated to a very high velocity by connecting the phosphor screen to a high potential (16 to 20kV) relative to the electron gun.

When the electron beam strikes the phosphor screen it produces a bright spot, the intensity of which is controlled by the beam current (rate of flow of electrons) which is, in turn, sensitive to variations in the control potentials associated with the electron gun. For television and most other display purposes, the screen is rectangular in format with an aspect ratio (width-to-height) of 4:3, corresponding to the standard aspect ratio of television pictures. Earlier tubes had a 5:4 aspect ratio, for ease of manufacture, but a complete picture could not be correctly displayed without underscanning in at least one direction. Screen size is described by the diagonal dimension of the screen. □

This series of articles is based on an Advanced Level course for schools and is prepared in consultation with Professor G. B. B. Chaplin, University of Essex.

STEREO FOR TELEVISION?

THE AUDIO systems most in use are those connected to television receivers (radio notwithstanding) and the lamentable output of these is well known. Stranger still is the lack of stereo for all those thousands of musical items televised every year. And lack of stereo may well be considered distortion in these days of i.c.s when the price of a receiver is reviewed.

It is high time that a modified Zenith-GE pilot tone system be introduced. F.m. standards need not necessarily be maintained. A clean flat signal to some 11kHz with some 40dB of stereo separation would not make tv set design unnecessarily difficult. Considering decoder degradation some 1% distortion and 30 dB of separation could well be achieved at the receiving end and thus stay within the limits of the tolerable, and this with a reasonable signal-to-noise ratio.

I suggest your journal runs a competition for the best specification of a modified Zenith-GE system suitable for use with a 625-line tv system. It would surely highlight the receiver problems involved and could well bring decent tv audio one step nearer. May we all live to hear it.

Peter Hirschmann
Haifa
Israel

MYSTERIES OF SPORADIC E

PAT HAWKER wrote in your February issue about the mysterious Sporadic E. Readers might like to know what has been learned, from a combination of ground-based and rocket observations.

Sporadic E was first seen to occur in the way it does, that is as very thin intense layers of ionisation, by a British Skylark rocket flown from Woomera in 1958. By 1966 an association between these layers and sharp reversals in wind direction at high altitude had become recognised. Wind measurements in the very rarefied atmosphere up to 150km or so revealed that a surprising pattern of wind reversals with height can occur; what is more the measurements showed that the pattern often descends slowly over a period of hours, with, for example, a sharp wind shear first appearing above 150km height then moving downwards to below 100km before fading. The cause of this rather unexpected wind structure appears to be the propagation of atmospheric waves horizontally over great distances.

The sharp wind shears are at the root of the sporadic E layers, though in rather complicated a way. The winds, tenuous though they are at such heights, act to move the ions and electrons in the ionosphere across the Earth's magnetic field, but interactions then occur in such a way as to displace the plasma vertically. Where strong wind shears of the appropriate sense exist the plasma is squeezed into a thin concentrated layer, being moved downwards from above, upwards from below. As the wind pattern descends the layer descends too into an ever denser atmosphere, until finally at a height of about 100km it is brought to a halt.

In a very productive experiment at Woomera in 1971 a Skylark rocket was



launched with a ground-based ionsonde showing a strong layer overhead. Instruments on the rocket measured the exact position of the layer and, something of a novelty, the ambient electric field as well; the wind structure was also charted, in better than usual detail. A very strong wind shear was found, but the layer was not quite where theory required until a correction was applied for the additional constraint imposed on the electrical charges by the electric field.

Sporadic E, then, owes its transient character to interactions between atmospheric waves, the ionospheric E layer and magnetic and electric fields. All but the magnetic field are constantly changing so that the right conditions for layer formation occur — well, sporadically. If the question is asked why the explanation has been so long in coming — I should explain that physicists the world over have contributed to the solution — the answer is that the region concerned, roughly 100-200km above the Earth's surface, is inaccessible to satellites and therefore to regular on-the-spot measurements.

One final point. Were the sporadic E layers to be composed simply of ionised atmospheric gases they wouldn't persist. They are, in fact, composed of ionised metallic atoms, mainly magnesium, silicon and iron, probably the remains of burned-up meteorites. The descending wind shears sweep up the metallic ions and bring them down as Sporadic E layers out of the thermosphere into the lower regions where atmospheric turbulence then churns them away into oblivion. Sporadic E layers seem to be the product of Nature's vacuum cleaning!

E. B. Dorling
Mullard Space Science Laboratory
University College, London
Holmbury St Mary
Surrey

QUESTIONS ABOUT FUSES

THIS is where I stand up and show my ignorance about fuses, perhaps to the amusement of the more knowledgeable ones. I was most interested to read Mr Connor's article in the January issue because, in my work mainly as a designer of electronic circuits and during my university training, I have not had to learn nor have been taught much about these humble components. I sometimes idly wondered how they behaved apart from the fact that they are likely to fuse

if the rated current is exceeded. I have even been confused enough to believe that transient or anti-surge fuses, which I infer are better described as time-lag fuses, were designed to guard against transients. In future I shall try to remember that the obvious assumption that occurs to me because of the names is the wrong one.

I get the impression that, out of the various types, only a limited range (generally unmarked as to their speed of operation) is available to the general public or amateur constructor, presumably due to lack of demand. Perhaps a little technical advertising on behalf of the manufacturers might stimulate designers like myself to use fuses in less conventional applications, especially if they are now being developed successfully to protect semiconductor devices.

I would like to ask two questions of Mr Connor (or of his obliging expert Mr Newbury of Brush Fusegear) which other readers might also be interested in.

First, can he give me some typical examples of the range of speed characteristics available and how these speeds are defined when considering different types of I/t fusing characteristics?

Secondly, is it safe to use fuses in normally pulsed conditions (e.g. without premature ageing and failure) as long as the average power dissipation ($\propto I^2 t/T$) is below the rated value and the pulse width t is somewhat shorter than the pre-arcing time for current I ? I suppose that in this case the speed of operation on a fault current could be limited by either average or pulsed power considerations assuming one effect to be dominant.

P. K. Cockings
Borehamwood
Herts

Mr Connor replies:

I would like to thank Mr Cockings for his letter, but would point out that it was not possible in a short article to cover the points he has raised. I assume his questions refer to miniature fuses of current ratings 32mA to 10A. These are covered by British Standard 4265 and IEC Specification No. 127 which give maximum and minimum pre-arcing times for class F and T types only. The accompanying figure, showing operating speeds of miniature fuses, is reproduced from a recent paper by P. G. Newbery and Prof. A. Wright ("Electric fuses," *Proc. IEE*, 124, 11R, Nov. 1977) which gives a review of all types of fuse at present in use and also refers to future developments. It will be seen that there is a wide difference in operating speed between the super-quick acting (FF) and the

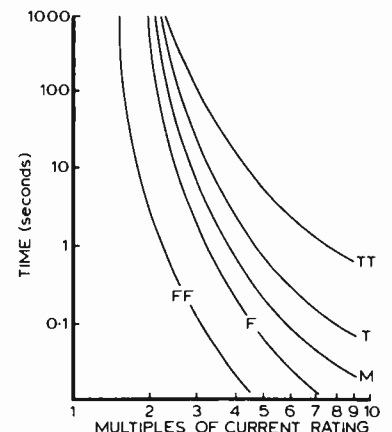

super time-lag (TT) fuse. Intermediate speeds are obtained with the other classes which were referred to in the penultimate paragraph of my article. These differences are achieved by specially designed fuse elements and the wide choice in operating speeds should cover the requirements of most users.

Regarding pulsed loading, manufacturers would, I feel sure, be most reluctant to publish withstand curves for their fuses under pulsed loading conditions. I suggest, however, that most industrial and miniature fuses will withstand indefinitely pulses of 75% of the currents for the corresponding times shown on their t/I characteristic curves. For semiconductor fuses this factor may have to be reduced to 50%; manufacturers should be consulted in cases of difficulty.

I entirely agree with Mr Cockings's remarks regarding technical advertising and hope that his letter will provide the stimulus.
R. A. W. Connor
Felixstowe

RECORDINGS OF WIRELESS TRANSMISSIONS

RECENTLY I have acquired a number of recordings of wireless transmissions of about 1935-36. They are recorded on discs of approximately 7in diameter. The material has a "celluloid" quality, is transparent, and pliable. The recording appears to have been indented on the sides of a shallow groove (as distinct from being cut into that groove), and revolves at 78 r.p.m. It is difficult to get an intelligible playback, having regard to the warped nature of the discs.

Can anyone tell me how and on what machine these recordings would have been made, and the recommended method of playback?

Edward S. Walker
Walsall
West Midlands

IMPORTANCE OF LEVEL IN AUDIO ASSESSMENT

I WAS very interested in your report on the hi-fi rumpus in the February issue. I am a little worried, too, and can sympathise somewhat with the KEF, Quad, Armstrong, B & W group. After all, most of them have been in the field a long time and have gained a lot of experience the hard way. We are not born with experience. On the other hand, I have no doubt that the "youngsters" really did hear differences that others have said should not have been there.

Now because we all learnt at college that any sound level change less than 1dB is not generally audible, we tend to take that as a rough dividing line between good and otherwise. Any modern amplifier should have a response flat within a small fraction of a dB over the whole frequency range, but when tone controls containing pre-amplifiers are added into the chain this is very doubtful unless there is a "cancel" switch position.

Centralized bass and treble controls are no guarantee of a truly flat response, and we have plenty of evidence that departures far less than a dB over the audible range can make very large subjective differences when we listen to music.

Adherence to a strict RIAA curve is also in doubt with many pickup-amplifier combinations.

Now our art has progressed to such high standards that tiny errors in, say, frequency response that we could safely ignore a few years ago because they were anyway swamped by other audible shortcomings can no longer be overlooked. Peter Walker and Peter Baxandall have often stressed the fact that you will hear differences apparently of quality in the sound if there is any difference in level between two systems being compared, even if the response curves really are identical and, of course, both systems running at levels well below limiting.

After all, 1dB is a voltage change of 12% and therefore a power change of getting on for 25%. A 1dB change when listening to a pure tone may not be very noticeable but listening to music with its whole range of frequencies with an ear whose frequency response varies with sound level is a very different thing. Now add to that the tiny deviations from RIAA responses and "level" tone control settings, no wonder we are at odds. Add further dubious contacts in plugs, sockets, switches and leads and it begins to be clear how very careful one must be before one passes judgment, especially in print. At the old Northern Polytechnic, now the Polytechnic of North London, we ran a series of evening courses on audio measurements some years ago. Our opening theme was always: "Are you measuring what you think you're measuring?"

Ralph L. West
Villereál
France

THE FLIGHT FROM REASON

THE idea that humans have occult sense-faculties which transcend physical measurement is by no means confined to the reviewers of amplifiers: people near New York airport lately complained that Concorde's intolerable noise was of the kind that did not affect a noise meter. All such beliefs are irrational, but it is impossible to persuade those who hold them that they may be mistaken. The only thing one can do is to insist that they are not allowed to design their own subjective experiments, if only because their beliefs so often go with limited technical understanding. Equally, nobody should take any notice of what they say unless those skilled in the design of subjective experiments have been let loose on them: unless observers are kept quite separate from the equipment they are examining their results cannot be reliable.

I myself suffered similarly when scientists insisted that visual judgements of brightness contrast could never be reconciled with physical photometric measurements. For six years it was impossible to persuade them that their sophisticated statistical analysis could not compensate for the variations introduced by the erratic experimental conditions they

had elected to adopt. But eventually pure chance made modifications essential, and it at once became clear that under correctly designed experimental conditions visual and physical measurements were identical. Even so, I am not certain whether the scientists really believe this

If readers think this last surprising, let them recall that Sir Arthur Conan Doyle was convinced that Houdini and Maskelyne were not really conjurers, but powerful mediums who prostituted their occult talents to make easy money.

P. C. Smethurst
Bolton
Lancs

AUDIO EQUIPMENT REVIEWS

IT IS SAD to see an internationally respected technical journal such as *Wireless World* descend to the level of village pump gossip. But given that gossip has a place in human affairs, the facts at least should be correct.

The news item "British hi-fi scene drama" in the February issue gives a very slanted view of a recent occurrence by suggesting obduracy, conspiracy and threats in matters of reviewing. So far as KEF Electronics is concerned, and I cannot speak for any other, there has been no change of policy. We continue to co-operate with the international consumer press and to provide products for *bona fide* tests on request. Several recently published reviews of KEF products bear witness.

In the matter of *Hi-Fi Choice*, staying out of a current large scale test of loudspeakers was my personal decision. I was initially asked to make laboratory facilities available for, and later to lend products to, a proposed test involving about sixty different pairs of loudspeakers. The timetable covered a period of six to eight weeks. I refused to accede to the first request on the grounds that it could have been unfair to our competitors. Argument about the veracity and validity of measurements and merit ratings would inevitably have arisen. In any case, our laboratories are in constant use and we could not tolerate the disruption. At the same time I objected to the proposed use of other manufacturers' facilities for similar reasons. It is my firm belief that the press should operate quite independently in the public interest.

So far as such large scale tests are concerned, I do not believe that they can be conducted fairly and effectively in present circumstances. Bearing in mind that we have an extremely experienced team at KEF Electronics, backed up by facilities of the very latest type, I would allocate a period of four or five months to this kind of evaluation. Yet we are seriously asked to believe that one man working with borrowed equipment and on a shoestring budget can accomplish a miracle in less than two months. I feel very strongly that such pseudo-scientific testing can only mislead the readers and serves no useful purpose in the long run.

I would like to make it clear that I am not against reviewing in the general sense. Competent evaluations fairly assessed can be both interesting and informative. However, when tests are carried out on an impossibly vast scale and taken to the point of de-

signating best buys, they become nonsense. In the case under discussion, even the name of the magazine is nonsensical since evaluation is concerned with matters of fact, whereas choice is subjective and must take account of the users' needs and circumstances.

Raymond E. Cooke
KEF Electronics Limited
Tovil
Kent

RADIO CLYDE IN SOUTH AFRICA

I WAS interested to read in your February issue (p.30) of Radio London's QSL report from South Africa.

Please find enclosed a postcard received here at Radio Clyde of a reception report also from South Africa. This seems even more remarkable since not only are we further north by approximately 400 miles but we broadcast on a frequency with a lot less power than that of Radio London. In fact our transmitter power is 2 kilowatts. Not only that, but we broadcast with a directional aerial which points in a north by north westerly direction.

Could the reception have been via two polar points?

John Lumsden
Radio Clyde
Glasgow

Editor's note: The postcard is from a Mr Edwin Rimmer of Cape Town. It refers to reception on 115kHz on January 4 at 0115 to 0150 hours GMT, using a long wire aerial and an HMV receiver.

LINSLEY-HOOD CASSETTE DECK

I WAS interested to read Mr Linsley Hood's comments on the tape head types which are supplied with the Lenco mechanism. While laboratory testing a cassette deck which I had obtained as a kit (from Powertran Ltd) I discovered that the best frequency response that I could obtain using good quality tape, even with low bias levels and large amounts of pre-emphasis, was from 25Hz to 4kHz. The highest discernible frequency was 10kHz, being 11dB below the reference level which I took as being -20dB at 600Hz, which is a fairly standard recording level used by cassette deck manufacturers. A reference tape showed a similar frequency response on replay. The results of these experiments suggested that the tape head, which bore the legend "MC" followed by "B24-05", was at fault. I decided to purchase the head for a very high quality Tandberg machine, assuming that the quality of the head would also be good. A shortage of bias was eliminated by using the Stuart circuit which gives a very high, linear output. These modifications resulted in a frequency response -3dB at 13.5kHz, a considerable improvement.

During the above tests, what appeared to be a major design oversight came to light. In

the original articles it is stated that the maximum record level at 660Hz should be given by 2.25V r.m.s. at the output of IC₃. The record pre-emphasis response requires a minimum of 16dB lift at approximately 14kHz. This is to give the same recorded flux on the tape at high frequencies as that at low frequencies, i.e. to offset "shortcomings in the tape and head characteristics". Since the record level meters are monitoring IC₃, any output in excess of 2.25V, as is required at high frequencies, will appear to the operator as an overmodulation when in fact the tape is nowhere near saturated. Hence we must assume that the overall record level when recording programme material is considerably reduced at all frequencies. Mr Linsley Hood admits this in his postscript and suggests in Fig. 7 that this reduction is about 3 decibels, but there is still a peak of 14dB at 10kHz.

This brings me to my second point, which is that the clipping level of the 741C operational amplifier when run on a power rail of 13.5V is only about 4V r.m.s. Thus even if the meters monitored the input, the record amplifier would not be capable of supplying the 14V r.m.s. or 31V peak-to-peak output which 16dB pre-emphasis requires.

When square-wave optimisation is attempted, a reasonable square wave can be recorded at 0dB. If the output of IC₃ is monitored at the same time, clipping of the "square-wave" overshoots can clearly be seen. The record level must be considerably lowered for this limiting to cease.

As to a solution, reducing the value of R₂₆, which appears to be a simple answer, is self-defeating as this reduces the head current at high frequency, requiring more pre-emphasis. A solution which I have adopted is to supply the record amplifiers and meter circuits with a negative rail and to short out R₁₅, which makes the output symmetrical about 0V, doubling the output range. Unfortunately the output from the replay amplifier to the meter must be disconnected.

These modifications improve the subjective quality quite considerably.

C. W. Beal
Bradford 7
West Yorkshire

Mr Linsley Hood replies:

The basic design specification which I set out to meet, for personal reasons, was that of a recorder which would operate from the 13.5V (nominal) output of a 12V battery. Using a 741 type operational amplifier in the "record" circuitry would therefore allow an output into a high impedance load of some 3V r.m.s. with low distortion.

The inductance of the heads was quoted as 130mH, which would have an impedance of 9.8kΩ at 12kHz, the intended upper frequency limit of the system, and the head saturation level was quoted as 0.126mA. Empirically the saturation level for several standard quality "low-noise" cassette tapes was found to correspond to a head current of 60μA at 660Hz. From these figures it appeared that a series resistor of 39kΩ for R₂₆ would provide an adequate safety margin on head saturation or recording amplifier overload, while swamping the effects of recording head inductance at the highest intended operating frequency (phase lag less than 15°).

With the circuit values shown, therefore, the limit on tape remanent flux was imposed, as intended, by the characteristics of the tape

itself, rather than by the circuitry of the recorder or the characteristics of the recording heads.

With regard to the effect of the recording pre-emphasis on the amplifier output, it is self-evident that in any system of this kind — where pre-emphasis is employed — if the programme material contains a uniform distribution of signal frequencies, the high frequency signals impose the recording level limit, and the low frequency ones will be present at a substantially lower level.

This is a fact of life — not a design shortcoming which I "admit". Fortunately, the recording level meters respond to the effective signal levels at the output of the recording amplifier, after pre-emphasis, and allow one to judge the extent to which one is overstepping the limits imposed by the flux saturation of the tape.

RADIO ON THE FLIGHT DECK

THANK YOU for the excellent articles by Alan Bramson (January and February), though I must take him to task on "the astonishing pace of aircraft radio development this past 20 years" — unless by "astonishing" he means "astonishingly slow." Doppler and inertial navigation, it must be agreed, fall within the period at least as far as their practical development is concerned but Decca Navigator, Omega, i.l.s. and Flight Director systems are all longer in the tooth than 20 years.

Decca was an immediately post-war development, though one is entitled to ask the connection between the pre-war "Chapman" method, GEE and Decca, all hyperbolic systems with the first two using pulses and the third continuous waves.

i.l.s. was well covered by your contributor, though mention might have been made of the disturbing characteristic of the normal glide slope to plunge to earth at about 150ft altitude.

A forerunner of the Flight Director systems was the Sperry "Zero Reader" which was on sale before 1950 and which combined attitude gyro, compass or directional gyro and i.l.s./v.o.r., really taking the sweat out of a manually-flown i.l.s. approach.

Omega, I suggest, is a tarted-up version of the wartime Loran and so falls outside the 20 years, at least in principle.

I must agree with Alan Bramson that "it would be a very unwise man who claimed an intimate knowledge of what the future holds for aircraft radio." The lesson of the last 33 years, I suggest, is that too much depends on international politics as opposed to technical/commercial merit which can be demonstrated, measured and judged by the laws of physics — and now we have yet another UK/USA battle on our hands, this time over a microwave landing system. All these wrangles not only impose delays in time but impose decisions based on entirely the wrong criteria. Thirty-one years ago we were capable of virtually touching-down on the same square of concrete, every time, after an automatic approach. Now we are back to square one and arguing over the ground radio equipment.

Astonishing progress indeed!
R. T. Townson, RAF (ret'd)
Reading, Berks.

Communications '78

An exposition of communications equipment and systems

THE fourth international communications equipment and systems exposition, Communications '78, is to be held at the National Exhibition Centre in Birmingham from 4 to 7 April. It will be inaugurated by HRH The Duke of Kent. In addition to an exhibition of equipment and systems, a four-day conference, on the themes of PTT telecommunications, fixed and mobile radio communications and defence communications, has been organised by the IEE in association with similar American and European organisations. (See News, March issue for further details.) The exhibition will be open daily from 9.30 a.m. to 6.00 p.m. (5.30 p.m. on the last day) and admission is free. Computer print-outs giving details of products, exhibiting companies and stand locations will be available, on request at the exhibition, to all visitors.

Grampian Reproducers Ltd, of Kingston-on-Thames, will be showing their new sound system, which recently won them a Ministry of Defence order worth £320,000. According to Grampian, a quantity of the systems will be used by the British Army at tattoos, displays and other military occasions where they need to provide their own facilities for broadcasting speech and music. The heart of the system is a 100W/100V-line mixer-amplifier which provides a protected, four-mixer input facility — typically two microphone and two auxiliary inputs. Each input has its own volume control, and the amplifier includes a wide range tone control for base and treble. An interlock facility, claimed by the makers to be a unique feature of the amplifier, enables two amplifiers to be used together to provide an 8-input/200W output capability. Included in the system are three microphones, having different response characteristics, four re-entrant horn units, four line-source column loudspeakers, and eight heavy-duty loud-speaker stands.

Facsimile telecopying equipment will be among the exhibits on the Siemen's stand. Included in these is a new telephoto transmitter, type TS1085, and a laser-based photo receiver, type TM4006, which will be on show for the first time in the UK. The TS1085 telephoto transmitter is a light-weight and compact machine for press, PTT and tv applications. It is suitable for a.m.



The UK/PRC320 manpack, illustrated, is a lightweight h.f., s.s.b. radio station which was designed as part of the British Army's Clansman range of radio equipment. This equipment will be among the products on the Plessey stand. The company also plans to show other Clansman products including a u.h.f. a.m. manpack, a range of v.h.f. antennas, and a hand-driven generator for charging the batteries used in the Clansman radio manpacks. Other products on the stand will include h.f. s.s.b. and v.h.f. f.m. vehicle stations, a v.h.f. f.m. squad radio, weapon control systems, and a range of airborne radio equipment.



Picture shows a 19GHz digital radio transceiver which will be featured on the GEC Telecommunications stand. The antenna, transmitter and receiver are combined in a pole-mounting unit. Also on show will be digital radio systems for the 2GHz and 11GHz bands. In addition to these products, GEC will be putting particular emphasis on fibre-optic transmission and digital muldex and line systems for up to 140Mbit/s. The highlight on their stand will be the SL-1 business communications system. This is a PABX that combines the flexibility of stored programme control (the use of a computer to control telephone calls) with the versatility of digital switching.

or f.m. operation and includes a scanning system with an automatic "black signal" optimization facility. It also has built-in facilities for digital picture transmission and faster drum speeds. The TM4006 is capable of producing pictures of photographic quality. Since this receiver uses a laser technique it allows the development of dry pictures, as compared with most photo receivers which require the incoming picture to be developed wet.

Previously unpublished details of the Ministry of Defence's secure mobile tactical network, known as the Ptar-

migan Project, will be disclosed at the Communications '78 conference. A discussion of the Ptar-migan Project will form the main topic for the conference's final day, which is devoted to defence.

About 100 papers are now being prepared by the IEE for the conference programme, including ones from Belgium, Canada, Denmark, France, Japan, Sweden and Yugoslavia.

List of exhibitors

Action Communication Systems
 AEG-Telefunken (UK)
 AEL Crystals
 Aero Electronics
 AIL Division of Cutler-Hammer
 Air Call
 Airtech
 Ameco (Personnel Services)
 Andrew Antenna Systems
 Antenna Specialists UK
 Aspen Electronics
 Audix Barkway Electronics
 Avey Electric

Bantex
 Barry Research Corporation
 Belling & Lee
 Besson, A. P.
 BICC
 Bird Electronic Corporation
 Boonton Electronics Corporation
 Bunzl Telecomm. Services

C & S Antennas
 Cable & Wireless
 Cablewave Systems Inc.
 Canadian Instr. & Electronics
 Cathodean Crystals
 Chase Electrics
 Clarbrook Engineering Co.
 Codex Corporation
 Cole Electronics
 Collins Group Rockwell Intern'l
 Collins Radio Co. of England
 Comelit, of GTE Telecomm's
 Commercial Cable Co.
 Comm's Access. & Equip.
 Communications International
 Computer and Systems
 Engineering
 Computer Transmission
 Consumer Microcircuits
 Cooke Engineering
 Cossor Electronics
 Crystallate (Holdings)
 Cyfas

Danbridge UK
 Data & Control Equipment
 Dataplex
 Decca Communications
 Defence Magazine
 Delta Electronics Inc.
 Derby Automation Consultants
 Dictaphone Co.
 Dielectric Communications
 Digi-Log Systems Inc.
 Digitech Data Industries
 DMW Associates (Electronics)

Ebonestos Industries
 Elcom Systems Inc.
 Electro-Mechanics Company
 Electronics Weekly
 Elmi AS
 Essco Collins
 Euro-Electronic Instruments
 Evans, F. W.

Farnell Instruments
 Feedback Instruments
 Ferranti
 Financial Times
 Francis & Lewis
 Frederick Electronics Corp.
 Frequency Electronics Inc.
 Future Film Developments

GEC—Telecommunications
 —Marconi Electronics
 —Marconi Communication
 Systems
 —Eddystone Radio
 —Mobile Radio
 —Marconi Instruments
 —Marconi Space and De-
 fence Systems

General Audio & Data Comm's
 General Telephone & Electronics
 Grampian Reproducers
 Granger Associates
 Green Electronics & Comm's
 GTE Communications Products

Halcyon Communications
 Harmer & Simmons
 Harris—RF Comm's USA
 Hatfield Instruments
 Hayden Laboratories
 Hewlett Packard
 Highland Electronics
 Home Office
 Horizon House International

IAL Group
 —Communications Services
 —Computer Systems
 —Data Communications
 —Digital Systems
 —Park Air Electronics

Ibex Telephones & Telecomm's
 IBM UK
 Imhof-Bedco
 Informer Inc.
 Inst. of Electrical Engineers
 Interface International
 International Broadcast Eng.
 Intern'l Manag. & Operat. Sys.
 Interphone
 InterScan Comm. Systems
 Interstate Electronics Corp.
 IPC Electrical-Electronic Press
 Italtel Societa Italiana Telecomm
 ITT Business Systems

Jaybeam
 Juniper Journals

Kabel und Metallwerke GHH AH
 KDI Pyrofilm Corporation
 Krone GmbH

LDV Electro Science Industries
 Lero Electronics
 Lero Engineering
 Lero Telecommunications Co.
 Lion Systems Development
 Logica

MCP Electronics
 MEL Equipment Co.
 Membrain
 Metex Corporation
 Microwave Associates
 Millbank Electronics Group
 Ministry of Defence
 Minister Automation
 Mitel
 Monks, Keith (Audio)
 Morse Equipment
 Motorola
 Motorola Electronics
 Muirhead Data Communications
 Mullard
 Multitone Electric Co.

Narda Microwave Corporation
 Neumann Comm. Systems
 New Electronics
 Newport Instruments
 Norlin Communications
 Nuclear & Silica Products

Olektron Corporation
 Olivetti, Ing.C. & Co. SpA

Pacific Measurements Inc.
 Panorama Antennas
 Panorama Radio Co.
 Petters Power Generation
 Pilkington PE
 Pirelli General Cable Works
 Plantronics Inc.
 Plantronics SA
 Plessey Group
 —Electronic Systems
 —Avionics & Communica-
 tions
 —Radar
 —EAE
 —Project Ptarmigan
 —Telecommunications
 —Public Telecomm. Sys.
 —Private Communication
 Systems
 —Controls
 —Aerospace
 —Semiconductors
 —Connectors
 —Assessment Services
 —Birkbys Plastics
 Post Office Telecommunications
 Precision Metal Spinnings
 Pye Business Communications
 Pye TMC

Racal Electronics
 —Amplivox Comm's
 —Antennas
 —Automation
 —Communications
 —Data Instruments
 —Datacom
 —Group Services
 —Milgo
 —Tacticom
 —Thermionic
 —S. G. Brown Comm's
 —Modern Aerials

Radio Systems (Enfield)
 Radio Masts
 Rank Telecommunications
 Rathdown Industries
 Raytheon Cossor Data Systems
 Redifon Telecommunications
 Roditi International Corp.
 Rohde und Schwarz GmbH
 RFL Electronics

Sagem
 Salford Electrical Instruments
 Scientific Control Systems
 Security Systems International
 SE Labs (EMI)
 Service 800 SA
 Shure Electronics
 Siemens
 Southcom International Inc.
 South Midlands Comm's
 Spectronics
 Sperry Gyroscope
 Spinner GmbH
 Standard Telephones and Cables
 Sunair Electronics
 Systems Designers
 Systems Reliability
 Systron Donner

Tandberg Radiofabrikk AS
 Tannoy Products
 Technical Comm's Corp.
 Technical Material Corporation
 Technology for Comm's Intern'l
 Tekelec Airtronic
 Telecommunications
 Telecommunications
 Telemit Electronic GmbH
 Telephone Rentals
 Telepower Systems
 Teletprinter Equipment
 Telex-Verlag Jaeger & Wald-
 mann
 Thomson-CSF
 Thorn-Ericsson Telecomm's
 Toa Electric Co.
 Transco Products Inc.
 Transtel Communications
 Trend Communications
 Trio Laboratories
 TRT
 TRW-Composants Electroniques
 —Electronic Functions
 —Globe
 —Semiconductors Inc.
 —UTC Transformers
 Tungstone Batteries

Uher

Vanderhoff Communications
 Varta (GB)
 Vero Electronics

Wandel und Goltermann
 Watkins-Johnson
 Webster Electronics
 Westcom UK
 Western Electronics (UK)
 Whitton Press
 Widney Dorlec
 Wireless World

NEW PRODUCTS

Shortwave receivers

Two radio receivers, introduced by National Panasonic, have been designed specifically for shortwave listeners. The Model RF-2200 is an eight-band portable priced at £134.95. It covers frequencies in the medium-wave, shortwave and f.m. bands. Tuning is by a two-speed tuning knob coupled to a band dial having 10kHz divisions, and two crystal markers at 50kHz and 125kHz. Its double-superheterodyne circuit and wide-or-narrow bandwidth selection ensure high selectivity. A b.f.o. is also provided for the reception of s.s.b. and c.w. The Model RF-4800, illustrated, is suitable for the radio amateur's shack and is a ten-band communications receiver priced at £319.95. The tuned frequency is indicated on a l.e.d. digital display. The ten bands cover the long-wave band from 145 to 410kHz, the medium-wave band from 520 to 1610kHz and the shortwave band, split into seven smaller bands, from 1.6 to 27.3MHz. A meter allows the receiver to be tuned for optimal signal strength. Other features include an antenna trimmer, a gain control, a b.f.o. and mode selection. The maximum variation in frequency is claimed to be only 500Hz during any 30 minutes after the warm-up time. National Panasonic (UK) Limited, 107 to 109 Whitby Road, Slough, Bucks SL1 3DR. WW301

Portable noise analyser

The SA-24 analyser has been designed primarily for the real-time analysis of noise and vibration. It is a portable instrument suitable for measuring the frequency distribution of noise, on-site. Twenty-five, or nine, frequency bands, according to the filter selected, are displayed on a c.r.t., and each band can be read directly in dB (normalized to a preset, calibrated datum). The display appears as vertical bars, each one representing the noise level of a discrete frequency band, so that a total graphic

representation of the entire noise spectrum emitted from a test subject is obtained. A hold button freezes the display when it is required to observe the spectrum pattern in detail, while an automatic hold stops the display when analysis of impulsive noise or vibration is undertaken. The SA-24, made by Rion in Japan, can operate from its own internal, rechargeable batteries, an external 12V direct-voltage source, or from the mains, as required. Outputs may be recorded on a high-speed recorder. Computer Engineering Limited, Wallace Way, Hitchin, Herts. WW302

I.f. filters

The Toko type LFY filter is a four section miniature ladder device encapsulated in a plastic case measuring $8 \times 7 \times 7$ mm. Centre frequency is 445 ± 1.0 kHz and the bandwidth at -6 dB is $F_c \pm 3$ or

6kHz minimum for the B and D types respectively. Type CFM2 is a two element ceramic filter measuring $7.5 \times 3 \times 9.5$ mm. Centre frequency is also 455 ± 2 kHz and the bandwidth at -6 dB is 4, 6, 8, 19, 12kHz for versions A to E respectively. Centre frequencies of 452, 460, 468 and 470kHz are also available. Ambit International, 2 Gresham Road, Brentwood, Essex CM14 4HN. WW303

Portable test equipment

Three precision measuring instruments, available from H. W. Sullivan Ltd, have been designed for both indoor and outdoor use. The model T2900, shown, is a portable, battery-powered megohmmeter which replaces the model 29A (the 20 million megohmmeter, as it was called). It may also be used as a picoammeter, d.c. voltage source or high input-resistance d.c. millivolt-

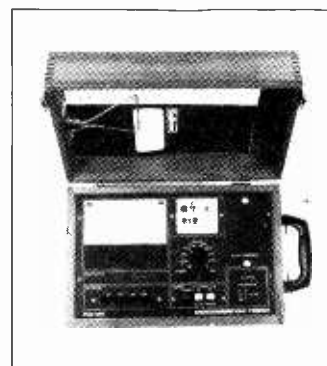

meter. The instrument has eight ranges covering from $100k\Omega$ to $100T\Omega$ for test voltages of 100, 250, 500 and 1000V. Current measurements may be made from 100pa to 1mA full scale, in eight ranges. The second instrument, type 3335, is a d.c. millivoltmeter and null detector. It has three linear voltage ranges of 100 μ V, 1 mV and 10mV full scale and three logarithmic ranges. The full scale accuracy is $\pm 5\%$ and the resolution on the most sensitive range is 2.5μ V/mm of the mirrored scale. The third instrument, T1190, is a resistance bridge having an accuracy of $\pm 0.1\%$ and a range from 0.001 to $10M\Omega$. This bridge may be used for Murray and Varley loop tests and as an accurate decade resistance box. H. W. Sullivan Limited, Archcliffe Road, Dover, Kent CT17 9EN. WW304

Audio test set

A test set, designated the TTI 1120, measures the transmission level, frequency, noise and weighted noise of audio frequency channels and systems. The set, which has been manufactured to CCITT specifications, includes a micro-processor and memory and, in addition to controlling measurement and transmit functions, tests all major instrument components automatically and gives the results on an alphanumeric display. This self-diagnosis takes only 12s. The unit's oscillator may be tuned over two bands (50Hz to 4kHz and 1kHz to 20kHz), or used in a fixed push-button mode at predetermined



WW301

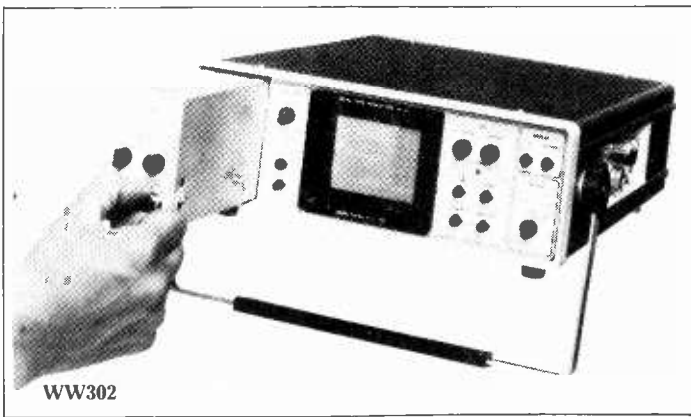

WW302

frequencies. Level measurements are autoranging from -50 to $+10.5$ dBm and the noise readings may be made from -90 to $+10$ dBm. Wandel & Goltermann (UK) Limited, 40 to 48 High Street, Acton, London W3. WW305

Cathode ray tubes

A comprehensive range of monochrome, industrial cathode ray tubes, introduced by Impectron Limited, is available with round or oblong screens in sizes from 1.5 to 23in. The tubes also come in a variety of neck sizes and deflection angles. Three different grades of resolution are also available. The first is a tv-grade having a maximum of 500 tv lines, the second is a medium-grade having between 500 and 700 tv lines, and the third is a high-grade having between 800 and 1000 tv lines. The choice of nine different phosphors allows a range of screen colours to be obtained. Impectron Limited, Impectron House, 23 to 31 King Street, London W3 9LH. WW306

Robust digital multimeter

The model DA116, from Avo, is a general-purpose digital multimeter which is similar in mechanical design to an analogue instrument, in particular the well-known Avo model 8. It has a similar mode of operation to the model 8, and it is also very robust. The display is of the liquid crystal type, giving a long battery life, 13mm high characters and a wide field of view. It also has easily recognisable characters which, it is claimed, may be read in all ambient light conditions. The instrument employs large scale i.c.s. and its a.-to-d. converter is a single i.c. which uses a dual-slope technique with automatic zero correction. The DA116 enables voltage measurements to be made for both a.c. and d.c. from 200mV to 1kV full scale, and current measurements from 200 μ A to 10A full scale. In all cases the maximum display indication is

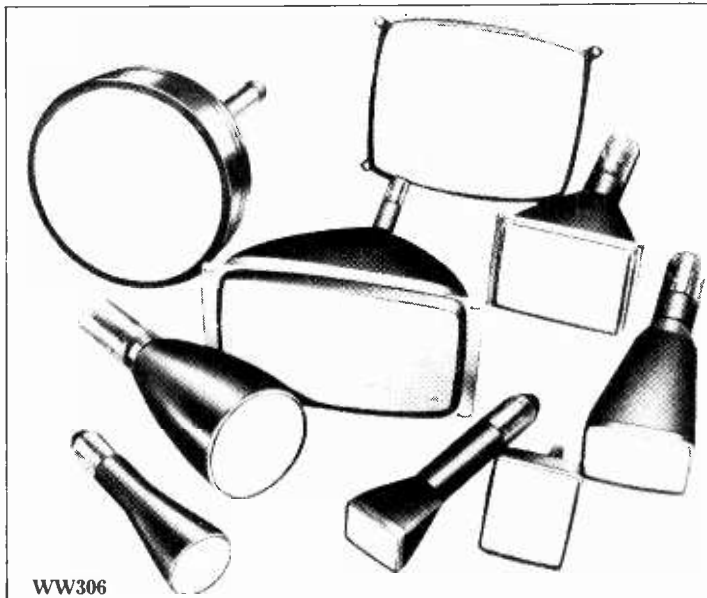

WW306

1999. All current ranges, except the 10A range, are protected by a 2A fuse located in the positive socket. Although the 10A range is unprotected it has a separate socket so that, even if it is damaged, it will in no way affect the rest of the multimeter. Two special ranges have been included in the meter. The first is a high-speed ohms range which is intended to speed up continuity testing. On this range the response time of the instrument and display is reduced by a factor of ten. The second special range can be used to test diode and transistor junctions under forward or reverse bias. On this range the display indicates the voltage drop across the junction for a nominal current of 0.5mA. There are also six ranges giving high-accuracy measurements of resistance up to 20M Ω . Four ordinary SP-11 zinc-carbon batteries are claimed to give life of well over 500h. The DA116 costs £99, including the clip-on case and test leads. Avo say that an additional carrying case and a 30kV d.c. probe will be available shortly. Avo Limited, Archcliffe Road, Dover, Kent CT17 9EN. WW307

Miniature capacitors

Polyester-film and aluminium-foil capacitors, from Nortronic Associates Ltd, are available in values from 0.001 to 0.1 μ F, with minimum working voltages of 160V. These components are offered in tubular cases with axial, tinned copper leads welded directly to the extended foil. For protection, the capacitors have polyester sleeves and epoxy-sealed ends. This covering is unaffected by cleaning solvents, and body markings are permanent, say Nortronic. Nortronic Associates Limited, Archcliffe Road, Nantwich, Cheshire. WW308

Digital panel meters

A range of $3\frac{1}{2}$ -digit panel meters is claimed by its makers, Lascar Electronics Ltd, to break new ground in terms of price, performance and physical size. The standard meter has auto-polarity, auto-zero and an accuracy of 0.1%. They are available with full scale readings of either ± 1999 mV or ± 199.9 mV, with both versions incorporating an overrange input indication — by suppressing the

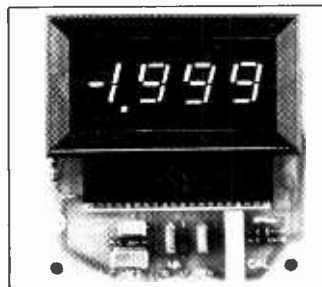

last three digits. Both types can be supplied with either 0.3 or 0.43in red l.e.d. displays, with or without mounting bezels. A programmable left-hand decimal point and a built-in 20-turn calibration preset are included, the latter being accurately set prior to despatch. The meter measures only $3 \times 2\frac{3}{4} \times \frac{3}{8}$ in and is priced (for 100 off quantities) at about £17. Lascar Electronics Limited, P.O. Box 12, Module House, Billericay, Essex CM12 9QA. WW309

U.h.f. transistors

Two u.h.f. transistors, types BFT92 and BFT93, are miniature versions of standard devices. Both transistors are p-n-p complements of the types BFR92 and BFR93, which have been available for some time. The devices, which are intended for u.h.f. and microwave amplification applications, have special connector tabs especially suited to thin and thick-film circuits. Brief details

are as follows for the type BFT92 and BFT93 devices: intermodulation distortion, typically 60dB in each case; noise figure, typically 2.4 and 1.9dB; transition frequency, 18 and 5GHz respectively.

V_{CBO} (max.), 20 and 15V; V_{CEO} (max.), 15 and 12V; I_C (max.), 25 and 35mA and P (total, max.), 180mW in both cases. Mullard Limited, Mullard House, Torrington Place, London WC1E 7HD. WW310

A.c.-to-d.c. adaptor

An a.c.-to-d.c. adaptor, suitable for both laboratory and do-it-yourself applications, can supply 3, 6 or 9V (direct) at up to 200mA from a 220 to 240V, 50Hz input. The appropriate voltage is selected by means of a three-position slide switch on the face of the unit. Supplied with the adaptor is a detachable connecting lead having a four-way connector which will fit most low-voltage coaxial and jack sockets. Two versions of the unit are available. One model has a flying lead for a mains plug and the other has integral square pins. Price of adaptor is about £2. C. Brandauer & Company Limited, 401 to 414 New John Street West, Birmingham B19 3PF. WW311

D.i.l. instrumentation amp.

A high-performance, hybrid instrumentation amplifier, Micro Network's MN2200, is supplied in an 18-pin dual-in-line package. Characteristics of the amplifier include a common mode rejection ratio of 110dB, fixed gains of 1, 10, 100 and 1000, and a gain accuracy better than 0.01% for gains of 1 and 10 and better than 0.1% for gains of 100 and 1000. The input impedance is greater than 1000M Ω and the input offset current is less than 7nA. Pascall Electronics, who supply the device, say that, because the gain resistors in the package are laser trimmed during production, the offset drift with temperature of less than 2 μ V/ $^{\circ}$ C can be guaranteed for practical operating conditions. The laser trimming also ensures a very low initial offset voltage of less than 200 μ V. Also included in the unit is a two-pole Butterworth filter which, by the addition of two external capacitors, can provide a 12dB per octave low pass filter, having a user-selectable 3dB point. Pascall Electronics Limited, Hawke House, Green Street, Sunbury-on-Thames, Middlesex TW16 6RA. WW312

Reactance

When a policeman accosts you as you drive along and asks you to blow up his balloon for him, what is he really doing, apart from applying the kiss of death to a perfectly good night out? Well, of course, he wants to know whether you've been bending the old elbow too much for safety.

But I think that the breathalyser is far too selective a test to be of maximum benefit. No one in full possession of their marbles would condone drunken driving, but there are those who can knock back four or five doubles without turning a hair and others who go cross-eyed after a couple of wine-gums. So why limit the elimination of incompetents to those suffering from alcohol indulgence? The breathalyser attacks only one cause of dangerous driving and is very leaden-footed in its approach.

Perhaps a better way would be a test for a direct cause of bad driving, caused by anything which reduces one's capabilities, including alcohol, but also illness, tiredness, old age, bad temper or just native dreaminess. The one thing that is common to these conditions is a slow reaction time and it would seem to be a relatively simple matter to provide each police car with a little reaction-time tester as an on-the-spot measure, to be followed by a visit to the local station for a more thoroughgoing test of reflexes. Maybe, even at the driving-test stage, candidates could be subjected to such a test, with a view to weeding out those whose future driving careers could profitably be abandoned.

The gadget could be made from three or four m.s.i. chips and a couple of seven-segment displays, battery-powered and pocketable. They shouldn't cost much more than a tenner and police would need no training in their operation. Furthermore, the result would be presented in numerical form.

Mystique-ism

Having spent far too much of Christmas cleaning out the carburettors on the monstrous, money-gobbling family totem that sometimes allows me to ride about in it, I felt reasonably sure, as I gazed with red-eyed hate at the thing, that this was still the trouble. Two hours of immobility on the A1, in biting cold, had not prepared me to face the thinly-disguised contempt of the garage mechanic as he had a quick look at the c.b. capacitor, consigned it to the gutter with a muttered oath and sent me on my way with a warning not to buy any more components made by people of non-European origin. That's almost what he said, at any rate. Apparently he had only to see the outside of the case to realize that it had developed an intermittent short.

Trembling with fury at the car, the mechanic, the weather and whoever invented fireproof pipe tobacco, I



streaked down the A1 in a highly accident-prone frame of mind. Easing into top at around a hundred and eighty, or maybe it only seemed like that, I began wondering why electronics people don't put on a bit more of the style. That garage mechanic had me sized up as a Grade 1 moron within seconds of my calling the condenser a capacitor and obviously considered anyone who couldn't recognize a Hong Kong component as the seat of the trouble ought not to be out alone.

And yet, when he wants the radio repairing and explains that he's sure it's alright, really, because he's only tightened up all the loose screws, including the crumbly grey ones, he doesn't expect to be told he's an ignorant

When the gardener next door pityingly compliments you on achieving a well-nigh perfect lawn-clover fertilizer and dandelion propagator, does it not occur to him he is as a babe in arms when it comes to a quick rescue job on "Match of the Day"?

I suppose it applies to all of us. Maybe all mechanics, fitters, repairmen and what have you should be made to memorize a salutary thought, such as "Before you say what you're thinking, how are you on brain surgery?"

Decline and fall

All designers, but particularly those in electronics, will recognize the feelings of frustration, fury, depression and, sometimes, relief, when overtaken by events. I suppose it's always been the way of the world — the hairy little chap beavering away at carving a wheel from the living rock must have been a bit put out when he saw them being mass produced from tree trunks. But the pace seems to be hotting up now and when one has slogged away for a year or so to design the best low-drift, low-noise, high-input-Z instrument amplifier ever seen, one is very apt to lose one's grundle when an integrated circuit to do the same job is announced just as the design is nearing completion. It's even the same with i.cs. Use a couple of

dozen m.s.i. chips to do a job and you can bet your life that sooner or later someone will produce an l.s.i. chip to do the same job, only more so. All this is extremely vexatious if one is the designer concerned, but more to the point is the waste of effort. There aren't so many good engineers around that their work can be allowed to drain away.

One can hardly expect the makers of i.cs to lose a couple of years' selling lead by announcing their development programme. So it seems that, when designers become too annoyed by being continually up-staged, they will cease to design discrete, s.s.i. or m.s.i. circuitry and the whole of electronic circuit design will pass to those employed by the makers of little black things with legs.

Anyone want to buy a soldering iron?

Time of reckoning

A few years ago, when pocket calculators really hit the fan, and predictions of an innumerate future for our descendants were rife, the debate became fairly heated. Calculators were good if you thought they would instil an interest in arithmetic and bad if you considered them only a way of avoiding it. Now, the talking seems to have stopped, and I am left wondering whether the O-level candidates of 1978 exhibit any marked arithmetical differences to those of 1972 or 1973. To those who claimed that constant use of a calculator would atrophy children's reasoning powers and expose them to disaster if caught calculatorless came the reply that these devices are only an extension of log. tables and the slide rule — both very respectable calculating aids. Not only that, it was said, but you had only to let a youngster loose with a calculator and in no time at all he would develop an inquiring and perspicacious mind. Well, I wonder. Admittedly, my own boy discovered the pattern of sevenths and ninths for himself, but he was so overcome with emotion that he must have decided his calculator was possessed. At any rate, he hasn't used it since.

Are children still taught their "times" tables? My own weren't, I remember, but I suspect that was because their teacher didn't know them either and was far too engrossed in implanting the rudiments of binary notation and Boolean algebra into their pathetically trusting little minds. There must now be a number of school leavers in that locality who can see that 1 and 1 make 10, but who aren't terribly sure about two and two. My wife, who teaches infants, bless her, tells me that the educationists' search for a method of avoiding educating children is gradually calming down a bit and that they are now floating less than a foot off the ground. When their feet touch, that's when I shall stop being resentful at paying my rates.

15 — 240 Watts!

HY5 Preamplifier

The HY5 is a mono hybrid amplifier ideally suited for all applications. All common input functions (mag Cartridge, tuner, etc.) are catered for internally, the desired function is achieved either by a multi-way switch or direct connection to the appropriate pins. The internal volume and tone circuits merely require connecting to external potentiometers (not included). The HY5 is compatible with all I.L.P. power amplifiers and power supplies. To ease construction and mounting a P.C. connector is supplied with each pre-amplifier.

FEATURES: Complete pre-amplifier in single pack — Multi-function equalization — Low noise — Low distortion — High overload — two simply combined for stereo

APPLICATIONS: Hi-Fi — Mixers — Disco — Guitar and Organ — Public address

SPECIFICATIONS:

INPUTS: Magnetic Pick-up, 3mV; Ceramic Pick-up, 30mV; Tuner, 100mV; Microphone, 10mV;

Auxiliary 3-100mV; input impedance 47k Ω at 1kHz

OUTPUTS: Tape 100mV; Main output 500mV R.M.S.

ACTIVE TONE CONTROLS: Treble \pm 12dB at 10kHz; Bass \pm at 100Hz

DISTORTION 0.1% at 1kHz; Signal/Noise Ratio 68dB

OVERLOAD 38dB on Magnetic Pick-up; SUPPLY VOLTAGE \pm 16-50V

Price £5.22 + 65p VAT P&P free

HY5 mounting board B1 48p + 6p VAT P&P free.

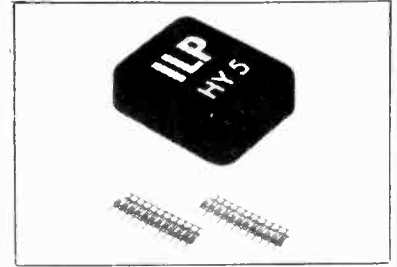

HY30 15 Watts into 8 Ω

The HY30 is an exciting New kit from I.L.P. It features a virtually indestructible I.C. with short circuit and thermal protection. The kit consists of I.C., heatsink, P.C. board, 4 resistors, 6 capacitors, mounting kit, together with easy to follow construction and operating instructions. This amplifier is ideally suited to the beginner in audio who wishes to use the most up-to-date technology available.

FEATURES: Complete kit — Low Distortion — Short, Open and Thermal Protection — Easy to Build

APPLICATIONS: Updating audio equipment — Guitar practice amplifier — Test amplifier — Audio oscillator

SPECIFICATIONS:

OUTPUT POWER 15W R.M.S. into 8 Ω ; DISTORTION 0.1% at 15W

INPUT SENSITIVITY 500mV; FREQUENCY RESPONSE 10Hz-16kHz — 3dB

SUPPLY VOLTAGE \pm 18V

Price £5.22 + 65p VAT P&P free.

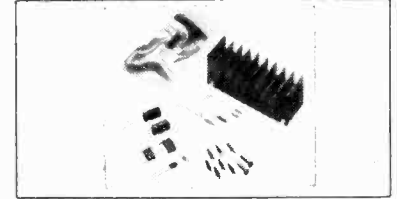

HY50 25 Watts into 8 Ω

The HY50 leads I.L.P.'s total integration approach to power amplifier design. The amplifier features an integral heatsink together with the simplicity of no external components. During the past three years the amplifier has been refined to the extent that it must be one of the most reliable and robust High Fidelity modules in the World.

FEATURES: Low Distortion — Integral Heatsink — Only five connections — 7 Amp output transistors — No external components

APPLICATIONS: Medium Power Hi-Fi systems — Low power disco — Guitar amplifier

SPECIFICATIONS: INPUT SENSITIVITY 500mV

OUTPUT POWER 25W RMS in 8 Ω ; LOAD IMPEDANCE 4-16 Ω ; DISTORTION 0.04% at 25W at 1kHz

SIGNAL/NOISE RATIO 75dB; FREQUENCY RESPONSE 10Hz-45kHz — 3dB

SUPPLY VOLTAGE \pm 25V; SIZE 105.50 x 25mm

Price £6.82 + 85p VAT P&P free



HY120 60 Watts into 8 Ω

The HY120 is the baby of I.L.P.'s new high power range, designed to meet the most exacting requirements including load line and thermal protection, this amplifier sets a new standard in modular design.

FEATURES: Very low distortion — Integral Heatsink — Load line protection — Thermal protection — Five connections — No external components

APPLICATIONS: Hi-Fi — High quality disco — Public address — Monitor amplifier — Guitar and organ

SPECIFICATIONS:

INPUT SENSITIVITY 500mV

OUTPUT POWER 60W RMS into 8 Ω ; LOAD IMPEDANCE 4-16 Ω ; DISTORTION 0.04% at 60W at 1kHz

SIGNAL/NOISE RATIO 90dB; FREQUENCY RESPONSE 10Hz-45kHz — 3dB; SUPPLY VOLTAGE \pm 35V

Size 114 x 50 x 85mm

Price £15.84 + £1.27 VAT P&P free.

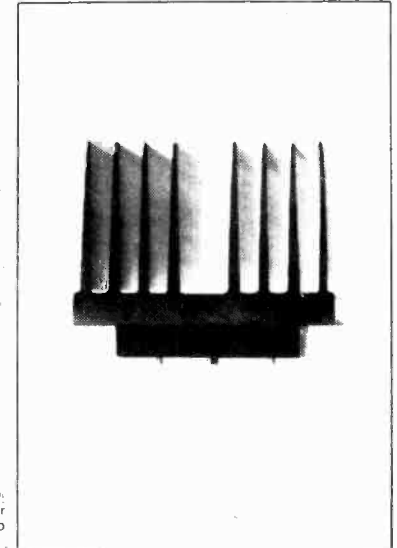

HY200 120 Watts into 8 Ω

The HY200, now improved to give an output of 120 Watts, has been designed to stand the most rugged conditions, such as disco or group while still retaining true Hi-Fi performance.

FEATURES: Thermal shutdown — Very low distortion — Load line protection — Integral Heatsink — No external components

APPLICATIONS: Hi-Fi — Disco — Monitor — Power Slave — Industrial — Public address

SPECIFICATIONS:

INPUT SENSITIVITY 500mV

OUTPUT POWER 120W RMS into 8 Ω ; LOAD IMPEDANCE 4-16 Ω ; DISTORTION 0.05% at 100W at 1kHz

SIGNAL/NOISE RATIO 96dB; FREQUENCY RESPONSE 10Hz-45kHz — 3dB; SUPPLY VOLTAGE \pm 45V

SIZE 114 x 100 x 85mm

Price £23.32 + £1.87 VAT P&P free.

HY400 240 Watts into 4 Ω

The HY400 is I.L.P.'s "Big Daddy" of the range producing 240W into 4 Ω ! It has been designed for high power disco or public address applications. If the amplifier is to be used at continuous high power levels a cooling fan is recommended. The amplifier includes all the qualities of the rest of the family to lead the market as a true high power hi-fidelity power module.

FEATURES: Thermal shutdown — Very low distortion — Load line protection — No external components

APPLICATIONS: Public address — Disco — Power slave — Industrial

SPECIFICATIONS:

OUTPUT POWER 240W RMS into 4 Ω ; LOAD IMPEDANCE 4-16 Ω ; DISTORTION 0.1% at 240W at 1kHz

SIGNAL/NOISE RATIO 94dB; FREQUENCY RESPONSE 10Hz-45kHz — 3dB; SUPPLY VOLTAGE \pm 45V

INPUT SENSITIVITY 500mV; SIZE 114 x 100 x 85mm

Price £32.17 + £2.57 VAT P&P free.

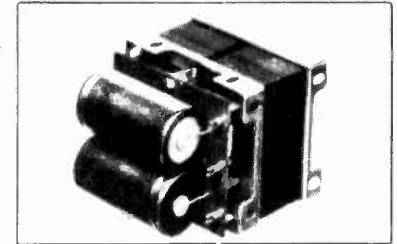

POWER SUPPLIES

PSU36 suitable for two HY30's £5.22 plus 65p VAT P/P free

PSU50 suitable for two HY50's £6.82 plus 85p VAT P/P free

PSU 70 suitable for 2 HY 120's £13.75 plus £1.10 VAT P/P free

PSU90 suitable for one HY200 £12.65 plus £1.01 VAT P/P free

PSU180 suitable for two HY2000's or one HY400 £23.10 plus £1.85 VAT P/P free

B1 48p plus up VAT

TWO YEARS' GUARANTEE ON ALL OF OUR PRODUCTS

I.L.P. Electronics Ltd
Crossland House
Nackington, Canterbury
Kent CT4 7AD
Tel (0227) 63218

Please Supply _____
Total Purchase Price _____
I Enclose Cheque Postal Orders Money Order
Please debit my Access account Barclaycard account
Account number _____
Name & Address _____
Signature _____

WW-001 FOR FURTHER DETAILS

The Only Firm for Quality Audio Kits

HART ELECTRONICS

Are proud to offer the only **DESIGNER APPROVED** kit for the

J. L. Linsley-Hood High Quality Cassette Recorder

Now offered with Super Quality Sendust Alloy Head at no extra cost, and incorporating noise reduction modifications given in the postscript article.



As these circuits are capable of such an excellent performance we feel that it is not sensible to sacrifice this potential by designing a kit down to a price. We have therefore spent a little more on professional hardware allowing us to design a very advanced modular system. This enables a more satisfactory electrical layout to be achieved, particularly around the very critical input areas of the replay preamps. These are totally stable with this layout and require no extra stabilising components. Many other advantages also come from this system which has separate record and replay amps for each channel plugging in to a master board with gold-plated sockets. The most obvious is the reduction of crosstalk and interaction which could cause trouble on a single plane board, with our modular system the layout is compact but there is no component crowding. Testing is very easy with separate identical modules and building with the aid of our component-by-component instructions is childishly simple, but the finished result is a unit designed not to normal domestic standards but to the best professional practice.

All printed circuits are of glassfibre material, fully drilled with a tinned finish for easy and reliable soldering. Component locations are printed on the reverse side of the board and are arranged so that all identification numbers are still visible after assembly.

- 71x Complete set of parts for Master Board, includes bias oscillator, relay, controls, etc. £9 83 + £1 23 VAT.
- 72x Parts for Motor Speed and Solenoid Control for Lenco CRV deck. This is the proper board layout as given in the articles. £3.52 + 44p VAT
- 73x Complete set of parts for stereo Replay Amps, and VU Meter drive £8.12 + £1.02 VAT
- 74x Complete set for stereo Record Amps £6 74 + 84p VAT.
- 75x Complete set of parts for Stabilised Power Supply to circuit given in Article. This uses a special low hum field transformer with better characteristics than the commonly used toroid £8 79 + £1.10 VAT
- 700M2 Individual High Quality VU Meters with excellent ballistics £8 48 + £1 06 VAT Per Pair

700C/2 High Quality Custom built steel Case Complete with Brushed aluminium front plate, mains switch, record microswitch, turned record level knob, plastic cabinet feet, all bolts, nuts and mounting hardware. All necessary holes are punched and all surfaces are electroplated. Complete step-by-step assembly instructions are included. The cover is finished in an attractive black crackle surface. £16 50 + £2 06 VAT

LENCO CRV CASSETTE MECHANISM — Now fitted with Super Quality Sendust Alloy Head.

High Quality, robust cassette transport for Linsley-Hood recorder. Features fast forward, fast rewind, record, pause and full auto stop and cassette ejection facilities. Fitted with Record / play and erase heads and supplied complete with Data and extra cassette ejection spring for above horizontal use. Price £21 60 + £2.70 VAT

Total cost of all parts £83.58
Special offer for Complete Kits £81 50 + £10 19 VAT

Complete with data and set up notes to achieve best results with the Super Head. Optional extra solid teak end cheeks. £3 pair + 38p VAT

Reprint of 3 Linsley-Hood Cassette Recorder articles. 45p post and VAT free.

OTHER CASSETTE SPECIALITIES

LENCO MECHANISMS For industrial or domestic use. We have in stock SPFF, FFR and CRV with DC and AC motors. Mini TB500, 502, 504 and Mini TB 'U' for endless loop cassettes. Send for details Super Quality Sendust Alloy R/P Stereo Head for replacement use. £6.50 + 81p VAT
Set of components and data for optimising L-H Cassette circuits for use with this head. 50p + 6p VAT
Standard Quality Stereo R/P Head. £4 50 + 56p VAT.
Economy Cassette Stereo R/P Head. £2.80 + 35p VAT
4-track Cassette R/P Head. £7 40 + 93p VAT
TEST CASSETTE to enable the user without instruments to easily set up the Head Azimuth, tape speed and VU level. £1 50 inc. VAT
Blank Cassettes, reliable mechanics and Super Ferric Low Noise tape. C90, 80p inc. VAT. C10, 35p inc. VAT.

ALL PARTS ARE POST FREE

Please send 9 x 4 SAE for lists giving fuller details and Price breakdowns

Penylan Mill, Oswestry, Salop

Personal callers are always welcome but please note we are closed all day Saturday

TV GAMES

Fully assembled attractively cased TV games black and white £14.95 Colour £26.95. AY 3-8500 £5.95 only £4.80 for 10th AY 3-8550 £9.95. AY 3-8600 £11.95. Black and white TV games kits. Standard model £8.50. Economy model £4.95. Colour TV games kits standard £17. Economy model £12.45. Colour Generator kit adds colour to most black and white games £7.50. Rifle kit £4.95. Send sae for giant free data



NEW COMPONENT SERVICE

Resistors 5% carbon E12 10 to 10M ¼W 1 ½p. 1W 3p. Preset pots subminiature 0 1W 100 to 4M7 9p. Potentiometers ¼W 4K7 to 2M2 log or lin. Single 30p, dual 95p. Polystyrene capacitors E12 63V 22pf to 9200pf 3 ½p. Ceramic capacitors 50V E6 22pf to 47000pf 3p. Polyester capacitors 250V E6 01 to 1mf 5 ½p, 15 22 33mf 7p, 47mf 11p. Electrolytics 50V 47 1 2mf 5p, 25V 5 10mf 5p, 16V 22 33 47mf 6p, 100ml 7p, 220 330 9p, 470 11p, 1000ml 16p. Zener diodes 400mW E24 3V3 to 33V 8 ½p

MAINS TRANSFORMERS

6V 150mA 94p. 9 0 3V 75mA 84p. 12 0 12V 50mA 94p. 13V ½A £1.10. 6 3V 1 ½A £1.89. 6 0 6V 1 ½A £2.35. 9 0 9V 1A £1.99. 12 0 12V 1A £2.49. 15 0 15V 1A £2.79. 30 0 30V 1A £3.59. 9 0 9V 2A £2.60.

PRINTED CIRCUIT MATERIALS

PC etching kits economy £1.70. Standard £3.82. 50 sqs pcb 40p. 1 lb FeCl1 £1.05. Etch resist pens: Economy 45p. Dalo 83p. Laminate cutter 75p.

S-DECS AND T-DECS*

S DeC £2.23. 1 DeC £3.98. u DeCA £3.97. u DeCB £6.67. 16 di adaptors — plain 99p. With socket £1.91. New S dekit £4.95.

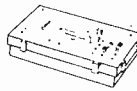

SINCLAIR PRODUCTS*

Cambridge Scientific programmable calculator £13.95. Prog library £4.95. Mains adaptor £3.20. Cambridge Scientific £8.45. Oxford Scientific £10.60. POM35 digital multimeter £25.95. Adaptor £3.24.

BI-PAK AUDIO MODULES

S450 Tuner £21.95. A160 £4.86. PA100 £14.85. MK80 audio kit £36.45. Stereo 30 £17.95. SPM80 £3.75. BMT80 £5.95. Send sae for free data

JC12, JC20 AND JC40 AMPLIFIERS

A range of integrated circuit audio amplifiers supplied with free data and printed circuits. JC12 6 Watts £1.95. JC20 10 Watts £2.95. JC10 20 Watts £4.20. Send sae for free data on all 3 models



FERRANTI ZN414

IC radio chip £1.44. Extra parts and pcb for radio £3.85. Case £1. Send sae for free data

BATTERY ELIMINATOR BARGAINS

TV games power unit stabilized 7 ½V 100mA £3.25. 3-way models with switched output and 4-way multi-jack £3.49. 6V 100mA £2.92. 9 ½V 150mA £3.30. 100mA radio models with press stud connectors. 9V £2.85. 6V £2.85. 1 ½V £2.85. 9V+9V £4.50. 6V+6V £4.50. 4 ½V+4 ½V £4.50. Cassette recorder mains unit 7 ½V 100mA with 5 pin din plug £2.85. Fully stabilized model switched output of 3 ½V 7 ½V 9V 400mA stabilized £6.40. Car converters 1 ½V DC input. Output 9V 300mA £1.80. Output 7 ½V 300mA £1.80.

BATTERY ELIMINATOR KITS

Send sae for free leaflet on range
100mA radio types with press stud battery terminals 4 ½V £1.80. 6V £1.80. 9V £1.80. 4 ½V+4 ½V £2.50. 6V+6V £2.50. 9V+9V £2.50.

Cassette type 7 ½V 100mA with din plug £1.80.

Transistor stabilized 8-way type for low hum 5 ½V £1.80.

Heavy duty 13-way types 4 ½V 6 ½V 7 ½V 9 ½V 11 ½V 13 ½V 14 ½V 17 ½V 21 ½V 25 ½V 28 ½V 34 ½V 42 ½V £4.85. 2 Amp £7.95.

Car Converter kit. Input 12V DC output 7 ½V 9V DC 1A in-rush stabilized £1.95.

Stabilised power kits 3 18V 100mA £3.60. 3 30V 1A £9.95. 3 60V 1A £10.95. 3 60V 2A £13.95.

BULK BUY OFFERS

Minimum purchase of one item £10. SN76023N 79p. ZN414 84p. 4 4MHz crystals 65p. J41 8 di 22p. NE555 3 di 35p. Dalo pens 58p. 2N3055B 31p. 8D131 30p. BC107 7p. BC109 7p. BC212 8p. 1N4002 4.2p. Bridge rectifiers 200V p.v. — 1A 26p. 2A 33p. Electrolytics axial 200mf 40v 36p.

CUT PRICE TELETEXT

Labgear CM7026 ready to use attractively cased complete unit which just plugs straight into the serial socket of the set, giving full colour and requiring no modification to the TV. Remote control page selection £323.

Texas Instruments Tifax Module for the experienced do-it-yourself man £120

SWANLEY ELECTRONICS

DEPT. WW, PO BOX 68, 32 GOLDSSEL ROAD, SWANLEY, KENT BR8 8TQ

Mail order only. Please add 30p to total cost of order for postage. Prices include VAT. Overseas customers deduct 7% on items marked * and 11% on others. Official credit orders welcome



The new SOUNDLEX PPM

- ★ Free standing, ideal for adding to existing equipment
- ★ Scaled in dB or PPM 1-7 ★ Illuminated Ernest Turner meter
- ★ 24V Power Supply also available

Send now for data sheet and catalogue of this and other items in the Soundex range

SOUNDLEX LIMITED

91 Farmer Road, Leyton, London E10 5DJ. Tel: 01-539 4347

WW—048 FOR FURTHER DETAILS

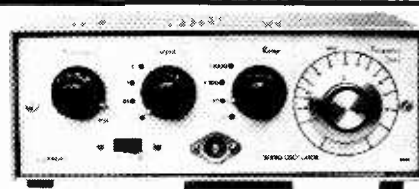

HIGH QUALITY

Very Low Distortion Audio Signal Generators
Ideal Instruments for Hi-Fi testing

Based on Linsley Hood designs

Distortion levels .02% and below .002%.

Frequency range 10hz-100Khz. Output 1v (attenuated).

Standard Model A0113 (Kit £20)

£23.50 .02%

— ditto — but with Push button freq. select.

£24.50 .02%

Standard model but in metal case

£26.50 .02%

Very Low Distortion model (A0146)

£35.00 .002%

— ditto — in Kit Form (less case and panel)

£17.90 .002%

Tax 8% extra. Post Pkg and insurance £1.25.

Other instruments Millivoltmeter, Frequency Meter, Reg. P.S. Units, THD Analyser, Also Hi-Fi Amp Kits 10-100 F.M. Tuners, Kef Speaker Units.

S.A.E. for instrument leaflets to **TELERADIO ELECTRONICS (W.W.)**, 325 Fore Street, Edmonton, London, N.9. 01-807 3719.

3% Measuring Accuracy
 Stabilised Power Supplies
 10 MHz Dual Trace
 10 mV Sensitivity

SCOPEX 4D10A

UK PRICE CORRECT
 AT TIME OF GOING TO PRESS

Now YOU can afford
 the Best at

£180
 UK ex VAT

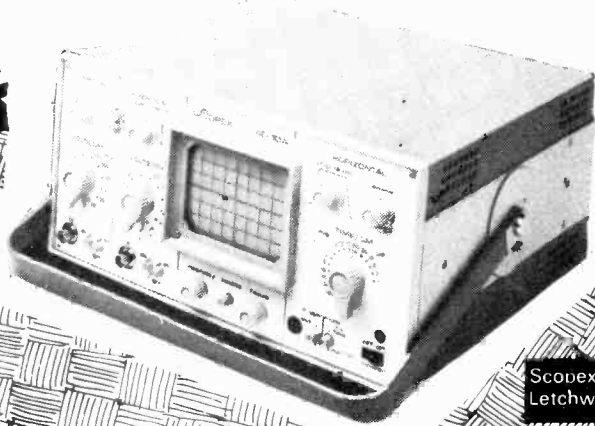

SCOPEX

Scopex Instruments Limited, Pixmore Industrial Estate, Pixmore Avenue,
 Letchworth, Herts. SG6 1JJ Letchworth 72771 (STD 046 26)

WW-063 FOR FURTHER DETAILS

TEN GOOD REASONS FOR BUYING THE NEW FLUKE 8020A DMM.



ONLY
£99
 PLUS VAT

1. 26 ranges of AC/DC volts and amps, ohms and conductance.
2. 0.25% vdc accuracy over 10°C range for 1 year.
3. 'High power' ohms for diode testing.
4. 'Low power' ohms for in-circuit resistance measurement.
5. Conductance ranges allow leakage measurement to 10,000 MΩ.
6. 9v battery gives typically 200 hrs. life.
7. Protected to 250v dc or rms on any range, any function.
8. Protects to 6kv for 10µs on any range, any function.
9. 2 year warranty on parts and labour.
10. Large liquid crystal display.

Harlow(0279)29522

ITT instrument services

Edinburgh Way, Harlow, Essex. CM20 2DF. Telex: 81525

The only way to buy.

WW-019 FOR FURTHER DETAILS



"We think your British speakers
are just wonderful"

The Americans think that, along with our policemen, our British loudspeaker technology is just wonderful. Probably the best in the world.

And who more than Celestion has contributed towards this international recognition?

Our famous Ditton and UL series give you everything you want for the price you are prepared to pay to get the best out of your hi-fi system.

From the small compact bookshelf loudspeaker up to the big Ditton 66,

whatever you choose you get the ultimate in speaker experience with Celestion.

Ask any hi-fi enthusiast and he'll confirm our claim. But first have a look for yourself at the sound we're selling. Send for our literature or visit your local stockist.



Rola Celestion Limited, Ditton Works, Foxhall Road, Ipswich, Suffolk, IP3 8JP.
Telephone: Ipswich (0473) 73131
Cables: Voicecoil Ipswich. Telex: 98365.

Name _____

Address _____

07.08.04

Celestion loudspeakers bring home the world of sound

FULL SPEC. MANUFACTURERS' BRANDED TTL ...
JUST LOOK AT THESE PRICES ...
DON'T HESITATE, ONLY LIMITED STOCKS AVAILABLE!

TTL I.C.s			TRANSISTORS			DIODES		
Device	1-99	100+	Device	Pack of 10	Pack of 100	Device	Pack of 10	Pack of 100
7400	08	07	AF118	4.20	36.00	BAV10	7.50	42.00
7401	10	09	AF124	2.40	20.00	BAV20	7.50	42.00
7402	10	09	AF126	2.40	20.00	BZY88 series		
7403	10	09	AF127	2.40	20.00	2 7V-36V	6.50	50.00
7404	10	09	AF139	3.00	26.00	BZX61 series		
7405	10	09	AF239	3.60	30.00	7.5V-75V	11.00	90.00
7406	25	23	BC107	85	7.50	OA10	4.70	40.00
7408	13	12	BC107B	85	7.50	OA47	7.00	60.00
7409	11	10	BC108	85	7.50	OA90	5.00	40.00
7410	09	08	BC108B	85	7.50	OA91	4.00	30.00
7412	21	20	BC109	85	7.50	OA202/CV8790	2.00	15.00
7412	25	23	BC109B	85	7.50	1N4148	4.00	35.00
7416	24	22	BC139	1.70	14.00	1N4148 (50V)	1.50	10.00
7420	10	09	BC154	80	6.50			
7422	18	17	BC157	1.20	8.00			
7423	20	19	BC159	1.20	8.00			
7426	24	23	BC167B	.80	6.00			
7430	10	09	BC178	1.20	8.00			
7437	26	25	BC179C	1.20	8.00			
7438	25	24	BC182	80	6.00			
7440	11	10	BC182B	80	6.00			
7442	60	50	BC182L	.80	6.00			
7445	75	72	BC182LB	.80	6.00			
7446	75	72	BC183LA	.80	6.00			
7450	11	10	BC183LB	.80	6.00			
7453	10	09	BC184	80	6.50			
7454	10	09	BC184L	80	6.50			
7460	11	10	BC237	80	5.00			
7470	23	20	BC238	80	5.00			
7472	19	18	BC239	.80	5.00			
7473	24	20	BC258B	.80	5.00			
7474	23	22	BC267	1.80	15.00			
7476	25	24	BC303	1.80	15.00			
7481	88	85	BC303-5	1.80	15.00			
7482	60	56	BC304	1.80	15.00			
7486	24	22	BC309A	.80	5.00			
7490	36	34	BCY71	1.10	8.00			
7491	62	60	BD135	2.60	22.00			
7493	37	35	BD136	2.60	22.00			
7494	60	55	BF179C	1.90	15.00			
7496	60	55	BF198	.70	5.00			
74104	45	40	BF336	2.00	19.00			
74118	80	75	BF337	2.00	19.00			
74125	35	32	BF371	1.00	8.00			
74153	50	40	BT 334	1.00	8.00			
74154	1 00	90	BT106	10.00	68.50			
74156	60	55	BTX94-400	40.00	300.00			
74162	70	60	BTX94-600	45.00	310.00			
74164	70	60	C106D	3.60	30.00			
74167	1 20	1 00	ME0413	.90	4.80			
74175	80	70	MJ2955	8.00	75.00			
74195	70	65						
74278	45	40						
74487	30	25						
74154	05	04						

MINIMUM ORDER VALUE
£5.00

LIGHT EMITTING DIODES

Device	Pack of 10	Pack of 100	
125 Red	200 Red	1.40	12.00
125 Green	200 Green	2.00	19.00
	200 Yellow	2.00	19.00

ALL PRICES EXCLUDE VAT

LINEAR I.C.s

Device	Pack of 10	Pack of 100
LM380N 14-pin	6.50	60.00
LM555 8-pin	3.20	28.00
LM741 14-pin	11.20	100.00
LM741 8-pin	2.50	20.00
LM3900 14-pin	6.00	56.00
TBA800	7.00	60.00
TBA810S	8.00	75.00

ORDERING PROCEDURE

Strictly cash with order. Minimum order value £5.00. Post and packing add 25p. Prices subject to alteration without notice.

MINIMUM ORDER VALUE £5.00. ALL PRICES EXCLUDE VAT. NO DISCOUNTS ON SALE PRICES. E. & O.E.

VAT. Please add 8% to all prices except those marked which are 12½%.

EXPORT ORDERS
Minimum order £10.00. Post and packing add £1.00.

AMATEUR COMPONENTS
 ORCHARD WORKS, CHURCH LANE, WALLINGTON, SURREY SM6 7NF
 MAIL ORDER DIVISION OF SEMICONDUCTOR SUPPLIES (CROYDON) LTD.

Z & I AERO SERVICES LTD.

Head Office: 44A WESTBOURNE GROVE, LONDON W2 5SF
 Tel.: 727 5641 Telex: 261306

RETAIL SHOP
 85 TOTTENHAM COURT ROAD, W 1
 Tel 580-8403

R.C. OSCILLATOR G3-36A

Made in USSR

Portable transistorized R.C. oscillator providing sinewave and 50/50 squarewave. Four separate output sockets give attenuation ratio of 1, 10, 100 and 1000. Output 0.5 volts R.M.S. Frequency range 20Hz-200KHz in four bands. Output impedance 600Ω for sinewave and 4000Ω for squarewave. Harmonic distortion 1-2%. Power supplies 200-240V AC.

Price **£37.00**
 Packing and delivery **£2.00**
 (VAT 8% to be added to the above figure)

TAUT SUSPENSION MULTIMETERS

Made in USSR

TYPE	U4313	U4315
Sensitivity D.C.	20.000 op.v	20.000 op.v
Sensitivity A.C.	2.000 op.v	2.000 op.v
D.C. Current	60µA-1.5A	50µA-2.5A
A.C. Current	0.6mA-1.5A	0.5mA-2.5A
D.C. Volts	75mV-600V	75mV-1000V
A.C. Volts	15V-600V	1V-1000V
Resistance	1K-1M	300Ω-500kΩ
Capacity	0.5µF	0.5µF
Accuracy	1.5% D.C.	2.5% D.C.
	2.5% A.C.	4% A.C.

Price complete with pressed steel carrying case and test leads.
 Packing and postage

£17.50 £14.95
£1.50 £1.50
 Plus VAT at 8%

FULLY GUARANTEED

VALVES

0A2	0.55	6J5GT	0.80	EY51	0.60	PL802	2.80
0A3	0.75	6J6	0.55	EY81	0.50	PY31	0.50
0B2	0.60	6L6GT	0.85	EY87	0.50	PY33	0.63
0C3	0.75	6SL7GT	0.70	EY88	0.55	PY80	0.60
1B3GT	0.65	6SN7GT	0.70	EY500A	1.50	PY81	0.70
1R5	0.50	12AL5	0.65	EZ80	0.50	PY82	0.55
1X2B	1.20	12AQ5	0.55	EZ81	0.50	PY83	0.70
5R4GY	1.10	12AT6	0.60	KT66	4.50	TT22	7.80
5U4G	0.60	12AT7	0.50	KT88	5.80	PY500A	1.30
5U4GB	0.95	12AU6	0.65	PC86	0.85	TT22	7.80
5V4G	0.60	12AU7	0.47	PC88	0.85	TT22	7.80
5Y3GT	0.65	12AV6	0.85	PC92	0.85	UAB80	0.58
5Z4GT	0.65	12AV7	1.00	PC96	0.50	UAF41	0.80
6A8A	0.55	12AX7	0.55	PC97	0.95	UAF42	0.70
6AL5	0.65	12AY7	0.85	PC84	0.50	UBC41	0.70
6AK5	0.55	12BE6	0.80	PC85	0.60	UBC81	0.60
6AL5	0.40	12BE6	0.80	PC89	0.75	UBF80	0.60
6AM6	0.70	12BH7	0.75	PC189	1.00	UBF89	0.60
6AS5	0.75	12X4	0.50	PCF80	0.65	UC84	0.75
6AS6	1.00	19AQ5	0.75	PCF82	0.45	UC85	0.55
6AT6	0.75	35A3	0.70	PCF84	0.65	UCF80	0.75
6AW6	0.75	35B5	0.65	PCF201	1.10	UC81	0.65
6AW8A	0.75	35C5	0.70	PCL81	0.65	UCL81	0.70
6AU6	0.50	35W4	0.70	PCL82	0.80	UCL82	0.75
6AW6	0.75	50C5	1.00	PCL84	0.75	UCL83	0.80
68A6	0.45	EA80C80	0.55	PC86	0.85	UF41	1.00
68E6	0.48	EA842	0.70	PC805	0.75	UF80	0.50
68J6	1.20	EA801	0.70	PD510	3.35	UF85	0.50
68N6	0.80	E8CA1	0.75	PL36	1.10	UF89	0.55
68Z6	0.65	E8CB1	0.70	ECL81	0.75	EL504	0.80
68Z7	0.70	E8FB0	0.50	ECL82	0.60	EM80	0.65
6C4	0.55	E8F83	0.50	ECL83	1.15	EMH1	0.60
6CB6	0.55	E8F89	0.45	ECL84	0.70	EM83	0.50
6CD6	2.20	EC86	0.75	ECL85	0.65	EM84	0.60
6GK5	0.70	EC88	0.75				
6GK6	0.90	EC91	2.80				
6J4	1.20	ECC84	0.60				

All prices are exclusive of VAT [12.5%]

When ordering by post please add (unless otherwise indicated) 30p in £ for packing and postage, plus appropriate rate of VAT

Minimum order charge for approved credit customers is £20.00. Any order below £20.00 (before VAT) should be accompanied by remittance

Minimum transaction charge for cash order, regardless of the value of goods is £1.00.

Our new 1978 Catalogue is now ready. Please send P.O. or stamps for 30p for your copy

WWW-073 FOR FURTHER DETAILS

www.americanradiohistory.com

If International Telecommunications is your line you should see our 'CAT.'



1

Torn Tape Relay Console
Typical of our custom building capability.

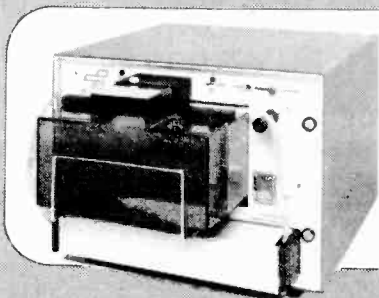

Model 770 Paper Tape Punch
5 or 8 level code.
Up to 600 Baud.
High reliability.

2

Model 724 Dual Head Transmitter with automatic heading and numbering.

3



Edi-Tel V.D.U.
For telegraph message preparation and editing.
5 unit code.
4,000 character storage.

4

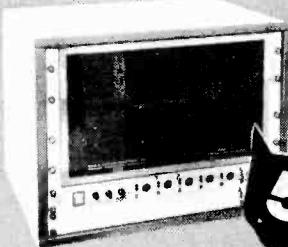

Model 730 and 731
Teleprinter line and message switching systems.

5



Model 754 Auto Transmitter
Universal 5, 6 or 8 level code.
50-1200 Baud.
Full/half/quarter rate, self clock. Built in signalling supply.

6

7

Code Converters Models 752, 772, 710.
Available with tape reader, tape punch or direct on line. ASCII, Baudot, TTS, EBCDIC to/from conversion.



Model 750
Teleprinter tape to Morse Code converter (illustrated).

Model 723
Single Head Transmitter.
With auto heading and numbering.

8

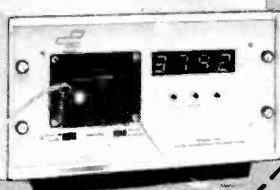

Please send a copy of your CATalogue.

I have a particular interest in the items marked below.

<input type="checkbox"/>	<input type="checkbox"/>
<input type="checkbox"/>	<input type="checkbox"/>
<input type="checkbox"/>	<input type="checkbox"/>
<input type="checkbox"/>	<input type="checkbox"/>

Data & Control Equipment Ltd. have wide experience in the design and supply of telecommunication equipment. Our engineers are always available to discuss and advise on both standard and special requirements. Our products are in use throughout the world, supported by an international network of agents and distributors.

Data & Control Equipment Ltd
Poppy Rd Princes Risborough 108-4441 3281 · Telex 837318 · Cable: Datrol Princes Risborough.

Name _____
Company _____
Position _____
Address _____
Tel: _____



Data & Control Equipment Ltd
Poppy Rd · Princes Risborough · Bucks HP17 9DD · UK
Tel: Princes Risborough (08-444) 3281 · Telex 837318
Cable: Datrol Princes Risborough.

Get a great deal from Marshall's

A. MARSHALL (LONDON) LTD., Dept. W.W.
LONDON — 40-42 Cricklewood Broadway, NW2 3ET
 Tel. 01-452 0161 Telex 21492
LONDON — 325 Edgware Road, W2. Tel. 01-723 4242/3
GLASGOW — 85 West Regent Street, G2 2QD. Tel. 041-332 4133
BRISTOL — 1 Straits Parade, Fishponds Rd., BS16 2LX
 Tel. 0272 654201

Call in and see us 9.5-3.30 Mon-Fri. 9.5-00 Sat. Trade and export enquiries welcome.

CATALOGUE 1978

Our new 40pp Spring 78 Catalogue is now available. Price 35p to callers, 45p post paid.

Our range covers over 8,000 items. The largest selection in Britain. Top 200 ICs, TTL, CMOS & LINEARS.

CA3020A	2.29	LM387N	1.05	SN76003N	2.20	TBA5000	2.30	CO4008	1.10	TIC 46	0.46
CA3028A	1.01	LM388N	0.90	SN76008K	1.50	TBA510	2.21	CO4009	0.64	TIC 47	0.67
CA3028B	1.29	LM389N	1.00	SN76013N	1.30	TBA510Q	2.30	CO4010	0.64	BS10246	1.35
CA3030	1.35	LM702C	0.75	SN76013N	1.50	TBA520	2.21	CO4011	0.24		
CA3036	1.40	LM709C	0.85	SN76018K	1.45	TBA520Q	2.30	CO4012	0.24	BRIDGE	
CA3045	1.40	LM709N	0.45	SN76023N	1.45	TBA530	1.98	CO4013	0.60	RECTIFIERS	
CA3046	0.89	LM710C	0.60	SN76023N	1.26	TBA530Q	2.07	CO4014	1.15	B40 CT1500	0.48
CA3048	2.23	LM710N	0.60	SN76033N	2.20	TBA540	2.21	CO4015	1.15	PW005	0.84
CA3049	1.80	LM723C	0.85	SN76111N	1.18	TBA540Q	2.30	CO4016	0.64	PW001	0.88
CA3052	1.82	LM723N	0.75	SN76115N	1.51	TBA550	3.13	CO4017	1.15	PW02	0.88
CA3053	0.80	LM741C	0.65	SN76116N	1.68	TBA550Q	3.22	DIL		PW04	0.88
CA3053A	0.75	LM741N	0.40	SN76131N	1.20	TBA560Q	3.22	SOCKETS		PW08	1.18
CA3080	1.88	LM741A-8	0.40	SN76226N	1.56	TBA570	1.29	8 pin	0.15	K05	2.10
CA3086	0.60	LM747CN	0.90	SN76227N	1.20	TBA570Q	1.38	14 pin	0.18	K01	2.10
CA3088	1.70	LM748-8	0.55	SN76228N	1.41	TBA641Q	2.70	16 pin	0.18	K02	2.48
CA3089	2.52	LM748N	0.55	SN76533N	0.75	TBA651	2.20	18 pin	0.27	K04	3.12
CA3090	4.00	LM7800	1.78	SN76582N	1.40	TBA700	1.52	22 pin	0.22	K06	3.86
CA3130	0.98	LM1808	1.92	SN76533N	1.20	TBA700Q	1.61	24 pin	0.35	PW164	3.57
LM307A	0.67	LM1828	1.75	SN76544A	1.44	TBA702Q	2.30	28 pin	0.45		
LM307N	0.40	LM3302N	0.85	SN76545N	1.65	TBA750	1.98	40 pin	0.55	RAMS	
LM304	2.45	LM3307N	0.85	SN76546N	1.44	TBA750Q	2.07	TRIACS		MM2101-2N	3.00
LM307N	0.65	LM3401N	0.70	SN76550N	0.35	TBA810	1.25	Plastic		MM2102-2N	2.10
LM308N	0.85	LM3900	0.75	SN76552N	0.52	TBA810	1.25	400V 6A	0.70	MM2111-2N	3.00
LM309K	1.85	LM3905	1.60	SN76570N	1.65	TBA820	1.25	400V 8A	0.75	MM2112-2N	3.00
LM317K	3.00	LM3909	0.68	SN76620N	0.90	TBA920	2.90	400V 12A	0.85	MM740920D	12.57
LM318N	2.26	MC1305	1.75	SN76650N	1.10	TBA920Q	2.99	400V 16A	1.10		
LM323K	6.46	MC1327P	1.54	SN76650N	0.75	TBA940	1.62	400V 20A	1.70	ROMS	
LM339N	1.40	MC1330P	1.00	TAA301A	1.00	TCA160B	1.61	400V 25A	2.00	MM5214	26.95
LM348N	1.50	MC1352P	1.10	TAA320A	1.00	TCA270	2.25	THYRISTORS			
LM360N	2.75	MC1435P	3.30	TAA521	1.00	TCA280A	1.30	100V 4A	0.35	DM745287	5.33
LM370N	1.70	MC1435G	2.00	TAA522	1.90	TCA290A	3.13	200V 4A	0.40	MM5204Q	10.95
LM372N	1.70	MC1437L	2.00	TAA550	0.60	TCA420A	1.84	300V 4A	0.44	MM1702AQ	10.80
LM373N	2.80	MC1439G	1.80	TAA560	1.75	TCA730	3.22	400V 4A	0.49	MM27080	35.00
LM374N	3.10	MC1445G	1.95	TAA570	2.30	TCA740	2.76	100V 8A	0.43		
LM377N	1.75	MC1455G	1.70	TAA611B	1.85	TCA750	2.30	200V 8A	0.49	SC/MP CHIPS	
LM378N	2.25	NE555	0.40	TAA621	2.15	TCA760	1.38	300V 8A	0.56	P Channel	12.00
LM379S	3.95	NE555	1.10	TAA661B	1.50	TCA800	3.13	400V 8A	0.82	N Channel	10.00
LM380-8	0.90	NE555	1.30	TAA700	3.91	TAA700	1.84	600V 8A	0.74		
LM380N	0.88	NE567	1.80	TAA930B	1.30	UA1180	2.00	100V 12A	0.57	8080A 8 BIT	
LM381AN	2.45	SAS560	2.50	RA100	1.95	CD4000	0.24	200V 12A	0.65	CHIPS	
LM381N	1.80	SAS560	2.50	RA100	1.95	CD4001	0.24	300V 12A	0.73	INS8080A	23.45
LM382N	1.25	SAS570	2.50	TB120	0.75	CD4002	0.24	400V 12A	0.81	DP8224N	6.18
LM384N	1.45	SO42P	1.25	TBA400	2.00	CD4006	1.34	600V 4A	0.87	DP8228D	7.30
LM386N	0.80	SN76001N	1.30	TBA500	2.21	CD4007	0.24	TIC 44	0.32	DP8212N	3.08

'WHAT IS A MICROPROCESSOR?' A COMPLETE TEACH YOURSELF COURSE WITH CASSETTES + BROCHURE - £9.95 INC. OF VAT & P&P

POPULAR SEMICONDUCTORS (A very small selection from our vast stocks, please enquire about devices not listed.)

2N696	0.35	2N3789	2.90	AF109	0.75	BC257A	0.17	BF154	0.25	MJ491	1.85
2N698	0.62	2N3791	3.10	AF125	0.65	BC258A	0.17	BF160	0.30	MJ540	0.58
2N708	0.28	2N3794	0.20	AF139	0.65	BC259B	0.18	BF166	0.40	MJ5370	0.58
2N718	0.27	2N3904	0.38	AF200	1.20	BC262B	0.24	BF173	0.35	MJ5371	0.60
2N720A	0.90	2N4036	0.67	AF240	1.14	BC263C	0.30	BF178	0.25	MJ520	0.45
2N916	0.30	2N4058	0.20	AF280	0.85	BC301	0.40	BF180	0.35	MJ5295	1.50
2N929	0.25	2N4060	0.20	BC108	0.15	BC303	0.50	BF182	0.35	MJ5305	0.95
2N1131	0.30	2N4062	0.18	BC113	0.20	BC308	0.15	BF184	0.38	MPB111	0.35
2N1893	0.38	2N4289	0.20	BC115	0.20	BC309C	0.15	BF194	0.15	MPB112	0.40
2N2245	0.75	2N4922	0.55	BC117	0.22	BC318	0.13	BF196	0.15	MPB113	0.45
2N2219	0.35	2N5190	0.60	BC121	0.22	BC328	0.18	BF198	0.18	MPF102	0.30
2N2220	0.35	2N5192	0.75	BC134	0.20	BC328	0.21	BF200	0.35	MPSA05	0.25
2N2221A	0.26	2N5245	0.34	BC136	0.19	BCY30	1.00	BF244	0.15	MPSA05	0.25
2N2222A	0.25	2N5295	0.40	BC140	0.35	BCY31	1.00	BF246	0.75	MPSA12	0.40
2N2369	0.25	2N5298	0.40	BC142	0.30	BCY33	1.00	BF257	0.37	MPSU05	0.50
2N2845	0.75	2N5448	0.15	BC147	0.12	BCY38	2.00	BF258	0.45	TIP29A	0.45
2N2904	0.36	2N5457	0.32	BC149	0.14	BCY58	0.25	BF259	0.48	TIP29C	0.60
2N2905	0.37	2N5459	0.29	BC154	0.27	BCY59	0.25	BF459	0.50	TIP30A	0.49
2N2906	0.28	2N5486	0.38	BC158	0.12	BCY71	0.26	BF521A	2.60	TIP30C	0.65
2N2907	0.25	2N6101	0.45	BC159	0.10	BD116	1.20	FBS61	0.30	TIP32A	0.55
2N2924	0.15	2N6109	0.50	BC160	0.35	BD131	0.51	BF598	0.30	TIP33A	0.80
2N3019	0.55	2N6122	0.41	BC167	0.12	BD136	0.37	BFX30	0.35	TIP34A	0.80
2N3354	0.60	40361	0.50	BC169	0.12	BD135	0.37	BFX30	0.35	TIP35A	2.50
2N3390	0.20	40362	0.55	BC170	0.18	BD136	0.37	BFX84	0.35	TIP36A	2.80
2N3391A	0.20	40406	0.60	BC172	0.14	BD137	0.38	BFX87	0.30	TIP41A	0.70
2N3393	0.16	40407	0.52	BC177	0.20	BD139	0.40	BFX98	0.30	TIP41A	0.70
2N3393	0.88	40409	0.60	BC179	0.23	BD140	0.40	BFY50	0.25	TIP42C	1.00
2N3441	0.81	40410	0.75	BC182	0.11	BD239	0.40	BFY52	0.25	TIP295	0.65
2N3638	0.16	40594	0.80	BC183	0.11	BD241	0.45	BFY52	0.30	TIS43	0.43
2N3639	0.30	40595	0.90	BC183L	0.14	BD243	0.60	BFY53	0.30		
2N3702	0.13	AC126	0.45	BC184L	0.14	BD244	0.65	BFY39	0.54		
2N3704	0.15	AC127	0.45	BC207	0.17	BD246	0.65	BSK20	0.33		
2N3706	0.16	AC151V	0.40	BC212	0.14	BD259	0.45	BSK21	0.32		
2N3708	0.13	AC152V	0.50	BC212L	0.17	BD530	0.50	BU205	2.20		
2N3710	0.16	AC153K	0.55	BC213L	0.16	BDY20	1.00	ME0402	0.20		
2N3712	1.20	AC176K	0.65	BC214	0.16	BF115	0.38	ME0412	0.20		
2N3714	2.45	AC187K	0.80	BC237	0.14	BF121	0.55	ME4102	0.10		
2N3716	3.00	AD161	1.00	BC238	0.12	BF152	0.25	ME4104	0.10		
2N3772	2.00	AD162	1.00	BC251	0.16	BF153	0.25	MJ490	1.35		

WHY NOT PAY US A VISIT AT OUR NEW CENTRAL LONDON BRANCH AT 325 EDGWARE ROAD, W2, ABOUT 100 YARDS NORTH OF THE WESTWAY FLYOVER. EXTENSIVE STOCK RANGE.

Prices correct 24 Feb. 1978, but please add VAT & p&p 40p

TRANSISTORISED 3cm RADAR AMPLIFIER SWITCH: with 24V waveguide switch, 9 x 4 cm ins. with crystal CV 2355 and spark gap VX.1046. £16.20 + £1.00 post.

TRANSISTORISED VIDEO INDICATOR (used with above amplifier): 1 1/2" C.R.T. £10.80 + £1.00 post.

VACUUM & PRESSURE SEAL TEST EQUIPMENT: Complete with 3 x 4" gauges indicating 0-20lbs p.s.i., 0-30lbs vacuum. With stand, hand pump, etc., £32.40 + £3.00 carr.

INSULATION TEST SET 0 to 10 KV, negative earth, with Ionisation Amplifier, 100/230 Volts. AC £45.90, carr. £3.00.

RACAL RA-17 RECEIVER 500KHz-30MHz, s/hand, good condition, £365.00 (including VAT 1 1/2%).

AVO TRANSISTOR ANALYSER CT.446: £37.80, carr. £2.20.

MARCONI FREQUENCY METER 1026/4: 2000-4000MHz 'as new' condition. £32.40 or secondhand condition £24.30. 1026/2: 100-160MHz £32.40 'as new' or s/hand £24.30. Carriage for all type £2.00.

BURGLAR ALARM BELL: 6-8v. d.c. £3.24 + £1.00 post.

MUIRHEAD ATTENUATORS: 75 ohms 0-8Mc/s 3V MAK 3 ranges 0-5, 0-25, 0-50dB. £3.24 + 75p post.

TELEPRINTER TYPE 7B: Pageprinter 24v. d.c. power supply, speed 50 bauds per min. S/hand cond. (excellent), no parts broken £21.60, carriage £3.50.

AUTO TRANSFORMER: 230v. 50c/s, 1000 watts. Mounted in strong steel case 5" x 6 1/2" x 7". Bitumen impregnated. £12.96, carr. £2.00.

CRYSTAL TEST SET TYPE 193: Used for checking crystals in freq. range 3,000-10,000kHz. Mains 230V 50Hz. Measures crystal current under oscillatory conditions and the equivalent resistance. Crystal freq. can be tested in conjunction with a freq. meter. £27.00, carr. £2.00.

CATHODE RAY TUBES: 5" screen, tube CV-1536 £4.32 + £1.00 post. Type 95J20 square face 5" x 3" £8.10 + £1.00 post.

WEATHERPLOTTER RECEIVING SET AN/GMH-5: Facsimile reproducing system for weather maps. Further details on request. £459.00 (inc. 8% VAT).

CLASS 'D' WAVEMETER NO: 1: Crystal controlled heterodyne frequency meter covering 2-8MHz. Power supply 6v. d.c. Good s/hand cond. £9.20 + £2.00 carr.

RING TOROIDAL DUST CORES: Size 2 1

The choice is yours

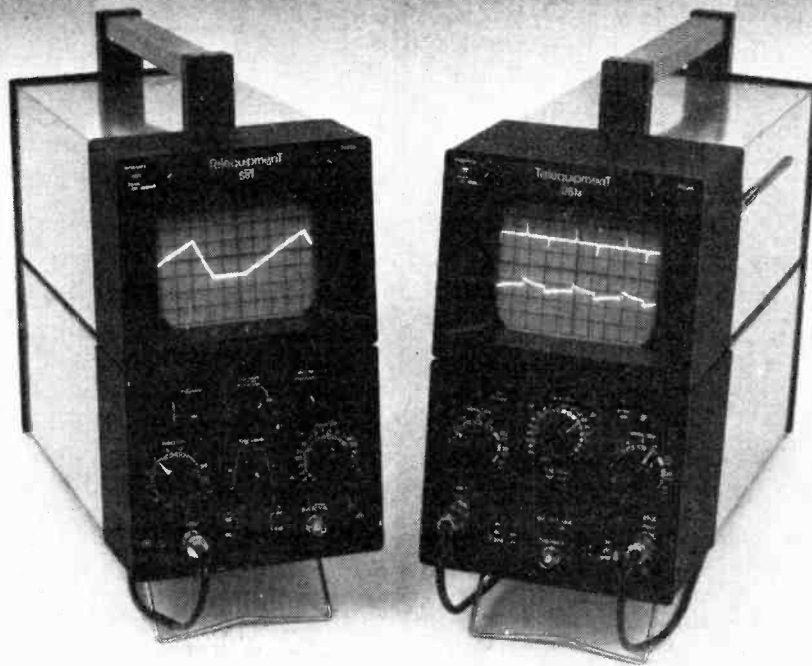

Prices at Feb '78

S61. £150 plus VAT and Nominal Delivery Charge.

D61a. £220 plus VAT and Nominal Delivery Charge.

When it comes to deciding on a general purpose oscilloscope for the laboratory or the service department, you have a choice between single or dual trace models and medium or high bandwidth.

Telequipment's D61a is an excellent instrument for the service bench, particularly for TV work when dual trace 10MHz bandwidth and special triggering features are needed.

For less demanding applications, the single trace 5MHz S61 will make most of your routine measurements.

You will get the same Telequipment reliability and Telequipment value - whatever your choice.

For your full catalogue and price list for Telequipment products - Circle No. 151

TELEQUIPMENT



Tektronix UK Ltd, P.O. Box 69, Coldharbour Lane, Harpenden, Herts.

Tel: 05827 63141 Telex: 25559

WW - 103 FOR FURTHER DETAILS

www.americanradiohistory.com

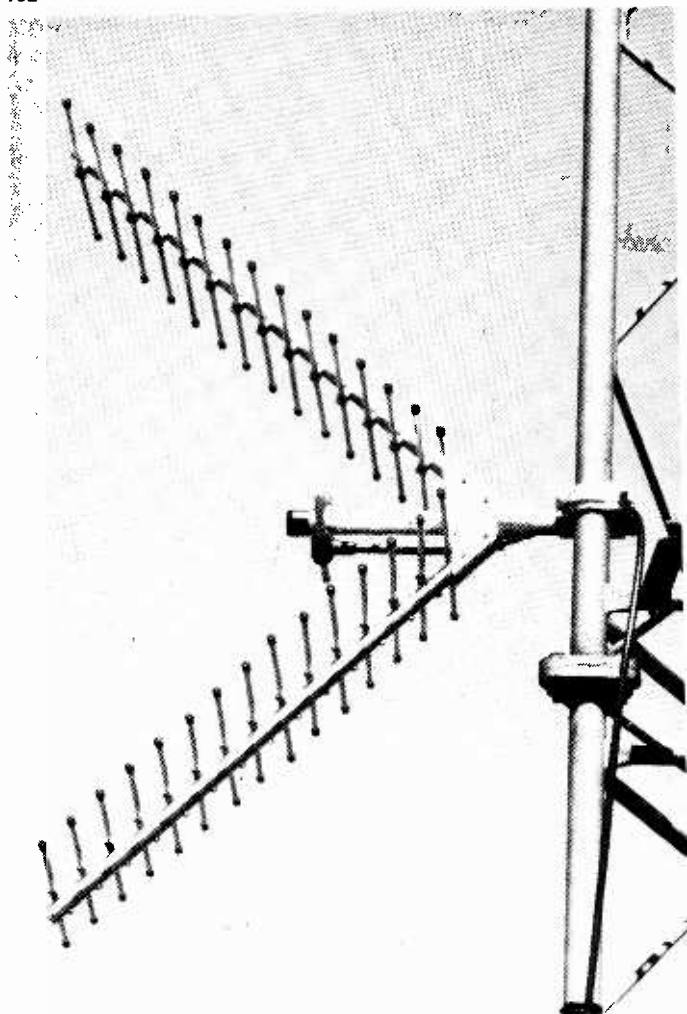

TELECOMMUNICATIONS ANTENNAS

The CA850 is a fixed station broadband antenna with a gain of 12dB over the dipole, front to back ratio average 20dB. In the lower part of the band from 350 700MHz the bandwidth is 150MHz and from 700 to 1500MHz it is 250MHz with a VSWR better than 1.5-1.0 with reference to 50 ohms. The antenna can be operated in either the horizontal or vertical mods. We not only design and manufacture antennas, but also a wide range of structures, both guyed and self-supporting towers. This enables us to offer a complete package to customers. You will find our prices are very competitive, and our deliveries are exceptionally fast, including overseas shipments. Are you satisfied with your present deliveries? Why not drop us a line or telex for a quotation.

RADIOMASTS LTD.

Moulton Park, Northampton
 Cables: RAMAR, NORTHAMPTON
 Telex: Headship (N'ton) 31355 (Ramar)
 Telephone: 0604 43728 and 491572
 Manufacturers of Radiotelephone, Masts, Towers & Antennas

VISIT US ON STAND 4100
 Communications 78 — 4th to 7th April
 National Exhibition Centre, Birmingham

WW-104 FOR FURTHER DETAILS



DRAKE

Radio Shack Ltd



DRAKE'S SUPERB TRANSCEIVER TR-4CW

S.A.E. for details please.

AS WELL AS DRAKE EQUIPMENT, WE ARE THE DIRECT IMPORTERS OF HAL RTTY AND MICROPROCESSORS, ATLAS, NYE MORSE KEYS, PRESTEL VHF/UHF PROFESSIONAL FIELD STRENGTH METERS, HAM RADIO, CIR ASTRO 200, HY GAIN, CDR ROTORS, HUSTLER, OMEGA-T SYSTEMS, MFJ FILTERS AND SPEECH PROCESSORS, SUPEREX WE ALSO STOCK SHURE MICROPHONES, YAESU, MICROWAVE MODULES, SOLID STATE MODULES, ICOM, COPAL CLOCKS, G-WHIPS, BANTEX, MOSLEY, DAIWA, ASAHI, JAYBEAM, DECCA AND THE USUAL ACCESSORIES—COAX, CONNECTORS, INSULATORS, VALVES, Etc

SEND FOR A COPY OF OUR PRICE LIST (Stamps please)

We are situated just around the corner from West Hampstead Underground Station (Bakerloo line) A few minutes walk away is West Hampstead Midland Region station and West End Lane on the Broad Street Line. We are on the following Bus Routes: 28, 59, 159. Hours of opening are: 9-5 Monday to Friday. Closed for Lunch 1-2 Saturday we are open 9-12 30 only. World wide exports

DRAKE * SALES * SERVICE

RADIO SHACK LTD.

188 BROADHURST GARDENS, LONDON NW6 3AY
 Giro Account No. 588 7151. Telephone: 01-624 7174. Cables: Radio Shack, London, N.W.6. Telex: 23718

WW-035 FOR FURTHER DETAILS

DIY HIFI

From the USA

THE AUDIO AMATEUR magazine, now eight years old, is totally dedicated to good sound for the do-it-yourself audiophile. TAA's thoroughly tested construction articles range from simple overload indicators to hand-made electrostatic speakers with their own direct drive power amplifiers to mixers and much, much more. Our authors include Reg Williamson, B. J. Webb, and Alan Watling.

Fill in the coupon, enclose cheque or money order payable to The Audio Amateur and send to TAA Dept. WW1, Yellow Oak Cottage, Tillington, Nr. Hereford HR4 8LQ.

- Enter my subscription to TAA for one year/four issues for £3.
- I want to know more. I enclose 75p plus 25p for postage for a sample issue of The Audio Amateur.
- Send free prospectus.

Name _____

Street _____

Town _____ County _____

Post Code _____

These rates are for the U.K. only.

Subscribe now on a satisfaction guaranteed basis or send for a FREE descriptive folder.

Rates for other areas available from head office TAA, P.O. Box 176, Peterborough N.H. 03458 USA.

THE DYNAMIC DUO

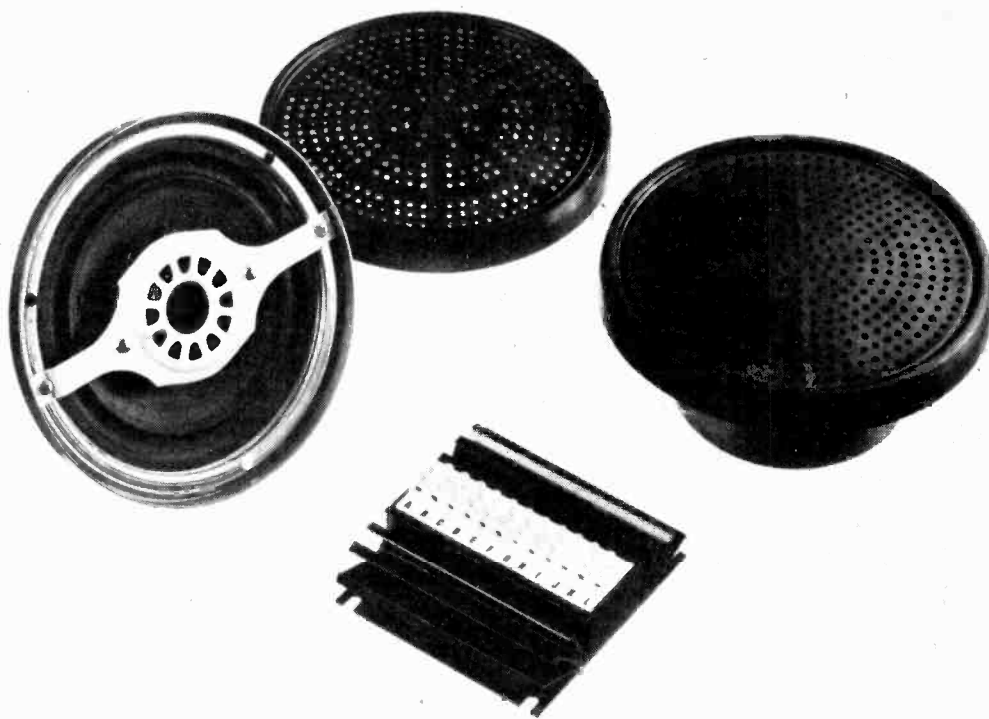

The C15/15 is a unique Power Amplifier providing Stereo 15 watts per channel or 30 watts Mono and can be used with any car radio/tape unit. It is simply wired in series with the existing speaker leads and in conjunction with our speakers S15 produces a system of incredible performance.

A novel feature is that the amplifier is automatically switched on or off by sensing the power line of the radio/tape unit hence alleviating the need for an on/off switch.

The amplifier is sealed into an integral heatsink and is terminated by screw connectors making installation a very easy process.

The S15 has been specially designed for car use and produces performance equal to domestic speakers yet retaining high power handling and compact size.

C15/15

15 Watts per channel into 4Ω
Distortion 0.2% at 1KHz at 15 watts
Frequency response 50Hz - 30KHz
Input Impedance 8Ω nominal
Input sensitivity 2 volts R.M.S. for 15 watts output
Power line 10 - 18 volts
Open and Short circuit protection
Thermal protection
Size 4 × 4 × 1 inches

Data on S15

6" Diameter
5¼" Air Suspension
2" Active Tweeter
20oz Ceramic magnet
15 Watts R.M.S. handling
50 Hz - 15KHz frequency response
4Ω Impedance

C15/15 Price £17.74 + £2.21 VAT P & P free

S15 Price per pair £17.74 + £2.21 VAT P & P free

TWO YEARS GUARANTEE ON ALL OF OUR PRODUCTS

I.L.P. Electronics Ltd
Crossland House
Nackington, Canterbury
Kent CT4 7AD
Tel (0227) 63218

Please Supply _____
Total Purchase Price _____
I Enclose Cheque Postal Orders Money Order
Please debit my Access account Barclaycard account
Account number _____
Name & Address _____
Signature _____

WW-023 FOR FURTHER DETAILS

West Hyde have more than 600 different instrument cases in stock + accessories

WH BRIGHTCASE



Adds sophistication to any equipment
In anodised aluminium with top and bottom panels grained black P.V.C.

	L	B	H	
BC2/121	432	268	89	23.01
BC2/222	219	268	89	16.63
BC3/121	432	268	133	25.24
BC3/222	219	268	133	18.61

WH ILEX & SORREL

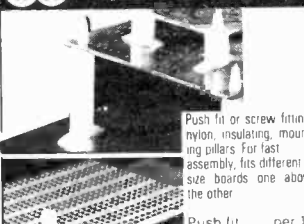

Push fit or screw fitting, nylon, insulating, mounting pillars. For fast assembly, fits different size boards one above the other.

Push fit	per 10
ILX 025	25" .35
ILX 050	5" .35
ILX 075	75" .39
ILX 100	1" .44
ILX 150	1.5" .59
Screw fix	per 10
SOR 012	12" .37
SOR 025	25" .47
SOR 050	5" .47
SOR 075	75" .53

WH MOD-2



A very popular case of universal use
Modular design. Stores flat. Chassis fixes between front and back panels of PVC/aluminium. Covers of PVC/steel. Cheap enough for production, ideal for development work.

MD2 A	9.05	MD2 I	14.51	MD2 Q	12.98
MD2 B	9.70	MD2 J	13.82	MD2 R	15.25
MD2 C	11.34	MD2 K	16.17	MD2 S	13.28
MD2 D	9.72	MD2 L	20.00	MD2 T	15.27
MD2 E	10.90	MD2 M	10.67	MD2 U	17.92
MD2 F	12.80	MD2 N	11.48	MD2 V	16.77
MD2 G	10.76	MD2 O	13.53	MD2 W	19.64
MD2 H	12.36	MD2 P	11.36	MD2 X	24.10

WH CUTTING TOOLS



Bradrad drills and deburrs, thin or thick, plastic or steel. £17.80
6-36mm or ¼"-1½"

Adel nibbling tool cuts virtually any shaped hole. £9.16

Conecut powered reamer.
6-20mm £5.15
16-30mm £8.37
25-40mm £12.50
37-52mm £15.28

Reamers for plastic or metal.
3-12mm £8.25
9-25mm £9.65

WH KNOBS



Send for Mentor Catalogue
Hundreds of knobs to choose from

West Hyde stock thousands of knobs: collet, screw fixing, plastic, aluminium, fluted, textured, smooth, wing, pointer, insulated, slow motion, digital, crank handle, heavy duty, contemporary, dual, diamond turned. With shafts 3mm to 10mm and diameters from 8mm to 58mm. See catalogue for prices.

WH HANDLES

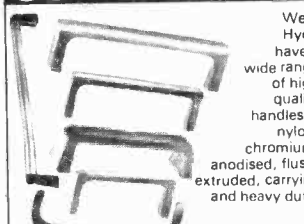

West Hyde have a wide range of high quality handles in nylon, chromium, anodised, flush, extruded, carrying and heavy duty.

Chromium from 81p	Extruded from 2.19
Nylon from 1.06	PVC from 76p
Pivoting from 4.37	
Flush precision from 5.28	
V. heavy duty from 8.25	

Send for catalogue
Prices are correct at time of going to press. Prices are one off inc P&P, but not VAT. Discounts for quantities.
Note new address

WH PANAVICE

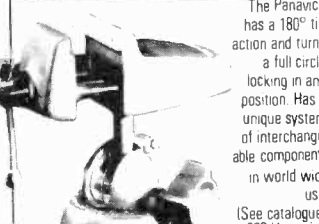

The Panavice has a 180° tilt action and turns a full circle locking in any position. Has a unique system of interchangeable components in world wide use.
(See catalogue)
303 Vert. vice head 8.44 304
Hor. vice head 9.05
366 Wide opening head 9.98
280 Vacuum base 17.63
305 Low base 11.50
311 Bench clamp 9.98 Jaws from 2.30 to 2.61

West Hyde have the greatest range of instrument cases

WH CONTIL

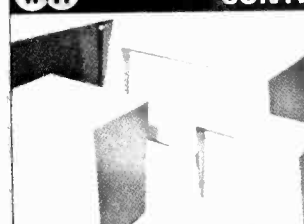

West Hyde's best selling case, strong, rigid and smart

L	B	H	Best selling range of
CON 755	178	127	8.68 Textured blue acrylic steel
CON 975	229	178	10.30 eyebrow cases Front
CON 867	203	152	178 10.30 panels white or PVC/
CON 127	305	178	178 11.86 aluminium, also unpainter
CON 161	406	305	178 16.36 up to size 1277
CON 191	489	267	22.53
CON 191D	489	381	26.36

WH SWIFT



It's a winner!

Swiftcase wins industrial design award at Hanover

A case for good looks, strength and efficiency. Particularly suitable for applications needing power dissipation.

L	B	H	
SWF 212	432	268	88 9 18.70
SWF 222	219	268	88 9 14.49
SWF 312	432	268	133 4 22.26
SWF 322	219	268	133 4 17.74

WH CONTIL WOODEND



Leather textured PVC steel body with polished teak ends.

Two wooden ends and two tie bolts, result in a simple, light, inexpensive case. A toroidal transformer of 130W is available to fit. Ideal for Hi-Fi applications and domestic and office equipment.

L	B	H	
WEC 801	202	240	80 12.80
WEC 802	417	240	80 14.97
WEC 803	550	240	80 16.29

WH CONTIL-DIN



The ready-made DIN case you have been waiting for

Heavy aluminium extrusions lock rigidly together providing, heat dissipation, screening and strength, with provision for 16 P.C. boards and quick component mounting

To order: See catalogue

DIN 212	6.01	DIN 215	7.10	DIN 914	10.07
DIN 211	6.25	DIN 912	8.19	DIN 915	11.01
DIN 214	6.57	DIN 913	9.01		

WH ENCASE

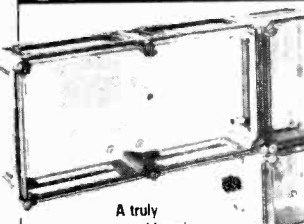

A truly environmental housing

Encase solves your waterproof and dustproof problems and because of its chemical resistance is ideal for the process industries. The polycarbonate is virtually unbreakable. Covers clean P.C. Case-glass filled P.C. Gaskets screws incl. gland plates things available

ENC A	190	190	130	8.87
ENC B	280	190	130	11.56
ENC C	480	190	130	15.40
ENC D	280	280	130	16.03
ENC E	380	280	130	20.51
ENC F	580	280	130	28.51
ENC G	580	380	130	39.29

WH SAMOS

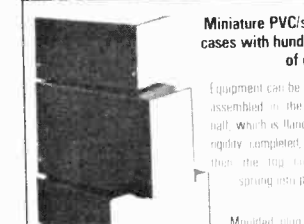

Miniature PVC/steel cases with hundreds of uses

Equipment can be assembled in the lower half, which is flanged for rigidity. Completed, tested, then the top cover is sprung into place.

Moulded, plug-in feet included

L	B	H	
S1	50	100	50 1.36
S2	100	100	50 1.56
S3	150	100	50 1.74
S4	50	125	75 1.96
S5	100	125	75 2.24
S6	150	125	75 2.63
S7	200	125	75 2.32

WH MINOS

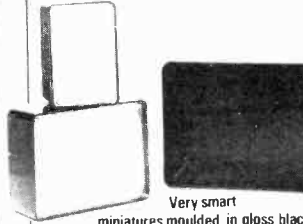

Very smart miniatures moulded in gloss black or white ABS with high impact strength

Front panels in aluminium, white PVC/steel or moulded. Guides for P.C.Bs, dividers or screens, also internal pillars for 'P' clips. Recess MIN 020 100 85 50 .73
MIN 025 115 85 50 .85
MIN 030 130 100 50 .94
MIN 140 200 130 65 1.77

WH MOD-3



Attractive gloss blue PVC/Steel cases of wrap-round construction. Removable front and back panels give full access. Grey PVC/steel panels incl. L-raster. Supplied with W.H. self adhesive feet. Black cases also available, slight extra cost.

L	B	H	
301	148	108	133 7.19
302	158	108	133 7.39
303	158	148	133 8.59
304	257	108	133 7.85
305	257	108	133 9.19
306	257	141	133 10.99

NOTE NEW ADDRESS

All West Hyde cases are available with substantial discounts for quantities. Most cases have discounts at 5, 10 and 25 off with discounts up to 25% at 100 off. Prices include P & P and are less 10% if collected on first two price breaks on cases only. Send for catalogue. Prices correct at press date.
WEST HYDE DEVELOPMENTS LIMITED, Unit 9, Park Street Industrial Estate, AYLESBURY, BUCKS. HP20 1ET. Phone: Aylesbury (0296) 20341. Telex: 83570

WW-080 FOR FURTHER DETAILS

sales hire repair



**You'll do better at Martin Associates
we guarantee it!**

AVO Precision Avometer	£145.00
ADVANCE 2100 Oscilloscope DC-25MHz	£285.00
SOLARTRON CD1400 Oscilloscope DC-15MHz	£135.00
TEKTRONIX 545A Oscilloscope with CA Plug In	£350.00
TEKTRONIX 5103 N/D10 Dual Beam Oscilloscope	£460.00
AIRMEC 204 AM/FM GENERATOR 1-320MHz	£275.00
TEKTRONIX 647 Oscilloscope DC-50MHz Dual Beam 1mV/cm	£500.00
TELEQUIPMENT D 54 DC-10MHz	£225.00
A.P.T. 504 P.S.U. 0-500V, 0.250mA	£95.00
A.P.T. TCU 250 0-50V, 2Amp	£50.00
ADVANCE J2 OSCILLATOR 15Hz-50KHz O/P 40V metered	£40.00
BOONTON 202H AM/FM GENERATOR 54MHz-216MHz	£200.00
KELVIN Climatic Oven -50°C - 100°C	£950.00
MARCONI TF.801D/1 Signal Generator 10MHz-470MHz	£285.00
MARCONI TF.1247 Oscillator 20MHz-300MHz	£350.00
HEWLETT-PACKARD 7035B X-Y Recorder	£650.00
TELSEC 700 Flat Bed Recorder 2 Pen	£550.00

Hundreds
more items
in stock!

<p>AIRMEC 248 Wave Analyser 5-300MHz £125.00</p> <p>S.T.C. 74600 Attenuators. 0-9db and 0.90db DC-50MHz £25.00</p> <p>EVERSHED & VIGNOLE BR6 Bridge Insulation Tester 500V. Battery operated PP9s £75.00</p> <p>MARCONI TF.868B Universal Bridge £195.00</p> <p>SOLARTRON LM7040 Digital Multimeter From £190.00</p> <p>SYSTRON DONNER 7050 Digital Multimeter £55.00</p> <p>HEWLETT-PACKARD Digital Voltmeter, 2401C £400.00</p> <p>MARCONI TF.2604 Electronic Voltmeter 20Hz-1500MHz £225.00</p>	<p style="text-align: center;">MARTIN ASSOCIATES</p> <p>34, Crown Street Reading, Berks. RG1 2SE Tele: Reading (0734) 51074</p>
--	--

WW-031 FOR FURTHER DETAILS

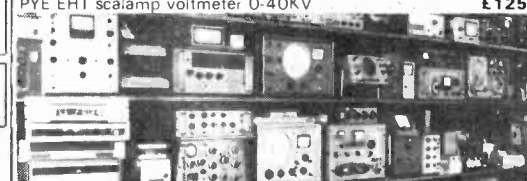
<h3 style="margin: 0;">MARCONI TEST EQUIPMENT</h3> <p>TF329G circuit magnification meter £125</p> <p>TF455E Wave analyser. New £135</p> <p>TF1101 RC oscillators £65</p> <p>TF1099 20MHz sweep generators</p> <p>TF1041B & C. VT Voltmeters</p> <p>TF1102 Amplitude modulator. 500MHz</p> <p>TF1020A Power meter. 100W. 250MHz £85</p> <p>TF1152A/1 Power meter. 25W 500MHz. £75</p> <p>TF890A/1 RF test set £425</p> <p>TF801B/3S Signal generator. £175</p> <p>TF1417 200MHz counter (imperfect)</p> <p>TF1400 Pulse generator</p> <p>TF675F Pulse generator</p> <p>TF1370 Wide-range RC oscillator £125</p> <p>TF2904 Colour gain delay test set</p> <p>TF1058 UHF/SHF signal generator</p> <p>TF 995A/4 AM/FM signal generator</p> <p>TF1066 AM/FM signal generator</p> <p>ZENITH 8 AMP VARIACS. £28.50 (carr. 150p)</p> <p>ADVANCE CONSTANT VOLTAGE TRANSFORMERS</p> <p>Input 190-260V AC. Output constant 220 Volts. 250W £25 (£2 carriage)</p> <p>POLARAD TYPE TSA. SPECTRUM ANALYSER. C/w type STU/2M plug-in unit covering from 950 to 4500 MHz</p> <p>EVER-READY NICKEL CADMIUM BATTERIES</p> <p>Size: F 7 QAH 1.24 Volts £2.75 (post 25p)</p> <p>SONNENSCHN DRYFIT BATTERIES</p> <p>6V 7.5AH £4.50 (50p post)</p> <p>12V 5.7AH £7.00 (50p post)</p> <p>POWER SUPPLIES</p> <p>ADVANCE type PM51. 0-30V @ 5Amps. brand new, boxed, with book £36.00. APT 10459/11. 10-15V @ 7.5Amp. £25.</p> <p>BECKMAN TURNS COUNTER DIALS</p> <p>Miniature type (22mm diam.) Counting up to 15 turn 'Helipot'. Brand new with mounting instructions. Only £2.50 each</p> <p>Wandel & Gotterman Equipment</p> <p>Level Meter 0.2-1600KHz</p> <p>Level Oscillator 0.2-1600KHz</p> <p>Level Transmitter 3-1350 KHz</p> <p>Carrier Frequency Level Meter</p>	<h3 style="margin: 0;">P. F. RALFE ELECTRONICS</h3> <p style="text-align: center;">10 CHAPEL STREET, LONDON, NW1 TEL: 01-723 8753</p> <p>TEST EQUIPMENT</p> <p>LEADER TV FM Sweep and marker generator</p> <p>ADVANCE HR100 X-Y Recorder. £105.00</p> <p>HEWLETT-PACKARD 302A Wave-Analyser.</p> <p>RACAL type 801R. 100mHz digital frequency meter.</p> <p>TEXSCAN X.Y oscilloscope. 9-inch CRT.</p> <p>TELETYPE ASR33 now in stock.</p> <p>COSSOR oscilloscope type CD100</p> <p>SOLARTRON 1420.2 digital voltmeter. 6 ranges to 1KV £105</p> <p>AIRMEC 254 High-power oscillator/amplifier £325</p> <p>BOONTON 80 Signal generator. 2-400MHz £45</p> <p>BOONTON 230A RF Power Amplifier £250</p> <p>BPL Capacitance decade (5) CD133. 100pf-1uF £350</p> <p>GERTSCH Frequency meter and deviation meter 20-1000MHz £110</p> <p>HEWLETT PACKARD 693D sweep oscillator</p> <p>DERRITRON. Digital Wheatstone Bridge</p> <p>MUIRHEAD K-134-A Battery op. wave analyser</p> <p>PYE EHT scalamp voltmeter 0-40KV £125</p>  <p>RADIO CORPS PB1 pulse & bar generator £45</p> <p>SIEMENS Level oscillator 12-160KHz</p> <p>SCHOMANDL type FD1 frequency meter £125</p> <p>Bruel & Kjoer type 3301 Automatic Frequency Response Recorder 200Hz-20KHz</p> <p>MUIRHEAD-PAMETRADA D489EM Wave Analyser</p> <p>TEKTRONIX 555 scope with plug-ins types CA (2 off), 21 and 22</p> <p>TEKTRONIX 545 main frames £210 Choice of plug-in units extra</p> <p>TEKTRONIX 585A oscilloscope with '82' P.I DC-80MHz £110</p> <p>TEKTRONIX type 180A Time-mark generator</p> <p>WANDEL & GÖTTERMAN Signal Gen. 10Hz-30MHz</p> <p>NOTICE. All the pre-owned equipment shown has been carefully tested in our workshop and reconditioned where necessary. It is sold in first-class operational condition and most items carry our three months guarantee. Calibration and certificates can be arranged at cost. Overseas enquiries welcome. Prices quoted are subject to an additional 8% VAT.</p>	<h3 style="margin: 0;">RÖHDE & SCHWARZ EQUIPMENT</h3> <p>HUZ Field Strength Meter 47-225MHz</p> <p>AMF TV Demodulator 470-790MHz</p> <p>Selective UHF v/meter, bands 4&5. USVF</p> <p>Selectomat. RF Voltmeter. USWV. BN 15221 £450</p> <p>Standard attenuator. 0-100db 0-300 mHz DPR</p> <p>UHF Sig. gen. type SDR 0.3-1 GHz £750</p> <p>UHF Signal generator type SCH £175</p> <p>UHF Test receiver type USVD £325</p> <p>POLYSKOP SWOB I</p> <p>PAPER TAPE READERS</p> <p>Tally model 1806. £150</p> <p>NCR with sound-proof case £55</p> <p>TEXTRONIX TYPE 561A OSCILLOSCOPES</p> <p>Supplied in first-class condition complete with types 3A1 and 3B3 plug-in units. DC-10MHz double-beam 10mV/div. Calibrated sweep delay and single-shot. Time-base 0.5us/div £350.00</p> <p>MUFFIN INSTRUMENT COOLING FANS</p> <p>Made by Rotron Holland. These are very high quality quiet running fans, specially designed for the cooling of all types of electronic equipment. Measures 4.5x4.5x1.5. 115V AC 11 Watts. The list price of these is over £10 each. We have a quantity available brand new for only £4.50 each.</p> <p>500V TRANSISTORISED INSULATION TESTER</p> <p>Lightweight, small size (13x7x4cms). Reads insulation from 0.2-100MΩ at 500V pressure. Runs from standard 9V PP3. Brand new £16.50</p> <p>TELEVISION MONITORS</p> <p>Phillips studio quality precision colour monitors and Pye monochrome 405/525/625 lines.</p> <p>PACE ELECTRONICS VARI PLOTTER</p> <p>Type 1100E £175</p> <p>MUIRHEAD DECADE OSCILLATORS type 890A.</p> <p>1Hz-110kHz in four decade ranges. Scope monitored output for high accuracy of frequency. Excellent generator.</p>
---	---	--

TILS by TEXAS		C-MOS I.C.s		OP. AMPS		TRANSISTORS		DIODES							
7400	16p	74107	36p	1458	Dual Op. Amp Int Comp	8 pin DIL	70p	AC125	35p	BFY50	22p	2N3055	85p	+SIGNAL	
74H00	28p	74109	89p	301A	Ext. Comp	8 pin DIL	36p	AC126	25p	BFY51	22p	2N3439	67p	OA47	9p
74S00	63p	74110	55p	3130	COSMOS/Bi-Polar MosFet	8 pin DIL	100p	AC127	25p	BFY52	22p	2N3442	140p	OA81	20p
74LS00	30p	74111	90p	CA3140	BIMOS	8 pin DIL	100p	AC128	25p	BFY90	90p	2N3565	48p	OA85	20p
7401	18p	74116	200p	CA3160	Int. Comp.	8 pin DIL	100p	AC141	20p	BRV39	45p	*2N3643	48p	OA90	9p
7402	18p	74118	84p	LM318N	High speed	8 pin DIL	120p	AC142	20p	*BSX19	20p	*2N3644	48p	OA91	9p
7403	18p	74120	120p	LM324N	Quad Op. Amp	14 pin DIL	120p	AC176	25p	BSX20	20p	*2N3702	12p	OA95	9p
7404	23p	74121	32p	LM348N	Quad Op. Amp	14 pin DIL	125p	AC187	25p	*BU105	140p	*2N3703	12p	OA99	9p
74H04	36p	74122	54p	NE531V	High slew rate	8 pin DIL	140p	AC187K	30p	BU108	250p	*2N3704	12p	OA200	8p
7405	26p	74123	76p	NE543K	Servo Amp	T099	200p	AC188	25p	*BU205	200p	*2N3705	12p	OA202	10p
7406	43p	74125	73p	3900	Quad Op. Amp	14 pin DIL	70p	AC188K	30p	*BU208	300p	*2N3706	12p	IN916	4p
7407	43p	74126	70p	709	Ext. Comp	8/14 pin DIL	36p	AD149	49p	*MJE320	85p	IN4148	4p		
7408	25p	74128	75p	741	Int. Comp	14 pin DIL	70p	AD161	45p	MJ481	175p				
7409	27p	74132	70p	747	Dual 741	14 pin DIL	70p	AF114	30p	MJ491	200p				
7410	18p	74136	75p	748	Ext. Comp	8/14 pin DIL	36p	AF115	30p	MJ2501	225p				
7411	24p	74142	320p	776	Programmable Op. Amp	T0-5	180p	AF116	30p	MJ2955	120p				
7412	25p	74145	90p					AF117	30p	MJ3001	120p				
7413	36p	74147	190p					AF139	43p	MJE3055	70p				
7414	35p	74148	160p					AF239	48p	*MPSA06	30p				
7416	33p	74150	140p					BC107/B	9p	*MPSA56	52p				
7417	36p	74151	72p					BC108/B	9p	*MPSU06	82p				
7420	18p	74153	85p					BC109/B	10p	*MPSU56	78p				
7421	40p	74154	150p					BC109C	12p	OC2	140p				
7422	22p	74155	90p					*BC117	22p	OC35	140p				
7423	37p	74156	90p					*BC148	9p	OC36	140p				
7425	30p	74157	90p					*BC149C	10p	*OC71	200p				
7427	37p	74159	190p					*BC157	11p	*OC710B	200p				
7428	36p	74160	120p					*BC158	12p	*TIP29C	55p				
7430	18p	74161	120p					*BC159	11p	*TIP30A	48p				
7432	36p	74162	120p					*BC169C	12p	*TIP30C	60p				
7437	36p	74163	120p					*BC172	11p	TIP31A	52p				
7438	36p	74164	120p					BC177	18p	TIP31C	52p				
7440	18p	74165	220p					BC178	17p	TIP31E	52p				
7441	75p	74166	160p					BC179	18p	TIP32A	58p				
7442	70p	74167	340p					*BC183	12p	TIP32C	82p				
7443	140p	74170	250p					*BC184	13p	TIP33A	90p				
7444	140p	74172	720p					*BC187	13p	TIP33C	115p				
7445	120p	74173	160p					*BC212	11p	TIP34A	115p				
7446	100p	74174	120p					*BC213	10p	TIP34C	190p				
7447	85p	74175	85p					*BC214	14p	TIP35C	29p				
7448	80p	74176	120p					BC461	36p	TIP36A	270p				
7450	18p	74177	120p					BC478	30p	TIP36C	340p				
7451	20p	74179	160p					*BC516	60p	TIP41A	85p				
7453	20p	74180	110p					*BC517	65p	TIP41B	70p				
7454	18p	74181	298p					BCV70	18p	TIP41C	78p				
7460	18p	74182	82p					BCV71	22p	TIP42B	78p				
7470	36p	74184	160p					BCV72	18p	TIP42B	78p				
7472	30p	74185	150p					BD131	63p	TIP42C	82p				
7473	34p	74186	920p					BD132	85p	TIP2955	78p				
7474	34p	74190	160p					*BD135	48p	*TIS93	30p				
7475	45p	74192	120p					*BD136	50p	*TIX108	10p				
7476	36p	74193	160p					*BD139	42p	2N3055	133p				
7478	90p	74195	95p					*BD140	58p	*2N457A	150p				
7482	90p	74196	120p					BD556	200p	2N697	22p				
7483	90p	74197	120p					BF115	22p	2N698	45p				
7484	110p	74198	250p					BF167	23p	2N706	20p				
7485	120p	74199	250p					BF170	23p	2N707	20p				
7486	34p	74221	160p					BF173	25p	2N918	40p				
7489	320p	74251	140p					BF177	25p	2N930	18p				
7490	40p	74265	90p					BF178	28p	2N930	18p				
7491	85p	74278	290p					BF179	33p	2N1131	18p				
7492	55p	74279	140p					BF180	33p	2N1132	18p				
7493	40p	74283	190p					BF184	22p	2N1304	75p				
7494	90p	74290	150p					*BF185	9p	2N1305	75p				
7495	70p	74293	150p					*BF195	9p	2N1306	75p				
7496	84p	74298	200p					*BF196	14p	2N1307	75p				
7497	340p	74365	600p					BF197	15p	2N1308	75p				
74100	120p	74366	150p					BF200	32p	2N1309	75p				
74104	65p	74390	200p					BF257	32p	2N1613	25p				
74105	65p	74393	225p					BF258	36p	2N1711	25p				
VOLTAGE REGULATORS - FIXED - PLASTIC		1 Amp Positive		1 Amp Negative											
5V	7805	115p	5V	7905	160p										
12V	7812	115p	12V	7912	160p										
15V	7815	115p	15V	7915	160p										
18V	7818	115p	18V	7918	160p										
24V	7824	115p	24V	7924	160p										
LM309K	1 Amp 5V T05	140p	T8A6258	12V 0.5A T05	120p										
LM309H	100mA 5V T05	75p	LM323K	3A 5V	700p										
VARIABLE VOLTAGE REGULATOR		100mA T092													
723	2V to 37V	150mA	14 pin DIL	45p	70p										
LM317T	2V to 37V	1.5 Amp	T0220	DIL	300p										
LM327N	+5 and -12V	100mA	14 pin DIL	300p	80p										
TL470	2V to 30V	100mA	T0-92	70p	80p										
LOW PROFILE DIL SOCKETS BY TEXAS		Minimum Order £2		Mail Order Only											
8 pin	13p	14 pin	14p	16 pin	15p	18 pin	36p								
22 pin	40p	24 pin	50p	28 pin	60p	40 pin	75p								
		P&P 25p		Govt., Colleges, etc. orders accepted.											
		+ please add VAT to total													

G.F. MILWARD - ELECTRONIC COMPONENTS

RESIST COATED FIBRE-GLASS BOARD SINGLE SIDED

This is first-grade 1/16" board coated with positive resist. The sensitised surface is protected with removable light-proof adhesive film making it possible to handle boards in normal lighting and to cut to exact size prior to exposure

Standard board	204mm x 114mm	£1.50
Double board	204mm x 228mm	£3.00
Quad board	408mm x 228mm	£6.00
Giant board	610mm x 456mm	£9.00

Developer - 40p. Ferric Chloride - 75p

Plain Copper-clad Fibre-Glass

Approx 3/18mm thick

Single-sided £1.20 square foot
Double-sided £1.50 square foot

Approx 2/00mm thick

Single-sided £2.00 square foot
Double-sided £2.25 square foot

Approx 1/0mm thick

Single-sided £1.50 square foot
Double-sided £1.75 square foot

Computer Boards containing:

21 ICs, 24 Diodes resistors, capacitors £1.00
17 ICs, 26 Diodes, 3 Reed relays, etc £1.00
8 BC107B, 8 BCY 70, approx 80 other components, 2 for £1.00
Copper-clad paxolin 245mm x 150mm x 1/16" Pack of 10 sheets £2.50
Edge Connectors 18 x 2" Pack of 10 £1.00
Vero Boards 90mm x 90mm x 1" pack of 8 £3.00
Colour convergence controls, 10 assorted £1.00; 1N4005, 15 £1.00; Plastic 8C108C, 10 £1.00; 1N4148, 20 £1.00; BY126 10 £1.00; MEU 22 (PUJ) 8 £1.00; MJE 340, 4 £1.00; 2N3053 equiv 10 £1.00; Silicon Rectifiers, 100 £1.00; Zener 8XV88 type zener, untested, 200 £1.00; Resistors, assorted 100 £1.00; Capacitors, s/mica, ceramic, etc 100 £1.00;
3 000 reels 10" diameter 1/2" magnetic tape, used once only, all in excellent condition, packed in individual tins and cardboard orders **OPEN TO OFFERS!!**

FOTOLAK Light-sensitive lacquer

Positive resist in handy aerosol form. Just spray board, allow to dry, place positive of required circuit on sensitised surface, expose, develop and etch. You can produce your own perfect circuits within minutes rather than weeks! Widely accepted by industry as the perfect medium for all prototype work. One can will coat 1-1/2 square metres of board. £1.80 per can inclusive.

12 Volt Fluorescent Lighting

12" 8-watt fittings £3.75
21" 13-watt fittings £5.00
Complete with tube
Inverter transformers £1.00

SPECIAL OFFER!!! Orders over £10
£1 Credit voucher included for each £10 value of order
£15 Credit voucher included with £100 orders!!!
This offer is for a limited period only! Order today!

TEL. 021-327-2339

POSTAGE AND VAT INCLUDED

369 ALUM ROCK RD. B'HAM B8 3DR

This FM Mobile Radiotelephone has a voice that you can live with



RC625 with superior audio quality

Nothing wears a radiotelephone user more than listening to a 'squawk box.' Marconi Communication Systems Model RC625 gives you speech quality you can listen to all day. Compact, lightweight, FM radiotelephone with 10-channel capability. Outstanding reliability, with extended life and built-in ease of servicing. Built to withstand agricultural and industrial use and hostile environments — vibration, heat, cold and dirt. Quick and easy to install. Full range of ancillary equipment and facilities available. Ask for details of Model RC625 and of the full range of radiotelephones. Please direct U.K. enquiries to Mr A. E. Robinson; overseas enquiries to Mr P. Metheringham.

Marconi Communication Systems Limited Mobile Radio Division

Marrable House, Great Baddow, Chelmsford, Essex CM2 7QW, England
 Telephone: Chelmsford (0245) 73331 Telex: 99201
 A GEC-Marconi Electronics Company

WW—102 FOR FURTHER DETAILS

TRANSFORMERS

ALL EX-STOCK — SAME-DAY DESPATCH
MAINS ISOLATING VAT 8% 12 and/or 24-VOLT
 PRI 120/240V SEC 120/240V
 Centre Tapped and Screened Separate 12V windings Pri 220-240V

Ref.	VA (Watts)	£	P&P	Amps		£	P&P	
				12v	24v			
07*	20	4.40	79	111	0.5	0.25	2.20	45
149	60	6.20	96	213	1.0	0.5	2.64	78
150	100	7.13	114	71	2	1	3.51	78
151	200	11.16	114	18	4	2	4.03	96
152	250	12.79	150	70	6	3	5.35	96
153	350	16.28	184	108	8	4	6.98	114
154	500	19.15	215	72	10	5	7.67	114
155	750	29.06	OA	116	12	6	8.99	132
156	1000	37.20	OA	17	16	8	10.39	132
157	1500	45.60	OA	115	20	10	13.18	208
158	2000	54.80	OA	187	30	15	17.05	208
159	3000	79.05	OA	226	60	30	26.82	OA

*15 or 240 sec only State volts required

30 VOLT RANGE
 Primary 220-240V
 SEC. TAPS 0-12-15-20-24-30V
 12V 0.12V or 15V 0.15V available by connection to appropriate taps

Ref.	Amps	£	P&P
112	0.5	2.64	78
79	1.0	3.57	96
3	2.0	5.27	96
20	3.0	6.20	114
21	4.0	7.44	114
51	5.0	8.37	132
117	6.0	9.92	145
88	8.0	11.73	164
89	10.0	13.33	184

60 VOLT RANGE
 Primary 220-240V
 SEC TAPS 0-24-30-40-48-60V
 24V 0.24V or 30V 0.30V available by connection to appropriate taps

Ref.	Amps	£	P&P
124	0.5	3.88	96
126	1.0	5.58	96
127	2.0	7.60	114
125	3.0	10.54	132
123	4.0	12.23	184
40	5.0	13.95	164
120	6.0	15.66	184
121	8.0	20.15	OA
122	10.0	24.03	OA
189	12.0	27.13	OA

AUTO TRANSFORMERS
 Primary 220-240V

Ref.	VA (Watts)	TAPS	£	P&P
113	15	0-115-210-240V	2.48	71
64	75	0-115-210-240V	3.95	96
4	150	0-115-200-220-240V	5.35	96
66	300	...	7.75	114
67	500	...	10.99	164
84	1000	...	18.76	208
93	1500	...	23.28	OA
95	2000	...	34.82	OA
73	3000	...	48.00	OA

SCREENED MINIATURES Primary 240V

Ref.	mA	Volts	£	P&P
238	200	3-0-3	1.99	55
212	1A, 1A	0.6-0-0.6	2.85	78
13	100	9-0-9	2.14	38
235	330	0.9-0-0.9	1.99	38
207	500	0.8-9-0.8-9	2.59	71
208	1A, 1A	0.8-9-0.8-9	3.53	78
236	200	0.15-0-0.15	1.99	38
239	50mA	1.2-0-1.2	1.99	38
214	300, 300	0.20-0-0.20	2.56	78
221	700(DC)	20-12-0-12-20	3.41	78
206	1A, 1A	0.15-20-0.15-20	4.63	96
203	500, 500	0.15-27-0.15-27	3.99	96
204	1A, 1A	0.15-27-0.15-27	5.39	96
5112	500	0-12-15-20-24-30	2.64	78

CASED AUTO. TRANSFORMERS
 240V Cable Input USA 115V
 Flat pin outlets

	£	P&P	Ref.
15VA	£4.96	96	113W
75VA	£6.03	114	64W
150VA	£8.48	114	4W
200VA	£9.92	145	65W
500VA	£15.73	164	67W
750VA	£18.55	176	83W
1000VA	£22.58	OA	84W
1500VA	£26.02	OA	93W
2000VA	£37.65	OA	95W

TEST METERS

AV08 Mk 5	£71.00
AV071	£29.00
AV073	£39.10
AV0MM5 MINOR	£24.00
WEE MEGGER	£58.80
AVO TT169 (tests transistors in circuit, no soldering)	£30.00
U4315 budget meter (42 ranges) 20K Ω /VDC 1000V AC/DC (9 ranges) 2.5A AC/DC 500K Ω resistance, in robust steel case with leads, full instructions.	£14.95

Avo Cases and Accessories
 Ex-stock. P&P £1.15. VAT 8%

MINI-MULTIMETER
 DC1000V AC1000V
 AC/DC 1000 Ω /V
 DC-100mA Res — 150K
 Bargain at **£5.86**
 VAT 8% P&P 62p

PLASTIC CASES

PB1—77 x 56 x 37mm	46p
PB2—95 x 71 x 35mm	56p
PB3—115 x 95 x 37mm	60p

p&p 29p. VAT 8%

STEREO F.M. TUNER
 Phase lock loop 4 pre selected stations varicap tuning, switched AFC Beacon
£20.45
 P&P 40p (VAT 12 1/2 %)

STEREO 30
 Complete chassis inc 7+7w r.m.s. amps. pre-amp. power supply, front panel, knobs (needs mains trans.) **£19.05**. Mains trans **£3.57**. Teak veneered cab **£5.25**. P&P £1.02. VAT 12 1/2 %

PLUG-IN — SAVE BATTERIES!
3300. 6, 7.5, 9v at 300mA plugs direct into 13A socket (fused) **£3.30**
B12. 3, 4.5, 7.9, 12v 500mA **£5.32**
STABILISED 3. 6, 7.5, 9v at 400mA **£6.61**

ANTEX SOLDERING IRONS
 15W **£3.75**. 18W **£3.75**. 25W **£3.75**
 Stand for above **£1.40**. P&P 46p. VAT 8%

PLEASE ADD VAT AFTER P&P
 SEMI CONDUCTOR RESISTOR CAPACITOR SEMI CONDUCTOR
 AUDIO ACCESSORIES & BARGAIN PACKS SAVE POSTAGE
 CALLERS WELCOME (MON-FRI) OR SEND 15p STAMP FOR LISTS
 PRICES CORRECT AT 25/12/77

Barrie Electronics Ltd.
3, THE MINORIES, LONDON EC3N 1BJ
TELEPHONE: 01-488 3316/8
NEAREST TUBE STATIONS: ALDGATE & LIVERPOOL ST.

WW—049 FOR FURTHER DETAILS



NEW PRODUCTS!

NRDC-AMBISONIC UHJ



SURROUND SOUND DECODER

The **first ever** kit specially produced by Integrex for this British NRDC backed surround sound system which is the result of 7 years' research by the Ambisonic team. W.W. July, Aug., '77.

The unit is designed to decode not only UHJ but virtually all other 'quadrophonic' systems (Not CD4), including the new BBC HJ 10 input selections.

The decoder is linear throughout and does not rely on listener fatiguing logic enhancement techniques. Both 2 or 3 input signals and 4 or 6 output signals are provided in this most versatile unit. Complete with mains power supply, wooden cabinet, panel, knobs, etc.

Complete kit, including licence fee **£45.00 + VAT**
or ready built and tested **£61.50 + VAT**

INTRUDER 1 RADAR ALARM



With Home Office Type approval

As in "Wireless World", designed by Mike Hosking, 240V ac mains operated and disguised as a hardback book. Detection range up to 30 feet.

Complete exclusive designer approved kit **£46.00 + VAT**
or ready built and tested, **£54.00 + VAT**

Wireless World DolbyTM noise reducer

Trademark of Dolby Laboratories Inc.



Featuring:

- switching for both encoding (low-level h.f. compression) and decoding
- a switchable f.m. stereo multiplex and bias filter.
- provision for decoding Dolby f.m. radio transmissions (as in USA)
- no equipment needed for alignment.
- suitability for both open-reel and cassette tape machines
- check tape switch for encoded monitoring in three-head machines.

Typical performance

Noise reduction better than 9dB weighted.
Clipping level 16 dB above Dolby level (measured at 1% third harmonic content)

Harmonic distortion 0.1% at Dolby level typically 0.05% over most of band, rising to a maximum of 0.12%

Signal-to-noise ratio: 75dB (20Hz to 20kHz, signal at Dolby level) at Monitor output

Dynamic Range >90db

30mV sensitivity

Complete Kit **PRICE: £39.90 + VAT**

Also available ready built and tested

Price £54.00 + VAT

Calibration tapes are available for open-reel use and for cassette (specify which) **Price £2.20 + VAT**

Single channel plug-in DolbyTM PROCESSOR BOARDS (92 x 87mm) with gold plated contacts are available with all components **Price £8.20 + VAT**

Single channel board with selected fet **Price £2.50 + VAT**

Gold Plated edge connector **Price £1.50 + VAT ***

Selected FETs **60p** each + VAT, **100p** + VAT for two, **£1.90** + VAT for four

Please add VAT @ 12½% unless marked thus*, when 8% applies (or current rates)

We guarantee full after-sales technical and servicing facilities on all our kits, have you checked that these services are available from other suppliers?



INTEGREX LTD.

Please send SAE for complete lists and specifications
**Portwood Industrial Estate, Church Gresley,
Burton-on-Trent, Staffs DE11 9PT
Burton-on-Trent (0283) 215432 Telex 377106**

INTEGREX

S-2020TA STEREO TUNER / AMPLIFIER KIT

SOLID MAHOGANY CABINET

A high-quality push-button FM Varicap Stereo Tuner combined with a 24W r.m.s. per channel Stereo Amplifier.

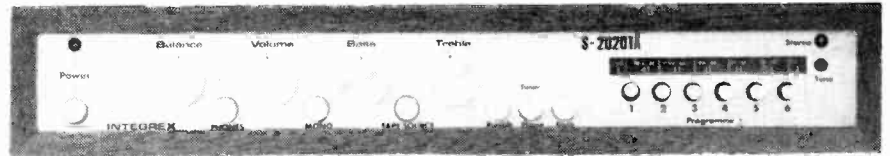

Brief Spec. Amplifier Low field Toroidal transformer, Mag. input, Tape In/Out facility (for noise reduction unit, etc.), THD less than 0.1% at 20W into 8 ohms. Power on/off FET transient protection. All sockets, fuses, etc., are PC mounted for ease of assembly. Tuner section uses 3302 FET module requiring no RF alignment, ceramic IF, INTERSTATION MUTE, and phase-locked IC stereo decoder. LED tuning and stereo indicators. Tuning range 88—104MHz. 30dB mono S/N @ 1.2µV. THD 0.3%. Pre-decoder 'birdy' filter.

PRICE: £58.95 + VAT

NELSON-JONES STEREO FM TUNER KIT

A very high performance tuner with dual gate MOSFET RF and Mixer front end, triple gang varicap tuning, and dual ceramic filter/dual IC IF amp.

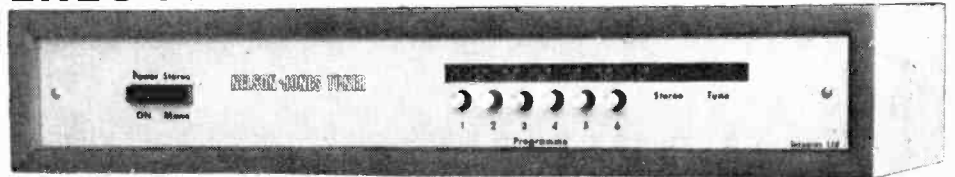

Brief Spec. Tuning range 88—104MHz. 20dB mono quieting @ 0.75µV. Image rejection — 70dB. IF rejection — 85dB. THD typically 0.4%. IC stabilized PSU and LED tuning indicators. Push-button tuning and AFC unit. Choice of either mono or stereo with a choice of stereo decoders.

Mono £32.40 + VAT

With ICPL Decoder £36.67 + VAT

With Portus-Haywood Decoder

£39.20 + VAT

Compare this spec. with tuners costing twice the price.



Sens. 30dB S/N mono @ 1.2µV
THD typically 0.3%
Tuning range 88—104MHz
LED sig. strength and stereo indicator

STEREO MODULE TUNER KIT

A low-cost Stereo Tuner based on the 3302 FET RF module requiring no alignment. The IF comprises a ceramic filter and high-performance IC Variable INTERSTATION MUTE. PLL stereo decoder IC. Pre-decoder 'birdy' filter Push-button tuning

PRICE: Stereo £31.95 + VAT



S-2020A AMPLIFIER KIT

Developed in our laboratories from the highly successful "TEXAN" design. PC mounting potentiometers, switches, sockets and fuses are used for ease of assembly and to minimize wiring

Power 'on/off' FET transient protection.

Typ Spec. 24+24W r.m.s. into 8-ohm load at less than 0.1% THD. Mag. PU input S/N 60dB. Radio input S/N 72dB. Headphone output. Tape In/Out facility (for noise reduction unit, etc.). Toroidal mains transformer

PRICE: £33.95 + VAT

ALL THE ABOVE KITS ARE SUPPLIED COMPLETE WITH ALL METALWORK, SOCKETS, FUSES, NUTS AND BOLTS, KNOBS, FRONT PANELS, SOLID MAHOGANY CABINETS AND COMPREHENSIVE INSTRUCTIONS

BASIC NELSON-JONES TUNER KIT	£14.28 + VAT	PHASE-LOCKED IC DECODER KIT	£4.47 + VAT
BASIC MODULE TUNER KIT (stereo)	£16.75 + VAT	PUSH-BUTTON UNIT	£5.00 + VAT
PORTUS-HAYWOOD PHASE-LOCKED STEREO DECODER KIT			£8.00 + VAT

U.K. RETURN OF POST MAIL ORDER SERVICE, ALSO WORLDWIDE EXPORT SERVICE

BSR HI-FI AUTOCHANGER STEREO AND MONO £21.50 Post 75p

Plays 12", 10" or 7" records Auto or Manual. A high quality unit backed by BSR reliability with 12 months' guarantee. A.C. 200/250V. Size 13 1/2 x 11 1/4 x 3 inches. Above motor board 3 3/4 in. Below motor board 2 1/2 in with Sonotone V100 magnetic cartridge



BSR P128/MP60 with magnetic cartridge. Balanced arm Cueing device Bias Compensator **£24.50**. Post £1

PORTABLE PLAYER CABINET

Modern design. Rexine covered Vynair front grille. Chrome fittings Size 17 x 15 x 8 in. approx Motor board cut for BSR or Garrard deck **£4.50** Post 75p

HEAVY METAL PLINTHS £6.50 Post £1 50

With P.V.C. Cover. Cut out for most BSR or Garrard decks. Silver grey finish Model A Size 12 1/2 x 14 3/4 x 7 1/2 in **£7.50** Model B Size 16 x 13 3/4 x 7 in Extra large plinth & cover teak wood base Size 20" x 17 1/2" x 9" **£18.50**. Callers only

BSR SINGLE PLAYER

ideal replacement or disco deck with cueing device and stereo ceramic cartridge. 3 speeds Large turntable, modern design **£15.50** Post 75p

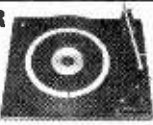

ELAC HI-FI SPEAKER 8in. TWIN CONE

Dual cone plastic roll surround. Large ceramic magnet 50-16,000 c/s. Bass resonance 40 c/s. 8 ohm impedance 10 watts. RMS **£5.95** Post 35p



SMITH'S CLOCKWORK 15 AMP TIME SWITCH

0-6 HOURS **£3.30** Post 35p Single pole two-way. Surface mounting with fixing screws. Will replace existing wall switch to give light for return home garage, automatic anti-burglar lights, etc. Variable knob. Turn on or off at full or intermediate settings. Brand new



TEAKWOOD LOUDSPEAKER GRILLES will easily fit to baffle board. Size 10 1/2 x 7 1/2 in - **45p.**

R.C.S. "MINOR" 10 watt AMPLIFIER KIT

This kit is suitable for record players, guitars, tape playback, electronic instruments or small P.A. systems. Two versions available. Mono. **£11.25**; Stereo. **£18**. Post 45p. Specification 10W per channel, input 100mV, size 9 1/2 x 3 x 2 in, approx. S.A.E. details. Full instructions supplied. AC mains powered.

VOLUME CONTROLS

5kΩ to 2MΩ LOG or LIN L/S **35p**. D.P. **60p**. STEREO L/S **85p**. D.P. **£1**. Edge 5K S.P. Transistor **45p**.

80 Ohm Coax 8p yd.

FRINGE LOW LOSS **15p yd.** Ideal 625 and colour PLUGS **10p**. SOCKETS **10p**. LINE SOCKETS **18p**. OUTLET BOXES **60p**. 300 ohm FEEDER **5p yd**

ELAC 9 x 5in HI-FI SPEAKER TYPE 59RM £3.45 Post 35p

This famous unit now available 10 watts 8 ohm

E.M.I. 13 1/2 x 8in. SPEAKER SALE!

With twin tweeter and crossover 10 watt 3 or 8 ohm. Ditto 15 watts. 8 ohm

£7.95 Post 45p **£10.50** Post 65p

With tweeter and crossover 20 watt Bass res 25 c.p.s. Flux = 11,000 gauss Post 75p 8 or 15 ohm 20 to 20,000 c.p.s

£11.50 Post 75p

Bookshelf Cabinet Teak finish. For EMI 13 x 8 speakers **£8.50** Post £1 00

THE "INSTANT" BULK TAPE ERASER AND HEAD DEMAGNETISER. Suitable for cassettes, and all sizes of tape reels. A.C. mains 200/250V. Leaflet S.A.E. **£4.95** Post 50p

RELAYS. 12V D.C. **95p**. 6V D.C. **85p**. 240V A.C. **95p**. **BLANK ALUMINIUM CHASSIS.** 6 x 4 - **70p**; 8 x 6 - **90p**; 10 x 7 - **£1.15**; 12 x 8 - **£1.35**; 14 x 9 - **£1.50**; 16 x 6 - **£1.45**; 16 x 10 - **£1.70**. **ANGLE AL.** 6 x 3/4 x 1/4 in - **15p**. **ALUMINIUM PANELS.** 6 x 4 - **17p**; 8 x 6 - **24p**; 14 x 3 - **25p**; 10 x 7 - **35p**; 12 x 8 - **43p**; 12 x 5 - **30p**; 16 x 6 - **43p**; 14 x 9 - **52p**; 12 x 12 - **68p**; 16 x 10 - **75p**. **ALI BOXES IN STOCK.** MANY SIZES. **VARICAP FM TUNER HEAD** with circuit & connections **£4.95**. **TAG STRIP** 28-way **12p**. **TAPE OSCILLATOR COIL.** Valve type. **35p**. **BRIDGE RECTIFIER** 200V PIV 1/2 amp **50p**. 8 amp **£2.50**. **TOGGLE SWITCHES** S.P. **30p**. D.P. S.T. **40p**. D.P. D.T. **50p**. **MANY OTHER TOGGLES IN STOCK**. **PICK-UP CARTRIDGES** ACOS. GP91 **£1.50**. GP93 **£2.50**. **SONOTONE** stereo **£2.00**. **SHURE** M75 ECS **£8**. **WIRE-WOUND RESISTORS** 5 watt, 10 watt, 15 watt **15p ea.**

R.C.S. SOUND TO LIGHT KIT Mk. 2

Kit of parts to build a 3 channel sound to light unit **£17** Post 35p
1,000 watts per channel
Easy to build. Full instructions supplied. Cabinet **£4**.
Will operate from 20MVA to 100 watt signal

R.C.S. LOW VOLTAGE STABILISED POWER PACK KITS £2.95 Post 45p

All parts and instructions with Zener diode printed circuit rectifiers and double wound mains transformer. Input 200/240V a.c. Output voltages available. 6 or 7.5 or 9 or 12V d.c. up to 100mA or less. Size 3 x 2 1/2 x 1 1/2 in. Please state voltage required

R.C.S. POWER PACK KIT £3.35 Post 30p

12 VOLT. 750mA. Complete with printed circuit board and assembly instructions

12 VOLT 300mA KIT. **£3.15**.

R.C.S. GENERAL PURPOSE TRANSISTOR PRE-AMPLIFIER - BRITISH MADE

Ideal for Mike. Tape. P.U. Guitar, etc. Can be used with battery 9-12V or H.T. line 200-300V d.c. operation. Size 1 1/4 x 1 1/4 x 1/4 in. Response 25 c/s to 25 kc/s. 26 dB gain. For use with valve or transistor equipment. Full instructions supplied. Details S.A.E. **£1.45** Post 30p

R.C.S. DRILL SPEED CONTROLLER/LIGHT DIMMER KIT. £3.25 Post 35p

Easy to build kit. Will control up to 500 watts AC mains

R.C.S. STEREO PRE-AMP KIT. £2.95 Post 35p

All parts to build this pre-amp. Inputs for high, medium or low imp. per channel, with volume control and P.C. Board. Can be ganged to make multi-way stereo mixers

MAINS TRANSFORMERS ALL POST 50p

240-0-250V 70mA. 6 SV. 2A	£3.45
250-0-250V 80mA. 6 3V 3 5A. 6 3V 1A or 5V 2A	£4.60
350-0-350V 80mA. 6 3V 3 5A. 6 3V 1A or 5V 2A	£5.80
300-0-300V 120mA. 2x6 3V 2A CT. 5V 2A	£6.50
220V 45mA. 6 3V 2A	£1.75
HEATED TRANS 6 3V 1/2 amp	£1.00
GEN. PURP. LOW VOLTAGE Tapped outputs 2 amp 3, 4, 5, 6, 9, 10, 12, 15, 18, 25 and 30V	£5.30
1 amp 8, 10, 12, 16, 18, 20, 24, 30, 36, 40, 48, 60	£5.30
2 amp 6, 10, 12, 16, 18, 20, 24, 30, 36, 40, 48, 60	£8.50
3 amp 6, 10, 12, 16, 18, 20, 24, 30, 36, 40, 48, 60	£11.00
4 amp 6, 10, 12, 16, 18, 20, 24, 30, 36, 40, 48, 60	£14.50
12V 100mA	£1.00
12V 750mA	£1.00
20V 3 amp	£2.45
30V 5 amp and 17V 0.17V 2 amp	£3.45
0.5 8 10 16V 1/2 amp	£1.95
9V 3 amp	£2.75
24V 3 amp + 48V 1/2 amp	£3.50
30V 1/2 amp	£2.75
AO TRANSFORMERS 115V to 230V or 230V to 115V 150W	£5.00
250W	£6.00
400W	£7.00
500W	£8.00
FULL WAVE BRIDGE CHARGER RECTIFIERS 8 or 12V outputs 2 amp 75p. 4 amp £1.00	
CHARGER TRANSFORMERS 1/2 amp £3.50	
4 amp £6.80	
12V 1/2 amp Half Wave Selenium Rectifier	25p

R.C.S. BOOKSHELF SPEAKERS £16 pair Post £1 30

13 x 10 x 6 in. 50 to 14,000 cps. 8 watts rms 8 ohms

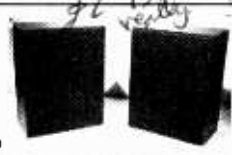

EXTENSION SPEAKERS £3.95 ea.

These little marvels of modern sound reproduction are ideally suited for today's domestic audio set-up. Two of these smart spheres, each with 5 watt deep throated ceramic magnets, will produce superb stereo reproduction.

The globe shaped cases in high gloss mouldings of red or green are finished with chrome frontal trim and provided with screw-on rubber inset protective bases. In addition, 2 1/2 metres of strong lead already fitted with phono plug is supplied. Full Range. Frequency Response Impedance 8 ohms Power Peak 5 watts



LOW VOLTAGE ELECTROLYTICS

1. 2. 4. 5. 8. 16. 25. 30. 50. 100. 200mF 15V **10p**. 500mF 12V **15p**; 25V **20p**; 50V **30p**; 1000mF 12V **17p**; 25V **35p**; 50V **47p**; 100V **70p**. 2000mF 6V **25p**; 25V **42p**; 420mF/500V **£1.30**. 2500mF 50V **£2.60**; 3000mF 25V **47p**; 50V **65p**. 3900mF 100V **£1.60**. 4700mF 63V **£1.20**. 2700mF/76V **£1.50**. 5000mF 6V **25p**; 12V **42p**; 35V **85p**; 5600mF/76V **£1.75**. **MANY OTHER ELECTROLYTICS IN STOCK**

SHORT WAVE 100pF air spaced gangable tuner. 95p.

TRIMMERS 10pF. 30pF. 50pF. 5p. 100pF. 150pF. 15p. CERAMIC 1pF to 0.01mF. 5p. Silver Mica 2 to 5000pF. 5p. PAPER 350V/0.1 7p; 0.5 13p; 1mF 150V 20p; 2mF 150V 20p; 500V/0.001 to 0.05 5p; 0.1 10p; 0.25 13p; 0.47 25p. MICRO SWITCH SINGLE POLE CHANGEOVER 20p. TWIN GANG, 385 & 385pF 50p; 500pF standard 75p. 365 + 365 + 25 + 25pF. Slow motion drive 65p. 120pF TWIN GANG, 50p; 365pF TWIN GANG, 50p. NEON PANEL INDICATORS 250V. Amber or red 30p. RESISTORS. 1/4W. 1/2W. 1W. 20% 2p; 2V. 10p; 100 to 10M HIGH STABILITY. 1/2W 2% 10 ohms to 6 meg. 12p. Ditto 5%. Preferred values 10 ohms to 10 meg. 5p.

ELECTRO MAGNETIC PENDULUM MECHANISM 95p Post 30p.

1.5V d.c. operation over 300 hours continuous on SP2 battery. fully adjustable swing and speed. Ideal displays. teaching electro magnetism or for metronome, strobe, etc.

BAKER MAJOR 12" £15.00 Post £1.00

30-14,500 c/s. 12in. double cone. woofer and tweeter cone together with a BAKER ceramic magnet assembly having a flux density of 14,000 gauss and a total flux of 145,000 Maxwells. Bass resonance 40 c/s. Rated 25W. NOTE. 4 or 8 or 16 ohms must be stated.

Module kit. 30-17,000 c/s with tweeter, crossover, baffle and instructions. Post **£1.60** each. Please state 4 or 8 or 16 ohms. **£19.00**

BAKER "BIG-SOUND" SPEAKERS. Post £1.00 each
Group 25' **Group 35'** **Group 50/15'**
12in **£12.00** 12in **£14.00** 15in **£26.00**
30W 4 or 8 or 16 ohm 40W 4 or 8 or 16 ohm 75W 8 or 16 ohm

BAKER LOUDSPEAKER, 12 INCH. 60 WATT. GROUP 50/12, 4 OR 8 OR 16 OHM HIGH POWER. FULL RANGE PROFESSIONAL QUALITY RESPONSE 30-16,000 CPS. MASSIVE CERAMIC MAGNET WITH ALUMINIUM PRESENCE CENTRE DOME. **£21.00** Post £1.60

TEAK VENEERED HI-FI SPEAKERS AND CABINETS For 12in. or 10in. speaker 20x13x12in **£14.50** Post £2 For 13x8in. or 8in. speaker **£8.50** Post £1 For 6 1/2in. speaker and tweeter 12x8x6in. **£5.80** Post 75p Many other cabinets in stock. Phone your requirements.

SPEAKER COVERING MATERIALS. Samples Large S.A.E. **LOUDSPEAKER CABINET WADDING** 18in wide 20p ft

R.C.S. 100 watt VALVE AMPLIFIER CHASSIS

Four inputs. Four way mixing, master volume, treble and bass controls. Suits all speakers. This professional quality amplifier chassis is suitable for all groups, disco, P.A., where high quality power is required. 5 speaker outputs, A/C mains operated. Slave output socket. Produced by demand for a quality valve amplifier 100V line output to order. Suitable carrying cab **£16.50** Price **£94** carr. **£2.50**



Horn tweeters 2-16kc/s 10W 8 ohm or 16 ohm **£3.60**. De Luxe Horn Tweeters 3-18kc/s. 30W 8 ohm **£7.50**. **CROSSOVERS. TWO-WAY** 3000 c/s 3 or 8 or 15 ohm **£1.90**. 3-way 950 cps/3 000 cps. **£2.20**. **LOUDSPEAKERS P.M. 3 OHM** 7x4in. **£1.50**; 6 1/2in. **£1.80**; 8x5in. **£1.90**; 8in. **£1.95**. **SPECIAL OFFER:** 80 ohm 2 1/2in., 2 3/4in., 35 ohm, 3in., 25 ohm, 2 1/2in., 3in., 5x3in., 7x4in., 8 ohm, 2 1/2in., 3in., 3 1/2in., 5in., 15 ohm, ohm, 3 1/2in. dia. 6x4in., 7x4in., 5x3in., 3 ohm, 2 1/2in., 2 3/4in., 3 1/2in., 5in. dia **£1.50 each**. **PHILIPS LOUDSPEAKER, 8in., 4 ohms, 4 watts. £1.95** **RICHARD ALLAN TWIN CONE LOUDSPEAKERS** Bin diameter 4W **£2.50**, 10in diameter **5W £2.95**; 12in. diameter 6W **£3.50**, 3/8/15 ohms, please state. **PIEZO ELECTRIC HORN TWEETER.** Handles up to 100 watts. No crossover required. **£7.95**.

Plastic Construction Box with brushed alu. facia. Size 6 1/4 x 4 1/4 x 2in **£1.50**

BAKER 150 WATT PROFESSIONAL MIXER AMPLIFIER

All purpose transistorised. Ideal for Groups, Disco and PA. 4 inputs speech and music 4 way mixing. Output 4 8/16 ohms a.c. Mains. Separate treble and bass controls. Master volume control. Guaranteed. Details S.A.E. **£75** £1 50 carr.

100 WATT DISCO AMPLIFIER

volume, treble, bass controls 500 M.V. or 1 volt input Four loudspeaker outputs 4 to 16 ohm All transistor **£59**

GOODMANS COMPACT 12-INCH BASS WOOFER

Standard 12in diameter fixing with cut sides 10 3/4 square. 14,000 Gauss magnet. 30 watts R.M.S. 4 ohm imp. Bass resonance = 30 c.p.s. Frequency response 30-8000 c.p.s. **£10.95 each** Post £1

ALUMINIUM HEAT SINKS. FINNED TYPE.

Sizes 6 1/2" x 4 1/2" x 2 1/4" **95p**. 6 1/2" x 2" x 2 1/4" **65p**. **BALANCED TWIN RIBBON FEEDER 300 ohms. 5p yd.** **JACK SOCKET Std. open-circuit 20p, closed circuit 25p;** **Chrome Lead-Socket 45p. Mono or Stereo.** **Phono Plugs 8p. Phono Socket 8p.** **JACK PLUGS Std. Chrome 30p; Plastic 25p; 3.5mm 15p.** **STEREO JACK PLUG 30p. SOCKET 25p.** **DIN SOCKETS Chassis 3-pin 10p. 5-pin 10p.** **DIN SOCKETS FREE 3-pin 25p; 5-pin 25p. DIN PLUGS 3-pin 25p; 5-pin 25p. VALVE HOLDERS, 10p; CANS 10p.** **TV CONVERGENCE POTS 15p each** Values = 5, 7, 10, 20, 50, 100, 200, 250, 470, 2000 ohms.

MONO PRE-AMPLIFIER.

Mains operated solid state pre-amplifier unit designed to complement amplifiers without low level phono and tape input stages. This free-standing cabinet incorporates circuitry for automatic R.I.A. equalisation on magnetic phono input and N.A.B. equalisation for tape heads. Power ON/OFF. PHONO/TAPE switches and pilot lamp are on the front panel, phono socket input and output are rear located. **£4.50 each or £8 pair.** Post 50p

WIRE-WOUND RESISTORS 5 watt, 10 watt, 15 watt 15p ea.

WIRE-WOUND RESISTORS 5 watt, 10 watt, 15 watt 15p ea.

WIRE-WOUND RESISTORS 5 watt, 10 watt, 15 watt 15p ea.

WIRE-WOUND RESISTORS 5 watt, 10 watt, 15 watt 15p ea.

WIRE-WOUND RESISTORS 5 watt, 10 watt, 15 watt 15p ea.

WIRE-WOUND RESISTORS 5 watt, 10 watt, 15 watt 15p ea.

WIRE-WOUND RESISTORS 5 watt, 10 watt, 15 watt 15p ea.

WIRE-WOUND RESISTORS 5 watt, 10 watt, 15 watt 15p ea.

WIRE-WOUND RESISTORS 5 watt, 10 watt, 15 watt 15p ea.

WIRE-WOUND RESISTORS 5 watt, 10 watt, 15 watt 15p ea.

WIRE-WOUND RESISTORS 5 watt, 10 watt, 15 watt 15p ea.

WIRE-WOUND RESISTORS 5 watt, 10 watt, 15 watt 15p ea.

WIRE-WOUND RESISTORS 5 watt, 10 watt, 15 watt 15p ea.

WIRE-WOUND RESISTORS 5 watt, 10 watt, 15 watt 15p ea.

WIRE-WOUND RESISTORS 5 watt, 10 watt, 15 watt 15p ea.

WIRE-WOUND RESISTORS 5 watt, 10 watt, 15 watt 15p ea.

WIRE-WOUND RESISTORS 5 watt, 10 watt, 15 watt 15p ea.

WIRE-WOUND RESISTORS 5 watt, 10 watt, 15 watt 15p ea.

WIRE-WOUND RESISTORS 5 watt, 10 watt, 15 watt 15p ea.

WIRE-WOUND RESISTORS 5 watt, 10 watt, 15 watt 15p ea.

WIRE-WOUND RESISTORS 5 watt, 10 watt, 15 watt 15p ea.

WIRE-WOUND RESISTORS 5 watt, 10 watt, 15 watt 15p ea.

WIRE-WOUND RESISTORS 5 watt, 10 watt, 15 watt 15p ea.

WIRE-WOUND RESISTORS 5 watt, 10 watt, 15 watt 15p ea.

WIRE-WOUND RESISTORS 5 watt, 10 watt, 15 watt 15p ea.

WIRE-WOUND RESISTORS 5 watt, 10 watt, 15 watt 15p ea.

WIRE-WOUND RESISTORS 5 watt, 10 watt, 15 watt 15p ea.

WIRE-WOUND RESISTORS 5 watt, 10 watt, 15 watt 15p ea.

WIRE-WOUND RESISTORS 5 watt, 10 watt, 15 watt 15p ea.

WIRE-WOUND RESISTORS 5 watt, 10 watt, 15 watt 15p ea.

WIRE-WOUND RESISTORS 5 watt, 10 watt, 15 watt 15p ea.

AUDIO KITS OF DISTINCTION FROM NEW! DE LUXE EASY TO BUILD LINSLEY-HOOD 75W AMPLIFIER

POWERTRAN

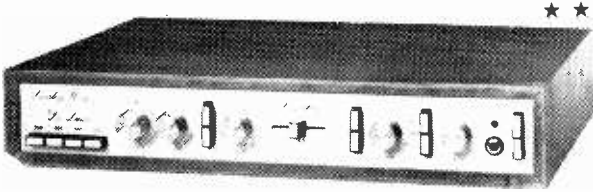

AVAILABLE AS SEPARATE PACKS
PRICES IN OUR FREE CATALOGUE

SPECIAL PRICE FOR COMPLETE KIT £99.30

PACK PRICES FOR STANDARD KIT

| Pack | Price | Pack | Price |
|---|--------|---|--------|
| 1. Fibreglass printed circuit board for power amp | £1.15 | 11. Fibreglass printed-circuit board for power supply | £0.85 |
| 2. Set of resistors, capacitors, pre-sets for power amp | £2.50 | 12. Set of resistors, capacitors, secondary fuses, semiconductors for power supply | £5.40 |
| 3. Set of semiconductors for power amp | £6.50 | 13. Set of miscellaneous parts including DIN skts., mains input skt., fuse holder, interconnecting cable, control knobs | £6.20 |
| 4. Pair of 2 drilled, finned heat sinks | £1.10 | 14. Set of metalwork parts including silk screen printed fascia panel and all brackets, fixing parts, etc. | £8.20 |
| 5. Fibreglass printed-circuit board for pre-amp | £1.90 | 15. Handbook | £0.30 |
| 6. Set of low noise resistors, capacitors, pre-sets for pre-amp | £4.10 | 16. Teak cabinet 18.3" x 12.7" x 3.1" | £10.70 |
| 7. Set of low noise, high gain semiconductors for pre-amp | £2.40 | | |
| 8. Set of potentiometers (including mains switch) | £3.50 | | |
| 9. Set of 4 push-button switches, rotary mode switch | £5.40 | | |
| 10. Toroidal transformer complete with magnetic screen/ housing primary: 0 117-234 V; secondaries: 33-0-33 V, 25-0-25 V | £12.95 | | |

2 each of packs 1-7, 1 each of packs 8-16 inclusive are required for complete stereo amplifier. Total cost of individually purchased packs £92.80

The standard model of our kit for Mr. Linsley Hood's 75 watt design has for a long time offered exceptional performance at a very modest cost with high quality high power ready built units of comparable quality generally being over three times the price

Features of the amplifier include very low distortion (less than 0.01%), 75W rms per channel power output, rumble filter, variable slope scratch filter, variable transition frequency tone controls, tape monitoring facilities and individually adjustable inputs. This model is based on 5 circuit boards which not having the controls mounted on them can, if desired, be effectively used separately in high performance audio systems not based on our metalwork

Our new De Luxe model uses 14 boards which interconnect with gold plated contacts and are designed to have the potentiometers and switches mounted upon them. This system almost eliminates internal wiring, making installation after their assembly delightfully straightforward and as each board can be easily removed in seconds from the chassis, checking and maintenance is so simple that even newcomers to electronics will be able to cope competently with the kit. Additional features of our new model are inclusion of the latest circuit improvements, generously sized heat sinks for heavy duty use, even in tropical climates, and metal oxide resistors throughout for long term stability and reliability.

STANDARD LINSLEY-HOOD 75W AMPLIFIER

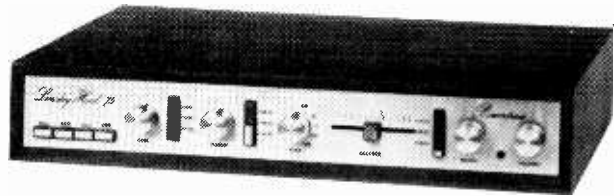

SPECIAL PRICE FOR COMPLETE KIT £79.80

Designed in response to demand for a tuner to complement the world-wide acclaimed Linsley-Hood 75W Amplifier, this kit provides the perfect match. The Wireless World (Skingley and Thompson) published original circuit has been developed further for inclusion into this outstanding slimline unit and features a pre-aligned front end module, excellent a.m. rejection and temperature compensated varicap tuning, which may be controlled either continuously or by push-button pre-selection. Frequencies are indicated by a frequency meter and sliding LED indicators, attached to each channel selector pre-set. The PLL stereo decoder incorporates active filters for "birdy" suppression and power is supplied via a toroidal transformer and integrated regulator. For long term stability metal oxide resistors are used throughout.

AVAILABLE AS SEPARATE PACKS - PRICES IN OUR FREE CATALOGUE

WIRELESS WORLD FM TUNER

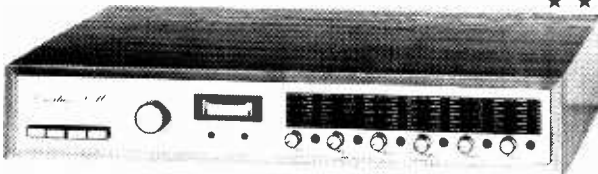

SPECIAL PRICE FOR COMPLETE KIT £70.20

LINSLEY-HOOD CASSETTE DECK

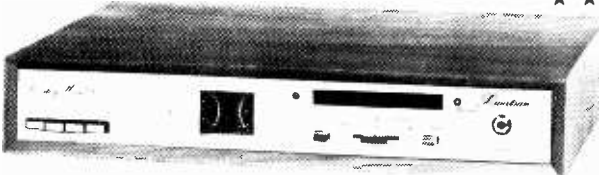

SPECIAL PRICE FOR COMPLETE KIT £79.60

Published in Wireless World (May, June, August 1976) by Mr. Linsley-Hood, this design, although straightforward and relatively low cost, nevertheless provides a very high standard of performance. To permit circuit optimization separate record and replay amplifiers are used, the latter using a discrete component front-end designed such that the noise level is below that of the tape back ground. Push button switches are used to provide a choice of equalization time constants, a choice of bias levels and also an option of using an additional pre-amplifier for microphone use. The mechanism used is the Goldring-Lenco CRV, a unit distinguished in its robustness and ease of operation. Speed control and automatic cassette ejection are both implemented by electronic circuitry. This unit which is powered by a toroidal transformer and uses metal oxide resistors throughout offers an excellent match for the Wireless World Tuner and the Linsley-Hood 75 Watt Amplifier. Circuit changes as published in February, 1978, follow-up article are included in the kit AT NO EXTRA COST! A higher performance head (Matsushita WY 436 AZ head as recommended in the follow-up article) is offered as an optional extra but this will be automatically supplied FREE OF CHARGE with all orders for complete kits!

| Pack | Price | Pack | Price |
|---|--------|--|--------|
| 1. Stereo PCB (accommodates 2 rep. amps, 2 meter amps, bias/erase osc. relay) | £3.35 | 10. Set of capacitors, rectifiers, I.C. voltage regulator P.C.B. for power supply (Powertran design) | £2.80 |
| 2. Stereo set of capacitors, M.D. resistors, potentiometers for above | £7.95 | 11. Set of miscellaneous parts, including sockets, fuse holder, fuses, interconnecting wire, etc. | £3.40 |
| 3. Stereo set of semiconductors for above | £8.50 | 12. Set of metalwork including silk screened fascia panel, internal screen, fixing parts, etc. | £7.10 |
| 4. Miniature relay with socket | £2.90 | 13. Construction notes | £0.25 |
| 5. PCB, all components for solenoid, speed control circuits | £3.80 | 14. Teak cabinet 18.3" x 12.7" x 3.1" | £10.70 |
| 6. Goldring-Lenco mechanism as specified | £18.50 | | |
| 7. Function switch, knobs | £1.90 | | |
| 8. Dual VU meter with illuminating lamp | £6.95 | | |
| 9. Toroidal transformer with E.S. screen prim. 0-117V, 234V, Sec. 15V | £4.90 | | |

One each of packs 1-14 inclusive are required for complete stereo cassette deck. Total cost of individually purchased packs £83.00

Matsushita WY 436 AZ head (optional extra) £4.50 (free with complete kit)

| Pack | T20 | T30 | Pack | T20 | T30 |
|--|-------|-------|--------------------------------------|-------|-------|
| 1. Set of low noise resistors | £1.60 | £1.70 | 9. Fibreglass PCB | £3.50 | £3.90 |
| 2. Set of small capacitors | £2.60 | £3.40 | 10. Set of metalwork, fixing parts | £5.20 | £6.20 |
| 3. Set of power supply capacitors | £2.20 | £2.50 | 11. Set of cables, mains lead | £0.40 | £0.40 |
| 4. Set of miscellaneous parts | £3.50 | £3.50 | 12. Handbook | £0.25 | £0.25 |
| 5. Set of slide, mains, P.B. switches | £1.50 | £1.50 | 13. Teak cabinet 15.4" x 6.7" x 2.8" | £4.50 | £4.50 |
| 6. Set of pots., selector switch | £2.80 | £2.80 | | | |
| 7. Set of semiconductors, I.Cs, skts. | £7.25 | £7.75 | | | |
| 8. Toroidal transformer-240V prim. e.s. screen | £5.60 | £7.20 | | | |

One each of Pack 1-13 are required for complete stereo amplifier. Total cost of individually purchased packs T20+20 £40.90, T30+30 £45.60.

Designed by Texas engineers and described in Practical Wireless, the Texan was an immediate success. Now developed further in our laboratories to include a Toroidal transformer and additional improvements, the slimline T20+20 delivers 20W rms per channel of true Hi-Fi at exceptionally low cost. The easy to build design is based on a single F/Glass PCB and features all the normal facilities found on quality amplifiers including scratch and rumble filters, adaptable input select for and headphones socket. In a follow up article in Practical Wireless further modifications were suggested and these have been incorporated into the T30+30. These include RF interference filters and a tape monitor facility. Power output of this model is 30W rms per channel.

T20 + 20 AND T30 + 30 20W, 30W AMPLIFIERS

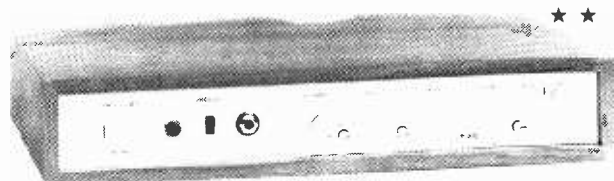

SPECIAL PRICES FOR COMPLETE KITS

T20+20 KIT PRICE £33.10

T30+30 KIT PRICE £38.40

EXPORT A SPECIALITY!

Our Export Department can readily despatch orders of any size to any country in the world. Some of the countries to which we sent kits last year are shown in this advertisement. To assist in estimating postal costs our catalogue gives the weights of all packs and kits. This will be sent free on request, by airmail, together with our 'Export Postal Guide' which gives current postage prices.

EXPORT ORDERS: No minimum order charge! Prices same as for U.K. customers but no Value Added Tax charged. Postage charged at actual cost plus 50p documentation and handling. Please send payment with order by Bank Draft, Postal Order, International Money Order or cheque drawn on an account in the U.K. Alternatively for orders over £500 we will accept Irrevocable Letter of Credit payable at sight in London.

MUSCAT & OMAN
FRANCE
DENMARK
GAMBIA
AUSTRALIA
HONG KONG
NAURU
GERMANY
TUNISIA
LUXEMBOURG
NIGERIA
FINLAND
AFRICA
SOUTH AFRICA
CZECHOSLOVAKIA
AUSTRIA

NEW GUINEA
ISRAEL
GUERNSEY
CYPRUS
BELGIUM
UGANDA
BRUNEI
TRINIDAD
SOUTH WEST AFRICA
ITALY
JAVA
SIERRA LEONE
WINDWARD ISLANDS
CANADA
MALTA

WWII TUNER ★ ★

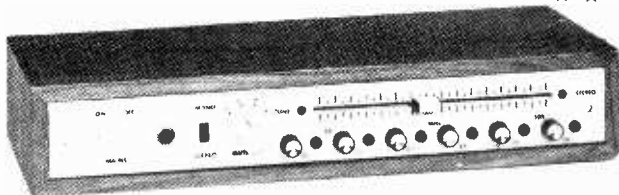

SPECIAL PRICE FOR COMPLETE KIT £47.70

AVAILABLE AS SEPARATE PACKS — PRICES IN OUR FREE CATALOGUE

Following the success of our **Wireless World FM Tuner Kit** this cost reduced model was designed to complement the **T20+20** and **T30+30** amplifiers and the cabinet size, front panel format and electrical characteristics make this tuner compatible with either. The frequency meter of the more advanced model has been omitted and the mechanics simplified however the circuitry is identical and this kit offers most outstanding value for money. Facilities included are switchable afc, adjustable, switchable muting LED tuning indication and both continuous and push-button channel selection (readily adjusted by controls on the front panel)

POWERTRAN SFMT TUNER ★ ★

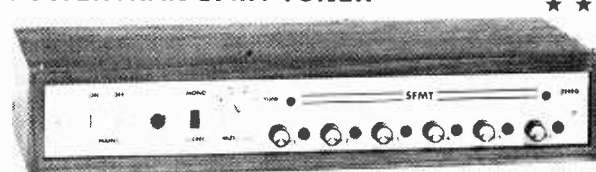

PRICE FOR COMPLETE KIT £35.90

AVAILABLE AS COMPLETE KIT ONLY

The requirement was a simple, low cost design which could be constructed easily without special alignment equipment but which still gives a first class output suitable for feeding any of our very popular amplifiers or any other high quality audio equipment. Not finding a suitable published circuit, the requirement was met by design and development work in our own laboratories and this tuner which uses a pre-aligned front end module can be set up with the aid of nothing more sophisticated than a multi-meter. A phase-locked-loop is used for stereo decoding and controls include switchable afc, switchable muting and push-button channel selection (adjustable by controls on the front panel). This unit matches well with the **T20+20** and **T30+30** amplifiers

**INTERNATIONAL POWERSLAVE
200 watt AMPLIFIER**

COMPLETE KIT AS FEATURED IN ELECTRONICS TODAY INTERNATIONAL

Super-Fi performance for studio/monitoring/h-fi use with the inherent reliability and ruggedness for the most demanding group/disco applications.

Features

- ★ over 200W rms continuous from each of 2 totally independent DC coupled amplifiers — over 800W peak power!
- ★ highly original fully complementary high linearity o/p stage utilizing the inherent symmetry of no less than 4 differential pairs!
- ★ ultra low feedback (an incredible low 14dB overall!) together with super high slewing rate (20/μS) banish ricochet effects and TID!
- ★ distortion only 0.03% at FULL power 1KHz rising to only 0.07% at 10KHz (how many high power amplifier producers dare to quote at this frequency?)
- ★ independent stabilized power supplies driven by custom designed TOROIDAL transformers
- ★ inherent reliability — monster heat sinks for cool running at the hottest venues — electronic open and short circuit protection — 4 rugged power transistors/amplifier — each 250W rating
- ★ professional quality — metal oxide resistors, cermet adjusters, fibre glass boards, sturdy 19" rack mounting cabinet complete with sieve and feet for free standing work too
- ★ easy to build — plenty of working space with ready access to all components, minimal wiring, extensive instructions suitable for both experienced constructors and newcomers to electronics — can be purchased one channel at a time
- ★ value for money — quality and performance comparable with ready-built amplifiers costing over £600!

NEW!



PSI 4001 SLAVE MODEL

**OVER 800W
PEAK POWER!**



PSI 4002 STUDIO MODEL

| Pack | Price |
|--|--------|
| 1. Fibre glass printed circuit board for power amp | £4.20 |
| 2. Set of capacitors, metal oxide resistors, thermistor, cermet pre-sets for power amp | £6.40 |
| 3. Set of semiconductors for power amp with mounting hardware, cooling tabs | £27.60 |
| 4. Pair of monster black drilled heat sinks, transistor mounting bracket | £6.90 |
| 5. Toroidal transformer, Primary 0-117V-234V, Secondaries 42-0-42V, 0-15V, 0-15V, Electrostatic screen | £19.20 |
| 6. Set of all parts for stabilized power supply including fibre glass printed circuit board, mounting bracket, semiconductors, resistors, capacitors, etc | £20.50 |
| 7A. Set of all parts for buffer/overdrive unit including fibre glass printed circuit board, semiconductors, resistors, capacitors, controls — required for PSI 4001 only | £3.00 |

| Pack | Price |
|--|--|
| 7B. Set of parts for peak power meter including professional quality meter, fibre glass printed circuit board, components, controls — required for PSI 4002 only | £11.50 |
| 8. Set of all miscellaneous parts including sockets, illum. mains switches, fuse holders, fuses, cut-outs, cable, etc | £12.10 |
| 9. Cabinet, including chassis, anodized silver on black panels, fixing parts etc. Please state whether Slave or Studio model required | £27.50 |
| 10. Handbook £0.50 or free on request when ordering any of above packs. | |
| 2 each of packs 1-7 (A or B), 1 each 8, 9 and 10 are required for complete 200 + 200W professional amplifier. | |
| Total cost of individually purchased packs | PSI 4001 £216.80
PSI 4002 £232.20 |

SPECIAL OFFER PRICES FOR COMPLETE KITS — (PSI 4001 £205.00 — PSI 4002 £220.00)

Wireless World Designs: Full kits are not available for the projects below but PCBs and component sets are stocked. Further details of these and other packs are in our Free Catalogue

| 30W Bailey Amplifier | Regulated Power Supply for Bailey Amplifier | Price |
|--|---|-------|
| BAIL Pk 1 F. Glass PCB | 60VS Pk 1 F. Glass PCB | £0.85 |
| BAIL Pk 2 Resistors, Capacitors | 60VS Pk 2 Resistors, Capacitors | £2.20 |
| BAIL Pk 3 Semiconductors | 60VS Pk 3 Semiconductors | £3.10 |
| | 60VS Pk 6A Toroidal transformer | £8.80 |
| Bailey Burrows Stereo Pre-Amp. | Stuart Tape Recorder | |
| BBPA Pk 1 F. Glass PCB (stereo) | TRRC Pk 1 Replay Amp F. G. PCB (stereo) | £1.30 |
| BBPA Pk 2 Resistor, capacitors (stereo) | TRRC Pk 1 Record Amp F. G. PCB (stereo) | £1.70 |
| BBPA Pk 3R Rotary potentiometers (stereo) | TROS Pk 1 Bias Erase F/G PCB (stereo) | £1.20 |
| BBPA Pk 4R Rotary switches (stereo) | | |
| Linsley-Hood Low Distortion Oscillator. | E. F. Taylor Pre-Amplifier | |
| LDO Pk 1 Fibreglass PCB | EFTP Pk 1 Fibreglass PCB (stereo) | £1.45 |
| LDO Pk 2 M.O. Resistors, capacitors | EFTP Pk 2 M.O. Res. Caps. (stereo) | £3.20 |
| LDO Pk 3 Semiconductors | EFTP Pk 3 Semiconductors (stereo) | £4.20 |

SQ QUADRAPHONIC DECODERS

These state of the art circuits described by CBS are offered as kits of superior quality with close tolerance capacitors, metal oxide resistors and Fibreglass PCBs designed for edge connector insertion. Further information on these kits is given in our FREE CATALOGUE

| | |
|---|--------|
| M1 Basic matrix decoder | £5.90 |
| L1 Full logic decoder | £17.20 |
| L2A Full logic decoder with variable blend | £22.80 |
| L3A As L2A but with high performance discrete component front end (or with carbon film resistors) | £30.10 |
| SOM1 30 Decoder complete with 30W rear channel amplifiers. Complete kit matches T30+30 amplifier | £25.90 |
| | £40.75 |

**Value Added Tax not included in prices
UK Carriage FREE**

SALES FACILITIES: Available for all ★★ complete kits
PRICE STABILITY: Order with confidence! Irrespective of any price changes we will honour all prices in this advertisement until May 31st 1978 if this month's advertisement is mentioned with your order. Errors and VAT rate changes excluded
U.K. ORDERS: Subject to 12½% surcharge for VAT (ie. add ½ to the price). No charge is made for carriage (or at current rate if changed)
SECURICOR DELIVERY: For this optional service (U.K. mainland only) add £2.50 (VAT inclusive) per kit
SALES COUNTER: If you prefer to collect your kit from the factory, call at Sales Counter (at rear of factory) Open 9 a.m.-4.30 p.m. Monday, Thursday

QUALITY: All components are brand new first grade full specification guaranteed devices. All resistors (except where stated as metal oxide) are low noise carbon film types. All printed circuit boards are fibreglass, drilled roller tinned and supplied with circuit diagrams and construction layouts

**FOR FURTHER INFORMATION PLEASE WRITE OR
TELEPHONE FOR OUR FREE CATALOGUE**

DEPT. VVV4

POWERTRAN ELECTRONICS

PORTWAY INDUSTRIAL ESTATE, ANDOVER
ANDOVER HANTS SP10 3NN (0264) 64455

EASY BUILD SPEAKER DIY KITS

Specially designed by RT-VC for cost-conscious hi-fi enthusiasts, these kits incorporate two teak simulate enclosures, two EMI 13" x 8" (approx.) woofers, two tweeters and a pair of matching crossovers. Supplied complete with an easy-to-follow circuit diagram, and crossover components.

STEREO PAIR £28.00
 Input 15 watts rms. 30 watts peak. each unit. + p & p £5.50 Cabinet size 20" x 11" x 9 1/2" (approx.)

- SPEAKERS AVAILABLE WITHOUT CABINETS.
 It's the units which we supply with the enclosures illustrated Size 13" x 8" (approx.) woofer (EMI). **£17.00** per tweeter, and matching crossover components. stereo pair Power handling 15 watts rms. 30 watts peak. + p & p £3.40

COMPACT FOR TOP VALUE These infinite baffle enclosures come to you ready mitred and professionally finished. Each cabinet measures approx. per stereo pair 12" x 9" x 5" deep, and is in wood simulate. **£8.50**
 Complete with two 8" (approx.) speakers for maximum power handling of 7 watts. + p & p £2.20

SPEAKERS Two models - Duo I lb. teak veneer, 12 watts rms. 24 watts peak. 18 1/2" x 13 1/2" x 7 1/2" (approx.). Duo III, 20 watts rms. 40 watts peak. 27" x 13" x 11 1/2" approx. Duo II lb. **PER PAIR £17.00** Duo III **PER PAIR £52.00** + p & p £7.50

DECCA 20 WATTS STEREO SPEAKER stereo pair This matching loudspeaker system is hand made. kit comprises of two 8" diameter approx. base drive unit, with heavy die cast chassis laminated cones with rolled P.V.C. surrounds. two 3 1/2" diameter approx. domed tweeters complete with crossover networks. **£4.00 p & p £20.00**

PERSONAL SHOPPERS

STEREO CASSETTE record/replay fully built P.C. board **£19.95**
 Ex equipment without guarantee

AM. FM. TUNER P.C.B. with Mullard L.P. 1186, 1185, 1181 modules. **£9.50**

100K Multiturn Varicap tuning pots. 6 for **£1.00**

PAIR STEREO 8 WATT SPEAKERS 8" bass units with 3 1/2" app tweeters Size 16 1/2" x 11" x 8 1/2" **£9.95**

Plinth & cover BSR or Garrard teak finish **£6.00**

DECCA DC1000 Stereo Cassette P.C.B. complete with switch oscillator coils and tape-heads **£2.95**

FERGUSON, 3-speed, 7" tape transport mechanism. Complete with top covers. **£15.95**

20 x 20 WATT STEREO AMPLIFIER

£29.90
 Superb Viscount IV unit in teak-finished cabinet. Silver fascia with aluminium rotary controls and pushbuttons, red mains indicator and stereo jack socket. Function switch for mic. magnetic and crystal pick-ups, tape, tuner, and auxiliary Rear panel features two mains outlets, DIN speaker and input sockets, plus fuse. 20 + 20 watts rms. 40 + 40 watts peak.

30 x 30 WATT AMPLIFIER KIT

Specially designed by RT-VC for the experienced constructor, complete in every detail. Same facilities as Viscount IV amplifier. 60 + 60 peak. p & p £2.50 **£29.00**
£39.00
 NOW AVAILABLE fully built and tested. Output 30 + 30 watts rms. 60 + 60 peak. p & p £2.50

SPECIAL OFFER - to Personal Shoppers
 BSR TYPE 131 Professional Series with C/balanced arm and removable head shell/ceramic cartridge auto manual deck complete with plinth and cover ready wired. **£18.95**

ADD-ON STEREO CASSETTE TAPE DECK KIT

Designed for the experienced D.I.Y. man. This kit comprises of a tape transport mechanism, ready built and tested record/replay electronics with twin V.U. meters and level control for mating with mechanism. Specifications: Sensitivity - Mic. 0.85 mV @ 20K OHMS; Din. 40mV @ 400K OHMS; Output - 300mV RMS per channel @ 1KHz from 2K OHMS source; Cross Talk - -30db; Tape Counter - 3 Digit. Resettable; Frequency Response - 40Hz - 8KHz ± 6db; Deck Motor - 9 Volt DC with electronic speed regulations; Key Functions - Record, Rewind, Fast Forward, Play, Stop & Eject. p & p £2.50 **£19.95**
 Opt. Extras - Mains Trans. to suit £2.50 p.p. £1.

Send stamped addressed envelope for further details. Order by giving credit card number ONLY.

RTVC
 323 EDGWARE ROAD, LONDON W2
 21c HIGH STREET, ACTON, W3 6NG
ALL PRICES INCLUDE VAT AT 12 1/2%
 All items subject to availability. Price correct at 1.2.78 and subject to change without notice

45 WATT MONO DISCO AMP

£35.00
 p & p £2.50
 Size approx. 13 1/2" x 5 1/2" x 6 1/2"
 45 watts rms, 90 watts peak output. Big features include two disc inputs, both for ceramic cartridges, tape input and microphone input. Level mixing controls fitted with integral push-pull switches. Independent bass and treble controls and master volume.

70 & 100 WATT MONO DISCO AMP

Size approx. 14" x 4" x 10 1/2"
 Brushed aluminium fascia and rotary controls
 Five vertical slide controls - master volume, tape level, mic level, deck level, PLUS INTER-DECK FADER for perfect graduated change from record deck No. 1 to No. 2, or vice versa. Pre-fade level control 70 watt (PFL) lets YOU hear next disc before fading it in. VU meter monitors output level. 100 watt **£57**
 Output 100 watts RMS 200 watts peak. p & p £4.00 **£65**

CHASSIS RECORD PLAYER DECKS

GARRARD DECK GC10A £7.95
 Record changer with cue, stereo ceramic cartridge. p & p £2.00

BSR MP60 TYPE Single play record player less cartridge. **£15.95**
 Cartridges to suit above
 Acos, magnetic stereo **£4.95**
 Ceramic stereo **£1.95**
 BSR automatic record player deck cueing device and stereo ceramic head. p & p £2.55 **£9.95**

BSR MP 60 type, complete with magnetic cartridge, diamond stylus, and de luxe plinth and cover. p & p £4.50 **£29**

Home 8 Track cartridge player. This unit will match with the Viscount IV 9" x 8" x 3 1/2". p & p £2.50 **£16.50**

EASY TO BUILD RECORD PLAYER KIT

The D-I-Y man who requires a stereo unit at a budget price, comprising read assembled stereo amp module, Garrard auto/manual deck with cueing device, pre-cut and finished cabinet work, Output 4 watts per channel, phono socket and record/replay socket. Without speakers. **£17.95 p & p £2.00**

Personal Shoppers EDGWARE ROAD LONDON W2 Tel: 01-723 8432. 9.30am-5.30pm. Half day Thursday. ACTON: Mail Order only. No callers. GOODS NOT DESPATCHED OUTSIDE UK

SEND FOR SINTEL FREE CATALOGUE

SINTEL

FAST SERVICE We guarantee that Telephone Orders for goods in stock, received by 4.15 p.m. (Mon-Fri) will be despatched on the same day by 1st Class Post (some heavy items by parcel post) and our stocking is good. Private customers should telephone and pay by giving their Access or Barclaycard number, with a minimum order value of £5. Official orders, no minimum.

RESEARCH MACHINES 380Z COMPUTER SYSTEM

AVAILABLE THROUGH SINTEL

RESEARCH MACHINES 380Z SYSTEM 16 + K
 (Ready built with 16K RAM, 2K ROM Monitor with Keyboard **£1081.00**
 As above but with 32K RAM **£1448** With 48K Ram **£1895.00**

RESEARCH MACHINES 380Z SYSTEM 4 / KIT
 Part assembled with 4K RAM 2K ROM Monitor. Without Keyboard **£539.00**

RESEARCH MACHINES 280Z
 2K ROM Monitor. 4K RAM **£398.00**

SOFTWARE: BK Extended Basic for 380Z
 Various combinations of the 380Z are available e.g. 4K-48K RAM. Assembled or Part-Assembled Kit Form, with or without Keyboard. PLEASE CONTACT SINTEL FOR FURTHER INFORMATION AND PRICES.
 DELIVERY c 8 weeks PRICES Exclusive of VAT and carriage.

DATA BOOKS

- Intel 8080 Microcomputer System User's Manual **£8.20**
- Intel 8085 Microcomputer System User's Manual **£8.25**
- Motorola Booklet From the Computer to the Microprocessor **£1.80**
- Motorola MCMOS Databook (Vol 5 Series B) **£3.50**
- Motorola M6800 Microprocessor Applications Manual **£12.95**
- Motorola M6800 Programming Manual **£5.35**
- National SC/MP Introkit User's Manual **£0.75**
- National SC/MP Technical Description **£1.80**
- National Semiconductor TTL Databook **£2.10**
- RCA CMOS and Linear IC Databook **£8.45**
- Texas Instruments Pin Configuration Guide A very useful set of gloss cards showing top and bottom pinout views of 7400 ICs plus many others (T1, Memories, Op Amps, etc) **£2.95**
- Z80 Assembly Language Programming Manual **£7.80**
- Zilog Z80-CPU Technical Manual **£5.80**
- Zilog Z80-CTC Product Specifications **£0.80**
- Zilog Z80-P10 Technical Manual **£3.30**

DATASHEETS at 75p each on IM6100, 6800, SC/MP, CDP1802, 2650, TMS5501, TMS8080, 9131, Z80, P, Intel 8085. Also free data on some components

MICROPROCESSORS

A SELF-CONTAINED MICROCOMPUTER KIT: THE MEK6800D2. Keyboard Data Entry, 6 Digit Hex Display, Integral Cassette Interface, 256 Words of RAM, Single +5V Power Supply. Order as MEK6800D2 **£190.00**

| | |
|--------------------------------|-------------------------------|
| MC6800 £15.97 | MC6820 £8.02 |
| Z80-CPU (2.5MHz) £28.44 | Z80A-CPU (4MHz) £36.98 |
| Z80-CTC £12.80 | Z80-PIO £12.80 |

COMPONENTS

| SOLDERCON | CLOCK CHIPS | DISPLAYS | CRYSTALS | MEK6800D2 | 100.00 |
|-----------|--------------|------------------|--------------|-----------|--------|
| PLMS | AY51202 | 3.10 TYPE | 32.768KHz | MC6800 | 15.87 |
| 100 | 0.50 AY51224 | 3.50 FM0500 C.C. | 5.12MHz | MC6820 | 8.02 |
| 1000 | 4.00 MK50253 | 5.60 TYPE | MEMORIES, Ps | Z80-CPU | 28.44 |
| 3000 | 10.50 | TL1321 CA. S/T0 | 2102A-6 | Z80A-CPU | 36.98 |
| | | | 2102A-5 | Z80-CTC | 12.80 |
| | | | 2112A-4 | Z80-PIO | 12.80 |

Free data is available on some of these items. SEND FOR FREE CATALOGUE.

CMOS

Mainly RCA

| | | | | | | | | | | | |
|--------|------|--------|------|--------|------|--------|------|--------|------|---------|------|
| CD4000 | 1.17 | CD4014 | 1.04 | CD4031 | 2.50 | CD4048 | 0.58 | CD4071 | 0.23 | CD4098 | 1.13 |
| CD4001 | 1.18 | CD4015 | 1.04 | CD4032 | 1.02 | CD4049 | 0.58 | CD4072 | 0.23 | CD7099 | 1.90 |
| CD4002 | 1.17 | CD4016 | 0.58 | CD4033 | 1.44 | CD4050 | 0.58 | CD4073 | 0.23 | CD4502 | 1.24 |
| CD4003 | 1.18 | CD4017 | 1.04 | CD4034 | 1.97 | CD4051 | 0.94 | CD4075 | 0.23 | CD4510 | 1.81 |
| CD4004 | 1.18 | CD4018 | 1.03 | CD4035 | 1.22 | CD4052 | 0.94 | CD4076 | 0.23 | CD4511 | 1.72 |
| CD4005 | 1.18 | CD4019 | 0.58 | CD4036 | 3.29 | CD4053 | 0.94 | CD4077 | 0.45 | CD4514 | 2.84 |
| CD4006 | 1.17 | CD4020 | 1.28 | CD4037 | 0.98 | CD4054 | 1.20 | CD4078 | 0.23 | CD4515 | 3.24 |
| CD4007 | 1.18 | CD4021 | 1.04 | CD4038 | 1.10 | CD4055 | 1.36 | CD4081 | 0.23 | CD4516 | 1.40 |
| CD4008 | 1.18 | CD4022 | 0.94 | CD4039 | 3.20 | CD4056 | 1.36 | CD4082 | 0.23 | CD4518 | 1.25 |
| CD4009 | 1.18 | CD4023 | 0.23 | CD4040 | 1.11 | CD4059 | 4.93 | CD4085 | 0.74 | CD4520 | 1.19 |
| CD4010 | 1.18 | CD4024 | 0.80 | CD4041 | 0.86 | CD4060 | 1.15 | CD4086 | 0.74 | CD4521 | 1.64 |
| CD4011 | 1.18 | CD4025 | 0.23 | CD4042 | 0.91 | CD4061 | 1.13 | CD4089 | 1.60 | CD4523 | 1.39 |
| CD4012 | 1.18 | CD4026 | 0.58 | CD4043 | 1.01 | CD4066 | 0.63 | CD4093 | 0.92 | CD4555 | 9.00 |
| CD4013 | 1.18 | CD4027 | 0.58 | CD4044 | 0.96 | CD4067 | 3.85 | CD4094 | 1.94 | CD4556 | 9.00 |
| | | CD4028 | 0.92 | CD4045 | 1.46 | CD4068 | 0.23 | CD4095 | 1.08 | MC14528 | 1.22 |
| | | CD4029 | 1.18 | CD4046 | 1.37 | CD4069 | 0.23 | CD4096 | 1.08 | MC14559 | 4.88 |
| | | CD4030 | 0.58 | CD4047 | 1.04 | CD4070 | 0.61 | CD4097 | 3.85 | IM6508 | 8.00 |

SINTEL ACK CLOCK KITS

| | CODE | PRICE |
|---|---------|--------|
| 6 Red Digit ALARM CLOCK w 205mm h 40mm d 140mm | ACK | £28.80 |
| 4 Red Digit DESK CLOCK w 154mm h 40mm d 85mm | 111-222 | £15.50 |
| 4 Green Digit DESK CLOCK w 154mm h 40mm d 85mm | GCK | £12.95 |
| 6 Red Digit CAR CLOCK WITH TIMER w 205mm h 40mm d 140mm | CKK | £41.90 |
| 4 Red Digit CAR CLOCK w 154mm h 40mm d 85mm | AUT-CK | £18.85 |
| 50Hz CRYSTAL TIMEBASE KIT | XTK | £5.45 |

A RANGE OF SINTEL INDUSTRIAL MODULE KITS

Latched Counter modules are now available from SINTEL, using both CMOS and TTL ICs. These kits will give you a very compact unit at less than the cost of the components bought separately and will save you considerable design, purchasing, building and de-bugging time. Each kit has a set of red LED displays, two PCBs, and the appropriate number of TTL or CMOS ICs, plus brackets, etc. resistors, capacitors, single in-line plug and sockets and instructions

KITS FOR LATCHED COUNTER MODULES

| Digits | Part No | TTL Price | Part No | CMOS Price |
|---------|---------|-----------|---------|------------|
| 2 digit | 526-412 | £10.52 | 548-470 | £10.42 |
| 4 digit | 857-412 | £17.98 | 191-470 | £18.11 |
| 6 digit | 721-412 | £25.86 | 889-470 | £25.85 |

For our full range of Counter PCB sets and Display PCBs - send for FREE CATALOGUE

Our offices are at 209 Cowley Road, Oxford, but please do not use this as a postal address. ALL PRICES ARE VALID UNTIL 30 APRIL 1978

OFFICIAL ORDERS ARE WELCOME from Companies, Govt. Depts., Natn. Inds., Univs., Polys., etc.

ORDERS: C.W.O. add VAT at 8% + 35p p.p. TELEPHONE and CREDIT (Invoice) Orders add VAT at 8% + 60p p.p. (minimum charge, the balance will be added at cost). FAST SERVICE: EXPORT Orders welcome, no VAT but add 10% (Europe), 15% (Overseas) for Air Mail p.p. For Export postage rates on heavy items - contact us first.

ORDERS TO: SINTEL
 PO BOX 75C, OXFORD
 Tel: 0865 49791

SERVICE TRADING CO

WHY PAY MORE?!

MULTI RANGE METERS Type MF15A A.C./D.C. volts 10 50 250 500 1000 Ma 0.5 0.10 0.100 Sensitivity 2000V 24 range diameter 133 x 93 x 46mm Price **£6.50** plus 50p P&P (**£7.56** inc VAT & P)



TRIAC

Raytheon tag symmetrical Triac Type Tag 250/500v 10 amp 500 p.w. Glass passivated plastic triac Swiss precision product for long term reliability **£1.25** P&P 10p (**£1.46** inc VAT & P) (inclusive of date and application sheet) Suitable Dec 22.

0 to 60 MINUTES CLOCKWORK TIMER. Double pole 15 amp 230AC Contacts (no dial) **£1.50** P&P 30p (**£1.94** inc VAT & P).

MERCURY SWITCH

Size 27mm x 5mm 10 for **£5.00** inc VAT **(£5.72)** Min quantity 10



CONTACTOR

Mfg by Hendrey Relays type C2839 220/250 AC ops Contact 4C/O at 20 amp at 440 volts AC. Price **£6.00** P&P 75p (**£7.29** inc VAT & P)



230 VOLT AC FAN ASSEMBLY

Powerful continuously rated AC motor complete with 5 blade 6 1/2" aluminium fan. New reduced price **£3.00** P&P 65p (**£3.94** inc VAT & P)



21-WAY SELECTOR SWITCH with reset coil

The ingenious electro mechanical device can be switched up to 21 positions and can be reset from any position by energising the reset coil. 230/240V A.C. operation. Unit is mounted on strong chassis. Complete with cover. Price **£5.50** P&P 75p (**£6.75** inc VAT & P)



VORTEX BLOWER AND VACUUM UNIT

Dynamically balanced to tally enclosed 9" rotor with max air delivery of 1.5 cubic metres per min. Max static pressure 600mm W.G. Suction or blow from 2 side by side 37mm I.D. circular apertures fitted to base of unit. Powerful continuously rated 115v a.c. motor mounted on alloy base with fixing facilities. Dimensions Length 22cm x width 25cm x height 25cm



These units are ex-equipment but have had minimum use. Fully tested prior to despatch. Price **£12** + £1.50 P&P (**£14.58** inc VAT & P). Suitable transformer for 230/240v a.c. **£6** + £1 P&P (**£7.56** inc VAT & P)

CENTRIFUGAL BLOWER

Mfg by Smiths Industries 230/240v a.c. Miniature Model Series SE7200 Size 35mm x 82mm x 82mm Aperture 38mm x 31mm 12 c.f.m. **£2.75** Post 50p (**£3.51** inc VAT & P). Smith type FF1 1906 022 220/240V A.C. Aperture 10x4 1/4 cm overall size 16x14cm Price **£3.75** p&p 75p (inc VAT **£4.86**). Other types available phone for details

NI-CAD BATTERY

| | Height (mm) | Width (mm) | Length (mm) |
|---------------------------------------|-------------|------------|-------------|
| 35 AH 1.2v Metal Postage 30p per unit | 219 | 75 | 29 |

UNISELECTOR SWITCH

4 bank 25 way 75 ohm coil 36-48V D.C. operation Ex new equipment **£4.25** P&P 75p Total price inc VAT **£5.40**

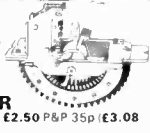

MINIATURE UNISELECTOR

12v 11 way 4 bank (3 non-bridging 1 homing) **£2.50** P&P 35p (**£3.08** inc VAT & P)

MICRO SWITCHES

As illustrated but fitted with 1" Lever 10 for **£2.00** P&P 30p (**£2.48** inc VAT & P). Sub-miniature Burgess type v 41 1 10 for **£2.50** P&P 30p (**£3.02** inc VAT & P). 50 for **£10.00** post paid (**£10.40** inc VAT & P). Type 3 115M 906T 10 for **£2.50** post paid (**£2.70** inc VAT & P).



BF lever operated 20a c/o mf. Unimax USA 10 for **£4.00** plus 50p P&P (min. order 10) (**£4.86** inc VAT & P). D.P. C/O lever m/switch, mfg by Cherry Co. USA. Precious metal low resistance contacts. 10 for **£2.50** P&P 30p Total inc VAT **£3.02** (min 10)

NEW HEAVY DUTY SOLENOID

Mfg by Magnetix Devices 240v A.C. Operation approx 20lb pull at 1 25" Price **£7.00** P&P 75p (**£8.37** inc VAT & P). Similar to above approx 10lb pull **£3.50** P&P 60p (**£4.43** inc VAT & P)

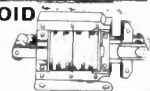

230-250 VOLT A.C. SOLENOID

Similar in appearance to illustration. Approximately 1 1/2 lb pull. Size of feet 1 1/4" x 1 3/16" Price **£1.00** Post 25p (**£1.35** inc VAT & P)



24 VOLT D.C. SOLENOIDS

UNIT containing 1 heavy duty solenoid approx. 25 lb. pull at 1 in travel. 2 solenoids of approx 1 lb. pull at 1/2 in travel. 6 solenoids of approx 4 or pull at 1/2 in travel. Plus 1 24V D.C. 1 heavy duty 1 make relay. Price **£3.00** Post **£1.00** (**£4.32** inc VAT & P) **ABSOLUTE BARGAIN**



240 A.C. SOLENOID OPERATED FLUID VALVE

Rated 1 p.s.i. will handle up to 7 p.s.i. Forged brass body stainless steel core and spring 1/2 in. b.s.p. inlet outlet. Precision made British mfg. PRICE **£2.75** Post 50p (**£3.57** inc VAT & P)



VARIABLE VOLTAGE TRANSFORMERS



Carriage extra

INPUT 230 v. A.C. 50/60 OUTPUT VARIABLE 0/260v. A.C.

- BRAND NEW. All types. 200W (1 Amp) fitted A/C volt meter**
- 0.5 KVA (Max. 2 1/2 Amp) **£15.00**
 - 1 KVA (Max. 5 Amp) **£19.50**
 - 2 KVA (Max. 10 Amp) **£32.00**
 - 3 KVA (Max. 15 Amp) **£39.50**
 - 4 KVA (Max. 20 Amp) **£60.00**

LT TRANSFORMERS

- 0.12v 24v at 1 amp **£2.50** p&p 50p (**£3.24** inc VAT & P)
 - 0.15v at 1 amp 4-0.15v at 1 amp 30v 1 amp **£2.50** p&p 50p **£3.24**
 - 25.0/25v at 2 1/2 amp **£4.50** p&p 75p (**£5.67** inc VAT & P)
 - 0.12v/24v 10 amp **£12.35** p&p **£15.00** (**£14.96** inc VAT & P)
 - 0.4v/6v/24v/32v at 12 amp **£13.00** p&p **£15.00** (**£15.66** inc VAT & P)
 - 0.12v at 20 amp or 0.24v at 10 amp **£12.00** p&p **£15.00** (**£14.58** inc VAT & P)
 - 0.6v/12v/17v/18v/20v at 20 amp **£14.00** p&p **£15.00** (**£16.74** inc VAT & P)
 - 0.6v/12v at 20 amp **£11.85** p&p **£15.00** (**£13.88** inc VAT & P)
- Other types in stock. phone in enquiries

COMPRESSOR, precision built by Emerson USA. Horizontally opposed twin head diaphragm type producing 20lbs P.S.I. per head 3 5 plus C.F.M. Output virtually pulse free. Powered by 110V A.C. motor size 30x22x1.5cm. Weight 7 kilos. Price **£20.00** inc VAT **£23.76**. Suitable transformer for 230 240v A.C. **£8.00** p&p **£1.00** (inc VAT) **£9.72**.

STROBE! STROBE! STROBE!

HY-LIGHT STROBE KIT MK. IV
Latest type Xenon white light tube. Solid state timing and triggering circuit. 230/240 volt A.C. operation. Speed adjustable 1/20 f.p.s. Designed for large rooms, halls, etc. Light output greater than many (so called 4 Joule) strobes. Price **£18.00** post **£1** (**£20.56** inc VAT & P). Specially designed case and reflector for Hy-Light **£8.25** Post **£1.00** (**£9.99** inc VAT & P)

ULTRA VIOLET BLACK LIGHT FLUORESCENT TUBES

4ft. 40 watt £7.75 (callers only). **2ft. 20 watt £5.50** Post 60p (For use in stan-by-pin fittings). Min 12in. **8 watt £2.50** Post 25p (**£2.97** inc VAT & P). **9in. 6 watt £2.00** Post 25p (**£2.43** inc VAT & P). **6in. 4 watt £1.75** Post 25p (**£2.16** inc VAT & P). Complete ballast unit. Either 6" 9" or 12" tube 230V A.C. or **£3.50** plus P&P 40p (**£4.21** inc VAT & P). Also available for 12V D.C. or **£3.50** plus P&P 40p (**£4.21** inc VAT & P)

XENON FLASH GUN TUBES

Range of Xenon tubes available from stock. S.A.E. for full details



RELAYS

Wide range of AC and DC relays available from stock. Phone or write in your enquiries

230/240V A.C. Relays: Arrow, 2c/o 15 amp **£1.50** (**£1.84** inc VAT & P). T.E.C. open type 3 c/o 10 amp **£1.10** (**£1.40** inc VAT & P). Mag. Devices 2 c/o 20 amp **£1.50** (**£1.84** inc VAT & P). Omron or Keyswitch 1 c/o 7 amp **£1.00** (**£1.30** inc VAT & P).

D.C. Relays: Open type 9/12V 3 c/o 7 amp **£1.00** (**£1.30** inc VAT & P). Sealed 12V 1 c/o 7 amp octal base **£1.00** (**£1.30** inc VAT & P). Sealed 12V 2 c/o 7 amp octal base **£1.25** (**£1.56** inc VAT & P). Sealed 12V 3 c/o 7 amp 11-pin **£1.35** (**£1.67** inc VAT & P). 24V Sealed 3 c/o 7 amp 11-pin **£1.35** (**£1.67** inc VAT & P) (amps = contact rating) P&P on any Relay 20p

Other types available — phone for details

RESET COUNTER

230 volts AC 3 digits mfg. Veeder Root type LL 144L **£1.75** P&P 25p (**£2.16** inc VAT & P). 7 fig 24v d.c. non-set **£1.50** P&P 25p (**£1.89** inc VAT & P). 6 fig 24v d.c. resettable **£3.00** P&P 25p (**£3.51** inc VAT & P)



BIG INCH

Tiny precision built 3 rpm USA motor size only 1 x 1 100 volt AC. or supplied with resistor for 230 volt AC price **£2.37** p&p 20p for **£5.40** post paid



INSULATION TESTERS (NEW)

Test to I.E.C. spec. Rugged metal construction suitable for bench or field work. constant speed clutch Size 8 in. W 4 in. H 6 in. weight 6 lb

500 VOLTS 500 megohms. **£48.00** Post 80p (**£57.78** inc VAT & P)

1000 VOLTS 1000 megohms. **£48.00** Post 80p (**£60.26** inc VAT & P)

SAE for leaflet



VAT AT CURRENT RATE MUST BE ADDED TO ALL ORDERS
FOR THE TOTAL VALUE OF GOODS INCLUDING POSTAGE UNLESS OTHERWISE STATED
ACCOUNT CUSTOMERS MIN. ORDER £10.00

GEARED MOTORS

100 R.P.M. 115 lbs. ins.!!
115 lb ins 110 volt 50Hz 2.8 amp single phase split capacitor motor. Immense power. Continuously rated. Totally enclosed. Fan cooled. In-line gearbox. Length 250mm Dia 135mm Spindle Dia 15.5mm Length 145mm ex-equipment tested **£12.00** Post **£1.50** (**£14.58** inc VAT & P). Suitable transformer 230/240 volt **£8.00** Post 75p (**£9.45** inc VAT & P)



BODINE TYPE GEARED MOTOR

(Type 1) 71 r.p.m. torque 10 lb in. Reversible 1/70th hp cycle 38 amp. This U.S.A. motor is offered in with transformer for 230/240v AC input. Price type **£6.25** Post 65p (**£7.56** inc VAT & P) or less transformer **£3.75** Post 65p (**£4.75** inc VAT & P). (type 3) 71 r.p.m. 230 volt A.C. continuously rated. Non reversible **£6.50** Post 75p (**£7.83** inc VAT & P)

28 r.p.m., 20lb. inch approx. 115v a.c. Reversible similar to above drawing. Mag by Wynstruments Price **£4.75** + 75p p&p. Total inc VAT **£5.94** inc. transf. 230/240v a.c. **£7.25** + p&p **£1** Total inc VAT **£8.91**

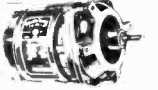

FRACMO

20 rpm 500m torque. Suitable for U/V unit. Working length 30mm. Total weight 6 kilos. 600 grams. Price **£15.00** P&P 1.50 (**£17.82**).



PARVALUX GEARED MOTOR

20 rpm 24 lb. ins. torque. 47 rpm. 4.5 lbs. ins. Price **£15.00** P&P 1.50 (**£17.82** inc VAT)



A.E.G. WATER PUMP

200/240v a.c. motor. 2850 rpm. 480w approx. 1/3 hp. driving a centrifugal pump with 1 1/2" inlet and outlet delivering approx. 40 galls per min at 10ft head. Ideal for pumping or circulating any non corrosive light viscosity liquid. Dozens of uses in industrial labs etc. Note this pump is not self priming. Price **£15** + 75p P&P (**£17.01** inc VAT & P)

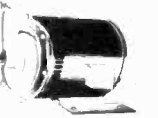

CITENCO 19 RPM

FHP motor type C 7333 15 220/240v a.c. 19 rpm reversible motor (torque 14.5 kg. Gear ratio 14:1). Brand new inc. capacitor. Price **£14.25** + £1.25 P&P (**£16.20** inc VAT & P)



REVERSIBLE MOTOR 230V A.C.

General Electric 230v A.C. 1 600 r.p.m. 0.25 amp. Complete with anti-vibration mounting bracket and capacitor. O.A. size 110mm x 95mm. Spindle 5/16" dia. 20mm long. Ex-equipment tested **£3.00** Post 50p (**£3.78** inc VAT & P)



METERS 90mm Diameter

A.C. 250v 500mA 0.5A 0.2A 0.1A 0.05A 1000A. A.C. 250v 500mA 0.5A 0.2A 0.1A 0.05A. D.C. volts type 0.1A 0.5A 1A 5A 10A. A.C. volts type 6.212 0.15A 0.30V 0.1A **£3.50** P&P 75p (**£4.32** inc VAT)



'VENNER TYPE' ERD TIME SWITCH

200/250V A.C. 30 amp 2 on/2 off every 24 hrs. at any manually pre-set time. 38 hour spring reserve and day omitting device. Built to highest Electricity Board specification. Price **£7.75** P&P 75p (**£9.18**).



SANGAMO WESTON TIME SWITCH

11-pin top entry plug complete with 11-pin PC socket **£3.50** for pair. p&p 60p + VAT (**£4.43**). Min. 10 pair.

200/250V A.C. 1 on/1 off every 24 hrs. 80 amps contacts with 1/2" storage heater. Price **£10.00** P&P 50p (**£11.34**).



A.E.G. TIME SWITCH

200/250V A.C. 1 on/1 off every 24 hrs. 80 amps contacts (ideal storage heater). spring reserve. Price **£10.00** P&P 50p (**£11.34**).

A.C. MAINS TIMER UNIT

Based on an electric clock with 25 amp single-pole switch which can be preset for any period up to 12 hrs. ahead to switch on for any length of time from 10 mins to 6 hrs then switch off. An additional 60 min. audible timer is also incorporated. Ideal for Tape Recorders. Lights. Electric Blankets etc. Attractive satin copper finish. Size 135 mm x 130 mm x 60 mm. Price **£2.25** Post 40p (Total inc VAT & Post **£2.87**).



POWER RHEOSTATS

New ceramic construction. vitreous enamel embedded winding. heavy duty brush assembly. continuously rated.

- 25 WATT** 10 25 100 150 250 500 1k 1.5k ohm **£2.40** Post 20p (**£2.81** inc VAT & P)
- 50 WATT** 100 500 1k ohm **£2.90** Post 25p (**£3.40** inc VAT & P)
- 100 WATT** 1 5 10 25 50 100 250 500 1k 1.5k 2.5k 5k ohm **£5.50** Post 35p (**£6.32** inc VAT & P)

Black Silver Skirted knob calibrated in Nos 1-9. 1 1/2 in. dia brass bush. Ideal for above Rheostats **24p ea.**



600 WATT DIMMER SWITCH

Easily fitted. Fully guaranteed by makers. Will control up to 600w of lighting except fluorescent at mains voltage. Complete with simple instructions **£3.95** Post 25p (**£4.53** inc VAT & P). 1000 watt model **£5.60** Post 25p (**£6.32** inc VAT & P). 2000 watt model **£9.75** Post 40p (**£10.96** inc VAT & P)

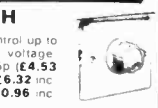

ALL MAIL ORDERS, ALSO CALLERS AT:

57 BRIDGMAN ROAD, CHISWICK, LONDON, W4 5BB. Phone: 01-995 1560. Closed Saturdays.

SERVICE TRADING CO.

SHOWROOMS NOW OPEN AMPLÉ PARKING

PERSONAL CALLERS ONLY

9 LITTLE NEWPORT STREET, LONDON, WC2H 7JJ. Tel.: 01-437 0576

POWER SUPPLY UNITS

IN A RANGE OF **9** MODELS FROM 12 TO 70V OUTPUTS

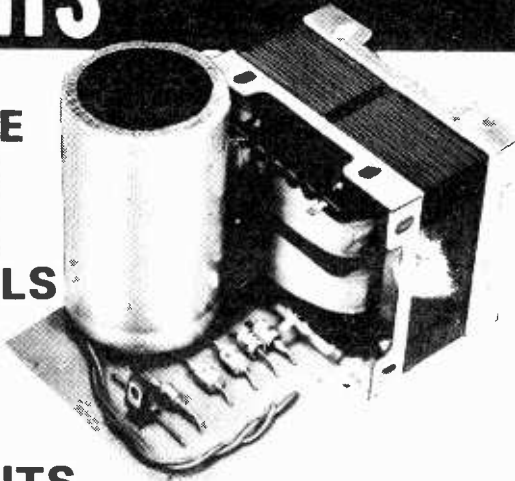

WITH STABILIZED LOW-VOLT TAKE-OFF POINTS

Tested and guaranteed. Stirling Sound power units offer supreme value and have the added advantage of including a stabilized take off point on all models except SS.312 and SS.300 add-on stabilizing unit. Output ratings quoted unloaded. **Prices include V.A.T.; goods sent post free in U.K.**

| | | | | |
|--------|--------|--------|-----------|--|
| SS.312 | 12V/1A | £6.60 | SS.300 | Output stabilizing unit to add to standard supply units. |
| SS.318 | 18V/1A | £6.95 | | Output adjustable from 10 to 50V. Short-circuit protection £5.50 |
| SS.324 | 24V/1A | £7.65 | SS.310/50 | Stabilized power supply unit with adjustable output 10 to 50V/2A. Short circuit protected £17.75 |
| SS.334 | 34V/2A | £8.75 | | |
| SS.345 | 45V/2A | £10.75 | | |
| SS.350 | 50V/2A | £11.75 | | |
| SS.360 | 60V/2A | £12.75 | | |
| SS.370 | 70V/2A | £14.75 | | |

POWER AMP MODULES, 3-100 W.R.M.S.

Ready assembled on P.C.B.s. tested and guaranteed. Appropriate power supplies can be found above. SS.103 is a small, but very efficient unit based on I.C. circuitry. All outputs rated ± 1 dB.

| | | |
|----------|--|--------|
| SS.103 | I.C. Amp 3W.R.M.S. into 8 Ω using 20V | £2.85 |
| SS.103-3 | Stereo version of above | £5.00 |
| SS.105 | 5W/13.5/3 Ω | £3.95 |
| SS.110 | 10W/24V/4 Ω | £4.65 |
| SS.120 | 20W/34V/4 Ω | £5.15 |
| SS.140 | 40W/45V/4 Ω | £6.50 |
| SS.160 | 60W/50V/4 Ω | £8.50 |
| SS.1100 | 100W/70V/4 Ω | £10.50 |

UNIT THREE

Introducing a unique stereo selector / filter unit with a practical money-saving offer.

UNIT THREE provides stereo selection for ceramic / mag. P.U. / radio / tape in / tape out with high pass and low pass filters. 3 DIN input sockets at rear. Made to fit with Stirling Sound modules. UNIT THREE may be cut across for fitting within a shorter or longer layout design. With 6 push-buttons and fascia £6.75

UNIT TWO pre-amp/ tone control unit - mag. P.U. (R.I.A.A.) / radio / aux. treble / bass / balance / vol with panel £12.45

Introductory Offer - Units Two and Three together (saving you £1.23) £17.95.

SIZE
220mm x
105mm x 12mm

Can be made longer or shorter as required

PAY ONLY THE PRICE YOU READ AND NO MORE
All prices quoted include VAT and Goods are sent post free in U.K. Owing to the time it takes for this ad. to appear, prices may be subject to alteration without notice. **CATALOGUE SHEETS FREE ON REQUEST.**

Stirling Sound

37 VANGUARD WAY, SHOEBURNESS, ESSEX

Telephone: Shoeburyness (03708) 5543

SHOP: 222-224 West Rd., Westcliff-on-Sea. Phone: Southend (0702) 351048

To: STIRLING SOUND, 37 Vanguard Way, Shoeburyness, Essex.

Please supply

For which I enclose £

(or pay by Access or Barclaycard)

Name

Address

ww4

WW — 086 FOR FURTHER DETAILS



REMOTE CONTROL FOR WW TELETEXT DECODER

A modification kit is now available to give Remote Control selection of all functions except setting the time select thumbwheel switches. The Remote Control Unit is housed in a cabinet approx. 6" x 3" x 2" and connected to the main decoder by approx. 5 yds. screened cable. PRICE ONLY £14.80 + 40p P&P

'Board 3' is also available as an additional unit to update the 'Wireless World' Teletext Decoder to give double height characters, colour background, conceal/reveal, etc., as described in December and January issues of 'Wireless World'.

Our Kit includes plated-through hole P.C.B.s, all components and installation instructions. Price £33.68 + VAT (£3.47) + P&P (30p) = £37.45 total. P.C.B. available separately at £19.30.

Our main kits contain all the printed circuit boards and components necessary to build the complete decoder.

A reprint of the series of articles is available at £1.50 + large 15p SAE (included free in complete kit)

PRICES INCLUDE VAT

| | | | |
|--------------------------------|---------|---------|--------------------|
| Set of 5 PCBs | £21.70 | £21.65 | Post & Packing 30p |
| Component Kit (incl. PCBs) | £120.95 | £133.70 | £1.50 |
| Add-on Unit for lower case PCB | £2.70 | — | — |
| Component Kit (incl. PCB) | £13.75 | — | — |
| Cabinet | £14.85 | £14.85 | £1.00 |

PLATED THROUGH hole PCBs for TEXAS version only at additional cost of £27.00

FULL FAULT-FINDING AND REPAIR SERVICE AVAILABLE.

COMPONENTS ALSO AVAILABLE SEPARATELY - SAE for price list

READY BUILT & TESTED DECODERS - £241.87 + £5 Carr.

DE LUXE VERSION WITH NEW FACILITIES - £292.50 + £5 Carr.

CHARACTER, GENERAT., MEMORY, 7400 I.C.S.

TEXAS 74S262N (X887) NOW ONLY £14.50

SIGNETICS 2513 £8.50; NATIONAL 2102/2602 £2.25

| | | | | | | | | | |
|------|-----|------|-------|------|-------|-------|-------|-------|-------|
| 7400 | 19p | 7420 | 19p | 7473 | 40p | 74107 | 52p | 74175 | £1.30 |
| 7402 | 19p | 7421 | 28p | 7474 | 38p | 74121 | 43p | 74177 | £1.40 |
| 7403 | 19p | 7427 | 34p | 7475 | 58p | 74123 | £1.05 | 74180 | £1.30 |
| 7404 | 24p | 7428 | 47p | 7483 | £1.00 | 74150 | £2.49 | 74198 | £1.82 |
| 7406 | 44p | 7430 | 21p | 7485 | £1.33 | 74153 | 90p | 74221 | £1.55 |
| 7408 | 26p | 7432 | 38p | 7488 | 35p | 74157 | 90p | 75107 | £1.82 |
| 7410 | 22p | 7440 | 21p | 7490 | 58p | 74184 | £1.38 | 74H00 | 35p |
| 7411 | 22p | 7442 | 84p | 7492 | 60p | 74165 | £1.70 | 74H04 | 44p |
| 7412 | 27p | 7447 | £1.00 | 7493 | 65p | 74174 | £1.19 | 74H10 | 39p |

Quantity discount on 7400 Series only: 25-99 less 10%; 100 or more less 20%

THESE PRICES INCLUDE VAT. PLEASE ADD 30p P&P



CATRONICS LTD. (Dept. 824)

Communications House

20 WALLINGTON SQUARE

WALLINGTON, SURREY

Tel: 01-669 6700

WW — 824 FOR FURTHER DETAILS

ELECTRONIC POWER UNITS

FOR XENON ARC AND MERCURY ARC LAMPS

UNITS AVAILABLE FOR LAMPS RANGING FROM 75 TO 6500 WATTS.

Lamp housings and lens systems manufactured as standard off the shelf models or to specific design.

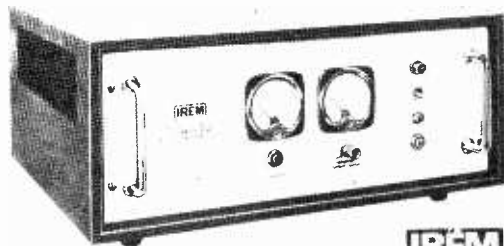

IREM

K. T. Manners Design Ltd.

P.O. Box 936, London, W.4. Telephone 994 7155

WW — 094 FOR FURTHER DETAILS

CONNECTORS

CANNON PAINTON

BELLING LEE PLESSEY

GREENPAR AMPHENOL

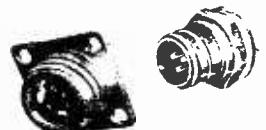

1,000s in stock from:

Servo and Electronic Sales

SERVO AND ELECTRONIC SALES LTD.

24 HIGH STREET, LYDD, KENT TN29 9AJ

TELEPHONE LYDD (0679) 20252 TELEX 965265 AB SERVOE G

Sanwa from: Quality Electronics Limited

At above address

WW — 040 FOR FURTHER DETAILS

NOW — A VDU BOARD WITHOUT KEYBOARD AND NO DISPLAY

A double-sided board with plated through holes 1 1/2" x 8" (4 Eurocard size). 960 Characters in a 40 x 24 line format. 64 ASCII characters. Flashing cursor. 32 control functions available. Adjustable baud rate. Provision for a keyboard. Serial input and output. Requires +5V and -12V and any modified television or video monitor. Board is crystal controlled to give a rock steady display.
Supplied in kit form (all components supplied) £95. P&P £1.75. Assembled and tested £125. P&P £1.75.

TEKTRONIX OSCILLOSCOPES
541A with G Plug-in £160. 545 with CA Plug-in £200. 547 Main Frame 581A Main Frame. 585 with B2 Plug-in £425. 661 with 4S1 £350.

Stocks of better oscilloscopes always changing. Enquiries please. Plug-in units not sold separately.

R & S Audio Freq. Spectrograph BN48301 £650.
MARCONI Sweeper TF1099 £45 each
R & S POLYSCOPE SW0B1 £450 ea
MARCONI OSCILLOSCOPE TF1330 15 MHz £70 each.
TELEQUIPMENT Oscilloscope D33R 6 MHz £90 each.
H.P. Oscilloscope type 185B £100 each.
TEKTRONIX OSCILLOSCOPE type 502 High gain. Limited bandwidth £185 each.
EX-MINISTRY X BAND SPECTRUM ANALYSER CT152 (Marconi: TF1035) 8.5GHZ to 9.7GHZ. Power input 115/250V 45.650HZ Pan-climatic £85 each.
J.A.C. ELECTRONICS FREQUENCY METER type 331. HZ to 3 GHZ In and Out £55 each.
MARCONI SIGNAL GENERATORS. Freq. range 10-470MHZ Type TF801D/1/S £260 each.
MARCONI AM/FM SIGNAL GENERATOR TF2002B £775
FM/AM SIGNAL GENERATOR type AN/USM 16. 10 to 420MHZ Limited quantity £300 each.

TRIPLOD P&T HEAD £22.50 each

BRUEL & KJOER Automatic Vibration Exciter type 1016. Sine Wave sweep from 5HZ to 10KHZ £75 each.
AIRMEC WAVE ANALYSER type 248 £40 each.
POLARAD RECEIVER Model FIM-B2. Complete 1-10GHZ £325.
MARCONI Wide Range Oscillator TF1370. Freq range 10HZ to 10MHZ. Sine Wave 10HZ to 100KHZ. Square Wave. High outputs up to 31.6V. Good value at £90 each.
MARCONI ADAPTOR TM6113 for TF2700, TF1313, TF8668B £20 each.
MARCONI TF142F DISTORTION FACTOR METER giving percentage distortion on a directly calibrated dial and includes any spurious components up to 30KHZ £29.50 ea
MARCONI PORTABLE FREQUENCY METER TF1026/11. 100 to 160MHZ. Very fine condition £25. TF1026/4M 2.4GHZ £35 ea.
COURTENAY MAJOR MK. 2. 250 joules. 5 outputs. Can be combined 1250 joules. No heads £30.
RHOE & SCHWARZ Turntable Indicating Amplifier UBM £75.

MARCONI VALVE VOLTMETER TF428B £12.50 each.

RHOE & SCHWARZ POWER METER. BNRD-BN 2412/50 £50.
MARCONI RF POWER METER. TF1020A/1 75 ohm £65.
RHOE & SCHWARZ Power Signal Generator BN41001. 100KHZ to 30MHZ £325.
JERROLD SWEEP GENERATOR 900A £165.
PRECISION AVOMETER. Meeting section 6-BSS 89/1954 eg +/-0.3% £75 ea.
MARCONI CT44 Watt Meter 0.6 watts £30 ea
EDWARDS HIGH VACUUM PUMPS 1SC30 £50.
MARCONI Signal Generator TF801B/3/S £160 each
AUTO TRANSFORMERS. 240V input; 110V output 1.25KVA. £25 ea. Carriage £2.75
H.P. WAVE ANALYSER type 302A £150.
R. & S. SWEEP GENERATOR BN4242 50KHZ-12MHZ £175 each.
FURZEHILL Valve Voltmeter V200A £25 each
POWER UNIT 3KV Stabilised £25 each
FENLOW Low Freq. Analyser 0.3HZ to 1KHZ £75.
REMSCOPE SO1 Basically working—tube good £75.
H.P. FREQ. CONVERTER type 5252B £50.
S.T.C. DISTORTION SET 74252B £65.

WANDEL & GÖLTERMANN and SIEMENS EQUIPMENT
LEVEL OSCILLATOR 3W518. **SWEEP UNIT** WZ-1. **LEVEL OSCILLATOR** 3D335. **RECEIVER** LDE-1. **SWEEP OSCILLATOR** 3W938b1a. **TRANSMITTER** LDS-1. **LEVEL TRACER** (Display) 3D346b1a. **CARRIER FREQUENCY LEVEL METER** TFFM-76. **LEVEL TRANSMITTER** TFFS-75. **CRT INDICATOR** with Plug-ins SG-1. **SWEEP CONVERTOR** WU-1.
Other units available. Average price £120 per unit. Reduction for quantity.

FEED BACK LTD. Wave Form Gen. Sin/Trap/Saw/Sq. + DC offset £80.
BARNETT DEAD-WEIGHT PRESSURE GAUGE TESTER. Complete with weights. £50.
GENERAL RADIO PULSE SWEEP GEN. Type 1391B £90
GENERAL RADIO. Osc. Unit 1209B. 250-920Mega. £50 each.
AIRMEC AM/FM SIG. GEN. Type 407. 200KHZ-80MHZ £300.
FLUKE AC-DC VOLTMETER. Model 803B £90 each.
WOODEN C.V. TRANSFORMERS. 230V input. 5.5V 5A output £2 each.
ALCAD CELLS 40APH Type EP4. Size 4 1/2 x 2 1/2 x 9" high. Supplied less fluid £4 each. P&P £1.75

TELETYPE ASR28 with built-in tape reproducer and print on tape facility £450.

EX-MINISTRY OSCILLOSCOPE CT436 Double Beam DC-6 MHZ £120

MARCONI TF801D/8/S SIGNAL GENERATOR
Very good condition
£425 each

PICK-A-PACK — 50 PENCE A POUND

From our "Pick-A-Pack" area weigh up your own components. No restrictions on what you take.

EX-DYNAMCO Oscilloscope INVERTERS 30V Input 6KV Output. Size 2" x 4 1/2" x 1 1/2". Complete with circuit £10 each. P&P £1.

TELEPHONES. Post Oke style 746. Black or two-tone £6.50 ea. Modern style 706. Black or two-tone grey £4.50 ea. P&P £1 each. Old black style £1.50 each. P&P £1.
HANDSETS only 706 style £1.25 each. Older style £1. P&P £1.
TELEPHONE EXCHANGES. Eg 15 way automatic fax range £100 ea.

FRESH MINISTRY RELEASE Solartron CT316 oscilloscope DC — 6 megs. Size 8 1/2" x 11" x 20" — Sorry £37.50 this time

PAPS Model 240V available at £7.50 ea. P&P 75p
PHOTOMULTIPLIER Type 913A £4 ea. P&P 75p. Older types available.

BEEHIVE TRIMMERS 3.5" core. Brand New. 10 off 40p P&P 15p. 100 off £3.50. P&P 75p. 500 off £15. P&P £1.25. 1,000 off £25. P&P £1.50.
LARGE RANGE OF ELECTROSTATIC VOLTMETERS. From 0-300V £3. to 20KV Max. General guide 5KV 3 1/2" £5. Thereafter £1 per KV. P&P 75p.
DON'T FORGET YOUR MANUALS. S.A.E. with requirements.
E.H.T. TRANSFORMERS
240KV SINGLE PHASE 20KVA. Output 2 x 2.5KV £85.
240V SINGLE PHASE 1KVVA. Output 40KV 25MA. £175.
Many other EHT Transformers and EHT Capacitors available.

NEW INTAKE OF TEKTRONIX 545A

Oscilloscope with CA plug-in (Dual Beam — 24 megs)
£220 each

*** I.C. BOARD PACK**
50 I.C.s and other useful components for £1 P&P 75p

MARCONI R.F. POWER METER

Type TF 1152A/1 (CT419)
2 ranges 10 watts fsd and 25 watts fsd. 50 ohms
£75 each

MULLARD & BRIMAR OSCILLOSCOPE TUBES BRAND NEW BOXED — ALL RECTANGULAR

D13-46GM P7 £35 ea
D13-51GH Green £65 ea
D10 210GH/32 £40 ea
GEC Type 1496B £75 ea.
Carriage all types £2.75.

SOLID STATE TIMEBASES

By LARGE BRITISH MANUFACTURERS
These are a Plug-in Modular Timebase covering 0.2 microsecs per cm to 5 secs per cm in 23 steps. Tunnel Diode triggering. 8 Front Panel Controls. 37 Transistors/FETs — all plug-in. Silver anodised front panel. Size 4 x 5 1/2 x 10 1/2" deep. Guaranteed absolutely brand new in original manufacturer's packaging. Complete with extremely comprehensive copy of manual. £17.50 ea. P&P £2.

DON'T MISS

The Telefunken DD14-131 replacement tubes for Solartron (Schlumberger) CD1740, Cossor CDU 150, S.E. Labs SM112 and the GEC/MOV 1474 tube.

These tubes were fitted in one of the above oscilloscopes, but were removed on the authority of the British Ministry because they were not of British manufacture. They are warranted by us as being of 'as new' condition.

PRICE £55 EACH, P&P £2.75

Also Mullard replacement for the Bradley 200 and Advance OS3000 at £85 ea, P&P £2.75.

DEC EQUIPMENT

PDP8L £575
PDP8I. Needs attention £350
PDP11-03. As new, minimum configuration £1,350
RXV11-BD New Twin £2,500
LSI-11. Back Plane with KD11F and DLV11 £750
Other options available.
PDP11-34. Processor boards and optional memories, static or core. No power supply, some back planes. Various combinations available.
LK02. Keyboard and Display £400
PDP11-04 with core memory and back plane. No P.U. and no case £900

Most of above goods warranted 90 days.

★ TRANSISTORS/DIODES/RECTIFIERS, ETC. ★

Guaranteed all full spec. devices. Manufacturers' Markings.
At 5p each
BC147-2N3707-BC172B-BC2518-BC348B-BC171A/B-BC413-D10-BC192-BC212-BAX13-1N937-BA102BE-BZX83-TIS61-2N5048
At 10p each
BFX85-1N4733A-5N7451N-BYX10-1.5KV-0.36A-BY210 15p ea. TIP30 20p ea. IP34A — 50p ea. BD538 — 40p ea. Heavy Duty Bridge Rectifier — 20p ea. TBA8105 — 75p ea. CA3123E — £1 ea. BDY55 — £1 ea. 2N3055 — 40p ea. TIP31B — 12p ea.
TBA560CO £2 ea. 1N4436T — TO3 Flat mount 10A 200piv £1 ea. 2N5879 with 2N5881 Motorola 150W Comp pair. £2 pr. BD535/BD538 Comp. pair — 25p pr.
Linear Amp 709 — 75p ea.
High Speed Voltage Comparator 710 — 15p ea.
P&P Extra on all items.
FINNED HEAT SINK — single TO3 — Size 4 1/2" x 3" x 1 1/4" 50p ea. P&P 75p.

DESKS with Punch Reader, Printer and Keyboard. Some ASC11. Various models from £200.

1/2" MAG TAPE

Approx. 2,000 ft. **NOW 25p each.** P&P £1. Or 5 for £1 carr. £2.75 p

FOR THE VDU BUILDER tube M28-13GH. 23 x 17cm at £12 ea. Base connections supplied.
Heads for **PERDEC 6000/7000** — enquiries.

PLESSEY VDU. No keyboard-weird electronics £75 ea

TELETYPE ASR 33 from £450
TELETYPE KSR33
NON-STANDARD KSR33 eg basic ASC11-20MA loop — but small print 0 to 9 above standard 0 to 9, some of the symbols having been relocated. £250.

TELETYPE 35 RO Cased £95.
TELETYPE 35 RO with 20MA interface. Few only £120 ea.

LITTON SYSTEM — Must go — £375 or offer.

CREED 7B TELEPRINTERS

THE CHEAPEST WAY OF GETTING A FULL ALPHA/NUMERIC PRINTOUT FROM YOUR MICRO

Large Ministry purchase enables us to offer these at **£25 each**

In good working condition. Requires 110 volts DC. Requires ASC11/BAUDOT converter for coupling to your micro-processor. These units are Processor tested before dispatch. Circuits included. Adequately packed to guarantee safe arrival for £3.25

A LARGE QUANTITY OF MISCELLANEOUS TEST GEAR — CHASSIS UNITS, ETC., ON VIEW AT LOW COST

Minimum Mail Order £2. Excess postage refunded. **Unless stated — please add £2.75 carriage to all units.**
VALUE ADDED TAX not included in prices — Goods marked with * 12 1/2 % VAT, otherwise 8 %
Official Orders Welcomed. Gov./Educational Dept., Authorities, etc., otherwise Cash with Order.
Open 9 a.m. to 5.30 p.m. Mon to Sat.

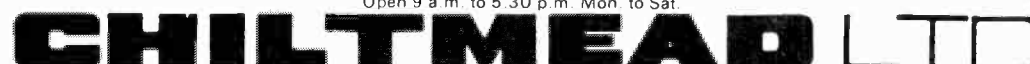

7/9 ARTHUR ROAD, READING, BERKS (near Tech. College, King's Road). Tel. Reading 582605

Electronic Brokers Ltd

The Test Equipment People

Calibrated & Guaranteed 12 Months

GOULD ADVANCE

Modular Pulse Generator PG.52. System of 5 signal generating & processing units. Repetition freqs up to 20MHz & output pulses to 20V (50Ω). Rise & Fall times 5 nsec. Its versatility enables the production of complex pulse & ramp waveforms not obtainable from conventional pulse generators. **£425.00**

PG55 High Power Double Pulse Generator. Produces ±50V into 50Ω with rise time variable between 12ns and 100ns. Main pulse width continuously variable 100ns to 100ms in decade steps with a 10:1 fine control. Rise Time 12ns up to 3.5MHz, variable to greater than 100ns. Fall Time, less than 15ns. Delay prepulse to main pulse 0.1μs to 100ms in decade steps with a 10:1 fine control. Repetition rate continuously variable 1Hz to 5MHz. Amplitude positive or negative from earth 0.4V to 50V into 50Ω in six ranges with vernier control. External triggering. **£150.00**

Double Pulse Generator PG5002D. Main pulse width 0.1μsec to 1sec. Rise time 12nsec. Amplitude 8mV to 50 volts. Repetition rate 0.1Hz-1MHz. **£150.00**

Double Pulse Generator PG.56. Pulse Amplitude 0.1V-10V Sq. wave 0-10V. Rise Time 10nsec (typically). **£100.00**

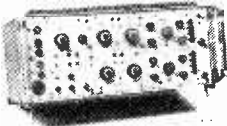

Pulse Generator PG59 (Type CT600). Produces a pulse controllable in frequency, width, amplitude, delay and rise and fall times. Also produces prepulse and gate outputs. Repetition frequency 1Hz to 10MHz. Pulse width 25nsec to 1sec. Rise and fall times 12nsec to 1 sec. Delay 25μsec to 1sec. Trigger. Internal, external and single shot. **£595.00**

LR100X-Y Plotter. Specification. Main frame. Frequency response 1Hz. Plug-in amplifiers, LR120 general purpose amplifier LR121 time base. Full specification on request. **£235.00**

R.F. Signal Generator B4B7. 30kHz-30MHz. O/p 1μV to 100mV. Output z -75Ω. Int Mod 400Hz. 0-80% Provision for Ext. Mod Audio o/p 0-10V at 400Hz into 600Ω. **£165.00**

AF Signal Generator H1E. Specification. Frequency range 15Hz-50kHz. AF Output. Sine Wave 200μV to 20V r.m.s. ±2 dB. Square Wave 1.4mV to 14V peak to peak approximately. **£80.00**

Signal Generator J3. Frequency range 10Hz to 100kHz. Sine & Square output. Metered o/p. **£150.00**

Signal Generator J4. Frequency range 10Hz to 100kHz. Sine and square o/p. **£140.00**

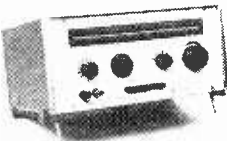

Wide range oscillator SG 67A. Frequency range 1Hz to 1MHz. Sine and square wave. **£95.00**

Low Distortion Oscillator SG 68A. 1.5Hz-150kHz. Output waveforms. Low distortion - <0.01% (40kHz-20kHz). Low distortion - <0.05% (20kHz-150kHz). Square wave. Typically 600Ω impedance. Max output 4V (r.m.s.) Battery operated. **£175.00**

True R.M.S. Voltmeter DRM6. 100mV-1kV (6 ranges) 100% over-range. C.M.R. 90dB (DC-50Hz). **£395.00**

Frequency Counter TC18. 5Hz-80MHz. 5 digit display. 1MHz crystal. Frequency and count functions. **£110.00**

Timer Counter TC17A. 6 digit. DC-80MHz. Gate times 10μs to 10s in decade steps. Sensitivity 25mV (r.m.s.) sine wave. Overload protected. **£215.00**

Timer Counter TC18. Specification. Frequency Measurement. Input 1 10Hz to 100MHz. Input 2 10MHz-512MHz. Both inputs direct counting. Sensitivity 35mV r.m.s. to 40MHz. 50mV r.m.s. at 100MHz. Input 2 sensitivity 35mV r.m.s. 40MHz to 400MHz. 50mV r.m.s. to 512MHz. Display 6 digit dot matrix L.E.D. **£245.00**

Timer Counter TC22. Measures Frequency DC-100MHz. 6 digit, time, period, period average, count, totalise, pulse width, ratio. **£275.00**

40MHz Frequency Divider TCD40. Range 1-40MHz. Divide by 100, 40, 10, 4 or 1. 50Ω impedance. Input sensitivity 50mV r.m.s. to 10V. **£30.00**

100MHz Frequency Divider TCD100A. Range 1-100MHz (Typically 150MHz). Input impedance 50Ω. Input sensitivity 50mV r.m.s. to 5V peak max. **£45.00**

Digital Multimeter DMM3. 3½ digit. Maximum reading 1999. 25 ranges of measurement AC and DC volts, AC and DC current. Resistance. Dual Polarity. Remote hold. **£115.00**

STRIP CHART RECORDER OMNISCRIBE A.5000 Series. One & Two Pen. "As New Condition". Full specification on request.

A 5110-1 **£200.00**

A 5112-2 **£225.00**

A 5123-1 **£300.00**

A 5120-5 **£300.00**

A 5132-4 **£320.00**

A 5221-4 **£400.00**

A 5212-4 **£380.00**

A 5230-4 **£450.00**

A 5222-2 **£410.00**

Off Air Frequency Standard OFS-2B **£200.00**

Off Air Frequency Standard OFS-1 **£185.00**

VHF Square Wave Generator SG21. 10kHz-100MHz. **£60.00**

A.F. Signal Generator J2E. 15Hz-50kHz. o/p (600Ω) 0.1mW-1W. **£120.00**

A.C. Millivoltmeter VM77C. 0.001V-300V f.s.d. (12 ranges) 15Hz-4.5MHz. **£55.00**

Timer Counter TC14. 9 digit. Display storage. DC-250MHz. Time gate selectable 0.1μs-100s. Multiple period average 10-10⁻⁷. Sensitivity 10mV, 100mV, 500mV. Overload protected. **£400.00**

Timer Counter TC15. 9 digit with storage and plug-in capability. DC-250MHz. Spec. similar to TC14. **£500.00**

Plug In Unit TC15 P1. 1MHz-500MHz. 10mV-1V. Full 500MHz display with 1Hz resolution in only 2 secs. **£150.00**

TEKTRONIX

Bench Oscilloscope Type 531A c/w dual trace vertical plug-in unit CA. DC-13.5MHz. Sensitivity 50mV-20V/Div. Time base ranges 100ns to 5S/Div. Timebase modes. A, X5. Internal voltage calibrator 0.2mV-100V. 1kHz square wave. **£290.00**

Bench Oscilloscope Type 647A c/w dual trace vertical plug in unit 10A2A & delayed time base plug in unit 11B2A. DC-100MHz. Sensitivity 10mV-20V/Div. Time base ranges 100ns-5S/Div on A & B. Time base modes A only. Intensified, delayed sweep, X10. Internal voltage calibrator 0.2mV-100V. 1kHz square wave. **£1200.00**

Bench Oscilloscope Type 585A c/w dual trace vertical plug in unit Type 82. DC-80MHz. Sensitivity 10mV-50V/Div. Time base ranges A 50ns-2S/Div, 2.2μs-1S/Div. Time base modes A, B, intensified, delayed, X5. Internal voltage calibrator 0.2mV-100V. 1kHz square wave. **£775.00**

Bench Oscilloscope Type 547 c/w dual trace vertical plug in unit 1A1. DC-50MHz. Sensitivity 5mV-20V/Div. Time base ranges 100ns-5S/Div A and B. Time base modes A, B, intensified, delayed sweep, alternate sweep, X 2-5-10. Internal voltage calibrator 0.2mV-100V. 1kHz square wave. **£775.00**

Bench Oscilloscope Type 546. c/w dual trace vertical plug in unit 1A1. As 547, but without alternate sweep. **£740.00**

Bench Oscilloscope 545B c/w dual trace vertical plug in unit CA. DC-24MHz. sensitivity 50mV to 20V/Div. Time base ranges A 100ns - 5S/Div. B2 μs-1S/Div. Time base modes A, B, intensified, delayed sweep, X5. Internal voltage calibrator 0.2mV-100V. 1kHz square wave. **£555.00**

Bench Oscilloscope Type 543B c/w dual trace vertical plug in unit CA. As 545B & CA, without B time base. With X2-X100 Horizontal gain. **£450.00**

Dual Trace Portable Oscilloscope 485. DC-350MHz. Sensitivity 5mV-5V/Div. Input impedance 1MΩ or 50Ω. Time base ranges 1ns-0.5S/Div on A and B. Time base modes A, B, intensified, delayed sweep, alternate sweep. **£2,900.00**

Time Marker Generator 184. 16 marker intervals. 5 sine wave frequencies. 500MHz sine wave output. Crystal controlled oscillator. 10MHz ± 0.001%. **£275.00**

2101 5ns Pulse Generator with Delay. 2.5Hz-25MHz repetition rate. Variable baseline offset. 5ns risetime and fall time. Paired, undelayed, delayed and output latched on modes. External gate input. Simultaneous positive and negative going pulses 10volts into 50Ω. **£575.00**

2901 Time Mark Generator. 16 marker intervals. 4 sine wave frequencies. 500MHz sine wave output. Crystal controlled oscillator. B trigger pulse intervals. **£450.00**

General Purpose Oscilloscope 515A. DC-15MHz. Single trace. 50mV-20V/cm. **£185.00**

TV Waveform Monitor 525 **£165.00**

Portable Battery/Mains Oscilloscope 212. DC-500kHz Dual Trace. 1mV-50V/Div. **£585.00**

Plug In Unit Power Supply 132 **£120.00**

Spectrum Analyser Plug In 3L10 (for 560, and 564 series 'scopes). 1-36MHz. **£415.00**

4-Trace Plug In Unit "IM" (for use with 530, 540 & 580 series) **£250.00**

Differential Plug In Unit "W" **£325.00**

Oscilloscope Camera Unit C12 **£190.00**

Digital Readout Oscilloscope 567. Choice of plug-ins available. Mainframe price. **£510.00**



Constant Amplitude Signal Generator 191. 350kHz-100MHz. Sine wave. 5mV-5V constant amplitude. 50kHz Amplitude reference. **£350.00**

ELECTRONIC BROKERS LIMITED
49-53 Pancras Road, London NW1 2QB
Tel. 01-837 7781. Telex: 298694
Hours of Business: 9 a.m.-5 p.m.
Mon.-Fri.: closed lunch 1-2 p.m.
Carriage and Packing charge extra on all items unless otherwise stated.
ADD 8% VAT TO ALL PRICES

WWW - 096 FOR FURTHER DETAILS

Calibrated & Guaranteed 12 Months

Electronic

The Test Equipment People

HEWLETT PACKARD

True R.M.S. Voltmeter 3400A. 1mV-300V (12 ranges) dB range -72+52 dBm Frequency range 10Hz to 10MHz
£415.00

D.C. D.V.M. 3430A. 3 digit 5 ranges 100mV-100V Input Resistance 10MΩ Overload protected £145.00

Digital Multimeter 34702A. C/w 34740 display 4 1/2 digit. 4 ranges of A.C. & D.C. & 6 ranges of ohms A.C. = 45Hz-100kHz
£400.00

U.H.F. Signal Generator 612A. 450-1200MHz in 1 band Output Voltage 0.1μV to 0.5V Output impedance 50Ω A.M. 0-90% Ext. A.M. Facility Pulse mod facility Various modern versions from £900.00-£1250.00

Frequency Doubler 10515A £75.00

A.M. Signal Generator 606A. 50kHz-65MHz £550.00

Bench Oscilloscope 175A. C/w Plug Ins 1754A & 1781B 4 trace 40MHz bandwidth Sweep Delay £550.00

Programmable Step Attenuator 355E. DC-1000MHz 0-12 dB in 1dB steps Un-used £60.00

Portable Oscilloscope 1707A. DC-75MHz Solid State Dual Trace 10mV/div Sweep delay £825.00

Distortion Analyser 332A. 5Hz-600kHz Distortion levels 0.1%-100% are measured full scale in 7 ranges A.M. Detector operating from 550kHz-65MHz £495.00

DC Standard/Differential Voltmeter 740B. Designed for calibrating digital voltmeters, differential voltmeters, potentiometers, voltage dividers and for general standards lab application 6 digit resolution with discrete steps of 1 p.p.m. of full scale Full specification on request £1,850.00

A.C. Voltmeter 400F. 100V to 300V 1 s (14 ranges) Freq range 10Hz-10MHz £195.00

Microwave Power Meter 430C. C/w Thermistor mount 477B 10MHz-10GHz Full scale ranges 0.1, 0.3, 1, 3 & 10mW £575.00

Portable Oscilloscope 1700B. DC-35MHz 10mV/div sensitivity Dual Channel Solid State £575.00

FLUKE

Multifunction Counter 1900A-01. Same spec as 1900A but with battery pack £215.00

Multifunction Counter 1900A-02. Same spec as 1900A but with BCD out £230.00

Frequency Synthesiser 6011A. Performs function of an oscillator counter and level meter 10Hz-11MHz Output 0.4mV-5V r.m.s. 7 digit LED display Accuracy ±3 parts in 10⁵ for one year Freq storage Full spec on request £2650.00

Frequency Synthesiser 6160A/DX. 4MHz-30MHz in 1Hz steps Output 1V into 50Ω Stability ±1 part in 10⁵ in 24 hours Full spec on request UNUSED. BARGAIN PRICE £675.00

Meter Calibrator 760A. Spec for DC Voltmeters -0.001V to 1kV Accuracy 0.1% Resolution 100μV DC Ammeters -1μA to 10A Accuracy ±0.25% Resolution 1μA AC Voltmeters -0.001V to 1kV 60Hz and 400Hz Accuracy ±0.25% Resolution 100μV AC Ammeters -1μA to 10A 600Hz and 400Hz Accuracy ±0.25% Ohmmeters -0 to 10MΩ 0.1% of setting +0.5MΩ Resolution 1Ω Full spec on request £2150.00

Reference Divider 750A. Used for calibration of precision DC Voltmeters Voltboxes, DC Calibrators etc. The equipment is a 10ppm (0.001%) divider with switched input taps ranging from 1100 to 1.1V and switched output taps ranging from 1100V to 0.1V £980.00

Industrial Counter Totaliser 1941A. 5Hz-40MHz 40mV sensitivity R.P.M. measurement £150.00

Communications Counter 1920A. 5Hz-520MHz 15mV sensitivity 9 digit LED display £400.00

VHF, UHF Telecomms. Frequency Counter 1980A. C/w Battery Pack 5Hz-515MHz 6 digit LED Display 50mV sensitivity over whole range £400.00

MULTIFUNCTION 6 DIGIT AUTORANGING COUNTER 1900A

Modes
Frequency period, totalize, Frequency range 5Hz-80MHz Input sensitivity 25mV
BRAND NEW
£175.00



GENERAL RADIO

Frequency Meter & Discriminator 1142A. Frequency Range 3Hz to 1.5MHz Accuracy ±0.2% Can be used with a recorder to produce records of frequency change and drift £235.00

Standard Frequency Multipliers. Type 1112 series. Providing microwave range standard freqs Output 20mW Output impedance 50Ω Low noise and excellent phase stability
Type 1112A £520.00
Type 1112B £495.00

Radio Frequency Bridge 1606A. 400kHz to 60MHz a generator & detector is required £390.00

Wave Analyser 1900A. C/w Graphic Level Recorder 1521B Spec 1900A 20Hz-50kHz 3 band widths 3, 10 and 50Hz Tracking averages 30mV-300V f.s.d Input impedance 1MΩ 3 meter speeds Spec 1521B 4 5Hz-200kHz, 1mV sensitivity Linear dB plot of r.m.s. ac-voltage level 20, 40 or 80dB range £2000.00

Electronic Voltmeter 1806A. AC+DC voltage, 9 resistance ranges ±2% accuracy Wide frequency range - up to 1500MHz £175.00

Adjustable Attenuator 874 GAL. 100MHz to 4GHz 120 dB range 50Ω Impedance BRAND NEW £150.00

METRONIX (POLAND)

Wide Range Multimeter UM11. 100 000Ω/V DC volts 150mV-1500V f.s.d AC Volts 1.5-1500V f.s.d (31.6K/V) DC current 10μA to 15A f.s.d AC Current 0.15A Supplied with Test leads & Carrying Case BRAND NEW Full specification on request £29.50

Function Generator G432. 1Hz-1.1MHz Sine, Square & Triangle BRAND NEW Full specification on request £79.50

RADIOMETER

Stereo Signal Generator SMG1C. Solid state, pushbutton operation. Full specification on request £350.00

AVO

Multimeter Mk. IV. Supplied with leads & plastic carrying case £14.00
Multimeter model 7 £40.00
Leads, prods & croc clips for models 7, 8 & 9 £4.50 set

PHILIPS

100MHz Single output Pulse Generator PM5775. Specification on request £800.00

100MHz Double Output Pulse Generator PM5776. Specification on request £900.00

50MHz Pulse Generator PM5712



£495.00

Specification on request

50MHz Pulse Generator PM5715. Specification on request £600.00
Low Frequency Generator PM5105. 10Hz-100kHz Sine & Square wave £156.00

Sine & Square Wave Oscillator PM5125. 10Hz-1MHz £145.00
U.H.F. TV Generator PM5525A. 470-850MHz Can be modulated with black & white as well as colour TV £95.00

RACAL

Freq. Period Meter 9520. 5Hz-10MHz £110.00

Universal Counter Timer 9838. Frequency single and multiple period time interval Freq range 10Hz-100MHz £285.00

H.F. Communications Receiver RA117E. 1-30MHz Full specification on request £350.00

Modulation Meter 210A. 2.5-300MHz A.M. range 0-100% F.M. range 0 to ±100kHz £245.00-£285.00



A.M./F.M. Modulation Meter 409. Freq 3-1500MHz A.M. 0-100% F.M. 0-600kHz £345.00

T.E.S. (Milan)

Distortion Meter D566B. Solid State 10Hz-1MHz 0.03%-100% incorporation also millivoltmeter £305.00

L.F. Signal Generator G1165B. Solid State, 10Hz-100kHz 1mV-10V 600Ω impedance Square Wave facility £195.00

Wow & Flutter Meter WF971. DIN & CCIR 1/2p signal 20mV-20V Flutter +0.1% +0.3% ±1% 1/p impedance 10KΩ £210.00

A.F. Power Meter MU964. 1mW-10W (4 ranges) 20Hz-50kHz Load input resistance 40 values £175.00

All ex-demonstrators as new condition



49-53 Pancras Road
London NW1 2QB

ADD 8% VAT
TO ALL PRICES

Tel: 01-837 7781. Telex: 298694

WW-097 FOR FURTHER DETAILS

Brokers Ltd



49-53 Pancras Road, London NW12QB
Tel: 01-837 7781

TELEQUIMENT

Portable Oscilloscope D75. DC-50MHz at 5mV/Div Dual Trace Delay/Mixed Sweep **£575.00**

MARCONI INSTRUMENTS

Signal Generator TF867. 15kHz-30MHz o/p 0.4µV-4V Int & Ext mod Supplied with Terminating Unit **£185.00**

F.M./A.M. Signal Generator TF995B/2. Frequency Range 200kHz to 22MHz in five bands Output 0.1µV-200mV Output Impedance 75Ω Modulation (F.M.) Normal deviation continuously variable in two ranges ±25kHz and ±75kHz on all bands Greater deviation is available on most bands Modulating Frequency Internal FM 1kHz External FM 50Hz to 15kHz Modulation (A.M.) Internal AM 1kHz, 0.50% External AM 50Hz to 10kHz, 0.50% **£675.00**

F.M./A.M. Signal Generator TF995B/5. This is the current narrow-deviation model for v.h.f. mobile radio testing. It differs from the TF995B/2 in the following respects - Tuning Controls Combination of Fine Tuning and calibrated Incremental Frequency controls permits rapid and accurate bandwidth measurement Modulation (F.M.) Normal deviation continuously variable from 0-5kHz and 0 to 15kHz in all bands Greater deviation is obtainable on most bands Modulation (A.M.) Internal AM 400Hz, 1kHz or 1.5kHz, 0.50% External AM 100Hz to 100kHz, 0.50% **£675.00**

U.H.F. Signal Generator TF1060. Frequency range 450-1250MHz (1 band) Output 0.15µV to 445mV Output Impedance 50Ω Int. sine A.M.-1kHz Ext. pulse mod **£400.00**

Solid State Signal Source 6058B. Frequency range 8-12.5GHz Internal and external modulation Min 0/p 20mW Frequency Stability (short term) 0.003% Output Impedance 50Ω **£530.00**

Microwave Sweep Oscillator 6600A. Together with Plug in Oscillator 6619 Frequency range 1.7 to 4.2GHz Output Impedance 50Ω **£2500.00**

A.M. Signal Generator TF144H & H/S. Frequency range 10kHz to 72MHz in twelve overlapping bands Output Attenuator 2µV to 2V Output Impedance 50Ω Modulation Internal AM 400Hz & 1kHz to 0 to 80% External AM 20Hz to 20kHz 0 to 80% **£275.00-£400.00**

A.M. Signal Generator TF144H/4. A later version of TF144H with similar spec **£375.00-£600.00**

A.M. Signal Generator TF144H/4S. Electrical specification as TF144H/4 **£375.00-£700.00**

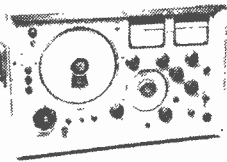

A.M. Signal Generator TF801D/1. Frequency Range 10MHz to 470MHz in five bands Output Attenuator 0.1µV to 1V Output Impedance 50Ω (Type N connector) Modulation Internal AM 1kHz 0 to 90% External AM 30Hz to 20kHz 0 to 90% **£400.00-£750.00**

A.M. Signal Generator TF801D/1/S. Special military version of TF801D/1 having fully sealed meters and carrier on/off switch The electrical specification is similar to the TF801D except for extended carrier and modulation frequency ranges as shown below Frequency Range 10MHz to 485MHz in five bands Modulation External AM 30Hz to 50kHz 0-90% **£450.00-£600.00**

Carrier Deviation Meter TF791D. Carrier Freq range 4 to 1024MHz Deviation range up to ±125kHz Modulating Frequency range Up to 35kHz Late models **£295.00**

20MHz Sweep Generator TF1099. Video sweep output Lower limit 100kHz fixed Upper limit continuously variable up to 20MHz 0.3 to 3V p-p Z=75Ω Input & Output detector probes Markers at 1MHz intervals **£295.00**

Oscillator TF1247 (can be used with Q Meter TF1245) 20MHz-300MHz **£350.00**

A.M. Signal Generator TF801D/8S. Same spec as TF801D/1S + freq. counter o/p facility **£695.00**

F.M./A.M. Signal Generator TF995A/2M. 1.5 to 220MHz 2µV to 200mV int & Ext A.M Int FM at 1kHz deviation 0-75kHz **£375.00-£475.00**

Sensitive Valve Voltmeter TF2600. 12 ranges 1mV-300V f.s.d. 1% accuracy up to 500kHz Usable up to 10MHz **£175.00**

R.F. Electronic Voltmeter TF2604. 7 ranges 300mV-300V f.s.d. from 20Hz-1500MHz 8 ranges 300mV-1kV DC 7 ranges Resistance 500Ω to 500MΩ **£225.00**

U.H.F. Signal Generator TF1060/3A. Frequency range 500 to 1200MHz Remainder of spec on TF1060 **£575.00**

R-C Oscillator TF1101. Frequency Range 20Hz to 200kHz in four bands Output Attenuator 1mV to 20V Maximum Output 20V across external 600Ω load Output impedance 600Ω **£120.00**

A.F. Signal Source TF2000. 20Hz to 20kHz Extremely low distortion 111dB attenuator-0.1dB steps **£325.00**

Phase A.M. Signal Generator TF2003. 0.4-12MHz **£150.00**



Two-Tone Signal Source TF2005R. The instrument comprises two identical low-distortion a.f. oscillators and a monitored attenuator unit to form a compact test set for the measurement of inter modulation distortion using the methods recommended by SMPTE and CCIF Frequency Range 20Hz-20kHz in six bands (each oscillator can be adjusted and used independently) Harmonic Distortion Less than 0.05% between 63Hz and 6kHz when using unbalanced output Generally less than 0.1% under other conditions Intermodulation Below 80dB with respect to the wanted signal Amplitude Reference Level Up to +10dBm from each oscillator Output Attenuator 111dB in 0.1dB steps **£415.00**

Colour Gain and Delay Test Set TF2904. 625 line N.T.S.C. or PAL Sub carrier frequency 4.43MHz Impedance 75Ω Used to measure relative gain and delay between luminance and chrominance channels **£495.00**

Blanking and Sync Mixer TF2908. For 405 525 and 625 line television systems Reshapes and mixes blanking and sync pulse waveform with video test waveform **£90.00**

L.F. Extension Unit TM6448. For use with Spectrum Analyser OA 1094A series 100Hz to 3MHz **£200.00**

Wide Range R.C. Oscillator TF1370A. 10Hz to 10MHz sine wave, 10Hz to 100kHz square wave Output up to 31.6V **£275.00**

DC Multiplier TM5033A. HV probe up to 30kV. Impedance 3000MΩ for use with TF1041 series or TF2604 **£25.00**

5 watt Dummy Load TM5582 for use with TF2604 **£25.00**

A.F. Oscillator TF2100. 20kc/s to 20Kc/s Extremely low distortion. Output Impedance 600Ω unbalanced **£150.00**

M.F. Oscillator TF2101. 30c/s to 550kc/s Stable frequency Low distortion. Output Impedance 600Ω unbalanced **£115.00**

F.M./A.M. Modulation meter TF2300S. Incorporating Oscillator TM8045/1. 3.5 to 1000MHz Full specification on request **£825.00**



M.F. Transmission Measuring Set TF2333. Frequency range 30Hz to 550kHz The TF2333 is a transmission measuring set of the conventional type that normally forms part of the essential test gear for audio and baseband equipment of multi-channel telecommunications systems Signal Source, oscillator-frequency range 30Hz to 550kHz in five ranges. Attenuator. Range 70dB in 10dB and 1dB steps **£600.00**

Quantization Distortion Tester TF2343. Checks A.F. to A.F. distortion of p.c.m. systems. Full Specification on request **£450.00**

F.M. Signal Generator TF1066B/6. 10-470MHz R.F. output 0.2µV-200mV e.m.f. Output Impedance 50Ω Modulation Internal AM 1kHz & 5kHz 0-40% External AM 30Hz to 15kHz 0-40% Internal FM 1kHz & 5kHz deviation 0 to 100kHz or up to 400kHz according to carrier freq. range. External FM 30Hz to 100kHz deviation same as int. Crystal Calibrator facility **£685.00**

Variable Attenuator TF338C. 0-105dB Freqs up to 100kHz 600Ω impedance **£90.00**



M.F. Attenuator TF2162. DC-1MHz 0-111dB in steps of 0.1dB **£120.00**

R.F. Attenuator TF1073A/2S. 0-100MHz 100dB in 1dB steps - 80dB in 20dB steps & 20dB in 1dB steps **£67.00**

Also TF1073A. Spec as A/2S **£55.00**

Portable Scope TF2203. Single beam DC-15MHz Rise time 23 nanoseconds 50mV/cm Z modulation available 18 present sweep speeds 100 nanoseconds to 200 nanoseconds Also X5 expansion **£150.00**

10-Watt A.F. Power Meter TF893A. Frequency range 20Hz to 35kHz Five power ranges, 1mW to 10W full scale Impedance 2.5Ω to 20KΩ in 48 steps Balanced or unbalanced inputs Direct calibration in watts and dBm **£165.00**

100-Watt R.F. Power Meter: TF1020A Series. Frequency range DC to 250 MHz Two power ranges 50 and 100W full scale Output Impedance 75Ω **£105.00**

R.F. Power Meter TF2502. Range 3 and 10W f.s.d. DC-1GHz Output impedance 50Ω VSWR 1-1.1 **£355.00**

Calibrated & Guaranteed 12 Months

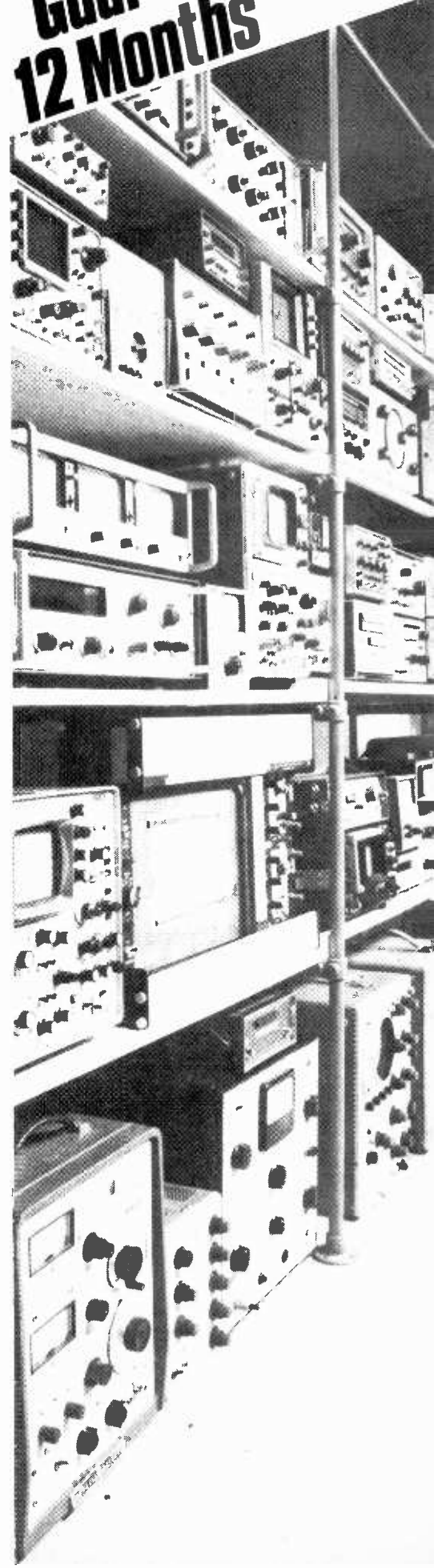

Carriage and packing charge extra on all items unless otherwise stated

Hours of business: 9a.m.-5p.m. Mon.-Fri. Closed lunch 1-2p.m.

WW-098 FOR FURTHER DETAILS

Please note: All instruments offered are secondhand and tested and guaranteed 12 months unless otherwise stated

BENTLEY ACOUSTIC CORPORATION LTD.

7A GLOUCESTER ROAD, LITTLEHAMPTON, SUSSEX, Tel. 6743

ALL PRICES SHOWN INCLUDE V.A.T. AT 12 1/2 %

| | | | | | | | | | | | | | | | | | | | | | | | | | | | | | |
|--------|------|-------|------|--------|------|---------|------|---------|------|---------|-------|-------|------|------|------|--------|------|--------|------|--------|------|------|------|-------|------|--------|------|------|------|
| 0A2 | 1.20 | 6AX4 | 0.75 | 6L12 | 0.50 | 12AU7 | 0.62 | 30PL14 | 1.50 | CV988 | 0.25 | EC53 | 1.00 | EL86 | 0.60 | PABC80 | 0.45 | PY81 | 0.60 | U12/14 | 1.15 | X65 | 2.00 | ACY28 | 0.35 | BY211 | 0.30 | OC42 | 0.73 |
| 0B2 | 0.40 | 6BB6 | 0.75 | 6L18 | 0.00 | 12AV6 | 0.60 | 30PL15 | 1.30 | CY1C | 1.00 | EC54 | 1.00 | EL90 | 0.75 | PC88 | 0.80 | PY83 | 0.60 | U16 | 1.00 | X66 | 2.00 | AD140 | 0.50 | BY212 | 0.30 | OC43 | 1.37 |
| 0C3 | 0.50 | 6BA6 | 0.65 | 6L19 | 2.00 | 12AX7 | 0.52 | 35A3 | 1.00 | CY31 | 1.00 | EC86 | 0.84 | EM30 | 0.85 | PC92 | 0.65 | PY88 | 1.12 | U18/20 | 2.50 | X119 | 1.10 | AD161 | 0.53 | BY213 | 0.30 | OC45 | 0.12 |
| 0Z4 | 0.00 | 6BE6 | 0.70 | 6L20 | 0.48 | 12BA6 | 0.58 | 38C5 | 0.00 | D1 | 0.50 | EC88 | 0.84 | EM36 | 0.50 | PC96 | 1.00 | PY301 | 0.50 | U19 | 4.00 | X142 | 1.00 | AF102 | 1.04 | CG12E | 0.23 | OC46 | 0.13 |
| 1A5GT | 0.55 | 6BG6G | 1.00 | 6N7GT | 0.70 | 12BH7 | 0.55 | 38L6GT | 0.90 | D93 | 0.50 | EC90 | 0.50 | EM43 | 1.00 | PC99 | 0.75 | PY302 | 0.50 | U22 | 0.85 | X150 | 1.00 | AF106 | 0.58 | CG64H | 0.23 | OC70 | 0.14 |
| 1A7GT | 0.60 | 6BH6 | 1.10 | 6PL12 | 0.60 | 12BY7 | 1.15 | 35W4 | 0.55 | DAF91 | 0.55 | EC97 | 0.75 | EM45 | 0.75 | PC99 | 2.05 | U22 | 0.85 | U22 | 1.00 | X159 | 0.55 | AF114 | 0.30 | FSY11A | 0.26 | OC71 | 0.13 |
| 1B3GT | 0.55 | 6B16 | 0.75 | 6P15 | 0.48 | 12E1 | 3.50 | 35Z3 | 0.90 | DAF96 | 1.00 | EC92 | 1.00 | EM48 | 1.00 | PC99 | 0.65 | PY300A | 2.05 | U25 | 1.00 | X179 | 0.55 | AF115 | 0.30 | FSY41A | 0.26 | OC72 | 0.13 |
| 1C2 | 1.00 | 6BK7A | 0.85 | 6Q7G | 0.75 | 12J5GT | 0.40 | 35Z4GT | 0.70 | DC90 | 0.70 | EC33 | 2.00 | EM49 | 1.00 | PC99 | 0.65 | PY300A | 2.05 | U25 | 1.00 | X199 | 0.55 | AF117 | 0.23 | GD4 | 0.38 | OC74 | 0.26 |
| 1D5 | 1.00 | 6BN8 | 1.50 | 6Q7GT | 0.75 | 12J7GT | 0.70 | 35Z5GT | 0.90 | DD4 | 0.80 | EC35 | 2.00 | EM51 | 1.00 | PC99 | 0.65 | PY300A | 2.05 | U25 | 1.00 | X215 | 0.55 | AF118 | 0.23 | GD4 | 0.38 | OC75 | 0.26 |
| 1G6 | 1.00 | 6BQ6 | 0.48 | 6Q7M | 0.75 | 12K5 | 1.50 | 50B5 | 0.95 | DF33 | 0.75 | EC40 | 1.00 | EM53 | 1.00 | PC99 | 0.65 | PY301 | 0.50 | U33 | 1.75 | Z329 | 0.70 | AF121 | 0.35 | GD5 | 0.32 | OC76 | 0.18 |
| 1H5GT | 0.60 | 6BQ7A | 1.40 | 6R7G | 0.70 | 12K7GT | 0.50 | 50C5 | 0.70 | DF91 | 0.30 | ECC1 | 0.52 | EM54 | 1.00 | PC99 | 0.65 | PY301 | 0.50 | U33 | 1.75 | Z329 | 0.70 | AF124 | 0.36 | GD6 | 0.32 | OC77 | 0.18 |
| 1L4 | 0.25 | 6BR7 | 1.00 | 6R7(M) | 1.00 | 12K8 | 0.75 | 50C8&G | 4.00 | DF96 | 1.00 | ECC2 | 1.00 | EM58 | 1.20 | PC99 | 0.65 | PY301 | 0.50 | U35 | 1.00 | Z729 | 0.52 | AF125 | 0.50 | GD8 | 0.23 | OC77 | 0.18 |
| 1LD5 | 0.70 | 6BR8 | 1.25 | 6SA7 | 0.70 | 12Q7GT | 0.50 | 50EHS | 0.85 | DH63 | 0.75 | ECC3 | 0.52 | EM61 | 1.00 | PC99 | 0.65 | PY301 | 0.50 | U35 | 1.00 | Z729 | 0.52 | AF125 | 0.50 | GD8 | 0.23 | OC77 | 0.18 |
| 1LW5 | 0.70 | 6BW6 | 3.75 | 6SC7GT | 1.00 | 12SA7GT | 0.75 | 50L6GT | 1.00 | DH76 | 0.50 | ECC4 | 0.50 | EM62 | 1.00 | PC99 | 0.65 | PY301 | 0.50 | U35 | 1.00 | Z729 | 0.52 | AF125 | 0.50 | GD8 | 0.23 | OC77 | 0.18 |
| 1NG5T | 0.75 | 6BW7 | 0.85 | 6SG7 | 0.70 | 12SC7 | 0.50 | 69KU | 1.00 | DH77 | 0.80 | ECC5 | 0.50 | EM63 | 1.00 | PC99 | 0.65 | PY301 | 0.50 | U35 | 1.00 | Z729 | 0.52 | AF125 | 0.50 | GD8 | 0.23 | OC77 | 0.18 |
| 1R5 | 0.50 | 6BX6 | 0.85 | 6SH7 | 0.70 | 12SG7 | 0.55 | 72 | 0.70 | DH81 | 1.00 | ECC6 | 2.00 | EM64 | 1.00 | PC99 | 0.65 | PY301 | 0.50 | U35 | 1.00 | Z729 | 0.52 | AF125 | 0.50 | GD8 | 0.23 | OC77 | 0.18 |
| 1S4 | 0.60 | 6BY7 | 0.45 | 6SJ7 | 0.70 | 12SH7 | 0.50 | 77 | 0.45 | DK40 | 1.00 | ECC7 | 0.52 | EM65 | 1.00 | PC99 | 0.65 | PY301 | 0.50 | U35 | 1.00 | Z729 | 0.52 | AF125 | 0.50 | GD8 | 0.23 | OC77 | 0.18 |
| 1S5 | 0.35 | 6BZ6 | 1.50 | 6SK7 | 1.00 | 12S17 | 0.60 | 85A2 | 1.40 | DK91 | 0.50 | ECC8 | 1.00 | EM66 | 1.00 | PC99 | 0.65 | PY301 | 0.50 | U35 | 1.00 | Z729 | 0.52 | AF125 | 0.50 | GD8 | 0.23 | OC77 | 0.18 |
| 1T4 | 0.30 | 6C4 | 0.50 | 6SK7GT | 0.70 | 12SK7 | 0.60 | 85A3 | 1.40 | DK92 | 1.00 | ECC9 | 1.00 | EM67 | 1.00 | PC99 | 0.65 | PY301 | 0.50 | U35 | 1.00 | Z729 | 0.52 | AF125 | 0.50 | GD8 | 0.23 | OC77 | 0.18 |
| 1U4 | 0.70 | 6C6 | 0.45 | 6SQ7 | 0.70 | 12SN7GT | 0.75 | 90C1 | 1.50 | DK92 | 1.00 | ECC10 | 0.90 | EM68 | 1.00 | PC99 | 0.65 | PY301 | 0.50 | U35 | 1.00 | Z729 | 0.52 | AF125 | 0.50 | GD8 | 0.23 | OC77 | 0.18 |
| 1U5 | 0.85 | 6C9 | 2.00 | 6U4GT | 1.00 | 12SQ7 | 0.90 | 90CV | 5.50 | DK96 | 1.00 | ECC11 | 2.00 | EM69 | 1.00 | PC99 | 0.65 | PY301 | 0.50 | U35 | 1.00 | Z729 | 0.52 | AF125 | 0.50 | GD8 | 0.23 | OC77 | 0.18 |
| 2D1 | 0.50 | 6C10 | 1.00 | 6U7G | 0.55 | 12SQ7GT | 0.90 | 108C1 | 0.48 | DL33 | 0.70 | ECC12 | 0.90 | EM70 | 1.00 | PC99 | 0.65 | PY301 | 0.50 | U35 | 1.00 | Z729 | 0.52 | AF125 | 0.50 | GD8 | 0.23 | OC77 | 0.18 |
| 2G3 | 0.75 | 6CB6A | 0.85 | 6U8 | 1.00 | 12SR7 | 0.75 | 150C2 | 1.20 | DL63 | 0.60 | ECC13 | 0.50 | EM71 | 1.00 | PC99 | 0.65 | PY301 | 0.50 | U35 | 1.00 | Z729 | 0.52 | AF125 | 0.50 | GD8 | 0.23 | OC77 | 0.18 |
| 2X2 | 0.70 | 6C12 | 0.55 | 6V6G | 0.58 | 13D8 | 2.00 | 215GG | 0.60 | DL82 | 0.60 | ECC14 | 0.50 | EM72 | 1.00 | PC99 | 0.65 | PY301 | 0.50 | U35 | 1.00 | Z729 | 0.52 | AF125 | 0.50 | GD8 | 0.23 | OC77 | 0.18 |
| 3A4 | 0.55 | 6CD6G | 4.00 | 6X2 | 0.90 | 14H7 | 0.75 | 305 | 1.20 | DL92 | 0.65 | ECC15 | 2.00 | EM73 | 1.00 | PC99 | 0.65 | PY301 | 0.50 | U35 | 1.00 | Z729 | 0.52 | AF125 | 0.50 | GD8 | 0.23 | OC77 | 0.18 |
| 3B7 | 0.35 | 6C88A | 0.90 | 6X4 | 0.95 | 14S7 | 1.00 | 305 | 1.20 | DL94 | 0.60 | ECC16 | 2.00 | EM74 | 1.00 | PC99 | 0.65 | PY301 | 0.50 | U35 | 1.00 | Z729 | 0.52 | AF125 | 0.50 | GD8 | 0.23 | OC77 | 0.18 |
| 3D6 | 0.40 | 6CL6 | 0.75 | 6X6GT | 0.50 | 1L | 1.25 | 807 | 1.10 | DL96 | 1.00 | ECC17 | 0.50 | EM75 | 1.00 | PC99 | 0.65 | PY301 | 0.50 | U35 | 1.00 | Z729 | 0.52 | AF125 | 0.50 | GD8 | 0.23 | OC77 | 0.18 |
| 3Q4 | 0.80 | 6C18A | 0.85 | 6Y6G | 0.95 | 19AQ5 | 0.85 | 956 | 0.50 | DM70 | 1.25 | ECC18 | 0.50 | EM76 | 1.00 | PC99 | 0.65 | PY301 | 0.50 | U35 | 1.00 | Z729 | 0.52 | AF125 | 0.50 | GD8 | 0.23 | OC77 | 0.18 |
| 3Q5GT | 0.70 | 6CMT | 1.00 | 6Y7G | 1.25 | 19B6GG | 1.00 | 1625 | 2.50 | DM77 | 1.75 | ECC19 | 0.75 | EM77 | 1.00 | PC99 | 0.65 | PY301 | 0.50 | U35 | 1.00 | Z729 | 0.52 | AF125 | 0.50 | GD8 | 0.23 | OC77 | 0.18 |
| 3S4 | 0.65 | 6CS6 | 0.75 | 7A7 | 1.00 | 19C6 | 6.50 | 1821 | 1.00 | DM4/350 | 1.15 | ECC20 | 0.55 | EM78 | 1.00 | PC99 | 0.65 | PY301 | 0.50 | U35 | 1.00 | Z729 | 0.52 | AF125 | 0.50 | GD8 | 0.23 | OC77 | 0.18 |
| 3V4 | 1.00 | 6CU5 | 0.90 | 7B6 | 1.00 | 19H1 | 4.00 | 5725 | 1.50 | DY51 | 2.00 | ECC21 | 0.50 | EM79 | 1.00 | PC99 | 0.65 | PY301 | 0.50 | U35 | 1.00 | Z729 | 0.52 | AF125 | 0.50 | GD8 | 0.23 | OC77 | 0.18 |
| 4C86 | 0.75 | 6D3 | 0.75 | 7B7 | 1.00 | 19Y3 | 0.40 | 5763 | 2.75 | DY87/6 | 0.52 | ECC22 | 1.50 | EM80 | 1.00 | PC99 | 0.65 | PY301 | 0.50 | U35 | 1.00 | Z729 | 0.52 | AF125 | 0.50 | GD8 | 0.23 | OC77 | 0.18 |
| 4GK5 | 0.75 | 6E7 | 0.80 | 7D6 | 2.00 | 20D1 | 0.70 | 6057 | 2.00 | DY802 | 0.50 | ECC23 | 0.90 | EM81 | 1.00 | PC99 | 0.65 | PY301 | 0.50 | U35 | 1.00 | Z729 | 0.52 | AF125 | 0.50 | GD8 | 0.23 | OC77 | 0.18 |
| 4GK6 | 0.75 | 6D7B | 0.85 | 7F8 | 2.00 | 20D4 | 2.50 | 6060 | 2.00 | E80CC | 4.75 | ECC24 | 0.50 | EM82 | 1.00 | PC99 | 0.65 | PY301 | 0.50 | U35 | 1.00 | Z729 | 0.52 | AF125 | 0.50 | GD8 | 0.23 | OC77 | 0.18 |
| 4GK7 | 1.00 | 6EW6 | 0.85 | 7H7 | 1.00 | 20F2 | 0.85 | 6067 | 4.70 | E80F | 6.00 | ECC25 | 0.60 | EM83 | 1.00 | PC99 | 0.65 | PY301 | 0.50 | U35 | 1.00 | Z729 | 0.52 | AF125 | 0.50 | GD8 | 0.23 | OC77 | 0.18 |
| 5T4 | 2.00 | 6E5 | 1.00 | 7K7 | 2.00 | 20L1 | 1.20 | 6146 | 4.70 | E80G | 5.50 | ECC26 | 0.50 | EM84 | 1.00 | PC99 | 0.65 | PY301 | 0.50 | U35 | 1.00 | Z729 | 0.52 | AF125 | 0.50 | GD8 | 0.23 | OC77 | 0.18 |
| 5U4G | 1.00 | 6F1 | 0.80 | 7V7 | 2.00 | 20P1 | 1.00 | 6463 | 2.00 | E81CC | 2.00 | ECC27 | 1.00 | EM85 | 1.00 | PC99 | 0.65 | PY301 | 0.50 | U35 | 1.00 | Z729 | 0.52 | AF125 | 0.50 | GD8 | 0.23 | OC77 | 0.18 |
| 5V4G | 1.00 | 6F6G | 0.70 | 7Y4 | 0.90 | 20R3 | 1.00 | 7025 | 2.00 | E82CC | 2.00 | ECC28 | 1.00 | EM86 | 1.00 | PC99 | 0.65 | PY301 | 0.50 | U35 | 1.00 | Z729 | 0.52 | AF125 | 0.50 | GD8 | 0.23 | OC77 | 0.18 |
| 5Y3GT | 0.85 | 6F12 | 0.70 | 7Z4 | 0.90 | 20P4 | 0.94 | 7193 | 0.60 | E83F | 3.50 | ECC29 | 1.00 | EM87 | 1.00 | PC99 | 0.65 | PY301 | 0.50 | U35 | 1.00 | Z729 | 0.52 | AF125 | 0.50 | GD8 | 0.23 | OC77 | 0.18 |
| 5Z3 | 1.00 | 6F14 | 0.90 | 8D2 | 0.50 | 20P5 | 1.50 | 7475 | 1.20 | E88CC | 1.20 | ECC30 | 1.00 | EM88 | 1.00 | PC99 | 0.65 | PY301 | 0.50 | U35 | 1.00 | Z729 | 0.52 | AF125 | 0.50 | GD8 | 0.23 | OC77 | 0.18 |
| 5Z4G | 0.75 | 6F15 | 0.85 | 8D8 | 0.52 | 25A6G | 1.00 | 9002 | 0.55 | E92CC | 4.50 | ECC31 | 0.75 | EM89 | 1.00 | PC99 | 0.65 | PY301 | 0.50 | U35 | 1.00 | Z729 | 0.52 | AF125 | 0.50 | GD8 | 0.23 | OC77 | 0.18 |
| 5Z4GT | 0.90 | 6F16 | 1.00 | 8E1W6 | 0.90 | 25L9G | 1.00 | 9006 | 0.45 | E180CC | 5.00 | ECC32 | 1.00 | EM90 | 1.00 | PC99 | 0.65 | PY301 | 0.50 | U35 | 1.00 | Z729 | 0.52 | AF125 | 0.50 | GD8 | 0.23 | OC77 | 0.18 |
| 6/30L2 | 0.90 | 6F18 | 0.80 | 9D7 | 1.00 | 25Y5 | 0.90 | A1834 | 1.50 | E190F | 5.00 | ECC33 | 1.70 | EM91 | 1.00 | PC99 | 0.65 | PY301 | 0.50 | U35 | 1.00 | Z729 | 0.52 | AF125 | 0.50 | GD8 | 0.23 | OC77 | 0.18 |
| 6A8G | 1.40 | 6F23 | 1.00 | 9R8 | 0.45 | 25Z4G | 0.50 | A3042 | 6.00 | E182CC | 5.50 | ECC34 | 0.50 | EM92 | 1.00 | PC99 | 0.65 | PY301 | 0.50 | U35 | 1.00 | Z729 | 0.52 | AF125 | 0.50 | GD8 | 0.23 | OC77 | 0.18 |
| 6AC7 | 0.70 | 6F24 | 0.90 | 10C2 | 0.70 | 25Z5 | 0.75 | AC2PENN | 1.80 | E188CC | 4.50 | ECC35 | 0.50 | EM93 | 1.00 | PC99 | 0.65 | PY301 | 0.50 | U35 | 1.00 | Z729 | 0.52 | AF125 | 0.50 | GD8 | 0.23 | OC77 | 0.18 |
| 6AG5 | 0.55 | 6F25 | 1.00 | 10C14 | 0.90 | 25Z6G | 0.90 | AC2PENN | 1.80 | E20F | 12.50 | ECC36 | 0.50 | EM94 | 1.00 | PC99 | 0.65 | PY301 | 0.50 | | | | | | | | | | |

Electronic Brokers The Computer People

STOP PRESS

SAVE OVER 1/3 of list price on these superb
**TEKTRONIX 611
STORAGE DISPLAYS**

Flicker-free bistable storage of combined alphanumeric and graphic information from digital computers and other data transmission systems
11" Storage Crt Vertical sensitivity 1V/16 2CM (sq format) or 1V/21CM (rect format) within 2% FSD Maximum input voltage $\pm 50V$ DC and peak AC Settling time 3.5 microsec/CM + 5 microsec. Stored resolution 4000 clearly legible characters (90 x 70mil matrix) viewing time 15 minutes or less recommended for specified resolution
OUR PRICE ONLY £950, WITH FULL THREE-MONTH WARRANTY.



Catalogue

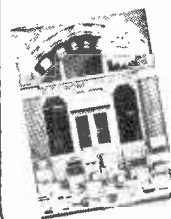

Send for your free copy including latest update sheets

Mini-Computer Exchange

SPECIALISTS IN DIGITAL EQUIPMENT, PROCESSORS, PERIPHERALS, FEATURES, ETC.

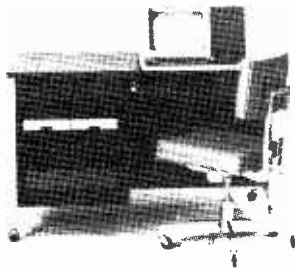

PDP8A SERIES

PDP8A SYSTEM WITH: MM8-AB 16K core memory. KM8-AA extended option board. DKC8-AA 1/0 option board. RX8-BD dual floppy disc drive VT50-AB DEC-scope. LA36 DECwriter Mounted in console/desk unit
PDP8A SYSTEM (Datasytem 310-FB) with 8K core. dual floppy disc. VT-52 DECscope. console-mounted
PDP8A PROCESSOR with 3K ROM memory and DKC8-AA 1/0 option board

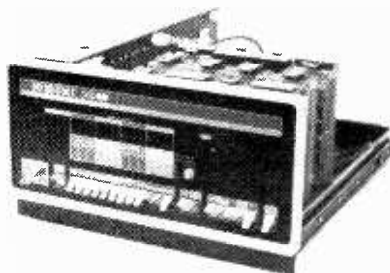

PDP8E SERIES

PDP8E and **PDP8M** Processors. 4K to 32K. various configurations available Prices from **£2300**

PDP11 SERIES

PDP11-05, PDP11-10, PDP11-34, PDP11-35 Processors available 8K to 96K. various configurations available Prices from **£3250**

DISCS

RK8E/RK05 DISK Drive and control from **£3950**
RK11/RK05 Disk Drive and control from **£5250**
RK05-BB, RK05-J and **RK05-F** slave drives
Prices from **£2700**

PAPER TAPE

PR11 high speed reader complete with PDP11 interface. **£1750**
PC11A high speed reader/punch complete with PDP11 interface. **£2250**

ADD-ON CORE

MF11UP 16K parity core including backplane **£2400**
MM11UP 16K expander parity core (prerequisite MF11UP) **£2000**

DEC MODULES

Large stocks of DEC modules — let us know your requirements

Printers and Terminals

SUPER SAVINGS ON SPECIAL PURCHASE OF PORTABLE TEXAS SILENT 700 TERMINALS.
Our special price **£695**

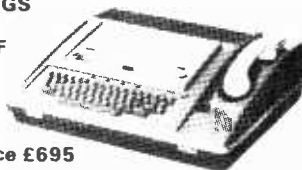

Model 725 KSR ASCII Keyboard Silent high speed operation up to 300 baud 5 x 7 dot matrix electronic printhead Full or half duplex operation Built in acoustic coupler Mounted in integral carrying case Gross weight 35lbs Dimensions 21 1/2" x 19" x 6 1/2"

LARGE STOCKS OF ASR33 AND KSR33 TELETYPE TERMINALS

- * ASC11 Keyboard
- * Hard-copy unit (friction or sprocket paperfeed)
- * Paper Tape punch and reader (ASR33 only)
- * Line Unit (20mA/6V/80V)

Overhauled in our own workshops to the highest standards and sold with 90-day warranty
Prices from **£425 (KSR 33)** and **£625 (ASR33)**

DATA DYNAMICS DD390 ASR and KSR TERMINALS

All the features of the well-proven Teletype terminal PLUS attractive acoustic cover — ideal for environments where noise reduction is important Prices from **£525 (KSR)** and **£795 (ASR)**

CENTRONICS 101 and 101A MATRIX PRINTERS

5 x 7 dot matrix 132 print positions 165 cps. ASC11 64 character set Prices from **£1250**

CASE CM120 RO Printer. 120 cps. 80 ch/line. 5 x 7 dot matrix. standard ASC11 64 character set. CC1TT-V24 Compatible Interface **£725**

HAZELTINE Thermal RO Printer. 30 cps — for use as band copy attachment to Hazeltine 2000 Visual Display unit **£595**

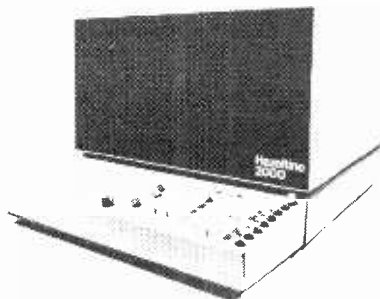

HAZELTINE VISUAL DISPLAY UNITS

Dramatic new savings on a further bulk purchase of these top quality CRT terminals Fully teletype — compatible with switch-selectable transmission up to 9600 baud and standard CC1TT V 24 interface (current-loop adaptor also available if required)
H-1000 12 lines & 80 characters
H-1200 24 lines & 80 characters
H-2000 27 lines & 74 characters with full edit facilities detachable keyboard foreground-background data
Please phone for details

Keyboards

NEW STOCKS OF ASC11 KEYBOARDS IMMINENT — PLEASE PHONE FOR DETAILS.



55SW3-1 54-station BCD-coded 4-bank alphanumeric keyboard. Hall-effect switches. input + 5VDC negative logic and strobed output. two-key rollover Set in attractive panel incorporating 5 indicator lamps and on/off switch Dimensions 15 1/2 x 5 1/2 x 2 1/2"
PRICE **£39.50 + £2 P&P + 8% VAT (send £44.82)**

18-KEY PUSH-BUTTON CALCULATOR KEYBOARD

Numerals 0-9 decimal point C K + - x = Mounted on PCB overall dimensions 5 1/2 x 4 3/8 x 1 1/2"
PRICE **£4.00 + 50p P&P + 8% VAT (send £4.86)**

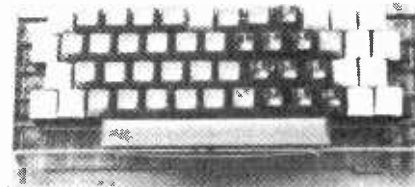

HONEYWELL KEYBOARDS

4-bank alphanumeric ex-equipment keyboards, 50 keystations diode-encoded. 7-bit positive logic, positive strobe. TTL/DTL-compatible Power requirements 5V 100mA Layout similar to IBM 029 Price **£25 + £1 P&P + 8% VAT (Send £28.08)**

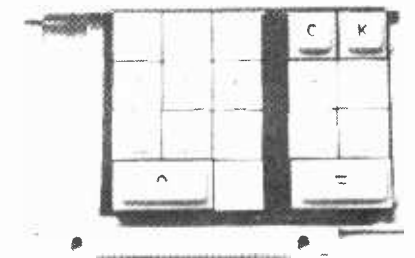

PAPER TAPE EQUIPMENT

FACTI 4060 high speed punch 150 cps complete with Facti 5107 control unit

BRAND NEW SURPLUS! OUR BARGAIN PRICE £950. FACTI 4001 high speed reader — up to 1000 cps Price **£625**

DATA DYNAMICS 1133 46cps Punch complete with integral supply and take-up spools and TTL-compatible logic Price **£450.00**

TELETYPE BRPE 110cps electro mechanical punch Mains-operated drive motor. punch operating coils require 28V at 1 Amp for each coil Signal requirements 4.5ms on 4.5ms off at 110cps Price **£145.00** plus £20 for sound-reducing cabinet if required

ELLIOT/ICL table-mounting high-speed photo-electric readers Power requirements Lamp 9.5V photo-sensors and amplifier circuits 6-10V Prices 250cps **£165**, 500cps **£200**, 1000cps **£275**.



ELECTRONIC BROKERS LIMITED (COMPUTER DIVISION)

49-53 Pancras Road, London NW1 2QB. Tel. 01-837 7781. Telex: 298694

Hours of business:
9 a.m.-5 p.m. Mon.-Fri. Closed lunch 1-2 p.m.

ADD 8% VAT
TO ALL PRICES

Carriage & Packing charge extra
on all items unless otherwise stated

WWW-1011 FOR FURTHER DETAILS
www.americanradiohistory.com

NEW SEASON'S COMPONENTS

BRIDGE RECTIFIERS

| SILICON 1 amp | Order No | Price |
|-----------------------|----------|-------|
| Type | | |
| 50V RMS | BR1/50 | £0.20 |
| 100V RMS | BR1/100 | £0.22 |
| 200V RMS | BR1/200 | £0.25 |
| 400V RMS | BR1/400 | £0.36 |
| SILICON 2 amps | | |
| 50V RMS | BR2/50 | £0.45 |
| 100V RMS | BR2/100 | £0.48 |
| 200V RMS | BR2/200 | £0.52 |
| 400V RMS | BR2/400 | £0.58 |
| 1000V RMS | BR2/1000 | £0.68 |

BOOKS BY BABANI

Purchase books to the value of £5.00 from the list below and choose any 60p pak from this page FREE.

| | | |
|------|--|-------|
| BP2 | Handbook of Radio, TV & Industrial & Transmitting Tube & Valve Equivalents | 60p† |
| BP3 | Handbook of Tested Transistor Circuits | 40p† |
| BP6 | Engineers and Machinists Reference Tables | 40p† |
| BP7 | Radio & Electronic Colour Codes and Data Chart | 15p† |
| BP10 | Modern Crystal and Transistor Set Circuits for Beginners | 35p† |
| BP14 | Second Book of Transistor Equivalents | 95p† |
| BP15 | Constructors Manual of Electronic Circuits for the Home | 50p† |
| BP16 | Handbook of Electronic Circuits for the Amateur Photographer | 60p† |
| BP18 | Boys and Beginners Book of Practical Radio and Electronics | 60p† |
| BP22 | 79 Electronic Novelty Circuits | 75p† |
| BP23 | First Book of Practical Electronic Projects | 75p† |
| BP24 | 52 Projects Using IC741 (or equivalents) | 75p† |
| BP26 | Radio Antenna Handbook for Long Distance Reception and Transmission | 85p† |
| BP27 | Giant Chart of Radio Electronic Semiconductor and Logic Symbols | 60p† |
| BP29 | Major Solid State Audio Hi-Fi Construction Projects | 85p† |
| BP32 | How to Build Your Own Metal & Treasure Locators | 85p† |
| BP34 | Practical Repair & Renovation of Colour TVs | 95p† |
| BP35 | Handbook of IC Audio Pre-amplifier & Power Amplifier Construction | 95p† |
| BP36 | 50 Circuits Using Germanium, Silicon & Zener Diodes | 75p† |
| BP37 | 50 Projects Using Relays, SCR's and TRIACS | 1.10† |
| BP39 | 50 (FET) Field Effect Transistor Projects | 1.25† |
| 129 | Universal Gram-motor Speed Indicator | 8p† |
| 160 | Coil Design and Construction Manual | 75p† |
| 161 | Radio, TV and Electronics Data Book | 60p† |
| 196 | AF-RF Reactance — Frequency Chart for Constructors | 15p† |
| 202 | Handbook of Integrated Circuits (ICs) Equivalents and Substitutes | 75p† |
| 205 | First Book of Hi-Fi Loudspeaker Enclosures | 75p† |
| 213 | Electronic Circuits for Model Railways | 85p† |
| 214 | Audio Enthusiasts Handbook | 85p† |
| 216 | Electronic Gadgets and Games | 85p† |
| 217 | Solid State Power Supply Handbook | 85p† |
| 219 | Solid State Novelty Projects | 85p† |
| 220 | Build Your Own Solid State Hi-Fi and Audio Accessories | 85p† |
| 222 | Solid State Short Wave Receivers for Beginners | 95p† |
| 223 | 50 Projects Using IC CA3130 | 95p† |
| 224 | 50 CMOS IC Projects | 95p† |
| 225 | A Practical Introduction to Digital IC's | 95p† |
| 226 | How to Build Advanced Short Wave Receivers | 1.20† |
| RCC | Resistor Colour Code Disc Calculator | 10p† |

BOOKS BY NEWNES

| | | |
|---------|---|--------------|
| No. 229 | Beginners Guide to Electronics | Price £2.25† |
| No. 230 | Beginners Guide to Television | Price £2.25† |
| No. 231 | Beginners Guide to Transistors | Price £2.25† |
| No. 233 | Beginners Guide to Radio | Price £2.75† |
| No. 234 | Beginners Guide to Colour Television | Price £2.25† |
| No. 235 | Electronic Diagrams | Price £1.80† |
| No. 236 | Electronic Components | Price £1.08† |
| No. 237 | Printed Circuits Assembly | Price £1.08† |
| No. 238 | Transistor Pocket Book | Price £3.90† |
| No. 225 | 110 Thyristor Projects Using SCRs & Triacs | Price £2.50† |
| No. 227 | 110 COS/MOS Digital IC Projects for the Home Constructor | Price £2.25† |
| No. 226 | 110 Operational Amplifier Projects for the Home Constructor | Price £2.50† |
| No. 242 | Electronic Pocket Book | Price £3.75† |
| No. 239 | 30 Photoelectric Circuits & Systems | Price £1.80† |

CASES

ALUMINIUM BOXES. Made from bright all., folded construction each box complete with half inch deep lid and screws.

| No. | Length | Width | Height | Price |
|-----|----------|----------|----------|--------|
| 159 | 5 1/4 in | 2 1/4 in | 1 1/2 in | 62p† |
| 160 | 4 in | 4 in | 1 1/2 in | 62p† |
| 161 | 4 in | 2 1/4 in | 1 1/2 in | 62p† |
| 162 | 5 1/4 in | 4 in | 1 1/2 in | 74p† |
| 163 | 4 in | 2 1/2 in | 2 in | 64p† |
| 164 | 3 in | 2 in | 1 in | 44p† |
| 165 | 7 in | 5 in | 2 1/2 in | £1.04† |
| 166 | 8 in | 6 in | 3 in | £1.32† |
| 167 | 6 in | 4 in | 2 in | 86p† |

INSTRUMENT CASES. In two sections vinyl covered top and sides, aluminium bottom, front and back.

| No. | Length | Width | Height | Price |
|-----|--------|----------|----------|--------|
| 155 | 8 in | 5 1/4 in | 2 in | £1.40† |
| 156 | 11 in | 6 in | 3 in | £1.80† |
| 157 | 6 in | 4 1/4 in | 1 1/4 in | £1.25† |
| 158 | 6 in | 5 1/4 in | 2 1/2 in | £1.60† |

SPECIAL OFFER!

AGFA CASSETTES

STEREOCROM

307 C60 RRP £2.03 Our price **£1.60**

308 C90 RRP £2.54 Our price **£1.80**

309 C120 RRP £3.49 Our price **£2.60**

SFD — Super Ferro Dynamic

310 C60 RRP £1.48 Our price **£1.00**

311 C90 RRP £1.89 Our price **£1.50**

312 C120 RRP £2.62 Our price **£2.00**

DIODES SIL G.P.

300mW 40 PIV (min) SUB-MIN FULLY TESTED
Ideal for Organ builders
30 for 50p, 100 for £1.50, 500 for £5, 1,000 for £9

INTEGRATED CIRCUITS CMOS

| Type | Price | Type | Price | Type | Price |
|--------|-------|--------|-------|--------|-------|
| CD4000 | £0.15 | CD4022 | £0.90 | CD4046 | £1.30 |
| CD4001 | £0.18 | CD4023 | £0.20 | CD4047 | £1.10 |
| CD4002 | £0.18 | CD4024 | £0.80 | CD4049 | £0.55 |
| CD4006 | £0.98 | CD4025 | £0.20 | CD4050 | £0.55 |
| CD4007 | £0.18 | CD4026 | £1.70 | CD4054 | £1.10 |
| CD4008 | £0.98 | CD4027 | £0.80 | CD4055 | £1.40 |
| CD4009 | £0.58 | CD4028 | £0.98 | CD4058 | £1.35 |
| CD4010 | £0.58 | CD4029 | £1.15 | CD4069 | £0.40 |
| CD4011 | £0.20 | CD4030 | £0.55 | CD4070 | £0.40 |
| CD4012 | £0.20 | CD4031 | £2.20 | CD4071 | £0.23 |
| CD4013 | £0.52 | CD4035 | £1.30 | CD4072 | £0.23 |
| CD4018 | £0.95 | CD4037 | £0.95 | CD4081 | £0.20 |
| CD4016 | £0.50 | CD4040 | £0.95 | CD4082 | £0.23 |
| CD4017 | £0.98 | CD4041 | £0.82 | CD4510 | £1.30 |
| CD4018 | £1.00 | CD4042 | £0.82 | CD4511 | £1.60 |
| CD4019 | £0.55 | CD4043 | £0.98 | CD4516 | £1.40 |
| CD4020 | £1.10 | CD4044 | £0.94 | CD4518 | £1.25 |
| CD4021 | £0.98 | CD4045 | £1.40 | CD4520 | £1.25 |

LINEAR

| Type | Price | Type | Price | Type | Price |
|-----------|-------|----------|-------|----------|-------|
| CA3011 | £1.05 | MC1303L | £1.48 | 709P | £0.25 |
| CA3014 | £1.70 | MC1304P | £1.90 | UA710C | £0.40 |
| CA3018 | £0.75 | MC1310P | £0.95 | 72710 | £0.30 |
| CA3020 | £1.70 | MC1312PQ | | UA711C | £0.32 |
| CA3028 | £1.02 | | £1.90 | 72711 | £0.32 |
| CA3035 | £1.70 | MC1330P | | UA723C | £0.45 |
| CA3036 | £1.35 | | £1.20 | 72723 | £0.45 |
| CA3024 | £1.50 | MC1350 | £1.20 | UA741C | £0.24 |
| CA3043 | £1.85 | MC1351P | £1.20 | 72741 | £0.24 |
| CA3046 | £0.80 | MC1352P | £1.40 | 741P | £0.20 |
| CA3052 | £1.60 | MC1456G | | UA747C | £0.70 |
| CA3054 | £1.35 | | £1.40 | 72747 | £0.79 |
| CA3075 | £1.50 | MC1466L | | UA748 | £0.35 |
| CA3081 | £1.50 | | £4.50 | 72748 | £0.35 |
| CA3089 | £2.10 | MC1469R | | 748P | £0.35 |
| CA3090 | £4.25 | | £2.95 | SN76013N | £1.75 |
| CA3123 | £1.90 | MC1496G | | | |
| CA3130 | £0.93 | | £0.98 | SN76023N | £1.75 |
| CA3140 | £0.90 | NE536 | £3.50 | SN76110 | £1.50 |
| LM301 | £0.39 | NE515A | £3.50 | SN76115 | £1.90 |
| LM304 | £1.60 | NE540 | £1.50 | SN76660 | £0.75 |
| LM308 | £1.40 | NE550 | £0.95 | SL414A | £1.95 |
| LM309K | £1.50 | NE555 | £0.32 | TAA550B | £0.35 |
| LM320-5v | £1.50 | NE556 | £0.82 | TAA621A | £2.00 |
| LM320-12v | | NE561 | £3.95 | TAA681A | £1.65 |
| | £1.50 | NE562B | £3.95 | TAD100 | £1.30 |
| LM320-15v | | NE565A | £1.75 | TAD100 | £1.30 |
| | £1.50 | NE566 | £1.50 | TBA540Q | £2.20 |
| LM320-24v | | NE567 | £1.80 | TBA641B | £2.25 |
| | £1.50 | UA702C | £0.46 | TBA800 | £0.80 |
| LM380 14p | | 72702 | £0.46 | TBA810S | £1.05 |
| | £0.85 | UA703A | £0.25 | TBA820 | £1.05 |
| LM381 | £1.55 | UA709C | £0.25 | TBA920Q | £3.40 |
| LM3900N | £0.65 | 72709 | £0.46 | TCA270S | £2.20 |

ORDERING

PLEASE WORD YOUR ORDERS EXACTLY AS PRINTED. NOT FORGETTING TO INCLUDE OUR PART NUMBER AND YOUR NAME AND ADDRESS IN CAPS

VAT

ADD 12 1/2% TO PRICES MARKED * ADD 8% TO OTHERS EXCEPTING THOSE MARKED † THESE ARE ZERO RATED

POSTAGE AND PACKING

Please add postage as follows:
Small orders Medium orders Large orders
25p 50p 75p.
Minimum order £1.00.

PANEL METERS

| 4" RANGE | | | 2" RANGE | | |
|-------------------------------|------|-------|-------------------------------|------|-------|
| Size 4 3/4" x 3 3/4" x 1 3/4" | | | Size 2 3/4" x 1 3/4" x 1 1/2" | | |
| Value | No | Price | Value | No | Price |
| 0-50U | 1302 | £6.70 | 0-50 UA | 1307 | £5.50 |
| 0-100UA | 1303 | £6.70 | 0-100UA | 1308 | £5.50 |
| 0-500UA | 1304 | £6.70 | 0-500UA | 1309 | £5.50 |
| 0-1MA | 1305 | £6.40 | 0-1MA | 1310 | £5.50 |
| 0-50V | 1306 | £6.40 | 0-50V | 1311 | £5.50 |

MIN. LEVEL METER

Size 2 3/4 x 2 2 x 2 6mm

Sensitivity 200UA

MR2P TYPE

Size 4 2 x 4 2 x 30mm

| Value | No | Price |
|--------|------|-------|
| 0-50UA | 1313 | £5.40 |
| 0-1MA | 1315 | £5.40 |

No 1320

Price £2.80

Vu METER

Size 40 x 40 x 29mm

BALANCE/TUNING

Size 4 5 x 2 2 x 34mm

Sensitivity 100/0/100UA

| No | Price | No | Price |
|------|-------|------|-------|
| 1319 | £2.00 | 1321 | £2.00 |

Sensitivity 130UA

MINI MULTI-METER

Size 60 x 24 x 90mm

MINIATURE BALANCE/TUNING METER

Size 2 3 x 2 2 x 2 6mm

Sensitivity 100/0/100MA

AC VOLTS 0-10, 50, 250, 1000

DC CURRENT 0-1, 100mA

Resistance 0-150K ohms

| No | Price | No | Price |
|------|-------|------|-------|
| 1318 | £1.95 | 1322 | £7.50 |

TRANSFORMERS

MINIATURE MAINS Primary 240V

with two independent secondary windings

| No | Type | Price |
|------|------------------------|--------|
| 2024 | MT280 0-6V, 0-6V RMS | £1.50† |
| 2025 | MT150 0-12V, 0-12V RMS | £1.50† |

MINIATURE MAINS Primary 240V

| No | Secondary | Price |
|------|-----------------|-------|
| 2021 | 6V-0-6V 100mA | 90p† |
| 2022 | 9V-0-9V 100mA | 90p† |
| 2023 | 12V-0-12V 100mA | 95p† |

1 AMP MAINS Primary 240V

| No | Secondary | Price | P & P |
|------|-----------------|--------|-----------|
| 2026 | 6V-0-6V 1 amp | £2.50† | P & P 45p |
| 2027 | 9V-0-9V 1 amp | £2.00† | P & P 45p |
| 2028 | 12V-0-12V 1 amp | £2.60† | P & P 55p |
| 2029 | 15V-0-15V 1 amp | £2.75† | P & P 66p |
| 2030 | 30V-0-30V 1 amp | £3.45† | P & P 86p |

STANDARD MAINS Primary 240V

Multi-tapped secondary mains transformers available in 1/2 amp, 1 amp and 2 amp current rating. Secondary taps are 0-19-25-33-40-50V.

Volts available by use of taps: 4, 7, 8, 10, 14, 15, 17, 19, 25, 31, 33, 40, 50, 25-0-25 V.

| No | Rating | Price | P & |
|----|--------|-------|-----|
|----|--------|-------|-----|



HOME MICROCOMPUTER



**NORTHERN
SEMINAR
MANCHESTER**

APRIL 1 £5.50

After the enormous success of the Wembley Seminar, Lynx have been persuaded that there are sufficient Northerners waiting to attend their own show. All day. Microprocessor Lectures and presentation of the Nascom I. Only 350 seats

**Z80
MONITOR PROGRAM
2K R.A.M.
P.C.B.**

**QWERTY KEYBOARD
VDU INTERFACE (TV)
CASSETTE INTERFACE
TELETYPE INTERFACE**

EXPANDABLE SYSTEM

NASCOM I £197.50

+ VAT

LYNX ELECTRONICS (LONDON) LTD., 92 BROAD STREET, CHESHAM, BUCKS.

02405 75151

Announcing the Winner...



Foundations of Wireless and Electronics

— 9th Edition by M. G. Scroggie

521 pages

"Mr Scroggie is authoritative without being academic or dogmatic"

' A rich compilation of many subjects so much so that any engineer, scientist or technician who has thoroughly digested it knows properly all the essential groundwork of electronics.'

Finlay (Tyne & Wear)

"We found important knowledge, adequately expounded, that is only skimmed over in other books we have"

Blake (New South Wales)

Congratulations to Mr John Chadwick Finlay of East Boldon, Tyne & Wear, the winner of the Quarter Million Competition. The prize is a beautiful crimson leather bound, gold embossed copy of the book.

"There is now, and there will always be, a strong demand for a book which combines the basic principles of Electronics and Wireless with a lucid and immensely readable style. This is such a book, and is in my opinion the definitive work for all beginners in the vast field of Wireless and Electronics."

Dickens (Leeds)

"The best book for the lab. or shelf"

Hall (Norwich)

"The popularity of "Foundations of Wireless and Electronics" is its completeness regarding the essential foundations of the subject"

Gibson (Leeds)

Order from your local bookseller
or from: **NEWNES TECHNICAL BOOKS**
Borough Green, Sevenoaks, Kent TN15 8PH



FULL ASCII KEYBOARD KIT

LOW COST!
Model 756
Full ASCII
Keyboard
Kit or
Assembled

- * Intended for professional micro-processor applications.
- * This one Keyboard will meet most present and future requirements.
- * Full 128-character ASCII 8-bit code
- * Tri-mode MOS encoding.
- * Applications notes for auto repeat, numeric pad, serial output.
- * Upper and lower case characters generated by keyboard with latching shift-lock.
- * Selectable polarity.
- * Size 305 X 140 X 32mm (12 1/4 X 5 1/2 X 1 1/4 in)
- * MOS/DTL/TTL compatible outputs.
- * New guaranteed OEM grade components.
- * Needs +5 and -12V supply

- * Board has space for small low-cost DC/DC converter so that entire unit operates off single 5 V rail.

- * User selection of positive or negative logic data and strobe output.
- * Alpha lock
- * Extra loose keys available.
- * Supplied complete with gold-plated PCB connector and full technical data.
- * Rugged mil. spec. G-10 PCB with plated through holes.
- * 2-key roll-over
- * DC level and pulse strobe signal for easy interface to any 8-bit input port microprocessor system, video display or terminal board. Strobe pulse width 1 ms.

PRICED LOWER THAN
SURPLUS KEYBOARDS

Please write for full technical details and price, and for names and addresses of our UK and European stockists.

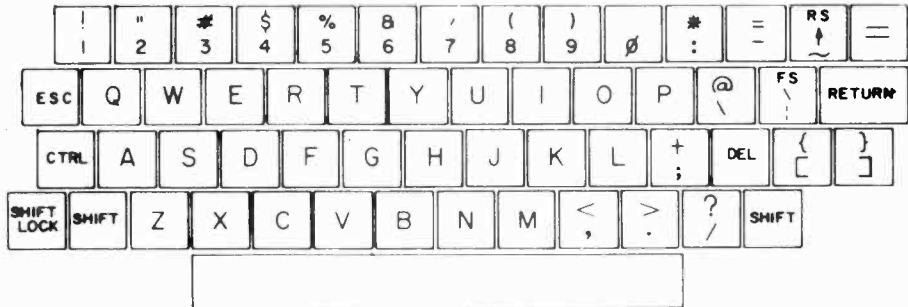

Carter Associates

P.O. Box 11262
VLAEBERG
South Africa
postal code 8018

WW-099 FOR FURTHER DETAILS

10 OUTLET DISTRIBUTION AMPLIFIER 2

One floating input. 10 independent floating outputs at 600 ohms for general studio work or feeding multiple slave pa amplifiers. Electronic input circuit which withstands mains or static voltages on the signal lines.

Total Harmonic Distortion, all outputs loaded, at +16dBV /

1KHz -80dB output
20KHz -66dB, 0.05%

Static Intermodulation Distortion, 50Hz + 7KHz 4:1

Output +12dBV / -86dB, 0.005%

The unit meets the IBA signal path specifications and is available as a complete unit or as a set of all parts excluding the case and XLR connectors.

STEREO DISC AMPLIFIER 2
SUPERLATIVE PERFORMANCE FOR BROADCASTING DISC MONITORING AND TRANSFER
Magnetic cartridge to balanced lines with HF and LF filtering. Mains powered. Meets IBA specification. Specifications February page 105.

PEAK PROGRAMME METERS Meets EC268 1/2A (1974) 550428
PPM2 Standard performance drive circuit under licence from the BBC. Reviewed Studio Sound September 1975. Ernest Turner meter movements 642, 643 and TWIN stocked.

STABILIZER FOR HOWL REDUCTION, BALANCED AND UNBALANCED VERSIONS BOXED OR RACK MOUNTING



PUBLIC ADDRESS: SOUND REINFORCEMENT

+5Hz Fixed Shift Circuit Boards as WW July 1973 article but improved noise level.

Small enough to be built inside the cabinets of many amplifiers

including PSU & mains transformer. DESIGNER APPROVED

SURREY ELECTRONICS
The Forge, Luckles Green, Cranleigh
Surrey GU6 7BG (STD 04866) 5997
CASH WITH ORDER less 5%
UK POST FREE ADD VAT at 8%

MAIL ORDER PROTECTION SCHEME (Limited Liability)

If you order goods from mail order advertisers in this magazine, except for classified advertisements, and pay by post in advance of delivery, Wireless World will consider you for compensation if the advertiser should become insolvent or bankrupt, provided:

1. You have not received the goods or had your money returned; and
2. You write to the publisher of Wireless World explaining the position not earlier than 28 days from the day you sent your order and not later than 2 months from that day.

Please do not wait until the last moment to inform us. When you write, we will tell you how to make your claim and what evidence of payment is required.

We guarantee to meet claims from readers made in accordance with the above procedure as soon as possible after the advertiser has been declared bankrupt or insolvent up to a limit of £3,550 per annum for any one advertiser so affected and up to £10,000 per annum in respect of all insolvent advertisers. Claims may be paid for higher amounts, or when the above procedure has not been complied with, at the discretion of Wireless World; but we do not guarantee to do so in view of the need to set some limit to this commitment and to learn quickly of readers' difficulties.

This guarantee covers only advance payments sent in direct response to an advertisement in this magazine (not, for example, payments made in response to catalogues, etc., received as a result of answering such advertisements). Personal advertisements are excluded.

COMPUTER APPRECIATION

86 High Street, Bletchingley, Redhill, Surrey RH1 4PA. Tel: Godstone (0883) 843221

- PDP 8L** system comprising 12K processor, high speed reader/punch, TU 55 dual DEC tape & LA 36 DEC writer. **£3,850.**
- PDP 8L 12K** processor with TTY interface. **£950**
- PDP 8S 4K** processor with TTY interface. **£325**
- IOMEC 500** MByte removable disc unit with hardware and software controller for PDP 8L/1. **£485**
- PERTEC** 9-track NRZI tape drive with controller and interface for PDP 8L/1. **£550**
- IBM 1130** system comprising 8K processor, removable disc unit, printer and reader/punch. Operating under FORTRAN IV and sold with IBM Letter of Maintenance dated Feb. 78. **£1,875**
- LITTON** Model 1231 computer with ROYTRON reader/punch, 40 cps keyboard-printer. Processor using plug-in TTL. **£275** (another, similar, with extending memory **£325**)
- TELETYPE** Model ASR 33 from **£425**; refurbished KSR 35 **£195**
- OLIVETTI** Model Te 318 terminal, teletype compatible, but with upper/lower case. **£345**
- UNIVAC** Model 100 VDU, RS 232 interface. **£550**
- ICL** Key-Edit VDU, RO, with MOS memory. **£55**
- FLEXOWRITER** Model 1 paper tape terminal typewriter. **£95**
- IBM 735 SELECTRIC** I/O typewriter. **£150** (correspondence coded and refurbished **£225**)
- ICL 7020** high speed paper tape terminal, RS 232. **£375**
- RACAL 9600** Baud to 19200 Baud Converter. **P.O.A.**
- ICL** Model 250 paper tape reader. **£78**
- TELETYPE BRPE** 110 tape punch. **£95**
- TREND HSR 500** P reader. **£225**

- ROYTRON** 50 cps punch (as PDP 11). **£75**
 - HONEYWELL** high speed card reader. **£225**
 - DATEK** Model 40 Paper Tape Reader. **£35** (NEW)
 - SINGER** punch. **£68** (new)
 - REPICO** 120 cps matrix printer. **£225**
 - PRINTEC** Model 100 printer. **£250**
 - PERTEC** 9-track NRZI tape unit. **£475**
 - DIABLO** Model 21 24 MBit disc (as new). **£345**
 - DF 32 32K** disc for PDP 8. **£275**
 - D112 4K** core memory cards compatible with PDP B1. **£75**
 - MDS 1102** key to mag. tape units comprising electronic keyboard, tape drive and read/write electronics with RS 232 option. **£95**
 - SOLARTRON** Model 1604/05AC digital voltmeter with internal reference. **£165**
 - TEKTRONIX** Model 585 oscilloscope. 80 MHz, sweep delay. **£275**
 - TEKTRONIX** Model 453 oscilloscope. **£600**
 - SEFRAM** chart recorder (5 analogue + 2 digital pens) **£85**
 - JAC INSTRUMENTS** frequency counter and standard. **£75**
 - PYE TV** camera and monitor. **P.O.A.**
 - HOUSTON T-Y** analogue servo recorder. **£45.**
- * Callers welcome, but by appointment please
* VAT and carriage extra on all items
* We are keen to bid competitively for all good used equipment

WW - 100 FOR FURTHER DETAILS

Appointments

Advertisements accepted up to 12 noon Monday, April 3, for the May issue, subject to space being available.

DISPLAYED APPOINTMENTS VACANT: £7.50 per single col. centimetre (min. 3cm).
LINE advertisements (run on): £1.10 per line, minimum three lines.
BOX NUMBERS: 50p extra. (Replies should be addressed to the Box Number in the advertisement, c/o Wireless World, Dorset House, Stamford Street, London SE1 9LU.)
PHONE: Eddie Farrell on 01-261 8508
Classified Advertisement Rates are currently zero rated for the purpose of V.A.T.

TEST ENGINEERS INSPECTORS

M.E.L., a division of Philips Electronic & Associated Industries Ltd., are Leaders in the development and manufacture of electronic defence systems and equipments.

We have vacancies for male and female TEST personnel to work on Radio and Avionic systems in a challenging environment with considerable opportunities. Outstanding success, technological progress and innovation in many areas of professional electronics has been achieved and credit for a large part of our reputation is due to our test engineers who have responsibility for ensuring that our equipment meets the exacting specifications which are necessary in our field.

Senior Test Engineers

To carry out testing and diagnostic fault finding on professional Avionic and Radio Systems including digital, analogue, microwave systems, units and sub assemblies, preferably qualified to H.N.C. or equivalent.

Test Engineers

To carry out production testing and fault finding on electronic units, sub assemblies and printed circuit boards. Preferred qualifications — C. & G. or equivalent.

Inspectors

We have vacancies in our Radio Systems Inspection Department. If you have experience of electronics, preferably experienced in working to professional Ministry of Defence requirements, why not join a Company with a real commitment to quality. The work spans the various levels of our production from components and printed circuit boards through to sub assemblies, complete equipments and systems.

All these positions carry excellent starting salaries and other conditions of employment you would expect from a large progressive company. Assistance may be available for housing in Crawley.

Write or phone for an application form from —
 Mrs. A. George, Senior Personnel Officer, M.E.L., Manor Royal, Crawley, Sussex.
 Tel: Crawley 28787 extension 368.

7972

Sony Broadcast Technology Centre to be established in the UK

Sony Broadcast announce the setting-up of a new Technology Centre in the UK to provide the necessary field support to their Marketing Division in system planning, special projects, installation and commissioning, as well as to participate in longer-term research and development programmes in co-operation with Sony, Tokyo and the newly-created Sony Technology Center in Palo Alto, California, USA.

As a result of this decision, several vacancies will shortly become available for **enthusiastic and versatile engineers experienced in video tape recording and editing, digital video and audio, ENG and allied technologies.** The engineers we are seeking will probably be in the age range 25-35, hold a degree in electrical engineering or an equivalent qualification, be keen to travel when necessary, have a background in industry or broadcasting, and enjoy working at the forefront of television technology, either individually or as a member of a team. An ability in other European languages would be a considerable advantage.

The search for suitable premises is being centred on the Basingstoke, Reading, Woking, Camberley areas at present, but it may be necessary to ask successful candidates to work out of Vianen, near Utrecht in Holland, for a few months whilst more permanent accommodation is being arranged. In this case, accommodation would be provided and generous overseas allowances paid.

Attractive salaries and, where appropriate, re-location expenses will be paid to the successful candidates.

Applications, which will be treated in strict confidence, should contain full details of qualifications, experience and salary required, and be addressed to:

Howard Steele
Managing Director
Sony Broadcast B V I O
Postbus 100
Vianen (ZH)
Holland

SONY®

7954

A CHALLENGING CAREER IN T.V.

Join Audio + Video Ltd in London's West End. If you are capable of maintaining RCA and Ampex quad VTRs, RCA and Rank telecines, TBCs and other associated equipment, then we would like to meet and talk to you. Now that we have just taken delivery of a Marconi DICE standards convertor, the position we are offering is even more interesting. A good working knowledge of helical scan machines would be a definite asset.

Why not call Cliff Carroll now on 01-580 7161

(7999)



METRO RADIO has a vacancy for a

SENIOR AUDIO ENGINEER (GRADE ILR1)

Applicants should have a good education background with relevant technical experience.

Please send full details of education and career to:

Station Engineer
METRO RADIO
Newcastle-Upon-Tyne
NE99 1BB

(7995)

TELEVISION ENGINEER

A vacancy occurs with an old establishment Retailer.

The Post requires someone with a wide range of experience in Television and Audio equipment, a clean driving licence is essential. Large flat available for suitable applicant.

HYDES OF CHERTSEY LTD.
56/60 Guildford Street, Chertsey
Telephone: Chertsey 63243

(8001)

DESIGN DEVELOPMENT TECHNICIAN

Kingston area

£4,000 p.a. salary

A young, experienced person (22-30) capable of good prototype wiring and construction with the ability to fault find at a low technology level. Experience in the layout of P.C. Boards desirable. We are a small company and the ability to work well without supervision is necessary. Ex-apprentice preferred.

Please write or phone to:

Mr Martin Dare
AUDIO VISUAL EQUIPMENT LTD.
73 Surbiton Road, Kingston, Surrey
Tel: 01-549 3464

(8021)

RESOURCEFUL ENGINEER

required by the London International Film School to maintain enormous range of audio, film and video equipment — 50 years of electronic history, from enormous bottles to teeny ICs. Not much money but terrific job satisfaction plus good hours, long holidays, friendly people, own workshop, use of company pushbike, etc.

Apply to:

The Administrator
LIFS, 24 Shelton Street
London, WC2

(7998)

Electronics Engineers on the move

**INVEST
5 MINUTES
IN YOUR
FUTURE**

DESIGN, TEST, Q. A; FIELD SERVICE, MANAGEMENT, ETC.

Take advantage of the best opportunities being offered in the Electronics Industry from amongst over 3000 U.K. Companies with whom we deal. We are seeking all categories of Electronics Engineers for equipment ranging from computers to communications.

By returning the application form below, your job requirements will be matched against our clients' numerous vacancies, many of which are not advertised. Your application will be treated in strict confidence and no approaches will be made to existing employers or to any other companies you care to specify. Please remember, our service is completely FREE to applicants. So don't delay - act now to give yourself the best chance of finding the perfect job. If you wish to discuss any aspect of the Electronics job market, you are welcome to phone anytime. Please ask for Brian Cornwell.

Capital Appointments Ltd. 29/30, Windmill St. London, W.1. ☎ 01-637 5551

PLEASE WRITE IN BLACK INK.

NAME: _____ ADDRESS: _____
 Tel: (Home): _____ (Office): _____

Date of Birth: _____ Place of Birth: _____ Nationality now: _____ If not British, is a
 Marital Status: _____ Car Driver: _____ Car Owner: _____ Work Permit req'd? _____

Type of Position required: _____ Approx. Salary level: _____

| | | | | | |
|--|--------------|-------------|-------|--------------------------------------|------------------------------|
| Please indicate areas in which you are prepared to work: | | | | Are you a houseowner? | Are you willing to relocate? |
| Cent. London | S. Coast | E. Midlands | | Are you prepared to travel - In U.K? | Overseas? |
| S. E. London | West Country | W. Midlands | | State of health: | |
| S. W. London | N. E. Engld. | E. Anglia | | Notice Period required: | |
| N. E. London | N. W. Engld. | Wales | | Availability for Interview: | |
| N. W. London | Scotland | Overseas | | | |
| Home Counties: N. W. | | N. E. | S. W. | S. E. | |

EDUCATION:
 Secondary School Qualifications:
 College or University Qualns:
 Any Professional Membership:

| INDUSTRIAL EXPERIENCE:
Period of
Employment | Company &
Location | Products | Job Title | Responsibilities | Reason for
leaving | Final
Salary |
|---|-----------------------|----------|-----------|------------------|-----------------------|-----------------|
| | | | | | | |
| | | | | | | |
| | | | | | | |

ELECTRONICS PROFILE: Indicate extent of experience- A-Extensive; B-Moderate; C-Limited; If Nil experience, leave blank.

| | | | |
|---|---|---|--|
| <input type="checkbox"/> Telephone Eqpt. | <input type="checkbox"/> Data Comms. | <input type="checkbox"/> Radio/Hi-Fi/T.V. | <input type="checkbox"/> Broadcast Eqpt. |
| <input type="checkbox"/> Digital/Logic | <input type="checkbox"/> Analogue Eqpt. | <input type="checkbox"/> Software/Programming | <input type="checkbox"/> Minis/Microprocessors |
| <input type="checkbox"/> Computers/Periphs. | <input type="checkbox"/> Test Gear/ ATE. | <input type="checkbox"/> Process Control | <input type="checkbox"/> Power Supplies |
| <input type="checkbox"/> UHF/VHF. Comms. | <input type="checkbox"/> Microwave | <input type="checkbox"/> Radar/Nav aids | <input type="checkbox"/> Medical Electronics |
| <input type="checkbox"/> Signalling Systems | <input type="checkbox"/> Security Eqpt. | <input type="checkbox"/> Avionics | <input type="checkbox"/> Simulators |
| <input type="checkbox"/> Weapons | <input type="checkbox"/> Scientific Eqpt. | <input type="checkbox"/> Data Recorders | <input type="checkbox"/> Photocopiers |
| <input type="checkbox"/> Phototypesetting | <input type="checkbox"/> Servo-mechs. | <input type="checkbox"/> Components-Active | <input type="checkbox"/> Components-Passive |
| <input type="checkbox"/> Production Eng. | <input type="checkbox"/> Electrical Eng. | | |

Others - Please state.

Please indicate any Companies you do not wish us to contact.

If you wish to detail further aspects of your experience or job requirements, please enclose on a separate sheet.

Land a good job

Your
Radio Officer's
qualifications
can mean a lot
here on shore

If you're thinking of a shore-based job, here's where you'll find interesting work, job security, good money, and the opportunity to enjoy all the comforts of home where you appreciate them most - at home!

The Post Office Maritime Service has vacancies at Portishead Radio and some of its other coast stations for qualified Radio Officers to undertake a wide variety of duties, from Morse and teleprinter operating to traffic circulation and radio telephone operating.

To apply, you must have a United Kingdom Maritime Radio Communication Operator's General Certificate or First Class Certificate of Proficiency in Radio-telegraphy or an equivalent certificate issued by a

Commonwealth Administration or the Irish Republic. And, ideally, you should have some sea-going experience.

The starting pay at 25 or over works out at around £4093; after three years' service this figure rises to around £5093. (If you are between 19 and 24 your pay on entry will vary between approximately £3222 and £3732). Overtime is additional, and there is a good pension scheme, sick-pay benefits, at least 4 weeks' holiday a year, and excellent prospects of promotion to senior management.

For further information, please telephone **Andree Trionfi** on 01-432 4869 or write to her at the following address: ETE Maritime Radio Services Division (L690), ET17 1.2, Room 64.3, Union House, St. Martins-le-Grand, London EC1A 1AR.

Post Office Telecommunications



Service and Test Engineers

As aircraft and electronics equipments become more sophisticated and our servicing programme expands, the need for experienced Service and Test Engineers increases.

At Stanmore, we are involved in the provision of spares and the repair, maintenance and overhaul of a variety of British and American airborne electronic equipment.

We need Engineers who can successfully maintain the high standards and efficiency required both in the aircraft and the workshop.

It's skilled work, calling for sound practical experience of radio and electronics theory, ranging from audio to microwave and including the use of advanced test equipment for fault diagnosis.

Training in this field will be given to suitable, less experienced engineers.

The Company offers excellent salaries and benefits together with first-class working conditions in well-equipped workshops. This Unit is conveniently situated in pleasant surroundings within easy reach of the A1 and M1.

**MARCONI
ELLIOTT
AVIONICS**

A GEC-Marconi Electronic Company

If the job sounds interesting and you'd like to put us to the test, write with details of experience to:

Mrs. E. Wagg,
Marconi-Elliott Avionic Systems Ltd.,
22-26 Dalston Gardens, Stanmore, Middlesex
HA7 1BZ. Tel: 01-204 3322.

7917

TELSEC

We are a small company manufacturing the widest range of X-ray spectrometers within the United Kingdom and we require two dedicated people in our Technical Services Department.

ELECTRONICS TEST ENGINEER

To join a team working on the testing and setting up of computerised spectrometers. Qualifications to HNC level is desirable with experience of instrumentation or computers.

SERVICE ENGINEER

For installations, commissioning and after sales service on our complete range of instruments. This will involve extensive travel throughout the U.K. and Europe and a company car is provided. A proven record in our, or other related field is required with a good practical background.

Salaries for both posts will be excellent with a good pension scheme and four weeks holiday.

Applications to

K. M. Field
Telsec Instruments Ltd.,
Sandy Lane West, Littlemore
Oxford OX4 5JX

(7966)



**CAPITAL
APPOINTMENTS LTD.**

FREE JOBS LIST

for
FIELD SERVICE ENGINEERS
BASIC SALARIES TO
£5,000 + CAR

(7707)

30 Windmill Street, London, W1
01-637 5551

H.M.G.C.C.

has vacancies for:

**ELECTRONIC
ENGINEERS**

to work in the fields of:

- a. H.F./V.H.F./U.H.F. communications equipment design and development.
- b. General circuit design, analogue and digital.

Appointment will be in the grades of Higher Scientific Officer and Scientific Officer for which the minimum academic qualification is HNC or equivalent. For Higher Scientific Officer 5 years post-qualification experience is required except for candidates with First or Second Class Honours degree when this is reduced to 2-year postgraduate experience.

Salaries are

Scientific Officer £2593-£4032
Higher Scientific Officer £3746-£4976

Also required are

**ELECTRONIC
D R A U G H T S M E N /
WOMEN**

Minimum qualification is Ordinary National Certificate or equivalent but preference will be given to more experienced candidates with higher qualifications.

Lower Salary Scale **£2875-£3951** for minimum qualifications
Higher Salary Scale **£3951-£4447**

All above salary scales include Phase I & II Supplements.

For application forms apply to:

The Administrative Officer
H.M. GOVERNMENT COMMUNICATIONS CENTRE
Hanslope Park
Hanslope
Milton Keynes, Bucks MK19 7BH

Electronics Technicians

Saudi Arabia £14,600 tax free per two year contract

At major airports throughout Saudi Arabia, Lockheed Aircraft International has responsibility for the maintenance and operation of a wide range of advanced radar and radio communications installations. Keeping them in first-class operational order is a vital task and we can, therefore, offer you an opportunity to carry out interesting and challenging work in a fascinating overseas environment. We're looking for Technicians to carry out station and base maintenance on the following equipment:

Ground Radio/Nav aids

To maintain VHF/UHF ground/air communication systems and radio navigational equipment such as ILS, TACAN and CADF. Sound relevant maintenance experience is required, preferably including some knowledge of point-to-point VHF and HF SSB systems.

ATC or Ground Radar

To maintain long range surveillance and precision approach radars, antennae and display systems in control tower installations. Several years' relevant radar maintenance experience on long range surveillance or approach radars is

required together with some knowledge of SSR and IFF equipments. **Technicians with airborne radar experience will also be considered and appropriate conversion training given.**

Radio Relay

To service and repair a variety of VHF/UHF, SHF and TROPO communications equipment and associated multiplex systems. Cross training in TROPO and multiplex can be provided. Good relevant experience, covering multiplex and microwave equipment is required.

As a Technician with Lockheed Aircraft International you will be able to earn £14,600 tax free for a two year contract. In addition, you will receive free bachelor accommodation, free food and laundry, free medical care and life insurance and two free flights home to the UK per year.

So, if you have the necessary experience and are looking for an interesting job with high earnings, phone The Recruitment Officer on 01-572 9844 or 01-572 9899 or write to him at International Aeradio Ltd., Aeradio House, Hayes Road, Southall, Middlesex. Quote Ref 062.



7960

Engineering Opportunities

Pye Business Communications Limited, a member of the Pye Group of Companies – part of the international Philips organisation – markets, installs, commissions and services a wide range of communications equipment.

The Engineers appointed to the following positions will enjoy the excellent employment conditions associated with a major company.

FIELD MAINTENANCE ENGINEER

— **Southern Area**, preferably resident in Greater London, to work on Intercom and CCTV systems. Radio and Inductive Paging equipment.

— **Scotland**, should reside in the Glasgow/Edinburgh area, to work on Intercom, CCTV, Private Telephone and Public Address systems, Radio and Inductive Paging equipment.

INSTALLATION & COMMISSIONING ENGINEER

— **Southern Area**, resident North of the Thames, for Private Telephone systems, Intercom and Public Address systems and Paging Equipment

A Final C. & G. Telecommunications Certificate, ONC or equivalent is essential for the above vacancies, together with a current driving licence. Company cars will be provided.

PABX INSTALLATION & COMMISSIONING ENGINEER

— **UK Area**, for Philips UH900 and UH200 exchanges. City and Guilds Final Certificate in Telecommunications is desirable, and experience in the installation and commissioning of electro-mechanical PABX exchanges. The position involves travel throughout the UK and regular absence from home during the week. A company car is not provided but realistic mileage and subsistence allowances are offered.

Please apply to:
Mrs. Ann Macnab, Personnel Manager,
Pye Business Communications Limited,
Cromwell Road, Cambridge CB1 3HE
Telephone Cambridge 45191



Pye Business Communications Ltd

A member of the Pye of Cambridge Group

7963

Are You Interested In Radio Communications

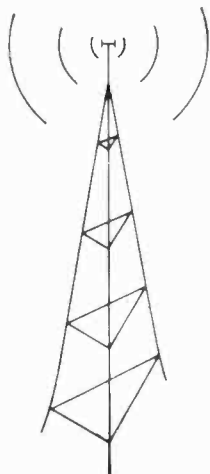

and do you have practical experience in this field

if you have City and Guilds Intermediate Certificate in Electronics or Telecommunications; ONC; or an equivalent qualification

then the Metropolitan Police Office has a job for you as a Radio Technician.

vacancies are at our depots in South London

we offer
Good pay, Excellent prospects
Secure employment
4 weeks holiday, Day release

For further information and an application form please apply to: The Secretary, Room 213/WW/RT, 105 Regency Street, London SW1P 4AN, or telephone 01-230 3122 (24-hour answering service).

(7977)

Electronic Engineers

Hunting Geology and Geophysics Limited is engaged in Mineral and Energy Exploration and Consultancy. Vacancies exist for engineers able to assume responsibility for the preparation and operation of sensing and recording systems designed to map earth resources from the air. Duties will involve flying and overseas service, normally on a bachelor basis, for approximately six months a year.

The openings could suit development engineers wanting greater variety and capable of problem solving by equipment modification and interfacing.

Applicants should hold at least HNC qualification and must be willing to turn a hand to the practical aspects of base and field teamwork.

Application to:

**The Personnel Manager,
HUNTING SURVEYS & CONSULTANTS LTD.,
Elstree Way,
Borehamwood,
Herts. WD6 1SB.**



7973

ELECTRONICS TECHNICIAN

required to assist with the servicing, maintenance and design of a wide range of scientific equipment. Computer interfacing experience essential.

HNC or City and Guilds qualifications. Salary range £3336-£4612. For further information and application form telephone or write to Miss S. M. Hurley, Imperial Cancer Research Fund, Lincoln's Inn Fields, WC2 on 242 0200, ext. 305.

(8019)

PRODUCTION TEST TECHNICIAN

required for work on our range of commercial metal detectors. Must have at least five years' experience in testing, fault finding and mechanical and electrical inspection, and be prepared to work at a fast production pace.

We offer good wages, three weeks' holiday plus sickness benefits, and work that is interesting and rewarding. Excellent opportunity for right person with small expanding company.

Application form from

YOUNG ELECTRONICS LTD.

132-134 Grafton Road

London NW5 4BA

Telephone: 01-267 0201

(7996)

Logic Engineers

STC need Logic Engineers to work on the design problems which arise during commissioning and testing of TXE4A Telephone Exchanges. The System uses both wired logic and programme controlled processors, designed with T.T.L. and M.O.S.L.S.I. components.

Applicants should have a degree or HNC in electronic engineering, and at least two years experience in logic design. Experience of telecommunications or real time control systems would be useful but is not essential.

These vacancies are at New Southgate which is situated on the outskirts of North London with easy access to Central London or rural Hertfordshire. We are part of a large well established and pleasantly situated location with all the facilities and amenities this implies.

We offer competitive benefits and very real prospects of advancement for the right man or woman.

Telephone or write to: Mike Randal (Department 32210), Standard Telephones and Cables Limited, Switching Main Exchange Products Division, Oakleigh Road South, New Southgate, London N11 1HB. 01-368 1200 Ext. 3066.

STC Changing the face of communications worldwide

7957

ELECTRONICS ENGINEERS

Ricardo have an international reputation in internal combustion research and development and are Consulting Engineers to the majority of the world's engine manufacturers. They urgently require Electronics Engineers for highly varied and challenging instrumentation work. Current projects include the design and implementation of automated engine test bed systems. Future projects will involve the application of microprocessors to engine control.

Applicants should preferably have a B.Sc. in electronics with a few years' experience. A good theoretical knowledge and some experience of modern digital techniques is essential.

Salary will be in the range £3500-£4850 and the appointments offer excellent fringe benefits including bonus and non-contributory pension schemes, free life assurance and generous assistance with relocation where necessary.

Apply in writing or telephone

Mr. R. Barrow
Personnel Manager
Ricardo & Co. Engineers (1927) Ltd.,
Bridge Works, Shoreham by Sea,
West Sussex BN4 5FG
Tel: (07917) 5611

RICARDO

(7980)

ENGINEER

Large advertising agency requires an engineer to maintain a Rank Cintel Mk III Flying Spot Scanner telecine unit, colour cameras, video recorders, monitors, and studio control equipment.

Ideally, applicants should be conversant with colour telecine operation.

Salary in the range of £5000 to £5500.

The company operates profit-sharing and pension schemes.

For more information please contact:

Malcolm Syers

DPBS Limited

67 Brompton Road

London SW3 1EF

Telephone: 01-589 4595

(8002)

THE UNIVERSITY OF HULL VISION/LIGHTING SUPERVISOR AUDIO VISUAL CENTRE

Applications are invited for the above post which is available immediately. Candidates should have an HNC or equivalent qualification, and relevant experience in operations and maintenance in broadcast and/or educational television. Salary will be in the Grade 7 scale for University Technical Staff (£4,254 x 4 increments — £4,782).

Applications, giving details of age, qualifications, experience, and the names of two referees, should reach the Personnel Officer, University of Hull, HU6 7RX by 14 April. Further particulars are available.

(7967)

BROMPTON HOSPITAL Senior Medical Electronics Technician

to undertake work involving maintaining, installing, and developing medical electronic equipment. A knowledge of ultrasonics and micro-computer based systems would be a distinct advantage.

Applicants should have a good general knowledge of electronics and be qualified to H.N.C. (Electrical and Electronic Engineering) standard or equivalent.

Salary will be on the scale £3,776-£4,708 according to experience.

Further information from Physicist in charge, Mr R. B. Logan-Sinclair, Tel 01-352 8121, Ext 4252

Application forms and job descriptions from Miss J. A. Jenks, Personnel Manager, Brompton Hospital, Fulham Road, London SW3 6HP (Tel as above, Ext. 4357)

7978

LATIN AMERICA RADIO ENGINEER

Required to work with the Radio Schools Federation in Guatemala. Responsibility for implementing an in-service training programme for local technicians in small rural-based radio stations which promote adult education among impoverished Indian communities.

A British Volunteer Programme post; intensive Spanish language training provided. For further information write with details of curriculum vitae to:

CIIR Overseas Volunteers
1 Cambridge Terrace
London NW1 4JL

(7997)

Marconi Instruments

ELECTRONIC TECHNICIANS

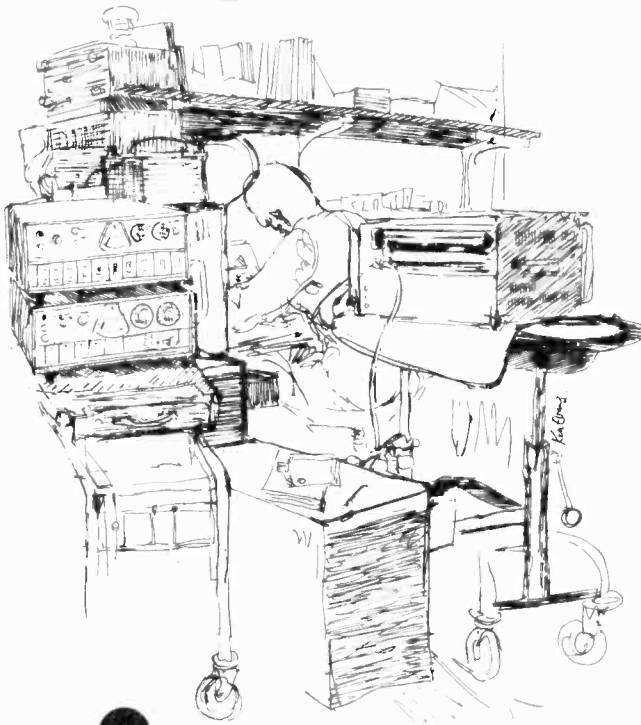

Opportunities for the experienced and sometimes inexperienced in St. Albans and Luton.

Work situations range from fault finding on PCB's and components, to batch product testing of equipment that utilise very advanced techniques including microprocessors and the repair/calibration of all manner and types of test instruments.

Attractive salaries and, where appropriate, relocation are offered for the right candidates. Further information may be obtained in confidence from John Prodger

Marconi Instruments Limited,
Longacres, St. Albans, Herts. tel: St. Albans, 59292



A GEC-MARCONI ELECTRONICS COMPANY

(7982)

mi

OVERSEAS APPOINTMENTS

ELECTRONICS TECHNICIANS

Petty-Ray is one of the leading Companies in the field of oil exploration and due to our ever increasing workload require single personnel, in the age range 21-25, who are looking for a varied and interesting career working overseas.

You should be educated to H.N.C./O.N.C. in Electronics or C & G Radio and T.V. Technician level. On appointment you will be assigned to one of our field crews either in Africa or the Middle East for on the job training in the operation and maintenance of digital seismic recording equipment.

Candidates must be in possession of a current driving licence.

We offer a good starting salary which is tax free. Food and accommodation will be provided and rest leaves are generous.



If you would like to have more information about these positions

Please write giving brief career details to the Personnel Officer.

Petty-Ray Geophysical Division
3-5 The Grove Slough Berkshire SL1 10G

(7974)

We pay top salaries for the right engineers
Starting at £4000 p.a. for Bench Engineers
Increasing appreciably for Field Service Engineers

London's largest independent radio-telephone company is expanding fast! We have built a reputation for reliable efficient service. If you have the capability we need you urgently.

Knowledge or experience of mobile V.H.F. equipment is what we're looking for. Call Mike Rawlings or Bill Clarke on 01-328 5344 Now! (7994)

London Communications

(Equipment) Ltd

30 Brentnary Road, London, NW8 01 328 5344

FRANK CODY ELECTRONICS LTD.
require
AN ELECTRONICS ENGINEER

with some experience of V.H.F. and U.H.F. R/Ts for interesting work on our range of Marine and land mobile communications and navigation equipment

Frank Cody Electronics Ltd.
40 Sunbury Cross Centre
Sunbury-on-Thames
Middlesex TW16 7AZ
Tel: Sunbury-on-Thames 88705
(8023)

Design and Development Engineers HF and Satellite Communications

International Marine Radio Co. Ltd., part of Standard Telephones and Cables Ltd., is the leader in the field of maritime HF communications and is now advancing into the satellite era.

Here is an important opportunity to join an expanding team engaged in the design and development of HF and satellite communications equipment for the marine field. The work requires familiarity with modern solid state technology in one or more of the following areas:

Small signal linear circuit design

TTL/ECL digital techniques

Micro processor software and hardware design

HF receiver and transmitter design

The positions offer first class career opportunities for both male and female engineers qualified to degree/HNC standard and with two-five years experience. There are also several openings for newly qualified graduates to obtain invaluable experience at an early stage in their careers.

Please write with brief career details or telephone Jonathan Smith, International Marine Radio Co. Ltd., Peall Road, Croydon CR9 3AX. Tel: 01-684 9771.

STC Changing the face
of communications worldwide

7956

TEST ENGINEERS

When reliability matters, people come to Pye



When the 1952 expedition, led by Sir John Hunt, made the first successful ascent of Everest, they carried with them Pye portable radiophone equipment – equipment with a long reputation for efficiency and reliability under arduous conditions.

Part of that reliability comes from the quality of the design and the components used, but the final seal is set by the highly skilled men and women who check our UHF/VHF systems to our very exacting specifications prior to delivery.

If you already have experience of fault diagnosis, alignment and testing of electronic equipment, especially communication equipment, perhaps gained in the Armed Forces, then why not get in touch and find out for yourself exactly why people come to Pye.

There's not room to tell you all the details here, but we can assure you of a competitive salary, company stability, job security and satisfaction, well equipped workshops and a variety of equipment, using both IC's and transistor.

Openings are available at Haverhill, Suffolk and at Cambridge, both extremely pleasant places to live, with key-worker housing available at Haverhill. In addition, considerable assistance is provided for those moving from other parts of the country.

Write or phone (reversing charges if necessary) to:

Catherine Dawe, Pye Telecommunications Ltd, Colne Valley Road, Haverhill, Suffolk CB9 8DU Tel: Haverhill 4422.

or Clare Barton, Pye Telecommunications Ltd, St. Andrews Road, Cambridge CB4 1OW Tel: Cambridge 58985



Pye Telecommunications Ltd



7969

ARE YOU IN MF/HF RADIO?

If so, then my client, the rapidly expanding marine equipment division of one of Britain's most respected engineering groups, wants to meet you. We are looking for a

Radio Communications Engineer

based Birmingham

up to £5,000

This newly-created post is tailor-made for a young engineer (ideally late 20s) with an HNC and at least 3 years' medium frequency radio communications experience.

Your role will be to develop their medium frequency marine communications receiver, from testing stage, through to initial production. This will involve you in fault finding and design modification, with some digital electronics as the project progresses.



Professional
& Executive
Recruitment

Telephone: Anita Blakemore on 021-236 6971

Applications from both men and women are welcome

UNIVERSITY OF SURREY

AUDIO VISUAL AIDS UNIT

Opportunities to join a team using a wide variety of photographic, film, television and graphic techniques in providing services for teaching and research illustration for all departments of a progressive technological university. The Unit has a young and lively staff and is very well equipped.

ELECTRONICS TECHNICIAN — GRADE 5 (£3186-£3720)

To take charge of a workshop servicing audio and projection equipment, and designing and making special apparatus. Experience in electronic servicing is essential and candidates must show evidence of ability to work unsupervised.

WORKSHOP TECHNICIANS — GRADE 4 (£2955-£3402)

With experience in the fields of electronic, mechanical or electro-mechanical servicing and construction, or instrument making. Training will be given, and day release where appropriate.

Applications for both posts are invited immediately, on forms obtainable from the Assistant Secretary (Personnel), University of Surrey, Guildford, Surrey GU2 5XH, or telephone Guildford 71281, Ext. 452.

(7968)

FOREIGN AND COMMONWEALTH OFFICE

has vacancies for

a. An Electro-Mechanical Draughtsman/Woman

Draughtsperson required for work involved in manufacture of electro-mechanical equipments. This requires a knowledge of associated production techniques, including finishing processes, materials, assembly fabrication and a rudimentary understanding of electronics and electronic components. A good working knowledge of Printed Circuit design (all branches) and manufacture would be an advantage.

and

b. A Printed Circuit Board Design Draughtsman/Woman

This work consists of the design and development leading to the manufacture of Printed Circuit Boards from prototype leading to batch production runs. The successful applicant should have experience of the techniques involved in single-sided boards, plated through-hole, flexible and micro-miniature circuitries. A knowledge of associated hardware would be advantageous.

Qualifications required for both vacancies:-
ONC in Mechanical, Electrical or Electronic Engineering

or

An equivalent or higher qualification acceptable to the Civil Service Commissioners.

All candidates must have served an apprenticeship, or have had equivalent training of at least 3 years appropriate to the duties of the post for which they are applying. In addition they must have had not less than one year's full-time experience on drawing office work.

Salary for posts a and b:

Starting salary is according to age eg age 21 — £2425 per annum, age 25 — £2785 per annum and age 27 (or over on entry) — £2970. The maximum of the scale is £3450 per annum. In addition, all points on the salary scale attract Pay Supplements of £13.20 per annum and 5% of total salary (minimum £10.88 per month — maximum £17.40 per month).

Please apply to:

Recruitment Section, Foreign and Commonwealth Office, Hanslope Park, Hanslope, MILTON KEYNES, MK19 7BH.

(7975)

DESIGN/ DEVELOPMENT ENGINEER

Labgear Limited, a member of the Pye of Cambridge Group of companies, involved in the development and manufacture of Television RF distribution, Service Test and Teletext equipment, requires an engineer of at least HNC or equivalent standard with a minimum of 2 years' experience in electronics, preferably associated with the television industry.

The post could, alternatively, offer an excellent opportunity to a University graduate to enter an industry which is continually expanding in both analogue and digital techniques.

This pensionable post carries an attractive salary, 20 days' holiday and, where applicable, assistance with relocation expenses.

Please write, giving details of your experience, to: Mr C. Houghton, Personnel Manager, LABGEAR LIMITED, Abbey Walk, Cambridge CB1 2RQ.

Telephone: Cambridge 66521.

(7958)

CITY OF LONDON POLYTECHNIC DEPARTMENT OF BIOLOGICAL SCIENCES ELECTRONICS TECHNICIAN GRADE 5

The City of London Polytechnic requires as soon as possible an Electronics Technician for the design and construction of electronic physiological and neurophysiological apparatus for teaching and research, together with day-to-day servicing of the neurophysiological teaching laboratory, and supervision of the electronics workshop. Candidates should possess an H.N.C. in an appropriate field. Starting salary, which will depend on qualifications and experience, will be within the scale of £3,376-£3,855 including London Weighting and pay supplement. Further details and an application form can be obtained from the Department Secretary, City of London Polytechnic, Department of Biological Sciences, Old Castle Street, London E1 7NT.

(7992)

APPOINTMENTS IN ELECTRONICS

Take your pick of the permanent posts in:

MISSILES — MEDICAL
COMPUTERS — COMMS
MICROWAVE — MARINE
HARDWARE — SOFTWARE

For expert advice and immediate action on career improvement, phone, or write to, Mike Gernat BSc

Technomark
Engineering and Technical Recruitment

11 Westbourne Grove
London W2. 01-229 9239.

CHELSEA COLLEGE

University of London

ELECTRONICS TECHNICIAN ENGINEERS/ TECHNICIANS

for interesting work for Electronics research and/or teaching, including prototype design and development. Day release for approved courses is available at the lower grades. Salary scales Grade 5: £3,651 to £4,185 per annum; Grade 4: £3,420 to £3,867 per annum; Grade 3: £3,153 to £3,525 per annum; Grade 2B: £2,994 to £3,345 per annum. (All salaries quoted are inclusive of London Allowances). Further information and application forms from Mr M E Cane (ET), Department of Electronics, Chelsea College, Pulton Place, London SW6 5PR.

(7964)

VIDEO TECHNICIAN - Manager required. Apply in writing to Video South Ltd, 101 Eden Vale Road, Westbury, Wilts BA13 3QD. (7942)

ELECTRONICS TECHNICIAN required to work with small group developing analogue and digital instrumentation for research into the mechanical properties of muscle. The instrumentation includes fast servo-mechanisms, electro-optical devices and computer interfaces. Salary in range £2,688 - £4,365 plus £465 London Weighting according to qualifications and experience. Appointment supported by funds from MRC for two years. Application form from Personnel Officer (Technical Staff FF18), University College London, Gower St, London WC1E 6BT. (7952)



Technical Buyer

Control Equipment/Harlow

To join the Group Headquarters Purchasing Division which, based at Harlow, provides a specialist and comprehensive procurement service for the world-wide operations of BP Group Companies and for new projects. Using international sources of supply, the Technical Buyer will prepare purchase enquiries, obtain and analyse quotations, make technical and commercial assessments, negotiate and place orders with suppliers, and liaise with and advise clients both in the UK and abroad. The range of equipment includes electrical, telecommunications, telemetry and instrumentation.

Applicants, preferably chartered engineers aged between 30 and 40, should have a degree or equivalent in electronic/control/instrumentation engineering, together with previous technical/commercial experience of related fields in, or for, the oil or petrochemical industry.

We offer a progressive salary range with a commencing figure dependent on experience, knowledge and professional qualifications. Excellent conditions of service. Please send career summary, quoting reference ZH.252, to: **The Personnel Unit, Technical Directorates, BP House, Third Avenue, Harlow, Essex CM19 5AG.**

(8003)

Turn your sound experience into a fine career



As a hi-fi enthusiast, you'll have heard of Hardman's if you live in the North West. Because there, we're the No. 1 name, with superb, spacious showrooms in Liverpool, Manchester, Chester and Preston. Now we're about to make our name in the Midlands too, with the best stocked hi-fi store in Birmingham. But we're not just a single fast-expanding company with five stores: we're part of a large and successful Group with interests throughout the leisure industry. To you that means the big benefits that only a large Group can offer you: security plus the almost unlimited scope that an enthusiast like you will relish. Expansion has created these vacancies in all five stores:

Senior Audio and Hi-Fi Sales Staff

You must have a proven sales ability and/or sound audio or hi-fi experience. We'll give you specific sales training and keep you up to date with regular seminars. Good salary plus commission. PLUS excellent opportunities for promotion to management within the group.

Hi-Fi Engineers

You're a qualified hi-fi/audio/video engineer, or you're mid way through an apprenticeship scheme with no immediate opportunities. You'd like to service, test and repair hi-fi equipment in our well-equipped premises.

We'll tell you all about the equipment and keep you updated on new developments. Excellent salary.

Please write for an application form to:
**The Managing Director, Hardman Radio Ltd,
26 Exchange Street East, Liverpool L2 3PH**

7965

Talk to the helpful Hi-Fi people

HARDMANS

Audio Engineer

The above vacancy has arisen with the Electronics Department of The Decca Record Company in New Malden, Surrey.

The work of the department is concerned with the design and maintenance of electronic audio equipment used by the Quality Control Department in testing of long-playing records.

Applicants, male or female, should be aged over 20 and must have audio experience. Preference will be given to those with a relevant City and Guilds or O.N.C. qualification.

The position carries a competitive salary and excellent general conditions of employment. Additional benefits include subsidised lunches, discounts on Company Products and Sports and Social Club.

Write or phone the Personnel Officer,
**The Decca Record Company Limited,
Burlington House, Burlington Road,
New Malden, Surrey. Telephone:
01-942 2464.**

7971

DECCA



The Queen's Award for
Export Achievement
to Decca Ltd 1976

SITUATIONS VACANT

Foreign and Commonwealth Office TELECOMMUNICATIONS OFFICERS

... in London and at Hanslope Park, Milton Keynes, for work on the installation, modification, maintenance and operation of HF, VHF, UHF and microwave receivers, associated test equipment, recorders, telephone and teleprinter equipment, electronic ancillary apparatus (some using analogue and digital techniques), voice frequency telegraph and other specialised equipment.

Candidates should normally have ONC in Engineering (with a pass in Electrical Engineering 'A') or Applied Physics, or an equivalent qualification, and have served an apprenticeship or had equivalent training; **but ex-Service** people who have had suitable training and at least 3 years' appropriate service (as Staff Sergeant or equivalent) will also be considered.

Salary, starting between £3000 and £3975 (according to age), rises to £4295; up to £485 more in London. Promotion prospects. Non-contributory pension scheme

For further details and an application form (to be returned by 10 April 1978) write to Civil Service Commission, Alencon Link, Basingstoke, Hants. RG21 1JB, or telephone Basingstoke (0256) 68551 (answering service operates outside office hours). Please quote T/9728.

(7970)

ELECTROSONIC

S.E. LONDON

Printed Circuit Designer £4,000 plus

Electrosonic Ltd. is a leading company in the rapidly expanding fields of lighting control, audio and audio visual systems, situated in S.E. London within easy reach of rural Kent.

An experienced and creative engineer is required to design and layout printed circuit boards from Logic and circuit diagrams.

The work will entail the preparation of artwork, component reference masters and other essential P.C.B. documentation.

The ability to produce fast and accurate results is essential.

The company offers an attractive working environment and excellent conditions of employment.

Applications to:

Mr. R. D. Naisbitt, Personnel Director
Electrosonic Ltd., 815 Woolwich Road, London SE7 8LT
Telephone: 01-855 1101

(8004)

UNIVERSITY OF SHEFFIELD

RESEARCH TECHNICIAN GRADE 5

required for the Space Physics Group within the Department of Physics for an initial period until 31st January, 1981. The successful candidate would be primarily concerned with the operation and maintenance of a high power VHF radar system used for ionospheric research. The post offers the opportunity of a wide variety of work with a small but enthusiastic team on an interesting project. Experience of design and/or construction of both digital and analogue circuitry would be an advantage. A current driving licence is essential and duties may include some travel away from home for periods of up to several weeks.

Salary on scale £3186-£3720 per annum. Please write to the Deputy Director of Services (Ref S910/WW), The University, Sheffield S10 2TN.

(7961)

UNIVERSITY OF
LIVERPOOL

ELECTRONICS TECHNICIAN

The successful applicant will work in the Department of Inorganic, Physical and Industrial Chemistry on the maintenance, repair and construction of a wide range of scientific instrumentation, involving high stability power supplies, amplification of low level signals (including lock-in amplification), R.F. techniques, and digital and analogue techniques. Salary in a range up to £3720 p.a.

Application forms may be obtained from the Registrar, The University, P.O. Box 147, Liverpool L69 3BX.

Quote Ref: RV/678/WW

(7962)

Television International

Europe's largest independent television broadcast facilities company.

Due to expansion of activities the company has vacancies for experienced broadcast staff in the following categories:

1. VTR Maintenance Engineers
2. VTR Operational Engineers
3. Telecine Engineers
4. Planning and Installation Engineers

Salaries in range £4,124-£5,561 dependent on qualifications and experience inclusive of Pay Code supplements and London Weighting.

The company operates a length of service incremental scheme and there are opportunities for overtime.

Contact Harold Gray at

TELEVISION INTERNATIONAL OPERATIONS LIMITED
9/11 WINDMILL STREET
LONDON W1P 1HF (REGISTERED OFFICE)
TELEPHONE: 01-637 2477

ARE YOU A TOP VIDEO ENGINEER

Teletape Video — Europe's most dynamic International Video and C.C.T.V. Systems Company, are currently expanding their operations in U.K. and throughout the World

It has been our policy to invest in the best people in the industry to provide a "Second to None" service to clients across all divisions of our Company. We currently require Top Class Engineers to work on the installation and after-sales service of all types of non-broadcast video equipment. We particularly need workshop engineers, fully experienced in U-Matic and allied video products. Two other all-rounders are required for 1-3 year contracts in the Middle East. All of these positions carry the highest salaries in the business and are genuine opportunities for top engineers to join The Top Company and go places.

Please apply to: Ian Crammond, M.D.

TELETAPE VIDEO

76 Brewer Street, London W1R 3PH. Tel. 01-439 6336/7/8

(8022)

ARTICLES FOR SALE

QUARTZ CRYSTAL UNITS from

- 1.0-90.0 MHZ
- FAST DELIVERY
- HIGH STABILITY
- TO DEF 6271-A



WRITE FOR
LEAFLET AT

**MCKNIGHT
CRYSTAL Co. Ltd.**

HARDLEY INDUSTRIAL
ESTATE MYTHE
SOUTHAMPTON SO4 6ZY

TEL MYTHE 848961
STD CODE 0703

(6044)

ENAMELLED COPPER WIRE

| *s.w.g | 1lb reel | 1/2lb reel |
|-----------|----------|------------|
| 10 to 19 | £2.95 | £1.60 |
| 20 to 29 | £3.15 | £1.80 |
| 30 to 34* | £3.45 | £1.90 |
| 35 to 40 | £3.65 | £2.10 |

All the above prices are inclusive of postage and packing in UK

COPPER SUPPLIES

102 Parrswood Road, Withington,
Manchester 20
Telephone 061-445 8753

(100)

ARTICLES FOR SALE

SEEN MY CAT? 5000 odds and ends. Mechanical, Electrical, Cat free. Whiston Dept. WW, New Mills, Stockport. (7983)

TIP31C POWER TRANSISTORS, 100 Volts, 40 Watts, T1 top grade. c/w hardware, 38p each, 6 for £2. Mammoth Electronics, Larkfield, Debden Road, Newport, Essex. (8020)

1926 WIRELESS WORLD. Bound extract "Wireless Circuits." Complete. — Box No. WW 8009. (8009)

SEA-KEN 6-channel V.H.F. Marine 1-watt transceiver, £139. **HY-SEAS** 6-channel V.H.F. marine 1-watt transceiver, £149. (Both fitted channels 6 and 16). **YAESU FRG-7** communication receiver .5Mhz to 30Mhz. AC mains, battery or 12V D/C operation — covers MF/HF AM/SSB marine frequencies, £145 (Digital version, £180). All plus 12 1/2 per cent VAT. (Send large S.A.E. for leaflets). Lee Electronics, 400 Edgware Road, Paddington. (7943)

SURPLUS LABORATORY and test equipment required with details. Contact Electrical Instruments Sales & Service. Tel: Leigh (0942) 675422. (7989)

ARTICLES FOR SALE

AN INTRODUCTION TO MICROCOMPUTERS

VOL 0 - BEGINNERS BOOK Price: £5.30

written for the complete beginner explains what a computer system consists of...

VOL 1 - BASIC CONCEPTS Price £5.30

takes you by the hand from elementary logic and simple binary arithmetic...

VOL II - SOME REAL PRODUCTS Price: £10.80

covers real microcomputers in considerable detail. Every major microcomputer 4 bit, 8 bit or 16 bit is described...

8080 PROGRAMMING Price: £5.30

for logic design. SOME COMMON BASIC PROGRAMS Price: £6.30

describes 76 short programs. 6800 PROGRAMMING Price: £5.30

for logic design.

* ALL PRICES INCLUDE POSTAGE *

THE MODERN BOOK CO. SPECIALISTS IN SCIENTIFIC & TECHNICAL BOOKS 19-21 PRAED STREET LONDON W2 1NP

NEW LOW PRICES!

Due to massive purchases, in many cases direct from the manufacturer, we are now able to offer TTL and CMOS at considerably reduced prices...

Table listing various electronic components like TTL, CMOS, and integrated circuits with their respective prices.

555 27p 741 20p LM380 76p LM381-105p

Prices VAT inclusive. Please add 20p for carriage. Send large SAE for our more detailed list containing semiconductors, resistors, capacitors, etc.

C. N. STEVENSON (WW6) 22 Tiverton Drive, London SE9 2BY, England

EXCLUSIVE OFFER

HIGHEST QUALITY 19" RACK MOUNTING CABINETS

Table listing rack mounting cabinet specifications including dimensions and prices.

AUDIO AND INSTRUMENTATION TAPE RECORDER-REPRODUCERS

- List of audio and instrumentation tape recorder-reproducers with prices.

Prices of above £70 to £500

We have a large quantity of 'bits and pieces' we cannot list - please send us your requirements...

All our aerial equipment is professional MOD quality

- Extensive list of aerial equipment including tape recorders, detectors, and amplifiers.

MANUALS We have a quantity of Technical Manuals of Electronic Equipment...

- List of technical manuals and other electronic components.

We have a quantity of Power Transformers 250 watts to 15kVA at voltages up to 40kV.

- List of power transformers and other electronic components.

PLEASE ADD CARRIAGE AND V.A.T.

P. HARRIS ORGANFORD DORSET BH16 6BR BOURNEMOUTH (0202) 765051

THE FABULOUS D2 MICROPROCESSOR EVALUATION KIT FROM MOTOROLA

Featuring 24 key keyboard, seven segment display, cassette interface, Rom & Ram Expandable, Interface Capability...

ENAMELLED COPPER WIRE

Table showing wire specifications: SWG, lb, oz, 2oz, 4oz, 55, 65, 70, 79, 125, 165, 176, 330.

Tinned Copper. Even Gauges 14-30 £3 per lb. Multicore 60/40 Solder 18SWG £3.24 per lb.

THE SCIENTIFIC WIRE COMPANY PO Box 30 London E4 (7771)

CAPACITOR SALE C280 - Price per 100 including postage. 0.01, 0.022, 0.033, 0.068, £1.75, 0.1, £1.00, £8.00/1,000, 0.22, £2.25, 0.33, £2.50, 0.47, £3.00, C281 - 0.01, 0.015, £1.75, 0.33, 0.47, £2.00, Erie 0.1/600V, £2.00, B. Malloy, 66 Woodvale Avenue, Belfast BT13 3EX N. Ireland. (8008)

MARCONI SIGNAL GENERATOR T.F. 801 D/1, good condition, price £120. - Phone Henlow Camp (Beds) 695 evenings. (8014)

PHILIPS Projection Television made early '50s project on wall 405 line 13 channel £50.00 o.n.o. Two very old valve radios, L.S. output £25.00 each send 60p plus s.a.e. for 3 color photos. Emens, 4 Tanners Lane, Hathern, Loughboro, Leics. or phone Lbro. 843214. (8007)

EX-RENTAL COLOUR T.V.'s working sets £60. Incomplete for £20. For details telephone 0622 79314 or call Kent Trade Supplies, 284 Forstal Road, Aylesford, Maidstone, Kent. (8010)

Quartz Crystal Units ACCURATE RELIABLE THE QUARTZ CRYSTAL CO. LTD. Q.C.C. WORKS, WELLINGTON CRESCENT NEW MALDEN, SURREY 01-942 0334 & 2988

OSCILLOSCOPE SALE: the following main frames and plug-ins have recently become surplus to the requirements of a large electronics company. Tektronix 545A + CA + type L £325, 545B + CA + type L £325, 581A + 1A1 £325, 585A + 1A1 £325, 453 50MHZ portable £650. Many other plug-ins available. All prices include VAT at 8 per cent. All items have been well maintained and carry full calibration certificates. Delivery by arrangement. Please reply to Box No. WW 8005. (8005)

STELLAVOX SM7 Stellamaster stereo recorder £1,620 shop-soiled. Stellavox AM148 professional mixer 5 channel mono/stereo cue selector sound surge limiters, £1,675, shop-soiled. Tel: 01-935 8161. AV Distributors (London) Limited, 26 Park Road, London NW1 4SH. (7990)

VHF/UHF MONITOR RECEIVERS, air, marine and business bands, all crystal controlled, from £50. Send 15p PO, not stamps. Radio Communications Ltd., St Sampsons, Guernsey, C.I. (7739)

NI-CAD. BATTERIES. Brand new. U2/SP2/HP2 size. 3.5 AH. £1.25, 5 or more £1 each, inc. p.p., c.w.o. (UK only). Charger circuit free if required. Refund if not delighted. - A. Philpott, 171 Great Brays, Harlow, Essex CM18 6DT. (8016)

INVERTERS To operate mains equipment from 12v to 24v DC on automatic stand-by CHARGING SAFETY CONTROLS Interport Mains-Store Ltd. 30 Old Bond Street, London W1 Tel: 01-727 7042 or 0225 310916

VALVES RADIO - T.V. Industrial-Transmitting. We dispatch valves to all parts of the world by return of post, air or sea mail, 2,700 types in stock 1930 to 1976. Obsolete types a speciality. List 20p. Quotation S.A.E. Open to callers Monday to Saturday 9.30 to 5.00. Closed Wednesday 1.00. We wish to purchase all types of new and boxed valves. Cox Radio (Sussex) Ltd., Dept WW, The Parade, East Wittering, Sussex PO20 5BN. West Wittering 2023 (STD Code 024366). (5392)

WE INVITE ENQUIRIES from anywhere in the world. We have in stock several million carbon resistors 1/4, 1/2, 1 watt, 1/2 million wire wound resistors 5 and 10 watt - 1 million capacitors - 1 million electrolytic condensers - 1/2 million transistors and diodes, thousands of potentiometers, and hosts of other components. Write, phone or call at our warehouse. - Broadfields and Mayco Disposals Ltd., 21 Lodge Lane, North Finchley London, N.12. 01-445 0749, 445 2713. (5907)

ARTICLES FOR SALE

COLOUR, UHF AND TV SPARES. CEEFAX, ORACLE IN COLOUR. MANOR SUPPLIES "EASY TO ASSEMBLE" TELETEXT KIT. Including TEXAS Decoder. Aerial input, completely external unit, no further connections to set. Full facilities, mixed TV programme and Teletext, Newsflash. Update, and many special features not found in other units. Demonstration model in operation at 172 West End Lane, NW6. Phone or write for further information.

TEXAS TIFAX XM11 Decoder module, new, £130, p/p £1.00.

NEW COMBINED COLOUR BAR GENERATOR PLUS CROSS HATCH KIT (Mk4) UHF Aerial input type. Eight vertical colour bars plus R-Y, B-Y, Luminance combinations, Grey scale etc. Pushbutton controls. Battery operated £35*, De Luxe case £4.80*, aluminium case £2.40*. battery holders £1.50*, mains supply kit £5.78*, p/p £1.00. Built and tested (battery) £58*, p/p £1.20.

CROSS HATCH KIT, UHF Aerial input type, also gives peak white and black levels. Battery operated, £11* p/p 45p. Add-on Grey Scale kit £2.90* p/p 35p. Aluminium case £2*, p/p 85p. Cross Hatch Unit, complete and tested in De Luxe case £20.80*, p/p £1.

"WIRELESS WORLD" TV Tuner and FM Tuner Projects by D. C. Read. Kits of parts available. CRT test and reactivator kit for colour and mono £19.80 p/p £1.20. UHF Signal Strength Meter kit £18* p/p 90p. 625 TV IF Unit for Hi-fi amps or tape recording £6.80 p/p 70p. Decca Colour TV Thyristor Power Supply Unit, incl. H.T., L.T., etc. Incl. circuits £3.80 p/p £120 Bush A823 (A807) decoder panel £7.50, p/p £1. Bush 161 T-B panel A634 £3.80, IF panel A583 £3.80 p/p 90p. Bush Portable TV 11V stab power supply unit £4.80 p/p £1. Bush CTV 25 Convergence Panel plus yoke, blue lateral £3.60 p/p 90p. Philips Single Standard Convergence Units complete, incl. 16 controls £3.75 p/p 85p. Colour Scan Coils. Mullard or Plessey, £6 p/p 90p. Mullard AT 1023/05 Converger. Yoke £2.50 p/p 75p. Mullard or Plessey Blue Laterals 75p p/p 35p. BRC 3000 type Scan Coils £2 p/p 90p. Delay Lines: DL20 £3.50, DL50 £3.50, DLLIE, DLLI 85p p/p 45p. Lum delay lines 50p p/p 40p. G8 Tripler £6. BRC 300 Tripler £6.80 p/p 75p. Others available. Philips G8 Decoder, part-complete £2.50 p/p 75p. GEC 2040 Ex-Rental Panels. Decoder £5.00. Time Base £5.00, p/p 90p. VARICAP TUNERS UHF: Gen. instr. £3.50. ELC 1043 £4.50, ELC 1043/05 £5.50. VHF: ELC 1042 £4.80, Philips VHF £3.80. Salvaged UHF & VHF Vari-caps £1.50 p/p 35p. VARICAP CONTROL UNITS, 3 position, £1.20. 4 PSN £1.50, 5 PSN £1.80, 7 PSN £2.80. Special offer 6 position £1, p/p 35p. UHF Transd. Tuners incl. slow motion drive £2.80, 4 position push button £2.50, 6 psn. £4.20, p/p 90p. Helical Pots 100K, 4 for £1.20 p/p 30p. Thorn 850 Dual Std. Time Base panels 50p. Philips 625 IF panel incl. oct. 50p p/p 70p. Mullard Mono Scan Coils for Philips Stella, Pye, Ekco, Ferranti, Invicta £2.00 p/p 85p. Large selection LOPTS, FOPTS available for most popular makes. MANOR SUPPLIES, 172 WEST END LANE, LONDON, N.W.6. Shop Premises. Callers welcome. Thousands of additional items available not normally advertised. (Nos. 28, 159 buses or West Hampstead-Bakerloo Line and British Rail). Mail Order: 64 Golders Manor Drive, London, N.W.11. Tel: 01-794 8751. V.A.T. Please ADD 12% TO ALL PRICES (EXCEPT WHERE MARKED). V.A.T. 8%). (60

60KHz MSF Rugby Receiver. BCD TIME OF DAY OUTPUT. High performance, phase locked loop radio receiver. 5V operation with 1 second LED indication. Kit complete with tuned ferrite rod aerial £14.08 (including postage and VAT). Assembled circuit and cased-up version also available. Send for details. Toolsex, Sherborne (4359), Dorset. (21

SOWTER TRANSFORMERS

FOR SOUND RECORDING AND REPRODUCING EQUIPMENT
We are suppliers to many well-known companies studios and broadcasting authorities and were established in 1941. Early deliveries. Competitive prices. Large or small quantities. Let us quote

SOWTER TYPE 3678
A recent release

MULTITAP MICROPHONE TRANSFORMER
Primary windings for 600 ohm, 200 ohm and 60 ohm with Secondary loadings from 2K ohm to 10 K ohm. Frequency response plus/minus 1/2dB 20 Hz to 25 KHz. Contained in well finished Mumetal box 33mm diameter by 22mm high, with colour coded and leads low distortion DELIVERY (small quantities) EX-STOCK. HIGHLY COMPETITIVE PRICE. FULL DETAILS ON REQUEST

E. A. SOWTER LTD.
Transformer Manufacturers and Designers
7 Dedham Place, Fore Street
Ipswich IP4 1JP. Tel. 0473 52794 7269

TRANSFORMER PROBLEMS?

1VA-1KVA Prototypes in 7-10 days. Phone Vince Sellar on 06076-66716.

TRENT TRANSFORMERS LTD
Chapel Street
Long Eaton, Nottm. 7909

SERVICES

EURO CIRCUITS

Printed Circuit Boards — Master layouts — Photography — Legend printing — Roller tinning — Gold plating — Flexible films — Conventional fibre glass — No order too large or too small — Fast turnaround on prototypes. All or part service available NOW 7669

EURO CIRCUITS TD.
Highfield House
West Kingsdown
Nr. Sevenoaks, Kent. WK2344

MICROPROCESSOR SOFTWARE

Software development available for all microprocessors. All applications, large or small, undertaken.

GRAFFCOM., 52 Shaftesbury Av., London, W1, 01-734 8862 (800)

LABELS, NAMEPLATES, FASCIAS on aluminium or plastic, Speedy delivery G.S.M. Graphic Arts Ltd., 1-5 Rectory Lane, Guisborough (02873-4443), Yorks, U.K. (5305)

SYSTEM DESIGN SERVICE. Have you a problem in control? Instrumentation Monitoring? Signal processing? Perhaps we can help — **BOORLEY ELECTRONICS SERVICES.** consultant engineers, specialists in minicomputer and microprocessor applications. Ring Botley (04892) 3096, or write. B.E.S., 33 Maddoxford La., Boorley Green, Botley, Hants. (7986)

QUALITY TEST SERVICES. Surplus test equipment bought, sold. Calibrated, repaired, Tektronix, Solartron, Hewlett-Packard, Marconi, AVO, Hazeltine, Phillips, Advance, Fluke, Sullivan, Pye, etc. M.C.L., Osborne Road, Luton, Beds. (0582) 414717. (7985)

CIRCUIT DESIGN and prototype construction. Instrumentation, test rigs, production run designs to your requirements. Professional audio, analogue, digital. SC/MP microprocessor circuits our specialities. **HAMILL ELECTRONICS LTD.,** Box BCM-2090, London WC1V 6XX. Tel.: 01-542 9203. (7984)

CAPACITY AVAILABLE

PRINTED CIRCUITS. Small catch-wiring, electrical testing, minicomputers undertaken by Wandtronics Ltd. Skilled ex Philips workers. Phone or write for details: Wandtronics Limited, Wandy Wharf, Frogmore, Wandsworth, London SW18 1HW. Tel. 01-870 6585. (7755)

ARTICLES WANTED

★ MINICOMPUTERS ★ PERIPHERALS ★ INSTRUMENTATION

For fastest, best CASH offer, phone

COMPUTER APPRECIATION
Godstone (088-384) 3221 7677

WE PURCHASE ALL FORMS OF ELECTRONIC EQUIPMENT AND COMPONENTS, ETC.

SPOT CASH
CHILTMead LTD.
7, 9, 11 Arthur Road
Reading, Berks.
Tel. (0734) 582 605

MINICOMPUTERS PERIPHERALS INSTRUMENTATION

For fastest, better CASH offer Phone

CHILTMead LTD.
Reading (0734) 586419

TURN YOUR SUPPLUS Capacitors, transistors, etc. into cash. Contact **COLES-HARDING & Co.** 103 South Brink, Wisbech, Cambs. 0945-4188. Immediate settlement. We also welcome the opportunity to quote for complete factory clearance. (7439)

B.D. ELECTRONICS offer prompt settlement for surplus electronic components, tv./audio spares are of particular interest. Contact Miss Hughes, 9 Westhawe, Bretton, Peterborough. Tel 265219. (7632)

WANTED Electrical Tool and Appliance Tester, Clair or similar, working or not. — Telephone Melton Mowbray 4475 (Leicestershire) evenings. (8013)

CAPACITY AVAILABLE

ELECTRONIC ASSEMBLY AND WIRING CAPACITY AVAILABLE

M.O.D. approved

J.N. Electronic Supplies
Osiers Road, London, SW18
Tel. 01-874 6162 7417

AIRTRONICS LTD. for coil winding Large or small production runs. Bobbin — Layer — Wave — Bifilar — Miniature Toroids, Airtronics Limited, Gardner Industrial Estate, Kent House Lane, Beckenham, Kent BR3 1UG. Tel. 01-659 1147. (7158)

BATCH Production Wiring and Assembly to sample or drawings. McDeane Electricals 19B Station Parade, Ealing Common, London, W.5. Tel: 01-992 8976. (7531)

PCB ASSEMBLERS and testers with calibration facilities, also PCB servicing contracts undertaken. Green-car Electronic Services, 26 Aviation Lane, Burton-on-Trent, Staffs. Tel: 0283 45786. (7894)

PCB ARTWORK DESIGN SERVICE with component notation masters and assembly drawings. PADS Electrical Ltd 01-850 6516, 45 Southwood Road, New Eltham SE9. (7905)

WANTED IN LARGE QUANTITIES

Electronic components, resistors capacitors, potentiometers, chassis loudspeakers, semi-conductors, diodes, TV tubes, especially colours, etc. etc. etc. First or second grades. Finished or incomplete products, record players, amplifiers, radios, tuners, tape recorders, enclosures, etc. etc. etc. We will buy complete factories and pay cash

TEL. 01-491 4636
E.C.E. AVON HOUSE
360/366-OXFORD STREET
LONDON, W.4 (7950)

WE PURCHASE, FOR CASH the following: R. F. Power Transistors, Varactor Diodes, and all special components normally used in VHF/UHF Transmitting equipment. **MODULAR ELECTRONICS,** 95 High Street, Selsey Sussex. PO20 0QL. Tel. Selsey 2916. (7696)

WANTED, all types of communication receivers and test equipment. Details to R. T. & I. Electronics Ltd., Ashville Old Hall, Ashville Rd., London, E.11. Ley 4986. (63

WILL BUY ANYTHING, any quantity if price is right. Ring Stan Willetts, West Bromwich, 021-553 0186. (7813)

WANTED. All types Pye radio telephone equipment. Top prices paid. Telephone (Cambridge) 0223 860555 or 50668. (7944)

WANTED, copy of book entitled "The Government Surplus Wireless Equipment Handbook" L. P. McMahon, 4 Auburn Ave., Dunlaughtaire, Co. Dublin, Ireland. Phone 855487. (8006)

ELECTRONIC SCRAP. Components, etc. Receivers, Transmitters Test Equipment wanted. Ferrographs from £15 in stock. Contact M & B Radio, 86 Bishopgate Street, Leeds 1. Tel. Leeds 35649. (8011)

SMALL BATCH PRODUCTIONS wiring assembly to sample or drawings. Specialist in printed circuits assembly. **Rock Electronics,** 42 Bishopsgate, Harlow, Essex. 0279 33018. (7674)

PCBs/WIRING/ASSEMBLY. Design, artwork, manufacture, assembly, wiring of small batches of boards, panels etc. to high standards. Quick turnaround and competitive prices. Contact us first: **HAMILL ELECTRONICS LTD.** 492 Kingston Road, London SW20. 01-542 9203.

PRINTED CIRCUIT ASSEMBLY. Assembly services to customer specification. Also, design, layout and wiring service available. A. E. Electronics, 4-6 Sandy Lane, Stockton Heath Warrington WA4 2AY. Tel. 0925-68339. (7912)

PRINTED CIRCUITS. Ultra fast turnaround. Very competitive prices paper or glass. Punched or drilled. Single or double sided. Also prototypes, artwork, photography. **Kibmore Circuits Ltd.,** 120 Garlands Road, Redhill, Surrey RH1 6NZ. Phone Redhill 68850. (7283)

A COMPLETE and efficient PCB Service from layout through to assembly. Incorporating quality reliability and price. No order too large or too small. Also mechanical detailing is undertaken. For details and free estimates please contact: J. S. Roberts on 01-533 2577 H.B.C. Artwork Design, 45 High Street, Maldon, Essex. (7731)

BOOKS

THE DALESFORD SPEAKER BOOK BY R. F. C. STEPHENS

This book is a must for the keen home constructor. Latest technology DIY speaker designs. Contains full plans for infinite baffle and reflex designs for 10-100 watts, also unusual centre-bass system for those who want HiFi to be "heard and not seen". £1 95 (£2.20 post paid) \$5 Overseas.)

VAN KAREN PUBLISHING
5 SWAN STREET, WILMSLOW
CHESHIRE (7506)

TV REPAIRS SIMPLIFIED. Full repair instructions any British TV for £4.50. Circuit Diagram on request; details unique books e.g. Every mono British TV circ. diag./layout £9.50. Also colour. Aus + WW, 76 Church Street, Larkhall, Lanarks. (7217)

"VINTAGE CRYSTAL SETS 1922-1927." Just published by Wireless World, contains 128 pages. Chapters on the first days of broadcasting. The Crystal Set, Vintage Wireless Trademarks. Also catalogue sections listing and describing crystal sets together with their original prices in £:s:d. A book for the collector or those interested in nostalgia. Available from main bookshops or direct from us. Please send £2.80 inclusive to IPC Business Press Ltd., Room 11, Dorset House, Stamford Street, London, SE1 9LU. (6125)

BUSINESS OPPORTUNITIES

RADIO COMPONENT and kit business for sale. Nominal payment for goodwill. Buyer purchases stock approx. £5,000. North London. Box No. WW 8015. (8015)

EQUIPMENT WANTED

BROADFIELDS AND MAYCO DISPOSALS

21 Lodge Lane, N. Finchley
London, N12 8JG
Telephone:
01-445 2713

01-445 0749 01-958 7624

MAY WE ASSIST YOU TO
DISPOSE OF YOUR SURPLUS
AND REDUNDANT STOCKS.

We will call anywhere in the British Isles, and pay **SPOT CASH** for Electronic Components and Equipment

RECEIVERS AND AMP

HRO Rx5s, etc. AR88, CR100, BRT400 G209, S640, etc., etc. in stock. R. T. & I. Electronics Ltd, Ashville Old Hall, Ashville Rd., London, E11. Ley 4986. (65)

SIGNAL Generators Oscilloscopes, Output Meters, Wave Voltmeters, Frequency Meters Multi-range Meter, etc., etc., in stock. R. T. & I. Electronics Ltd, Ashville Old Hall, Ashville Rd., London E11. Ley 4986. (64)

RACAL RA17L, MA168B diversity switch. MA150G Synthesiser. Murphy SSB Adaptor. — Telephone West Drayton 43694 after 6 pm. (8012)

TENDERS

BEDFORDSHIRE COUNTY COUNCIL, Surveyor's Department, have for sale by tender, surplus Pye radiotelephone equipment, comprising of: 41 W30 AM Westminster high band radiotelephones with ancillary equipment, 4 base control units, 1 base F27 AM high band transmitter and receiver, and 2 Bantam high band portables. Apply in writing or telephone for further information and tender documents. Bedfordshire County Council, County Surveyors Department, County Hall, Bedford. Tel.: Bedford 63222, extension 508. (7991)

COURSES

RADIO and Radar M.P.T. and C.G.L.I Courses Write: Principal, Nautical College, Fleetwood, FY7 8JZ (25)

"COMPUTERS FOR HOME & SMALL BUSINESS" Exhibition Sat, 8 April Winter Gdns Malvern (10-6, 35p. Adm.) Also **Personal Computing Seminar**, Limited no. of late places — Tel. Worcester (0905) 55658. (8017)

**FOR
CLASSIFIED ADVERTISING
RING
EDDIE FARRELL
ON
01-261 8508**

CLASSIFIED ADVERTISEMENTS

Use this Form for your Sales and Wants

To "Wireless World" Classified Advertisement Dept., Dorset House, Stamford Street, London, SE1 9LU

PLEASE INSERT THE ADVERTISEMENT INDICATED ON FORM BELOW

- Rate £1.10 PER LINE. Average six words per line. Minimum THREE lines
- Name and address to be included in charge if used in advertisement.
- Box No. Allow two words plus 50p
- Cheques, etc., payable to "Wireless World" and crossed "& Co"

NAME.....

ADDRESS

.....

.....

| | | | |
|-----------------------|--|----------|--|
| | | | |
| | | | |
| | | | |
| | | | |
| | | | |
| | | | |
| | | | |
| | | | |
| REMITTANCE VALUE..... | | ENCLOSED | |

PLEASE WRITE IN BLOCK LETTERS. CLASSIFICATION..... NUMBER OF INSERTIONS.....

MINIATURE PLUG-IN RELAYS (with perspex dust cover and base) 24-48v D.C. in stock.
2 pole c/o 60p 6 make 60p 4 post c/o 75p P&P 10p

FIBREGLASS COPPER-CLAD BOARD
9x 4 1/2 x 1/16in. 40p P&P 10p
9 x 6 x 1/16in 50p P&P 15p
12 x 9 x 1/16in. £1 P&P 20p
Double sided 1/2p per sq. in. extra

MAGNETIC COUNTERS
3 **Digit Reset** (240v A.V.) £1.75 P&P 25p
6 **Digit Reset** (24v D.C.) £4 P&P 25p
4 **Digit Non-Reset** (24v D.C.) £1 P&P 25p
6 **Digit Non-Reset** (240v A.C.) £1.50 P&P 25p

MULTICORE CABLES
4 **CORE RIBBON (RAINBOW) CABLE** 4 — 10/ 2m.m
Forming 1/4in. wide strip. 10m—75p 50m—£3 100m—£6 P&P 1p per metre
8 **CORE RIBBON (RAINBOW) CABLE** 8 x 14/76
Forming 1/2in. wide strip. 10m—£1.50 50m—£6.50 100m—£12 P&P 1p per metre
10 **CORE CABLE** 10 x 7/76 (10 colours) P.V.C.
O.D. 7m.m 10m—£2 50m—£8.50 100m—£16 P&P 2p per metre
12 **CORE SCREENED CABLE** 12 x 14/76 with outer screen —P.V.C. covered. O.D. 9m.m
10m—£4 50m—£18.50 100m—£35 P&P 2p per metre

16 **PAIR RIBBON CABLE** 16 x 2 core P.V.C.
Double sheathed forming 2in wide strip
10m—£3.50m—£13.50 100m—£25 P&P 2p per metre

E.H.T. MODULES (Resin encapsulated in metal box)
Input 240v 50hz. **Type 1** O/P 8kv @ 15 watts £8.75 P&P £1
Type 2 O/P 13.7kv @ 7 watts £10 P&P £1

P.C. EDGE CONNECTORS
32 way (1 pitch) finished ends 40p P&P 10p
56 way (1 pitch) cuttable 65p P&P 15p
64 way (1 pitch) cuttable 75p P&P 15p
64 way gold plated pins 90p P&P 15p
Mounting pillars for 56/64 way 15p per pair

'DRYFIT' RE-CHARGABLE BATTERIES (Lead/Acid)
Ex. Equip. Good condition, tested
6v @ 6 A.H. £3.50 P&P 75p
6v @ 7.5 A.H. £4.00 P&P 75p

TELEPHONE HANDSET WITH "PRESS TO SPEAK" SWITCH
New Stock £1.50 P&P 40p

STABILISED POWER SUPPLY (ADVANCE PM24)
2 x 4—15 volt @ 3 amp (gives 4-30v) £17.50 P&P £1.50

J. B. PATTRICK

191/193 London Road
Romford, Essex RM7 9DJ
Romford 44473

reprints

If you are interested in a particular article/special Feature or advertisement published in this issue of

WIRELESS WORLD

why not take advantage of our reprint service?

Reprints can be secured at reasonable cost to your own specifications providing an attractive and valuable addition to your promotional material.

For further details contact:

Brian Durrant, IPC Electrical-Electronic Press Ltd.
Phone: 01-261 8597 or simply complete and return the form below.

To: Brian Durrant, Reprints Department
Dorset House, Stamford Street, London SE1 9LU

I am interested in copies of the article/
advertisement headed featured in

WIRELESS WORLD

on page(s) in the issue dated
Please send me full details of your reprint service by return of post.

Name

Company

Address

Tel. No.

Heard any good books lately?

HIFI YEAR BOOK 1978

Pickups/Motors, Tuners/Amplifiers/Microphones
Recorders, Speakers/Cabinets/Audio Systems

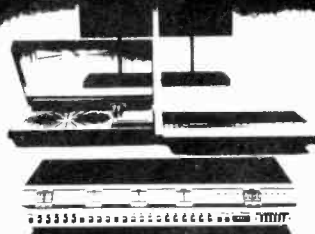

Bang & Olufsen

We think differently

Good listening begins with the right equipment — and the Hi-Fi Year Book gives you the low down on just about everything the market has to offer. With separate illustrated sections for every major category of equipment, it's got descriptions, prices, specifications, who makes it, where to buy it — everything you need to know. And all this information is backed by authoritative articles on the latest hi-fi developments, including quadrasonic recording. But you'd better order your copy quickly — lots of people will be pricking up their ears at news of this latest edition.

HI-FI YEAR BOOK 1978

Available direct from the publishers @ £3.40 inclusive
or from leading booksellers and newsagents price £3.00

To: IPC Business Press Ltd., Room CP34 **ORDER FORM**

Dorset House, Stamford Street, London SE1 9LU

Please send me copy/copies of Hi-Fi Year Book 1978 @

£3.40 a copy inclusive, remittance enclosed

Cheque/P.O. should be made payable to IPC Business Press Ltd.

NAME

(please print)

ADDRESS

Registered in England No. 677128

Regd. Office: Dorset House, Stamford Street, London SE1 9LU

WW

Hurry for your copy!

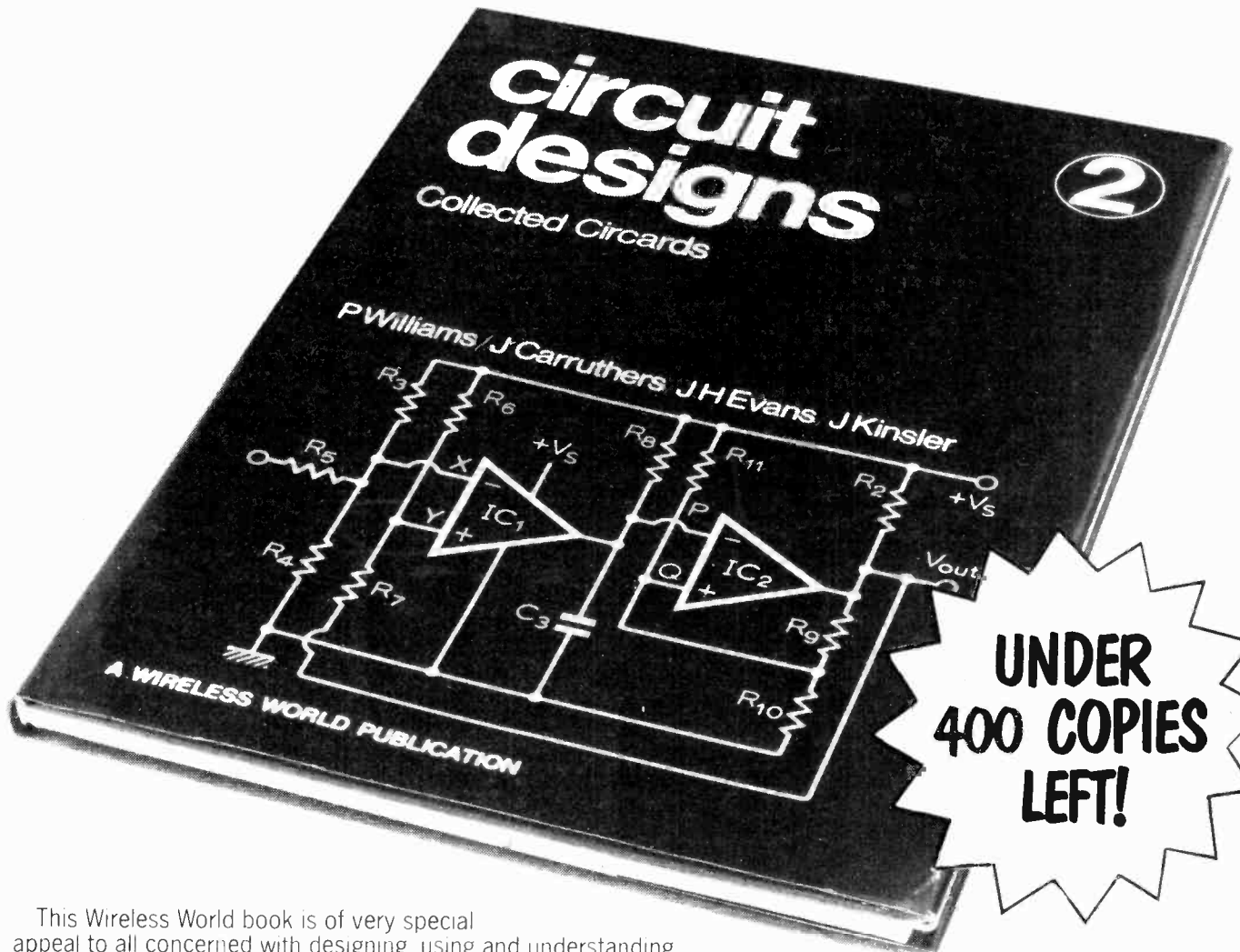

This Wireless World book is of very special appeal to all concerned with designing, using and understanding electronic circuits. It comprises information previously included in the second ten sets of Wireless World's highly successful Circards—regularly published cards giving selected and tested circuits, descriptions of circuit operation, component values and ranges, circuit limitations, modifications, performance data and graphs. The book follows on from Circuit Designs No. 1—now sold out. It is magazine size in hard cover and contains information on the ten sets of Circards plus additional circuits and explanatory introduction. Like its predecessor, this second book has been deservedly popular since its first appearance and may soon be out of print. You are advised to order your copy without delay.

- Basic logic gates
- Wideband amplifiers
- Alarm circuits
- Digital counters
- Pulse modulators
- C.d.as—signal processing
- C.d.as—signal generation
- C.d.as—measurement and detection
- Monostable circuits
- Transistors pairs

A BOOK FROM
wireless world

ORDER FORM

To: General Sales Department
IPC Business Press Limited
Room CP34, Dorset House
Stamford Street, London SE1 9LU

Please send me copy/copies of Circuit Designs—Number 2 at £12.50 each inclusive. I enclose remittance value £..... (cheques payable to IPC Business Press Ltd.).

Name.....
(please print)
Address.....

.....
.....

WW 7B 77

Company registered in England and a subsidiary of Reed International Limited. Registered No. 677128. Regd. office Dorset House, Stamford Street, London SE1 9LU

I.C.E. MULTIMETERS

TWICE the information in **HALF** the size

The I.C.E. range of multimeters provides an univalued combination of maximum performance within minimum dimensions, at a truly low cost. Plus, a complete range of add-on accessories for more ranges, more functions.

All I.C.E. multimeters are supplied complete with unbreakable plastic carrying case, test leads, etc., and a 50-plus page, fully detailed and illustrated Operating and Maintenance Manual

Now available from selected stockists Write of phone for list or for details of direct mail-order service

Supertester 680R (illustrated)

20k Ω /V - 1% fsd on d.c.
4k Ω /V - 2% fsd on a.c.
80 Ranges - 10 Functions
140 x 105 x 55mm
£25.25 + VAT
(For Mail Order add 80p P&P)

Supertester 680G

20k Ω /V - 2% fsd on d.c.
4k Ω /V - 2% fsd on a.c.
48 Ranges - 10 Functions
109 x 113 x 37mm
£19.95 + VAT
(For Mail Order add 80p P&P)

Microtest 80

20k Ω /V - 2% fsd on d.c.
4k Ω /V - 2% fsd on a.c.
40 Ranges - 8 Functions
Complete with case - only 93 x 95 x 23mm
£14.95 + VAT
(For Mail Order add 80p P&P)

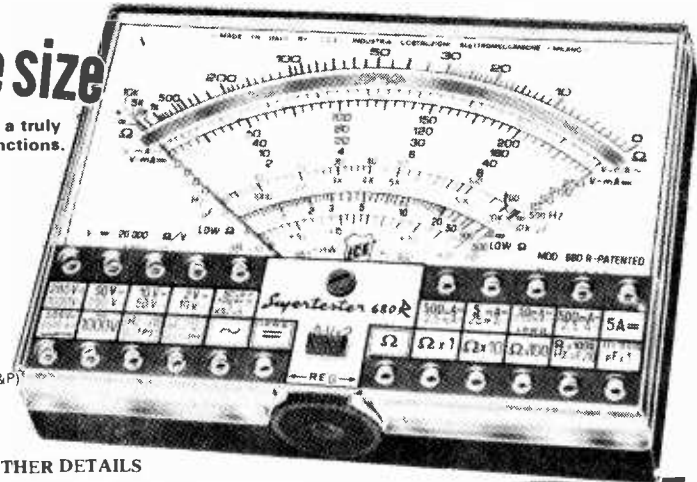

Electronic Brokers Ltd.
49-53 Pancras Road, London NW1 2QB
Tel. 01-837 7781

WW-088 FOR FURTHER DETAILS

INDEX TO ADVERTISERS

Appointments Vacant Advertisements appear on pages 127-141

| | PAGE | | PAGE | | PAGE |
|---|--------------------|------------------------------------|-----------|---------------------------------|------------|
| AEL Crystals Ltd. | 22 | Genrad Ltd. | 6 | Olympic TV Prods. | 122 |
| Amateur Components | 98 | Greenway Elec. Comps. | 98 | Patrick, J. B. | 142 |
| Ambit International | 29 | Greenwood Electronics | 13 | Plessey Windings | 15 |
| Antex | 69 | Gould Advance | 70 | Powertran Electronics | 112, 113 |
| Arrow Electronics Ltd. | 31 | H/H Electronics | 32 | Q-Max Electronics Ltd. | 9 |
| Aspen-Electronics Ltd. | 26 | Harmsworth Townley & Co. Ltd. | 17 | Quality Electronics | 116 |
| Astra-Pak | 95 | Harris Electronics (London) Ltd. | 17, 29 | Radio Components Specialists | 111 |
| Audio Amateur | 107 | Hart Electronics | 94 | Radio Masts Ltd. | 102 |
| Audio Design Recording Co. | 95 | Heyco Mfg. Co. Ltd. | 18 | Radio Shack Ltd. | 102 |
| Audix Ltd. | 80 | Hi-Fi Yearbook | 142- | Raffe P. Electronics | 105 |
| Avo Ltd. | 4, 5 | Icon Designs | 2 | R.C.S. Electronics | 30 |
| Baker Loudspeakers Ltd. | 20 | ILP Electronics Ltd. | 93, 103 | Rola Celestion Ltd. | 97 |
| Barrie Electronics Ltd. | 107 | Industrial Tape Applications | 33 | R.S.T. Valves Ltd. | 110 |
| Bayliss, A. D. & Sons Ltd. | 16 | Integrex Ltd. | 108, 109 | RTVC | 114 |
| Bell & Howell | 8, 9 | Interport Mains-Store Ltd. | 139 | Samsons (Electronics) | 118 |
| Bentley Acoustic Corp. Ltd. | 122 | ITT Instrument Services | 96 | Scopex Instruments Ltd. | 96 |
| Bi-Pak Semiconductors Ltd. | 124 | JPS Associates | 30 | Scott, James (Elec. Eng. Ltd.) | 26 |
| Boss Industrial Mouldings Ltd. | 7 | KGM Electronics | 12, 18 | Semi Conductor Supplies Ltd. | 98 |
| C.A.E. Ltd. | 15 | Keithley Instruments Ltd. | 80 | Servo & Elec. Sales Ltd. | 116 |
| Cambridge Learning | 17 | Langrex Supplies Ltd. | 110 | Service Trading Co. | 115 |
| Cardross Eng. Co. Ltd. | 34 | Leavers-Rich Equipment Ltd. | 16 | Shure Electronics Ltd. | 24, 25 |
| Carter Associates | 126 | Levell Electronics Ltd. | 3 | Sintel | 114 |
| Catronics | 116 | Light Soldering Developments Ltd. | 10 | Soundex Ltd. | 94 |
| CEC Corporation | 18 | Linstead Mfg. Co. Ltd. | 14 | Southwest Technical Prods. Ltd. | 19 |
| Chiltmead Ltd. | 117 | Lion House | 35 | Sowter, E. A. | 140 |
| Chromasonics | 28 | Lloyd, J.J. Insts. Ltd. | 21 | Special Products Ltd. | 16 |
| Circuit Design | 143 | Lowe Electronics Ltd. | 26 | Stirling Sound | 116 |
| Comark | 32 | Lynx (Electronics) London Ltd. | 125 | Strumech Engineering Ltd. | 12, 29 |
| Colomor (Electronics) Ltd. | 118 | McKnight Crystals | 138 | Sugden, J. E. & Co. Ltd. | 21 |
| Computer Appreciation | 126 | MacInnes Laboratories Ltd. | 14 | Surrey Electronics Ltd. | 126 |
| Computer Weekly | 31 | Manners, K. T. | 116 | Swanley Electronics Ltd. | 94 |
| Continental Specialities Corp. | 79 | Maplin Electronic Supplies | Cover iii | Swift of Wilmslow | 35 |
| Crimson Elektrik | 21 | Marconi Instruments Ltd. | Cover ii | Technomatic Ltd. | 106 |
| Data & Control Equipment Ltd. | 99 | Marconi Communication Systems Ltd. | 107 | Teknomic (Tequipment) | 101 |
| Datong Electronics Ltd. | 32 | Marshall, A. (London) Ltd. | 100 | Teleradio Hi Fi | 94 |
| Dau (U.K.) | 31 | Martin Associates | 105 | Trampus Electronics | 95 |
| Doram Electronics | 35 | Milward, G. F. | 106 | Vero Electronics Ltd. | 14 |
| Drake Transformers Ltd. | 10 | Mills, W. | 100 | Vero Verospeed Ltd. | 28 |
| Eagle Int'l. | 34 | Modern Book. The | 139 | West Hyde Developments Ltd. | 104 |
| Eddystone Radio Ltd. | 11 | Monolith Electronics Co. Ltd. | 34 | Wilkinson, L. (Croydon) Ltd. | 22 |
| E.L. Instruments | 22 | Multicore Solders Ltd. | Cover iv | Wilmslow Audio | 23 |
| Electro/Eurotech | 22 | Newbear, Computer Stores | 30 | Z. & I. Aero Services Ltd. | 18, 20, 98 |
| Electro Systems & Timing Co. | 34 | Neal Ferrograph | 13 | | |
| Electronic Brokers Ltd. | 119, 120, 121, 144 | Newnes-Butterworth | 125 | | |
| Electronic Brokers Ltd. (Second User Computer Div.) | 123 | | | | |
| Erie Electronics Ltd. | 21, 28 | | | | |
| 4 Books from W/World | 27 | | | | |
| Farnell Instruments Ltd. | 36 | | | | |
| Future Film Developments | 32 | | | | |

OVERSEAS ADVERTISEMENT AGENTS:

Hungary: Mrs. Edit Bajusz Hungexpo Advertising Agency Budapest XIV Varosliget Telephone 225 008 - Telex Budapest 22-4525 INTFOIRE

Italy: Sig. C. Epis Etas-Kompass, S.p.A. - Servizio Estero Via Mantegna 6, 20154 Milan Telephone 347051 - Telex 37342 Kompass

Japan: Mr. Inatsuki, Trade Media - IBPA (Japan) B 212, Azabu Heights, 1-5-10 Roppongi, Minato-ku, Tokyo 106 Telephone. (03) 585-0581

United States of America: Ray Barnes IPC Business Press, 205 East 42nd Street, New York, NY 10017 - Telephone (212) 689-5961 - Telex 421710 Mr. Jack Farley Jr., The Farley Co. Suite 1584, 35 East Wacker Drive, Chicago, Illinois 60601 - Telephone (312) 63074 Mr. Richard Sands, Scott, Marshall, Sands & Latta Inc. 5th Floor, 85 Post Street, San Francisco, California 94104 - Telephone (415) 421-7950 - Telephone Dascotto San Francisco Mr. William Marshall, Scott, Marshall, Sands & Latta Inc. 1830 West Eighth Street, Los Angeles, California 90057 - Telephone (213) 382-6346 - Telegrams Dascotto, Los Angeles

Mr. Jack Mentel The Farley Co. Suite 650 Ranna Building Cleveland Ohio 44115 - Telephone (216) 621-1919 Mr. Ray Rickles, Ray Rickles & Co. P.O. Box 2008 Miami Beach, Florida 33140 - Telephone (305) 532-7301 Mr. Jim Parks, Ray Rickles & Co. 3116 Maple Drive N.E. Atlanta, Georgia 30305 Telephone (404) 237-7432 Mike Loughlin, IPC Business Press 15055 Memorial Ste 119, Houston Texas 77079 - Telephone (713) 783-8673

Canada: Mr. Colin H. MacCulloch International Advertising Consultants Ltd., 915 Carlton Tower 2 Carlton Street Toronto 2 - Telephone (416) 364-2269

*Also subscription agents

MAPLIN

everything for the modern D.I.Y. electronics enthusiast and more.



THE 'DRUMSETTE' RHYTHM GENERATOR

Organists, pianists, guitarists... an automatic drum set to accompany you! Nine highly realistic instruments play fifteen different rhythms. Fifteen rhythm select touch switches and a touch plate for stop/start without rhythm change gives absolute ease of operation. Build it yourself for under £65 including smart teak-effect cabinet. See it and hear it in our shop! Send for full construction details now. MES49 price 25p.



REVERBERATION SYSTEMS

High quality spring line driver module uses 4 integrated circuits and two transistors. Built and tested circuit board with wiring instructions for spring line. XB85G, price £6.00. Power supply to suit driver module costs around £2.50 and construction details are in catalogue, or ask for leaflet MES24. Mechanical spring lines. Short line (XLD8J) £4.49; Long line (XB84F) £10.39. (All prices include V.A.T. and p & p.)

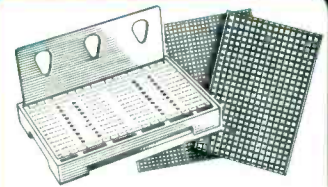

BOARDS AND PCB'S

Pages 59 to 61 of our catalogue show you our range of Veroboards and S-Decs or if you prefer to make your own PCB's a range of etching systems including the novel etch-in-a-bag system, plus printed circuit transfers for the professional finish to your boards.

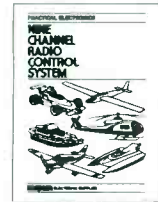

9-CHANNEL RADIO CONTROL SYSTEM

A comprehensive model control system, featuring nine independent fully proportional channels achieved by a design using very few components thus keeping the cost to a minimum. Full construction details in our booklet (XF030) price £1.20.

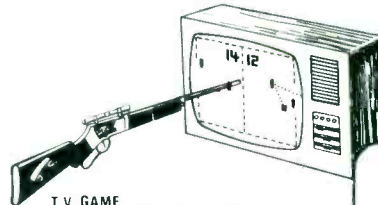

T.V. GAME

A fascinating TV game kit that plays football, tennis, squash and practice for only £21.59. Reprint of construction details 25p. Add on rifle kit only £10.60. (All prices include V.A.T. and p & p.)



MASSIVE RANGE OF COMPONENTS

For instance the capacitor section in our catalogue includes non-polarised electrolytics and our resistor section includes even 1% tolerance types. Get our fascinating catalogue now—you won't regret it.



AUDIO MIXER

A superb stereo audio mixer. It can be equipped with up to 16 input modules of your choice and its performance matches that of the very best tape recorders and hi-fi equipment. It meets the requirements of professional recording studios, concert halls and theatres. Full construction details in our catalogue. A component schedule is available on request.



ELECTRONIC ORGAN

The only organ you can build in stages and tailor to your requirements as you go along—and at each stage you'll have a fully working instrument! We haven't got the gimmicks yet—they're coming soon! but we have got the most beautiful sounds—you won't find them on any organ less than twice our price. So get our MES50 series leaflets now! 65p buys the three available so far.

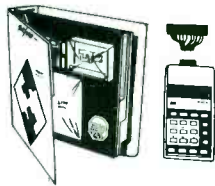

MICROPROCESSOR

Build a mini-computer with our microprocessor kit. Features: 46 different instruction types, 256 bytes of read/write memory (more are easily added) microprocessor can address up to 65,536 8 bit-bytes. Complete kit for use with teletype etc (XB91Y) £74.10. 20-key keyboard for use with a home (in place of teletype) (XB92A) £71.11. Both kits with detailed instruction books. See our newsletter for details of additional RAM's, tri-state interfacing chips, number-cruncher and standard cassette tape-recorder interface to store your programmes. (All prices include V.A.T. and p & p.)



Our bi-monthly newsletter keeps you up to date with latest guaranteed prices - our latest special offers - details of new projects and new lines. Send 30p for the next six issues (5p discount voucher with each copy).



POST THIS COUPON NOW FOR YOUR COPY OF OUR CATALOGUE PRICE 60p

Please rush me a copy of your 216 page catalogue I enclose 60p, but understand that if I am not completely satisfied I may return the catalogue to you within 14 days and have my 60p refunded immediately.

NAME _____

ADDRESS _____

IT'S A FANTASTIC BESTSELLER!
216 big (11" x 8") pages! Over a thousand illustrations! Over 30 pages of complete projects to build! Thousands and thousands of useful components described and illustrated! No wonder it's a bestseller!

DON'T MISS OUT! SEND 60p NOW!

MAPLIN ELECTRONIC SUPPLIES

P.O. BOX 3 RAYLEIGH ESSEX SS6 8LR

Telephone: Southend (0702) 715155

Shop: 284, London Road, Westcliff-on-Sea, Essex

(Closed on Monday) Telephone: Southend (0702) 715157

Even if tin prices stabilised, a change from 60/40 alloy to Savbit Solder could save you £100/tonne, ensure a better job...

The reason is that Multicore Savbit not only solves the problem of fine copper wires and thin foils deteriorating during soldering, but also contains less tin than 60/40 alloy. **We make both so we are just offering to alleviate your rising metals costs.**

During normal soldering, a dissolving action causes the wire to weaken and embrittle – often to break during subsequent field use.

Savbit, however, is a rosin based, 5-core wire solder comparable in joint quality to standard high performance alloys, but capable of dramatically inhibiting the copper dissolving action.

As this diagram shows*, compared with a 60/40 alloy, Savbit can reduce the dissolution of copper by as much as 100 times. Yet wetting rate, flow, conductivity and capillary force are almost identical – with creep strength and shear strength actually increased.

*(Indicative of product advantages only; not to scale)

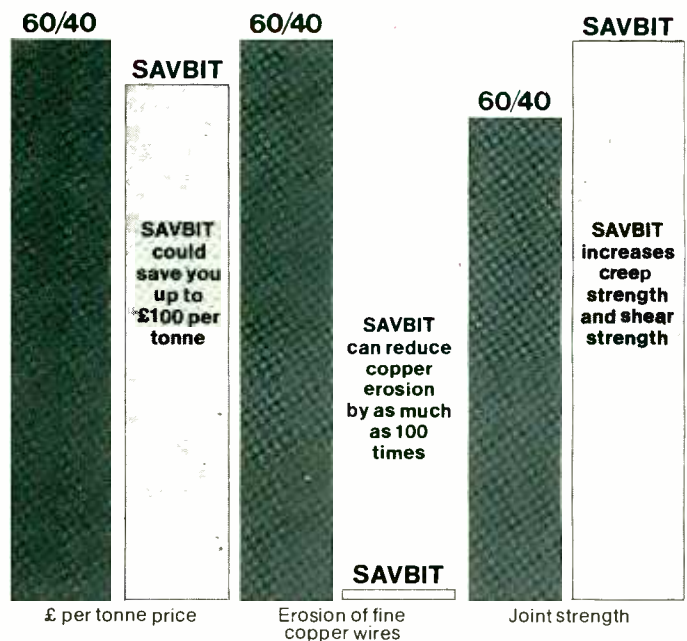

...and more



Cracked iron-plated bit, after 40,000 simulated operations using 60/40 Solder.

Some people think Savbit alloy is only usable with plain copper soldering iron bits, but this isn't true.

As these photographs illustrate dramatically, Savbit also saves significantly on the cost of iron-plated soldering iron bits, which have a copper core. This is exposed through cracks in the plating.

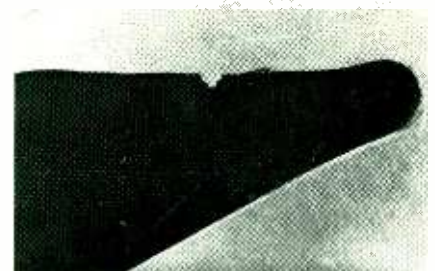

Cracked iron-plated bit, after 40,000 simulated operations using SAVBIT Solder.

Add this advantage to the increased reliability and joint quality Savbit offers, and you'll understand why more and more 60/40 users are making the change – and profiting. The Ministry of Defence have given a special new Approval No. DTD 900/4535A for Savbit alloy with ERSIN 362 flux to be used in lieu of Solders to B.S. 219 and B.S. 441.



For full information on Savbit or any other Multicore products, please write on your company's letterhead direct to:

Multicore Solders Limited,
Maylands Avenue, Hemel Hempstead, Herts. HP2 7EP.
Telephone: Hemel Hempstead 3636. Telex: 82363.