

Wireless World

Outlook for m.w. sound broadcasting

Editor:

H. W. BARNARD

Technical Editor:

T. E. IVALL, M.I.E.R.E.

Assistant Editors:

G. B. SHORTER, B.Sc.
W. E. ANDERTON, B.Sc.

Drawing Office:

L. DARRAH.

Production:

D. R. BRAY

Advertisements:

G. BENTON ROWELL (*Manager*)
Phone 01-261 8339

G. J. STICHBURY
Phone 01-261 8037

A. PETERS (*Classified Advertisements*)
Phone 01-261 8508 or 01-928 4597

In 1974 the International Telecommunication Union will be holding a conference that will discuss the vexed question of re-planning the medium- and long-wave sound broadcasting bands in the adjacent continents of Europe, Asia and Africa. Whether this will go any way towards rectifying the chaotic conditions resulting from the use of channels and powers by stations unauthorized by the Copenhagen Plan remains to be seen. Whatever is decided still has to be implemented, and coercion is not possible. But in the meantime it is encouraging to see some preliminary moves which indicate a willingness for co-operative improvement. China is now a member of the United Nations and will be taking part in future I.T.U. deliberations. In the past few weeks initial contacts have been made through a visit of Chinese broadcasting officials to European countries, including the U.K. Earlier in the year the European Broadcasting Union took a step which one would have expected to happen decades ago. It recognized that technical planning of sound broadcasting cannot take place in isolation, by bringing together, for the first time, its programme and engineering working parties. Statements by receiver manufacturers in Europe indicate that they are not worried about possible technical changes in transmission systems as long as the programmes put out are attractive enough to ensure good markets for sets. And finally, the E.B.U. is attempting to tackle the whole business of replanning in a rational, systematic manner that is based on scientific fundamentals and ignores the politics, prejudices and polemics which have obscured the subject for too long.

An excellent account of the systematic engineering approach was recently given by Dr. F. T. Von Rautenfeld, Chairman of an E.B.U. working party on sound broadcasting, at an I.E.E. Western Centre meeting in Bristol. The problems are being considered under two heads: optimum frequency allocations and optimum transmission systems. One of the most critical aspects of frequency planning is establishing the optimum geographical distance between co-channel transmitters. Here it was interesting to note that Dr. Von Rautenfeld took as a fundamental fact of life the existence of sky-wave propagation at night-time — not as a nuisance, responsible for inter-station interference, as most of us have become conditioned to think of it, but as something to be utilized, a “gift of Nature” as he called it. So far conferences on m.w./l.w. planning have only considered ground-wave coverage, as this is the way in which these frequencies have been traditionally used for local, regional and national programmes within a given country. Whether many people are interested in being able to receive about a dozen foreign transmissions is very doubtful, but at least it is realistic to take sky-wave propagation into account when planning optimum frequency allocations. Dr. Von Rautenfeld also stressed that any future plan including Europe, Asia and Africa should be based on common channel operation, that administrations in individual countries must be persuaded to reduce their requirements for frequencies (ultimately for their own benefit), and revealed that recent studies have shown that the optimum channel spacing for m.f. band is 8kHz.

The possibility of changing the transmission system from the present double-sideband a.m. to, say, single-sideband is more remote, but the difficulties, according to Von Rautenfeld, are as much to do with frequency planning as with design changes in receivers. The most common objection to a change of system is based on the existing public investment in a.m., d.s.b. sets. But is this really an insuperable problem? With the likely coming of cheap, large-scale integrated circuits incorporating synchronous detectors, the willing attitude of the receiver manufacturers towards technical change and the theoretical possibility of a gradual, phased transition from d.s.b. to s.s.b. operation, we should not have to consider this investment as a permanent millstone round our neck.

Modular Integrated Circuit Audio Mixer

by J. H. Evans,* Dip. Tech.(Eng.) and P. Williams,* B.Sc.

An audio mixer is always a complex constructional project and many must have fallen by the wayside in the face of the difficulties of layout and wiring complexity. A modular approach has been adopted which considerably reduces these problems and at the same time takes advantage of the simplicity of using low cost, readily available integrated circuits. As an additional aid, very complete details of the wiring and front panel design have also been given, which if accurately reproduced should negate hum and instability often associated with home constructed mixers.

The system to be described was designed at the request of the audio-visual aids department of a College of Technology. The requirements were rather unusual in several respects, and as a result the system, though following standard audio practice, has many unusual features. The first, and perhaps the most attractive to many users, is that it was of necessity designed with minimum cost in mind. To that end the active devices used throughout (with one exception) were the lowest cost operational amplifiers available at that time. Since designing and building the equipment the choice seems to have been justified on this ground at least, in that the cost of these operational

amplifiers (type 741) has fallen still further. At the time of writing the total cost for the amplifiers used in this system would be about £4.00 costed at the 100-up rate. However, the price of the amplifiers (of the order of 20-25p each) is such that they can now be thrown around with the gay abandon previously allotted to surplus transistors.

From a circuit standpoint the main difference between this and more usual mixer systems is that a larger number of channels have to be accommodated and, most important, that each channel was required to have separate bass and treble tone controls. This was a user requirement stemming from experience with multiple microphone inputs in locations where little control was possible over the acoustics. The

results had previously been that a single tone control on the mixed channels was inadequate to compensate for the variation in the individual speakers, the microphones and their placements. Since it appeared, from a study of the literature, that passive tone controls were unlikely to cover the wide range of bass and treble lift and cut that might be required in such circumstances, then it became even more important that the active element used in the tone control should have the lowest possible cost. It is clearly arguable that, since a single transistor still costs less than a single operational amplifier, the choice is weighted in favour of the transistor. However, advantages of circuits based on the operational amplifier are that separate biasing networks are not required and the input and output are at almost zero d.c. voltage. By eliminating both coupling and decoupling capacitors in the tone control circuit together with the bias resistors, a saving of fourteen components proved to be possible over a recent transistor tone control circuit of otherwise similar type. For the private user it is not easy to quantify the saving in component cost and the saving in time, although this must be considerable. As with all decisions of an engineering nature other compromises are introduced, and the requirement of both positive and negative supply rails for the amplifier would seem to be a more serious disadvantage. If it is noted that in this circuit, for example, there are eight separate tone control stages together with nine other amplifying and filtering circuits using operational amplifiers, then the additional cost of such a supply, spread over the circuits, is a relatively minor factor.

* Paisley College of Technology.

Parameters	Typ N5741	Supply voltage rejection ratio	10
		Large signal voltage gain	200,000
		Output voltage swing	±14 ±13
Parameters	Typ N5741	Output resistance	75
Input offset voltage	2.0	Output short circuit current	25
Input offset current	20	Supply current	1.4
Input bias current	80	Power consumption	50
Input resistance	2.0	Transient response (unity gain)	
Input capacitance	1.4	Risetime	0.3
Offset voltage adjustment range	±15	Overshoot	5.0
Input voltage range	±13	Slew rate	0.5
Common mode rejection ratio	90		

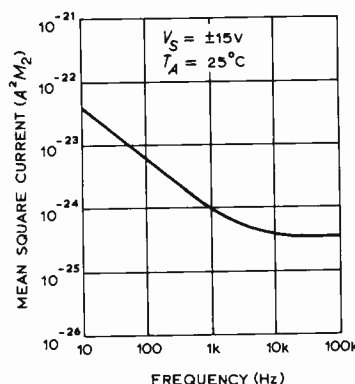
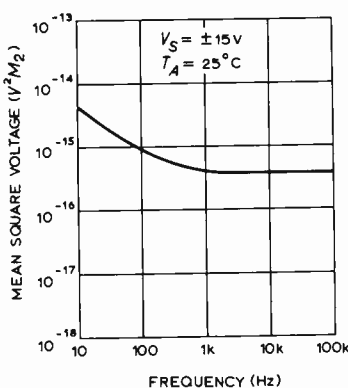

Fig. 1. Typical characteristics for a type 741 op-amp. (Courtesy Signetics Corporation)

Noise considerations

Once the decision has been taken on the grounds of cost and simplicity to use operational amplifiers of a particular type, then the user no longer has the very wide range of choices available to him in other designs. Thus, where the absolute minimum of input noise is the most important factor in the design, it would be necessary to revert to one of the excellent designs published in this field by other authors. Alternatively, the same system could be adopted but using an operational amplifier of higher cost specifically designed for low-noise input performance. That is not to say that the present circuit has poor noise performance,

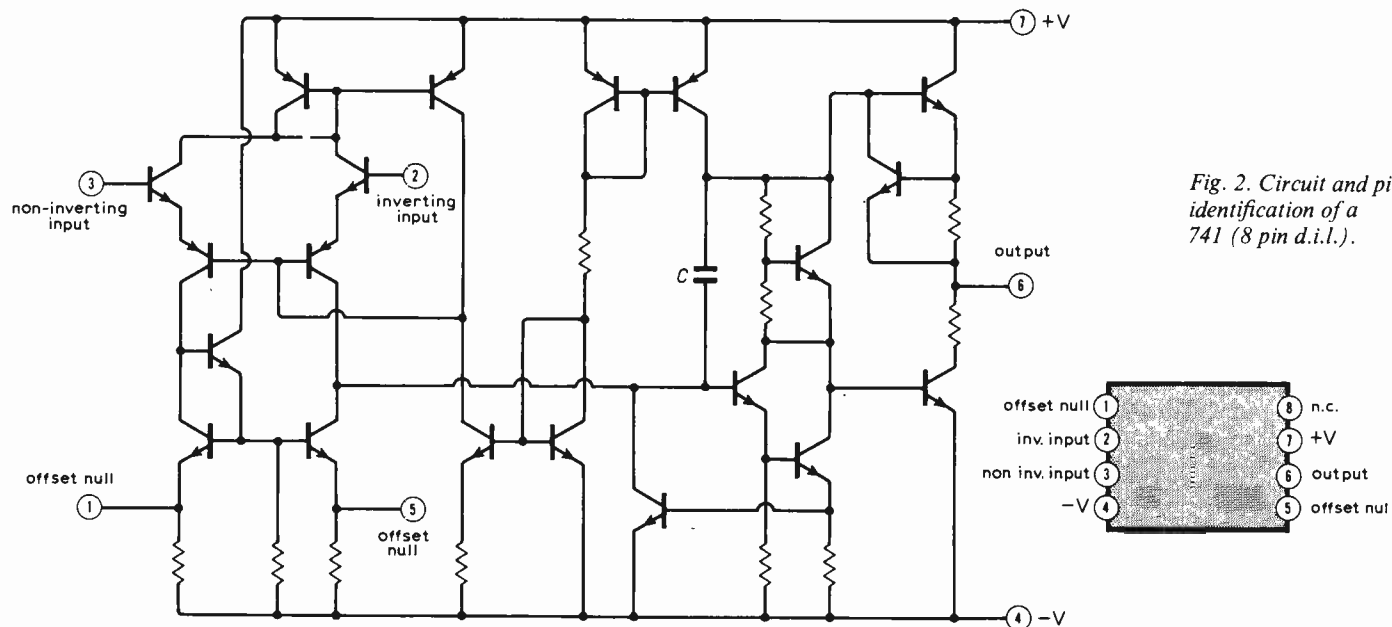

Fig. 2. Circuit and pin identification of a 741 (8 pin d.i.l.).

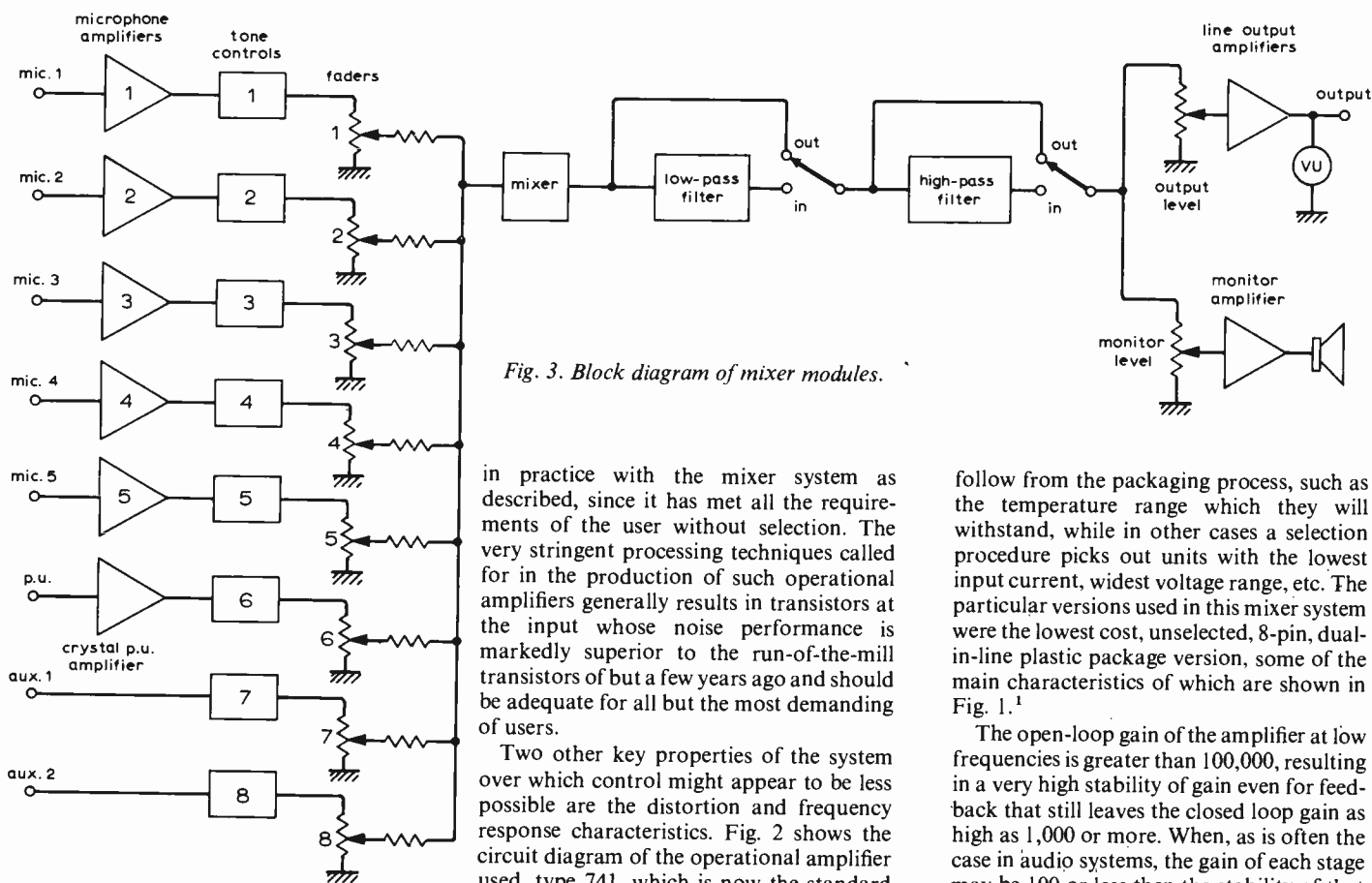

Fig. 3. Block diagram of mixer modules.

as is seen from Fig. 1 which gives the characteristics of the type 741 operational amplifier. The input noise voltage and currents given are only typical figures, and where optimum performance is required at the input, a further advantage of using the same active device throughout becomes apparent: the user may simply interchange the operational amplifiers at the input until the unit with the minimum noise performance is found. This has not proved to be necessary

in practice with the mixer system as described, since it has met all the requirements of the user without selection. The very stringent processing techniques called for in the production of such operational amplifiers generally results in transistors at the input whose noise performance is markedly superior to the run-of-the-mill transistors of but a few years ago and should be adequate for all but the most demanding of users.

Two other key properties of the system over which control might appear to be less possible are the distortion and frequency response characteristics. Fig. 2 shows the circuit diagram of the operational amplifier used, type 741, which is now the standard operational amplifier for the majority of routine industrial circuits, though of course the integrated circuit manufacturers are continually producing newer i.c.s of ever-increasing performance. This particular operational amplifier is offered by nearly every manufacturer under different code numbers although usually the numbers 741 appear somewhere in the code. The same circuit is produced in a variety of packages: flat pack, TO-5, 14 pin dual-in-line, 8 pin dual-in-line, etc. The circuit is also produced to various specifications which sometimes

follow from the packaging process, such as the temperature range which they will withstand, while in other cases a selection procedure picks out units with the lowest input current, widest voltage range, etc. The particular versions used in this mixer system were the lowest cost, unselected, 8-pin, dual-in-line plastic package version, some of the main characteristics of which are shown in Fig. 1.¹

The open-loop gain of the amplifier at low frequencies is greater than 100,000, resulting in a very high stability of gain even for feedback that still leaves the closed loop gain as high as 1,000 or more. When, as is often the case in audio systems, the gain of each stage may be 100 or less then the stability of that gain depends only on the stability of passive components. At higher frequencies the picture is different. Because the amplifier is designed to be stable and free of oscillations with feedback of up to 100% then great care has to be taken in the control of the frequency response of each stage within the amplifier. If at any time the phase shift around the loop reaches 180° then feedback intended to be negative becomes positive and if the loop gain is still above unity self-sustaining oscillation will result. This explains the presence of capacitor C in the

circuit of Fig. 2. This capacitor is connected at a critical point in the circuit where the impedance is relatively high, and ensures that the gain of the amplifier has fallen to a very low level before the frequency is reached at which the phase shift in the other stages becomes significant. Thus, at no time does the total phase shift of the amplifier approach 180° before the gain has fallen below unity. To achieve this effect the reduction in gain begins at a very low frequency so that the gain is reduced by a factor of 100,000 before the critical frequency is reached; i.e. the cut-off frequency for the open loop condition is of the order of 10Hz. In a system in which there is only a single dominant high frequency time constant the gain-bandwidth product remains constant for all values of the feedback. A resistive feedback network that reduces a low frequency gain from 100,000 to 10 will roughly increase the upper cut-off frequency from 10Hz to 100kHz. Broadly speaking, with amplifiers of this type gains of up to 100 in each stage may be achieved with no serious attenuation in the audio frequency band. In the particular circuits used in this mixer the gain per stage is typically $\ll 100$ and a bigger problem is that of restricting the high frequency performance from a noise standpoint.

The output stages of a 741 operational amplifier can be seen from Fig. 2 to be a

form of Class-B push-pull. Without feedback the resulting cross-over distortion would be serious, but, as explained above, the feedback is usually heavy and the feedback is correspondingly reduced. This is not the full story; at higher frequencies the reduction in open loop gain makes the feedback network less effective in reducing distortion and it would not be an ideal circuit for obtaining large output swings at frequencies above 100kHz, certainly not with light feedback. Direct measurements on the amplifier are discussed later and it will be seen that it meets most audio requirements with ease, though once again it must be stressed that the very highest quality amplifiers specifically designed for this application should be capable of better performance. The very low cost of the 741 operational amplifier means that competing systems are likely to suffer a heavy cost penalty for any significant improvement in performance.

System requirements

To meet the needs of the audio-visual aids department concerned, the system as shown in block diagram form in Fig. 3 was devised. The specifications it was intended to meet are shown in Table 1. Each of the eight channels was required to have separate bass and treble, lift and cut tone controls, five of the channels being microphone amplifiers,

one from a ceramic pickup and two line inputs receiving signals from tape recorders and the like. A line output stage was required capable of operating into 600Ω although generally operating into a higher impedance. A monitor amplifier of 1-3W output was also included. To cope with signals having an excessively high or low frequency content, it was decided to have both a low-pass and a high-pass filter and to make these with widely-variable cut-off frequencies. This solution was adopted because the system, of which this mixer was to form a part, was still in the process of considerable expansion and the precise requirements were not known. All of the circuits described so far were based on the 741 operational amplifier but, at a later stage, a VU meter was added and this uses the only separate transistor in the system. Figs. 4-13 show the circuit diagrams of the various functional blocks included in the system. The only components not shown in these figures are the coupling capacitors C_{4a} and C_{4b}, which connect the two line input channels to their respective tone control circuits. A fuller discussion of the component values used in the mixer and the reasons for their choice are given in the following sections.

Input amplifiers

The low output impedance and low voltage generated by high quality microphones is in conflict with the input characteristics of the operational amplifier. If the noise properties are to be optimized then the effect of both noise current and noise voltage must be investigated. The noise voltage of a typical 741 amplifier over the audio band is about 3 microvolts. Since the voltage generated by a microphone might be as low as a few tens of microvolts, the signal-to-noise ratio for direct connection would clearly be poor. If we note that the noise current, however, is of the order of 20 pico-amp, then we see that its contribution to the total noise, depending as it does on the low resistance of the microphone input combination, is small. It is this which forces the use of a microphone transformer upon us. From a purely electronic standpoint, there would be much to be said for using a microphone with a high resistance obtained by winding a larger number of turns. A microphone with an impedance in the range 50-500Ω may be used with a transformer of step-up ratio 5-50 such that the impedance presented to the input of the amplifier is of the order of thousands of ohms, or higher. The step-up ratio ensures that the voltage presented to the amplifier input terminals is now much greater than would have been the case for direct connection. Hence, the input noise voltage is less significant, but the input current is now flowing through a greater source impedance and is more significant. For any given type of amplifier there will be an optimum turns ratio which ensures that the contribution of noise due to voltage and current is comparable. For any other turns ratio, or variation in microphone impedance, the reduction in equivalent noise due to either voltage or current will be less than the increase due to the other. It does not follow that the ratio which

Table 1
Specification for c.c.t.v. audio mixer

- Frequency response**
Flat response from 30Hz to 20kHz.
- Hum-noise**
70dB below rated output.
- Input noise**
200Ω source, 120dB below 1 volt.
- Channels**
Eight inputs as follows:
- (a) Five mic. input
 - (i) Source impedance 50 to 500Ω.
 - (ii) Source e.m.f. 0.125 to 0.28mV.
 - (b) One tele-cine
 - (i) Source impedance 8Ω (or 16Ω).
 - (ii) Source e.m.f. 500mV.
 - (c) One record player
 - (i) Source impedance high.
 - (ii) Source e.m.f. 100mV.
 - (d) One tape-recorder
 - (i) Source impedance 15Ω.
 - (ii) Source e.m.f. 100mV.
- Tone control**
To be provided on all input channels.
Bass ±10dB; treble ±10dB.
- Outputs**
- (a) (i) to input of video recorder; unbalance impedance bridging for 600Ω line.
(ii) 0.5mV into 200Ω.
 - (b) To supply 3-W loudspeaker.
- VU meter**
To be provided on output (a).
- Type of controls**
- (i) Slider-type potentiometers for volume control.
 - (ii) Rotary-type potentiometers for bass and treble.
- Console dimensions**
Dependent on the case or cabinet available, but the operational position of control surface to be 30° to the horizontal.
- Power supply**
240V, 50Hz.

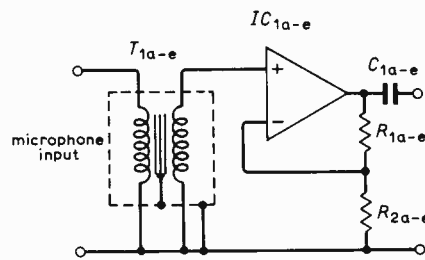

Fig. 4. Practical microphone pre-amplifier.

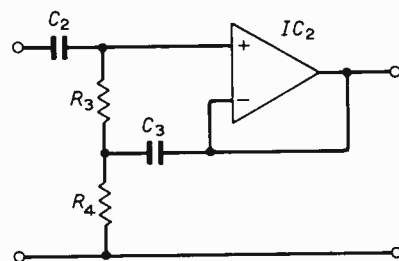

Fig. 5. Pre-amp for ceramic cartridges.

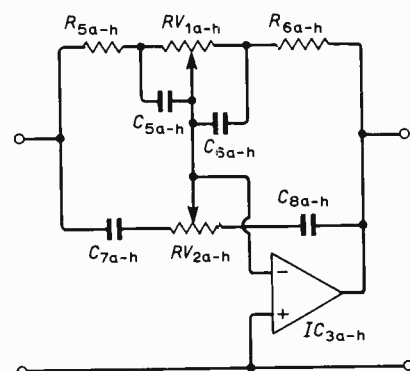

Fig. 6. Tone control circuit.

is optimum from a noise standpoint will also be the optimum ratio for extended frequency response. For example, if the turns ratio is too high the effective source impedance of the microphone may be such that capacitive effects cause a fall in the upper cut-off frequency while it may be difficult to maintain a sufficiently high inductance to avoid losses at low frequencies.

The practical circuit used in this mixer is shown in Fig. 4. For a typical microphone resistance of 200Ω the 15:1 turns ratio of the transformer results in an equivalent source resistance of 45kΩ. It is tempting to select feedback resistors that give gain in this stage to eliminate the risk of noise pick-up in subsequent stages, but this is inadvisable for two reasons. Firstly, the smaller the feedback the less is the input impedance of the amplifier raised, while it is important that the input of the amplifier should not place an excessive load on the secondary of the transformer. Secondly, it must be remembered that operational amplifiers of this kind are compensated internally to make them stable for all feedback ratios and hence the compensation reduces the gain-bandwidth product sharply. A low-frequency gain of 1000 is easily obtained, but the upper cut-off frequency might then fall well below 10kHz. With the component values indicated, the overall voltage gain from the microphone to the output of this stage is well in excess of 100. The output voltage thus obtained is of the order of a few tens of millivolts and is comparable to that expected at the line inputs.

For gramophone use the mixer was intended to operate from a ceramic cartridge and a high input impedance is required. The circuit of Fig. 5 provides this with a voltage gain of unity since the output voltage of the cartridge is already equal to or greater than that of the preceding cases. As such a cartridge does not provide a d.c. path for the amplifier input current, it is necessary to provide such a path as with resistors R_3 and R_4 . These would provide a load resistance for the cartridge which would result in a poor low-frequency response, since the cartridge impedance is capacitive. The centre tap of the resistors is therefore bootstrapped from the output of the amplifier by capacitor C_3 . This ensures that the p.d. across R_3 is very small and hence that the current through it is negligible, corresponding to a very high dynamic input impedance. Much has been written recently about alternative input stages for ceramic pickups but there is some advantage to retaining at least one input of this form which may accommodate any voltage source including those of high internal impedance.

Tone controls. The Baxandall tone control is standard within high quality amplifier circuits² and meets all the requirements of the present unit (Fig. 6). Since there was to be additional voltage gain in the following mixer stage and in the line output unit, the resistor values in this stage were chosen for a mid-band gain of unity. The intended input voltages are of the order of a few tens of millivolts, i.e. well above noise level, while leaving a very large overload margin. In an attempt to reduce the component count as

low as possible, advantage has been taken of the almost zero d.c. output voltage of the amplifier by omitting the electrolytic capacitor that would normally be used between stages. Since the overall voltage gain from the input of the tone control circuit to the line output is little more than 30 and the equivalent input offset voltage is but a few millivolts, the line output offset is very much less than 1V. This must be allowed for if d.c. coupled into the load but is not of sufficient magnitude to contribute anything to the non-linearity of the output stage. It is in such modifications as this that the inherent balance at the input of an operational amplifier combined with its large dynamic output range allows for such simplifications. Only experience will show whether the small amount of d.c. voltage that remains across the gain controls will result in noisy operation.

Mixer stage

This is a conventional summing amplifier (Fig. 7) with an output voltage equal to about five times the sum of the input voltages. It would be perfectly possible to use this stage for line output functions, if necessary increasing the gain of the stage as appropriate. As the equipment was at the experimental stage, it was decided to include high-pass and low-pass filters of variable cut-off frequency to be switched in or out as required. It then became advisable to follow these with a final line output stage which also contributed voltage gain. Since no individual stage was called on to provide a high voltage gain, the bandwidth easily exceeded the specification of 20kHz.

Low pass filter. The circuits used for both this and the following filter (Fig. 8) are standard in industrial practice, making use of the operational amplifier in its unity gain mode, i.e. as a voltage follower. The filter has a second order response with cut-off frequency controlled by the ganged variable resistors in the range 500Hz to 20kHz. This range is clearly wider than would be required for audio applications alone, but it was felt that the availability of the filter for experimental demonstrations might be worth while. For this, as with the preceding

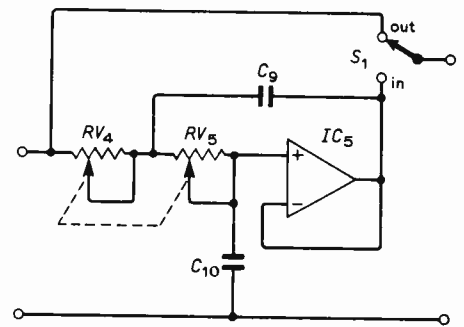

Fig. 8. Low-pass filter.

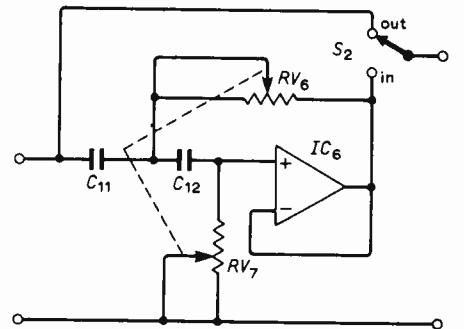

Fig. 9. High-pass filter.

circuits, the output impedance is low, partly because of the low output impedance of the amplifier itself, and partly because of the heavy negative feedback.

High pass filter. This function is simply obtained from the previous circuit by interchanging resistors and capacitors (Fig. 9). Once again the cut-off frequency, in this case a lower cut-off frequency, is variable over a wide range and was chosen to be from about 10Hz to 5kHz.

Monitor amplifier. The increasing availability of low cost integrated circuit power amplifiers greatly simplifies the job of the audio designer. Advantage was taken of the amplifier module type EA1000 (Fig. 10) since this fulfilled all the requirements for this unit. The supply voltage needed was a

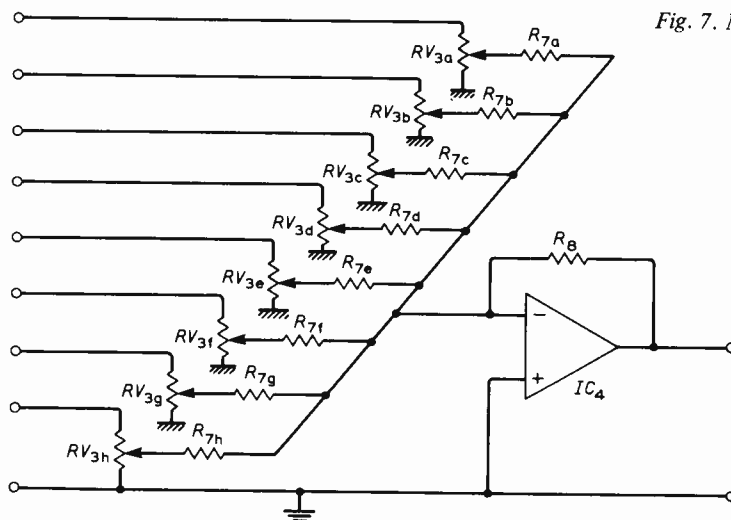

Fig. 7. Mixer amplifier.

single-ended positive supply of some 20V and the circuit operates from the smoothed, but unregulated, supply from which the +15V regulated supply is also derived. On load this supply falls from an initial value of 24V to 21V with a peak output power of 2-3W. At lower powers the distortion of the amplifier is more than adequate and the frequency response, particularly at high frequencies, is very good. The sensitivity of

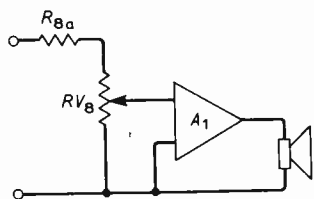

Fig. 10. Monitor amplifier.

the amplifier is such that it can be used directly from the ceramic pickup and the excess gain is, in this application, almost an embarrassment and explains the need for the additional 1MΩ resistor in series with the monitor gain control. For the given value of supply voltage the load resistance should be 15Ω.

Line output stage. This is basically similar to the mixer (Fig. 11), consisting of a virtual earth amplifier preceded by a gain control. Since the integrated circuit used has current limiting, no damage should occur either to the amplifier or to external circuits under any short term fault conditions. Alternative

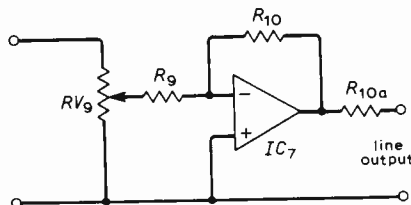

Fig. 11. Line output stage.

values of R_{10} may be used if the sensitivity range provided by RV_9 is not suitable for particular applications. The 600-Ω resistor R_{10a} was included to provide matched operation with a video tape recorder but may be omitted if a lower output resistance is required.

VU meter. (Fig. 12). Lack of experience with the meter circuits of this type led the authors to adopt a circuit described in a recent article.³ It is the only circuit in this unit that uses a transistor and performs admirably. Again, replacement by an operational amplifier might lead to some economy in bias components but this is presumably one circuit where a high open-loop gain is less necessary. The VU meter directly monitors the line output which, because of the relatively high supply voltage, might cause overloading of the meter in some cases.

Power supply. This is entirely conventional (Fig. 13) providing a nominal ±15V for the operational amplifiers and +15V for the VU meter circuit. The positive unregulated

Edge connector wiring details

P.C.B.1: Mic. chans. 1 and 2

Pin No.	Externally wired to:	Pin No.	Externally wired to:
1	+15V	13	RV _{2b}
2	RV _{2a}	14	0V (ground)
3	RV _{1a} and RV _{2a} *	15	n.c.
4	n.c.	16	RV _{1b}
5	n.c.	17	n.c.
6	RV _{3a}	18	RV _{1b}
7	RV _{1a}	19	RV _{3b}
8	n.c.	20	T _{1b}
9	RV _{1a}	21	n.c.
10	T _{1a}	22	RV _{1b} and RV _{2b} *
11	n.c.	23	RV _{2b}
12	RV _{2a}	24	-15V

*Wiping contacts.

P.C.B.2: Mic. chans. 3 and 4

Pin No.	Externally wired to:	Pin No.	Externally wired to:
1	+15V	13	RV _{2d}
2	RV _{2c}	14	0V (ground)
3	RV _{1c} and RV _{2c} *	15	n.c.
4	n.c.	16	RV _{1d}
5	n.c.	17	n.c.
6	RV _{3c}	18	RV _{1d}
7	RV _{1c}	19	RV _{3d}
8	n.c.	20	T _{1d}
9	RV _{1c}	21	n.c.
10	T _{1c}	22	RV _{1d} and RV _{2d} *
11	n.c.	23	RV _{2d}
12	RV _{2c}	24	-15V

P.C.B.3: Mic. chan. 5 and crystal p.u.

Pin No.	Externally wired to:	Pin No.	Externally wired to:
1	+15V	14	0V (ground)
2	RV _{2e}	15	n.c.
3	RV _{1e} and RV _{2e} *	16	RV _{1f}
4	n.c.	17	n.c.
5	n.c.	18	RV _{1f}
6	RV _{3e}	19	RV _{3f}
7	RV _{1e}	20	n.c.
8	n.c.	21	Crystal p.u.
9	RV _{1e}	22	i/p socket
10	T _{1e}	23	RV _{1f} and RV _{2f} *
11	n.c.	24	-15V
12	RV _{2e}		
13	RV _{2f}		

*Wiping contacts.

P.C.B.4: Aux. chans. 1 and 2

Pin No.	Externally wired to:	Pin No.	Externally wired to:
1	+15V	13	RV _{2h}
2	RV _{2g}	14	0V (ground)
3	RV _{1g} and RV _{2g} *	15	n.c.
4	n.c.	16	RV _{1h}
5	n.c.	17	n.c.
6	RV _{3g}	18	RV _{1h}
7	RV _{1g}	19	RV _{3g}
8	n.c.	20	Aux. chan. 2
9	RV _{1g}	21	i/p socket
10	Aux. chan. 1	22	n.c.
11	i/p socket	23	RV _{1h} and RV _{2h} *
12	n.c.	24	-15V

P.C.B.5: Mixer

Pin No.	Externally wired to:	Pin No.	Externally wired to:
1	+15V	14	0V (ground)
2	n.c.	15	RV _{3f} *
3	RV _{3a} *	16	n.c.
4	n.c.	17	RV _{3g} *
5	RV _{3b} *	18	n.c.
6	n.c.	19	RV _{3h} *
7	RV _{3c} *	20	n.c.
8	n.c.	21	n.c.
9	RV _{3d} *	22	n.c.
10	n.c.	23	RV ₄ and S ₁
11	n.c.	24	'Out' contact
12	n.c.		
13	RV _{3e} *		

P.C.B.6: L.P. and h.p. filters and line output amplifier

Pin No.	Externally wired to:	Pin No.	Externally wired to:
1	+15V	13	n.c.
2	n.c.	14	0V (ground)
3	RV ₇	15	Junction RV ₄ -RV ₅
4	n.c.	16	n.c.
5	RV ₆ and S ₂	17	n.c.
6	'In' contact	18	n.c.
7	RV ₆ *	19	n.c.
8	n.c.	20	RV ₅ *
9	RV ₆ *	21	S ₁ 'In' contact
10	n.c.	22	n.c.
11	C ₁₃ and Line o/p socket	23	n.c.
12	S ₁ 'Lever' contact and S ₂ 'Out' contact	24	-15V

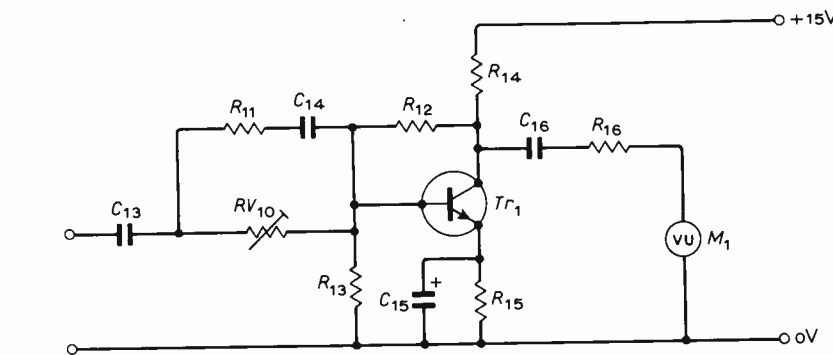

Fig. 12. V.U. meter circuit.

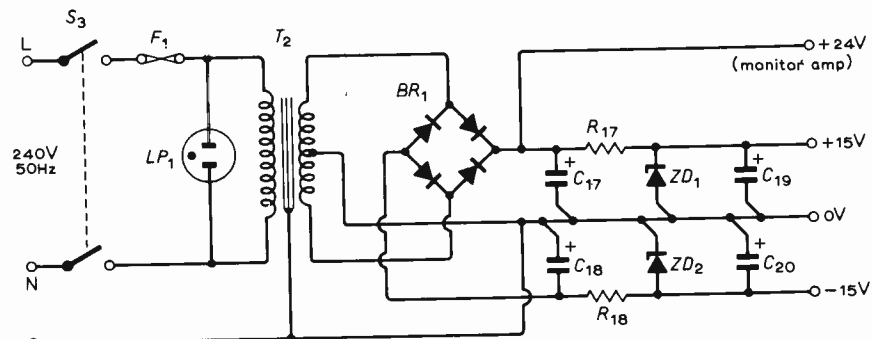

Fig. 13. Power supply.

output is used for the monitor power amplifier, the open-circuit voltage being 24V with the components used. With a continuous sinewave output, just short of clipping, in the power amplifier this unregulated output falls to about 21V, leaving an adequate margin for the operation of the resistor-zener diode stabilizer.

Since each operational amplifier typically consumes less than 2mA—the exception is the line amplifier when driving into a low load resistance—the standing current in the zener need not be high. A simple regulator of this kind seems adequate in view of the excellent rejection of line voltage variation offered by the operational amplifiers. Even on the most sensitive inputs, a total hum and noise of 60dB below the signal level was achieved.

Construction

The mixer was to be incorporated in a combined audio/video control-room console, which led to a requirement that the overall width of the mixer should not exceed about twenty inches. A standard 19in panel carrying all components was used to meet this requirement.

The controls to be accommodated at the front of this panel consisted of eight linear-motion faders, twenty rotary-motion potentiometers, two slide switches and a mains on/off switch. The VU meter, a mains fuse and a neon indicator were also required to be mounted on the front of the panel. The rear of the panel carried a sub-chassis for the power supply, brackets for the input and output sockets, monitor amplifier and input transformers, six edge connectors for the printed circuit boards and a printed circuit board for the VU meter circuit.

Such a large number of front panel components required that a compromise be made between the separation of controls, for ease of use, and the length of the wired interconnections, to reduce noise and crosstalk. The resulting front panel layout (Fig. 14), shows that the tone controls and fader for each channel are in vertical alignment and that this approach lends itself to modular construction. The common apparatus in the system is all mounted to the right of the panel, allowing the tone control and fader components for the desired number of channels to be added to the left.

The tone control and input circuit components were mounted on commercially-available printed circuit boards carrying power supply distribution tracks for the integrated circuits. Each board carries all the components for two channels and is mounted in a 24-way edge connector located between the faders. The high-pass and low-pass filter components were mounted on a single board, and the mixer components were accommodated on a separate board. These two boards were of the same type as those used for the tone control circuits and were mounted in the same manner. A printed circuit board was designed to carry all the components in the VU meter circuit so that it could be mounted directly on the pins at the rear of the meter.

The power supply and mains plug were supported on a small sub-chassis raised above the output volume controls and

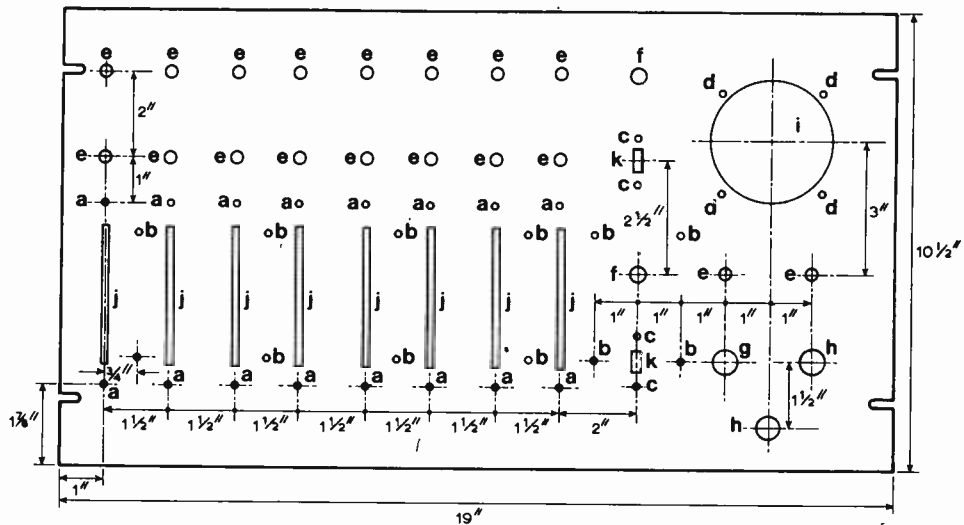

- a fixing holes (8 pairs) 6BA clear on 4 3/16" centres
- b " " (6 pairs) " " " 2 7/16" "
- c " " (2 pairs) " " " 1 1/8" "
- d four fixing holes 6BA clear on 3 1/4" dia.
- e component holes 5/16" dia.
- f " " 3/8" "
- g component hole 9/16" dia.
- h " " 1/2" "
- i " " 2 3/4" "
- j " slots 3 5/16" x 1/8"
- k " " 1/2" x 1/4"

Fig. 14. Front panel layout.

mains switch by means of pillars. The line output socket and monitor loudspeaker socket were fixed to a single bracket supported by the bolts holding the mixer and filter edge connectors. The monitor amplifier printed circuit board was fixed to the other mixer-board pillar by means of a simple bracket. The eight input sockets and five input transformers were mounted on a single bracket running along the front panel below the faders.

Most of the wired interconnections were made by means of 8-way, unscreened, twisted cable running underneath the bracket carrying the input sockets and transformers. Screened pairs were found to be unnecessary, the only screened wire being a 3-in length between the line output volume control and the high-pass filter output. The edge connectors need to be raised from the front panel by small pillars to allow a clearance for the wiring pins. The wired interconnections can easily be made by fixing the edge connectors in the inverted position during construction and then restoring them to the correct position when the work is completed.

Results

Appendix 1 gives a comprehensive picture of the behaviour of the system and should allow the individual to use whatever combination of the sub-sections is most convenient. Other amplifier/mixer circuits have been described having performance that exceeds that of the present unit. In most cases, however, the component count has been considerably higher with a corresponding increase in constructional costs. It is recognized that the component cost may not show the same advantage; this will clearly depend on the cost of the integrated circuits to the individual user. As in industrial engineering, the shortening of design time, the increased flexibility and the reduc-

tion of auxiliary components makes the case for integrated circuit operational amplifiers in audio frequency designs almost unanswerable.

Appendix 1

Performance data

Line output

NOTE: All measurements made with $R_{10} = 1k\Omega$ and $R_{10a} = 0$.

(1) *Line input auxiliary channel 1:*

Tone controls: 3 o'clock. Filters: out. Freq.: 1 kHz. Reference level: 10mW into 600Ω, i.e. +10dB.

Frequency response relative to above:

+0dB to -1dB at 5Hz and 20kHz.
 Response sensibly flat to 40kHz - 5dB
 Attenuation at 100kHz - 23dB
 Rise time 15μs.

Maximum power into 600Ω (undistorted)

> 50mW at 100Hz.
 > 50mW at 1kHz.
 ~ 40mW at 10kHz.
 Output resistance at 1kHz $\ll 1\Omega$.

Tone controls

Bass: +13.5dB } 50Hz
 -15dB }
 Treble: +13dB } 12kHz
 -15dB }

Filters

For 30dB attenuation at 10Hz and 50kHz. 3dB bandwidth is 50Hz-14kHz.

Filter cut-off frequency range

Low-pass (scratch) filter ~ 500Hz-20kHz.
 High-pass (rumble) filter ~ 10Hz- 5kHz.

Distortion

Output +10dBm into 600Ω.

(a) Frequency 1kHz: 2nd harmonic < -65dB
 3rd harmonic < -64dB
 4th and higher harmonics -not measurable.

Total harmonic distortion ~ 0.04% (including test oscillator distortion).

(b) Frequency 100Hz:

Total harmonic distortion ~ 0.04%.

- (c) Frequency 10kHz:
Total harmonic distortion ~0.18%.
- Noise At maximum sensitivity:
- (a) Input 30mV r.m.s. for 0dBm into 600Ω:
Total noise - 58dB (~0.13%).
- (b) Input >300mV r.m.s.:
Total noise <0.04%.
- (c) With all gain controls at minimum, residual noise more than 70dB below rated output.
- (2) Microphone input channel 1
- Tone controls: 3 o'clock. Filters: out.
- Reference level: 10mW into 600Ω, i.e. +10dBm.
- Frequency response: for source resistance of 200Ω:
+0dB to -3dB at 45Hz and > 20kHz.
- With bass boost ±1.5dB 20Hz-20kHz.
- Sensitivity
500μV for +10dBm into 600Ω.
- Equivalent voltage gain ~5000.
- Noise
Equivalent input noise for 20kHz bandwidth ~0.5μV r.m.s.
- Noise -60dB w.r.t. 500μV signal.
- Further reduction of 2dB by restricting bandwidth to 10 kHz.
- NOTE: Theoretical noise performance for industrial grade operational amplifier in audio range 20Hz-20kHz.
- Noise voltage ~ $5 \times 10^{-16} \text{V}^2 \text{Hz}^{-1}$.
- Noise current ~ $2 \times 10^{-26} \text{A}^2 \text{Hz}^{-1}$.
- For 20kHz bandwidth this gives:
Noise voltage ~ 3.1μV r.m.s.
- Noise current ~ 20pA r.m.s.

Optimum noise performance will be achieved when the noise contribution from current and voltage sources are equal. This occurs when the effective noise source resistance is:

$$\frac{\sim 3.1 \times 10^{-6}}{78 \times 10^{-12}} \Omega$$

$$\approx 40\text{k}\Omega.$$

With a 15:1 step-up transformer this requires a source resistance of:

$$\frac{\sim 40\text{k}\Omega}{225} \approx 178\Omega.$$

Hence, a microphone having a resistance of about 200Ω will give optimum noise performance.

Monitor output

Line input auxiliary channel 1:

Tone controls: 3 o'clock. Filters: out.
3dB bandwidth 45Hz-25kHz at 300mW into 15Ω.

n.b. For low distortion, low-frequency cut-off should be kept to ~80Hz.

Distortion

- (a) Frequency 1kHz, 0.5W into 15Ω.
Second harmonic ~0.1%
Third harmonic ~0.2%
Fourth harmonic ~0.2%
Fifth and higher harmonics <0.1%
Total harmonic distortion ~0.3%

- (b) At 100Hz and 10kHz.
Total harmonic distortion under above conditions <3%.

R_8	100kΩ	0.3W	5%	Mullard
R_{8a}	1MΩ	0.3W	5%	Mullard
R_9	10kΩ	0.3W	5%	Mullard
R_{10}	220kΩ	0.3W	5%	Mullard
R_{10a}	600Ω	0.3W	5%	Mullard
	(1.2kΩ//1.2kΩ)			
R_{11}	47kΩ	0.5W	5%	Piher
R_{12}	39kΩ	0.5W	5%	Piher
R_{13}	5.6kΩ	0.5W	5%	Piher
R_{14}	4.7kΩ	0.5W	5%	Piher
R_{15}	270Ω	0.5W	5%	Piher
R_{16}	3.6kΩ	0.5W	5%	Piher
	(2 × 1.8kΩ)			
R_{17}	270Ω	1W	10%	Morganite
R_{18}	270Ω	1W	10%	Morganite

Capacitors

$C_{1a}-C_{1e}$	10μF elect.	15V		Radiospares
C_2	0.1μF	10%		Mullard
C_3	1μF non-pol.	20%,		Radiospares
		63V		
$C_{4a}-C_{4b}$	4.7μF non-pol.	20%,		Radiospares
		63V		
$C_{5a}-C_{5h}$	47nF	10%		Mullard
$C_{6a}-C_{6h}$	47nF	10%		Mullard
$C_{7a}-C_{7h}$	10nF	10%		Mullard
$C_{8a}-C_{8h}$	10nF	10%		Mullard
C_9	1nF	2.5%		Radiospares
C_{10}	1nF	2.5%		Radiospares
C_{11}	0.1μF	10%		Mullard
C_{12}	0.1μF	10%		Mullard
C_{13}	1μF non-pol.	20%,		Radiospares
		63V		
C_{14}	150pF	2.5%		Radiospares
C_{15}	50μF elect.	15V		Radiospares
C_{16}	2.2μF non-pol.	10%		Mullard
C_{17}	2000μF elect.	25V		T.C.C.
C_{18}	2000μF elect.	25V		T.C.C.
C_{19}	500μF elect.	25V		Radiospares
C_{20}	500μF elect.	25V		Radiospares

Variable resistors

RV_{1a}				
RV_{1b}	100kΩ log.	50mW		Radiospares
RV_{2a}				
RV_{2b}	22kΩ log.	50mW		Radiospares
RV_{3a}				
RV_{3b}	10kΩ log.	0.2W		Preh
RV_4	250kΩ log.	} ganged 0.25W		Radiospares
RV_5	250kΩ log.			
RV_6	250kΩ log.	} ganged 0.25W		Radiospares
RV_7	250kΩ log.			
RV_8	100kΩ log.	50mW		Radiospares
RV_9	100kΩ log.	50mW		Radiospares
RV_{10}	22kΩ lin. preset	0.25W		Radiospares

Integrated circuits

$IC_{1a}-IC_{1e}; IC_2; IC_{3a}-IC_{3h}; IC_4; IC_5; IC_6; IC_7$;
All Signetics Type N5741V.

Transistor

Tr_1	ME4103	Micro-Electronics
--------	--------	-------------------

Transformers

$T_{1a}-T_{1e}$	U204	A.K.G., G.m.b.H.
T_2	MT112C	Douglas

Zener diodes

D_1 and D_2 ZL15 15V, 1.5W

Amplifier

A_1	EA1000	S.G.S.
-------	--------	--------

VU meter

M_1	MR65F	Shinohara
-------	-------	-----------

Bridge rectifier

B_{r1}	BS1	International Rectifier
----------	-----	-------------------------

Switches

S_1	250V, 1A Slide	Radiospares
S_2	250V, 1A Slide	Radiospares
S_3	250V, 1A	Radiospares
	d.p.d.t.	

Fuse

F_1	100mA, 20mm, ant sururge	Radiospares
-------	--------------------------	-------------

Neon indicator

LP_1	220-250V	Radiospares
--------	----------	-------------

Hardware

1 off:	Front panel 19" × 10 $\frac{3}{4}$ "	Lektrokit
6 off:	24-way edge connectors, type LK2271	McMurdo
6 off:	24-way printed circuit boards, type LK3111	Lektrokit
20 off:	Black knobs plus red pointers	Radiospares
1 off:	20mm fuse holder	Radiospares
1 off:	VU meter printed circuit board	P.C.T.
1 off:	3-way miniature mains plug	Bulgin
1 off:	3-way miniature mains socket	Bulgin

References

1. Signetics Corporation, 'High Performance Operational Amplifier Linear Integrated Circuit, Type N5741V', August 1970.
2. Quilter, P. M., 'Low Distortion Tone-Control Circuit', *Wireless World*, April 1971, pp. 199-200.
3. Walker, H. P., 'Stereo Mixer', *Wireless World*, June 1971, p. 298.

Appendix 2

Components list

Resistors

$R_{1a}-R_{1e}$	1kΩ	0.3W	5%	Mullard
$R_{2a}-R_{2e}$	100Ω	0.3W	5%	Mullard
R_3	47kΩ	0.3W	5%	Mullard
R_4	47kΩ	0.3W	5%	Mullard
$R_{5a}-R_{5h}$	10kΩ	0.5W	5%	Piher
$R_{6a}-R_{6h}$	10kΩ	0.5W	5%	Piher
$R_{7a}-R_{7h}$	22kΩ	0.5W	5%	Piher

PUBLICATION DATE

We regret the all-too-frequent delays in publication during the past year. It will be impossible for us to get back to publishing on the third Monday of the preceding month immediately. The January issue will not, therefore, appear before January 5th.

News of the Month

Finger-tip wire testing

In complex wiring harnesses it is often the case that only one end of each individual wire is connected up initially. In the past, each individual wire therefore had to be checked for continuity with a bell tester prior to the second connection being made, which meant that the identification of the wires took up a lot of time. With a wiring tester developed by Siemens and called the VD36, all this testing work has been considerably reduced. The circuit between the test object and the tester is closed by touching the free end of the wire with the finger (see photograph), which is why it is possible to speak of finger-tip identification. The hand is connected to the tester via a high-ohmic plastic-coated strap on the arm, whilst the other end of the wire being tested is joined up to the tester directly. A d.c. voltage of 25V is used

as the measuring voltage, and the total resistance is so high that it can be directly measured through the human body. The tedious and cumbersome work with test probes can therefore be dispensed with (such probes are only used where the tie-points are close together).

In the "search" mode, the number of the conductor which must be located can be preset at two rotary switches. The number of the correct wire is indicated both audibly and visually (digitally) upon being touched. In the "identification" mode, the index number of the touched wire is also indicated digitally. If several conductors run in close proximity, then several wiring ends are touched simultaneously, and should there be short-circuits between some of the wires, the display is overwritten several times. However, all the conductors involved can be identified individually by turning the switches on the tester (for

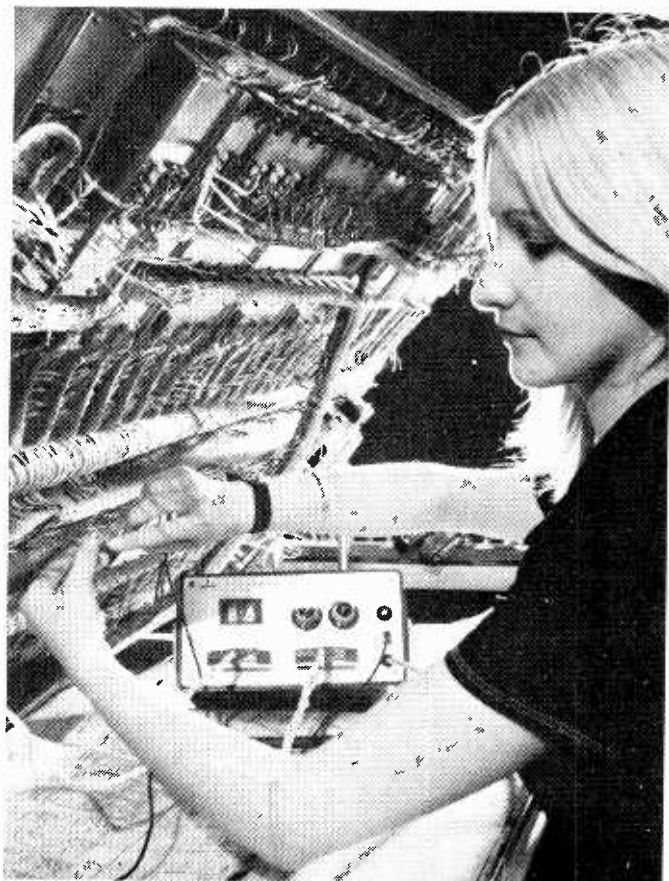

The test circuit, using the Siemens wiring tester VD36, is completed by a touch of the finger.

the ones and the tens). The VD36 wiring tester has 100 tie-points for connecting the wires as desired. The unit is particularly suitable for installation work, for testing wiring connections and for servicing, and typical fields of application include the construction of cable harnesses, the connecting of multi-pin plugs, the equipping of printed circuit boards and the wiring of equipment, cubicles and racks.

Closed-circuit TV at level crossings

British Rail, with the approval of the Department of the Environment, has introduced a system for closed-circuit television supervision of level crossings with full barriers operated from distant signal boxes. It has chosen the Rediffusion Industrial Services' h.f. closed circuit television system to view two level crossings in Chichester, Sussex.

The two Chichester crossings are to be observed from the same signal box, and the signalman will keep watch on the crossings through the c.c.t.v. Flashing red lights, initiated by the signalman, stop road traffic before the barriers descend. While they are coming down, the signalman will watch his monitor screen to ensure that no vehicles are trapped in the crossing before he clears his signal for a train to proceed. Each crossing is equipped with a 30ft pole on which are mounted two manually controlled platforms and on each of these is an RT100 camera fitted with a fixed focus lens; one platform can be moved independently of the other. There is an optical shutter to cover the camera lens when not in use so that any light reflected or directly shone into it will not damage the tube of the camera. A weatherproof housing and remotely controlled windscreen wipers, plus a thermostatically controlled heater are also provided for each camera.

In the signal box, at a distance of approximately 500 yards from the cameras, there is an 11in. monitor for each pair of cameras at the crossing. There is a third monitor on standby which can be switched into either circuit by the signalman in the event of a fault. Whenever a picture is called for, the optical shutter is automatically removed from the front of the lens thus relaying the picture to the monitor — one of the conditions laid down by the British Railways Board is that a picture must be seen on a monitor within two seconds of selection of the appropriate camera.

Visual image processing robot

A new system that is capable of automatically recognizing and selecting objects has been developed by Hitachi. The system was completed after a number of visual image processing experiments pre-

viously carried out for a robot that would assemble objects after looking at a diagram. The HIVIP (Hitachi Visual Image Processing) robot is expected to effect savings in labour by its application to production processes and distribution systems.

Devices of this type up to now have been incapable of selecting different kinds of objects that passed by in disorder on a belt conveyor. HIVIP employs a simple device that quickly recognizes the form, position, posture and size of objects, just as the human eye does, for application to automatic inspection and selection processes. A camera connected to a computer scans and picks up the image of objects flowing along a conveyor belt and determines their form after comparing with patterns filed in the computer. The system consists of a control computer, an input-output transducer of visual images, a servo control and conveyor device and a handling mechanism. The tip of the handling device can be made in various ways, but a vacuum type that sucks up the objects is used in the present system.

By simply placing an object beneath the camera and pushing a button, an image of the object is sent to the computer where it is instantly filed as a standard pattern. A total of 12 kilowords can be stored by the associated computer. Objects in any position can be recognized, at a maximum rate of one per second, by employing a rotational pattern matching method and filing possible patterns of a single object in a number of stable positions. Also if a fixed mark is placed on the surface of the objects, they can be arranged in an orderly direction.

Doubling transatlantic telephone calls

A manned midget submarine will help to lay and maintain the new £30m undersea telephone cable which is to link Britain and Canada next year. The submarine will help surface vessels to bury a 170-mile section of the new cable CANTAT 2 beneath the ocean floor on the Canadian continental shelf. CANTAT 2 will be able to carry 1,840 telephone calls at once — more than twice as many as all the other transatlantic telephone cables combined. A breakdown on a cable of this importance could have serious repercussions on the transatlantic telephone service and special measures are needed to protect it from damage and to repair it quickly if necessary.

Biggest single risk is from damage by fishing trawlers, whose gear may ensnare the cable on shallow sections. To overcome this, the British Post Office and Canadian Overseas Telecommunications Corporation, joint financiers of the project, have decided to bury the cable beneath the seabed where it crosses the

Canadian shelf. A cable-laying ship, equipped with a seabed plough will bury the cable to a depth of between 12 and 18in. but the torpedo-shaped repeaters, which are inserted at regular intervals, present a problem. The surface vessel will simply lay the repeaters on the bottom and the submarine will use powerful water jets to excavate the sand and silt to sink the repeaters and then cover them over.

The likelihood of faults developing in the cable's 473 repeaters is remote, as the 4,800 transistors used have a design life of 25 years.

Minicomputer uses emitter coupled logic

A very high speed e.c.l. central processor has been applied by Motorola Semiconductors Europe to an experimental minicomputer demonstrating the potential improvement in performance obtained by using e.c.l. For some time now the performance of minicomputers has remained constant while the price has continued to fall. A very high speed central processor coupled to n.m.o.s. semi-conductor stores could be extremely powerful and might have a minimum storage capacity of 32k words (against 4k) rising to a maximum of 256k words. It is stressed that Motorola have no intention of manufacturing computers. The exercise was carried out to assess the feasibility of constructing a high-speed processor using MECL10,000 series m.s.i. logic. The demonstration minicomputer employs a 16 bit word length with a microcontrol word length of up to 56 bits. Arithmetic is carried out in two's complement form, the execution time being typically 100ns. logical operations are carried out in typically 66ns.

Radiotelephone service

A new radiotelephone service offering message handling facilities to its subscribers has been launched under the name Mobilefone. This service, which operates in the Greater London area, caters for third party users who need to maintain a contact, especially when in their cars. Pye Telecommunications has supplied the system and the control centre is based at Mobilefone's headquarters at Barnet, Hertfordshire. Using Post Office land lines, this centre controls radiotelephone transmitters at Highgate and Hampstead in north London and Crystal Palace in the south.

The Pye Mascot controller was selected for the radio operators at Barnet. Each operator also has an encoder/decoder and a visual display unit to operate the selective calling, vehicle identification and status facilities which Mobilefone is using. Selective calling means that the mobile is silent until it receives its specific code so the subscriber does not have to listen to unwanted chatter on the radio channel.

This system allows for up to 960 codes — one per mobile.

Coded signals are also used to provide the headquarters with the number, and therefore identity, of every caller immediately he begins to transmit. This is shown automatically on a visual display. Status number "0" means "I can receive your message/I want to pass a message", status "1" means "I am at home", status 2 "I am at the office" and so on.

Large-screen TV projector

General Electric of America has announced its intention to build large-screen monochrome video projectors to operate on various scan-rate raster systems up to 1,023 lines, providing extremely high resolution pictures for closed circuit application. The projector consists of a projection head assembly with integral pan and tilt adjustments, and an electronics assembly in the supporting base. The head contains a sealed beam Xenon lamp, the sealed light valve and the projection lens. Another new monochrome video projector designed to meet European standards can provide a TV picture from 2 to 20ft wide via either front or rear screen projection methods. It is designed to operate on a wideband video signal with either composite or external sync at the rate of 625 lines/50 fields per second.

Safety in ship-to-shore communication

Development of an electronic system that could provide all the position-locating, identification and communications functions necessary for ships to navigate in increasingly congested harbours and inland waterways has been disclosed recently by RCA. The system permits ship-to-shore, shore-to-ship and ship-to-ship position-locating, identification and digital communications. It could thus significantly improve safety and even reduce environmental pollution by preventing collisions and groundings that often occur in near-shore areas.

The system, which employs an inexpensive interrogator/transponder at shore stations and aboard ship, is called HATRIC for Harbour Traffic Ranging Identification and Communication. Any equipped vessel or shore station would send and receive replies to all other units in the area using a common signal format. A ship in line of sight of two shore stations could obtain the stations' identity, determine precisely its own position by trilateration and receive digital messages. Conversely, shore stations could obtain the same information from each ship.

Data received by shore stations would be fed through telephone lines to a traffic control centre where it would be processed and each ship's position and identity plotted and displayed on the

centre's charts. Thus the centre would have precise, up-to-date information on every vessel in the area. The exchange of signals would also enable a ship equipped with the system to determine the position and identity of all other similarly equipped ships in the area.

Light interface technology

A U.S. Naval research report gives a comprehensive state of the art review of improvements in light interface technology, L.I.T., as a data transmission system. The feasibility of transmitting information through fibre optics has been established. It gives advantages over conventional wired systems, particularly as the increasing use of digital as opposed to analogue signals tends to add to the complexity of interface systems. It also facilitates the integration of subsystems into a complete system involving complex interconnections which can be restricted by current wiring techniques.

Work has been done which establishes a baseline model for L.I.T. link design and surveys have been made of fibre optic guide characteristics. Loss mechanisms of coupling into and out of fibre bundles and the scope of space division multiplexing, which involves the coding of various signals by means of their spatial locations at the entrance and exit of a fibre optic bundle, have been investigated. The model establishes important signal parameters (e.g. signal level, rise time, delay and signal-to-noise ratio) as a function of the independent variables associated with the link (fibre length, light emitting diode and photodiode circuit rise times, and light emitting diode drive current). This information can be used to design a link for a particular application, or to determine the capabilities of a particular configuration of the link. The four major areas of the L.I.T. link are: light emitting diodes, fibre optic light guides, fibre optic/diode interfaces and photodiodes. Further information is contained in U.S. report NR 215-166 reference AD733076. "Light Interface Technology Improvement Investigation", by R.C. Clapper et al. September 1971. 138pp available from Techlink Unit, Technology Reports Centre, Orpington, Kent BR5 3RF, as either microfiche (a film negative) price 20p or reproduced paper copy, price £2.60 including postage. Remittances, payable to Department of Trade & Industry, should accompany orders.

U.S.A. electronics exhibitions

Following on the success of British participation at this year's WESCON, the electronics show and convention held annually in California, and the prediction of a 17% increase in capital spending in the U.S. electronics industry during 1973, the Electronic Engineering Association



Research scientists from Zenith Radio demonstrated and presented a technical paper about a newly developed thin-panel television display employing the gas discharge principle. The demonstration, showing an experimental version of the panel, took place at the I.E.E.E. conference on display devices in New York on 11th October. On the left, a 25in diagonal standard colour TV picture has been masked and the brightness and contrast turned down to display and match the same area shown on the new flat panel display. Since the current version of the thin panel produces a red picture, the TV picture was filtered to the same shade of red. The thin-panel picture has 80 columns and 212 rows of gas cells. This produced a picture 2.4in wide by 6.3in high with the same resolution as the visible part of the colour TV set. The panel is only 0.63in thick.

is to sponsor three joint industry/Department of Trade and Industry ventures in the coming year. These are the I.E.E.E. '73 Intercon, N.A.B. '73 and I.C.A. '73.

The I.E.E.E. '73 Intercon exhibition and associated convention will again be held in New York from 26th to 29th March. E.E.A. will organize and co-ordinate the joint venture.

E.E.A. will also sponsor and run the U.K. participation at the N.A.B. '73 convention and exhibition in Washington, D.C., 25-28th March 1973, which will cover all equipment and services required by TV and sound broadcasting stations. Another E.E.A. sponsorship (13th to 17th May) will be the U.K. contingent to the 26th annual conference and exhibition in Boston of the International Communications Association.

Statistics for sound reproducing equipment

A new statutory quarterly inquiry into the sales of the broadcast receiving and sound reproducing equipment industry, designed to provide up-to-date statistical information to the industry as well as to the Government, has been launched by the Business Statistics Office. The product headings on the inquiry form have been compiled after consultation between the Department of Trade and Industry and the British Radio Equipment Manufactur-

ers' Association. A similar inquiry into the sales of the disc and tape recording industry is to be launched. Forms will be sent to establishments in the specified sections of industry employing 25 people or more. The first return covers the third quarter of 1972 and will replace the existing monthly inquiry into gramophone records. Results of the inquiries will be published in the quarterly Business Monitor series available from H. M. Stationery Office.

British study courses through the I.E.E.E.

In a move designed to strengthen a growing educational bond between the I.E.E.E. in America and the I.E.E. in Great Britain, agreement has been reached to offer specially developed individual study courses of the I.E.E. to the electrical/electronics engineering community in the U.S. by the I.E.E.E. At first, four courses will be available: "Field Effect Transistors", "Pulse Code Modulation", "Digital Instrumentation", and "Modern Control Theory". In April 1973 a fifth course "Colour Television" will be available.

The courses aim to provide an engineer who qualified between five and twenty years ago with opportunities to bring himself up-to-date in post-graduate specialist subjects in electrical, electronic and control engineering.

Electronica '72

This year's Electronica exhibition, held from November 23rd to 29th at the Munich trade fair grounds, was not only impressive from the point of view of sheer physical size but also in the number of visitors attending. In the first four days, 32,000 people representing over 500 nations passed through the turnstiles — an increase of 20% on the previous Electronica exhibition held in 1970. There were more than 1,600 exhibitors spread over 20 halls and the variety of components and electronic assemblies shown represented all aspects of the industry. Apart from the Continental companies which occupied the largest part of the exhibition, there was a very strong British contingent centred in two of the halls, and one of approximately equal size from the U.S.A.

General impressions obtained from a cross-section of exhibitors during the first three days were that trade was good and several British stands reported securing important new contracts.

Of revolutionary new products, few were in evidence at the exhibition, although it was obvious that many recent ideas have now taken commercial form. Typical of this category were liquid crystal displays, which have long been talked about but were presented in a practical form by Electrovac of Vienna who were demonstrating two versions of seven segment numeric arrays. The two versions permit the use of incident (reflected) illumination or internal transmitted light. It was obvious that in the form shown they are significantly better for large displays than the more expensive l.e.d. units. An example of the use of gallium phosphide green emitting diodes was shown in the *Wireless World* calculator on one of the Ferranti stands, where it was claimed that the use of a diffused epitaxial structure produced considerable increases in brilliance over other forms of green emitting diodes. Showing the way in which space technology produced a "spin-off" into earth bound industry, Radiall GmbH displayed a dummy of the French satellite "Diapason", first launched in February 1966 and which operated until January '72, to demonstrate their range of u.h.f. connectors.

A symposium was held concurrent with the last three days of the exhibition, at which leading engineers described new technologies being developed and how production problems were being overcome in the current generation of products. Predominant among the subjects discussed were those relating to m.o.s. techniques and their application in integrated circuits.

Electronic push-button dialling

Pye TMC have applied the concept of m.o.s./l.s.i. integrated circuits to a commercially viable push-button telephone dialling system known as the repertory call unit. The unit, which will be in

production during 1973, can be added to or substituted for the standard rotary dial of a telephone. It contains a memory for ten numbers of up to 18 digits, which can be individually repeated by pressing two buttons. A "try again" facility is also provided, so that the last number manually keyed is always remembered after the handset has been replaced. The Repertory call unit is based on m.o.s./l.s.i. circuit techniques, which replace the standard electromechanical operation. The advantages, apart from ease and accuracy of operation, are 1/1,000th the necessary operating power and a reduction in production cost.

Announcements

The Institution of Electrical Engineers is to hold a **Vacation School** on modern practice in r.f. and microwave measurements at the University of Surrey, Guildford, from Sunday 9th to Friday 21st September 1973. Enquiries should be addressed to The Secretary, I.E.E., Savoy Place, London WC2R 0BL.

The Electrical Research Association has recently made an arrangement with SEMKO (Svenska Eletriska Materielkontrollanstalten) of Sweden under which the E.R.A. Approved Test House can carry out the SEMKO **safety tests** for British electronic component manufacturers. Until now components have had to be sent to Sweden for test. E.R.A. is also now in a position to carry out for British component manufacturers on behalf of the Swedish Military Laboratories (FTL) all those tests to FTL specifications which are necessary on components for use in Swedish military equipment.

A mixed committee has been set up on the initiative of the Chartered Institute of Patent Agents to review the profession of Patent Agency, and particularly to consider qualifications and abilities patent agents should have to enable them to meet adequately the professional needs of inventors and industry generally.

Lennard Developments Ltd, 206 Chase Side, Enfield, Middlesex EN2 0QX, have notified us they intend to discontinue the trademark on the "Miniflux" range of products manufactured by Tech-Phys.Lab.Dipl-Ing. B. Woelke, Munich. In addition the name of this company has now been simplified to Woelke Magnetbandtechnik.

Welwyn Electric Ltd announce that they have relinquished their exclusive U.K. marketing licence for Vishay trimmer potentiometers known as the Welwyn type 1202 series. They point out however that they will remain the exclusive manufacturers and marketing source for other **Vishay products**. Enquiries for the Vishay Trimmer potentiometers should be addressed to Vishay Resistor Products U.K., Haywood House, 64 High Street, Pinner, Middx.

The R.E.C.M.F. announces the formation of a **Printed Circuit Manufacturers Group**. The inaugural meeting of the Group was held on 9th November when the officers were elected. Chairman Mr P. A. Trigg (Technograph & Telegraph Ltd) and vice-chairman Mr. C. M. Amies (Exacta Circuits Ltd). The Group's secretary is Mr. P. Costley (Deputy-Secretary, R. E. C. M. F.)

Suivicon Ltd, Hagley House, Hagley Road, Birmingham B16 8QW, has been appointed the exclusive U.K. agent for the **Voltronics Corporation**, of East Hanover, New Jersey. The new product range available is mainly precision concentric ring air trimmer capacitors for the telecommunications industry. Suivicon is a subsidiary of Steatite Insulations Ltd.

GTE Sylvania Incorporated, a subsidiary of General Telephone & Electronics, and their U.K. agents FieldTech Ltd, of London Airport, announce the receipt of a large order from Hawker Siddeley Ltd, the British aircraft manufacturer of the U.S. Marine Corps V/STOL Harrier. The order is for **airborne transmitter/receivers** for the new Hawker Siddeley 1182 jet trainer of which 175 have been ordered by the Royal Air Force.

Best Electronics (Slough) Ltd, Michaelmas House, Salt Hill, Bath Road, Slough, Bucks, have been established as a subsidiary of GDS (Sales) Ltd to provide a specialist consumer products service for Motorola, ITT, Weller, Adcola and a variety of other components and accessories.

Colour Video Transfers, St. Annes-on-Sea, Lancs, has installed a broadcast quality colour telecine "suite" for the purpose of transferring film and slides of all gauges to video-tape for the Philips video cassette recorders.

The agreement between Guest International Ltd, Nicholas House, Brigstock Road, Thornton Heath, Surrey CR4 7JA, and A.B. Bofors Electronics was terminated on an amicable arrangement on the 26th September 1972. All existing orders placed before that date will be honoured by Guest International. Subsequent orders will be handled by A.B. Bofors Electronics (U.K.) Ltd, 3 Boltro Road, Haywards Heath, Sussex. Guest International are to move by March 1973 to new premises at Redlands, Coulsdon, Surrey CR3 2HT.

Hisonic Ltd, of Tovil, Maidstone, ME15 6QP, have been appointed U.K. distributors of audio equipment made by **Braun AG**, of West Germany. The selection of Braun equipment to be handled initially includes the Cockpit 260 stereo compact, Regie 510 tuner-amplifier, CES1020 tuner-preamplifier, PS500 turntable, TG1000 tape recorder together with various loudspeaker enclosures.

Acoustic Research International of High Street, Houghton Regis, Beds., have advised us that their associates Tedelny Audio Products have been appointed sole U.K. distributors for the stereo headphones made by **Superex Inc.**, of New York.

Martron Associates, Station Road, Marlow, Bucks, is entering the **instrument hire** business. A subsidiary company has been formed, titled Techrent, which will start operating in January 1973. Yokagawa u.v., XY and lab recorders, with digital equipment such as wattmeters, and Williamson infra red temperature measurement instruments will be the main product lines.

Edmundsons Electronics Ltd., 30-50 Ossory Road, London SE1 5AN, distributors of electronic components have been appointed stockists for the Astralux range of reed relays.

GEC Telecommunications Ltd., P.O. Box 53, Coventry CV3 1HJ, is to supply **microwave equipment** worth \$3M to MCI Communications Corporation of U.S.A. for part of a new nationwide communications network in the U.S.A.

Fane Acoustics Ltd, loudspeaker manufacturers, has set up new headquarters in Bradford Road, Batley, Yorkshire.

The **Sanders Division** of Marconi Instruments, St. Albans, Herts, is offering British Calibration Service certificates with its 6049 range of direct-reading frequency meters.

Empresa Nacional de Minería in Chile are to be equipped with comprehensive radio systems supplied by **Racal Communications Ltd**. The order, worth over £100,000, was placed by Head Wrightson Process Engineering Limited as part of a major project they have in hand for ENAMI.

Letters to the Editor

The Editor does not necessarily endorse opinions expressed by his correspondents

Tree effects in TV reception

Like Mr Scroggie (Oct. issue, p. 478) I am on the wrong side of a tree-fringed hill (in my case a deep valley between two ridges) and can confirm his findings that satisfactory reception at u.h.f. is possible only during the six months when the branches are bare.

Absorption by leaves is mentioned by Englund, Crawford and Mumford *et al.* in *Proc. I.R.E.* 1933 *et seq* and has to be lived with on Bands IV and V by people like myself whose only reliable all-the-year-round service comes from Band I stations, the lower frequencies of which are less absorbed and also give deeper penetration of diffracted energy at steeper angles into the geometric shadow. And here may I interpolate a plea to the B.B.C. to keep their 405-line service going until the transmitters rot away, or at least until the Minister of Posts and Telecommunications authorizes the piping of TV over my telephone line as has been successfully tried in Holland and probably in other civilized countries.

My contribution to this discussion is to suggest that some of the perturbations Mr Scroggie observes are more likely to be due in windy weather to turbulence in the boundary layers between air masses of different humidity and temperature (therefore of refractive index) than to movement of the trees. Much will depend upon the distances of the receiver from the trees and from the transmitter, in my case approximately 1000 ft and 40 miles respectively. From observations extending over many seasons I am convinced that bad reception does not correlate with the local wind and tree movement but originates further afield, possibly in air turbulence over the top of the Downs when receiving Rowridge.

Leaf absorption in my case operates in quite a different way and relates to the trees in the bottom of the valley rather than to those on the ridge. When I came to live at this site it was soon apparent that Yagis and other directional aerials depending for their gain on the plane progressive waves of the textbooks just didn't work. Further, that an aerial sited traditionally on the cottage chimney was not going to give any picture at all of BBC-2. The reason is that the feeble signal filtering over the ridge by diffraction rattles about in the bottom of the valley, producing ferociously complex standing-

wave patterns rather like those experienced at sea after several changes of wind direction, with anomalous and frequently enormous crests at unexpected times and places. A little judicious probing with a simple dipole on a bamboo rod provides a wide choice of minima and maxima though not all the latter are usable, some being a little too 'multipath' for clarity. One can have fun with a wire mesh ground plane spaced $\lambda/4$ from the dipole to observe the general confusion, but this usually suppresses more input than it collects and must be removed for general programme viewing.

So my problem during the summer is loss of energy normally conserved by reverberation. How green and anechoic is my valley! F. L. Devereux, Hindhead, Surrey.

Whilst it is well known that u.h.f., v.h.f., and even h.f. radio signals are attenuated by trees in leaf, I wonder if the more random effects upon Mr Scroggie's colour TV receiver during windy conditions are wholly due to tree movement?

Amateur radio mobile operators are cursed with signal flutter, especially on the 2-metre band.

Mr Scroggie mentions that $\lambda/2$ is about 20cm. Could it be that his 16-element array moves a comparable amount in windy conditions, thus altering the path length? This possibility could be tried out in still conditions by wobbling the mast somehow and monitoring the effect, if any, upon the receiver.

This could account for the sharply defined ghosts since the a.g.c. would tend to open up the front end of the set when the direct path signal strength dropped, allowing the ghost path signals to become more clearly visible.

I would imagine that the ghosts are there all the time but that they become more objectionable in windy conditions coupled with summer foliage attenuation.

Regarding the virtual absence of these effects upon BBC-1 and IBA, I wonder how the received signal strengths compare with BBC-2?

N. A. S. Fitch (G3FPK), Purley, Surrey.

Op-amp pre-amp

I was interested to read Mr Meyer's article in the July *Wireless World* which confirmed my own views on distortion and noise performance of conventional discrete and integrated circuit pre-amplifier designs. I have tried to combine the low noise of a discrete design with the simplicity and high open-loop gain of an integrated circuit design in the circuit shown in the diagram. The operational amplifier used is the 741 which is readily available at about 38p. A 1nF capacitor between the inputs may be needed for stability. The transistors used were 2N3708 which happened to be available and could probably easily be improved on. The noise performance is slightly better than a virtual earth circuit using BC109s and

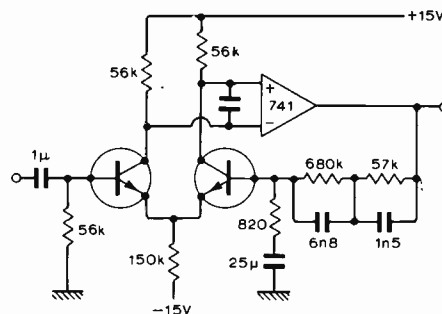

is vastly better than a circuit using just an operational amplifier. The available output swing is, of course, large, and the output impedance is low so that the circuit could probably drive headphones directly.

D. R. S. Hedgeland, Selwyn College, Cambridge.

Desk calculator construction

I discovered a faulty component when I had reached the stage of construction of your calculator kit which involved checking the voltage lines. A phone call to Advance Electronics produced a return call from their Service Department to confirm the nature of the fault and the promise of a replacement component under warranty. The component arrived by post in a couple of days and I was able to complete the construction of the calculator which now functions perfectly.

Such good service and courtesy deserve some recognition, and I hope you may find it possible to print this letter.

D. H. Meech, Bristol.

Low-noise audio amplifiers

In his article 'Low-noise Audio Amplifiers' in the May 1972 issue H. P. Walker indicated that a lower noise figure could be obtained from a series voltage fed-back amplifier than from a parallel current fed-back one. Since this result is contrary to the fact that an amplifier's noise figure is independent of the feedback configuration, with the usual provisos, some investigation seemed called for.

On inspection of Mr Walker's Fig. 1, it is obvious that the two circuits are not treated equally. If we remove all the noise-performance-degrading resistors, the equations for the two connections do in fact become the same, i.e.

$$\frac{V_o}{V_n} = \frac{V(f)}{\left[4kT\Delta f \left(\frac{|Z(jf)|^2}{R_{ni}} + R_{nv} + R(f) \right) \right]^{1/2}}$$

where R_{nv} and R_{ni} are the series and parallel noise resistances of the amplifier. With an ideal (noiseless) amplifier and $R(f) = 500\Omega$, this gives a weighted equivalent input noise of $0.26\mu\text{V r.m.s.}$, 78dB below 2mV r.m.s.

It is instructive to note that adding a $50\text{k}\Omega$ resistor in parallel with the input to our ideal amplifier results in a minimum 8dB noise figure (with a 0.6H, 500Ω cartridge). From this, it is obvious that the parallel feedback case, provided the series resistance is omitted, can in fact give an 8dB improvement in noise figure over the more usually used series feedback connection, as the parallel resistor is no longer necessary.

I. Buckner,
University of Reading.

The author replies

Mr Buckner is correct when he points out that I treated the two circuits differently; in the series circuit I decreased R_{ni} by shunting the input with R_{in} and in the shunt circuit I effectively increased R_{nv} by placing R_{in} in series with the input. Thus the optimum source impedance, $Z(jf)$, being a function of R_{ni} and R_{nv} , is low for the series circuit (voltage drive, $Z_s < R_{in}$), and high for the shunt circuit (current-source conditions, $Z_s > R_{in}$), if we neglect transistor noise for the moment.

The noise figures of the two circuits are the same at the point where the feedback is applied, i.e. at the input of the amplifier block itself, provided the source impedances are the same which of course is not the case since in one instance R_{in} shunts the source whereas in the other it is in series with it. I considered R_{in} as an essential part of the input network since I wished to differentiate between noise attributable to the circuit configuration and that due to active devices.

One can argue that the specified input resistance, required for terminating the cartridge, tape-head, microphone, etc., should be established by feedback, as Mr Buckner is suggesting in the last paragraph of his letter. Incidentally, this is equally true for either the shunt circuit or the series circuit. In either case, we cannot rely on the open loop gain of the amplifier, and, furthermore, if it is frequency dependent, the input impedance becomes partially reactive ($Z_{in} = R_f/A_v(jf)$ for the shunt circuit). The solution is to define the voltage gain with series feedback and the input impedance with shunt feedback, as I suggested in a footnote on page 234 of my article ($Z_{in} = V_{f.b.}/I_{f.b.}$). There are some practical problems however, particularly when a frequency-dependent feedback loop is required (e.g. R.I.A.A.) in which case this must be carried out in a later amplifier or the network duplicated for the two feedback paths. These techniques

may be applicable in professional equipment or when several similar inputs (e.g. pickups) can be mixed into a common equalizing amplifier, but usually, because of economic considerations, the input resistance is defined simply by a physical resistor although this compromises the noise performance.

It was with this limitation in mind that I described the optimum conditions for the two circuits, which can perhaps be demonstrated more elegantly and with greater insight by using Mr Buckner's equation.
H. P. Walker.

Graphical analysis of pulses on lines

The article by B. L. Hart on the above subject in the September issue usefully drew attention to a valuable technique. However, although he notes a number of references there are a couple of others which are well worth recording and which perhaps are more easily constructed.

Both the methods to be mentioned are based on the fundamental transmission line equations:

$$V_x = A \cdot e^{-Px} + B \cdot e^{+Px}$$

$$I_x Z_o = A \cdot e^{-Px} - B \cdot e^{+Px}$$

which refer to the voltage and current at a point x along the line, P the propagation constant and Z_o the characteristic impedance. As Mr Hart mentions P is imaginary (lossless) and Z_o real in the graphical solutions. A and B are the equation solutions which are determined by the loads either end of the line, but will be non-linear if the loads are non-linear.

One method described very fully by Arlett and Murray-Shelley¹ has also been extended so that it can be run on a digital computer and accommodates non-linear loads and line discontinuities.

The second method² is perhaps less well known and merits a short description here. It is based on the solution of the above equations which end up as an expansion because of the many possible reflections at the source and load terminations.

A simple example can be used to describe the method. Consider the system shown in Fig. 1. $R_s = 25\Omega$, $R_o = 50\Omega$ and $R_L = o/c$. The response to a 6V step waveform at time $t = 0$ is shown in Fig. 2. This was derived from the Fig. 3 construction as follows:

- (1) Select a voltage and current scale so that V_s is accommodated and the transmission line conductance is a 45° line.
- (2) Construct the sending end conductance (negatively) so that its point of origin on the voltage axis corresponds to the source voltage step V_s .
- (3) Construct the receiving load conductance R_L normally.
- (4) Add the transmission line conductance. This will intersect the sending end conductance at the input voltage $V_o^{(0)}$, that is, the voltage value before it is sent down the line.

Now proceed as follows:

At right angles to the transmission line and through the last point draw a line, shown dashed, until it intersects the re-

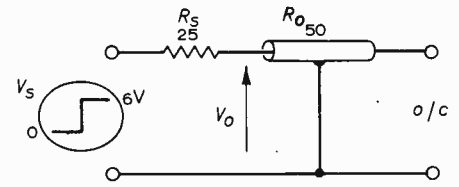

Fig. 1.

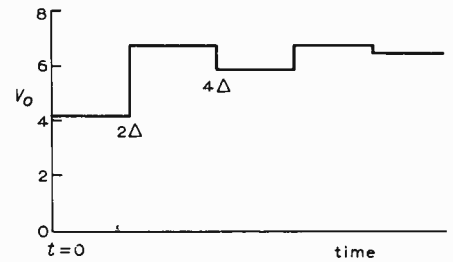

Fig. 2.

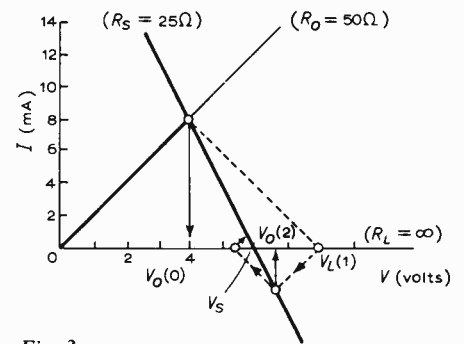

Fig. 3.

ceiving end line. This intersection point represents the voltage and current at the load at a time $t = \Delta$, where Δ is the propagation delay of the line. A perpendicular line is drawn from this point until it again intersects the sending end line. This new intersection represents the voltage and current at the sending end at the time $t = 2\Delta$. The process is continued until the dashed line converges to a point.

Note that when the source resistance = R_o , then only one construction is possible, namely the converging point occurs where the conductance lines R_s and R_L intersect, which is as expected since there is no subsequent reflection from the source if such a match is arranged.

For non-linear loads the programme of construction is the same, except now the load is non-linear and its V/I characteristic is available. Again the constructed lines correspond successively to propagation forward and backward along the line.

References

1. P. L. Arlett and R. Murray-Shelley, 'The teaching of travelling wave techniques using an improved graphical method', *Ins. J. Elect. Eng. Educ.*, Vol. 3, 1965, and Vol. 4, 1966.
2. R. S. Singleton, 'No need to juggle equations to find reflections—just draw three lines', *Electronics*, 28th October, 1968.

R. C. V. Macario,
University College of Swansea.

The author replies

I would like to thank Dr Macario for pointing out two further references which relate to the subject matter of my article.

Before dealing with the construction he cites and gives, I would like to make a brief general comment. To describe a step-by-step (or 'cook-book') procedure for obtaining reflection behaviour necessitates only a few paragraphs. However, the enquiring mind might, and often does, ask 'why?'. The main aim of the article was to give (as far as possible) a non-mathematical validation for the procedure. To this end the 'sliding Thévenin source' concept was introduced and developed.

With regard to the construction offered by Dr Macario; there is, in fact, no fundamental difference between it and the one I described. It is, basically, a question of whether I is plotted vertically and V horizontally (as he shows) or vice-versa, as in my article. To give a simple theoretical validation for his construction all one need do is to use the Thévenin-Norton transformation. Thus the sliding current source shown in Fig. 1, here, is equivalent to, and should be compared with, Fig. 8 of my article, to which it is correspondingly labelled.

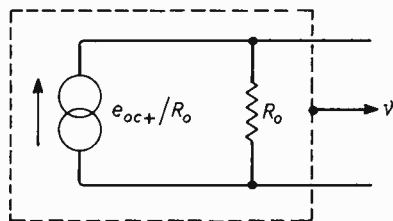

Fig. 1. Illustrating the sliding current source concept for the forward wave.

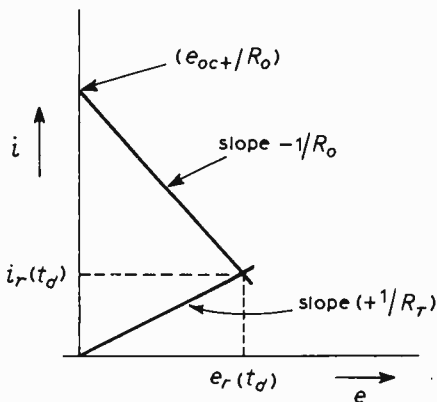

Fig. 2. Line conditions at the termination at $t = t_d$.

Fig. 2 corresponds to Fig. 10 in my article. Obviously, as previously, $e_T(t_d) = e_{oc+} R_T / (R_T + R_0)$. Personally, I find the voltage source representation somewhat simpler from a conceptual viewpoint; others may find the current source description easier. There is certainly no difference in the amount of graphical work to be done. The 'new' element in the construction which Dr Macario quotes is that of drawing the 'Bergeron lines' at right angles. This results from a convenient choice of scales for our axes and is an obvious economy in drawing effort—and thus to be recommended—if the choice of scales is at our disposal (it isn't always). The method obviously applies, with equal validity, to the graphical approach I described.

B. L. Hart.

Self-biasing class A power amplifier

When applied to class A power amplifiers the sensitivity to drift in conventional biasing circuitry becomes alarmingly apparent. This is particularly noticeable during the initial setting up of the quiescent current which is made notoriously delicate and tedious by the large thermal drifts in the output transistors before they achieve thermal equilibrium.

The solution to this problem is clearly to find some simple automatic biasing circuit. In *Wireless World* of March 1970 Nelson-Jones considered the problem, the difficulty involved in designing such a circuit being that of how to prevent the system turning itself off as soon as a signal is applied and signal currents begin flowing in the output transistors. His solution involved filtering the signal components from the output current before applying feedback to control this current. While this technique works well at higher frequencies there exists the possibility of severe intermodulation distortion when the signal contains low frequency components that are not adequately filtered before feedback. In the submitted circuit the class-A amplifier's inherent linearity is taken advantage of and the configuration described below is applicable from d.c. upwards in frequency.

With reference to Fig. 1, it can be seen that the circuit is a straightforward quasi-complementary output stage, the only additional components being transistors Tr_1 and Tr_2 and resistors R_1 and R_2 . (Current values indicated in the diagram are typical for an amplifier providing approximately 10W into 8Ω .) Operation of the circuit is best understood by first considering the quiescent state. Here the current through Tr_3 and Tr_4 increases until such time that it produces a sufficiently large potential difference across resistors R_1 and R_2 to turn on transistors Tr_1 and Tr_2 . Any further increase in the output current turns these transistors on harder with the result that the driver transistors are starved of base current. This in turn tends to turn off the output transistors and the current through these transistors is therefore stabilized.

When an input signal is applied so as to send the output positive, Tr_3 passes a greater current and hence the potential difference across R_1 increases. However, class-A operation is such that while the current through Tr_3 is required to increase, that through Tr_4 suffers a corresponding decrease and hence the voltage across R_2 drops. The net result is that the total voltage drop across $R_1 + R_2$ is constant under all drive conditions. As it is this voltage that controls the biasing of the output stage no filtering is required.

Ideally R_1 and R_2 are equal. However the percentage open loop distortion introduced by an inequality in these resistors is $(\Delta R/R) \times 100$ where ΔR is the inequality and thus the required open loop gain to reduce this distortion to the desired closed loop value can be determined. 10% tolerance resistors were used in the prototype, these being readily available.

Capacitor C is optional but is introduced

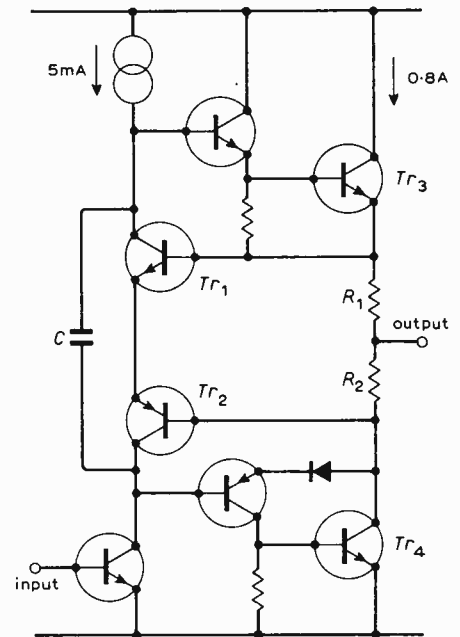

Fig. 1.

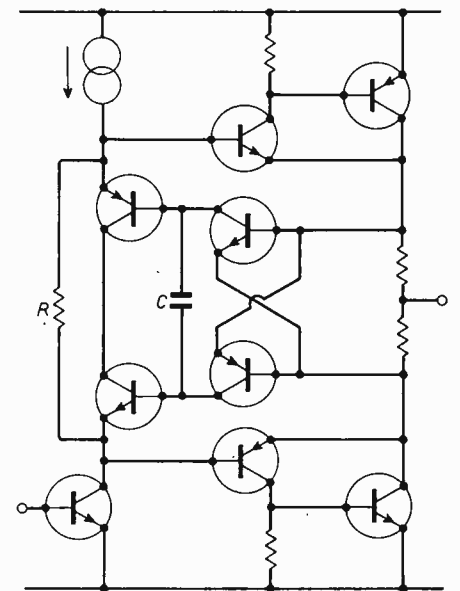

Fig. 2.

as it removes any possibility of high frequency instability; a value of approximately $0.1\mu F$ is suitable.

Should efficiency or power supply voltage be at a premium the more extravagant circuit of Fig. 2 offers better performance in these respects. Here the quasi-complementary output stage is discarded in favour of a fully complementary one and the values of R_1 and R_2 are halved from those in Fig. 1. With this arrangement the output voltage can swing within a little over 1 volt of either rail. In this circuit values of $10nF$ for C and $10k\Omega$ for R were found to improve the performance though these values were by no means critical.

The configuration is such that in both circuits the output transistors are instantaneously protected from short circuits as in theory under no circumstances can the power dissipated in both output transistors exceed that under quiescent conditions.

W. Allison,
University College,
London.

Circards 3

Waveform Generators

Introducing the third set of Circards

by J. Carruthers, J. H. Evans, J. Kingler and P. Williams*

As electronics is largely concerned with the generation and processing of electrical signals, the subject of this article could include half of all known circuits. It will be easiest first to exclude certain well-defined classes of generator to be dealt with in later series. For example sine waves are perhaps the most commonly generated waveforms, and the great variety of such circuits warrants separate treatment. Similarly, pulse waveforms have ever-widening applications in communication and digital systems and correspondingly numerous circuits have been published. There remain a number of well-defined waveforms of general usefulness, sufficiently important to qualify for a series to themselves. They include triangle, ramp (linear and exponential), staircase and trapezium waveforms, together with others that are conveniently generated from them. For example, an excellent means of generating a triangular wave requires the repetitive reversal of bias to an integrator by a Schmitt trigger, the output of which is thus a square wave. Where it is possible to modify an existing waveform simply, to provide an approximation to some other desired function, the method is indicated below. It is not possible within the confines of a short article or single set of Circards to do more than outline such methods.

The majority of these generators depend on the charging of a capacitor, though dual circuits using inductors may be devised. To provide a repetitive waveform, the direction of charge flow has to be periodically reversed, and this leads to a major subdivision. The reversal may be such that the charge-rate is comparable for the two directions, in which case the capacitor waveform belongs to the triangular class. If the charge rates differ markedly the waveform approximates to a saw-tooth. In either case the charge rate may be constant or may vary during a half-cycle.

If charge is passed into the capacitor in discrete quantities at regular intervals, then a third type of waveform, the staircase waveform, Fig. 5, is produced. Digital waveform generators using digital-to-analogue (or d/a) converters can also produce stepped waveforms, the staircase being a particular version. If the steps are small enough and sufficient in number then waveforms can

be synthesized to any required accuracy and the cost of such generators continues to fall with the increasing range of digital circuits of low cost. To remove the steps from the output is not possible but the use of suitable filters, such as those of series 1 Circards, can reduce the ripple at the step frequency without seriously distorting the synthesized waveform. A particular advantage of the d/a converter method is that no reactive elements are employed as the output frequency is defined exactly by the clock frequency and the division ratio of the counter used.

Ramp and sawtooth generators

In ramp generators a capacitor receives a defined current, constant if the ramp is to be linear. If the current flows for a period determined by some external agency the ramp is said to be triggered, and normally at the end of the ramp period the capacitor is discharged and the source of current removed (or the current by-passed). Such an action is required for the triggered timebase of oscilloscopes. A second mode of operation is where the capacitor discharge is immediately followed by the re-establishment of current flow and the restarting of the cycle is a free-running mode. The parameters of the waveform of interest are linearity of the ramp, accuracy of definition of the end-points and duration of the interval between the end of one forward stroke and the next (flyback). Most applications require a linear ramp, Fig. 2, though the natural tendency is for current and hence rate of charging to fall as the capacitor p.d. increases, Fig. 3. Some circuits have bootstrapping of the voltage drive, so that the p.d. across the current-defining resistor remains constant. Compensation for leakage-current effects to maintain linearity or over-compensation to obtain waveforms as in Fig. 4 are other possibilities if the bootstrap circuit has a gain greater than unity.

Flyback duration is determined by the rapidity with which the charge may be withdrawn from the capacitor, i.e. by the current capability of the discharge device/circuit. Perhaps the simplest device having a well-defined firing point, reasonably low leakage and satisfactory discharging capability is the unijunction transistor. With the so-called programmable unijunction device, which is internally more akin to a thyristor, a wide variety of circuits has been

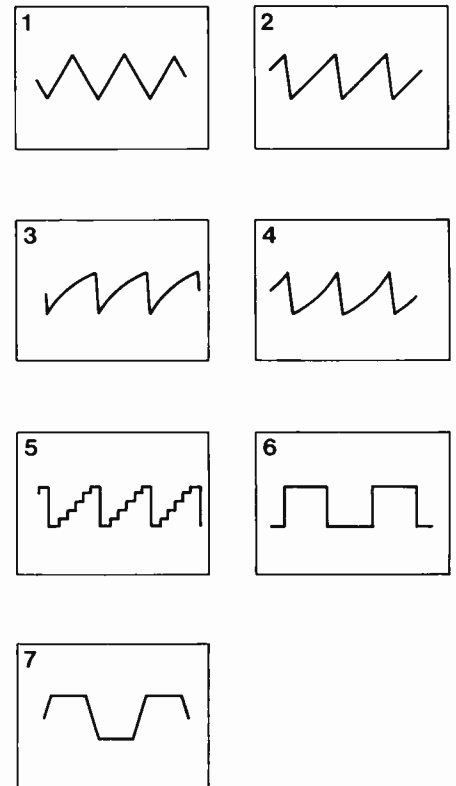

These waveshapes illustrate those dealt with in series 3 of Circards, being triangular (1), sawtooth (2), 'exponential' (3), over-compensated (4), staircase (5), rectangular (6) and trapezoidal (7) waveforms.

devised with linearity and definition of end points of around 1%. Constant-current sources are used to achieve linearity. Recent developments have included integrated circuits consisting of comparators, bi-stables and switching transistors, which though designed as timing circuits can produce similar waveforms. All such circuits suffer from the disadvantage that the load current flows in the charging circuit, disturbing the linearity.

If the capacitor is placed in the feedback path of an amplifier, as in the integrator due to Blumlein, though now more often called the Miller integrator, then a constant current may flow in the capacitor without load current disturbing that flow. This method is

*All with Paisley College of Technology.

widely used in the circuits of the following section.

Triangular wave generator

The slopes of a triangular wave generally have equal positive and negative values, giving a symmetrical waveform. If desired, inequality may be introduced which if great enough yields an asymmetry that results in a near-sawtooth waveform. Combining an integrator of this type, often using an i.c. operational amplifier, with a Schmitt trigger (see series 2 Circards) both triangular and square waves are produced: a positive output from the Schmitt trigger drives the integrator to produce a negative-going ramp that in turn reverses the trigger output at some defined potential. Asymmetry is introduced by varying the effective input resistance of the integrator on the output swing of the trigger circuit for the two sections of the cycle. Control of the triangular wave amplitude is by means of the trigger-circuit input switching levels.

There are many applications which require voltage control of the frequency, e.g. remote programming, frequency modulation, amplitude-frequency response testing. To achieve this, the output of the square-wave circuit is used to reverse the charging current, rather than feeding the integrator directly, leaving the magnitude of the current controlled by some external voltage or current source. Several methods are possible. An inverting amplifier provides a second voltage of equal magnitude but opposite sign to the control voltage, and the square wave activates electronic switches such as f.e.t.s to select these opposite-polarity voltages alternately. Amplifiers may be designed in which the gain can be switched from positive to negative leaving the magnitude of the output again proportional to the controlled source. Finally, the integrator itself may be designed so that the switching is achieved directly, the current flow being reversed within the integrator.

In all these approaches the accuracy with which the frequency tracks the applied voltage depends on the switch. It should have that legendary performance of zero on-resistance and infinite off-resistance. Field-effect transistors, both junction and insulated gate, come close to achieving the latter parameter, but the low-cost units have on-resistances high enough to introduce errors, though first-order compensation by a deliberate unbalancing of the symmetry control could be used. In other cases bipolar transistors or even diodes are applicable, while for the highest accuracy more complex switches involving pairs of complementary f.e.t.s provide a solution.

Square/trapezium generators

A square-wave output is an integral part of many triangular-wave generators. Rise-time is defined by the particular op-amp or comparator used, while the amplitude may approach supply voltage levels (though saturation effects are significant at lower supply voltages). By applying the square wave to a second integrator with sufficient over-drive, a trapezium wave, Fig. 7, with defined amplitude and variable-slope rising and falling edges results. The slopes may

How to obtain Circards

Order Circards by sending remittance (£1 per set, postage included) to "Circards" *Wireless World*, Dorset House, Stamford Street, London, SE1 9LU, indicating which set(s) you are buying. A limited number of series 1 entitled "Basic active filters" and series 2 "Comparators and Schmitts" are still available.

The Circard concept was outlined in the October issue, which included an introductory article to the first series. An article introducing the second series on switching circuits appeared in the November issue.

again be independently controlled if the drive conditions differ for the positive and negative portions of the input.

Staircase generators

The diode pump is the classic circuit for obtaining a stepped output waveform that approximates to a linear ramp when the steps are of equal height and provided there is no change in amplitude during the interval between the steps. This implies that the capacitor should not discharge appreciably between input pulses and puts a lower limit

on the repetition rate for any given circuit. To maintain equal step size at all outputs, amplifiers may be introduced to provide functions similar to bootstrapping as in the ramp circuits. This brings with it the upper frequency limit of the amplifier.

Digital-to-analogue converter methods extend the amplitude response down to d.c., with high accuracy also available, and an indefinite variety of wave-shapes that can be synthesized by selection of suitable resistor values.

Wave-shaping circuits

In waveform-shaping circuits the options are very wide and the topic requires separate treatment, but some simple methods of shaping a triangular wave into an approximate sine wave can be suggested. In a seesaw amplifier the gain can be reduced as the magnitude of the input increases in two distinct ways, each of which gives a rounded peak to the output when fed by a triangular wave. The first method places a f.e.t. in the input with its increasing slope resistance at high amplitudes, while the second uses p-n diodes across the feedback network.

A second type of shaping involves the use of a switch to reverse a given waveform at some point in the cycle. This technique can be used to convert triangular waves into saw-tooth waves for example.

The Cover Picture: 5km Radio Telescope

This month's cover picture shows some of the 12.8m diameter steerable dish aerials of Britain's latest radio telescope, recently inaugurated at the Mullard Radio Astronomy Observatory of Cambridge University at Lord's Bridge, south-west of Cambridge. Known as the "5km" radio telescope because this is the distance it occupies and because it is equivalent to a single huge dish of 5km diameter, the new instrument is notable for having an angular resolution comparable with that of optical telescopes — actually 2 seconds of arc at 6cm wavelength and 1 second of arc at 3cm. As a result it will permit a much more detailed examination than has been possible before of electromagnetic energy sources in space — mainly radio galaxies, quasars (thought to be galaxies in which a vast release of energy has occurred), supernova remnants (the debris of exploding stars), and the dense hydrogen concentrations within which stars are forming.

Eight of the 12.8m dishes, built by Marconi, are spaced out along an east-west line nearly 5 km long. Four of the aerials are fixed, at intervals of 1.13km, and the remaining four are mounted on a rail track, of total length 1.17km, so that they can be positioned (with an accuracy of 1mm) at pre-determined distances from the fixed aerials. In the middle of the line is a control room, for automatic positioning and steering of the aerials and for recording the received energy from the radio sources on a plotting machine. Automatic operation is achieved by a Marconi Myriad II digital computer in the control room, which

provides servo driving information for steering and controls the switching of a cable delay network that equalizes phase delays between signals from different aerials. The computer also processes the e.m. energy information which arrives at the control room by cable at an i.f. of 45MHz from the eight 5GHz parametric receivers in the aerial dishes.

The equivalence to a 5km diameter dish aerial, mentioned above, is achieved by a process known as aperture synthesis. In general this is a procedure by which the aerials are moved about, partly by the machine and partly by the Earth itself, so that they occupy successively the positions of the individual elements of a much bigger aerial. More precisely the dishes are arranged to operate in interferometric pairs, each pair having one fixed and one moving aerial. With eight aerials altogether, 16 such pairs are available. Seen from outer space any dish can be considered as a centre with the others rotating around it, as a result of the Earth's rotation. Thus 16 circles of different diameters are described and these form one large circle with a diameter equal to that of the line of aerials. It is of course the narrow lobes of the interferometric radiation patterns that give the radio telescope its fine angular resolution. The computer combines the energy information from the individual aerials in the grouping required and, in fact, reproduces the focusing action of the simulated 5km diameter dish. When a synthesis is complete the computer plots a "contour map" of the energy source.

Magnetic-tape cassette video recorders

Recording standards and techniques in current use

Although there is no international agreement on recording standards, the engineering design of small magnetic-tape video recorders, in the £300 price region, intended for domestic and certain professional markets, is beginning to stabilize into a recognizable pattern. One result, for example, is that a manufacturer who has designed a machine for a particular recording 'standard', say for the 525-line N.T.S.C. television signal, can produce a modified version for 625-line PAL or SECAM signal standards, and vice versa.

The recognizable pattern referred to is broadly as follows: a machine occupying about the same table space as a television set, though only about 6 inches high; recording a colour television signal, fed to it either as an r.f. or video signal, on a linearly moving narrow magnetic tape (typically $\frac{1}{2}$ in or $\frac{3}{4}$ in) which is fed out of and back into a flat cassette. The kind of tape speed is that already familiar in sound recorders, typically $3\frac{3}{4}$ in/sec to $7\frac{1}{2}$ in/sec. The tape passes in a helical path round part of a drum (see Fig. 1) within which several (2, 3 or 4) vision recording heads on a wheel are rotating at an angular speed related to the television field, and hence picture frequency, e.g. 25 rev/s in Europe. Each rotating head, in making one traverse of the tape in a helical path, records one television field in a slanting track typically at about 3° to the tape edge (see Fig. 2). The head-to-tape recording and playback speed, resulting from the

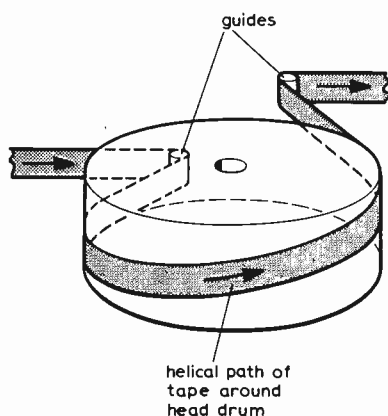

Fig. 1. Showing in exaggerated form the helical path of the tape round the drum in a helical-scan recorder.

relative motions of the tape and the heads, is of the order of 300 in/sec. (Compare this with the head-to-tape speeds of sound recorders.) Fixed recording heads produce longitudinal magnetic tracks, one for control purposes, synchronizing the head rotation with the television signal, and one or two for sound signals; these tracks are formed along the outer edges of the tape. The recorded signal is played back into a conventional colour or monochrome television receiver, and the overall horizontal resolution possible through the recording/playback process is about 3 MHz.

Before considering the technical features of this type of equipment in more detail we should put it in perspective with the other media and equipment which are now being developed and/or manufactured to provide low-priced vision records for playing into television sets. These are:

- **Film. Playback only.** Either super-8 intermittent-motion film scanned by a flying-spot scanner (e.g. Vidicord in U.K.; Nordemende, Germany; possibly Kodak or Polaroid, U.S.A.) or special 8.75mm electron-beam recorded film, with separate luminance and chrominance tracks, moving continuously and flying-spot scanned (e.g. EVR, see *Wireless World*, August 1970, pp. 366-371). Also a report of digitally encoded information recorded photographically on cards (Digital Recording Corp., U.S.A.).

- **Plastics disc. Playback only.** Mechanically modulated and played back by a piezoelectric pickup; 1500 rev/min rotation. (Teldec, Germany and U.K., see *Wireless World*, August 1970, pp. 377-378. RCA, U.S.A., 400-500 rev/min). Mechanically formed and optically played back (Philips Video Long Playing Record, 1500 rev/min, see *Wireless World*, October 1972, p. 474).

- **Hologram. Playback only.** Information recorded by laser beam as surface deformations on cheap p.v.c. film and played back optically (RCA system; formerly known as Selectavision, now Holotape, still very much in the laboratory stage and not yet widely demonstrated).

It will be noted that these media are essentially records already carrying programmes and are thus equivalent to the gramophone disc: unlike magnetic tape they do not allow

the user to record his own material originating from television broadcasts or closed-circuit television cameras. However, some of them, particularly the plastics discs and holographic tape, are potentially extremely attractive because of the low cost of the media for mass-production. If any of these playback-only systems becomes commercially established it seems possible that video records and magnetic-tape video recording could both find wide acceptance, side by side, in much the same way as l.p. records and magnetic tape sound recorders have already become accepted. Thus, although competition between different systems is inevitable, co-existence is also possible.

The main requirements of a domestic or 'semi-professional' magnetic-tape video recorder are low cost, of equipment and medium, and simplicity in use. The simplicity in use is helped, first, by packaging the tape in cassettes or cartridges, and so eliminating the tape handling problems of open-reel recorders; secondly, by the use of fairly narrow tape (see above), so that the cassettes are not awkward and cumbersome to store, load and unload; and thirdly by making the machines as automatic as possible, and so reducing the number of user controls required. The cost of the equipment is kept low by the general method of 'manufacturing down to a price' used in the mass-production of radio and television sets. This inevitably means designs of lower performance (e.g. information-rate handling, horizontal resolution, signal/noise ratio, timing stability, colour accuracy) than those typical of broadcast quality v.t.r.s. The cost of the medium is reduced by adopting a tape 'format'—the magnetic pattern in which video, sound and control information is held on the tape—that will give the lowest 'consumption' of tape (area) for a given length of programme to be recorded and played back. It is the choice of this format—sometimes described as a 'standard' because it is a fixed spatial pattern analogous to the temporal pattern of a television signal standard—that is crucial in determining the overall design, capital cost and running cost of the whole recorder.

The maximum information packing density† achievable on a magnetic tape is

† A useful but loose figure to bear in mind for density is 20,000 bits per sq. in., though much higher densities can be obtained.

limited by the shortest wavelength (highest frequency) that can be recorded and played back. In practice this is determined by the width of the head gap and the speed of head-to-tape relative motion that can be achieved at a given manufacturing cost. Each half cycle of an a.c. waveform being recorded produces a half-wave 'bar magnet', SN or NS according to its polarity, so that a complete wave or cycle produces an end-to-end SNNS or NSSN magnetic pattern on the tape. For a given gap length and head-to-tape speed there is a frequency above which distinguishable SN or NS bar magnets cannot be recorded on, and played back from, the tape. (For example in playback when a complete SNNS or NSSN cycle of wave pattern occupies the width of the head gap there will be zero magnetic flux in the head, and this is known as the extinction frequency.) A compromise therefore has to be made between (a) head gap width achievable in mass production, (b) head-to-tape speed achievable without too complicated drive mechanisms and too high 'consumption' of tape, (c) an acceptable recording/playback upper frequency limit and hence horizontal resolution in the reproduced picture, and (d) the required signal/noise ratio.

Two extremes of recording method to give an acceptable ratio of tape area consumption to recorded information can be envisaged: (1) longitudinal; an extremely narrow tape, say about 1 millimetre wide, moving past a fixed recording/playback head at a high speed of about 300in/s; and (2) transverse; a wide tape, e.g. 2-inch, moving relatively slowly, at 'sound recorder speed', past a rapidly rotating head which scans it at right angles to its length, to give a series of tracks across the width of tape (as in some broadcasting quality v.t.rs). In the first case the tape is no wider than is required to carry the longitudinal video and sound tracks, each a fraction of a millimetre, side by side. In the second case the successive video tracks across the tape width are packed as close together as possible.

Both these extremes, although making good use of a given tape area, impose severe mechanical problems and hence high cost. The method which has been adopted for the low-cost domestic or professional machines is, in fact, a sort of compromise between these two extremes: the video tracks are recorded slantwise across a tape of moderate width running at 'sound recorder' speed (see table) by a rotating head-wheel running at a moderate speed, typically 1500 rev/min. The audio and control tracks are formed longitudinally by fixed heads as mentioned above.

One great advantage of this technique is that it makes possible a simple relationship between the video head scanning repetition rate and the field repetition rate of the television signal, thereby simplifying synchronization between machine and signal. In fact, the head-to-tape writing speed with this method is sufficient that each slanting video track (see Fig. 2) can be arranged to carry exactly one field of video information of the television signal. Consequently the angular velocity of the head, and the rota-

Table of helical-scan recording formats (refer to Fig. 2)

Parameters	Philips	E.I.A.J.	Sony	Cartrivision
TV standard	625-line PAL 525-line N.T.S.C.	525-line N.T.S.C.	525-line N.T.S.C. 625-line PAL	525-line N.T.S.C.
Tape width	½in	½in	¾in	½in
Tape speed	5.62in/s	7½in/s	3¾in/s	3.8in/s
Drum diameter	105mm	115.82mm	110mm	218mm
No. of video heads	2	2	2	3
Video writing speed	206in/s	424in/s	404in/s	543in/s
Drum speed	1500 rev/min 1800 rev/min	1800 rev/min	1800 rev/min 1500 rev/min	1200 rev/min
Video head movement	with tape	against tape	with tape	against tape
Video track length	162mm	185.1mm	171.2mm	244mm
Video track angle	3° 45'	3° 11'	4° 57'	2° 24'
Video track width	130µm	40µm	85µm	140µm
Video track pitch	187µm	173µm	137µm	203µm
Tape width for video	10.6mm	10.65mm	15.5mm	10.4mm
No. audio tracks	1*	1	2	2
Audio track width	0.7mm	1.0mm	0.8mm	0.6mm
Audio-video guard	—	150µm	200µm	—
Control track width	0.3mm	0.8mm	0.6mm	0.8mm
Control-video guard	—	100µm	200µm	76µm
Luminance recording signal	f.m.	f.m.	f.m.	pulse rate modulation
Luminance nominal frequency	—	3.8MHz	4.6MHz	—
Luminance deviation	3–4.4MHz	3.1–4.5MHz	±0.8MHz	3.2–4.7MHz
Luminance bandwidth	2.7MHz	not in spec.	3.5MHz	2.5MHz
Luminance hor. resolution	—	not in spec.	300 lines	250 lines
Chroma rec. signal	a.m. 562.5kHz subcarrier	not in spec.	a.m. —	a.m. 0.1–1.1MHz sidebands
Chroma bandwidth	650kHz	not in spec.	0.5MHz	0.8MHz
Video s/n ratio (p-p video/r.m.s. noise)	≥40dB	not in spec.	>40dB	≥40dB
Control signal	25 p.p.s. 30 p.p.s.	30 p.p.s.	30 p.p.s. 25 p.p.s.	20 p.p.s.

* Provision on tape for second audio track

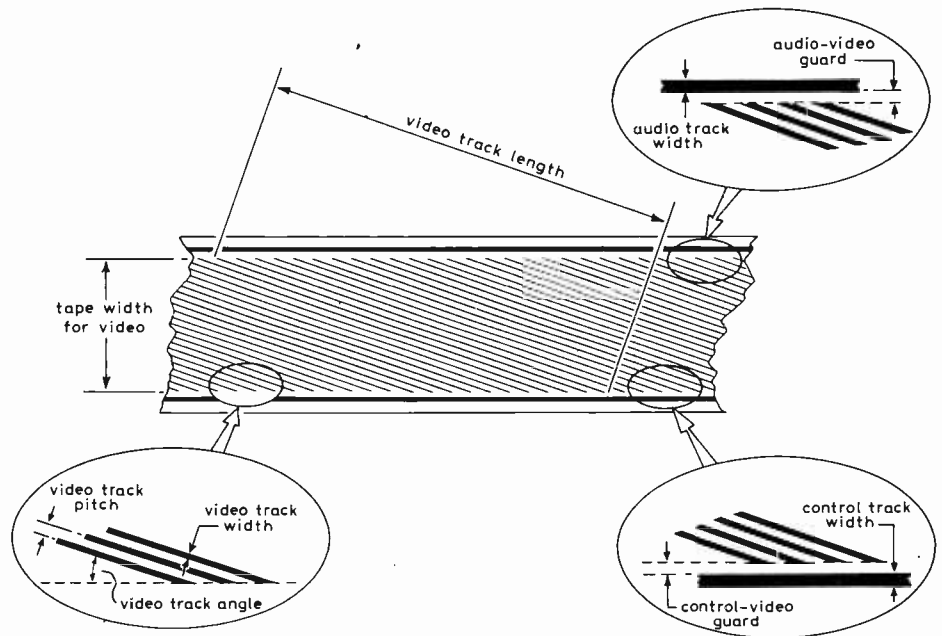

Fig. 2. Generalized tape format (not to scale) showing the main parameters which constitute a format or 'standard'.

tion speed of the head-wheel driving motor, are related to the signal field rate and hence to the electricity mains frequency.

If the head wheel carried only one video recording head, as is done in some broadcasting quality helical-scan machines to avoid the risk of heads having different characteristics, the head wheel rotation speed would have to be equal to the field repetition rate (e.g. 50 rev/s and 50 field/s in Europe); but by increasing the number of rotating heads the required head wheel speed can be reduced in inverse proportion. Typically, two heads, spaced at 180°

on the wheel, allow the drum speed to be reduced from 50 rev/s to 25 rev/s (1500 rev/min); so that one revolution of the head wheel causes two television fields, or one complete picture, to be recorded as two successive slanting video tracks on the tape.

If the television field information is to be recorded accurately in the video tracks formed by the head and tape movement (the beginning and end of each field occurring at the corresponding beginning and end of a track), the machine action must be correctly synchronized with the incoming video signal. This is analogous to the timebases

of a television set having to be synchronized with the received signal. Likewise, during playback, the head and tape movement must be such that the recorded video tracks are kept accurately aligned with the rotating heads and presented to these heads at the correct instants to achieve a proper reconstitution of the video signal. All these functions are achieved by servomechanisms controlling the speed and phasing of the head-wheel drive and the tape-capstan drive systems. During recording the servos use the field sync pulses of the incoming television signal as a reference. At the same time pulses derived from these incoming field sync pulses are recorded in the longitudinal control track (Fig. 2). Thus on the tape there is a fixed positional relationship between these pulses in the control track and the corresponding field information in the video tracks, equivalent to the fixed time relationship in the signal itself. During playback the servos use these pulses recorded in the control track as a reference.

Some of the parameters mentioned above are shown in the table comparing four major commercial 'standards' for video cassette recorders. These particular ones have been selected for comparison because they have been in existence for several years and have established substantial markets for recorders. Note that the E.I.A.J. (Electrical Industries Association of Japan) column is the only one that can be considered as a 'standard' in a true sense, in that several different manufacturers produce machines conforming to it. When first promulgated it was mainly applicable to $\frac{1}{2}$ -inch tape open-reel machines, and even now there are not many cassette machines based on it. The other 'standards' are more in the nature of formats established by the particular manufacturers. Whether these will become widely adopted remains to be seen. Certainly, as

the situation appears at the moment, the Philips format seems to be bidding fair to becoming a European standard.

In order to record a colour television signal with machines of this type the chrominance information must be separated from the luminance information in the composite signal. This is because of the limited bandwidth, about 3MHz, of this type of machine. With the 625-line PAL system, for example, it would be impossible to record a signal with a vision bandwidth of 5.5MHz and a colour subcarrier at a frequency of 4.43MHz. Consequently the chrominance information is separated from the incoming composite signal and recorded as amplitude modulation of a low-frequency subcarrier, e.g. 562.5kHz in the Philips system. This subcarrier is imposed on a carrier signal which conveys the luminance information to the recording head.

Frequency modulation is used for the luminance recording carrier. There are two reasons for this. First, an f.m. carrier avoids the effects of signal amplitude variations that result from varying head-to-tape contact during recording and playback. Secondly, it avoids the need for linearizing bias, as is necessary, for example, in conventional audio tape recorders when amplitude information in analogue form is recorded on the tape.

The Cartrivision format, at present exclusive to the U.S.A., is different from the other three listed in the table in that it includes a method of reducing the rate of tape consumption called 'skip field' recording. As the name implies, not every field of the incoming television signal goes on to the tape. In fact every third field is recorded, so that tape consumption is theoretically reduced by a factor of three relative to the other systems. In practice, bearing in mind the different head-to-tape writing speeds,

this means that whereas the largest Philips or Sony cassette gives a maximum recording/playing time of 60 minutes, the largest Cartrivision cartridge gives a maximum of 1 hour 54 minutes. It will be seen from the table that the machine has three video heads; these are angularly spaced 120° apart. During recording only one head is used; during playback all three. The heads are mechanically staggered so that during playback each field recorded on the tape is reproduced three times, thereby maintaining the continuity of field sequence of the original signal. Of course there is a loss of picture information as a result of 'skip field' operation and this is the compromise the manufacturers have made in order to reduce the running cost of the equipment.

Some idea of the design features of cassette video recorders can be gained by a detailed look at the Philips N1500 machine, illustrated in the photograph, the cassette loading diagram Fig. 3 and the system block diagram Fig. 4. This machine will record and play back into a television set colour and monochrome programmes, and for these purposes it includes a u.h.f./v.h.f. tuner for recording 'off air' and a u.h.f. modulator for playing back into a 625-line u.h.f. receiver. The equipment measures $22 \times 13 \times 6\frac{1}{2}$ in (high) and weighs 35lb.

First the cassette itself. The package is a rectangular box measuring $5\frac{1}{4} \times 5 \times 1\frac{1}{8}$ in (thick) containing two concentric tape reels. The reel on top is the take-up reel and is rotated by the tape drive motor of the machine. In passing from the bottom to the top reel the tape is carried over rollers close to one edge of the box, moving in a slanting path which contributes towards forming a helical tape path round the drum. The cassette is first inserted into a raised 'lift' on the machine, and this is then pushed down by the operator. As a result the tape in the cassette engages with two pins fixed to a movable carriage inside the machine. Then, when a button is pressed, these pins withdraw the tape from the cassette and wrap it around the head-wheel drum so that the tape path round the heads is outside the cassette.

Referring to the block diagram Fig. 4 (which is simplified and does not show all facilities), the input signal comes from the aerial which is disconnected from the television set and plugged instead into the recorder. The r.f. signal passes into an aerial amplifier, then into a splitter which feeds it (a) directly into the tuner of the recorder, and (b) via a second splitter to an r.f. output socket. This socket can be connected to the aerial socket of the television set by coaxial cable, and via this link the aerial amplifier will feed the received signal to the television set so that all broadcast programmes can be viewed normally on the set without altering any connections. In order to play back from the recorder the channel selector of the television receiver is set to the playback channel of the u.h.f. modulator in Fig. 4 and thus the recorder becomes another signal source available to the television set in the same way as the broadcast channels.

The recorder's tuner is a varicap type,

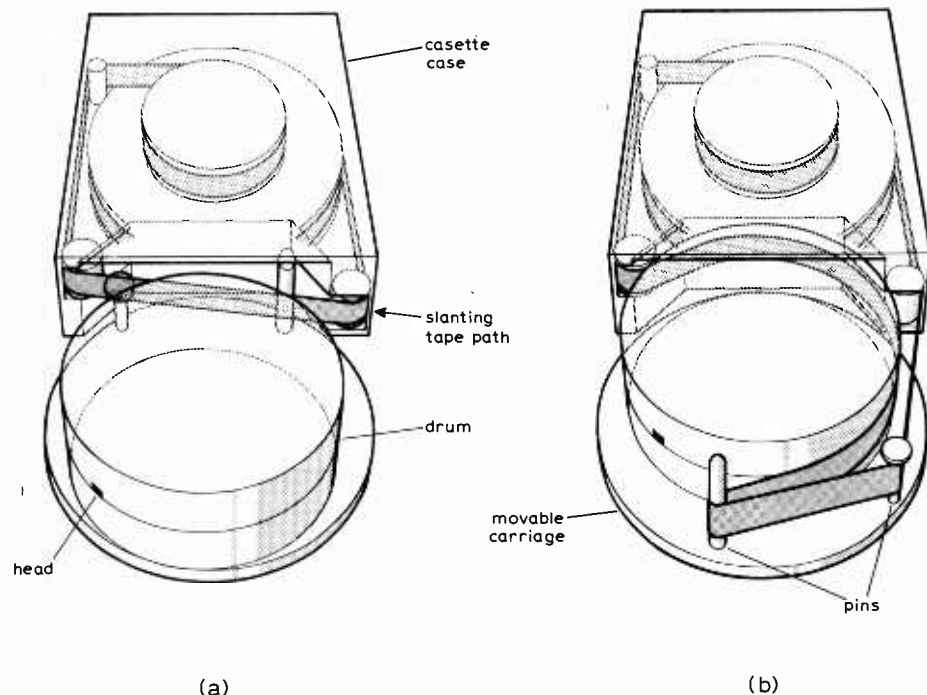
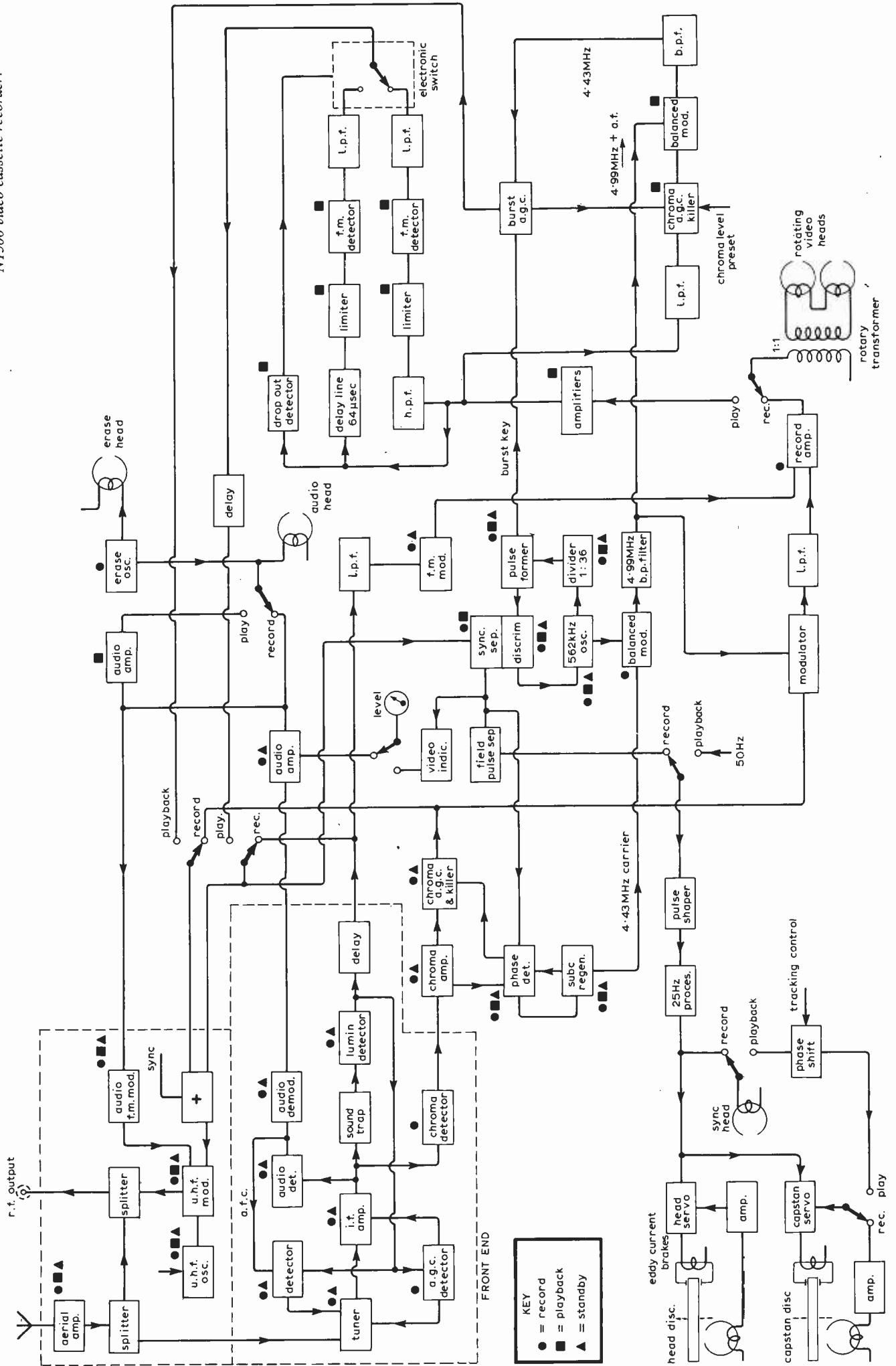

Fig. 3. Action of loading the Philips N1500 recorder with a cassette: (a) tape located behind pins on movable carriage; (b) tape pulled out by pins to wrap round the drum. (Simplified and not to scale.)

Fig. 4. Simplified block diagram of electronic signal processing in Philips N1500 video cassette recorder.



covering v.h.f. and u.h.f. transmissions in three switched frequency ranges—Band 1, Band 3 and Bands 4 and 5. In the U.K., however, the recorder is intended to work only on the 625-line PAL standard, so the tuner operates only on u.h.f.

The output signal from the tuner is fed in the conventional way into an i.f. strip, and it is at this point that the television signal starts to be processed for video recording. As can be seen, the signal is split into three components—audio, luminance and chrominance. It is quite common practice in Continental equipment to use the audio signal for a.f.c. purposes, and this is the function of the a.f.c. loop and detector shown. The demodulated audio signal emerging from the inter-carrier sound f.m. demodulator is fed to a sound recording amplifier and thence to the audio head. Just above this point on the block diagram can be seen the erase head and erase oscillator.

The luminance carrier emerging from the i.f. amplifier passes through a sound trap, to remove the audio information, to the luminance detector. The output of the detector is fed through a delay line and a low-pass filter, which restricts the frequency response to the range to be recorded, into a frequency modulator. From the last-mentioned the frequency-modulated signal (3 to 4.4MHz) is supplied to a recording amplifier and thence to the rotating video heads. The signal is transferred to the moving heads by means of a rotating transformer, and, as shown, the two heads are permanently connected in series.

To allow the user to tune the recorder to various transmissions and enable him to monitor what he is doing on the television set at the same time, there is provision for the recording signal to be sent back to the 'r.f. output' socket. To achieve this, the luminance, chrominance and audio signals

are separately fed into the u.h.f. modulator used for playback and thence to the r.f. output socket. This condition is described as 'standby' in the key to the block diagram. When the recorder is installed the tuner is set to the local channels, the tuner cover is closed—which automatically switches on the a.f.c.—and the user need not open it again. Any programme he wishes to record can be selected by push buttons on the machine, and similarly any programme he wants to watch can be obtained by the channel selector on the television set.

In the system for recording the chrominance information (broadcast as sidebands of a suppressed subcarrier at a frequency of 4.43MHz), the problem of the limited bandwidth of the recorder (about 2.7MHz) is dealt with, as already mentioned, by shifting the colour carrier to a lower frequency and recording it separately. A difficulty which arises from this technique is that if the colour subcarrier is shifted to a lower frequency, that frequency must always be, like the original subcarrier (4.43361875MHz), an exact multiple of the line scanning frequency. This is a basic requirement of the N.T.S.C. and PAL compatible transmission systems, enabling the chrominance information to be fitted into gaps in the frequency spectrum occupied by the luminance signal. Consequently the low-frequency subcarrier used in the recorder must always be related to the line scanning frequency of both the recorded and the played back signal.

As can be seen in Fig. 4, the chrominance signal is separated from the luminance signal and applied to a separate chrominance recording system, the first part of which is the chrominance detector. There is a local low-frequency oscillator operating at 562.5kHz, which is 36 times the line scanning frequency (15.625kHz). The frequency of this oscillator is compared, by



Ampex battery-operated machine operating on E.I.A.J. format, used with a hand-held camera for reporting work. (Not yet on British market.)

means of a divide-by-36 stage, a pulse former and a discriminator, with that of the line pulses, which are separated, both on recording and on playback, from the luminance signal. The resulting error signal is then used to lock the oscillator in frequency and phase at exactly 36 times the frequency of the line pulses. The 562.5kHz output from the oscillator is mixed, in a balanced modulator, with a 4.43MHz signal coming from a colour subcarrier regenerator, to produce sum and difference signals. The upper sideband at 4.99MHz is separated as shown by a bandpass filter. The chrominance information modulated on the 4.43MHz carrier is passed into a modulator where it beats with the unmodulated 4.99MHz emerging from the bandpass filter. The resulting amplitude modulated 562.5kHz signal is selected by means of a low-pass filter and applied, along with the luminance signal, to a recording amplifier and thence to the video heads. The chrominance information is therefore recorded as an amplitude-modulated signal, and the presence of the luminance frequency-modulated signal provides the required high-frequency bias for it.

A comparable technique is used in the American Cartrivision system for N.T.S.C. transmissions. The composite video signal is separated by filters into two paths, luminance and chrominance. In the luminance path, the signal is first band limited by a low-pass filter, and, after further processing, is used to produce a series of pulses, the repetition frequency of which varies with the instantaneous amplitude of the luminance signal. In the chrominance path the modulated 3.58MHz colour subcarrier is heterodyned in a mixer with a local oscillation of 2.9MHz from a crystal controlled oscillator. The resulting lower sidebands,

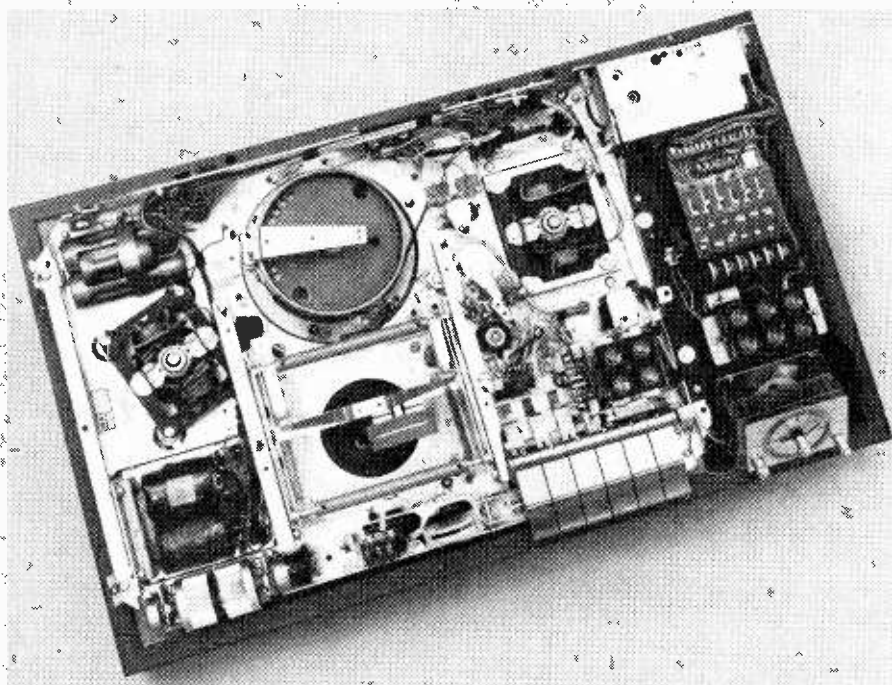

Interior of Philips N1500 machine, showing drum (left of centre) and part of cassette 'lift'.

in the range 100kHz–1.1MHz, are then superimposed on the luminance rate-modulated pulses in an adding circuit, and the combined signal is passed to a recording amplifier and thence to one of the three video recording heads.

In the Philips machine a 25Hz pulse signal, derived from a field pulse separator, is recorded in the control track on the tape by the 'sync head' (bottom left). During recording this 25Hz signal is fed as a reference to both the head-wheel and tape capstan servo-mechanisms. Each servo measures the difference in frequency between the 25Hz reference pulses and pulses induced in two stationary heads by small magnets fixed to aluminium discs which rotate underneath the head wheel and the capstan. The error signal derived is applied to an eddy current brake, which brings the speed of the rotating parts into synchronism with the 25Hz pulses.

On playback the signal processing is the reverse of recording. The 562.5kHz colour signal from the tape is heterodyned with a 4.99MHz signal obtained from a free-running 4.43MHz oscillator and a 562.5kHz signal derived from the line sync pulses on the tape. In this way any variations in the colour carrier frequency are compensated by the same variations occurring in the line pulses.

In the luminance playback system the main notable feature is the incorporation of a drop-out compensator. This is essentially an electronic switch which normally selects the direct off-tape signal for playback, but, when the presence of a drop-out is detected, changes over to receiving the luminance signal through a 64µs delay line. By this means the previous line of picture information is substituted for the line in which the presence of drop-out is detected. The complete signal is then applied to the playback u.h.f. modulator and fed to the r.f. output socket and thence to the television set.

For picture synchronism during playback, both the video head-wheel and the capstan are synchronized directly with the mains frequency through the '25Hz processor'. In addition the signal played back from the control track, given by the sync head, is used to set the tape capstan servo and hence adjust the speed of the tape, in order to compensate for any difference between the mains frequency on playback and the field frequency on recording. A manual adjustment to bring these two signals initially into synchronism is provided by means of the 'tracking control'.

Cassette tapes. The magnetic tapes in video cassettes are basically similar to those used in open reel machines, broadcasting quality v.t.r.s and audio magnetic recorders. Any development in tape generally, such as reduction of tape noise, is equally applicable to video cassettes. The tape has a plastic film base coated with a ferrimagnetic or ferromagnetic material in the form of crystalline particles dispersed in a binder. The surface of the coating is polished to reduce wear on the recording/playback heads.

There are three main types of magnetic material in common use as tape coatings:

an iron oxide called gamma ferric oxide, which is ferrimagnetic; gamma ferric oxide treated with cobalt, also ferrimagnetic; and chromium dioxide, which is ferromagnetic. The first, gamma ferric oxide, is the oldest, and considered the 'standard' tape coating. Chromium dioxide and gamma ferric oxide with cobalt have appeared in the past few years and differ from the standard coating material in having a coercivity about 50% higher and in allowing shorter wavelengths to be recovered—which, of course is important in video applications. The coercivity of the standard material is typically 24kA/m, while that of chromium dioxide and gamma ferric oxide with cobalt is controlled during manufacture to a typical value of 40kA/m, though in fact higher values can be obtained. The remanence of chromium dioxide tape (measured in tesla, units of flux density) is on average higher than for gamma ferric oxide with cobalt tapes, and this results in a higher output from the recorded tape at low frequencies. In general, chromium dioxide and gamma ferric oxide with cobalt tapes both give a high-frequency signal output and signal/noise ratio which are about 4dB above the corresponding values for standard tape.

Of the video cassettes corresponding to the table of standards, both Philips and Sony use chromium dioxide tape (which these companies manufacture themselves under licence from Du Pont). In addition, the 3M Company are supplying Philips cassettes using gamma ferric oxide with cobalt tape. The Cartrivision cassettes use standard gamma ferric oxide tape. Philips cassettes have maximum recording/playback times of 30, 45 and 60 minutes, Sony cassettes 30 and 60 minutes, and Cartrivision cassettes 30 and 114 minutes.

Sixty Years Ago

A book "Wireless Telegraphy and how to make the apparatus" is reviewed in the December 1912 issue of *The Marconigraph*. The reviewer states "The 'electrical amateur' to whom this up-to-date and practical little book is addressed should have no difficulty, if he has a very average collection of tools and the power to borrow the occasional use of a lathe, in obtaining the results indicated. Indeed, we think that at times the author is even inclined to over-estimate difficulties; as, for instance, when he states that with an ignition coil giving an eighth of an inch spark the signalling distance, using the receivers described, would only be a few yards. The least satisfactory chapter is perhaps the first, where the author deals with theory rather than with practice. In striving, for instance, to give a clear idea of the functions of the ether, he states that it conducts light, heat and sound by means of etheric waves."

H.F. Predictions — December

The winter anomaly of increased absorption at mid latitudes can be offset by the availability of higher daytime frequencies. Day-to-day variations in circuit performance will be greater; possibly up to three times that experienced during summer months. Paths in mid to high latitudes are subject to periods of very poor working lasting several days.

The lowest usable frequencies (LUFs) are for reception at good sites in the U.K. of commercial medium-power telegraphy using directive aerials. For domestic reception of high-power broadcast transmissions, LUFs would be very similar and consistent reception on frequencies approaching the highest probable frequency (HPF) is often possible. Graphs prepared by Cable & Wireless.

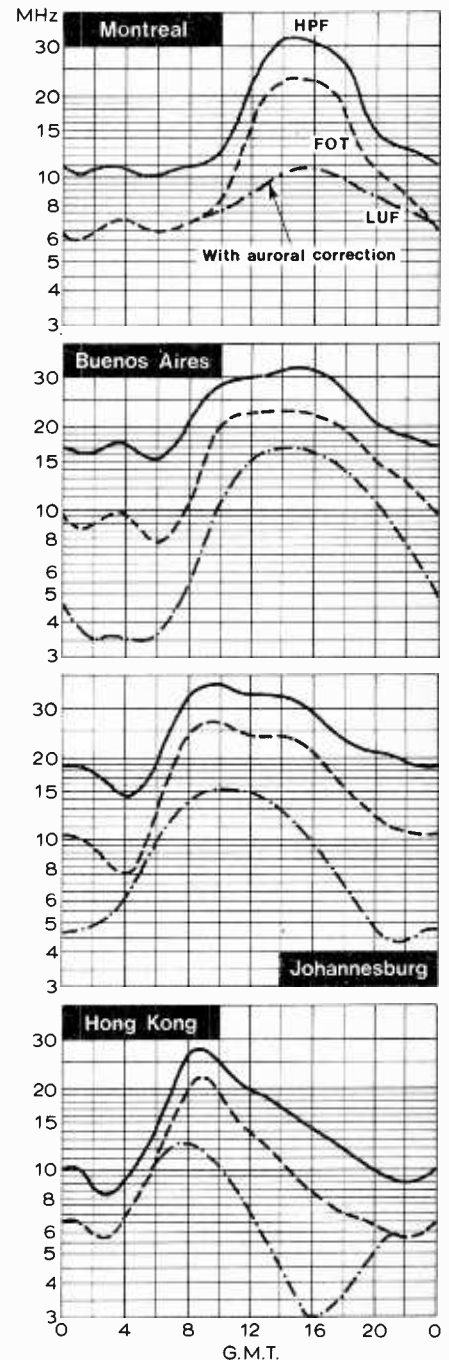

Digital Display using an Oscilloscope

A design producing a high-density, low-cost, seven-segment c.r.t. display of numbers from 0 to 9

by C. Attenborough

This article describes a way of displaying large amounts of digital data cheaply. The method used is to draw a row of seven-segment patterns on an oscilloscope, and to brighten appropriate segments to display any number on any of the patterns. Fig. 1 shows the numbers 0 to 9 formed by illuminating segments of the pattern (the numbers and letters on the segments will be explained later). This type of display has an almost constant total cost, and thus the cost per digit can be low for large amounts of data. This contrasts with gas-discharge display tubes, which have a constant cost per digit. If several numbers are to be displayed simultaneously, they can be presented one above the other. The display lends itself well to displaying data stored in serial-in, serial-out shift registers as it is not necessary to have access to all the bits stored in the register, only the end one. This helps to make the display cheaper, because serial-in serial-out registers are cheaper than those with parallel outputs.

Simplified description of the display

The display has eight digits and it will be made clear how different numbers of digits can be accommodated. Fig. 2 is a simplified block diagram of the display. The clock oscillator times the segment definition counter, which feeds analogue and digital circuitry generating X and Y deflection signals to draw one seven-segment pattern on the c.r.o. screen. With the exception of state 6, a different segment of the pattern is being drawn while the counter is in each state. The numbers on the segments in Fig. 1 are the states of the counter during which each segment is being drawn.

When a pattern has been completed, the segment definition counter goes from state 7 to state 0. This transition does two things; first, it clocks the gross X deflection counter and, secondly, it clocks the shift registers in which the data to be displayed is stored. The gross X deflection counter is connected to a circuit which generates a signal proportional to the state of the counter. This is added to the output of the X deflection circuit. Because the first pattern is drawn while the counter is in state 0 and the second one is drawn while it is in state 1, the second pattern is drawn by the side of the first one. Similarly, subsequent patterns are displaced sideways, until there is a row of them across the screen. There will be as many patterns in

the row as the number of states of the gross X deflection counter: when the left-hand pattern is completed, the counter goes from its all-ones state to its 0 state, and the next pattern is drawn in the same place as the first one.

The 1-of-8 decoder, b.c.d. to seven segment decoder, AND gates and OR gate all serve to decide whether or not a bright-up signal is sent to the c.r.o. on which the display is presented. Because the gross X deflection counter and the registers are clocked simultaneously, the information presented to the b.c.d.-to-seven segment decoder changes when the c.r.o. beam moves from one pattern to the next. This ensures that when a new pattern is drawn, the decoder is fed with information corresponding to that digit in the display.

Generating a seven segment pattern

The patterns in Fig. 1 are tilted for better legibility. In designing the deflection circuitry, it is easiest to design for untilted patterns and to add the tilt later. Fig. 3 shows the deflection voltages for drawing

one pattern (assuming that positive voltages on the c.r.o.'s X and Y inputs move the trace to the right and upwards respectively). These voltages are generated at a transistor's collector: it is easier to consider the collector current than the collector voltage. Fig. 4 shows the current waveforms (which are the voltage waveforms inverted) and shows them expressed as a sum of ramps and steps. The ramp and step currents are generated separately and added in the emitter of a common-base stage, the deflection voltage being taken from the stage's collector.

Fig. 5(a) is the X deflection circuit. Transistor Tr_4 is the common-base stage already mentioned, while Tr_3 switches the step current and can be turned off by a logic 'zero' at the end of its base resistor or saturated by a logic '1'. When saturated, its collector current (the step current) is defined by R_1 , its collector resistor. Transistors Tr_1 and Tr_2 generate the ramp current and when Tr_1 is saturated, the voltage on C_1 is held at about 3.5V (the saturation voltage of Tr_1 plus the zener voltage). The zener diode ensures that the emitter current of Tr_2 is

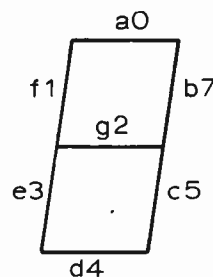

a		✓	✓		✓		✓	✓	✓	✓
b	✓	✓	✓	✓			✓	✓	✓	✓
c	✓		✓	✓	✓	✓	✓	✓	✓	✓
d		✓	✓		✓	✓		✓		✓
e		✓				✓		✓		✓
f				✓	✓	✓		✓	✓	✓
g		✓	✓	✓	✓	✓		✓	✓	

Fig. 1. Seven-segment display of numbers from 0 to 9. A tick indicates that a segment is illuminated.

defined, even when Tr_1 is saturated. When Tr_1 is turned off, the voltage across C_1 rises exponentially until the transistor is turned on again. The collector current follows the voltage across C_1 , and is added to Tr_3 's current in Tr_4 .

Fig. 5(b) is the Y deflection circuit, which works in the same way as the X deflection circuit, but has two step current switch transistors as the pattern has three vertical levels and only two horizontal levels. Resistor R_2 is adjusted so that the change in collector current of Tr_2 , during a ramp, is equal to the step current. This ensures that the smooth waveforms of Fig. 4 are produced, making the pattern closed without any overlapping of the vertical strokes by the horizontal strokes. Resistor R_4 performs

a similar function for the Y deflection circuit. For ramps and steps to be made at the right times, transistors 1, 3, 5, 7 and 8 must be turned on during certain states of the segment definition counter and off during others. The logic circuitry in Fig. 6 switches the transistors in the correct sequences. Remember the selected output of the 1-of-8 decoder is at logic '0'. The decoder used is actually a 1-of-10 device, two outputs being left unused.

Generating a row of patterns

The row is formed by clocking the gross X deflection counter at the end of each pattern, generating a signal proportional to the state of the counter, and adding it to the X deflection signal. It is convenient to generate

a current proportional to the counter's state, and to add it into the emitter of Tr_4 in Fig. 5(a). Fig. 7 shows how this is done. Transistors 10, 11, and 12, like Tr_4 in Fig. 5(a), are saturating switches. Because their collector resistors are in a 4-2-1 ratio, the sum of their collector currents is proportional to the state of the counter. For a display, say, 16 digits in a row, the counter would be made up of four bistables ($2^4 = 16$) and there would be four transistors in the digital-to-current converter.

If more than one row of patterns were needed (to display more than one multi-digit number at once, for example), the last bistable of the gross X deflection counter would clock a gross Y deflection counter. This counter would have a number of states equal to the number of rows of patterns in the display and its outputs would be connected to a digital-to-current converter, whose output would be added to the emitter current of Tr_9 in the Y deflection circuit.

Intensity modulation logic

We need to know what segments of the pattern to illuminate to form each number. The 7448 i.c. provides this information. It has four inputs to accept a b.c.d. digit, and seven output lines, labelled a to g by the

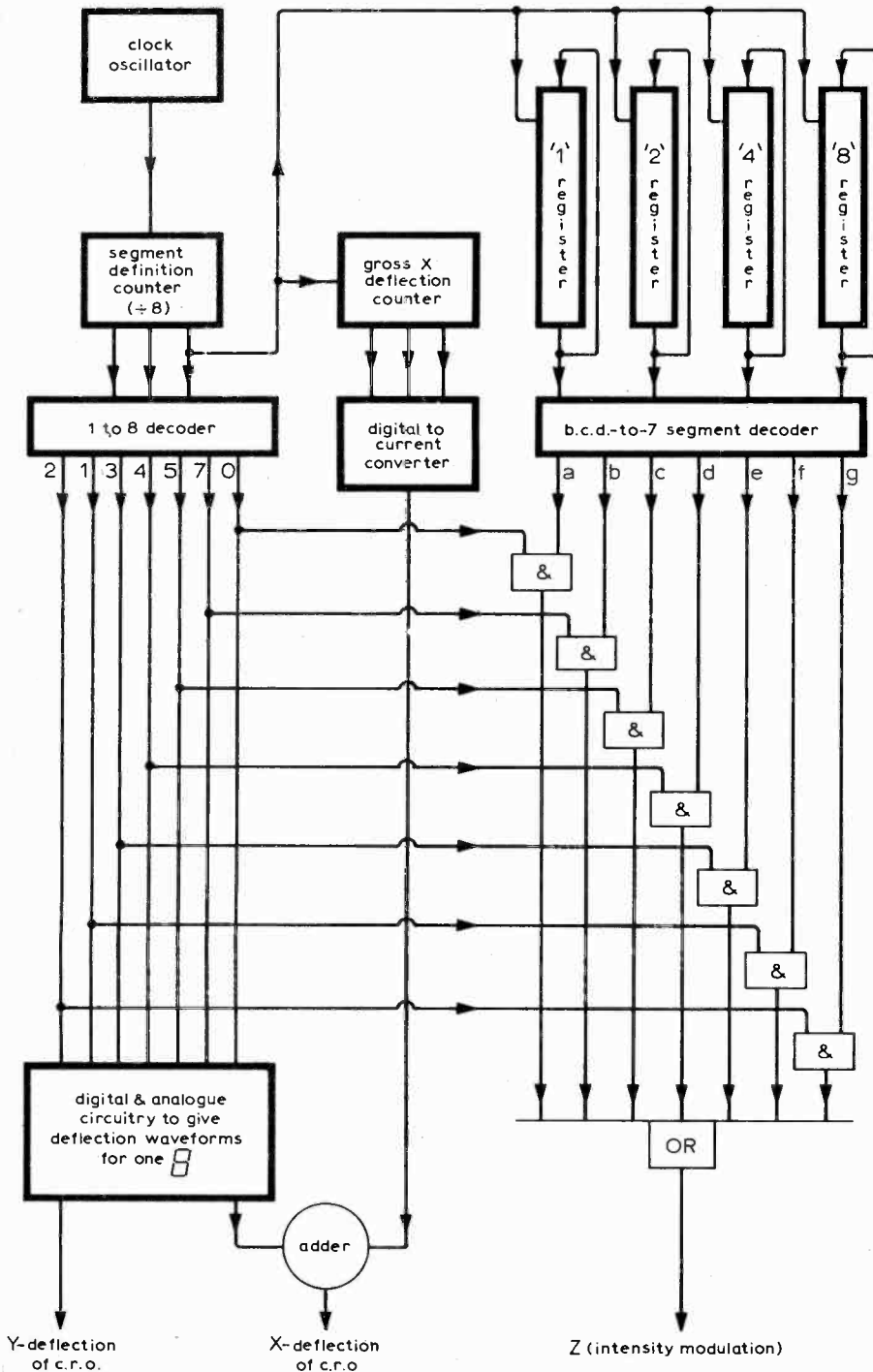

Fig. 2. Simplified block diagram of the display.

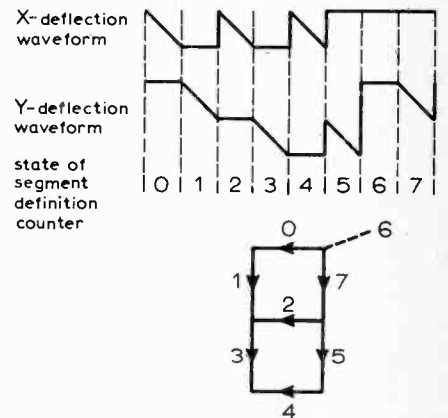

Fig. 3. Deflection waveforms for one seven-segment display.

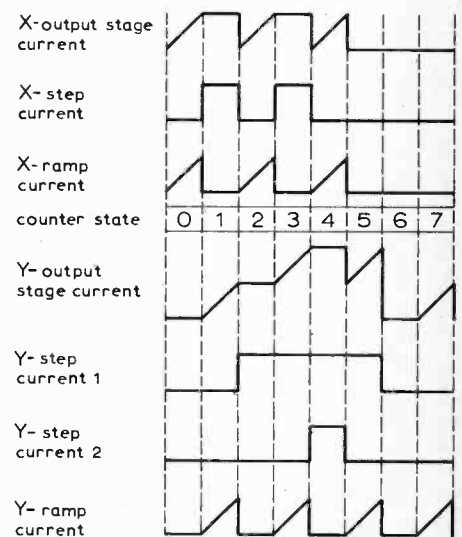

Fig. 4. Resolution of output stage currents into steps and ramps.

manufacturer, one for each segment of the pattern. The letters on the segments in Fig. 1 are those used to identify the outputs of the decoder. When a segment is to be illuminated, the corresponding output line goes to logic '1'.

The seven-segment decoder tells us which segments must be illuminated: the outputs of the 1-of-8 decoder tell us that state of the segment definition counter, and thus which segment is being drawn at any instant. Suppose a b.c.d. nine is fed into the seven-segment decoder; outputs *a*, *b*, *c*, *f* and *g* will go to logic '1'. To present a nine on the c.r.o. screen, a 'bright-up' pulse must be generated during states 0, 1, 2, 5 and 7 of the segment definition counter. Fig. 8 shows the logic circuitry needed to generate the bright-up waveform for any number: the outputs of the 1-of-8 decoder are inverted because the selected output is low.

Fig. 8 shows a practical version of the intensity modulation drive: it avoids the possible AND and OR gates using instead NAND gates, which are the most easily available type in t.t.l. The intensity modulation signal may be a.c. coupled inside the display c.r.o., so a steady level of direct voltage cannot be used as the bright-up signal. Instead, when a segment must be illuminated, a train of pulses is used. When the output of the 8-input gate is high, a train of pulses goes from the clock oscillator through a 2-input gate to the output amplifier: when it is low, the train of pulses is not passed by the 2-input gate. The segment definition counter input signal is obtained by dividing the clock oscillator frequency by 16. The effect on the display is that each illuminated segment is made up of 16 bright dots. This is hardly noticeable, and certainly not objectionable.¹

Some c.r.os have intensity modulation applied to the c.r.t. cathode, others have it applied to the grid. The former need a negative signal to increase brightness, the latter need a positive signal, therefore the inverter shown dotted in Fig. 8 should be included for grid modulation and omitted for cathode modulation. Output transistors raise the level of the intensity modulation signal and feed it to the display c.r.o. from a low impedance.

Storage register circuitry

Fig. 9 shows the essentials of the data storage circuitry. The top register in the diagram holds the '1' bits of all the stored b.c.d. digits, the one below holds the '2' bits, the next one the '4' bits and the bottom one the '8' bits. When the registers are clocked, the data moves to the right and a new b.c.d. digit is presented to the seven segment decoder. The outputs of the registers are connected to their inputs to re-enter the data. The c.r.t. beam must move from one character to the next at the same time as new data is presented to the decoder. As the gross X deflection counter changes state on the negative-going edge of the clock pulse and the data in the registers shift on the positive edge, an inverter must be connected between the clock terminals of the counter and the registers.

How is information put into the registers

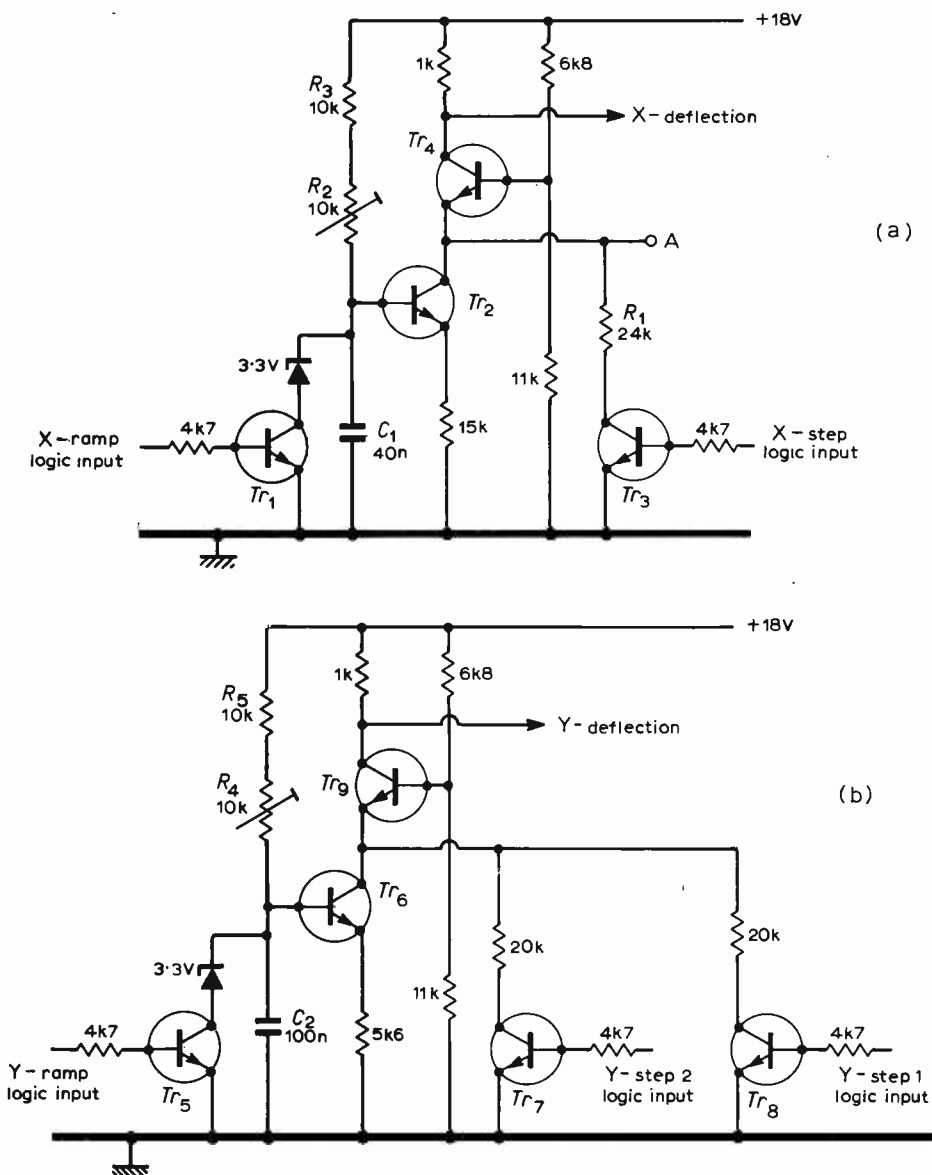

Fig. 5. (a) shows the X-deflection circuit for one seven-segment figure and (b) the Y-deflection circuit.

initially? This depends on the device which generates the information and so no one answer can be given to cover all requirements. Fig. 10 shows the method used in the prototype. Transistors 15 and 16 are the clock oscillator, Tr_{17} is a buffer amplifier. Pins 11 and 12 are the inputs of the 7491 shift registers. Both must be at logic '1' to enter a '1' in the register. If one of these pins is held low and the register is clocked at least eight times (the registers being eight bits long), all its bits will go to logic '0'. Switch S_1 in Fig. 10, normally open, is connected to one input of all the registers and is closed to clear the registers. Having done this, we must stop the counters to prevent the registers being clocked. This is done by opening S_2 which holds the counters in their all-zeros state. Information is entered by using S_3 ; there is an S_3 for each register.

While information is being displayed, all poles of S_3 are opened; the inverted output of the register is then inverted again by the two-input NAND gate and fed back to the input. When the registers have been cleared, the inverted output goes to logic '1', the gate's input goes to logic '0' and this is fed into the register. When S_3 is opened,

the gate's output goes to logic '1' and this is likewise fed to the register's input. The appropriate poles of S_3 are closed to enter a digital 9 (1001 in b.c.d.)—logic '1' must be put into the eight and one registers, and logic '0' must be put into the one and two registers. This can be done by closing the S_3 s of the eight and one registers, and leaving open those of the one and two registers.

Now the required information is at the input of the registers they must be clocked so that the next digit of the number to be displayed may be entered. A single clock pulse can be applied to the registers by pressing S_4 once. This is a biased change-over switch, connected to the inputs of a latch circuit using two input NAND gates to avoid multiple pulses being produced by switch bounce. When S_4 is pressed, the output of the upper gate of the latch goes from logic '1' to logic '0'. The reverse transition occurs when the switch is released, and this shifts the data in the register.

The least significant digit of the number to be displayed must be entered first: when all eight of the digits have been entered, the least significant digit will be at the right hand end of the registers. The procedure

for entering information is summarized below:

- (1) close S_1 to clear registers: open S_1
- (2) open S_2 to stop counters
- (3) set the S_3 s to enter the least significant digit (close S_3 to enter a '1', open S_3 to enter a '0')
- (4) press S_4 once

(5) repeat (3) and (4) for each digit

(6) open all S_3 s

(7) close S_2 to allow counters to run.

If several multi-digit numbers are to be displayed, then additional logic will be needed to connect the appropriate registers to the inputs of the b.c.d.-to-seven segment decoder, so that each number is displayed in

the correct row of patterns (assuming that several rows of patterns are drawn, one for each number).

Tilting the patterns

Fig. 11 shows how the deflection circuits can be modified to give tilted patterns as in Fig. 1. As the beam moves towards the bottom of the screen, the current taken by the X deflection circuit increases. This increases the voltage dropped across the 100Ω resistor in Fig. 11, and so the voltage from the output of the Y deflection circuit to earth decreases, moving the beam to the left, and thus tilting the patterns. This simple circuit has one minor disadvantage: not only does the Y-deflection affect the X-deflection, as described, but the X-deflection affects the Y-deflection, making the left-hand end of a row of patterns lower than the right-hand end. In practice, this is hardly noticeable with a full screen-width of patterns: it can be made entirely unnoticeable by adjusting the 'trace rotate' control of the display c.r.o.

Calculations

Clock oscillator. The clock oscillator must run at a high enough frequency to avoid flickering of the display. This means that the screen full of information must be scanned at least 50 times per second. In the prototype, the clock oscillator frequency is the number of rows scanned per second (50) times the division ratio of the gross X deflection counter (8) times the division ratio of the segment definition counter (8) times the division ratio of the counter connected between the clock oscillator and the input of the segment definition counter (16), i.e. about 50kHz. Choosing 1kΩ as the collector resistor of an astable multivibrator, the cross-coupling capacitor is found to be 15nF.

X deflection circuit. The c.r.o. used with the prototype has a full-screen X deflection sensitivity of 5V; thus the width of each pattern is 400mV, and the separation between the patterns and between the end patterns and the edge of the screen, is 200mV. We choose Tr_4 's collector resistor to be 1kΩ; this simplifies some arithmetic, since 1mA drops 1V across 1kΩ. During the right-hand strokes of the right-hand pattern, Tr_4 passes 200μA (assuming that the c.r.o. beam is at the right-hand edge of the screen when Tr_4 is cut off, and Tr_1 is saturated). The voltage across C_1 is about 3.5V; since Tr_2 's collector current is equal to the current through Tr_4 , R_1 can be calculated as 14kΩ, 15kΩ being used in practice.

When the horizontal strokes of the right-hand figure are being drawn, the voltage across C_1 increases until, at the end of the stroke, Tr_4 is passing 600μA and its collector resistor is dropping 600mV. Thus the voltage across C_1 at the end of the stroke can be calculated as about 9.7 (600μA through 15Ω plus the emitter-base voltage of Tr_2). The time during which the stroke is being drawn is known (16 times the clock period, i.e. about 320μs), so the time constant of C_1 , R_2 and R_3 can be calculated. It is given by $T/\ln [(V - V_0)/(V - V_T)]$ where T is the capacitor's charging time (320μs), V is the supply voltage (18V), V_0 is the initial

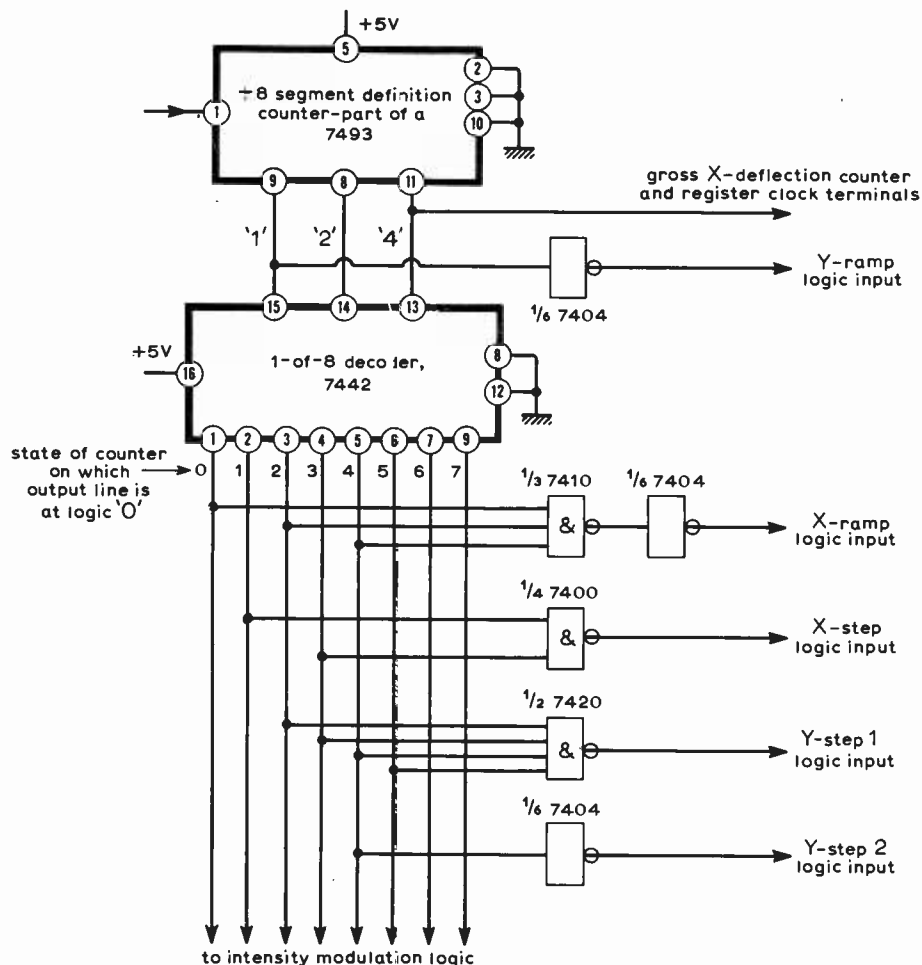

Fig. 6. Circuitry to provide logic inputs to analogue deflection circuitry.

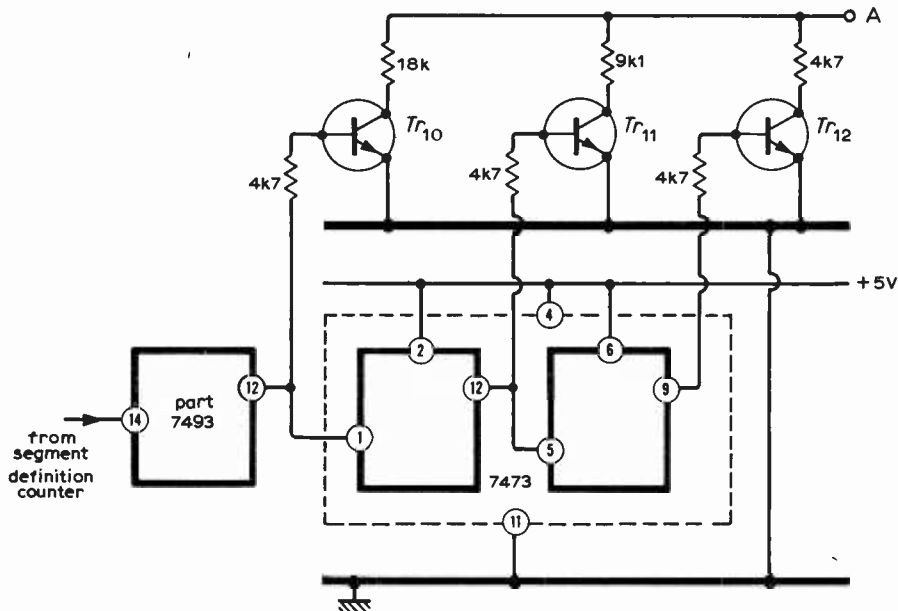

Fig. 7. Gross X deflection counter and digital-to-current converter.

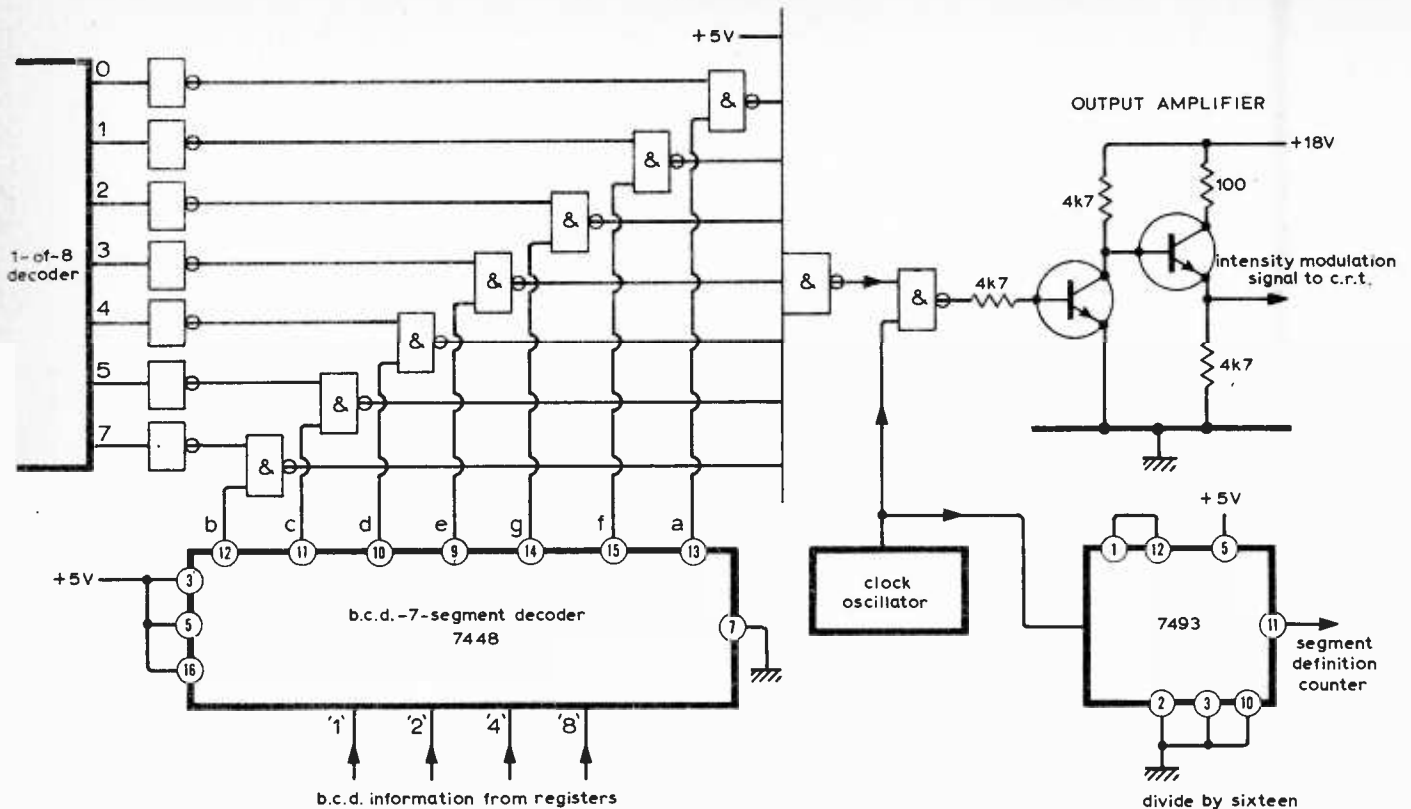

Fig. 8. Practical form of intensity modulation logic using NAND gates with gated a.c. drive to intensity modulator/output amplifier.

capacitor voltage (3.5V) and V_T is the capacitor voltage after time T (9.7V). The time constant can be calculated as $570\mu s$ and so R_2 and R_3 are $10k\Omega$, and C_1 is $0.04\mu F$.

The base voltage of Tr_4 must be above 9.7V so that Tr_2 does not saturate even when C_1 is at its maximum voltage: it must be below 13V so that Tr_4 does not saturate even when 5V are dropped across its collector resistor (that is, when the left-hand pattern is being drawn). The values shown in Fig. 5(a) hold the base of Tr_4 at about 11V. Resistor R_1 can now be calculated. When Tr_3 saturates, the current through R_1 moves the beam of the c.r.o. from one side of a pattern to the other. This current must be $400\mu A$ to drop 400mV across the collector resistor of Tr_4 . Since R_1 has about 10V across it, its value may be calculated as $25k\Omega$. The nearest preferred value, $24k\Omega$, may be used.

Next the values of the resistors in Fig. 7 can be calculated. When the gross X deflection counter goes from state '0' to state '1', the c.r.o. beam moves from the left-hand pattern to the next one along. For this to happen, Tr_{10} must put $600\mu A$ into Tr_4 , as there is 600mV between any point on a pattern and the same point on the adjacent pattern. The collector resistor of Tr_{10} has about 10V across it, and thus its value is about $17k\Omega$; $18k\Omega$ is used in practice. For the patterns to be equally spaced, the sum of the collector currents of Tr_{10} , Tr_{11} and Tr_{12} must be proportional to the state of the gross X deflection counter. This means that the collector resistor of Tr_{11} must be half that of Tr_{10} . Fig. 7 shows the nearest preferred values used.

Y deflection circuit. Assume there is a voltage drop of 500mV across the collector

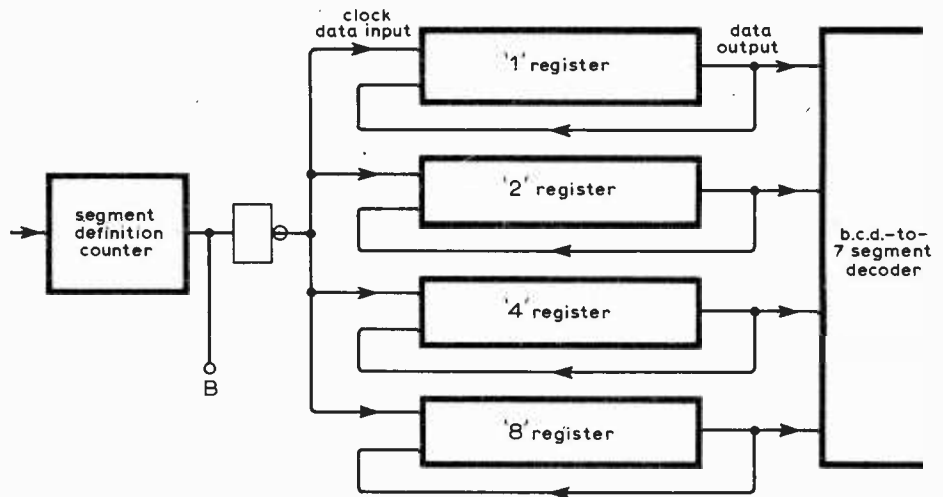

Fig. 9. Circuitry of the data storage registers.

resistor of Tr_9 when the c.r.o. beam is at the top of a pattern. Under these conditions, Tr_5 is saturated, and thus there is about 2.8V across the emitter resistor of Tr_6 . Since Tr_6 is passing $500\mu A$, this resistor can be calculated as $5.6k\Omega$. When the central bar of a pattern is being drawn, one volt is dropped across Tr_9 's collector resistor so there must be about 6.3V across C_2 at the end of its charging period. Using the formula already given, the time constant of C_2 , R_4 and R_5 can be calculated to be 1.5ms: R_4 and R_5 is $10k\Omega$, and C_2 is $0.1\mu F$. Transistors Tr_7 and Tr_8 must both pass $500\mu A$ when saturated (to move the beam vertically through the pattern) and since they have about 10V across their collector resistors, these must be $20k\Omega$.

The transistors must be silicon types with breakdown voltages greater than 18V.

BC108s were used in the prototype. The supply to every few logic circuits should be decoupled with a $0.01\mu F$ disc ceramic capacitor.

Centring the figure one

As the figure one is made up of the two right-hand vertical segments of the pattern, it is not centred in the space between the two adjacent characters. This can be avoided by detecting a figure 1 at the end of the registers, and putting a current of the right amplitude into the emitter of Tr_4 , to move the figure into the centre of the space. Fig. 12 shows how this may be done.

Possible developments

It is possible to display both letters and numbers on a 5-by-7 matrix of dots, the numbers being better shaped than those

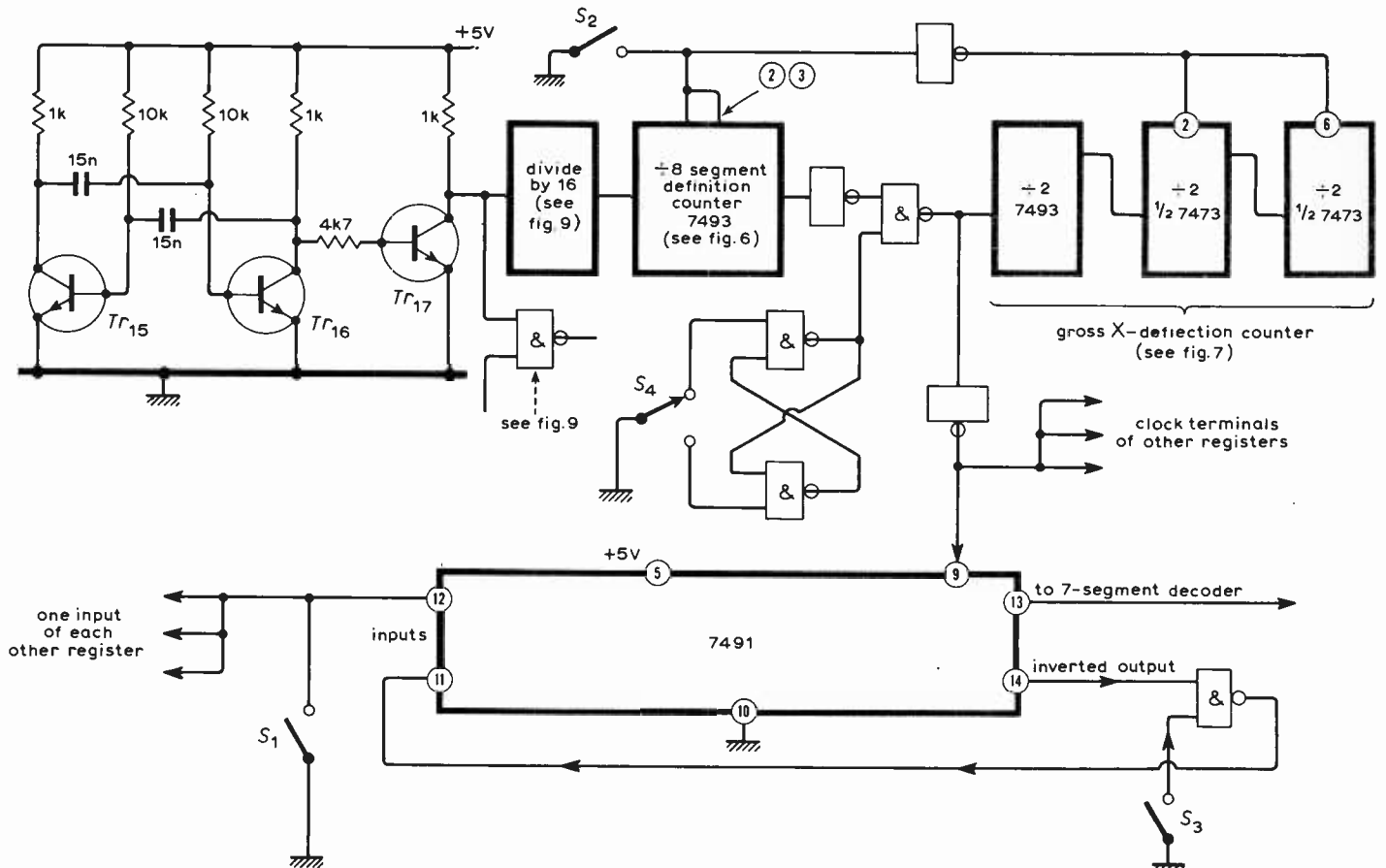

Fig. 10. Data entry in the prototype. Only one register is shown as the other three are similar. The segment definition counter and first 'divide by 2' in the gross X-deflection counter are in the same 7493 and thus clear simultaneously.

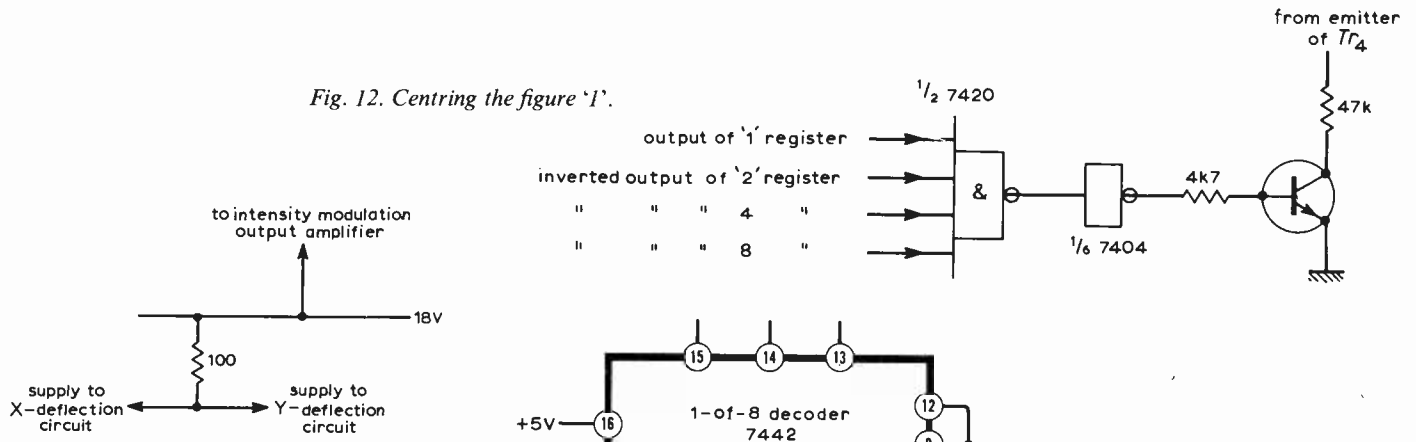

Fig. 11. Tilting the patterns.

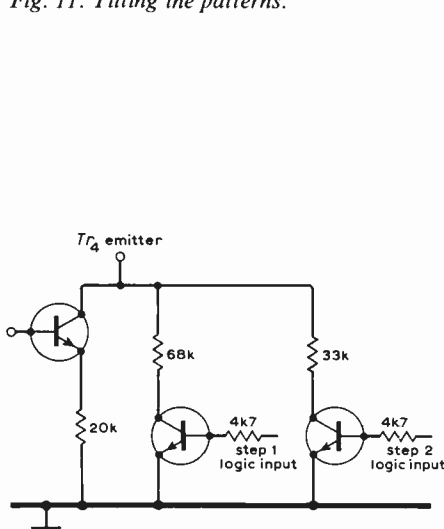

Fig. 13. X-deflection circuit for the decimal point version.

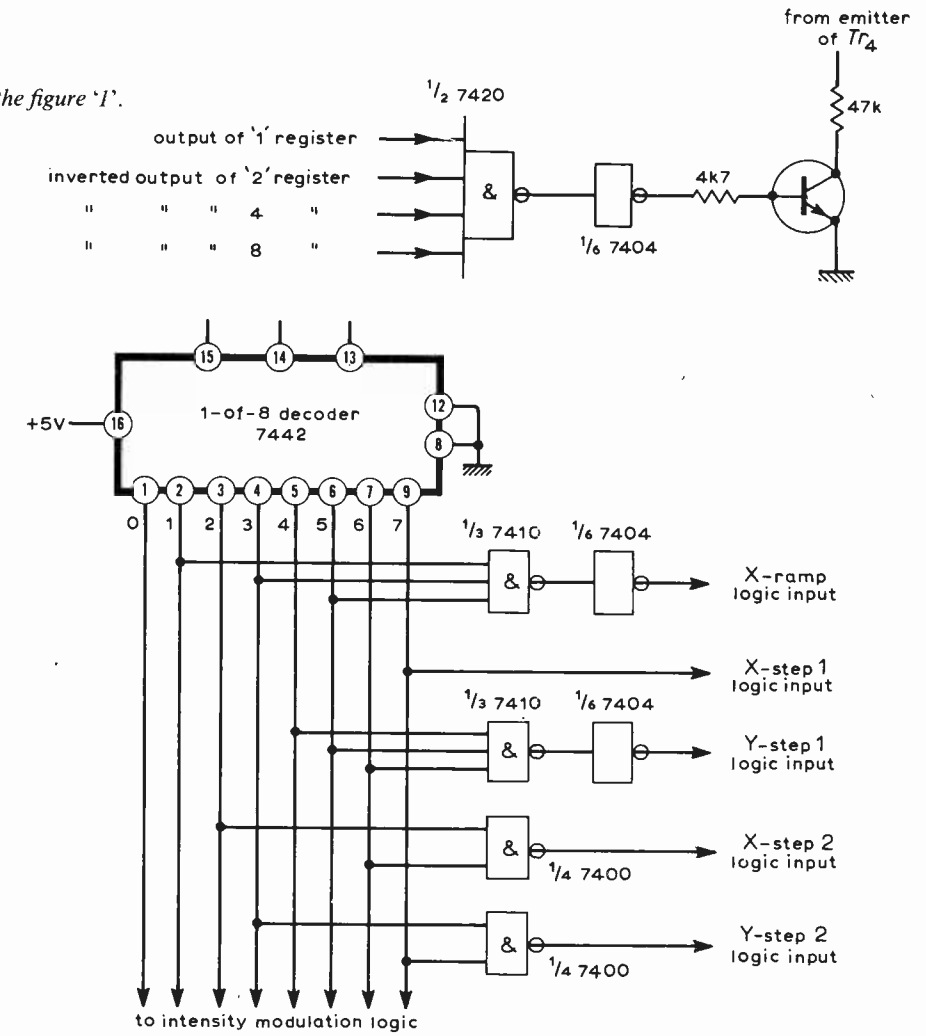

Fig. 14. Logic to control the analogue deflection circuitry in providing the decimal point.

formed on a seven-segment pattern. The blanking logic needed to form the characters on the dot matrix seems prohibitively complex to implement with t.t.l. If the m.o.s. read-only memories used to implement the logic become available to the amateur, the dot-matrix display will become attractive.

The design of the prototype was prompted by an interest in calculating machines: the bit-parallel, digit-serial arrangement of the data to be displayed fits in well with the bit-parallel, digit-serial arrangement of some of the commonly used b.c.d. adder/subtractors, but other register layouts can be used if necessary. For example, some adder/subtractors need bit-serial, digit-serial layouts: these can be accommodated by running the data into a four-bit register until it contains one b.c.d. digit, memorizing the register outputs in four latches, and presenting the output of the latches to the inputs of the b.c.d.-to-seven segment decoder. When the next digit has entered the four-bit register, it is entered into the latches, and so on for all the digits.

State of segment definition counter	Segment drawn
0	c
1	g
2	e
3	d
4	b
5	a
6	f
7	decimal point

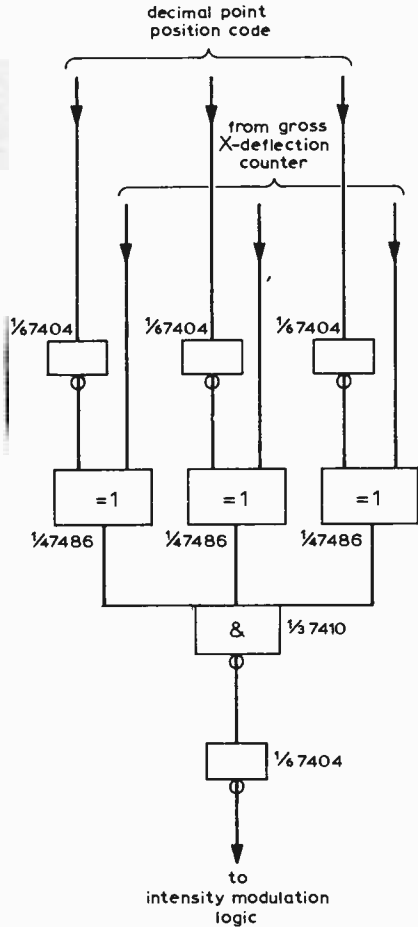

Fig. 15. Decimal point control logic comparator.

Appendix—Adding a decimal point

The addition of a decimal point to the display requires two things: that a decimal point is added to each basic seven-segment pattern and that additional logic circuitry is provided to turn on the decimal point which is to be used.

In the system already described, the c.r.o. beam is stationary at the top right-hand edge of the pattern during state 6 of the segment definition counter. A different route of the c.r.o. beam round the pattern can give a stationary spot at the bottom right-hand corner. An added transistor in the X-deflection circuit can then move this stationary point to the right, giving a decimal point to the right of the lower edge of the figure. The following table of segment letters and segment definition counter states gives a stationary point in the correct position.

Fig. 13 is the modified X deflection circuit with an added switch transistor to move the c.r.o. beam to the right during state 7 of the segment definition counter, i.e. during the drawing of the decimal point. Fig. 14 is the modified logic circuitry giving digital inputs

to the X and Y deflection circuitry (while the Y deflection circuit is unaltered, the transistors are switched in a different sequence).

Additional intensity modulation logic is needed to control the decimal point. This is done by comparing a binary word with outputs of the bistables in the gross X deflection counter. When the word is identical with the outputs, the decimal point is illuminated. This is done by sending a 'bright-up' pulse to the oscilloscope during state 7 of the segment definition counter. Because the gross X deflection counter is in state 000 while the extreme right-hand pattern is drawn and in state 001 during the next pattern and so on, the extreme right decimal point will be turned on by the binary word 000, the next one by the binary word 001 and so on.

Fig. 15 is the circuit used to compare the binary word with the gross X deflection counter output. The circuit shown accepts a 3-bit word, sufficient for a display with $2^3 = 8$ figures. Larger numbers of figures can be accommodated by adding an inverter, an exclusive-OR gate and an input to the NAND gate for each bit of the binary word.

Fig. 16 is the modified intensity modulation circuit. It has an input from the decimal point control comparator and also differs from Fig. 8 in the relationship between the segment being drawn and the state of the segment definition counter which has been changed to allow the stationary dot state to occur at the bottom right-hand corner of the pattern.

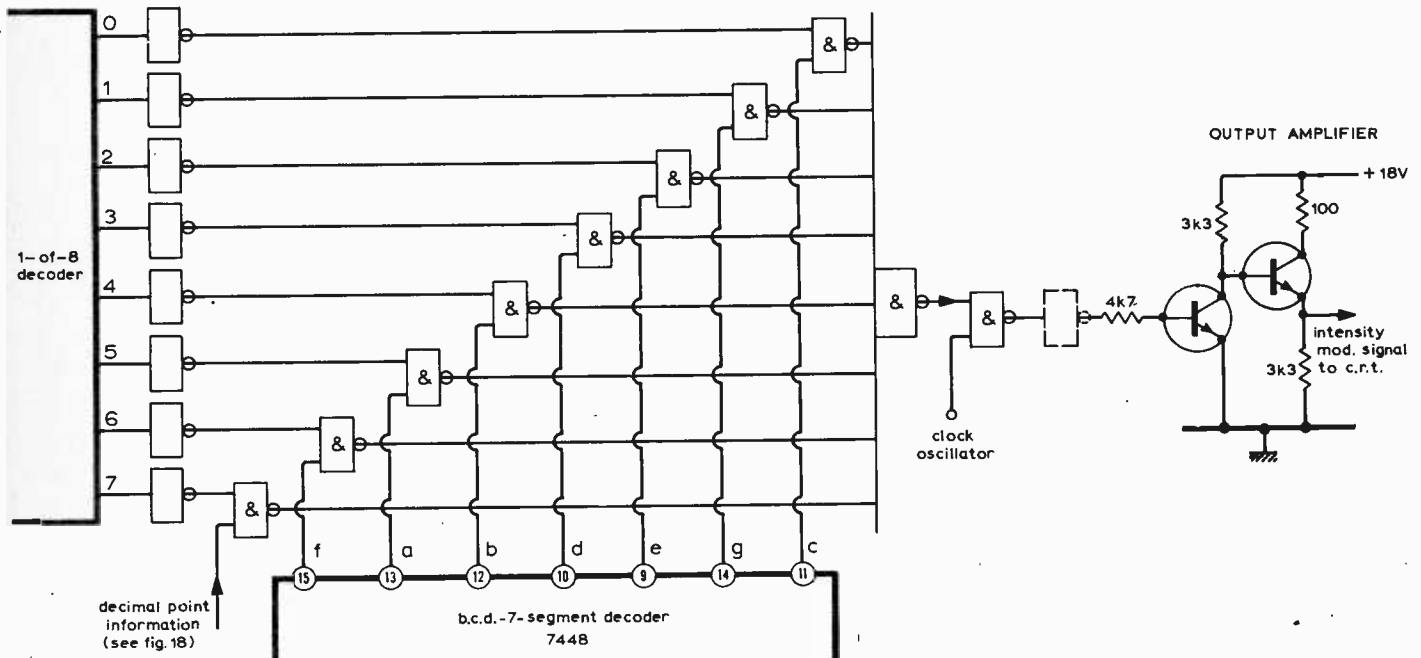

Fig. 16. Intensity modulation logic for the decimal point version.

Free Roving Machine

A device which will "explore" a room and, by finding and tracing the path of a length of tape laid on the floor, return to a charger at intervals to recharge its batteries

by M. F. Huber, B.Sc.

A number of years ago, Dr. Grey Walter first demonstrated that quite simple machines could mimic the goal-seeking ability of animals. The machine described here will avoid the obstacles in a room and return at intervals to a battery charging point. For safety reasons, the machine charges at a low voltage. The charger consists of a step-down transformer in an insulated box, with sockets in which the probes on the machine engage. The charger is placed against a wall of the room, and a few feet of white tape are laid on the floor from a point midway between the socket holes towards the centre of the room, with the blind end formed into a small loop (Fig. 1).

The machine is driven by two motors, one for each of the rear wheels, so that steering can be obtained by reversing one of the motors. A third, castor wheel, is fitted to the front of the machine.

The front bumper is made from springy piano wire and has two associated contacts. In a head-on collision both contacts are

made, but if the machine hits an object with a glancing blow only one contact is made.

The probes at the rear of the machine have to make contact with the charger unit. They are mounted on single turn springs of light piano wire and are arranged so that if one probe is depressed more than the other a contact is broken.

The machine roams the room with the bumper at the front. If the machine strikes an obstacle head-on, pressure on the bumper will cause capacitors C_4 and C_5 (Fig. 2) to charge to 15V. Relays B and C will be energized by Tr_4 and Tr_5 for unequal periods dependent on the time-constant C_4R_5 and $C_5R_6R_8$. Relays B and C reverse the motors, and consequently the machine will back away, turn, and proceed in a new direction. If the obstacle is struck a glancing blow, only the motor on the opposite side is reversed and the machine sheers away because only one of the bumper switches make; obstacles which energize RLC also energize RLD . Relay D puts the machine in a

"search" mode by lighting LP_1 with contact $RLD/1$. Contact $RLD/2$ holds the relay on.

Lamp LP_1 is situated underneath the machine and its purpose is to illuminate a strip of white tape on the floor as mentioned earlier. The tape is sensed by a pair of phototransistors, which are used to control the motors in such a way that the machine follows the tape. Lamp LP_2 lights at the same time as LP_1 and provides a visual indication that the machine is in the search mode. Potentiometer R_{10} is used to set the brightness of the lamps.

After a number of collisions the machine will eventually cross the white tape. Whichever of the phototransistors (Tr_1 and Tr_2) is over the tape (which is now illuminated by LP_1) it will, by energizing the appropriate relay, cause the motor on the opposite side to reverse. Zener diodes D_7 and D_8 ensure that the relays operate without backlash; diodes D_6 and D_9 prevent overdriving¹. The machine will thus shunt to and fro over the tape until it has aligned itself along it. It will then follow the tape with the probes at the front. Quite sharp changes in direction are permissible for the tape, since if both phototransistors lose the tape on a corner, the machine merely reverses back onto the tape.

When the machine arrives at the charger the probes may enter the holes first time. Slight misalignment of the machine can, however, cause one or both of the probes to strike the charger face instead. The probe contacts are designed to separate immediately if one probe is depressed more than the other, or after a certain equal pressure on both probes is reached. Thus when the holes are missed, LP_1 is extinguished as the probe contacts open. In cases of severe misalignment, which occur when the tape is first acquired very close to the charger, the machine may make a dozen or more stabs at the holes before insertion. Usually though two or three attempts suffice.

When the probes contact the supply, the output from the bridge D_1 to D_4 charges C_1 causing Tr_1 to conduct heavily. Diode D_5 prevents overdriving and, together with R_1 forms a discharge path for C_1 . Relay A is energized by the current through Tr_1 and is held on via contact $RLA/1$ with the battery charging current, if the batteries are in need of charge. When $RLA/1$ changes over, only a reduced voltage can reach the motor control circuits through the motors. Resistor R_9 is large enough to cause RLD to de-energize.

Fig. 1. How the white tape is laid on the floor in relation to the charger unit.

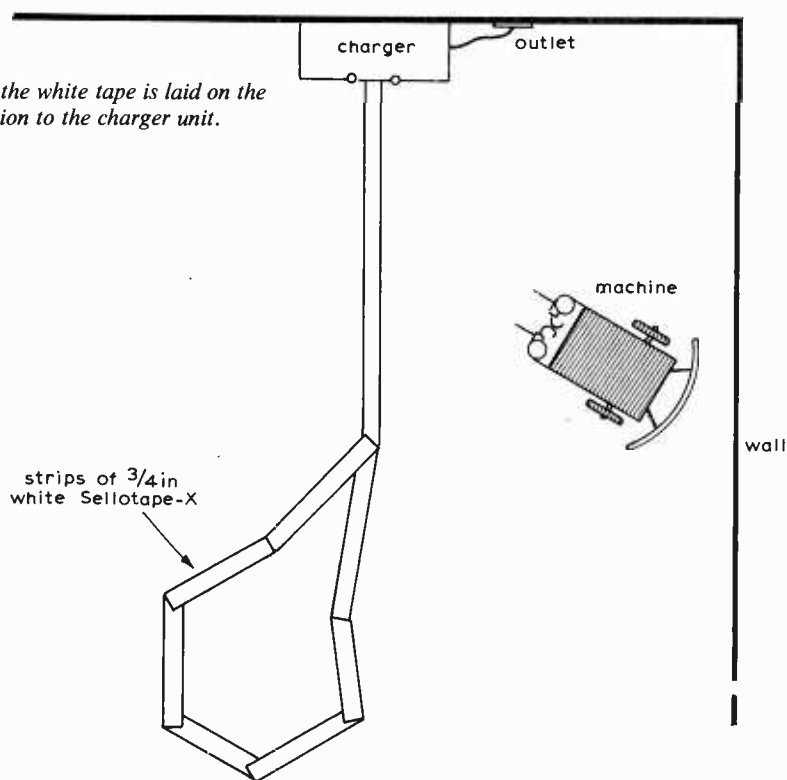

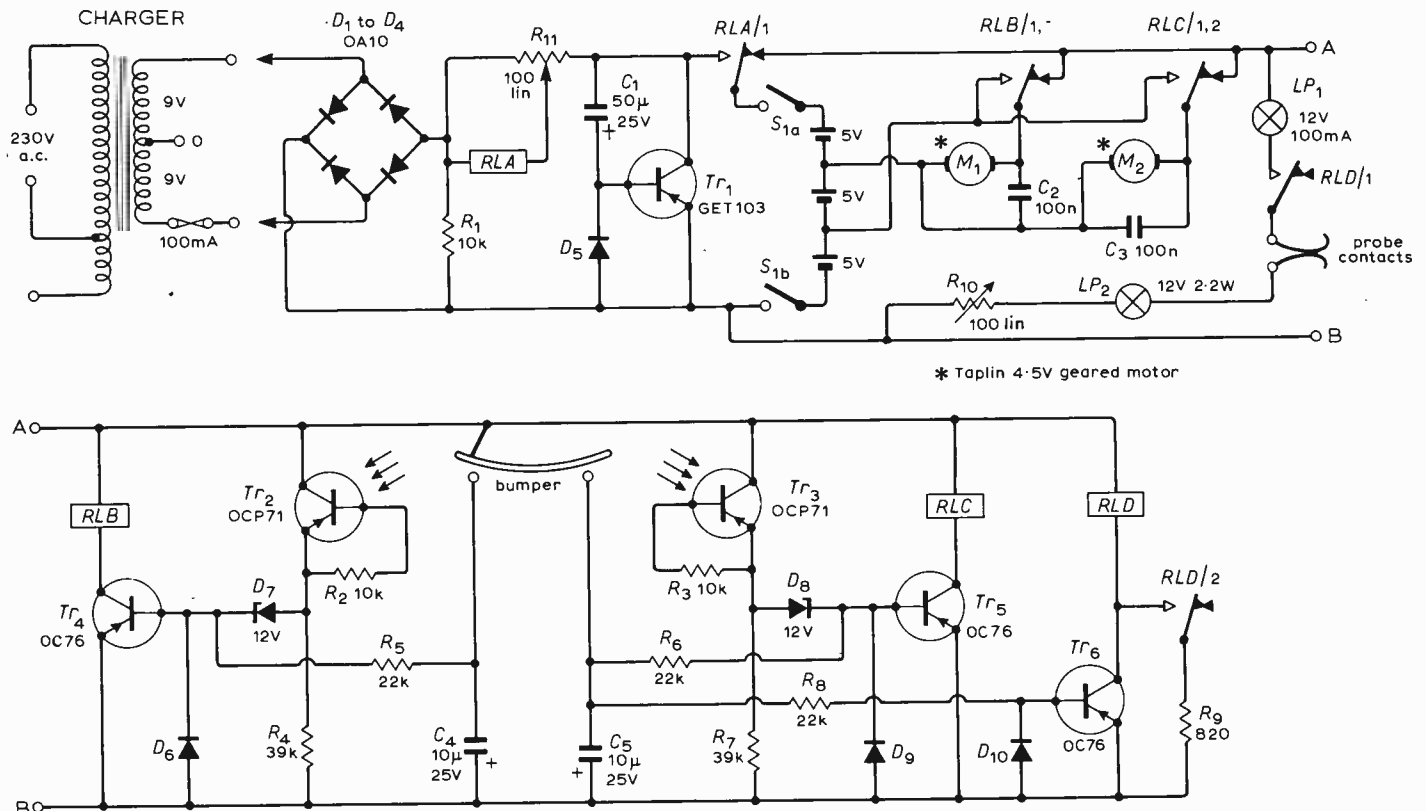

Fig. 2. Circuit diagram of the machine and the separate charger unit.

Lamp 1 is extinguished and *RLB* and *RLC* de-energize. The motor control circuits can now draw only a negligible discharge current. The motors are disconnected since contacts *A*, *B* and *C* have changed over and the machine will thus remain at the outlet until charging is complete. This period will vary from a few seconds to many hours.

When the battery charging current falls below a certain level set by *R*₁₁, *RLA* de-energizes. The lamp is no longer lit so the machine ignores the tape and moves off to explore the room.

Control *R*₁₀ is set for optimum tracking along the tape. The setting will depend on the degree of contrast between the tape and the floor; the machine will function properly only on dark or green floors. Control *R*₁₁ is set so that the machine emerges from the charger when the battery reaches between 15.5 and 16V.

Component notes

The individual constructor will no doubt modify the design to suit the components he has available. All the transistors in the pro-

totype were general purpose germanium types. The transformer was type MT98 with a 9-0-9V 80mA secondary but practically any transformer which will supply around 18V will suffice. The expensive items are the rechargeable DEAC L-type cells. Three 9.6V 225mA were used split in half and connected in series/parallel to give 15V. The motors can be either Taplin 4.5V geared motors or Meccano No. 11057 or any similar geared motors. The relays need not be exactly as

mentioned below but if relays of significantly different characteristics are employed it may be necessary to alter other component values: *RLA*, 100Ω, s.p.c.o. (sensitive relay control type); *RLB*, *C*, *D*, 340Ω, 2 p.c.o. (Clare miniature).

Reference

I. T. D. Towers, "Relay-semiconductor Control Circuits", *Wireless World*, May 1968, pp. 126-9.

Corrections

We regret the transposition of some captions in the article "Some Early Radio Receivers" in our November issue. On p.512 the captions at the foot of col.1 and top of col.2 were transposed as were those for the Ultra and Marconiphone speakers on p.513.

In Fig.2 in Mr Oldfield's letter on p.521 of the November issue the "greater than" sign after + *V*_{out} should be "less than".

The table accompanying the *loudspeaker enclosure survey* in the November issue omitted details of those models for which information had not been received from manufacturers; the table below gives data on eight more enclosures. In the article, the ordinate on the Mordaunt-Short MS235 free-field response curve should have been marked in 10dB and not 5dB steps, with the 5dB marking being 0dB. In the third column of page 557 the equation for inductor values of Fig.8(a) should read $L = Z/(2\sqrt{Z} \cdot \pi f)$.

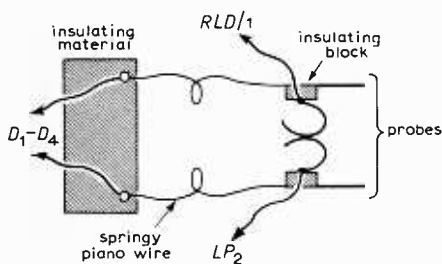

Fig. 3. Construction of the probes at the rear of the machine.

Model	Power rating (w)	Size (in)	Impedance (Ω)	Drive units	Finish	Price £	P. Tax
B. & W. Electronics, Meadow Road, Worthing, Sussex BN11 2RX							
DM70	25-100	32½ × 26½ × 15½	8	2	Walnut or satin white	159.50	—
DM2	25-60	25½ × 14 × 13½	8	3	Teak, walnut, rosewood or satin white	69.99	Inc. tax
DM4	10-30	21 × 10 × 10	8	3	Teak, walnut, rosewood or satin white	49.66	Inc. tax
DM1	up to 15	16½ × 9 × 8	8	3	Teak, walnut, rosewood or satin white	37.39	Inc. tax
D5	10-25	18 × 9 × 7	8	2	Teak, walnut or satin white	29.74	Inc. tax
*Including electrostatic unit							
Spendor Audio Systems Ltd, Kings Mill Lane, South Nutfield, Redhill, Surrey RH1 5NF							
BC1	40	25 × 11½ × 12	8	3	Teak or white*	77	Inc. tax
BC11	50	25 × 11½ × 12	8	3	Teak or white*	85.75	Inc. tax
*Walnut and rosewood extra. Trolleys available: black and white £8.50. satin-chrome £10.90.							
Goodmans: data on new enclosure							
Goodwood	60	30 × 14½ × 10½	4-8	3	Teak or walnut*	55	—
*White extra							

London Audio Fair Review

New developments in sound reproduction

An attendance figure at the Olympia Audio Fair of 98,953, compared with 76,099 last year, is indicative of the crest that the "hi-fi" industry is riding. Technical advances are being made in each link of the sound reproduction chain, as is shown by the equipment described in this report, the greatest number of new items being in the realm of cassette and reel-to-reel recorders and in the quadraphonic field.

The Audio Fair was chosen by the B.B.C. as a platform to demonstrate their new stereo service, and daily transmissions of Radio 2 programmes were made in stereo from a studio set up in the main hall. In order to demonstrate the quality of the new stereo service, the B.B.C. arranged for visitors to watch the transmissions and tune in via headphones either direct to the studio or to "off-air" reception from an aerial mounted on the roof of Olympia.

Magnetic recorders

The growing popularity of magnetic recorders as a part of the domestic high fidelity installation was reflected in the enormous number of new models. It would seem that the largest growth area is cassette recorders where for example, one exhibitor, Rank Audio Visual showed a range of six new machines in addition to seven new reel-to-reel models and three cartridge machines.

It is interesting to compare the various techniques employed to reach the goals required and typical of the highly individual approaches is that adopted by National Panasonic in their pre-production prototype of the RS279US. The mechanism of this cassette recorder is completely controlled by solenoids operated by microswitch buttons on the panel. The motor is again unique, being a direct drive type where the capstan is actually the motor shaft. Here the difficulties of maintaining a constant tape speed are even worse than normal since the motor revolves at such a low speed that sheer momentum cannot be used as a means of smoothing the normal wow and flutter associated with tape recorders. In this case a fairly sophisticated servo control circuit is used which applies small corrections to the motor torque every one third of a revolution. The servo has eight

transistors in all (Fig. 1.). One is used as an oscillator which provides a chain of pulses to three control transistors. The pulses are switched in turn by three more transistors operated from sense coils wound with the drive coils. The net result of this arrangement is to switch the oscillator output to each of the drive coils in turn. Speed control is produced by a third set of windings in the motor which supply an induced chain of pulses to a comparator, which also receives a feed from the oscillator. Variations in the phase difference between the two sources alter the collector-emitter impedance of the comparator transistor which is wired to the emitters of the three switching transistors, thus adjusting the drive current available to the motor. In this fashion a closed servo loop is formed which gives a very tight control on the motor speed.

A further interesting feature of this machine was the use of a third head to monitor the recording process. For a cassette machine this is really very unusual, largely because the original

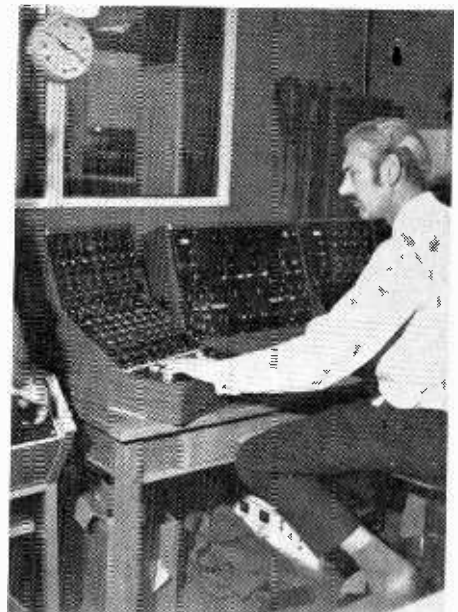

Control unit which monitored the B.B.C. Radio 2 programmes transmitted in stereo from a studio at the fair.

National Panasonic RS279US stereo cassette deck.



Philips concept did not allow for such an eventuality in the cassette itself. As a result the additional head has had to be sited in a very small hole in the cassette intended for other purposes. One big difficulty associated with such an idea is that when Dolby processed recordings are being made on the machine, since the processor is already occupied with the recording operation, it cannot be used to "decode" the output from the monitor head, and as a result it does not represent an accurate example of the final sound quality obtained from the normal replay head.

Other notable new products came from Tandberg who were not only launching a new reel-to-reel machine and tuner but also produced a new cassette recorder. One of the most intriguing aspects of this is that it represents the first new cassette deck of high quality, also incorporating a Dolby processor, originating from this side of the Atlantic. Yamaha have also introduced a new Dolby cassette deck with the rather unusual facility for changing the pitch of the replayed recording by adjusting a top panel slide control. Using this feature it is said to be possible to adjust the tuning of the recording to permit accompaniment by any musical instrument. Several other interesting features are hidden in the circuitry, one providing an electronic mute for occasions when the pause control is operated. Since the operation of this control is not mechanical and only removes the power from the motor, the

start time is not instantaneous and so the mute circuit takes this into account and restores fairly slowly, preventing any unpleasant wow or jitter becoming noticeable.

Apart from Akai, the only other stand showing a number of new reel-to-reel machines was Acoustico who launched, among other products, two four channel recorders, one of which, designated the Teac A3340, boasted a top tape speed of 38cm/sec and permitted the use of ten inch reels. The most impressive machine was, however, the Teac A720, a console mounted reel-to-reel recorder designed primarily for the professional market and representing one of three models in the range. At a price (without the console) of £812 it is almost certainly outside most "hi-fi" budgets. Uher, a company noted for the number of its portable machines used in professional circles, showed a new model. This was the 4000IC, an internally modified version of a very popular model. The principal change was the introduction of integrated circuits into some of the amplifying functions.

Turntables and arms

Only a few new turntables were shown but it was interesting to see that two trends were being followed, first an improvement in quality and technical excellence without undue increases in price, and secondly, technical innovation which either radically modified the character of the turntable or considerably improved the performance of a "budget" priced product.

A very good example of the former was to be found at the Bang and Olufsen stand where the new model 4000 turntable attracted large crowds all week. The main feature of this unique machine was the employment of a parallel tracking arm, which although not a completely new concept in itself showed up in a new form here. The tracking operation of the arm was initially controlled by a photocell and lamp combination mounted in a sense arm alongside the pickup arm, this being used to determine the diameter of the disc on the platter, and in turn, through internal logic circuitry, switch the platter speed to the appropriate standard. The pickup was then automatically lowered in the correct place and its motion across the disc controlled by a sensitive closed loop servo actuated by two further photocells. Since it is proposed to describe this turntable in more detail in a future issue, suffice it to say that it does seem to represent a considerable advance for turntables and very much follows the two philosophies of designing for the future and approaching the product as a complete unit with an integral cartridge and arm.

Leading examples in the area of quality at low price were the new Pioneer PL12D, an elegant turntable with integral arm, and the new Goldring G101, which departs from the makers' consistent policy of variable speed idler wheel transmission to adopt the principles of belt drive. BSR also extended their range with a lower priced version of their model 810 transcription unit which appeared last year. The new product, designated model 710, is a two speed unit with an optional facility for automatic operation with inter-changeable spindles, low mass pickup arm and viscous damped cuing. In the slightly higher price bracket, Thorens introduced a new addition to their range in the TD160 which features an improved pickup arm. Again from Japan, some technical innovation was seen from National Panasonic who showed a direct drive turntable, the SL1100, a two speed machine with an integral arm.

New cartridges were few and far between and only three appeared at the Audio Fair. These were the ADC XLM, a low mass, high compliance cartridge from Hisonic Ltd, the G820 series from Goldring and the recently improved M75ED type 2 from Shure Electronics.

SME have introduced an improved version of the 3009 Mk II pickup arm. The weight of the arm has been significantly reduced and a different method of counterbalance decoupling employed. Tracking weight is adjustable from 0 to 1.5g and the range of cartridge weights accepted is 2 to 12g. Setting up the arm can be quickly and easily done by following a clearly laid out pictorial instruction booklet. Standard SME arms require 3½in clearance under the bed-plate, but an alternative version with horizontal cable entry requires 2½in clearance.

Loudspeakers

The absence of several major loudspeaker manufacturers, coupled with large

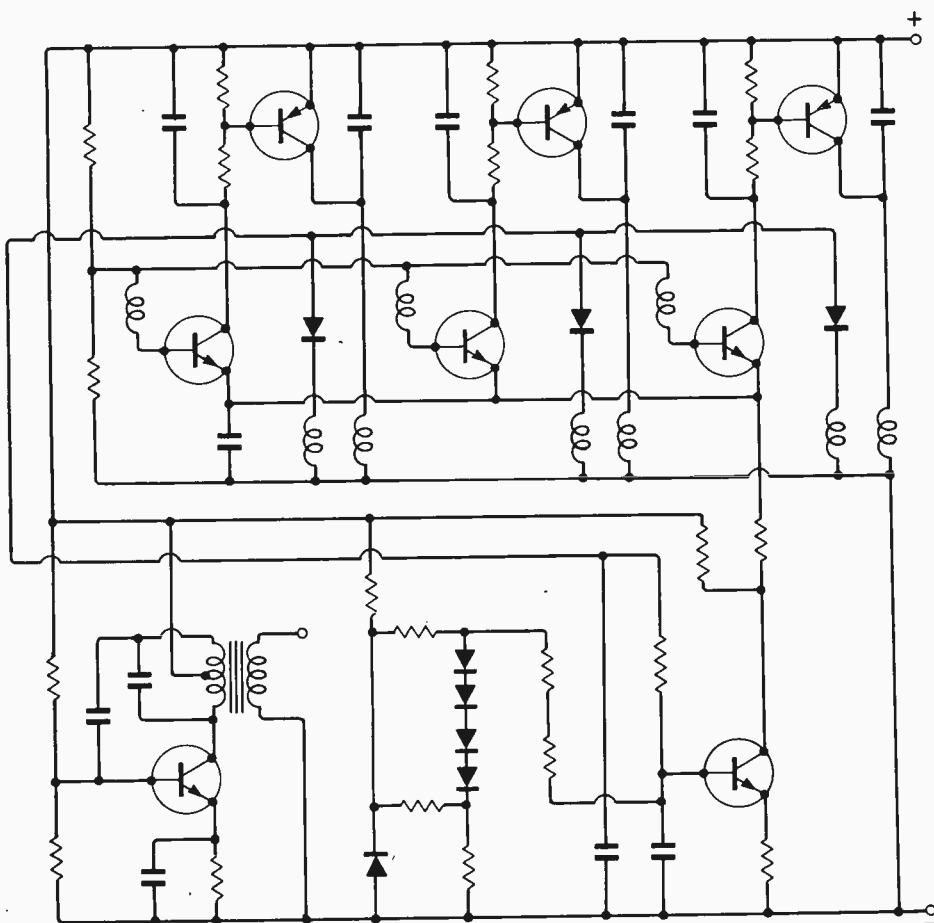
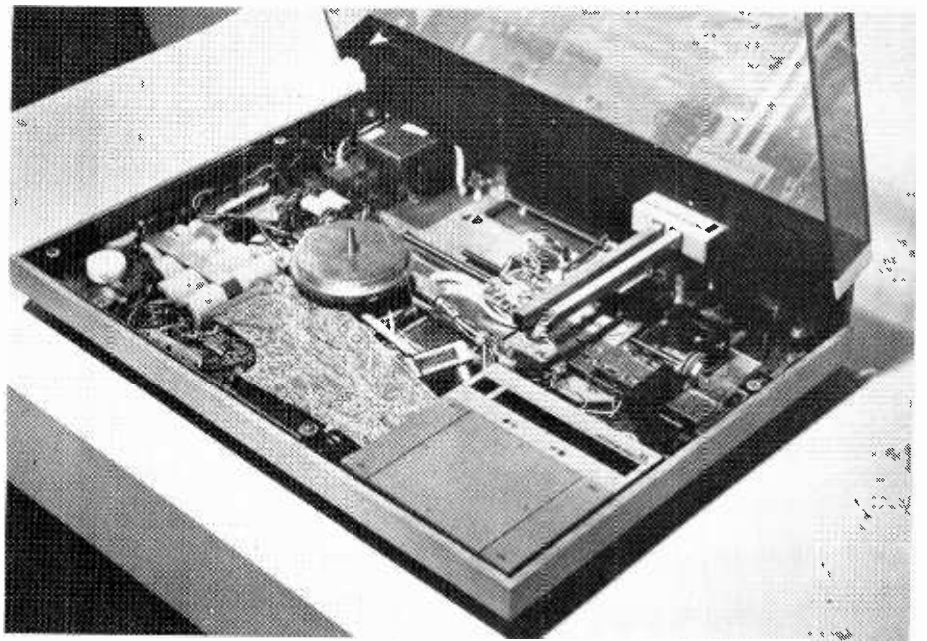

Fig. 1 The control circuitry for the direct drive motor in the RS279US cassette deck.

attendances at the show implies that the missing companies have missed much valuable trade. A second look reveals however that the problem is not to maintain a full order book, but to keep orders down to the maximum limit that production lines can cope with.

Lecson Audio, a new name at the show, were demonstrating a horn loaded loudspeaker system, the HL1, which comprises a bass horn, a mid range horn and a Melinex diaphragm tweeter. The bass horn takes up four fifths of the total height and is fed from two elliptical drive units. Crossover to the mid range horn occurs between 400 and 500 Hz. This is a short horn operating over the range 500 Hz-5kHz and its direction of radiation is adjustable so that an optimum position for the best stereo image can be obtained. At 5kHz the tweeter takes over. The main specifications are: frequency response 30Hz-25kHz, handling capacity 50 W continuous, nominal impedance 8Ω. Size is 14½ in wide, 36 in high and 17 in deep. The HL1 has been designed to stand across a corner for optimum performance but it can be stood against a wall.

Acoustic Research, who were demonstrating their range of loudspeakers, provided a direct, switched comparison between each model using the same programme material throughout the comparison. Perhaps this is a brave way of presenting their products under poor acoustic conditions, but all were impressive. The design philosophy of creating the "best possible" unit and trying



B & O 4000 parallel tracking turntable shown together with a view of the interior electronic circuitry.

to match this performance with smaller models in the range was demonstrated clearly by the switch to the new infinite baffle AR-7 system costing £52 per pair (inc. tax). The criterion by which AR judge their standards is the AR-LST which uses a 12in acoustic suspension woofer, four 1½in mid-range hemispherical radiators and four ¾in hemispherical tweeters. Crossover frequencies are 575

and 5,000 Hz. The AR-LST contains an autotransformer with taps at 1dB increments from 0 to -6dB.

Two new models have been added to the Bowers & Wilkins range of loudspeakers. The D5 is an i.b. two-unit system comprising a Bextrene coned bass/mid range unit with a 25mm dome type high frequency unit. The crossover and filter unit (3rd order Butterworth) gives an

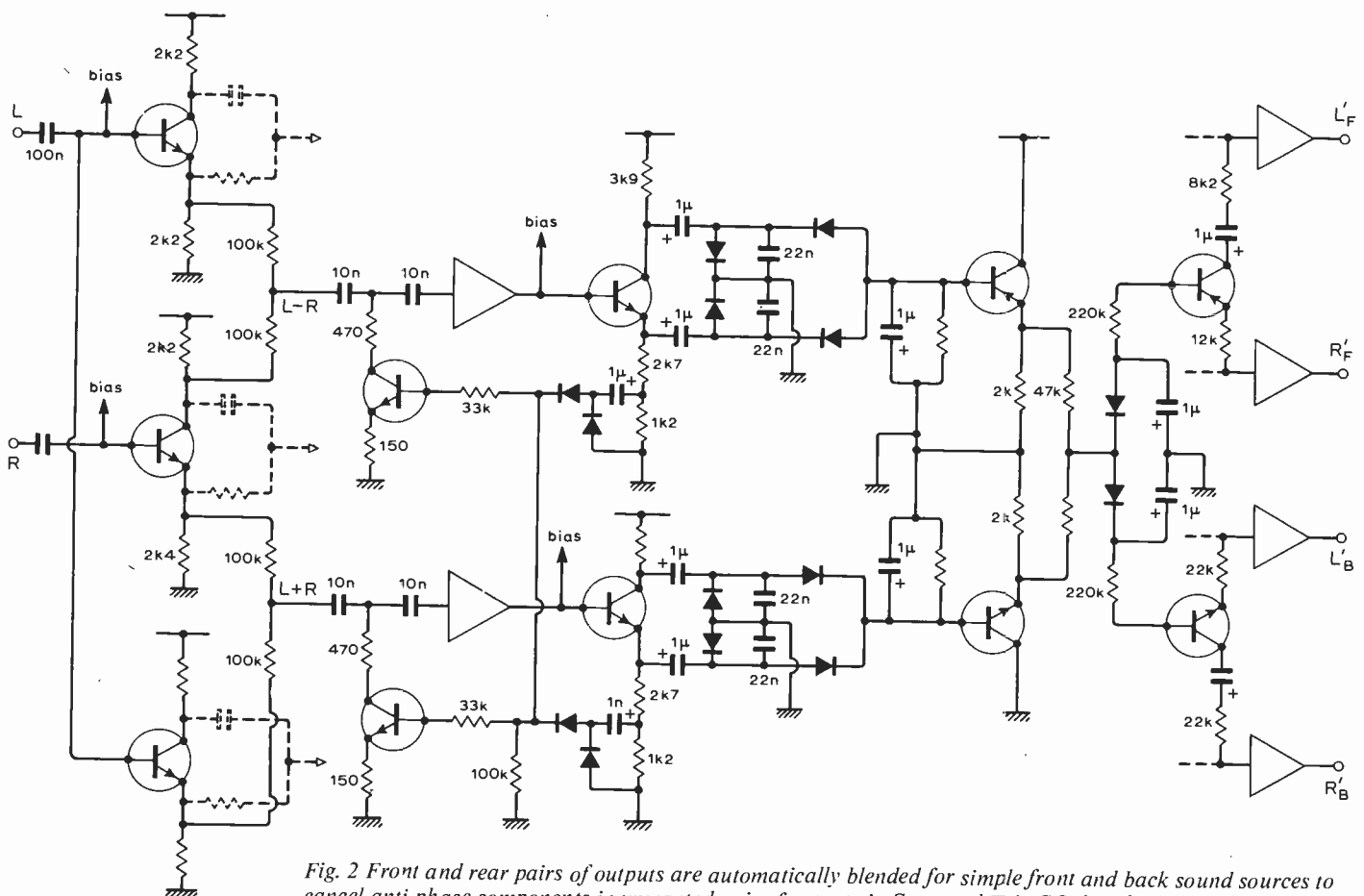

Fig. 2 Front and rear pairs of outputs are automatically blended for simple front and back sound sources to cancel anti-phase components in unwanted pair of outputs in Sony and Trio SQ decoders. (Component values are for Sony decoder.)

18dB per octave attenuation in the stop band. Ten watts into the nominal impedance are required to produce a sound pressure level of 95dB at one metre at 400Hz. The DM4 (see photograph) is a 3-unit loudspeaker. Low frequency loading is by means of a critically damped enclosure with a small controlling vent to control the response between 60Hz and 120Hz and to reduce cone excursions from 30Hz to 60Hz. Sensitivity is 3.6W into the nominal 8Ω impedance producing a sound pressure level of 95dB at one metre at 400Hz. The bass drive unit in this model, designed by B. & W., consists of a 143mm diameter Bextrene cone driven from a 26mm voice coil on an aluminium former. The voice coil is coated with a bonding agent and is heat cured.

The new Goodmans Goodwood loudspeaker demonstrates the philosophy of trading efficiency for reduced distortion -- if the driving amplifier is capable of providing the high output levels demanded from it. Other benefits can be obtained by accepting a low efficiency, the prime advantage being smaller cabinet size without sacrificing the overall frequency range. Main specifications of the Goodwood are: frequency range (in anechoic conditions) typically ± 3 dB 55-22,000Hz and -10 dB at 35Hz, power handling peak at 60W r.m.s. into 4Ω , 9W are required to give 96dB at 1m, impedance 4- 8Ω , crossover frequencies 600Hz and 4000Hz. Size is 76 x 36 x 27 cm.

Amplifiers

Coupled with the trend towards lower efficiency loudspeakers with high power handling capabilities, several new high power amplifiers were introduced at the show. The Ferrograph F608, which can supply 60W continuous power per channel into a nominal 4 or 8Ω load, was demonstrated by Ferrograph, but will not be released until Spring 1973. Preliminary specifications reveal a total harmonic distortion of less than 1% and we were informed that the 2nd harmonic component will be reduced to less than 0.08% in the production version. Signal-to-noise ratio using the magnetic pickup input is better than 60dB and an input of 2.7mV will produce maximum output into 8Ω . Magnetic input overload is 30dB. A variety of filters is provided by independent push-buttons on the front panel (see photograph). Low pass filters cut the high frequency response by 3dB at 10kHz, 7kHz or 5kHz and by 30dB in the next octave. A rumble filter reduces the low frequency response below 50Hz. The output stage of the power amplifier is fully complementary and includes circuit protection from transient overloading. The amplifier is also fused for protection from more permanent overloads. Silicon transistors have been used throughout and f.e.t.s have been used on all inputs except the magnetic input, where low noise transistors have been used. The price of this amplifier will be £135.00.

The Trio KA6004 stereo amplifier is

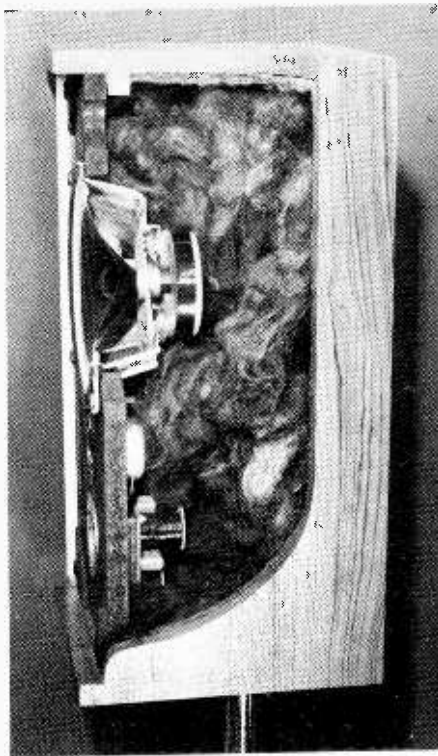

Cut-away view of the B & W DM4 loudspeaker showing the three drive units, part of the crossover and filter network and the long fibre natural wool which reduces standing waves, reflections and colouration. The inner cabinet surfaces are also absorbent lined.

rated at 40W continuous per channel into 8Ω (20-20,000Hz both channels driven). A comprehensive specification sheet for this amplifier gives separate distortion figures for harmonic and intermodulation distortion rather than the less meaningful t.h.d. figure. Harmonic distortion is less than 0.5% at the rated output from 20Hz to 20kHz and less than 0.05% at -3 dB from the rated output. Intermodulation distortion is measured with input frequencies of 60Hz and 7kHz and a relative input level of 4:1 respectively. The resulting intermodulation distortion is less than 0.3% at the rated output and less than 0.05% at -3 dB rated output. The specification sheet, possibly a Japanese translation, also mentions a "table control" -10 dB at 10,000Hz with a 2dB step switch!

A preamplifier, AC1 and power amplifier, AP1/AP2, of unusual styling were introduced by Lecson Audio. A flat, slim profile preamplifier with slider controls has a tape monitor and remote control facilities. Inputs for magnetic pickup, two radio and the auxiliary inputs (one and two) have signal-to-noise ratios of better than 70, 80 and 80dB respectively. Overload on the magnetic pickup input is 50dB. The frequency response is 10Hz to 25kHz ± 0.5 dB. The accompanying cylindrical AP1 power amplifier has a typical power maximum of 50W per channel into 4 or 8Ω ; minimum power is 35W and the power bandwidth is 20Hz to 20kHz. Distortion is low. At

1kHz distortion is less than 0.005% at 35W, and less than 0.02% at 50W. Intermodulation products are less than 0.05%. Lecson also says that the amplifier produces no transient distortion effects. This statement is in keeping with the importance they attach to this form of distortion in sound reproduction -- including loudspeaker performance. The AP2 amplifier has the same specifications as the AP1 but minimum power is rated at 70W per channel into 8 or 4Ω .

Four-channel progress

Now that the Japanese Record Association has produced standards for matrixed discs records (as well as for discrete four-channel discs) many Japanese makers are producing equipment with circuitry for decoding both regular matrix and SQ coded discs. The Pioneer add-on unit QL-600A, QC-800A amplifier, QX 4000 tuner-amplifier, and QC800A preamplifier, fall into this category. The Trio KSQ20 decoder (£47.50), Rotel RX-154A receiver (£129.50), Sony SQA200 rear-channel amplifier and decoder (£57.75) and the Teleton SQ446 tuner-amplifier (about £150) also feature SQ decoding circuitry. Both the Sony and the Trio include so-called "logic" circuitry which acts to reduce crosstalk for simple input signals. The new Harman Kardon series of receivers, called the 50+ (£175), 75+ (£275), 100+ (£325) and the 150+ (£375) features SQ decoders and all except the 50+ have two SQ decoding functions, one with blend circuitry to increase front-to-back separation at the expense of left-right separation.

A decoder designed by Connaught Equipment, first European SQ licensees, is marketed by Lasky's Radio. Sold under the Audiotronic brand name, it costs £11.95 in kit form and £25 built. This includes 6-pole phase difference networks giving a phase frequency response of $90 \pm 10^\circ$ from 20Hz to 18kHz. The unity-gain decoder has an output impedance of less than 300 ohms so that it can be used remotely from amplifying equipment. Harmonic distortion quoted for this is 0.025% for its nominal input of 250mV (0.08% at 1V input).

With a "raw" SQ decoder, a centre front signal is accompanied by antiphase signals from the rear speakers, all four speakers producing the same signal level. Similarly this occurs with a centre back signal if recording engineers choose to use this position, which is suppressed when reproducing monophonically. (This happens too at the sides, where the signals to the two speakers producing unwanted outputs are in antiphase and are nearly 5dB down on the wanted signals. For corner signals, undesired outputs are 90° different in phase and 3dB down.)

The blend-type decoder circuit is one way of alleviating the front-to-back situation; the other is to reduce the gain in the unwanted channels. While this may be fine for such simple input signals, any other signals from different directions may

either be attenuated, cause odd effects if they are time-varying, or defeat the "logic" circuitry. The circuitry on the Sony (Fig. 2) and Trio models is intended to operate in the front-to-back mode.

What happens is this. With a front signal the magnitude of $L + R$ is greater than $L - R$, so these two signals are formed in an auxiliary matrix circuit (connected from the first stages of the phase difference circuits in Fig. 2), rectified and compared. For $L + R > L - R$ a positive voltage is obtained from the comparator which causes the collector emitter resistance of the bottom transistor to decrease, thus blending the back two channels. As they are in antiphase, the signals will cancel to a degree. A similar situation holds for a back signal, when a negative voltage will cause the two front channels to blend. As the signal level fed to the full-wave rectifying stages needs to be within certain limits, an a.g.c. circuit taken from the transistor emitters of the rectifier stages is necessary, the outputs from each chain of the circuit being combined so that a difference in one input relative to the other is not affected by the a.g.c. circuit. All this additional circuitry — and the two models mentioned are not full "logic" models — makes for these units' relatively high cost. Integrated circuit chips will be available in 1973 for the automatic blend and a.g.c. functions, as well as the phase shift functions, and we might then see some cheaper decoders.

Two other brands of equipment shown are indicated as suitable for playing SQ discs. The new Sanyo "music centres", combining tape and disc players with receiver and loudspeakers, have a matrix circuit but they do not appear to include phase difference circuitry (GXT4521K cassette model, £169.95, GXT4531K cartridge model, £159.95). Onkyo models Y-3A (receiver, £130.76) and X-1E (disc player and receiver with speakers, £360) have matrix circuits, but phase shift circuits seem to have been added later and this circuit detail is not included in the service data.

Heath showed a pre-production prototype SQ decoder which will be available spring, 1973.

Tuners and tuner-amplifiers

Many new tuners and tuner-amplifiers were introduced this year, and there were so many that lack of space prevents a detailed treatment of each, but in general the circuits follow now well-established lines. Two of the new ones are Cambridge Audio T55 tuner at £97.90 and the Goodmans Module 90 tuner-amplifier at about £120. The Goodmans tuner incorporates the comparatively rare feature of an a.m. tuning indicator. Along with an increasing number of U.K. makers, the Module 90 has sockets for connecting two rear speakers to give antiphase difference signals.

Shown for the first time in the U.K. were the Philips RH621 tuner (£109), the AR receiver (£240), and the Marantz 2010 tuner-amplifier at £148. The Scan-Dyna 2400 (£125.90) is interesting with its roller-type tuning control and

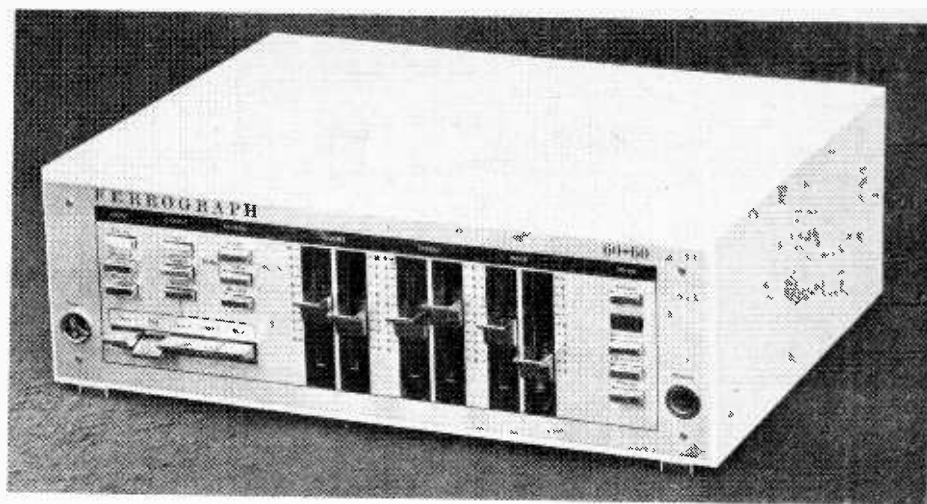

Ferrograph 60 + 60 amplifier was demonstrated at the show but will not be available until Spring 1973.

multi-purpose meters. For pre-selecting f.m. stations, the left-hand meter indicates frequency while the right-hand meter acts as a tuning indicator. For audio mixing the meters indicate output levels for both channels. And for a.m. reception the left meter is a tuning indicator with the right acting as an S meter.

There were many other new tuners and tuner amplifiers — from Tanberg, Rotel, Akai, Heath, Grundig, Nikko, Luxman, Trio, Pioneer, Sony, Teleton, Alpha, Steepletone, Sharp, Nivico, Metrosound, Hisound, Decca, B & O, Audiotronic (Lasky-Smiths), as well as new composite units from Hacker, Pye, BRC and RBM.

Additional items

- Antiference introduced two aeriels. The FM264 is a six element folded dipole array and the FM214/EM is a surface mounting dipole. Both join the established dipole, "H", three and four element arrays which have been improved and tuned for optimum performance throughout the U.K. f.m. Band II, 88-100MHz. (Previous aeriels were designed for 88-104MHz.) The FM264 costs £6.95 and the FM214/EM £2.20.

- Changes to the Ferrograph tape recorder test set RTS2 include a dBm scale added to the millivoltmeter ranges and an extra range for wow and flutter tests. Peak wow and flutter measurement uses a carrier frequency of 3.15kHz provided by an internal oscillator. Model RTS2/A has a carrier frequency of 3kHz. The price of the unit remains unchanged at £250. The RTS test set is now complemented by an auxiliary unit which contains two sections; one modifying the output from the RTS oscillator for feeding to the tape recorder or amplifier under test, and the other modifying the signals being fed to the RTS meter section. Each facility (gain, filters, balanced or unbalanced loading) is selected by push buttons.

- For stereo amplifiers having output sockets with a common earth, the Scan-Dyna "4D" adaptor is a convenient way of hooking up two rear speakers to

existing amplifiers. The rear speakers are fed with antiphase difference signals at an adjustable level. At £12.90 it is the cheapest adaptor of its kind.

- The Min-Ster headset from Cowley Instruments can be used directly from a record player deck because of its built-in amplifier. Powered by internal 3V batteries it weighs 450g and is claimed to deliver 450mW per channel. It could also be used for practice on musical instruments fitted with pickups. Price about £20.

- Sanyo's Stereocast adaptor allows stereo headphone reception from Sanyo portable radio sets. It features an f.m. stereo decoder and amplifier and takes its power from the portable set. Intended for use with RP5210, RP5310, RP7412, RP8110 and RM5430 sets. Price £9.95.

- The Tripletone Hi Fi 1818 amplifier has an output power of 15W continuous into 8 Ω at 1kHz (both channels driven) and a total distortion of 0.25% at 1kHz and the maximum rated output. The characteristic bass, middle and treble dual concentric tone controls have been retained. Silicon transistors, used throughout the power amplifier section, have replaced the previous germanium output devices and an f.e.t. at the ceramic input to the pre-amp provides a true input impedance of 2M Ω . Signal to noise ratios are: magnetic 65dB, ceramic, tuner and tape 70dB. The price of this amplifier is £46.50.

- A solid-state range of audio test gear, the "E" series, available from Trio, has been made available for amateur users. Each instrument is lightweight and small in size. The series consists of a 75mm d.c. to 1MHz portable oscilloscope, a sine and square wave signal generator (20Hz to 200kHz), a 100kHz to 30MHz signal generator, which includes a 400Hz signal source for modulation of the output signal or modulation from an external source, and finally a portable f.e.t. volt/ohm meter which measures a.c. voltages in the range 15Hz to 5MHz.

Letter from America

The 4-channel or quadraphonic war is still on. CBS have made some gains with their SQ system and now have more than 50 licencees including such big names as Fisher, Sony, Marantz and Pioneer. The Sansui system is being used by a number of f.m. stations and record companies like Command, ABC and Ovation. They have been demonstrating the new Vario-matrix system recently and most people have been very impressed. Although it operates like a logic system, the "gain riding" does not depend on amplitude but on phase. Early SQ and other logic circuits were criticized for the rather annoying "pumping" action, but this effect is not noticeable on the later versions. I heard no sign of it during the Sansui demonstrations either, but would hesitate to comment further until I can test a decoder in my own home. It would make an interesting comparison with the new Sony 2020 SQ unit for instance. One thing I *can* say, the separation with the Vario-matrix is excellent and it was quite difficult to tell which was matrix and which was the discrete tape.

RCA's latest discrete record has a playing time of 25 minutes per side*. JVC were demonstrating this one at the recent A.E.S. Convention and subsequent Audio Show in New York. Emphasis was on separation which I personally do not feel is as important as other factors that affect musical values. However, it must be said that these discrete (a misnomer, really) discs have come a long way in terms of frequency range, dynamic range, signal-to-noise, and so on. I am now in the process of installing a JVC discriminator decoder and pickup and will report on the results in due course.

One of the most interesting records from CBS is the Bernstein Mass. It is a fascinating mixture of grandeur and utter banalities. The sound itself and the dramatic use of quadraphonics in the CBS SQ record is simply superb. The listener is really engulfed in sound with the variously placed choral groups, vocalists and instrumentalists making a stunning impact. It shows what can be achieved with this new medium. Another CBS record that

demonstrates the potential of this medium is "Music for Organ, Brass and Percussion" with Power Biggs. It was recorded in New York's St. George's Church which has a Möller 5 section organ with one unit in the rear gallery. The SQ record has succeeded in capturing the acoustics, the *ambience* of the church, remarkably well. With good equipment and plenty of power, the listener can really get the impression of being there. It is true that many quadraphonic discs tend to stress the location effects but when I hear what *can* be achieved with quadraphonic sound I know it will eventually replace 2-channel stereo. And that's a prophecy.

One of my duties in 1957 (or maybe it was 1958), was to advise manufacturers on 2-channel amplifier design and so on, as stereo records were about to be released. I well remember the reactions; some thought it was just a gimmick, "couldn't possibly catch on old boy", others thought it was a plot hatched up by the greedy record companies and quite a few were dubious about the practicality. I have not forgotten the comment of a prominent executive "Stereo? who wants to listen to music coming from two portholes!" I am sure he would prefer that I didn't mention his name now

Now for a few words about the A.E.S. convention which was held in New York's swish Waldorf-Astoria. As always, there were some beautifully styled, streamlined studio control desks on view (some were in operation) including one from Rupert Neve now established here. But what attracted attention on this stand was a tiny card bearing the words "Delivery in 30 days". Upstairs, quadraphonic demonstrations were in full swing (if that is the right word) and Electro-Voice were also using their new speaker systems which are a little unusual. Cabinet size is quite small, being less than a cubic foot and a 6-inch bass unit is used with a much larger direct radiator acting as a vent substitute. A wide-dispersion h.f. unit is employed and the system is electrically equalized from about 100 Hz down. It is claimed that two systems could radiate more than one-sixteenth acoustic watt at 32.7 Hz. Some of the design concepts are based on the work of A. Thiele and R. H. Small† — duly acknowledged. It is

notoriously difficult to judge loudspeakers at demonstrations but the Electro-Voice systems certainly sounded clean with a smooth, uncoloured bass. EPI were demonstrating some new column speakers which are regaining some popularity here. Hegemann make one with an 8-inch driver facing upwards and about 15° forward. Mounted coaxially is a 1-inch dome h.f. unit providing some loading for the bass speaker which, incidentally, has an aluminium cone.

The New York Audio Show was held a few days after the A.E.S. affair, and very successful it was too. Harman-Kardon had their new Dolby f.m. tuner — so far the only one to use this system. Several stations here, including WQXR of New York, use a Dolby system but I found the refinement worth while even when listening to non-Dolbeyized stations. In my location just North of Philadelphia it is difficult to receive New York stations free of background but. I found the Harman-Kardon tuner reduced the noise considerably. I had to use some treble lift to maintain balance (a frequency selective equalizer was better still). Sony were demonstrating a very elaborate tuner with 100 channel-selection push-buttons. It has a memory band which still functions after the unit is switched off — just like an old-fashioned manual tuner: Price is fixed at \$1200.

Another, even more exotic, tuner was shown by Sequerra: this one had a c.r.t. display among other features. At \$1600, it cannot be called cheap even in this affluent society, but many people want state-of-the-art products and will pay almost any price to get them. Saul Marantz is one of the pioneers of the industry and he has now come out of retirement to market loudspeakers. Two prototypes were demonstrated; one a dynamic type with five units mounted on a kind of baffle similar to the Quad in appearance and the other a full-range electrostatic system. This has the top end supplemented by a piezo-electric transducer — probably because of dispersion difficulties. Both systems sounded very transparent with low distortion. Many designers are still attracted to the electrostatic concept for loudspeakers and there are now a number of hybrid systems (dynamic-e.s.l.) available, with more in prototype stage. A full-range system that has been in production for some time is the Dayton-Wright which is made in Canada. Features include curved plates at the edge of the diaphragm and the complete systems are filled with an inert gas and sealed. The gas used is sulphur hexafluoride and it enables the polarizing voltage to be increased before corona takes place. Thus, sensitivity is increased and the system is capable of handling quite high power levels. I heard them at the Toronto Hi-Fi Show and was impressed — in spite of the indifferent demonstration material.

† Thiele A. N., "Loudspeakers in Vented Boxes" Parts 1 and 2, *Journal AES*, May and June 1971. Small R. H., "Efficiency of Direct-Radiator Loudspeaker Systems," *Journal AES*, November 1971.

G. W. Tillett

* We reported in our September issue, p. 424, a playing time of 22 minutes. Ed.

Mobile/Portable Power Unit for H.F. Transceiver

by D. R. Bowman, G3LUB

From the start of the development of the 10-80 metre transceiver* (described earlier this year), it was planned eventually to use the equipment in a mobile installation. Here, the author describes a power supply unit designed to operate from a 12V negative earth vehicle system which is compatible with his transceiver design.

Amateur radio systems installed in motor cars have provided quite remarkable results, transatlantic contacts on the 20m band being commonplace. The limits to the performance inherent in h.f. mobile operation are primarily a restricted power supply, which is usually derived from the 12V car battery and short, rather low efficiency, aerials which have to be used. S.S.B. transceivers lend themselves extremely well to mobile operation and their ratio of communicable range against power supply size is extremely high. The communications efficiency of the s.s.b. mode of transmission

when compared with normal amplitude modulation has been discussed in previous articles.

When we come to examine the power requirements of the 10-80 metre transceiver we notice that both the heaters and transistor circuits require 12V at a total of about 1.5A, which is easily obtained directly from a car battery. The other requirements of 700V at 100mA peak, 350V at 50mA and the bias supply of 5mA at about -100V are somewhat difficult to provide. These supplies have also to be obtained from the 12V battery and therefore a voltage converting unit is required.

The power unit to be described is intended for use with a negative earth vehicle; there is likely to be some difficulty if a positive

earth system is required. The inverter can be easily modified, but the negative earth of the transceiver is not amenable to change. For positive earth vehicles the author suggests that a separate battery be carried in the boot of the car. Even with the author's negative-earth car a separate battery is used because of the difficulty of starting an automatic transmission vehicle if the battery is allowed to discharge too far.

There are many types of voltage converter, but the transistor blocking oscillator is by far the most efficient and reliable. The most commonly used circuit requires two germanium transistors operating in a push-pull circuit driving a single transformer, wound in this case on an old line output transformer cannibalized from a TV receiver. The blocking oscillator generates a square wave current in the primary of the transformer and with the appropriate turns ratio, almost any output voltage can be provided across the secondary winding. The

*'10-80 Meter Amateur Transceiver', by D. R. Bowman, *Wireless World*, June, July, August and September 1972.

Fig. 1. Circuit diagram of power supply.

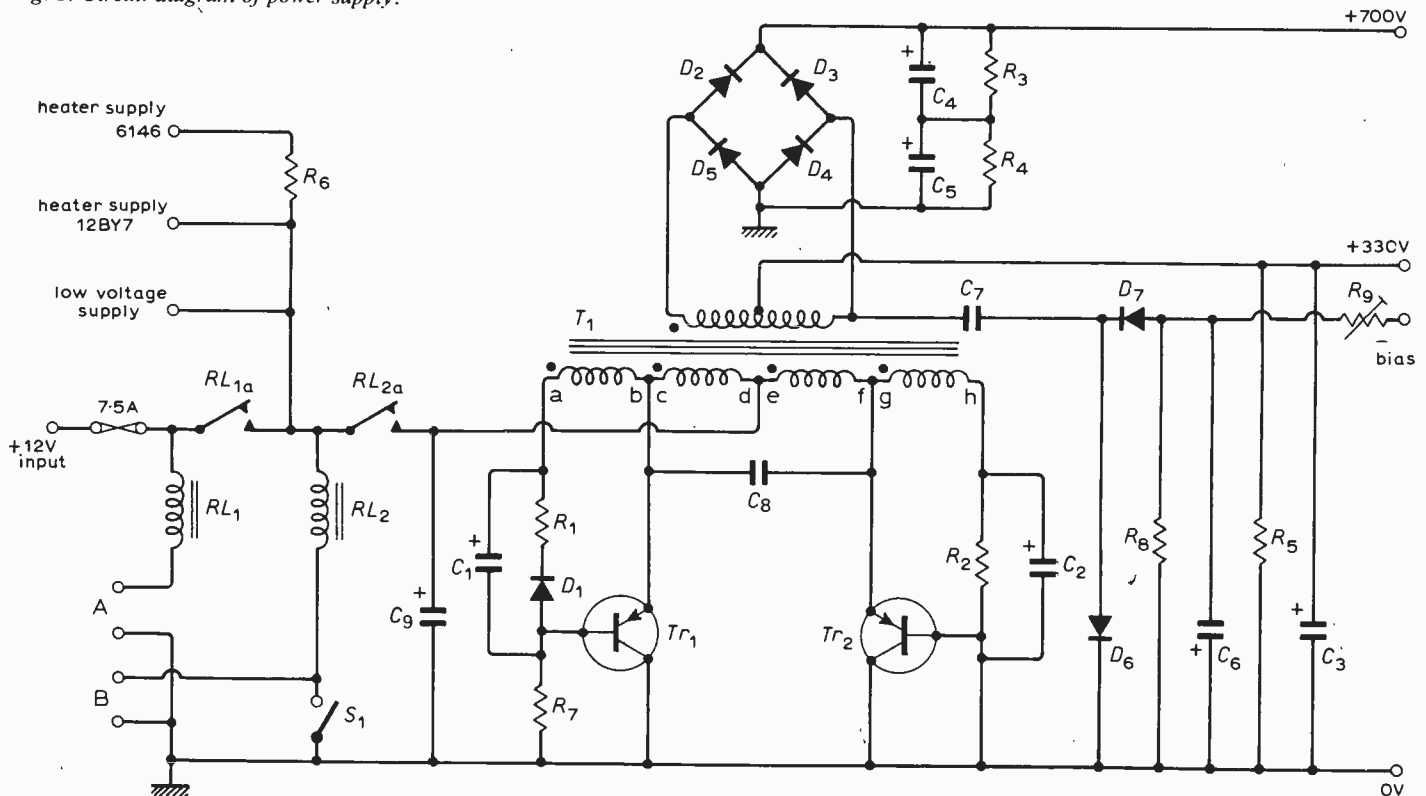

output is obviously in the form of an a.c. square wave and a standard rectifier circuit is used to reconstitute the d.c. The frequency of oscillation is essentially determined by the primary inductance and in the author's case was about 3kHz. As the frequency is relatively high, the effectiveness of the ripple-removing capacitors is also high.

The maximum current drain taken by the transceiver from the 12V battery is about 6.5A on transmit and 1.5A on receive which is quite modest.

All d.c. switching within the inverter unit is done using relays as this allows either remote positioning of the unit or, as in the author's case, mounting on the rear of the transceiver. The mains on-off switch on the transceiver front panel is a two-pole component, only one pole of which is utilized to switch the mains. The other pole is connected via the rear panel multiway socket to *A* on the inverter circuit diagram (Fig. 1). This allows front panel switching of the power supply from the transceiver by energizing *RL*₁. The other relay *RL*₂ is operated via the external control jack socket on the transceiver rear panel and thus allows a considerable saving in power as the inverter need be in use only when transmitting. This can be overridden for fast press-to-talk operation via *S*₁.

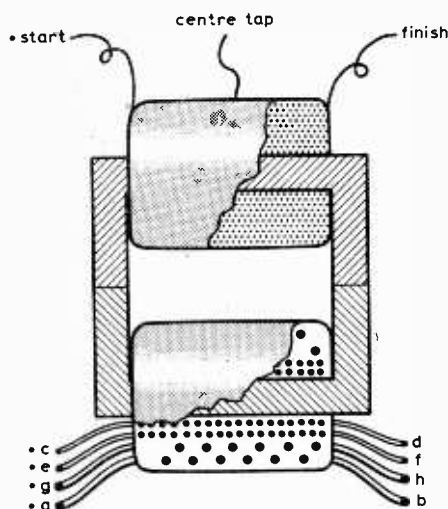

primary	{	c-d = 18 turns, 14 s.w.g.
		e-f = 18 " , 14 "
		g-h = 6 " , 20 "
		a-b = 6 " , 20 "
secondary	{	= 1,300 turns, 34 s.w.g.
		centre tapped at 600 turns from start

Fig. 2. Construction and winding detail of *T*₁.

In view of the rather high dissipation of the OC36 transistors, they were mounted directly on to the main inverter box. Care must be taken to remove any burrs around the mounting holes. A smear of silicon grease should also be applied to the two mating surfaces. The reader may have noticed that the various ripple smoothing capacitors are rather small in value. The reason for this is economy of volume as the main capacitors in the transceiver are used for both mobile and mains

operation. This is not normal practice but the capacitor values are large enough to eliminate the 3kHz ripple and the main transceiver capacitors provide the reservoir effect required. No interference on either transmit or receive has been noticed from the 3kHz and no special precautions were found necessary.

The rectifier circuits are conventional with the exception of the grid bias generator. It is considered bad practice to upset the balance of bridge rectifiers by connecting extra circuits but the bias load via *C*₇ is so light that it has no detrimental effect. The bias adjusting potentiometer *R*₉ is set so that the main bias potentiometer on the transceiver does not require resetting when changing from mains to battery operation.

The only problem likely to cause the constructor any trouble is the winding of the inverter transformer *T*₁. Almost any TV line-output transformer may be used. All old windings must first be removed, the core carefully split into its two halves, and all grease and dirt removed. A layer or two of tape, preferably the so-called empire tape or plastic type, should be wound over one of the non-split ends of the core. Next 18 turns of 14 s.w.g. enamelled wire should be wound linearly on to the core followed by a second isolated 18 turns of similar wire (windings *c-d* and *e-f* in Fig. 2). The two windings should now be connected in series in a bifilar manner, i.e. *d* of the first winding being connected to *e* of the second. This junction point becomes the centre tap of the primary. The two free ends and the centre tap are then left protruding about 1 inch from the ends of the core. These windings are covered with one or two layers of tape and then winding *g-h*, composed of six turns of 20 s.w.g. enamelled copper wire, is laid. This winding is connected in series with those previously laid by connecting together ends *f* and *g*. A further layer of insulating tape is applied and a second six turns of 20 s.w.g. enamelled wire are then wound to form winding *a-b*. The process of winding the transformer primary is completed by connecting ends *b* and *c* together. If the constructor wishes, the transformer can now be tried in-circuit. Immediately the 12V h.t. is applied to the circuit, a shrill whistle should be heard. If this does not occur try alternating the end leads that feed the transistor base connections. This should produce the required oscillation.

The secondary winding details are as follows: The other unused half of the core is insulated using at least three layers of tape. Throughout the following winding details at least one layer of tape must be carefully positioned between each winding as high voltages are present. In fact, approaching 1kV will be present between the start and finish of this secondary. A total of 1300 turns of 34 s.w.g. enamelled wire has to be wound. In the author's case there were ten layers with a tap at the end of the fifth, being approximately the 600th turn. Remembering that very few constructors have access to coil-winding equipment the author decided to construct this entirely by hand and set himself the task of winding two layers per day until the job was completed.

Components List

<i>R</i> ₁	1.5Ω	5W	w.w.
<i>R</i> ₂	2Ω	5W	w.w.
<i>R</i> ₃	100k	2W	carbon
<i>R</i> ₄	100k	2W	carbon
<i>R</i> ₅	100k	2W	carbon
<i>R</i> ₆	5Ω	10W	w.w.
<i>R</i> ₇	1k	1W	carbon
<i>R</i> ₈	220k	0.5W	carbon
<i>R</i> ₉	20k		linear potentiometer
<i>C</i> ₁	25μF		6V
<i>C</i> ₂	25μF		6V
<i>C</i> ₃	2μF		350V
<i>C</i> ₄	8μF		450V
<i>C</i> ₅	8μF		450V
<i>C</i> ₆	32μF		350V
<i>C</i> ₇	0.005μF ceramic		600V
<i>C</i> ₈	0.1μF ceramic		30V
<i>C</i> ₉	125μF		20V
<i>Tr</i> ₁ , <i>Tr</i> ₂	OC36 alternatives 2G220, OC28, OC35.		
<i>RL</i> ₁ , <i>RL</i> ₂	12 volt coil relay with 1 set of high current normally open contacts.		
<i>D</i> ₁	1N4002 or any 50V p.i.v. medium current diode (1A).		
<i>D</i> ₂ - <i>D</i> ₇	BY100 or any 1000V p.i.v. silicon diode.		
<i>T</i> ₁	See text and Fig. 2.		

Insulated sleeving was threaded over the wire at the beginning, end and at the centre tap to reduce the chance of short circuits. When completed, the two core halves must be either clamped together or Araldite resin adhesive used to hold them together. Take care that the windings are correctly oriented.

There is one extra point of interest. In view of the difficulty of obtaining 12V heated P.A. valves a circuit has been included using a 5-Ω wire-wound voltage-dropping resistor thus allowing, with a very small power wastage, the use of conventional 6146 type valves. Theoretically the value should be increased slightly if a 6146B is used, but the battery voltage variation will be so much greater that it is hardly worth worrying about.

Electric Heater Control

Readers who have had difficulty in locating the IRT 84 triac used in the unit described by R. M. Marston in the June 1972 issue may like to know that it is obtainable from Arrow Electronics, Eceptfold Rd., Brentwood, Essex. Price £2.90.

New Products

Laboratory power supply

APT Electronics Ltd have just announced the production of a laboratory standard bench power supply combining the advantages of both switching (transformerless) and linear regulation circuitry. Designated type SSU 10-50, the power supply will provide a variable voltage output from 0 to 50V at 10 amps.

Basically the power supply uses an inverter operating at 20kHz to eliminate the heavy 50Hz mains transformer and to provide an isolated d.c. output for a conventional series linear regulator. The voltage across the series control element is measured and a feedback system incorporating a pulse width modulator varies the output of the switching regulator to limit the dissipation across the series transistor to 30W. The technique has resulted in a 500W power supply of laboratory standard weighing only 7.5kg (16.51lb).

Constant voltage or constant currents within the range of the unit can be obtained with setting accuracies of $\pm 10\text{mV}$ or $\pm 5\text{mA}$. In the constant voltage mode, line regulation is $0.001\% + 1\text{mV}$ for a 10% mains input change and $0.05\% + 10\text{mV}$ for a 10 to 100% load variation. Ripple and noise on the output does not exceed 5mV peak and the output spike attributable to the inverter is typically 20mV.

In the constant current mode line re-

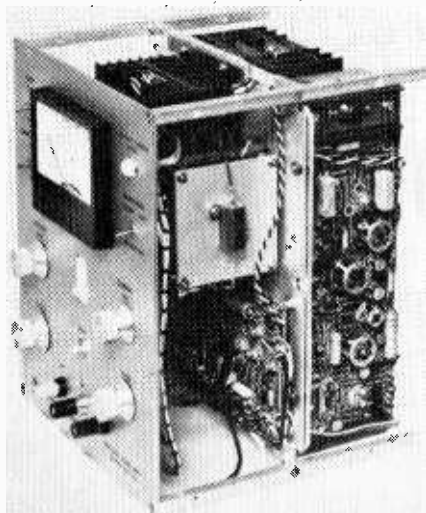

gulation is $0.01\% + 2\text{mA}$ for a 10% mains variation and $0.1\% + 10\text{mA}$ for a 10 to 100% load variation.

When used in the temperature range 0 to 40°C a temperature coefficient of $0.02\%/^\circ\text{C}$ is achieved. The SSU 10-50 measures $203 \times 216 \times 260\text{mm}$ ($8 \times 8.5 \times 10.25$ ins).

Also available is the SSU 5-50 which is similar to the 10-50 in all but output current capability: it has a maximum output of 5 amps. APT Electronics Ltd, Fernbank Road, Ascot, Berks.

WW327 for further details

Wide-band coaxial switch

RLC Electronics Inc. have announced a range of miniature coaxial switches. These feature low v.s.w.r. and insertion loss from d.c. to 18GHz; they also exhibit high isolation over this frequency band (60dB minimum).

The "Miti-Min" package utilizes high density packaging techniques, hence the overall volume of the switch is less than $3/4$ cubic inch. Fail-safe, latching, d.c. and a.c. options can be provided. Tony Chapman Electronics Ltd, 3 Cecil Court, London Road, Enfield, Middx.

WW303 for further details

Tape recorder heads

A tape recorder head developed for long life in digital cassette recorders, is announced by Mullard. Designated ER503501, it is made of hard-wearing, non-metallic ferrite. After a continuous test of 1000 hours, the wear measured on one of the new recorder heads was only $0.2\mu\text{m}$; on a laminated head that underwent the same test the wear was 500 times greater, $100\mu\text{m}$. Furthermore, because it is made of layers of different materials, the laminated head showed irregular wear that so affected the head-to-tape contact that its reading ability had greatly deteriorated.

The ER503501 is a half-track read-after-write head, and is the first of a new series of heads for cassette recorders. A similar quarter-track model will be available soon,

and in the near future half-track single gap and quarter-track single gap types will be introduced.

The ER503501 and future models will conform to the European Computer Manufacturers' Association standards for data interchange on 0.15in tape at 800 bits per inch, phase encoded. The gap lengths are 12 and $2.5\mu\text{m}$, on the write and read sides respectively. Separation between the two is 3.81mm. Mullard Ltd., Mullard House, Torrington Place, London W.C.1.

WW326 for further details

Sound and vibration kit

Dawe Instruments Ltd have announced a sound and vibration kit comprising:

Sound level meter type 1400G — battery operated. Octave band analyser type 1464A — passive network. Vibration adaptor type 1400G/10 — requires no power. Acoustic calibrator, type 1417A or type 1418A. Telescopic tripod type 1400G/14, extends to 4ft (1.2m). Extension lead type 1351B/3 — 20ft long. Microphone windshield type 1400G/13. These are housed in a carrying case and weigh 19lb. The kit provides instrumentation for carrying out comprehensive sound level surveys over the range 24dB to 140dB and is suitable for measuring industrial and other kinds of environmental noise.



A frequency analysis of the noise can be made, using the octave band analyser, for determining the most effective methods of noise reduction. The vibration adaptor converts the sound level meter to measure vibration levels and the acoustic calibrator is designed to provide, on site, overall calibration of the sound level meter. The instruments and accessories may be purchased separately.

This kit is suited for carrying out sound level measurements in compliance with the recently published Department of Employment's Code of Practice for reducing the exposure of employed persons to noise. It also meets the requirements of B.S. 3489:1962 and I.E.C. Publication 123 for sound level meters as well as B.S. 2475:1964 and I.E.C. Publication 225 for octave filters. Dawe Instruments Ltd., Concord Road, Western Avenue, London W3 OSD.

WW306 for further details

Small calculator

Busicom Corporation have introduced what is claimed to be the world's smallest electronic calculator — the same size as a flip-top cigarette packet. The device offers 3-register operation which allows calculation and presentation of 8-digit numbers with a floating decimal point.

Capabilities include addition, subtraction, multiplication, division, combination and constant calculation. Fixed decimal point operation is available for rounding-off to 2 places.

The display is an array of light emitting diodes and the total power consumption is 1.6W being supplied by 4 × 1.5V penlight battery cells. Size is 2.2in × 3.18in × 0.83in and weight 100 grams (0.22lb). Sole importers and distributors, Broughton and Co. (Bristol) Ltd, 6 Priory Road, Bristol BS8 1TZ.

WW330 for further details

300 volt f.e.t.

GDS Sales Ltd announce the availability from stock of a 300 volt n-channel f.e.t. This high voltage f.e.t., the Teledyne 2N4881, features a V_{FS} spread of 350 to 1000 micromhos, I_{DSS} range of 0.4 to 2.0 milliamp, and 2 nanoamp maximum I_{GSS} . Maximum pinch-off voltage is 15 volts. Supplied in the standard metal can TO-39 case, this 300 volt f.e.t. costs £1.95 in quantities of 100 and above.

Where the full 300 volt rating of the 2N4881 is not required, a 200 volt version designated 2N4883 is also available from GDS at £1.60 (100 up). GDS (Sales) Ltd, Michaelmas House, Salt Hill, Bath Road, Slough, Bucks.

WW320 for further details

Long-life planar triode

Claimed to offer reliable, long-life operation and guaranteed for 4,000 hours, the new 8906AL planar triode from EMI-Varian Ltd, is suitable for high altitude airborne radars (TACAN/DME).

Designed for use as a grid- or plate-pulsed oscillator or amplifier up to 3GHz, the 8906AL has ceramic/metal construction, low inter-electrode capacitance, high transconductance and high μ . An arc resistant cathode is used to provide stable, reliable long-life operation under adverse conditions and to minimize catastrophic failure due to arc-over during circuit malfunction.

The 8906AL is derived from the 7815AL/7211/7698 series and incorporates the same longer grid-anode ceramic insulator for high altitude airborne service. In addition, the new improved tube features a 60% larger cathode area than the 7815/7815A type, thus lowering cathode current loading per unit area while maintaining as high or higher current capability. EMI-Varian Ltd, Hayes, Middx.

WW315 for further details

Automatic dialling unit

Computronic Services claim that with their latest product it is now possible for unattended equipment to automatically originate telephone calls over the public switched network. Telemetry and logging systems, for example, can now be improved, since automatic dialling may dispense with routine interrogation. In such a system the remote terminal might be a comparatively simple data collecting type of device, or it could be a complicated computer installation in a network of similar installations. Each such installation might be required to dial several if not all of the other installations.

When data is to be transmitted via modems over Post Office lines and the calls are to be established automatically, it is obligatory to use the Post Office Data Control Equipment No. 1A. (DCE. 1A). The DCE.1A interfaces directly to the Post Office lines and it is this equipment which produces the dial pulses.

The automatic dialling unit performs the following functions.

1. It acts as a junction point and isolating barrier for all of the 12 lines to and from the modem. These are the C.C.I.T.T. 100 series circuits.
2. It accepts on a front panel socket the telephone numbers of the remote terminal it is required to dial. The number may contain up to 15 decimal digits. There are two main ways in which this number may be presented to the unit.

(a) The number is diode encoded in a shrouded plug which is inserted into the

front panel socket.

(b) In more complicated systems where there are many numbers to be called or where the number has to be changed automatically the number may be presented in b.c.d. form, decimal digit by decimal digit.

3. The unit also provides the barrier protected interface signals to the C.C.I.T.T. 200 series circuits used by the DCE.1A. It also performs the necessary timing and control functions. On receipt of a "call initiate" signal, the logic checks the conditions on various Post Office lines and commences a dialogue with the DCE.1A. This dialogue includes the transmission of the numbers to be dialled to the DCE.1A and it terminates in either a "distant station connected" condition or "abandon call" condition. In the event of the latter, the unit automatically makes 3 further attempts at 5 minute intervals. If the fourth attempt fails for any reason; audible and visual indications are given and no further attempts are made. When a successful connection has been established, control is passed to the modem which then behaves in the normal manner.

4. The automatic dialling unit also contains answering circuitry which enables it to receive calls automatically.

5. Additional power supplies and board space have been provided to enable customers' circuits to be incorporated within the unit. Computronic Services, Spirella Building, Letchworth, Herts. SG6 4ET.

WW329 for further details

60W transceiver

A product range from Trans World Communications are h.f. s.s.b. transceivers and accessories. The model TWC5A is a single channel 60W transceiver and the TWC10A is a 4 channel 120W transceiver featuring modular construction fitted with VOX*, squelch and c.w. as standard features. The equipment makes extensive use of

integrated circuits and the complex circuitry is contained on printed circuit boards for simplicity of construction. Trans World Communications, Inc., P.O. Box 2253, Escondido, Ca.92025, U.S.A.

WW317 for further details

* VOX — Voice operated switch

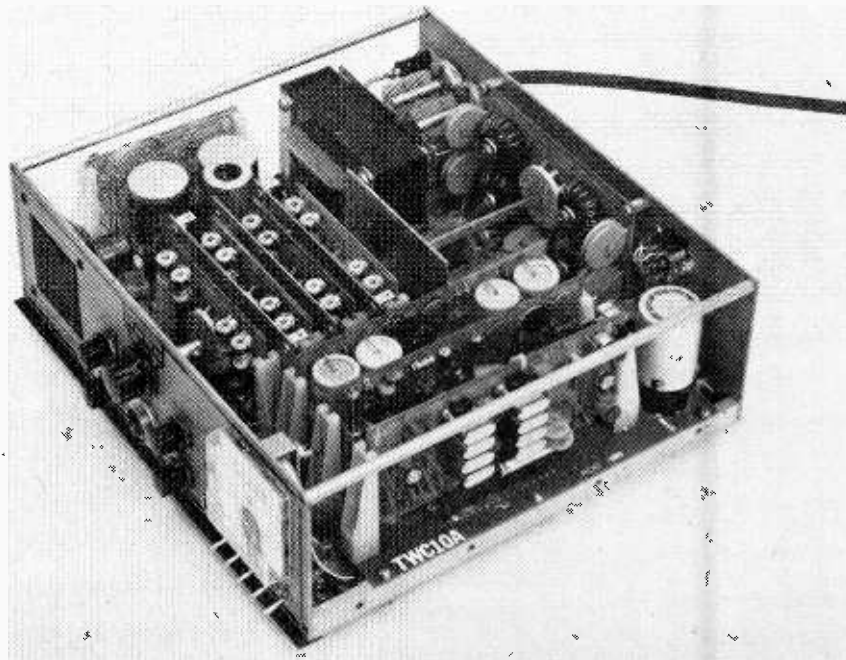

Digital counter/timer

The XLC 1000, from Exel Electronics, is claimed to include all the facilities and options normally associated with expensive and versatile counter/timers, but is sold at a one-off price of £75. This price has been achieved by omitting all external switches, plugs and sockets, plus the associated testing and setting-up routines required to ensure their full use.

Selection of the basic operating mode is achieved by the insertion of one of the plugs supplied with the unit into a socket easily accessible after removing the sliding top. Employing four decades, two counter chains, a crystal oscillator and a logic



control circuit, the basic measuring units are selected by interconnection of rear edge connectors which can also be used to select the operating mode if required. Thus, the unit can be used in a simple one mode operation with one or two links and one plug, or if connected to suitable switches, as many functions as required may be selected from the user's own front panel controls. B.c.d. outputs are available as standard, and a six digit version of the counter will be available shortly.

The unit operates from a single supply of 5 volts, and a cost saving can be effected on the standard units for very simple applications where no crystal oscillator or only one counter chain is required. Exel Electronics Ltd., Wolterton Road, Bournemouth, Hants.

WW307 for further details

Data generator

The GEPL Data Generator, Model 216, made by Grange Electronics, provides a serial data word pulse output which is programmable by means of front panel switches. Any length of word, up to a maximum of sixteen bits can be programmed. Words can be cycled continuously, at bit rates defined by the internal clock, or single words can be initiated from external trigger signals or from the operation of a manual switch. A feature of the instrument is the provision of the output data in phase encoded format. "Non return to zero" format is also provided as a switched option. Bit rates are adjustable continuously from 5Hz to 2.5MHz. Output signals are provided for synchronizing to both the word and bit timing. All of the input and output signal levels are t.t.l. compatible.

The data generator fills a broad range

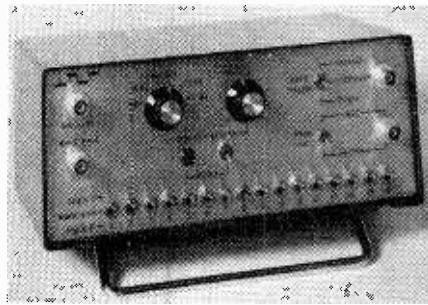

of requirements occurring during development and production in areas such as those of serial memories, modems and telemetry. Grange Electronics (Production) Ltd, Stone Lane, Wimborne, Dorset. BH21 1NF.

WW304 for further details

Matching transformers

Gardners Transformers Ltd announce the introduction of three ranges of miniature and sub-miniature microphone and line-matching transformers. Forty-seven different transformers cater for a wide range of applications. The constructions used are suitable for either printed circuit or direct chassis mounting.

Typical characteristics include frequency response of $\pm 2\text{dB}$, 60Hz - 25kHz under matched conditions, with input impedances ranging from 15Ω to $10\text{ k}\Omega$ and output impedances from 15Ω to $2.4\text{ k}\Omega$. The three ranges are designed for maximum input levels of 1mW, 2mW and 16mW at 16Hz respectively, or 25mW, 50mW and 400mW at 300Hz. Gardners Transformers Ltd, Christchurch, Hants. BH23 3PN.

WW325 for further details

New multimeter

Avo Ltd announce the redesign of the Avometer model 8 to achieve a greater accuracy, improved polarity reverse facilities and a more efficient overload protection. In addition a new meter move-

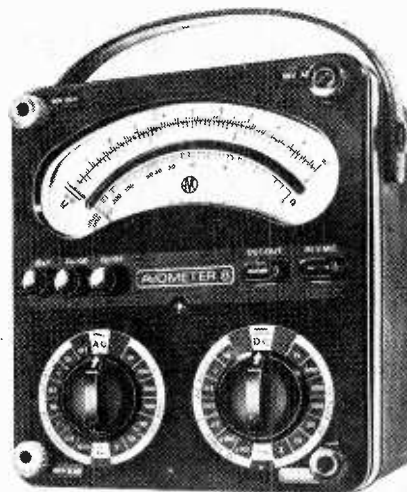

ment has been fitted, which, it is claimed, is more reliable and robust.

A feature of the circuitry is printed circuit shunts with improved accuracy and stability. The new polarity reverse switch has been made self latching and a visual warning is displayed when it is operated. Heavy damping of the meter movement is provided when the range selector switches are in the off position. Avo Ltd., Avocet House, Dover, Kent.

WW332 for further details

Opto-electronic readers

The opto-hybrid readers from Centralab Semiconductor Division (a subsidiary of Globe Union Inc. U.S.A.) are complete light sensor sub-systems for punch card and tape reading. The readers combine silicon photovoltaic detectors and stable hybrid amplifier/digitizer microcircuitry in the same package. They are claimed to have high photosensitivity, and low impedance outputs compatible with d.t.l./t.t.l. logic circuits. The reader circuits give a speed of

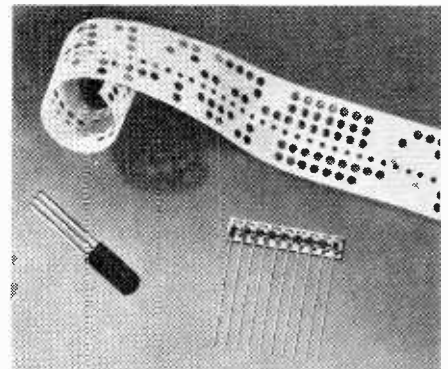

response of $1\mu\text{s}$ or less with a sharp threshold for light detection.

The devices are available in various configurations to suit particular applications. The size and weight of the photovoltaic detector and hybrid circuit are one tenth or less that of discrete layouts. Simplicity brought about by minimized bimetal contact interfaces and decreased handling in production is claimed to raise the level of device reliability. Joseph Lucas (Electrical) Ltd, Electronics Product Group, Mere Green Road, Sutton Coldfield, Warwickshire.

WW321 for further details

Simple r.f. leak detector

For a total cost of a few pence engineers can obtain an r.f. leak detector which will "sniff out" leaks from transmitter cabinets and cables. This r.f. "sniffer" is simply a Vitality 7L miniature neon indicator which will glow red in an r.f. field.

If the field is strong enough, the neon will glow without ancillary components. To sensitize the neon to detect low level leaks, 240V a.c. is applied through two $5\text{M}\Omega$ resistors in series with the neon leads. This arrangement will cause the

neon to ionise and glow slightly and constantly. In the presence of a weak r.f. field the neon will glow considerably brighter, indicating the point of leak. Vitality Ltd, Beetons Way, Bury-St-Edmunds, Suffolk.

WW308 for further details

Auto-index/search for recording tapes

Edit 900, produced by Hodges Engineering, can be used in conjunction with all professional makes of magnetic tape recorder to index tapes with an "electronic number" and subsequently recall any predetermined point.

Produced as model 900, which both edits and searches, there is also a portable 300 model for editing only, and a 500 model for search only. The 300 and 500 can be used in conjunction in place of a 900.

The system indexes tapes at up to 999 places with an electronic number, which is entered into the Edit 900 via push button control and is displayed on the indicator. On pressing the "label" button the number on the display is recorded on the tape in binary coded decimal. A sequential mode is also available whereby the next number is automatically entered each time the "label" button is pressed.

In order to search, the index number representing the required point on the tape is entered into the Edit 900 via the push buttons. The "search" button is then pressed and, if positioned at "auto", the machine will find and play back the recording at that number. Alternative modes are "manual", where the Edit 900 will find the correct position and then stop, or "continuous", where the required recording and subsequent recordings will be played until stopped by the manual override.

In the "search" mode, the indicator displays either the required or true number, so that a tape can be monitored as it is played back.

The system is self-clocking and speed independent, so that the "search" speed can be varied to suit the operator. Hodges Engineering, P.O. Box 26, Camberley, Surrey.

WW301 for further details

High-speed optical isolators

Three optically coupled isolators are announced by Hewlett-Packard. These isolators couple a light-emitting diode to a p-n photodiode which drives a high speed transistor amplifier. Designated 5082-4350 series, the isolators have a propagation time of 225ns. Bandwidth is 5MHz, compared to previously available units with bandwidths to about 200kHz. All are contained in one mini-d.i.p.

The 5082-4350, with a typical d.c. current transfer ratio (c.t.r.) of 11%, is designed for general purpose isolation applications; the 5082-4351 is a high gain device with a c.t.r. of 22%. The 5082-4352

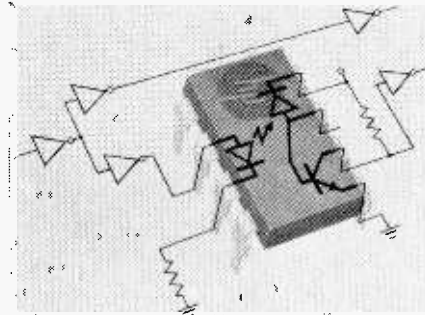

isolator, with c.t.r. between 15 and 22%, is designed for critical gain control applications. All three devices can be direct-coupled to t.t.l. loads at t.t.l. speeds without additional buffers or triggers.

Common mode rejection of the 5082-4350 series is 10V at 2MHz. D.c. isolation (input-output) is 2500V. Maximum forward d.c. current is 20mA; forward peak current is 40mA maximum. Since the output of the photodiode is amplified by the transistors, gain as well as a high degree of a.c. and d.c. coupling is obtained. Hewlett-Packard Ltd, 224 Bath Road, Slough, Bucks. SL1 4DS.

WW316 for further details

Large solid-state display

Developed by Hewlett-Packard Ltd and now available from Celdis Ltd is the 5082-7500 Numeric Indicator.

This display comprises an array of light emitting diodes arranged to produce 1.5in high characters readable at 60 feet, an on-board decoder/driver which receives b.c.d. inputs, and has d.t.l./t.t.l. compatibility. Characters are shaped by using a 7x5 dot matrix format. The board has standard edge connector mountings (0.156in centres), a wide viewing angle and is claimed to be rugged and have a long operating life. Unit price for small quantities £17.38 each. Celdis Ltd, 37/39 Loverock Road, Reading, Berks RG3 1ED.

WW310 for further details

Microwave switching modules

Single pole, single and multi-throw switching modules have been added to the range of microwave semiconductors in the GHz Devices range. The modules operate in three bands — 0.5 to 4GHz, 4 to 8GHz and 8 to 18GHz. with c.w. power ratings

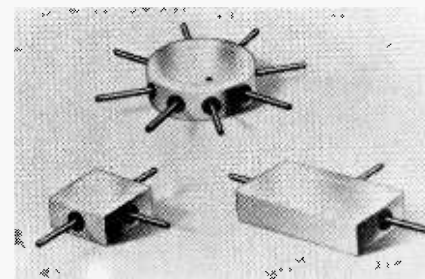

up to 20W (at 25°C). The operating ambient temperature range is -65 to +150°C. All the units are guaranteed hermetically. Other qualities of the modules are high isolation (up to 70dB); low loss (0.5 to 3.5dB maximum, depending on model); low v.s.w.r.

Units are available with fast (10 to 40ns) or slow (200 to 500ns) switching and in a choice of four package styles. They can also be supplied as complete switches with OSM* connectors.

The factory representative for GHz Devices in the U.K. is Auriema Ltd, 442 Bath Road, Slough SL1 6BB.

WW319 for further details

*OSM connector is a miniature 50Ω coaxial connector manufactured by Omni-Spectra Incorporated.

Aluminium multicore solder

Multicore Solders Ltd now believe that they have made a significant advance and are announcing ALU-SOL 229 Multicore solder which, it is claimed, readily solders aluminium and many aluminium alloys, does not require any extra flux, and provides joints having significantly better resistance to subsequent electrolytic corrosion than any other soft solder/flux combination considered previously for aluminium soldering.

The soldering temperature range for ALU-SOL 229 is 280-370°C (536-700°F). The melting point of the solder, which contains 4 cores of flux, is 229°C (445°F). Multicore Solders Ltd, Hemel Hempstead, Herts.

WW 331 for further details

Silicon planar diodes

A miniature diode designed for use in thick and thin-film circuits is announced by Mullard. Type BAV70, it is a silicon planar epitaxial device containing two diodes with a common cathode. It is intended for high-speed switching, having a recovery time of only 6ns after a current pulse of 10mA. The diode has a steady reverse voltage rating of 25V and a peak value of 50V, and will conduct a current of up to 100mA per diode.

Three other new Mullard diodes are intended for switching and general purpose applications in oscilloscopes, digital voltmeters and the video output stages of colour television receivers. Types BAV19, BAV20 and BAV21, they are also silicon planar epitaxial devices and differ only in their voltage ratings as follows.

	Max. V_R	Max. V_{RRM}
BAV19	100	120 V
BAV20	150	180 V
BAV21	200	250 V

All three diodes have a forward current rating of 250mA and a typical recovery time of 50ns after being switched from 30mA. The diodes have a DO-35 encapsulation. Mullard Ltd, Mullard House, Torrington Place, London WC1E 7HD.

WW312 for further details

Night-time TV camera

A surveillance aid which enables factory security staff, police, armed forces and oceanologists or marine salvage experts to "see" in near-darkness conditions has been introduced by EMI Electronics Ltd. The equipment is a closed-circuit television camera developed by the company's Systems & Weapons Division for a variety of portable and fixed surveillance roles from perimeter security to deep-sea search operations. Known as the EMI-Sony MTV-1, this monochrome camera is claimed to be 500 times more sensitive than a standard vidicon television camera. It provides bright pictures in "half moonlight" conditions and can identify darkened scenes or objects which may be invisible to the human eye.

The MTV-1 can be fitted with a variety of lenses. There is a housing available for underwater work while others provide protection against the environment in remotely operated outdoor applications. An automatic sensitivity control covers the 1000:1 range.

Developed by EMI from a standard Sony c.c.t.v. camera, the MTV-1 incorporates the Ebitron intensifier vidicon developed by EMI's Central Research Laboratories.

Measuring 12¼ in (311mm) long, 3½ in (89mm) wide and 7½ in (190mm) high, the MTV-1 camera can be supplied as either a 525-line (60 fields) or 625-line (50 fields) model. Its horizontal resolution is better than 400 lines. It can operate from mains power supplies or from a 12 volt d.c. battery pack. Its weight is 8½ lb (3.85kg), without lens. EMI Electronics and Industrial Operations, Blyth Road, Hayes, Middlesex.

WW328 for further details

Capacitor Cascade

A new component from Steatite Insulations Ltd is a ceramic capacitor cascade, for use in voltage multipliers and oscilloscopes. The leads may be on one side or both sides, and there may be from 2 to 18 discs in a

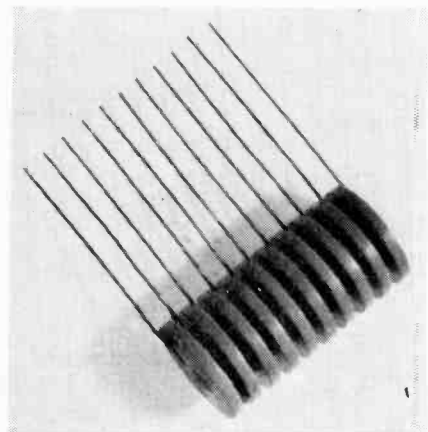

cascade. At present capacitance values from 270 to 4700pF are available. The rated voltages of individual discs are from 1kV to 3kV. Steatite Insulations Ltd, Hagley House, Hagley Road, Birmingham B16 8QW.

WW322 for further details

Electronics kit

Limrose Electronics have announced their new electronics kit which has been developed to meet the requirements of the Nuffield "A" Level Physics course.

The kit consists of a number of modules which can be plugged into each other in any order and carry their own power rails. Some of the modules can accept other modules in both directions which is particularly useful in setting up large experiments. Electronic components are mounted on the front panel so that students can see how the circuits they are using have been constructed. The modules can be supplied

either in kit form or fully assembled.

All modules measure 124 × 124 × 50mm and require 4mm patch leads for making interconnections.

In addition to the basic unit, lamp indicator, switch (contact-bounce free), AND gate, multivibrator, bistable and beam splitter modules required to make up the Nuffield Starting and Working Kits, a number of extension modules such as digital readout, triple lamp and binary counter are available. Limrose Electronics Ltd, 8-10 Kingsway, Altrincham, Cheshire WA14 1PJ.

WW318 for further details

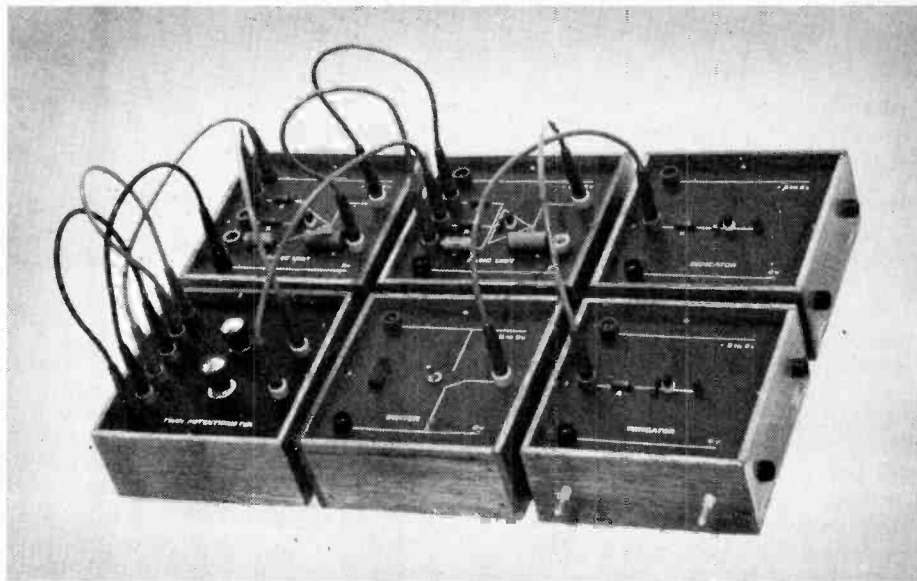

Integrated circuit timer

SDS Components Ltd announce off-the-shelf availability of an integrated circuit, manufactured by Signetics International and designated type 555, comprising two comparators, a flip-flop, an output stage and several auxiliary components.

When used as a monostable, two external resistors and a capacitor are required, and the timing period, which is independent of the supply voltage, can be from a few microseconds to an hour. The timing period is initiated by a negative-going trigger pulse and once started further trigger pulses will have no effect. During the timing period a negative-going pulse to the reset input will reset the device and start a new timing period.

For astable operation, the same configuration as for monostable operation is employed with the addition of a link between two pins. The frequency is independent of supply voltage.

If the device is connected as a monostable and is triggered by a continuous string of input pulses a modulating voltage applied to the control voltage input pin will alter the width of the output pulses.

A pulse position modulator (or frequency modulator) results when the 555 is connected for astable operation and the modulation signal is applied to the control voltage input pin. In this configuration the

position (or frequency) of the constant width output pulses varies in direct proportion to (or frequency of) the input modulating voltage. The deviation range available is -90 to +30% of the natural frequency set by the external components.

The fact that the device in the monostable configuration ignores input pulses when the timing cycle has started, means that it can be used as a frequency divider provided that the input frequency is known.

When several 555 monostable circuits are connected one after the other a sequence timer results that could be used, for instance, to control test sequences or industrial processes.

There are two versions of the device. The SE555 which will operate over the temperature range -55 to +125°C; and the NE555, which will operate over the range 0 to +70°C. Other differences include a timing error of 0.5% for the SE555 with 1% for the NE555, and a time temperature drift of 30 p.p.m. per °C for the SE555 and 50 p.p.m. per °C for the NE555.

The NE version is available in either the "T" (8-pin can) package or the 8-pin d.i.l. "V" package. The SE version is only available in the "T" package. SDS Components Ltd, Gunstore Road, Hilsea Trading Estate, Portsmouth, Hants. **WW313 for further details**

World of Amateur Radio

Oscar 6 — working but some problems

The amateur satellite Oscar 6, carrying a 145.95 to 29.5 MHz repeater (see p.296, June 1972) was launched on October 15th and many two-way contacts (including a number across the Atlantic) have been made via the satellite. Oscar 6 is about 930 miles above the earth, with a period of 114.99 minutes and a track separation of 28.75° and an inclination of 101.755°. Although the repeater is working well the 29.45-MHz beacon is apparently not functioning, making it rather difficult to be sure when Oscar 6 is in range. Because of excessive drain on the batteries, it has been necessary to switch the repeater off at times — once for about a week — and amateurs have been asked to limit their power on 145.95 MHz to reduce power consumption and allow the solar cells to recharge the battery. An operational problem is the difficulty of determining whether signals heard between 29.38 and 29.62 MHz (extended passband limits) are coming from the satellite or are normal ten-metre transmissions. But despite the problems Oscar 6 is giving two-metre operators an unrivalled chance to work long distances using c.w. or s.s.b.

Transatlantic Tests 1922 and 1972-73

Exactly 50 years ago, the first British amateur stations were heard in the United States during the Transatlantic Tests of 1922. First to get across were the special stations 5WS and 5MS built by the R.S.G.B. and the Manchester society. Station 5WS at Wandsworth transmitted on about 215 metres and gained the first positive report, including check code, at 02.00 on December 24th, 1922. Also heard in the States was the French station 8AB. European amateurs heard between 300 and 500 American stations.

The tradition of these tests will be continued in the 40th Transatlantic Tests on 1.8 MHz being held this winter from 05.00 to 07.30 G.M.T. on the Sunday mornings of December 24th, January 14th, and February 11th. North American stations will use 1800 to 1807 kHz,

others 1825 to 1830 kHz. North American stations call first in 5-minute alternate periods. With the present low sunspot numbers, outlook for Top Band transatlantic working seem excellent. Stew Perry, W1BB, is again using a 1000ft Beverage receiving aerial with which he finds he can copy long-distance stations better than on any other available aerials.

Loss to amateur radio

Amateurs in many countries will mourn the recent deaths of three amateurs who have for many years been known throughout the world. W. H. ('Bert') Allen, M.B.E., G2UJ, of Challock Lees, died in Lisbon while on his way to a holiday in South America — for many years he contributed notably to the encouragement of home construction of v.h.f. equipment. Peter Pennell (G2PL), an engineer with Redifon, was for many years an outstanding DX operator. Bo Brondum-Lieisen, OZ7BO, was one of the best-known Danish amateurs renowned for his c.w. "fist" and for his work in developing "el-bug" (electronic fully-automatic) keyers.

Amateurs around the world

The number of licensed British amateurs now exceeds 18,250 (Class A 14,386; Class B 3651, amateur TV 226) but how does this compare with other countries?

World figures (inevitably not quite so up-to-date as the local figures) indicate that there are now about 580,000 amateurs — but over 70% of them are in two countries: the United States with about 280,000 and Japan with 145,000. West Germany has a few hundred more than the United Kingdom and the Argentine a few hundred fewer. In sixth place is the U.S.S.R. with some 15,000 licences (although a much larger number participate in amateur radio through the very active Russian club stations). Both Brazil and Canada have totals exceeding 12,500 but then there is a big drop to about 6500 in Australia and in France.

Europe's total is over 90,000; South America's around 45,000; the most sparsely "amateur populated" continent is

Africa with about 3000 amateurs of whom possibly a half are in South Africa. China does not normally permit amateur operation.

The latest R.S.G.B. Call Book (1973) shows that in the U.K., pre-1939 call-signs are now less than ten per cent of the total, although I find that of those issued at the same time as my own (1938) almost one half are still held — a remarkable indication of the ability of the hobby to hold its adherents. There are now some 318 local clubs and societies in affiliation with the R.S.G.B. It is also interesting to note that Class B licences (v.h.f. phone operation) now amount to almost exactly 20% of the total.

Modified band-plans

Recommended frequencies for f.m. operation have recently been added to the U.K. voluntary band-plan for 144 MHz. The national f.m. calling frequency is 144.48 MHz; regional divisions are: south-west 144.40 Mhz; south-east 144.80 MHz; Midlands 145.20 MHz; north, Scotland, Northern Ireland 145.60 MHz.

After many months of speculation and some controversy, the American F.C.C. has decided not to extend the United States telephony sub-bands (which are legally binding in that country) on the 14, 21 and 28 MHz bands. But changes have been agreed for the 3.5 and 7 MHz bands where the telephony sub-bands will be extended and will start at 3775 kHz (formerly 3800 kHz) and 7150 kHz (formerly 7200 kHz).

In brief

Finances of the R.S.G.B. appear to be healthier — the annual accounts to June 30, 1972 show a surplus on the year of £4045 compared with a deficit of £7081 the year before . . . The National D/F contest final was won this year by P. J. Tyler, of Oxford. For the first time finalists were expected to seek out and find three well-hidden transmitting stations in a few hours; four of the 14 finalists succeeded in locating all three transmitters. . . . Raymond Evans, G3LQC, has worked across the Atlantic using an all-transistor transmitter with two 2N5591 transistors in the power amplifier running at 35 watts output — he worked Graham Williams, VE2WA, of Pointe Claire, Canada, on 14 MHz c.w. . . . William D. Johnston, WB5CBC, of 1808 Pomona Drive, Las Cruces, New Mexico 88001, U.S.A., is offering a service, based on a computer programme of great circle bearings and distances of 660 major towns and cities from any location in the world at a nominal cost of one-dollar (\$1.75 airmail worldwide) or seven international reply coupons; applicants should give name and postal address, the city for which the chart is wanted (if population is less than 10,000 or location is a rural area give latitude and longitude).

Pat Hawker, G3VA

Literature Received

For further information on any item include the WW number on the reader reply card

ACTIVE DEVICES

A brochure of Texas Instruments optoelectronic devices as supplied by Quarndon Electronics Ltd, Slack Lane, Derby, has been received. It includes a wide range of discrete light emitting sources and details of a solid-state numerical display fully integrated with counter, latch, decoder and drivers. A price list is included WW401

Four thyristor device data sheets of the TO-48, "rock-top" form, types CR12'03RC (12A, 1500V), CR18'03RC (18A, 1500V), CR24'03RC (26A, 1500V) and CR27'03RC (32A, 1500V), from AEI Semiconductors Ltd, Carholme Road, Lincoln, LN1 1SG WW402

A number of semiconductor data sheets have been received from RCA Ltd, Solid State, Customer Technical Data Service, Sunbury-on-Thames, Middlesex. They cover:

- TA8411, 8412, 8413 and 8414 which is a range of fast-recovery silicon rectifier diodes ranging from 100-600V p.i.v. at 6A WW403
- TA8719, a u.h.f. power transistor designed for 0.5W output, 9V supply WW404
- TA8720, a u.h.f. power transistor designed for 2W output, 9V supply WW405

Two data sheets providing primary specifications for different types of microwave generating devices from Microwave Associates Ltd, Dunstable, Bedfordshire, are:

- Bulletin L/0013 describing the ML 13000 series of low-noise crystal-controlled sources providing various power outputs at custom selected frequencies from 1.25 to 17GHz WW406
- Bulletin L/0109 concerned with type ML4704S high efficiency, double chip, silicon impatt diode which provides c.w. output in the band 8 to 10GHz WW407

A combination display "eye chart" and buyers guide which compares the appearance of Nixie tubes, light-emitting diodes and Sperry planar numerical displays is available from REL Equipment and Components Ltd, Croft House, Bancroft, Herts. WW408

PASSIVE DEVICES

Broad-band, high-frequency antennas is the subject of a leaflet from Grange Associates Ltd, Grange Corner, 1 Brooklands Road, Weybridge, Surrey. It is a summary of antennas for all requirements and for which specific data sheets are available WW409

A leaflet showing the full range of illuminated push-button switches, signal lamps and accessories is available from Highland Electronics Ltd, 33-41 Dallington Street, London EC1V 0BD. Accessories include mushroom headed screens, flaps, guards, film legends and engraving WW410

A 180-page catalogue and price list of the full range of "Blue Line" products covering rotary switches (10-2000 Amp application), contactors, starters and relays (up to 300 h.p. motor application) is available from U.K. Solenoid Ltd, 115 London Road, Newbury, Berkshire WW411

A short-form catalogue has been received from Key-switch Relays, Bendon Valley, Garratt Lane, Wandsworth, London S.W.18, which provides a quick reference guide to their industrial range of relays and associated products. It includes timing units, custom built relays, solenoid assemblies, reed relays, key switches, plug-in component modules and sockets WW412

Three data sheets describing the range of ALCAD nickel-cadmium battery cells available from Alkaline Batteries Ltd, Power Sources Division, P.O. Box 4, Union Street, Redditch, Worcestershire, are:

- A150 describing type RV and RVP heavy-duty cells WW413
- A151 describing type E and EP cells for intermittent operation where they are required to stand open-circuit or floating for long periods WW414
- A152 describing types DLS and DLP cells for use where high rates of discharge are expected WW415

A brochure and price list entitled "Cressall Aluminium Heatsink Resistors" deals with a range of wire-wound resistors designed to have dissipation ratings of between 10 and 300 watts with a standard tolerance of $\pm 5\%$. The Cressall Manufacturing Company Ltd, Birmingham WW416

Industrial components is the subject of a brochure from EMI Industrial Components Division, EMI Sound and Vision Equipment Ltd, 252 Blyth Road, Hayes, Middlesex, and provides preliminary information on the extended range which includes miniature transformers, potentiometers, switches, capacitors and printed circuit amplifiers ... WW417

EQUIPMENT

A leaflet from the distributors Lauriestone Electronics Ltd, 1 Shepfield, Witham, Essex, CM8 3TH, describes the range of Micromeccanica, precision micro-drilling machines WW418

A catalogue describing in detail, new scientific research instrumentation was received from DISA U.K., 116 College Road, Harrow, Middlesex. The range of this catalogue includes devices for electrical and mechanical measurement, signal processing electronics and a description of laser energized doppler anemometry WW419

A brochure from Research Communications, Peel House, Porters Lane, Ospringe, Faversham, Kent, deals with modular units designed for low-noise receiver systems in the v.h.f./u.h.f. range. It includes r.f. pre-amplifiers, r.f./i.f. amplifiers, u.h.f. strip-line pre-amplifiers, signal frequency converters and phase-lock loop receiver systems up to 500MHz WW420

The C1000, Electronic Count Controller which can be pre-scaled in such a way as to allow digital display directly in units required, is the subject of a leaflet from Dynalco Corporation, 4107 N.E. 6th Avenue, Ft. Lauderdale, Florida 33308 WW421

A brochure providing a full specification of the new AVO 8 mark 5 multimeter is available from AVO Ltd, Dover, Kent. It also covers the range of standard accessories suitable for the AVO 8 range of instruments WW422

APPLICATIONS

A high-level logic applications handbook concerned with the characteristics and uses of elements available in the SGS/ATES H.100 series of devices. The 78-page handbook, which introduces the principal characteristics of high level logic techniques for those who are not accustomed to dealing with such circuit design, is available from SGS (United Kingdom) Ltd, Planar House, Walton Street, Aylesbury, Bucks, price £1.20.

GENERAL INFORMATION

"A guide to Enthoven solders and fluxes" is the title of a pocket guide designed primarily for the research and production engineer and covers the full range of Enthoven products. Enthoven Solders Ltd, Dominion Buildings, South Place, London EC2M 2RE WW423

A short-form catalogue has been received from F.C. Lane Electronics Ltd, Slinfold Lodge, Horsham, Sussex, who are distributors of electronic components manufactured by A.B. Electronic Components Ltd, Miniature Precision Components Ltd, Plessey Co. Ltd, Pye Connectors Ltd, Rendar Instruments Ltd, Servisol Ltd and Transradio Ltd WW424

A leaflet giving some idea of the size and complexity of London's telecommunications services throughout the G.L.C. area and parts of Essex, Hertfordshire, Kent, Surrey, Buckinghamshire and Berkshire was received. It is called Telecommunications in London and is available from the Public Relations Officer, Post Office Telecommunications Region, Camelford House, 87/90 Albert Embankment, London SE1 7TS

An application of the "Series 200, Video Terminal Controllers" for classroom educational purposes is shown in an information sheet from Ann Arbor Terminals Inc., 6107 Jackson Road, Ann Arbor, Michigan 48103 WW425

The 1972-73 prospectus for the Department of Engineering Technology at the Twickenham College of Technology, Twickenham, Middlesex TW2 7SJ, includes general college information, departmental information and information on the courses available.

Data sheets with specifications of SEFOLIT, a new paper phenolic laminate material, is available from Kent Insulations Ltd, Power Road, Chiswick, London W4 5PZ WW426

A leaflet showing a new range of low-loss, crimped outer-conductors, solid dielectric, coaxial cable manufactured by Kabelmetal is available from Hayden Laboratories Ltd, Hayden House, 17 Chesham Road, Amersham, Bucks. WW427

An I.B.A. engineering bulletin entitled "Independent Local Radio", providing answers to some of the most frequently asked questions about the technical aspects of independent radio operation, has been issued by the Engineering Information Service, Independent Broadcasting Authority, 70 Brompton Road, London SU3 1EY.

A dual-purpose chart has been received from BICC Ltd, P.O. Box No 1, Prescott, Lancs L34 5SZ. On one side is an inches to millimetres conversion table and on the other, a colourful materials comparison chart concerned with compositions used for cable insulation WW428

The "Imp Riveter", is the subject of a data/operating instruction brochure from MSD Retrofit Automation Ltd, Church Street, Newcastle-upon-Tyne NE6 3XW. A new principal is claimed which allows up to a 5ton riveting pressure to be applied by hand or pedal control without the use of protecting guards WW429

December Meetings

LONDON

5th. IEE Grads. — "Automatic patching for a 'hybrid' computing system" by Maurice Bacon at 18.30 at Savoy Pl., WC2.

6th. IEE/IERE — Colloquium on "Data capture systems — applications and equipment" at 10.00 at Savoy Pl., WC2.

7th. IEE — "The future for the British electrical and electronics industries inside the E.E.C." by Dr. F. E. Jones at 17.30 (followed by discussion) at Savoy Pl., WC2.

7th. RTS — The Shoenberg Memorial Lecture, "Video in vacuo — television's role in the exploration of space" by Dr. G. Brown at 19.00 at The Royal Institution, Albemarle St., W1.

12th. AES — "Heating in loudspeaker voice coils" by Timothy Holl at 19.15 at the IEE, Savoy Pl., WC2.

13th. I.Phys./IEE — Colloquium on "Microwave transistors" at 10.30 at Imperial College, SW7.

13th. IEE — "British satellite technology" by W. M. Lovell at 17.30 at Savoy Pl., WC2.

13th. IERE — "Engineers in the boardroom?" by R. Medlock at 18.00 at 9 Bedford Sq., WC1.

13th. SERT — "Biomedical engineering — the impact of electronics" by W. J. Perkins at 19.00 at IBA, 70 Brompton Rd., SW3.

20th. R. I. Phys. — "Collision avoidance systems" by Capt. K. D. Jones and P. J. Houseley at 19.00 at the Royal Institution of Naval Architects, 10 Upper Belgrave St., SW1.

BELFAST

12th. IEE Grads. — "Pattern recognition" by Dr. A. M. Rosie at 18.30 at Ashby Institute.

BIRMINGHAM

1st. SERT — "Television today" by B. Rogers at 19.00 at Byng Kenrick Suite, University of Aston, Gosta Green.

BRADFORD

7th. IERE — "Parametric amplifiers" by Dr. J. C. Downing at 19.00 at The University.

12th. IEE Grads. — "Music and acoustics" by Dr. J. M. Berman at 19.00 at the University.

BRIGHTON

12th. IERE — "Electronic switching in telephone exchanges" by G. D. Rudram at 18.30 at The Technical College.

CAMBRIDGE

7th. IEE — Seminar on "Taking the heat out of electronics" at 10.00 at Churchill College.

CARDIFF

13th. IEE/IERE — "The history of some major inventions and concepts in electrical communications" by Prof. D. G. Tucker at 18.30 at the Pharmacy Lecture Theatre, U.W.I.S.T.

EDINBURGH

12th. IEE/IERE — "The operation of the Eurovision system" by A. R. Elliott at 18.00 at South of Scotland Electricity Board Showrooms, 130 George St.

EVESHAM

11th. IEE — "50 years of engineering in the B.B.C." by E. L. E. Pawley at 19.30 at the B.B.C. Engineering Training Centre, Woodnorton.

13th. IERE — "Colorimetry of colour television" by W. N. Sproson at 19.30 at B.B.C. (Evesham) Club.

GLASGOW

11th. IEE/IERE — "The operation of the Eurovision system" by A. R. Elliott at 18.00 at The Institution of Engineers and Shipbuilders, Rankine House, 183 Bath St.

GUILDFORD

6th. IEE Grads. — "Post Office telecommunication developments" by E. Fennessy at 19.30 at the University of Surrey, Stag Hill.

LEICESTER

5th. IERE — "Introduction to numerical control" by A. D. Murphy at 6.45 at the Lecture Theatre 'A', Physics Block, The University.

LIVERPOOL

6th. IERE — "On-line analogue adaptive control" by K. R. Jones at 19.00 at The Department of Electrical Engineering and Electronics, The University.

MAIDSTONE

4th. IEE — "Post Office research" by C. F. Floyd at 19.00 at the Royal Star Hotel.

MANCHESTER

5th. IEE — "50 years of engineering in the BBC" by E. L. E. Pawley at 18.15 at Renold Building, U.M.I.S.T.

7th. IEE/IERE — "Optical fibre communication systems" by F. F. Roberts at 18.15 at Renold Building, U.M.I.S.T.

MIDDLESBROUGH

6th. IEE — "Broadcasting in the seventies" by A. Shaw at 19.30 at Cleveland Scientific Institution.

NEWCASTLE-UPON-TYNE

13th. IERE — "V.L.F. Propagation and the D region of the ionosphere" by W. C. Bain at 18.00 at Ellison Building, The Polytechnic.

NORWICH

6th. IERE — "A sound-in-sync system for television distribution networks" by D. Allanson at 19.00 at the Assembly House, Norwich.

NOTTINGHAM

12th. IEE — "Electronics in ocean technology" by Dr. V. G. Welsby at 19.00 at T1 Building, The University.

READING

6th. IERE — "Media: a continuous digital process control system" by J. R. Halsall and I. J. Kirby at 19.30 at the J. J. Thomson Laboratory, University of Reading, Whiteknights Park.

SOUTHAMPTON

12th. IEE Grads. — "The radio ham — the real truth" by K. Taylor at 19.30 at Lecture Room A, Lanchester Building, The University.

TORQUAY

14th. IEE — "Recent developments in radio communications" by Dr. R. C. V. Macario at 14.30 at Toorak Hotel.

WARWICK

13th. IEE/IERE — "Pulse frequency & pulse number techniques" by T. H. Thomas at 18.30 at University of Warwick.

WHITEHAVEN

5th. IEE — "Colour Television" at 19.15 at West Cumberland College of Science and Technology.

Early January Meetings

LONDON

3rd. I. Phys. — "On-line computers for laboratory experiments" at Imperial College, SW7.

4th. IEE — 64th Kelvin lecture "Conduction in amorphous materials — theory and applications" by Prof. Sir Nevill Mott at 17.30 at Savoy Pl., WC2.

10th. IEE/IERE — Colloquium on "Micro-computers and electronic calculating aids" at 14.30 at 9 Bedford Sq., WC1.

AYLESBURY

11th. IEE/RAeS — "The Skynet satellite communication system" by Air Commodore F. C. Padfield at 19.30 at Kermode Hall, RAeS, Halton.

BIRMINGHAM

8th. IEE — "50 years of B.B.C. Engineering" by J. Redmond at 18.00 at MEB Offices, Summer Lane.

10th. RTS — "The development of u.h.f. television" by Leo G. Dive at 19.00 at B.B.C. Broadcasting Centre, Pebble Mill Road.

CAMBRIDGE

11th. IEE — "Electronic aids to night vision" by P. Schagen at 18.30 at University Engineering Department, Trumpington St.

MALVERN

8th. IEE — "Tomorrow's world in telecommunications" by W. J. Bray at 19.30 at Abbey Hotel.

NEWCASTLE-UPON-TYNE

10th. IERE — "Recent developments in nucleonics and scanning systems as applied to medicine" by J. W. Haggith at 18.00 at the Main Lecture Theatre, Ellison Building.

Books Received

Two recent books by Dr. F. R. Connor in a series of introductory topics in electronics and telecommunications have been published. **Wave Transmission**, provides the classic definitions and partial differential solutions to the open wire/coaxial transmission-line problem. Electromagnetic field theory is then exercised which resolves into solutions for multimode field propagation in waveguides. A broadening of the subject matter is achieved by a chapter generalizing on the subject of microwave techniques. **Antennas**, deals with the subject from elementary principles of radiation, antenna and antenna arrays to the quasi-optical solutions to large area, microwave antennas. A chapter is included on propagation characteristics and effects. Both books are presented in a concise manner and are augmented by the use of worked examples, throughout. **Wave Transmission** — 103pp, Antennas — 96pp. Price £1.00 each. Edward Arnold (Publishers) Ltd, 41 Maddox Street, London W1.

The following series of new publications have been released by Pitman Publishing, 39 Parker Street, London WC2B 5PB:

Dictionary of Radio and Television Terms, English-German, German-English. Pp.199. Price £2.25.

Pocket Handbook on Electrical Measurements. Pp.257. Price £1.50.

Data Processing Dictionary, English-German or German-English. Pp.190 Price £2.50 (each).

Circuits with Semiconductor Components, Vols. 1, 2, 3. Pp. 304, 304, 263. Price £2.90 (each).

Real and Imaginary

by "Vector"

The Stone Age of Broadcasting

In celebrating the transmission and programme aspects of the birth of British broadcasting, let's not forget that largely unsung body of men, the pioneer retailers and their service technician-engineers. I am delighted, therefore that the editor has agreed to my suggestion that, for this issue, I hand over my page to one of my correspondents, J. T. Chaffe, to reminisce about the far-off days of 2LO.

The original service engineers came into the business by various doors. My introduction to electricity came at the age of eight, when the village milkman showed me how to make a Morse key using a block of wood, two nails and a strip of Meccano. Three years later I was operating my first spark set, but this sounds much more grandiose than it really was. I was scarcely more than a tea-boy in the enterprise; the prime mover was an older boy who lived a few doors away. He was much more knowledgeable than I, but we had a common interest in reading all the textbooks we could lay our hands upon, even though we didn't understand nine-tenths of what we read.

The breakthrough came when one author in an unguarded moment informed us that an electric bell could, when suitably modified, be used as a feeble generator of wireless waves. Hitherto our schemes for building an induction coil had been thwarted by an excruciating lack of cash; now, the pearly gates were open wide. We cajoled two defunct shunting bells from a friendly railway linesman and rewound them, adding capacitance plates across the spark gap *à la* Hertz. Our aerials were wire mattresses and our receivers crystal detectors and single telephone earpieces (the latter by the unwitting courtesy of the L. & S.W. Railway Co.). To our amazement the set-up worked, although our Morse would have given any Naval instructor apoplexy. May the Post Office forgive two youthful pirates!

In (I think) March 1922 I was on holiday at a cousin's at Surbiton. He was some years my senior and an advanced wireless fanatic; his den housed, amid other mysteries, a crystal detector coupled to a one valve note magnifier. This was the first

thermionic valve I had ever seen; you could read by the light it gave off. One Tuesday evening at 8 o'clock, Jack fiddled with the catswhisker then put a pair of 'phones into my trembling hands. Hastily I donned them . . . Wr-r-rattle calling . . . Wr-r-rattle calling . . . Oh, the magic of the moment! P. P. Eckersley was in fine fettle; he clowned throughout and sang a ditty called "She sat in the sink and sank". I was hooked. From that moment any other than a career in wireless was quite unthinkable.

But the harsh reality of school intervened. 2LO, run by the Marconi Company, began transmissions in May 1922. The station was taken over in November by an association of wireless manufacturers who called themselves the British Broadcasting Company. Other B.B.C. stations came on the air in rapid succession, but with no help from me; I had to submit to the horrors of Latin, trigonometry and differential calculus while all these exciting things were going on around me.

I filled in my time devouring any wireless periodical I could acquire (*W.W.* was a weekly at sixpence in 1922 and went down to 4d in 1923). I haunted the physics lab. and plagued the life out of my physics master. I extorted cash from my impecunious parents and bought components with which to build sets for neighbours (our own set was almost permanently disembowelled). In short, I became that *bête noir* of all service engineers, the "young chap next door who knows all about wireless". How I was to hate his guts in the years to come!

By the time I left school in 1926 the home-constructor craze was at its height and wireless dealers were legion — some good, some bad and many indifferent. I was lucky, I got taken on by a really good one; he offered me an apprenticeship at 7/6 per week; hours 9 to 6 (or later, if there was a backlog of repairs) and a half-day on Wednesdays. My parents were horrified; they thought I had gone to the city to apply for a civil service clerical job. Times were bleak, and wireless, they said, was a passing fad. But, bless them, they didn't stand in my way, so I took the job.

The shop was manned by assistants, the boss and I doing all the servicing and

installation work. By this time the sloping panel type of set, upon which I had cut my teeth (and many square yards of ebonite) had given place to the oblong box approach. We had our own design of detector-21.f. with swinging coil reaction and we undercut the commercial sets by a bland disregard of such details as royalties. Bare wire of square cross-section formed the connections and right-angled bends were obligatory (never mind about stray capacitance — it looked good!). Soldered joints had to be immaculate if I wished to avoid a kick on the posterior.

In addition, kit sets were coming into vogue; some of these, such as the Cossor Melody Maker and Mullard Master Three, were sponsored by the valve manufacturers. I used to supplement my income by building these at home for four bob a set. We also built the designs of the wireless magazines to order, including in 1926, the immortal *W.W.* "Everyman Four" designed by W. James. I well remember the Scott-Taggart "Omni" and the subsequent S.T. series; the Lodge "N" circuit, and many others.

Most receivers of the early period were battery-driven but h.t. "eliminators" were rapidly coming into favour in areas where a mains supply was available. Some cities in those days had two, and sometimes three, different supplies — 230V a.c., 200V d.c. and 110V d.c., so both customer and service engineer had to go warily to avoid fry-ups.

Our best-selling commercial receiver was the Brandes III, a det. — 21.f. of neat design. The loudspeaker was a discrete item; most models were horn types, with the Amplion "Dragon" the status symbol. We carried our gear in a bull-nosed Morris open tourer, or if that wasn't available we parcelled the equipment and staggered aboard a tram. I remember vainly trying to make the top deck with a Langham portable. This was housed in two massive hide suitcases, either one of which could be carried only by those in peak physical condition.

Before I sign off I should like to mention Frank Murphy, who brought many wholly revolutionary concepts into receiver manufacturing, servicing and manufacturer-dealer relationships, not the least of which was the supply of full service information and intelligent service diagrams. Frank's heyday was in the mains receiver era, a bit beyond the early days; his disappearance from the radio scene was, in the long term, a great loss to the industry.

I should like to ramble on, but space will not permit me to talk of the nutters (including a death-ray inventor) one met. Of the house in which I found a body that had been there for weeks — ugh! Of the tobacco millionaire I mistook for a minor servant; I used him as a soldering iron hander-upper for the best part of an afternoon. Or I could tell you of a set installed in a certain notorious district, after which the lady of the flat invited me into the bedroom in lieu of a tip. Or of an inexplicable spooky mystery — but I must stop. I'm sure today's service engineers meet the descendants of those odd-ball characters, anyway.

GENERAL INDEX

Volume 78, January-December 1972

- A.M. receivers, noise silencer for, D.A. Tong, 483 Oct.
- ABOUT PEOPLE, 43 Jan., 93 Feb., 150 Mar., 184 Apr., 248 May, 297 June, 352 July, 397 Aug., 444 Sept., 468 Oct., 550 Nov.
- Aerial, h.f. hybrid, T.A. Lindsey, 151 Mar.
- Amateur transceiver, 10-80 metre, D. R. Bowman, 256 June, 325 July, 371 Aug., 437 Sept., *Corrections*, 480 Oct.
- Amplifier for muscle voltages, simple, R.E. George, 495 Oct., *Correction*, 544 Nov.
- , special purpose, W.T. Cocking, 283 June
- , universal meter, A.J. Ewins, 61 Feb., *Letters*, 175 Apr.
- Amplifiers, low-noise audio, H.P. Walker, 233 May, *Letters*, 388 Aug., 520 Nov., 575 Dec.
- Analogue recursive computer, R. J. Lamden, 487 Oct.
- Audio amplifier, high-power, R.B.H. Becker, 79 Feb., *Letters*, 114 Mar., 226 May
- Fair, London-Review, 595 Dec.
- mixer, modulated integrated circuit, J.H. Evans & P. Williams, 564 Dec.
- pre-amplifier using operational amplifier techniques, D. Meyer, 309 July, *Letters*, 479 Oct., 575 Dec., *Correction*, 544 Nov.
- telephone exchange, miniature, G. F. Goddard, 90 Feb., *Modifications*, P. F. Gascoyne, 194 Apr., *Letters*, 177 Apr., 265 June
- Batteries, metal-air, 541 Nov.
- Battery saving circuit for portable communication receivers, D.A. Tong, 124 Mar.
- Beacon system, British Isles, v.h.f., Jack Hum, 491 Oct.
- BOOKS RECEIVED, 5 Jan., 86 Feb., 142 Mar., 177 Apr., 228 May, 340 July, 380 Aug., 539 Nov., 610 Dec.
- British broadcasting, 506 Nov.
- Building bricks, electronic, James Franklin, 28 Jan., 74 Feb., 126 Mar., 178 Apr., 238 May, 286 June, 350 July, 390 Aug., 418 Sept., *Correction*, 285 June
- Calculator, Wireless World desk, R. Alexander & B. Crank, 406 Sept., 456 Oct., *Letters*, 575 Dec.
- Capacitor, high-voltage, 113 Mar.
- Cassette tape recorder decks, stereo, Brian Crank, 129 Mar., 187 Apr., *Letters*, 264 June
- video recorders, magnetic-tape, 580 Dec.
- Cheap, stable local oscillator, 218 May
- Circards J. Carruthers, J.H. Evans, J. Kinsler & P. Williams 1: Basic active filters, 469 Oct., 2: Switching circuits, 514 Nov., 3: Waveform generators, 578 Dec.
- CIRCUIT IDEAS, 18 Jan., 77 Feb., 139 Mar., 185 Apr., 239 May, 274 June, 348 July, 366 Aug., 443 Sept., 475 Oct., 540 Nov.
- Communication receivers, battery saving circuit for portables, D. A. Tong, 124 Mar.
- Communications '72, 376 Aug., List of exhibitors, 282 June
- Computer, analogue recursive, R.J. Lamden, 487 Oct.
- CONFERENCES AND EXHIBITIONS, 44 Jan., 123 Mar., 166 Apr., 228 May, 281 June, 315 July, 426 Sept., 490 Oct.
- Constant-current source, high-voltage, D.A. Williams, 29 Jan.
- Current-limited power supply, A. Royston, 67 Feb., *Corrections*, 110 Mar., 424 Sept.
- D.C. motors, towards better control of small, P.L. Hollingberry, 333 July
- scope, trace quadrupler, D. Bollen, 204 May, *Letters*, 479 Oct.
- Decibel meter, linear, J. H. Smith, 488 Oct.
- Decoder, stereo, phase-locked-loop, 315 July
- Desk calculator, Wireless World, R. Alexander & B. Crank, 406 Sept., 456 Oct., *Letters*, 575 Dec.
- Digital and analogue dividers, P. R. Darrington, 529 Nov.
- display using an oscilloscope, C. Attenborough, 586 Dec.
- stereo sound recorder, A. H. Jones & F. A. Bellis, 432 Sept.
- Digitally, displaying frequency, correction to Dec. 1971 article, 13 Jan.
- Dimensional display, unified, R. N. Baldock, 117 Mar.
- Directional information in reproduced sound, P. B. Fellgett, 413 Sept., *Correction*, 544 Nov.
- phasor diagrams, A. R. Carruthers & J. H. Evans, 381 Aug.
- Distortion monitor, portable, J. L. Linsley Hood, 306 July, *Correction*, 480 Oct.
- Dividers, digital and analogue, P. R. Darrington, 529 Nov.
- Domestic receiver survey, 464 Oct.
- video recorder, 435 Sept., *Letters*, 523 Nov.
- Doppler effect, "Cathode Ray", 240 May, 267 June, *Letters*, 387 Aug., 423 Sept., 477 Oct., 523 Nov.
- radar with sense, K. Holford, 535 Nov.
- Dual-trace oscilloscope unit, W. T. Cocking, 19 Jan.
- EDITORIALS, 1 Jan., 53 Feb., 103 Mar., 153 Apr., 203 May, 255 June, 305 July, 357 Aug., 405 Sept., 455 Oct., 505 Nov., 563 Dec.
- Educational television network, Aubrey Harris, 87 Feb.
- Electric heater control, R. M. Marston, 287 June, *Letters*, 480 Oct.
- Electricity meter, experimental, L. A. Trinogga, 33 Jan.
- Electronic building bricks, James Franklin, Closed loop follower, 178 Apr. Function generator, 74 Feb. Logic gates, 350 July. More logic gates, 390 Aug. Noise, 286 June. The channel, 418 Sept. The gate, 238 May, *Correction*, 285 June. The rectifier, 28 Jan. Units and dimensions, 126 Mar. multimeter, simple, J. L. Linsley Hood, 279 June, *Addition*, 319 July, *Letters*, 388 Aug. — retina, N. A. Singer, 161 Apr.
- Experiments with operational amplifiers, G. B. Clayton, 272 June, 324 July, 391 Aug., 425 Sept., 524 Nov., *Letters*, 387 Aug., 480 Oct.
- F.e.t., junction, as a voltage controlled resistance, R. M. Lea, 337 July, 394 Aug. — tester, correction to Dec. 1971 article, 110 Mar.
- F.M. tuner design — 12 months later, L. Nelson-Jones, 179 Apr., *Letters*, 318 July
- Farnborough-Europe '72, 481 Oct.
- Feedforward error control, 232 May
- Fixed aerial for satellite reception, J. M. Osborne, 335 July
- Four-channel stereo, Geoffrey Shorter, 2 Jan., 54 Feb.
- Free roving machine, M. F. Huber, 593 Dec.
- Frequency meter, linear, D. Anderson, 38 Jan. — synthesizers, J. R. Philpott, 269 June
- Function generator, non-linear, H. McPherson, 485 Oct.
- Generator, variable pulse rate, D. T. Smith, 137 Mar. —, white-noise, H. R. Beastall, 127 Mar., *Letters*, 223 May, 264 June
- Graphical analysis of pulses on lines, B. L. Hart, 427 Sept., *Letters*, 576 Dec.
- H.F. aerial, hybrid, T. A. Lindsey, 141 Mar.
- H.F. PREDICTIONS, 32 Jan., 86 Feb., 125 Mar., 160 Apr., 244 May, 268 June, 332 July, 375 Aug., 410 Sept., 493 Oct., 519 Nov., 585 Dec.
- Hand-portable transceiver, D. A. Tong, 154 Apr., *Corrections*, 285 June, 424 Sept.
- High-power audio amplifier design, R. B. H. Becker, 79 Feb., *Letters*, 114 Mar., 226 May — loudspeaker voice coils, working temperatures of, A. E. Falkus, 543 Nov. — quality tape recorder p.c.b.s., 336 July — voltage capacitor, 113 Mar. — constant-current source, D. A. Williams, 29 Jan.
- Horn loudspeaker — Mk II, John Greenbank, 14 Jan.
- How to simplify logic circuits, N. Darwood, 173 Apr.
- Hybrid h.f. aerial, T. A. Lindsey, 141 Mar.
- Integrated circuit audio mixer, modulated, J. H. Evans & P. Williams, 564 Dec.
- I.c. peak programme meter, L. Nelson-Jones, 515 Nov.
- I.E.A. Exhibitors, 246 May, report, 341 July
- I.E.E.E. show New York, 243 May
- Instant intelligence, the mirage of, M. B. Hawton, 294 June
- Junction f.e.t. as a voltage-controlled resistance, R. M. Lea, 337 July, 394 Aug. — f.e.t.s, use of, L. Unsworth, 219 May
- LETTER FROM AMERICA, 244 May, 600 Dec.
- LETTERS TO THE EDITOR, 9 Jan., 72 Feb., 114 Mar., 175 Apr., 223 May, 264 June, 316 July, 387 Aug., 423 Sept., 476 Oct., 520 Nov., 575 Dec.
- Linear decibel meter, J. H. Smith, 488 Oct. — frequency meter, D. Anderson, 38 Jan.
- Linearity of the transistor amplifier, W. T. Cocking, 210 May
- LITERATURE RECEIVED, 52 Jan., 101 Feb., 152 Mar., 201 Apr., 254 May, 298 June, 356 July, 403 Aug., 454 Sept., 502 Oct., 551 Nov., 609 Dec.
- Local oscillator, cheap, stable, 218 May
- Logic circuits, how to simplify, N. Darwood, 173 Apr.
- Long-playing records, video, 474 Oct.
- Loudspeaker enclosure survey, S. Kelly, 552 Nov., *Corrections*, 594 Dec. —, transmission-line, A. R. Bailey, 215 May, *Letters*, 477 Oct. —, horn, Mk II, John Greenbank, 14 Jan. —, voice coils, working temperatures of high-power, A. E. Falkus, 543 Nov.
- Low-impedance microphone pre-amplifier, J. M. Howells & J. R. Jones, 36 Jan.
- noise audio amplifiers, H. P. Walker, 233 May, *Letters*, 388 Aug., 520 Nov., 575 Dec.
- Magnetic-tape cassette video recorders, 580 Dec.
- Medium waves, s.s.b. on, G. Wareham, 358 Aug., *Letters*, 476 Oct., 523 Nov.
- MEETINGS, 46 Jan., 100 Feb., 151 Mar., 195 Apr., 237 May, 266 June, 503 Oct., 534 Nov., 610 Dec.
- Metal-air batteries, 541 Nov.
- Meter amplifier, universal, A. J. Ewins, 61 Feb., *Letters*, 175 Apr. —, i.c. peak programme, L. Nelson-Jones, 515 Nov. —, linear decibel, J. H. Smith, 488 Oct. —, frequency, D. Anderson, 38 Jan. —, recording level and a.g.c., J. M. Bryant, 169 Apr. —, sound pressure-level, J. L. Linsley Hood, 167 Apr.
- Microphone pre-amplifier, low-impedance, J. M. Howells & J. R. Jones, 36 Jan.
- Miniature automatic telephone exchange, G. F. Goddard, 90 Feb. *Modifications*, P. F. Gascoyne, 194 Apr. *Letters*, 177 Apr., 265 June
- Mirage of instant intelligence, M. B. Hawton, 294 June
- Modulated integrated circuit audio mixer, J. H. Evans & P. Williams, 564 Dec.
- Mobile/portable power unit for h.f. transceiver, D. R. Bowman, 601 Dec.
- Multimeter, simple electronic, J. L. Linsley Hood, 279 June, *Addition*, 319 July, *Letters*, 388 Aug.
- Multivibrators with seven-decade range in period, D. T. Smith, 85 Feb., *Letters*, 265 June
- Muscle voltages, simple amplifier for, R. E. George, 495 Oct., *Correction*, 544 Nov.
- Nearer the tubeless TV camera, 138 Mar.
- NEW PRODUCTS, 47 Jan., 95 Feb., 145 Mar., 196 Apr., 249 May, 299 June, 353 July, 399 Aug., 449 Sept., 497 Oct., 546 Nov., 603 Dec.
- NEWS OF THE MONTH, 6 Jan., 58 Feb., 111 Mar., 170 Apr., 212 May, 259 June, 313 July, 364 Aug., 411 Sept., 472 Oct., 532 Nov., 571 Dec.
- Noise reduction, tape, J. R. Stuart, 104 Mar., *Letters*, 266 June — silencers for a.m. receivers, D. A. Tong, 483 Oct.
- Non-linear function generator, H. McPherson, 485 Oct.
- Operational amplifiers, experiments with, G. B. Clayton, 272 June, 324 July, 391 Aug., 425 Sept., 524 Nov., *Letters*, 387 Aug., 480 Oct.
- Oscillators, temperature stabilization, D. A. Tong, 41 Jan.
- Oscilloscope unit, dual-trace, W. T. Cocking, 19 Jan.
- PAL decoder, A. Becker, 26 Jan.
- Paris components show, 276 June
- Peak programme meter, i.c., L. Nelson-Jones, 515 Nov.
- Phase-locked-loop stereo decoder, 315 July — sensitive detector, ubiquitous, K. L. Smith, 367 Aug.
- Phasor diagrams, displaying, A. R. Carruthers & J. H. Evans, 381 Aug.
- Photographing television pictures, R. E. Knight & D. J. Bryan, 290 June
- Physics Exhibition, notes from the, 229 May
- Plotting sound fields by colour light, 60 Feb.
- Portable communication receivers, battery saving circuit, D. A. Tong, 124 Mar. — distortion monitor, J. L. Linsley Hood, 306 July, *Correction*, 480 Oct.
- Power supply, current-limited, A. Royston, 67 Feb., *Corrections*, 110 Mar., 424 Sept. — unit for h.f. transceiver, mobile/portable, D. R. Bowman, 601 Dec.
- Pre-amplifier, audio, using operational amplifier techniques, D. Meyer, 309 July, *Letters*, 479 Oct., 575 Dec., *Correction*, 544 Nov. — low impedance for microphone, J. M. Howells & J. R. Jones, 36 Jan.
- Pulse-rate generator, variable, D. T. Smith, 137 Mar.
- Pulses on lines, graphical analysis of, B. L. Hart, 427 Sept., *Letters*, 576 Dec.
- Quadrphony news, 424 Sept.
- Radar, Döppler with sense, K. Holford, 535 Nov.
- Radio receivers, some early, A. M. Peverett, 510 Nov., *Corrections*, 594 Dec. — reception developments, 445 Sept. — synchronous detection in, Pat Hawton, 419 Sept., 515 Nov., *Letters*, 523 Nov.
- REAL & IMAGINARY "Vector", 102 Feb., 202 Apr., 304 June, 404 Aug., 504 Oct., 611 Dec.
- Receiver survey, domestic, 464 Oct.
- Receivers, noise silencer for a.m., D. A. Tong, 483 Oct.

Recorder, domestic video, 435 Sept., *Letters*, 523 Nov.
 Recording level meter and a.g.c., J. M. Bryant, 169 Apr.
 Records, video long-playing, 474 Oct.
 Reproduced sound, directional information in, P. B. Fellgett, 413 Sept., *Correction*, 544 Nov.
 Reshaping information to suit the channel, 320 July
 Retina, electronic, N. A. Singer, 161 Apr.
 Roving machine, free, M. F. Huber, 593 Dec.

S.S.B. on medium waves?, G. Wareham, 358 Aug., *Letters*, 476 Oct., 523 Nov.
 *Scope, d.c. trace quadrupler, D. Bollen, 204 May, *Letters*, 479 Oct.

Seven-decade range in period multivibrators, D. T. Smith, 85 Feb., *Letters*, 265 June
 Simple amplifier for muscle voltages, R. E. George, 495 Oct., *Correction*, 544 Nov.
 ——— electronic multimeter, J. L. Linsley Hood, 279 June, *Addition*, 319 July, *Letters*, 388 Aug.

Simplifying logic circuits, N. Darwood, 173 Apr.
 SIXTY YEARS AGO, 40 Jan., 84 Feb., 142 Mar., 192 Apr., 217 May, 285 June, 312 July, 375 Aug., 422 Sept., 480 Oct., 544 Nov., 585 Dec.

Solder tests, B. M. Allen, 75 Feb.
 Sonex 72, 227 May, preview, 143 Mar.
 Sound adaptors for television, 65 Feb.
 ——— field plotting by colour lights, 60 Feb.
 ——— pressure-level meter, J. L. Linsley Hood, 167 Apr.
 ——— recorder, digital stereo, A. H. Jones & F. A. Bellis, 432 Sept.

Special-purpose amplifier, W. T. Cocking, 283 June
 Stereo by four-channel Geoffrey Shorter, 2 Jan., 54 Feb.
 ——— cassette tape recorder decks, Brian Crank, 129 Mar., 187 Apr., *Letters*, 264 June
 ——— decoder, phase-locked-loop, 315 July
 ——— sound recorder, digital, A. H. Jones & F. A. Bellis, 432 Sept.

Survey, loudspeaker enclosure, S. Kelly, 552 Nov., *Corrections*, 594 Dec.

Synchronous detection in radio reception, Pat Hawker, 419 Sept., 525 Nov., *Letters*, 523 Nov.

Synthesizers, frequency, J. R. Philpott, 269 June

T.T.L. trigger circuits, H. A. Cole, 31 Jan., *Letters*, 73 Feb., 116 Mar.

TV sound — the poor relation, J. C. G. Gilbert, 16 Jan., *Letters*, 114 Mar.

Tape noise reduction, J. R. Stuart, 104 Mar., *Letters*, 266 June
 ——— recorder decks, stereo cassette, Brian Crank, 129 Mar., 187 Apr., *Letters*, 264 June

Telephone exchange, miniature automatic, G. F. Goddard, 90 Feb. Modifications, P. F. Gascoyne, 194 Apr., *Letters*, 177 Apr., 265 June

Television network, educational, Aubrey Harris, 87 Feb.
 ——— pictures, photographing, R. E. Knight & D. J. Bryan, 290 June
 ——— sound adaptors, 65 Feb.

Temperature stabilization of oscillators, D. A. Tong, 41 Jan.

Tester, f.e.t., correction to Dec. 1971 article, 110 Mar.
 Towards better control of small d.c. motors, P. L. Hollingberry, 333 July

Trace quadrupler for d.c. scopes, D. Bollen, 204 May, *Letters*, 479 Oct.

Transceiver, amateur, 10-80 metre, D. R. Bowman, 256 June, 325 July, 371 Aug., 437 Sept., *Correction*, 480 Oct.

——— hand-portable, D. A. Tong, 154 Apr., *Corrections*, 285 June, 424 Sept.

Transistor amplifier, linearity of the, W. T. Cocking, 210 May

Transmission-line loudspeaker enclosure, A. R. Bailey, 215 May, *Letters*, 477 Oct.

Trigger circuits, t.t.l., H. A. Cole, 31 Jan., *Letters*, 73 Feb., 116 Mar.

Tubeless TV camera, nearer the, 138 Mar.

Tuneable phonon sources, 211 May

Tuner design, f.m. — 12 months later, L. Nelson-Jones, 179 Apr., *Letters*, 318 July

Ubiquitous phase sensitive detector, K. L. Smith, 367 Aug.

Unified dimensional display, R. N. Baldock, 117 Mar.

Universal meter amplifier, A. J. Ewins, 61 Feb., *Letters*, 175 Apr.

Using junction f.e.t.s. L. Unsworth, 219 May

V.h.f. beacon system, British Isles, Jack Hum, 491 Oct.

Variable pulse-rate generator, D. T. Smith, 137 Mar.

"Vector" articles:
 This and that: but mostly Raudive, 102 Feb.
 "It will not last the night —". 202 Apr., *Letters*, 304 June
 What hath Babbage wrought?. 304 June
 "... through a glass, darkly ...". 404 Aug.
 Crisis in the West, 504 Oct.
 The stone age of broadcasting, 611 Dec.

Video long-playing records, 474 Oct.
 ——— recorder, domestic, 435 Sept., *Letters*, 523 Nov.
 ——— recorders, magnetic-tape cassette, 580 Dec.

White-noise generator, H. R. Beasall, 127 Mar., *Letters*, 223 May, 264 June

Wireless World desk calculator, K. Alexander & B. Crank, 406 Sept., 456 Oct., *Letters*, 575 Dec.

Working temperatures of high-power loudspeaker voice coils, A. E. Falkus, 543 Nov.

WORLD OF AMATEUR RADIO, 45 Jan., 94 Feb., 144 Mar., 193 Apr., 245 May, 296 June, 351 July, 398 Aug., 448 Sept., 494 Oct., 545 Nov., 608 Dec.

CLASSIFIED INDEX

AUDIO & ACOUSTICS

Amplifiers, low-noise audio, H. P. Walker, 233 May, *Letters*, 388 Aug., 520 Nov., 575 Dec.
 Audio amplifier, high-power, R. B. H. Becker, 19 Feb., *Letters*, 114 Mar., 226 May
 ——— mixer, modulated integrated circuit, J. H. Evans & P. Williams, 564 Dec.
 ——— pre-amplifier using operational amplifier techniques, D. Meyer, 309 July, *Letters*, 479 Oct., 575 Dec., *Correction*, 544 Nov.

Cassette tape recorder decks, stereo, Brian Crank, 129 Mar., 187 Apr., *Letters*, 264 June

Decoder, stereo, phase-locked-loop, 315 July
 Digital stereo sound recorder, A. H. Jones & F. A. Bellis, 432 Sept.

Directional information in reproduced sound, P. B. Fellgett, 413 Sept., *Correction*, 544 Nov.

Döppler effect, "Cathode Ray". 240 May, 267 June, *Letters*, 387 Aug., 423 Sept., 477 Oct., 523 Nov.

F.M. tuner design — 12 months later, L. Nelson-Jones, 179 Apr., *Letters*, 318 July

Feedforward error control, 232 May
 Four-channel stereo, Geoffrey Shorter, 2 Jan., 54 Feb.

High-power audio amplifier design, R. B. H. Becker, 79 Feb., *Letters*, 114 Mar., 226 May
 ——— loudspeaker voice coils, working temperatures of, A. E. Falkus, 543 Nov.

Horn loudspeaker — Mk II, John Greenbank, 14 Jan.

I.C. peak programme meter, L. Nelson-Jones, 515 Nov.
 Integrated circuit audio mixer, modulated, J. H. Evans & P. Williams, 564 Dec.

Loudspeaker enclosure survey, S. Kelly, 552 Nov., *Correction*, 594 Dec.

——— transmission-line, A. R. Bailey, 215 May, *Letters*, 477 Oct.

——— horn, Mk II, John Greenbank, 14 Jan.

——— voice coils, working temperatures of high-power, A. E. Falkus, 543 Nov.

Low-impedance microphone pre-amplifier, J. M. Howells & J. R. Jones, 36 Jan.

Low-noise audio amplifiers, H. P. Walker, 233 May, *Letters*, 388 Aug., 520 Nov., 575 Dec.

Meter, i.c. peak programme, L. Nelson-Jones, 515 Nov.
 ——— recording level and a.g.c., J. M. Bryant, 169 Apr.

——— sound pressure-level, J. L. Linsley Hood, 167 Apr.
 Microphone pre-amplifier, low-impedance, J. M. Howells & J. R. Jones, 36 Jan.

Modulated integrated circuit audio mixer, J. H. Evans & P. Williams, 564 Dec.

Noise reduction, tape, J. R. Stuart, 104 Mar., *Letters*, 266 June

Peak programme meter, i.c., L. Nelson-Jones, 515 Nov.
 Phase-locked-loop stereo decoder, 315 July

Pre-amplifier, audio, using operational amplifier techniques, D. Meyer, 309 July, *Letters*, 479 Oct., 575 Dec., *Correction*, 544 Nov.

——— low-impedance, for microphone, J. M. Howells & J. R. Jones, 36 Jan.

Quadruphony news, 424 Sept.

Radio receivers, some early, A. M. Peverett, 510 Nov., *Correction*, 594 Dec.

Recording level meter and a.g.c., J. M. Bryant, 169 Apr.

Reproduced sound, directional information in, P. B. Fellgett, 413 Sept., *Correction*, 544 Nov.

Sound pressure-level meter, J. L. Linsley Hood, 167 Apr.
 ——— recorder, digital stereo, A. H. Jones & F. A. Bellis, 432 Sept.

Stereo by four-channel, Geoffrey Shorter, 2 Jan., 54 Feb.
 ——— cassette tape recorder decks, Brian Crank, 129 Mar., 187 Apr., *Letters*, 264 June

——— decoder, phase-locked-loop, 315 July

——— sound recorder, digital, A. H. Jones & F. A. Bellis, 432 Sept.

Survey, loudspeaker enclosures, S. Kelly, 552 Nov., *Correction*, 594 Dec.

TV sound — the poor relation, J. C. G. Gilbert, 16 Jan., *Letters*, 114 Mar.

Tape noise reduction, J. R. Stuart, 104 Mar., *Letters*, 266 June

——— recorder decks, stereo cassette, Brian Crank, 129 Mar., 187 Apr., *Letters*, 264 June

Transmission-line loudspeaker enclosure, A. R. Bailey, 215 May, *Letters*, 477 Oct.

Tuner design, f.m. — 12 months later, L. Nelson-Jones, 179 Apr., *Letters*, 318 July

Working temperatures of high-power loudspeaker voice coils, A. E. Falkus, 543 Nov.

BROADCASTING

A.M. receivers, noise silencer for, D. A. Tong, 483 Oct.
 Aerial for satellite reception, fixed, J. M. Osborne, 335 July
 Another PAL decoder, A. Becker, 26 Jan.

British broadcasting, 506 Nov.

Cassette video recorders, magnetic-tape, 580 Dec.

Digital stereo sound recorder, A. H. Jones & F. A. Bellis, 432 Sept.

Domestic receiver survey, 464 Oct.
 ——— video recorder, 435 Sept., *Letters*, 523 Nov.

Educational television network, Aubrey Harris, 87 Feb.

Long-playing records, video, 474 Oct.

Magnetic-tape cassette video recorders, 580 Dec.
 Medium waves, s.s.b. on, G. Wareham, 358 Aug., *Letters*, 476 Oct., 523 Nov.

Nearer the tubeless TV camera, 138 Mar.
 Noise silencer for a.m. receivers, D. A. Tong, 483 Oct.

PAL decoder, A. Becker, 26 Jan.
 Photographing television pictures, R. E. Knight & D. J. Bryan, 290 June

Radio reception developments, 445 Sept.
 ——— synchronous detection in, Pat Hawker, 419 Sept., 525 Nov., *Letters*, 523 Nov.

Receiver survey, domestic, 464 Oct.

Receivers, noise silencer for a.m., D. A. Tong, 483 Oct.
 ——— some early radio, A. M. Peverett, 510 Nov., *Correction*, 594 Dec.

Recorder, domestic video, 435 Sept., *Letters*, 523 Nov.
 Records, video long-playing, 474 Oct.

S.S.B. on medium waves? G. Wareham, 358 Aug., *Letters*, 476 Oct., 523 Nov.

Sound adaptors for television, 65 Feb.

Stereo sound recorder, digital, A. H. Jones & F. A. Bellis, 432 Sept.

Synchronous detection in radio reception, Pat Hawker, 419 Sept., 525 Nov., *Letters*, 523 Nov.

TV sound — the poor relation, J. C. G. Gilbert, 16 Jan., *Letters*, 114 Mar.

Television network, educational, Aubrey Harris, 87 Feb.
 ——— pictures, photographing, R. E. Knight & D. J. Bryan, 290 June

——— sound adaptors, 65 Feb.

Tubeless TV camera, nearer the, 138 Mar.

Video long-playing records, 474 Oct.
 ——— recorder, domestic, 435 Sept., *Letters*, 523 Nov.
 ——— recorders, magnetic-tape cassette, 580 Dec.

CIRCUIT IDEAS

A.C. waveforms, zero marking of, T. Palmer, 185 Apr.

Active filter, low-pass, S. J. Morris, 186 Apr.
 ——— zener with slow run up, J. Skjeldstad, 185 Apr.

Amplifier, op-amp meter, H. MacDonald, 443 Sept.

Automatic car parking lamp, P. Lacey, 274 June

Battery charger, constant-current, D. Allen, 185 Apr.

Class B amplifiers, output transistor protection, J. R. I. Piper, 77 Feb.

Constant-amplitude triangular-waveform generator, D. J. Price, 348 July

——— current battery charger, D. Allen, 185 Apr.
 Converter, stable voltage-to-frequency, S. Tesic, 78 Feb.

Crystal marker identification, G. Dann, 77 Feb.

D.C. amplifier, simple, R. M. Carter, 239 May, *Letter*, 424 Sept.

Diode pump, R. Barrett, 274 June

Electronic thermometer uses i.c., B. E. Kerley, 366 Aug.

Equalization, remote switching of tape, J. B. Cole, 348 July

F.M. demodulator, low distortion, P. Keenan, 185 Apr.

Failure indicator, J. George, 275 June

Fast rise-time multivibrator, C. R. Masson, 239 May

Filter and oscillator, voltage controlled, D. G. Malham, 443 Sept.

——— voltage-controlled high-pass, D. G. Malham, 349 July

Five-volt logic power supply, J. Taylor, 139 Mar.

Frequency doubler, R. E. Webb, 540 Nov.

Function generator, ultra-slow, N. S. Nicola, 139 Mar.

Generator, triangular waveform, H. Macdonald, 77 Feb.

High impedance input protection at microvolt level, A. Ivanov, 140 Mar.

——— level low-distortion tone control, J. N. Ellis, 78 Feb.

——— pass filter, voltage-controlled, D. G. Malham, 349 July

Input protection at microvolt level, high impedance, A. Ivanov, 140 Mar.

Inverted Wien bridge oscillator, G. W. Short, 78 Feb.

Long-pulse relay trigger, R. L. Bratby, 349 July

Low distortion f.m. demodulator, P. Keenan, 185 Apr.

——— pass active filter, S. J. Morris, 186 Apr.

Matching unit for tuners and i.f. strips, A. Clements, 18 Jan.
 Meter protection circuit, C. Shenton, 475 Oct., *Correction*, 540 Nov.
 Monostable with long adjustable recovery, D. A. Tong, 349 July
 Multivibrator, fast rise time, C. R. Masson, 239 May
 Op-Amp meter amplifier, H. MacDonald, 443 Sept.
 Oscillator, inverted Wien bridge, G. W. Short, 78 Feb.
 —, Wien bridge, L. D. Thomas, 275 June
 Output transistor protection in class B amplifiers, J. R. I. Piper, 77 Feb.
 Overtone oscillator, L. V. Gibbs, 186 Apr.
 Peak detector, P. E. Pinnock, 348 July
 Power supply, five volt logic, J. Taylor, 139 Mar.
 Prolonging effective switch contact time, A. C. Grillet, 274 June
 Protection circuit, meter, C. Shenton, 475 Oct., *Correction*, 540 Nov.
 Pulse generator for diode emitters, D. M. Bussell, 18 Jan.
 Relay trigger, long pulse, R. L. Bratby, 349 July
 Remote switching of tape equalization, I. B. Cole, 348 July
 Sample-and-hold circuit, J. Kilvington, 275 June
 Schmitt trigger with op-amp, J. Rowley, 366 Aug.
 Scratch filter, A. E. Prinn, 140 Mar.
 Simple d.c. amplifier, R. M. Carter, 239 May, *Letters*, 424 Sept.
 Stable voltage-to-frequency converter, S. Tesic, 78 Feb.
 Switch contact time, prolonging effective, A. C. Grillet, 274 June
 Tape equalization, remote switching of, J. B. Cole, 348 July
 Tester for f.e.t.s., simple, J. Skjelstad, 443 Sept.
 Thermometer, electronic, uses i.c., B. E. Kerley, 366 Aug.
 Tone control, high-level low-distortion, J. N. Ellis, 78 Feb.
 Touch controlled tuner, J. W. Richter, 475 Oct.
 Transistor protection, output in class B amplifiers, J. R. I. Piper, 77 Feb.
 Triangle generator, voltage controlled, J. W. Howden, 540 Nov.
 — /square generator, voltage-controlled, R. J. Tidey, 239 May
 Triangular waveform generator, H. Macdonald, 77 Feb.
 — — — — —, constant-amplitude, D. J. Price, 348 July
 Triggered single-shot, K. J. Montgomery, 139 Mar.
 Tuner, touch controlled, J. W. Richter, 475 Oct.
 Tuners and i.f. strips, matching unit, A. Clements, 18 Jan.
 Ultra-slow function generator, N. S. Nicola, 139 Mar.
 Variable-gain volume control, A. Jenkins, 186 Apr.
 Voltage-controlled filter and oscillator, D. G. Malham, 443 Sept.
 — — — — — high-pass filter, D. G. Malham, 349 July
 — — — — — triangle generator, J. W. Howden, 540 Nov.
 — — — — — /square generator, R. J. Tidey, 239 May
 — — — — — dropper, P. Rice, 274 June
 — — — — — stabilizer, simple, P. S. Ewer, 366 Aug.
 Volume control, variable gain, A. Jenkins, 186 Apr.
 Waveform generator, constant-amplitude triangular, D. J. Price, 348 July
 Wien bridge oscillator, L. D. Thomas, 275 June
 Zero current zener reference, J. Double, 475 Oct.
 — — — — — marking of a.c. waveforms, T. Palmer, 185 Apr.

CIRCUITRY & CIRCUIT DESIGN

A.M. receivers, noise silencer for, D. A. Tong, 483 Oct.
 Amateur transceiver, 10-80 metres, D. R. Bowman, 256 June, 325 July, 371 Aug., 437 Sept., *Corrections*, 480 Oct.
 Amplifier for muscle voltages, simple, R. E. George, 495 Oct., *Correction*, 544 Nov.
 — — — — —, special-purpose, W. T. Cocking, 283 June
 — — — — —, universal meter, A. J. Ewins, 61 Feb., *Letters*, 175 Apr.
 Amplifiers, low-noise audio, H. P. Walker, 233 May, *Letters*, 388 Aug., 520 Nov., 575 Dec.
 Another PAL decoder, A. Becker, 26 Jan.
 Audio amplifier, high-power, R. B. H. Becker, 79 Feb., *Letters*, 114 Mar., 226 May
 — — — — — Amplifiers, low-noise, H. P. Walker, 233 May, *Letters*, 388 Aug.
 — — — — — mixer, modulated integrated circuit, J. H. Evans & P. Williams, 564 Dec.
 — — — — — pre-amplifier using operational amplifier techniques, D. Meyer, 309 July, *Letters*, 479 Oct., 575 Dec., *Correction*, 544 Nov.
 Automatic telephone exchange, miniature, G. F. Goddard, 90 Feb. Modifications, P. F. Gascoyne, 194 Apr., *Letters*, 177 Apr., 265 June
 Battery saving circuit for portable communication receivers, D. A. Tong, 124 Mar.
 Calculator, Wireless World desk, R. Alexander & B.

Crank, 406 Sept., 456 Oct., *Letters*, 575 Dec.
 Circards, J. Carruthers, J. H. Evans, J. Kinsler & P. Williams — 1: Basic active filters, 469 Oct., 2: Switching circuits, 514 Nov., 3: Waveform generators, 578 Dec.
 Communication receivers, battery saving circuit for portables, D. A. Tong, 124 Mar.
 Constant-current source, high-voltage, D. A. Williams, 29 Jan.
 Current-limited power supply, A. Royston, 67 Feb., *Corrections*, 110 Mar., 424 Sept.
 D.C. motors, towards better control of small, P. L. Hollingberry, 333 July
 — — — — — scope, trace quadrupler, D. Bollen, 204 May, *Letters*, 479 Oct.
 Decibel meter, linear, J. H. Smith, 488 Oct.
 Desk calculator, Wireless World, R. Alexander & B. Crank, 406 Sept., 456 Oct., *Letters*, 575 Dec.
 Digital and analogue dividers, P. R. Darrington, 529 Nov.
 — — — — — display using an oscilloscope, C. Attenborough, 586 Dec.
 Displaying phasor diagrams, A. R. Carruthers & J. H. Evans, 381 Aug.
 Distortion monitor, portable, J. L. Linsley Hood, 306 July, *Correction*, 480 Oct.
 Dividers, digital and analogue, P. R. Darrington, 529 Nov.
 Doppler radar with sense, K. Holford, 535 Nov.
 Dual-trace oscilloscope unit, W. T. Cocking, 19 Jan.
 Electric heater control, R. M. Marston, 287 June, *Letters*, 480 Oct.
 — — — — — multimeter, simple, J. L. Linsley Hood, 279 June, *Addition*, 319 July, *Letters*, 388 Aug.
 Experimental electronic electricity meter, L. A. Triogga, 33 Jan.
 Experiments with operational amplifiers, G. B. Clayton, 272 June, 324 July, 391 Aug., 425 Sept., 524 Nov., *Letters*, 387 Aug., 480 Oct.
 F.E.T., junction, as a voltage-controlled resistance, R. M. Lea, 337 July, 394 Aug.
 F.M. tuner design — 12 months later, L. Nelson-Jones, 179 Apr., *Letters*, 318 July.
 Feedforward error control, 232 May
 Free roving machine, M. F. Huber, 593 Dec.
 Frequency meter, linear, D. Anderson, 38 Jan.
 — — — — — synthesizers, J. R. Philpott, 269 June
 Function generator, non-linear, H. McPherson, 485 Oct.
 Generator, variable pulse rate, D. T. Smith, 137 Mar.
 — — — — —, white-noise, H. R. Beastall, 127 Mar., *Letters*, 223 May, 264 June
 Hand-portable transceiver, D. A. Tong, 154 Apr., *Corrections*, 285 June, 424 Sept.
 High-power audio amplifier design, R. B. H. Becker, 79 Feb., *Letters*, 114 Mar., 226 May
 — — — — — voltage constant-current source, D. A. Williams, 29 Jan.
 I.C. peak programme meter, L. Nelson-Jones, 515 Nov.
 Integrated circuit audio mixer, modulated, J. H. Evans & P. Williams, 564 Dec.
 Junction f.e.t. as a voltage-controlled resistance, R. M. Lea, 337 July, 394 Aug.
 — — — — — f.e.t.s., use of, L. Unsworth, 219 May
 Linear decibel meter, J. H. Smith, 488 Oct.
 — — — — — frequency meter, D. Anderson, 38 Jan.
 Linearity of the transistor amplifier, W. T. Cocking, 210 May
 Low-impedance microphone pre-amplifier, J. M. Howells & J. R. Jones, 36 Jan.
 — — — — — noise audio amplifiers, H. P. Walker, 233 May, *Letters*, 388 Aug., 520 Nov., 575 Dec.
 Meter amplifier, universal, A. J. Ewins, 61 Feb., *Letters*, 175 Apr.
 — — — — —, i.c. peak programme, L. Nelson-Jones, 515 Nov.
 — — — — —, linear frequency, D. Anderson, 38 Jan.
 — — — — —, recording level and a.g.c., J. M. Bryant, 169 Apr.
 — — — — —, sound pressure-level, J. L. Linsley Hood, 167 Apr.
 Microphone pre-amplifier, low impedance, J. M. Howells & J. R. Jones, 36 Jan.
 Miniature automatic telephone exchange, G. F. Goddard, 90 Feb. Modifications, P. F. Gascoyne, 194 Apr., *Letters*, 177 Apr., 265 June
 Mobile/portable power unit for h.f. transceiver, D. R. Bowman, 601 Dec.
 Modulated integrated circuit audio mixer, J. H. Evans & P. Williams, 564 Dec.
 Multimeter, simple electronic, J. L. Linsley Hood, 279 June, *Addition*, 319 July, *Letters*, 388 Aug.
 Multivibrators with seven-decade range in period, D. T. Smith, 85 Feb., *Letters*, 265 June
 Muscle voltages, simple amplifier for, R. E. George, 495 Oct., *Correction*, 544 Nov.
 Noise reduction, tape, J. R. Stuart, 104 Mar., *Letters*, 266 June
 — — — — — silencer for a.m. receivers, D. A. Tong, 483 Oct.
 Non-linear function generator, H. McPherson, 485 Oct.
 Operational amplifiers, experiments with, G. B. Clayton, 272 June, 324 July, 391 Aug., 425 Sept., 524 Nov., *Letters*, 387 Aug., 480 Oct.

Oscillators, temperature stabilization, D. A. Tong, 41 Jan.
 Oscilloscope unit, dual-trace, W. T. Cocking, 19 Jan.
 PAL decoder, A. Becker, 26 Jan.
 Peak programme meter, L. Nelson-Jones, 515 Nov.
 Phase sensitive detector, K. L. Smith, 367 Aug.
 Phasor diagrams, displaying, A. R. Carruthers & J. H. Evans, 381 Aug.
 Photographing television pictures, R. E. Knight & D. J. Bryan, 290 June
 Portable communication receivers, battery saving circuit, D. A. Tong, 124 Mar.
 — — — — — distortion monitor, J. L. Linsley Hood, 306 July, *Correction*, 480 Oct.
 Power supply, current-limited, A. Royston, 67 Feb., *Corrections*, 110 Mar., 424 Sept.
 — — — — — unit for h.f. transceiver, mobile/portable, D. R. Bowman, 601 Dec.
 Pre-amplifier, audio, using operational amplifier techniques, D. Meyer, 309 July, *Letters*, 479 Oct., 575 Dec., *Correction*, 544 Nov.
 — — — — —, low-impedance for microphone, J. M. Howells & J. R. Jones, 36 Jan.
 Pulse-rate generator, variable, D. T. Smith, 137 Mar.
 Radar, Doppler with sense, K. Holford, 535 Nov.
 Radio reception, synchronous detection in, Pat Hawker, 419 Sept., 525 Nov., *Letters*, 523 Nov.
 Receivers, noise silencer for a.m., D. A. Tong, 483 Oct.
 Recording level meter and a.g.c., J. M. Bryant, 169 Apr.
 Roving machine, free, M. F. Huber, 593 Dec.
 Scope, d.c., trace quadrupler, D. Bollen, 204 May, *Letters*, 479 Oct.
 Seven-decade range in period multivibrators, D. T. Smith, 85 Feb., *Letters*, 265 June
 Simple amplifier for muscle voltages, R. E. George, 495 Oct., *Correction*, 544 Nov.
 — — — — — electronic multimeter, J. L. Linsley Hood, 279 June, *Addition*, 319 July, *Letters*, 388 Aug.
 Sound adaptors for television, 65 Feb.
 — — — — — pressure-level meter, J. L. Linsley Hood, 167 Apr.
 Special-purpose amplifier, W. T. Cocking, 283 June
 Synchronous detection in radio reception, Pat Hawker, 419 Sept., 525 Nov., *Letters*, 523 Nov.
 Synthesizers, frequency, J. R. Philpott, 269 June
 T.T.L. Trigger circuits, H. A. Cole, 31 Jan., *Letters*, 73 Feb., 116 Mar.
 Tape noise reduction, J. R. Stuart, 104 Mar., *Letters*, 266 June
 Telephone exchange, miniature automatic, G. F. Goddard, 90 Feb., Modifications, P. F. Gascoyne, 194 Apr.
 Television pictures, photographing, R. E. Knight & D. J. Bryan, 290 June
 — — — — — sound adaptors, 65 Feb.
 Temperature stabilization of oscillators, D. A. Tong, 41 Jan.
 Towards better control of small d.c. motors, P. L. Hollingberry, 333 July
 Trace quadrupler for d.c. scopes, D. Bollen, 204 May, *Letters*, 479 Oct.
 Transceiver, amateur, 10-80 metre, D. R. Bowman, 256 June, 325 July, 371 Aug., 437 Sept., *Corrections*, 480 Oct., Power unit 601 Dec.
 — — — — —, hand-portable, D. A. Tong, 154 Apr., *Corrections*, 285 June, 424 Sept.
 Transistor amplifier, linearity of the, W. T. Cocking, 210 May
 Trigger circuits, t.t.l., H. A. Cole, 31 Jan., *Letters*, 73 Feb., 116 Mar.
 Tuner design, f.m. — 12 months later, L. Nelson-Jones, 179 Apr., *Letters*, 318 July
 Ubiquitous phase sensitive detector, K. L. Smith, 367 Aug
 Universal meter amplifier, A. J. Ewins, 61 Feb., *Letters*, 175 Apr.
 Using junction f.e.t.s, L. Unsworth, 219 May
 Variable pulse-rate generator, D. T. Smith, 137 Mar.
 White-noise generator, H. R. Beastall, 127 Mar., *Letters*, 223 May, 264 June
 Wireless World desk calculator, R. Alexander & B. Crank, 406 Sept., 456 Oct., *Letters*, 575 Dec.

COMMUNICATIONS

Aerial, h.f. hybrid, T. A. Lindsey, 141 Mar.
 Amateur transceiver, 10-80 metre, D. R. Bowman, 256 June, 325 July, 371 Aug., 437 Sept., *Corrections*, 480 Oct.
 Another PAL decoder, A. Becker, 26 Jan.
 Battery saving circuit for portable communications receivers, D. A. Tong, 124 Mar.
 Beacon system, British Isles v.h.f., Jack Hum, 491 Oct.
 Cheap, stable local oscillator, 218 May
 Doppler radar with sense, K. Holford, 535 Nov.
 Fixed aerial for satellite reception, J. M. Osborne, 335 July
 Graphical analysis of pulses on lines, B. L. Hart, 427 Sept., *Letters*, 576 Dec.
 H.F. aerial, hybrid, T. A. Lindsey, 141 Mar.
 H.F. transceiver, mobile/portable power unit for, D. R. Bowman, 601 Dec.

- Hand-portable transceiver, D. A. Tong, 154 Apr., *Corrections*, 285 June, 424 Sept.
- Local oscillator, cheap, stable, 218 May
- Medium waves, s.s.b. on, G. Wareham, 358 Aug., *Letters*, 476 Oct., 523 Nov.
- Noise silencer for a.m. receivers, D. A. Tong, 483 Oct.
- PAL decoder, A. Becker, 26 Jan.
- Portable communication receiver, battery saving circuit, D. A. Tong, 124 Mar.
- Pulses on lines, graphical analysis of, B. L. Hart, 427 Sept., *Letters*, 576 Dec.
- Power unit for h.f. transceiver, mobile/portable, D. R. Bowman, 601 Dec.
- Radar, Doppler with sense, K. Holford, 535 Nov.
- Radio reception developments, 445 Sept.
- , synchronous detection in, Pat Hawker, 419 Sept., 525 Nov., *Letters*, 523 Nov.
- Reshaping information to suit the channel, 320 July
- S.S.B. on medium waves?, G. Wareham, 358 Aug., *Letters*, 476 Oct., 523 Nov.
- Satellite reception, fixed aerial for, J. M. Osborne, 335 July
- Synchronous detection in radio reception, Pat Hawker, 419 Sept., 525 Nov., *Letters*, 523 Nov.
- Telephone exchange, miniature automatic, G. F. Goddard, 90 Feb., Modifications, P. F. Gascoyne, 194 Apr. *Letters*, 177 Apr., 265 June
- Transceiver, amateur, 10-80 metre, D. R. Bowman, 256 June, 325 July, 371 Aug., 437 Sept., *Corrections*, 480 Oct.
- , hand-portable, D. A. Tong, 154 Apr., *Corrections*, 285 June, 424 Sept.
- V.H.F. beacon system, British Isles, Jack Hum, 491 Oct.
- ### COMPUTING
- Analog recursive computer, R. J. Lamden, 487 Oct.
- Digital and analogue dividers, P. R. Darrington, 529 Nov.
- , display using an oscilloscope, C. Attenborough, 586 Dec.
- Electronic retina, N. A. Singer, 161 Apr.
- Graphical analysis of pulses on lines, B. L. Hart, 427 Sept., *Letters*, 576 Dec.
- Logic circuits, how to simplify, N. Darwood, 173 Apr.
- ### CONSTRUCTIONAL DESIGNS
- A.M. receivers, noise silencer for, D. A. Tong, 483 Oct.
- Amateur transceiver, 10-80 metre, D. R. Bowman, 256 June, 325 July, 371 Aug., 437 Sept., *Corrections*, 480 Oct.
- Power unit, 601 Dec.
- Amplifier for muscle voltages, simple, R. E. George, 495 Oct., *Correction*, 544 Nov.
- , universal meter, A. J. Ewins, 61 Feb., *Letters*, 175 Apr.
- Audio amplifier, high-power, R. B. H. Becker, 79 Feb., *Letters*, 114 Mar., 226 May
- , Mixer, modulated integrated circuit, J. H. Evans & P. Williams, 564 Dec.
- , Pre-amplifier using operational amplifier techniques, D. Meyer, 309 July, *Letters*, 479 Oct., 575 Dec., *Correction*, 544 Nov.
- Battery saving circuit for portable communication receivers, D. A. Tong, 124 Mar.
- Calculator, Wireless World desk, R. Alexander & B. Crank, 406 Sept., 456 Oct., *Letters*, 575 Dec.
- Communication receivers, battery saving circuit for portables, D. A. Tong, 124 Mar.
- Constant-current source, high voltage, D. A. Williams, 29 Jan.
- Current-limited power supply, A. Royston, 67 Feb., *Corrections*, 110 Mar., 424 Sept.
- D. C. 'scopes, trace quadrupler, D. Bollen, 204 May, *Letters*, 479 Oct.
- Decibel meter, linear, J. H. Smith, 488 Oct.
- Desk Calculator, Wireless World, R. Alexander & B. Crank, 406 Sept., 456 Oct., *Letters*, 575 Dec.
- Displaying phasor diagrams, A. R. Carruthers & J. H. Evans, 381 Aug.
- Distortion monitor, portable, J. L. Linsley Hood, 306 July, *Correction*, 480 Oct.
- Dual-trace oscilloscope unit, W. T. Cocking, 19 Jan.
- Electric heater control, R. M. Marston, 287 June, *Letters*, 480 Oct.
- Electronic electricity meter, experimental, L. A. Trinogga, 33 Jan.
- , multimeter, simple, J. L. Linsley Hood, 279 June, *Addition*, 319 July, *Letters*, 388 Aug.
- Free roving machine, M. F. Huber, 593 Dec.
- Frequency meter, linear, D. Anderson, 38 Jan.
- Generator, white-noise, H. R. Beastall, 127 Mar., *Letters*, 223 May, 264 June
- H.F. transceiver, mobile/portable power unit for, D. R. Bowman, 601 Dec.
- Hand-portable transceiver, D. A. Tong, 154 Apr., *Corrections*, 285 June, 424 Sept.
- High-power audio amplifier design, R. B. H. Becker, 79 Feb., *Letters*, 114 Mar., 226 May
- , voltage constant-current source, D. A. Williams, 29 Jan.
- Horn loudspeaker, J. Greenbank, 14 Jan.
- I.C. peak programme meter, L. Nelson-Jones, 515 Nov.
- Integrated circuit audio mixer, modulated, J. H. Evans & P. Williams, 564 Dec.
- Linear decibel meter, J. H. Smith, 488 Oct.
- , frequency meter, D. Anderson, 38 Jan.
- Loudspeaker enclosure, transmission-line, A. R. Bailey, 215 May, *Letters*, 477 Oct.
- Low-impedance microphone pre-amplifier, J. M. Howells & J. R. Jones, 36 Jan.
- Meter amplifier, universal, A. J. Ewins, 61 Feb., *Letters*, 175 Apr.
- , i.c. peak programme, L. Nelson-Jones, 515 Nov.
- , linear decibel, J. H. Smith, 488 Oct.
- , frequency, D. Anderson, 38 Jan.
- , recording level and a.g.c., J. M. Bryant, 169 Apr.
- , sound pressure-level, J. L. Linsley Hood, 167 Apr.
- Microphone pre-amplifier, low impedance, J. M. Howells & J. R. Jones, 36 Jan.
- Mobile/portable power unit for h.f. transceiver, D. R. Bowman, 601 Dec.
- Modulated integrated circuit audio mixer, J. H. Evans & P. Williams, 564 Dec.
- Multimeter, simple electronic, J. L. Linsley Hood, 279 June, *Addition*, 319 July, *Letters*, 388 Aug.
- Muscle voltages, simple amplifier for, R. E. George, 495 Oct., *Correction*, 544 Nov.
- Noise silencer for a.m. receivers, D. A. Tong, 483 Oct.
- Oscilloscope unit, dual-trace, W. T. Cocking, 19 Jan.
- Peak programme meter, i.c., L. Nelson-Jones, 515 Nov.
- Phasor diagrams, displaying, A. R. Carruthers & J. H. Evans, 381 Aug.
- Portable communication receivers, battery saving circuit, D. A. Tong, 124 Mar.
- , distortion monitor, J. L. Linsley Hood, 306 July, *Correction*, 480 Oct.
- Power supply, current-limited, A. Royston, 67 Feb., *Correction*, 110 Mar., 424 Sept.
- Power unit for h.f. transceiver, mobile/portable, D. R. Bowman, 601 Dec.
- Pre-amplifier, audio, using operational amplifier techniques, D. Meyer, 309 July, *Letters*, 479 Oct., 575 Dec., *Correction*, 544 Nov.
- , low-impedance for microphone, J. M. Howells & J. R. Jones, 36 Jan.
- Receivers, noise silencer for a.m., D. A. Tong, 483 Oct.
- Recording level meter and a.g.c., J. M. Bryant, 169 Apr.
- Roving machine, free, M. F. Huber, 593 Dec.
- 'Scopes, d.c., trace quadrupler, D. Bollen, 204 May, *Letters*, 479 Oct.
- Simple amplifier for muscle voltages, R. E. George, 495 Oct., *Correction*, 544 Nov.
- , electronic multimeter, J. L. Linsley Hood, 279 June, *Addition*, 319 July, *Letters*, 388 Aug.
- Sound pressure-level meter, J. L. Linsley Hood, 167 Apr.
- Telephone exchange, miniature automatic, G. F. Goddard, 90 Feb., Modifications, P. F. Gascoyne, 194 Apr. *Letters*, 177 Apr., 265 June
- Trace quadrupler for d.c. 'scopes, D. Bollen, 204 May, *Letters*, 479 Oct.
- Transceiver, amateur, 10-80 metre, D. R. Bowman, 256 June, 325 July, 371 Aug., 437 Sept., *Corrections*, 480 Oct.
- , hand-portable, D. A. Tong, 154 Apr., *Corrections*, 285 June, 424 Sept.
- Transmission-line loudspeaker enclosure, A. R. Bailey, 215 May, *Letters*, 477 Oct.
- Universal meter amplifier, A. J. Ewins, 61 Feb., *Letters*, 175 Apr.
- White-noise generator, H. R. Beastall, 127 Mar., *Letters*, 223 May, 264 June
- Wireless World desk calculator, R. Alexander & B. Crank, 406 Sept., 456 Oct., *Letters*, 575 Dec.
- ### DOMESTIC EQUIPMENT
- Another PAL decoder, A. Becker, 26 Jan.
- Cassette tape recorder decks, stereo, Brian Crank, 129 Mar., 187 Apr., *Letters*, 264 June
- , video recorders, magnetic-tape, 580 Dec.
- Domestic receiver survey, 464 Oct.
- , video recorder, 435 Sept., *Letters*, 523 Nov.
- F.M. tuner design — 12 months later, L. Nelson-Jones, 179 Apr., *Letters*, 318 July
- Horn loudspeaker — Mk II, John Greenbank, 14 Jan.
- Long-playing records, video, 474 Oct.
- Loudspeaker enclosure survey, S. Kelly, 552 Nov., *Corrections*, 594 Dec.
- , transmission line, A. R. Bailey, 215 May, *Letters*, 477 Oct.
- , horn — Mk II, John Greenbank, 14 Jan.
- Magnetic-tape cassette video recorders, 580 Dec.
- PAL decoder, A. Becker, 26 Jan.
- Receiver survey, domestic, 464 Oct.
- Recorder, domestic video, 435 Sept., *Letters*, 523 Nov.
- Records, video long-playing, 474 Oct.
- Sound adaptors for television, 65 Feb.
- Stereo cassette tape recorder decks, Brian Crank, 129 Mar., 187 Apr., *Letters*, 264 June
- Survey, loudspeaker-enclosure, S. Kelly, 552 Nov., *Corrections*, 594 Dec.
- TV sound — the poor relation, J. C. G. Gilbert, 16 Jan., *Letters*, 114 Mar.
- Tape recorder decks, stereo cassette, Brian Crank, 129 Mar., 187 Apr., *Letters*, 264 June
- Television sound adaptors, 65 Feb.
- Transmission-line loudspeaker enclosure, A. R. Bailey, 215 May, *Letters*, 477 Oct.
- Tuner design, f.m. — 12 months later, L. Nelson-Jones, 179 Apr., *Letters*, 318 July
- Video long-playing records, 474 Oct.
- , recorder, domestic, 435 Sept., *Letters*, 523 Nov.
- , recorders, magnetic tape cassette, 580 Dec.
- ### EDITORIALS
- Appreciation; apology; appeal, 305 July
- Broadcasting — retrospect and prospect, 505 Nov.
- Editorial conventions, 405 Sept.
- Electronic calculators, 357 Aug.
- Electronics and telephone exchanges, 255 June
- , education or vocational training? 203 May
- Exhibitions — general or specialized, 153 Apr.
- Information retrieval, 455 Oct.
- Is the manufacturer always right? 103 Mar.
- Licence for what? 1 Jan.
- Walter Cocking retires, 53 Feb.
- ### EDUCATION & TRAINING
- Batteries, metal-air, 541 Nov.
- Capacitor, high voltage, 113 Mar.
- Circards, J. Carruthers, J. H. Evans, J. Kinsler & P. Williams, 1: Basic active filters, 469 Oct., 2: Switching circuits, 514 Nov., 3: Waveform generator, 578 Dec.
- Dimensional display, unified, R. N. Baldock, 117 Mar.
- Doppler effect, "Cathode Ray", 240 May, 267 June, *Letters*, 387 Aug., 423 Sept., 477 Oct., 523 Nov.
- Educational television network, Aubrey Harris, 87 Feb.
- Experiments with operational amplifiers, G. B. Clayton, 272 June, 324 July, 391 Aug., 425 Sept., 524 Nov., *Letters*, 387 Aug., 480 Oct.
- Function generator, non-linear, H. McPherson, 485 Oct.
- Graphical analysis of pulses on lines, B. L. Hart, 427 Sept.
- How to simplify logic circuits, N. Darwood, 173 Apr.
- Instant intelligence, the mirage of, M. B. Hawton, 294 June
- Junction f.e.t.s., use of, L. Unsworth, 219 May
- Logic circuits, how to simplify, N. Darwood, 173 Apr.
- Metal-air batteries, 541 Nov.
- Mirage of instant intelligence, M. B. Hawton, 294 June
- Non-linear function generator, H. McPherson, 485 Oct.
- Operational amplifiers, experiments with, G. B. Clayton, 272 June, 324 July, 391 Aug., 425 Sept., 524 Nov., *Letters*, 387 Aug., 480 Oct.
- Pulses on lines, graphical analysis of, B. L. Hart, 427 Sept.
- Simplifying logic circuits, N. Darwood, 173 Apr.

Television network, educational, Aubrey Harris, 87 Feb.

Unified dimensional display, R. N. Baldock, 117 Mar.
Using junction f.e.t.s, L. Unsworth, 219 May

EXHIBITION REPORTS

Audio Fair, London — Review, 595 Dec.

Communications '72, 376 Aug., List of exhibitors, 282 June

Farnborough-Europe '72, 481 Oct.

IEA show, 341 July, exhibitors at, 246 May
I.E.E.E. show New York, 243 May

Paris components show, 276 June
Physics Exhibition, notes from the, 229 May

Radio reception developments, 445 Sept.
Reshaping information to suit the channel, 320 July

Sonex 72, 227 May, preview, 143 Mar.

LETTERS TO THE EDITOR

ASP strikes again, P. W. van der Walt, 265 June
Amateur record?, D. H. Johnson, 223 May
Automatic telephone exchange, N. Monk, 117 Apr., G. F. Goddard, 265 June

Baxandall speaker, T. Magchielse, 223 May, P. J. Baxandall, 316 July
Bootstrapping, C. R. Cathles, 225 May, H. P. Walker, 423 Sept.

Cassettes and cartridges, L. F. Odell, 523 Nov.
Ceramic pickup performance, G. H. Baker, 11 Jan.

Desk calculator construction, D. H. Meech, 575 Dec.
Differential discriminator circuits, R. W. Penny, 12 Jan., H. A. Cole, 73 Feb.
Digital frequency meter mods, J. Gardner, 13 Jan.
Displaying frequency digitally, J. A. Titus, 115 Mar., H. F. Lewis, 226 May
Doppler effect, P. J. Unwin, A. F. Jervis, 387 Aug., J. E. Foggitt, 423 Sept., H. D. Harwood, L. Gray, 477 Oct., "Cathode Ray", 523 Nov.

Electric heater control, M. J. Shilling, 480 Oct.
Electrostatic headphones, J. Halliday, 9 Jan., P. D. Harvey, 72 Feb.

F.M. tuner bandwidth, J. E. A. Fison, 10 Jan.
— instability, R. Ellis, 318 July
Free bump testing, D. M. Willoughby, 73 Feb.
Frequency response of discs, S. W. Davies, 116 Mar.

Graphical analysis of pulses on lines, R. C. V. Macario, 576 Dec.

High-load transistor voltage amplifier, G. W. Short, 521 Nov.
— power audio amplifier, G. N. Patchett, R. B. H. Becker, 114 Mar., A. G. Jones, 226 May
History repeats?, R. E. Smith, 424 Sept.
Horn loudspeakers, S. W. Gilbert, 72 Feb., 116 Mar.
Hydrokinetic interference, C. D. Newman, 116 Mar.

Illegal listening, R. Cox, 266 June, T. H. Patinson, 389 Aug.
Imported equipment, S. Braidford, 176 Apr.
Incremental computer, W. F. Lovering & R. E. H. Bywater, 177 Apr.
Ingenious tuning indicator, M. Gavins, 318 July

Karnaugh map display, A. Potton, 319 July

Liniac, P.W. van der Walt, 11 Jan., H. Harper, 115 Mar., B.J.C. Burrows, 225 May, P.W. van der Walt, 265 June

Linking schools with industry, P.D. Noakes, 478 Oct.
Low-cost horn loudspeaker, D.R. Schaller, 389 Aug.
— noise audio amplifiers, J.L. Linsley Hood, 389 Aug., H.P. Walker, 520 Nov. Lunar epic, C.F. Green, 389 Aug., I. Buckner, 576 Dec.

Multiplex TV transmitters, L.W. Turner, 13 Jan.

Noise — white, pink, red, R.N. Baldock, 476 Oct., H.D. Harwood, 522 Nov.

Op-amp pre-amp, D.R.S. Hedgeland, 575 Dec.
Op-amp transfer characteristic, B.L. Hart, 387 Aug., T. Roddam, 480 Oct.

Power supply for f.m. tuner and decoder, P. Lacey, 10 Jan.
Pre-amp for ceramic pickups, B.J.C. Burrows, 10 Jan.
Pre-amplifier using op-amps, M. Dreyfus, 479 Oct.

Regulated power supplies, M.L.G. Oldfield, 520 Nov., Correction, 594 Dec.

S.S.B. on medium waves? G.M. Ward, 476 Oct.
Self-biasing class A power amplifier, W. Allison, 577 Dec.
Servicing help needed, A.J. Smale, 523 Nov.
Simple d.c. amplifier, P.D. Bailey, 424 Sept.
— electronic multimeter, D. Jones, 388 Aug.

Sinclair pocket calculator, C.M. Sinclair, 423 Sept.
Soldering aluminium alloy, W.S. Williams, 389 Aug.
Stereo cassette tape decks, H.V. Hempleman, 264 June
— decoder, phase locked loop, P. Lacey, 177 Apr.
Swept-frequency audio oscillator, R. Curling-Hope, 73 Feb.
Synchronous detector, H. Leopold, 523 Nov.

T.T.L. trigger circuits, D.B. Stiles, 73 Feb., M.F. Arnold, 116 Mar.

TV standards abroad, B.E. Graham Goodger, 176 Apr.
Tape messages by post, F.L. Devereux, 114 Mar.
— noise reduction, W.H. Myall, 266 June

Television sound quality, D.T.N. Williamson, G.J. King, 114 Mar.

Trace quadrupler, J.A. Titus, 479 Oct.
Transmission-line speakers, P.A. Sheppard, 477 Oct.
Tree effects in TV reception, M.G. Scroggie, 478 Oct., F.L. Devereux, 575 Dec.

Turntable construction, R.G. Brown, R. Ockleshaw, 115 Mar.

Universal meter amplifier, G. Hibbert, A.J. Ewins, 175 Apr.

Voltage controlled oscillators, D.B. Stiles, 265 June

White-noise generator, H. Sutcliffe, H.R. Beastall, Nicholas Lewis, 223 May, D.E.O'N. Waddington, 264 June

Why cassettes?, Ian Leslie, 264 June
Wow and flutter meter, B.J.C. Burrows, 226 May

MEASUREMENT & TEST

Amplifier for muscle voltages, simple, R.E. George, 495 Oct., Correction, 544 Nov.
—, universal meter, A.J. Ewins, 61 Feb., Letters, 175 Apr.

Constant-current source, high voltage, D.A. Williams, 29 Jan.

D.C. 'scopes, trace quadrupler, D. Bollen, 204 May, Letters, 479 Oct.

Decibel meter, linear, J.H. Smith, 488 Oct.
Digital and analogue dividers, P.R. Darrington, 529 Nov.
Distortion monitor, portable, J.L. Linsley Hood, 306 July, Correction, 480 Oct.
Dual-trace oscilloscope unit, W.T. Cocking, 19 Jan.

Electronic multimeter, J.L. Linsley Hood, 279 June, Addition, 319 July, Letters, 388 Aug.
Experiments with operational amplifiers, G.B. Clayton, 272 June, 324 July, 391 Aug., 425 Sept., 524 Nov., Letters, 387 Aug., 480 Oct.

Frequency meter, linear, D. Anderson, 38 Jan.

High-power loudspeaker voice coils, working temperatures of, A.E. Falkus, 543 Nov.
— voltage constant-current source, D.A. Williams, 29 Jan.

I.C. peak programme meter, L. Nelson-Jones, 515 Nov.

Loudspeaker voice coils, working temperatures of high-power, A.E. Falkus, 543 Nov.

Meter amplifier, universal, A.J. Ewins, 61 Feb., Letters, 175 Apr.
—, i.c. peak programme, L. Nelson-Jones, 515 Nov.
—, linear decibel, J.H. Smith, 488 Oct.
— frequency, D. Anderson, 38 Jan.
—, recording level and a.g.c., J.M. Bryant, 169 Apr.
—, sound pressure-level, J.L. Linsley Hood, 167 Apr.
Multimeter, simple electronic, J.L. Linsley Hood, 279 June, Addition, 319 July, Letters, 388 Aug.
Muscle voltages, simple amplifier for, R.E. George, 495 Oct., Correction, 544 Nov.

Operational amplifiers, experiments with, G.B. Clayton, 272 June, 324 July, 391 Aug., 425 Sept., 524 Nov., Letters, 387 Aug., 480 Oct.

Oscilloscope unit, dual-trace, W.T. Cocking, 19 Jan.

Peak programme meter, i.c., L. Nelson-Jones, 515 Nov.
Phase sensitive detector, ubiquitous, K.L. Smith, 367 Aug.
Portable distortion monitor, J.L. Linsley Hood, 306 July, Correction, 480 Oct.

Recording level meter and a.g.c., J.M. Bryant, 169 Apr.
'Scopes, d.c., trace quadrupler, D. Bollen, 204 May, Letters, 479 Oct.

Solder tests, B.M. Allen, 75 Feb.
Sound pressure-level meter, J.L. Linsley Hood, 167 Apr.

Trace quadrupler for d.c. 'scopes, D. Bollen, 204 May, Letters, 479 Oct.

Ubiquitous phase sensitive detector, K.L. Smith, 367 Aug.
Universal meter amplifier, A.J. Ewins, 61 Feb., Letters, 175 Apr.

Working temperatures of high-power loudspeaker voice coils, A.E. Falkus, 543 Nov.

AUTHORS

Alexander, R. & Crank, B., 406 Sept., 456 Oct.
Allen, B.M., 75 Feb.
Anderson, D., 38 Jan.
Attenborough, C., 586 Dec.

Bailey, A.R., 215 May, Letters, 478 Oct.
Baldock, R.N., 117 Mar.
Beastall, H.R., 127 Mar., Letters, 224 May
Becker, A., 26 Jan.
Becker, R.B.H., 79 Feb., Letters, 115 Mar.
Bellis, F.A. & Jones, A.H., 432 Sept.
Bollen, D., 204 May, Letters, 479 Oct.
Bowman, D.R., 256 June, 325 July, 371 Aug., 437 Sept., 601, Dec.
Bryan, D.J. & Knight, R.E., 290 June
Bryant, J.M., 169 Apr.

Carruthers, A.R. & Evans, J.H., 381 Aug.
Carruthers, J., Evans, J.H., Kinsler, J. & Williams, P., 469 Oct., 514 Nov., 578 Dec.
"Cathode Ray", 240 May, 267 June, Letters, 388 Aug., 523 Nov.
Clayton, G.B., 272 June, 324 July, 391 Aug., 425 Sept., 524 Nov.
Cocking, W.T., 19 Jan., 210 May, 283 June.
Cole, H.A., 31 Jan.
Crank, B., 129 Mar., 187 Apr., Letters, 264 June
Crank, B. & Alexander, R., 406 Sept., 456 Oct.

Darrington, P.R., 529 Nov.
Darwood, N., 173 Apr.

Evans, J.H. & Carruthers, A.R., 381 Aug.
Evans, J.H., Kinsler, J., Williams, P., & Carruthers, J., 469 Oct., 514 Nov., 578 Dec.
Evans, J.H. & Williams, P., 564 Dec.
Ewins, A.J., 61 Feb., Letters, 175 Apr.

Falkus, A.E., 543 Nov.
Fellgett, P.B., 413 Sept.
Franklin, J., 28 Jan., 74 Feb., 126 Mar., 178 Apr., 238 May, 286 June, 350 July, 390 Aug., 418 Sept.

Gascoyne, P.F., 194 Apr.,
George, R.E., 495 Oct.
Gilbert, J.C.G., 16 Jan.
Goddard, G.F., 90 Feb.
Greenbank, J., 14 Jan.

Harris, A., 87 Feb.
Hart, B.L., 427 Sept.
Hawker, P., 419 Sept., 525 Nov.
Hawton, M.B., 294 June
Holford, K., 535 Nov.
Hollingberry, P.L., 333 July
Howells, J.M. & Jones, J.R., 36 Jan.
Huber, M.F., 593 Dec.
Hum, J., 491 Oct.

Jones, A.H. & Bellis, F.A., 432 Sept.
Jones, J.R. & Howells, J.M., 36 Jan.

Kelly, S., 552 Nov.
Kinsler, J., Williams, P., Carruthers, J., & Evans, J.H., 469 Oct., 514 Nov., 578 Dec.
Knight, R.E. & Bryan, D.J., 290 June

Lamden, R.J., 487 Oct.
Lea, R.M., 337 July, 394 Aug.
Linsley, T.A., 141 Mar.
Linsley Hood, J.L., 167 Apr., 279 June, 306 July, Letters, 388 Aug.

McPherson, H., 485 Oct.
Marston, R.M., 287 June, Letters, 480 Oct.
Meyer, D., 309 July, Letters, 479 Oct.

Nelson-Jones, L., 179 Apr., 515 Nov., Letters, 318 July

Osborne, J.M., 335 July

Peverett, A.M., 510 Nov.
Philpott, J.R., 269 June

Royston, A., 67 Feb.

Shorter, G., 2 Jan., 54 Feb.
Singer, N.A., 161 Apr.
Smith, D.T., 85 Feb., 137 Mar.
Smith, J.H., 488 Oct.
Smith, K.L., 367 Aug.
Stuart, J.R., 104 Mar., Letters, 266 June

Tong, D.A., 41 Jan., 124 Mar., 154 Apr., 483 Oct.
Trinogga, L.A., 33 Jan.

Unsworth, L., 219 May

"Vector", 102 Feb., 202 Apr., 304 June, 404 Aug., 504 Oct., 612 Dec.

Walker, H.P., 233 May, Letters, 520 Nov.
Wareham, G., 358 Aug., Letters, 476 Oct.
Williams, D.A., 29 Jan.
Williams, P., Carruthers, J., Evans, J.H. & Kinsler, J., 469 Oct., 514 Nov., 578 Dec.

8031/3