

Wireless World

August 1968 Three Shillings

Inexpensive quality speaker

Printed TV scanning coils

JUL 26 1968

REFERENCE COPY

JOHN F. WATKINS SPACE CENTER
NASA LIBRARY

ALL POINTS FAVOUR VERSATILE KEYSWITCH TAILOR-MADE RELAYS

Keyswitch Relays Ltd,
Cricklewood Lane,
London NW2 (01-452 3344; telex 262754)

There are more than a million variations of the 10 basic Keyswitch relays illustrated here; at least one of them will suit your particular requirements.

They're all top-quality and top-performance, as demonstrated by an impressive list of 'approvals' that includes Post Office, Atomic Energy Authority, NATO, National Coal Board, British Rail and Central Electricity Generating Board. And every Keyswitch 'tailor-made' is also available in plug-in form. So when you need the best relays, at competitive prices and delivered on time, contact

KEYSWITCH RELAYS

- 1 MIL mechanically interlocked pair, operating A releases B
- 2 P33 plug-in version of P.O. 3000, at least 30m operations
- 3 600 compact version of P.O. 3000, up to 10A contacts
- 4 KTR replaces two P.O. 3000's in space of one, 30% cheaper
- 5 DA33 two independent armatures and contact assemblies
- 6 KR31 remanent latching, holds indefinitely
- 7 MRL latches mechanically, releases electrically, up to 8 contacts
- 8 K700 miniature contactor, very sensitive coils, up to 30A contacts
- 9 P.O. 3000 meets full GPO specs, up to 30A contacts
- 10 MSW any of these relays fitted with up to 8 microswitches

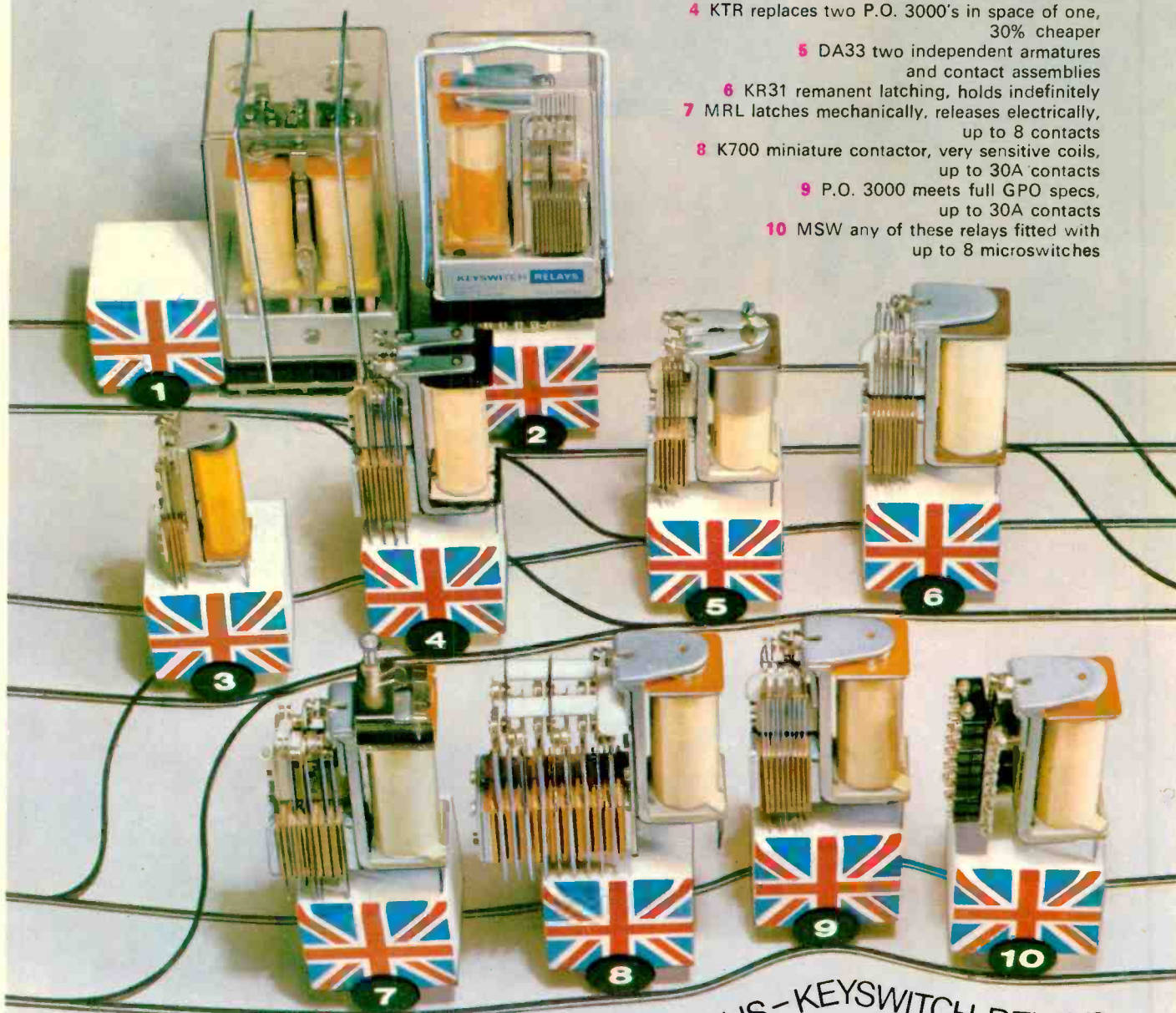

KEYSWITCH RELAYS - WHERE THE ACTION IS - KEYSWITCH RELAYS

Wireless World

Electronics, Television, Radio, Audio

Fifty-eighth year of publication

August 1968

Volume 74 Number 1394

Contents

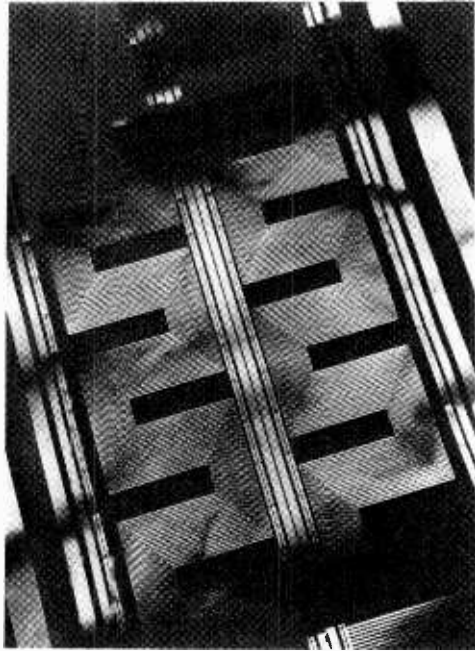

This month's cover illustrates a section of etched laminate as used in the production of printed scanning coils, the advantages of which are discussed on p. 260

- 241 Hi-fidelity or Hi-felicity?
- 242 Low-cost High-quality Loudspeaker by P. J. Baxandall
- 248 Demonstrating Radar Using Sonar — 1 by B. A. Wyndham
- 252 Wireless World Colour Television Receiver — 3
- 258 Books Received
- 259 Letter from America
- 260 Printed Scanning Coils by E. W. Bull
- 262 Conferences & Exhibitions
- 263 News of the Month
- Skynet
 Colour Receiver Integrated Circuit
 Thorn-Radio Rentals Merger
- 266 Personalities
- 267 Letters to the Editor
- 269 Balanced Transistor D.C. Amplifiers by T. D. Towers
- 275 Wideband Oscilloscope Probe by L. Nelson-Jones
- 280 New Products
- 285 Test your Knowledge questions & answers by L. Ibbotson
- 286 World of Amateur Radio
- 288 Literature Received
- 288 H.F. Predictions

Iiffe Technical Publications Ltd.,
Managing Director: Kenneth Tett
Editorial Director: George H. Mansell
Advertisement Director: George Fowkes
Dorset House, Stamford Street, London, SE1

PUBLISHED MONTHLY (3rd Monday of preceding month). Telephone: 01-928 3333 (70 lines). Telegrams/Telex: Wiworld Iiffepres 25137 London. Cables: "Ethaworld, London, S.E.1." Annual Subscriptions: Home; £2 6s 0d. Overseas; 1 year £2 15s 0d. Canada and U.S.A.; \$6.75; 3 years £7 0s 0d. Canada and U.S.A.; \$17.50 Second-Class mail privileges authorised at New York N.Y. Subscribers are requested to notify a change of address four weeks in advance and to return wrapper bearing previous address. BRANCH OFFICES: BIRMINGHAM: 401, Lynton House, Walsall Road, 22b. Telephone: Birchfields 4838. BRISTOL: 11 Marsh Street, 1. Telephone: Bristol 21491/2. COVENTRY: 8-10, Corporation Street. Telephone: Coventry 25210. GLASGOW: 123, Hope Street, C.2. Telephone: Central 1265-6. MANCHESTER: 260, Deansgate, 3. Telephone: Blackfriars 4412. NEW YORK OFFICE U.S.A.: 300 East 42nd Street, New York 10017. Telephone: 867-3900.

© Iiffe Technical Publications Ltd., 1968
Permission is writing from the Editor must first be obtained before letterpress or illustrations are reproduced from this journal. Brief extracts or comments are allowed provided acknowledgement to the journal is given.

CONSUMER

ELECTRONICS

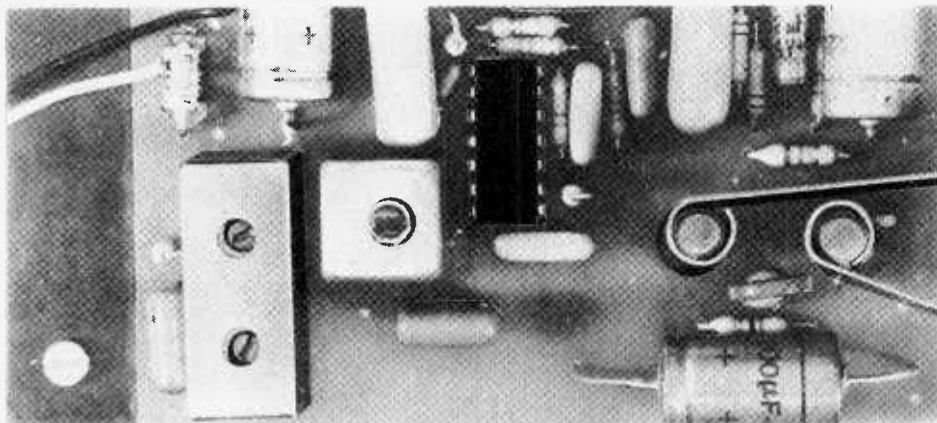

Beat these for size and simplicity

Integrated circuit TAD100
Ceramic i.f. block filter LP1175
Audio output transistors AC187/188

Take a Mullard linear integrated circuit, two output transistors, a block filter and a few passive components and you have the equivalent of an 8 transistor radio with a performance which compares with any of the quality radios, using conventional components, available today. This remarkable receiver has an

a.g.c. range of 65dB for a change in a.f. output of 10dB. The overall sensitivity is $50\mu\text{V/m}$ for 100mW a.f. output and this only changes to $160\mu\text{V/m}$ when the battery voltage drops from 9V to 4.5V. The TAD100 combines in a single package all the necessary active devices to form the oscillator, mixer, i.f. amplifier, detector, a.g.c. and a.f. pre-amp and driver. The only other active devices required to form the complete receiver are

a pair of complementary output transistors, AC187/188. Thus the designer retains a large degree of flexibility in the circuit configuration and the output powers chosen for his particular requirements. Excellent selectivity is obtained by means of the ceramic block filter LP1175 which has a -3dB bandwidth of 5kHz and a -24dB skirt response at 9kHz.

The filter also prevents the oscillator voltage from reaching the wide-band i.f. amplifier as its attenuation is greater than 70dB. The TAD100 integrates the major part of the radio and brings with it large savings in material handling, stock and labour costs. The TAD100 is one of the first of a series of Mullard integrated circuits developed specially for consumer electronic manufacturers. Others for FM and TV circuits will follow soon. Equipment manufacturers wishing to receive combined information on these items should write to the address below on their company headed notepaper.

Ring Trap traps spark

In the past external circuits have been developed to overcome the problems arising from picture tube flashover, but to be effective they are complicated and expensive. Mullard have developed a complete, efficient protection system—the Ring Trap base—which gives built-in flashover protection for all

external electrode circuits and components. It is made possible by a multiple spark trap built into the tube base, affording protection to *all* the electrodes. To ensure freedom from damage anywhere in the set and because of the very high currents present during a flashover, the Ring Trap connections

should be made in accordance with the published Mullard recommendations. Flashover protection has been incorporated on all the latest Mullard monochrome push-through tubes. Set makers wishing for more details should write to the address below on their company headed notepaper.

Time well spent

There can't be many firms who've been in business as long as we have who have used the time to such advantage. Our past experience guides our future plans: provides us with an insight into the industry we serve; allows us to anticipate needs and deploy our resources over the most

fruitful areas of research and development—and thereby provide modern, technically excellent products ready for the demands of tomorrow. We have co-operated in so many consumer electronics projects that it's quite likely we are working along similar lines to yours. So why not get in touch?

Mullard

CONSUMER ELECTRONICS DIVISION

Mullard Limited, Mullard House,
Torrington Place, London WC1

CE057

WW-110 FOR FURTHER DETAILS

Wireless World

Hi-Fidelity or Hi-Felicity?

Editor-in-chief:
W. T. COCKING, F.I.E.E.

Editor:
H. W. BARNARD

Technical Editor:
T. E. IVALL

Assistant Editors:
B. S. CRANK
J. H. WEADEN

Drawing Office:
H. J. COOKE

Production:
D. R. BRAY

Advertisements:
G. BENTON ROWELL (*Manager*)
J. R. EYTON-JONES

Debates about high-fidelity sound reproduction, such as the one on loudness controls* now proceeding in our correspondence columns, are potentially endless because they are basically "ideological". They are not concerned with demonstrable truths but with subjective questions—the beliefs, emotions, imagery, of separately evolved human beings—and consequently the points at issue can never be resolved. The debaters take up positions which are basically irrational and then proceed with great skill to rationalize them, thus convincing themselves of the logic of their arguments and becoming more and more fixed in their viewpoints. Long may this situation continue! In the case of the loudness-controls debate the existence of the loudness control seems to have forced a distinction between what is realistic to listen to and what is enjoyable to listen to. This is an unnatural situation because one feels sure that most people, including the debaters, really want both of these things.

It is proper for a journal concerned with other matters besides sound reproduction to step back and take a wider, cooler view. For example it is legitimate for us to consider sound reproduction as a communication process, in which the human "receiver" must be understood in terms of the psychology of perception. In the first place, then, it is obvious that the process cannot literally "reproduce" the original musical (or other) event. To do this it would be necessary to put the listener in an environment identical to that which he would have experienced if he had been sitting in the original concert hall. What is really happening in the listener's living room is that an electro-acoustic apparatus controlled from a record or from a distant radio transmitter, is sending out stimuli in the form of air-pressure variations. (And the loudspeaker doing this is certainly not an ideal transducer—a piston with zero mass, stiffness and friction—but more like the sounding board of a musical instrument being excited into a multiplicity of resonances by an electromechanical vibrator.) These stimuli are meaningless in themselves (in an unoccupied room they cannot be *sounds*) and only become truly signals in a communication process when they evoke responses in a human "receiver".

The "receiver" contains a store of experiential information about music that he has assembled himself over years of conscious and unconscious listening—the information being that a certain pattern of auditory nerve stimuli "means" a certain subjective response. While the "receiver" is thus interpreting and recognizing the incoming stimuli he is simultaneously building a mental model, which is in fact the musical reality for him. He does this by continuously attempting to predict the musical structure from his store of information, while the incoming stream of stimuli continuously amends the details of the model. He may in fact ignore some of the signals because he *wants* his model to have a certain structure and these signals would not fit into it.

Thus, considered in this sense, the phenomenon is not so much one of reproducing reality but of assisting the listener to produce his own illusion of reality, by sending him skilfully devised stimuli. It is not a case of the listener believing what he hears, but of hearing what he believes is there. In a world in which make-believe plays such a significant part it is unrealistic to confine our attention purely to the physical characteristics of the stimuli produced by our electro-acoustic equipment. Neither fidelity nor felicity depends on these alone.

*This, of course, is by no means a new controversy. See, for example, "Reproduction Levels," a letter to the Editor by P. G. A. H. Voigt, in *Wireless World* August 24th 1939.

Low-cost High-quality Loudspeaker

Design for frequencies above 100Hz. 1-Construction and assembly

by P. J. Baxandall, B.Sc. (Eng.), F.I.E.E., F.I.E.R.E.

This loudspeaker may be built by the home constructor for a total expenditure in the region of £6. While it does not have the extended bass response of some much more expensive loudspeakers, it is nevertheless unusually free from the colourations and hangover effects which are unfortunately still a feature of the majority of commercial designs¹. Consequently, on many types of programme material, it will be found to give considerably better reproduction than is obtained with many much more costly loudspeakers.

On speech, both male and female, the loudspeaker reaches a very high standard of performance. Using a high-grade capacitor microphone out of doors, an almost deceptive degree of realism can be achieved in the reproduction of familiar voices.

While many people who have heard the loudspeaker on music seem to find the bass response fairly adequate, direct comparison, particularly on organ music or large-scale orchestral music, with a good loudspeaker, such as a B.B.C. monitor¹, leaves listeners in no doubt that the reduced response below about 100 Hz constitutes the main shortcoming of the design*. Consequently it is recommended that, where space permits, the basic low-cost loudspeaker should be augmented, at frequencies

* Of course, some small-scale music of great beauty contains almost no frequencies below 100 Hz and is therefore virtually unaffected by this shortcoming.

The complete low-cost loudspeaker. The size of the cabinet is 18in. × 12in. × 10in. (deep).

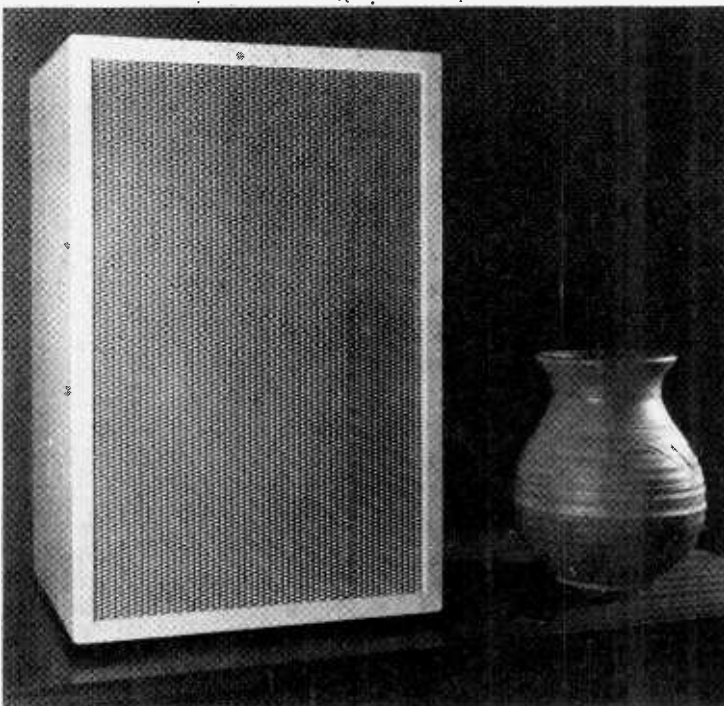

below about 100 Hz, by a separate woofer. Because this has to cover a frequency range of only about one octave, in a rather uncritical part of the spectrum, there is much latitude in its choice and almost any old 12-in. unit, such as can be bought second-hand for a pound or two, can be pressed into service.

In a stereo system, one such woofer can be shared very satisfactorily between the two channels, and because these very low frequencies convey almost no sense of position, the woofer can be placed in any convenient position in the room. When circumstances permit, the possibility of mounting the woofer unit in a hole in the floor, ceiling or a wall may be worth considering, as it saves the space and labour of cabinetwork.

Suitable circuit arrangements for such a three-speaker stereo system will be discussed in Part 2 of this article, and it will be shown how the relative levels from the woofer and the other two loudspeakers may be adjusted to give nicely balanced reproduction in listening rooms having different acoustical properties.

A complete stereo system on the above lines can thus be built for no more than about £15, and is capable of a surprisingly high standard of reproduction. Even direct comparison with a pair of Quad electrostatic loudspeakers does not always reveal any obvious shortcomings, though careful listening over a period of time makes it evident, in particular, that the lower intermodulation and hangover distortion of the electrostatic speakers results in greater clarity and separation of instruments particularly at high volume levels. Nevertheless, the low-cost system is capable of quite impressive volume and clarity in the reproduction of orchestral and choral music in rooms of normal living room size, and in much music of a quieter nature listeners have shown no marked preference for one or the other speaker system.

Evolution of the design

The following thoughts were significant in the evolution of the present design, which aims to satisfy an evident demand for the best possible quality of reproduction at a really low price:

(a) Large loudspeaker units suitable for a wide frequency range are expensive and need augmenting by a tweeter for really first-class results.

(b) Smaller circular units, e.g. 8 in., often suffer from undesirable hangover effects in the lower-middle-frequency range^{1,4,5} and the unpleasant sound of these cannot be fully removed by electrical equalization. However, it was mentioned by Dr. G. F. Dutton of E.M.I. at the discussion following Mr. Shorter's paper¹ that the use of elliptical rather than circular diaphragms gives a marked reduction in hangover distortion, which is caused by diaphragm vibration persisting in low-damped radial modes after the cessation of the signal.

(c) The surprisingly good results given by a commercial loudspeaker known as the 'CQ Reproducer', which used a cheap

elliptical unit almost the same as that employed in the present design, served further to direct the author's attention to the virtues of elliptical diaphragms, and preliminary measurements on such a unit showed that it had an axial frequency response which, if its main departures from levelness were to be corrected by a cheap and simple electrical equalizer, would give a sufficiently uniform and wide-range response to meet the requirements of very high quality reproduction—except that some sacrifice of performance at very low frequencies seemed virtually unavoidable.

(d) The use of a single unit to cover the whole frequency range also simplifies matters by avoiding the problem of the unnatural changes in polar response which are liable to occur in the cross-over regions of multiple-unit systems¹.

(e) While the exploitation of cabinet panel resonances to modify the frequency response over certain ranges is a dodge which has sometimes been employed with a degree of success in cheap designs, it was felt to be such a tricky and unpredictable technique that it would probably be much better avoided.

(f) The notion that very high flux densities are essential for good transient response, while a widely propagated belief, is not in accordance with much practical experience[†].

Consequently the fact that the cheap elliptical unit being considered had a rather small magnet was not regarded as of much significance in this context.

(g) Of much greater significance was felt to be the fact that only quite small diaphragm excursions, in the region of ± 1 mm, can be made without running into considerable suspension non-linearity and non-linearity caused by the rather skimpy nature of the coil and magnet geometry. Indeed it is still a source of some surprise that such substantial volume can be obtained in practice without these non-linear effects giving any obvious subjective impairment of the reproduction.

The basic recipe adopted thus involves no more than the use, in association with a simple electrical equalizer, of a particularly suitable, though quite cheap, elliptical unit having a plasticized surround, mounted in a totally enclosed box made rigid by internal bracing and containing felt damping material to reduce standing-wave effects and provide some additional damping of the main diaphragm resonance.

The size of the box is such that the stiffness of the enclosed air at low frequencies, referred to the diaphragm is about equal to the mechanical stiffness of the diaphragm suspension, resulting in a resonant frequency of about 100 Hz. This size of box is quite convenient to accommodate, and the improvement in bass performance given by even quite a large increase in volume would not be great. Moreover, the greater the overall stiffness, the less will be the intermodulation distortion when strong low-frequency signals are fed to the unit, e.g. at 40 Hz, at the same time as higher frequencies. The size of box adopted is thus thought to be a good all-round compromise.

While the use of a vented enclosure has been carefully considered, such an arrangement would either result in a considerable increase in intermodulation distortion in the presence of large inputs at very low frequencies, or, if the Helmholtz resonant frequency were made low enough to avoid this danger, the response at very low frequencies would be at a lower level than that at higher frequencies, requiring further electrical equalization. For normal circumstances, the simple totally enclosed box seemed to be the best choice, therefore.

The use of an equalizer of fixed design, not adjusted to suit individual loudspeaker units, will obviously be satisfactory only

[†] A weak magnet may give rise to a peak in the frequency response in the region of the main resonant frequency of the diaphragm². While this is not necessarily undesirable if it occurs well below 100 Hz, where some degree of ringing does not seem to give subjectively noticeable impairment of transient response, it can in any case be damped down by acoustic means, e.g. by a close-fitting felt cover over the loudspeaker unit, if this is thought desirable. At higher frequencies, many of the diaphragm resonances are so weakly coupled to the coil that little electromagnetic damping can occur even if the flux density is very high.

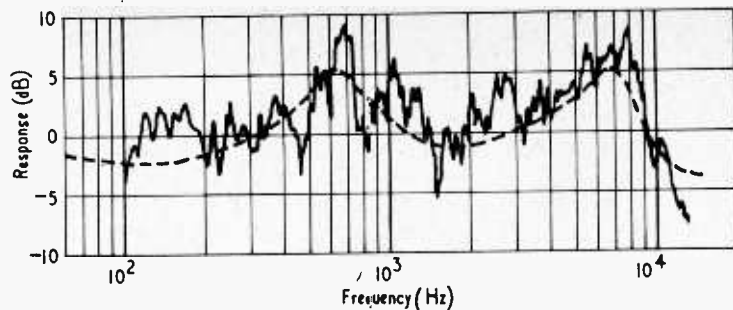

Fig. 1. Full-line: unequalized axial frequency response of loudspeaker. Broken line: inverse of equalizer frequency response.

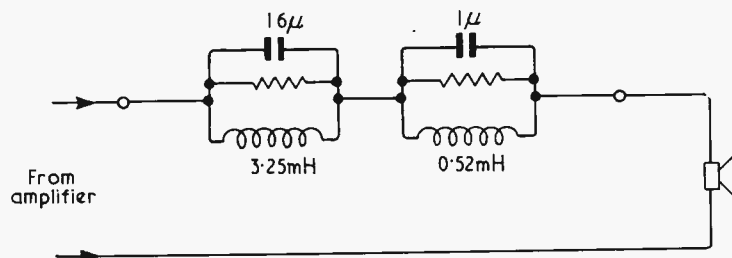

Fig. 2. Basic equalizer circuit.

if the variations in response of the units in production is sufficiently small. All that can be said is that of several units checked, bought over a period of several years, all have had the same main features in their frequency responses, fairly closely matched by the equalizer characteristic. Thus, while it cannot be guaranteed that every loudspeaker built to the present design will have quite such a good frequency response as the prototype, it seems virtually certain that the equalizer will always effect a marked improvement in the results.

Frequency response curves

The full-line curve in Fig. 1 shows the measured axial frequency response of the loudspeaker without the equalizer[‡]. It will be seen that, ignoring the numerous small wiggles (which appear in virtually all loudspeaker response curves if the frequency is varied slowly enough), the main features of this curve are a region of excessive output centred broadly just below 700 Hz, and another similar region centred at about 7 kHz.

The basic equalizer circuit designed to correct the Fig. 1 response is shown in Fig. 2. However, because 16 μ F is an inconveniently large capacitance, the practical equalizer circuit is arranged as in Fig. 3. The full-line curve in Fig. 4 shows how the equalizer causes the voltage across the speech coil to vary with frequency for a constant amplifier output voltage. Referring to Fig. 1 again, the broken-line curve is an inverted version of the full-line curve in Fig. 4, and shows that the equalizer characteristic is quite well matched to the main features of the loudspeaker response. (The broken-line curve in Fig. 4 simply shows the effect of removing the damping resistors from the equalizer circuit.)

Fig. 5 shows the overall axial response curve of the loudspeaker with the equalizer incorporated and it will be seen that most of this lies within ± 3 dB limits from 100 Hz to over 10 kHz,

[‡] This measurement was made out of doors using a small home-made omnidirectional capacitor microphone at a distance of 2 ft 6 in. from the front of the loudspeaker and at a height of 4 ft above ground, on axis. The microphone was used in the r.f. bridge system described in Reference 6, and its pressure calibration was obtained by developing a constant alternating force on the diaphragm by means of an oscillator voltage applied in series with a d.c. polarizing voltage. To avoid any significant error at high frequencies due to pressure doubling, the capsule was then placed in front of the loudspeaker with its $\frac{1}{2}$ in. diameter diaphragm in a horizontal plane.

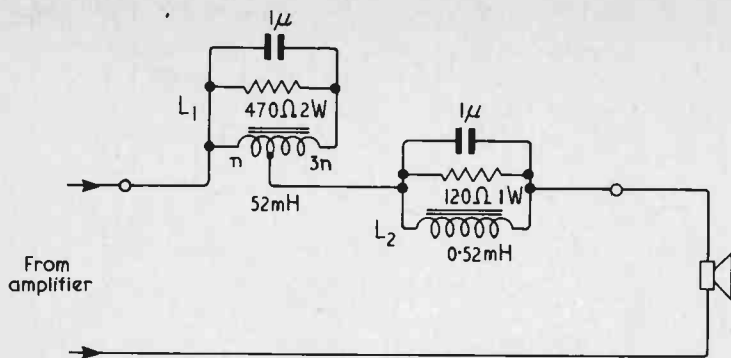

Fig. 3. Practical equalizer circuit.

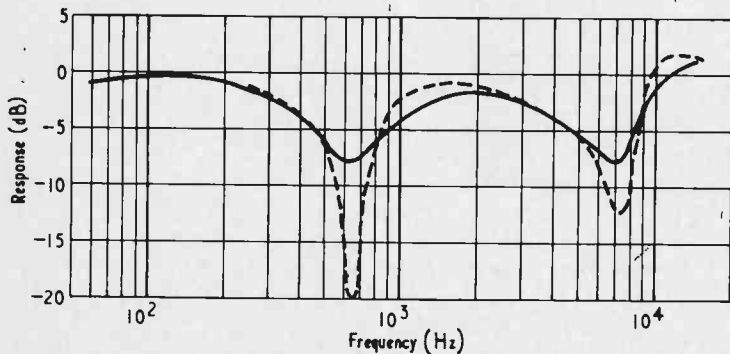

Fig. 4. Measured frequency response from amplifier output to speech-coil. Full line: with damping resistors as in Fig. 3. Broken line: without damping resistors.

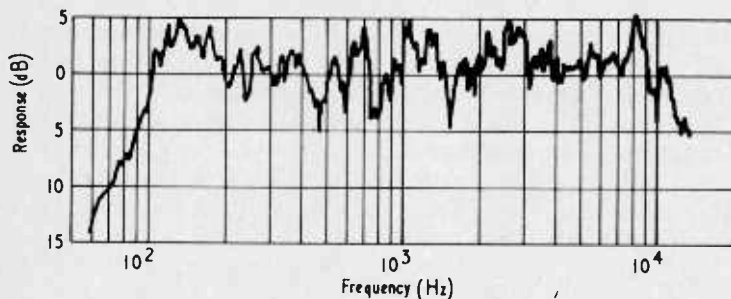

Fig. 5. Axial frequency response of loudspeaker, with equalizer.

the general balance of low, medium and high-frequency response being within even finer limits.

The loudspeaker unit. The unit is an Elac 15-ohm 9in × 5in elliptical unit, Type 59 RM/109, manufactured by Electro Acoustic Industries Ltd., Stamford works, Broad Lane, Tottenham, London N.15. The retail price is £2 6s 2d. When ordering state that 15-ohm impedance is required.

Constructing the equalizer

The equalizer circuit has already been given in Fig. 3. The inductors both employ 0.014 in. silicon iron laminations, Inter-Service No. 421. These are conveniently obtainable in kits from The Belclere Company Ltd., 385/387, Cowley Road, Oxford. Each kit consists of a stack of Silcor 107 laminations, a bobbin and a steel shroud. For each equalizer, two kits are required:—

Kit GN/Silcor ($\frac{7}{16}$ in. stack) Price 6s 6d

Kit GX/Silcor ($\frac{3}{4}$ in. stack) Price 7s 0d

It is essential to specify 'T' and 'U' laminations when ordering, as the firm now normally supplies 'E' and 'I' types, but has agreed to supply 'T' and 'U' laminations for this equalizer when requested to do so.

L₁ winding. The tapped inductor L₁ uses the larger GX size core stack. First wind on 110 turns of 28 s.w.g. enamelled copper wire in four neat layers. Then wind on, in the same direction, 330 turns of 34 s.w.g. enam., making 440 turns for the whole bobbin. The 330 turns need not be wound in accurate layers—just wound on reasonably tidily. There is no need for any insulation between sections, but the outside of the winding should preferably be protected by empire cloth or thick paper.

L₁ core. Place all the T's through the bobbin tunnel from one side. Place all the U's in the shroud, with small pieces of cardboard, or $\frac{1}{16}$ in. s.r.b.p. ('Paxolin') $\frac{1}{4}$ in. × $\frac{3}{4}$ in. as shown in Fig. 6, to prevent the steel shroud coming too close to the core gaps.

Each of the three gaps should be 0.025 in., which must, of course, be formed by inserting suitable insulating material. In the absence of other facilities, use may be made of the fact that the outside cover of *Wireless World* has been made of paper of thickness approximating closely to 0.005 in. for at least ten years! Thus insert five thicknesses of this paper in each gap. It will be found convenient to cut strips of widths approximately $\frac{1}{8}$ in. and $\frac{5}{8}$ in. for the outside and central gaps respectively and to fold these strips in zig-zag fashion to form five thicknesses. With these gap-spacers in position, the shroud should be screwed down tightly onto the wooden baseboard, $\frac{3}{8}$ in. No. 6 roundhead woodscrews being suitable.

L₁ connections. The enamelled wires from the bobbin should be carefully bared with sandpaper or emery paper and soldered to the three tags of a tagstrip screwed down to the baseboard as shown in Fig. 6 and the photograph below. The beginning of the winding (inner end of the 28 s.w.g. section) should go to the tag nearest to the end of the baseboard, the outer end of the 28 s.w.g. section and the inner end of the 34 s.w.g. section going to the middle tag to form the tapping point. The outer end of the 34 s.w.g. section goes to the tag nearest the middle of the baseboard.

L₂ winding. The untapped inductor uses the smaller, size GN, core stack. Wind on 86 turns of 24 s.w.g. enam. in four neat layers and cover with empire cloth or paper. (For winding this and the other inductor, a simple gadget may be improvised, using bits and pieces from the junk box, Meccano, etc., for rotating the bobbin. There is no need for a turns counter—the number of turns is small enough to be counted without difficulty mentally!) If an aluminium or other non-ferrous shroud is used instead of the sheet steel one employed in the prototype (supplied by Belclere), the winding turns should be increased to 95. Also, because of the increased shunt loss resistance then obtained, the damping resistor value (Fig. 3.) should be reduced from 120 ohms to 68 ohms. The use of an aluminium shroud for inductor L₁ has no significant effect on the inductance value or losses, owing to the much smaller air gap.

L₂ core. Insert all the T's through the bobbin tunnel from one side and place the shroud over the core so that the tops

The equalizer.

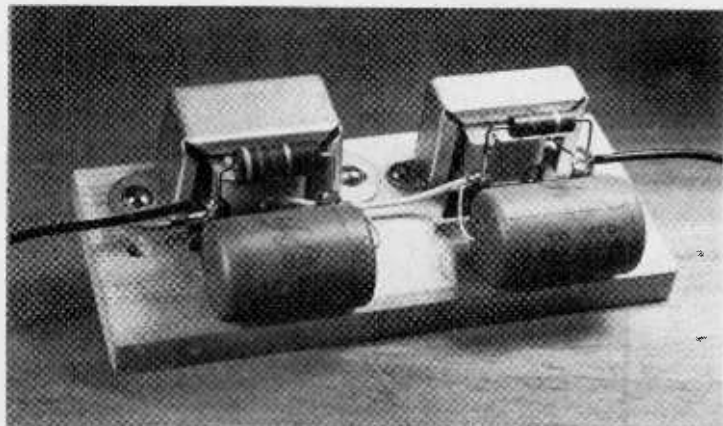

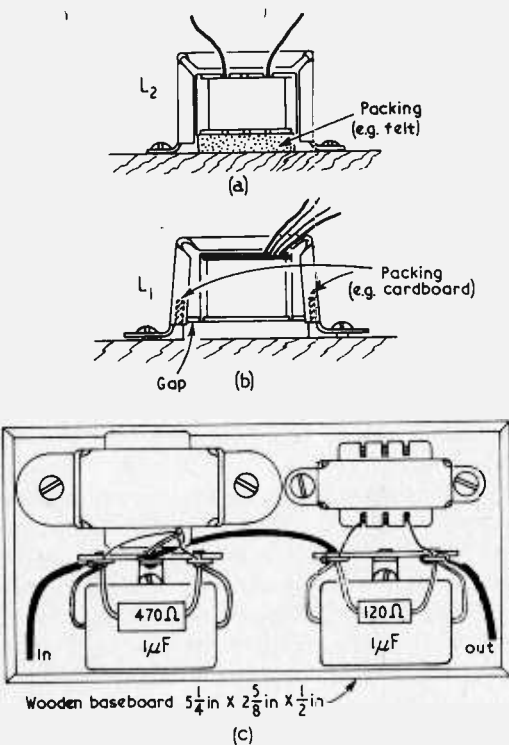

Fig. 6. Constructional details of equalizer.

of the T's lie inside the top of the shroud. A piece of $\frac{3}{16}$ in. thick soft packing material measuring 1 in. \times $\frac{3}{4}$ in. should now be obtained. This is placed between the bobbin and the wooden baseboard so that the bobbin and laminations are pressed securely up into the shroud when the latter is screwed down.

No U laminations are employed for this inductor.

Wire supply. The three gauges of enamelled copper wire required (24, 28 and 34 s.w.g.) may be conveniently obtained, in a minimum quantity of 2 oz each, from Post Radio Supplies, 33, Bourne Gardens, London, E.4.

The three 2-oz reels contain enough wire for at least four equalizers.

Other components. The other components required for the equalizer are all readily obtainable, including tag strips, from Radiospares Ltd. through any radio dealer. Tubular $1 \mu\text{F}$ paper capacitors, 250V d.c. wkg., $\pm 20\%$ tolerance, are suitable.

Tests: Provided the above instructions have been carefully carried out, it is virtually certain that the equalizer will function correctly. However, if an oscillator is available, it is worth while to check that, with a constant voltage fed to the series combination of equalizer and loudspeaker, the voltage across the loudspeaker varies with frequency approximately as shown in Fig. 4.

The exact position of the lower-frequency dip is slightly dependent on the a.c. voltage at which it is determined. With a source voltage of 2V r.m.s., the dip will occur about 20 Hz lower in frequency than with a source voltage of 0.2V r.m.s. For voltage levels above 2V r.m.s., the fall-off in dip frequency with increasing level is more gradual. (This effect is due to the fact that the initial a.c. permeability of silicon iron is rather low compared with its value at higher flux densities; the effect is well diluted by the presence of gaps, however, and does not seem to give rise to any subjectively noticeable distortion.)

The performance of the equalizer may be regarded as satisfactory provided the measured results fall within the following limits:

- (a) Low-frequency dip, with a test voltage of about 2V r.m.s. applied to the combination of equalizer and loudspeaker, 580 to 800 Hz.
- (b) High-frequency dip (almost independent of test voltage) 6200 to 7900 Hz.
- (c) Magnitude of dips (almost independent of test voltage), relative to response at 1700 Hz, -5 to -8 dB.

In the unlikely event of the performance falling outside any of the above limits, adjustments may be made as follows:

To correct (a), adjust gap of L_1 . Increasing the spacer thickness by 0.005 in. will raise dip frequency about 40 Hz.

To correct (b), the value of C_2 may be modified or, alternatively, the number of turns on L_2 may be adjusted. Removing 5 turns will raise the dip frequency about 400 Hz.

To correct (c), alter the appropriate damping resistor value.

Equalizer intermodulation distortion. Variation in inductance of L_1 and L_2 with the instantaneous value of large low-frequency signal currents flowing through them is a possible cause of intermodulation distortion. A test showed, however, that the inductance of L_1 dropped by less than 2% when a direct current of 0.25A was passed through the whole winding, equivalent to a current of 1A through that part of the winding traversed by low-frequency signal currents. The effect in L_2 , because of the much larger gap, will be even smaller. It is obvious, without further calculation, that the distortion caused will be considerably smaller than that introduced by non-linearities in the loudspeaker unit itself.

Alternative equalizer design. While the above method of constructing the equalizer is attractively cheap, some readers may find it more convenient to use Mullard Vinkors. Brief winding details are:

L_1 : 99 turns of 28 s.w.g. plus 297 turns of 34 s.w.g. on Mullard 35mm, $\mu_c = 63$, Vinkor. (LA2102 core and slug, DT2180 bobbin, plus DT2151 or DT2187 casing or DT2234 mounting clip.)

L_2 : 49 turns of 24 s.w.g. on Mullard 25mm, $\mu_c = 63$, Vinkor. (LA2302 core and slug, DT2179 bobbin, plus DT2149 or DT2185 casing or DT2228 mounting clip.)

The resistor R_2 across L_2 should be 68 ohms as compared with 120 ohms in the Belclere version—this allows for the lower losses of the Vinkor. R_1 remains at 470 ohms.

Equalizer kit. A complete kit of parts for the equalizer, including ready-wound inductors on laminated cores, may be obtained from Peak Sound (Harrow) Ltd., 32 St. Judes Road, Englefield Green, Egham, Surrey. The price is £1 16s. The author understands that this company will also supply a kit of parts for the complete loudspeaker (including cabinet parts).

Constructing the cabinet

While some readers may prefer to buy a cabinet and adapt it to the present design, there must be many others who, like the author, find woodwork an enjoyable and rewarding pastime and would prefer to make their own. For this reason full details and a few constructional hints and tips are given.

The author used $\frac{1}{2}$ -in. gaboon plywood, but veneered chipboard ('Weyroc') is a satisfactory alternative. While minor changes to the dimensions shown in Fig. 7 may be made to suit individual requirements, the volume of the cabinet should preferably be kept about as shown.

The cabinet is held together by a combination of Cascamite glue and $\frac{7}{8}$ in. countersunk woodscrews, screwed into the inside of the cabinet sides through the $\frac{1}{2}$ -in. \times $\frac{1}{2}$ -in. wooden strips shown. The local timber yard supplied the latter, and also the 1-in. \times $\frac{1}{2}$ -in. strip for fixing the speaker mounting board, in ramin, a beautifully straight-grained, but quite cheap, hardwood ideally suited to the purpose.

The bottom of the cabinet should be fixed with screws only (no glue) so that it can be removed easily for extracting the speaker mounting board, should this become necessary at any time for renewal of the expanded aluminium or Tygan covering—see photograph on page 246.

The use of mitred corner joints at the top corners of the cabinet allows the veneer to extend right up to the corner, and unlike some other corner joints⁷ can be cut by the amateur without

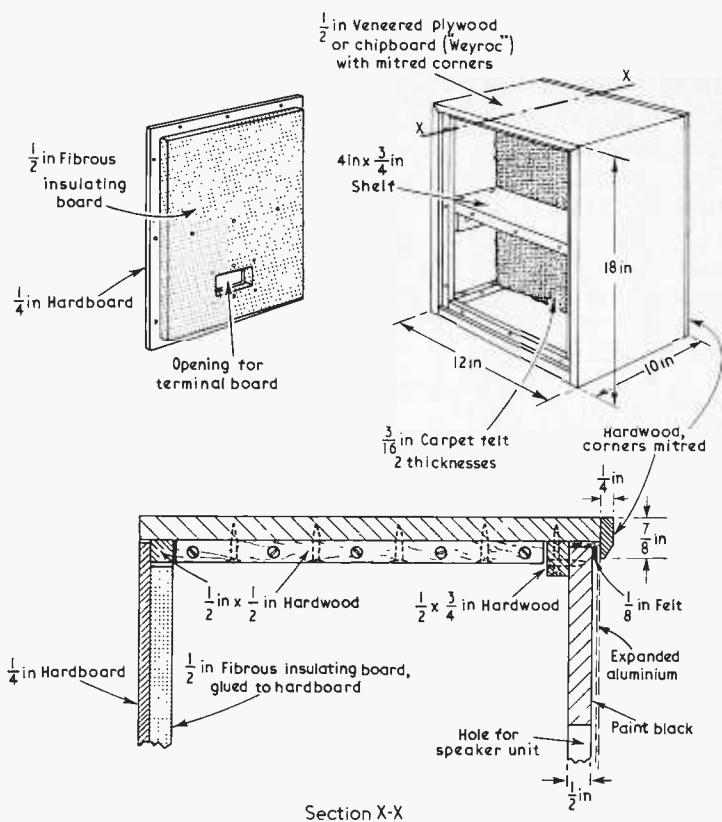

Fig. 7. Cabinet construction details.

special rabbet-cutting tools. The author had not previously tried cutting mitred joints for box corners, but found it surprisingly easy to produce a thoroughly neat job.

The aim should be to cut the wood *very* slightly off 45°, so that when the screws are tightened into the 1/2-in. × 1/2-in. strip, the mitred joint is sure to close tightly at the outside of the box.

Either Tygan or expanded aluminium may be used for the front of the loudspeaker, according to choice⁷. While expanded

Components of cabinet, showing removable base, and the elliptical loudspeaker unit.



aluminium causes slightly less acoustic obstruction, many people prefer the appearance of Tygan. Expanded aluminium may be obtained from The Expanded Metal Company Ltd., P.O. Box 14, Stranton Works, West Hartlepool, Co. Durham.

A suitable type is List Ref. No. 363A in plain aluminium (22 s.w.g.). It is made in standard sheets 4 ft × 2 ft, in which the 'long way of mesh' (which must be horizontal when mounted in the loudspeaker, for satisfactory appearance) runs along the 4-ft dimension. Half a sheet, 2 ft × 2 ft is therefore a sensible quantity to order for two loudspeaker cabinets. A piece 2 ft × 6 in. will be left over, but will probably come in useful sooner or later.

Tygan may be obtained from A. C. Farnell Ltd., 81, Kirkstall Road, Leeds 3. A book of samples may be obtained. The material is available in cut pieces 27 in. × 24 in. or at any length × the width of the roll, which is 54 in.

Two of the four cabinets made by the author are wax polished with expanded aluminium fronts. After very thorough sandpapering, finishing with No. 1 sandpaper, one thin coat of white French polish was put on quickly with a cloth rubber, followed by wax polishing with Meltonian white shoe polish. Nothing could be much easier and quicker than this finish, which is nevertheless very pleasing. The other two cabinets, however, are painted white and have pattern U528 Tygan.

If expanded aluminium is used, it is important that it should be fixed in such a way that it cannot rattle. The author glued a 1/4-in. wide strip of 1/8-in. thick felt round the periphery of the front surface of the speaker mounting board, thus separating the main area of the expanded aluminium from the board. To make doubly sure the aluminium would not vibrate against the board, 1/2-in. squares of 1/8-in. felt were stuck to the board at four positions round the outside of the speaker hole. This felt, the speaker mounting board and the edge of the cone-fixing cardboard on the speaker unit should be painted matt black, to prevent any of these being visible through the expanded aluminium. As previously mentioned, the 'little louvres' of the expanded aluminium should be horizontal rather than vertical; there is also a right way up to mount this material which gives minimum transparency from the usual viewing angles. Even the two sides of a piece of expanded aluminium will be found on careful inspection to be slightly different, and it is worth putting it the same way round if two cabinets are being built for stereo working.

When Tygan is used, the strips to space it from the speaker board need not be of soft material, and 1/8-in. hardboard is suitable**. The Tygan may be stuck round the edges of the board with Evo-stik impact adhesive, care being taken to keep the warp and woof running parallel to the board edges. If this is not got quite right at first, it is possible to pull the Tygan off in the appropriate place and reposition it slightly—but every effort should be made to get it right first time nevertheless.

Finally, the heat treatment recommended by Mr. Briggs in Reference 7 should be applied—a bar-type electric radiator 'should be held about six inches away from the mesh for about five seconds, when the heat begins to contract the fibre. Remove the radiator *immediately* a slight movement is seen in the Tygan, otherwise excessive contraction will be induced'.

Before finally mounting the speaker unit, check that the coil leads are correctly positioned and in no danger of rattling against the diaphragm or the speaker chassis.

Wooden strips of cross-section 1-in. × 1/2-in. should be screwed and glued edgewise on, using 1 1/4-in. No. 8 countersunk screws, to the insides of the cabinet sides, top and bottom at a distance from the front edges sufficient to accommodate the thickness of the speaker mounting board after it has been fitted with expanded aluminium or Tygan. This distance is 3/4 in. in the

** It might be thought that with cloth there would be no need to space it away from the board. It is easily demonstrated, however, that if the cloth is touching the board but is not stuck to it, buzzing sounds are produced at certain low frequencies. The trouble with sticking the Tygan to the front of the board is that it is liable to make the outline of the speaker hole visible from the front.

author's cabinets, but it is as well to tailor it to suit the speaker boards as made. The aim is to make the latter an easy sliding fit between the 1-in. \times $\frac{1}{2}$ -in. strips and the inside of the front mitred mouldings when later fitted. The board is secured in place by screws into it through holes drilled in the 1-in. \times $\frac{1}{2}$ -in. strips.

The $\frac{1}{2}$ -in. \times $\frac{1}{2}$ -in. strips shown may then be screwed and glued suitably in place and the carcass of the cabinet assembled. The bottom, however, should not be glued in position, so that it can be removed by undoing screws only, as previously mentioned. The strips should, of course, be spaced from the back of the cabinet by an appropriate amount, to accommodate the thickness of the back cover.

The cabinet back could be made of $\frac{1}{2}$ -in. plywood or Weyroc like the sides, but the author used a slight modification of a B.B.C. recipe¹, $\frac{1}{4}$ -in. hardboard being glued to $\frac{1}{2}$ -in. builder's insulating board, as shown in the photograph on the right. This gives a composite board which is considerably lighter than wood of the same thickness and which also possesses desirable self-damping properties.

The choice of cross-section for the mitred front mouldings of the cabinet exerts a subtle effect on the appearance, and can be left to individual preference. The moulding should be glued to the carefully planed front edge of the cabinet, but a few 1-in. or 1 $\frac{1}{4}$ -in. panel pins will make it much easier to position the mouldings nicely and ensure that they remain properly positioned while the glue sets. The panel pins should be punched down below the wood surface, and each hole filled with plastic wood made by mixing a drop or two of Durofix with plenty of wood dust obtained from sandpapering a nearby part of the same moulding. Allow to dry very thoroughly before finally sandpapering flush—the pin positions should then be almost invisible.

The moulding attached to the bottom of the cabinet should not be glued near its corners, otherwise the bottom will cease to be easily removable.

The $\frac{3}{4}$ in. thick 'shelf' provides a firm anchorage for both the sides and the back of the cabinet (the back being screwed to the edge of the shelf) and thus reduces the tendency for these parts to vibrate in 'drum' fashion.

There are obviously various possibilities for the signal connections. The author made a rectangular cut-out in the back of the cabinet, 2 $\frac{1}{2}$ -in. \times 1 $\frac{1}{4}$ -in., and fitted behind it a $\frac{1}{8}$ -in. s.r.b.p. ('Paxolin') board carrying two nickel plated 2 B.A. screw terminals—all available from Radiospares Ltd. through radio dealers.

It is important to keep the cabinet reasonably free from air leaks. One easily overlooked source of leak can arise when expanded aluminium is used, if it is bent right round the edges of the speaker mounting board and onto the back surface of the board. Even though the board is held tightly by screws against the 1-in. \times $\frac{1}{2}$ -in. strips fixed to the cabinet sides, there is nevertheless an air leak round the edges of the board through the interstices of the expanded aluminium. It was found experimentally that the diaphragm displacement at 40 Hz was reduced *several times* on sealing this leak, and there must, of course, be an accompanying reduction in intermodulation distortion. There is a good case, therefore, for cutting the expanded aluminium only $\frac{1}{2}$ in. larger than the speaker mounting board all round, and fixing it with tacks into the edge of the board, thus obviating the leak.

After finally assembling the cabinet, with the unit in place, about 30 in. of red-and-black flex should be soldered to the speaker tags, of which one is marked red by the makers. One piece of ordinary carpet felt, about $\frac{3}{16}$ in. thick and measuring 14 in. \times 11 in.†† should now be tacked in place with six tacks spaced out round the unit, producing a sort of roughly fitting felt hat over the unit. This will provide considerable damping of the low-frequency resonance and will consequently reduce the acoustic output in the 100 Hz region. Without it, there may be

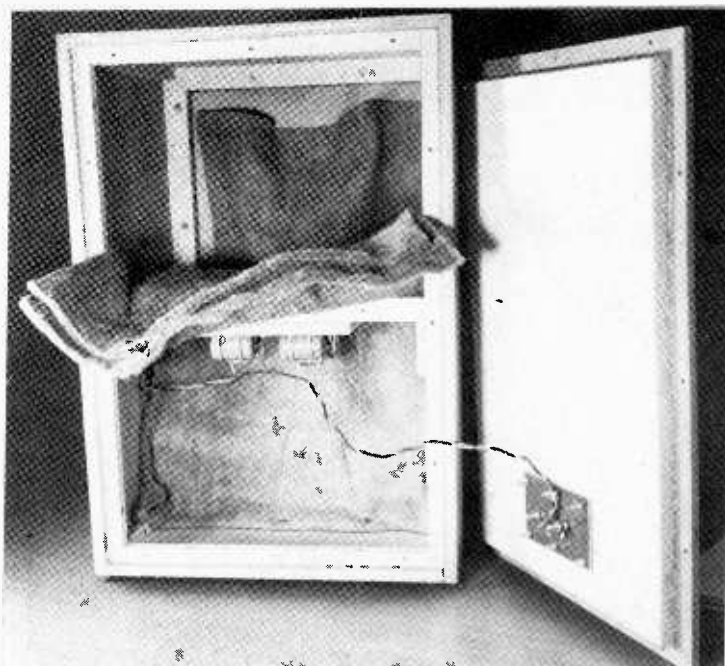

Interior of completed loudspeaker, with the two-layer felt 'curtain' partly removed to show the felt 'hat' over the drive unit. The removable back (right) is made from hardboard and insulating board.

a slight tendency towards colouration of male speech. With two thicknesses of felt tacked down more closely with a larger number of tacks, the bass response will be decidedly thin. If no woofer is to be used, some constructors may prefer the compromise of omitting this felt cover altogether—speech may then sound a little too full in the bass, but the musical reproduction may be thought better.

After dealing with the above, a 'curtain' made from two pieces of approximately $\frac{3}{16}$ in. carpet felt, each measuring about 19 in. \times 13 in., should be tacked loosely in place inside the cabinet as a sort of diaphragm dividing the space into two halves, with the loudspeaker unit in one half.

The equalizer should now be screwed to the shelf and wired in series with one of the leads from the unit to the terminal board. The terminal connected to the red lead should be marked appropriately if stereo operation is envisaged.

The back should be thoroughly screwed on, using three screws along each edge plus three more along its middle to fix it to the edge of the shelf.

Finally, four rubber feet, available from most hardware shops, may be screwed to the bottom of the loudspeaker—or a piece of felt may be stuck on if preferred.

REFERENCES

1. 'A Survey of Performance Criteria and Design Considerations for High-Quality Monitoring Loudspeakers' by D. E. L. Shorter. *Proc. I.E.E.*, Part B, Vol. 105, No. 24, pp. 607-623, Nov. 1958.
2. 'Sidelights on Loudspeaker Cabinet Design' by D. E. L. Shorter. *Wireless World*, Vol. 56, Nos. 11 & 12, pp. 382-385 & 436-438, Nov. & Dec. 1950.
3. 'High-Quality Loudspeakers' by D. E. L. Shorter. *Journal I.E.E.*, Vol. 9, pp. 253-257, June 1963.
4. 'Loudspeaker Transient Response: Its Measurement and Graphical Representation' by D. E. L. Shorter. *B.B.C. Quarterly*, Vol. 1, p. 121, 1946.
5. 'The Design of a Low-Frequency Unit for Monitoring Loudspeakers' by H. D. Harwood. B.B.C. Engineering Monograph No. 68, July 1967.
6. 'New Low-Noise Transistor Circuit for Electrostatic Microphones' by P. J. Baxandall. *Wireless World*, Vol. 69, Nos. 11 & 12, pp. 538-542 & 593-597, Nov. & Dec. 1963.
7. 'Cabinet Handbook' by G. A. Briggs. Wharfedale Wireless Works, Bradford (1962).

†† The pieces used by the author weighed approx. 1.6 oz.

Demonstrating Radar Using Sonar

A device for demonstrating the principles of radar and pulse compression that requires only a simple oscilloscope for indication. 1: Circuit Details

by Brian Wyndham*, M.I.E.R.E.

Sound or ultrasonic waves, travel relatively slowly so that a radar-like device exploiting them need only employ the simplest oscilloscope to indicate quite short distances. For instance, if it is decided that the device is to have a maximum range of 20 feet then the minimum period between consecutive pulses would have to be:

$$(2 \times 20) / 1,120 = 0.036\text{s (approx)}$$

for sound travelling at 1,120ft/s. Further, if discrimination between targets is allowed to be six inches (= 0.5ft), then the maximum pulse length is fixed at:

$$(2 \times 0.5) / 1,120 = 0.0009\text{s (approx)}$$

or nearly 1ms.

With these basic parameters, a demonstration radar-like device has been constructed which is small enough to be carried under the arm, and is sufficiently similar to a full-size radar as to be classified as a not too expensive instructional toy. The device also allows pulse compression to be demonstrated whereby a 1ms pulse is able to discriminate targets closer than 6 inches. The reader is referred to an earlier issue of *Wireless World*† for a simplified account of the principles of pulse compression.

The requirements for a sonar are similar to those for a radar and are: (a) a transmitter, including the basic timing circuit, modulator, oscillator and output stage. (b) a transmitting aerial or transducer. (c) a receiving aerial or transducer. (d) a receiver. (e) a display. (f) power supplies.

Fig. 1(a) shows the arrangement without pulse compression, and for pulse compression Fig. 1(b) applies. Additional circuitry is required in the transmitter for pulse compression to cause the carrier frequency to sweep during the pulse. Also the receiver is complicated by being split into two amplifiers

*Royal Radar Establishment.

†"Radar Pulse Compression" by B. A. Wyndham, *Wireless World*, May 1968, p122.

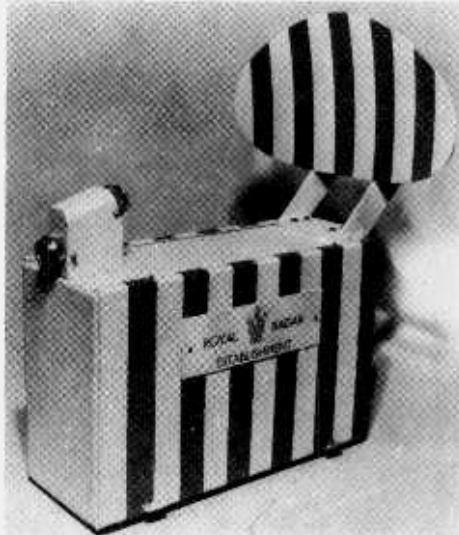

coupled by the dispersive line. The dispersive line to be described is somewhat different from those mentioned in the earlier article, since in order to avoid a frequency conversion, it is required to operate at the relatively low frequency of 100kHz. Those used in full size radars work at intermediate frequencies.

Transmitter

The transmitter (Fig. 2) generates the pulses of ultrasonic energy which are fed to the transmitting transducer. The pulse length, as already mentioned, is 1ms and the carrier frequency is about 100kHz. This figure was chosen because it propagates well in air and is within the range of the transducer producing a well defined beam.

The pulse repetition frequency is determined by C_1 and R_1 in an emitter coupled

multivibrator made up of transistors Tr_1 and Tr_2 , fed from constant current sources Tr_3 and Tr_4 . The square waveform of about 25Hz, is taken from the collector of Tr_2 . The waveform is differentiated by C_2 and R_2 , whilst diode D_1 removes the negative spike and allows the positive spike to trigger the cross-coupled monostable circuit of Tr_5 and Tr_6 . The circuit provides a negative going pulse of 1ms duration from the collector of Tr_6 , which is fed to the bases of Tr_9 and Tr_{10} . These two transistors provide constant current sources for another emitter coupled pair, Tr_7 and Tr_8 which is timed by C_4 , R_4 and RV_1 to run at 100kHz. It will be seen that this circuit will only oscillate when the 1ms pulse is present at Tr_9 and Tr_{10} , otherwise these two transistors will be cut-off and Tr_7 and Tr_8 will be deprived of their supply. There is, therefore, at the collector of Tr_8 , a train of pulses of 1ms duration modulating a square wave carrier of 100kHz.

For pulse compression it is required to sweep the carrier frequency, within the pulse, over a defined range, in this case from 95 to 110kHz. By shunting the resistors R_4 and RV_1 with transistor Tr_{15} carrying a linearly increasing current, the effect is to reduce the total resistance so that the frequency rises. Tr_{13} and Tr_{14} form a Miller sweep circuit gated by the 1ms pulses on the base of Tr_6 . As the collector voltage on Tr_{14} increases linearly, the current in Tr_{15} rises accordingly, a slight non-linearity occurs because Tr_{15} is normally cut-off and there is a toe in the characteristic as it starts to conduct, but the overall performance is not greatly reduced. RV_1 allows the centre frequency to be adjusted to 102.5kHz, and RV_2 varies the sweep range. The switch S_A , S_B permits simple pulse or pulse compression modes to be selected. When unswept, in the simple pulse mode, the carrier frequency would lie at 95kHz, since Tr_{15} is not conducting, and

Fig. 1. Block diagram of the unit, (a) without pulse compression, (b) with pulse compression.

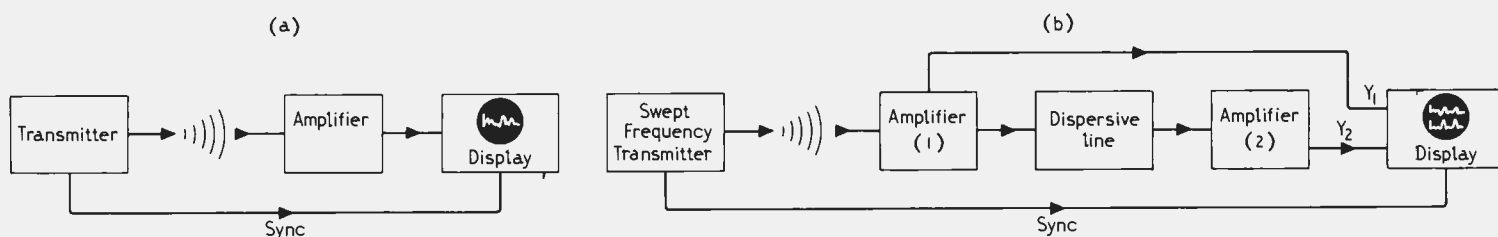

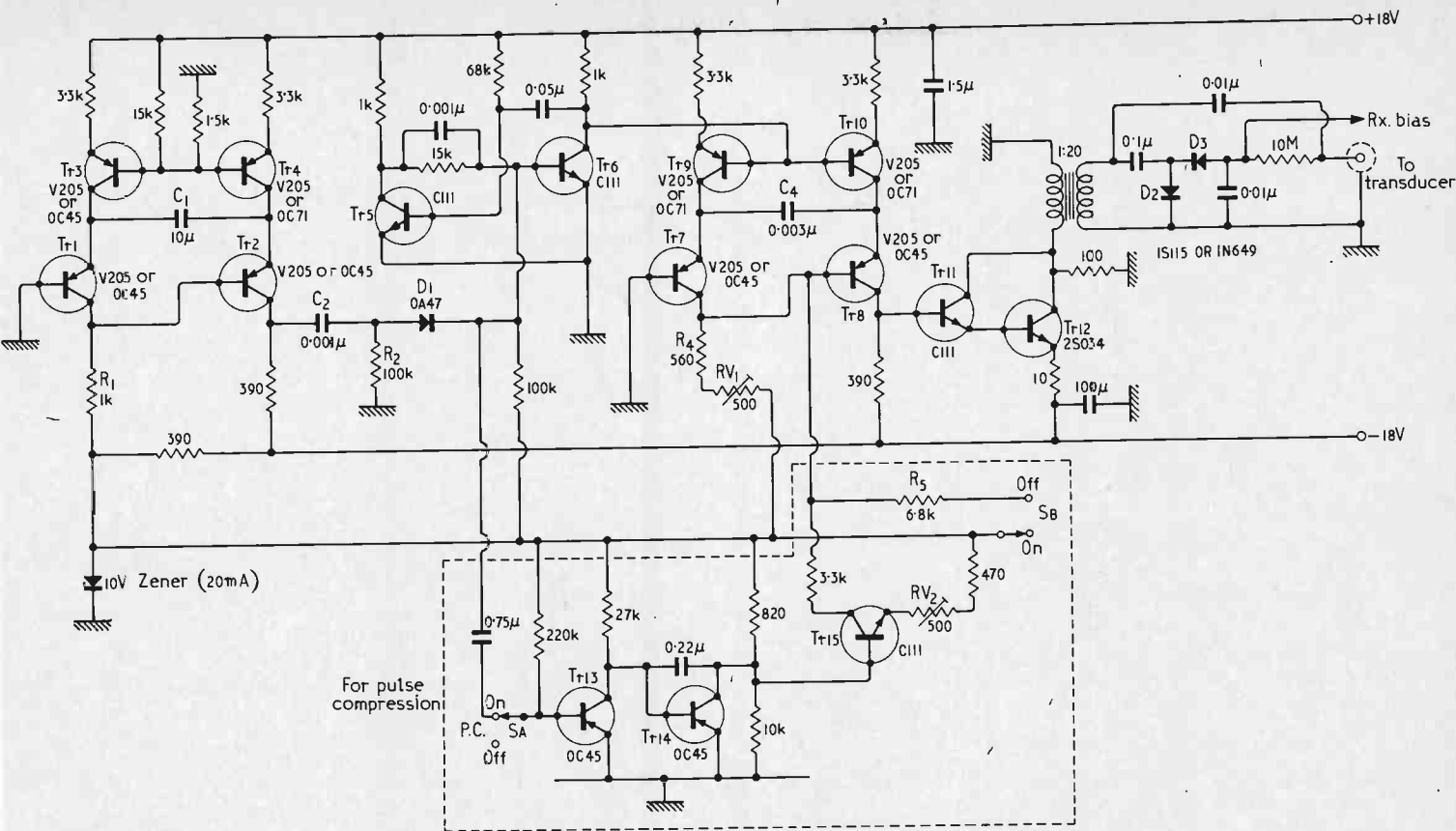

Fig. 2. The transmitter circuit. If pulse compression is not required, the circuitry within the dashed area is omitted.

would be on the skirt of the receiver pass band. R_5 is therefore introduced to raise the frequency when the transmitter is switched to this mode.

If a pulse compression facility is not required, the circuitry within the dashed area of Fig. 2 may be omitted. Under these conditions the operating frequency is not so critical provided it coincides with the receiver tuning.

The transmitting transducer requires a high voltage drive superimposed upon a d.c. biasing voltage which must be at least equal to the peak value of the drive voltage. The signal voltage from Tr_8 must, therefore, be increased and a 1:20 step-up transformer fulfils this task. The transformer cannot be driven directly from Tr_8 but is fed from Tr_{12} , via the driver transistor Tr_{11} . The emitter resistor of Tr_{12} controls the peak current in the transformer primary and affects the secondary voltage.

The transformer output feeds the transducer via a $0.01\text{-}\mu\text{F}$ capacitor. The bias voltage is also derived from the transformer output by means of a voltage doubler rectifier circuit D_2/D_3 feeding the transducer through a $10\text{M}\Omega$ resistor, this arrangement assures that there is always sufficient bias available, making certain that the voltage on the transducer can never reverse its polarity. Although the rectifier is operating with a pulsed input, the transducer, which has a capacitance of 100-pf, charges up to working voltage in a second or so.

As already mentioned, the carrier is generated as a square wave in Tr_7 and Tr_8 , but since the secondary inductance of the transformer is approximately tuned by the transducer capacitance, the final voltage waveform is sinusoidal. It may be found

necessary to add a small capacitance in parallel with the transformer secondary in order to tune it more accurately.

The maximum d.c. plus a.c. voltage reached in practice may be as high as 800V which is about the limit set by the dielectric strength of the transducer diaphragm. Although the bandwidth is adequate for the simple pulse system, it has been found convenient to widen the bandwidth for pulse compression by means of a damping resistor in the primary of the transformer. This also reduces the working voltage.

The voltage doubler rectifier also feeds a d.c. bias to the receiving transducer and the transducers associated with the dispersive line.

Receiver

The receiver (Fig. 3) has the task of amplifying the minute signals appearing at the transducer's terminals to a level which may be seen on an average oscilloscope.

For the simple non-pulse-compression version, only one amplifier is needed, feeding a simple detector. This comprises the circuit of Fig. 3(a) coupled with the output circuit on the left hand side of Fig. 3(b), but not including the components within the box.

The first three transistors form part of a low-noise, wide-band, high input impedance pre-amplifier having a gain of 30dB. This is followed by three tuned stages contributing a further 60dB gain. The overall bandwidth is about 5kHz, somewhat wider than theory suggests, which is $(\text{Pulse length})^{-1}$, but because the circuit was designed with pulse compression in mind, the larger figure is used.

The detector is a voltage doubling rectifier. This may seem unusual but since many standard oscilloscopes have insufficient deflection for a d.c. coupled input, a larger signal is thereby made available without adding a d.c. amplifier. Each tuning coil is in fact a single "Pie" cut out from a standard 1.5mH choke having four such "Pies", and containing 150 turns wavewound.

For pulse compression, two amplifiers are required, one preceding and one following the dispersive line. Both amplifiers are similar but have different output circuits. The first amplifier is required to drive the transducer forming the input of the dispersive line. The signals on the transducer must therefore be at a high level.

The output of the dispersive line is another transducer which in turn feeds the second amplifier whose output is rectified to produce the compressed video pulse. The 1st amplifier comprises the circuit of Fig. 3(a) and the entire left hand output circuit of Fig. 3(b). In this, it will be seen that there is an extra current gain stage which drives the transformer circuit of Fig. 3(c). This latter circuit is mounted beneath the dispersive line ensuring that the capacitance of the connecting cable is on the primary side of the transformer where its detuning effect is least. This sub-chassis circuit also couples to the output transducer of the dispersive line and the d.c. bias to both transducers is fed along the cable carrying the compressed pulse to the 2nd amplifier.

The detected signals in the 1st amplifier are of wider bandwidth than those in the simple non-pulse compression case, and the voltage doubler detector is not suitable. A resistor is therefore used in place of one of the diodes as shown in Fig. 3(b).

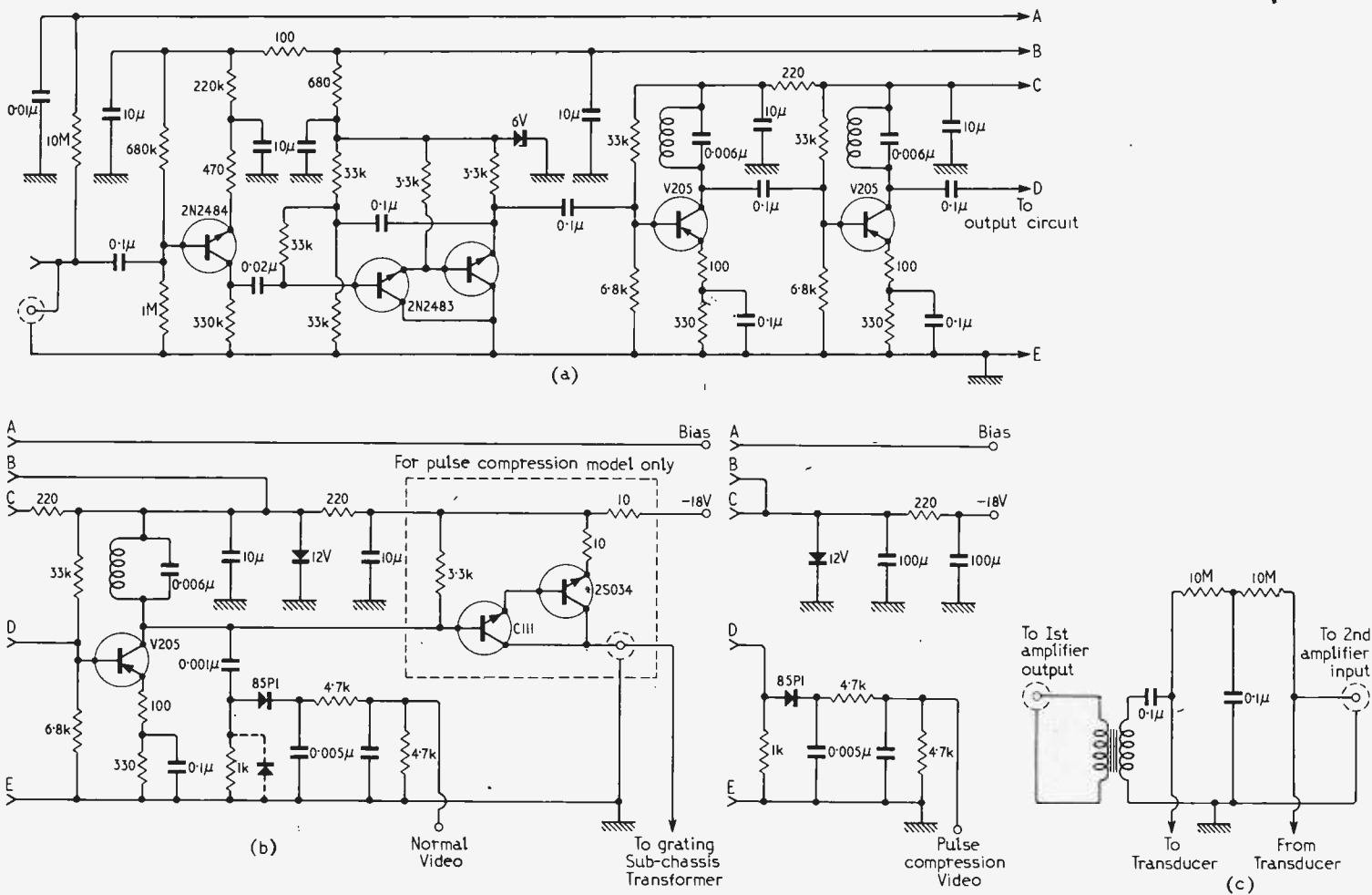

Fig. 3(a). Part receiver circuit. (b) Part receiver circuit. (c) Subchassis circuit for grating—pulse compression version only.

The 2nd amplifier consists of the circuit of Fig. 3(a) with the right hand circuit of Fig. 3(b).

Both amplifiers should be tuned to 102.5 kHz, the 1st amplifier having a gain of 90dB from input to detector, the 2nd 78dB.

The line marked "A" in Fig. 3 goes to the point marked "Rx Bias" in Fig. 2, and carries the d.c. bias generated in the transmitter to all three receiver transducers.

The sub-chassis circuit, being associated with two of these, must prevent direct

electrical coupling between them. The two 10MΩ resistors and the 0.01-μF capacitor fulfils this task while allowing the d.c. bias to pass.

Transducers

The transducers (Fig. 4) act as the aerials would in a radar, and convert the electrical energy into acoustic energy and vice-versa. Crystal transducers are unsuitable for this

application because their inherently narrow bandwidth prevents them from coping with the relatively short pulses. The amount of damping necessary to allow them to respond to such pulses would absorb too much energy. Because of their very wide bandwidth reaching up to 200kHz or more, capacitive transducers were chosen for both transmission and reception. These are made by lightly stretching a 0.00025 inch Meculon (see box at end of article) film over a 0.5" diameter backplate. The aluminized front surface is connected to the body and the electrical signal is fed to or from the backplate together with the polarizing voltage.

Owing to the high voltages present on the transducers, "common aerial" working is difficult. A transmit-receive switch would have to prevent the transmitter pulse from reaching the receiver and, immediately the pulse has ended, allow unattenuated echo signals to pass to the receiver. It would also have to prevent switching transients from damaging the receiver input circuit. No doubt the switching could be performed in the primary of the transformer, but in any case, separate transducer operation allows a much simpler circuit to be used.

The transducers*, must be carefully constructed and absolute cleanliness is essential during assembly. The backplate must be free of any sharp edges. The grooves in the backplate help to tune the transducer acoustically, but in some versions the backplate has been left smooth, sand blasted or file finished to

Fig. 4. Constructional details of the transducers.

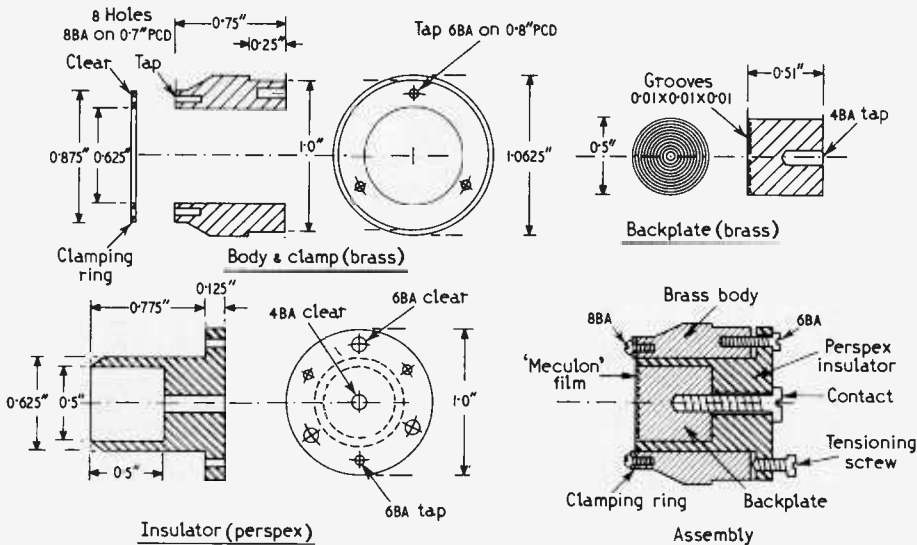

*Acustica, Vol. 4, p519.

leave microscopic cavities behind the diaphragm. The author has not explored all the variations, but the grooved version has so far yielded the best results.

The writer has found the easiest method of assembly to be as follows. A piece of Meculon film is cut somewhat larger in size than the body of the transducer and lightly brushed to remove any dust. The body is carefully cleaned and a thin layer of impact adhesive quickly spread over the end endeavouring to avoid getting any down the screw holes. The Meculon film is then laid, metallised side down, on a clean sheet of paper, and the body is carefully lowered and lightly pressed onto it. With the body lying on the film, the latter is manipulated by the protruding edges so as to remove any wrinkles in the centre. By the time this is done, the adhesive will hold the film firmly. Turning the body over, the screw holes can be cleared by placing the end of a hot needle on the film exactly over the holes in the body, being careful not to accidentally puncture the film anywhere else. After removing surplus adhesive from the holes, the clamping ring can be screwed in place and the protruding edge of the film trimmed off.

The grooved backplate should be cleared of sharp edges and dust before being fitted into the Perspex insulator, the assembly is then lowered into the body. The tensioning screws should be used to avoid forcing the backplate against the film. The three securing screws will hold the complete transducer together and a quick check for insulation between body and backplate is advisable. Tension is best found by actually running the entire sonar until the best response is found, but for a start, the backplate should be brought into light contact with the film. It is not necessary to deliberately stretch the film by the backplate in too far, as this will weaken the film and cause a breakdown.

From the dimensions of the transducers it may be expected that they would have an acoustic gain of about 20dB over an isotropic radiator, at a frequency of 100kHz. The transmitting transducer faces forward on a horizontal axis and directly illuminates the target, while the receiving transducer is placed at the focus of a parabolic reflector which increases the acoustic gain by a further 20dB. The paraboloid measures 6×11 inches and has a focal length of 10 inches, with the elliptical shape usually associated with real radars. This is done merely for appearance but no doubt the gain is increased thereby, yielding an approximate beamwidth of 3° vertically and 1.5° horizontally. In order to reduce the obstructing effect of the receiving transducer placed in front of the reflector, the latter is made off-set with the transducer pointing up into it at an angle. In this way the effective beam axis is horizontal. Because the receiver beamwidth is narrower than the transmitter beamwidth, the setting of the two in relation to each other is not critical.

A total of four transducers are required for the pulse compression model, two of these forming part of the dispersive line, which was especially designed for use in the 100kHz range and whose operation and construction will now be described.

Ultrasonic Dispersive Grating

Dimensions of the dispersive grating are given in Fig. 5 which is represented diagrammatically in Fig. 6(a). The surface, *c*, of an acoustic reflector whose properties will be described shortly. At *C* are placed two transducers side by side, one radiating a frequency swept pulse towards *c*, the other receiving the reflected acoustic signal from *c*. The geometry of the arrangement is such that the difference in time for the wave travelling along path *a*, and the wave travelling along path *b*, is exactly equal to the pulse length of the radiated signal. Supposing now that the surface of *c* is in the form of an acoustic diffraction grating. In general a diffraction grating will reflect different frequencies at different angles, which depend upon the spacing of the parallel scattering elements which make up the grating. Fig. 6(b) shows the end view of two such idealised elements near the bottom corner *A*. A wave approaching this structure from the direction of the arrows will be reflected back to the source if (and only if) the horizontal spacing of the two elements is half a wavelength or a multiple of this. An ultrasonic signal whose frequency is changing will only be reflected back to the second transducer at the one frequency corresponding to the spacing of the two elements. All other frequencies will be reflected off at different angles and will miss the receiving transducer.

Fig. 6(c) shows the arrangement at the other end of the grating at *B*. The signals arrive at a different angle and here the spacing must be such that the projected distance onto the signal path must be half a wavelength for the wave to be returned to its origin. It is arranged for the frequency at the commencement of the pulse, f_1 , to be reflected back to its source from the top of the grating, while the frequency at the tail of the pulse is reflected back from the lower end. Since the difference in delay introduced by the differing path lengths at these frequencies is equal to the pulse length, it is seen that they arrive back at *C* simultaneously. The problem is to design a system of spaced elements such as to introduce the correct amount of delay to each frequency component of the swept pulse. If the grating is assumed to be flat, the element spacing should vary slightly along its length since the delay versus frequency function should be linear whereas the grating geometry includes a trigonometric function of the angle. The appendix (next month) will show how the equations governing the basic design have been derived. For simplicity, a grating of constant spacing has been designed considering only the conditions at the ends of the grating, since the device is only required as a demonstration model.

This simplification allows slide rule calculations to be made, but a more precise grating, designed with the aid of RREAC, the R.R.E. digital computer, has also been made, but the discrepancy is negligible.

A few basic parameters were decided upon. The frequency sweep was to be 15kHz from 95kHz to 110kHz during a pulse of 1ms. Also the beam width of the transducers to the half power points was taken to be $16^\circ (= \theta)$. One condition to be satisfied is that the difference in path lengths ($a-b$), Fig. 6(a),

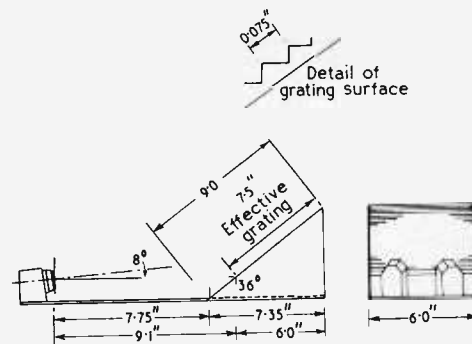

Fig. 5. The ultrasonic dispersive grating.

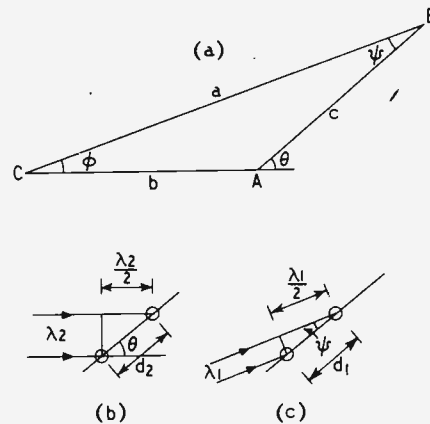

Fig. 6. Operation of the dispersive grating.

should be equivalent to a delay of 1ms. In air this is a distance of 13.45 inches and since the paths are traversed twice, $(a-b) = 6.725$ inches. The grating is constructed by cutting the face of a light alloy plate with a number of parallel grooves so as to have the calculated spacing. This operation requires a milling machine or shaper and would be beyond the scope of most amateurs, but a system of parallel wires having the same spacing would act as effectively. The wires could be stretched over a frame having notches along two opposite sides to locate the wires. It should be mentioned that the element spacing of 0.075 inches, (Fig. 5) is the minimum, but no worse a performance will be found if this is exactly doubled, thus making the construction easier by having half as many elements.

(Next month, in the concluding article, construction and setting up details will be given.)

The aluminized material required is normally only supplied by the manufacturers in 1 cwt. reels. However, the components group of the Plessey Company, who use the material in capacitor manufacture, have kindly made available a small supply. Readers who wish to construct the sonar may obtain a sufficient quantity of Meculon by writing to *Wireless World*, Dorset House, Stamford Street, London S.E.1. enclosing a postal order for 1s to cover postage and packing costs.

Wireless World Colour Television Receiver

3. Line timebase and e.h.t.

The complete circuit diagram of the line timebase, e.h.t. and focus supplies and the sync separator are given in Fig. 1. All these parts, together with the frame timebase described in Part 2, are housed in one unit.

The present circuit seems at first to be very complex, but it is basically very little different from standard monochrome practice. The main differences lie in the e.h.t. supply and in the arrangements for feeding the convergence circuits. It is, however, a higher power job than the usual monochrome timebase.

It is best to start considering the circuit with V_2 , which is the pentode section of a triode pentode, type PCF802. This acts as a triode sinewave oscillator, the screen grid acting as the triode anode. It is a tuned-grid oscillator, the coil L_1 having three times as many turns between its tapping point and grid as between that point and anode. The tuning capacitor is C_{11}

which, in series with R_{14} , is connected between the tapping and the grid end of the coil. An adjustable ferrite core enables the frequency to be set to the line-scan frequency of $625 \times 25 = 15,625\text{Hz}$.

The other components connected to cathode and grid are concerned with the flywheel sync arrangements and can be ignored for the present. The oscillator is self-biased by grid current in R_{16} and operates under class C conditions so that cathode current flows only for a short time on the positive peak of the grid waveform. The pentode anode can, therefore, draw current only during this short time.

When V_2 is conductive there is a considerable voltage drop across R_{18} and the anode potential is of the order of a few tens of volts above chassis. When V_2 is cut off the anode potential rises by some 200 volts. If it were not for $C_{16}R_{20}$ the net result

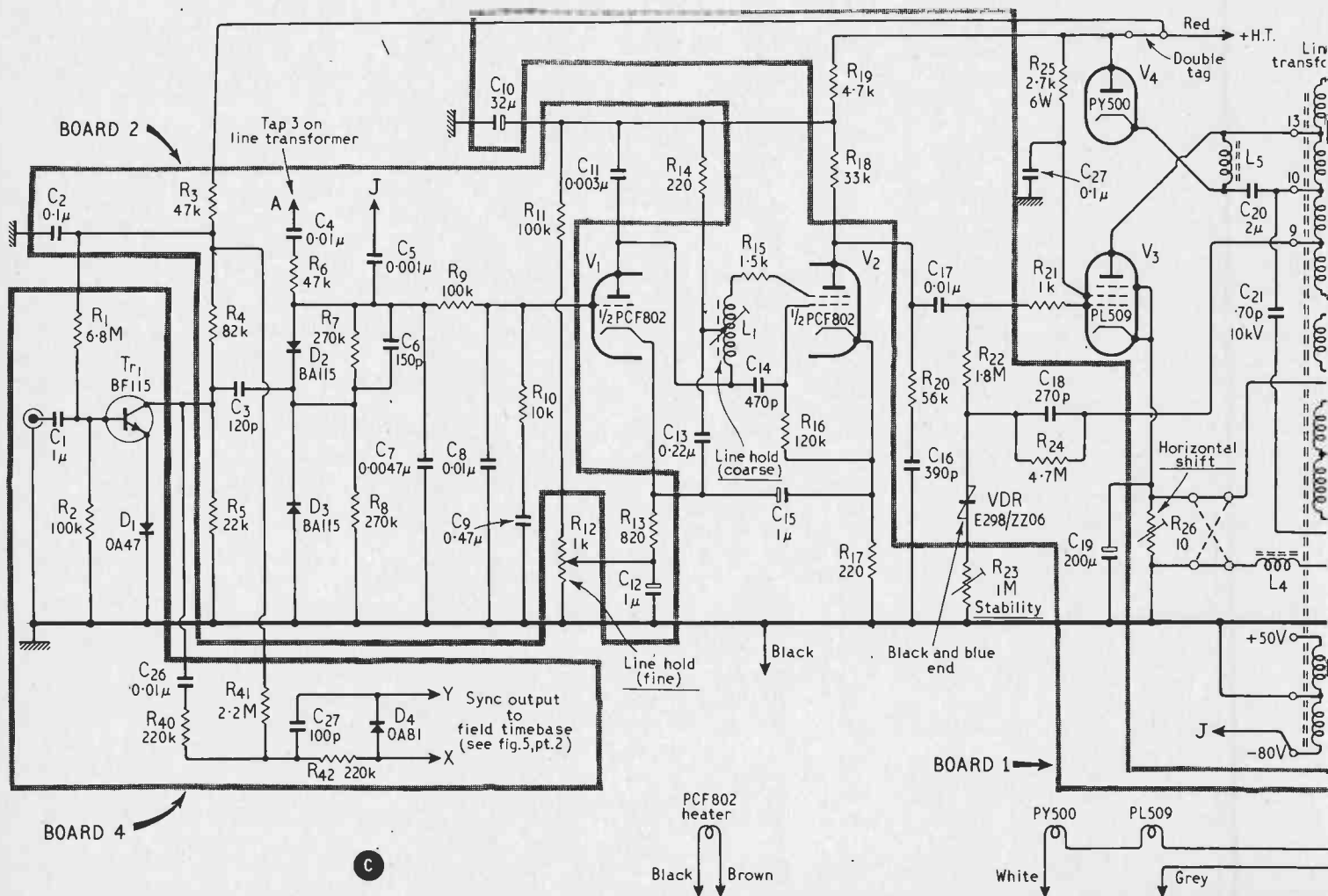

would be the production of a rectangular waveform of about 200 volts amplitude at the anode of V_2 , the voltage being a minimum during the short periods when V_2 is conductive and a maximum during the much longer periods when it is cut-off. This is modified by $C_{16}R_{20}$, however. When V_2 becomes conductive the anode voltage drops very rapidly and while V_2 is conductive C_{16} discharges somewhat through R_{20} . Because of this the voltage does not rise so rapidly when V_2 is cut-off. In addition to this the valve and stray circuit capacitances are discharged very quickly through V_2 when it becomes conductive, but charge again much more slowly when it is cut-off. The net result is a waveform which falls very rapidly when V_2 conducts, stays at a low value while V_2 is conductive and then rises exponentially and relatively slowly when V_2 is cut-off again.

This forms the grid drive waveform for the output pentode V_3 , the d.c. component being removed by C_{17} . Grid current in V_3 provides d.c. restoration so that towards the end of the scan and just prior to V_2 becoming conductive the grid of V_3 is at about zero volts. When V_2 becomes conductive for the flyback, therefore, the grid of V_3 is driven about 200 volts negative and cut-off. The relatively slow rise of voltage after this provides the proper driving wave for V_3 during the scan.

For the moment ignore C_{23} , L_2 and L_3 , and assume that terminals 5 and 6 of the autotransformer are joined together. The deflector coils are then joined to terminals 3 and 7. The earthy terminal 6 is mid-way between 3 and 7 with the result that the deflector coils are balanced to earth. When the potential of one side is positive to earth that of the other is negative. This not only reduces the insulation needed on the connecting leads but it reduces radiation from the leads. For the present we can also ignore L_3 and C_{20} .

At the end of the scan the current is a maximum both in V_3

and in the deflector coils, and the anode voltage of V_3 is at its minimum. Then V_3 is cut-off and its anode current falls to zero. The current in the coils then flows into the circuit capacitance of which C_{21} is a part. The circuit is effectively a tuned circuit with losses due partly to winding resistances and partly to the cores. If it were left to itself the stored energy at the end of the scan would be dissipated as a damped oscillation. As it is the circuit is allowed to perform only one half-cycle of free oscillation. The current follows a cosine law and the voltage a sine law. The current falls from its value at the end of the scan through zero to a negative value which is less than that at the end of the scan because of circuit losses. The voltage rises from the low value at some 50–80 volts appropriate to the end of the scan to several kilovolts when the current is changing most rapidly, which is when the current is at about zero. It then reverts to somewhere near the scan value when the current reaches its most negative value.

The voltages on the autotransformer follow those across the deflector coils but are changed in magnitude by the winding ratios; similarly also for the currents. The peak voltage on terminal 3 reaches some 8kV and is around 6.5kV on the anode of V_3 . During the whole of the flyback period V_3 is cut-off by its grid voltage, and the diode V_4 is cut-off by the large positive voltage on its cathode from the transformer. The valve is a special type having a top cap for the cathode connection and heater-to-cathode insulation to withstand some 6kV!

At the end of flyback V_3 may be still cut-off but even if it were not it could not carry the deflector-coil current for it is flowing in the wrong direction. However, V_4 now becomes conductive and carries the deflector-coil current as modified by the transformer ratio. This current flows in C_{22} which thereby accumulates a considerable charge. After a while V_3 starts to

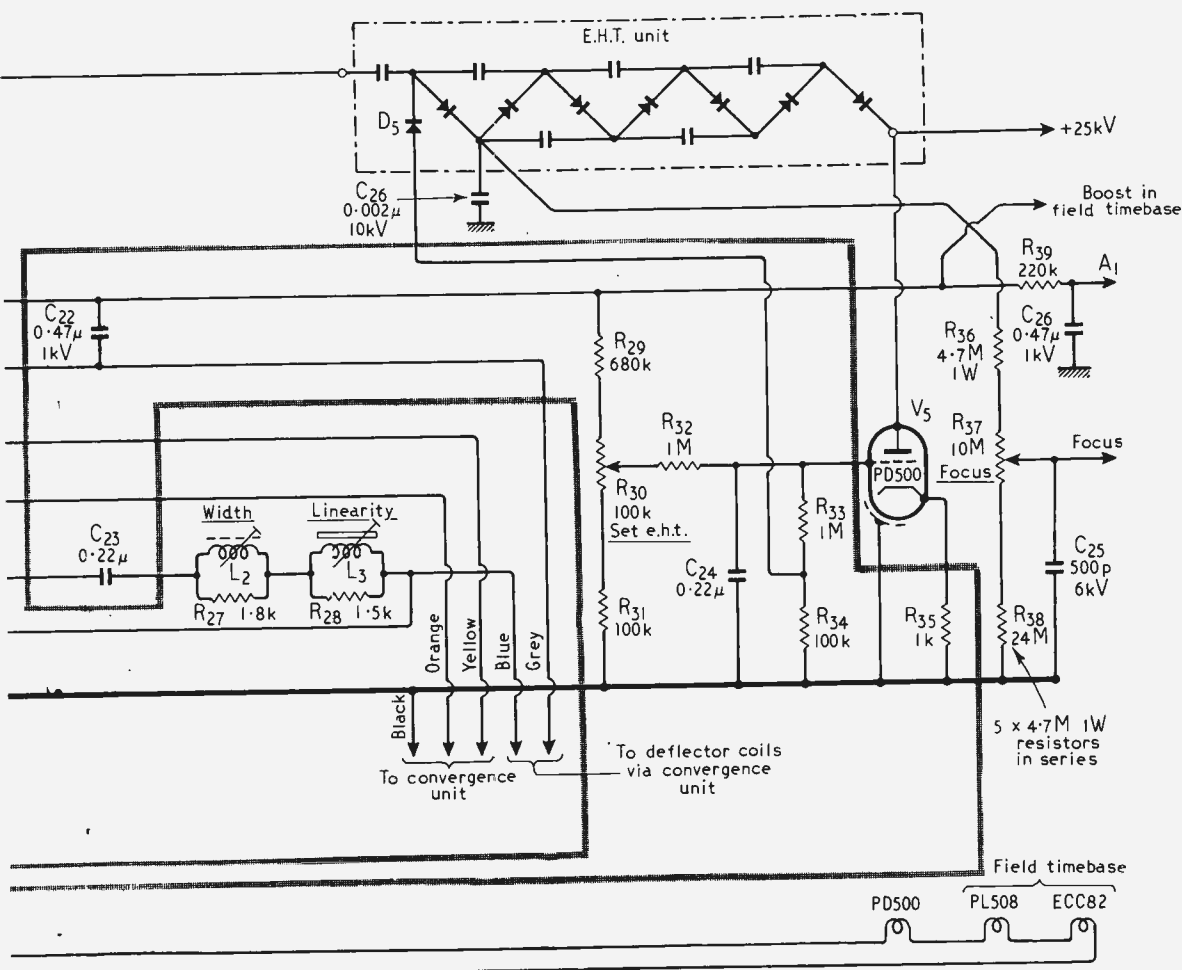
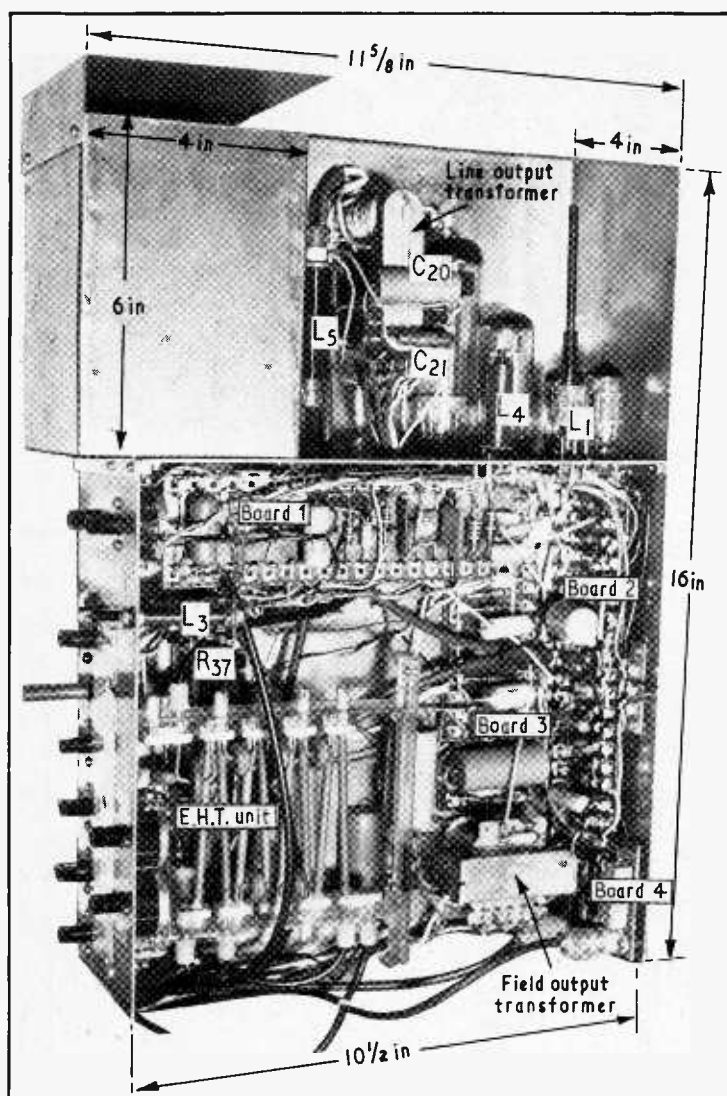

Fig. 1. Complete circuit diagram of the line timebase together with the flywheel sync system and the sync separator. The video signal is fed in by a coaxial cable to the sync separator. Most of the components are mounted on three large and one small board and the dotted contours in the diagram indicate which components go on which board. Components which are not surrounded by a contour are mounted elsewhere.



General view of the timebase unit with dimensions

conduct again and supply current to the circuit. In doing this it draws current from C_{22} . The mean voltage on this capacitor augments the h.t. supply and provides the so-called boost voltage. This voltage is available for use on other circuits but because of its position in the circuit it is available only with line-frequency pulses of about 1kV superimposed on it. The boost supply for any other circuit must be smoothed therefore. The boost supply before smoothing is about 740V and after smoothing is usually some 550–600V.

The components L_5 and C_{20} are included merely to keep the mean anode currents of V_3 and V_4 out of the transformer and so to avoid any core saturation effects. The capacitor C_{23} has two functions. One is to keep d.c. out of the deflector coils; the other is to modify the deflector-coil current waveform, by making it somewhat S-shaped instead of linear. As explained in Part 2 in connection with the field timebase, this is necessary to obtain a linear scan on the screen.

The variable inductor L_2 provides a small measure of control of the picture width and L_3 controls linearity. This coil has a fixed core the static flux density in which can be adjusted by a movable permanent magnet. The back e.m.f. across it can then fall with increasing current and so offset the rising voltage drop across the winding resistances, to obviate the non-linearity which these resistances would otherwise cause.

For picture centring in the horizontal direction it is necessary to bleed a small amount of direct current through the deflector coils. Terminal 5 of the transformer is connected to chassis through the very low resistance convergence circuits. Terminal 6 is joined to one end of a 10- Ω variable resistor R_{26}

in the cathode circuit of V_3 to the other side of which the deflector coils are returned through the choke L_4 . Adjustment of R_{26} enables the picture to be moved only one way; if this happens to be the wrong way the connections must be reversed.

Terminal 12 on the transformer is connected to the e.h.t. supply unit. This is a commercial product which contains everything enclosed by the dotted rectangle; that is, eight selenium rectifiers and six capacitors. The capacitors, with all the rectifiers except D_5 , form a voltage quadrupler circuit the final reservoir capacitance being provided by the capacitance between the internal and external coatings of the cathode-ray tube in the usual way. Voltage-multiplying rectifiers never give their full multiplying factor under load. A doubler, for instance, usually gives out about 1.8 times the input voltage. A quadrupler, therefore, in fact gives only a little over three times the input and with an input of some 8kV provides 25kV output.

An output at around 8kV is taken off after the first rectifier in the chain to provide the voltage for the focus anode of the tube. This needs around 6kV which is obtained from the potential divider R_{36} to R_{38} . Smoothing is effected by C_{25} .

The capacitor C_{26} is essential to the proper operation of both supplies. So far as e.h.t. is concerned it could equally well be connected between the last two rectifiers in the unit, and was so connected in some early models of the unit. However, its connection as shown is of advantage from the point of view of the focus supply.

The triode V_5 is connected in shunt with the 25-kV supply and its grid voltage is controlled so that when the tube current increases the valve current decreases and the load on the e.h.t. unit is kept nearly constant.

A fraction of the positive boost voltage on C_{22} is applied to the grid of the triode; this is obtained from the potentiometer R_{29} , R_{30} and R_{31} and the pulses on C_{22} are smoothed out by R_{32} C_{24} . To offset this a negative voltage is derived through D_5 in the e.h.t. unit. This rectifier is non-conductive during flyback when the others conduct to provide e.h.t. It is conductive during the scan and has R_{34} for its load. Its voltage output is smoothed by R_{33} and C_{24} . The negative voltage provided is somewhat greater than the positive voltage from R_{30} and so the grid of V_5 is negative to its cathode. This is a negative control voltage which may vary in the region of perhaps 5 to 20 volts negative.

The cathode resistor R_{35} is included purely to enable the anode current of V_5 to be readily checked. As its value is 1k Ω a high-resistance voltmeter connected across it will indicate current in milliamperes. The normal procedure is to connect a voltmeter on its 10-V range across R_{35} and to adjust R_{30} with the tube blacked out so that the meter reads 1.2V. This corresponds to 1.2mA in V_5 with the tube taking no current and it also corresponds to the maximum normal tube current. Ideally, when the tube takes 1.2mA, V_5 cuts-off and if the tube attempts to take more current the stabilization fails because V_5 is inoperative and the basically poor regulation of the e.h.t. system causes the voltage to drop greatly with increasing load. In its turn the fall of voltage causes an increase of picture size and a drop in picture brightness.

In normal operation within the control range, an increase of tube current increases the load on the timebase and drops the boost voltage a little. It does also necessarily drop the negative voltage from D_5 somewhat, but the effect on the boost voltage predominates and so the grid of V_5 moves negative and this valve draws less current. As in all feedback circuits control is not perfect, but in practice a quite adequate degree of stabilization is obtained.

Two windings marked +50V and -80V are shown on the transformer. These are not provided on the transformer as supplied by the manufacturers and must be put on the transformer by the constructor. As the peak flyback volts are 8 volts

per turn the windings need only 6 and 10 turns respectively and they are wound on the limb of the core opposite to that which carries the main windings. The -80-V pulse is used in several places; it is used for flywheel sync, for blanking in the luminance amplifier and also in the chrominance circuits. The 50-V pulse is used for black-level clamping in the chrominance output stages.

Turning now to the input side of Fig. 1, the video signal is fed in by a coaxial cable with positive-going sync pulses. A transistor Tr_1 is used as the sync separator and d.c. restoration is effected in the usual way in the base circuit. The diode D_1 in the emitter circuit is purely a safety device to safeguard the base-emitter junction of Tr_1 against voltage surges. The separated sync pulses appear at the collector and are fed through C_3 to the line circuits and through C_{26} to the field. Integration takes place with $R_{39}C_{27}$ with the result that the field pulses come through at a much higher level than the line. These pulses are, of course, negative-going. The diode D_4 is normally conductive because of the current bled through it from R_{41} . It does not, therefore, pass the line pulses, but the greater amplitude field pulses cut-off the diode so that these pulses pass to the field timebase.

Returning to the line circuit, the line pulses pass through C_3 to a phase detector where they are compared with line pulses from the timebase and a d.c. control voltage is developed which depends in magnitude and sign on the error between the two. One pulse is taken from terminal 3 on the transformer and is a pulse negative-going on flyback and of about 600V amplitude. This is integrated by R_6C_7 to a sawtooth of some 25V amplitude. To this is added the 80-V negative pulse from one of the extra windings on the transformer. This is reduced in amplitude to nearly one-sixth by the capacitance potential divider C_5C_7 . The resulting modified sawtooth across C_7 has no d.c. component and passes through zero about halfway through flyback. The negative sync pulses coming through C_3 make both diodes D_2 and D_3 conduct equally when the voltage across C_3 is zero. No voltage from the sync pulses is then developed across C_7 and none is applied to the grid of V_1 .

However, if a sync pulse does not coincide with a zero of the sawtooth the balance of the circuit is upset and one of the diodes passes a greater current than the other so that C_7 is charged with a polarity which depends on whether the sawtooth is positive or negative when the sync pulse occurs and with a magnitude which depends on the amplitude of the voltage of the sawtooth at that time. The filter R_9C_8 removes most of the sawtooth and the mean voltage on C_7 is passed to V_1 where it varies the mutual conductance of this valve.

In the anode circuit of V_1 , C_{11} and R_{14} in series are across the grid part of L_1 and carry the circulating current of the tuned circuit. The voltages across these components thus have a phase angle of 90° . The voltage across R_{14} is applied through C_{13} to the cathode of V_1 and it drives through this valve a sine-wave current whose magnitude depends on the grid voltage of V_1 . This current flows through C_{11} and is at 90° to the circulating current in C_{11} . The phase angle of the total current in C_{11} is thus altered by an amount which depends on the grid voltage of this valve. As a result, the frequency of the tuned circuit is altered and any frequency error of the oscillator is corrected.

Since a phase detector is used a frequency error can always be brought to zero unless it is initially too great. There will generally be a phase error, of course, which manifests itself in a very slight sideways displacement of the picture on the raster.

The whole system forms a negative-feedback loop and for stability requires the usual anti-hunting components R_{10} and C_9 . In order to speed up the rate of cut-off of V_2 some extra positive feedback is provided by coupling a voltage from the cathode of V_2 through C_{15} to the cathode of V_1 .

The core in L_1 provides a coarse pre-set adjustment of the

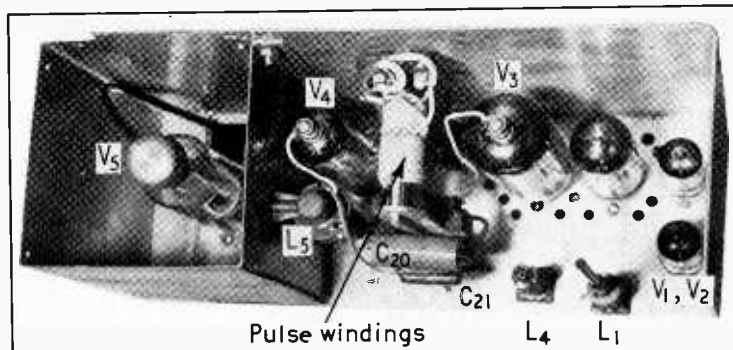

View of the top deck with cover of the V_5 compartment removed

oscillator frequency. A fine adjustment is provided by the bias on V_1 which is adjustable by the potentiometer R_{12} .

One other thing needs mentioning. A positive-going pulse is taken from terminal 9 on the transformer through C_{18} shunted by R_{24} to the bottom end of the pentode grid resistor R_{22} . The grid return is completed by a voltage-dependent resistor and a variable resistor R_{23} . The purpose of these components is to stabilize the timebase against variations in the h.t. supply voltage and R_{23} is adjusted for the minimum change of picture width with a change of h.t.

As can be seen from the photographs the valves are all carried on a shelf across the chassis. The line-scan transformer and the two chokes associated with it are mounted above this shelf, but most other components are mounted below it. Most of the small components are carried by two tagboards. One,

Side view showing the controls

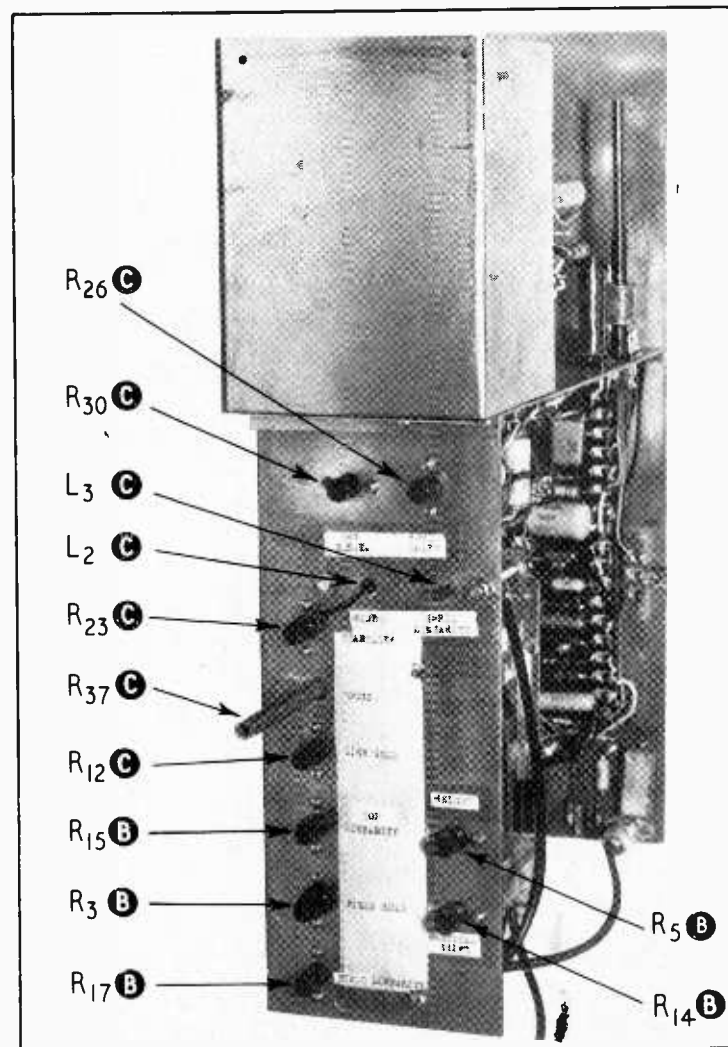

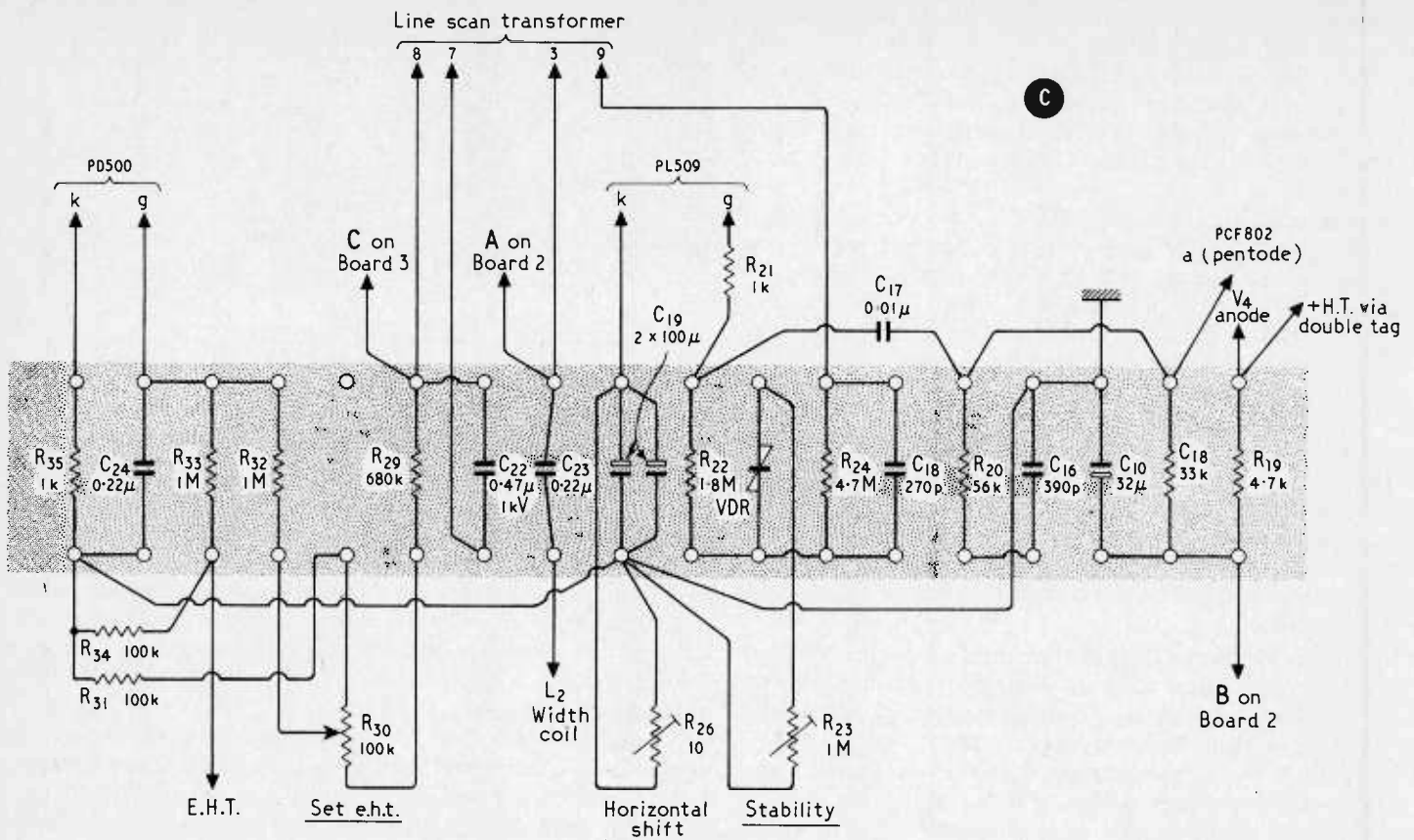

Fig. 2. This diagram shows the arrangement of Board 1, which holds most of the components associated with the output stage and the e.h.t. stabilizer.

Board 1, is mounted parallel to the shelf and stood off from the back on two lengths of studding; this board carries a few of the larger capacitors on its under side. The other board is mounted on the side of the chassis. The chassis itself is 16 inches high, 4 inches deep and 10½ inches wide and is hinged along its bottom edge to the baseboard. The valve shelf is 6 inches below the top.

The coil L_1 is also mounted above the shelf and some of the components associated with V_2 are connected directly to its holder or between that and the coil tags. The sync separator parts are mounted on a small board, Board 4, which is mounted on the side of the chassis between that and the field output transformer. This board carries a coaxial socket for the sync input and is indeed mounted by that socket.

A series of ¼-inch holes is drilled around the valveholders for V_3 and V_4 to increase the ventilation for these valves. Most of the shelf around the holder for V_5 is cut away, leaving enough only to support the holder. As a protection against X-rays this valve must be screened. Originally, the back and one side of the chassis formed two sides of the screen and a single additional piece of metal formed the other two sides and so gave a square screen of 2-inch sides. This was not found to be large enough and flash-overs from the anode cap to the screen were frequent. Eventually the screen was enlarged to a square one of 4-inch sides. The chassis is deep enough for this but not quite long enough; the side above the shelf was, therefore, cut away so that, as the photographs show part of the screening is an extension sticking out above the control knobs.

It would be simpler mechanically to make the whole chassis that much larger and this would also be advantageous in giving more room inside for the parts. It would mean, however, making the whole set that much deeper and it was not done because it was desired to avoid this.

Probably the greatest practical difficulty lies in avoiding corona at the anode cap of the stabilizer. Even when the screen was enlarged to prevent flash-overs trouble from corona was still experienced. The most suitable top-cap which seems to be

available is the Bulgín. This comprises the usual spring clip inside a metal shielding cap; the two are held together by an eyelet in the top. The wire must be passed through the hole and soldered on the *inside*. This is essential. The cap appears to be satisfactory provided that the polythene insulation of the cable can also be passed through the hole to the inside of the cap. Unfortunately, the cap gets very hot, the polythene soon softens and falls back from the wire and a discharge starts from the bare wire at its point of entry to the cap.

The only way which has been found to overcome this is to turn on the lathe a special shielding cap for the commercial one. This was turned from a piece of 1-inch diameter brass rod. A ½-inch hole was drilled in one end and this was then enlarged and its end squared off with a lathe tool. A blind hole was drilled in the centre and tapped 6 B.A. so that the Bulgín top-cap could be attached with a short screw. A side-entry hole for the cable was drilled and the bared end of the wire clamped between the two. The top end of the shield was carefully domed on the lathe, the bottom edges were all rounded and the whole shield smoothed with very fine emery cloth.

This cap has so far been satisfactory but is undoubtedly rather clumsy. It might be thought that its large diameter would make it more likely to produce flash-overs since it is nearer the screen. The reverse is the case, however. The situation is analogous to that of a coaxial cable where for a given diameter of outer conductor there is an optimum diameter of the inner conductor for minimum voltage stress. For a 4-inch diameter outer the optimum for the inner is about 1.5 inches, and the 1-inch which we have used is rather under this, but as the cap may well not be exactly centred in the outer screen it is better to make the cap smaller rather than larger.

The focus supply is taken off after the first rectifier of the e.h.t. unit; that is, across C_{26} . The potential divider comprises R_{36} , R_{37} and R_{38} . This last is nominally 24MΩ and is made up of five 4.7-MΩ 1-W resistors in series; R_{36} is also a 1-W type. This rating is necessary not for the power dissipation but for the

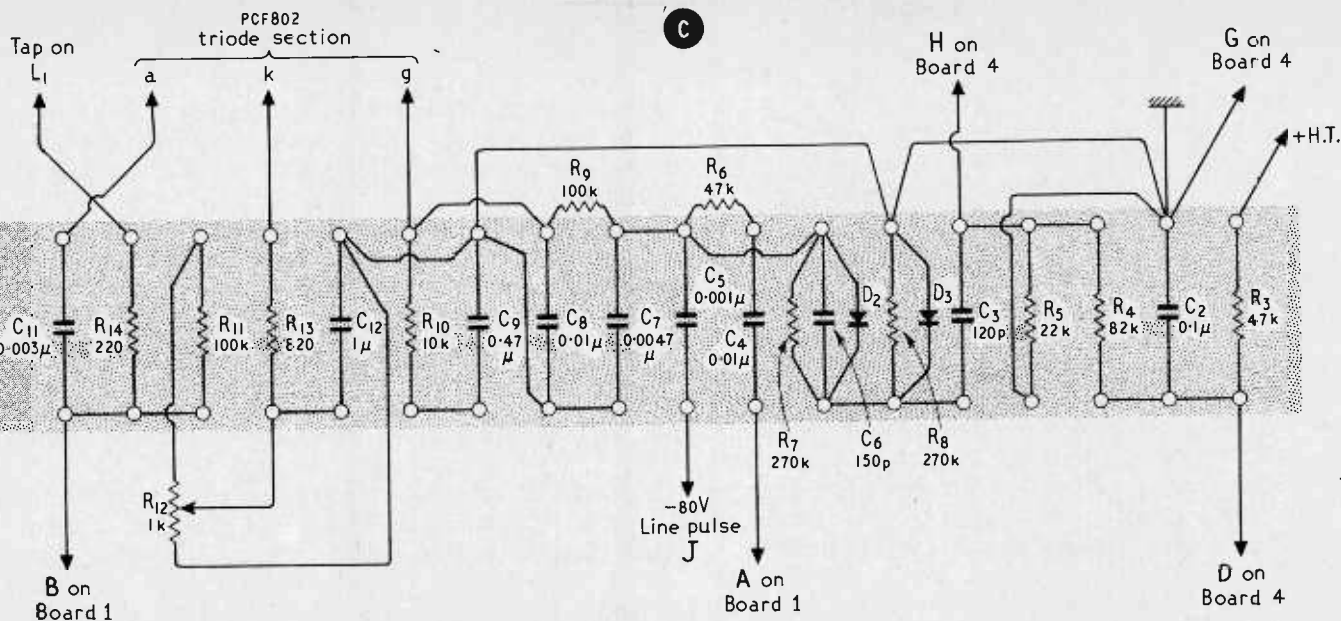

Fig. 3. Board 3 carries components associated with the flywheel sync circuits and a few belonging to the sync separator.

voltage across them. The focus potentiometer itself is R_{37} of 10-M Ω . This is a high-voltage type. These components, together with C_{26} and C_{25} are mounted on a small board held to the back of the chassis by a bracket so that the spindle of the potentiometer faces the front side. An extension to the shaft is readily made from a piece of $\frac{1}{4}$ -inch inside diameter paxolin tubing which can be further extended by $\frac{1}{4}$ -inch rod to form a panel control if desired. This is hardly necessary, however, for the focus appears to be quite stable.

The high voltage ends of C_{26} and R_{36} are 7kV or more above chassis and so tags on the board to which they are joined must be on the side of the board away from the chassis. All sharp points and whiskers of wire must be avoided and soldered joints finished off as smooth rounded blobs. This applies not only here but in every place where the voltage exceeds 5kV or so.

The e.h.t. unit itself is an assembly of resistors and capacitors held in a plastics moulded framework and it is screwed to the side of the chassis by its mounting feet. The connectors are sunk within the plastic and the connecting cables are held in place by screw-on plastic cups through which the cables pass.

The proper size and kind of cable must be used. This is 14/0.0076, a tinned copper wire with 0.05-inch wall polythene insulation covered overall by a p.v.c. sheath of 0.175-inch outside diameter. It is necessary to remove about $\frac{9}{16}$ -inch of the sheath, then $\frac{3}{8}$ -inch of polythene, leaving $\frac{3}{16}$ -inch of bare wire. The bared conductor is doubled back on itself so that it becomes $\frac{3}{16}$ -inch long. A cup is threaded over the cable and a small helical spring is placed over the conductor. The cable is then pushed into the socket on the e.h.t. unit so that the spring is fully compressed and the p.v.c. sheath is well inside; the cup is then screwed in place to clamp the cable firmly.

The connections are quite easy to make and give no trouble at all provided that the cable is pushed firmly home. If it is not there may be arcing between the contact and the spring, and if this occurs the spring may be welded to the contact. It cannot then be withdrawn again! All is not lost, however, the spring must remain in situ but the wire can be poked down inside it without undue difficulty.

The cable itself withstands 25kV and need not be disposed with any particular care. Other cables and wires must be kept well clear of the high voltage parts of the e.h.t. unit itself, however. If, for instance, an insulated coaxial cable happens to rest against the insulated 25-kV terminal of the unit a flash-over between them can occur.

General wiring is carried out in the usual p.v.c. insulated

wire. All leads from the line-scan transformer which have to pass through the shelf are taken through one large hole with a grommet. The higher voltage ones of these, from terminals 3, 7, 8 and 9 are run with a heavier conductor just because this has heavier insulation. This is also used throughout for the boost-line wiring. For the deflector-coil connections, however, the ordinary wire appears perfectly adequate.

Most of the components of the line timebase are mounted on two tag boards which are designated Boards 1 and 2; the arrangement of the parts on them is shown in Figs. 2 and 3. Because of their physical size C_{22} and C_{19} are mounted under Board 1 and C_{19} actually comprises two 100- μ F capacitors in parallel rather than one 200 μ F. This board is stood off from the back of the chassis on two lengths of studding.

Board 2 is mounted on the side of the chassis and comprises parts mainly associated with the flywheel-sync circuits. The collector load of the sync separator is included, however. The sync separator parts are mounted on a very small board, No. 4. The circuit with its interconnections is shown in Fig. 4.

With the exception of the input to the sync separator, which plugs into a socket on Board 4, all the connections to the timebase unit are in the form of wires taken directly to various points. They are all bundled together and clamped to the chassis close to the bottom and then twisted to form individual cables.

Fig. 4. The circuit of the parts mounted on Board 4 is given here. This could be a printed circuit, but is readily fabricated from a piece of Veroboard and strips of adhesive copper, such as CIR-KIT

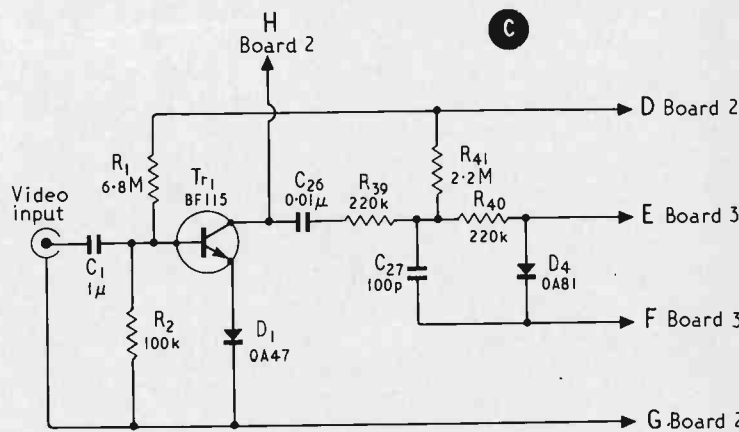

There is a 12-wire cable, including the first-anode supply of the tube, which goes to the convergence unit. There is a 6-wire cable to the power supply and the separate focus and 25-kV cables to the tube.

The power supply demands six wires because of the valve heaters. Because of the differing heater-cathode voltage ratings of the valves some of the valves in the timebase must be near the chassis end of the heater supply while others must be at the other end. Actually, it is the PCF802 which must be at the chassis end, so valves in other units must be connected between them. Hence four heater connections to this chassis are needed. The interconnections are all made on the power unit, however.

The form of connector used will become apparent when the other units are described. It has been found particularly convenient to use multi-way screw connectors and to duplicate them all! One connector is fixed to a unit and another identical one to terminate a cable. The two are joined together by short lengths of stiff wire and so form a kind of plug and socket arrangement, save that on insertion one set of screws must be tightened.

There are, of course, plenty of proper plugs and sockets which could be used and which would take up less space and permit quicker insertion and removal. The arrangement adopted, however, has been found much better in experimental equipment because it is much more flexible. Any individual connection can be disconnected at will with only a screwdriver. The sunk screwheads are accessible for test prods and there is little limitation on the side of conductors which may be used.

Reverting to Fig. 1, it will be seen that provision is made for breaking the whole h.t. supply to the timebase line. The incoming h.t. line is taken to a tag from which it is connected to the field timebase and to the sync separator. Another tag is mounted adjacent to it to which is connected the whole of the line timebase. The two tags are close together and can be shorted to provide the full h.t. to the line timebase. The line timebase can thus readily be put out of action, and with it the e.h.t. supply, if one wants to work on the field timebase alone. However, in this case a temporary connection must be made between h.t. and the charging resistor of the field timebase, because there is no boost supply available.

By connecting an external variable resistor of some 600- Ω 30-W rating between the tags, the line timebase can be operated at reduced output. This is essential when first getting the timebase into operation and is desirable when doing any extensive work on it. With the full resistance in the e.h.t. will be around 10kV only and one can check the general operation with an oscilloscope, etc. Unless there is something very wrong there is little fear of any flash over and X-ray production is virtually nil.

The voltage can be gradually increased to some 15kV and if there are no signs of corona or an audible discharge after an hour or so, it can be further increased. It is quite probable that after half-an-hour or so at some voltage some form of discharge will be evident. If nothing is done about it there will sooner or later be a flash over. This will be a really vicious sounding crack or series of cracks.

The drill is to increase the voltage in increments of a few kilovolts at a time until signs of a discharge are evident. One must then find where it is occurring and remedy it.

Unless one is very experienced with high-voltage work it is unlikely that there will not be some defect in the construction which leads to a discharge. If one switches on at high power there may well be such a violent flash over that one hastily switches off, and unless one is particularly lucky one may have no idea of just where it occurred. The only wise thing to do is to bring up the voltage gradually and so give oneself a chance to pin point the trouble spots before they become violent. There is also, of course, the definite advantage that X-ray production is low at reduced voltage. A good picture can be

obtained at 20kV and when it is necessary to work for any length of time on the set with a picture it is advisable to reduce the voltage as much as possible for the job in hand.

The maximum voltage rating for the colour tube is 27.5kV and this must not be exceeded under any circumstances. The nominal normal voltage is 25kV so that a 10% rise in voltage can be tolerated.

When switching on from cold the e.h.t. supply rises very slowly at first and then more quickly and it reaches its final value without overshoot. However, if the set is switched off and then on again after an interval of only a minute or two the voltage rises at least 10% above the final value and then drops back to the final value. Unless one is working with a voltage of about 20kV or less, therefore, it is advisable to leave an interval of at least 10 minutes after switching off before switching on again.

The normal operating voltage should not be above 25kV to allow a 10% tolerance on the tube rating to cover mains voltage increases and, of course, this 25kV should be with the mains at their nominal voltage. When the whole equipment is working right, therefore, the external resistor should be adjusted, at a time when the mains voltage is correct, to give 25kV on the tube or, if one prefers, a somewhat lower voltage. The value of the external resistor can then be measured and a fixed resistor substituted internally between the tags.

Waveform checking in the output circuits is difficult because of the nature of the circuit. Normally, it is useful to insert a low-value resistor in series with the deflector coils and to connect an oscilloscope across it to observe the current waveform. This cannot be done here because neither end of the coils is earthy. The nearest that can be done is to insert a 1- Ω resistor between terminal 6 of the transformer and chassis. This enables one to look at the transformer current, which is similar to the deflector-coil current but not necessarily identical with it. In particular, minor ripples, such as those due to ringing, may be very different.

Corrections

In the photograph on p.194, Part 2, the 1st anode terminals were lettered R, G, B downwards. The lettering should be B, G, R.

In the July issue reference was made to the Thorn-A.E.I. V3506A and V3508A 19-inch and 25-inch tubes. These are development type numbers and the current tubes are respectively the Mazda CTA 1950 and CTA 2550

New Books

Radio and Electronic Handbook by G. R. Wilding aims at condensing the fundamentals of electronics into four separate easily assimilated sections providing rapid reference to important principles, formulae and applications. The four main sections are—direct current theory, alternating current theory, valve theory and applications, and transistor theory and applications. Circuit diagrams and practical worked examples of theoretical matters are used extensively throughout. The presentation is lucid, concise and well ordered. Pp. 149 including 84 diagrams. Price 17s 6d. Illiffe Books Ltd., Dorset House, Stamford Street, S.E.1.

Amateur Radio Circuits Book, second edition 1968, compiled by G. R. Jessop, G6JP, provides a variety of valve and transistor circuits for the home constructor and experimenter. Circuit diagrams are accompanied by short notes on, for example, choice of component types, layout, and coil winding data. The contents are laid out under suitable general headings beginning with aerial matching. Receivers and transmitters are considered from the standpoint of circuit function, and details are given of pre-amplifiers, converters, detectors, power amplifiers, linear amplifiers, modulators, etc. Towards the end of the book are details of oscillators, power supplies, and a range of test equipment. The book ends with three pages of valve base connections and a good index. Pp. 119. Price 10s 6d. Radio Society of Great Britain, 28 Little Russell Street, London, W.C.1.

Letter from America

In my last letter (May), I queried whether the handful of U.K. exhibitors at the New York I.E.E.E. Show was really representative of Britain's electronic capabilities. The same question was put to Lord Mountbatten when he visited the Show and he replied "It's a beginning" and went on to say "we have to find the gaps where we fit naturally—but who would have known a few years ago that we had capabilities in triple gap thyratrons, a field in which we presently lead the Americans?" He was referring to English Electric's deuterium thyratron tetrode which is used as a high voltage switch in particle accelerators. R. L. Snelling of English Electric said that "Buy American" policies may limit large contracts to U.S. firms but foreign instrument firms have no trouble in selling their products". Support for this point of view came from B. L. Robinson of the Canadian EMI-Cossor group who said "The U.S. military services want the best product for the lowest price and we can compete hand-somely against U.S. manufacturers". It is understood that Lord Mountbatten will use his influence to press for greater British participation in the 1969 I.E.E.E. show.

TV sales are still holding up, with a total of 3,164,784 for the first three months of 1968. These comprise 1,555,924 colour and 1,608,860 monochrome compared with 1,367,579 colour and 1,611,171 monochrome for the same period last year. Japanese colour TV imports were not very high at 77,435 but they are certainly regarded as a potential threat. A development that could mean greater market penetration is Sony Corporation's new Trinitron three-beam single-gun tube. This uses electrostatically controlled symmetrical prisms for beam deflection and Sony claim that the picture is twice as bright as and sharper than the conventional shadow-mask arrangement. Because it has fewer parts the Trinitron could be substantially cheaper too, and so prices of colour TV may well drop in the near future. There are strong rumours that a Sony 12-inch model will sell for \$360 (say £150).

Colour tubes are quite expensive at about \$200 for 23-inch types and even in this affluent society \$200 is a substantial sum to pay the TV serviceman! Some makers are trying to overcome sales resistance by increasing the tube warranty to 2 years. R.C.A. were the first to do this last March

and they were quickly followed by Magnavox and Admiral—the latter extending the period to 3 years. It is felt that a 2-year warranty should become the industry standard, but so far this has not been adopted. I ought to point out that most people here—certainly over 90%—own their sets.

More than 9 million Americans watch their TV programmes via c.c.tv. (community cable television), which has grown tremendously over the past few years. The first systems started in Pennsylvania back in 1948 and today there are about 1,800 systems in operation with another 400 on the way. Some of these installations are quite small (the average is around 2,000 subscribers) but at the other extreme there are big operations like the one at San Diego in California with more than 40,000 subscribers! No doubt about it, c.c.tv. is now big business, and commercial interests like General Electric, Westinghouse, RKO, Time-Life and many newspapers have large stakes in this field. Early systems provided only 5 channels, but 7 or 12 are now more common. Operators of c.c.tv. claim that the viewer not only gets a better signal but he gets a bigger selection of programmes as well! The majority of programmes are taken from the large networks like NBC, CBS and ABC but quite a few systems also put out their own—usually with a strong local flavour. Cable costs in the large cities are very high and one of the New York concerns is experimenting with microwaves and a firm called The Laser Link Corporation has developed a "quasi-laser" system working in the 40 to 90 GHz band.

Car mirror—or what? See last paragraph.



At the moment, c.c.tv. operators are fighting all kinds of legal battles with the broadcast companies, city authorities etc. Recently the New York State court decided that a c.c.tv. operator using telephone lines to distribute TV signals does not require a city franchise—a decision that will certainly be challenged, as city authorities usually collect part of the subscriber's fee. Some 60 cases are pending before various other American courts. Then there is the question of copyright, and critics say c.c.tv. operators have no right to take programmes off the air and charge for them without paying a penny for the privilege! Finally, there are arguments with the F.C.C., who said in 1966 that their jurisdiction extended to c.c.tv. This contention is being examined by the Supreme Court but regardless of the outcome, c.c.tv. keeps on growing.

My own local concern in State College, Pennsylvania, has some 15,000 subscribers and they have an enterprising subsidiary company busily engaged in making trunk amplifiers and ancillary equipment. James Palmer, the President, has written a number of technical articles for I.E.E.E. publications etc. and last year he presented a paper on cable transmission system design criteria. I was of course aware of the effects of temperature on cable attenuation, but I did not realize how wide these temperature variations are in the U.S. For instance, Greeley in Colorado has an average high temperature of 107°F and low of -40° and Keene in New Hampshire a high of 104 with a low of -32! Periodic adjustments can be made to give some kind of compensation but Mr. Palmer told me that his amplifiers are built to operate in the range from -40°F to 140°F.

Firms specializing in studio equipment, programme material etc. are growing rapidly and many people feel that the identification of c.c.tv. with local affairs will eventually mean that the u.h.f. stations (created for this very purpose) will cease to exist.

A videophone for every home will soon be a possibility according to Bell Telephone who are developing a solid state camera using the Gunn effect. The camera plate is composed of a thin film of gallium arsenide or cadmium sulphide with raster lines etched in to give the required picture resolution. The light sensing properties are used with a Gunn effect diode which naturally sweeps from anode to cathode when a voltage is applied. Thus no complex and expensive sweep circuitry or electron scanning is required. One of the problems at the moment is the dissipation of power, and Bell scientists are working on various heat sink ideas.

If you thought that the picture shows a car mirror you would only be partly correct. This ingenious device actually conceals a broadband u.h.f./v.h.f. aerial operating in the 150 or 450 MHz ranges. The makers, Sinclair Radio Laboratories of New York, claim that the efficiency is equal or even in some cases superior to that of a normal $\frac{1}{4}$ -wave whip aerial. Power rating is given as 50 watts and bandwidth for 1.5 to 1 v.s.w.r. at 450 MHz is ± 5 MHz. The radiation pattern is omnidirectional with vertical polarization.

G.W. TILLET

Printed Scanning Coils

Manufacturing technique giving compact assemblies with good geometrical accuracy and repeatability in production

by E. W. Bull,* M.Sc.(Eng.), F.I.E.E., F.R.S.A.

A television system usually contains at least two sets of scanning coils, one at the camera and one at the receiver. These scanning coils determine to a large extent the geometry and edge resolution of the received picture. Since they may not much exceed one inch in diameter and yet the displayed picture may be 20 inches in diameter, the coil construction must be held to close limits. This is of particular importance in colour television, where three rasters have to be superimposed, and calls for extremely small tolerances.

Wire-wound deflecting systems usually consist of two pairs of coils arranged at right angles to one another. The four coils are wound separately, and since they are essentially pile wound, the overall dimensions of the assembly are dependent upon tolerances in wire size and winding tension. The coils when wound have to be mounted in pairs parallel to one another on either side of the axis of a central mounting tube. To achieve parallel mounting while avoiding twisting or relative axial displacement is an extremely difficult operation, and is at best something of a compromise. If both pairs of coils are mounted on central tubes one of which slides over the other, then one tube can be rotated until there is no mutual inductance between the sets of coils. Although this method of manufacture has been used since the early days of television the accuracy of the finished coil is very dependent upon the

skill of the assembler, and is falling short of present requirements.

The idea of printing the conductors of a scanning coil is not new—indeed it has been realised for many years that accurate coils could be produced by this method. Only during the past few years, however, have techniques and materials become available as a result of work on printed circuits in general. The basic material is a sheet of good quality insulating material such as Mylar (about 0.001 in. thick), coated on one or both sides with copper. The copper thickness may be between about 0.0015 in. and 0.005 in., according to the application. A pattern of conductors is formed by etching away unwanted copper, as is done in the preparation of printed circuit boards, the pattern being derived from a master transparency prepared photographically. Any number of identical sets of coil windings may be produced from the single master.

Spiral winding

The form in which the conductors are printed naturally tends to follow the spiral shape employed with wound coils, but a difficulty arises in that connection to the centre of the spiral cannot be made without crossing the outer conductors. This has been overcome² by printing another, reversed, spiral on the other side of the insulating base, and soldering through

* Research Laboratories, Electric & Musical Industries Ltd.

Fig. 1. Current paths in spiral coils: (a) upper and lower conductor patterns forming a set of coils, with lower pattern shown displaced to right; (b) composite current flow for the set.

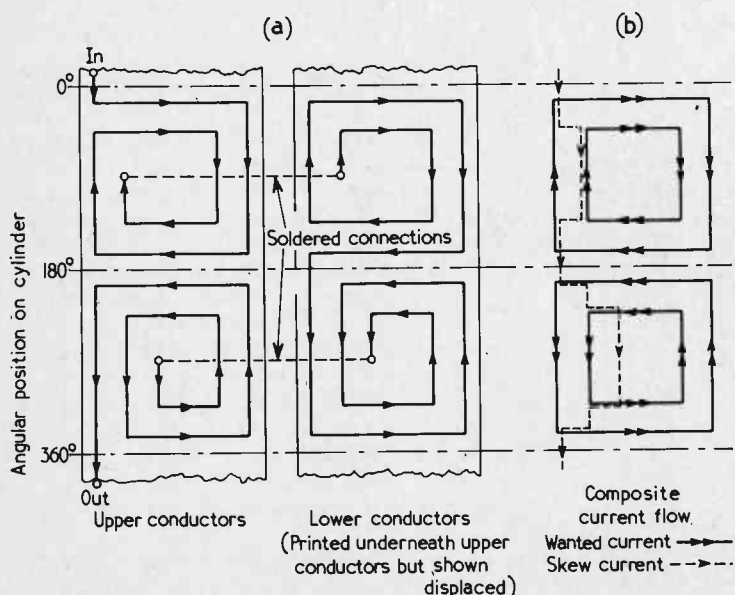
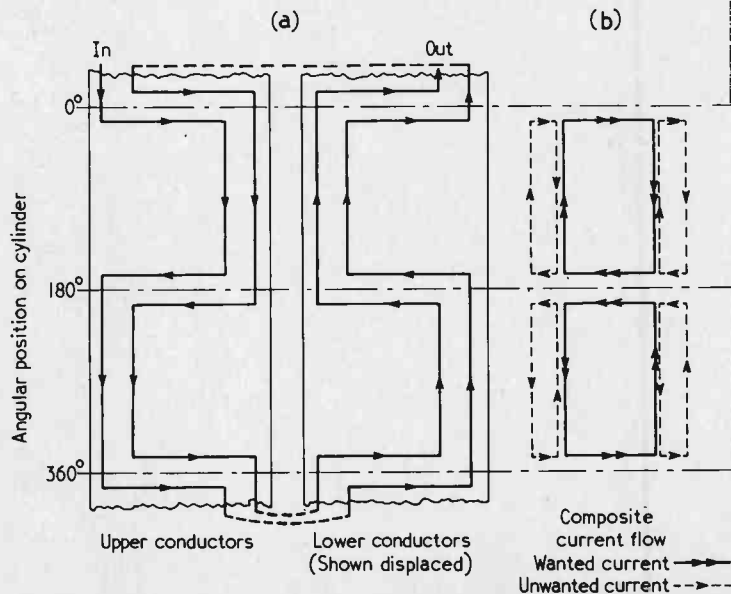

Fig. 2. Current paths in square wave coils: (a) upper and lower conductor patterns with lower pattern shown displaced to right; (b) composite current flow.



Angular position

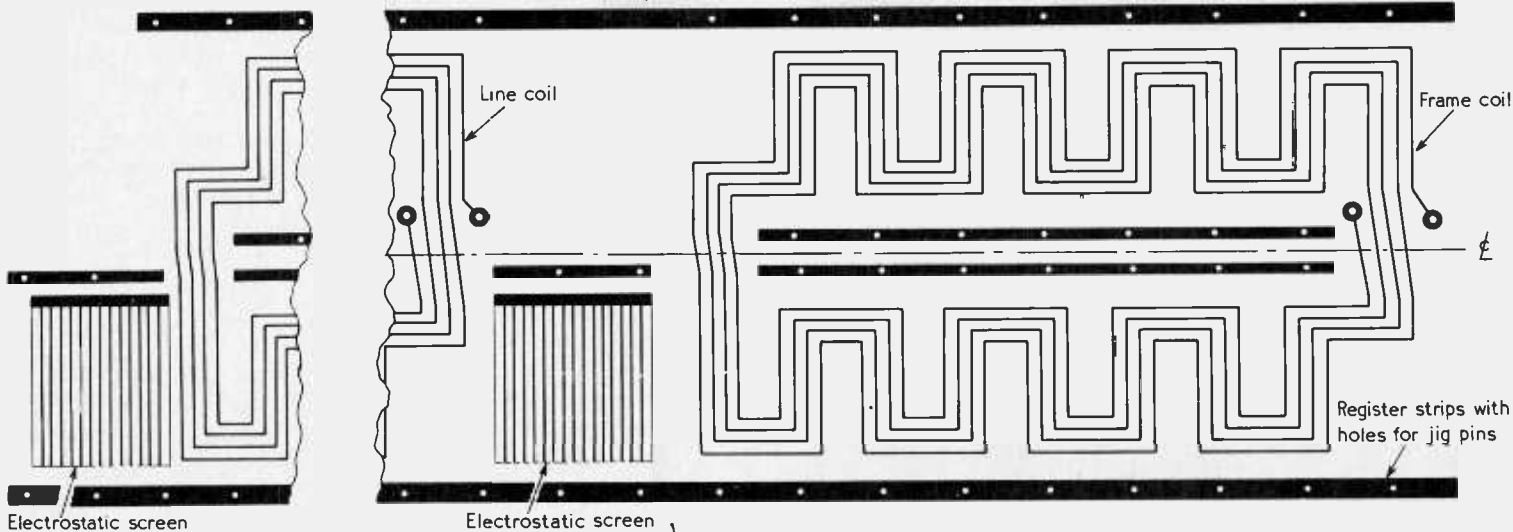

Fig. 3. Etched laminate strip before winding. The base material is folded along the centre line so that the upper wave pattern lies over the lower.

the insulating material to join the centres of the two spirals, as shown in Fig. 1(a). Both current leads now emerge at the outside of the double spiral and connections can be made to subsequent spirals arranged side by side in a long strip. The single conductor joining consecutive spirals makes the printed strip weak at this point and the conductor is liable to fracture unless carefully handled.

A more serious effect is the skew field produced by the spiral form of winding. In Fig. 1(b) the currents in the two spirals have been added, to produce the wanted currents (solid lines) together with unwanted currents (broken lines) which produce a skew component of field. This effect is of course present in wire wound coils but usually to a small extent. It can be reduced from Fig. 1 that the ampere turns producing skew field are $\frac{1}{n}$ th of those producing wanted field (where n is the number of turns), so that if the number of turns is large the error is small. With a printed coil the number of turns in a layer may not exceed twenty, and distortion of field will occur.

Wave winding

An alternative method³ of arranging the conductors, in the form of a pair of square waves, overcomes several of the disadvantages of the spiral form, and is shown in Fig. 2(a). These conductors (only two are shown) may be deposited on opposite sides of a single insulator, or on separate insulators since no interconnection is needed at each layer, all connections being made only at the ends of the complete coil set. The conductor arrays are uniformly strong and have little tendency to fracture with handling. Fig. 2(b) shows the composite current paths, which do not have a skew component. The unwanted currents now produce a gradual fall of field along the axis.

Assembly of coils

Scanning coils usually require more turns than can be accommodated in a single layer of printed circuit, so that the conductor pattern has to be repeated several times along a strip and then wound in a spiral to present a cylindrical form. To preserve correct alignment of the conductors in successive layers the scale of the conductor pattern in the axial direction must increase in steps, being proportional to the winding radius. These increments have to be calculated

from the thicknesses of the component layers, but as these may vary slightly it is useful to make a fairly generous allowance and apply a system of registration. For this purpose additional copper strips are printed alongside the active conductors, containing small holes at equiangular intervals, as shown in Fig. 3. When the strip is wound, a jig with radial pins engages the holes in the copper strips and thus ensures that there is no cumulative error in position. The layers may be held together by some form of adhesive to form a self-supporting structure, and the strips used as a register are finally removed.

Some of the most recent⁴ ideas in the development of printed coils are illustrated in Fig. 3. The two wave windings are printed on the same base material side by side (shown one above the other in Fig. 3), together with their interconnections. The base material is subsequently cut (except where conductors are present) along the centre line, and then folded over along this line. A thin sheet of insulating material is inserted to avoid contact between the two copper faces. The cutting of the base material is necessary because the two waves are not of equal length when printed flat, but when wound in the form of a cylinder they will assume their correct angular positions. The coils for two co-ordinates of deflection, together with electrostatic screens between the windings are all printed

Photograph of a section of etched laminate corresponding to Fig. 3. (Picture taken with light shining through the base material.)

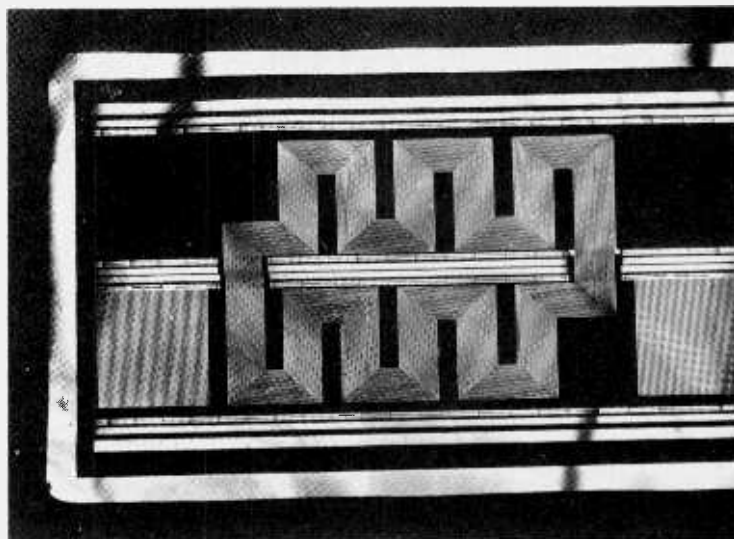



Not a new line in stoles, but illustrating the general appearance of a length of printed conductors before winding.

on the same sheet of base material. The strip, when folded with a layer of insulating material inserted, is wound on a simple jig with projecting pins to engage the register holes. If an adhesive is applied during winding the coil system can be made self-supporting, and the register strips removed subsequently.

A number of printed coils for various sizes of vidicon camera tube have been made, two of which are shown in Figs. 4 and 5; and from measurements on these it is possible to assess the relative merits of printed and wire wound coils:

Advantages of printed coils

1. The geometrical accuracy is very good and dependent on the accuracy of the original "master", not on the skill of the assembler. Angular position of the vertical and horizontal axes can be held to less than 0.2 degree, and other errors are generally less than those inherent in the camera tube itself.
2. Variations from coil to coil are very small, and no selection into matching sets is required for colour cameras.
3. Very compact coil assemblies such as that shown in Fig. 4 can be made. This coil together with its focus coil is part of a television camera having an outside diameter of 0.9 in.

Disadvantages

1. Capacitances are higher due to the flat strip form of the conductors.
2. The winding space factor of the copper laminate is not as good as that of enamelled wire, but this can usually be counter-balanced by the omission of winding formers and winding tolerances.

References

1. Brit. Patent 633,625. E. W. Bull and H. E. Holman, 1946.
2. Brit. Patent 795,469. Centre Cedel d'Etudes Scientifique, 1954.
3. Patent Application No. 32578/65. E. W. Bull.
4. Patent Application No. 8555/66. A. M. Sampeys, E. W. Bull.

August conferences

Further details are obtainable from the addresses in parentheses

EDINBURGH

Aug. 5-10

Information Processing Conference

(Int. Fed. for Information Processing, 23 Dorset Sq., London, N.W.1)

ST. ANDREWS

Aug. 29-31

A.C. Properties of Superconductors and their Applications
(I.P.S., 47 Belgrave Sq., London, S.W.1)

The University

OVERSEAS

Aug. 13-16

Energy Conversion Engineering Conference

(Paul Rappaport, RCA Labs., Princeton, New Jersey 08540, U.S.A.)

Boulder

Aug. 18-20

Acoustoelectronics

(Prof. Kimio Shibayama, Research Inst. of Electrical Communication, Tohoku University, Sendai, Japan)

Sendai

Aug. 20-23

National Electronics Convention

(Nelcon, P.O. Box 3266, Auckland 1, New Zealand)

Auckland

Aug. 20-23

Western Electronic Show

(Wescon, 3600 Wilshire Blvd., Los Angeles, Calif. 90005, U.S.A.)

Los Angeles

Aug. 21-28

6th International Congress on Acoustics

(Acoustical Society of Japan, University of Tokyo, Komaba, Meguro-ku, Tokyo, Japan)

Tokyo

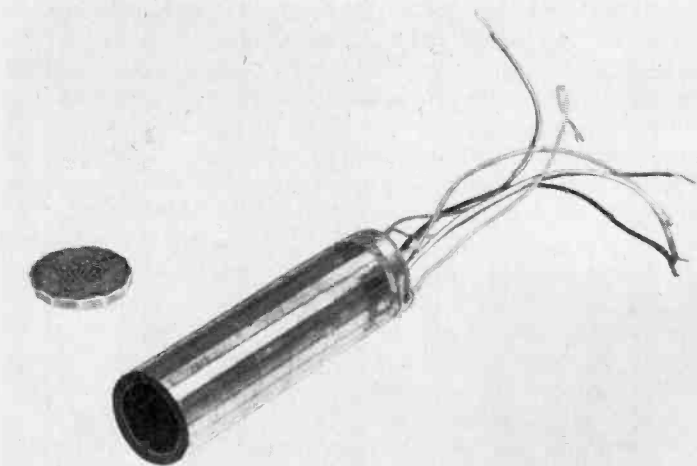
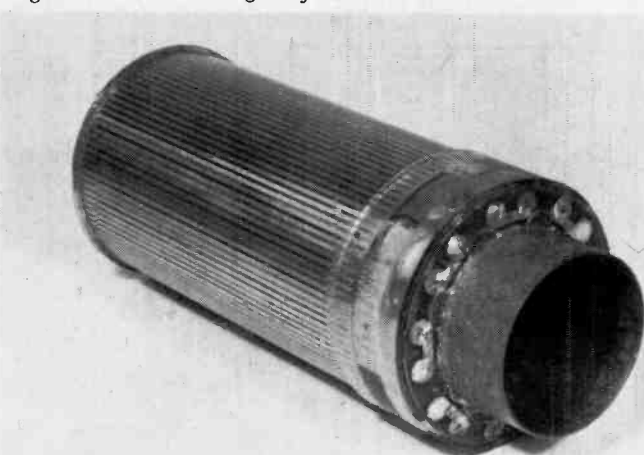

Fig. 4. Printed scanning coils for $\frac{1}{2}$ -in. vidicon camera tube. The overall diameter is $\frac{3}{4}$ in.

Fig. 5. Printed scanning coil for colour camera.



rying luminance, chrominance and the final R, G, B colour signals. The designers say that the introduction of the integrated circuit permitted all of these requirements to be fulfilled, since the bandwidths available are very large and as a result the signal delays introduced are very small.

Skynet

In a paper given at the recent Space Communications Symposium at the Northern Polytechnic, London, Wing Commander D. Salkeld described the military satellite communications system, Skynet, which is at present being implemented.

It was first decided in 1962 that satellites would provide a viable military communications system and in 1964, at the invitation of America, this country participated in the Interim Defence Satellite Communications Programme (I.D.S.C.P.) (see "News of the Month", *Wireless World*, April 1968, p.69.)

Experience accumulated while operating within I.D.S.C.P., a sub-synchronous satellite system, and results of continued work at Governmental research laboratories, were used to draw up the specification of the Skynet.

A contract for two Skynet satellites was placed with Philco-Ford of America early in 1967. The first of these is due to be launched in the first half of 1969 by a three-stage, thrust augmented, Douglas Thor Delta 3L. Initially the satellite will be in a highly elliptical orbit with an apogee at synchronous altitude. When apogee occurs near the satellite's required final position, near 40°E , a solid-fuel motor will be fired forcing the satellite into a circular synchronous orbit. Other small motors will be used for station keeping and attitude correction.

The satellite, which is cylindrical in shape measuring 136cm in diameter and 147cm in height, is to have a minimum design life of three years, although five years is the target. The space-borne communications repeater employs the double-conversion principle and operates in two channels providing a final output of between 2 and 3 watts from a t.w.t. With the exception of the aerial all components are duplicated and can be switched in and out by commands from earth

Colour Receiver Integrated Circuit

A range of Bush and Murphy colour television receivers to become available in September will have part of the colour decoder contained in a silicon integrated circuit. The functions provided by the single package—a 20-lead flat pack—are shown in the block schematic. The device replaces 65 discrete components. Research and design work was done by Rank Bush Murphy Ltd., and the i.c. is being manufactured for them by The Plessey Company Ltd.

Although the most common reason for changing from discrete components to integrated circuits is to reduce the cost of electronic equipment, this does not seem to be the case here. Indeed there must have been a suspicion somewhere that the cost of the new version could be greater, because R.B.M. take care to assure us that the use of the integrated circuit in the colour receivers "will not increase the regular market price". The reduction in size offered by integrated circuitry does not seem highly significant when the size of a television set is controlled largely by the cathode-ray tube. It appears that the main advantage is one of performance, resulting in an improvement in picture quality—better definition, colour accuracy and colour stability. Certainly the demonstrations seen by *Wireless World* indicated that such improvements have been obtained, although these demonstrations were under closely controlled conditions.

It will be noted from the block schematic that the matrixing circuits produce R, G and B signals, not the more usual $R - Y, G - Y$ and $B - Y$ colour-difference signals. This means, of course, that all the matrixing operations are done in the electronic circuitry and no use is made of the opposing effects of the grid and cathode of the cathode-ray tube to obtain an arithmetic operation. Normally the R, G, B type of drive is restricted to studio monitors because of its circuit complexity and the difficulty in achieving adequate stability, making frequent adjustments necessary. For really accurate colour performance, however, this drive method is superior. The main problems in designing circuitry for it result from the need for high stability of voltages on the various tube electrodes, of amplification and of response in the three channels. The resulting integrated circuit, however, eliminates the need for a quantity of very accurate components or the necessity for a large number of preset adjustments. A discrete-component amplifier has been developed to raise the level of the output signals from the integrated circuit to that required by the picture tube, and this is claimed to have all the stability of black level voltage, consistency of gain and matched transient response that is needed.

The original research showed that two other factors had a major influence upon picture quality. These are the maintenance of extremely accurate timing of the various picture components and the use of carefully defined overall responses in the circuits car-

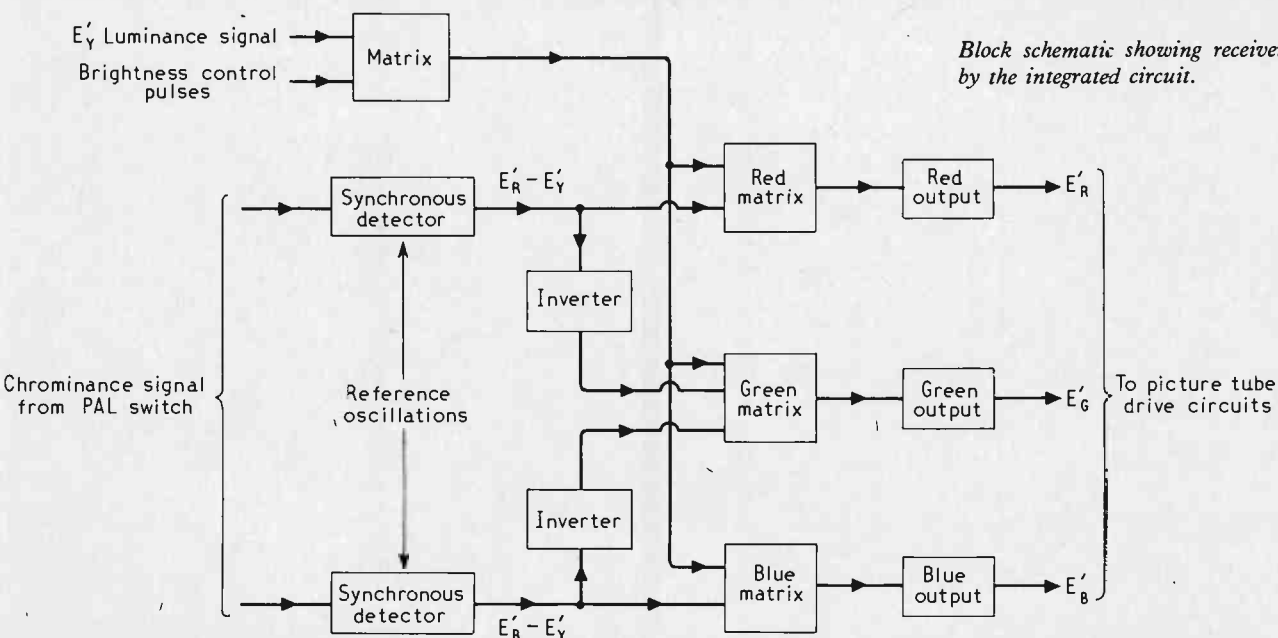

Block schematic showing receiver functions performed by the integrated circuit.

to provide a high overall level of reliability. The satellite is spin stabilized so that the aerial, a horn plus reflecting plate, has to be mechanically despun to maintain its 19° beam towards earth. The motor that accomplishes this receives its information from earth and sun sensors. An e.r.p. of 44.5dBm is achieved at the beam edges providing a usable signal for earth stations using only very small dish aerials.

A telemetry link keeps "ground" informed of the internal state of the satellite subsystems, and the bulk of the data received will be analysed by a computer at the Royal Aircraft Establishment.

The main earth station in the network will have a 40-ft diameter dish and is being erected by the Marconi Company at Oakhanger in Hampshire. In addition two stations in the middle and far east, built as part of the I.D.S.C.P. system, with 40-ft aerials are being modified for incorporation into Skynet. Two further ground stations are being built by G.E.C. with 20-ft diameter aerials. All these stations are built to a basically similar conventional specification. Shipborne stations with 6-ft aerials are being built by Plessey and were described in "News of the Month" *Wireless World* March 1968, p.17.

The primary communications channel has a bandwidth of 20MHz for use by the earth stations while the shipborne units will operate in a secondary band 2MHz wide. The standard communications 2,400 baud rate will be employed and the code-division multiple-access techniques will be used because of the limitations of conventional f.m./f.d.m. methods.

Several types of traffic will be handled within the network including synchronous and non-synchronous streams whose rates range from 45 to 100 bauds and which employ 5 and 7 unit codes. The design of equipment to handle any combination of these without corruption was a major problem.

Thorn-Radio Rentals Merger

The monopolies commission have announced that the proposed merger between Thorn and Radio Rentals does not operate, and may not be expected to operate, against the public interest and may therefore proceed.

Thorn have estimated a pre-tax profit of £14.5M for the year ending March 1968, against £10.5M for the same period last year. New acquisitions during the year contributed about £1.4M to this. Radio Rentals profit before taxation for the year was £9,348 (£7,664).

G.E.C. are now the only major television receiver manufacturer without their own rental company. However, they have an agreement to supply receivers to Radio Rentals that will be honoured.

Some rationalization of Thorn and Radio Rentals premises is inevitable in the future as in many places each own an outlet serving the same area and operating in competition.

Radio Trade Shows

Over 33 manufacturers and agents will be staging their individual trade exhibitions of domestic radio and television products during London's traditional national show

period this year. They will be all located in a number of London's West End hotels and will be held from Sunday 25th August to Thursday 29th August, with minor variations in a few cases. A list of exhibitors and venues will appear in the September *Wireless World* which is due out on 19th August.

Rise in Exports

Export deliveries for the engineering industries are estimated to have been five per cent higher since devaluation than in the corresponding period immediately before devaluation. This is one of the conclusions to be drawn from the statistics prepared by the Ministry of Technology on orders, deliveries, production and exports in the engineering industries up to the end of April. The preliminary seasonally adjusted delivery figures for April for all markets show a continued rise over deliveries during the first three months of the year. Home orders have also risen slightly although the average level for February, March and April was actually 1 per cent lower than for the preceding three months.

Scientific Instrument Firms Merge

For some time past W. G. Pye & Co. Ltd., and Unicam Instruments Ltd., both members of the Pye of Cambridge Group, have occupied adjacent premises, have had joint managing directors and have shared the services of some departments. The two concerns are now to merge under the name Pye Unicam Ltd., and will market in addition to their own range of scientific instruments, a complementary range of apparatus manufactured by Philips who now own Pye.

Radio Telephones and The Battle of Britain

The manufacturers of the Bantam three-channel radio telephone, Pye of Cambridge, could not have foreseen that the sets would be employed in an air-to-air, and air-to-

ground communications system in military aircraft. The Bantams are being used in the "private air force" of over 100 Spitfires, Hurricanes, Messerschmitts and Heinkels being used in the film "The Battle of Britain", currently being produced by Spitfire Productions Ltd.

A sound engineer, Ron Butcher, responsible for installing the sets in the aircraft told us that a big problem is too many aircraft and not enough Bantams. In order that equipment can be rapidly removed from one aircraft and replaced in another the radio telephones are held in only by rubber packing and adhesive tape. In the confines of the aircraft and in such a temporary installation, providing an aerial could have been a major problem. In most cases all that is used is a piece of welding rod that can easily be bent to fit the available space under the canopy. Under these conditions the 0.5-W output of the radio-telephone has provided communications over distances of up to 120 miles without difficulty.

The radio telephone, which is fitted with a remote transmit/receive switch, feeds one-half of the set of headphones and is fed from a throat microphone worn by the pilot, while the normal aircraft communication equipment uses the other half of the headset and a microphone in the pilot's mask. The Bantam is used to enable the director to communicate with the pilot either from the ground or from a camera plane which is a converted wartime B52 Mitchell bomber.

Standing Committee Kindred Societies

The Institution of Electrical Engineers, the Institution of Electrical and Radio Engineers, the Institution of Mathematics and its Applications, and the Institute of Physics & the Physical Society have formed a Standing Committee to extend the co-ordination of their activities arising from their many common interests. The committee is called the Standing Committee of Kindred

The first contacts from GB2LO, the amateur radio station operating in a shack on the forecourt of the Daily Mirror Building, Holborn, during the City of London Festival (July 8-20), were made by J. C. Graham (G3TR) president of the Radio Society of Great Britain. Mrs. Sylvia Margolis, the society's public relations officer is shown keeping the log. The equipment was supplied by K. W. Electronics. Loudspeakers enable passers-by to hear the conversations with overseas amateurs.



Societies and the first chairman is Mr. J. A. Ratcliffe, C.B., C.B.E., F.R.S., F.I.E.E., F.I.E.R.E., who is the immediate past-president of the Institution of Electrical Engineers and a past-president of the Physical Society.

One of the first matters considered by the committee was the desirability of opening the meetings and conferences of the four societies more widely to those in a position to benefit from them, and the following arrangements were agreed. All technical meetings of each society (for which no fee is charged to its members) will be freely open to all of the other three societies and when one of the four societies proposes to hold a technical conference it will invite the other three societies to be joint sponsors. Those societies which accept such an invitation will join in organizing the programme and their members will be admitted to the conference on the same terms as those of the originating society.

The committee will continue to consider ways in which the four societies may work together to provide improved services to their members and to the professions which they represent.

Committee on Medical Ultrasonics

The United Kingdom Hospital Physicists Association has set up a group called "Topic Committee on Ultrasonics" that intends to study the field of medical and biological ultrasonics and to see what advances can be made. The group will co-operate as much as possible with other bodies having similar interests. Interested readers should contact: Dr P. N. T. Wells, Department of Medical Physics, Bristol General Hospital, Guinea St., Bristol 1.

Breaks in BBC 2 trade-test transmissions will occur between nine and eleven o'clock on mornings when the weather in the Crystal Palace area is fine. These breaks will continue until work on a new aerial being installed at Crystal Palace is complete, probably in the Autumn. The new aerial will radiate both BBC 2 and the duplicated u.h.f. BBC 1 channels and, in addition, a second aerial to be erected on this site will handle u.h.f. ITA transmissions. The relay stations at Tunbridge Wells, Reigate, Guildford and Hertford will be affected and no trade-test programme will be radiated from these while Crystal Palace is not in operation. The BBC 2 station at Dover is also dependent on Crystal Palace and initially will radiate the monochrome test card during breaks. It is thought, however, that arrangements will be made later to provide an alternative normal trade-test transmission to Dover BBC 2, for use when required. As well as frequent announcements on BBC 2 at 10.00, 11.30 and 14.30 to keep users informed, an explanatory caption will be radiated at intervals on BBC 1 (Crystal Palace) on Channel 1.

A **semiconductor amplifier** that provides an output in the 1kW region between 300 and 400MHz has been produced by the industrial tube division of R.C.A. Electronic Components. The output stage of the amplifier uses 16 modules containing four tran-

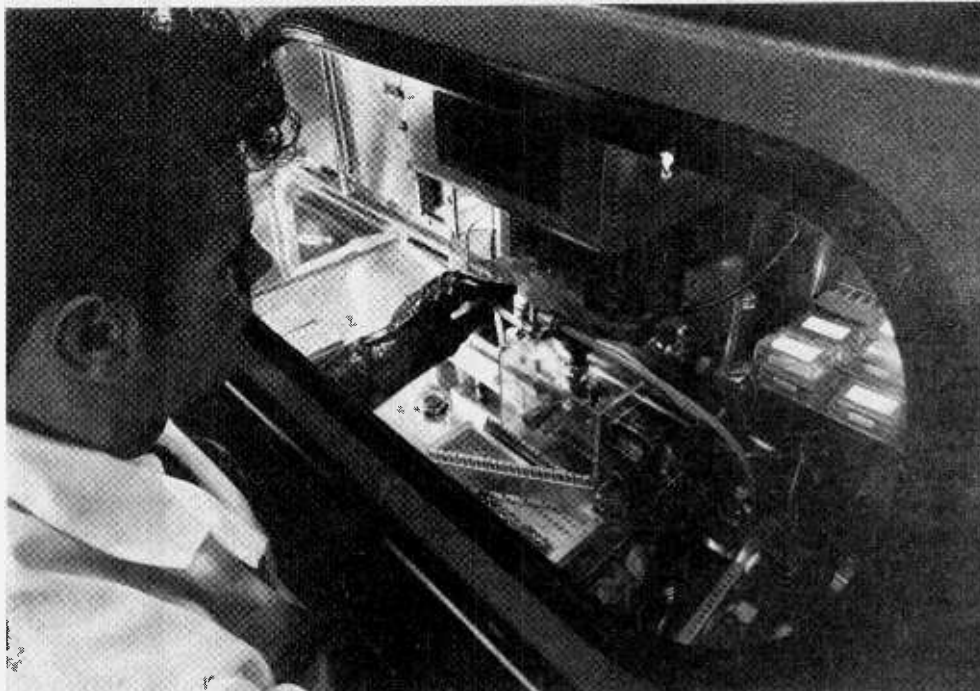

An operator controlling a semi-automatic encapsulation machine at the new Marconi-Elliott Microelectronics plant at Witham, Essex, officially opened by the Minister of Technology on July 5th. The process in which semiconductors are put into cans and sealed in an atmosphere of dry nitrogen, is carried out in a cabinet into which nitrogen gas is fed at above atmospheric pressure. The operator works through two gloved portholes.

sistors connected in parallel, a total of 64 transistors. The outputs of the modules are added together in a combiner which ensures that a single transistor failure will not put the whole amplifier out of operation. The amplifier has produced 800W of c.w. at 400MHz with a gain of 33dB at an overall efficiency of 49%. It has also been pulsed at 1,170W at the same frequency and used to drive a power tetrode with a final output of 310kW. During this test, which was performed at a duty cycle of 0.058 and a pulse width of 480 μ s, no isolation was used between the transistor stages and the tetrode and faults simulated in the tetrode stage did not damage the transistor amplifier.

The University of Birmingham contribution to the **British satellite Black Arrow X-3**, to be launched in 1971, is a micrometeorite counter that will detect extra-terrestrial dust particles entering the atmosphere. The University's equipment senses the charge released when the particles collide with a solid surface and can detect particles as small as 1×10^{-6} inch in diameter. The British Aircraft Corporation who are making the satellite structure have been awarded the contract for making the micrometeorite counter by the University.

Asian members of ECAFE (Economic Commission for Asia and Far East) are being urged to allocate more resources to the development of an **Asian telecommunications network** which could be linked into a global satellite network. A committee of experts in Canberra has prepared plans and targets aimed at setting up earth-satellite stations in countries of the region. The final targets of the committee will involve the nations in the region in ground and space

networks estimated to cost more than \$A4000 million by 1975. The plans include links between regional groups of nations with inter-nation dialling systems and long-range microwave and radio-telephone links between places as far apart as Afghanistan and Japan, Moscow and Ceylon. The committee has set targets in more than 14 countries for doubling and trebling the number of installed telephones by 1975. The chief of the ECAFE communications division, Mr. Masood Husain, said in Canberra that developing telecommunications in the Asian countries could make extensive use of the global satellite system. "This is nearer than you would think," he said. "India, Pakistan, and Thailand will be in the world network in the next year or two and they will be soon joined by earth stations in South Korea, Malaysia, Taiwan and Hongkong." Mr Husain said the most important and immediate task was to survey the technical gaps that had to be overcome in Asia.

A **staff suggestion scheme award of £200** is to be shared equally between two technicians of the Board of Trade Civil Aviation Flying Unit (CAFU) based at Stansted Airport, Essex. They are Robert W. Phillips of Saffron Walden and Patrick M. Moylette of Bishop's Stortford.

Both men are employed on the evaluation, planning and operation of flight-inspection equipment for radio and navigational aids. Their award-winning suggestion involves a modification to the Telescopescope equipment used by the Unit in checking the accuracy of the glide path of runways using the Instrument Landing System. The Telescopescope equipment used by CAFU has been modified and its performance at difficult sites has shown a remarkable improvement.

Personalities

Sir Ian Orr-Ewing, Bart., O.B.E., M.A., F.I.E.E., M.P., has been elected vice-chairman to the council of the Electronic Engineering Association for 1968/69. Sir Ian, who is chairman of Ultra Electric (Holdings) Ltd, and also of the company's



Sir Ian Orr-Ewing

operating subsidiary Ultra Electronics Ltd, graduated at Trinity College, Oxford, and served for three years (1934/7) as a graduate apprentice with E.M.I. He joined the B.B.C. in 1937 and after war service as a radar officer in the R.A.F. returned to the Corporation in 1946 for three years. Sir Ian became a director of the Cossor group of companies from which he resigned in 1957 on his appointment as Under Secretary of State for Air. He subsequently became Financial Secretary and Civil Lord of the Admiralty (1959/63). Sir Ian, who is 56, is vice-chairman of the Parliamentary and Scientific Committee and member of the new Select Committee on Science and Technology.

Geoffrey G. Gouriet, F.I.E.E., head of the B.B.C. Research Department, has been elected chairman of the council of the Royal Television Society. Mr. Gouriet is well known for the extensive work he did in colour television when he was head of the television section of his department. He succeeds **John Ware** who retires after a two-year term as chairman of the R.T.S. Another B.B.C. man, **A. J. Pilgrim**,

who is engineer-in-charge (services) of the B.B.C. Midland Region, has been elected vice-chairman of the Society.

H. G. Lubszynski, D.Ing., F.Inst.P., of E.M.I. Research Laboratories, has won an award for "the most progressive component" at an international conference of television development engineers, EXCOT '68, held in Milan. This component is in fact an all-electrostatic vidicon camera tube, produced by the development group at E.M.I. of which Dr. Lubszynski is head. One of the original members of Sir Isaac Shoenberg's team of television pioneers, he is well known as an authority on camera tubes and has 94 patents in this field.

E. Wolfendale, B.Sc.(Eng.), F.I.E.E., F.I.E.R.E., deputy managing director of Racal Research Ltd at Tewkesbury, has been appointed a director of Racal Communications Ltd. Mr. Wolfendale, who joined the organization in 1966 as technical director of Racal Research was responsible for introducing the REDAC service (Racal Electronic Design and Analysis by Computer) which is available to industry. Immediately, prior to joining Racal he was on the staff of the Royal College, Nairobi, for four years from 1962 having previously been head of the Mullard Semiconductor Measurement and Application Laboratory at Southampton.

E. Wolfendale



Alexander Russell, head of a measurement and control section of the Machine Tools and Metrology Division at the National Engineering Laboratory, East Kilbride, has won a £500 award for his work on the N.E.L. absolute position measuring system (described in the July issue, p. 216). The award, made under the will of the late James Perrin Wolfe for outstanding research work, was presented by John Stonehouse, formerly Minister of State, Ministry of Technology, and now Postmaster-General. Mr. Russell joined the N.E.L. in 1954 after 13 years as a radio engineer with the Marconi Company. He received his early technical training at the old Scottish Signal School and his interests include amateur radio transmitting.

Ferranti Ltd, announce the appointment of **L. S. Gaskell**, B.Sc., as sales manager of the Electronic Display Department at Gem Mill, Chadderton, Lancs. Mr. Gaskell, aged 38, obtained a degree in physics at Durham University in 1951, and in 1954, after National Service in the Fleet Air Arm, joined the Electronics Department of Ferranti Ltd where he was concerned with the quality control and inspection of c.r.t.s. In 1967, shortly after the formation of the Electronic Display Department, he became responsible for the sales activities of this new department which is divided into three main groups: the components group, covering the development and manufacture of c.r.t.s, gas discharge devices and semi-conductor display components; the equipment group, manufacturing flying spot scanners, tele-recorders, character recognition machines, etc., and a group working on the development of photochromatism.

Marconi International Marine Company, has formed a new Product Planning Division of which **G. H. W. Johnson**, previously U.K. sales and automation manager, is appointed manager. Mr. Johnson's career with the company began in 1938 as a radio officer. He served at sea until 1942, when he was transferred to the shore staff. In 1957 he went to Cape Town as marine director of Marconi (South Africa) Ltd., to take over responsibility for the depots there and at Durban. In 1960 he was appointed chief executive and director of Marconi's associates in Norway, the Norsk Marconikompani, A/S. He has been U.K. sales manager since 1963. Mr. Johnson is succeeded in that post by **C. J. Lydall** who has been with the company since 1935. In 1950 he was made responsible for sales of sound reproducing equipment and since the end of 1964 has been London manager (sales).

J. A. Harper, M.I.E.E., has been made director and general manager of the Industrial Instrument Division of Smiths Industries. Mr. Harper, who is 35, served a student apprenticeship in thermionic valve engineering at A.E.I. (Woolwich)



J. A. Harper

Ltd. and later was in charge of their transistor production engineering department. He joined Plessey in 1961 and eventually became divisional manager of the professional components division of the firm's Components Group.

Eric W. Hall, B.Sc., Ph.D., A.Inst.P., has joined S. Davall & Sons Ltd., of Greenford, Middx., as technical manager. Dr. Hall, aged 36, graduated at Birmingham University where he also carried out post-graduate research for his doctorate. Until recently he was head of the physics section of the Cementation Group's Research Department.

OBITUARY

N. W. McLachlan, D.Sc.(Eng.), who is well-known for his work in electro-acoustics and for his books on loudspeakers published in the 1930s, died recently. Dr. McLachlan was a visiting professor to a number of American universities, and had also been Walker-Ames professor at the University of Washington. He did development work on the Rice-Kellogg loudspeaker and was a frequent contributor to *Wireless World* in the 1930s.

H. Dagnall, managing director of Dagnall Electronics (Cranfield) Ltd., died on June 3rd aged 66. He was in the radio industry from the early days of broadcasting and was at one time manager of the accessories department of the Igranic Company at Bedford. In 1946 he founded Dagnall & Kendall Ltd., the name of which was subsequently changed to the present title, who manufacture wound components.

Jack Hammond, assistant sales manager (Lincoln) of the English Electric Valve Co. Ltd., died on June 4th aged 49. He served throughout the war in R.A.F. Signals, and joined the English Electric Company in 1950. In 1957 he transferred to E.E.V. at Chelmsford as a sales engineer. After E.E.V. had acquired the former A.E.I. valve works at Lincoln, Mr. Hammond moved there to take charge of sales, and was made assistant sales manager in February 1967.

Letters to the Editor

The Editor does not necessarily endorse opinions expressed by his correspondents

Loudness Control for a Stereo System

Mr. Lovelock's comments on my criticisms of his loudness control (July issue) are rather misleading in several respects. Had readers known that the circuit was evolved to satisfy the preferences of two particular musicians rather than because of a supposed general need for such a facility, then perhaps we could have discounted the considerable element of generalization in Mr. Lovelock's original article. However, I entirely agree that the matter should be settled by subjective pleasure, so I will simply mention in passing that the 'latest research' to which I referred concerned the now generally accepted Robinson-Dadson curves, which show a smaller mean fall in h.f. acuity at low listening levels than do the older Fletcher-Munson findings—in fact, there is practically no change above 1kHz between 40 and 80 phons.

Regarding different types of music, what matters surely is not the size of room used by Haydn's employers or Schubert's friends, but the subjectively apparent size of studio used by recording and broadcasting organizations when presenting music in stereo. This depends on microphone techniques, recorded ambience, etc., and determines the natural sounding replay level fairly closely. Chamber music is usually offered in the sort of acoustics suggesting a modest recital hall, and only in a small minority of cases is the setting so "dead" that an in-the-room replay level is appropriate. I agree that in such cases a piano quintet may peak to 90dB or more, just like a full orchestra set farther back, but this is unusual. Using typical programme material, then, if various types of music are set to give equal peak amplitudes this does not give a satisfactory reference level for a loudness control; and if it did, gramophone records would still need individual pre-setting to cope with wide variations in recorded level.

Within the aural limits imposed by recorded acoustics, the volume control is, as Mr. Lovelock remarks, a distance control. But coupling it with frequency compensation does not in some magical way cancel this, it merely makes it into an unnatural sounding distance control. To combine a distant loudness with a close tonal balance is every bit as artificial as the amplified chamber music in a large hall which Mr. Lovelock condemns—and with which, incidentally, I am unfamiliar despite frequent concert-going.

Mr. Lovelock found two musicians who applied some tonal correction when listening at low levels—excellent, by all means let tone controls be used to suit personal taste. However, professional *players* are notoriously poor at judging tonal balance as heard from a distance, and I repeat that serious music *listeners* not brain-washed by amplifier manufacturers are in general averse to the use of loudness controls—and so are most musicians in my experience.

JOHN CRABBE
Editor, *Hi-Fi News*.

In his article on loudness controls in your June issue Mr. Lovelock mentions the problem of matching the loudness compensation to the actual sound levels generated. Unfortunately the situation is more complex than he suggests. Take, for example, a sound reproduction system with a record player as the signal source: if the compensation is correct for one record, another record with a different value of modulation for the same sound level in the studio will require a different setting of the loudness control in order to recreate that sound level in the listening room. For this reason the tonal balance will vary from one disc to another. Changing the loudspeakers in the system for others with different efficiencies will have the same effect.

The compensation can be precisely adjusted only if the recording level corresponding to a given programme sound level, the output of the pickup, the gain of the amplifier from disc input to output, the efficiency of the loudspeaker and the characteristics of the listening room are all known. A reproduction chain based on this principle would have two "volume" controls: a variable computed from the fine factors mentioned above would be set on a frequency-independent *system gain control*, while the perceived sound level would be adjusted to personal taste by a compensating *loudness control*. Given accurate frequency compensation, it would even be possible to calibrate the loudness control in phons.

Unprecedented co-operation would be demanded of manufacturers in order to make this proposal practical, but until such a situation exists loudness controls must be regarded with the deepest suspicion.

R. E. PICKVANCE
London, W.C.1.

I read with considerable surprise the condemnation of the ganged carbon composition potentiometer given by Mr. Lovelock in his article on stereo volume controls (June issue). It would appear that he is completely unaware of both the types and specifications of carbon potentiometers that are available to the design engineer from both stockists and manufacturers.

The article is based on the typical performance curve given in Fig. 1 of the article and the statement, I quote, "The root of the problem lies in the fact that no two log-law carbon track potentiometers have nearly identical laws and if they are ganged together their outputs will not remain in balance over more than a very limited portion of the range". Both the performance curves and the above statement are, in practice, found to be totally incorrect.

- Fig. A shows:
- The typical law curves taken from the article for linear controls.
 - The DEF specification limits it is said to be derived from.
 - The true typical performance of controls manufactured by my company.

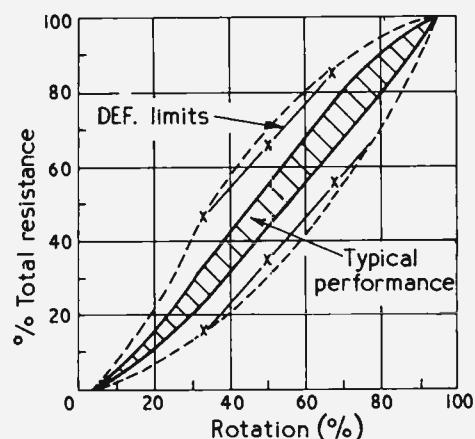

Fig. A. Linear controls.

Fig. B again shows the law curves taken from the article, this time for logarithmic controls. Also shown are typical curves for four types of log law control that are manufactured. The table below shows the variation in law permitted for each type.

Available Gradings for Single Log Law Controls.

Graph Reference	Law or Grading	% resistance at 50% rotation
1	2%	1—3
2	5%	3—10
3	10%	5—17
4	20% (semi log)	15—28

This range of log law controls originally introduced in 1959 has been made available to the entertainment industry to satisfy the demand for accurate sound level control.

It can be appreciated that if any two controls of one type are ganged together a considerably higher degree of matching will be obtained than that indicated in Fig. 2 of Mr. Lovelock's article. This is most easily understood for the logarithmic controls where all four types fall almost within the extremes of the curve given.

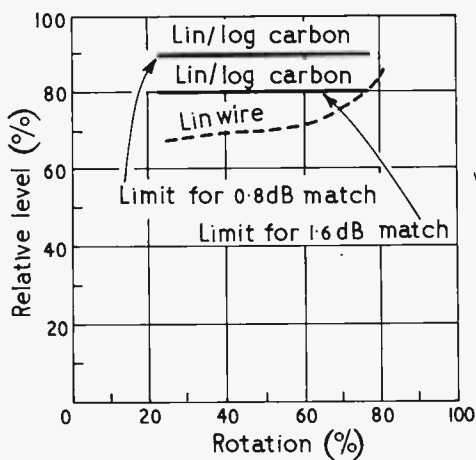

Fig. B. Log controls; typical performance.

Nevertheless such matching is not considered adequate, and all ganged controls, linear and logarithmic, manufactured by my company are individually matched to within 0.8dB or 1.6dB as required. This has been achieved at very little cost by the use of modern production techniques and rigid quality control. See Fig. C.

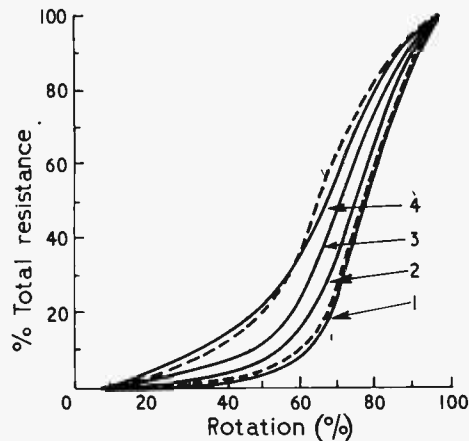

Fig. C. Maximum difference between channels (Lower channel as percentage of higher).

From this we can conclude that a matched ganged control will produce a difference level much less than a wirewound in either Mr. Lovelock's circuit or in a normal configuration.

Finally, I would like to point out that cost is of prime importance to all users and that the carbon control is considered by the entertainment industry as that having the best price, performance and reliability for their application.

B. S. METHVEN,
Morganite Resistors Ltd.,
Jarrow, Co. Durham.

The author replies: Mr. Crabbe has misread my letter. The circuit was not evolved to "satisfy the preferences of two particular musicians". Whether Mr. Crabbe thinks the practice theoretically justified or not, a large number of people, myself included, prefer such an adjustment of response, and the two musicians were used to determine the amount of rise for a 20dB variation of gain.

I am puzzled by Mr. Crabbe's words "by all means let tone controls be used to suit personal taste", which are inconsistent with

his objections to this circuit. As is said in the article, many listeners are not sufficiently skilled to operate the several controls on a fully adjustable amplifier, and this circuit is a means of providing automatically that amount which will satisfy very many of them. I fail to see the difference in principle between teaching them to adjust several controls, and providing them with a switch which will give what they desire.

The fact that American manufacturers do not fit h.f. filters is no logical reason why a loudness control should not be fitted to British equipment. The cost of the extra components is negligible, and one is free to have both facilities if one wishes. I can assure Mr. Crabbe that I have not been "brain-washed by amplifier manufacturers", never having owned a commercially available amplifier.

Mr. Crabbe has not stated the fundamental basis of his objection very clearly. I gather that he holds, as a purist, that the level at the ears of the listener, and also the tonal balance, should be a precise duplicate of that in the live performance. On the other hand, the very reason why nature has evolved a logarithmic response to the ear is to make it adaptive, so that subjectively we can hear well over a wide range of levels. If there is a personal preference for a lower level than that of the concert hall, there is no reason why the listener should not turn down gain. Likewise, because there is a universal preference for the tonal balance of the orchestra stalls rather than the gallery, there is no reason why he should not also have this. The ear is only able to judge level in comparison with higher or lower values: the impression of "loudness" is mainly a product of association in our minds between tonal balance and our location in a concert hall. There seems no logical reason why we should not enjoy the sensation of loudness without listening at a level which disturbs our neighbours.

The problem raised by Mr. Pickvance, which is also mentioned by Mr. Crabbe, is a real one, but not insuperable. It is reduced to negligible proportions in my own equipment by comparatively simple means, which are however too detailed to be described in a letter.

I feel that Mr. Methven's comments are a little naive. The limits shown on his Fig. A are only "typical", and not true limits, while none at all are shown on his "typical" laws in Fig. B. I would remind him that the nationally published specifications which form purchasing agreements were negotiated with component manufacturers, and it is their responsibility if such specifications really define a standard inferior to the general manufacture.

I can only commend Mr. Methven for arrangements whereby intending users may purchase ganged controls which are matched, but I must assure him that very many of the controls available to the home constructor are not so matched, and neither are some fitted to commercial equipment. That the carbon control is considered the best in value is evident by the almost universal use of them, but I know of very many users who suffer from noise over the central portion of the track after a few months in service; a

fault with which I have been afflicted when using carbon controls, but not when using wire-wound types.

R. T. LOVELOCK

"High-Frequency Analogue Multiplier"

In your June issue, Messrs. Whatton and Crisp mention the use of the ring modulator for multiplying two signals together; but since they go on to describe a complicated quarter-squares multiplier I presume they considered only the switching mode of operation of the ring modulator.

I should like to bring back to the notice of your readers the circuit of the balanced ring modulator (below) with reference to a

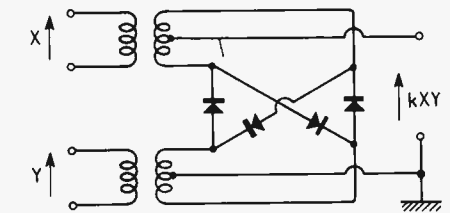

paper by Wilcox¹ in which he describes its operation as a quarter-squares multiplier by using the square law characteristic of the germanium diode up to about 200mV.

Like the circuit by Whatton and Crisp it uses balanced input transformers, but the formation of the sum and difference voltages, the squaring, and the subtraction of the squares is all done in the diode ring.

My colleagues and I first used this arrangement in the demonstration of a new s.s.b. modulator by Dr. Saraga² at the 1961 Phys. Soc. Exhibition (see *W.W.* March 1961, p. 112). We found the OA73 diode very suitable and easy to match for this purpose. Since then we have used the circuit for several purposes, but the highest frequency application I can recollect was at only 100kHz. However, in an earlier paper, Wilcox³ describes the use of a modified arrangement at 1.2GHz.

The main problem in the realisation of an inexpensive fully integrated analogue multiplier appears to be that of providing electronic balanced input sources with sufficiently low d.c. offset and drift to replace the transformers needed to drive the various squaring circuits like the diode ring in Fig. A, the transistor circuit of Whatton and Crisp and another transistor circuit actually made as a monolithic circuit but requiring one balanced input⁴.

While this problem remains unsolved*, I believe the Wilcox multiplier is hard to beat in terms of accuracy, bandwidth, convenience and, of course, cost.

R. K. P. GALPIN
British Telecommunications Research Ltd.,
Taplow, Berks.

1. R. H. Wilcox, *Rev. Sci. Inst.*, 30, 1009 (1959)
2. W. Saraga, *Electr. Tech.*, 39, 168 (1962)
3. R. H. Wilcox, *Proc. I.R.E.*, 42, 1512 (1954)
4. W. G. Howard, *Proceedings, 1967 International Solid State Circuit Conf.*, Philadelphia, p. 124.

*In this context it was interesting to see a relatively inexpensive analogue multiplier (Fenlow Electronics MX 101) with unbalanced inputs at the I.E.A. exhibition this year.

Balanced Transistor D.C. Amplifiers

How modern diffused silicon transistors and f.e.t.s are used to amplify d.c. low-level currents and voltages

by T. D. Towers*, M.E.E. M.A.

Read the instructions on the back of an AVO 8 meter and you will see that its most sensitive d.c. $50\mu\text{A}$ f.s.d. range has a 125mV f.s.d. Keeping above one-third f.s.d., you can thus read direct currents down to about $20\mu\text{A}$ and voltages down to 50mV . At some time you will want to measure lower than this, and will look round for some form of stable linear d.c. amplifier. Such amplifiers, of course, find much use in the field of instrumentation (where metering and telemetering of small currents and voltages is commonplace) and in analogue computer circuits (where linear amplification of d.c. signals is a fundamental circuit requirement).

These days, your first thoughts are likely to be some form of transistor d.c. amplifier, but, as soon as you set out to make one up, you come up against a serious difficulty. Transistor characteristics change markedly with temperature.

Fundamental problems of drift

In d.c. amplifier practice, you will often come across the term "thermal drift". This is the quantity, whether current or voltage, that must be applied to the input terminals of the amplifier to prevent a change at the output terminals when a change in operating temperature occurs. It is an important concept and worth thinking over. It is clearly little use trying to measure a current of, say, $1\mu\text{A}$ with a d.c. amplifier whose thermal drift is about $10\mu\text{A}/^\circ\text{C}$. During the measurement, the drift could be several times greater than the current being measured. It is then not really possible to determine whether the amplifier output reading is caused by the input signal or the drift. A good target to aim at is that the thermal drift of the amplifier should not be more than 1% of the signal being measured.

In d.c. amplifiers, drift may also result from causes other than temperature variation; e.g. supply voltage changes or device ageing. Such non-thermal drift can fairly easily be eliminated by special circuitry, such as negative feedback. When we talk of "drift", we commonly mean only thermal drift.

In multistage amplifiers some drift originates in each stage, but, where, as is usually the case, the first stage is high-gain, the drift arising in later stages is relatively unimportant.

All the characteristics of a transistor are temperature-dependent to some extent. For practical purposes only three are so temperature-sensitive that they cause serious drift in d.c. amplifiers. These are (1) the collector-base leakage current, I_{CBO} , (2) the base-emitter voltage for a given collector current, V_{BE} , and (3) the d.c. current gain, h_{fe} . They vary with temperature as follows:

- (1) I_{CBO} increases exponentially, doubling approximately for each 9°C temperature rise.
- (2) V_{BE} falls linearly about 2mV for 1°C temperature rise.
- (3) h_{fe} increases linearly with rising temperature, doubling in about 150°C .

The drifts mentioned above are additive. They all tend to cause an increase of collector current with temperature. Two main methods are used in practice to reduce d.c. amplifier drift: either balanced direct-coupled circuits are employed ("differential" amplifiers), or the d.c. is modulated, passed through a driftless a.c. amplifier and de-

modulated ("chopper" amplifiers). In this article we deal only with the solution of the drift problem by balancing.

Basic balanced d.c. amplifiers

Of the many arrangements used to compensate for the drift of transistor characteristics in the input stage of a d.c. amplifier, by far the most common is the ordinary balanced emitter-coupled circuit, or "long-tailed" pair, shown in Fig. 1. In one form or another, this configuration, first described by D. W. Slaughter in "The Emitter-coupled Differential Amplifier", *I.R.E. Transactions on Circuit Theory*, Vol. CT-3, No. 1, pp 51-53, March, 1956, appears in most balanced transistor d.c. amplifiers. It is often known simply as the "Slaughter" circuit. It is the transistor equivalent of a valve circuit first described by F. F. Offner in "Push-pull Resistance Coupled Amplifiers", *Revue of Scientific Instruments*, Vol. 8, pp 20-21, January, 1937.

In the ideal case of Fig. 1(a), so long as the transistors and other components are perfectly matched, and the base resistor R_J is equal to the signal source resistance, R_S , voltage levels on both sides of the symmetrical circuit change equally with temperature. As a result, when V_{IN} is zero, V_{OUT} across the two collectors also remains zero, and there is no "zero drift".

For the simple Slaughter circuit, it can be shown that the differential voltage gain, $A_{VD} = V_{OUT}/V_{IN}$, is given in rough approximation by $A_{VD} = h_{fe} R_C / (R_S + h_{ie})$, where h_{ie} is the transistor common-emitter input d.c. "h" parameter.

In practice it is impossible to match components exactly for a balanced amplifier. Manufacturers can supply transistors matched within certain limits on V_{BE} and h_{fe} , but not usually with I_{CBO} matched. It is therefore normally necessary to include in the Slaughter circuit adjustable resistances to balance out unavoidable residual mismatches. A common arrangement for this is shown in Fig. 1(b), where the potentiometer R_{VV} balances out the V_{BE} mismatch, and R_{VH} the h_{fe} mismatch. With zero input, R_{VV} is adjusted for zero output when the two transistor bases are shorted together. R_{VH} is then adjusted for zero output when the base shorting link is removed.

The lack of transistors matched for I_{CBO}

Fig. 1 Long-tailed pair "Slaughter" differential amplifier pair: (a) Basic ideal circuit with perfectly matched components, (b) Practical version with adjustments for imperfect matching.

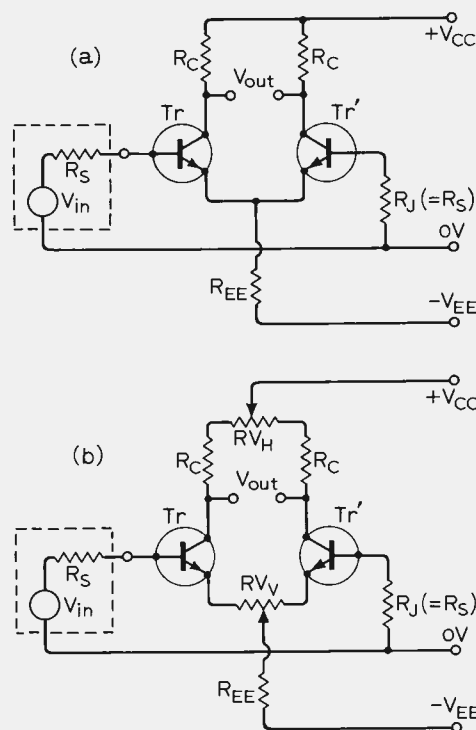

*Newmarket Transistors Ltd.

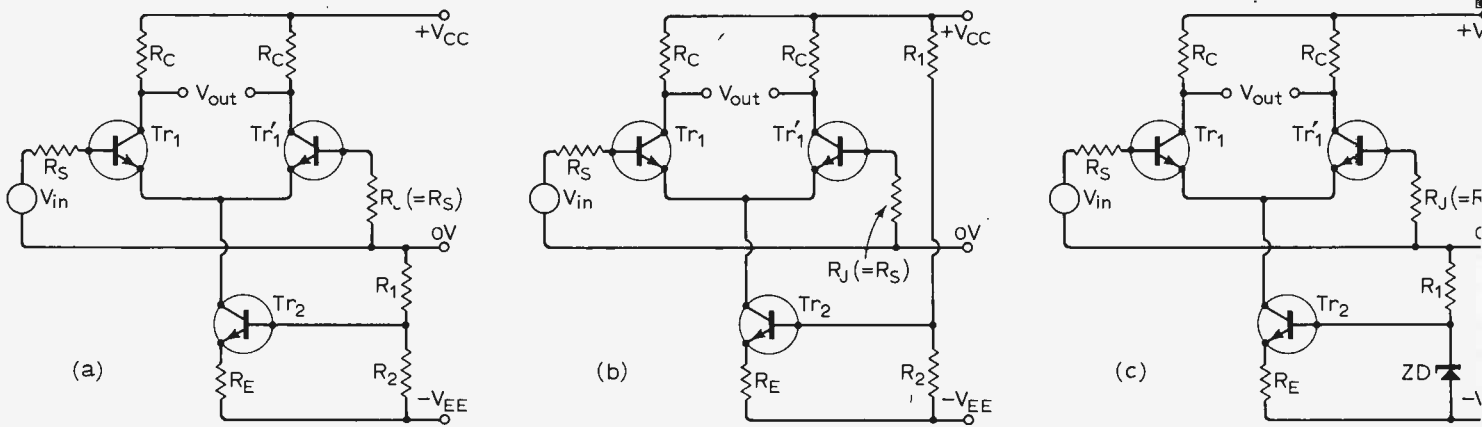

Fig. 2 Transistor as high-resistance constant-current source substitute in balanced emitter-coupled amplifier: (a) Bias resistance network from 0V to $-V_{EE}$, (b) Bias resistance network from $+V_{CC}$ to $-V_{EE}$, (c) Zener-diode-stabilised bias network.

is not so serious as it sounds, provided modern, low-leakage, diffused silicon transistors are used. In these the I_{CB} leakage currents (which flow through the base resistors and create drift possibilities) are reduced to the nanoamp ($1/1000\mu A$) level. This usually permits accurate measurements of currents in the submicroamp region without I_{CB} matching.

By the long-tailed pair arrangement, the transistor base-emitter voltage, which contributes $-2mV/^\circ C$ to the temperature drift, is balanced out in the pair to give an improvement of the order of 100-200 times; i.e. the drift referred to the input can be reduced to something like 10 to $20\mu V/^\circ C$. This permits measuring voltages down to around 1mV with relative ease at normal ambient temperatures.

Of itself, the simple Slaughter circuit of Fig. 1 does not have sufficient gain to enable adequate feedback to be applied to compensate for h_{fe} variation with temperature. The low gain also means that relatively high base bias currents must flow through the base resistors, and this can contribute significantly to overall drift. Even so, for less exacting requirements, the circuit finds use as it stands.

Common mode rejection

Before we go on to look at more refined, higher-gain balanced amplifiers, we should consider the "common mode rejection" (c.m.r.)

properties of the basic circuit of Fig. 1(a). In the differential mode, signals are applied between the two transistor inputs. However, does the circuit react to a signal applied in common to both inputs? A full mathematical analysis is beyond the scope of this article but anyone interested can consult R. D. Middlebrook, *Differential Amplifiers*, Wiley, New York, 1963, for an exhaustive treatment. For our purposes here it is enough to note that the common mode voltage gain of the circuit is given approximately in practice by $A_{VC} = R_C / (2R_{EE})$.

Now the power of the balanced circuit to amplify differential signals, while rejecting common mode interfering signals is an important characteristic of the amplifier and is measured by the "common mode rejection

Fig. 3 Compound transistor arrangements in long-tail pairs to give higher current gains than possible with single transistor pair: (a) Darlingtons ("super-alpha") common collector pairs, (b) D.C. "ring-of-three" arrangement, (c) Complementary Darlington pair, (d) "Ring-of-three" arrangement.

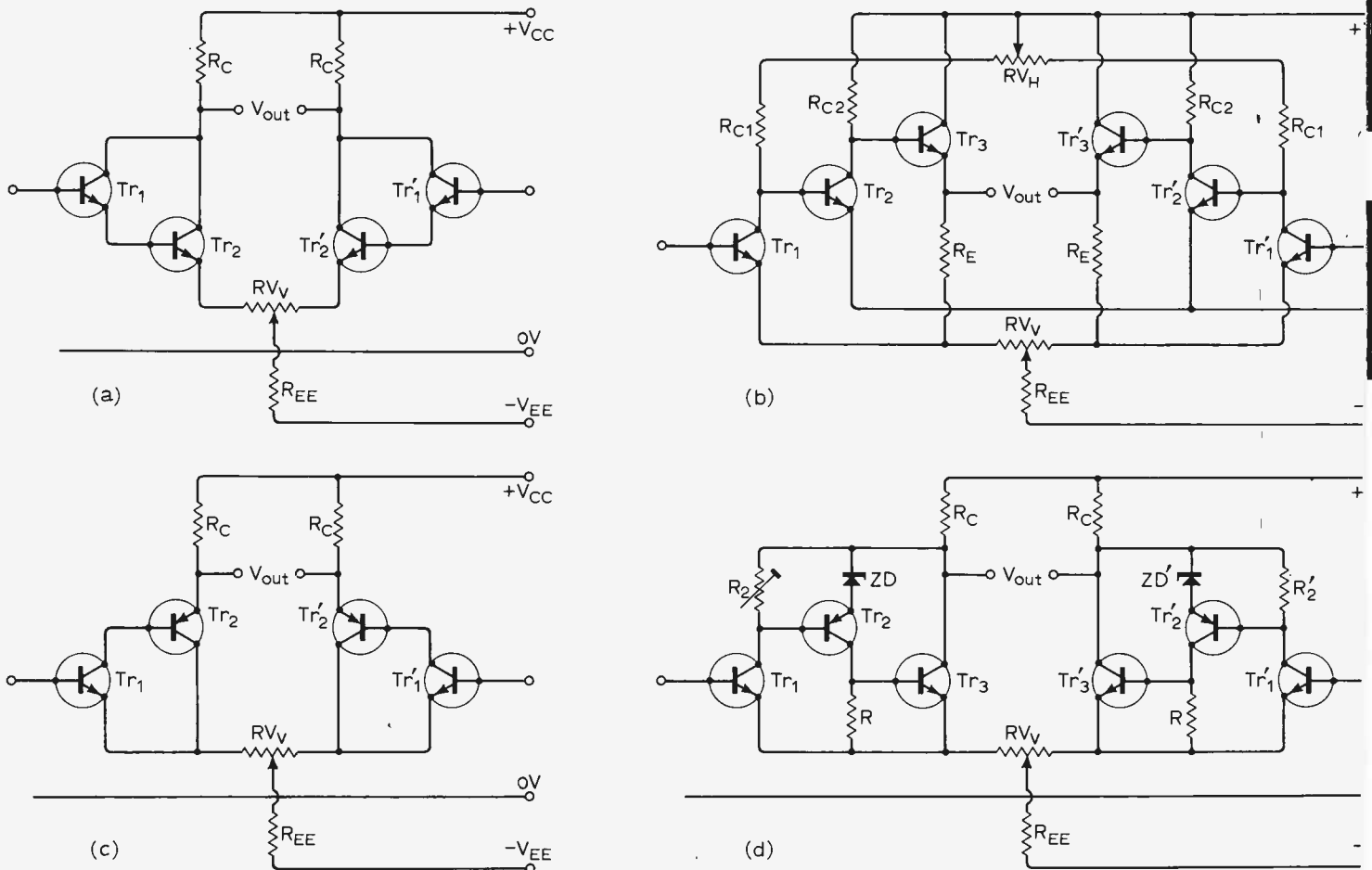

ratio", $c.m.r.r. = A_{VD}/A_{VC}$, usually expressed in dB. Clearly, from the formulae given above for differential and common mode voltage gains, increasing R_{EE} reduces A_{VC} without effecting A_{VD} . Thus it increases the $c.m.r.r.$ For any designed collector bias current, the only way to increase R_{EE} is to increase the negative supply voltage proportionately. This can soon lead to obvious practical difficulties.

A commonly used expedient to get a large effective common emitter resistance without going to a high rail voltage is to replace the "tail" resistor (R_{EE} in Fig. 1) with a transistor biased as a constant current source as T_2 in Fig. 2(a). Variants of the same arrangement are shown in Fig. 2(b), where the top end of the constant current transistor base bias network is taken to the positive supply instead of to zero volts, and in Fig. 2(c). In this a Zener diode is used to fix the current in the tail transistor independently of the supply rail voltages.

The collector output resistance of the constant current transistor in any of the above arrangements is high, looking like anything from 1 to $3M\Omega$, as seen by the emitters of the balanced transistors. This high effective resistance gives much higher common mode rejection than a simple resistor "tail".

Compound-transistor long-tailed pairs

To get higher differential gain in the long-tailed pair, many designers use compound transistor arrangements. Fig. 3(a) shows the use of a common-collector Darlingtong compound pair, in which the current gain of the two d.c.-connected transistors, T_1 - T_2 , is effectively the product of the current gains of each. This means that the base bias current required for a given collector current is reduced by a factor h_{fe} and contributes proportionately less to drift. The base-emitter voltages in this arrangement are, however, additive, and the drift from this cause can be doubled.

Fig. 3(b) shows a three-transistor compound, T_1 - T_2 - T_3 , of direct coupled n-p-n transistors (derived from a report by S.T.C. Semiconductors) that avoids the triple addition of V_{BE} errors, and yet achieves a tripled current gain. With an arrangement of this sort, input drifts of less than $10\mu V/^\circ C$ have been achieved without matching transistors closely and below $2\mu V/^\circ C$ with matched transistors, carefully temperature controlled.

Combinations of n-p-n and p-n-p transistors can also be used to avoid the doubled drift of added V_{BE} s in compound n-p-n circuits. In Fig. 3(c) (derived from D. F. Hilbiber "A New D.C. Transistor Differential Amplifier", *I.R.E. Transactions on Circuit Theory*, Vol. CT-8, No. 4, pp. 434-439, December, 1961), transistors T_1 and T_2 are d.c. coupled to provide a current gain equal to the product of the current gains of the separate transistors. A refinement (not shown) which makes the circuit less dependent on matching of T_2 and T_2' is to include bias resistors from the collectors of T_1 and T_1' to the positive supply line.

Fig. 3(d) finally shows a triple complementary-symmetry combination of n-p-n - p-n-p - n-p-n transistors (also due to Hilbiber) with even higher current gain without the comp-

lications of further added V_{BE} drifts.

Whichever of the front-ends shown in Fig. 3 is used, in general most practical balanced d.c. amplifiers use at least one subsequent stage of balanced voltage amplification often with some form of stabilising feedback.

Practical transistor balanced d.c. amplifiers

Fig. 4(a) gives a simple, single-stage circuit for obtaining $10\mu A$ and $10mV$ f.s.d. readings from a $50\mu A$, $125mV$ meter movement (e.g. the d.c. $50\mu A$ range of the AVO 8). It uses standard germanium p-n-p transistors, operates from a single 3V battery, and has provision for setting open-circuit and short-circuit zero. All resistors used should be matched to 5% or better.

For improved gain, common-mode rejection and temperature stability, it is customary nowadays to go to some silicon circuit such as Fig. 4(b). This particular example (adapted from a Mullard circuit) is essentially a three-stage silicon transistor amplifier with a voltage gain of about $\times 8,000$. It can give an output up to $\pm 10V$ from about $\pm 1.25mV$ input, with a total zero drift referred to the input of less than $125\mu V$ over the range $25-75^\circ C$. The BFY55 is a matched pair of TO18 n-p-n transistors supplied in a prefabricated heatsink. Although we treat it as a d.c. amplifier, the circuit has in fact a 3dB bandwidth of $100kHz$. Apart from the conventional differential balance $10k\Omega$ potentiometer, it has a $20k\Omega$ variable tail resistance to enable both outputs to be brought simultaneously to zero level.

Internal feedback is featured in Fig. 4(c).

Fig. 4 Practical resistance-tail balanced d.c. amplifiers using transistors: (a) Single-stage meter amplifier without feedback, (b) Three-stage amplifier without feedback (Mullard), (c) Two-stage amplifier with feedback (Texas Insts.).

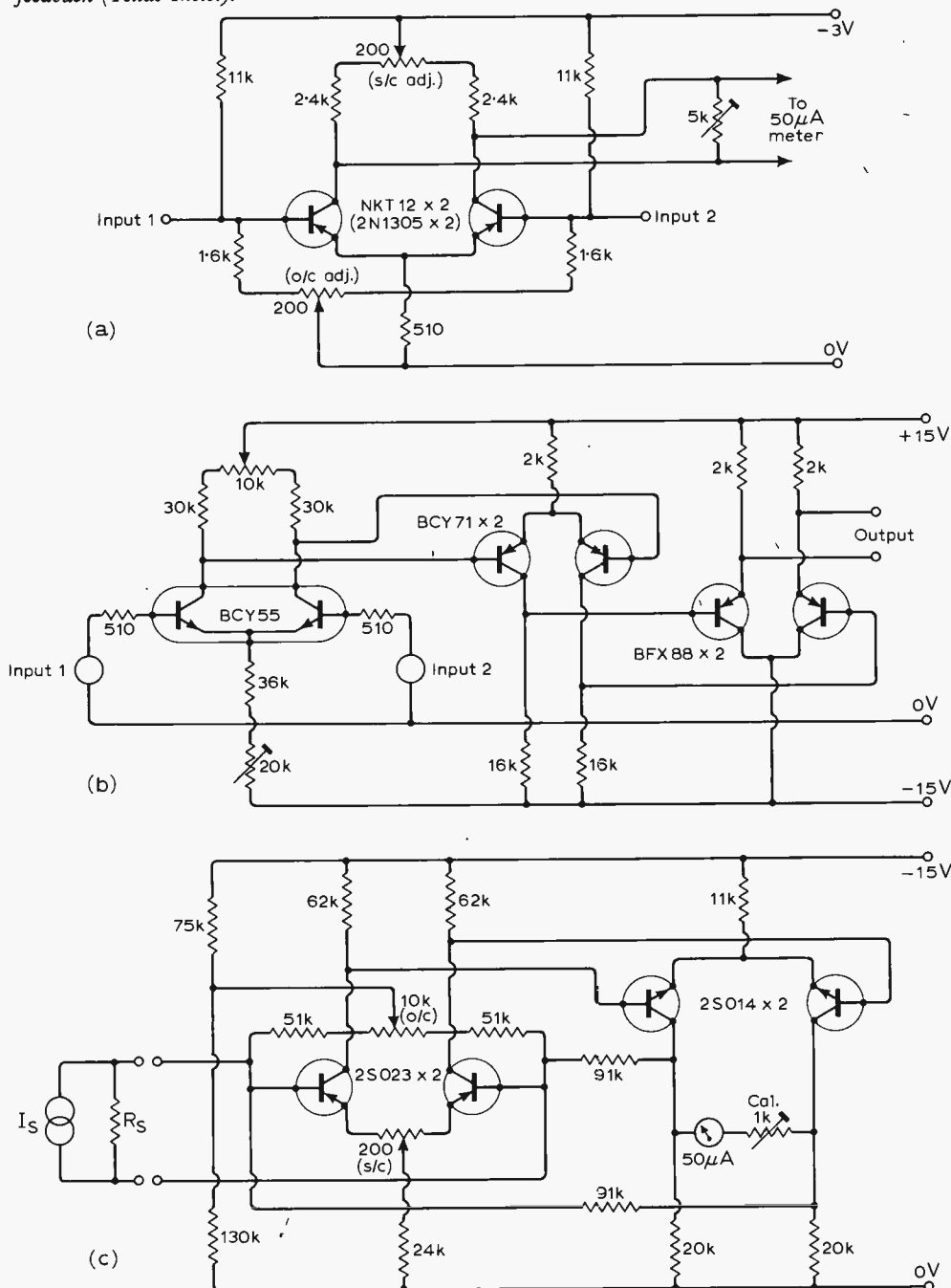

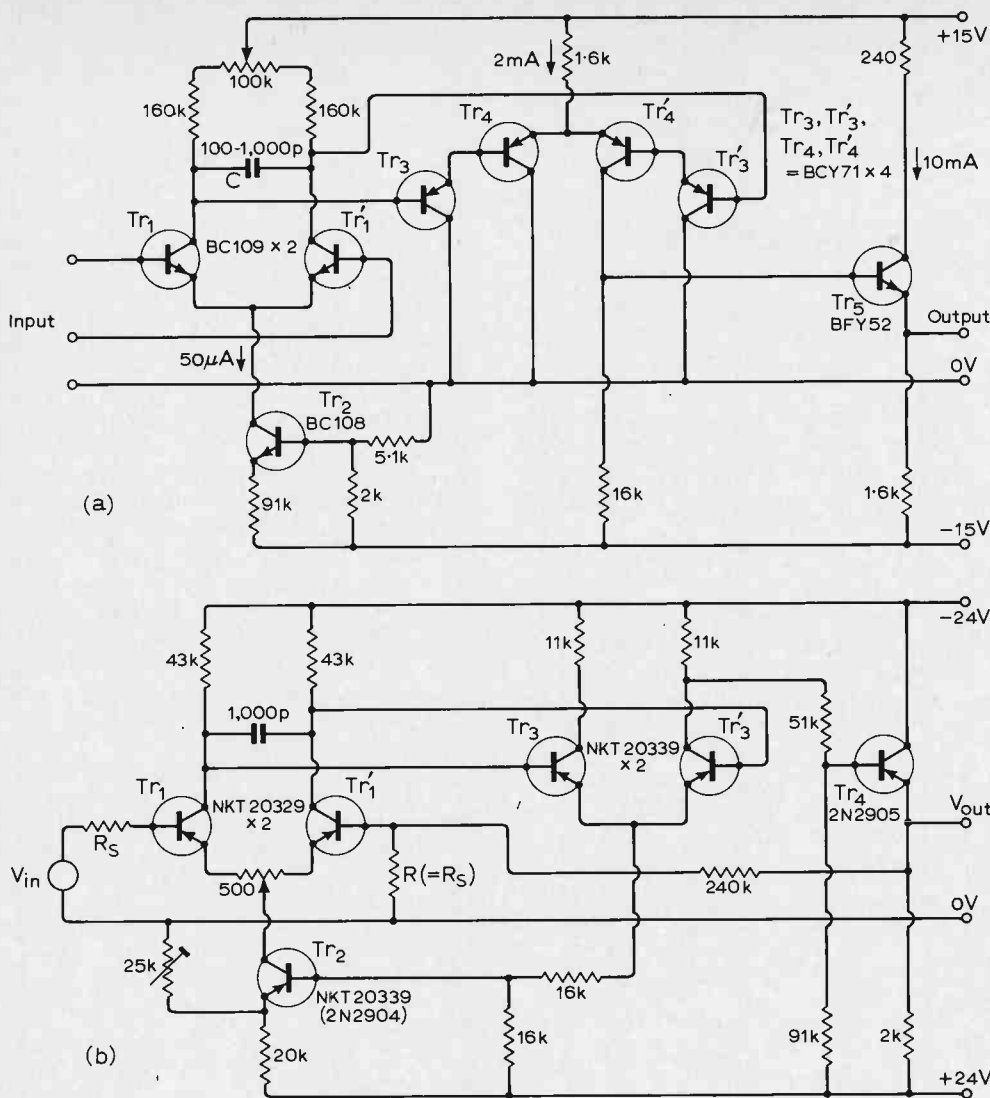
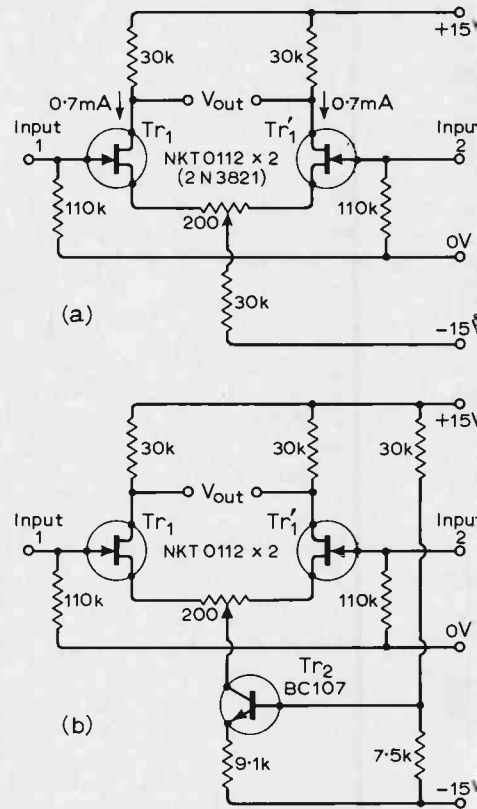

Fig. 5 Practical constant-current-tail balanced d.c. amplifiers using transistors: (a) Three-stage, single-ended output, without feedback, (b) Three-stage, single-ended output, with feedback.

Fig. 6 Practical single-stage f.e.t. long-tailed-pair balanced d.c. amplifier: (a) With resistance "tail", (b) With transistor, constant-current source tail.



This circuit (based on a Texas Instruments design) has a current gain of about $\times 50$, and thus provides $1\mu A$, 1mV f.s.d. readings on a standard $50\mu A$ meter. Zero deflection is less than 5% f.s.d., input resistance greater than $10k\Omega$ and total battery drain less than 1mA. In practice nowadays, designers tend to replace the low-frequency, silicon alloy, p-n-p type 2SO23 shown with a high frequency diffused silicon type such as the 2N2904 or the NKT20339. When this is done, increased gain will be obtained, but instability may occur and should be suppressed by connecting a suitable capacitance, 0.001 to $0.1\mu F$, between the input transistor collectors.

Fig. 5 gives two examples of d.c. balanced amplifiers with a transistor constant-current source substituted for the tail resistor.

In the four-stage circuit of Fig. 5(a), which has no internal feedback, the voltage gain is about $\times 10,000$. This gives an output of $\pm 10V$ for $\pm 1mV$ input, with an input resistance of greater than $100k\Omega$ and an output resistance not more than 100Ω . Over normal equipment ambient temperature ranges the circuit can give a total input drift of less than $20\mu V$ and $25nA$ with reasonable balancing and heatsinking precautions. The constant current to the input differential pair is supplied by the transistor Tr_2 though the $5.1k\Omega$ and $2k\Omega$ base bias network between 0.V and $-15V$ and the $91k\Omega$ emitter resistance.

In the more complex transistor-tail circuit

of Fig. 5(b), the constant current supplied to the input pair $Tr_1-Tr'_1$ by the transistor Tr_2 is set partly by the $20k\Omega$ resistor and the $20k\Omega$ potentiometer from 0.V to $+24V$, and partly by the feedback from the emitter load resistor string of Tr_3, Tr'_3 . In addition, differential mode feedback from the output through a $240k\Omega$ resistor linearises the d.c. response. The circuit gives a current gain of $\times 100$ with some 20dB of negative feedback. Input current drift is about $5nA/^\circ C$ with an input resistance of around $25k\Omega$. The circuit gives approximately 1V output for $5\mu A$ input.

F.E.T. balanced d.c. amplifiers

Although single-stage f.e.t. balanced amplifiers on their own are not widely used because of their high output resistance, the practical circuit of Fig. 6(a) illustrates the basic resistor-tail arrangement. Provided the n-channel f.e.t.s that are used are matched for I_{DSS} within 10%, this provides a useable amplifier with a d.c. voltage gain of $\times 22$ (26dB), a common mode rejection ratio of $\times 250$ (48dB), and a maximum output of not less than $\pm 4V$. Although designed as a d.c. amplifier, it has a 3dB bandwidth of 100kHz. Input total voltage drift for ambient temperature range $25-60^\circ C$ is less than 5mV against an input voltage of about 20mV for full output. By selecting I_{DSS} for the

f.e.t.s to within 3%, the total input drift can be reduced to 1mV and common mode rejection increases to 60dB.

Fig. 6(b) illustrates an f.e.t. single-stage balanced d.c. amplifier with a transistor constant-current tail. It has only the same input drift and maximum output as Fig. 6(a), from which it is derived. However, with 10% I_{DSS} -matched f.e.t.s, the c.m.r. ratio has been improved from 48 to 76dB and if I_{DSS} is matched within 3%, the rejection ratio improves to 85dB. Some indication of the sensitivity of the circuit of Fig. 6(b) to supply voltage variation can be gained from the fact that a 1V variation in either of the 15V rail voltages does not lead to an input drift of more than 0.2mV.

For lower output resistance, extra stages must be added to the f.e.t. circuit of Fig. 6. A typical three-stage example is given in Fig. 7(a), where Tr_3, Tr'_3 give additional voltage gain, and Tr_4, Tr'_4 emitter-follower connected, gives a low output resistance. The additional voltage gain is used to provide negative feedback via the $30M\Omega$ resistor R_f . The resultant overall voltage gain is only 28dB, much like Figs. 6(a) and (b), except that it is now heavily stabilised. Although the amplifier input resistance is not less than $10M\Omega$, the input voltage thermal drift can be held to $50\mu V/^\circ C$ in the range $0-60^\circ C$, provided the input f.e.t.s are I_{DSS} -matched within 10%. The output resistance is less

than $1k\Omega$. The $100k\Omega$ variable base bias resistance of the constant-current transistor Tr_2 permits setting bias currents in Tr_1, Tr_1' to zero-temperature-coefficient operating point. In the emitter circuit of Tr_3, Tr_3' the 100Ω potentiometer and the $20k\Omega$ variable resistance control the short and open circuit zeroing.

Fig. 7(b) gives another three-stage f.e.t.-input balanced amplifier, which is a refinement

of Fig. 7(a) in that common mode feedback is applied through a resistor and potentiometer in the emitter long-tail circuit of Tr_3, Tr_3' to the base of the constant-current input transistor Tr_2 . With the $51k\Omega$ differential feedback resistor removed, the voltage gain is 53dB, but it reduced to 34dB when it is connected. From a 50Ω voltage source, the 3dB bandwidth is 25kHz without feedback and 250kHz with feedback. Input voltage

zero drift with temperature is less than $250\mu V$ in total from $25-60^\circ C$. Input drift with variation of the 15V supply rail voltages is less than $0.5mV$ per volt on the positive rail and $1.0mV$ per volt on the negative, the drifts being in opposite directions.

The last multistage f.e.t.-input amplifier illustrated in Fig. 7(c) finds the input f.e.t.s followed by four stages of amplification to give a total voltage gain of 98dB (and incidentally a 3dB bandwidth of 10kHz). The circuit provides an input resistance in the megohms range with an output resistance of a few hundred ohms and a maximum output voltage swing of $\pm 10V$. The input gate resistor, R_s of Tr_1' is selected to be approximately equal to R_s the resistance of the source of voltage being measured. The 30Ω variable and $1k\Omega$ potentiometer in the source circuit of Tr_1, Tr_1' permit adjusting the residual mismatch in these f.e.t.s. The $5k\Omega$ variable in the emitter of Tr_4' adjusts for the residual mismatches on the second and third stage transistors, and the $5k\Omega$ variable in the emitters of Tr_5, Tr_5' is for setting up the bias currents in the f.e.t.s. The input temperature drift of the circuit is of the order of $8\mu V/^\circ C$ over the range of $-10^\circ C$ to $+80^\circ C$. With supply voltage variation, the input drifts are $140\mu V$ per volt of drain voltage and $-120\mu V$ per volt of source voltage. Holding rail voltages to $\pm 1\%$ restricts input drift from supply voltage variation to less than $\pm 20\mu V$.

Integrated circuit balanced d.c. amplifiers

With modern developments in integrated circuits, balanced d.c. amplifiers are now becoming readily and cheaply available in monolithic microcircuit form. Typical of these is the S.G.S.-Fairchild $\mu A702$ of which the circuit is given in Fig. 3. This is a fairly

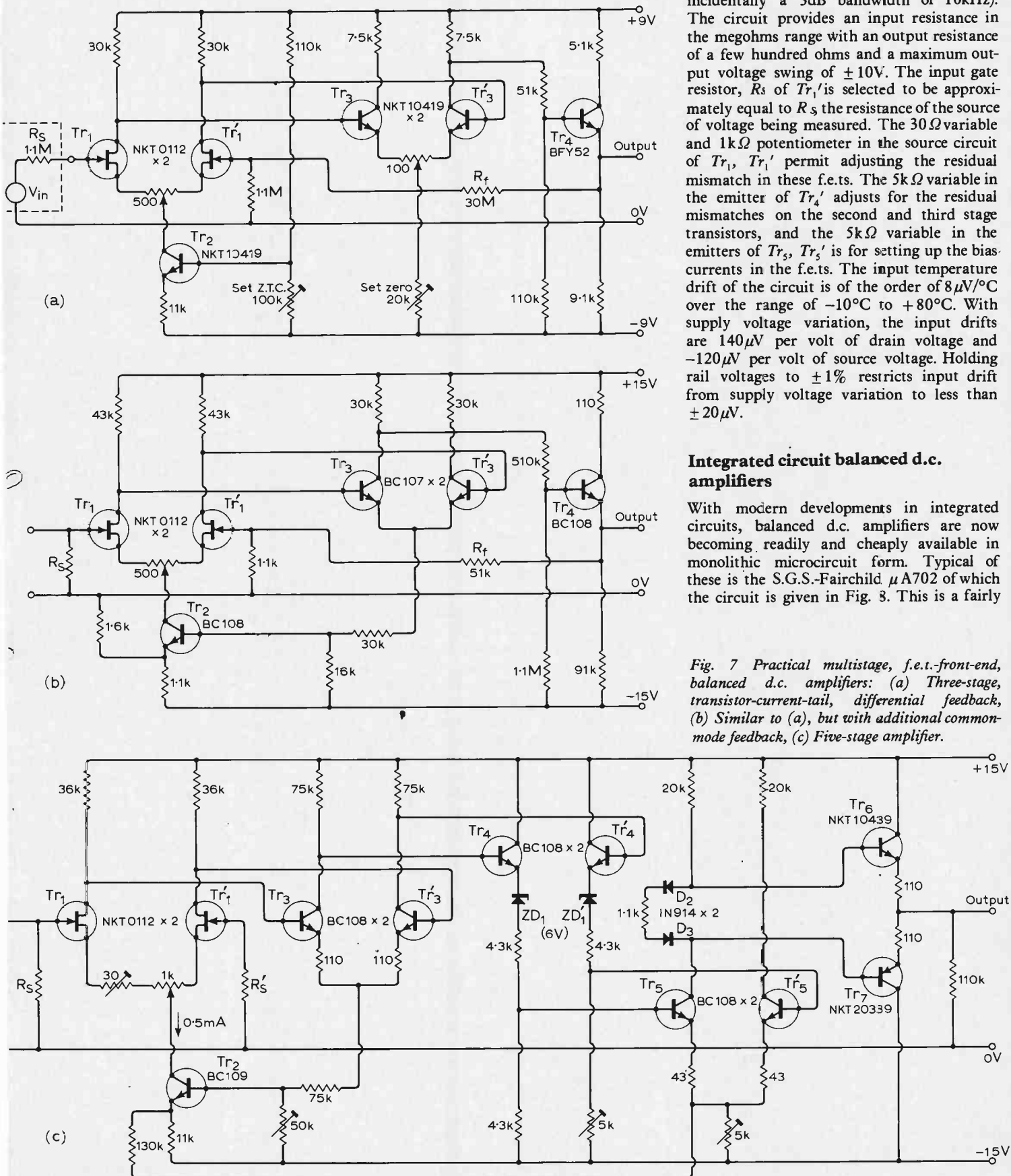

Fig. 7 Practical multistage, f.e.t.-front-end, balanced d.c. amplifiers: (a) Three-stage, transistor-current-tail, differential feedback, (b) Similar to (a), but with additional common-mode feedback, (c) Five-stage amplifier.

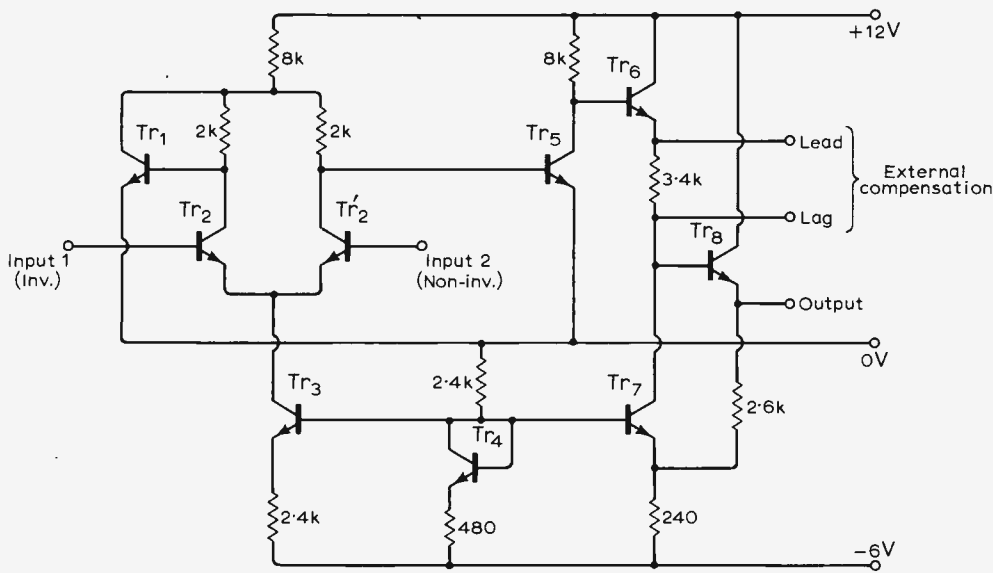

Fig. 8 An example of a monolithic integrated circuit balanced d.c. amplifier.

conventional balanced-input, single-ended-output, transistor-tail amplifier. There are, however, unusual features, resulting from the limitations of monolithic manufacture. Tr_1 holds the collector of Tr_2 at about 650mV above the common rail, 0V, and thus keeps the input differential pair in a low dissipation state. Tr_1 is a transistor connected as a diode, whose forward voltage drop varies with temperature identically with the base-emitter forward voltage drop of the constant-current transistor Tr_3 , and thus keeps the tail current in the input differential stage constant. The transistor Tr_7 acts as a constant-current load to the transistor Tr_6 and permits a wider output voltage swing than if a resistive bias load were used.

Constructional aspects of balanced d.c. amplifiers

The discrete component amplifier designs given in Figs. 4 to 7 above are all practical designs, but, if you care to try to make up any of them, you are advised first to read carefully the notes set out below covering practical aspects in the construction of such amplifiers.

In high gain, precision, balanced d.c. amplifiers you will give attention to electrical design first naturally, but you must always keep in mind that the best circuit can go sadly astray if you do not give much attention to component selection and to assembly.

Electric design ground rules: Most of the drift arises in the input stage, and you should concentrate on this. Particular points that emerge from practical experience are:

- (1) Select $I_C = 50-500 \mu A$ (with f.e.t., $I_{DON} = 100-1,000 \mu A$).
- (2) Select I_B greater than $100 \times I_{CBO}$ and less than $I_C/100$.
- (3) Select $V_{CE} = 2-5V$ (with f.e.t., $V_{DS} = 2-5V$).
- (4) Select $R_B = 100-10,000 \Omega$ (with f.e.t., $R_S = 100k \Omega - 10M \Omega$).
- (5) Select R_{EE} (tail resistor) greater than $100(r_e + \frac{1}{2}R_K)$, where R_K is the inter-emitter resistance.
- (6) Keep rail voltages stable within 0.1 to 1.0%.
- (7) Keep input offset voltage less than 1/100

of f.s.d. signal voltage

- (8) Keep input offset current less than 1/100 of f.s.d. signal current.
- (9) Keep rail voltages as high as practicable to improve common mode rejection.
- (10) Shunt paralleled, oppositely phased, low-leakage silicon overload protection diodes across the input.
- (11) Equalise input bias resistors to reduce unbalance from I_{CBO} differences.
- (12) Aim for equal collector resistors (1% to 5%).
- (13) Design for equal I_C 's and I_B 's (by matching h_{FE} 2% to 10%).
- (14) Use equal temperature coefficient devices in balanced circuits.
- (15) Use equal voltage coefficient devices in balanced circuits.
- (16) Use closely matched transistors as indicated in the next section.

Component selection ground rules:

- (1) Resistors (particularly at low level): use 5%, 2% or 1% cracked carbon, because they are less noisy than metal film and less costly than the more stable, lowest-noise, wire-wound. Use 2W and 1W in preference to lower wattages, since noise decreases as physical size increases, and large-size resistors are also less subject to drift on solder heating (which can be up to as much as 3% with some types). Use only values in the 5% preferred series, i.e. 11, 13, 16, 20, 24, 30, 36, 43, 51, 62, 75, 91. If you keep possible 10% or 20% values out of your circuits you run less chance of putting wide tolerance resistors in by mistake.
- (2) Capacitors: use good silver mica, or, if you must go to something else, use specifically low leakage types. This way you will avoid leakage problems and associated noise.
- (3) Diodes: use only silicon, very-low-leakage.
- (4) Transistors: use only silicon, low-leakage, non-doped types such as the 2N930 or 2N2484 families. Use n-p-n as standard because of ready availability, turning to p-n-p only when complementary circuitry is called for. Use high voltage devices (V_{CEO} not less than 30V) and high gain (h_{FE} at $100 \mu A$ not less than

100). Use the physically largest package available to avoid short interlead leakage paths. Use transistors with V_{BE} ($I_C = 100 \mu A$) matched within 10, 5, 2 or 1mV depending on cost, and for h_{FE} ($I_C = 100 \mu A$) matched within 10, 5 or 2% with the tightest tolerance you can afford.

(5) Printed circuit board: use high-grade fibre-glass, if possible, in preference to commercial grade s.r.b.p. with its leakage dangers.

Mechanical assembly ground rules:

(1) Aim for completest geometrical symmetry in board layout, and try always for a mirror image, with equal lead lengths, equal stray capacitances, equal solder connection layout and equal insulation paths.

(2) Heat-sink the input differential device adequately, and, for ultra precision, even the second differential devices. Use one of the readily commercially available anodized aluminium special dual heat sinks such as the Jermyn Industries type A1010HA or A1092HA. Remember that a temperature difference of only one-hundredth of a °C between two input device junctions can produce a V_{BE} difference of $20 \mu V$. In extreme requirements, enclose the input transistor in a constant temperature oven such as the Cathodeon Crystals crystal oven type MCO-2M, which can hold the overall temperature variation of the pair within 1°C. Thermal gradients between differential transistors are by far the biggest cause of drifts in differential amplifiers.

(3) Keep the circuit compact to reduce noise pickup from thermal, electric, magnetic and radiation field gradients.

(4) Keep the assembly as rigid as possible by clipping, glueing or otherwise fixing components tightly.

(5) Keep the assembly clean, because in dealing with sub-microamp currents, it is essential to avoid noise and drift arising from I_{CBO} and other leakage current changes. Use plastic mounting pads beneath transistors to avoid trapping contamination and moisture. Always clean, bake, and, if possible, encapsulate your circuit. A good practice is to finish up with a clean in methylated spirits or trichloroethylene and a dip in wax or one of the proprietary silicone rubbers.

(6) Look carefully to shielding. As a rule remove as little copper as possible from the printed circuit board in your design, and consider the advantages of a double-sided board from the screening point of view. In the ultimate, screen the whole circuit in a metal box.

(7) Pay special attention to soldering to avoid dry joints with their instability, drift and noise possibilities. Also remember that solder overheating can cause permanent change in component values which can seriously unbalance an amplifier. An overheated resistor can change in value up to 3%, as mentioned earlier, and can throw an amplifier beyond the ability of a balance potentiometer to zero it.

References

- "D.C. Amplifier Using Transistors" by D. Beneteau and E. Murari, *Electronic Engineering* Vol. 35, p. 257, 1963.
 "Limitations of Transistor D.C. Amplifiers" by A. Hoffait and R. D. Thornton, *Proc. I.E.E.* Vol. 52, No. 2, pp. 179-184, Feb. 1964.

A Wideband Oscilloscope Probe

An active probe with unity gain overcomes test problems on high impedance circuits

by L. Nelson-Jones*, M.I.E.R.E.

For many of the measurements made with an oscilloscope it is very desirable that the instrument should not load the circuit being tested, and for this reason great use is made of passive probes. The most common of these uses an unbalanced 'L' attenuator with capacitive compensation, and usually has an attenuation ratio of 10, which together with its resistive coupling cable gives a wide band probe of $10\text{ M}\Omega$ and around 10 pF equivalent input impedance. The use of a resistive coupling cable is necessary to avoid reflections on an unmatched line, but it does have the unfortunate effect of making the input capacitance referred to above rather a 'lossy' one¹, since the input capacitance is partially in series with this resistive cable. This is shown in Fig. 1, which is a simplified equivalent circuit of such a probe.

The use of such passive probes is normally satisfactory in work with pulse circuitry and in other similar applications, where circuit impedances are in general low, but when such probes are used in high impedance circuits, and especially when tuned circuits are involved, very misleading results can be obtained.

The shortcomings of the passive probe, not the least of which is that it is an attenuator, and therefore involves loss of sensitivity, caused the author to look at the possibility of manufacturing an active unity gain probe. The author's own oscilloscope (Heathkit 10-12U) also has different input impedances and capacitances on its various sensitivities, which again makes the use of a passive probe difficult.

There are two possible lines on which such a probe could have been designed. (1) A source follower or emitter follower. (2) An impedance converter feeding a matched transmission line to a termination at the oscilloscope (the termination being either active or passive).

The latter solution has its limitations, not the least of which is the high power dissipation involved, unless the dynamic range is severely limited, and the transmission line impedance is high. The system is however capable of operation over a very wide bandwidth.

The author therefore designed the probe to be described using the first approach, and although this does not result in such a wide bandwidth, the resultant design has a very wide

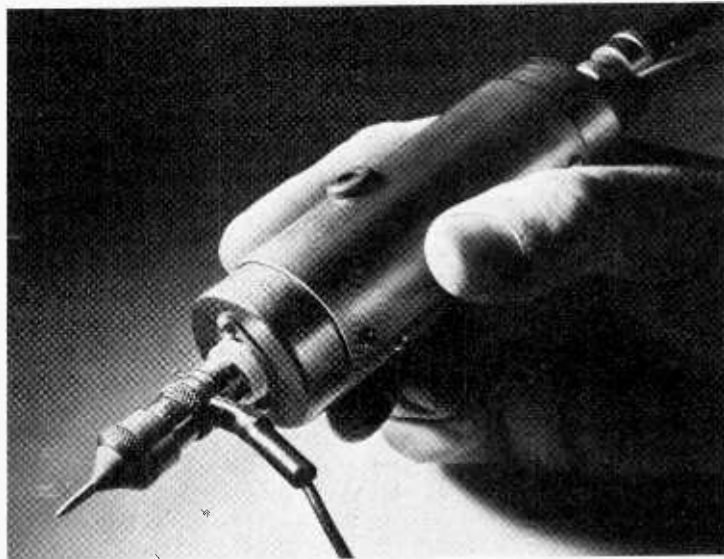

dynamic range. The design which should meet all normal requirements, has the dynamic range of ± 5 volts and a bandwidth of 23 MHz. In addition an attenuator attachment is described which extends the dynamic range to ± 500 volts. In general the characteristics are similar to a passive probe but the input capacitance is not seriously 'lossy', there is no loss of gain, and there is the additional advantage that the probe need not be readjusted every time it is transferred from one input of an oscilloscope to another, or to another oscilloscope.

Source Followers

Whilst it is possible to design a circuit using bipolar transistors, which has an input resistance of the order of megohms at low frequencies, it will almost certainly suffer from limited bandwidth, together with a complex input impedance particularly at the higher frequencies. By contrast the currently available n-channel f.e.t.s such as 2N3823 can offer a very high input resistance, which also approaches a pure capacitance more nearly than is possible with other devices. It is possible to achieve an exact value of input resistance by the use of a separate resistor since the input resistance of the f.e.t. is several orders higher than the typical value of resistance required.

In order to achieve a gain as close as possible to unity it is necessary to use a high value of source resistor, and this is most easily achieved by using a current source, consisting of an n-p-n transistor with emitter degeneration, in order to further raise the effective value of slope resistance seen at the collector.

*Plessey Automation Group, Poole, Dorset.

Fig. 1. $10\text{ M}\Omega$ passive probe circuit.

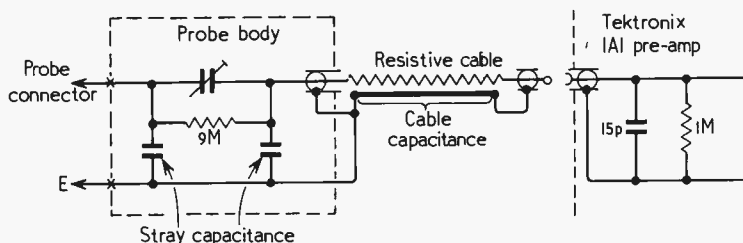

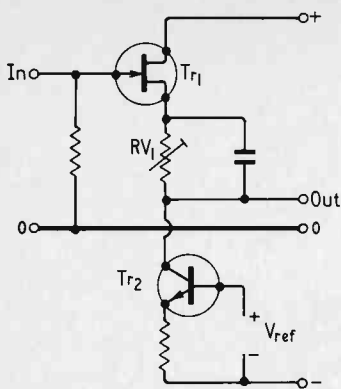

Fig. 2. Current source with gain close to unity.

The basic circuit of such a stage is shown in Fig. 2. With suitable values such a stage achieves a gain very close to unity. A variable resistor RV_1 is included so that the d.c. output level can be set to equality with the input, and provided that it is bypassed to high frequencies, does not greatly affect the gain since the value of RV_1 is small compared with the slope resistance of the current source. If a wide bandwidth is desired this variable resistor should be of a non-inductive type.

This type of source follower makes an excellent input stage for a wide-band probe, but it is unable to drive any large value of capacitive load, such as the cable to the oscilloscope, even though to avoid reflections this cable must be of the resistive low-capacitance type used with passive probes. The reason for this lack of drive lies partly in the nature of the f.e.t. used, and partly from the fact that due to dissipation limits the current in this first stage must necessarily be low.

The basic problem is that although the f.e.t. is able to supply additional current to charge the load capacitance on positive going excursions (at the expense of some error in the voltage following), there is only the current source to discharge the load capacitance. This is well illustrated in one of the earliest references² to such a high input impedance probe, which although it uses additional loop gain to bring the gain very close to unity, has no active 'pull-down' to discharge the load capacitance.

The current required to achieve a given rate of rise (or fall) is easily calculated from the basic charge formula $Q = CV$.

Differentiating with respect to time we get:—

$$\frac{dQ}{dt} = C \frac{dV}{dt} \dots \text{but } \frac{dQ}{dt} = i$$

$$\text{so that } i = C \frac{dV}{dt}$$

Inserting practical values of . . . $C = 75 \text{ pF}$ (cable + oscilloscope) and a desired rise time of 5 volts in say 10ns, i.e. $5 \times 10^8 \text{ V/second}$. We get $i = \pm 75 \times 10^{-12} \cdot 5 \times 10^8 = \pm 37.5 \text{ mA}$.

Thus to achieve this degree of performance in the absence

Fig. 3(a). Transistor equivalent of White cathode follower.

Fig. 3(b). Grounded base stage Tr_3 added to feedback loop of (a).

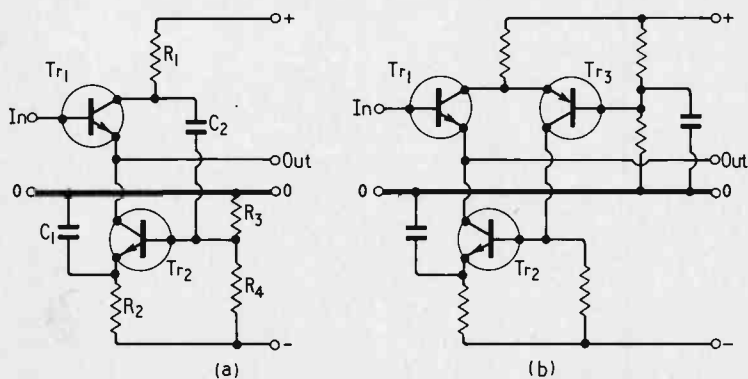

of any other factors, would need, in such a simple source follower, a standing current of at least 37.5 mA . . . hardly a practical value with currently available, and reasonably priced f.e.t.s.

The simplest remedy has proved to be the use of an output stage following the input source follower. Using bipolar transistors, in a suitable circuit, it is possible to achieve a sufficiently low loading on the input stage to ensure that it can drive the output stage at a reasonable rate of rise and fall.

The Output Stage

Two types of output stage were tried out. Both are transistorised versions of the White cathode follower³, which will be familiar to those with experience in the generation of fast pulse waveforms with thermionic valves.

Fig. 3 (a) shows a direct transistor equivalent of the White cathode follower, whilst in Fig. 3 (b) an additional grounded base stage Tr_3 has been added to the feedback loop. Tr_1 and Tr_2 can in fact be considered as a 'folded' cascode stage so far as the feedback loop is concerned.

Practical results indicate little to choose between these two types of stage for this application. The circuit of Fig. 3 (a) was therefore used for the probe output stage, as it is the simpler of the two, and avoids the use of a rather expensive p-n-p transistor (Tr_3). This transistor is at present expensive since it must withstand the full voltage difference between the positive and negative supply lines, and at the same time have a high value of f_T . In the limit it seems likely that the circuit of Fig. 3 (b) would be the best for more general application because of the higher potential loop gain, and reduction of Miller effect in Tr_1 .

In Fig. 3 (a) the gain is very close to unity because of the very high effective emitter resistor presented to Tr_1 by the current source Tr_2 . At the higher frequencies the emitter of Tr_2 is bypassed and the feedback through C_2 ensures that the gain is still close to unity. The emitter is bypassed in this way in order that Tr_2 may supply high values of transient current for rapid 'pull-down' of the output on negative going edges.

The action of this circuit under transient conditions can now be considered.

Positive edges. The current in Tr_1 rises causing a fall in the collector potential, which is coupled to the base of Tr_2 causing a fall in the collector current of Tr_2 . The amount of this fall will depend on the rate of the positive going edge. If the load at the emitter of Tr_1 is capacitive the collector current of Tr_1 will for a short time be in excess of the normal value whilst this capacitance charges up. The resultant transient fall in the collector potential of Tr_1 fed to Tr_2 will assist the charging of the load capacitance by turning off Tr_2 .

Negative edges. For negative going signals the reverse is the case. The reduction in the current in Tr_1 causes increased current in Tr_2 . A capacitive load at the emitter of Tr_1 causes an additional transient reduction in the current in Tr_1 on a negative going edge, and the resultant increase in the collector potential of Tr_1 causes the lower transistor Tr_2 to take a high transient current, and thus discharges the load capacitance rapidly. The purpose of the emitter decoupling capacitor of Tr_2 is now evident in that it allows a much higher value of transient current to be turned on in Tr_2 than would be allowed by R_2 alone.

The circuit of Fig. 3 (b) operates in a similar manner as there is no phase inversion in the grounded base stage Tr_3 . The feedback in this arrangement does however function down to zero frequency.

The circuit of the complete probe shown in Fig. 4 will be

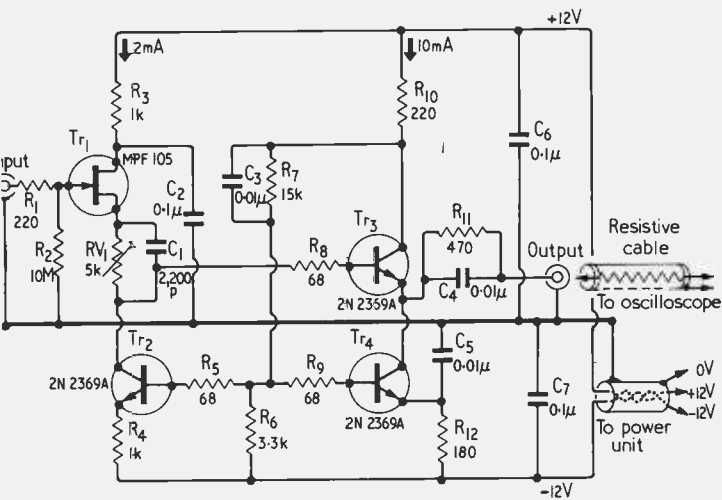

Fig. 4. Complete probe circuit.

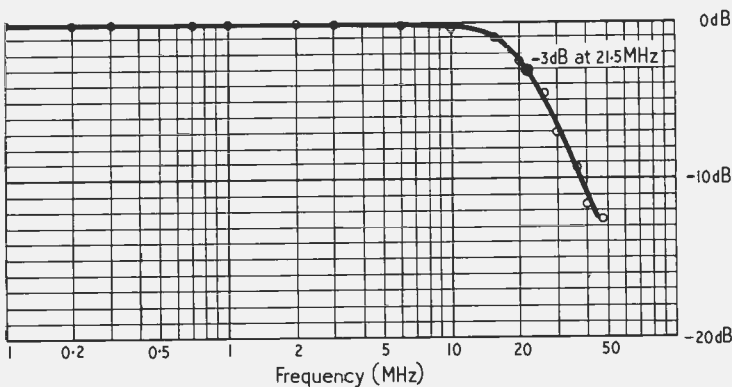

Fig. 5. High frequency response of the probe, using a Tektronix 545B oscilloscope, with the 1A1 preamplifier, having an input impedance equivalent to $1M\Omega$ in parallel with $15pF$.

seen to be the circuits of Figs. 2 and 3 (a) combined, but with one or two differences.

First, the base potentials of Tr_2 and Tr_4 are derived from a potentiometer between the collector of Tr_3 and the 12 volt line. This results in a small degree of negative d.c. feedback over Tr_3 and Tr_4 yielding a small improvement in d.c. stability. The use of a common feed to the base of these two transistors also results in a small degree of positive feedback around Tr_2 and Tr_3 , but as the emitter of Tr_2 is unbypassed the effect is negligible, so far as stability is concerned.

A 470 ohm resistor R_{11} is included in series with the output of the resistive cable in order to protect the output transistors from damage by any short-circuiting of the socket connecting his cable to the probe. The resistor is bypassed by a capacitor C_4 to preserve the high frequency performance.

Fig. 6. Photographs of the probe's pulse response using a Venner pulse generator type TSA 628 as signal source. The oscilloscope scale is $X=100ns/cm$ and $Y=2V/cm$ (a) and (b) with probe load $10M\Omega 10pF$ (c) with probe load $1M\Omega 15pF$.

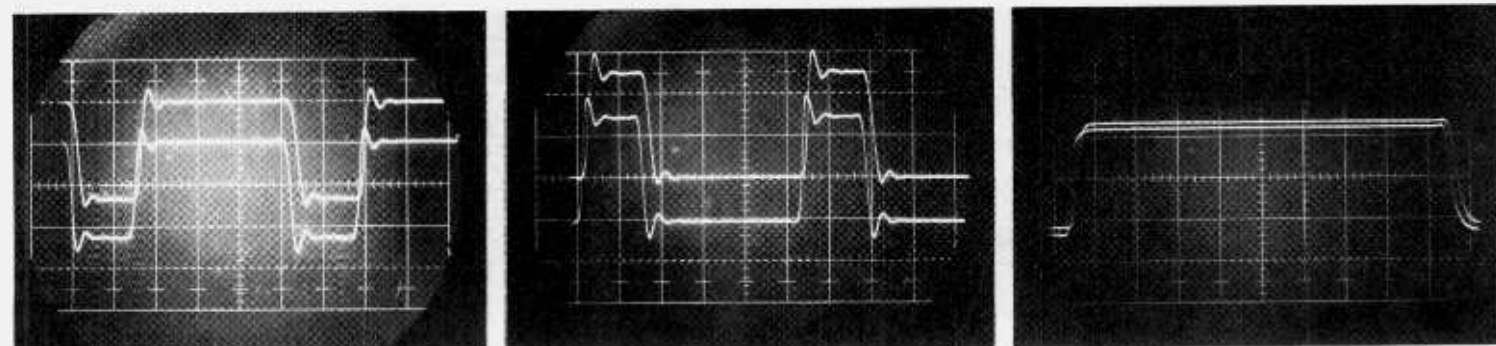

As in the circuit of Fig. 2 the output of the probe may be set to equality with the input by means of a variable resistor in the source of Tr_1 . When this is achieved the voltage across RV_1 will be equal to the bias required for a drain current of 2 mA in Tr_1 less the forward bias voltage of Tr_3 .

Performance

Fig. 5 shows the high frequency performance of the probe the response is level from 100kHz to 6MHz with an average loss of 0.05dB. The maximum measured loss being at 600kHz where a loss of 0.15dB was found. Above 6MHz the gain falls to -1dB at 15MHz, and the response reaches the -3dB point at 21.5 MHz. These figures were obtained working into a Tektronix 1A1 pre-amplifier which has an input equivalent to 1 Mohm in parallel with 15 pF. A higher value of capacitance will result in a slight reduction in the cut-off frequency.

For frequencies below 100kHz, measurements (using a mean reading r.m.s. calibrated, valve millivoltmeter) show that for the full signal amplitude of 10 volts pk to pk, the response is maintained close to the figure of -0.05dB down to 20Hz, the lowest frequency at which a.c. measurements were made.

D.c. measurements with levels in the range -6 volts through zero to +6 volts show an average slope of 0.97 and a departure from the line having this slope of 1.5% at the limits of +5, and -5 volts. The departure is due, it would seem, to the square-law characteristic of the f.e.t., but with such a small departure from a straight line it is hard to detect if other causes are present. There is little additional departure from the straight line even at the limits of the measurements made of +6, & -6 volts input. Plotted on graph paper 20 inches wide it is necessary to draw the straight line with a slope of 0.97 in order to detect that the characteristic is in fact a slight curve.

With the a.c. probe tip in position the response is theoretically -3dB at 15.9Hz. However, because of the wide tolerance of suitable ceramic capacitors the actual cut-off frequency was measured as 18Hz.

The pulse response of the probe at the limit of its performance is shown in Figs. 6 (a), (b) and (c). The signal source was a Venner pulse generator type TSA 628 and for the first two figures was unterminated so that overshoot was intentionally present on the waveform. Fig. 6 (a) shows a true negative 5 volt 150ns pulse and Fig. 6 (b) a true positive 5 volt 150ns pulse. The two traces are the input and output of the probe including the resistive output cable as viewed by two passive probes set up for exact equality. The bandwidth of the viewing oscilloscope was 33MHz (Tektronix 1A1 pre-amp in 545B oscilloscope).

It can be seen that there is an overall delay of about 15ns in the probe, of which about half is due to the resistive output cable. The rise time of the probe appears slightly shorter than

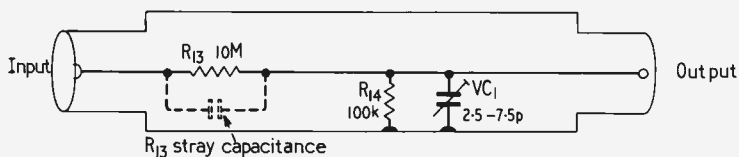

Fig. 7. The attenuator circuit to divide by 100.

the fall time as evidenced by the slight reduction of the negative overshoots in these two photographs.

Fig. 6 (c) shows a properly terminated pulse from the same pulse generator with a duration of 900ns, and with the probe driving the 1A1 pre-amplifier direct. The input waveform is still however as viewed by a passive probe. Bearing in mind that this illustrates the very limit of the performance of the probe it is felt that there is a very good agreement between the traces, which have of course been separated in the vertical direction for clarity.

The input resistance of the probe is of course 10 MΩ and the input capacitance is low, as with a passive probe, but this capacitance is of much lower loss than with such a passive probe due to the isolation afforded by the active circuit from the resistive cable.

Capacitance of the probe alone	
(at the input socket)	6.1 pF
Capacitance with ÷ 100 Attenuator (see below)	3.0 pF
To which must be added:—	
Additional capacitance of a.c. probe tip	4.5 pF
Additional capacitance of d.c. probe tip	3.0 pF

The Resistive Coupling Cable. The probe is coupled to the oscilloscope with a 5-foot length of coaxial cable, in which the solid inner conductor has been replaced with a fine 'Eureka' wire (47 s.w.g. . . . 0.002in).

The details of the removal of the solid copper inner core, and its replacement with the fine resistance wire, are given in the appendix. The use of this type of cable is essential if the presence of serious reflections is to be avoided.

Bootstrapping. It is tempting to bootstrap the drain of the f.e.t. to the output of the probe, in order to reduce the input capacitance of the probe, instead of decoupling it as in Figure 4. Such a reduction does in fact take place at low and medium frequencies. However due to the small time delay, between the input and output of the probe (approximately 7-10 ns), there is a side effect at high frequencies, which results in overshoot on the reproduced waveform. Bootstrapping is therefore unacceptable on a wide band probe. If the design of the probe had been for a band width of 2-3 MHz, then bootstrapping would have been of use.

Fig. 8. The interior of the probe.

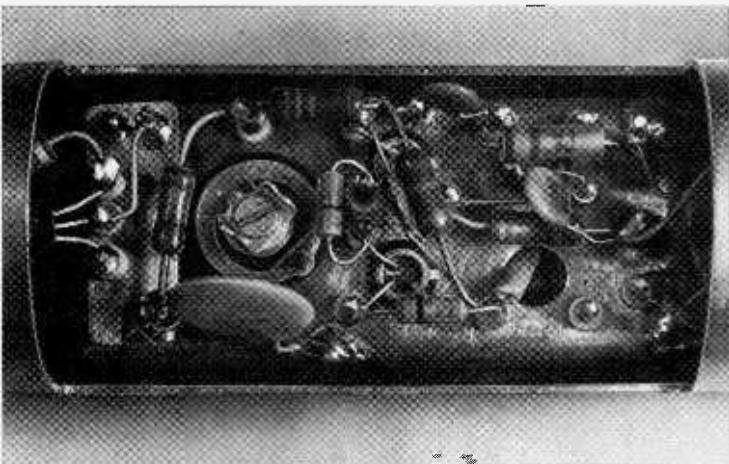

÷ 100 Attenuator

As can be seen from the oscilloscope traces, Fig. 6, the dynamic range of the probe is good to at least ± 5 volts, but for some purposes this is not sufficient, and so a ÷ 100 attenuator was designed. The circuit of this attenuator is shown in Fig. 7, and gives the probe a dynamic range of ± 500 volts. The high attenuation of this design was chosen since with a sensitivity of 50mV/cm available on most oscilloscopes there is really no need for a ÷ 10 attenuator. However if such an attenuator is desired, then R₁₃ should be 9.1 MΩ, R₁₄ 1.1 MΩ. VC₁ should be of 3 or 4 pF and should be across R₁₃, with a fixed capacitor of the order of 10-15 pF across R₁₄. The construction of the attenuator is shown in Fig. 9 and is described in the appendix.

Constructional Notes

The following notes will be found helpful in the construction of the oscilloscope probe.

Probe body. 1½in internal diameter copper pipe (thin wall water pipe), with end plates of 20 swg copper. Cover made of 20 swg sheet or a section of the 1½in pipe split along its length and opened in diameter to fit smoothly over the body. End plates are soldered in the body, and the finish of all parts is dull nickel plate.

Probe components. All resistors are ¼ watt rating. R₁ is ± 10% moulded carbon, R₂ is ± 5% carbon film, all others are ± 5% carbon film, or metal oxide. RV₁ is moulded carbon potentiometer (Radiospares 'Mouldtrim', or Plessey types MP or G). All capacitors are ceramic discs. C₁ is 500 v, C₂₋₇ are 20 volt working. Tr₁ Motorola MPF 105 (alternatives:— 2N3823, 2N3819 selected for I_{ass} above 5mA, Texas TIS 34, Union Carbide UC 734, Mullard BFW 10 or 13). CAUTION there is no general connection convention with f.e.t.s: check the connections for the type used! All other probe transistors, 2N2369A (Alternatives Taxes TIS 49, Mullard BSX 20). Coaxial Sockets Belling-Lee L604/S/Ni, p.t.f.e. Stand-offs A.E.I., Polytags PT 23 (from Electronics).

Attenuator components & body. Body, ½in copper tube: cover of ½in tube split along the length and opened to be a good fit on the body. Plug and socket caps soft soldered to the ends of the tube. Finish dull nickel plate.

Resistor R₁₃ carbon film, R₁₄ carbon film or metal oxide. Strictly R₁₃ should be 9.9MΩ and R₁₄ 101 kΩ, however, a suitable compromise is R₁₃=10 MΩ. and R₁₄ 102 kΩ: these resistors should be selected to these values for the best accuracy. VC₁ Jackson Bros type C16 No 5440/80, 2.5pF min, 5pF swing. 'Electronics' list this as JB/5440/5. Socket Belling-Lee L734/J/Ni, plug L734/P/Ni. The lower edges of the trimmer capacitor should be chamfered, by careful grinding to ensure clearance of the rotor under the cover, before fixing the capacitor into the body with epoxy adhesive (Araldite). The body of the 10 MΩ resistor should be kept clear of the body of the socket by means of ceramic beads or p.t.f.e. or glass tubing not p.v.c., as shown in Fig. 9. Also all sleeving and wiring in the probe must be of low-loss insulation (not p.v.c. which is very lossy). Failure to observe this precaution will result in an unsatisfactory pulse response.

Resistive coupling cable. Cable, 6 feet of Radiospares 'Low Loss' or equivalent. (Central core is 1/048, insulation foamed polythene and outside diameter 0.3in.) Plugs Belling-Lee L734/P/Ni. Replacement conductor, plain or enamelled 47 s.w.g. 'Eureka' (cupro-nickel) wire.

The cable is cut back one end to expose the centre conductor only, and at the other the outer covering is removed for about 1½ inches, the braid combed back and both the insulation and centre conductor cut right back. The braid at this end is used to hold the cable whilst the inner is pulled out from the other end. It will be found easiest if the centre conductor is held and the cable pulled by the braiding. When the centre conductor has been removed, a 'pull-through' wire (22, or 24 s.w.g. tinned copper) is inserted into the cable bore. The fine resistance wire is soldered to this and drawn into the bore. The plugs are fixed in the normal way, except that the fine centre conductor is

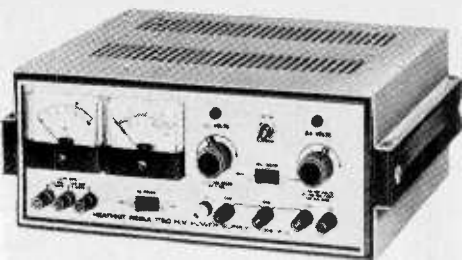

a variable regulated h.v. power supply which provides 0-400V d.c. at 100mA continuous, with better than 1% regulation from zero to full load and $\pm 10V$ mains variation. Also 0-100V d.c. bias at 1mA maximum. Two panel meters are fitted for separate monitoring of output voltage and current. Designated model IP-17, the new instrument operates from 120/240V 50/60Hz a.c. and is priced in kit form (K/IP-17) at £37 4s plus 10s 6d p.p. Assembled price on request. Daystrom, Gloucester, Glos.

WW 315 for further details

Function Generator Plug-in

A new plug-in sweeps the Hewlett-Packard Model 3300A function generator over three possible ranges of 10,000-to-1 without interruption for range changing. The generator with this new plug-in (HP Model 3305A) can sweep from 0.1Hz to 1kHz, 1Hz to 10kHz, and 10Hz to 100kHz. It may also be programmed by an external voltage to sweep or step to any frequency within a selected 4-decade range, and is thus well suited for automatic testing systems. The swept frequency output waveform can be a sine wave, a square wave, or a triangular wave. Any portion of any of the three frequency ranges may be swept, so a sweep from 10Hz to 40kHz, spanning the audio range with overlap, is simple. Characteristics of high-Q devices may also be evaluated by using very narrow band sweeping. The rate of change of the output frequency increases exponentially as the sweep progresses. Thus each swept octave (or decade) gets equal time, making the wide sweep practical for plotting, without loss of resolution or crowding of data at the low frequency end. The model 3305A Sweep Plug-in, which works with any Model 3300A Function Generator, costs £369 13s 8d (the main frame costs £235 13s 11d). Hewlett-Packard, 224, Bath Road, Slough, Bucks.

WW 325 for further details

Mobile Radiotelephones

Pye Telecommunications are producing a new series of fully transistorized radiotelephone equipment. The "Westminster Series", with alternative models for f.m. or a.m., has been designed for mounting in motor vehicles as well as on motorcycles and open trucks. For vehicles, the "remote" mounted model has a small control unit which fits easily under the dashboard, allowing the main transmitter/receiver unit to be mounted elsewhere, while a locally operated transmitter/receiver is available for underdash mounting. Motorcycles are catered for by a weatherproof version of the

"remote" mounted model which is not affected by vibration or dust. The main unit can be mounted behind the driver's saddle, and the compact control unit attached to the petrol tank. A small directional loudspeaker, which clamps unobtrusively to the handlebars, provides sufficient output to be heard clearly in heavy traffic. The transmitter power output of the series ranges from 5 to 15W with 1-10 channels. Other features include anti-flutter squelch and illuminated channel indicators. Each member of the Westminster series operates from 12V d.c. (small weatherproof converters for 6-24V operation are available), and with the exception of the motor-cycle unit which has a lower limit of 68MHz—the frequencies covered are between 25 and 174MHz in ten bands. Pye Telecommunications Ltd., Newmarket Road, Cambridge.

WW 322 for further details

Linear Picoammeter

Keithley Instruments Inc. have released a linear picoammeter, Keithley Model 414S. It is completely solid-state and warms up in 10 minutes. Overloads up to 1,100V can be withstood and there is an output of 1V or 1mA available for a recorder. Convenient and reliable operation is assured in the 10^{-2} to 10^{-4} ampere range. The instrument is ideally suited to measuring photo-cell or photo-multiplier outputs and is useful for measuring radiation. Also possible is the measurement of back currents in transistors and diodes where constant



low voltage drop is essential, but reliability and cost are important factors. In combination with appropriate accessories or companion instruments the measurement of insulation resistance and capacitor leakage is possible. The instrument can also be used as the amplifier in a variety of systems. Model 414S weighs 4.5kg and measures 14cm high, 22cm wide and 25cm deep. Keithley Instruments Inc., 28775, Aurora Road, Cleveland, Ohio 44139.

WW 311 for further details

Tunable YIG Microwave Filters

Marconi have developed a range of compact, solid state tunable microwave filters. Single crystals of yttrium iron garnet (y.i.g.) are used to provide



resonance which can be electromagnetically varied. By means of these, microwave tuning-in radio and radar systems is possible without any mechanical movement.

Two parallel stripline circuits of copper-plated lightweight plastic connect to 50- Ω coaxial cable input and output sockets. These two striplines are laterally displaced with a slight overlap and one or two exact spheres of yttrium iron garnet are mounted in a line at right angles to the joint axis of the striplines. A small electromagnet in the unit provides a magnetic field parallel to the coupling axis of the y.i.g. spheres, and the field strength controls the frequency at which the spheres provide a low impedance path between the striplines.

The lower limit of the frequency passband is determined by the y.i.g. composition and the upper limit by the magnetic field strength. The width of the passband is determined by the size and position of the sphere, and the insertion loss of the whole system depends on frequency and bandwidth.

Each unit weighs 1kg. and is approximately 9cm \times 7.5cm \times 6.5cm. Centre frequency ranges from 1.5GHz to 10GHz with bandwidths of 15 and 100MHz available. The tuning range is up to 1 octave. With reference to the passband, off-band rejection is better than 40dB. Linearity of tuning is better than $\pm 0.5\%$ including hysteresis, and a 1mA change in current causes approximately 3MHz change in tuning. Power to the electromagnet depends on frequency but is generally between 0.5W and 5W.

Filters can be built to order. Marconi Company Limited, Chelmsford, Essex.

WW 310 for further details

Circuit Breaker Units

Saunders Electronics offer a range of "Micro-tector" electronic circuit breaker modules designed to detect when the current and/or voltage applied to a system has exceeded pre-determined limits, and then to "crowbar" the power supply through a thermo-magnetic circuit breaker which cuts off the power supply within 10 microseconds—the turn-on time of the diverting thyristor. Standard units are available for nominal d.c. supplies of 12, 24, 36 and 48 volts. The actual input voltages can be within $\pm 15\%$ of the nominal, and the trip point can be pre-set by means of a trip control to any desired voltage from zero to maximum. Each nominal voltage type is available with maximum current ratings of 1, 2, 5, 7 and 10 amps. Actual current trip points can be pre-set by fine and coarse trip controls to any desired current from zero to maximum. Units can be supplied factory set to specified voltage/current trip values if required. Alternatively each unit can easily be set up using the actual power supply involved, a simple test meter to measure current and voltage, and a

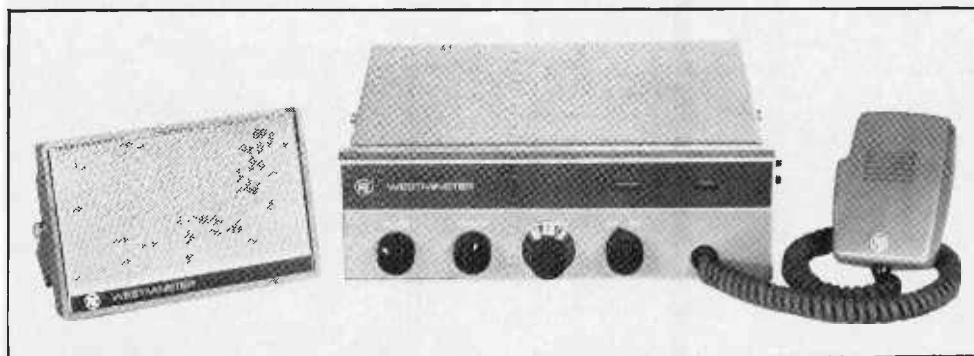



dummy resistive load. Suitable for panel mounting, each unit is housed in a protective aluminium case, measuring approximately 13×9×5cm, with rear terminal block. Saunders Electronics Ltd., Faraday Road, Hinckley, Leicestershire.
WW 320 for further details

High Power Avalanche Diode Oscillators

The Sylvania SYA-3200A avalanche diode oscillator has a minimum output power rating of 25mW, and the SYA-3200 a rating of 50mW. Both are available in waveguide configuration and coaxial. Together with the original 10mW type SYA-3200 the units are for use in waveguide systems. As pumps for parametric amplifiers, performance is equal to that of klystron drivers. Only one d.c. input is required and d.c. power consumption is 10 to 20mA at 60 to 90V. The operating temperature range is -40 to +85°C. Small and lightweight (less than 200g) they are mechanically tunable by a simple screw adjustment over at least 200MHz.

Particularly well suited for use in doppler radar, these oscillators can function as local oscillators in heterodyne receivers as well as beacon transponder sources. Sylvania International, 21, rue du Rhône, Geneva, Switzerland.
WW 309 for further details

Compression Amplifier

A new limiter/compressor, type 2252, has been released by Rupert Neve. It was designed to put into i.s.e.p. guide rails of the Neve modular system, but it can be adapted for a variety of systems. The control element is a semiconductor full-wave bridge in a balanced circuit. The bridge forms part of an attenuator and its impedance is controlled by symmetrical positive and negative direct currents. The direct currents are derived from a full-wave rectifier and separate side amplifier. Attack time is about 1ms for a 20dB gain reduction. The reduction is variable over the range of 75ms to 6 seconds by means of a switch on the front panel. Gain is sufficient to allow full limiting with a signal of -25dB. This threshold of limiting function can be reduced in 5dB steps by a front panel control until a signal



of +10dBm is required before limiting begins. A further switch allows slope to be changed from the high ratio "limiter" characteristics to a choice of lower ratio "compression" characteristics. The output level is controlled in 2dB steps to allow for the change in effective gain on different compression ratios. Rupert Neve & Co. Ltd., Little Shelford, Cambridge, Cambs.

WW 308 for further details

A.F. Oscillator

Designed specifically for the audio engineer, the JES a.f. oscillator model Si453 by Sugden is a general purpose oscillator with a frequency coverage from 13Hz to 30kHz in six overlapping ranges. Each range gives approximately a 3:1 ratio over the range before thus preventing the usual end-clamping associated with decade oscillators. A calibrated attenuator provides outputs of 0.1mV, 1.0mV, 10mV, 0.1V, 1V and 2V r.m.s. plus an infinitely variable fine attenuator. On later models (serial numbers 0901 upwards) the 0.1mV output position has been replaced by an output conforming to BS1928 fine groove recording characteristics enabling direct checks of equalizing characteristics to be made. The modified output level of 10mV at 1kHz simulates a cartridge with a sensitivity of 2mV/cm/sec. Output impedance is low and the output is constant over the full range to better than 0.2dB. A square wave output with a rise time

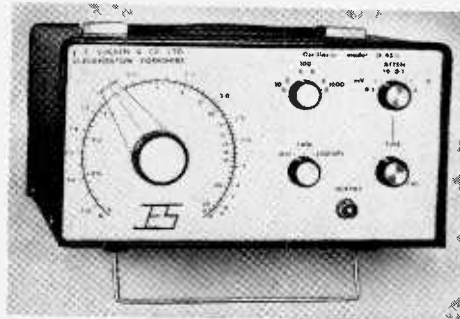

better than 0.5μs is available. As the instrument is battery-operated, hum on the output is eliminated. The Si453 measures 25.5×12.75×17.8cm and weighs 5kg. Price is £35. J. E. Sugden & Co. Ltd., Bradford Road, Cleckheaton, Yorkshire.

WW 316 for further details

Marine Communication Receiver

The International Marine Radio Company have produced a new marine communication receiver, type SR.401. A British G.P.O. approval certificate has been obtained for this for its use as a reserve receiver or additional main receiver on British registered vessels. In addition to the marine bands, continuous tuning is provided between 80kHz and 26MHz in seven separate ranges for reception of A1, A2 and A3 type signals. A large slide-rule type dial fitted with a logging scale permits accurate frequency selection, and, in conjunction with the reduction drive system, provides an effective scale length of 400 inches. Fixed tuned 500kHz and 2182kHz distress frequencies selected by the range switch are interlocked to provide optimum reception conditions for each service. A push-pull transistor stage feeds a built-in loudspeaker and a 600-Ω line connection allows extension of the audio output to a remote point. Automatic changeover to a 24-volt battery without interruption of service occurs in the event of an a.c. supply failure, high tension supply being provided by an integral transistor inverter. The equipment is fully fused and high voltage protection is provided by interlocks. A muting and receiver protection unit guards against the application of excessive radio frequency



voltages to the input circuits. The dimensions of the receiver are to international rack panel standards, and it weighs 160kg. International Marine Radio Company Ltd., Peall Road, Croydon, Surrey.

WW329 for further details

Cassette Tape Recorder

A new Bush portable tape recorder type TP.60 marks the entry of Rank Bush Murphy into the cassette-loading recorder market. This Japanese-made machine, which weighs under 2kg, is fully transistorized and is designed to take Philips type C60 or C90 tape cassettes with a tape speed of 4.75cm/s. Four self-contained 1.5V HP11 batteries supply operating power and a dual purpose meter indicates battery level and recording level. The recording level can be controlled by the volume control, or automatic level control can be selected by operation of a slide switch. Piano-key type press buttons are used for tape mechanism control. Sockets are provided for inputs from a microphone, radio or record player, and for feeding the output to an external amplifier. Price of the TP.60, complete with carrying case and microphone, 26gn. Rank Bush Murphy Ltd., Power Road, Chiswick, London, W.4.

W.W. 318 for further details.

Precision Rotary Attenuators

Flann Microwave Instruments Ltd. have designed a range of rotary attenuators for use in waveguide systems where broadband direct reading is required. The principle behind the design is the attenuation of a phase-polarized wave in a cylindrical waveguide caused by a thin resistive film introduced longitudinally across the diameter of the waveguide. When the film is parallel to the electric field, attenuation is maximum, and conversely, when the film lies at right angles to the field, attenuation is a minimum. If the maximum attenuation is substantially infinitely high, then through attenuation can be directly related to the angle between the field and the film. The attenuators are designed around precise electroformed circular waveguide sections with stepped transitions to rectangular waveguide. A high-precision 10-turn helical drum carries the direct reading scale giving extremely high resolution. Over the range 0-1dB, graduations of 0.01dB are marked. From 1 to 25dB the increments are 0.1dB. From 25 to 50dB 0.5dB graduations are used and these can be visually subdivided. The range 50-60dB has

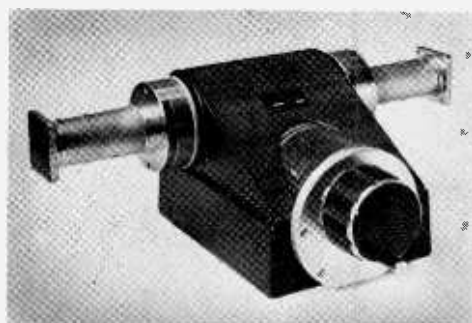

Wireless World, August 1968

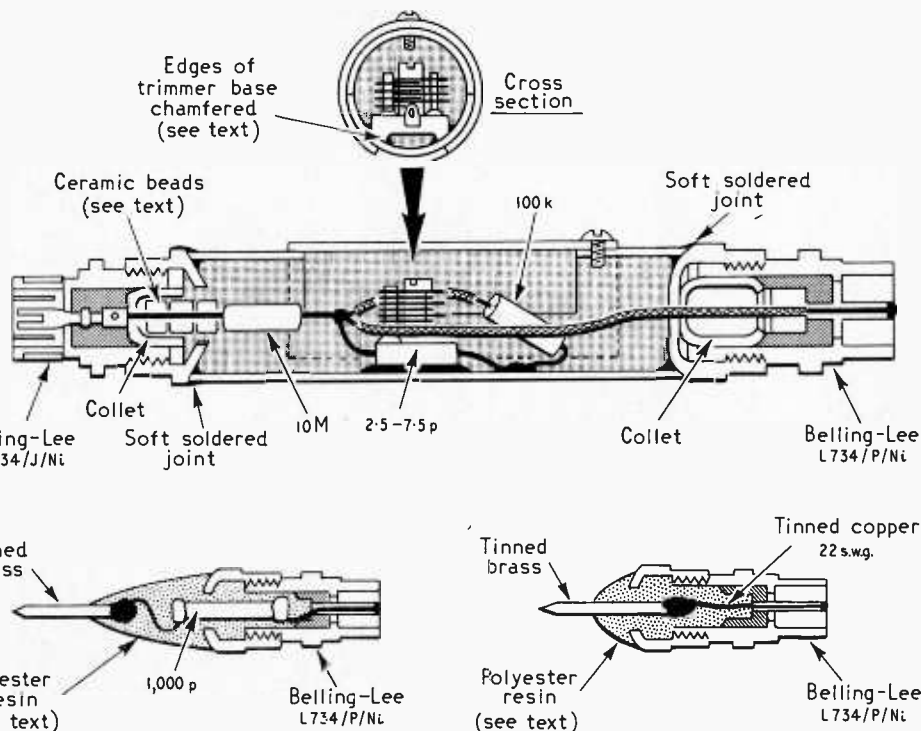

Fig. 9 (Left). The construction of the attenuator and a.c. and d.c. probe tips.

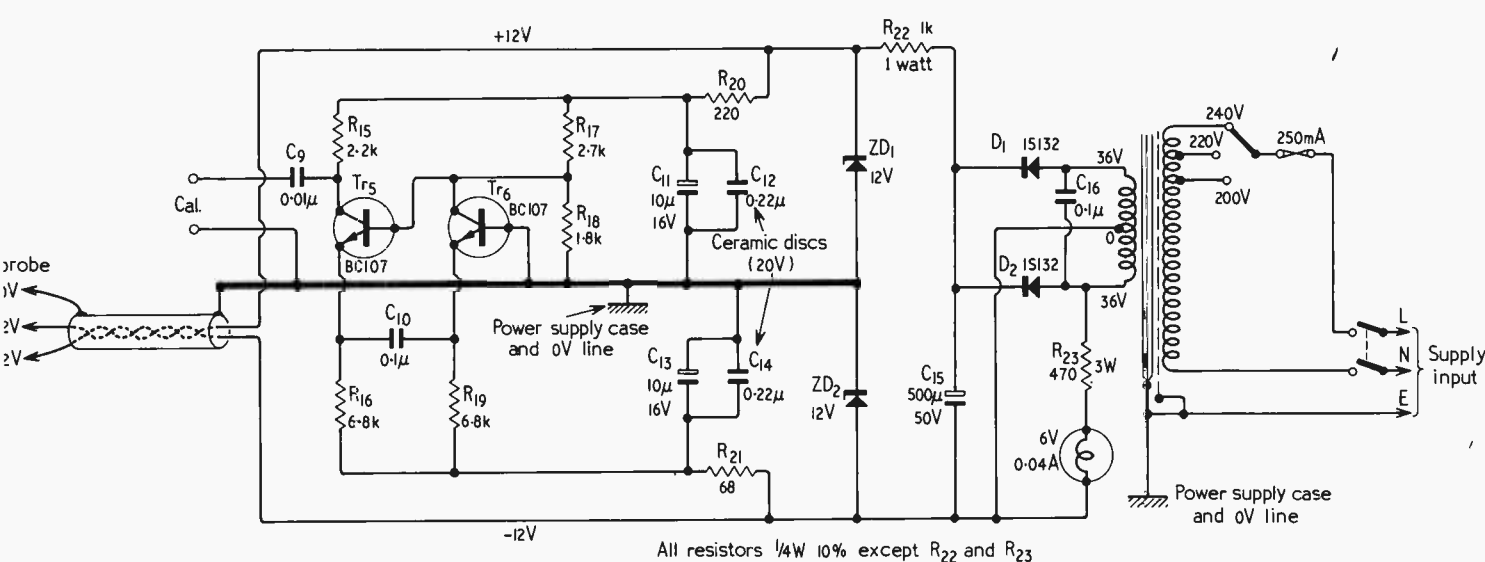

Fig. 10 (Below). The power supply and calibration oscillator.

...iled round a short length of 22 or 24 s.w.g. tinned copper as a former (which is then removed) before being passed into the plug body. The coil will lie easily in the pin of the plug and serves to relieve any strain or stretch in the cable so that it does not snap the central conductor. Such a coil of a few turns only should be made at both ends. The resistance of the finished cable will be of the order of 300Ω.

Probe tips. The construction of the tips is well illustrated in Figure 9. Both the a.c. and d.c. tips use an L734/P/Ni plug as the body, but without the collet. The resin used is 'Holts Cataloy' freely available at many accessory shops. The contour of the body is shaped after the resin has hardened, and the point is then tinned carefully and cleaned. An arth clip was made for the probe tips as shown in the photographs to ensure a short path to earth, an essential point when examining very fast waveforms.

Power supply. Fig. 10 shows the circuit of the power pack developed for the probe. This is straightforward and zener regulated. (Suitable zener diodes are 1S2120A, 1S7120A, BZY94, C12, CV 7145, STC ZF 2.)

The power supply includes an emitter timed astable multi-vibrator⁴ to provide a square wave of almost flat top and bottom levels, and very fast rise, and fall times free of overshoot. The frequency of this oscillator is 2.5kHz. The output of this oscillator is brought out to the front

panel of the power pack so that the capacitive compensation of the attenuator may be set up.

When correctly set, the response with and without the attenuator should be identical (i.e. a square wave without overshoot or undershoot). The decoupling of the multivibrator is essential if the waveform is not to find its way into the probe output in normal use.

The probe may also be used with audio and wide band valve voltmeters having a high input impedance. (The noise level in the band 10Hz-100kHz does not exceed 0.25mV with the probe input open or short circuit, when read on such a voltmeter.)

References

1. Marconi Instruments publication 'Measuretest' No. 6. Probes with Sinewaves by M. W. G. Hall.
2. 'An A.C. Probe with Low Input Capacitance & Unity Gain' by W. H. T. King. *Electronic Engineering* March 1966 pp 176-177.
3. Methuens Physical Monographs, 'Elements of Pulse Circuits' pp 105-107.
4. 'Emitter Coupled, Emitter Timed Multivibrators,' No. 1. Astable Circuits, by G. B. Clayton. *Wireless World* January 1968.

New Products

Electronically-tuned Gunn Oscillators

A range of Gunn oscillators capable of providing continuous outputs of 5, 10 and 15mW at X-band frequencies has been introduced by Mullard. Most of the types in the new series incorporate an electronic tuning facility and can give sufficient power to drive a balanced mixer under a wide variety of conditions. They can, therefore, often replace with advantage the more expensive klystrons, and their associated power supplies, in many applications. (The change in output power of a Gunn oscillator when it is tuned electronically is less than that obtained when a klystron is tuned in the same way.) Of the ten available types, the CL8300 and CL8310 have a very wide electronic tuning range (200MHz). Types CL8401 and CL8404 are intended for use in laboratory test oscillators, wideband receivers and other applications where precision oscillators with a wide mech-

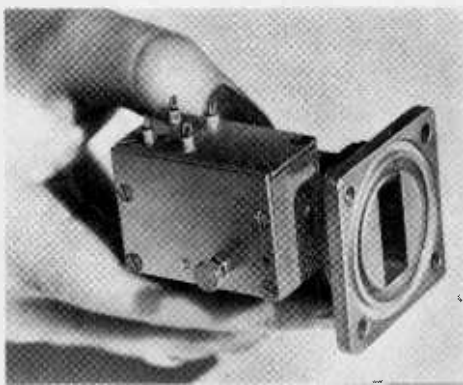

anical tuning range are required. Their mechanical tuning range is $\pm 1,000\text{MHz}$ and $\pm 1,500\text{MHz}$ respectively. Both are micrometer-tuned to ensure high reset accuracy. Also included in the range are six general purpose Gunn oscillators designed to cover the frequency range 9.2 to 9.5GHz. Two types, CL8420 and CL8440, incorporate temperature compensation so that their frequency/temperature coefficient is as low as that of an X-band magnetron. Mullard Ltd., Torrington Place, London, W.C.1.

WW 317 for further details

Equipment Refrigerator

A miniature refrigerator, type SES251, for laboratory, workshop or field uses, giving 5W of useful cooling at 77°K and costing £170 has just been introduced by the Hymatic Engineering Co. Applications include the cooling of lasers, infra-red devices, contamination shields and specimens in electron microscopes; also diodes in parametric amplifiers used in radio astronomy and telecom-



munications. The refrigerator is a portable, self-contained unit requiring only a supply of high-pressure nitrogen gas which is liquefied by the Joule-Thompson effect when expanded through a small nozzle. Cool-down to 77°K can be achieved in under one minute, after which time gas consumption is approximately 0.0141m³/min. The refrigerator is based on the Hymatic Minicooler, a miniature gas liquefier which is coupled to an integrated control assembly comprising a gas control valve, molecular sieve and filter and two pressure gauges. The control unit is connected to the Minicooler by up to 1.5m of pipe, allowing the Minicooler to be situated at the centre of the equipment being cooled. The Hymatic Engineering Co. Ltd., Aerospace and Advanced Products Division, Glover Street, Redditch, Worcs.

WW336 for further details

Large Scale Integrated Circuits

The Philco-Ford Corporation recently announced a number of l.s.i. arrays including a 1024-bit read-only memory (r.o.m.) containing 1,250 transistors on a 70×100mm chip and a 16×16 random access serial memory containing 1,400 transistors on a 100×120mm chip. Also an experimental 2048-bit memory (at present under development) contain-

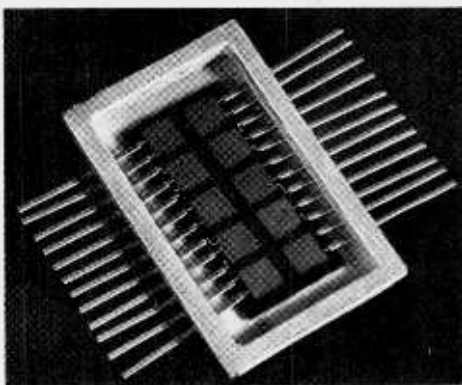

ing 12,000 transistors on a 117×117mm chip designed to operate at speeds greater than 5MHz—all in m.o.s. A dual-function bipolar complex array containing 400 components on a 110×88mm chip is designed to operate either as a four-stage binary counter (divide by 11) or as a b.c.d. counter (divide by 10) by arranging for a different logic level of a control input. Philco-Ford Corporation, Tioga and C Streets, Philadelphia, Pennsylvania 19134, U.S.A.

WW 305 for further details

70-pin Connectors for Circuit Boards

Cambion Electronic Products Ltd. are manufacturing two new 70-pin (double column) connectors designed for use with their i.c. logic assemblies and Cambi-card circuit boards. These new connectors are available in two termination styles; part no. 706-7029-01, with solder lugs; part no. 706-7014-01, with wire-wrap terminals. The key feature of the 7014 wire-wrap connector is the use of gold-plated bifurcated contacts on 0.1in centres for dense packaging of microelectronic circuitry. Both connectors permit greater input/output pin densities and greater flexibility of system design. Cambion Electronic Products Ltd., Cambion Works, Castleton, Nr. Sheffield, Yorkshire.

WW331 for further details

Silver Zinc Battery Charger/Discharger

Unit type 306/AW/76 battery charger/discharger has been developed by Industrial Instruments Ltd. for re-charging silver zinc batteries to manufacturers' recommendations in order to obtain maximum life from this type of battery. The instrument discharges each cell individually before re-charging at a constant current with minimum a.c. ripple current. A built-in "battery charged"

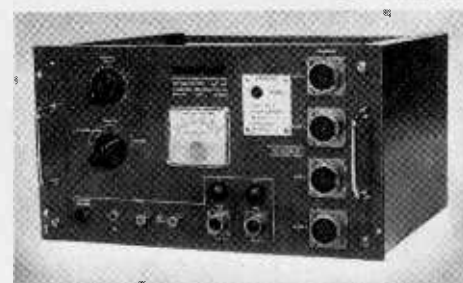

indication prevents overcharging. Discharging is carried out by means of resistors connected directly across individual cells via cables connected to the main unit through MK4 plugs and sockets. All discharge lines are fused, and monitoring of each cell voltage is provided by a front panel rotary selector switch.

The charger section is completely separate from the discharger except for an inhibit function which makes the charger inoperative when any one discharger plug is inserted. Magnitude of the constant charge current is adjustable to $\pm 20\%$ by means of a front panel control. Input is 110V or 200-240V 50/60Hz, and output 3A d.c. $\pm 10\%$ at up to 160V (76 silver-zinc cells). Monitoring facilities are (1) cell voltages on discharge, (2) battery voltage on charge, and (3) battery current on charge. Suitably constructed for 19in rack mounting, the 306/AW/76 measures 50×32×31.5cm and weighs approximately 22kg. Industrial Instruments Ltd., Stanle Road, Bromley, Kent.

WW 314 for further details

Regulated Power Supply

Featuring a new Heathkit instrumentation styling the latest addition to this well-known kit range is

1dB separation. Flann Microwave Instruments Ltd., 9 Old Bridge Street, Kingston-Upon-Thames, Surrey.

WW 327 for further details

Connectors for Miniaturized Circuits

The McMurdo Instrument Co. Ltd. have produced a new series of electrical connectors. The new "Redette" connectors complement the "Red" range and are approximately half the size. They are available in 16-, 26-, 38- and 52-way types for rack and chassis and line mounting. The connector bodies are keyed for polarization, and a plug shroud will ensure pre-alignment in, for example, line applications. Plastic covers with clamps allowing top or end cable entry are available, and accidental disengagement can be prevented by fitting with latching clips. For rack and chassis applications, the stainless steel fixing plates have floating

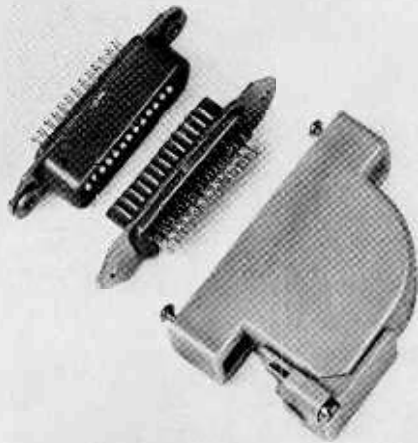

bushes, but for line use fixed mounting types are available. Each Redette connector contact will carry a maximum of 3 amps. The maximum working voltage is 1,500V d.c. or a.c. peak. The McMurdo Instrument Co. Ltd., Rodney Road, Fratton, Portsmouth, Hants.

WW 312 for further details

Metal Encapsulated Photo-cells

A new range of photoconductive cells encapsulated in metal housings with glass windows is available from Photain Controls Ltd. These photocells provide a variable resistance value directly related to the amount of light falling upon them. Two sizes of cell are available; the SPK5 series being 6.2mm in diameter and the SPK10 series being 11.6mm in diameter. The element can be of cadmium sulphide or cadmium selenide, the latter giving a response speed three times greater than the sulphide type. Power dissipation is 50mW for the SPK5 series and 150mW for the SPK10's. The highest d.c. resistance in total darkness is 5MΩ (dropping to 16kΩ at 100 lux) and is given by the SPK5-2. The SPK10-7 has a d.c. resistance of 1MΩ in the dark falling to 0.8kΩ at 100 lux. The maximum d.c. voltage is either 100 or 200 volts. The prices of the SPK5 range vary from 4s 6d to 8s 6d each and the SPK10 range from 5s 6d to 9s 6d each, depending on quantity. Photain Controls Ltd., Randalls Road, Leatherhead, Surrey.

WW 334 for further details

Transistor Radiotelephone

Covering business needs, where considerations of size and cost have previously precluded the use of radio communications, Cossor Electronics is

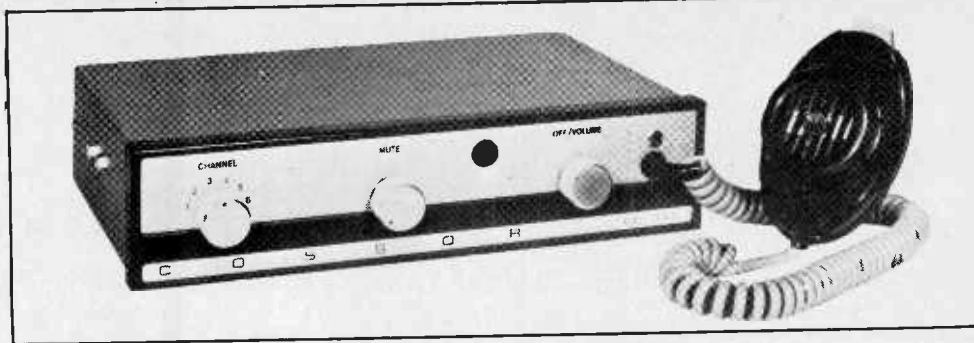

marketing a 5-W all-transistor v.h.f. mobile radio-telephone type CC701. It is little bigger than a car radio and provides up to six channels with single- or two-frequency working. Current drain is said to be extremely low and, when transmitting, the power used is equivalent to that used by two vehicle side lamps. The radio-telephone is designed to operate from 12V d.c. supply with either positive or negative earth and is available in standard communications bands with 12½, 25 and 50kHz channel spacing. The transmitter output is 5 watts into 50Ω and the a.m. capability is 100%. Receiver sensitivity is 0.5μV for 2W output; maximum output is 3W. An electronic adjustable mute facility is provided. Current drain from a 12V battery is 150mA (receive) and 1.25A (transmit). Dimensions of the unit are 26cm wide, 5.7cm high and 14.9cm deep; weight is 3.06kg. List price including aerial and cabling is £135. Cossor Electronics Ltd., The Pinnacles, Elizabeth Way, Harlow, Essex.

WW338 for further details

Miniature Transistors

A low level high speed switch and an r.f. amplifier are recent additions to Motorola's new Micro-T transistor line. The switch, MMT2369, and the amplifier, MT918, are each housed in a reliable one-piece, injection moulded Unibloc package about one-tenth the size of a TO18 can. Spaced leads radiating at 90° from the centre of their body allow them to be mounted right-side up or upside-down to facilitate layout. For high-speed low-current switching, the MMT2369 provides a t_{on} of 12ns max and t_{off} of 18ns max at 5.0V d.c., and a collector-emitter breakdown voltage of 15V d.c. For v.h.f./u.h.f. work the MMT918 provides a high current gain—bandwidth product of 600MHz min. Collector-emitter breakdown voltage is 15V d.c. The MMT918 is priced at 15s 3d each and the

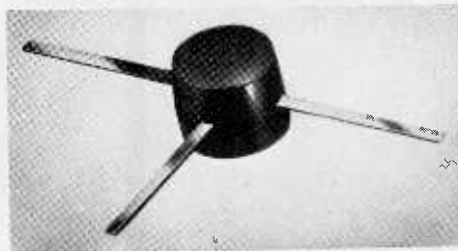

MMT2369 at 10s 2d each in 100 up quantities. Motorola Semiconductors Ltd., York House, Empire Way, Wembley, Middx.

WW 313 for further details

Uniphase D.C. Gas Laser

Several features of the Scientifica B/30 Gas Laser are the result of a detailed analysis of the various parameters affecting long and short-term output stability of high power gas lasers. The optical cavity is both thermally and mechanically isolated from the outside housing and the cavity has been designed to minimize the effects of lateral and axial distortion. The power output is 25mW

at $6,328 \times 10^{-10}$ m with a beam diameter of about 2.5mm at the exit aperture. The tube is fitted with silica Brewster windows with isotope filling, and mirrors are hard coated and finished to $\frac{1}{100}$ th wavelength. The hot cathode has d.c. drive and is guaranteed for a lifetime of more than 1,000 hours. The drive unit is solid state and has a single control to adjust output. Output power stability is given as better than $\pm 5\%$. The laser can also be supplied for wavelengths of $11,523 \times 10^{-10}$ m or $33,912 \times 10^{-10}$ m. The price, including power

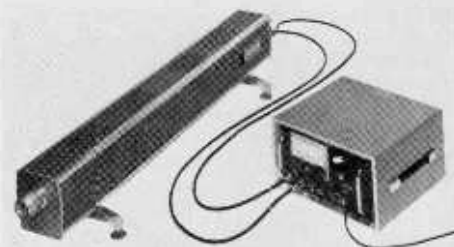

supply, is £1,195. Scientifica and Cook Electronics Ltd., 148 St. Dunstan's Avenue, Acton, London, W.3.

WW 328 for further details

Step Recovery Diodes

Interplanetic are marketing a range of step recovery diodes having a typical transition time of less than 1 nanosecond and capable of delivering 5 watts at C-band with a 10 watt input. This power is available over a 7% bandwidth. The multiplication is 4 times. With minimum breakdown voltage at 175 volts, the devices are available in subminiature or standard configuration. Interplanetic, 39-49 Cowleaze Road, Kingston upon Thames, Surrey.

WW 319 for further details

High-power Twin-channel Amplifier

A new high-performance solid-state twin-channel amplifier with a total power output greater than 300 watts is now being marketed in the U.K. by Carston Electronics Ltd. Made by Crown International of Elkhart, Indiana, U.S.A., and designated DC300, it is suitable as a drive amplifier for vibration work, as well as for high-quality audio applications. The amplifier is d.c. coupled throughout and has a frequency response at 1 watt within ± 0.1 dB from zero to 20,000Hz and within ± 0.5 dB from zero to 100kHz. Power output is typically 190 watts per channel with an 8-ohm load and 340 watts at 4 ohms. Response at a power level of 150 watts is within 1dB from zero to 20kHz, with hum and noise typically 110dB down. Input impedance is nominally 100kΩ, and less than 2 volts are needed to give full output. Two regulated power supplies per channel contribute stability and complete inter-channel isolation. Instantaneous current and voltage limiting gives complete short-circuit and mismatch

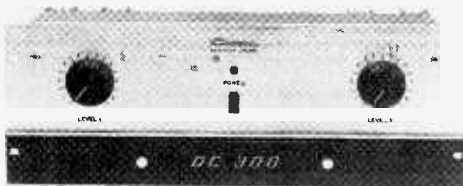

protection. The amplifier is designed for rack mounting and costs £297 including duty. Carston Electronics Ltd., Electra House, Wigganham Road, Watford, Herts.

WW333 for further details

Complementary Symmetry Amplifier

Radford have released a stereo power amplifier, the SCA 30, with a complementary symmetry output stage eliminating cross-over distortion. The power output is rated at a minimum of 30 watts r.m.s. per channel into any load impedance from 3.5Ω to 15Ω . Thyristor regulated power supplies make the amplifier virtually indestructible, and the makers say it may be left open-circuited or short-circuited at the output for extended periods without any ill-effect. Feedback circuits in the main power amplifiers result in the "power/frequency rating" being fully maintained over the range 10Hz to 100kHz at 0.1% distortion with absolute stability. In the preamplifiers, low noise 40V transistors allow considerable overloading. The 3mV disc input will



accept more than 100mV before overloading. The recommended retail price is £106. Radford Marketing Division, Eastbrook Road, Gloucester.

WW337 for further details

Tuning Fork Oscillators

Claude Lyons are marketing the Straumann series EM-104 miniature tuning fork oscillators. Tuning fork oscillator modules with fundamental frequencies from 1,000Hz to 6,000Hz may be used with associated divider and multiplier modules to cover the frequency range of 1Hz to 30kHz. Other modules provide output signal shaping (sine, square or pulse) and power amplification. The fork and drive coil system is available without associated electronic components. Short term stability is better than 0.1p.p.m. and accuracy not less than 0.005%. Each module is contained in a hermetically sealed metal can and will operate over the temperature range -55 to $+85^\circ\text{C}$. The output is 10V peak-to-peak for a 12V d.c. supply. Claude Lyons Ltd., Instruments Division, Hoddesdon, Herts.

WW 303 for further details



Electrochemical Timer

Mercron Mk 10 is an electrochemical elapsed time indicator in the form of a glass capillary, containing a mercury column divided by an electrolyte gap. When an electric current passes through this cell, the mercury is electroplated from one column across the electrolyte gap on to the opposite column. Thus, current flow causes the gap to move along the capillary, acting as a pointer. The movement is in exact proportion to the magnitude of the electric current through the cell and the time duration. When the gap has reached the end of the scale, the cartridge can be removed from the fuse cradle and re-inserted the opposite way, so that the pointer gap is effectively at "zero". In this way the Mk 10 can be used again and again. The cell is exactly the same size as a size 0 standard fuse cartridge. A current of $72.8\mu\text{A}$ causes the electrolyte gap to move along the capillary once in 100 hours. The cell will work in any position and

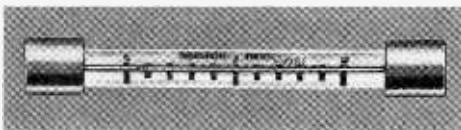

will last indefinitely. Industrial Instruments Ltd., Stanley Road, Bromley, Kent.

WW 323 for further details

Texas Triad Range

A new range of Triad semiconductor switches, three-terminal thyristor devices, has been announced by Texas Instruments. Available from 6A current capacity at up to 500V, through six voltage/current combinations to 25A at 600V, the devices are available in two package types—stud or press fit as specified. Turn-on time is typically $1\mu\text{s}$, the gate losing control when the device becomes conducting. Once turned on, current of either polarity will be carried up to the rated maximum. Turn-off occurs when the current between the main terminals falls below a minimum holding current (I_H), turn-off time being typically $50\mu\text{s}$. These devices are designed for all types of a.c. motor control applications in fields such as

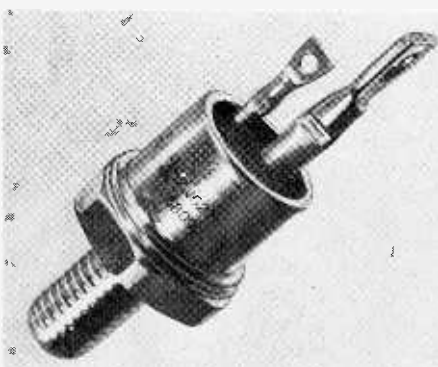

machine and power tools, and in computer peripheral control. Texas Instruments Ltd., Manton Lane, Bedford.

WW335 for further details

Differential Operational Amplifier

Computing Techniques have designed their differential operational amplifier type D3-1 to operate from a wide range of supply voltages ($\pm 8\text{V}$ to $\pm 25\text{V}$) and from supplies with little stabilization. Besides its high supply rejection, the D3-1 has greater than 120dB common mode rejection, making it highly suitable for use as a voltage fol-

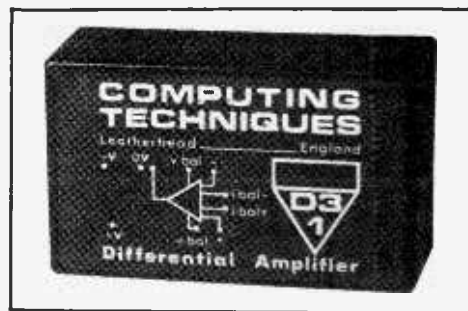

lower with high input impedance and accurate transfer. It will drive up to $\pm 30\text{mA}$ into a load with the output swinging to within 4 volts of the supply voltage. Reversal of supply voltage will not cause damage.

The common mode input impedance is $10^3\text{M}\Omega$, and the offset voltage change $2\mu\text{V/V}$. The d.c. gain, loaded with 600Ω , is 10^6 . Computing Techniques Ltd., 67 High Street, Leatherhead, Surrey.

WW 324 for further details

100 Ampere Triac

International Rectifier have introduced a new 100A high power triac series which complements the recent 200A triac. The new triac can handle 500kW and weighs only 100g. Available voltage ratings are from 400 to 1,000V. In applications where the triac can replace two thyristors con-

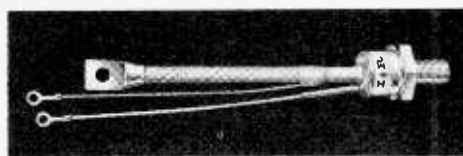

nected in inverse parallel, the heat sink requirement is less and there is self-protection against damage by transients. These units are designated 100AC40 to 100AC100. International Rectifier, Hurst Green, Oxted, Surrey.

WW 307 for further details

Miniature Resistor Network

Electrosil's Micro-R resistor network technique has been applied in the production of attenuators and a 5cm square matrix containing 256 resistors. Among the attenuators are five-pad balanced units typical of those used in G.P.O. 62 practice equipment. In the matrix package (see photo), glass-tin-oxide resistor blanks are packed into a framework which makes provision for interconnections in such a way that the package's 32 leads can give individual access to any resistor. This gives a high degree of flexibility. The matrices may also be "tailored" to meet varied user requirements. Electrosil Ltd., Pallion Trading Estate, Sunderland, Co. Durham.

WW332 for further details

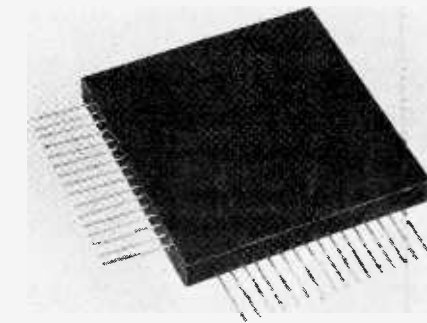

Test Your Knowledge

Series devised by L. Ibbotson*, B.Sc., A.Inst.P., M.I.E.E., M.I.E.R.E.

3. Electrical fundamentals

1. In copper the number of electrons per cubic centimetre which can take part in the conduction process is about

- (a) 10
- (b) 10^{10}
- (c) 10^{19}
- (d) 10^{23}

2. In a copper wire 1 millimetre in diameter carrying 1 ampere of direct current the drift velocity of the electrons (that component of their velocity which is associated with the current) is about

- (a) 0.3 metre/hour
- (b) 1.5 metre/second
- (c) 100 metre/second.
- (d) 3×10^8 metre/second.

3. Electric currents in solids may be carried by either electrons or positive holes. Assuming that only one type is present in a given specimen, which one it is may be determined by:

- (a) observing the variation of conductivity with temperature
- (b) deflecting the carriers by a magnetic field (the Hall effect)
- (c) producing thermionic emission and observing the sign of the emitted particles
- (d) observing whether or not the specimen will form a rectifying contact with another specimen of which the carrier type is known.

4. The resistivity of a solid:

- (a) is unaffected by temperature
- (b) increases with increasing temperature
- (c) decreases with increasing temperature
- (d) in some cases increases and in others decreases with increasing temperature.

5. The accompanying sketch represents the electrode system of a simple electron gun; the electrode potentials are marked.

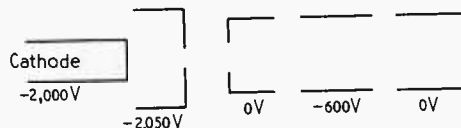

The kinetic energy of an electron emerging from the gun is approximately.

- (a) 2000 electron volts
- (b) 2050 electron volts
- (c) 0 electron volts
- (d) 600 electron volts.

6. A free electron in passing through a static magnetic field:

- (a) always gains energy

- (b) always loses energy
- (c) sometimes gains and sometimes loses energy
- (d) neither gains nor loses energy.

7. A time varying magnetic field cannot exist inside a perfect conductor because of

- (a) its low permeability
- (b) electron spin resonance
- (c) eddy currents
- (d) gyromagnetic resonance.

8. The permeability of a ferromagnetic or ferrimagnetic material

- (a) is constant
- (b) varies with temperature
- (c) varies with magnetizing force (H)
- (d) varies with both temperature and magnetizing force.

9. The magnetizing force, H , in amperes per metre at a distance r metres from an infinite straight wire carrying a current of I amperes is

- (a) $I/2\pi r$
- (b) $2\pi I/r$
- (c) $2I/r$
- (d) $I^2 r$

10. Two parallel wires carry steady currents in the same direction. The two wires

- (a) have no effect on one another
- (b) attract each other
- (c) repel each other
- (d) may attract or repel depending on their distance of separation.

11. A variable capacitor is charged and isolated. If the plates are moved farther apart in this condition the energy stored

- (a) drops to zero
- (b) remains constant
- (c) increases
- (d) decreases.

12. If a perfect inductor could exist and a constant potential difference were suddenly applied across it

- (a) no current would ever flow
- (b) constant current would flow
- (c) the current would increase linearly with time
- (d) the current would increase as an exponential function of time.

13. Thevenin's theorem—that a two terminal network can be represented by a

particular source of e.m.f. with a particular internal impedance—

- (a) applies to d.c. circuits only
- (b) applies to a.c. circuits only
- (c) applies to linear circuits only
- (d) applies to all circuits.

14. In the accompanying diagram R_1 and R_2 are equal.

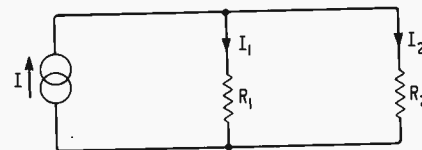

If the value of R_1 is doubled the current flowing through it is:

- (a) still I_1
- (b) $I_1/2$
- (c) $\frac{2}{3}I_1$
- (d) $I_1/3$

15. A sinusoidal generator and two components are connected in series. The r.m.s. values of the voltages across the two components are measured as V_1 and V_2 respectively. The r.m.s. value of the generator voltage must therefore be:

- (a) $V_1 + V_2$
- (b) $\sqrt{V_1^2 + V_2^2}$
- (c) $\sqrt{\frac{V_1^2 + V_2^2}{2}}$
- (d) not calculable.

16. The accompanying circuit is resonant at an angular frequency ω_0 .

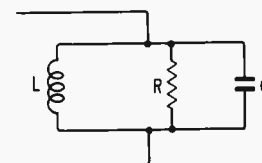

The value of Q is given by

- (a) $R/(\omega_0 L)$
- (b) $(\omega_0 L)/R$
- (c) $1/\sqrt{LC}$
- (d) $L/(CR)$

Answers and comments, page 287

September Issue

A novel pocket-size i.c. pattern generator for use in setting up a colour receiver will be described for home-construction in our September issue which will also include the fourth part of the colour television receiver series.

In addition to these and the usual quota of articles and regular features the issue will contain a supplement on tape recorders and accessories. In this there will be a survey article on the latest techniques and a selection of new products in this field.

*West Ham College of Technology, London, E.15.

World of Amateur Radio

Amateur Licence Fees Going Up

As predicted last month the Post Office has announced that as from October 1, 1968, the annual fee for Amateur (sound) A, Amateur (sound) B and Amateur television licences will be increased from £2 to £3 each. As from the same date the Amateur sound mobile licence will cost another 10/- per year (30/- against the current 20/-). Although these are the first increases in U.K. amateur licence fees for more than 20 years, the R.S.G.B. has registered a protest with the G.P.O. and at the same time has outlined a method of avoiding the need for any increase by combining the various types of licence as suggested in this column a month ago. This would have the effect of reducing administrative work connected with the issue of licences, the official reason given for the increases.

Beginner's Licence

In answer to an inquiry by Sir Ian Orr-Ewing (C. Hendon North), the then Postmaster-General, Roy Mason, wrote that he was considering the terms under which a beginner's licence (promised by his predecessor Edward Short) can be issued, and the qualifications required from candidates. Mr. Mason was aiming to have the licence ready in the autumn of 1968 but at the time he replied to Sir Ian he was not able to say whether holders of this class of licence would be confined to frequencies above 144 MHz. Our guess is that the announcement will be made on the opening day of the R.S.G.B. Amateur Radio Exhibition, Wednesday, October 2.

Teleprinter to further Amateur Radio in Space. A teleprinter will assist radio amateurs in developing a 432 MHz radio relay station to be placed on the moon in the early 1970s. Donated by International Telegraph and Telephone World Communications Inc. the teleprinter will be used by Nassau College Amateur Satellite Tracking (NASTAR) organization in Garden City, U.S.A. for relaying progress reports, specifications and other data on project Moonray to radio amateurs in all parts of the world. The aim of the Moonray project is to send an active electronic radio repeater to the moon, so that radio amateurs can communicate with each other by line-of-sight radio via the lunar station. Project Moonray's objective is to have the repeater (weighing

between 2½ and 4½ kg) placed on the moon by members of the third United States manned expedition.

VHF/UHF Beacons. The June issue of *Radio Communications*, official journal of the R.S.G.B., records the frequencies and call signs of three beacon stations operating in the 28-29 MHz amateur band, three in the 70 MHz band, 29 in the 144-146 MHz band and six in the 432-434 MHz band. The U.K. beacons operate on 28.195 MHz (GB3SX), 70.305 MHz (GB3GM), 144.250 MHz, (GB3GW), 144.500 MHz (GB3VHF) 145.985 MHz (GB3ANG), 145.990 MHz (GB3GI), 145.995 MHz (GB3GM), and 434.000 MHz (GB3GEC).

Czechoslovak DX Contest. The Czechoslovakian National Society (C.C.R.C.) announces that an International DX Contest will be held "every second Sunday in November from 0000 GMT to 2359 GMT" using all bands from 1.8 to 28 MHz. Stations will exchange five-figure numbers consisting of the RST report and two figures indicating the number of years the operator has been active in amateur radio. Club stations will give the years of their existence. Full details of this contest can be obtained by writing to Czechoslovakia Central Radio Club, P.O. Box 69, Prague 1. The closing date for logs is December 31, 1968.

Amateur Radio at C.C.I.R. Study Group Meetings. An amateur station operated from Palma de Mallorca, Balearic Islands, during the recent series of C.C.I.R. study meetings. Among the 160 delegates were 18 licensed amateurs including Jack Herbstreit, HB9ASI/WODW (Director of the C.C.I.R.), Gerald Gross, W3GG (former General Secretary of the I.T.U.), Prose Walker (W4BW) and R. Haviland (W3MR). Using the call EA6ITU the station made many contacts during the conference period (April 29-May 10). Permission for third-party traffic with the United States was granted by the Spanish telecommunication authorities.

Mobile Licences. Although the number of U.K. amateurs authorized to operate from a moving vehicle continues to increase (the total had risen to beyond 2,500 by the end of April 1968), membership of the Amateur Radio Mobile Society, according to a recent report, had fallen to 375 representing only

about 20% of all holders of a sound mobile licence. Curiously, the number of all mobile licence holders is again about 20% of the number of all sound licence holders (approximately 13,700).

News from Ireland. L. Purcell, EI6D, was elected president of the Irish Radio Transmitters' Society at the annual general meeting on April 6. S. Rossiter, EI7R, is the new vice-president. Radio amateurs who visit Eire and who wish to operate from that country in accordance with a reciprocal licensing agreement will be issued with a call-sign in the series EI2VAA-EI9VAA.

Amateur Radio in Cyprus. Since amateur radio licences were withdrawn in Cyprus four years ago the Cyprus Amateur Radio Society has been pressing the authorities for the restoration of licence facilities. The first break came during National Field Day weekend (June 8/9) when a station was licensed to operate from the Famagusta area using the call sign 5B4SS. The licence was valid for the weekend only and operation was authorized on 80 and 40 metres. The Cyprus Amateur Radio Society hope that the n.f.d. concession will lead to the full return of licence facilities at an early date.

St. Helens Centenary. St. Helens Radio & Electronics Society will be operating an amateur radio station, under canvas, from Sherdley Park, St. Helens, on 25, 26 & 27th July, in connection with the "Centenary Gala", arranged to celebrate the 100th anniversary of the granting of the Charter of the Borough. The special call sign GB3SH has been allocated.

Drilling-Rig Call Signs. C. G. Griffiths (K4JGS), an employee of Mobil Oil, Fernando Po, is anxious to operate an amateur station from one of the off-shore drilling rigs in Mobil's Nigerian concessions but he queries whether these rigs are located in what would be considered to be international waters in so far as amateur radio is concerned. Apparently Nigeria holds the mineral rights, although the drilling rigs are about 18 miles from the coast. Mr. Griffith's inquiry has some legal significance although it is doubtful whether a Nigerian licence would be granted to a foreigner in the present unsettled conditions in that country. Possibly K4JGS/MM would be the most appropriate call for Mr. Griffiths to use assuming that an amateur radio station installed on a drilling rig far out at sea counts the same as a station installed on board ship.

England-Gibraltar Contacts on 4 Metres. Considerable activity on the 4 metre (70 MHz) amateur band has been reported between stations in England and Gibraltar. Among the first contacts this season were those between ZB2BO and ZB2VHF on "the rock" and G3TTG (R.A.F. St. Ivel, Wadebridge, Cornwall). E16AS (Dun Laoghaire, Co. Dublin) also contacted both stations in Gibraltar. The maximum usable frequency (MUF) has, at times, reached 94 MHz this year—an exceptionally high figure.

JOHN CLARRICATS G6CL

Wireless World, August 1968

Answers to "Test Your Knowledge"—3

Questions on page 285

1. (d). Every atom contributes one conduction electron and there are about 10^{23} atoms per cm^3 in the average solid.
2. (a). Signals associated with current changes travel at or near 3×10^8 m/s.
3. (b). When a current passes through a specimen subjected to a transverse magnetic field a voltage arises which is perpendicular to the magnetic field and to the current. By observing the direction of this voltage and using Fleming's left-hand rule the sign of the carriers can be determined.
4. (d). In metals resistivity increases with temperature, in non-metals it generally decreases. Extrinsic semiconductors show increase of resistivity with increasing temperature at some temperatures and decrease at others.
5. (a). The kinetic energy gained by an electron in moving from the cathode to the final anode must be equal to the potential energy lost, and this, in electron volts, is equal in value to the difference in potential between cathode and final anode whatever the potentials of intermediate electrodes. The small cathode emission energy has been neglected in the answer.
6. (d). The force exerted on the electron by the magnetic field is always at right angles to its direction of motion and thus does no work.
7. (c). Any change of the magnetic flux in a conductor induces an e.m.f. surrounding the flux which drives an eddy current producing a magnetic flux to oppose the change. Thus if the conductor resistivity is zero no change in flux can ever occur.
8. (d). Permeability decreases with increasing temperature up to the Curie temperature, above which it is approximately unity. The fact that permeability varies with magnetizing force is indicated by the shape of a hysteresis loop.
9. (a). Solution (c) is the formula for H in the c.g.s. electromagnetic system of units.
10. (b).
11. (c). We do work against the electric field in moving the plates farther apart so that the stored charges have greater potential energy.
12. (c). The usual current formula, involving an exponential function of time, occurs because the resistance in the circuit ultimately limits the current.
13. (c). It is usually possible to find a linear "equivalent circuit" which approximates to the behaviour of a non-linear device over a range of its operation so that Thevenin's theorem can be applied in these restricted conditions.
14. (c). $I_1 = I/2$. When R_1 is increased the supply current, I , remains unaltered. The current divider theorem indicates that R_1 now takes $I/3$ which is thus $2I/3$.
15. (d). To find the r.m.s. value of the generator voltage we must know the relative phases of the voltages across the two components.
16. (a) Solution (b), which seems more familiar, is for a series resonant circuit or a parallel circuit in which the resistance is in series with the inductor.



BULGIN EIGHT POLE SHROUDED CONNECTOR

SEVEN POLE PLUS EARTH.

PATENT APPLICATION NUMBER 13283/68

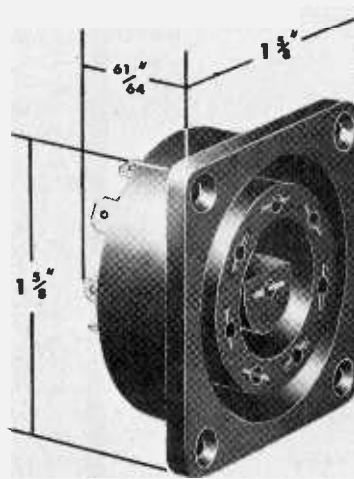

Socket List No: P.551

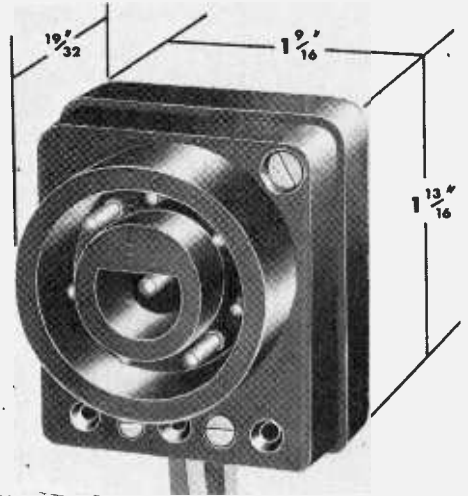

Together List No: P550

Plug List No: P.551

This versatile and unique 8-Pole (7+ EARTH) connector has a 6A. 250V. A.C. 'mains' rating and both Plug and Socket members are so designed that when un-mated the live parts are shrouded and safe to handle; they are also constructed with positive polarity keying to prevent incorrect insertion and therefore may be used for both INLET or OUTLET applications. The plug member has generous Screw Terminal Connectors, clearly coded for 'mains' and Auxiliary lines and efficient cable grip facility. This Connector is essential for all Multi-Way Applications where time, money and space is a premium.

P.550 PLUG AND SOCKET WIRING CODES.

14 COMBINATIONS

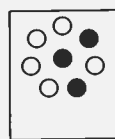

P.551/1-2-4
Mains In
Only

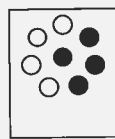

P.551/2-3-4
Mains In &
One Out
1st Choice

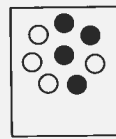

P.551/1-2-3-4-5
Mains In &
One Out
2nd Choice

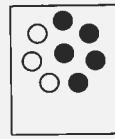

P.551/1-2-3-4-5
Mains In &
2 Out

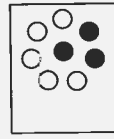

P.551/1-3-4
Mains 1
Out Only
1st Choice

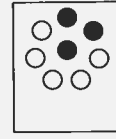

P.551/1-4-5
Mains 1
Out Only
2nd Choice

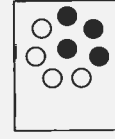

P.551/1-3-4-5
Mains 2
Out Only

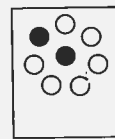

P.551/1-6
Aux V. 1
Pole & Earth
1st Choice

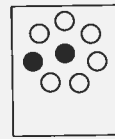

P.551/1-7
Aux V. 1
Pole & Earth
2nd Choice

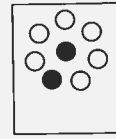

P.551/1-8
Aux V. 1
Pole & Earth
3rd Choice

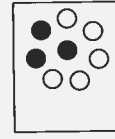

P.551/1-6-7
Aux V. 2
Pole & Earth
1st Choice

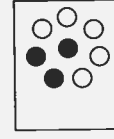

P.551/1-7-8
Aux V. 2
Pole & Earth
2nd Choice

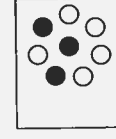

P.551/1-6-8
Aux V. 2
Pole & Earth
3rd Choice

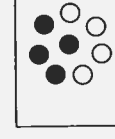

P.551/1-6-7-8
Aux V. 3
Pole & Earth

CONNECTION CODE DIAGRAM

- 1 = EARTH
- 2 = LIVE IN, LIN.
- 3 = SECOND LIVE, L OUT 1
- 4 = NEUTRAL N, (IN OR OUT)
- 5 = THIRD LIVE, L OUT 2

MAINS UP
TO 250V. ~

- 6 = FIRST AUX.
- 7 = SECOND AUX.
- 8 = THIRD AUX.

RETURN E (1)
VIA PIN 1

A. F. BULGIN & CO. LTD., BYE-PASS RD., BARKING, ESSEX.
TELEPHONE :- 01-549 5588 (12 LINES) Private Branch Exchange

Literature Received

"Practical Planar for Transmitters" is the title of a leaflet from Mullard Ltd., Torrington Place, London, W.C.1, in which brief details are given of Mullard planar transistors intended for transmitter operation. Also included are a number of representative circuits using the devices.

WW 361 for further details

We have received two leaflets from Brimar describing new **c.r.t.s** available from them. The first of these (a) is concerned with a readout demonstration tube type M31-100GH; This has a 30cm rectangular screen and is intended for use with low-voltage electrostatic focus and magnetic deflection. The second leaflet (b) deals with a 4 × 5cm instrument tube designed for use with transistor drive circuitry. Thorn-AEI Radio Valves & Tubes Ltd., 7 Soho Square, London, W.1.

(a) WW 362 for further details

(b) WW 363 for further details

Aluminium sheet, extruded round and flat bars, plate, strip and coils are listed in three leaflets from Feralco Ltd., Canal Street, Stourbridge, Worcs. The company will supply a certificate of analysis giving the chemical and mechanical properties of aluminium plate produced by them.

WW 364 for further details

The products of Salford Electrical Instruments are summarized in a leaflet that is available from them. Included in the leaflet are details of capacitors, rectifiers, magnetic materials, wound components, crystals, potentiometers, thermostats and a range of test equipment. Salford Electrical Instruments Ltd., Peel Works, Barton Lane, Eccles, Manchester.

WW 365 for further details.

The range of Contil instrument cases together with transformers, logic modules, neon panel lamps, a low-voltage neon driver and other items are outlined in a leaflet obtainable from West Hyde Developments, 30 High St., Northwood, Middlesex.

WW 366 for further details.

An inductive loop paging system for one- or two-way conversations is described in a leaflet received from Modern Telephones (Great Britain) Ltd., Chalcot Road, Regent's Park, London N.W.1. As well as enabling conversations to be carried out from remote points to a central control, communications between remote points is also possible.

WW 367 for further details.

It is claimed that any container can be converted into a constant temperature bath in one simple operation with a portable Thermoregulator from Techné (Cambridge) Ltd. The units, which are described in a leaflet, consist of a heater, temperature regulator and stirrer all in one compact unit.

WW 368 for further details.

Details are given of a large range of Thermocouples suitable for numerous applications in a new 40-page catalogue available from Ether Ltd., Caxton Way, Stevenage, Herts.

WW 369 for further details.

An index which gives the E.E.V. equivalents of over 2,000 valve types has been released by the English Electric Valve Co. Ltd., Chelmsford, Essex.

WW 370 for further details.

The "CVP Resin Finder for 1968" consists of eight pages listing a variety of resins for industrial purposes. The materials included seem to be primarily intended for use in the manufacture of paints, varnishes and other protective coatings although some adhesives are covered.

WW 371 for further details.

Acoustic panels with a pleasing appearance and an average coefficient of absorption of 0.7 between 400Hz and 4kHz (measured as per BS3638/1963) are described in a leaflet received from Langley London Ltd., The Tile Centre, 163-7 Borough High St., London S.E.1. The panels feature a simple invisible jointing method.

WW 372 for further details.

Printed circuit connectors, plugs and sockets, printed wiring test-point connectors and other similar components are included in the 11-page "Comprehensive Connector Catalogue" produced by Ultra Electronics (Components) Ltd., 419 Bridport Road, Greenford, Middlesex.

WW 373 for further details.

The 1968 edition of the Mazda valve and picture tube data book is now available. As usual, a comprehensive equivalents list is included.

WW 373 for further details.

A modular interlocking bread-board system in which component leads are pushed directly into small sockets is described in a leaflet from S.D.C. Products (Electronics) Ltd., 1 Grosvenor Road, Sale, Cheshire. The board, called S-Dec, is suitable for industrial, educational and home constructor applications.

WW 374 for further details.

A new catalogue describing the range of image orthicon camera tubes available from R.C.A. Electronic Components, Harrison, New Jersey, U.S.A. features in particular the BIALKON (Bialkali-photocathode electronically-conducting target) tubes. It is claimed that this line of six types will replace 80 different image orthicons with little or no camera modifications.

WW 375 for further details.

H.F. Predictions—August

The general level of geomagnetic activity is increasing slowly and the first week of the month may be disturbed, otherwise conditions are expected to be almost identical with those of August 1967. A seasonal change is that daytime MUFs are beginning to rise on routes within the northern hemisphere though this is masked by a drop in the forecast IF2 from 133 for the previous month to 124. The coming autumnal equinox produces strong signals on trans-equatorial paths which during sunspot maximum, as at present, are generally rendered useless after sunset by multiple echoes. LUF curves shown, drawn by Cable & Wireless Ltd., are for specific commercial telegraph circuits but serve as a guide for other types of service.

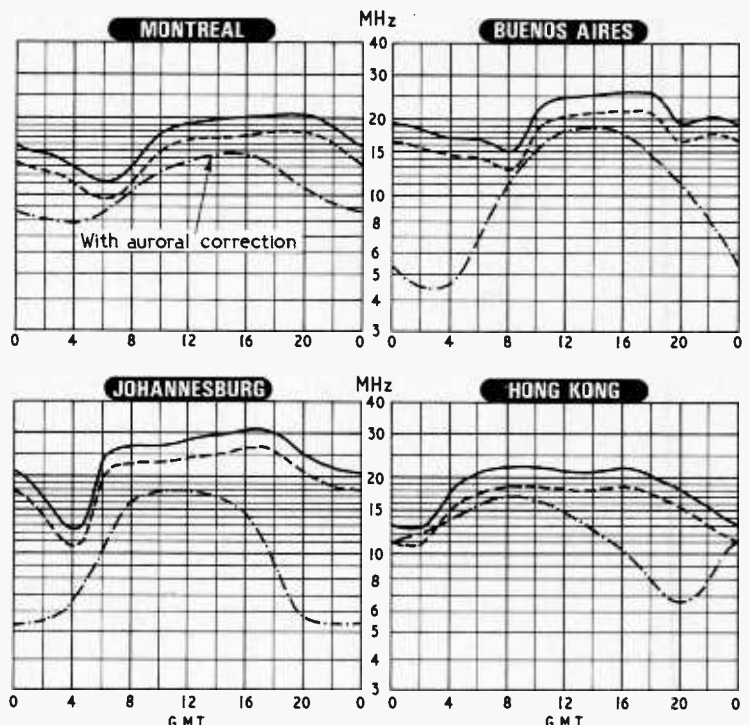

— Median standard MUF
 - - - - Optimum traffic frequency
 - · - · - Lowest usable HF



We make our monolithic capacitors in Britain

Monobloc ; an advanced product for sophisticated applications. A tiny component that has become the most exciting prodigy this side of the Atlantic. Its capacitance is vast, its size minute – up to 1 uf in $0.3 \times 0.3 \times 0.1$ in. (nine times smaller than a postage stamp). This capacitance-to-volume ratio is achieved by the unique monolithic construction. Wafer-thin ceramic dielectrics and platinum electrodes are fused into a solid, layered structure, to give a volumetric efficiency 10 to

100 times that of conventional capacitors. It's a rugged little device. The layered construction gives excellent stability and resistance to every form of shock and environmental stress. We manufacture a preferred range, concentrated on the individual requirements of the British designer. There are other configurations available for more complicated designs: glass-encased, precision moulded, phenolic coated, and unencapsulated chips for hybrid integrated circuits.

The monolithic capacitor is already a pretty important contribution to the progress of modern electronics – our Monobloc Ceramicon design caters for projects of the future.

Contact us for the full details. Technical Sales,
Erie Electronics Limited,*
South Denes,
Great Yarmouth, Norfolk.
Phone : 0493 4911
Telex : 97421

Monoblocs are to be featured in the 1968 edition 6 catalogue of S.T.C. Electronic Services. Monobloc and Ceramicon are registered trade marks.



*Formerly Erie Resistor Limited.

**over 60
countries
buy
British made**



ERSIN

Multicore
5 CORE SOLDER

**Ersin Multicore Solder helping
operatives in 4 of the 60 Countries**



CANADA

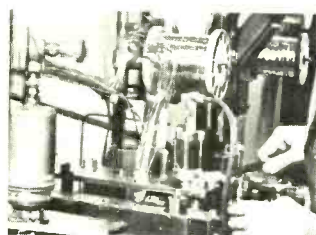

SWEDEN

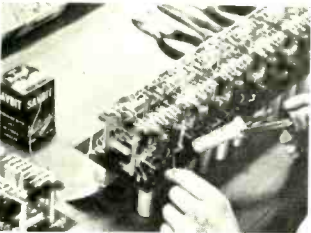

HOLLAND



NIGERIA

In some of these 60 countries cored solder is produced locally.

However, it is the consistent high quality of ERSIN MULTICORE SOLDER, that provides the utmost reliability of soldered joints, making it advantageous for manufacturers to import this British made product.

If in Britain or overseas you make or service any type of equipment incorporating soldered joints and do not already use ERSIN MULTICORE SOLDER it must be to your advantage to investigate the wide range of specifications which are available.

Besides achieving better joints – *a/ways* – your labour costs will be reduced and substantial savings in overall costs of solder may be possible.

Solder Tape, Rings, Preforms and Pellets – Cored or Solid – and an entirely new type of cored disc, can assist you in high speed repetitive soldering processes. If you solder printed circuits, our complete range of chemicals, fluxes and extra pure alloys can help you.

Engineers are invited to apply on their Company's notepaper for a comprehensive copy of the 30 page, seventh edition, of "Modern Solders". Ask us to help you with your soldering problems.



Multicore Solders Ltd.,

Hemel Hempstead, Herts.
Tel. Hemel Hempstead 3636.
Telex 82363

"Also ask for details of new **EXTRUSOL**", the first oxide-free high purity extruded solder for printed circuit boards, soldering machines, baths and pots".