

Wireless World

ELECTRONICS • TELEVISION • RADIO • AUDIO

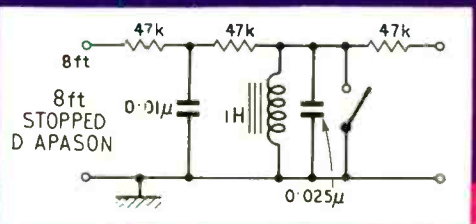
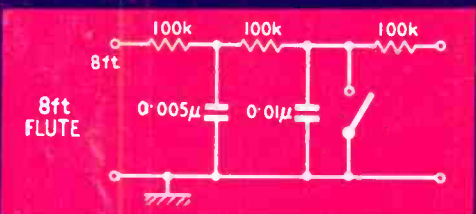
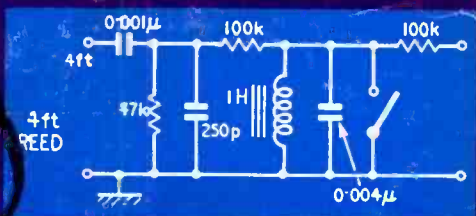
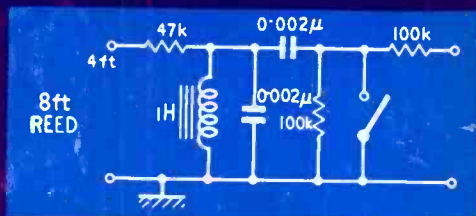
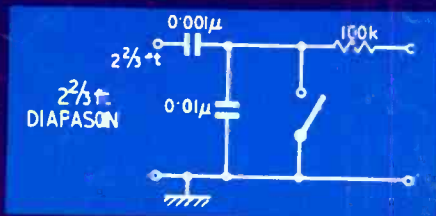
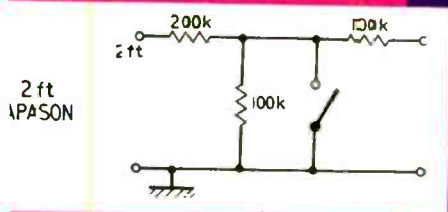
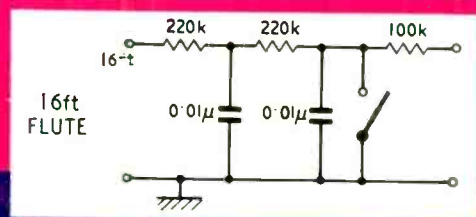
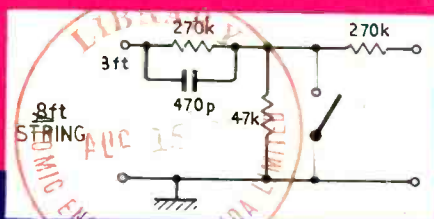
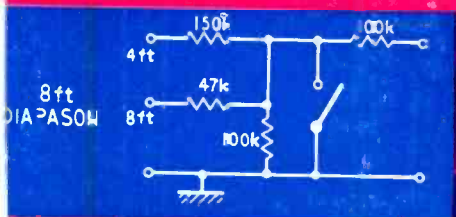

Construction of Transistor
Electronic Organ

KEYSWITCH

RELAYS

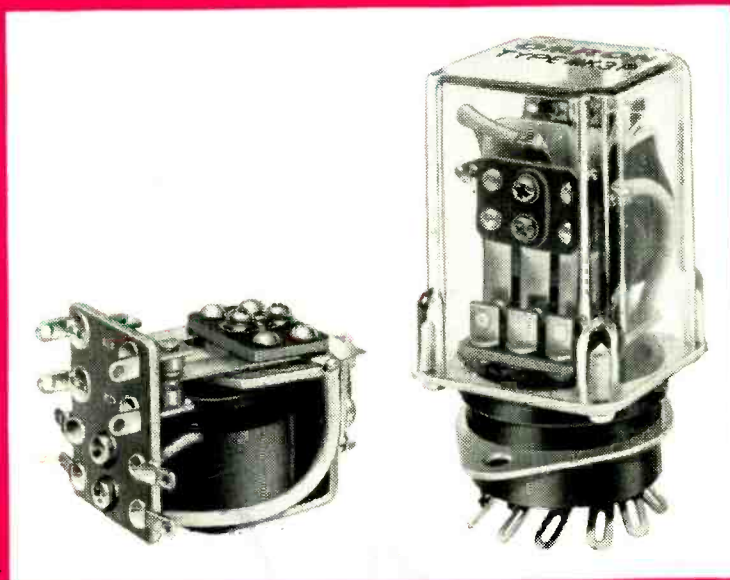

why say Keyswitch?

It's a difference of quality, often not visible until you look at performance data. Keyswitch miniature and sub-miniature relays are exhaustively tested . . . each one individually. All conform precisely to a very fine specification. Their reliability is proven. They have all the benefits of Keyswitch delivery → and that's quick, every time.

TYPE MK2 Illustrated approx. actual size. Inexpensive double-pole double-throw midget power relay. 99.9% pure silver contacts switch to 7.5A or 250V d.c./500V a.c. Operation and release 5-30 milliseconds. Universal coil range to 250V a.c./d.c. This relay can cost as little as 11/0.

TYPE MK3P Illustrated approx. actual size. 3-pole plug-in version with clear cover, and complete with socket. Contacts de-rated. This relay can cost as little as 17/8.

always to price ✕ **always to specification** ✕ **always on time**

KEYSWITCH RELAYS LIMITED · CRICKLEWOOD LANE · LONDON · NW2 · TELEPHONE: GLADSTONE 1152 · TEL'EX: 262754

WW 001 FOR FURTHER DETAILS.

"Wireless World"
Iliffe Electrical Publications Ltd.,
Dorset House, Stamford Street,
London, S.E.1

Managing Director:
W. E. MILLER, M.A., M.I.E.R.E.

Editor-in-chief:
W. T. COCKING, M.I.E.E.

Editor:
H. W. BARNARD

Technical Editor:
T. E. IVALL

Editorial:
F. MILLS
B. L. SEXTON, Grad. I.E.R.E.
G. B. SHORTER, B.Sc.

Drawing Office:
H. J. COOKE

Production:
D. R. BRAY

Advertisements:
G. BENTON ROWELL
(Manager)
J. R. EYTON-JONES

© Iliffe Electrical Publications Ltd., 1966. Permission in writing from the Editor must first be obtained before letterpress or illustrations are reproduced from this journal. Brief extracts or comments are allowed provided acknowledgement to the journal is given.

VOLUME 72 No. 8
PRICE: 3s.

FIFTY-SIXTH YEAR
OF PUBLICATION

Wireless World

ELECTRONICS, TELEVISION, RADIO, AUDIO

AUGUST 1966

- 381 The Engineer Shortage: Cause and Effect
- 382 Simplified Transistor Amplifier Calculations *by C. H. Banthorpe*
- 385 Construction of the Simple Electronic Organ *by T. D. Towers*
- 391 Direct-reading Phasemeter *by G. B. Clayton*
- 399 Switching Without Relays *by Aubrey Harris*
- 403 Simple Constant Current Circuit *by G. Watson*
- 407 Random Signal Testing for Evaluating System Dynamics *by W. D. T. Davies*
- 413 Using Integrated Circuits
- 417 Two More Impedance Converters *by Philip H. Briggs*
- 420 Root-locus Special Cases *by W. Tusting*

SHORT ITEMS

- 394 Cycloidal Path Mass Spectrometer
- 395 B.B.C. Stereophonic Transmissions
- 406 Print Quality Monitoring
- 406 Another Fase in the Sad Story of Man's Subjection to the Machine

REGULAR FEATURES

- | | |
|-----------------------------|---------------------------|
| 381 Editorial Comment | 414 Letters to the Editor |
| 395 World of Wireless | 424 New Products |
| 397 Personalities | |
| 405 H.F. Predictions—August | 430 News from Industry |

PUBLISHED MONTHLY (3rd Monday of preceding month). Telephone: Waterloo 3333 (70 lines). Telegrams/Telex: Wiworld Iliffepres 25137 London. Cables: "Ethaworld, London, S.E.1." Annual Subscriptions: Home £2 6s 0d. Overseas: £2 15s 0d. Canada and U.S.A. \$8.00. Second-class mail privileges authorised at New York N.Y. BRANCH OFFICES: BIRMINGHAM: 401, Lynton House, Walsall Road, 22b. Telephone: Birchfield 4838. BRISTOL: 11, Marsh Street, 1. Telephone: Bristol 21491/2. COVENTRY: 8-10 Corporation Street. Telephone: Coventry 25210. GLASGOW: 123, Hope Street, C.2. Telephone: Central 1265-6. MANCHESTER: 260, Deansgate, 3. Telephone: Blackfriars 4412. NEW YORK OFFICE U.S.A. 300 East 42nd Street, New York 10017. Telephone: 867-3900.

silicon planar

for audio, radio and hybrid television applications

Mullard now offer a comprehensive range of Silicon Planar Transistors for all new design requirements. These devices are outstanding in performance and are available at competitive prices.

Complete information is available to Design Engineers from:—

Mullard Limited · Entertainment Markets Division
Mullard House · Torrington Place · London · W.C.1
Tel: LANgham 6633 · Telex 22281

BC107

Low-frequency high-gain driver.

BC108

Low-frequency high-gain amplifier.

BC109

Low-noise high-gain A.F. amplifier.

BF115

V.H.F. mixer and oscillator for television.

BF167

'Integrated Screen' transistor for television I.F. amplifiers (A.G.C.)

BF173

'Integrated Screen' transistor for uncontrolled television I.F. amplifier stages.

BF180

Low-noise R.F. amplifier for U.H.F. and integrated tuners.

BF181

High-gain mixer and mixer/osc. for U.H.F. and integrated tuners.

BF184

High-gain I.F. amplifier for A.M., F.M. and television sound.

BF185

R.F. and I.F. amplifier for portable radios.

Mullard

planar

20/C88E

WW 092 FOR FURTHER DETAILS.

Wireless World

ELECTRONICS, TELEVISION, RADIO, AUDIO

The Engineer Shortage : Cause and Effect

THE electronics industry, complaining of the crippling shortage of engineers and technicians, is tempted to ascribe this to the general malaise that is currently affecting the whole of British industry—the unwillingness to do a full day's work—and so accepts it as inevitable. But discussions with enthusiastic young men with a professional attitude to work who have joined the electronics industry in the past few years lead us to the conclusion that the electronics industry also has a particular malaise of its own. Is what the industry considers to be the cause of its troubles not really the effect?

The immediate reasons for the shortage are well known; not enough people are being trained as engineers and technicians, and too many of those who are trained are going down the "brain drain" to the United States. The root cause of the training problem is that engineering in general does not appear an attractive occupation to boys at school considering their future careers. Consequently engineering courses at universities are under-subscribed while arts courses are bulging at the seams. The Council of Engineering Institutions is attempting to raise the social status of engineers by creating the new title of chartered engineer (C.Eng.). This seems rather like trying to pull oneself up by one's bootlaces. Does the rest of society really care? What is wrong here is the whole concept of the social ranking of different jobs. Young men with their eyes on America have little patience with such manoeuvring in the engineering establishment.

This brings us to the "brain drain" problem. Big money is not the basic reason for the brain drain—though we know of graduates in their late twenties who are currently being offered about 16,000 dollars p.a. by American electronics companies. Good salaries are only the concomitant of the principal attractions of jobs in the U.S.A.—more responsibility and freedom of action entrusted to young men and a generally fluid industrial situation which offers greater opportunities because people can move freely between different types of jobs. Too often young engineers and technicians complain of the stifling effect of working in British companies. They are kept locked up as tame specialists with little chance of moving into management or even into different fields of electronics engineering to gain experience. The attitude to engineers of many who control British industry is only too well expressed by that contemptuous phrase one sometimes hears: "Oh, my technical chappies will tell you all about that."

These are the obvious, surface reasons for the shortage. But beneath them lies the malaise we have hinted at above. It is simply that the British electronics industry has lost heart. It no longer seems to believe in its freedom of action, its power to initiate, its will to go its own way. Admittedly, large sections of the industry are owned and controlled, financially and technically, by U.S. companies: this is an inescapable feature of Britain's economic situation. But we do not have to be so be-dazzled by American technology that we have to give up all hope of achieving our own "break-throughs" in certain fields.

By all means let us stand on the shoulders of U.S. technology—not, like a child, just to be taken for a ride, but in order to see farther and leap higher. The recent initiative of the U.K. National Industrial Space Committee (which includes strong representation from the electronics industry) in trying to establish a British foothold in space technology shows the right kind of spirit—although there may be other, less prestigious, projects which could be more profitable in the end. The ability to do new things, to initiate and develop, to carry projects through successfully, is undoubtedly there—especially among our young engineers and technicians (that is why they are so much in demand in the U.S.A.). Let us use it to the full, and so encourage other young men to find better opportunities in this exciting field.

VOL 72 NO 8
AUGUST 1966

SIMPLIFIED TRANSISTOR AMPLIFIER

By C. H. BANTHORPE

TRANSISTORS appear to be very simple devices indeed but have become regarded by many experimenters and engineers as very difficult to design into circuits as predictably as desired. Due to wide spreads in published data for particular types they have also come to be regarded as rather wide tolerance devices and as the calculations published in good books on the subject seem quite formidable, many experimenters proceed on a trial and error basis only. This is unfortunate as very simple calculations provide a lot of practical information and can save much time and effort and experimental failures. Such simple short cuts are not substitutes for a proper understanding of transistor circuits but are often good enough for many practical purposes.

If a few assumptions can be made and a couple of statements taken on trust, then the following notes can be very useful.

It is first of all assumed that the types of transistors considered are of the type normally used in low power circuits. They can be of p-n-p, n-p-n, silicon or germanium types.

It is further assumed that the current gain is reasonably high—say more than 50, so that the emitter and collector currents can be considered to be equal. If the current gain is 50 and the base signal current is 1 unit then the emitter signal current will be the sum of the collector and base signal currents, i.e. $50 + 1$ units.

It is sufficiently accurate for many practical purposes to assume 51 is close enough to 50 to be called equal. Higher current gains are better still.

Finally, it is assumed that the transistors are operating at frequencies well below their limits. A common emitter circuit is considered.

Where signal voltages and currents are mentioned, voltage and current changes are meant.

A transistor can be considered as consisting of a mutual resistance r_m between emitter and collector, Fig. 1. The input voltage causes an input current to flow and amplified current flows through r_m . The current gain, usually called β (beta) can be measured or obtained from data on the particular transistor. This is the current gain of the transistor when used in a common emitter circuit.



C. H. Banthorpe has been technical director of Derwent Television (Central Equipment Ltd.) since 1956, having originally started with the company in 1936 as a service engineer. He joined the Telecommunications Research Establishment in 1939 where he worked on ground and airborne radar and on receivers and display devices for the Countermeasures Group, leaving in 1945 to return to Derwent Television. He was for several years works manager of the Perivale, Middx. factory and subsequently responsible for the design of television receivers.

The slope of a valve in mA/V is given the symbol g_m (mutual conductance). $1/g_m$ is volts divided by current so it is like a resistance. The term g_m of a transistor represents current change in the emitter divided by voltage change at the base and $1/g_m = r_m =$ mutual resistance.

One of the statements to be accepted is that in the case of a common emitter circuit any resistance in the emitter path appears to be β (the current gain) times as big when considered from the base.

This is a reasonable statement to accept as we would accept the fact that although a small voltage at the input causes a small *input* current to flow, a much bigger current (β times) flows in the *emitter* path and a small voltage causing a high current is the characteristic of a low resistance. Similarly, the resistance in the base path appears to be β times smaller when considered from the emitter.

Looking into the base, therefore, one would see a resistor of value current gain times r_m , (βr_m), Fig. 2, and looking into the emitter a resistor of value r_m , Fig. 3.

The other statement which must be taken on trust here is that 25 divided by the emitter current in mA = $1/g_m$ or r_m . This is a basic property of semiconductors and although the explanation is straightforward it is not necessary for these notes.

When a load R_L is connected in the collector circuit an input voltage at the base causes an input current to flow and a current β times as large will flow through r_m and R_L . As the same current flows through r_m and R_L , the voltage gain will be merely the ratio of the two resistors R_L/r_m or $g_m \times R_L$. This is the same expression as the voltage gain of a valve amplifier when the anode load R_L is much smaller than the anode resistance. This happens in many pentode voltage amplifiers, such as video stages.

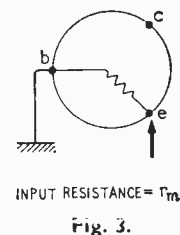
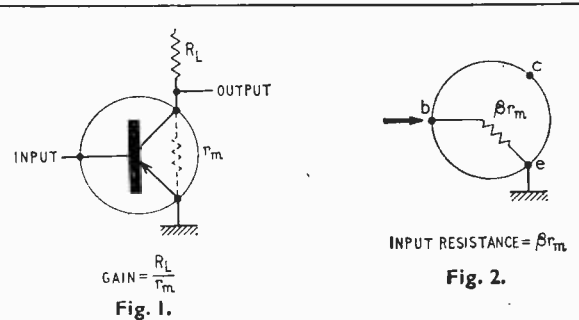

CALCULATIONS

A down-to-earth approach to the application of transistors operated in amplifier configurations. It is assumed that the transistors are of low power type with reasonably high current gain and are operated well within their frequency limits.

Inside the transistor there is also an ohmic resistance in series with each connector due to the resistance of the connecting leads and material itself. They can be neglected in many cases (when the current is very small for instance), but can be taken into consideration quite simply.

The resistance in series with the base, Fig. 4 can be called r_b and its effect is to increase the input resistance and reduce the voltage applied to the "works" of the transistor, r_m .

The input resistance becomes $r_b + \beta r_m$, the sum of the two input resistances, and the gain is reduced by a

factor $\frac{\beta r_m}{r_b + \beta r_m}$.

In fact, the input voltage is "potted down" by the two resistors r_b and βr_m .

The resistance in series with the emitter r_e , Fig. 5, also increases the emitter input resistance and reduces the gain by negative feedback.

Neglecting r_b the input resistance to the emitter therefore appears as $r_e + r_m$, and the input resistance to the base, Fig. 6, as $\beta(r_m + r_e)$. When r_b is included, Fig. 7, then the input resistance to the base equals $r_b + \beta(r_m + r_e)$

and the input resistance to the emitter equals $\frac{r_b}{\beta} + r_m + r_e$,

Fig 8. The term r_b becomes divided by the current gain, when considered for the emitter and is then added to r_m and r_e but when considered from the base r_m and r_e become multiplied by the current gain and are then added to r_b .

In many cases an external resistor R_e is included in the emitter circuit to reduce distortion or to make the perfor-

mance of a circuit less dependent on transistor characteristic or temperature changes, Fig. 9. As is to be expected, the resistor increases the input resistance and reduces the gain in a similar way to r_e .

The input to the base then appears as $r_b + \beta(r_m + r_e + R_e)$. That is, all the resistors associated with the emitter are added together and multiplied by the current gain and are then added to the base resistance r_b .

Viewed from the emitter, R_e is in parallel with the emitter input resistance $r_b/\beta + r_m + r_e$, Fig. 10.

It was stated at the beginning that neglecting the effects of the ohmic resistance r_e and r_b , the voltage gain of a common emitter stage was merely $\frac{R_L}{r_m}$.

If the effect of r_e is considered then the gain becomes $\frac{R_L}{r_m + r_e}$ and r_e usually comes out between 2 and 5Ω and can be taken as about 3Ω for most purposes.

If r_b is to be taken into account the calculated gain should be multiplied by $\frac{\beta(r_m + r_e)}{\beta(r_m + r_e) + r_b}$ to allow for the voltage drop across r_b .

This last correction is of little importance in many practical circuits and the error made by neglecting it is small, particularly if there is an uncoupled resistor R_e in the emitter circuit.

Three examples of the application of these notes will be given.

The first is to find the expected voltage gain of a simple amplifier under typical working conditions, and the second to design for a particular gain, of 10, using negative

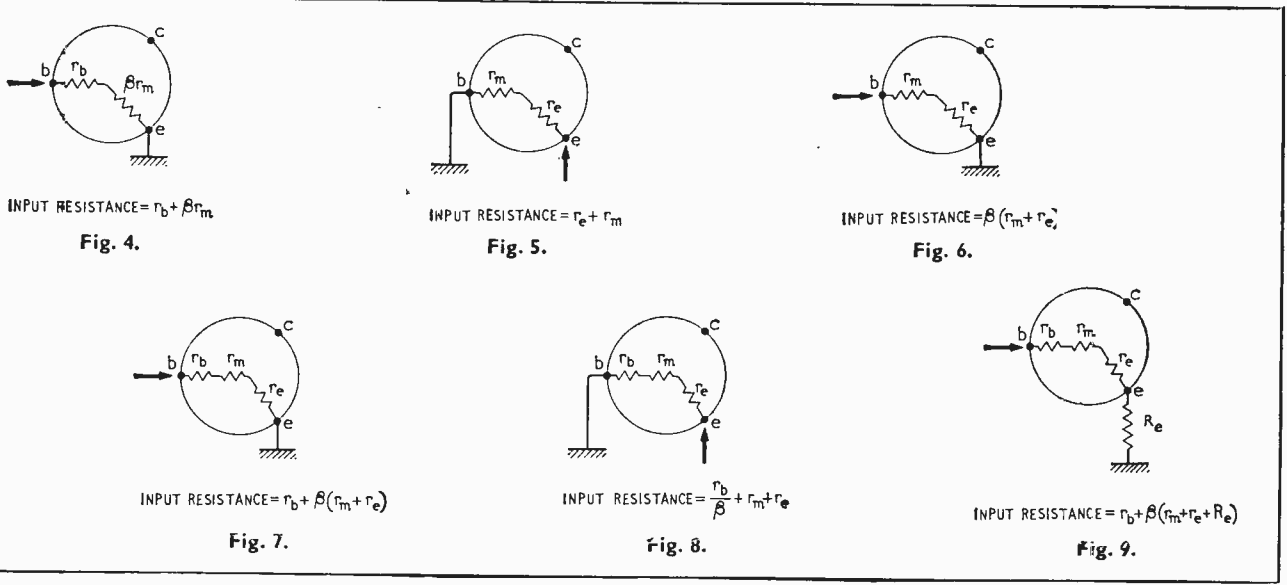

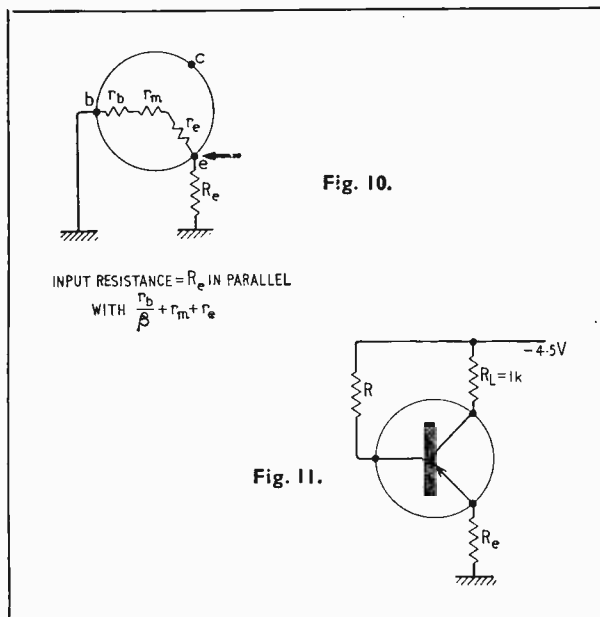

Fig. 10.

Fig. 11.

feedback as a control of gain. The input and output resistance of both amplifiers will also be estimated.

The Mullard OC71 is used as a good example of a general purpose transistor of the type considered above.

Thermal runaway is not usually a problem in the type of amplifier considered here, but it is useful to know that if the voltage across the transistor is equal to or less than one-half the supply voltage, then any increase of collector current due to an increase of junction temperature will not result in an increase of collector dissipation.

In this amplifier a collector load of 1 kΩ is satisfactory and reduces the collector/emitter voltage to about one-half the supply voltage. If the load is much higher it is possible for the transistor to run out of collector voltage under high temperature conditions. If it is lower, gain is reduced and the collector dissipation is increased. The choice of collector load is sometimes restricted by other considerations such as the load into which the amplifier must work.

In the basic circuit Fig. 11 the value of R is adjusted until the collector current is 2 mA. If the emitter current

$$\text{is 2 mA, } r_m = \frac{25}{2} = 12.5 \Omega.$$

Adding the ohmic resistance of the emitter lead and material of between 2 and 5Ω, say 3.5Ω, makes a total of 16Ω. The voltage gain is the value of the collector load R_L

$$\text{divided by this value} = \frac{1000}{16} = 62.5 \text{ if } R_e = 0.$$

Assuming $\beta = 50$ the input resistance will be approximately $r_b + (\beta \times 16) = 300 + 800 = 1100 \Omega$.

The output resistance would be close to 1 kΩ as the output resistance of the transistor itself is considerably higher than 1 kΩ, typically 25 kΩ - 50 kΩ and although it is effectively in parallel with the collector load it would reduce it by only a small amount.

If the collector load was much higher it might be necessary to take into account the output resistance of the transistor.

Similarly if the resistor or resistors supplying the initial current to the base were approaching the value of

the calculated input resistance, then account would have to be taken of their effect, since they would reduce the effective input resistance of the circuit.

If the amplifier is to produce a gain of 10 then the combined 16Ω "within" the transistor + the added emitter resistor R_e must be equal to the collector load

$$\text{divided by the wanted gain} = \frac{1000}{10} = 100 \Omega.$$

The value of the added R_e must thus be $100 - 16 = 84 \Omega$.

The input resistance would now be $r_b + (\beta \times 100) = 300 + 5000 = 5300 \Omega$.

The output resistance will again be very close to the value of the collector load = 1 kΩ.

Emitter followers, like cathode followers, are widely used as buffers or for impedance changing without any change of signal sign or any appreciable change of signal magnitude. The above simple calculations can also be applied to give the input and output resistance and voltage "gain" of emitter followers.

Choosing an emitter load of 1 kΩ for the same reason as discussed for the collector load of the previous amplifiers, the input resistance is given by Fig. 9, R_e being 1 kΩ, as $300 + 50(12.5 + 3.5 + 1000) = \text{just over } 51 \text{ k}\Omega$.

$$\text{Fig. 10 gives the output resistance in this case as } \frac{300}{50}$$

+ 12.5 + 3.5 in parallel with $1000 \Omega = \text{just under } 22 \Omega$. A very appreciable resistance change indeed.

The voltage gain can be calculated by assuming the resistors in the circle of Fig. 10 are in series with R_e of 1 kΩ, the input being across the combination and the output taken across R_e . The input signal is potted down by the

$$\text{ratio of the resistor } R_e \text{ to } 22 \Omega + R_e = \frac{1000}{1022}.$$
 There is

thus virtually no loss of signal magnitude.

If the transistor amplifier is considered in the simplified way above, several important points become clear. Since the gain of the transistor depends partly upon the current it is obvious that it must produce distortion as a voltage amplifier because as the current increases, the gain increases and voltage waveforms causing an increase of current will be amplified more than voltage waveforms of the same magnitude, but of opposite sign. This distortion can be reduced by making the signal current small compared to the standing current, and/or by including a resistor in the emitter circuit which is as large as possible compared to r_m . Voltage gain can thus be exchanged for a reduction of distortion.

Also it is very apparent how the introduction of a quite small resistance in the emitter lead (84Ω) reduces the gain to less than $\frac{1}{5}$ and increases the input resistance by nearly five times. This is because of the high "slope" of the transistor, in this case over 60 mA/V.

Measurements have been made on the circuits described and practice was in close agreement with theory. If the load R_L is divided by $r_m + 3 \Omega$ this will usually give the gain of the stage within 20%. If there is an undecoupled emitter resistor R_e as in Fig. 11 and the load R_L is divided by $r_m + 3 \Omega + R_e$, it will usually give much closer results.

Material for this article was gleaned from a number of sources, but particularly from an article by L. Reiersen and R. Olson in the December 1964 issue of *Service Scope* issued by Tektronix and a series of articles by G. P. Hobbs in the *Wireless World* September, October, November 1964.

Construction of the Simple Electronic Organ

By T. D. TOWERS,* M.B.E.

THE three previous articles in this series covered design trends (May, 1966 issue), the use of semi-conductors (June), and a simple transistor design for the amateur constructor (July). This article rounds the series off with some notes on the mechanical construction of the simple, single-manual transistor design given in the July issue.

Previously we examined design logically forward from the generators to the loudspeaker, "following the signal." When it comes to building, it is often better to work backwards, from the console to the generators. This is because, if you abandon the project half-way through, working backwards can involve you in the least expense.† (Also the console makes a good work bench.)

CONSOLE CONSTRUCTION

Fig. 1 shows the general construction of the console. Aesthetics apart, the dimensions are fixed mainly by three things: the convention that the tops of the natural "white" keys on the manual should be some 31in above the floor; the size of the keyboard used; and the need to get the instrument through an ordinary door, which can have as little as 24in effective clearance. It is scarcely necessary to point out also that there should be plenty of room for the knees under the keyboard and the right foot should be able to operate the swell pedal comfortably.

Front panel.—The front panel underneath the organ serves several purposes. It is primarily a loudspeaker baffle board, but on it are also mounted the power amplifier, the d.c. power supply and the swell pedal. Fig. 2 shows the main dimensions and cut-outs used. Only one speaker is really necessary, but four speakers with different cone resonances were used to reduce "wolf notes."

The main design points to be covered are that a sufficiently stout baffle ($\frac{3}{8}$ in or, better, 1in thick) be used, with all attachments *securely* screwed on. At C1, 62.5 c/s, vibration is considerable, and quite a time can be spent winking out odd buzzes and rattles over the whole range of frequencies, if you do not give sufficient attention to firm mounting.

The swell pedal cut-out is conventionally centred on a line about one-third from the right hand edge of the baffle. In the completed organ the baffle board is covered with a cloth material, which should not be too

close a weave, as this reduces bass response. In the prototype, the material used was oil painting canvas with the dressing washed out.

The baffle board is designed to be attached to the sides of the console by 3in corner braces, top and bottom, on the back at each end. The only connections to the

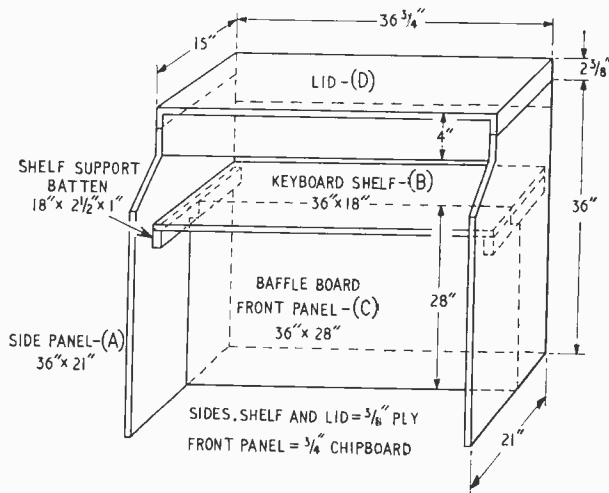
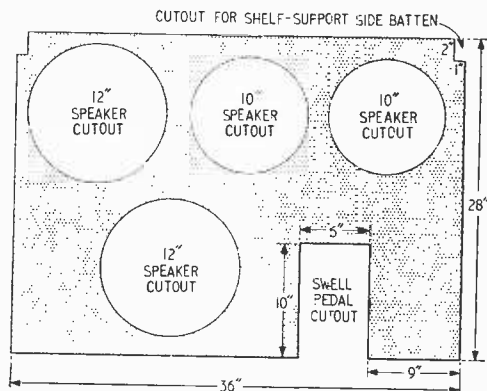

Fig. 1. Oblique sketch of main dimensions of console frame of author's organ.

Fig. 2. Front-panel baffle-board assembly on back of which are mounted the loudspeakers, the swell-pedal, power amplifier and unregulated 12/15V d.c. power supply unit. The sketch shows the main dimensions and panel cut-outs used by the author.



*Newmarket Transistors Ltd.

† Mention of possible abandoning of the project reminds me that I had reached over 7,000 soldered joints before I gave up counting. The weaker brethren who blanch at this thought would be advised to turn to partially assembled kits, which would give them a much better chance of finishing with a working instrument.

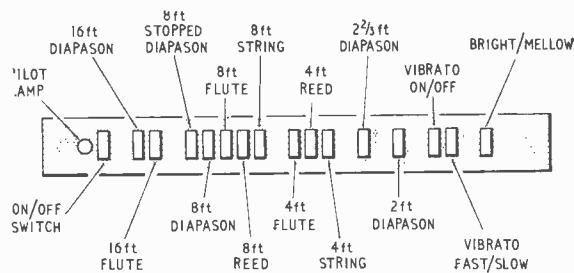

Fig. 3. Sketch of layout of stop-tab facia panel from the front. Dimensions: 36in x 4in x 3/8in. Stops spaced at 1 1/4in grid.

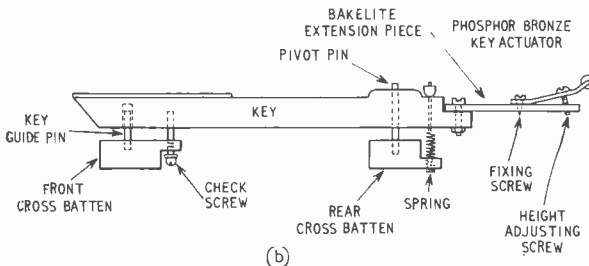
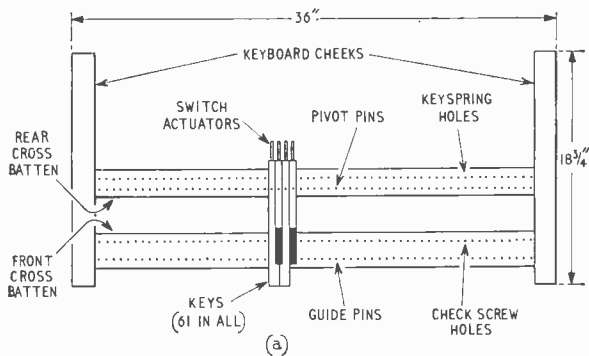

Fig. 4. Diagram of keyboard used by author: (a) overall features, (b) details of individual key.

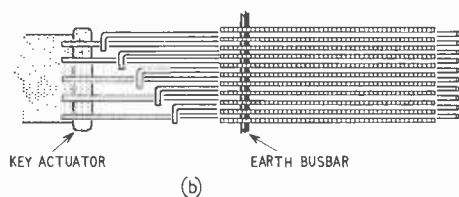
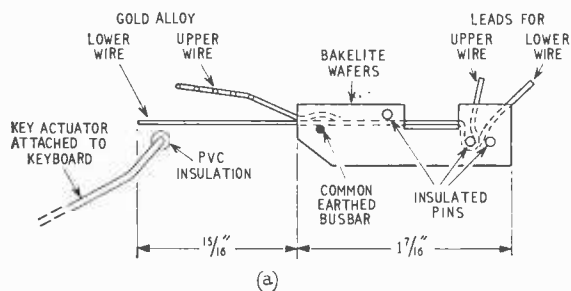

Fig. 5. Details of key-operated switch used in prototype organ: (a) side view, (b) plan view.



Young instrumentalist tries out the author's prototype organ.

keyboard assemblies are a coaxial cable bringing the signal to the swell pedal, and a five-way cable taking the mains and 12 V d.c. to the generators, etc. Thus the baffle board can be stood away from the remainder of the organ, supported on the swell pedal projecting behind, to make working on the keyboard easier.

Stop panel or facia.—The stop panel is fitted across the keyboard just clear of the back of the black keys. Fig. 3 shows the general layout and switch arrangements used. The stops are arranged in a logical order in groups from deep 16ft on the left to shrill 2ft on the right. The "bright/mellow" stop at the right-hand end merely switches a small top-cut capacitor (between 0.001 and 0.01 μ F) across the output busbar after the stop filters, thus doubling the variety of tones obtainable.

The stop switches used are a standard cheap "Veto" single-pole on/off wall-light switch from Woolworths. The stop panel is mounted on the keyboard side cheeks with 3in corner braces. Each of the filter circuits is assembled on a separate board and soldered behind its corresponding stop switch. The main pre-amplifier is also a small board mounted at the right-hand end on the back of the stop panel.

In the stop panel the main design requisites are that the switches should be conveniently near to, but clear of, the playing keys. They should be light in action and easy to see whether they are on or off. The stop labels should be above the switches, to be clearly visible at all times; constructors will find the now ubiquitous "Dymo" adhesive tape labels give a professional touch.

KEYBOARD ASSEMBLY

The keyboard is one part of the electronic organ that the amateur constructor seems to find great trouble with. Some people come into possession of an old organ keyboard, and try to adapt it. Because so much of the

design depends on the keyboard, it is recommended that a new unit be used. There is no detailed standardization of dimensions yet, but the diagrams in Fig. 4 show some details of the keyboard used by the author. This particular keyboard was obtained from Stern-Clyne Ltd. and had originally been specified for their Mark III valve organ. It was used because all the springs, bakelite keytail extension slips, adjustable key control actuators, etc., were available in kit form. The keys are "back hung," pivoting on pins in the rear cross-batten. Many other arrangements are possible.

The constructor will almost certainly find difficulty in securing light action in the keys. In the prototype, the keyboard was taken to pieces and reassembled three times before it came right. The principal points to watch are the easing of the rear pivot pin holes with a fine rat-tail file, the clearing of the guide holes for the stop check screws under the fronts of the keys (by which the key heights are set level at the front), and the fitting of felt washers under the stop check screw heads to eliminate clicks as keys are released.

The keyboard is important not only in itself but as the sub-frame for all the electronics on the organ up to the swell pedal. In the prototype a firm 5in-wide strip of 16 s.w.g. aluminium, 36in long, was first screwed on top across the rear of the keyboard side cheeks. Butt hinges were next fixed below the back ends of the side cheeks and screwed down at the rear of the shelf in the console. The keyboard could then be swivelled up to get at the underside for adjustments without one having to crawl about underneath. This is one feature of conventional practice it is well to follow.

Keyswitch assemblies.—When the playing keys are depressed, they actuate the signal switches. Many constructors exercise ingenuity in devising their own switches. These are so critical, however, that it is by far the safest to use standard switches. In this country, almost always, switches by Kimber-Allen, specialists in this field, are used, and this was done in the present organ. Fig. 4 illustrates the details of their type GH contact assemblies used. These are changeover switches fitted with five individual pairs of contact wires made in gold alloy. The straight wires at the resting position press

on an earthed busbar rod stretching the whole length of the keyboard, and when actuated move up from earth to independent contacts. The busbar is 18 s.w.g. silver wire, rhodium plated.

The wires in these keyswitches are very fine gauge, and the keyswitches must be handled most carefully. A wise precaution is to assume you will spoil some before you get the hang of them; so order a few extra beyond the 61 required.

As the lower wires carry independent signals, the switch actuator attached to the playing key shown on the left in Fig. 5 must have an insulated tip. The author employed two thicknesses of Radiospares' adhesive p.v.c. tape to cover the ends of the phosphor bronze actuators used.

The switches are mounted on a 36 in \times 2½ in \times ¼ in paxolin cross-batten screwed to the key checks. It is essential to support the cross batten with another batten underneath. *Great attention must be paid to ensure no flexing in the switch support.*

This is a common mistake constructors make which can lead to erratic switch action. The switches are glued in position, and also held down by a wooden 1 in \times 1 in batten across their tops. This last batten is also used to mount tag strips to support the five output busbars to which the switch outputs are connected.

DISTRIBUTION OF SIGNALS FROM TONE BOARDS

Fig. 6. illustrates the arrangements for transferring the square wave outputs from the tone generator boards to the related key-switch inputs, illustrated for one key.

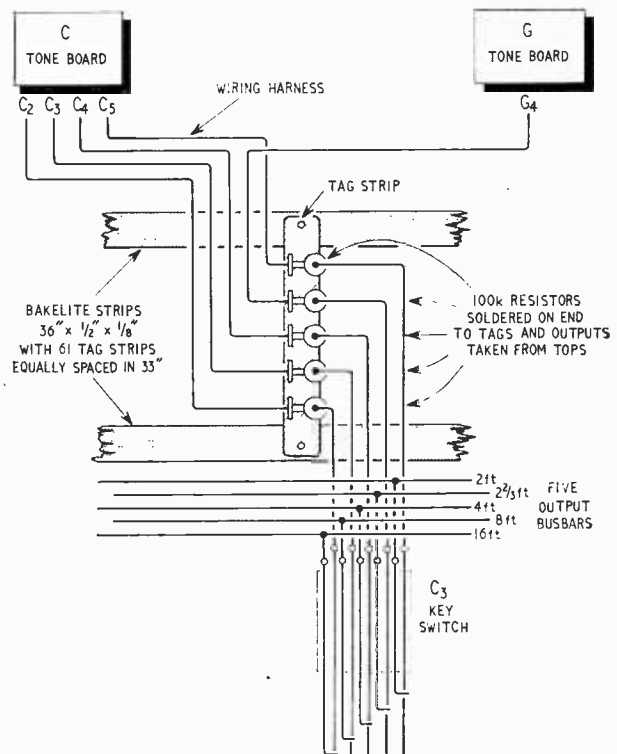
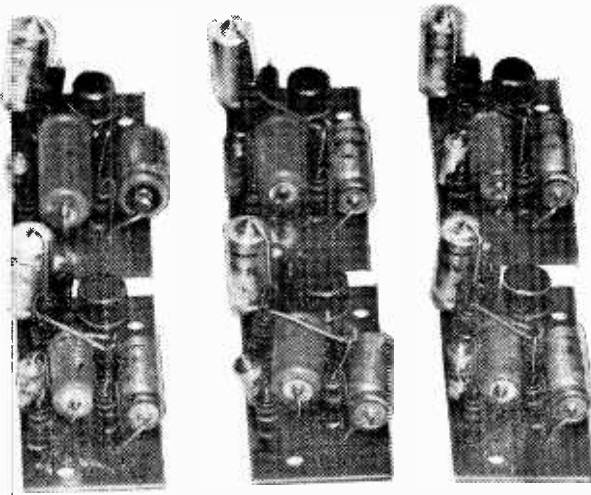
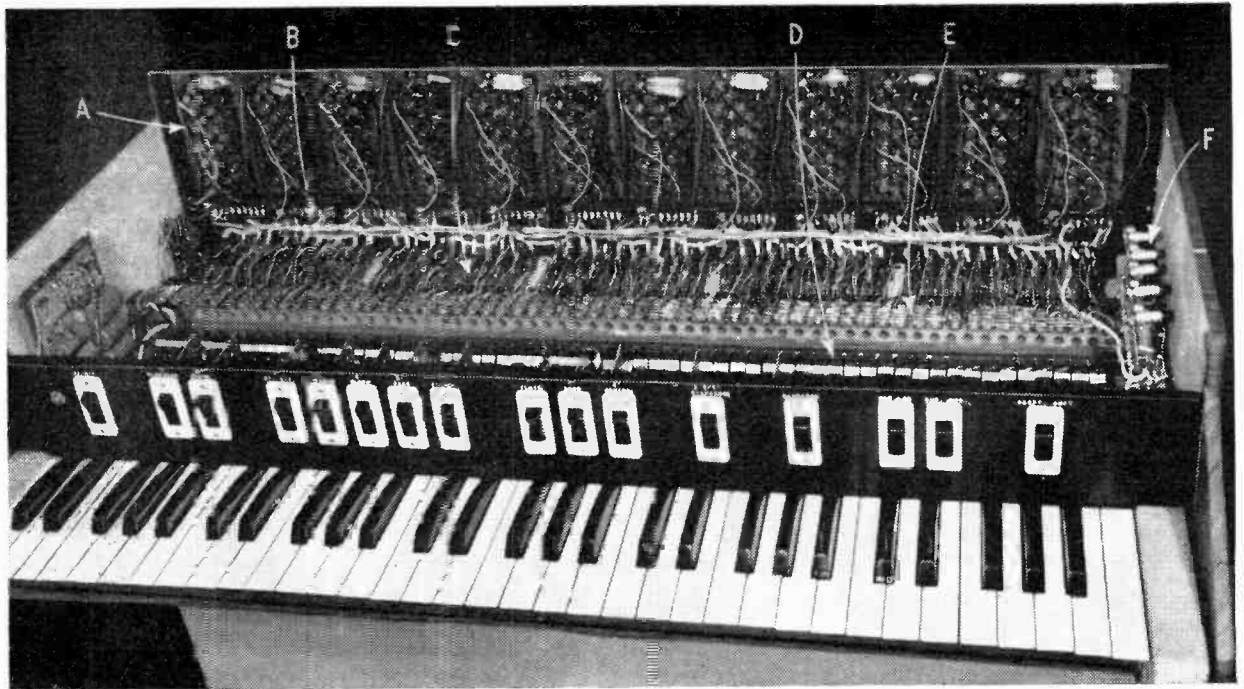

Fig. 6. Wiring harness, distributing tone board outputs to appropriate isolating resistors for individual note keyswitches — illustrated for keyswitch controlled by note C₃ (middle C).



Showing the construction of the single-transistor bus pre-amplifier modules (Fig. 5 (b), July issue).



▲ Fig. 7. This view of the organ from the front with top removed illustrates the interconnecting of the sections from the tone generators at the rear (A), feeding via harness wiring (B), to the 100kΩ isolating resistors (C), connected to the input of the switches (D). From the switch outputs signals pass to the five busbar pre-amplifiers (F) passing through to the tone filters on the stop facia panel.

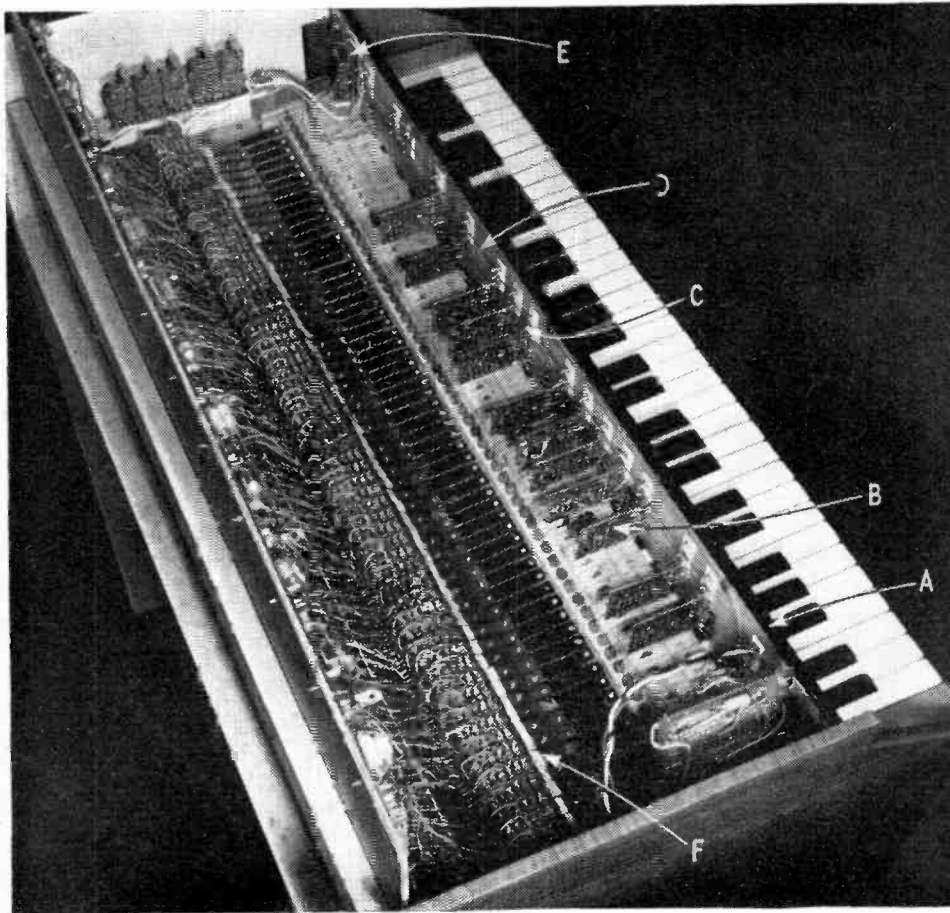

▲ Fig. 8. View of organ downwards from rear, illustrating back of stop switch panel (A), with five busbars switched into twelve filter boards (B), by stop switches (C). Filter board outputs are connected on to a single output busbar (D), which feeds into the main preamplifier (E). The line of key-operated switches (F) can also be seen.

From the tone boards, the signals pass via wiring harness to a set of 61 tag strips mounted on two transverse bakelite strips. On each tag strip five 100-k Ω $\frac{1}{4}$ W resistors are mounted standing on one end. From the free ends of these isolating resistors, leads are soldered to the back ends of the lower wires of the key switches. Thus when the keys are at rest, the tone generator outputs are shunted to earth. When a key is actuated, the corresponding signals are transferred to the switch upper wires and into the five output busbars which feed into the busbar preamplifiers.

The wiring harness is best made up separately, by driving 1 in nails into a board in the appropriate layout, which can only be decided after the tone boards and the distributor tag strips have been mounted. The harness wires should be whipped together before detaching from the nail board.

This is a convenient point to mention wire colours. The author used the following colour code generally, and in particular in the harness wiring, to simplify assembly: C=brown, C $\#$ =red, D=orange, D $\#$ =yellow, E=green, F=dark blue, F $\#$ =violet, G=grey, G $\#$ =white, A=light blue, A $\#$ =pink, and B=black. Something in the order of 1/0.0148 p.v.c. covered wire is about the right thickness.

Tone generator boards.—Each of the twelve tone generators (comprising a master LC oscillator plus five dividers) was pre-assembled on a 4 $\frac{1}{4}$ in \times 2 $\frac{1}{4}$ in board. The smaller dimension is fixed by the consideration that the set of twelve have to fit in a length of some 33 in (i.e., the length between the outsides of the end keys of a normal 61-note organ keyboard). The boards are mounted side by side on a vertical sub-panel at the back of the organ so that the tuning adjustment screws on the master oscillator pot cores are easily accessible at the top from the front. Also the distribution wiring harness can thus be laid conveniently along beneath the tone boards.

No detailed drawing is given for a generator board

because most experimenters prefer to work out their own layout of components and, apart from accessibility of the tuning adjustments, nothing is critical here.

The regulated 9V d.c. supply for the tone boards is made up in small module form and mounted towards the rear on top of the left-hand keyboard cheek. The vibrato drive unit for the tone boards, also in module form, is similarly mounted towards the front of the same cheek.

OVERALL DESIGN FEATURES

Amplifying the section descriptions and diagrams given above, Fig. 7 gives an actual view of the inside of the prototype organ, taken from the front with the lid removed. In it you can trace the tone generator boards at the top rear feeding down through the harness wiring to the isolating resistor assembly and thence into the back of the switches. The five busbars fed from the switch outputs can be seen running along above them, and feed into five busbar preamplifiers on the right. At the other end the vibrato drive unit projects above the stop facia, with the 9V d.c. regulator mounted behind it, below and to the left of the tone boards.

The layout of the back of the stop facia can be seen in the view given in Fig. 8. The twelve filter boards are visible, hung on the backs of the stop switches, fed from five busbars running along the back and feeding into a single output busbar along the top. This last busbar feeds into the main preamplifier at the far end of the facia.

Finally the view from the rear below given in Fig. 9 illustrates the layout of the components on the baffle-board sub-assembly which include the four loudspeakers, the swell pedal, the power amplifier and the unstabilised 12/15V d.c. supply.

The reader will note that everything in the upper organ is laid out to be accessible from the top and front except

Fig. 9. View of organ rear below, showing back of loudspeaker front panel with power amplifier (A), taking its input via swell-pedal volume control (B), through coaxial cable (C), from main preamplifier on stop panel above. The unstabilised power supply (D) provides 12/15V d.c. for the 9V regulated power supply at the tone generator assembly.

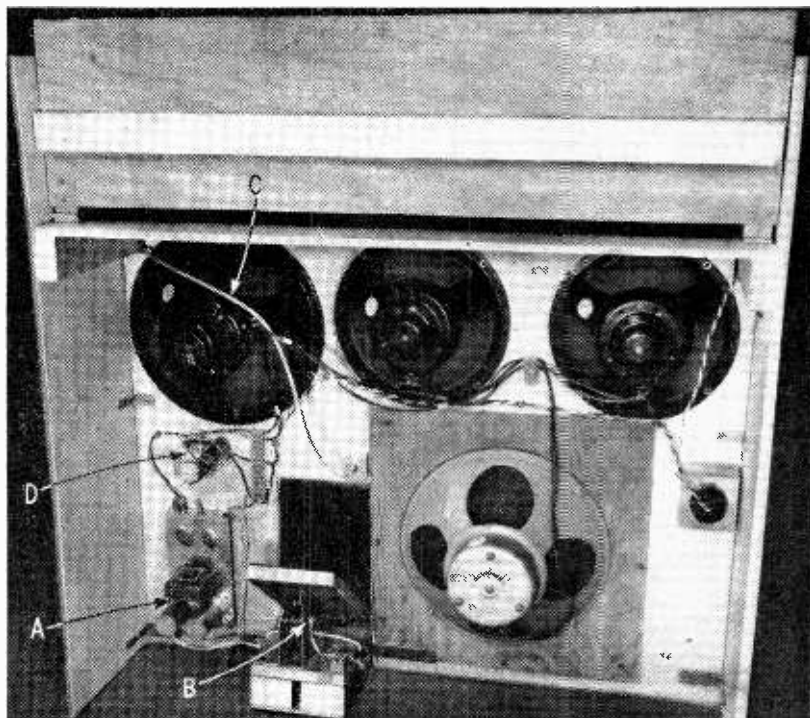

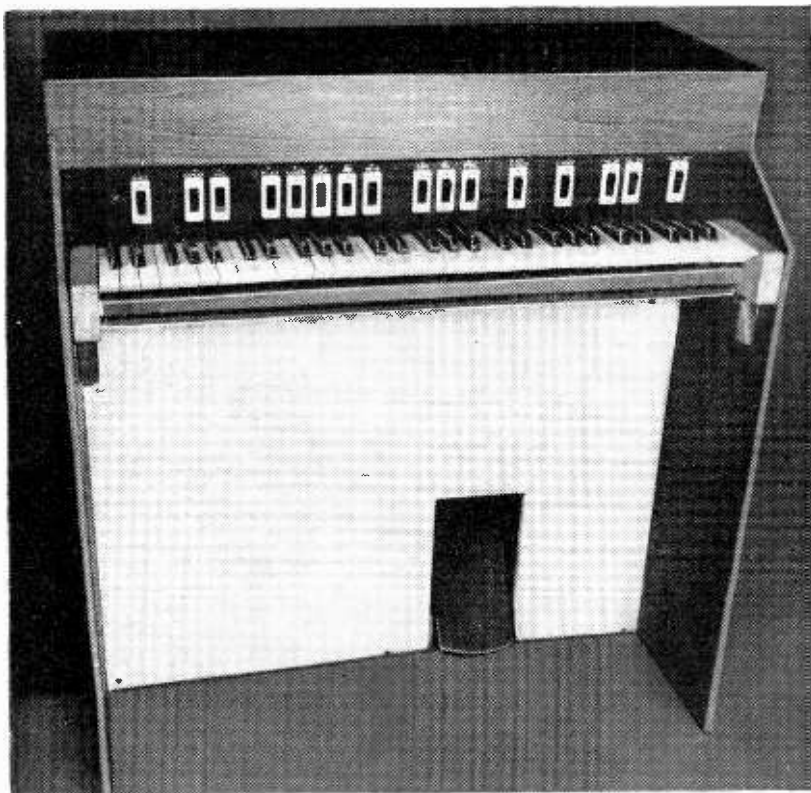

The completed transistor electronic organ.

the level-setting screws for the playing-keys. All the sections up to the output to the volume control (swell pedal) are conveniently attached to the keyboard so that they can be worked on as a single assembly. The output level from the main preamplifier can drive a pair of high resistance headphones comfortably, and a 12V dry battery can be used to make the keyboard assembly completely independent of the baffle-board assembly for test purposes. This has obvious advantages in saving one's family from the sometimes agonizing noises that can emanate from an organ in the throes of construction!

Tuning.—Quite a bit of expertise is necessary in the exact tuning of an electronic organ, but a constructor can get reasonable results without tears, by buying a chromatic pitch pipe for a few shillings from any large music shop. This is a little twelve-note mouth organ giving the scale notes in the standard equal-tempered scale. If you wear a pair of headphones to listen to the organ note, and blow the pitch pipe at the same time, you can *feel* the beats in your head as you adjust the corresponding tone generator oscillator towards the right frequency. Even the most unmusical will find that he can adjust easily and precisely for zero beat.

Parts suppliers.—A major difficulty with amateur constructors is that they often do not know where to go for piece parts. All the electronic components specified in the design are standard items obtainable from radio shops. In most cases values are uncritical and can be varied by 20% without detriment.

For piece parts peculiar to the mechanical structure, such as consoles, keyboards, key switches, swell pedals and stop switches, no firm specializes in these items, but several do handle at least some of them.

For convenience a few are listed below:

Harmonics (Bromley), Ltd., Clarion Works, Upper Park Road, Bromley, Kent.

Copeman Hart & Co., Ltd., 3, Barandon Street, N. Kensington, London, W.11.

Stern-Clyne Ltd., 162, Holloway Road, London, N.7.

Ernest Holt, 101, Wolverhampton Street, Walsall.

AVE ATQUE VALE

It is hoped that this series of four articles will at least have pointed the way for the would-be organ constructor, but he must be warned that the information it has been possible to give in the limited space available cannot be adequate for him to set about constructing an organ unless he has considerable electronic, mechanical and musical experience. He is therefore advised to read assiduously the references quoted in the May, 1966, issue (p. 224) and compare notes with other would-be constructors. In this connection it is worth noting that there exists an Electronic Organ Constructors' Society which holds regular meetings in London. The current Secretary is Mr. E. Kirk, of 66, Arnold Crescent, Isleworth, Middlesex, who will, I am sure, be glad to furnish information on their activities.

“Transistor 2-Metre Converters”

IN Fig. 1 of this article in the July, 1966, issue, the source resistors of the two 2N3823/T1S34 field effect transistors should be 1.6 k Ω and 1 k Ω respectively instead of the 16 k Ω and 10 k Ω shown. Also, the diode type number should be OA73.

DIRECT-READING PHASEMETER

By G. B. CLAYTON, B.Sc., A.Inst.P.

The first part of this article consists of a general discussion of phase measurement techniques which includes the use of an oscilloscope and a counter timer. Details are then given of the circuit and construction of a direct reading phasemeter. A view of the instrument showing the positioning of the circuit boards and other components is given in the accompanying illustration.

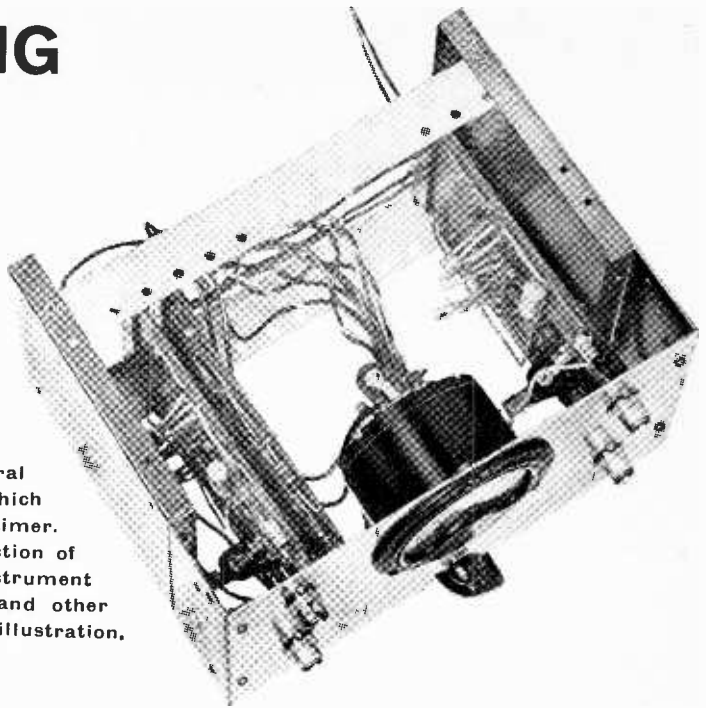

IN dealing with sinusoidal voltage variables a frequent requirement is a measurement of the phase relationships existing between them. Some of the methods available for the measurement of phase difference will be reviewed and a circuit for a direct-reading transistor phasemeter will be described.

Phase measurements with an oscilloscope

An oscilloscope may be used to measure phase over a fairly wide frequency range. Several methods are available. One method involves the application of the two sinusoids whose phase difference is required to the horizontal and vertical inputs of the oscilloscope. The phase difference is calculated from measurements made on the resultant elliptical trace shown in Fig. 1.

In Fig. 2 the horizontal deflection is given by, $X = a \sin \omega t$ and the vertical deflection by,

$$Y = b \sin (\omega t + \theta)$$

where θ is the phase angle that it is desired to measure and a and b are the two sinusoids' peak amplitudes.

When $\omega t = 0$, $Y = b \sin \theta = c$. Thus $\sin \theta = c/b$

Another method using an oscilloscope enables the

direct display of the phase position of a signal of unknown phase with respect to a reference signal. The reference signal is used to create a circular sweep and the signal of unknown phase is used to intensity modulate the oscilloscope beam. The oscilloscope trace then shows the phase angle directly as in Fig. 3.

The circular sweep is obtained by applying the reference signal directly to either the vertical or horizontal input and a 90° phase shifted signal to the other input. An integrator may be used to obtain the 90° component. The simple integrating circuit shown in Fig. 4, together with the circuit shown in Fig. 5 (for producing the voltage spikes necessary to modulate the electron beam intensity) was used in obtaining Fig. 3.

A double beam oscilloscope permits measurements of phase difference by a fairly direct method. One of the signals is applied to one of the vertical input channels and is also used to synchronize the horizontal time sweep. The second signal is applied to the other vertical input channel. The position of the traces may be arranged so as to make both signals symmetrical about a common horizontal axis. The distance between zero crossings can be measured and divided by the distance representing one cycle.

This fraction of 360° measures the desired phase angle. It is of course essential for accuracy that the horizontal time sweep is linear.

Phase measurement with a counter-timer

A direct reading counter-timer may be readily adapted to the measurement of phase difference. The sinusoidal voltages whose phase relationship is required are made to generate pulses as they pass through some definite phase. The counter is set to measure time. The pulses obtained from the reference sinusoid are made to start the timer, and the pulses from the signal of unknown phase are arranged to stop the timer. The time interval t between them is then obtained directly from the timer



G. B. Clayton started his career as a physics master in a grammar school, after which, for two years, he was lecturer in the Science Department of the Birkenhead Technical College. In 1954 he joined the staff of the Liverpool College of Technology where he is now principal lecturer with administrative responsibility as course tutor for the B.Sc.(Hons.) sandwich course in applied physics.

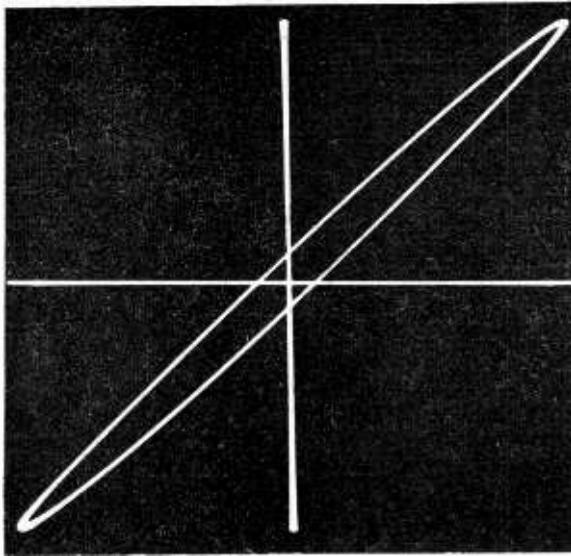

Fig. 1. Elliptical trace obtained from the phase difference of two sinusoids applied to the horizontal and vertical inputs of an oscilloscope.

which is then used to measure the period T of the sinusoidal signals. The phase lag is found from, $\theta = \frac{t}{T} 360^\circ$.

If it is assumed that the start and stop pulses are accurately locked to a definite phase of the sinusoids, the accuracy of phase measurement is then dependent on the frequency and stability of the timing generator used in the counter-timer.

It is generally found convenient to arrange for the pulses to occur as the sinusoidal voltages pass through zero phase, any change in signal amplitude will then ideally not cause a change in phase position of the pulse.

A pulse locked to zero phase of a sinusoid may be obtained by first converting it to a square wave; the square wave is then passed through an RC differentiating circuit and a diode is used to select the desired pulse polarity. The squaring circuit described later (Fig. 7) has been found to operate satisfactorily.

A direct reading phasemeter

In most direct reading phasemeters the two sine waves whose phase difference is to be determined are applied to separate channels where they are converted into square waves. There are then several ways in which these square waves can be made to give an output voltage proportional to phase (Ref. 1).

The method adopted here is outlined in Fig. 6. The two square waves are applied to a phase-coincidence detector. This gives an output voltage (V) only when both inputs are in their positive state. The average value of the output voltage from the detector is thus $V \frac{t_+}{T}$ where t_+ is the time for which both square waves are in their positive state and T is the period of the alternating signals.

The phase difference θ between the two signals, is given by

$$\theta = \left(\frac{T - t_+}{T} \right) 360^\circ = 180 - 360 \frac{t_+}{T}$$

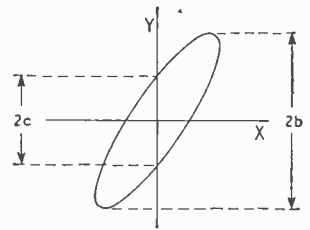

Fig. 2. The phase angle can be calculated from the dimensions of b and c on the oscillogram.

Thus when there is zero phase difference between the two signals, i.e. $t_+ = \frac{T}{2}$, the average output voltage is a maximum and equal to $\frac{V}{2}$. When there is 180° phase difference the average output voltage is zero. There is a linear relationship between average output voltage and phase as shown in the simple graph in Fig. 6. The average output voltage from the gate does not depend on the frequency of the signals nor does it depend on the amplitude of the two square waves provided they are large enough to operate the gate.

Squaring circuit

A squaring circuit for use with a phasemeter must produce a square wave in which the transitions are locked as accurately as possible to zero phase of the sinusoidal waveform. Several methods are available (Ref. 2).

A direct method consists of a process of successive amplification, and clipping which is symmetrical with respect to the zero of the sinusoid. If the input sinusoids are of small amplitude several stages of amplification are required and clipping between narrow limits needs to be performed on each stage. This requires a well defined low impedance voltage reference source for each clipping process.

An alternative method if valves are used is the cathode coupled clipper, but this circuit does not readily adapt itself to use with transistors (Ref. 2).

Other methods involve the use of some form of regenerative switching circuit such as a multivibrator; this is the method used here, with a negative feedback loop included to stabilize the trigger point of the multivibrator.

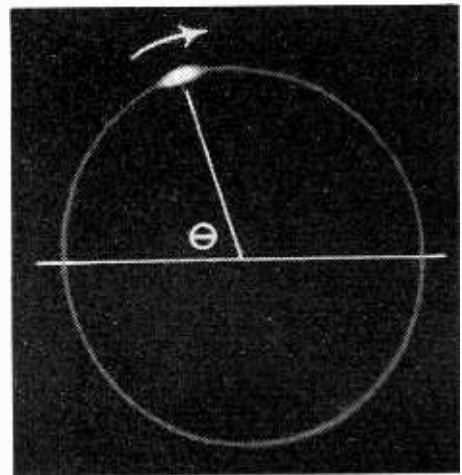

Fig. 3. An oscillogram depicting the direct display of phase relation.

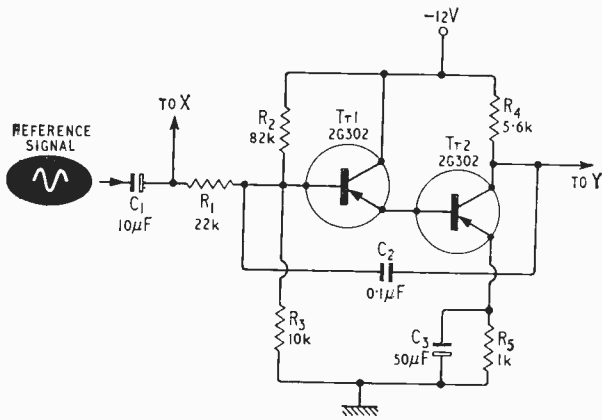

Fig. 4. The circuit of a 90° phase shifter.

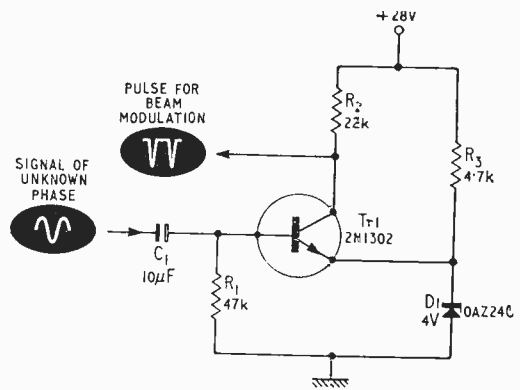

Fig. 5. Circuit for intensity modulation used in conjunction with the 90° phase shifter to obtain the oscillogram in Fig. 3.

The circuit (Fig. 7) uses inexpensive germanium transistors and is designed for operation with a wide range of input signal amplitudes. The input to the circuit is applied through a limiting circuit consisting of a series resistor, R_1 , and two silicon diodes D_1 , D_2 . No appreciable forward conduction occurs with these diodes until the voltage across them reaches about 0.4V. The diodes thus have no effect on small amplitude signals but symmetrically clip the larger amplitude signals. The voltage across the diodes is capacitively coupled to the emitter follower Tr_1 which is used to increase the input impedance. The output from Tr_1 is applied to the common-emitter amplifier Tr_2 , an n-p-n transistor is used to enable direct coupling.

Transistors Tr_3 and Tr_4 form a Schmitt multivibrator which is designed to have only a very small amount of hysteresis. With no hysteresis, the circuit would be unstable. The loading on the output of the Schmitt circuit by the detector is made small by using the emitter follower Tr_5 . An n-p-n transistor is again used here to enable direct coupling.

The output of the Schmitt circuit, integrated by R_{10} and C_2 , is then fed back through Tr_1 and Tr_2 to the base of Tr_3 . Should the mean level of the alternating signal

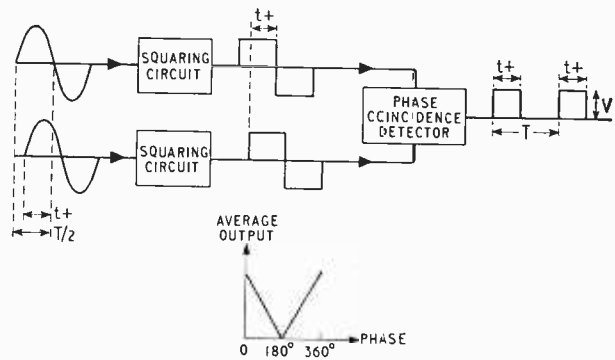

Fig. 6. Block diagram of the direct reading phasemeter.

applied to Tr_3 increase, the "on" period of transistor Tr_4 will be longer. This will cause the integrated output from Tr_4 to rise, and this rise, amplified and phase changed by Tr_2 will tend to reduce the mean level of the signal at the base of Tr_3 . This feedback arrangement holds the trigger point of the multivibrator stable. The mark space

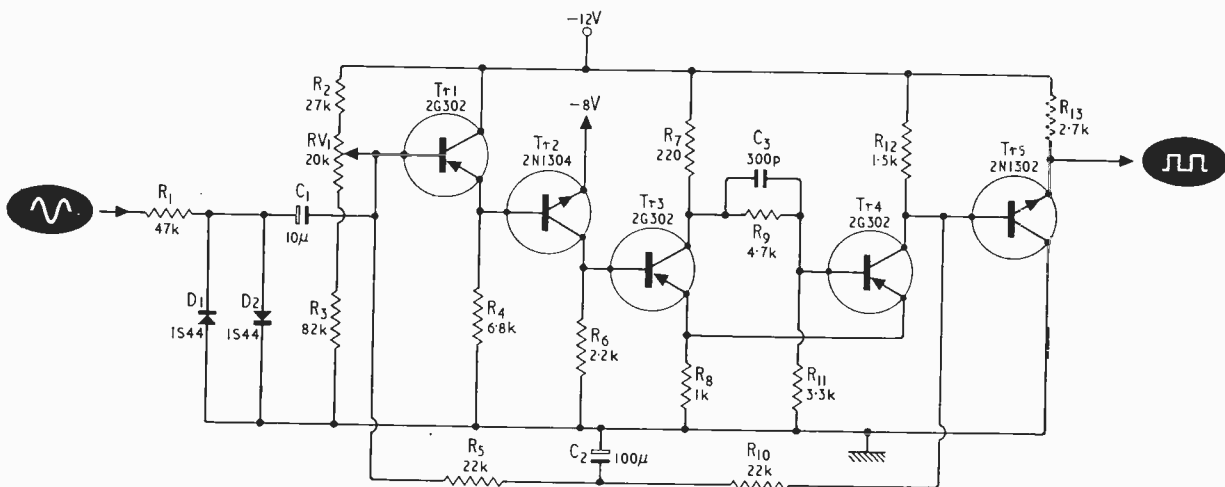

Fig. 7. The squaring circuit used in the direct reading phasemeter.

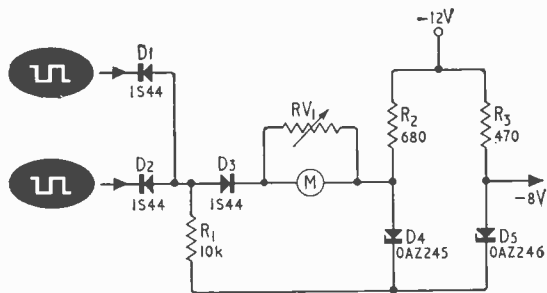

Fig. 8. The phase-coincidence detector used in the direct reading phasemeter.

ratio of the square wave is initially set to unity by RV_1 . The mark-space ratio is sensitive to supply voltage variations and so it is essential to use a well stabilized supply.

Phase-coincidence detector

Fig. 8 shows the circuit for the detector and also the -8 V zener reference supply for the squaring circuits. If either or both of the two input square waves, i.e. the two separately squared sinusoids, are in their more negative state, then either or both of the diodes D_1 , D_2 will be conducting and diode D_3 will be non-conducting. Only when both input square waves are in their more positive state will both D_1 and D_2 be cut off and D_3 conducting. The average value of the current through D_3 is indicated by the d.c. meter M. With in phase signals the average current is approximately $300 \mu\text{A}$. A meter giving full scale deflection for a smaller current than this should be used. The variable resistor, RV_1 , connected in parallel with the meter is adjusted so that the meter gives full scale deflection with in phase signals applied to the phasemeter. The meter reads zero when the phase difference between the two signals is 180° .

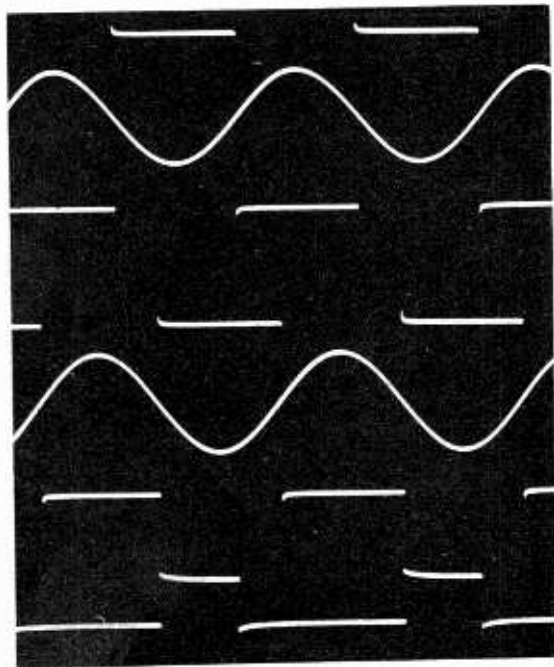

Fig. 9. Waveforms obtained in the squaring circuit.

The performance of the phasemeter has been checked using a commercial phasemeter. The commercial instrument gave a quoted accuracy of phase measurement of $\pm 2^\circ$ for frequencies in the range 20 c/s to 20 kc/s, and $\pm 5^\circ$ for the frequencies up to 50 kc/s. The readings obtained agreed with the commercial instrument within these limits. The lowest frequency at which the circuit will operate is determined by the meter. At low frequencies the meter reading is unsteady and no longer indicates the average current through the diode D_3 . The high frequency limit is determined by the switching performance of the transistors in the squaring circuit.

Typical waveforms are shown in Fig. 9. This shows two out of phase sinusoids with their associated square waves derived from the squaring circuits. The lower trace shows the output from the gate which is applied to the meter. The reading of the meter indicates the average value of this output.

Construction

The construction of the instrument was quite straightforward. Three Veroboard panels were used, one for each squaring circuit and the third for the gate components. Simple capacitor-resistor differentiating circuits and diodes were also mounted on this third panel. These enable positive or negative pulses derived from the output of the squaring circuits to be provided by each channel. The components are not shown in the circuit diagram. A switch mounted on the front panel of the instrument was arranged to select the desired pulse polarities and make them available at two output coaxial sockets. Another setting of the switch was made to connect the output of the squaring circuits directly to these coaxial sockets.

The circuit panels were for convenience mounted in a Lektrokit chassis assembly. Holes were drilled in the top of the case of the instrument to enable a screwdriver to be used to adjust the three preset resistors, one on each squaring circuit panel, and one in parallel with the meter. A meter with an f.s.d. of $100 \mu\text{A}$ was in fact used and this was mounted on the front panel of the instrument. The value of the meter sensitivity preset resistor to be used must obviously depend on the resistance of the meter movement actually used.

REFERENCES

1. "Methods of Experimental Physics. Vol. 2 Electronic Methods." Academic Press. New York and London, 1964.
2. "Pulse and Digital Circuits". Milman and Taub. McGraw-Hill. 1956.

Cycloidal Path Mass Spectrometer

NORMALLY, in a cycloidal-path mass spectrometer, the electric and magnetic fields are at right angles to each other causing a cycloidal path to be traversed by the ions. In order to obtain a uniform electric field a stack of parallel plates has been used in the past, with holes cut in appropriate places. An alternative method has been developed by Mullard Research Laboratories and involves the use of a wire helix which is rectangular in plan. Actually two are used, one for the part of the path for which the ions have turned through less 180° and a large one for the remainder of the path. The resistance of the wire is chosen to give the required voltage gradient.

This method results in a more simplified structure giving a reduced residual gas problem. Further, control is simplified since it is easier to obtain a uniform electric field using this method. Mass range scanning can be achieved with either the electric or magnetic fields.

WORLD OF WIRELESS

London Television and Radio Show

THIS year's London radio show, promoted and presented by Industrial Trade Fairs Ltd., is to be held at Earls Court from August 22nd to 26th, but unlike previous shows this one will not be open to the public and, moreover, it will include overseas exhibitors for the first time. Most British receiver manufacturers will be exhibiting as well as some component and accessory makers. There will also be exhibitors from Denmark, France, Germany, Holland, Italy, Japan and Poland.

A feature of the Show will be a representative display of colour television receivers to be marketed in time for the opening of the service in 1967. News of new products that exhibitors will be adding to their range is not expected to become available until nearer the opening date and we hope to give a brief summary of the Show in our next issue.

For the first four days the show will be open from 10 a.m. to 9 p.m. but on the last day it will close at 6 p.m. Admission will be by invitation tickets obtainable by bona fide members of the trade from exhibitors or from the organizers at 1-19 New Oxford Street, London, W.C.1.

International Amateur Conference

THE seventh triennial Conference organized by the International Amateur Radio Union, Region I (Europe and Africa) Division, took place in Opatija, Yugoslavia, last month and representatives from Austria, Belgium, Finland, France, Germany, Ireland, Italy, the Netherlands, Norway, Poland, the Soviet Union, Sweden, Switzerland, United Kingdom and Yugoslavia were present.

Some of the matters dealt with during the Conference were the defence of the amateur bands at future I.T.U. conferences. Proposals were discussed for introducing amateur radio into new and developing countries and an amended European Band Plan was adopted, recommending that radio teleprinting transmissions shall take place at a nominal frequency of 14.09 Mc/s. The Technical Subcommittee recommended that 45.45 Bauds and 50 Bauds should be provisionally adopted as standard speeds for radio teleprinting.

The Conference agreed to sponsor the construction of a European OSCAR (Orbiting Satellite Carrying Amateur Radio) during 1966 and to make 2,000 Swiss Francs available annually for the next three years for the construction of at least one Region I Satellite per annum.

The Radio Society of Great Britain was responsible for a number of contributions to the Conference of which one describing work done during the International Quiet Sun Year was of special significance. The R.S.G.B. submitted a comprehensive survey of licensing conditions in European and African countries prepared by Mr. L. E. Newman (G6NZ), a past president of the Society. The survey showed that considerable progress had been made during the past two years in the extension of reciprocal agreements between European administrations.

R.E.C.M.F. Annual Report

THE 33rd Report of the Radio and Electronic Component Manufacturers' Federation as at March 1966 has been published.

The report discloses that in 1965 Radio and Electronic exports rose by 3% to £96.1M which included a figure of £42.175M for components and accessories. Imports declined by only 2% to £67.5M of which £16.23M was for components and accessories. The slight decline in imports of radio and electronic products in general reversed the trend of recent years. Components continue to show a favourable balance of trade overall.

The Federation now has a membership of 196 firms.

Mention is made in the Report of a new look for the Federation, but although the form that this may take is not recorded, it is stated "that during the next few months the Federation should make a close and objective study of its functions and status and formulate a policy for the future, consider whether an extension of present activities may be desirable in the interests of the membership as a whole and take such action as may be necessary to safeguard the status and autonomy of the Components sector within an expanding and virile electronics industry"

The following members have been elected to the 1966/67 Council—Belling and Lee Ltd. (N. D. Bryce), A. F. Bulgin & Co. Ltd. (R. A. Bulgin), Formica Ltd. (C. A. Jennings), A. H. Hunt (Capacitors) Ltd. (S. H. Brewell), Morganite Resistors Ltd. (J. Thomson), Mullard Ltd. (Dr. F. E. Jones), Multicore Solders Ltd. (R. Arbib), Painton & Co. Ltd. (C. M. Benham) and Plessey Co. Ltd. (E. E. Webster).

B.B.C. Stereophonic Transmissions

THE B.B.C. is to undertake a substantial development in stereophonic sound transmissions. Starting on 30th July, two or three stereophonic programmes each day will be broadcast on v.h.f. in the Third Network using the pilot-tone system which is the established system for the stereophonic services in the United States, Germany, France, Italy and Holland. The system is a fully compatible one. This means that listeners who live within the service areas of the transmitters and who equip themselves with stereophonic receivers or with adaptors for their existing v.h.f. receivers will be able to listen to the programmes stereophonically, while other listeners using ordinary receivers, whether v.h.f. or medium wave, will be unaffected and will hear the programmes in the normal way. The stereo transmissions will be available at first only to listeners within the service area of the Third Network v.h.f. transmitters at Wrotham and Dover (South East England) but it is planned to extend the service to the Sutton Coldfield v.h.f. transmitter (Midlands) in approximately twelve months and to the Holme Moss v.h.f. transmitter (North of England) in approximately fifteen months.



Cash after the bank has closed will soon be a possibility on the continent due to an automatic paying out machine developed by Telefunken in co-operation with Ostertag-Werke AG. The bank issues the customer with an identification token for use with the machine as well as a punched card. The equipment compares the punched card with the identification token and then pays out a 100 mark note.

British Space Age Telecommunications

BRITAIN is moving further forward with plans for satellite communications for public services. Seventeen manufacturers including five British firms—Marconi Company, G.E.C. Electronics, Plessey Radar, A.E.I., and Standard Telephones & Cables—have been invited by Cable & Wireless Ltd. to tender for three earth stations in a world-wide network. The specifications set out detailed requirements for an earth station—estimated to cost £2.5M. The first of these stations is to be sited at Hong Kong, and is to be completed and operational by the middle of 1968.

The station, planned to operate initially via the proposed Intelsat II Pacific satellite with other earth stations expected to be operational in the Far East and Pacific at about the same time as the Hong Kong station, will be engineered for transmitting and receiving up to 300 telephone channels or the equivalent in telegraphic, data or facsimile traffic. Alternatively the station could be used for 625-line television signals. The aerial structure will be specially developed to withstand typhoon conditions—a 210 miles/hour survival wind speed has been specified.

The tender specifications do not state the countries in which the second and third stations will be sited.

Thick Film Circuits

THE Electrical Research Association started three research programmes in 1962 to study materials for integrated electronic circuits. Part of the programme has entailed technical discussions with representatives of the American electronics industry and as a result this has disclosed the trend of the rapid expansion of the thick film process. One of the advantages of the method is that the cost and complication of high vacuum technology required for thin film circuits is avoided. Instead, a development of the silk-screen method used in the printing industry is employed to produce fired-on conductors, resistors or insulators on a ceramic substrate. However, the circuit elements produced by the thick film process are inferior to thin film and it is probable that the main application will be in the domestic entertainment market where great numbers of cheap components are required. The increasing interest in thick film techniques is, however, evident from the fact that in 1965 only one paper in fifteen read at the I.E.E.E. Electronic Components Conference was devoted to the subject whereas this year it was one paper in two.

Blind Computer Programmers

FOR the first time in this country, blind people are being trained to become computer programmers. Recently a specially designed five-week course started at English Electric Leo Marconi's Training Centre at Ealing and is being attended by 12 trainees from users of LEO III computers. Programming requires the application of high level intellectual effort and it thus offers an important extension of career opportunities available to blind people. During the course, the trainees learn how to use the CLEO programming language for LEO III or System 4 machines; to minimize the need for note-taking a comprehensive training manual printed in Braille (by the R.N.I.B.) is used. The trainees use tape recorders to record the exercises dictated to them, including the specification for a model programme which they prepare during the course and also for recording any discussion that arises. For the programme, the blind trainees produce Braille and typescript versions of a set of successively numbered instructions. To obtain a Braille printout from the computer requires special modification to the computer output printer and also the use of special software to produce printed information in a Braille type of format. Three software programmes have been written by English Electric Leo Marconi to produce the various types of printout that a programmer normally needs. Each

alphabetic and numeric character is represented as a 6-bit code and this code is formed into a rectangular pattern of dots similar to that used in standard Braille. A normal line of print information comprising up to either 120 or 160 characters is represented in mirror image in the special "Braille" pattern of dots. The printer has a sheet of rubber secured to the backing plate so that when the dots are printed, the soft backing of rubber causes the hammers to indent the stationery. The blind programmer can then read or sense the printed information by feeling the impressions on the reverse side of the paper.

Inter-train Radio Link.—The entire rolling stock of London Transport's new Victoria Line is to be supplied by the Elettra Sound Systems Department of the Marconi International Marine Co. Ltd., with equipment for an inter-train communication system, a wired public address system and an intercommunication installation. The required facility will be selected by the train operator. Inter-train communication is in the form of a two-way radiotelephone conversation effected by a low power v.h.f. transmitter-receiver housed in the train operator's cab. For inter-cab communication on the same train, a calling tone is produced in small loudspeakers in other cabs throughout the train. Lifting a handset stops the tone and a two-way telephone communication becomes possible. The public address facility will normally be used when the train is stationary and will enable the train operator to speak to passengers over six loudspeakers fitted in each car. Victoria line trains will normally comprise two four-car units with a cab at each end of the unit.

1967 Paris Components Show.—The annual exhibition of electronic components organized by the Fédération Nationale des Industries Electroniques will be held from April 5th to 10th. Because the Mesucora Exhibition will be held in Paris from the 14th to 21st there will not be a section devoted to measuring equipment at the components show. The conference organized in conjunction with the components show will be devoted to "electronics in space" and run from the 10th to 15th.

Short-wave Radio.—Specimen copies of the monthly duplicated news sheet of the International Short Wave Club, giving the latest information on transmission schedules from s.w. broadcasting stations, are available from the club secretary at 100 Adams Gardens Estate, London, S.E.16.

Collecting TV Licences.—The Postmaster General has been under fire recently from the director of the Radio and Television Retailers Association who has stated "We consider it outrageous that the Post Office, having failed lamentably to enforce legislation which already exists to deter licence dodging, can ever think of foisting its responsibility [for collecting licence fees] on to suppliers of television receivers."

The Mesucora Association, which is a confederation of 13 trade associations, is planning its third exhibition of measuring, testing and control equipment in Paris from April 14th to 21st next year. During the exhibition there will be an international congress organized by eight scientific societies.

Next year's London Audio Festival and Fair will be held from March 30th to April 2nd at the Hotel Russell.

Pickup Arm Design.—In Figs 7, 8 and 9 of J.K. Stevenson's second article on pickup arm design in the June issue, the ordinate should have been labelled $60\phi/x$ and not $60\theta/x$. The expression $C_x > 1/5C_1$ on p. 318 (col. 2) should have read $C_x > C_1/5$ and in the last expression on that page C_x^2 should be taken as C_1^2 . In Appendix II the sentence containing "... the maximum negative value of $x \dots$ " should read "... the maximum negative value of ϕx is less than the values x_2 and x_3 ".

PERSONALITIES

Professor Martin Ryle, F.R.S., who received a knighthood in the Queen's Birthday Honours, has been professor of radio astronomy at the University of Cambridge since the chair was established in 1959. He left Oxford University in 1939 with an M.A. degree and joined the staff at the Government Telecommunications Research Establishment where he worked throughout the war on the development of radar. Soon after the war he went to the Cavendish Laboratory, Cambridge, as lecturer in physics and in 1957 transferred to the newly established Mullard Radio Astronomy Observatory of which he is director as well as occupying the chair of radio astronomy at the University.



Sir Martin Ryle

Professor Ryle, who operates an amateur transmitting station (G3CY), was the first recipient (in 1964) of the van der Pol gold medal of the International Scientific Radio Union presented triennially "to an outstanding radio scientist."

Captain W. H. R. Armstrong, Assistant Commissioner of Police, Barbados and officer-in-charge of telecommunications in the Royal Barbados Police, has retired after 24 years in the Colonial Police and Her Majesty's Overseas Civil Service and has been appointed managing director of Balmoral Ltd., suppliers of electronic and telecommunications equipment, of Barbados, West Indies. During his Police Service in the West Indies (1941-1965) Captain Armstrong specialized in Police communications and was responsible for the planning and development of the telecommunications service. He received the Queen's Police Medal for Distinguished Service in the recent Birthday Honours.

Harold White, M.Sc., formerly senior assistant director-general of the Australian Department of Civil Aviation, has been appointed general manager of the

country's Overseas Telecommunications Commission. Mr. White, who is 51 and has been specially concerned with navigational aids in relation to air safety, succeeds **T. A. Housley** who has be-



H. White

come director-general of the Australian Post Office. During World War II Mr. White was in the R.A.A.F. and specialized in ground radar and after a period of research in Melbourne University joined the Department of Civil Aviation in 1948.

J. Bell, O.B.E., B.Sc., F.Inst.P., managing director of the M-O Valve Company, has been elected chairman of VASCA—the Electronic Valve and Semiconductor Manufacturers' Association—for 1966/7. Mr. Bell was deputy



J. Bell

director of the G.E.C. Research Laboratories, Wembley, until becoming managing director of M-O Valve and from 1953 to 1958 was manager of the telecommunications division. The new vice-chairman of VASCA is **Dr. F. E. Jones, M.B.E.**, managing director of Mullard Ltd.

Sir Jules Thorn, chairman of Thorn Electrical Industries and president of the British Radio Equipment Manufacturers' Association, has been elected chairman of the Radio Industry Council, in succession to **C. O. Stanley**. The constituent member organizations of the R.I.C., which co-ordinates the interests of the domestic consumer products sector of the electronics industry, are British Radio Equipment Manufacturers' Association, Radio and Electronic Component Manufacturers' Federation, British Radio Valve Manufacturers' Association and Electronic Valve and Semi-Conductor Manufacturers' Association.

John Ware, F.R.I.B.A., the new chairman of the Council of the Television Society was with Murphy during the latter part of the war but in 1945 started his present career as an architect. He is now with the Ware Macgregor Partnership specializing in work for the electronics and television industry. Mr.



J. Ware

Ware was chairman of the British Amateur Television Club for two years from 1964. The new vice-chairman of the Television Society is **K. A. Russell, B.Sc., A.M.I.E.E., M.I.E.R.E.**, who is chief engineer and a member of the board of British Relay Wireless & Television Ltd.

G. Seear, M.I.E.E., has joined Standard Telephones and Cables Ltd. as manager of the installation division in the Transmission Systems Group. Based at Basildon, he is responsible for the installation of all products of the group, for the project engineering of integrated systems involving landline and microwave equipment, and for maintenance and training contracts. Mr. Seear joined S.T.C. from the Plessey Company, where he was manager of the Microwave Systems Division. Previously he

spent eleven years with the Marconi Company, and prior to that was with the Malayan Telecommunications Department and at Automatic Telephone and Electric Company.



G. Seear

J. Greer, recently appointed by the Marconi International Marine Company as its representative in Takoradi, Ghana, has been with the company since 1927, when he joined as a sea-going radio officer. He transferred to the shore staff in 1943 and has been in the company's Hong Kong depot since 1954 where he became service manager in 1962.

V. G. Oastler, who has been in charge of the Marconi Marine Company's depot in East Ham, London, since 1955, has become manager of the London area and will be responsible for co-ordinating the company's work in the ports of south-east England. Mr. Oastler joined the company as a sea-going radio officer in 1929, but after two years transferred to the shore staff. In 1945 he was placed in charge of a temporary wartime servicing station in Antwerp.

John Critch, A.M.I.E.E., has been appointed divisional manager and **Feter Conway**, A.M.I.E.E., chief engineer, magnetic devices, of the Magnetic Materials Division of S.T.C. at Harlow, Essex. Mr. Critch joined S.T.C. in 1937



J. Critch

as a student apprentice at North Woolwich, becoming a development engineer in the magnetic materials laboratory in 1942. Since 1949 he has been production manager of the department. Mr. Conway has joined S.T.C. from Ericsson Telephones in Nottingham, where he has been in charge of coil and filter design since 1952. In his new position he will be responsible for the development of all types of coils, including pulse transformers, transducers, signal transformers, and novel magnetic devices like counter reactors and magnetic modulators.

Tony Ayling has joined Vero Electronics Ltd., at their new factory and offices at the Industrial Estate, Chandler's Ford, Hampshire, as chief engineer. He was formerly design engineer with Elliott Automation and previously with Hawker Siddeley Dynamics.

J. Snitch has been appointed director and general manager of the recently formed company Belling-Lee Aerials Ltd. He joined the parent company Belling & Lee in 1952 and became distribution manager three years later. In 1958 he went to Melbourne to join the associated company Belling-Lee (Australia) as general manager, and in 1961 also



J. Snitch

became a director. He returned to the U.K. in April to manage the new company in Liverpool, which was previously only a manufacturing unit. Mr. Snitch will retain his directorship of the Australian company.

P. J. Moger has joined Debenhams Electrical & Radio Distribution Company as their technical and service manager. Mr. Moger who was previously service manager for Grundig (U.K.) will be responsible for the servicing of both Bang & Olufsen and Sony equipment.

R. F. Vigurs, A.M.I.E.R.E., Assoc. I.E.E., is appointed senior engineer in the B.B.C.'s New York office, in succession to **L. G. Dive**, A.M.I.E.E., A.M.I.E.R.E., who is returning to the U.K. after completing his two-year term

of office. Mr. Vigurs joined the B.B.C. in 1936 and since 1946 has been in the television group of the Research Department where latterly he has been particularly associated with work on standards conversion and colour television. He has recently spent six months in the United States, on secondment to the Columbia Broadcasting System where he has been working on colour television problems.

QUEEN'S BIRTHDAY HONOURS

RECIPIENTS of honours in Her Majesty's Birthday Honours List included the following in the fields of electronics and communications.

Knight Bachelor

Martin Ryle, F.R.S., professor of radio astronomy, University of Cambridge.

K.B.E.

Major General Leonard H. Atkinson, O.B.E., B.Sc., M.I.E.E., M.I.E.R.E., Corps of R.E.M.E.

Charles Reginald Wheeler, C.B.E., chairman of A.E.I.

C.B.E.

Instructor Captain G. B. C. Britton, A.D.C., Comp.I.E.R.E., Royal Navy.

R. M. Fairfield, B.Sc., M.I.E.E., deputy chairman and managing director, B.I. Callender's Cables.

O.B.E.

E. G. Brentnall, B.E.M., chief signal and telecommunications engineer, London Midland Region, British Railways.

C. R. Cook, A.M.I.E.E., principal scientific officer, Government Communications Headquarters.

Lt.-Col. D. B. Emley, M.A., A.M.I.E.E., Royal Corps of Signals.

C. S. Hudson, Ph.D., B.Sc., A.C.G.I., M.I.E.E., senior principal scientific officer, R.A.E., Farnborough.

A. M. Humby, M.I.E.E., for services to the British Joint Communications Electronics Board.

K. H. R. C. Kreuchen, head of a power klystron section.

F. W. Lovell, A.M.I.E.R.E., director of telecommunications, Mauritius.

G. K. Nicholls, Assoc.I.E.E., manager, Cable & Wireless Engineering Training College, Porthcurno.

W. E. C. Varley, M.I.E.R.E., Assoc.I.E.E., chief engineer, transmitters, B.B.C.

Captain F. J. Wylie, M.I.E.R.E., lately director, Radio Advisory Service, U.K. Chamber of Shipping.

M.B.E.

A. H. Atherton, B.Sc., A.M.I.E.E., manager, Ruislip factory of E.M.I. Electronic Valve Division.

Sqn. Leader D. H. Bernard, Assoc.I.E.R.E., R.A.F.

G. M. Parsons, chief radio officer, *Queen Elizabeth*, International Marine Radio Company.

S. J. Pearce, installation engineer, Marconi Company.

N. D. Penfold, asst. chief engineer, Digital Systems Department, Ferranti's Bracknell Laboratories.

P. E. White, asst. executive engineer, Post Office Research Station.

Lt.-Colonel F. D. Williams, B.Sc., A.M.I.E.E., Royal Corps of Signals.

B.E.M.

B. E. Good, model shop superintendent, Research & Development, E.M.I. Electronics, Hayes.

Switching without Relays

SOME SWITCHING CIRCUITS USING TRANSISTORS AND VARIOUS TYPES OF THYRISTOR

By AUBREY HARRIS,* A.M.I.E.E., A.M.I.E.R.E.

Recent years have seen the introduction of many semiconductor devices which have found application in both d.c. and a.c. power switching circuits. Semiconductor switching circuits may now be used for virtually all the functions for which relays were previously used.

There are many advantages of semiconductors over relay contacts, among them are greater reliability, no mechanical wear, no adjustment or maintenance required and no contact arcing or sparking.

Against these benefits must be weighed the disadvantages: above the lowest powers heat sinking of the power transistor or other device is necessary and some devices may be destroyed by surges due to line transients or reactive load conditions. However, proper care in design can eliminate these problems.

ONE very common circuit required in present day equipment is a solenoid or other electro-magnetic driver. Circuits of this type are often needed for driving the coils of printing hammers in electric typewriters and teleprinters, electric paper punches, brake actuators in tape recorders and in other similar functions.

Fig. 1 shows a typical simple solenoid driver capable of switching up to 5 amps. The driver stage Tr1 is necessary to provide sufficient base current to the output stage. In the unoperated state Tr1 is cut off, there being no voltage applied between emitter and base. The collector of Tr1 is at approximately +20 V and this voltage is applied to the base of Tr2 through R₄. No base current flows into Tr2 because its emitter is held negative with respect to the base by the voltage drop across the silicon diode D₁ which is passing a small current through R₅. The emitter is thus held constant at approximately 19.3 V and the transistor is cut off.

A positive voltage of 6 V applied to the input of the circuit at R₁ will saturate Tr1 and lower the potential of the collector almost to earth level. Tr2 becomes forward biased and base current flows from the positive supply through D₁, Tr2 emitter and base, R₄ and Tr1 to earth. Tr2 is saturated and current flows through the load solenoid connected between Tr2 collector and earth.

When the circuit is de-energized a voltage transient is developed across the coil due to the rapid decay of current through the coil inductance. This voltage, $e = -L di/dt$, may reach several hundred volts in amplitude and unless suppressed is likely to destroy

the transistor Tr2. Assuming a coil inductance of 5 mH, coil current immediately before switching of 1 amp and a switching time of 10 μs:—

$$e = \frac{-5 \times 10^{-3} \times 1}{10 \times 10^{-6}} = -500 \text{ V.}$$

A diode connected across the coil (D₂) is satisfactory for this suppression, conducting only under the transient condition. The diode should be capable of carrying the full load current of the coil.

The circuit just described may be converted to a latching arrangement by the addition of Tr3 and associated resistors as shown in Fig. 2. The coil will then be energized even when the operate voltage to Tr1 is removed. When the coil is energized, the positive

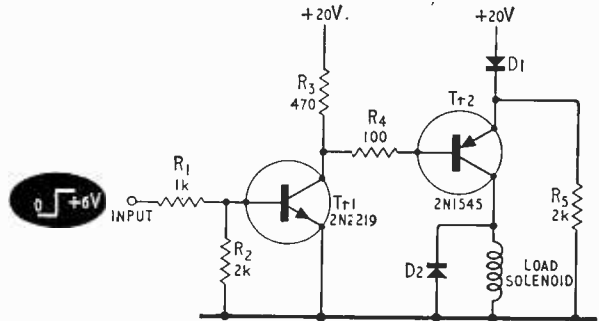

Fig. 1. Solenoid driver circuit for switching up to 5 A. D₁: 1S410, 1N3569, D₂: 1N4385, 1S025.

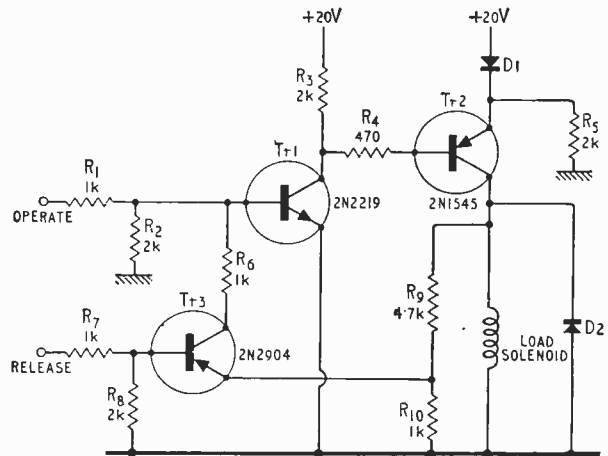

Fig. 2. Addition of Tr3 provides a latching facility to the circuit shown in Fig. 1.

* Ampex Corporation, California

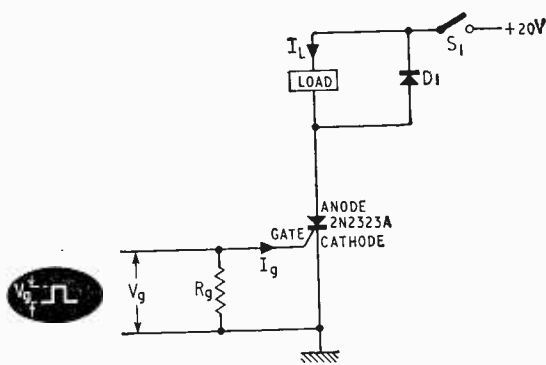

Fig. 3. A simple latching circuit for d.c. loads using an s.c.r.

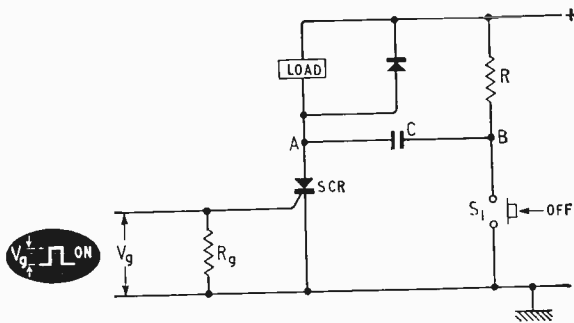

Fig. 4. Circuit for switching off an s.c.r. latching circuit.

voltage at the collector of Tr2 is applied by the potential divider action of R_9 and R_{10} to the emitter of Tr3 (p-n-p). Base current flows in Tr3 through R_8 to earth. Tr3 saturates feeding base holding current to Tr1 through R_7 , Tr3, and R_6 .

To de-energize the coil a positive voltage (6 V) is applied to the release input, at R_7 ; this reverse biases Tr3 which is thereby cut-off and current ceases to flow through R_6 to Tr1 base.

Switching by controlled rectifiers

In many cases it is desired to switch a large load with only a small control current and for this purpose the silicon controlled rectifier is ideal. A range of units is available for switching currents of from one or two amps to many hundreds of amps. The trigger or gate current required varies from less than one milliamp to five amps. The operation has been described previously by Thomas Roddam.*

The s.c.r. is inherently a latching device. Once load current (I_L) is flowing from anode to cathode the only way to stop the current flow is to remove the supply voltage or reduce the current through the s.c.r. to below the device holding current (I_H). The holding current is the value of anode current below which the s.c.r. will block, that is, will not conduct. Typical values of I_H are: for a 1.6 A device, 1-2 mA; and for a 7.4 A device, 10-50 mA. It is thus necessary for I_L to exceed I_H under all conditions or the device will not stay latched on.

A simple latching circuit is shown in Fig. 3. With

S_1 closed and without gate current, I_g , no load current I_L flows. If a pulse (V_g) at the gate terminal of about 3 to 5 volts is applied, gate current will flow, the s.c.r. will conduct and stay in the conducting state after the gate trigger pulse has been removed. A minimum gate current I_g of 10-200 microamps (for sensitive low current devices, such as the 2N2323A) is required to initiate the conduction. Load current will continue to flow until the supply is removed by opening S_1 . It is obviously inconvenient to have to remove the supply voltage in order to turn the s.c.r. off, so it is usual for other means of reducing I_L below I_H to be employed.

A simple method of switching the s.c.r. off using a momentary contact switch S_1 is shown in Fig. 4. The s.c.r. is made to conduct by application of gate voltage (V_g). Point A, the s.c.r. anode, is then only 1 or 2 volts above earth potential and the capacitor, C, charges from the supply voltage through R. When fully charged the plate connected to B is positive with respect to A by the supply voltage less the voltage drop across the s.c.r. When it is desired to switch the s.c.r. off, S_1 is operated. Point B is then earthed and as the charge on the capacitor cannot change instantaneously the left hand plate of the capacitor drops below earth by the amount of its charge. This makes the anode of the s.c.r. negative with respect to its cathode and the device cuts off and stays off until another gate trigger pulse is applied.

The value of the capacitor is found approximately from:—

$$C = \frac{1.5 t_{off} I_L}{V} \mu F$$

where V is the supply voltage in volts, I_L the load current in amps, and t_{off} the turn-off time of s.c.r. in microseconds.

A typical case with a supply voltage of 30 volts, load current of 1 amp and s.c.r. turn-off time 40 microseconds, gives:—

$$C = \frac{1.5 \times 40 \times 1}{30} = 2 \mu F$$

The value of R is not too critical and a value in the range 10-100 k Ω would be typical.

A slight variation of this circuit in which S is replaced by another s.c.r. is shown in Fig. 5. This allows turn-on and turn-off of the load-carrying s.c.r. to be accomplished by remote low power feeds. SCR1 and SCR2 work in a flip-flop arrangement; when one is on, the other

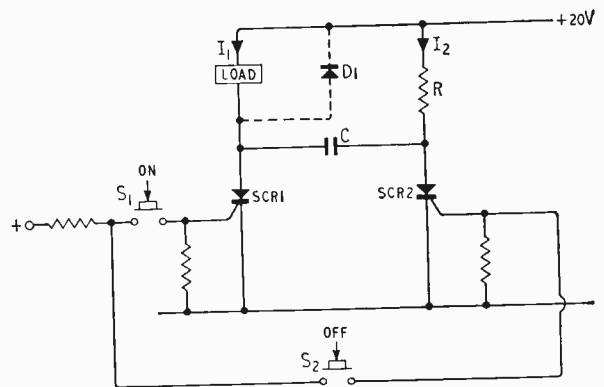

Fig. 5. Alternative switch-off circuit using a further s.c.r. to enable remote on and off control. D1 is required only if the load is inductive. SCR1 must carry full load current and SCR2 must carry $20/R$ amps.

* Wireless World, Sept. 1963 p. 459

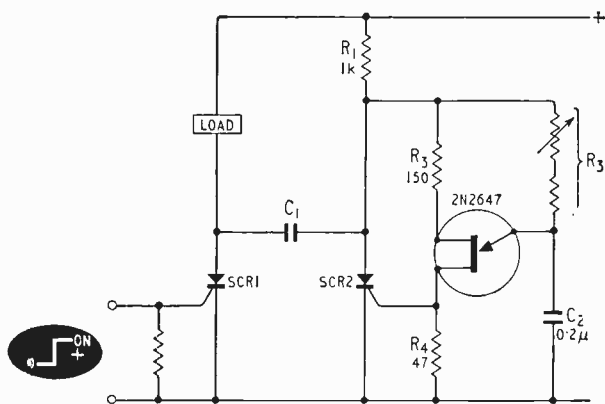

Fig. 6. A development of Fig. 5 in which the load current is turned off after a fixed time interval.

is off. When SCR 2 is used to turn off SCR 1, SCR 2 stays on after its gate pulse is removed. The capacitor then charges in the opposite direction through the load and SCR 2, and when SCR 1 is turned on the capacitor charge lowers SCR 2 anode voltage and cuts off the device. The value of C is calculated as before. The resistance value R is given approximately by:—

$$I \times \frac{V_{(BR)FX}}{I_{FX}}$$

where $V_{(BR)FX}$ is the forward breakover voltage in volts and I_{FX} the leakage current in amps.

A further development of this circuit in which the load current is turned off after a fixed time period is illustrated in Fig. 6. The gate of SCR 2 is connected to R_4 , the base 1 resistance of a unijunction transistor (UJT). (For details of the operation of these devices see *Wireless World*, March 1964, p. 110.)

A pulse of several volts is developed across this resistance at a time $T = R_2 C_2$ (very approximately) after the application of the supply.

The circuit operates in the following manner. Assume SCR 1 is off and SCR 2 is on. No current is flowing in the load. The junction of R_1 and SCR 2 is approximately at zero and the unijunction transistor part of the circuit is inoperative at present. When a gate driving pulse is applied to SCR 1, SCR 1 turns on, commutates SCR 2 off via C_1 , and the potential at the junction of R_1 and SCR 2 rises almost to the supply voltage. The unijunction transistor now has voltage supplied to it and starts timing. At the end of time T , the pulse developed across R_4 provides gate drive to SCR 2. This turns on SCR 2, commutates SCR 1 off through C_1 and prevents UJT from operating further. The circuit is thus returned to its original state with no load current flowing in SCR 1.

Lamp driver

A further application of the s.c.r. is as a lamp driver. With this arrangement, large power lamps may be controlled with an s.c.r. requiring only a small amount of gate power. For example, the 2N688 is capable of switching 35 A r.m.s. at up to 400 V peak with a gate drive of 3 V at 40 mA.

A typical circuit is shown in Fig. 7. The lamp loads to be switched are connected in series with the s.c.r. across the supply voltage. As the s.c.r. is a unidirectional

Fig. 7. Control of lamp loads using a single s.c.r. and a full-wave rectified supply.

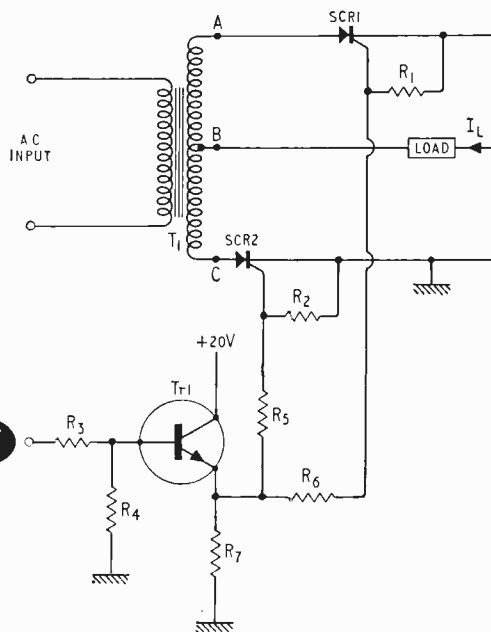
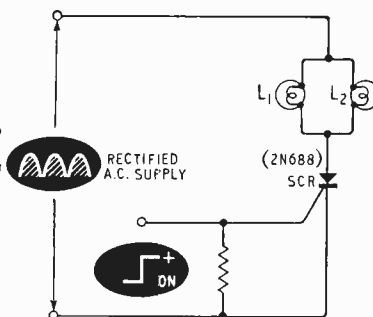

Fig. 8. Using s.c.r.s. to perform the rectifying action of a full-wave rectifier. $R_1, R_2, R_3, R_4: 1 \text{ k}\Omega; R_5, R_6, R_7: 3.3 \text{ k}\Omega; Tr1: 2N1304; SCR1, SCR2: 2N688.$

device, the supply must first be full-wave rectified. For each half cycle during which the gate drive is present, the s.c.r. will conduct. When the gate drive is removed the s.c.r. conducts only until the end of that half cycle. If the gate drive is not re-applied, the s.c.r. will not conduct and the load will not be energized. The reason for using a rectified a.c. input to the circuit is apparent; the s.c.r. drops out of conduction at the end of each half cycle. If a d.c. supply were used the s.c.r. would continue conducting for the whole of the time during which the d.c. supply were connected, even after the gate drive was removed.

It is possible to use the s.c.r.s to carry out the rectifying action as well as the switching as shown in Fig. 8. SCR 1 and SCR 2 are supplied from the centre tapped transformer T_1 . Positive gate drive is supplied from the emitter of the transistor $Tr1$, via R_3 to SCR 1 and via R_6 to SCR 2.

When point A of T_1 is positive with respect to B, SCR 1 conducts and feeds current to the load. Point C is negative with respect to B and SCR 2 does not conduct. During the next half cycle, as the polarities of A and C

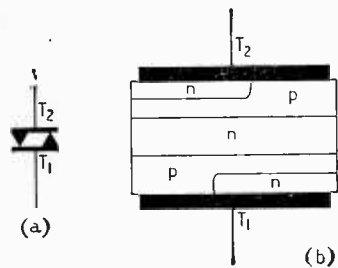

Fig. 9. (a) Symbol in current use for a bi-directional switch (Silicon Symmetrical Switch, Diac or BiSwitch). (b) Structure of bi-directional switch showing the five layers of semiconductor material.

Fig. 10. (a) Symbol in current use for the bi-directional switch with gate (Triac). (b) Diagrammatic representation of the Triac structure.

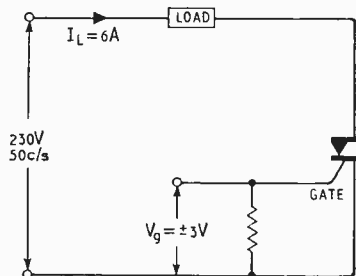
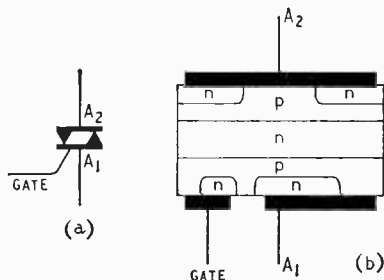

Fig. 11. D.C. control of a.c. load with a gated bi-directional switch (e.g. General Electric SC40D or RCA TA2685.)

Fig. 12. A.C. triggering of a 2.3 kW load by a low current switch S1. Current only flows through the switch at the start of each cycle.

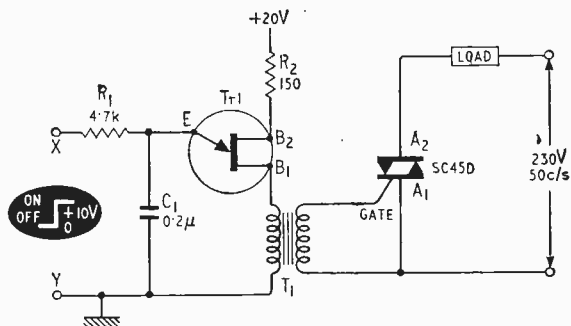
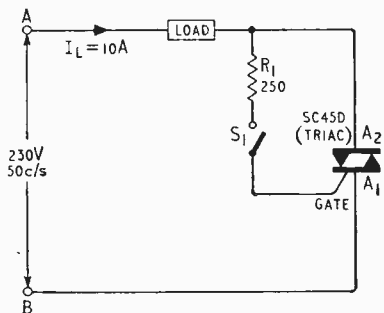
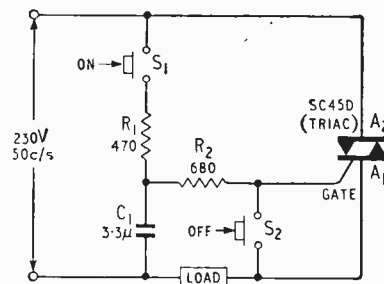

Fig. 13. Isolated control of an a.c. load by a unijunction fired Triac.

Fig. 14. Triac in a latching configuration. Gate current is maintained by C1 discharging through R2.



reverse, SCR 2 conducts and SCR 1 does not. The s.c.r.s will only conduct when gate drive is applied. When the drive is removed, conduction ceases as the input waveform next crosses the zero axis.

Thyristors for a.c.

A recent development in the thyristor field is the bi-directional controlled rectifier, known under such trade names as BiSwitch, Diac or Silicon Symmetrical Switch. They are available for switching voltages of up to 400 V at 20 A (Fig. 9). These devices differ from the s.c.r. basically in that they will conduct in either direction instead of only in one direction. They may then be used to switch a.c. loads directly. Most of these units have a particular value of rated voltage under which they will not turn on. When this voltage is exceeded (the breakover voltage, V_{BR}) conduction takes place between T1 and T2 for the rest of the half cycle; the device is then triggered once more and it conducts for the next half cycle. Conduction continues as long as trigger pulses are provided.

A more versatile form is the Triac (Fig. 10), which is similar to the above described units except that it has the addition of a gate. The Triac may be made to conduct by exceeding the breakover voltage, but the conduction is usually initiated by applying gate voltage. Either negative or positive gate drive may be used to trigger the device into conduction. It will conduct when either A1 is positive or negative with respect to A2 for either polarity of gate voltage. Like the s.c.r. conduction continues until the end of the half cycle during which the gate drive is removed.

Some circuit applications are shown in Fig. 11. The first circuit shows d.c. control of a Triac, in which the load is switched on by the constant voltage applied to the gate.

The mains input may be used to trigger the device on as shown in Fig. 12. The operation is as follows. Assume first that the Triac is off, that S1 is open, and that at the instant being considered point A is positive with respect to B. The full supply voltage appears across the Triac. Thus point A2 is positive with respect to A1. When S1 is closed current flows through R1 to the gate terminal G. The Triac conducts, the potential between A1 and A2 drops to a very low value, and gate current ceases. However, conduction continues through the half cycle and is initiated again at the start of each succeeding half cycle for as long as the switch S1 is closed.

In many cases it is necessary to isolate the controlling circuit from the load, which is often at mains potential. It is convenient to control the Triac by a transistor circuit, one side of which is connected to earth. One means of accomplishing this is shown in the circuit in Fig. 13. The gate and A1 terminals are connected to

the secondary of the small pulse transformer, with insulation between windings adequate for the mains supply voltage.

R_1 , C_1 , $Tr1$, R_2 , and the primary of $T1$ form a uni-junction relaxation oscillator. When X is positive with respect to Y , pulses of current due to the successive discharge of C_1 through the emitter-base junction of $Q1$ and the primary of $T1$ induce voltage pulses in the secondary of $T1$. These pulses are directly coupled to the gate terminal of the Triac. The frequency of the oscillator should be about 10 to 100 times the mains supply frequency. During every half cycle of the mains waveform there are many gate trigger pulses from $T1$. The Triac fires on the first trigger pulse in the half cycle, ignoring the succeeding pulses, but continuing to conduct throughout the rest of the half

cycle. The load is thus energized continuously for as long as X is supplied with a positive potential.

The Triac may be used in a latching circuit as shown in Fig. 14. Two, normally open, momentary-contact push switches ($S1$ and $S2$) control the operation. Assume the circuit is in the off state. On closing $S1$ current flows through R_1 and R_2 to the gate of the Triac, switching it into conduction. During the first half cycle C_1 charges through R_2 and the Triac towards the load voltage. At the end of the half cycle, C_1 discharges through the gate, triggering the Triac on for the next half cycle. The processes continue until $S2$ is operated, which discharges the capacitor directly, by-passing the Triac gate. The Triac stops conducting, de-energizing the load, and the circuit remains in this condition until $S1$ is operated again.

SIMPLE CONSTANT CURRENT CIRCUIT

THREE TRANSISTOR CIRCUIT PROVIDING CURRENT CONSTANT TO $\pm 0.25\%$

By G. WATSON*

A TWO-terminal circuit is described which draws a constant current when the direct voltage applied across its terminals is varied between the limits of 8 and 40 volts. An overall accuracy of current of $\pm 0.25\%$ is obtained over a temperature range of from 0° to 40°C . Component values are given for fixed currents of 10, 20, 50, 100 and 150 mA. The unit may be used as a discrete circuit element. It finds greatest application where the precise value of the current is of primary interest. The circuit may well be used to control the filament current of electrometer valves where these are combined with transistors in hybrid operational amplifiers, etc. Its two terminal nature also makes it ideal for applications where a constant current is to be obtained from a battery, possibly with a facility for polarity reversal and where disconnecting one lead should interrupt all current flow from the battery. Such applications include transistor and diode testing where adjustments for battery voltage are to be avoided.

Circuit details

The circuit (Fig. 1) comprises a long tailed pair comparator, a Zener diode voltage reference, and a series transistor. The comparator compares the Zener reference voltage with a proportionate version of the voltage drop across a current sampling resistor plus the reference voltage. The output of the comparator drives the base of the series transistor, and this transistor has the Zener circuit and a potentiometer chain as its collector load. The circuit connections are such that a negative feedback loop is formed, which tends to reduce any change in the overall current of the circuit. A loop gain of about 35 is obtained. Primary causes of current change in the circuit are the finite value of h_{OE} and the temperature dependence of h_{FE} in the series transistor. Temperature

effects in the comparator stage are largely balanced out, and the Zener diode is chosen to have a low temperature coefficient of voltage. The balanced nature of the collector currents drawn by the long tailed pair means that their contribution to the overall circuit current does not vary. The current passing through the Zener diode is essentially constant and so the diode works under ideal conditions, and is able to deliver a stable reference voltage to the rest of the circuit.

Temperature effects

Small variations in the overall current with temperature are present in the basic circuit and are caused by the following effects:—firstly, there is the V_{BE} offset variation in both $Tr1$ and $Tr2$ of about 2.2 mV deg C^{-1} . This varies the total comparator current at the rate of some

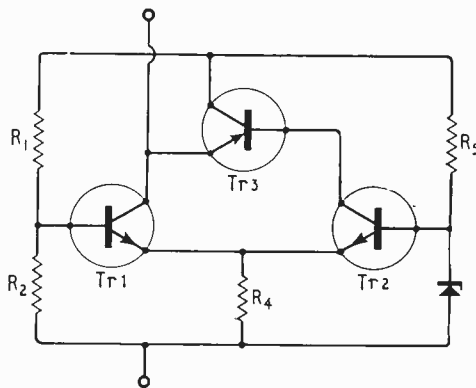

Fig. 1. Prototype constant current circuit.

*The Marconi Company Ltd.

COMPONENTS

| Current (mA) | R ₁ | R ₂ | R ₃ | R ₄ | R ₅ | R ₆ | RV ₁ | Tr1 | Tr2 | Tr3 |
|--------------|----------------|----------------|----------------|----------------|----------------|----------------|-----------------|------|--------|---------|
| 10 | 1.8kΩ | 3.9kΩ | 820kΩ | 6.2kΩ | 270Ω | — | — | 1kΩ | 2N929 | 2N1131 |
| 20 | 200Ω | 430Ω | 470kΩ | 3.9kΩ | 270Ω | — | — | 100Ω | 2N929 | 2N1132 |
| 50 | 200Ω | 430Ω | 220kΩ | 2.7kΩ | 270Ω | 240Ω | (0.5W) | 100Ω | 2N929 | 2N1136A |
| 100 | 200Ω | 430Ω | 100kΩ | 2.0kΩ | 270Ω | 91Ω | (1W) | 100Ω | 2N1613 | 2N1136A |
| 150 | 200Ω | 430Ω | 68kΩ | 1.5kΩ | 270Ω | 56Ω | (2W) | 100Ω | 2N1613 | 2N1136A |

Note:—All resistors are $\pm 2\%$ tolerance except for R₃ which may be grade II carbon. 0.25W rating is suitable for all except R₆.

+ 450 ppm deg C⁻¹ and in the 10 mA version of the circuit represents an overall increase of circuit current of about 63 ppm deg C⁻¹. Secondly, there is the h_{FE} variation in Tr3. Very approximately this is + 6000 ppm deg C⁻¹ over the temperature range of interest. Allowing for a loop gain of 35, this represents an overall increase in circuit current of some 170 ppm deg C⁻¹. Thirdly, the tracking of V_{BE} between the comparator pair represents a somewhat indeterminate source of current variation with temperature. If these transistors are mounted close together and thermally isolated from the major sources of heat, a reduction in the individual V_{BE} temperature coefficient of some 25 : 1 should be possible. This gives an overall current variation of $\pm 0.15\%$. Self heating of Tr3 will also vary its h_{FE} , and this should be minimized if a further overall current variation dependent on circuit voltage is to be avoided. Other small temperature effects are present, but these may be ignored as may be the leakage current in all three transistors.

The positive temperature coefficient introduced by both the common mode V_{BE} variation in Tr1 and Tr2, and h_{FE} variation in Tr3 can be compensated for by choosing a Zener diode with a slightly negative temperature coefficient. A figure of -200 ppm deg C⁻¹ is suitable. It is advisable, however, to use a diode actually selected for this coefficient since production diodes often have a rather wide tolerance on this parameter.

Design for 10 mA

The final schematic is shown in Fig. 2 and component values are shown in the attached table. It will be noted that R₆ is only included in the higher current circuits

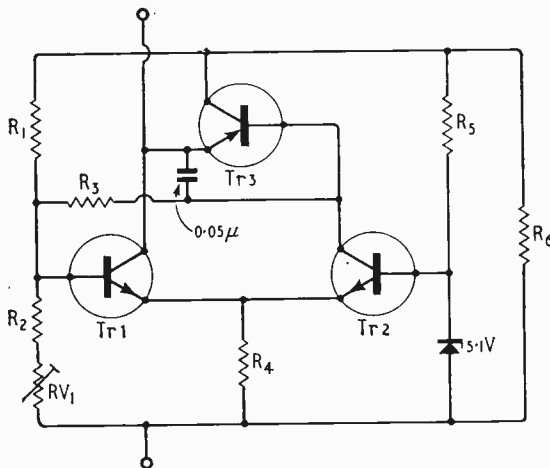

Fig. 2. Final version of the circuit. The Zener diode should be selected for a temperature coefficient of -200 ppm deg C⁻¹.

in order that RV_1 which forms part of the potentiometer chain shall not have a very low ohmic value with its attendant low resolution. The effect of the finite h_{ob} of the series transistor is compensated for by injecting a small current, proportional to the overall circuit voltage, into Tr1 base by means of a resistor. This resistor also makes the circuit self-starting since it is returned to the base instead of the emitter of Tr3. There is thus

a small initial current available for Tr3 so that as the overall terminal voltage rises, Tr3 conducts and makes Tr2 conduct, and so ensures correct operation when the overall voltage exceeds the minimum. This minimum voltage for correct operation is determined by the combined voltage drops of the Zener diode, the current sampling resistor R₅, and the saturation voltage level of Tr3. A figure of more than eight volts is not likely to be required.

The a.c. stability of the feedback loop is unsatisfactory unless a suitable correction network is added. This is simply done by connecting a $0.05\mu\text{F}$ capacitor across the base-emitter junction of Tr3. The high frequency performance of the loop then has a corner frequency of about 30 kc/s. Externally the circuit appears as the common base output impedances of Tr1 and Tr2 in parallel.

A Zener current of 8 mA was chosen since this gives a reasonably low slope resistance for the diode, and allows a fairly small current only to be consumed by the potentiometer chain. The current through the potentiometer chain is a compromise between that necessary for a fairly low source resistance available to Tr1 base, and yet not so high that the potentiometer chain shunts R₅ too much, with consequent loss of gain. The values chosen give the highest loop gain consistent with the fact that no improvement may be obtained by shunting the base-emitter junction of Tr3 with a resistor, in order to bring up the comparator's g_m as the self-starting property of the circuit would then be lost. The loop gain in fact tends to remain the same for quite wide variations in the design centre value of the series transistors h_{FE} . This is because an increase in its h_{FE} must be allowed for by a reduction of current through the comparator stage if its individual currents are to remain equal, and this results in a lower g_m which offsets the higher gain from the series transistor. The 10 mA circuit has a total comparator current of 0.75 mA. Close tolerance high stability resistors are of course required for all except the compensator resistor R₃.

Designs for other currents

The principal difficulty with higher current circuits is the greater dissipation from Tr3. For all except the 10 mA circuit it is necessary to mount Tr3 on a heat sink, a power transistor being necessary for the higher currents. Proper steps must be taken to ensure that the heat dissipated does not produce differential heating of the long tailed pair or appreciably heat up the Zener diode. Sufficient heat removal from Tr3 is also necessary to avoid a large change of h_{FE} in this transistor. It is convenient to use a germanium power transistor for the higher currents and this makes the heat sink requirements even more stringent if the leakage current is not to become excessive. It must also be remembered that a potentially unstable thermal situation exists owing to the lack of a base-emitter resistor.

Acknowledgement:—The author wishes to thank the Director of Engineering, The Marconi Company Limited, for permission to publish this article.

APPENDIX

Approximate calculation of the loop gain acting to reduce inherent current changes in the circuit for the 10 mA case.

Assuming a finite resistance between the two terminals of the circuit, that $h_{OB} = \infty$, and that the emitter feed resistor to the comparator may be squared, the equivalent circuit is:—

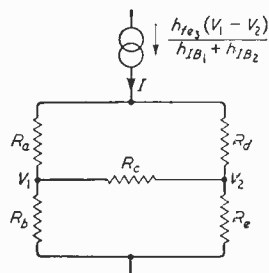

where

- $R_u = 1.8k\Omega$
- $R_b = 4.3k\Omega$
- $R_c = h_{IE1} + h_{IE2} = 20\Omega$
- $R_d = 270\Omega$
- $R_e = 20\Omega$, the slope resistance of the Zener diode at 8 mA.
- $h_{fe3} = 28$
- $(h_{IB1} + h_{IB2}) = 133$, for the design current.

This may be redrawn as follows, using the star-delta transformation:—

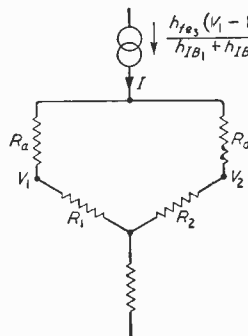

Hence:—

$$R_1 = \frac{R_b R_c}{R_b + R_c + R_e} = 3.54k\Omega$$

$$R_2 = \frac{R_c R_e}{R_b + R_c + R_e} = 16.5\Omega$$

$$\text{Also, } (V_1 - V_2) = I \frac{(R_a + R_1)(R_d + R_2)}{R_a + R_1 + R_d + R_2} \left[\frac{R_1}{R_1 + R_a} - \frac{R_2}{R_2 + R_d} \right] = 165I.$$

$$\begin{aligned} \text{Loop gain} &= \frac{\text{Current out of Tr3 collector}}{\text{Current into resistive network}} \\ &= \frac{h_{fe3}(V_1 - V_2)}{(h_{IB1} + h_{IB2})} \\ &= \frac{28 \times 165I}{133I} = 34.8 \end{aligned}$$

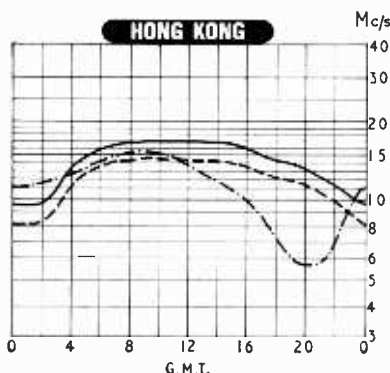
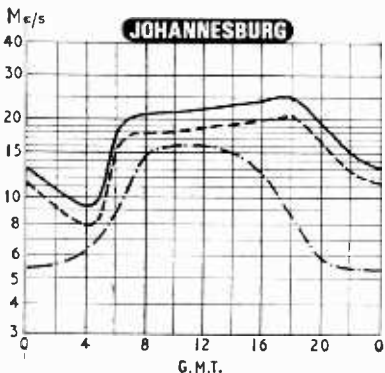
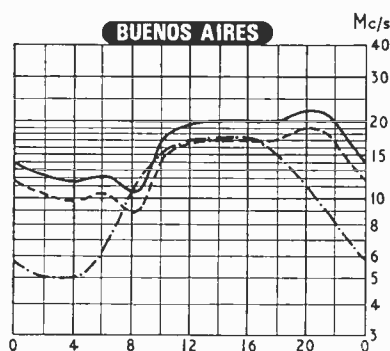
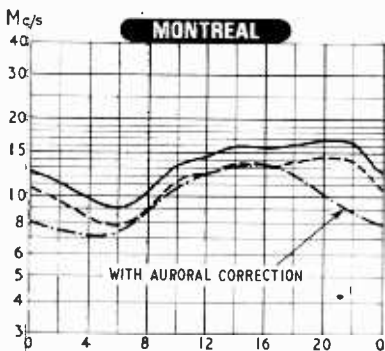

H. F. PREDICTIONS AUGUST

The prediction curves show the median standard MUF, optimum traffic frequency and the lowest usable frequency (LUF) for reception in this country. Unlike the standard MUF, the LUF is closely dependent upon such factors as transmitter power, aerials and the type of modulation. The LUF curves shown were drawn by Cable and Wireless Ltd. for commercial telegraphy and assume the use of transmitter power of several kilowatts and aerials of the rhombic type.

As mentioned last month, frequencies considerably above the MUF may be usable during the daytime. For example, for the Hong Kong-London circuit, frequencies up to 20 Mc/s will probably be usable at 0800 GMT. These increases in MUF are thought to be due to sporadic-E ionization.

PRINT QUALITY MONITORING

CHARACTER recognition machines are now being developed by the computer manufacturers to enable printed information on documents to be read directly into computers. A big problem here is the variability of print quality, and it is desirable that there should be some way of specifying the quality of print that a recognition machine will accept—preferably in the manner in which the machine reads it. For this purpose International Computers and Tabulators Ltd. have developed a print quality monitoring instrument. It operates on one character at a time. Quality is assessed on the basis of whether the various parts of the character have been printed with sufficient density to permit the overall ink pattern to be recognized as that character.

By use of television flying-spot scanning a video signal representing the character is produced, and is processed so that all shades of grey lighter than a given discrimination level are suppressed and all shades darker than this are converted to a constant black level. The discrimination level is manually pre-set by the operator. The processed character is then displayed on a c.r.t., magnified, in terms of black and white only (no greys) and the resulting outline represents that of the original character at a particular value of ink density—the discrimination level. Print quality is then determined on a “pass-or-fail” basis by observing whether or not the character outline falls between maximum and minimum limits engraved as outlines on a perspex graticule. A separate graticule is required for each character to be checked.

The monitor can also be used to make detailed absolute measurements of print parameters, and a graticule engraved with a rectangular grid calibrated in thousandths of an inch

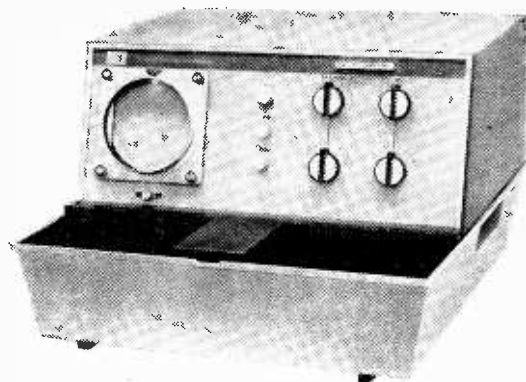

Print quality monitor, showing c.r.t. screen.

or millimetres is then used. Characteristics that can be measured include print dimensions, ink density, paper whiteness, paper blemishes, print reflectance, extraneous inking, spots (external to the character boundaries), voids (spaces within the printed character), and “droop”—the variation of ink density over a character.

I.C.T. expect that the monitor will be used on a sampling basis. For instance, samples from a computer print-out may be checked to ensure that the print is generally up to standard. Alternatively, if rejects from a document reading machine become unacceptably frequent, the monitor may be used to discover whether the print or the reading machine is at fault, indicating where corrective action is needed.

Another Fase in the Sad Story of Man's Subjection to the Machine

THE second word in the above title is not a mis-spelling but an acronym, standing for “Fundamentally Analyzable Simplified English.” This new version of the language, developed by Dr. Lee E. McMahon, a psychologist working at Bell Telephone Laboratories, U.S.A., is a kind of Basic English for computers. The idea is to eliminate the confusion which can occur in information retrieval systems based on computers about the relation of words in a sentence. Translation into FASE is a matter of re-arranging the words in a sentence so that it can be easily parsed by a computer. The result, however, is indistinguishable from ordinary English—so that even though man is having to adapt his mode of communication to the needs of the machine at least he is not being made unduly aware of it! This can be confirmed from the following quotation from a Bell Labs information bulletin which is itself written entirely in FASE (making due allowances for American characteristics):—

“Dr. McMahon has reduced the English language to a strict form in which syntax is clear and sentences are easily broken into component grammatical parts to avoid ambiguity. For example, ‘Time flies’ would be ambiguous to a computer because the roles of the noun and verb are interchangeable. In addition to its popular interpretation, this expression could well be an imperative statement demanding that we clock the little insects.

“However, a sentence in FASE strictly maintains the sequence of subject, verb and object; modifiers like adjectives and adverbs, and other parts of speech must fall into line. A complicated set of rules has been devised to ensure unambiguous syntax.

“Consider ‘Time flies’ again. A computer which reads FASE would interpret this correctly, since ‘time’ would be taken as a noun. To demand that someone clock the insects, we would have to rewrite the sentence. For example, we might say ‘Determine the speed of flies.’

“In a FASIC operation, abstracts or documents would be written or rewritten in FASE. They would then be punched on cards, and stored in a computer. The computer might then be instructed at any time to index or to retrieve information by a special program based on FASE grammar. These documents can be indexed and retrieved on the basis of grammatical units and relations which are not useful in present systems because of the syntactic ambiguity of natural English.

“Dr. McMahon estimates that a competent writer of English would need a few months to learn how to write FASE fluently.

“FASE also may provide a more accurate computer translation of foreign languages. Automatic translation of foreign scientific papers is growing into a big business; but the results are not always reliable. Although present mechanical translation is based on grammar to an extent, it involves complicated series of computer decision-making. To some degree, these necessary complications compensate for inherent ambiguities in the language being used. FASE, which removes the syntactic ambiguities in English, would simplify the task of the computer and lessen the chance of error.”

Bell Labs point out, however, that while syntactic ambiguity has been eliminated in FASE, there are still problems arising from semantic ambiguity to be overcome.

Random Signal Testing for Evaluating System Dynamics

By W. D. T. DAVIES,* B.Sc. Ph.D.

ADVANTAGES OF PSEUDO RANDOM BINARY SEQUENCES AS EXCITATION FOR OBTAINING IMPULSE RESPONSE

There is a great deal of interest in the properties of random signals for determining the characteristics of systems, and a particular kind of signal, the pseudo-random binary sequence (p.r.b.s.), has been shown to have special advantages for measuring impulse response. This article explains the principles of the p.r.b.s. technique and relates it to more familiar methods used in electronics such as frequency response testing.

It is usually necessary at some time or another to evaluate the characteristics of a system, whether it be an electrical network, a process control system or some piece of mechanism. This may be simply to prove that the system is working as it was designed, or may be the first step in a much more sophisticated scheme such as the design of a self-adaptive control system.

In the former case, the "system" may in fact be simply one component of a much larger system and be available on its own, completely separated from the environment in which it was designed to work. Any chosen signal can then be introduced into the input of the equipment and the resulting output measured. This kind of "off-line" evaluation is often the measure of goodness of a system—the frequency response curve of a high quality audio amplifier being one familiar example. In this case, where the amplifier is under test, it is not connected to the complete audio system to which it belongs but is on a "test bed," and the frequency response curve is obtained off-line.

The other extreme is, of course, "on-line" testing. This kind of testing is more prominent in the process industries where the characteristics of large, expensive systems are required. In this case, the problem of parameter evaluation is much more complex. More often than not, the system is in operation 24 hours a day and it would be prohibitively expensive, both in manpower and in lost production, to even consider taking it off line in order to carry out the experiments. A further restriction is that, if the experiment needs a disturbance signal at the input, this disturbance must be applied together with the normal operating input and its amplitude must be small enough

that the system is not disturbed too far from its (presumably) optimum operating condition. Another reason for the disturbance signal having to be small is to ensure that the characteristics so obtained describe a system which may be considered to be linear about its operating condition.

This last requirement is quite important in practice because most of the theories of feedback control, stability of systems, etc., are only valid for linear systems.

This article is concerned with the use of a particular type of disturbance signal or "forcing function" for system evaluation—the random signal. Before considering this relatively new technique,¹ however, it will be helpful to look briefly at the older, well-established methods of evaluation using forcing functions. These are: direct sinusoidal testing to obtain a frequency response curve; step response testing; and impulse response testing.

Sinusoidal testing.—The frequency-response curve of a system can be determined directly by forcing it with a family of sinusoidal inputs. If the system, Fig. 1, is considered to be in a steady state and the input is disturbed by a signal $x(t) = A \sin \omega t$ (where again the ampli-

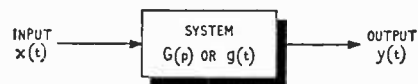

Fig. 1. Generalized linear system with input signal $x(t)$ and output signal $y(t)$.

tude A must be small enough for the system to behave in a linear fashion), then the output signal $y(t)$, after the transient response has died away, will be $B \sin(\omega t + \phi)$.

It must be stressed again that this will not hold unless

W. D. T. Davies entered the University College of Swansea in 1958 and graduated in electrical engineering in 1961. He continued at Swansea for a further three years working on the identification problem associated with self-adaptive control systems, and was awarded a Ph.D. for this work in 1965. In 1964 he joined I.C.I. Ltd., at their Central Instrument Research Laboratory, where he has been working on optimum and self-adaptive control theory, plant identification and the problems arising in the applications of direct digital control.

*Imperial Chemical Industries, Ltd., Central Instrument Research Laboratory.

the system is considered linear about its operating condition, which in this particular case would be its steady state condition.

The signal gain B/A , and the phase shift ϕ , enable the frequency response curve to be evaluated at the frequency ω . The complete curve may thus be obtained by repeating the experiment using a series of different frequencies ω . Typically, a series of about 20 to 30 points might be used in the experiment, the frequencies ranging from a very low value up to a value at which the gain becomes too small to be measured. However, in each experimental run, the forcing sinewave must be applied long enough to allow the transient to die away completely. This period depends on the longest time constant of the system, and so the complete experiment may become quite time consuming.

The signal gain B/A , and the phase shift ϕ may be obtained by directly comparing the input and output records. However, since the amplitude A of the input signal will not be large, and the output signal will almost certainly be contaminated with noise, the determination of B/A and ϕ will probably be quite difficult.

An effective way to get round this difficulty is to multiply the output signal $y(t)$ by the input signal $x(t) = A \sin \omega t$ and a signal $z(t) = A \cos \omega t$. In this case two new signals are obtained which are

$$i(t) = y(t).x(t) = B \sin(\omega t + \phi)A \sin \omega t \quad \dots \quad (1)$$

and

$$j(t) = y(t).z(t) = B \sin(\omega t + \phi)A \cos \omega t \quad \dots \quad (2)$$

Therefore, by trigonometry

$$i(t) = \frac{AB}{2} \left\{ \cos \phi - \cos(2\omega t + \phi) \right\} \quad \dots \quad (3)$$

and

$$j(t) = \frac{AB}{2} \left\{ \sin \phi + \sin(2\omega t + \phi) \right\} \quad \dots \quad (4)$$

Therefore by using simple low pass circuits the fluctuating components $\cos(\omega t + \phi)$ and $\sin(\omega t + \phi)$ may be eliminated so that the two signals become

$$\dot{i}(t) \simeq \frac{AB}{2} \sin \phi \quad \dots \quad (5)$$

$$\dot{j}(t) \simeq \frac{AB}{2} \cos \phi \quad \dots \quad (6)$$

so that $\frac{\dot{j}(t)}{\dot{i}(t)} = \tan \phi$, giving the phase shift ϕ

and $i^2(t) + j^2(t) = (AB)^2/4$, giving B/A since A is known.

Step response testing.—Although the results of sinusoidal testing give exactly the required result (the frequency response curve), the whole experiment is a little long-winded. The step response of the system on the other hand is very easily obtained. All that is required in this case is a step change in the input. The resulting output curve is a function of time and since a step function contains all frequencies, the step response contains all the information required to characterize the system. From the curve, which in the case of a simple system is usually in the form of a damped sinusoid, it is simple to evaluate the damping of the system from the envelope of the response and the natural frequency directly from the sinusoid.

Curve fitting techniques can be then employed to obtain the system transfer function. On the other hand, since, as previously mentioned, the step contains all frequencies, it is theoretically possible to derive the frequency response curve.

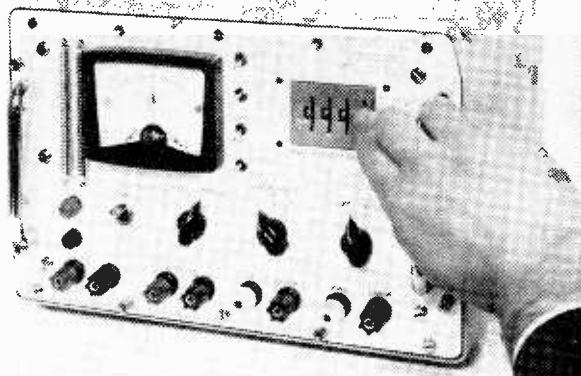

Pseudo random binary sequences and correlation techniques are used to derive impulse response in this automatic "go, no-go" servo tester made by the Sperry Gyroscope Co. Ltd. The cross-correlation coefficient between the p.r.b.s. excitation and the resulting response is measured for a number of different delays to give the cross-correlation function, which is identical to the servo's impulse response if the delay parameter is considered as real time. The tester runs automatically through 11 pre-selected delays. At the end of each measurement a voltage representing the c-c coefficient (point on the impulse response curve) is examined and if it is within required acceptance limits the tester passes on to the next measurement. If all 11 tests are passed the tester indicates "go." If any test is failed it can be repeated, and if the servo continues to fail this test "no-go" is indicated. Acceptance limits are entered by a programme plug. An instrument of this type, but working on a larger time scale, could be produced for testing process control systems.

Impulse response testing.—The main disadvantage of step response testing is that although the step may be made small (consideration of linearity), the steady state value which is assumed to be the optimum operating condition is essentially changed—and, to add to the difficulty, the smaller the step the more difficult it is to measure the response.

The impulse test on the other hand does not have this inherent difficulty. In this case the impulse, which in the practical case must be a pulse of short duration, is applied on the system steady state input and the corresponding impulse response curve obtained, the final value of which is of course zero.

The integral of the impulse response curve is the steady gain of the system.

Random signal testing.—The essence of this method is that a random signal, $x(t)$, from a noise generator, is applied as excitation to the input of the system, and the cross-correlation between this input and the resulting output signal, $y(t)$, is obtained by analogue computing equipment. With a white noise input the cross-correlation function so computed is an amplitude/time curve which, it can be shown, is the impulse response of the system multiplied by a constant. This curve therefore characterizes the system. The theoretical basis of this method of testing is explained in Appendix A.

This technique has two main advantages over the methods described earlier. First, the experiment may be performed while the system is functioning in its normal mode, thus making it unnecessary to disconnect the



Fig. 2. Autocorrelation function of periodic white noise.

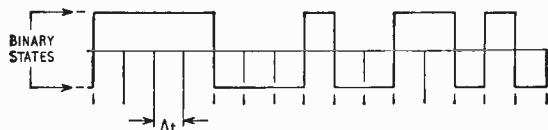

Fig. 3. Example of a pseudo random binary sequence 15 bits long.

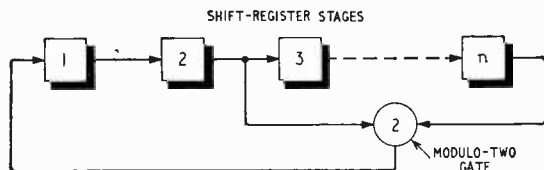

Fig. 4. Shift register with feedback for generating p.r.b.s.

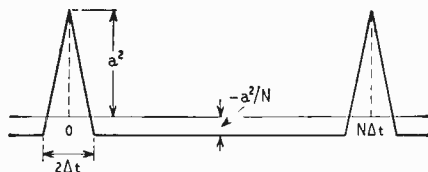

Fig. 5. Autocorrelation function of a maximum length sequence. Δt is the bit interval.

system from its associated components. This is possible since the noise excitation energy is spread over a wide frequency range, with a resulting low noise intensity that will not affect the normal operation of the plant and its controls. The second advantage is that the measurements are immune from the extraneous effects of unwanted noise provided they are stochastically independent of (i.e. not correlated in any way with) the input noise source, regardless of whether the unwanted noise originated internally or externally.

However, the method has a serious disadvantage. This is the long time required to obtain an accurate cross-correlation function, a time which in the ideal case would of course be infinite. This disadvantage can be overcome, however, by generating what could be called periodic white noise. This type of noise would have to have the same type of autocorrelation function as white noise (i.e. an impulse) which would be repeated with a period T . This type of autocorrelation function is illustrated in Fig. 2. By use of such periodic white noise, the cross-correlation function may be computed to its full accuracy by integration over one period of the noise only (see Appendix B).

A periodic noise signal that meets the requirements is the maximum length sequence, sometimes called the pseudo random binary sequence (p.r.b.s.) and sometimes referred to as a chain code. These codes are binary sequences (i.e. have two possible states) as shown in Fig. 3 and the state can only change at discrete intervals of time Δt . The probability of such a change occurring is thus 0.5 at a cross-correlation time delay $\tau = k\Delta t$

(where k is an integer) and zero for any other values of τ . These maximum length sequences are dealt with in detail in Reference 2.

Although these sequences are by no means the only way to obtain the periodic noise required, they do present a very simple way, especially in the hardware sense, of obtaining such an approximation. The maximum length sequences are basically generated by an n -stage shift register which has the output of two or more of its stages fed back, through a modulo-two gate to the input of the first stage (see Fig. 4). A modulo-two gate is a special form of logic element which supplies an output whenever its inputs are not equal. The truth table may be written

| | | |
|----|----|----|
| | +1 | 0 |
| +1 | 0 | +1 |
| 0 | +1 | 0 |

The feedback is always taken from the last stage of the shift register, but the choice of the stage or stages from which the other feedback paths may be taken is much more restricted. If the shift register stages are represented by pure delays of transference D then the characteristic equation of the shift register may be written

$$1 \textcircled{+} D^k \textcircled{+} D^n = 0 \quad \dots \quad (7)$$

where the symbol $\textcircled{+}$ represents modulo-two addition and where for the sake of simplicity it is assumed that feedback is only taken from the n th (the last) and the k th ($k < n$) stage. The rule is therefore that the characteristic equation must be irreducible and primitive. Tables of such n th order equations may be found in the literature up to the order $n = 33$, from which it may be found that the majority of such equations are of only three terms (as in equation 7) and therefore in the hardware sense represent the minimum number (two) of feedback paths.

Now since a shift register contains n stages, there is a total of 2^n possible states, but the state in which the shift register contains all zeros in its stages must be prohibited because then the modulo-two output of the gate would be a zero, and the shift register would remain in its all zero state.

Therefore there are $(2^n - 1)$ digits in the resulting binary sequence—hence the name maximum length sequences.

Now an important property of these sequences is their "shift and add" property. This means that if a maximum length sequence is gated (modulo-two) with a delayed version of the sequence, the resulting sequence is yet another delayed version of the original sequence.

The autocorrelation function of a maximum length sequence is illustrated in Fig. 5. In this sequence the two stages of the binary sequence are plus and minus a , the time interval Δt is the bit interval (i.e. the time between shifts in the shift register) and N is the number of bits, i.e. $N = (2^n - 1)$. Therefore, as may be seen from Fig. 5, this is quite a good approximation to the required noise (Fig. 2) provided N is large and Δt is small.

This autocorrelation may be analysed by splitting it into two parts, an "impulse" of area $(N + 1)a^2\Delta t/N$ and a d.c. level of $-a^2/N$. The power density spectrum of this signal is its Fourier transform and may be expressed in the form

$$\Phi_{xx}(\omega) = \frac{(N + 1)a^2\Delta t}{N} \sum_r \left[\frac{\sin(r\pi/N)}{(r\pi/N)} \right]^2 \dots (8)$$

and therefore has the shape illustrated in Fig. 6. Because the state of the sequence can only change at discrete intervals of time this spectrum is a line spectrum with a

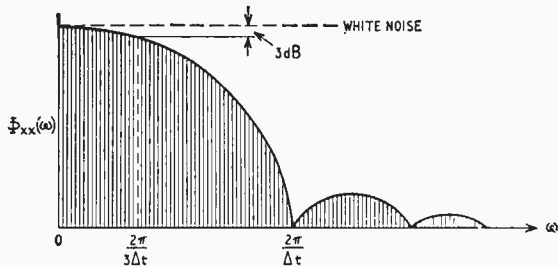

Fig. 6. Power density spectrum showing effective frequency band covered by maximum length sequence.

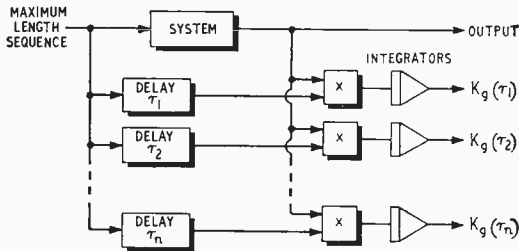

Fig. 7. Block schematic of test equipment needed for system evaluation, using a parallel method.

harmonic separation of $2\pi/N\Delta t$. Therefore, since the requirement was that the spectral density should be constant over the bandwidth of the system under investigation we can define "constant" as being constant to within 3dB. Therefore it may be seen that the frequency at which the 3dB point is reached is approximately $2\pi/3\Delta t$ rads/sec so that the bandwidth of the system under investigation should be less than $2\pi/3\Delta t$ rads/sec, from which a value for Δt may be found. Thus the effective frequency band covered by the maximum length sequence is in the range $\omega = 2\pi/N\Delta t$ to $2\pi/3\Delta t$ rads/sec.

Again, since it was required that the impulse response had to die down to zero in a time less than the period of the sequence, this gives an estimate of the period $T = N\Delta t$ to use, from which a value for N , and consequently of n , may be obtained. From this information the best chain code for the particular application may be constructed. If neither the bandwidth nor the settling time of the system under investigation is known then a few experimental runs with different values of N and Δt will soon suggest the best sequence to use.

Since the autocorrelation function is therefore an impulse of area $(N+1)a^2\Delta t/N$ and a d.c. shift of $-a^2/N$, it may be expressed as

$$\phi_{xx}(\tau) = \frac{(N+1)a^2\Delta t}{N} \delta(\tau) - \frac{a^2}{N} \quad \dots \quad (9)$$

The cross-correlation function is

$$\phi_{xy}(\tau) = \frac{a^2(n+1)\Delta t}{N} g(\tau) - \frac{a^2}{N} \int_0^{n\Delta t} g(s) ds \quad \dots \quad (10)$$

where the second term is constant and very small for large N .

Therefore, either assuming this second term to be zero,

or by biasing the measured cross-correlation function by this constant, it may be again seen that the cross-correlation function is directly proportional to the impulse response.

A block diagram illustrating the parallel approach of system evaluation is shown in Fig. 7. Of course, a serial approach may be used in which the experiment is re-run with different values of delay τ , so that the impulse response curve is built up by a number of separate runs. However, if the minimum number of runs is required, then a number of parallel paths as shown in Fig. 7 must be used so that a large number of points on the impulse response curve are obtained in one run.

As may be seen from this figure, as many time delays, multipliers and integrators are needed as the number of points on the impulse response curve. On the surface, this seems a severe limitation, but one advantage of the use of maximum length sequences in this respect is their shift-and-add property. This, to recap, means that by taking the modulo-two addition of two separately delayed versions of the sequence, a further delayed version of the original sequence may be obtained.

Since there are $(n-1)$ delayed versions of a maximum length sequence available in the shift register itself, then by simply adding (modulo-two) the outputs of some chosen shift register stages, any required delayed version of the original sequence is readily available. The required connections for the specified delayed version may be obtained by taking the original irreducible primitive polynomial and its continually squared (modulo-two) version. This may best be illustrated by means of an example:—

Consider a 4-stage shift register whose characteristic equation is

$$D^4 \oplus D^1 \oplus D^0 = 0 \quad \dots \quad (11)$$

(where I is written as D^0).

By continually squaring (modulo-two) this equation, the following equations are obtained.

$$D^8 \oplus D^2 \oplus D^0 = 0 \quad \dots \quad (12)$$

$$D^1 \oplus D^4 \oplus D^0 = 0 \quad \text{remembering that } D^{15+n} = D^n \quad (13)$$

$$D^2 \oplus D^8 \oplus D^0 = 0 \quad \dots \quad (14)$$

$$D^4 \oplus D^1 \oplus D^0 = 0 \quad \dots \quad (15)$$

which is the original equation again.

Therefore, if a delayed version of 9 bits delay is required

$$\begin{aligned} D^9 &= D^1 D^8 \\ &= D^1 [D^2 \oplus D^0] \text{ from equation (12)} \\ &= D^3 \oplus D^1 \end{aligned}$$

i.e. by taking the modulo-two sum of the outputs of the first and third shift register stages, the sequence delayed 9 bits from the original sequence is obtained.

Thus the required delayed versions of the input sequence are simply obtained from the original shift register (Fig. 7) with the addition of only a relatively small amount of hardware representing the necessary modulo-two gates.

Another operation in Fig. 7 which is greatly simplified by the use of binary sequences is the multiplication. Since there are only two possible states, the multiplication reduces to simple gating by which the output of the system or its inverse is selected according to the state of the sequence.

A third thing which may be simplified is the form of the integrator. If the bandwidth of the system under investigation is high, for example in the kc/s range, as could arise in communication systems, the integrators illustrated in Fig. 7 could be replaced by low pass filters.

On the other hand, if the system bandwidth is low (as in chemical plants) digital techniques could be used to counteract any drift problems that may arise with analogue integrators.

These integrators, on the other hand, have to integrate over one period of the noise only, but the circuitry for accomplishing this is fairly simple.

From the method considered above, it may be gathered that the use of maximum length sequences for the derivation of the impulse response has several advantages which make it very attractive to use for process characteristics evaluation. To summarize, these are

1. The integration time required to obtain an accurate estimate of the impulse response is one period of the sequence only.
2. The maximum length sequences themselves are extremely simple to generate
3. A sequence is exactly reproducible at any time
4. The stochastic properties of the sequences are known to any level.
5. Delayed versions of the original sequence are also easily generated.
6. The multiplication involved in evaluating the cross-correlation function reduces to simple gating, using a relay.
7. The noise intensity is low so that the evaluation of the characteristics of the system may be carried out while the system is operating in normal fashion.

REFERENCES

1. "Random Signal Testing and Pseudo Random Methods," *Wireless World*, August, 1965, p. 384.
2. Davies W.D.T. "The Generation and Properties of Maximum Length Sequences", *Control*, June 1966, p. 302.

APPENDIX A

Random signal testing.—In order to understand the theoretical basis of this method it becomes necessary to define the following relationships.

(a) The convolution integral. This states that the input signal $x(t)$ and the output signal $y(t)$ obey the relationship,

$$y(t) = \int_0^{\infty} g(\tau) \cdot x(t - \tau) d\tau \quad \dots \quad (16)$$

where $g(t)$ is the system impulse response and τ is the time delay between the application of an instantaneous input signal and the measurement of the output.

(b) The auto-correlation function of $x(t)$ is

$$\phi_{xx}(\tau) = \text{Limit}_{T \rightarrow \infty} \frac{1}{2T} \int_{-T}^T x(t) \cdot x(t + \tau) dt \quad \dots \quad (17)$$

and

(c) The cross-correlation function of $y(t)$ is

$$\phi_{yy}(\tau) = \text{Limit}_{T \rightarrow \infty} \frac{1}{2T} \int_{-T}^T x(t) \cdot y(t + \tau) dt \quad \dots \quad (18)$$

Note that if $x(t) = y(t)$, the cross correlation function reduces to the auto-correlation function.

Now since the impulse response must be zero before the input is applied $g(t) = 0$ for $t < 0$ and the lower limit of the convolution integral, equation (16), may be extended to infinity so that the equation may be re-written

$$y(t) = \int_{-\infty}^{\infty} g(s) \cdot x(t - s) ds \quad \dots \quad (19)$$

The cross-correlation function equation (18) may thus be re-written

$$\phi_{xy}(\tau) = \text{Limit}_{T \rightarrow \infty} \frac{1}{2T} \int_{-T}^T x(t) \left\{ \int_{-\infty}^{\infty} g(s) \cdot x(t + \tau - s) ds \right\} dt \quad (20)$$

which, by interchanging the order of integration becomes

$$\phi_{xy}(\tau) = \int_{-\infty}^{\infty} g(s) \left\{ \text{Limit}_{T \rightarrow \infty} \frac{1}{2T} \int_{-T}^T x(t) \cdot x(t + \tau - s) dt \right\} ds \quad (21)$$

$$= \int_{-\infty}^{\infty} g(s) \phi_{xx}(\tau - s) ds \dots \dots \dots (22)$$

Therefore, by comparing this with the convolution integral above, it may be seen that if a signal whose auto-correlation function is $\phi_{xx}(\tau)$ is applied to a system with impulse response $g(t)$, the cross-correlation function of the input and output signal is equal to the time response of the system when subjected to an input signal $\phi_{xx}(t)$.

In particular, if the input signal is white noise, its power density spectrum is flat, i.e. $\Phi_{xx}(\omega) = 2\pi K$ (example). The relationship between the auto-correlation function and the power density spectrum is the Fourier transform, i.e.

$$\phi_{xx}(\tau) = \frac{1}{2\pi} \int_{-\infty}^{\infty} \Phi_{xx}(\omega) e^{j\omega\tau} d\omega \dots \dots \dots (23)$$

which becomes

$$\begin{aligned} \phi_{xx}(\tau) &= K \int_{-\infty}^{\infty} e^{j\omega\tau} d\omega \dots \dots \dots (24) \\ &= K\delta(\tau) \end{aligned}$$

where $\delta(\tau)$ is the Dirac delta function. Thus equation (22) becomes

$$\phi_{xy}(\tau) = K \int_{-\infty}^{\infty} g(s) \delta(\tau - s) ds \dots \dots \dots (25)$$

$$\phi_{xy}(\tau) = Kg(\tau) \dots \dots \dots (26)$$

That is, for a white noise input, the cross-correlation function of the input and the output is a constant times the impulse response. Note that any noise whose power density spectrum is flat over a frequency range much greater than the band width of the system may be considered as being white noise.

APPENDIX B

Referring back to Fig. 2, the auto-correlation function of the periodic white noise would be

$$\phi_{xx}(\tau) = \frac{1}{T} \int_0^T x(t) \cdot x(t + \tau) dt \dots \dots \dots (27)$$

because of its periodicity. Or by taking an argument $(\tau - s)$

$$\phi_{xx}(\tau - s) = \frac{1}{T} \int_0^T x(t) \cdot x(t + \tau - s) dt \dots \dots \dots (28)$$

Therefore the auto-correlation function can now be expressed as

$$\phi_{xy}(\tau) = \int_{-\infty}^{\infty} g(s) \left\{ \frac{1}{T} \int_0^T x(t) \cdot x(t + \tau - s) dt \right\} ds \dots \dots (29)$$

which by interchanging the order of integration becomes

$$\phi_{xy}(\tau) = \frac{1}{T} \int_0^T x(t) \left\{ \int_{-\infty}^{\infty} g(s) x(t + \tau - s) ds \right\} dt \quad (30)$$

$$= \frac{1}{T} \int_0^T x(t) y(t + \tau) dt \quad \dots \quad (31)$$

Therefore by using this periodic white noise, the cross-correlation function may be obtained to its full accuracy by integration over one period of the noise only.

Because of the periodicity of this noise, the cross-correlation function may now be written as

$$\phi_{xy}(\tau) = K \{ g(\tau) + g(T + \tau) + g(2T + \tau) + \dots \} \quad (32)$$

but if it is so arranged that the impulse response has decayed to zero in a time less than T , equation (32) becomes

$$\phi_{xy}(\tau) = K g(\tau) \quad \dots \quad (33)$$

as before.

APPENDIX C Some Simulation Studies

In order to test the theory presented in the article, a measuring equipment and two systems including Figs. 4 and 7 were simulated on a digital computer.

The systems whose characteristics were to be evaluated were:

(a) A first-order system with a transfer function

$$G_1(p) = \frac{1}{(p+1)} \quad \dots \quad (34)$$

so that the impulse response becomes

$$g_1(t) = e^{-t} \quad \dots \quad (35)$$

(b) A second-order system with transfer function

$$G_2(p) = \frac{1}{(p^2 + 3p + 9)} \quad \dots \quad (36)$$

so that the corresponding impulse response is

$$g_2(t) = 2\sqrt{3}e^{-1.5t} \sin 1.5\sqrt{3}t \quad \dots \quad (37)$$

In each case the corresponding maximum length sequence was generated and introduced as an input to the system. This input and the corresponding output were

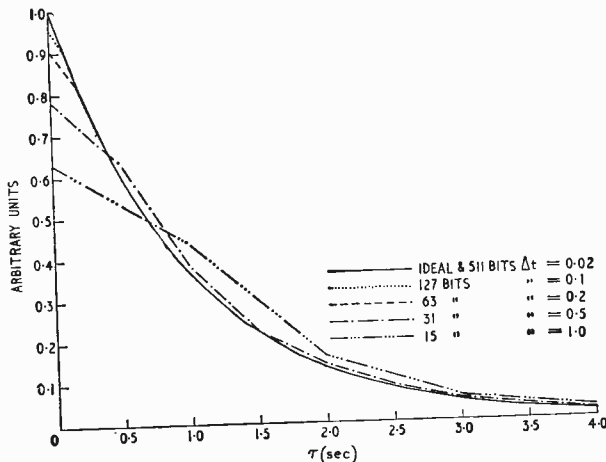

Fig. 8. These decay curves are the simulated impulse responses of a first-order system obtained with various p.r.b. sequences. Printing limitations do not allow the very slight differences between the 127-bit, 511-bit and ideal curves to be shown fully.

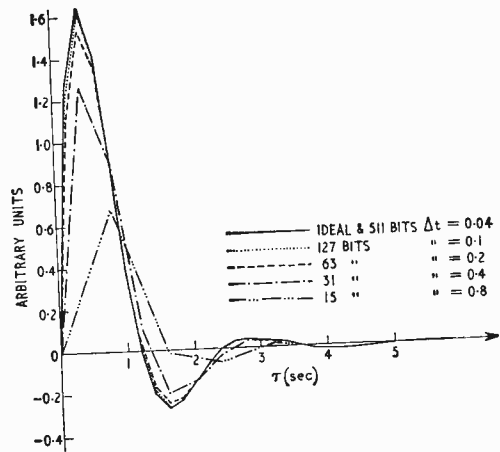

Fig. 9. This "heavily damped oscillation" is the simulated impulse response of a second-order system obtained with various p.r.b. sequences. Again, printing limitations apply as in Fig. 8.

then recorded in the form of discrete logged points within the computer memory.

The input sequence was delayed by one time interval Δt and the cross-correlation carried out. The corresponding value of the impulse response at the value $\tau = \Delta t$ was then calculated and printed out together with the theoretical value calculated from equations (35) or (37). The input sequence was then delayed by $2\Delta t$ and the whole procedure repeated, etc., so that a total of N points on the impulse response curve was finally available.

Although this procedure may sound rather complicated, the actual digital programme is relatively simple and the complete curve is calculated in less than one minute.

For each process, the impulse responses corresponding to five different length maximum length sequences were obtained. The characteristics of these sequences were:—

For system (a):

- | | | |
|-------------|---------------------|--------------------------------|
| (1) $N=15$ | $\Delta t=1.0$ sec | so that $N\Delta t=15$ secs |
| (2) $N=31$ | $\Delta t=0.5$ sec | so that $N\Delta t=15.5$ secs |
| (3) $N=63$ | $\Delta t=0.2$ sec | so that $N\Delta t=12.7$ secs |
| (4) $N=127$ | $\Delta t=0.1$ sec | so that $N\Delta t=12.7$ secs |
| (5) $N=511$ | $\Delta t=0.02$ sec | so that $N\Delta t=10.22$ secs |

For system (b):

- | | | |
|-------------|---------------------|-----------------------------|
| (1) $N=15$ | $\Delta t=0.8$ sec | i.e. $N\Delta t=12$ secs |
| (2) $N=31$ | $\Delta t=0.4$ sec | i.e. $N\Delta t=12.4$ secs |
| (3) $N=63$ | $\Delta t=0.2$ sec | i.e. $N\Delta t=12.6$ secs |
| (4) $N=127$ | $\Delta t=0.1$ sec | i.e. $N\Delta t=12.7$ secs |
| (5) $N=511$ | $\Delta t=0.04$ sec | i.e. $N\Delta t=20.44$ secs |

so that in each case $N\Delta t$ is greater than the time taken by the corresponding impulse response to decay to zero.

The results are illustrated in Fig. 8 for system (a) and Fig. 9 for system (b). The improvement in each case as N is increased and Δt is decreased is immediately obvious, which supports the requirement shown in Fig. 5. The portion of the curve in the region, $0 < \tau < \Delta t$ is rather an unknown quantity, however. The reason for this is again shown in Fig. 5 where it may be seen that the "impulse" has not yet finished.

It seems from these two figures, that a maximum length sequence of 127 bits is adequate for the experiment described.

Acknowledgements are made to the directors of Imperial Chemical Industries Ltd. for permission to publish this article.

Using Integrated Circuits

APPLICATIONS APPROACHES DISCUSSED AT BRUNEL COLLEGE SYMPOSIUM

HAVING now accepted integrated circuits as regular "components," to be wired-in like resistors, capacitors and transistors, the equipment side of the U.K. electronics industry has launched into a phase of circuit evaluation and tentative application to commercial products. An attempt to present an informative picture of current applications was made by Brunel College, London, recently when they held a symposium on "The Use of Integrated Circuits in Electronic Equipment." The general aim of all users, of course, is to explore what can be done within the natural limitations of i.c.s (power dissipation, R and C values, price, etc.). From the symposium it seemed that there are three main classes of user, with somewhat different approaches. First there is the small organization that is content to work with the standardized "off the shelf" i.c.s available on the market and to adapt its equipment design to suit the characteristics of these products. Secondly there are the big and powerful users who are not only assessing existing i.c.s but are in a position to influence the development of future devices through the manufacturers. Thirdly there are the equipment makers who have their own "in-house" facilities for manufacturing i.c.s and can therefore have circuits "custom built" for particular projects.

The first type of user has the advantage of working with mass-produced i.c.s which are readily available, often at very competitive prices. He does not have to know anything about i.c. manufacturing technology. Such users have already shown much ingenuity in adapting these standardized i.c.s to applications not thought of by their manufacturers. But there is a limit to what can be achieved by this approach. As S. O. Davidsen (Marconi Company) pointed out at the symposium, if we are to exploit fully the tremendous opportunities in equipment design offered by i.c. technology, close collaboration between the user and the manufacturer is essential. One solution, said Davidsen, would be for equipment designers to be made fully conversant with i.c. manufacturing technology—in fact to become i.c. designers as well. But he felt that only a few exceptional individuals would be capable of performing this double duty and that a more practical method for the industry as a whole would be to form i.c. design teams from both device designers and equipment designers.

One British company that got into integrated circuits at an early stage (actually before i.c.s were known as such—see "Solid Circuits" *W.W.* Nov. 1957, p. 516)—is The Plessey Company. Two papers bore evidence of the considerable experience that they have built up already—one, by M. J. Gay, on i.c. wideband amplifiers, and the other, by P. J. Forrest, on the use of i.c.s in a mobile transmitter/receiver.

Gay claimed that it was possible to produce r.f. amplifiers with well defined characteristics, greatly simplifying the design of r.f. equipment, at costs no greater than those of conventional amplifiers. The capacitance of any resistor and the capacitances and f_T of any transistor could be readily calculated to within a few percent.

Contrary to general belief an i.c. could give superior performance to that of a conventional circuit because of the reduction in stray capacitances: the isolation capacitance could be less than 1pF (with junction isolation) which was far smaller than the strays in a conventional circuit. One i.c. wideband amplifier (Fig. 1), developed 18 months ago for use in a radar i.f. strip, had a current gain of $\times 20$ and an upper cut-off frequency of 100 Mc/s. Another, developed later for use in successive-detection logarithmic i.f. strips (requiring accurately defined but low gain) had a $\times 4$ voltage gain and an upper cut-off frequency of 170 Mc/s.

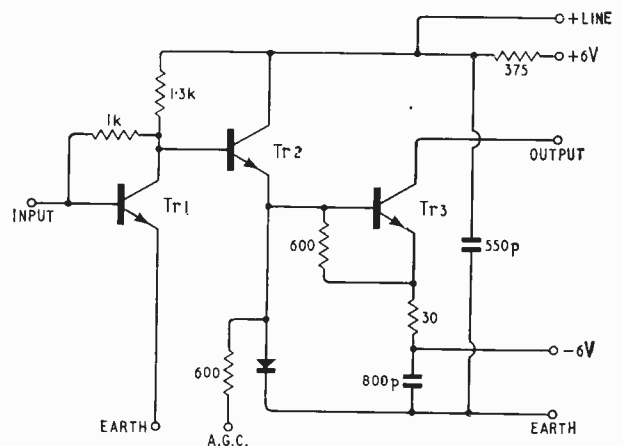

Fig. 1. Circuit of Plessey SL501 integrated wideband amplifier. (*Wireless World* uses un-circled symbols for i.c. active elements to distinguish them from discrete active elements in conventional circuits.)

In the mobile transmitter/receiver for operation at v.h.f. and u.h.f. outlined by P. J. Forrest, considerable use had been made of i.c. differential-input operational amplifiers. These were identical flat-pack devices from which different functions were obtained by manipulation of the external feedback circuits. These functions included active filters in the a.g.c. loops and a.f. output stages, clock-pulse generators, supply-line stabilizers and summing amplifiers. Capacitors used were normally discrete components. The i.f. amplifier stages were Plessey i.c.s of the type mentioned above, and i.f. tuned circuits were eliminated by the use of crystal filters. The main a.f. detector at present used integrated transistors in a flat pack with a few external resistors, but eventually a single monolithic device would probably be available. Bulky a.f. transformers had been eliminated by means of a pulse-width modulation system operating at 78 kc/s and all the controlling functions were carried out at low level, permitting the use of i.c. gates and amplifiers. Frequency synthesis was achieved by digital methods, thereby avoiding the need for multiple crystals, and

here the integrated circuits consisted mainly of binary elements and gates. Tuning was effected by variable capacitance diodes, for which the control voltages were supplied from digital-to-analogue converters (made from the summing amplifiers mentioned above).

Forrest pointed out that it would be necessary to use non-standard i.c.s to achieve an equipment design that was the optimum with regard to space utilization, weight, power consumption and reliability. When contemplating the design of such "specials," he remarked, designers should bear in mind that with slight concessions they might be arranged to give standard functions.

How to obtain high power outputs from integrated circuit equipments is one of the major application problems to be solved. The method adopted in the transmitter of an experimental airborne radar equipment described by J. S. Walker (Texas Instruments) was to operate a multiplicity of i.c. "cells" in parallel. The reason for using integrated circuits in this project had been to improve the reliability of the r.f. power output stages, which, in conventional radar equipment were known to fail more frequently than the earlier stages. By means of pulse compression techniques the 60-kW power output that would be required with conventional

radar had been reduced to 600 W, and this power had then been spread over 600 solid-state elements, each delivering 1 W at 9 Gc/s. Each 1-W "cell" was virtually a complete radar set with its own T/R cell. The multiple aerial took the form of a honeycomb, and beam scanning was achieved by appropriate phasing of the signals fed to the 600 aerial elements. With this type of design approach, any one of the individual cells could break down without greatly affecting the overall functioning of the radar equipment.

Walker also discussed the general technique of "large scale integration," or L.S.I. as it has become known in the U.S.A., by which a large section of, say, a computer can be fabricated on a single slice of silicon. He thought that British equipment makers would be using L.S.I. in only a few years' time.

I. R. Head (Marconi Company) dealt with the extension of i.c. technology in computers from logic circuits to functions requiring higher power, such as magnetic-core store drive amplifiers. He mentioned as an example a typical i.c. giving a 200-ns output current pulse of 450 mA (with 40 ns rise time and 15 ns fall time). Total device dissipation was 185 mW, allowing TO-5 size encapsulation.

LETTERS TO THE EDITOR

The Editor does not necessarily endorse opinions expressed by his correspondents

"Whither British Television?"

YOUR Editorial in the July issue of *Wireless World* poses the very pertinent question whether our new 625-line system has been accepted as inevitable. There were certainly many long and, at times, heated arguments prior to the Government statement in 1962 that all new programmes in the U.K. should be on 625-line standards, but once the decision was taken the industry, whose job it is to meet the public's requirements, turned its full attention to making the changeover of all the television services in the U.K. to these new standards a success. It was never thought that this would be an easy task, particularly since the change in standards was further complicated by an extension of television broadcasting to the u.h.f. Bands IV and V.

The question of colour television has again given rise to a spate of arguments that the I.T.A. should be authorized to radiate colour on its 405-line service—and this would presumably also mean colour on BBC-1. B.R.E.M.A. is fully in support of means being found for the I.T.A. to radiate colour—preferably by having its own 625-line programme or, if the Government is not prepared to authorize this, by a sharing arrangement on BBC-2 on the lines you suggest. We are firmly opposed to any moves to put colour on the 405-line services since this can only further complicate the achievement of the eventual aim of a single standard service.

Regarding your comments on the recent B.B.C. report on colour systems, I realize that it must be frustrating for engineers not to have full access to information. However, a single report of this nature can be very misleading unless it is read in conjunction with other reports giving a much wider picture; such a summary

of its investigations from all aspects has been issued by the E.B.U., in whose exercise there were representatives from all interested parties. So far as this country is concerned the Television Advisory Committee and its Technical Sub-Committee are the official bodies charged with making recommendation on these matters, and they again are representative of all interests; it would be quite impracticable to extend consultation beyond this unless we had another Pilkington Committee with all the attendant delay and uncertainty. Incidentally, I am informed that the point referred to by your second correspondent (Mr. D. Smart) has been taken into consideration.

With regard to the letter from Mr. Michael Cox which appears in the same issue, the acceptance of BBC-2 has admittedly fallen far short of what we in the receiver industry would have wished, but this is for other than technical reasons. In spite of statements to the contrary it is significant that on a strictly technical basis the *official* evidence is that reception of BBC-2 is very closely in line with predictions and with an efficient installation may be even better than expected; to quote TAM programme ratings is quite unrealistic since viewers' acceptance of a programme depends much more on programme content than on technical performance, and it is only comparatively recently that there have been serious attempts to win viewers from the already established giants BBC-1 and I.T.A.: experience of u.h.f. coverage is incomplete since there is as yet not a single area which has its proper complement of low and very-low power fill-in transmitters.

A figure not quoted by Mr. Cox is the additional cost borne by the viewing public for the additional 625-line and u.h.f. facility on their receivers—so far this amounts

to about £60 million and will continue at the rate of £10 to £12 million per annum until such time as dual-standard receivers are no longer needed. One can understand the reluctance of the broadcasting organizations to spend the £130 million quoted by Mr. Cox for a 625-line network, but this figure has not yet been substantiated—most estimates are very much less; moreover this is a capital, not a recurring outlay, and provides the facility for a complete new programme—it cannot, therefore, be compared with the cost of modifying an existing 405-line network for colour.

I have not mentioned the technical aspects of putting colour on 405-line standards since the whole question is primarily one of following principles which have already been established, but the thought of a fully dual-standard colour receiver—assuming that one which gave passable results could be made by modern mass production methods—can only fill receiver designers and maintenance engineers with horror.

As a last comment on Mr. Cox's letter, it is not possible to judge export performance only by the number of sets leaving the country; "invisible exports" have benefited by this country having a 625-line system, even though it has minor differences from systems used in other countries.

The British Radio Equipment Manufacturers' Association, London, W.C.1.
D. P. DOO,
Technical Secretary.

I READ with interest your Editorial in the July edition. May I be permitted to put a rather different viewpoint?

One gets the impression that you feel that your consistent support of the 405-line television system has, in some way been vindicated. This may be so but a strong argument could be made to show that if we had changed to a higher line standard after the war, a great deal of the present chaos of British television could have been avoided.* It is impossible to avoid the fact that there is a strong demand for large pictures of the 23in type, and these cannot be seen to advantage on a sharply focused 405-line picture.

As a service engineer, I deal directly with the public, and know that the demand through the years has been for reliable reception, larger pictures, and colour. There is not, and never has been, any clamour for a third programme.

For this reason I had consistently maintained before the introduction of BBC-2, that the best policy would have been to duplicate the existing programmes on u.h.f. 625 lines (the basic system would have had to be 625 lines with a standards convertor used to produce 405 lines for Bands I and III). This would have resulted in large sales of 23in single standard receivers, and would have given an alternative channel for reception in areas such as Worthing, where 20 years after its inception, BBC-1 is often quite unviewable in the summer due to Continental interference. Furthermore B.B.C. and I.T.A. would then have been in an equal position to commence colour. After a suitable time had elapsed, a single additional programme could have been introduced on 625 lines in the v.h.f. band, for which there would have been ample channels.

It is not too late to re-think the whole matter now, and possibly adopt some such system, before the introduction of colour, and thus introduce a little logic into the muddle and chaos which has been produced so far. If it is seriously proposed to jeopardise reliability by intro-

ducing colour in receivers which will have to be dual standard so far as black and white is concerned, then the writer, in spite of having attended a year's evening-class course in colour television, proposes to give up working in this field.

Worthing, Sussex.

L. E. SEARLE.

Electronic Organs

AS a comment on Mr. B. W. Daniels' interesting letter in the July issue perhaps the following may be of some interest.

After many years of experiment I have come to the conclusion that random mistuning at the generator end is not the answer although slight mistuning apparently does give better purchasing appeal on the commercial level. The answer seems to lie in breaking up the sound at the loudspeaker end. If the electronic organ is not to become quickly unsatisfying musically some means has to be found to cause random changes in frequency. If, for example, a typical Leslie speaker is made up and caused to revolve at the extremely slow rate of, say, one revolution in three seconds and some means of avoiding a regular pattern is found, the effect is marked. If some measure of reverberation or sustain is added the whole business becomes quite exciting.

I have not tried it but perhaps two such speakers would be even better. As it is, however, with just one speaker the divider organ I am building at the moment is enhanced beyond words.

This, of course, falls short of the chorus effect of the pipe organ but if the idea could be extended together with sophisticated keying circuitry the electronic organ could come quite close to being a really satisfying musical instrument.

Rothsay, Isle of Bute.

C. D. KIRK

The author replies:—

Mr. Kirk's proposal is interesting and certainly worth investigating as another method of achieving the random variation in tone which is the hallmark of the pipe organ. I have made a study of the many methods advocated in the last four decades for more effective simulation of "real" organ tone and perhaps some day will find the time to classify them for the guidance of others.

T. D. TOWERS

MAY I suggest that a pipe organ with a semiconductor logic switching action (see footnote p. 220, May issue) might be termed "electrotonic" (of which, in fact, electrotonic is a contraction).

Ideally, of course, the so-called electronic organ should be termed electrotonic or even electrophonic to show that the organ sounds are produced electronically. The term electronic could then be applied to a pipe organ with a semiconductor logic switching action in much the same way as the term electric is used for a pipe organ with an electromagnetic relay switching action.

Maidenhead, Berks.

REX I. G. PALMER

I NOTICE with interest the letter from B. W. Daniels and the reply from Mr. T. D. Towers regarding the merits or otherwise of mistuning the semitonal "bearings." If you accurately produce a scale which is a strict geometric progression ($^{12}\sqrt{2}$), then the beats between the fifths will be very slow and those between

* The only alternative to 405 lines in 1946 was 525 lines.—ED.

the fourths far too quick. Also a chord played, say, in C, will sound exactly the same as the same chord held a semitone higher, with no change of character, except that it has gone up a semitone. One cannot deny that a cord played in C# sounds much richer than a C chord, and so on throughout the different keys, when played on a piano or pipe organ.

An organ tuner, of course, compromises and he makes the beats between fourths and fifths almost, if not quite, equal. The result is that you haven't a geometrical progression—quite. If this distorted scale is produced on an electronic instrument, it will produce "key characteristic," which is a subtlety well worth reproducing.

LESLIE E. A. BOURN
Technical Director

The John Compton Organ Company, Ltd.,
London, N.W.10.

U.J.T. Technology

IN his article, "The Diode-transistor Pump," in the July issue, Mr. D. E. O'N. Waddington points out in the section on frequency dividers that a unijunction transistor would be an ideal discharge device at low frequencies but that the switching time would be too long at 100 kc/s and above. The unijunction transistor (u.j.t.) has already been described in your pages¹ and this together with Mr. Waddington's remarks prompts me to mention the developments that have taken place in u.j.t. technology and its future possibilities.

By far the most common device geometry used in u.j.t. manufacture has been the "bar" construction in which an alloy emitter is used together with ohmic contacts for base one and base two. A later development was the "cube" structure alloy junction device in which the alloy process is used for the emitter and base one. The main difference between these geometries is the structure size. The base one to emitter spacing in a cube structure may be considerably smaller than in a bar device having the same intrinsic stand-off ratio and interbase resistance. The result of this is a considerable reduction in turn-on time together with a reduction in emitter saturation voltage. A typical cube structure has a turn-on time of some 100 ns, which is some forty times better than an average bar type.

The latest development² in device geometry has been the introduction of two types of oxide passivated u.j.t.s. In the first of these types base one is diffused into the silicon substrate, and the base two contact is made on the same surface. The processing techniques are thus very similar to the production of monolithic integrated circuits. It would seem the major drawback of this technique is the difficulty in controlling the device parameters.

Following this, the next logical step was to diffuse both base one and base two into the silicon substrate. By diffusing two small base contacts of different diameters into the *n* type silicon it was possible to accurately control the intrinsic stand-off ratio and interbase resistance. Apparently there are several advantages in the use of the double diffused technique in that it allows considerable flexibility over the control of the electrical properties of the u.j.t.

High costs have been a factor restricting the widespread use of the u.j.t., however, one of the cube devices

¹ "The unijunction transistor." H. R. Henly, *Wireless World*, March, 1964.

² "Now new unijunction geometries," Lowell Clark, *Electronics*, June 14th, 1965.

is currently priced at around ten shillings in small quantities.

As experience grows in the use of the passivated u.j.t. it seems likely that switching times will come down together with cost, and this could well result in their widespread use in integrated circuits.

Cheadle, Cheshire.

M. HARDING

Pickup Arm Design

I WAS alarmed to read Mr. King's suggestion in the July issue that constructors should pack the arm tube of the pickup described in the January and February issues with some damping compound. Packing the tube thus or covering with p.v.c. sleeving as suggested would alter its weight/unit length ratio. This would upset the arm characteristics and necessitate re-design. It is important that the dimensions and materials specified should be adhered to unless the arm is re-designed to suit.

I am not sure to what Mr. King's "h.f. resonance of the arm" refers. The h.f. resonance of a pickup is usually taken as that due to the mass of the stylus tip and the compliance of the record material and it would seem unlikely that packing or covering the arm tube as suggested would have any significant effect on this.

The higher order tone arm resonances, however, could be damped thus and may be it is these Mr. King is worried about. At frequencies above the h.f. resonance of the arm and stylus compliance, the stylus compliance will "decouple" the arm from groove modulation and this decoupling will become more effective at higher frequencies. In consequence, the higher frequency arm resonances are very difficult to excite *via* a groove modulation and are normally easily rendered harmless by the means suggested. (In fact the required *Q* values for these resonances to be excited to the extent of affecting pickup response seem to be much higher than those obtained with an "undoctored" arm and damping is not normally needed).

The lower frequency tone arm resonance however, being more easily excited by virtue of the tighter coupling between arm and groove modulation at these frequencies, can be a source of trouble and may require a relatively large amount of damping to render them harmless.

When investigating this problem some years ago, it was found that covering an arm with p.v.c. sleeving or packing with candlewax, sawdust, sand and even (as a last resort!) concrete, while damping the higher order resonances, had no significant effect in damping the lowest. A resiliently mounted counterweight, however, was found to be a very effective (and simple) damper for the lower resonances. (Undamped higher frequency resonances, incidentally, are available as a "ringing" noise when the tube is tapped whereas the lowest resonance is not so easily heard directly and requires vibration tests to study.)

Since Mr. King experiences the trouble he describes despite his arm being packed with a damping compound and having a resiliently mounted counterweight, I would suggest that the source of the trouble is not tone arm resonances but:

- (a) a faulty cartridge (and now damaged records?),
- or (b) insufficient tracking weight,
- or (c) a loose fit in some part of the arm or pivot assembly which is producing a rattle at high modulation levels.

It is also possible, of course, that the trouble lies in the amplifier or loudspeaker and not in the pickup.

Appleby, Westmorland. J. BICKERSTAFFE

Two More Impedance Converters

DESIGN CONSIDERATIONS FOR TWO IMPEDANCE CHANGING DEVICES

By PHILIP H. BRIGGS, B.Sc.Tech., M.Sc.Tech.

IN a recent article in this journal by F. Butler¹ attention was drawn to those interesting groups of devices which can change the apparent electrical form of an impedance. In one case this is done by modifying its characteristics either by effectively "adding" a further real or reactive part, thus, for example, cancelling an undesired component of the original, or by multiplying a desired component by some constant. The other case being four terminal negative impedance converters which, when presented with an impedance across one pair of terminals, had the ability to present at the other pair the effect of an "inverted" impedance, $-R$ for R for example, or inductance for capacitance, etc.

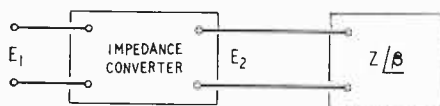

Fig. 1. Four terminal impedance converter.

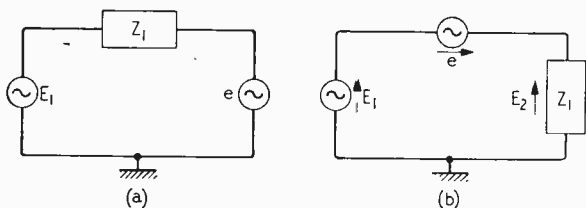

Fig. 2. (a) Basic converter; (b) Re-arranged basic converter.

The majority of the devices described had the advantage of being relatively simple.

There are two interesting, though not so simple extensions to the above devices. The first of these, an "impedance of variable angle", is an impedance converter which, as a four terminal device, again accepts an impedance Z across one pair of its terminals (E_2 in Fig. 1). It also has the ability to present at its other pair (E_1), the appearance of an impedance of identical magnitude, but having any chosen electrical angle, that is to say an impedance Z/β can be made to appear as $Z/\beta + \theta$ where $0^\circ \leq \theta \leq 360^\circ$.

The second apparatus is an analogue of the phase shifting transformer (a unit which in real life only occurs in multi-phase circuits)² and is again a four terminal device accepting any type of impedance across one pair of its terminals, but in this case having the ability to present at its other pair the identical impedance, both in magnitude and electrical angle. Across this device, both voltage and current have been shifted by the same angle, that is to say an impedance Z/β may be subjected to $E_1/0^\circ$ and draw I/β whilst the converter is fed from

an external source of E_2/ϕ supplying $I/\beta + \phi$ where $0^\circ \leq \phi \leq 360^\circ$, and $|E_1| = |E_2|$.

The important feature of this device is that the input watts and vars (reactive volt-amperes) must be identical with the output watts and vars—the converter supplies nothing! Examination of its operation is possible by comparison with the fundamental features of the simple impedance converter described in Mr. Butler's earlier article.¹ In this he shows in the form of circuit given in Fig. 2(a) that if the required impedance denoted by him as Z_2 is to appear at the input fed with signal E_1 then an auxiliary generator e is necessary in order to modify the "commencing" impedance Z_1 . Mr. Butler gave the dimensions of e from the equation

$$\frac{E - e}{Z_1} = \frac{E}{Z_2} \text{ which after transposition became}$$

$$e = E \left(1 - \frac{Z_1}{Z_2} \right) \dots \dots \dots (1)$$

Because it is required that the input and output currents of the phase shifter shall have the same magnitude but differ only in phase angle, and also since Z_1 must equal Z_2 , then from equation (1)

$$|E - e| = |E| \dots \dots \dots (2)$$

and this means that our "input" and "output" voltages E_1 and E_2 are of equal magnitude but of different phase angle. Fig. 2(b) shows a rearrangement of Fig. 2(a) to allow for this. Fig. 3 is the corresponding vector diagram from which it may be observed that the conditions required for equation (2) are fulfilled for any value of ϕ provided that e is 90° displaced from V , the vector mean of the input and output voltages E_1 and E_2 . The magnitude of e is k_1V where k_1 is a function of ϕ .

One requirement is thus fulfilled in that Z is still receiving a voltage of magnitude equal to that of E_1 and must therefore be passing a current I_2 , which has the magnitude $\frac{E_1}{Z}$, so that the impedance seen at the input by E_1 is unchanged. However the angle of the imped-

Philip H. Briggs graduated in electrical engineering at Manchester University in 1940. After a short time with Ferranti Ltd., Moston, on radar, he was commissioned in the Army, spending most of his service in R.E.M.E. Experimental Units with the rank of captain. He returned in 1947 to Ferranti, to work first on industrial electronic devices and then on domestic appliances. After three years he joined Fielden Electronics as joint chief engineer and in 1953 was co-founder of Dukes & Briggs Engineering Co. Ltd. of Urmston.



ance has unfortunately been changed from β to $\beta + \phi$, due to the real and imaginary energy components added by generator e operating with current I_2 at relative angle $\frac{\pi}{2} - \frac{\phi}{2} - \beta$. Somehow, therefore, further equipment is required which will remove to a sink the same quantity of real and imaginary energy which has been added, whilst correcting the currents in the equipment to establish I_1 displaced from E_1 by the correct angle β . Since the desired voltage condition was previously obtained by adding a voltage generator, e , it does not seem unreasonable to attempt to obtain the desired current condition by adding a current generator i . The manner of connection of a generator which can be shown to fulfil all the requirements is indicated in the skeleton circuit Fig. 4, in which it should be noted that the voltage

e is now being supplied in two parts, each of $\frac{e}{2}$ to the

junction of which is fed the current generator i . The complete vector diagram, Fig. 5(a), shows the requirements of I_1 relative to I_2 , from which it may be seen that for any value of ϕ , i needs to be 90° displaced from I , the vector mean of I_1 and I_2 . The magnitude of i is $k_2 I$ where k_2 is a function of ϕ . In this vector diagram, triangles OE_1E_2 and OI_1I_2 may be seen to be similar, so that

$$e : V = i : I \quad \dots \quad (3)$$

and therefore $k_1 = k_2 (= k \text{ say})$

$$\text{Now the angle between } e \text{ and } I \text{ is } = \left(\frac{\pi}{2} - \beta \right)$$

therefore the voltage generator supplies

$$\left. \begin{aligned} |e| |I| \cos \left(\frac{\pi}{2} - \beta \right) \text{ watts} \\ \text{and } |e| |I| \sin \left(\frac{\pi}{2} - \beta \right) \text{ vars} \end{aligned} \right\} \dots \quad (4)$$

$$\text{The angle between } V \text{ and } i \text{ is } = \left(\frac{\pi}{2} + \beta \right)$$

therefore the current generator (sink) supplies

$$\left. \begin{aligned} |V| |i| \cos \left(\frac{\pi}{2} + \beta \right) = \\ \text{and } -|V| |i| \sin \left(\frac{\pi}{2} + \beta \right) = \\ -|Vi| \cos \left(\frac{\pi}{2} - \beta \right) \text{ watts} \\ -|Vi| \sin \left(\frac{\pi}{2} - \beta \right) \text{ vars} \end{aligned} \right\} \dots \quad (5)$$

Due to equation (3) above, equations (4) and (5) may be seen to be equal in magnitude but of opposite sign and thus fulfil the requirements of the phase shift transformer analogue.

Impedance of variable angle

From a practical point of view, there is a limit to the size of k in order that the VA product produced by the voltage and current generators may be kept to a reasonable size relative to the VA product handled by the device as a whole, and a value of 0 to 1.5 would permit

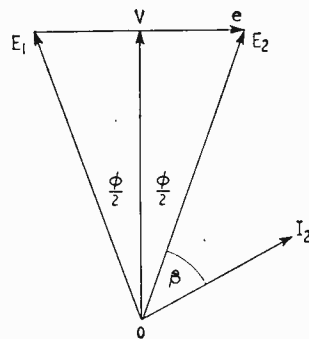

Fig. 3. Basic vector diagram.

ϕ to be adjusted between 0° and $> 90^\circ$. Figs. 4 and 5(a) show the system to be symmetrical, so that input and output terminations may be interchanged, thus also allowing the alternative phase shift of from 0° to $> -90^\circ$. If full 360° operation is required, the remaining two quadrants are readily covered by the use of a phase inverting transformer either at input or output termination.

Fig. 6 shows a block diagram of the device. It should be noted that the ohmic value of the two resistors R_1 and R_2 is very low. They act both as current-to-voltage transducers and adder.

Rather conveniently, Fig. 6 is also the block diagram of the other impedance changing device mentioned, the "impedance of variable angle." This gives $Z/\beta + \theta$, but there is one difference in the actual circuit—no longer is there the need to ensure that the equipment does not supply energy. In fact it must supply some, for it is necessary that the four terminal box shall act as a two terminal one (input) and look like some type of impedance, whilst connected to its other two terminals (they were the "output" pair but are now "internal") will be some specified impedance Z (see Fig. 4). This will dissipate real and/or reactive energy not normally obtained from the external circuit feeding the "input" terminals. The change is obtained by reversing the phase of i injected by the current generator. This means that both voltage and current generators additively supply a VA product.

The requirements of balance in this device are that when Z/β has absorbed its real and reactive power quota from the energies supplied by the two generators, the remainder shall feed via the input terminals to (or from) the external circuit in such a manner as to make the whole device look like $Z/\beta + \theta$. This can be done by reference to the vector diagram Fig. 5(b), whose similarity to Fig. 5(a) is to be expected, the main difference

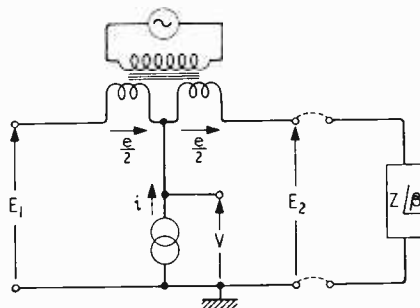

Fig. 4. Skeleton circuit.

being the reversal of direction of i and the resultant interchange of positions of I_2 and I_1 .

The voltage generator supplies

$$\left. \begin{aligned} &|e| |I| \cos \left(\frac{\pi}{2} - \beta - \phi \right) \text{ watts} \\ \text{and } &|e| |I| \sin \left(\frac{\pi}{2} - \beta - \phi \right) \text{ vars} \end{aligned} \right\} \dots \dots \dots (6)$$

and the current generator supplies

$$\left. \begin{aligned} &|V| |i| \cos \left(\frac{\pi}{2} - \beta - \phi \right) \text{ watts} \\ \text{and } &|V| |i| \sin \left(\frac{\pi}{2} - \beta - \phi \right) \text{ vars} \end{aligned} \right\} \dots \dots \dots (7)$$

which quantities are equal, for reasons similar to those applying to equations (4) and (5), so that the total energy supplied is twice that from either generator.

The "internal" impedance Z/β , can be seen to consume

$$\left. \begin{aligned} &|E_2| |I_2| \cos \beta \text{ watts} \\ \text{and } &|E_2| |I_2| \sin \beta \text{ vars} \end{aligned} \right\} \dots \dots \dots (8)$$

so that, simplifying from equations (6), (7) and (8), and considering watts only, the energy given up to the system externally connected to the input terminals is

$2|e| |I| \sin(\beta + \phi) - |E_2| |I_2| \cos \beta$ watts which, if you examine the vector diagram, and enjoy a little mathematical exercise, you will find can be re-written as:

$$\left. \begin{aligned} &|E_1| |I_1| [2 \sin \phi \sin(\beta + \phi) - \cos \beta] \text{ watts} \\ \text{which may be converted to} \\ &- |E_1| |I_1| \cos(\beta + 2\phi) \text{ watts} \dots \dots \dots (9) \end{aligned} \right\}$$

$$\left. \begin{aligned} \text{and similarly may be calculated} \\ &+ |E_1| |I_1| \sin(\beta + 2\phi) \text{ vars} \dots \dots \dots (10) \end{aligned} \right\}$$

Equations (9) and (10) indicate that the whole device

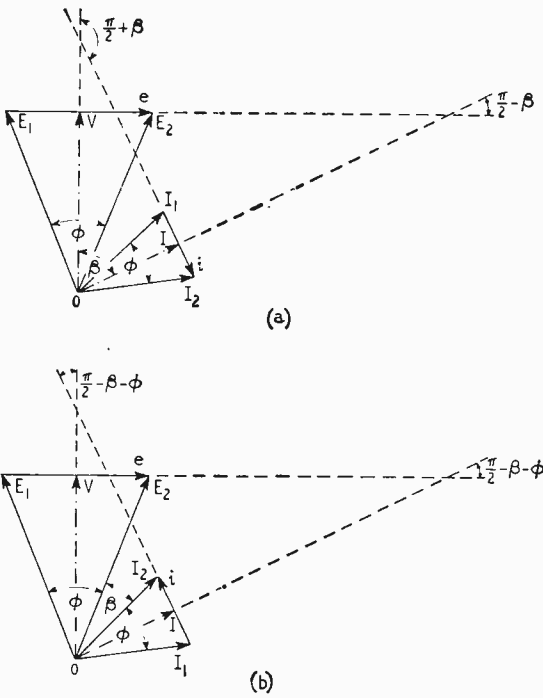

Fig. 5. Vector diagrams; (a) phase shifter and (b) impedance at variable angle.

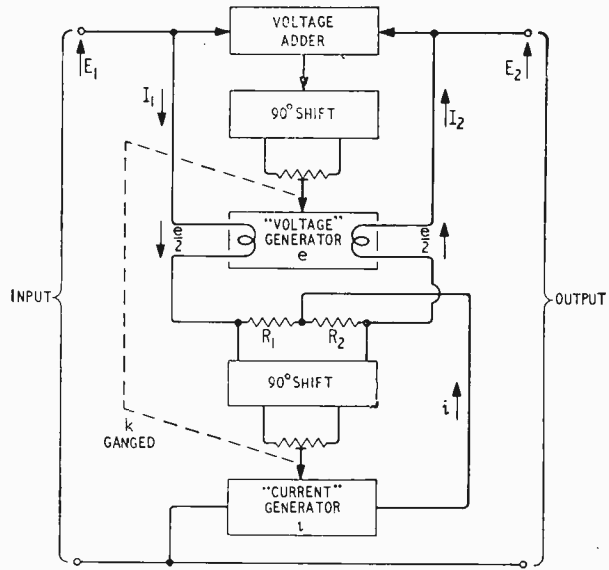

Fig. 6. Block diagram of two impedance changing devices.

looks at its input terminals like an impedance Z' where

$$|Z'| = \frac{|E_1|}{|I_1|} = \frac{|E_2|}{|I_2|} = |Z|$$

but the angle has increased from β by 2ϕ ($=\theta$), thus fulfilling the requirement of the "impedance of variable angle".

Operating region

If the circuit details remain as for the phase shift analogue in that k is available from 0 to 1.5, (thus permitting availability of ϕ from 0° to $\pm 90^\circ$), then this device may be operated with θ from 0° to $\pm 180^\circ$ without the need of a phase inverting transformer. Since none of the description given above has specified the form that Z must take, any type of component may be employed. If the main requirement of the device should be to work in the region of negative resistance and varying between a small leading and lagging reactive component, then it is convenient and economic to let Z be a capacitor (i.e. $\beta = 90^\circ$) thus avoiding the need for a phase advance/retard switch, and permitting operation in the region of $k = 0.7$, thus keeping the generator VA requirements low.

The unit described above is intended for use when variations in impedance magnitude and angle are required (if mere negative resistance is required, you would be well advised to re-read Mr. Butler's article—there are simpler methods of fulfilling your needs!) There is one further benefit here, when working as a negative resistance (or at any other angle), it possesses both open circuit and short circuit input stability, whereas simpler devices are generally stable for one or the other of these conditions 1, 3.

REFERENCES

- (1) "Active impedance converters," Butler, F. *Wireless World*, December 1965, pp. 600-604 (Vol. 71).
- (2) "Electric Power System Control", Young, H. P., pp.281 and 311. Chapman & Hall, London (1942).
- (3) "Filtnerics." Roddam, T. *Wireless World*, August 1962, pp.370-374 (Vol. 68).

3—Root-locus Special Cases

By W. TUSTING

In this third article of the series some special cases are considered, including complex poles and zeros and several equal poles or zeros. The root-locus diagram for an RC amplifier at low frequencies is derived and it is shown how by a little ingenuity it is possible to make the high-frequency diagram serve also for this case with a big saving in labour.

THE basic procedure for the use of the root-locus technique has now been explained and this suffices for most practical problems. When complex poles and zeros occur, however, additional steps are needed. Also, the beginner is likely to be puzzled about what he should do when there are two or more equal poles or zeros. Apart from these matters, only practice is needed to become familiar with the method. When one has acquired this familiarity and when one can remember all the procedure, the plotting of rough root-locus diagrams is very quick and easy; in fact, one can often see at a glance their general form from the pattern of poles and zeros.

Equal poles and zeros.—When a number of equal real poles (or zeros) occurs little or no difficulty arises if they are imagined to be infinitesimally separated, for then the ordinary rules for distinct poles (or zeros) can be applied. Fig. 1 illustrates the sort of thing that happens. At (a) there is just a pair of real poles and by application of the ordinary rules we find that the locus exists on the real axis between them, p_a and p_b coincide and are midway between them, and the asymptotes are at $\pm 90^\circ$. When G_0H_0 increases the roots move from the poles towards each other and become equal at p , in the usual way. Thereafter, as G_0H_0 increases further the roots become complex and move away from the real axis at $\pm 90^\circ$. Because there are only two poles and no zeros in this example the whole path of the complex roots is at 90° to the real axis; in other words, the real part of the complex roots is constant and only the imaginary part varies.

If we move the poles together nothing changes in the general form of the locus, and it is easy to see that when they coincide as at (b) the locus is merely a vertical line through them.

Now consider three poles. When these are all distinct (c) we have the normal picture as discussed fully in Part 2. Now let the pole at -2 move to -1 , to give two equal poles of -1 . The breakaway point now coincides with these poles and we get the picture (d). On the other hand, we have a different picture if the pole at -2 moves to -3 . This is shown at (e). The root locus now exists on the real axis at all points to the left of -1 . One root moves to the left from one of the poles at -3 , another to

the right from -3 and the third to the left from -1 , all as G_0H_0 increases. The breakaway point comes between these last two poles. The picture is really the same as that of (c) save that there is no gap on the real axis.

When we come to three equal poles (f) we have a very simple diagram. One root moves to the left on the real axis, the other two move away as complex roots at $\pm 60^\circ$ on the asymptotes. The points p_a and p_b both coincide with the poles. This diagram lends itself to a very simple algebraic evaluation. Referring to Fig. 1 (f) $\cos \theta = BC/AB$ and $\tan \theta = AC/BC$. Therefore

$$AB = BC/\cos \theta \text{ and } AC = BC \tan \theta$$

Now $BC = 1/T$ where T is the time constant and $K = 1/T^3$, so $G_0H_0 = (AB)^3/K = (AB)^3T^3 = 1/\cos^3\theta = 8$ since $\theta = 60^\circ$.

$AG/BC = \tan \theta = 1.7321 = \omega T$, since $AC = \omega$. Therefore critical stability is reached for any cascade of three equal time constants at a gain of 8 times and the frequency concerned is $f = 1.7321/2\pi T$.

What happens if there are more circuits of equal time constant? The case of four equal poles is shown in Fig. 2 (a). There is no locus on the real axis, so there must be two pairs of complex conjugate roots for all finite values of G_0H_0 . The asymptotes are at $\pm 45^\circ$ and $\pm 135^\circ$ and are also the loci. The previous relations apply, so

$$G_0H_0 = 1/\cos^4\theta = 4$$

$$\omega T = \tan \theta = 1$$

For five equal poles (b) one branch of the locus lies on the real axis and the others are at $\pm 36^\circ$ and $\pm 108^\circ$. We have

$$G_0H_0 = 1/\cos^5\theta = 1.236^5 = 2.9$$

$$\omega T = \tan \theta = 0.72654$$

Thus generally if there are m equal poles we have $G_0H_0 = 1/\cos^m\theta$, $\omega T = \tan \theta$ and $\theta = 180^\circ/m$. Therefore, the critical gain is

$$G_0H_0 = 1/[\cos^m(180/m)]$$

$$\omega T = \tan(180/m)$$

This well illustrates the well-known fact that it is a bad thing to have many equal time constants in a feedback system.

Equal zeros are of course treated in the same way as equal poles. In practice, however, zeros do not occur alone. Poles can and commonly do occur without any zeros being present. Zeros never do and, normally, there are more poles than zeros.

Complex poles and zeros.—When there are complex poles and zeros the procedure described in Part 2 is largely unaltered, they are just counted in with the real poles and zeros. However, in Step 1 they are completely ignored. In Steps 2 and 3 they are counted in like any other poles and zeros. Thus in enumerating P_n , a pair of complex poles adds two to the number of poles. In evaluating ΣP , the values of the complex poles are added to the values of the real poles. For example, if the complex poles are $-2 + j3$ and $-2 - j3$, their sum is -4 and this is added to the sum of the values of the real poles. The imaginary parts of the complex poles and zeros always cancel out in this.

When computing the breakaway point in Step 5 the

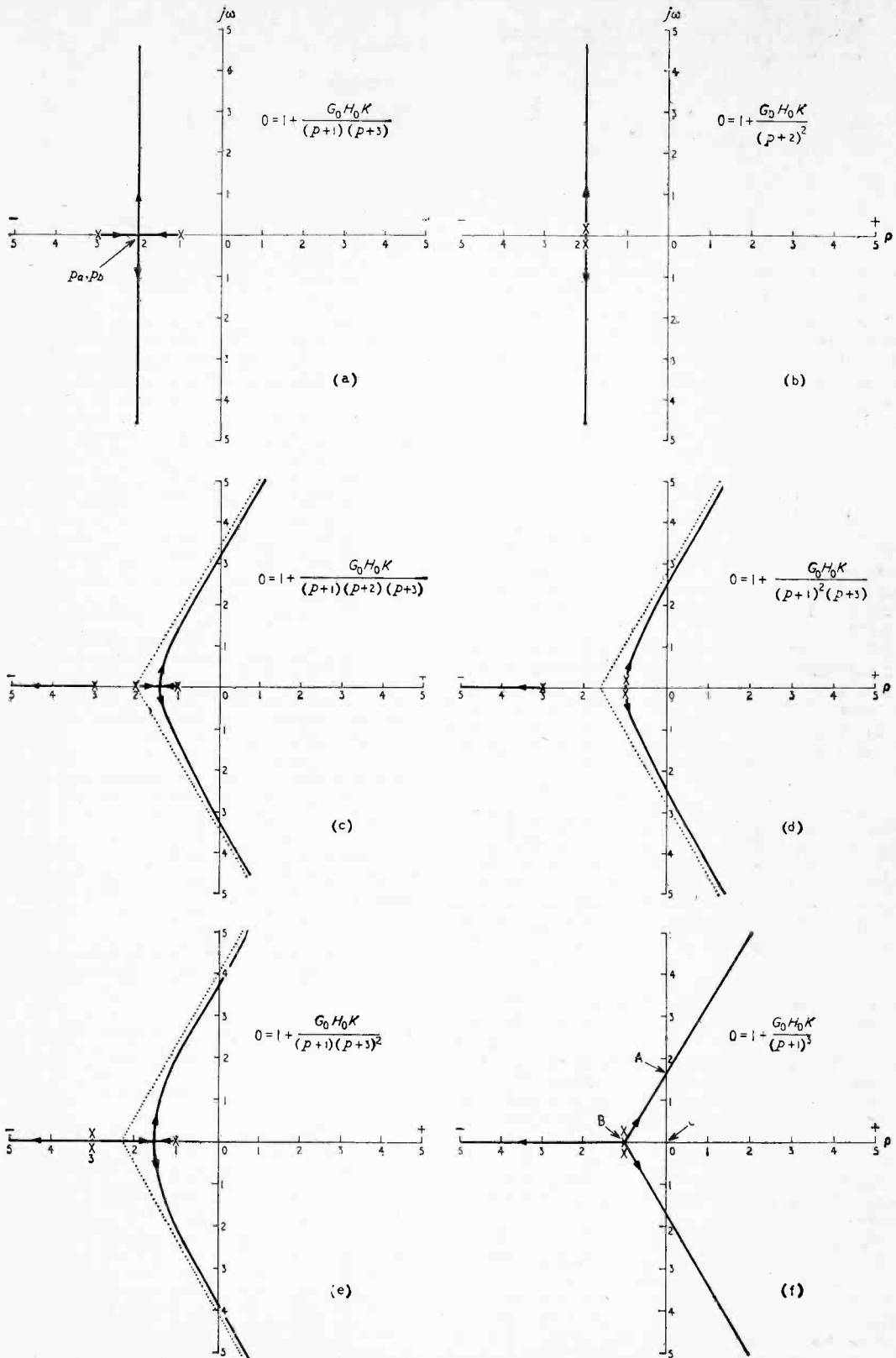

Fig. 1. Various root-locus diagrams: (a), two poles; (b), two equal poles; (c), three poles; (d), three poles, two equal; (e), three poles, two equal; and (f), three equal poles.

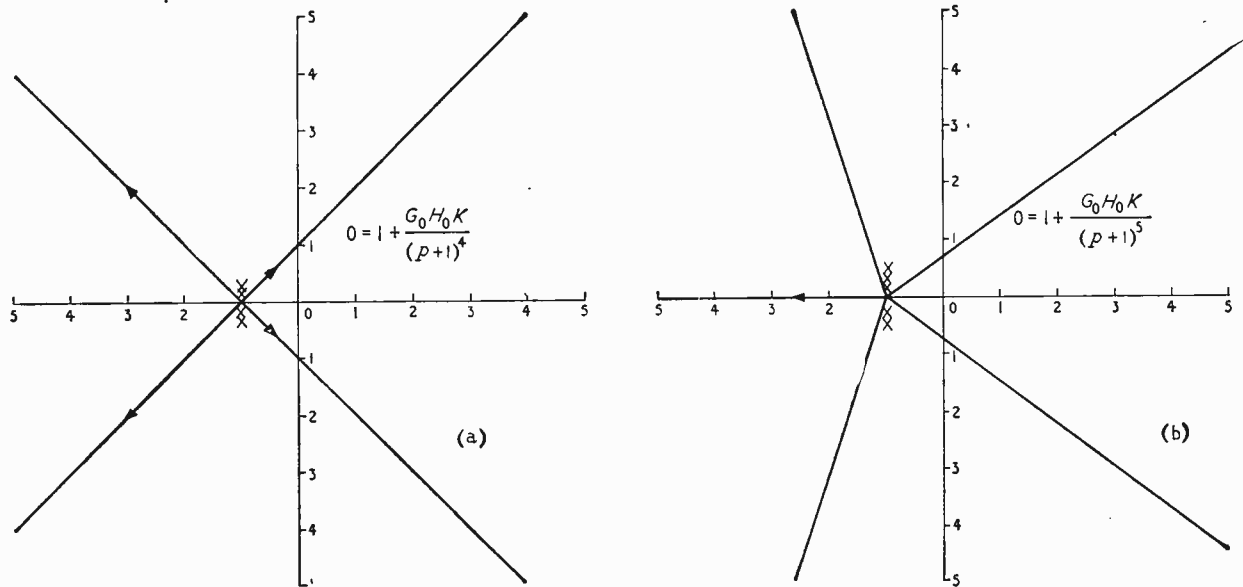

Fig. 2. The cases of four equal poles (a) and five equal poles (b) are shown here.

complex poles (and zeros) must be taken into account. How to do this was explained in Step 5.

Step 7 is unaffected by the presence of complex poles and zeros. Lines to them are drawn from the given point just as if they were real poles and zeros.

The presence of such poles and zeros, however, brings in an extra aid for drawing the root-locus. It is possible to compute the angle at which the branch of a locus leaves a complex pole or departs from a complex zero. This is therefore another step in the procedure.

Step 9. To determine the angle of arrival at, or departure from, complex zeros or poles. Take one of a pair of complex poles (or zeros). Draw lines from it to every other pole and zero, including the conjugate pole (or zero). Measure the angles between these lines and the horizontal through the pole or zero, taking the angles as increasing anti-clockwise and zero angle as the horizontal to the left. The angles

formed by lines to poles are treated as negative, while those formed by lines to zeros are treated as positive. The angles are all added with due regard to sign and then a further -180° is added. The angle of arrival or departure at the pole or zero is then this angle measured from the horizontal through the pole or zero to the right. The angle is measured clockwise if it is a departure angle from a pole, anti-clockwise if it is an arrival angle at a zero.

In Fig. 3(a) and (b) are shown respectively a pair of complex poles and zeros with identical real poles and zeros. In each case the angles are $\theta_1 = -125^\circ$, $\theta_2 = +109^\circ$, $\theta_3 = -90^\circ$, $\theta_4 = -72^\circ$ and $\theta_5 = -56^\circ$. The positive sign for θ_2 is because this angle is to a zero. The angles total $109 - 343 = -234^\circ$. Adding -180° gives us -414° . This is shown in Fig. 4 for the complex poles (a) and zeros (b).

Let us now consider a practical example. We have already considered a three-stage RC amplifier at high-frequencies. Let us now consider one at low frequencies. The response of an interstage coupling is of the form

$$\frac{R}{R + 1/pC} = \frac{p}{p + 1/T}$$

where $T = CR$ and C is the coupling capacitor and R the grid leak. The equation is thus

$$0 = 1 + G_0 H_0 K \frac{p^3}{(p + 1/T_1)(p + 1/T_2)(p + 1/T_3)}$$

with $K = 1$.

The high-frequency equation had three poles and no zeros. This has three poles and three zeros. Now let all the grid leaks be $1M\Omega$ and the coupling capacitances be $0.01\mu F$, $0.04\mu F$ and $0.1\mu F$, giving time constants of 0.01, 0.04 and 0.1 second. The reciprocals are 100, 25 and 10 so our equation becomes

$$0 = 1 + G_0 H_0 \frac{p^3}{(p + 10)(p + 25)(p + 100)}$$

The pole-zero plot is shown in Fig. 4. Applying Step 1, the locus exists on the real axis between $p = 0$ and $p = -10$ and between $p = -25$ and $p = -100$. If we now apply Steps 2 and 3 we run into trouble. Since

(Continued on page 423)

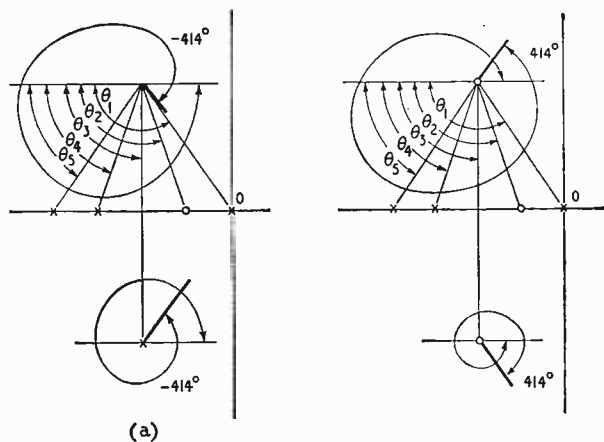

Fig. 3. These diagrams illustrate the way of finding the angles of departure from (a) and arrival at (b) complex poles and zeros.

$P_n = 3$ and $Z_n = 3$, $P_n - Z_n = 0$ and we get $p_a = -\infty$ and $\theta = \infty$. The reason is, of course, that there are no asymptotes. There is a breakaway point between -25 and -100 which we shall have to find but the complex roots do not go to infinity but terminate on two of the zeros at $p = 0$. There are three zeros at $p = 0$, and as we saw earlier the angles of arrival are 180° and $\pm 60^\circ$. The 180° line is on the real axis and is the path of the real root from $p = -10$. We thus draw in lines at $\pm 60^\circ$ to indicate the arrival angles of the complex branches of the locus. These lines are in the positive half of the diagram so with high enough gain there will be instability, as we should expect.

This is all the guidance that we can get simply, so we have to determine the breakaway point with very little idea of where it may be. We guess $p_b = -50$ as a first trial and the working in Table 1 shows the difference between the left and right sums as -0.015 . We next try $p_b = -40$ and, as Table 1 shows, the difference is now $+0.0083$. Because of the change of sign in the differences we know that p_b lies between -40 and -50 . The magnitude of the positive distance is slightly more than one-half of that of the negative difference, so we may expect p_b to be rather less than one-third of the distance between -40 and -50 ; that is, at a bit less than -43.3 . Let us try $p_b = -42.5$. The difference of the sums to left and right of the point is now only $+0.0001$ and we may consider this near enough.

We have now departure angles of $\pm 90^\circ$ from $p_b = -42.5$ for the start of the complex branches of the locus and arrival angles of $\pm 60^\circ$ at $p = 0$ for the ends.

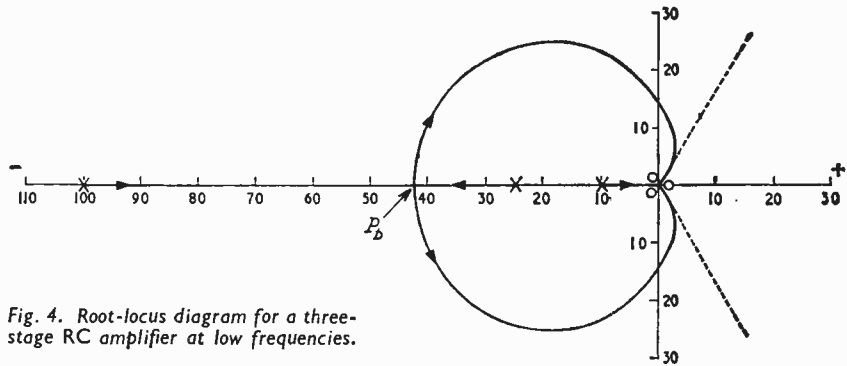

Fig. 4. Root-locus diagram for a three-stage RC amplifier at low frequencies.

In this case, however, it is hard to draw the locus with any approach to accuracy from this information alone. We need at least two points on the curve to do so. Let us try to locate a point on the -10 axis. It looks as if $\omega = 20$ might be about right. So we try this by summing the angles from it. They are -12.5° , -52.5° ; -90° and $+117.5^\circ$ three times; the sum is 197.5° . Table 2 shows the various trials to find four points and we find, approximately that the locus passes through $-10 \pm j23$, $-25 \pm j24$, $0 \pm j14$ and $-35 \pm j18.5$. From these points we can complete the locus. It is quite a different shape from anything which we have met hitherto.

We find the critical gain by measuring the distances of the poles and zeros from the critical point $0 + j14$. The pole distances are 101, 28.7 and 17 while the zero distances are all 14. Since $K = 1$ we have

$$G_0 H_0 = 101 \times 28.7 \times 17 / 14^3 = 17.9$$

This should actually be 19.5, so we have not achieved quite as high accuracy as in the earlier example. However, it is still accurate enough for most engineering purposes. The frequency is $14/6.28 = 2.23$ c/s.

This has been rather an awkward locus to draw and it is interesting to notice that we need not have done so! We had the equation

$$0 = 1 + G_0 H_0 \frac{p^2}{(p+10)(p+25)(p+100)}$$

Let $p = 1/q$ and substitute. We then have

$$0 = 1 + G_0 H_0 \frac{1}{(1+10q)(1+25q)(1+100q)}$$

Taking out the coefficients of q we get

$$0 = 1 + G_0 H_0 K \frac{1}{(q+0.1)(q+0.04)(q+0.01)}$$

with $K = 1/25000$. This is for time constants measured in seconds. If we measure them in tenths of seconds we get

$$0 = 1 + G_0 H_0 K \frac{1}{(q+1)(q+0.4)(q+0.1)}$$

with $K = 1/25$.

Now this is exactly the equation that we had in Part 2 for the high-frequency response save that it is in $q = 1/p$ instead of in p and the numbers now represent time constants instead of the reciprocals of time constants. The root-locus diagram of Fig. 4, Part 2, thus applies exactly if we remember that the ω scale is now one of $1/\omega$.

We previously found the critical gain to be 19.5 and this is the same here. We had $\omega = 0.74$ megaradians/second. We now have $1/\omega = 0.74$ in seconds per ten radians so $\omega = 1/0.74$ or 1.35 and $f = 0.215 \times 10 = 2.15$ c/s.

Thus by a little ingenuity it is possible to use the same root-locus diagram for two quite different circuits and two quite different basic equations.

TABLE 1

| Poles and Zeros → | -100 | -25 | -10 | 0 three times |
|------------------------------|-----------------|----------|-------------|---------------------|
| $p_b = -50$ | | | | |
| Distances to poles and zeros | 50 | 25 | 40 | 50 |
| Reciprocals | -0.02 | -0.04 | -0.025 | +0.02 |
| Sum to left of p_b | -0.02 | | | |
| Sum to right of p_b | 3×0.02 | -0.065 | $= -0.005$ | |
| Difference left-right | | | | -0.015 |
| $p_b = -40$ | | | | |
| Distances | 60 | 45 | 30 | 40 |
| Reciprocals | -0.0166 | -0.0666 | -0.0333 | 0.025 |
| Sum to left | -0.0166 | | | |
| Sum to right | 0.075 | -0.1 | $= -0.025$ | |
| Difference | 0.025 | -0.0166 | $= +0.0083$ | |
| $p_b = -42.5$ | | | | |
| Distances | 67.5 | 17.5 | 32.5 | 42.5 |
| Reciprocals | -0.0174 | -0.0572 | -0.0308 | -0.0235 |
| Sum to left | -0.0174 | | | |
| Sum to right | 0.0705 | -0.088 | $= -0.0175$ | |
| Difference | +0.0001 | | | |

TABLE 2

| p | Angles | | | Sum |
|---------------|---------------|---------------|---------------|-------------------------|
| $-10 + j20$ | -12.5° | -52.5° | -90° | $+3 \times 117.5^\circ$ |
| $-10 + j21$ | -13° | -54° | -90° | $+3 \times 116^\circ$ |
| $-10 + j23$ | -14° | -57° | -90° | $+3 \times 114^\circ$ |
| $-10 + j26$ | -16° | -60° | -90° | $+3 \times 111^\circ$ |
| $-25 + j25$ | -18° | -90° | -121° | $3 \times 135.5^\circ$ |
| $+25 + j24$ | -17° | -90° | -123° | $3 \times 137^\circ$ |
| $0 + j20$ | -11° | -39° | -63.5° | $3 \times 90^\circ$ |
| $0 + j15$ | -8° | -31° | -56° | $3 \times 90^\circ$ |
| $0 + j14$ | -8° | -29° | -54° | $3 \times 90^\circ$ |
| $-35 + j18.5$ | -15.5° | -119° | -144° | $3 \times 153^\circ$ |

NEW PRODUCTS

Modulation Meter

FOR measurement of both f.m. deviation, and a.m. depth over a wide range of carrier frequencies, Marconi Instruments offer the TF 2300, a general purpose modulation meter. This can be used for all modulation measurement applications in point to point communications as well as a high proportion of



those in telemetry and broadcasting—including stereo. The instrument is basically a low sensitivity superheterodyne receiver possessing very linear (switch selected) f.m. and a.m. demodulators. The demodulated signal is amplified, rectified and applied to a panel meter, which is calibrated directly in kc/s peak deviation, and percentage modulation depth as appropriate. For f.m. measurement the instrument has a carrier frequency range of 4 to 1,000 Mc/s, and is capable of indicating peak deviations up to a maximum of 500 kc/s. This is in five ranges with full-scale indications of 5, 15, 50, 150 and 500 kc/s, with positive or negative deviation indication selected by a switch. Accuracy is $\pm 5\%$ of full scale for modulating frequencies between 30 c/s and 150 c/s. For measurement of very low values of deviation, there is provision for connecting a sensitive external indicator via a pair of terminals to the output of the i.f. amplifier. This outlet is useful for applying the demodulated signal to secondary test equipment—e.g., an oscilloscope or wave analyser—for checks on waveform, modulation frequency, etc. The a.m. section of the instrument has a carrier frequency range of 4 to 500 Mc/s, and it is designed to measure modulation depth by two ranges with full-scale indications of 30% and 100% (maximum usable reading: 95%). The accuracy is

$\pm 5\%$ of full scale for modulating frequencies between 30 c/s and 15 kc/s, but although this is the nominal modulation frequency range, the bandwidth of the a.f. system actually extends up to 50 kc/s in order to measure harmonics. To indicate the symmetry of the modulation envelope, the meter may be switched to indicate the peak or trough amplitude, relative to the mean carrier level.

The internal oscillator has two ranges: 5.5 to 11 Mc/s and 22 to 44 Mc/s, harmonics being used for other local oscillator frequencies. Provision is made for connecting an external oscillator (the internal oscillator being switched out), the required input level being nominally 200 mV e.m.f. from a 50 Ω source. It can be powered by a.c. mains 95 to 130 V or 190 to 260 V (45 to 500 c/s), or with an external d.c. supply 21.5 and 30 V d.c., 300 mA at 24 V d.c. Height 7 $\frac{1}{4}$ in., width 18 $\frac{1}{4}$ in.; depth 14 $\frac{1}{4}$ in.; weight 24 lb.

WW 301 for further details

VARIABLE CAPACITOR

THE air dielectric trimmer C903 is produced by Wingrove and Rogers Ltd., 75 Uxbridge Road, London, W.5. Fitted with a locking device, it has a minimum capacitance of 3.5 pF, with a swing of up to 34 pF. Voltage proof 550 V peak. Power factor—less than 0.001 at 1 Mc/s. Insulation resistance—greater than 1,000 M Ω at 500 V d.c.

WW 302 for further details

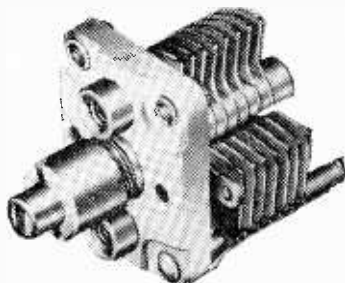

Line Impedance Measurement

MARKETED in this country by Avey Electric Ltd., South Ockendon, Essex, the Kieler Howaldtswerke impedance measuring set (T74/1) is set up to read the line impedance directly through a decade switch system, eliminating the need for mathematical calculation. The T74/1, measuring impedance with the aid of a bridge, obtains quotients that are formed from current and voltage measurements. Accuracy of measurement is ensured by selecting a relatively large measuring current, with the result that external voltages and induction currents have little effect on the measured result. The measurement is made by making the line dead, and short circuited at the opposite end, so that the set measures the impedance of this line loop. Measuring range is from 0.02 to 4.5 Ω with an accuracy of $\pm 2.5\%$.

WW 303 for further details

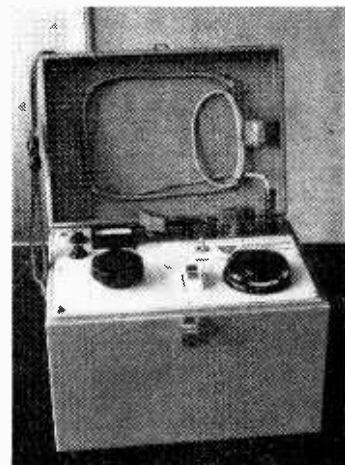

Hole Deburring

THE Cogsdill Burraway, consisting of a plain shank with a spring loaded cutting blade inserted near one end, can produce a chamfer or light edge trim on a hole, depending on the angle of the blade and the pressure of the spring, which can be adjusted. The Burraway, which can be used in a drill press or hand drill, enters a hole, and the leading edge of the blade removes the burr from the top of the hole; as the shank travels down the bore, the blade retracts and as the shank returns a reverse cutting edge removes the bottom burr. Information and leaflet from Douglas Kane (Sealants) Ltd., Swallowfields, Welwyn Garden City, Herts.

WW 304 for further details

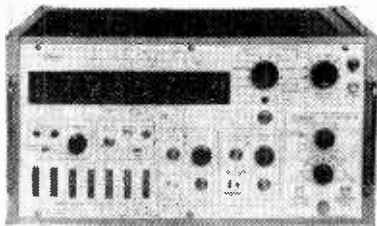

10 Mc/s Timer Counter

THE Advance TC3 is a 7-decade instrument, which, in its basic form with a PC1 plug-in module will count regular or random pulses up to 10 Mc/s, with a sensitivity of 10 mV. It has facilities for measuring frequency, period, phase angle, and pulse width. The variable time scale consists of seven rotary switches permitting gate times between 10 μ s and 10 s in 1 μ s steps. The frequency divider plug-in module PC2 has a range of 1 to 105 Mc/s and a sensitivity of 50 mV. The PC3 module permits measurement of capacitance and resistance values by converting them to periods of time that can be measured and displayed as a digital readout with a 0.25% accuracy. Resistance values are measured over two ranges that overlap, and cover 100 Ω to 10 M Ω . Measurable capacitance values lie between 10 pF and 10 μ F, in two overlapping ranges, while a front panel meter indicates the percentage error introduced due to leakage resistance. Advance Electronics Ltd., Roebuck Road, Hainault, Ilford, Essex.

WW 305 for further details

TRIAC WASHERS

A HARD anodized washer for stud mounted G.E. Triacs and silicon controlled rectifiers insulates the device from its heat sink. It is claimed that the conduction rate is five times better than that of a mica washer. Insulation of the washer is tested to 500V d.c. Complete with nylon bush from Jermyn Industries, Vestry Estate, Vestry Road, Sevenoaks, Kent.

WW 306 for further details

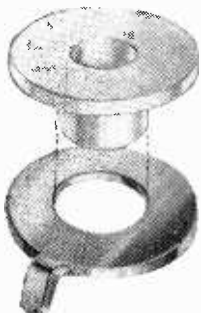

REED RELAYS

"FLAT-PAK" encapsulated reed relay assemblies are available from Electrothermal Engineering Ltd., 270 Neville Road, London, E.7, in standard and miniature sizes, employing replaceable single or multiple reed switch inserts, in three switching forms. Form A is the basic switch with normally open contacts, giving a single-pole, single-throw action. Form B is the A switch biased (usually by permanent magnet) to give a normally closed condition. Form C is a single-pole, changeover reed, comprising a long magnetic reed moving between two fixed contacts. Other switching functions such as d.p.s.t. and d.p.d.t. can be obtained—the former with two Form A, and the latter with two Form C switches. Printed circuit board styles have been added to the range, and these have variable pin spacings to suit most printed circuit grids and layouts. Typical operating

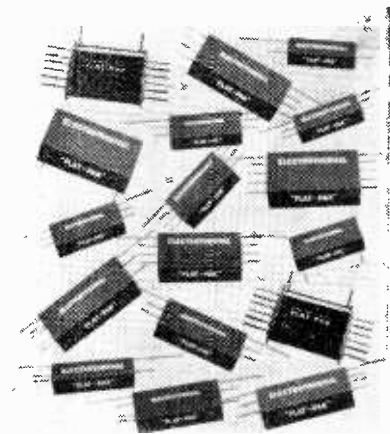

times are from 1 ms to 2 ms, this includes contact bounce time.

WW 307 for further details

12 V SILICON TRANSISTOR MOBILE Tx

A TOP-BAND (2 Mc/s) mobile transmitter using silicon transistors has been recently released by Contactor Switchgear (Electronics) Ltd. The transmitter represents a diversification for C.S.E., who manufacture static switching systems, process control units and other industrial equipment and is the first 12 V solid state transmitter intended for mobile amateur use.

The transmitter, weighing 60 oz, operates directly from a 12 V car battery and with an input of 10 W consumes just over 1A. The supply can be either + or - earthed and diodes are built in for protection in the event of wrong supply connection. Three modes of operation are possible, c.w. transmission (A1), netting and a.m. phone transmission (A3). Send/receive switch and c.w. key connections are brought out at a 5-way connector, together with a receiver power supply.

The oscillator is a common collector Colpitts type using a BSY95A and being fed from a Zener stabilized voltage (8 V). This stabilized voltage is also used to supply a BSY95A r.f. amplifier, a key being switched into its emitter for A1 operation. A transformer coupled C426 driver follows and feeds a class C (C426) push-pull p.a. stage, also transformer coupled. (The transformers are ferrite cored and potted.) Aerial coupling is *via* a pi network, the first capacitor being variable and the second switched to cater for resonant loads of 10-300 Ω . Since the gain of the C426 output transistors falls

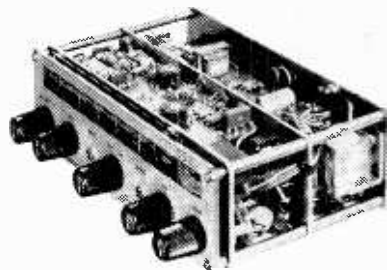

at high collector currents, resulting in an asymmetrical output waveform, the positive peaks of the modulation waveform are caused to override the stabilized supply voltage to the BSY95A amplifier, the peaks themselves providing the supply and thus increasing the r.f. drive. The class B modulator uses a BSY95A first stage followed by push-pull output stage with two Darlington stages (2 \times BCY42-C426) and operates from an 8 V line.

The transmitter may be operated in a truly portable fashion by using the new Ever Ready 12 V portable television battery (TV1) providing about one week's use for up to 1 hour per day operation.

The transmitter costs £43 7s directly from Contactor Switchgear (Electronics) Ltd., Moorfield Road, Wolverhampton, Staffs. A tunable mobile whip aerial and lip microphone are available as extras. A companion top band receiver has been developed and is to be announced shortly.

WW 308 for further details

RESONANT DUAL REED DEVICE

THE series of Vibra-Fork dual reed devices constructed on tuning-fork principles, and manufactured by Perry Laboratories Inc. of U.S.A., are available from Kynmore Engineering Co. Ltd., 19 Buckingham Street, London, W.C.2. They are suitable for selective signalling, personnel paging, coding and decoding, remote control and remote indicating systems, or wherever contact closing at a precise audio frequency ($\pm 1.0\%$ of the nominal resonant frequency within the

range 300 c/s to 1 kc/s) is required. The DR-6 resonant reed relay is a dual reed fork, surrounded by a single control coil, so that an input signal at the resonant frequency causes the contacts to close for a nominal 5% of each cycle, enabling an external circuit to be controlled. Contact rating is 100 mA at 12 V d.c. dropping to 2 mA at 150 V d.c. The DR-6C, a sealed unit, is $1\frac{1}{8}$ in long \times $\frac{3}{4}$ in diameter. The DR-6U, an unsealed unit, is $1\frac{1}{2}$ in long \times $\frac{5}{8}$ in diameter. Other devices include a DR-06 oscillator control, TM-6 tone control, and DM-6C decoder module. The DRO-6DM contactless decoder module permits up to 100 channels to be accommodated within one octave anywhere between 500 c/s and 3 c/s, with a claimed channel separation of 40 dB.

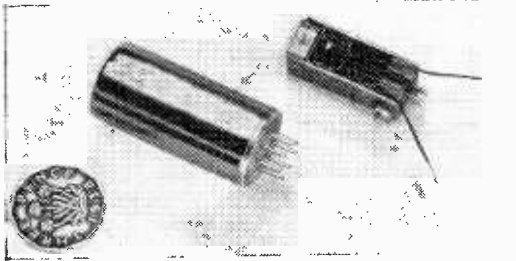

WW 309 for further details

Temperature Bridge

THE Tinsley Type 5596 bridge has been developed for use with the four terminal expendable thermometer elements (210D). This instrument measures the change in resistance (in ohms) of these elements by the four terminal method. The resistance range covered is 75 to 165 Ω readable to $\pm 0.1 \Omega$. The temperature range is -50° to $+150^\circ\text{C}$ using 100 Ω expendable thermometer elements with a reproducibility of $\pm 0.25^\circ\text{C}$. The bridge is supplied with 1 kc/s at 2.5 V by a square wave oscillator, and the detector is a centre zero meter driven from a transistor detector amplifier. The sensitivity available allows a change of 0.05 Ω to be detected. The use of a square wave generator eliminates reactive errors, and lead errors are reduced by the four-terminal method of measurement. The use of an a.c. supply reduces thermal effects to a negligible amount. The overall accuracy is normally determined by the stability of the



thermometer elements. Dimensions: 29 \times 22 \times 15 cm. Weight: 4 $\frac{1}{2}$ kg. H. Tinsley & Co. Ltd., Werndee Hall, South Norwood, S.E.25.

WW 310 for further details

INFORMATION SERVICE FOR PROFESSIONAL READERS

To expedite requests for further information on products appearing in the editorial and advertisement pages of *Wireless World* each month, a sheet of reader service cards is included in this issue. The cards will be found between advertisement pages 16 and 19.

We invite professional readers to make use of these cards for all inquiries dealing with specific products. Many editorial items and all advertisements are coded with a number, prefixed by WW, and it is then necessary only to enter the numbers on the card.

Postage is free in the U.K. but cards must be stamped if posted overseas. This service will enable professional readers to obtain the additional information they require quickly and easily.

General Purpose Microphone

A GENERAL purpose moving coil microphone (L.E.M. type DH80) is announced by Douglas A. Lyons & Associates Ltd., of 32 Grenville Court, London, S.E.19, who are the sole U.K.



agents for L.E.M. microphones which are manufactured in France.

The "omni" microphone is available with a transformer enabling models to be provided for three impedances: 50 Ω , 200 Ω and 80 k Ω . Sensitivity is 0.085 mV per dyne/cm² (or -82 dB relative to 1 V per dyne/cm²) for 50 Ω impedance, 0.16 mV per dyne/cm² (-76 dB) for 200 Ω impedance and 2.4 mV per dyne/cm² (-52 dB) for 80 k Ω impedance.

The response is 4 dB down at 70 c/s and 10 kc/s for high impedance operation and at 70 c/s and 14 kc/s for low impedance operation. A speech setting is provided which attenuates frequencies below 200 c/s.

The microphone may be either hand-held, lapel, table or stand mounted, and is provided with 6 $\frac{1}{2}$ ft of cable.

WW 311 for further details

MINIATURE RELAY

SPECIALLY developed for printed circuit applications, the Type 416 miniature d.c. relay by Eberle, of Germany, distributed in the U.K. by G. A. Stanley Palmer Ltd., Island Farm Avenue, West Molesey Trading Estate, Surrey, measures 1.4 \times 1.37 \times 0.67 in without socket, and weighs 1.13 oz. Voltage ratings of coils are from 1.5 to 115 V d.c., and the two sets of changeover contacts have a break before make action. The contacts are rated at 250 V a.c., 125 V d.c. max., both at 1.5 A max., with a contact resistance of approximately 12 milliohms. The stated mechanical life expectancy is 10⁷ cycles. Pull-in time is 12-15 ms and drop-out time 2 to 4 ms.

WW 312 for further details

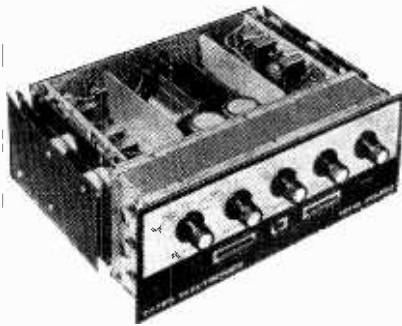

10W + 10W AMPLIFIER

BASED on a Mullard design, the **Tates 10W+10W** transistor integrated pi-mode stereo amplifier is available in kit form. The detachable pre-amplifier unit employs a BC107 low noise device, and has input facilities for ceramic, crystal and magnetic pickups, radio and tape. It also possesses separate switched bass and treble controls, i.f. and h.f. switched filters, balance control, and a combined volume control with on/off switch. The main amplifier has a loudspeaker phase reversal switch. The complete amplifier breaks down into several separate kits for ease of construction (pre-amplifiers, main amplifiers, control pack and power supply), which can be purchased separately or as a complete kit for 47½ gn from **Tates Electronic Services Ltd.**, 3 Waterloo Road, Stockport, Cheshire.

WW 313 for further details

Batch Counters

AVAILABLE from **Darang Electronics Ltd.**, Restmor Way, Hackbridge Road, Hackbridge, Surrey, is the 667 series of digital batch counters. These instruments are available in 2, 3 or 4 decade versions, capable of counting batches of 99, 999, 9,999 respectively; with or without a total batch indicator and with or without in-line digital display. Each instrument is fitted with pre-batch facilities which may be pre-selected depending on requirements. Batch selection is by 10-way rotary switches, with numbered dials protected by the front panel. Input signals range from 2V to 300V peak while the input circuit is d.c. coupled and responds to positive going signals from earth; the input resistance is 50kΩ. Counts may also be actuated by external contacts. The main batch relay operates at zero while the pre-batch relay operates at the predetermined number of counts before zero. Both relays have contacts rated at 5A 230V a.c. The counting may be single batch, or automatically repeating, and the total batch indicator is an electro-mechanical type re-settable to zero.

WW 314 for further details

Temperature Control

MOST industrial control systems using thyristors employ proportional control, where the phase angle at which thyristors are fired during each half cycle of the a.c. mains voltage is varied. In the solid state temperature control device by **Kent Precision Electronics Ltd.**, however, integrated half cycle proportional control is the principle of operation, where the thyristor output circuit is switched on for a half cycle and off for a half cycle, proportional control being obtained by variation of the ratio of the number of on and off cycles. It is stated that this overcomes disadvantages such as switch-on surges, interference, and thyristor deterioration. The instrument (available from **Kent Precision Electronics Ltd.**, Vale Road, Tonbridge, Kent) is housed in a 4in×5in long panel mounting case, this has a calibrated dial of 270° for setting of the required temperature. The circuitry incorporates



a Triac or two thyristors for control of output loads up to a maximum of 1kW at 240V a.c. using thyristor stacks mounted externally to the instruments. The instrument is compatible with many measuring elements including thermistors, resistance thermometers, potentiometric slide-wires, thermocouples, and radiation pyrometers.

WW 315 for further details

Digital Information Display

DIDS 400 is a series of Raytheon digital information display equipment which enables letters, figures, and characters to be displayed by a self-contained unit suitable for standing on an office desk. The information displayed (viewing surface on the standard model is 6½in×8½in) may be originated locally by means of an associated keyboard, or remotely by a readout from a computer digital store, or another DIDS display. The information can be amended by the keyboard, irrespective of whether it is of local or remote origin and can then be transmitted to a remote location. This basic range of equipment can display thirteen lines of forty characters. Each character is 0.17in high by 0.14in wide and a total of sixty two different characters can be provided. Any character can be made to appear at any one of 520 positions resulting from the above format. A marker is provided which can be made to occupy any position in the format while the information at the position indicated by the marker can be amended by use of the keyboard. By means of the DIDS series of displays, the editing and correcting of copy stored in digital form can be carried out at one location and the corrected information passed by telephone lines to the type setting equipment.

This display system provides a man-machine interface either by direct cable at the computer site or by communication transmission lines to a remote location. Each console can be used for

entering, updating, editing and retrieving data file information from a computer under programme control. The system is connected to the computer and editing is accomplished "off line" and is operator controlled.

Character codes available are BCD, ASC II and others. The keyboard (detachable) can be fully alphanumeric or numeric and special function keys are available in accordance with particular customer requirements. Display unit size is 14½in by 16½in and 20in deep, the keyboard adding 6½in to the depth. All models control up to 63 displays with as many as 1040 characters per display. **Data Systems Sales, Cossor Electronics Ltd.**, The Pinnacles, Elizabeth Way, Harlow, Essex.

WW 316 for further details

Polyester Capacitors

THE Wima range of small metallized polyester capacitors with axial leads has now been extended to include larger values—up to 22µF. These capacitors have a standard tolerance of ±20%, are marked MKG and are available in the following ranges at 100V d.c. 6.8, 10, 15, and 22µF; at 250V d.c. 3.3, 4.7, 6.8 and 10µF; at 400V d.c. 1.5, 2.2, 3.3 and 4.7µF. Dimensions are 16×34×56mm. **Waycom Ltd.**, Wokingham Road, Bracknell, Berks.

WW 317 for further details

TRANSDUCER AMPLIFIER

A TRANSDUCER amplifier by Fenlow Electronics offers full facilities for operation of resistance type strain gauges, pressure transducers and accelerometers in instrumentation and servomechanism applications. This ZA2 unit possesses: low drift ($<5\mu\text{V}/^\circ\text{C}$) d.c. differential amplifier; fixed amplifier gain steps 100, 200, 400 and 800 with multi-turn potentiometer interpolation between steps for fine gain control; stabilized mains operated power supply; variable bridge power supply; multi-turn bridge balance control; multi-turn bridge voltage control. There is a six-wire shunt calibration system, precision wire-wound bridge completion resistors, and provision for half-bridge or full bridge operation. The ZA2 has a linearity of 0.01%, an output impedance of $<1\Omega$ and an input impedance of $>2\text{M}\Omega$. The available output current of 36 mA into 330Ω is more than sufficient to drive loads such as servo valves and high-frequency ultra-violet galvanometers. The output voltage is 40 V peak to peak into $10\text{k}\Omega$ and 20 V peak to peak into 300Ω . Overload recovery takes $100\mu\text{s}$.

Power requirements are 200-240 V or 100 V at 40 to 60 c/s. Common mode rejection at $\pm 5\text{V}$ is 120 dB and at $\pm 10\text{V}$

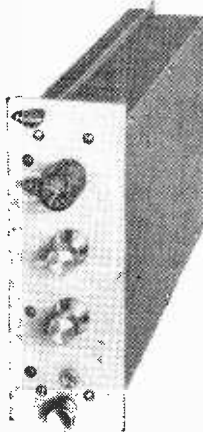

is 100 dB. More information is available from Fenlow Electronics Ltd., Springfield Lane, Weybridge, Surrey.

WW 318 for further details

Portable P.A. System

A COMPLETELY self-contained transistor p.a. system (the Verbaflex) is announced by Douglas A. Lyons & Associates Ltd. (32 Grenville Court, London, S.E.19). The system is a larger version

of the Bouyer 5 W model mentioned briefly in the A.P.A.E. exhibition report in the May issue, where we regret the company name was incorrectly given as Claude Lyons. The 5 ft column houses six loudspeakers, a 7-8 W transistor amplifier and two 6 V dry batteries. The dynamic microphone, offering a cardioid directional characteristic, has an on-off switch which switches the amplifier *via* a relay. A pre-set gain control is at the rear of the loudspeaker column. Sockets are provided for an additional loudspeaker and microphone. The tripod stand permits both column height and angle to be adjusted.

The system includes a folding microphone stand, 30 ft of cable, a carrying bag and weighs about 37 lb.

WW 319 for further details

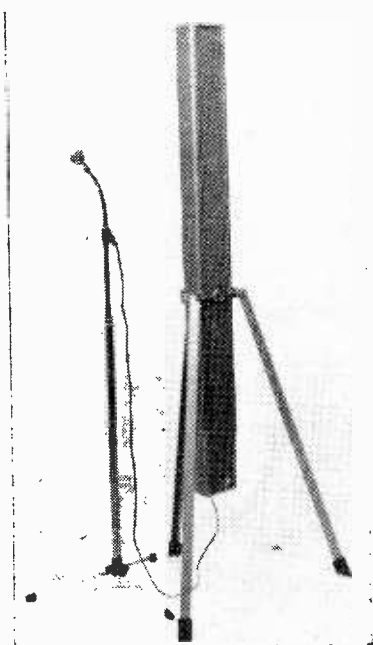

Changeover Relay

A CRYSTAL can relay type JH-6D offering two-pole changeover at 5 A, 29 V d.c. or 3 A at 115 V a.c. with a contact resistance of 0.05Ω and switching time of 5 ms is manufactured by Allied Control, U.S.A., and is available from Lectropon Ltd., Kinbex House, Wellington St., Slough, Bucks.

WW 320 for further details

OPTO-ELECTRONIC ISOLATOR

SOME of the difficulties encountered when using electromechanical switching devices in systems (e.g. telecommunications) can be eliminated, it is claimed, by using the solid-state opto-electronic device TIXL101 by Texas Instruments. In a cylindrical opaque epoxy package $0.22\text{in} \times 0.35\text{in}$, it permits high voltage electrical isolation up to 5,000 V. Although capable of handling high voltages, this device is sensitive to small signal changes, making it particularly suitable, it is stated, for high voltage, low current telecommunications relay lines. A typical reverse switching time is $1.5\mu\text{s}$, and a forward switching time is $15\mu\text{s}$. The input current rating is 50 mA and the output is $250\mu\text{A}$ minimum, a signal level capable of driving a simple amplifier circuit. Contact "chatter" or "bounce" simply doesn't exist. This device provides stable performance over a broad temperature range from -55° to $+125^\circ\text{C}$. Texas Instruments, Manton Lane, Bedford.

WW 321 for further details

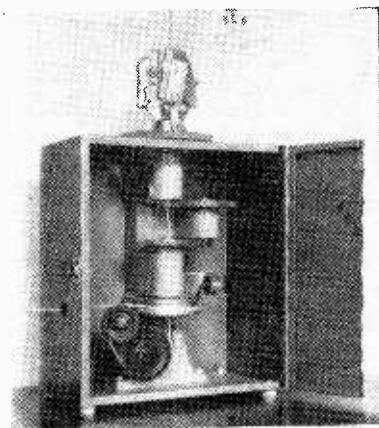

COLOUR CODING P.V.C. WIRE

USERS of p.v.c.-insulated wire now need only stock white covered wire and colour code it to their own requirements by means of a colour coding machine from Formulabs Industries Ltd., Elstree Road, Elstree, Herts. About the size of an office typewriter and weighing less than 40 lb, it can spiral code with one, two or three differently coloured stripes simultaneously at a rate of over 3,000 ft per hour. All wire sizes from $3/64\text{in}$ to $3/2\text{in}$ diameter are automatically accommodated. The colour penetrates the insulation surface, is resistant to solvents and abrasion, is instant drying and permanent.

WW 322 for further details

Battery Operated Motors

THE battery-operated motor LB 65 by Lenco of Switzerland is intended for applications such as record players and tape recorders. This motor has a dynamically balanced 3-pole rotor, and two centrifugal governors for maintaining constant speed under varying loads. The motor operates in either direction and possesses a voltage control range of 4-12 V. Current consumption is in the order of 20 mA under off-load conditions and 40 to 60 mA on-load. Stalling current is 200 mA. Brush life is quoted as approximately 2,000 hours. Distributed by Goldring Manufacturing Co (Gt. Britain) Ltd., 486-488 High Road, Leytonstone, E.11.

WW 323 for further details

LOW FREQUENCY DELAY UNIT

AN unusual delay unit that can be used with an ordinary l.f. input for delaying low-frequency signals in radiotelephony is made by M.E.L. Equipment Co. Ltd., Manor Royal, Crawley, Sussex. This unit was designed for compressor expanders where the amplitude and frequency information is separated during transmission requiring a difference of as much as 8 ms between the amplitude and frequency information signals. The M.E.L. unit YL2109 is employed to delay one of the two signals in order to restore them to their original time relationship. The YL2109 consists of a "modulator" magnetostrictive wire delay line and "demodulator." A voltage controlled multivibrator converts speech frequency information into a frequency modulated pulse train. This is delayed by the delay line (a standard YL2108 digital delay module) and then reconverted to the same form as the original speech. The dynamic range of the delay units is 55 dB, and frequency response over the telephone band (200 to 3,200 c/s) is flat within ± 1 dB. Overall distortion and linearity are better than 1%. The circuit is completely solid state and an 8 ms equipment consists of three units each measuring $9\frac{1}{2}$ in \times $6\frac{1}{2}$ in \times $1\frac{1}{2}$ in.

WW 324 for further details

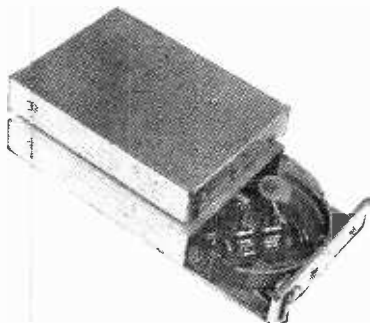

THE HOUSE OF BULGIN
AT YOUR SERVICE

THE NEW SECURITY ALARM

COMPLETE KIT OF PRECISION, ENGLISH MADE COMPONENTS

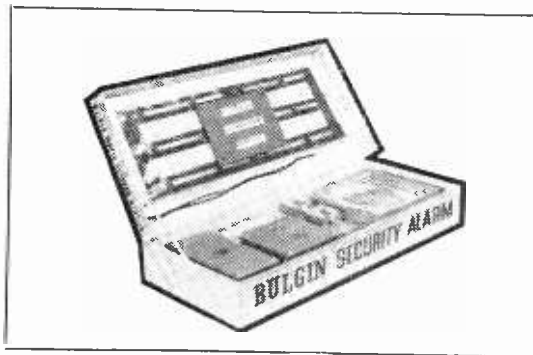

RIGID CARDBOARD DISPLAY AND TRANSIT BOX

MAXIMUM SECURITY FOR
MINIMUM COST
COMPLETE & READY FOR
INSTALLATION

In 1964, over 300,000 houses were broken into and to-day house breaking is on the increase. This Kit has been designed to afford the average householder maximum protection in his home for a minimum of outlay. The system can be easily installed by anyone who can wire a simple bell circuit.

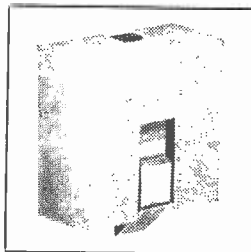

LATCHING SWITCH

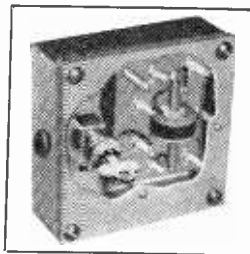

KEY SWITCH CONTROL

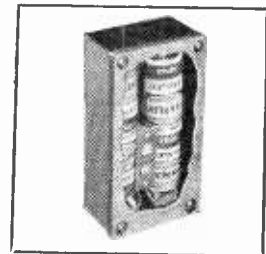

BATTERY MAGAZINE

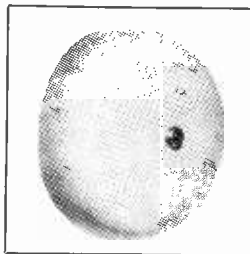

4in. UNDERDOME
BELL

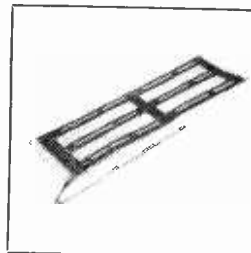

PRESSURE PAD
SWITCH



WIRE, SCREWS AND
TACKS

COMPLETE KIT. LIST No. KIT FIVE £12-17-6

FOR FURTHER DETAILS SEND TODAY FOR LEAFLET No. 1523/C

A. F. BULGIN & CO. LTD.,
Bye Pass Rd., Barking, Essex.
Tel: R1Ppleway 5588 (12 lines)

MANUFACTURERS AND SUPPLIERS OF RADIO
AND ELECTRONIC COMPONENTS TO

| | | |
|--------------|-------------------------|----------|
| ADMIRALTY | MINISTRY OF WORKS | B.C.C. |
| WAR OFFICE | MINISTRY OF AVIATION | G.P.O. |
| AIR MINISTRY | MINISTRY OF SUPPLY | I.T.A. |
| HOME OFFICE | RESEARCH ESTABLISHMENTS | N.P.L. |
| CROWN AGENTS | U.K.A.E.A. | D.S.I.E. |

WW 103 FOR FURTHER DETAILS.

NEWS FROM INDUSTRY

SOLAR-POWERED TELEPHONES

"SUNCALL" is a sun-powered telephone system which has been installed over 12 miles of a new motorway between Accra and Tema in Ghana, West Africa. Developed by A. T. & E. (Bridgnorth) Ltd., part of the Plessey Electronics Group, this system is based on a transistor 1W radio telephone which is hermetically sealed, and mounted on or close to an aerial pole adjacent to a standard motorway call-box. A motorist in trouble can get in touch with a toll booth or section control point from a call box. During his conversation any other station attempting to call is "busied out" until the original call is completed. The call boxes are distributed in pairs along the motorway at two-mile intervals. All roadside stations are powered by solar energy converters, the radio power output on this system being about 0.3 W.

ANGLO-AMERICAN SATELLITE AGREEMENT

THE Guided Weapons Division of the British Aircraft Corporation has signed a long-term license and technical assistance agreement with the Hughes Aircraft Company of the U.S.A. on space vehicle design, development and manufacture. This agreement will cover navigation, meteorological, experimental, and scientific satellites. Hughes have been responsible for the Syncom, Early Bird and Surveyor space programmes and they are also designing and building a series of applications technology satellites for the National Aeronautics and Space Administration. Some of B.A.C.'s work in space projects includes UK3, the first all-British scientific satellite (due to be launched in the spring of 1967); spacecraft instrument and control instrumentation in UK1 and UK2; the attitude sensors for the ESRO Heos satellite; and the Skylark upper-atmosphere sounding rockets supplied for the United Kingdom and ESRO research programmes.

This latest new agreement will be of great assistance to B.A.C. as prime contractor (in collaboration with leading European companies) in tendering for the Thor Delta series of scientific satellites for ESRO. The experiments in this series of satellites are primarily to study the relationship between the earth and

the sun during periods of maximum solar activity, and to study stellar astronomy and the measurement of cosmic rays.

£1.5M ORDER FOR CABLE SYSTEM

A 760-MILE submarine cables system linking the United States Air Force base at Cape Kennedy, with Grand Turk Island in the Bahamas is to be supplied by Standard Telephones and Cables Limited. They will supply cable, repeaters, equalizers and terminal equipment to the value of over £1.5M. The link will form part of the global network required for manned space exploration. Intermediate shore stations will be located at Grand Bahama Island and San Salvador. The cable system will be capable of carrying 270 simultaneous telephone conversations, or high-speed data equivalent, from Cape Kennedy to Grand Bahama Island, and 60 channels from Grand Bahama to San Salvador and Grand Turk. Multiplexed signals travelling along the coaxial cable are amplified by repeaters at intervals of 30 nautical miles between Cape Kennedy and Grand Bahama Island to provide the 270 channel system, and at 9.7 nautical mile intervals between Grand Bahama Island, San Salvador and Grand Turk to give the 60-channel system.

A contract to construct the £100M Nato Air Defence Ground Environment (NADGE) project has been given to HUCO. This is an international consortium led by Hughes Aircraft Co. of the U.S.A. consisting also of the Compagnie Francaise Thomson-Houston of France, The Marconi Co. Ltd. of England, Celenia S.P.A., Italy, Signaal Apparaten, Netherlands, and Telefunken AG., Germany. The NADGE programme will be the biggest European electronics air defence project to date.

More than 1,000 Decca Navigator airborne installations, with spares, have been ordered by the United States Army. This order, worth \$10m, has been placed with the Laboratory for Electronics Inc. (L.F.E.) of America (a licensee of the Decca Navigator Co. Ltd.). The installations will be used by Army helicopters to assist in orienting themselves when supporting ground forces.

Dawley New Town Development Corporation has awarded a £750,000 contract to Rentaset Wired Services Division. This is for a relay system that will provide four television and four v.h.f. radio services now, and will have a capacity of up to nine 625-line standard television services including colour. Cables will be put down with public services and concealed, as the town's construction progresses.

Designed and manufactured by Le Matériel Téléphonique (S.T.C.'s French associate) the Concorde simulator will be used in the study and analysis of the Concorde's behaviour, and crew work loads in flight based on the many design and manufacturing parameters. The simulation methods employed will reduce the number of hours of engineering and flight trial analysis and also minimize the risk involved. The research simulator will also be used in the design of training flight simulators that will be required by airlines who will use the Concorde.

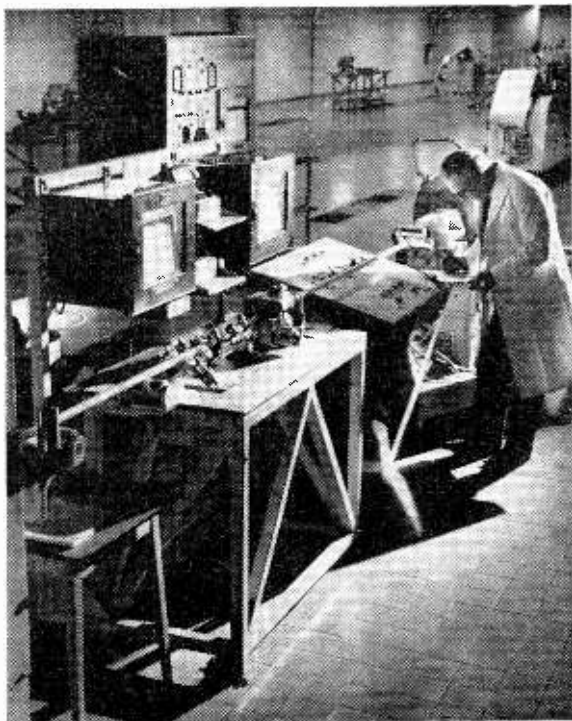

A three-bladed rotary cutter is shaving the polyethylene dielectric of the S.T.C. submarine cable to a diameter of lin. ± 0.001 in. In the foreground the dielectric diameter is being continuously monitored before the copper tape outer conductor is applied in the next process.

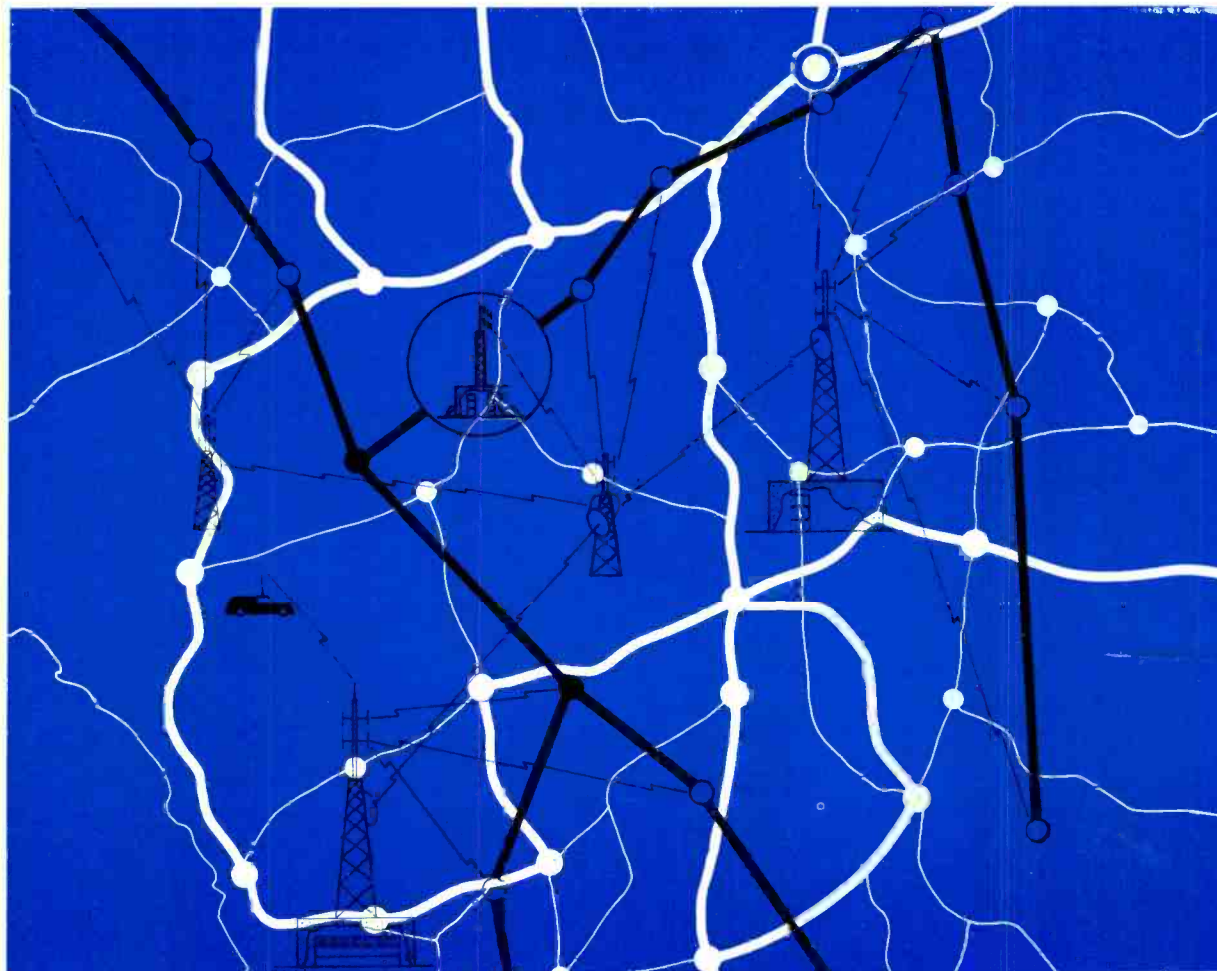

Integrated communication systems for public utility services

The extensive experience of STC in all aspects of telecommunications enables the Company to offer a complete service to all public utility authorities requiring integrated communication systems.

For such projects as the distribution of gas, oil, water or electricity, STC can provide

equipment and detailed systems planning embracing the following facilities:

- Telemetry systems
- Radio systems HF, VHF, UHF, SHF
- Troposcatter
- Microwave
- Mobile communications
- Telephone systems
- Teleprinters
- Cables.

STC advanced design employing

solid state techniques introduces a degree of reliability previously unattainable thereby facilitating centralized control and unattended operation.

For further information write to: Standard Telephones and Cables Limited, Radio Division, Oakleigh Road, New Southgate, London, N.11.

STC

world-wide telecommunications and electronics

WW 002 FOR FURTHER DETAILS.



The world's finest cored solder



FOR THE FACTORY

STANDARD GAUGES IN WHICH MOST ALLOYS ARE MADE AND LENGTHS PER LB. IN FEET.

| S.W.G. | INS. | M.M. | FT. PER LB. | |
|--------|------|-------|-------------|--------|
| | | | 60/40 | SAVBIT |
| 10 | .128 | 3.251 | 25.6 | 24 |
| 12 | .104 | 2.642 | 38.8 | 36 |
| 14 | .080 | 2.032 | 65.7 | 60.8 |
| 16 | .064 | 1.626 | 102 | 96.2 |
| 18 | .048 | 1.219 | 182 | 170 |
| 19 | .040 | 1.016 | 262 | 244 |
| 20 | .036 | .914 | 324 | 307 |
| 22 | .028 | .711 | 536 | 508 |
| 24 | .022 | .558 | 865 | 856 |
| 26 | .018 | .46 | 1292 | 1279 |
| 28 | .014 | .375 | 1911 | 1892 |
| 30 | .012 | .314 | 2730 | 2695 |
| 32 | .010 | .274 | 3585 | 3552 |
| 34 | .009 | .233 | 4950 | 4895 |

STANDARD ALLOYS INCLUDE LIQUIDUS

| TIN/LEAD | B.S. GRADE | MELTING TEMP | |
|-------------|------------|--------------|-----|
| | | C. | °F. |
| 60/40 | K | 188 | 370 |
| Savbit No 1 | — | 215 | 419 |
| 50/50 | F | 212 | 414 |
| 45/55 | R | 215 | 419 |
| 40/60 | G | 234 | 453 |
| 30/70 | J | 255 | 491 |
| 20/80 | V | 275 | 527 |

HIGH AND LOW MELTING POINT ALLOYS

| ALLOY | DESCRIPTION | MELTING TEMP. | |
|--------|---|---------------|---------|
| | | °C. | °F. |
| T.L.C. | Tin/Lead/Cadmium with very low melting point | 145 | 293 |
| L.M.P. | Contains 2% Silver for soldering silver coated surfaces | 179 | 354 |
| P.T. | Made from Pure Tin for use when a lead free solder is essential | 232 | 450 |
| H.M.P. | High melting point solder to B.S. Grade 5S | 296-301 | 565-574 |

- Contains 5 cores of non-corrosive high speed Ersin flux. Removes surface oxides and prevents their formation during soldering. Complies with B.S. 219, 441, DTD 599A, B.S.3252, U.S. Spec. QQ-S-571d.
- Savbit alloy contains a small percentage of copper and thus prolongs the life of copper soldering iron bits 10 times. Liquidus melting temperature is 215°C—419°F. Ministry approved under ref. DTD/900/4535
- Solder Tape, Rings, Preforms and Washers, Cored or Solid, are available in a wide range of specifications.
- Liquid fluxes and printed circuit soldering materials comply with Government specifications. Ask for special details.

FOR THE MAINTENANCE ENGINEER AND ELECTRONICS ENTHUSIAST

SAVBIT ALLOY REDUCES WEAR OF SOLDERING IRON BITS.



Size 12 reel 15/- (subject)
Contains 102 ft. approx. 18 s.w.g. on a plastic reel.

Size 1 carton 5/- (subject)
C1SAV14 11ft. of 14 s.w.g.
C1SAV16 16 ft. of 16 s.w.g.
C1SAV18 30 ft. of 18 s.w.g.



Size 5 dispenser 2/6 (subject)
Contains 12 ft. of 18 s.w.g. in a handy dispenser.



60/40 HIGH TIN CONTENT



Size 1 carton 5/- (subject)
C16014 9 ft. approx. 14 s.w.g.
C16018 29 ft. approx. 18 s.w.g.



Size 4A Dispenser 2/6 (subject)
Contains 9 ft. of 18 s.w.g. 60/40 alloy in a handy dispenser.

PRINTED CIRCUIT AND TRANSISTOR SOLDER. FOR SOLDERING TEMPERATURE SENSITIVE COMPONENTS



Size 10 15/- (subject)
Contains 212 ft. of 22 s.w.g. 60/40 alloy on a plastic reel.



New! Size 15 Dispenser 3/- (subject)
21 ft. coil of 60/40 alloy, 22 s.w.g. Solder used direct from dispenser, cannot tangle or fall back inside.

BIB INSTRUMENT CLEANER



Anti-static cleaner for tape heads, dials, plastic, glass and chrome. **4/6** (subject)



MODEL 3 BIB WIRE STRIPPER AND CUTTER
Strips insulation, cuts wires and splits plastic twin flex. **4/-** (subject)

Write for full details to: **MULTICORE SOLDERS LTD., MAYLANDS AVENUE, HEMEL HEMPSTEAD, HERTS. (HEMEL HEMPSTEAD 3636)**

WW 003 FOR FURTHER DETAILS