

BUILDING THE TAPE RECORDER

Wireless World

ELECTRONICS • TELEVISION • RADIO • AUDIO

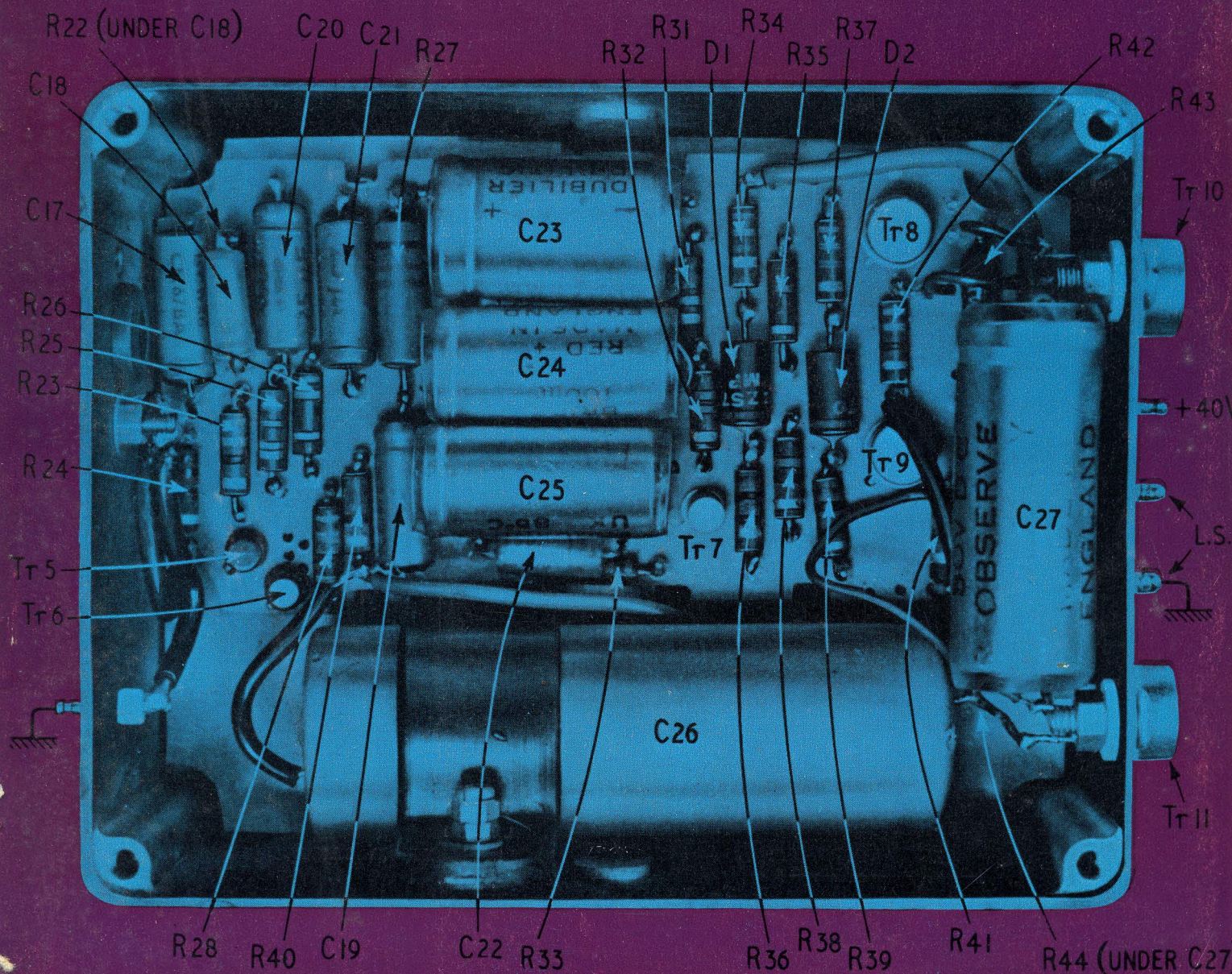
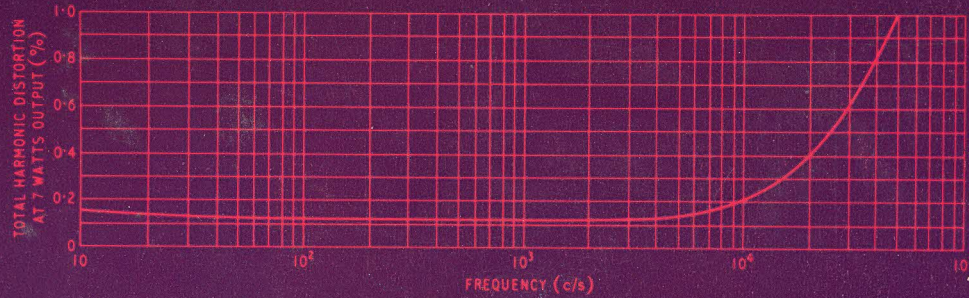

"Wireless World"
Iiffe Electrical Publications Ltd.,
Dorset House, Stamford Street,
London, S.E.1

Managing Director:
W. E. MILLER, M.A., M.I.E.R.E.

Editor-in-Chief:
W. T. COCKING, M.I.E.E.

Editor:
H. W. BARNARD

Technical Editor:
T. E. IVALL

Editorial:
D. C. ROLFE
G. B. SHORTER, B.Sc.

Drawing Office:
H. J. COOKE

Production:
D. R. BRAY

Advertisements:
G. BENTON ROWELL
(Manager)
J. R. EYTON-JONES

© Iiffe Electrical Publications Ltd., 1965. Permission in writing from the Editor must first be obtained before letterpress or illustrations are reproduced from this journal. Brief extracts or comments are allowed provided acknowledgement to the journal is given.

VOLUME 71 No. 8
PRICE: 3s. 0d

FIFTY-FIFTH YEAR
OF PUBLICATION

Wireless World

ELECTRONICS, TELEVISION, RADIO, AUDIO

AUGUST 1965

- 371 Editorial Comment
- 372 Optimum Experiment Kits *by S. L. Hurst*
- 376 Silicon Transistor Tape Recorder—2 *by D. L. Grundy and J. Collins*
- 381 Miniature D.C. Converters *by D. Bollen*
- 384 Random Signal Testing
- 385 World of Wireless
- 387 Personalities
- 389 Double line Sync *by H. M. Workman*
- 391 H.F. Predictions—August
- 392 Local Broadcasting
- 394 Books Received
- 396 Experimental Thyristor Control Circuits—1 *by N. M. Morris*
- 400 Commercial Literature
- 401 Letters to the Editor
- 405 New Products
- 411 Electronic Laboratory Instrument Practice—8 *by T. D. Towers*
- 416 The Gunn Effect
- 418 News from Industry
-

PUBLISHED MONTHLY (4th Monday of preceding month). Telephone: Waterloo 3333 (70 lines). Telegrams/Telex: Wiworld Iiffepres 25137 London. Cables: "Ethaworld, London, S.E.1." Annual Subscriptions: Home £2 6s 0d. Overseas: £2 15s 0d. Canada and U.S.A. \$8.00. Second-class mail privileges authorised at New York N.Y. BRANCH OFFICES: BIRMINGHAM: King Edward House, New Street, 2. Telephone: Midland 7191. BRISTOL: 11, Marsh Street, 1. Telephone: Bristol 21491/2. COVENTRY: 8-10, Corporation Street. Telephone: Coventry 25210. GLASGOW: 123, Hope Street, C.2. Telephone: Central 1265-6. MANCHESTER: 620, Deansgate, 3. Telephone: Blackfriars 4412. NEW YORK OFFICE U.S.A.: 111 Broadway, 6. Telephone: Digby 9-1197.

PANORAMA....
 PANORAMA....
 PANORAMA....
 PANORAMA....
 PANORAMA..

PANORAMA..

NOORA



FF

**the
 picture
 with life in it**

New PANORAMA tubes bring a fresh exciting sparkle to television. For the first time ever you're in touch with direct vision. There are no protective screens, no multiple reflections, no dust—nothing to spoil the clearest, truest-to-life reproduction ever seen.

And PANORAMA has long-life too. All the proven features of world-famous Mullard "Radiant Screen" tubes have been built into PANORAMA to make doubly certain that PANORAMA is the picture with life in it.

Mullard

8WW-098 FOR FURTHER DETAILS.

Wireless World

ELECTRONICS, TELEVISION RADIO, AUDIO

Satellites and TV Standards

A VISIT from Arthur C. Clarke, who propounded the theory for synchronous satellites in his article "Extra-terrestrial Relays" in *Wireless World* twenty years ago, and the recent successful transatlantic transmissions of colour television via Early Bird, the first commercial synchronous satellite, prompt us to re-open the discussion on television standards. There is a growing feeling on both sides of the Atlantic that in order to gain the maximum cultural, and we hope peace engendering, benefits which television offers, every effort should be made to establish a global, or near-global, standard.

The suggestion of a truly international standard is not made purely to facilitate the exchange of programmes; this can be done with films, as we suggested in a previous leader. It is because the successful launching of Early Bird has brought within sight the purpose for which Clarke put forward his scheme for synchronous satellites, namely, that they could be used to broadcast television programmes direct to millions of viewers throughout whole continents.

The problems of line standard and field frequency have been ventilated in *W.W.* on many occasions. With the ending of the French and Belgian 819-line transmissions the remaining two standards, 625 and 525 lines, are used almost entirely in the eastern and western hemispheres respectively. The only countries in the western hemisphere employing 625 lines are Argentina, Barbados and Jamaica, and the only countries east of the Greenwich meridian which have adopted 525 lines, we believe, are Cambodia, Iran, Japan, Korea, Kuwait and the Philippines. The situation however, is now further complicated by the introduction of colour and it would seem to be short-sighted and parochially minded for us in the U.K. to talk of "going it alone" if agreement is not reached internationally soon. With two line standard blocks, American and European, it would indeed be a tragedy for the future development of colour television if with each of these a colour standard was not established. As we see it, therefore, although a world-wide colour system would be ideal, if this is unobtainable, then, as engineers, we must ensure that our voice is heard in the political arena in which the subject has been dragged so that engineering considerations are fully appreciated before an irrevocably false step has been taken.

Local Broadcasting

ELSEWHERE in this issue local broadcasting is discussed and a scheme put forward for the introduction of such a service. The scheme, which provides for the financing of the stations from advertising revenue, has the advantage that the licensing of these stations would not provide the operators with a "licence to print money" as has been said of the television programme contractors. The income after certain deductions would be used to finance local projects and ease the rates burden. The article also proposes the introduction of the service in Band II. We in this country certainly do not seem to be making the best use of this band. In response to a recent enquiry for a British made car radio set covering the v.h.f. band we were told there is not one; apparently there is no demand for one. The situation is very different on the Continent, especially in Germany where most car radio sets cover the v.h.f. band.

It could well be that the introduction of local broadcasting in the v.h.f. band would revive interest in this section of the spectrum and incidentally revive the flagging spirit of the domestic radio industry.

VOL 71 NO 8
AUGUST 1965

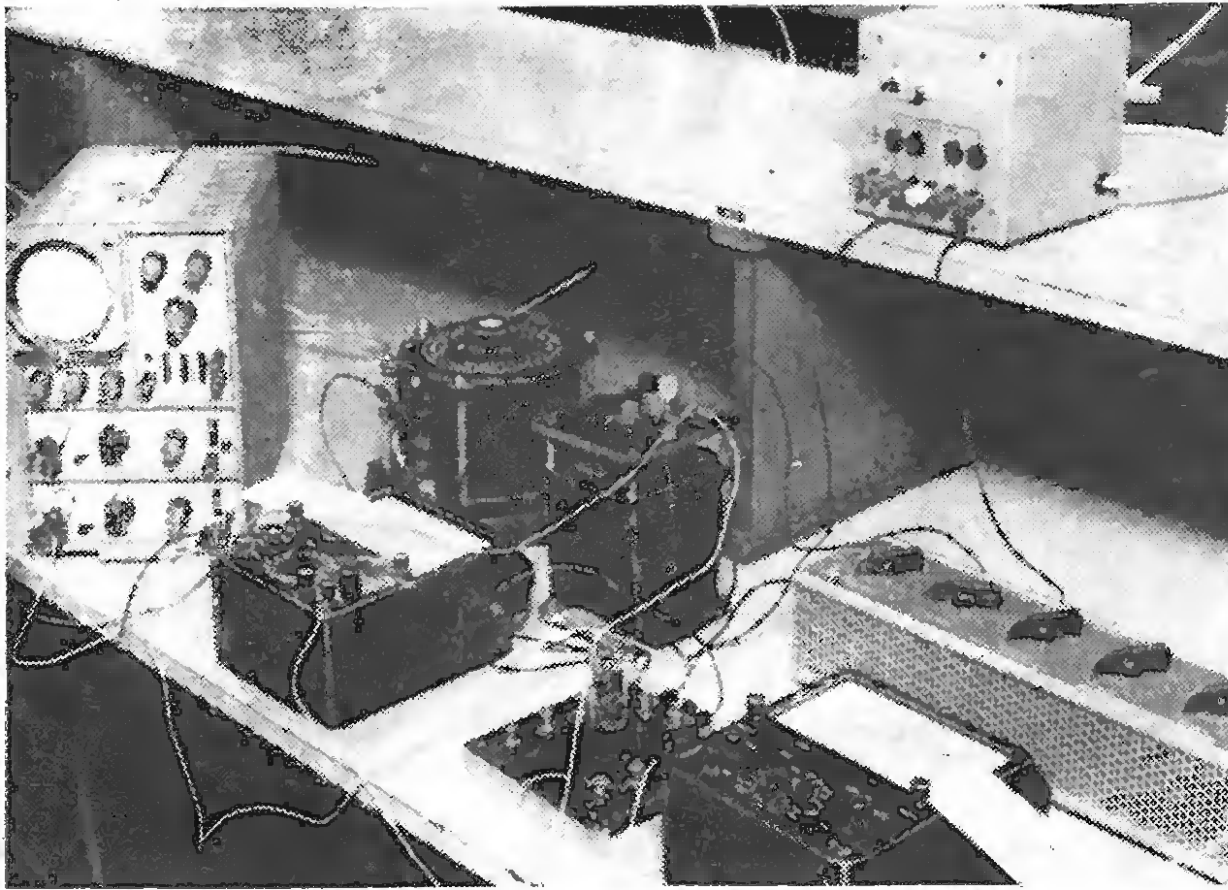

BEFORE.—Vacuum diode half-wave rectification experiment, using separate components.

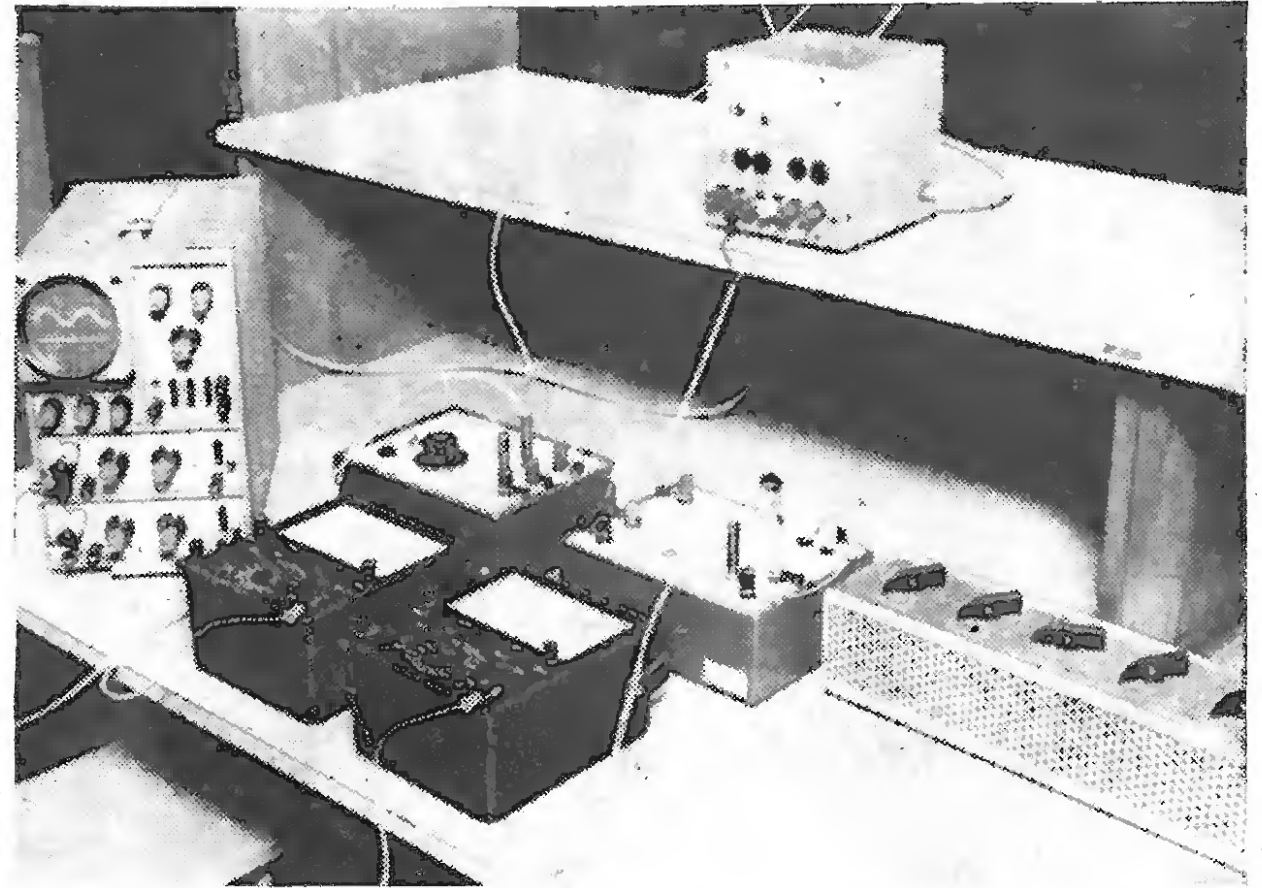

AFTER.—Identical vacuum diode experiment but using an optimum experiment kit. Note the simpler and more compact layout.

OPTIMUM EXPERIMENT KITS

For teaching basic electronics

By **S. L. HURST**,* B.Sc.(Eng.), A.M.I.E.E., A.M.I.E.R.E.

THE object of electronic engineering experiments is not, or should not be, to give the student practice in wiring up separate components with odd lengths of wire—though to go to the opposite extreme of giving him a completely connected test circuit with the power supplies, meters and other necessary equipment all wired in is obviously equally undesirable. Thus an optimum between these two extremes should be sought, such that the student will not have to spend an inordinate amount of time in making initial connections, but not “pre-packaged” to such an extent that polarities of supplies or instruments or earth connections, etc. may not be appreciated.

Some kind of test circuit “box” or panel is inherent in the above requirements, and here the following points of principle are important:—

- (a) Never more than one connection per terminal should have to be made by the student.
- (b) All d.c. or a.c. supplies should be connected directly to the test circuit. Any supply voltmeter and ammeter connections should be made within the test circuit, using appropriate sockets.
- (c) All external decade resistor or capacitor boxes should each have their individual pair of terminals on the test circuit.
- (d) Fixed value resistors and capacitors should be permanently mounted within the test circuit to avoid possible loss of such small components.

The first of the above rules avoids the practical disadvantage of several external connections per terminal

in the working circuit. Also, with rules (b) and (c), no interconnections between meters, resistor boxes etc. have to be made at the terminals of these items, remote from the test circuit layout. This eliminates a very common source of incorrect, omitted, or even duplicated connections in experimental work.

Circuit layout and mechanical design

To incorporate the above features in the circuit layout of an experiment necessitates the use of appreciably more terminals and sockets than the minimum theoretically necessary—these additional items being the price paid for the increased clearness and “traceability” of the wired up circuit.

Consider, for example, a test circuit for determining the static characteristics of a triode valve plus load line. First, variable anode and grid voltage supplies are required. Next provision for measuring these voltages must be made. Provision for a variable anode load resistor R_A may be considered desirable also, and finally means for measuring the anode current I_A and anode-to-cathode voltage V_A are necessary.

A test circuit layout incorporating these facilities is shown in Fig. 1. Hence six supply terminals, two decade resistor box terminals, one two-pin ammeter socket and two two-pole voltmeter sockets are used in this layout, compared with the absolute minimum of five terminals (two heaters, anode, cathode and grid) if interconnections between items external to the test circuit layout had been permitted. However, peripheral items, all of which are two-terminal devices, each have their individual connect-

*Bristol College of Science & Technology.

ing leads brought to the test circuit. This lends itself to the exclusive use of 2-core connecting leads for all such peripheral items.

To summarize, it will be found that in any experiment circuit, simple or complex, about twice as many connecting points are required on the test circuit to comply with the above stated principles, compared with the same test circuit not employing these principles. The resultant use of 2-core connecting leads, however, means that only about half the number of separate leads are required in wiring up the circuit compared with the single-core item-to-item connected test circuit.

There are currently available on the market a number of different makes of electronic experiment "boxes" designed for students' use. The majority appear to have little to recommend them from the student's point of view, when rapid appraisal of the test circuit and speed of interconnection are desirable. The most common faults to be found are:—

- (1) Multiple connections necessary at the terminals.
- (2) No provision for easy connection and reconnection of ammeter and voltmeter leads.
- (3) Use of terminals with non-captive heads, often un-insulated terminals as small as 6 B.A.
- (4) Non-compliance with B.S. 530 graphical symbols.
- (5) Incorrect voltage and current quantity and subscript symbols on the panel circuit diagrams.
- (6) In an attempt to make the circuit "boxes" more versatile, extra variable connecting strips and other complications and ambiguities are often introduced.

The question of versatility of circuit layout involves economics versus simplicity and correctness of use. For example, consider a simple test circuit for determining the static characteristics of a junction transistor in (a)

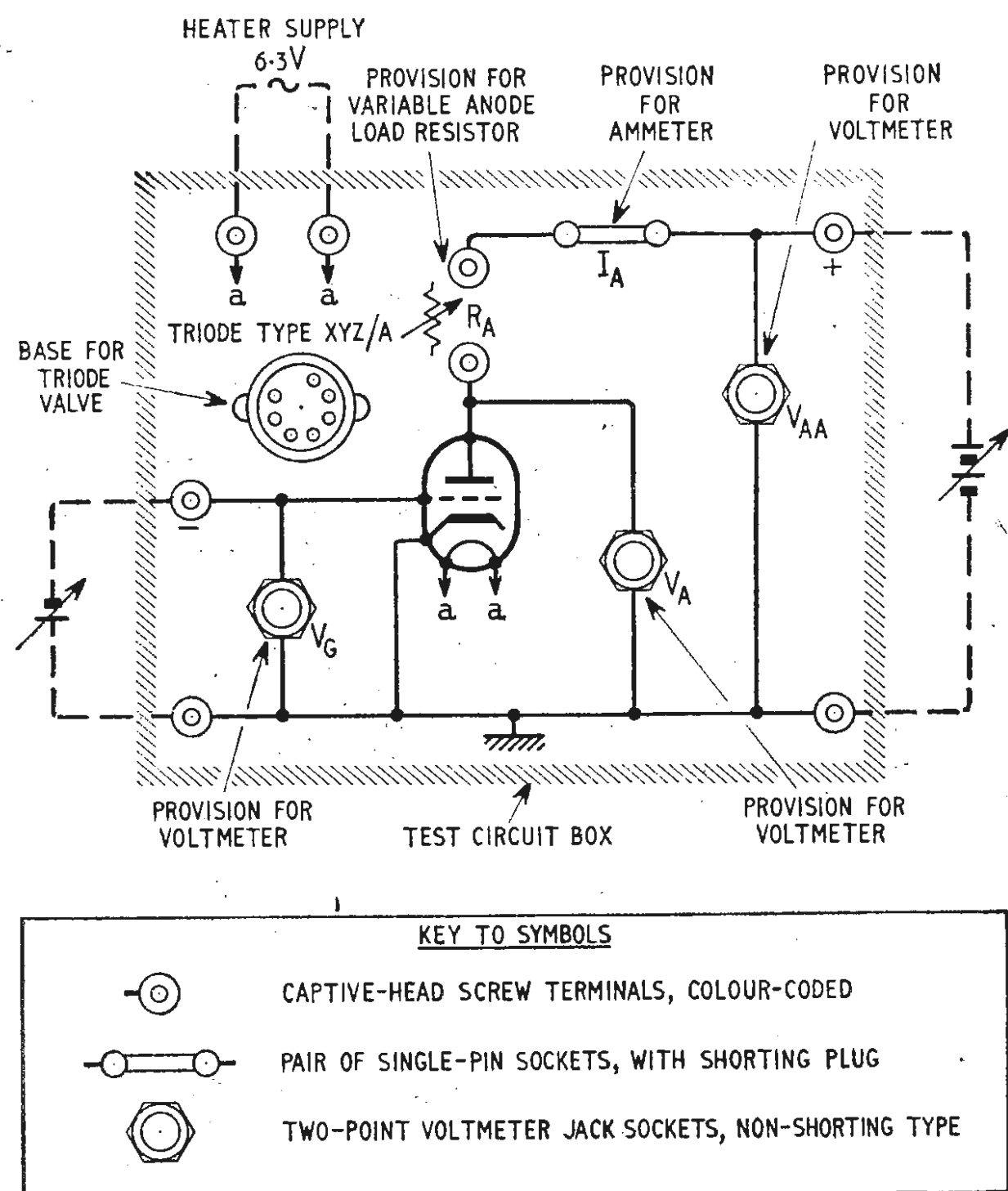

Fig. 1. Possible layout of test circuit for determining triode valve characteristics.

common base configuration, (b) common emitter configuration; and (c) common collector or emitter follower configuration. Obviously one single transistor in a box would suffice for all these tests, with provision for inserting appropriate resistances in collector, base, and emitter circuits. To draw out and label the test circuit suitable for all these three conditions, however, immediately involves conflicts that cannot be neatly resolved. The "input" to the transistor does not always appear on the left-hand side of the panel, as it preferably should; input voltage V_{EB} in the common base configuration should be re-labelled V_{BE} in the common emitter case, and so on. Hence it always appears preferable to have a separate circuit layout for each type of experiment.

The first decision to be made is the form of construction, the choice being basically between a "box", with fixed components mounted internally, and an open "panel." Both require some form of circuit diagram on the facing surface. Experience indicates that the "box" type construction is a far more robust and practical proposition for day-to-day student use.

With the "box" construction, there may well be some points in a more complex test circuit that are not brought out to the top plate, and so are not available to the student. This is one of the drawbacks of the box type of construction. Against this adverse feature, however, are advantages, particularly useful in transistor experiments. First, "critical" points, such as directly on to the base of a transistor, can be deliberately made non-available. Secondly, hidden small series limiting resistors can be connected in certain circuits, their values being swamped by the normal external series resistance but sufficient to protect the circuit in the event of a mal-adjustment. An internal series 100-ohm resistor in transistor base circuits is usually undetectable by the normal external measurements.

Components used should be of the highest quality, both technically and aesthetically. This applies particularly to terminals, and captive-head insulated types are essential if the experiment kit is to be used continuously and to best advantage. Voltmeter and oscilloscope connections to the circuit are preferably made by means of telephone-type jacks sockets, which enable immediate voltage connections to be made, with no danger of supply-to-earth short circuits when earthed a.c. instruments are used.

Ammeter connections into the circuit may also be made by using shorting jack sockets, but in order to avoid any ambiguity between voltmeter sockets and ammeter sockets, separate 2-pin sockets with a shorting plug should preferably be used for current purposes. With low-voltage low-current transistor circuits it may be preferable to have gold plated ammeter sockets; in no case is a split radio-type "banana" plug a satisfactory article for continuous use.

The question of whether thermionic valves should be mounted inside the box or plugged in on the working face of the experiment remains to be settled. In semiconductor experiments there is no point in being able to view the semiconductor device, and internal mounting of these long-life components helps to protect them. Thermionic valves, with their limited life, however, are preferably mounted outside the box, and visual inspection of the heater when in use is then possible.

Fig. 2 shows two electronic experiments incorporating the above features—one a valve experiment with the valve externally mounted and the other a semiconductor experiment with the semiconductor device mounted internally. The remaining general arrangement of termi-

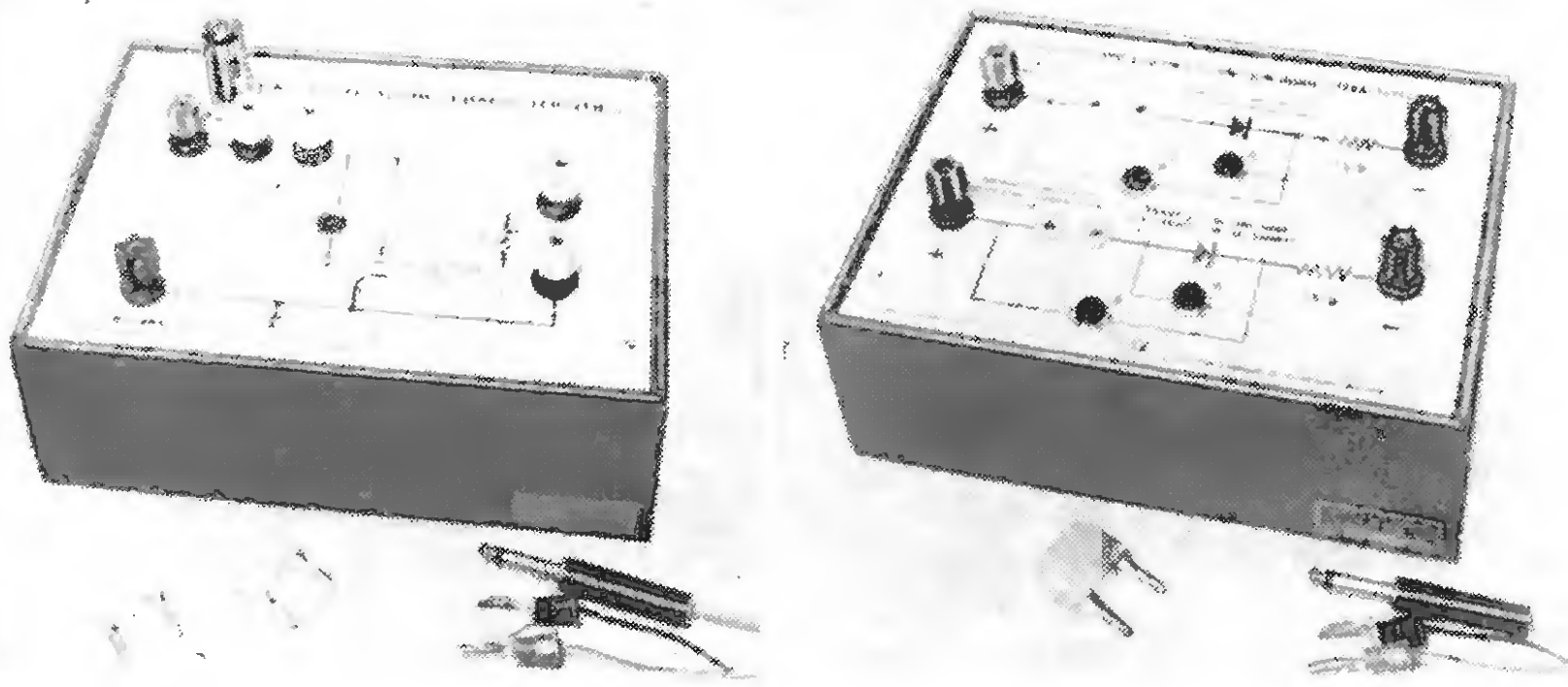

Fig. 2. Typical thermionic valve and semiconductor experiment layout.

nals, jack sockets, etc. for the two experiments is basically the same.

Interconnecting leads

Equally important to the student as clear layout and good construction is the provision of a set of interconnecting leads that are as clear in use as possible. The exclusive use of two-core interconnecting leads, referred to above, lends itself to this end.

Several versions of these leads differing in termination may be necessary to suit the peripheral equipment in use, and the table indicates possible requirements.

Terminations	Peripheral Equipment
Spades/spades	Decade boxes, d.c. supplies, etc.
Jack plug/spades	Voltmeters
2-pin plug/spades	Ammeters
Jack plug/coax. connector	Oscilloscopes

Assuming that the frequency of operation does not demand the use of coaxial cable, a most suitable size of two-core lead for all these duties is a readily available oval twin 14/0.0076in p.v.c. insulated p.v.c. sheathed flexible cable. The two cores of all such standard cables are colour-coded red and black respectively, with the outer p.v.c. sheath available in a range of colours.

The red and black colour-coding on spade-terminated leads ensures correct polarity of interconnections. The colour-coding of the outer sheath can also be utilized, for example, red outer for supply leads, white for ammeter leads, and black for voltmeter leads. Should there be a need for three rather than two interconnections per item, for example with an external potentiometer, then the use of a three-core flexible cable is an obvious advantage in these cases.

Two-core flexible lead is not satisfactory for a.c. interconnections if frequencies in the megacycle region are being used. The capacitance of normal 250V p.v.c. insulated 2-core cable is approximately $80\mu\text{F}/\text{metre}$, and hence at 1 Mc/s such a lead one metre long would present a capacitive load of 2000 ohms to the experiment. Obviously, an appropriate coaxial cable with properly matched coaxial connectors would be necessary.

More complex experiments

The use of the "box" type of construction rather than the open "panel" has yet a further advantage. This

advantage may be exploited principally in semiconductor experiments, where, because of the small physical size of components, it becomes possible to build within the "box" suitable pulse or other circuits to provide the required driving signals.

The exact nature of these internal driving circuits is not significant to the experiment itself, and being hidden from sight, they can be represented schematically on the experiment face, without causing distraction to the student. A jack-socket to enable the student to monitor the voltage or waveform of the driving signal must, however, be provided. Should any student wish to investigate the driving circuit, then a copy of the complete circuit

diagram of the "box" should be made available to him. The inclusion of small mains transformers within the assembly to provide any required 50 c/s alternating voltage is of course equally feasible, and has the advantage that live 240V connections can be made inaccessible to the student.

Several basic electronic experiments lend themselves to the incorporation of these additional drive facilities. One example is a simple experiment on the characteristics and application of a p-n-p-n thyristor. Using a low power type of thyristor, typical d.c. (static) characteristics can be evaluated in a straightforward manner by applying and measuring suitable direct voltages and currents. The a.c. application of the device also can be investigated by changing to an a.c. anode supply and feeding the gate with variable timing input pulses. Fig. 3 shows an experiment circuit for this purpose, the student not being specifically concerned with the mode of action of the pulse driving circuit.

Further examples are circuit investigations requiring repetitive driving signals to enable steady output oscilloscope waveforms to be displayed and measured, such as monostable multivibrators and triggered linear time bases. In all these types of experiment, a simple internal driving circuit can be utilized, often taking the place of a far more complex and expensive external pulse generator or oscillator.

There may be in some circumstances practical advantages in splitting an experiment into two or more "boxes". For example, in a binary counter experiment, separate, obviously identical boxes would bring out immediately the "sameness" of the stages that coupled together form the complete counter. Another example is basic oscillator experiments where the positive feedback network is separate from the amplifier circuit. These two halves can first be investigated separately by the student, then coupled together to give results that should be predictable from the separate earlier measurements.

Experiment kits in use

The main object of the arrangements discussed above is to reduce to a minimum the time spent in initial wiring up and checking of circuits. This object is successfully achieved, typical times for initial assembly being about five or ten minutes, with a further one or two minutes at most for checking by the lecturer if required. These figures compare with possibly three or more times as long if single-core interconnections, with no colour coding and random wiring patterns with multiple connections per terminal, are used. Students are thus

normally taking initial readings within a quarter of an hour of receiving an experiment.

The time saving is further improved during the course of the experiment, as voltmeters and ammeters can be individually and immediately removed and replaced in the test circuit without having to undo terminals, or disconnect supply leads, decade box leads, or any other leads. The overall saving is such that an experiment that might normally require three hours using "bird's-nest" wiring techniques can be successfully accomplished in two hours.

The ease of removal of voltmeters in particular means that it is often possible to utilize only one voltmeter in an experiment, instead of two or three or more. Care must be taken in high impedance circuits, however, to ensure that removing a voltmeter from one position and inserting it in another position does not introduce any appreciable effect on the circuit under test, and more than one meter may sometimes be preferable. This effect of meter impedance on circuit performance is often forgotten by students, and it may be argued that easy removal of meters from test circuits is one way of reminding them of this danger.

The use of only one a.c. or d.c. voltmeter is obviously an economic advantage, and it also avoids the need to calibrate one meter against another in order to avoid errors between meters. Also eliminated is the need to label with small pieces of paper or chalk marks the circuit parameters which individual meters are recording.

The use of two-core leads tailor-made to suit each experiment drastically reduces the lead maintenance and replacement rate. Experience over two years with several hundred two-core leads, during which they were used about 15,000 times per annum, resulted in no losses or mutilations in one year, and in only one loss in the second year. This compares with a loss or mutilation rate of about 10% per annum with single-core leads—due partly to lack of respect for odd lengths of single-core wire and also possibly to the greater usefulness of single-core wire for private purposes!

In all, student respect appears to be generated by a well engineered experiment kit which employs good quality terminals and other components. As a result little abuse or maltreatment is encountered and, as a bonus, some small education of the electrical engineering student in good mechanical design of electrical and electronic equipment may be incidentally achieved.

The two photographs at the beginning of the article show extremes that a student may face when performing the relatively simple experiment of investigating the characteristics of a vacuum diode and its use as a half-wave and full-wave rectifier. The left-hand picture shows the test circuit interconnected for half-wave rectification using random wiring with a kit of separate components, whilst the right-hand picture shows the same test circuit but

using an experiment kit designed on the principles described. The greater clarity and compactness of the latter arrangement is immediately apparent, and there is greater ease of conversion from half-wave to full-wave working.

All other experiments show a similar advantage for the properly designed kit. The more complex the experiment, or the measurements necessary during the experiment, then the more clear does this advantage become.

Questions of cost

Undoubtedly this type of experiment kit with its extra terminals, provision of jack sockets, special leads etc. is noticeably more expensive than a simple collection of components plus lengths of single-core wire. Against this extra initial expense must be weighed the following powerful factors:—

- (i) fewer meters need be provided—possibly only one voltmeter per experiment instead of two or more;
- (ii) external equipment such as signal or pulse generators may often be dispensed with, owing to the provision of simple internal drive circuits;
- (iii) maintenance costs are reduced because of the smaller number of separate components involved, and because of greater student respect for a well designed assembly.

The financial saving of just one multi-range a.c./d.c. meter is probably more than the difference in cost between a collection of components and a comprehensive experiment kit, and thus the economics of the overall picture should always be borne in mind.

Acknowledgements.—The author would like to thank A. J. Eales, Head of the Department of Electrical Engineering of the Bristol College of Science and Technology, for permission to publish this paper, and for all facilities made available in the course of its preparation.

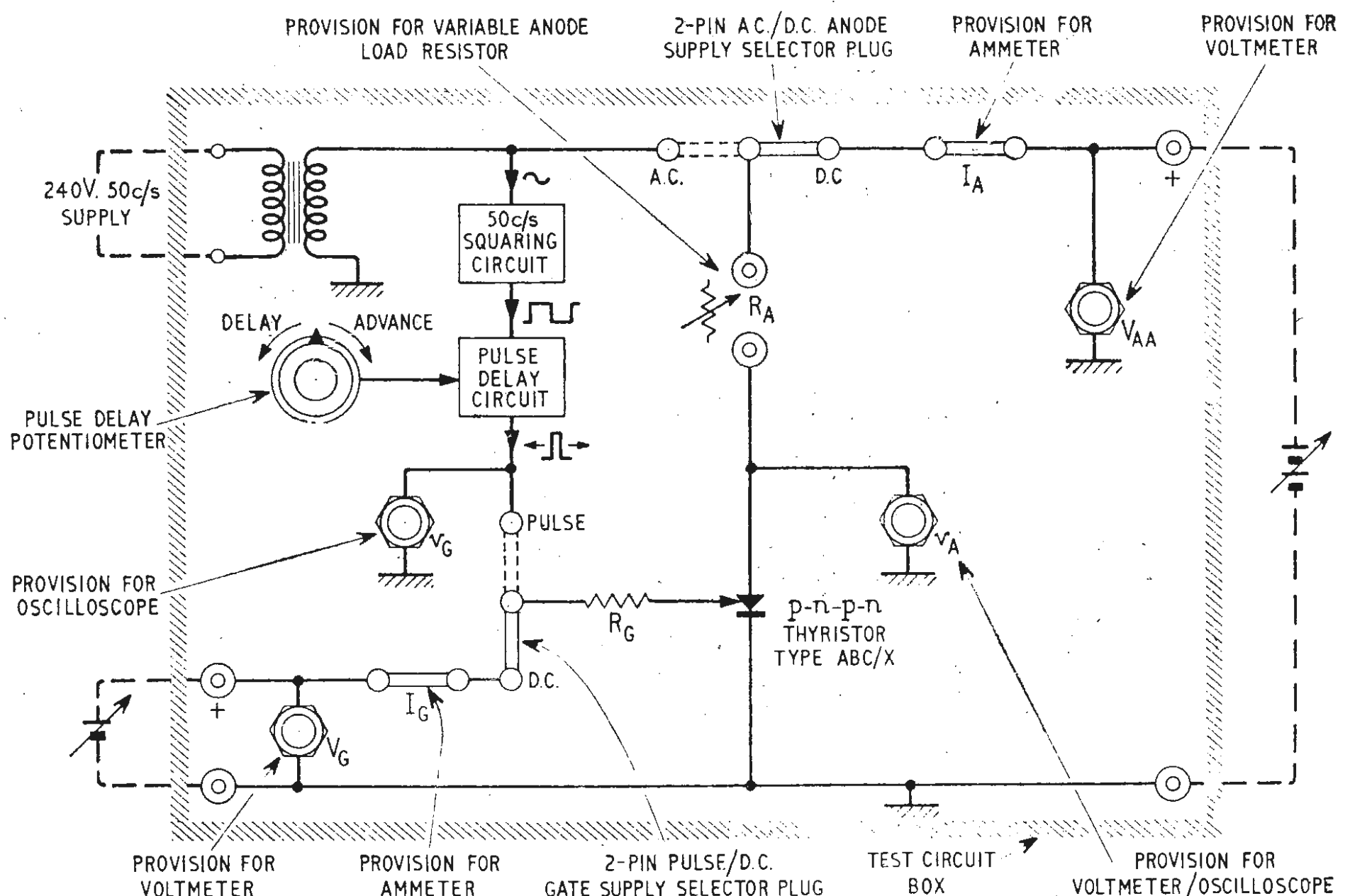
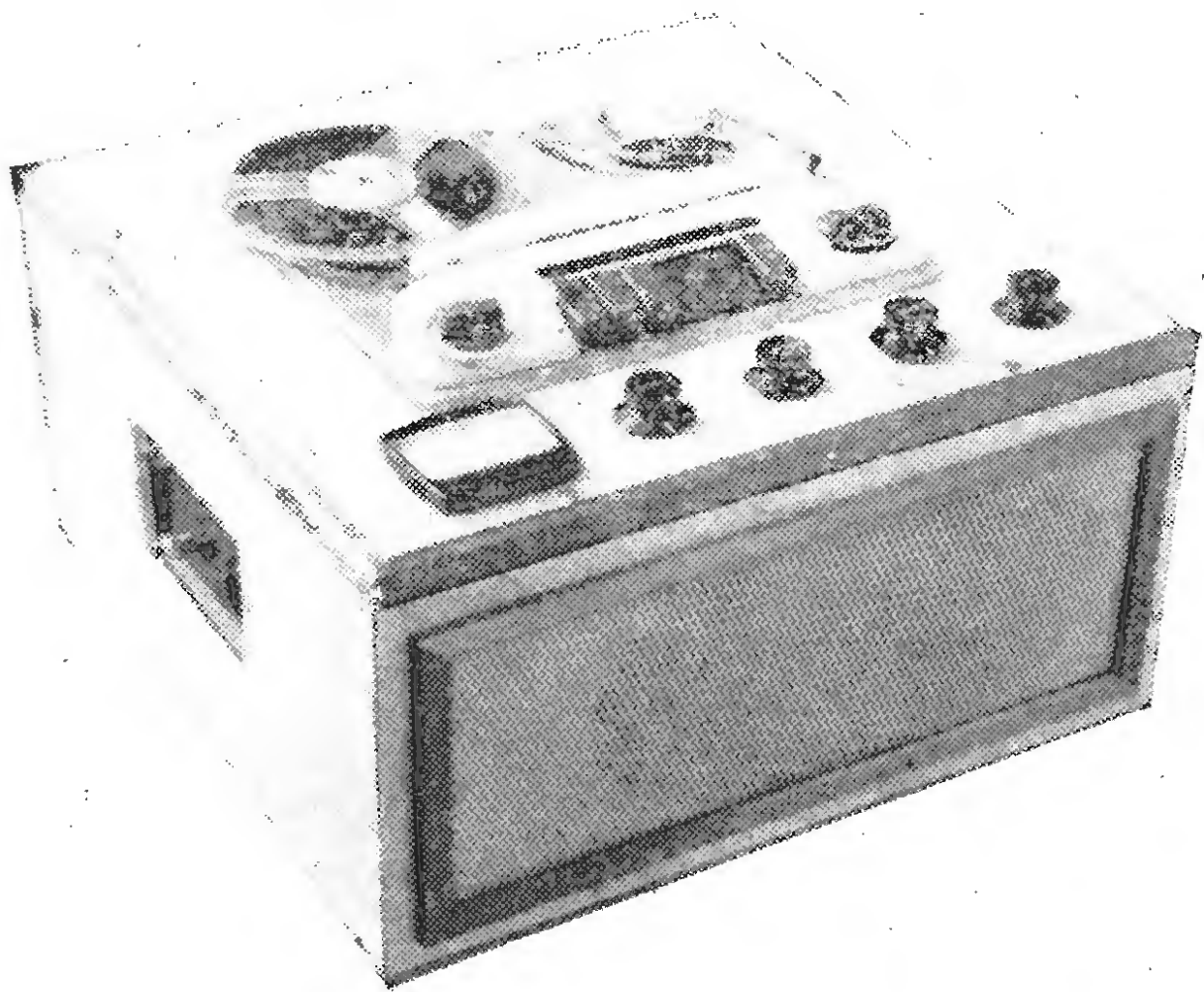

Fig. 3. Possible layout of test circuit for p-n-p-n thyristor experiment.



The article is concluded with details of the power supply and constructional notes. A complete list of components was given in the July issue.

By D. L. GRUNDY* and J. COLLINS*

Silicon Transistor Tape Recorder

2.—POWER SUPPLY AND CONSTRUCTIONAL NOTES

BECAUSE of the heavy current drawn by the playback channel when operating at full power output, the 40 V supply voltage has to be well regulated. For this reason the stabilized supply circuit shown in Fig. 10 is recommended. Ripple currents which impair general performance are effectively avoided, and danger of low frequency instability due to a fluctuating supply line is greatly reduced. The good regulation of this power pack is of particular advantage at high frequencies when the amplifier becomes less efficient.

It comprises a full-wave voltage doubler and stabilizing network employing series regulation. A silicon voltage regulator ZD_4 is used as the voltage reference. Tr_{25} is an amplifier which samples the output voltage, and its collector current reflects the potential difference between its base and emitter. Tr_{25} is directly coupled to the emitter-follower pair Tr_{26} and Tr_{27} , thus controlling the voltage drop across Tr_{27} and hence the

* Applications Laboratory, Ferranti Ltd.

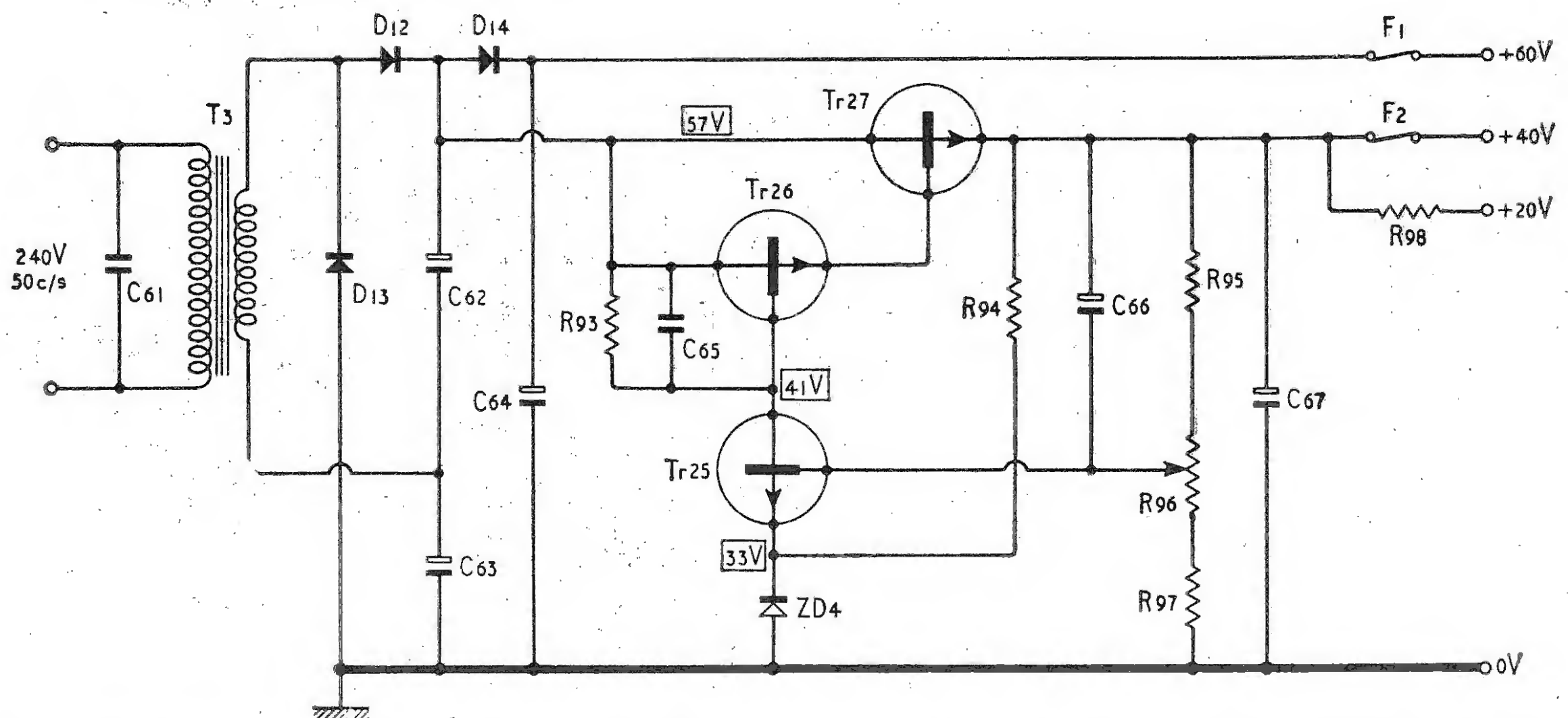
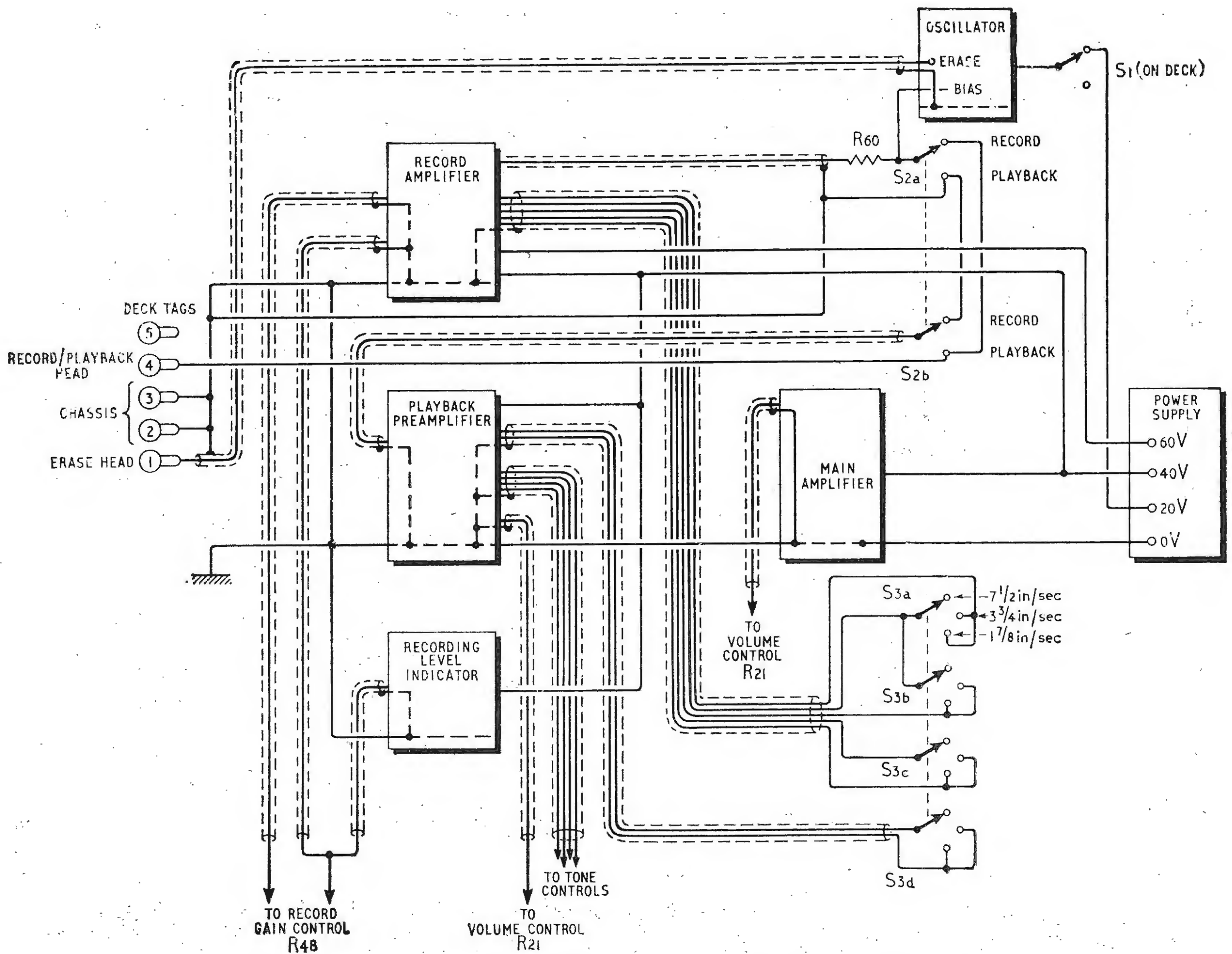

Fig. 10. Power supply. Tr_{26} and Tr_{27} should be mounted on a common heat sink, $3 \times 3 \times \frac{1}{16}$ in. copper or aluminium, and insulated from the chassis. ZD_4 must be bolted to the chassis.



▲ Fig. 11. Wiring diagram.

output voltage. The output voltage is set to 40V by the potentiometer R_{96} . Peak-to-peak ripple at 40 V 1 A d.c. is 20 mV and the output impedance is 0.5Ω .

A 20 V line is required for the oscillator, and this is obtained from the 40 V line *via* a dropping resistor R_{98} . Because of the size of this resistor (and power dissipated in) it is advisable to include it with the power supply. Its decoupling capacitor C_{51} is situated on the oscillator board.

For the output stage of the recording amplifier, 60 V at 10 mA is required which is accomplished by additional filtering *via* D_{11} and C_{61} at the output of the voltage doubler.

Construction and layout

The individual units using the Collaro deck have been photographed and are shown in Figs. 12-17. Excluding the power pack, each unit has been assembled on a paxolin board using connecting pins, to fit into a standard Eddystone box with approximate

▼ Fig. 12. Playback pre-amplifier layout.

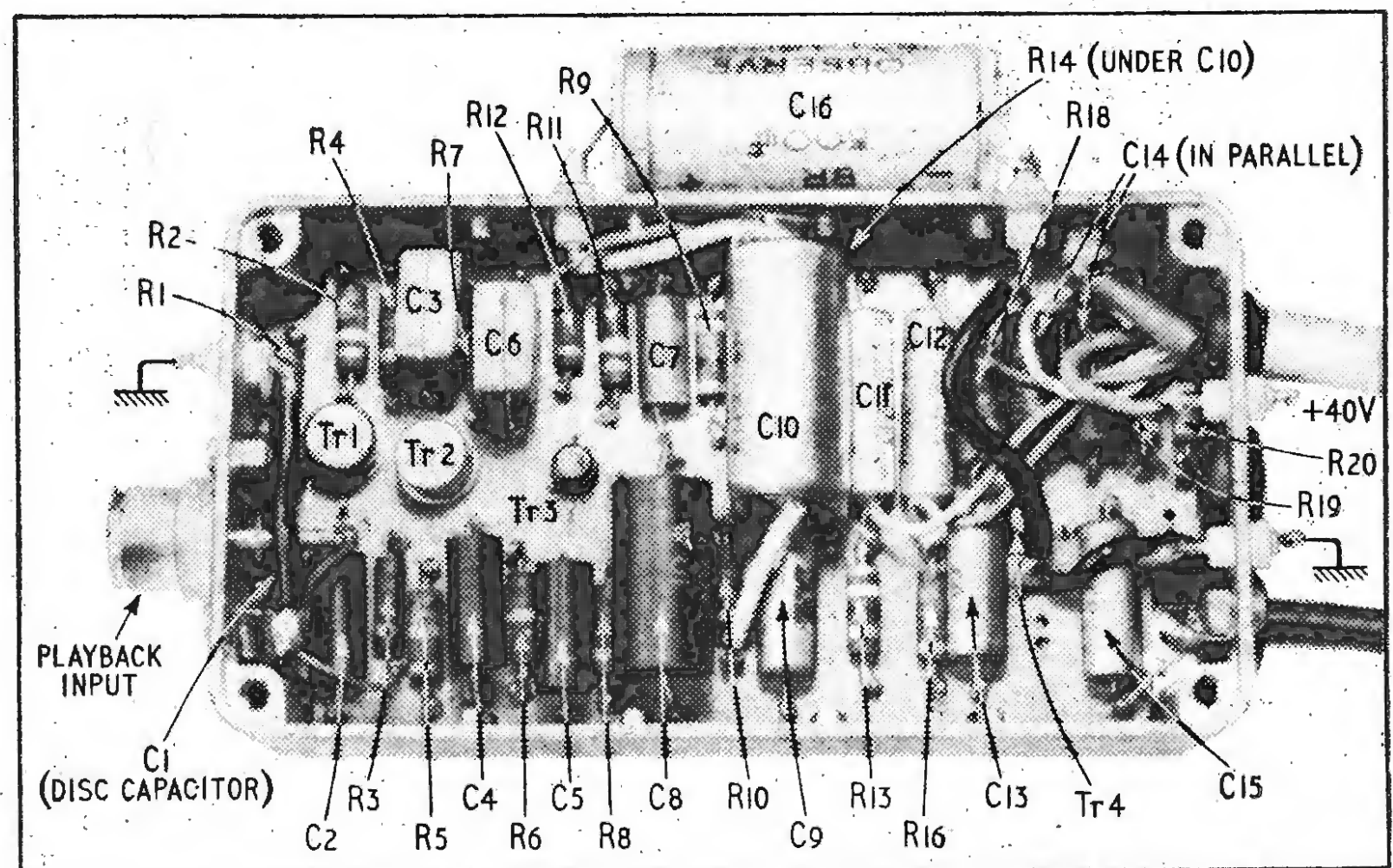

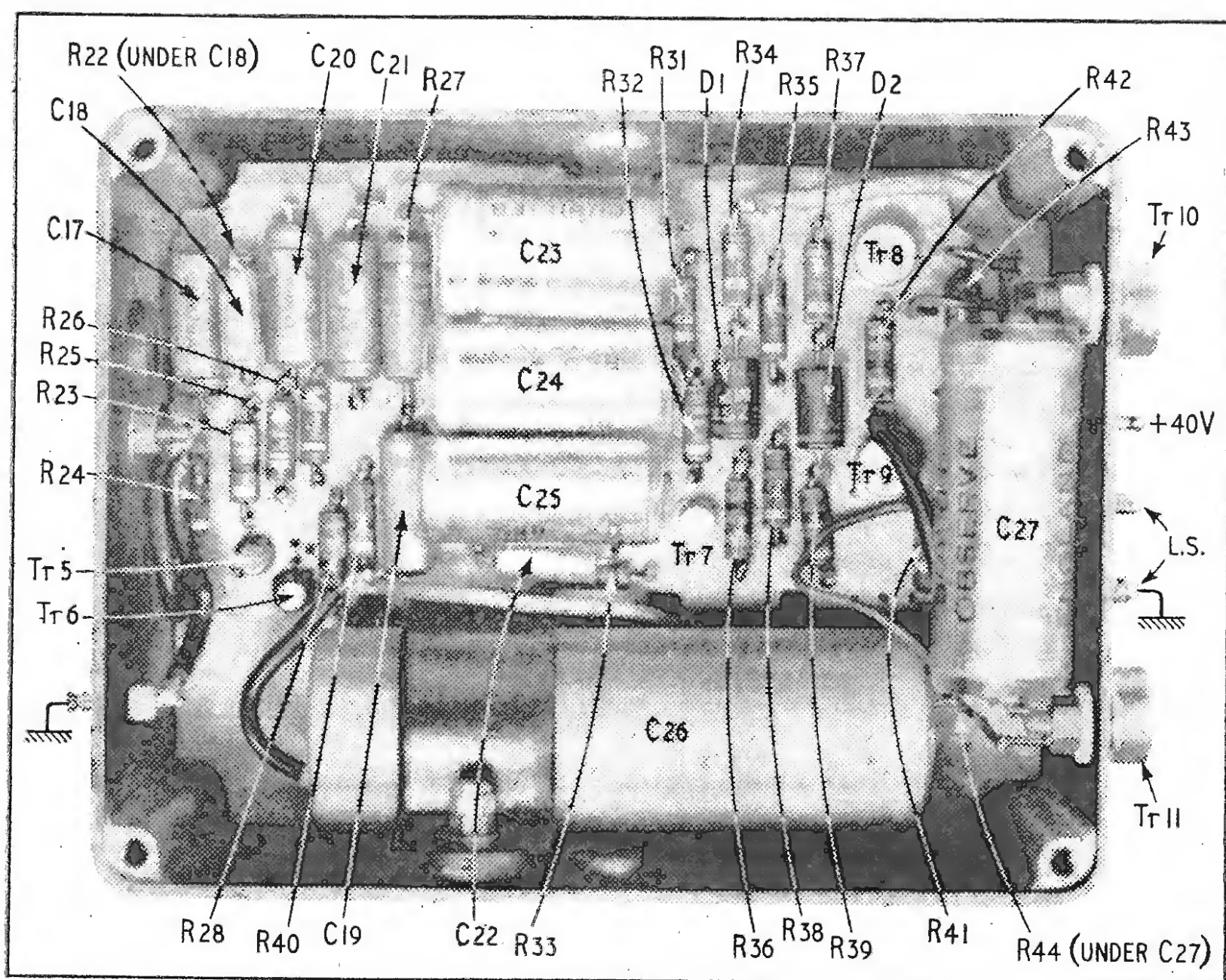

▲ Fig. 13. Power amplifier layout.

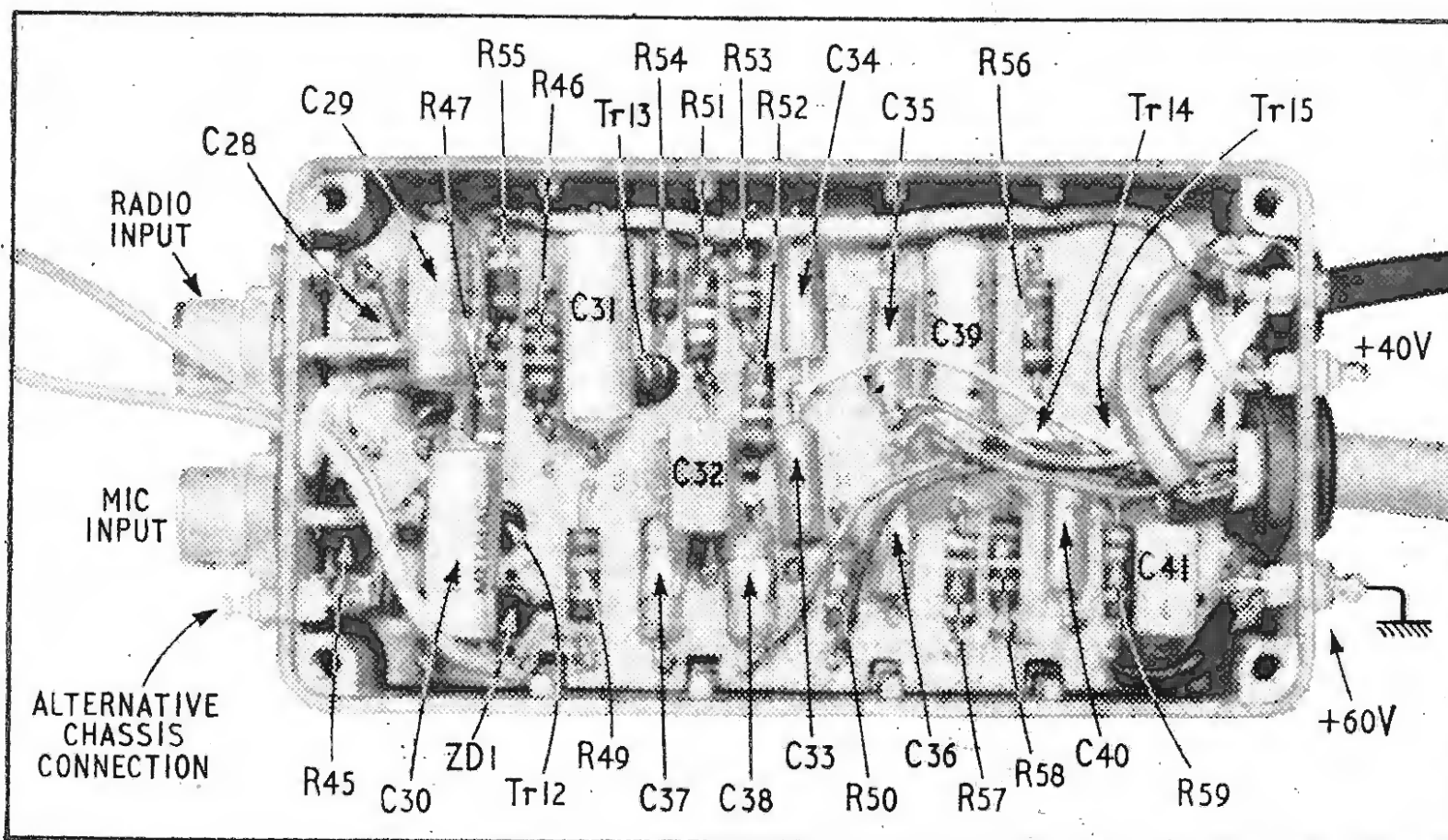
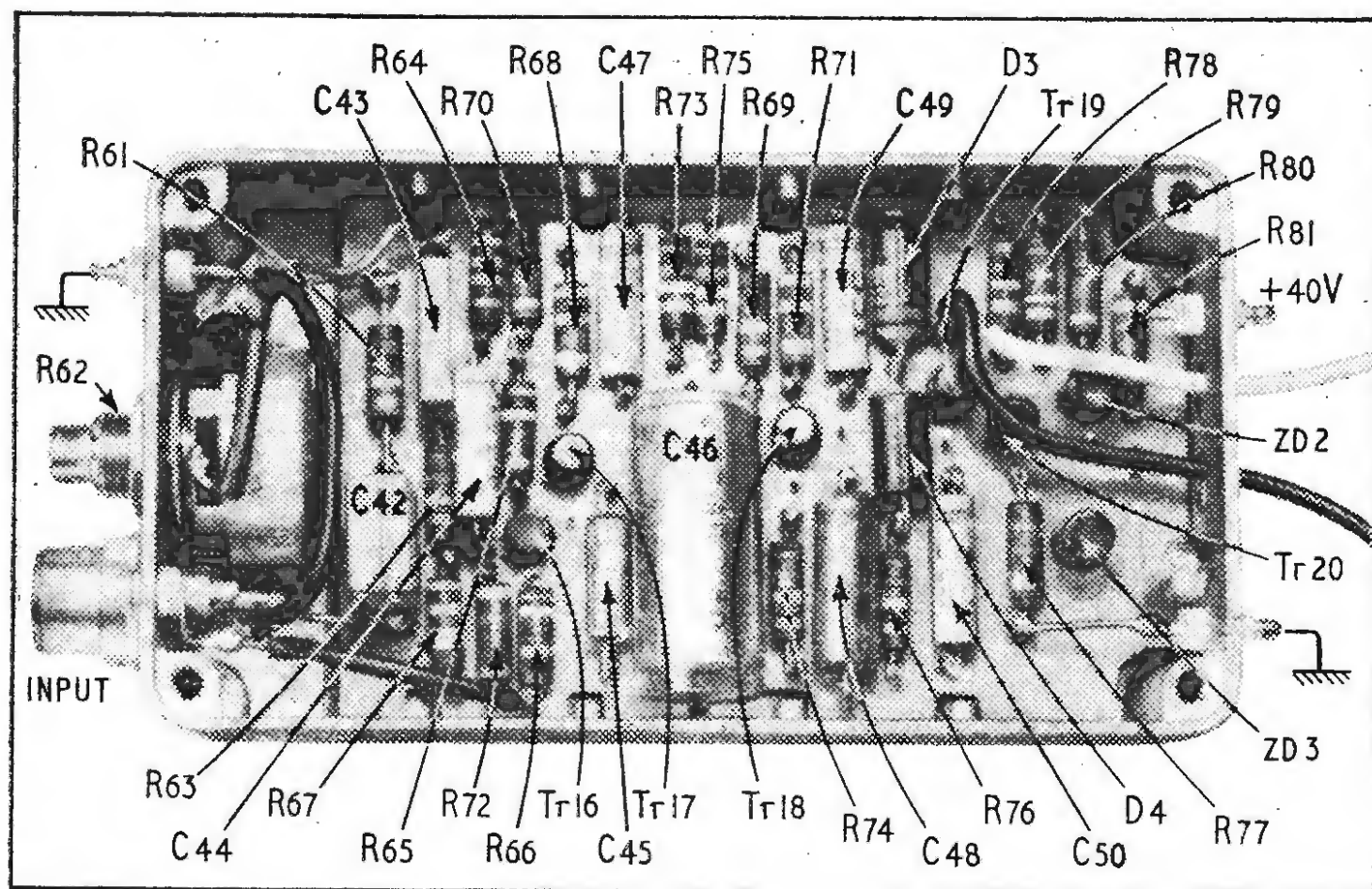

Fig. 14. Record amplifier layout. ►

▼ Fig. 15. Recording level indicator layout.



dimensions $4\frac{1}{4} \times 2\frac{1}{4} \times 1\frac{1}{4}$ in. Because of the bulky loudspeaker coupling capacitor C_{26} the power amplifier is housed in a $4\frac{1}{2} \times 3\frac{1}{2} \times 2\frac{1}{4}$ in Eddystone box. The power supply is mounted on a $7 \times 5 \times \frac{1}{4}$ in aluminium plate.

Apart from their electrostatic and electromagnetic screening advantages, the boxes permit a flexibility of layout and a compact accessible assembly. While they are not essential for every unit the oscillator and playback preamplifier must each be housed in a screened container. This is to prevent swamping the system with 55 kc/s radiation from the oscillator and also reduce 50 c/s pick-up by the play preamplifier due to its high input impedance and large amount of bass lift.

A satisfactory earthing arrangement is of prime importance in order to avoid all manner of instability and spurious oscillation which can arise. This is frequently detrimental, especially with transistor power output stages where high frequency oscilla-

tion can result in transistor "burn-out." It is essential that all construction boards are provided with a low-impedance earth path using, say, 20 s.w.g. A practical earthing arrangement of the various units is shown in Fig. 11.

The recording amplifier, playback preamplifier and level indicator are all earthed at their input end to one point on the front panel or chassis. Also earthed to this point are the tape deck, record gain control, volume control and the metal cases of these controls.

The oscillator derives its earth from the screen of the cable connecting it to the erase head, while the main amplifier derives its earth directly from the power supply at its output

Fig. 16. Erase and bias oscillator for use with Collaro Studio tape deck.

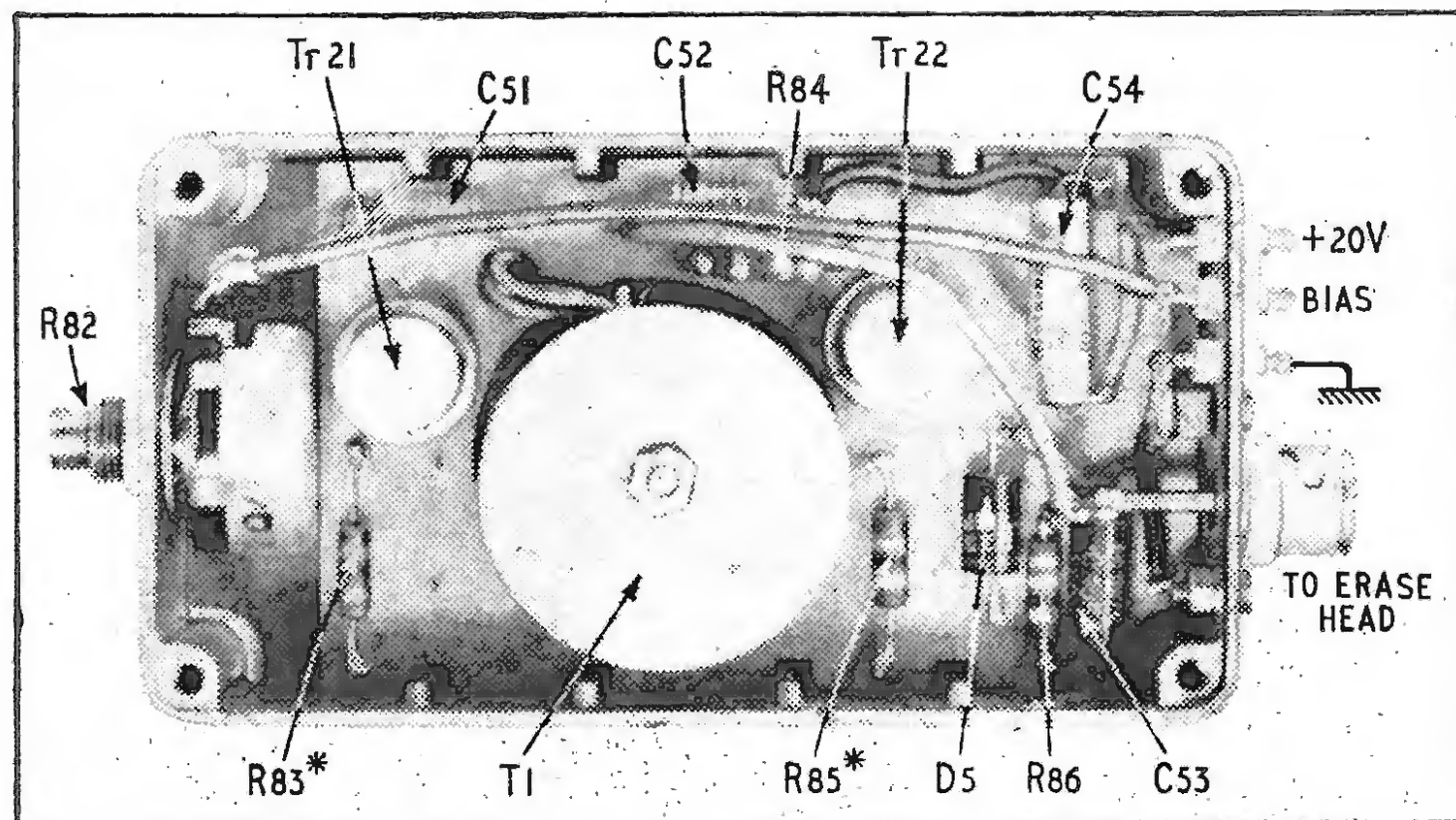

end. It should be noted that the screens of all interconnecting cables are earthed at one end only.

All switching functions on the deck are performed by switches S1, S2 and S3; S1 being already included on the deck. S1 switches on the oscillator supply voltage for recording. S2 is a double-pole changeover

S3 is a 4-pole three-way switch which alters the playback and record equalization when changing tape speeds.

Suppressing unwanted noises

Precautions have to be taken to eliminate "plops" and "bangs" from a variety of sources which can be transmitted through the system to the loudspeaker. The magnitude of these overloads is such that permanent damage to the loudspeaker might result.

It was found that to reduce bangs originated by depressing the control buttons it was necessary to connect a $1\mu\text{F}$ capacitor across the terminals to each motor.

Another effect is the possibility of a 10W "plop" when switching on the power supply. To overcome this the values of decoupling capacitors C_{10} and C_{16} in the playback preamplifier have been made deliberately high so that the low level stages turn on slowly due to the long time constant.

Switching off the power supply with the selector switch S2 in the playback position can also result in a 10W "plop" due to the collapse of flux in the mains transformer being radiated to the head. This is effectively suppressed by C_{61} connected directly across the primary winding of the mains transformer.

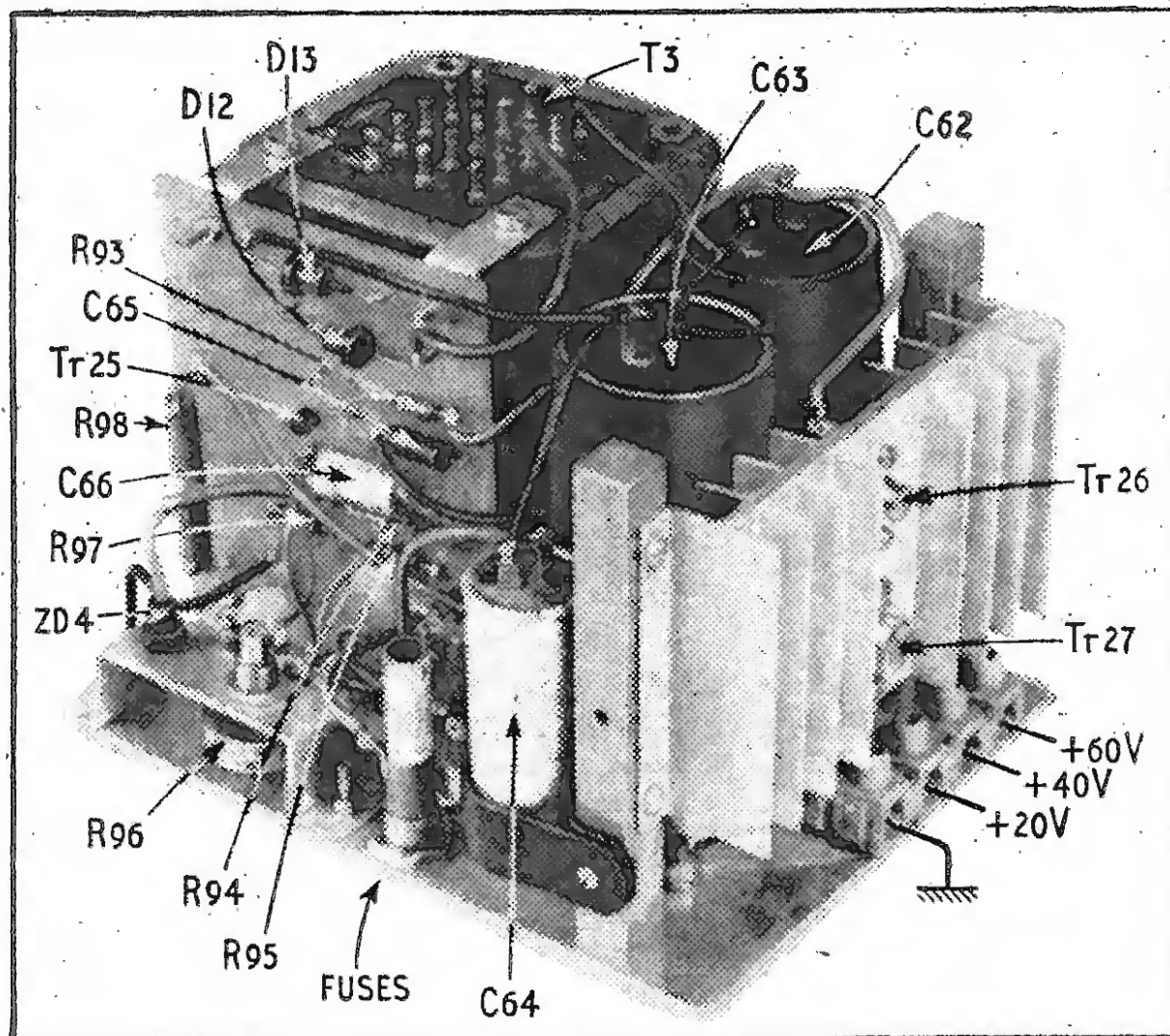

Fig. 17. Power supply layout.

switch to select the recording and playback positions. The record/playback head is switched between the recording amplifier output and the playback amplifier input. When recording, the playback preamplifier input is grounded, while on playback the recording amplifier output is grounded.

It is important to observe that the swamp resistor R_{60} has one end connected through screened cable to the recording amplifier output, and its other end connected directly to the switch pole S2. If the connections were reversed and screened cable used to connect the resistor to the switch pole then, depending on its length, the cable capacitance could impose a considerable load on the erase/bias oscillator. The net result would be reduced bias voltage and a possible increase in harmonic distortion. For a similar reason a single wire is used to connect the bias to S2 in preference to screened cable.

CONFERENCES & EXHIBITIONS in August and early September

- | | |
|----------------------------------------------------------------------------------------------------------------|---------------|
| Aug. 24-27 | San Francisco |
| Western Electronics Show and Conference
(WESCON, 3600 Wilshire Blvd., Los Angeles, Cal.) | |
| Aug. 27-Sept. 5 | Stuttgart |
| German Radio & TV Show
(Stuttgarter Ausstellungs-GmbH, Stuttgart, Postfach 990) | |
| Aug. 29-Sept. 3 | Tokyo |
| Medical Electronics Conference
(Prof. K. Sahara, 26 Otsukakubomachi, Bunkyo-ku, Tokyo) | |
| Aug. 30-Sept. 1 | Washington |
| Antennas and Propagation
(Dr. R. J. Adams, Naval Research Lab., Washington D.C.) | |
| Sept. 1-7 | Cambridge |
| British Association Meeting
(British Assoc., 3 Sanctuary Bldgs., London, S.W.1) | |
| Sept. 7-11 | Basle |
| INEL—Industrial Electronics Exhibition
(Swiss Industries Fair, Postfach, Basle 21) | |
| Sept. 7-14 | Liège |
| International Congress on Acoustics
(Congrès International d'Acoustique, 35 rue Saint-Gilles, Liège) | |
| Sept. 9-19 | Paris |
| International Radio & TV Show
(F.N.I.E., 16 rue de Presles, Paris 15) | |

TWO-STATE DOUBLE-INJECTION DIODE

A NEW type of semiconductor device which can be switched from one stable state to the other by a voltage pulse or a flash of light has been developed by Standard Telecommunication Laboratories. It comprises a gallium arsenide semiconductor slice with two film electrodes, one gold and one aluminium, deposited on the same side and separated by about 0.1 mm. A typical characteristic is shown in the figure. In the forward

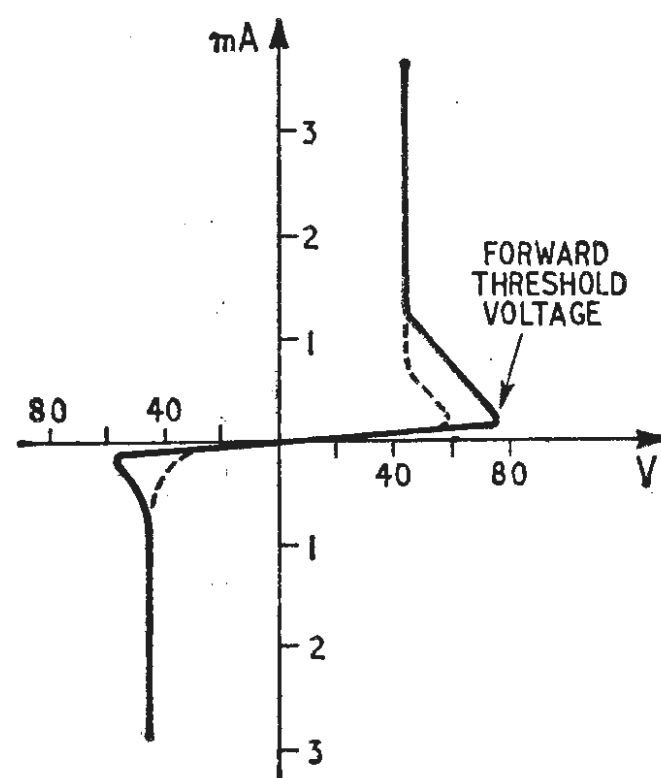

direction, for which the gold electrode is the anode, the initial slow rise of current with applied voltage is a single current-carrier process. There is then a negative resistance region (full line) followed by an extremely rapid rise of current resulting from a double current-carrier process (2nd stable

state) in which the aluminium electrode preferentially injects electrons while the gold electrode preferentially injects holes. During switching back from the double-carrier state to the single-carrier state, the negative resistance region is absent or much reduced (broken line). The reverse characteristic can be similar, as shown, with a small negative resistance region, or it may have a single-carrier flow up to voltages many times greater than the forward threshold voltage—depending on the diode used. If the diode is biased to a point just below threshold, illumination from a weak light source (40 W lamp 2-3 ft away) will lower the threshold and so switch it into the double-carrier high-current state. The photosensitive effect is greatest with light having a wavelength of about $7 \mu\text{m}$. Threshold voltages between 20 V and 200 V can be achieved, and it is hoped to produce diodes with thresholds below 20 V.

LASER BEAM TRANSMITS POWER

Devices which have to operate in situations which do not allow electric supply cables to be connected to them (e.g. in nuclear reactors) can be powered by means of laser beams. This is a new technique developed by the National Aeronautics and Space Administration of the U.S.A. A laser beam, produced by stimulated emission in a gallium arsenide p-n junction, is directed at the remote apparatus, where the light energy is converted back to electrical energy by a gallium arsenide photodiode. The resulting constant electric current is then used to power the apparatus. Applications are restricted by the low efficiency of the system.

REDUCING LOCAL OSCILLATOR DRIFT

IN most receivers the effects of oscillator drift must be minimized, particularly to maintain the signal within the bandwidth of the i.f. amplifier. In v.h.f. receivers this is normally achieved by introducing a feedback a.f.c. system. It is possible to stabilize an i.f. without using a servo system and to the accuracy of a crystal oscillator, and a system for use in high quality u.h.f. television receivers, where the stability was required to be high, has been developed by P. A. C. Segrave, P. R. J. Court and A. M. Reiter of the International Telemeter Company, U.S.A.

The output of the tuner $f \pm \Delta f$ with its associated drift $\pm \Delta f$ is applied to a mixer with a frequency $f_0 \pm \delta f_0$ from a crystal oscillator (see diagram). Assuming that $f > f_0$ and that the difference frequency of the mixer is selected, the output is $(f \pm \Delta f) - (f_0 \pm \delta f_0)$. This signal, together with the original tuner signal, $f \pm \Delta f$, is then fed to a second mixer to give a difference frequency of $(f \pm \Delta f) - [(f \pm \Delta f) - (f_0 \pm \delta f_0)]$ which is $f_0 \pm \delta f_0$. Thus the resulting i.f. is independent of the signal frequency and has the frequency and stability of the crystal oscillator.

The oscillator drift in poor u.h.f. tuners can be compensated by this means and a drift of $\pm 1.5 \text{ Mc/s}$ (with the tuner

output at 45 Mc/s) has been accommodated. Drift range is dependent on the choice of intermediate frequencies and crystal frequency. With this system it may be possible to eliminate the fine tuning control in television receivers.

CARBON RESISTOR TRANSDUCERS

Although carbon has been used as the sensitive element in pressure transducers, piezo-resistivity in ordinary carbon composition resistors appears to have attracted little attention. A note published in *Rev. Sci. Inst.* February 1965, outlines results of the measurement of the pressure sensitivity.

The test apparatus consisted of a pressure chamber maintained at ice point, a precision test gauge and a resistance bridge, giving an overall accuracy of 0.1% full scale. Five different $1 \text{ k}\Omega$ composition resistors were tested up to a pressure of 500 lb in^{-2} . All appeared to have a linear response, but a slight hysteresis was noted. Measurements were repeatable to within 1%. Pressure-resistance sensitivity was between -0.5 and $-2.0 \times 10^{-5} \text{ ohm lb}^{-1} \text{ in}^2$. Since the temperature sensitivity was found to be about $-2.5 \times 10^{-4} \text{ ohm deg C}^{-1}$, it was necessary to maintain constant temperature; otherwise, of course, a method of temperature compensation is necessary. The low cost, simplicity and availability of carbon composition resistors could provide a useful technique for both static and dynamic pressure measurements.

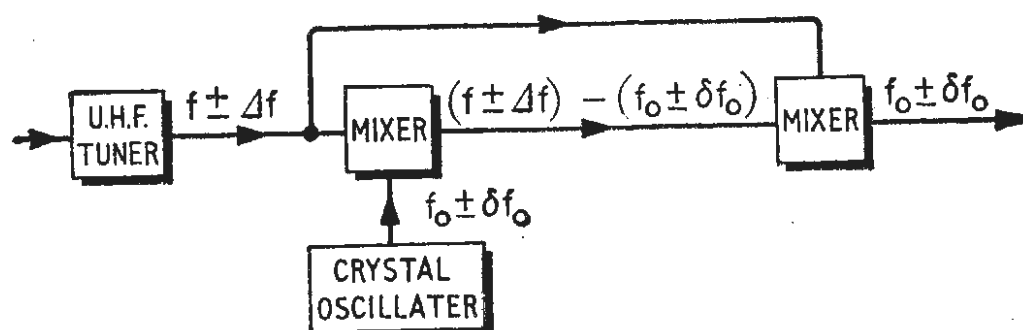

Miniature D.C. Converters

By D. BOLLEN

100V and 1,000V battery-powered h.t. supply units : neon stabilization : circuits use a multivibrator-inverter feeding a Cockcroft Walton voltage multiplier.

PRIMARY aims of the author's experimental work on transistor d.c. converters were to avoid the bulk and complexity of most existing designs and, equally, to dispense with the necessity for special components. Examination of the two circuits presented here will show that these aims have been met. Both are powered by low voltage dry batteries, consume less than the average flash-lamp bulb, but have in common the ability to supply a stabilized high tension voltage to a wide range of equipment where the current demand is reasonably low.

The first circuit was developed specifically to replace the h.t. battery in portable valve receivers and gives 100 V output at 1 W. Although this type of set can give excellent performance, the cost of h.t. batteries is high, and as the voltage, upon which the set's sensitivity so much depends, drops quite rapidly if used continuously for long periods, efficient operation becomes uneconomical when compared with transistor receivers. Another factor is the difficulty of obtaining some of the older types of battery. By reducing the cost of maintaining an adequate h.t. voltage, this converter can give a new lease of life to an old set.

The second circuit has a maximum output of 1,000 V

at 75 mW and is likely to be useful where Geiger tubes, oscilloscopes and kindred equipment are to be battery operated.

100V circuit

The inverter section of Fig. 1 is based on a multivibrator which, oscillating at about 400 c/s with the components specified and feeding into a centre tapped inductor, produces a square-wave output of approximately 12 V under load. Tr1 and Tr2 act as low dissipation switches. The prototype has been successfully run for long periods with an input of $2\frac{1}{2}$ W, using 200 mW transistors without heat sinks. The inductor, a push-pull output transformer with the 3-ohm winding ignored, was also tested well beyond its normal rating, the result simply being that laminations became slightly warm after some hours of operation.

To convert the 400-c/s output from the multivibrator to a high direct voltage, a Cockcroft Walton multiplier circuit is used. The capacitors, in two series chains, are charged by the "pump" action of the diodes or, to put it another way, are charged in parallel and discharged in series. The circuit can be regarded as several voltage doublers placed end to end.

The 12 V output from the inverter is multiplied eight times, giving approximately 100 V at 10 mA. Silicon diodes were used in the multiplier but, as the peak inverse voltage is not greater than 40 V and the maximum mean current handled by each diode is less than 20 mA, there is no reason why an ordinary point contact germanium signal diode, such as the OA81, should not prove equally suitable. Bearing in mind the circuit requirements, the choice of diode can quite well be determined by price and availability.

Stabilization is achieved by matching the working point

Fig. 1. 100V converter, using a multivibrator. For 15V working Tr1 and Tr2 are both XB102 or OC72. For 10V working both are OC81 or TK23. In the multiplier all the diodes are OA202 and all the capacitors 30 μ F, 25V working.

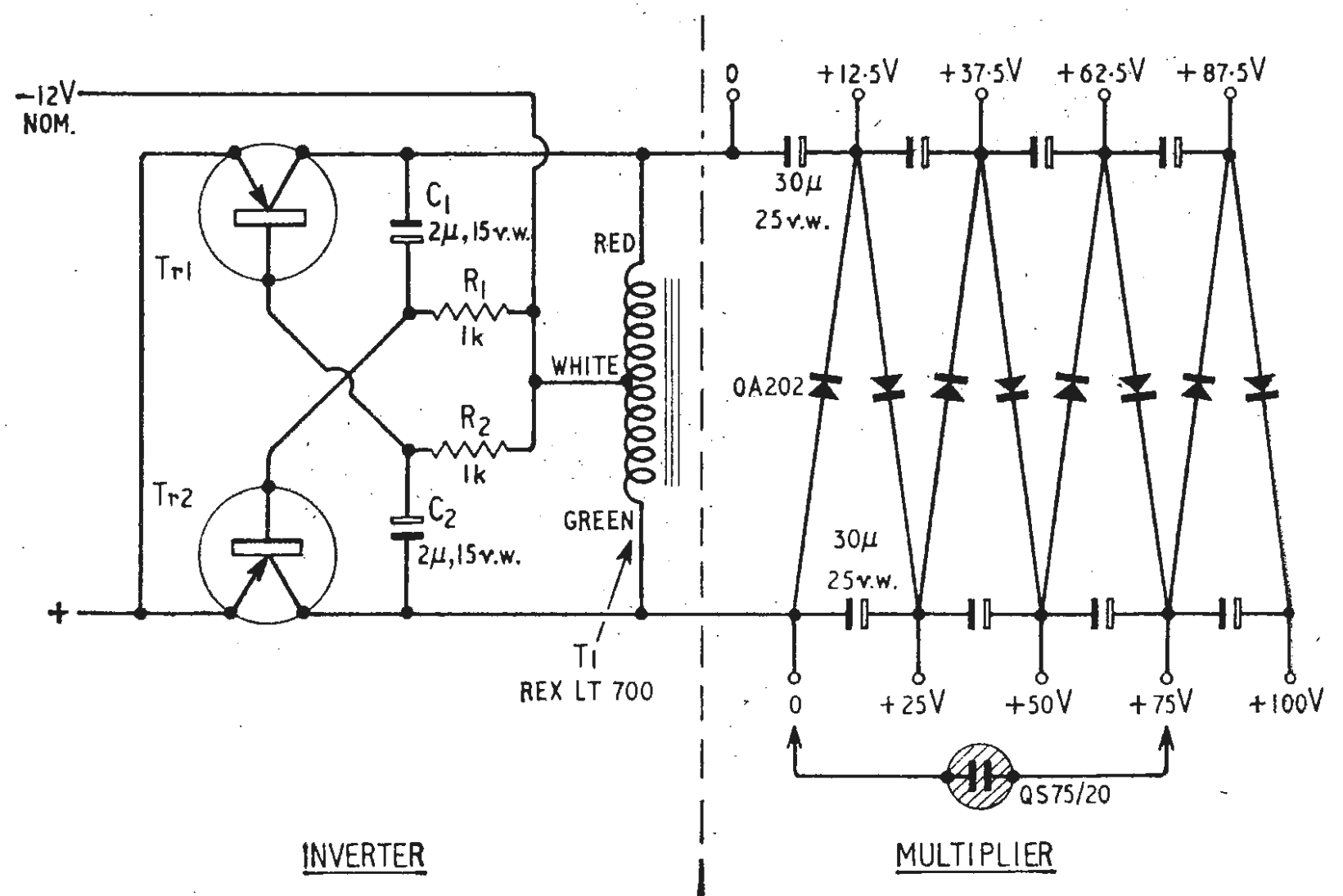

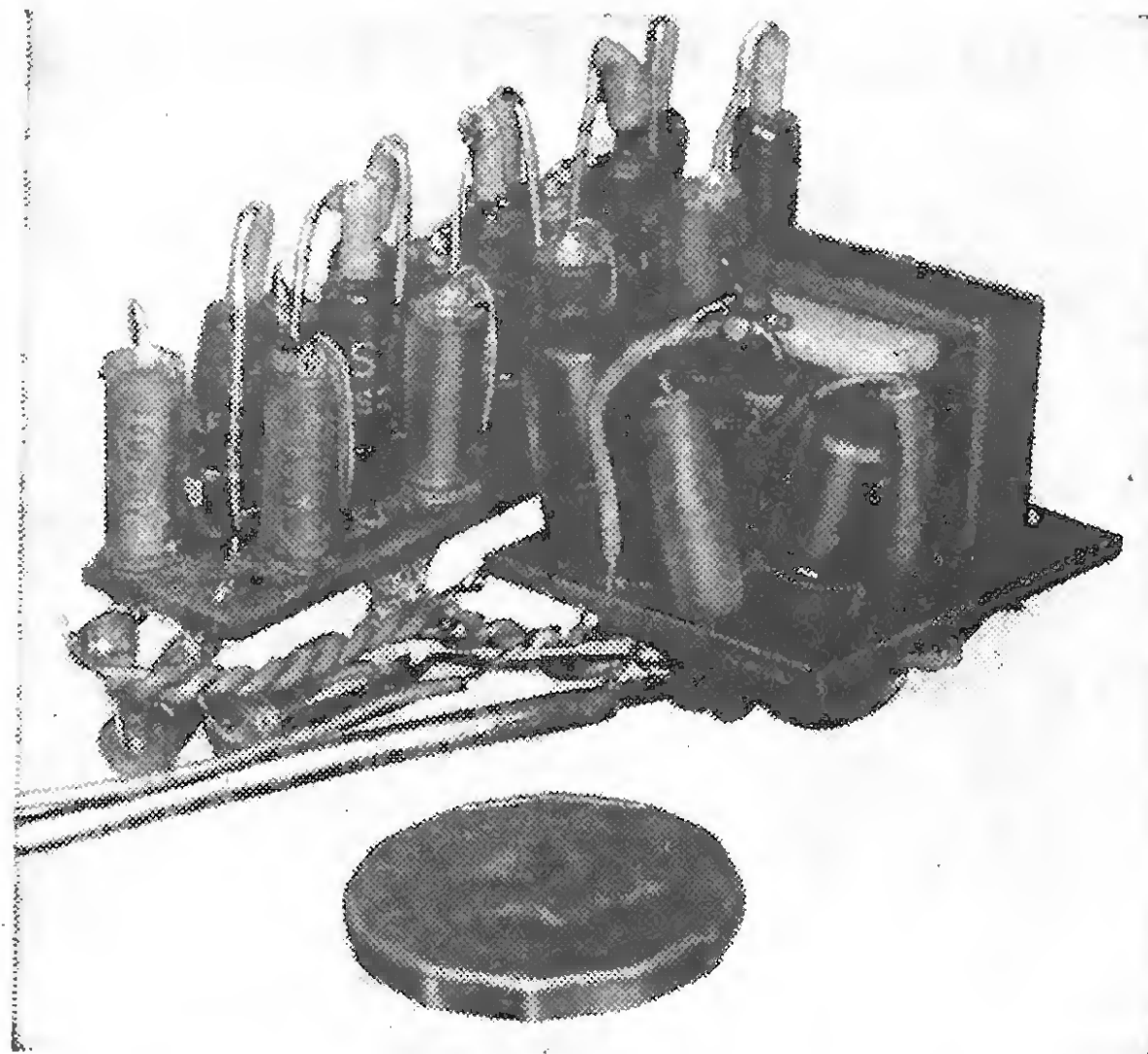

The 100 converter, compared in size with a 3d piece.

of a neon to one of the output voltage taps. It will be seen that the capacitors are arranged in two chains, linked across by the diodes. If a neon is placed in part of either chain it will effectively stabilize the whole. The output should be taken from one chain only, or both independently, not only to avoid a.c. ripple but also to prevent possible breakdown of the transistors if a short-circuit occurs. For example, if an 87.5 V output is required then the zero supply point would be the one on the same chain as the 87.5 V tap. Although an Osram QS 75/20 tube is specified, because it has an ample rating and is reasonably small, any neon capable of handling 10mA could be used provided its working voltage is less than 100V. In the prototype, in fact, an obsolete type was used. The output variation is within

2½% from zero to full load. Stabilization also compensates for falling battery voltage over quite a wide range with moderate loads.

1,000V circuit

Design requirements for the 1,000 V converter are a little more stringent than for the first circuit. Silicon diodes capable of handling 200 p.i.v., and capacitors of the same voltage rating are necessary. This multiplier chain (Fig. 2) is similar in principle to the first, but increases the input by a factor of ten, and can be fed from either end to give a positive or negative output. Three miniature wire-ended neons are sufficient for stabilization as the current handled is only 50 μA. When a cathode-ray tube is being supplied, the taps eliminate the need for a resistive divider and none of the limited current available is wasted. A 2 MΩ potentiometer, with a 2 MΩ fixed resistor in series, can be wired across the appropriate capacitor in the chain for focus adjustment.

The inverter, which uses two driver transformers, is in the form of a push-pull amplifier with its output fed back, via C₁ to the primary of T₁, at such a level that it is overdriven to produce a steep-sided square wave. T₂ has a ratio of 4.5:1 and 100 V peak a.c. appears on its secondary. Once again, though never intended for this type of circuit, the transformer seems well able to cope with the unaccustomed voltages involved. As the output winding is isolated, a normal system of consistent earthing may be adopted, either to the negative or positive battery line. Any voltage between 70 V and 1,000 V can be arranged by different groupings of neons. If only one 70 V neon is placed across the 200 V tap this will limit the total output to 350 V, for example. This is particularly useful for Geiger tubes, as they tend to have individual working points and sometimes, if aged, a limited plateau length. Here stabilization also maintains pulse height consistency at high levels of radiation. A diminishing output, as the count rate increases, is so often a fault when Geiger

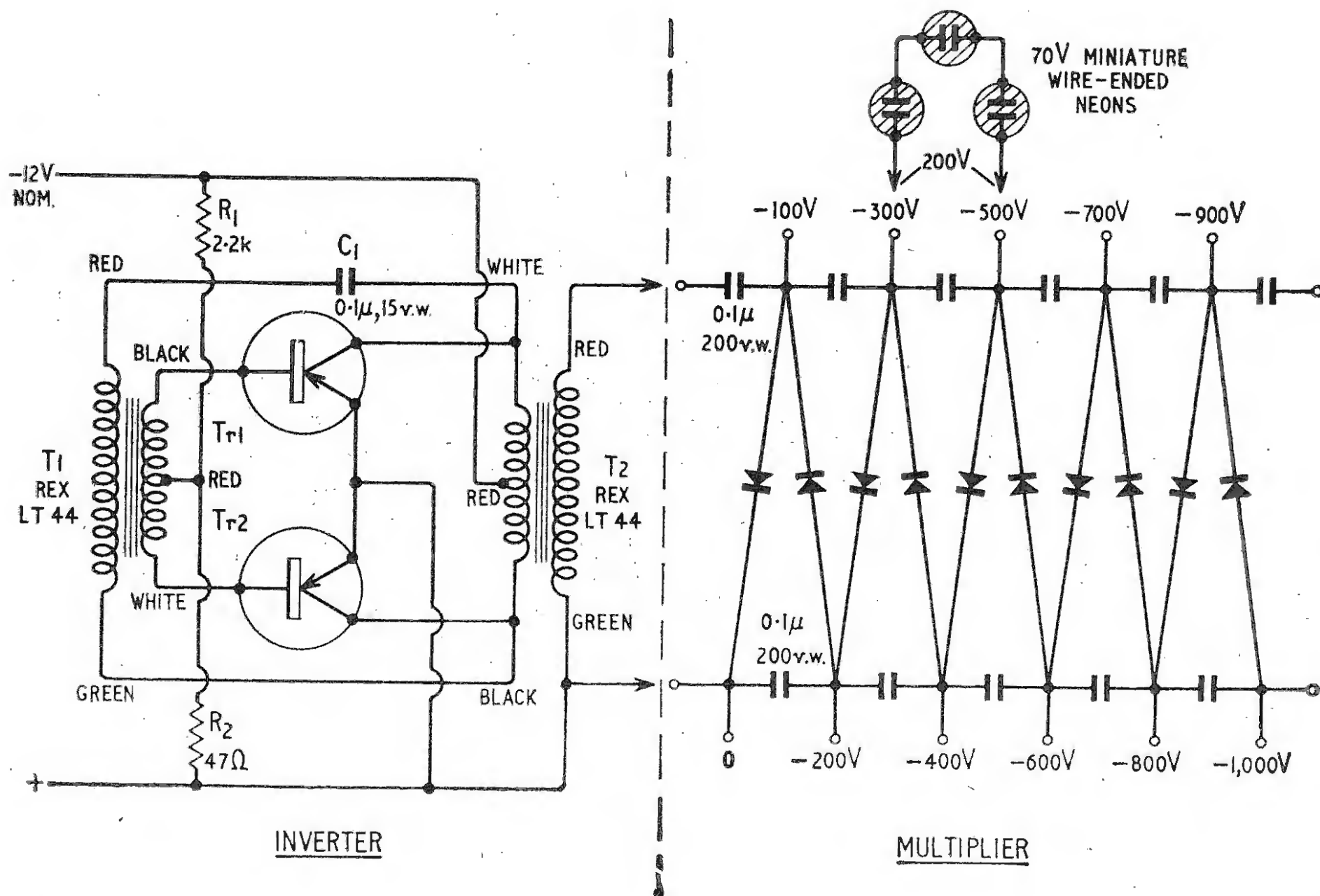
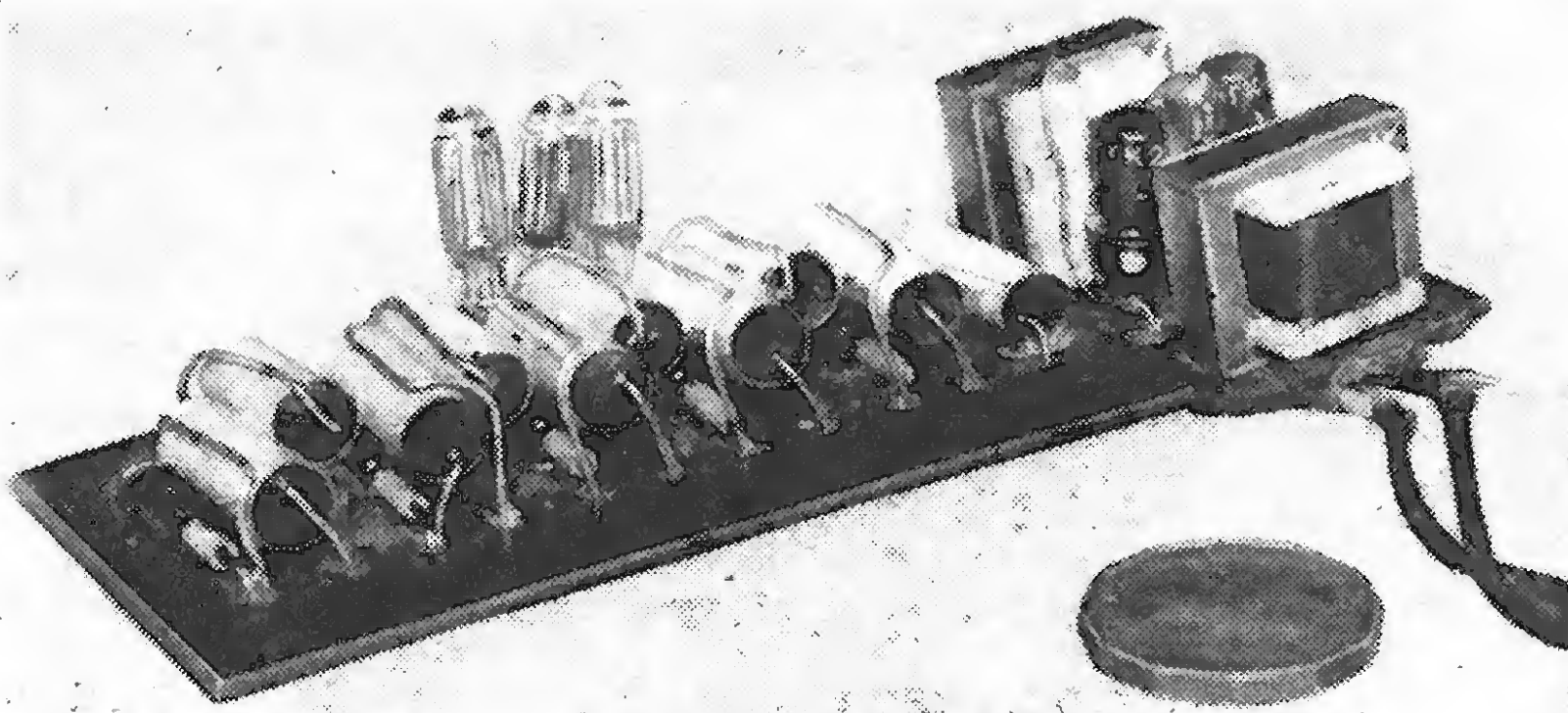

Fig. 2. 1000V converter. For 15V working Tr1 and Tr2 are both XB102 or OC72. For 10V working both are OC81 or TK23. In the multiplier all the diodes are T140, OA210, RS220AF, or FST 3/2; and all the capacitors are 0.1μF, 200V working.



The 1,000V converter, again compared in size with a 3d piece.

counters are powered by the simpler types of transistor or vibrator converters.

Incidentally, the inverter unit of Fig. 2 makes a powerful isolated bridge source.

Construction

Considerable individual variation is possible in construction. The multiplier networks may be tailored or cut down to obtain a lower output as there is obviously no need to have a complete chain of rectifiers and capacitors unless the full voltage is required. Similarly, the networks may be extended if higher maximum voltages are desired. The converter may be built as a complete unit, or the inverter kept separate as an a.c. source to drive multipliers wired permanently into different items of equipment. However, as the original layouts were satisfactory for a variety of uses, the principal dimensions are given in Fig. 3.

Paxolin $\frac{1}{16}$ th in thick is suitable and may be drilled before assembly with holes of $\frac{1}{4}$ in spacing. The components are laid out in logical order, closely corresponding to the circuit diagram, to occupy as little space as possible. The size of the 100 V multiplier will depend, to a large extent, on the capacitors, but a little juggling with the actual components will soon reveal the best disposition.

When the units are complete it is advisable to give them a thin coating of polystyrene cement to exclude damp, paying special attention to the 1,000 V multiplier and the bobbins of the transformers.

Operation

Both units, depending on the output power required, may be fed from relatively small dry batteries of 6 to 15 V. Transistor equivalents are given, but it should be noted that with an input in excess of 10 V the

rating of the OC81 and TK23 is exceeded, owing to the reverse voltage developed across the collector inductances. Although tests have shown that operation at higher battery voltages is quite feasible, there is always a risk that the transistors will break down under no-load conditions. This warning does not, of course, apply to the other transistor types mentioned.

Once set, the output is maintained at a constant level and the glow from the stabilizer neon gives visual indication of correct operation. When a converter is employed as a h.t. supply for a receiver the neon could be arranged as a panel light—a useful extra for a portable set. In this application a high value capacitor of

correct rating should be inserted in the h.t. line to eliminate harmonics from the square wave generator; 10-50 μ F is usually sufficient in the case of the 100 V converter, while from 0.1 to 1 μ F is suitable for the 1,000 V converter. When ferrite aerials are close to the inverter transformers, inductive pick-up can result, but this can be reduced to a reasonable level by orientation for minimum interference or by placing the inverter in a small metal box. As the physical dimensions of the units are small this should not present any special difficulty.

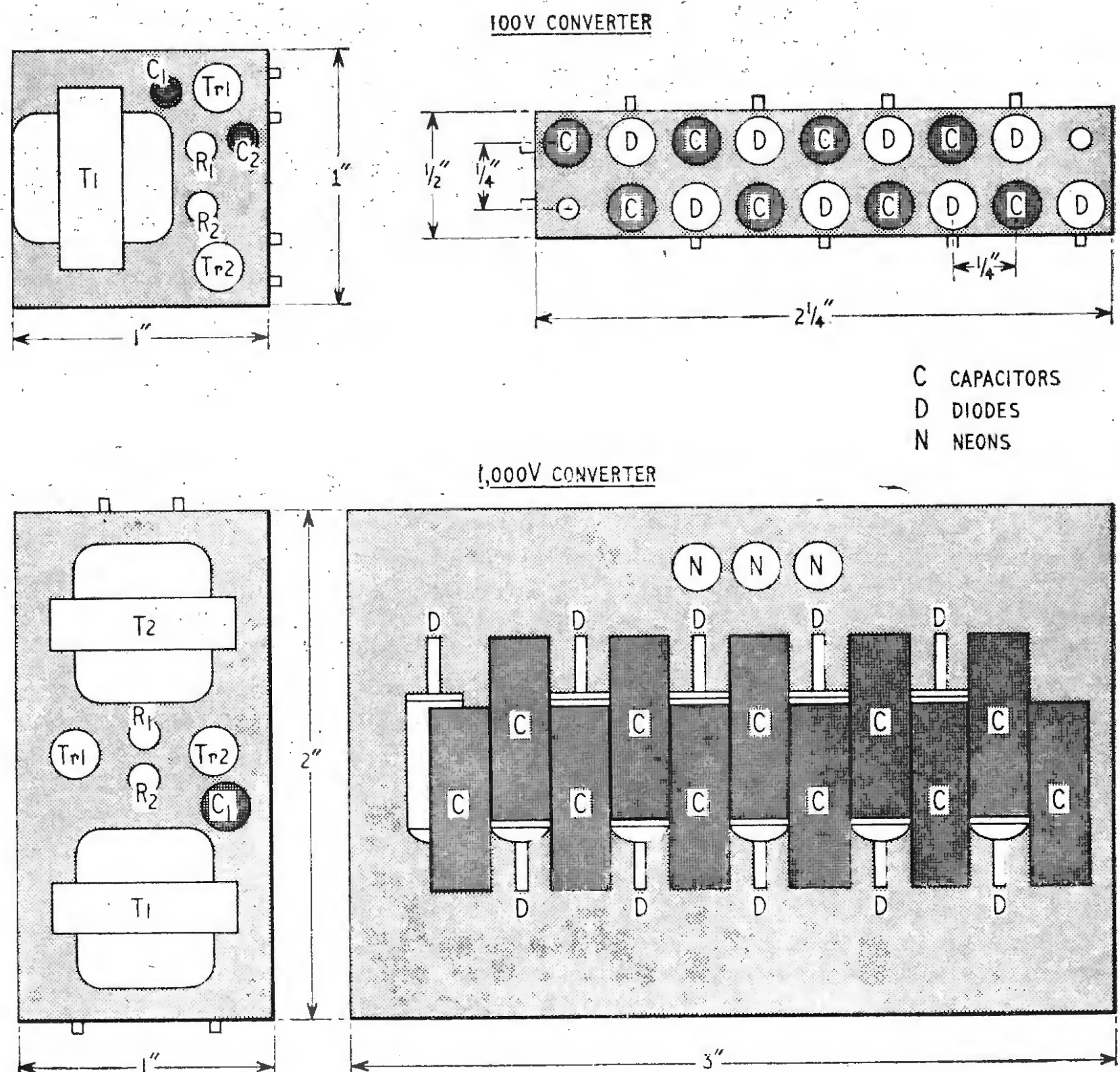

Fig. 3. Layout and principal dimensions of the two converters.

RANDOM SIGNAL TESTING—AND PSEUDO RANDOM METHODS

USERS of electronic systems are discovering that noise—traditionally regarded by designers as an unwanted by-product of their systems—has many useful properties for testing purposes. A random signal can be arranged to have as wide a frequency spectrum as necessary, so that only one test need be made instead of a succession of sinewave tests at different frequencies. A random signal contains sudden transitions between amplitudes—of a kind that systems are subjected to in normal operation—which cannot be simulated in sinewave testing. Random signal testing allows transient responses to be obtained in situations where it might be difficult or impossible to generate sharp impulse test signals because of mechanical inertia problems. In continuously operating systems where the application of conventional test signals may be highly inconvenient (e.g. chemical process plant), the noise produced by the system itself may be used for measurement purposes.

Many of these advantages were well brought out by two recent conferences on random signal testing, one at the I.E.E. in London, which dealt mainly with the determination of process plant dynamics, and another at Southampton University, which was biased towards vibration testing of mechanical structures. The last-mentioned was sponsored by the Institute of Sound and Vibration Research at the University, the Society of Environmental Engineers and the Advisory Group for Aeronautical Research and Development. Other growing applications for random excitation are in acoustic measurements and servo testing.

Statistical properties of signals

The two conferences underlined the fact that random signal work is concerned mainly with statistical properties of signals—*stochastic* functions—rather than *deterministic* functions expressed by mathematical laws such as $e = E \sin \theta$. Properties of interest are: mean and r.m.s. values; probability density functions (e.g. Gaussian distribution) and joint probability density functions; power spectra and cross spectral density functions; and autocorrelation and cross-correlation functions. From the autocorrelagram of a random signal it is possible to find any hidden periodicities and to determine the power spectrum. From the cross-correlagram, the frequency and transient response of a system can be obtained. Probability density functions are useful for detecting, among other things, the presence of hidden non-linearities.

An unusual application described at Southampton was an investigation by the Autonomics Division of the N.P.L. into the characteristics of the human operator as part of a control loop. P. H. Hammond explained that this could be done by statistical analysis of the non-linearities and random noise introduced by the operator. The control task was to centre a spot on a c.r.t. by means of a joystick, and an autocorrelation analysis was made of the operator's wrist tremor (the noise) during this process under various environmental conditions. From the autocorrelagrams power spectra were obtained.

The random signals used for testing are not usually "white" noise—this demands amplifiers and other equipment of wide bandwidth and considerable power handling capacity and requires correlation analyses to have extremely long integration times if they are to give reliable results. In practice some kind of noise spectrum limitation, or a compromise signal, partly random and partly periodic, is used. At Southampton, for example, J. T. Broch described a random vibration testing technique which was similar to a swept sinewave frequency test except that the single frequency was replaced

by a narrow band of noise. By sweeping this narrow-band random excitation over the entire frequency range required the equivalent of a wide-band random vibration test was obtained, but with simpler and less expensive equipment.

An example of partly random and partly periodic excitation is the "pseudo-random binary signal," and many of the contributions to the London conference brought out its advantages for determination of process plant dynamics. Features of this type of signal are illustrated in Fig. 1, taken

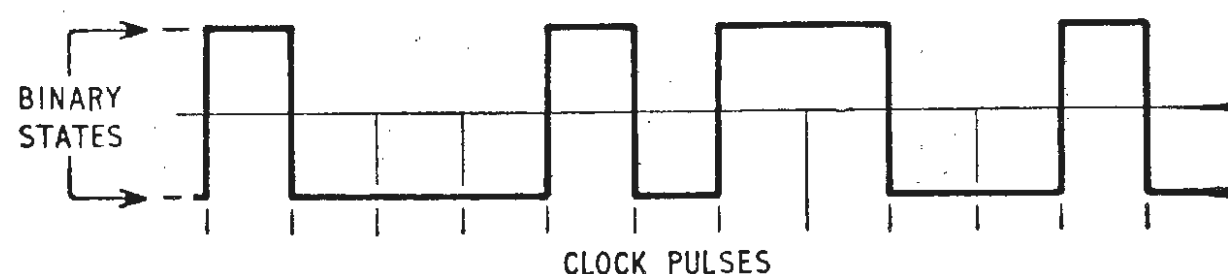

Fig 1. Part of a pseudo random binary test signal.

from a paper by B. W. Finnie and G. T. Roberts of Edinburgh University. The randomness exists in the sequence of the binary states, while the periodicity is introduced because the random sequence is cyclic, repeating after perhaps several hundred or several thousand digits, and because the transitions between states can only occur at regularly spaced instants (on clock pulses). Such sequences are usually generated by special shift registers with feedback connections, and the random patterns have a length of $2^n - 1$ bits, where n is the number of two-state elements in the register. One advantage of these signals is that they can be easily injected into a plant because the variable concerned has to be switched between two values only. In cross-correlation measurements, integration is only necessary over the time of the random pattern length (i.e. $(2^n - 1) \times$ clock pulse interval); furthermore, convenient digital methods may be used to obtain the necessary delay, and multiplication is readily achieved.

Finnie and Roberts gave an illustration of the superior accuracy obtained with pseudo-random binary signals when used for input/output measurements on systems. Fig. 2 shows the results of two cross-correlation experiments on a first-order system, one using the background white noise as the test signal and the other using a pseudo-random binary signal in the presence of the background noise. The drawn lines indicate the theoretical responses, and it can be seen that the measurements using white noise show a much larger deviation from the calculated values.

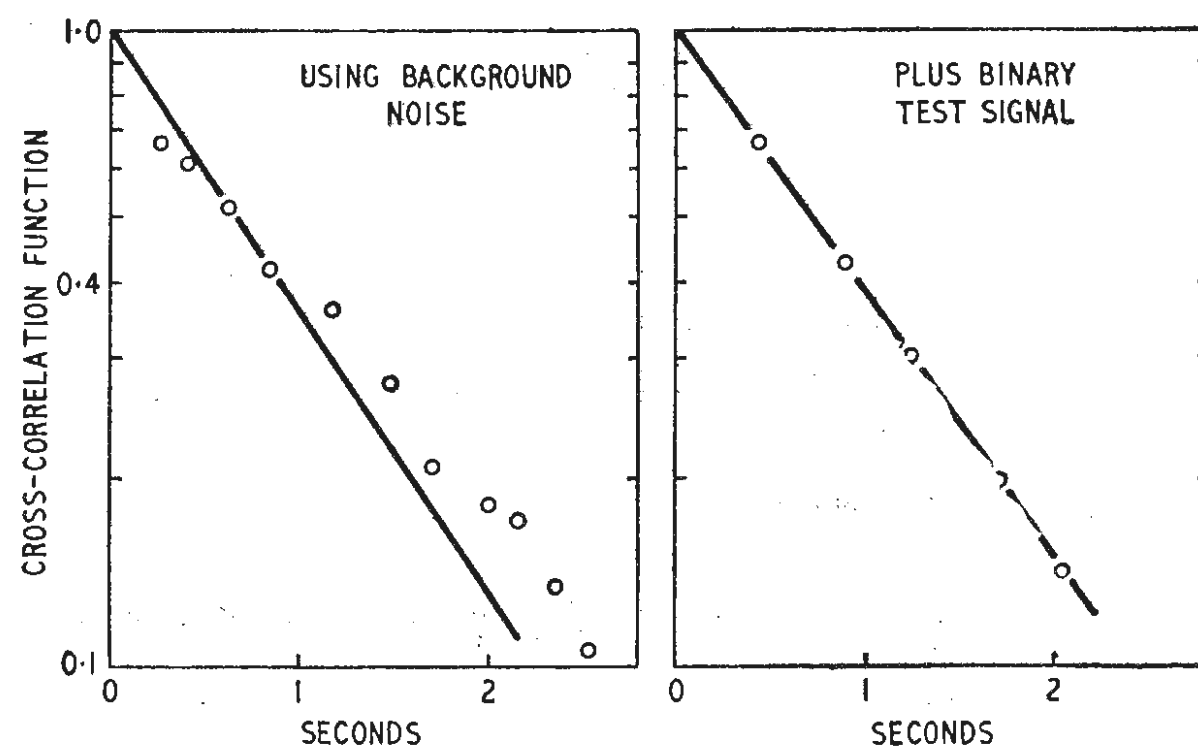

Fig 2. Results of cross-correlation measurements on a 1st-order system using (left) white noise, (right) pseudo random binary signal.

Civil Airways Radar System

AS part of the National Air Traffic Control Service being set up in the U.K. a new radar station was recently brought into service near Ventnor, Isle of Wight. This station, which is equipped with both primary and secondary radar, is linked by radio with the chain of stations integrated into the Southern Air Traffic Control Centre (S.A.T.C.C.) at London



The three dishes on the tower at the S.A.T.C.C., near London Airport, receive via microwave links radar information from sites at Ash, near Dover, Ventnor, I.o.W., and Clee Hill, Shropshire.

(Heathrow) Airport. There is also a northern counterpart (N.A.T.C.C.) and these will work into the National A.T.C. Centre now being built at West Drayton.

This civil/military programme, with the code name "Mediator," for the integration of this country's A.T.C., is planned to be complete by 1969.

An order has just been placed with the Marconi Company by the Ministry of Aviation for the final link (between Clee Hill, Shropshire, and Manchester) in the chain of microwave radio paths which will bring the total route mileage of the national chain to 384 miles. The whole chain, including ten terminal stations and ten unattended repeater stations has been equipped by Marconi.

Goonhilly Aerial Modifications

AS considerable interest has been shown in the drawing of the modifications made to the aerial at the Post Office satellite terminal station at Goonhilly, published in our May 1965 issue, we would like to take this opportunity of acknowledging that the designers of the modifications are Husband & Co., of Sheffield, whose copyright drawings were of great assistance to us in the preparation of Fig. 1 (p. 249).

Picture Transmission from Mars

THE pictures of the surface of the planet Mars, taken by the Mariner IV spacecraft in July, were transmitted the 134,000,000 miles to earth by a 10-watt transmitter using binary digital coding. Because of signal/noise ratio limitations the television pictures, generated at a high information rate of 10,700 bits/second, were first recorded on magnetic tape then subsequently played back for transmission to earth at a slow rate of 8.33 bits/second. A picture generated in less than a minute consequently required about 8 hours to transmit to Earth.

Each transmitted picture was made up of 40,000 picture elements arranged in 200 lines. The tonal scale of the picture from black to white was quantized into 63 levels, and the level for each element was signalled to Earth by a 6-bit code. Interlaced with the digitized picture information were other digitized data from the spacecraft telemetry system. Received signal power at Earth stations at Johannesburg, Madrid and Goldstone, Calif., was about 10^{-20} watt.

Electronics at Sea

EARL MOUNTBATTEN, who retired as Chief of the Defence Staff on July 16th, speaking at the dinner of the Institution of Electronic and Radio Engineers on June 24th drew comparisons between the cost of radio and electronics in the vessels of the Royal Navy during his 42 years in the Service in which he was commissioned as a wireless officer. The wireless equipment in his first ship, the battlecruiser *Lion*, was valued at £900. The electronic equipment of the aircraft carrier *Ark Royal* in 1939 was valued at £13,500 and our latest guided missile destroyer the *Fife* will have electronic equipment worth £3.2M.

Amateur Moonbounce

KP4BPZ, the amateur transmitting station near Arecibo, Puerto Rico, which helped to make history last summer when the first transatlantic contacts were made by moon reflection on 432 Mc/s recently provided further opportunities for a repeat performance. The hemispherical reflector at the Cornell University Ionospheric Laboratory Arecibo was used in moonbounce communication with amateurs while the moon was within range. Initial reports include reception by two or three amateur stations in the U.K. and an unconfirmed report of two-way working from Zurich.

Standard Frequency Stations.—The services and schedules of the National Bureau of Standards stations are given in Miscellaneous Publication 236. They include standard radio frequencies, standard audio frequencies, standard musical pitch, standard time intervals, time signals, UT2 corrections, radio propagation forecasts and geophysical alerts. These broadcasts are radiated by four transmitters:—WWV, Greenbelt, Maryland, 2.5, 5, 10, 15, 20 and 25 Mc/s; WWVH, Hawaii, 5, 10 and 15 Mc/s; WWVB, Fort Collins, Colorado, 60 kc/s; and WWVL (also at Fort Collins) 20 kc/s. The publication can be ordered from U.S. Government Printing Office, Washington, D.C., price 15 cents.

Journals Merge.—The journal *British Communications and Electronics* has ceased as a separate publication and has been merged with our sister journal *Industrial Electronics*. The scope of *I.E.* is to be broadened to cover the fields which came within the purview of *B.C. & E.*

The potentialities of an internationally managed global **satellite communications system** are reviewed in a survey by G. K. C. Pardoe, of Hawker Siddeley Dynamics, in the August issue of *Science Journal*.

Technical Co-ordination of European Manufacturers.—Formed during 1964, the Committee of European Associations of Manufacturers of Passive Electronic Components (C.E.P.E.C.), has been responsible for fostering co-ordination in technical matters between European manufacturers. Six nations are represented on the board, and a committee of seven technical executives has been established. Each executive is responsible for a particular subject—capacitors, resistors, ferrites, electro-mechanical components, general questions and microcircuits. Gt. Britain is represented on the committee by two R.E.C.M.F. members, A. G. Manson (Plessey) and P. G. Williams (Mullard) who deal with resistors and microcircuits respectively.

Collation of Component Failure Data.—The question of the reporting of component failures has been discussed unofficially by the Reliability Sub-Committee of the Radio and Electronic Component Manufacturers' Federation, the Electronic Engineering Association, the Society of British Aerospace Companies and representatives of Government establishments. The R.E.C.M.F. states that if a suitable central collating body were established, there is much useful data which could be passed back to component manufacturers, thus leading to greater reliability and improvement in design.

Royal Society Award.—The Royal Society's S. G. Brown Award and Medal has been presented this year to F. T. Bacon, consultant to Energy Conversion Ltd., for his work on the development of fuel cells. The award is made for an outstanding contribution to the promotion and development of mechanical inventions. Mr. Bacon was nominated by the Institution of Mechanical Engineers.

Electronics and Shipping.—With the aim of bringing to the attention of shipbuilders, shipowners, and specialist engineers "the impact that electronics can have on the economies of building and running ships" the Scottish sections of the I.E.E. and I.E.R.E. are planning a symposium for next year. It will cover electronics, measurement and control and will be held at the University of Strathclyde, Glasgow, from April 12th to 15th. Further information can be obtained from K. A. Murphy, 50 Holeburn Rd., Newlands, Glasgow, S.3.

Conference on Phonons.—The Institute of Physics and Physical Society is arranging a conference on phonons to be held at the University of Edinburgh on April 6th and 7th, 1966. The conference will be concerned with theoretical and experimental work on phonons, including electron-phonon, neutron-phonon, photon-phonon and phonon-phonon interactions, the interpretation of phonon dispersion curves and phonons in imperfect crystals and in liquids.

Northern Electronics Exhibition and Convention.—The twentieth annual Electronics, Instruments, Controls and Components Exhibition and Convention, organized by the Northern Division of the Institution of Electronics will be held during the period September 28th to October 2nd, inclusive, at Belle Vue, Manchester. Admission tickets are obtainable, free of charge, from the General Secretary, W. Birtwistle, 78 Shaw Road, Rochdale, Lancs.

I.A.R.U.—Yugoslavia is to be the venue of the next Region 1 Conference of the International Amateur Radio Union. It will be held in Opatija from May 22nd to 29th next year and the Radio Society of Yugoslavia (S.R.J.) will be the host society.

Reprints are now available of the *Wireless World* Crystal-Controlled F.M. Tuner (originally published in July 1964), price 3s, and J. Dinsdale's Transistor High-Quality Audio Amplifier (originally published in January and February 1965), price 5s.

Correction.—We regret the error in Fig. 2 on p. 204 of the April issue where Tr3 and Tr4 should have been shown as n-p-n transistors.

Divisional Organization of E.E.A.—To facilitate collective action by member companies in both home and overseas markets for British electronic capital equipment, the council of the Electronic Engineering Association has formed aviation, space, maritime, computer, broadcasting, industrial electronic and radio communication divisions to cover individually markets for equipment in these fields. A Central Technical Committee is responsible for the implementation of Council policies in the common matters of standardization, environmental and reliability testing, components, techniques, inspection, etc., but the divisions will be entitled also to initiate activities in these fields on their own account.

TV Levy to Help Finance B.B.C.?—The suggestion that the money derived from the Government levy on independent television companies should be used to help finance the B.B.C. and thus reduce the licence fee, has been made by R. B. Henderson, managing director of Ulster Television. In the course of an address to the Institute of Public Relations in London he said "If the B.B.C. is in financial trouble let it be given the millions of pounds taken by the levy on I.T.V. This might reduce, instead of increase, the licence fee. The money has been earned by television—why not let it stay there?"

I.E.E.T.E. Membership.—By the end of May—two months after recruitment began—5,000 members of the Association of Supervising Electrical Engineers had been admitted members of the recently formed associate organization the Institution of Electrical & Electronics Technician Engineers. Among the new members of the Council are Prof. M. W. Humphrey Davies (Queen Mary College, London), J. Redmond (B.B.C.), and H. Stanesby (G.P.O.).

BBC-2 for the West.—On September 12th, the B.B.C. introduces BBC-2 on channel 51 (vision 711.25 Mc/s, sound 717.25 Mc/s) when the new u.h.f. transmitter at Wenvoe commences broadcasting to viewers in parts of North Somerset and South Wales. Test transmissions are expected to start about three weeks before.

PAL Transmission Times Altered.—The times of experimental colour transmissions by the B.B.C. from Crystal Palace on Channel 33 were changed on 19th July. Transmission times—Monday to Friday inclusive—are 14.15 to 17.00 and for about 45 minutes after the close-down of BBC-2.

Broadcast Subscription TV which has been operating experimentally for over two years in Hartford, Conn., has been given a three-year extension by the Federal Communications Commission. Zenith's Phonevision system is used in this pilot scheme operated by RKO General.

Duty Remission on Instruments and Apparatus.—The President of the Board of Trade has raised from £20 to £30 the minimum value of instruments and apparatus on which remission of import duty can be claimed.

Increased Use of Transistors by G.P.O.—The Post Office is using more transistors in its inland telephone networks. The use of valve amplifiers necessitated large power supplies and buildings sited near power cable routes. Use of transistor amplifiers has reduced size and power requirements so that amplifiers can be housed in footway boxes at the roadside and fed by lower current capacity cables.

"Electrons in Harness."—The Mullard Film Service recently released their latest colour production "Electrons in Harness." The film tells an interesting story of electrons in the research laboratory, and covers a wide range of applications including quantum electronics in transistors, lasers and masers. Running time 40 minutes. Available on free loan on application to Mullard Film Service, Mullard House, Torrington Place, London, W.C.1.

PERSONALITIES

Dr. Vladimir K. Zworykin, who earlier this year received the I.E.E. Faraday Medal, "for his notable achievements, including the invention of the iconoscope, and for his important role in medical electronics" has been elected a Fellow of the Television Society. Dr. Zworykin, who is 75, has been with R.C.A. since 1929 and is now honorary vice-president. He has throughout devoted himself to the activities of the company's research laboratories and is also responsible for the direction of a Medical Electronics Centre at the Rockefeller Institute in New York.

F. C. McLean, C.B.E., director of engineering with the B.B.C. for the past two years, has also been elected a Fellow of the Television Society. Mr. McLean, who is a graduate of Birmingham University, was with Standard Telephones & Cables for 12 years before joining the B.B.C. as head of the transmitter section in 1937.

T. Kilvington, B.Sc. (Eng.), M.I.E.E., head of the Radio Planning and Provision (Internal) Branch of the Post Office Engineering Dept., has succeeded **G. B. Townsend**, B.Sc., as chairman of the Council of the Television Society. Mr. Kilvington, who graduated at University College, London, in 1934, joined the Post Office Research Laboratories, Dollis Hill, in 1936. He was for two years secretary of the Technical Subcommittee of the Government Television Advisory Committee and has been a member of a number of delegations to international conferences. In his present post he is responsible for the planning and provision of microwave radio relay networks in the U.K.

E. H. Bruce-Clayton, who has held executive positions with International Aeradio Ltd. since its formation in 1947, recently joined Standard Telephones and Cables as Aviation Marketing Manager.



E. H. Bruce-Clayton

W. R. Fletcher, B.Sc.(Eng.), A.M.I.E.E., has been appointed Superintendent Engineer (television studios and outside broadcasts) in the B.B.C. to succeed **J. E. F. Voss**, B.Sc., A.M.I.E.E., who, as announced last month, has been appointed Chief Engineer, Administration. Mr. Fletcher joined the Corporation in 1936 and served at various transmitters until 1949, when he was seconded to serve as Chief Engineer of Radio Ceylon. Two years later he became resident engineer at the B.B.C. Far Eastern Broadcasting Station near Singapore. He returned to this country in 1955 and since 1958 has been Head of Engineering, North Region, with responsibility for the engineering services of the sound and television studios and outside broadcast units in the North of England.

R. H. L. Cooke, a director of M.E.L. Equipment Company Ltd., has been installed as president of the Scientific Instrument Manufacturers' Association. For some time he has been active in the nucleonic section and has served on the medical group and central publicity committees; he was elected to the Council in 1963. Mr. Cooke is a founder member of the Society of Non-destructive Examination.

Matthew J. H. Brady, who joined Bush Radio 18 years ago and was until recently in charge of the Bush service department at Kew, has been appointed technical liaison manager of the Rank-Bush Murphy marketing department. Prior to joining Bush he was with the Philco Radio Corporation.

G. P. Hobbs, B.A., Grad.I.E.E., who contributed the series of articles on practical transistor circuit design in *Wireless World* last year, has gone to the U.S.A. and joined the Ampex Corporation. He had been with Marconi's in the closed-circuit television division working on the design of transistor equipment since graduating at Christ Church, Oxford, in 1961.

J. I. Bernard, B.Sc.Tech., M.I.E.E., until recently director and secretary of the Electrical Development Association, has joined the board of Oliver Pell Control Ltd., the Woolwich manufacturers of Varley products. While with the E.D.A., Mr. Bernard was responsible for the establishment of the Association's Testing House at Leatherhead.

Henri de France, inventor of Secam, the French colour television system, has been awarded the cross of the Legion of Honour by President de Gaulle.

J. W. Soulsby has been elected chairman of the Radio Officers' Union for the eleventh successive year. He became a seagoing radio officer with the Marconi Company in 1918 and has been a member of the Union's executive committee since 1944. He has been chief radio officer of the British India Steam Navigation Company's *Uganda* for some years.

R. F. Wilson, B.Sc., A.R.C.S., has been appointed research commercial manager of the Electrical Research Association at Leatherhead, Surrey. After graduating at Imperial College, London, he joined the Material Department of E.R.A. in 1959 and worked on



R. F. Wilson

research on the dielectric properties of aluminium oxide. He then went into industry until his new appointment with the Association where he will be engaged on negotiating research contracts with member firms.

E. R. Ponsford, one of the founders of Solartron, who has been managing director of the group for the past year has also assumed the chairmanship on the resignation of **J. Riboud** who has become president of Schlumberger Ltd., the American parent company. **John E. Bolton**, M.A., who joined Solartron in 1951, and was deputy chairman, has resigned.

Donald S. Reid, M.A., who two years ago became chief engineer of Sierra Leone Television, Freetown, has been appointed chief engineer of the Eastern Nigeria Broadcasting Corporation in Enugu. He was at one time with Marconi's at Chelmsford but immediately prior to going abroad was at the Rank Cintel Television Development Laboratory. Mr. Reid was for some years honorary secretary of the British Amateur Television Club.

Alan E. Crawford, M.I.E.R.E., Assoc. I.E.E., has joined Radyne Ltd., as manager of the new Ultrasonic Products Group. He was recently divisional manager of the Sonics Division of Elliott Bros. (London) Ltd., and previously chief engineer of Brush Clevite Co. Ltd., which he joined in 1955.

John E. Rees, B.Sc.(Eng.), A.M.I.E.E. has been appointed chief engineer of Hatfield Instruments Ltd. of Plymouth,



J. E. Rees

Devon. Mr. Rees who studied electrical engineering under Professor R. O. Kapp at University College, London, went to G.E.C., Coventry, after graduating in 1945. Four years later he joined Marconi's where until his present appointment he had been leading a section at Great Baddow concerned with the design and development of marine radar and associated equipment.

J. W. Woods, who earlier this year resigned as director of Antiference Ltd. and the Antiference Group of Companies, has joined the board of the J Beam Aerials Group as commercial director. He had been with Antiference since shortly after leaving the R.A.F. in 1946. J Beam Aerials Ltd., who until recently were connected with Associated Aerials Ltd., of Strood, are now established in their new factory in Northampton.

S. R. Jarvis, who joined the Advance Group in 1958 and has successively been export manager, instrument sales manager and, since last year, sales manager of Advance Controls Ltd., has been appointed to the board of the latter company. Prior to joining Advance he was an engineer with F. C. Robinson and Partners, in Manchester.

D. G. Troll, B.Sc.(Mech.Eng.), recently joined Dewhurst & Partner, manufacturers of electro-mechanical equipment, as chief development engineer. Mr. Troll has been for several years in the United States where he was a consultant.

OUR AUTHORS

S. L. Hurst, B.Sc., (Eng.), A.M.I.E.E., A.M.I.E.R.E., who on p. 372 describes electronic experiment kits, has been a lecturer in the Electrical Engineering Dept. of Bristol College of Science and Technology since 1961. He was a graduate apprentice with B.T.H. (now part of A.E.I.) from 1945 to 1950. He then joined Westinghouse Brake and Signal Co., as an electronics design and development engineer. While with Westinghouse he was engaged on the development of the first transistor remote control and supervisory railway signalling equipment.

H. M. Workman, author of the article in this issue on double line synchronization, joined Ferguson Radio Corporation in 1950 after attending a technical college in India. After experience in test and inspection procedures he transferred to television development work in 1952. He was in Australia in 1957/58 helping to establish a Television Engineering Department for Thorn Electrical Industries. After returning to the U.K. he took a leading part in the development of one of the first all transistor television portables in this country, and since then has concentrated on dual system and colour television techniques.

OBITUARY

Sir Ernest Fisk, who retired from the managing directorship of Electric and Musical Industries Ltd. in 1952, recently died in Sydney at the age of 78. Sir Ernest, who was knighted in 1937, was with Marconi's for four years before going to Australia in 1910. He was

general manager and later managing director of Amalgamated Wireless (Australia) Ltd. from 1913 until returning to this country in 1944 to join E.M.I. He received the first direct transmissions from this country to Australia in 1918.

Frank Axon, O.B.E., D.C.M., who retired from the position of chief engineer, external broadcasting, in the B.B.C. three years ago, died on June 8th. Mr. Axon joined the Corporation in 1941, in what was then the overseas and engineering information department, of which he became head in 1951. Two years later he was appointed to the post from which he retired. He was responsible for much of the modernization of the B.B.C.'s short-wave installations, both in this country and overseas.

John Thoroughgood, at one time a sales engineer and latterly chief publicity executive of English Electric Valve Co., died on June 15th at the age of 56. After war service with R.E.M.E., during which he lectured on radar equipment, he joined Denco (Clacton) Ltd., as an engineer. Since 1951 Mr. Thoroughgood had been with the English Electric organization, first with the parent company where he produced instruction manuals and promotional literature for the Television Department, and for the past 11 years with E.E.V.

John E. Harris, chairman and managing director of Bullers Ltd., the porcelain insulator manufacturers of Stoke-on-Trent, died on June 28th, aged 62. He had been with the company over 43 years.

CLUB NEWS

A **symposium** on amateur radio is to be held at the Residential Youth Centre, Ollerton, Notts., on September 11th and 12th. Organized by the Newark and District Amateur Radio Society, it is primarily intended to introduce amateur radio to youth leaders and others, although there will be lectures for radio amateurs. A radio station (GB3RH) will be set up at the centre and will be operated by members of radio societies attached to two Newark schools. The fee for the full residential course is two guineas. Further details can be obtained from S. Denner, 68 Hawton Road, Newark, Notts.

Manchester V.H.F./U.H.F. Convention.—The North West V.H.F. Group is organizing a convention and dinner at the Grosvenor Hotel, Deansgate, Manchester, on September 18th. The cost will be 25s. Further details from G. Barnes (G3AOS), 5 Prospect Drive, Hale, Barnes, Cheshire.

Basildon.—With the co-operation of the town's education committee, the Basildon and District Amateur Radio Society is sponsoring a course at the Fryerns Evening Institute in preparation for the Radio Amateur Examination. It will be held on Monday evenings commencing September 20th. Details are obtainable from C. Roberson (G8AAO), Milestone Cottage, London Road, Wickford, Essex.

Halifax.—At the August 4th meeting of the Northern Heights Amateur Radio Society, N. Niman (G3LGN) will discuss d.f. equipment. On the 18th a recorded lecture by an American amateur, S. S. Perry (W-BB), entitled "Top-band DX-ing" will be given to members. Fortnightly meetings are held at 7.30 at the Sportsman Inn, Ogden. The club will be operating a demonstration station at the Halifax Agricultural Show on August 14th.

DOUBLE LINE SYNC

By H. M. WORKMAN*

INCREASING TELEVISION LINE SYNCHRONIZATION RANGE BY DELAYED PULSES

WITH the introduction of dual-system television receivers there has been a tendency to standardize on the use of line flywheel synchronization. One reason for this is due to the difficulty of obtaining acceptable phasing (correct positioning of the picture information within the raster) on both systems without considerable line tear. Another likely factor could be the widespread use of line flywheel sync on continental receivers. It has to be remembered that in operating on the v.h.f. bands satisfactory line sync, i.e. minimum line tear, must be considered in the presence of high amplitude impulse interference, whereas in the U.K., the 625-line system is only used on u.h.f. where impulse interference is almost non-existent.

The use of flywheel sync introduces its attendant problems of:—

- (a) difficulties of servicing loop systems,
- (b) a more involved adjustment procedure for setting the line hold control, from the user's viewpoint,
- (c) circuit reliability is decreased with the increase in the number of sync components, and the dependence upon the line output stage for a reference voltage involving yet further components or additional windings.

Direct sync does not suffer from any of these disadvantages, but has a greater tendency to random line synchronisation due to noise (line tear) than flywheel sync in medium to low signal strength areas.

However, the service area for the u.h.f. transmissions is quite considerable and this together with the growth of line-operated television receivers does not really justify the use of flywheel sync circuits, except in very exceptional cases and these can be satisfied by an add-on flywheel unit.

The conditions for direct sync can now be examined. In direct synchronization the sync pulse controls the timing of the line oscillator without the use of any additional circuits. The phasing of the oscillator is determined by the duration of the front porch of the composite video waveform, the flyback time of the line circuit and the tightness of lock.

The duration of the front porch is a fixed parameter but the flyback time and tightness of lock are under the control of the circuit designer.

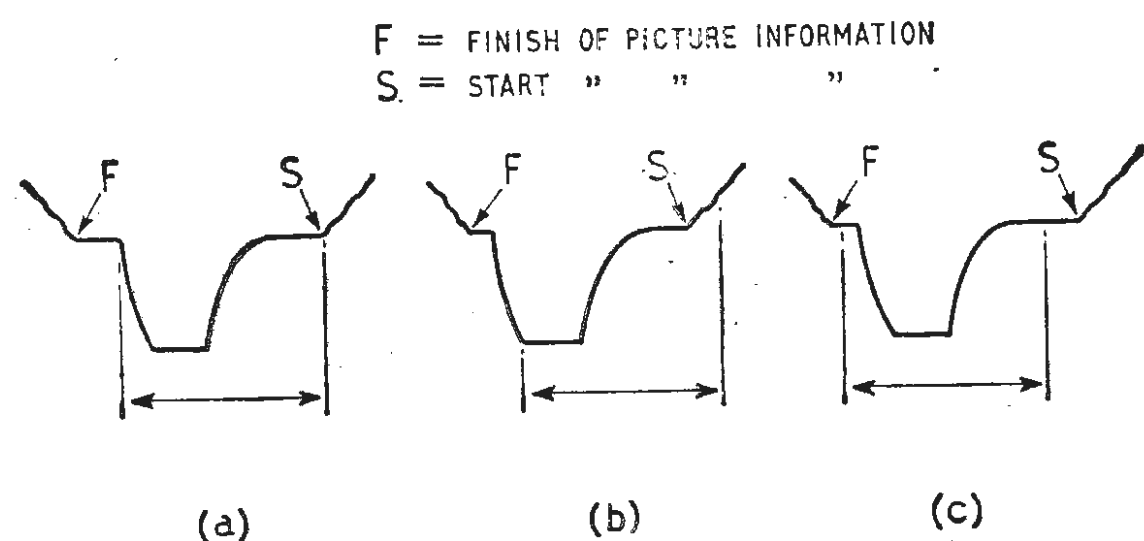

Fig. 1. (a) Foldover just not occurring when flyback commences at start of sync pulse. (b) Foldover occurring at start of picture when flyback commences after start of sync pulse. (c) No foldover when flyback commences before start of sync pulse.

If the flyback time were fast enough ($10.5 \mu\text{s}$ for a 625 line transmission) the picture information could be centrally disposed with equal areas of the raster each side of it. The more practical flyback time of $11 \mu\text{s}$ leaves no margin for phasing errors. (By phasing is meant the positioning of the picture information within the raster during rotation of the line hold control which is illustrated in Fig. 1.) Phasing the picture to the right to avoid fold-over on the left introduces a condition of incipient loss of synchronism on changing channels or due to warm-up drift within the receiver. Phasing the picture to the left causes fold-over along that side.

The delay in the start of the flyback caused by the front porch produces the basic problem of avoiding fold-over at the start of the scanning cycle, requiring that the line output valve is capable of being cut-off immediately the sync pulse starts. This condition is almost achieved by using a lock so tight that the commencement of the sync pulse and flyback occur simultaneously. This permits very little mis-phasing of the picture information with setting of the line-hold control but this causes a poor noise performance, i.e. excessive line tearing in medium to weak signal areas.

The unwanted delay introduced by the front porch can be overcome by delaying the picture information relative to the sync pulse by a time period equivalent to the front-porch interval. Then the finish of the picture information would coincide with the start of the sync pulse. The delay line would have to be placed before the detector load and an additional amplifier would be necessary to drive the sync separator. Such a line of the former-wound type suitable for working into a $2\text{k}\Omega$ load would be about 15in long by $\frac{1}{16}$ in dia. to have a satisfactory response up to 6Mc/s .

Attempts to use the back edge of the sync pulse suitably delayed to switch the line oscillator off gives loss of synchronism during the frame flyback because of loss of the back edges.

Neither of these methods is satisfactory and a more direct method is desirable which allows the picture to be phased to the right until fold-over commences without loss of synchronism, enabling correct phase within the total picture time to be achieved.

This thinking has led to the development of a novel line sync circuit in which the line oscillator can be locked solidly at any phasing between the extremes of picture fold-over at the left to fold-over at the right. A further important feature is that at a particular setting of the line hold control there is a very great reduction in line tear.

Basically the circuit employs a supplementary sync pulse in addition to the direct or normal sync pulse in such a manner that when the normal sync begins to lose control over the phasing of the line oscillator, the supplementary sync extends the useful synchronization range over which correct phasing occurs. Fig. 2 shows the extra synchronization range obtained with such an arrangement.

The supplementary sync pulse of the correct polarity is

*Ferguson Radio Corporation Ltd.

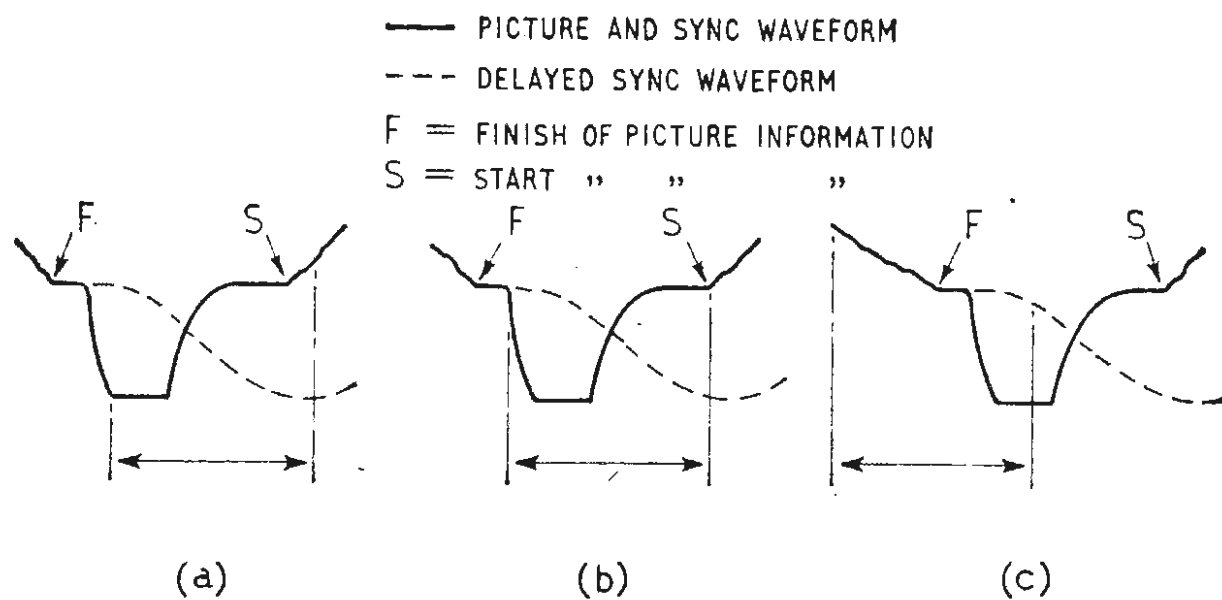

Fig. 2. (a) Foldover occurring at start of picture when flyback commences after start of sync pulse. (b) Foldover just not occurring when flyback commences at start of sync pulse. (c) Foldover occurring at finish of picture when flyback commences before scan period is over. (a) and (b) show synchronization range with direct sync. (a) and (c) show synchronization obtained with direct and delayed sync.

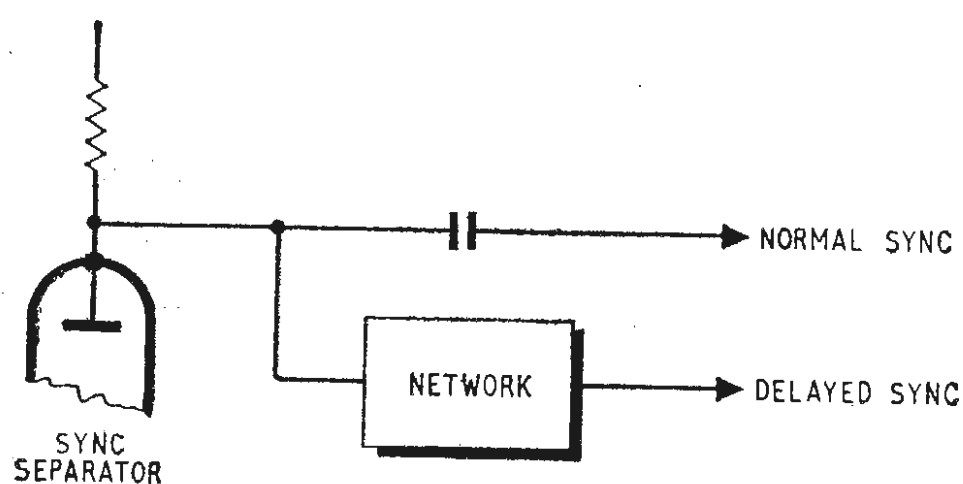

Fig. 3. Location of delay network.

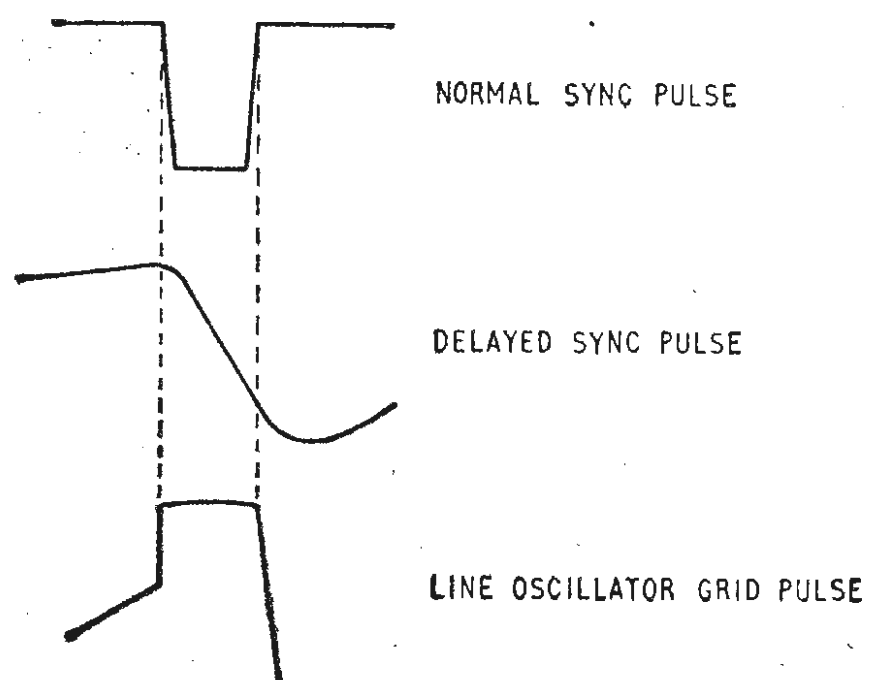

Fig. 4. Relative positions of pulses.

delayed and suitably shaped so that when the normal sync commences to lose control over the oscillator, the supplementary or delayed sync takes command and acts to switch-off the line oscillator. The form of the delayed sync pulse is important. Should it be too steep it will tend to take over earlier from the normal sync and thus cause jitter. If it is too slow, the phase of the picture will move rapidly as the line-hold control is varied beyond the lock-in range of the normal sync. Fig. 3 shows the basic essentials of the circuit, whilst Fig. 4 shows the relative positions of the pulses for one particular phasing.

A delay line may be used to produce the delayed sync and a mismatch is allowed by raising the terminating resistance value, in order to avoid large coils. A diode is necessary to damp ringing which would otherwise extend to the succeeding sync pulse period causing additional

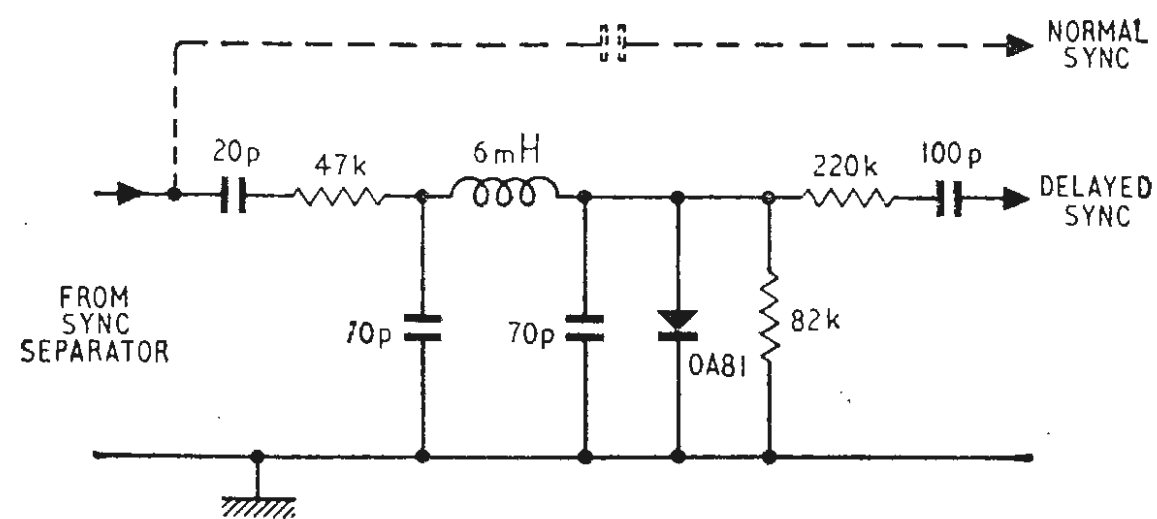

Fig. 5. Delay line with $3\mu\text{s}$ delay.

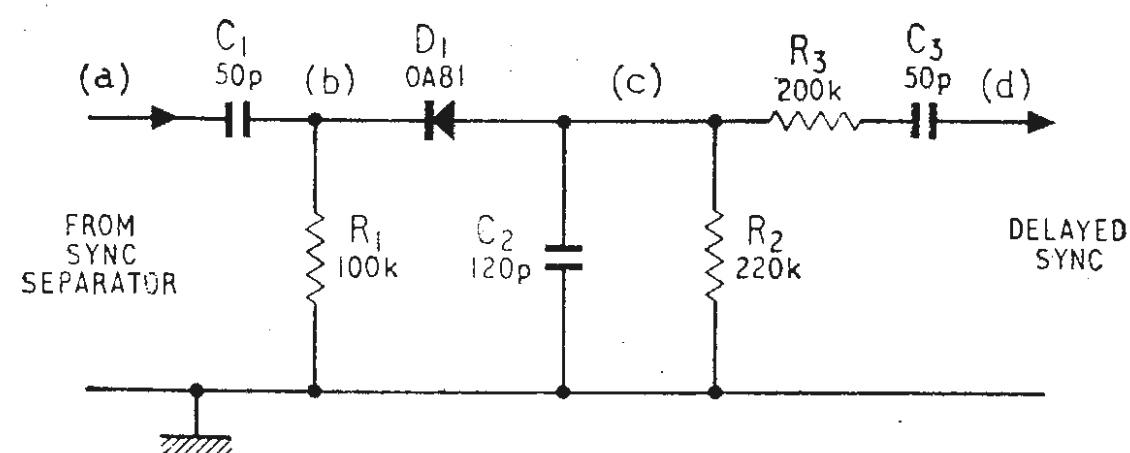

Fig. 6. Delay circuit avoiding use of inductor.

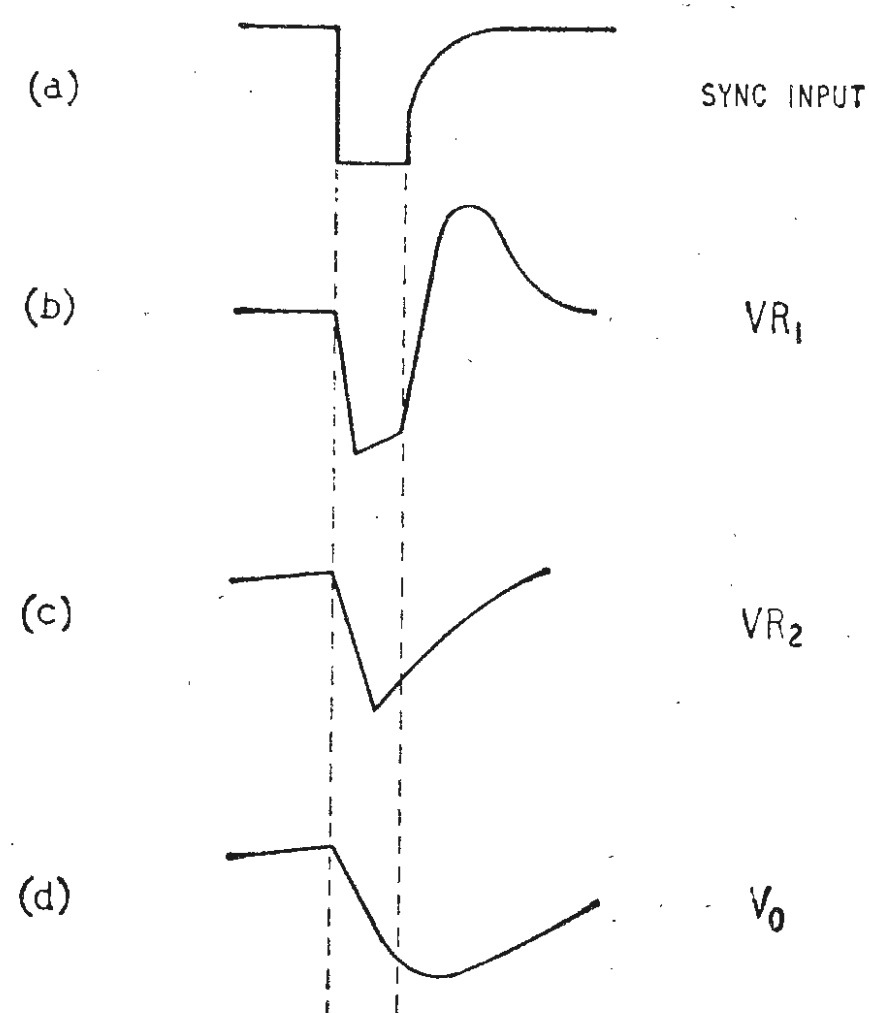

Fig. 7. Formation of delayed sync pulse. The waveforms are those occurring at points indicated in Fig. 6.

tear in low signal strength areas. The input to the delay line is differentiated to avoid disturbance by the frame sync pulses. This differentiator also helps to reduce the loading on the sync separator anode. The output pulse is integrated by a series resistance and the oscillator grid capacitor in series with 100 pF . The simple single section line shown in Fig. 5 has a delay of $3\mu\text{s}$, a nominal termination of $20\text{ k}\Omega$ and a cut-off frequency of 100 kc/s . The pulse produced is considerably rounded but this is not of any consequence. The delay is just sufficient for a line oscillator grid pulse width of $6\mu\text{s}$.

Another circuit is shown in Fig. 6, the use of a wound component being avoided. The input pulse is differentiated as previously by R_1, C_1 . The diode D_1 and time constant R_2C_2 form a pulse lengthening circuit; C_2 is charged during the sync pulse cycle and then discharges

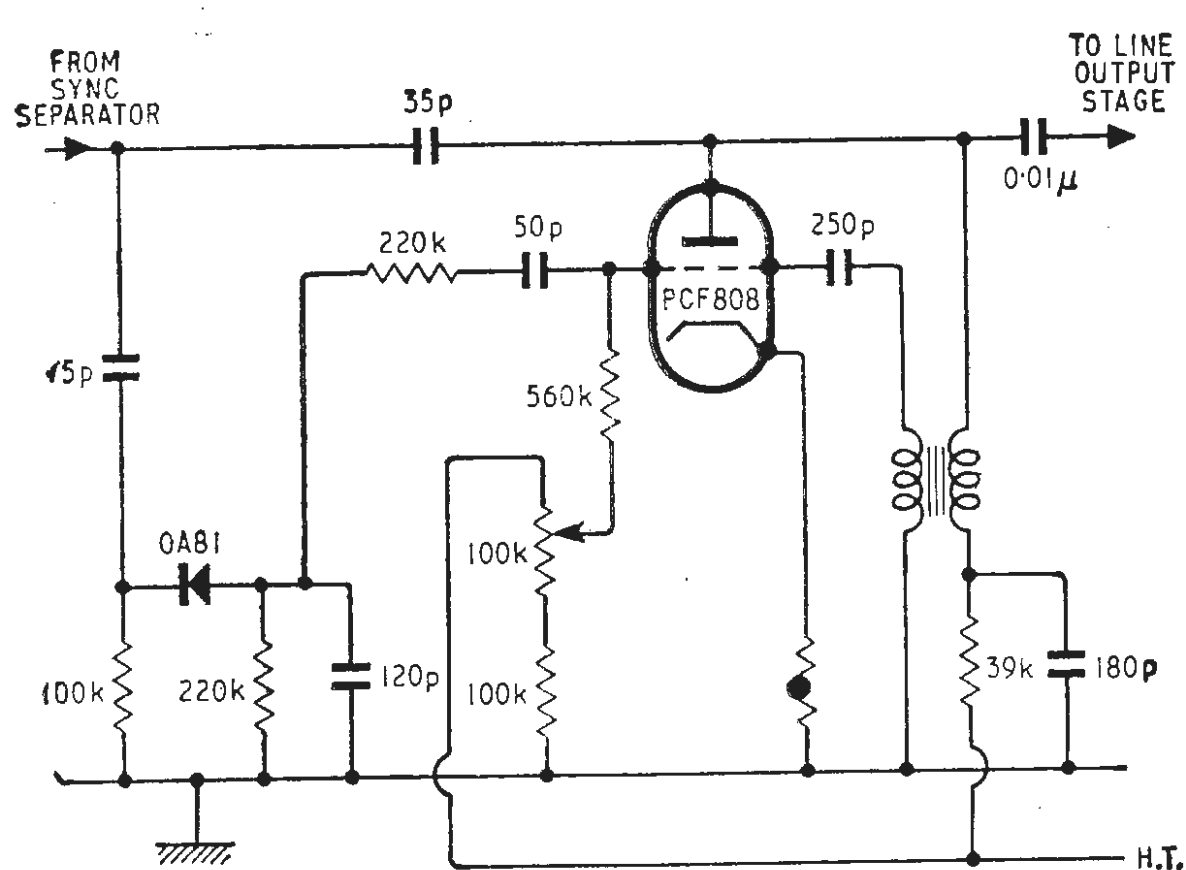

Fig. 8. Delay network applied to the Thorn 900 chassis.

slowly through R_2 . This output is then integrated into the oscillator grid by R_3 and C_1 . Fig. 7 shows the formation of the delayed pulse.

On weak signals the voltage developed across R_2 , C_2 during the leading edge of the sync pulse will contain noise since D_1 is conducting. The amplitude of the noise will be attenuated due to the integrating action of R_2 , C_2 . The further integrating action of R_3 , C_3 additionally attenuates the amplitude of noise, and a fairly clean sync pulse is obtained. The voltage of the normal (anode) sync will also contain noise from the same edge of the sync pulse.

When the normal sync just loses control and the

delayed sync assumes control of the oscillator, D_1 (Fig. 6) has been cut-off by the trailing edge of the differentiated sync pulse input, Fig. 7a. Thus when the picture is phased to the right or left some line tear may occur. Between these extremes a setting occurs where minimum line tear results. This setting is arranged to occur when the picture is approximately correctly phased. Hence, starting with the line hold control at the low-frequency end where the normal sync is operative, line tear due to noise results. Moving the hold control toward the high-frequency end the line tear reduces sharply to a minimum, and is the condition when the normal sync has just lost control of the oscillator, the latter being held in synchronization by the delayed sync. As the line hold is rotated still further, the oscillator is controlled by the rounded portion of the delayed sync pulse, Fig. 7. Under these conditions errors of small amplitude will cause large phase shifts and line tear becomes evident again.

Fig. 8 shows this application to a line blocking oscillator as used in the Thorn 900 chassis. Since the delayed sync has a relatively low slope (Fig. 7) the phase shift of the picture for a given change in the free-running oscillator frequency, can be large and therefore frequency drift of the line oscillator is an important factor.

The h.t. stability of the oscillator is acceptable but the temperature stability during the first 15 minutes requires correction. This drift is of the order of $+200$ c/s (free running) and is largely due to the temperature coefficient of the oscillator grid resistor. This drift can be countered by the use of a high stability resistor together with a grid capacitor of positive temperature coefficient. In practice a coefficient of greater than P470 is required which is difficult to manufacture in large quantities. An alternative solution of using a thermistor in the oscillator cathode was adopted which reduced the drift to less than 50 c/s.

H. F. PREDICTIONS — AUGUST

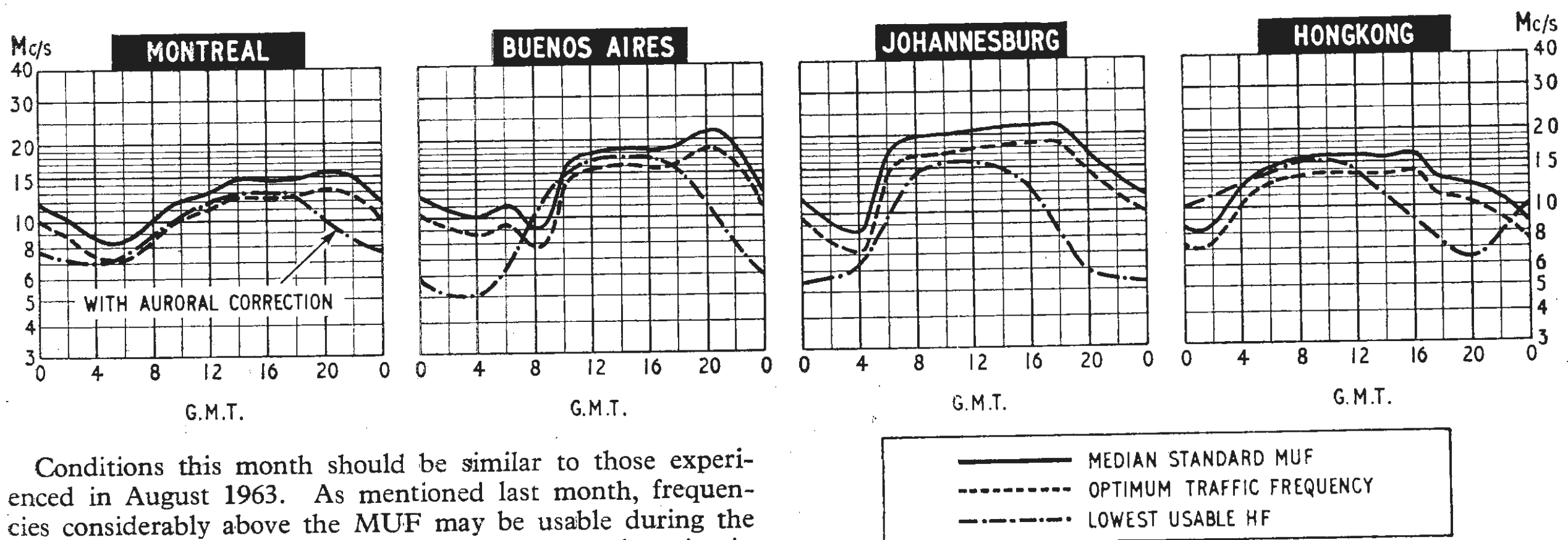

Conditions this month should be similar to those experienced in August 1963. As mentioned last month, frequencies considerably above the MUF may be usable during the daytime. For example for the Hong Kong-London circuit, frequencies up to 22 Mc/s will probably be usable at 0800GMT. These increases in MUF are thought to be due to Sporadic-E ionization.

The prediction curves show the median standard MUF, optimum traffic frequency and the lowest usable frequency (LUF) for reception in this country. Unlike the standard

MUF, the LUF is closely dependent upon such factors as transmitter power, aerials, and the type of modulation. The LUF curves shown are those drawn by Cable & Wireless for commercial telegraphy and assume the use of transmitter power of several kilowatts and rhombic type aerials.

LOCAL BROADCASTING

IS IT PRACTICABLE IN THE U.K. AND IF SO HOW?

SINCE the change of government last year, the new Postmaster-General, the Rt. Hon. Anthony Wedgwood Benn, has been looking into the country's broadcasting services for ways to improve what we already have and also into the possibilities of introducing new services—local broadcasting being one of these. The P.M.G. has refused to comment on any of these topics, except to say the whole situation is under review and that a White Paper will be issued as soon as possible. Until that time—probably in the Autumn or perhaps later—many questions remain unanswered and it is the intention of this article to survey the local broadcasting situation and outline what is considered to be a workable plan.

The majority of people in this country live close to their work and spend most of their time within ten miles of their "castles." It follows, therefore, that many have interests in local affairs—a fact that can be confirmed by consulting the net sales of local newspapers. Would they, however, be interested in another communications medium? This seems to be the question at stake.

According to the Pilkington Report, presented to the previous Government three years ago, there is a need for local broadcasting, but the Report adds, "In representations submitted to us there was little evidence of significant, spontaneous public demand. . . . The B.B.C.'s plan for local sound broadcasting was supported by the Corporation's National Broadcasting Councils, by several of its Advisory Committees and by many external organizations. The Corporation reported that its 'trial runs' [discussed later] had aroused much interest in the towns where they had been conducted. The companies proposing to engage in local commercial sound broadcasting offered almost no evidence of public demand. Their proposals were supported by a few external organizations; but the support was addressed mainly to the use of sound broadcasting for advertising rather than for an additional service. In short, the evidence of demand is inconclusive."

But surely, as the Report points out, if people do not know what they are missing, they cannot be said not to want it?

Are the frequencies available?

With reference to frequency space there seem to be two alternatives open to local broadcasting: to use the medium-waveband or to use Band II, part of which is used by the B.B.C. for its national v.h.f. sound services. Neither of these contravene any of the conventions upheld by the British Government concerning frequency allocations.

Medium-wave band

At the European Broadcasting Convention held in Copenhagen in 1948, the United Kingdom was allocated two exclusive medium-waveband frequencies and eleven shared frequencies. In addition to this Britain is allowed to use the two International Common Frequencies (1484 and 1594 kc/s) but power must not exceed 2 kW.

Since the Copenhagen Agreement, the number of medium-waveband stations in Europe has increased considerably and the Agreement can no longer be regarded as effective for interference-free listening. During daylight hours, however, radiation from these stations is limited, making the medium-waveband suitable for local broadcasting from dawn to dusk. Should Britain require more frequencies, she could transmit on frequencies other than those allocated to her, provided no interference is caused to the countries observing the Agreement.

If a system is to be introduced, surely it must not be restricted to day-light hours as would be the case if the medium-waveband were selected?

V.H.F. bands

The European Broadcasting Conference in Stockholm in 1961 assigned the frequencies to be used in the v.h.f. and u.h.f. bands (I to V). Those allocated to countries in the European Broadcasting Area for sound broadcasting are in Band II which extends from 87.5 to 100 Mc/s. Not all of this Band is used for broadcasting in the United Kingdom as (according to the radio regulations issued by the International Telecommunication Union in 1959) the frequencies between 87.5 and 88 Mc/s and from 95 to 100 Mc/s may also be used—and are—for the fixed and mobile services. In all some 40% of Band II is used for non-broadcasting purposes in this country.

Although the B.B.C. occupies most of the 100 kc/s channels in the 88 to 95 Mc/s section of Band II, it is still possible—by geographical separation—to accommodate a large number of low-power stations. The Post Office has stated that well over 200 single-frequency stations could be accommodated within this section, and if more were wanted at a later date, the 95 to 100 Mc/s part of Band II could provide as many again. There is, it would seem, room to launch a local broadcasting service in Band II.

The B.B.C.'s proposals

Sir Hugh Carleton Greene, the B.B.C.'s director-general, and Frank Gillard, the director of sound broadcasting, have both said publicly that the time has come to start the important task of introducing a service to meet local needs now that a 98% coverage has been achieved with the Corporation's national v.h.f. sound services which were started ten years ago.

The Corporation suggested to the Pilkington Committee that they should be allowed to build eighty to ninety local broadcasting stations in Band II over a period of four to five years. The staff required to run these stations, the B.B.C. stated, would, of course, vary according to local needs, but probably average twelve.

In an article published in the *Yorkshire Post* nearly two years ago, the B.B.C.'s director-general said "We played over to the Pilkington Committee a selection of recordings made during closed-circuit experiments in various localities and we told them about the local activities which we should expect our stations to cover—local

administrative politics, sport, weather, traffic problems, shopping and marketing facilities, schools and universities, libraries, museums and art galleries, industry and business, employments prospects, and so on. A pretty long list.

"As for public reactions, our experiments . . . brought us into close touch with local interests, and at least gave us more information on this subject than anyone else has. One can state with complete certainty that wherever we carried out our experiments we had the enthusiastic support of the local authorities, of the churches, of local industry . . . and the reactions of thousands of people who listened to the demonstration seemed to show that a service of this sort would meet with a very genuine welcome."

Educational possibilities

Sir Hugh has said that if the B.B.C. were required to make out a new case for local broadcasting, "we should put educational possibilities right in the forefront . . . as the whole atmosphere in the educational world and among politicians about the use of broadcasting for education has changed since the Pilkington Committee was hearing evidence.

"Let us turn over the evenings, when the mass audience is watching television, to meet the needs of people who are prepared to follow systematic courses in various subjects.

"Let us run the educational service as trustees for the local authority, the local university, the W.E.A., and other educational interests. The B.B.C. would provide the technical skill and the broadcasting expertise. It would offer the use of a central library of recorded

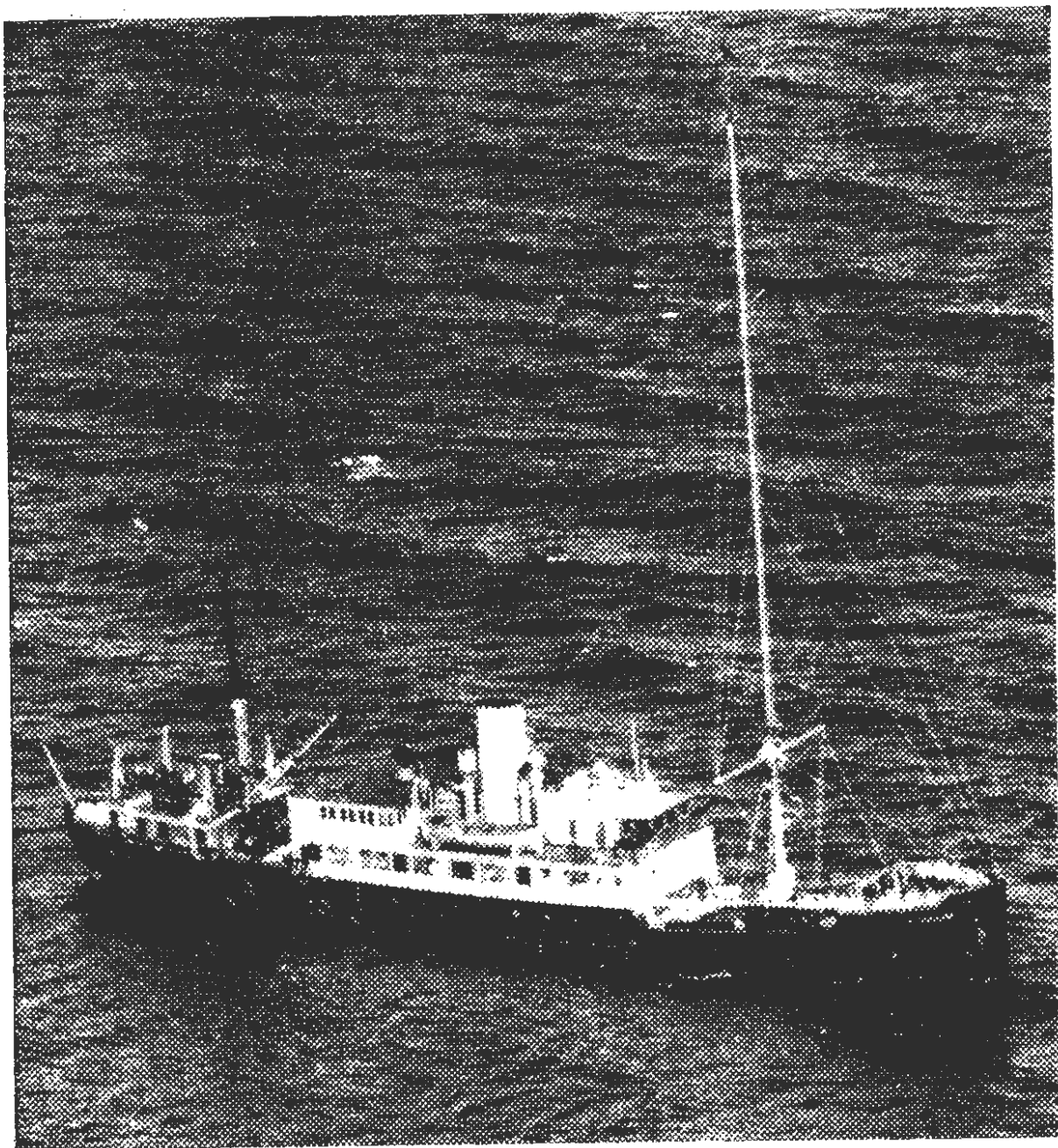

Radio Caroline, the 'pirate' ship shown above began broadcasting illegally on 28th March, 1964. Since that time the number of 'pirates' working off our shores has increased (now at five), as have their audience ratings which are now counted in millions. Whatever one may feel about these floating stations, they should not be confused with local broadcasting stations.

educational programmes. According to the availability of teaching talent, local interests would mount their own courses and series from the local studio.

"Education through broadcasting could, on this local basis, be a genuine two-way affair with the sort of intimate relationship between teachers and pupils which a national 'University of the Air' could never provide."

Commercial interests

More than one hundred private radio companies have been registered in recent years, with central bodies formed to look after their interests; one being the Local Radio Association. Another interested party in local broadcasting is the National Broadcasting Development Committee.

If licences were to be issued to these companies, would we have to put up with continuous pop music interlaced with ads? The "pirates" have shown this to be an easy way of making money. It is all too easy for a commercial organization to allow money-making to override all other considerations.

Cost of stations

Local radio stations are surprisingly inexpensive to build, according to Pye of Cambridge, who have been doing a lot of work in this field. They quote figures of approximately £1,000 for a 250-watt medium-wave transmitter and £2,000 for a 1,000-watt v.h.f. transmitter, both of which should provide adequate coverage for an area having a ten-mile radius. In addition one must of course add the cost of a studio, with all the necessary ancillary equipment. The estimated total capital cost for a station serving a town with a population of 50,000 to 100,000 would be in the region of £15,000 to £20,000.

Running costs vary considerably—and since there has been no similar service in this country which to base them upon—it is difficult to offer an estimate. However, operating costs in other countries suggest that small stations could be run for between £20,000 and £30,000 a year.

Number of stations

The number of stations needed seems to depend on two factors which, to some extent, are interlinked—how many frequencies are available and how local the service should be. To deal with the latter point first. According to the 1961 Census Preliminary Report there are 120 Boroughs or Urban Districts in the United Kingdom with populations exceeding 75,000. Nineteen of these are Metropolitan Boroughs (Greater London having a population of 8,172,000 and four are Scottish. This, however still leaves a lot of the United Kingdom not covered (for example, the whole of Northern Ireland and large parts of Scotland). Therefore, the minimum number of stations is in excess of 100 and probably nearer 200.

While it is not impossible to accommodate this number of stations in the medium-waveband, as stated earlier, they would not give a satisfactory service. In Band II, however, at least 220 single-frequency stations can be accommodated, with room for 500 or so later (if and when the 95 to 100 Mc/s part of the Band is returned).

Choice of scheme

The best choice, in my opinion, is a B.B.C. run local service with slot advertising—such as that employed in this country's commercial television service. Although

it is not possible to do this at the moment, according to the Licence and Agreement issued to the British Broadcasting Corporation on 19th December 1963, it needs only a letter from the Postmaster-General giving his permission.

The relevant clause (13) in the Licence and Agreement—which does not expire until 1976—is as follows: “The Corporation shall not without the consent in writing of the Postmaster-General receive money or any valuable consideration from any persons in respect of sending or emitting, or the refraining from sending or emitting, of any matter whatsoever by means of the stations or any of them, and shall not send or emit by means thereof any sponsored programme.”

Workable system

Assuming this permission is given, the system I envisage is as follows: Let the B.B.C. construct between 100 and 200 stations to serve areas with populations of 75,000 and above. This venture could be financed under a Government loan; the cost for say 150 single-frequency stations being in the region of £3,000,000.

A financially independent group, with its own director, should be set up for local broadcasting within the Corporation; as is already done for the external services. This group could then use the Corporation's facilities without—as some would say—prostituting the whole of the B.B.C.'s programmes through the inclusion of advertising.

The B.B.C. could easily provide balanced programmes, but to give an element of local control, a representative (or representatives) from each community should be given a say in the running of the station. Also, I believe that local newspapers, who have been providing the main communications medium for many years, should play a

part in local broadcasting. For example, they could provide the local news bulletins and—through their own medium—give programme information.

Advertising programme contractors should be appointed for each regional group of stations and be responsible for the whole of the advertising side—the B.B.C.'s job being to radiate it. As to the amount of advertising to be carried, the time ratio laid down for commercial television seems to be reasonable—six minutes in every hour. This, of course, would be specified by the Postmaster-General.

With regard to the number of hours allowed for broadcasting, a realistic daily period would seem to be from 6.0 a.m. to midnight, with three hours in the evening devoted to educational broadcasting (which would contain no advertising). This would make possible 90 minutes of advertising daily.

If one were to take the running costs to be in the region of £125 daily (£30,000 per annum), advertising revenue must be at least £250 and probably £500 daily to make the scheme profitable. In terms of cost per minute, this works out to be just under £3 for the lower figure to just over £5 to achieve the £500 mark. Based on these figures and giving the advertising contractor 30% for his services (and not a taxation on profits as in commercial television) a very handsome surplus would be obtained from the stations after deducting the running costs. In figures, taking both extremes of charges, the advertising contractor would receive something between £18,000 and £36,000 annually from each station leaving a surplus between £27,000 and £90,000. Thus, according to the estimated capital cost of stations, the Government loan could be re-paid within six months if necessary.

Couldn't the surplus revenue of these *local* sound broadcasting stations be used to relieve some of the burdens put upon the ratepayer?

D. C. R.

Books Received

Handbook of Transistor Circuits, by Allan Lytel. Describes the operation of more than 200 circuits reproduced by courtesy of American manufacturers. The circuits cover a wide range of applications of interest to the amateur and experimenter. Component values are specified, but some of the circuits are intended for operation from American mains, and when operated from 240 V mains supplies, relevant component values will require changing. Pp. 224. Price 35s. W. Foulsham & Co. Ltd., Yeovil Road, Slough, Bucks.

Transistors Applied, by H. E. Kaden. An interesting treatment of the theory of transistors covering their characteristics and operation as circuit elements. In the introduction, the transistor is compared with the valve; transistor theory is then unfolded in a logical sequence which includes the physics of the transistor, four quadrant characteristics, equivalent circuits, negative feedback, influence of temperature, high-frequency behaviour and circuit operation. Worked examples, given at various stages throughout the book, are used to illustrate practical applications of the theory. Pp. 194; Illustrations 128. Price 37s. 6d. Cleaver-Hume Press Ltd., 10-15, St. Martin's Street, W.C.2.

Signal Flow Analysis, by J. R. Abrahams and G. P. Coverley. A general exposition on the application of signal flow diagrams to circuit networks with particular reference to basic circuit configurations of transistors and thermionic valves. A feature of interest to the lecturer and student is the inclusion of a series of questions at the end of each chapter. Answers are given in an appendix. Pp. 157; Figs. 215. Price 17s. 6d. Pergamon Press Ltd., Headington Hill Hall, Oxford.

Matrix Algebra for Electronic Engineers, by Paul Hlawiczka. A presentation in two parts of the concepts of matrix algebra. Part 1 describes basic notation and manipulation and then progresses to applications of matrix algebra to equations of linear two-part networks. In part 2, the theory is developed to cover differentiation and integration of matrices and the methods of dealing with differential equations of passive linear circuits. Pp. 216; nearly 40 Figs.; price 45s. Iliffe Books Ltd., Dorset House, Stamford Street, London, S.E.1.

Transistor Specification Manual, by the Howard W. Sams Engineering Staff. Lists useful data on more than 3,500 transistors. American types are dealt with mainly, but many British, European and Asian types are included. Outline diagrams of all the listed types—both TO and non-standard—are given. Pp. 159; nearly 200 diagrams. Price 24s. W. Foulsham & Co. Ltd., Yeovil Road, Slough, Bucks.

Precision Electrical Measurements in Industry, edited by J. R. Thompson. Edited version of seven papers presented during the Proceedings of the Symposium on Procedures and Practices held at Hatfield College of Technology, November, 1963. Subjects covered by the papers are:—Precise Electrical Measurement—Some General Principles; Electrical Standards—Construction, Qualities, Care and Maintenance; Audio Frequency Measurements; A Simple Method for Checking Precision Decade Bridges; Precision Frequency Measurements; Radio Frequency Measurements; Measurement Laboratory Procedures and Records. Pp. 123; nearly 40 Figs.; Price 37s. 6d. Butterworth & Co. Ltd., 88 Kingsway, London, W.C.2.

PULSE SHARPENING WITH NON-LINEAR CAPACITORS

TWO methods of sharpening the leading edges of pulses and other waveforms to give risetimes of the order of 2 ns have been developed by A. R. Owens, G. White and colleagues at the University College of North Wales, Bangor. Both methods use non-linear capacitors formed by reverse-biased p-n junction diodes, in which an increase of applied reverse voltage causes a decrease of capacitance. In the first technique the diodes act as voltage-controlled shunt capacitors in a transmission line, into which the waveforms are fed (see figure). Since the delay of each LC section is \sqrt{LC} secs, the reduction of C by negative-going swings

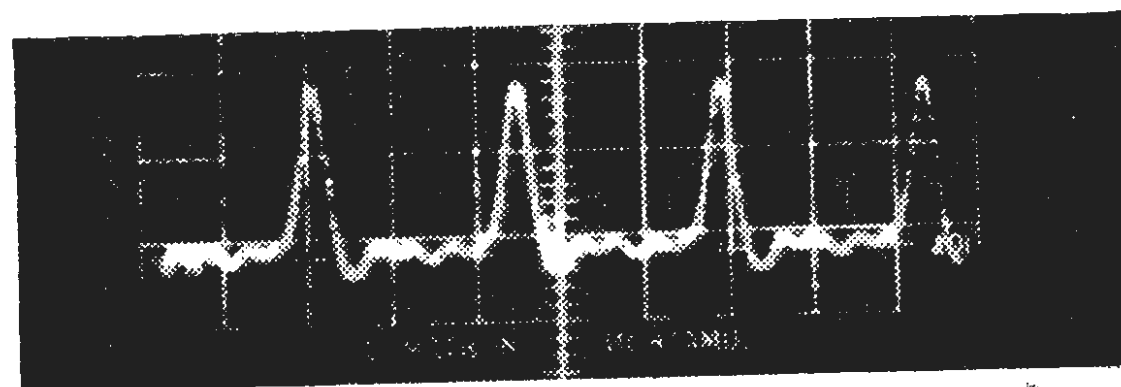

of the transmitted waveform reduces the total delay of the line for troughs (V_2) relative to crests (V_1). As a result the waveform at the output of the line is deformed, as shown, in such a way that the risetimes are reduced (and trailing edges are lengthened). Actually the output risetime of a pulse $t_{r(out)} = t_{r(in)} - n(\sqrt{LC[V_1]} - \sqrt{LC[V_2]})$ where n is the number of LC sections. This "shock wave effect" can be used either to generate sharp impulses from sinewave or other similar waveforms or to sharpen the leading edges of existing impulses or square waves.

The second technique uses the same principle of voltage-controlled capacitance in a simple differentiating circuit, and makes possible the generation of large-amplitude pulses with widths narrower than those of the corresponding input waveform risetimes. Field-effect transistors have been used as reverse-biased diodes to provide the non-linear capacitance (the gate being one terminal and the source or drain the other) as they give a large capacitance change (e.g. 7:1) for a small change of applied voltage. A typical RC combination is the BA110 with 100 Ω . The oscillogram shows pulses produced by such a non-linear differentiator from a quasi-triangular waveform obtained from a non-linear transmission line. The time scale is 5 ns per graticule division. It is hoped eventually to obtain risetimes of fractions of nanoseconds by this method.

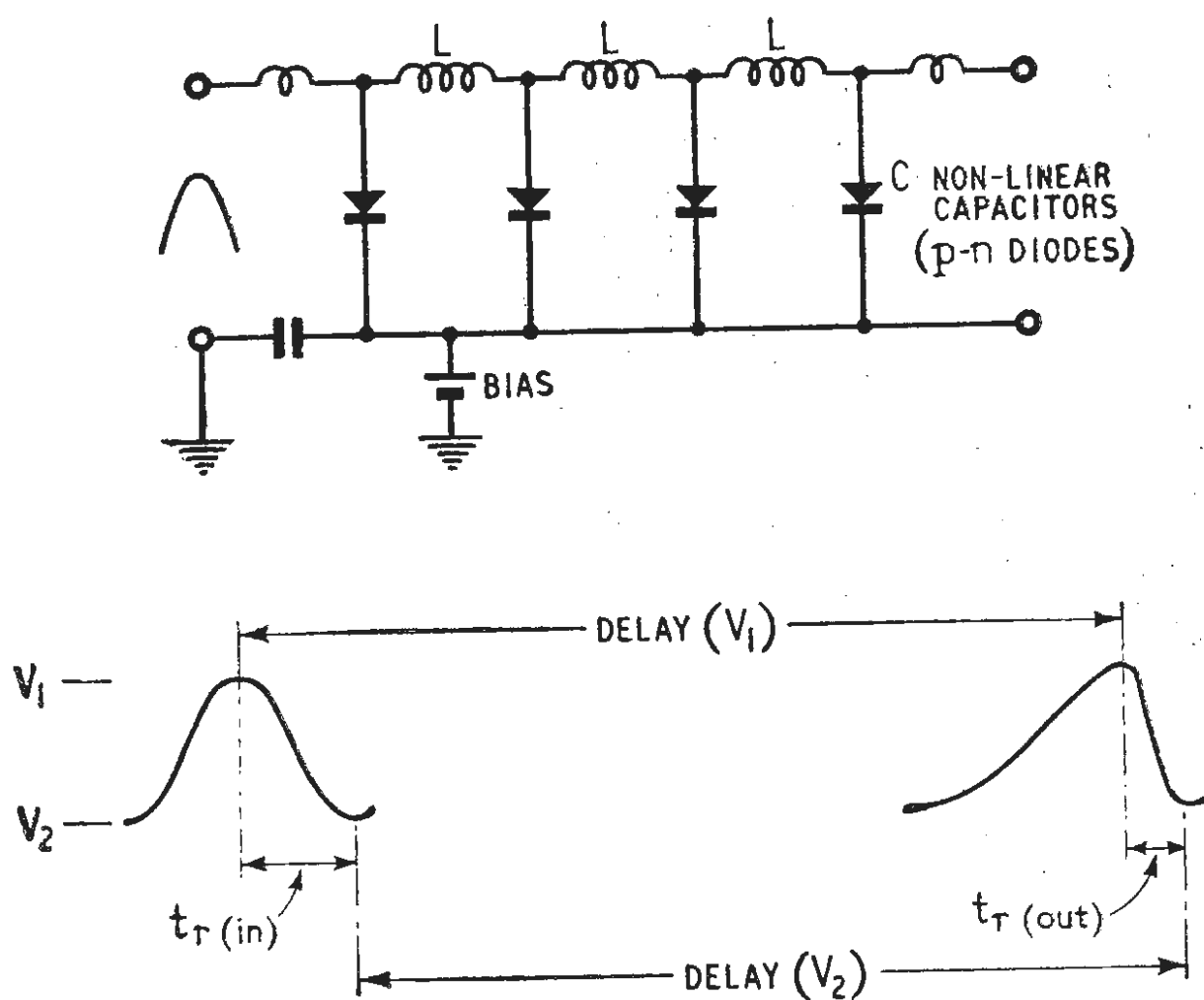

ISOTOPE-POWERED THERMOELECTRIC CONVERTER

RESEARCH into possible uses of radioactive isotopes as electric power sources has produced, amongst other devices, a series of thermoelectric energy converters, pioneered by the A.E.C. in the U.S.A. These were developed initially for satellites, but recently such devices have been used for terrestrial applications, where unattended operation is required. The U.S. Navy, for example, have placed such a generator on the bed of the Atlantic to serve as a power source for a navigational beacon.

A British contribution in this field is the RIPPLE generator (Radio-Isotope Powered Pulsed Light Equipment), developed at A.E.R.E., Harwell, and intended for use as a marine navigational aid. The fission product strontium 90, in the form of strontium titanate, is used as the energy source and is β -active,—unfortunately requiring heavy shielding. Suitable α -emitters (i.e. suitable in terms of power density, half-life, chemical stability and so on) would require less shielding, but these are expensive.

The half-life of Sr 90 is 28 years and this permitted a 10 year design lifetime. The absorbed radiation produces heat which is then converted to electrical energy by the Seebeck thermoelectric effect. (Thermionic converters would require temperatures of 1200°C or above, whereas the thermoelectric types can operate at much lower temperatures.) The RIPPLE generator has an array of bismuth telluride semiconductor thermocouples in module form to generate a low voltage supply (400mV) with an efficiency of 3-4%. Conventional transistor converters cannot readily operate at good efficiency at low voltages and so a tunnel diode converter has been developed to provide a more usable 6 volts. The power output at 6 V is 30 mW, and normal techniques are then used to provide excitation for the xenon flash tube. The generator provides a 0.2 joule flash of 5 μ s (visible at a range of 2 miles) about every 3½ seconds. A mean power of 2-3 watts could probably be obtained without significantly altering the design.

Experimental Thyristor Control Circuits

By N. M. MORRIS,* B.Sc., A.M.I.E.E., A.M.I.E.R.E.

This two-part article presents a range of thyristor control circuits suitable for use by students and experimenters. Part 1, this month, starts with some basic gate firing circuits then goes on to pulse control circuits using transistors.

ELEMENTARY SWITCHING CIRCUIT

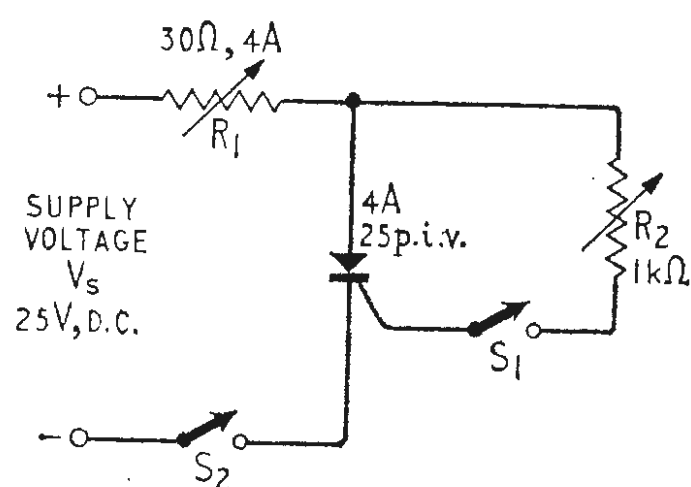

THIS circuit uses a 4 A, 25 p.i.v. thyristor (chosen simply because it was handy at the time), the values of V_s and R_1 being set by the rating of the device. Most thyristors can carry a peak gate current of 2 A, but reference should be made to the characteristic curves of the device used. To be on the safe side R_2 should be made much greater than $V_s/2$ ohms. Closing S_1 switches the thyristor on while S_2 switches it off. This is one of the most basic circuits which allows a combination of switching S_1 and S_2 to display the device's limitations; if R_1 is increased sufficiently the thyristor holding current can be measured. If R_2 is made large enough the lower limit of gate switch-on current can be measured.

SIMPLE PHASE CONTROL

TO produce a controlled current in a load it is necessary to either switch the load current on and off for known time intervals, or smoothly regulate the circuit resistance. The former method is more efficient and is used in thyristor circuits. If an alternating supply is used the thyristor will switch off when the anode is negative with respect to the cathode, i.e., conduction can only take place in the positive half-cycles. The necessary control is obtained by controlling the switch-on point in the positive half-cycle.

* North Staffordshire College of Technology.

is phase-shifted with respect to the anode voltage, the firing point is delayed by the appropriate time. In this simple phase control circuit, R_2 and C enable a voltage of 15 volts r.m.s. between points O and A to be phase-shifted over nearly 180° . Diode D_1 eliminates the negative half-cycle in the gate circuit and ZD limits the positive voltage to 4.7 V. Waveforms can be obtained by connecting a c.r.o. at the points indicated. Typical waveforms at circuit points (1)-(4) for 90° conduction are shown. (4) has a flattening of the positive peak due to loading.

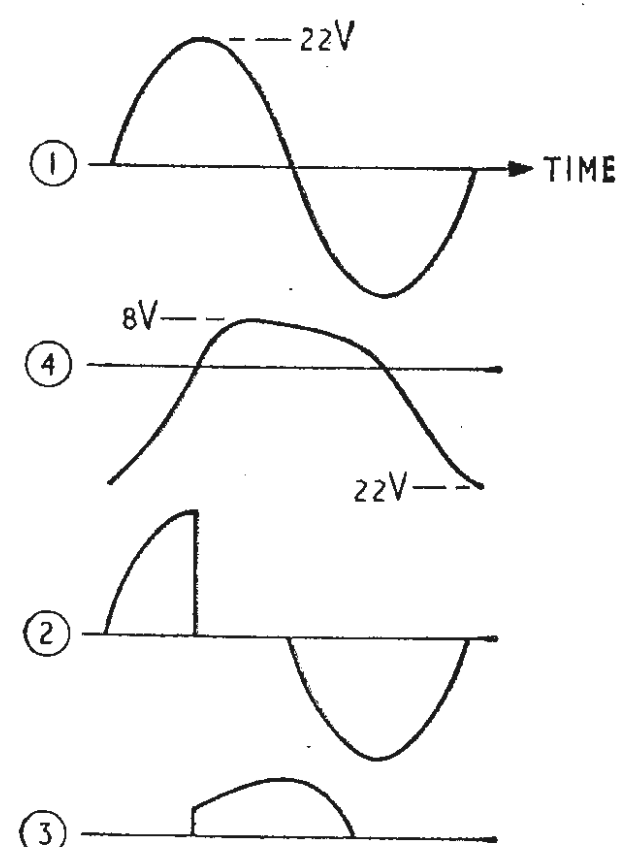
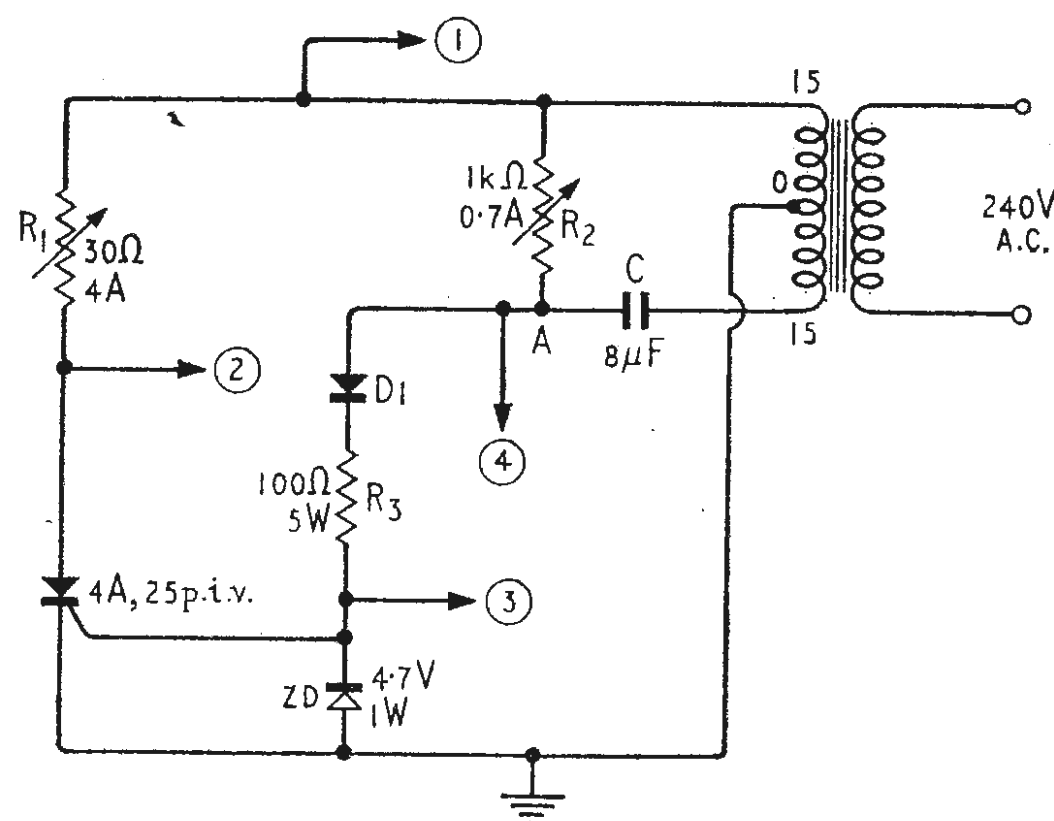

TRANSISTOR CONTROL

THE most convenient way to control thyristors in experimental work is to use solid state devices. Transistors, unijunction transistors or Shockley diodes can be used. Thyristors may be damaged if a positive gate voltage is applied when the anode is negative, owing to increased leakage current. It is therefore convenient to use a pulsed gate current, the power dissipated in the thyristor under reverse bias conditions being negligible if the pulse width is only a few microseconds. If the pulse is of sufficient amplitude, the first pulse will switch the thyristor on. Any subsequent pulses will not have any effect and could well be eliminated by suitable circuitry.

A suitable pulse generator consists of two transistors in a Hook configuration with associated components. Waveforms at points (1), (2) and (3) are shown. The voltage across C rises exponentially, depending on the time constant RC, until the voltage at (1) is sufficient to make Tr1 and Tr2 conduct, when the capacitor discharges rapidly through the 22 Ω resistor. This results in a sawtooth at (1) and a positive going pulse at (3). The pulse is of sufficient amplitude and duration to turn on most thyristors.

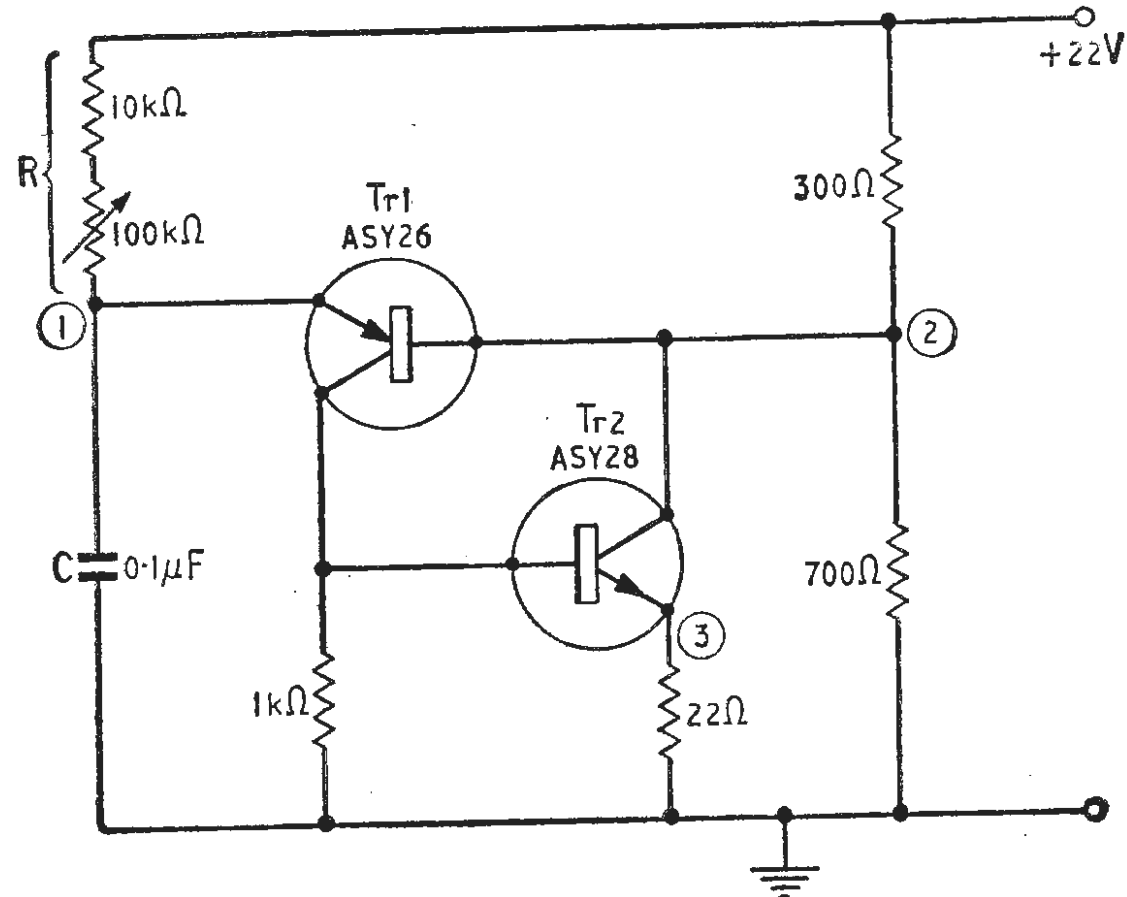

◀ PULSE GENERATOR

SYNCHRONIZATION OF PULSES TO THYRISTOR SUPPLY

TO ensure that the first pulse occurs at the same point in each positive half-cycle, it is necessary to start charging capacitor C in the transistor pulse generator (above) at the beginning of each half-cycle. This can be achieved using the circuit shown. At the end of each half-cycle the voltage across the Zener diode falls to zero. This ensures that the capacitor is discharged at this instant if the circuit is used as the power supply for the above pulse generator. Pulse generator waveforms at (1) and (3) with this supply are shown. The first large pulse in each positive half-cycle in (3) would fire the thyristor, the small pulses corresponding to the final discharge of the capacitor in that half-cycle.

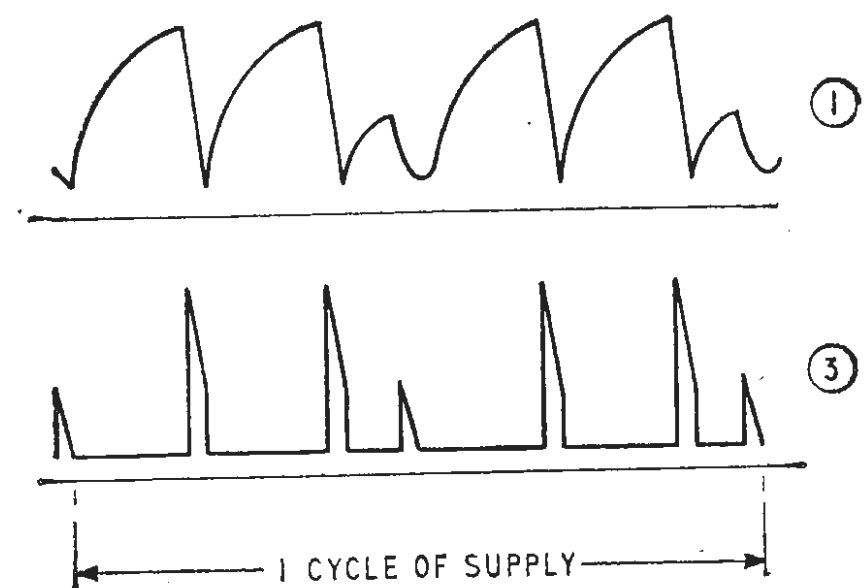

▶ POWER SUPPLY

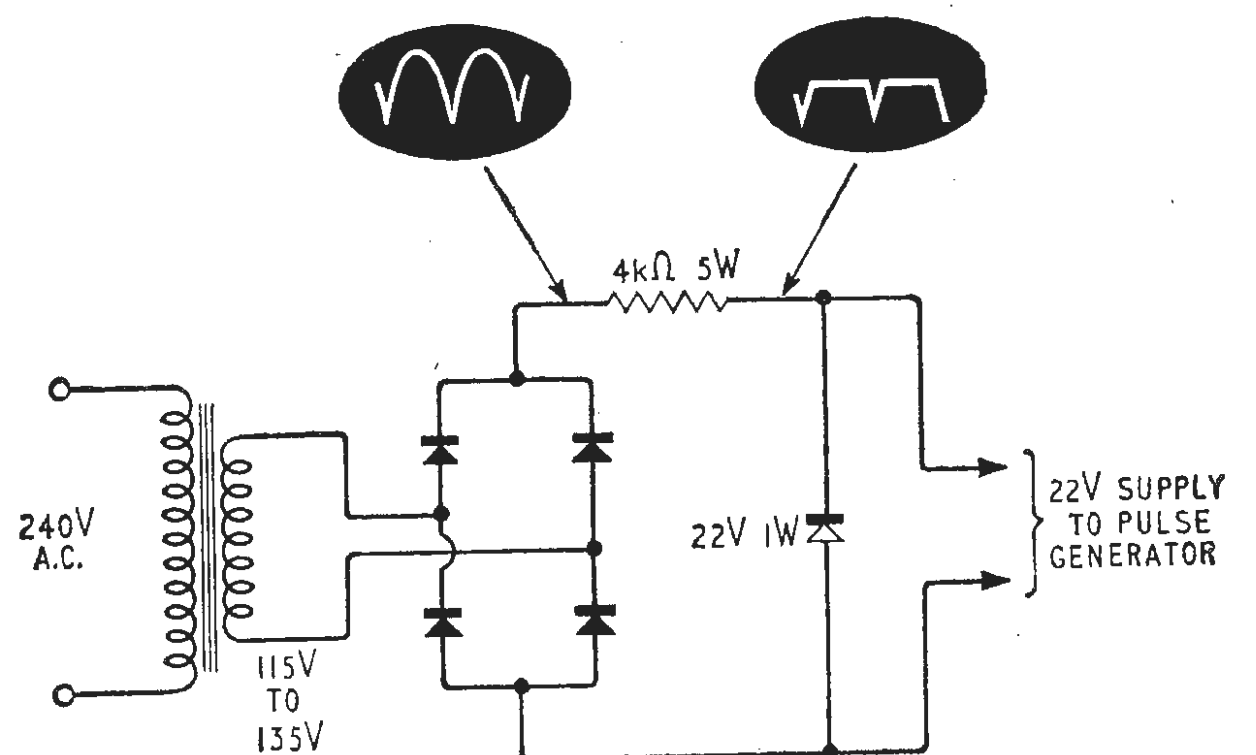

CONNECTION TO THE THYRISTOR

THE pulse generator may be coupled directly to the thyristor as in (a) or through a C R circuit as in (b). Alternatively a pulse transformer can be used if it is required to isolate the two circuits from one another. (See "Controlled rectifiers in stabilized power supplies" by F. Butler, *Wireless World*, October 1963.) With direct connection care must be taken to ensure that the voltage developed across the $22\ \Omega$ resistor of the pulse generator does not trigger the thyristor at the start of the positive half-cycle. Use of a capacitor of about $0.1\ \mu\text{F}$ overcomes this difficulty, but a resistor of about $560\ \Omega$ must be connected between the gate and cathode. The value of this resistor, R, is not critical.

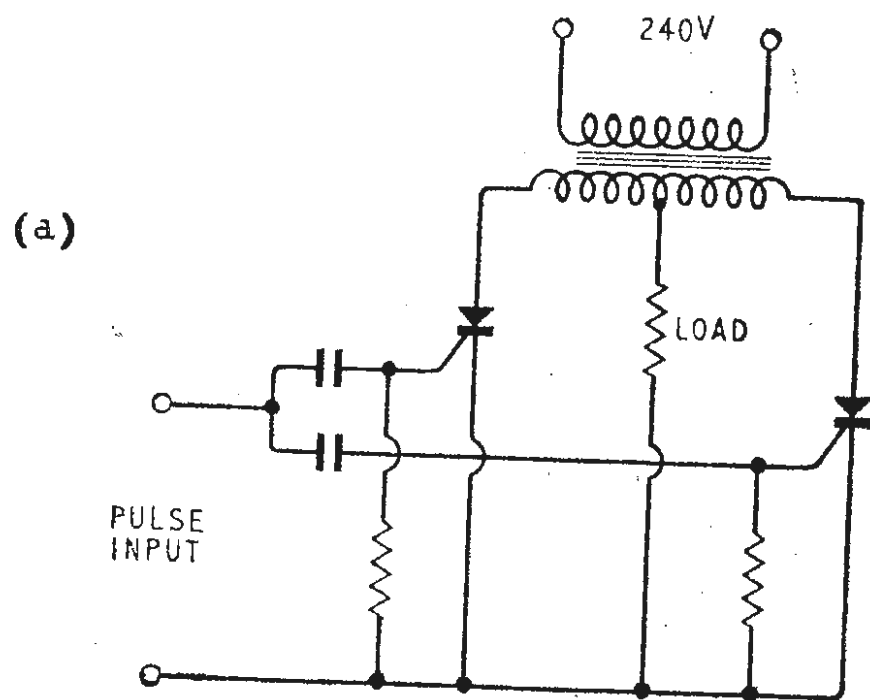
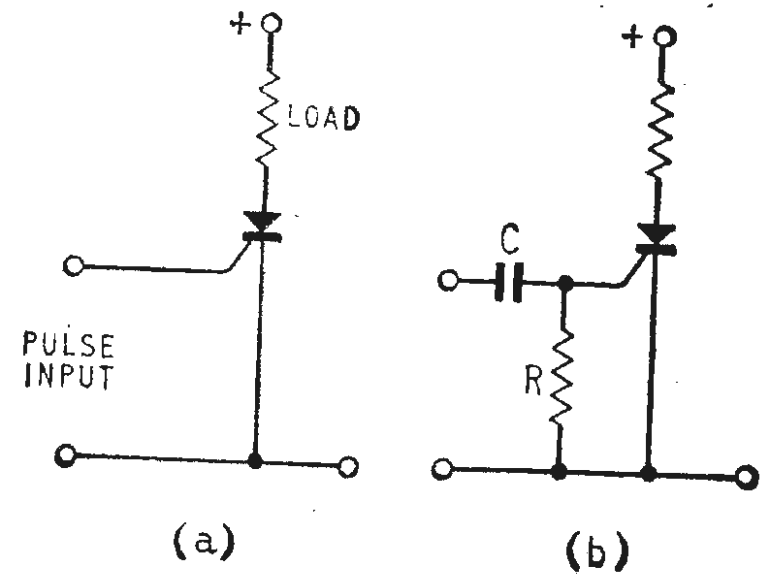

FULL-WAVE POWER CONTROL

A SINGLE-PHASE, full-wave output can be obtained using the circuit (a), the capacitors here ensuring equal distribution of charge between the two gates. As an alternative the pulses may be coupled through resistors of about $30\ \Omega$ instead of capacitors. A cheaper way of obtaining a full-wave output is shown at (b), and full-wave control of an alternating current output at (c).

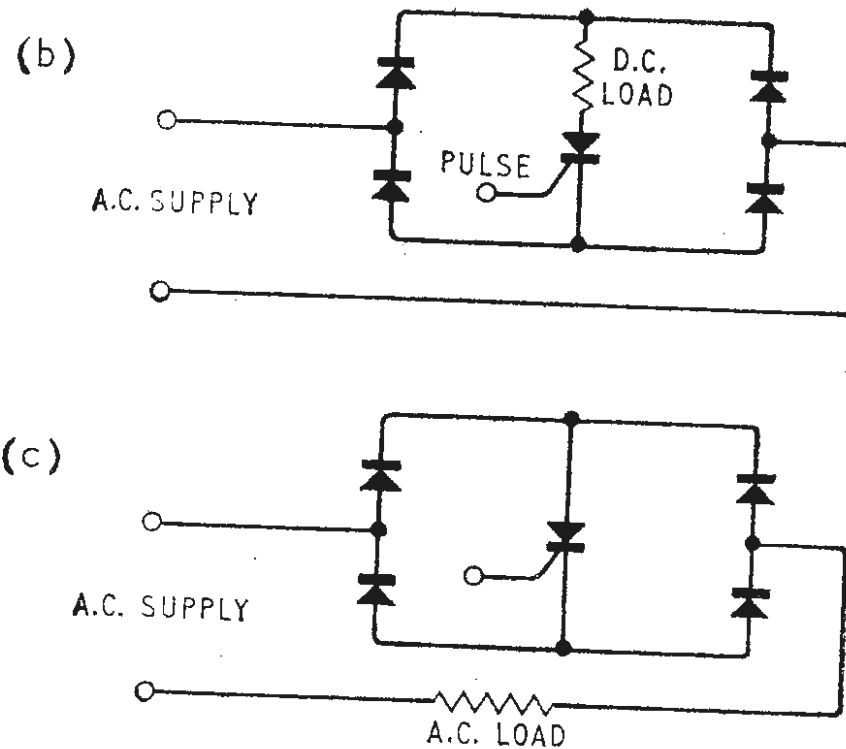

CONTROL OF PULSE RATE BY SHUNT TRANSISTOR

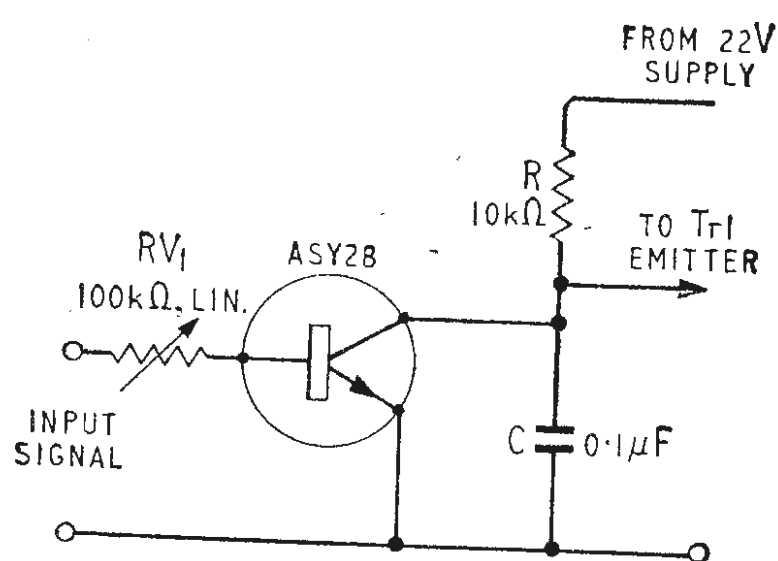

IF the capacitor in the pulse generator is shunted by a transistor, as shown here, the pulse repetition rate will be reduced owing to the increased rise time of the capacitor voltage. With zero input to the transistor, the capacitor is shunted by a high resistance and it charges up at its maximum rate, so giving maximum pulse repetition rate from the pulse generator. With an input signal some of the capacitor charging current is shunted away and the capacitor charges more slowly. This results in a lower repetition rate. This circuit has a very high gain, a small input signal resulting in a large change of output current from the thyristor. In order to obtain zero current from the thyristor it is necessary to set the input at its maximum value and adjust RV_1 until the controlled thyristor just fails to fire. Because of the high gain of the circuit, difficulty may be experienced in controlling it smoothly unless some form of feedback is employed. The 22 V power supply already described is quite suitable for this circuit.

SERIES-TRANSISTOR P.G. CONTROL

USING a series transistor (a) ensures a roughly constant capacitor charging current and linearizes the capacitor voltage waveform. With zero input to the transistor the charging time constant is large, giving a low pulse repetition rate. If the circuit is powered by the 22 V supply already described the charging rate could be so slow that the first pulse is generated in the last few degrees of the positive half-cycle, giving practically no output from the controlled thyristor. Adjustment of base-bias by RV_1 allows for zero adjustment in the practical circuit. This circuit can be used as linear ramp generator by taking an output from the capacitor. By the introduction of an integral of the ramp voltage as a feedback term it should be possible to generate an ultra-linear ramp. A difficulty with circuit (a) is that the common rail for input signals is the positive line, while the common connection to the thyristor is the negative line. This can be overcome by the addition of another stage of amplification, as shown at (b). Adjustment of RV_2 enables zero output to be obtained from the thyristor for zero input signal. An input to this circuit of 3 to 4 volts is adequate to give a phase-shift of 170° to the pulses from the pulse generator.

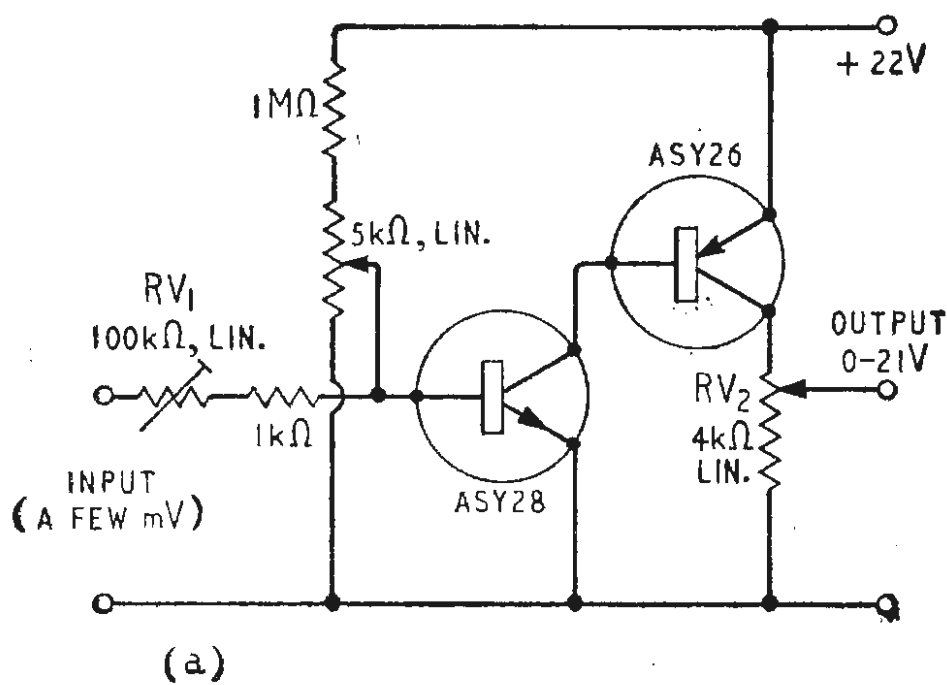
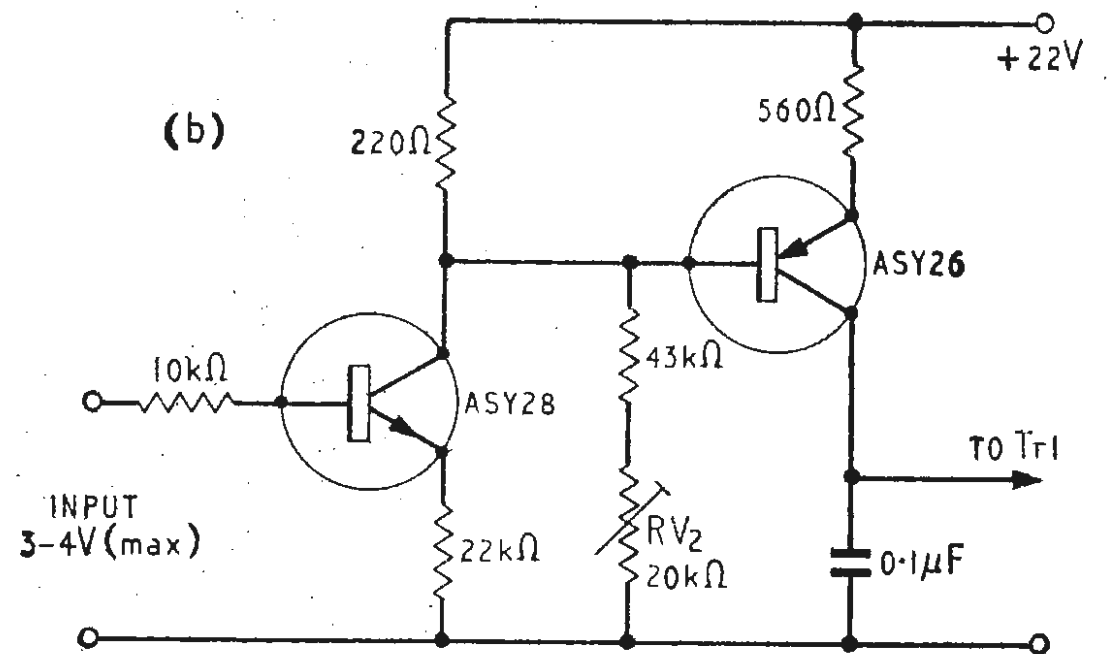
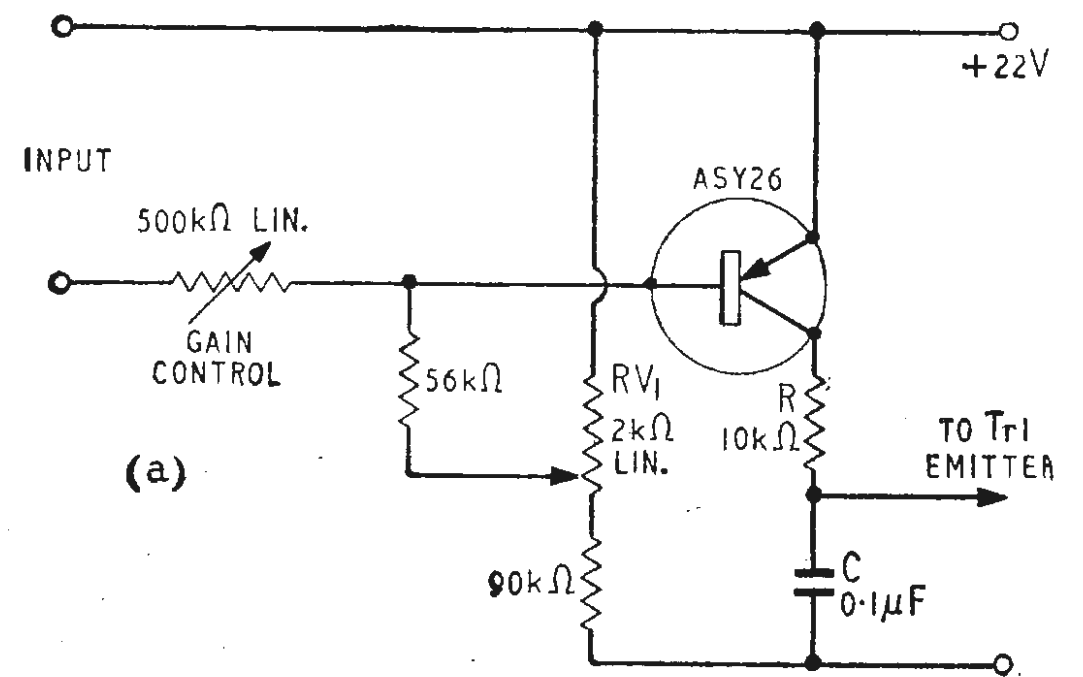

PRE-AMPLIFIER FOR CLOSED-LOOP APPLICATIONS

IN closed-loop applications an input signal of a few millivolts is sometimes required to control the thyristor, and a further stage of amplification is required. One experimental circuit is shown at (a). A controlled output voltage swing of up to 21 V can be obtained with an input of a few mV. Gain control is achieved by means of RV_1 while RV_2 can be used as a set-zero control. The completed system is shown at (b), comprising circuits already given. Variable resistor RV_3 here is used as a set-zero control. The input voltage needed to give full output from the thyristor is about 40 mV.

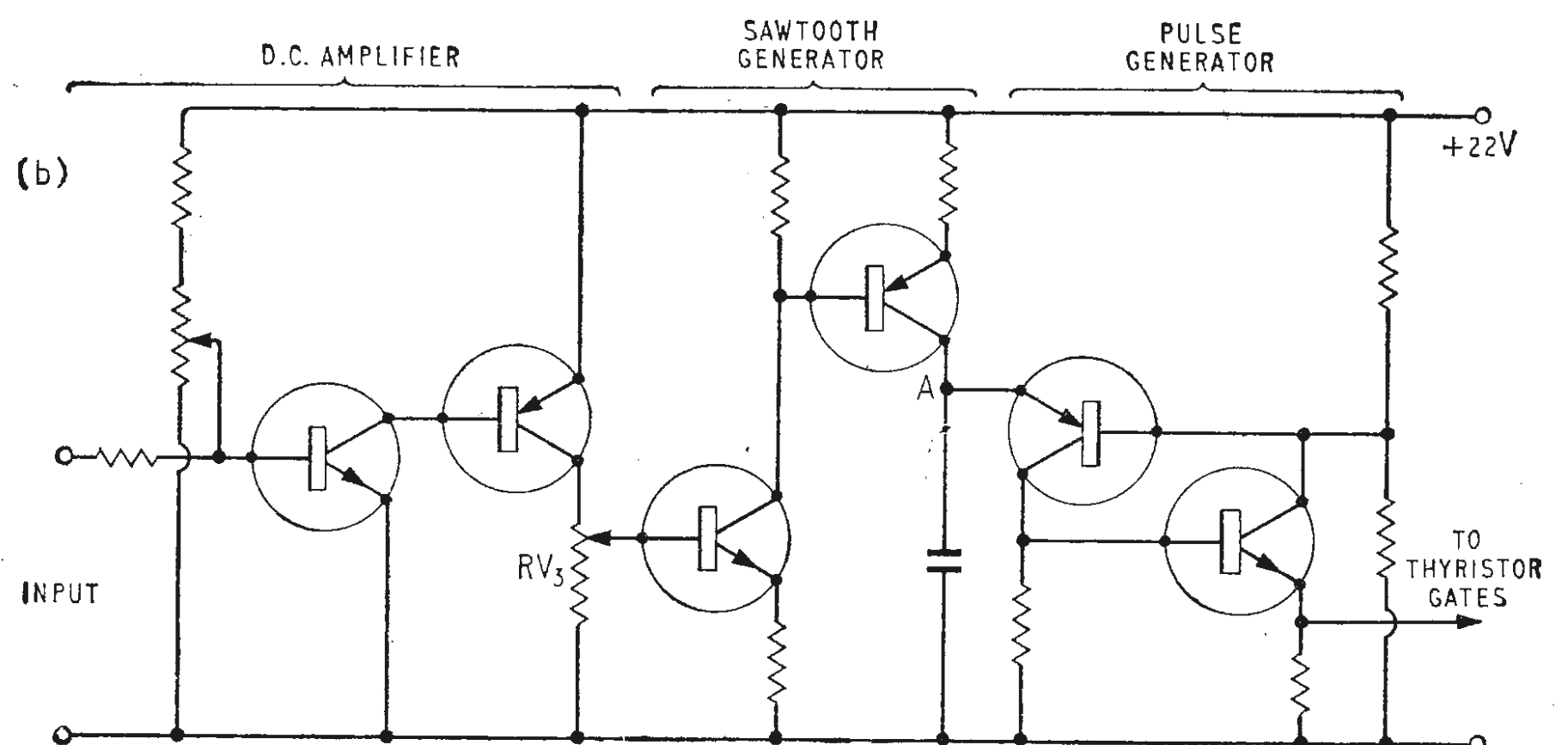

(Article to be concluded)

"ONE-MILE" RADIO TELESCOPE AT CAMBRIDGE

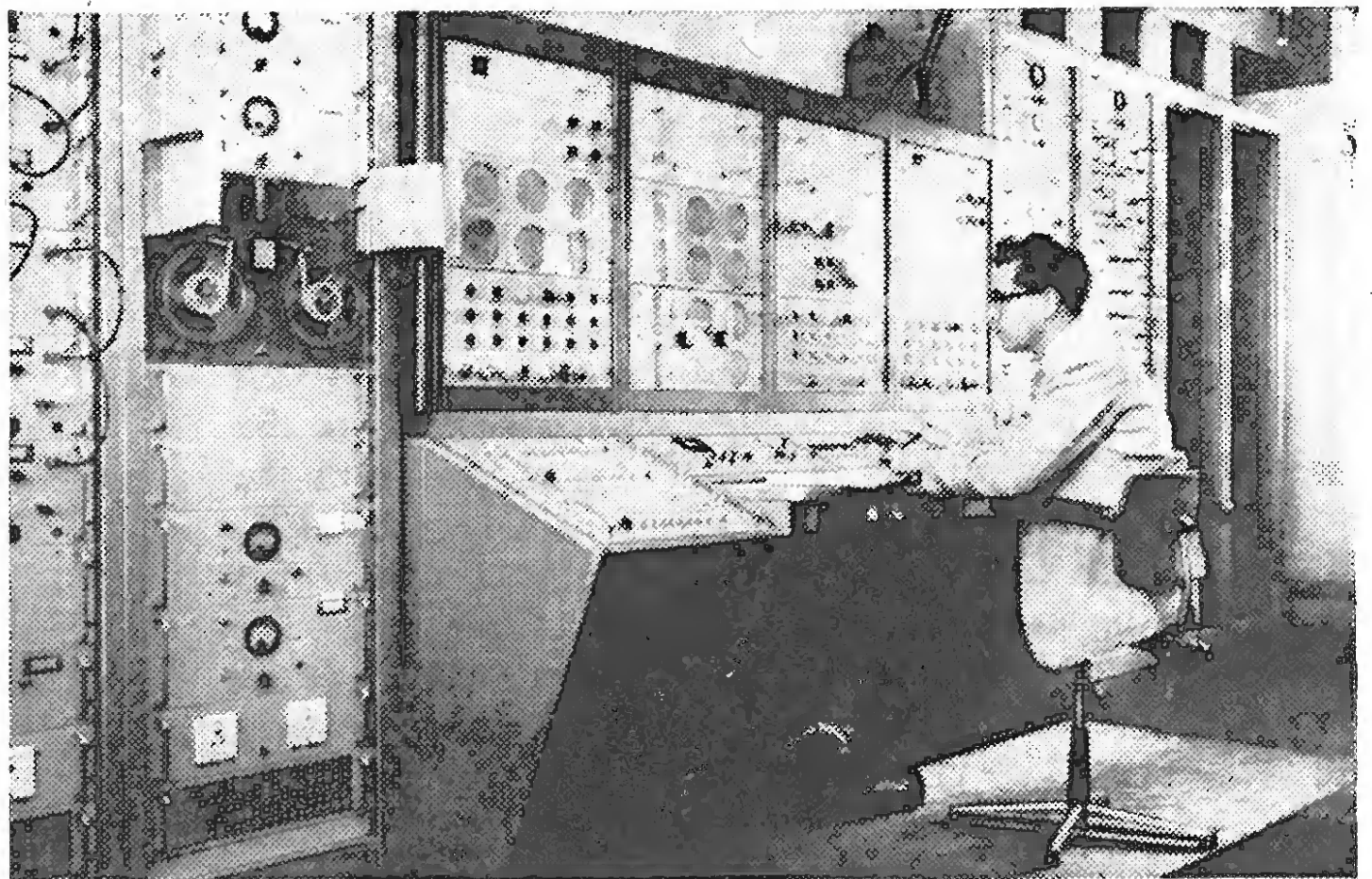
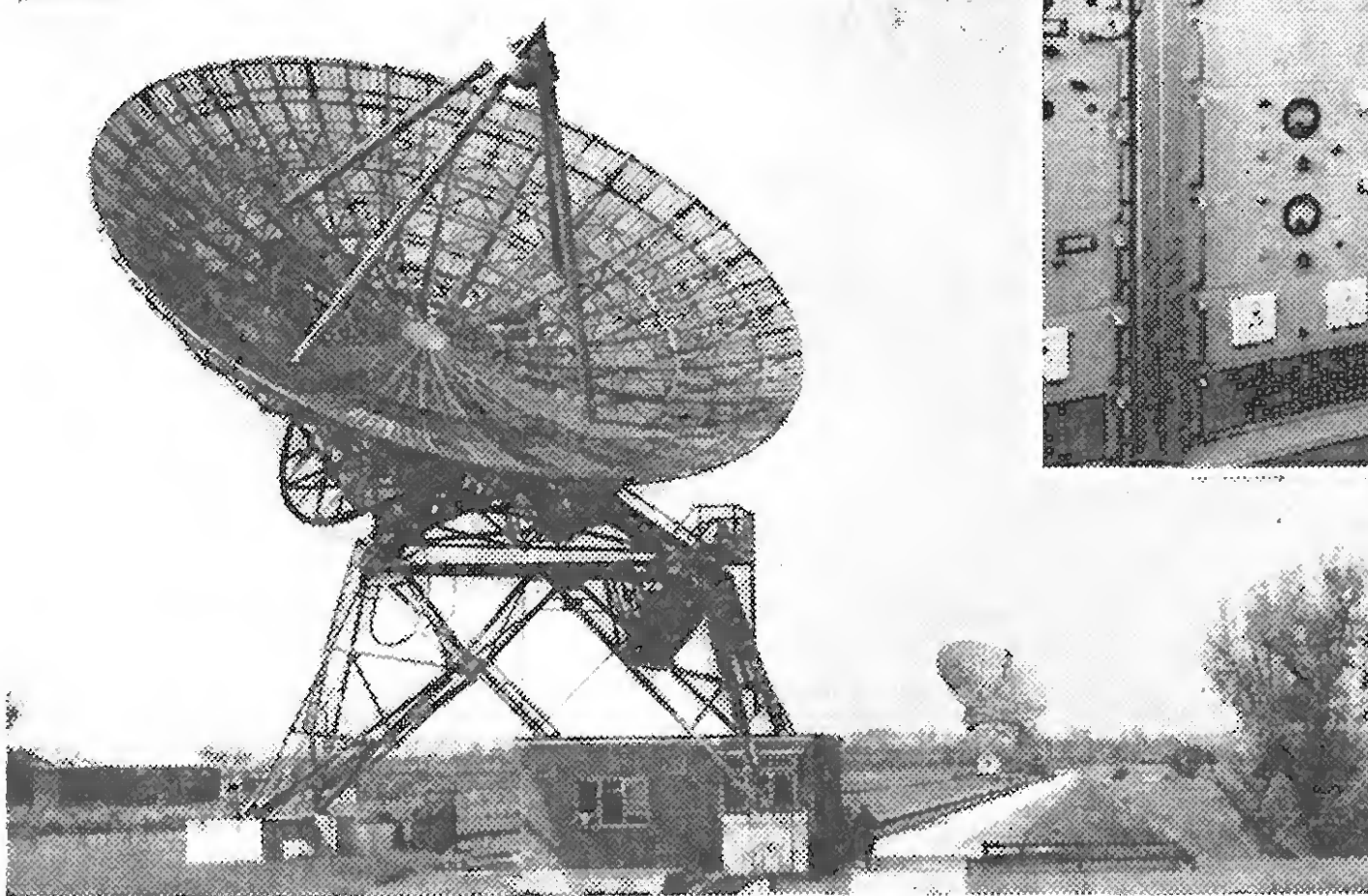

The control room of the new "one-mile" radio telescope at the Mullard Radio Astronomy Observatory, Cambridge. The positions of the three paraboloids, which are controlled automatically by the programme tape and reader on the left, are shown on dials on the console.

Two of the three paraboloids of the new Science Research Council radio telescope at Cambridge. The receiving dipoles are mounted on the quadrupod at the focus where the amplifiers are housed.

LORD BOWDEN, Minister of State for Education and Science, officially inaugurated the latest radio telescope at the Mullard Radio Astronomy Observatory of the Cavendish Laboratory at Lord's Bridge, Cambridge, on July 6th. All the main radio telescopes at the Observatory employ the aperture synthesis technique in which two or more small aerials are moved so that they occupy successively the positions of the individual components of a much larger radio telescope. The latest one, which was financed by a grant of £570,000 from what is now the Science Research Council, comprises

three 60 ft paraboloidal reflectors. Two are fixed 2,464 ft apart and the third travels on a 2,600 ft track. They are arranged on an east-west axis and may be made to follow any point in the sky. Because of the rotation of the earth two rings of a much larger equivalent aperture are built up each day. By altering the position of the movable aerial other rings are then filled in on successive days until a resolving power equal to that of a paraboloid one mile in diameter is achieved. The latest telescope observes at two wavelengths (21 and 75cm) simultaneously.

Commercial Literature

Sealectro Ltd. have recently published a 52-page catalogue on their "ConheX Subminiature R.F. Connectors." Electrical and mechanical specifications for over 300 standard connectors as well as bulkhead jacks, semi-rigid cable connectors, and adaptors of various kinds, are included in this catalogue, which is available from Sealectro Ltd., of Walton Road, Farlington, Portsmouth, Hants.

8WW 324 for further details

Over 200 products, including hi-fi components, test and measuring equipment, amateur equipment and educational training aids, are contained in the "EICO 1965 Catalog." Specifications and illustrations are provided for each product in this 36-page catalogue, which is available on request from EICO Electronic Instrument Company Incorporated, 131-01 39th Avenue, Flushing, New York 11352.

8WW 325 for further details

A catalogue describing "Public Address Equipment" has been sent to us by C. T. H. Electronics, of Burford Works, Burford Street, Hoddesdon, Herts. Transistor amplifiers with output ratings from 15 to 1,000 W and accessories such as mixers, line transformers and re-entrant speakers are included.

8WW 326 for further details

An article entitled "Solid State Oscilloscope Circuitry" (reprinted from *Electronic Products*, February 1964 issue), which covers the design criteria on which the Tektronix Type 647 oscilloscope is based, is now available from Tektronix U.K. Ltd., of Beaverton House, Station Approach, Harpenden, Herts.

8WW 327 for further details

A three and half-inch "Image Orthicon Television Camera" is described in pamphlet No. 1427a, which is now available from Barr & Stroud Ltd., of Caxton Street, Anniesland, Glasgow, W.3 (London office Kinnaird House, 1 Pall Mall East, S.W.1). Transistors are used throughout this camera which has been developed for industrial applications where poor lighting conditions prevail.

8WW 328 for further details

Communications Cable Shielding.—A technical data bulletin describing a new form of shielding material made by Metal and Controls Incorporated for communication cables is available from its parent, Texas Instruments Incorporated, whose address is 34 Forest Street, Attleboro, Massachusetts. This shielding is formed by sandwiching copper between stainless steel. A small sample is included with each bulletin.

8WW 329 for further details

LETTERS TO THE EDITOR

The Editor does not necessarily endorse opinions expressed by his correspondents

Pulse Width Modulated Audio Amplifiers

SOME very interesting contributions concerning Class D techniques have appeared in the correspondence columns in recent months. Some of these suggestions merit closer examination.

F. Butler in the July issue says, "Quite clearly a pure resistance load is inadmissible". In my article in February 1963, I put forward a suggestion under the heading "Modes of operation" (page 80) whereby a cross-over type filter is used to separate the h.f. components of the pulse spectrum from the a.f. components. The h.f. components are diverted into a terminating resistor, whilst the a.f. components pass through to the loudspeaker. In these circumstances the amplifier "thinks" it is feeding a resistance load, and is quite unaware of the stored energy in the filter components. Auxiliary diodes shunting the output transistors are unnecessary in this case, and the associated distortion described by B. D. Josephson (July) does not occur. In my experience, distortion in this type of amplifier can be so low as to almost defy measurement—without recourse to negative feedback. I hope Mr. Josephson will forgive me if I therefore suggest, with respect, that what he really meant to say was not that "... the open loop system [is] unsuitable for applications which require the lowest distortion"; but rather that a particular type of open loop amplifier used in conjunction with a particular type of filter can introduce distortion which may be significant unless it is corrected by negative feedback. This is not really surprising, because the output waveform is not what we set out to achieve. It should be remembered that a.f. negative feedback can if necessary be used in "open loop" amplifiers. They are, after all, only "black boxes" into which one feeds audio at low level, and from which, after filtering, amplified audio is obtained.

I submit that it is inappropriate to suggest that the magnitude of any distortion may be compared with that in a Class B amplifier with similar standing current, as this current, and distortion, are determined by totally different factors in the two types of amplifier.

The current drawn in a Class D amplifier when the load is resistive as suggested above, is constant, and the maximum efficiency cannot exceed 50%.

A few years ago, many of us built or bought Class 'A' amplifiers, which have a maximum efficiency of 50%, because they gave us the best quality of reproduction.

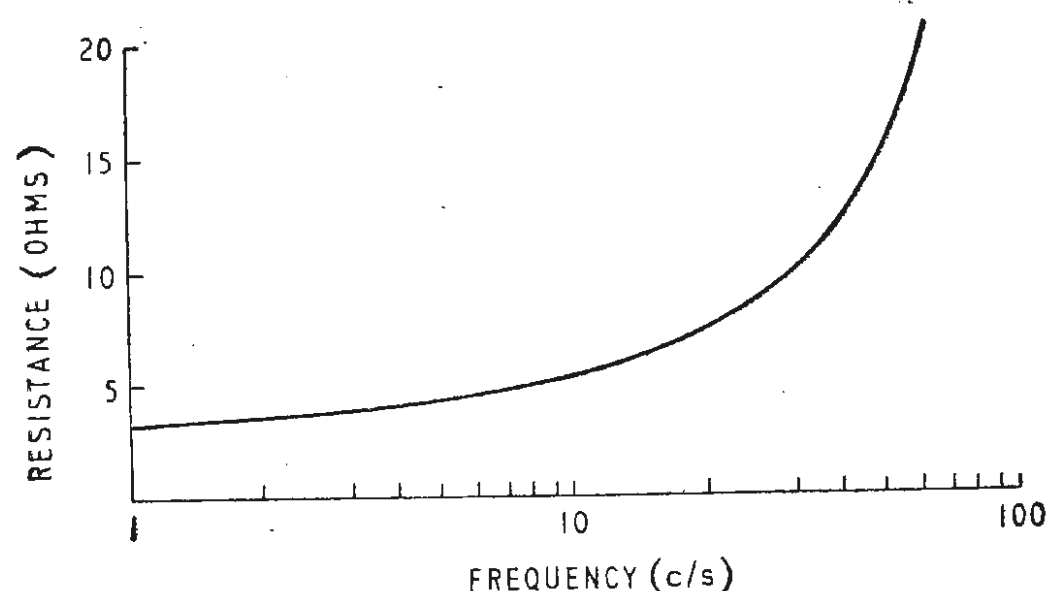

Fig. 1.

It is a curious thing that we were quite happy when the waste power, and that bit more from the valve heaters was dissipated in an active device. Now we have separated this power from the active device, and put it in a resistor there is a tendency to feel that this "waste" is morally wrong. Perhaps this is because the ad. men these days tell us that we don't want quality anyway, but the brighter, whiter-than-white "transistor sound"!

It does seem a pity not to take advantage of the very high inherent efficiency of the Class D mode, and there is even more incentive to do so when the power output runs into kilowatts.

I feel that the characteristics of a moving-coil loudspeaker give us a clue. Fig. 1 shows the measured resistance (not impedance) of a typical cheap loudspeaker from which it can be seen that the resistance at the pulse repetition frequency is very much higher than it is in the audio band. The h.f. resistance is increased partly by skin effect, and more significantly by eddy currents induced in the lossy magnet system. Such a loudspeaker has therefore quite a good inbuilt filter.

We may simulate such a filter by the circuit shown in Fig. 2. In the audio band, the amplifier "sees" a low resistance, that of the load, whilst at h.f. it again sees a

Fig. 2.

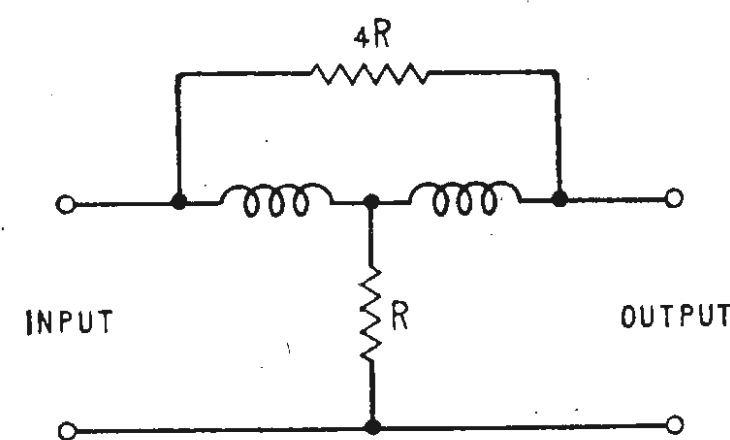

resistance, but a much higher one, assuming $X_L > R$. At very high frequencies the attenuation is theoretically infinite. There is nothing novel about this: it is just a hybrid transformer.

Mr. Butler's suggestion for splitting up the audio band, has in my view a lot to commend it when two loudspeakers are used, whether the amplifiers are Class A, B or D. I have in fact used such a system at home for several years. Significant advantages are:—

(1) The low output impedance of the h.f. amplifier damps the fundamental resonance of the tweeter effectively in contrast to conventional cross-over systems which remove the amplifier damping effect just when it is wanted.

(2) There is much greater flexibility in the cross-over filter design. I have actually used two double section RC filters with staggered cut-off frequencies, and with a high degree of sum feedback. This gives an absolutely flat combined response through the cross-over region, and yet provides an ultimate rate of attenuation of 12dB/octave.

In conclusion may I raise one aspect of the closed loop system which has not so far been mentioned. Namely, what does one do when something goes wrong? In my experience there is a smell of burning and one observes that roughly half the transistors are hard-on, and the rest are hard-off. The only waveforms to be found are on the input socket, and with luck, the mains plug! In an open

loop system, traditional fault finding methods can be employed, as each stage of the amplifier functions as a separate entity.

Oxted, Surrey

D. R. BIRT

A STANDARD problem I have been facing recently is to square a sine wave, maintaining a mark-to-space ratio of one. The output switches a phase-sensitive rectifier which is very sensitive to changes in the mark-to-space ratio. I tried the usual a.c. coupled preamplifier followed by a limiter followed by a Schmitt trigger but found that the mark-to-space ratio varied with temperature and with the amplitude of the input.

At this stage I read the article, in the April issue, by Turnbull and Townsend on a pulse width modulated amplifier. With just a little modification I was able to apply the idea directly to the solution of my problem. If the square wave output is integrated and used to bias the first transistor, and if the squarer is d.c. coupled throughout and has an odd number of stages, then the feedback maintains the mark-to-space ratio constant by adjusting the bias on the first transistor.

The initial setting up is critical in the choice of bias resistors but no more than in the limiter stages of the more orthodox method. The device is most effective for a small sine wave or a triangular wave input, where the small slope at the mid-point gives the feedback more control of the switching point—and this is when the device is most useful. With no input, the circuit oscillates at a low frequency determined by the filter network, but any signal above about 20mV stops this oscillation. Rapid fluctuations in the signal amplitude or hum superimposed on the signal are not compensated for and

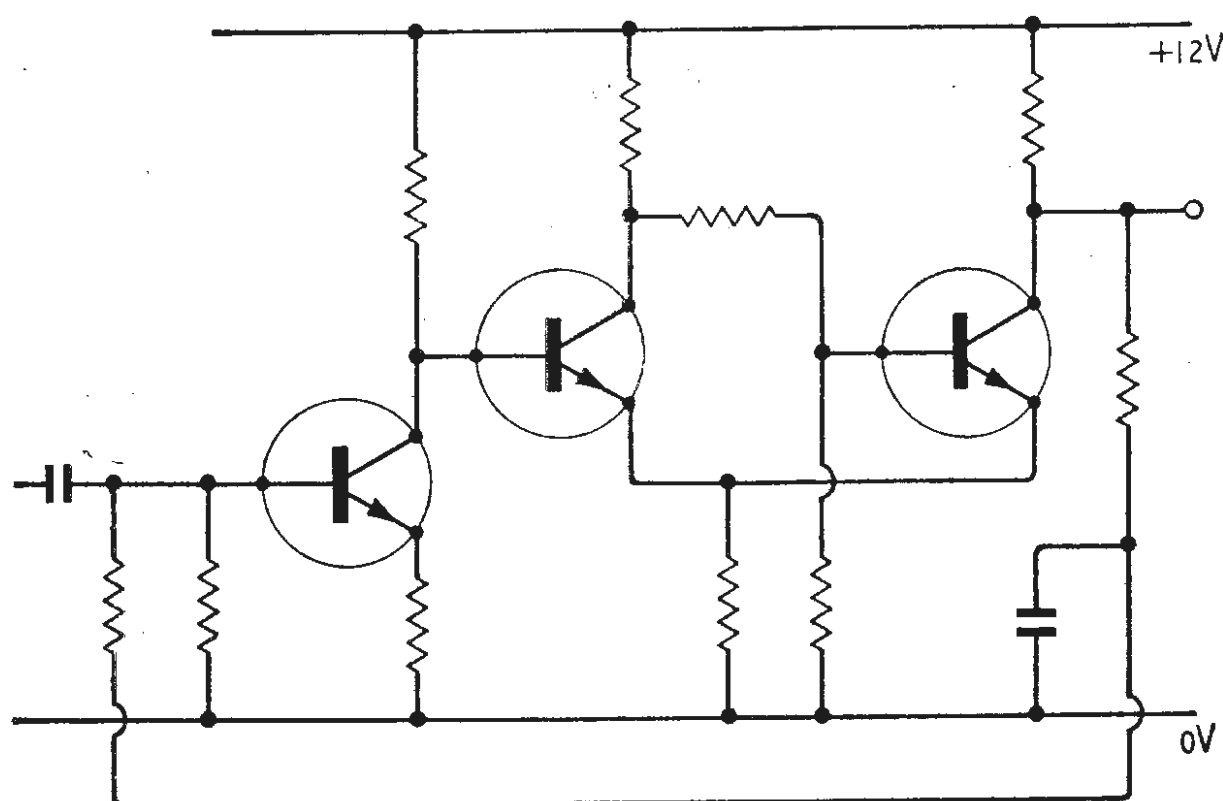

cause corresponding rapid fluctuations in the mark-to-space ratio, but the average remains constant.

In its simplest form the circuit is as shown though it lends itself to modifications. I hope that others may find the idea useful. I have not made an exhaustive analysis but the device seems a distinct improvement on the other method.

DEREK R. LANE-SMITH

Freetown, Sierra Leone

Units

ON the question of what units are actually used, raised in the April correspondence, I have not the leisure to make a survey with any statistical value. With some attempt at impartiality, I glanced through a recent copy of a journal concerned mainly with semiconductors. The authors were from the U.S.A., England, Germany and

Japan. None used m.k.s. units. Neither did they use c.g.s., except for magnetic fields. They all used units such as the ohm cm., cm²/volt sec., and so on. I think this is fairly typical, and those who wish to make SI universal may well have to devote most of their energies to persuading such authors to measure the volume of germanium in their transistors in cubic metres, and the current density in their transformer windings in amperes per square metre. For my part, I certainly would not want such matters discussed exclusively in c.g.s. units, either. I think the main reasons why c.g.s. units are retained are: (i) There is a vast body of literature and data which employs them, and which any serious student must understand. (ii) For many scientific purposes, c.g.s. units are the most convenient and elegant. (iii) For the novice, ϵ_0 and μ_0 are mysterious stumbling blocks, the comprehension of which may take some years, if it is achieved at all. (iv) The scientific basis of c.g.s. units is unexceptionable.

It is only point (iv) with which I feel concerned here, and I shall therefore consider only points (4) and (5) of "Cathode Ray's" letter in your April issue, as the others seem to me matters of convenience rather than principle.

On point (4), the question of the "fundamental difference" between H and B, there has, of course, been much discussion, which is bound to be inconclusive unless we can agree on the precise meaning of "fundamental difference." (Is there a "fundamental difference" between ice and water?) In macroscopic magnetic matter there are indeed two useful magnetic vectors which may differ in direction, magnitude, and if desired, dimensions. In a vacuum they are coincident in direction and proportional in magnitude, so that in this case at least it seems simpler to define our units so that they are equal, in much the same way that we usually use the same units for gravitational and inertial mass. On the atomic scale, matter is regarded for magnetic purposes as a space populated by electronic motions, and electronic and nuclear spins. These result in a very complicated microscopic field h . If a microscopic b is defined, it will merely be proportional to h everywhere. The (macroscopic) b is a volume average of h over many atoms, and H is that part of B which is not contributed by the atomic dipoles. From the atomic point of view, then, a distinction between the units of B and H is a considerable inconvenience, and I would have thought this point of view had a good claim to be regarded as "fundamental." The engineer may indeed prefer to use units such that his fields are simply calculated from his ampere turns, and his e.m.f.'s appear directly in volts, but surely it is clear that this is better called a practical expedient than an indication of any fundamental distinction?

On point (5), if fractional indices occur in algebraic equations, why should they be rejected in the dimensional equations which reflect them? Those who find difficulty with fractional indices sometimes ask such questions as "what is the square root of a time?" If they find this nonsensical they might first ask themselves "what is a time to the power minus two?" whatever their philosophy of dimensions (there are at least two, e.g. see Silsbee, *J. Res. Nat. Bur. Standards* 66C, 137) I think they will find that when they have answered, or perhaps re-framed, the second question, then they will have little difficulty with the first. But in any case the avoidance of fractional indices by the use of a fourth dimensional quantity is not the exclusive property of m.k.s. systems, it can be applied equally to c.g.s. systems, and oddly enough, "Cathode Ray" seems to think that Maxwell regarded this fourth dimension as unavoidable.

I gave no single definition of "quantity" of sugar. If I

have a packet, I might measure its mass M , its volume V , or I might conceivably count the number of molecules N . I regard these as all more or less satisfactory measures of "quantity." "Cathode Ray" seems worried that N and V may not be strictly proportional, though when I raised the matter of variable density before, he said it had "nothing to do with the principle." As a matter of fact I think M and N may not be strictly proportional either, owing to the slight variation in binding energy per molecule with size of crystal, but I will not split that particular hair. At all events, M and V are conventionally, and sensibly, regarded as dimensionally different, and any attempt to adjust the definitions to make them the same is regarded by "Cathode Ray" as impossible or at least suspect.

With a charged door knob, I might measure the electrostatic charge e , the electromagnetic charge q , or conceivably count the (negative) surplus of electrons n . All are again reasonably called measures of "quantity" of electricity. "Cathode Ray" now insists that q and e (and presumably n) must be dimensionally equal. Why? Is it because the proportionality between q , e , and n is believed to be strict, so that more than one unit is superfluous, as with gravitational and inertial mass? That would seem to me reasonable, and that is why I mentioned the wave velocity as a reliable constant, but I have the impression that "Cathode Ray" has a more metaphysical notion of "quantity of electricity" which transcends mere measurement. Maybe if e and q happened to have been given different names, such as perhaps "charge" and "activity" the temptation to insist on their dimensional equality might be less.

On the question of whether Maxwell thought electrical quantities expressible in purely mechanical terms, I would have thought my quotation dogmatic enough, but "Cathode Ray" quotes Art 623, where Maxwell has marshalled his equations, with the exception of either form of Coulomb's law, between charges or poles. Naturally they are insufficient at this point to determine all quantities in terms of L , M and T , and either e or m may be regarded as an independent unit. Using one or other form of Coulomb's law, however, he then proceeds to deduce the dimensions of e or m , and hence all the other quantities, in purely mechanical terms. He even provides a table of dimensions (complete with fractional indices)

in these two systems, the c.g.s. electrostatic and electromagnetic, which he describes as "the only systems of any scientific value." If "Cathode Ray" still believes that Maxwell regarded electromagnetic quantities as inexpressible in purely mechanical terms, I can do little more than express my astonishment. Even if his interpretation should be correct, I am still astonished that he chose in the first place to enlist the support of an author whose units he finds fundamentally unsound and whose dimensions repugnant to common sense.

By all means let us use SI units, or any other system, if after careful examination we find them most suited to our purposes and understood by as many as possible of our fellows, but let us not make them into a kind of religion which condemns all others on insufficient grounds, and which seeks to enforce conformity in those of other persuasions by the mere force of legislation.

Bristol.

D. F. GIBBS

Silicon Transistor Tape Recorder

YOUR contributors D. L. Grundy and J. Collins, in their tape recording amplifier described in the July issue achieve a constant current drive to the record head with the aid of a high resistance between head and amplifier. This arrangement, though eminently suitable for valve circuits where large undistorted voltage swings are easily obtainable, requires an unusually high power supply rail and a high-voltage output transistor for acceptable results. Taking the case of the Ferrograph Mk. V tape deck, the head having an impedance of 18 k ohms at 15 kc/s, only 2.2 volts are needed to produce the peak recording current of 120 μ A. It is obviously an extremely wasteful procedure to generate ten times this voltage in the amplifier and then to lose most of it in the head feed resistor.

The circuit shown below, which I have used successfully for two years, meets the constant current drive requirements more elegantly, I feel, than many other designs. The output stage is a complementary common-emitter configuration. Each transistor then acts as a high impedance load for the other, local negative feedback from R_4 and R_5 increasing the effective output impedance.

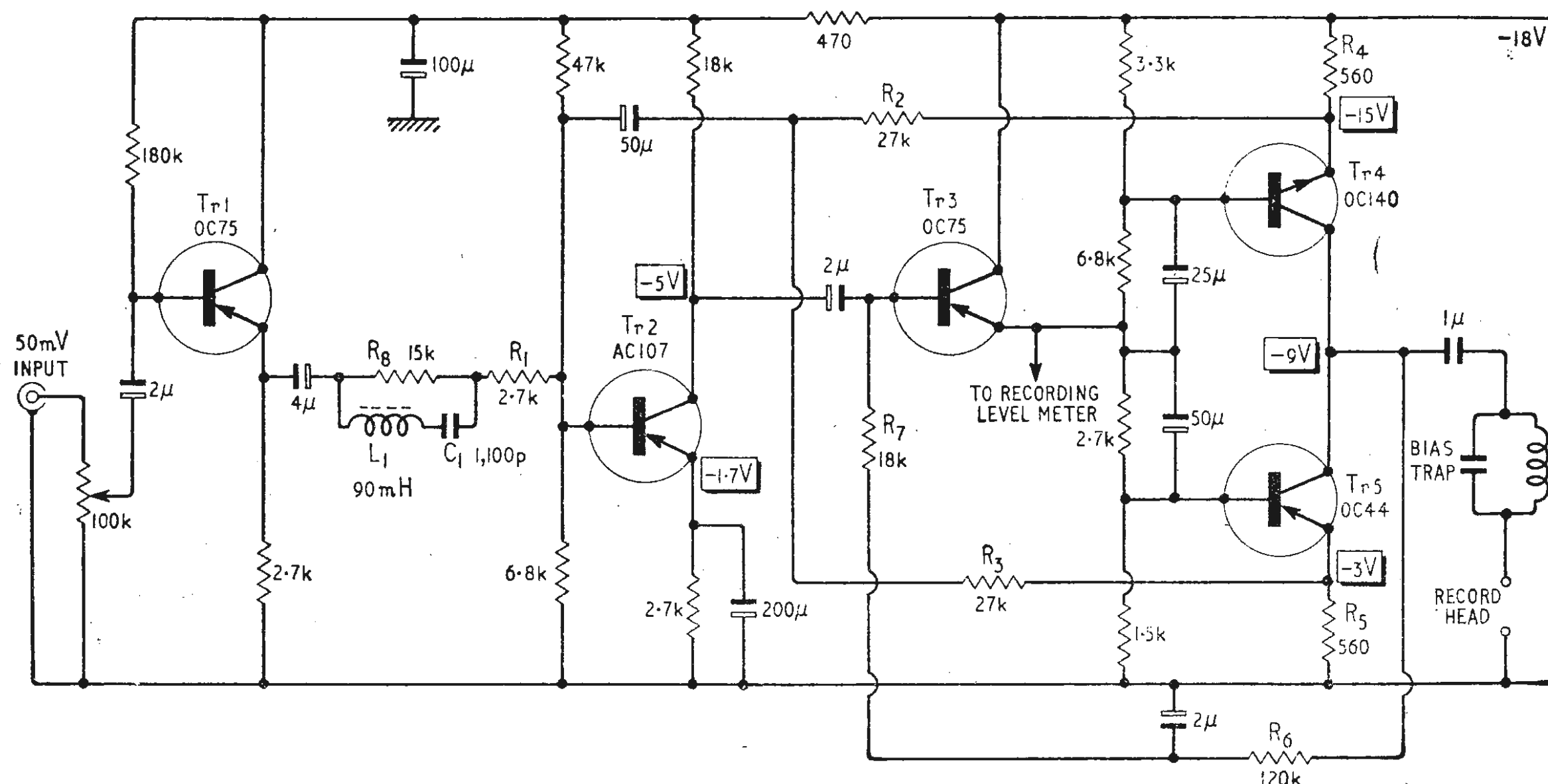

R_6 and R_7 provide a d.c. feedback path from the output to the base of the emitter follower TR3, and ensure the maximum available output voltage swing by holding the collectors of TR4 and TR5 at half the supply voltage.

At audio frequencies the output terminal is shunted by R_6 , which then becomes the amplifier output impedance, being much lower in value than the combined collector impedances of TR4 and TR5. Still more feedback is taken via R_2 and R_3 to the base of the pre-amplifier TR2, reducing the input resistance of this stage to a fraction of the value of R_1 . The output current for a voltage V applied at the input end of R_1 is then given by

$$\frac{V \cdot R_2}{R_1 R_4} \text{ since } R_2 = R_3 \text{ and } R_4 = R_5$$

A simple passive equalizer ($L_1 C_1 R_8$) providing 15dB boost at 17.5 kc/s, and an emitter follower buffer stage complete the design.

The heavy negative feedback around the circuit, coupled with the use of the push-pull configuration in the output stage enable distortion figures to be obtained which are negligible when compared with the non-linearities introduced by the recording medium.

London, S.W.20

J. B. WATSON

Duality

IT is with a sense of oppressive penance that I can claim to be with those who have persisted with you "Cathode Ray" for long. Fanciful or not I regard you as a skilled chef who serves up carefully prepared and, more important, satisfying meals.

Two points arise from your May article.

(1) You say "Its dual must be a current source with no conductance in itself, and *such things are not practical*" (my italics). Surely there are at least two practical examples of such, to wit, the Wimshurst machine and the Van de Graaf generator.

There ought to be ammunition there for a discussion on the properties of conduction *v.* displacement currents. However that may be, the notion offers one solution to the problem of the pictogram for a current generator. Formalising the segments on a Wimshurst wheel we get



which is reasonably easily drawn.

(2) Thank you for confirming my reasonableness in being "awkward" by the use of V_{kg} —voltage from k to g , rather than V_{gk} —voltage at g w.r.t. k .

Glasgow, W.2.

W. GRANT

The author replies:—

Mr. Grant does well to call attention to the "electrostatic" generator as the dual of the familiar electromagnetic machines. I have just been reading an interesting article on this very subject by Prof. N. J. Felici in *Electronics & Power* (Journal of the I.E.E.), May 1965, (pp. 169-171) in which he develops this duality in detail. While it is true, as I said, that no strictly constant-current source is practicable (since on open-circuit it would build up an infinite p.d.) one could also say that no strictly constant-voltage source is practicable (since on short-circuit it would pass infinite current). So I readily take the point.

I did have something to say on conduction *v.* displacement currents some time ago ("What is an Electric

Current?", Feb. 1963) and briefly made the point that, if displacement currents are included, Kirchhoff's first law applies generally—a.c., capacitive circuits, even spaces—just as the second law holds for all closed paths, conducting or not. It is a pity that so many spoil the duality of these laws by discriminating between E_s and V_s .

"CATHODE RAY"

Record Reproduction

YEARS of reading depressing articles on how a gramophone needle chews up vinyl records almost led me to discontinue playing mine.

I decided to look for a suitable lubricant to supplement that included in the record material by the manufacturer. I started collecting samples of different unguents and have found one that doesn't seem to spoil them.

Molybdenum Disulphide comes in powder form with particle sizes of under 1 micron. It has a coefficient of friction of 0.04, shears easily, resists pressure and is easily applied with a camel-hair brush.

To my prejudiced ear the reproduction of a record brushed with MoS_2 sounds smooth and there seems to be a reduction in the usual accompanying pops and hiss.

Perhaps one of your contributors would care to waste a record on some "before and after" measurements. Any slight justification to the use of MoS_2 would greatly improve marital relations for the undersigned.

Haifa, Israel.

P. HIRSCHMANN

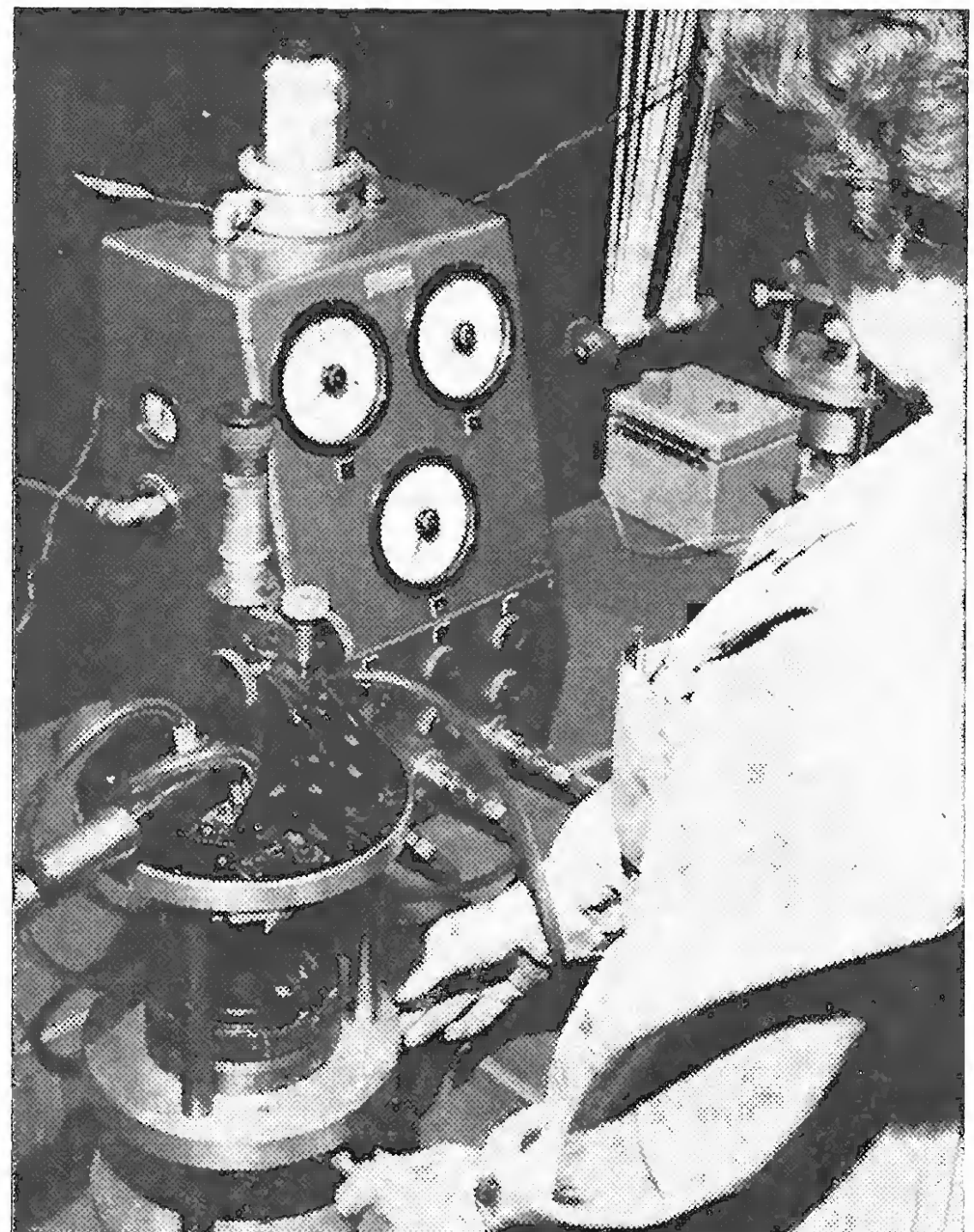

Final adjustments being made to a cathode-ray tube designed for use in projection radar systems. To enable the tubes to be automatically positioned into the associated radar optical system under operational conditions they are fitted with a plastic collar. The operator at EMI Electronics Ltd., Hayes, is adjusting the precise location of the collar in relation to the undeflected spot.

NEW PRODUCTS

equipment systems components

Admittance Neutralizer

THE latest admittance neutralizer from the Micronia Amplifier Corporation, of New York, the Model MC-205A has a frequency response of 2 c/s to 2.5 Mc/s, with amplifier rise time of 0.04 μ sec. This represents a considerable improvement on the earlier model (MC-204A, 10 c/s to 250 kc/s) which, however, has proved adequate in many fields and is still available.

As with the earlier model, the MC-205A allows test instruments and the like to be connected to low impedance sources without loading. For example, if used with an oscilloscope that normally has an input impedance of 1 M Ω and 47 pF, the combination retains the

original sensitivity, voltage calibration and frequency response of the oscilloscope, but the input impedance is then adjustable from 100 M Ω to infinity and 4 pF down to zero.

Other specifications of the MC-205A include dynamic range of 10 μ V to 1 V r.m.s., gain adjustable from 98-102% (normally set to unity) with gain drift of less than 0.05% per 8 hours, and an output impedance of 25 Ω (maximum load 2.5 k Ω and 200 pF). The overall dimensions of the instrument, which is driven from an internal rechargeable 12 V battery, are $7\frac{3}{4} \times 2\frac{3}{4} \times 2\frac{3}{4}$ in.

The price of the new instrument complete with all accessories is £185 15s; the price of the MC-204A is £153 15s. Micronia are represented in the United Kingdom by the instruments division of Claude Lyons Ltd., of 76 Old Hall Street, Liverpool 3 (Southern offices Hoddesdon, Herts.).



8WW 301 for further details

Heavy-Duty Rotary Wafer Switch

WITH a rating of 5 amps at 250 volts a.c., the model SD rotary wafer switch from N.S.F. Ltd. can be used for many applications including switching the tapings on mains transformers, etc. Non-shorting, break-before-make contact configurations are as follows: 1 pole, 2 to 12 positions; 2 pole, 2 to 6 positions; 3 pole, 2 to 4 positions; and 4 pole, 2 or 3 positions.

The current switching capacity at 30 volts d.c. is 10 amps (resistive load); contact resistance is less than 5 m Ω with an insulation resistance of greater than 10⁵ M Ω . Thirty or 60 degree indexing is available on the standard units, which have double ball location with a full circle pressure spring. Improved J types

(single ball location) or heavy duty cam and roller mechanisms (for biased types and Service requirements) are optional.

8WW 302 for further details

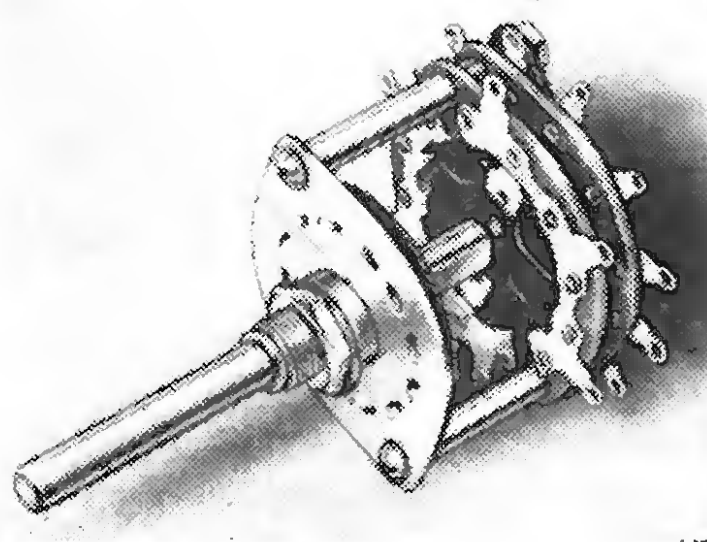

Flexible Printed Circuit Kit

AN engineer's kit for producing flexible circuits photographically is being offered by the electrical products division of the Schjeldahl Company, Minnesota. The kit includes opaque tape and tape washers, etc., to make up the original layout, light sensitive copper-Mylar laminate circuit materials, developers and etchants.

The first step in the process is to make a master. For this, the tapes and washers are laid out on a sheet of glass—which, with the other items needed in the process, is included in the kit—to resemble the finished printed circuit. The master is then laid face down on top of one of the light-sensitive laminates. After exposure, the laminate is developed and etched to produce the final circuit. Time taken, including making-up a simple circuit layout, can be as little as fifteen minutes.

The European agents for the Schjeldahl Company are Oswald E. Boll Ltd., 4a Commercial Road, Woking, Surrey.

8WW 303 for further details

Soldering Products

FLUXALL, a new flux that will tackle most common metals without pre-cleaning or after-cleaning, is being offered by the Welding Equipment Service Company, of Wescol Works, Lower Horseley Field, Wolverhampton, Staffs. This flux, which is suitable for use with all types of soft solder, will disperse tenacious oxides such as the chromium and nickel oxides on stainless steel, and has a low viscosity. The flux residue is almost completely inert and is easily removed if desired. Fluxall is unsuitable for aluminium, magnesium and zinc diecast objects. The price varies from 6s 6d for a 4 oz dispenser to £9 17s 6d for five gallons.

Also announced is a new soft silver solder that is completely free from cadmium and lead making it perfectly safe when in contact with food. A kit containing 4 ft of this new 1/16-in soft silver solder (Wescolite 220) and a small dispenser bottle of Fluxall is offered at 7s 6d.

8WW 304 for further details

Infra-Red Cameras

USING high-resolution scanning and advanced radiometric techniques, the Barnes Engineering Company, of Connecticut, offer two infra-red cameras for producing thermal photographs. These photographs, known as thermographs, are not dependent on external sources of illumination, but respond to the infra-red energy naturally radiated by all objects, to produce photographs depicting temperature distribution.

The two cameras, the Model T-4 and the Model T-5 are quite similar and consist of an optical head—comprising a scanning system and an eight-inch radiometer head—and an electronics unit. A large mirror, which is oscillated in the horizontal and vertical planes, by cams, is used to deflect the optical beam of the radiometer in a horizontal pattern over the plane of the target. The radiometer head contains elements which collect and focus incoming radiation, an infra-red detector, a temperature-controlled black body radiation standard and a pre-amplifier. In this section of the apparatus, the incoming radiation is compared with that from the radiation standard, converted to an electrical signal and, after amplification, applied to the electronics unit.

The electrical signal from the radiometer head is used to control a driver amplifier, which in turn drives a glow modulator tube on an image scanning mirror (which is attached to the back of the target-scanning mirror and precisely duplicates the target-scanning motion) to produce an image on sensitive Polaroid Land picture material.

True thermal photography, the manufacturers of this apparatus claim, has been made possible only by recent advances in the field of radiometry, especially at the longer infra-red wavelengths. In the past infra-red pictures have been made by means of either infra-red sensitive film or image converter tubes; but such pictures were not thermographs. Those techniques were limited to the near infra-red region (approximately 0.8 to 1.2 microns), and could produce images only in response to radiation from an incandescent source. However, if the desired subject was not incandescent an external auxiliary source of near infra-red radiation was required. The images were then produced by reflected radiation and contained no thermal information. With the advent of long wavelength radiometric techniques, it has become possible to produce images of non-incandescent as well as incandescent objects, by means of the thermal radiation emitted by those objects. Such images depict the thermal conditions of the surfaces of those objects.

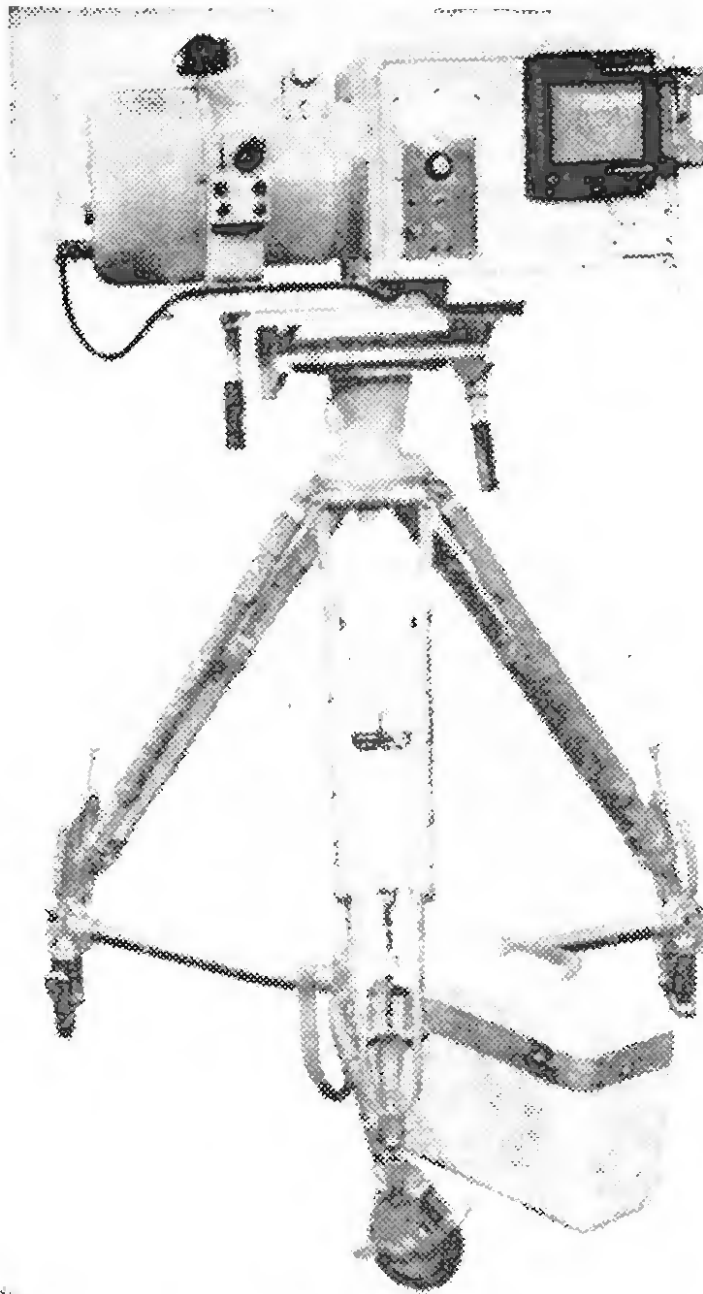

The basic price of these cameras, which are available in the United Kingdom through B. & K. Laboratories Ltd., of 4 Tilney Street, Park Lane, London, W.1, is £10,890. This price does not include any Government import charges which may be applicable.

8WW 305 for further details

Small Toggle Switch

HAVING a body length of only 0.5 in and a diameter of 0.25 in, the new TS single-pole toggle switch from Miniature Electronic Components Ltd. should find many applications in the industry. Two models are available, the TS70, which has fine silver contacts and is rated at 1 amp (resistive) at 50 volts d.c. (and 20 mA at 230 V a.c.), and the TS71, which has heavily gold-plated contacts and is rated at 100 mA at 1 volt d.c.

Both models have identical dimensions, designed for panel mounting,

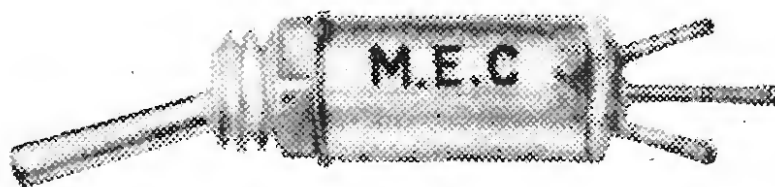

and are suitable for operation in temperatures of up to +85° C. Initial contact resistance for the TS70 is 10 mΩ and for the TS71 6 mΩ.

The company's address is The Lye, St. John's, Woking, Surrey.

8WW 306 for further details

Integrated Logic Circuits

A COMPREHENSIVE range of monolithic high-level transistor logic circuits (HLTTL) that have several advantages over earlier types have been developed by Transitron Electronic Ltd., of Gardner Road, Maidenhead, Berks. Noise immunity of the new devices is better than 600 mV at 125°C, propagation delay is less than 10 nsec, capacitive driving capability is 300 pF and minimum fan out is twenty. These improvements have come about by the use of new manufacturing techniques such as improved chip layout design (assisting in the reduction of parasitic capacitance) and also through the use of v.h.f. transistors (resulting in improved propagation delay and resistance to irradiation). The range includes single 8 input NAND/NOR gates, dual 4 input NAND/NOR gates and dual 4 input NAND-OR (exclusive OR) gates.

The latest addition to the HLTTL range is a 20 Mc/s single-phase d.c. coupled flip-flop. All HLTTL circuits are available in either a multi-lead low height TO-5 package or a ceramic-glass flat package.

8WW 307 for further details

Solar Cell Powered Transistor Portable

THREE banks of solar cells are used in conjunction with four nickel-cadmium cells to power the new Royal 555 portable transistor receiver from the Zenith

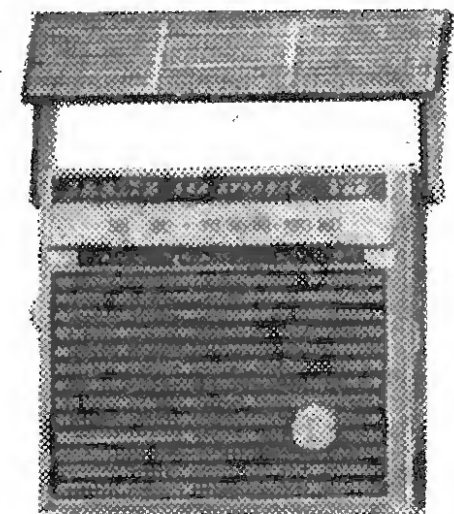

Radio Corporation. In addition to this power source an internal battery charger is also provided. This can in fact be used to drive the receiver directly from the mains if required.

Eight transistors are used in the receiver, which covers the medium-wave band and has a push-pull output of 80 milliwatts. Other features of the portable include vernier tuning, a slide-rule scale and side-mounted controls.

According to the Zenith Sales Corporation, of 1900 North Austin Avenue, Chicago, Illinois, from which this portable is available (\$59.95) the battery life with frequent rechargings is up to five years.

8WW 308 for further details

Analogue Computer for Students

A SMALLER version of the standard 18-unit EMIac II analogue computer, known as the Mini EMIac, has been introduced by EMI Electronics Ltd. for teaching purposes. Six amplifier positions, each able to accept either dual or single operational amplifiers, are provided.

The computing function of each amplifier is determined by selection of the appropriate computing box. The amplifiers and computing boxes available for the "Mini" (both linear and non-linear) are identical to those of the

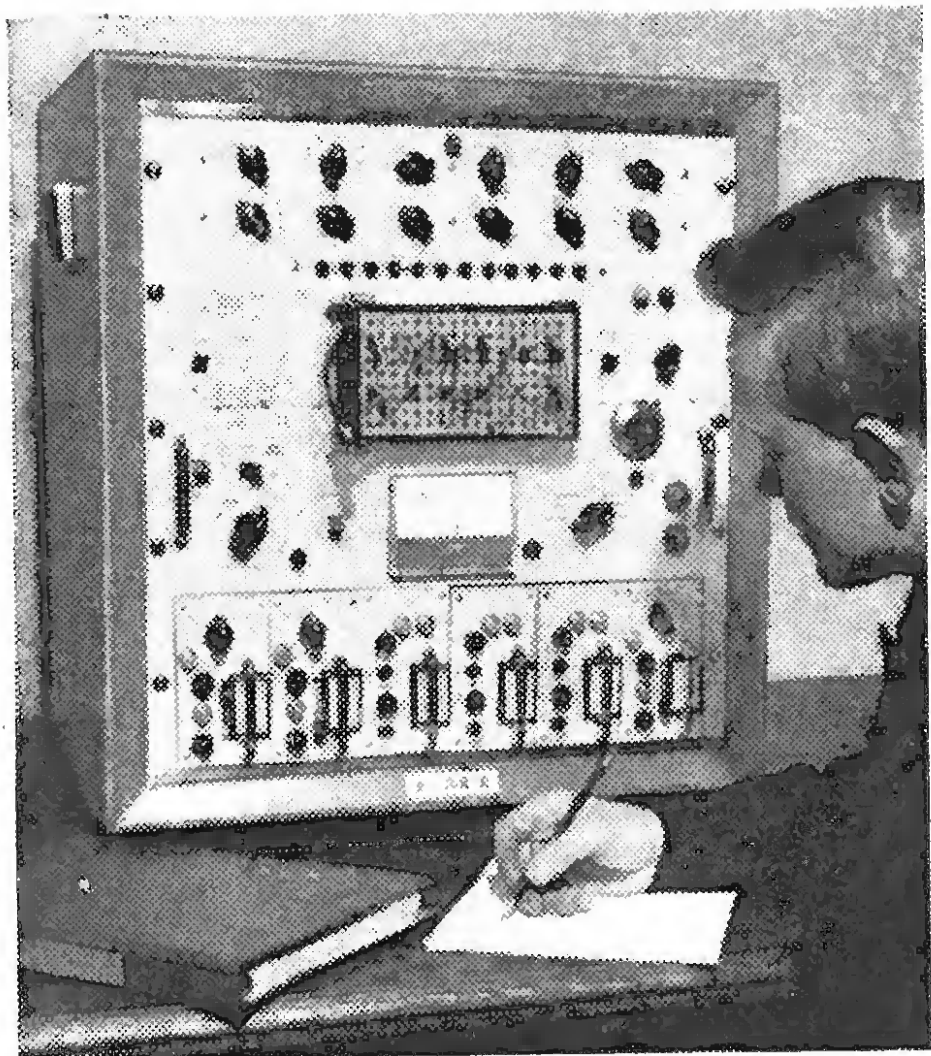

standard EMIac II. Mode control positions provided include discharge, earth inputs, preset, compute, freeze and repetitive. Setting-up and measuring facilities are provided by means of a master Helipot and null-balance meter; with provision for external monitoring, using a digital voltmeter or oscilloscope.

Twelve coefficient-setting potentiometers are provided and the patchboard is detachable for problem storage. Provision has also been made on the patch panel for linking computation and control signals to two or more "Minis" or to standard EMIac II units.

8WW 309 for further details

Wire Stripper and Cutter

THE latest Bib wire stripper and cutter to be added to the range of accessories offered by Multicore Solders Ltd., of Hemel Hempstead, Herts., is the Model 8. This is fitted with a selector gauge which can be pre-set for any Standard Wire Gauge between 12 and 26.

The retail price is 7/6.

8WW 310 for further details

V.H.F. & U.H.F. Transistors

USING a new fabrication technique of selective metal-etching, Motorola claim they have overcome the limitations of germanium transistors produced by the conventional evaporation processes. This apparently allows a higher emitter perimeter-to-area ratio, which improves operation at higher frequencies. Also, a higher resolution is achieved with the new process and allows closer spacing of the emitter and base contacts which reduces the base resistance and improves the noise figures. For the new series of semiconductors (2N3783-2N3785), made by these techniques, noise figures as low as 2.2 dB are claimed at 200 Mc/s.

Another germanium transistor (MM2503) recently introduced by Motorola is also said to have better characteristics than those for conventional germanium mesa and currently available high-frequency silicon types. A gain-bandwidth product of 1,000 Mc/s, a maximum noise figure of 3 dB at 200 Mc/s, and a breakdown of 30 volts are claimed. This has been achieved by

using annular construction methods and SiO₂ passivation of all junctions in addition to the surface of the semiconductor. This p-n-p device is housed in a four-lead TO-18 case.

In the silicon field, Motorola Semiconductor Products Inc. have produced a 25-watt n-p-n device in a TO-60 package that can handle 15 watts at frequencies of up to 100 Mc/s. A typical power gain for this device, which is designated 2N3818 and has been designed for Class C operation, is 7 dB. Operating at 60 volts, the continuous collector current rating is 2 amps; collector efficiency is about 65%.

These semiconductors are stocked in the United Kingdom by Celdis Ltd., of Reading, Berks.

8WW 311 for further details



New Ferrite Material

A MATERIAL, basically a cobalt ferrous ferrite, that has bistable magnetic switching properties resulting from a re-entrant hysteresis loop characteristic, has been developed by the Standard Telecommunication Laboratories, of Harlow—part of the S.T.C. organization. Whereas the conventional square loop ferrite has a range of minor loops as the flux density is increased and thus has a series of remanent states depending on the amplitude of the applied field, no flux reversal is obtained with the new material until a critical field strength is obtained. Above this critical field strength, the coercive force (half the loop width) and flux change (height of the loop) are almost independent of the field strength, but the loop becomes re-entrant. It is this phenomenon that gives the new material its bistable characteristics.

As the field required to initiate flux reversal is greater than that required to continue it (coercive force), a pulse can be used to switch the material directly from one remanent state to another.

The new material, as earlier stated, is basically cobalt ferrous ferrite. This is annealed at about 200° C in an alternating magnetic field of sufficient amplitude to saturate the material magnetically during positive and negative half cycles.

Annealing induces a preferred axis for magnetization along the direction of the field and reduces the number of domain walls (a layer, separating two volumes magnetized in different directions), through which the magnetization gradually rotates from one direction to another) whose motion is responsible for flux reversal.

At the end of the annealing process, only one wall remains, which sweeps between the two near-saturation states in which it spends most of its time. These two states are thus established as low energy positions, by local annealing. The excess of field required to detach the domain wall from these low energy states over that required to drive the wall through the material gives rise to the re-entrant loop.

Flux reversal is effected by only one domain wall, which must sweep through the entire section. This, however, means the switching time of the new material is slow and dependent upon the size of the sample. The good fail-safe characteristics of the new material should, however, make it particularly suitable for magnetic logic applications in control systems where fail-safe characteristics of the bistable loop are of greater importance than switching speed. Development is continuing.

8WW 312 for further details

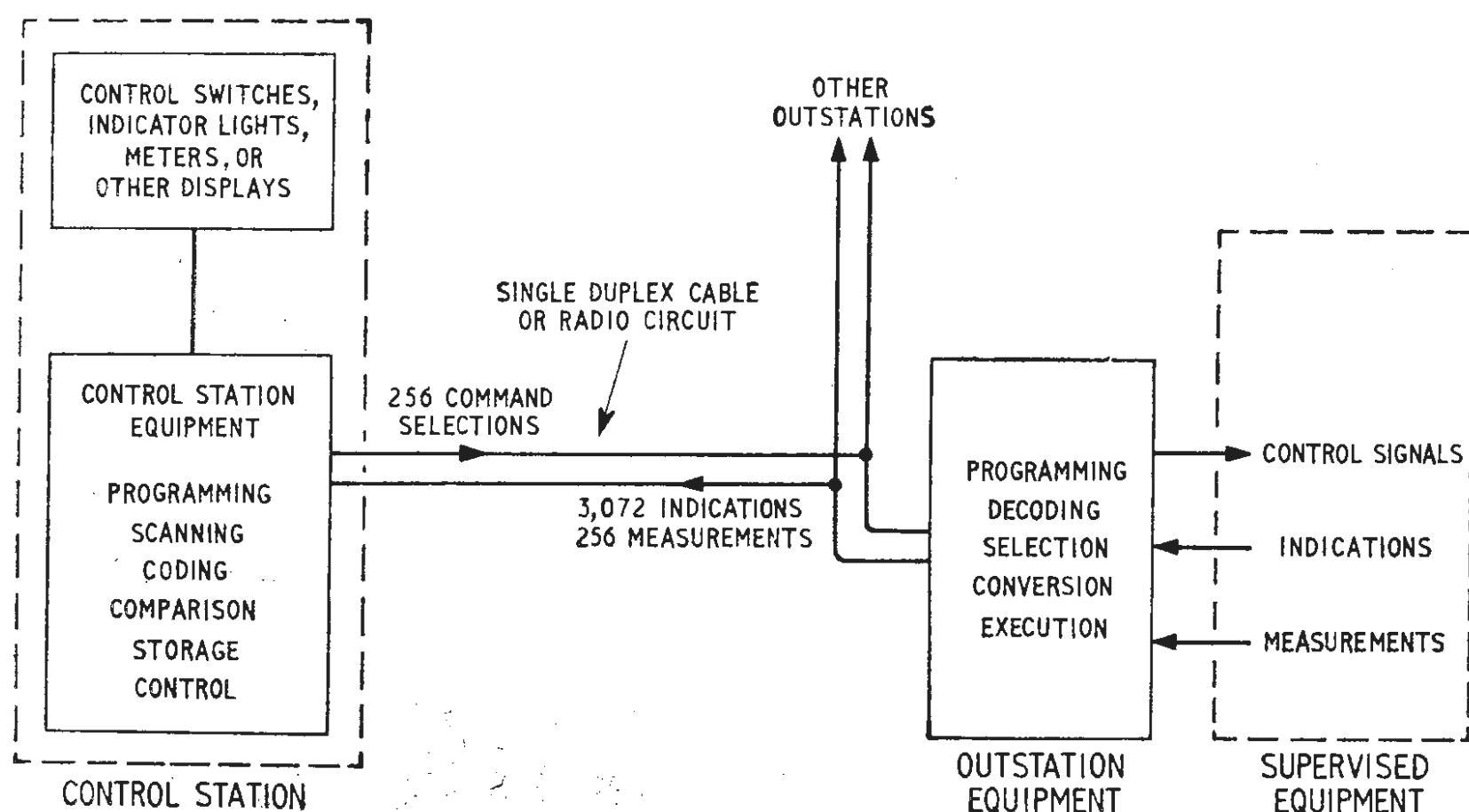

Supervisory System for Remote Control

TO convey numerous on-off and positional commands from a control station to one or more outstations and to transmit alarms, indications and meter readings in the reverse direction, fast time multiplex techniques are used in the Selectronic 701 supervisory remote control equipment recently developed by the Integrated Systems Division of Standard Telephones and Cables Ltd. Telephone lines, electrical power lines or radio links may be employed to connect the control stations with the outstations; outgoing commands, incoming indications and measurements being sent over the same duplex circuit.

Before transmission the multiple inputs corresponding to command, indication or measurement functions are converted into serial form for transmission in binary code; simple two-condition signalling is used as in standard telegraph practice. On the receiving side—both at the control station and at the outstations—the procedure is reversed to regain the transmitted data.

Each message contains 16 bits of information. Four of these are used for a cyclic parity check, eight for selection purposes (making 256 command selections possible) and four to designate the functions to be carried out. In messages from the outstations all twelve information bits are used to convey indications or measurements, giving a total capacity of 3,072 (12×256).

All supervised parameters at the outstations are continuously scanned; the frequency of interrogation for each being determined by its significance for operational purposes. If the scanning speed is not fast enough (that being dependent upon the transmission speed, which, of course, is related to the bandwidth of the circuit), rapidly changing quantities can be measured more than once in the

scanning cycle. A plug and socket arrangement has been adopted for the programming of the monitoring sequence. This allows a choice of which parameters are scanned, in which outstations, in what sequence and how often. If a change in condition is signalled, a repeat transmission confirming the change is called for by the control station before the relevant display is up-dated. The same principle is applied to meter readings when a significant change is detected.

Measurements may be displayed in either digital or analogue form, all twelve bits being needed for transmission if an accuracy of three significant places is required. An analogue to digital converter can be provided within the outstation equipment to cater for primary measuring devices with analogue outputs.

The Integrated Systems Division of S.T.C. is at Burleigh House, 101-145 Great Cambridge Road, Enfield, Middx.

8WW 313 for further details

Small V.H.F. Variable Capacitor

A VARIABLE capacitor designed for use in transistor v.h.f. frequency-modulated tuners was recently introduced by Jackson Brothers (London) Ltd., of Kingsway, Waddon, Croydon, Surrey. Two- and three-gang units are currently available, the dimensions being $0.550 \times 0.809 \times 1.040$ in and $0.640 \times 0.809 \times 1.450$ in respectively and a four gang version will be available shortly.

The capacitance swing per section is 14.5 pF; the minimum capacitance being 3 pF and the air gap 0.010 in. These units are tested at 500 volts and have an integral three-to-one reduction gear.

8WW 314 for further details

Self-contained Level Detector

APPLICATIONS of the Saunders-Roe & Nuclear Enterprises "Betalights" have been extended to include the "Betaresistor," an optical level detector using a self-contained light source (Betelight) and a CdS photoconductive cell. Betaresistors can be used for on-off level control in powders, liquids, slurries and smoke.

The Betelight uses the unstable nucleus of tritium (an isotope of hydrogen) to provide β -particles which cause a phosphor to emit visible radiation. The tritium is enclosed in a phosphor-coated glass tube, providing a safe self-contained light source. The half-life of the tritium is such that a life of 15-20 years can be expected from Betalights.

For level control of opaque liquids and light-coloured powders, a reflection Betaresistor is used. The source and cell are shielded, and on immersion light is reflected by the surrounding medium causing the cell to be illuminated. An absorption type of Betaresistor is also available for level control of opaque liquids.

For transparent liquids an internal reflection type is used which is set in a solid glass block so that in air, light is internally reflected and illuminates the cell. The change of refractive index of the surrounding medium on immersion causes light to pass into the medium and the cell is not illuminated. Betaresistors can also be used in density control and for measurements of small displacements.

The operating temperature range is -40°C to $+75^{\circ}\text{C}$ and the cell resistance decreases by 1% per $^{\circ}\text{C}$ rise in temperature. Stability is $\pm 10\%$ after 24 hours and response time is 1 sec. Maximum pressure is 300 lb in^{-2} but higher pressure

types are under development.

A relay unit (to enable level to be controlled to within $\frac{1}{2}$ in with a single Betaresistor and over any greater range using a pair) and continuous level control types are also under development.

The address of Saunders-Roe & Nuclear Enterprises Ltd. is North Hyde Road, Hayes, Middlesex.

8WW 315 for further details



Frequency Standard

A HIGH-STABILITY oscillator having a frequency variation of only thirty millionths of a cycle at 100 kc/s has been developed by the Marconi Company, of Chelmsford. Short-term accuracy of the oscillator is better than ± 3 parts in 10^{10} with an aging stability of less than one part in 10^9 per month.

The oscillator, which produces three simultaneous outputs of 100 kc/s, 1 Mc/s and 2.5 Mc/s, uses a highly polished 5th overtone 2.5 Mc/s crystal developed within Marconi's. There are eight perfect interfaces within the crystal which has a Q value of over six million.

"Staircase divider" circuits are employed to obtain the 1 Mc/s and 100 kc/s outputs with high-phase stability. Transistors are used in these circuits and also in the associated buffer stages.

The complete unit, the Type F3160, is designed for rack mounting and contains its own power supply units which will operate from any mains supplies. Emergency batteries are provided in the F3160 and allow the oscillator to continue with the same frequency stability, during a power failure.

8WW 316 for further details

Thin-film Sputtering Equipment

LOW-ENERGY triode sputtering for thin films is used, in contrast to conventional evaporation by diode sputtering, in the "PlasmaVac" unit announced by Consolidated Vacuum, of 14 Commercial Road, Woking, Surrey; a division of Bell & Howell. A hot tungsten filament (2,500°C initially) provides an electron source which ionizes argon (which can be welding-grade) at a pressure of 10^{-3} torr. A current of a few amps flows from filament to anode with a voltage drop of about 50 V. A potential of up to -1500 V is applied to the target which attracts the positive plasma ions causing them to impinge with sufficient energy to sputter atoms of the target material onto an adjacent substrate. A magnetic field provided by a circular electromagnet situated around the bell jar provides control over the plasma density.

The PlasmaVac gives a closer control of thickness, uniformity and composition than diode sputtering and the deposition rate is greater. The deposition rate is constant and determined by the material, and the target voltage and current, both of which are monitored. Thickness uniformity can be held to 1% over a 1x1in substrate.

A wide range of elements can be sputtered, including Si and Ge. Also some alloys and compounds can be formed, by using two targets with control over the composition by varying the

target potentials. The low substrate temperature enables plastic materials to be coated. (In the manufacture of an optical filter gold has been sputtered onto a polycarbonate substrate and the deposition time was used to control the optical transmission.) Better adherence is claimed for the films as a result of the higher velocities of the atoms.

Although this equipment is currently being made in the United States, it is hoped that production in the United Kingdom will commence later this year.

8WW 317 for further details

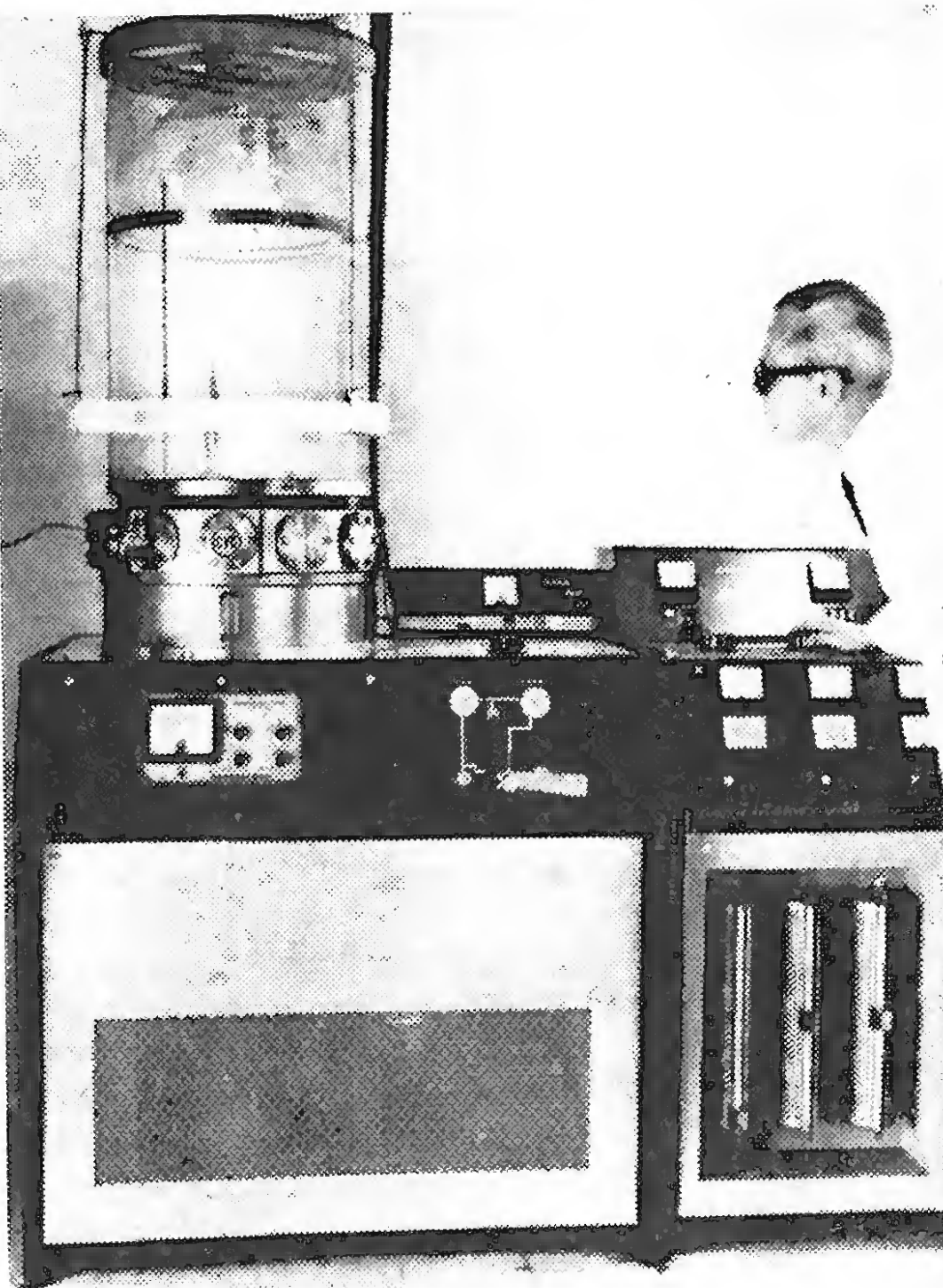

Novel Norwegian Record Player

THE Norwegian radio and television manufacturers, Radionette, have developed a small, transportable record player that will hold up to 25 seven-inch discs and play either side automatically. As can be seen from the photograph, it looks similar to the smaller "juke boxes." The discs all rotate simultaneously at a constant speed of either 33 or 45 r.p.m. on the magazine shaft, to which a flywheel, weighing nearly 5lb, is attached to maintain constant speed and keep the unit free of "wow."

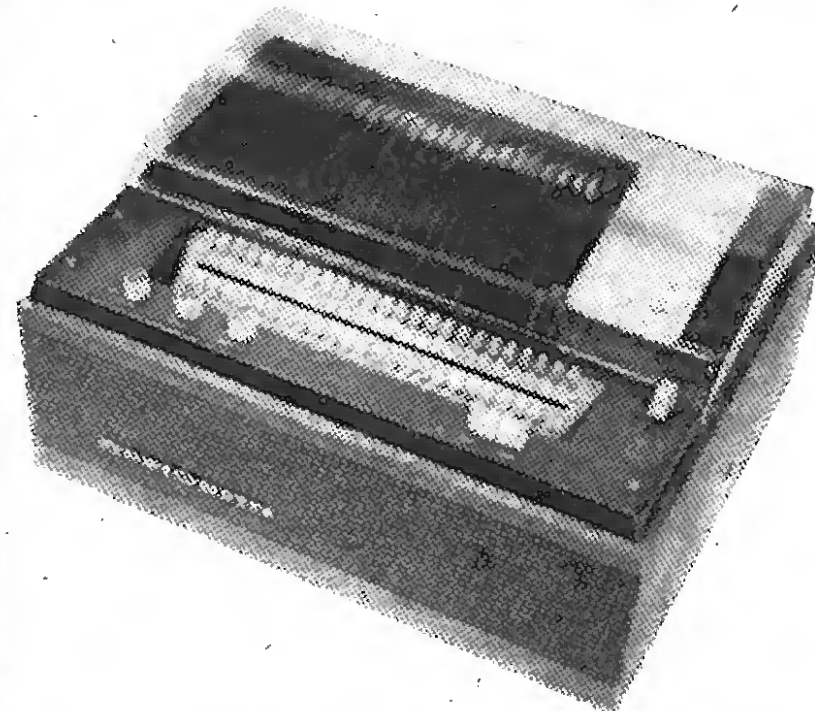

Disc selection in this Radionette Multiplayer is made through two banks of push-button switches, one for each side of each record contained in the magazine. Between discs there are spacing rings which make room for the two pick-up arms, one for either side of the disc. These are mounted on a guide rail running alongside the magazine and are driven by the main 25-watt motor.

A fifteen-watt transistor amplifier is incorporated in this unit. If full output is required, it is necessary to employ external speakers, as the internal one can handle only three watts. With a power output of one watt, the frequency range (within ± 3 dB) is from 45 to 17,000 c/s. Harmonic distortion at 14 watts output is less than 1%. Eight transistors are used in the amplifier, with two AD 149's operating in push-pull in the output stage. The overall dimensions of the player are 20x41x31 cm; weight is 13 kgs.

In Norway, the sterling price of the Multiplayer is £73. The company's address is Trondheimsveien 100, Oslo 5.

8WW 318 for further details

Edge Connectors

PRINTED CIRCUIT edge connectors for $\frac{3}{16}$ in boards with up to 80 contacts are being offered by the Wiring & Connectors Division of the Plessey Components Group, Cheney Manor, Swindon, Wilts.

8WW 319 for further details

General Purpose Scope

A LOW-COST oscilloscope with a 10 c/s to 250 kc/s bandwidth (± 3 dB approx., with useful gain extending up to 10 Mc/s) is announced by Tonbridge Laboratories of 14 Ogle Street, London, W.1. Known as the Model T.L.4, this instrument has four sensitivity ranges covering 100 mV/cm to 50 V/cm and an input impedance of 1 M Ω and 20 pF on all ranges.

The timebase is variable from 1 μ sec/cm to 0.1 sec/cm (four overlapping ranges) and provision is made for an external timebase, with or without internal amplifier. In addition to automatic synchronization, provision for triggering from an external source is also provided in this three-inch portable scope.

Consumption of the T.L.4 is 35 watts (230/250 V a.c.), dimensions are 7 \times 5 \times 10 $\frac{1}{2}$ in, and weight is 10 lb. It costs

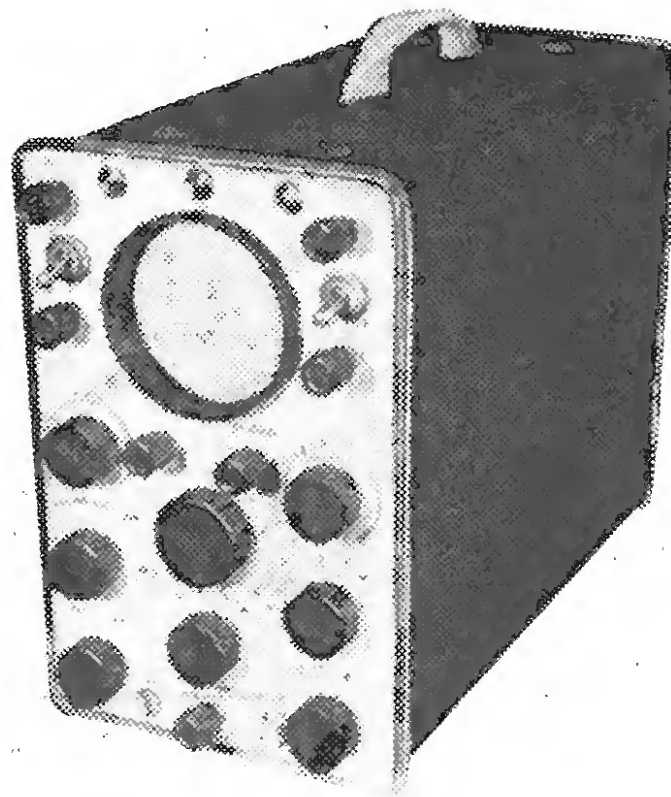

£29 19s 6d, plus 8s 6d for postage and packing.

8WW 320 for further details

Insertion Loss Measuring Set

AN accuracy of ± 0.005 dB absolute and ± 0.001 dB relative over nearly one-third of its range, which is 0 to 25 dB, is claimed for the Model DB-3000 precision insertion loss measurement set from the De Mornay-Bonardi Division of Datapulse Incorporated, California. Between 15 and 25 dB, the accuracy is at its lowest and falls to ± 0.100 dB. The frequency range of the DB-3000 is from 100 c/s to 90 Gc/s.

This instrument operates on the bridge principle, comparing the input and output signals, and the transmission line system used is the same as that employed for most dual channel comparator systems. The DB-3000 has a noise level of better than 70 dB and its dynamic range of 25 dB may be extended by two or more steps with standard calibrated attenuators.

The only accessories needed for this instrument are an amplitude modulated r.f. generator and a v.s.w.r. indicator. In Britain, the instrument is available through C. T. (London) Ltd., of 27 Ashley Place, London, S.W.1, for approximately £825.

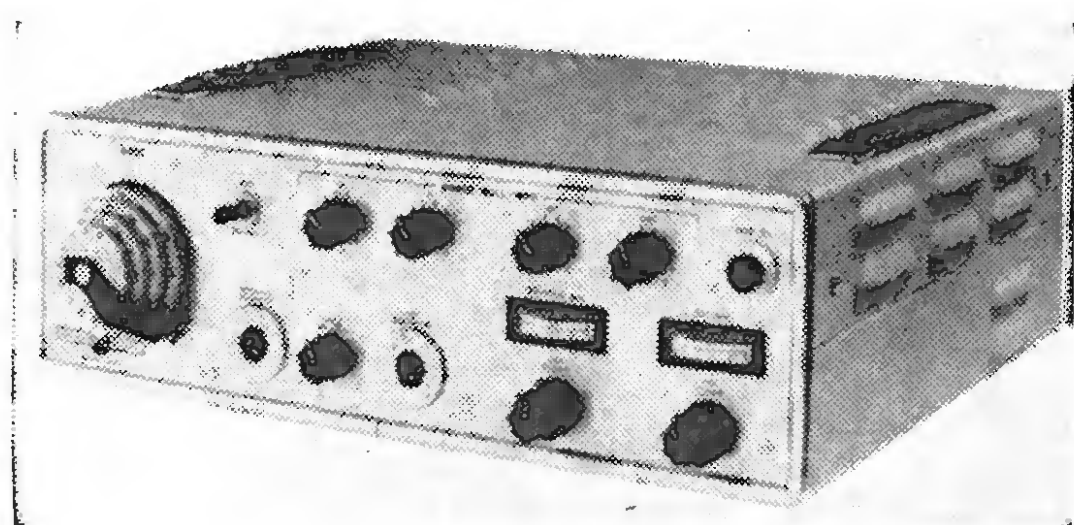

8WW 321 for further details

INFORMATION SERVICE FOR PROFESSIONAL READERS

To expedite requests for further information on products appearing in the editorial and advertisement pages of *Wireless World* each month, a sheet of reader service cards is included in this issue. The cards will be found between advertisement pages 16 and 19.

We invite professional readers to make use of these cards for all inquiries dealing with specific products. Many editorial items and all advertisements are coded with a number, prefixed by 8WW, and it is then necessary only to enter the number(s) on the card.

Postage is free in the U.K. but cards must be stamped if posted overseas. This service will enable professional readers to obtain the additional information they require quickly and easily.

Relay in TO-5 Can

A MICROMINIATURE relay that has been designed primarily for missile applications and has a mounting area equal to that of a TO-5 transistor case is being made by the Professional Components Division of Plessey-UK Ltd. Designated CJ, this unit, which weighs only 3.4 gm, is capable of switching loads of up to 0.5 amps at 28 V d.c. (resistive) and has an operate and release time of 3.5 milliseconds maximum, including bounce time.

Standard coil voltages of 1.3, 6, 12, 18, 24 and 30 V are available for this one-pole changeover relay which has a minimum contact life of 10^6 operations. Other specification details include a minimum power requirement (at 20°C) of 150 mW, a contact resistance of 100 m Ω maximum and insulation resistance of 100 M Ω at 500 V d.c.

The address of Plessey's Professional Components Division is Abbey Works, Titchfield, Fareham, Hants.

8WW 322 for further details

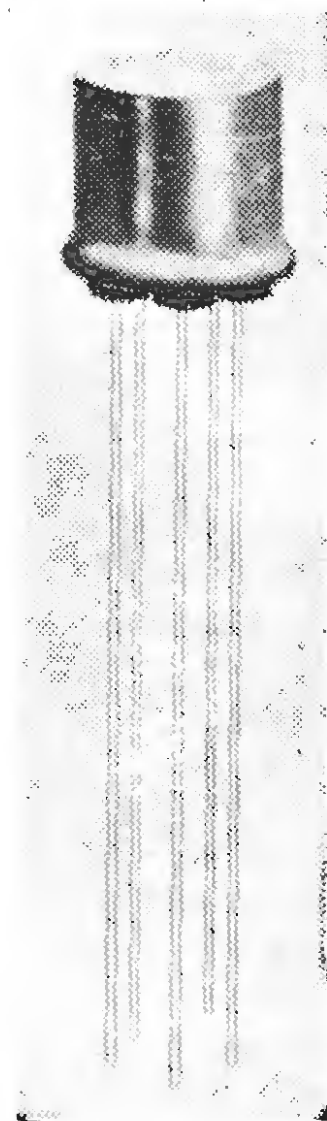

Semiconductor Replacements for Thermionic Rectifiers

TO replace conventional thermionic rectifiers used in high-power television and radio transmitters and other like equipment, Semikron Rectifiers and Electronics Ltd. have produced a range of plug-in silicon avalanche rectifier assemblies for direct replacement of a number of British and American types.

As an example, the Type SKA 857/9600, designed to replace the 875B rectifier, consists of a number of series-connected six-amp avalanche diodes giving 10,000 volts d.c. at 18 amps from a three-phase bridge feeding into a choke input filter. The output of this assembly may be increased to 28 amps average, if forced air cooled.

All the assemblies in the range are rated for operation at ambient temperatures of up to 50°C. The address of the company is 77 Gloucester Road, Croydon, Surrey.

8WW 323 for further details

Electronic Laboratory Instrument Practice

8.—MEASURING POWER AND GAIN

By T. D. TOWERS*, M.B.E., A.M.I.E.E., A.M.I.E.R.E.

POWER is one of the few fundamental characteristics of a system that can be measured throughout the whole electromagnetic spectrum.

At low frequencies, as we have seen in previous articles in this series, voltage, current and impedance can be readily determined. At these frequencies, therefore, power (being equal to the voltage across a load multiplied by the current through it) can be computed easily indirectly from voltage and current measurements. Direct power measurements become more and more important as the frequency rises, because it becomes more and more difficult to measure voltage and current separately. By the time you get to microwave frequencies (above, say, 1000Mc/s) power measurements become of primary importance because in this region voltage, current and impedance become rather arbitrary (or even impossible) in definition. Systems sometimes begin to be characterised by power measurements from as low as a few hundred megacycles.

D.C. power measurements

For an occasional d.c. power measurement the commonest way of arriving at the power dissipated in a load

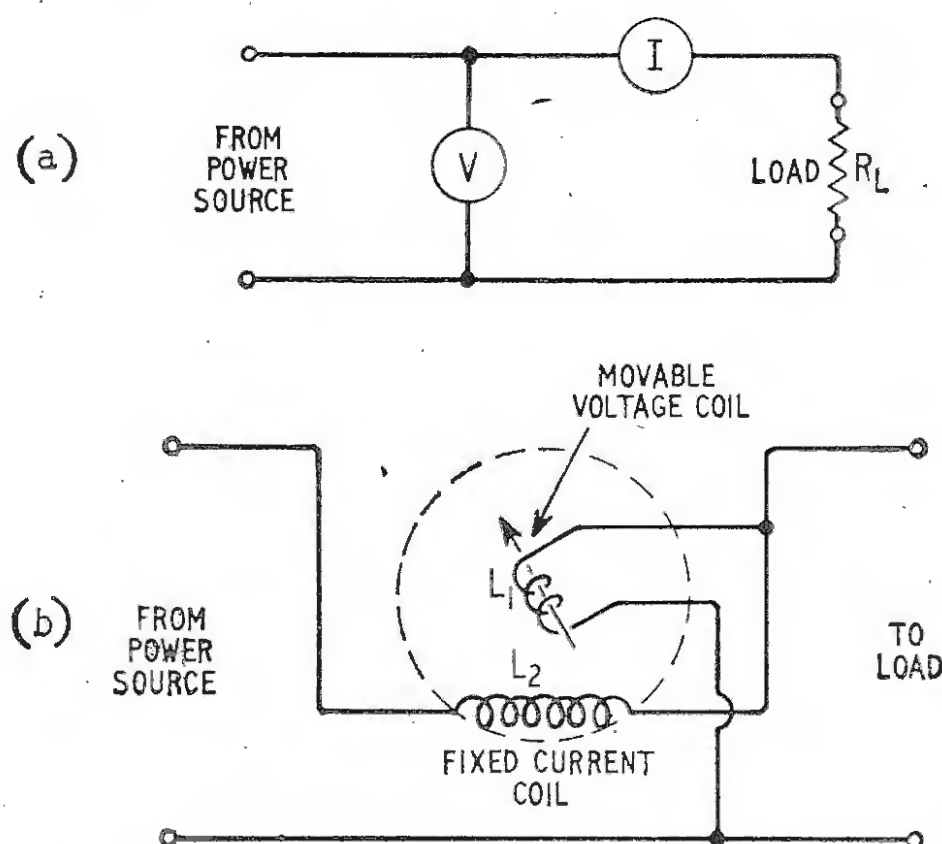

Fig. 55. Basic d.c. power measurements: (a) by voltage and current product; (b) by dynamometer wattmeter.

is to compute the product of voltage across, and current through, it as shown in Fig. 55(a). When using separate meters like this, remember to take into account the voltage drop across the current meter (which can be as much as 150-200 mV at full scale).

For repetitive d.c. power measurements, you will often find special power meters used to give a direct

indication without computation. By far the commonest of these is the "dynamometer" wattmeter, the basic circuit of which is illustrated in Fig. 55(b). Here a voltage coil, L_1 , attached to the meter pointer moves in the field of a fixed current coil, L_2 . The deflection of the pointer against its spring tension mounting is proportional to the product of the current into the load and the voltage across it. Thus, the meter reads directly the power dissipated in the load. Most of the meter manufacturers referred to in previous articles market dynamometers which can be used to measure d.c. power.

D.c. power could also be measured directly by other special instruments such as hot-wire or thermocouple meters, but these are seldom used in practice for this purpose in ordinary laboratories.

While d.c. power measurements are relatively simple, a.c. power measurements tend to be more complicated because the current in the load can be out of phase with the applied voltage. Different methods of measurement apply at different frequencies; for the purpose of discussion, it is convenient to consider four main bands: (1) "mains" frequency, 50-400 c/s; (2) audio frequency, up to about 30 kc/s; (3) "r.f.," up to about 100 Mc/s; and (4) v.h.f., above about 30 Mc/s.

Mains-frequency power measurements

The dynamometer wattmeter mentioned above for the direct reading of d.c. power can also be used for mains-frequency a.c. power measurements. Normally the instrument looks like an ordinary "pointer-type" meter, but special high-accuracy versions available may

Fig. 56. Example of special laboratory standard dynamometer wattmeter: Tinsley Type 5558.

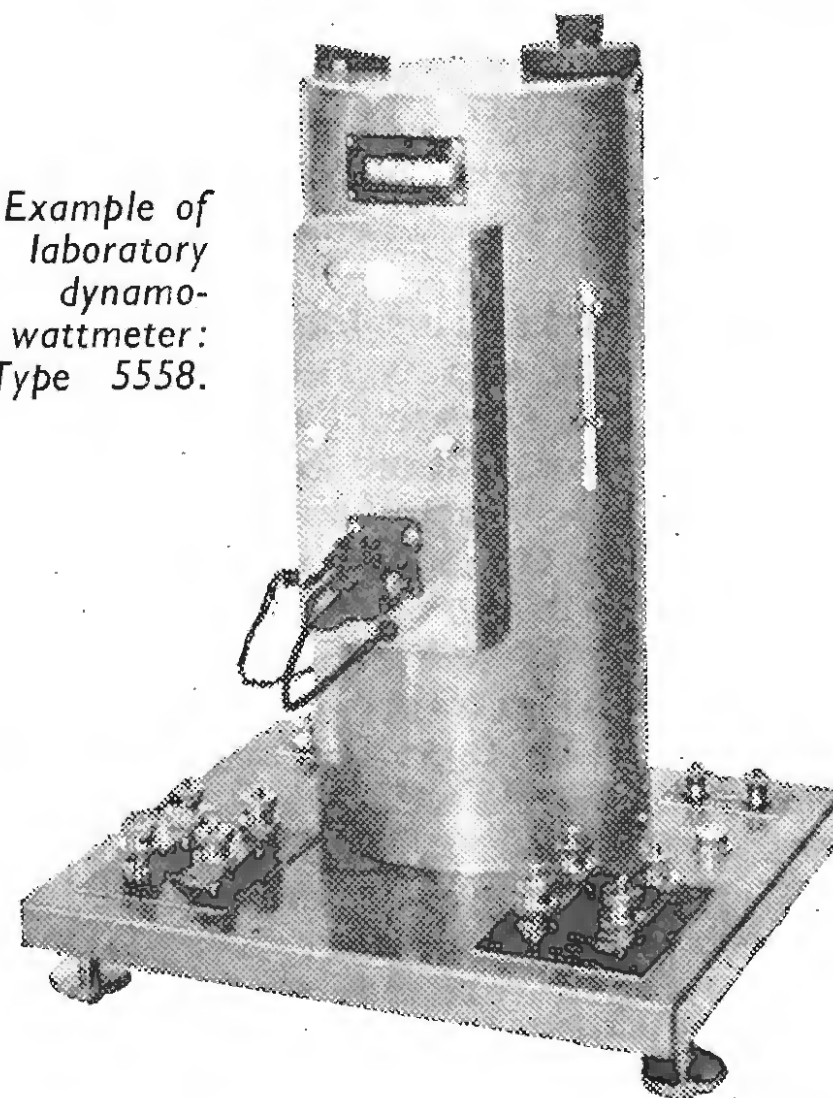

*Newmarket Transistors, Ltd.

not. For example, the well-known Tinsley Type 5558 laboratory standard wattmeter illustrated in Fig. 56 uses an optical system pointer and has an accuracy of 0.1% up to 2,000 c/s. "Ordinary" dynamometer wattmeters rarely are better than 1% accuracy and retain their accuracy only up to about 200 c/s.

It is often overlooked that a mains wattmeter can serve as a useful service instrument, in that overall power drain can often establish the condition of an equipment. I occasionally use one when I am measuring the efficiency of the output stage of a transistor audio power amplifier. In particular, with Class B stages, the product of metered voltage and current measurements can give inaccurate estimates of the true power drawn from the mains.

Audio frequency power measurements

Engineers making occasional measurements of the power output of an a.f. amplifier or oscillator usually measure the a.c. r.m.s. voltage, V , across a resistive load R_L and compute the power from the formula $P_o = V^2/R_L$. Often, too, they take the precaution to monitor the output waveform on an oscilloscope to ensure that undue distortion does not vitiate the readings on the voltmeter, and to cross-check the accuracy of the meter reading (r.m.s. = 0.353 of peak-to-peak).

When you measure audio power output in this way, don't forget to choose a load resistor with a wattage rating several times higher than the expected power to be measured; with too low a wattage rating, the power being dissipated may overheat the resistor and increase (or even permanently change) its resistance. This can easily lead to an unsuspected error in the power measurement. Again, use a resistance with no material inductance or capacitance at the measurement frequency as this too may lead to errors. Finally make a check measurement of the load resistance on a bridge or accurate ohmmeter before using it.

For the r.m.s. voltage measurement, it is best to use a valve voltmeter because its input impedance is high enough not to shunt the load resistance materially. Alternatively you can use the a.c. voltage range of a multimeter, but remember that there may be a d.c. path through the multimeter in this range. Because of this you may get erroneous readings or upset the d.c. bias of the circuit under test. Also the input impedance of some multimeters is low enough to shunt the load resistance and cause the power to be read low. For really accurate measurements, you should use a true r.m.s. meter of the type discussed in earlier articles. However, so long as you monitor with an oscilloscope that the waveform is not distorted, you can attain reasonable accuracy with an "ordinary" a.c. meter

Where you have to make many repeated measurements of audio frequency power, you may use a special "output power meter." This has its own internal load resistance, and the meter reads power input into the load directly in watts. There are two kinds of these in common use: simple "passive" meter types and electronic types.

The passive a.f. power meter comprises an input coupling transformer with variable tapped primary and secondary windings for selecting the appropriate load resistance reflected to its input terminals. A resistor network between the transformer and the meter provides the load resistance at the same time as it compensates for varying copper losses in the different switched position of the transformer. The indicating meter is a rectifier type voltmeter calibrated to read in watts by reading the a.c. volts across the load resistance. Switching the meter shunts provides a selection of wattage ranges. Switching

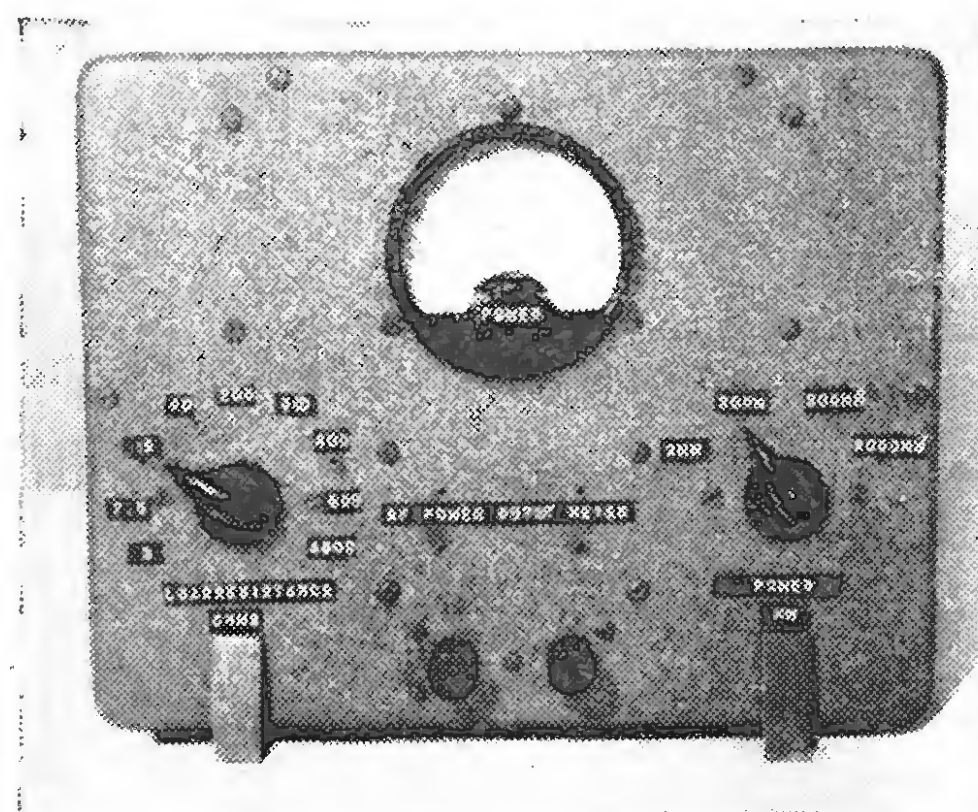

Fig. 57. Example of "passive" audio output power meter (built by author for special headphones investigation).

the input transformer taps provides a range of load resistances reflected at the input terminals. Commercial instruments of this type are available from a number of firms, e.g., the Marconi TF893A AF Power Meter, and the Daystrom (Heathkit) AW-1U Audio Wattmeter.

Workers with interests in special fields often make up their own version of a passive wattmeter because the switched impedances and power ranges in the commercial instrument are not exactly suited to their requirements. I myself, at a time when I was doing detailed work on headphones, built the a.f. power meter illustrated in Fig. 57 which provides loads equal to a number of "standard" headphone impedances. This gave me four power ranges from 3 mW to 3,000 mW full scale and load resistances of 3, 7.5, 15, 40, 200, 300, 400, 600 and 4,000 ohms.

The other main type of audio power meter available commercially is electronic. It comprises essentially a valve-voltmeter with a selection of load resistors switch-connected across its input. By displaying the a.c. volts across a selected load resistor, the voltmeter is scaled to read the power dissipated in the load. The great advantage of the electronic type is its wider frequency response (usually up to at least 250 kc/s) as compared with the passive type (usually not more than 20 kc/s).

In measuring power, the a.f. power meter, whatever the type, is switched to the correct resistance value and connected to the working power source in place of the normal load resistance. For accurate readings, the signal being tested should be sinusoidal, and it is prudent to connect an oscilloscope in parallel with the power meter to ensure visually that this is so. Some engineers even go so far as to connect a distortion meter across the power meter to ensure low distortion in the drive signal.

R.F. power measurements

Ordinary wattmeters used for low-frequency work cannot be used for higher frequencies because of their inductive and capacitive effects. For high frequency, special arrangements are needed.

In the r.f. range up to about 100 Mc/s or so, circuit components can still be treated as lumped-constant, i.e. as effectively discrete resistances, capacitances and inductances. One simple way of determining high frequency power is first to measure the effective parallel resistance, R_p , of the circuit under test. Then measure the r.m.s. voltage, V , across the circuit with a high-input-impedance

valve voltmeter. From these two values, the power in the circuit can be measured from the formula $P = V^2/R_p$. In practice, the effective parallel resistance can be measured with a v.h.f. bridge such as the Wayne Kerr B801 admittance bridge, or calculated from a Q-meter measurement.

Another approach to r.f. power measurement up to 100 Mc/s is to multiply the effective series resistance of the circuit by the square of the r.m.s. current through it. A Q-meter can be used to establish the effective series resistance, and an r.f. current meter (such as a thermocouple instrument) for the current.

From a few tens of megacycles up to over 1000 Mc/s, much of the work of handling r.f. signals is carried out along coaxial lines with a characteristic impedance between 50 and 100 ohms. Circuits are often matched into these lines and power measurements are commonly made in terms of the power dissipated in non-inductive resistances equal to the characteristic impedance of the coaxial line used. Out of this has grown up a range of commercial r.f. power meters, available nowadays usually with 50 or 75 ohm input impedance. A good example of these is the Marconi TF1152A/1 illustrated in Fig. 58. In this instrument, indication is by means of a moving-coil meter and a robust vacuum thermocouple connected across part of the load resistor. Such an instrument finds uses in measuring the power output of small transmitters; in this application, too, it can be used to calculate modulation depth from the power increase on application of modulation. Another useful application is the measurement of the mean power output of pulse transmitters or modulators.

Measuring indicated output power in a dummy load as above may not give a true indication of actual r.f. power in a circuit, and an alternative is to insert a series-connected instrument in the transmission line between the generator and its actual load. The inserted instrument is sometimes a "slotted line," i.e. a coaxial line with a slit along its outside conductor in which a probe can be slid along and positioned at any point on the line. When power is fed through to the load, the probe samples the voltage in the line and by means of a diode detector gives a reading of the line voltage on a meter. As a first step, the line is tuned to the generator frequency by means of a variable tuning stub provided on the probe carriage, which is adjusted until a maximum reading is obtained on the meter. The probe is then slid along until the maximum meter deflection V_{max} is obtained. Next it is slid to the

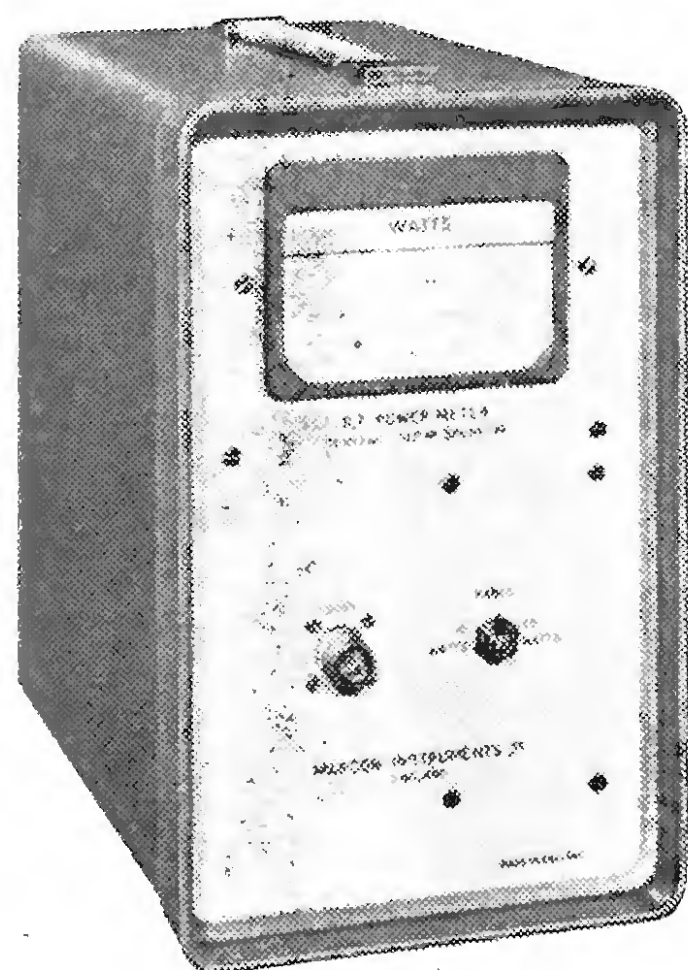

Fig. 58. Commercial example of r.f. power measuring instrument: Marconi TF1152A/1 RF Power Meter (50-ohm input, d.c. — 500Mc/s, 0-10/5-25W).

minimum deflection point, giving V_{min} on the meter. From these two values, the power, W , can be calculated from $W = (V_{max} \cdot V_{min})/Z_0$, where Z_0 in ohms is the characteristic impedance of the slotted line. A well-known example of a standing-wave type of r.f. power meter (although not specifically of this basic type) is the Daystrom (Heathkit) Type HM-11U which is widely used in the amateur radio transmitting field.

The slotted-line mentioned above is only one of a number of r.f. power measuring instruments, such as the reflectometer (or directional coupler) and the calorimetric power meter, that will be found in use. As this field is largely a specialist one, it is not considered advisable to go into further detail in this general article on laboratory practice.

Microwave power measurements

With microwave circuits the technique or equipment used depends to a large extent on the power level being measured. In the microwatt and milliwatt range, a bolometer is mostly used, and for higher powers a calorimeter type instrument. The bolometer employs a heat sensitive element such as a barretter or thermistor whose resistance changes with temperature or with current flow through it. In the calorimeter, a thermometer measures the change of temperature in an element in which the microwave power is dissipated, e.g. oil, water or sand.

Those seeking fuller information on r.f. and microwave power measurements are recommended to consult Chapter 3 of the "Handbook of Electronic Measurements" by Moe Wind published by the Microwave Research Institute of the Polytechnic Institute of Brooklyn, New York, which covers this field exhaustively.

Power gain measurements

A knowledge of power measurement techniques is obviously necessary if you want to carry out power gain measurements on an equipment. (N.B. I always refer to "gain" or "loss" in connection with power and to "amplification" or "attenuation" in connection with voltage or current. Some engineers tend to use these terms loosely as if interchangeable.)

Most people intuitively take the power gain of an equipment to be the output power into the load divided by the power into the input from the generator. There are several other ways of specifying the power gain of a system, but this approach is a very practical one and is significant provided both the generator source resistance and the load resistance are clearly specified.

Audio power gain

As an example, the power gain of an audio amplifier is often tested as shown in Fig. 59(a). The test signal is applied to the input from a sinewave audio oscillator of source resistance R_S , and the output fed into a load resistance R_L . The output voltage, V_{OUT} , across R_L is compared, by the switching arrangement shown, with the input voltage V_{IN} across the input terminals. (The oscilloscope is used to check that the measured values are not inaccurate due to distortion). This test gives us the voltage amplification, V_{OUT}/V_{IN} , of the amplifier. To get the power gain we calculate the ratio $P_g = (V_{OUT}^2/R_L)/(V_{IN}^2/R_{IN}) = (V_{OUT}^2/R_{IN})/(V_{IN}^2R_L)$.

In this last expression we know everything except R_{IN} . To measure R_{IN} you can use the arrangement of Fig. 59(b) where the output V_o from an audio signal

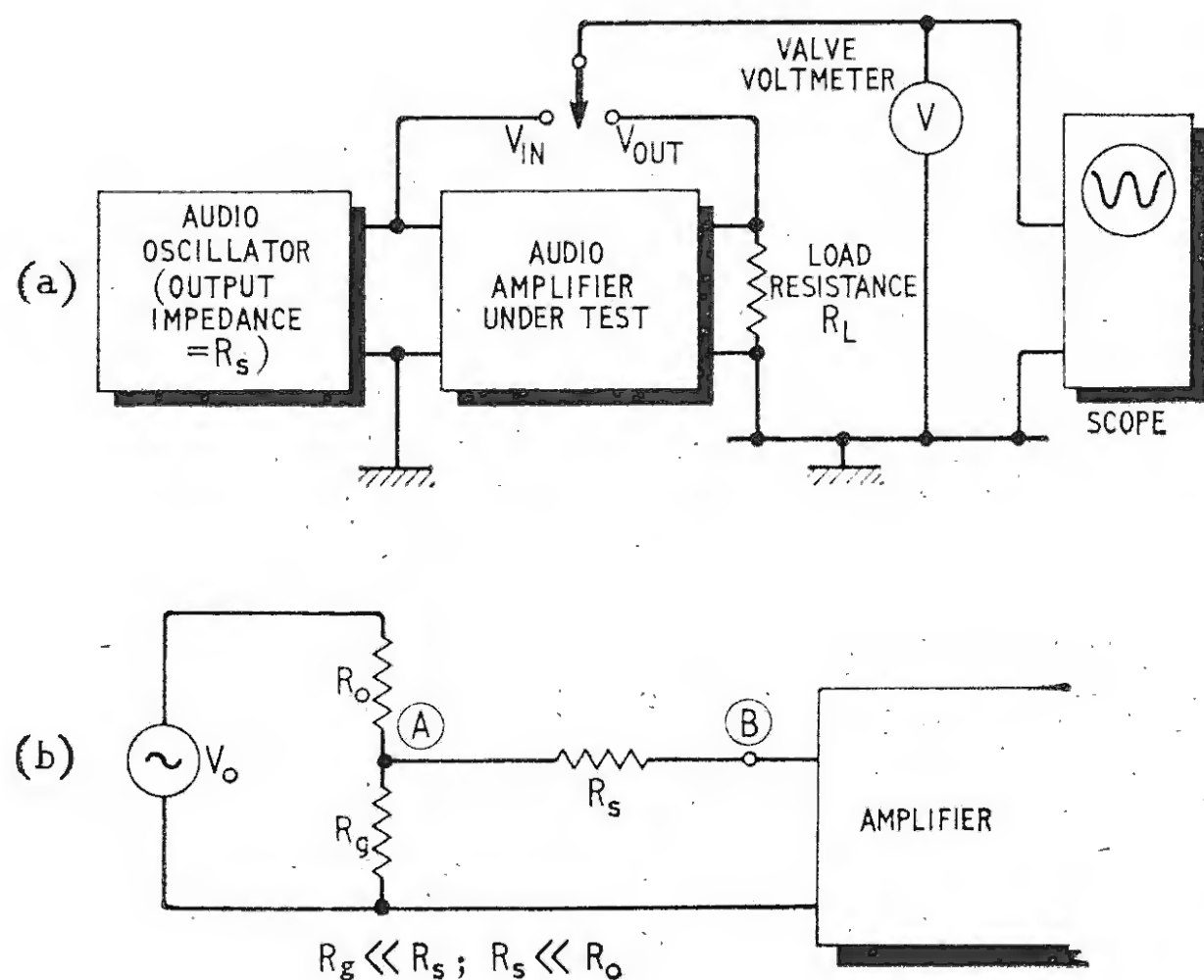

Fig. 59. The measurement of power gain of an audio amplifier, (a) general arrangement, (b) measuring amplifier input resistance.

generator is fed via a very large value resistor R_o to current-drive a very low value resistor R_g . The input is applied to the amplifier via a resistor, R_s , with a value equal to the output impedance of the signal generator used in Fig. 59(a) for the voltage gain test. The a.f. voltage is then measured with a valve voltmeter at points (A) and (B) and the amplifier input resistance computed from $R_{IN} = R_s V_B / (V_A - V_B)$.

It is important to realize that in some amplifiers (with feedback across the input stage) the input resistance and voltage amplification can both vary with the source resistance of the generator applying the input signal. It is always wise therefore to specify source and load resistances when dealing with amplification or gain in an audio amplifier.

Measuring a.f. amplifier voltage amplification and power gain in the way described above tends to require rather a lot of equipment. A typical laboratory set-up is illustrated in Fig. 60 where a transistor audio amplifier, A, is being tested with an input from a Heathkit a.f. signal generator, B, the output being fed into a dummy load resistor, C. The Comark multimeter, D, and Dartronic scope, E, are used to measure and monitor the input and output voltages. This particular voltmeter (the Comark Type 130S) is a high-sensitivity, high-input-impedance battery-operated transistorized electronic a.c./d.c. multimeter with the advantage in this application that its high input impedance does not affect the circuits being tested and its battery operation makes one less demand on the power points!

The method of a.f. amplifier testing outlined above has one major defect. The output will often be volts and the input millivolts. When you switch from output to input, you have to switch ranges on the voltmeter. This can clearly lead to errors between ranges. For higher accuracy measurement, a better method is to use a constant-output-resistance variable attenuator between the generator and the amplifier. The attenuator output is first connected direct to the load resistor and the output voltage level set to a fixed value. The attenuator output is then transferred to the amplifier input, the signal being reduced to give the same output into the load as before. The signal reduction shown on the calibrated attenuator scale then equals the amplifier voltage amplification. The major advantage of the attenuator method is that greater accuracy can be attained with a passive resistive attenuator than with separate scales on an active electronic voltmeter. The method can give rise to errors, however, if the load resistance is not equal to the amplifier input resistance.

Where a laboratory has to carry out many tests of audio amplifier voltage amplification or power gain, it becomes uneconomic to tie down indefinitely a set of general-purpose instruments as in Fig. 60. In such cases you will often find a "gain set" or "transmission measuring set" in use. This combines in one instrument case an a.f. oscillator, an attenuator, an input level meter, a

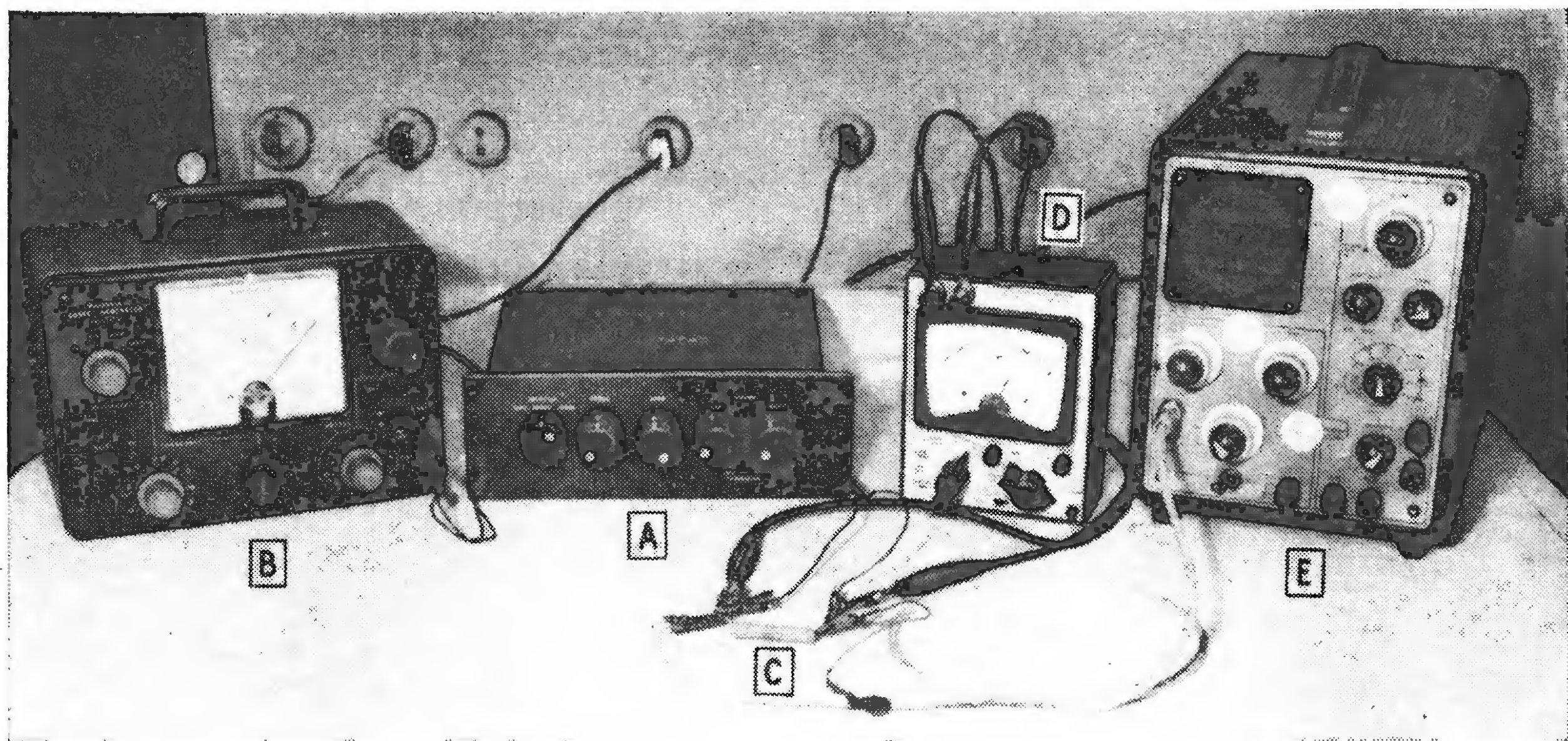

Fig. 60. Typical laboratory set-up for measuring a.f. amplifier power gain: A = amplifier under test, B = signal generator, C = dummy load resistor, D = electronic multimeter, E = oscilloscope.

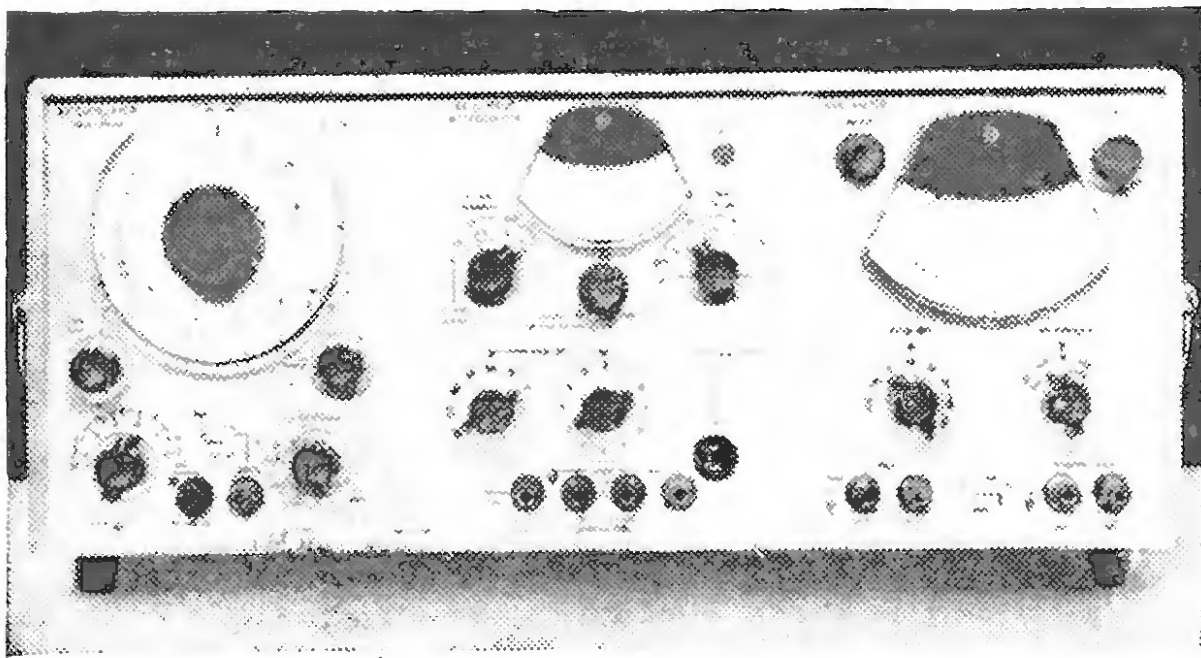

Fig. 61. Commercial example of self-contained audio gain set for amplifier gain measurements: Marconi Type TF2332 Transmission Measuring Set.

dummy load, and an output level meter, i.e. all the ingredients (except the oscilloscope) previously discussed in connection with gain or amplification measurements. A good commercial example of such a gain set is the Marconi TF2332 illustrated in Fig. 61, which covers the frequency range 20 c/s-20 kc/s.

R.F. power gain

As mentioned earlier, r.f. power measurements are not so easy as a.f. Some of the difficulties can be illustrated in the measurement of the 100 Mc/s power gain of a v.h.f. transistor, for which a typical test circuit is given in Fig. 62. Because of the difficulties of characterizing transistors satisfactorily in the v.h.f. range, some form of functional test (i.e. power gain in a specified practical circuit) such as this is common in manufacturers' data sheets. (This particular test is used in specifying the Newmarket NKT675 germanium p-n-p alloy-diffused device.)

In the circuit the transistor is operated at 100 Mc/s in grounded base with tuned input and output circuits.

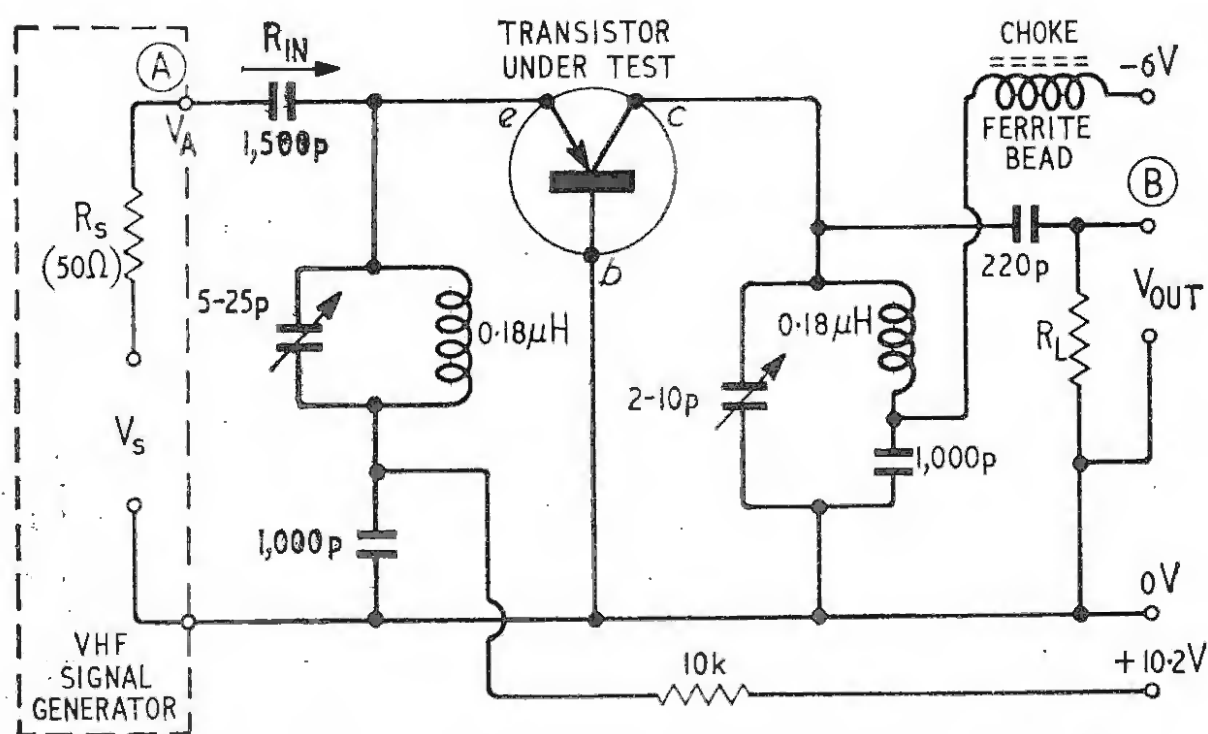

R_L SELECTED SO TOTAL TUNED CIRCUIT PARALLEL RESISTANCE $R_p = 3.3k$

Fig. 62. Typical v.h.f. transistor 100Mc/s power gain functional test circuit.

The circuit gives at point (B) an r.m.s. output voltage V_{OUT} across a load resistor R_L . The input is provided from a signal generator with source resistance R_s which provides a voltage V_A at the circuit input point (A). The actual power gain of the circuit is then given by $(V_{OUT}^2/R_L)/(V_A^2/R_{IN}^2)$, where R_{IN} is the input resistance seen looking into the transistor emitter from point (A).

In practice it would be difficult (and tedious) to measure

V_A and R_{IN} as they both may vary with different samples of the transistor. In the test, therefore, a notional power gain is measured instead which relates fairly closely to the actual power. This notional gain is the maximum available power gain (m.a.g.) which would be obtained if the circuit input impedance matched the generator source impedance R_s . The m.a.g. value is given by the formula $(V_{OUT}^2/4R_L)/(V_{IN}^2/R_s)$ where V_{IN} is the open-circuit voltage of the generator.

The value of R_L is selected to represent the typical input resistance of another stage as seen through a coupling transformer. To make different test equipments read the same without specifying coils too closely, R_L is specified so that the total parallel resistance of the output tuned circuit (including R_L) is equal to 3.3kΩ in this case. In practice R_L is arrived at by adjusting it until the composite parallel resistance, R_p , measured on a v.h.f. admittance bridge, reaches the desired value of 3.3kΩ.

In setting up the test circuit a standard 50-ohm v.h.f. signal generator is set up tuned to 100 Mc/s and with an open circuit voltage V_s . It is then connected to the input point, A. A high input impedance v.h.f. millivoltmeter is next connected across the output and the tuned circuits adjusted for maximum output V_{OUT} . The maximum available power gain of the transistor can then be computed from $(V_{OUT}^2 R_s)/(4V_s^2 R_p)$. Since R_s , R_p and V_s are fixed, the output millivoltmeter can be calibrated directly in terms of maximum available power gain. One practical drawback of the method is that for each device tested the input and output tuned circuits must be adjusted for maximum output.

Unusual instruments

So far, we have taken a look, particularly on the practical side, at some of the problems of measuring power and gain, confining ourselves largely to the lower frequency ranges where most laboratory measurements tend at present to be required. In fact, it is clear that, by and large, engineers tend to avoid making absolute power measurements directly, probably mainly because direct reading power meters are unusual in the ordinary laboratory.

Further aspects of power and gain measurements will be dealt with in the next article in this series, which deals with bandwidth, distortion and noise.

Educational Electronic Experiments

THE Mullard Educational Service has recently made available three new pamphlets—numbers 12, 13 and 15—in the series "Educational Electronic Experiments."

Number 12, six pages plus pull out circuit diagram, describes a simple low-speed binary counter, intended to demonstrate the arithmetic of binary numbers. Hints on applications are given together with a table of binary numbers and denary equivalents.

Number 13, four pages, describes a pupil's oscilloscope. The circuit is very simple—shift brilliance and focus controls are not incorporated—and contains two transistors, a triode pentode valve and a 1 in diameter tube. Time-base oscillator frequency is 15 c/s to 10 kc/s in two ranges: vertical amplifier requires 1.6 V r.m.s. for full scale deflection with maximum gain: power supply required is 12 V d.c., 550 mA.

Number 15, seven pages, describes a series of simple logic gates to demonstrate digital computer principles, Boolean algebra and binary arithmetic. Details of the following gates, inclusive NOR, inclusive OR, NAND, AND and exclusive OR, are given together with a suitable lamp indicator circuit.

Pamphlet number 14 describing a resistance/capacity substitution box will be available shortly.

THE GUNN EFFECT

SELECTED POINTS FROM SYMPOSIUM ON MICROWAVE APPLICATIONS OF SEMICONDUCTORS

ONE of the most recent and interesting developments in the microwave field has been the discovery of oscillations in gallium arsenide by J. B. Gunn¹, reported in 1963. Some of the papers presented at the recent I.E.E. & I.E.R.E. joint symposium entitled: "Microwave Applications of Semiconductors," were concerned with this effect. The symposium incidentally proved to be more popular than anticipated—nearly 450 delegates (100 from overseas) attended the three-day session, during which 39 papers were given.

Short specimens of n-type GaAs (and InP) about 10^{-3} cm thick and mounted between two alloyed Sn contacts (forming ohmic junctions) were found to exhibit current instabilities when fields of around a few thousand $V\text{cm}^{-1}$ were applied. The applied potential from a constant-voltage source was pulsed at a low p.r.f. and with a low duty cycle—around 1-100ns duration. The voltage-current characteristic exhibited an approximately linear relationship up to a certain threshold voltage (V_T) after which the current fell, exhibiting instability, in which the current peaks did not exceed the corresponding threshold current I_T . The current-time relationship showed oscillations continuing for the duration of the pulse. The threshold voltage was in the region of 10-100 volts depending on specimen thickness. In many cases the oscillations were non-sinusoidal giving harmonics of a fundamental which appeared to be the reciprocal of the electron transit time. (Drift velocity is calculated from a knowledge of electron mobilities.) Measurements of efficiency showed that this was around 1-2%.

A paper by Robson and Mahrous (Sheffield University) outlined the generally accepted explanation which was first proposed by Ridley and Watkins² and Hilsum³ and known as the transferred electron effect. (Hilsum predicted the effect would occur in GaAs and in a GaAs and GaP alloy).

A transferred electron oscillator requires a semiconductor with two conduction bands, separated by a small energy gap, say δE , ($\delta E = 0.36\text{eV}$ for GaAs) and both populated by carriers, the ratio being dependent on the ambient lattice temperature (T_0), the number of allowed states and δE . At low field strengths and at room temperature most of the electrons reside in the lower band, since $kT < \delta E$, and will have a certain mobility μ ($\mu = v/E$ where v is the electron drift velocity and E the applied field). As the field is increased, the electrons are accelerated more rapidly between collisions and assume a temperature $T > T_0$. As T increases more electrons

are able to transfer to the upper band and when $kT > \delta E$ the majority will be in the upper band, assuming there are more available states, and will have a mobility μ' . If the rate of heating increases sufficiently with field strength the transition from μ to μ' on the $v-E$ characteristic may be negative (See figure).

In contrast to the tunnel diode it is not possible to stabilize the negative resistance by loading with a low impedance. Gunn investigated the field distribution along the sample with a fine electric probe and observed a narrow region of high field strength (domain) moving across the specimen in the direction of the electron flow (when $V > V_T$ or $E > E_T$). During the domain transit time the current remained constant at a value I_V below I_T and rose to I_T when the domain reached the anode contact. A new domain was then formed at the cathode and the current returned to its original value. The domain is considered to be formed by a perturbation of some form which causes an increase in the field about the perturbation (nucleating centre). This results in a decrease in current within the domain giving a charge build up at the domain walls which causes a further increase in domain field strength. The field amplitude limits at E_V when the incremental mobility is positive again.

Within the last year c.w. oscillations have been reported, both by Gunn and other workers, resulting from efforts to reduce the dissipation. Some of the results obtained are: 1.8W at 4.9 Gc/s (pulsed); 2.5W at 3 Gc/s (pulsed) and 15mW at 4 Gc/s (c.w.). Some degree of tunability has been achieved by mounting the GaAs in a tunable cavity. This has also resulted in improved coherence.

It was suggested in a paper by Heeks, Woode and Sandbank (S.T.L.) that the device could operate as a pulse amplifier by biasing to just below threshold and superimposing a signal on the bias to produce a domain each time the threshold was exceeded. Although pulse shape was not well preserved, the position in time was accurately maintained, and this might be useful in p.p.m. systems.

Acoustic amplification

A review paper on piezoelectric semiconductor acoustic amplifiers was presented by Harcourt, Froom and Sandbank (S.T.L.). The principle of operation is similar to that of the travelling wave tube with the electron beam replaced by the carriers of a semiconductor. (In fact a theory has been developed which includes electron beam tubes as a special case.) An ultrasonic pressure wave is transmitted along a piezoelectric semiconductor crystal along with the accompanying electric wave. A d.c. electric field is applied across the crystal so that the carriers drift in the wave direction. Interaction between carriers and the travelling wave occurs and when carrier velocity exceeds wave velocity and energy is transferred from the carriers to the wave giving amplification.

Most of the experiments to date have been in the 10-100 Mc/s region and using a CdS crystal, illuminated to provide the necessary carriers. (CdSe, ZnO and GaAs have also been used in experiments). The theoretical frequency limit appears to be about 100 Gc/s but there are considerable problems when one enters the microwave region. One, that of acoustic loss arising from scattering of the phonons by random thermal phonons, is eased by cooling, but scattering due to crystal

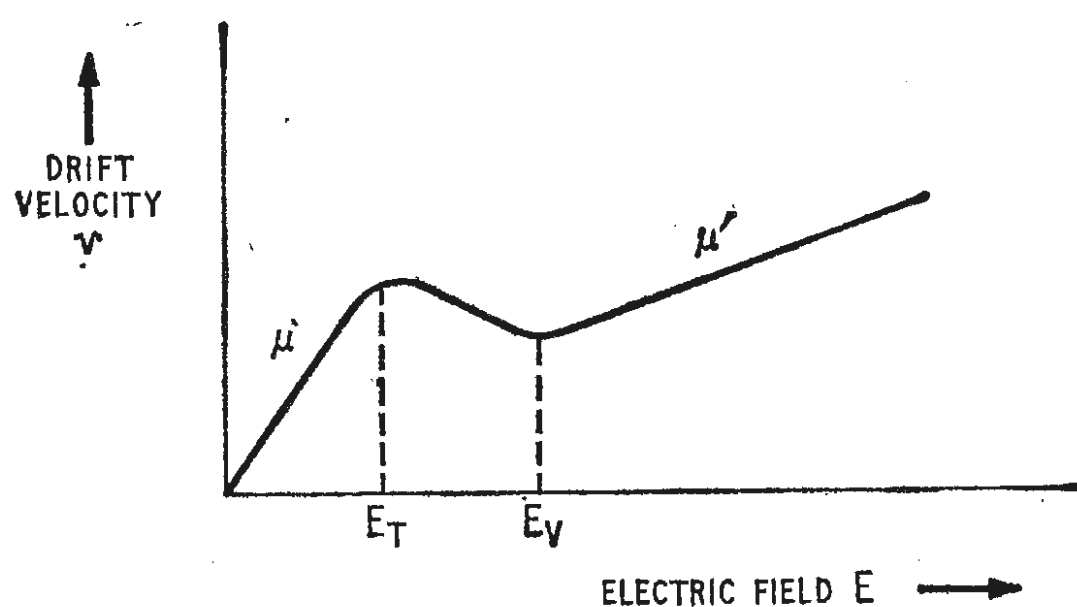

Negative mobility in GaAs.

inhomogenities remains. (No figures of acoustic loss in the microwave region have been published). Also, the crystal faces are required to be optically flat, since acoustic wavelengths in the microwave region are comparable with optical wavelengths, but this problem may be eased if harder materials become available. At frequencies above 1 Gc/s tuned quartz transducers become impractical and cavities have been used to couple to the E field, but the insertion loss is high. Evaporated CdS has been used to form polycrystalline layers, and by a similar technique transducers have been made to resonate at a fundamental of 3 Gc/s and have been operated at 9 Gc/s.

In conclusion the authors noted that oscillations of similar nature to Gunn oscillations had been observed in some CdS crystals, but the transit time of the carriers was lower. In one experiment a narrow slit of light was used to cause formation of a nucleation centre. A variation in period of oscillation of more than 2.5 : 1 was obtained by moving the slit across the specimen. Such experiments may lead to a clearer view of the phenomenon of domain formation.

Microwave transistors

Another was read by H. F. Cook of T.I. (U.S.A.) who described some advances in the transistor field. The maximum frequency of oscillation (f_{max}) at the present time appears to be 11 Gc/s for Ge and 9 Gc/s for Si transistors. This latter figure has been increased from 2 Gc/s over the past year or so and has been achieved by reducing diffusion widths. For low-noise small-signal amplifiers the frequency at which the common-emitter gain is unity (f_T) is more significant, and for currently available Si and Ge transistors this is about 2.5 Gc/s. Si transistors achieve this value with a minimum drift field and the f_a/f_T ratio is close to 1.2 : 1. Some Ge transistors incorporate an appreciable drift field to achieve a low base transit time. As a result, the f_a/f_T ratio is close to 2 : 1 and since noise is related to f_a and not f_T , Ge transistors with a higher f_a have a lower noise figure.

Transistors are being used to replace parametric amplifiers in the 1-2 Gc/s range—the noise figure for the L78A Ge transistor at 1 Gc/s is about 3.5 dB. The advantage, of course, is that neither pump nor circulator is required. Varactor multiplier chains can obviously be simplified, e.g. one transistor and two diodes can produce over 30 mW at 16 Gc/s.

1. *I.B.M. Journal*, p. 141, April 1964.
2. *Proc. Phys. Soc.*, p. 293, 1961.
3. *Proc. I.R.E.*, p. 185, February 1962.



THE HOUSE OF BULGIN AT YOUR SERVICE

STANDARDISED BY MANY LEADING MANUFACTURERS

Ingeniously designed and precision built from the highest grade material, all Bulgin components are guaranteed to published electrical and mechanical specification. This reliability is assured by design and construction methods embodying the wealth of experience gained from over 42 years in this field.

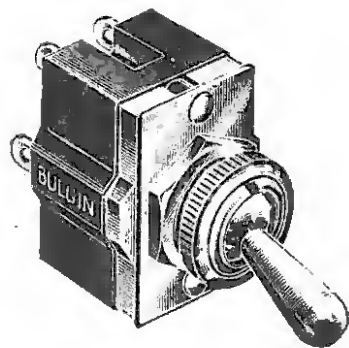

D.P.C.O. moulded switch, pat. pend., high elec. spec. following 5 years' research.

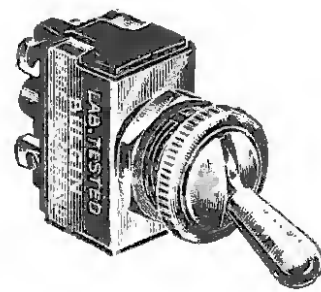

S.P.C.O. toggle switch, moulded insulation, high elec. ratings, many other models in range.

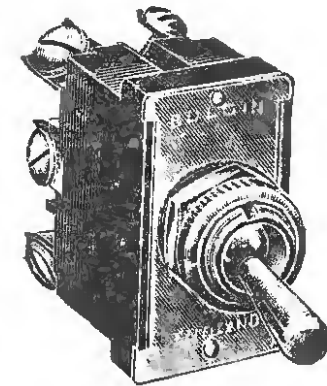

D.P. switch, 3 position, centre off type 6-10A. 250V. ratings. 8 other types in range.

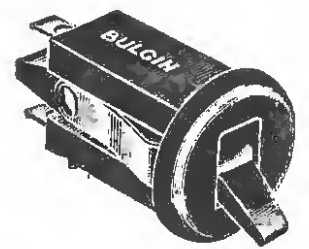

All moulded push fit to panel S.P.M.B. switch, 10A. 250V. rating, connections to AMP type push-on tags.

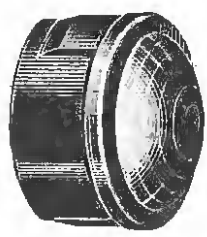

Range of 3 push-fit to panel lesion bushes. Five colours, transparent or translucent.

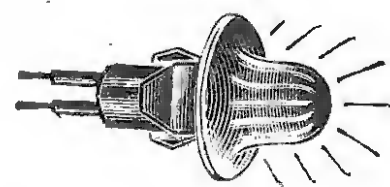

Push fit neon signal lamp, red or green neons for mains use, inexpensive but reliable.

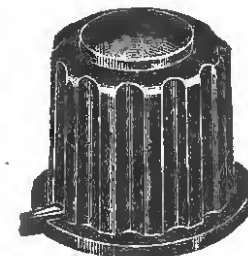

One of 9 collet fixing knobs, moulded in black or grey, coloured bung conceals collet screw.

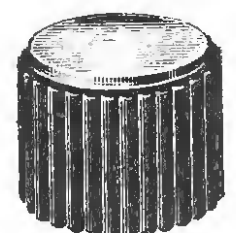

New range of three modern style knobs, black or grey, with metal decor face.

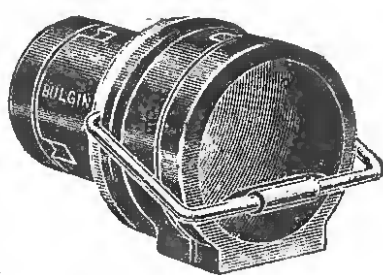

Safety mains connector, simple but reliable, cannot be pulled apart when in position.

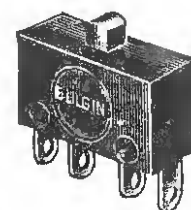

Sub-miniature micro switch, up to 5A. at 250V. Millions of operations depending upon conditions of use.

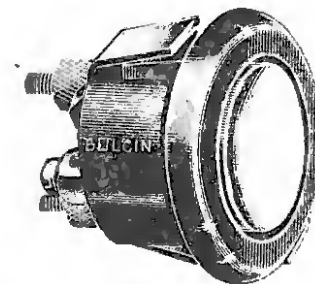

Heavy duty meter push, fully insulated, unique clamp fixing, sunk button to prevent accidental operation.

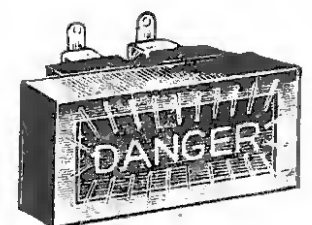

L.E.S. lamp holders, Legend indicator, secret-until-lit messages, 5 lens colours, modern appearance.

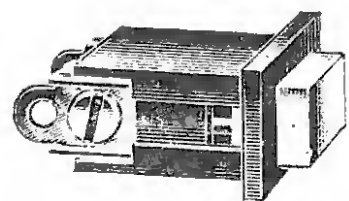

Contemporary self-fixing S.P.M.B. push switch, mains rating, tag or terminal connections.

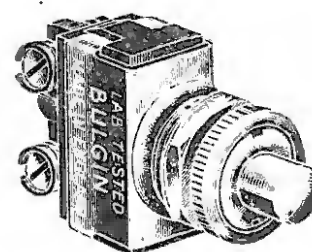

S.P.C.O. moulded insulation push switch 2A. at 250V. Chrome front of panel parts, terminal connections.

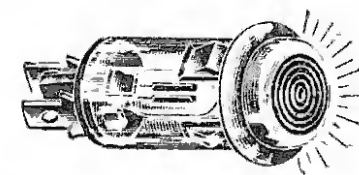

Neon signal lamp for mains use, has AMP 250 series tag connections, push fits to panel.

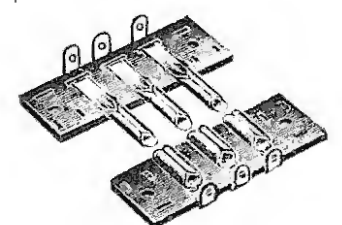

Strip connectors mating edge to edge, highly rated, one to twelve poles.

SEND FOR FURTHER DETAILS AND BROCHURES

A. F. BULGIN & CO. LTD.,
Bye Pass Rd., Barking, Essex.
Tel: RIPpleway 5588 (12 lines)

MANUFACTURERS AND SUPPLIERS OF RADIO AND ELECTRONIC COMPONENTS TO
ADMIRALTY MINISTRY OF WORKS B.B.C.
WAR OFFICE MINISTRY OF AVIATION G.P.O.
AIR MINISTRY MINISTRY OF SUPPLY I.T.A.
HOME OFFICE RESEARCH ESTABLISHMENTS N.P.L.
CROWN AGENTS U.K.A.E.A. D.S.I.R.

8WW-107 FOR FURTHER DETAILS.

NEWS FROM INDUSTRY

£A7 Million Defence Contract.—The Plessey Company are to supply to the Royal Australian Air Force two new mobile radar systems that are air-transportable (in Hercules aircraft of the R.A.A.F.). Each contains primary three-dimensional and secondary radars, display and data handling equipment, data links, h.f., v.h.f. and u.h.f. communications equipment, and the necessary power supplies. The overall system will be used to obtain early-warning information, to carry out surveillance on aircraft movements, to assign weapons, and to control interceptions. Although Plessey are the prime contractors, the radars will be manufactured in the United States by the Westinghouse Electric Corporation and the computers will be made by the Marconi Company.

Semiconductor Patent.—Texas Instruments Incorporated have been granted by the United States Patent Office, a patent covering the process used to make silicon planar transistors. The patent, number 3,184,823, describes the widely used steps of impurity diffusion using silicon oxide masking and photo-lithographic techniques for defining diffusion masks and metal contacts. Transistors made by this process have base-collector and base-emitter junctions extending to the upper surface of the wafer to avoid contamination of the junctions. These features are also used in the manufacture of monolithic integrated circuits, which Texas Instruments have produced commercially since 1959. The U.S. Patent Office concluded that the silicon planar process was invented by Texas Instruments' engineers prior to the 1959 filing date of the patent application by Fairchild Camera and Instrument Corporation.

A new television recording centre that is independent of the B.B.C. and the I.T.A. is nearing completion at 9-11 Windmill Street, London, W.1. This centre, which is to be run by the newly formed company Television Recordings Ltd., will be linked to the national television networks and will have access to both the European and trans-Atlantic links. Multi-standard Ampex recording machines and ancillary Marconi equipment, capable of recording and reproducing in black-and-white and colour is being installed. Its services will be available to existing television companies and advertising agencies, as well as independent production companies, education authorities and users of closed circuit systems, who require full recording facilities. Mobile recording facilities are also to be provided by the centre, which has cost around £250,000.

A chain of **Decca Navigator transmitting stations** is to be set up along the west coast of Norway. Contracts for this venture which are worth approximately £2,500,000 are at present being finalized. The Norwegian Authorities are also co-operating with the Swedish Board of Shipping to set up a new Decca Chain in the Skagerrak.

The Marconi International Marine Company have purchased, for a cash sum of £700,000, the marine radio business of Associated Electrical Industries. According to the vendors, the business consists of "the supply of marine radio communication and allied equipment; and operating and traffic services, together with apparatus and spares on ships or in stock." Marconi Marine will market A.E.I. marine radio equipment for as long as may be necessary and, with the agreement of individual owners, will also assume responsibility for A.E.I.'s rental-maintenance contracts. This acquisition does not affect A.E.I.'s marine radar business, which comes under the electronics group. Most of the radio officers and others employed in the marine communications department of A.E.I.'s telecommunications group are being offered equivalent employment (retaining full seniority) with Marconi Marine. Those on the manufacturing side are not affected.

C.C. TV for British Railways.—An experimental closed circuit television installation is being evaluated at Elm Park, Essex, as an aid in combating trespassers on railway property. It was in this area that a train was derailed by hooligans in March of this year. The installation includes a gantry-mounted camera, monitor and associated equipment for the camera, and a video recorder that has a playing time of 30 minutes. The equipment, which is to be operated by the station's porters, was supplied by Peto Scott Electrical Instruments Ltd. and costs £1,800.

The Westinghouse Electric International Company, of New York, have received a contract from the Sperry Gyroscope Company to develop solid state transmitters for a prototype LORAN-D (Long-Range Navigation) system which is to be air-transportable. This low-frequency navigational aid is to be used in the movement of infantry, surface vehicles, helicopters and aircraft. As the dimensions of the conventional quarter-wave LORAN aerial make it impracticable for air transport, a top-loaded aerial for rapid erection has been specially designed under this contract, which is worth \$500,000.

Servicing facilities for Bush Radio, Murphy Radio and Rank Telecommunications have been amalgamated to form a single service department at Welwyn Garden City; within the Rank-Bush Murphy factory. Mr. J. A. Hutton is the general service manager.

Electrosil Ltd. have formed a micro-electronics division to sell integrated circuits manufactured by Corning Electronics, which is part of Corning Glass who have a financial interest in Electrosil. Counting speeds of 80 Mc/s are claimed for one of the flip-flops.

Seven electro-encephalographs, which are to be used for psychiatric studies, have now been dispatched to the Chinese Government by the AEI Electronics Group.

Elcom Sold.—Painton & Co., Ltd., the component manufacturers from Northampton, have acquired the whole of the issued share capital of Elcom (Northampton) Ltd. Elcom will continue as in the past with only minor changes of emphasis.

B & K Laboratories Ltd., who specialize in handling test and measuring equipment, have opened a northern sales and service office on the Bradshaw Trading Estate, Greengate, Middleton Junction, Manchester.

The Livingston Group have formed a new company Livingston Electronics Ltd. Mr. D. J. Davis, former head of Livingston Laboratories industrial electronics and X-ray division, is general manager of the new company, which will widen the Group's activities in industrial and scientific instrumentation. It will operate from 31 Camden Road, London, N.W.1.

SGS-Fairchild Ltd. announce price reductions for some of their integrated circuits. As an example, the full military range of JK flip-flop elements have been reduced from £16 5s to £9 10s at the 100 up level. The industrial version of this element is now only £4 4s.

Elliott-Automation are to establish a new 70,000 sq ft factory for the manufacture of microelectronic devices on the new Eastfield Industrial Estate, Glenrothes. It will be completed by the end of next year.

A thin film study on silicon monoxide capacitors has recently been completed for the London Electrical Manufacturing Company by Cambridge Consultants Ltd.; a company which offers a liaison service between industry and research workers in university establishments.

A complete television station, to give Bermuda a second commercial television programme, is being supplied by Pye TVT Ltd. A 3-kW, 525-line Band III transmitter is employed.

G.E.C. (Telecommunications) Ltd. have received a contract from the Post Office to supply equipment for a new microwave link between London and Leeds.

A northern branch office has been opened by EMI Electronics Ltd. at Regent House, 30 Cannon Street, Manchester 4 (Tel.: Deansgate 6378).

H.C.D. Research Ltd. has been formed to conduct the semiconductor business of Semikron Rectifiers and Electronics Ltd., of 77 Gloucester Road, Croydon, Surrey. (Tel.: THOrnton Heath 7485.)

Derritron Research & Development Ltd. and Derritron Telecommunications Ltd. are moving from Hythe, Southampton, to new premises adjacent to the Derritron Instrument Company at Parkland, Stroud, Gloucestershire. (Tel.: Stroud 331.)