

Wireless World

ELECTRONICS, RADIO, TELEVISION

APRIL 1963

Editor:

F. L. DEVEREUX, B.Sc.

Assistant Editor:

H. W. BARNARD

Editorial:

P. R. DARRINGTON

D. C. ROLFE

D. R. WILLIAMS

Drawing Office:

H. J. COOKE

Production:

D. R. BRAY

Advertisement Manager:

G. BENTON ROWELL

- 155 Editorial Comment
- 156 *Wireless World* Oscilloscope—2
- 161 Non-linearity Distortion Measurement *By J. Somerset Murray and J. M. Richards*
- 165 H.F. Predictions—April
- 166 World of Wireless
- 168 News from Industry
- 169 Personalities
- 171 Stylus Mass and Distortion *By J. Walton*
- 179 Transistor Amplifier Output Stages—4 *By O. Greiter*
- 182 Letters to the Editor
- 187 H.T. Supplies for High-gain Amplifiers *By J. R. Ogilvie*
- 189 Audio Fair—List of Exhibitors
- 190 Manufacturers' Products
- 194 C.C.I.R. Geneva Conference
- 195 Transistors as Switches *By D. A. Smith*
- 201 Books Received
- 202 Unbiased *By "Free Grid"*
- 204 April Meetings

VOLUME 69 No. 4

PRICE: 2s 6d.

FIFTY-THIRD YEAR

OF PUBLICATION

Managing Director: W. E. Miller, M.A., M.Brit.I.R.E.

Iliffe Electrical Publications Ltd., Dorset House, Stamford Street, London, S.E.1

Please address to Editor, Advertisement Manager or Publisher as appropriate

© Iliffe Electrical Publications Ltd., 1963. Permission in writing from the Editor must first be obtained before letter-press or illustrations are reproduced from this journal. Brief abstracts or comments are allowed provided acknowledgement to the journal is given.

PUBLISHED MONTHLY (4th Monday of preceding month). *Telephone:* Waterloo 3333 (70 lines). *Telegrams:* "Ethaworld, London, Telex." *Cables:* "Ethaworld, London, S.E.1." *Annual Subscriptions: Home and Overseas,* £2 0s. 0d. *Canada and U.S.A.* \$5.50. Second-class mail privileges authorized at New York, N.Y. *BRANCH OFFICES: BIRMINGHAM:* King Edward House, New Street, 2. *Telephone:* Midland 7191. *COVENTRY:* 8-10, Corporation Street. *Telephone:* Coventry 25210. *GLASGOW:* 62, Buchanan Street, C.1. *Telephone:* Central 1265-6. *MANCHESTER:* 260, Deansgate, 3. *Telephone:* Blackfriars 4412. *NEW YORK OFFICE:* U.S.A.: 111, Broadway, 6. *Telephone:* Digby 9-1197.

SPECIAL MULLARD VALVES FOR DUAL-STANDARD TV

Mullard Voltage Dependent Resistors for TV

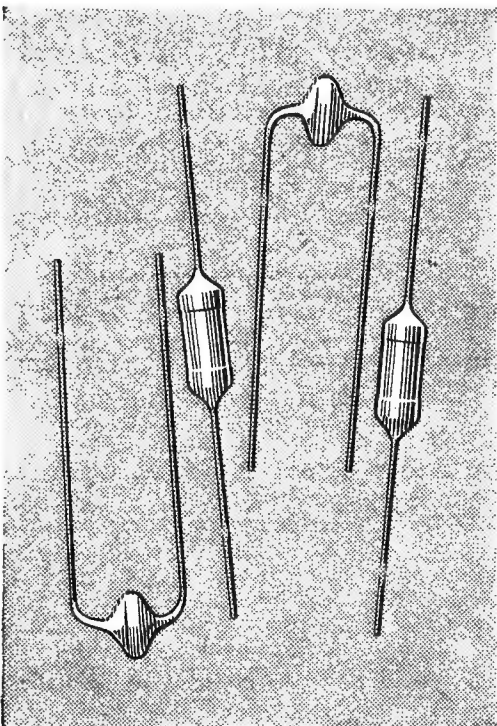

New voltage dependent resistors are the outcome of continual research by Mullard on materials whose resistance changes with the voltage applied to them.

Six v.d.r. are available in the two ranges recently released by Mullard for the latest television receivers: two rod-type components, and four disc-type.

The scope of application of these components is wide. They are ideally suited for surge suppression circuits which protect other parts of the receiver from damage by voltage surges. They provide a simple means of preventing switch-off spot-burn, and of stabilising the brightness against supply voltage variations. And they are used to stabilise the line and field time-bases, so that an almost constant picture size is produced despite variations in the mains voltage. The effectiveness of Mullard v.d.r. in these and other applications readily explains why the two new ranges are being used in ever increasing numbers.

Six Mullard valves solve circuitry problems

SINCE the publication of the Pilkington report, this series of articles has featured the entirely new valves which Mullard has designed for the development of dual-standard television receivers. Here we describe the way that the complete range meets the special requirements of dual-standard circuitry.

The need for tuner valves capable of operating at ultra high frequencies is met by the PC88 and the PC86. The former operates as an i.f. amplifier and the latter as a self-oscillating mixer. Both valves use frame grids and consequently possess a high value of mutual conductance, and in both, grid-lead inductance and internal capacitances are reduced to a minimum.

The EH90 and the PCL86 are appearing in sound stages of dual-standard receivers. The EH90 is intended for f.m. detection purposes in anticipation of f.m. sound transmissions when the 625-line system is introduced. In this capacity, the valve operates as a locked-oscillator discriminator. The high performance PCL86 functions in these receivers as an a.f. output valve.

Interference pulses which are in the same sense as the sync pulses occurring in the video wave form, tend to disrupt synchronisation. This is overcome by the heptode section of the ECH84 which is designed as an interference-cancelling sync separator, while the triode section can be used as a pulse amplifier or oscillator. The PL500, which is characterised by an

WHAT'S NEW IN THE NEW SETS

These articles describe the latest Mullard developments for entertainment equipment

exceptionally high ratio of anode current to screen-grid current, is capable of delivering large values of deflection power. It is ideally suited for the line output stage where it helps to prevent any detectable change in performance when the receiver is switched from one line standard to the other.

These six valves allow the maximum advantage to be taken of the benefits accruing from u.h.f., 625-line transmissions.

HIGH GAIN TRANSISTOR PACKAGE FOR CAR RADIOS

To meet the need for high a.f. gain in transistor car radios, Mullard has introduced the LCR2 package comprising the OC82M miniature driver transistor and the AD140 output type. The latter has a high current gain and possesses good linearity and frequency characteristics.

Now appearing in the newest car radios the package forms a

two-stage class A audio amplifier, capable of delivering an output of 3W when driven directly from the detector of an all-transistor receiver. The sensitivity of the amplifier, with respect to a 1k Ω source, is typically 25mV for the full output. The LCR2 package offers an economic design and ensures an excellent standard of performance.

MVE/CA 1075

World Television

THE future course of television in the U.K. having been debated, and first decisions taken by the Government, we have now entered on a period of waiting while the good ships "U.H.F.," "625" and "Third Programme" are being made ready for their maiden voyage next spring. The fitting-out operations are being watched with some impatience by receiver manufacturers, anxious to sell the dual-standard 405/625 sets which they have developed for the send-off, and not without interest by those of the viewing public who seek wider horizons and a change of scene.

It is not surprising, therefore, that something of a diversion has been caused by the appearance on the quayside of Mr. Paul Adorian, Managing Director of Associated-Rediffusion Ltd., who at this eleventh hour asks if we are building on the right lines. In letters to *The Times* (5th, 21st and 25th Feb., 1963), commenting on a fourth leader in that newspaper on 4th Feb. he suggests that television across frontiers would be facilitated and that we would once again lead the world if we adopted now a 525-line, 60-field/625-line, 50-field dual standard—both for transmission and reception. This, he argues, would enable us to receive, direct via the Eurovision link or satellites, programmes from either Europe or America in their original form without the need for standards conversion with its inherent loss of picture quality. Further, it would enable the public to judge whether the European or the American standard gives the better picture, and thus to move one step nearer to the ideal of a single world standard. He contends, and no one has effectively refuted him on this point, that the cost of establishing a dual (or as would be necessary in the first instance a triple) line standard would not appreciably increase the £1,000M which we are already committed to spend over the next 10 years in changing from 405 lines.

Reactions to Mr. Adorian's proposition have been vigorous, and letters to *The Times* from all quarters have shown no reluctance to reopen the whole question of line standards. The possibility of adding the 525-line, 60-field standard when the 625-line, 50-field is introduced was raised in the House of Commons by Sir Wavell Wakefield (St. Marylebone), and the P.M.G. intimated that he had decided to refer this many-sided question to the Television Advisory Committee.

The programme producers are generally in favour of the widest possible flexibility of standards, which would enable them to buy and sell programmes in both the 625 and 525 regions of the world. In the *B.B.C. Handbook*, 1963, the numbers of television receivers in different countries are given, from which we deduce that in 1961 there were approximately

71M on the 525-line standard, 26M on 625 lines, 12M on 405 and 3M 819. So 525 has a flying start, but as Mr. S. E. Allchurch, Director of B.R.E.M.A., pointed out (*The Times*, 21/2/63) many of the countries of the Middle and Far East and of Africa (in which present prospects for exports are highest) have adopted the 625-line standard, which is consequently gaining some ground. But Mr. Walter D. Kemp, Technical Controller of TWW, Ltd. (*The Times*, 15/2/63), says: "A world standard for television will undoubtedly come. I, and many other engineers, feel that this will not be 625 lines. Why should Britain back the 625-line horse to win when we can place an each-way bet on the dual standard?" Mr. B. R. Greenhead, Technical Controller of A.B.C. Television Ltd. (*The Times*, 11/2/63), favours the 525-line, 60-field system "mainly for two reasons: a brighter picture can be obtained before flicker appears objectionable and the picture appears to contain more lines than it does in actual fact." Sir Harold Bishop (*The Times*, 20/2/63), says: ". . . The B.B.C. suggested a dual system of this kind in a paper to the Technical Subcommittee of the T.A.C. in January 1960. . . . The B.B.C. believes that, if this flexibility could be achieved without undue complication, it would be worth while in the long term bearing in mind the probable development of world-wide television. It would be of particular value for colour television because at the moment there is no satisfactory way of converting a video tape recording of 525-line colour to the 625-line system. . . ."

Taking a realistic view of the world television situation as it exists and as it is likely to develop we support Mr. Adorian's plea which amounts to saying that the ship should not be spoilt for a ha'p'orth of tar—or if that is putting it too cheaply, that we should add the good ship "525" to the fleet we are about to launch. And we say it is a good ship not because it has more than 405 lines, but because it has more than 50 fields.

We acquiesce in this suggested extension of the television services to include the 525-line system because it is too late now to revise the decision to abandon 405 lines. But we still think that the proper place for standards conversion is neither at the receiver nor the transmitter but in the studio, where simultaneous magnetic tape recordings of impeccable quality on all required standards could be made for export as well as for the convenience of home consumption. There are few occasions when the immediacy of a live broadcast is really important. Those who disagree must themselves be the judges of whether they will be getting good value for the price they are being asked to pay.



Wireless World

OSCILLOSCOPE

2. — "No. 1" Y AMPLIFIER CONSTRUCTION

HAVING discussed oscilloscopes in a general way last month, we are now in a position to get down to specifics, and this month we will describe the first plug-in unit—the "No. 1" y amplifier. This is a very simple circuit, suitable for low-frequency applications such as audio testing and l.f. experimental work.

Vertical Amplifier

The sensitivity of this first amplifier is 3mV per screen division. This means that a voltage of 3mV peak-to-peak applied to the input will deflect the c.r.t. spot one graticule division, or about half a centimetre. This is a reasonable amount of gain and, as no special precautions have been taken to obtain a wide bandwidth, the amplifier is most suitable for audio work. The output is push-pull, this being the type of drive required by the tube we use, and calibration is provided.

The first bit of circuitry that the signal encounters behind the front panel is a frequency-compensated step attenuator, which is used to keep the signal presented to the amplifier within reasonable limits. The compensating capacitors are needed to make the attenuator work at higher as well as at low frequencies. In Fig. 1(a) we see one step of our attenuator and at low frequencies it is easy to see that the signal on the valve grid will be $R_2/R_1 + R_2$ times the input. However, at frequencies where the stray capacitance C_s gives a low reactance, we find that the output is very much less than before. The impedance of C_s in parallel with R_2 is dependent on frequency, and the attenuator becomes useless. Steps

are therefore taken to avoid this state of affairs, and the solution is the long string of capacitors shown in the circuit diagram, Fig. 6.

Effectively, the capacitors form a second attenuator, one step of which is shown in Fig. 1(b). This time the input to the grid is $C_1/C_1 + C_5$ times the input, and combining the two we get Fig. 1(c). To render the network independent of frequency, C_1R_1 must equal C_5R_2 . The complete attenuator has nine steps and accepts signal amplitudes from 30 mV to 300Vp-p. The total resistance of the chain is $1M\Omega$, and as there is no separate grid resistor to the first valve, this is the input resistance of the amplifier. A probe will be described later which has a resistance of $10M\Omega$, for use when a reduction in sensitivity of ten times can be tolerated. The amplifier is calibrated by using a fraction of the heater voltage, on the slider of a calibrated potentiometer, to provide a known y signal, which is compared with the unknown signal. The procedure is to adjust the input, by means of the attenuator and gain control, until it fits between two convenient lines on the c.r.t. screen graticule. The "CAL./USE" switch is then turned to "CAL." and the "CAL. VOLTS" dial adjusted until the signal again fits the same two lines, when the amplitude can be read from the dial.

Having reduced the signal, if necessary, to manageable proportions we now have to amplify it again to drive the c.r.t. The first valve is an EF184, which is a frame-grid pentode with a mutual conductance (g_m) of 15 milliamperes per volt. No attempt is made at inductive compensation, and the high-frequency 3dB point is 500 kc/s. The circuit is

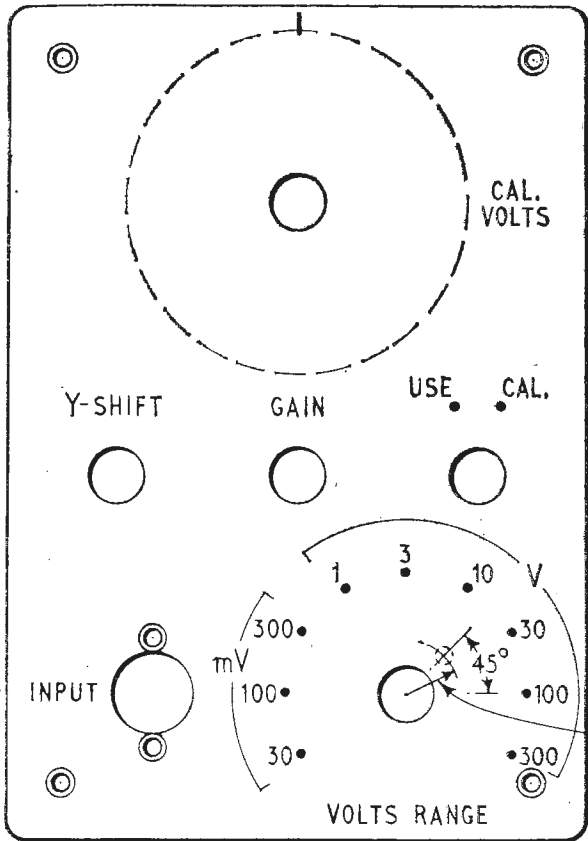

MECHANICAL CONSTRUCTION

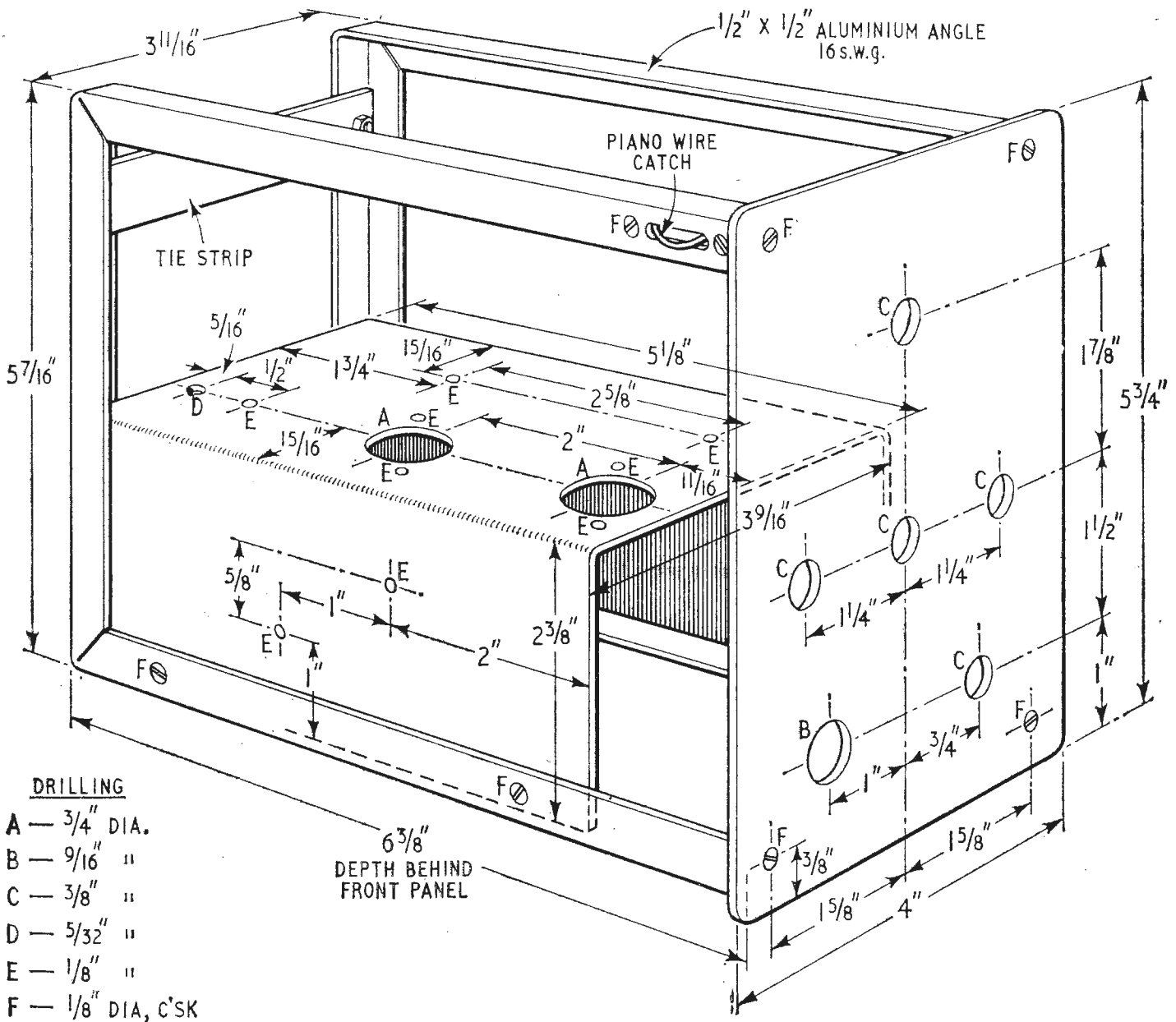
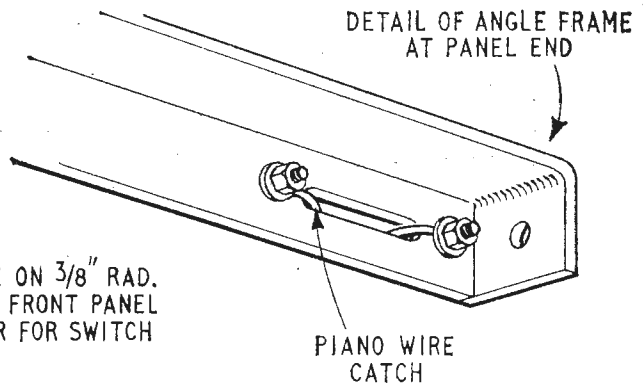

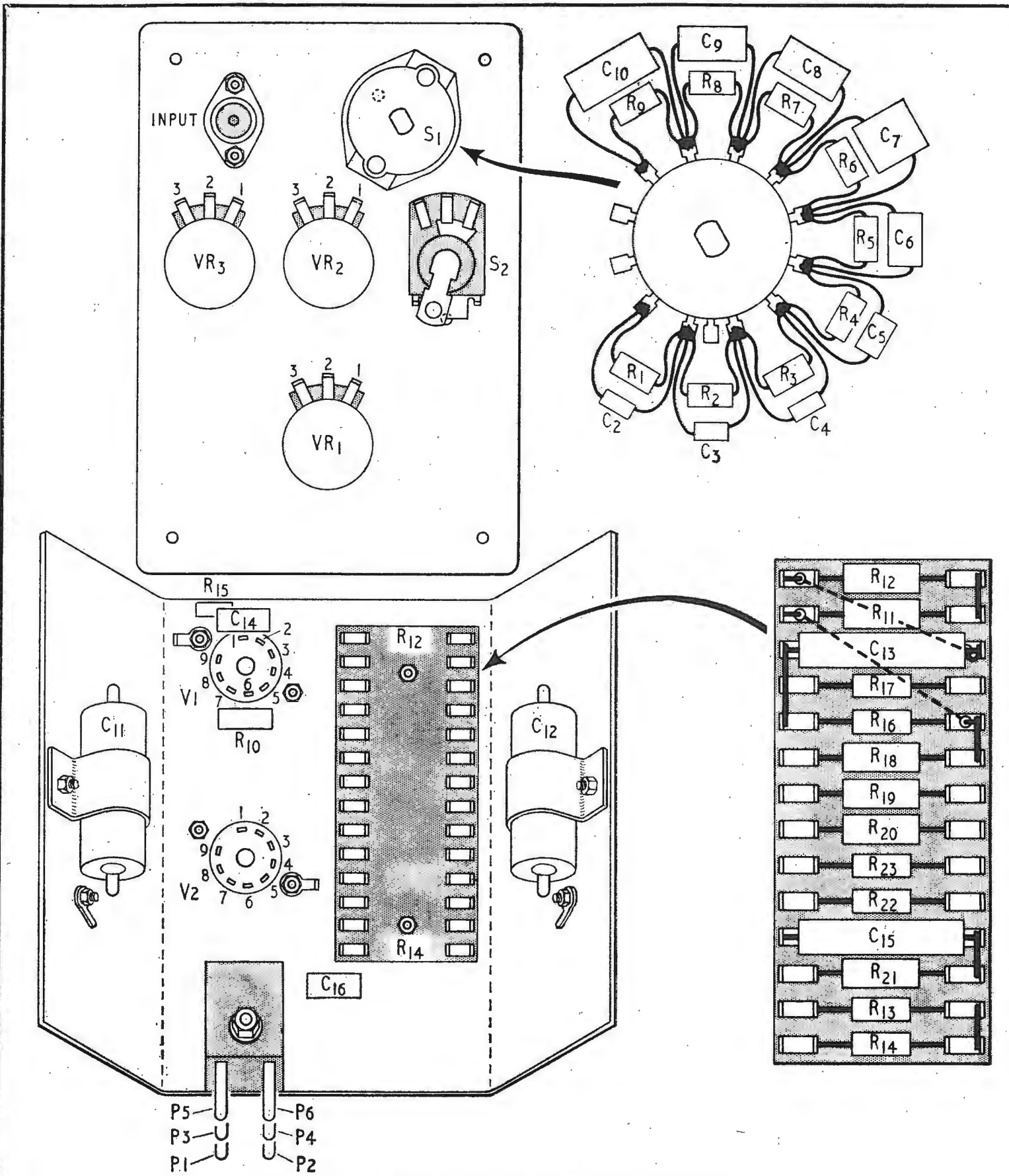

LAYOUT OF COMPONENTS AND COMPONENT LIST

R ₁	680k	1/2 W	R ₁₄	1.5M	1/2 W	C ₁	0.1μ	350V	C ₁₄	0.01μ	150V
R ₂	220k	1/2 W	R ₁₅	82	1/2 W	C ₂	10p		C ₁₅	0.1μ	250V
R ₃	68k	1/2 W	R ₁₆	1.5M	1/2 W	C ₃	33p		C ₁₆	0.04μ	150V
R ₄	22k	1/2 W	R ₁₇	470k	1/2 W	C ₄	100p		Coaxial socket		
R ₅	6.8k	1/2 W	R ₁₈	10k	1W	C ₅	330p		(Belling Lee)		
R ₆	2.2k	1/2 W	R ₁₉	10k	1W	C ₆	1000p		"Domina" plugs		
R ₇	680	1/2 W	R ₂₀	10k	1W	C ₇	3000p		(Bulgin)		
R ₈	220	1/2 W	R ₂₁	10k	1W	C ₈	0.01μ		"Makaswitch" 1-pole		
R ₉	100	1/2 W	R ₂₂	330k	1/2 W	C ₉	0.03μ		12 way (Radiospares)		
R ₁₀	47k	1W	R ₂₃	100k	1/2 W	C ₁₀	0.1μ		Changeover switch		
R ₁₁	6.8k	1W	VR ₁	10k	1/4 W	C ₁₁	16μ	350V	EF 184		
R ₁₂	10k	1W	VR ₂	5k	1/4 W	C ₁₂	16μ	350V	12AT7 or ECC81.		
R ₁₃	1.5M	1/2 W	VR ₃	100k	1/4 W	C ₁₃	0.1μ	350V			

shown simply in Fig. 2. and although it looks simple, a few remarks are needed.

Although, as we have said, no inductive compensation is used, we have made a virtue of necessity and played a rather unkind trick on the cathode-bias resistor. Normally, of course, an enormous electrolytic capacitor would be used to by-pass signal currents and avoid negative feedback, which would reduce the gain of the stage. The trouble is, at low frequencies, the reactance of the capacitor increases, and we lose gain just at the point where other causes are having the same effect. If, however, we accept the negative feedback, we can discard the capacitor and obtain a level response, at least as far as the cathode is concerned, down to zero frequency. On the other hand, a small capacitor in its place will have no effect at low frequencies, but as gain begins to fall due to stray capacitance at the anode, the cathode capacitor takes effect and decouples the cathode, holding the gain up. The g_m of a valve with a resistor in the

cathode is $g_m / (1 + g_m R_k)$ which in our case is $15 / (1 + 15 \times 0.082) = 6.7$. To sum up, we have accepted a loss in gain over the whole band to obtain an extended frequency response at both ends.

An equally good low-frequency response could be obtained by returning the grid or cathode to a fixed bias point. The full gain of the valve is then usable, but additional voltage dropping and decoupling components are needed.

The low-frequency response of an R.C.-coupled amplifier can never extend to zero frequency because of the coupling capacitor. Looking at it another way, the coupling capacitor C_1 and the following grid resistor R_1 are effectively a differentiating circuit, and at extremely low frequencies, a square wave would appear at the grid as a series of spikes. This must be so but, as we saw last month, avoiding action can be taken. To recapitulate, the anode decoupling components $C_2 R_2$ perform a second function of compensation. As the signal across R_{71} Fig. 5 decreases, due to the increased impedance of C_{13} at low

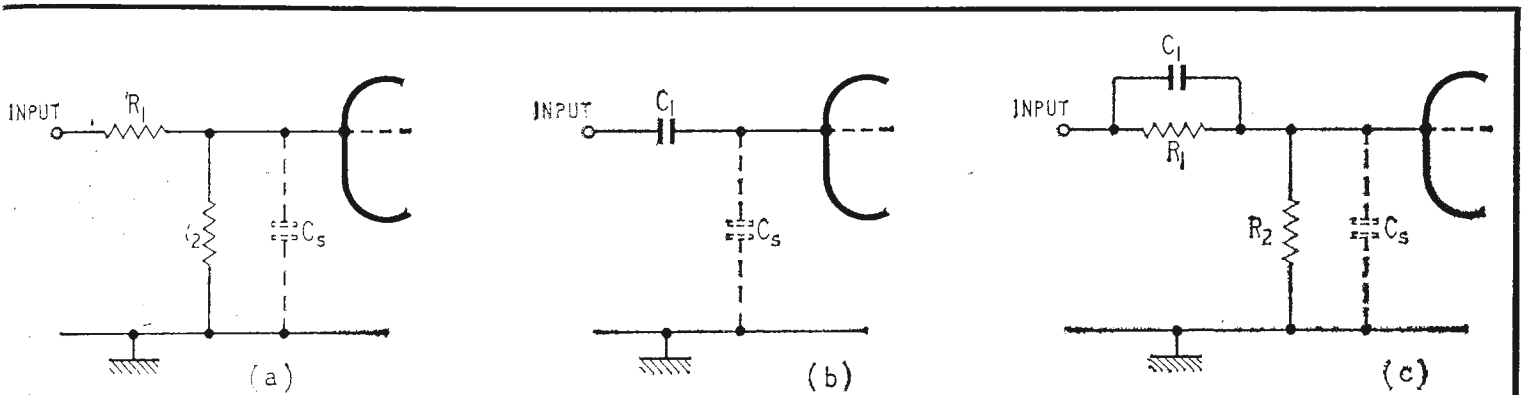

Fig. 1. Step attenuator is two types in parallel—resistive and capacitive.

Fig. 2. First stage of amplifier.

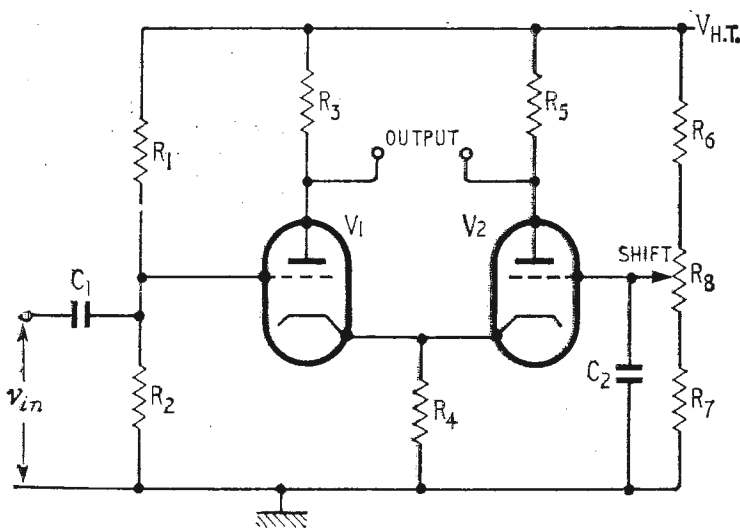
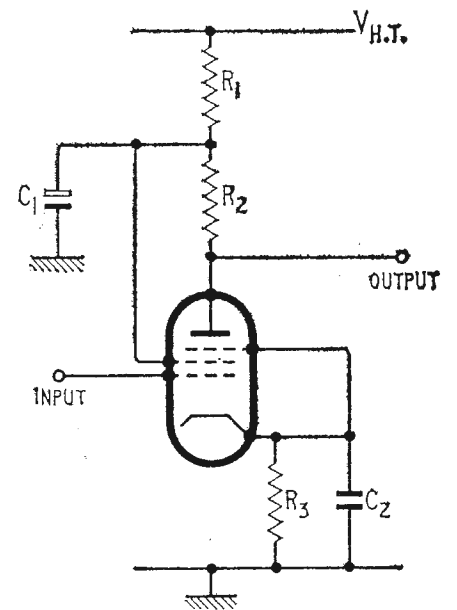
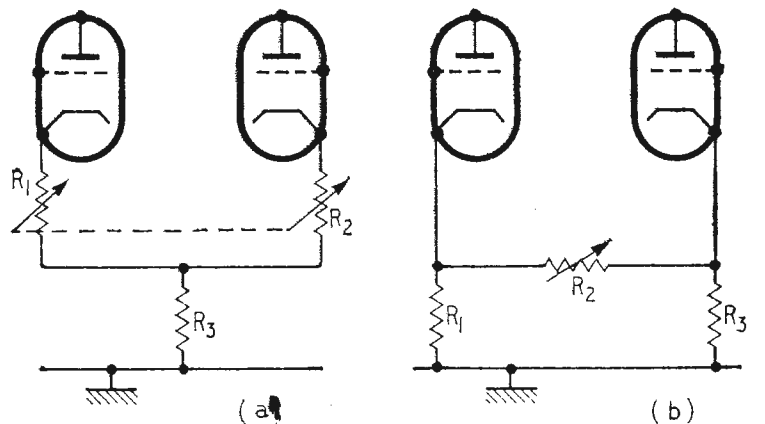
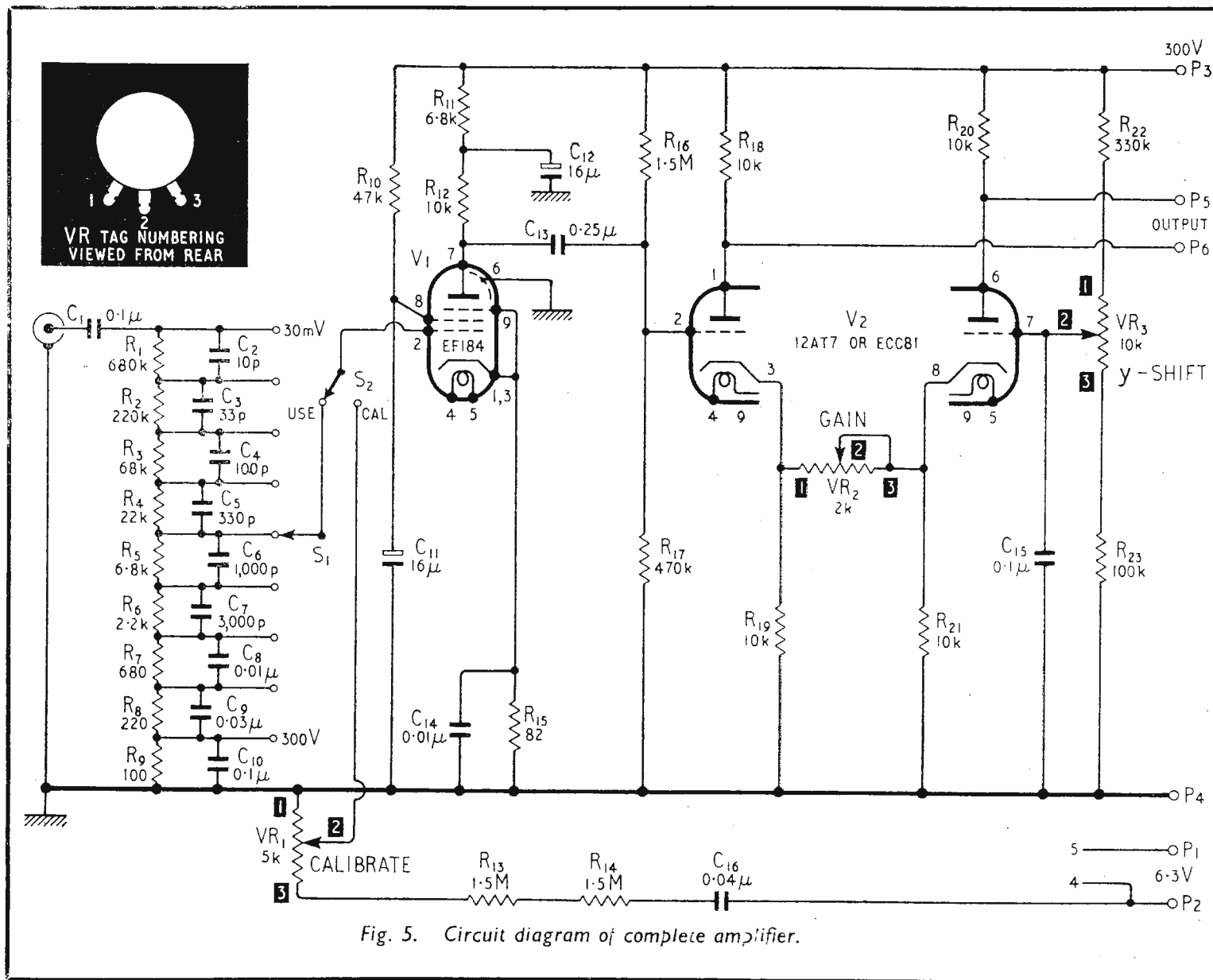

Fig. 3. Long-tailed pair phase-splitting amplifier.

Fig. 4. Addition of gain control to circuit of Fig. 3. The two circuits are equivalent.





frequencies, the impedance of C_{12} increases and R_{11} becomes part of the anode load, giving increased gain. If R_{11} is large compared with R_{12} , best results are obtained by making $R_a C_{12} = R_{in} C_{13}$ where R_a is the parallel combination of R_{11} and R_{12} , and R_{in} the combination of R_{16} and R_{17} . In our case, R_{12} could not be made bigger than R_{11} because this would give too low an anode voltage, but some compensation is obtained.

The cathode-ray tube we will use is the Mullard DN7-78, which requires push-pull deflection. This, of course, means that a phase-splitter is required, and we have used the type shown in Fig. 3. Known as a long-tailed pair or Schmitt cathode-coupled pair, the circuit gives outputs of opposite polarity at the two anodes. The input signal v_{in} is divided into two approximately equal parts, half appearing between the cathode and grid of V_1 and the rest across the cathode resistor R_4 . The grid of V_2 is effectively earthed to the signal by C_2 , and its signal is therefore applied to its cathode. In other words, it is an earthed-grid stage (or grounded-grid if one's accent is American). The output from V_2 anode is in phase with the input and in antiphase with that from V_1 anode. The output is directly coupled to the c.r.t. deflection plates, which means that shift can be applied to the amplifier, and this function is performed by R_8 . A continuously variable gain control is used to "fill in the gaps" of the step attenuator. If resistors are inserted in the cathodes of the

two valves, negative feedback is introduced and the gain reduced. Unfortunately, as this is shown in Fig. 4 (a), it would require a ganged variable resistor, which one always likes to avoid if possible. It is a simple matter, however, to transform the T-network R_1 , R_2 and R_a into its equivalent Π -network, as shown in Fig. 4(b). If this seems to be a bit of a fiddle, read "Cathode Ray" in our October, 1956, issue, where it is shown to be quite respectable.

Construction

The unit takes the form in which all future plug-ins will be made. The chassis is a simple two-sided affair, mounted on aluminium-angle frames, which will slide into the instrument on runners. In our prototype, the front panel is made of aluminium with a decorative facing of laminated plastic, but individual builders will no doubt have their own ideas on this subject. Layout of the amplifier is not particularly critical, as only fairly low frequencies are involved, and it was found feasible to use tagboard construction.

The connecting plug is a stack of three Bulgin "Domina" connectors, which will mate with sockets on the main chassis. The only other component that we need to specify is the attenuator switch. A Radiospares "Makaswitch" 1-pole, 12-way type is used, as it is rather smaller than usual. Incidentally, Radiospares components can only be obtained through retailers.

Non-linearity Distortion Measurement

WITH PARTICULAR REFERENCE TO WHITE NOISE AND SLOT FILTERS

By J. SOMERSET MURRAY, B.A., A.M.I.E.E., and J. M. RICHARDS, B.A.

This article is based on a paper read at the Silver Jubilee Convention of the British Sound Recording Association on 14th October, 1961, and is intended to give a rapid survey of the methods which have so far been used to measure non-linearity distortion in amplifiers and transmission systems and will introduce some of the results obtained in the carrier telephone field to the measurement of distortion in audio equipment.

The greater part of the theory is taken from two classical papers by Brockbank and Wass¹ of the British Post Office, by Fedida and Palmer² of Marconi's Wireless Telegraph Company, and other references^{3,4}. It will propose a method of measurement for audio systems which is closely related to the methods which are in frequent use in the testing of communication links.

DISTORTION may be defined as the difference between the input signal and the output signal of a system. Such a definition includes the effects of non-linearity distortion, variation of the amplification of the system with frequency, phase distortion, and noise and hum inside and outside the useful pass band of the system. In practice the frequency response, phase distortion and effects outside the pass band are not nearly as important as the other distortions and a useful criterion of non-linearity distortion may ignore them.

Elementary non-linearity distortion theory is based on a single distorting element with a transfer characteristic which is independent of frequency:

$$V = av + bv^2 + cv^3 + \dots \quad (1)$$

where V is the output voltage v is the input voltage and a , b and c are constants.

Under normal operation the higher-order terms become increasingly less important and we can concentrate on the first three in the series.

Single-tone signal: For a single-tone input the first term is responsible for amplification of the fundamental, the second for the second harmonic and a shift in the d.c. level and the third for the third harmonic and an imperceptible addition to the fundamental. The voltage ratio of the second harmonic to the fundamental is $bv_0/2a$ and that of the third $cv_0^2/4a$, where v_0 is the amplitude of the input. (Appendix 1(a).)

Two-toned signal: The effect of such a transfer characteristic on two equal tones is to produce harmonics of both frequencies and also, as in the frequency changer of a superheterodyne, sum and difference tones which are of greater intensity than the harmonics of the same order. (Appendix 1(b).)

Many-toned signal: If we extend the analysis to a mixture of N equal tones of constant total power the number of intermodulation products increases rapidly, while the power in each product remains

greater than the harmonic of the same order. So that even when N is fairly small the total distortion power is nearly all in the intermodulation frequencies. It is also practically independent of N . To take an example from Table I (reproduced from the paper by Brockbank and Wass, reference 1) when there are 30 equal tones applied simultaneously, the total third order distortion power is 600,000 times as big as the power in the third harmonic of one tone by itself. There will of course be 30 such harmonics—one for each tone, and the power in the third-order intermodulation products is therefore 20,000 times as great as in the third harmonics themselves. As the order increases the figures become even more astronomical.

The total distortion power for a many-toned signal is given by:

$$T = 4t_2P^2 + 24t_3P^3 + 192t_4P^4 + \dots + 2^{r-1}r!t_rP^r \quad (2)$$

where T is the total distortion power from all orders t_r is the r th harmonic output power produced by a sinusoidal input which gives a fundamental output tone of unit power and P is the output power of the system.

Brockbank and Wass¹ have shown that this analysis also applies to a mixture of many tones of different but reasonably equivalent amplitudes.

Methods of Measurement

All accurate methods of measurement of distortion must take into account the frequency dependence of distortion in practical equipment. This complication will be treated later in the article.

Single-tone test. The simplest method uses a single very pure tone and looks for its harmonics in the output. This is satisfactory at low frequencies in the audio range, but as the test frequency is increased the relevant harmonics leave the pass band of the equipment and are no longer useful. It should never be assumed from this that so-called "harmonic" distortion is unimportant in the upper

TABLE I
Characteristics of Distortion Products

Order	Type of product	Number of products	Power per product relative to harmonic of same order	Total power per type of product when <i>n</i> is equal to—				
				2	3	10	30	100
2nd	$\left. \begin{array}{l} 2A \\ A+B \\ A-B \end{array} \right\}$	n $n(n-1)$	1	2	3	10	00	100
			4	8	24	360	3,480	40,000
3rd	$\left. \begin{array}{l} 3A \\ 2A+B \\ 2A-B \\ A+2B \\ A-2B \end{array} \right\}$ $\left. \begin{array}{l} A+B+C \\ A+B-C \\ A-B+C \\ A-B-C \end{array} \right\}$	n $2n(n-1)$ $\frac{2}{3}n(n-1)(n-2)$	1		3	10	30	100
			9		108	1,620	15,660	178,000
			36		144	17,280	585,000	23×10^6
4th	$2A \pm B \pm C$ $A \pm B \pm C \pm D$	$2n(n-1)(n-2)$ $\frac{1}{3}n(n-1)(n-2)$ $(n-3)$	144			207,500	7×10^6	
			576			968,000	126×10^6	
5th	$2A \pm B \pm C \pm D$ $A \pm B \pm C \pm D \pm E$	$\frac{2}{3}n(n-1)(n-2)$ $(n-3)$ $\frac{1}{15}n(n-1)(n-2)$ $(n-3)(n-4)$	3,600			24×10^6	3×10^9	
			14,400			58×10^6	33×10^9	

half of the pass band, because difference tones within the audio range will always occur from any normal multi-tone signal and, as we have shown, will be much greater in power than the harmonics.

Two-tone test. Two-tone testing is a more general method for measuring distortion. It has three advantages over the single-tone method. First, that absolutely pure tones are not required. Secondly, that its application is not limited to the lower frequencies of the pass band and, thirdly, that since intermodulation products have higher powers than the harmonic of the same order, lower levels of distortion can be measured.

Two tones are used as the input signal. The output consists of these, their harmonics, and intermodulation products whose most general form is $pf_1 + qf_2$ for the r th or $(p + q)$ th order. One of these intermodulation products is selected, separated out by a frequency-selective receiver and its power is compared with the output power of the two fundamentals. This measurement is repeated for each important order of distortion and for a well distributed range of fundamental and product frequencies. Two-tone testing is satisfactory but laborious and it is essential to identify the product in each case. This may be done by observing that the product vanishes when either of the tones is removed and that any change in the level of the tones is followed a proportionate change in the product level. Great care must be taken with the design of the selective receiver to ensure that it does not introduce appreciable distortion of its own, since this may subtract from the product to be measured and may lead to impressive though meaningless results.

Selective receivers or wave analysers which are freely tunable over the band, almost invariably work on the superheterodyne principle in which the signal input is first attenuated very strongly in order that the oscillator level in the first mixer can be made very large in relation to the signal tone. If this were not done, the first mixer would produce intermodulation products of its own, indistinguishable from those which we are seeking. This process cannot be carried beyond the condition

in which the basic thermal noise in the receiver would mask the intermodulation products we are looking for. Thus, design is a compromise between limitation due to the thermal noise and limitation due to self-generation of intermodulation products. One cannot in practice rely on measurements in which the difference between the tone and the product in the selective amplifier is greater than about 70 dB even when the input is at the optimum level. It is almost always possible, however, to increase the levels passing through the equipment under test until the ratio between tone and product is less than 50 dB, but it may be necessary to attenuate the whole signal externally to prevent overloading of the first mixer.

Many-tone test. The distortion of a system can be tested in conditions closer to the ones to be expected in an audio application if many simultaneous tones are used as the test signal. However, in this case the identification of any single product becomes very difficult and only the total distortion power in a region can be measured. If a very large number of frequencies are used, the intermodulation frequencies tend to resemble a band of noise.

In the limit of a test signal consisting of an in-

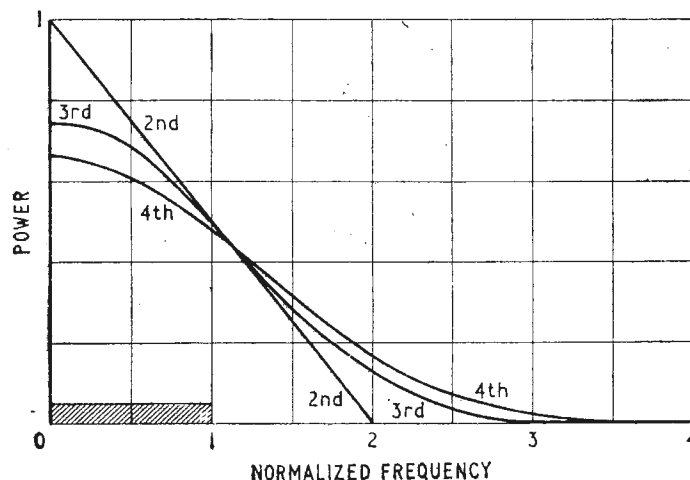

Fig. 1. Normalized curves of intermodulation product powers (after Fedide and Palmer, reference 2).

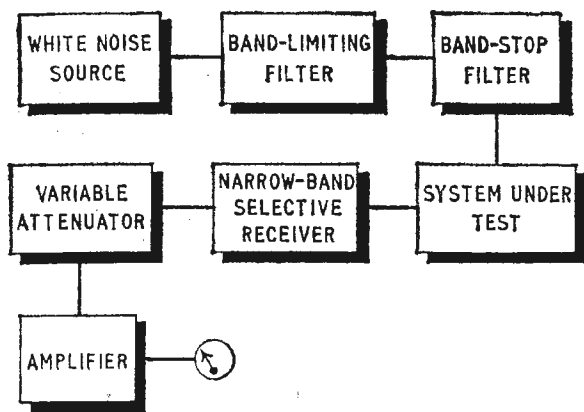

Fig. 2. Essential elements of the white noise method of intermodulation testing.

finitely large number of frequencies uniformly distributed in the audio band, all the distortion is in the form of intermodulation products whose frequency distribution can be calculated with the usual elementary assumption that the distortion is independent of frequency.

Fig. 1 shows the distribution of the first few orders of intermodulation products. The curves are normalized to the highest frequency in the signal and to the same power in each order so that the area under each curve is identical. Although, as one would expect, the second order runs up to twice and the fourth order to four times the maximum signal frequency, most of the power in each order is in the signal band.

It is now perfectly clear from this analysis that the distortion which is carried by the system depends very greatly on the complexity of the signal which is being passed through it. Simple signals give very little unwanted power in the output, but complex signals give an increasingly important quantity of intermodulation products increasing almost indefinitely as the number of tones increases.

It is suggested that the signal-to-noise ratio for such a test signal, where noise includes the total distortion power in the audio band and all other unwanted noise of any kind, is a useful figure of merit for an equipment.

Choice of Test Level

Before proceeding to describe the method of measurement it is necessary to decide on an output power level at which to test the equipment. A reasonable power would depend on the rated output of the equipment. The peaks of a random or many toned signal are far larger than the r.m.s. level. Amplifiers are necessarily run at power levels well below their rating for a single-tone output. If the random test signal is not to overload the amplifier for more than one ten thousandth of the time (see Appendix 2), the r.m.s. level of the random test signal must be a quarter or less of the peak level of the system, so the signal power must be at least 9 dB down on the single-tone rating of the system. To allow a 1 dB tolerance in output power a level 10 dB down on the rated power is suggested as the standard output loading for intermodulation distortion measurements. This loading can be measured either with a thermal ammeter or by an average meter if allowance is made for the fact that it reads 1 dB below the true level of a random signal if it has been calibrated on a sine wave. (Appendix 2).

Method of Measurement

A schematic diagram of the equipment is shown in Fig. 2. A test signal is produced from a white noise source by filtering out frequencies outside the selected band and amplifying the remainder if necessary. It is then filtered to reject all frequencies in a narrow slot by about 90 dB and passed through the system under test. The system is loaded at a tenth of the maximum single tone output power. The output passes through a variable attenuator and a filter which has a high rejection of frequencies in the test signal, but accepts some part of the slot frequency band. The output of this is fed to an uncalibrated sensing device which is set to give any convenient reading. The band-stop filter is next taken out of the system, the input level is altered to give the same average output power and the attenuation of the variable attenuator is increased until the sensing device is again at the same setting. The change in the reading on the attenuator is the signal-to-noise ratio or noise power ratio at the slot frequency. Ideally the two filters should be available at a number of frequencies in the band, but a measurement at a low, a medium and a high frequency will be sufficient to give a very good measurement of the system's distortion. A further measurement

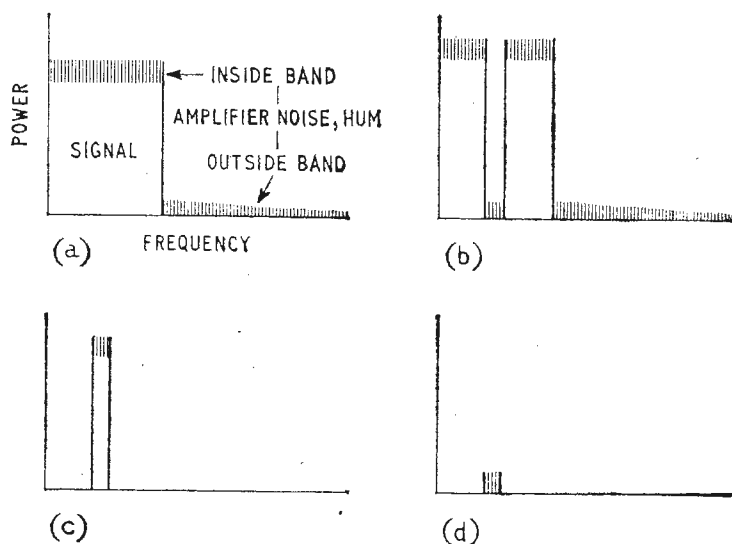

Fig. 3. Stages in the measurement of distortion by a white noise signal.

of amplifier noise and hum in the absence of a signal will give the dynamic range of the system at this level of distortion.

Theory of the Method

In Fig. 3 (a) shows the composition of the output of the system. The suggested figure of merit is the ratio between the power in the distortion noise over the band and the output signal power. Diagram (b) shows the output if a slot rejection filter is placed in the input; the level at frequencies outside the slot has been slightly increased to maintain the total output power and thus the distortion power constant. Diagrams (c) and (d) show the signal accepted by the narrow-band filter in both cases. Clearly the ratio of their powers is the desired noise power ratio at the slot frequency.

Tables II and III show how the signal-to-noise ratio due to non-linearity distortion may be predicted from the more usual statement of harmonic distortion as a percentage of amplitude.

Table II gives the power in the harmonic of a

TABLE II

Distortion (volts) %	0.1	0.2	0.5	1.0	2.0	5.0	10.0
Power t_r (dB)	-60	-54	-46	-40	-34	-26	-20

TABLE III

Harmonic	T_r at P = -10dB	T_r at P = -7dB	Proportion (k_r) of T_r in band
	dB	dB	dB
2.	-14.0	- 8.0	-1.2
3.	-16.2	- 7.2	-1.8
4.	-17.2	- 5.2	-2.2
5.	-17.2	- 2.2	-2.6
6.	-16.5	+ 1.5	-2.9
7.	-15.0	+ 6.0	-3.2
8.	-13.0	+11.0	...

The noise power ratio in dB is $T_r + k_r - P$.

single tone for a range of levels of distortion. Table III, column 2 gives the correction factor required to calculate the total distortion power at a tenth rated load, given the order and magnitude of the harmonic distortion at full rated power. Column 3 gives the equivalent correction factor for a 3 dB overload while column 4 gives the further correction factor for the proportion of distortion power produced in the pass band.

As an example of the use of these tables, if the noise power ratio is found experimentally to be -51.2 dB at -10 dB of rated loading it corresponds to a second harmonic distortion at rated load of -51.2 + P - T_r - k_r

$$= -51.2 - 10.0 + 14.0 + 1.2$$

$$= -46.0 \text{ dB, or } 0.5\% \text{ harmonic distortion.}$$

A similar calculation for third harmonic distortion gives -43.2 dB or 0.7%. Thus as far as intermodulation products are concerned, third harmonic distortion is of less importance than an equal percentage of second harmonic distortion at power levels 10 dB down on the rated r.m.s. output power.

The rapid increase in distortion power with signal power makes the logic behind the design of amplifiers of very high rating more evident. If one amplifier has the same distortion at full power as another of half its rating and both are loaded to the same level, the larger will have half the second harmonic and a quarter the third harmonic distortion power of the smaller. This may account for the tendency for the use of amplifiers of apparently excessive power in domestic equipments in America.

There does not appear to be any figure available for the ultimate sensitivity of the ear to noise in the presence of signal. However, in one experiment, carried out by the authors, it was found possible to detect the presence of white noise which was 50 dB below the 1-kc/s sine wave being transmitted. If the figure proves to be in the neighbourhood of 50 dB you will see from above that the performance will be met by a transmission system of minimum rating in which the total harmonic distortion is better than 46 dB; this is equivalent to less than 0.5% distortion of any low order. Distortion lower than this is necessary in each element of a system.

As an example of the use of white noise as a test signal we may examine its application to the measurement of a transmission system beginning with a microphone and ending with a loudspeaker, passing through the intermediate stages of a tape recorder, disc, pickup, pre-amplifier and power amplifier.

The microphone would be placed in a sound field from two loudspeakers, each radiating a narrow band of noise, and a selective receiver tuned to the sum or difference frequency. The microphone distortion can thus be measured by a modification of the two tone method, which eliminates much of the difficulty with the standing waves that occur with sinusoidal test signals.

The tape machine is then tested by recording slotted white noise and determining the relation between the noise power ratio and loading. This can assist in setting the safe peak power level. The noise power ratio in this case will include modulation or Barkhausen noise with the intermodulation noise. The bias level can be adjusted while observing the noise in the slot.

The disc recording and playback stages can be tested in a similar manner, again making use of slotted white noise, and the loudspeaker tested by a modification of the method used for the microphone. Two bands of white noise are fed into the loudspeaker and a microphone, which has already been checked for low distortion, is used to detect the sum or difference frequencies.

Finally the whole system may be checked by breaking the loop at some point, for example at the output of the microphone amplifier, and passing slotted white noise round the whole system. The method described above may then be used to give an overall figure of merit for the equipment.

Throughout the theoretical analysis we have assumed a characteristic independent of frequency, but this assumption is rarely true.

The errors of the analysis are of two kinds:

(1) The coefficients in the transfer characteristic of a system, given in equation (1) vary with frequency. For the second harmonic component

$$\begin{aligned} V &= b(f)v^2 \\ &= b_0k(f)v^2 \\ &= b_0[k^2(f)v]^2 \end{aligned}$$

where b_0 is a constant and $b_0k(f) = b(f)$

The distortion of a uniform signal is equivalent to the distortion corresponding to a constant second-order coefficient b_0 of a signal which varies with amplitude over the band, proportional to $k^2(f)$.

Curves for the distortion from several such distributions are given in reference 1. A measurement at a low, a medium and a high frequency will still give an average which is in nearly every case a good measure of the total distortion noise present in the band.

(2) In some systems the fall-off of feedback at high frequencies causes the high-frequency distortion products to be larger than the distortion present at the fundamental frequency would warrant. Such an effect is rightly measured if it occurs in the audio band, but outside the band it may usually be ignored since (a) the output could be attenuated at that frequency if necessary, (b) the products will be inaudible and (c) most of the intermodulation products are within the band. So the amplification of the small fraction of the total noise which is at high frequencies will make only a very small change to the loading.

Conclusions

1. If the transfer function of an equipment is known and is independent of frequency, both the harmonic distortion of a sine wave signal and the intermodula-

tion distortion noise from a complex signal can be calculated at any given output level.

2. For this case and also for the case where the transfer function is frequency-dependent, the performance of a system can be estimated by means of determinations of the noise power ratios at a few frequencies in the audio band. Such figures of merit, when coupled with a measurement of total noise and hum, provide an excellent criterion for the performance of a system.

3. The measurement may easily be made even on a complex system involving a number of separate links.

APPENDIX 1

Consider the second harmonic term:

$$V = bv^2$$

(a) For a single tone

$$v = v_0 \sin \omega t$$

$$\therefore V = bv_0^2 \sin^2 \omega t$$

$$= bv_0^2/2 (1 - \cos 2\omega t)$$

$$\therefore V = -bv_0^2/2 \cos 2\omega t + \text{constant}$$

The amplification of the fundamental is given by:

$$V = av$$

$$= av_0 \sin \omega t.$$

\therefore the ratio of the second harmonic to the fundamental is $bv_0/2a$.

(b) For two equal tones

$$v = v_0 (\sin \omega_1 t + \sin \omega_2 t)$$

$$\therefore \frac{V}{b} = v^2 = v_0^2 (\sin^2 \omega_1 t + 2 \sin \omega_1 t \sin \omega_2 t + \sin^2 \omega_2 t)$$

$$= v_0^2 - \frac{1}{2} \cos 2\omega_1 t - \frac{1}{2} \cos 2\omega_2 t - \cos (\omega_1 + \omega_2)t + \cos (\omega_1 - \omega_2)t + \text{constant}$$

\therefore the power in the intermodulation products is four times the power in the harmonics.

APPENDIX 2

The average meter is usually set to read r.m.s. sine-wave values. For a sine wave the average value is $\frac{2\sqrt{2}}{\pi}$ times

the r.m.s. value. For a complex or random signal the instantaneous value has a gaussian distribution about the mean.

$$\psi \quad V \text{ (r.m.s.)} = 1, \quad P(M) = \sqrt{\frac{2}{\pi}} \exp\left(-\frac{V^2}{2}\right) dV$$

$$\therefore (V \text{ average}) \text{ random} = \sqrt{\frac{2}{\pi}} \int_0^{\infty} V \cdot \exp\left(-\frac{V^2}{2}\right) dV = \sqrt{\frac{2}{\pi}}$$

\therefore for the same output power and thus r.m.s. value

$$\frac{(V \text{ average}) \text{ random}}{(V \text{ average}) \text{ sine wave}} = \sqrt{\frac{2}{\pi}} \cdot \frac{\pi}{2\sqrt{2}} = 0.886$$

\therefore the average meter will read low by 1.05 dB for a random signal if set to read the r.m.s. value of a sine wave.

For a complex signal the proportion of time spent in overload will depend on the ratio of the peak level to the r.m.s. output voltage as follows:

V (r.m.s.)	Period in overload %
2.0	31.73
2.0	4.55
3.0	0.270
4.0	0.00634
5.0	5.7×10^{-5}
6.0	2.0×10^{-7}
7.0	2.6×10^{-10}

REFERENCES

- (1) R. A. Brockbank and C. A. A. Wass. "Non-linear Distortion in Transmission Systems". *J. I. E. E.* Vol. 92, Part III, No. 17, p.45 (1945).
- (2) S. Fedida and D. S. Palmer. "Some Considerations for Links Carrying Multichannel Telephony". *Marconi Review* Nos. 119 and 120 (1955, 1956).
- (3) J. L. Slow. "Intermodulation Noise in V.H.F. Multichannel Telephone Systems". *J. Brit. I.R.E.* Vol. 15, No. 2, p.67, Feb. 1955.
- (4) W. T. Brown. "Some Factors in the Engineering Design of V.H.F. Multichannel Telephone Equipment". *J. Brit. I.R.E.*, Vol. 14, No. 2, p.51 (Feb. 1954).

H.F. PREDICTIONS—APRIL

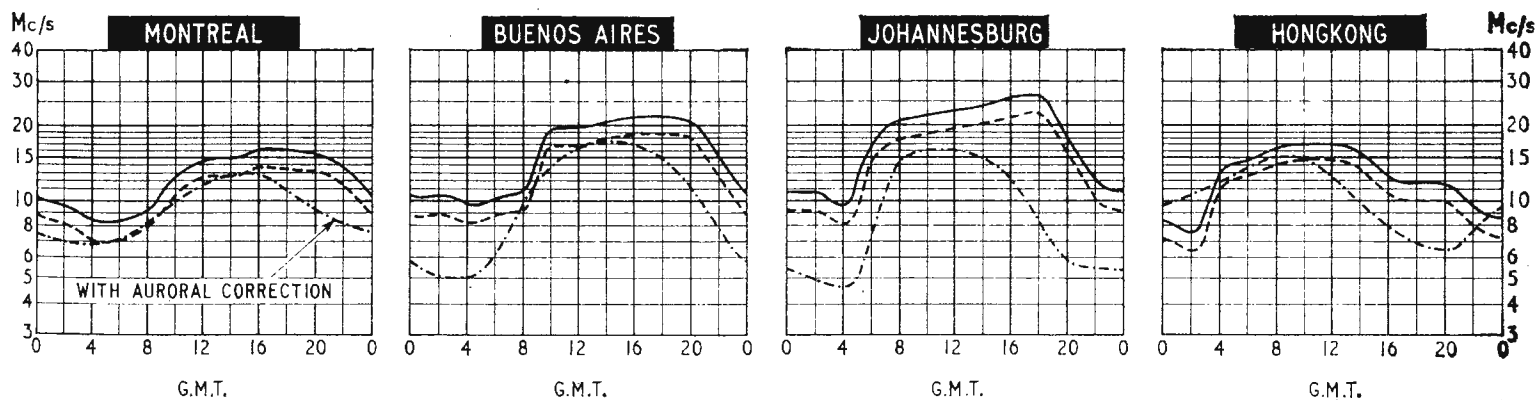

The prediction curves now show the median standard MUF, optimum traffic frequency and the lowest usable high frequency (LUF) for reception in this country. Unlike the MUF, the LUF is closely dependent upon such factors as transmitter power, aerials, local noise level and the type of modulation: it should generally be regarded with more diffidence than the MUF. The LUF curves shown are those drawn by Cable and Wireless, Ltd., for commercial telegraphy and they serve to give some idea of the period of the day for which communication can be expected. The MUF curve for a given route shows the highest frequencies which it is predicted the ionosphere will be capable of reflecting. However, even allowing for day-to-day variability, it does not necessarily follow that communication can be established on these frequencies. The reason for this is that a

simplifying assumption is made to the effect that aerials can always radiate at the optimum angle in the vertical plane to match the assumed ray path. In practice horizontal aerials are not sensitive at low angles on account of partial cancellation by reflections from the ground in the vicinity of the aerial. This effect can, of course, be minimized by raising the aerial as high as possible although amateurs are rarely able to obtain heights over 50 feet. As a consequence it is often true that the standard MUFs err on the optimistic side—particularly so for amateurs.

WORLD OF WIRELESS

Pay-TV

AS a first step towards assessing the public interest in pay-television the Postmaster General on March 1st invited companies interested in providing a service to "write for a statement of the general requirements for the experiment." The experiment will be conducted over wire "under controlled conditions" in a small number of different areas and will last for two or three years.

Several different pay-TV schemes have been demonstrated in this country during the past year or so by, for instance, British Telemeter Home Viewing (the U.K. offshoot of the International Telemeter Company of America), Rank-Rediffusion (whose system is called Choiceview), Marconi's (Payvision) and British Relay Wireless.

The experiment will provide one pay-TV programme in an area and the wire networks used will have to make available both the B.B.C. television services (when the second one starts) and the I.T.A. programmes.

It is understood applications for details of the experiment have been received from about 60 organizations; this number presumably includes not only sponsors of systems but also programme originators and operators of existing wire networks.

TV Receiver Performance.—The first of a series of British Standards dealing with methods of measuring and expressing the performance of sound radio and television receivers and audio amplifiers has been published by the British Standards Institution. Entitled "Methods for Measuring and Expressing the Performance of Television Receivers," BS 3549 describes methods of measuring the electrical, acoustical and optical properties of monochrome 405-line television receivers but does not specify standards of performance. Limiting values are given only where it is necessary to specify the conditions of individual measurements. Comprising 80 pages, it costs £1.

Physics Prizes.—The Thomas Young Medal and Prize has been awarded by the Institute of Physics and Physical Society jointly to Prof. C. H. Townes, of M.I.T., and Prof. A. L. Schawlow, of Stanford University, for their work in originating the principle of the optical maser. The Charles Vernon Boys Prize has been awarded to Dr. K. D. Froome, of the N.P.L., "for his contributions to experimental physics, particularly his determination of the velocity of light, his invention of a source of continuous short waves and his method for accurate measurement of length."

Civil Estimates.—The biggest single item (over £12M) in the 1963/64 Civil Estimates is to go to universities and scientific research. An increase of £2.66M has been allocated to the Department of Scientific and Industrial Research bringing their estimated expenditure up to £20.6M, of which £1M will be for the European Organization for Space Research.

The Army estimate spending £10,550,000 on communications and radar equipment in the year ending 31st March, 1964. This is an increase of £624,000 over last year's estimates.



Historic Milestone.—A little more than 60 years ago the first American transatlantic "radiogram" was transmitted. On the corner of Wireless Station Road which led to the site of the transmitting station, WCC, on Cape Cod, Mass., is a bronze tablet with this inscription "Site of first American transatlantic radio telegraph station built by Marconi Wireless Telegraph Company of America predecessor of R.C.A. in 1902. Through this station was transmitted on January 19th, 1903 the first American transatlantic radiogram". Our contributor, A. Dinsdale, who recently took this photograph, reminds us that the original station was lost by coastal erosion 40 years ago, but that the call sign WCC is still used by the station at Chatham on the southern tip of Cape Cod.

Honorary membership of the I.E.E. has been granted to Professor E. B. Moullin, "in recognition of his extensive contributions to electrical engineering education and to post-graduate research, notably on measurements relevant to radio communication." Dr. Moullin occupied the chair of electrical engineering at Cambridge University from its establishment in 1945 until 1960, when he retired. For 16 years before going to Cambridge Dr. Moullin, who is 68, was Donald Pollock reader in engineering science at Oxford.

A conference on **Solid State Physics** is to be held at the H. H. Wills Physics Laboratory, University of Bristol, from the 1st-4th of January, 1964. Invited speakers are Professor A. B. Pippard, F.R.S., of the University of Cambridge, and Professor M. H. Cohen of Chicago. Residential accommodation will be available at one of the University Halls of Residence. Enquiries regarding attendance should be made to the Institute of Physics and Physical Society, 47 Belgrave Square, London, S.W.1.

Television Home Deliveries Down 9%.—According to B.R.E.M.A. returns for last year, 1,375,000 sets were delivered by manufacturers to the home trade. This figure includes receivers supplied to the specialist rental and relay companies. Radiogram deliveries rose to 203,000, a 7% increase on 1961 figures. Sound radio receivers had a slight lift of 2,000 bringing the total to 2,578,000.

At the **United Nations Conference**, at Geneva, 4th-20th February, 2,000 papers were read on the application of science and technology for the benefit of the less developed areas. Of these, about eighty dealt with telecommunications and included nine papers from British contributors.

Record Exports.—Electrical and allied products are providing an increasingly large proportion of Britain's export trade, states the annual report of the British Electrical and Allied Manufacturers' Association. The increase amounted to an additional £14M, or 4.4%, on the figure for 1961, resulting in a new record of £332.6M. This represents 10.4% of all manufactured goods exported from Britain and the most notable increase in exports by the electrical industry in 1962 were in electronics and telecommunications.

At the annual general meeting of the **Electronic Engineering Association**, W. D. H. Gregson (Ferranti) was elected chairman and W. C. Morgan (E.M.I. Electronics) vice-chairman. Other members of the new executive council for 1963 are: V. M. Roberts (A.E.I.), C. H. T. Johnson (Decca Radar), W. R. Thomas (Elliott), J. O. Trundle (English Electric), R. J. Clayton (G.E.C.), R. Telford (Marconi's W/T Company), R. R. C. Rankin (Mullard Equipment), M. W. Clark (Plessey), J. R. Brinkley (Pye Telecommunications), K. S. Davies (Rank-Bush Murphy), C. G. White (Smith & Sons), and L. T. Hinton (S.T.C.).

The Electronic Valve and Semiconductor Manufacturers' Association (VASCA) has joined the **Radio Industry Council**. VASCA representatives on the Council are: S. S. Eriks (Mullard)—who is also a representative for the British Radio Valve Manufacturers' Association (BVA)—J. Bell (M-O Valve Company), C. A. W. Harmer (Pye), and A. N. Provost (Texas Instruments).

V.H.F./U.H.F. Convention.—The ninth international convention organized by the Radio Society of Great Britain and the London U.H.F. Group will be held at the Kingsley Hotel, Bloomsbury Way, London, W.C.1, on May 18th. In the morning there will be an exhibition and in the afternoon a symposium.

Optical Masers.—Four of the 40 papers being presented at the three-day New York symposium (April 16th-18th) on optical masers are being given by authors from the U.K. This is the thirteenth annual symposium organized by the Polytechnic Institute of Brooklyn.

An international conference on magnetism is being organized by the Institute of Physics and Physical Society for 7th-11th September, 1964, on behalf of the International Union of Pure and Applied Physics and the British National Committee for Physics, at the University of Nottingham. Further particulars and registration forms are obtainable from the Inst. P. & Phys. Soc., 47 Belgrave Square, London, S.W.1. Prof. L. F. Bates, Lancashire-Spencer Professor of Physics at the University will give the Guthrie lecture during the conference.

Borough Polytechnic.—An introductory six-week course on "Modern electronic circuits," with special reference to switching circuits, is to be held on Tuesdays and Thursdays, commencing 23rd April (fee £3). A course of nine lectures, "Introduction to transistor theory and applications," is to be given on Wednesday mornings, starting on 1st May (fee 25s), followed in the afternoon by a laboratory course in "Basic transistor measurements" (fee £1). A summer school on "Digital circuit techniques" consisting of a two-week, full-time, course of lectures and tutorial sessions in the morning, followed by laboratory work in the afternoon is to start on 10th June; admission is £15. Further details may be obtained from the secretary, F. J. Packer, Borough Polytechnic, Borough Road, London, S.E.1.

Colour Television Receiver Servicing.—The six-lecture course on colour television receiver servicing run by the Norwood Technical College is being repeated from April 23rd and will be given on successive Tuesday evenings. Fee 15s.

Admiralty have recently announced that SONAR is to replace ASDIC in Naval terminology. This change has been made to conform with NATO practice.

B.B.C.'s television station at **Ballachulish**, Argyllshire, was brought into service on 18th March, transmitting in Channel 2 (vision 51.75 Mc/s, sound 48.25 Mc/s) with vertical polarization. This is the second of several small stations which the B.B.C. is building to extend and improve its television and v.h.f. sound services in the Scottish Highlands and Islands. Two combined television and v.h.f. sound stations at Kinlochleven and Oban are nearing completion. The Ballachulish station receives its programmes for retransmission via a radio link from the station at Fort William, which was opened earlier this year.

Sound carriers of four I.T.A. stations operating in Channel 9 are, from March 25th, being altered slightly to avoid interference from signals from the Kilkenny, Eire, station which was recently brought into service by Telefis Eireann. The present carrier frequencies and, in brackets, the new ones are: Croydon, 191.27 (191.266); Black Mountain, 191.23 (191.234); Durriss, 191.27 (191.266) and Stockland Hill 191.23 (191.234).

1963 Hanover Fair.—For the sixth year, the British Electronic Centre is to present a composite display of some 11 manufacturers at the Annual Trade Fair at Hanover which opens on 28th April and runs to 7th May.

Transistor Amplifier and Pre-amplifier.—A reprint is now available of the two articles by R. Tobey and J. Dinsdale which appeared in our November and December 1961 issues. It is obtainable from this office price 3s.

Hearing Aids.—Technical notes on an inductive loop system and headphone adaptor for domestic sound and television receivers are included in "Special Aids To Hearing," a booklet, price 1s, issued by the Royal National Institute for the Deaf.

WHAT THEY SAY

Lion's Share.—"We [the Ministry of Aviation] sponsor most of the research in the aviation industry and very nearly half the research in the electronics industry"—*Mr. Julian Amery, Minister of Aviation.*

Music Hath Charms.—"Providing high signal-to-noise ratios coupled with very low levels of *harmonious distortion*"—From a manufacturer's announcement.

CLUB NEWS

Bexleyheath.—At the meeting of the North Kent Radio Society on April 11th an informal talk will be given by W. Hackney of the Wireless Engineering Branch of the Metropolitan Police. Fortnightly meetings are held at 8.0 at the Congregational Hall, adjacent to the Clock Tower.

Derby & District Amateur Radio Society reports a record membership of 170 at the end of the year. Transmitting members number 65.

Edinburgh.—"Ancient Radio at Sea" is the title of the talk to be given by T. Spiers (GM3OWI) at the April 11th meeting of the Lothians Radio Society. On the 25th S. Laurie (GM3PQU) will give a demonstration of "television interference proofing." Meetings are held at 7.30 in the Y.M.C.A., 14 South Saint Andrew Street, Edinburgh 2.

Heckmondwike.—At the April 4th meeting of the Spenn Valley Amateur Radio Society A. R. Bailey (G3IBN) of the Bradford College of Technology will discuss aerial problems. The club meets fortnightly at 7.15 at the Grammar School.

Melton Mowbray.—The April meeting of the Melton Mowbray Amateur Radio Society will be held on the 18th at 7.30 at the St. John Ambulance Hall, Asfordby Hill. I. A. Brown (G3OWR) will discuss transmitter construction for the national field day.

Trentham.—The annual North Midland Mobile Rally, organized jointly by the Midland and Stoke-on-Trent Amateur Radio Societies, will be held on Sunday, April 21st, at Trentham Gardens, Trentham, Staffs. Talk-in stations will be G3GBU/A on 160 metres and G3MAR/A on 2 metres.

News from Industry

English Electric group profit for 1962, after all charges including taxation of nearly £3M, was £3,143,280, an increase of some £400,000 on the previous year. The Marconi's W/T group of companies, which are part of the E.E. group, made a profit (after all charges including a subvention payment of £275,000 to a fellow subsidiary) of £187,285 compared with £194,858 in 1961. Marconi Marine's net profit was £311,912; an increase of £740 on the previous year.

Ultra-Avco Agreement.—Ultra Electronics Ltd. and Avco Corp. of New York have completed a broad licence agreement, licensing Ultra to utilize certain Avco patents, in addition to general communications developments and techniques applicable to specific types of equipment and systems.

Associated Electrical Industries are to reduce the number of their research establishments from four to two "to increase the effectiveness of the Company's research and reduce its cost." These will be at Rugby and Manchester. The Harlow laboratory will be used for the development of advanced telecommunications equipment and cables and the Aldermaston laboratory will be closed down.

Elliott-Automation has acquired from Solartron the whole of its interests in the field of X-ray fluorescence spectrometry. Equipment will now be made and marketed by Elliott's Quality Control Division.

£1,000,000 worth of oscilloscopes were sold by Solartron in 1962, who have quadrupled their turnover since 1954. Forty per cent of last year's scopes were exported and of the remaining 60%, Her Majesty's Services and Establishments have taken the major quantity.

Marconi closed circuit television has been fitted in the 20,000 ton tanker *Border Chieftain*, owned by the Lowland Tanker Company, to aid manoeuvring the vessel in harbour or restricted waters. Marconi's have also been instructed to supply similar installations for two 53,000 ton tankers being built in Tokyo for the Kuwait Oil Tanker Company. This is in addition to a comprehensive range of Marconi communications and navigational equipment.

A. N. Clark (Engineers) Limited are now in full-scale production at their new Binstead, Isle of Wight, premises. One of their new orders is to supply fifteen trailer-mounted 70ft air-operated masts for the Royal Air Force.

Carrion Compatible Component Co. Ltd., of which E. Brown Dickson was recently appointed managing director, has moved from Hounslow West to 15 Station Road, Reading, Berks. (Tel.: Reading 51866).

Painton S. A., associate company of Painton and Company, have moved to new premises in Brussels. The new address is 11 rue Keyenveld, Brussels, Belgium, and the sales force is now headed by J. G. Owen.

The Special Services Division of British Relay Wireless Limited has now moved to 36 Victoria Street, London, S.W.1. (Tel.: Abbey 4782.)

Newlyn Electronics Ltd. are now in the Star Hotel Buildings, New Street, Penzance, Cornwall.

Electronic Tubes Ltd. sales and technical information offices have been transferred to 2-16 Torrington Place, London, W.C.1.

Computer Firms Join Forces.—The English Electric Company and J. Lyons & Co. have merged their computer interests and Sir Gordon Radley, a director of English Electric, becomes chairman of the new company, not yet named.

A new company called Enfield Phelps Dodge Limited has been formed jointly by Enfield Rolling Mills, of Enfield, and Phelps Dodge Corp. of New York, to manufacture enamelled copper winding wires. Production at the Brimsdown factory is expected to start later this year.

Marconi's W/T Company has formed an International Division to co-ordinate and expand the company's overseas activities. The Associated Companies Division and former Export Department have been absorbed by the new division, a principal function of which will be to sell Marconi designs and "know-how" throughout the world.

C. F. Taylor (Electronics) Limited has recently been formed within the C. F. Taylor Organisation. F. D. Telling has been appointed general manager, and R. G. Kinch, works manager.

Evershed and Vignoles have formed a French company, Evershed-Enraf-France S.A., Paris. The new company will handle the U.K. company's electronic process control and instrumentation equipment.

Takbro Industrial Limited has been formed in England to market solderless terminals and flexible wire connectors made by the Japan Solderless Terminal Manufacturing Company. H. F. Collison is sales manager and further details may be obtained from Takbro Industrial Limited, 85 Regent Street, Leamington Spa, Warwickshire.

Associated Aerials Ltd. is the title of the company formed to co-ordinate the activities of J-Beam Aerials Ltd. and G.S.V. (Marine & Commercial) Ltd. and their respective subsidiaries.

Aero Electronics Limited have been appointed the sole U.K. agents and distributors for Vaisala Oy of Helsinki, Finland, manufacturers of radiosonde and radiowind equipment.

The **Gulton 1404 Ultrasonic Transducer** (which we wrote about in our December, 1962, issue, p. 594) is to be distributed by the D.T.V. Group, 138 Lewisham Way, New Cross, London, S.E.14.

Japanese Car Radio.—University Electrics Ltd., 7 Hertford Street, London, W.1, have been appointed sole U.K. distributors for the Clarion 85A, an all transistor car radio manufactured by the Clarion Trading Company of Tokyo.

R.C.A. Great Britain Limited are to sell "Student" twin track professional tape recording equipment in the U.K. and the Republic of Ireland; manufactured by Cedamel, of Paris.

Telefunken semiconductors, valves, c.r. tubes and certain other components are now distributed in the U.K. by Britimpex Ltd., 16-22 Great Russell Street, London, W.C.1. (Tel.: MUSEum 7600.) Tellux Ltd. were the previous distributors.

Decca Radar are to provide full sales and service facilities in the U.K. for the Simrad range of echo sounders and sonar equipment made in Norway by Simonsen Radio, A.S. of Oslo.



A portable TV tape recorder has been produced by Ampex. It employs conventional 2-in tape and operates at a tape speed of 5in/sec which is one-third the speed of their standard models. The VR-1500 is designed for closed-circuit television recording and operates on either 525 or 625 lines. While this recorder is heavy by comparison with the lightweight equipment produced by Ampex for use in satellites, it weighs only about 130lb, measures 30 x 18 x 14in and costs about a quarter of the standard broadcasting machine shown in the background

Pye Telecommunications Limited are to install a county radiotelephone system for the Essex Fire Brigade. The new system valued at £20,000 will cover the county from five divisional headquarters which will normally operate separately, but the headquarters at Brentwood can control the whole area.

The Home Office have placed a contract with Pye Telecommunications for three hundred 450 Mc/s point-to-point radiotelephone equipments, for use in the Police, Fire and Civil Defence Networks.

Elliott-Automation are to supply 150 ten-watt radio link terminals for Britain's Civil Defence Network. The terminals are designed to operate in the u.h.f. band.

Hudson Electronic Devices Ltd. have been awarded the contract to supply the Leicester County Council Surveyor's Department with v.h.f. radiotelephone equipment. This is an extension of their existing scheme and the new equipment includes a 25-watt fixed station with talk-through facilities and sixteen mobile units.

Standard Telephones and Cables Ltd. have received an order, valued at about £500,000, for one hundred radio altimeters and monitors from Vickers-Armstrong (Aircraft). These are for use in conjunction with the Elliott all-weather landing system and will be fitted to the B.O.A.C. fleet of VC-10 aircraft.

Westrex has been awarded a contract by the B.B.C. amounting to over £48,000 for the supply of magnetic sound recording and reproducing equipment for its second television service.

International Computers and Tabulators Limited have received an order, valued at about £600,000 for four I.C.T. 1500 machines from the Central Electricity Generating Board. The computers will be equipped with magnetic tape input and output facilities. Orders for the I.C.T. 558 computer introduced in October 1961 now exceed sixty. These machines have a capital value of £20,000.

Computer Devices of Canada Ltd. which established a London office two years ago, recently registered a British subsidiary, Computing Devices Co. Ltd. The company has opened new offices at Bury House, 126/128 Cromwell Rd., London, S.W.7 (Tel: FREmantle 4861).

OVERSEAS TRADE

The Australian Government has placed an order with Decca and their Australian associates Electronic Industries Ltd. for nearly £A1M worth of meteorological radar. Equipment to be supplied includes sixteen 3cm windfinders and eight 10cm windfinder/weather radar installations. Part of the 3cm equipment will be manufactured in Australia and the whole of the 10cm equipment will be made in Decca's new Isle-of-Wight factory, which is due to be completed this autumn.

Tape-controlled Recording Automatic Checkout Equipment (TRACE) manufactured by de Havilland has been delivered to the French Admiralty. This equipment, under the control of its punched-tape memory, is to be used to automatically test complex electronic installations. Later production models of TRACE will be made in France by Société Anonyme Engins Matra, who are de Havilland licensees for the production of checkout equipment.

Singapore is the latest area to have a Marconi-equipped television service. Initially there will be one programme channel, radiated via a 5kW vision and 1kW sound transmitter with a second pair as standby units. The transmitters are sited at Bukit Batok and operate in Band III to 625-line standards with horizontal polarization. Two 4-stack quadrant aerials are mounted on a 350 ft tower. A microwave link carries the signals from the studio to the transmitting site and v.h.f./f.m. links are provided for supervisory circuits between various units of the broadcasting organization.

The General Electric Company has completed the installation of a radio system in Gambia, to provide the major telephone and telegraph communications throughout the country; using 5-circuit v.h.f. junction radio equipment.

International Aeradio Limited have been awarded the task of providing telecommunication and navigational aids throughout the Sheikdom of Abu Dhabi in the Arabian Gulf during the development, and exploitation, of a new oil field.

Personalities

Captain C. F. Booth, C.B.E., M.I.E.E., deputy engineer-in-chief of the Post Office since 1960, is retiring on March 31st after 40 years' service. He was at the Dollis Hill Research Station for 25 years and became assistant e.-in-c. in 1954. The title deputy e.-in-c. for Captain Booth's office has become assistant e.-in-c. and he is succeeded by J. H. H. Merriman, O.B.E., M.Sc., A.Inst.P., M.I.E.E., who is a physics graduate of King's College, London, and joined the staff at Dollis Hill in 1936, and was closely associated with the development of the steerable aerial system—M.U.S.A. He has been staff engineer in charge of the Inland Radio Planning and Provision Branch since 1961. His successor is T. Kilvington, B.Sc.(Eng.), M.I.E.E., who joined the Post Office in 1936 and was appointed secretary of the technical sub-committee of the Television Advisory Committee in 1961.

G. J. Williams, B.Sc., A.Inst.P., has joined Rank Cintel, a division of the Rank Organisation, as general manager of the Electronic Tubes Division. Mr. Williams was a graduate apprentice with Marconi's Wireless Telegraph Company and was subsequently employed on the development of radar systems and the planning of v.h.f. communication systems. For the past two years he has been with S.T.C.

Ray L. Mawby, M.P. for Totnes, has been appointed Assistant Postmaster General by the Prime Minister. He succeeds **Miss Mervyn Pike**, member for Melton, who has been A.P.G. since 1959. Mr. Mawby, who is 41, is a member of the Electrical Trades Union.

John H. Gayer the new chairman of the International Frequency Registration Board of the International Telecommunication Union has been a member of the Board since 1953. He succeeds **N. I. Krasnosselski**. After studying at the Massachusetts Institute of Technology Mr. Gayer became a lecturer and then entered the American radio and electronics industry. He is president of the International Amateur Radio Club (founded last year at the headquarters of the I.T.U.) which operates station 4U1TU.

Roger Williamson, B.Sc., Grad.I.E.E., has been appointed international liaison engineer with the International Rectifier Company. Mr. Williamson gained his physics degree at the Imperial College in 1959 and after graduating he joined the rectifier division of Standard Telephones and Cables Limited. He joined International Rectifier's in 1961.

E. A. J. Hall, B.Sc., Ph.D., M.I.E.E., has been appointed technical manager of the Avionics Department of Rank Cintel, a division of the Rank Organisation. Dr. Hall's previous post was with Cottage Laboratories Limited as assistant chief engineer.

H. C. Maguire has been elected to the boards of the Radio Communication Company and Marconi Sounding Device Company, subsidiaries of the Marconi International Marine Company. Last year he was appointed general manager of M.I.M.C. which he joined as a sea-going radio officer in 1927.

Charles B. Bovill, A.M.I.E.E., M.Brit.I.R.E., who joined Multisignals Ltd. two years ago as executive engineer has become chief executive of the company. From 1946 until joining Multisignals Mr. Bovill was with Decca.

Raymond E. Cooke, B.Sc., M.I.E.E., managing director of K.E.F. Electronics Ltd., one of the K.E.F. group of companies of Maidstone, Kent, has been appointed to the board of the parent company, Kent Engineering and Foundry Ltd. Mr. Cooke, who is 37, formed K.E.F. Electronics in 1961. Prior to this, he was technical director of Wharfedale Wireless Works.

The B.B.C. announces the appointment of **J. Redmond**, M.I.E.E., as senior superintendent engineer, television, in succession to **H. W. Baker**, M.I.E.E., who is retiring on 12th April after thirty-seven years' service with the Corporation.

D. H. Cummings, B.Sc., A.C.G.I., A.M.I.E.E., has been appointed by the B.B.C. superintendent engineer, sound broadcasting (operations). Mr. Cummings joined the Corporation in 1947 and was appointed assistant (operations) to the superintendent engineer, sound broadcasting in 1961.

A. E. Robertson, B.Sc., A.M.I.E.E., has been appointed head of the B.B.C.'s engineering training department. He succeeds **Dr. K. R. Sturley**, who, as announced in our February issue, has been appointed chief engineer of external broadcasting. Mr. Robertson joined the Corporation in 1936 and has been assistant head of the department since 1948.

Wing Commander Harry Ball transferred to the headquarters of Signals Command, Medenham, Bucks, for Technical Staff duties in February. Prior to this, he spent two years as Senior Technical Officer of the No. 2 School of Technical Training at R.A.F. Cosford. Wing Cdr. Ball joined the Royal Air Force as an apprentice in 1933 and was commissioned in 1941.

Wing Commander L. Davies, A.F.C., took up his new appointment as chief instructor at the Air Electronics School R.A.F. Topcliffe, Yorkshire, on the 25th February. Prior to this, he was at the Headquarters of Bomber Command undertaking signals training duties. Wing Cdr. Davies joined the R.A.F. in 1940 and was commissioned in 1943.

Sebastian de Ferranti, managing director of Ferranti Limited since 1958, was appointed chairman of the Company on 16th February; he also remains managing director. He has, incidentally, agreed to serve as president of the Radio Industries Club for 1963-64.

John Scott-Taggart, M.I.E.E., has been awarded by the President of the Italian Republic the decoration of *Cavaliere Ufficiale* (knight officer) of the Order "Al Merito della Repubblica Italiana." During the last war he served with the rank of Wing Commander in the R.A.F., and was responsible for the training of radar personnel in the early years. He then became the C.O. of No. 73 Wing and, as such, was responsible for two-thirds of the radar stations in England and Wales.

OUR AUTHORS

J. R. Ogilvie, Grad.I.E.E., contributor of the article on h.t. supplies for high-gain amplifiers in this issue, served with Royal Signals as an engineering cadet from 1942 to 1947, and is now at the Royal Armament Research & Development Establishment of the War Office.

D. A. Smith, contributor of the article on page 195 on the use of transistors in switching circuits, is a senior engineer at Elliotts which he joined two years ago. He started his industrial career with Marconi's where he served a five-year apprenticeship. After a further year on the staff he spent some time with Redifon and later Furzehill Laboratories before joining English Electric where he worked for six years on guided missiles.

OBITUARY

Henry Arthur Maish ("Ham") Clark, B.Sc.(Eng.), M.I.E.E., died suddenly at his work on 14th February, aged 56. He graduated from the Northampton Engineering College and joined the Columbia Graphophone Company in 1928, where he was chosen by the late A. D. Blumlein to be his chief collaborator in designing a completely new electrical recording system, and this was satisfactorily accomplished by 1930. As a research engineer in E.M.I., Mr. Clark started work in 1931 on a scheme of stereophonic recording, and with Blumlein made many contributions to the development of a successful system, which is in use today. In 1938 he adapted the principles used for stereophonic recording to aircraft location, and engineered equipment which was later used by the Services during the early part of the war. He then assisted in the development of airborne and naval radar equipment. After the war he took charge of the development of high-powered video transmitters. In 1953 he joined the Record Division of E.M.I. and subsequently became Technical Director Records and International Division. Mr. Clark was, from 1926 onwards, an active amateur transmitter (G6OT) and became a life vice-president of the Radio Society of Great Britain.

Milton B. Sleeper, the well-known American radio journalist and publisher, died on 31st January. He was a prime mover for the first transatlantic amateur radio tests conducted by the A.R.R.L. in February 1921. At that time he was radio editor of *Everyday Engineering*. In recent years his main interest was in high-quality domestic sound reproduction and he founded two journals which were subsequently amalgamated in *High Fidelity*, which is published from Great Barrington, Mass.

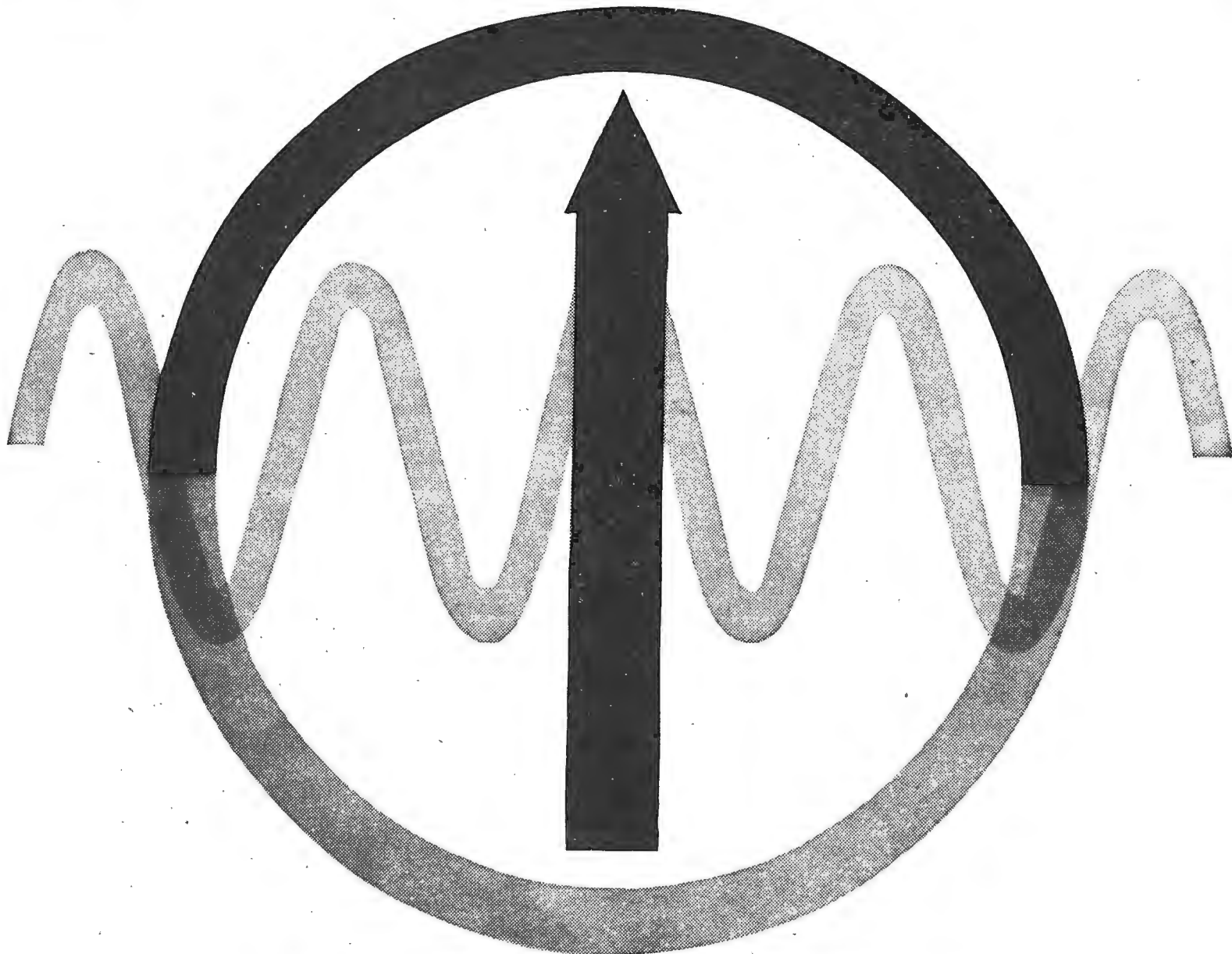

1 Mc/s to 320 Mc/s and constant output level

A highly stable signal from a constant impedance over the frequency range 1 Mc/s to 320 Mc/s is provided by the advanced design of the Airmec VHF Signal Generator Type 204. The facilities for modulation are comprehensive and the output may be either continuous wave, amplitude-modulated, frequency-modulated, pulse-modulated or combined amplitude- and frequency-modulated. The open-circuit output may be adjusted to any value from 2 μ V to 220 mV RMS and, being stabilised over the whole frequency range, there is no need for tedious checking and adjustment of the output. The VHF Signal Generator Type 204 is one of the complete range of VLF, LF, HF and VHF Signal Generators designed and manufactured by Airmec. This range is part of the comprehensive selection of high quality electronic instruments which Airmec produce for use in laboratories and workshops.

- FREQUENCY RANGE:-**
1-320 Mc/s in 5 ranges,
scale length 29 ft.

- CRYSTAL CALIBRATION:-**
0.05% calibration accuracy

- ATTENUATORS:-**
0-80 dB in 20 dB steps
0-20 dB in 2 dB steps
0-2 dB continuously
variable

- STABILISED OUTPUT:-**
2 μ V - 220 mV to RMS
from 52 or 75 ohms

- CHECK DEVIATION:-**
Enables deviation to be
checked against crystal and
provides fine tuning control

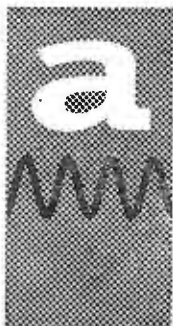
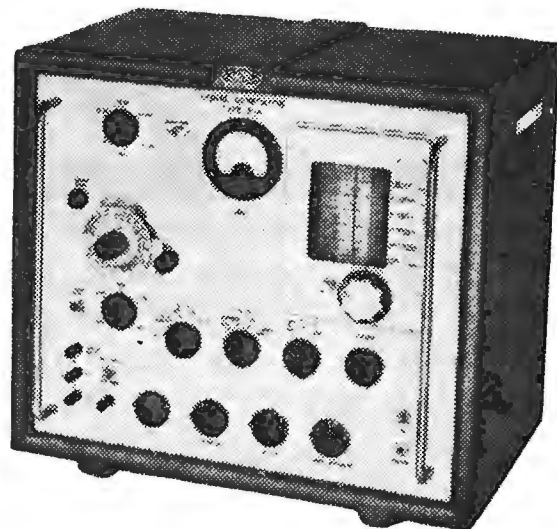

Airmec for peak performance consistently

The Airmec Range includes:- Signal Generators, Oscilloscopes, Wave Analysers, Valve Voltmeters, Ohmmeters and Phasemeters

LABORATORY INSTRUMENTS DIVISION
AIRMEC LIMITED, HIGH WYCOMBE BUCKINGHAMSHIRE ENGLAND
TELEPHONE: HIGH WYCOMBE 2501 (10 LINES)

ACOS ADVANCE | styli ✱

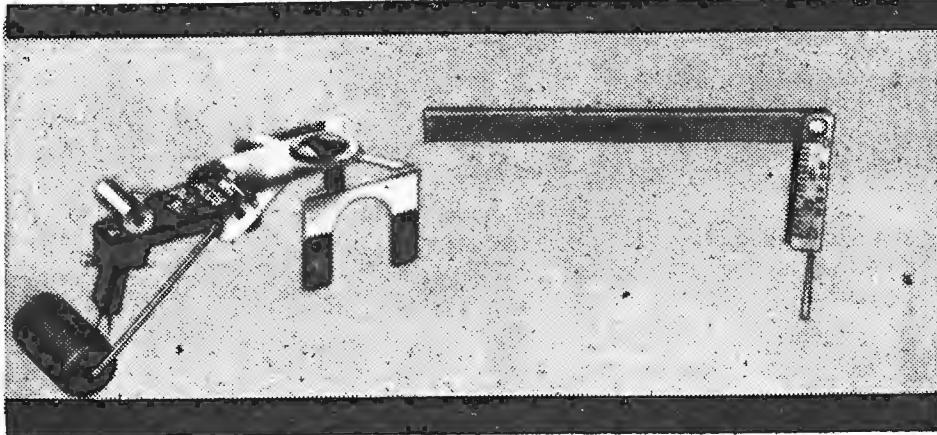
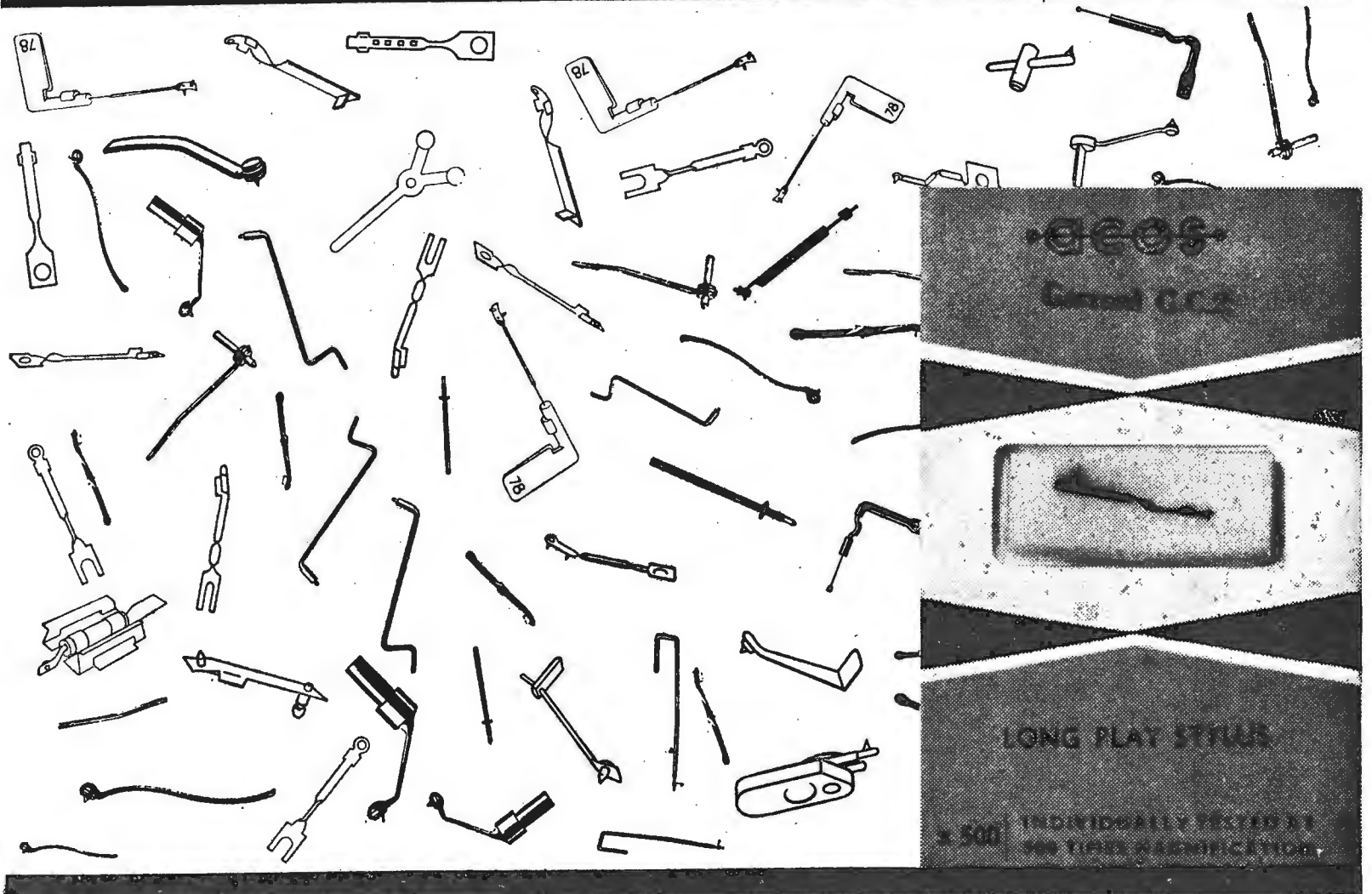

✱
& changer dust bug
& stylus pressure
gauge

Acos continue to advance and be recognised. Recognised as the finest range of replacement styli now available. Diamond and sapphire, mono and stereo, there are now over 150 types of Acos x500 styli, to fit all makes of pick-ups and cartridges. There is one to fit *your* equipment. All Acos x500 styli are individually tested at 500-times magnification, yet they cost no more than other makes. Look for Acos styli in the characteristic pack. *Accessories after the fact:* Don't overlook the Acos Changer Dust Bug that sweeps all before it, and the Acos Stylus Pressure Gauge which stops pick-ups from throwing their weight about.

Other Acos products: mono and stereo pick-ups, cartridges, microphones.

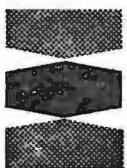

acos

ARE DOING THINGS IN STYLI

See us at the Audio Fair, Room 204, Booth 57.

COSMOCORD LTD, WALTHAM CROSS, HERTS. TEL: WALTHAM CROSS 27331

STYLUS MASS AND DISTORTION

RECORD GROOVE DEFORMATION MAY OFF-SET OR EXCEED TRACING DISTORTION

By J. WALTON*

EVEN with "ideal" record materials and mass-less pickups the constraints imposed by the geometry of the stylus-groove relationship must first be observed. These are well known and the limiting ones are summarized in Fig. 1. When the properties of the groove wall material and its deformation under the reaction forces applied in accelerating the stylus mass are taken into account the assessment of overall distortion becomes more difficult.

In 1961 were published¹ the first electron microscope pictures of a record groove. These together with measurements of gliding indents² were made to investigate record wear. It was noticed that the stylus path did not coincide with the recorded modulation, and that there appeared to be a theoretical basis for this in the spherical nature of the stylus as an indenter when under the varying forces of acceleration due to recorded modulation.

The work presented here is a survey of the effect of gramophone pickup stylus inertia (i.e., the dynamic effect of stylus mass) on the modulated record groove and upon the reproduced signal. It shows that not only does stylus inertia cause distortion of the modulated groove, but that this causes very considerable harmonic distortion to be reproduced in the pickup output, and that, because of this, most

pickups in use today fall far shorter than expected in their ability to reproduce the recorded information.

This approach to the work has been made possible by the adaptation of the two measuring techniques^{1, 2} which involve:—

1. Measurement of sub-optical indents at 50,000 times magnification³.
2. Observation and measurement of not only the *residual* indentation of the groove by the stylus, but also observation and measurement at several thousand times magnification⁴ of the *instantaneous* path of the stylus (whether or not this keeps contact with the modulated groove wall).

Non-linear Indentation. To the very first approximation the depth of elastic indentation due to stylus inertia would have a linear relation to instantaneous modulation acceleration. But as shown in reference 2, the effect of the spherical nature of the stylus as an indenter is such as to make the indent depth vary as the two-thirds power of the force on the stylus. This is derived from the Hertzian equation as follows:—

$$w = \left[\frac{3}{4} Wgr \left(\frac{1 - \sigma_1^2}{E_1} + \frac{1 - \sigma_2^2}{E_2} \right) \right]^{\frac{2}{3}}$$

* Decca Recording Studios.

¹ J. Walton, "Versatile Stereophonic Pickup," *Wireless World*, August, 1961, p. 407.

² J. Walton, "Gramophone Record Deformation," *Wireless World*, July, 1961, p. 353.

³ Taylor-Hobson Talysurf adaptation and measurements, by Dr. P. Lord.

⁴ Electron micrographs and replicas of grooves by Dr. P. Chippindale.

(Drs. Lord and Chippindale are at The Royal College of Advanced Technology, Salford.)

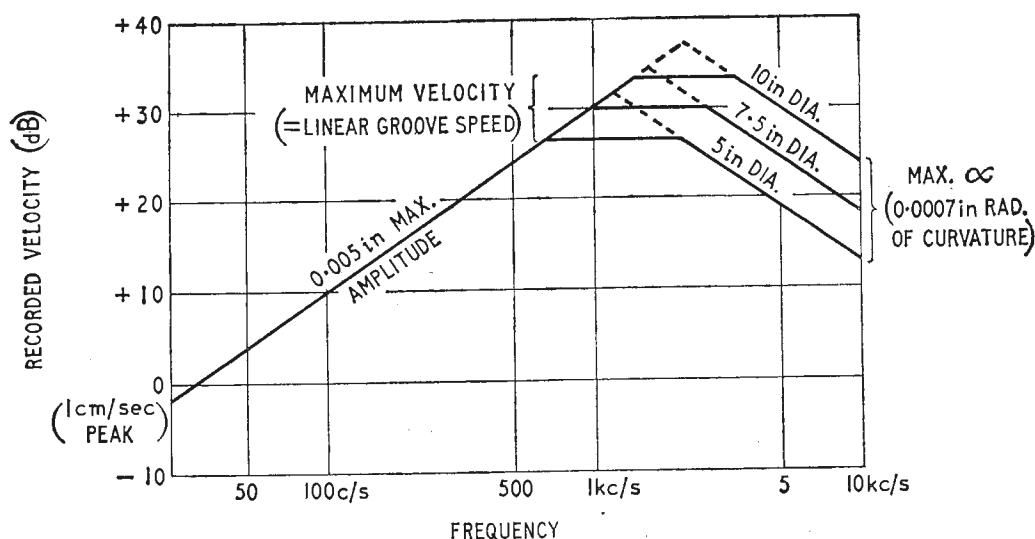
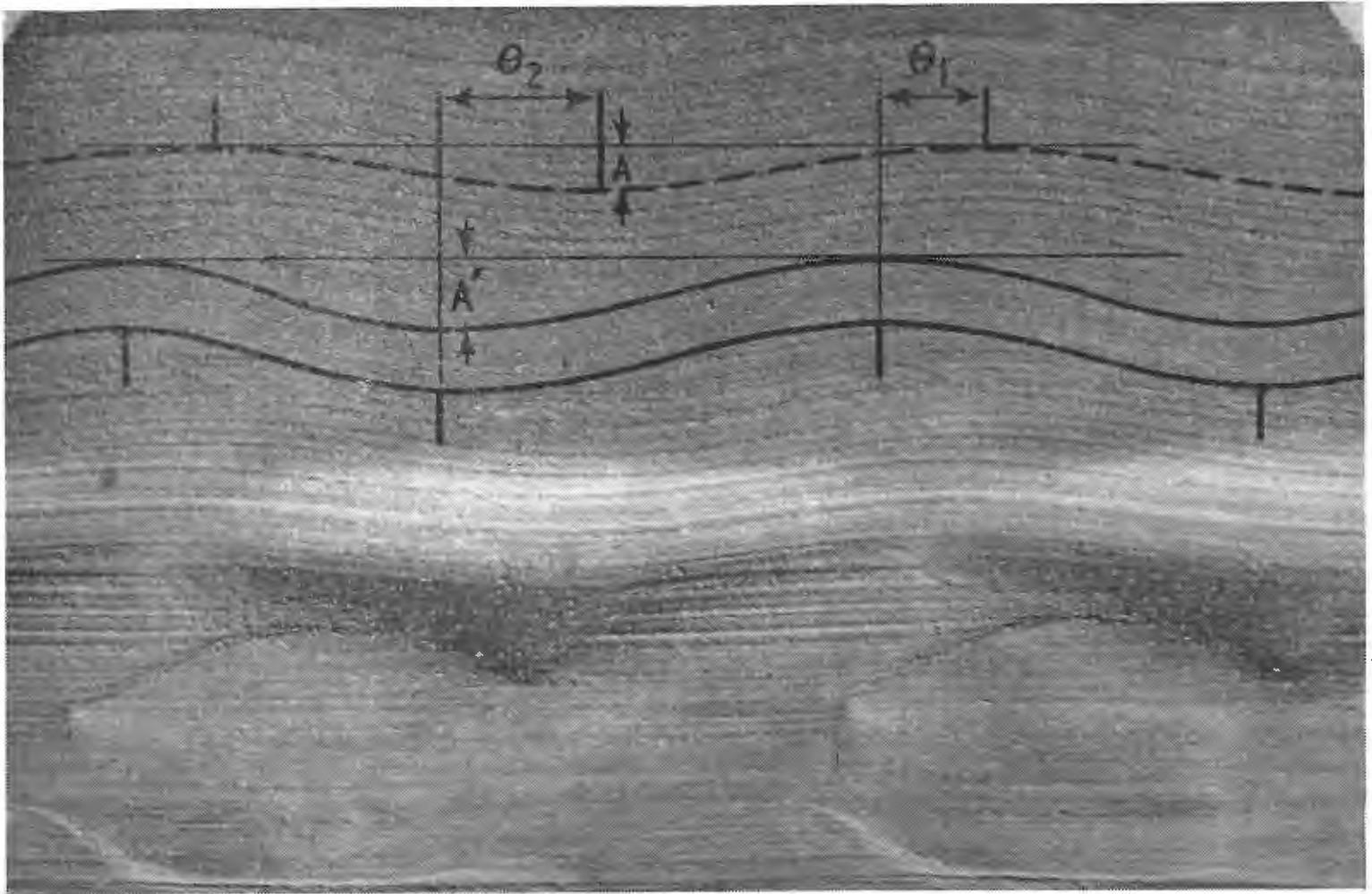

Fig. 1. Maximum reproducible velocities are subject to physical limitation even with an ideal pickup. The upper frequency velocities are finally limited by the stylus radius where this equals the radius of modulation curvature. The lower frequency velocities are basically limited by the permissible groove excursion in relation to playing time. At frequencies between those where these limitations operate, "normal" stylus groove relations would demand that lateral velocity (for an ideal stylus) should not exceed linear groove speed.

(An ideal stylus is considered to be one with physical dimension but without mechanical impedance or restriction, i.e. infinite compliance, zero tip mass and no mechanical resistance).



Above: Fig. 2(a). Flattened replica of part of a stereo record groove magnified in the original 2300 times under an electron microscope. Sine-wave motion of the cutter, in modulating the lower side of groove (10kc/s, 5cm/sec at 11 in dia), leaves marks (reinforced by dotted line) on unmodulated upper groove wall. Comparison with the marks (enclosed by solid lines) left by the reproducing stylus after one playing with a nominal 2-gm pickup (stylus mass 3mgm) shows phase differences θ_1 and θ_2 of 50° and 72° respectively between the recorded and reproduced maximum excursions of cutter and stylus, and an estimated harmonic distortion of 20%. The "instantaneous" indent depth at max. is equal to the modulation amplitude.

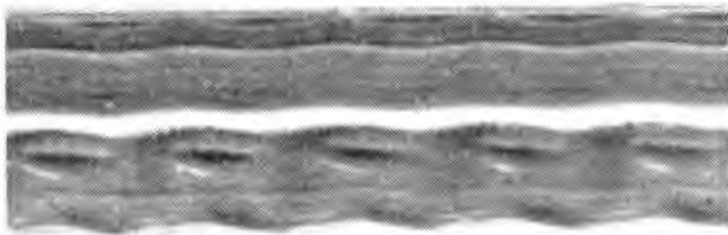

Fig. 2(b). Optical (unflattened) photograph (with lower magnification) of same groove as Fig. 2(a).

i.e. $w = k(Wr)^{\frac{1}{3}}$ for an inelastic sphere on an elastic plane.

Now $w = \sqrt{2rD - D^2}$
and for small D/r (elastic condition) we can write

$$w = \sqrt{2rD}$$

$$\text{or } D = k_2 W^{\frac{2}{3}} r^{-\frac{1}{3}} \quad \dots \quad (1)$$

where r = stylus radius

D = depth of indent

w = $\frac{1}{2}$ width of indent

E_1, E_2 = Young's modulus } of stylus and
 σ_1, σ_2 = Poisson's ratio } groove materials

W = force on the stylus

g = accel. due to gravity

which shows the non-linear relation between the force on the stylus and the elastic indentation produced therefrom. (It incidentally shows that the

effect of stylus radius in this is only a cube-root parameter and not therefore in significant conflict with any requirement for smaller tip radius on grounds of tracing distortion.)

The above effect is explained simply by saying that a spherical indenter has a smaller area of contact for lower applied forces and therefore has a higher pressure under the indenter, which gives a greater incremental penetration than for larger applied forces.

From this it follows that any displacement of the stylus (due to indentation of the groove wall that is caused by stylus inertia under varying instantaneous acceleration forces) will bear a non-linear relation to the accelerating force, and therefore to the recorded modulation.

Indentation pattern: Fig. 2(a) is a photograph of part of a flattened replica of a stereo record groove taken by an electron microscope and has a magnification ≈ 2300 . This groove has had one playing only by a pickup with a tip mass of just under 3 milligrams, tracking at 2.7 grams, the force calculated to keep this stylus in continuous contact with the modulation under practical conditions. The modulation was a 10 kc/s sine wave of 5 cm/sec velocity, recorded at 11 in diameter on one wall only. Fig. 2(b) with reduced magnification shows the indents more "dramatically" since no flattening was necessary for this photograph. This signal is one where the tracing distortion is at a comparatively low figure, in

fact a calculated figure of some 6%; a moderate condition that is normally accepted without complaint. It is, in fact, merely the frequency test record with a 1 cm/sec level at 1 kc/s.

Returning to an examination of Fig. 2(a) it will be seen that one can measure the maximum depth of this groove wall deformation from a knowledge of the stylus radius and a measurement of the maximum width of the track imprinted on the groove. This in the photograph works out to be a depth equal to about half the modulation amplitude. Now examination of the unmodulated wall reveals the *actual* path taken by the stylus. This is clearer in Fig. 3 where five playings have emphasised this track. Returning to Fig. 2(a) again, one can see by comparison with the lines left by the cutter, which trace the actual recorded modulation on the unmodulated wall, that the instantaneous indentation reached a greater depth than that of the residual deformation, in fact the stylus penetrated to a depth nearly that of the modulation amplitude itself. One can also see that there is a phase difference between the stylus path and modulation. It is also obvious that the path is no longer sinusoidal so that not only is the record groove distorted but, more important, the reproduced signal is also distorted and to an extent apparently far greater than that expected from the tracing distortion phenomena at that level. It is thought that the phase angle between stylus and modulation is due to a property of the record material.

Harmonic Distortion due to Stylus Inertia.—

From the above relation $D \propto W^{\frac{2}{3}}$ (and a knowledge of constants for the record material) the distortion

due to stylus tip inertia could be calculated on the following basis:—

$$\text{From equation (1) } D = k_3 W^{\frac{2}{3}}$$

$$\text{where } k_3 = \frac{\left[\frac{3}{2} g \left(\frac{1 - \sigma^2}{E} \right)^{\frac{2}{3}} r^{-\frac{1}{2}} \right]}{2} \text{ from the Hertzian equation}$$

$$\text{also } z = \phi \left[\frac{D}{A} \right]$$

$$\text{i.e. } z = \phi \left[\frac{k_3 W^{\frac{2}{3}}}{A} \right]$$

$$W = 2m\alpha \text{ (see footnote 5)}$$

$$\text{also } \alpha = \omega V \text{ and } A = \frac{V}{\omega}$$

$$\therefore z = \phi \left[\frac{k_3 (2m\omega V)^{\frac{2}{3}} \omega}{V} \right]$$

$$= \phi k_3 [m^{\frac{2}{3}} \cdot f^{\frac{2}{3}} V^{-\frac{1}{3}}]$$

where ϕ = "function of"

z = distortion fraction

A = recorded amplitude

f = recorded frequency

V = recorded velocity

ω = $2\pi f$

m = stylus mass

α = stylus acceleration

This is the basic primary principle of what I call "tip mass distortion" and whilst the above

$$\begin{aligned} &^* W(\text{force on advancing groove wall}) \\ &= m\alpha + \frac{\text{Min. reqd. tracking weight}}{\sqrt{2}} \end{aligned}$$

and in order to keep contact with receding groove wall, the "min. reqd. tracking weight" is $\sqrt{2}m\alpha$, i.e., $W = m\alpha + m\alpha$. (Any tracking weight in excess of W gives nominally equal deformation to both sides of groove.)



Fig. 3. Same groove as Fig. 2(a) after 5 consecutive playings with same stylus shows very little further deformation. The stylus track on the unmodulated wall is however clearer.

relation applies to the elastic portion of any indentation, the phenomenon should have similar significance in the plastic region. The electron micrograph of Fig. 2(a) shows that with a 3 mgm stylus the elastic range is soon exceeded. The indentation curves (measured from the 50,000 times magnification of the Taylor-Hobson Talysurf) also show particular non-linearity in the region of change from elastic to plastic deformation, but a more linear relationship in the plastic region proper. A set of curves from the article is shown (Fig. 4) in which a more indirect method of measurement shows more of the elastic region and therefore demonstrates this effect more clearly.

Harmonic Distortion and Recorded Level:—

In the purely elastic region one finds that the same factor that causes record deformation to be synonymous with reproduction distortion should also cause the distortion to have an *inverse* relation to recorded level, i.e. the elastic indentation follows the law $D \propto W^{\frac{2}{3}}$ so that the smaller indent depths (where the contact area of the stylus is small) is a greater *proportion* of the smaller signal amplitude that produced the smaller instantaneous force on the stylus, than is the larger indent depth (where the contact area of the stylus has increased). The expression for distortion shows $z = \phi \left[\frac{k}{V^{\frac{2}{3}}} \right]$

For pickups with tip masses of 2 mgm or over one is obliged to consider that the higher modulations at least will produce plastic deformation of the waveform. The distortion could then remain a more constant percentage of recorded amplitude, according to the more linear relation between instantaneous stylus force and indentation depth, only if the whole waveform were subject to plastic deformation. Since $\alpha = 0$ when $A = 0$ this seems unlikely for pickups tracking at 3 gm or under. One might therefore expect a sudden increase in distortion as the plastic region is entered. (There could be some smaller inverse effect, however, as the area of contact between stylus and groove

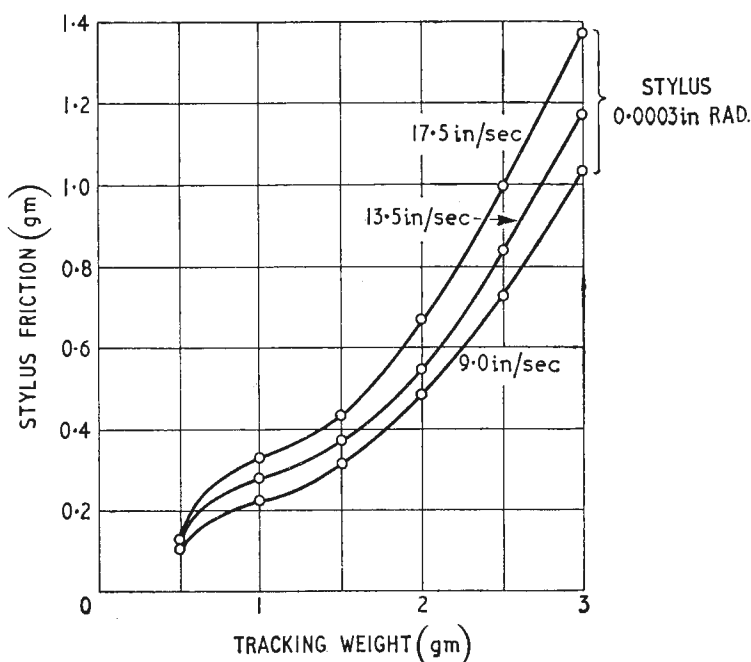

Fig. 4. Readings of stylus friction against tracking weight on a moving flat record surface. These are considered as an indication of the relation between indent depth and tracking weight in both the elastic and the plastic regions.

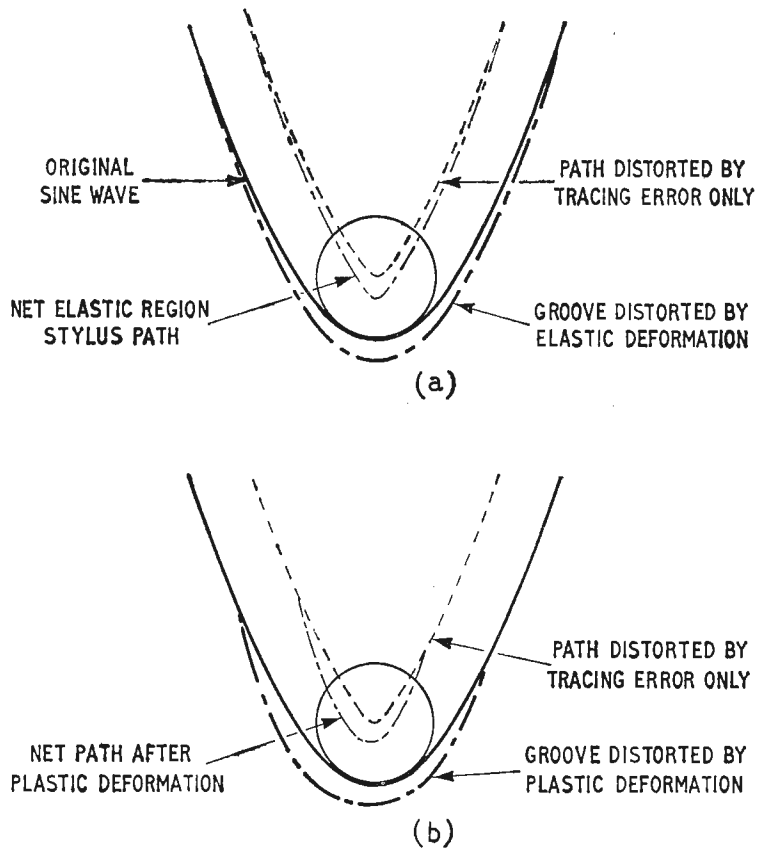

Fig. 5(a). Shows how it would be possible to imagine "tip mass distortion" acting to cancel tracing distortion in the elastic condition, and (b) in the plastic condition.

increases when the modulation curvature increases with increasing record amplitude.)

Thus not only is there an inverse relationship between recorded level and tip mass distortion for pickups with tip mass of 1 mgm or under, working in the elastic region, but an inverse relation at least at lower levels for some pickups that work otherwise in the plastic region, i.e. *tip mass distortion bears a generally inverse relation to recorded level at the lower recorded accelerations.*

There would appear to be a conception among some recording engineers that loud records can sometimes sound clearer or better than if the same is recorded at a lower level—*provided*, of course, that the upper limits of Fig. 1 are not grossly exceeded.

Cancellation of Tracing Distortion by Groove Deformation:—Whilst the foregoing description of the concept of tip mass distortion concerns the main phenomenon it will be seen that there will be modifying phenomena due to interaction with tracing phenomena, etc.

It can be seen (Fig. 5(a)) that the effect of tip mass (in the elastic region) on the shape of the groove would appear to be somewhat in opposition to the distortion of the stylus path due to the tracing distortion effect.

A similar effect would appear to apply also to the plastic conditions since it must be remembered that every sinusoidal modulation cycle with large maximum acceleration also has lower instantaneous accelerations at either side of the maximum amplitude. Thus the plastic condition only affects a *portion* of the sine wave, its greater indentation there giving an even more distorted path than if the effect covered the whole cycle. This distortion is also in opposition to the distortion caused by tracing geometry (Fig. 5(b)).

Thus under some conditions tip mass distortion should effect considerable cancellation of tracing distortion. It seems possible that this could be the explanation why a poor pickup (with high tip mass) can occasionally give a good performance on a poor (over modulated) record.

Magnitude of Tip Mass Distortion

So much for the principle of quality of tip mass distortion. Its quantity however is more important, for if this were a second-order distortion it might not be of great concern.

Whilst I have so far been unable to develop an expression for tip mass distortion in the *plastic* region and have not yet even had the function of either the plastic or elastic relations developed into a form that will produce quantitative answers on a theoretically indisputable basis, the means of *measuring* the distortion directly from the electron micrographs has been used and found to give a close resemblance to measurements taken by a harmonic analyser of the panoramic frequency display type. The measurements taken by a rough Fourier analysis of the trace left by the stylus on the unmodulated wall in Fig. 2(a) for instance, show that a total harmonic content in the region of 20% has been produced. This should be compared with the calculated tracing distortion figure of 6.5%.

The above is no limiting case but a reasonable modulation on a "mint" record during the first playing by a high-quality pickup with a tip mass of about 3 mgm that *audibly* tracks heavy modulations at the manufacturers' figure of 2 gm weight. Reference to Fig. 1 will show that this same *amount* of

distortion of the groove should occur over a wide range of frequencies, though the distortion *fraction* of the recorded amplitude will reduce by some 10 dB per octave ($\propto f^{-5/2}$ from expression for tip mass distortion) on account of the increase in the permissible amplitude with decrease in frequency, whilst acceleration, or radius of curvature of modulation, remains constant.

This should still mean a corresponding distortion for this comparatively exceptionally good pickup of some 6% to 7% at 5 cms/sec 5 kc/s with a range of distortions in excess of this on a normal musical recording. I contend that even such *comparatively* modest magnitudes of distortion (compared with those produced by the vast majority of pickups still available) have only been tolerable on account of a discrepancy between audible distortion on steady sine waves and audible distortion on music signals, which might be expected due to the existing heavy proportion (near 100%) of harmonics already produced by musical instruments, etc.

The above 20% distortion was produced by a stylus that transgresses the elastic limit of the record material (even though by a comparatively small amount). Fig. 6 shows how the distortion is reduced from 20% to less than 5% on this same modulation (as shown in Fig. 2(a)) even after 250 playings by a 1 mgm (decoupled) stylus which will track all reasonably traceable modulations within the elastic limit. It will be seen that the groove is not only undamaged but the groove surface is improved in smoothness after these 250 playings.

This can be compared with results of tracking the 3 mgm stylus (incidentally a higher compliance, lower tracking weight pickup) at the same 2.7 grams for

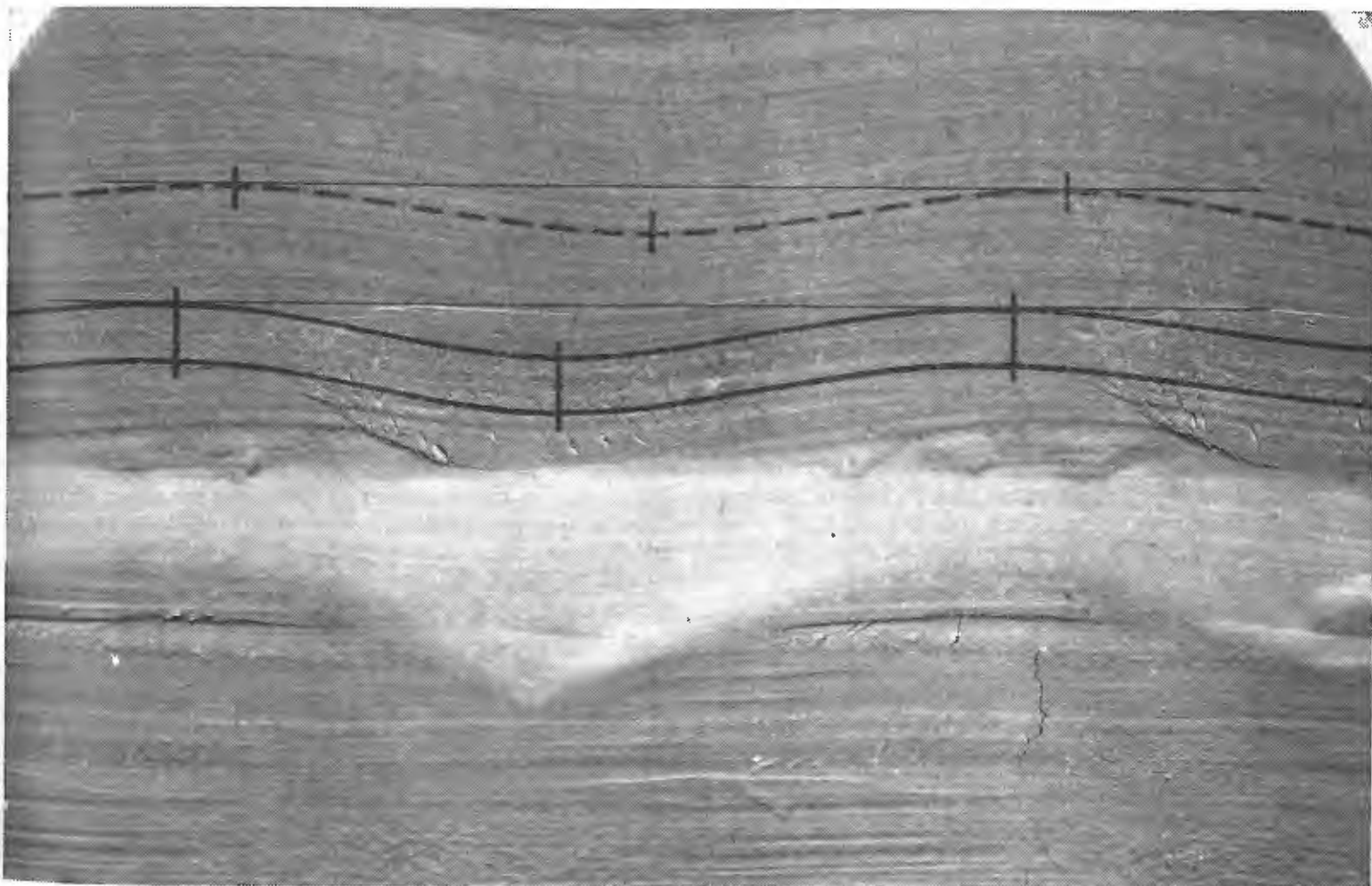

Fig. 6. Same modulation as in Fig. 2(a) but this time after 250 playings with a nominally 3 gm pickup but with a 1 mgm stylus mass. Distortion remains below 5%.

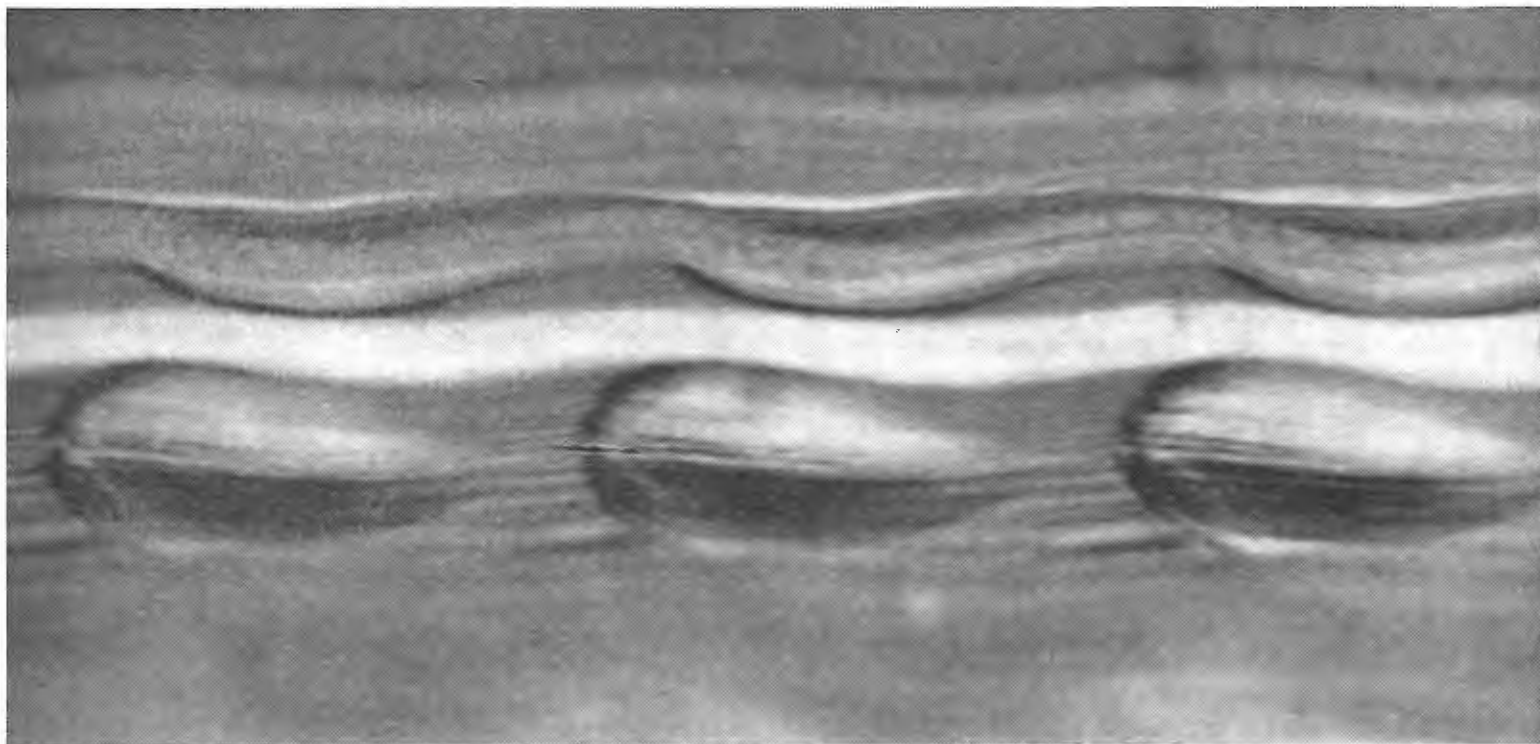

Fig. 7. Optical micrograph of same modulation as Fig. 2(a) after 120 playings with the nominally 2-gm pickup with the 3-mgm stylus.

half the number of playings (120) on the same moderate modulation (Fig. 7). Note the phase angle between recorded modulation and stylus path is nearly 180° , i.e. the original modulation has been completely obliterated in the path of the stylus, and the pickup has itself implanted a distorted modulation. The effect of this upon the reproduction of continuously varying music signals appears to approach the incalculable but I think may be readily imagined.

Measurements of Total Playback Distortion:—The following measurements were taken on a waveform analyser and are a summary of a thousand or so fairly consistent readings.

Fig. 8 shows the total harmonic distortion produced by the 3 mgm stylus previously mentioned. The dotted lines show the calculated tracing distortion after allowing for scanning loss (as mentioned by Prof. Hunt in his paper "The Rational Design of Phonograph Pickups," which he read at the 4th International Congress on Acoustics, Aug. 1962).

The three sets of curves show distortion at various velocities at 10in., $7\frac{1}{2}$ in. and 5in. diameter of recording.

It will be noticed first of all that whereas tracing distortion is highly dependent on wavelength (i.e. much higher distortion at lower groove speeds) total distortion and therefore tip mass distortion is not seriously effected in this way, in this case.

It will also be seen that the distortion at both low and high accelerations usually exceeds the figure for tracing distortion but shows a considerable reduction below the tracing distortion figures over an "inter-

mediate" range of frequencies. This dip in the distortion curve I believe is due to the cancellation effect mentioned. These results appear to be consistent with tip mass distortion varying *mainly* with frequency ($\zeta \propto f^{\frac{2}{3}}$).

Note the inverse portion at low acceleration (see 1 cm/sec curves). It would be interesting to see if this "inverse effect" would be more pronounced at lower accelerations than those produced by a velocity of 1 cm/sec. Further such measurements will therefore be made.

Fig. 9 shows the distortion variation when three pickups of different tip mass reproduce the same modulation. (A brief check made by altering the tip mass of one pickup has, I believe, eliminated first doubts about any *gross* effects of the individual pickup impedance curve.)

One must deduce (if the curves for the 0.6 mgm pickup were extended to 20 kc/s) that one would find that each tip mass had its own particular frequency range of low distortion production, above which the pickup rapidly becomes useless as a faithful reproducer.

One also wonders if much could be gained at present by using a lower tip mass than 0.6 mgm since the region of cancellation of tracing distortion would then be above the audio range. The relation between stylus mass and stylus radius for optimum results should therefore be determined prior to any dogmatic reduction of stylus mass below 1 mgm.

In this respect, Fig. 10 showing the effect of different disc materials is interesting in that it would indicate that there is nothing to be gained in this matter of inertia distortion from using a harder disc

Fig. 8. Total reproduction distortion for 3 mgm stylus (0.0006in rad.) at different levels and frequencies. Dotted curves show calculated and corrected tracing distortion.

Fig. 9. Total reproduction distortion for three different stylus masses, at $7\frac{1}{2}$ in diameter.

Fig. 10. Total reproduction distortion for three different record materials, played by 0.6 mgm stylus. Tracking diameter $7\frac{1}{2}$ in

Fig. 11. Total reproduction distortion for 0.6 mgm stylus at same levels as in Fig. 8.

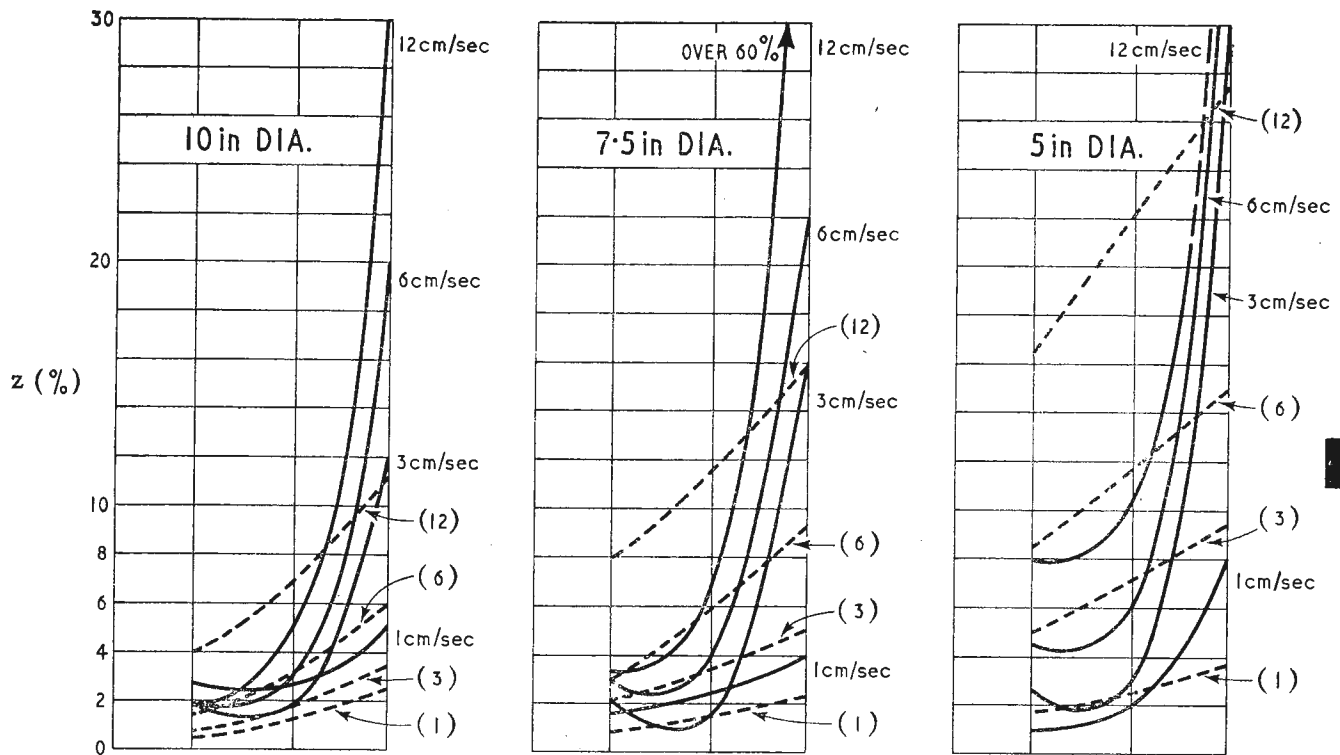

Fig. 8

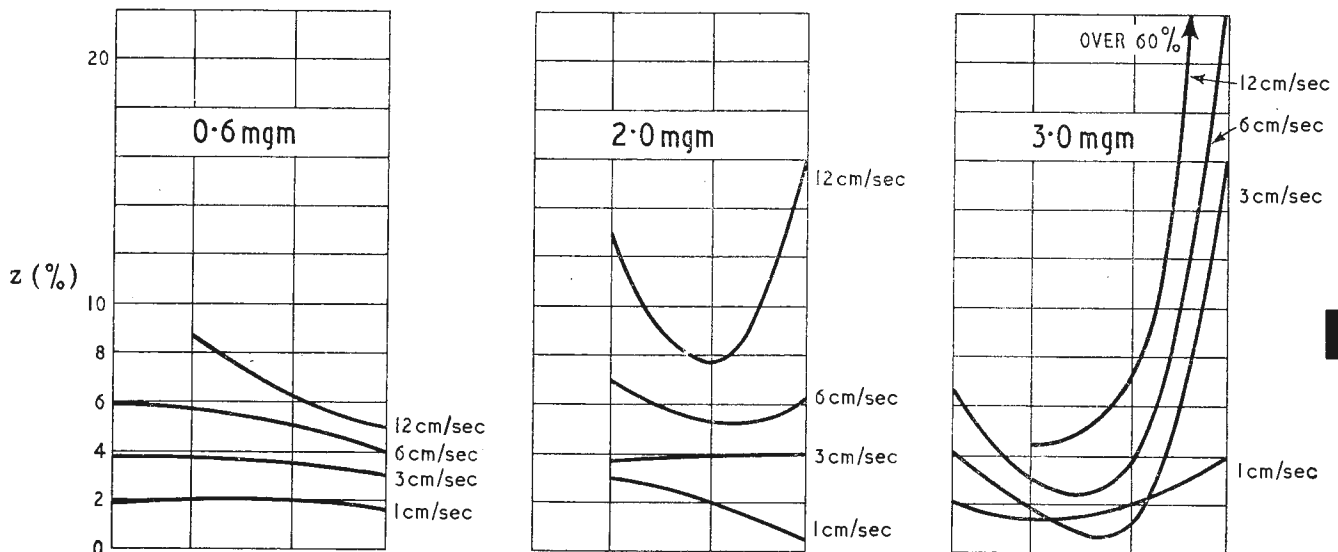

Fig. 9

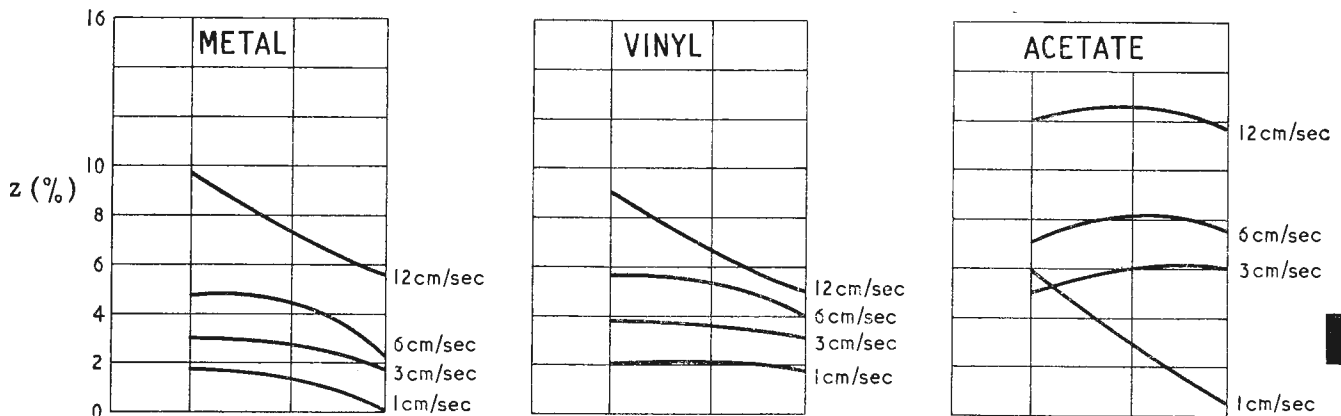

Fig. 10

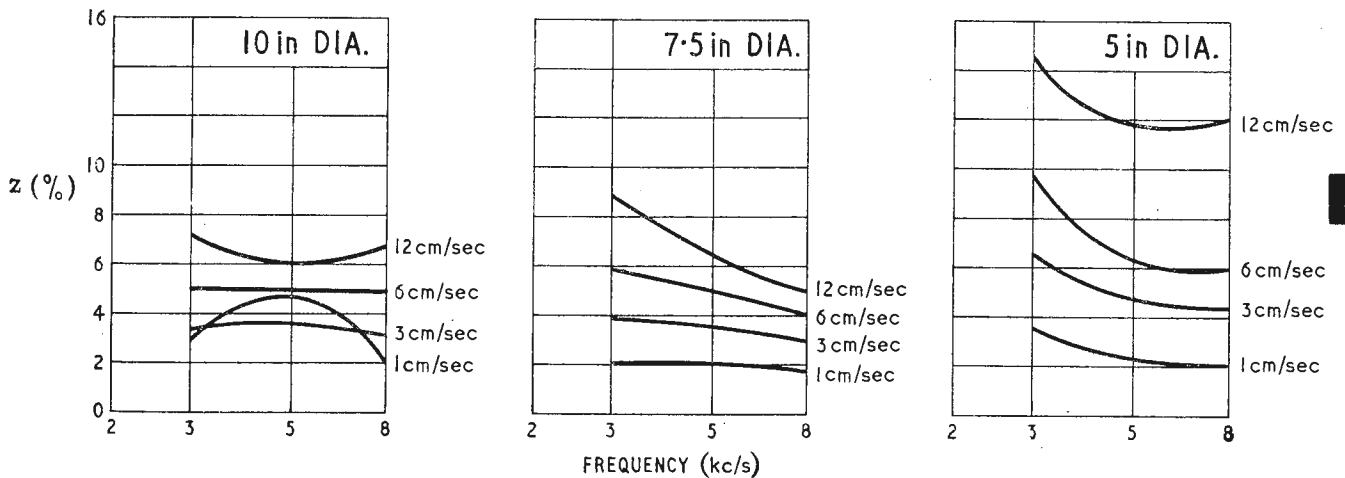

Fig. 11

material. The "inverse effect" described above could be a factor that would help explain this. Fig. 11 shows that distortion for a 0.6 mgm stylus under the same conditions as those in Fig. 8.

Note the *decreasing* distortion with increasing frequency, *i.e.*, tracing distortion is apparently effectively countered above 3 kc/s. The results at 5 in., 3 kc/s, whilst disappointing, are little different from the figures expected from tracing distortion. Further measurements have indicated a reduction with further decrease of frequency. However from Fig. 1 it may be ascertained that a pickup's performance below about 3 kc/s *should* generally not be determined by its stylus inertia, since velocity, then amplitude, become the modulation limiting factors. It is possible that the factor of velocity was influencing the results at 3 kc/s since the 0.6 mgm pickup (apart from its h.f. performance) otherwise requires a higher tracking weight than the 3.0 mgm pickup.

The above distortion measurements were taken at constant tracking weight regardless of the acceleration to be reproduced. It was considered that this was the method to give the answers that were significant in gramophone practice. However, since the "inverse effect," in particular, might be masked due to the constant force of the tracking weight, it was decided to repeat the measurements with the tracking weight adjusted to the requirements of stylus mass and acceleration. It soon became evident, however, that there was no great difference between the two sets of results. There was a tendency for the sets of curves covering 1 to 12 cm/sec to sit more closely together, and somewhat higher distortion figures at lower frequencies for the heavier stylus (3 mgm). The differences, however, were considered to be too small to warrant separate reproduction here.

Conclusions

(a) Groove deformation due to stylus inertia produces harmonic distortion in the reproduced signal.
(b) The distortion so produced should bear a generally inverse relation to recorded level in the elastic region, where "tip mass distortion" may first cancel the distortion produced by tracing errors, then as the acceleration is increased until the elastic condition is exceeded, the inertia distortion grossly exceeds that of tracing error.

(c) Since a tip mass of 3 mgm imposes a more stringent upper frequency limitation on gramophone reproduction *quality* than does a 0.0006in radius stylus, then tip mass distortion is of immediate primary importance in reproduction quality. Considering pickups that are otherwise capable of reproducing the audio spectrum and dynamic range (Fig. 1) at a reasonable tracking weight (say, under 5 gm), one must conclude that *the most significant feature of any pickup is its stylus mass.*

(d) The above results not only show no unfavourable relation to measurements on other recording media, but that the gramophone record is not yet exploited in the optimum manner. The results indicate the necessity of further measurement and analysis if optimum dimensions for the gramophone system are to be deduced (e.g., relation between stylus radius and stylus mass). Another factor not yet considered in the construction of gramophone pickups would appear to be an optimum relation between

stylus inertia and stylus resistance. It would seem feasible that some suitably graded mechanical resistance could partially offset the non-linear effects of stylus inertia by causing a more uniform deformation of the groove wall throughout the cycle. (e) In the meantime the principle of the "decoupled" stylus rondel with its effective tip mass reducing towards zero at some frequency towards the top end of the audio spectrum should be of the greatest value in improving quality without the unnecessary expense of precision micro-engineering.

Commercial Literature

Transistorized test equipment designed for carrying out full maintenance test procedures on v.h.f. radio installations in outlying areas where the use of more conventional test equipment would prove too cumbersome, has been produced by A. T. & E. (Bridgnorth) Ltd., Bridgnorth, Salop. A series of illustrated leaflets describe the equipment which includes signal generators, audio test oscillator, tuning fork oscillator and a general-purpose test meter.

Rectifiers.—A selection of catalogues covering selenium and copper oxide rectifiers is available from Salford Electrical Instruments Limited, Brook Green, Hammersmith, London, W.6.

Airmax Miniature Blowers.—New catalogue sheets are available, describing part of the standard range of Airmax miniature blowers. These include electrical and mechanical data and are obtainable from A.K. Fans Ltd., 20 Upper Park Road, London, N.W.3.

Switches and Indicator Lamps.—Catalogue supplement No. 134, describing switches and indicator lamps introduced since July, 1959, is available from Arcoelectric Switches Limited, Central Avenue, West Molesey, Surrey. It includes dimensional and electrical data.

Synchronous Motors and Timers.—Leaflets on a.c. and d.c. electric timing motors, elapsed time indicators and industrial time controls, manufactured by Haydon Torrington, Conn., U.S.A., are obtainable from Ether-Haydon Ltd., Caxton Way, Stevenage, Herts.

"Valves & Cathode-Ray Tubes."—The Mazda 1962-1963 data booklet is available, free to the radio trade in Britain, from Thorn-A.E.I. Publicity Department, 155 Charing Cross Road, London, W.C.2.

Texas Instruments.—Several leaflets on Texas equipment and components manufactured in the U.S.A. are available in the U.K. from Texas Instruments Limited, Manton Lane, Bedford. These include subminiature hermetically sealed switches, general purpose and programmed pulse generators, transistor and component testers, analog-digital converters, tunnel diode curve tracers, single and dual channel galvanometric recorders, self-balancing integrating recorders, and "Multilayer" clad metal wire.

Optical crystals and components are described in a leaflet available from Mervyn Instruments, St. John's, Woking, Surrey. It includes information on a wide range of doped laser crystals, together with the optical characteristics of a comprehensive range of single crystal materials, including barium fluoride, potassium bromide, lithium fluoride and sodium chloride.

Sealed terminals made in ElectroX, a new white high-alumina material, and approved by the Ministry of Defence (DEF 5331) are described in a leaflet obtainable from the Royal Worcester Industrial Ceramics Limited, Components Division, Durban Road, South Bersted, Bognor Regis, Sussex.

Power valves, vacuum switches and accessories manufactured by Penta Laboratories Inc., Santa Barbara, Calif., U.S.A., are described in a catalogue available from the Chelmer Valve Company, 130 New London Road, Chelmsford, Essex.

RAMPS (Resource Allocation and Multi-project Scheduling) is a technique in the use of computers in planning and control of operations. A brochure is available from C.E.I.R. (U.K.) Ltd., Turriff Building, Great West Road, Brentford, Middx.

New and Government surplus components (more than 500 items) are listed in an illustrated catalogue issued by Arthur Sallis Radio Control Ltd., 93 North Road, Brighton. Price 2s 6d by post.



These Advanced Features give the Vanguard **EXTRA PERFORMANCE**
UNIT PRINTED BOARD CIRCUIT ELEMENTS

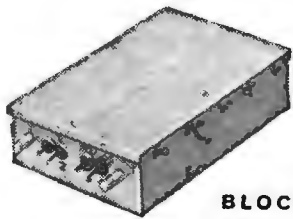
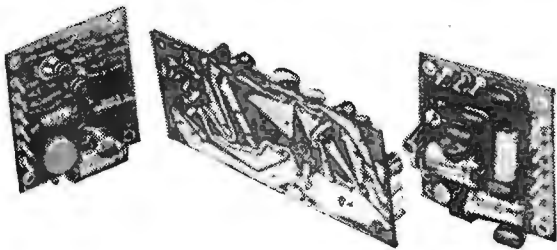

**SEALED
BLOCK I.F. FILTERS**
Need no tuning



INTRODUCE THE
VANGUARD
A Magnificent

25-Watt Transistorised

RADIOTELEPHONE

ONLY the VANGUARD has ALL these qualities

- 25/30 & 50/60Kc/s channels
- Extensively Transistorised
- Sealed Block I.F. Filters
- Printed Circuitry
- Very low Battery Drain
- All Aluminium Construction
- Dust-proof and splash-proof
- One—Six Channels
- 25 Watts Output
- Very low-noise Receiver
- High Stability Mute
- 4 Watts Audio Output

Meets British, American, Canadian and Continental Specifications

PYE TELECOMMUNICATIONS LIMITED . . . CAMBRIDGE

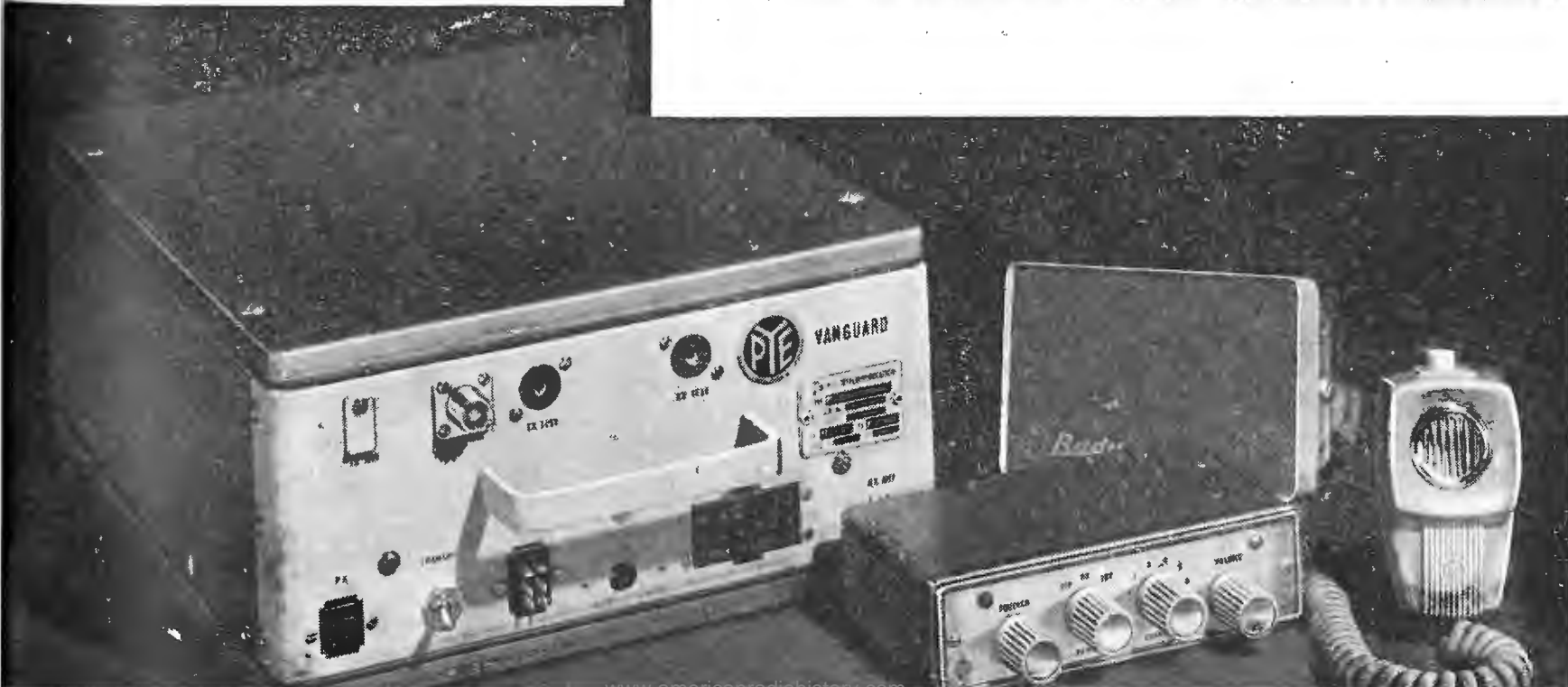

UA14

Favourite of long standing for its reliability, excellent reproduction and good looks.

**UA16**

Latest BSR star—last word in elegance—first in performance and dependability.

Right to the Fore!

It's Monarchs all along the line—leading manufacturers the world over select BSR Monarch autochangers—they know the BSR tradition of reliability is based on the latest techniques, duration-testing and scientific control.

Perfectionists select the model with the Monarch for excellence of performance and styling. Be sure that the Monarch is in the player you choose.

Check these star features of UA16.

Featherlight tracking, dynamically balanced, self-lubricating motor, precision adjusted tone-arm and beautifully sheer styling to match the perfection of its performance.



BSR LIMITED

BETTER SOUND REPRODUCTION

OLD HILL STAFFS

TRANSISTOR AMPLIFIER OUTPUT STAGES

4.—FREQUENCY RESPONSE IN THE COMMON-EMITTER STAGE

By O. GREITER

LAST month's article, which dealt with the effect of drive impedance on the distortion in a common-emitter amplifier stage, quoted an expression for the frequency characteristic as it is affected by the base and emitter resistance. From the general form of this expression it is apparent that the addition of resistance in the emitter lead will give an extended frequency response. This is not a surprising result, since the resistance in the emitter lead provides local negative feedback and thus helps to maintain the system gain constant as the transistor gain falls with increasing frequency. Claims are sometimes made for the extended frequency response to be obtained by the use of a low base drive impedance. The expression $1 - \alpha + \frac{R_e}{R_e + R_b}$ which was quoted as the factor by which f_α must be multiplied to find the common emitter cut-off does suggest that by making R_b small there is much to be gained.

This factor is a deceptive one, for the R_e and R_b terms include the internal transistor resistances. These internal impedances may exercise a dominating influence on the situation. One typical power transistor has the following values:

$$\begin{aligned} 1 - \alpha &= 0.006 \\ r_e &= 0.06 \text{ ohm} \\ r_{bb'} &= 60 \text{ ohms} \end{aligned}$$

If this unit is operated with zero impedance base drive externally, the value of R_e ($R_e + R_b$) is still only 0.001. The cut-off frequency with a current drive to the base will then be $0.006 f_\alpha$ while the zero-impedance voltage drive, and zero impedance implies here well below 60 ohms, the cut-off frequency will be extended to $0.007 f_\alpha$. Although there is some improvement it is probably of less magnitude than the difference between two transistors. It

driven common-emitter amplifier. Since the emitter resistance is very current-dependent the bandwidth of an amplifier of this type will be modulated by the signal. Given a transistor in which the effect is more pronounced the gain at high frequencies will be varied as a large-amplitude low-frequency signal swings the emitter current up and down. This modulation of the gain may produce intermodulation or it may, by changing the shape of the Nyquist diagram, lead to instability.

There is another aspect of the behaviour of this type of stage which appears to demand a rather critical examination, especially as it may reveal that the terminology above has led us into error. The equivalent circuit which will be used is shown in Fig. 17. The impedance of the driving source is shown as R_g , while the external emitter resistance is shown as R_e . The remainder of the circuit is the reduced form of the hybrid- π equivalent circuit which omits the collector impedance and the feedback impedance on the grounds that a power stage will be loaded with an impedance which is relatively low and which will justify this approximation.

It is only necessary to consider the input loop, since the equation for the output loop is quite simply $I_2 = g_m V_{b'e}$ and this substitution can be made directly. We have, in consequence,

$$V_{in} = I \left[R_g + r_{bb'} + \frac{r_{b'e}}{1 + j\omega C_{b'e} r_{b'e}} \right] + (I + g_m V_{b'e}) R_e$$

We also have

$$V_{b'e} = I r_{b'e} / (1 + j\omega C_{b'e} r_{b'e})$$

so that when this expression for $V_{b'e}$ is substituted in the loop equation

$$V_{in} = I \left[R_g + r_{bb'} + \frac{r_{b'e}}{1 + j\omega C_{b'e} r_{b'e}} + R_e \left(1 + \frac{g_m r_{b'e}}{1 + j\omega C_{b'e} r_{b'e}} \right) \right] = I \left[R_g + r_{bb'} + R_e + \frac{r_{b'e} (1 + g_m R_e)}{1 + j\omega C_{b'e} r_{b'e}} \right] \quad \dots \quad (1)$$

would, no doubt, be possible to find transistor types with which a more substantial improvement could be demonstrated. The reader is invited to attempt this for himself.

Reversing the substitution, by putting

$$I = V_{b'e} (1 + j\omega C_{b'e} r_{b'e}) / r_{b'e}$$

we obtain

$$V_{in} = \left[R_g + r_{bb'} + R_e + \frac{r_{b'e} (1 + g_m R_e)}{1 + j\omega C_{b'e} r_{b'e}} \right] \left(\frac{1 + j\omega C_{b'e} r_{b'e}}{r_{b'e}} \right) \frac{1}{g_m} \cdot g_m V_{b'e}$$

This result is easily reduced to

$$V_1 = \frac{1}{g_m} \left[\frac{R_g + r_{bb'} + R_e}{r_{b'e}} (1 + j\omega C_{b'e} r_{b'e}) + (1 + g_m R_e) \right] g_m V_b \dots \dots \dots (2)$$

The chief importance of this result is that it draws attention to the limitations of the simple voltage-

Since V_1 is the generator voltage and $g_m V_{b'e}$ is the load current, this equation is an overall trans-

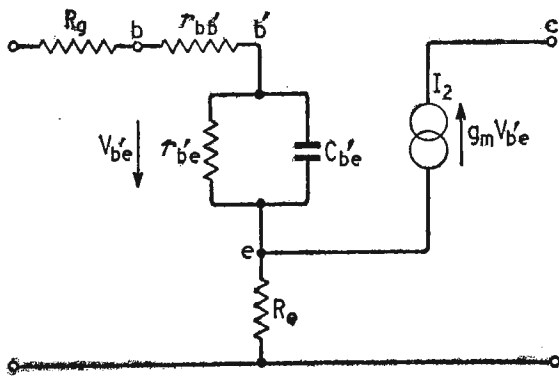

Fig. 17 Equivalent of common-emitter output stage.

impedance equation for the system. The term inside the square brackets is the term which really describes the behaviour of the system and if this is written as T we have

$$T = \frac{R_g + r_{bb'} + R_e}{r_{b'e}} + (1 + g_m)R_e + j\omega C_{b'e}(R_g + r_{bb'} + R_e) = \frac{R_g + r_{bb'} + R_e}{r_{b'e}} \left[1 + \frac{(1 + g_m)R_e r_{b'e}}{R_g + r_{bb'} + R_e} + j\omega C_{b'e} r_{b'e} \right]$$

By writing the expression inside these square brackets in one form $(A + j\omega B)$, we can express the overall frequency response in the form $(1 + j\omega B/A)$, a form which is well known to have its 3 dB point at $\omega_o = A/B$. Since the effect of R_e is to increase the A term it also has the effect of increasing the cut-off frequency ω_o .

Expressions of this kind are of less value than might be expected because of the difficulty of finding the values of the numbers which must, in the end, be substituted in the equations. What is usually done is to assume that the gain-bandwidth product remains unchanged, so that if the emitter resistance used gives a gain reduction of six decibels the bandwidth is automatically doubled. The logic behind this is seen in the plot of Fig. 18, which is a comparison, on an arbitrary log-log scale, of the behaviour of α and α' . Any modified gain system is then assumed to lie between these two graphs and to share this asymptotic cut-off characteristic.

Much more interesting, in some ways, is equation (1). Without trying to make use of the precise expression we can see from this equation that the input impedance contains a term in ω . We can see at once that if ω is small the input impedance contains a term in $g_m R_e$, clearly a feedback term and, in fact, the term which will take control when we have a fair amount of feedback. If ω is very large, however, the input impedance is only $(R_g + r_{bb'} + R_e)$, of which R_g is provided by the driver in any event. This expression is exactly the same as we should obtain if we were to work out the input impedance for the same transistor connected in the common-base configuration.

It is now possible to embark on a long and involved analytical study which would lend stiffening to the conclusions which it is proposed to draw here without providing the corresponding mathematics. The term $\omega C_{b'e} r_{b'e}$ is equivalent to a term ω/ω_o , and from the way in which this term appears in the various equations it is pretty clear that in fact we have $\omega_o = 2\pi f\alpha'$. The enhanced input impedance due to the external emitter resistance thus begins to drop away at the common-emitter cut-off frequency. It is this result which is of such enormous significance.

We know that because of the negative feedback we

shall have an extended frequency response but we now see that the reason why we get this extended response is because we drive into the input terminals from a constant-voltage source a current which increases with frequency. An internal mechanism is being used to provide the result obtained in pulse work with the speed-up capacitor shown in Fig. 19. When a circuit of this kind is used explicitly we know that we must expect a high initial current demand. We regard this as a capacitance charging current.

Theoretically, at least, this situation simply reinforces the view that a low-impedance source is desirable, but in a practical circuit this approach is not easily maintained. First of all the impedance is required to be small compared with the input impedance of the transistor in the common-base connection. This introduces a new order of lowness into the discussion. Following from this we must take into account the fact that the amplifier stage

under consideration is operating at a fairly high level. During the period when holes are, as it were, being put into store the driving stage will be required to produce the specified base-emitter voltage across the common-base impedance and since this is the requirement for a common-base amplifier the driver will be supplying the full emitter current.

No normal drive will be capable of making this demand. It is academically true that the circuit could probably be run into very large current in its "on" direction, if the feedback arrangements would get the drive to the base and the transistor could survive. In the other half-cycle, however, the driver can only drive down to zero current. It is not profitable to speculate on the way in which the inter-stage transformer would affect the result. The basic fact is that the frequency at which the transistor starts to cut off is the frequency at which the available

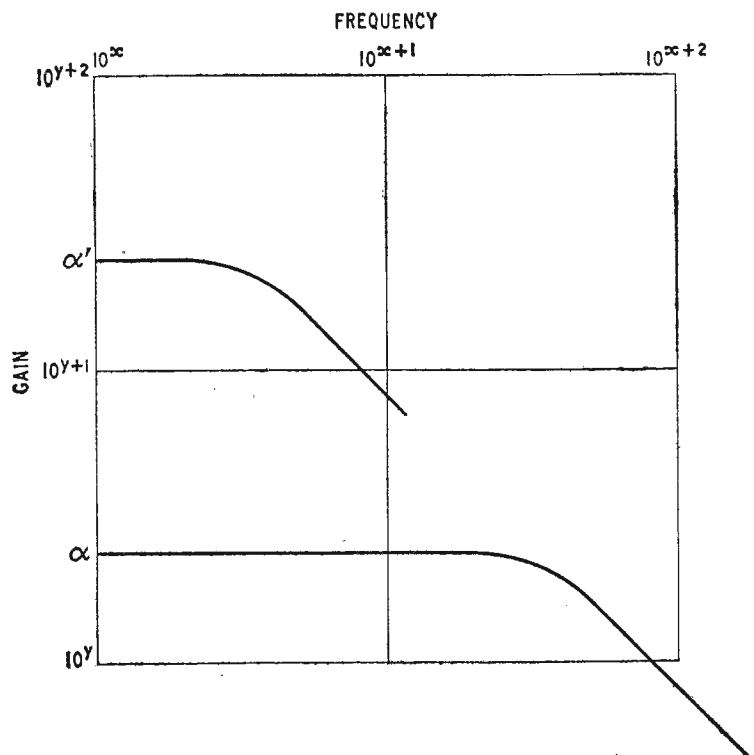
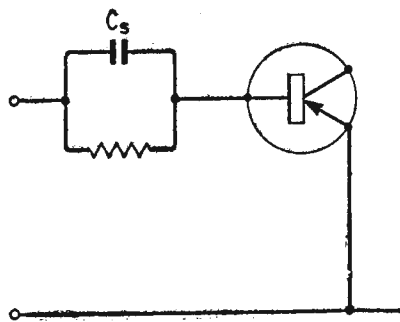

Fig. 18 Variation of α and α' with frequency.

Fig. 19 "Speed-up" capacitance analogy.



power output begins to fall. Looking back to equation (1) it will be seen that the frequency term of the input impedance is simply a factor

$$(1 + j\omega C_{b'e} r_{b'e})$$

the term which defines the common-emitter cut-off frequency. If we make use of the expressions

$$r_{b'e} = r_e / (1 - \alpha)$$

$$\text{and } f\alpha = 1.22 / 2\pi C_{b'e} r_e$$

we come to the same sort of conclusion apart from the appearance of the 1.22 term which appears in a more precise analysis. The important point which must be noted is that the input impedance begins to fall at the common-emitter cut-off frequency of the transistor even if the amplifier response is sustained to a higher frequency by the use of emitter resistance degeneration.

When transistors of the 5-15 amp class are being used the frequency at which this effect occurs may be somewhere in the range between 4000 c/s and 10,000 c/s. Amplifiers used for the reproduction of speech and music, of ordinary programme material, are rarely required to handle large amplitudes of signals in this frequency range. It might appear, therefore, as though this effect would not be of very great importance. This is not true.

We are now considering a situation which is simply one particular form of a rather general problem and which can be treated quite generally. We have an amplifier with a limited frequency response to which negative feedback has been applied in order to improve the apparent performance. The fact that in the specific example the negative feedback forms a local loop and has been analysed without writing down the expression $\mu / (1 - \mu\beta)$ in no way invalidates the argument.

The signal band can be divided into two parts, the signal frequencies which can be regarded as low frequencies and which will be amplified uniformly even without the negative feedback, and the frequencies which rely on the negative feedback for the flatness of the response. In Fig. 18 the division occurs at about $10^{x+0.5}$. We know that most of the signal energy will be in the low-frequency band, since the division will be at a frequency of at least 3,000 c/s. These low-frequency signals are amplified faithfully but they will occupy most of the available signal swing. It is perhaps unfortunate that the expression "grid base" has long been used in this context, for it is hardly possible to write "base base" when transistor amplifiers are under consideration.

Let us consider that the input electrode of the transistor can be driven over a range of ± 1 volt. At full output of programme the low-frequency components may represent ± 0.9 volt for the high-frequency components. When the two groups of signal combine to give maximum peaks the amplitude will just reach the ± 1.0 volt limit. Suppose now

that we consider a frequency at which the amplifier without feedback has 6dB less gain than at low frequencies. In order to maintain the gain the feedback path modifies the drive so that twice the signal appears at the input electrode. For the total excursion not to exceed 1.0 volt the high frequency component must not be more than 0.05 volt, since only (1.0-0.9) volt is available for this double drive.

Alternatively, the operating level must be reduced so that the low-frequency term becomes only 0.8 volt instead of 0.9. This is a reduction of only one decibel, which may seem unimportant, but expressed in term of power it reduces the available power output from 25 watts to 20 watts, which looks much more significant.

It is easy to read too much meaning into numerical examples, especially where the numbers are selected to provide simple and striking results. It is also easy to read too little meaning into simple examples. By the use of graphs of the distribution of energy in speech and in orchestral music we could proceed to derive some simple criterion which would determine whether the choice of the 0.8 volt above would deal completely with the typical situation. In doing this we would note that when the response was 12 dB down (at $4f\alpha'$) we should multiply the high-frequency signal amplitude by 4, and so on. A more sophisticated treatment would note that this analysis needs modification to allow for the phase shift in the amplifier and that to carry out this more accurate analysis properly we should need to use the full RC ladder equivalent for the transistor base system, since the phase shift is much greater than we have to expect from a simple CR equivalent. This kind of study of a typical average sound leads us to a curve of the kind used for f.m. pre-equalization.

The result of this sort of treatment is to define the maximum power output which can be obtained from an average typical programme. The engineer who considers this to be a satisfactory solution is invited to consider sound made by a singer who, on average, is perfectly in tune, being flat and sharp in equal amounts for equal lengths of time. The effect of a momentary burst of distortion is not to be measured in terms only of the duty period (duration of distortion)/(duration of undistorted signal). Like all subjective effects the taste lingers on long after the cause has departed.

For the professional engineer this is a rather difficult matter to handle. At the Audio Fair one can hear a good deal of talk about the need to listen to equipment rather than relying on measurements. So far as valve amplifiers are concerned there should be no problems of this kind and it is difficult to see how a well-designed system can contain hidden traps. The designer can hardly rely on listening during the design period. Even if comparisons are made using the same recording of the same music it is difficult, if not impossible, to carry a reliable scale of unpleasantness from one day to the next.

Probably the only reliable way of obtaining a single number which will describe the performance of an amplifier which suffers from this defect is the use of square-wave testing. Intermodulation measurements are, of course, of very great value but whether there is sufficient information in the arbitrarily chosen pair of frequencies and levels is open to doubt. The author is most unwilling to do anything which will discourage the use of intermodulation testing, which represents the most fundamental approach to the

metrical expression of the infidelity of reproduction. The only defect in this particular aspect of the designer's problem is that the two tones represent the average programme and may not be sufficiently revealing.

When square-wave tests are chosen there is the advantage of speed and probably also the advantage that the result is a conservative one. The disadvantage is that we must rely on a subjective assessment of the output waveform. This is most easily carried out when the square-wave response shows a "ring" due to a fairly sharp cut-off in the overall characteristic. As the signal level is increased the output stage should remain unaltered until the level at which transient overloading occurs is reached. This will be shown quite clearly as clipping of the tip of the ringing wave which follows the switching edges.

Designs which do not have a ringing response will demand a more critical examination of the shape of the leading edge. It will usually be possible to detect the break in shape where the transistor changes from voltage control to the current-limited drive of the hole-storing period. If this is happening the

signal is more than the amplifier can reproduce without the risk of intermodulation.

The problems associated with the limited frequency response of inexpensive power transistors are seen to be rather more complex than might be expected from a simple assessment of the response behaviour. As so often happens in the design of transistor circuits, difficulties which appear in one stage react strongly on the design of the preceding stage and the interaction between the driver system and the output stage is especially strong. There seems to be relatively little published which deals with the design requirements of transistor amplifiers of high quality and substantial power output. There are in fact very few such amplifiers available.

Some designers have sought to evade the problem by the use of compound pair, the so-called Darlington connection. These demand only a very small base drive current and according to the textbooks they are extremely linear and can have a very good frequency characteristic. A more critical examination of these and of other types of multi-transistor system must be made in a later article.

LETTERS TO THE EDITOR

The Editor does not necessarily endorse opinions expressed by his correspondents

Modulated Pulse A.F. Amplifiers

I READ with considerable interest the article by D. R. Birt, in your February issue. However, I would first like to correct the misapprehension that there are no semiconductor devices equivalent to double valves, as stated in this article. There are several manufacturers who produce multiple transistors etc. "grown" onto the same slab of silicon. This enables the parameters of each section to be matched as closely as two halves of a double valve. The proximity of the sections ensures that the change in parameters due to change in temperature is the same for each section. At a recent exhibition, one manufacturer was showing complete circuits looking like conventional transistors.

Mr. Birt touched on the use of pulse-modulated tape recording, which seems to offer improvement in the signal-to-noise ratio at present available, and also removes the non-linearity associated with the magnetic medium. Let us examine the theoretical S/N ratio of such a system to see if it is worth considering.

Domestic tape, carefully erased, can give a signal-to-noise ratio of about 60dB, assuming no contribution from the electrical and electronic parts of the system. This noise is "off white," and is most objectionable in the region above 3kc/s. In the frequency-modulated system, S/N is improved at the expense of bandwidth; although the bandwidth can be improved by increasing the speed, and hence the quantity of tape used. Noise is present in this system due to speed variations in the tape transport mechanism. 0.1% change in speed will produce a noise signal much worse than 60dB down on the peak signal. If the speed variations of this amplitude occur at frequencies above 20c/s, they may well be audible as rumble.

The sources of noise in the pulse-modulated system are different from either of the other two systems mentioned. First, there is noise due to pulse-to-pulse

jitter in the modulator and successive stages of the chain. This jitter has a random distribution, but causes noise at subharmonic carrier frequencies. A jitter of ± 10 nano-sec. on a 50kc/s square-wave carrier would produce a noise signal of 60dB below peak output. It is possible to improve on this using either valves or transistors, and jitter noise in the audio band should be about 70dB down relative to peak level in a well-designed system.

Frequency drift of the carrier will cause no noise signal, but there is noise associated with the rate of change of carrier frequency. The flutter of a good machine is better than 0.1%/msec. This represents a maximum change of speed of 20 per cent per second for a flutter of frequency of 20c/s. This figure is the maximum acceleration likely to be encountered due to the smoothing effect of the mechanical inertia, and the maximum force applied to it.

An unmodulated 50kc/s carrier will have a $10\mu\text{sec}$ mark and $10\mu\text{sec}$ space when the tape is transported at nominal speed. If the tape speed increases by 0.2 parts per unit per second, in $10\mu\text{sec}$ the speed will be approx. 2×10^{-6} parts per unit faster. The mean speed will be 1×10^{-6} p.p.u. faster, and the mark will be 1×10^{-6} p.p.u. less in duration. The mean speed during the space is 3×10^{-6} p.p.u. faster, and the duration of the space 3×10^{-6} p.p.u. shorter. The difference in duration between mark and space is 2×10^{-6} p.p.u. Since, in this case, one unit is the maximum peak output, the noise signal is 114dB down on peak signal.

Clearly, any reduction in the carrier frequency would worsen the S/N ratio, but 60dB is theoretically possible with a carrier frequency of only 100c/s.

Since wow and flutter cause negligible noise, the use of less exotic motors in the drive mechanism is possible, and flywheels may be jettisoned. This scheme certainly has an application in portable machines.

We can see from this and Mr. Birt's article, that

improvements in linearity and S/N ratio are possible using a pulse-modulated system of tape recording.

Westcliff-on-Sea.

J. S. CHURCHILL.

The author comments:

First, I would like to compliment Mr. K. C. Johnson on his most elegant circuit published in the March issue. Without in any way belittling this, may I just mention that placing the de-emphasis network after the amplifier does result in a higher level of beat-note distortion (p.r.f. to a.f.) due to the enhanced high-frequency energy. However, in the design given, the overall feedback is effective in reducing this distortion to an acceptable level. The power output quoted is, I think, a little optimistic as with a 10-V supply, the output stage can only produce 5V peak, with 100% modulation and infinitesimal transition times. This would give 830mW power in a 15-Ω load. However, transistors with a slightly higher voltage rating, and use of a 13.5-V supply restore the status quo.

Turning now to tape recording, I would like to draw attention to an article by L. H. Bedford in *Electronic and Radio Engineer*, September 1959, p. 320, which draws a parallel between the orthodox method of recording with sinusoidal bias, and a modulated pulse system. If this hypothesis is accurate it would appear advantageous to employ a sawtooth rather than sinusoidal bias current to give a linear rather than part-sinusoidal transfer characteristic.

The merit of applying a ready-formed pulse waveform to the record head rather than relying on the magnetic medium to provide the slicing action is that one is able to apply overall feedback as Mr. Johnson has done, and thus reduce the amplitude of beats between the audio and bias frequencies. Perhaps one could then record at a higher level, and achieve an improved S/N ratio.

In order to achieve the enormous improvement predicted by Mr. Churchill, I suspect one would have to recover the pulse train as such from the replay head, and then limit in order to remove random amplitude modulation due to the magnetic medium. This would require a tape speed at least an order of magnitude greater than normal. In other words, one trades bandwidth for signal-to-noise ratio.

Although wow and flutter introduce negligible noise, variations in pitch still arise, and on this score, I feel the mechanical requirements are just as stringent.

Finally, may I just say a word about linear-scale decibel meters, which seem to me an application for the logarithmic transfer characteristic facilitated in a p.d.m. system. My experiments to date have used a series RC circuit (2.5 msec) to produce a 10-volt exponential. A transistor periodically short-circuits the capacitor. The transistor is made conductive for 1 msec by a 2-volt negative spike from a small saturating transformer supplied with a 50-c/s sine wave of mains origin. The exponential feeds one input of a long-tailed pair and d.c., proportional to peak programme level, feeds the other input. A moving-coil meter is connected to the output via a series diode (or emitter follower) which maintains constant pulse amplitude. With this quite simple arrangement, the scale is found to be linear over a range of 18 dB, and thereafter expands at the low level end.

D. R. BIRT.

Transistor R-C Oscillators and Selective Amplifiers

I WAS interested to read Mr. Butler's article in the Dec. 1962 issue and the correspondence in Feb. 1963 as I have used another variety of high input impedance circuit which can be used conveniently to form an R-C oscillator or selective amplifier.

The basic amplifier is shown in Fig. A, and uses a p-n-p and n-p-n transistor. They are connected as amplifier stages in cascade with heavy negative feedback. The gain is thus very close to $(R_1 + R_2)/R_1$. If R_2 is

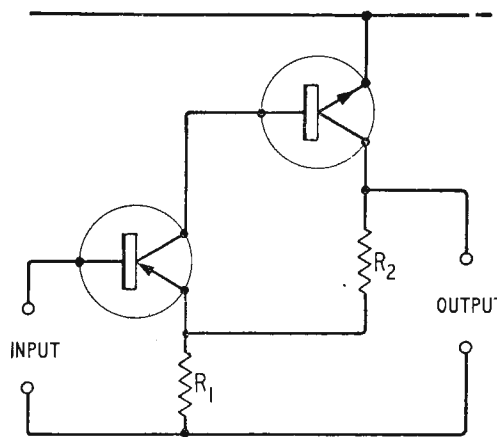

Fig. A. (D. T. Smith)

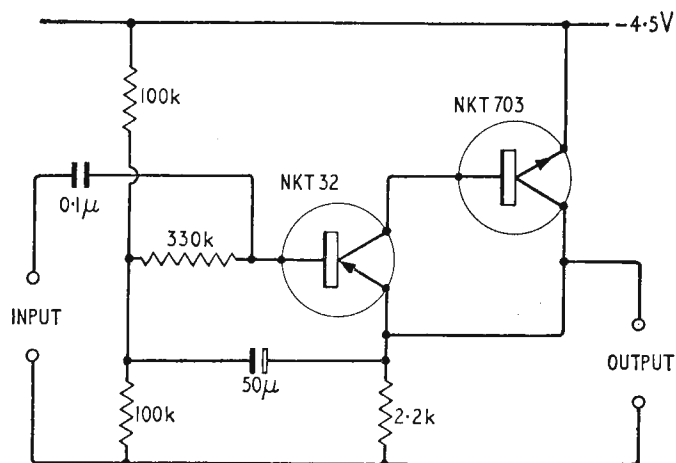

Fig. B. (D. T. Smith)

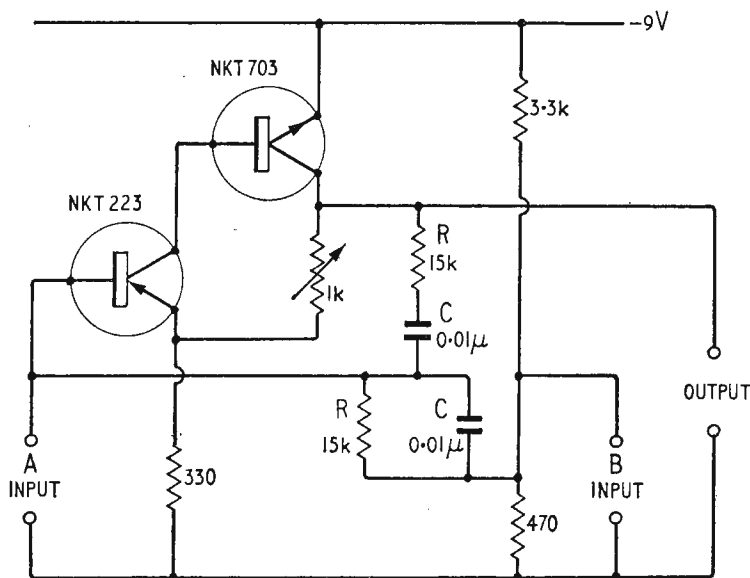

Fig. C. (D. T. Smith)

made zero the general characteristics become similar to the super-alpha pair described by Mr. Butler, but the gain is very close to unity, compared with about 0.9 for the super-alpha pair. The circuit is useful therefore if a buffer amplifier is required with a high input impedance, low output impedance and an accurate gain of unity.

Fig. B shows a practical circuit with an input impedance of about 2 MΩ and output impedance of less than 100Ω. If, however, $R_2 = 2R_1$ then the amplifier has a gain of 3 and can be used to make an oscillator or selective amplifier by connecting a "Wien" network between output and input.

A practical circuit is shown in Fig. C with values for use at 1 kc/s. When used as a selective amplifier it can be fed at point A from a high-impedance source or B from a low-impedance source. Useful features of this circuit

are that the frequency can be varied using a 2-gang potentiometer for the resistances R, that the circuit can readily be used at very low frequencies, and that the stability is good because of the heavy negative feedback in the amplifier.

Oxford.

D. T. SMITH

The author comments:

I have used a bootstrapped version of a high-impedance amplifier otherwise similar to that described by Mr. Smith and can confirm that it is well suited for use with RC oscillators and selective amplifiers. Interested readers will find a brief description of my circuit in the January 1963 issue, (Fig. 9 on p. 25).

His complete oscillator circuit is an excellent arrangement and its only disadvantages are those which I have

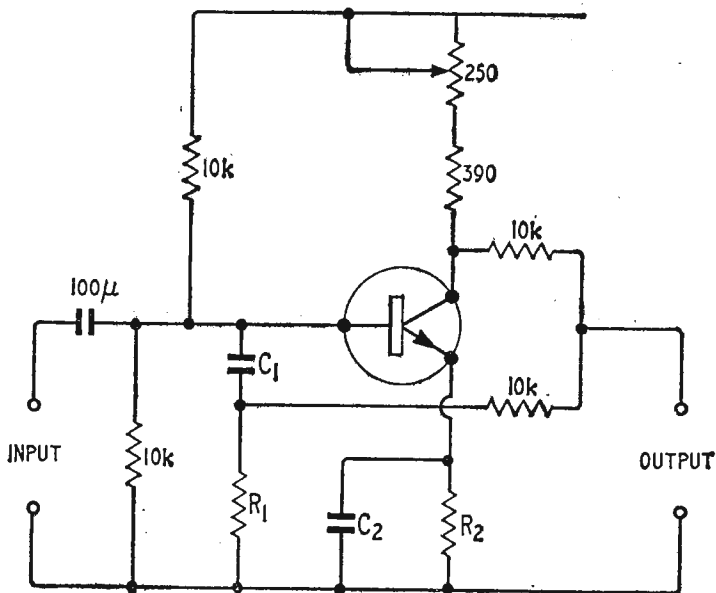

Fig. (a) Slot filter due to A. J. Adler

previously mentioned and which are common to most others which rely on resistance tuning. One of the Wien network resistances necessarily forms part of the base bias network of the input transistor. Changes of resistance therefore cause bias changes and the design problem is to accommodate these. The second point is that the amplifier loading due to the Wien network also varies with changes

a resistance setting. Strictly speaking, the circuit should provide some compensation for this.

A letter in the February issue from Mr. G. W. Short described still another simple and effective Wien bridge arrangement and he drew attention to the points mentioned above. A virtue which he claimed for his circuit was that the base of one transistor was left free for use as an input terminal. One or two cautionary remarks need to be made on this point. To be fully effective, shunt feedback applied to the emitter of a transistor, developing a voltage across an unbypassed emitter resistance, requires that the base of this transistor is supplied from a constant voltage (low impedance), source. The feedback loop is open-circuited if the signal source is of high impedance. Conversely, of course, if feedback is applied through a resistance to the base of the input transistor, the input signal must come from a constant-current source. The feedback would be short-circuited if a constant-voltage source were used.

To conclude, I would like to mention still another approach to the design of RC oscillators and amplifiers of the type in which a notch filter is used in the negative feedback path of an amplifier. Fig. (a) shows a slot filter described by A. J. Adler in *Electronic Design*, (December 6th, 1962, p. 56). An input applied to the series combination of C_1 and R_1 develops a voltage of calculable amplitude and phase across R_1 . This same input applied to the base of the transistor would normally produce an amplified but phase-reversed voltage across the collector load. Its magnitude is adjustable by means of the variable part of the load resistances. Because of the $C_2 R_2$ combination in the emitter circuit there is an additional phase shift of the output voltage and it is possible to arrange matters so that the collector output voltage is exactly equal in magnitude but opposite in phase to the voltage developed across R_1 . If these two voltages could be added they would in fact cancel to give an output null at one particular frequency. If the output load is a low resistance, summing is easily done by making use of two large isolating resistances, shown as 10 kΩ, to feed the load.

By choosing $C_1 = C_2$ and $R_1 = R_2$ the slot filter can be adjusted for zero output by adjustment of the 250Ω variable resistance. The rejection slot will appear at the frequency given by, $R_1 = 1/\omega C_1$ or $R_2 = 1/\omega C_2$.

Fig. (b) shows how the notch filter may be connected into a negative feedback path in a two-stage amplifier using Q_1 and Q_2 . The input stage Q_1 is a common base amplifier. Three separate signals are fed to its emitter;

- (1) the input signal to be selectively amplified;
- (2) a positive feedback signal from the emitter of Q_2 , applied through the variable resistance R_3 and
- (3) an output from the slot filter, giving negative feedback at all frequencies except that of the output null. R_5 (a few thousand ohms) sets the overall gain; R_3 is the regeneration and selectivity control. If R_3 is sufficiently reduced the system will generate continuous oscillations. The resistance R_4 sets the working bias on all the transistors. It should be set to give the maximum possible undistorted output, taken from the collector or emitter of Q_2 .

A feature of the circuit is that C_1, C_2, R_1 and R_2 need not be accurately matched unless one wishes to calculate the operating frequency precisely. Adjustment of R_6 will give a sharp null without using selected components in the phase shift circuits.

F. BUTLER

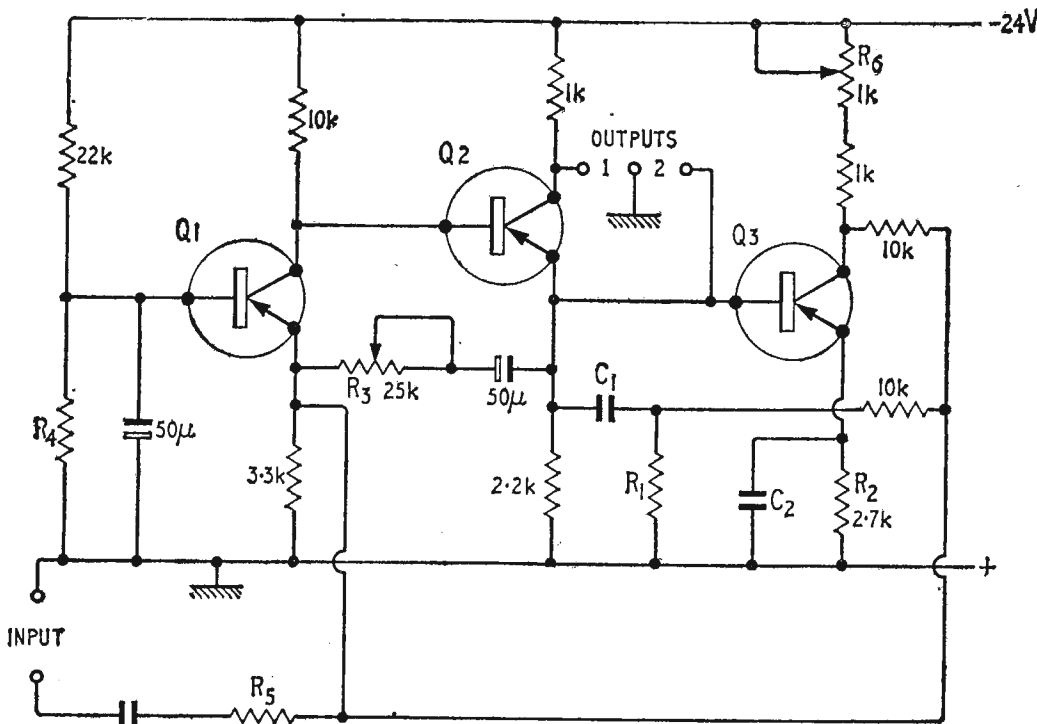

Fig. (b) Oscillator/selective amplifier base on Fig. (a)

G. W. SHORT and M. R. Nicholls (February issue) show two ways of applying frequency selective feedback to a directly-coupled transistor pair one of which (Mr. Short's Fig. (c)) uses a partly current-derived Wien network. Readers may be interested in the fully current-derived configuration used in this Company's Automatic Noise Spectrum Analyser, which is even simpler than that offered by Mr. Nicholls—see Fig. 1. The frequency-selective network shown in heavy lines is derived from a well-known Wien network as in Fig. 2.

This network is in the forward path of a positive feedback loop, and has a transfer function identical to that of the circuits of Fig. 3. Note that the elements of Fig. 3 are pure, and do not vary with frequency. The amplifier proper is arranged to have a very low input impedance and very high output impedance, and a well-defined current gain (I_2/I_1) adjustable to exactly 3 times. Then the transfer function of the forward path of the feedback loop is given by:—

$$A = \frac{I_3}{I_1} = \frac{1}{1 + \frac{1}{3}j(\omega)} \quad \text{where } (\omega) = \frac{\omega}{\omega_0} - \frac{\omega_0}{\omega}$$

This is better written as:— $1/A = 1 + \frac{1}{3}j(\omega)$

When a fraction β of the output current is fed back we have

$$\frac{I_3}{I_{in}} = A' = \frac{A}{1 - \beta A}$$

$$\text{or } \frac{1}{A'} = \frac{1}{A} - \beta = 1 - \beta + \frac{1}{3}j(\omega)$$

$$= (1 - \beta) \left[1 + \frac{1}{3(1 - \beta)} j(\omega) \right]$$

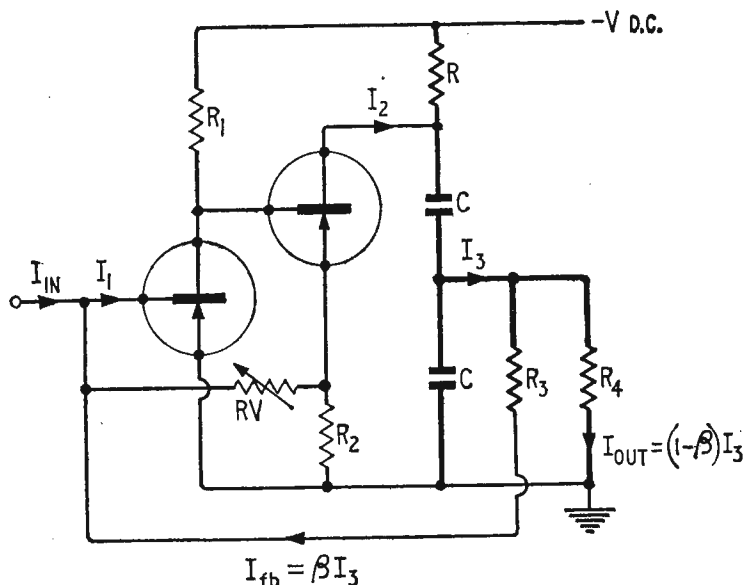
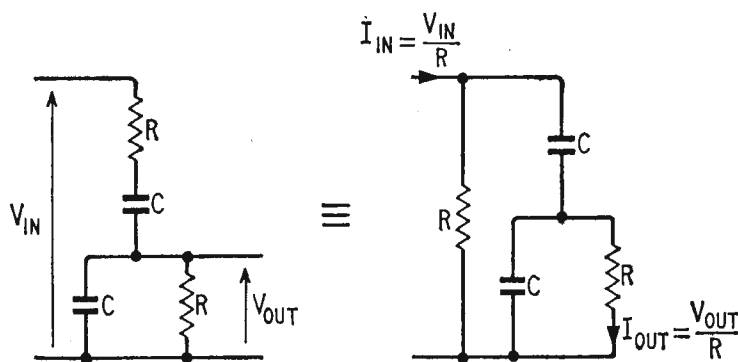

Fig. 1. Selective current amplifier. R is made equal R₃ and R₄ is parallel



$$\frac{V_{IN}}{V_{OUT}} = \frac{I_{IN}}{I_{OUT}} = 3 + j \left(\omega CR - \frac{1}{\omega CR} \right) = 3 \left[1 + j \frac{1}{3} \left(\frac{\omega}{\omega_0} - \frac{\omega_0}{\omega} \right) \right]$$

$$\text{WHERE } \omega_0 = \frac{1}{CR} \quad \text{BY DEFINITION } Q = \frac{1}{3}$$

Fig. 2. Derivation of selective network

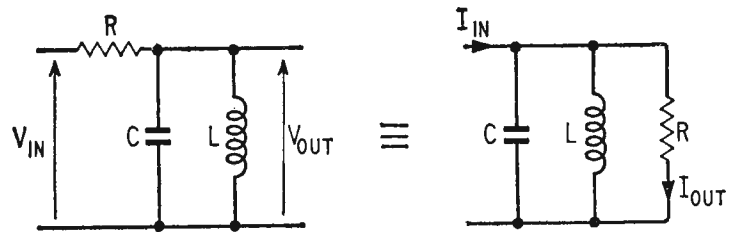

$$\frac{V_{IN}}{V_{OUT}} = \frac{I_{IN}}{I_{OUT}} = 1 + R \left(j\omega C + \frac{1}{j\omega L} \right) = 1 + jR \sqrt{\frac{C}{L}} \left(\frac{\omega}{\omega_0} - \frac{\omega_0}{\omega} \right)$$

$$\text{WHERE } \omega_0 = \frac{1}{\sqrt{LC}} \quad \text{BY DEFINITION } R \sqrt{\frac{C}{L}} = Q, \text{ THE SELECTIVITY FACTOR}$$

Fig. 3. Equivalents of Figs. 1 and 2

that is, both the gain and the selectivity of the system have been increased by the factor $1/(1 - \beta)$. Note that there is absolutely no change of shape of the frequency function as β is changed. Note further that if the output to be passed on to subsequent stages is taken as the current in R₄ (Fig. 1) then the overall gain (I_{out}/I_{in}) is exactly unity.

The advantages of the arrangement can be summarized thus:—

1. The selectivity function is that of an ideal tuned circuit, having true geometrical symmetry and an ultimate slope of 6dB per octave. This is important where a complex response is to be synthesized.
2. A minimum of components is involved. In particular, only two capacitors are used.
3. Filters can be cascaded by direct connection with negligible interaction.
4. Correct amplifier gain is easily set by connecting a suitable resistor between input and output adjusting RV till the circuit just oscillates. In particular, if R₄ is temporarily connected in parallel with R₃ while the circuit is adjusted for just oscillation, then with R₄ feeding out into a negligibly small load impedance the current gain (I_{out}/I_{in}) will be exactly unity, with a Q determined exactly by $\frac{1}{3}$ the ratio of R₄ to the parallel resistance of R₃ and R₄. This without the use of any measuring instrument!

Farnborough, Hants.

D. A. G. TAIT

The Solartron Electronic Group Ltd.

Amplifier-Rectifier

WHEN rectifying a.c. for measurement purposes there are several prime considerations. These include sensitivity, linearity, stability and frequency response. The accompanying circuit rates well in all these areas.

Operation is as follows. With no input signal, both transistors are cut off. With a positive-going input Q1 conducts and C stores up a resulting charge. Then on negative-going excursions Q2 conducts and discharges C through M. There is, of course, current gain which is equal to the average current of the transistors, thus giving much greater sensitivity and input impedance than that afforded by simply rectifiers and a meter.

For linearity and stability the variation of internal emitter resistances of the transistors, a function of current, temperature and frequency, must be negligible compared with R. For flat low-frequency response, the reactance of C (X_c) must be negligible compared with R. High-frequency response depends upon transistor cut-off frequency. The emitter resistance of small signal transistors is typically of the order of 20-50 ohms.

The greater the value of R, the greater the input impedance, linearity, stability and frequency response with, of course, a proportional sacrifice of gain. In general, the same beneficial effects can be achieved by applying negative feedback to previous stages from R.

A very useful and interesting property of this circuit is its use as a frequency meter. If R is made zero and X_c small compared with the emitter resistances, output

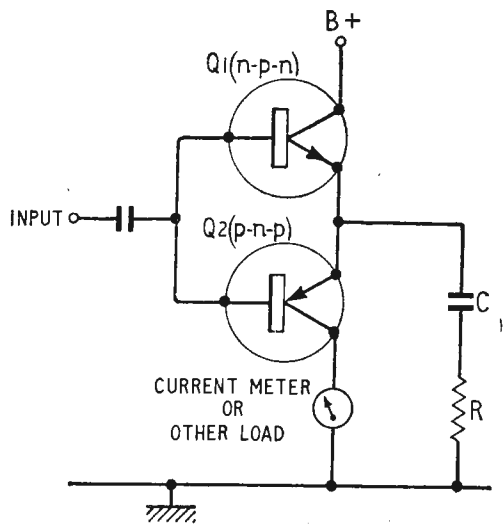

Amplifier-rectifier (S. E. Bammel)

to the meter is extremely linear in direct proportion to the frequency. A great advantage of this circuit over most frequency differentiating circuits is that output is not sensitive to waveform variation, but only peak amplitude. Therefore, a sine wave will give the same output as a square wave of the same peak amplitude. In practice, linear frequency measurement has been made up to 2Mc/s. with transistors having an alpha cut-off of only 3Mc/s.

In the case where R is the only significant impedance in the emitter circuit, the output current is equivalent to half-wave rectification of the current in R and therefore is equal to half the average of this current. Hence, for a sine wave, output current = $0.318 E_p/R = 0.451 E_{r.m.s.}/R$, where E_p is peak voltage.

For the case where C is the only significant impedance in the emitter circuit, output current = peak-to-peak charge of C per cycle ÷ time per cycle = $2E_p C/(1/f) = 2E_p f C$.

By substituting a load resistor or transformer for the meter, the circuit can be used as a sensitive, low-distortion a.m. or f.m. detector, by appropriate selection of R and/or C.

STANLEY E. BAMMEL.

Wheaton, Illinois, U.S.A.

The "W.W." Quality Amplifier

I HAVE in daily use a similar American valve version of the *Wireless World* Quality Amplifier to that described by Mr. Keel (March issue). I made it up of parts from a pre-war amplifier, and the Dubilier electrolytics are now over 25 years old! I have had to replace only the 6V6s.

In another room I have modern hi-fi equipment, which I find not significantly better.

Guildford.

H. GELLATLY.

Oscillator Analysis

THE opening remarks of Thomas Roddam's interesting article¹ raise an issue in results in applied research that is basic—namely, that the applications of theoretical techniques depend upon the properties of the devices ("hardware") available at the time.

As Mr. Roddam indicates, the use of matrix algebra in the solution of electrical problems is well established, and it is interesting to note that the result attributed to me² was available at an earlier date, as has been pointed out³. However, with the advent of the transistor it is perhaps of greater use in application than it was in the valve days, because of the accepted description of transistor behaviour in terms of two-port parameters.

The analysis in application is not as simple as Mr. Roddam suggests. For example, if the transistor is con-

sidered non-reactive a general analysis is available in the case of the phase-shift oscillator⁴. If reactance effects are taken into consideration the problem becomes most cumbersome. An outcome of the analysis is the answer to the problem: under what impedance level conditions in the case of a phase-shift oscillator is a simple analysis of the oscillator involving an ideal current-controlled-source model of the transistor valid? I agree with Mr. Roddam's sentiments on the "classification" problems raised in the issue—this has been briefly discussed by Pritchard⁵ who suggests a three-terminal approach, subject to the view that a two-port view may be more convenient for certain problems.

Hobart.

J. H. BRODIE

Department of Electrical Engineering
University of Tasmania.

1. Roddam, T., "Oscillators: a Monistic Approach," *Wireless World*, January, 1963, page 33.

2. Brodie, J. H., "Matrix Analysis of Oscillators," *Trans. I.R.E.*, Vol. CT-7, No. 1, pp. 69-70, March, 1960.

3. Brodie, J. H., "Matrix Analysis of Oscillators," *Trans. I.R.E.*, Vol. CT-7, No. 3, p. 357, September, 1960.

4. Brodie, J. H., "The Matrix Analysis of Transistor Linear Oscillators," *Proc. I.R.E. (Aust.)*, Vol. 22, No. 10, pp. 641-645, October, 1961.

5. Pritchard, R. L., "Discussion of matrix analysis of transistor oscillators," *Trans. I.R.E.*, Vol. CT-8, No. 2, p. 169, June, 1961.

Resonance

IN spite of his rather emotional outburst against my suggestion (Dec. 1962 issue), I am pleased that Mr. N. F. Hall (January issue) feels that some improvement is desirable in the naming of resonance effects. Personally, I would be quite happy with any clear and precise terminology, provided it had some chance of gaining universal acceptance. Of this, more later.

Your correspondent's suggestion, "impedant" and "conductive" resonance, has considerable merit, though it is a little inconsistent. Surely the combination should be either "impedant" and "admittive" on the one hand, or "resistive" and "conductive" on the other. However, I am not sure that any of these would require less explanation to the novice than my suggested pairing of "pro-resonance" with the already accepted "anti-resonance." The prefixes here are simply related to the effect of a device on current trying to pass through it.

Perhaps the most important factor in the situation, and one which a novice might better appreciate with increasing maturity, is the far greater likelihood of persuading one's fellows to add one new but related term to another already widely accepted, than of persuading them to scrap one accepted term and add two others, a change of three in all.

Joondanna, Western Australia. D. FARQUHAR.

INFORMATION SERVICE FOR PROFESSIONAL READERS

The reply-paid forms introduced recently to replace the postcards hitherto included have proved to be very helpful to professional readers, judging by the number of forms returned to us. This improved *Wireless World* service is therefore being continued.

The forms are on the last two pages of the issue, inside the back cover, and are designed so that information about advertised products can be readily obtained merely by ringing the appropriate advertisement code numbers. Space is also provided for requesting more particulars about products mentioned editorially.

By the use of these forms professional readers can obtain the additional information they require quickly and easily.



**Mazda
all glass
TWIN-PANEL
TV tubes
with the
EXTRA
safety
factor**

- * Laminated screen construction gives greater protection in or out of cabinet .
- * Separate implosion screen eliminated
- * All-glass construction reduces chance of accidental scratching in home, van or workshop .
- * External room reflections halved
- * Contrast increased by halving inward light reflections
- * No inside screen surfaces to be cleaned

Fine sets are fitted with **MAZDA** picture tubes

19"	CME1906 A47-13W	Tinted glass safety screen on full strength tinted glass bulb. Rectangular aluminised screen. Straight unipotential gun. No ion-trap magnet. 110° scanning. 6.3V heater Short neck.	£15.10.0
23"	CME2306 A59-13W		£19.10.0

Please ask for data sheets

Thorn-AEI Radio Valves & Tubes Limited

COMMERCIAL DIVISION: 155 CHARING CROSS RD · LONDON · W.C.2 · Telephone: GERrard 9797

EXPORT DIVISION: THORN HOUSE · UPPER ST. MARTIN'S LANE · W.C.2



E88CC

BRIMAR

IMMEDIATELY AVAILABLE



Special Quality, Long Life Miniature Double Triode, WITH LOW CATHODE INTERFACE IMPEDANCE featuring a high mutual conductance and low drift of characteristics over long periods of operation

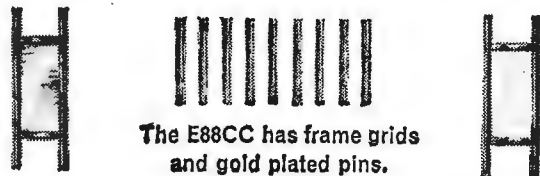

for Application in:

LOW NOISE CASCODE AMPLIFIERS

WIDE BAND AMPLIFIERS

HIGH SPEED

SWITCHING CIRCUITS

COMPUTERS

CIRCUITS WHERE STABILITY OF CHARACTERISTICS & LONG LIFE ARE CALLED FOR

OPERATING CHARACTERISTICS (EACH SECTION)

Heater Voltage	V_h	6.3	V
Heater Current	I_h	0.3	A
Cathode Resistance	R_k	680	Ω
Anode Supply Voltage	$V_a(b)$	100	V
Grid Voltage	$V_g(b)$	+9	V

		MIN.	BOGEY	MAX.	
Anode Current	I_a	14.2	15	15.8	mA
Mutual Conductance	g_m	10.5	12.5	15	mA/V
Amplification Factor	μ	33			
Anode Impedance	r_a	2.65			$k\Omega$

E88CC

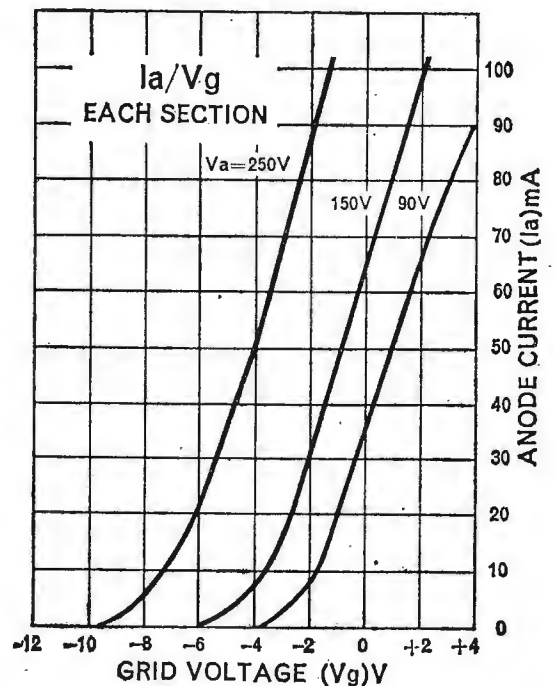

Please ask for data sheets

Thorn-AEI Radio Valves & Tubes Ltd.

COMMERCIAL DIVISION: 155 CHARING CROSS ROAD · LONDON, W.C.2 · Telephone: GERrard 9797

BRIMAR EXPORT DIVISION: THORN HOUSE · UPPER ST. MARTIN'S LANE · LONDON, W.C.2



H.T. Supplies for High-gain Amplifiers

USE OF LOW-POWER SERIES CONTROL VALVES TO ELIMINATE MOTORBOATING

By J. R. OGILVIE, Grad., I.E.E.

THE design of ripple-free h.t. supplies of low enough impedance to ensure adequate stability margin is not always straightforward, particularly in equipment designed for the domestic market. Tape recorders and high-fidelity amplifiers are familiar examples. Cost invariably rules out the use of the more sophisticated supply circuits found in apparatus designed for laboratory use. Most of us have come across high-gain equipments which exhibit low-frequency instability when the volume control is well advanced.

The frequency of oscillation is usually less than 1 cycle per second so that the output transformer will introduce severe distortion of the programme material being fed into the system. The loudspeaker cone possesses very little radiation resistance at such low frequencies and will therefore undergo large non-linear excursions adding further to the distortion. If the loudspeaker cone cannot be observed the user may be unaware of the nature of the fault.

The overall gain from a magnetic pickup through the various equalizing circuits to the power output valve anodes is about 80 dB. However, most high-fidelity systems employ several negative-feedback loops to achieve playback equalization and adequate linearity in the power amplifier which implies an internal gain of perhaps 130 dB. The various negative-feedback loops in the complete amplifier are usually quite stable in themselves, but if a conventional unregulated power unit is employed low-frequency instability may occur (motorboating) due to positive feedback through the h.t. supply line.

Passive Decoupling.— A simple bi-phase rectifier power supply with capacitor input possesses

an output impedance of about 500Ω at very low frequencies. This impedance cannot easily be reduced because of the increasing size and cost of the reservoir and filter capacitors required. Furthermore, the rectifier peak current rating is likely to be exceeded. Silicon rectifiers, however, are capable of delivering higher peak currents, but the advantage over vacuum rectifiers is not very great.

Positive feedback or "motorboating" occurs because the power supply output impedance is common to several stages. The schematic diagram in Fig. 1 illustrates the feedback mechanism in a five stage circuit. Consider the interstage coupling between stages 4 and 5 as broken. The signal appearing at the point P will be:

$$V_p = g_m e_g Z_o \dots \dots (1)$$

where g_m is the mutual conductance of V5 and e_g the signal at V5 grid.

A series valve stabilized supply would reduce Z_o to a few ohms even at zero frequency and hence V_p but cost and space considerations preclude its use in domestic apparatus. The power consumption would also be raised by about 30%. Equipment designers therefore often resort to resistance-capacitance networks to remove ripple and decouple the stages.

Referring again to Fig. 1 we may consider the interstage coupling between stages 3 and 4 as broken and that between 4 and 5 as remade. The coupling from P to V5 is clearly negative feedback and therefore stable. If the interstage coupling between stages 2 and 3 is now broken and that between stages 3 and 4 restored then a positive feedback loop is provided from P through R_1 , C_1 and R_2 , C_2 which may render the last 3 stages unstable. Some attenuation of the

Fig. 1. Schematic amplifier to illustrate coupling via the h.t. supply impedance.

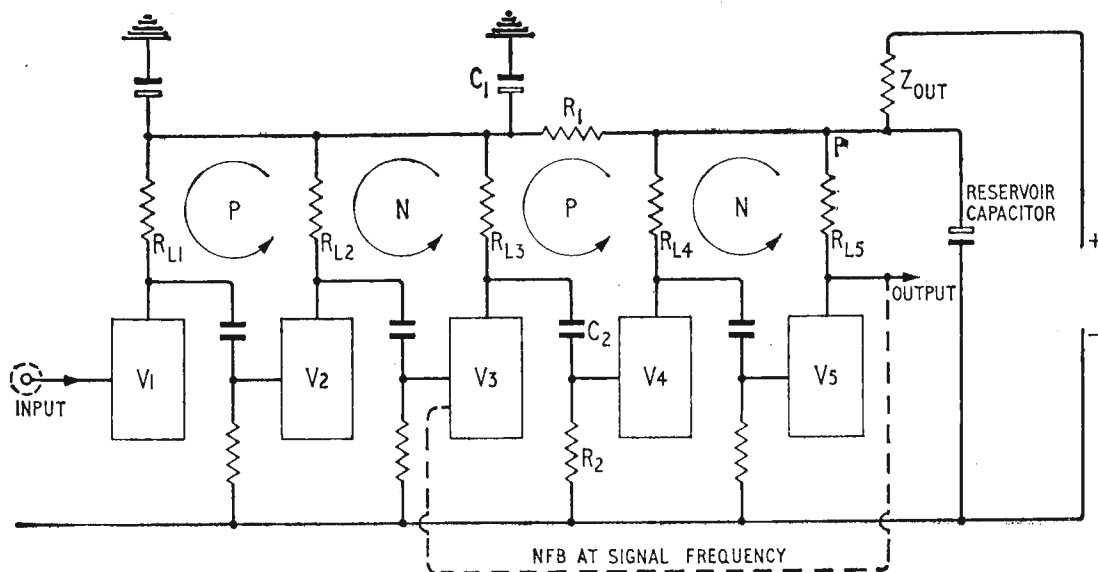

feedback signal occurs by reason of the potential divider formed by the anode load of stage 3 and the anode impedance of V3.

To determine the conditions for stability of these three stages the amplitude and phase of the feedback signal must be known for both loops. A mathematical treatment of this problem is not particularly straightforward. However, if the phase angle is ignored the conditions for stability may be determined on a signal amplitude basis only. This analysis shows that if the ratio $R_1 C_1/R_2 C_2$ exceeds the stage gain of V4 then the circuit will be stable. The frequency response of $R_1 C_1$ and $R_2 C_2$ in cascade is shown in Fig. 2. At f_c the attenuation exceeds the gain of V4 leaving the negative feedback through V5 predominant and the circuit remains stable.

The turnover frequencies f_l and f_h are given by $1/2\pi C_1 R_1$ and $1/2\pi C_2 R_2$ respectively as is well known.

The attenuation rates are 20 dB per decade. By inspection therefore the attenuation in decibels through the mesh between stages 3 and 4 will be twice the depth of the notch. If the gain of V4 is 40 dB then the notch depth must be 20 dB and the ratio $R_1 C_1/R_2 C_2$ not less than 100. It is advisable to allow a margin of 6 dB for component tolerances in a practical design. The value of $R_2 C_2$ should be selected first to suit the lowest signal frequency handled by the amplifier. The ratio of R_1 to C_1 will then be governed by the size of C_1 available and the voltage drop permissible in R_1 , and $R_1 C_1$ should be not less than $200 R_2 C_2$.

Suppose that $R_2 C_2 = 1 \text{ M}\Omega \times 0.02 \mu\text{F}$, then $R_1 C_1$ may need to be $100 \text{ k}\Omega \times 40 \mu\text{F}$. These values are large but probably acceptable in a finished design. However, if a negative feedback loop to operate at signal frequencies has been introduced between stages 3, 4 and 5 then $R_2 C_2$ may have to be increased to a value in excess of that required to pass the signals merely to keep this feedback loop itself stable at low frequencies. The value of $R_1 C_1$ will now have to be increased again, which is not always practicable. The cost of providing C_1 and the space it requires, particularly in a stereophonic system, becomes prohibitive. To raise the time-constant by increasing R_1 is also unsatisfactory because the voltage drop will restrict the design and performance of the preceding stages. The fore-

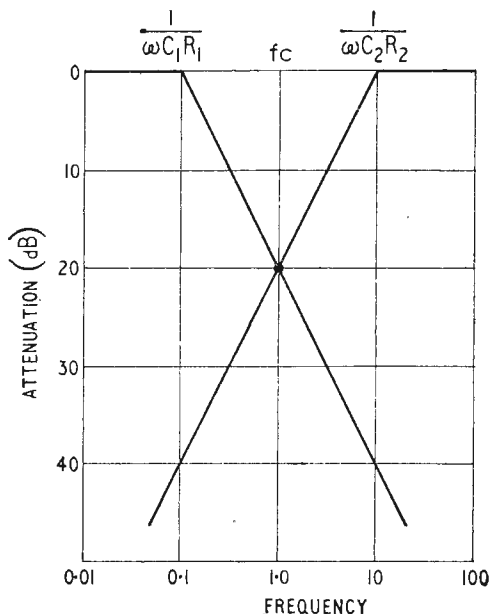

Fig. 2. Attenuation characteristics.

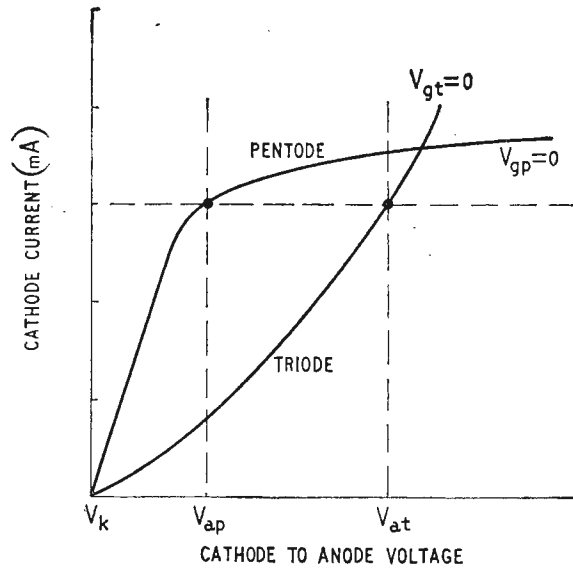

Fig. 3. Comparison of triode and pentode.

going discussion is sufficient to indicate the difficulties which are likely to arise when stages 1 and 2 are designed.

Normal practice, however, is to take the supply to stages 1 and 2 through a decoupling circuit from point P. This raises the voltage available for stages 1 and 2, but the problem of securing an adequate stability margin remains. In the case of a high-fidelity amplifier a steep-cut rumble filter between stages 2 and 3 will assist stability. A mathematical solution for a five-stage amplifier is beyond the scope of the present article, and it is pertinent therefore to consider breaking the amplifier into two parts and to use a low-power series regulator to feed stages 1 and 2 only. If $R_2 C_2$ for reasons previously indicted has to be very large then it may be necessary to feed stage 3 from the regulator as well.

Low-power Series Regulator

We have seen before that a series-valve regulated supply is to be preferred because of its low output impedance. It is economical and quite practical to provide a low-power regulated supply to the early stages only and operate it from the supply to the power amplifier. A complete pre-amplifier for a high-fidelity playback system with equalizer, rumble filter, bass and treble controls usually consumes about 5mA. A single valve with a power rating of $2\frac{1}{2}$ watts can provide an h.t. supply of 130 volts to both channels of a stereophonic system without increasing the cost of the complete equipment.

It is usual to specify a triode valve with a low anode impedance to serve as the series control element. However, it would seem that there is some confusion about anode impedance and anode resistance in the design of series valve stabilizers. The ideal series control valve should possess a low anode resistance and the highest possible anode impedance. A pentode valve closely approaches this ideal. It will pass a large current with a small anode-to-cathode voltage drop and its high anode impedance implies that if the screen voltage is held constant the cathode current will only be slightly altered by a considerable change in anode voltage. A pentode also dissipates less power for a given current output and is self-stabilizing as far as input voltage changes are concerned. The efficiency of pentode stabilizers is therefore much higher than the triode counterpart.

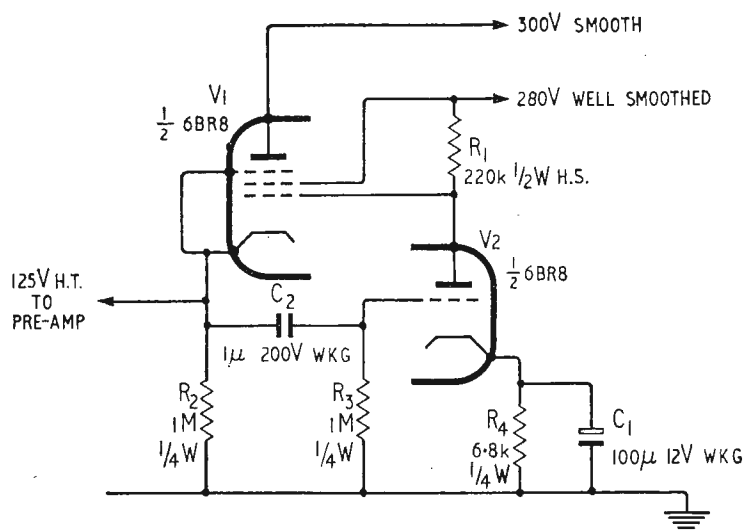

Fig. 4. Circuit of series valve stabilized decoupling circuit for a high-gain pre-amplifier.

This is illustrated in Fig. 3. A modern r.f. pentode will pass a current of about 15mA. with an anode-to-cathode voltage of about 150V. The anode resistance is therefore approximately 10kΩ. The anode impedance (r_a) will, however, be of the order of 400kΩ. If the mutual conductance is 5mA/volt the output impedance (r_o) will be approximately $1/g_m$ (200Ω) when operated as a cathode follower.

The mains ripple and motorboating signal (V_n) in the h.t. supply line will be reduced in the cathode circuit to V_o since:—

$$V_o = V_{in} [r_o / (r_o + r_a)] \dots \dots \dots (2)$$

$$\approx 0.0005 V_{in}$$

The attenuation of the ripple and motorboating signal is therefore 66 dB. However, the performance of such a circuit may be considerably improved by employing a triode-pentode frequency changer valve in which

case the triode portion is used as a shunt amplifier. V_o now becomes:—

$$V_o \approx V_{in} \left(\frac{r_o}{r_o + r_a} \right) \left(\frac{1}{A} \right) \dots \dots \dots (3)$$

where A_s = gain of shunt amplifier.

Practical Circuit:—A practical circuit employing these features is illustrated in Fig. 4. The circuit will deliver 12mA at 125 volts. The output impedance measures 20Ω from 0.25c/s to 1Mc/s and rises to 200Ω at zero frequency. Motorboating and mains ripple signals are reduced by 86 dB over the same frequency range falling to about 60 dB at zero frequency. A passive decoupling circuit approaching this performance would require a series resistance of 15kΩ and a decoupling capacitance of 30,000μF.

The output voltage is controlled by R_4 the latter being decoupled by C_1 . It is convenient to mount this circuit on the power amplifier chassis in which case resistance R_2 provides a d.c. path to the cathode of V1 if ever the pre-amplifier is disconnected. The ripple signal appearing at the cathode of V1 is fed through C_2 and R_3 and amplified by V2 and applied to the grid of V1. Any of the following valves may be used: 6 BR 8, ECF 82 and ECF 804. If a larger current output is required, as for example to feed a v.h.f. tuner the ECL 82 and ECL 86 output triode pentodes will meet this requirement, but the value of R_4 will need adjustment.

The circuit described is economical and avoids the necessity for large decoupling capacitors in a multi-stage amplifier. A considerable saving in space is often possible and the circuit has obvious applications in the sphere of electronic instrumentation.

Acknowledgement:—The author would like to acknowledge the assistance of Mr. R. Leman in preparing the test circuits and making the necessary measurements.

AUDIO FESTIVAL AND FAIR

THE London Audio Festival and Fair opens at the Hotel Russell on Thursday, April 18th, for four consecutive days. Most of the eighty or so exhibitors listed below have demonstration rooms as well as booths in the hotel. Some of the overseas exhibitors are represented by their U.K. agents whose names are given in parentheses in the list. Tickets admitting two to the show are obtainable free from exhibitors and audio dealers. Postal requests to *Wireless World* should include a stamped-addressed envelope. The exhibition is open daily from 11.0 to 9.0 (except on the last day, when it closes at 8.0), but admission on the opening day is reserved until 4.0 for holders of invitation tickets to the private pre-view.

A.K.G. (Politechna)
Acoustical Mfg. Co.
Amateur Tape Recording
Ampex
Armstrong Wireless & TV

B.A.S.F.
Brenell Eng'g Co.
Butoba (Denham & Morley)

C.B.S. Tapes (Desmond Burgess Co.)
Clairtone (Argelane)
Clarke & Smith
Cosmocord

Decca Radio & TV
Derriton Ultrasonics
Design Furniture
E.M.I. Electronics

Fed. of Brit. Tape Recording Clubs
Ferroglyph Co.
Fi-Cord
Field & Co.

G.K.D.
Garrard Eng'g & Mfg. Co.
Gevaert
Goldring Mfg. Co.

Goodmans Industries
Gramophone
Gramplan Reproducers
Grundig

Hanover Press
Hansom Books
Harwood & Martin

Iliffe Electrical Publications
Instrumatic

K.E.F. Electronics

Leak & Co.
Lockwood & Co.
Loewe-Opta (Highgate Acoustics)
Long Playing Record Library
Longacre Press
Lowther Mfg. Co.
Lustraphone

M.S.S. Recording Co.
Miles-Henslow Publications
Minnesota Mining & Mfg. Co.
Mordaunt Sound Reproducers
Mullard

Ortofon (Metro-Sound Mfg.)

Philips Electrical
Planet Projects
Pye

Radford Electronics
Record Retailer
Revox

Rogers Development
Rola Celestion

S.M.E.
S.T.C.
Scott Inc. (Elstone Electronics)
Sherwood Electronics Labs. (Audison)
Shure Electronics
Siemens Norge (Denham & Morley)
Sony (Tellux)
Stuzzi (Recording Devices)
Sugden
Symphony Amplifiers

Tandberg (Elstone Electronics)
Tannoy Products
Tape Recording Magazine
Telefunken (Welmecc Corp.)
Teppaz
Thorens (Metro-Sound Mfg.)
Truvox
Twinsonic

Vitavox
Vortexion

Waverley Records
Wharfedale Wireless
Whiteley Electrical Radio
Williman, K.H.
Wireless & Electrical Trader
Wireless World

Zonal Films

MANUFACTURERS' PRODUCTS

NEW ELECTRONIC EQUIPMENT AND ACCESSORIES

Precision Oiler

THE LUBRICATION of moving parts in electronic and electrical apparatus can present difficulties when an excess of oil would be detrimental. Another handicap appears when an amount of oil is required in a small aperture. Both of these problems are solved in the Swiss-made Lubristyl. The size of a fountain-pen, the oiler discharges its oil through a surgical type needle of small diameter. Pressure on the needle ejects the oil,

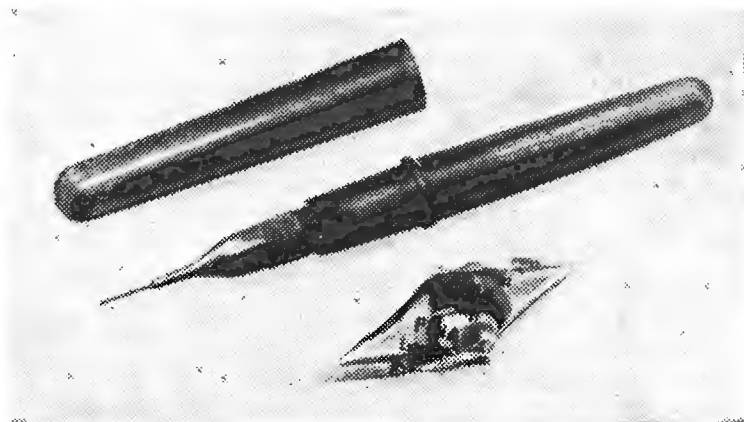

Lybristyl Oiler with one oil refill.

the amount of which can be precisely controlled. An excess of oil can be withdrawn into the reservoir by easing the pressure slowly. Supplied with two charges of oil, the Lubristyl costs 12s 6d. The sole agents for the U.K. are Haynor Ltd., 167 Greyhound Road, London, W.6.

For further information circle 301 on Service Sheet.

Transistor Analyser

IN ADDITION to straightforward tests, design and development engineers frequently require characteristics of individual transistors to be determined accurately and in detail. The Philips Transistor Analyser Type PM6505 introduced recently covers a very wide range of measurements on p-n-p and n-p-n transistors and semiconductor diodes. Measurements that may be made with

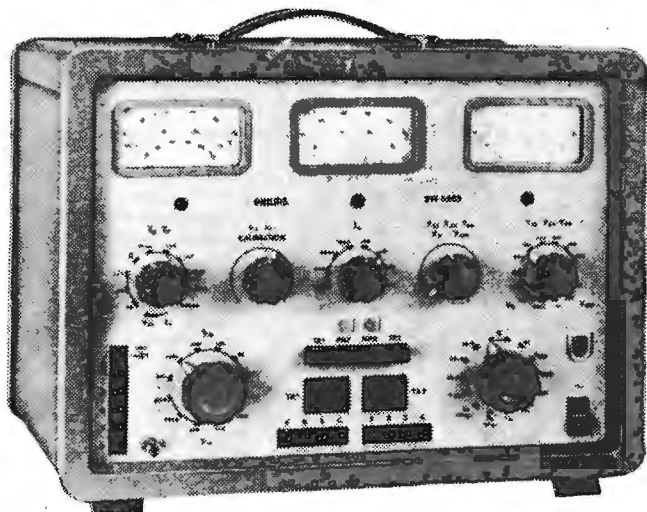

Philips transistor analyser type PM 6505.

this instrument are collector-emitter short circuit test; collector-emitter, emitter-base and collector base leakage currents; collector-current as a function of base current and as a function of base-emitter voltage; knee voltage, and h parameters h_{11e} and h_{21e} at 420c/s. Collector voltage is adjustable from 0-60 volts in six ranges, current is adjustable from 0-3 amps in eight ranges. Dynamic impedance h_{11e} may be measured from 0 to 30k Ω and current gain h_{21e} from 0-1000 with an accuracy of 5%. Provision is made for the simultaneous connection of two transistors and for rapid switching from one to the other. The test voltages and currents are derived from four stabilized supply units within the instrument.

Three moving-coil meters display the voltages and currents of the component under test. An output for display of diode and junction curves on an oscilloscope is provided. The instrument is marketed by Research and Control Instruments Ltd., Instrument House, 207 King's Cross Road, London, W.C.1.

For further information circle 302 on Service Sheet.

Transistor Tester

THE ability to test transistors either out of circuit or *in situ* is a useful feature of the Advance Components Transistor Tester Type T.T.1/S. This instrument will measure the betas of transistors (n-p-n or p-n-p) in the range 10-500. It will also measure leakage current (I_{co}) out of circuit and perform simple tests on semi-

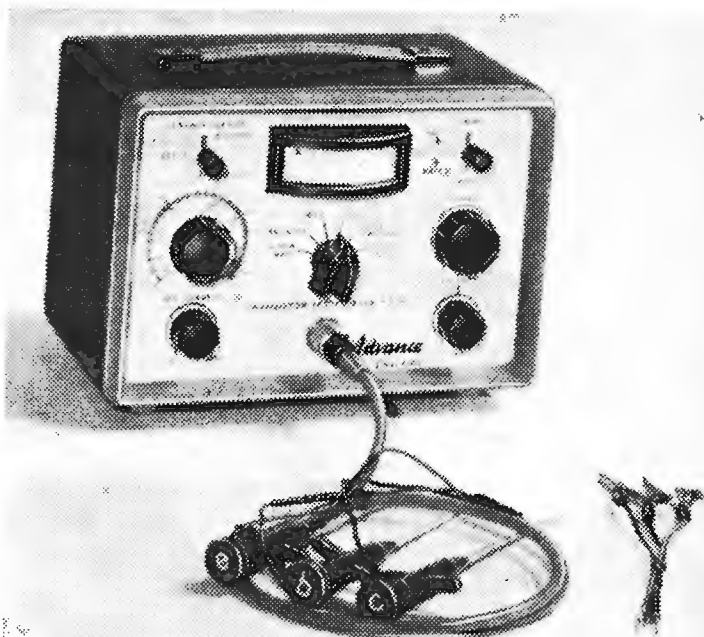

Advance Transistor Tester Type T.T.1/S.

conductor diodes, such as forward characteristic measurements. The test circuit has a bridge configuration energized by two 4V batteries in series. These are centre-tapped by a double emitter-follower circuit which is duplicated with complementary transistors for n-p-n measurements. This system ensures a low output impedance and offers the facility of current limiting; 15mA can be drawn at low impedance and 30mA under short circuit conditions. The component under test forms the

third arm of the bridge. The balancing potentiometers form the fourth.

A "Set Current" control enables up to 0.5 mA of bias current of either polarity to be provided. When fully clockwise it is capable of turning off all but the most heavily saturated transistor circuits. A "Coarse Current" control permits the balancing operation to be carried out at high currents. This covers the range 1-100mA. Medium and high power transistors can be measured at currents up to 50mA.

For further information circle 303 on Service Sheet.

Multi-range Meter

THE Avo Multiminor Mark 4 test instrument shows many improvements over earlier versions. Nineteen ranges are provided, which are selected by a single switch. The same two sockets are used for all measurements. The voltage ranges are up to a 1,000V d.c. in six ranges with a sensitivity of 10,000 Ω /V. A.c. measurements are possible up to a 1,000V with a sensitivity of 1,000 Ω /V in five ranges. Direct current may be measured



Avo Multiminor Mark 4.

up to 1A in five ranges. Using an internal battery, resistance may be measured in two ranges, 0-20,000 Ω and 0-2M Ω . All ranges can be extended by the use of external accessories. The instrument is constructed with use in arduous climatic conditions in mind. Supplied in a carrying case with leads, prods, clips and instructions in six languages, the overall dimensions are 7.55 \times 2.75 \times 1.5 inches. The Multiminor Mark 4 will be sold in the U.K. at a price of £9 10s. The manufacturers are AVO Ltd., 92-96 Vauxhall Bridge Road, London, S.W.1.

For further information circle 304 on Service Sheet.

Miniature Oxide Resistors

THE range of "Metox" metal oxide film resistors has been extended by the addition of a fully insulated type, the F25, measuring only 0.098in dia. (max.) and 0.25in long (max.). The spiral tin-oxide resistance element is rated at $\frac{1}{4}$ watt at 70°C and is protected by an epoxy resin moulding. Values from 47 Ω to 47k Ω are available with selection tolerance of \pm 5%. Made by Welwyn Electric Ltd., Bedlington, Northumberland.

For further information circle 305 on Service Sheet.

Capacitance Bridge

DEVELOPMENTS in the realms of printed circuitry, micro-miniaturization and film techniques involve the measurement of small capacitances. The transformer ratio-arm bridge is ideally suited to this work since three-terminal measurements can be made even in the presence of large capacitances to ground. In fact, this type of bridge with internal shielding permits one terminal of the unknown to be grounded so that both two-



G. R. precision capacitance bridge type 1615-A.

terminal and three-terminal measurements can be made. Based on this, the General Radio Precision Capacitance Bridge Type 1615-A provides capacitance measurement facilities down to the value of 0.00001pF. The upper limit is 1 μ F and throughout the range a direct reading tolerance of \pm 0.01% is possible. All internal standards can be quickly checked against each other for consistency and only one external standard is required to establish the absolute calibration accuracy. A complete capacitance-measuring assembly is available comprising source, bridge and detector. The U.K. representatives are Claude Lyons Ltd., Valley Works, Hoddesdon, Herts. For further information circle 306 on Service Sheet.

Electrolytic Marking Unit

MANY methods exist for the identification marking of metal components. Of these, electrolytic etch-marking has many points in its favour. The result is permanent and can be carried out quickly. Stencils are easily prepared by typing, handwriting or die-stamping. Elaborate patterns can be prepared photographically or electronically. A new unit for this type of work has been developed by Electromark (G.B.) Ltd., Harlequin Avenue, Brentford, Middlesex. The small size of this instrument enables it to be used in the field. Transistorized it weighs complete with batteries and accessories, only four pounds. Marking takes a few seconds. The depth of penetration can be closely controlled.

An oscillator converts the output of two dry batteries

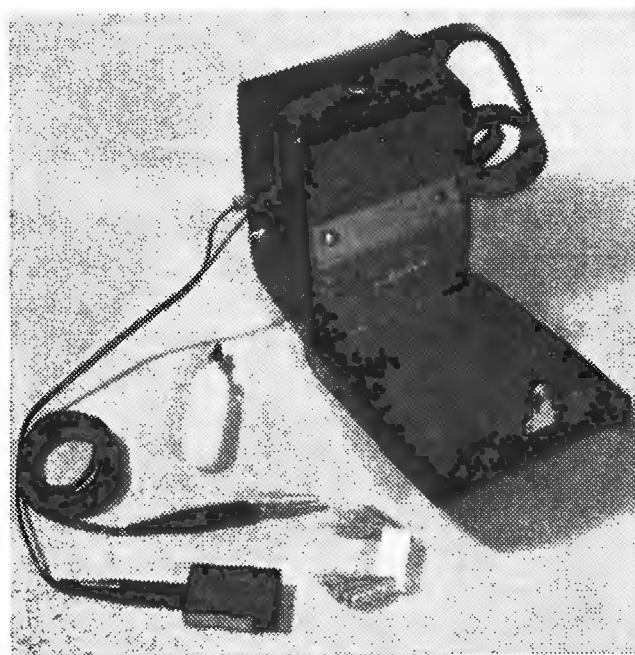

Electromark Type BT 400 portable electrolytic marking unit.

(or a rechargeable accumulator) into an alternating current of 200mA, 9.5V. Although a d.c. output is available a.c. etching is the more versatile, producing on most metals a permanent dark mark composed of re-deposited metallic oxide. Current is applied to the work by the marker and an earthing clip. The marker electrode is fitted with an absorbent pad moistened with electrolyte. The only control is an a.c./d.c. switch. The oscillator is switched on automatically by the insertion of the marker cable jack plug.

In operation the stencil is applied to the work and the moistened marker placed on the stencil for a few seconds. One stencil can be used for a number of operations. If a new stencil is required in the field, it can be prepared with a ball-point pen.

For further information circle 307 on Service Sheet.

Trimming Component Leads

DESIGNED for preparing components for assembly in printed circuit boards the "Circuitformer" trims and bends the leads of resistors and capacitors ready for insertion. Distance between slides can be adjusted to a

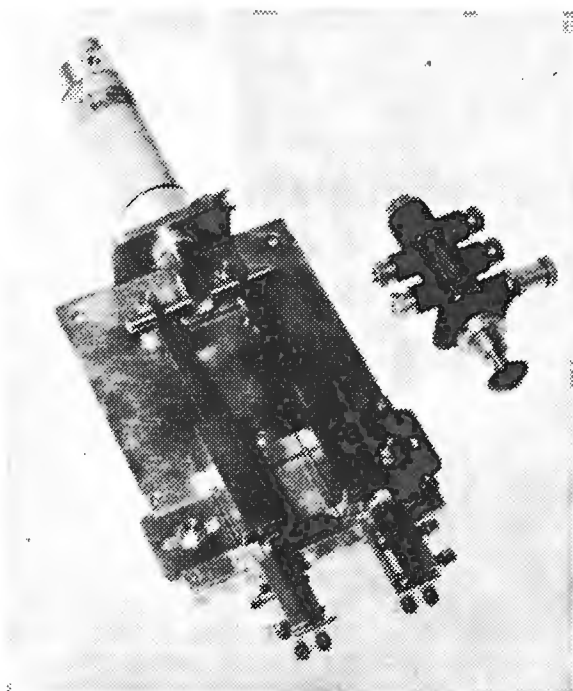

Pneumatically-operated "Circuitformer" (Work Study Equipments.)

pitch between bends of $\frac{1}{2}$ in to 3in with a length of up to $\frac{3}{4}$ in for the formed ends. Powered by a double-acting air cylinder an output of 1,200-1,800 components per hour is possible.

The machine complete with control valve costs £92 10s from Work Study Equipments, 4, Woodman Lane, Sewardstonebury, E.4.

For further information circle 308 on Service Sheet.

Wafer Thermistor

IDEALLY suited for all temperature compensation applications, directly heated wafer thermistors made from ceramic material are being introduced by Gulton Industries. The wafers are manufactured in large sheets. These are cut to obtain a specified resistance; the tolerance of which is determined only by the accuracy of cutting.

Thermistors with resistances between 2Ω and $1000M\Omega$ can readily be made. The standard tolerance on resistance is $\pm 10\%$; if requested $\pm 1\%$ versions can be supplied. Within this range of resistance, thermistors with temperature coefficients from -3.4% to -6.8% are manufactured. The components can be supplied with axial, radial or no leads. They can be obtained

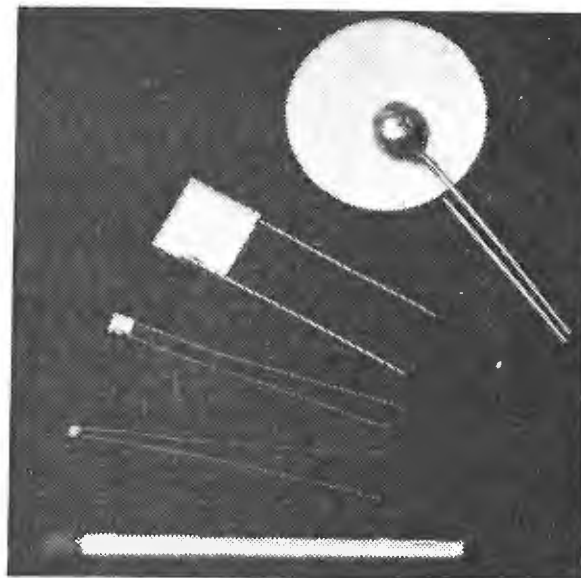

Gulton wafer thermistors.

from Gulton Industries (Britain) Ltd., 52 Regent Street, Brighton 1.

For further information circle 309 on Service Sheet.

Thin Film Capacitors

A NEW range of miniature ceramic capacitors is available from the Plessey Company. Specially designed for bypass, coupling and decoupling applications in transistor circuitry these "Cascap" capacitors have an epoxy coating to improve mechanical strength and humidity protection. Three values are available, $0.02\mu F$, $0.04\mu F$ and $0.05\mu F$ at 30V d.c. working. Each capacitor has a thickness of approximately 0.1in and a lead spacing of approximately 0.19in. The insulation resistance is greater than $5000M\Omega$ and these components are also suitable for v.h.f. use.

The capacitors are manufactured by the Chemical and Metallurgical Division of the Plessey Company (U.K.) Ltd., Wood Burcote Way, Towcester, Northants.

For further information circle 310 on Service Sheet.

Magnetic Recorder

A COMPACT 14-track, 300kc/s magnetic record/reproduce system the F.R.-1300 has been introduced by Ampex. In addition to the 300kc/s direct recording response a 20kc/s f.m. facility is provided. A number of features make this instrument ideal for use by non-technical operators. These include ease of tape threading; interlocked controls to safeguard tape; the six tape speeds ($1\frac{1}{2}$ to 60in/sec) all electrically switchable from a single front panel control. A tape speed constant to

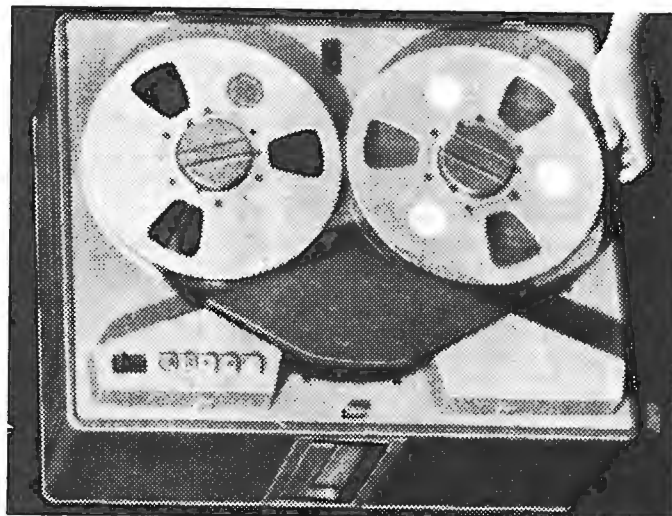

Ampex Type FR-1300 Recorder.

within $\pm 0.05\%$ is attained by a capstan-drive system which dispenses with a motor-control amplifier.

Weighing only 110lbs the overall dimensions are $24 \times 18 \times 12\frac{1}{2}$ in.

For further information circle 311 on Service Sheet.

Ultra-Violet Oscillograph

DIRECT recording of up to 18 channels from z.f. to 10kc/s at a maximum amplitude of 6 inches is a feature of the Southern Instruments Ultra Violet Oscillograph M1250 series. Two reference or data lines, timing lines and grid lines may be added to the record. A manually-operated event marker simplifies subsequent location of particular occurrences observed while recording. An

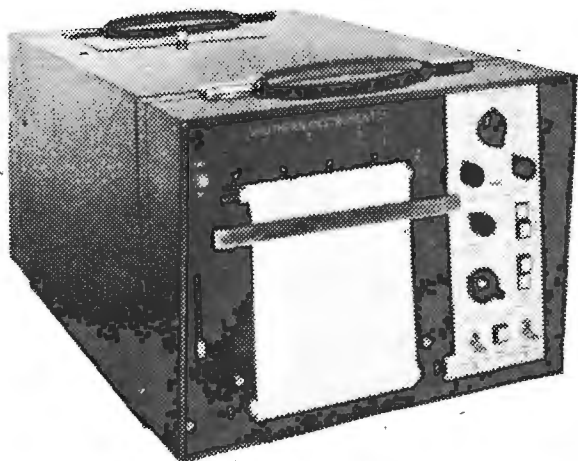

Direct-recording Ultra Violet Oscillograph (Southern Instruments M 1250 series).

automatic trace identification system can be used whenever over-lapping traces are recorded to interrupt momentarily each trace in sequence every 8 inches. To save paper, especially at high recording speeds, recording lengths may be pre-set. At recording speeds from 0.02 to 100 inches per second, an automatic respooling facility is available. The traces become visible when the completed record is exposed to light. The image is permanent if it is not unnecessarily exposed to bright sunlight. The record can of course be wet processed. For further information circle 312 on Service Sheet.

Combined Shock/Vibration Isolators

A SYSTEM of anti-vibration mounting marketed under the name of "Vibrashock" makes use of woven stainless steel wire mesh as a combined mechanical compliance and frictional resistance for absorbing sustained vibration. This is backed by a lower-compliance conventional spring to take up large-amplitude shocks. With this system a very high initial compliance is combined with high stability.

A wide variety of mountings for electronic instruments as well as for heavy machinery is available from Delaney Gallay Ltd., Vulcan Works, Edgware Road, London, N.W.2.

For further information circle 313 on Service Sheet.

Packaged Circuits

PRE-ASSEMBLED transistor amplifiers are the first of a new line of packaged circuitry introduced by Newmarket Transistors. Intended for electronic equipment manufacturers, it is hoped that they will dispense with special design, stock listing and purchasing of individual components. Four types of amplifiers are immediately available. One, a general purpose audio amplifier with 125mW output uses complementary symmetry p-n-p/n-p-n circuits. The other three are 330mW output amplifiers with input sensitivities and

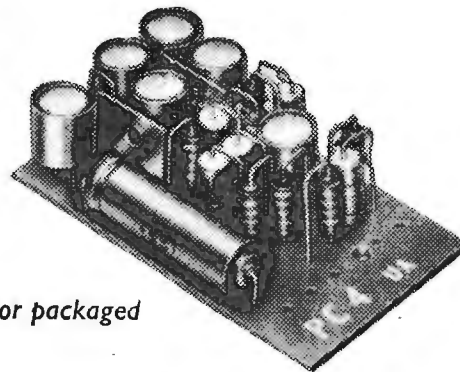

Newmarket transistor packaged circuit amplifier.

impedances designed for a variety of purposes. All the designs are intended for 9V operation. Newmarket Transistors will consider special designs for quantity production.

For further information circle 314 on Service Sheet.

Electroplating Unit

INTENDED primarily for the electro-deposition of noble metals, the Johnson Matthey 2-litre electroplating unit can also be used for plating base metals such as copper, nickel, indium, cadmium, tin and zinc. The unit consists of a cabinet housing the control equipment integral with a platform on which stand electrically heated containers for cleaning and electroplating solutions. Plating current is controlled by saturable reactor. The current is measured by a dual-range ammeter; also incorporated in the current-control system is a timing mechanism. The water-jacketed solution containers can be maintained at desired temperatures by immersion heaters. The electrical circuits are protected against cathode to anode short circuits by cut-outs.

The unit is designed to work on 200-250 V a.c. at 50 or 60c/s. It should be of great value for small-scale production runs where large quantities of solutions are not required.

For further information circle 315 on Service Sheet.

FM/AM Signal Generator

A SIGNAL generator providing frequency or amplitude modulated signals from 4 to 230 Mc/s in six ranges is announced by Advance Components. The generator Type S.G.63D has a directly calibrated frequency dial with slow motion drive. A tuning tolerance of $\pm 1\%$ is claimed. An internal crystal oscillator permits calibration checks at 5 Mc/s intervals to an accuracy of 0.03%. Facilities are available for external f.m. modulation in addition to the internal modulation sources.

The output level is continuously variable from $1\mu\text{V}$ to 100 mV at an output impedance of 37.5Ω terminated (75Ω unterminated). The oscillator circuits are triple screened to keep r.f. leakage down to a low level.

For further information circle 316 on Service Sheet.

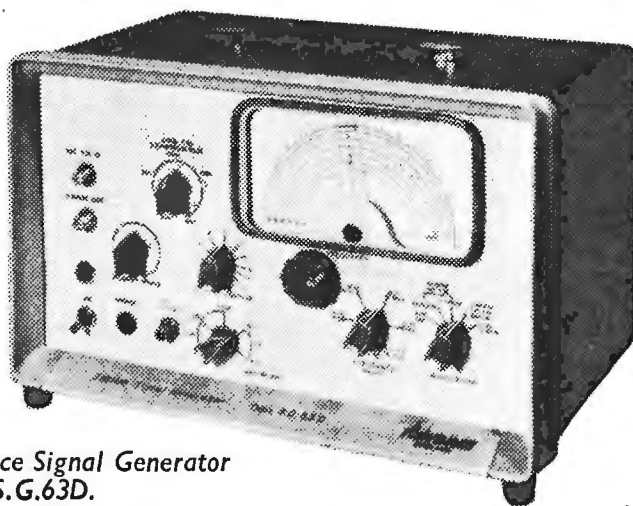

Advance Signal Generator Type S.G.63D.

C.C.I.R. GENEVA CONFERENCE

A TOTAL weight of some 35 tons of paper, comprising reports, recommendations and resolutions, is calculated to have been distributed to the delegates at the Xth Plenary Assembly of the International Radio Consultative Committee (C.C.I.R.) held in Geneva in February. Incidentally it cost about £5 to send one set of documents to the U.K.! The information contained in approximately one-fifth of the papers will be included in the Final Documents of the Conference to be published by the International Telecommunication Union. With this volume of material it is impossible to give a full assessment within the limits of a short article in *W.W.* and we will therefore confine ourselves to some of the main results. Capt. C. F. Booth, of the Post Office, who led the U.K. delegation, is to give a report on the Conference at a meeting of the Electronics Division of the I.E.E. on April 10th in London.

The C.C.I.R. which is one of the three "permanent organs" of the I.T.U. is charged with the study of technical radio questions and operating questions of a technical nature. The study of the questions tabled at each plenary assembly (the next will be in France in 1966) is undertaken by fourteen international study groups and it is the task of these groups to present their findings at the plenary assemblies.

Although it would be wrong to say that "space" dominated the Geneva conference it did loom large on the agenda and in fact about one-third of the material presented deals with the subject. The Conference was indeed viewed as a necessary preparatory step towards the Extraordinary Administrative Radio Conference to be held in October to fix regulations for space communication systems. Unanimous agreement was reached on the basis for the sharing of the same frequency bands by satellite and line-of-sight communication systems. Matters agreed upon included the limitation of e.r.p. for line-of-sight systems, and of the power flux on earth from satellite transmitters. Agreement was also reached on establishing a "co-ordination distance" to avoid interference between satellite ground stations and line-of-sight relay transmitters in neighbouring countries.

Two subjects considered by the Conference which will be of particular interest to readers are stereo broadcasting and colour television. At the interim C.C.I.R. meeting held at Bad Kreuznach last year, the European Broadcasting Union proposed the adoption of the GE-Zenith stereo system (which, incidentally, is now described officially by the generic term "pilot-tone system.") However, the E.B.U. proposal was not accepted, mainly because no country seemed anxious to embark on a service. Such questions as the extent to which the service area of existing v.h.f. sound stations would be reduced and the feasibility of transmitting stereo over land lines are not yet answered. Moreover, the pilot-tone system is not the only potential system; the Soviet Union presented a paper on what they term a "polar-modulated" system.

On the question of colour television standards the consensus of opinion seemed to be that it was too early to take a decision. However, the U.K. has now taken a lead in this matter and has issued an invitation to all European Administrations to attend a special meeting in this country at the end of this year or at the latest

early 1964 to discuss the choice of a colour television system for the European Broadcasting Area. Tests of Secam and N.T.S.C. with sundry variations are being conducted by a number of European countries (including the U.S.S.R.) and it is hoped that at this proposed meeting the final parameters will be decided upon. Non-standardization of colour television in Europe would present problems far greater than those posed by differing monochrome line standards. While talking of standards readers may be interested in the following table of preferred values of i.f. for monochrome receivers in several countries which was included in one of the reports of Study Group II (receivers).

Country	I.F. (Mc/s)	
	Sound	Vision
U.S.A.	41.25	45.75
Italy	40.25	45.75
France { (bands IV, V)	39.2	32.7
{ (band III)	39.2	28.05
U.K.	38.15	34.65
Spain	33.4	38.9
Netherlands		
Fed. German Republic		
Switzerland		
U.S.S.R.	27.75	34.25
Japan	22.25	26.75

Much of the work undertaken by Study Groups V & VI (tropospheric and ionospheric propagation) was concerned with "over the horizon" propagation. The radio engineer needs to know not only the ranges which can be reliably obtained by tropospheric propagation but also wants to know the ranges at which abnormal conditions will cause interference to other services. Study Group V produced several sets of curves which provide data for these two purposes. These include in the former category curves for ground waves below 10 Mc/s and for line-of-sight and tropospheric scatter in the v.h.f., u.h.f. and s.h.f. bands; in the latter group there were curves specially for broadcasting problems in temperate and tropical climates.

The main questions that are always posed by users of the h.f. band are, the choice of optimum frequency at any particular time, and the signal strength that will be produced at the receiver under given conditions. Study Group VI has made further progress in both these spheres. It has set up a working party to prepare a new atlas of the ionosphere which could be the basis of a C.C.I.R. frequency prediction method, and another group is charged with the task of developing a field strength prediction method with a better degree of accuracy than is at present in general use.

Other questions studied by the appropriate group, and on which reports or recommendations were made, include the problem of a protection ratio for medium wave stations. This is of particular interest in view of the forthcoming N. African Conference (1964) for the allocation of frequencies to broadcasting stations in that area as this might have repercussions in Europe and may necessitate a new Copenhagen Plan. At the request of Unesco a study was undertaken to draw up a specification for a low-cost sound broadcasting receiver for the new and developing countries. Unesco's aim is to make it practicable for every family in these "young" countries to own a set and it is estimated that this would provide a potential market for 420,000,000 receivers.

Transistors as Switches

OVERCOMING EXCESS POWER DISSIPATION DURING TRANSIENTS

By D. A. SMITH*

THIS article deals with the precautions necessary in the use of transistors to control d.c. power in most types of load commonly used in electronic and light electrical engineering.

It has a practical rather than a theoretical bias, and is intended to assist the user to obtain maximum utilisation of the potentialities of transistors without sacrificing reliability. No attempt is made to cover the drive requirements in detail.

Introduction

Small transistors operating in a switching mode are capable of handling high volt-ampere products without exceeding their average dissipation ratings. Since all transistors have leakage currents and bulk resistance, they can only provide a change of resistance. This change is more than adequate for most purposes, but care in selection of the type is required. For example, where the minimum "on" resistance is required, a power germanium transistor is indicated, whilst a maximum "off" resistance at high temperatures would be best achieved by the use of a small silicon planar device.

The load itself may take many forms, and the characteristics of the load have a considerable influence on the power-handling capacity of the transistor switch.

Since the maximum power gain is obtained by using the transistor in the common-emitter configuration, this method of connection will be assumed throughout.

The text and figures will refer to pnp transistors, but are equally applicable to npn devices.

Limitations

The limitation on the power-handling capacity of transistors is determined by their maximum current and voltage ratings, which are normally specified by the transistor manufacturer.

Current limitation is usually due to dissipation in the bulk resistance of the semiconductor, and to the fall in current gain at high currents, with a consequent increase in emitter-base dissipation. Voltage limitation may be due to a "soft" collector-base diode characteristic, the punch-through phenomenon, or avalanche breakdown.¹

The soft characteristic is usually due to surface leakage between collector and base. The increasing cleanliness of modern semiconductor manufacture, and the care used in surface treatment before encapsulation, renders this less common in modern transistors. Punch-through is most frequently a limiting factor in transistors having a thin base layer and hence a good high-frequency performance.

The phenomenon is due to the collector depletion region extending, under the influence of a high collector voltage, far enough into the base region to touch the emitter depletion region. When this occurs, current flow between collector and emitter is limited only by the bulk resistance of the semiconductor and any resistance in series with the emitter-to-collector voltage source. A convincing and non-destructive test is to apply a voltage between collector and base, connecting a high resistance valve voltmeter between base and emitter. As the voltage is increased, a point will be reached at which the meter will deflect. The difference between the meter reading and the supply voltage is the voltage

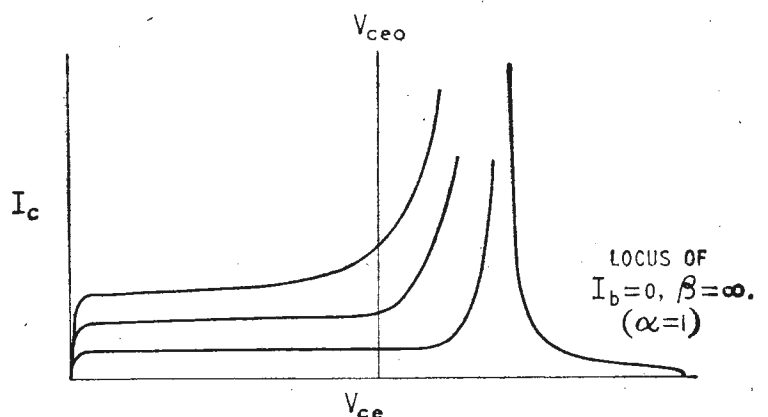

Fig. 1. Transistor output characteristic in common-emitter configuration, with base current as parameter, showing avalanche region.

necessary to cause the collector depletion layer to extend through the base region far enough to touch the emitter depletion layer. The current flowing between collector and emitter, multiplied by this punch-through voltage, gives the dissipation for a transistor under these conditions. Where the punch-through voltage is a limitation, the fact is usually indicated on the transistor data sheet, as the effect is destructive unless carefully controlled.²

Fig. 1 shows a typical transistor avalanche characteristic. Under the influence of a strong electric field, minority carriers in the collector depletion layer may attain sufficiently high energies to ionise atoms within the crystal lattice upon impact, and, instead of the primary carriers recombining, additional carriers are generated. The effect is known as avalanche multiplication, since, for a given electric field, the number of ionising collisions increases as the current so caused increases. Unless carefully controlled,² the effect is usually destructive.

It will be noted that it is possible, with careful

* Elliott-Automation Ltd.

design, to operate a transistor as a switch with supply voltages beyond the V_{ceo} line shown in Fig. 1, provided the load line does not intersect the locus of $\alpha = 1$ when switching off. A significant reverse bias is required in the "off" condition.

Dissipation

The steady-state dissipation in the "on" state is

$$V_{ce} \cdot I_c + I_b \cdot V_{be} \quad \dots \quad (1)$$

In the "off" state, with the base reverse-biased, dissipation is

$$I_{co} \cdot V_{bc} + I_{co} \cdot V_{be} \cdot \beta_{INV} \quad \dots \quad (2)$$

the latter term seldom being significant. Dissipation during a transition, using a resistive load, is considerably greater than during a steady-state condition.

When a transistor is switched on or off with adequate drive currents, the collector current changes with time in an approximately linear manner.³ The peak power during the transition will occur when the transistor and load resistances are matched, and will be

$$\frac{V_s^2}{2} \cdot \frac{1}{R_L} \quad \dots \quad (3)$$

Assuming a linear change of collector current, the mean dissipation during the transition time t may be calculated as

$$\frac{V_s^2}{6R_L} \quad \dots \quad (4)$$

The above equation shows the average dissipation during the transition time to be independent of t . The average dissipation over a complete switching cycle will be

$$\frac{T_{on} \cdot (V_{ce} \cdot I_c + V_{be} \cdot I_b)}{T_{on} + T_{off} + 2t} + \frac{T_{off} \cdot I_{co} \cdot V_s}{T_{on} + T_{off} + 2t} + \frac{2 \cdot t \cdot V_s^2}{(T_{on} + T_{off} + 2t) 6R_L} \quad \dots \quad (5)$$

assuming $I_{co} \cdot R_L$ and α_{INV} to be negligible.

The third term will be dominant if $2t$ is a large proportion of $(T_{on} + T_{off} + 2t)$. For very low speed switching, t must still be much less than the thermal time constant of the transistor, if the power controlled is large compared with the permissible dissipation. The switching time may be reduced by

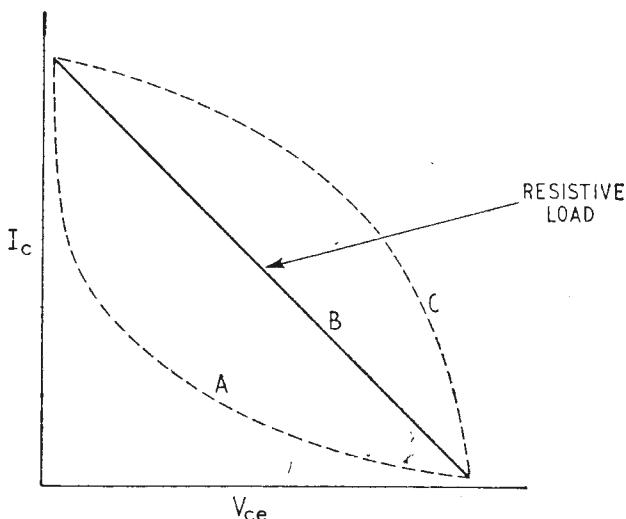

Fig. 2 Dissipation during transition is given by area under relevant curve.

Definitions

V_{ce}	Voltage between collector and emitter.
I_c	Collector current.
I_b	Base current.
V_{be}	Voltage between base and emitter.
V_{ceo}	Maximum voltage between emitter and collector, with the base open-circuit.
V_{bc}	Voltage between base and collector.
I_{co}	Collector leakage current, emitter open-circuit.
β	Current gain, common emitter.
β_{INV}	Common emitter current gain in the inverted connection, i.e. emitter treated as collector and vice versa.
V_s	Supply voltage.
R_L	Load resistance or resistive component of load.
t	Transition time.
T_{off}	Transition time, "on" to "off."
α	$\frac{I_c}{I_e}$
T_{on}	Transition time, "off" to "on."
R_s	Surge-limiting resistor.
R_h, R_c	Hot and cold lamp resistances.
R	Damping resistor.
L	Inductance, or inductive component of load.
C_s	Stray capacity across load.
C	Damping capacity.
R_f	Diode forward resistance.
τ	Drop-out time.

increasing the drive voltage, thus increasing the permissible switching frequency. The importance of adequate turn-on drive for a minimum gain transistor and adequate turn-off drive for one with a high gain (and hence large stored charge) and a high leakage current must not be overlooked. In this context, perhaps the most reliable method of design lies in the use of the charge-control parameters.^{4, 5, 6}

The dissipation during transitions can be greatly decreased if the $V_{ce} \cdot I_c$ locus can be persuaded to follow path A rather than path B or C, Fig. 2. Such elliptical load lines are associated with reactive rather than resistive loads. It is seldom worth while adding reactors to raise the power handling capacity of a given transistor, due to their cost and physical size.

Lamp loads: Probably the most common resistive loads controlled by transistors are lamps. These, however, are a less simple problem than appears at first sight, due to the high positive temperature coefficient of resistance for tungsten, the usual filament material. A lamp chosen at random, having a rating of 12 volts, 3 watts, had a resistance of 48.5 ohms at its rated voltage, but only 4.5 ohms at 20°C. Since a lamp may run at or above 2400°K,⁷ and tungsten has specific resistances of 4.9×10^{-6} and 39×10^{-6} ohm cms at 0°C and 1200°C respectively,⁷ these figures may be taken as typical.

The transition time of a transistor is fast compared with the thermal time constant of lamp filaments (typically 5 to 15 milli-seconds for small panel indicating lamps) hence dissipation must be calculated using the cold lamp resistance for switching on and the hot resistance for switching off. The use of the cold lamp resistance for the turn-on condition implies a high drive requirement for the transistor. Since

the large drive is no longer needed when the lamp is at normal working temperature, a time constant in the base circuit may be used to provide a transient drive which is high compared with the steady-state "on" condition, thereby reducing the $I_b \cdot V_{be}$ term in the dissipation equation. The base region would otherwise have a large excess of minority carriers, although this is usually unimportant provided a reasonable turn-off drive is available, as the lamp time-constant (and that of a human observer!) swamps the storage time of the lowest frequency transistors.

A resistor may be used in series with the lamp to reduce the magnitude of the initial current surge. R_s , the series resistor required, may be calculated using the hot and cold lamp resistances R_h and R_c , from the formula

$$R_s = \frac{R_h - nR_c}{n-1} \dots \dots \dots (6)$$

where n is the permissible ratio of peak to steady current. The method can be seen from the formula to be subject to the law of diminishing returns, and has the further disadvantage of variable lamp brilliance if n is low, unless the lamps used have a tight current specification. Resistor tolerances worsen this effect.

The maximum lamp power controlled by a given transistor depends on the maximum permissible surge-to-mean current ratio and the collector voltage rating of the transistor.

Let m = ratio of maximum peak to maximum steady collector current;

Let n = ratio of peak to steady current for a lamp with series resistance;

Maximum lamp current = $\frac{n}{m} I_{c \max}$

Maximum lamp voltage = $\frac{V_{c \max} R_h}{R_h + R_s}$

Maximum lamp power = $\frac{n}{m} I_{c \max} \cdot \frac{V_{c \max} R_h}{R_h + R_s}$

But $n = \frac{R_h + R_s}{R_c + R_s}$

Thus, maximum lamp power =

$$I_{c \max} \cdot V_{c \max} \cdot \frac{R_h}{m(R_c + R_s)} \dots \dots (7)$$

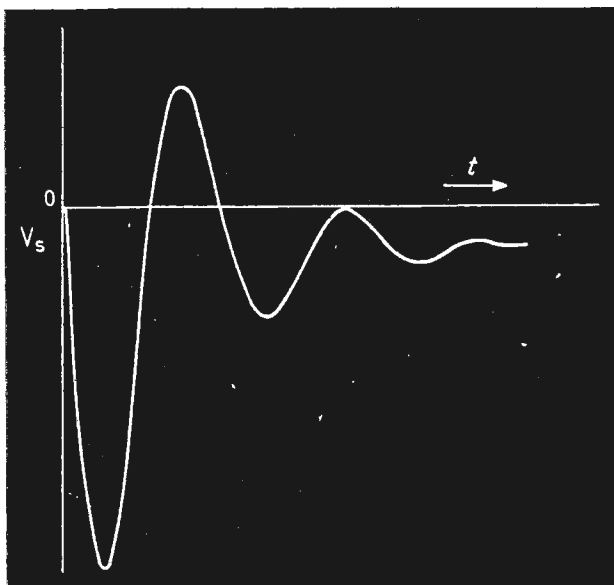

Fig. 3. Voltage waveform at switch-off.

If the voltage limitation is due to avalanche considerations, it may be possible to avoid this by the use of a capacitor at the junction of R_s and the lamp, to alter the V_{ce}, I_c locus during switch-off. This locus has already been moved in the required direction by the high temperature coefficient of the filament. There may be little point in avoiding the avalanche locus during the turn-on transition, as it helps to turn on the transistor, and hence reduces the dissipation by reducing turn-on time.

Inductive loads: When current flowing in an inductive load is switched off, the voltage across the switch increases rapidly (Fig. 3) as the load inductance, together with circuit strays, form a parallel tuned circuit L, C_s excited by a rapid change of current. Usually, the energy stored in the inductance

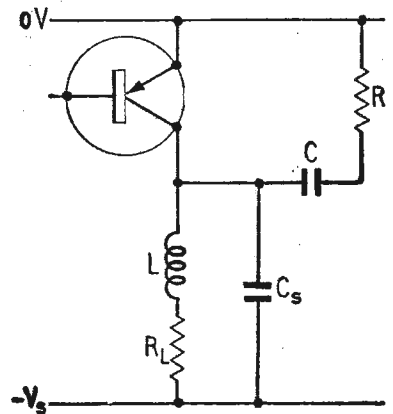

Fig. 4 CR network absorbs surge.

of relays and similar electromechanical devices can produce destructively high voltages across a transistor switch. The problem is by no means new, the life of relay contacts with inductive loads also, on occasion, being spectacularly short!

A series capacitor-resistor network (Fig. 4) may be used to protect a transistor or a relay contact, but the transistor is rather less tolerant of voltage variations in an upward direction. If R is sufficiently low, the tuned circuit L, C_s will have a damping factor equal to, or greater than, unity. At the instant of switch-off, the whole of the current in the inductance may be considered to flow in the circuit R_L, L, C, R . The voltage across the resistor will be approximately

$$\frac{V_s R}{R_L} \dots \dots \dots (8)$$

C should be small, in the interests of space and economy, and R as high as possible to increase the rate of energy dissipation. Thus, we require R maximum and C minimum for a given impedance, i.e., $(R + X_c)/\sqrt{(R + X_c)}$ should be a maximum. For this, it can be shown that:

$$R = X_c \dots \dots \dots (9)$$

Ignoring losses in the tuned circuit and equating the stored energies in inductance and capacity gives a fairly simple formula for voltage which errs on the safe side. (The error is introduced by neglecting the exponential term.)

$$\frac{1}{2} L \cdot I^2 = \frac{1}{2} C \cdot V^2$$

$$V^2 = \frac{L \cdot I^2}{C} \dots \dots \dots (10)$$

Let V_m be the difference between the supply voltage and the permitted peak emitter-collector voltage for the transistor. The overswing voltage on

the capacitor must not exceed $V_m/\sqrt{2}$, neglecting the exponential term, whilst I is V_s/R_L . Substituting in equation (9) we have

$$C = \frac{2LV_s^2}{V_m R_L} \dots \dots \dots (11)$$

R is readily obtained by putting $\frac{V_m}{\sqrt{2}}$ equal to $\frac{V_s R}{R_L}$ in

(8) above, giving

$$\frac{V_m R_L}{\sqrt{2} V_s} = R \dots \dots \dots (12)$$

The damping resistor should remove sufficient energy from the tuned circuit to prevent the undershoot introducing difficulties by taking the collector

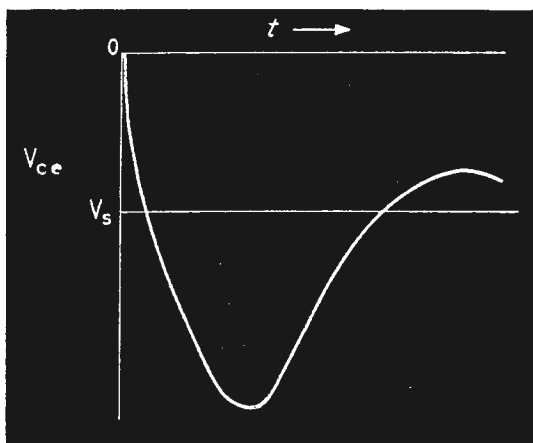

Fig. 5. Collector waveform during switch-off, using circuit of Fig. 4.

potential beyond the base potential. This requirement seldom introduces difficulties, but where V_m is larger than V_s the undershoot may be calculated approximately as

$$V_m e^{-\pi R / 2 \sqrt{LC}} \dots \dots \dots (13)$$

and should not be greater than V_s . If the undershoot is too great, the damping must be increased or an alternative method of damping used, which avoids the difficulty. The alternative method is dealt with later in this article.

In practice, a transistor voltage rating of a little over twice the supply voltage appears to be the most satisfactory from many points of view. Fig. 5 shows the waveform obtained using the above method. For calculation of capacity, L and V_s should be assumed to have the highest possible and R_L the lowest possible values.

At the end of the switch-off transition, the emitter-to-collector voltage of the transistor will be $V_s R / R_L$ (from (8) above). The average transistor dissipation during the transition may be calculated, using equations (4) and (5), by treating the circuit as a resistive load R fed from a voltage source $V_s R / R_L$, giving

$$P = \frac{V_s^2 R}{6 R_L^2} \dots \dots \dots (14)$$

During the transition from off to on, C starts to charge via R , and the switch-on dissipation is the same as for a resistive load R , since the voltage change across C during the transition is usually negligible. For a given relay and supply voltage, transistor

dissipation may be reduced by reducing the switching time.

Catching Diode

An alternative way of protecting the transistor from an excessive voltage swing is shown in Fig. 6 and the waveform in Fig. 7. As the transistor switches off, the collector potential changes rapidly, until it becomes greater than the supply by the small amount necessary to bring the diode into conduction. The inductance then has almost zero volts across its terminals and the load current will decay on the time constant L/R_L . The main advantage of this method lies in its simplicity. Also, in cases where avalanche conditions are not a limitation it enables a supply voltage close to the maximum transistor voltage rating to be used.

Transistor dissipation when switching on the inductive load will be small if, as is usually the case, the transition time is small compared with the load time constant L/R_L . When switching off, the collector current may, with a fast transistor and large stray capacities, be reduced to a small value before the voltage applied to the transistor becomes significant. More usually, however, the voltage reaches the supply potential whilst the collector current is significant, and the worst case occurs if the collector current has scarcely changed. The dissipation in the latter case will be

$$\frac{(V_s)^2}{2 R_L} \dots \dots \dots (15)$$

An extension of the method which can be used on occasion is to connect the diode to a supply voltage more negative than that used for the load. The voltage on the transistor collector will fall rapidly until the diode conducts. The current in the inductance decreases, the voltage being maintained until the current reaches zero. If the potential difference between the two supplies is V_z , then $V_z = L di/dt$, from which the turn-off time may be calculated as

$$t = \frac{L}{R_L} \cdot \frac{V_s}{V_z} \dots \dots \dots (16)$$

The turn-on transistor dissipation is negligible but during turn-off, the power will be

$$\frac{(V_s + V_z)^2}{2 R_L} \dots \dots \dots (17)$$

It should be noted that the stored energy in the inductance is returned to the supply by the diode. The power source MUST be capable of absorbing this energy without a significant increase in voltage. A Zener diode provides a very elegant and effective

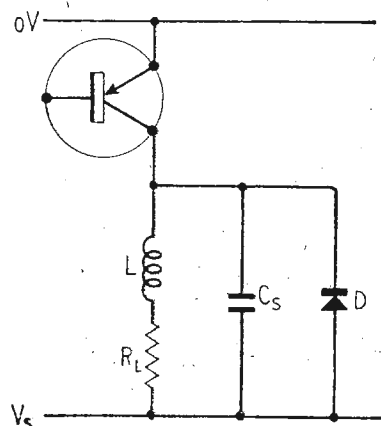

Fig. 6. Catching diode for surge absorption.

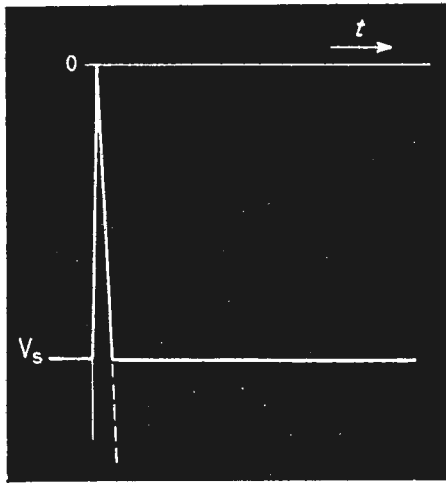

Fig. 7. Collector waveform using catching diode.

means of absorbing the energy at a convenient voltage, avoiding the necessity of providing another supply.

At high supply voltages, care must be taken to ensure the transistor collector current is sufficiently small before the catching diode conducts, for any transistor having an avalanche region inside the area bounded by the maximum voltage and current ratings, in the particular application. This criterion frequently necessitates the use of a capacitor to prevent the voltage exceeding a safe value during the fall of collector current. A resistor in series with the capacitor will then be needed to limit the peak current when the transistor turns on. Thus, it would appear that nothing is gained by the use of a diode when operating at high voltages. In fact, the capacitor required is much smaller than it would be for CR damping alone, and very much smaller than the capacitor required to achieve the same result by critical damping of the tuned circuit.

It should be noted that the use of high supply voltages with resistive or lamp loads is equally capable of causing the transistor to enter the avalanche region, rendering a CR network necessary. Dissipation in the transistor may be calculated as in (14) above, as the capacitor is usually sufficiently large to render the change of voltage across it negligible during the transition.

An alternative damping circuit for use with a catching diode is given in Fig. 8. At switch-on, current commences to flow in L and R_L , the damping circuit having no effect. At switch-off, the collector potential will fall instantly to a value slightly below V_s , charging C via D. However, at the peak, D ceases to conduct, leaving the major portion of the energy from L stored in C, to be dissipated in R. The only energy remaining on the left-hand side of the diode is that stored in strays and the collector depletion capacity of the transistor. This energy is not sufficient to cause difficulties and is rapidly dissipated. Equation (9) is equally applicable to this circuit, and it can be shown that the optimum capacitance is a quarter that obtained in (11) and the resistance twice that obtained in (12) above. Thus, a saving in space may be achieved for the cost of the diode. The switch-on dissipation becomes equal to that of (14) above. However, the capacitor must completely discharge through R before the next turn-off transition, or the design must be modified taking into account the energy remaining in C.

If R is a low value, C may be omitted. In this case,

the current in the inductance will fall on the time constant

$$\frac{L}{R + R_L} \dots \dots \dots (18)$$

This may provide a satisfactory compromise between cost and performance. Switch-on dissipation is again negligible. Switch-off dissipation is now

$$V_s^2 \frac{3R_L + 2R}{6R_L^2} \dots \dots \dots (19)$$

A second variation on this theme is shown in Fig. 9. At switch-on C, which is at $-V_s$, is discharged via R and the transistor. At switch-off, C charges via the diode and the voltage on C falls, the peak negative value being determined by C. The formula for capacity may be derived from (10) as

$$C = \frac{LI^2}{V^2} \dots \dots \dots (20)$$

where V is the maximum permissible overshwing. If the capacitor voltage falls below V_s , the current in L will reverse. A fairly high value of R may be used to prevent this reverse current re-operating the inductive device. Transistor dissipation can be

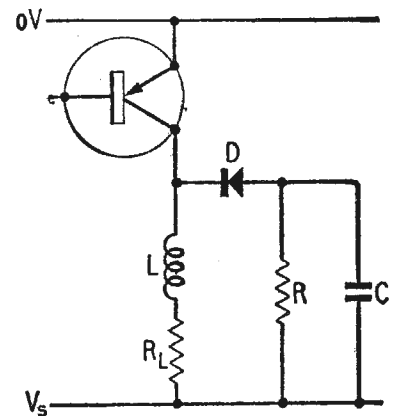

Fig. 8. Alternative catching diode circuit. Smaller C affords space saving.

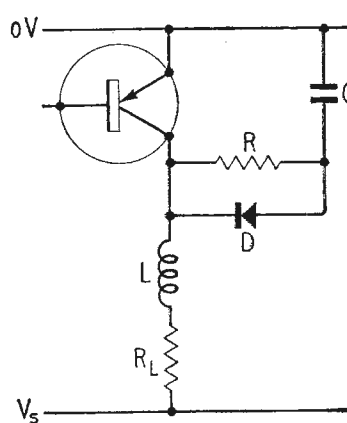

Fig. 9. High value R gives very low transistor dissipation.

kept to a very low value with this circuit by making R high. The turn-on dissipation is $V_s^2/6R_L$ as given in (4) above, whilst turn-off dissipation is due mainly to forward volts drop in the diode and is negligible.

The duration of the "on" state should be sufficient to allow C to reach the collector potential before the next transition.

Switching time: The method used to control the surge voltage has a considerable effect on the time required to reduce the current in an inductive circuit below a given value. When diode protection is used, the current will decay exponentially with a time constant, for a perfect diode, of L/R .

When a damping resistor-capacitor combination

is used, the energy stored in the capacitor will cause the current in the load to reverse, with a maximum rate of load current change at zero. This contrasts with a rate of current change of near zero for the diode protected circuit and a steady rate of change for the diode + zener diode circuit.

The time taken for the current to fall to zero in the case of CR damping may be obtained approximately by calculating the time occupied by a quarter of a cycle at the tuned circuit resonant frequency.

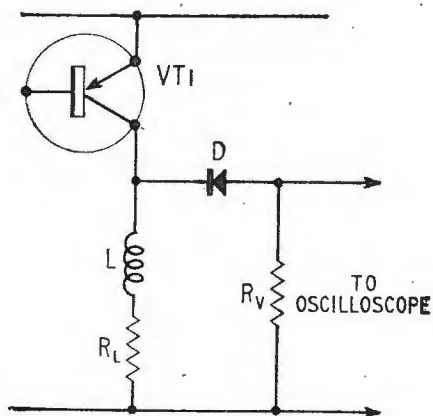

Fig. 10 Inductance-measuring circuit.

For values other than zero, the current waveform may be treated as of sinusoidal form and the time estimated using a cosine table. The accuracy of this method is generally satisfactory, except for L, C, R values near critical damping, the estimated time erring on the high side in all cases.

A more precise expression for the time taken may be obtained by operational methods, but the variation in inductance with current for most iron cored coils would reduce the potential accuracy of such a method, whilst the variation of inductance between samples renders its accuracy of less value.

Measurement of inductance: Where possible, all calculations should be done on the maximum values of inductance given by the manufacturers of the inductive device in question. When the figures are not obtainable, it is necessary to resort to measurements on individual samples, and often wise to verify manufacturers' figures on one or two units to ensure that test conditions are similar. An adequate safety factor must be taken where measurements are used, as there is considerable variation in inductance between samples.

The core of a relay is often solid, hence measure-

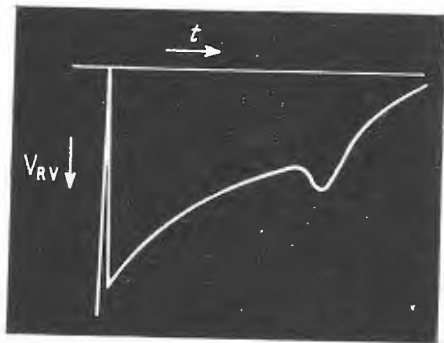

Fig. 11 Waveform on R_V using circuit of Fig. 10.

ment of inductance by means of audio frequency bridge methods introduces errors due to eddy currents and other effects. In one case, a 1 kc/s bridge reading indicated an inductance of one hundredth of the value found by the method to be

outlined below, although the armature of the P.O. type 3000 relay concerned was held in by hand.

To measure the inductance of a relay or similar device, it is recommended that the circuit of Fig. 10 be used.

R_V is used to provide a voltage proportional to current and may be of any convenient value although values higher than R_L require the use of an unnecessarily high collector voltage rating for the transistor VT1, and should be avoided. Any diode with a low forward volts drop and a low reverse leakage will be satisfactory. The drive frequency should be sufficiently low for the device under test to follow easily.

The oscilloscope is adjusted to observe the exponential decay of voltage across R_V (Fig. 11), and the time taken from the front edge of the wave to a given fraction of the peak deflection measured. If this fraction is chosen to be 36% of the peak amplitude, then the time constant $L/(R+R_V+R_f)$ is obtained, from which the inductance may be readily calculated. R_f , the (non-linear) diode forward resistance may be neglected, if a suitable type is chosen.

The secondary spike which is shown in Fig. 11 is due to the movement of the relay armature. The reluctance of the magnetic circuit is much lower when energized, due to the armature movement. Assume that the change of energy in the magnetic



Fig. 12 A commercial power-control module.

circuit is zero during the armature movement. Let L_c and L_o be the inductances with the armature closed and open respectively. Then, $\frac{1}{2}L_c I^2 = \frac{1}{2}L_o I^2$. Thus, a change of 4:1 in inductance will cause a change of 1:2 in current, and therefore of volts across R_V . Obviously, the spike will not have a very sharp rise, due to inertia, whilst its amplitude will be less than the calculated value for the same reason. Since L is smaller, the exponential decay is faster after armature movement.

A momentary drop in the current taken by a relay will be noted when the coil is energized, due to a similar effect. Both may be examined in relation to contact operation by means of a double beam oscilloscope.

An alternative method of measuring the inductance is to check the time taken between switching off the energizing current and the occurrence of the voltage spike (or the contact movement), using the circuit of Fig. 10. If the inductance is then energized via a variable resistor, as the current is decreased from the maximum value, the drop-out current can be

measured. From the maximum and the drop-out currents, the time and the coil resistance, the inductance may be calculated.

$$L = \frac{R}{\log_e \left(\frac{I_{\text{drop-out}} R_L}{V_s} \right)} \quad \dots \quad (21)$$

Conclusion

The formulae outlined above were obtained during the design of the Mark II power-controlling elements, Types 3, 4, 5 and 6, marketed by the Process Computing Division of Elliott Brothers, a member of the Elliott-Automation Group. Some thousands of the latter two types are in service, operating continuously in industrial equipment driving lamp and relay loads respectively, with an extremely high order of reliability. A photograph of one of these elements is shown in Fig. 12.

Acknowledgement

The author wishes to acknowledge the assistance of his colleagues, in particular the painstaking work of Mr. D. J. Tipple, and to thank the Manage-

ment of Elliott-Automation for permission to publish this article.

REFERENCES

The references given below are necessarily only a selection from the literature on various aspects.

¹H. Schenkel and H. Statz. "Voltage Punch-Through and Avalanche breakdown, and their effect on the Maximum Operating Voltages of Junction Transistors." *Proceedings of the National Electronics Conference* Vol. 10, 1954. Page 614.

²D. Gage. "Pulse Circuits using Avalanche Transistors." *Proc. Nat. Elect. Conf.* Vol. 14, 1958. Page 32.

³G. M. Ettinger. "Some Methods of Measuring Power Loss in Switching Transistors." *Proc. Nat. Elect. Conf.* Vol. 14, 1958. Page 464.

⁴R. Beaufoy and J. J. Sparkes. "The Junction Transistor as a Charge-Controlled Device." *A.T.E. Journal* 1957. 13. No. 4. Page 310.

⁵R. Beaufoy. "Transistor Switching Circuit Design using the Charge Control Parameters." *Proc. I.E.E.* 1959 Part B. Supplement No. 17. Paper 2970, Page 1685.

⁶J. J. Sparkes. "Measurement of Transistor Transient Switching Parameters." *Proc. I.E.E.* 1959, Part B. Supplement No. 15 Paper 3006. Page 562.

⁷G. W. C. Kaye and T. H. Laby (1957) *Tables of Physical and Chemical Constants*. Longmans, Green, & Co.

BOOKS RECEIVED

Selected Papers on New Techniques for Energy Conversion, edited by Summer N. Levine. Collection of 37 recent articles from technical journals and the proceedings of American learned societies on thermoelectric, thermionic, photovoltaic, electrochemical and thermonuclear fusion methods of generating electric power. Pp. 444. Dover Publications, Inc., 180 Varick Street, New York 14, price \$2.85, or from Constable & Co. Ltd., 10 Orange Street, London, W.C.2. Price 22s 6d.

Radio and Television Test Instruments by Gordon J. King, Assoc. Brit. I.R.E., M.I.P.R.E., M.T.S. Modern test equipment being so versatile, the television and radio service technician may not be making full use of it. The book describes many classes of test-instruments and their applications. Intended primarily for the radio and television service engineer this work might appeal to other electronics technicians. Pp. 175. Odhams Press Ltd., Long Acre, London, W.C.2. Price 25/-.

Communal Aerials and Coaxial Relay Practice by Gordon J. King, Assoc. Brit. I.R.E., Grad. T.P.A. An advocate of distribution of TV and radio signals to the consumer by a coaxial cable system, the author deals with the practical considerations of such a scheme. Included in the book are chapters on planning, aerial station, distribution techniques and an equipment review. Pp. 71. Gordon J. King (Enterprises) Ltd., South Furzham Road, Brixham, Devon. Price 8/6.

Transistor Radios, Circuitry and Servicing by the Mullard Technical Information Department. Prepared originally as a series of articles in "Mullard Outlook" for apprentice service engineers, the material has been revised in book form. The book introduces the semiconductor, its manufacture and chemistry. Before dealing with transistor receiving circuits, a portion is devoted to printed wiring. The work ends with a discussion on the servicing of transistor radios. Pp. 71. Mullard House (Technical Information), Torrington Place, London, W.C.1. Price 5/-.

Analogue Computing at Ultra-High Speed by D. M. Mackay, B.Sc., Ph.D., and M. E. Fisher, B.Sc., Ph.D. An experimental and theoretical study, this work is designed to draw attention to the versatility and reserves of power still latent in analogue technique. Although devoted to repetitive analysers the ideas described should find uses in other branches of computer technology. The book is divided into three parts. The first part surveys the field of ultra high speed computing, the second the techniques involved. The third and final, applications of such a system. Pp. 395. Chapman and Hall, Ltd., 37 Essex Street, London, W.C.2. Price 65/-.

Radio Data Reference Book compiled by G. R. Jesop, A.M.Brit.I.R.E. A very wide range of radio and electronic formulæ, tables, graphs, abacs and symbols are presented in a convenient form. Generally the data have been presented with only sufficient text to permit their effective use. In adopting this method of presentation it is assumed that the reader will have sufficient fundamental knowledge for the direct application of the data. Pp. 136. The Radio Society of Great Britain, 28 Little Russell Street, London, W.C.1. Price 12/6.

Modern Infrared Technology by Barron Kemp. Written for the electronic technician wishing to broaden his field the book deals with most aspects of infra-red technology. Sources, detectors and applications are covered. A chapter is devoted to optical systems. Pp. 225. Howard W. Sams & Co. Inc., Indianapolis. \$4.95.

Units and Standards of Measurement employed at the National Physical Laboratory—Number III—Electricity—second edition. This pamphlet gives an account of the units employed at the N.P.L. for the measurement of electrical quantities. It also describes the standards by means of which these units are determined and preserved. Historical events, international agreements and legal aspects are briefly reviewed. Pp. 16. Her Majesty's Stationery Office. Price 1/6d.



By "FREE GRID"

Etymological Error and Exegesis

I AM afraid that my note in the March issue, entitled *Etymological Enquiry*, in which I made certain suggestions about the origin of the word "radio," was wildly astray.

I quoted from the October 1962 issue of *Proc. I.R.E.* in which Süsskind said that Branly had named his coherer a radioconductor as far back as 1897. I also quoted the opinion of one of my correspondents that as Branly was a Frenchman, one would have expected him to use the word *radioconducteur*. I then went on to suggest that probably Branly had used the word radioconductor because the termination "or" had a more international flavour than the obviously French "eur." I couldn't have been more wrong because Branly never did use the termination "or".

As a result of my etymological error I have touched off a blast of reproach and an etymological exegesis from Eugène Aisberg, Editor of *Toute l'Electronique*, well known not only in France but also in other civilized countries as one of the elder statesmen of radio journalism.

By a strange coincidence, which in a letter to me he explains as "*les grands esprits se rencontrent*", he has included in the March issue of *Toute l'Electronique* a note on this very subject of the origin of the word "radio".

This makes it quite clear that Branly wrote *radioconducteur* and had no thought of turning the French "eur" into "or"; also that Branly didn't care much for the word coherer proposed by Sir Oliver Lodge, but suggested *radioconducteur* in its place. Confirmation of this, including Branly's own words, is to be found in *Comptes rendus de l'Academie des Sciences*, Vol. 125, 6th Dec., 1897.

The author of the *Toute l'Electronique* article, writing under the pseudonymic initials A.Z. (which being the first and last letters of the alphabet are suggestive of Alpha and Omega), states that these facts are brought out in a letter by H. Drubba, of Hanover, in *Proc. I.R.E.* for September, 1962.

Herr Drubba quotes the words of the late Sir William Preece who did so much to further the cause of radio. Preece, writing in *Engineering* on 8th July, 1881, pointed out that the term radiophony had been

used by Mercadier, Bell and Tainter which was, of course, prior to the date when he was writing, therefore, before Hertz had demonstrated in 1888 the existence of what we call electromagnetic waves or radio waves. Of course in those days the word radiophony was used in a much broader sense than it is today. Thus it included transmission of speech by means of the photophone which was dealt with in an article in *Nature* of 4th November, 1880.

Hamfatters

SEVERAL readers in the U.S.A. have replied to my query in the February issue as to the origin of the term "ham" as applied to amateur radio transmitters. One of them, Ken Greenberg, of Chicago, sent my remarks to the headquarters of the American Radio Relay League. The secretary replied telling him frankly that the origin of the word is unknown but that the generally accepted explanation is that it is an abbreviation of the cockney pronunciation "hamateur." This is more or less what I stated to be a belief which I personally had discarded. Actually, of course, cockneys pronounce the word "hammer-chewer."

On the whole, however, most of my correspondents agree that the word has come from the world of the stage where a ham actor means (or used to mean in the U.S.A.) an actor who is second-rate. Probably the word was first applied to radio amateurs because of professional jealousy, for we all know how professionals in any walk of life are apt to look down upon amateurs. However, any such stigma applying to radio amateurs has long since passed, even if it ever existed.

As to why a second-rate actor was ever dubbed a ham actor, it appears that negro actors used to employ lard (i.e. ham fat) to remove the grease-paint from their faces after the show. Jack Darr, whose name is well known to *W.W.* readers, wrote to tell me this, but failed to say why the negroes used lard. I suppose it was because it was cheaper.

A reference book tells me that there used to be a song called "The hamfat man," and that the appellation "hamfatter," later abbreviated to "ham," was applied to negroes who were at that time all regarded as being rather poor at their art.

Thus the term "hamfatter" or "ham" came to be synonymous with "second-rate," and later the term was applied to second-rate actors of any colour.

Electrovision

DURING the past thirty years and more, I have made several long-shot prophecies in these columns about the shape of things to come in the world of wireless and electronics.

I don't think, however, that I have ever made a more long-shot prophecy than the one I put forward in *W.W.*'s golden jubilee issue just two years ago, in April 1961, under the title of "electrovision."

I was thinking of what readers of our centenary number in the year 2011 A.D. would be likely to see in the way of applied electronics, I had one particular development in mind which was, to quote my own words, "that before 2011 our electronics experts and ophthalmic surgeons will have got together to do something very drastic for people like myself suffering from failing sight."

I went on to suggest that a miniature camera tube, of the special kind we use for transmission, would take the place of the eye, and convert vision into pulses along the optic nerve, as the natural eye does. I certainly did not expect this idea to become practicable within so short a time as two years.

Yet I see in the *Daily Telegraph* of 30th January that an electronic eye of the type I suggested is being developed in California by Dr. John Doyle, a neuro-surgeon, and his brother who is an electronics specialist. The user would have to wear a device rather like a miner's cap but with a tiny tube in place of the lamp.

Agnoia Waves

YEARS ago we all used to believe in the existence of the ether and talked glibly of ether waves. But all that has gone since certain experiments failed to show that the ether had any real existence. This has reduced us to talking of waves in nobody knows what. "Cathode Ray" (Nov. 1958) has dealt with all this in more detail, and there is no need for me to go over the ground again.

It seems hard to believe that we can have waves without something in which they can travel or do their

waving, and since the word ether is taboo I suggest that we call them agnoia waves. Agnoia simply means "not known" or in other words "ignorance," so it is I think a suitable term for us to use.

It is a noun, and it is, I know, rather bad form to use a noun as an adjective, but unfortunately its associated adjective is agnostic, and we just can't speak of agnostic waves without risk of being misunderstood in certain quarters. I think, therefore, we will use agnoia as an adjective as well as a noun. After all, we did this in the case of ether, for most people used to refer to ether waves and not to etheric ones.

Therefore I propose that in future we speak of the great unknown through which our wireless waves travel as "the agnoia," and call the waves themselves agnoia waves. We could, I suppose, add an "n" and speak of agnoian waves but that would bring down on our heads the wrath of all the pedagogues who peruse these pages. If you have a better suggestion please do not hesitate to write to me.

Marine Radio

IN the very early days of wireless, it was quickly realized that its main sphere of usefulness would be at sea, to enable ships to communicate with each other and with the shore. The first British merchant ship to be fitted with a wireless installation appears to have been the s.s. *Lake Champlain* and the year was 1901.

It might be thought, therefore, that the Royal Navy was rather lagging behind its mercantile counterpart in pioneering the use of wireless. This is, however, far from being the case as the R.N. was using wireless eight years earlier—in 1893; before, in fact, Marconi had come to England, and only five years after Hertz had first demonstrated the existence of electromagnetic waves.

The R.N. pioneer who put the navy on the map, wirelessly speaking, was the late Admiral of the Fleet Sir Henry Jackson who, when in command of H.M.S. *Edinburgh* in 1893, conceived the plan of using Hertzian waves for naval signalling purposes and did, in fact, carry out his idea, using, of course, a coherer and spark transmitter.

It would seem, therefore, that the R.N. had a big lead over the M.N. in the matter of wireless pioneering. But if anybody who is anxious to preserve the honour of the M.N. can beat the date 1893 I will gladly withdraw my statement if he will write to me or the Editor.

Many radio ideas seem, like this, to have originated earlier than is generally thought, another instance being the pioneer demonstration of wireless telephony by R. A. Fessenden in 1902.

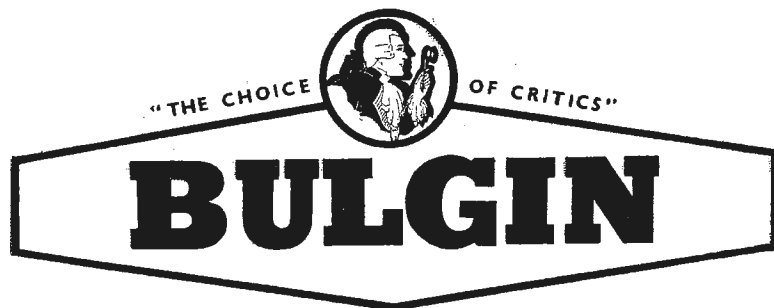

ENGLISH MADE

MICRO SWITCHES

WITH THE EXCLUSIVE ROLLING SPRING ACTION

BASIC TYPES

Bulgin Micro Switches are the finest obtainable, having a simple but effective action combined with a consistently long life; all springs are of hardened tempered Beryllium Copper with heavy contacts of Fine Silver and operating buttons are of Nylon, for long working life and highest insulation.

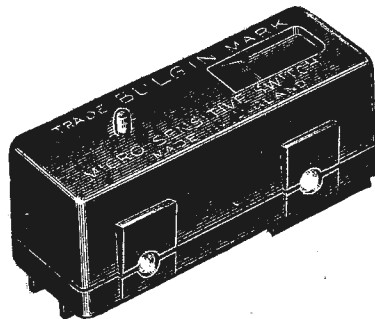

List Nos. S.500—S.502

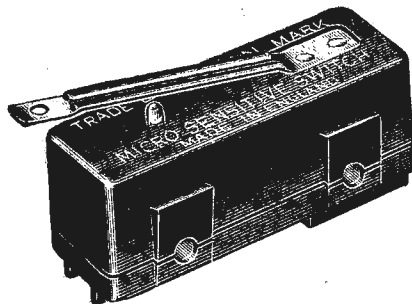

List Nos. S.506—S.508

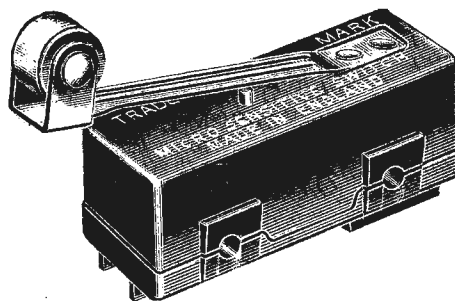

Stainless Steel Roller for S.506—S.511 range. Add /RSS to List No.

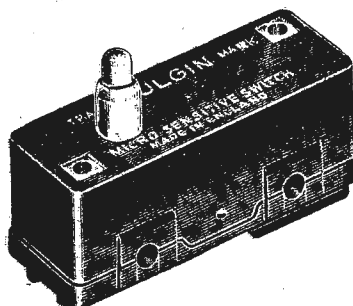

List No. S.778

OPERATING LEAF AND ROLLER

All Bulgin Basic type Micro Switches are available with added external-leaf-operators, two of which are illustrated here. These extra fittings made in Stainless Steel spring alloy will provide a working life of normal deflexions equal at least to the normal working life of the Basic Switch. The fitting acts as a lever which multiplies the distance of movement for operating the Switch, and slightly lessens the operating force, as well as increasing the permitted over travel. These operator fittings are essential where Button deflexion is not by direct push—as by Slides or Curves, and Drive or Wipe should always be away from leaf anchorage.

The Roller is available in Graphic Compound, Tufnol, Stainless Steel or Brass.

FACE MOUNTING PLUNGER OPERATION

This particular Micro Switch is designed for direct drive operation and also face mounting to panel, fixing by 2 x 6 BA. screws on the button face. Best result in operating this type of switch is by axial movement rather than sliding or rotating surfaces and it is therefore exceptionally useful for window and door alarm circuits for burglar prevention etc.

FOR FURTHER DETAILS, SEND FOR LEAFLET NO. 1501/C

A. F. BULGIN & CO. LTD., BYE-PASS ROAD, BARKING, ESSEX
Telephone: RIPpleway 5588 (12 lines)

APRIL MEETINGS

Tickets are required for some meetings; readers are advised therefore, to communicate with the secretary of the society concerned.

LONDON

2nd. Society of Relay Engineers.—“Large TV and f.m. relay systems on the Continent” by Mons. L. Richard, of Brussels, at 2.30 at 21 Bloomsbury Street, W.C.1.

3rd. Brit.I.R.E.—“The display and processing of data from the Harco navigation system” by G. E. Roberts, B. Parker and C. Powell at 6.0 at the London School of Hygiene and Tropical Medicine, Keppel Street, W.C.1.

4th. Television Society.—“Colour TV picture problems: factors affecting subjective picture quality” by R. N. Jackson at 7.0 at the Cinematograph Exhibitors' Association, 164 Shaftesbury Avenue, W.C.2.

8th. I.E.E.—Discussion on “Applications of superconducting materials” at 5.30 at Savoy Place, W.C.2.

9th. I.E.E.—Discussion on “Optoelectronics” at 5.30 at Savoy Place, W.C.2.

10th. I.E.E.—“C.C.I.R.—1963” by Capt. C. F. Booth at 5.30 at Savoy Place, W.C.2.

10th. Brit.I.R.E.—“A telecommunications and telecontrol system for a crude oil pipeline” by W. T. Brown at 6.0 at the London School of Hygiene and Tropical Medicine, Keppel Street, W.C.1.

18th. I.E.E. and Brit.I.R.E.—Discussion on “Applications of television techniques to medicine and biology” at 6.0 at Savoy Place, W.C.2.

19th. B.S.R.A. — “Stereophonic broadcasting with special reference to the Zenith-G.E. system” by Dr. G. J. Phillips at 7.15 at R.S.A., John Adam Street, W.C.2.

22nd. I.E.E.—Discussion on “Hybrid digital-analogue computation” at 5.30 at Savoy Place, London, W.C.2.

29th. I.E.E.—“Colloquium on components and devices for computers” at 2.30 and 5.30 at Savoy Place, W.C.2.

BRIGG

15th. I.E.E.—North Midland Centre Chairman's Address by Dr. G. N. Patchett at 7.0 at Angel Hotel.

BRISTOL

9th. Television Society.—“Colour television” by Dr. G. N. Patchett at 7.30 at Royal Hotel, College Green.

24th. Brit.I.R.E.—“The principles and technology of lasers” by Dr. R. C. Smith at 7.0 at the University Engineering Lecture Rooms, Queens Building, University Walk.

CAMBRIDGE

1st. I.E.E.—“The application of radio-frequency techniques to the investigation of gaseous optical masers” by E. A. Ballik at 7.0 at the College of Arts and Technology.

CHELMSFORD

1st. I.E.E.—“Applications of microwaves” by Prof. A. L. Cullen at 6.30 at the Lion and Lamb Hotel.

CHELTENHAM

26th. Brit.I.R.E.—“Radar for civil aviation” by K. Slater at 7.0 at the North Gloucestershire Technical College.

CHRISTCHURCH

2nd. I.E.E. Graduates.—“Control circuits for silicon controlled rectifiers” by R. A. Payne at 6.30 at King's Arms Hotel.

EXETER

4th. I.E.E.—“The B.B.C. Television Centre and its technical facilities” by F. C. McLean, H. W. Baker and C. H. Colborn at 3.0 at the Washington Singer Laboratories, The University, Prince of Wales Road.

FARNBOROUGH

4th. Brit.I.R.E.—Annual general meeting of the Southern Section at 6.30 followed by “The propagation of i.f. and v.l.f. waves” by Dr. B. Burgess at Farnborough Technical College.

LOUGHBOROUGH

9th. I.E.E.—“Oscillating machines—synchronous and asynchronous” by Dr. E. R. Laithwaite at 6.30 at Loughborough College of Technology.

LUTON

22nd. I.E.E.—“Computers and the engineer” by Dr. D. B. Edwards at 7.0 at Vauxhall Motors Ltd.

LIVERPOOL

18th. Society of Instrument Technology.—“Miniature receivers and recorders” by R. H. Sutherland and J. L. Watts at 7.0 at the M.A.N.W.E.B. Industrial Centre, Paradise Street.

MANCHESTER

24th. I.E.E.—“The sun, the earth and radio” by J. A. Ratcliffe (Electronics Division chairman) at 6.15 at the New Lecture Block, Manchester College of Science and Technology, Altrincham Street.

MORECAMBE

17th. Society of Instrument Technology.—“Miniature receivers and recorders” by R. H. Sunderland and J. L. Watts at 7.15 at the Imperial Hotel, Regent Road.

NEWCASTLE-ON-TYNE

10th. Brit.I.R.E.—“Switchable standard television receivers” by J. H. Haslett and P. L. Mothersole at 6.30 at the Institute of Mining and Mechanical Engineers, Neville Hall, Westgate Road.

17th. Society of Instrument Technology.—“Telecommunications” by D. Rees at 7.0 at the Conference Room, Roadway House, Oxford Street.

NORWICH

24th. I.E.E.—“The B.B.C. Television Centre and its technical facilities” by F. C. McLean, H. W. Baker and C. H. Colborn at 7.30 at the Norwich City College and Arts School, Ipswich Road.

PORTSMOUTH

4th. I.E.E. Graduates.—“Production engineering of the analogue computer” by D. Paskins at 6.30 at College of Technology.

SHEFFIELD

10th. I.E.E.—“System aspects of long-distance communication by waveguide” by Dr. A. E. Karbowiak at 6.30 at the University, Mappin Street.

SOUTHAMPTON

16th-20th. Brit.I.R.E.—Convention “Electronics and productivity” at the University of Southampton.

STONE

22nd. I.E.E.—“The present state of colour television” by S. N. Watson at 7.0 at Duncan Hall.

SWANSEA

11th. I.E.E.—“Some improved methods for digital network analysis” by A. Brameller and J. K. Denmead at 6.15 at the College House, University College of Swansea, Singleton Park.

“WIRELESS WORLD” PUBLICATIONS

	Net Price	By Post
PRINCIPLES OF SEMICONDUCTORS M. G. Scroggie, B.Sc., M.I.E.E.	21/-	21/11
COLOUR TELEVISION: N.T.S.C. System, Principles and Practice. P. S. Carnt, B.Sc. (Eng.), A.C.G.I., A.M.I.E.E. and G. B. Townsend, B.Sc., F. Inst.P., M.I.E.E., A.K.C. . .	85/-	87/3
RADIO VALVE DATA Compiled by the staff of “Wireless World.” 7th Edition . .	6/-	6/10
RADIO AND ELECTRONIC LABORATORY HANDBOOK M. G. Scroggie, B.Sc., M.I.E.E. 7th Edition	55/-	57/3
PRINCIPLES OF TRANSISTOR CIRCUITS S. W. Amos, B.Sc.(Hons.), A.M.I.E.E. 2nd Edition	21/-	22/-
HIGH-QUALITY SOUND PRODUCTION AND REPRODUCTION. H. Burrell Hadden.	42/-	43/5
SOUND AND TELEVISION BROADCASTING. General Principles. K. R. Sturley, Ph.D., B.Sc., M.I.E.E.	45/-	46/4
GUIDE TO BROADCASTING STATIONS Compiled by “Wireless World.” 13th Edition	3/6	4/-

A complete list of books is available on application.

Obtainable from all leading booksellers or from

ILIFFE BOOKS LTD., Dorset House, Stamford Street, London, S.E.1.