

Television Anniversaries

THIS month the British Broadcasting Corporation celebrates the 25th anniversary of the start of its "high-definition" television service, which was inaugurated by Lord Selsdon on 2nd November 1936. We offer our sincere congratulations to the Corporation on its fine record, and on the technical quality of its transmissions which, in spite of the handicap of what is now called a low standard of definition, are admitted by our friends on the Continent to be among the best if not *the* best in Europe. Picture quality is not determined by the number of lines alone, but is a product of good studio lighting and camera work, and the work of the B.B.C. in these sectors is second to none, as indeed it is in the technical development of the means of transmission.

Looking back through the pages of this journal of 25 years ago we are reminded of the activity in the Baird and Marconi-E.M.I. camps as the day drew near when regular 2-hour daily transmissions were decreed to start, with Baird on 240 lines, 25 pictures per second, sequential scanning and E.M.I. on 405 lines, interlaced 50 fields, 25 pictures per second taking turns on alternate weeks. Baird used an intermediate film technique for scanning the scene, but E.M.I. were able to start from scratch with "direct" pick-up using the Emitron electronic camera on which work had been proceeding for some time before under the leadership of Isaac Shoenberg.

One feature of this period which is often forgotten is that the few receivers which were in service were more often than not dual-standard types, but these were never produced in any large quantities. In February 1937 the P.M.G. decided in favour of the 405 line system.

As in other countries interest in this latest wonder of science was first stimulated by public demonstrations, and weekly lists were published in this journal of the places where people could go to see the demonstrations. After a slow start the growth of viewing became exponential. The industry quickly met the demand for privately-owned receivers and in September 1939 when, with the outbreak of hostilities, the service closed down, there were at least 20,000 sets in operation.

This, rather than the actual date of commencement of a regular service should be Britain's claim to fame in the history of television. Other highly-developed countries were carrying out development work and appreciated the vast future possibilities of television, but we—that is the authorities, the industry and the public were quicker off the mark than any nation in the world, including America, in expanding our service.

We have no wish to put a damper on the festivities currently organized by the B.B.C. in celebration of its Silver Jubilee, but when it is said that "twenty-

five years ago Britain alone in the world started a television service" the good feelings of our overseas admirers are apt to become tempered by a certain, and in our view a justifiable, irritation. Even if, as a correspondent in this issue suggests, the words "high definition" are interpolated—as indeed they are by the B.B.C. when it remembers to do so—this does not entirely dispose of the matter. It all depends on what one means by "regular," "public" and "high definition." The last of these is purely relative. Taking a world view in 1934 it meant "not 30 lines"; in 1935 it was applied to the German 180-line service which started in March and to the French 180-line service which began in December. A year later the B.B.C. were still using the positive and not the comparative form of the adjective to describe the 240- and 405-line systems with which their service started. In 1948 France established the superlative with 819 lines. (If we must continue to split hairs, may we suggest a nomenclature for the degrees of "high definition": Mark I=180, Mark I*=240, Mark II=405 (and 441), Mark II*=525, Mark II**=625 and Mark III=819 lines?)

More hair splitting is possible when argument shifts to the ground of what constitutes a "service" as distinct from a public demonstration of television. In the Unesco report (1953) "Television, a World Survey" it is stated for example (pages 57 and 58) that in America prior to 1939 . . . "public demonstrations of television were undertaken by a number of companies" but that "Television broadcasts for the general public began on 30 April, 1939, the day the World's Fair opened in New York." But these were on 441 lines and the Federal Communications Commission felt "that the public had to be warned against investment in receivers which, by reason of technical advances, when ultimately introduced, may become obsolete in a relatively short time." The decision to raise the American standard to the present 525 lines was in fact made on 3rd May, 1941, and in the latter part of that year there were, according to the Unesco report, an estimated 5,000 receivers in use. The highest estimate of the number of television receivers in use in Germany before the war was 500†.

If a service means the regular emission of programmes which may or may not reach a viewing public, then the B.B.C.'s claim to priority is open to question, but if it is argued that a service is not established until it is widely accepted, then there is no question that in 1939 Great Britain, with more than 20,000 receivers, led the world.

† "Das Fernsehen in Deutschland bis zum Jahre 1945" by Gerhart Goebel. *Archiv für das Post- und Fernmeldewesen*, Vol. 5, No 5, August 1953.

Subscription Television

By L. S. WHITE*

BASIC REQUIREMENTS AND THEIR TECHNICAL FULFILMENT BY THE TELEMETER SYSTEM

A SUBSCRIPTION television service provides entertainment in the home and uses the subscriber's television receiver to display it. It differs from the familiar television services in that a price is set for each programme offered and this demand must be met, one way or another, before the selected programme can be seen. The service can be distributed throughout a community by means of a cable network, or it can be broadcast over an area by a transmitter.

Whichever method of distribution is used, the nature of the service creates a number of basic requirements that must be met and places squarely before the designers of a Pay TV system a number of problems that must be solved if technical and commercial success is to be realized. In the discussion that follows some of these problems are stated and the method by which the "Telemeter" system solves them is described in some detail.

FLEXIBILITY. The system must be engineered in such a manner that it can be used in conjunction with most established and acceptable transmission media without placing too many or too restrictive conditions upon the means of distribution. It must be capable of shouldering responsibilities that good commercial practice places upon it and provide facilities that satisfy the needs of both the system operator and the subscriber to the service.

The Telemeter system is a multi-channel system that is basically capable of handling any number of programmes in monochrome or colour. The broadcast system transmits coded signals at frequencies in the spectrum assigned to the service by an authority. The cable system either "stacks" the programme channels in the conventional way,

using a band of frequencies not normally acceptable to a television receiver (h.f. coaxial network), or uses cable circuits that are available and which are peculiar to a particular design of network (l.f. multi-pair networks).

In all three cases, the subscriber is provided with a unit which is inserted in series with the input terminals of a receiver and the aerial or cable lead; in no instance does the installation of the unit involve interference with the receiver or its circuitry. The facilities provided by the unit ensure that there can be no doubt in the subscriber's mind as to the transaction he is entering into. The price of the programme is clearly displayed and on payment of the demand the programme is seen in its entirety. The fundamental principle behind the Telemeter system establishes a relationship between the system operator and the subscriber that is the common experience of everyone who has purchased entertainment, whether it be films, the theatre, a football match or a boxing match. In this manner, the interests of the system operator, the programme supplier and the subscriber are adequately protected.

PRICE. The system must be able to set a particular price on a programme, to vary this price easily from programme to programme from a central station and to inform the viewer of this price. As the times at which subscribers may select a programme are random the pricing information and control must always be accessible during the course of a programme; in like measure the pricing principle should not exclude the possibility of running "continuous shows" of two or more "houses" to enable those who entered late to see a complete performance.

On turning the selector switch to a particular channel, the Telemeter pricing system automatically enables the subscriber to see the price asked

* British Telemeter Home Viewing Ltd.

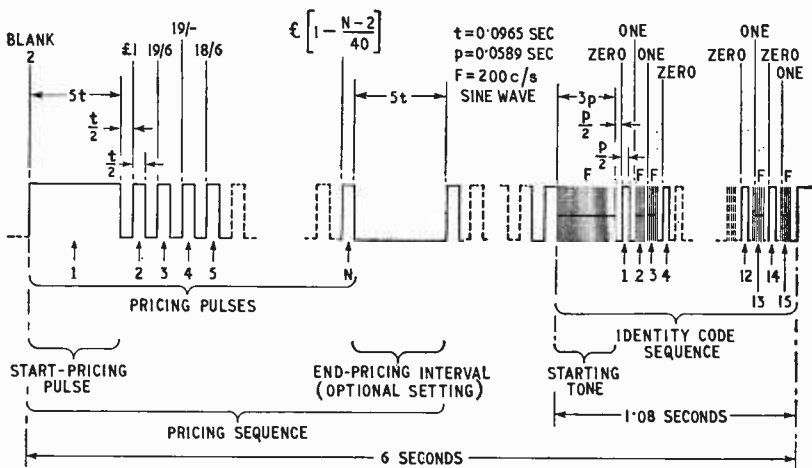

Fig. 1. Pulse code modulation of control channel for pricing and recording transactions.

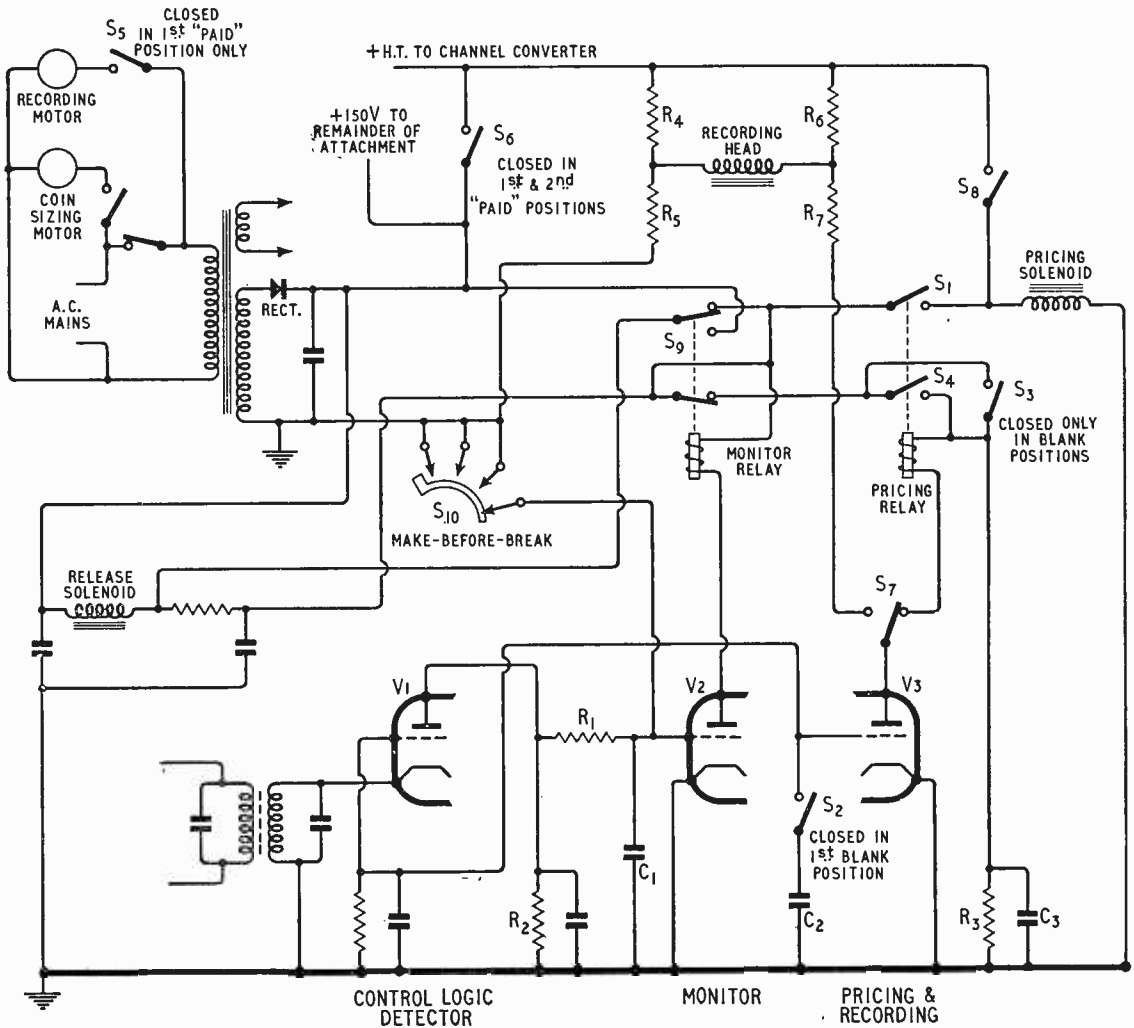
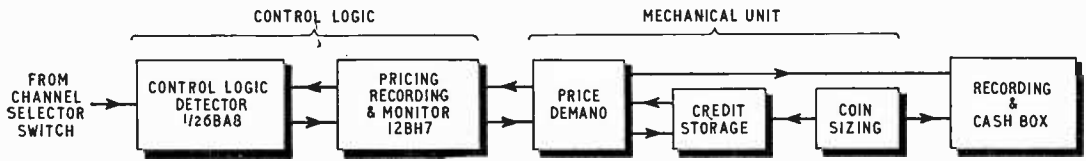

Fig. 2. Control logic circuit of subscriber's unit.

for the programme. Associated with each programme channel is a control channel which contains the pricing information. This information consists of a pulse train, each pulse representing a value of sixpence. The logic which controls the pricing mechanism recognizes the start and end of a price sequence by arranging for the price pulses to be preceded and followed by pulse intervals which are ten times as long as the price pulses themselves. The position of the end-price interval is variable with respect to the entire sequence and by varying this position the programme price is set. The waveform, shown on the left of Fig. 1, is generated by a rotating perforated disc. The disc

has two perforated tracks which extend into a gap in a "lighthouse" which contains two semiconductor photo-diodes with their source of illumination. The disc rotates at 10 r.p.m. and the output pulses so produced form the substance of the price information contained in the control channel. The price pulse repetition rate is approximately 10 per second with a 50% duty cycle.

At the input to the subscriber's unit the programme selection is made and the appropriate control channel is demodulated by the control logic detector, V1 (Fig. 2). The pulse output from the detector is direct-coupled to the grid of the pricing and recording valve, V3, and has sufficient ampli-

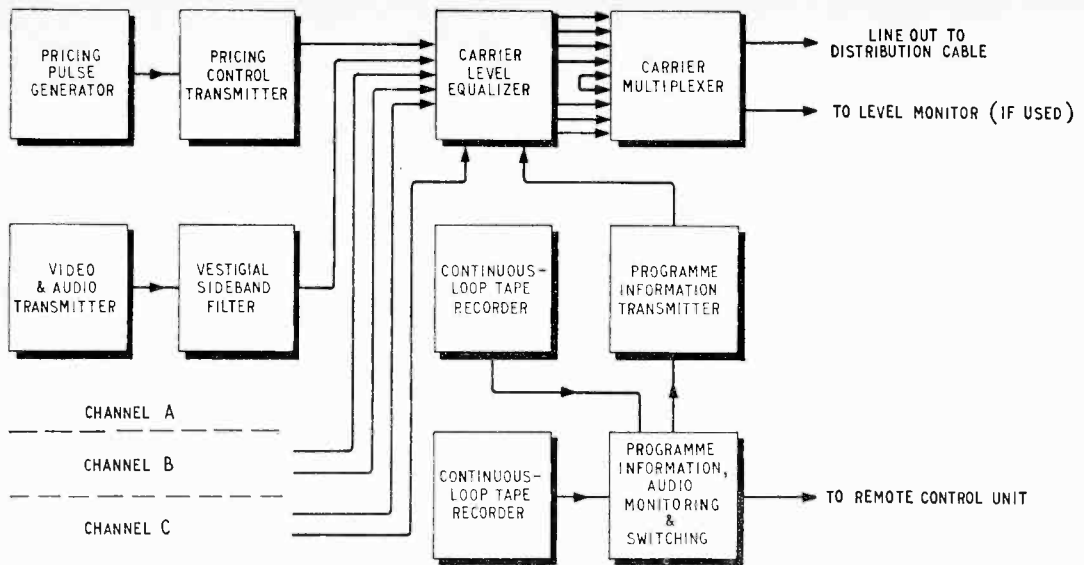

Fig. 3. Block diagram of transmitter for a cable distribution system.

tude to drive this valve from cut-off to full conduction at each pulse. The pricing relay is thus operated, and in turn energizes the pricing solenoid. This solenoid steps a price indicator drum in decrements of sixpence to a position where the price asked is displayed behind a window on the front of the unit. The beginning of the pricing pulse train is recognized by the time-constant of C_2R_2 , and only during the 0.5 sec start-price pulse will the grid voltage of V3 reach such a value that this valve will conduct, advancing the price drum from the 1st to the 2nd "blank" position which, in turn, opens S2. This removes C_2 from being in parallel with the load R_2 and allows the subsequent short price pulses to be resolved by the detector. The end-price pulse is recognized by the time-constant C_3R_3 .

PAYMENT. The system must provide means for receiving payment of the price demand, or, in the case of a billing system, indicate the acceptance of the charge by the subscriber. Where cash payment is required, a multi-coin acceptance mechanism is highly desirable and a credit storage facility should be provided to register and hold against future payment any money inserted in excess of the programme price. The latter facility should be accessible at all times (whether the unit is switched on or off) to enable it to be used as a savings bank for the payment of future entertainment.

The Telemeter unit contains a coin mechanism that accepts any silver coin from a sixpence to half-a-crown. On inserting a coin an evaluating and credit-accumulating cycle is initiated and for each coin deposited the evaluating disc makes one complete revolution. This disc determines the value of the coin by measuring its diameter and it is coupled to the credit drum for a period of time during each revolution which is proportional to the coin value. On the periphery of the credit drum is printed in increments of sixpence the value of credit represented by a given angular displacement.

After the insertion of each coin the drum takes up

a position which is proportional to the value of the coin, and as each successive coin is deposited this angle is increased so that the total angular displacement represents the total sum inserted; this sum is displayed behind the credit window in front of the unit and adjacent to the price window.

If a programme is selected before coins are inserted, a price demand will be displayed behind the price window. On depositing coins the mechanism operates in the manner described above except that at a certain point in each revolution of the evaluating disc the credit drum is released and by spring tension drives the pricing drum towards the "paid" position by an amount equal to the value of the coin deposited. As this happens quite quickly, it appears that the coins inserted pay directly for the programme, as their value is deducted from the price shown. This is not the case, but the method of operation does enable the subscriber to see at any moment the balance still required to pay for the programme, and the mechanism does store and register any excess sum paid if exact change is not available. If the credit store registers a sum of money, this credit can be used to pay partly or wholly for a selected programme by pressing a button which initiates the cycle of operations just described.

The "billing" unit is the same as the "cash" unit except that the coin acceptance mechanism is not provided. If a subscriber selects a programme a price demand is set up in the same manner as described above whereupon a button is pressed, the programme appears on the receiver screen, and the recording cycle, which is described in the next section, is initiated. At regular intervals the record is read and the information it contains is used to make up the subscriber's bill.

RECORDING. An accurate record must be made of each transaction entered into by each subscriber. This record enables disputes between subscriber and system operator to be resolved and provides information

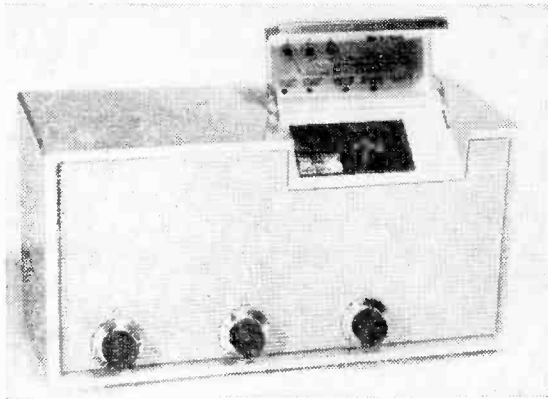

Telemeter Unit with lid lifted to show coin slot, price and credit windows.

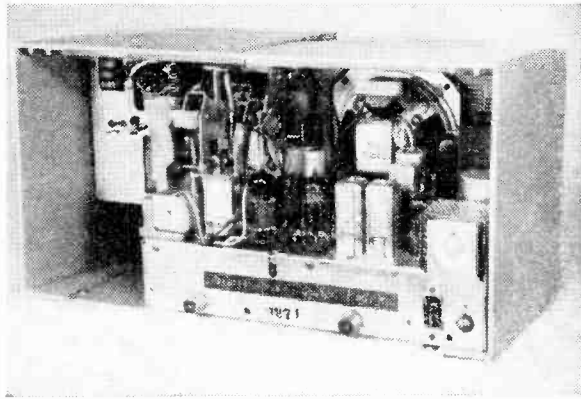

Rear view of Telemeter with coin box removed showing (left) coin mechanism.

whereby the accounts of the various parties engaged in the enterprise may be prepared. As very large numbers of subscribers to the service are envisaged, the record should be of such a form as to be readily handled by data processing equipment.

In the interests of simplicity, accuracy and reliability, magnetic tape recording is used in the Telemeter systems. The information to be recorded consists of a programme identification number and a price; no further data is needed to satisfy all the necessary requirements.

The information is coded in binary form and is transmitted over the control channel on a time-sharing basis along with the price-control information. A code sequence of 15 binary bits is used in which zeros are transmitted as pulses and ones as 200 c/s tones. The sequence is preceded by a long starting-tone burst of 200 c/s to enable the data processing equipment to recognize the start of the identity code sequence. Fig. 1 shows on the right the waveform which is produced by the perforated disc described in the section on pricing. As stated, the disc has two perforated tracks, the outer

one generating the start-pricing pulse, the price pulses and the zeros of the programme identity code, and the inner track generating the starting tone and the ones of the identity sequence. Fifteen adjustable tabs expose openings either in the outer or inner track to create the binary code. When a subscriber purchases a programme, the pricing drum closes switches S_5 and S_6 (Fig. 2). The closing of S_6 enables the subscriber to view the programme and switch S_5 furnishes power to the tape recorder drive motor. This, in turn, after 4 seconds, moves S_7 to the "recording" position and V3 now serves to drive the recording head with the composite waveform generated by the perforated disc. After 8 seconds, enough time for one complete identity code sequence to be recorded, S_5 opens and the recording cycle is completed.

The recording head and tape are contained in the cash box which, on collection, is taken intact to the central office. There, while the tape record is being read by the data processing equipment, the money is machine counted. The total provided by the tape record is compared with the cash in the

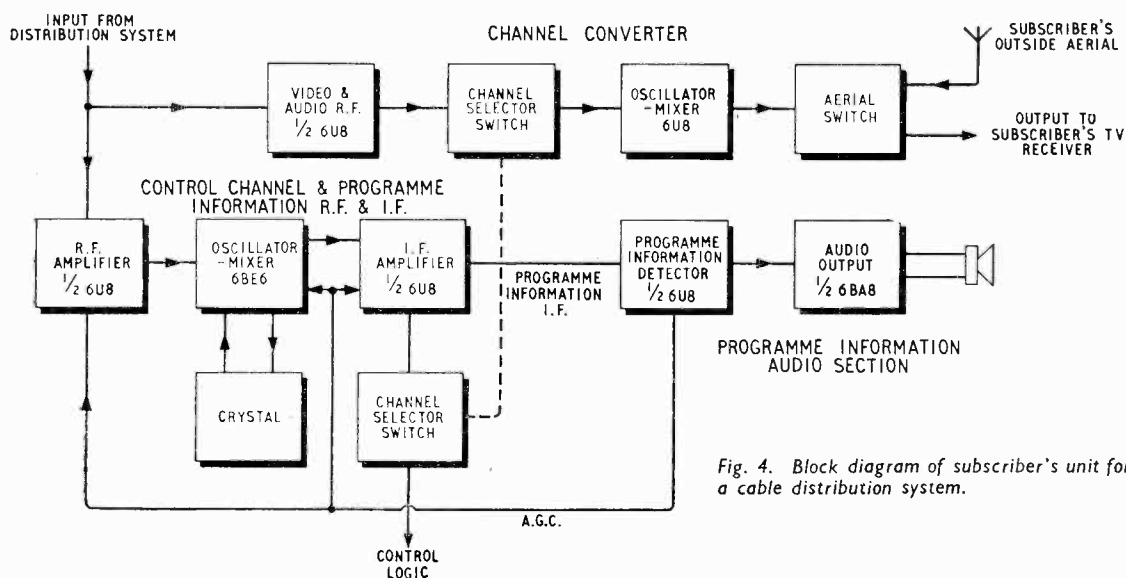

Fig. 4. Block diagram of subscriber's unit for a cable distribution system.

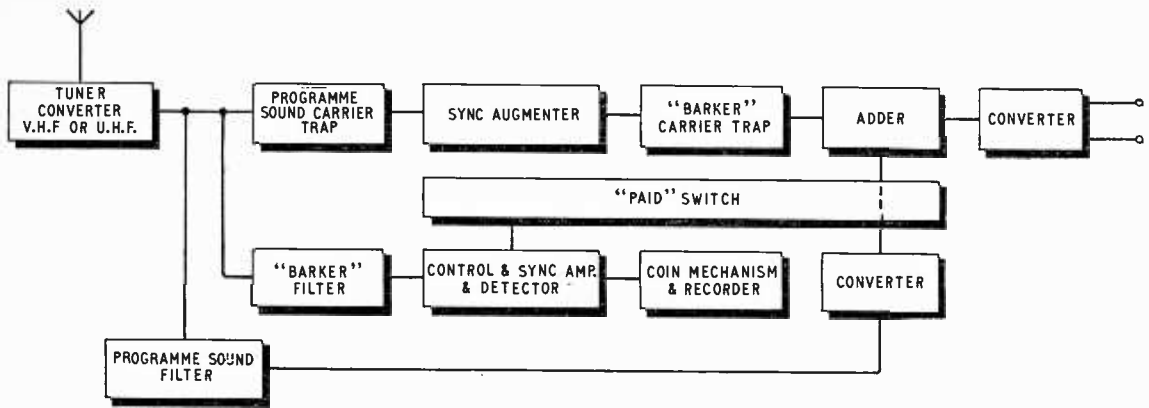

Fig. 5. Block diagram of subscriber's unit for broadcast transmission of Pay TV.

box and a note made in the subscriber's file of any adjustments that may be necessary. Also, at the time the data processing equipment is reading the tape, it records on a tally board the programmes viewed by the subscriber. This tally board displays the identity numbers of all the programmes offered within the accounting period and so the cumulative totals of viewers who have purchased a particular programme may be read-off at any time.

PROGRAMME INFORMATION. Information on current and future programmes should be readily available to subscribers.

The Telemeter system provides an audio programme information channel the substance of which is recorded on a magnetic tape loop and is transmitted continuously from the central station. This channel, together with the control channel, forms a group which is handled collectively by the distribution system. Three control and one programme information channels occupy a band of frequencies some 200 kc/s wide. The programme information carrier furnishes a.g.c. to the input stages of the subscriber's unit and the delay is set to provide 20 volts each of detected audio and control signals. This enables a wide range of input voltages to be accommodated. The power output to the loudspeaker contained in the unit is 0.6watts.

SECURITY. The security of the system must be such that unauthorized persons cannot receive the Pay TV programmes.

In the case of the cable system Telemeter rely on the inherent security of a "closed circuit" network together with the use of bands of frequencies for transmitting the programmes which are not normally acceptable to a television receiver. Fig. 3 shows in block diagram the transmitting station arrangement of a three-programme system and Fig. 4, in similar fashion, the programme and programme information circuits of a subscriber's unit.

The broadcast system has quite a different set of problems to solve as the frequencies on which these programmes are transmitted are readily acceptable to a normal television receiver. If a subscriber (or any TV receiver owner) were to tune his receiver to a Pay TV channel the programme of which was being transmitted by means of the

Telemeter system, he would hear, on the sound channel normally associated with the programme, the programme information (on what is aptly described in America as the "Barker" channel) being transmitted through his loudspeaker; the picture would be so "scrambled" as to be unintelligible; and a price demand would be set up automatically on his unit in the manner previously described. This state of affairs would have come about at the transmitting station as a result of the normal sound content of the programme being translated to a new carrier frequency not receivable by the set, the programme information and the control and recording information being transmitted on the frequency normally occupied by the television sound signal, and by the line-synchronizing pulse being reduced. After payment of the price demand, the subscriber's unit operates to restore the programme sound to its correct position in relationship to the video signal and to amplify the line-synchronizing pulses to their full amplitude so that the picture "locks." A block diagram of the subscriber's unit is given in Fig. 5.

Radio Hobbies Show

THIS year's International Radio Hobbies Exhibition, sponsored by the Radio Society of Great Britain, will be opened on November 22nd at the Royal Horticultural Society's Old Hall, London, S.W.1, by Henry Loomis, director of Voice of America, which, incidentally, transmits a monthly programme for radio amateurs. The exhibition will be open for four days from 11.0 to 9.0. Admission is 2s. At the time of going to press the following had booked space.

Avo
Bernards Publications
British Amateur TV Club
Copp Communications
Daystrom
Diatronic
Electroniques (Felixstowe)
Enthoven Solders
K. W. Electronics
Labgear
Minimitter Co.
Newnes, George
Philpott's Metalworks

Post Office
R.A.F.
R.S.G.B.
Radar & Electronics Assoc.
Royal Naval Reserve
Selray Book Co.
Short Wave Magazine
Sound Vision Services
Territorial Army
V.H.F. Group,
Webbs Radio
Wireless World
Withers (Electronics)

It is understood the British Amateur Television Club is putting on a colour TV demonstration during the Show. There will be a competition for home-constructed equipment for a trophy and also a competition to win a Hammarlund HQ170 communications receiver.

B.B.C. TELEVISION

25TH ANNIVERSARY OF "HIGH-DEFINITION" SERVICE

THIS page of illustrations records the start of regular television by the B.B.C. in 1936. Experimental transmissions had been radiated during the run of the National Radio Show of that year but it was not until November 2nd that a regular programme service began. Even then the transmitting techniques were still to some extent experimental as two systems (Baird 240-line sequential scanning and Marconi-E.M.I. 405-line interlaced scanning) were used on alternate weeks. From February 8th, 1937, the television service used only the Marconi-E.M.I. system.

Control desk for the Marconi-E.M.I. transmitter.

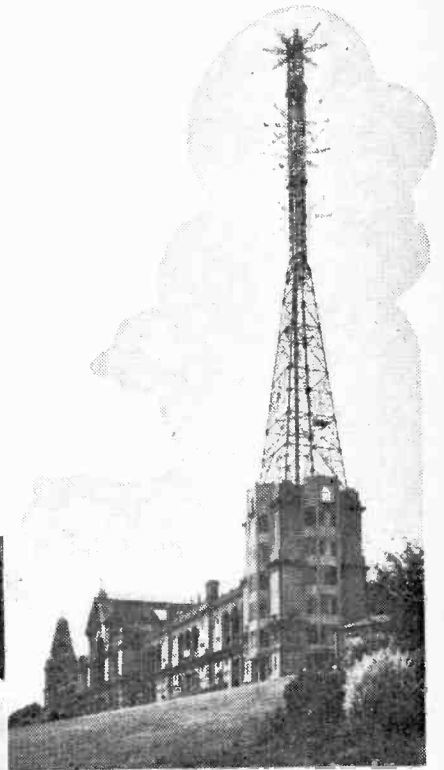

The original London transmitting aerial and tower at Alexandra Palace.

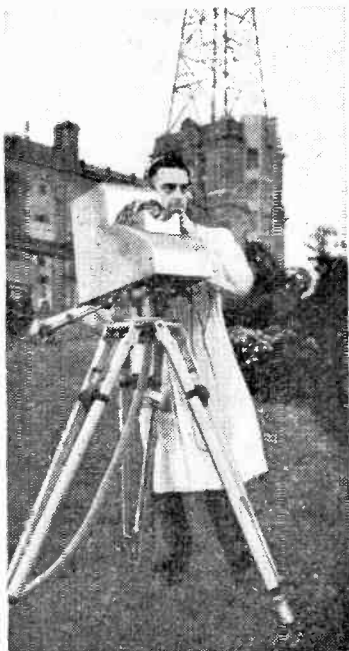

(Left) Marconi-E.M.I. "instantaneous" camera, so-called because the Baird system employed intermediate film scanning. The cameraman is D. C. Birkinshaw, now Superintendent Engineer, Television.

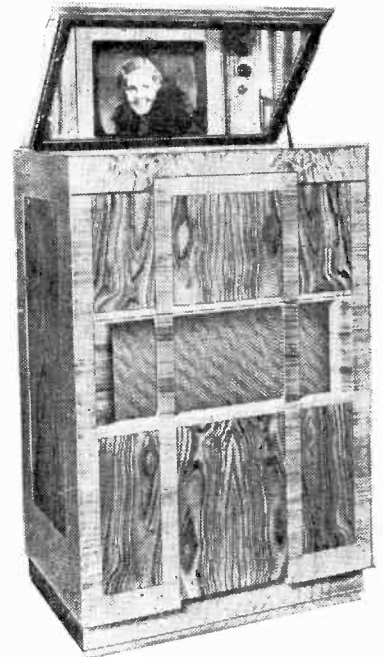
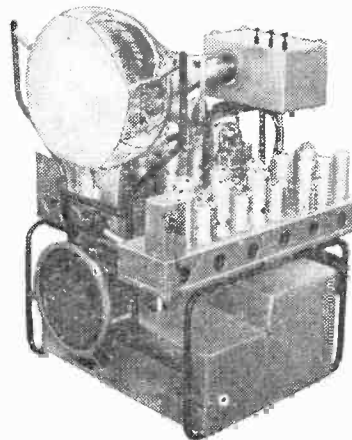

Two examples of 1936 television receivers. Left, the chassis of a Pye direct-viewing receiver and, above, Marconiphone model 702 indirect-viewing receiver, both for 240- and 405-line pictures.

Electronic Computer Exhibition

NEW TECHNIQUES AND EQUIPMENT

THE advent of the "second generation"—as it was often referred to—seems to have brought a greatly increased air of respectability to computers, the emphasis at this exhibition being very much on practical, immediate use. The possibility of building up an installation piece by piece (even by the addition of internal (storage) units) together with flexibility of connection to different types of input and output (peripheral) equipment were both also emphasized. Transistorization seems complete—if any of the computers shown did use valves to any great extent, their manufacturers were too ashamed to inform us of the fact.

Logic.—Simple programming in a sort of pidgin or basic English is often possible now. Several "languages" are in use—most of them said to be compatible with each other.

The bottleneck often set up by the relatively slow speed of the input and output readers and printers is being increasingly obviated by the provision of "time sharing" facilities, by which several (usually up to three or four) programmes can be run at once on a computer. Thus, for example, several data transcription programmes (which use mainly the relatively slow peripheral equipment) might be run simultaneously with one data processing or scientific programme (which uses mainly the much faster arithmetic unit). Time sharing thus increases computer flexibility by allowing several input and output units to be used in parallel, and also obviates the necessity for very fast "off-line" printers to make full use of the computer calculation speed. Individual programmes also need not be optimized to make best use of the computer facilities and speeds of calculation, storage, input and output. Each programme can be independently written as well as read in and read out.

The time-shared programmes are arranged by the operator in a priority order. For example, as in the Ferranti "Orion", first might come those programmes using peripheral equipment which it is difficult to interrupt, secondly those programmes needing much slower mechanical peripheral equipment, and finally those needing tape peripheral equipment or the arithmetic unit. In the Ferranti "Atlas", this programme priority order may even be partly modified by the computer itself—depending on the requirements for peripheral equipment. In the A.E.I. 1010 an interrupt switch is provided to allow additional urgent work to be given overriding priority.

Whenever a programme is interrupted and the arithmetic unit no longer employed (for example, while information is being transferred, or by non-availability of peripheral equipment or working storage) the next programme in the priority order which is not interrupted is proceeded with, until the original programme can continue, or until a further interruption occurs.

The time sharing supervisory system usually automatically allocates and reserves to the individual programmes storage space and peripheral devices (the latter are not usually individually shared); this naturally being done in such a way as to prevent any mutual interference between the programmes. Should any attempt at interference occur, the programme causing it is interrupted and an alarm given. The possibility of such interference is further reduced in the Leo III and Ferranti "Atlas" computers by "tagging" each stored block of information by the number of the programme to which it refers.

When automatic storage allocation is provided, the task of the programmer is simplified since he need not consider absolute addresses nor arrange and optimize storage transfer.

An unusual feature of the English Electric KDF9 are its "nesting" core stores. Each of these can store up to sixteen items of information in a fixed serial order in such a way that transfer in or out of the store occurs only at the beginning of the series and automatically causes the remaining items to shift down or up a place respectively. This automatic shifting motion allows arithmetic and certain other simple operations to be carried out without reference to the main store, thus increasing the speed of computation. Such stores can also be used to facilitate the ordering of sub-routines.

Data transfer between the main store and peripheral equipment is carried out in the A.E.I. 1010 via buffer stores whose capacity has been reduced to only one word per peripheral unit. This reduction has been made possible by transferring data one word at a time and at such a rate that all the thirty-two buffer stores provided can be sequentially scanned in less than the time taken to store one word.

By addressing each character individually and by the use of end-of-word symbols, fully variable word length is provided in the English Electric KDF10. This naturally economizes the capacity required for data storage. **Storage.**—Fast but relatively small ferrite core stores backed up by larger but slower magnetic drums (or sometimes tape systems) are now almost invariably used. The possibility of extending their drum stores by mechanically coupling up to three additional units is a feature of the Sperry Type C and E series. A different type of store which consists of a set of vertically stacked rotating magnetic discs with an interlinking "comb" of read/write heads was used by De La Rue Bull Machines in their Gamma 30 and by I.B.M. (1301).

The normally somewhat contradictory requirements of size and speed of store can be better satisfied by providing random access. One popular system has similarities to the rotatable "ring" of records often used in juke boxes; such a (magnetic disc) storage system being used in the De La Rue Bull Machines "Gamma 30". What might be described as a juke box magnetic tape storage system is used in the Facit ECM 64 (of Swedish origin) shown by A.E.I. Here the information is stored in 64 separate 30-ft long reels of magnetic tape spaced along the circumference of a rotatable circle. To address a particular reel, the circle is rotated until this reel is at the bottom. A weight on the free end of the tape then falls through guides so as to lead the tape past the read/write head and pinch roller. When reading or writing has been completed, the reel is rewound and the store then ready for further use.

In a Card Random Access Memory (CRAM) shown by the National Cash Register Company, information is stored in the form of seven magnetic strips on each card. The cards are individually identified and selected from the stack by means of eight notches through which pass eight independently rotatable rods: each notch can have one of two shapes (corresponding to 0 and 1) and quadrangular cross-section rods are used so that, depending on their angular position, each rod engages with either only 0 or 1 notches. Thus, by rotating the rods individually to correspond to the set of notches in the card required, this card only may be freed from the pack. (A similar system of selection by means of cylindrical rods and holes/notches is used in the Anson

Visipoint edge punched card system shown at the neighbouring Business Efficiency Exhibition.) In CRAM, when a card is released, it is pneumatically drawn on to a rotating drum against which bears the read/write head. On release from the drum, it is seized by pinch rollers and passed at a fixed speed to one side of the pack, against which it is pushed by a synchronized vibrating plate.

Fast semi-permanent stores are being increasingly used for fixed sub-routines. In the Ferranti "Atlas" computer, these stores consist of ferrite rods inserted to provide magnetic coupling at the desired junctions of the (orthogonal) input and output wires. Mullard showed two semi-permanent single-plane ferrite core stores. In one of these stores two layers of cores separated by copper foil are used, the cores being coupled together at the desired points through holes in the copper foil: in the other, the fixed storage is provided by permanent magnets plugged in above the desired cores.

Data Recording.—An increasing trend—seen in equipment shown mainly at the adjacent Business Efficiency Exhibition—is towards recording information straight away in a format (such as punched cards or paper tape) which is immediately acceptable by a computer—a written record being often simultaneously also produced. This avoids errors arising from the normal double process of first recording the information in written form and then later re-recording it for use by the computer. In simultaneous recording systems for accounting shown by Burroughs and the National Cash Register Company, the information is simultaneously typed and recorded on magnetic strips on the back of the ledger. A recording which is both legible and acceptable to a computer is provided by the Cummins Perf-O-Data punched hole system shown by Original Documents Processing. In this the normal punched in-line five-hole code patterns are spread out to three columns, and extra redundant holes added to produce legible figures.

Input Readers.—An alternative to recording input data in a form which, though not legible, is acceptable to the computer is to provide equipment in the computer for reading legible letters and figures. Although a number of such systems have already been described and were discussed in a paper by M. B. Clowes and J. R. Parks given at the Electronic Data Processing Symposium held concurrently with the Exhibition, only one such system was shown at the Exhibition. This was the I.B.M. 1412

which follows the popular general idea of using a suitably modified type face which is scanned so as to subdivide it into a number of sensing areas. The presence or absence of ink in each area is recorded and compared by logic circuits with the corresponding data for permissible variations of the symbols so as to determine the actual symbol being read. In the I.B.M. 1412 magnetic ink is used and the pre-aligned characters are scanned seven times by a ten-track magnetic head to break them up into seventy rectangular sensing areas.

Normal punched tape readers generally use photo-transistors and lamps to detect the presence or absence of holes. However, in the Facit ETR 500 shown by A.E.I., the holes are detected rather by the changes in capacity they produce between a set of metal pins and a plate on opposite sides of the tape. This system has the advantages that it is not affected by light, and much less affected by dust, dirt and ageing.

Data Transmission by Telephone.—A considerable amount of development is going on in this field and a number of different systems were shown at the exhibition. Except for the I.B.M. 1001 all these were for binary data.

As regards the choice of modulation system for binary data, manufacturers seemed to be almost equally divided between (180°) phase modulation and (≈ 500c/s) frequency shift keying. Although the latter system is theoretically somewhat slower and more susceptible to interference, it does avoid the necessity for carrier synchronization.

Even more varied provisions were made for error detection or correction. This is reasonable since the complexity and cost of the equipment required depends greatly both on the degree of protection desired (and in particular on whether correction or only detection is required) as well as on the type of telephone link used (since this latter determines the number and type of errors to be expected). Most manufacturers used the standard method of adding one or more redundant "parity" bits and checking the known redundant information after transmission. Nearly complete detection was provided by Ferranti and Plessey—the latter by retransmitting the received signal back for direct comparison with the original, and the former by transmitting with each character its binary inverse.

The I.B.M. 1001 system transmits fifteen different characters in the form of pairs of frequencies. In this system any errors are unlikely to produce a valid digit.

SHORT-WAVE CONDITIONS

Prediction for November

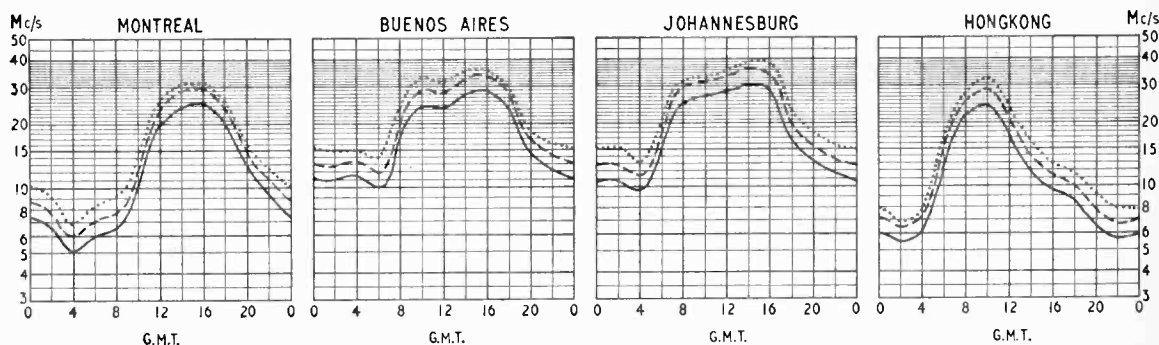

THE full-line curves indicate the highest frequencies likely to be usable at any time of the day or night for reliable communications over four long-distance paths from this country during November.

Broken-line curves give the highest frequencies that will sustain a partial service throughout the same period.

- FREQUENCY BELOW WHICH COMMUNICATION SHOULD BE POSSIBLE FOR 25% OF THE TOTAL TIME
- - - - - PREDICTED MEDIAN STANDARD MAXIMUM USABLE FREQUENCY
- FREQUENCY BELOW WHICH COMMUNICATION SHOULD BE POSSIBLE ON ALL UNDISTURBED DAYS

French Radio Show

LA DEUXIÈME CHAÎNE

IN general the changes this year in the French Radio Show were similar to those in our own. There was less high-quality sound reproducing equipment, decreased emphasis on stereo, little essential change in sound receivers and, finally, the most striking resemblance, a preoccupation with provision for receiving a new television programme, although major details of this have not yet been settled.

Television

So far as we could tell, all manufacturers felt it necessary to make some provision for receiving the alternative programme (deuxième chaîne), although the date for its commencement has not yet been definitely settled and is at least a year away.

The French are, however, better off than us in that the major technical details of this second chain have been decided. It will be in the u.h.f. Band IV using 625 lines with positive vision modulation and a.m. sound.

The use of 625 rather than 819 lines for the second programme has two advantages. First, if and when colour television comes into use throughout Europe, conversion between the various standards will be easier, and secondly, the bandwidth occupied is halved so that more transmitters can be provided in the band.

A variety of arrangements were made for receiving the second programme. Most sets were already modified to receive both standards, but provision only was made for the addition of a u.h.f. tuner. A few receivers were, however, already fitted with such a tuner and capable of receiving a second programme: no such programme was, however, laid on at the show, even for demonstration purposes.

Switched tuning in the u.h.f. band is difficult, so that continuously variable tuners will almost invariably be used.

Standards switching was in some cases provided by a special position on the normal turret tuner and in others by a separate control—this latter produced alarming results on 819-line pictures!

As might be expected, these provisions for the second programme have encouraged the production of multi-standard sets and these were more in evidence, though often only for the various 819-line standards. In the Philips and Radiola multi-standard 819-line receivers the switch for standards conversion is motor driven and set in operation by the channel selector switch.

Most, though not all, receivers now use 110° tubes, often of the “square”-faced variety. Although introduced some years back, 27-in screens do not seem to have caught on, in fact we did not notice any.

Popular are the 114° square American Twin-Panel 19 and 23-inch tubes. In the Twin-Panel construction the protective glass cover is already attached to the c.r.t. (and usually protrudes somewhat more from the front of the set) in an arrange-

ment which is claimed to reduce light reflected from the screen. The slightly dark tint of the cover also reduces image “flicker”.

We have previously noted a greater attention in France to the sound side of television receivers shown, for example, by frequent provision of a tone control, a “tweeter”, or one speaker on each side of the receiver. This year we noted two ways of diffusing forwards the sound from such side-facing speakers. One way, seen on the Pathé-Marconi (La Voix de Son Maître) T1049MD, is simply to use two reflecting side doors. Another, seen on the Titan “Dauphin” receiver, is to use a specially shaped (elliptical) speaker cone with the voice coil mounted asymmetrically towards one (long) side.

An unusual facility we noticed in some Oceanic, Radio-Celard and Titan receivers was the provision of a “magic-eye” indicator for the fine tuner. (Indicators that are unusual either in themselves or in the circumstances in which they are utilized were, in fact, noted occasionally in all types of French equipment and examples will be found in most of the sections of this review.)

Although, in general, the emphasis on remote control facilities seemed to have largely disappeared, we did note the first (in France) “wire-less” remote control. This was for Oceanic receivers and used a battery, transistorized, three-frequency (10, 11 and 12 kc/s) ½-watt oscillator (and mains receiver) to separately control the sound, contrast and on/off switch from up to 15 feet away. Pressing the contrast or sound remote control button alternately continually increases and decreases the contrast or sound (as the case may be) so that the desired position may be reached by successive approximations.

Another unusual facility noted in some Point-Bleu (Blaupunkt in Deutschland, Blue Spot in U.K.) and Schneider receivers was arrangements for locking the controls against tampering by children—and, dare we say, adults also?

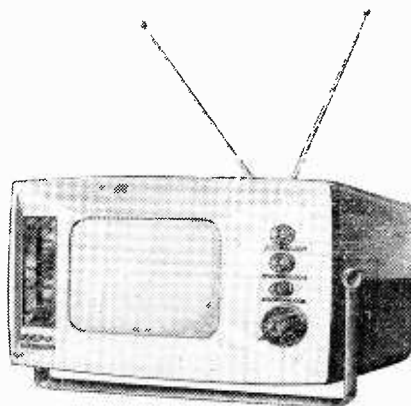

Combined transistor TV and a.m. radio—the Télécapte—shown by Radio-Celard.

A transistorized battery combined radio and television receiver—the Télécapte—even this could be adapted for the alternative programme) was shown by Radio-Celard. This can operate from batteries or mains, has an 8-in tube and uses 27 transistors.

Transistor Receivers and Record Reproducers

These are very popular in France and seem to come in all sizes without much evidence of the English trends towards either miniature or table models. Push-buttons are much in evidence, and are used to provide on/off and aerial as well as wave-change switching. Two push-button long-wave stations are provided in the Martial "Vancances".

Tone controls (push-button or continuous) are much more common in France than here. We even noted the provision of continuous bass as well as the normal treble controls in the L.M.T. Super T420 a.m./f.m. receiver.

As regards external connections, sockets for car aerials are very common in France as in this country. Much more common than in this country is the provision of an external speaker socket (usually intended alternatively for use with an earphone). Much less common is the provision of a socket for tape recording (we could only find one example, in the L.M.T. Super T420). This may be a reflection of the general lack of interest in tape recording at this Show. Pick-up sockets were noted in the Martial "Europe"—one of the table models—and the Pygmy "Varitron".

As in this country, manufacturers are increasingly using drift transistors in the h.f. stages. Unlike the case here, however, in France at least one manufacturer is using them to allow the number of transistors required to be reduced rather than to increase the receiver sensitivity.

A circuit feature seldom found necessary in this country but very often used in France is the provision of a thermistor or other temperature-sensitive resistive element to prevent thermal runaway in the output stage.

Although still rather unusual, transistor receivers combined with clocks are more common than in this country.

Although short-wave bands are very frequently provided, f.m. is much less so. Where we were able to obtain sufficient details (and people with such knowledge seemed, if anything, to be even rarer than at our own show) the combined a.m./f.m. sets seemed to follow the same basic circuitry as is used here, with a separate r.f. stage and combined mixer/oscillator two-transistor f.m. front end followed by three i.f. stages (or a mixer/oscillator and two i.f. stages on a.m.).

Unusual features of the Pygmy "Varitron" are—besides the pickup socket already mentioned—the provision of a filament bulb for use either as a dial light or as a signal level and direction indicator and a local/distance combined selectivity/sensitivity control.

Several record reproducers with unusual features were shown by Dentzer-Eden. For example, their S200 and S250 operate from the mains and have class-A output stages giving a power as high as 2 watts. Their S270 can be operated from mains or, if this supply is not available for any reason, automatically from batteries (and thus continues operating when unplugged from the mains). But most unusual is their 600—a battery model which combines a



Combined transistor record reproducer, tape recorder and a.m. radio shown by Dentzer-Eden.

record reproducer, a.m. radio and tape recorder. The latter is simply driven from the 3-in take-up spool by placing this spool on the record spindle: a separate motor is used for fast rewind. A permanent magnet provides erase facilities.

Aerials

Band IV arrays were, as might be expected, much in evidence.

A broadband (41-54 Mc/s) folded "dipole" shown by Ara Sefara used one closed and two open rods to reduce the s.w.r. in much the same way as would the use of two dipole elements with different diameters.

Two reflectors were used in a Portenseigne aerial to secure a high front-to-back ratio and smaller side lobes. The same company also showed a bent dipole omnidirectional f.m. aerial.

A three-element indoor aerial mounted (partially concealed) under a television table was shown by Telescopictv.

Amplifiers

Filament light bulbs were used as level indicators in models shown by Teppaz and Claude.

In two Claude stereo amplifiers two such bulbs can be switched in instead of the two speakers: at the same time a signal at 100c/s and its harmonics (derived from the mains) is fed to the two amplifier inputs. The two amplifiers can then be balanced by adjusting the two lamps for equal brightness.

In the high-power (80W) Teppaz 780S amplifier such an indicator is used to show overload. This amplifier is also protected by electromagnetic and thermal "fuses".

Tape Recorders

Unlike the case with this country, these do not appear to be popular since they were shown by only about five of the eighty or so radio and television exhibitors.

A fully transistorized recorder which operates however not from batteries but from the mains was shown by Radiola (RA 9546). This uses six transistors and has high-frequency erase as well as the other usual facilities.

In conclusion, we are glad that we can at last find space in a review of this show to commend the catalogue, which for only 2.50 Nouveaux Francs (slightly under 4 shillings) provides a considerable amount of technical detail on all the models exhibited.

WORLD OF WIRELESS

Pay TV

THE question of the possible introduction of subscription television both in this country and on the Continent is currently being discussed and an article on the subject will be found elsewhere in this issue. This deals with the Telemeter equipment which is now being used in a pilot scheme in Toronto. A demonstration of another system was given in London on October 16 by Choiceview Ltd., a company in which the Rank Organisation and Rediffusion are partners.

Choiceview has not only developed a system but is also planning to provide a programme service to relay or broadcasting organizations. Two methods of payment have been developed—both applicable to either “over the air” or wire services, although only the wire system was demonstrated. One employs a coin box on a “deferred payment” system; the user being unable to see a second programme until the first is paid for. The other employs a credit meter which will be read and an account submitted.

1962 Audio Festival

NEWLY elected chairman of the exhibitors’ committee for the 1962 International Audio Festival, to be held at the Hotel Russell, London, from April 26-29, is R. Merrick of British Ferrograph.

The 1962 Audio Festival is expected to be the most comprehensive exhibition of sound reproduction equipment yet staged by the organizers, by virtue of the increased interest shown by overseas firms. Already 56 companies have applied for entry.

It is expected that one of the attractions to enhance the festival aspect of the exhibition is that Gilbert Briggs (Wharfedale) will give a live demonstration of immediate recordings.

It has been decided to exclude the public from the first day of the show, devoting it almost exclusively to a preview for trade visitors.

Do You Know?

WHICH countries operate on the 625-line television standard and which on 525 lines?

What are the frequency limits of the X-band?

Which country uses call signs beginning VE?

What spacing is required between the dipole and radiator for a Band II aerial?

Is there a colour code for fuses?

What is the address of the National Council for Technological Awards?

The answers to these and very many other questions will be readily found in the 80-page reference section of the 1962 “Wireless World” Diary. Features introduced or re-introduced in the Diary, which is in its 44th year of publication, include transistor types and connections; the world’s television standards; some historic radio dates; and international call sign prefixes. The Diary costs 5s 9d, plus 1s 1d purchase tax, in leather, or 4s (plus 10d) in rexine.

B.B.C. Annual Report

ALMOST a third of the year’s cost of £18M for running the B.B.C. television service was for engineering services (including £760,000 paid to the Post Office for line rentals) and of the £12.6M for the home sound broadcasting services a quarter was devoted to engineering (including £260,000 for Post Office lines). These and the following facts are culled from the 1960/61 Report of the B.B.C.*

The Corporation’s income from licences increased by £2.25M to £33.5 compared with the 1959/60 figure. The number of v.h.f. receivers in use (estimated at 4M) has not increased “as rapidly as had been hoped.”

On the question of stereophonic broadcasting, using one v.h.f. station for both channels, the Report says “much research has been done, but no satisfactory system has yet emerged that would not reduce the area covered by the v.h.f. transmitter.” It also points to the difficulty presented by the fact that the Post Office lines used for linking studios, etc., for normal broadcasting “are not suitable as they stand” for stereo signals.

*Cmd. 1503. H.M.S.O. 10s 6d.

An exhibition coinciding with the 25th anniversary of the introduction of this country’s television service is being staged by the B.B.C. at the headquarters of the National Book League, 7 Albemarle Street, Piccadilly, London, W.1. It opens on October 31 for four weeks and will be devoted to both sound radio and television broadcasting. It will include books, scripts, models and historic items from the archives of the B.B.C. Admission is free and the exhibition will be open on weekdays from 11.0 to 8.0 (closing at 5.0 on Saturdays).

Universal Programmes Corporation are holding their third “At Home” on November 24, 25 and 26 at 35 Portland Place, London, W.1. A unique feature will be the recording of a live group on 3-track equipment and then allowing selected members of the audience to follow the processes through to editing, dubbing, reduction to 2-track and mono, and finally to master cutting both stereo and mono. Admittance is by ticket only on application to the company at the above address.

The Technique of Sound Recording is the title of a series of six lectures to be delivered by Peter Ford, hon. historian, B.S.R.A., on consecutive Fridays, commencing November 10 next, at 7.0 at the British Institute of Recorded Sound, 38 Russell Square, London, W.C.1. Fee for the course is 10s, or 2s 6d per lecture.

I.T.A. Headquarters Move.—New headquarters for the Independent Television Authority are located at 70 Brompton Road, London, S.W.3 (Tel.: Knightsbridge 7011). E.M.I. Electronics Ltd. have installed a wired TV and sound system at the new H.Q.

Television licences in the U.K. have now passed the 11.5M mark. Sound only licences total 3.8M including 0.49M for sets fitted in cars.

“Stratovision” was developed by the Westinghouse Electric Corp. not Western Electric as stated in error in the note on “Flying TV Classroom” in the September issue.

A sub-committee for stereophonic broadcasting has been set up by the technical committee of the west German industry and broadcasting organizations. The sub-committee will study stereophonic broadcasting problems in close co-operation with the Institut für Rundfunktechnik, a research institute working for all German broadcasting organizations on a participation basis. First part of the studies will cover aspects of an eventual introduction of stereophonic standards now in use in the U.S.A. for west Germany. The problem is expected to be discussed throughout the year of 1962, and stereophonic broadcasting in west Germany may start by 1964.

Radio Show Attendances.—Highest attendance since the National Radio Exhibition moved to Earls Court from Olympia in 1951 was recorded at this year's Radio Show when the grand total was 385,925—an increase of 39,855 over the 1960 figure. Also attracting more visitors was the recent Italian National Radio Show with a total attendance of 220,000, up by 10,000 on last year. Understandably, in view of the political situation in Berlin at the time, the west German Radio Show registered a smaller number of admissions (387,500) than originally expected.

Two new v.h.f. sound broadcasting stations have been brought into service recently by the B.B.C. That for the Channel Islands is located at Les Platons, Jersey, and transmits on 91.1, 94.45 and 97.1 Mc/s. The other new station, at Sherriffs Mountain, Londonderry, Northern Ireland, transmits on 88.3, 90.55 and 92.7 Mc/s.

An improved microphone network has been installed in the Chamber of the House of Commons by Tannoy who provided the original installation introduced in 1950. This involved replacing the fifteen existing microphones with twenty-three of an improved pattern. They are laid out in four lines of five microphones down the length of the Chamber, one over the Speaker's chair, and two over the despatch boxes.

The Junior Institution of Engineers have awarded their Vickers Prize and Medal to John Heywood for his paper on "Radio Investigation of the Solar Atmosphere." Mr. Heywood is a lecturer at the Birmingham College of Advanced Technology.

S.E.E. Programme.—The Society of Environmental Engineers, Suite 7, 167 Victoria Street, London, S.W.1, have issued their programme of technical papers and factory visits for the 1961-1962 session. Now in its third year, the Society has a membership approaching the 250 mark.

"Philips Awards," each consisting of a Philips Electrical Ltd. service kit, are to be presented to the three candidates judged to be the most meritorious in the City and Guilds of London Institute's final examinations in radio and television servicing.

Polarad Microwave Tuning Unit: The marketing rights for the Polarad Microwave Tuning Unit type RE-T, were inadvertently attributed to Brüel & Kjaer in the October issue. In fact, the equipment is marketed in the U.K. by B & K Laboratories Ltd., 4 Tilney Street, Park Lane, London, W.1.

Blaupunkt Printed Circuits.—In connection with the report on the Berlin Exhibition (1st column, p. 533, October issue) Blaupunkt ask us to point out that they have used printed boards in their television receivers for several years, but this year a single panel is used instead of three separate units.

"Parametric Amplification with Transistors."—In the circuit diagram on p. 498 of our October issue the 20 μ H inductance should have been labelled 20 μ H.

A Ferranti Atlas Computer is to be installed at the University of London towards the end of 1963 at a cost of approximately £2M. The machine is claimed to be in speed and capacity the most powerful computer in the world and should accelerate Britain's scientific research. Orders worth about £1M from the Universities of Birmingham, Glasgow, Leeds and Liverpool, for their KDF9 high speed data processing system have been received by the English Electric Company.

Colour Television Refresher Courses organized by The Television Society recently have proved so popular that arrangements have been made to repeat the series of lectures in London in January, 1962. Lecturers will again be S. N. Watson, B.B.C. Designs Dept., and G. B. Townsend and P. Carnt of the G.E.C. Hirst Research Centre. Early application for enrolment forms from the Society at 166 Shaftesbury Avenue, London, W.C.2, is advised.

International Short Wave Club, 100 Adams Gardens Estate, London, S.E.16, are conducting an official vote to determine the favourite stations of all listeners, whether members of the Club or not. Postcards, listing listeners' five most popular s.w. stations in order of merit and a few words about their No. 1 choice, are requested before January 1 next.

Personalities

Sir Willis Jackson, F.R.S., has relinquished his appointment as Director of Research and Education of A.E.I. (Manchester), formerly Metropolitan-Vickers Electrical Co., to return to academic life as Professor of Electrical Engineering at Imperial College, University of London. He is continuing as an A.E.I. research consultant. Sir Willis' long association with the company began with a vacation apprenticeship in 1928. Ten years later he left the organization on being appointed Professor of Electrotechnics at Manchester University, and in 1946 became Professor of Electrical Engineering at Imperial College. He returned to the company in 1953.

J. M. Dodds, O.B.E., Dr. Ing., M.A., B.Sc., who is appointed director of the A.E.I. Research Laboratory, Manchester, was awarded the degree of Dr. Ing. from Aachen University, where he went with a travelling scholarship on completion of a graduate apprenticeship with Metro-Vick in 1931. Dr. Dodds was appointed physicist in the radio section of the Research Laboratory in 1933, and became responsible in 1937 for the development of the C.H. radar transmitters. In 1956 he was appointed assistant manager of the Research Laboratory and became manager the following year.

A. F. Gibson, Ph.D., A.Inst.P., leader of the semiconductor physics research division of R.R.E., which he joined in 1944, has been promoted to Deputy Chief Scientific Officer in the Scientific Civil Service. He is among several officers who have been given special promotion in recognition of research work of exceptional quality. Dr. Gibson has made a special study of the microwave properties of germanium and the effect of carrier injection and extraction on the absorption. His most recent work has been concerned with "hot" electrons in germanium.

J. F. Gittins, B.Sc., A.R.C.S., of the Services Electronics Research Laboratory at Harlow, Essex, is among several scientific civil servants promoted to Senior Principal Scientific Officer. He has undertaken research in the field of high-power microwave valves and particularly travelling-wave tubes. He is chairman of the Services Power Valve Research Advisory Panel.

Major General Eric S. Cole, C.B., C.B.E., Director of Telecommunications at the War Office from 1958 until last April when he retired, has joined Ultra Electronics as operational manager of its new Telecommunications Division. General Cole, who was deputy chief signals officer, Allied Command Europe, prior to his War Office appointment, was at one time chairman of the British Joint Communications Electronics Board. Well-known in amateur radio circles—he has operated his own transmitter in many parts of the world—General Cole has been president of the Radio Society of Great Britain for the past year.



Maj. Gen. E. S. Cole



N. Hughes

Rear-Admiral Sir Philip Clarke, K.B.E., C.B., D.S.O., has, on his doctor's orders, retired from the board of Ether Langham Thompson Ltd. He joined the Langham Thompson organization after retiring from the directorship of the Naval Electrical Department in 1955. Sir Philip was president of the Brit. I.R.E. from 1954 to 1956.

Air Vice-Marshal G. P. Chamberlain, who retired from the R.A.F. a year ago after 37 years' service, has joined Collins Radio Company of England as managing director. A.V.-M. Chamberlain was deputy controller of electronics in the Ministry of Aviation from 1957 until his retirement.



L. G. F. Shuttleworth

L. G. F. Shuttleworth, assistant engineer - in - charge of the B.B.C. Tatsfield Receiving and Measurement Station since 1940, has been appointed engineer-in-charge in succession to the late **H. V. Griffiths.** He has been on the staff of the station since it was built in 1929—starting as a maintenance engineer — having previously been for four years at the Keston Receiving Station which was the forerunner of the one at Tatsfield.

Nathan Hughes, B.Sc., A.M.I.E.E., A.M.Brit.I.R.E., at present chief engineer and deputy manager at the studios of Television Wales and the West, at Pontcanna, Cardiff, has been appointed general manager of Wales Television, the programme contractor for the I.T.A. stations to be built in Pembrokeshire and on the Llyn Peninsula. Mr. Hughes, who is 37, graduated at University College, Swansea, and served with the Royal Navy and Royal Signals from 1942 to 1947. He then went to Marconi's W/T Company as an installation engineer and in 1955 joined Associated Rediffusion. He has been with T.W.W., the I.T.A. programme company serving South Wales and the West of England, since 1957.

Leslie H. Bedford, C.B.E., M.A., B.Sc., F.C.G.I., M.I.E.E., M.Brit.I.R.E., for the past two years director of engineering, Guided Weapons Division of English Electric Aviation Ltd., is one of five new members appointed to the Council for Scientific and Industrial Research. Mr. Bedford, who is 61, was director of research at A. C. Cossor Ltd. from 1931 to 1947. He then joined the English Electric Group as chief television engineer of Marconi's W/T Co., and subsequently became chief engineer of the English Electric Guided Weapons Division. The present constitution of the Research Council is: Sir Harold Roxbee Cox (chairman), L. H. Bedford, Professor B. Bleaney, Professor C. F. Carter, Dr. J. W. Cook, Frank Cousins, Sir Walter Drummond, G. B. R. Feilden, Professor E. R. H. Jones, Vice-Admiral Sir Frank Mason, Professor O. A. Saunders, Dr. C. J. Smithells, H. C. Tett, and Lewis T. Wright. Sir Harry Melville is secretary.

George E. Partington, B.Sc., A.M.I.E.E., chief engineer of Marconi's Broadcasting Division, was the only British contributor at the 90th Semi-annual Convention of the American Society of Motion Picture and Television Engineers held in New York at the beginning of October. He read a paper on operationally simplified camera channels at the session covering television equipment and techniques. Mr. Partington has been with Marconi's since 1938 and was appointed to his present position two years ago.

J. W. L. Johnson has joined Fidelity Radio as assistant general manager. For the past 11 years he has been with Amplion where he was at one time chief engineer and latterly general manager. After war service in the R.A.F. signals, Mr. Johnson, who is 48, went to Multitone where he was for three years production manager.

OUR AUTHORS

R. A. Tobey, M.A., Grad.I.E.E., and **Jack Dinsdale, B.A.,** who are working on instrumentation magnetic recording systems at Elliott Brothers, contribute an article in this issue on their spare-time interest—sound reproduction. They describe a transistor audio amplifier. Mr. Tobey, who graduated at Magdalene College, Cambridge, in 1955, has been with Elliotts since 1957 working mainly on transistor circuitry. Mr. Dinsdale, who is 23 and graduated at Trinity College, Cambridge, in 1959, joined the Weapons Division of Elliotts the same year. He recently completed one year of post-graduate study at the College of Aeronautics, Cranfield, where he worked mainly on magnetic tape recording.

W. McMillan, author of the article on page 570, has been with Standard Telephones & Cables since 1956. Educated at Ayr Academy and Glasgow University, he joined S.T.C. as a technical writer dealing with microwave transmission systems and submarine cables, but for the past two years has been on the headquarters staff for liaison work with the technical press.

OBITUARY

Thomas Brown Watkins, Ph.D., M.Sc., A.M.I.E.E., who died on September 19th at the age of 40, had been with the Mullard Research Laboratories since 1952. Dr. Watkins graduated at Edinburgh with 1st class honours in electrical engineering in 1941, and obtained his M.Sc. in mathematics in 1950. He served in the R.A.F. as a Technical Officer from 1941 to 1947. Dr. Watkins, who obtained his Ph.D. degree at London University on a thesis entitled "Modulation noise as a surface property in germanium junction diodes" in 1958, held a leading position in semiconductor research.

TRANSFORMERLESS TECHNIQUE RESULTS
IN GOOD PERFORMANCE, ALLIED WITH
SIMPLICITY AND COMPACTNESS

Transistor Audio Power Amplifier

By R. TOBEY, M.A. and J. DINSDALE, B.A.

THE object of this design is to produce a transistor amplifier comparable in performance with good modern practice using thermionic valves, but with all the advantages of transistorized equipment.

This object is best achieved by the elimination of all transformers from the design, when the following advantages are obtained:—

- (i) Smaller size and weight, since transformers account for a large portion of the bulk and weight of a conventional power amplifier.
- (ii) Better frequency response.
- (iii) Greater efficiency.
- (iv) Less distortion without feedback.
- (v) More feedback may be used to reduce this distortion still further, without causing instability.
- (vi) One expensive component less required.

The basic circuit is shown in block diagram form in Fig. 1. It consists of a high-gain, low-noise, voltage amplifier, directly coupled to a current amplifier, with overall d.c. negative feedback to stabilize the working points of the transistors, and a.c. feedback to reduce distortion to a sufficiently low level.

Current Amplifier.—This matches the low impedance of the loudspeaker to the output of the voltage amplifier. Two stages are needed to give the required current gain of about 1,000.

There are various ways of matching a Class-B

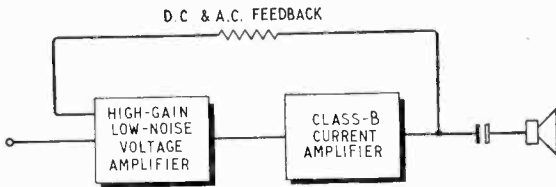

Above: Fig. 1.
Block diagram of
amplifier.

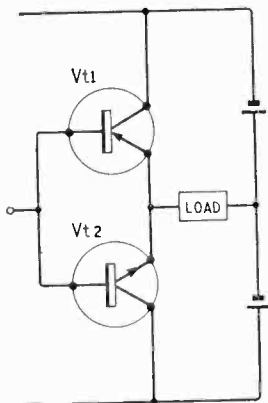

Left: Fig. 2. Push-
pull Class-B
emitter follower.

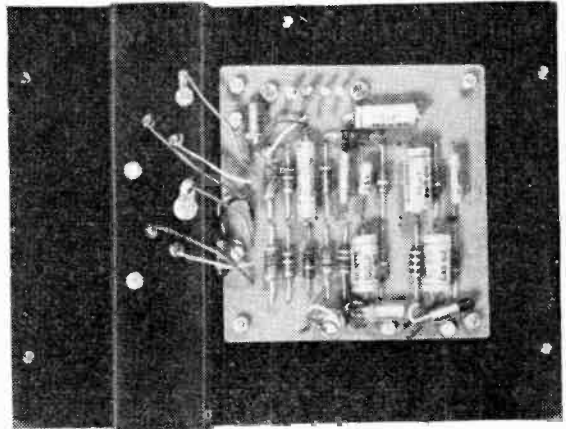

Power amplifier showing components mounted on a printed circuit plate.

push-pull output stage to a loudspeaker load without incorporating transformers. These all hinge round the use of complementary symmetry, i.e. a p-n-p/n-p-n pair of transistors.

Fig. 2 shows a single stage of what may be considered as a Class-B emitter follower. Vt1, a p-n-p transistor, acts as an emitter follower for the negative half cycles of the input, while Vt2 is cut off. Similarly, Vt2, an n-p-n transistor, emitter follows the positive half cycles.

Fig. 3a shows a two-stage Class-B emitter follower having a total current gain equal to the product of the current gains of the individual stages. The voltage gain is slightly less than unity, as would be the case with the analogous cathode-follower circuit, each stage having 100 per cent voltage feedback.

A different arrangement of the same transistors giving the same result is shown in Fig. 3b. This consists of two grounded-emitter stages with 100 per cent voltage feedback over the two stages together (as opposed to over each stage separately as in Fig. 3a). The voltages, currents and dissipations of the various transistors are the same at any point of the waveform in both arrangements.

From Figs. 3a and 3b is derived the arrangement of Fig. 3c which has the advantage that both output power transistors may be of the p-n-p type.

All three arrangements will give equally satisfactory results, however, with suitable transistors.

The voltage amplifier (see Fig. 4) consists of two directly-coupled grounded-emitter stages in cascade. Vt1 works with a low value of collector-

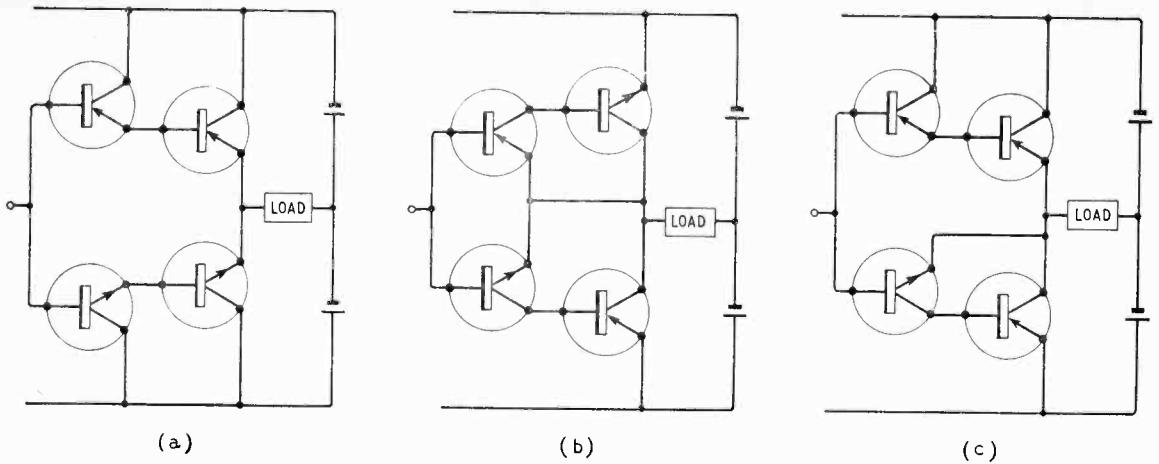

fig. 3 (a) Two-stage push-pull Class-B emitter follower. (b) Two-stage push-pull Class-B grounded-emitter amplifier with 100 percent voltage feedback. (c) Hybrid circuit derived from (a) and (b).

emitter potential and with a small collector current, thus ensuring a low noise factor.

Complete Amplifier (Fig. 4).—The voltage and current amplifiers are d.c. coupled, and the complete amplifier has d.c. feedback around it via R_{16} , which stabilizes the working points of all the transistors. The quiescent current in the output stage $Vt5, Vt6$, is set by R_9 , in series with the diode $D1$, about 10-20 mA being suitable. The d.c. working point of the output of the amplifier ($Vt6$ collector) should be half the supply voltage with respect to earth, and should be set up if necessary by varying R_1 .

The diode $D1$, is biased in the conducting direction on a portion of its characteristic giving a high degree of voltage stabilization across it, with change of current through it (Fig. 5). This stabilizes the output stage quiescent current against supply voltage variations, and also reduces the effects of temperature on the output stage quiescent current, provided that the diode is attached to the same heat sink. R_{14}, R_{15} are included to give good thermal stability under adverse conditions.

Values of components are given for two typical versions of the amplifier (see Table 1). Version 1 is designed to give 10 watts into a 15-ohm speaker from a 40-volt supply. Version 2 is designed to give 10 watts into a 4-ohm speaker (or $3\frac{1}{2}$ watts into a 15-ohm speaker) from 24 volts. The design is extremely flexible and easily adapted for other needs. Maximum theoretical power output is $V_{batt}^2/8R_L$, but in practice is only about $V_{batt}^2/10R_L$.

It might be thought that the use of a Class-B output stage in an amplifier for high fidelity applications is undesirable, and would lead to consider b e distortion, especially high order harmonics. The distortion introduced at the cross-over point of the output stage characteristic may, however, be kept low by a suitable choice of quiescent current, and the total amplifier distortion may be reduced to any desired level by negative feedback. The application of the high values of

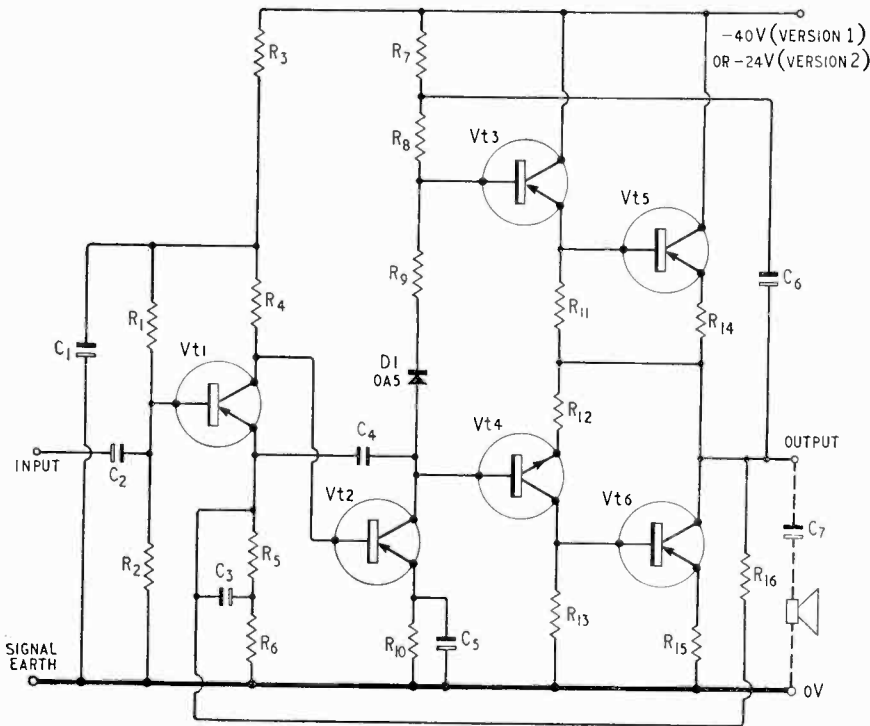

Fig. 4. Power amplifier circuit.

TABLE 1
Component Values for Power Amplifier

Component	Version 1: 40 volts 15 ohms		Version 2: 24 volts 4 ohms	
	Resistor	Value	Remarks	Value
R1	270k Ω	See Text	330k Ω	See Text
R2	56k Ω		56k Ω	
R3	68k Ω		22k Ω	
R4	22k Ω		22k Ω	
R5	220 Ω		150 Ω	
R6	33 Ω	H.S.	33 Ω	H.S.
R7	1k Ω		470 Ω	
R8	4.7k Ω		1.5k Ω	
R9	22 Ω	See Text	10 Ω	See Text
R10	560 Ω		270 Ω	
R11	150 Ω		150 Ω	
R12	10 Ω		3.3 Ω	W.W.
R13	150 Ω		150 Ω	
R14	1 Ω	W.W.	0.5 Ω	W.W.
R15	1 Ω	W.W.	0.5 Ω	W.W.
R16	3.9k Ω	H.S.	2.2k Ω	H.S.

Capacitor	Value	Remarks	Value	Remarks
C1	1 μ F	25V wkg	1 μ F	25V wkg
C2	50 μ F	25V wkg	50 μ F	25V wkg
C3	100 μ F	6V wkg	100 μ F	6V wkg
C4	1000 pF		2200 pF	
C5	100 μ F	6V wkg	100 μ F	6V wkg
C6	25 μ F	50V wkg	50 μ F	25V wkg
C7	1500 μ F	25V wkg	2500 μ F	25V wkg
C8	1500 μ F	50V wkg	2500 μ F	25V wkg
(power supply)				

feedback needed to produce low distortion is facilitated by the transformerless technique, and the absence of transformers removes one source of particularly objectionable cross-over distortion in Class-B amplifiers, which is produced by imperfect coupling between the two halves of the primary of the output transformer.

This amplifier has feedback totalling over 60 dB (34 dB via the main loop, 26 dB locally in the output stage), and the distortion is satisfactorily low (see Table 3) being predominantly third harmonic, as would be expected in a normal well-balanced push-pull amplifier.

Advantages of Class-B Output Stage Operation.—By operating the output stage under conditions which approximate to Class B, important economies are possible in several directions, namely, in the design of the heat-sink and power supplies.

When used to amplify a speech or music input, the average dissipation in the output transistors is very small; they would, in fact, remain cool even without a heat-sink. However, with sine-wave drive (which is used for example in routine testing), a heat-sink of about 50 square inches of 16 s.w.g. aluminium bent to any convenient shape is required. A 10-watt amplifier with a Class-A output stage would require a heat-sink to dissipate at least 20 watts continuously, which would result in a large and cumbersome design. The prototype amplifier

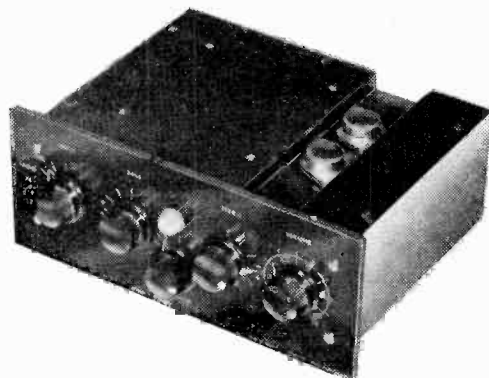

Stereo power amplifier and pre-amplifier showing one pair of output transistors.

was built into an aluminium box which itself served as the heat-sink.

The amplifier is suitable for operation from a wide variety of power supplies. For permanent use a mains power unit may be used, which can, however, be quite rough and ready. Provided a large reservoir capacitor is used, further smoothing and

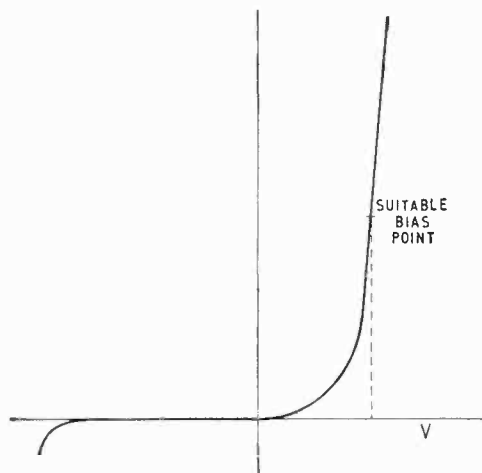

Fig. 5. Diode current/voltage characteristic.

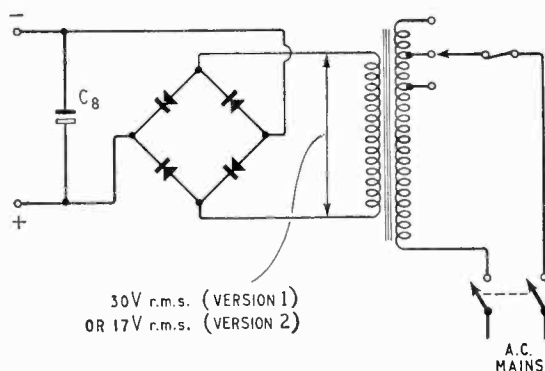

Fig. 6. Simple mains power supply circuit.

TABLE 2
Guide to suitable types of transistor for power amplifier

Transistor Number	Type	Gain (Typical)	Version 1		Version 2	
			Voltage wkg	Typical Types	Voltage wkg	Typical Types
Vt 1	p-n-p Small signal high frequency	High (100)	6	GET874 OC44 XA102	6	GET874 OC44 XA102
Vt 2	p-n-p	Medium (50)	40	GET111 XB121	24	GET102 OC71 XB103
Vt 3	p-n-p	Medium (30 at 100mA)	40	GET111 XB121	24	GET102 OC72 XC121
Vt 4	n-p-n	Medium (30 at 100mA)	40	2N385A 2N388A SYL1750	24	XA702 2N385 SYL1750
Vt 5 } Vt 6 }	p-n-p Power	Medium (30 at 3A)	40	OC35 GET573 2N257 2N457 XC141	24	OC35 GET572 2N257 2N457 XC141

a high degree of regulation are not necessary (see Fig. 6), since under zero or low signal input, when hum is most noticeable, the quiescent current drawn by the amplifier is small, and hence the hum producing ripple on the reservoir capacitor is low.

Battery supplies may also be utilized, and a surprisingly long life can be obtained from ordinary dry batteries (e.g. grid-bias batteries), especially if the quiescent current of the amplifier is reduced, at the expense of a slight increase in distortion, by shorting out R_{10} . The amplifier will operate satisfactorily down to less than half nominal voltage without component alterations, but with a reduction in power output, which is proportional to V_{batt}^2 .

Transistor Characteristics Required.—The choice of transistors used in the amplifier is not critical, but the basic requirements of each part of the circuit must be satisfied.

It will be seen from Table 2 that ordinary p-n-p power transistors are used in the output stage, whose

current gain falls appreciably at the high end of the audio-frequency band. However, this does not cause a corresponding reduction in performance because the impedance of a typical moving-coil speaker increases with frequency, see Fig. 7, (and hence the current it draws falls) at a rate which, in fact, more than offsets the decrease in current gain

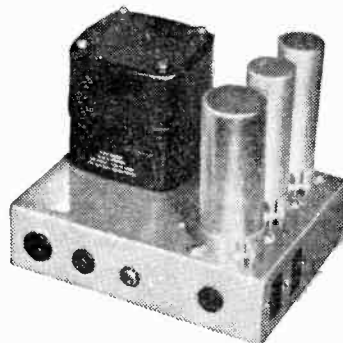

Power supply for stereo power amplifier and pre-amplifier.

Fig. 7. Impedance characteristic of typical moving-coil loud-speaker.

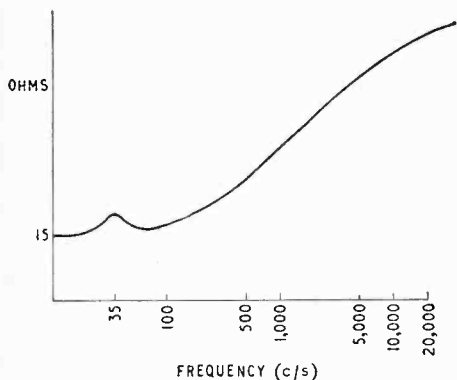

of the output transistors. The amplifier is designed to work into an inductive load, as given by a normal speaker or speaker combination.

If, however, an amplifier is required to work into a resistive or capacitive load (e.g. an electrostatic speaker) the use of power transistors having a high α cut-off frequency, such as the Mullard OC23, would be worth-while.

Transistors Vt2 to 6 must be able to stand the full supply voltage in the cut-off condition.

Stability.—Even though the feedback loop does not contain a transformer, care is needed if the

(Continued on page 569)

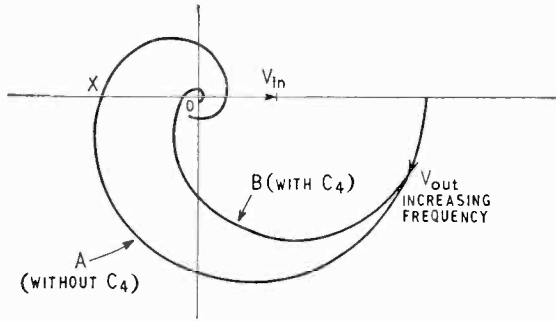

Fig. 8. Open-loop Nyquist diagrams of amplifier with (curve B) and without (curve A) the stabilizing capacitor C_4 .

amplifier is to have an adequate margin of stability under all conditions, since the transistors give appreciable phase shift at frequencies where high loop gain is needed for good performance.

The amplifier contains two subsidiary feedback loops within the main feedback loop, both of which contribute to maintaining stability. One loop consists of the output stage and driver stage, which have 100 per cent voltage feedback, thus reducing the phase shift at high frequencies due to these two stages. The voltage amplifier stages Vt1, Vt2, have feedback around them at high frequencies, via C_4 , so that the voltage amplifier approximates to a single active dominant lag.

In Fig. 8 Curve A shows the open-loop Nyquist diagram of the amplifier without the stabilizing capacitor, C_4 . From the length of the intercept OX, on the X axis it will be seen that very little overall loop gain is required to make the amplifier unstable. The addition of C_4 gives Curve B, which is much more satisfactory.

Earthing.—The correct connection of earths (see Fig. 9) is essential if distortion is to be avoided, since the earth wire to the output stage carries large asymmetric earth currents, from the Class-B output stage, which can produce appreciable voltages across quite short pieces of wire. If these voltages are coupled into the input of the amplifier even harmonic distortion will be produced.

Noise.—The performance of the amplifier with regard to noise, and, when used with a mains unit, hum, is extremely good, being better than 85 dB down on full output.

A word of warning however: the noise depends almost entirely on Vt1, and, although the conditions of operation are chosen to minimize noise, the

TABLE 3
Performance of Power Amplifier

Power output	10 watts at 400 c/s
Total harmonic distortion	0.25 per cent
Second harmonic distortion	0.1 per cent
Third harmonic distortion	0.2 per cent
Fourth harmonic distortion	0.05 per cent
Fifth harmonic distortion	0.04 per cent
Sixth harmonic distortion	0.02 per cent
Distortion for harmonics higher than the sixth	Less than 0.01 per cent
Output impedance	Less than 0.25 ohm
Input impedance	33 kilohms
Input voltage for 10 watts output	100mV
Voltage gain constancy	Within ± 1 dB from 40 c/s to 20 kc/s. (The bass response can be extended if desired by increasing C_3)

occasional specimen may be found unsatisfactory in this respect, when it should be changed. In fact, transistors are extremely variable in this parameter—the author has found variations of 50 dB in noise factor between transistors of the same type from the same packet. Transistors with a doubtful past history of use (or abuse) are particularly to be avoided on this account.

Layout.—The layout of the power amplifier is not at all critical, and with suitable screening they may be mounted in close proximity to the pre-amplifiers. Thus, for the prototype, two of the 40-volt, 10-watt amplifiers were made up on printed circuit boards, and used in conjunction with a four-transistor stereophonic pre-amplifier. The complete unit has a front panel $8\frac{1}{2}$ in \times $3\frac{1}{2}$ in and is 6in deep. (Power supplies were kept separate, as the unit is very suitable for operation from batteries.)

The power amplifiers are mounted on the top and base plates of the unit, and a channel in each of these housed the output transistors (see photographs). This heat-sink is quite adequate for the output dissipation, even on short-term sine-wave testing at full output power.

As with all transistor apparatus, a little care when first switching on the newly-built equipment will often save an expensive catastrophe. The voltage should be applied slowly, preferably from a dry battery, so that the presence of any fault current is discovered before damage is done.

Associated Equipment.—While the amplifier is sensitive enough to work directly from a crystal

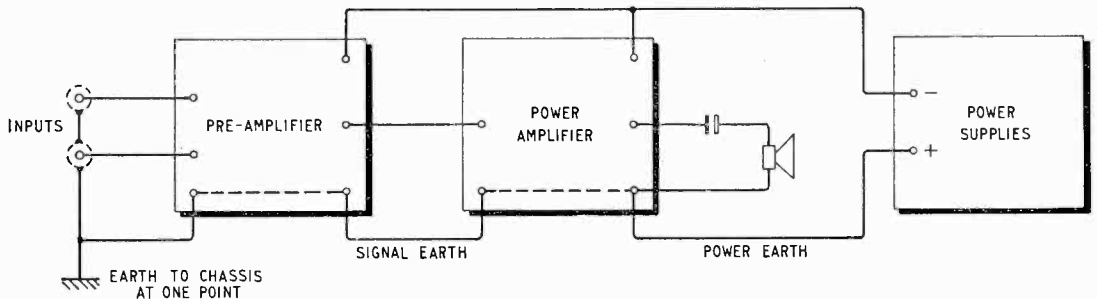

Fig. 9. Earthing diagram for power amplifier and associated equipment.

pick-up, it must be driven from a low impedance source (i.e. less than 10 kilohms) if the full value of feedback is to be operative.

The design of a suitable pre-amplifier, incorporating all the usual refinements, will be the subject of a future article.

Performance.—The performance of the amplifier has proved very satisfactory, and subjective listening tests have confirmed the results obtained in the laboratory (see Table 3). It is possible to apply

more feedback to the amplifier and reduce the distortion still further, but it is doubtful if any worthwhile benefit would result, and the lower sensitivity would complicate the design of the pre-amplifier.

High frequency tests on the amplifier should be carried out using a dummy load simulating the impedance of a loudspeaker, i.e.: for a 15 ohms loudspeaker: 15 ohms + 1 mH; and for a 4 ohms loudspeaker: 4 ohms + 0.25 mH.

Putting the Computer to Work

SEQUENCE OF OPERATIONS ILLUSTRATED BY A SIMPLE ELECTRICAL CALCULATION

By WILLIAM McMILLAN*

Although readers of this journal have been kept up to date on the electronic elements of digital computers, they may be less clear about what people do with the complete machine when it is assembled and ready for use. This article describes a computer installation and illustrates its use by a familiar example.

THE upsurge of interest in computers, accelerated to some extent by the recent Electronic Computer Exhibition, has caused many electronic engineers and businessmen to take a fresh look at the subject. Unfamiliar terms used by logical designers and programmers have perhaps tended to make computer operation appear more difficult than it is. This article is intended to help dispel this illusion.

The various units which make up a typical computer installation are shown in Fig. 1. The particular installation shown here consists (reading from left to right) of:—

1:—The computer cubicle, which contains the

electrical circuits and storage medium. The computer draws its special power supplies from a separate cubicle which is not shown in this picture. The power cubicle is about half the size of the computer cubicle.

2:—Two high-speed tape readers.

3:—The computer input control panel.

4:—The "on-line" teleprinter.

5:—Two "on-line" high-speed tape punches.

6:—The "off-line" tape reader.

7:—The "off-line" teleprinter.

8:—The keyboard tape perforator (for the preparation of the "programme" and "data" tapes).

From this it will be obvious that although the computer is the heart of the installation, a great deal of other equipment is needed to make full use of its capabilities.

These "Input" and "Output" devices are necessary to put information into a form which is usable by the computer and to reconvert the computer output signals—electrical pulses—into printed form.

The Computer — What's Inside?—The most important feature of an electronic computer is its ability to store numbers. In many computers a magnetic drum is used for this purpose, there being many

* Standard Telephones and Cables Ltd

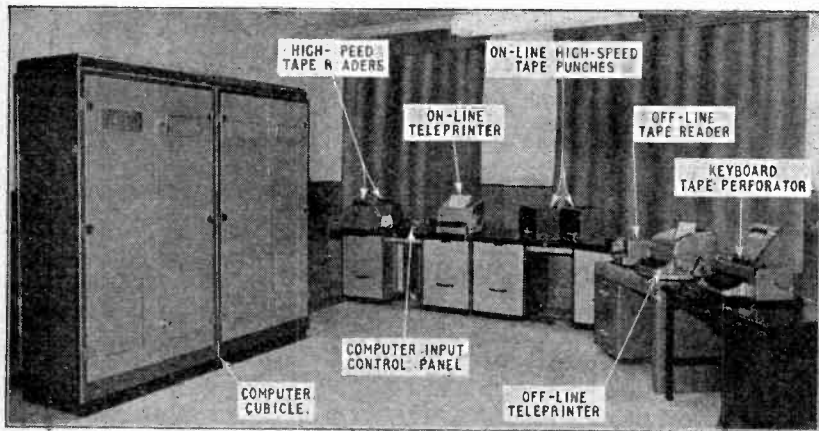

Fig. 1. Typical Stantec Zebra installation showing the computer and peripheral equipment.

different "locations" on the drum to which numbers can be directed for storage. Each location consists of a narrow strip of the magnetic coating on the surface of the drum; each strip will accommodate a number of discrete, magnetized, "spots" which make up a "word".

The convenience of using binary (two-state) techniques in the electronic circuits of computers becomes evident when the magnetic drum is considered; it means that only two magnetic conditions are needed—magnetized and unmagnetized.

The drum store has a large number of read/write (record/reproduce) heads placed around it, each a little further down the drum than its neighbour. Some idea of the compactness of this type of store is given from Fig. 2. This drum, which revolves at 6,000 r.p.m., is only 6 inches in diameter and 15 inches long, yet it can hold 8,192 computer words, each of 33 digits. This is a density of nearly 1,000 magnetic spots every square inch of drum surface. It is not surprising, therefore, that storage drums have to be made to a very tight specification.

Whenever something mechanical is introduced into electronic circuitry, an appreciable delay is also introduced. The mechanical element here is the rotating drum. When a word has been written into a location on the drum, the drum has to complete one revolution before the word can be read again. Even at 6,000 r.p.m. this takes time!

Some computer calculations require the reading of particular words every revolution of the drum and this mechanical delay—it is called "access time"—can accumulate into many minutes. The maximum access time on a store of the type described is 10 msec. Much of this time can be saved, however, by the well-trained programmer, who writes the instructions for the machine.

The whole operation can be speeded up immensely by the use of "immediate access registers". These are a number of tracks on the drum with several read/write heads connected together. No sooner has a word been written than it is available for reading.

But why not do this to the whole store to give higher overall speed? The answer is simply that this technique is wasteful of drum space. A compromise solution is to provide a small number of immediate access registers which are used for storing those numbers which are most frequently required in calculations. This increases considerably the overall speed of the computer.

For really high speeds, this mechanical link in the computer chain is gradually being replaced by the ferrite store. This consists of a grid of tiny ferrite rings each of which can have one or other of two magnetic states and thus can store one binary digit signal. Because there are no moving parts, ferrite stores give fast access and make for a faster computer. For the same storage capacity, however, ferrite stores take up more room than a drum and, at present, cost more. Nevertheless, more and more computers in the future will have ferrite or other rapid access stores. For example, thin films of magnetic material can also be used for storage; discrete, small areas of the film each forming a one-digit store.

Where a great deal of information has to be stored for use in calculations in a computer, it is necessary to have "backing" stores which back up the rela-

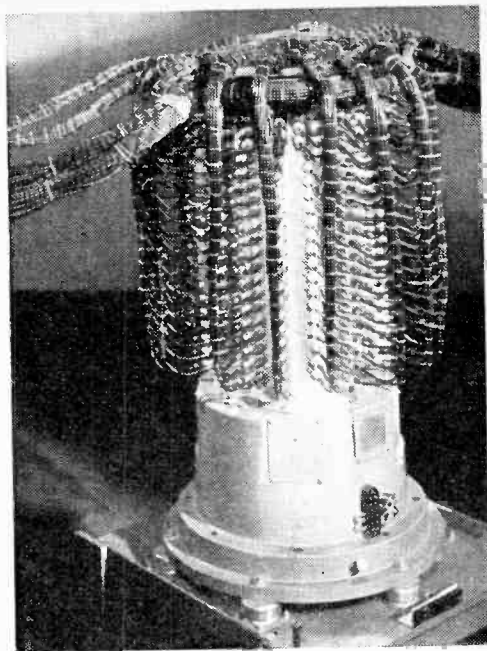

Fig. 2. Magnetic storage drum used in the computer of Fig. 1.

tively small, main store. Backing stores are usually reels of magnetic tape, driven by fast electric motors. Naturally, as it takes the computer some time to run through a reel to look for a number, the numbers stored there are those not often required. Magnetic tape stores can be speeded up by using more tape mechanisms, with a correspondingly shorter length of tape in each.

The recent introduction of several types of "random access" store will overcome some of the delays inherent in large magnetic-tape stores. Random access stores may use magnetic cards or punched cards which can be picked out quickly from a stack, have their information read, and be put back again without the necessity for reading all the cards, one after the other. Using a random access store is akin to using the index of a book: it saves you reading every page to find a particular reference.

Inputs.—There are several ways of feeding information into a computer: by the use of punched paper tape, a telephone dial, a prepared magnetic tape, or punched cards. At present the most widely used medium is punched paper tape. A typical machine uses a 5-hole punched tape. The 32 combinations of "hole" and "no hole" in these five positions make it possible to use this number of characters in any code used for operating the machine.

To feed instructions into the computer one must begin by producing a punched tape on the keyboard perforator (Fig. 3). Operated like a typewriter, the perforator punches patterns of holes in a paper tape according to which keys are pressed. The perforator has several differences from a typewriter, however, but very little practice is needed for perfection.

The operator must first "run-out" enough blank tape to allow for threading it later into a tape reader. To run-out blank, the O key is pressed once, followed by the "run-out" key; this results in a machine-gun-like issuing forth of tape as long as the run-out key is held down. This done—about

12in of blank is enough—the programme of instruction may be punched on the tape. The make-up of a typical programme is described later.

At the end of the programme, more blank tape should be obtained by the O key, followed by a short burst of # and run-out. The final # pattern distinguishes the end from the beginning of the tape. It is essential that this tape is now marked for identification, to avoid confusion later.

Depending on the importance of the work, the complexity of the computer instructions and the competence of the operator, this tape may be used as it stands or, more usually, it is checked using a tape verifier. The verifier has a keyboard upon which the instructions are again keyed. As keying proceeds, the tape is passed through the verifier and, in the event of a difference between the first and second keying of the programme, an alarm lamp indicates a possible error in the original tape or in the second keying.

When a "clean", verified tape is produced, it can then be "read" and its instructions fed into the computer, via a tape reader.

There are several types of tape reader. One type which is widely used is the high-speed photo-electric tape reader (Fig. 4). This illuminates the tape from one side, the pattern of holes producing voltages in five tiny photo-transistors. These voltages are fed into the computer.

The tape is loaded into the reader and the guide clamp is pressed to hold it in position. A button on the reader is pressed "to set" it ready for action. The computer control panel (Fig. 4) has a key marked CLEAR, which is held down for a second or two; it sets the computer circuits so that when the new tape information is read into the instruction store, it automatically over-writes, erasing all previous information held in this store. Our typical computer is of the "stored-programme" type, which takes in its instructions and stores them for execution when required.

The tape reader is set. The clear key has been pressed. All that remains is the START key on the control panel which, when pressed, starts the reading operation on the tape. With a short programme this will take only a few seconds, with long

programmes, it can take many minutes to read the whole tape into the store.

When the tape has been read, it may be removed from the tape reader and stored for future use.

Some computer programmes are arranged so that numbers can be dialled into the computer, using an ordinary telephone dial on the control panel; usually, the various digits have to be dialled in fairly quick succession in case the computer accepts a part as the whole number. There is a small loudspeaker on the computer control panel which "squeaks" when the computer reaches a dynamic stop, or when dialling has been completed. This gives a check on the response of the computer to the dialling process.

Outputs.—Computers work so quickly that it is difficult to feed information into them and print out results fast enough to use their capabilities to the full. But high-speed tape readers have been developed and there have been important advances in print-out machines. One recently announced printer prints 2,880 lines per minute.

However, a very fast printer may cost almost as much as the computer itself, or even a lot more. Its cost would be justified only on highly repetitive data processing work such as invoicing, stock control and payrolls.

For solving straightforward scientific or engineering problems on a computer where time is not too severely rationed, a teleprinter may be coupled "on line", that is, directly to the computer.

As with tape readers, perforators, verifiers, punches and the rest, one must not forget to switch on the teleprinter before expecting it to print results! Other than this, and checking that there is sufficient paper to feed the teleprinter, there is nothing more to be done about printing out. In the latest Creed teleprinter the paper does not move laterally as a typewriter roller does; instead, the type mechanism moves across the roller. This makes for easier reading of the message while it is still being printed; it also means a more compact design of teleprinter.

An alternative to the fast printer which is connected directly to the computer is the technique of using an on-line high-speed paper tape punch or a magnetic tape unit to store the output data for printing out at leisure on relatively much slower teleprinters. Many computers for research work use this "off-line" printing technique, which keeps the cost of the computer installation low.

The choice of on-line teleprinter or tape punch is normally made when the computer programme is written, the appropriate instruction being punched into the input tape, although the decision can be deferred until the computer is being set up for a run.

The on-line punch has a RUN OUT button on top which is held pressed for a few seconds before computation begins. This gives a length of blank tape upon which its identity is written. The operation of the punch is automatic, the tape being poured out into a bin. When the computation is complete, the tape is torn off the punch and rewound to form a spool, ready for printing out on the off-line teleprinter.

The equipment for off-line printing usually consists of one or more sets of tape readers (medium speed) and teleprinters, the number of sets depending upon the amount of work and the time available.

The tape from the on-line punch is threaded into

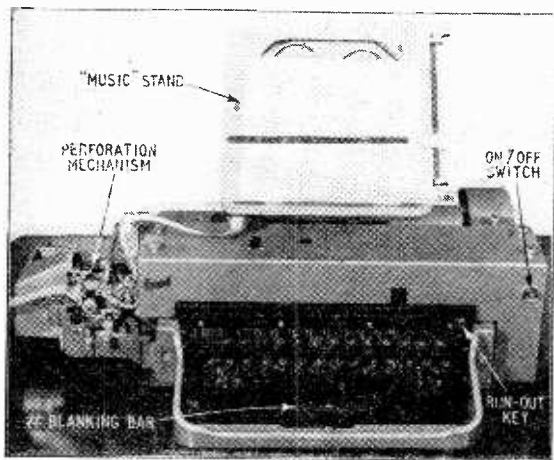

Fig. 3. Keyboard tape perforator.

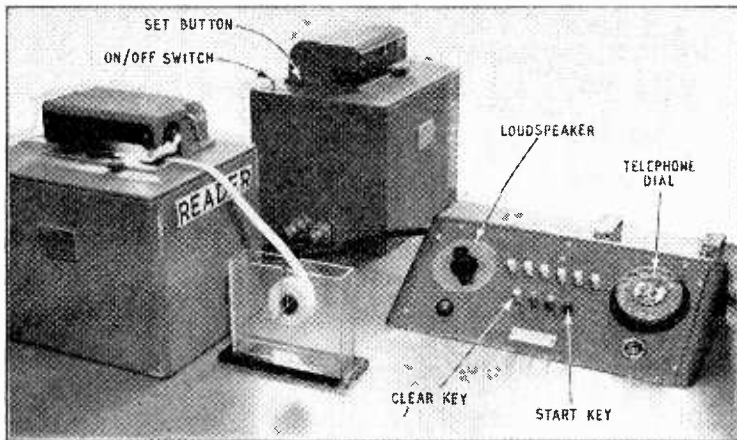

Fig. 4. Two tape readers (left) and computer control panel (right).

a tape reader. The teleprinter, suitably loaded with paper, can be left to print out results without attention. Any fault in the tape which jams the reader will stop the operation and an audible or visual alarm can be given.

When the computer is used for regular data processing, such as invoicing, stock control or payroll, the teleprinter paper is pre-printed with standard details and column ruling on the top and carbon copies. After the initial lining up on the teleprinter, this stationery emerges with the teleprinter information in the appropriate places.

Programming.—A programme is a set of instructions to enable the computer—a rather dumb creature in itself—to carry out a particular kind of calculation.

Programmes for early machines were written by skilled mathematicians who often found it difficult to explain the operation to less mathematically minded people. But most manufacturers soon realized that if they were to sell computers on sufficiently large a scale, new, simplified methods of programming would be needed, which would enable the intelligent layman to use a computer. Thus, gradually, more and more manufacturers announced facilities for automatic coding of programmes. One of these simplified procedures is described here.

Almost without exception, the use of such an “auto-code” means a sacrifice in operating speed and computer storage capacity. But this is offset by the fact that more and more people can operate the machine, with the minimum of training.

The normal codes for individual machines are complicated enough to require a training course lasting many weeks. The simplified codes reduce the

professional programmer before the programme is obtained. In these circumstances, the use of an auto-code is well justified.

The auto-code makes use of various “sub-routines” which are built into the computer to produce computers within a computer. Auto-code instructions are fed into the computer which operates on them to produce an internal equivalent programme in basic machine code before carrying them out.

All this takes up computer time and storage space. Sometimes a calculation takes four or five times as long when written in the easy, auto-code, compared with normal machine code. This difference is usually minimized by the programmer when he writes the programme.

In the computer described here, the usable store,

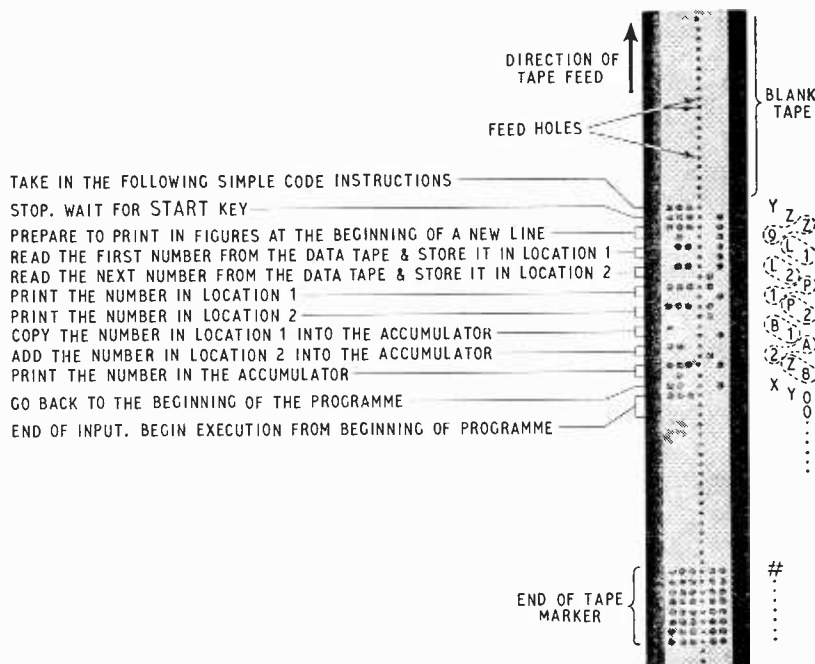

Fig. 5. Programme tape for the addition of two numbers.

+1234567+7654321+64721+53610+2731·5678+1689·7430

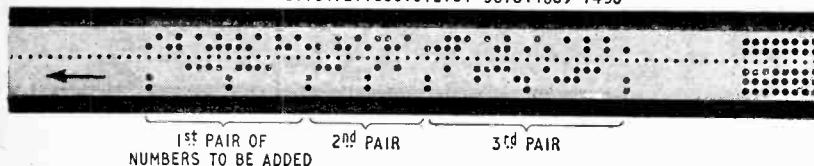

Fig. 6. Data tape for the addition of three pairs of numbers.

normally 8,192 words, is reduced to about 3,000 words by the storage of auto-code routines.

To illustrate the Zebra Simple Code, which is a typical auto-code, the following problem is set out and solved:—

Programme: Read and print two numbers, add them together and print the answer.

Data: 1234567 + 7654321
64721 + 53610
2741.5678 + 1689.743

Once the programme has been fed into the computer, an unlimited number of pairs of numbers can be fed in, the answers being printed out within a few milliseconds of the second number of each pair being read by the tape reader.

The programme for adding two numbers is shown in relation to the punched programme tape, in Fig. 5. It is derived as follows:—

The first symbol, the letter Y, is pressed on the tape perforator. Y always comes first in a Simple Code programme and it tells the computer that the programme and data to follow are written in Simple Code and to set the internal switching circuits accordingly. The Y symbol then, introduces the subroutines which convert the instructions which follow into basic machine code.

The next instruction, Z, is inserted at this point so that when the programme is later executed by the computer, the computer will stop and wait for the operator to press the start key. It introduces a pause to enable the operator to remove the programme tape from the reader and to insert the tape containing the numbers required for the calculation (the "data tape").

The instruction which follows is a composite one, Z9, which sets the circuitry so that the output teleprinter prints in figures at the beginning of a new line.

Most Simple Code instructions begin with a letter, which may be followed by a one- or two-digit number.

The machine automatically knows when a particular instruction is completely read when it reads another letter, i.e., the first part of the next instruction.

Having warned the computer that we are about to instruct it in Simple Code language, and prepared it to print out figures, we then ask it to read the first number of the first pair to be added (1234567) and to store this number in location No. 1 of the store. The instruction for this is L1.

The next instruction, L2, means "read the next number from the data tape and store it in drum location No. 2".

So that there is a complete printed record of each calculation, we next tell the computer to print out these two numbers which are to be added together. The instructions are P1 and P2, meaning "print the numbers in locations Nos. 1 and 2". These numbers will be printed on the same line, since

we have not instructed the teleprinter to execute a "carriage return". Care has to be taken that the number of digits (and spaces) likely to be printed out on the teleprinted page does not exceed 68; if this is likely, a Z9 instruction has to be inserted in the programme in the appropriate place.

As all calculations are carried out in the computer's "arithmetic unit", or "accumulator" as it is also called, these numbers must be brought from their respective drum locations into the accumulator. The instruction B1 means "copy the number in location No. 1 into the accumulator".

The copying of a number from its location does not remove it from the location; the number remains, in the same way as the music on a tape recording remains in spite of being read over and over again by the reproducer.

The next instruction is A2, which is the key instruction in this particular programme, namely, "add the number in location No. 2 into the accumulator". If we wanted a programme to multiply these two numbers, all other instructions would have been the same as in the programme, except that A2 would become V2. Similarly, to subtract these two numbers, A2 would read S2. To divide the first number by the second, the instruction would be D2.

Having done what we set out to do, namely, to add two numbers, we print out the answer. The instruction is Z8, which means "print what is in the accumulator".

The X instruction means "go back to the beginning of the programme". It is followed by Y and at least two zeros; this Y00 instruction means that we have reached the end of the programme. It tells the computer to start carrying out the programme which it has now stored away.

To finish off the programme tape, a succession of # codes is punched. By this means one can tell the end of the tape from the beginning. The tape is then torn off from the perforator and an identification message written on it such as "programme tape for the addition of two numbers".

This tape is now ready for verification and for feeding into the computer tape reader. The method of feeding the programme tape into the computer has already been described: the clear key and the start key are used.

When the computer stops, as signified by a whistle in the loudspeaker, the operator knows that it has taken in the programme, started executing the instructions and has reached the Z stopping point. He then removes the programme tape from the reader and inserts the data tape on which the various pairs of numbers have been punched, ready for summing.

The data tape is punched with a + sign between each number and the next. The sign has the added

(Continued on page 575)

significance of separating the numbers. Tapes using + signs can equally well be used on a programme for subtracting, dividing or multiplying two numbers, the + meaning a positive number.

Unless the start key is locked on, the computer will deal with only one pair of numbers at a time, stopping each time to wait for the start key.

The time taken to feed in the programme is only a second or two, and this does not need repetition for each pair of numbers. The time taken up on operation consists almost wholly of teleprinter time; the computation time being negligible. In fact, the answer is queuing up waiting for the teleprinter to print it out!

To make more efficient use of the computer, it is possible to insert an instruction into the programme to have the teleprinted message recorded on another paper tape at a high speed. Instead of the on line teleprinter giving the numbers and their sum, these figures are punched out on the Teletype punch for processing on the off-line reproducer equipment at the slower, teleprinter speed. Meanwhile, the computer is free to go on with other work.

The programme given above would be modified as follows:—

Y Z Z23 L1 L2 P01. P02 B1 A2 Z22 X Y00.

the instructions which are underlined are those concerned specifically with producing an output from the on-line tape punch.

The data tape for all of these programmes of addition, subtraction, multiplication, division for on-line or off-line printing would be punched as shown in Fig. 6. This shows the figures separated by plus signs and the tape finished off in the usual way.

Printing The Answers.—One of the advantages of this Simple Code is that it has "floating point" decimal notation. In this notation all numbers are expressed as decimal fractions followed by a digit which indicates the number of places by which the decimal point must be moved to give the true number.

Thus 0.1674932+4 means 1674.932 (move point four places to the right), and 0.65012437-7 means 0.00000065012437.

Although the computer can print out only nine significant figures, the floating point technique enables it to handle very small and very large numbers. This is because the conversion to floating point form occurs only after the calculation has been completed and before printing out.

Quite often it is difficult to forecast the order of magnitude of the answer to a problem and it may well be outside the handling range of the normal machine code. In these circumstances the Simple Code should be used.

The print-out in Fig. 7 shows how the floating point technique appears.

More Complex Programmes.—Using the Simple Code "dictionary" and some common sense it is possible to write programmes for more complicated problems. Obviously, there is little point in using up time and effort in writing a programme for a problem which arises just once. In research work, however, there is often a complicated formula which occurs, involving a set pattern of variables and constants. For this type of problem the time spent writing a programme becomes worthwhile.

It would defeat the object of this article to go into the working of complex problems but the following example should be sufficient to show how Simple

1st. NUMBER OF EACH PAIR		2nd. NUMBER OF EACH PAIR		SUM	
↓		↓		↓	
+ 0.123456700	+ 7	+ 0.765432100	+ 7	+ 0.888888800	+ 7
+ 0.647210000	+ 5	+ 0.536100000	+ 5	+ 0.118331000	+ 6
+ 0.273156780	+ 4	+ 0.168974300	+ 4	+ 0.442131080	+ 4

↑
FLOATING POINT DECIMAL NOTATION

Fig. 7. Print-out answer to the problem of adding three pairs of numbers, illustrating the "floating point" decimal notation.

Code is applied. It forms part of a longer calculation in electrical network design. The purpose of this little part of the programme is to evaluate $R_1 R_2$ ($R_1 + R_2$) and put the answer in location No. 12 for use later. The formula is the well-known one for obtaining the equivalent resistance of two resistors in parallel. (The values of R_1 and R_2 are already stored in locations 10 and 11.)

The programme is:—

B10:—Copy R_1 value in location No. 10 into accumulator.

A11:—Add R_2 value to the accumulator.

T13:—Transfer the number in the accumulator ($R_1 + R_2$) into location No. 13.

B10:—As before.

V11:—Multiply the contents of the accumulator by the number in location No. 11.

D13:—Divide the contents of the accumulator by the number in location No. 13 ($R_1 + R_2$).

T12:—Transfer the contents of the accumulator into location No. 12 for future use.

To take the above calculations as typical of all computer work would be misleading. Nevertheless they are typical of the use of the auto-codes which are enabling an increasing number of people to use computers directly, without the need for skilled programming services. Auto-codes also serve as a useful introduction to more advanced programming techniques.

Club News

Basingstoke.—Readers in the Basingstoke area interested in the formation of a local amateur radio group are invited by P. J. Sterry, of "Ashley," Orchard Road, Basingstoke, Hants., to get in touch with him.

Birmingham.—A demonstration of stereo equipment will be given to members of the Slade Radio Society by F. B. Griffin on November 3rd. The Club meets on alternate Fridays at 7.45 at Church House, High Street, Erdington.

Bradford.—"Modern methods of communication" is the title of the talk to be given by E. M. Price at the November 15th meeting of the Bradford Radio Society. Meetings are held at 7.30 at Cambridge House, 66 Little Horton Lane.

Cardiff Group of the R.S.G.B. meets at 7.30 on the second Monday of each month at the Territorial Army H.Q., Park Street.

Derby & District Amateur Radio Society has sent us a copy of its golden jubilee booklet giving a brief history of the Society, which incorporates the Derby Wireless Club started in 1911. This interesting 32-page booklet includes a list of Derbyshire amateur transmitters.

Halifax.—The November meetings of the Northern Heights Amateur Radio Society, which meets at 7.45 at the Sportsman Inn, Ogdens, include a demonstrated talk on "hi-fi" by A. E. Falkus (1st) and a talk on converters for 2 and 4 metres by D. Millard, G3OGV (29th).

Spenn Valley Amateur Radio Society now meets on alternate Wednesdays in the Infants' School, Hill Top, Gomersal, at 7.30. On November 22nd J. C. Belcher, of the G.P.O., will be discussing interference problems.

Measurement of Harmonic Distortion

SENSITIVE DETECTOR-AMPLIFIER METHOD USING TRANSISTORS

By C. BAYLEY

HARMONIC-DISTORTION measurement is a most necessary part of the test procedure for apparatus which is supposed to exhibit a "linear" relationship between output and input. Although in itself a relatively simple test to make, the apparatus employed sometimes uses complicated filter networks which often limit the range over which measurement can be made. Described here is one of the methods which avoids the use of high-performance filters which are difficult to design and make.

Conventional Methods

There are two methods generally used in practice for measurement of harmonic distortion. One is a direct method (Fig. 1(a)) where the fundamental frequency is suppressed by the rejector network "A" and remaining harmonic frequencies are passed through the selective amplifier "B", being finally recorded by the output meter "C". The second approach (Fig. 1(b)) is indirect in that intermodulation products are measured: for this the basic fundamental frequency f_1 and an additional frequency f_2 are passed through the nonlinear network ("X") under test. As a result of distortion the output from the network has, apart from the original frequencies f_1 and f_2 , in intermodulation products $f_2 \pm f_1$, $f_2 \pm 2f_1$, etc. The former have to be suppressed by the rejector network "A" and the latter, being functions of

the harmonics, are passed through the selective amplifier and recorded by "C".

It is worth mentioning that the required total discrimination in the intermodulation method is approximately 12dB less than that needed in the direct system. This means that the loss for intermodulation components while passing through "A" is smaller than the similar loss of harmonic components when using the direct method.

Consequently the intermodulation method is more sensitive and also more flexible because free choice of f_2 can be made: thus this method is usually preferred for h.f. distortion measurements. Even so, while attempting to measure low distortion at a low fundamental level, very considerable gains are required in the selective amplifier "B". If, for instance, the fundamental level is 100mV and harmonic margin say -100dB, the absolute value of harmonic voltage before entering the filter "A" is only 1μV and could be as low as 0.1-0.2μV at the input of the selective amplifier "B". The problem of measurement of such low magnitudes is difficult and by no means is a subject only of academic interest. For instance, in multichannel carrier-telephony networks, repeater circuits etc., the presence of even very low harmonic distortion can cause cross-talk as a result of intermodulation between carrier frequencies.

It can thus be seen that the measurement of

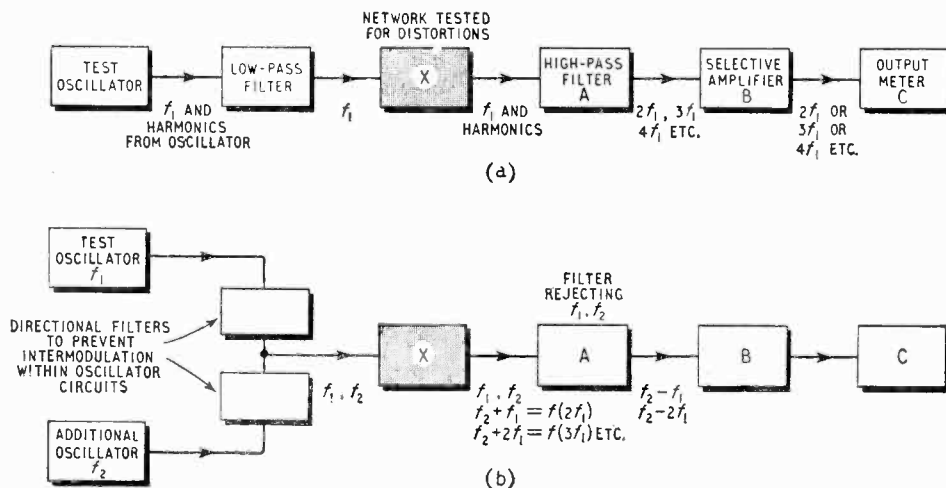

Fig. 1. (a) One conventional method for measurement of harmonic distortion: here filter "A" and selective amplifier "B" must reduce fundamental to less than experimental error allowable on smallest harmonic component. (b) Intermodulation-distortion method is less severe in demands on filter-amplifier combination.

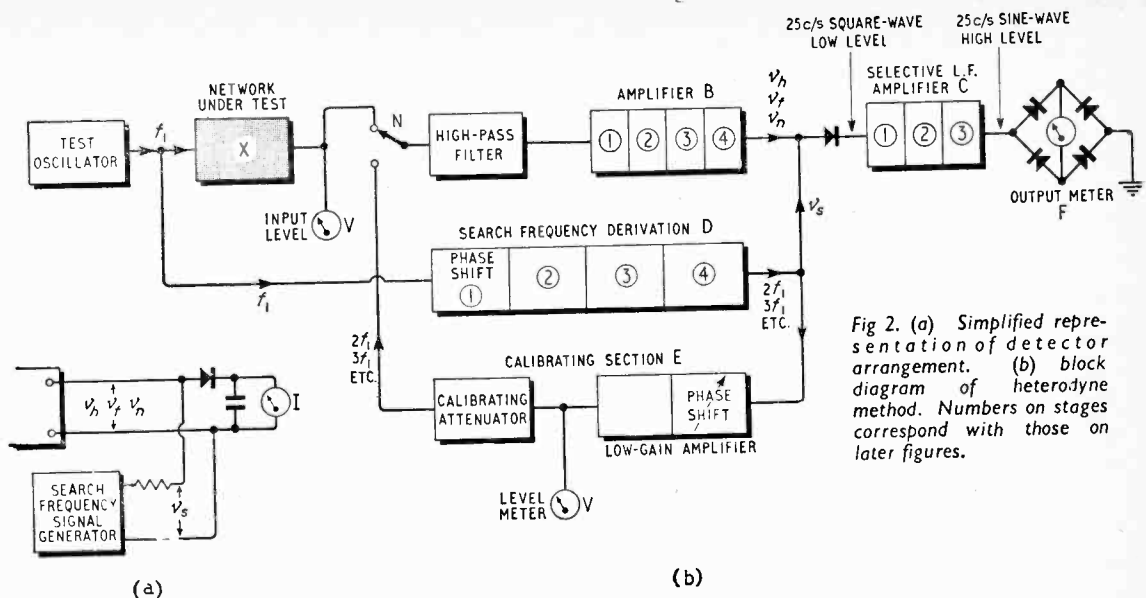

Fig 2. (a) Simplified representation of detector arrangement. (b) block diagram of heterodyne method. Numbers on stages correspond with those on later figures.

harmonic signals of the magnitude of 0.05—1 μ V is of importance and a method for carrying out such measurements without the use of conventional selective networks such as sharply tuned circuits or crystal filters is described here.

Selective Detection without Tuned Circuits

Application of the well-known heterodyne search method to harmonic measurements makes it possible to set up a circuit (block diagram Fig. 2(b)) which has very high selectivity. The simplified basic circuit (Fig. 2(a)) helps to illustrate how, in a heterodyne search detector, all noise plus the remains of the fundamental frequencies are suppressed and only the wanted harmonic signal is selected. We assume that linear detector "D" replaces the output meter from section "C" of Fig. 1(a). Under such conditions four signals will be applied to the detector: these are various harmonic frequencies v_h , remains of fundamental v_f , noise v_n and voltage from the search-frequency generator v_s . Assuming that if v_s is substantially larger than the other voltages and that the instantaneous value of $v_h + v_f + v_n + v_s$ would never go below the linear portion of detector characteristic during, say, 90% of the positive half cycle, the rectified current I will depend entirely upon v_s .

However, if the search frequency approaches very closely the frequency of v_h , the slow beat between these two frequencies would cause variation of I ($I \pm i$) which could be registered on a d.c. meter and the output harmonic signal v_h can be calculated from the simple relation:—

$$v_s/I = v_h/i$$

It is significant that the presence of the unwanted voltages v_f and v_n up to even 10dB higher than v_h do not interfere with this measurement. Hence the required discrimination between v_h and the unwanted signals (within stages "A" and "B") can be about 30dB smaller in comparison with a conventional detector-amplifier system (Fig. 1 (a)(b)). The arrangement shown in Fig. 2(b) employs the heterodyne principle of detection, modifying it to

the specific conditions of harmonic-distortion measurements.

This circuit has four additional features which are:— 1. The search-frequency generator is replaced by the amplifier "D" whose purpose is to produce an output voltage v_s of frequency identical with the desired harmonic frequency f_h ($2f_1$ $3f_1$ etc.). The amplifier "D" is driven by a fundamental frequency f_1 which is derived from the same signal generator which is used for the main harmonic-measurement chain.

In such a case the beat frequency applied to the detector "C" will be zero and, assuming that the relative phase of v_s and v_h is $\pm 180^\circ$, the detector current I will be smaller or bigger by an amount i (there is no "swing" of I).

2. The harmonic-signal amplifier "B" has an additional stage "B₃" which reverses the phase of the output voltage v_h by 180° at a rate of, say, 25 c/s (in other words v_h is 100% phase-modulated).

3. As a result of 1 and 2, in the detector output circuit, apart from current I, there will be also present a square-wave current of amplitude i and frequency 25c/s. This current which is proportional to the harmonic signal v_h is amplified in the selective low-frequency amplifier "C" (tuned to 25c/s) and finally registered by the output meter "F".

4. To calibrate harmonic meter, a known calibrating voltage of the frequency of f_h should be injected at the point "N" (after disconnecting the fundamental input) to obtain exactly the same output meter indication. The calibrating voltage is derived from block "E" which consists of an attenuator and a low-gain amplifier which is fed by v_s . The low-gain amplifier is provided with a continuous phase-shift control whose function will be explained later in the text.

Operating Conditions

Before giving more details about each stage "A" to "F" it will perhaps help the clarification of the system to outline the test procedure using its principal controls. It is assumed that distortion measurements have to be made on 100mV output of network

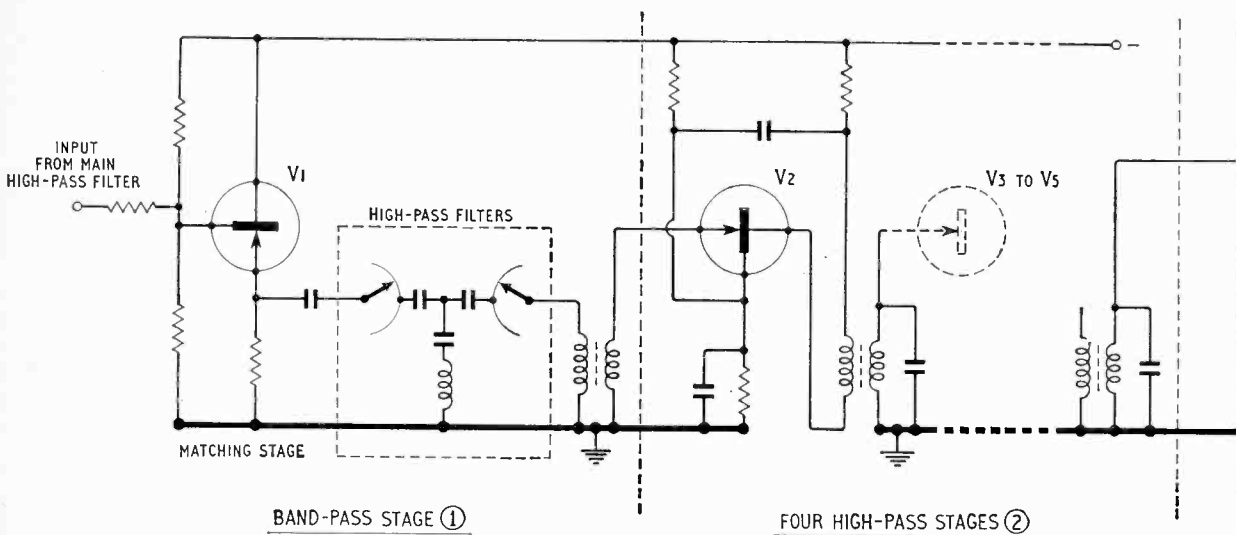

Fig. 3. Amplifier and modulator of heterodyne harmonic test-set. Circuit has been simplified by omission of detail. (Corresponds to Block B and high-pass filter of Fig. 2 (b).)

"X". The fundamental frequency is, say, 300kc/s.

Measurement of Harmonic Signal v_h .— 1. The test-oscillator frequency and the output of the network "X" are set.

2. The high-pass filter is set to a suitable range (cut-off frequency in this case is about 450kc/s).

3. Amplifiers "B" and "D" are "tuned" to the desired harmonic frequency.

4. Sensitivity of amplifier "B" is set to the estimated range of v_h .

5. By variation of phase shift of the search fre-

quency v_s (in block "D") a maximum indication on the output meter should be obtained (condition for 0 or 180° phase shift between v_h and v_s). This deflection should be recorded as v_{h1} (output meter "F").

Calibration of v_h .— 6. Input to "B" should be switched over to the output of calibrating attenuator.

7. By operation of the calibrating attenuator and phase-shift control (in block "E") maximum indication of the output meter identical with v_{h1} should be obtained.

Fig. 4. Simplified circuit of Block "D" of Fig. 2 (b) containing phase-shift network and frequency multiplier for production of heterodyne frequency. V11a and V11b circuits generate respectively odd and even harmonics.

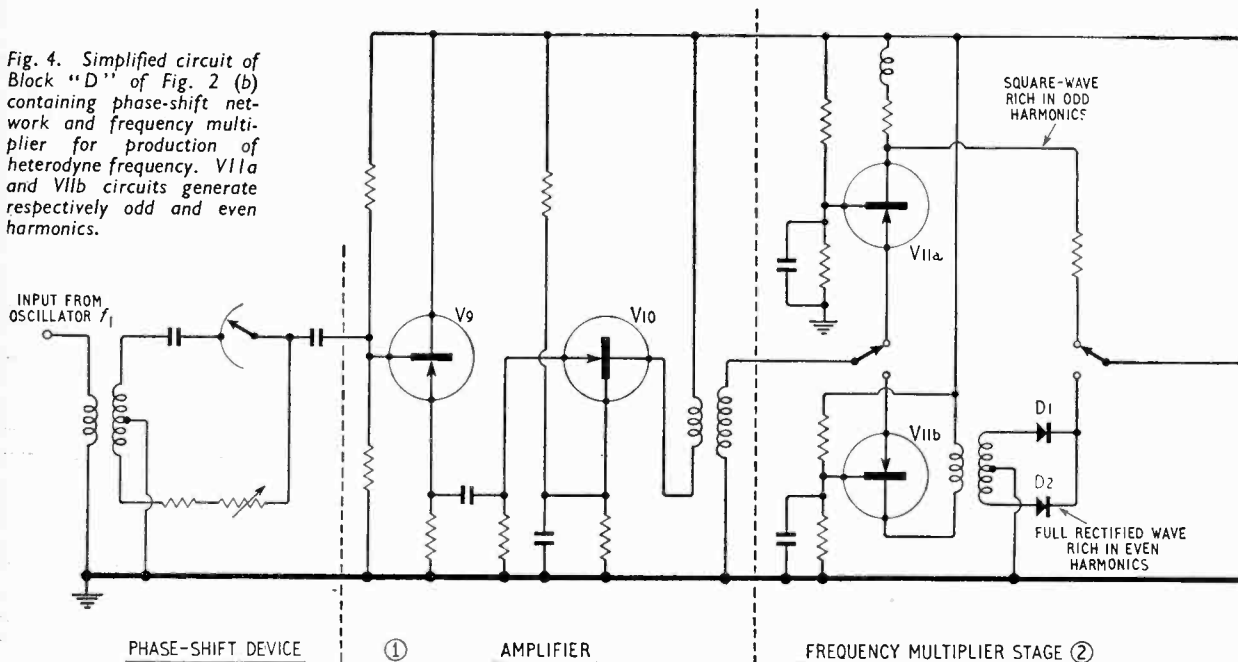

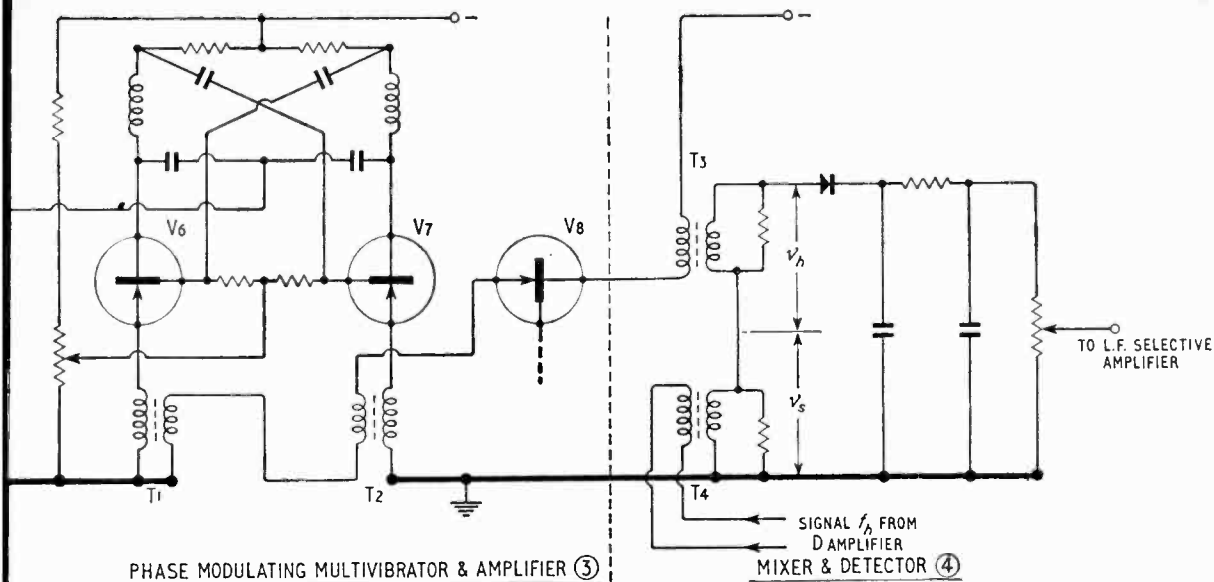

8. Absolute value of v_{h1} is read then from calibrating attenuator (say $2\mu V$).
9. Finally, the harmonic component may be computed as, say, $2\mu v/100mV=0.0002$ (i.e. $-86dB$).

Analysis of System

As can be seen from the above operating procedure the measurement of harmonic content is relatively simple with this apparatus. This simplicity extends to the demands made by the circuit details themselves.

Amplifier-Modulator.—(Fig. 3). Wide-pass-band filters with step-selection of cut-off are employed

in the first section of amplifier "B" (their purpose is to reduce noise and remnants of the fundamental) and these filters are the only frequency-discriminating networks in the whole of block "B". The second part of "B" consists of multistage h.f. untuned transistor amplifier (only one stage is shown).

This is followed by the modulator which works on the principle of an electronic switch (employing an l.f. multivibrator). The h.f. signal is applied to both collectors of the multivibrator and is alternately directed to the primary windings of the h.f. transformers T_1 and T_2 . The secondary windings of these transformers are connected in series and by the proper connection and by balancing of the

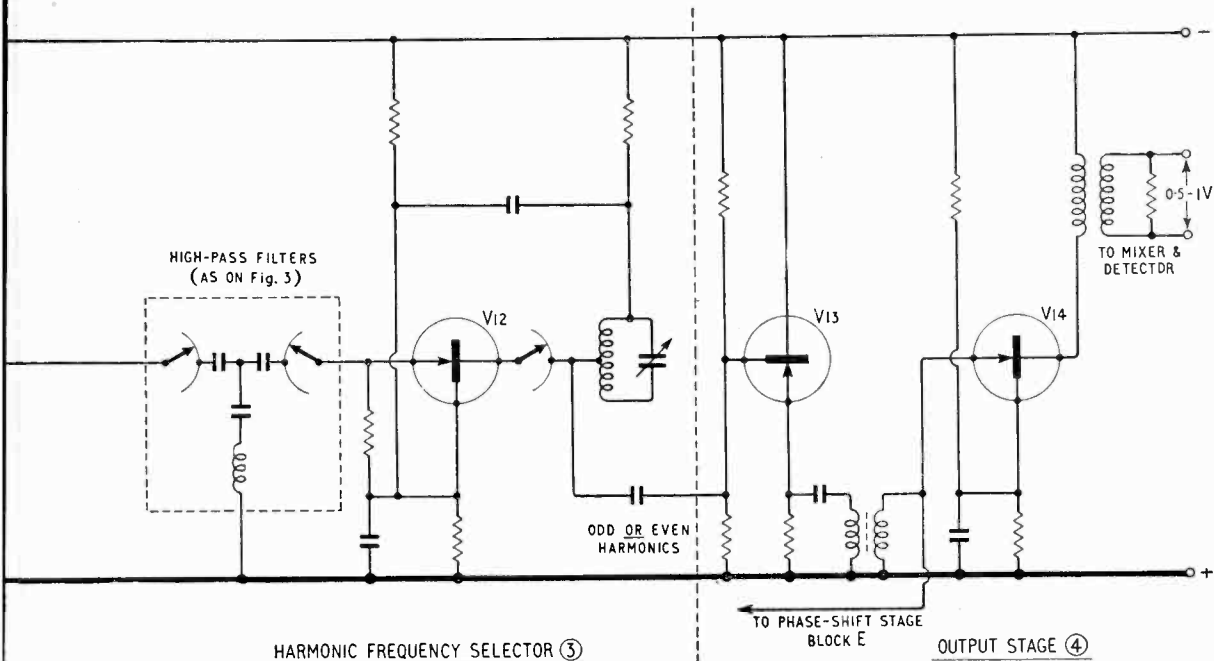

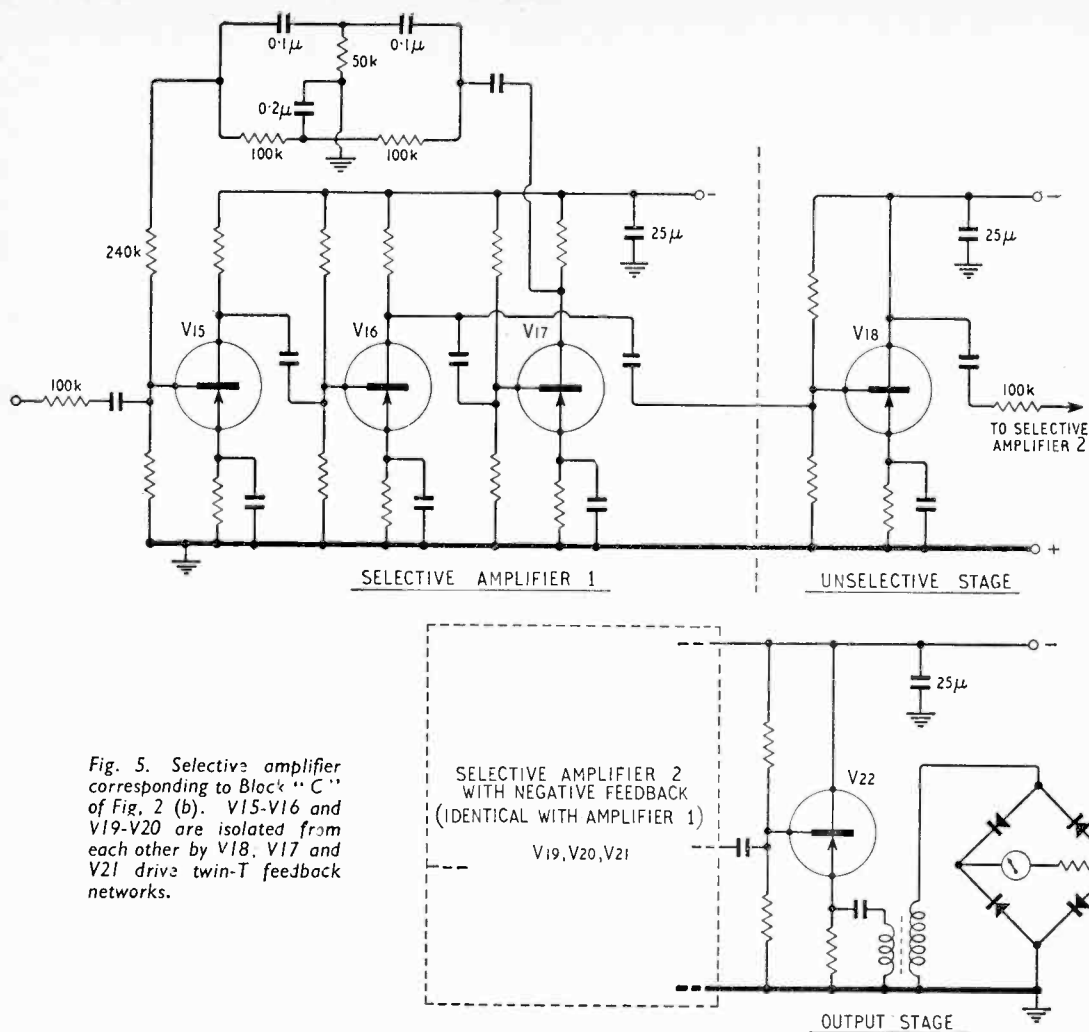

Fig. 5. Selective amplifier corresponding to Block "C" of Fig. 2 (b). V15-V16 and V19-V20 are isolated from each other by V18. V17 and V21 drive twin-T feedback networks.

transformer inductances, a 180°-phase-modulated output is obtained which feeds the common-base amplifier stage (V8).

The output from V8 collector, via a matching transformer, is applied to the detector which also receives the strong signal v_s (of identical frequency with v_h), derived from the output of amplifier "D".

Amplifier "D".—The special amplifier "D"—as has been explained already—is fed by the fundamental frequency f_1 from the test oscillator and has four principal stages shown on the simplified circuit of Fig. 4. The first stage consists of a conventional phase-shift control giving a range 0-100° followed by an untuned amplifier (transistors V9 and V10).

The output from V10 should be large enough to obtain frequency multiplication in the next stage (V11b and diodes D_1 and D_2 or overloaded transistor V11a). The frequency-multiplication circuit works on the principle of producing a square wave or an asymmetrical waveform (half- or full-wave rectification of the fundamental)—so that the requirement for odd or even harmonics, respectively, can be met. The third stage is a high-pass filter combined with a selective amplifier (transistor V12). The filter is tuned in steps and the amplifier con-

tinuously to obtain from its output the desired harmonic frequency. The conversion gain of this stage (including the loss of the high-pass filter) is only 1 or so for the 2nd or 3rd harmonics. For higher harmonics however, two or even three tuned stages should be employed as the percentage of harmonic components in the distorted fundamental (input to this stage) usually decreases rapidly with increase of harmonic order. The last stage of block "D" is an untuned amplifier (V13, V14) whose purpose is to deliver sufficient output (0.5-1V) to the detector.

Variations of this output (depending on frequency, etc.) do not affect seriously the performance of the whole system provided only that the level should not drop below say 0.5V. It is worth mentioning that the phase-shift device in the first stage of circuit "D" works very effectively for harmonic frequencies as the shift is applied to the fundamental. By shifting fundamental up to 100°, angles $n \times 100^\circ$ for harmonic frequencies are obtainable (where n is the order of the harmonic), hence the required 0—180° is easily obtained for every desired frequency. **Mixing of v_h and v_f Detection.**—As a result of superposition of v_h (100% square-wave phase-modulated) on v_s by the mixing transformers T_3 and

T₄ a large a.m. carrier is produced at the input to the detector. The depth of modulation is usually very low (it should be set to the maximum by manipulating the phase-shift control—as explained previously) and the l.f. square-wave components should be tuned to the multivibrator frequency.

L.f. Selective Amplifier.—The l.f. signal proportional to the investigated harmonic signal is usually at very low level (see Fig. 5). In spite of the good gain obtained in the untuned h.f. amplifier in block "B" (of the order of 60dB) a loss of signal of approximately 26dB is unavoidable in the modulator stage (including the buffer amplifier preceding the detector)—if a wide band of harmonic frequencies (30kc/s up to 1,500kc/s) has to be received with a flat response and without employing tuning arrangements. Consequently having on top of this additional loss, a loss of about 10dB in the detector stage, the net conversion gain between h.f. input and the input to the l.f. amplifier is only 24dB. If, for instance, the input harmonic signal is of the 1μV order, the gain in the l.f. amplifier should be at least 110dB to obtain sufficient a.c. output on the bridge of the output meter (a few volts). Such a high gain could be achieved by two selective amplifiers connected in cascade with one unselective stage (V18) separat-

ing them. Each amplifier has two transistor RC-coupled stages (V15, V16, V19, V20) with negative feedback applied through a selective twin-T network between the output of transistor V17 (V21) and input of V15 (V19). Transistor V17 (V21) serves as buffer feedback stage (to prevent instability).

The second selective amplifier is similar to the first with an additional common-collector output stage (V22) which employs a step-up l.f. output transformer. The secondary winding of this transformer feeds a conventional bridge circuit with a moving-coil meter (1mA f.s.d.) as the output meter.

Design Conditions

To prevent instability in the amplifier certain conditions should be fulfilled by the designer:—

1. Separate and adequately decoupled power supplies for each amplifier should be used.
2. The input of each selective amplifier should be fed from a high impedance (100kΩ or so).
3. The selective feedback network must be terminated by a high impedance on the input of the amplifier side (0.25MΩ).

RESISTANCE AND CAPACITANCE CALCULATOR

THE eternal problem of how to obtain an exotic resistance of something like 4.1kΩ from two standard values is rendered rather less wearisome by the "Paristor" Parallel Resistor and Series Capacitor Calculator, which takes the form of a slide rule with a combined slide and cursor. A tolerance scale is provided and an indication of relative power dissipations in the two resistors is given by the cursor. Referring to the photograph, the procedure is as follows. Suppose a resistance of 4.1kΩ is required; set the cursor line marked "R or C" to 4.1 and scan the hyperbola inscribed on the cursor to find a position where it cuts an intersection of two bold diagonal lines. Each of the lines cuts the top scale at a preferred value of resistor, these being the two values which, when in parallel, give the combined value of 4.1kΩ. In the case illustrated, the two values are 15 and 5.6. If the hyperbola does not cut an intersection exactly, it may be moved on until it does so, when the departure from the required combined value can be read on the tolerance scale marked either side of the "R or C" line on the cursor. The ratio of power dissipations in the two resistors is given by the series of horizontal lines marked

on the hyperbola. The process of calculation is, of course, identical for two capacitors in series. The calculator is available at 44s 6d from Paristor, Ltd., 96, Park Lane, Croydon, Surrey.

Commercial Literature

Ultrasonic control gear working at 45kc/s is added to the range of PERRAM equipment. Consisting of transmitter, receiver and control unit, the transistorized equipment can be used in level control, counting and intruder alarm applications and, as the wavelength is long, is not affected by fog or smoke. Details from Tyer and Co., Ltd., Perram Works, Merrow Siding, Guildford, Surrey.

Low-Frequency signal generator Type 252 covering the range 30c/s to 300kc/s is announced by Airmec. A thermistor-stabilized Wien-bridge oscillator is followed by a push-pull amplifier providing 100mW into 600 ohms. Leaflet 187A gives full details and can be obtained from Airmec Ltd., High Wycombe, Bucks.

Measuring Instruments by the Canadian firm of Bach-Simpson are described in a leaflet from Aveley Electric Ltd. The instruments are for use in education and scientific laboratories. Details from Aveley Electric Ltd., Ayrton Road, Aveley Industries Estate, South Ockenden, Essex.

Encapsulated Mica capacitors by Johnson Matthey are available in values between 5pF and 0.033μF at working voltages of 200V and 350V d.c. Lead spacing is to a 0.1-in module. Information on type C22 E and C33 E is obtainable from Johnson Matthey and Co. Ltd., 73-83 Hatton Garden, London, E.C.1.

Microsecond Triggered Relay by Ericsson will operate on the application of a pulse about 4μsec wide and at a p.r.f. of up to 100c/s. Two sets of changeover contacts are provided. Details from Ericsson Telephones, Ltd., 22, Lincoln's Inn Fields, London, W.C.2.

Soldering Irons with element ratings from 10 to 55W, weighing between ½oz and 7oz respectively, irons with bits resistant to erosion by high-tin solders (Permabit), solder pots, bench stands, a bench cable stripper, transformers and guards to reduce risk of damage when soldering complicated close-packed assemblies, are listed in a catalogue from Light Soldering Developments Ltd., 28 Sydenham Road, Croydon, Surrey.

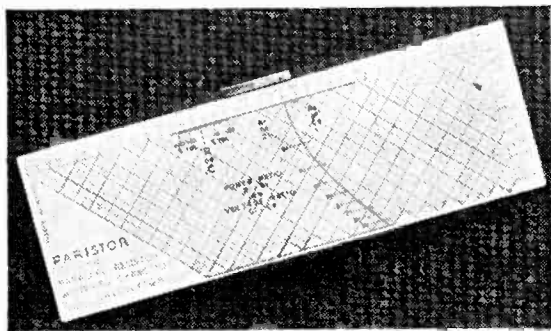

The Paristor calculator indicating the two values 5.6 and 15, which give the required value of 4.1 when paralleled.

TRENDS AND TECHNIQUES
SEEN AT
THE MILAN EXHIBITION

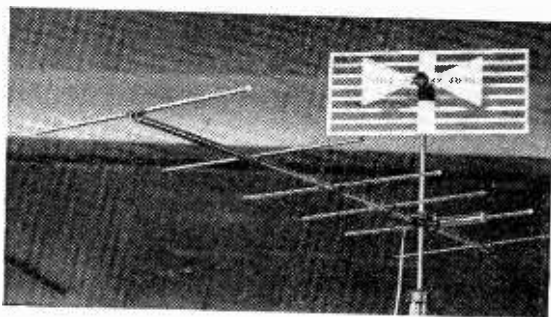

Offel Band III/IV combined aerial.

Italian National Radio Show

THE starting of the second television programme on 4th November was the major topic of interest and a display by the R.A.I. (Radiotelevisione Italiana) gave viewers a foretaste of what they might expect. The second programme is to be run by the R.A.I. on the same basis as the existing network, i.e. financed by both licence fees and advertising revenue, and the examples given of a typical week's programme showed that true alternatives are to be offered; a variety show on one channel, for example, with a documentary and news programme on the other.

The second service will, of course, use u.h.f. and R.A.I. are to be congratulated on the amount and quality of both technical and general information that they were giving out at the show. Booklets illustrated the ways in which receivers might be converted and aerial installations set up, gave a summary of the factors affecting propagation and the difficulties that might be experienced, even going so far as to suggest suitable channels in Bands I and III for down-conversion for communal-aerial networks and old sets without internal u.h.f. tuners.

At the start a potential 50% coverage will be achieved from 14 transmitters serving the more densely populated areas. Then over the next thirteen months the opening of an additional 28 transmitters will raise the coverage to 70%. Channels 21 to 34 (Band IV) each 8 Mc/s wide, are being used but, as Italy has 7-Mc/s channelling in Bands I and III (i.e. the Gerber system is used), the existing signal characteristics are preserved.

Naturally, sets with u.h.f. tuners were practically universal at the exhibition; but receiver design, apart from minor improvements to the *de luxe* models, such as remote control and the fitting of automatic brightness or contrast controls, seems to have stabilized over the last year. This is probably a very wise move on the part of the manufacturers as the advent of the second programme is expected to help precipitate a television boom which might be halted by teething troubles of new designs. Even the diversity of u.h.f. tuner design seen last year had almost disappeared: most manufacturers were using the two-valve r.f. stage and self-oscillating frequency changer type. In many cases changeover between the two tuners is effected by push-buttons on the front of the set although a few manufacturers have models which use one position of the v.h.f. tuner to select the u.h.f. band. Naturally, the use of separate switching provides a push-button "tuning" facility and some sets have the controls for both tuners tucked away at the side or even the back ("Nuclear"). Pye Electronics have, as in their English dual-standards set, an extra i.f. amplifier stage for u.h.f. and another feature is the use of two loudspeakers, one facing forward, the other to the side.

Even extremes of presentation were less noticeable than at last year's show, but a few examples were seen.

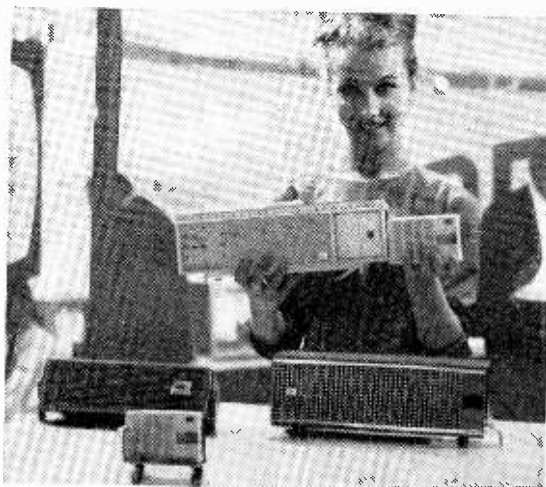

"Cucciolo" by Radio Allocchio Bacchini is a multi-purpose transistor pocket portable.

Firte had on show a very futuristic set with an eight-pointed mask round the tube. Brion-Vega's "Yades" luxury 23-in table model has its bonded-face-plate tube mounted outside the housing and retained by four small chromium-plated U-bolts, instead of, as is more usual, being "pushed through". This set is mounted on a small pedestal which has piano-sized piano-key controls on it, automatic u.h.f./v.h.f. tuning and ultrasonic remote control facilities.

Dark filters on television sets are very popular—the majority are greyish; but a few khaki and brown ones were seen—and the Firte set mentioned above had a polarizing filter.

A novel idea in this field was shown by Atlantic as *lo specchio magico* (the magic mirror) in which the dark filter was replaced by a half-silvered mirror. Thus the receiver, when not in use, appears to be a mirror with a rather deep frame; but on dimming room lighting and turning on the set the picture appears. Although shown built into various items of furniture (even a fireplace and overmantel), there are two main versions of this set, one self-contained, the other with the main chassis in a shallow flat box with the c.r.t. unit available for separate mounting.

Aerials for Band IV television are, in the main, small narrow-band Yagi arrays but a few bow-ties (Offel, for instance) were noted. The Yagi-type arrays can, for

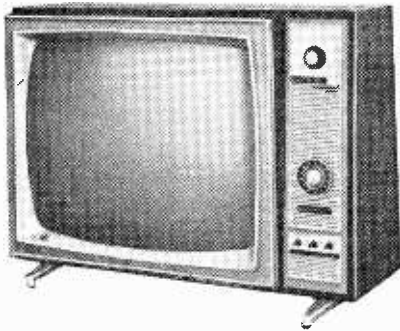

Pye Type T235 television receiver. One of the models made by Pye in Italy.

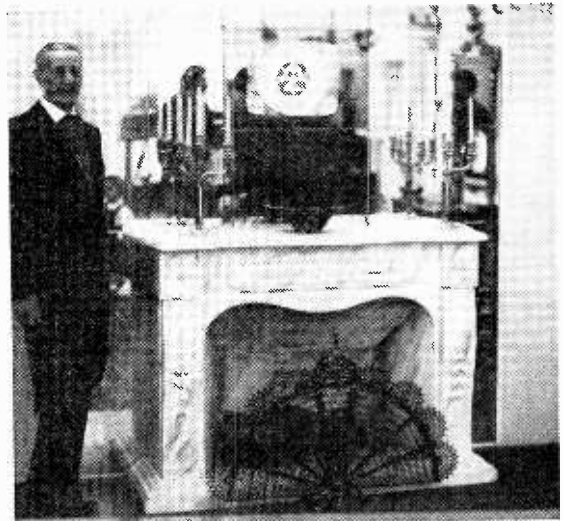

"Magic Mirror" television receiver by Atlantic shown, for demonstration, built into a mantelpiece. Chassis is inside mantelshelf with controls at left.

Luxury television-radio-gramophone (Ultravox) uses twin-panel c.r.t. and offers push-button selection of all functions.

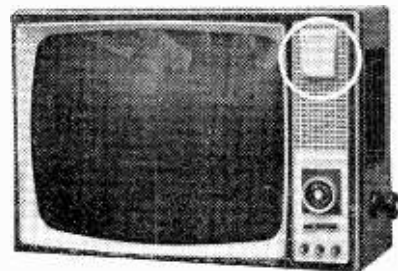
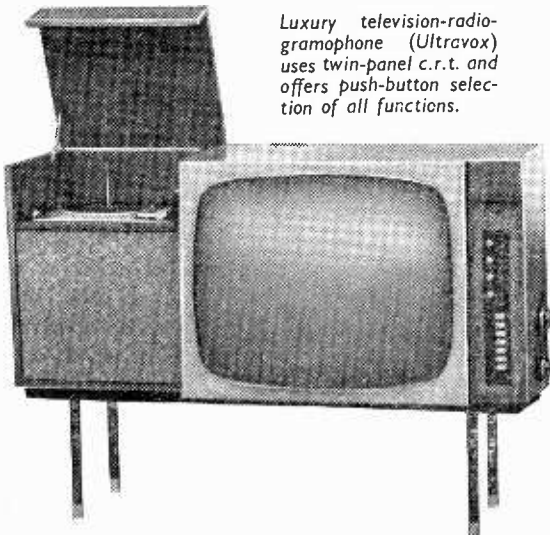

"Roma" television receiver by Televidon incorporates plug-in transistor pocket portable radio (ringed).

long-range reception, run to fantastic complexity—a Fracardo model had no fewer than 80 elements, consisting of eight ten-element arrays stacked—but some models exhibited some novel ideas. Napoli, for instance, use very small section elements and dip seal the whole aerial with p.v.c. whilst Fracardo were using a folded dipole stamped from a flat sheet and bent to adjust the impedance and provide mechanical rigidity.

No pattern of using either coaxial cable or twin feeder has yet emerged and impedance-changing devices are common, as are v.h.f./u.h.f. diplexers.

Radio Receivers, particularly transistor types, have undergone great development during the last year and some very ingenious equipment was on show. There is, with the national love for music *everywhere*, a very large market for transistor portables in Italy, particularly the pocket-sized sets. Consequently the manufacturers have exerted their ingenuity to offer something that is different: for instance, a great selling feature is the idea that one need not be limited to using the transistor set solely as a pocket portable. Radio Allocchio Bacchini were showing their "Cucciolo"—a combination set for living room, bedroom, car and pocket—having at its heart a seven-transistor pocket portable (using two drift transistors) with a power output of 70mW. For use in the living room this plugs into a larger wooden cabinet containing extra batteries, a larger loudspeaker and amplifier. A plastics case contains in addition a clock-cum-time-switch for use as a radio-alarm for the bedroom whilst for use in the car the set clips into a bracket on

the dashboard and is so used as a driver for the bigger amplifier-loudspeaker system mounted in the car. In spite of the meaning of *cucciolo* we don't think that purchase of this set could be described as "buying a pup"!

Another approach was illustrated by Televidon in their "Roma" television receiver. On the loudspeaker grille is a small pocket into which a transistor receiver can be plugged. Used separately it plays through its own small loudspeaker, using its ferrite aerial; but when attached to the TV set the larger loudspeaker is brought into circuit and the television aerial is coupled up to improve radio reception.

The Autovox "Transmobil" 2 is a transistor portable of the larger type, with a top-mounted scale and edge controls. Fitted in the car is a rack for the receiver which is complete with a spring-loaded "letterbox" flap so that a neat appearance is preserved when the set is not in place. Pushing in the receiver connects it up to an extra power amplifier and loudspeaker, various models being available for 6- or 12-V supplies with either negative or positive earth. Equally versatile over its power requirements is the Autovox RA 141 car radio tuning over long and medium waves and f.m. This is a hybrid set; but it uses ordinary high-voltage valves in the f.m. and a.m. "front-end" stages, deriving the h.t. by an internal transistor converter. The use of valves for the "critical" stages side-steps the drift and sensitivity-loss problems that might beset transistors if overheated.

A.m./f.m. transistor sets, in marked contrast to last year, were fairly widespread. Parkanal's "Caravelle"

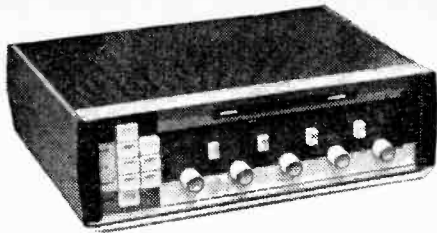

"Stereomatic" twin 12-W stereo amplifier has push-button controls, "centre" channel facilities and "magic eyes" to indicate power outputs. Also incorporated is an f.m. tuner with a.f.c. (Prodel).

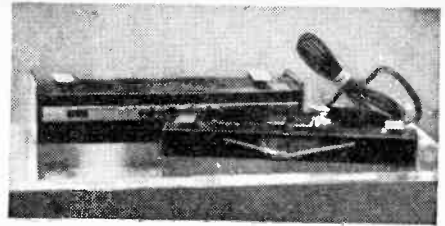

Mains power units for Voxson portables. Set clips onto top of unit.

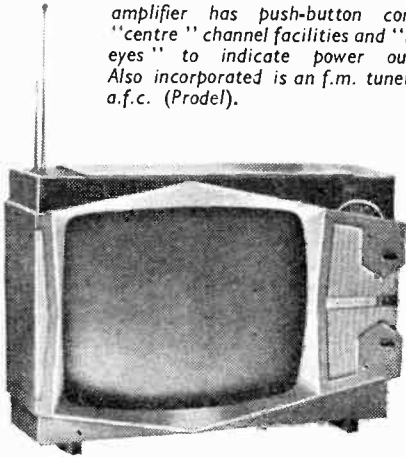

Left: Firté 19E44 19in TV receiver in moulded-plastics case.

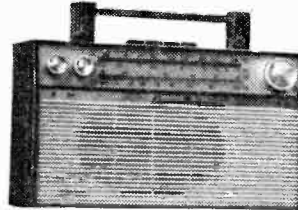

Twelve-transistor "Caravelle" by Parkanal tunes over long-, medium-, short- and f.m.-wavebands.

Radio Marelli a.m./f.m. transistor portable.

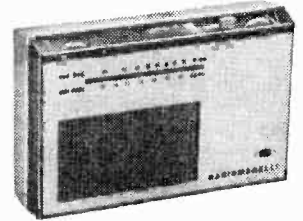

is a luxury-class set: it uses twelve transistors, has a 700-mW output and covers long and short wavebands as well as medium and f.m. Automatic frequency control is provided on f.m. and the telescopic f.m. and s.w. aerials fold into the handle when not in use. Nine-transistor sets were shown by C.G.E. (Compagnia Generale d'Electricità) and Radio Marelli, this latter being notable for its clean-lined styling. The G.C.E. "Cottage 2" receiver, like many of the mains sets, also tunes to the v.h.f. television-sound frequencies.

The prize for disguise must go to Krundall, who have mounted transistor receivers in pictures roughly 50 cm square, the controls being hidden under the edge of the frame. The picture itself is on permeable material and forms the loudspeaker grille. Voxson offer small mains power units which clip onto their pocket size transistor receivers, and also serve as stands.

An unusual arrangement of loudspeakers is employed in a La Voce della Radio small stereo-radio-gram (one of the models incidentally, with wire-distribution facilities). One loudspeaker is at one end of the front whilst the other is on the underside of the remote end of the lid over the turntable and is exposed when the lid is opened. Compared with another model with the two loudspeakers at either end of the four-foot long cabinet the lid arrangement provided better separation. The television sound reception facility continues on many f.m. models, but this year most incorporated tuning for both Bands I and III.

Wire Broadcasting in Italy is carried out in the long-wave band over the telephone system and is available free to telephone subscribers who have a wireless licence. Six channels are provided, the first three carrying the four radio programmes (which follow roughly the basis of our own). Channel 4 provides a "classical" music service and 5 "popular" material, whilst 6 is used for special purposes such as stereophonic diffusion. This latter group of three is available only from the network, which was extended to cover another eight cities on October 1st. A subscriber's terminal apparatus can consist of a push-button or switch-tuned receiver and amplifier or an ordinary radio receiver tuning over the long-wave band can be employed. To this end many of the newer

sets incorporate long-wave coils, which also makes them suitable for export to countries where l.w. broadcasting is employed.

High-fidelity reproduction tends to be provided by the luxury radio-gram rather than by assemblies of separate units, as is more common in England. Particular examples of this were noted on the C.G.E. stand, where we saw a range of apparatus culminating in a very large cabinet containing a.m./f.m. radio-reception and disc-playing facilities and a well into which a new four-track three-speed stereo tape recorder can be dropped and connected up to sockets provided. The companion loudspeakers are full range bass-reflex types. However, the "unit" trend in "hi-fi" is starting: Radio Marelli, for instance, were showing their "Belform" series which contains turntable and amplifier combinations giving a range of systems from 3.5W/channel upwards, and Prodel also offer a wide selection of units. A feature of several of their amplifiers is the use of a pair of strip-type tuning indicators to give an approximate indication of power output, whilst a twin twelve-watt transistor amplifier (Selene) has transformerless output stages that can be adjusted for 4- to 16-Ω loudspeakers. Two of Prodel's professional combined stereo pre-amplifier-amplifier units (SR2040 and SR2051) are fitted with difference-channel gain controls, allowing variation of the apparent separation of stereo signals, and a combined amplifier and tuner (SR1040) has a sum-channel output for a centre loudspeaker.

Radio Communication without the need for a transmitting licence has been allowed in Italy since the 8th June, 1960. A frequency of 29.5Mc/s is reserved for this and the maximum power output allowed is 5mW. Radio Mazza were showing a two-transistor "walkie-talkie" (the Babyphone) for use under these conditions. Although intended primarily as a toy, the set, which is switched on by pulling out the telescopic aerial and uses a super-regenerative detector (whose wide bandwidth avoids the need for tuning) should be of more general use.

There need be no doubt that this has "caught on": your reporter spent an hour waiting for the return flight. Several sets were in use by children who were, needless to say, within shouting distance of each other!

NEW 19" AND 23" TELEVISION CATHODE RAY TUBES

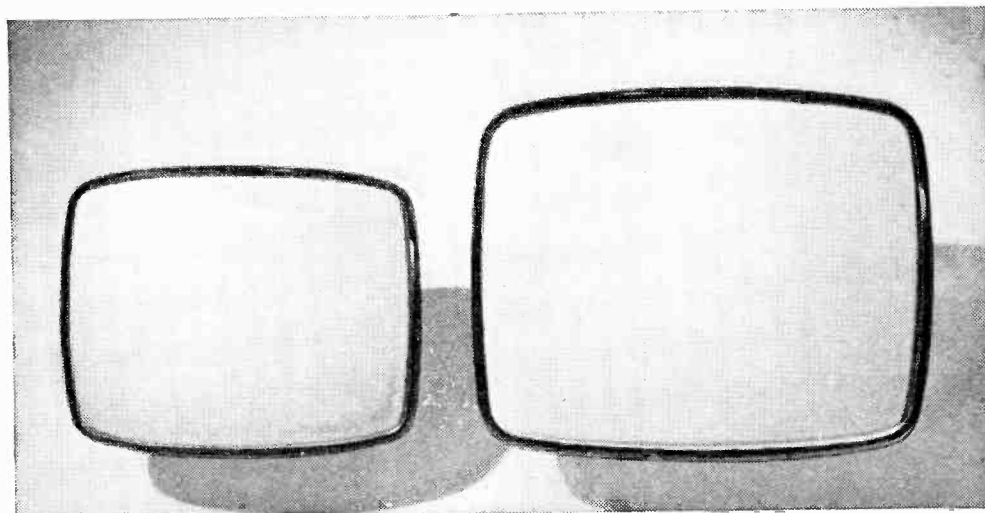

EDISWAN MAZDA TYPES CME1901 AND CME2301

The CME1901 and CME2301 are, respectively, 19in. and 23in. cathode ray tubes using magnetic deflection and electrostatic focus. The diagonal deflection angle of CME1901 is 114° and that of CME2301 is 110°. The shape of these tubes differs from the shape of conventional 110° tubes in that the face plates are more nearly rectangular. In addition the radii of curvature of the faces of the 19in. and 23in. tubes are greater than those of the 17in. and 21in. tubes. These changes result in a more pleasing presentation of the picture.

The external shape of the glass in the deflection region of these tubes is identical to that of conventional 110° tubes, enabling coils with conventional 110° internal mechanical contours to be used.

With equal values of final anode voltage, beam deflection in the CME1901 and CME2301 can be carried out with no more power consumption than in the CME1703 and CME2101.

GENERAL DETAILS

Rectangular face	Aluminised screen
Electrostatic focus	Silver activated phosphor
Magnetic deflection	Grey glass
Straight gun—non ion trap	External conductive coating
Heater for use in series chain	

Heater Current (amps)	I_h	0.3
Heater Voltage (volts)	V_h	12.6

TENTATIVE RATINGS AND DATA

Design Centre Ratings	CME1901	CME2301
Maximum Second and Fourth Anode Voltage (kV)	$V_{a2, a4(max)}$ 17	17
Minimum Second and Fourth Anode Voltage (kV)	$V_{a2, a4(min)}$ 14	15
Maximum Third Anode Voltage (volts)	$V_{a3(max)}$ ±700	±700
Maximum First Anode Voltage (volts)	$V_{a1(max)}$ 500	500
Maximum Heater to Cathode Voltage—Heater Negative d.c. (volts)	$V_{h-k(max)}$ 180	180

Inter-electrode Capacitances (pF)	CME1901	CME2301
Cathode to All*	$C_{k\ all}$ 5	5
Grid to All*	$C_{g\ all}$ 8	8
Final Anode to External Conductive Coating (approx.)	$C_{a2, a4-M}$ 1500	2000

*Inter-electrode capacitances including AEI "Clix" B8H holder VH68/81 (8 pin).

TYPICAL OPERATION

	CME1901	CME2301
Second and Fourth Anode Voltage (kV)	$V_{a2, a4}$ 16	16-17
First Anode Voltage (volts)	V_{a1} 450	450
Third Anode Voltage for Focus-Mean (volts)	$V_{a3(BV)}$ 180	180
Grid Bias for cut-off of Raster (volts)	38 to 72	38 to 72
Average Peak to Peak Modulating Voltage for Modulation up to 350μA (volts)	34.5	34.5

Note: All voltages given with respect to the cathode.

Maximum Dimensions (mm)	CME1901	CME2301
Overall Length	322	386
Face Diagonal	476†	598†
Face Width	420†	524†
Face Height	342†	422†
Neck Diameter	29.4	29.4

†The maximum dimension at the face seal may be 3.5 mm larger than this dimension but at any point around the seal the bulge will not protrude more than 2 mm.

Tube Weight (lb.)	CME1901	CME2301
Nett (approx)	13.5	27

Side Contact: CT8 (Cavity) Base: B8H

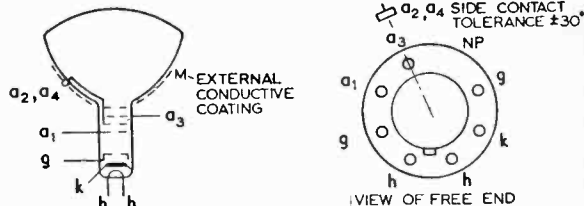

Thorn-A.E.I. Radio Valves & Tubes Ltd

155 Charing Cross Road, London, W.C.2.
Tel: GERrard 9797. Grams: Sieswan, Westcent, London

M A Z D A

TRIODE TETRODE FOR VIDEO OUTPUT APPLICATIONS

MAZDA 30FL12

The 30FL12 consists of a high slope tetrode with frame grid construction for use in a video output stage, and a general purpose triode.

Higher peak current with an appreciably higher slope is available from the tetrode, as compared with the 30FL1, so enabling adequate video drive to be provided for the cathode ray tube, with anode loads down to 4,700 ohms. This low value of load eases the problems of HF video compensation.

The triode has identical characteristics to the 6/30L2.

Heater current (amps)	I_h	0.3
Heater voltage (volts)	V_h	9.8

TENTATIVE RATINGS AND DATA

Maximum Design Centre Ratings

	Triode	Tetrode
Anode Dissipation (watts)	$P_{a(max)}$ 1.5	2.5
Screen Dissipation (watts)	$P_{g2(max)}$ —	0.8
Anode Voltage (volts)	$V_a(max)$ 250	250
Screen Grid Voltage (volts)	$V_{g2(max)}$ —	250
Heater to Cathode Voltage (volts rms)	$V_{h-k(max)/rms}$ —	150*

*Measured with respect to the higher potential heater pin.

Inter-Electrode Capacitances† (pF)

	Triode	Tetrode
Input	C_{in} 2.3	8
Output	C_{out} 2.0	2.6
Control Grid to Anode	C_{g-a} 2.4	0.04
Grid Triode to Grid 1 Tetrode	C_{g1-g1} —	0.003
Anode Triode to Anode	C_{at-aq} —	0.012
Tetrode	C_{gt-aq} —	0.004
Grid Triode to Anode Tetrode	C_{gt-aq} —	0.004
Anode Triode to Grid 1	C_{at-g1} —	0.008
Tetrode	C_{at-g1} —	0.008

†Measured in fully shielded socket without can.

CHARACTERISTICS

	Triode	Tetrode
Anode Voltage (volts)	V_a 200	180
Screen Grid Voltage (volts)	V_{g2} —	180
Anode Current (mA)	I_a 10	10
Mutual Conductance (mA/V)	g_m 3.4	12.5
Amplification Factor	μ 18	—

TETRODE OPERATION AS VIDEO AMPLIFIER

Allowance must be made in circuit design, not only for component variation, but also for valve spread and deterioration during life. Values of tetrode peak anode current, for an average valve when new and at the assumed end-of-life point for any valve, are as follows:—

	V_a (V)	V_{g2} (V)	V_{g1} (V)	I_a (mA)
Average New Valve	70	180	-1	40
Assumed End of Life Condition	60	180	-1	25

Mounting position: Unrestricted.

Base: B9A (Noval).

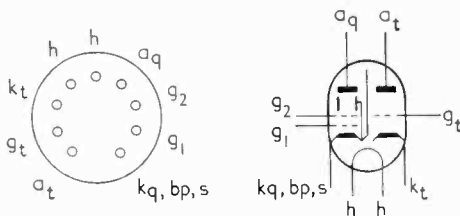

Maximum Dimensions (mm)

Overall Length	56
Seated Height	49
Diameter	22.2

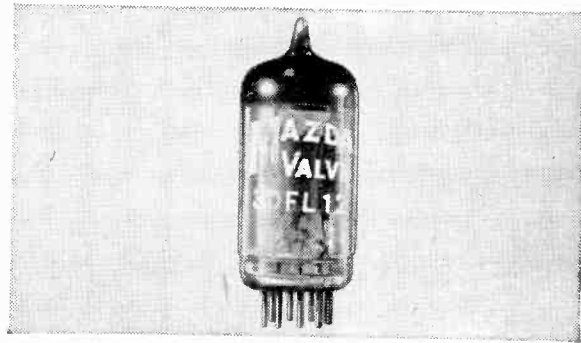

Tentative Characteristic Curves of Mazda Valve Type 30FL12

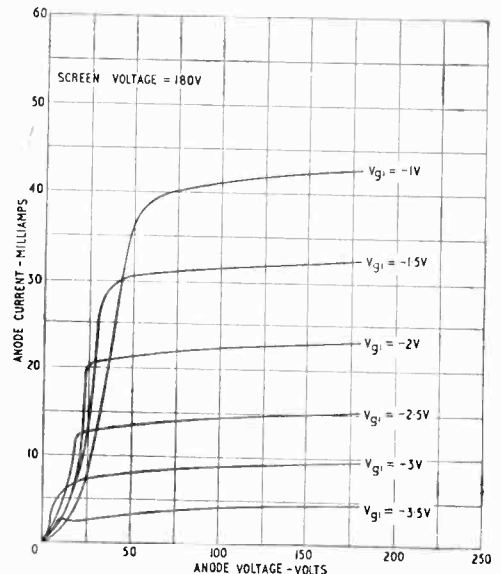
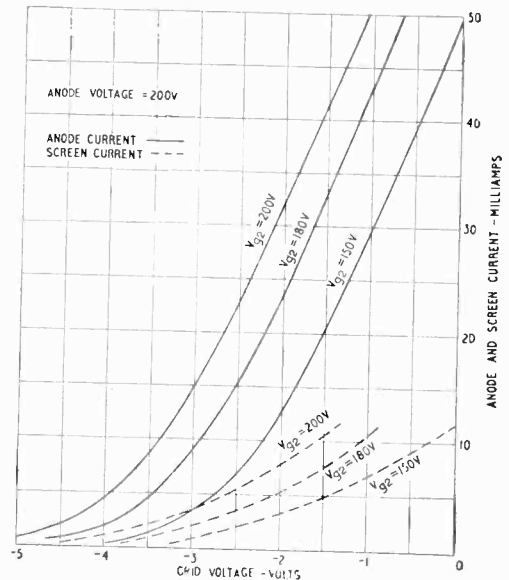

Thorn-AEI Radio Valves & Tubes Ltd

155 Charing Cross Road, London, W.C.2

Telephone: GERrard 9797

Telegrams: Sieswan Westcent London

MAZDA

LETTERS TO THE EDITOR

The Editor does not necessarily endorse the opinions expressed by his correspondents

Television in 1936

I WRITE on the occasion of the 25th anniversary of television in Great Britain, first to offer my congratulations. The B.B.C. and the British radio industry did good work during this period, both technically and in the production of programmes, and British television must be included among the leading institutions of its kind in the world.

My second object in writing is to comment on statements made in two recent books* to the effect that the first public television service anywhere in the world began with the B.B.C.'s regular television broadcasts in November 1936. There is here a small but important omission, namely the words *high definition* between "public" and "television."

In fact the first regular public television service in the world was opened in Germany on 22nd March, 1935 in Berlin. The service began with a two-hour programme every second day in the week. In August 1935 the transmitter was destroyed by fire, but the public service was reopened in 15th January 1936 with a *daily* programme of two hours between 8 p.m. and 10 p.m. During the Olympic Games in 1936 the service was extended with live transmissions from the Olympic Stadium, the Swimming Stadium, etc., during the periods 10 a.m.-12 noon and 3 p.m. to 7 p.m. Hamburg-Meindorf

KARL TETZNER.

* Page 4 of "Television by Design," by Richard Levin (*Bodley Head*), and page 9 of foreword by H. Carleton Greene, O.B.E., to "Television Jubilee," by Gordon Ross (*W. H. Allen*).

Hearing High Frequencies

I HOPE that "Free Grid" will not be too disappointed when he finds his "senescence adjuster" or "presbyotic tone control" (October issue) unused by senescent presbyotic listeners to receivers equipped with this device: and not only because of difficulty in reading the wording on the knob (or the small print of the dictionary)!

A person affected to a noticeable degree of progressive insensitivity to the higher audio frequencies (senile nerve deafness) is compelled to seek less, rather than more "bite," and he would not choose to expose himself to the effects of treble boost.

Hearing loss due to the nerve cannot be made up by amplification if the sounds heard as a result of that amplification are to have any dynamic range. Within the affected frequency range a sound level 10 dB above the threshold of hearing can be as unpleasant as toothache.

The most acceptable type of radio receiver for the elderly is that which many of them have, with plenty of built-in top-cut.

K. W. MAWSON,
Royal Eye and Ear Hospital, Bradford.

625 Lines are Quieter

MUCH is being currently written and said about the possible conversion of our TV line standard, but I have yet to see a reference to what, to my mind, would be the greatest advantage of the change to 625 lines—an improvement to television's Cinderella, the sound channel. Anything which would get rid of that inescapable 10 kc/s whistle would be a great improvement. Not only is the whistle generated within our receivers, it is

an all pervading scream in any TV studio or control room, transmitted by direct acoustic pick-up on microphones and insidious induction on every line and cable-form associated with TV sound circuits.

Of course, it is well known that audio engineers engaged on 405-line TV work develop a notch in their ossicles, and so far as 10 kc/s is concerned they are completely deaf (and I suppose by a process of evolution the viewing public is developing the same self-defence); but I for one would like 10 kc/s to return to the human audio spectrum. Push up the line time base frequency and our TV system will not have to whistle while it works. (Later, of course, you will be in correspondence with the Canine Defence League, but every action must have a reaction).

Uxbridge.

J. LONGDEN.

Impedance-Magnitude Measurement

MR. R. C. WHITEHEAD, in his article on "Impedance-Magnitude Measurement" in the September issue, gives two conditions in which the error due to voltmeter loading is zero, first when the unknown and standard impedances have phase angles identical in magnitude and sign, and secondly, when the phase angles are equal in magnitude and opposite in sign and the voltmeter impedance is resistive. He did not mention that in the latter case the generator impedance must also be resistive. If, however, it was intended that the generator impedance be assumed zero, then the error due to voltmeter loading is always zero, whatever the unknown, standard, and voltmeter impedances, since the impedance of the circuit to which the voltmeter is connected is the same for either position, being that of the unknown and standard impedances in parallel, as can be seen by the application of Thévenin's theorem. The effect of a generator of zero impedance can of course be obtained by using a second voltmeter to measure the generator voltage, and adjusting it to equality for the two measurements.

London, E.C.1.

K. S. HALL.

Northampton College of Advanced Technology.

Voltage or Current Operated?

IT is most kind of "Cathode Ray" (September issue) to give us qualified permission to call our transistors what we will. Some of us, however, consider that the idea of a Third Force is more healthy than the Uncommitted Nation and that the transistor user should always use the word "and" in place of "or".

The case for the current operator is, essentially, the constancy of the current gain. We have in our minds an ideal transistor in which all the current injected at the emitter junction is balanced by current at the collector junction. In terms of the OC45 this may seem a little academic. When we turn to non-linear applications, especially with power transistors, there seems little alternative. The transistor is required to be held well into saturation by a voltage which is usually a good deal more than the normal range of V_{be} . We have, let us say, a minimum large signal current gain of 20 and our load line shows we should get a current of 10 amps. The transistor base is then fed with 0.5 amps and the characteristics look after the rest.

In linear amplifiers the voltage operators have a stronger case than "C.R." makes for them. The transconductance, g_m , shown in the table of "C.R.'s" article

is not constant, but taking at random the E80F pentode, the transconductance at $-0.6V$ bias is $2,500 \mu A/V$ and at $-6.0V$ is $25 \mu A/V$, a ratio, max/min. of 100 compared with the 20.6 which so alarms "C.R." We still use g_m for pentode circuit design, though. The first result is to warn us that increasing the load resistance may not give us more gain because we may lose more on the fall in g_m than we gain by the increase in R . The second result, which I am exploring in detail in an article half-written, is to warn us that a voltage-operated amplifier, that is, one fed from a low impedance, will give us a good deal of distortion. Even if you think about the nice constant current gain you cannot exercise the variations of transconductance.

When we look at some of our circuits we come much more positively to voltage control. With 1,000 ohms in the emitter lead we have, quite definitely, a g_m of $1mA/V$ and an input impedance which is relatively high. What is more, we can think of bias in voltage terms, too.

Do we use transistors to economize in current? Not, I think, to the extent that "C.R." suggests. Once you make the great advance from the 150mW, or whatever it is the smallest battery valve consumes, to the 6 volts $\frac{1}{2}$ -2mA of a transistor it is carrying economy too far to pinch fractions of a milliamp at the cost of gain. Many of us use transistors because we want the added reliability

both of devices and of associated components.

Must we say that negative resistances are voltage or current controlled? Surely all we mean is short- or open-circuit stable?

THOMAS RODDAM.

Norwegian V.H.F. Reception

AFTER trying for five days of this period of DX reception on the v.h.f./f.m. band, I was able to pick up for a short time on 4th Sept. a Norwegian station which I believe to be Bjørkreim on 90.6 Mc/s. 9 p.m. B.S.T.

This was giving the weather reports from the three districts, North, West and Oslo and was 100% readable, but began to fade out after the news. A Danish station on a slightly higher frequency was still strong later, and in fact several Danish stations were heard during the evening, but the German and Dutch which came in strongly two days earlier were absent.

I should be interested to hear if Norwegian v.h.f. stations have been heard by any other readers at any time, as I have tried unsuccessfully several times before.

There are two other 60 kW stations listed, Voss 93.3 Mc/s, and Stord 91.8 Mc/s which is on the West Coast south of Bergen which might also be receivable if clear of interference.

Burniston, Yorks.

L. TRANMER.

CONFERENCES AND EXHIBITIONS

Further details are obtainable from the addresses in parentheses.

LONDON

Nov. 8-10 Savoy Place
Non-Destructive Testing in Electrical Engineering
 (I.E.E., Savoy Place, W.C.2.)

Nov. 22-25 Horticultural Hall
Radio Hobbies Exhibition
 (R.S.G.B., Little Russell Street, W.C.1.)
 Savoy Place

Nov. 30-Dec. 1
Nuclear Electronics Symposium
 (I.E.E., Savoy Place, W.C.2.)

1962

Jan. 15-19 R.H.S. Halls
Physical Society Exhibition
 (Institute of Physics & Phys. Soc. 47 Belgrave Square, S.W.1.)

Feb. 26-28
The Importance of Electricity in the Control of Aircraft
 (I.E.E., Savoy Place, W.C.2.)

April 26-29 Hotel Russell
Audio Festival & Fair
 (C. R. x-Hassan 42 Manchester Street, W.1.)

May 8-18 Earls Court
Mechanical Handling Exhibition
 (Mechanical Handling, Dorset House, Stamford Street, S.E.1.)

May 28-June 2 Olympia
Instruments, Electronics & Automation Exhibition
 (Industrial Exhibitions, 9 Argyll Street, W.1.)

May 31-June 7 Savoy Place
International Television Conference
 (I.E.E., Savoy Place, W.C.2.)

July 2-6
The Ionosphere *
 (Institute of Physics & Phys. Soc. 47 Belgrave Square, S.W.1.)

Aug. 22-Sept. 1 Earls Court
National Radio & Television Show
 (Radio Industry Exhibitions, 59 Russell Square, W.C.1.)

CRANFIELD

April 16-18 College of Aeronautics
International Flight Test Instrumentation Symposium
 (College of Aeronautics, Cranfield, Bucks.)

EXETER

July 16-20 The University
Physics of Semiconductors
 (Institute of Physics and Phys. Soc., 47 Belgrave Square, S.W.1.)

* Venue not yet announced.

FARNBOROUGH

Sept. 3-9 R.A.E.
Farnborough Air Show
 (S.B.A.C., 29 King Street, London, S.W.1.)

OVERSEAS

Jan. 9-11 Washington
Reliability & Quality Control
 (R. Brewer, Hirst Research Centre, Wembley, Middx.)

Feb. 6-7 Washington
Redundancy Techniques for Computing Systems
 (Miss J. Leno, Office of Naval Research, Washington.)

Feb. 14-16 Philadelphia
International Solid-State Circuits Conference
 (E. G. Nielsen, General Electric Co., Syracuse, N.Y.)

Feb. 16-20 Paris
International Components Exhibition
 (Fédération Nationale des Industries Electroniques Francaises, 23 rue de Lübeck, Paris 16.)

April 10-14 Paris
International Conference on Stress Analysis
 (Joint British Committee for Stress Analysis, 1 Birdcage Walk, London, S.W.1.)

May 8-10 Washington
Electronic Components Conference
 (I.R.E., 1 East 79 Street, New York 21.)

May 22-24 Boulder
Microwave Theory and Techniques
 (I.R.E., 1 East 79 Street, New York 21.)

June 25-30 Copenhagen
Electromagnetic Theory & Antennas
 (J. Brown, Department of Electrical Engineering, University College, London.)

June 27-29 New York
Automatic Control Conference
 (I.R.E., 1 East 79 Street, New York 21.)

Aug. 14-16 Boulder
Standards and Electronic Measurements
 (Dr. J. M. Richardson, N.B.S., Boulder, Col.)

Aug. 21-28 Copenhagen
International Congress on Acoustics
 (Professor S. Ingerslev, Royal Technical University, Ostervoldgade 10, Copenhagen)

Sept. 27-Sept. 1 Munich
Information Processing & Digital Computers
 (International Federation of Information Processing Societies, c/o British Computer Society, Finsbury Court, London, E.C.2.)

Sept. 3-7 Brussels
International Symposium on Information Theory
 (Dr. F. L. Stumpers, Philips Research Laboratories, Eindhoven, Netherlands)

MANUFACTURERS' PRODUCTS

NEW ELECTRONIC EQUIPMENT AND ACCESSORIES

Miniature Inspection Lamp

CLINTON Laboratory's "Prodlite" consists of a miniature lamp incorporating a lens set into a $\frac{1}{8}$ -in diameter "stalk" fitted with a standard "torch bulb" screw at the other end. Current rating of the lamp is about 0.25A at 2.5V (two-cell torch) and an intense spot of light is produced up to several inches from the lamp. The stalk, even when fitted with an insulating sleeve, is easily inserted into a tightly-packed assembly; thus the "Prodlite" should prove most useful to service

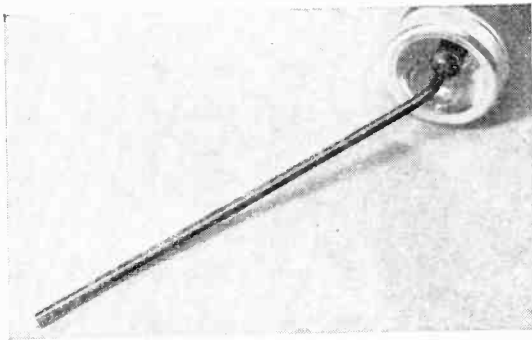

"Prodlite" miniature inspection lamp for illumination of "inaccessible" corners.

engineers, inspectors and amateurs for work on electronic equipment.

The "Prodlite" costs 15s 6d and a switched handle and flex lead is available (12s 6d) for use with, say, a step-down transformer or an accumulator.

The Clinton Laboratory, 43 Broomhall Place, Sheffield, 10.

Wire Stripper

DESIGNED to strip insulation from wires used in electronic equipment and telephone systems without nicking the wire or crushing the remaining insulation, the H35 series weighs 14 ounces. The standard model is intended for commercial use, while the de-luxe version is for use in aircraft and guided-weapon wiring. An automatic device holds the jaws open without crushing. Details can be obtained from Hellermann, Ltd., Gatwick Road, Crawley, Sussex.

Range of Car Radio Aerials

SIX different car-radio aerials are manufactured by Antiference for differing requirements and utilizing various mounting position methods. "Top of the range" is the extensible 45 $\frac{1}{2}$ -in "Autex" designed for universal mounting and particularly suitable for wing use where there is no weather-shield between wheel and aerial. It requires only one hole and can be fitted without the necessity for access to the underside of the mounting surface. Lead length is 5ft (the plug is already fitted) and the price is £2 5s. Next down the price scale is another telescopic type 39-in long, the "Silverstone."

This has a spring and swivel base, is fitted with an 80-in lead and plug and can be fixed (again one hole only) in any position which affords a weather-proof underside for the lead termination. Price is 2gns.

At £1 19s 6d comes the "Continental de Luxe"—a 35-in stainless-steel whip—especially designed for use with transistor receivers. This aerial clips on to the gutter and the feeder enters via a flat plastics ribbon which fits round the top of the door frame. 6ft 6in of lead and a 180° swivel for the whip complete the specification. £1 17s 6d will buy a simpler version of the "Silverstone" without the spring mount, whilst the "Continental," a 30-in long model of the "Continental de Luxe" costs £1 12s 6d.

Cheapest aerial of the range is the "Monte Carlo," which employs the same mounting principle as the "Silverstone," but has its 31-in flexible whip spring mounted at an angle of 45° to the base. Price of this is £1 9s 6d.

Antiference Ltd., Bicester Road, Aylesbury, Bucks.

Pure Water Supply

THE Permutit Company's Mark 7 portable "Deminrolit" water purifier can produce up to 12 gal/hr of water pure to the B.P. standard. Conductivity is given as the order of 1/10 cm and dissolved matter less than 1 part in 10⁶. The Mark 7 employs two processes taking place simultaneously in a resin bed through which the water flows: the first replaces the metallic ions by hydrogen, so forming the acid corresponding to the salt of the original impurity, then the acid so produced is absorbed. A feature of the device is the incorporation of a transistor "purity" meter which indicates in arbitrary units the conductivity of the outflowing water.

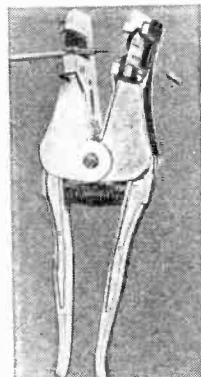

Above: The Hellermann Wire Stripper Model H35.

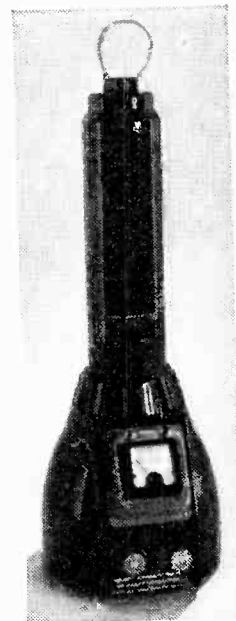

Right: Permutit Co's "Deminrolit" Mark 7 portable water purifier.

The cartridge of de-ionizing material is replaceable and will purify about 16 gal of London's water before requiring replacement, which costs £5 6s for five. The Mark 7 "Deminrolit" costs £35 and should prove useful in laboratories working on printed circuits and semi-conductors and on the factory floor for a final on-the-spot "clean up" of already purified water.

The Permutit Company Ltd., Permutit House, Gunnersbury Avenue, London, W.4.

Microvolt Oscilloscope

A Y-SENSITIVITY of $50\mu\text{V}/\text{cm}$ enables the Du Mont Type 403-B oscilloscope to display signals produced by strain gauges, biological transducers, etc., without the need for further amplification. The Y-amplifier is direct-coupled and, at its most sensitive, has a -3dB bandwidth of 0-150kc/s, increasing to 0-1Mc/s at a sensitivity of $5\text{mV}/\text{cm}$. The input to the

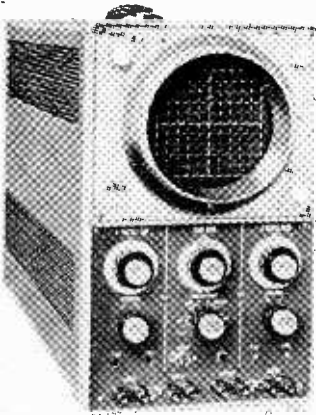

Du Mont 403-B sensitive oscilloscope.

amplifier is differential, with a common-mode rejection of more than -40dB ; drift is nominally $500\mu\text{V}/\text{hr}$. Sweep times are continuously variable from $1\mu\text{sec}/\text{cm}$ to $25\text{sec}/\text{cm}$ and single-sweep operation is possible, with resetting from an external switch, such as a camera shutter, if required. External X-sensitivity is $10\text{mV}/\text{cm}$. Full details are available from Aveley Electric, Ltd., Ayron Road, Aveley Industrial Estate, South Ockendon, Essex.

Professional Transistor Recorder

THE Nagra III professional battery portable transistor tape recorder is provided with separate record and replay heads and amplifiers. Even at $3\frac{1}{2}\text{in}/\text{sec}$, the slowest of its three alternative speeds, the signal-to-noise ratio is 50dB (for 3% distortion at $1\text{kc}/\text{s}$), the frequency response within $\pm 3\text{dB}$ from $50\text{c}/\text{s}$ to $7\text{kc}/\text{s}$ and the wow and flutter 0.35% (peak to peak). At $7\frac{1}{2}\text{in}/\text{sec}$ these figures become respectively 51dB (for 2.5%), $\pm 1.5\text{dB}$ from $30\text{c}/\text{s}$ to $12\text{kc}/\text{s}$ and 0.2%, and at $15\text{in}/\text{sec}$ 52dB (for 2%), $\pm 1\text{dB}$ from $30\text{c}/\text{s}$ to $15\text{kc}/\text{s}$ and 0.15%. The speed difference between the beginning and end of a 5-in reel is 0.1%, between new and nearly discharged batteries 0.05%, and between horizontal and vertical recorder positions 0.03%. The speed is electronically stabilized using a transistorized f.m. tachometer. Battery voltage and line output can be indicated on the recording level meter. Automatic adjustment of the recording level (at the cost of some distortion) may be obtained by means of a volume compressor. A 50 to $200\text{-}\Omega$ microphone impedance change only alters the input sensitivity from $100\mu\text{V}$ to $200\mu\text{V}$. The output is

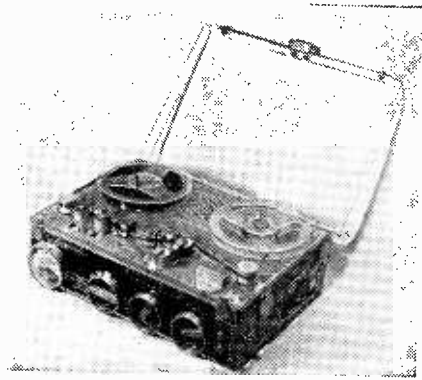

Nagra III professional battery portable tape recorder.

1.55V at $100\text{-}\Omega$ and a built-in monitor speaker is provided. The current consumptions on record and replay are 180 and 120mA respectively. Twelve 1.5-V torch batteries are used as the power supply. The dimensions of this recorder are $12\frac{1}{2}$ by $8\frac{3}{4}$ by $4\frac{1}{2}\text{in}$ and up to 7-in reels can be used with the lid open (5in when closed). Its weight is $16\frac{1}{2}\text{lb}$. This recorder costs £340 (approximately) and is distributed in this country by Livingston Laboratories of 31, Camden Road, London, N.W.1.

Field Intensity Meter

ESSENTIALLY a frequency-selective microvoltmeter, the Stoddart Type NM-62A covers the band 1-10Gc/s, in four bands. Automatic frequency-scanning is provided, and outputs are available to allow an X-Y plotter to trace the spectrum analysis of the input signal. The maximum sensitivity is $5.5\mu\text{V}$ at $1\text{Mc}/\text{s}$ bandwidth and an internal calibration-pulse generator is included. When used as a voltmeter, the range is $6\mu\text{V}$ -10V, and field intensity measurements may be made from $78\mu\text{V}/\text{m}$ to $130\text{V}/\text{m}$. Rejection of

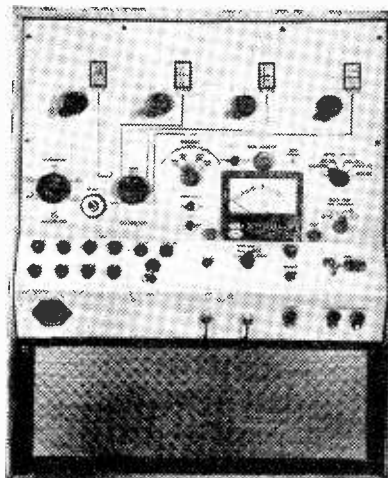

Aveley Electric Stoddart type NM-62A field intensity meter.

signals outside the selected pass-band is better than -80dB . The NM-62A is marketed in the U.K. by Aveley Electric, Ltd., Ayron Road, Aveley Industrial Estate, South Ockendon, Essex.

Radio-Frequency Measurements

1.—WAVEMETERS AND HETERODYNE TECHNIQUES

By R. BROWN

FREQUENCY measurement can be carried out with greater accuracy than probably any other type of measurement in the electronic field, and this high measurement accuracy was achieved quite early. By 1938, for example, it was possible to measure frequency with an accuracy of about 0.0001%, and improvements in technique since then have resulted in considerable improvement even on this accuracy.

The top-grade frequency measuring systems are, however, usually rather difficult to operate; certainly considerable practice is necessary before their full accuracy can be made use of and before measurements can be made with any speed. The result is that while the accuracy of measurement is still being improved upon, and top-grade measuring systems find many applications, there is a tendency, strange in the electronics field where the demand is always for greater and greater accuracy, to use measuring techniques which, while they have a useful accuracy, are less accurate than the best, but which are much easier to use.

There have been as many different methods of frequency measurement suggested, tried out, and put into use as there have been of other types of measurement. Many of these different techniques have not, however, stood the test of time. Yet anybody faced with the problem of choosing a frequency measuring system still has an almost bewilderingly wide range to choose from.

Measurement by Lecher-Wire System

Probably the cheapest and simplest means of frequency measurement is by the Lecher line system^{2, 5}. To carry out measurements by this system two wires,

insulated at each end, are stretched out parallel to each other, to form a transmission line. The signal to be measured is injected into one end of the line, and the other end of the line is left open-circuited. If a shorting link is now placed across the line at some point a standing wave pattern will be set up along the line, maximum and minimum values of current occurring at half-wavelength intervals along the line.

To make a measurement a detector and milliammeter are coupled to the end of the line at which the signal is injected, and the position of the shorting link adjusted until the meter indicates a maximum. This is shown in Fig. 1. In this condition there are a whole number of half wavelengths in the standing wave pattern. The position of the shorting link is then moved along the line until the meter again shows a maximum. There are, as before, a whole number of half wavelengths in the standing wave pattern, and the distance the shorting link has been moved is equal to one half wavelength of the signal in the line.

The true wavelength, λ_1 , in free space differs slightly from the measured wavelength, the error usually being less than 0.5%. If greater accuracy is required the true wavelength can, however, be found with the help of a correction term, Δ ^{1, 3}. This term depends upon the frequency, the inductance and the resistance of the line. It is given by:—

$$\Delta = \frac{\sqrt{r_0}}{8 \log_e B \sqrt{\{1 - (d/a)^2\}}} \dots \dots (1)$$

where d is the diameter of each conductor
 a is the distance between the conductors

$$B \text{ is equal to } \frac{1 + \sqrt{1 - (d/a)^2}}{d/a}$$

and r_0 is the d.c. resistance per cm. length of the double line in the c.g.s. system.

Once the correction factor, Δ , has been found the true wavelength can be found from the expression

$$\lambda_1 = 2\lambda(1 + \Delta)$$

where λ is the measured half-wavelength.

Provided that λ is in metres the corresponding frequency f is given by:—

$$f = \frac{1.499 \times 10^8}{\lambda(1 + \Delta)} \text{ kc/s} \dots \dots (2)$$

This is a useful method of frequency measurement; practical considerations prevent its use below about 15 Mc/s, however, and even long before this frequency is reached the line becomes excessively long. A capacitor can be connected across the input end of the line, so as to keep the length of the line down to a minimum. There is little to be gained, however, by simply measuring the length of the first half wavelength, and restricting the line to slightly

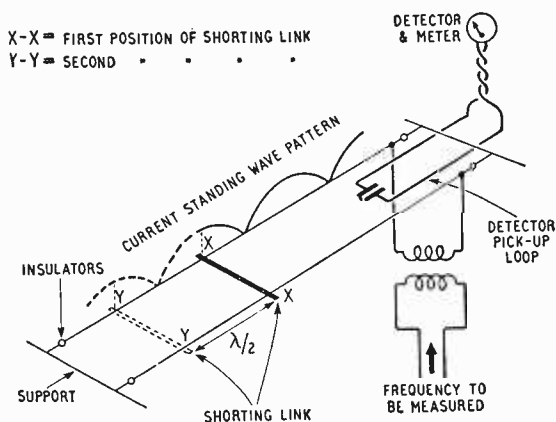

Fig. 1. The lecher line method of measurement.

greater than this, for the distance between the end of the line and the first current maximum is not an accurate half wavelength because of the influence of the signal and detector coupling circuits. The length of the free end of the line, that beyond the short circuit, should be kept small compared with a quarter wavelength, or a multiple of a quarter wavelength to prevent interaction between the two sections of the line.⁴

Absorption Wavemeters

This is a very robust and portable class of instrument with which frequency can be measured with an accuracy which varies from about $\pm 3\%$ to about 1 part in 10^5 . It consists essentially of a simple variable frequency resonant circuit which can be coupled to the signal to be measured, plus some indicating device to show when the circuit is in resonance. The chief advantage of this type of wavemeter is its simplicity, and an additional advantage is that if the indicator consists of a crystal detector and a meter no power supplies are required.

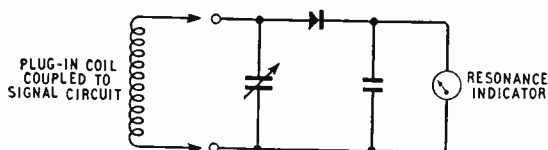

Fig. 2. A simple absorption wavemeter.

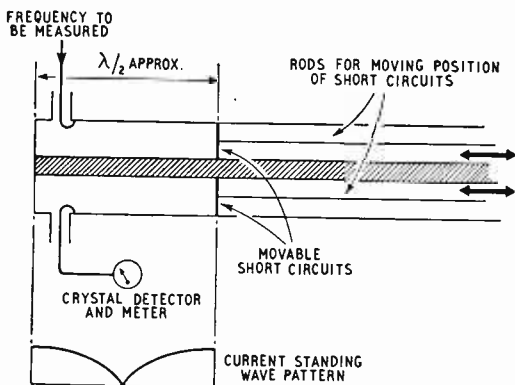

Fig. 3. A coaxial line wavemeter.

A simple type of wavemeter suitable for use up to about 300 Mc/s is shown in Fig. 2⁶. The variable capacitor has a calibrated dial, and in use it is tuned for a peak reading on the indicator. The frequency can then be read directly off the dial.⁷

The tuned circuit of a wavemeter of this type should have as high a "Q" as possible so as to give a sharp indication of resonance, thus giving good frequency discrimination. Loose coupling is essential if a high "Q" is to be obtained, but this reduces the sensitivity of the instrument, and a compromise is usually made between these two conflicting requirements. Special instruments have, however, been described in which loose coupling and high sensitivity are achieved together.⁸ Another important requirement is that the instrument should be free of spurious

responses or resonance in an unwanted mode. If this requirement is not met considerable ambiguity of reading can result.

Up to about 300 Mc/s conventional lumped LC circuits are used, a wide operating range being obtained by changing coils. The accuracy is, however, usually low because of the inherent poor stability of the components.

The relationship between capacitor setting and frequency usually follows one of two laws; either a straight-line frequency law, where one division of the capacitor scale always represents the same alteration of frequency, or a logarithmic law where equal alterations of capacitor setting produce equal percentage frequency changes.

The straight-line frequency law capacitors are almost the ideal for some wavemeters. Here the relationship between capacitor setting θ , frequency f , and capacitance C is:—

$$\theta \propto f \propto \frac{1}{\sqrt{C}}$$

At the low frequency end, however, the accuracy becomes rather poor, for as the frequency is decreased each division of the capacitor dial will correspond to a larger percentage frequency change.

If, however, instead of the capacitor being made so that $\theta \propto f$, it is made in such a way that the rate of change of capacitance is always proportional to capacitance, then equal alterations of the capacitor setting ($\delta\theta$) will produce equal percentage frequency alterations. This will result in a wavemeter which has constant percentage frequency error over the whole scale.

Coaxial Line Wavemeters

At frequencies above about 600 Mc/s the coaxial line wavemeter becomes practicable. This type of wavemeter makes use of the fact that a half-wavelength length of coaxial line is equivalent to a resonant circuit. This is shown in Fig. 3. The movable short circuits are usually operated by push rods, which in turn are linked to a calibrated dial.

The distance between the front of the short-circuit and the end of the coaxial line is not an exact half wavelength owing to end effects. This instrument has, therefore, to be calibrated against a standard. The sharpness of resonance is usually very high, and provided an accurate mechanical drive system for the push rods is achieved, a drive system in which back lash is eliminated, the accuracy can be as high as 0.05%.

Resonant Cavity Wavemeters

At microwave frequencies resonant cavities are widely used. These cavities are the microwave equivalent of parallel tuned circuits. They are always in the form of a cylinder, and tuning is accomplished either by using a piston to vary the length of the cavity, or by means of a plunger projecting into the cavity.

Many field configurations are possible in such a cavity for any given setting of the piston, and as a result many resonant frequencies are possible. The choice of the mode to be employed in any given wavemeter will depend upon the function of the wavemeter^{9, 10}.

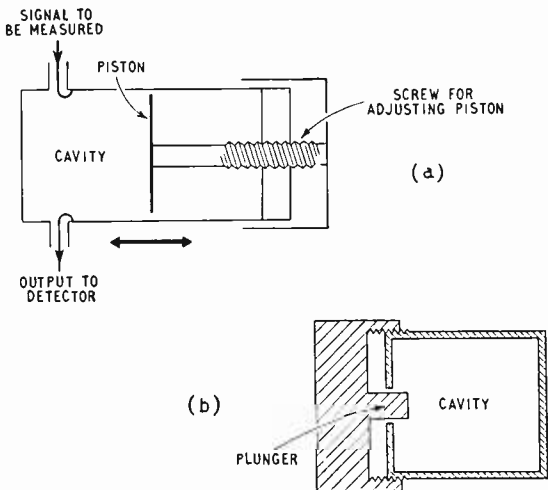

Fig. 4(a) A simple cylindrical wavemeter with piston tuning; (b) Plunger tuning.

The H_{111} mode is frequently preferred for simple cylindrical wavemeters of the type shown in Fig. 4, since it has the lowest resonant frequency, thus reducing mode troubles to a minimum. The H_{011} mode is, however, often used, since although mode troubles are increased, the 'Q' obtained is about twice that obtained with the H_{111} mode.

Wide frequency coverage consistent with freedom from unwanted modes is the most important quality required in general purpose wavemeters. It has been shown that this can best be achieved by the use of a hybrid mode, the E_{010} -EH hybrid mode. The length of the cylinder in a wavemeter using this mode is made much larger than its diameter, and the plunger can be inserted into the cylinder to almost its complete length. Fig. 5 shows the constructional details of a wavemeter of this type. In the region X-X the field configuration is like that of the E_{010} mode, while in the region Y-Y the field configuration is similar to that in a coaxial line.

Comparison Method

In this method of measurement the frequency to be measured is compared with the frequency of an accurately known standard frequency. The source of this standard frequency is usually a crystal controlled oscillator, a caesium atomic standard or a standard radio signal controlled by one of these two standards.

An instrument having only one output frequency would have only a few applications. A number of comparison frequency measuring techniques have, therefore, been devised in which the system provides a large number of comparison frequencies from a single standard frequency.

The simplest example of such a system is the crystal calibrator.¹¹ In such an instrument there is usually a single crystal controlled oscillator working at, say 1 Mc/s, or possibly 100 kc/s, while some instruments have a 1 Mc/s crystal and a 10 to 1 divider circuit, which allows either a 1 Mc/s or 100 kc/s output to be obtained. This output is fed into a harmonic generator, and by suitable

design a large number of harmonics of the selected frequency can be obtained. There are, therefore, a series of crystal controlled frequencies available, the spacing between frequencies being either 1 Mc/s or 100 kc/s.

A series of frequency markers of this sort is particularly useful when checking the calibration of a receiver, say, or of a variable frequency transmitter, a variable test oscillator or a signal generator. The instrument is usually completed by a mixer, a detector, and a pair of headphones, and in use the output from the equipment being checked is mixed with the output from the crystal calibrator. The frequency of the equipment under test is varied, and as the frequency approaches one of the crystal harmonics an audio frequency beat note will be heard. The equipment can then be tuned to give a zero beat note, and once it is found which crystal harmonic is actually being used the frequency to which the equipment is tuned can be accurately determined.

The question of deciding just which harmonic of the crystal oscillator is being used, is very easily solved when using low order harmonics, but it can become very troublesome when using high order harmonics. A further disadvantage of this simple instrument is that it is impossible to measure frequencies which lie between crystal harmonic frequencies.

Heterodyne Frequency Meters

A more versatile instrument is the heterodyne wavemeter, which, in addition to a crystal oscillator, a 10 : 1 divider, detector, and 'phones, has a calibrated variable frequency oscillator. This oscillator covers a large section of the desired working range

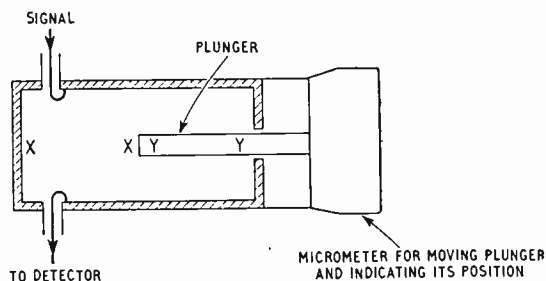

Fig. 5. Hybrid cavity.

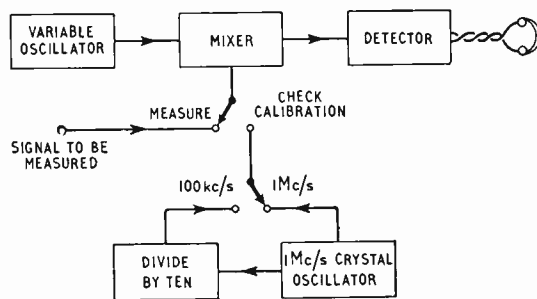

Fig. 6. Heterodyne frequency meter block diagram.

of the instrument, and immediately before use its calibration is standardized against the nearest harmonic of the crystal oscillator. The oscillator is then tuned to zero beat with the frequency to be measured, and the frequency determined from the setting of the oscillator tuning dial. Fig. 6 shows a typical arrangement.

The variable oscillator calibration must be reasonably accurate over the range between crystal harmonics. This can be achieved by calibrating the main tuning dial in degrees, and then checking and plotting the oscillator frequency against the dial reading—a lengthy business which results in a complicated and bulky calibration chart. An instrument has, however, been produced in which the manufacturing tolerances in the variable capacitor are allowed for by a cam driven by the main tuning control¹². A true straight-line frequency law is obtained, and the oscillator dial is direct-reading in frequency.

To obtain the maximum use of a heterodyne wavemeter the harmonics of the variable oscillator are used to extend the frequency coverage. When doing this the problem of the identification of the high order harmonics can be solved using the following method¹³.

The oscillator frequency is adjusted until its n th harmonic is brought into zero beat with the higher frequency signal being measured. This oscillator frequency is noted and the oscillator retuned so that its $(n-1)$ th harmonic is brought into zero beat with the frequency being measured. This second oscillator frequency is noted, and the value of the frequency being measured can be found in the following way.

Let f_0 = the unknown high frequency.

f_1 = the first (lower) oscillator frequency.

f_2 = the second (higher) oscillator frequency.

n = the order of the harmonic of f_1 , causing the first beat.

Then $(n-1)$ will equal the order of the harmonic of f_2 causing the second beat.

$$\text{Thus } f_1 n = f_0 \quad \dots \quad (3)$$

$$\text{and } f_2 (n-1) = f_0 \quad \dots \quad (4)$$

$$\text{hence } f_1 n = f_2 (n-1)$$

$$\text{or } f_1 n = f_2 n - f_2$$

$$\therefore n (f_2 - f_1) = f_2$$

$$\text{and } n = \frac{f_2}{f_2 - f_1} \quad \dots \quad (5)$$

$$\text{But from (3) } f_1 n = f_0$$

$$\text{so } f_0 = \frac{f_1 f_2}{f_2 - f_1} \quad \dots \quad (6)$$

Analogue Frequency Meters

This technique, frequently used for very low frequency measurements, has recently been adapted for use at radio frequencies.¹⁴ The idea is to convert each cycle of the frequency to be measured into a narrow pulse. This pulse is then used to trigger a monostable multivibrator which produces a pulse of accurately determined height and width (that is, area) for each pulse. These pulses are then integrated to produce a voltage which is proportional to the number of pulses per second. A voltage is thus produced which is proportional to frequency and a voltmeter can then be calibrated directly in frequency and used to measure this voltage. Accuracy is about 0.2%.

Fig 1 Accuracy System

The accuracy obtainable with a simple heterodyne wavemeter is limited, usually to about 1 part in 10^3 for simple systems. A variable frequency interpolating oscillator can only be accurate at the crystal check points, and the limited accuracy attainable between check points only holds for a short period after the calibration has been checked.

A number of alternative methods for filling the gap between the crystal harmonics are in use. They all rely on the production of sub-harmonics of the crystal frequency by frequency division,¹⁵ and obtaining a series of closely spaced harmonics from these sub-harmonics. As an example of the production of these sub-harmonics a one megacycle crystal oscillator could be used as the primary standard, and a series of 10 : 1 dividers can then be used to provide 100 kc/s, 10 kc/s, 1 kc/s and 0.1 kc/s sub-harmonics. These sub-harmonics can then be converted to pulses which are rich in harmonics, and the desired harmonic selected by means of a tuned amplifier, the tuning of this amplifier being adjusted by a switch to the required harmonic frequency.

The technique of measurement by successive reduction is an example of the use of a series of sub-harmonics. This is shown in Fig. 7. The seventh harmonic of the 1 Mc/s standard is mixed with the frequency to be measured. The fifth harmonic of the 100 kc/s is then mixed with the 546.255 kc/s resultant,

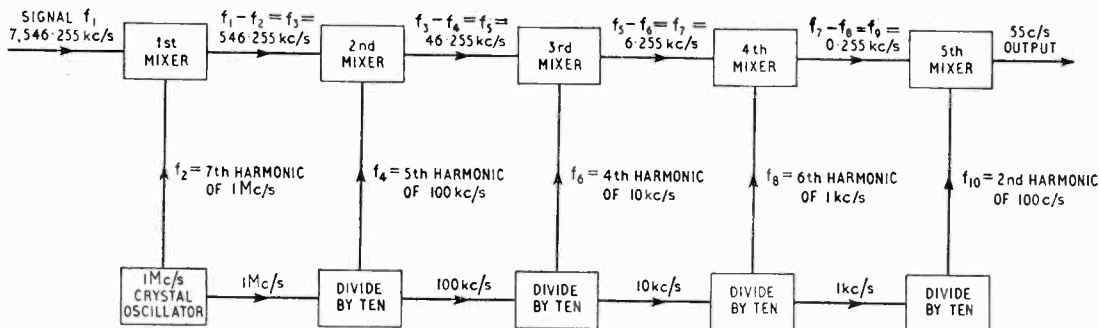

Fig. 7. Frequency measurement by successive reduction using harmonics from divider chain.

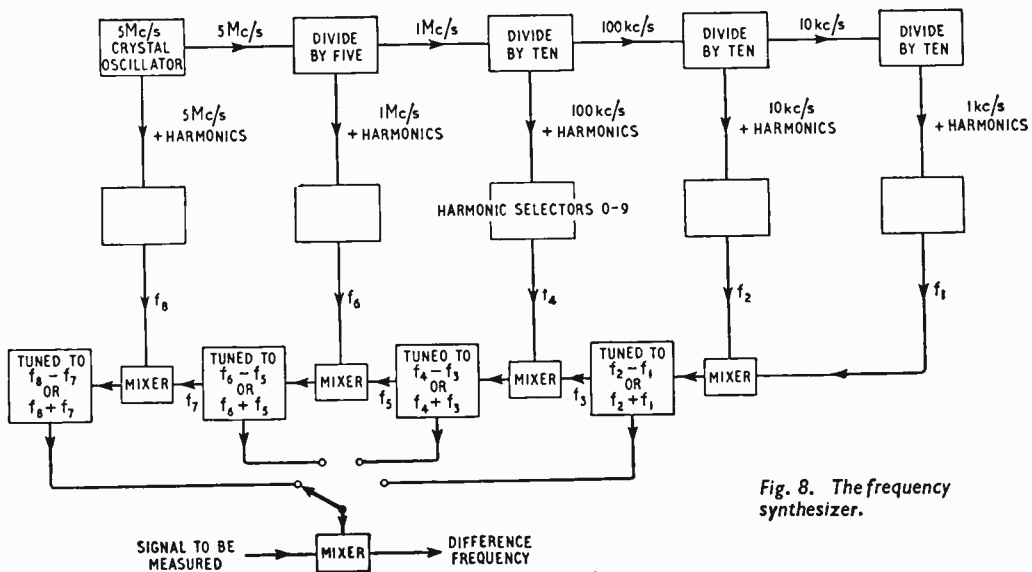

Fig. 8. The frequency synthesizer.

and the fourth harmonic of the 10 kc/s sub-harmonic is mixed with the 46.255 kc/s difference frequency. The result, 6.255 kc/s, is mixed with the sixth harmonic of the 1 kc/s sub-harmonic giving 0.255 kc/s. This is mixed with the second harmonic of the 0.1 kc/s sub-harmonic giving an output of 55 c/s. This latter frequency is low enough to be measured by comparing it with a stable, accurate, low frequency oscillator, using Lissajous figures.

An alternative approach is to use the sub-harmonics to lock a variable oscillator. An arrangement on these lines which will produce a standard frequency which is within 100 c/s of the frequency to be measured is shown in Fig. 6. A variable oscillator which covers the frequency range 1 Mc/s to 2 Mc/s can be locked anywhere in this range to one of the harmonics of the 0.1 kc/s. The output from this oscillator is then mixed with one of the harmonics of the 1 Mc/s. The difference frequency can then be easily checked (see later). By suitably combining different harmonics of the 1 Mc/s, the frequency coverage can be extended up to at least 30 Mc/s.

The Frequency Synthesizer

With this device it is possible to produce a very great number of marker frequencies, only one of which is present in the output at any one time.^{16,17} Each marker is locked to the standard crystal oscillator, and is a pure tone, so that there can be no possible difficulty in identifying the frequency marker in use. Equipment can easily be designed to produce markers in steps of 1 kc/s or of 100 c/s and individual frequencies at 100 c/s intervals up to 30 Mc/s can be produced. Thus no matter what the frequency of a signal in this range, the equipment can produce an accurate frequency marker which is within 100 c/s of it. The two frequencies, the signal to be measured, and the standard frequency, can then be combined and their difference frequency accurately measured by one of the l.f. comparison methods.

How this is done can best be seen with the aid of the block diagram of the basic arrangement as shown in Fig. 8. The standard crystal oscillator usually operates at 5 Mc/s, and one of the standard harmonic

divider chains is used to produce harmonically rich frequencies of 1 Mc/s, 100 kc/s, 10 kc/s and 1 kc/s. Any individual harmonic, up to the 9th, of the 1 kc/s, 10 kc/s, 100 kc/s and 1 Mc/s frequencies, and of the standard frequency can be selected by tuned amplifiers. The harmonic, or harmonics selected can then be combined in a series of balanced modulators to produce the desired output.

Any two selected harmonics, say the n_1 th harmonic of the standard frequency f , and the n_2 th harmonic of the output of the first divider $f/5$ are fed to a balanced modulator system. The output from this modulator will contain a number of products, the most important two being $n_1f + n_2f/5$ and $n_1f - n_2f/5$. These modulation products are fed to a continuously variable calibrated tuned amplifier which is tuned to the wanted product, and is sufficiently selective to reduce the level of the other products to a negligible figure. If the required output frequency is simply $n_1f + n_2f/5$ this can now be fed to the output of the equipment where it can be mixed with the signal.

To produce other frequencies which are multiples of $f/50$, $f/500$ and $f/5000$, a similar process occurs. For example, suppose the frequency to be measured is say, 76.5 kc/s. A frequency output of 76 kc/s from the equipment will produce a difference frequency of 500 c/s when it is mixed with the frequency to be measured, and 500 c/s is a suitable frequency for measurement by one of the low frequency comparison methods. This 76 Kc/s signal is produced in the following way. The sixth harmonic of the 1 kc/s frequency is selected by its harmonic selector, and combined in the balanced modulator with the seventh harmonic of the 10 kc/s frequency which has been selected by its harmonic selector. The output from the modulator will consist of 70 kc/s + 6 kc/s and 70 kc/s - 6 kc/s. The product at 76 kc/s is selected by the tuned amplifier and passed on to be compared with the frequency to be measured.

The output must be reasonably pure if the synthesizer is to exhibit its chief attractions—ease of operation, and no ambiguity. This can be easily achieved in the case of the example just considered, for the main unwanted modulation product is at 70 kc/s - 6 kc/s i.e., at 64 kc/s, 12 kc/s away from the

wanted product at 76 kc/s. Trouble arises when the second digit of the wanted product, instead of being 5, 6, 7, 8 or 9, is 1, 2, 3 or 4. In the worst possible case, which in the example considered would be 71 kc/s, the unwanted product, at 69 kc/s would be only 2 kc/s away, and it would be difficult and expensive to adequately suppress it. This difficulty can be overcome, and relatively simple tuned circuits retained, by always selecting a harmonic which is the complement of these low value digits. If a frequency of say 72 kc/s is required, the 8th, instead of the second harmonic of the 1 kc/s is selected, and this is mixed with the eighth, instead of the seventh harmonic of the 10 kc/s signal. The modulation product will now be $80 \text{ kc/s} \pm 8 \text{ kc/s}$, i.e. 72 kc/s and 88 kc/s. The wanted product of 72 kc/s is selected quite easily for it is separated by 16 kc/s from the unwanted product at 88 kc/s.

As a further example of the operation of the synthesizer consider the production of a frequency of say 15.678 Mc/s.

The eighth harmonic of the 1 kc/s frequency is selected and mixed with the seventh harmonic of the 10 kc/s frequency. Their sum, 78 kc/s, is selected and mixed with the sixth harmonic of the 100 kc/s signal. The product, 678 kc/s, is then selected and mixed with the fifth harmonic of the 1 Mc/s frequency to produce 5,678 kc/s, and this is combined with the second harmonic of the 5 Mc/s crystal standard. Their sum, 15.678 Mc/s, is the wanted signal.

If it should be necessary to produce marker frequencies at intervals which are smaller than 1 kc/s either one of two methods can be used. A further 10:1 divider chain can be used to produce a frequency of 100 c/s from the 1 kc/s frequency. Individual harmonics of this 100 c/s frequency can then be selected and mixed with a selected harmonic of the 1 kc/s frequency, and so on, to produce marker frequencies at intervals of 100 c/s. Alternatively a variable 500 c/s to 1000 c/s oscillator can be used. The output from this oscillator is combined with the selected harmonic of the 1 kc/s frequency, thus providing a variable frequency signal in between the fixed frequency markers spaced at 1 kc/s intervals. The oscillator need only cover the frequency range 500 c/s to 1000 c/s because frequencies between 0 and 500 c/s are produced by mixing the 500 to 1000 c/s frequency with a harmonic of the 1 kc/s frequency, which is one higher than the required harmonic, the difference being selected. The harmonics of a 100 c/s frequency obtained by dividing down from the 1 kc/s frequency, can be used to provide 100 c/s calibration check points on the oscillator, and the calibration of the oscillator need then only hold over the 100 c/s spacing between these calibration check points.

References

1. J. E. Thwaites, and F. J. M. Laver. *The Technique of Frequency Measurement and its Application to Telecommunications*, *J.I.E.E.*, Vol. 89 part III, p. 139, September, 1942.
2. F. W. Dunmore, and F. H. Engels, *A Method of Measuring Very Short Radio Wavelengths and their Use in Frequency Standardisation*, *Proc. I.R.E.*, Vol. II, p. 467, October, 1923.
3. August Hund, *Correction Factor for the Parallel Wire System used in Absolute Radio Frequency Standardisation*, *Proc. I.R.E.*, Vol. 12, p. 817, December 1924.
4. Eijiro Takagishi, on a *Double Hump Phenomenon of*

Current through a Bridge Across Parallel Lines, *Proc. I.R.E.*, Vol. 18, p. 513, March 1930.

5. H. B. Dent, *Measuring Decimetric Wavelengths*, *Wireless World*, Vol. 64, p. 319, July 1958.

6. P. M. Ratcliffe, *Marconi Absorption Wavemeters*, *Marconi Instrumentation*, Vol. 6, p. 73, September 1957.

7. W. H. F. Griffiths, *Direct Reading of the Frequency of Resonant Circuits*, *Wireless Eng.*, Vol. 20, p. 254, November 1943.

8. G. W. Short, *Transistorised Absorption Wavemeter*, *Wireless World*, Vol. 65, p. 193, April 1959.

9. *Technique of Microwave Measurement (Vol II Radiation Laboratory Series)*, p. 286, 1947.

10. L. Essen, *The Design, Calibration and Performance of Resonance Wavemeters for Frequencies between 1000 and 25000 Mc/s*, *J.I.E.E.*, 1946. Part IIIa, p. 1413.

11. G. de Visme, *Crystal Calibrator*, *Wireless World*, December 1959.

12. L. G. White, *Heterodyne Frequency Meters*, *Marconi Instrumentation*, Vol. 7, No. 7, p. 215, 1960.

13. L. H. Moore, *The Identification of Harmonically Related Frequencies*, *Electrical Engineering*, Vol. 19, p. 134, April 1947.

14. *An Analog Frequency Meter for Modern Measurements*, *The General Radio Experimenter*, Vol. 35, Nos. 1 and 2, p. 3. Jan./Feb. 1961.

15. J. E. Attew, *Decade Multivibrator Design*, *Wireless World*, Vol. 58, No. 3. p. 114, March 1952.

16. H. J. Finden, *The Frequency Synthesiser*, *J.I.E.E.* 1943, Vol. 90, Part III, p. 165.

17. H. J. Finden, *Developments in Frequency Synthesis*, *Electronic Engineering*, Vol. 25, p. 178, May 1953.

(To be continued)

Miniature Tape Recorder

AN hour's playing time is provided by the Stuzzi "Memo-Cord" which measures only $4\frac{1}{2} \text{ in} \times 3\frac{1}{4} \text{ in} \times 1\frac{1}{2} \text{ in}$ and weighs 11oz. Standard $\frac{1}{4}$ -in tape is used and there are four tracks, selected by shifting the record/playback head with a miniature gate-change mechanism. Alternate tracks are played in opposite directions and there are therefore two erase heads, using d.c. to saturate the tape. Separate batteries are used for the 3-transistor amplifier and for the motor which drives the spool rims. Fast rewind can be effected manually, and a numbered backing ensures accurate tape location.

The price of the "Memo-Cord," which as the name implies is primarily a pocket dictating machine, is £26 5s and it is supplied in the U.K. by Recording Devices Ltd., 44 Southern Row, London, W.10.

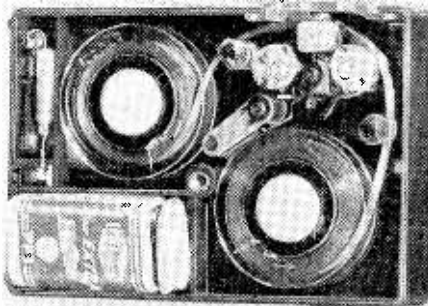

Interior view of the Stuzzi "Memo-Cord." The carrying case is in the form of a book.

VIRTUAL EARTH

By "CATHODE RAY"

THIS is a term that appears from time to time in *Wireless World** and other technical literature, but perhaps not often enough to be familiar to all. In fact, although it was invented something like 20 years ago (I believe by Prof. F. C. Williams) a substantial radio encyclopedia published in 1950 contains no mention of it. So when it does occur it is liable to interrupt the flow of comprehension, unless explained, and if it is explained the explanation interrupts the main stream of the argument. Although it can be quite quickly explained, it is worth some less hurried consideration, because it ties in rather interestingly with other ideas.

Fig. 1 shows the essentials for producing a virtual earth. It comprises an amplifier, with two impedances (in this simplest case, two resistances, R_1 and R_2) connected so as to apply negative feedback in a particular way. Provided the amplifier has a large voltage gain and reverses the sign, the potential of the point P stays relatively constant, almost as if it were earthed.

So what? Couldn't one do even better, without any amplifier, simply by connecting P to earth directly or (if constant p.d. had to be maintained) through a battery, Zener diode, electrolytic capacitor or whatever? But to be effective these would all have to be paths of very low impedance compared with R_1 and R_2 . The special feature about the virtual earth is that there is no need to connect it to earth at all, let alone through a low impedance. It need only

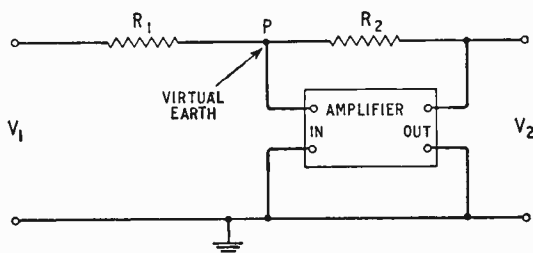

Fig. 1. Basic virtual-earth circuit, comprising an amplifier and two resistors (or other impedances). The higher the gain of the amplifier the better.

go to a negatively biased grid. In which case no current passes out of the circuit there; all that goes through R_1 must go through R_2 as well.

That again, by itself, is nothing remarkable; the same is true of any impedances in series. It is the near-earthing of the junction without any appreciable current-carrying path to earth that is special and yields interesting results.

One notable result (with resistances, as shown) is that V_2 is a copy of V_1 , but reversed in sign and enlarged or reduced to any desired extent, the ratio

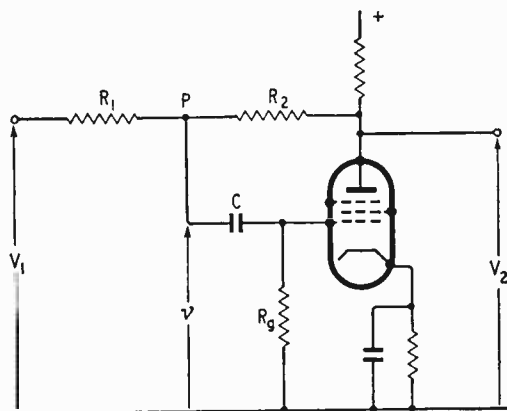

Fig. 2. How Fig. 1 is directly utilized in the see-saw phase inverter circuit. Here $V_2 = -V_1$.

being R_2/R_1 . This is true whatever the waveform of V_1 , so long as the amplifier covers the requisite range of frequency. With other kinds of impedance other phase relationships can be obtained, as we shall see later.

The best known application, using equal resistances to get an opposite and nearly equal V_2 , is what is appropriately called the see-saw circuit. It is identical with Fig. 1, the amplifier normally being a single high-gain stage. Fig. 2 is a practical version. Its usual purpose is as a so-called phase splitter or phase inverter, to drive the balancing half of a push-pull amplifier. V_1 is the alternating voltage output of an amplifying valve—often, but not necessarily, of the same type as the valve shown—and V_2 is the resulting equal and opposite voltage.

The voltage gain of the amplifier is V_2/v , so the greater it is the smaller v is, and the closer P is to earth potential.

Perfect equality of V_1 and V_2 can be represented as in Fig. 3; as one potential goes up the other goes down, and so on alternately—hence the name "see-saw." The diagonal lines represent the peak potentials all along the path R_1R_2 . If these resistances were equal, P would be exactly at earth potential, but then there would be no signal to drive the amplifier, so the thing wouldn't work. Fig. 3 shows that in order to get the necessary v and still keep $V_2 = -V_1$, R_2 has to be slightly greater than R_1 . Applying a little elementary geometry to the diagram gives the correct value of R_2 as $R_1(A+1)/(A-1)$, where A is the gain, V_2/v .† So, for example, if $A = 100$, R_2 would have to be about 2% more than R_1 . If however $R_1 = R_2$, V_2 would be about 2% less than V_1 , which in practice would often be near enough.

These calculations assume that the same current passes through R_1 and R_2 , but according to Fig. 2

*E.g., March 1961 issue, p. 121.

†Strictly, A is negative, but its sign is disregarded here.

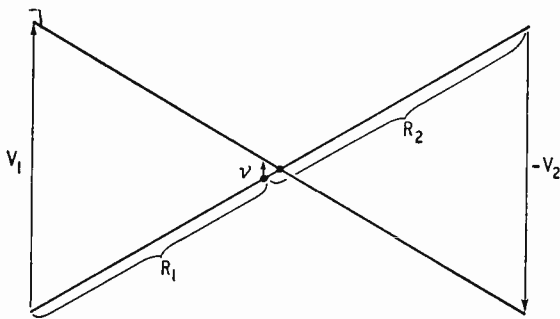

Fig. 3. Peak potential diagram showing how, because V_1 and V_2 are in opposite phase, there is an earth-potential point somewhere on R_2 . The drive for the amplifier (v) is taken off quite close to this, at the junction P, which is the virtual earth.

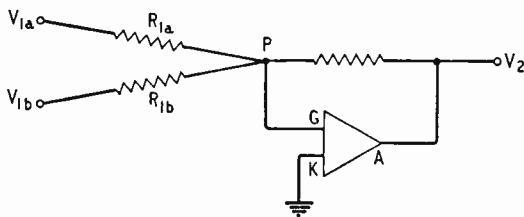

Fig. 4. Basis of electronic adding and subtracting machine. Here (because it is the fashion) the conventional triangular sign for an amplifier is used instead of the block in Fig. 1. Oddly enough, the big signal comes out of the small end.

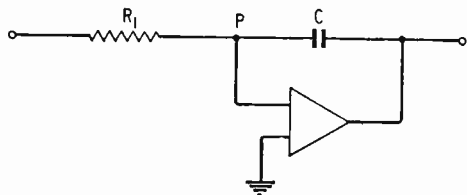

Fig. 5. This slightly modified version can be used for mathematical integration, or as a time base, or for tone control. The first two of these uses are explained by Fig. 6.

some current must branch off to earth via C and R_g . C is chosen so as to have negligible impedance at any working frequency, so only R_g need be considered. And that needn't be considered long, because its resistance is likely to be at least as great as R_1 and R_2 , but the voltage across it is only $1/A$ as much, so with A of the order of 100—or even 50—the effect of R_g is usually negligible. There is therefore no need to go to the trouble—as some do—of avoiding the use of R_g by various circuit modifications. These are more likely to introduce complications than R_g , which is located at almost the lowest-potential part of the circuit.

It may help you to get a still more complete picture of the action of the basic circuit if you discard R_1 and apply the input voltage V_1 direct to P. The only current path (assuming a high-impedance amplifier input) is through R_2 . If the far end of R_2 were earthed, it would appear as a resistance of exactly R_2 and the current would be V_1/R_2 . But for every volt applied at P, the far end of R_2 has $-A$ volts applied to it by the amplifier. So the total voltage across R_2 is

$V_1(A + 1)$ volts, and the current through it is $V_1(A + 1)/R_2$, and so R_2 looks to V_1 (which can't see what the amplifier is up to at the far end of it) like resistance $R_2/(A + 1)$. This is normally quite low—almost a short-circuit to earth; hence the "virtual earth." The amplifier turns R_2 into a sort of transformer, stepping down the impedance between P and earth.

Going back to the see-saw circuit, one of its several advantages is that the ratio of V_2 to V_1 depends almost entirely on the ratio of R_2 to R_1 and hardly at all on the actual amplification, so long as that is reasonably large. And V_2 is an almost perfect upside-down copy of the V_1 input; in other words, hardly any distortion is introduced. These features, of course, are typical of negative feedback, which is here used to a maximum extent.

Because another single-valve circuit with maximum negative feedback, but on the cathode side, is called the cathode follower, some people call the see-saw circuit the anode follower. But that is typical of the muddled thinking that informs our terminology. The point of the name "cathode follower" is that the potential of the cathode closely follows that of the grid. But precisely the opposite is the case with the so-called anode follower. One might just as well call a mouse a cat follower.

Another name is "paraphase circuit." But it too is liable to confuse, because the name has been used for another circuit that looks very similar, the only difference being that the point P is directly earthed and the valve is driven from a tapping on R_1 ; this entirely alters the way the thing works, and prevents it from being self-balancing.

The virtual-earth principle in what is basically the same circuit is even more in evidence when it is used in analogue computers. These (for any who are not familiar with the term) are computers in which the numbers in the problem are represented by the magnitudes of potential differences or currents. The most elementary operation in arithmetic is addition, and if two or more voltages, V_{1a} , V_{1b} , etc. are applied through equal resistances, as in Fig. 4, the current flowing in them will be very nearly proportional to the applied voltages. This is because P is virtually earthed, so that no appreciable voltages are applied at that end. And because both or all of these currents have to flow through R_2 the total current therein (and therefore V_2) is proportional to $V_{1a} + V_{1b} + \dots$. Subtraction is automatically included, because a negative voltage causes a corresponding reduction in voltage output.

It is a simple matter to introduce coefficients, by making R_{1a} , R_{1b} , etc. different. For instance, the sum

$$x + 2y$$

can be done by making V_{1a} proportional to x , V_{1b} proportional to y , and R_{1b} $1/2$ times R_{1a} so that V_{1b} causes twice as much current per volt as V_{1a} .

The scheme can be designed for a.c. or d.c. With a.c. there are greater possibilities, because instead of simple positive and negative there is a continuous range of phase difference. If a capacitor is substituted for R_2 , as in Fig. 5, the equal-current rule still holds, but because of the nature of capacitance the voltage across C is equal to the *time integral* of the current. For instance, if a constant voltage V_1 is applied it will cause a constant current, which will charge the capacitor at a constant rate, making the voltage across

it increase likewise, as in Fig. 6. Mathematically V_2 is the time integral of V_1 , so the device can be used to solve differential equations.

This is also in principle the so-called Miller integrator, developed by Blumlein, which is the basis for many time-base and delay circuits as well as computer circuits. The fault of the ordinary time-base circuits that charge a capacitor through a simple resistor is that the rise in voltage across the capacitor is at the expense of the voltage available for charging it, so that the rate of charge falls off exponentially. In Fig. 5, by contrast, the virtual earth keeps point P at constant potential and the amplifier provides the rising voltage across C, up to the limit of its output.

Substituting C for R_1 instead of R_2 does the opposite thing—differentiation. V_2 is then a measure of the rate at which V_1 is changing.

The now famous Baxandall tone control circuit ‡ was designed around the virtual earth, which allows continuously variable bass and treble lift and cut to be applied independently up to a maximum of about ± 20 dB. In the treble control a capacitor feeds to P a controllable proportion of V_1 (for lift) or V_2 (for cut), varying the impedance ratio and hence the ratio V_2/V_1 progressively at high frequencies. With Fig. 6 still in mind, one might for a moment fear distortion as a result of the integrating and differentiating effects of using the capacitor. But although it is true that the waveform is altered by such a tone control, that has no effect on hearing, which is interested only in the sine-wave components present.§ And it happens that the sine wave has the unique property that its form is not altered by integrating and differentiating; only its magnitude and phase are affected.

Bass control is provided by making P a slider tapping on a middle section of $R_1 + R_2$, thus varying the ratio R_2/R_1 and thereby V_2/V_1 . This effect is confined to low frequencies by shorting out this middle section to high frequencies by means of two equal and relatively large capacitances.

Fig. 7 shows the essentials of the complete tone control system. It is worth noting that negative feedback of the same basic type is adopted in many radio receiver output stages (see my contribution in last July issue), sometimes with fixed tone-adjusting intent.

Ability to bring part of a circuit to earth potential or thereabouts without actually earthing it (i.e., without providing a route for current to escape) is particularly interesting to designers of a.c. measuring bridges. Their problem is that the bridge arrangement (Fig. 8(a)), which is an outstandingly versatile and precise scheme for measuring impedances of all kinds, allows either the signal source or the signal detector to be earthed, but not both. In Fig. 8(a) the detector is earthed, and in the normal operation of the bridge it is adjusted so that the detector has nothing to detect. In other words, there is no p.d. across it, and both terminals are at earth potential. There are inevitably some stray capacitances from the source to earth, shown dotted. These shunt Z_3 and Z_4 , altering their effective values to an unknown extent and so introducing errors.

If the link joining the bridge to earth were removed,

‡“ Negative-feedback Tone Control,” by P. J. Baxandall. *Wireless World*, October 1952, pp. 402-5.

§High Quality Sound Reproduction, by J. Moir; p. 52 (Chapman & Hall).

stray capacitances to earth would be disconnected from the detector and so would not cause misleading currents to flow through it, provided they did not enter via stray capacitance C_3 between detector and earth as in Fig. 8(b). Such entry can be prevented by bringing the detector to earth potential so that no p.d. exists across C and therefore no current can flow that way.

What is called the Wagner earth (totally uncon-

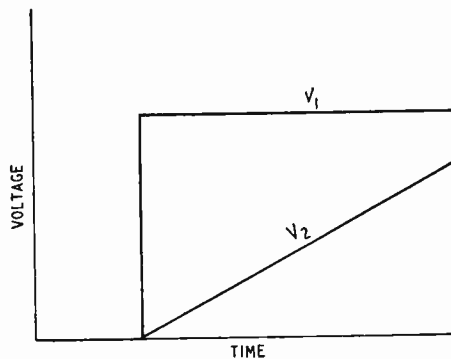

Fig. 6. If V_1 takes the form of a step, as shown here, V_2 comes out as a steady slope.

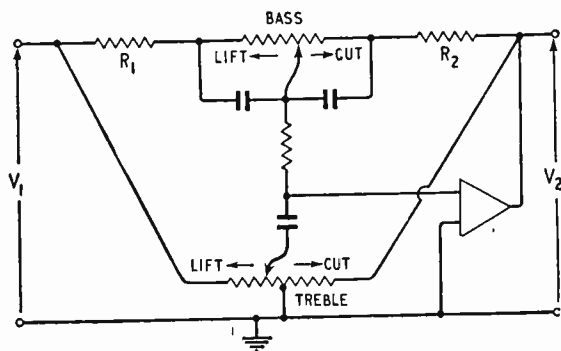

Fig. 7. Essentials of the Baxandall tone control system, which is an elaboration of the same basic circuit.

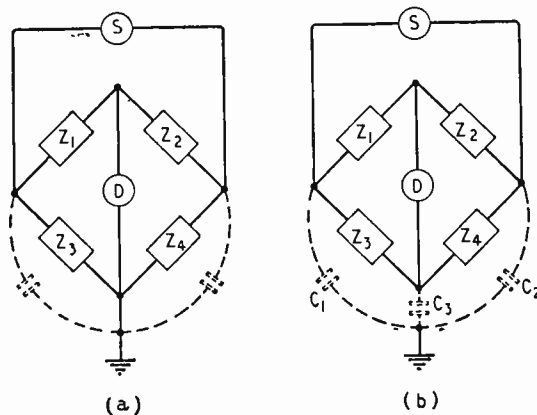

Fig. 8. (a) General a.c. bridge circuit, with the detector directly earthed, in which stray capacitances cause errors. If the detector can be brought to earth potential without direct connection (b) this is avoided.

ected with the composer of *Tannhäuser*) does this by shunting C_1 and C_2 with variable impedances, which are adjusted to bring the detector to earth potential. To ensure that all the stray capacitances are connected to earth and none to the detector (other than C_3), the bridge arms are enclosed in earthed screens.

The snag about this is the adjusting of the Wagner impedances. To avoid it, C. G. Mayo¹¹ made use of the virtual-earth principle as in Fig. 9. As before, the amplifier input is connected between earth and the point P which is to be made a virtual earth. The output is connected to one side of the source, at Q. The part of R_2 is played by the bridge network between P and Q. Remember, at any one frequency—in this case the frequency of the source—any network, however complicated, is equivalent to one resistance and one reactance, either in series or parallel as desired. And the part of R_1 is played by the bridge network between X and P. A slight departure from the arrangement we have been considering is that the signal source is connected between X and Q instead of between X and earth,

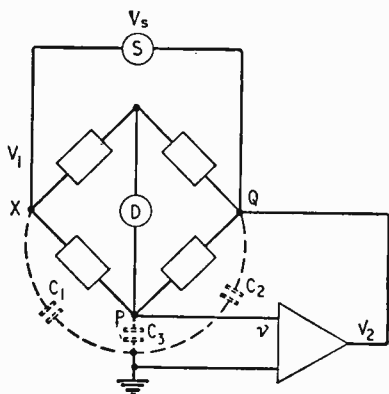

Fig. 9. Mayo-Muirhead-Wagner system for accomplishing (b) in Fig. 8.

but this makes no difference in principle; it just means that V_1 is $V_s - V_2$.

At balance, there is no p.d. across D, and the source voltage V_s divides itself according to the ratio of the bridge, with D at virtual earth potential. For instance, with a 1 : 1 bridge ratio, points X and Q would be at opposite and very nearly equal signal potentials, just as in the see-saw circuit. The stray capacitances C_1 and C_2 from the source to earth occur across the amplifier output and the source, so can be regarded as parts of them, perhaps very slightly altering the signal voltage but not affecting the bridge impedances or its accuracy. All stray capacitance to earth from the detector (and from any bridge-arm screens connected thereto) are rendered insignificant by the relative smallness of the p.d. across it.

Sometimes it may be desirable to minimize potential to some point other than earth. That is where the cathode follower comes in. Fig. 10 shows how. V_2 now has the same sign as V_1 , and v is the difference between the two—and is relatively small if the internal gain (A) of the valve is large. When a single valve doesn't give enough, there are more elaborate cathode followers.¹² In Fig. 10 the device

Fig. 10. By making use of the cathode following action in a cathode follower, the effective capacitance between the input lead and its screen can be reduced to a small fraction of its directly earthed value.

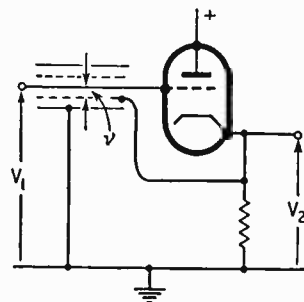

is being used to reduce the p.d. between the input lead and its screen. This greatly reduces its effective capacitance. But, as I emphasized in the May issue, one has to be careful that the cathode follower isn't put out of action by large-amplitude negative-going steep-fronted signals.

Incidentally, the cathode follower is the extreme case of the other main form of negative feedback. That form can be derived from the first one in Fig. 1 simply by changing over the earth connection from one input terminal to the other. But as it looks rather unfamiliar to have the earthed input terminals on top, I have redrawn it in more conventional form as Fig. 11. Just as R_1 and R_2 in Fig. 1 can be regarded as a potential divider controlling the overall gain V_2/V_1 , which is nearly R_2/R_1 if A is large, so in Fig. 11 R_1 and R_2 is a potential divider straight across the amplifier output, controlling the amount of feedback and hence the overall gain, which is approximately $(R_1 + R_2)/R_1$. To apply this form it is necessary, as we have seen, for the amplifier output to be in phase with the input, instead of opposite as in Fig. 1. P is still the junction between R_1 and R_2 , and now follows the potential of the "live" input terminal instead of the earthed one.

The cathode follower is distinguished by the fact that (1) all the output voltage is fed back, by making $R_2 = 0$, so that the overall gain is approximately 1 (again, assuming A is large), and (2) the output is taken from cathode instead of anode, so that it is in phase with the input instead of inverted. So we see there is a very close relationship between our virtual-earth circuit and the cathode follower. In fact, the

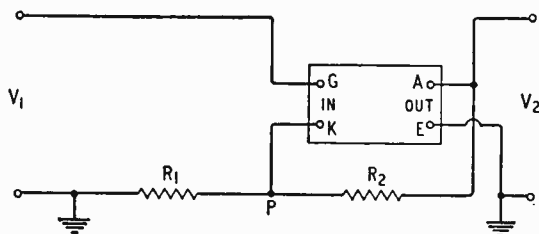

Fig. 11. This, for comparison with Fig. 1, is an alternative main type of negative feedback connection. If $R_2 = 0$ and the anode is transferred to earth, it is a cathode follower.

amplifier in the Mayo circuit can be seen as a cathode follower if point Q is earthed, instead of the cathode as in Fig. 9. (The source S then has one terminal earthed.) The cathode-follower action makes the potential of the bridge screening (which is in effect its local "earth") follow that of the grid, in the usual manner.

¹¹"An Electronic Wagner Earthing Device." *Muirhead Technique*, January 1957, pp. 6-7.

¹²"Multi-valve Cathode Follower Circuits," by J. G. Thomason. *Wireless World*, July and August 1957, pp. 310-3 and 373-7.

News from Industry

British Relay Wireless & Television Ltd.—A 40% increase in trading profit is reported for the year to April 30 last. At £3,516,985, trading profit shows an increase over last year of £1,042,379. Chairman, Sir Robert Renwick, Bart., K.B.E., states that more subscribers were gained to their rental and relay services than in any single previous year. B.R.W. opened seven main stations and 24 substations during 1960-61 bringing the network coverage to over 3M people.

Electric & Musical Industries Ltd. report a group profit before taxation of £5,448,000 for the year to June 30, 1961. This compares with £5,348,000 for 1959-60. Group net profit, after all charges including taxation, was virtually the same at £2,443,000.

Pye and Ekco Profits Drop.—Both Pye Ltd. and E. K. Cole Ltd. experienced set-backs in the financial year to March 31 last. E. K. Cole incurred a group loss of £665,429 as against a previous profit of £675,031 and Pye's group profits contracted from £2.4M to £1.4M. British Electronic Industries Ltd., the company formed just a year ago for the merger between Pye and Ekco, is paying a 15% dividend out of Pye's profits.

Telefunken Annual Report for the year to March 31 last reveals that sales rose in all divisions of the business. Domestic sales increased by 22% and export business by 18%. Including companies wholly owned by Telefunken, the sales amounted to approximately DM740 million.

The Antiference Group Ltd.—Trading profit of £440,375 shows a reduction of some 6% on the previous year, but the company's policy of diversification is starting to bear fruit, states chairman N. M. Best.

British Aircraft Corporation Ltd. announce the following new appointments: Sir George Edwards, C.B.E., (Executive Director, Aircraft), is appointed managing director of British Aircraft Corporation Ltd. He will cease to be managing director of Vickers-Armstrongs (Aircraft) Ltd. and will become deputy chairman of that company. The Rt. Hon. Viscount Caldecote (Executive Director, Guided Weapons), is appointed deputy managing director and chief executive (guided weapons) of British Aircraft Corporation Ltd. Marshal of the Royal Air Force Sir Dermot Boyle, G.C.B., K.C.V.O., K.B.E., A.F.C., has been appointed to undertake special responsibility for co-ordinating the administration of personnel and training and education within the Group. A. W. E. Houghton is to be managing director of Vickers-Armstrongs (Aircraft) Ltd.

Graetz K.G. and Standard Elektrik Lorenz A.G. have merged as far as financial control is concerned. S.E.L. already have an interest in domestic radio through the Schaub-Lorenz firm, but the identities of Graetz and Schaub-Lorenz are to be kept separate as far as development, production and sales are concerned. There will, however, be an exchange of know-how.

Nigerian Telecommunications Corporation is the title of a company newly formed in Nigeria by Marconi's Wireless Telegraph Co. Ltd. and L. M. Ericsson Company of Sweden. The purpose of the new Corporation is threefold; to provide an "on-the-spot" organization which can deal rapidly and efficiently with all aspects of telecommunication requirements; to promote the expansion of technical education in Nigeria, and to introduce local assembly of some types of telecommunication units rather than import them already assembled.

Garrard Engineering Board.—Following the recent announcement that the Garrard Engineering Manufacturing Co. Ltd., of Swindon, had become a wholly owned subsidiary of the Plessey Co. Ltd., the formation of a reconstituted board of directors is announced by Plessey. New directors of the company are A. E. Underwood (chairman); Hector V. Slade (managing director); K. J. Slade; J. Tyldesley; John A. Clark; and Michael W. Clark. Plessey also announce that Sir William Stanier has resigned from the Garrard board, and has accepted an appointment as a director of Machine Products Ltd. Donald F. Brown has also resigned from the Garrard board and has joined the board of Hawley Products Ltd.

Pye have signed a long-term technical agreement with the French company, Schneider Radio-Television, covering the manufacture of specified electronic products but excluding sound radio and TV receivers. Under the agreement Schneider will manufacture Pye products in France and market them throughout the franc area through a joint sales subsidiary which the two companies have agreed to establish.

C.E.C. (U.K.) Ltd. Formed.—The American electronic instrument makers Consolidated Electrodynamics Corporation, Inc., of Pasadena, California, has formed a U.K. subsidiary to manufacture in Britain for both home and export markets. The headquarters of the new Consolidated Electrodynamics Corporation (U.K.) Ltd., is at 14 Commercial Road, Woking, Surrey (Tel.: Woking 5633).

Veroboard Marketing Company.—Expansion of the Electronics Division of Vero Precision Engineering Ltd. has resulted in the formation of that division into a new self-supporting company named Vero Electronics Ltd., to produce and market Veroboard and its accessories. Trading continues from the same address at 7 South Mill Road, Southampton (Tel.: Southampton 71061), and it is pointed out that the new company's formation in no way affects the present or future trading operations of the parent company.

Aveley Electric Ltd., of South Ockendon, Essex, have introduced into the U.K. a number of tubes newly developed by Allen B. DuMont Laboratories for whom they are agents. Among these is the new scan converter Type K.2070. This is a double ended, electrical input—electrical output, non-destructive readout storage tube capable of resolution in excess of 1,000 lines at 50% modulation.

Plessey Co. Ltd., of Ilford, Essex, have granted an exclusive licence to the Centralab Division of Globe Union Inc., of U.S.A., to manufacture, sell and use in the U.S.A. moulded track potentiometers made to Plessey designs.

British Telemeter Home Viewing Ltd. announce that they have appointed Marconi's Wireless Telegraph Company Ltd. as technical consultants in the field of broadcast subscription television and associated matters. British Telemeter have moved recently to 1 Albemarle Street, London, W.1 (Tel.: Hyde Park 5494).

Winter Trading Co. Ltd., of Ladbroke Grove, London, W.10, have acquired all the branches of L.P.F. Ltd., the old-established national radio and electrical wholesalers. The four branches involved, in Manchester, Sheffield, Leicester and Ipswich, will be integrated into the existing Winter Trading organization.

Tannoy Equipment for Border TV.—Comprehensive studio intercommunication equipment and monitoring equipment is being installed by Tannoy Ltd. for the new Border Television Studios. This follows the pattern of similar equipment for radio and TV studios throughout the country. In this instance multi-channel transistorized selective intercommunication equipment is used, together with the new Tannoy 3LZ monitor loud-speaker units mounted in Tannoy "infinite baffle" enclosures.

Lufthansa German Airlines are to equip their entire jet airliner fleet with a new radar-navigation set supplied by Collins Radio Company. Called the DN-101/NC-103 Doppler Radar Navigation System, the unit continuously measures and displays ground speed and displays present aircraft position.

Ship-board Television.—Two special broadband aerial arrays designed by Belling-Lee are being used on board the liner *Canberra* owned by P. & O. Orient Lines. During the preliminary trials of the liner *Oriana* which plies the same route as the *Canberra* and is equipped with a similar system, the aerials were subjected to a force 9 gale which they withstood without any damage. TV programmes continued to be received up to 120 miles from the transmitter. The complete system was installed by the Marconi International Marine Communication Co. It provides for the reception of TV broadcasts employing the 405-line system used in Britain, the 625-line system used in Australia, and the greater part of Europe, and the 525-line system used in the Western Hemisphere and Japan.

New A.M.P. Factory.—Aircraft-Marine Products (Great Britain) Ltd. have opened a 60,000 sq ft plant at the Industrial Estate, Port Glasgow, Scotland. A wide diversity of A.M.P. terminals are used in the electronics industry and in commercial applications the most common use is for loudspeaker connections. Headquarters of the American parent company are located at Harrisburg, Pennsylvania.

Ultra Radio & TV Service Department, under service manager J. S. Lawson, has moved to Eley's Estate, Angel Road, Edmonton, London, N.18 (Tel.: Edmonton 3060).

Perdio Factory at Sunderland.—Perdio Ltd., the London manufacturers of transistor radios and TV sets, components and other related products, are to build a new 115,000 sq ft factory, which will provide, initially, jobs for 700 women and 300 men, on a six-acre site at the Pallion Industrial Estate, Sunderland, Co. Durham.

Brimar Move.—All orders and enquiries, other than those concerned with export and publicity, should now be addressed to Brimar Commercial Division, Thorn-A.E.I. Radio Valves & Tubes Ltd., Rochester, Kent (Tel.: Chatham 44411). London area telephone enquiries can still be made to Footscray 3333. Commercial manager is G. P. Thwaites.

Racal Change Name.—The broadening of their activities in the radio communications field has prompted Racal Engineering, of Western Road, Bracknell, Berks., to change their name to Racal Electronics Ltd. A 24,000 sq ft addition to their Bracknell Works is scheduled for completion next spring. Racal (Australia) Pty. Ltd., Baulkham Hills, Sydney, has been formed to market Racal and other products in Australia.

OVERSEAS TRADE

Indian Industries Fair.—A representative selection of Ekco nucleonic counting and gauging equipment will be featured at the Indian Industries Fair, New Delhi (November 14, 1961-January 1, 1962). The Ekco display will be on the stand of Greaves Cotton & Co. Ltd., Ekco Electronics distributors in India. The Board of Trade is providing an official U.K. exhibit and organizing a large commercial display of British products.

Dexion Radio Mast.—A 60ft radio transmitting mast built entirely in Dexion Slotted Angle is being supplied to Emissores do Norte Reunidos, a commercial broadcasting station in Portugal.

Marconi Marine equipment has been chosen for six fishing vessels being built in British yards for the Ghana Supply Commission. They will be fitted with Marconi Marine radio equipment and electronic navigation and fishing aids.

NOVEMBER MEETINGS

Tickets are required for some meetings; readers are advised, therefore, to communicate with the secretary of the society concerned.

LONDON

1st. I.E.E.—"Generation of power in satellites" by H. J. H. Sketch at 6.0 at Savoy Place, W.C.2. (Joint meeting with Royal Aeronautical Society.)

1st. Brit.I.R.E.—"The teaching of the theory of transistors and other semiconductor devices" by Professor M. R. Gavin at 6.0 at London School of Hygiene and Tropical Medicine, Keppel Street, W.C.1.

2nd. I.E.E.—"Acoustics and the electrical engineer" by T. Somerville at 6.0 at Savoy Place, W.C.2.

3rd. I.E.E.—Discussion on "Information theory in relation to biology" opened by Professor D. M. Mackay at 6.0 at Savoy Place, W.C.2.

6th. I.E.E.—"The general problems of f.m. multi-channel communications" by R. G. Medhurst at 5.30 at Savoy Place, W.C.2.

6th. Society of Instrument Tech-

nology.—"Semiconductor diodes and rectifiers in control engineering" by P. R. Wyman and "The transistor in control engineering" by Dr. G. D. Bergman at 7.0 at Manson House, 26 Portland Place, W.1.

8th. Brit.I.R.E.—"Electronics in chromatography" by E. L. Gregory and E. A. Piper at 6.0 at London School of Hygiene and Tropical Medicine, Keppel Street, W.C.1.

9th. Radar & Electronics Association.—"Space communications" Part II by Dr. W. F. Hilton (Hawker Siddeley Aviation) at 7.0 at Royal Society of Arts, John Adam Street, W.1.

9th. Television Society.—"The colourimetric requirements of monochrome television phosphors: when is your white screen white?" by C. G. A. Hill (Levy West Laboratories) at 7.0 at the Cinematograph Exhibitors' Association, 164 Shaftesbury Avenue, W.C.2.

13th. I.E.E. Graduate & Student Section.—"The Work of the B.B.C., with particular reference to transistors" by R. W. Leslie at 6.45 at Savoy Place, W.C.2.

15th. Brit.I.R.E.—"Infra-red applications in navigation" by C. M. Cade at 6.0 at London School of Hygiene and Tropical Medicine, Keppel Street, W.C.1.

17th. Institute of Navigation.—"The navigation and guidance of supersonic aircraft" by Capt. W. L. Polhemus, at 5.30 at The Royal Geographical Society, 1 Kensington Gore, S.W.7.

22nd. Brit.I.R.E.—Computer Group Symposium on "Adaptive optimizing control" at 6.0 at London School of Hygiene and Tropical Medicine, Keppel Street, W.C.1.

24th. Television Society.—"Television distribution by wire: factors influencing the choice of system" by A. Cormack (Hirst Research Centre), G. J. Hunt (General Piped Television), R. P. Gabriel (Rediffusion) and R. E. Billham (Rediffusion) at 7.0 at the Cinematograph Exhibitors' Association, 164 Shaftesbury Avenue, W.C.2.

29th. I.E.E.—“Recent developments in semiconductor devices and their applications” by E. Wolfendale at 5.30 at Savoy Place, W.C.2.

29th. British Kinematograph Society.—“Radar recording” by Dr. R. E. Eastwood and N. R. Pheip (Marconi’s) at 7.30 at Central Office of Information, Hercules Road, Westminster Bridge Road, S.E.1.

29th. Brit.I.R.E.—“An experimental assessment of loudspeaker performance” by R. York at 6.0 at London School of Hygiene and Tropical Medicine, Keppel Street, London, W.C.1.

ABERDEEN

10th. I.E.E.—“Thermistors—their theory, manufacture and application” by Dr. R. W. A. Scarr and R. A. Settingerton at 6.0 at Robert Gordon’s Technical College.

ABORFIELD

20th. I.E.E. Graduate & Student Section.—“History of modern television” by A. D. G. Wheatley at 7.0 in the Unit Cinema, 3 (Tels.) Training Bn., R.E.M.E.

BATH

8th. I.E.E.—“Silicon power rectifiers” by A. J. Blundell, A. E. Garside, R. G. Hibberd and I. Williams at 6.0 at the S.W.E.B. Demonstration Theatre.

BEDFORD

20th. I.E.E.—“Some recent advances in semiconductor circuits” by Dr. G. B. B. Chaplin at 7.0 at the Swan Hotel.

BELFAST

14th. I.E.E.—“The potentialities of artificial earth satellites for radiocommunication” by W. J. Bray at 6.30 in Lecture Theatre LG25, David Keir Building, Queen’s University.

BIRMINGHAM

15th. Television Society.—“The S.E.C.A.M. French colour television system” by Pierre Cassagne (Compagnie Française de Television) at 7.0 at the Physics Lecture Theatre, The University.

22nd. I.E.E.—“Experimental investigation of space” by J. A. Ratcliffe, C.B.E., at 6.30 at the Midland Institute.

23rd. Brit.I.R.E.—“Tunnel diodes” by Dr. K. Hulme at 6.15 at the Electrical Engineering Dept., The University.

27th. I.E.E.—Third Hunter Memorial Lecture on “The Application of electronics to the electricity supply industry” by Dr. J. S. Forrest at 6.0 at the James Watt Memorial Institute.

BRISTOL

15th. Brit.I.R.E.—“Introduction to analogue computers” by P. G. Davies at 7.0 at the College of Science and Technology, Ashley Down.

21st. I.E.E.—Faraday Lecture on “Expanding horizons in communications” by D. A. Barron at 6.30 at the Colston Hall.

CARDIFF

8th. Brit.I.R.E.—“High-frequency induction heating and dielectric heating” by W. D. Wilkinson at 6.30 at the Welsh College of Advanced Technology.

23rd. I.E.E.—Faraday Lecture on “Expanding horizons in communications” by D. A. Barron at 6.45 at the Sophia Gardens Pavilion.

CHATHAM

29th. I.E.E. Graduate & Student Section.—“Some aspects of the control and guidance of guided weapons” by J. A. Miller at 7.0 at the Medway College of Technology, Maidstone Road.

CHESTER

20th. I.E.E.—“Transistors” by P. Godfrey at 6.30 at the Town Hall.

23rd. Society of Instrument Technology.—“Transistors applied to modern instrumentation” by J. E. Fielden at 7.0 at Stanley Palace, Watergate Street.

DUNDEE

9th. I.E.E.—“Thermistors—their theory, manufacture and application” by Dr. R. W. A. Scarr and R. A. Settingerton at 6.0 at the Electrical Engineering Department, Queen’s College.

EDINBURGH

7th. I.E.E.—“Brushless variable-speed induction motors using phase-shift control” by Professor F. C. Williams, C.B.E., Dr. E. R. Laithwaite, J. F. Eastham and W. Farrer at 7.0 at the Carlton Hotel, North Bridge.

FARNBOROUGH

28th. I.E.E.—“Brushless variable-speed induction motors using phase-shift control” by Prof. F. C. Williams, C.B.E., Dr. E. R. Laithwaite, J. F. Eastham and L. S. Piggott at 6.15 at the Technical College, Boundary Road.

28th. Brit.I.R.E.—“Data acquisition systems” by K. L. Smith at 7.0 at the Technical College.

GLASGOW

8th. I.E.E.—“Education: why bother?” by Dr. K. R. Sturley at 6.0 at the Institution of Engineers and Shipbuilders, 39 Elmbank Crescent, C.2.

29th. I.E.E.—“The banana-tube display system—a new approach to the display of colour-television pictures” by Dr. P. Schagen at 6.0 at the Institution of Engineers and Shipbuilders, 39 Elmbank Crescent, C.2.

IPSWICH

15th. I.E.E.—Third Hunter Memorial Lecture on “The application of electronics to the electricity supply industry” by Dr. J. S. Forrest at 6.30 at Electric House.

LIVERPOOL

15th. Brit.I.R.E.—“The guidance of bats and men by echo-location” by L. Kay at 7.30 at the Walker Art Gallery.

MALVERN

2nd. Brit.I.R.E.—“Transistor portables” by R. A. Lampitt at 7.0 at the Winter Gardens.

MANCHESTER

2nd. Brit.I.R.E.—“V.H.F. communications receivers and transmitters using transistors” by A. J. Rees and D. C. Carey at 7.0 at Reynolds Hall, College of Technology.

7th. I.E.E.—“Some recent developments in oscillating electrical machines” by Prof. F. C. Williams, C.B.E., at 6.15 at the Electrical Engineering (Dover Street) Laboratories, The University.

8th. I.E.E.—“Data transmission” by R. H. Franklin and J. Rhodes, M.B.E., at 6.15 at the Engineers’ Club, Albert Square.

21st. I.E.E.—“Transistor instrumentation in rockets” by G. G. Haigh at 6.15 at the Engineers’ Club.

21st. Incorporated Practitioners in Radio & Electronics.—“Operational use of radio by the police” by a member of Manchester City Police Radio Dept., at 7.30 at the Central Hall, Oldham Street.

MIDDLESBROUGH

1st. I.E.E.—“Thermistors—their theory, manufacture and application” by Dr. R. W. A. Scarr and R. A. Settingerton at 6.30 at the Cleveland Scientific and Technical Institution.

NEWCASTLE-UPON-TYNE

1st. I.E.E.—“The potentialities of artificial earth satellites for radio-communication” by W. J. Bray at 7.0 at the Conservative Club, Pilgrim Street.

6th. I.E.E.—“Microminiaturization” by L. J. Ward at 6.15 at the Rutherford College of Technology, Northumberland Road.

8th. Brit.I.R.E.—“A pulse time multiplex system for stereophonic broadcasting” by G. D. Browne at 6.0 at the Institute of Mining and Mechanical Engineers, Neville Hall, Westgate Road.

20th. I.E.E.—“Simulation of intelligence” by Professor D. M. Mackay at 6.15 at Rutherford College of Technology, Northumberland Road.

NEWPORT

10th. Institute of Physics and Physical Society.—“Colour television: principles and practice” by K. Hacking (B.B.C.) at 6.0 at the College of Technology.

NOTTINGHAM

28th. I.E.E.—Third Hunter Memorial Lecture on “The application of electronics to the electricity supply industry.” by Dr. J. S. Forrest at 6.30 at Nottingham University.

PORTSMOUTH

10th. Brit.I.R.E.—“Recent Advances in low noise microwave valves” by Dr. D. G. Kiely at 7.0 at the College of Technology.

SOUTHAMPTON

1st. I.E.E.—“Brushless variable-speed induction motors using phase-shift control” by Professor F. C. Williams, C.B.E., Dr. E. R. Laithwaite, J. F. Eastham and L. S. Piggott at 7.0 at The University.

14th. I.E.E.—“High speed ferrite core stores” by P. Cooke at 6.30 at The University.

STONE

13th. I.E.E.—“Data transmission” by R. H. Franklin and J. Rhodes, M.B.E., at 7.0 at Duncan Hall.

TAUNTON

9th. I.E.E.—Third Hunter Memorial Lecture on “The application of electronics to the electricity supply industry” by Dr. J. S. Forrest at 3.0 at the Lecture Theatre, S.W.E.B., Electric House, The Parade.

WOLVERHAMPTON

1st. Brit.I.R.E.—“Electronics in biological engineering” by W. J. Perkins at 7.0 at the College of Technology.

WORKINGTON

7th. I.E.E.—“Silicon power rectifiers” by A. J. Blundell, A. E. Garside, R. G. Hibberd and I. Williams at 7.0 at the College of Further Education.

RANDOM RADIATIONS

By "DIALLIST"

One Year Old

I HEAR that the members of the Pilkington Committee recently held a small informal party to celebrate its first birthday. I wonder how old it will be before it speaks! The P.M.G. has certainly made it clear in his reply to the recent appeal from the Radio & Television Retailers' Association for an early decision on line standards that there will not be an interim report from the Committee. I understand that during the year there have been 56 full-day meetings. In addition a sub-committee of four spent 10 days in N. America. The 11 members of the Committee (there were originally 13) are certainly putting in a tremendous amount of time one way and another. They have already had almost as many meetings as its immediate predecessor—the Beveridge Committee of 1949—which held 62 meetings and produced its 900-page report (including appendices) in 19 months.

Simply a Question Of . . .

DUE, undoubtedly, to the disproportionate amount of publicity given in the lay press to the questions of TV line standards and colour, there is in the mind of the man in the street the idea that these are the Committee's only problems. This is, of course, far from the truth but I can't, myself, be sure of the scope of the terms of reference. I wonder if the Editor would refresh our memories by reprinting them.* Can you remember, by the way, the "familiar" titles of the earlier committees of enquiry into broadcasting set up by the Government? The first was the Sykes Committee of 1923; the second, the Crawford Committee

of 1925; the third, the Ullswater Committee of 1935 and the fourth, the Beveridge Committee of 1949. What a simple task the first committee must have had by comparison with the major problems facing the present members. In those far off days it was simply (*sic!*) a question of sound broadcasting.

Colour TV

DID you see what Jules Thorn had to say about colour television in his statement at the recent annual general meeting of Thorn Electrical Industries, which, as you know, markets domestic sound and television sets under a number of trade names, including Ferguson, Philco, Pilot and Ultra. He said: "As to colour, I am appalled at the irresponsible statements that have been appearing in the Press. It is certainly possible to give colour demonstrations under carefully controlled closed circuit conditions, but I believe it is wrong to mislead the public into thinking that we can have it as a satisfactory broadcast service." He then went on to quote a few facts from the American scene where colour TV was introduced as far back as 1954. In the seven years since then only 590,000 colour sets have been sold to the trade. During the same period over 50M monochrome receivers were

sold. Mr. Thorn added: "Although we (Thorns) have developed a system which we think has many advantages over the U.S.A. system we do not believe it to be at the stage when we can put colour on the market."

A Worthwhile Job

THE Editor has passed to me a letter from the Nuffield Talking Book Library for the Blind appealing for help for the servicing of talking book machines. In his letter, D. Finlay-Maxwell, the honorary organizer of servicing volunteers—of which there are already some 1,500—says that volunteers would be called upon to install machines (some disc and some tape) for the blind and also to service these should faults develop. This valuable and worth-while activity involves no financial obligation as all spare parts, etc., are provided by the Library. Circuit diagrams and technical data are also provided. From the information given in the letter it would appear that, if you volunteered, you would not be called upon very frequently. My present state of health prevents me from offering my services, but I do hope that this note will stir some of my readers to volunteer. Your offers should be addressed to D. Finlay-Maxwell, A.M.I.E.E., Hon. Or-

* Yes, certainly, here are the terms of reference and, for full measure, the names of the members of the Committee.—Ed.

"To consider the future of the broadcasting services in the United Kingdom, the dissemination by wire of broadcasting and other programmes and the possibility of television for public showing; to advise on the services which should in future be provided in the United Kingdom by the B.B.C. and the I.T.A.; to recommend whether additional services should be provided by any other organization; and to propose what financial and other conditions should apply to the conduct of all these services."

Members:—H. Collison, Elwyn Davies, Miss Joyce Grenfell, R. Hoggart, E. P. Hudson, Prof. F. H. Newark, J. S. Shields, Dr. R. L. Smith-Rose, Mrs. Elizabeth Whitley, W. A. Wright and D. G. C. Lawrence (secretary).

"WIRELESS WORLD" PUBLICATIONS

	Net Price	By Post
PRINCIPLES OF SEMICONDUCTORS M. G. Scroggie, B.Sc., M.I.E.E.	21/-	21/11
COLOUR TELEVISION: N.T.S.C. System, Principles and Practice. P. S. Carnt, B.Sc. (Eng.), A.C.G.I., A.M.I.E.E. and G. B. Townsend, B.Sc., F.Inst.P., M.I.E.E., A.K.C.	85/-	87/3
PRINCIPLES OF FREQUENCY MODULATION B. S. Camies	21/-	21/10
RADIO VALVE DATA Compiled by the staff of "Wireless World." 7th Edition	6/-	6/10
INTRODUCTION TO LAPLACE TRANSFORMS for radio and electronic engineers, W. D. Day, Grad.I.E.E., A.M.Brit.I.R.E.	32/6	33/6
BASIC MATHEMATICS FOR RADIO AND ELECTRONICS F. M. Colebrook, B.Sc., D.I.C., A.C.G.I. Revised by J. W. Head, M.A. (Cantab.). 3rd Edition	17/6	18/6
PRINCIPLES OF TRANSISTOR CIRCUITS S. W. Amos, B.Sc.(Hons.), A.M.I.E.E. 2nd Edition	21/-	22/-
SOUND AND TELEVISION BROADCASTING. General Principles. K. R. Sturley, Ph.D., B.Sc., M.I.E.E.	45/-	46/4
GUIDE TO BROADCASTING STATIONS Compiled by "Wireless World." 13th Edition	3/6	4/-

A complete list of books is available on application.

Obtainable from all leading booksellers or from

ILLIFFE BOOKS LTD., Dorset House, Stamford Street, London, S.E.1.

ganizer of Servicing Volunteers, c/o John Gladstone & Co., Ltd., Galashiels, Scotland. It would help the organizer if you would state the approximate area you would be prepared to cover.

A Retrograde Step?

SO France has taken the retrogressive step of introducing the 625-line standard for its second television programme which, when started next year, will operate in Bands IV and V. Although there is no indication that the present 819-line standard is to be abandoned for existing services, I am more than surprised that our French cousins have weakened in their stand to foster the world's highest definition TV. The official announcement from the Ministry of Information states that an 8-Mc/s channel will be employed, and that the spacing between vision and sound carriers will be 6.5Mc/s. The vision carrier will employ positive modulation and sound will be a.m., as in their present 819-line transmissions. One wonders if the introduction of a second service will give an impetus to the growth of TV in France which, as I said a few months ago, has not been very spectacular.

U.H.F./V.H.F. Co-Siting

TALKING of a second programme: I was interested to see the note in last month's "World of Wireless" on the introduction of Italy's second chain of stations. I was particularly interested in the decision to install the u.h.f. stations at the same sites as the existing v.h.f. transmitters. At first sight (sorry!) this seemed odd as, of course, the service area of stations in Bands IV and V is considerably less than those in the lower bands. However, when one reflects that the majority of Italy's 550 or more v.h.f. television stations each cover only a very limited area—almost every valley has its own station—the decision on co-siting is logical. As you know, the Italian TV channels in Bands I and III are lettered A-H, but I see that they will be using numerals for the channels in Bands IV and V. Incidentally, be very cautious when referring to the numbering of channels in the u.h.f. bands. They are no longer continuous from those of Bands I and III. It was agreed at the recent Stockholm Conference to start numbering the 61 channels in Bands IV and V at 21—an advance of seven on the old temporary numbering.

WIRELESS WORLD, NOVEMBER 1961

"THE CHOICE OF CRITICS"

BULGIN

NEW LINES

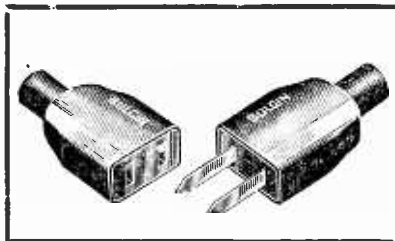

NEW Insulation Covers for our Domina Connectors to enable safe external flex connection, thus widening their use to many more applications. Quickly slipped-on to the connectors holding extremely tightly once in place. P/No. 9452 fits P. 490-491 and P/No. 9461 fits P.501/502.

An additional range of Strip Connectors. List Nos. T.122-124 have both "AMP" tags and solder tags on opposite sides of the base board. List Nos. T.127-129 have "AMP" tags both sides, List Nos. T.132-134 have "AMP" tags and solder tags at right angles (Illus.).

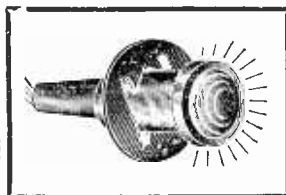
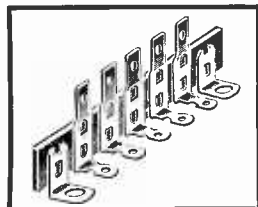

A Competitive, all moulded NEON Signal Lamp, List No. D.841 for either 200-250V or 100-150V working. One hole fixing by a quick-grip stamping. Leads for connection with resistor included and either Red or Colourless lens. Simple, but fulfils a variety of purposes.

Another of our NEW range of Collet-fixing Knobs, List No. K.463, incorporating the same features as the other models, moulded in glossy black bakelite (standard), with other colours to quantity order. The Collet tightening screw is hidden under a moulded clip-in plug. Write for details quoting reference of 2000/C. Brit. Pat. App. No. 18175/61.

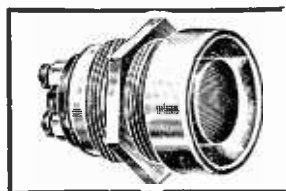

Meter Push, List No. M.P.12/1, designed for use where accidental operation can be dangerous, has a recessed safety-bezel. Operations cannot be obtained unless a direct, intentional finger movement is made.

A further development, adding to our range of skeleton switches to enable manual operation. A bracket fixed to the side of any of these switches holds the biased plunger, which operates the switch. Fixing is by a 3/8in.-clear panel hole, in panels up to 1/4in. thick. Order as: List No. of switch required plus "S.768."

FURTHER INFORMATION ON ALL ITEMS AVAILABLE ON REQUEST. PLEASE REFER TO THIS ADVERTISEMENT.

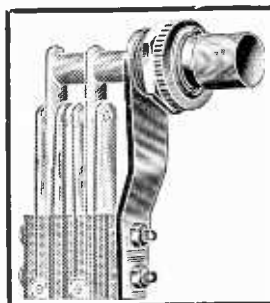

A. F. BULGIN & CO. LTD., BYE-PASS RD. BARKING, ESSEX. TEL: RIP 5588 (12 lines)



By "FREE GRID"

"Steam" P.A. Link

ONE day last summer, when paying a brief visit to one of our more popular seaside resorts, I went to the show being given by the concert party on the pier. The building itself was modern and its p.a. system was first-class in all respects but one.

I noticed it first during a performance by a ventriloquist who, as he walked about the stage with his dummy, was using a microphone and a trailing cable connected to the p.a. system to enable his voice to carry to all parts of the theatre. His performance as a ventriloquist was very good indeed, but the out-of-date technique of the trailing cable struck a jarring note.

This cable was obviously a nuisance and a snare to the feet of the ventriloquist, more especially when he came down among the audience, as he did. In addition to this disadvantage, the very presence of the cable drew unkind remarks from some of the "know-alls" in the audience to the effect that the mike was really a loudspeaker and that the dummy's "voice" came along the cable from a backstage confederate.

Surely in these days it should not be necessary to employ a "steam" p.a. link, such as a trailing cable, to couple a portable mike to the amplifier. It should be the simplest thing in the world to have a tiny microwave and microwatt transmitter in-

side the dummy, linking to a backstage receiver feeding into the p.a. system. The absence of the trailing cable would make the performance much more realistic.

In fact I would go even further and put the tiny transmitter on the person of the ventriloquist and have a receiver in the dummy as well as backstage. By this means the ventriloquist would be able to leave the dummy on one side of the stage, while he took up his stance on the other, or just walked about. It would naturally be a simple matter of telegraphic technique to control also the movements of the dummy's lips and eyes from the "micromitter" on the ventriloquist's person, the controls being in his trousers' pocket. He could then call himself by the Graeco-Latin hashup of "teleloquist".

If my suggestion was adopted, a performance of greatly enhanced entertainment value could be given. There should be no difficulty about getting a transmitting licence from the P.M.G. as the apparatus would, I think, come into the same category as that used for controlling model boats and aircraft.*

* It is not quite so simple as "F.G." imagines. The risk of interference with the receiver associated with the radio microphone raises difficulties in finding a suitable frequency. However, we understand the Post Office has drawn up a proposed specification for equipment to operate in the 174.6-175 Mc/s band.—Ed.

Hospital Sales Resistance

IN the August issue, I complained of the heavy and old-fashioned type of headphones used in hospital wireless installations, and put forward a plea for lightweight headphones of the stethoscope type. In October I amended my plea and suggested a system whereby there was one ear-piece in the control box on the wall to feed the sound by an ordinary type of stethoscope, to the patient's ears.

I am pleasantly surprised to learn that both these systems are already available, the first being marketed by Hadley Telephone & Sound Systems Ltd., of Smethwick, Staffs., and the second, under the name of Stethophone, by Goring Kerr Ltd., of Gerrards Cross, Bucks. Although the latter is at present not well known in this country it is in widespread use in Scandinavia and Holland.

Judging from details sent to me, I think both these systems are worthy of the highest praise and are "just what the doctor ordered" except that the doctors—or at any rate the hospi-

tals—seem very reluctant to order them, despite the fact that they have been supplied with full details.

This does not altogether surprise me as hospital authorities are very conservative in these matters, as was shown in the 'twenties when they showed no great enthusiasm toward the introduction of hospital radio itself, in spite of the fact that it acts as a psychological anaesthetic to those spending long, weary hours in bed.

Perhaps indeed it was just because broadcast listening did act as an anaesthetic that the hospitals were suspicious of it, as was the greater part of the medical profession in 1847 when Sir James Simpson began the extensive use of *physical* anaesthetics. His fellow medics continued their opposition even when Simpson pointed out to them that an anaesthetic was used at the very earliest recorded physical operation when, prior to the removal of his rib, a deep sleep was caused to fall upon Adam (Gen. II 21).

Etymological Exactitudes

THE expression "in vacuo" is to be found quite a lot in electronics literature when, for instance, discussing the phenomenon recurring in a valve or c.r.t., and is, of course, commonplace in other branches of physics. The use of the word "vacuo" although an etymological exactitude is, in my opinion, irritatingly pedantic.

In my vulgar and ignorant way, I usually write "in a vacuum," since I regard the word "vacuum" as having become as completely a part of the English tongue as, for instance, the Latin word "inertia." What physicist, for instance, speaks of over-coming "inertiam" (note the final M) as he rightly but pedantically should.

I raise this question here because some months ago, I was shocked to read in a learned journal an article in which occurred the truly dreadful expression "Loss of Vacuum," which only a vulgar person like myself would use. Matters were made much worse in that hard on the heels of this philological philistinism came the pedantically correct "in vacuo."

I am quite aware that the English preposition "of" is embodied in the Latin genitive "vacui" but that is all to the good; after all, the English indefinite article "a" is embodied in the Latin abative "vacuo." Maybe you don't agree with my argument, but I don't think you can deny that it is logical; or can you?



"F.G." will be interested in this radio microphone designed by Associated Television.—Ed.