

AUGUST 1956

TWO SHILLINGS

Wireless World

ELECTRONICS
Radio · Television



FORTY-SIXTH YEAR OF PUBLICATION

**PRECISION TELEVISION
RELAY CABLES**
to meet severe system
requirements

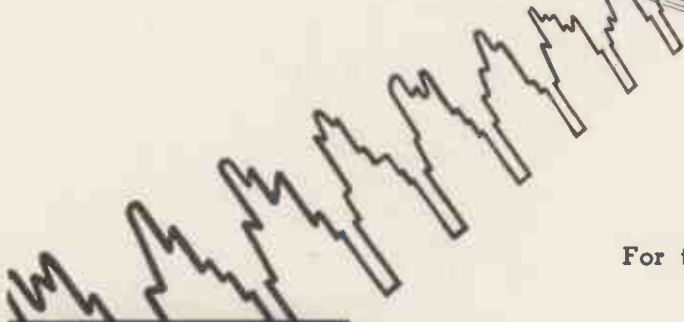
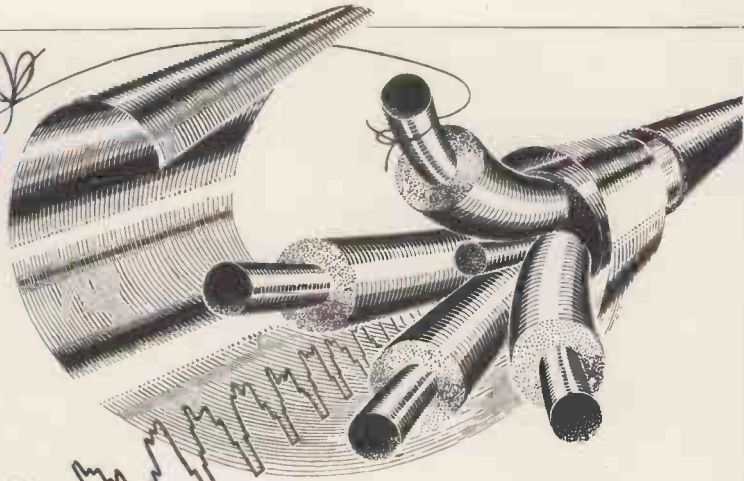

BICC

For the highest standards
of television and radio
relay engineering

**POLYTHENE INSULATED
& SHEATHED CABLES**

Further information is
available on request.

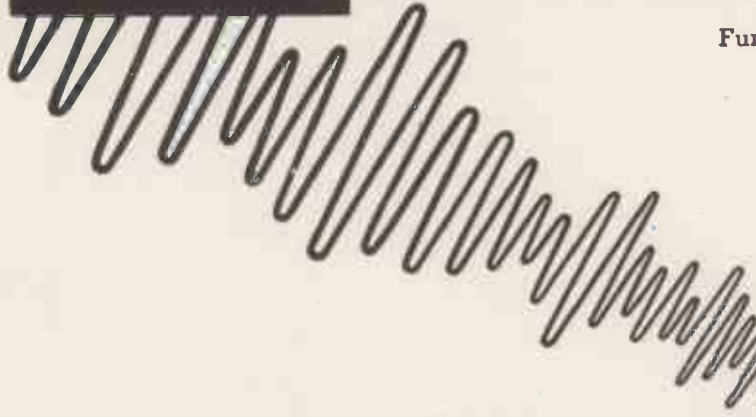

AUDIO FREQUENCY CABLES
of quad, double quad and
figure '8' construction



BRITISH INSULATED CALLENDER'S CABLES LIMITED

21 BLOOMSBURY STREET · LONDON, W.C.1



Wireless World

ELECTRONICS, RADIO, TELEVISION

Managing Editor : HUGH S. POCOCK, M.I.E.E.

Editor : H. F. SMITH

Assistant Editor : F. L. DEVEREUX, B.Sc.

AUGUST 1956

In This Issue

Editorial Comment	353
Junction Diode A.F.C. Circuit <i>G. G. Johnstone</i>	354
World of Wireless	356
Colour Fundamentals <i>H. Henderson</i>	360
Looking at Square Waves <i>T. D. Crook</i>	364
Television Picture Quality	367
Servo Tuning System <i>D. Smart</i>	369
Letters to the Editor	373
Wide-Band Linear R.F. Amplifier <i>B. F. Davies</i>	374
Broadcasting in the U.S.S.R.	379
Electronic Machine-Tool Control	382
More Effective Speech <i>O. J. Russell</i>	385
Economy in Receiver Design <i>S. W. Amos</i>	388
Semi-Conductors—2 " <i>Cathode Ray</i> "	394
Short-Wave Conditions	398
Books Received	399
Random Radiations " <i>Diallist</i> "	400
Unbiased " <i>Free Grid</i> "	402

VOLUME 62 NO. 8
PRICE: TWO SHILLINGS

FORTY-SIXTH YEAR
OF PUBLICATION

PUBLISHED MONTHLY (4th Tuesday of preceding month) by ILIFFE & SONS LTD., Dorset House, Stamford Street, London, S.E.1.
Telephone: Waterloo 3333 (60 lines). *Telegrams:* "Ethaworld, Sedist, London." *Annual Subscription:* Home and Overseas £1 12s. 6d.
U.S.A. and Canada \$5.00. BRANCH OFFICES: *BIRMINGHAM:* King Edward House, New Street, 2. *Telephone:* Midland 7191.
COVENTRY: 8-10, Corporation Street. *Telephone:* Coventry 5210. *GLASGOW:* 26B, Renfield Street, C.2. *Telephone:* Central 1265.
MANCHESTER: 260, Deansgate, 3. *Telephone:* Blackfriars 4412. OVERSEAS OFFICES: *U.S.A.:* 111, Broadway, New York, 6, N.Y. *Telephone:* Digby 9-1197. *CANADA:* 74, College Street, Toronto, 2 Ontario *Telephone:* Walnut 4-5631

Transistors



at Small Signals (h-Parameters)

The most convenient way of describing the electrical characteristics of a transistor, like any other electronic device, is by means of a set of static characteristic curves. These graphs show how the voltage or current at the input electrode varies with the voltage or current at the output electrode.

The primary function of transistor static characteristic curves is to enable the circuit designer to choose the direct voltage and current for the working point. In the second place these graphs are used for designing circuits where large signals occur, for example in output stages or pulse amplifiers. However, for applications where the signal is small in comparison with the direct voltages and currents it is possible to calculate performance accurately from the slopes of the characteristic curves at the working point. Under small signal conditions the transistor never moves far away from this point and hence the characteristics in the immediate neighbourhood can be taken as linear. It is generally impracticable to read the slopes with sufficient accuracy from the graphs given, and so they are quoted in transistor data for some nominal working point such as collector voltage —2V and collector current —3mA. The h-parameters are the slopes of a particular set of characteristic curves but are in fact measured by small-signal a.c. methods.

- $h_{11} = v_1/i_1 =$ slope of input characteristic
 = input impedance for constant output voltage
 = input impedance for output short-circuited to a.c.
 = r_{in} (in ohms or kilohms)
- $h_{22} = i_2/v_2 =$ slope of output characteristic
 = output admittance for constant input current (= reciprocal of output impedance)
 = output admittance with input open-circuited to a.c.
 = $1/r_{22}$ (usually in micro-mhos)

In transistor data, this set of four characteristic curves consists of:—(1) the input characteristic giving the variation of input current I_1 with input voltage V_1 , for constant output voltage: slope = h_{11} ; (2) the output characteristic showing the relation between the output current I_2 and the output voltage V_2 for a series of fixed input currents: slope = h_{22} ; (3) the transfer characteristic giving the variation of output current I_2 with input current I_1 for a fixed output voltage: slope = h_{21} ; (4) the feedback characteristic showing the connection between the input voltage V_1 and the output voltage V_2 for a series of fixed input currents: slope = h_{12} .

By drawing the axes of the static characteristic curves and using the subscripts 1 and 2 to refer to the input and output electrodes, the notation h_{11} etc. can easily be explained and three of the h-parameters are seen to be related simply to parameters in the Mullard system. Thus h_{11} is the ratio of two quantities measured at the input electrode, hence it is the slope of the input characteristic, and is equal to r_{in} . V_1, I_1 represent the direct voltage and current at the input electrode and V_2, I_2 similarly apply to the output electrode. The a.c. quantities are v_1, i_1 and v_2, i_2 . The formal definition of h-parameters is then as follows:—

- $h_{21} = i_2/i_1 =$ slope of transfer characteristic
 = current gain for constant output voltage
 = current gain with output short-circuited to a.c.
 = a (a ratio, that is, a pure number)
- $h_{12} = v_1/v_2 =$ slope of feedback characteristic
 = voltage feedback ratio for constant input current
 = voltage feedback ratio with input open-circuited to a.c.

In defining the h-parameters the transistor is treated as a 'black box' with an input and output, paying no regard to whether the transistor is in a common base, common emitter or common collector configuration. In an actual circuit the values of these slopes will depend on which configuration is used. Thus the undashed terms such as the a.c. current gain h_{21} are reserved for grounded base applications, whereas a single prime as in h'_{21} shows the value required for calculations on grounded emitter circuits, and h''_{21} etc. apply to grounded collector circuits.

Grounded Base	Grounded Emitter	Grounded Collector
$h_{11} = r_e + (1-\alpha)r_b = r_e + \frac{r_b}{1+\alpha}$	$h_{11}' = (1+\alpha)h_{11}$	$h_{11}'' = h_{11}'$
$-h_{21} = \alpha = \frac{\alpha}{1+\alpha}$	$h_{21}' = \alpha$	$-h_{21}'' = 1 + h_{21}'$
$h_{22} = 1/r_c$	$h_{22}' = (1+\alpha)h_{22}$	$h_{22}'' = h_{22}'$
$h_{12} = r_b/r_c$	$h_{12}' = h_{22}'r_e$	$h_{12}'' = \frac{1}{1+h_{12}'}$

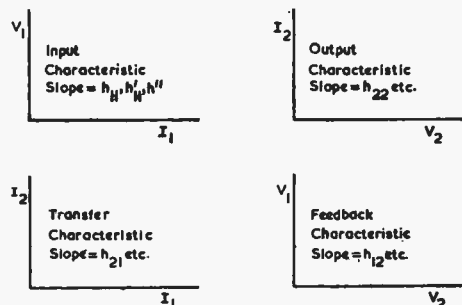

Grounded base: e=1, c=2.
 Grounded emitter: b=1, c=2.

2709



Progress on V.H.F.

DUE to the chaotic conditions prevailing on the medium- and long-wave bands, sound broadcasting on v.h.f. has become a virtual necessity in several European countries. In some of them, large sections of the population are unable to get a tolerable signal, particularly after dark. But, as was stressed in an article which we printed last month, v.h.f. has often been regarded as an "unwelcome complication"; the growth rate has hardly been spectacular.

This applies to some degree in Great Britain, though it would be unreasonable to expect a vast increase in the number of v.h.f. listeners as yet. After all, only some 38 per cent of the population have a service at present. But by the end of the year the figure will have risen to 84 per cent, according to a B.B.C. statement. Can we expect a rapid rise in the number of v.h.f. listeners?

Many of those who stand to benefit from the service have no idea of the advantages to be gained from it. But the knowledge must be spreading, particularly now that the B.B.C. is using its powerful machinery to publicize v.h.f. Then it seems probable that the more attractive receivers which may be expected to make their first appearance at the forthcoming National Radio Exhibition will exert an appeal. There can be no doubt that many of the present sets have their shortcomings. Of these, frequency drift must be one of the most annoying, but in some designs it seems to have been reduced to negligible proportions at no great cost.

Then there is the question of tuning. To us, and no doubt to many of our readers, the right system of channel selection for a three-programme service is by means of a switch or push-buttons. Fiddling with continuous tuning for such a purpose is surely an anachronism. It must be admitted though, that it is not too easy to fit switch tuning into a receiver in which v.h.f. is merely an adjunct to the normal wavebands. That is one of the reasons why we think v.h.f.-only sets should prove attractive to many people, and we hope their number will increase.

Can we learn from the United States anything useful on means of popularizing v.h.f.? In that country the service has for some time been in decline but it now appears to be undergoing a revival. The ever-increasing American interest in high-quality reproduction is apparently responsible,

and it seems that the more important surviving stations are concentrating their efforts on programmes of high-class music. According to a report in the American journal *Audio* the listenership for these so-called "music stations" is already large and shortly there will be four of them in New York and six in Boston. But that is not to say the future of v.h.f. in Britain lies in special programmes; conditions are different here and the service must be used mainly to reinforce transmissions on the normal wavebands.

Though the British v.h.f. service cannot be conducted entirely or even mainly for those whose principal interest is in high-quality reproduction of music, their needs should be borne in mind. They are, in a sense, the pioneers of the service and, up to the present, constitute a large proportion of the audience. The B.B.C. has already given assurances that, subject to land-line limitations, the transmissions will permit a substantial improvement in receiver performance, both in frequency range and dynamic range. It should be borne in mind, too, that the quieter background makes all of us—not only the quality enthusiasts—much more critical. In the long run, quality will attract an ever-growing number of listeners.

An interesting proof of the way in which the critical faculty is stimulated by v.h.f. broadcasting has recently come to our notice. When the B.B.C. cut down the frequency range of the Wrotham transmitter, a surprisingly large number of readers observed the falling-off in output and wrote to tell us about it. Here is the explanation of the cut, provided by the B.B.C. engineering department:

"The audio-frequency bandwidth of the transmissions broadcast by B.B.C. v.h.f. stations is, in general, limited by that of the line network connecting the studios with the transmitters in various parts of the country. In the case of broadcasts from local studios a greater range is possible, but it has been found desirable, for the present, to restrict the upper limit to 10 kc/s. Filters have recently been put in at Wrotham to achieve this, and the effect has been observed by keen-eared readers of *Wireless World*. This is a temporary measure, pending the investigation of the causes of a type of distortion that has occasionally been observed in the highest frequency range. It is hoped that the filters will be removed in the fairly near future."

Junction Diode A.F.C. Circuit

A Simple Circuit for Reducing Tuning Drift in F.M. Receivers

By G. G. JOHNSTONE*, B.Sc.

THE junction diodes, such as the Mullard OA10 and G.E.C. SX641 now becoming available are primarily intended for rectification and detection at low frequencies, but in addition they have a property which makes them suitable for entirely different applications.

This property concerns the capacitance between the two electrodes; if a junction diode is biased to non-conduction, the capacitance varies with the applied voltage, being approximately inversely proportional to the square root of this voltage. Thus the diode provides a very compact and simple method of controlling a capacitance by adjustment of a voltage. There are a number of applications for such a facility. An obvious one is the provision of a.f.c. in receivers and this article describes in detail one method of using a junction diode to provide a.f.c. in an f.m. receiver where, in spite of the simplicity of the circuit, it is as effective as a conventional reactance-valve. Another application is the provision of remote tuning for f.m. or other receivers, or the provision of a very fine or "inching" tuning control. It could also be used for f.m. modulation of an

oscillator in a transmitter or a wobblator and no doubt other applications will occur to radio engineers. An effect of this kind is also exhibited by a junction transistor at low frequencies and the amplification of the device could perhaps be used to enhance the effect.

The manufacturers of the OA10 quote the capacitance as less than 30 pF at -0.5 volts bias and less than 10 pF at -3.0 volts bias. These figures apply at low frequencies and it was not expected that they would hold at frequencies as high as 100 Mc/s, such as apply in f.m. receivers. To determine the suitability of the junction diode for providing a.f.c. in such a receiver the circuit shown in Fig. 1 was used. An OA10 is in effect connected directly across the frequency-determining circuit L_1C_1 , the 50-pF capacitor C_2 being included to permit application of bias to the diode. The resistor R_2 was included to simulate the internal impedance of the source of control voltage in an a.f.c. circuit, but in addition it prevents undue shunting of the oscillatory circuit and it also behaves as a diode load when the oscillator output voltage exceeds the bias; this has an effect on the shape of the characteristic obtained and is discussed later. The bias voltage is obtained from the potential divider R_3R_4 connected across the h.t. supply and can be varied by adjustment of R_4 . To apply the bias in the correct sense to the diode, the diode lead marked in red (which corresponds to the cathode in a thermionic diode) is connected to the positive terminal of the bias voltage.

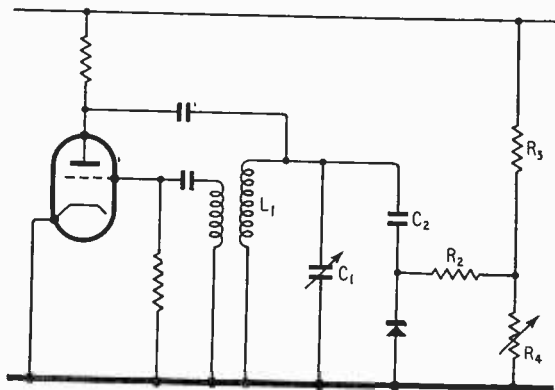

Fig. 1. Circuit used for test purposes.

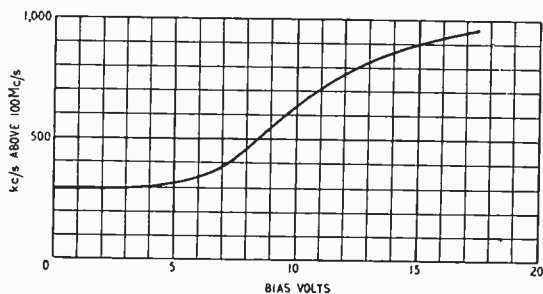

Fig. 2. Frequency shift v. bias for Mullard OA10 germanium diode. Reference frequency 100 Mc/s.

By varying R_4 and measuring the oscillation frequency the curve shown in Fig. 2 was obtained; at the centre of the characteristic the curve has a region of maximum slope of approximately 100 kc/s per volt, which is of the order of magnitude of control obtained with a conventional reactance-valve circuit. The curvature of the characteristic for low control voltages is due to conduction of the diode, the rectified voltage developed by the diode across R_2 opposing the bias voltage and therefore reducing the change in capacitance. The diode damps the oscillator and in the particular experiment the oscillator output fell from 8.5 volts to 6.0 volts peak value when the diode was connected. This particular characteristic was obtained with a germanium junction diode OA10, but the experiment has been repeated with silicon junction diodes type SX641 which give a curve of substantially the same shape. No doubt other types of junction diodes would also give successful results.

Three silicon diodes were available for testing and their frequency/bias-voltage characteristics are shown in Fig. 3. They show divergences at low bias voltages where rectification occurs, but are in substantial agreement at other bias voltages. The curves were made to agree with each other at -10

* B.B.C. Engineering Training Department

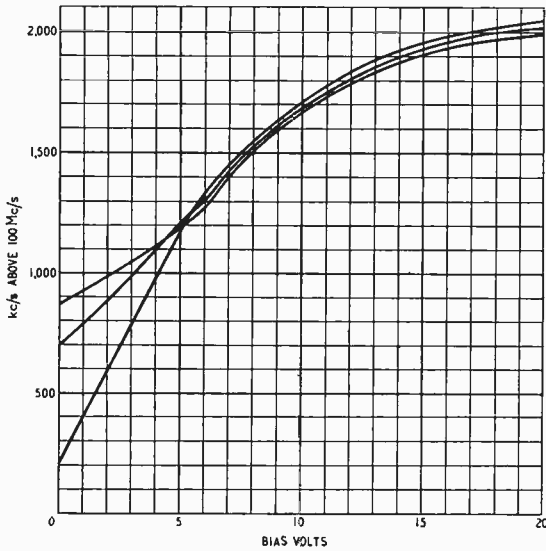

Fig. 3. Frequency shift v. bias for three G.E.C. type SX641 silicon diodes. Reference frequency 100 Mc/s.

volts bias by adjustment of the tuning capacitor C_1 . It is not recommended that the region of low bias voltages should be used because there is increased damping of the oscillator circuit and marked divergences of curve shapes.

The experiments showed that the junction diode would operate satisfactorily at 100 Mc/s without undue loss of oscillator amplitude and the next step was to use the diode in an f.m. receiver. The receiver employed is that described in *Wireless World* for May, 1955, and the relevant part of the circuit is reproduced in Fig. 4. It has much in common with Fig. 1, R_{33} and R_{34} being used to provide standing bias for the diode. For most effective a.f.c., and to keep oscillator damping at a minimum, the standing bias should coincide with the centre of the linear portion of the characteristic. This was obtained by making $R_{33} = 100\text{ k}\Omega$ and $R_{34} = 5.6\text{ k}\Omega$ and returning R_{33} to the oscillator h.t. supply point of the feeder unit.

The control voltage is derived from the ratio detector and must be filtered of a.f. signals before application to the junction diode, otherwise negative feedback is obtained and there is a loss of a.f. output. Filtering is achieved by the $470\text{ k}\Omega$ series resistor R_{37} and the $0.1\text{-}\mu\text{F}$ shunt capacitor C_{48} . The series resistor forms a potential divider with the diode back resistance causing a reduction in the effectiveness of the circuit and the value of the series resistor must not be made too high for this reason.

A readjustment of the oscillator fixed capacitance is necessary when the a.f.c. circuit is added to the

feeder unit because of the standing capacitance of the junction diode. For an OA10 this capacitance is approximately 1.6 pF and can be allowed for by replacing the 8.2-pF capacitor C_9 by a 5-pF component and by advancing the trimmer capacitance C_{13} to restore the original calibration.

The $47\text{-k}\Omega$ resistors R_{35} and R_{36} are included to isolate the diode and to prevent oscillator output from entering other parts of the receiver.

When the a.f.c. circuit is added to the receiver it may tend to reduce oscillator tuning errors or to increase them. Three factors determine the behaviour. They are:—

(1), the sense of the discriminator or ratio detector output; (2), whether the oscillator frequency is above or below the signal frequency; and (3), whether the control voltage is applied to the diode anode or cathode.

If the a.f.c. circuit tends initially to increase the tuning error, it may be made to work correctly by alteration of one of the parameters listed above. It is most convenient to apply the control voltage to the diode anode, because this requires the cathode to be returned to a source of positive voltage which can readily be obtained from the h.t. supply. If the control voltage is applied to the diode cathode, the anode must be returned to a negative potential, which is inconvenient to produce; thus alteration of factor (3) is not really practicable. It is inconvenient to alter the oscillator circuit frequency to the other side of the signal frequency because this may upset the frequency coverage or the ganging of the receiver. If the a.f.c. circuit does tend to increase tuning errors it is best to reverse the connections to the ratio detector diodes and the associated electrolytic capacitors to put matters right.

The circuit illustrated gives a reduction in mistuning of approximately 3 : 1. Tuning the receiver with the a.f.c. system operative is somewhat disconcerting because signals appear to have a large spread, and the error-reduction makes the location of the correct tuning point difficult. It may be desirable, therefore, to include a means of removing the a.f.c. whilst tuning the unit. This may be done by the inclusion of a single-pole switch across C_{48} as shown dotted in Fig. 4. A non-locking type is preferable for this application to ensure that the a.f.c. is not permanently defeated!

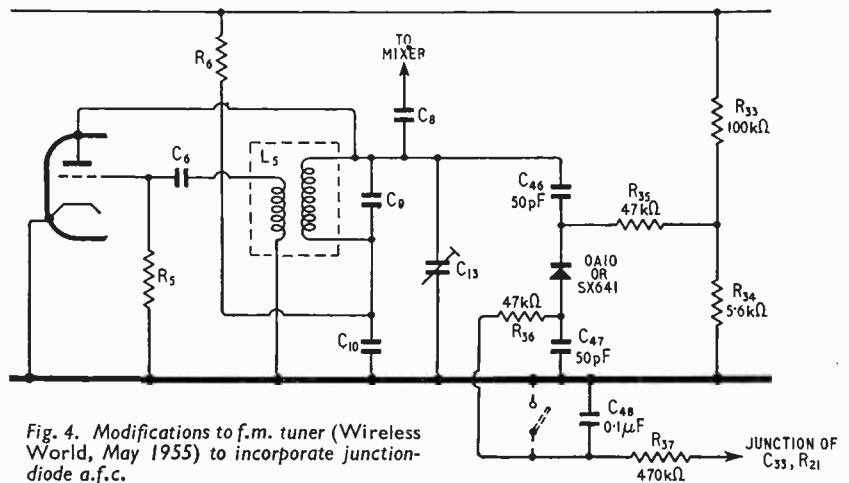

Fig. 4. Modifications to f.m. tuner (*Wireless World*, May 1955) to incorporate junction-diode a.f.c.

WORLD OF WIRELESS

Marine V.H.F.

WRITING in *Wireless World* last October on the subject of the P.M.G.'s announcement that f.m. is being adopted by the U.K. for marine v.h.f., R. I. T. Falkner, of Pye Marine (champions of a.m.), said, "If the new P.M.G. can restore confidence and show sincerity by positive action we would be the first to support him." It is interesting, therefore, to note that Pye have, in fact, secured the contract for supplying and installing the first frequency-modulated v.h.f. coastal radio-telephone station to be set up by the G.P.O.

The station, which will be located south of Rothesay, on the Isle of Bute in the Firth of Clyde, will open in the autumn and will provide radio-telephone communication between telephone subscribers in this country and suitably equipped ships operating within a radius of up to thirty-five miles of the station.

The station will operate on the frequencies tentatively agreed for "marine v.h.f. public correspondence"—157.4 Mc/s (receive) and 161.9 Mc/s (transmit). It is hoped that these and the other frequencies recommended at the Gothenburg Conference (*see W.W.*, April, 1956) will be approved at the next international conference.

It was stated by Mr. Falkner that in consequence of the adoption of f.m. the a.m. station on Shooters Hill, London, for the Thames Radio Service would eventually be scrapped.

Amateur Recording Contest

IT is hoped that this year a greater number of British entries will be received for the Concours International du Meilleur Enregistrement Sonore (C.I.M.E.S.) which is organized by the leading amateur recording associations of the world to find the best examples of recording technique as applied to a variety of subjects. Valuable prizes are offered, and in past years many of the entries have subsequently been broadcast.

Copies of the rules and entry forms (English version) are in the hands of the British Sound Recording Association and can be obtained from H. J. Houlgate, 12, Strongbow Road, London, S.E.9 on receipt of a stamped addressed envelope. The closing date is September 15th.

I.E.C. Meeting

STANDARDIZATION of electronic equipment and components was one of the many subjects discussed at the 21st general meeting of the International Electrotechnical Commission. The meeting, held at Munich from June 26th to July 6th, was attended by a number of British delegates representing industrial firms, trade and research organizations and Government departments. In this country the British Standards Institution is responsible for participation in the work of the I.E.C., which is a

Organizational, Personal and Industrial Notes and News

non-government association of electrical manufacturing and power-producing and consuming industries of 33 countries.

Valve Prices

THE British Radio Valve Manufacturers' Association (B.V.A.) announced on July 2nd reductions of from 10 to 33% in valve prices—the first change since 1950. Reductions of from 14 to 17½% are also made in c.r.t. prices. It is, however, stressed by the B.V.A. that these reductions apply only to current makes of valves and tubes bought by the general public and will not necessarily affect the cost of receivers.

The vice-chairman of the Association, G. A. Marriott, has stated that the reductions have not been introduced because the Monopolies and Restrictive Practices Commission is investigating the supply of valves but because of economies resulting from extensive capital expenditure on plant. These economies, incidentally, will not affect the cost of production of obsolescent valves, the prices of which may even have to be increased.

We learn from manufacturers who are not members of B.V.A. that their prices have been similarly reduced.

"Transistorized" Car Radio

BY USING transistors in the output stage and for the generation of h.t. for the preceding valves, the drain on the car battery has been considerably reduced in the new Pye TCR16 car radio receiver.

The transistors are new power types (Pye V30/20P), and two in push-pull give an output of four watts. A third (V30/10P) is used as a high-frequency relaxation oscillator, the output of which

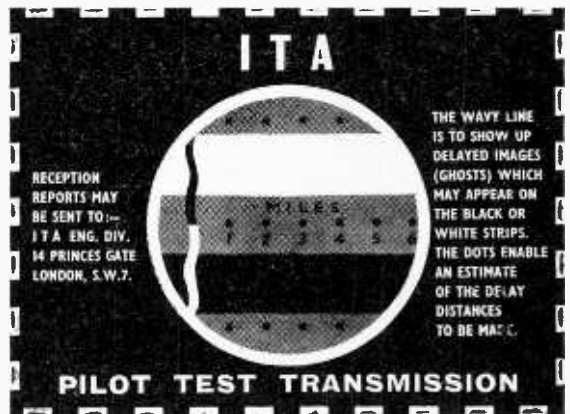

TEST CARD now being transmitted from the site of I.T.A. station on Emley Moor, Yorks., due to open in the late autumn. The card helps in locating sources of reflection causing "ghosting". Times of test transmissions are: Monday-Friday: 10 a.m.-12.30 p.m., 2-5.30 p.m., 6-7 p.m. Saturdays: 10 a.m.-12.30 p.m.

is stepped up in a ferrite-cored transformer to give, after rectification and smoothing, 10mA at 100 V.

A frequency changer valve (12BE6) is followed by a single i.f. stage (12BA6), germanium diode detector and a triode-pentode (PCL83) first a.f. amplifier and driver for the Class B output transistors. To assist in achieving thermal stability a thermistor is included in the transistor base circuit.

I.L.S.-S.B.A. Decision

ALTHOUGH the standard pilot-interpreted approach aid in Europe is I.L.S. (instrument landing system), there are a number of aerodromes in the United Kingdom still equipped with S.B.A. (standard beam approach). This is obviously undesirable as it may entail an operator having to carry two sets of airborne equipment. The Ministry of Transport and Civil Aviation is, therefore, withdrawing S.B.A. from its civil aerodromes as soon as this can be done without causing undue inconvenience to those operators who use it.

S.B.A. is, however, being retained at some of the aerodromes not directly the responsibility of the M.T.C.A., as for instance on the Isle of Man where it is stated it "will not be withdrawn until the aid is no longer fitted in the majority of the smaller aircraft."

PERSONALITIES

Sir George H. Nelson, Bt., has relinquished the position of managing director of the English Electric Company in order to devote the whole of his time to the duties of executive chairman of the company. His son, **H. G. Nelson, M.A.(Cantab.), M.I.E.E.**, who has been deputy managing director since 1949, has been appointed managing director. He is 39 and has been a director of the Marconi companies since they joined the English Electric group in 1946. Sir George, who is this year's president of the I.E.E., is a member of the governing body of the Imperial College of Science and Technology.

W. H. Stephens, head of the guided weapons department of the Royal Aircraft Establishment, Farnborough, since 1953, has been appointed deputy director (equipment) of the R.A.E. on the retirement from Government service of Dr. F. E. Jones. Mr. Stephens, who was with the Ministry of Aircraft Production during the war, was for three years a member of the British Scientific Mission in Washington. It will be recalled that his lecture on guided weapons to the Radar Association during the last session formed the basis of an article in our February issue.

E. W. Chivers, B.Sc., has been appointed principal superintendent of the electronics division of the Armament Research and Development Establishment (M.o.S.) at Fort Halstead, Sevenoaks, Kent. Mr. Chivers, who is 49, held a number of Government scientific appointments during the war and was for two years superintendent of the General Physics Committee of the Scientific Advisory Council. He became superintendent at the Radar Research and Development Establishment at Malvern in 1947 and on the fusion in 1953 of R.R.D.E. and T.R.E. into the Radar Research Establishment was appointed deputy director of ground radar. His rank in the Scientific Civil Service is deputy chief scientific officer.

R. E. Burnett, M.A.(Oxon), A.M.I.E.E., A.Inst.P., has succeeded J. M. Furnival, M.B.E., who has retired, as general manager of Marconi Instruments. Mr. Burnett, who joined Marconi's in 1950 as principal of Marconi College and manager of education and technical personnel, was appointed deputy general manager of Marconi Instruments last November.

In order to co-ordinate television engineering development Marconi's have created the post of chief television engineer, to which **V. J. Cooper, B.Sc., A.C.G.I., M.I.E.E., M.Brit.I.R.E.**, has been appointed. His deputy is **G. E. Partington, B.Sc., A.M.I.E.E.** For the past eighteen months Mr. Cooper, who has been with the company since 1936, has been chief engineer, advanced development. Mr. Partington joined Marconi's in 1938 when he attended a post-graduate engineering course at the Marconi College. Since 1947 he has been in charge of the development of television studio equipment. Under this scheme of unification Marconi's have formed three television development groups under **E. Davies, N. N. Parker-Smith, B.Sc., A.M.I.E.E.**, and **J. E. Nixon, B.Sc., A.C.G.I., A.M.I.E.E.**, and an audio development group with **S. J. Gooderham** in charge.



V. J. COOPER



G. E. PARTINGTON

C. G. Mayer, M.I.E.E., has been appointed chairman and managing director of R.C.A. Great Britain, Limited, on the resignation of P. A. Turnor, who will continue to serve as a director and executive of the company. Mr. Mayer, who has been European technical representative of the parent company, Radio Corporation of America, since 1947, was responsible for the recent formation of Laboratories R.C.A., Limited, in Zurich, Switzerland, of which he became president and managing director. He will continue as a consultant to the Laboratories.

Joseph R. Pernice, who has been chief of the electronics section of N.A.T.O.'s production and logistics division for the past six years, has been appointed managing director of Collins Radio Company of England, Limited, the recently formed subsidiary of Collins Radio Company, of Iowa, U.S.A. He took up his new appointment on July 1st and will be responsible for all Collins' operations in Europe.

Brian Cape, Associate I.E.E., has been appointed technical services manager to Kelvin and Hughes (Aviation), Ltd., in succession to John Rivaz who recently joined Smiths Aircraft Instruments, Ltd. After seven years in the R.A.F., where he specialized in airborne radar equipment, Mr. Cape became manager of the radio department of Flight Refuelling, Limited. He joined Kelvin and Hughes in 1947 as a development engineer, working principally on airborne navigation equipment. He is 38.

H. Henderson, B.Sc., A.Inst.P., who, in this issue, contributes an article on the theory of colour, is a senior lecturer in the engineering training department of the B.B.C. where he lectures on this subject during the short colour television courses organized by the Corporation for its senior technical staff. After three years as an experimental officer with the Admiralty Signals Establishment, Witley, he spent six years as physics master at grammar schools in London and Leeds before joining the B.B.C.

NATIONAL RADIO EXHIBITION

(Earls Court, Aug. 22nd—Sept. 1st, 11 p.m.—10 p.m.)

WIRELESS WORLD SHOW NUMBERS

September: Show Guide (publication date August 21st*). Plan of the stands with stand-to-stand guide to the exhibits.

October: Show Review (publication date September 25th). An analysis of design trends in television and sound receivers.

* Note advanced publication date.

OBITUARY

E. A. Richards, M.B.E., B.Sc., A.C.G.I., M.I.E.E., formerly chief rectifier engineer of Standard Telephones and Cables, Limited, died on June 20th, aged 71. His engineering career began with Siemens Brothers. In 1929 he joined the European Commercial Department of the International Standard Electric Corporation; was transferred to S.T.C. two years later and from 1934 until 1936 was chief engineer of Broadcast Relay Services. Returning to S.T.C. in 1936, he took charge of the engineering and development groups of the rectifier division, pioneering in the United Kingdom the selenium metal rectifier. It was for his work on increasing the production and improving the manufacture of selenium rectifiers during the war that he was appointed an M.B.E.

IN BRIEF

More than half the 2,617,429 holders of receiving licences in the London postal area now operate television receivers—1,315,921. There were 14,293,902 broadcast receiving licences—including 5,863,473 for television and 299,749 for car radio—current in the U.K. at the end of May.

Additional sound and vision transmitting equipment has been installed at the I.T.A.'s Lichfield station. Although at present available as a standby in the event of a breakdown, when certain ancillary equipment has been installed early in the autumn it will be utilized to increase the transmitter's e.r.p. from 50 to 200 kW.

Professional Engineers' Pensions.—A scheme to provide continuous pension cover for a professional engineer throughout his career, whatever changes of employment take place, is to be launched in the autumn by the Engineers' Guild (78, Buckingham Gate, London, S.W.1). It will be open to all members of the institutions of electrical, civil and mechanical engineers.

1957 Audio Fair.—It is announced, by the organizing committee of London's first Audio Fair held in April, that the 1957 exhibition will be held at the Waldorf Hotel, London, W.C.2, from April 12th to 15th—immediately following the R.E.C.M.F. Components Show (April 9th to 11th). The scope of the Fair is to be extended—including a day reserved for overseas and trade buyers—but the plan of the show will be unaltered, each exhibitor having at his disposal a demonstration room.

The scope of the Instruments Exhibition, which has been sponsored in previous years by five trade associations (including the British Electrical and Allied Manufacturers' Association and the Scientific Instrument Manufacturers' Association) is being broadened, and the 1957 show will have the title "**Instruments, Electronics and Automation.**" It is being promoted by the same five associations, and will be held at Olympia, London, from May 7th to 17th. The organizers are Industrial Exhibitions, Limited, 105-106, New Bond Street, London, W.1.

The theory, preparation, properties and applications of Ferrites will be covered at a convention to be held at the Institution of Electrical Engineers, Savoy Place, London, W.C.2, from October 29th to November 2nd. The convention will be open to non-members on payment of a registration fee of £1. Registration forms and further particulars are obtainable from the Institution.

I.E.E. Officers.—Sir Gordon Radley, K.C.B., has been elected president of the I.E.E. for 1956/57 and G. S. C. Lucas, O.B.E., chief electrical engineer of B.T.H., is a vice-president. The new chairman and vice-chairman of the Radio and Telecommunication Section are, respectively, Dr. R. C. G. Williams, B.Sc., chief engineer of Philips and G. Millington, M.A., B.Sc. (Marconi's). New ordinary members of the section committee are W. J. Bray, B.Sc. (Post Office), H. A. M. Clark, B.Sc. (E.M.I.), C. W. Earp, B.A. (S.T.C.) and V. J. Francis, B.Sc., F.Inst.P. (G.E.C.).

"**CABMA Register**" is published annually for the Canadian Association of British Manufacturers and Agencies whose object is to develop the Canadian market for British goods through the British trade centres in Toronto, Vancouver and Montreal. The 1956/57 edition of the Register, issued jointly by our publishers and Kelly's Directories, includes a buyers' guide, listing alphabetically some 4,000 British products, and directories of over 4,500 British manufacturers, proprietary names and trade marks. It costs two guineas (postage 2s).

An appeal has been received from the secretary of the Wembley and District Group of the Multiple Sclerosis Society, asking for receivers for sufferers from multiple or disseminated sclerosis (previously known as "creeping paralysis"). They are also in need of sound recording equipment for gatherings organized by the Group. Offers of help should be addressed to the Honorary Secretary, R. A. L. Dumsday, 75, Rugby Avenue, Wembley, Middlesex.

Since the advertisement pages went to press Metropolitan-Vickers have asked us to point out that the supply voltage quoted in the specification of their miniature oscilloscope on page 86 is for overseas models. Those for the home market are for 200/250V, 50c/s supplies.

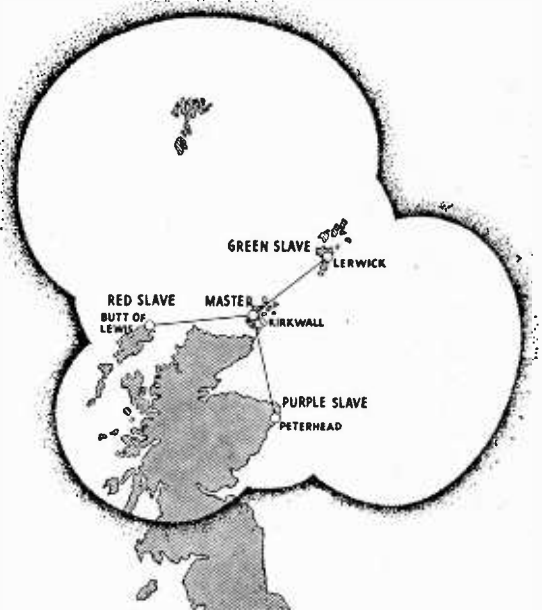

COVERAGE provided by the four stations of the latest Decca Navigator Chain—the North Scottish—which was inaugurated at the end of June, is shown on this diagram.

The address of the **Radio Advisory Service** (established by the Chamber of Shipping and the Liverpool Steam Ship Owners' Association), of which Capt. F. J. Wylie, R.N.(Retd.), is director, is now 7th Floor, 12-20 Camomile Street, London, E.C.3. (Tel.: Avenue 6941.)

WHAT THEY SAY

"**Electronics** is rapidly taking over electrical engineering education. Ten years from now electrical engineering will be synonymous with what to-day we call electronics. Electrical engineering of the pre-war era which concentrated its attention on phenomena at 60 cycles in general, and rotating machinery in particular, will be regarded as a small part of the broad subject of electronic science. Whether we will call it electrical engineering or electronics ten years from now I do not know."—Frederick E. Terman, Stanford University, California, in *Proc. I.R.E.*, June, 1956.

"**Wanted.**—TV aerial, preferably with fringe. Phone"—Advertisement in Provincial newspaper.

"**Resistor fixed variable linear.**"—Label on box containing potentiometer in Ministry store.

BUSINESS NOTES

R. B. Pullin and Co., Ltd., of Great West Road, Middlesex, have concluded an agreement with the Kearfott Company, of America (a subsidiary of the General Precision Equipment Corporation), for the manufacture in this country of a range of Kearfott products, including servomotors and electronic components.

Substantial contracts for supplying the Services with equipment for testing drive units, transmitters and receivers for h.f. point-to-point communication systems have been awarded to **Marconi Instruments**.

James A. Jobling and Company, of Sunderland, the manufacturers of Pyrex heat-resisting glass, are producing Multiform glass parts for c.r.t. electrode assemblies and glass-to-metal seals. The Multiform process of manufacture from specially treated glass powders compressed in moulds and subsequently fused to form a uniform opaque glass was originally developed in the United States.

Closed-circuit industrial television equipment was recently installed by **Marconi's** at the Steel Company of Wales works at Port Talbot to facilitate the handling of ingots at the rolling mill.

The maintenance vehicles operated by four of the North Western Gas Board's South Lancashire groups (Manchester, Liverpool, Wirral and St. Helens) are now equipped with radio telephones. The latest installation, at St. Helens, by **Automatic Telephone & Electric Co.**, includes six mobile stations and a fixed station, the aerial for which is on top of a 225-foot gas holder.

Dovnin Instruments, Limited, of Electrion Works, Winchester Street, Acton, London, W.3 (Tel.: Acorn 4995), now a member of the Pullin group of companies, is to specialize in the speedy repair and recalibration of all types and makes of indicating and measuring instruments.

Shandon Automation & Electronics, Limited, of 6, Cromwell Place, London, S.W.7, has been formed to produce industrial and scientific electronic equipment. It is associated with the Shandon Scientific Company of the same address (Tel.: Kensington 9001).

Permanently impregnated marking of customers' own p.v.c., rubber or Neoprene sleeving is undertaken by **Permark Service**, of Devon House, High Street, Cranleigh, Surrey. (Tel.: Cranleigh 499.)

The telephone number of **Aero Research, Limited**, Duxford, Cambridge, has been changed to Sawston 2121.

Cosmocord, Limited, have closed their Enfield factory and are now concentrated at their works at Eleanor Cross Road, Waltham Cross, Herts. (Tel.: Waltham Cross 5206.)

Standard Telephones & Cables have opened regional offices at Leeds (Norwich Union Buildings, City Square) and Glasgow (49, Queen Street, C.1).

Cementation (Muffelite), Ltd., manufacturers of anti-vibration mounts, have moved from 39 Victoria Street, S.W.1, to 20 Albert Embankment, London, S.E.11. (Tel.: Reliance 6556.)

The address of the **Wilkesden Transformer Company, Ltd.**, is now Manor Works, Manor Park Road, Harlesden, London, N.W.10 (Tel.: Elgar 5445).

OVERSEAS TRADE

A new monthly record of radio and electronic exports totalling nearly £3.4M in May is announced by the Radio Industry Council. The overseas sales of transmitting and navigational equipment totalled nearly £1.4M. The next highest of the five groups within the industry was sound reproducing equipment which totalled £731,000.

A report on the market for sound and television receivers in **Portugal** issued by the Export Services Branch of the Board of Trade shows that in 1954 (the last year quoted) Germany and the Netherlands supplied between them nearly 85% of the country's £600,000 radio imports. The United Kingdom's share dropped from 14% in 1951 to 7.5% in 1954 whilst during the same period Germany's share rose from 14% to 45% and by so doing displaced the Netherlands as the main supplier.

Switzerland.—An order for s.h.f. radio equipment to provide 600 telephone circuits between Berne and Geneva over a single radio channel has been placed with Standard Telephones & Cables through their associates, Standard Telephone & Radio S.A., Zurich. One repeater station, at Chasseral, will be used for the system which will be capable of being extended to provide additional r.f. channels either for telephone or television circuits.

Substantial quantities of radio-telephone equipment are being provided by Redifon for the **Iraq** police force. In addition to the equipment already supplied to the Baghdad police, which includes mobile four-channel v.h.f. transmitter-receivers and base stations, a number of h.f. transmitter-receivers (GR250) has now been ordered.

U.S.A.—Manufacturers contemplating participation in the World Trade Fair, which will be held in New York next April, are advised by the Board of Trade to get in touch with the London representative of the Fair, A. P. Wales, Dudley House, Southampton Street, London, W.C.2.

Transmitting equipment for three stations for air-to-ground communications on trans-polar air routes has been supplied by Marconi's for installation in **Greenland**. Each station is being equipped with two HC205 transmitters (one being a standby) which are designed to radiate up to three simultaneous telegraph or telephone transmissions on separate crystal-controlled h.f. channels.

The supply and installation of sound reproducing equipment in the six-storey General Hospital at Colombo, **Ceylon**, is being undertaken by Hadley Telephone and Sound Systems, of Smethwick, Birmingham. The installation will provide a four-channel service to 320 beds.

An agency for a low-priced five- or six-valve all-dry battery receiver of United Kingdom manufacture is being sought by Narseys, Limited, P.O. Box 145, Suva, Fiji. It should cover the short-wave bands between 16 and 37 metres and be fully tropicalized.

Colour Fundamentals

PRINCIPLES OF COLORIMETRY WITH PARTICULAR REFERENCE TO TELEVISION

By H. HENDERSON,* B.Sc., A.Inst.P.

A NUMBER of articles have appeared in *Wireless World* in the last few months on the subject of colour television. The American N.T.S.C. system modified to British standards has so far received major attention. This is largely due to its being a two-way compatibility system which the Americans felt was essential to the successful launching of a new and expensive service. Such a requirement may not assume the same importance here and other systems are being tested. Whichever is finally chosen a full understanding of its operation will demand a knowledge of colorimetry and colorimetric terms. It is also true to say that a knowledge of the theory of colour is essential so that one may clearly recognize which equations derive from colour considerations and which are pure circuitry relations; these are often confused.

The Visible Spectrum.—There are at least 50 octaves in the electromagnetic spectrum. Visible light occupies less than one and extends from about 4,000 to 7,500 Angstrom units (1 Angstrom unit (Au) = 10^{-8} cm). The actual limits depend upon the observer and the intensity of the light. In practice the limits are taken as those wavelengths where the eye response is 10^{-5} of peak value, i.e., 3,800-7,800 Au.

The eye is not equally sensitive to the wavelengths present in this band but has a peak of sensitivity in the yellow-green as shown in Fig. 1. This curve may be obtained by measuring the energy required for each wavelength to match a given brightness, then plotting the reciprocal of energy required against wavelength. A photocell with a filter having an overall response of the same shape as the luminosity curve would give equal outputs when illuminated by lights of different colours which are judged by the eye to be equally bright. Once a standard luminosity curve for the average eye is agreed, such photocells may be used for photometric work with much greater convenience.

A black and white television camera should have such a colour response if it is to transmit brightness information faithfully.

Colour Perception.—It is useful to assume that the eye contains three wideband receptors, one sensitive to the middle region of the spectrum, one to the blue and one to the red end. The colour sensation produced in the brain depends upon the relative excitations of these receptors. It follows that any colour, whatever the mixture of wavelengths in its composition, can be matched by suitable mixtures of three colours, red, green and blue, each stimulating the appropriate receptor to the same extent as the matched colour. These three colours are referred to as the primaries and they may be monochromatic or wideband. For colorimetry the primaries are monochromatic and are generally red

(7,000 Au), green (5,461 Au) and blue (4,358 Au). In colour television the three primaries used for colour matching are the three phosphor colours found in the colour receiver. Suitable activation and combination of the light output from these phosphors may produce any colour match and it is the camera's function to produce signals of suitable amplitudes to achieve this.

Additive and Subtractive Mixing.—The process of combining coloured lights referred to above is known as additive colour mixing and for this purpose the primaries are red, green and blue. The mixture colours obtained by combination of these primaries may be represented qualitatively by means of a triangle as shown in Fig. 2.

As blue and yellow together in suitable amounts match white they are referred to as complementary colours. Other complementary colours are red and cyan, green and magenta.

Where the colours of pigments and filters are involved—that is, things which have no colour in their own right—the process of mixing is a subtractive one. For example a yellow filter is one which absorbs blue from light falling upon it and allows red and green to pass. It is often referred to as a “minus blue” filter. Similarly a magenta filter is a “minus green” and a cyan filter is a “minus red.” Yellow, magenta and cyan are the primaries of subtractive colour mixing. If a yellow filter is followed by a cyan filter and white light falls on the system, yellow subtracts blue, cyan subtracts red, and only green emerges.

In this sense cyan and yellow make green. The colours obtained by subtractive processes are indicated in the triangle shown in Fig. 3.

Colorimetry.—Colour is measured by first matching the chosen colour with a suitable mixture of red, green and blue light and then quoting the amounts of each primary present in the mixture. The ratio of the three amounts specifies the colour. Doubling each primary contribution does not change the colour but only its brightness.

Two units are available for the measurement of the amount of each primary in the match. One derives from photometry and is the lumen. The other is the trichromatic unit, which will be dealt with later. A lumen of any colour appears equally bright. It follows from the luminosity curve (Fig. 1) that a lumen of yellowish-green light contains least energy. A standard candle, treated for the moment as an omnidirectional point source of light, gives off light at the rate of 4π lumens. This may be taken as the definition of the lumen. The photocell with the eye-response filter mentioned earlier will give outputs directly proportional to the number of lumens falling on it.

Supposing white were to be matched by light from the three cathode-ray tube phosphors (as

*Engineering Training Dept., B.B.C.

used at present), it might be found that 1 lumen of white is matched by 0.3 lumens of red plus 0.59 lumens of green plus 0.11 lumens of blue. This may be written

$$1 \text{ lumen of white} \equiv 0.3(R) + 0.59(G) + 0.11(B).$$

Notice that the luminance of the mixture colour is the sum of the luminances of its components. These quantities are important and continually recur in colour television literature. If different phosphors are used they will need modification.

Because of the unequal values assigned to the amounts of red, green and blue to match white,

which is regarded as unbiased to any particular colour, a different unit is favoured, and is of particular convenience in colour television. This unit is defined by the statement that 1 unit of red + 1 unit of green + 1 unit of blue match 1 lumen of white

$$\text{or 1 lumen of white} \equiv 1(R) + 1(G) + 1(B).$$

These units are referred to as trichromatic units or T-units. To preserve the law of additivity 1 lumen of white is taken as equal to 3 T-units

$$\therefore 1 \text{ T-unit of white} \equiv 0.33(R) + 0.33(G) + 0.33(B).$$

If we are still thinking of the same white as above and the c.r.t. phosphors it follows that

$$1 \text{ T-unit of red} = 0.3 \text{ lumens}$$

$$1 \text{ T-unit of green} = 0.59 \text{ lumens}$$

$$1 \text{ T-unit of blue} = 0.11 \text{ lumens.}$$

When a colour is quoted as matched by so many T-units of red, green and blue, its brightness can be found by multiplying the red T-units by 0.3, the green by 0.59 and the blue by 0.11 and adding.

At present the electrical outputs from the red, green and blue camera tubes are adjusted to be equal when the camera is looking at the standard white. The camera outputs are in effect then in T-units. To obtain a signal proportional to brightness it is necessary to multiply the red output by 0.3, the green by 0.59, the blue by 0.11 and add. Thus we have the often recurring equation

Luminance signal $E_V = 0.3 E_R + 0.59 E_G + 0.11 E_B$ where E_R , E_G and E_B are the camera outputs when looking at the particular colour and they would be equal if the colour were standard white.

Standard White.—There is unfortunately no single standard white. Equal-energy white is the white observed when all spectral colours are present with equal energy—this is somewhat blue. What is known as Illuminant B is the white of direct sunlight while Illuminant C is the white of sky-scattered sunlight. Illuminants B and C may be obtained by placing suitable filters in front of a tungsten lamp—known as Illuminant A. The figures quoted above refer to Illuminant C.

The Colour Triangle.—If a colour be matched by R T-units of red, G T-units of green and B T-units of blue, this may be written:—

$$(R + B + G) \text{ T-units of colour} \equiv R(R) + G(G) + B(B)$$

$$\text{or } 1 \text{ T-unit of colour} \equiv$$

$$\frac{R}{R+B+G}(R) + \frac{G}{R+B+G}(G) + \frac{B}{R+B+G}(B)$$

Now write

$$r = \frac{R}{R+B+G}, \quad g = \frac{G}{R+B+G} \text{ etc.}$$

$$\text{then } 1 \text{ T-unit of colour} \equiv r(R) + g(G) + b(B)$$

$$\text{where } r + g + b = 1$$

The values of any two coefficients, say r and g, specify the original colour without any reference to its brightness. These two quantities can be plotted and a colour triangle based on the primaries chosen is obtained. If now each colour of the visible spectrum is treated in this way and its colour point is plotted as in Fig. 4; a continuous line is obtained which is called the spectrum locus. It will be observed that many r and g values appear together greater than unity and some are in fact negative. What is the significance of negative colour? Here the truth must be revealed that it is in fact not possible to match all colours by suitable mixtures of

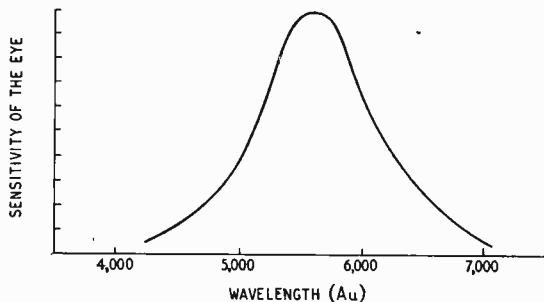
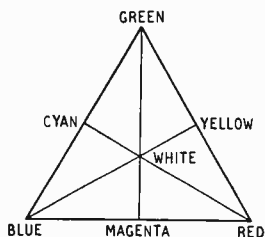
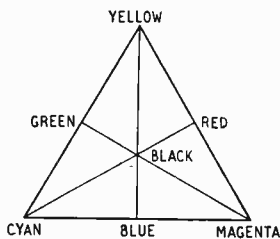

Fig. 1. Curve showing the sensitivity of the eye with different wavelengths of light (in Angstrom units).



Left: Fig. 2. Colour triangle illustrating the additive mixing of coloured lights.



Right: Fig. 3. Colour triangle illustrating the subtractive mixing of colours by filters.

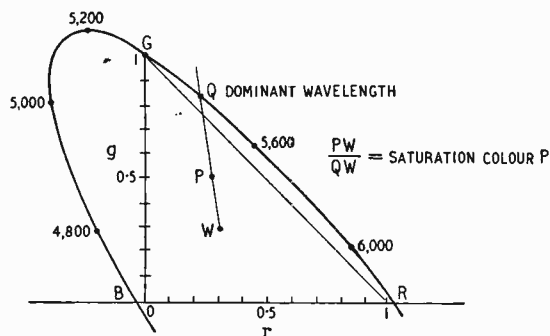

Fig. 4. Spectrum locus diagram. Note that white (point W) occurs at $r = g = 0.33$.

three primary colours. Taking sodium light as a single example, it is possible to come fairly close to a match with red and green primary mixtures. If blue is added to the sodium light, however, a match can be obtained. Thus:

sodium yellow + blue \equiv red and green
 or allowing mathematical processes to intrude
 sodium yellow \equiv red + green - blue
 the amounts of the three primaries being measured in T-units.

In fact all colours lying outside the RGB triangle cannot be matched by the three chosen primaries and no real colour can exist outside the spectrum locus. Between the red and blue end lie the purples, the non-spectral colours which are mixtures of red and blue.

Properties of the Colour Triangle.—If two colours represented by two points on the diagram are mixed, the mixture colour lies on the line joining these points. Where it lies depends on the relative amounts of each colour used. Colours lying at the extremities of a line passing through white are called complementary colours, for suitable mixtures of complementary colours match white.

A colour may be specified on such a diagram by drawing a line through the colour point (P), and white (W), and producing it to cut the spectrum locus at a point (Q), corresponding to some particular wavelength called the dominant wavelength. The ratio of the distance of the point from the white point to the distance from the spectrum locus to the white point measures the purity or saturation of the colour. Dominant wavelength and saturation specify the colour. A suitable mixture of white and the dominant wavelength would match the colour. The presence of white in a colour desaturates it—it becomes paler; for instance red tends to pink. Dominant wavelength and saturation thus offer an alternative means of specifying colour.

Colours of No Brightness.—Once negative amounts of colour are accepted it must follow that there are points on the diagram corresponding to colours having no brightness. The brightness, it may be remembered, may be obtained by multiplying the T-units of each primary by the appropriate factors (0.3, 0.59 and 0.11).

$$\text{i.e., brightness} = 0.3r + 0.59g + 0.11b$$

If this is zero we have:—

$$0 = 0.3r + 0.59g + 0.11b$$

$$\text{but } r + g + b = 1$$

$$\therefore 0 = 0.3r + 0.59g + 0.11(1 - r + g)$$

$$\text{i.e., } 0 = 0.19r + 0.48g + 0.11$$

This is the equation of a straight line. Colours lying on this line have no brightness. The line is called the alychne and will have importance in the later development of the subject. Fortunately this line does not pass through the region of real colours so that we are not faced in practice with colours of no brightness. They would no doubt be singularly difficult to detect! Below this line lie colours of "negative brightness."

Colours of Surfaces.—A surface is coloured by virtue of the light it reflects after selective absorption of the incident illumination. Because the spectrum locus is fairly straight between greenish-yellow and red it follows that mixtures of spectral colours in this region will themselves be on the spectrum locus. A wide spectral band may be reflected from a surface, i.e., it will appear bright, and yet it can have a saturated colour if the reflected colours lie between

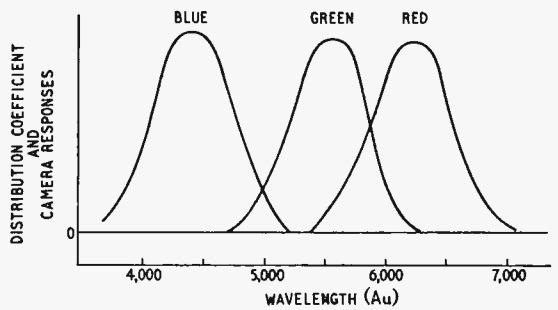

Fig. 5. Red, green and blue distribution coefficients.

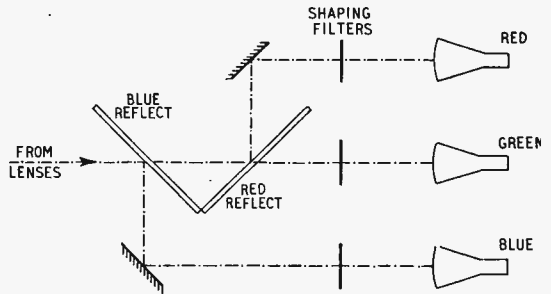

Fig. 6. Method of splitting light into three colour components in a colour television camera.

greenish-yellow and red. Yellow and orange are in consequence usually bright saturated colours.

Because the spectrum locus in the green region of the spectrum is so convex it follows that any wide band of reflected light in this region of the spectrum will inevitably produce a mixture colour which lies within the spectrum locus, i.e., a desaturated colour. Thus, bright greens are invariably desaturated greens. Saturated greens are very dull. At the blue end of the spectrum the eye sensitivity is falling away and saturated blues are also very dull colours. These facts are important when choosing the primary colours to be used for matching. It is more important to be able to match saturated yellows and oranges than greeny blues as the last-mentioned only occur at very low brightness levels.

Colour Analysis.—The colour television receiver should produce a coloured picture which matches at every point the colour of the original scene. This means that the camera outputs must control the point by point magnitudes of the red, green and blue phosphor brightnesses. A close connection must therefore exist between the colours of the primary phosphors and the colour filters used in the camera.

To obtain the overall camera response curves, the standard white is imagined split up into a large number of narrow spectral bands and each band in turn is matched by measured amounts of red, green and blue primary. A plot of these amounts (distribution coefficients) against wavelength give curves of the sort shown in Fig. 5. As the addition of all the wavelengths gives the standard white so the areas under the three curves are equal, for equal quantities of red, green and blue are, by definition, required to match this white. The colour responses of the red, green and blue cameras must have the shape of these curves.

It is not, of course, possible to cater for the negative-going portions of the response curves in the

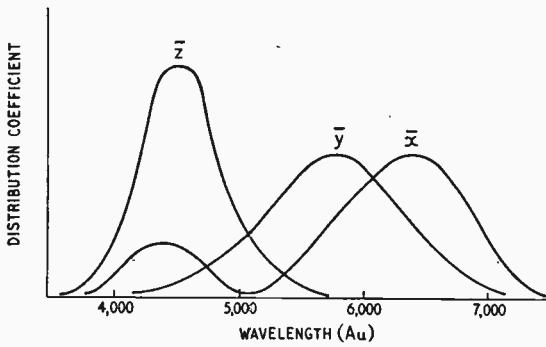

Fig. 7. Plot of distribution coefficients \bar{x} , \bar{y} and \bar{z} .

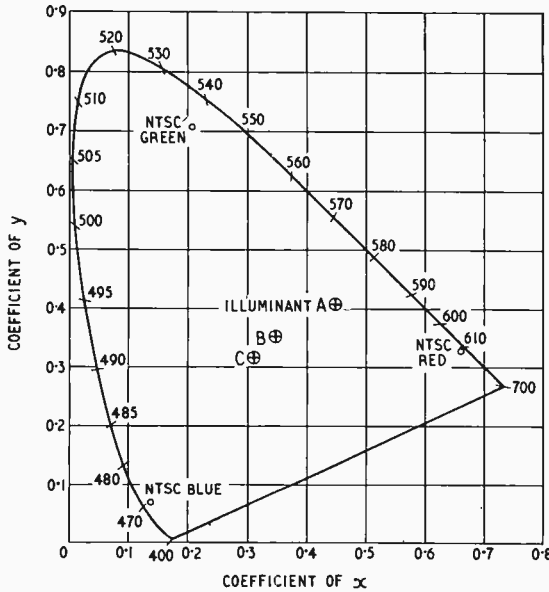

Fig. 8. C.I.E. trichromatic co-ordinates with spectrum wavelengths in millimicrons, Illuminants A, B and C, and N.T.S.C. primaries.

present state of the art. This implies, as has been stated earlier, that only colours lying within the RGB triangle formed by the phosphor colours can be accurately matched.

The light falling on the colour camera may be split into three components by devices known as dichroic mirrors, as shown in Fig. 6. One mirror reflects the blue end of the spectrum and transmits the rest. The second reflects the red end of the spectrum and transmits the remainder which is a band in the middle of the spectrum. The reflection (or transmission) wavelength characteristic of the dichroics multiplied by the camera's characteristic may approximate quite well to the desired response for analysis. In general, however, further filters are required and they are known as shaping filters.

International Colour Specification.—Colour points and triangles referred to earlier depend entirely on the original choice of the three primary colours. Figures mentioned have been derived from primaries which are the phosphors at present in use in colour tubes. For accurate and reproducible colour measurement such primaries would be undesirable

and in practice monochromatic colours from the red, green and blue regions of the spectrum are chosen (7000Au—red, 5461Au—green and 4358Au—blue).

These colours are not easy to produce at any great level of brightness or with simple apparatus and many experimenters would prefer to use different primaries. It is clear, however, that no comparison of the work by one experimenter with that of another is possible unless the results of one can be translated from one set of primaries to another.

The three monochromatic colours mentioned above might well have been chosen as the basis of international colour specification and all those desirous of communicating their results to others would have translated their practical observations taken with their own primaries to the international ones. This is a straightforward process once it is known where one set of primaries lie on the RGB diagram of the other; it is just a question of mathematics.

As any such transformations are possible it was decided to choose three primary colour points for the international specification of colour which would dispose of negative values for colour co-ordinates, i.e., the triangle formed by three such points must completely enclose the spectrum locus. The points must therefore lie outside it and will represent imaginary or super-saturated colours. This triangle is referred to as the XYZ triangle. X and Z lie on the alychne and are therefore "colours" of no brightness. Y is chosen so that the line YX lies along the straight portion of the spectrum locus. This means that many spectrum colours are specified by YX values alone.

By means of a change of axes the XYZ triangle can be made a right-angled triangle and the white point (this time equal-energy white) arranged to be at $x = 0.3, y = 0.3$. This is the C.I.E. chromaticity diagram and represents the international reference frame for colour specification.

A plot of the distribution coefficients \bar{x} , \bar{y} and \bar{z} gives curves as shown in Fig. 7 (the bars over the letters being used to distinguish distribution coefficients from trichromatic coefficients). It may be observed that the \bar{y} curve has the shape of the luminosity curve referred to at the beginning of this article. This implies that X and Z values contain no brightness information and this is a consequence, of course, of choosing X and Z to lie on the alychne.

No negative-going portions exist as the whole of the spectrum locus lies within the XYZ triangle. Filter photocell arrangements can be made to have responses of the shape of the \bar{x} , \bar{y} , \bar{z} curves shown in Fig. 7. With three such cells nothing is easier than to determine the C.I.E. chromaticity of a particular light source. The output of each cell when illuminated with equal-energy white (obtained by means of a suitable filter over a tungsten lamp) is made equal (electrically—say by means of a variable meter shunt). Each cell is then illuminated with the colour to be measured and the X, Y and Z outputs noted. Y gives the relative brightness of this colour to the white. The chromaticity co-ordinates are then

$$x = \frac{X}{X + Y + Z}, \quad y = \frac{Y}{X + Y + Z},$$

$$\text{and } z = \frac{Z}{X + Y + Z}$$

and the x, y values are plotted. A number of points obtained in this way are shown on the diagram Fig. 8.

Looking at Square Waves

A Direct Approach to the Interpretation of Distortion

By T. D. CROOK

THE advanced textbooks on electronic subjects apply mathematical analysis to the question of what happens to a square wave in passing through an amplifier, and fill their pages with exponentials; or perhaps soften up the problem by a determined brandishing of mathematical atom bombs in the shape of Laplace transforms, or Heaviside operators—all of which leave the average not-too-mathematical enthusiast trudging along miles behind, and very likely regarding the whole business as akin to devikry, or as just clever examples of "Senior Wrangling." The real "amateurs' books," on the other hand—and particularly two modern American ones—sometimes include in their illustrations examples of square-wave distortion that never were on land or sea, and also provide interpretations which are often quite erroneous.

It is possible, however, to explain the process of square-wave distortion in an amplifier by simple physical methods, and though (apart from "Cathode Ray's" famous series of articles) descriptive explanations may seem to be rather *infra dig.* in a paper such as *Wireless World*, an attempt in this direction may perhaps not come too much amiss, particularly when augmented by diagrams which show the amount of variation in frequency response and phase-shift indicated by different degrees and kinds of wave-form distortion. Therefore, leaving the mathematicians to their fun and games I will endeavour to explain to fellow readers the results of much reading and a few experiments.

As is so well known that I am repeating it here, all regularly recurring wave-forms—square, triangular, pulsed, or as "wiggly" as you please—can be shown to be built up from sine waves, and a Fourier series shows that to produce a square wave of amplitude A and frequency f , the following recipe is essential:—

1. A sine wave of frequency f and amplitude $4A/\pi$.

2. Another sine wave of frequency $3f$ and amplitude $4A/3\pi$.

3. Another sine wave of frequency $5f$ and amplitude $4A/5\pi$

and so on using all the odd harmonics of f in the proportions indicated, theoretically up to infinity.

Incidentally all the sine-wave harmonics must be in phase with the fundamental; if one takes the same recipe but adds the harmonics in antiphase the resulting concoction is a sharply peaked wave-form—a culinary *contretemps* which would puzzle Philip Harben no end!

If such a square wave is pushed through an amplifier which either attenuates or accentuates the higher harmonics, it is obvious that its wave shape will be somewhat changed in the process—but in what way, and why?

A rough physical idea of the how and why is gained by concentrating on the "verticals" of the square wave. The quotes here have their common ironical

significance, since the "verticals" are never truly vertical: if a good square wave is produced on a c.r.o. screen, and then the time base is speeded up sufficiently, these verticals will be found to have a decided slope, showing that they take a definite time (as represented by distance along the horizontal axis) to be traced out. This "rise-time" is, of course, the standard test of an amplifier's high-frequency response. Now if the verticals are thought of as being produced by one "side" of a sine wave with a frequency 100 times (say) that of the square wave and of the same amplitude, it is obvious that at a time-base speed slow enough to show several complete square waves the "sides" of the sine wave would be indistinguishable from a vertical trace, though there would, of course, be fifty of them to each horizontal of the square wave. Thus it seems physically more than likely that it is the higher harmonics of the square wave that are together responsible for the verticals, despite their continual decrease in amplitude with increasing frequency. In fact, if we draw a bow at venture and claim that attenuation of the higher harmonics of the square wave will reduce the straight upright part of the verticals, and accentuation will lengthen them, a practical test shows that we are toxophilites of no mean order, for this is just what does happen: attenuation of the square wave's higher harmonics rounds off the leading (left-hand to you) edge of the wave-form to an increasing degree till eventually, with large attenuation, no vertical part remains; accentuation lengthens the verticals, producing pronounced peaks, or over-shoots, which very rapidly drop back to their proper horizontal level. The two effects are shown in Figs. 5 and 6 respectively.

The above reasoning may seem to be a rather shady piece of "Junior Wrangling"—more *post hoc* than *propter hoc*, in fact—but it is generally true,

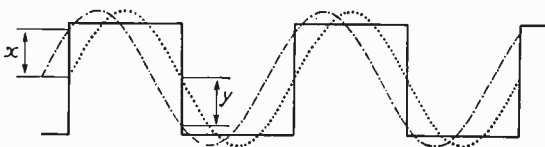

Fig. 1. Square wave with its sine-wave fundamental (dotted line), and the same fundamental with a phase-lead (dashed line).

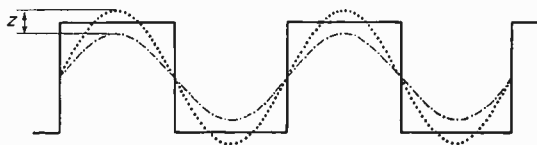

Fig. 2. Square wave with its sine-wave fundamental (dotted line), and the same fundamental after attenuation without phase-shift.

though of course the problem is complicated first by the fact that *all* the harmonics above the amplifier's turn-over point are affected, and, secondly, by the co-existence of phase-shift, which has its own undetermined effect.

However, at the low-frequency end the effects of variation in response and of phase-shift are quite distinct, and both amenable to a direct diagrammatic explanation.

A possible square-wave frequency for a low-frequency test might be 50 c/s, and if such a square wave is injected into an amplifier so decidedly "Low-Fi" that its response begins to fall off at 5 kc/s (the 100th harmonic of 50 c/s), the verticals and edges of the wave will still be reproduced in all their pristine perfection, since all harmonics up to the 99th are being fully catered for. On the other hand, since the square wave contains no frequencies below its fundamental, provided this is passed through without phase-shift or amplitude variation, the output square wave will be a replica of the input. Thus if the amplifier included a fantastic filter which allowed it to have perfect response at 50 c/s, but negligible response with appalling phase-shift at 45 c/s, it would still reproduce perfectly a 50 c/s square wave. This fact is emphasized because more than one book which deals with this subject implies or states that square-wave distortion gives an indication of amplifier response below the square-wave frequency. One could, by extrapolation from existing distortion, deduce the probable response below the square-wave frequency, but extrapolation can be a snare (cf. Scroggie's "Radio Laboratory Handbook," p. 355). As an example, one Williamson amplifier had a small peak at around 10 c/s: a test with a 15-c/s square wave might show perfect response, whereas 10 c/s would reveal the slight peak. If then the amplifier has phase-shift or change in amplification at 50 c/s, what sort of distorted square wave will come out of its spout? And why?

Phase-shift

First, the effect produced by phase-shift. Fig. 1 shows a square wave on to which has been superimposed as a dotted line its sine-wave fundamental, whose amplitude is $4/\pi$ times that of the square wave. The two wave-forms are of course exactly in phase with each other. If after passing through the amplifier the phase of the fundamental is given a lead of 5° , say, without any appreciable variation in gain (as would normally be the case), its new position would be as shown by the dashed line. Incidentally with only 5° phase-shift at the fundamental, the amount taking place at the 3rd harmonic (150 c/s) would be nearly negligible. The result of this shift in the position of the fundamental relative to the original square wave will obviously be to lift the leading edge by the amount x , and to drop the trailing edge by the amount y , and in actual fact all other points on the horizontal are similarly raised or lowered to such a degree that the horizontal remains quite straight, but tilts, as shown in Fig. 3(a). The actual amount of tilt for 5° shift is about 12%—i.e., the corners are lifted or dropped by an amount equal to 12% of the whole vertical side of the wave. In just the same way a phase-lag—shifting the fundamental to the right on the diagram—would cause the same amount of tilt, but in the opposite direction. The shift shown in the diagram has of course been

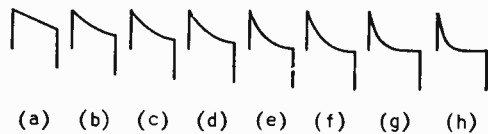

Fig. 3. Diagrams showing square-wave distortion when the fundamental is attenuated (with phase-shift) to the following degrees: (a) negligible attenuation; (b), 0.9 (-1 dB); (c), 0.8 (-2 dB); (d), 0.7 (-3 dB); (e), 0.6 (-4.5 dB); (f), 0.5 (-6 dB); (g), 0.4 (-8 dB); (h), 0.3 (-10.5 dB).

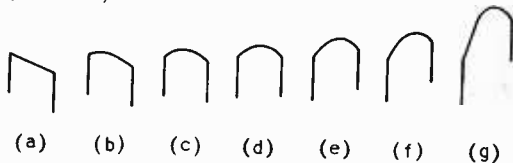

Fig. 4. Diagrams showing square-wave distortion when the fundamental is accentuated (with phase-shift) to the following degrees: (a) "flat" condition; (b), 1.2 (+1.5 dB); (c), 1.4 (+3 dB); (d), 1.6 (+4 dB); (e), 1.8 (+5 dB); (f) 2 (+6 dB); (g), 3 (+9.5 dB).

exaggerated for clearness. As a detector of phase-shift the method is very sensitive, and as little as 1° shift causes a noticeable tilt.

Secondly, amplitude attenuation or accentuation. Fig. 2 shows a square wave with its normal sine-wave fundamental, but this time the fundamental (dashed line) has been reduced in amplitude but not shifted in phase (unlikely, but assumed for clearness). If only the fundamental is affected, the result will be to lower the middle of the horizontal by the amount z , leaving the ends unaffected, and also to lower all other points so that the horizontal now curves downwards. This concave curvature is the indication of falling response at the fundamental, and when this is so large that some drop also occurs at the 3rd and perhaps 5th harmonic as well, the wave-form begins to take on an exponential shape, as shown in Fig. 3(e). If there is accentuation of the fundamental it is also apparent that the curvature will be convex, instead of concave.

Normally, of course, the two effects appear together, but phase-shift always shows up first. As stated above, a 5° phase-shift gives 12% tilt, which is very easily seen, but the change in amplification that accompanies this in a normal R-C-coupled amplifier can be shown to be about $\frac{1}{2}\%$, or 0.04 dB, which would produce a quite undetectable amount of curvature in the horizontals. Fig. 3(b) shows the amount of curvature produced by a 1-dB drop at the fundamental: it is quite small, but the tilt for the corresponding phase-shift is pronounced. The normal falling-off in low frequency response due to the increasing reactance of coupling capacitors causes a phase lead, whereas the normal "bass-lift" tone-control causes a phase lag: the latter effect can be seen in Fig. 4, where, owing to the bass-lift circuit, the normal phase-lead produced in the "flat" position is overridden and eventually turned into a large phase lag, with a tilt in the opposite direction.

If a band-stop filter is included which removes a narrow band of frequencies centred on f , one gets practically the same result as for normal l.f. attenuation, with the difference that the loss at f is very high, whereas that occurring at $3f$, $5f$, etc., is much less than would take place when the falling

response was due to normal R-C couplings. In this case the horizontals show a deep central dip which slopes evenly up to the corners. If the band of frequencies removed is situated at the h.f. end, the horizontals have a sharp narrow dip near the leading edges. There may be a mathematical explanation or analysis of this, but I doubt if it can be explained in physical terms.

The above descriptive explanations may be debatable, and perhaps of limited interest, but it is hoped that the diagrams may prove to be of practical value.

Measurement of phase-shift is of less importance in audio work, since the ear is insensitive to it, and in any case equalizers and tone-controls necessarily produce phase-shift—though surely a perfect record characteristic equalizer should restore the correct phase relations that were altered by the circuits used in the recording process. Since, however, the main amplifier should cause minimum phase-shift, square waves can easily be used to ascertain the amount it does produce by applying the formula: $\sin \theta = \pi x / 4$, where θ is the phase-shift in degrees at the testing frequency, and x is the fraction of the whole vertical side of the square wave that any corner is moved away from its normal position by the phase-shift tilt.

Amplitude Variations

More important are variations in amplification over the audio band. Unfortunately it is impossible to apply any method for measuring the actual curvature produced, owing to the simultaneous phase-shift effect, and to the fact that the curves soon take on an exponential shape. Therefore a series of tracings were made from a c.r.o. screen under specified conditions, and these do give a fairly accurate idea of the amount of gain or loss involved.

The equipment used for this purpose was—apart from a sine/square-wave generator—part of a pre-amplifier having the Williamson low-pass sharp-cut filter (used in its "flat" position), and the Baxandall tone-control. Tests showed that these circuits had only about 1 dB loss at 25 kc/s, and the output connections to the c.r.o. were taken direct to the Y-plate, under which conditions the c.r.o. would produce perfect square waves at 10 c/s and 20 kc/s. In any case small deficiencies in the whole set-up could be corrected at the start of each measurement by very small adjustments to the tone control: actually the correct "flat" position of the control could best be found, especially on h.f. tests, by ensuring that a good square wave was produced. The Baxandall tone-control has a peak in its response well above the audio range, and to ensure that this did not vitiate the results the h.f. tests were carried out mainly at 1 kc/s, using up to about 3 kc/s when a large "drop" or "lift" was required. In any case the diagrams are intended to be useful only for audio work when the normal types of R-C voltage amplifiers would be used.

Procedure at l.f. was as follows. A 50-c/s square wave was passed through the amplifier and into the c.r.o., and the bass control adjusted to its "flat" position. The resulting trace, Fig. 3(a), shows that there was considerable phase-shift, but no visible attenuation, as the slopes are quite straight. The square wave was then changed to a sine wave, also at 50 c/s and the c.r.o. tracing adjusted to give a peak-to-peak reading of 10 divisions on the calibrated screen, the tone control was then moved to reduce

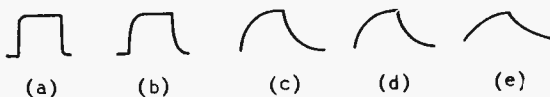

Fig. 5. Diagrams showing square-wave distortion when there is 6 dB loss at the stated multiples of the square-wave frequency (f): (a) $10f$; (b), $5f$; (c), $3f$; (d), $2f$; (e), at f .

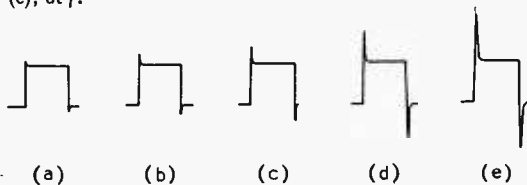

Fig. 6. Diagrams (except e) showing square-wave distortion when there is the stated amount of over-amplification at 10 times f : (a), 1.1 (1 dB); (b), 1.2 (1.5 dB); (c) 1.4 (3 dB); (d), 2 (6 dB); (e), 2 (6 dB) at $5f$.

the response at this frequency to 9 divisions, a drop of about 1 dB. The wave-form was then returned to a square-wave shape, and the actual wave-form on the screen was traced through transparent paper, giving the result shown in Fig. 3(b). The whole process was repeated, with the bass control adjusted to reduce the gain at 50 c/s from 10 to 8 divisions, and the resulting wave-form again traced, as in Fig. 3(c). Other values down to 10.5 dB drop were also obtained as shown. The same procedure was used to deal with given values of "lift" at 50 c/s, as in Figs. 4(a)-(g).

The diagrams are, of course, independent of frequency, although actually made at 50 c/s, and in the cases where they represent only a small attenuation at the square-wave frequency, it can be assumed that there is a drop at this frequency only, and none at $3f$ even; where there is a large drop at f , there is likely to be some drop at $3f$ too, but in any case the response curve is that of a typical tone control, and should apply with a minimum of error to any normal audio amplifier. Therefore, in order to test the l.f. response of an amplifier, one need only pass through it a square wave of 75 c/s, say, adjusting the c.r.o. sweep speed so that the wave-form is about the same size as that in the diagrams, and reduce the frequency until a suitable amount of curvature is produced, when the attenuation at the test frequency can be estimated with reasonable accuracy from the diagrams given.

H.F. Response

The procedure at the upper end of the audio band is more complicated, and the results unfortunately less certain in their significance, since in this case *all* the square-wave harmonics above the amplifier's turn-over point are attenuated to a steadily increasing degree, and at a rate depending on the nature of the response curve above that point. Luckily the response usually falls off at about the same rate for normal types of amplifier, but it may possess a noticeable rise at supersonic frequencies, as when negative feedback is applied over a transformer. Nevertheless, I think that the appended diagrams for h.f. response would have a general application.

To produce the diagrams, first a 1-kc/s square wave was used, and the treble control adjusted

slightly to give a good square-wave shape. The input was then changed to a 9-kc/s square wave, and the output set to give a 10-division trace, as before, which was reduced by the treble control to 5 divisions—a drop of 6 dB at 9 kc/s. The original 1-kc/s square wave was then again injected, and the new wave-shape traced, as in Fig. 5(a), showing the effect of a 6 dB drop at the 9th harmonic of the square wave, with an increasing drop above that frequency. Similar tests produced the diagrams in Figs. 5(b) to (e), for a 6 dB drop at 5 kc/s, 3 kc/s, 2 kc/s and 1 kc/s, respectively, when using a 1-kc/s square wave. Actually, as mentioned above, a slightly higher square-wave frequency had to be used when the tone-control was unable to give sufficient drop, but the proportions between the square wave and the harmonic frequency at which the attenuation was taken were kept the same, and the resulting change in amplifier response to the much higher square-wave harmonics (only 1 dB down at 25 kc/s as stated above) should not have made any really marked changes in the wave-shape. Note that with the 6 dB drop occurring at $2f$, the output square-wave amplitude was about $13/14$ ths of its original value, since there was also a few dB drop at f as well; also with 6 dB drop at the fundamental, f , the amplitude of the output (now far from square) was about 0.7 of its original value. It is also worth noticing the difference between the square-wave distortions produced by attenuating the fundamental 6 dB when working at the l.f. end, and so having only small simultaneous attenuations at $3f$ and perhaps $5f$, but full reproduction of all harmonics from $7f$ onwards (Fig. 3(f)), and attenuating the fundamental 6 dB, and all higher harmonics to an increasing degree, as when working at the h.f. end (Fig. 5(e)).

The effects caused by “top-lift” were traced in

the same way, except that four values of “lift” were used at 9 kc/s, and one at 5 kc/s, giving the results shown in Figs. 6(a) to (e).

Again, as suggested for the l.f. end, if a 1-kc/s square wave is passed through an amplifier, and the frequency increased until the corners become rounded, about as in Fig. 5(a), it can be assumed that there is about 6 dB drop at $9f$, if the response curve above that point falls off at a normal rate, as would usually be the case. As an illustration of what happens when the response curve is abnormal, a test was made with a 5-kc/s square wave which was reproduced quite well when all controls were in the “flat” position, but when the sharp-cut filter was switched to its 12-kc/s position, the square wave was converted to a somewhat triangular-shaped sine-wave. In this position of the filter there was 6 dB drop at 12 kc/s with an attenuation of some 30 dB per octave above this frequency, and a slight rise at a considerably higher frequency: the more-or-less complete removal of the 5th and higher harmonics of the square wave completely destroyed its shape.

Luckily no normal “straight” amplifier or pre-amplifier has this kind of h.f. response curve: one gets it only by the use of parallel-T networks, negative feedback, and expensive 1% resistors and capacitors—and then, if like me you are no connoisseur of antique 78 r.p.m. records, you hardly ever have occasion to use it!

“Unconventional F.M. Receiver”

Correction.—On page 261 of the June issue the core of B4 Ferroxcube should be list No. FX.1146 (as in Fig. 6). The list No. FX.1595 refers to the B2 Ferroxcube core tried as an alternative.

TELEVISION PICTURE QUALITY

This comparison of the relative definitions offered by different television systems appeared as an Editorial in the July number of our associated journal Wireless Engineer.

ALTHOUGH there is no immediate prospect of a colour television system coming into operation in this country, there is a good deal of discussion going on about the standards which should be adopted. There is a school of thought which considers that compatibility with the present black-and-white television service is unnecessary and that when colour does come it can be, or even should be, on different standards.

A view which is quite often expressed is that Great Britain should adopt the same colour standards as the Continent and there is good reason to believe that this means a 625-line version of the American N.T.S.C. system. There is, of course, no suggestion that the present 405-line system should be abandoned so far as monochrome transmission in Bands I and III are concerned. The suggestion is that no attempt should be made to introduce colour into these but that colour should

be developed as a parallel service in Bands IV and V.

Although superficially attractive, there are a good many objections which can be raised against such a scheme. We do not propose to discuss them now, however, for we are more concerned with the underlying idea that 625 lines is a more suitable standard for television than 405 lines. In some circles, it seems to be taken for granted that it is greatly superior. The fact that the Continent only adopted 625 lines after a lengthy examination of our 405-line and the American 525-line systems is often thought to be evidence of its superiority.

We ourselves think that they made a mistake in choosing their standards. We thought so at the time and, having seen 625-line television, we still think so. We do not mean that the 405-line system is better than the 625-line. What we do mean is that the 625-line system does not make the best

use of the 5-Mc/s bandwidth allotted to it. We feel strongly that, for this bandwidth, the number of lines should be around 500 and that this would give better pictures than either 405 or 625 lines.

The important factors concerned with this matter of lines are not always as clearly realized as they should be. We propose, therefore, to compare them for the two existing systems.

First of all, in the 405-line system there are 377 active lines; that is, lines conveying visible picture information. In the 625-line system there are 575 active lines. There is no doubt at all that, in respect of vertical definition, the 625-line system is $575/377=1.53$ times as good as the 405-line. This improvement of 53% in vertical definition is accompanied by a proportional reduction in the visibility of the line structure, which is in itself a good thing. Too much importance should not be attached to it, however, for methods exist (e.g., spot-wobble) by which the visibility of the line structure can be reduced.

In the horizontal direction, the definition depends on the velocity of the scanning spot and the bandwidth. It is quite usual to assess horizontal definition in terms of a chess-board type of pattern. The fundamental component of the waveform produced by scanning such a pattern is a sinusoid of which one cycle corresponds to two adjacent elements of the chess-board. If the duration of the active part of a line is τ_1 and there are n elements per line, the duration of one cycle of this sine wave is $2\tau_1/n$. The frequency is thus $n/2\tau_1$ and this is taken as the upper limit of the video bandwidth.

This is rather an arbitrary relation, but it is practically useful and, in any case, it is valid for comparing different systems. With 405 lines, the frequency is 3 Mc/s and τ_1 is 80.95 μ sec. Therefore, $n=2 \times 3 \times 80.95=485.7$ elements per line. With 625 lines, the frequency used is 5 Mc/s and τ_1 is 52.32 μ sec, so $n=2 \times 5 \times 52.32=523.2$ elements per line. The horizontal definition is thus $523.2/485.7=1.075$ times that of the 405-line; that is, an improvement of 7.5%.

The facts are thus, that 625 lines gives 53% better vertical and 7.5% better horizontal definition than 405 lines. For this, it requires a greater bandwidth. The video bandwidth is greater in the ratio of $5/3=1.66$ and the channel bandwidth (i.e., the band occupied by both sound and vision transmissions) in the ratio $7/5=1.4$.

The aspect ratio is $4/3$ in both cases. With 405 lines, there are $485.7 \times 3/4=364$ elements in the same linear distance as the 377 active lines. The definition is thus virtually the same in both the vertical and horizontal directions. With 625 lines, there are $523.2 \times 3/4=392$ elements in the same linear distance as the 575 active lines. The vertical definition is thus $575/392=1.46$ times as good as the horizontal.

It is clear that the 625-line system gives better definition than the 405-line but at the expense of 40% more channel width. The improvement is almost entirely in vertical definition. For practical purposes the two are virtually the same in horizontal definition.

If the bandwidth is kept constant, altering the number of lines improves the definition in one direction across the picture at the expense of the other. It is clear that there must be an optimum number of lines and it is not unreasonable to suppose that

it occurs when the definitions in the two directions are the same, as in the 405-line system. If the two are not the same, in which direction should the definition be the better? We ourselves feel that horizontal definition is more important.

In support of this view, we instance the following:—

- (a) In the cinema, the tendency is all to wide screens, emphasizing the horizontal direction.
- (b) In laboratory tests of 405-line and 625-line pictures, each having the bandwidth of its particular standard, we find it hard to say with certainty which is which, unless there is a direct comparison.
- (c) In laboratory tests of the 405-line system with unrestricted bandwidth against 625 lines with 5-Mc/s bandwidth, we find that the 405-line system gives the better picture.

In the 625-line system, the extra 2 Mc/s of bandwidth is used almost entirely to increase the vertical definition. It is this that we think wrong. We think that 405 lines with a 5-Mc/s bandwidth would give a better picture. We do not say, however, that the proper number of lines for this bandwidth is 405. Probably the right thing to do is to keep the definition in both directions the same and, for 5-Mc/s bandwidth, that means about 500 lines, as we said earlier.

It should be unnecessary but, in view of the figure of 500, perhaps we should point out that this does not mean that we think the American 525-line standard is the right one. That has a 60-c/s frame frequency and a 4-Mc/s bandwidth and gives inferior horizontal definition to the 405-line system.

In saying all this, we are not advocating any change of standards by anyone. So far as monochrome television is concerned, that is impracticable. What we are concerned about is that, if the introduction of colour is made on standards other than 405 lines, the new standards should be the right ones. If it is practicable to have different standards for colour, we do not think that 625 lines with 5-Mc/s bandwidth is right. For this bandwidth, 500 lines or so would be better but, better still, would be 625 lines with the 7.4-Mc/s bandwidth necessary to equalize the definition in the two directions. W. T. C.

Four-speed Record Changer

A NEW version of the "Monarch" automatic record changer (type UA8) has been introduced with a choice of four turntable speeds including $16\frac{2}{3}$ r.p.m. for "talking book" records. The new mechanism includes a neutral position in which the jockey wheel is disengaged from the motor spindle, and particular attention has been given to the reduction of "rumble." There is provision for manual operation of single records and the playing weight of the pickup arm is adjustable. Power consumption of the 4-pole motor is 8 watts at 240 V, 50 c/s.

The makers are Birmingham Sound Reproducers, Ltd., Old Hill, Staffordshire.



B.S.R. type UA8 four-speed record changer.

Servo Tuning System

Remote Position Control of Transmitter Tuning Elements

By D. SMART

THE ground-to-air radio communications system of an airport has to be arranged so that any of the frequencies allocated for aircraft approach or landing control can be used without delay. This could be done by having a number of transmitters tuned to the different predetermined frequencies. By far the most economical solution, however, is to use a single multi-tuned transmitter with remote selection facilities. An example of this is a 1-kW transmitter designed by Redifon which can be pretuned to ten frequencies in the 2-26 Mc/s range, any one of which may be selected from a remote operating position. The maximum distance between the remote control point and the transmitter is limited only by the loop resistance of the single pair of control wires required for remote switching, modulating and keying. This loop resistance must not exceed 1,000 ohms, which means that control distances up to 25 miles can be achieved.

Fig. 1 shows a simplified diagram of the r.f. circuit. A ten-position crystal oscillator feeds into an aperiodic buffer stage, ensuring maximum frequency stability. This is followed by another buffer stage with tuned anode load which feeds a driver stage for the power amplifier. Crystal and wave-band selection are carried out by solenoid-operated switches. Within each band, however, a two-to-one frequency coverage is needed, and this involves continuously variable elements. It can be seen from Fig. 1 that three such elements are involved, viz., driver tuning capacitor, p.a. tuning coil, and aerial loading capacitor. For automatic tuning to any of ten preset channels some means of accurately resetting these three variables had to be devised.

The difficulties entailed in engineering a purely

A great deal has been heard about servomechanisms recently in connection with electronic control devices for automatic factories. This article gives an example of how a servo system is designed for a particular application, and has added interest because the application is in the field of radio.

mechanical system with the necessary degree of accuracy and reliability, coupled with simplicity required for production, were judged too great. It was therefore decided to concentrate on an electro-mechanical servo system which combined accuracy and simplicity.

A simple remote position-control servo system of the form shown in Fig. 2 was finally adopted. This is commonly known as a self-balancing bridge system. The two potentiometers R_s and R_t connected across the voltage supply form the bridge. The amplifier input is connected across the potentiometer slides and constitutes the bridge load. When the bridge is balanced there is no potential across the slides. Under these conditions there is no input to the amplifier and no resultant motion of the motor and load. When the slider of the setting potentiometer R_s is moved from its initial position, a potential is developed across the input of the amplifier. This is amplified and drives the

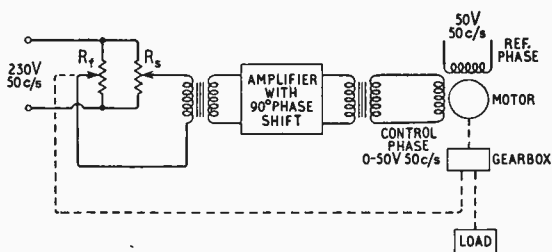

Fig. 2. Schematic of the remote position-control servo system used for tuning.

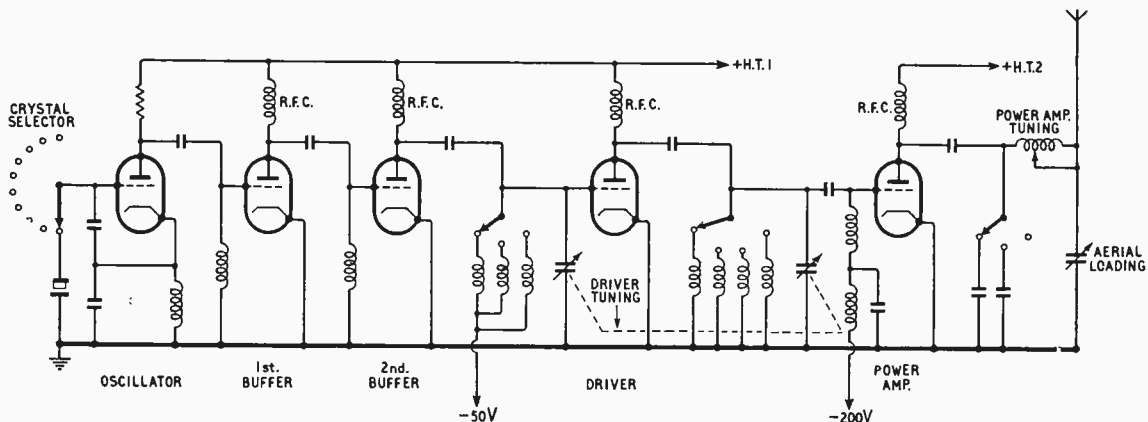

Fig. 1. Simplified diagram of the r.f. circuit of the transmitter.

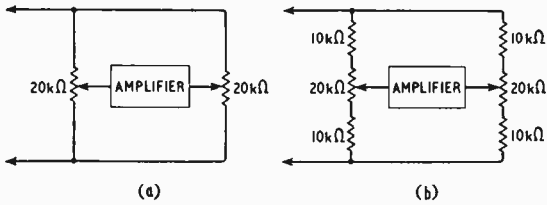

Fig. 3. Angular- to voltage-error translator: (a) simplified bridge network; (b) actual circuit.

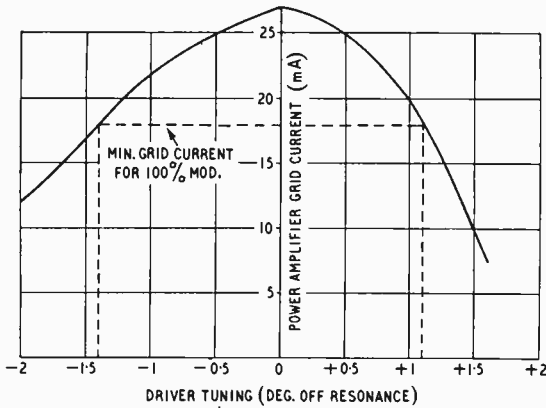

Fig. 4. Curve showing variation of power-amplifier grid current with angular error in the driver tuning of the transmitter.

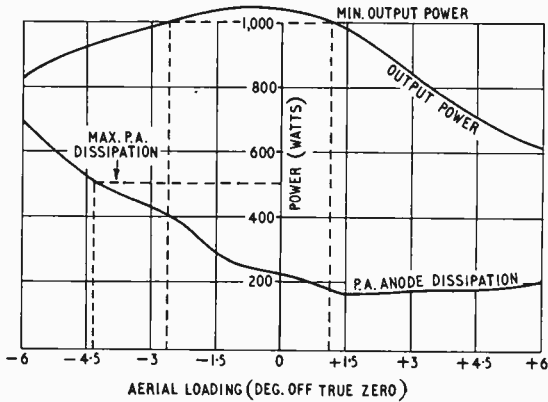

Fig. 5. Variation of output power and p.a. anode dissipation with angular tuning error in the aerial loading of the transmitter.

motor, gearbox and load. The follow-up potentiometer (R_f) slider is mechanically coupled to the gearbox and therefore moves in such a way as to restore the bridge to balance. It can be seen that by sufficient amplification this system can be made very sensitive to potentiometer setting, thus achieving the high degree of accuracy required for tuning applications. Furthermore, by having ten setting-up potentiometers and switching from one slider to another, it is possible to make the load move to any of ten predetermined positions or tuning points.

Any remote position-control servo system can be broken down into a number of basic elements. As they operate by virtue of an initial positional

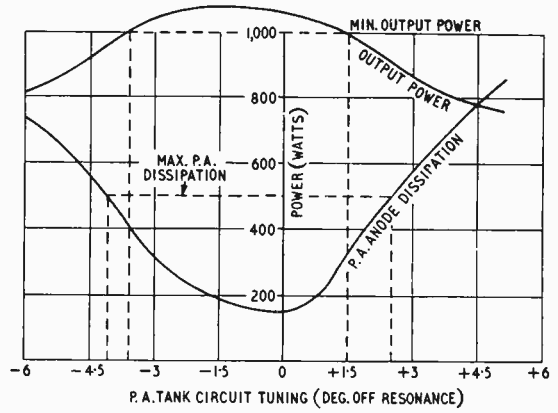

Fig. 6. Variation of output power and p.a. anode dissipation with angular tuning error in the p.a. tank circuit of the transmitter.

error between the input and output members, there must always be some error-measuring device. This angular error can be written down as

$$\theta = \theta_i - \theta_o \quad (1)$$

where θ_i = input angle, θ_o = output angle and θ = error angle

and is converted into a voltage error, the magnitude and phase of which must correspond to the magnitude and direction of the angular error. The angular- to voltage-error translator is shown in Fig. 3; (a) is the bridge network in a simplified state, while the actual circuit is at (b). The object of the 10-kΩ series resistors is to keep the impedance presented to the amplifier at balance more constant. This makes the system sensitivity more constant over the potentiometer range. With the values shown the impedance varies by 25%. The higher the value of R the smaller will be the percentage variation in impedance. This, however, calls for a larger voltage supply across the bridge or greater amplifier gain for a given sensitivity. The bridge is energized by 230 volts, 50c/s, which is the most convenient supply available. Although the use of a higher frequency supply, e.g., 400 c/s, would have considerably eased the design of the amplifier, this was not considered important enough to offset the disadvantage of having to provide a 400-c/s generator in an equipment where the servos are an important but small part of the whole.

The follow-up potentiometers are ten-turn wirewound helical potentiometers having an effective angle of rotation of 3,600°. They consist of 11,500 turns of resistance wire, giving a very good voltage resolution combined with compactness. This makes them very suitable for coupling to a gearbox. It can be seen that the error voltage is developed at a rate of 30 mV/degree.

The thirty setting-up potentiometers are again ten-turn wirewound helical potentiometers with an effective angle of rotation of 3,600°. They have slightly poorer voltage resolution, consisting only of 6,500 turns of resistance wire. This, however, affects only the accuracy of the initial setting-up, which can be made very great with care.

The equation of motion of any remote position control servo can be set up from a knowledge of the accelerating and retarding forces. The accelerating force is $K\theta$, where K = controller factor, i.e.,

output torque per unit angle error in oz-ins/radian. The retarding forces are given by the product of the output moment of inertia and output angular acceleration ($J \frac{d^2\theta_o}{dt^2}$), plus the product of the friction coefficient and output speed ($F \frac{d\theta_o}{dt}$), where J = output moment of inertia in oz-ins² and F = friction torque per unit output speed in oz-ins sec/radian.

$$\text{Thus } K\theta = J \frac{d^2\theta_o}{dt^2} + F \frac{d\theta_o}{dt} \dots \dots (2)$$

θ_o increases linearly with time at a rate determined only by the motor speed and gear ratio: thus $\theta_o = \omega_o t \dots \dots \dots (3)$

$$\therefore \frac{d\theta_o}{dt} = \omega_o \dots \dots \dots (4)$$

$$\text{and } \frac{d^2\theta_o}{dt^2} = 0 \dots \dots \dots (5)$$

Substituting (4) and (5) in (2) we have $K\theta = F\omega_o$

$$\therefore \theta = \frac{F\omega_o}{K} \dots \dots \dots (6)$$

Equation (6) gives the steady state error in terms of output speed and system parameters. It would appear that by sufficient amplification, i.e., making K large, θ can be made very small. There is a limit, however, to how large K can be made without incurring instability. This can be seen by examining the transient solution to equation (2). This is not dealt with in this article because of its length and complexity. In practice K was made variable and adjusted to achieve a compromise between accuracy and prolonged oscillation.

The design procedure applied to all three servos was as follows:—

- (1) Knowing θ , F and ω_o , K was calculated from equation (6).
- (2) Knowing the error volts per radian and the motor torque per volt, the required amplifier gain was calculated.

It was first necessary to determine the resetting accuracy required of all three servos. Figs. 4, 5 and 6 show how p.a. grid current, power output and p.a. anode dissipation vary with angular error in tuning. From these it is possible to determine the maximum error permissible in each case. These are:

- ± 1.08° for aerial loading capacitor servo.
- ± 1.1° for driver tuning capacitor servo.
- ± 1.5° for p.a. tuning coil servo.

We shall consider only the aerial loading capacitor servo in detail. One important requirement was that the time required to change channels should be as small as possible.

This means that the servos should have fairly high output speed. In the case of the aerial loading capacitor, with an angle of rotation of 180°, the gear ratio was made 400:1 between motor and load. This results in a maximum operating time of 5 seconds for a motor speed of 3,000 r.p.m.

The static friction in the system, mainly introduced by the follow-up potentiometer and gearbox, determines the minimum starting torque, hence the size of motor required. It was found to be 2 oz-ins. A two-phase servo motor with the following characteristics was chosen: moment of inertia, 0.16 oz-in²; stalled torque, 4 oz-ins; reference phase, 50 volts 8.6 watts; control phase, 50 volts 11 watts.

Fig 7, curve (b), gives the torque v. speed characteristic of this motor. It can be seen that the friction damping introduced by the motor

$$F = \frac{\Delta T}{\Delta S} = \frac{4 \text{ oz-ins}}{3,000 \text{ r.p.m.}} = \frac{4}{3,000 \times 2\pi/60}$$

$$= 0.012 \frac{\text{oz-in}}{\text{rad/sec}}$$

or $0.012 \times 400^2 \frac{\text{oz-ins}}{\text{rad/sec}}$ at the output shaft.

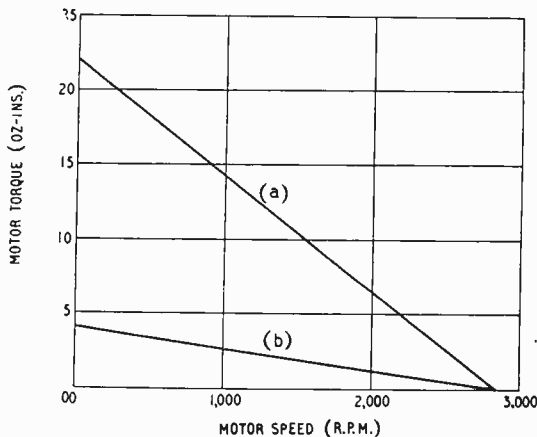

Fig. 7. Torque/speed characteristic of the electric motor used in the servo system.

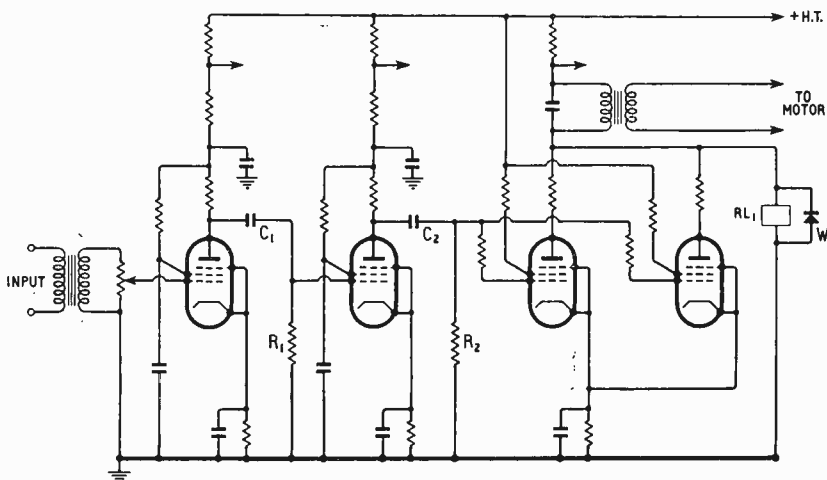

Fig. 8. Circuit of the 10-watt servo amplifier.

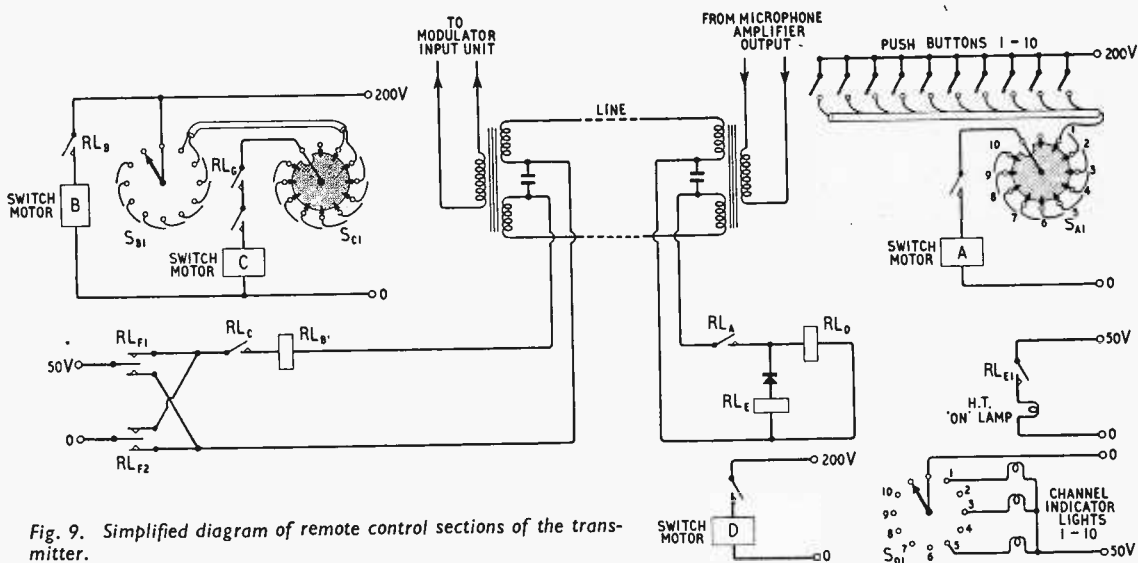

Fig. 9. Simplified diagram of remote control sections of the transmitter.

The output speed was $\omega_o = 0.785$ rad/sec. Knowing F , ω_o and θ

$$K = \frac{0.012 \times 0.785 \times 400^2}{0.019} = 7.93 \times 10^4 \frac{\text{oz-in}}{\text{rad}}$$

The error volts are 30 mV/degree or 1.72 volts/rad. The motor torque is 0.08 oz-ins/volts or 0.08×400 oz-ins/volts at the output shaft. Therefore

$$\text{amplifier gain} = \frac{7.93 \times 10^4}{0.08 \times 400 \times 1.72} = 1,440.$$

The amplifier circuit is shown in Fig. 8. It can be seen to consist of two pentode voltage amplifiers driving a power output stage consisting of two valves in parallel. The noise level is 60dB below full output of 10 watts. The interstage coupling components C_1R_1 and C_2R_2 are arranged to introduce a 90° phase shift at the operating frequency (50 c/s). This ensures that the reference phase of the motor can be fed from the mains via a step-down transformer without the need of a phase-shifting network. The relay and rectifier (RL_1, W_1) form part of an arrangement for switching off the h.t. from the p.a. during the tuning operation. It ensures that no h.t. is applied until all three servos are stationary. In practice the servo comes to rest with two overshoots and one undershoot, and the resetting accuracy is greater than anticipated.

Fig. 9 shows a simplified diagram of the remote control sections of the transmitter. Use is made in these of similar solenoid-operated rotary switches, to those employed for waveband selection. Two modes of operation are possible with these switches. In the first, application of the operating volts to a suitable contact on the "homing wafer" causes the switch to "motor" round to the desired position, when the supply is broken and the switch comes to rest. In the second mode, the solenoid is pulsed by suitable current pulses. Both these modes of operation are used in the remote control section.

Assuming the normal switching-on procedure has been carried out, the remote selection of frequency is carried out as follows. Switch motor A at the remote end is made to "motor" to the position (1-10) selected by depressing an appropriate push-

button switch (1-10). In doing so its associated relay contact RL_A keys the line. Relay RL_B , at the transmitter end, is energized by the pulses produced by relay RL_A . Relay RL_B "pulses" switch motor B to the desired position. After a short delay switch motor C is made to "motor" to the same position by means of a wafer on switch motor B and delayed relay contact RL_C . In doing so its associated relay RL_C keys the line again. The pulses are used to energize relay RL_D which "pulses" switch motor D to the appropriate position. The latter part of the operation is merely "signalling back" that the correct position has been selected at the transmitter.

Switch motor B also controls a similar switch, the master selector switch, which controls all the tuning potentiometers' sliders and wavechange switches. This master selector switch can also be controlled locally by means of a switch on the front panel of the transmitter power supply bay. Full local control is thus possible in the event of line failure, etc.

When all the tuning operations have been carried out, after a short delay the h.t. is applied. The p.a. cathode current which flows operates a relay ($RL_{F1,2}$) which reverses the polarity of the 50 volts d.c. on the line. This causes relay RL_E at the remote end to be energized and indicates that the transmitter is operating satisfactorily. All the normal overload protection methods are, of course, also included.

Thermistor Thermometer

FOR medical research the low heat capacity and rapid response of the thermistor, when connected to measure temperature, has obvious advantages, and much interest was shown in a brief description of an American instrument which appeared in our April issue (p. 164).

We understand that a British-made thermistor skin thermometer is in production by Chapman Anderson, Ltd., 7, Oak Hill Park, London, N.W.3. The basic element is the S.T.C. Type F thermistor and the instrument is designed for use with ordinary flashlamp batteries. An industrial version for measuring surface temperatures is also available with a scale calibrated from 0 to 300°C .

LETTERS TO THE EDITOR

The Editor does not necessarily endorse the opinions expressed by his correspondents

“Unconventional F.M. Receiver”

CONGRATULATIONS to Mr. Scroggie (and to *Wireless World*) on again breaking new ground even though the a.f.c. method may call for second thoughts. I don't think Mr. Banks' method (February issue) is the answer either; devices where the error signal itself applies the correction are inherently unstable and tend to oscillate (or “hunt” as the control instrument engineer would word it).

I don't mean that Mr. Banks' device does not work. Merely that the circumstance that it does not hunt is almost certainly fortuitous and consequently is not readily reproduced.

Could it be, therefore, that the real answer to this a.f.c. problem lies with the voltage sensitive capacitors mentioned in the April issue (p. 175) and may we have some more details regarding them?

Hornchurch, Essex.

L. D. STUART.

Unconventional Interference

I REALLY must protest at what M. G. Scroggie refers to as “a less awkward band,” when explaining his choice of a local oscillator frequency in his article on an unconventional f.m. receiver in the June issue.

If my mathematics are correct, this would be the band between 29.33 and 31.33 Mc/s, part of which is in the ten-metre amateur band.

With propagation m.u.f.s on the increase due to the rise in the sunspot cycle, this band provides no less a measure of enjoyment to many hundreds of British amateurs than does v.h.f. to those who have adopted this method of receiving B.B.C. programmes. I suggest Mr. Scroggie might be reminded that tolerable receiver oscillator radiation in the various bands of the radio frequency spectrum have been conventionally agreed by the industry.

The harmful interference radiated by this unconventional receiver (the author admits this with respect to Band I television), arises from a very inferior design which can have no place in the present advanced state of this branch of science.

The distasteful way in which the interference is deliberately removed from a broadcast to a non-broadcast band is no credit to the writer, and *Wireless World* is cheapened by the publication of such material.

London, S.E.25. DAVID DEACON (G3BCM).

The Author Replies :

I AM sorry that the description of my precautions against interference should have been open to such misinterpretation as that put on it by David Deacon. May I therefore call attention to the following points:

(1) I did not admit that the type of receiver I described “radiates harmful interference.”

(2) Even if, as a result of its being designed contrary to my recommendation, it were to do so on Band I, this would not necessarily mean that the design described interferes in the 29.32-31.45 Mc/s band. The vulnerability of Channel I viewers to oscillation in the band 44-47 Mc/s, to which I referred, is far greater than that of amateurs to oscillation between 29.32 and 31.45 Mc/s, in the following respects:

(a) The strength of radiation is likely to be substantially greater. As I pointed out, use of the lower frequency “still further reduces radiation.”

(b) Whereas radiation on any frequency between 44 and 47 Mc/s inevitably comes within the reception band of every Channel I receiver, only about one-sixth of the 29.32-31.45 Mc/s band comes within only about one-fifth of the 10-metre amateur band, and at any given time occupies only one of perhaps 20 telephony channels within that fifth.

(c) The number of Channel I viewers is vastly greater than the amateurs necessarily working within that particular one-fifth of that particular band.

(d) Television receivers, being usually present in the same house, and often only a few feet away on the other side of a party wall, are liable to be affected by a source of radiation that would be inappreciable even a dozen yards away.

(3) No reason has been given for concluding that this “very inferior” unconventional receiver radiates any more than conventional types; in fact, quite the contrary.

(4) An oscillator is not one of the unconventional features of my receiver; it is included in almost every receiver in the world. Millions of receivers, products of “the present advanced state of this branch of science,” have no r.f. stage to separate the frequency changer from the aerial, and their continuously tunable oscillators sweep across the whole of the amateur 7 and 14-Mc/s bands. Why does Mr. Deacon not turn his fire on them? By contrast, my receiver has a r.f. stage, an exceptionally low oscillator frequency for a Band II receiver, and a much higher ratio between the receiving and oscillator frequencies than any conventional type. Moreover its oscillator works only on a few spot frequencies.

On the whole, then, I feel there is no immediate cause for alarm.

M. G. SCROGGIE.

Two-channel Stereophonic Sound Systems

IN reply to the questions raised by P. B. Vanderlyn and Ian Leslie in the July issue the following comments may help to clarify the situation.

First, the statement in the above article that “the reproduced sound image is more accurately positioned if arrival time differences are overruled and the sound image is positioned by intensity differences only” was not meant to apply to the sounds actually at the two ears of the listener. What was meant was that the sounds at the loudspeakers should differ only in intensity level and that for the best stereophonic effect the listener should be seated so that there is no overall time difference between the sounds from the loudspeakers for the hearing mechanism as a whole. The fact that there must be a small time difference between the sounds at the individual ears when the sound image is not in the centre was not meant to be included in this statement. That such a time difference is produced, with unequal intensities at the loudspeakers, is well appreciated. For off-centre listening this criterion obviously no longer holds, but it has been found that fairly satisfactory compensation can be applied, as was shown in the article.

Secondly the theory underlying P. B. Vanderlyn's remarks, although apparently straightforward, does not in practice appear to agree very well with the results obtained experimentally using speech or other sounds of a very irregular nature. This is not altogether surprising since the hearing mechanism is not at all simple in its operation. The fact that only a difference in the sound level at the loudspeakers of between 12 dB and 18 dB is necessary to give the impression of “hard over”

to one side is certainly not confirmed by this theory. Experimental results of other investigators^{1,2} confirm this finding. An alternative theory³, although with limitations, is also in agreement. The figure of 12 dB difference for "hard over" used in obtaining the microphone responses was sufficient to give this sensation for all the subjects tested.

Referring to Ian Leslie's comment about the controversy over loudspeakers, it is agreed that this difference should be settled. The results given in the article agree quite closely with the work of other investigators^{1,2,4} and although the results might be subject to experimental error it is felt that the specified correction is definitely needed. To obtain this correction by using directional loudspeakers, although simple, cannot be said to be perfect; but it does result in very much improved results.

Tone controls are still needed to correct for scale distortion due to different listening levels to the original and to compensate for the acoustics of the listening room. Also, studio engineers are after all only human and it is

nice to be able to correct for differences of opinion between them and oneself.

Ruislip, Middx.

D. M. LEAKEY.

REFERENCES

- ¹ W. B. Snow, *J. Acoust. Soc. Amer.*, Nov. 1954.
- ² V. L. Jordan, *Acustica* Vol. 4, No. 1, 1954.
- ³ J. C. Steinberg and W. B. Snow, *Electrical Engineering*, Jan. 1934.
- ⁴ H. Haas, *Acustica*, Vol. 1, No. 2, 1951.

Three Minutes' Silence

THOUGH not a professional marine radio operator, I have done a good deal of listening on the 500-kc/s channel and so can make an unbiased comment on "Free Grid's" observations (May issue) about alleged non-observance of the three minutes' silence. My experience is that a fairly pronounced silence descends on the channel at 15 and 45 minutes past the hour. In fact, if anyone is looking out for "600-metre Dx," as I still do, these silence periods are very profitable.

AS3.

Wide-Band Linear R.F. Amplifier

For Use in Ships' Communal
Aerial Systems

By B. F. DAVIES,* A.M.I.E.E.

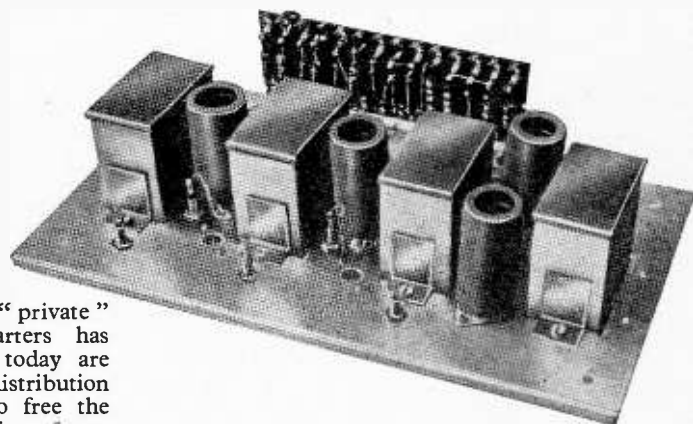

SINCE the last war the need for the "private" broadcast receiver in the crew's quarters has been recognized and many new ships today are planned to be fitted with an aerial distribution system. In many cases this is done to free the ship's superstructure from the multiplicity of unsightly wires that would otherwise appear as more of the crew obtained receivers. In a small ship a multiplicity of "private" aerial wires may constitute a positive danger by altering the calibration of the d.f. loops and in oil tankers there is a fire hazard if sparking occurs in a badly installed aerial when the ship's MCW transmitter is working.

The obvious solution is to install one "official" aerial for broadcast reception and to serve all receiving points through a wide-band r.f. amplifier and coaxial cables.

Basic Requirements.—Considering the aerial first, it will be appreciated that the position, height

and length of the aerial will be largely dictated by the layout of the ship and the position of the transmitting aeriels. Difficulties are greater on the smaller ship and resort has often to be made to a smaller active length of aerial wire. It has not been uncommon with a transmitter of 500 watts and a main aerial length of 200ft to obtain with a receiving aerial of 100ft about 50 volts of r.f. across the 75-Ω coaxial cable termination. From statistics available this high voltage is to be found at transmitting frequencies somewhere in the region of 6 Mc/s. Length of aerial and spacing will modify this resonance considerably. At other frequencies usually less than 1 volt will be induced for the same transmitted power. No amplifier can handle 50 volts of input, and in practice a limit of about 25 volts would be set, adjusting aerial length or position to keep the "resonant" voltage down.

Some means of rejecting the transmitting frequencies has to be adopted and a standard form of filter was used. Assuming the worst case of 25 volts on the aerial coaxial lead-in cable and a minimum filter attenuation of 36 dB, the amplifier must handle 0.4 volt. From Table 1 it will be appreciated that

TABLE 1.

MARINE TRANSMITTING BANDS		
415 —525 kc/s	M.F. Band	
1.6 —3.8 Mc/s	L.F. Band	
4.063—4.238 "	H.F. Band	
6.20 —6.357 "	"	
8.195 —8.476 "	"	
12.33 —12.714 "	"	
16.46 —16.952 "	"	
22.00 —22.400 "	"	

* Formerly with the Marconi International Marine Communication Company Limited.

considerable band filtering would be required. It was decided that the standard amplifier should incorporate two band-stop filters covering the M.F. and I.F. bands only. In regions of dense shipping, transmissions in these two bands from ships close by can give rise to a total r.f. voltage on the aerial of as much as 50 mV. A filter unit for the H.F. bands used by the ship's transmitter would be separate and would be an optional extra. Where H.F. band transmissions are likely to be few in comparison with those in other bands, such a filter unit could be saved by using a remotely controlled relay to disconnect the aerial completely in order to keep high voltages out of the amplifier input during periods of transmissions in the H.F. bands.

To cover all the broadcast bands, the amplifier should possess a sensibly flat frequency response between 150 kc/s and 25 Mc/s. The input impedance to suit the aerial coaxial cable should be 75Ω and the outputs also suitable for feeding into 75Ω coaxial cables. The method of distribution is shown in Fig. 1, from which it is evident that although the loading, and consequent slight mis-match at each outlet point, is quite small a large number of receiver outlets could load the cable and introduce a cabling loss. The input impedance of each receiver differs considerably at any one frequency according to the tuning of the receiver and consequently the summation of all the loading effects is modified. It was decided to cater for up to 20 outlets and that four amplifier outlets would give a good economic compromise. In standardizing on equipment the circuit complexity and reliability have to be weighed against the average demands. In isolated cases, as indicated by present market demands, a ship requiring more than 80 outlets could be covered with two or more amplifiers working in parallel.

The amplification required was fixed at approximately 15 dB. As will be evident later, this again was a compromise between producing voltages at the receiver outlet points identical with that on the aerial terminated with 75Ω and keeping spurious responses within the amplifier to a minimum. In practice the overall gain of the system between aerial and the input terminals of the receiver also takes into account the fact that the aerial fitted for the distribution system will have a greater effective height than the average length of wire that can be slung haphazardly. Thus the equivalence of voltages at aerial and receiver can be disregarded. Emphasis was laid on making available in the cabin a "clean" signal free from machine noise interference, spurious responses, etc.

Effects of Amplifier Non-linearity.—The term a "linear amplifier" is, of course, only relative, but it does imply that in addition to producing an amplifier with a wide-band response attention has also been paid to obtaining the maximum degree of linearity. The wide-band amplifier suffers from the inherent disadvantage that in amplifying many signals simultaneously any non-linearity will produce other signals at the output. A power series can be used to represent the "curvature" and is in the familiar form $ax + bx^2 + cx^2$. This is equivalent to saying that the amplifier is capable of producing, as in audio techniques, the second and third harmonics of a fundamental sine-wave input. The two input signals are represented by $p \sin \alpha$ and $q \sin \beta$, and where one is considered to be

modulated, p becomes $p(1 + m)$ where $m \neq \pm 1$. Analysis shows that the first term can be neglected, but the second term produces the expression $bpq [\cos(\alpha - \beta)t - \cos(\alpha + \beta)t]$. Thus the original carriers α and β have produced spurious carriers $(\alpha - \beta)$ and $(\alpha + \beta)$ both of which are dependent on the product $p q$. This means that modulation of either original carrier will produce modulation of the spurious carriers. This is called inter modulation (I.M.).

The third term produces the expressions $3cp^2q [\sin \beta t - \frac{1}{4}\sin(2d + \beta)t + \frac{1}{4}\sin(2\alpha - \beta)t]$ and $3cpq^2 [\sin \alpha t - \frac{1}{4}\sin(\alpha + 2\beta)t - \frac{1}{4}\sin(\alpha - 2\beta)t]$. The second and third terms in each of the brackets are similar to the I.M. terms discussed above except that the spurious responses are at different frequencies and that the spurious carrier modulation is proportional linearly to one original carrier and to the square of the other. This would mean that for low levels of original modulation the spurious carrier modulation would be double that for modulation of either p^2 or q^2 compared with modulation of p or q . Thus if p carrier is modulated the spurious carrier modulations at $(2\alpha + \beta)$ and $(2\alpha - \beta)$ will be double that at $(\alpha + 2\beta)$ and $(2\beta - \alpha)$. For modulation levels over 50%, severe distortion will be present in the spurious modulation of the first two frequencies. To discriminate between the two forms of inter modulation caused by the b and c coefficients in the power series expression, they will be called first-order intermodulation (1st I.M.) and second-order intermodulation (2nd I.M.) respectively.

The first parts of the third term expressions show that the original frequencies α and β are being produced, but whereas the modulation of carrier α was represented by an amplitude variation of p , this spurious response, at the same frequency, has

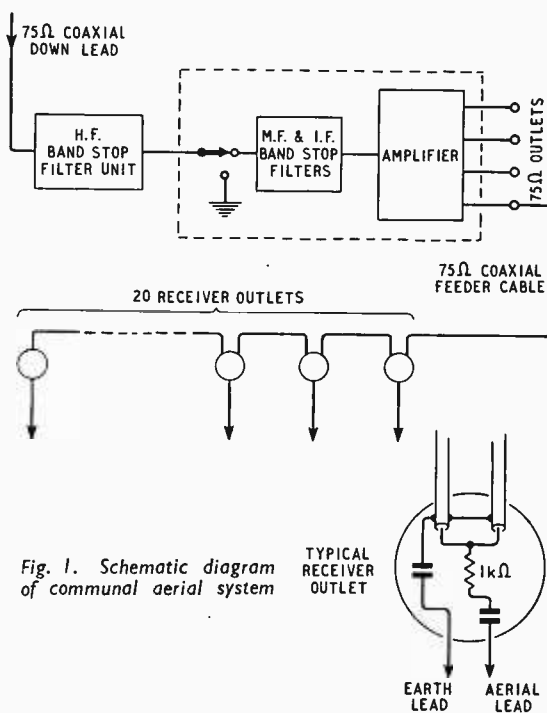

Fig. 1. Schematic diagram of communal aerial system

a modulation proportional to q^2 . Thus the modulation of one carrier has become superimposed on the other. This effect is known as cross-modulation (X.M.). In this instance the unwanted effect will not be measured as the amplitude of an unwanted carrier, but as the amount of background modulation existing on a true carrier having its own modulation.

In order to assess the linearity of an amplifier for this application, a limit on the unwanted responses enumerated above has to be set and a criterion based on the interpretation of test results has to be laid down. These matters will be referred to later.

Calculations have shown that in terms of the ultimate performance criteria laid down for I.M. products, the amplifier linearity is such that at the maximum voltage levels concerned, the 2nd harmonic production would be 0.0025% and for the 3rd harmonic 0.0004%. Although these figures are theoretical, they give some idea of the order of linearity required. Adoption of negative feedback methods would entail a considerable amount of feedback over the amplifier which, coupled with satisfying the Nyquist stability criterion over a very wide band, would be extremely difficult. The use of large valves working over a small portion of their characteristics would be most uneconomic if taken to the stage where linearity could be considered acceptable.

Current Amplification.—The amplifier circuit finally developed is actually one that amplifies the input current although to all intents and purposes it may look like a variation of a voltage amplifier.

The basic amplifier circuit is that of the grounded grid triode, as shown in Fig. 2. The input impedance

at the cathode is $R_c' = \frac{r_a + R_L}{1 + \mu}$. Now if $R_L \ll r_a$,

R_c' becomes $\frac{r_a}{1 + \mu}$ or approximately $1/g_m$ for a

high- μ value. Now if the cathode is fed from a constant-current source ($Z = \infty$) any non-linearity of the $I_g - V_g$ characteristic resulting in a non-linear R_c' , will have no effect and V_o will be truly proportional to the input current. If now the

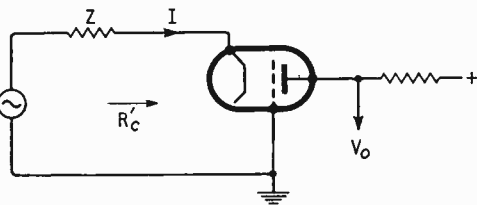
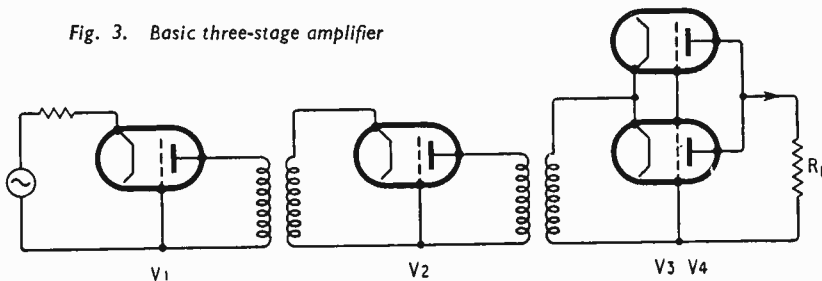

Fig. 2. Triode in the grounded-grid connection

Fig. 3. Basic three-stage amplifier



impedance R_c' is presented to a valve, as in Fig. 3, and the impedance presented to the first triode is low compared with its r_a , then there is a good approximation to a constant-current feed. If V1 were a pentode, the approximation would be very good, but for reasons to be discussed later the pentode must be discounted. Further still, if the impedance in the cathode of V2 is high, the effective output impedance of V2 will become $r_a + (1 + \mu)R_c$, where R_c is the impedance in the cathode. If, say, for V2 the anode load to V1 is $r_a/10$, then the output

impedance of V2 becomes $r_a + (1 + \mu) \frac{10r_a}{(1 + \mu)} = 11r_a$

The effect of R_c in V1 and the anode load in V2 is neglected for simplification. It should be noted that as the cathode and anode currents are one and the same thing in each valve, the amplification, as such, takes place in each transformer which serves to step up the current between valves. The amplification being substantially independent of the valve parameters, stability of h.t. and heater volts is unimportant; nor is the amount of h.t. ripple voltage, within reason, of any great importance. In the final circuit (Fig. 4) it was decided to use a push-pull arrangement because (a) greater linearity would be expected, (b) the circuit would be inherently more free from extraneous noise pick-up (i.e. mains borne interference), (c) it could provide means of adjusting the "balance" of the circuit and thus permit of some correction of dissimilar valves, and (d) the impedance presented to a previous stage would be held more constant.

As already mentioned, the pentode would appear to offer a very good approximation to a constant current source and might successfully be used as a grounded-grid amplifier in preference to the triode. Used in that manner the cathode current would be the sum of the screen and anode currents and any input current would be divided between screen and anode. In addition to reducing the current gain in the circuit (the screen circuit acting as a partial current bypass) the output current at the anode would no longer be truly proportional to the input current. Inspection of valve characteristic curves shows that the ratio of anode current to screen current is not constant for variations of grid-to-cathode potential and non-linearity would obviously be present.

Linearization Factor.—This term has been introduced as a way of expressing the capability of the circuit in reducing non-linearity of the valves. In Fig. 2, a generator of internal impedance Z is used to feed a current into the non-linear impedance R_c' . The greater Z compared with R_c' , the smaller the effect of variation in R_c' will be on the relationship between I and E .

The linearization factor is

defined as $\frac{Z + R_c'}{R_c'}$ and if

$Z = 9 R_c'$ we can expect harmonic distortion products to be reduced by 10.

Circuit Considerations.—From the point of view of economy, the four 75- Ω outputs were arranged to be fed from one output stage. Only one output

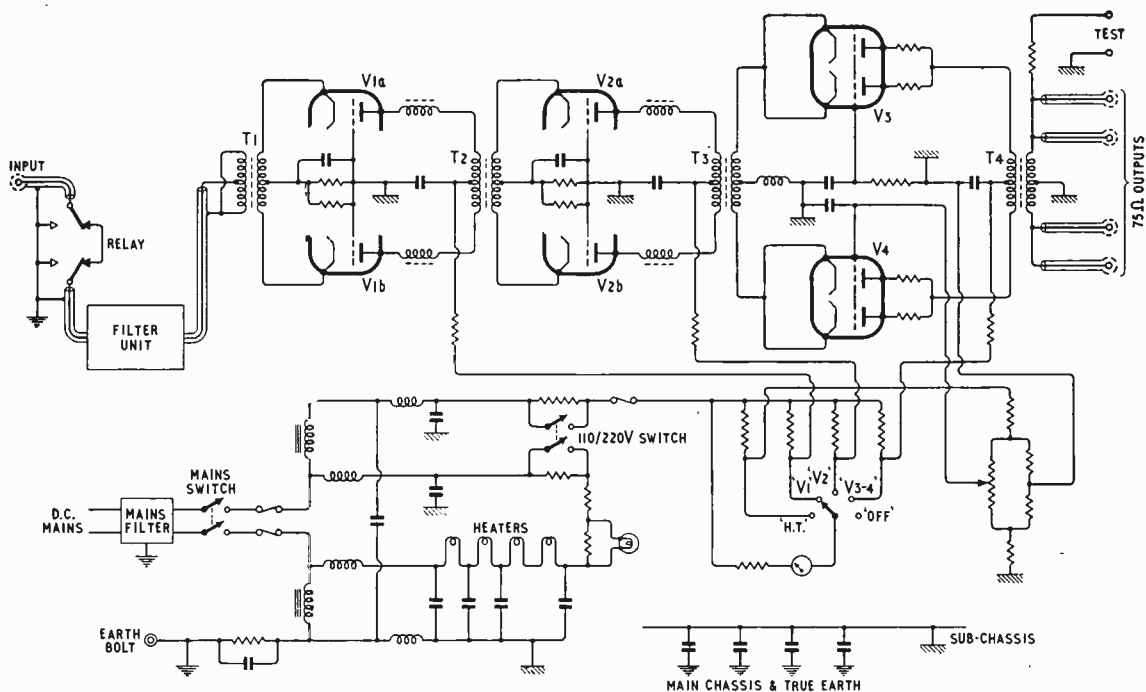

Fig. 4. Complete circuit diagram of final design

transformer was therefore required, but to obtain sufficient power gain in the last stage, a parallel push-pull arrangement of valves was adopted. Actually this meant a lower effective load impedance on the secondary of T3 and consequently a higher current amplification in the transformer could be obtained. This practice of paralleling valves to obtain greater current amplification by the preceding transformer cannot be carried out indefinitely owing to other limitations due to circuit capacities. The use of PCC84 valves enabled the whole amplifier to be constructed using four valves, which permitted the chassis to be packed in a very small space.

The success of the amplifier largely depended on the r.f. transformers which should have (a) good frequency response, (b) an effective high shunt loss impedance, and (c) an effective from non-linear hysteresis losses. An obvious choice of core material was Ferroxcube which proved to be very satisfactory. Shunt capacities across transformer primaries will serve as a current bypass at the anode of each valve with the result that at high frequencies the amplifier gain will be reduced. This effect sets an upper limit to the reflected primary impedances and, consequently, the turns ratio. From this basic consideration the gain per stage can be derived for the type of valve in question, and finally, the overall gain of the amplifier, which was calculated to be 15.2 dB.

It will be realized that shunt losses on the transformers will serve to bypass some of the current fed from the preceding valve with the result that the "constancy" of the current feed is impaired and the linearization factor will suffer. Alternatively, the impedance feeding the following valve is lowered. It is interesting to note that the linearization factor for the output stage, calculated for the valves alone, was 72.5. The transformers do not permit this figure to be fully realized in practice, but it indicates the measure of linearization that takes place.

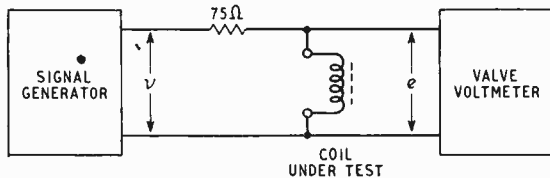

Fig. 5. Test circuit for effective shunt loss impedance

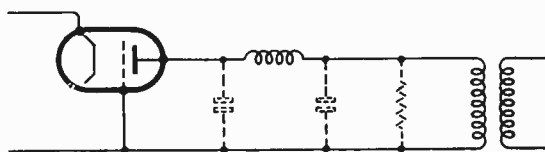

Fig. 6. Use of inductance to improve the gain at high frequencies

To assess the effective shunt loss impedance caused by core losses, a test circuit as shown in Fig. 5 was set up. Tests on various core and windings were carried out by measuring the change of voltage across the test terminals when the coil was connected in parallel. Shunt losses are of no particular consequence in T1 and T4 as they do not reduce the linearization factor by bypassing current fed into the cathode of a following amplifier. The shunt losses were found to be remarkably constant up to 30 Mc/s. In order to reduce the effects of winding capacities, which would be in parallel with the shunt losses, no secondary was coupled to the test winding.

When winding the transformers, care was taken to ensure a high coupling coefficient. Frequency response tests showed that up to 25 Mc/s, under

conditions that were not as favourable as those in the valve circuit, the responses were within ± 1 dB of the 1 Mc/s response.

As already mentioned, shunt capacities will cause loss of gain at high frequencies and to mitigate this compensating coils were introduced in the second stage. Fig. 6 shows the circuit capacities between which a coil of a few microhenries can give a useful "lift" up to 25 Mc/s.

The balance control in the grids of the output valves provides a differential bias voltage of ± 0.2 volt which was found adequate to deal with all normal dissimilarities between valves.

Amplifier Details

It was found on test that the signal-handling capacity of the amplifier was improved by introducing a high impedance into the common cathode connection. This results in the two cathode input impedances on each side of the circuit being in series instead of effectively in parallel. To explain the beneficial action of the choke, consider Fig. 7(a) in which a transformer is shown with series loss resistances across which must be developed a voltage proportional to the input current of the valve. Any non-linearity of R_c' will produce harmonic voltage components e_1 and e_2 across r_1 and r_2 . From the point of view of even harmonics, if the valves were identical e_1 would cancel e_2 , but with dissimilar valves a difference voltage would exist. Now with the secondary centre tap earthed, a difference voltage ($e_1 - e_2$) acting in one cathode will

effectively be applied between the cathodes (Fig. 7(b)), and will cause a current to circulate round the push-pull circuit. With a high impedance to earth from the centre tap, the resistances can be considered as being in series with the constant-current source on the primary side and will have no effect other than to cause half the difference voltage ($e_1 - e_2$) to appear across the choke. Although conclusive proof of this explanation, as to the advantageous effect of the choke, has yet to be established, the practice appears to be sound. The introduction of 10Ω into one cathode, for instance, was found to reduce considerably the signal handling capacity where 2nd harmonic distortion products were concerned.

The meter circuit enables the valve currents and the h.t. to be monitored, while various dropper resistances serve to reduce the voltages when working on 220 volt d.c. mains. The total consumption from the mains on 220 volts was 82 VA.

The amplifier was constructed as a small sub-chassis and mounted at the four corners by four v.h.f. type, bush-mounted, mica condensers. The amount of chassis work at d.c. mains potential was considerably reduced, while at the same time a satisfactory r.f. bypass to the main chassis at true earth potential was ensured. In addition to the r.f. chokes, a standard all-wave mains filter was incorporated to reduce the likelihood of mains-borne interference reaching the amplifier. The sub-chassis, measured overall, was $10\frac{1}{2}$ in. long, 6 in wide and 4 in deep. The greater part of the main chassis and space within the case was taken up with components associated with supply circuit and filtering arrangements.

The r.f. double band-stop filter circuit in Fig. 8 is conventional, each half consisting of a full constant- k section bounded by two half m -derived sections, having $m = 0.6$. Each band-stop filter has nine coils, a number which it was not possible to reduce, owing to the necessity of having to maintain a certain minimum attenuation between the resonant peaks. By judiciously laying out the filter to reduce magnetic coupling between the dust-iron cores to negligible proportions the filter was constructed within a box measuring 10 in \times 4 in \times 2 in high.

(To be concluded.)

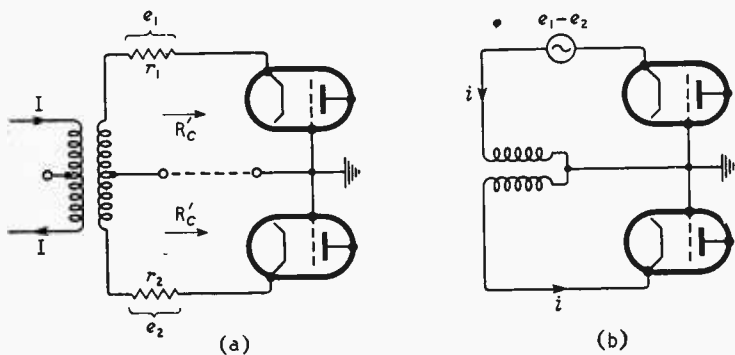
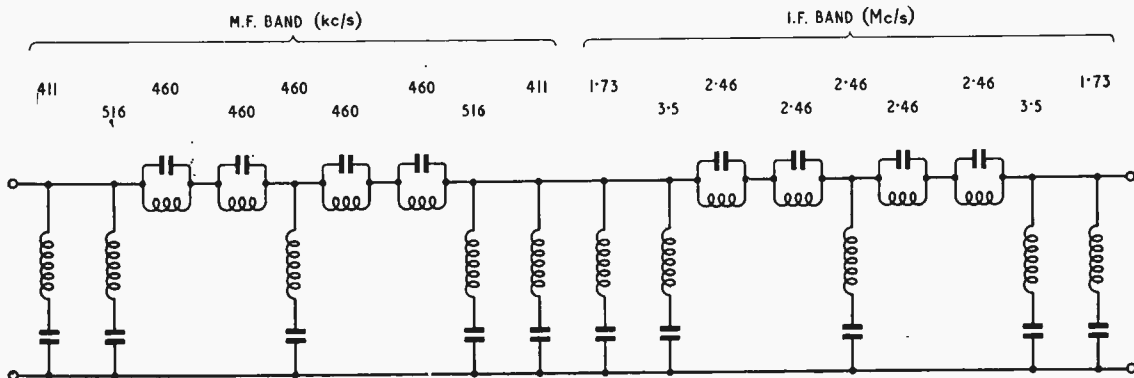

Fig. 7. Explaining the action of the cathode choke

Fig. 8. Outline of double band-stop filter

RESONANT FREQUENCIES



Broadcasting in the U.S.S.R.

FROM A CORRESPONDENT

IN the Soviet Union, broadcasting is primarily the responsibility of the Ministry of Culture. This is the programme body; its transmitting equipment and engineering staff is provided by the Ministry of Communications for which, in turn, much of the technical development work is done by the Ministry of Radio Engineering.

The internal sound service radiates three programmes. The first is of mixed material, rather like our Home Service; the second is essentially artistic, with music and literature mixed, while the third is all music, with no talks. Some 85-90% of all material radiated is from recordings, so studios are provided accordingly; in this respect there is a marked difference between Russian and British practice. Ribbon, moving-coil and condenser microphones are used, depending on the nature of the programme material being recorded or broadcast.

Another difference is to be found in the choice of wavelengths for the internal sound services. Due to the vast distances to be covered, extensive use is made of short waves. Long waves are used for intermediate ranges, while medium-wave transmitters cover the main cities and the areas surrounding them.

A typical medium-wave transmitter is rated at 100 kW, and feeds a mast radiator slightly over 500 ft in height. High-level Class B anode modulation is employed with 20 dB negative feedback. A long-term frequency stability of ± 3 c/s is claimed; harmonic distortion at 95% modulation is given as 2%. Overall efficiency is 35%.

The short-wave transmitting centre, about 40 kilometres from Moscow, is something quite exceptional, combining as it does more or less the functions of our own Daventry and Rugby stations rolled into one. There are at present eight high-power broadcasting transmitters (80-120 kW) and twenty-five medium-power transmitters (15-50 kW) for telegraph and telephone traffic. The site, which covers 2,000 acres, provides space for 36 aerial arrays for broadcasting and about 60 rhombic aerials mainly for telegraphy and telephony, though some are used for broadcasting. The transmitter buildings, together with the houses and flats for the staff, make up something more like a town than a radio station. Shops, a school and a bank are all on the site.

A typical high-power short-wave transmitter has five r.f. stages, all being push-pull except the first. The last two stages use water-cooled valves, only the final being earthed-grid. The modulator, working in Class B, has four stages of amplification, with water cooling in the last two. Transmitter-to-aerial switching is largely remotely controlled, though there is still a certain amount of manual switching.

Energetic steps are being taken in the U.S.S.R. to build up a frequency-modulated v.h.f. service, though few transmitters are as yet in operation. The incorporation of sound broadcasting channels in television receivers is being encouraged: the transmission characteristics for both services are identical. V.H.F. broadcasting is being introduced because of congestion on other bands and to allow regional areas to be served with signals of better quality.

Generally speaking, v.h.f. stations are of rather lower power than those operated by the B.B.C. Most are of 5 kW, with aerial gains of between 5 and 10. These stations are said to give good reception up to 60 km and tolerable signals up to 120 km, depending on the terrain. The transmitters work on frequencies just above our Band I; frequency spacing between transmitters on the same site is 2.25 Mc/s. Contrary to the practice in this

SOME DETAILS

OF THE

SOUND AND VISION SERVICES

country, v.h.f. sound broadcasting aerials are not mounted on the television masts: this is thought likely to give trouble from interaction between the two transmissions.

For feeding all these stations there is an extensive network of high-quality landlines between Moscow and the various main cities of the Soviet Union. Screened pairs are generally used for distances up to 4,000 km, but plans are being made to change over to the use of two or three channels of the co-axial or screened pair carrier systems. To lighten the load on the lines, tape recordings are often sent to distant cities.

As already stated, recordings are more widely used than here. Magnetic tape is almost universal; the advantage offered by discs for taking rapid excerpts is considered unimportant and the quality obtainable from tapes has been a deciding factor. All the Soviet recording and reproducing equipment now follows the C.C.I.R. standards.

Three types of tape recorder are used: studio, two-channel mobile and midget portable. The studio machines run at either 15 or 30 inches per second, the slower speed being generally used. The mobile equipment, installed in a 30-cwt van which serves as a small studio, runs at 15 in/sec. Midget recorders (7½ in/sec) are now being manufactured in large numbers for use in news reporting or on-the-spot commentaries.

In studio work it is usual to record the master tape with a dynamic range of the order of 56 dB and the producer has seldom to adjust his volume control. This wide-range master tape is then used to make a tape for broadcasting, "dubbed" down to the required 22 dB dynamic range. The Soviet librarians have not encountered any difficulties over deterioration of master tapes, which are stored at a temperature of 15°C and a humidity of 50-60%.

Wired distribution plays an important part in Soviet broadcasting in the big cities. Out of a total of 35 million sound licences, some 25 million are "on the relay" though a number of these use radio reception as well.

The type of receiver to be supplied to the public is decided mainly by the Ministry of Communications after discussion with the Ministry of Radio Engineering. Roughly speaking, sets cost the same as in England, but without the purchase tax. Transistors are not in general use for domestic purposes, but it is considered important that their application should be developed rapidly, as many listeners still have no mains supplies.

Television in the Soviet Union began to develop rapidly only during the last year or two. At present there are 15 "centres"; this number will be increased to 75 during the next five-year plan, ending in 1961. A television centre comprises a transmitter and a source of programmes—studios, film scanners, O.B. units, etc., depending in extent and number on the importance of the centre.

In the principal cities the hours of transmission are from 7 p.m. to 11 p.m. every day, except Thursdays, when the stations close down for maintenance work. Extra transmissions are radiated during public holidays and broadcasts of topical events are made at various times outside the normal programme hours.

The system corresponds very closely on the video side to the C.C.I.R. 625-line standards.* Stations operate on the frequencies set out in the accompanying table. Radiation is horizontally polarized. The sound transmission is frequency modulated with a deviation of 75 kc/s.

Channel	Band Limits (Mc/s)	Vision Carrier Frequency (Mc/s)	Sound Carrier Frequency (Mc/s)
1	48.5-56.5	49.75	56.25
2	58 -66	59.25	65.75
†	66 -73	—	—
3	76 -84	77.25	83.75
4	84 -92	85.25	91.75
5	92 -100	93.25	99.75

†V.H.F. sound broadcasting

The main Moscow transmitter (there is also a low-power experimental station) has a peak power of 15 kW and an aerial gain of the order of 3. Allowing for feeder losses this means that the e.r.p. is about 40 kW. The accompanying sound transmitter is stated also to have a power of 15 kW. High-power modulation is used in the vision transmitter and all the high-powered valves are water cooled in both vision and sound transmitters.

Television transmitting aeriels are of the bat-wing type with three such aeriels stacked one above the other. These aeriels are carried by self-supporting towers of about 500 ft in height. The most-recently built mast (at Kiev) is of unconventional design, being made up of tubular members which provide an economical, effective and very good-looking structure.

At a range of 70 miles these main stations are said to provide a field strength of the order of 200 μ V/m

which produces a satisfactory picture on the ordinary Soviet receiver when used with a receiving aerial having one reflector and one director. But a field strength of 500 μ V/m is considered necessary for a first-class picture when using such a three-element receiving aerial. Much of the land around Moscow is almost flat so the transmitter has a not-too-difficult job in putting down a satisfactory signal at the edge of the service area.

In the 1,500-sq ft studio of the Moscow television centre 5 cameras are installed, all with image iconoscope tubes. Electronic viewfinders with 5-in tubes are in general use in the Soviet equipment. The film scanners at Moscow are 35-mm machines, optically multiplexed on two iconoscope-type cameras. Each machine has its own associated optical sound head. Two transparency scanners, each with its own iconoscope camera, are used for producing test cards and captions. This equipment is shortly to be replaced by new gear using image iconoscopes.

In the Soviet image iconoscope the cylindrical part of the envelope containing the mosaic is about 5 in in diameter. The mosaic is about 3 in \times 2½ in and the photo-cathode is 1¼ in in diameter. It has a short scanning gun with an external neck diameter a little less than 1 in; overall length of the tube is about 9 in.

In Moscow there are two outside broadcast units of Soviet manufacture. Each of these consists of two vehicles adapted from standard omnibuses. In one vehicle is housed the camera control unit producer's desk and switching system, picture monitors and power supplies. The other vehicle contains the sound equipment only, the rest of the space being available for carrying cameras, radio link equipment and cables, etc. The O.B. cameras employ image orthicon tubes of Soviet manufacture. The camera itself is compact, measuring, with viewfinder, 12 \times 12 \times 20 in. Weight, without lenses, is about 100 lb.

The latest type of radio link used for O.B. work operates on 300 Mc/s and employs frequency modulation. A klystron in the output stage delivers 100 mW with a frequency deviation of 1.5 Mc/s to a dish aerial of about 5-ft diameter. This equipment is stated to give a useful range of about 13 miles. The sound channel works on the same carrier frequency, but the aerial polarization is at right angles to that of the vision aerial.

With the exception of a temporary co-axial cable between Moscow and Kalinin (140 km), there is at present no system for linking together the various stations. Some 6,000 miles of two-way link, partly radio and partly cable, is due to be provided during the course of the present five-year plan.

Television receivers on sale in the shops employ 7-in, 14-in and 17-in tubes. It is stated the 7-in set is no longer in production, but at present the majority of sets have that size of tube. The prices of the sets in Moscow are, respectively, 1,275, 1,900 and 2,300 roubles. To give a basis for comparison with our own receiver costs, it may be said that a skilled workman earns about 2,000 roubles a month, while the basic worker's wage is 800 to 1,000 roubles.

Most observers agree the Soviet receivers provide a most excellent interlace, but, judging by brightness and contrast of the picture, the tubes are not aluminized or else the e.h.t. is rather low. The general policy on future television receiver design at present seems to provide for the inclusion of three v.h.f. sound channels.

* Details are given in the Appendix.

Domestic receiving aerials are very much as in Britain, except for the difference in polarization. Near the transmitters simple dipoles are used, and as one goes farther towards the limits of the service areas the aerials become more complex.

For domestic power supply the Soviet Union has adopted 220 volts, 50 c/s. But at present there are large areas, including most of Moscow, on 127 volts. For this reason it is not possible to standardize television receivers with series-connected valve heaters. This has, in turn, had some influence on valve design. Most of the valves used in domestic receivers are octals based on the American types. A series of miniature valves based on the Philips "E" series is also in production. Germanium diodes are to be used for rectifying anode supplies in the new television and sound receivers becoming available to the public later this year.

The number of television receivers in use in the Moscow area is given as 600,000 to 700,000; in Leningrad 100,000 and in Kiev about 70,000. It is expected that by the end of the five-year plan there will be a total of 40 million. The annual licence fee for a television receiver is 120 roubles, for a sound broadcast set 36 roubles and for connection to the wired relay system 60 roubles (which does not include the loudspeaker).

Transmissions from film and outside broadcasts take up more of the Soviet television programme time than here; more than half of the time seems to be occupied by films. That explains why the studio space is relatively small.

So far as colour television is concerned, the experimental frame sequential system has been abandoned

and development work has begun on a 625-line simultaneous colour system. Experimental transmissions are expected to begin in about two years' time; a regular service might start within the period of the present five-year plan. It is thought possible that, unless the C.C.I.R. come to a quick decision on a standardized colour system for Europe, the Soviet Union might well work on independent lines, introducing the system thought best for their needs. Transmissions would probably be on frequencies corresponding to our Band III.

Television is being given high priority in the next five-year plan, with the emphasis on getting a service into the homes of the people without too many technical "frills." There can be no doubt that Soviet research workers, development engineers, manufacturers and technicians will be able to produce and operate the gear needed to fulfil the plan.

APPENDIX

Soviet Television Standards

THE width of the line synchronizing pulse is 8% of the total line time (approximately 65 microseconds); the front porch is 2% and the total line blanking period $12\frac{1}{2}$ % of the line time. The frame synchronizing signal consists of five equalizing pulses followed by five broad pulses, which in turn are followed by fifteen equalizing pulses giving a total frame blanking of $12\frac{1}{2}$ lines (the exact number of these pulses cannot be guaranteed). The transmitted picture/sync ratio is 75:25, the picture modulation being negative going. The radio-frequency bandwidth is 8 Mc/s. The spacing between sound and vision carriers is 6.5 Mc/s, giving a video bandwidth of approximately 6 Mc/s.

Battery-driven Record Player

IT is estimated that 1,500 sides of 7-in, 45-r.p.m. records can be played at a cost of 2s 4d for four standard U2 cells on the "Transistor" record player recently introduced by Philco. A pull-pull output is provided in the three-stage transistor amplifier which is built by the printed circuit technique, and the motor-driven turntable and pickup is of Garrard design and manufacture. The motor switch is incorporated in the pickup arm and is operated when the arm is moved to and from its rest position.

Storage space is provided for up to 16 records in their covers or 24 without covers. There are three controls; namely, volume, motor voltage compensation and circuit function, the last with the following four choices.

A. Normal record reproduction, either from the built-in pickup and turntable or, through sockets at the rear, from an external pickup and turntable for, say, existing 78 r.p.m. records.

B. Morse practice oscillator, with key connected to the sockets.

C. With a microphone "speech unit" connected to the input sockets the amplifier and loudspeaker can be used as a "baby alarm."

Under quiescent conditions the standby current is only of the order of 5 mA.

D. The internal loudspeaker acts as a microphone and the "speech unit" is used as an extension loudspeaker for an "intercomm." system. By returning the switch to position C for the reply, a two-way conversation is possible.

The price of the Philco "Transistor" excluding batteries and accessories is £26 5s, inclusive of purchase tax.

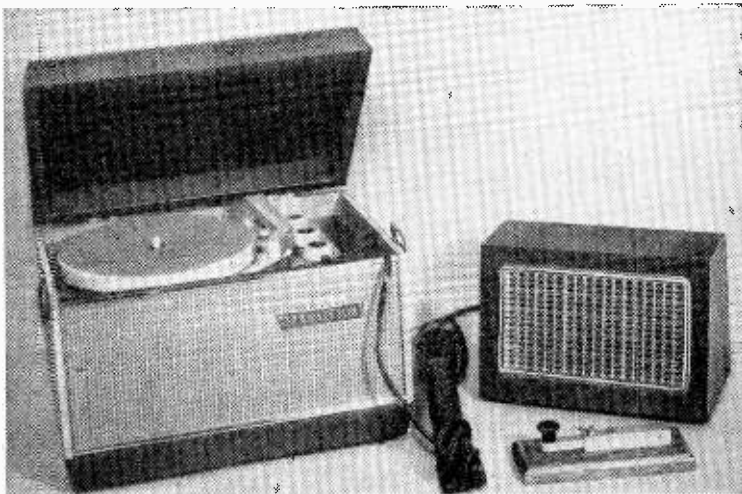

Philco "Transistor" combined battery portable gramophone, Morse practice set and "intercomm." system.

Electronic Machine-Tool Control

SYSTEMS NOW FINDING THEIR WAY INTO INDUSTRY

WHAT is generally meant by electronic machine-tool control is the control of operations such as drilling, turning or milling by numerical information supplied by magnetic or paper tape, punched cards, or hand settings on control knobs. In this respect it is distinct from copying methods in which the machining information comes from jigs or templates taking the actual form of the work to be reproduced (although it must be admitted that many copying systems do, in fact, employ electronics).

The main purpose of this numerical control, like many other such techniques in the field of "automation," is to save expensive man-hours of human labour. But it is applicable only when small quantities of parts are to be machined. In large-scale production it is worth while making expensive jigs and templates because their cost is shared out between a great number of parts reproduced by semi-skilled labour and adds very little to the cost of each one of them. With small-quantity production, however, the use of jigs becomes uneconomic, especially if precision work is being done. The other alternative, of using a skilled machinist to turn out the small number of parts individually, is also expensive and time consuming.

Numerical control, on the other hand, requires neither jigs nor skilled craftsmen. It certainly involves an extra process—that of translating the

Fig. 2. B.T.-H. position control system used on a Kearns horizontal boring machine.

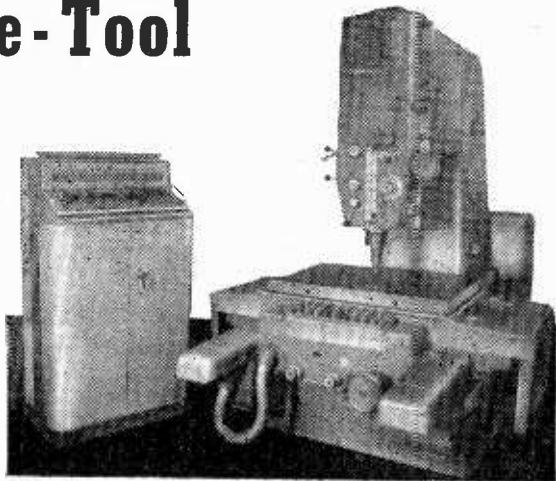
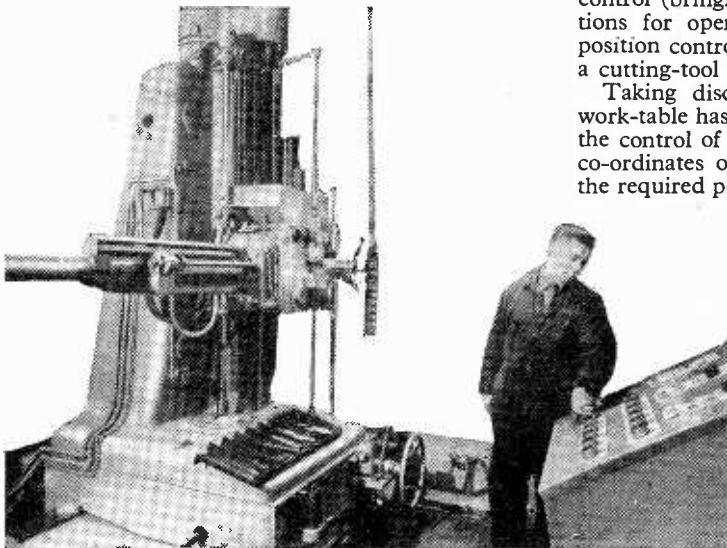

Fig. 1. Electronic positioning equipment by Mullard applied to a Coventry Gauge and Tool jig boring machine. The row of signal lights are situated at the top of the control console.

spatial information from the drawing-board into numerical control signals—but the time taken for this is quite short compared with the slow, head-scratching progress inseparable from careful craftsmanship. And once the translation is done the electronic control system will carry the job straight through with the maximum speed at which the machine tool is capable of operating.

Positioning Methods

Most of the control systems in use have already been described in *Wireless World* but on the occasion of the recent International Machine Tool Exhibition it was possible to see all of them together, in their latest stages of development, and to get an impression of how they are actually being applied in the machine-tool industry. Several methods of control were to be seen in operation and these could be divided into two distinct groups: discrete position control (bringing the work to a series of fixed positions for operations like drilling), and continuous position control (moving the work continuously past a cutting-tool for processes like milling).

Taking discrete position control first, here the work-table has to be moved in two dimensions under the control of numerical information on the x and y co-ordinates of, say, the hole to be drilled. When the required point is under the drilling bit the work-table stops. In most systems this is done by a form of servo-mechanism. For each co-ordinate, the distance to be moved by the work-table is set up manually in digital form on a series of control knobs which produce an error signal, either in electrical or mechanical form. The appropriate lead-screw of the work-table is driven by an electric motor and at the same time the distance moved is measured by an electro-mechanical or electro-optical device. This device

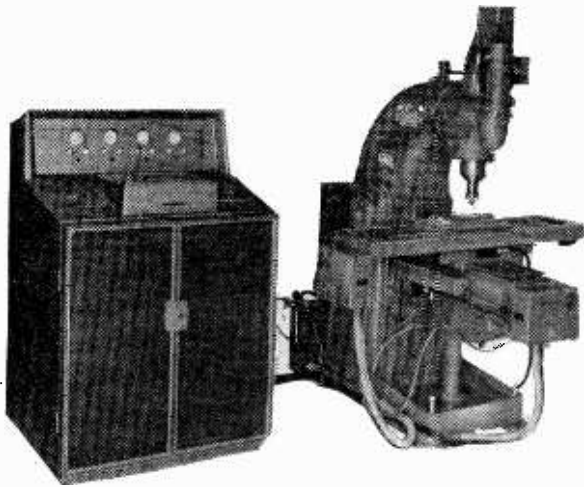

Fig. 3. Ferranti equipment for controlling a Kearney and Trecker milling machine. The magnetic tape is "played back" in a compartment on the top of the control console.

generates a corresponding signal which is arranged to cancel the original error signal. When the cancellation is complete—that is, when the work-table has moved the distance specified by the error signal—the driving motor is stopped.

For example, in the Ferranti system (displayed on their own stand at the exhibition) the required dimension, or error signal, is established by the initial positions of the glow discharges in a series of Dekatron tubes forming an electronic counter. The work-table movement is measured by an electro-optical interference-pattern system which produces a pulse for each ten-thousandth of an inch of displacement, and these pulses cancel the number set up on the Dekatrons by causing the initial glow discharges to move backwards step by step to zero. The system has been described fully in our January, 1955, issue.

Another system using an electronic counter and an electro-optical displacement measuring device has been developed by Mullarć and was shown at the exhibition controlling a jig boring machine on the stand of the Coventry Gauge & Tool Company (see Fig. 1). Here, however, the equipment has not yet reached the stage of fully automatic positioning. When the error signal is reduced to zero a lamp lights up and an operator has to press a button to stop the work-table drive. The optical measuring system (also described in the January, 1955, issue) makes use of a scale of alternate opaque and transparent bars, an image of which emerges from behind a vertical edge as the work-table moves. The number of bars revealed (representing displacement) is then counted by means of a flying-line scanner and photocell arrangement.

The required dimension for each ordinate is set up by a series of 10-position dials on an electronic counter (of the four-stage binary type, with feedback). Pulses from the photocell are fed to the counter which, at the end of each scan of the flying line, registers the difference between the number set up on the dials and the actual distance (in ten-thousandths of an inch) which the work-table has moved. The output from the counter then passes through a matrix circuit to a series of cold-cathode

trigger tubes which are used to switch on indicating lamps.

The purpose of the matrix circuit is to break down the difference or error numbers into groups. Thus, if the error is 100 ten-thousandths or more one of the lamps lights. If between 50 and 99 units the adjacent lamp lights, and so on in steps of decreasing size, until, as the correct setting is approached, indication is given in steps of one ten-thousandth. The error is in fact displayed on a row of 17 lamps, with the centre one for zero and the end ones for an error of 100 or more ten-thousandths in either direction.

In the B.T.-H. system of discrete position control (shown operating on boring machines by H. W. Kearns and Company, see Fig. 2, and The Newall Engineering Company) a magnetic system is used for the distance measurement on the work-table. For each direction of motion the scale consists of a bar of magnetic material (fixed to the work-table) with a series of holes bored at exactly one-inch centres and filled with non-magnetic material. As the work-table moves this bar varies the flux in a differential pick-up head mounted (but movable) on the fixed part of the machine. The coils of the head are connected to an electronic circuit which detects the difference of flux in the two magnetic paths, and this difference is amplified and used to control the servo motor driving the lead-screw so that the difference is reduced to zero. As a result the measuring bar becomes automatically positioned with one of its filled holes in exact alignment with the pick-up head.

Two-stage Positioning

It is, in fact, the initial placing of the pick-up head relative to the bar which provides the error signal on which the system partly depends. The required dimension is actually set up manually on six dials as a row of digits, for example 11.3054. The four dials corresponding to the "decimal" portion of the dimension operate a system of synchros and a servomechanism which positions the pick-up head in accordance with that part of the dimension. The two dials displaying the "integer" portion of the dimension, however, operate another synchro system which controls the lead-screw drive until the work-table is within $\frac{1}{4}$ in of its correct position. Control of the drive is then transferred to the differential pick-up head, which operates as described above. Positioning is completed when the poles of the pick-up head are symmetrically placed relative to the nearest hole in the scale bar.

Incidentally, the initial setting-up of dimensions on this B.T.-H. equipment can also be done from information on punched cards. A mechanical card-reading device senses the positions of the holes in the cards and automatically positions the setting dials by means of a clutch and detent mechanism. The two sets of co-ordinates are fed in simultaneously.

While the accuracy of the measuring devices used in all the above systems is as high as 0.0001 inch, the overall accuracy of the positioning depends on a number of factors and may be somewhat less. In all cases, however, it is appreciably better than half a thou' which is quite sufficient for most engineering purposes.

Compared with discrete position control the con-



Fig. 4. The digital computer used with the Ferranti system. The input paper tape can be seen on the left and the magnetic tape recording the output signals on the right.

tinuous position control systems are a great deal more complicated. Here the general principle for, say, milling a piece of metal to a certain contour is that the numerical input information provides sets of co-ordinates of marker points defining the contour while a computer interpolates the points between in suitable curves.

In the Ferranti system (demonstrated on their stand, see Fig. 3) the information taken from the original drawing consists of co-ordinates of points of change on the contour and specifications of the types of curves between them. With a semi-circular part of the contour, for example, it is necessary to have the co-ordinates of the points where the semi-circle begins and ends and the co-ordinates of its centre point. This kind of information is put on to a planning sheet, then punched into a paper tape in the form of a code pattern of holes.

The punched tape is fed into a digital computer (see Fig. 4) and the information is "read" group by group by the machine, which has circuits for "recognizing" the dimensions and the instructions for particular curves as they appear. The output of the computer consists of two sets of pulses recorded on magnetic tape which constitute command signals to the two lead-screw drives of the machine tool. These pulses specify completely the contour to be cut in terms of increments of distance in two directions from a given reference point. Each pulse represents a work-table movement of 0.0001 inch and the density of the x-direction pulses relative to the y-direction pulses is indicative of the type of curve which is being traced.

Overall Accuracy

The completed magnetic tape carrying the command pulses is then played back into the electronic control mechanism of the milling machine. The method of control (described in our January, 1955, issue) involves a servomechanism in which the work-table driving motor is stopped every time a pulse from the interference-pattern displacement-measuring device cancels a command pulse from the magnetic tape. In this way the train of pulses from measuring device is locked to the command pulse

train to an accuracy of one pulse. Actually an overall accuracy of 0.0002 inch is claimed for the equipment.

The E.M.I. system for continuous position control (see Fig. 5) is somewhat simpler and does not include the intermediate stage of passing the numerical information through a computer. The sets of co-ordinates define marker points at regular intervals of $\frac{1}{8}$ inch round the contour to be cut, and these measurements are punched into a paper tape (in code form) which is used to control the machine tool directly. When the tape is "read" the co-ordinates of a few successive marker points are held in a temporary storage system, and since the tape movement

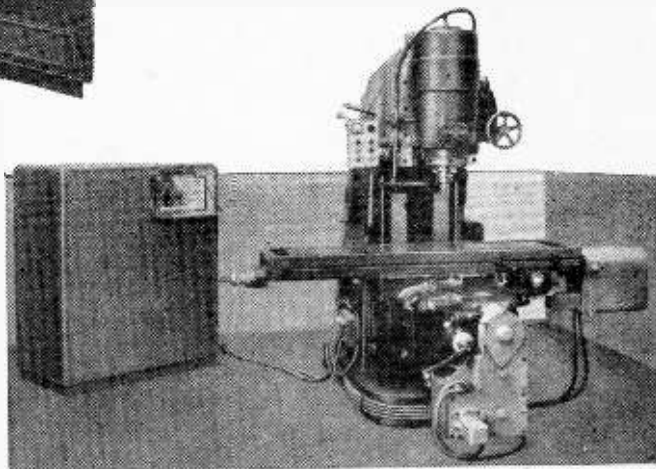

Fig. 5. E.M.I. control equipment used in conjunction with a Cincinatti milling machine. A built-in analogue computer performs the interpolation between the input marker points.

is controlled by the cutting speed of the machine tool the information held always refers to points on either side of the cutting point. The dimensions from the store are then applied to a simple analogue circuit which derives interpolation points lying on a smooth parabolic curve between the marker points. The complete information—marker and interpolation points—is then used to control the servo-mechanisms (using displacement-measuring devices) which position the slides of the work-table.

In this system the accuracy of the information from the control equipment is better than 0.001 inch. At the exhibition the equipment was shown controlling milling machines on the stands of Cincinatti Milling Machines and H. W. Kearns and Company, but because the displacement-measuring devices here were operating from the lead-screws and not directly from the slides of the work-tables the overall accuracy of positioning was probably somewhat worse than this 0.001 inch.

The general impression gained from the exhibition was that although electronically controlled machine tools have aroused a great deal of interest by their novelty, they are not taking on like wildfire and creating a revolution in the industry. There are several possible reasons for this—the limited application of such equipments, their present high cost, practical problems still to be overcome, prejudice against electronics and innate conservatism. In these conditions one must expect the initial progress to be rather slow.

More Effective Speech

Peak Clipping to Increase Average Modulation

By O. J. RUSSELL, B.Sc., A.Inst.P.

THE "communication effectiveness" of speech transmitters is often enhanced by some form of clipping or limiting device. This is frequently employed in amateur transmitting stations and military communication systems; even in broadcasting stations limiters are used not only to prevent over-modulation on peaks, but also to boost the "commercial" speech level in sponsored broadcasts. As the transatlantic idiom has it, the "talk power" of propaganda stations is also boosted by clipping techniques in order to override jamming.

There is also the possibility of improving intelligibility by modifying frequency response and one often comes across references to "cutting the lows" and "boosting the highs" and to "concentrating on the intelligence-carrying portions of the speech spectrum."

Examination of these ideas is clearly necessary. Thus *a priori*, the customary attenuation of frequencies below some 250 c/s would seem to serve no useful purpose if the amplitude of speech components were uniformly distributed over the frequency spectrum. Moreover, telephone systems

approximating to a response sharply peaked at 1 kc/s have been used without any complaints of lack of intelligibility. A system peaked at 1 kc/s would clearly tend to overmodulate at the most favoured frequencies in the 1-kc/s region, while the rest of the speech frequency band would not reach over-modulation amplitudes. Hence it would seem that a level speech response curve is required to ensure that the modulation capability of a speech transmitter is not unduly degraded by some frequencies being preferentially boosted in amplitude. However, in a typical male voice the amplitude of the lower bass frequencies is much higher than the middle and upper register components. In fact the energy content of male voices sharply increases towards the low-frequency end of the audio spectrum. By attenuating the lower register below some 250 c/s these high-amplitude components can be reduced, and the intelligence-carrying middle and upper register frequencies may then be raised in amplitude to the maximum modulation capability of the transmitter.

That this process of bass attenuation may give useful gain is shown by the fact that some 60 per cent of the energy content of male speech waveforms lies below 500 c/s. Speech in which frequencies below 500 c/s have been removed, still has an

articulation index of 95 per cent.¹ As the articulation index is determined on the basis of recognition of "nonsense syllables", and even high-quality systems are rated at an articulation index of 98 per cent, the figure of 95 per cent represents a well-nigh perfect communication system—particularly as plain speech, in contrast to arbitrary "nonsense syllables", has a high degree of redundancy.

The preferential boosting of the middle and upper register is useful, as the general speech level may be lifted once the high-amplitude bass frequencies are attenuated, thus giving an effective gain over a "wide range" speech system. Moreover, in practical communication systems operating under "competitive" conditions, as in amateur and military communications, the frequencies above some 4 kc/s may be omitted. The higher speech frequencies contribute little to intelligibility, and, with sharp tuning of receivers to minimize interference under "competitive" conditions, are in any case removed. Furthermore, an unduly extended upper register may cause severe sideband interference to adjacent communication channels.

The use of a limited speech frequency response (Fig. 1) does not imply that unnatural speech results. The ordinary domestic receiver removes frequencies above 4 kc/s most effectively. Moreover, due to re-synthesis of the missing bass frequencies in the ear from their harmonic components, the speech does not sound "thin" and the characteristic timbre and "personality" of a voice is remarkably well preserved.

Peak/R.M.S. Ratio

Speech clipping introduces further problems. Observation of voice oscillograms shows that sharp spiky peaks extend to an amplitude well above the general level. In fact the ratio of peak amplitudes to r.m.s. amplitudes may be between three and four for speech waveforms as contrasted to the $\sqrt{2}$ ratio for sinusoids. Clearly if the peaks can be clipped and removed without destroying intelligibility, the mean level of the speech waveforms could be increased some three or four times without over-modulation occurring, as compared with the level permissible with the peaks present.

The above reasoning suggests that an effective increase of "talk power" equivalent by some 10 dB could be achieved by incorporating a peak clipper

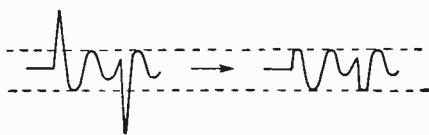

Fig. 2. Sharp peaks in speech waveforms may be clipped without serious effect on intelligibility.

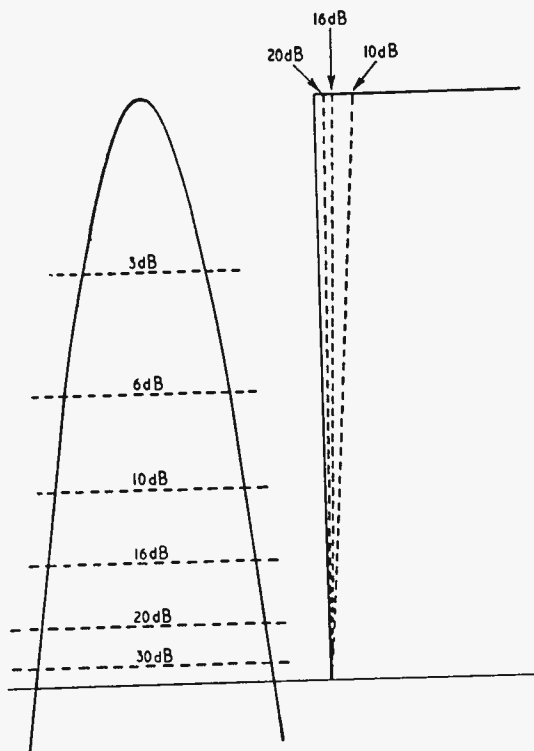

Fig. 3. Showing that as the degree of clipping is increased, a sine wave approaches a square waveform.

in an existing modulator. However, it is generally found that some degree of peak clipping takes place in the speech amplifier or modulator stage of an amateur transmitter. When an oscilloscope check reveals that no overmodulation occurs, reports are commonly given of apparent undermodulation. In fact the "full" modulation often heard as clean speech without noticeable "splatter" generally represents almost continuous overmodulation on speech peaks. Due to the sharp nature of the speech waveform spikes, however, the percentage of time during which overmodulation is occurring is small. Really gross overmodulation or speech amplifier nonlinearities are necessary to produce obvious overmodulation on casual listening tests.

Clipper action is idealized in Fig. 2, which shows how peaks may be clipped in speech waveforms without affecting the signal quality noticeably. Speech clippers of the peak limiting type are commonly employed in broadcasting to prevent sudden orchestral transients from overloading the system, as well as to boost the "talk power" of the commercial announcements. Speech waveforms are often asymmetric,² with peaks of one polarity higher than the other. Thus it is possible to arrange the speech waveform polarity so that the highest peaks produce positive modulation levels exceeding the 100 per cent mark, while the negative peaks do not extend to the zero level. This gives a limited degree of enhanced speech levels in communications systems. It is uneconomic as the "oversize" modulator must be capable of handling the extreme peaks which may correspond to positive modulation levels of 200 per cent to 300 per cent.

Peak limiting within the speech amplifier is better,

as the modulator and transmitter modulation capability need only conform to the usual requirements. However, clipping may be pushed much further than the removal of sharp peaks. It is possible to clip the main speech waveforms. Speech waveforms may be clipped so savagely as to reduce the signal to a series of "on and off" rectangular impulses . . . a sort of "super-morse". In fact speech waveforms may be applied to a trigger circuit to convert them into a series of rectangular pulses. Despite this, intelligible speech can be reconstituted from systems operating on an "infinite clipping" basis.³ The only factor conveying intelligence in such systems being the crossover points where the polarity of the rectangular pulses change polarity. Practically "infinite" clipping is obtained when the ratio of peak waveform amplitude to clipping level exceeds some 30 to 40 dB. A sine wave clipped to this degree is virtually a square wave, as Fig. 3 indicates. Moreover with a high degree of clipping the speech level is highly compressed, so that the modulation level is virtually independent of the loudness of the speaker's voice, which can change by some 20 dB without the output level changing noticeably. This has the disadvantage that background and room noises are greatly accentuated. A background whisper may for example produce the same output as a speaker close to the microphone.

High clipping levels imply the introduction of a high level of harmonic distortion. It also entails a high level of intermodulation products. Fig. 4 illustrates the intermodulation effect for a weak h.f. speech frequency in the presence of a strong low-frequency component. There are two approaches to the problem of dealing with the distortion products. The usual method is to follow the clipper stage by a low-pass filter attenuating sharply above some 3 kc/s. This prevents harmonics generated in the clipping process from reaching the modulator, so

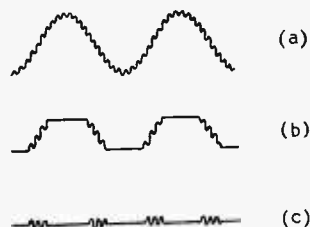

Fig. 4. (a) Small-amplitude h.f. component superimposed on a low-frequency component, (b) after clipping and (c) residual h.f. component.

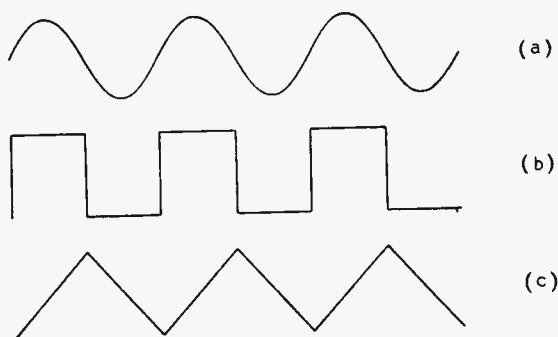
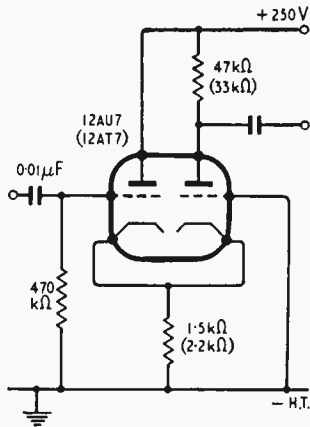

Fig. 5. The sine wave (a) assumes an approximately square shape after amplification and clipping (b), and is restored to a semblance of a sine wave (approx. 12 per cent harmonic distortion) by integration (c).



Left:—Fig. 6. Cathode-coupled clipping stage. The values in brackets should be used with a 12AT7 valve.

Below:—Fig. 7. Schematic diagram of typical clipping circuit sequence.



that the sideband spread is not broadened by "hash" and "splatter". The use of a low-pass filter does not affect distortion products within the 3-kc/s pass band, although perfectly intelligible speech may be radiated with such a filter.

Another approach favoured in some quarters, does reduce distortion products within the pass band. This technique precedes the clipper stage by a differentiating circuit, so there is effectively a top boost of 6 dB per octave. The clipping stage is followed by an integrator stage, which may be regarded as restoring the original frequency balance. Harmonic distortion products are attenuated. This is illustrated (Fig. 5) for a sine wave input. The square wave resulting from the clipper is integrated to a triangular wave. As far as the final result is concerned there is remarkably little difference between a sine wave and a triangular wave, as can be observed when a sine wave of increasing amplitude is fed into such a clipper integrator system. In terms of harmonic distortion, the square wave represents some 50% harmonic distortion, while a triangular wave corresponds to some 12% distortion. Intermodulation products will also be reduced in some cases by the integrator.

The clipping stage may employ many types of circuit such as the classical biased diodes, valves with low anode voltages to limit simultaneously at grid and anode, and so on. One convenient circuit is the so-called "transient-less" clipper shown in Fig. 6. The values shown gave good symmetrical clipping action with 12AU7 and 12AT7 valves. The shorter grid base of the 12AT7 results in the limiting action starting at lower signal inputs than a 12AU7. The simplicity of this circuit, and the symmetry of clipping without critical circuit values are features of some interest.

Circuits of clipping systems are best adjusted with the aid of an oscilloscope. The overall schematic of a clipper system is shown in Fig. 7. The gain control following the clipper stage enables the audio output to be set at a level which does not overmodulate the transmitter. The gain control preceding the clipper stage enables the input to the clipper to be varied from slight clipping action up to the limit set by pre-amplifier gain. In practice it is doubtful whether an apparent effect of more than 10 dB of gain is achieved. Moreover, under conditions of selective fading a heavily clipped system is liable to severe

sideband distortion effects unless exalted-carrier receiving techniques are used. This follows because the transmitter operates virtually all the time at the 100% modulation level. When the carrier fades below the sidebands the effect is one of gross over-modulation. Thus a clean speech signal may change to a severely distorted one with a slight change in propagation conditions. The use of exalted-carrier reception methods is clearly the first step that leads logically to the use of single-sideband, suppressed-carrier techniques at the transmitting end. The combination of single-sideband operation together with speech clipping and limiting should provide about the most effective communication system possible for present-day amateur use.

However, while "clipped" speech methods may be used to convert speech into a still intelligible succession of "on-off" pulses, it is necessary to remem-

ber that "Vocoder" techniques have shown that speech may be compressed into a few cycles per second of bandwidth by coding speech waveforms into the keying impulses for a small number of waveform generators. The ultimate adoption of such techniques by amateurs may well end the traditional rivalry between telephony and c.w. operators, as speech will then occupy about the same bandwidth as c.w.

REFERENCES

- ¹ "Radio Designer's Handbook," pp. 628-9. (Iliffe & Sons.)
- ² "Amplitude Modulation Up to Date," O. J. Russell. *Wireless World*, March, 1943.
- ³ "Effects of Amplitude Distortion Upon the Intelligibility of Speech," J. C. R. Licklider. *Journal Acoustical Society of America*, vol. 20, p. 42, 1948.
- ⁴ "Remaking Speech," H. Dudley. *Journal Acoustical Society of America*, vol. 11, p. 169, 1939.

Pressurized Valve Factory

AS part of the precautions against airborne dirt which Hivac have adopted at their new Ruislip valve factory, the atmospheric pressure in the air-conditioned assembly shop is kept above normal to ensure that no dust can enter from outside. The same principle is used on some of the individual assembly benches, which are enclosed and have glass shields in front to prevent any moisture from the assemblers' breath from condensing on the electrode components.

The hospital-like nature of the factory is further enhanced by polished wood-block floors, a self-supporting roof structure to avoid dirt-collecting stanchions and girders, and white nylon overalls and head scarves for the girl operatives. All supplies of electricity, gas, water and "vacuum" are piped into the main shop from a specially constructed basement so that contaminating oil fumes and dust-harboring pipes and wires are eliminated.

The factory is mainly concerned with manufacturing subminiature valves, and the precautions are particularly necessary when work is being done on "special quality" types in this category.

Economy in Receiver Design

Simple Superhet with an Unconventional Smoothing Circuit

By S. W. AMOS,* B.Sc.(Hons.), A.M.I.E.E.

THIS article describes a small medium-wave receiver for a.c. mains operation suitable for use as a second receiver, e.g. in a dining room or a bedroom. It does not require an external aerial but is nevertheless capable of receiving Hilversum, Brussels and a number of provincial Home Services when used in the London area. The receiver is economical of components but it has a.g.c. operating on two valves and the gain control incorporates variable negative feedback. A 5-inch diameter loudspeaker is used and although the upper frequency response is limited by the selectivity of the i.f. transformers, the quality is smooth and pleasant due to reduction of harmonic distortion in the a.f. amplifier by the feedback.

The circuit described here uses international octal valves namely 6K8 (frequency changer), 6K7 (i.f. amplifier), 6Q7 (detector and 1st a.f. amplifier), 6V6 (output valve) and 6X5 (rectifier). The circuit is, however, not at all critical of the valves used and the only component value likely to require adjustment if other types of valve are used is the bias resistor of the output valve. The author has made a receiver of this type using modern B7G and B9A valves namely 12AH7 (frequency changer), 9D6 (i.f. amplifier), EABC80 (detector and 1st a.f. amplifier) and N78 (output); no changes in component values were required other than that mentioned.

Economical Smoothing

The circuit diagram of the receiver is given in Fig. 1 and the first feature of interest is the smoothing circuit and the method of supplying h.t. to the valve electrodes. The full-wave rectifier circuit is conventional but the anodes of the output stage, i.f. amplifier and frequency changer are all fed directly from the rectifier cathode. At this point the h.t. supply is 260 volts from a mains transformer secondary winding supply 250-0-250 volts. By adopting this technique the current in the smoothing resistor R_9 is reduced to a small value which comprises the screen-grid currents of the output valve, i.f. amplifier and frequency changer together with the anode currents of the oscillator triode and the 1st a.f. amplifier triode. This current amounts to approximately 12 mA, approximately 1/5th the total h.t. current of the receiver. With such a small current the smoothing resistor can have a value as high as 5 k Ω yet still giving a smoothed supply of 200 volts for the screen grid of the output stage and the anode of the 1st a.f. amplifier.

A supply of approximately 100 volts is required for the screen grids of the i.f. amplifier and frequency changer and the oscillator anode; this is

obtained from the 200-volt smoothed supply via a series resistor R_{12} of 10 k Ω ; a 0.1- μ F capacitor C_3 has proved adequate for decoupling the 100 volt supply so obtained.

This simple h.t. supply circuit has proved entirely successful and gives a very low level of hum. This is to some extent due to the use of a pentode as output valve and a triode as 1st a.f. amplifier as illustrated in the following calculations. A 100-c/s ripple voltage can occur at the anode of the output valve (giving hum in the loudspeaker) from three mains sources:

(1) By direct modulation of the anode current of the output stage by ripple on the h.t. supply. If the output valve is a triode this voltage is 2/3rds that at the rectifier cathode because the optimum load of a triode is twice the anode a.c. resistance. Hum due to this cause is reduced by using a pentode because the anode a.c. resistance of this type of valve is of the order of 50 k Ω , 10 times the optimum load (assumed 5 k Ω). Thus the ripple voltage at the anode of a pentode is only 1/11th that at the rectifier cathode. The ripple voltage at the rectifier cathode can be simply calculated as shown in the Appendix: for this particular circuit the voltage is 20 volts peak-to-peak. Thus a triode output stage will give 16.7 volts ripple at the anode and a pentode less than 2 volts.

If a feedback voltage is taken from the anode of the output valve the effective reduction in anode a.c. resistance of the pentode increases the ripple. This can be avoided by taking the feedback voltage from the secondary winding of the output trans-

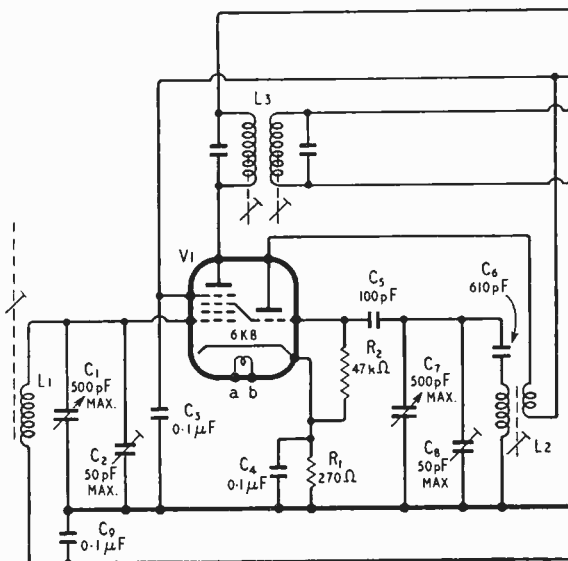

* B.C.C. Engineering Training Department.

former, when the feedback is effective in reducing hum. This has the additional advantage of reducing any harmonic or attenuation distortion occurring in the transformer. The inclusion of the output transformer in the feedback loop increases the tendency towards oscillation at a frequency outside the passband. The measures adopted to prevent this possibility are discussed later.

(2) By modulation of the anode current of the output pentode by ripple on the h.t. supply to the screen grid. This effect can produce serious hum and smoothing of the screen-grid supply is essential to minimize it. The smoothing circuit employed is, in fact, more than sufficient to reduce hum from this source to negligible proportions. The smoothing resistor is $5\text{ k}\Omega$ and the smoothing capacitor $32\ \mu\text{F}$. The latter has a reactance of 50 ohms at 100 c/s and the 100 c/s ripple on the 220-volt supply has therefore $1/100$ th the amplitude at the rectifier cathode, and is only $20/100 = 0.2$ volt peak-to-peak value. The voltage gain of an output pentode from screen grid to anode is less than 5 under normal conditions and the ripple is thus unlikely to generate more than 1-volt at 100 c/s at the anode. The smoothing was introduced primarily to reduce the hum described under (3) below and also to minimize the possibility of impressing 100 c/s on the r.f. signals in the frequency changer and i.f. amplifier valves. The 100 c/s ripple on the 200-volt supply is applied at nearly full amplitude to the screen grids of these valves and modulation hum from this cause is a possibility unless the ripple is kept to a small amplitude.

(3) By modulation of the anode current of the output stage by ripple applied to the control grid. This ripple is applied via the anode load resistor R_7 ($220\text{ k}\Omega$) and the anode a.c. resistance (say $80\text{ k}\Omega$) of the triode a.f. amplifier which together form a fixed potential divider across the 200-volt supply. The step down ratio is 4 : 1 and the ripple at the control grid is thus $0.2/4 = 0.05$ volt. If



Front view of the receiver.

the gain of the pentode is 30, the ripple at the anode from this source has an amplitude of $0.05 \times 30 = 1.5$ volt peak-to-peak, less than that due to direct modulation of the anode current by the ripple at the rectifier cathode. If the 1st a.f. amplifier had been a voltage-amplifying pentode with an anode a.c. resistance of $1\text{ M}\Omega$, the ripple at the pentode anode would have been 5 times greater, i.e., 7 volts, possibly sufficient to produce audible hum.

These calculations show that by using the types of valve specified the hum can be kept to negligible proportions in spite of resistance smoothing and without the need for an additional smoothing section for the h.t. supply to the triode anode. The calculated ripple voltages at the pentode anode apply when the gain control is set at maximum, for there is then no negative feedback. When the gain control is turned down for reception of a strong signal, negative feedback is automatically applied and the ripple voltage is less than calculated above. In practice the hum level is negligible at all settings of the gain control.

We shall now consider the design of the valve circuits in detail, beginning with the mains equip-

Fig. 1. Complete circuit diagram of receiver. All resistors are rated at $\frac{1}{4}$ watt unless otherwise specified. L_1 , 40 turns 9/45 Litz wound to occupy $\frac{1}{8}$ in length on paper sleeve on Mullard "Ferroxcube" rod, type FX 1247; L_2 , Osom type Q08; L_3, L_4 , Eddystone type 851 or Wearite type M800.

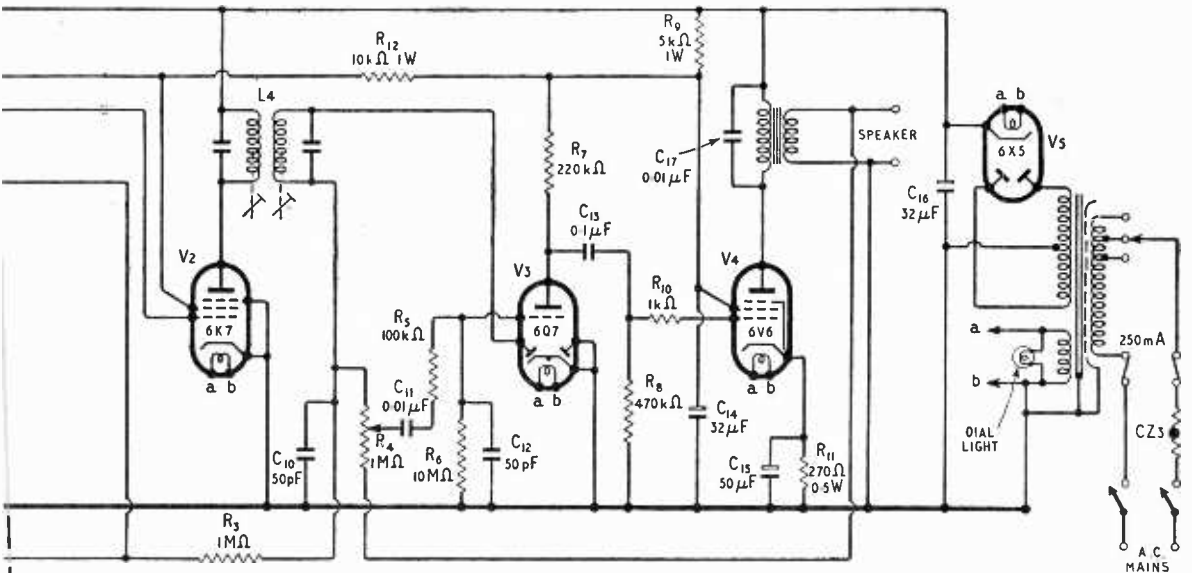

ment which is conventional, except for the provision of the Brimistor CZ3 in the primary circuit of the mains transformer. This is included to reduce the magnitude of the surge current immediately after switching on, so prolonging the life of the valves and the dial light. It also permits the use of 250 mA mains fuses; without the CZ3 the fuse rating would need to be raised to at least 1 amp to stand the surge current.

Grid-current Bias

The a.f. amplifier consists of the triode voltage amplifier V3 and the pentode output stage V4. The two valves are RC-coupled and V4 has a bias resistor R_{11} and decoupling capacitor C_{15} . V3 is biased by grid-current flow in R_6 which has the high value of $10\text{ M}\Omega$. This saves the cost and bulk of a cathode decoupling capacitor. If a triode valve of a type different from that specified is to be used, it is necessary to check that it is suitable for biasing in this manner. The diode load resistor R_4 functions as gain control and the components R_5 and C_{12} are an i.f. filter. These components are placed subsequent to the gain control deliberately. If placed between the diode output and the gain control, it would not be possible to remove the feedback completely at the maximum setting of the gain control.

To receive weak signals the full gain of the receiver may be necessary, but for local-station reception, where the full gain is not required, it is possible to employ negative feedback to improve quality by reducing harmonic distortion. In the feedback circuit used by J. L. Osbourne¹ the gain control is used simultaneously to control the magnitude of the signal applied to the a.f. amplifier, and also the feedback factor. He achieved this by returning the gain potentiometer to the junction of two resistors connected in series across the secondary winding of the output transformer, the resistance values being chosen to avoid any possibility of oscillation at a very high or very low frequency. However, it was found possible to avoid instability by suitable design of the a.f. amplifier and the two resistors are unneces-

sary. Thus the volume control can be returned to one end of the secondary winding and, at zero setting of the volume control, the whole of the secondary voltage is used for feedback. The use of the volume control for two purposes alters its effective law and a linear control gives smoothest control of volume; a logarithmic control tends to be fierce near its maximum setting.

Instability tends to occur in a feedback amplifier at frequencies outside the passband, in an a.f. amplifier at very low frequencies such as 1 or 2 c/s (an effect known as motor-boating) or at a high frequency such as 50 kc/s. Oscillation at such high frequencies is, of course, inaudible but can nevertheless ruin the performance of the amplifier by causing excessive noise or low power output. This oscillation is perhaps best detected by an a.c. meter connected across the output; a steady reading is obtained even with no input to the amplifier. Instability is caused by phase shifts in the amplifier and can be avoided by correct choice of the time constants controlling the phase shift. At very low frequencies the significant time constants are R_6C_{11} , R_6C_{13} and the anode circuit of the output valve. The latter time constant is given by the quotient of the primary inductance of the output transformer (say 8 henrys) and the load resistance (say 5 k Ω) and is equal to $L/R = 8/(5 \times 10^3)$ second = 1.5 milliseconds. As shown by Brockelsby² the instability can be avoided by making the other two time constants large compared with this; in this way two of the phase-shift circuits are made wide-band and the third is narrow-band. The values chosen are $R_6 = 470\text{ K}\Omega$, $C_{13} = 0.1\text{ }\mu\text{F}$ giving a time constant of 50 milliseconds and $R = 10\text{ M}\Omega$, $C = 0.01\text{ }\mu\text{F}$ giving a value of 100 milliseconds and have proved effective in avoiding instability in three receivers all using different makes of output transformer. The interval time constants are much larger than is necessary purely from considerations of frequency response. If feedback were not used it would be quite satisfactory to have time constants as small as 0.006 second (e.g., 680 k Ω and 0.01 μF), for this corresponds to 1 dB loss at 50 c/s.

The phase shift in the a.f. amplifier at frequencies immediately above the passband occurs principally at three points in the circuit; in the anode circuit of V3, in the output transformer and in the circuit which includes the gain control and i.f. filter. The circuit controlling the phase shift at the first point comprises the anode load resistance of V3 in parallel with the anode a.c. resistance of the valve and the stray capacitance shunting the two resistances. The phase shift in the output transformer is a function of the leakage inductance, the shunt capacitance in the primary winding and the loudspeaker impedance and is by no means simple to calculate. If no additional components are introduced to control phase shift at this point in the circuit, the time constant is likely to be of the same order as that due to

(Continued on page 391)

Rear view of receiver with back removed showing the ferrite rod and method of mounting.

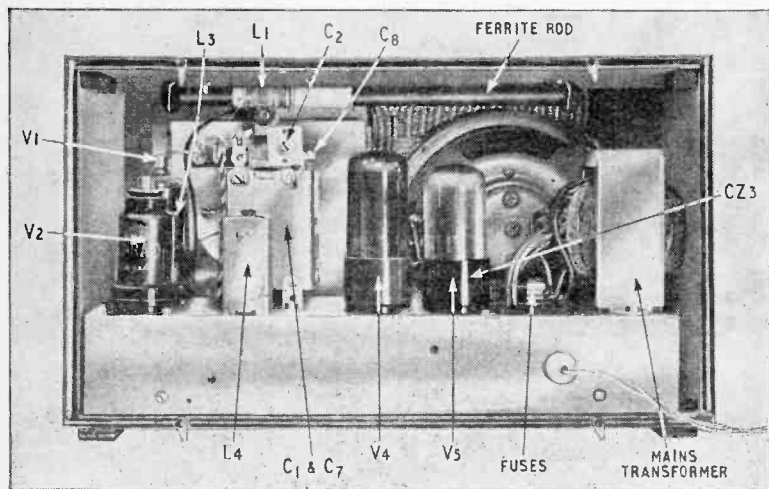

V3 anode circuit. The phase shift introduced by the gain control and i.f. filter is also of the same order as the two previous circuits and, when conventional component values are used, the overall phase shift generally gives continuous oscillation around 50 kc/s when the gain control is near zero setting. To obtain stability it is necessary to give one of these three phase-shift circuits a larger time constant. We have then satisfied the criterion of Brockelsby that two of the phase-shift circuits give wide-band responses and the third is narrow-band. One way of achieving this is to connect a capacitor in parallel with the primary winding of the output transformer. A value of $0.01 \mu\text{F}$ has proved suitable.

At the frequencies at which instability is likely to occur the components effectively controlling the phase shift are the anode a.c. resistance of the output valve (say $50 \text{ k}\Omega$) and the capacitor C_{17} giving a time constant of $0.01 \times 10^{-6} \times 5 \times 10^4 \text{ second} = 500 \text{ microseconds}$, very large compared with that of the other two phase shift circuits. This value of capacitance does not cause any perceptible loss of "top" when the gain control is advanced to maximum setting where there is no feedback. This value of C_{17} has given unconditional stability in a number of receivers employing this circuit and constructed with different types of output transformer.

I.F. Stages

The gain and selectivity of a superhet receiver are determined almost entirely by the properties of the i.f. transformers and these must therefore be well designed. The space available for these components is limited and miniature types 13/16-inch square were used. The types listed under Fig. 1 must be used if the performance of the original receiver is to be duplicated. An interesting feature of some of these transformers is that the coupling between the windings is both inductive and capacitive. These two forms of coupling can aid or oppose and thus there may be a significant change of gain on reversing the connections to one winding. In particular it was found that higher gain can be obtained from Eddystone transformers in this particular receiver if the connections to one winding are reversed relative to those indicated on the can.

The cathode of the i.f. amplifier is directly earthed no automatic bias components being included. This economy is justified because there is a standing bias of -1 V on the a.g.c. line from the signal diode and this provides grid bias in the absence of a signal.

The frequency changer circuit is conventional and here it was found that automatic bias is essential because the 6K8 gives maximum conversion conductance with approximately -3.0 volts on the control grid. The oscillator circuit is a tuned-grid type, C_8 and C_9 being trimming and padding capacitors respectively. The value of the padding capacitor proved to be unexpectedly critical and it is recommended that this component should have a tolerance of no more than $\pm 2\%$. This is partly due to the use of a ferrite-rod aerial in the signal-frequency circuit. The Q value of this circuit is very high—about 300—and even a small tracking error results in a significant loss. The tuning of a superhet receiver is, of course, fixed by the i.f. and oscillator circuits and tracking errors result in a loss due to mistuning of the signal-frequency circuit. At

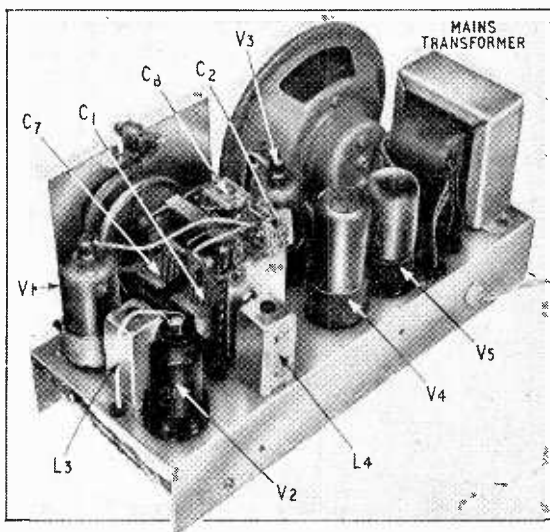

View of upper side of chassis showing layout of valves, mains transformer, tuning capacitor and i.f. transformers.

1 Mc/s a tracking error of as little as 5 kc/s results in a loss of 10 dB if the Q value is 300. Tracking error must thus be minimized and the authors carried out a series of experiments, using different values of padding capacitance, to determine the capacitance for least loss averaged over the medium waveband. The reduction of these losses to a minimum requires correct choice of alignment frequencies as well as correct padding capacitance and it was found that best results were obtained by aligning at 1530 kc/s and 620 kc/s and by using a padding capacitance of 610 pF . This gave zero loss at 1050 kc/s and at the alignment frequencies with maximum losses of 6 dB at 550 kc/s, 850 kc/s, 1300 kc/s and 1600 kc/s.

The signal-frequency circuit consists simply of a Litz winding on a ferrite rod 8 inches long and $\frac{3}{8}$ inch diameter (Mullard type FX 1247). The coil consists of 40 turns of 9/45 Litz wound to occupy a winding length of $1\frac{1}{2}$ inches on a paper sleeve which is free to slide along the rod. With this number of turns the normal position of the sleeve is approximately 2 inches from one end of the rod and a slight movement of the coil produces a comparatively large change of inductance. This movement is used in aligning the receiver at the low-frequency end of the band. Alignment at the high-frequency end is achieved by variation of the trimmer C_2 which is mounted in a vertical position on the rear section of the two-gang tuning capacitor so that it can be adjusted when the receiver is in the cabinet.

Alignment

Adjustment of the i.f. and oscillator sections of the receiver can be carried out with the receiver on the bench but in the models constructed by the author the ferrite rod is mounted in the cabinet and the receiver must be in the cabinet for adjustment of the signal-frequency circuits. With the receiver on the bench adjust a signal generator to give a modulated output at 465 kc/s and apply the output to the receiver; the output may be connected directly across L_1 . With the receiver gain at maximum adjust the level of the signal-generator

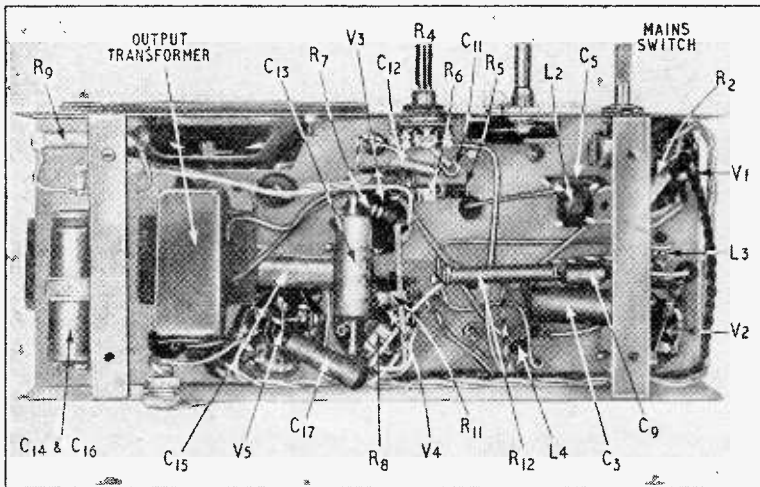

Under-chassis view identifying the principal components.

output until the modulation is barely audible. Adjust the two dust-iron cores of both i.f. transformers to give maximum output from the receiver. As the receiver output increases, decrease the output of the generator to keep the receiver output barely audible.

To align the signal-frequency circuits, a different form of coupling is required between generator and receiver. A method which has proved successful is to connect the generator output to the ends of a small coil, which need consist only of a few turns, looped over the ferrite rod at the end remote from the winding L_1 . Set the generator to give a modulated output at 1600 kc/s, the receiver tuning to 187 metres and tune the signal in by adjustment of C_8 . Now set the generator to 545 kc/s, the receiver tuning to 550 metres and tune the signal in by adjustment of the dust-iron core of L_2 . Retune the generator to 1600 kc/s, the receiver to 187 metres and repeat the adjustment of C_8 . Now return to the low-frequency end of the band and repeat the adjustment of L_2 . Continue these adjustments until no further change in setting of C_8 or L_2 is required. The frequency range of the receiver is now correct and the indications of the tuning scale should be accurate. At this stage it is a good plan to check the accuracy of scale readings at a few points in the band, e.g., 750 kc/s (400 metres), 1000 kc/s (300 metres), 1200 kc/s (250 metres) and 1500 kc/s (200 metres). Any slight errors can sometimes be minimized by re-setting the pointer with respect to the tuning capacitor and re-aligning.

Aerial Adjustment

The receiver must now be mounted in the cabinet in order to align the aerial input circuit. Set the signal generator to 1530 kc/s and tune in the signal by rotating the tuning control to approximately 196 metres. Adjust C_2 to give maximum output from the receiver. Set the signal generator to 620 kc/s and tune in the signal by rotating the receiver tuning capacitor to approximately 484 metres. Slide L_1 along the ferrite rod to the position which gives maximum receiver output. Retune the generator and receiver to 1530 kc/s and repeat the

adjustment of C_2 . Repeat the adjustment of L_1 at the low-frequency end of the band and continue these two adjustments until no further re-setting of C_2 or L_1 is required. The alignment is now completed and the paper sleeve carrying L_1 should be secured to the ferrite rod.

The receiver is housed in a wooden cabinet measuring $11\frac{1}{2}$ inches by 7 inches by 5 inches and the steel chassis supplied with the cabinet measures $10\frac{1}{2}$ inches by 4 inches by $1\frac{3}{4}$ inches. The chassis was intended for a 3-valve t.r.f. receiver using a metal rectifier and was modified for the superhet by punching two large holes for the additional two valves and a number of smaller holes for the two i.f. transformers. The layout of the receiver is evident from

the photographs and except for the provision of a small screen and the method of supporting the ferrite rod does not require detailed description. The screen is necessary to prevent slight instability and shields the grid lead of the first i.f. transformer from the anode pin of the i.f. amplifier. The ferrite rod could be supported by brackets mounted on the chassis, permitting the receiver to be completely aligned on the bench but in the model illustrated the rod is supported by two rubber grommets held in position by short lengths of wire which fit into the grooves and are secured by short wood screws to the underside of the top of the cabinet. The wire loops must not form closed loops around the rod for these, if closely coupled to the tuned winding, may reduce the effective Q-value. The ferrite rod should be handled with great care because it is extremely brittle and will almost certainly break if allowed to fall more than a few inches on to a hard surface. The ferrite rod is directional, giving maximum signals when broadside on to the direction of the transmitter. It may happen if the rod is mounted parallel to the long dimension of the chassis as shown in the photographs that the signals from the local station are at a minimum with the receiver placed in the desired position. This difficulty can be avoided by arranging for the ferrite rod to be at an angle to the long dimension of the chassis. The angle cannot exceed approximately 30 degrees but this may be sufficient to avoid the difficulty. The choice of position for the ferrite rod is further complicated by a hum which becomes apparent on strong signals when the rod is situated near the mains transformer. This effect may be confused with modulation hum but appears to be due to the properties (possibly non-linearity) of the ferrite rod and can be minimized by suitable choice of position.

References

- ¹ J. L. Osbourne. "Midget Sensitive T.R.F. Receiver." *Wireless World*, April, 1954.
- ² C. F. Brocklesby. "Negative Feedback Amplifiers." *Wireless Engineer*, February, 1949.

APPENDIX

THE voltage across the reservoir capacitor connected across the output of a rectifier consists of a series of

exponential rises, coinciding in time with the periods of conduction of the rectifier, alternating with exponential falls due to discharge of the capacitor by the current taken by the load. To simplify calculation of the amplitude of this ripple, we can assume that the voltage has a sawtooth form, rising instantaneously to the maximum value when the rectifier conducts and falling linearly in the intervening periods. The assumption of a linear fall in voltage is justified if, as is usually true in practice, the fall is a small fraction of the maximum voltage across the capacitor. If the load current is assumed to have a constant value i during discharge periods, the charge q lost by the capacitor in one of those periods is it , t being the duration of the period. This produces a fall in voltage given by q/C , i.e., it/C .

For a full-wave rectifier the discharge period t is half that of the alternating voltage supply and is thus given by $1/2f$.

Substituting for t in the above expression gives the general result—

$$\text{Ripple voltage (peak-to-peak value)} = \frac{i}{2fC}$$

For the receiver described in the article $i = 60 \text{ mA}$, $f = 50 \text{ c/s}$ and $C = 32\mu\text{F}$. Substituting these values in the general expression—

$$\begin{aligned} \text{Ripple voltage} &= \frac{60 \times 10^{-3}}{2 \times 50 \times 32 \times 10^{-6}} \text{ volts} \\ &= \frac{60 \times 10^3}{2 \times 50 \times 32} \\ &= \frac{60 \times 10^3}{64 \times 50} \\ &= 20 \text{ volts approximately (peak-to-peak)} \end{aligned}$$

COMMERCIAL LITERATURE

Standing-Wave Indicator (for waveband centred on 3.2 cm); rotary attenuator, 3.2 cm, using nichrome-coated glass vanes; and monitor dices for 3.2 cm and 10 cm. Leaflets for their catalogue of microwave instruments from Elliott Brothers (London), Elstree Way, Borehamwood, Herts. Also a price list and a leaflet on power supplies for klystrons.

Silvering Glass and Ceramics to provide a surface for soft-soldering. Two-coat method using silver pastes, described in Electrical Engineering Data Sheet 1300:473 from Johnson, Matthey and Co., 73-83, Hatton Garden, London, E.C.1.

Non-Destructive Testing of engineering materials. Booklet on electronic methods from A. E. Cawkell, 6-8, Victory Arcade, The Broadway, Southall, Middlesex.

Thermistors, as used in receivers for surge suppression, picture-height correction, temperature compensation, etc. Leaflet giving technical data, equivalents, prices and list of receivers in which Mullard Varite types are fitted, available to dealers from Mullard, Century House, Shaftesbury Avenue, London, W.C.2.

Bench-Type R.F. Heater, 750-W, for "pre-heating" plastics powders before they are put in moulds. Will plasticize at rate of up to 80z per minute. Has air-cooled triode oscillator (35-36 Mc/s) and xenon rectifiers, with process timer and automatic lid opening. Leaflet from Radio Heaters, Eastheath Avenue, Wokingham, Berks.

Instrument A.C.-D.C. Converter, using thermocouple, for precise measurements of a.c. voltages and currents with d.c. potentiometers. Voltage ranges from 7.5 V to 300 V and current ranges from 18 mA to 5 A; accuracy $\pm 0.05\%$ over frequency range of 25 c/s to 10 kc/s. Leaflet from the Croydon Precision Instrument Company, 116, Windmill Road, Croydon, Surrey. Also a leaflet on Precision Instrument Switches.

Components and Accessories; the July, 1956, illustrated catalogue from Radiospares, 4-8, Maple Street, London, W.1.

Direct Reading Magnetometer, for measuring fields of transformers, electric motors, focusing electromagnets, etc. Three ranges: 0-5, 0-50 and 0-500 oersteds, using one probe. Short-term accuracy better than $\pm 1\%$. Calibrating solenoid available if required. Leaflet from Newport Instruments (Scientific and Mobile), Newport Pagnell, Bucks.

High Quality S.R. Equipment; amplifiers, pickups, loudspeakers and cabinets, control units, tuners, gramophone motors, tape recorders and other accessories by well-known makers. Also suggestions for equipment combinations, with prices. Illustrated catalogue from the Classic Electrical Company, 352-364, Lower Addiscombe Road, Croydon, Surrey.

Band-III Television Pre-amplifiers, for fringe areas, using earthed-grid low-noise stage followed by neutralized triode stage, giving a gain of 20 dB at full bandwidth. Two aerial inlets, for Band I and Band III, with changeover

switch; also a gain control. Leaflet from Spencer West, Quay Works, Great Yarmouth, Norfolk.

Crystal Calibrator for communications receivers. Usable range to 55 Mc/s with check points at every 100 kc/s. Also a Codan squelch unit, a mechanical filter adapter and two loudspeakers. Leaflet on accessories designed specifically for Hammarlund communication receivers, from the Hammarlund Manufacturing Company, 13th East 40th Street, New York 16, N.Y., U.S.A.

Small Direction Finding Aerial (marine) weighing only 17oz, for mounting on hand bearing compass. Can be used with any communications receiver covering beacon signals (290-310 kc/s) and includes a sense finder. Range 50 miles with 20 μV receiver sensitivity. Descriptive leaflet from Brookes and Gatehouse, Shirley Holms, Lymington, Hants.

Waveguide Attenuators, fixed and variable, high-power impedance meters, tees, fixed and sliding terminations and u.h.f. coaxial directional couplers are among the new items in a catalogue of u.h.f. and microwave test equipment from the Narda Corporation, 160, Herricks Road, Mineola, L.I., New York, U.S.A. British representative at 86, Holly Road, Uttoxeter, Staffs.

Resistance Boxes with low, constant switch contact resistance and bifilar windings to reduce inductance. Three or four dials provided, with resistance coil values from 0.1 Ω to 100 k Ω . Accuracy of adjustment 0.1%. Also Wheatstone bridges—precision, portable and self-contained types. Leaflet from the Doran Instrument Company, Stroud, Glos.

Composite Band-I/Band-III Television Aerials with Band-I dipole element "electronically coupled" to Band-III resonator, thereby eliminating coupling bars, so avoiding impedance mismatching, and utilizing Band-I elements on both bands. Leaflet, among others, from Antiference, Bicester Road, Aylesbury, Bucks.

Tape Recorder, two-speed, with 10-inch elliptical loudspeaker in detachable lid. Facility for mixing two inputs, and amplifier which can be used separately for reproduction from tuner units, etc. Leaflet on the Wyndson Regent from the Magnetic Recording Company, 99, Shacklewell Lane, London, E.8.

Communications Receiver with expanded tuning scale, enabling frequency to be read very accurately, and facility for choosing L/C ratios of tuned circuits for optimum performance. Coverage of amateur bands from 1.8 Mc/s to 30 Mc/s in six ranges. Detailed description of the Eddy-stone Model "888" from Stratton and Company, Alvechurch Road, Birmingham, 31.

Clip-on Voltmeter-Ammeter, measures current without breaking circuit by means of magnetic induction in current-transformer core. Five current ranges, from 0-10 A to 0-1000 A a.c. and two voltage ranges 0-150 V and 0-600 V a.c. Also a high-frequency model (up to 400 c/s, 2.5 kc/s or 20 kc/s depending on current). Leaflet from Ferranti, Hollinwood, Lancs.

SEMI-CONDUCTORS—2

By "CATHODE RAY"

Another Step on the Way to Transistors

QUITE clearly we will all have to become acquainted with transistors—those who are not already. And one cannot go far without at least some notion of what goes on in the materials of which they are made—semi-conductors. Last month we got the length of seeing why semi-conductors semi-conduct. Unlike metals, which are good conductors of electricity because all their atoms have active or "valency" electrons that are free to drift about as electric currents, semi-conductors' valency electrons are in fixed jobs, linking up with their mates in adjoining atoms to form a regular lattice-like structure that we know as a crystal. Unlike perfect insulators on the other hand, these permanently employed electrons are not altogether immune from being tempted into absenteeism. Typical tempters are heat and light. At ordinary room temperatures an appreciable proportion—getting on for one in a million—of the valency electrons in germanium have shaken loose and are available for electric currents. It is the relative fewness of these absentee electrons that accounts for the "semi." In silicon they are fewer still, unless the temperature is considerably higher.

The atoms from which electrons have gone ("holes") are minus one negative charge. Minus negative is the same thing as plus positive, so electrically these deprived atoms are positive charges. Unlike the freed electrons, they are fixed parts of the crystal structure. But when an electron moves from a complete atom A to a hole B it is just as if the hole moved from B to A. The point of looking at it like this is that a very large number of short electron movements can often more easily be described as perhaps only one long hole "movement." So if, for instance, an electron shook loose in the middle of a crystal of germanium, to the ends of which a battery was connected, the electron would be attracted to the positive terminal, constituting a tiny electric current; at the same time the hole left behind might quickly be filled by an electron from a near-by atom on the negative side; that hole might be filled by one still nearer the negative terminal; and so on, the net result being the same as if the original hole had moved to the negative terminal, constituting another tiny electric current to add to the electronic current. Rather surprisingly, it is found that holes in semi-conductors can move about half as fast as electrons.

That was as far as we got last month, and before going on it would be as well to make quite sure of this hole business, and especially what is meant in transistor literature when it said that holes move. A thing to remember is that only the electrons really move; strictly speaking the holes are fixed, but some kinds of electron movement have the same electrical effect as if holes moved, and are more conveniently described and calculated as such. Fig. 1 is a picture of a dozen people forming a queue

(a), for whom the management have thoughtfully provided seats. No. 6 is called in first, so he leaves his seat and goes forward (b), thus creating a vacancy or "hole." This vacancy, strictly speaking, is a fixed seat; but if, in the natural desire to get as far forward as possible, No. 7 moves into it, then No. 8 moves into the newly created vacancy, and so on; the final result is as if the influence that induced the forward movement of person No. 6 also had the effect of repelling the "hole" to the rear (c). The total human current is the movement of a man from position 6 to the left hand or positive end, plus all the short movements of Nos. 7 to 12 inclusive; but the latter part can be described much more concisely as the movement of a vacancy from position 6 to the right-hand or negative end, or as the movement of a person from 12 to 6.

Holes, then, are imaginary positive charges, about half as mobile as electrons, used for convenience as an alternative way of describing certain real but complicated movements of electrons in the opposite direction.

Intrinsic Conductivity

So far we have an explanation for the small but appreciable conductivity of pure semi-conductors such as silicon and germanium, and also for its fairly steep increase with rise of temperature; because the normal state of these materials is full employment of electrons on fixed sites, they tend to be insulators; but except at very low temperatures this state is upset by a small proportion of electrons being freed by heat energy. The actual proportion depends on the temperature (the higher the greater) and on the structure of the atoms (i.e., on the material; the proportion is much greater in germanium than silicon). In a given material at a given temperature it cannot be altered. So it is called the *intrinsic* conductivity* of the material.

That doesn't get us very far towards transistors, or even crystal rectifiers, for intrinsic conductivity is no more than an incidental nuisance. It means that an e.m.f. always causes some current through semi-conductor devices, even when they are supposed to be biased to "cut-off." And the increase with temperature means that germanium devices are more or less out of action at the temperature of boiling water, though silicon can still be used—hence the development effort being put into silicon at the present time.

Light has been mentioned along with heat as a disturbing influence in semi-conductor crystalline structure and, therefore, a causer of conductivity. But it is a simple matter to keep light out where it

* Does anyone wonder what is the difference between conduction and conductivity? It is rather like the difference between production and productivity: a production of 1,000 tons of coal doesn't tell one whether it was obtained efficiently or not; for that one needs to know the productivity, which is the production per man per week or shift. Conductivity is the proper figure for comparing the conduction of different materials, in amps per volt per metre (or centimetre) cube.

isn't wanted (in ordinary transistors) and to let it in where it is—in photo-transistors, which enable a current to be controlled by light. So we are not going to bother about light just now.

Why use materials such as germanium, when they are subject to this intrinsic conductivity nuisance? Well, it happens that atomic structure which is liable to have the odd electron knocked off here and there by heat energy is also the kind that enables rectifiers and transistors to be made. That comes about in a curiously indirect sort of way. The only hint so far lies in a word you probably overlooked—"pure." When the semi-conductors are not pure, the picture becomes much more complicated. And for this purpose the standard of purity is so high that it would make the best "pure water supply" look like a cesspool. The uninitiated might suppose that if there were no more than one impurity atom to every 100,000,000 of germanium the material would reasonably pass as "pure." The chemical analyst would have no doubts about it. Yet this incredibly small impurity is enough to have quite an effect on the conductivity.

Cuckoo in the Nest

As it happens, the main natural impurity in germanium is arsenic, which is No. 33 in the list of elements. Germanium, you remember, was 32, so each of its atoms has 32 electrons, of which (as we saw last month) all but four—the valency electrons—can for our purpose be lumped in with the nucleus to form a body having a net positive charge equal to four electron units. So we simplified the diagram of a normal neutral germanium atom down to Fig. 2(a)—the augmented nucleus with its net charge of +4 surrounded by its four valency electrons each with a -1 charge. These are the electrons that link up with four neighbouring atoms to form the crystal lattice. On the same basis, as we might expect, the diagram of an arsenic atom looks like Fig. 2(b).

Now the interesting thing is that the arsenic atoms present in a piece of germanium find themselves accepted as units in the crystal lattice, just like a young cuckoo in a nestful of sparrows. But, of course, only four of the five electrons can find fixed employment; the odd one has to seek his fortune elsewhere. So in germanium with arsenic impurity there are free electrons, over and above any that are released by heat energy. The conductivity is

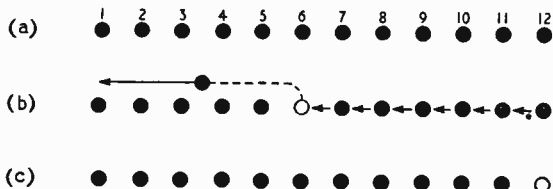

Fig. 1. (a) Queue of people waiting in seats. (b) No. 6 is called forward. (c) Apparent movement of his vacant seat backwards.

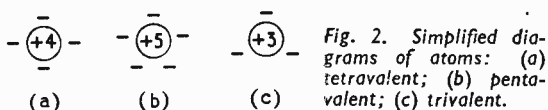

Fig. 2. Simplified diagrams of atoms: (a) trivalent; (b) pentavalent; (c) trivalent.

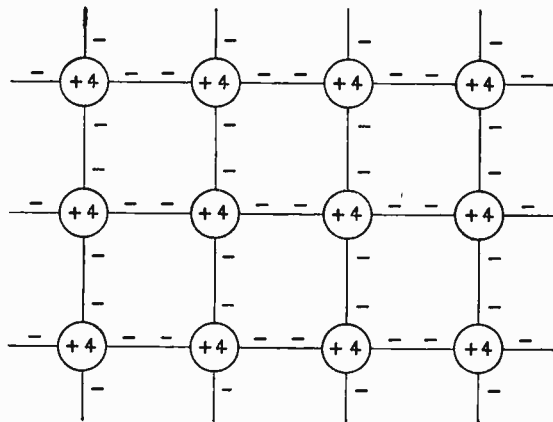

Fig. 3. Diagram of pure crystal lattice built up of Fig. 2(a) atoms.

consequently greater. Even with what would be considered chemically an insignificant amount of impurity the conductivity might be 100 times greater. In silicon, the effect would be even more marked if one could compare it with really pure silicon, which unfortunately is difficult to obtain.

And so another of the peculiarities of semi-conductors—the widely varying conductivities of "chemically pure" samples—has been accounted for. But it still doesn't seem to get us very near transistors.

However, arsenic (or phosphorus, or antimony, whose atoms also can be represented as in Fig. 2(b)) is not the only kind of impurity that can get into the semi-conductor crystal lattice. There is gallium, which, being element No. 31, looks like Fig. 2(c). Others in the same group are aluminium and indium. These come with only three valency electrons per atom, so when they are in the lattice they resemble germanium atoms from which an electron has been shaken out by heat—except that the nucleus has only three units of positive charge instead of four, so the atom as a whole is neutral. But they are, in effect, holes.

Vital Minority

Being familiar with the nomenclature of valves according to the number of their electrodes, we do not have to be Greek scholars to see why the atoms diagrammed in Fig. 2 are referred to as tetravalent, pentavalent and trivalent respectively.

The position, then, is that when either of the tetravalent elements germanium or silicon is contaminated by even minute proportions of a pentavalent element such as arsenic its electrical conductivity is increased well above the intrinsic conductivity of the pure element, because of the presence of one surplus electron per impurity atom. And with trivalent impurity much the same thing happens because of the presence of one hole per impurity atom. In the first case the conduction is by electrons; in the second it is (or, if you are a stickler for accuracy, *appears* to be) by holes.

We are now getting to the heart of the matter. And for quick reference to these two different impurity materials there are some technical terms, which can easily be remembered by noting the occurrence of the letters *n* and *p*. Pentavalent

atoms, which provide spare electrons, which are negative charges, are called donors; and a semi-conductor containing them is *n*-type. Trivalent atoms, which are holes, or positive charges, ready to receive electrons, are called acceptors; and a semi-conductor containing them is *p*-type. Note very particularly that calling a material *n*-type does *not* mean that as a whole it is negatively charged. Both *n* and *p* materials are normally neutral; the letters refer only to the loose charges.

And now we can carry the simplification of our atom and lattice diagrams a stage farther. We saw last month that a perfect germanium (or silicon) crystal consists of a lattice of Fig. 2(a) atoms, each one holding on to four others, as shown diagrammatically in Fig. 3. Each atom is electrically neutral and fixed—except for the small minority disturbed by heat, which we are going to ignore for the time being. So electrically the material hardly exists; Dr. Shockley has in fact drawn an analogy between it and the vacuum in a valve. It merely provides a space for the impurity electrons and holes to play about in. We are going to omit it entirely from our following diagrams in order to concentrate attention on the very small but vital minority of impurity atoms. These of course are scattered at random throughout the crystal, so form no particular pattern. And only the net electrical charge of each unit will be shown. There is first the loose electron, shown as before by a single minus sign. Then there is the hole which, although not truly movable, does (owing to successive transfers of electrons) virtually move nearly as readily as an electron; it is represented by a plus sign. Then a donor atom (Fig. 2(b)) having lost its one unemployed electron is a fixed unit positive charge, represented by a plus sign in a ring; and lastly an acceptor atom (Fig. 2(c)) is a fixed negative charge, represented by a minus sign in a ring. Fig. 4 shows a sample of each.

It would be a good idea at this point if you would make sure that the meaning of *n* and *p* material, and the conventional symbols just explained, have been grasped, by drawing diagrams of samples of

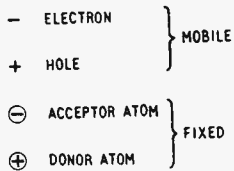

Fig. 4. Standard symbols for charged particles in semi-conductors.

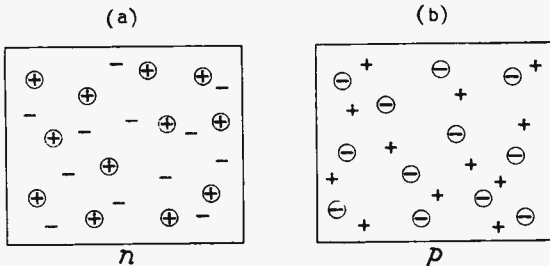

Fig. 5. Diagrams of (a) *n*-type and (b) *p*-type semi-conductor, using Fig. 4 symbols. Only the impurity atoms are shown; the atoms of germanium or silicon, which are usually millions of times more numerous, are omitted for clarity.

these two materials using the symbols. And then checking that they agree with Fig. 5. Remember that these diagrams show *only* the impurities; the millions of times as many germanium and silicon atoms are there but not shown. And whereas the minus signs in Fig. 5(a) represent real electrons floating around, the plus signs in Fig. 5(b) represent only the fact that *p*-type material behaves very much as if there were real positive charges, analogous to electrons, floating around. The real cause of this—and I am sorry if my insistence on this point is becoming a bore—is the movements of electrons from one acceptor to another.

P-N Junctions

There is an important point to clear up before at long last getting to the uses of all this. It has probably occurred to you that impurities of *both* types would almost inevitably be present to at least the minute extent that is significant electrically; and what then? As one might guess, the opposite effects neutralize one another, so that if there are exactly equal quantities of opposite impurities the material behaves electrically as if it were pure; its conductivity is no more than the intrinsic conductivity of the material at that temperature. The neutralizing effect is called *compensation*. This might seem to be a short cut past the obvious difficulties of purifying anything to better than 1 part in 10^9 . But if one were to try "purifying" germanium containing 1 part in 1,000 of arsenic—not very bad, by ordinary chemical standards—by adding an equal proportion of gallium, the problem of ensuring that the amount added was correct to 1 in a million might be worse than the problem being dodged. Anyway, in practice the germanium is purified in the proper straightforward way and the desired impurity added later; rather as crude iron is freed from carbon and then sufficient is added to make the grade of steel required. However, *over-compensation* is used to convert *n*-type to *p*-type or vice versa.

None of these three types of material—*n*, *p* or *i* (for "intrinsic")—is particularly useful on its own; it is when *n* and *p* types are brought closely into contact that results become really interesting. Just bringing two different pieces together is not good enough; in practice a single piece is caused to have *n* and *p* regions by introducing the appropriate impurities. The boundary between the regions—or often the whole combination of two kinds of material—is called a *p-n* junction.

The tendency of any concentration of electrons or holes is to scatter so as to fill the whole available solid uniformly. This movement is called diffusion, and is quite apart from movements caused by electric fields. So when the free electrons in the *n* half of a *p-n* junction look across the boundary and see the absence of electrons in the *p* half, they start drifting across. Similarly the holes in the *p* half start diffusing into the *n* region. Opposite charges moving in opposite directions are electric currents moving in the *same* direction—conventionally, the direction the positive charges (in this case, holes) move. However one looks at it, the *n* region, previously neutral, is becoming positively charged, and the *p* region negatively charged. The result is the growth of a potential difference between the regions. This p.d. tends to put a stop to the diffusion; the electrons that have

(Continued on page 397)

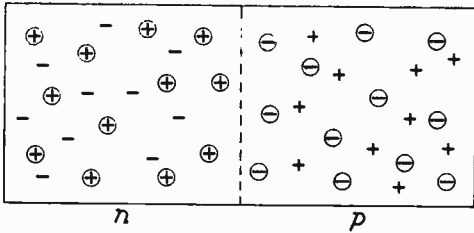

Fig. 6. A p-n junction, showing how the p side of the boundary becomes negatively charged because holes there are neutralized by electrons diffusing across from the n region. Similarly the n side becomes positively charged.

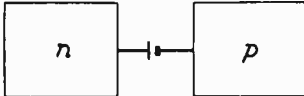

Fig. 7. The potential difference between the two sides of the boundary in Fig. 6 can be represented symbolically by an imaginary cell. But it must be realized that its voltage alters if an external e.m.f. is applied, as in Figs. 8 and 9.

already diffused, having no accompanying positive charges to neutralize them, form a negative charge that repels those coming on behind ("like charges repel"). Similarly with the holes.

Perhaps you think the trespassing electrons have plenty of positive charges around—a whole regionful of holes—to neutralize them. But in so far as these holes combine with the electrons and cancel them out, they themselves are cancelled out and can no longer balance the acceptor atoms (which are fixed negative charges). So either way the diffusing electrons make the p region go negative. Similarly the diffusing holes make the n region positive. On the assumption that the diffusing bodies disappear by combining with their opposite numbers, the general effect can be represented as in Fig. 6. The charged atoms cause a positive excess on the n side of the boundary and a negative excess on the p side. When this p.d. is just enough to balance the tendency to diffuse, the process stops. The situation can be represented even more simply as in Fig. 7, the p.d. being indicated by an imaginary cell.

The Junction Rectifier

The next thing is to see what happens when an external e.m.f. is applied in the direction + to n and - to p, as in Fig. 8; that is to say, in series opposition to the imaginary e.m.f. in Fig. 7. This charges the n region still more positive by attracting more electrons out of it; similarly the p region is made more negative. And again, after a very small temporary flow of current a balance is reached in which there is no current (except for intrinsic conductivity, which we are still neglecting so as not to become confused by trying to take in more than one thing at a time). In the Fig. 7 style of diagram, the result would be represented by an increase in the number of imaginary cells, sufficient to balance the diffusion tendency plus the externally applied e.m.f.

Unlike either of the n or p pieces separately, the combination appears to be a non-conductor.

After a pause to tick off yet another piece of previously incomprehensible behaviour on the part of a semi-conductor, we reverse the battery. Its e.m.f. is now series-assisting the internal p.d., tending to

make current flow. Electrons and holes trespass more or less freely on one another's regions; many of them annihilating one another no doubt, but the external battery replenishes the supply (Fig. 9). So in this direction current flows easily. The Fig. 7 "e.m.f." has meantime almost if not entirely disappeared, to represent the fact that the fixed junction charges shown in Fig. 6 are neutralized by the mobile charges.

In brief, a p-n junction is a rectifier.

According to the simplified theory just outlined, a p-n junction rectifier would be perfect—at least, in the reverse or no-current direction, because there really would be no current. How much resistance, if any, there would be to current in the forward direction does not appear. There would, presumably, be a bit of a bottom bend while the applied forward voltage was overcoming the junction p.d. indicated variously in Figs. 6 and 7, and after that the steepness would be greater the more the impurities present to contribute current carriers. The forward-current characteristic does in fact conform pretty well to that guess. It is the reverse behaviour that is more complicated.

First let us combine the impurity theory with the intrinsic theory. Then instead of Fig. 6, with nothing but donors and electrons on the n side and acceptors and holes on the p side, we would have to show a few heat-released electrons and holes on both sides. Some of the holes on the n side would no doubt be cancelled by electrons, which would be in a majority (they are, in fact, officially termed *majority carriers*, the holes being *minority carriers*), but those near the junction would find the p.d. there to be of the right polarity for carrying them across it to where they would be in a majority. Similarly, there would be a small current of electrons from p to n. This double current would tend to destroy

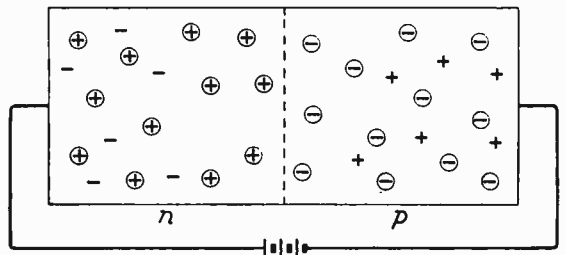

Fig. 8. An external e.m.f. of this polarity ("reverse") increases the p.d. shown in Figs. 6 and 7, and little or no current flows.

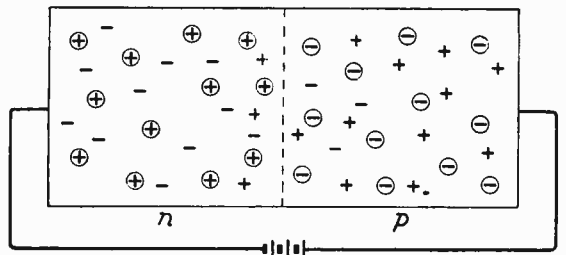

Fig. 9. An e.m.f. with "forward" polarity causes a relatively large current by enabling electrons and holes to flow freely across the junction.

the junction p.d., but if it did so the p.d. would be restored by diffusion. So instead of our previous picture of a balance with no current crossing the junction we have to substitute one with equal and opposite (and, at reasonable temperatures, relatively small) currents. Which for practical purposes comes to the same thing.

When the reverse e.m.f. is applied (Fig. 8) the junction p.d. no longer depends for its existence on diffusion current, which comes to a stop. But the intrinsic current carries on regardless, for the p.d. actually assists the minority carriers across the frontier. Therefore there is some reverse current, not much affected by the amount of applied voltage once that has become sufficient to stop the diffusion current. This is an example of intrinsic conductivity being a nuisance. And, as we know, it increases with temperature, so if a germanium rectifier gets hot for any reason it may pass so much reverse current as to be useless for the purpose. Silicon, which requires greater heat energy to break up its co-valent bonds, is not so bad.

But that is not all. If the reverse e.m.f. continues to be raised a point is reached (sooner, if the proportion of impurities is large) at which the electric field strength due to it is sufficient to break up the co-valent bonds and release electrons and holes on a catastrophic scale. When that happens the crystal has practically no resistance at all and one says it has broken down. The large current that flows is known, by the way, as Zener current.

Putting together all the things we now know, we should have no difficulty in accounting for the shape

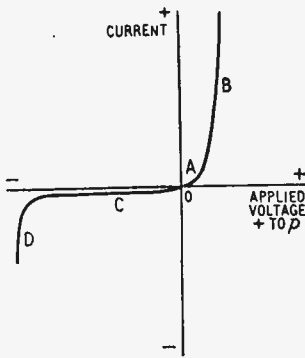

Fig. 10. Typical current/voltage characteristic of p-n junction.

of a p-n junction current/voltage characteristic, which is something like Fig. 10. A is the bottom bend, where the applied e.m.f. is busy overcoming the junction p.d. B is the steep current rise when it has succeeded. C is the nearly constant but small (if you are lucky) reverse current due to intrinsic conduction. And D is Zener current, plunging to its doom.

Still nothing about transistors, I fear. But Fleming's diode was soon followed by De Forest's triode, and history repeated itself after a fashion with semi-conductor devices.

New Life for the "Personal" Portable?

THERE has always been a strong public demand for the small "personal" portable receiver and nothing is more certain than that many more would have been sold were it not for the fact that running costs have hitherto been high. Battery power in the form of miniature high-tension units is necessarily expensive—much more so than in the form of batteries made up of larger cells.

The obvious solution is to use transistors, which dispense with filament heating and can also be operated entirely from inexpensive low-tension cells. Already the transistor has ousted the valve in hearing aids, and at least one portable radio receiver has appeared with transistors in all its stages. This is quite an achievement as it is not so easy to match valve performance at high frequencies with the junction transistors.

Another solution, which has been adopted in the Grundig "200" portable, is to use valves for the r.f. and i.f. stages and transistors in the output stage. In any receiver the output stage accounts for the greater part of the power consumed and if this drain can be transferred from the h.t. to the l.t. battery, running costs are materially reduced. In the Grundig circuit the valve h.t. consumption totals only 3.5 mA from a 67.5-V battery. This is divided between the DK96 frequency changer (1.77 mA), DAF96 i.f. amplifier (1.07 mA) detector and 1st a.f. amplifier (0.055 mA) and DF97 driver (0.6 mA). In the output stage two OC72 transistors in push-pull require a standing quiescent current of 1.7 mA from the 6-V l.t. battery and an interesting feature is the use of a thermistor in parallel with one of the bias stabilizing resistors to help in compensating for changes in ambient temperature. The output stage would take about 15 to 20 mA on average music, and the filaments about 25 mA.

SHORT-WAVE CONDITIONS Predictions for August

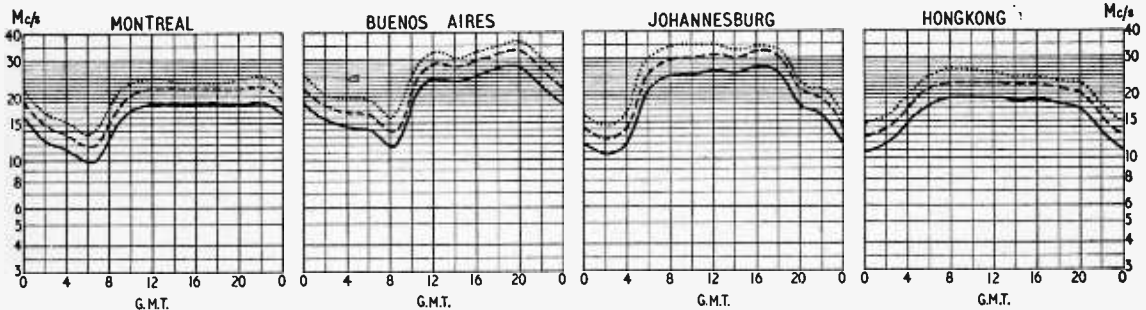

THE full-line curves given here indicate the highest frequencies likely to be usable at any time of the day or night for reliable communications over four long-distance paths from this country during August.

Broken-line curves give the highest frequencies that will sustain a partial service throughout the same period.

- FREQUENCY BELOW WHICH COMMUNICATION SHOULD BE POSSIBLE FOR 25% OF THE TOTAL TIME
- PREDICTED AVERAGE MAXIMUM USABLE FREQUENCY
- FREQUENCY BELOW WHICH COMMUNICATION SHOULD BE POSSIBLE ON ALL UNDISTURBED DAYS

BOOKS RECEIVED

Color Television Receiver Practices. Edited by C. E. Dean. Based on a series of lectures given to visiting engineers by the Hazeltine Corporation (U.S.A.) covering basic concepts, the colour television signal, display devices, three-gun shadow-mask tubes, decoders, colour synchronization, i.f. and video amplification and test equipment. Includes selected references to the literature. Pp. 200+viii; Figs. 96. Price 36s. Chapman and Hall, 37, Essex Street, London, W.C.2.

Elements of Pulse Circuits, by F. J. M. Farley, M.A., Ph.D. Monograph, addressed to physicists and research workers with an elementary knowledge of radio valves and circuits, covering all the well-known pulse forming and amplifying circuits and explaining their action on a physical rather than a mathematical basis. The concluding chapter deals with applications in television, radar and nuclear research. Pp. 143+viii; Figs. 74. Price 8s 6d. Methuen and Co., Ltd., 36, Essex Street, London, W.C.2.

MK Buizen Handbook. International valve manual covering American and Continental types, in which the relevant information is displayed, for rapid reference, in circuit-diagram rather than tabular form. Quick access to sections on diodes, triodes, tetrodes and pentodes, output valves, frequency changers, combined valves, thyatrons, crystal diodes and transistors, and cathode-ray tubes is given by colour-coded pages. Pp. 334 with numerous diagrams. De Muiderkring, Bussum, Netherlands. British agents, The Modern Book Company, 19-23, Praed Street, London, W.2. Price 15s.

Definitions and Formulae for Students—Modern Physics (3rd Edition). Compiled by L. R. B. Elton, Ph.D. Selection of memorable data including electronic and atomic constants, electron and field equations, the photoelectric effect, etc. Pp.+v. Price 2s. Sir Isaac Pitman and Sons, Ltd. Parker Street, London, W.C.2.

Contribuicao para o Estudo de Antenas Lineares—Teoria e Projecto de Antenas Rombicas by A. A. de Carvalho Fernandes, A.M.I.E.E., M.I.R.E. Comprehensive treatise (in Portuguese) on the theory of rhombic aerials, which includes formulae for the intensity of the radiated field, taking into account components with both vertical and horizontal polarization. Practical data is given for the design of arrays of stacked, and stacked and inter-laced rhombics. Pp. 415; Figs. 119. Price Esc. 150. Coimbra Editora, Lda., Avenida do Arnado, Coimbra, Portugal.

Studien über einkreisige Schwingungssysteme mit zeitlich veränderlichen Elementen by B. R. Gloor, Dr. Sc. Techn. An exhaustive study of the basic principles underlying the operation of super-regenerative receivers and an account of experimental work in verification of the theory. Pp. 234; Figs. 156. Price, Swiss Fr. 15. Verlag Leemann Zürich, Arbenzstrasse 20, Zürich 34.

Time-saving Network Calculations, by Harry Stockman, S.D. General advice on the approach to mathematical solutions of network problems with examples of the use of Thévenin's theorem, the potentiometer method and other techniques applied both for the transient and steady states. Pp. 120; Figs. 36. Price \$1.75. SER Company, 543, Lexington Street, Waltham, Mass., U.S.A.

Abacs or Nomograms, by A. Giet. Written for engineers rather than mathematicians and shows how abacs for routine calculations may be constructed to correspond with formulae involving any number of variables. Pp. 235; Figs. 152. Price 35s. Iliffe and Sons Ltd., Dorset House, Stamford Street, London, S.E.1.

Solution of Problems in Telecommunications, by C. S. Henson, B.Sc.(Eng.), A.C.G.I., A.M.I.E.E. Worked examples taken from papers of University of London B.Sc.(Eng.) and Graduate I.E.E. examinations to illustrate the application of basic theory to specific cases. Pp. 258+x; Figs. 122. Price 25s. Sir Isaac Pitman and Sons, Ltd., Parker Street, London, W.C.2.

Radio Electronics, by Samuel Seely, Ph.D. Mathematical analysis applied to the elements of communication systems and to the general problems of information theory and the effects of noise. Pp.487+viii; Figs. 438. Price 52s 6d. McGraw Hill Publishing Co., Ltd., 95, Faringdon Street, London, E.C.4.

Maintaining Hi Fi Equipment, by Joseph Marshall. Guide for service technicians to current American practice in high-quality sound reproducing systems, with practical hints on the tracing and elimination of distortion, hum, etc. Pp. 223; Figs. 135. Gernsback Library No. 58. Obtainable from Modern Book Company, 19-23, Praed Street, London, W.2. Price 23s.

Public Address and Sound Distribution Handbook. Advisory editor Alex. J. Walker. Description of amplifiers, microphones, loudspeakers, etc., used in p.a. work, and an analysis of typical complete installations. Pp. 160; Figs. 145. Price 21s. George Newnes, Ltd., Southampton Street, London, W.C.2.

THIS IS HI-FI

the heart of
your sound
system

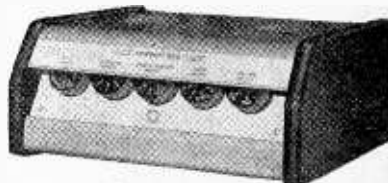

SPECIFICATION :

OUTPUT POWER. 8 watts normal to 12 watts peak.

OUTPUT IMPEDANCES. 3, 8 and 15 ohms.

FREQUENCY RESPONSE. 30 c/s to 15,000 c/s within ± 1.5 db at 6 watts output, controls level.

HARMONIC DISTORTION. Below 0.5% at 6 watts output at 1,000 c/s.

These are overall figures including output and pre-amp stages.

LOUDNESS COMPENSATION. Extra bass and treble boost automatically inserted at low volume:

- At 20 db below full output: 8 db lift at 50 c/s, 8 db lift at 10 Kc/s.
- At 40 db below full output: 20 db lift at 50 c/s, 15 db lift at 10 Kc/s.

RUMBLE FILTER. A high-pass filter incorporated with fixed slope of 18 db per octave below 30 c/s.

HUM and NOISE LEVEL. Better than—60 db.

NEGATIVE FEEDBACK is applied through a triple-loop circuit.

PICK-UP EQUALISATION. A wide range of pick-ups is covered by a unique rotating-plug equaliser in the pre-amp. stage. Sensitivity covers all types of magnetic, crystal, moving coil, variable reluctance, etc.

POWER. 110/115 and 200/240 volts, 40/60 cycles.

HT/LT SUPPLY is available for feeding Radio Tuner Unit, etc.

(1) INPUT SELECTOR

- 3-position switch
- LP sensitivity 2 mV
- 78 " 6 mV
- Radio/Tape ,, 100 mV

(2) LOUDNESS

- Automatic tonal balance adjustment at low volume

(3) TREBLE CONTROL

- Continuously variable ;
- 24 db range at 10 Kc/s.

(4) BASS CONTROL

- Continuously variable ;
- 24 db range at 40 c/s.

(5) FILTER

- Steep slope with 18 db per octave cut, between 5 Kc/s and 15 Kc/s, with cut-off frequency indication. (Continuously variable).

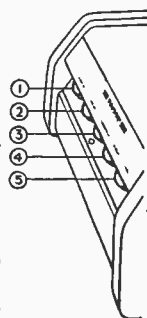

PRICE: 32 GNS.

THE TRIX ELECTRICAL CO. LTD.

MAPLE PLACE, TOTTENHAM COURT ROAD, LONDON, W.1.

Tel.: MUS 5817. Grams.: Trixradio, Wesdo. London

RANDOM RADIATIONS

By "DIALLIST"

F.C.C. and Receiver Radiation

YOU may recall that I suggested a while ago that there couldn't be much interference radiated from the line timebase or otherwise by American television receivers, and that a Baltimore reader wrote that this was in fact the case. The position has now been cleared up by an article in the June number of *Radio-Electronics*, which describes a certification scheme for sound and vision broadcast receivers which is now being made compulsory by the F.C.C. This body, which has in some ways even greater powers than those given to our G.P.O. by the Wireless Telegraphy Act, regulates radio communications of all kinds, including broadcasting, in the United States. With the co-operation of most American radio manufacturers it has now brought out permissible radiation limits for receivers of every kind working on frequencies from 0.45 to 1,000 Mc/s. Every set sold after a certain date will have to be provided with "a distinctive seal or label" on which the manufacturer certifies that it complies with the F.C.C.'s radiation regulations. The scheme is progressive. The rule became applicable on May 1st this year to all kinds of v.h.f. receivers; u.h.f. sets put into production after December 31st must fall into line, and from the beginning of July next year no uncertified receiver of any kind may be offered for sale.

Can't We, Too?

The F.C.C. schedule of the maximum permissible field strength of the radiation by any receiver is the result of five years of close consultation between the U.S. government and industry. It is much to be hoped that something of the kind will be done in our country. It shouldn't take anything like five years, though, for much work has already been done and we have the American figures—the results of a vast amount of investigation and experimental work—to help us. If, for example, the maximum permissible field strength of receiver radiation between 25 and 70 Mc/s has been found in America to be 32 $\mu\text{V/m}$, that between 70 and 130 Mc/s to be 50 $\mu\text{V/m}$, and that

between 174 and 260 Mc/s to be 50–150 $\mu\text{V/m}$, those figures should be suitable here for television and f.m. sets. There can be no great manufacturing difficulties about turning out receivers which comply with such limits, for the American radio industry has accepted them most enthusiastically. Couldn't some of our manufacturers give a voluntary lead by guaranteeing that their sets don't and won't interfere with other people's reception?

"Bournemouth Effect"

YOU remember the "Bournemouth Effect," which I recorded recently in these notes? A reader gave an f.m. receiver to his parents, then living in an apartment near the top of a large block of flats in Bournemouth. It worked perfectly; but when they moved later to a flat on a lower floor and the feeder was lengthened accordingly, he was told that they now heard the "chuffs" of every locomotive as it left the station. My best thanks to the many readers who wrote to me about this queer effect. All agree that the lengthening of the feeder provides the key to the problem. The increased attenuation brought signal strength down to a point at which the limiter was normally only just working; a very

small further fall, whatever the cause, would put it temporarily out of action and produce the chuffing. Several letters suggest that aeroplane flutter may be responsible; but I understand that the noise occurred when a train was actually leaving. The clouds ejected from the funnel consist largely of steam and hot gases at high pressure. One correspondent suggests that these might give rise to an electrostatic effect and mentions that interference with v.h.f. reception has been noticed in launches driven by compression ignition engines.

Tough Luck

HOW easy it is, as things are, for the best of good citizens to become a nuisance to his neighbours is shown by a letter I've had from a Yorkshire reader, who lives in a semi-detached house. His hobby is wireless; he likes receiving distant stations and he has spent quite a lot of money on suitable receiving sets and aerials. Not long ago he began to suffer severely from unwanted noises and concluded that the receiving set, which he had had for some years, was packing up. Having bought a new one of a more sensitive type he was not a little surprised to find the unwelcome noises worse than ever; they were in fact strong enough to make



"WIRELESS WORLD" PUBLICATIONS

	Net Price	By Post
WIRELESS SERVICING MANUAL. W. T. Cocking, M.I.E.E. 9th Edition	17/6	18/6
TELEVISION ENGINEERING: Principles and Practice. S. W. Amos, B.Sc. (Hons.), A.M.I.E.E. and D. C. Birkinshaw, M.B.E., M.A., M.I.E.E. in collaboration with J. L. Bliss, A.M.I.E.E.		
Volume I: Fundamentals, Camera Tubes, Television Optics, Electron Optics	30/-	31/2
Volume II: Video-Frequency Amplification	35/-	36/2
Volumes III and IV in preparation.		
SECOND THOUGHTS ON RADIO THEORY. "Cathode Ray" of <i>Wireless World</i>	25/-	26/2
THE OSCILLOSCOPE AT WORK. A. Haas and R. W. Hallows, M.A. (Cantab.), M.I.E.E.	15/-	15/10
RADIO LABORATORY HANDBOOK. M. G. Scroggie, B.Sc., M.I.E.E. 6th Edition	25/-	26/5
STUDIO ENGINEERING FOR SOUND BROADCASTING. B.B.C. Engineering Training Manual by members of the B.B.C. Engineering Division. General Editor J. W. Godfrey	25/-	25/11
RADIO INTERFERENCE SUPPRESSION: As Applied to Radio and Television Reception. G. L. Stephens, A.M.I.E.E. 2nd Edition	10/6	11/1
ADVANCED THEORY OF WAVEGUIDES. L. Lewin	30/-	30/10
FOUNDATIONS OF WIRELESS. M. G. Scroggie, B.Sc., M.I.E.E. 5th Edition	12/6	13/6

A complete list of books is available on application

Obtainable from all leading booksellers or from

ILIFFE & SONS LTD., Dorset House, Stamford Street, London, S.E.1.

reception of any station but the local one quite impossible. He then discovered that the noises occurred only when the occupier of the other half of the "semi" was using his television receiver, an instrument of reputable make, bought in all good faith, and in good working order. The matter was reported to the G.P.O., but their engineers explained to my correspondent that they can't go into action unless interference spoils reception of the B.B.C.'s local station. And he couldn't honestly say that it did so.

Sunspots and Dx

DURING the next few months we shall probably reach the period of maximum activity in the present sunspot cycle. Spots and flares have already been responsible for some queer effects, including the big radio blackouts which occurred earlier this year. At or near previous maxima television reception has been recorded at times at almost uncanny distances. The Alexandra Palace transmissions were received on occasion in the United States, and, if I remember rightly, in South Africa. At the last sunspot maximum period there were few TV transmitters in action and receivers numbered only a tiny fraction of the present total; but during that period which we are now nearing when a huge number of transmitters will be in action and millions of receivers in use in different parts of the globe, I shouldn't be surprised if some remarkable Dx feats were recorded.

A Cry Over Spilt Milk

BEING one of those in favour of higher-definition television, I can't help feeling that it's perhaps a pity that we didn't decide to devote Band III entirely to 819-line television, clearing the whole of it from end to end and dividing the available channels between the B.B.C. and the I.T.A. The B.B.C. could have put on either its proposed second programme, or an 819-line version of its Band I transmissions. We'd have had vastly better television. We'll get that better television one day, of course; but there are so many snags in the way that it is not likely to come now until much water has flowed beneath the bridges. The French were luckier, as well as wiser. Very few 441-line receivers were in use when the 819-line system began to take shape and fate lent a hand a while ago when the 441-line station on the Eiffel Tower was burnt out.

"THE CHOICE OF CRITICS"

SWITCHES

MANY TYPES FOR MANY USES

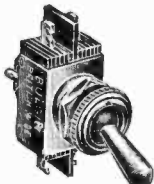

DOUBLE-POLE



SEMI-ROTARY KEY



SEMI-ROTARY

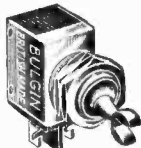

SLOTTED DOLLY

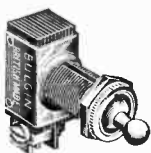

LONG-BUSH

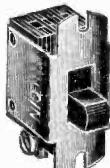

SLIDE-ACTION

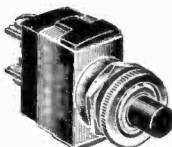

PRESS-ACTION



MOULDED

★ FOR FULL INFORMATION ON THESE AND OTHER BULGIN COMPONENTS — SEND FOR LATEST CATALOGUE

Ref. 195/WW — Price 1/- post free.



BULGIN

A. F. BULGIN & CO. LTD.
BYE-PASS ROAD,
BARKING, ESSEX

Telephone R1Ppleway 5588 (5 lines)

Mastering Morse

IT is not often that I omit to mention jubilees and centenaries of wireless landmarks, but I am reminded by an article in the May issue of the *R.S.G.B. Bulletin* that I forgot all about the centenary of the international morse code in 1951.

This highly informative article points out that Morse's original code was compiled in 1837 and revised a year later. Both these codes used variable spacing between the elements of certain letter symbols but this practice was abandoned in the International code adopted by the Vienna Conference in 1851, and still in use.

An interesting point about the work of Morse is that he adopted the principles of what we now call information theory and arranged that letters in most frequent use—or in other words letters conveying the most information—should be given the shortest code symbols. He found that the letter E headed the list in the English language and so it was given the shortest code symbol. The Vienna Conference had to make compromises between the needs of the various languages. The letter O was apparently a stumbling block, being frequent in English but relatively infrequent in French and German. I wonder if the Polish delegate protested about the length of the symbol allotted for Z.

A curious point brought out by the author of the *R.S.G.B. Bulletin* article is that those learning morse get stuck at a speed of 7 to 10 words per minute. A writer in *W.W.* discussed this same problem fifteen years ago in June 1941 and I added a few remarks of my own in the October issue. He called it the "psychological pause," but differed slightly from the writer in the *R.S.G.B. Bulletin* as he gave a higher figure for it—about 15 w.p.m.

The real difference between the two writers, however, is in their remedies for overcoming this strange

mental barrier. The writer in the *R.S.G.B. Bulletin* counsels perseverance or, in other words, hard work! Ugh! The *W.W.* writer gave a far more palatable remedy which was to get slightly drunk and he meant it in all seriousness. The effect of alcohol is to remove certain mental or psychological inhibitions which cause the speed barrier.

Similar tactics can be used to get over certain other brain and muscle co-ordination difficulties and it is possible for instance to dodge the drudgery of learning to type at high speed by the judicious use of alcohol. However, the system has never been adopted by the business colleges as, in certain of the more staid and reactionary City offices, girls who have learned to type rapidly in this manner are thought to be fast in more senses than one. I recollect once in my younger days dictating to a typist who—but there! readers of *W.W.* wouldn't be interested in personal reminiscences of a non-technical nature.

Triangular Television Wanted

TELEVISION screens seem to be getting bigger and bigger to cater for people who want to compete with the Jones's, for I cannot think people really want these big screens in the average small house. Big screens mean bigger cabinets with WX dimensions not only in the plane of the picture but in the fore and aft direction, too, as the tail end of the bigger C.R.T. has to be housed.

For the large family party I think the best type of set is one which I myself designed and built over three years ago for a Coronation viewing party at home. It was a console receiver modelled on the lines of Big Ben and had a moderate-sized screen on each of the four sides of the tower like the famous clock. Thus we were all able to sit round in a circle and view the long programme in comfort. The four tubes were all slightly different in their height above ground so that their tails didn't foul each other in the tower-like cabinet.

For ordinary family viewing I am at present using a set having two screens, one set at a slightly obtuse angle to the other so that each member of the family has a full-faced undisturbed view of the picture. This is much better than all crowding round a large screen with some people viewing the screen at an acute angle where they get an uncomfortable lop-sided view like the unfortunate rich people who patron-

ize the boxes at a theatre. Here again, one tube is slightly higher than the other to avoid fouling of tails.

The ideal set for the ordinary man with a small family in a small house is one which will take up least room; namely, one with a triangular cabinet so that it will fit neatly into a corner. Why on earth some enterprising manufacturer doesn't produce such a set, I just don't know.

Car-Owners Corner

CERTAIN motoring experts seem recently to have discovered that cars which are, of course, insulated from the ground by their tyres acquire a static charge in dry weather which is said to cause car sickness. The result is that many dealers are selling small anti-static chains to trail behind cars.

It is no concern of mine, writing in a radio journal, whether static charges do or do not cause car sickness but I do know from experience that this trailing lightweight chain, owing to the poor connection it makes with the ground, causes intermittent discharge of the static charge and therefore bad interference with the car's radio set when receiving weak signals.

The real remedy is to earth the chassis so firmly that no static can even accumulate and this can be done by affixing to the tyres the chains sold for use on snowbound roads. This will undoubtedly attract the attention of the police and cause much licking of pencils, but it is not an offence. By the way, what has happened to the special anti-static tyres which were available in pre-war days when I last touched on this subject? (*W.W.*, 8.12.38.)

Tele-Pictures in 1842

WE are all so accustomed to seeing pictures in our newspapers which have been transmitted by radio that we are apt to take them for granted. Yet most people would laugh to scorn any suggestion that the telegraphic transmission of pictures dated back to Victorian or even Edwardian days; it is regarded as essentially a modern invention.

Yet the basic idea goes back not only to the days of Queen Victoria but to within five years of the death of William IV. It was in 1842 that Alexander Bain first proposed a scheme for transmitting pictures electrically, using two pendulums of identical dimensions as transmitter and receiver, respectively, for synchronizing purposes. Synchronization is the whole essence of picture transmission as it is of television, and this basic principle was realized by Bain. Thus picture telegraphy was conceived almost as early as ordinary telegraphy, but its period of gestation proved many decades longer.



A morse miasma.

Designed for

See the complete range of "Avo" Instruments at the **RADIO SHOW** Stand **3**



dependability



The "AVO" Valve Characteristic Meter, Mk. III is typical of the ingenuity of design and high standard of workmanship that exemplify all of the multi-range instruments in the wide "AVO" range.

It is a compact and comprehensive meter that will test quickly any standard receiving valve or small transmitting valve on any of its normal characteristics under conditions corresponding to a wide range of D.C. electrode voltages. The method of measuring mutual conductance ensures that the meter can deal adequately with modern T.V. receiver valves. It does many useful jobs too numerous to mention here, but a completely descriptive pamphlet is available on application.

List Price **£75** complete with Instruction Book and Valve Data Manual.



The **AUTOMATIC COIL WINDER & ELECTRICAL EQUIPMENT CO., LTD.**

AVOCET HOUSE • 92-96 VAUXHALL BRIDGE ROAD • LONDON • S.W.1 • VICTORIA 3404 (9 lines)

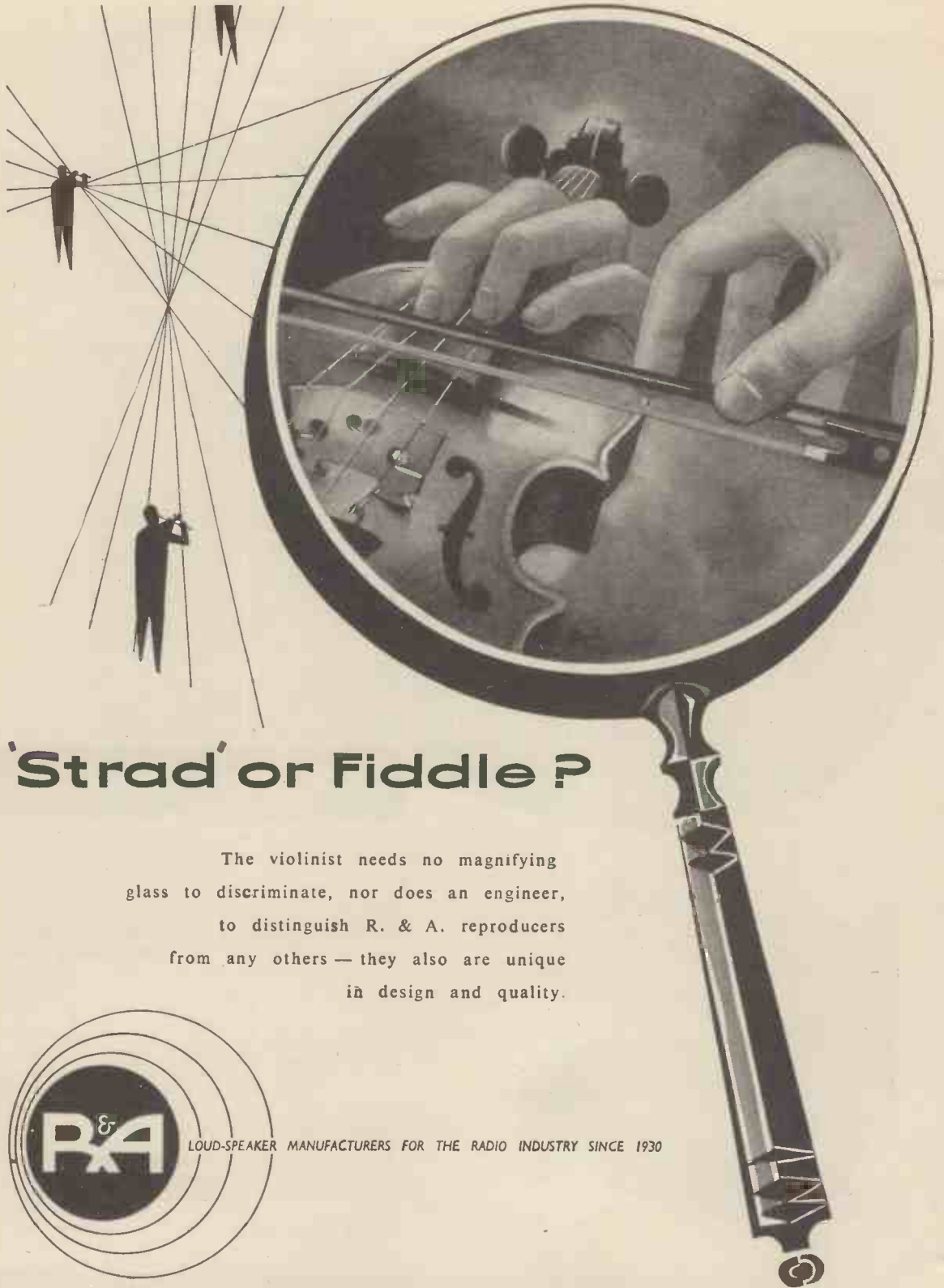

'Strad' or Fiddle ?

The violinist needs no magnifying glass to discriminate, nor does an engineer, to distinguish R. & A. reproducers from any others — they also are unique in design and quality.



LOUD-SPEAKER MANUFACTURERS FOR THE RADIO INDUSTRY SINCE 1930

REPRODUCERS AND AMPLIFIERS LTD.

WOLVERHAMPTON · ENGLAND.

Telephone: 22241/2/3/4. Cables: AUDIO.

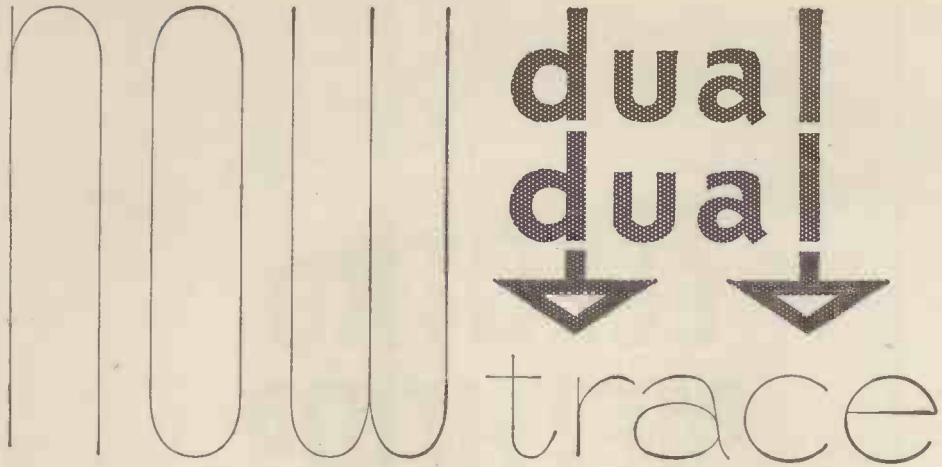

oscilloscope mark 2

... two input signals displayed for direct comparison and their characteristics accurately measured by the turn of a knob ... such are the facilities and convenience afforded by the Mullard Dual Trace Oscilloscope, type L.101.

Well-engineered and reliable, the L.101 Oscilloscope is the oscilloscope where the demand is for a high grade general purpose instrument. It employs two identical amplifiers with bandwidths of 4 Mc/s irrespective of sensitivity. Each amplifier is aligned for good transient response, has a rise time of 0.1 μ sec, and a maximum sensitivity of 20 mV pk-pk/cm.

The time base may be free running, synchronised or triggered. Its velocity is continuously variable between 0.1 μ sec/cm and 10 msec/cm. Both time and voltage may be measured by the nul method and a well-regulated power supply preserves calibration accuracy.

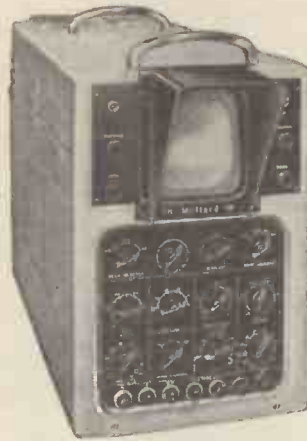

mark 2 features

- **Post Deflection Acceleration** gives a brighter display at low repetition rates.
- **R. C. Probe** ensures that only negligible damping is imposed on high impedance circuits. (This probe is also available to users of the Mark 1 model.)
- **Improved Triggering Circuit** starts the time base with the minimum delay from either positive or negative signals of only $1\frac{1}{2}$ V amplitude.

Full details of the L.101 Mark 2 are readily available from Mullard at the address below or from any of their distributors.

Belfast: James Lowden & Co. Ltd., Tel. 57518. **Birmingham:** Gothic Electrical Supplies Ltd., Tel. CEN 5531.

Bristol: T. Neesham & Co. Ltd., Tel. 22732. **Glasgow:** Land Speight & Co. Ltd., Tel. CEN 1082.

Manchester: F. C. Robinson & Ptners. Ltd., Tel. Chorlton 5366. **Newcastle:** Electricals Ltd., Tel. 28617.

London: Mullard Equipment Division, Tel. CHA 8421.

Mullard



SPECIALISED ELECTRONIC EQUIPMENT

MULLARD LIMITED, EQUIPMENT DIVISION, CENTURY HOUSE, SHAFTESBURY AVENUE, LONDON, W.C2

ELECTRO METHODS LTD OF STEVENAGE

BRITAIN'S FOREMOST DESIGNERS

AND MANUFACTURERS OF

**HIGH
STABILITY MAGNETIC
AMPLIFIERS**

An extensive range
of our standard types of
SINGLE-STAGE or PUSH-PULL

Magnetic Amplifiers
is always available for
prompt delivery

*

**SPECIAL TYPES CAN BE DESIGNED
TO SUIT YOUR NEEDS**

*

Full technical data
and illustrated leaflets promptly
forwarded on request

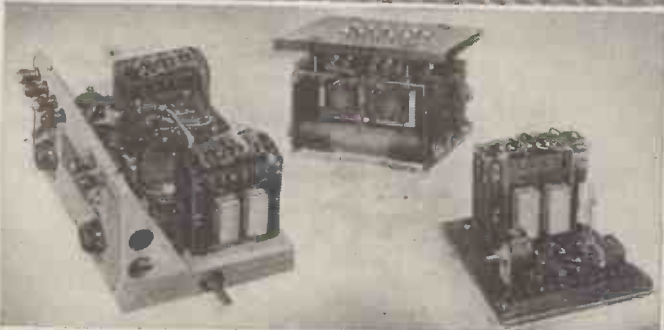

ELECTRO METHODS LTD. 12-36 CAXTON WAY, STEVENAGE, HERTS. Phone: STEVENAGE 780

NEW use for old Oak chests!

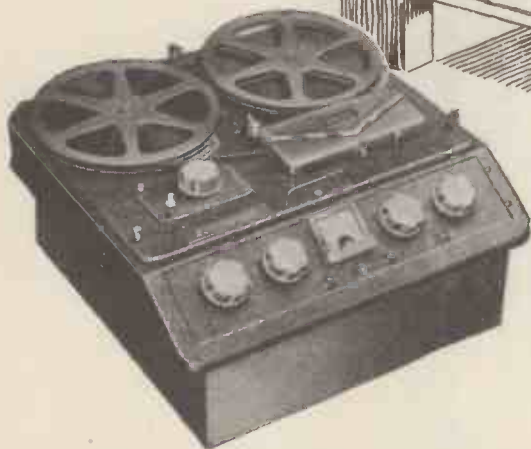

All metal construction, with overlap to fit snugly on any flat surface with opening $15\frac{3}{8}'' \times 16\frac{1}{2}''$. Incorporating all Ferrograph proved features of design, including synchronous proved features of design, including synchronous main drive motor, separate tone controls, two speeds, $2\frac{1}{2}$ watts undistorted output, source selection switch, automatic motor cut-off. Finished in gold bronze with cream knobs and accessories.

Model 66N

Model 66H

$3\frac{1}{2}''$ & $7\frac{1}{2}''$ p.s.

$7\frac{1}{2}''$ & $15''$ p.s.

84 gns

88 gns

(including 1,750 ft. Ferrotape on $8\frac{1}{4}''$ reel)

IN great-grandma's time the old oak chest was generally the place where the household linen was stored. But to-day it has another use—at least in the home of Mr. Geoffrey Parnell, of Leeds. He writes: "Wondering how I could house the Ferrograph 66 I had on order, I suddenly noticed an old oak chest which had belonged to my wife's grandmother. It offered the ideal solution because not only did it take the Ferrograph but there was ample room, in addition, for a Garrard turntable and an F.M. Tuner unit".

Yes—you've certainly got something there, Mr. Parnell! The combination of these three units in one permanent installation—with an external loudspeaker—is the last word in home entertainment forecasting an important trend for the future. For not only does it permit tape recordings of the highest quality to be made from radio, disc or microphone at the touch of a switch, but the owner can use the high fidelity amplifier incorporated in the Ferrograph with the F.M. tuner as a superb radio receiver or with the turntable as a luxury gramophone. He has, in fact, three instruments in one at a very substantial saving in cost and space.

Ferrograph "66"

BRITISH FERROGRAPH RECORDER CO. LTD

131 SLOANE STREET · LONDON · S.W.1 · Tel: SLOANE 2214/5 and 1513

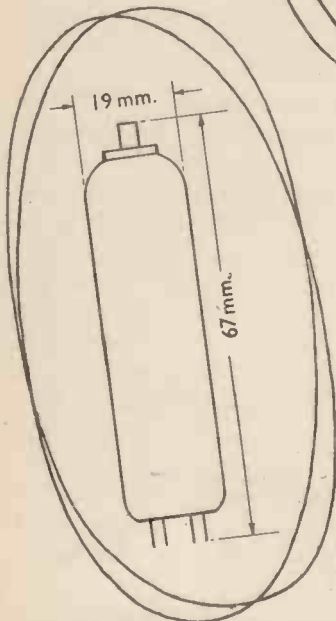
G.E.C.**CORONA STABILISER****SC1**

A hydrogen filled gas discharge tube capable of providing a stable voltage source for such devices as Geiger-Müller Counter Tubes.

These devices are available for providing stable H.T. supplies of 400, 600, 800, 1000, 1200 and 1400 volts. For higher voltages any combination of tubes may be operated in series.

TYPICAL RATING

	SC1/600	SC1/1000	
Stabilised output	600	1000	V
l tube (max.)	300	300	μA
l tube (min.)	20	20	μA
Tube resistance	50	50	kΩ
Stability	1	1	%

For further information, write to the Valve & Electronics Dept.

THE GENERAL ELECTRIC CO. LTD., MAGNET HOUSE, KINGSWAY, W.C.2

Garrard

AUDIO PERFECTION

301 TRANSCRIPTION MOTOR

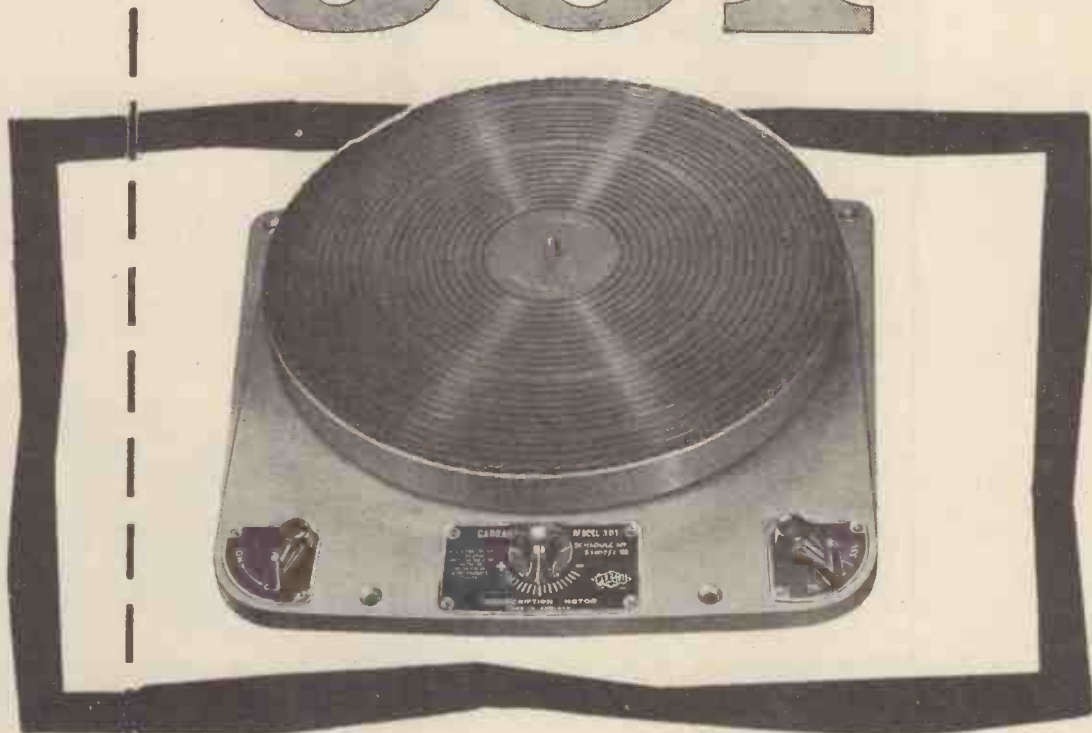

THE GARRARD MODEL 301 TRANSCRIPTION MOTOR

The Garrard Model 301 Transcription Motor is recognised as supreme in its class. With its introduction a hitherto unattainable standard in the manufacture of High Fidelity Gramophone Components has been reached. Features that the enthusiast will appreciate are the suppression of switch clicks, the extra heavy balanced turntable and the very fine degrees of speed control available . . . multi-speed can be adjusted by approximately 2½%.

Wow and Flutter have been reduced to the minimum, being less than 0.2% and less than 0.05% respectively. The unit is equipped for dual voltage ranges of 100 to 130 and 200 to 250 volts, 50 or 60 cycles according to the motor pulley fitted.

The Model 301 is finished in high quality grey tone enamel, is fully tropicalised and is supplied complete with a plastic stroboscope, a tube of special grease, all fixing screws, washers, template and instruction manual. . . . see your Dealer now.



**THE GARRARD ENGINEERING
AND MANUFACTURING CO., LTD.**

Swindon, Wilts, England

50%
EXTRA PLAYING TIME
 with this
 new tape!

For greater convenience and vastly improved performance, get 'SCOTCH BOY' *Extra Play* magnetic recording tape, No. 150. The new polyester base film is one-third thinner — *and still it is stronger!* — than other bases. That is why a reel carries half as much tape again, and gives you 50% EXTRA PLAYING TIME . . . 1800 feet of tape instead of the usual 1200 on a 7' reel!

The specially developed oxide coating of 'SCOTCH BOY' 150 tape is also thinner than usual. This new, potent coating gives exceptionally crisp and clear reproduction. Response to the higher frequencies is particularly improved.

'SCOTCH BOY' *Extra Play* 150 tape is *limp*, flexible, strong, and easy to handle. It hugs the contours of recording heads, winds trimly, and tracks smoothly. It has an indefinite life in storage and is the ideal tape if you are an archivist.

'SCOTCH BOY' III, acetate-base tape, world-famous for faithfulness and clarity, is still available, of course, in lengths up to 1200 feet.



GO FOR THE TAPE THAT GIVES YOU BETTER PERFORMANCE AND 50% EXTRA PLAYING TIME

SCOTCH BOY extra play

REGD. TRADE MARK

MAGNETIC RECORDING TAPE 150

with polyester base



MINNESOTA MINING & MANUFACTURING COMPANY LIMITED

LONDON • BIRMINGHAM • MANCHESTER • GLASGOW



FREQUENCY STANDARD

Type 761

- Standard signals provided at 100 c/s, 1 kc/s, 10 kc/s, 100 kc/s and 1 Mc/s.
- Outputs available with both pulse and sinusoidal waveform simultaneously.
- Complete built-in Oscilloscope provided.
- Heterodyne Amplifier and Loudspeaker incorporated.
- A built-in clock enables the equipment to be used as a time standard.
- Immediate delivery.

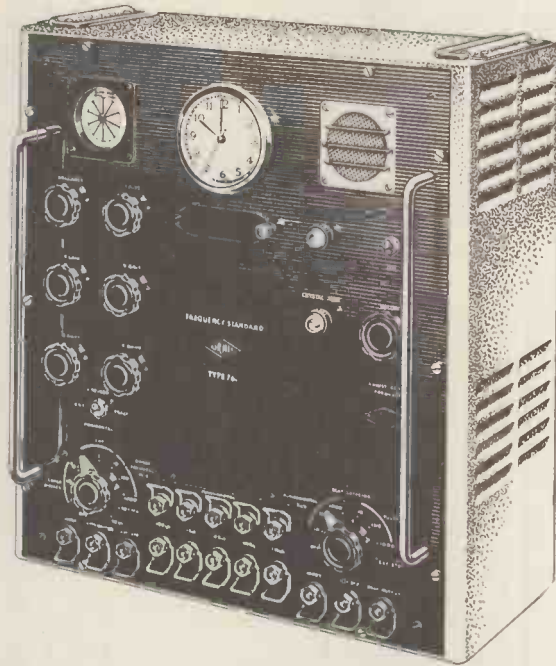

THIS instrument has been designed to fill the need for a versatile, self-contained, crystal-controlled frequency standard of moderate cost. Although relatively small in size a short-term frequency stability of better than 1 part in 10^8 is obtainable upon installation. This short-term stability improves with time and correct treatment up to a limit approaching 1 part in 10^7 .

Sine wave and pulse signals are produced at five standard frequencies, the pulse waveforms being rich in harmonics, and since the instrument includes both an Oscilloscope and Heterodyning Circuit as independent facilities, it is extremely flexible in operation.

Full details of this or any other Airmec Instrument will be forwarded gladly on request

AIRMEC LIMITED

HIGH WYCOMBE, BUCKINGHAMSHIRE, ENGLAND

Telephone: High Wycombe 2060. Cables 5 Airmec, High Wycombe



MARCONI

SURVEYED

PLANNED

V. H. F. MULTI-CHANNEL SYSTEMS

VHF radio-telephony was welcomed in its early days as an economic means of providing communication over terrain where the cost and difficulty of erecting line or cable routes was prohibitive. Today Marconi's have developed multi-channel systems

which, by employing frequency modulation to widen the bands, provide up to 48 telephone channels and are recognised as being preferable to line systems in many instances on grounds of performance as well as installation cost.

COMPLETE COMMUNICATION SYSTEMS — *all the world over*



INSTALLED

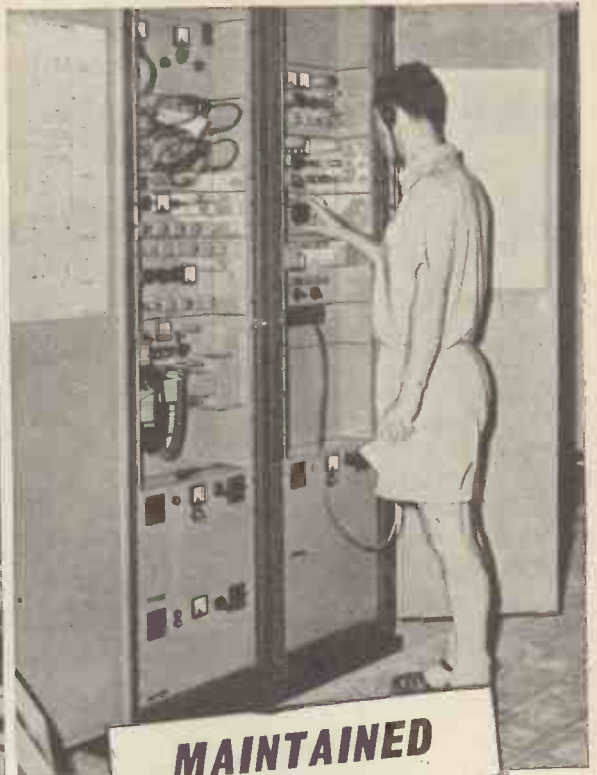

MAINTAINED

Over 80 countries now have Marconi-equipped communication systems. Many of these are still giving trouble-free service after more than 20 years in operation.

The lifeline of communication
is in experienced hands



MARCONI

Complete Communication Systems

MARCONI'S WIRELESS TELEGRAPH COMPANY LIMITED, CHELMSFORD, ESSEX.



HIGH FIDELITY plus HIGH VERSATILITY

Behind the new RCA High Fidelity Amplifier stands over a quarter of a century's skill and experience in designing professional sound reproducing equipment. This Amplifier includes several exclusive features entirely new to audio engineering, thus making it many years ahead of its time both in design and construction.*

The resulting performance will be found to give a new meaning to high fidelity reception and a new realism to recorded music.

The RCA High Fidelity Amplifier can be incorporated successfully into any existing home audio system. The versatility of its input and output facilities coupled with the wide measure of control afforded by the Pre-Amplifier means that it can be used in conjunction with most high quality audio equipment.

Pre-amplifier
and
Main Amplifier
£48 . 0 . 0

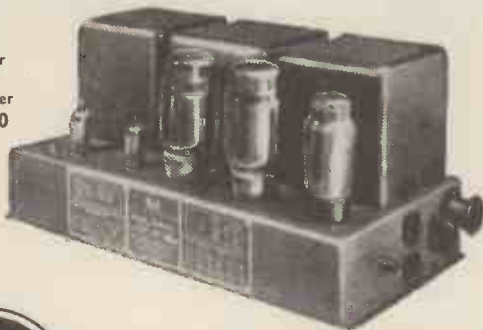

*New Orthophonic
High Fidelity*

RCA GREAT BRITAIN LIMITED

An Associate Company of Radio Corporation of America

Lincoln Way, Windmill Rd., Sunbury-on-Thames, Middx.

Telephone: Sunbury-on-Thames 3101.

PRE-AMPLIFIER

INPUTS—Magnetic Pickup

B.78. 16 mv input for rated output. 300 c/s Turnover. 6 DB Roll-off at 10 Kc/s.

A.78. 14 mv input for rated output. 500 c/s Turnover. 16 DB Roll-off at 10 Kc/s.

L.P. 13.5 mv input for rated output. 500 c/s Turnover. 12 DB Roll-off at 10 Kc/s. Flattened LF at 50 c/s to + 13 DB.

R.I.A.A. 11.5 mv input for rated output. 500 c/s Turnover. 14 DB Roll-off at 10 Kc/s. 3 DB Flattening at 50 c/s.★

Crystal Pickup. .35 volt with inbuilt equalisation from constant amplitude to constant velocity output enabling switched replaying characteristics to be accurately employed.

Radio/Tape High Level 200 mv. Flat characteristic. Low level 50 mv. Flat characteristic.

Microphone 6.5 mv for rated output. Flat characteristic.

Mixer Facilities for microphone input, with radio/tape gramo inputs.★

OUTPUT. 1.2 volts from cathode follower stage.

TAPE RECORDING OUTPUT. 1.2 volts cathode follower independent of monitoring.

BASS & TREBLE. Plus and minus 14 DB at 50 c/s and 10,000 c/s.

VOLUME. Twin ganged control giving correct gradation.★

LOW-PASS FILTER. Switched 10 Kc/s, 7 Kc/s, 5 Kc/s and Flat.

HIGH-PASS FILTER. Inbuilt, attenuating below 20 c/s.

FILTER SLOPE. Variable to 35 DB per octave.

POWER REQUIREMENTS. 375 v/7 ma, 6.3 v/1 amp.

MAIN AMPLIFIER

OUTPUT. 12 watts rated. Peak in excess of 20 watts over 25-20,000 c/s.★

DISTORTION. Total harmonic less than .1% at 10 watts—700 cycles.

NOISE LEVEL. 85 DB below rated output.

DAMPING FACTOR. Variable from positive to negative values.

FREQUENCY RESPONSE. Within 0.2 DB 20—25,000 c/s ± 0.5 DB 10—60,000 c/s.

FEEDBACK. 40 DB total.★

OUTPUT IMPEDANCES. 4 ohms, 7 ohms, 15 ohms.

INPUT VOLTAGE. 1.2 v. for rated output.

ANCILLARY POWER SUPPLIES. 375 Volts 45 milliamps. 6.3 volts 2.5 amps available for VHF

Tuner, Pre-amplifier and Tape Reproducer amplifier.

POWER CONSUMPTION. 130 VA at full load.

AC Input 100/150 and 200/250 volts.

PRINTED CIRCUIT CONNECTORS

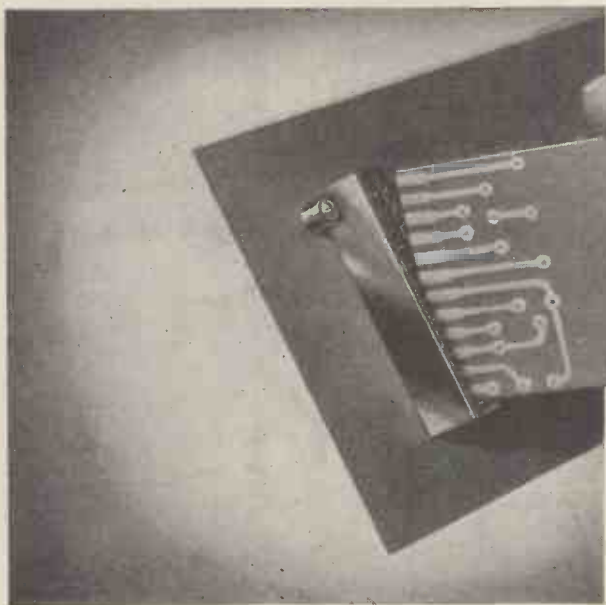

*Printed Circuit Connectors in high grade black
moulded bakelite.*

Six, twelve or eighteen way.

Specially designed not to damage printed circuit foil.

Silver plated Phosphor Bronze Contacts.

Current carrying capacity : 5A.

Polarising keys available, if required.

Insertion pressure : 175—200 grammes per contact.

Contact centres : 5/32".

6 BA. fixing.

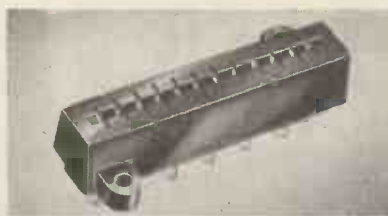

EXNING ROAD · NEWMARKET · SUFFOLK
TELEPHONE: NEWMARKET 3181·2·3 **TELEGRAMS: POWERCON · NEWMARKET**



Announcing

The first of the Elac
"ELMAG"

*Series of
 High Fidelity Units*

**9 x 5 Elliptical Speaker
 Type 59T.**

This unit is designed to give good quality at domestic volumes, it can be operated successfully in conjunction with a normally good receiver.

Where a Power Output Stage providing more than 4 watts is used, 2 or more speakers are recommended.

Flux Density, 8000 gauss (27,500 Maxwells) Frequency
 Response 40-12,000 Cps.

RETAIL PRICE.....38/2 inc. Tax

With Transformer49/4 inc. Tax



ELECTRO ACOUSTIC INDUSTRIES LTD

STAMFORD WORKS. BROAD LANE. TOTTENHAM, N.15 TEL: TOTTENHAM 0505-9



**Solderless terminals
speed assembly
eliminate rejects**

The AMP precision method of wire termination reduces production costs and provides connections of the highest electrical and mechanical efficiency. The use of AMP precision crimping tools and automatic machines achieves exceptionally high rates of output, a uniformly high standard of quality and the elimination of human error. AMP terminations and connections are of particular value in electronics and aircraft installations. They withstand vibration, corrosion and provide high tensile strength, with low resistance, and no noise at R.F.

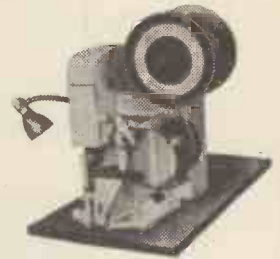

Automatic wire terminator operates at up to 4,000 an hour.



Pneumatic hand tool eliminates operator fatigue.



Certi-crimp hand tool. Positive closure ensured.

Brochure W.W. sent or demonstration at your own works on request.

AMP terminals are made for every type and size of wire.

AIRCRAFT-MARINE PRODUCTS (GT. BRITAIN) LTD.
London Sales Office: 60 KINGLY STREET, LONDON, W.1. Tel: REGent 2517/8
Works: SCOTTISH INDUSTRIAL ESTATES, PORT GLASGOW, SCOTLAND

Ahead of the present —



— abreast of the future

Distortion detected - Transmission unaffected

with the T.D.M.S.

The T.D.M.S. 5A and 6A are portable sets designed to measure distortion at any point in a radio teleprinter or line telegraph circuit without interfering with normal transmission. The equipment consists of two units each $18\frac{1}{2}$ " x $11\frac{1}{2}$ " x $13\frac{1}{2}$ " both mains driven and electronically controlled. Either may be used independently for certain tests or both may be used in combination to cover a comprehensive range of testing operations.

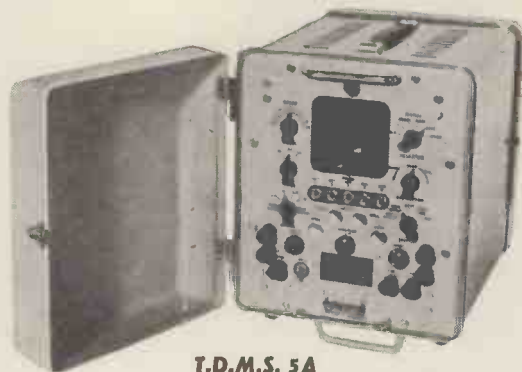

T.D.M.S. 5A

Sends an automatic test message, or characters, or reversals at any speed between 20-80 bands with or without distortion. The CRO has a circular time base for distortion measurements on synchronous signals only, or relay adjustment. Weight 37 lb.



T.D.M.S. 6A

For distortion measurements on working circuits without interrupting service. Each element of a start-stop signal appears separately on the spiral time base display. Adjustable speeds from 20-80 bands. Weight 33 lb. Higher speed versions can be supplied to order.

You are invited to apply for a copy of a descriptive leaflet.

AUTOMATIC TELEPHONE & ELECTRIC CO. LTD.,

RADIO AND TRANSMISSION DIVISION,
STROWGER HOUSE, ARUNDEL STREET, LONDON, W.C.2.
TELEPHONE : TEMPLE BAR 9262. CABLEGRAMS : STROWGEREX LONDON.



AT14611-BX107

7.5 to 250 Mc/s

ON FUNDAMENTALS
IN FIVE RANGES

SINE AND SQUARE WAVE MODULATION

R.F. OUTPUT 1 μ V to 100 mV

This "Advance" V.H.F. Signal Generator covers 7.5 to 250 Mc/s, a range that embraces Bands 1 and 2 and also the impending Very High Frequency Television Transmissions on Band 3.

Moreover, this instrument is available at a price well within the reach of every service man. In the traditional "Advance" manner, this instrument is designed for simple operation and with a versatility that not only fulfils present needs, but anticipates the even more exacting requirements to deal with the television test problems of tomorrow.

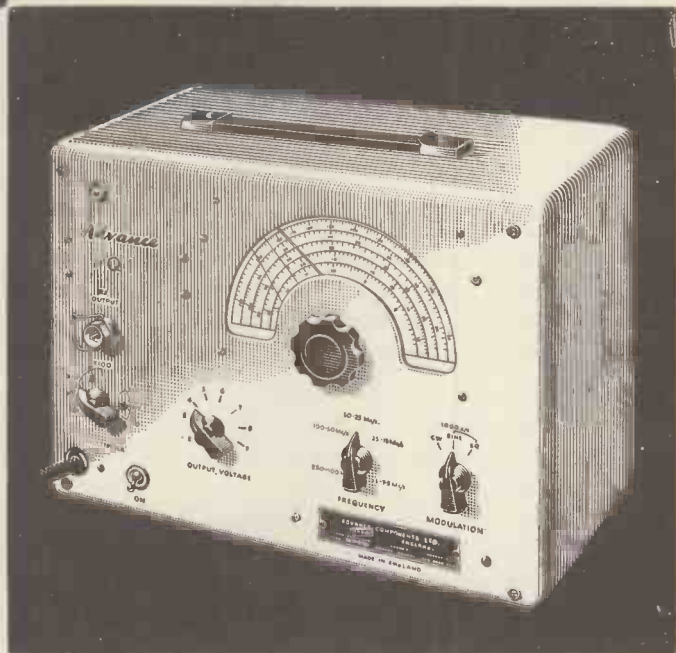

Below are some outstanding features :-

- WIDE RANGE—7.5 to 250 Mc/s
- SINE AND SQUARE WAVE MODULATION
- RELIABLE ATTENUATION
- LOW LEAKAGE—less than 3 microvolts
- TRULY PORTABLE—weighs only 17lb.
- COMPETITIVE PRICE



The Q1 provides the ideal complement to the Model E2. These together give complete coverage from 100 kc/s to 250 Mc/s.

Full technical details available in Folder W23 on request.

Advance

MODEL **Q1**
V.H.F. SIGNAL GENERATOR

£45

(List price in U.K.)



*all
the world's
a stage*

—and all (well, many of) the men and women Classic customers.

They have their fancies and their preferences, and each one in his time buys many parts. In his time—we never rush a customer, and if he knows what he wants, we never try to sell him something else. Our stocks are so wide, and the choice of high quality equipment so varied, that whatever he wants, it's more than likely that we have it in stock.

It is natural, though, that confronted with so wide a choice, customers often seek guidance, which we are well able to give. Our showrooms are equipped for note-for-note comparisons and we test everything so that we know exactly what equipment to choose for a particular result.

Wide and varied stocks of all the latest and best equipment—good advice when it is asked for and the promptest attention possible, particularly for export orders—these are some of the reasons why so many of the (record) players on the world's stage come to Classic. Send for our new 1956 catalogue, and you'll see what we mean.



CLASSIC

CLASSIC ELECTRICAL COMPANY LIMITED
The Quality Specialists

352-364 LOWER ADDISCOMBE ROAD, CROYDON, SURREY

Telephone: ADDiscombe 6061

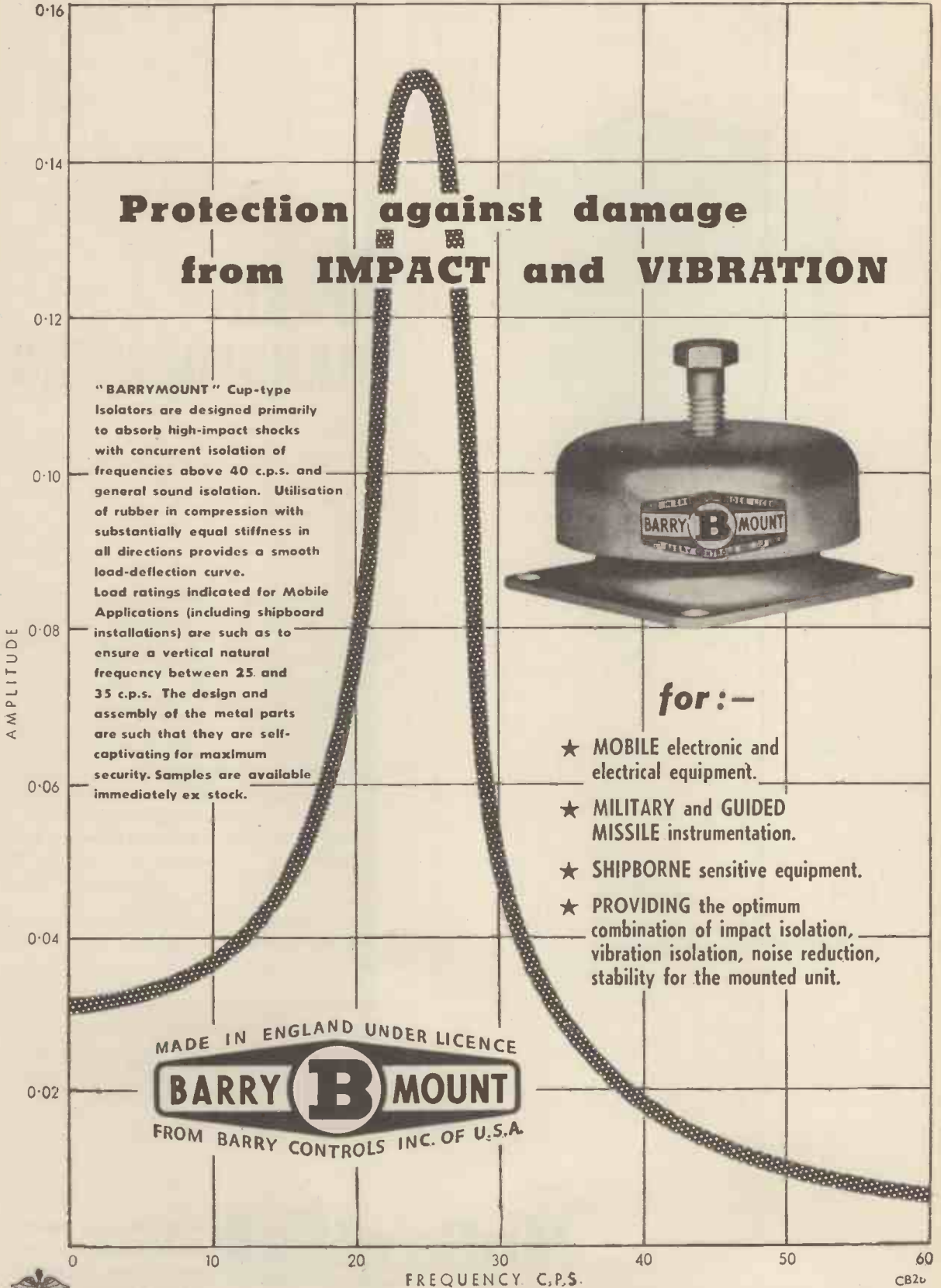

Protection against damage from IMPACT and VIBRATION

"BARRYMOUNT" Cup-type Isolators are designed primarily to absorb high-impact shocks with concurrent isolation of frequencies above 40 c.p.s. and general sound isolation. Utilisation of rubber in compression with substantially equal stiffness in all directions provides a smooth load-deflection curve. Load ratings indicated for Mobile Applications (including shipboard installations) are such as to ensure a vertical natural frequency between 25 and 35 c.p.s. The design and assembly of the metal parts are such that they are self-captivating for maximum security. Samples are available immediately ex stock.



for:—

- ★ MOBILE electronic and electrical equipment.
- ★ MILITARY and GUIDED MISSILE instrumentation.
- ★ SHIPBORNE sensitive equipment.
- ★ PROVIDING the optimum combination of impact isolation, vibration isolation, noise reduction, stability for the mounted unit.

MADE IN ENGLAND UNDER LICENCE
BARRY B MOUNT
 FROM BARRY CONTROLS INC. OF U.S.A.



Write for technical bulletins:

CEMENTATION (MUFFELITE) LTD., 20 Albert Embankment, London, S.E.11.

Telephone: RELiance 6556
 CB2b



H.F. POWER TRANSFORMERS

RATING UP TO 2 kW

FREQUENCY RANGE 2 Kc/s to 2 Mc/s

H.F. power transformers of outstanding efficiency are the latest additions to the Mullard range of high quality components designed around Ferroxcube magnetic cores.

Utilising the unique characteristics of Ferroxcube to the full, Mullard H.F. transformers are smaller, lighter, and less costly than transformers using alternative core materials. These advantages are particularly marked in transformers required to handle powers of up to 2kW, between the frequency range 2kc/s to 2Mc/s.

Mullard transformers are already finding wide use in applications as diverse as ultrasonic H.F. power generators and aircraft power packs operating from an aircraft's normal A.C. supply. In the latter application, the low leakage field of Ferroxcube can eliminate the need for external screening, thereby reducing the size and weight of the transformer even further.

As with all Mullard high quality components, these H.F. power transformers are designed and built to engineers' individual specifications. Write now for details of the complete range of components available under this service.

Mullard



'Ticonal' permanent magnets
Magnadur ceramic magnets
Ferroxcube magnetic cores

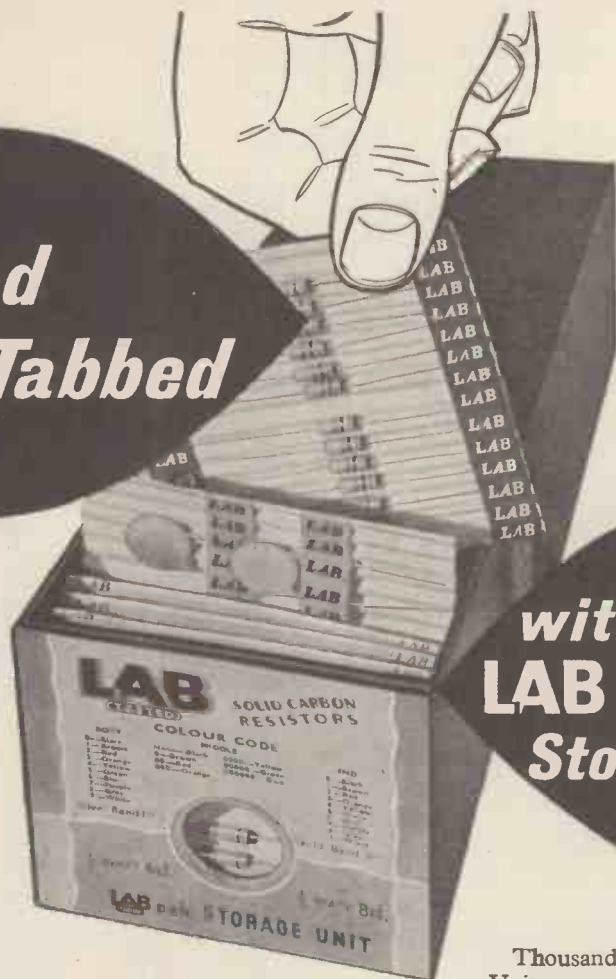

**Typed
and Tabbed**

**with
LAB Continuous
Storage Units**

Thousands of LAB Continuous Storage Units are daily solving the problem of control and storage of the great range of resistors. Compact, and capable of storing up to 720 separate resistors, LABpak make selection positive, simple and speedy. Now that Ceramicaps, Histabs and Wirewound resistors have been added to the carded range the usefulness of LABpak storage units is enhanced.

FREE with any purchase of the LABpak range, these units are the complete answer to the storage problems of small production units, laboratories, etc.

MAKE UP YOUR ORDER TODAY — DELIVERY EX-STOCK

All LABpak resistors are carded in ohmic value, rating and tolerance, colour indexed and tabbed for easy selection.

REF.	WATTS	MAX. VOLTS	OHMS	MIN. ORDER FOR FREE UNIT	UNIT STORAGE CAPACITY
------	-------	------------	------	--------------------------	-----------------------

RESISTORS

T	½	250	10 to 10M	240	720
R	1	500	10 to 10M	180	500

Tolerances available ±20% 10% 5%

HIGH STABILITY RESISTORS

HS3	½	750	1 to 500M	93	500
-----	---	-----	-----------	----	-----

Tolerances available ±5% 2% 1%

WIREWOUND RESISTORS

LM	5 & 10	—	5 to 100K	72	300
LP	5 & 10	—	5 to 100K	72	300

CERAMICAPS

CER	Tubular	500	3 to 470pf	141	500
HK	Tubular	500	470 to 5000pf	141	500
HKD	Disc	500	470 to 5000pf	141	500

Tolerances available ±2% 10%

The LAB Continuous Storage Units are available from your normal source of supply, but more detailed information and literature can be obtained from

THE RADIO RESISTOR COMPANY LIMITED

50 ABBEY GARDENS, LONDON, N.W.8 • Telephone: Malda Vale 5522

No engineer
can resist
a resistor*
by
DUBILIER

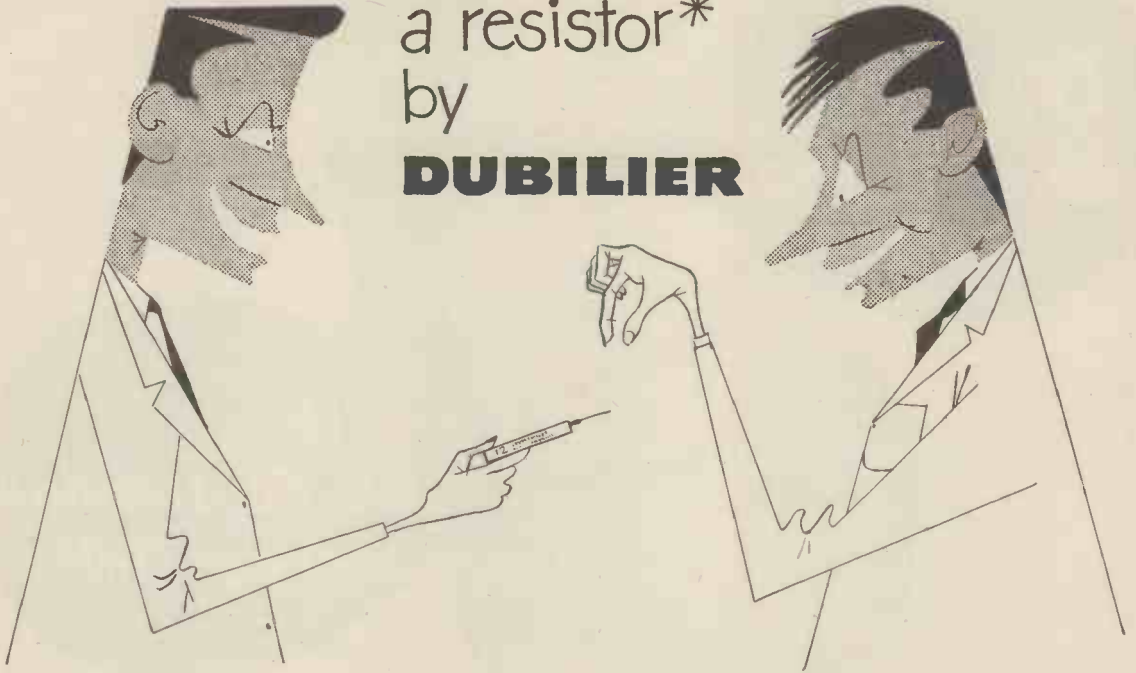

* An extremely wide range of Dubilier resistors is available both for development and production purposes. This range covers insulated wire-wound, power wire-wound, precision wire-wound, ultra high range, high stability, high voltage and high frequency resistors.

Type BT insulated resistors are completely protected by a phenolic resin housing which is sealed at the ends. Type BTS is rated at $\frac{1}{2}$ watt and Type BTB at 1 watt at 70° C. Resistance range is 100Ω to 10MΩ (BTS) and 390Ω to 22MΩ (BTB).



Type BTS resistors are also available in attractive handy cartons of twelve. These cartons protect the resistors from dirt and permit easy storage and selection in the laboratory or workshop. Save time and trouble by ordering all your $\frac{1}{2}$ watt resistors in the handy carton.

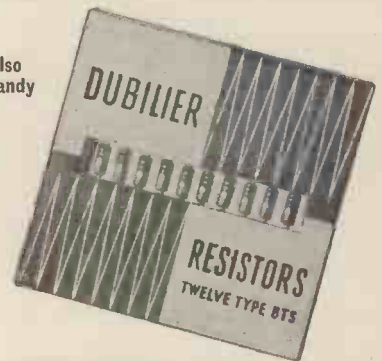

DUBILIER

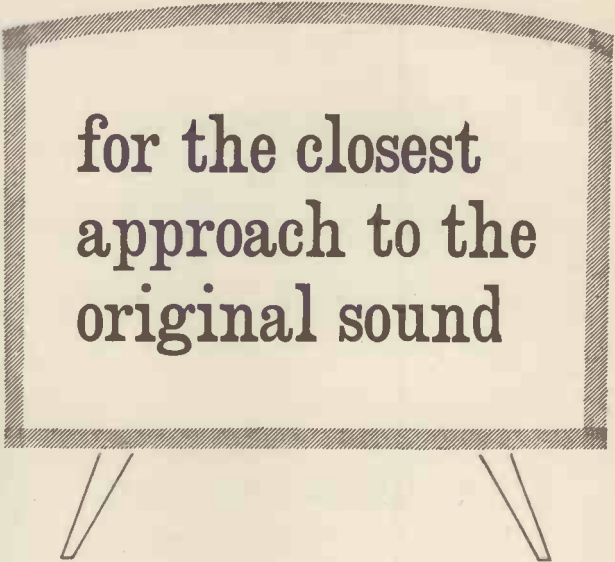

for the closest
approach to the
original sound



QUAD II AMPLIFIER

The criterion, as always, is that the reproduced sound shall be the closest approach to the original — that the enjoyment and appreciation of music may be unimpeded. This is reflected throughout the design of the QUAD II. It is reflected, too, in the straightforward and logical system of control, achieved without the sacrifice of a single refinement or adjustment capable of contributing to the final objective.

Send for further details and booklet:



ACOUSTICAL
MANUFACTURING CO LTD
HUNTINGDON · HUNTS · TEL. 151

VAGANCIES FOR ENGINEERS

If you have a genuine interest in Audio Engineering and a sound technical background, we will be pleased to discuss the possibility of your joining our Company.

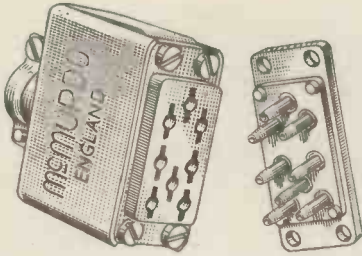

8 WAY

★ STANDARD CONNECTORS

in 8, 12, 18 and 25 way
 Low priced Unitor
 Natural colour Nylon-PF moulding
 Silver plated contacts
 Breakdown voltage 3.5 KV

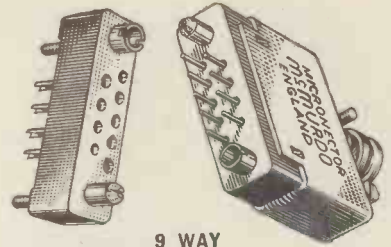

9 WAY

★ MICRONECTOR

in 9, 18, 26 and 34 way
 Precision miniature connector
 Brown Nylon-PF moulding
 Gold plated contacts
 Breakdown voltage 2.4 KV

McMURDO *connectors*

Covers can be supplied for either plugs or sockets or both in all these types.

★ STRIP CONNECTORS

in 2, 4, 6, 8 and 10 way
 Inexpensive flat connector
 for Printed Circuits
 Woodflour-filled PF moulding
 Cadmium plated contacts
 Breakdown voltage 3.5 KV

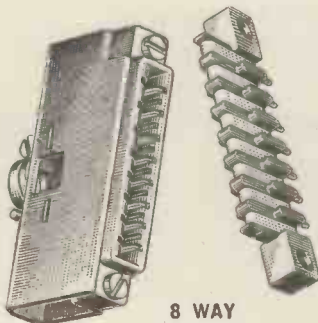

8 WAY

★ RED-RANGE CONNECTORS

in 8, 16, 24 and 32 way
 Medium priced
 Low insertion force — self-aligning
 Red Nylon-PF moulding
 Gold plated contacts
 Breakdown voltage 3.0 KV

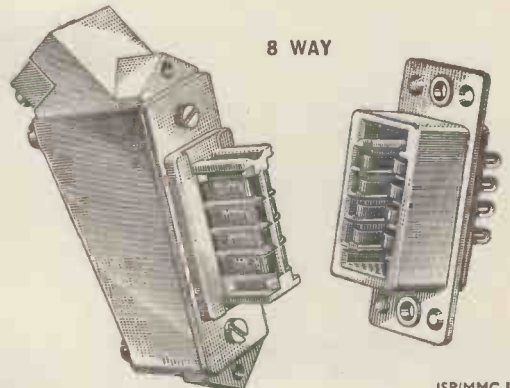

8 WAY

ISP/MMC.1

Full details on request

THE McMURDO INSTRUMENT CO. LTD. ASHTEAD, SURREY.

Telephone ASHTEAD 3401

New!

Tubular and Disc Ceramics

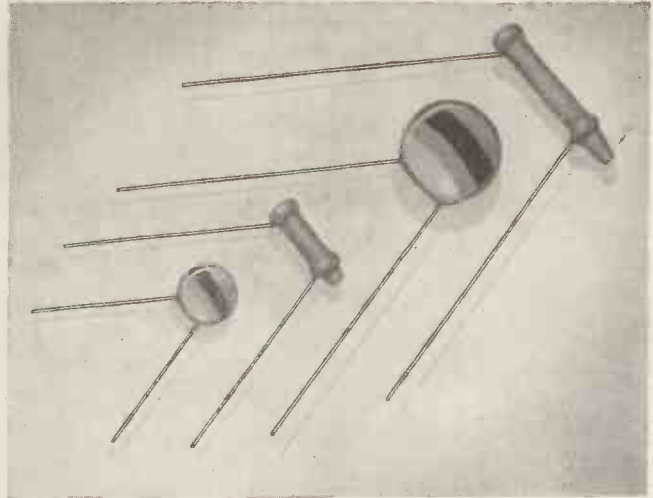

Hunts announce their new ranges of Tubular and Disc Ceramics. Precise in their characteristics and robust in design, these capacitors are available in High-K, High-Q and Special Purpose Tubulars and in High-K Discs.

Full technical specifications on request.

HIGH-Q TUBULAR STANDARD CAPACITANCE RANGES		HIGH-K TUBULAR STANDARD CAPACITANCE RANGE			HIGH-K DISC STANDARD CAPACITANCE RANGE		
Capacitance Range Picofarads	Length of Insulated Tube Millimetres	Capacitance Picofarads	Length of Insulated Tube Millimetres		Capacitance Picofarads	Type Number	Diameter (over insulation) Millimetres
*Type P103. Temperature Coefficient (+100±100) × 10 ⁻⁶ pF/pF/°C			TB1000	TB3000			
1.5 to 7	11	470	11	—	470	CD8K/2	9
7.1 to 11	13	680	11	—	680	CD8K/2	9
11.1 to 16	16	800	11	11	1000	CD9K/2	10.5
16.1 to 26	21	1000	13	11	1500	CD9K/2	10.5
26.1 to 33	26	1500	16	11	2200	CD11K/2	12
33.1 to 40	31	2000	19	11	3300	CD12K/2	13
40.1 to 50	36	2200	19	11	4700	CD14K/2	14.5
50.1 to 60	41	3000	—	16			
*Type N33. Temperature Coefficient (-33±60) × 10 ⁻⁶ pF/pF/°C		3300	—	16			
5.0 to 27	11	4000	—	19			
27.1 to 45	13	4700	—	19			
45.1 to 69	16	5000	—	21			
69.1 to 100	21						
100.1 to 140	26						
140.1 to 180	31						
180.1 to 220	36						
220.1 to 250	41						
*Type N750. Temperature Coefficient (-750±250) × 10 ⁻⁶ pF/pF/°C							
10.0 to 80	11						
80.1 to 110	13						
110.1 to 180	16						
180.1 to 240	21						
240.1 to 350	26						
*350.1 to 450	31						
450.1 to 550	36						
550.1 to 650	41						
*Capacitors with closer limits of Temperature Coefficient can be supplied by special arrangement.							

MATERIAL EMPLOYED

The temperature coefficient graph of the material is such that the capacitance increases with temperature from 20°C until it reaches a peak at approximately 50°C. With a further increase of temperature the capacitance falls, reaching its 20°C value again at approximately 80°C. Maintenance of capacitance is thus ensured from 20°C to 80°C.

POWER CERAMICS

Ranges of Power Ceramics and Temperature Compensating types are also available. Details on application.



A. H. HUNT (Capacitors) LTD.

WANDSWORTH, LONDON, S.W.18. BAT 1083-7

And in Canada HUNT CAPACITORS (Canada) LTD. AJAX. ONTARIO



For Hospitals, Factories,
 Reception Lounges,
 Departmental Stores,
 Banks & Clearing Houses,
 Arenas, Theatres, Offices.

Radiopage

an entirely new
concept of staff
location

Radiopage

locates key men
Instantly . . .
unerringly

Radiopage

calls are selective
. . . private . . .
exclusive

Radiopage

receives the
spoken word
clearly . . .
infallibly

Radiopage

a complete solu-
tion to con-
tact "elusive"
personnel

BCC

BRITISH COMMUNICATIONS CORPORATION LIMITED
Second Way, Exhibition Grounds, Wembley, England

Telephone: WEMbley 1212

Telegrams: BEECECEE, WEMBLEY

MARCONI'S

*new '428' type
valve voltmeter
is available!*

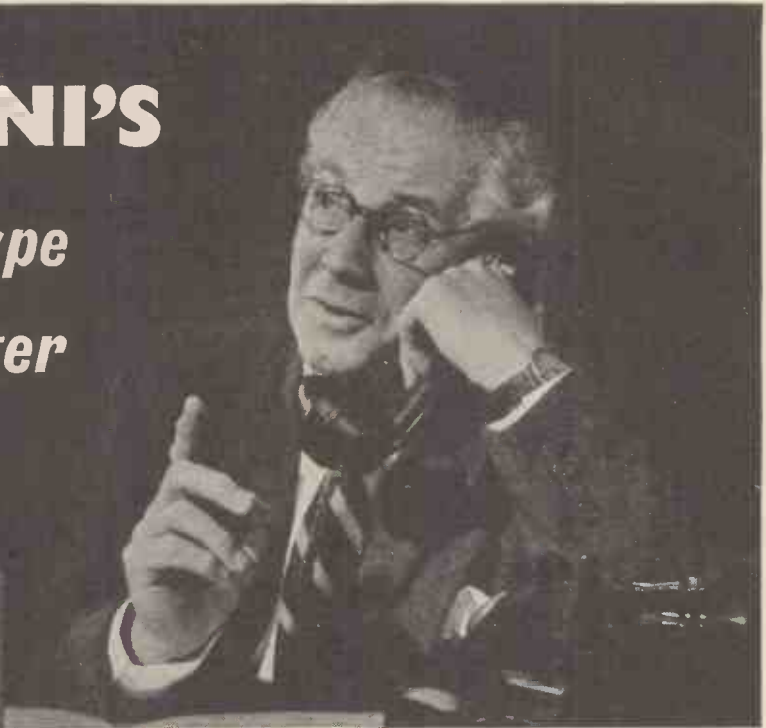

**THE MARCONI
VALVE VOLTMETER
Type TF 428C**

Measures both a.c. and d.c. potentials

The TF 428C first introduced in the 1956 Marconi Instruments catalogue and now available from stock, is the latest of the famous "428" series of valve voltmeters. It has all the well-known "428" advantages in an improved form.

The new cylindrical a.c. probe unit is only $\frac{3}{8}$ " in diameter. It is easy and convenient in use and has a flat response up to 150 Mc/s. A four-valve bridge circuit gives the instrument a really stable "zero" which is not affected by changes in the setting of the range selector. Robustness and compactness are important features of the new design. Light-alloy castings frame the front and rear panels of the welded steel case and the base of the instrument occupies a bench space only $8\frac{1}{2}$ " x 9".

ABRIDGED SPECIFICATION

A.C. MEASUREMENTS. Range: 0.1 to 150 volts in five ranges. Accuracy: $\pm 2\%$ of f.s.d. ± 0.02 volt. Frequency Characteristic: 0.2 dB from 100 c/s to 100 Mc/s, 1 dB from 20 c/s to 150 Mc/s. Input Conditions: 1 M Ω at 1 Mc/s with 6.5 μ F in shunt.
D.C. MEASUREMENTS. Range: 0.04 to 300 volts in five ranges. Accuracy: $\pm 3\%$ of f.s.d. Input Resistance: 50 M Ω .

**MARCONI
INSTRUMENTS**

AM & FM SIGNAL GENERATORS · AUDIO & VIDEO
OSCILLATORS · VALVE VOLTMETERS · POWER METERS
Q METERS · BRIDGES · WAVE ANALYSERS · FREQUENCY
STANDARDS · WAVEMETERS · TELEVISION AND RADAR
TEST EQUIPMENT · AND SPECIAL TYPES FOR THE
ARMED FORCES

MARCONI INSTRUMENTS LTD., ST. ALBANS, HERTFORDSHIRE. TELEPHONE: ST. ALBANS 56168

London and the South: Marconi House, Strand, London, W.C.2. Tel: COVent Garden 1234

Midlands: 19, The Parade, Leamington Spa. Tel: 1403 North: 30, Albion Street, Kingston-upon-Hull Tel: Hull Central 16347

REPRESENTATION IN MOST COUNTRIES

TC80

20A3 MINIATURE TETRODE THYRATRON

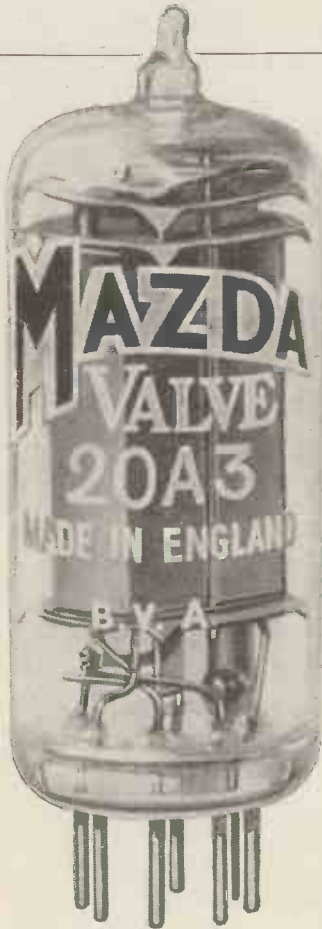

The 20A3 is a miniature indirectly heated tetrode thyatron which can be used as a high speed relay. It has a high control ratio, low grid/anode capacitance and passes a very low grid current. Used in conjunction with a high resistance circuit, the 20A3 can be operated directly from a high-vacuum photo-cell.

RATING

Heater Voltage	6.3 volts
Heater Current	0.6 amps.
Arc Voltage Drop	8 volts
Max. Forward Anode Voltage	650 volts
Maximum Peak Invoice Anode Voltage	1300 volts
Max. Shield Grid Voltage	-100 volts
Max. Control Grid Voltage	-100 volts
Max. Peak Cathode Current	500mA
Max. Average Cathode Current	100 mA
Control Grid Circuit Resistance	0.01-10.0 MΩ
Control Ratio G1	250*
" " G2	1000†

BASE B7G MINIATURE

This valve is equivalent to the 2D21

LIST PRICE 15/-

NOTE.—All maximum ratings are absolute values, not design centres. Heater to cathode voltage must never exceed 25 volts peak. The heater must be switched on for a minimum of 10 seconds before the anode voltage is applied.

* $V_{g2}=0$; $R_{g1}=0$
 † $V_{g1}=0$; $R_{g1}=0$; $R_{g2}=0$

EDISWAN

M A Z D A

RADIO VALVES AND CATHODE RAY TUBES

THE EDISON SWAN ELECTRIC COMPANY LIMITED

155 Charing Cross Road, London, W.C.2

Telephone : Gerrard 8660

Member of the A.E.I. Group of Companies

Telegrams : Ediswan, Westcent, London

HIGH GRADE INSTRUMENTS



Left: B.P.L. Trans. Ranger. A portable Test Set with D.C. Transistor Amplifier—1 megohm/volt.

Right: Pulse Height Valve Voltmeter. 0-100 volts in 3 ranges. Model PV 812.



2½in. scale moving coil D.C. meter, square flush mounting. Type S.25.



3½in. scale moving coil. Centre zero meter. Round flush mounting. Type S.35.



"Fulscale" meter 4in. dia. scale moving coil having 270° arc with a 9in. scale length.

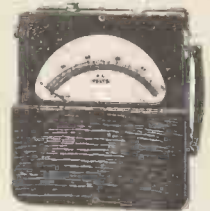

High torque moving coil portable meter. Precision grade to BS.89.



Multi-purpose test set for simultaneous measurement of current and voltage.



Universal multi-range test set for electrical and radio engineers.



Ohmmeter for the rapid and direct measurement of very low values of resistance. Model RM.155.



Left: Audio and Supersonic Frequency Signal Generator covering a wide range of both frequency and voltage. Model LO.63G.



Right: Electronic Frequency Meter providing direct measurement of frequency whilst being substantially independent of applied voltage and wave form. Model FM.406A.

BRITISH PHYSICAL LABORATORIES

Radlett, HERTS

Tel: RADLETT 5674-5-6

London Stockist: M. R. SUPPLIES, 68, NEW OXFORD STREET, W.G.1

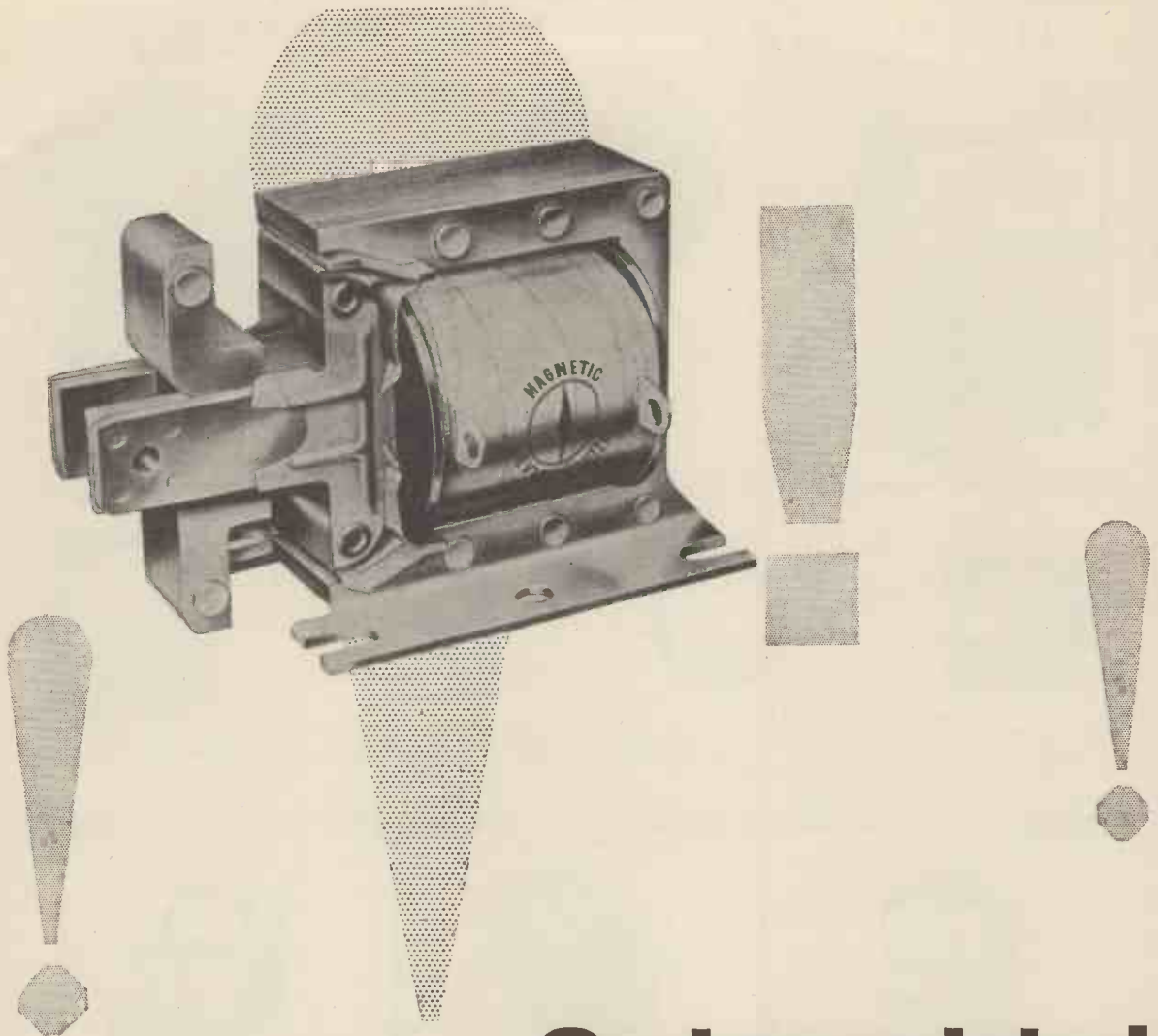

Solenoids!



For several years we have been studying user requirement of Solenoids and are now tooling on a **CAREFULLY DESIGNED RANGE.**

First types are available and we can supply a wide range of samples.

Your immediate enquiries will assist us to meet your precise needs.

If your requirements are **unusual**, we are interested in discussing tool costs.

Magnetic Devices

A.I.D. and A.R.B. approved.

LTD.

Magnetic Devices Ltd., Exning Road, Newmarket, Suffolk.
Telephone: Newmarket 3181-23. Telegrams: Magnetic Newmarket.

Now in production!

FERRANTI SILICON JUNCTION DIODES

TYPE No.:-	ZS10A.	ZS10B.	ZS20A.	ZS20B.
Max. P.I.V.	60	60	120	120 volts
Max. Voltage for 100mA. Forward Current	1.5	1.5	1.5	1.5 volts
Max. Reverse Current				
for — 50 volts at {				
25°C	0.05	0.5	—	— μ A
100°C	1.0	5.0	—	— μ A
for — 120 volts at {				
25°C	—	—	0.05	0.5 μ A
100°C	—	—	1.0	5.0 μ A
Max. Mean Dissipation at 20° C	150	150	150	150 mWV
Max. Operating Temp.	150	150	150	150°C

REVERSE VOLTS

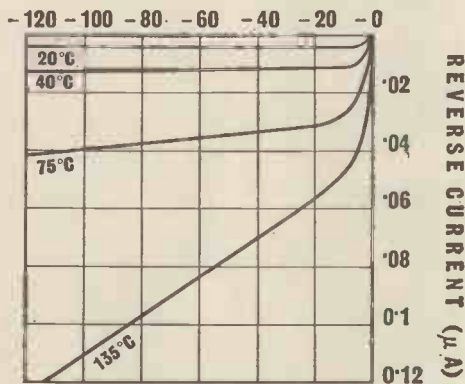

TYPICAL REVERSE CHARACTERISTICS

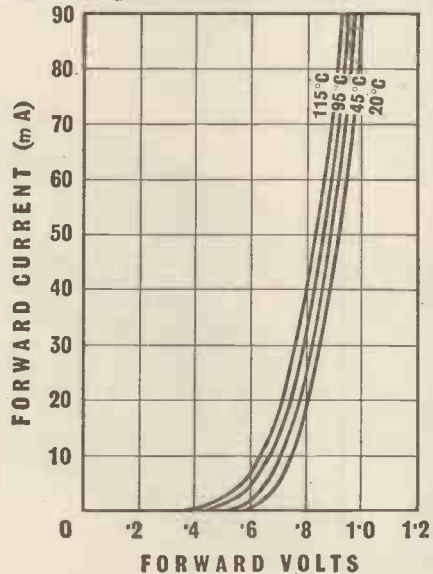

TYPICAL FORWARD CHARACTERISTICS



- LOW REVERSE CURRENT
- HIGH FORWARD SLOPE
- HIGH TEMPERATURE OPERATION
- SMALL PHYSICAL DIMENSIONS
- HIGH MECHANICAL STRENGTH

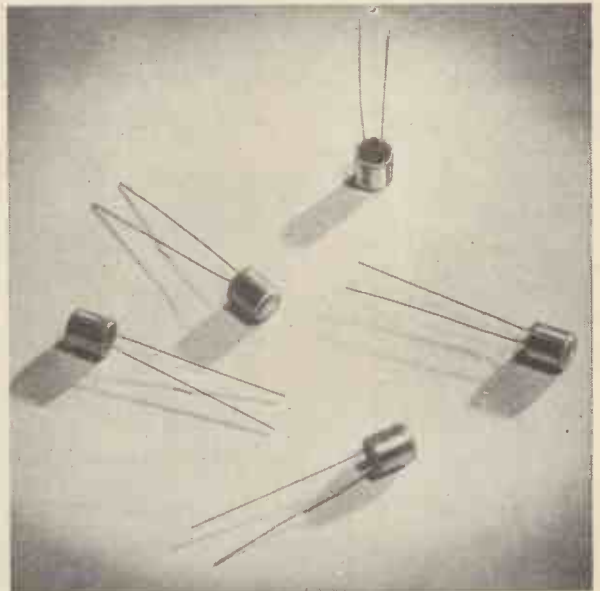

Overall length (including leads) 35 mm.

FERRANTI LTD · GEM MILL · CHADDERTON · OLDHAM · LANCs

London Office: KERN HOUSE, 36 KINGSWAY, W.C.2

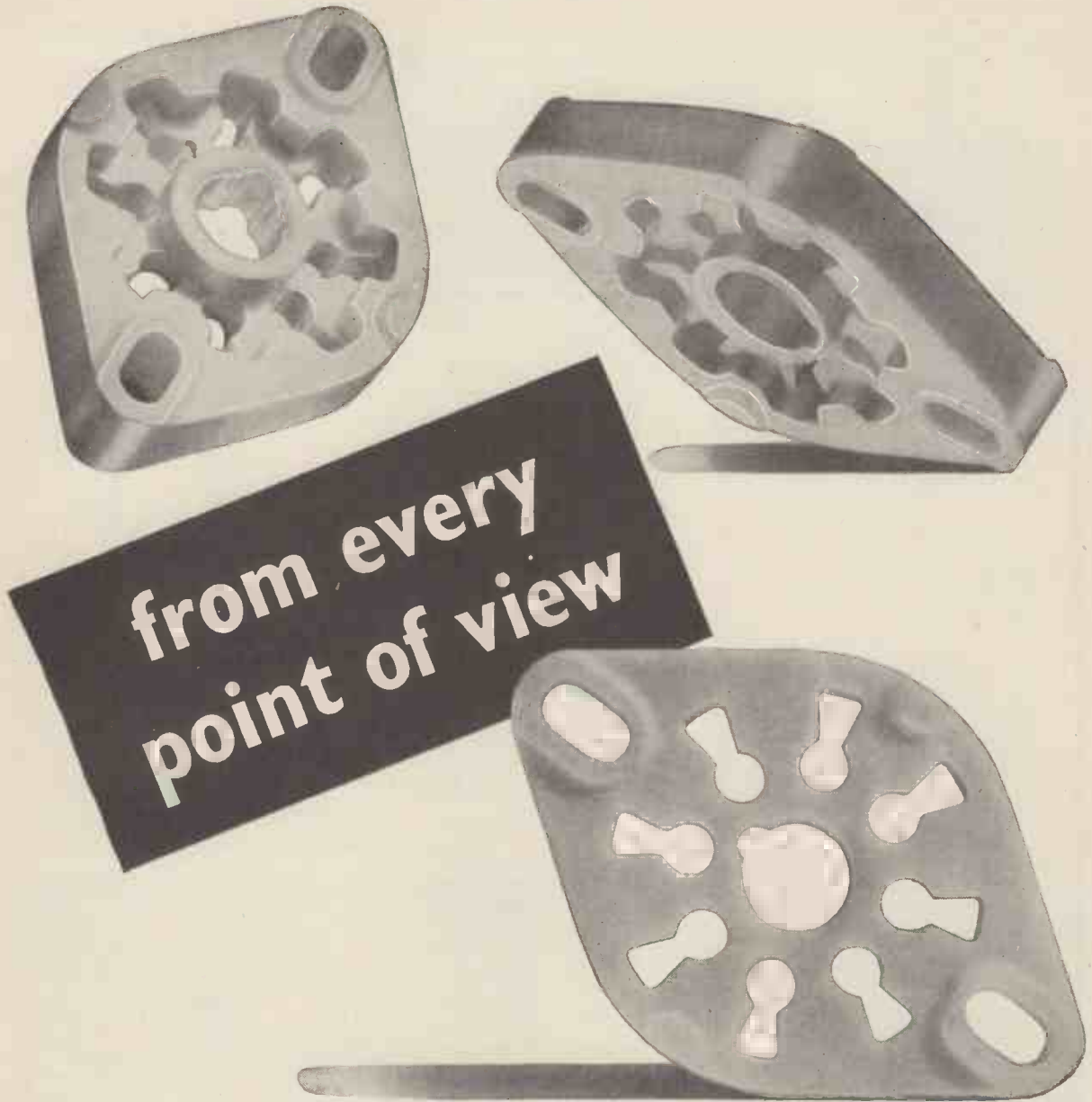

'Frequentite' is the most suitable insulating material for all high frequency applications. Seventeen years ago we introduced the first British-made low-loss ceramic, and consultation with us before finalising the design of new components is a wise precaution.

STEATITE & PORCELAIN PRODUCTS LTD.

Head Office: Stourport-on-Severn, Worcestershire. Telephone: Stourport 111. Telegrams: Steatoin, Stourport



VALVES



ENGLISH ELECTRIC VALVE COMPANY LIMITED

for INDUSTRY
COMMUNICATIONS
RADAR
SOUND & TELEVISION
BROADCASTING

HIGH VACUUM
RECTIFIERS

POWER RECTIFIERS

THYRATRONS

TRANSMITTING VALVES

MAGNETRONS

VALVES FOR
RF. HEATING

VOLTAGE STABILISERS

KLYSTRONS

TRAVELLING WAVE
TUBES

T.V. PICK-UP TUBES

CATHODE
RAY TUBES

TRANSISTORS

The new English Electric Valve brochure gives data of the widest range of valves for industry, communications, radar and broadcasting made in Great Britain. A copy of this publication will gladly be sent on request.

'ENGLISH ELECTRIC'

ENGLISH ELECTRIC VALVE CO. LTD.



Waterhouse Lane, Chelmsford
Telephone: Chelmsford 3491

Another DALY Electronic Achievement

CAPACITORS IN REDUCED SIZES WITH FULL VALUES AND WORKING VOLTAGES

SEND NOW for new leaflets with up-to-date information on this new range of capacitors.

DALY has succeeded in maintaining full capacity values and working voltages in more compact designs specially suited to ultra-modern equipment.

PHOTO-FLASH EQUIPMENT · DEAF AIDS · PRIVATE TELEPHONE INSTALLATIONS · AMPLIFIERS · D.C. POWER UNITS · SPOT WELDING EQUIPMENT · TEST-GEAR · MAGNETISATION EQUIPMENT

Behind **DALY** capacitors lies 20 years of making only electrolytics, highly specialized experience which engineers throughout the world are finding invaluable, and which is readily available to you.

DALY

ELECTROLYTIC CAPACITORS

CONDENSER SPECIALISTS FOR OVER 20 YEARS

DALY (CONDENSERS) LTD., WEST LODGE WORKS, THE GREEN, EALING LONDON, W.5. Phone: EALING, 3127-8-9 Cables: DALYCON, LONDON

Electrolytic **ELECTRONICS & COMMUNICATIONS**

For use in cone **ELECTRONIC APPARATUS** and **TELECOMMUNICATIONS**

Electrolytic Capacitors

MOTOR START

MOTOR STARTING

DALY **LTD.**

Condenser Specialists for over 20 years
WEST LODGE WORKS, THE GREEN, EALING, LONDON, W.5, ENGLAND
Telephone: EALING 3127-8-9 Cable: DALYCON, LONDON

MAXI-Q

REGD.

"MAXI-Q" IS THE REGISTERED TRADE MARK OF DENCO (CLACTON) LTD. IT IS ALSO A MARK OF TECHNICAL SUPERIORITY and GUARANTEED QUALITY

Coverage from 3.8 to 2,000 metres in 7 ranges—Each coil is packed in an aluminium container which may be used as a screening can for the coil itself—Brass threaded adjustable iron cores—Colour coded moulded polystyrene formers—Chassis/Plug-in Technical Bulletin DTB.1 1/6—Dual Purpose Technical Bulletin, DTB.4 1/6—Colour Code Identified Coils: BLUE Signal Grid Coil with Aerial Coupling winding—YELLOW Signal Grid Coil with intervalve coupling winding—GREEN Grid Coil with reaction and coupling windings—RED Superhet Oscillator for I.F. of 465 Kc/s—WHITE Superhet Oscillator for 1.6 Mc/s. Prices range from 3/11 to 4/9 each. Five Colour Glass Scale, Back Plate, Pointer, Pulleys and Cord for use with 315 pF tuning condensers. Coverage (1) 150-400 Kc/s; (2) 530-1600 Kc/s; (3) 1.5-4 Mc/s; (4) 4-12 Mc/s; (5) 10-30 Mc/s. Price 12/6.

Obtainable from all reputable stockists or direct from works. General Catalogue covering technical information on full range of components 1/- post paid.

DENCO (Clacton) LTD · 357/9 Old Road · Clacton-on-Sea · Essex
STOP PRESS: "MAXI-Q" F.M. Tuner Unit assembled & valved at £9/19/6 inc. Power pack at £3. "OSRAM" F.M. Tuner completely assembled and valved at £30/16/- inc. Complete metalwork for the T.C.C. printed circuit versions of the "OSRAM 912" and "MULLARD 5-10" Amplifiers, 15/- each.

"5-10" Pre-Amplifier Chassis and Front Panel, Type "A" 8/6; Type "B" 12/6. Separate Printed Gold finished panels available. Type "A" 1/6; Type "B" 2/6.

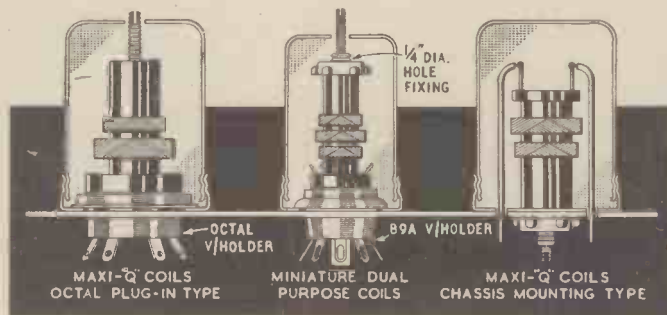

“The ultimate fidelity of a sound reproducing system can be no higher than that of any one of its individual units.”



The Pye FM/AM Tuner (Model HFT111) has been critically designed to give true high fidelity reproduction when used with equipment of comparable quality. Features: built-in power pack; 8-valve chassis for good fringe area reception; stabilised permeability tuning; noise limiter and phase discriminator. Attenuators provided for both FM and AM outputs. In chassis form, with either horizontal or vertical scales, or housed in an elegant sycamore and walnut veneered cabinet (with built-in FM aerial)

Right The vertical scale model and, *below* the HFT111 in chassis form.

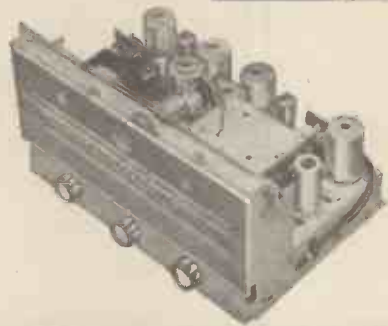
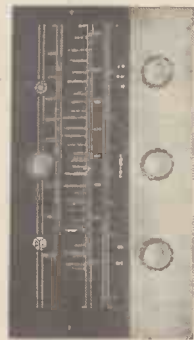

HIGH FIDELITY SYSTEMS

The New Sound in Home Entertainment

Pye Limited, Auckland, New Zealand;

Pye Canada Limited, Toronto, Canada;

Pye (Ireland) Limited, Dublin, Eire;

Pye Pty. Limited, Melbourne, Australia;

Pye Corporation of America, 270 Park Avenue, New York;

Pye Limited, Tucuman 829, Buenos Aires;

Pye Limited, Mexico City;

Pye Radio & Television (Pty.), Limited, Johannesburg, South Africa;

Pye Limited, Stuttgart, West Germany.

PYE LIMITED · CAMBRIDGE · ENGLAND



HARTLEY-TURNER "315" LOUDSPEAKER

Power Handling Capacity	15 Watts Peak A.C.
Flux Density	14,000 Gauss
Voice Coil Impedance	4 or 15 ohms. (Please state on order)
Fundamental Resonance	30 c/s
Frequency Coverage	25 c/s-15 Kc/s.
Chassis	Die Cast non-magnetic alloy
Overall diameter	12½ in.
Overall Depth	6½ in.
Nett weight	7 lbs. 9 ozs.
Packed weight	9 lbs. 9 ozs.

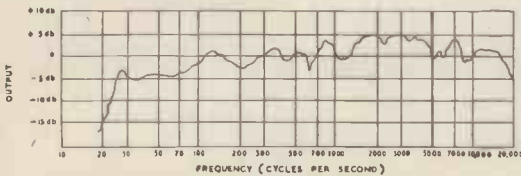

Retail Price 10 Guineas
(Carriage paid in Great Britain)

Hartley Equipment will be on show at the Siemens Ediswan Stand No. 19 at the Radio Show, Earls Court.

H. A. HARTLEY CO. LTD.
66, WOODHILL, WOOLWICH,
LONDON, S.E.18.
Phone : Woolwich 2020. Ext. CB32

ADCOLA

(Regd. Trade Mark)

SOLDERING INSTRUMENTS
& ALLIED EQUIPMENT



ILLUSTRATED
DETACHABLE
½" BIT MODEL
LIST No. 64

Protective
Shield
List No. 68

CATALOGUES HEAD OFFICE SALES & SERVICE

ADCOLA PRODUCTS LTD.,
GAUDEN ROAD,
CLAPHAM HIGH ST.,
LONDON, S.W.4.

TELEPHONES :
MACaulay 3101
& 4272



High Grade
QUARTZ
CRYSTALS
by
Standard

High quality, stable characteristics, robust construction, proven performance, are inherent features of the quartz crystal units developed and manufactured by S.T.C.

Crystals in hermetically sealed cans to meet the rigid Inter-Service specification; crystals in evacuated glass envelopes with wire ends or with valve base; G.T. Cut crystals for absolute frequency standards; high frequency Overtone crystals for V.H.F. applications . . . these are the principal types in the S.T.C. range.

There is almost certain to be an S.T.C. quartz crystal unit to meet your specification . . . if not, our engineers are ready to discuss your special requirements.

The quartz crystal units illustrated are in hermetically sealed cans equivalent to the Inter-Service Style "D" or the American HC6U. This unit has been widely adopted for use in modern equipments.



Standard Telephones and Cables Limited

Registered Office : Connaught House, Aldwych, W.C.2

TELEPHONE LINE DIVISION : NORTH WOOLWICH · LONDON · E.16

TWO SPEAKER SYSTEM COMPRISING SUPER 3 TWEETER & BRONZE REFLEX

Illustrated on the right is an attractive combination of the new Super 3 Tweeter and the Bronze Reflex Cabinet. This small and compact Two-speaker System gives a well-balanced, wide range response. The total cost, including 10in. Bronze/CSB and Super 3 units, would come to £30 1s. 2d., purchase tax on the two speaker units included, made up as follows:—

Bronze Reflex Cabinet	£14	0	0
Super 3 Cabinet (10/15 ohms) ...	£3	10	0 inc V.C. & Capacitor
10in. Bronze/CSB	£5	11	3 inc. Tax
Super 3	£6	19	11 " "
	£30	1	2

Owing to the limited space occupied by this Two-speaker System it is ideal for stereophonic reproduction. The non-directional properties of the Super 3, which has open mounting, also help enormously in obtaining natural results. Construction sheet for Reflex cabinet with acoustic filter free on request.



Size of main cabinet
28" x 14" x 12½"

Wharfedale

WHARFEDALE WIRELESS WORKS LTD.
Idle, Bradford, Yorks. Tel: Idle 1235-6

For efficient service on Bands I and III



(Made in Holland)

For leaflet giving detailed specifications, write to:



PHILIPS ELECTRICAL LTD.

CENTURY HOUSE • SHAFESBURY AVENUE • LONDON • WC2

PHILIPS PATTERN GENERATOR GM 2891/05

The GM 2891/05 has been designed for 405-line transmissions, but similar instruments are available for use on Continental and American systems.

Frequency range 40-80 Mcs. Band I and 170-225 Mcs. Band III.

Tuning scale calibrated in Mcs. and Channel number.

Video output voltage either positive or negative with 1V modulation and 0.4 V sync.

Sound output variable between 300-500 c/s at 1 V r.m.s.

H.F. output of 100 mV and 2 mV unbalanced into 300 ohms.

Choice of 4 test patterns by selector switch.

INSTRUMENT DEPARTMENT,
INDUSTRIAL PRODUCTS DIVISION

THE

ANTIFERRENCE

**STANDARD
Plug & Socket**

**FOR
CO-AXIAL
CABLES**

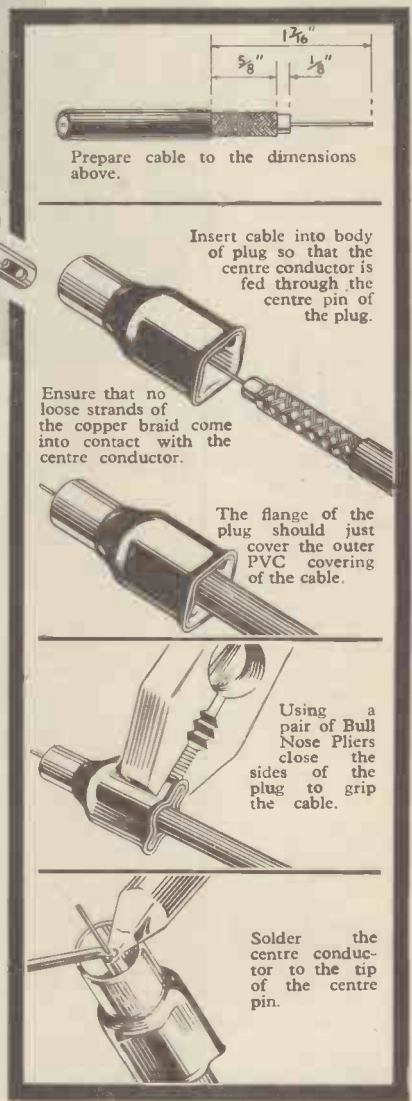
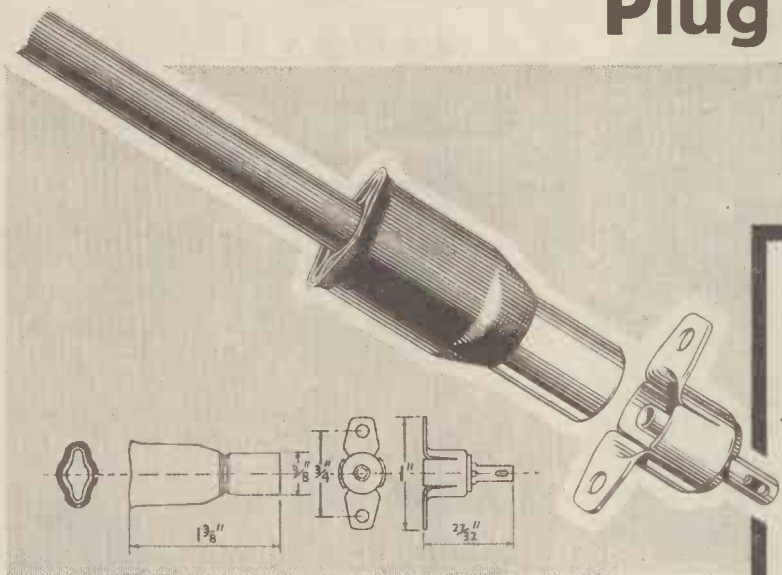

Prepare cable to the dimensions above.

Insert cable into body of plug so that the centre conductor is fed through the centre pin of the plug.

Ensure that no loose strands of the copper braid come into contact with the centre conductor.

The flange of the plug should just cover the outer PVC covering of the cable.

Using a pair of Bull Nose Pliers close the sides of the plug to grip the cable.

Solder the centre conductor to the tip of the centre pin.

The illustrations above show the extremely simple and speedy method of fitting the plug.

- **CONFORMS TO R.E.C.M.F. SPECIFICATION**
- **ROBUST CONSTRUCTION**
The Plug is constructed as a "one-piece" unit with no small parts to dismantle.
- **SIMPLE TO FIT**
After preparation of the co-axial cable the plug can be fitted in a few seconds.
- **EFFICIENT IN OPERATION**
The plug pin is mounted in a permanently housed POLYSTYRENE interior which has low-loss V.H.F. properties, and is not affected by heat when soldering to the same extent as polythene and other similar materials.
- **TROUBLE FREE GRIP**
Permanent contact is maintained by pressure on the copper braid over a large contact area which holds the cable so that it cannot slip or place any strain on the centre conductor.
- **FULLY INSULATED**
It is unnecessary to remove the neoprene insulating sleeve when fitting the plug.
- **HIGHLY COMPETITIVE PRICE**
Both the Plug and the Socket are 8d. each (retail)
—THE PRICE OF AN EXPENDABLE ITEM.
CO-AXIAL PLUG TVP/1 8d. each.
CO-AXIAL SOCKET TVS/1 8d. each.

VISIT US AT THE RADIO SHOW, EARLS COURT
AUG. 22 — SEPT. 1, on STAND 69

YOU CAN RELY ON ANTIFERRENCE EXPERIENCE

ANTIFERRENCE LTD. AYLESBURY, BUCKS.
Telephone: Aylesbury 1467/8/9

AYLESBURY LONDON • TORONTO, CANADA SYDNEY, AUSTRALIA



TRUVOX

Tape Recorder Model R1

(Release Mid-July)

It has taken a long time to produce a Recorder that is really worthy of the name TRUVOX and all that the name implies, but it has come—an instrument that does full justice to the world-famous Truvox Tape Recording products. A high-fidelity instrument in every sense of the word, giving not only endless hours of enjoyment recording and replaying one's own programmes but also providing perfect reproduction of the new, outstanding and ever-growing number of pre-recorded tapes of the world's finest music, with all those finer gradations of tone that are there for those who can hear the difference.

Frequency response 50–12,000 cps. 10" x 6" Loudspeaker.

Contemporary cabinet styling is in keeping with the high standard set by the equipment it contains.

Price complete with crystal microphone and 1,200 ft. reel of standard tape.

Fitted with precision 'place' locator, 3 gns. extra.

66 GNS.

Additional optional equipment

Truvox Senior and Standard Radio Jack
Truvox Foot Control and Headphones for transcription of recorded material
Truvox telephone attachment for recording two-way telephone conversations

Credit and Hire Purchase facilities available through Selected Retailers.

Send for full details

TRUVOX LIMITED

Sales Office : 15, Lyon Road, Harrow, Middlesex.
Harrow 9282

Tech. & Service Dept. : 328, Station Road, Harrow,
Middlesex. Harrow 4455.



YOU'RE ON THE RIGHT TRACK with

EGEN

components

In design, dependability, accuracy and freedom from wear these Egen components are quite outstanding. They are backed by unrivalled experience of the requirements of television and electronic equipment manufacturers.



DUAL POTENTIOMETERS

with concentric operating spindles. Incorporating many outstanding design features, including multiple contact rotors and thorough screening between sections. Control spindles can be supplied to suit customers' requirements. Type 136 less switch. Type 137 with SPST switch. Type 138 with DPST switch.

PRE-SET POTENTIOMETERS

Completely enclosed in high-grade phenolic mouldings. Solder tags heavily silver-plated for quick soldering. Fully insulated spindles with integral control knobs. Tapped for 2-hole 6 B.A. fixing on $\frac{1}{2}$ " centres. Type 126, wire-wound. Type 127, carbon.



MINIATURE POTENTIOMETERS

$\frac{1}{4}$ " diameter: utmost reliability within a very small compass. Positively located soldering tags, silver-plated for easy soldering. All steel parts rustproof. Standard values available, from 5000 ohms to 2 megohms. Type 115 less switch, Type 105 with specially designed 2-pole Q.M.B. switch.

CONCENTRIC SWITCH POTENTIOMETERS



Thorough screening between switch and potentiometer. Concentric operating spindles give independent operation of switch or potentiometer with 'one-control' simplicity. Quick make-and-break action mains switch. Knob location to suit specified requirements. Type 154 with SPST switch, Type 155 with DPST switch.

The wide range of EGEN controls includes also: Standard Carbon Potentiometers Type 102, Pre-set Resistors, Inductance Coil Assemblies, Sub-Miniature Potentiometers, (for use in miniature electronic apparatus) and TV Aerial Plug and Socket.

EGEN ELECTRIC LIMITED

CHARFLEET INDUSTRIAL ESTATE

CANVEY ISLAND · ESSEX · Phone: Canvey Island 691/2

m-i-n-u-t-e-s into seconds...

with the brilliant **NEW**
Superspeed
SOLDERING IRON

MANUFACTURED FOR ENTHOVEN SOLDERS LTD. BY SCOPE LABORATORIES, MELBOURNE, AUSTRALIA



STAR FEATURES

- ★ Heats up from cold in 6 seconds—by a light thumb pressure on the switch ring.
- ★ When not in use, current is automatically switched off—thus greatly reducing wear of copper bit. Electricity consumption is correspondingly reduced.
- ★ It is 10" long, weighs 3½ ozs., can be used on 2.5 to 6.3-volt supply. 4-volt transformer normally supplied.
- ★ More powerful than conventional 150-watt irons and equally suitable for light wiring work or heavy soldering on chassis.
- ★ Simple to operate, ideal for precision work. Requires minimum maintenance at negligible cost. Shows lowest operating cost over a period.
- ★ Can be used from a car battery.
- ★ It is by far the most efficient and economical soldering iron ever designed for test bench and maintenance work.



STAR APPLICATIONS

Designed on an entirely new principle, this light-weight, versatile iron is eminently suitable for soldering operations in the RADIO, TELEVISION, ELECTRONIC and TELECOMMUNICATION industries, particularly for all SERVICE work. For general purpose work the Superspeed Iron is the ideal stand-by soldering tool.

The **Superspeed** soldering iron is available **NOW**

Write for full particulars, including guarantee terms and free trial facilities, to the sole concessionaires in this country—

ENTHOVEN SOLDERS LIMITED
 (Industrial Equipment Division), 89 Upper Thames St.,
 London, E.C.4. Telephone: MANsion House 4533



A BBC Training Manual by S. W. Amos, B.Sc. (HONS.)

A.M.I.E.E. and D. C. Birkinshaw, M.B.E., M.A., M.I.E.E.

TELEVISION ENGINEERING

Principles and Practice

VOL. II: Video-Frequency Amplification

Here is the second volume of a series of four which will form the most comprehensive survey ever compiled of modern television principles and practice. Originally written for instruction of the B.B.C.'s own operating and maintenance staff, this volume describes the fundamental principles of video-frequency amplifiers, and examines the factors which limit their performance at the extreme of the passbands. A wide variety of circuits is described and particular attention is paid to the use of the feedback. There is also a section dealing with the special problems of camera-head amplifiers.

Self-contained mathematical derivations are included at the ends of chapters.

Second volume of a comprehensive work **NOW READY**

8 $\frac{3}{4}$ " x 5 $\frac{1}{2}$ " 272pp. Illustrated

35s. net. By Post 36s. 2d.

Published for "Wireless World"

Obtainable from booksellers or direct from Iliffe & Sons Limited, Dorset House, Stamford Street, London, S.E.1.

HIGH TEMPERATURE LIGHTWEIGHT RECTIFIERS

- For operation in ambients of up to 85°C
- Elimination of cooling fins for compactness
- Light alloy construction for lightweight
- High stability

are some of the salient features of this new range of rectifiers, primarily developed for Service requirements, but now available in production quantities for all applications. Units can be supplied with various finishes to comply with RCS.1000 categories H.1 and H.2.

Details of this new range of



RECTIFIERS

can be obtained from

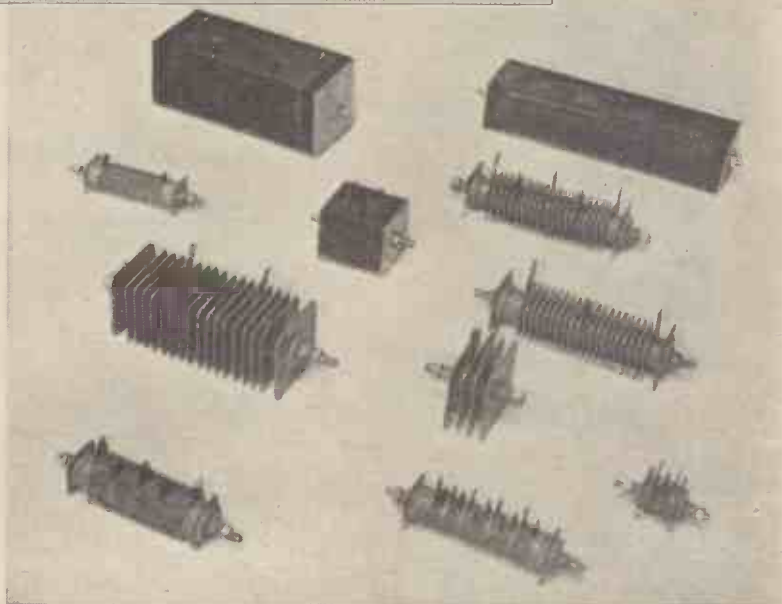

See them on **STAND No. 102, Radio Show, August 21st to September 1st.**

Dept. WW.8. WESTINGHOUSE BRAKE & SIGNAL CO., LTD., 82, York Way, King's Cross, London, N.1.

TERminus 6432.

The NEW Marconi

GENERAL PURPOSE RECEIVER Type NS. 702



Combines exceptional versatility with rugged reliability

—an integral part of an efficient communications system

- Continuous frequency coverage 15 Kc/s to 28 Mc/s in ten bands.
- Directly calibrated main tuning and band-spread scales with built-in crystal oscillator for precise band-setting. 80 : 1 flywheel action tuning drive, and electrical fine tuning control of ± 3 Kc/s above 800 Kc/s.
- Magnetostriction filter providing the narrowest of four I.F. bandwidths of 8 Kc/s, 3 Kc/s, 1000 c/s and 100 c/s.
- Unwanted beats between interfering signals minimized by balanced demodulator for C.W. reception.
- Facilities for working with an associated transmitter include desensitizing, either electronically or by internal high-speed relays, and reproduction of transmitter sidetone on C.W., M.C.W., or telephony.
- Very low level of oscillator radiation and spurious whistles.
- Can operate direct on 110v. or 220v. D.C., or 115v. or 230v. A.C. supplies, without vibrator or rotating machine.
- Meets the latest international regulations and complies with the G.P.O. specification for General Purpose Receiver for ships.

Write for descriptive literature.



Lifeline of Communication

MARCONI

Complete Communication Systems

MARCONI'S WIRELESS TELEGRAPH COMPANY LIMITED, CHELMSFORD, ESSEX

Cellular Polythene



INSULATED TELEVISION DOWNLEAD CABLES
 To meet the exacting demands being made on the efficiency of aerial systems, the Glover range of Cellular Polythene insulated downleads have been designed to utilise the superior electrical properties of this new form of polythene.

Details of three designs are given as being most representative of modern practice.

The two Cables G.R.1., G.R.2. are intended for use in the service area and one G.R.3. for use in fringe areas and in situations where interference is high.

Reference No.	CO-AXIAL TELEVISION DOWNLEADS				
	CELLULAR		POLYTHENE.		
	G. R. 1. S	G. R. 1. F.	G. R. 2. S.	G. R. 2. F.	G. R. 3.
Characteristic Impedance ohms.	75	75	75	75	75
Service Area	LOCAL	LOCAL	LOCAL	LOCAL	FRINGE
Attenuation dB/100 ft. at 50 Mc/s.	3.0	3.4	2.3	2.6	1.5
.. .. 200 Mc/s.					3.3
Copper Conductor	1/022"	7/0076"	1/029"	7/010"	1/044"
Diam in inches:-					
Over Polythene.	0.093	0.093	0.128	0.128	0.200
.. Wire Braid.	0.117	0.117	0.152	0.152	0.230
.. P.V.C. Sheath.	0.157	0.157	0.202	0.202	0.290

W. T. GLOVER & CO. LTD.



MEMBERS OF THE C.M.A.

TRAFFORD PARK MANCHESTER 17
 TRAFFORD PARK 2141



TRANSFORMERS



CAST RESIN TRANSFORMERS

Give complete mechanical and climatic protection for core and windings. Good heat dissipation.

HERMETICALLY SEALED "C" CORE UNITS

A complete range covering transformers from 1 Va to 2 kVa and the usual range of chokes.

POTTED COMPOUND FILLED TRANSFORMERS

A wide range of capacities for transformers and chokes. Complete reliability. Suitable for exacting industrial and climatic conditions.

SHROUDED AND OPEN-TYPE TRANSFORMERS

Combines first-class engineering with a popular highly competitive product. Vacuum impregnated and rigidly tested.

MICROPHONE TRANSFORMER

for use with moving coil microphone, minimum hum, pick-up and maximum efficiency.

In addition to the types shown, we manufacture a great variety of Transformers for all electronic applications. Also Power Transformers up to 750 kVa.



WODEN TRANSFORMER CO. LTD.
BILSTON, STAFFS. Tel. BILSTON 41959

Catalogues available on request.

NEW ARCOLECTRIC SIGNAL LAMPS

For Low Voltage or Mains

Illustrated are a few signal lamps taken from our wide range. The insulation of every Arcoelectric signal lamp will resist a flash test of 1,500 volts A.C. The S.L.90 illustrated here is a typical Arcoelectric low voltage signal lampholder. It is designed to accept popular M.E.S. bulbs. The bulb is accessible from front or rear of panel. The domed plastic lens surrounded by a polished chrome bezel gives a most attractive panel appearance. This holder can be fixed in a single $\frac{3}{4}$ in. hole. The mains voltage signal lamp S.L.88/N is supplied complete with an M.E.S. neon tube and a suitable series resistance.

Write for Catalogue No. 129



ARCOLECTRIC
SWITCHES · LTD

CENTRAL AVENUE, WEST MOLESEY, SURREY. TELEPHONE: MOLESEY 4336 (3 LINES)



YOU CAN COUNT ON COLD CATHODE TUBES

Hivac

Continuing development in the field of cold cathode tubes has brought a new

COLD CATHODE TRIODE XC18

This electrically reliable and mechanically robust tube is contained in a 10mm round bulb, 34 mms in length $V_{sa} \leq 200V$; $V_{ma} \approx 70V$; $V_{st} \approx 68V$.

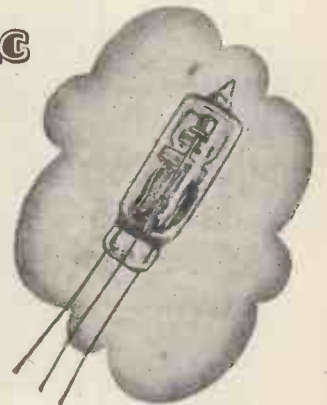

ACTUAL SIZE

DATA SHEET ON REQUEST

Perfection in *miniature*

Hivac Limited

Telephone: Ruislip 3366

Cables: HIVAC, RUISLIP

STONEFIELD WAY, VICTORIA ROAD, SOUTH RUISLIP, MIDDLESEX

Bullers CERAMICS FOR INDUSTRY

High quality material and dimensional precision are attributes of Bullers die-pressed products. Prompt delivery at competitive prices.

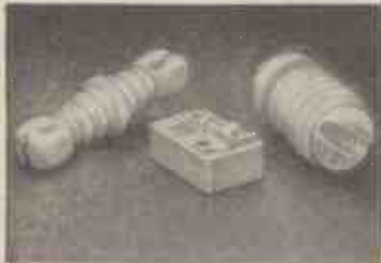

We specialise in the manufacture of—**PORCELAIN**

for general insulation

FREQUELEX

for high-frequency insulation

RÉFRACTORIES

for high-temperature insulation

PERMALEX & TEMPLEX

for capacitors



BULLERS LIMITED

MILTON · STOKE-ON-TRENT · STAFFS

Phone: Stoke-on-Trent 21381 (5 lines) · Telegrams & Cables: Bullers, Stoke-on-Trent

Ironworks: TIPTON, STAFFS London Office: 6 LAURENCE POUNTNEY HILL, E.C.4

Phone: Tipton 1691 Phone: MANsion House 9971

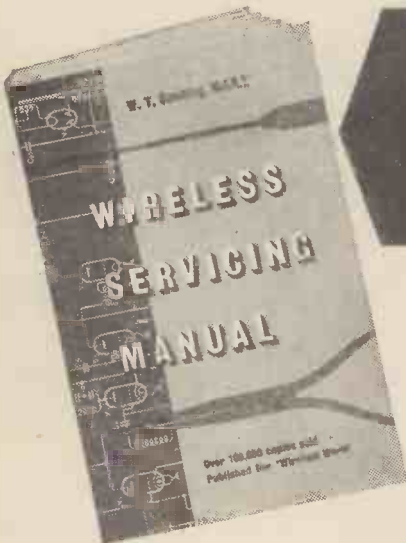

9th

EDITION

of a comprehensive and reliable guide for professionals and amateurs **NOW READY**

WIRELESS SERVICING MANUAL

By **W. T. Cocking** M.I.E.E.

This is a new, carefully revised edition of the handbook known since 1936 as an invaluable, comprehensive guide for radio servicemen and others. Completely up to date, it deals in a lucid, practical way with the problems that arise in the repair, maintenance and adjustment of modern wireless receivers. All recent developments in receiving equipment have been incorporated, and the servicing of frequency-modulated v.h.f. receivers—a development of great importance to all servicemen—is thoroughly covered in a completely new chapter.

Published for "Wireless World"

8 $\frac{3}{4}$ " x 5 $\frac{1}{2}$ " 270pp. Over 100 diagrams.

17s. 6d. net BY POST 18s. 6d.

Obtainable from booksellers or from :—

Recognised as a standard work of reference

Iiffe & Sons Limited • Dorset House • Stamford Street • London • S.E.1

MUTUAL & SELF INDUCTANCE BRIDGE



Designed for the accurate measurement of either mutual or self inductance and resistance in the range $0.001\mu\text{H}$ to 30mH and $100\mu\Omega$ to 3000Ω respectively.

All measurements are made in the form of a four-terminal network and inductance and resistance of leads and clips are not included in the measurement.

Accuracy within $\pm 1\%$ frequency 1592c/s ($\omega = 10\,000$)

Full technical information on this and other 'Cintel' Bridges is available on request.

CINEMA TELEVISION LTD

A COMPANY WITHIN THE RANK ORGANISATION LIMITED

WORSLEY BRIDGE ROAD • LONDON • S.E.26
HITHER GREEN 4600

SALES AND SERVICING AGENTS:

Hawnt & Co. Ltd., 59 Moor St. Birmingham, 4

Atkins, Robertson & Whiteford Ltd., 100 Torrisdale Street, Glasgow, S.2

F. C. Robinson & Partners Ltd., 122 Seymour Grove, Old Trafford, Manchester 16

GOLDRING PRODUCTS
Leading in the HI-FI field

CARTRIDGE N°500

acclaimed the world over as one of the best



LATEST MODEL THE SUPER No. 500/M.S.D NOW AVAILABLE

- ★ **GOLDRING SUPER QUALITY** Diamond and Sapphire Styli for GOLDRING Cartridges and replacements for other well-known Pick-Ups.
- ★ **GOLDRING ANTI-STATIC CLEANING PADS** Specially developed for removing dust from L.P. Records.
- ★ **GOLDRING JUBILEE MICRO BALANCED TRANSCRIPTION ARMS.**

GOLDRING PRE-AMPLIFIER FOR USE WITH No. 500 CARTRIDGE

THE GOLDRING MANUFACTURING CO. (GREAT BRITAIN) LTD.

486 & 488 HIGH ROAD, LEYTONSTONE, LONDON, E.II.

Telephones LEYtonstone 8343-4-5.

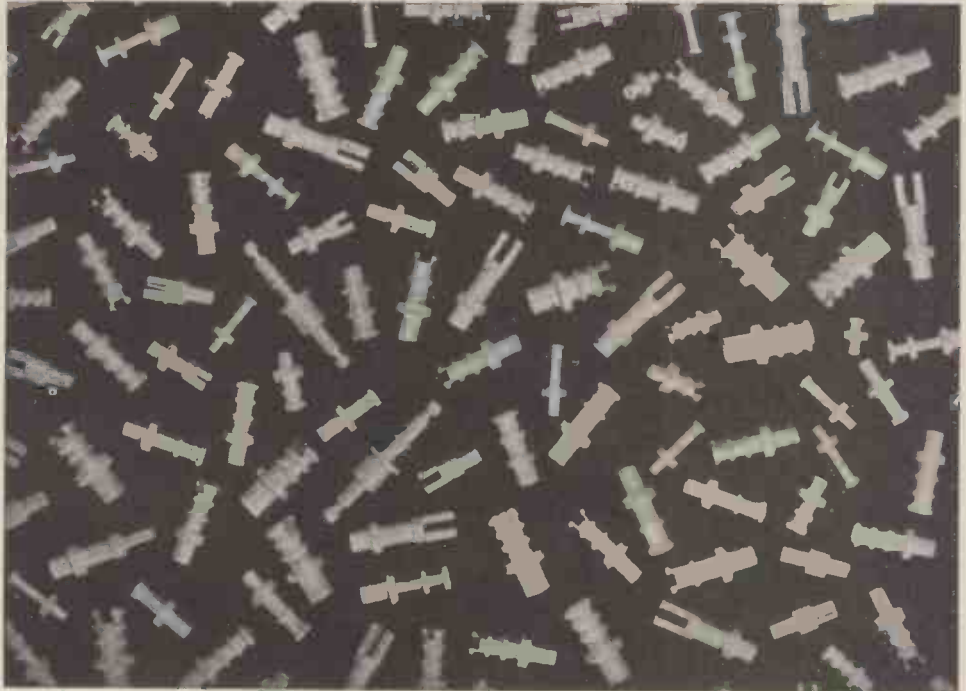

HARWIN

— Engineers Ltd. —

HARROW

MIDDX.



FLEXIBLE REMOTE CONTROL OUTFITS

Our experience in the industrial field has indicated that there is a definite need for this type of outfit offering facilities for making prototype flexible remote controls as required.

The two gauges of Remote Control flexible shafts in these outfits cover the range of torque loadings required for • volume controls • all types of wave change switches • condensers • all controls likely to be met in electronic, radio and television equipment.

The outfits are reasonably priced and comprise:

- No. 130 (.130 in. dia.) for remote controls up to 4 in. length.....£7. 0.0
- No. 150 (.150 in. dia.) for remote controls up to 6 in. length.....£7.10.0

(For use without flexible casing)



BRITANNIA WORKS, 25-31 ST. PANCRAS WAY, LONDON, N.W. 1.

Telephone: EUSton 5393

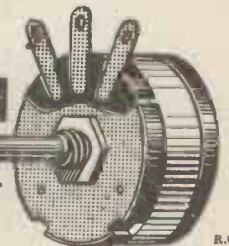

The S. S. White Company will be pleased to advise which Outfit is most suitable for specific applications.

A detailed Parts List is available upon request.

THE MISSING LINK

PABO-1 TAPE PRE-AMPLIFIER AND ERASE UNIT

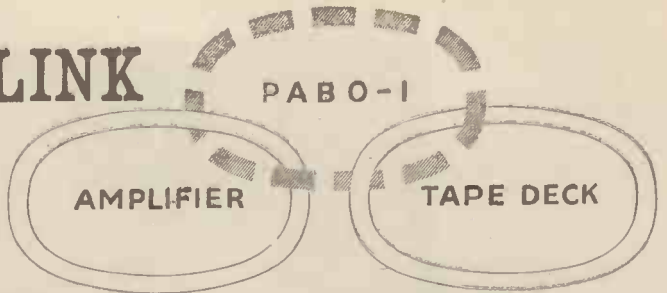

PRICE : £12.10.0

This compact unit provides the necessary link between the Tape Deck and Amplifier Control Unit in a high fidelity system. The circuit has been critically designed to preserve faithfully the quality of the signal fed to it and to pass it on without distortion or alteration except in so far as the built-in equalising circuits apply. These enable the standard tape recording curve to be applied in recording and the corresponding equalisation on play back. PABO-1 can be used with almost all makes of High Fidelity Amplifier and Tape Deck.

PLAYBACK—One amplifying stage is utilised to increase the tape head signal to the amount required to load the main pre-amplifier to normal working level.

RECORD AND ERASE. The oscillator circuit energises the erase head to clear the tape of all previously recorded material, and supplies the bias voltage for the recording head. A two stage amplifying circuit operates on record.

RECORDING LEVEL. A "magic eye" type valve is used as a recording level indicator, providing an accurate means of setting the correct signal level. The quick rise time and delayed fall away enable transient peaks to be observed for the level to be adjusted accordingly.

SPECIFICATION

CONTROLS: 1. Record/Replay switch. 2. Monitoring volume control. 3. Record level gain control.

DIMENSIONS: 9in. x 9in. x 4½in. high.

INPUT REQUIRED: On Replay—2.3 mV for 100 mV output. On Record—100 mV for full modulation of the tape.

POWER SUPPLIES: 300 volts at 40 mA; 6.3 volts at 1.2 amps.

HUM/NOISE LEVEL: Better than 40 dB down at max. volume.

BIAS/ERASE FREQUENCY: 60 Kc/s—ensuring negligible inter-modulation of Audio, and Erase and Bias frequencies.

VALVES (Mullard): EF 86, ECG 83, EL 84, EM 34.



ARMSTRONG WIRELESS AND TELEVISION CO. LTD., Warblers Rd., Holloway N.7. Phone North 3213

Demonstrations at your local High Fidelity specialists or at our showrooms in Holloway. If you are unable to visit us please complete the coupon so that we may send you full descriptive literature.

Please send me descriptive literature of PABO-1 and details of Hire Purchase, Home Trial facilities and Guarantee.

NAME (BLOCK CAPITALS PLEASE.)

ADDRESS

WW

At Your Service

Even the best instruments sometimes fail. It is then that quick and ready service is appreciated. Our Service Department, operating from new and larger premises, is more than ever ready to "do its job."



THE LARGEST STOCKISTS OF ELECTRONIC INSTRUMENTS IN THE NORTH OF ENGLAND



ADVANCE · AVO · CINTEL · COSSOR · DAWE
ELECTRONIC INSTRUMENTS · HIVOLT
KELVIN & HUGHES · MULLARD · SARGROVE
J. LANGHAM THOMPSON · WAYNE KERR
WAVEFORMS ETC.



F. C. Robinson & Partners Ltd.
122 SEYMOUR GROVE : OLD TRAFFORD
MANCHESTER 16 · Telephone CHOrlton 5366

Good ELECTRICAL EQUIPMENT



is Better

with NEON

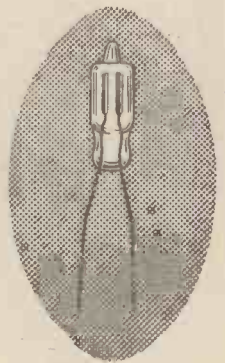

Indicator LAMPS

For all A.C. or D.C. mains voltages—long life—negligible power consumption—extreme reliability.



MAY WE SEND YOU A DETAILED FOLDER ?

HIVAC LIMITED
STONEFIELD WAY, VICTORIA ROAD
SOUTH RUISLIP, MIDDLESEX

Telephone : Ruislip 3366



By Appointment to the Professional Engineer



TOGGLE SWITCHES

6 AMPS. TOGGLE SWITCHES

6 Amps./250 Volts A.C. or D.C. Double-pole-changeover operation.
Bush and Lever chromium plated, or black finish.

10 AMPS. TOGGLE SWITCHES

10 Amps./250 Volts A.C. or D.C. Double-pole on/off operation.
Type Approved to RCS/RCL151
Bush and Lever chromium plated, or black finish.



PAINTON
Northampton England

TECHNICIANS AND ENTHUSIASTS WHO KNOW SPECIFY

Dulci

FM (VHF) TUNER CHASSIS COMPLETE

SELF POWERED

- Designed for use in conjunction with radiograms, receivers with pick-up sockets, tape recorders and Quality Amplifiers.
- Switching is incorporated for direct intercommunication. The tuner is connected to the PU terminals and the PU leads transferred to the tuner so that GRAM or FM may be selected without changing any connections.

CIRCUIT: Permeability tuned super-heterodyne with R.F. stage and additive mixer. 3 stage I.F. amplifier, ratio detector and triode audio-amplifier. Magic eye tuning indicator. Latest type all glass miniature B.V.A. designed for FM application ECC85, two EF89, EABC80, EM80, 6X4. **FREQUENCY RANGE CONTROLS:** Two front panel controls, OFF-FM-GRAM and FM TUNING.

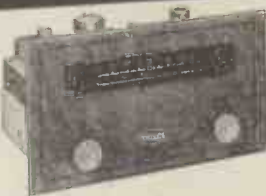

At rear: PRESET VOLUME CONTROL for adjusting output level. DIMENSIONS: front panel 10 1/2 in. x 5 1/2 in., depth from front panel 6 1/2 in., depth overall inc. knobs 7 1/2 in. CONSUMPTION 22.5 watts.

THIS F.M. UNIT OFFERS THE CUSTOMER HIGHEST VALUE PRICE INC. TAX.

£17 · 10 · 0

RADIO & RADIOGRAM

CHASSIS TYPE H.4

MAINS: A.C. 200-250 volts, 50 cycles. **FOUR WAVEBANDS:** Long-1,000-2,000 metres, 300-150 kc/s. MEDIUM: 187-540 metres, 1,600-540 kc/s. **SHORT:** 16-50 metres, 19-6 mc/s. **V.H.F. (Frequency Modulated)** 87-101 mc/s. Intermediate frequencies 10-7 mc/s and 471 kc/s. **VALVES:** B.V.A. Glass-seal miniature of latest type. Developed specifically for frequency modulation receivers. ECC85, ECH81, EF89, EABC80, EL84, EZ80, EM80. High "Q" inductances used throughout. Separate Ferrite rods are used for medium and long waves and all other coils have high performance adjustable iron dust cores. Signal and oscillator circuits of V.H.F. section are permeability wound and ganged. The oscillator is temperature compensated for zero drift and enclosed in die-cast case for minimum radiation.



EXTRAS: ESCUTCHEON FOR DIAL. Plastic extrusion, available in brown or cream. Made to fit wood panels 1/2 in. thick.

MATCHED SPEAKERS. Goodmans 8 in. or 10 in. P.M.

RECORD CHANGERS. Fully auto. B.S.R. latest model "Monarch."

PRICE INC. TAX.

£27 · 16 · 0

Write for details of these Fully Guaranteed high quality units—

Direct to the manufacturers

FULL TRADE TERMS AVAILABLE

Dulci

COMPANY LTD.

97 VILLIERS RD., LONDON. N.W.2

TELEPHONE: WILLESDEN 6678

Write also for details of PRE-AMPLIFIER for the New COLLARO Tape Transcriptor



A SPARK OF GENIUS!

I.C.S. training supplies the spark you need to further your career. The Courses I.C.S. offer are practical and up to date, they recognise the present emphasis on Frequency Modulation, and they can help you attain one of the many well-paid posts that exist today in the radio world. Prepare yourself now, at home and in your own time, with the expert help of I.C.S. tutors.

The cost of an I.C.S. Course is moderate and includes all books.

Among the I.C.S. Courses available are:

- FREQUENCY MODULATION ENGINEERING
- T/V ENGINEERING
- RADIO SERVICING
- RADIO ENGINEERING
- RADAR ENGINEERING

Basic Electronics • Industrial Electronic Electronic Engineering

Complete the coupon below and post it to us today for further details of the Course which interests you. Write to: Dept. 223E, I.C.S., 71 Kingsway, W.C.2

INTERNATIONAL CORRESPONDENCE SCHOOLS
Dept. 223E, International Buildings, Kingsway, London, W.C.2.

Please send FREE book on Age.....

Name..... Occupation.....
(Block letters please)

Address

INTERNATIONAL CORRESPONDENCE SCHOOLS

M. R. SUPPLIES Ltd.

(Established 1935)

Special notice to PRODUCTION and RESEARCH managers.—We hold large stocks of F.H.P. GEARED MOTORS for immediate delivery. A copy of our list GM/365, giving details, sent on request. The following first-class ELECTRICAL MATERIAL is also for immediate delivery. Prices net.

VOLTAGE STABILISERS—FREQUENCY INDEPENDENT. Very limited offer of brand new Philips 880 units—exceptional opportunity. Input 180/250 volts. Frequency range 47-51.5 cycles. Rating 150 vA. Output voltage 220 v. Regulation—negligible variation between 0 and 100% load. Rapid Response—time for complete recovery 1 cycle or 0.02 second. The stabiliser is temperature compensated over the range +10 deg. C. to +50 deg. C. Further details, if required, on request, but we have very few left. £27/10/- each net (despatch 12/6).

B.T.H. SHADED POLE INDUCTION MOTORS. 200-250 v. A.C. 1,400 r.p.m. Size: 4in. by 3 1/2 in. dia., with 1/2 in. screwed shaft, torque 500 gm./cms. The ideal silent running motor for many lab. and domestic uses. Very limited supply at 37/6 each (despatch 2/-).

TOTALLY ENCLOSED A.C. MOTORS (English Electric Co.). 230-250 v. 50 c. 1 ph., 1,425 r.p.m. split-phase induction, ball bearings. Conservatively rated at 1/10th H.P. for continuous duty—developing 1/6th H.P. Frame size approx. 7in. by 5 1/2 in. dia. Brand new—£9/15/- (despatch 5/6). We can fill a large variety of small motor requirements from stock.

EXTRACTOR FANS. Very well made new units much below normal price. 200/250 v. A.C. (induction motor, silent running, no interference). With mounting frame and back grille, ready for easy installation. With 8in. impeller (12,000 c. ft./hr.), £5/5/- With 10in. impeller (18,000 c. ft./hr.), £5/12/6 x des. either 3/-.

OPERATION COUNTERS, latest G.F.O. type, electromagnetic, brand new, 1in. square by 4in. long. Counting up to 9,999. Resistance 2,300 ohms, therefore suitable for electronic operation, 18/6 (des. 9d.). Also MECHANICAL type, counting to 999, forwards and backwards, with re-set and flexible drive, size approx. 1in. by 2 1/2 in., flex. drive 3in. long, at right angles, 15/6 (des. 1/-). These count one digit per rev. and can be used for testing motor speeds.

COMPLETE SEWING MACHINE MOTOR OUTFITS—there is no better quality job at any price, 200/250 v. A.C./D.C., fitted suppressors, including motor with fixing bracket, foot control, needle light with switch, belt, etc., with instructions for fixing to any machine, £8/15/- (des. 2/9).

HIGH DUTY AIR BLOWERS (or extractors). We have in stock a large and useful range. Examples: powered with B.T.H. type CFS 2615 repulsion-induction motor. Estimated delivery 1,500 c. ft./min. at 6in. W.G. Overall length 24in., width 20in., height 18in. Inlet 7in. dia. Outlet 7in. by 3in. Weight approx. 1 cwt. Brand new, in original cases, £22/10/- (despatch mainland U.K. 20/-).

SYNCHRONOUS TIME SWITCHES 200-250 v. 50 c. Brand new Sangamo-Weston, in compact black plastic housing 4in. dia. by 3 1/2 in. deep, providing up to three on-off operations per 24 hours, with day-omitting device (use optional), capacity 20 amps. A.C. (240 v.), £5/8/6 (despatch 2/-).

RELAYS, 12 v. 3 pole C.O., low capacity, suitable for R.F. switching, new, boxed, 7/6 (despatch 9d.). THERMAL DELAY SWITCHES, 6.3 volt, delay approx. 1/2 minute, 4/6. MINIATURE RELAYS, approx. 1in. cube, 2 pole "make," 650 ohms coil, 5/6. CONDENSERS (paper) 8 mfd. 500 v. D.C. wkg., best makes, 5/6 (despatch 1/6).

E.P.L. MEASURING INSTRUMENTS. Shelf-stock again available for immediate delivery: 8.50 (5in. rectangular) 25, 50, 100 and 500 Microammeters, and 0/1 Milliamp. Also 8.35 (3in. round) 100 Microammeters and 0/1 Milliammeters. And others—please enquire.

M. R. SUPPLIES. Ltd., 68, New Oxford St., London, W.C.1

Telephone: MUSeum 2958

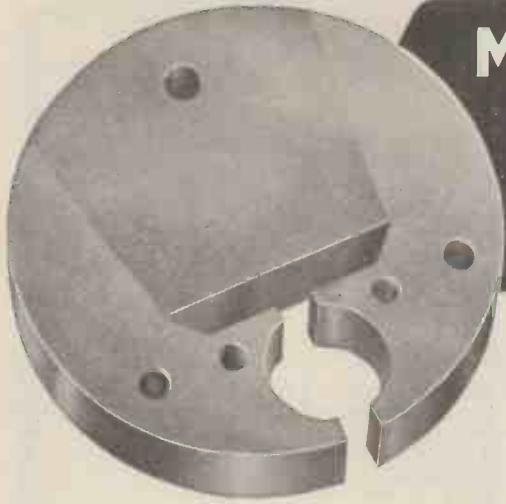

MUREX 'SINCOMAX' MAGNETS
are used in this **EVERETT, EDGCUMBE**
MOVING COIL MILLIAMMETER



A further example of the use of Murex 'Sincomax' Magnets where a high energy product with high magnetic stability is essential.

Murex 'Sincomax' Magnets, with an alloyed bond between magnet and soft iron, continue to give accurate and reliable service in this and many other applications.

MUREX LIMITED (Powder Metallurgy Division)
RAINHAM · ESSEX · Rainham, Essex 3322
 Telex: 8632. Telegrams: Murex, Rainham — Dagenham Telex.
 LONDON SALES OFFICE: CENTRAL HOUSE
 UPPER WOBURN PLACE, W.C.1 EUSon 8265

Photograph of
 3½" Moving Coil Milliammeter
 by courtesy of Everett, Edgumbe & Co. Ltd.

An essential reference book for *ALL* users of TRANSFORMERS & CHOKES

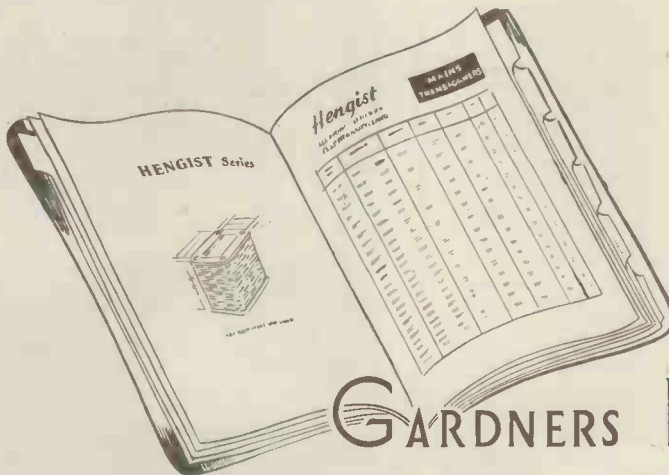

GARDNERS RADIO
CATALOGUE

The full catalogue is available free to industrial concerns. An abridged edition is forwarded to private users.



GARDNERS RADIO LTD., Somerford, Christchurch, Hants.

Tel. Christchurch 1024

ARE YOU SEARCHING ?



FOR HIGH QUALITY ELECTRONIC MINIATURES

Make contact with Arden Acoustic Laboratories Limited, for details of high-quality Miniature Earphones, Transformers, Switches, Volume Controls, Plugs and Sockets; also of the widely-known ARDENTE Hearing Aids.

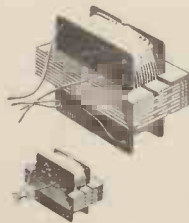

SUB-MINIATURE TRANSFORMER

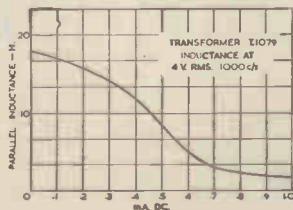

SIZE
.315" x .425" x .530"

Of robust construction; its unique design of laminations enables Transformer characteristics to be closely controlled, despite its small size. Weight: .12 ozs. Lead-out wires are colour coded for phase sense of windings applications.

Specially designed apparatus, capable of detecting one short-circuited turn of 50 SWG in 5,000 turns, is used in manufacture to safeguard against premature failure caused by electrolytic action on the fine wire at short-circuited points.

A comprehensive range is available. A typical example is a Transformer with primary inductance of 100 Henries with no D.C. in the winding. The graph shows variation of primary inductance with D.C. in a similar unit.

Special designs of Transformers are produced to meet individual requirements.

THE MINIATURE EARPHONE

will be featured in a following advertisement; details will gladly be sent on request.



ARDENTE ELECTRONIC COMPONENTS

Details on request to

ARDENTE ACOUSTIC LABORATORIES LTD.
8-12 Minerva Road, North Acton, London, N.W.10
Telephone: ELGar 3923 (5 lines)

RELAYS

P.O. TYPES
TO YOUR
SPECIFICATION

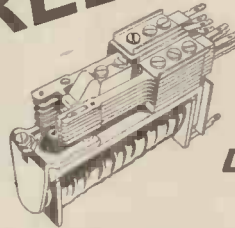

PROMPT
DELIVERY

3000 TYPES

COILS standard or special
up to 80,000Ω.
CONTACTS up to 8 c/o's.
600 and HIGH-SPEED
TYPES also Supplied.

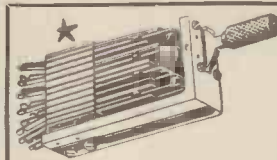
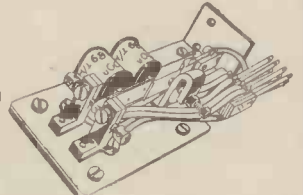

LARGE
STOCKS
OF
KEYSWITCHES

THE KEYSWITCH CO.

ALL POST OFFICE EQUIPMENT

Enquiries to Sales Manager

126 KENSAL ROAD, LONDON, W.10

Telephone: LAD. 0666, 4640. Grams: "Fonequipt", London, W.10

VARIACS for S-M-O-O-T-H Voltage Control



The "VARIAC"† is the original, continuously adjustable auto-transformer... the ideal control for varying the a-c voltage applied to any electrical, electronic, radar or communications equipment. Voltages from Zero to 17% above line are obtained by a 320-degree rotation of the shaft, which is equipped with a direct-reading dial, calibrated accurately.

"VARIAC" offers many real advantages over any other type of a-c control: compared with the losses of resistive controls they save their initial cost within about one year. They are available in various sizes from 170 VA up to 25 Kilowatts. 3-gang assemblies are also available for 3-phase working. Prices vary from £7.10.0. upwards.

Write for our Catalogue—Technical Manual V-549, which gives all possible information, to:

CLAUDE LYONS LTD.

Head Office and Works: 76 Oldhall Street, Liverpool 3, Lancs.
Southern Factory: Valley Works, Ware Road, Hoddesdon, Herts.
†Registered Trade Mark.

Connoisseur 3 SPEED MOTOR

The turntable with a 4% variation on all three speeds.

The Connoisseur motor is made for the perfectionist. It is one of the finest turntables in the world.

The speed change is arranged mechanically and gives a 4 per cent variation on all speeds. A synchronous motor, which is virtually vibrationless with low noise level and hum induction, maintains a constant speed at all settings. There is no braking action to obtain speed change.

The 12-in. turntable is lathe turned in non-ferrous metal. The main spindle, which is precision ground and lapped to mirror finish, runs in phosphor bronze bearings.

A sound, precision engineering job, the Connoisseur motor provides the foundation for perfect reproduction.

Price £20, plus P. Tax £8/11/-.



Matching Connoisseur Pick-up Mark II with a frequency range from 20-20,000 cycles:

Pick-up complete with I head fitted with Diamond armature £8/19/- plus P. Tax £3/16/6.

A. R. SUGDEN & CO. (ENGINEERS) LTD.

WELL GREEN LANE, BRIGHOUSE, YORKSHIRE. Phone: Halifax 69169. Grams: Connoisseur Brighouse.

OVERSEAS AGENTS:

SOUTH AFRICA: W. L. Proctor (Pty.) Ltd., 63, Strand Street. Cape Town. CANADA: The Astral Electric Co. Ltd., 44, Danforth Road, Toronto 13, Ontario. NEW ZEALAND: Turnbull & Jones Ltd., Head Office, 12/14, Courtenay Place, Wellington. HONG KONG: The Radio People Ltd., 31, Nathan Road, Hong Kong.

MAIN DISTRIBUTORS:

AUSTRALIA: British Merchandising Pty. Ltd., 183, Pitt Street, Sydney, and J. H. Magrath (Pty.) Ltd., 208, Little Lonsdale Street, Melbourne. EAST AFRICA: International Aeradio (East Africa) Ltd., P.O. Box 3133, Nairobi. MALAYA: Eastland Trading Co., 1, Prince Street, Singapore.

ABIX SLOTTED ANGLE

NOW IN A NEW RANGE OF 3 SIZES

DELIVERY FROM STOCK



SENIOR
3" x 1 1/2"



UNIVERSAL
2 1/2" x 1 1/2"



JUNIOR
1 1/2" x 1 1/2"

USE ABIX SLOTTED ANGLE FOR SHELVING, RACKS, BENCHES AND "ONE HUNDRED AND ONE" OTHER JOBS.

ABIX SLOTTED ANGLE manufactured from 14 G Steel. Phosphated and stove enamelled grey. In packets of 100 ft. with 72 sheradized nuts and bolts. The junior size contains 20 gusset plates and 60 nuts and bolts (minimum quantity 100 ft.).

ORDER A TRIAL 100 ft. PACK TODAY!

Write for illustrated catalogues to:

ABIX

(METAL INDUSTRIES) LTD.

FACTORY EQUIPMENT SPECIALISTS

Also Manufacturers of: DOUBLE SKIN PARTITIONING

ABIX STEEL CLOTHES LOCKERS



ABIX Clothes Lockers are of All-Steel construction, with separate hat and coat compartments. Single units or banks of two, three or four. Stove enamelled olive green. With lock and die-cast handles.

SIZE OF SINGLE UNIT:
75" high
12" wide
15" deep

TAYBRIDGE HOUSE,
TAYBRIDGE ROAD,
BATTERSEA, LONDON, S.W.11
Phone: BAttersea 8666/7
Grams: ABIX, BATT., LONDON

only VENNER make
Silver-Zinc
accumulators
 IN GREAT BRITAIN

only Silver-Zinc accumulators have such—

small measurements

high rates of discharge

high power to weight ratio

constancy of output



actual size

This typical Vanner Silver-Zinc cell with a capacity of 1.5 ampere hours weighs only 1 1/8 ounces.

For full particulars please write to Dept. WW

VENNER

ACCUMULATORS LTD.

Kingston By-Pass, New Malden, Surrey. Tel: MALden 2442

Member of the Vanner Group of Companies, manufacturers of Time Switches • Park-0-Meters • Electronic & Electro-Mechanical Instruments

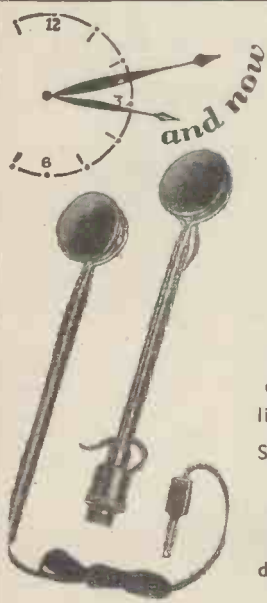

S.G. Brown
AUDIO AIDS

Handphones with individual volume control. Ideal for use with church and cinema deaf aid installations or for individuals with Impaired hearing. They provide the essential clarity of reception when listening to Radio and T.V. Send for Brochure "W" of all types available. If desired, advice is given on selection of type most suited to individual needs.

S. G. Brown provide Headphones and associated equipment for all known purposes.

S.G. Brown, Ltd.

SHAKESPEARE STREET, WATFORD, HERTS.
 Telephone: Watford 7241

BROOKES *Crystals*



mean DEPENDABLE frequency control

• Illustrated above are two Type G Crystal units from a range covering 111 kc/s to 500 kc/s, and 3 Mc/s to 20 Mc/s.

ALL Brookes Crystals are made to exacting standards and close tolerances. They are available with a variety of bases and in a wide range of frequencies. There is a Brookes Crystal to suit your purpose—let us have your enquiry now.



Brookes Crystals Ltd.

Suppliers to Ministry of Supply, Home Office, B.B.C., etc.
 181/3 TRAFALGAR ROAD, LONDON, S.E.10.
 Phone: GREenwich 1828 Grams: Xtals, Green, London



BASF magnetic recording tape

GIVES ALL FOR THAT LITTLE EXTRA

1,000 metre for professional use

1,200 ft. on plastic spool

600 ft. on plastic spool

300 ft. on plastic spool

150 ft. miniature tape for postal recordings.

Special tapes for GRUNDIG TK. 9, TK. 819 and STENOLETTE.

Also

the New Thin Long Playing Tape giving 50% more tape on the same spool.

Please write for further details.

Wear doesn't tear; nor do scratches impair . . . **TAPE** for recording designed for withstanding all halts and all faults from sonic events . . . What's more it prevents all defects on repeats . . . it's as tough as tape can be since it's based on **PVC** . . . for that little more initially you get precious durability.

In short :

You get so much more — For that little extra.

F. A. HUGHES & CO. LTD.
DEVONSHIRE HOUSE PICCADILLY LONDON W1

Telephone: Mayfair 8867

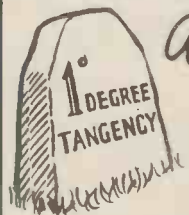

A new milestone in Hi-Fi Reproduction



The cradled interchangeable disks are a coarse counterbalance for all heads and cartridges.

The two slide weights give complete fine adjustment gradation within 8 grammes.

A finger-touch calibrated pedestal gives a new approach to rapid precision alignment of all heads and cartridges.

Closure of the feed lead gives freedom from interference both mechanically and electrically.

Friction-free spheres give the ultimate in tracking smoothness.

The plug-in shell will take ALL popular cartridges (two shells are included with each arm). The fitting is standard for direct plug-in heads.

We believe this to be the LAST WORD in Pickup arm refinement

ASK YOUR LOCAL DEALER FOR FULL DETAILS

ANOTHER MAGNUM PRODUCT manufactured by

BURNE-JONES SUNNINGDALE ROAD CHEAM SURREY ENGLAND

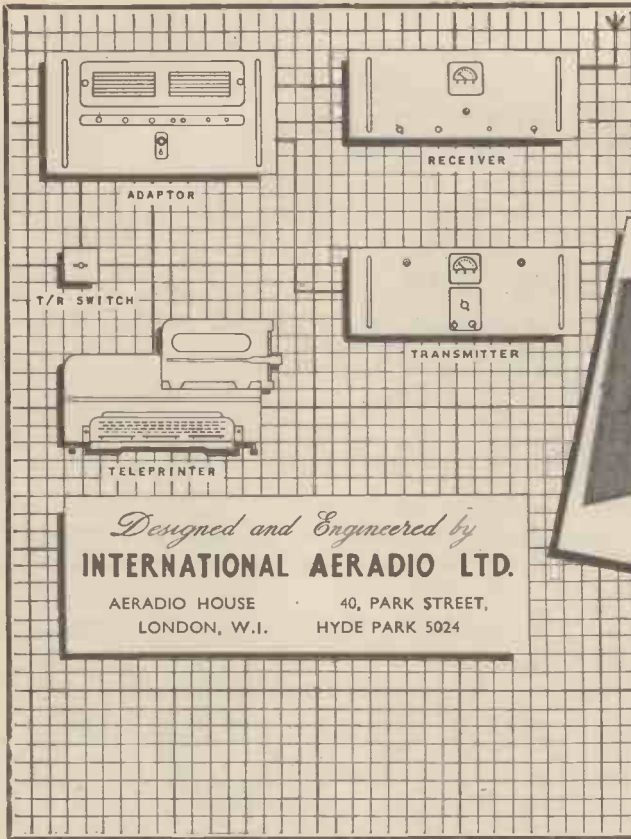

THE I-A-L SHORT RANGE RADIO TELEPRINTER TERMINAL

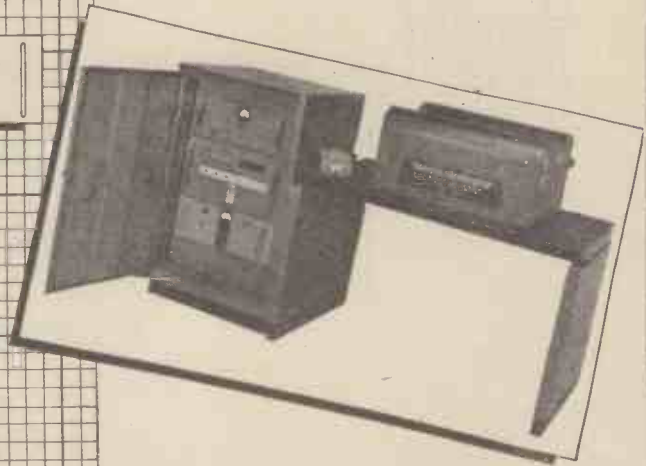

The International Aeradio VHF short range radio teleprinter terminal is designed to combine the highest engineering standard with low initial cost. This equipment is especially valuable where landline facilities are unreliable or not available, as may happen between a town and its airport.

EXECUTIVES REQUIRE CRISP, CONCISE REPORTS—DICTATE THOSE DETAILS IN YOUR CAR! VALRADIO DC/AC CONVERTERS MAKE DICTATING MACHINES AND TAPE RECORDERS MOBILE



For use too with Record Changers, Radiograms, Electric Gramophones, Television Receivers, and T.V. from country house lighting plants. (Prices according to instrument.)

INPUTS . ENTREES . ENTRADAS
6, 12, 24, 32, 50, 110 or 200/250 v.
OUTPUTS . SORTIES . SALIDAS
110 v. or 230 v. AC, 50 or 60 c/s., 30 to 300 w.

Prices DC/AC Converters:
From £8.16.0—for Small Motors
From £11.16.0—for Radiograms (including 3-speed Types).

Units complete ready for use. **VALRADIO.** Write for descriptive folder, WW/C. ACCEPTED AS THE STANDARD by RADIO MANUFACTURERS, the Trade and the Aircraft Industry.

Les rapports destinés aux chefs de service doivent être rédigés d'une façon bien concise—ditez-les donc dans votre voiture!
Les convertisseurs C.C./C.A. "VALRADIO" consentent la mobilité aux machines à dicter et aux enregistreurs sur bandes.
Ils peuvent également être utilisés pour changeurs de disques, appareils combinés, électrophones, téléviseurs, etc., partant d'installations d'électricité particulières.

Las relaciones destinadas a los jefes tienen que redactarse de modo muy conciso—dícenlas en el coche!
Los inversores C.C./C.A. "VALRADIO" les prestan movilidad a las máquinas de dictar y a los grabadores de cinta.
También pueden utilizarse para cambiadores de discos, radio-combinados, gramófonos eléctricos, aparatos de televisión, etc., aprovechando las instalaciones eléctricas privadas.

Specialists in converters since 1937. **VALRADIO LIMITED.**
BROWELLS LANE · FELTHAM · MIDDX. · Phone: Feltham 4242/4837
OVERSEAS ENQUIRIES TO:— DEMANDES D'OUTRE-MER A:—
TODA INFORMACION DE EXPORTACION HA DE PEDIRSE A:—
E.M.I. SUPPLIERS LTD. · HAYES · MIDDLESEX · ENGLAND.

JASON MW/FM TUNER with A.F.C.

Price **£28.13.6** (inclusive)



A highly sensitive, self-powered tuner for medium waves and V.H.F.-F.M. The following features contribute to the excellent performance—low noise cascade R.F. stage—automatic frequency control to reduce tuning errors and give perfect tuning stability—diode circuit to reduce inter-station noise—cathode follower output with voltage level control—input 75 ohms, co-axial feeder or 300Ω balanced. Output voltage 500 m.v.

★ Now being demonstrated in the West End ★

The JASON MOTOR & ELECTRONIC Co.,

328 CRICKLEWOOD LANE, LONDON, N.W.2 SPE 7050



We will gladly send you our catalogue and full information on request

VITAVOX LIMITED, Westmoreland Road,
London, N. W. 9. Telephone: COLindale 8671

THE "WEYRAD" AM/FM RECEIVER

A COMPLETELY NEW DESIGN SPECIALLY DEVELOPED FOR THE AMATEUR CONSTRUCTOR.

THIS PUBLICATION GIVES FULL INFORMATION ON THE ASSEMBLY AND ALIGNMENT OF A FOUR-BAND, SEVEN-VALVE RECEIVER, INCLUDING ALL CHASSIS DETAILS, CIRCUITS AND WIRING DIAGRAM.

UP-TO-THE-MINUTE COMPONENTS AND VALVES PROVIDE A HIGH STANDARD OF PERFORMANCE (EQUIVALENT TO AN EIGHT VALVE CIRCUIT) AND COMPLETE COVERAGE OF THE SOUND BROADCAST BANDS, ENSURING THAT THE SET WILL NOT "DATE" FOR MANY YEARS.

- ★ LATEST TYPE MULLARD VALVES.
- ★ "WEYRAD" COIL PACK, I.F. TRANSFORMERS, TUNING SCALE, I.F. FILTER, MAINS AND OUTPUT TRANSFORMERS.
- ★ ALUMINIUM CHASSIS AVAILABLE WITH ALL PUNCHING AND BENDING COMPLETE.
- ★ ALL CONDENSERS, RESISTORS AND OTHER COMPONENTS BY WELL-KNOWN MANUFACTURERS.

FULLY ILLUSTRATED BOOKLET PRICE 2s. 6d.

WEYMOUTH RADIO MANUFACTURING CO., LTD., CRESCENT STREET,
WEYMOUTH, DORSET

A book for every viewer, home-
constructor and service engineer

Correcting TELEVISION PICTURE FAULTS

By John Cura and Leonard Stanley

Uses about 150 remarkable photographs of actual faults appearing on the screen of a television receiver to enable quick diagnosis of trouble. The accompanying text explains what action can be taken to remedy the faults and is primarily written in everyday language for the ordinary viewer. Further details of a more technical nature are included in differently displayed text for the service engineer, the advanced amateur, and the home constructor.

7 1/4" x 4 3/4" 77 pp. Illus. 3/6 net. By post 3/10.

Over 150 pictures of actual picture faults

from all booksellers

Iliffe & Sons Ltd., Dorset House, Stamford St., London, S.E.1

REDUCE YOUR PRESS TOOL COSTS

**THE HUNTON UNIVERSAL BOLSTER OUTFIT
FOR SHEET METAL PIERCING AND
BLANKING ON FLY PRESSES**

Bolster Frame with 2 adjustable gauges and insertable steel Holders for Dies 1/4 in. to 3 3/4 in. bore diameter.

Two Punch Holders with detachable positive-action Strippers take the complete range of Punches 1/4 in. to 3 3/4 in. diameter.

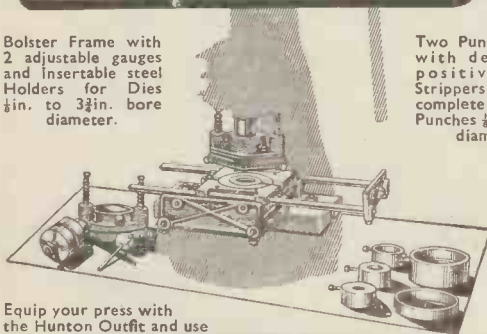

Equip your press with the Hunton Outfit and use inexpensive standardised Punches and Dies 1/4 in. to 3 3/4 in. diameter, obtainable from stock—in 1/8 in. sizes—when required.

Standardised Tools also available at short notice for Square, Oblong and other shapes, Louvre Forming (up to 8 in. long), Corner Notching, Corner Radiusing, Angle Iron Notching and Piercing, etc.

Get the Outfit now—Buy Punches, Dies and Tools as you need them

Descriptive brochure and price list W.B. on request.

HUNTON LIMITED

Phoenix Works, 114-116 Euston Road, London, N.W.1

Telephone: EUSton 1477-8-9.

Telegrams: Untonexh, London



THIS MAGNIFICENT RECORDER TAKES EVERYTHING IN ITS STRIDE

The remarkable performance on standard or pre-recorded tapes of the Celsonic high-fidelity magnetic Tape Recorder is world famous. It also takes in its stride the superimposing of words over music and the conversion of silent films to sound.

Long playing times possible on reels up to 3,280 ft. Full track and half track available.

CELSONIC

Send for details:

EXCEL SOUND SERVICES LTD., (Dept. W.D.O.)
Garfield Avenue, Bradford 8, Yorkshire. Tel.: 45027
Please PRINT your name and address.



METERS

TO B.S. 89-1954
AVAILABLE
FOR
PROMPT DELIVERY

EXAMPLES OF TYPES AVAILABLE IN 2 1/2 in. FLUSH PATTERN MOVING COIL INSTRUMENTS

AMPERES D.C. 0-1, 2, 3, 5, 10, 15, 20, 25, 30, 50.
MILLIAMPS. 0-1, 1-0-1, 0-5, 10, 15, 20, 25, 30, 50, 100, 250, 500.
MICROAMPS. 0-25, 0-50, 100, 200, 250, 400, 500, 750, 50-0-50, 100-0-100, 250-0-250, 500-0-500.
AMPS. R.F. 0-1, 3, 5, 10, 15, 25, 50.
VOLTS D.C. 0-1, 5, 10, 15, 25, 50, 100, 250, 500, 750, 1,000, 1,500, 2,500.
VOLTS A.C. 0-5, 10, 15, 25, 50, 100, 250, 500, 750, 1,000.

We can supply meters with NON-STANDARD CURRENT and VOLTAGE RANGES to any specification. DELIVERY 7-14 days. MOVING IRON. THERMO AND ELECTROSTATIC INSTRUMENTS. 2 in. SQUARE FLUSH, 3 1/4 in. ROUND FLUSH and INDUSTRIAL SWITCHBOARD INSTRUMENTS ALSO AVAILABLE FOR PROMPT DELIVERY.

ELECTRONIC TEST EQUIPMENT AND INSTRUMENTATION DEVELOPED AND MANUFACTURED FOR SPECIALISED APPLICATIONS.

ANDERS ELECTRONICS LTD.

91, HAMPSTEAD ROAD, LONDON, N.W.1.

Telephone: EUSton 1639

Suppliers to Govt. Depts., B.B.C., Tech. Colleges,
Leading Manufacturers & Research Laboratories

PRESENTING

We are proud to represent the products of these internationally famous Makers chosen by our Experts at the recent **AUDIO FAIR** and now available to every Audiophile on the M.O.S. Personal Credit Plan.

LONDON'S NEWEST HI-FI SHOWROOM

**RONETTE
WOOLLETT
LEAK
COLLARO
BURGOYNE**

**CONNOISSEUR
LOWTHER
GARRARD
ACOUSTICAL QUAD
WHARFEDALE**

**ROGERS
GOODMANS
G.E.C.
W.B.
E.A.R.**

	CASH	CREDIT	HIRE	EXPORT	Tape Recorders and Decks			
	PRICE	SALE	PURCHASE	PRICE	Editor 2-speed Standard	L.P. Tape	Editor Super Hi-Fi	Playtime (complete)
	£ s. d.	9 mthly. pmts. of	Deposit 50% 12 mthly. pmts. of	nett	50 8 0	123/3	25 4 0	46/8
BRITISH MADE EQUIPMENT—					65 2 0 <td>189/1 <td>32 11 0 <td>60/4 </td></td></td>	189/1 <td>32 11 0 <td>60/4 </td></td>	32 11 0 <td>60/4 </td>	60/4
Amplifiers (complete)					31 4 6 <td>76/4 <td>15 12 6 <td>29/- </td></td></td>	76/4 <td>15 12 6 <td>29/- </td></td>	15 12 6 <td>29/- </td>	29/-
Acoustical Quad Mk. II..	42 0 0	103/1	21 0 0	38/11	36 15 0	89/10	18 8 0	34/-
Leak TL 10 and Point One	28 7 0	70/4	14 3 6	26/3	84 0 0	205/4	42 0 0	77/10
Rogers RD Junior	26 0 0	63/7	13 0 0	24/2	99 0 0	242/-	49 10 0	91/9
W.B. 12 Hi-Fi	25 0 0	61/1	12 10 0	23/4	79 16 0	195/1	39 18 0	74/-
E.A.R. Mullard 510	18 18 0	46/5	9 9 0	18/3	90 6 0	218/6	45 3 0	83/8
					20 0 0	48/11	10 0 0	19/2
					35 0 0	85/7	17 10 0	32/5
					23 2 0	56/5	11 11 0	21/9
					18 10 0	45/3	9 5 0	17/11
								18 10 0
Loudspeakers					Gramophone Motor Units			
Wharfedale W16CS	17 10 0	42/9	8 15 0	17/1	17 10 0	Garrard R0110 Changer	14 13 3	35/11
Super 12CSA	17 10 0	42/9	8 15 0	17/1	17 10 0	RC80M	18 6 8	44/9
W12CS	10 5 0	26/1	5 2 6	11/-	10 5 0	Collaro RC54 Changer	13 17 0	34/1
Golden 10	8 0 11	21/3	4 0 6	9/2	5 15 0	2010 and Pickup(T)	19 10 0	47/8
Super 8CSAL	7 6 11	19/8	3 13 6	8/7	5 5 0	2010 less Pickup(T)	14 18 0	36/5
G.E.C. Metal Cone	9 5 0	23/11	4 12 6	10/2	6 13 7	Connoisseur Variable (T)	28 11 4	71/-
Goodmans 150 Mk. II	10 15 9	27/4	5 8 0	11/6	10 15 9	Garrard 301 (T)	28 8 2	66/7
Axiom 80	24 4 9	59/3	12 2 6	22/8	17 10 0	We detail above selected Equipment available to you by Credit Sale (9 equal monthly payments) or Hire Purchase terms, and the latter can be extended up to 18 months for amounts over £50, the Equipment being despatched to you shortly after receipt of the initial deposit.		
Audiom 60	9 2 9	23/8	4 11	10/1	9 2 9	Export Prices are shown separately for easy import facilities.		
Axiom 22	15 9 0	35/6	7 14 6	15/4	15 9 0			
Axiom 102	10 7 9	26/5	5 4 0	11/2	7 10 0			

9 DEPARTMENTS covering:

- HI-FI
- TAPE RECORDERS
- TEST METERS
- ELECTRIC TOOLS
- REFRIGERATORS
- ELECTRICAL APPLIANCES
- RADIOGRAMS
- TELEVISION
- SERVICE DEPT.

Staffed by a team of qualified technicians offering a 24-Hour service.

E & G MAIL ORDER SUPPLY CO.

The Radio Centre

33 Tottenham Court Road, London, W.1

Tel: MUSEum 6667



have you a DC 'bug-bear'?

No longer need D.C. current be a 'bug-bear'. The Felgate **ELECTRONIC INVERTER** will transform 200/250 volt D.C. current to operate almost any A.C. apparatus needing a power of between 25 and 78 watts.

The instrument consists of a hard valve push-pull power amplifier driven by a separate oscillator; there are no moving parts. It is silent in operation and its frequency is very stable. Measuring 9 3/4" x 6 1/2" x 5 1/2" it can be fixed inside a large instrument such as a radiogram, with control switch on the dial.

PRICE £12. (no P.T.)

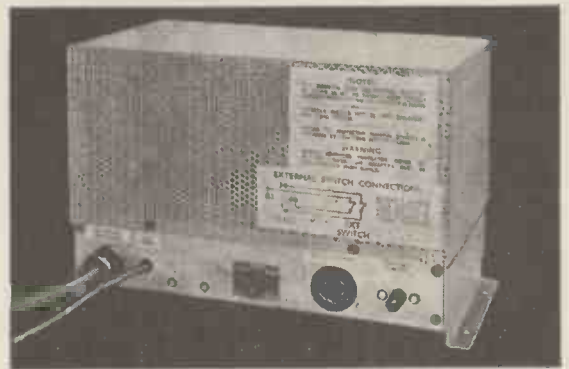

FELGATE

electronic inverter

See your dealer today. If any difficulty write to:

FELGATE RADIO LTD. FELGATE HOUSE, STUDLAND STREET, HAMMERSMITH, W.6.

You'll do better

Build these New **PREMIER TELEVISORS!**

★ **13 CHANNEL DESIGN No. 1**

MAY BE BUILT FOR £32 - 7 - 11 PLUS COST OF C. R. T.

★ **5 CHANNEL DESIGN No. 2**

MAY BE BUILT FOR £27 - 9 - 4 PLUS COST OF C. R. T.

BUILD IN 5 EASY STAGES. FULL CONSTRUCTIONAL DETAILS AVAILABLE. INSTRUCTION BOOK 3/6 POST FREE INCLUDES BOTH DESIGNS

CONSOLE CABINETS with full length doors for 14in., 16in. and 17in. tubes PRICE £14/14/- H.P. Terms: Deposit £7/7/6 and 9 monthly payments of 18/6

CONSOLE CABINETS previously advertised, still available at £12/12/- H.P. Terms: Deposit £6/6/- and 8 monthly payments of 18/3

On above cabinets add 21/- for pkg. & carr.

ILLUSTRATED LIST AVAILABLE GIVING FULL DETAILS OF BUREAU TYPE CABINETS

A RANGE OF BAND 3 AND F.M. AERIALS IS NOW AVAILABLE

Air spaced co-axial wire, 1/9 per yard.

MAKE YOUR OWN ROD AERIAL

Ferrite rod 6in. x 1/8in., complete with descriptive constructional details. These aerial rods are suitable for medium and long wave reception. Price 5/3. post free.

THE JASON "ARGONAUT" MW/FM DESIGN

All Premier Components are designer approved

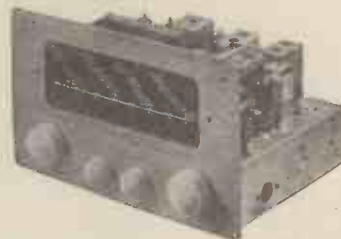

The very latest FM Receiver design PLUS a medium waveband, as described in "The Radio Constructor." ALL components to build the complete Receiver, including output stage, may be purchased for £15/5/-, or all components less output stage but including Power Supply, for £13/19/6, plus packing and postage 3/6 on each. The chassis, front plate, dial, flywheel drive assembly, special tuning condenser and wavechange switch (which includes main switch) supplied completely assembled. This is also available separately at £4/4/- plus packing and postage 2/6.

MULLARD AMPLIFIER KIT

WHY NOT MAKE THE BEST!

All the components for model 510, PLUS pre-amplifier on one chassis (total six valves) may be purchased for £12/12/- plus pkg. & post 7/6, or pre-amplifier and tone control in a separate unit £14/14/- plus pkg. and post 7/6.

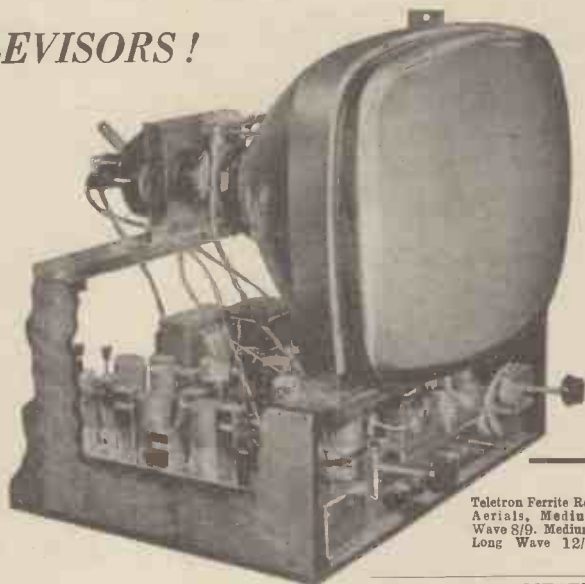

Teletron Ferrite Rod Aerials. Medium Wave 8/9. Medium/Long Wave 12/8.

T.S.L. **ELECTROSTATIC SPEAKERS**

Type LSH75Price 12/6
Type LSH100Price 21/-
Type LSH518Price 17/6

SPECIAL OFFER

Limited Quantity

The well-known Band 3 Univerter in chassis form suitable for any home-built or commercial Television, will fit into existing Cabinet complete with own A.C. Power Supply, tested and ready for use, two models, London or Midland. Cash price £6/6/-, plus packing and postage 3/6.

LATEST B.S.R. MONARCH 4-SPEED AUTOCHANGER

Designed to play 12in., 10in. and 7in. Records Intermixed in any order at 16, 33, 45 or 78 r.p.m. Capacity 10 Records. New reversible Dual Stylus Crystal Pick-up, for use on 100/150 v. 50 cycle A.C. mains. £9/15/0, plus packing and postage 5/-.

B.S.R. MONARCH 3-Speed Autochanger still available at £7/19/6. Plus pkg. & post 6/-.

LATEST TYPE 3-SPEED SINGLE PLAYER

By famous manufacturer, with crystal turnover head. For use on 100-250 v. 50 cycle A.C. mains. £6/19/6. Plus pkg. & carr. 5/-.

COMPACT GRAM AMPLIFIER

Suitable for any type of Pick-up. Volume and tone control fitted with knobs. Overall size 7 1/2in. long x 3 1/2in. wide x 2 1/2in. high. Complete and ready for use. £2. 19. 6

Plus packing and postage 2/6

METER RECTIFIERS. Miniature type with leads 1-5 mA. 6/9, post paid.

SEND FOR DETAILS OF OUR H.P. AND CREDIT TERMS

TERMS OF BUSINESS:

Cash with order or C.O.D. over £1. Please add 1/- for Post Orders under 10/-, 1/6 under 40/-, unless otherwise stated.

BARGAIN OFFER

DARK SCREEN FILTER IN TRIPLEX GLASS 18in. x 14in. SUITABLE FOR ALL TUBES UP TO 17in. 10/- PLUS PACKING AND POSTAGE 1/6. LATEST TYPE RUBBER ESCUTCHEON SUITABLE FOR 17in. RECTANGULAR TUBES AT A SPECIAL PRICE OF 10/- PLUS PACKING AND POST 1/6.

We carry a comprehensive stock of components by all leading manufacturers.



The most efficient **BAND III CONVERTER** available

Includes 2 valves plus metal rectifier utilising the latest circuit technique. Midland, North and London Models A.C. Mains only 200/240 v., complete with power supply. Provision is made by means of a four position switch to cover all Band III channels. Size—Height 2 1/2in., Width 5 1/2in.

PRICE COMPLETE **£8. 8. 0** Plus 2/6 pkg. & carr.

Credit Terms: Deposit £1/1/4 and 8 monthly payments of £1/2/1.

SEND 2d. STAMP FOR OUR 1956 CATALOGUE



COMMUNICATION RECEIVER P.C.R.2.

Send for leaflet.

6-Valve 3 wavebands 13-50, 190-570 and 900-2,000 metres, in black case with crackle front, illuminated calibrated dial, flywheel tuning, size 17 1/2 x 10 x 8in. Cash £7/10/-, plus packing and carriage 10/6. Supplied complete with built-in A.C. Power Supply. Brand new and ready for use. Cash £9/19/6, or H.P. terms. Plus packing and carriage 10/6. Circuit diagram available, 9d. post free.

PREMIER RADIO COMPANY,

with PREMIER

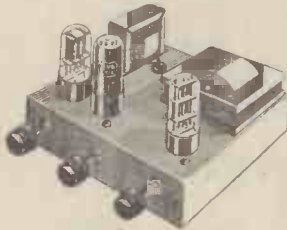

4 WATT AMPLIFIER

MAY BE BUILT FOR **£4.10.0** Plus 2/6 Pkg. & Postage

A steel case is now available, complete with engraved panel, for 21/- extra. The amplifier may be supplied complete for £5/5/- plus pkg. and post 3/6, or fitted in case at £6/6/- plus pkg. and post 3/6.



3 BAND SUPERHET RECEIVER

MAY BE BUILT FOR **£7.19.6** Plus 3/- Pkg. & Postage

2-BAND TRF RECEIVER MAY BE BUILT FOR £5.15.0 plus pkg. & post 3/-

These two receivers use the latest type circuitry and are fitted into attractive cabinets 12in. x 6 1/2in. x 5 1/2in. in either walnut or ivory bakelite or wood. Individual instruction books 1/- each, post free.

AM/FM RADIOGRAM CHASSIS

9 Valves (including Magic Eye), output 2 x 6BW6 valves in push-pull, output suitable for 3 or 15 ohms speakers. Ferrite Rod Aerials on medium and long "Gorler" permeability Unit on FM. A.C. mains 200-250 volts, chassis 15in. long, 7 1/2in. deep, 8in. high, dial 14 1/2in. x 8in. Cash price £27/6/-, or on H.P. terms. Plus packing and carriage 7/6 extra.

T.S.L. LORENZ SOUND SYSTEM

Type LP 312-2

Consists of a 12in. Unit and two LP665 Treble Units. Co-axially placed to give the widest listening angle. Bass and treble Units have magnetic systems of the highest efficiency, each magnet having a flux density of 17,500 gauss. This Speaker system gives a level response from 20 to 20,000 cycles. No expensive cross-over Units are required.

Leaflet available. Price £14/19/6 H.P. terms available. giving full details.

Postage and packing 7/6 extra

Single Treble Units available separately at 39/6 each plus packing and postage 1/- extra.

Improve your existing Speaker system with this Unit giving an output of 2 k/c to 20 k/c ± 1db.

A range of High Fidelity Amplifiers, Speakers and Record Players, the following makes in stock: Leak, E.A.R., Rogers, Goodmans, Wharfedale, W.B. Stentorian, Lorenz, B.S.R., Collaro, Garrard, Lenco, Connaisseur. We shall be only too pleased to demonstrate any of the above equipment.

PORTABLE TAPE RECORDER CABINETS

All Resins covered

Tape Deck	Amplifier	Type	Price
Lane Mk. VI	Premier	Mk. VI	£4/19/6
Lane Mk. VI	Premier	de Luxe	£4/19/6
Truvox Mk. III	Truvox C	T.D.3	£4/4/-

Plus Postage and Packing 5/-

ALUMINIUM CHASSIS 18 s.w.g.

Substantially made from Bright Aluminium with four sides:

7 x 5 1/2 x 2in.	4/-	10 x 9 x 3in.	7/-
7 x 3 1/2 x 2in.	3/9	12 x 10 x 3in.	7/9
9 1/2 x 4 1/2 x 2in.	4/3	14 x 10 x 3in.	7/11
10 x 8 x 2 1/2in.	5/6	16 x 10 x 3in.	8/3
12 x 9 x 2 1/2in.	7/-	16 x 8 x 2 1/2in.	8/-
14 x 9 x 2 1/2in.	7/6		

ALUMINIUM PANELS 18 s.w.g.

7 x 6in.	1/3	7 x 4in.	1/-
9 1/2 x 6in.	1/8	9 1/2 x 4in.	1/5
10 x 9in.	2/2	10 x 7in.	1/11
12 x 9in.	2/8	12 x 7in.	2/5
14 x 9in.	3/2	14 x 7in.	2/11
16 x 9in.	3/8	16 x 7in.	3/5
20 x 9in.	4/8	20 x 7in.	4/5
22 x 9in.	5/2	22 x 7in.	4/11

CAN WE HELP YOU!

IF THE EQUIPMENT OR COMPONENTS YOU REQUIRE ARE NOT IN OUR ADVERTISEMENT, DON'T HESITATE TO WRITE TO US—WE PROBABLY HAVE THEM IN STOCK.

THE NEW

T.S.L. FM TUNER MARK 2

6 Valves including Magic Eye and Power Supply, using the latest type Gorler permeability Unit complete with first audio stage and preset output volume control. Maximum radiation less than 10 microvolts per metre. Sensitivity better than .5 microvolts. Cash price £17/10/- (inclusive), or on H.P. terms, deposit £8/15/- and 9 monthly payments of £1/1/8. Credit terms, deposit £2/3/9 and 8 monthly payments of £2/3/4. Postage and packing 5/- extra.

WILLIAMSON AMPLIFIER

MAY BE BUILT FOR **£15.15.0** Plus 7/6 Pkg. & Postage

Supplied completely wired and tested for £20, or available on H.P. or Credit terms, postage and packing 10/-.

PRE-AMPLIFIER & TONE CONTROL UNIT

Available completely constructed, £5/5/-, plus 2/6 packing and postage.

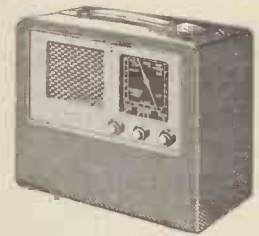

ALL DRY BATTERY PORTABLE RADIO RECEIVER

MAY BE BUILT FOR **£7.8.0** Plus 3/- Pkg. & Postage

4 Miniature valves in a superhet circuit covering medium and long waves, Rexine covered cabinets 11 1/2in. x 10in. x 5 1/2in., in two contrasting colours, wine with grey panel or blue with grey panel. Please state choice when ordering. Instruction book 1/6 post free, which includes full constructional details and list of priced components.

The New "PREMIER"

TAPE RECORDER

£5 DEPOSIT & 8 MONTHLY PAYMENTS OF £4.18.6 or CASH PRICE £40 plus 21/- pkg. & carr.



★ Case finished in Brown and Antique Fawn. Size 15in. x 12 1/2in. x 7 1/2in., with the very latest type continental gilt fittings. For A.C. mains 200-250 volts, 50 cycles.

207, EDGWARE RD., LONDON, W.2. Tel: Ambassador 4033 & Paddington 3271

PERFECTED BY **COSSOR**

PRINTED CIRCUITS

Now available to manufacturers of Radio, Electronic Instruments and other electrical equipment.

Since 1947 Cossor engineers have been studying the problems associated with Printed Circuits and Wiring. The present standard of perfection achieved and the experience gained over these years are now offered to the Electrical and Radio Manufacturing Industry which is ready to take advantage of this revolutionary technique.

Economy in materials, production time, weight and space, together with consistency of production, are the major attractions.

Above all, a reliability factor hitherto unobtainable is now **within** the reach of all manufacturers engaged on circuit and wiring problems.

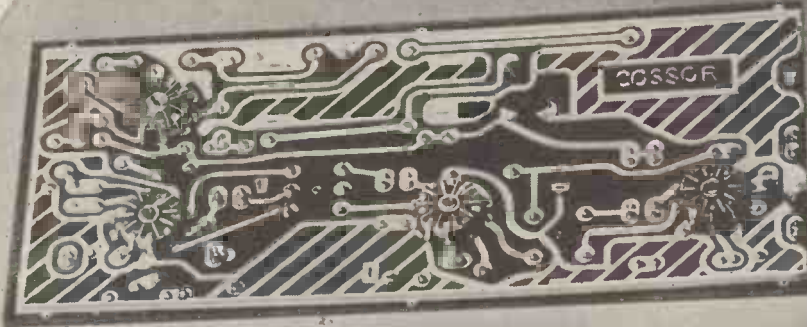

C192

COSSOR

A. C. Cossor Limited
Cossor House, Highbury Grove, London, N.5

Cossor engineers will be pleased to advise on designs for printed components and circuit assemblies, and complete layout designs.

Cossor printed circuit and wiring panels are subject to the most rigorous humidity and electrical tests prior to final approval by our Design and Development Section.

Please send your enquiry to the Technical Sales Department, A. C. Cossor Limited, Cossor House, Highbury Grove, London, N.5.

ii a
AGS

Wireless World

ELECTRONICS, RADIO, TELEVISION

Managing Editor: **HUGH S. POCOCK**, M.I.E.E.
Editor: **H. F. SMITH**
Assistant Editor: **F. L. DEVEREUX**, B.Sc.

AUGUST 1956

In This Issue

Editorial Comment	353
Junction Diode A.F.C. Circuit <i>G. G. Johnstone</i>	354
World of Wireless	356
Colour Fundamentals <i>H. Henderson</i>	360
Looking at Square Waves <i>T. D. Crook</i>	364
Television Picture Quality	367
Servo Tuning System <i>D. Smart</i>	369
Letters to the Editor	373
Wide-Band Linear R.F. Amplifier <i>B. F. Davies</i>	374
Broadcasting in the U.S.S.R.	379
Electronic Machine-Tool Control	382
More Effective Speech <i>O. J. Russell</i>	385
Economy in Receiver Design <i>S. W. Amos</i>	388
Semi-Conductors—2 "Cathode Ray"	394
Short-Wave Conditions	398
Books Received	399
Random Radiations "Diallist"	400
Unbiased "Free Grid"	402

VOLUME 62 NO. 8
PRICE: TWO SHILLINGS
FORTY-SIXTH YEAR
OF PUBLICATION

PUBLISHED MONTHLY (4th Tuesday of preceding month) by **ILIFFE & SONS LTD.**, Dorset House, Stamford Street, London, S.E.1.
Telephone: Waterloo 3833 (60 lines). Telegrams: "Ethaworld, Sedist, London." Annual Subscription: Home and Overseas £1 12s. 6d.
U.S.A. and Canada \$5.00. BRANCH OFFICES: **BIRMINGHAM**: King Edward House, New Street, 2. Telephone: Midland 7191.
COVENTRY: 8-10, Corporation Street. Telephone: Coventry 5210. **GLASGOW**: 26B, Renfield Street, C.2. Telephone: Central 1265.
MANCHESTER: 260, Deansgate, 8. Telephone: Blackfriars 4412. OVERSEAS OFFICES: **U.S.A.**: 111, Broadway, New York, 6, N.Y. Telephone: Digby 9-1197. **CANADA**: 74, College Street, Toronto, 2 Ontario. Telephone: Walnut 4-5631

Transistors

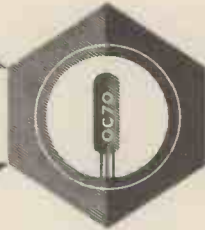

at Small Signals (h-Parameters)

The most convenient way of describing the electrical characteristics of a transistor, like any other electronic device, is by means of a set of static characteristic curves. These graphs show how the voltage or current at the input electrode varies with the voltage or current at the output electrode.

The primary function of transistor static characteristic curves is to enable the circuit designer to choose the direct voltage and current for the working point. In the second place these graphs are used for designing circuits where large signals occur, for example in output stages or pulse amplifiers. However, for applications where the signal is small in comparison with the direct voltages and currents it is possible to calculate performance accurately from the slopes of the characteristic curves at the working point. Under small signal conditions the transistor never moves far away from this point and hence the characteristics in the immediate neighbourhood can be taken as linear. It is generally impracticable to read the slopes with sufficient accuracy from the graphs given, and so they are quoted in transistor data for some nominal working point such as collector voltage $-2V$ and collector current $-3mA$. The h-parameters are the slopes of a particular set of characteristic curves but are in fact measured by small-signal a.c. methods.

In transistor data, this set of four characteristic curves consists of:—(1) the input characteristic giving the variation of input current I_1 with input voltage V_1 , for constant output voltage: slope = h_{11} ; (2) the output characteristic showing the relation between the output current I_2 and the output voltage V_2 for a series of fixed input currents: slope = h_{22} ; (3) the transfer characteristic giving the variation of output current I_2 with input current I_1 for a fixed output voltage: slope = h_{21} ; (4) the feedback characteristic showing the connection between the input voltage V_1 and the output voltage V_2 for a series of fixed input currents: slope = h_{12} .

By drawing the axes of the static characteristic curves and using the subscripts 1 and 2 to refer to the input and output electrodes, the notation h_{11} etc. can easily be explained and three of the h-parameters are seen to be related simply to parameters in the Mullard system. Thus h_{11} is the ratio of two quantities measured at the input electrode, hence it is the slope of the input characteristic, and is equal to r_{in} . V_1, I_1 represent the direct voltage and current at the input electrode and V_2, I_2 similarly apply to the output electrode. The a.c. quantities are v_1, i_1 and v_2, i_2 . The formal definition of h-parameters is then as follows:—

- $h_{11} = v_1/i_1 =$ slope of input characteristic
= input impedance for constant output voltage
= input impedance for output short-circuited to a.c.
= r_{in} (in ohms or kilohms)
- $h_{22} = i_2/v_2 =$ slope of output characteristic
= output admittance for constant input current (= reciprocal of output impedance)
= output admittance with input open-circuited to a.c.
= $1/r_{22}$ (usually in micro-mhos)

- $h_{21} = i_2/i_1 =$ slope of transfer characteristic
= current gain for constant output voltage
= current gain with output short-circuited to a.c.
= a (a ratio, that is, a pure number)
- $h_{12} = v_1/v_2 =$ slope of feedback characteristic
= voltage feedback ratio for constant input current
= voltage feedback ratio with input open-circuited to a.c.

In defining the h-parameters the transistor is treated as a 'black box' with an input and output, paying no regard to whether the transistor is in a common base, common emitter or common collector configuration. In an actual circuit the values of these slopes will depend on which configuration is used. Thus the undashed terms such as the a.c. current gain h_{21} are reserved for grounded base applications, whereas a single prime as in h'_{21} shows the value required for calculations on grounded emitter circuits, and h''_{21} etc. apply to grounded collector circuits.

Grounded Base	Grounded Emitter	Grounded Collector
$h_{11} = r_e + (1-\alpha)r_b = r_e + \frac{r_b}{1+\alpha}$	$h_{11}' = (1+\alpha)h_{11}$	$h_{11}'' = h_{11}'$
$-h_{21} = \alpha = \frac{\alpha}{1+\alpha}$	$h_{21}' = \alpha$	$-h_{21}'' = 1 + h_{21}'$
$h_{22} = 1/r_c$	$h_{22}' = (1+\alpha)h_{22}$	$h_{22}'' = h_{22}'$
$h_{12} = r_b/r_c$	$h_{12}' = h_{22}'r_e$	$h_{12}'' = \frac{1}{1+h_{12}'}$

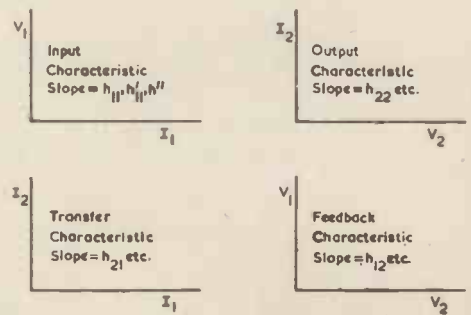

Grounded base: $\alpha=1, c=2$.
Grounded emitter: $b=1, c=2$.

2709



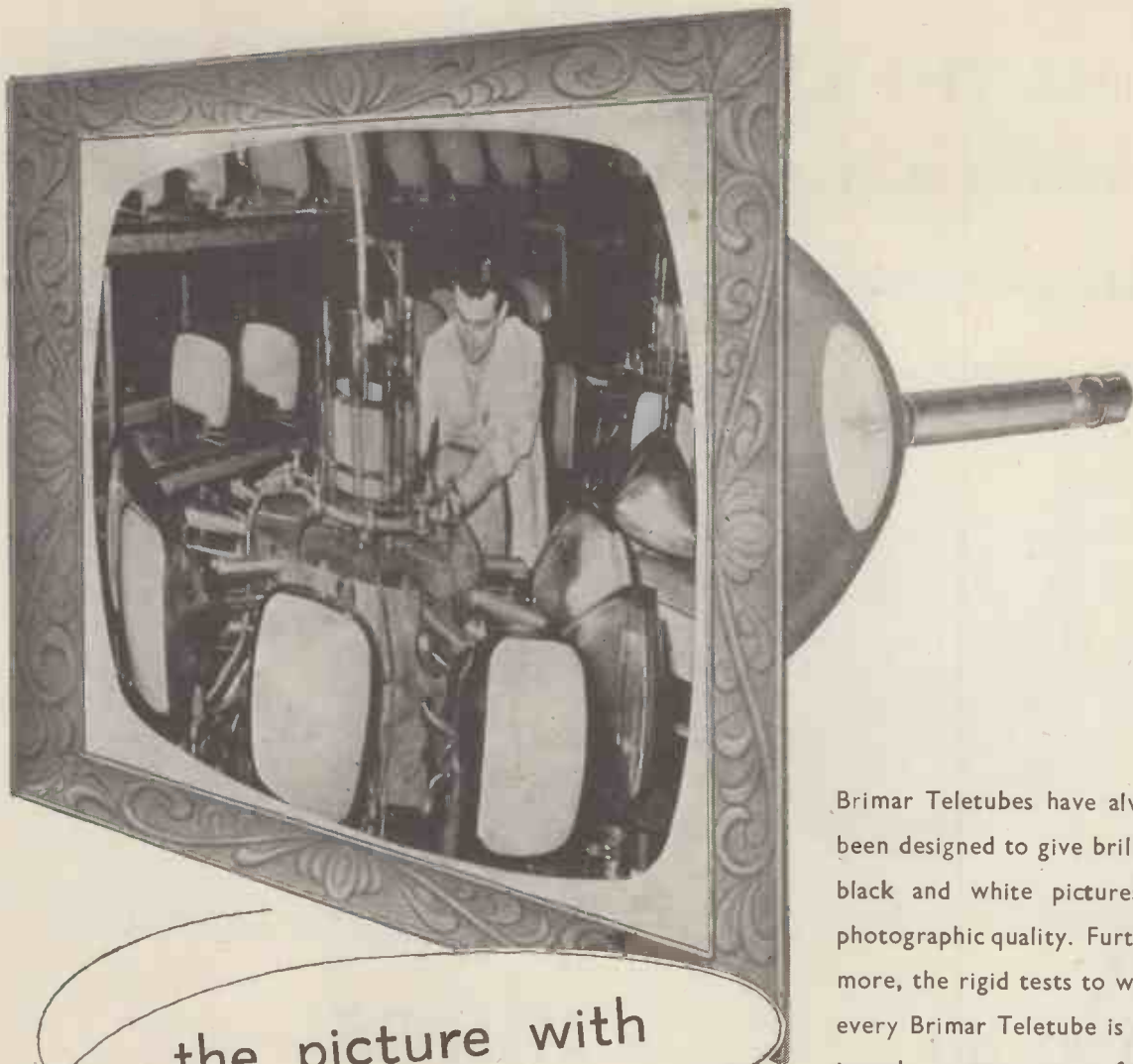

the picture with

real black and white

photo quality

Brimar Teletubes have always been designed to give brilliant black and white pictures of photographic quality. Furthermore, the rigid tests to which every Brimar Teletube is subjected ensures an unfailing high standard of excellence and reliability.

Always use Brimar Teletubes for photo-quality black and white pictures.

BRIMAR *Teletubes*

Standard Telephones and Cables Limited

Regd. Office: Connaught House, 63, Aldwych, London, W.C.2

FOOTSCRAY · SIDCUP · KENT · FOOTscray 3333



IF YOU WANT A GOOD Microphone

WITHOUT HAVING TO PAY TOO MUCH FOR IT

What about one of these ?

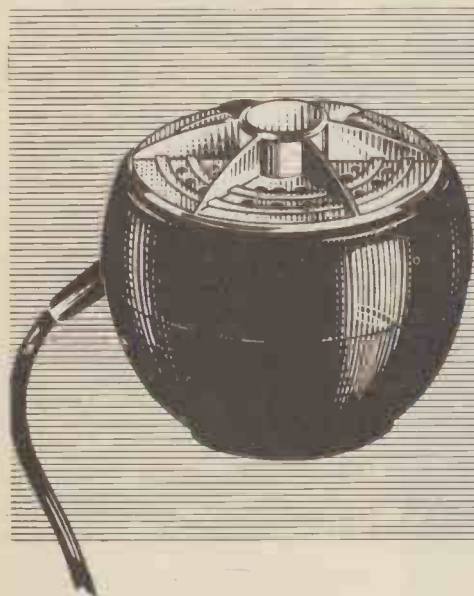

MIC 33

A crystal microphone that fits the hand perfectly. For the high quality public address and tape recording field, incorporating a specially designed acoustic filter giving a flat response from 30 to 7,000 c/s.

RETAIL PRICE £2.10.0

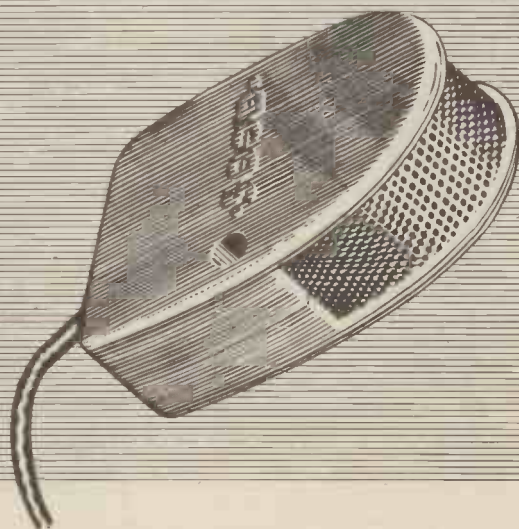

MIC 35

A general purpose hand microphone of robust construction and convenient "handling" qualities with substantially flat response from 50 to 5,000 c/s. Suitable for recording apparatus, Public Address equipment, etc.

RETAIL PRICE £1.5.0



always well ahead

ACOS devices are protected by patents, patent applications and registered designs in Great Britain and abroad.



STAND NO. 202

COSMOCORD LIMITED · Eleanor Cross Road · Waltham Cross · Herts.
Telephone : Waltham Cross 5206

"BELLING-LEE" NOTES

By the time you are reading this, it will be common knowledge that our television test transmitter G9AED has been purchased by the Independent Television Authority, and will be doing its job on their behalf from Emley Moor. We will continue to take an interest in the performance of the equipment.

We will be asking for reports from the trade, and we ask all readers in the area to let us know how they receive the test signals and on what type of aerial. The reports will all be acknowledged by Q.S.L. card, and will be entered on a large map of the area which will be published as a service to anyone who is interested or who requires to know what can be expected.

It is expected that the first signals will be radiated on Monday, July 2nd, but at the time of writing we do not know the time schedule.

We try to be particularly careful not to take sides between our very old and good friends the B.B.C. and the newcomers to our industry—the I.T.A. But we do feel it is a pity that so many viewers, particularly in Lancashire, don't do justice to I.T.A., by not putting up the appropriate aerial and then adversely criticizing the technical quality of the I.T.V. picture received on a B.B.C. aerial. We know that these are locations of strong signal and where "in-line" conditions prevail under which the I.T.V. signal is adequate with a B.B.C. aerial, but there are tens of thousands of cases where a band III aerial would show an incomparably improved picture.

To continue this discussion a little further, if a band III channel 9 signal is received on a band I channel 2 aerial, the signal is more than 10 dB down on band III. The addition of the "Belling-Lee" adaptor kit* to a band I "H" has been known to increase the band III signal by as much as 18 dB, though we would not claim this gain in every case. What it all amounts to is that you can only

hope to have a comparable balanced picture using a B.B.C. "H" if you are in such a location that you have considerably more than 10 dB useful signal than is required, and if your picture is free from interference and ghost.

Quite a number of people ask why it is necessary or desirable to radiate a test signal for, say, three months prior to the official opening of a new transmitter. Of course, the answer is to give the trade—the radio dealers—an opportunity to arrange conversions where necessary, and to erect or modify aerials. In general, by the very nature of band III, multi-element aerials are required, and all multi-element aerials are very directional, so much so that it is just not worth while trying to orientate aerials on compass bearing, a signal really is necessary anywhere other than in the swamp areas. There are hundreds of thousands of aerials to be erected, and they take time. Emley Moor main transmitter will not open up till some time in October, short days and indifferent weather don't lend themselves to quick work on the rooftops—and viewers can be very impatient once the alternative programmes are available. It isn't so much the programme that matters as the ability to change from one to the other.

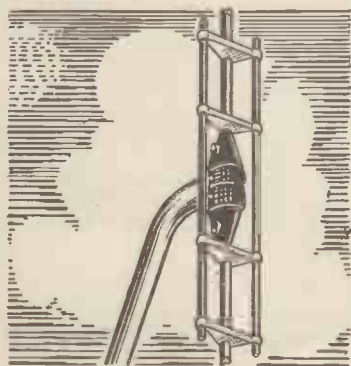

★ "Belling-Lee" L924 adaptor kit fitted to band I dipole

Advertisement of
BELLING & LEE LTD.
Great Cambridge Rd., Enfield, Middx.
Written 20th June, 1956

L.1055 STANDARD GLASS FUSE-LINKS

(1¼" x ¼")

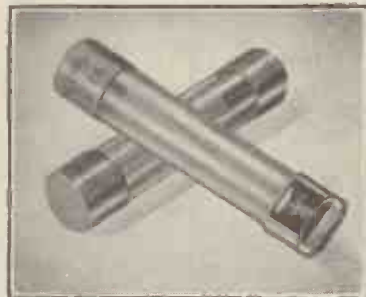

In the manufacture of these fuse-links the unique internal soldering technique bonds caps, elements and glass into one unit. The possibility of caps becoming loose is remote. This method of construction applies to ratings from 500 mA up to 25 A. Lower ratings, down to 60 mA, are at present supplied in our original design, in which we have minimised the problems that are obviated by the "all-in-one" construction.

These fuses have a specified life of 1,000 hours minimum at rated current and will blow within 10 seconds on 100% overload.

● L.1055 Fuse-Links are supplied in cartons of 12, or in display packs of one gross (12 cartons), in single or mixed ratings.

L.754 "MINIFUSE" MINIATURE CERAMIC

These measure only ½ in. x 3/16 in. and are available in ratings of .010, .015 and .025 A. They are the result of long development to enable such a fine element to be handled in production to give reliable service.

Primarily designed for the protection of small meters, also test and laboratory gear, etc., "Minifuses" will carry their rated current indefinitely and blow within 0.01 sec. at 3½ times rated current.

L.338 "MAG-NICKEL" FUSE-LINKS

now available up to 750 mA

These fuses conform to the dimensions (1½ in. x ½ in.) and blowing requirements of the standard L.1055 fuse, but can withstand a surge current of 10/30 times their rated current for up to 0.01 sec., without shortening their normal life through embrittlement. In 250 mA (brown), 500 mA (yellow) and 750 mA (green) ratings, colour coding conforming to B.S. 646 (B).

BELLING & LEE LTD
GREAT CAMBRIDGE RD., ENFIELD, MIDDX., ENGLAND

Telephone: Enfield 2322 Telegrams: Radiobel, Enfield

NEW! THE PRACTICAL WAY

of learning RADIO • TELEVISION • ELECTRONICS

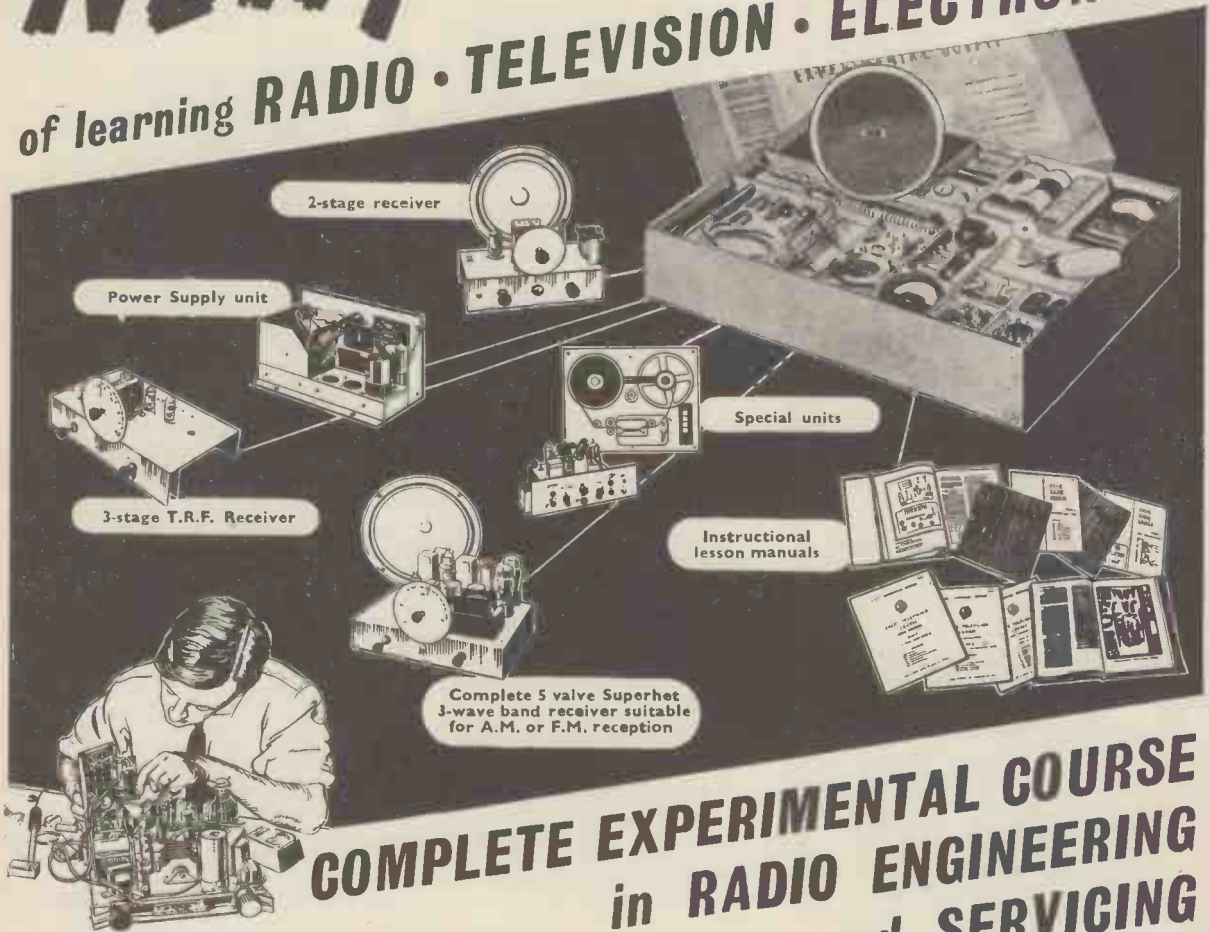

COMPLETE EXPERIMENTAL COURSE in RADIO ENGINEERING and SERVICING

An entirely new series of courses designed to teach Radio, Television and Electronics more quickly and thoroughly than any other method. Specially prepared sets of radio parts are supplied and with these we teach you, in your own home, the working of fundamental electronic circuits and bring you easily to the point when you can construct and service radio receivers, etc.

Whether you are a student for an examination; starting a new hobby; intent upon a career in industry; or running your own business — these Practical Courses are ideal and may be yours at very moderate cost.

With these outfits, which you receive upon enrolment and which remain your property, you are instructed how to build basic Electronic Circuits (Amplifiers, Oscillators, Power Units, etc.) leading to designing, testing and servicing of complete Radio and Television Receivers.



FILL IN COUPON
FOR
FREE
PROSPECTUS

NEW TELEVISION COURSE including a complete set of equipment dealing with the design, construction and servicing of a high quality television receiver.
Courses (with equipment) also available in many other engineering subjects.
COURSES FROM 15/- PER MONTH

To E.M.I. INSTITUTES,
Dept. 127X, Grove Park Road, London, W.4.
Please send me your FREE book on Practical Courses.

Subject(s) of interest.....

NAME

ADDRESS

AUGUST/56

EMI INSTITUTES
An educational organisation serving the E.M.I. Group of Companies which include
"HIS MASTER'S VOICE," MARCONIPHONE, COLUMBIA, ETC.



You could call it gilding the lily...

SIMON F.M. TUNER UNIT

The Unit is designed primarily for use with the SP/2 Tape Recorder, and is styled to match. It can however be used with any existing amplifier (or conventional radio receiver which has pick-up input terminals) with an input sensitivity of 0.75 volt.

It employs the well proven Jason Circuit and is designed to receive the new B.B.C. V.H.F./F.M. transmissions. The Tuner incorporates its own power supply and is designed for operation on A.C. 50 cycles supplies, 200/250V.

but restless souls like ourselves, who feel that nothing is ever quite good enough, will understand. We simply couldn't resist adding the *sauce piquante* of F.M. to the SP/2 Tape Recorder. When you've heard it yourself you'll not only understand our point of view . . . you'll want to know where, when, and how much. *Your dealer will tell you . . .*

or see it at the Radio Show

The Simon F.M. Tuner Unit will be demonstrated at Earls Court, with the SP/2 Tape Recorder, the new Simon "Library" Tape and the new Simon Microphone

... on Stand no. 46

Post the coupon below for illustrated literature.

Simon is *Sound* recording

SIMON SOUND SERVICE LTD.
46-50 GEORGE STREET, LONDON, W.1. WEL 2371

Northern Depot:

J. D. MORRISON & CO. LTD., WAKEFIELD HOUSE,
11-13 NEW WAKEFIELD ST., MANCHESTER, I. CENTRAL 2959

To: SIMON SOUND SERVICE LTD. 46-50 GEORGE STREET, LONDON, W.1.
Full details of the SP/2 and F.M. Tuner please

Name.....

Address.....

WW856



INSTRUMENTS

ADMITTANCE BRIDGE TYPE B.801

1 Mc/s—100 Mc/s

For balanced and unbalanced measurement.

Susceptance: Equivalent
to ± 230 pF.

Conductance: 0-100 mmho.

Accuracy: $\pm 2\%$, ± 0.5 pF.

Accuracy: $\pm 2\%$, ± 0.1 mmho.

This is one of a range of bridges for use with external source and detector for the measurement of aërials, cables, feeders, and a variety of components and materials between 15 kc/s and 250 Mc/s. Bridge sources and detectors are available for use between 1-100 Mc/s and 50-250 Mc/s.



PRICE £150 NET EX WORKS

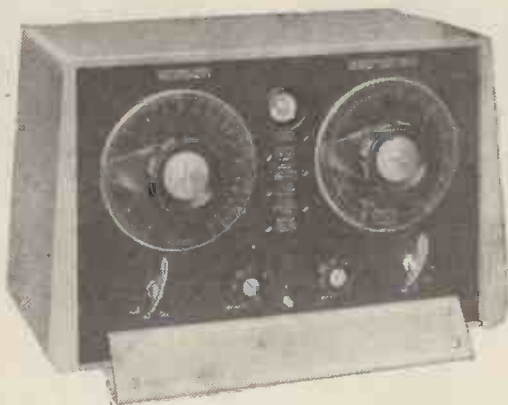

COMPONENT BRIDGE TYPE B.121

A general purpose 50 cps 3 terminal transformer ratio arm bridge for the measurement of Resistance, Capacitance and Inductance in the ranges 3-100 M Ω , 1 pF-100 μ F and 100 mH-10,000H, accuracy $\pm 2\%$. Direct readings of the resistive and reactive components of impedance and facilities for "in situ" measurements are notable features.

PRICE £60 NET EX WORKS

AUDIO WAVEFORM ANALYSER

TYPE A.321

A portable instrument to measure the relative levels of the components of a complex waveform over a range of 75 db between 50 c/s and 20 kc/s. Input impedance 100K Ω unbalanced or >25 K Ω balanced. In transportable case as shown, or for standard 19" mounting.

PRICE £250 NET EX WORKS



FOR FURTHER DETAILS WRITE OR TELEPHONE

THE WAYNE KERR LABORATORIES LTD · NEW MALDEN · SURREY · MALDEN 2202

E·M·I for Oscilloscopes

MEASURING OSCILLOSCOPE W.M.I.

*See what you
measure....*

*....measure
what you see*

Because of its handy size this Oscilloscope (9 $\frac{1}{4}$ " \times 8 $\frac{1}{4}$ " \times 11 $\frac{1}{4}$ "") can be used in a dozen different ways—ranging from industrial research and production testing to television and radio servicing. It is also eminently suitable for use in technical schools and colleges.



Pulse Base at
cursor voltmeter
reads 0 volts

Pulse Peak at
cursor voltmeter
reads 4 volts

Measured Pulse amplitude 4 volts

£49.0.0



LIGHTWEIGHT OSCILLOSCOPE TYPE 2300

The latest addition to our range of instruments.

Designed and manufactured by Industrial Electronics

BRIEF SPECIFICATION

Dimensions: 4 $\frac{1}{2}$ in. \times 7 $\frac{1}{2}$ in. \times 7 $\frac{1}{2}$ in.
 Weight: 6 $\frac{1}{2}$ lb.
 Cathode Ray Tube: 2 $\frac{1}{2}$ in. diameter.
 Sensitivity:
 Wide-band operation (-6dB at 3 Mc/s) 0.7 cm/V.
 Narrow-band operation (-3dB at 100 Kc/s) 7 cm/V.
 Time Base Range. 7 c/s to 50 Kc/s.

- Direct coupled amplifiers.
- Wide range of horizontal expansion.
- Input attenuator.
- Internal, external or 50 c/s synchronisation.
- Direct access to tube defectors.

£39.10.0



E. M. I. ELECTRONICS LTD. INSTRUMENT DIVISION
 HAYES · MIDDLESEX · ENGLAND · Telephone: SOUthall 2468, Ext. 655, 1013, 857

SenTerCel H.T. RECTIFIERS

from 125V 30mA
to 250V 300mA

Specially designed for use in domestic Radio & Television receivers, these miniature rectifier stacks have an established position with manufacturers to whom reliability, small dimensions and low costs are important.

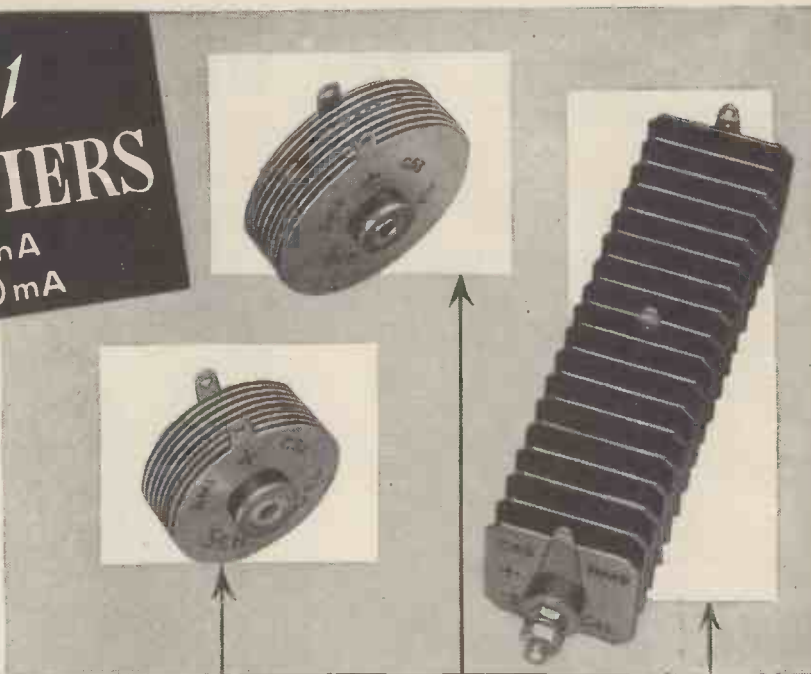

TYPE	RM0	RM1	RM2	RM3	RM4	*RM5
Maximum ambient temperature	35°C 55°C	35°C 55°C	35°C 55°C	35°C 55°C	40°C 55°C	40°C 55°C
Maximum output current (mean)	30mA 15mA	60mA 30mA	100mA 60mA	120mA 90mA	250mA 125mA	300mA 150mA
Maximum input voltage (r.m.s.)	125V 350V	125V 350V	125V 350V	125V 350V	250V 700V	250V 700V
Maximum peak inverse voltage	Unlimited	Unlimited	Unlimited	Unlimited	Unlimited	Unlimited
Max. instantaneous peak current	0.82 oz.	1 oz.	1.4 oz.	2 oz.	4.5 oz.	4.75 oz.
Weight						

* For use in voltage doubler circuits the peak inverse and maximum input voltages are halved, current output being as for half wave operation.

- Instant starting—no warming-up period
- Unlimited instantaneous overload
- No limit to size of reservoir capacitor
- Simple mounting—no valve holder
- Withstand overloads such as charging current of de-formed electrolytic capacitors
- Low heat dissipation
- Practically indestructible in service
- Simple wiring—two connectors only
- Small size . . . low weight
- Low cost

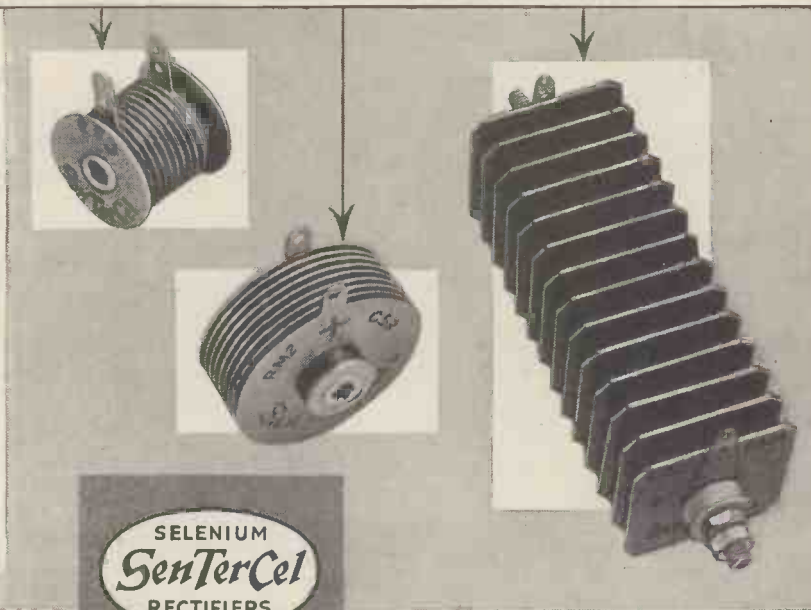

Standard Telephones and Cables Limited

Registered Office : Connaught House, Aldwych, London, W.C.2

RECTIFIER DIVISION : EDINBURGH WAY · HARLOW · ESSEX

Telephone : Harlow 26811

Telegrams : SenTerCel, Harlow, Essex

valveholders

for industry

Ediswan Clix Valveholders give continuous trouble-free operation under the most exacting conditions encountered by Industrial Electronic equipment.

The very wide range includes B7G, B8A, B9A, B9G and a number of larger types such as B4A, B4D and B4F all complying with the appropriate specifications for Government equipment. Insulation materials include P.T.F.E., Nylon-phenolic and Quartz-phenolic; contact material is silver-plated Beryllium copper. Catalogue of complete range of Radio, Television and Electronic components available on request.

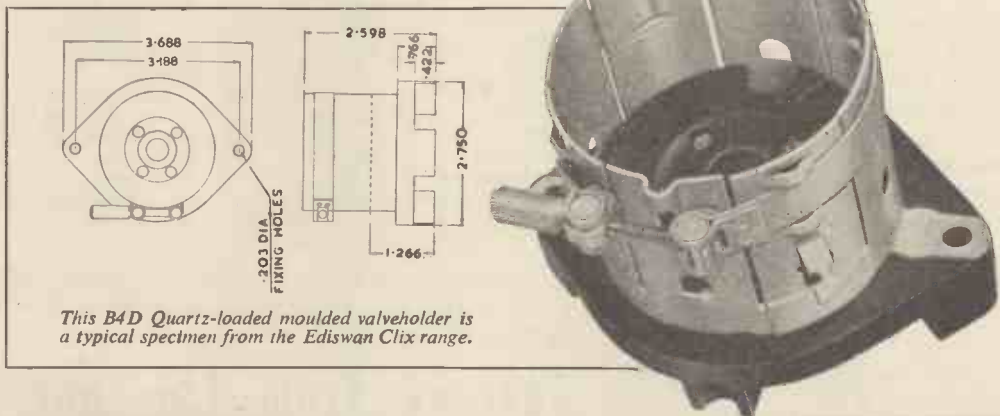

EDISWAN

CLIX

RADIO, TELEVISION & ELECTRONIC COMPONENTS

STAND 19
NATIONAL RADIO SHOW
EARLS COURT
AUG. 22 — SEPT. 1

THE EDISON SWAN ELECTRIC COMPANY LIMITED

155 Charing Cross Road, London, W.C.2 and Branches

Telephone: Gerrard 8660

Member of the A.E.I. Group of Companies

Telegrams: Ediswan, Westcent, London



**POST THE COUPON TODAY
FOR OUR BROCHURE ON THE
LATEST METHODS OF HOME
TRAINING FOR OVER
150 CAREERS AND HOBBIES**

THE ADVANTAGES OF E.M.I. TRAINING

- ★ The teaching methods are planned to meet modern industrial requirements.
- ★ We offer training in all subjects which provide lucrative jobs or interesting hobbies.
- ★ The student is taken carefully and thoroughly through his chosen subject.
- ★ A tutor is personally allotted by name to ensure private and individual tuition.
- ★ Free advice covering all aspects of training is given to students before and after enrolment with us.

NEW

**LEARN THE PRACTICAL WAY
— COURSES WITH EQUIPMENT**

With many courses we supply actual equipment thus combining theory and practice in the correct educational sequence. The equipment, specially prepared and designed, remains your property. Courses include: Radio, Television, Electronics, Draughtsmanship, Carpentry, Photography and Commercial Art, Amateur S.W. Radio, Electricity, Languages, Mechanics, etc.



Equipment supplied upon enrolment and remains your property.

PRIVATE AND INDIVIDUAL TUITION IN YOUR OWN HOME

Accountancy	Customs & Excise Officer	M.C.A. Licences	Secretaryship
Advertising	Draughtsmanship	Mechanical	Shorthand &
Aeronautical	Engineering	Engineering	Typing
Automobile	Engineering	Motor Engineering	Sound Recording
Engineering	Economics	Photography	Structural
Engineering	Electrical	P.M.G. Licences	Engineering
Banking	Engineering	Police	Tele-
Book-keeping	Electronics	Production	communications
Building	Fashion Drawing	Engineering	Television
Business	Heating & Ventilating	Public Speaking	Time & Motion
Management	Engineering	Radar	Study
Carpentry	Industrial	Radio & Television	Tracing
Chemistry	Administration	Radio Engineering	Welding
Civil Service	Journalism	Refrigeration	Writing
Civil Engineering	Languages	Retail Shop	Workshop Practice
Commercial Subjects	Marine	Management	Works
Commercial Art & Drawing	Engineering	Salesmanship	Management
	Mathematics	Sanitation	and many others.

Also courses for University Degrees, General Certificate of Education, B.Sc. Eng., A.M.I. Mech. E., L.I.O.B., A.C.C.A., A.C.I.S., A.M. Brit. I.R.E., A.M.I.I.A., City & Guilds Examinations, R.S.A. Certificates, etc.

Courses from 15/- per month

**EMI
INSTITUTES**

**THE ONLY POSTAL COLLEGE WHICH
IS PART OF A WORLD-WIDE
INDUSTRIAL ORGANISATION**

POST THIS COUPON TODAY

Please send without obligation your FREE book.
E.M.I. INSTITUTES Dept. 127k,
 Grove Park Road, London, W.4.

NAME

ADDRESS

SUBJECT(S) OF INTEREST

(We shall not worry you with personal visits)

AUGUST IC38a

VORTEXION TAPE RECORDER

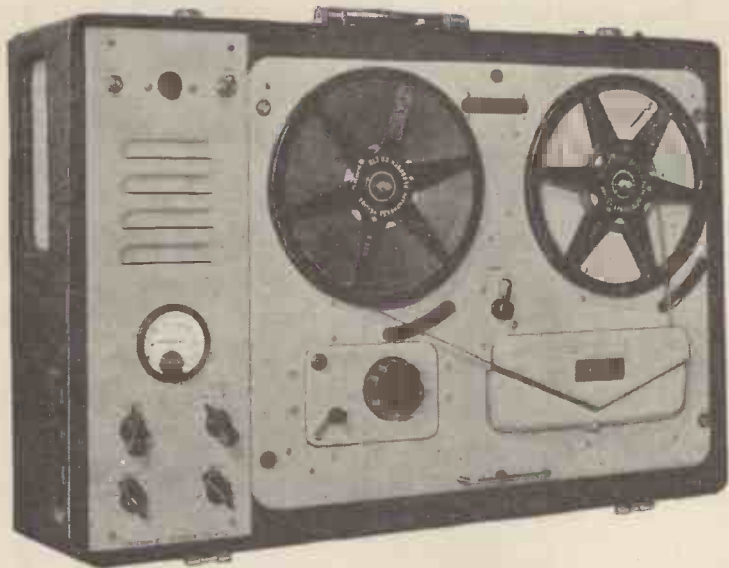

The amplifier, speaker and case, with detachable lid, measures 8½ in. x 22½ in. x 15½ in. and weighs 30 lb.

PRICE, complete with WEARITE TAPE DECK £84 0 0

- ★ The play back amplifier may be used as a microphone or gramophone amplifier separately or whilst recording is being made.
- ★ The unit may be left running on record or play back, even with 1,750ft. reels, with the lid closed.

★ The total hum and noise at 7½ inches per second 50-12,000 c.p.s. unweighted is better than 50 dbs.

★ The meter fitted for reading signal level will also read bias voltage to enable a level response to be obtained under all circumstances. A control is provided for bias adjustment to compensate low mains or ageing valves.

★ A lower bias lifts the treble response and increases distortion. A high bias attenuates the treble and reduces distortion. The normal setting is inscribed for each instrument.

★ The distortion of the recording amplifier under recording conditions is too low to be accurately measured and is negligible.

★ A heavy mu-metal shielded microphone transformer is built in for 15-30 ohms balanced and screened line, and requires only 7 micro-volts approximately to fully load. This is equivalent to 20ft. from a ribbon microphone and the cable may be extended 440 yds. without appreciable loss.

★ The .5 megohm input is fully loaded by 18 millivolts and is suitable for crystal P.U.s, microphone or radio inputs.

★ A power plug is provided for a radio feeder unit, etc. Variable bass and treble controls are fitted for control of the play back signal.

★ The power output is 3.5 watts heavily damped by negative feedback and an oval internal speaker is built in for monitoring purposes.

POWER SUPPLY UNIT to work from 12 volt Battery with an output of 230 v., 120 watts, 50 cycles within 1%. Suppressed for use with Tape Recorder. **PRICE £18 0 0.**

3-WAY MIXER AND PEAK PROGRAMME METER

FOR RECORDING AND LARGE SOUND INSTALLATIONS, ETC.

One milliwatt output on 600 ohm line (.775V) for an input of 30 micro-volts on 7.5-30 ohm balanced input.

Output balanced or unbalanced by internal switch. The meter reading is obtained by a valve voltmeter with 1 second time constant, which reads programme level, and responds to transient packs.

Calibration in 2 db steps, to plus 12 db and minus 20 db referred to zero level. Special low field internal power pack supplies 8 valves including stabilising and selenium rectifier, consumption 23 watts.



Manufactured by

VORTEXION LIMITED, 257-263, The Broadway, Wimbledon, London, S.W.19

Telephones: LIBerty 2814 and 6242-3

Telegrams: "Vortexion, Wimble, London."

When you buy a tape recorder

*your choice will be governed by
two factors—*

PRICE AND SPECIFICATION

*The best tape recorder won't be cheap—
but it will be good value for money.*

The Grundig 'Specialist' TK.820/3-D is the best value for your money. Its presentation, its versatility, its performance, its push-button track changeover, makes it the only possible choice for so many people. Provided the machine has the facilities, appearance and ease of control you demand, it remains to check whether or not its specification will stand up to your requirements.

Here is the complete technical specification of the TK.820/3-D. Read it critically—and write to us if there is anything else you would like to know.

GRUNDIG

Makers of the finest tape recorders in the world.

GRUNDIG (Great Britain) LTD., Dept. WW,

Advertising Dept. & Showroom:
39-41, NEW OXFORD STREET, LONDON, W.C.1
Sales Dept. & Works:
KIDBROOKE PARK ROAD, LONDON, S.E.3.
(Electronics Division, Gas Purification & Chemical Co. Ltd.)

GRUNDIG 'SPECIALIST'

Mains voltage: suitable for A.C. only, 105–115, 190–210, 210–230, 230–250 volts, 50 cycles. Power Consumption: approximately 90 watts maximum. Mains Fuses: 2 amps (for 105–115 volts), 1 amp (for 190–250 volts). H.T. fuses:

500 m/A Surge Resisting, 120 m/A Surge Resisting. Valve line-up: EF 86, BCC 81, EL 84, EL 42, EM 71 + 2 metal rectifiers. Mains tapping panel and fuses instantaneously available. Two tape speeds— $3\frac{1}{2}$ ins/sec and $7\frac{1}{2}$ ins/sec: speed change instantaneous by electrical means—heavy duty dual speed split phase induction motor: recording time (with 1,200 feet recording tape) 2×30 minutes at $7\frac{1}{2}$ ins/sec— 2×60 minutes at $3\frac{1}{2}$ ins/sec: half track recording, track change without spool reversal: track changeover by press button approximately 2 seconds. Trackbutton remains down to indicate which track was played last: frequency range 50–9,000 cycles at $3\frac{1}{2}$ ins/sec, 40–14,000 at $7\frac{1}{2}$ ins/sec: noise is down at least 40 dBs and wow and flutter less than 0.3% at $7\frac{1}{2}$ ins/sec, less than 0.5% at $3\frac{1}{2}$ ins/sec.

Automatic stop foil at end of spools: fast forward and fast rewind time approximately two minutes per full spool. Illuminated precision place indicator: recording level meter by 'magic eye', tone control for treble or bass emphasis.

Loudspeakers: elliptical high-flux permanent magnet moving coil + two $2\frac{1}{2}$ inch tweeters. Special four-position speaker control. Connections for low impedance extension speaker and high impedance external amplifier remote controls, earphones. Microphone, diode and radio input sockets.

Overall dimensions: 17 inches \times $17\frac{1}{2}$ inches \times $9\frac{1}{2}$ inches. Weight approximately 48 lb.

Retail Price 98 gns.



Incremental Inductance Bridge?

What he needs is this

FURZEHILL B.800

- * 50 mH to 500 H
- * D.C. polarising up to 1.5 A
- * Tunable selective amplifier null detector
- * Excitation 25 c/s to 3000 c/s

B.800 Bridge £192.10.0

B800P D.C. supply £82.10.0

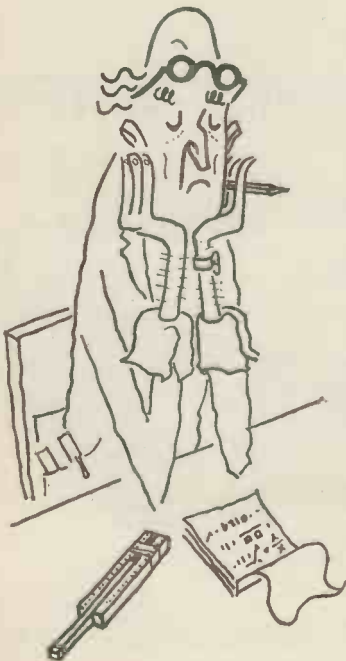

Furzehill Laboratories Ltd.

OLYMPIC HONOUR FOR BRITAIN

We are proud to announce that our TL/12 amplifiers have been chosen for use at the 1956 Olympic Games to be held in Australia.

It was in 1945 that H. J. Leak revolutionised the performance standards for audio amplifiers by designing the original "Point One" series, and we became the first firm in the world to market amplifiers having a total distortion content of 0.1 per cent. This claim was received with incredulity, but it was subsequently confirmed by the National Physical Laboratory and since then hundreds of TL/12 amplifiers have been used by the B.B.C., and Commonwealth and foreign broadcasting authorities, and thousands have been used by recording studios, leading musicians and music-lovers throughout the world. We were the only British exhibitor at the world's first Audio Fair which was held in New York in 1949 and the volume of our exports to the United States of America has grown steadily since then.

Further development work resulted in our producing, at a much lower price but with the same high performance standards, the TL/10 amplifier. The TL/10 amplifier and "Point One" pre-amplifier received such an excellent reception when they were first exhibited at the Audio Fair in New York in October, 1953, that we received an initial order for 1,000 sets. Since then several thousand sets have been sold throughout the world. The output of the TL/10 is ample for high-fidelity home music systems, and the quality of reproduction obtained is equal in every respect to that of the TL/12. We always use the TL/10 amplifier and "Point One" pre-amplifier for our public demonstrations of high-fidelity reproduction of gramophone records and radio. The TL/10 amplifier, when used with the best available complementary equipment, gives to the music-lover a quality of reproduction unsurpassed by any equipment at any price. Even when the complementary equipment falls below that of the best obtainable, the use of these amplifiers will enable one to obtain very marked improvements in reproduction.



**HIGH FIDELITY
EQUIPMENT**



POWER AMPLIFIER

Circuitry

A triple loop feedback circuit based on the famous TL/12. The output transformer is the same size as in the TL/12.

Maximum power output: 10 watts.

Frequency Response: ± 1 db 20 c/s to 20,000 c/s.

Harmonic Distortion: 0.1%, 1,000 c/s, 7.5 watts output.

Feedback Magnitude: 26 db, main loop.

Damping Factor: 25.

Hum: -80 db referred to 10 watts.

Loudspeaker Impedances: 16 ohms, 8 ohms, and 4 ohms.

OTHER LEAK PRODUCTS

Varislope II pre-amplifier	£16 16 0
TL/12 power amplifier	£28 7 0
TL/25A power amplifier	£34 7 0
Leak dynamic pickup—	
Arm.....	£2 15 0 p.t. £1 3 1
LP head with diamond stylus	£5 15 0 p.t. £2 8 4
78 head with diamond stylus	£5 15 0 p.t. £2 8 4
Mu-metal cased transformer	£1 15 0
Trough-Line FM tuner unit with built-in power supply	£25 0 0 p.t. £10 10 0

Those seeking to obtain the highest quality of gramophone and radio reproduction are invited to ask their dealer for a demonstration of Leak products which, with their tradition of excellence, represent the best that can be obtained.

LEAK TL/10 AMPLIFIER, £17. 17. 0.

& 'POINT ONE' PRE-AMPLIFIER, £10. 10. 0.

Prices made possible only by world-wide sales

"POINT ONE" PRE-AMPLIFIER

The handsome gold escutcheon plate contributes to the elegant appearance and blends with all woods.

★ Pickup

The pre-amplifier will operate from any pickup generally available in the world. A continuously variable input attenuator at the rear of the pre-amplifier permits the instantaneous use of crystal, moving-iron and moving-coil pickups.

★ Radio

The radio input sockets at the rear permit the connection of the LEAK V.S. tuner unit. An input attenuator is fitted. H.T. and filament supplies are available from the pre-amplifier.

★ Distortion

Of the order of 0.1%.

★ Hum

Negligible, due to the use of recently developed valves and special techniques.

★ Input selector

Radio, tape, records: any and all records can be accurately equalised.

★ Treble

Continuously variable, + 9 db to - 15 db at 10,000 c/s.

★ Bass

Continuously variable + 12 db to - 13 db at 40 c/s.

★ Volume Control and Switch

The switch controls the power supply to the TL/10 power amplifiers.

★ Tape Recording Jacks

An exclusive feature. Readily accessible jacks are provided on the front panel for instantaneous use with Tape Recorders which have built-in (low level) amplifiers.

ELECTROSTATIC LOUDSPEAKERS

Reprints of "The Gramophone" article (May, 1955) by H. J. Leak, summarising his work and findings on Electrostatic and Dynamic Loudspeakers, are available on request, free of charge.

★ Write for leaflet W ★

H. J. LEAK & CO. LTD., BRUNEL ROAD, WESTWAY FACTORY ESTATE, ACTON, W.3

Phone: SHEpherd's Bush 1173/415

Telegrams: Sinusoidal, Ealux, London

Cables: Sinusoidal, London

BAND III AERIALS

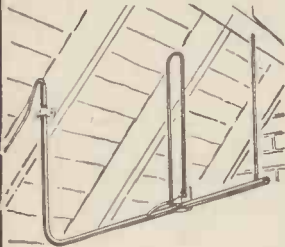

THE 'READY'

This is a 1/2 wave-length, 3 element array. Of all alloy construction, the aerial is completely assembled and ready for instant mounting in loft, bedroom cupboard, window frame, etc. Price 12/6, plus 2/-.

- 3 element array with swan-neck mast with "U" bolt clamp for fitting to existing masts from 1/4 in. to 2 in. dia. 41/6
- 3 element array with cranked mast and wall mounting bracket 42/6
- 3 element array with cranked mast and chimney lashing equipment 65/-
- 5 element array with swan-neck mast and "U" bolt clamp for fitting existing mast from 1/4 in. to 2 in. dia. 52/6
- 5 element array with cranked mast and chimney lashing equipment 67/-
- 8 element array with swan-neck mast and "U" bolt clamp for fitting to 1/4 in. to 2 in. dia. mast 69/-



THE
"CRISPIAN"
BATTERY
PORTABLE

A 4-valve truly portable battery set with very many good features as follows:—

- Low consumption valves.
- Superhet circuit with A.V.C.
- Ready built and aligned chassis if required.
- Beautiful two-tone cabinet.
- Guaranteed results on long and medium waves anywhere.

All parts, including speaker and cabinet, are available separately or if all ordered together the price is £7/15/- complete. Post & insurance 3/6d. Ready built chassis 30/- extra. Instruction booklet free with parts or available separately price 1/6.

CAR STARTER CHARGER KIT

All parts to build 6- and 12-volt charger which can be connected to a "Bat" battery and will enable the car to be started instantly. Kit comprising the following—

- Main transformer 19/6
 - 5-amp rectifier 17/6
 - Regulator Stud Switch 3/8
 - Resistance Wire 2/-
 - Resistance Forme 2/6
 - Mains on/off Switch 1/-
 - 0.5 amp. Moving Coil Meter 9/6
 - Constructional Data 1/8
- or if bought all together price is 52/6, plus 2/6 post and packing.



CONNECTING WIRE
P.V.C. covered in 100ft. coils—most colours—four coils, different colours, 10/-, post free.



MINI-RADIO
Uses high-efficiency coils—covers long and medium wavebands and fits into the neat white or brown bakelite cabinet—limited quantity only. All the parts, including cabinet, valves, in fact, everything, £4/10/-, plus 3/6 post. Constructional data free with the parts, or available separately. 1/6.

MAINLY FOR EXPERIMENTS AND INDUSTRIAL USERS

VACUUM RELAY

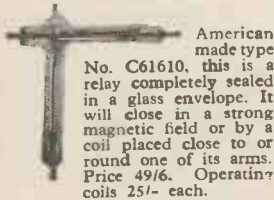

American made type No. C61610, this is a relay completely sealed in a glass envelope. It will close in a strong magnetic field or by a coil placed close to or round one of its arms. Price 49/6. Operating coils 25/- each.

WESTINGHOUSE (U.S.A.) METERS

- All flush mounting type, outside diameter of face 3 1/4 in.
- 0-500 v. D.C. 25/-
- 0-1.5 kV D.C. external multiplier 35/-
- 0-2.5 kV D.C. external multiplier 35/-
- 0-15 v. A.C. moving iron 30/-
- 0-1 mA. 25/-
- 0-50 mA. 25/-
- 0-100 mA. 25/-
- 0-150 mA. 25/-
- 0-250mA 25/-
- 0-500 mA. 25/-

CONTACTOR

Solenoid operated—completely enclosed in cast-iron case, contacts rated at 7.5 amps D.C.—suitable for up to 30 amps. A.C. — coil volts 24 D.C. price 8/- each.

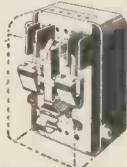

NAVY MODEL TCK-7

Seen at Eastbourne by appointment

We have a few only American transmitters still in original packing cases. Designed for the Navy, these are really beautifully made and most impressive, standing 5ft. high by 2ft. wide and finished in instrument crackle. All meters and controls are on the front panel. The transmitter tunes over the range of 2 megacycles to 18 megacycles and it is designed for high speed precision communication without preliminary calling. Frequency control and stability is particularly good being better than .005% under the worst conditions. Power output is 400 watts on C.W. and 100 watts on phone. Tuning is very simple—a unit control mechanism—gives a direct reading in frequency.

Complete with valves and instruction manual. Price £95. ex works.

NOTE.—The transmitter will work off A.C. or D.C. with the appropriate power unit. Power units are not available at present.

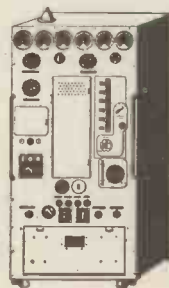

UNITS FOR CONTROLLED AUTOMATIC ROTATION

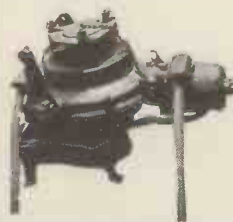

We have brand new, still in original unopened packing cases as shipped from America two items of equipment which form part of the radar system RC84. These two units work together to form a Tower rotating device with remote control.

Item 1, known as Tower 24A, is in fact the geared driving motor which rotates the mast. This is quite a heavy construction and would rotate a heavy scanner, reflector. Beam array etc. etc.

Item 2, known as Indicator 1-221-A is the remote controller which enables the azimuth position of Tower 24A to be controlled from a remote point. Conversely, it enables the Indicator to contain selsyn transmitter/receivers and it is these that provide the impulses which cause the aerial to rotate backwards or forwards. The equipment intended for 117 volt A.C. mains but will operate from our mains if connected through step down transformer of 1 K.W. rating.

Prices 1-221-A £25 plus carriage, TB24A £35 plus carriage. Special discount of £5 for cash with order or C.O.D. If both units purchased together.

OVERCURRENT RELAY

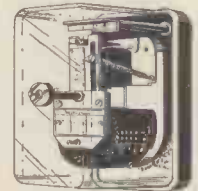

Beautifully made by the famous American Westinghouse Company. These are the surface through panel type with clear Pyrex glass covers. They have coils for remote push button resetting. Type A—calibrated for currents between .1 and .4 amps. Type B—calibrated for currents between .5 and 2 amps. Price, unused and perfect, £3/17/6 each.

RACKING EQUIPMENT

STANDARD OPEN RACK

6ft. high and 19in. wide, heavy steel construction. Holes drilled and tapped at the standardized spacings. Price £3/15/-, plus carriage.



MICA PANELS

Pure mica panels size 2in. x 3in. 3/- per dozen.



GRAMOPHONE AUTO-CHANGER
Latest types by all famous makers are invariably in stock at competitive prices. B.S.B., Monarch, Garrard, etc. Latest models from £7/15/0, plus 5/- carriage and insurance.

THIS IS ON OFFER AT APPROX. HALF COST TO MAKE



An impressive costly looking cabinet originally designed for T.V. but simple modification makes the cabinet suitable for radiogram, amplifier, tape recorder, or reflex speaker—size 23in. wide, 22in. deep and 37 1/2in. high. Limited quantity at £8 15/- each, carriage 12/6.

E.H.T. GENERATOR

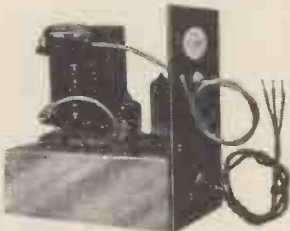

This is a made-up unit, power consumption (6.3 volt 8 amp. filament and approx. 59 mA. H.T.). Contains three BVA valves. Output from 6 kV to 9 kV rectified with normal H.T. rail input but somewhat higher outputs can be obtained with higher H.T. supply. Dimensions are 6 1/2 x 4 1/2 x 7in. Price 69/6, post, packing, etc. 5/-



MULLARD AMPLIFIER "510"

A High Quality Amplifier designed by Mullard engineers. Robust high fidelity with a power output exceeding 10 watts and a harmonic distortion less than 4% at 10 watts. Its frequency response is extremely wide and level being almost flat from 10 to 20,000 C.P.S.—three controls are provided and the whole unit is very suitable for use with the Collaro Studio and most other good pick-ups. The price of the unit completely made up and ready to work is £12/10/-, plus 10/- carriage and insurance. Alternatively, if you wish to make up the unit yourself we shall be glad to supply the components separately. Send for the Mullard amplifier shopping list.



CABINETS FOR ALL

WE CARRY A VERY VARIED STOCK PLEASE CALL

The one illustrated is the "Empress," it is undoubtedly a beautiful piece of furniture. It is elegantly veneered externally in figured walnut, internally in white sycamore. The radio section is raised to convenient level but is not drilled or cut. The lower deck acts as the motor board, again is uncut, it measures 16 x 14 and has a clearance of 5in. from the lid. There is a compartment for the storage of recordings. Overall dimensions of this essentially modern cabinet are 3ft. wide, 2ft. 8in. high and 1ft. 4 1/2in. deep. Price £14/14/-, carriage and insurance 20/-.

RECORD PLAYER FOR £4/10/-

SPEED INDUCTION MOTOR
3-speed motor with metal turntable and rubber mat. Latest rim drive with speed selection by knob at the side.



HI-FI PICK-UP

Using famous Cosmocord Hi-G turnover crystal. Separate sapphire for each speed. Neat bakelite case with simple adjuster for weight compensation.

SPECIAL SNIP OFFER THIS MONTH

The two units for £4/10/-, or 30/- deposit and four payments of 18/-, post and insurance, 5/- . Or fitted upon base, as illustrated, £5/10/-, plus 7/6 post and insurance.

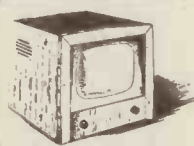

14" T.V. CABINET

14in. T.V. cabinet of the latest styling made for one of our most famous firms—beautifully veneered and polished—limited quantity—19/6 each. Carriage and packing 3/6 extra.

The "ESTRONIC" BAND III CONVERTER

To-day's best value in Band III converters suitable for your T.V. or money refunded. Complete ready to operate. 59/6 non mains or 85/- mains, post and insurance, 3/6.



HALF-PRICE OFFER BEETHOVEN CHASSIS

Extremely well built on chassis size approx. 9 1/2 x 7 1/2 x 8 1/2, using only first-class components, fully aligned and tested. 110-240 volt A.C. mains operation. Three wave bands covering medium and two shorts. Complete with five valves, frequency changer, double diode triode, pentode output and full wave rectifier. Special cash-with-order price this month, £5/19/6, carriage and insurance 7/6 Polished cabinet, 49/6

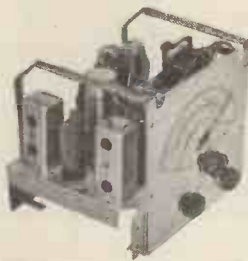

NEW CIRCUIT

OCASIONAL 56—We have evolved a new T.R.F. circuit and have had really good results, equal in fact to many superhets. You really should try this circuit. All parts including valve (6X7, 6J7, 6P8, and 6X5) and Bakelite case with back coat only £5/10/- plus 2/6 post and insurance. Data included with the parts is also available separately, price 2/-.

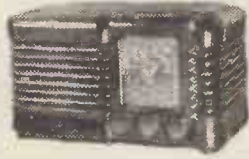

PLEASE INCLUDE POSTAGE WHEN ORDERING

R1155 YOURS FOR £2



The R1155 is considered to be one of the finest communication receivers available to-day. Its frequency range is 75 kc/s. to 18 Mc/s. It is complete with 10 valves and is fitted in a black metal case. Made for the R.A.F. so obviously a robust receiver which will give years of service. Completely overhauled and guaranteed in perfect working order. Price £9/10/6 or 5 payments of £2 each. Carriage and Transit case 15/- extra. Mains Power Pack, with built-in speaker, £5/10/- or in polished cabinet, £6/15/-.

OFFICE TELEPHONES



New G.P.O. telephone sets with Internal well and push button switch easily connected together to form office intercom. Price £2/10/- each. Post, etc., 2/6.

TRANSFORMER SNIP

11/6

Post 2/-

Fully shrouded—standard 200-240 v. primary 250-0-250 at 80 mA. 6.3 v. at 3 amp. 5 v. at 2 amp.

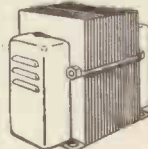

FINE TUNERS

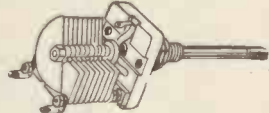

Ceramic trimmers all with 1/2in. spindle of fair length. 5, 10, 15 30, P.F. at 2/3 each or 24/- per dozen.

CIRCUIT DETAILS

Diagrams and other information extracted from official manuals. All 1/6 per copy. 12 or 15/-.

American Service	R.109
Sheets	78 receiver
A.1134	78 recs ver
BC.348	R28/ARC5
BC.312	R1116/A
R.103A	RA-1B
B.C.342	AR88D
RA-1B	AN/APA-1
R-208	78
R-1165	78
B-1124A	RT.19
R-1132A/E-148)	CAY-46-AAM
R-1147	RADAB
R-1234A	A.S.B.-3
R-1082	Indicator 62A
R-1355	Indicator A.F.B.3
B.C.1205-A/B	Indicator 62
B-45-A (or -B)	Indicator 6K
B-45-A (or -B)	R.F. unit 24
B-45-A (or -B)	R.F. unit 25
Transmitter T1154	R.F. unit 26
B.D.J.N.	R.F. unit 27
11/6y-eight wall-to	Wireless set No. 19
talkie	Deboxed valves
Frequency mete	
B.C. 221	

ELECTRONIC PRECISION EQUIPMENT LTD.

249 Kilburn High Road
Kilburn.
Phone: MAI 4921
Half-day Thursday

42-46, Windmill Hill, Ruislip
Middlesex.
Phone: RUISLIP 5780
Half-day Wednesday

152-153 Fleet St., E.C.4.
Phone: FLEET 2833
Half-day Saturday

29 Stroud Green Road, Finsbury
Park, N.4.
Phone: ARCHWAY 1049
Half-day Thursday.

Post orders should be addressed to E.P.E. LTD., M.O. Dept. 2, 123, TERMINUS ROAD, EASTBOURNE.
All enquiries to Eastbourne address and please enclose S.A.E., terms are cash with order.

See them...hear them...

Stand No. 105

Demonstration Room D. 7



New Pressure Driven HIGH FIDELITY Reproducers



NEW PRODUCT

Trebax

A new high efficiency pressure driven reproducer covering the treble register from 2,500 c.p.s. to 16 k/cs.

Used with the new MIDAX, the crossover point between these two units should not be below 4 k/cs. to allow for the "overlap" region. (Impedance 15 ohms. at 10 k/cs.)



NEW PRODUCT

Midax

Horn-loaded mid-range pressure driven unit. (Frequency coverage 400 c.p.s. to 8 k/cs.)

When used in a 3-way system the crossover between Midax and the bass unit should be at 750 c.p.s. (Impedance 15 ohms at 400 c.p.s.)

● These units combine to form outstanding 3-WAY SYSTEMS when used with an AUDIOM Loudspeaker fitted with a 35c.p.s. resonance cone.

15 WATT SYSTEM



AUDIOM 60
12 in. 15 watts

20 WATT SYSTEM



AUDIOM 70
12 in. 20 watts

25 WATT SYSTEM



AUDIOM 80
15 in. 25 watts



MIDAX



MIDAX



MIDAX

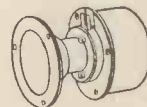

TREBAX

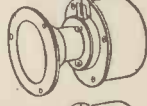

TREBAX

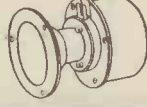

TREBAX

3 way systems

20 c.p.s. to 750 c.p.s. to 5000 c.p.s. to 16000 c.p.s.

15 WATT SYSTEM



AXIOM 150 Mk. II
12 in. 15 watts

20 WATT SYSTEM



AXIOM 22 Mk. II
12 in. 20 watts

● Trebax may be combined with the AXIOM 150 Mk. II or the AXIOM 22 Mk. II to form an excellent two-way system crossing over at 5,000 c.p.s.

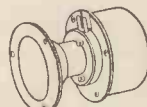

TREBAX

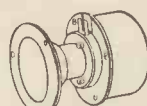

TREBAX

2 way systems

Crossover networks suitable for all these systems are available. TYPE XO 5000 (crossover frequency 5000 c.p.s.) should be used with Trebax and Axiom 150 Mk. II (or Axiom 22 Mk. II) in the 2-way systems. TYPE XO 750/5000 is suitable for all 3-way systems having crossover frequencies at 750 c.p.s. and 5000 c.p.s.

at the Radio Show Aug. 22nd to Sept. 1st

Goodmans

Axiom Full Range HIGH FIDELITY Loudspeakers



AXIOM 150 Mk. II
15 watts 12 in.
30-15,000 c.p.s.



AXIOM 22 Mk. II
20 watts 12 in.
30-15,000 c.p.s.



AXIOM 80
6 watts 9 1/2 in.
20-20,000 c.p.s.



AXIETTE
6 watts 8 in.
40-15,000 c.p.s.



Acoustical Resistance Unit . . .

The Acoustical Resistance Unit (*illustrated*), developed and manufactured exclusively by GOODMANS INDUSTRIES LTD., enables the cubic content of the Bass Reflex System to be reduced by one-third, while retaining full bass performance when used with Audiom or Axiom loudspeakers. (*Full dimensional drawings for enclosures supplied with all Audiom and Axiom loudspeakers*).

Axiom Enclosures . . .

Illustrated is a typical AXIOM Enclosure designed to incorporate GOODMANS LOUDSPEAKERS when used with an Acoustical Resistance Unit. Styling and shape of cabinet need only conform to the correct volume for any particular speaker system. Overall size is two-thirds that of an equivalent Bass Reflex Chamber. The bass response of the AXIOM or AUDIOM Loudspeaker, when used in these cabinets, is extended down to 20 c.p.s. No objectionable resonances occur above this frequency. Air loading of the loudspeaker cone is fully maintained to zero frequency, reducing harmonic and intermodulation distortion due to excessive cone displacement.



tickets?

See Goodmans Loudspeakers at Stand No. 105 . . . hear them in Demonstration Room D.7. Daily Demonstrations throughout the show every half-hour. Tickets available on the Stand. Avoid disappointment by posting the coupon, indicating preference of day and time. Tickets for SATURDAYS only available at the Stand on the day.

TO: GOODMANS INDUSTRIES, LTD.,
AXIOM WORKS, WEMBLEY, MIDDX.

Please send . . . tickets for your demonstration
at . . . a.m./p.m. on . . . (date)

OR at . . . a.m./p.m. on . . . (date)

Name . . .

Address . . .

WW856

MULTITONE

SPECIALIZE

in equipment for the DEAF
and for PHYSIOTHERAPY



The ADAPHONE

enables the deaf to hear TV and Radio programmes in comfort and safety and with a clarity unobtainable when using a hearing aid for this purpose. It is also ideal for those with normal hearing who wish to hear the programmes without disturbing others.

The Adaphone has an attractive grey plastic case (3in. x 2in. x 1½in.). Weighted straps hold it in position on any chair arm. The input is matched for 2 to 10 ohms connection and the transformer tested to withstand 2,000 volts D.C. The listener can adjust the volume to his individual need without affecting the loudspeaker volume.

Tone control is obtained by alternative output sockets; 'Normal' and 'High.'

The M3 model has Automatic Volume Compression.

A low-impedance insert-type magnetic miniature receiver of D.C. resistance 30-40 ohms is supplied, but a bone-conduction receiver is available instead, at extra cost, for those who prefer it.

- MODEL M4. Complete with miniature ear piece, standard earmould, and leads £4 19 0
- MODEL M3. Incorporating Automatic Volume Compression, complete as above..... £5 15 0
- MODEL M5. Incorporating Loudspeaker Switch for "silent" listening £5 15 0

Obtainable through all leading Radio Dealers or direct from Multitone Electric Company Limited.

Enquiries should be addressed to

MULTITONE ELECTRIC CO. LTD.
12/20 Underwood Street, London, N.1.
PIONEERS IN SOUND AMPLIFICATION

L·R·S

Estd.

1925

EASY

TERMS

LEAK QUALITY EQUIPMENT
for the Connoisseur

If you want the Finest Quality Reproduction together with Workmanship of the Highest Order your choice must be LEAK.

AS USED BY BROADCASTING CORPORATIONS THROUGHOUT THE WORLD.

LEAK "TL/10;" AND "POINT ONE" PRE-AMPLIFIER. Cash Price £28/7/-, or sent for £4/10/- Deposit and 18 monthly payments of 30/-, carr. and crate free.

LEAK DYNAMIC PICK-UP

Complete with two detachable diamond heads and transformer. Cash Price £21/19/9 or sent for £4 Deposit and 10 monthly payments of 40/-. Post and packing paid.

Delivery of all the above is from stock. We can also supply the **LEAK F.M. TUNER.** Wharfedale, Goodmans and Tannoy loudspeakers, etc., Connoisseur Variable 3-speed Motors and all other Quality Equipment on EASY TERMS. Please send us your requirements. Quotation by return of post.

The L · R · SUPPLY COMPANY, LTD.
BALCOMB (Tel. 254) SUSS. X.

... 19,801 contacts (as shown) soldered in one working week with the new ORYX model 18 soldering iron. For rapid soldering on your production assembly line without fatigue. Patented construction ensures maximum efficiency. Send for leaflet or a sample on sale or return and try for yourself. **ORYX** for reliability, for efficiency, for comfort, economy, safety, speed.

ORYX
MODEL 18
SOLDERING INSTRUMENT
6-6.3 v. 18 WATTS
7½" LONG. WEIGHT 1 oz.
BIT SIZE 3/16". LIST PR. 35/-
3 TOWER HILL ANTEX LONDON, E.C. 3

Direct readings of

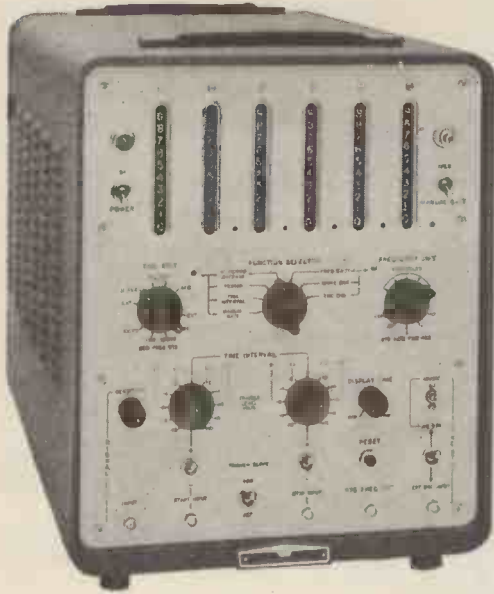
New  523B

ELECTRONIC COUNTER

- ▲ Extreme dependability
- ▲ Etched, unitized circuits
- ▲ Permits viewing time-interval start and stop points on oscilloscope
- ▲ High accuracy crystal oscillator circuit
- ▲ Trouble-localizer lights
- ▲ Counts pulses of selected voltage level

Construction of the new *-hp- 523B* is highest quality throughout. Etched circuits are rugged, ultra-dependable. Circuits are arranged for complete visibility. Trouble-localizer lights and plugs disconnecting circuit elements further simplify maintenance.

Exclusive features include a pulse output for oscilloscope Z-axis modulation permitting visual identification of the time-interval start and stop points on the input waveform measured. There is also a pulse count discriminator counting only pulses of voltage above a pre-determined level; and a high accuracy, high stability crystal controlled oscillator. Controls are color-coded, concentric, functionally arranged. Readings are direct in clear, bright numerals; decimal is automatic and illuminated.

The broad range and versatile usefulness of *-hp- 523B* is indicated by the Specifications at right. Model 523B is designed for utmost speed and simplicity in measuring production quantities, rpm, nuclear pulses, power line frequencies, repetition rates, time intervals, pulse lengths, shutter speeds, velocities, relay times, frequency ratios, phase delay, etc.

FREQUENCY

TIME

PERIOD

10 cps to 1.1 MC!

With transducers, *-hp- 523B* also provides local or remote measurement of weight, pressure, temperature, acceleration, etc.

BRIEF SPECIFICATIONS

FREQUENCY MEASUREMENT:

Range: 10 cps to 1.1 MC
 Accuracy: ± 1 count \pm crystal stability
 Input Minimum: 0.2 v RMS
 Input Impedance: Approx. 1 megohm, 30 μ mf shunt
 Gate Time: 0.001, 0.01, 0.1, 1, 10 seconds
 Reads Directly In: KC, Automatic decimal

PERIOD MEASUREMENT:

Range: 0.00001 cps to 10 KC
 Accuracy: $\pm 0.3\%$ (1 period); $\pm 0.03\%$ (10 periods)
 Input Minimum: 1 v RMS
 Input Impedance: Approx. 1 megohm, 40 μ mf shunt
 Gate Time: 1 or 10 cycles of unknown
 Standard Counting: 10 cps, 1 KC, 100KC, 1 MC, External Sec, msec, μ sec, automatic decimal
 Reads Directly In:

TIME INTERVAL MEASUREMENT:

Range: 3.0 μ sec to 100,000 sec (27.8 hrs)
 Accuracy: ± 1 /std. freq. counted \pm stability
 Input Minimum: 1 v peak, dc coupled
 Input Impedance: Approx. 1 megohm, 25 μ mf shunt
 Trigger Slope: Pos. or neg. on start/stop independent or common channels
 Trigger Amplitude: -300 to +300 v adjustable
 Standard Counting: 10 cps, 1 KC, 100 KC, 1 MC, External Sec, msec, μ sec, automatic decimal
 Reads Directly In:

STABILITY:

DISPLAY TIME:

OUTPUTS:

PRICE:

2/1,000,000 per week. Also WWV
 Variable 0.1 to 5 sec, or indefinite
 Secondary standard: 10 cps, 1 KC rectangular, 100 KC, 1 MC sine wave.
 \$1,175.00

Data subject to change without notice. Price f.o.b. factory.

HEWLETT-PACKARD COMPANY

Represented by

LITHGOW ELECTRONICS LTD.

1 GRANGE COURT, SUDBURY HILL • HARROW, MIDDLESEX

Telephone: Byron 8783



complete coverage in quality counters

Portable

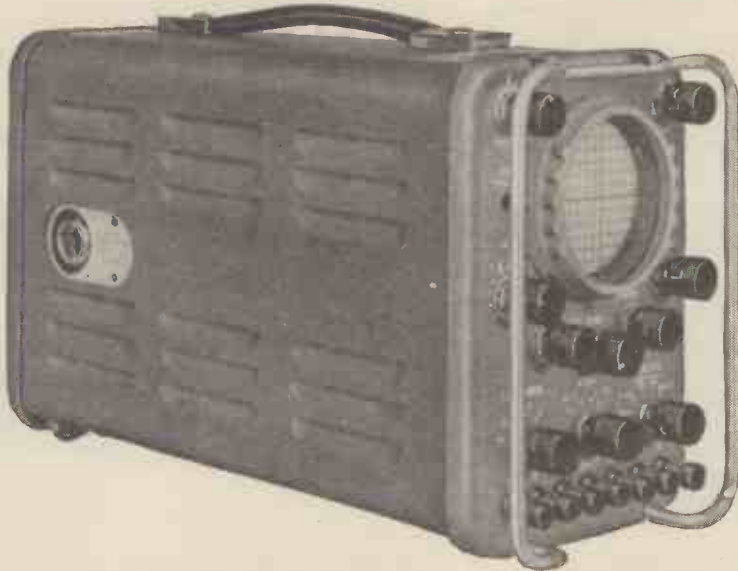

Type CT52 MINIATURE OSCILLOSCOPE

Designed as a general-purpose instrument, the Metrovick miniature oscilloscope is particularly useful for radar servicing. Its light weight and compact construction result in a portable and robust instrument designed to withstand rough use, so that it has now become standard equipment for the fighting services.

Weight:
Approx. 15 lb.
Size:
13½" × 8" × 5½"
approx.
Finish:
Dark Battleship
grey

SPECIFICATION

- SUPPLY:** With A.C. Power Pack (CT52)—100/125 volts 50/60 c/s. With D.C. Power Pack (CT84)—28 volts D.C. Power consumption 50 VA approx.
- CATHODE RAY TUBE:** Hard tube—2¼ in. diameter screen. Standard tube fitted has Green screen with medium afterglow. Alternative tubes can be fitted.
- TIME BASE:** Free-running linear time base, paraphrase amplifier and synchronising. Repetition range 10 c/s. to 40 Kc/s. Single-sweep linear time base with paraphrase amplifier, triggered by 30-volt pulse. Repetition range—50 c/s to 3,000 c/s. Sweep range—50 milliseconds to 3 microseconds.
- Y PLATE ATTENUATOR:** Resistance Attenuator, capacitance compensated. Flat response—3 db from D.C. to 100 kc/s. Fixed attenuation of 14 db (5 times).
- Y PLATE CONNECTION:** Direct or series capacitor connection. Input resistance—2.5 megohms. Input capacitance—50 pf. approx.
- Y PLATE AMPLIFIER:** 1. Max. gain of 38 db. (80 times) flat to 3 db. from 25 c/s. to 150 Kc/s.
2. Max. gain of 28 db (25 times) flat to 3 db. from 25 c/s to 1 Mc/s.
- CALIBRATION:** An internal supply of 50-volt peak $\pm 10\%$, sine wave, at the supply or vibrator frequency.
- DELAY LINE:** A delay network brought to the Y plate switch, and the displayed signal is delayed by approximately 0.5 microseconds, provided that its source impedance is of the order of 75 ohms.
- RATING:** Continuous operation at ambient temperatures between 32° C. and + 50° C.

Write for leaflet 652/14-1 for technical details

METROPOLITAN-VICKERS

ELECTRICAL CO LTD · TRAFFORD PARK · MANCHESTER 17

Member of the A.E.I. group of companies

B174

SERIES REGULATOR VALVE 6080

a new double triode with REALLY low impedance

A quick reference to the anode characteristics of the 6080 reveals its unusually low impedance and the very small voltage drop produced across each of its triode sections. These are the factors that are making the 6080 indispensable in the design of more efficient series regulation and servo control systems.

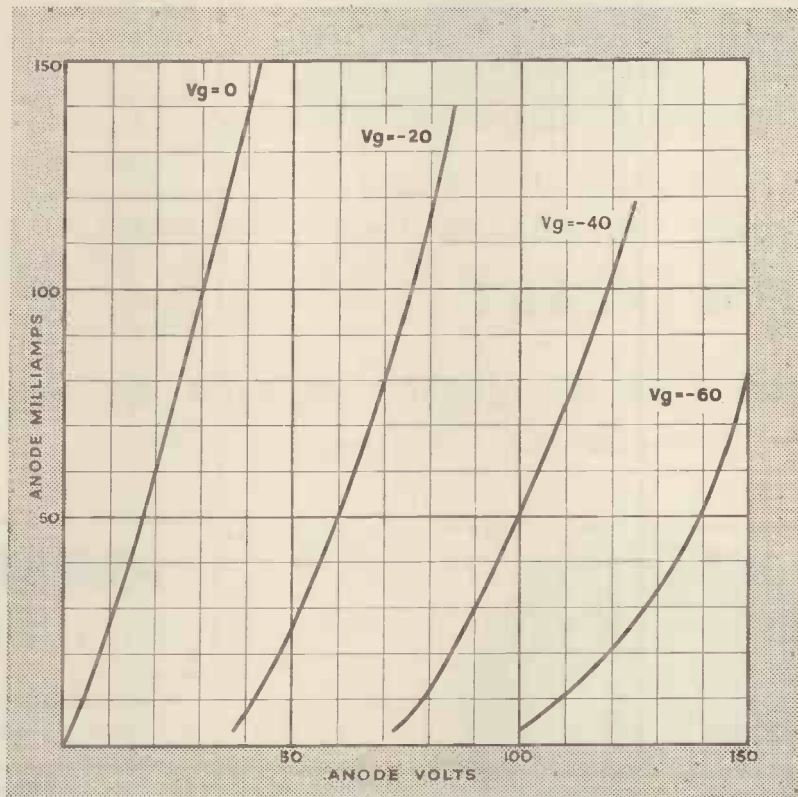
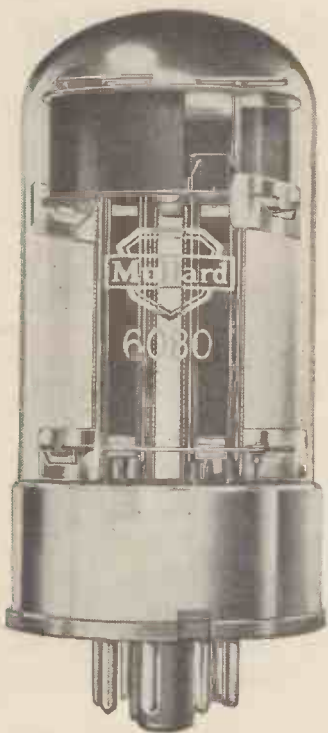

Anode characteristics of each triode section of the 6080.

6080 (CV2984) Double triode with separate cathodes

V_h : 6.3 volts.

I_h : 2.5 amps.

Base: Octal.

Abridged data for each triode section

V_a max. 250 volts

g_m 7.0 mA/V

I_a max. 125 milliamps

μ 2.0

r_a 280 ohms

p_a max 13 watts

The 6080 is the modern version of the 6AS7-G and is available from Mullard to the American MIL-E-1 Specification.

Mullard



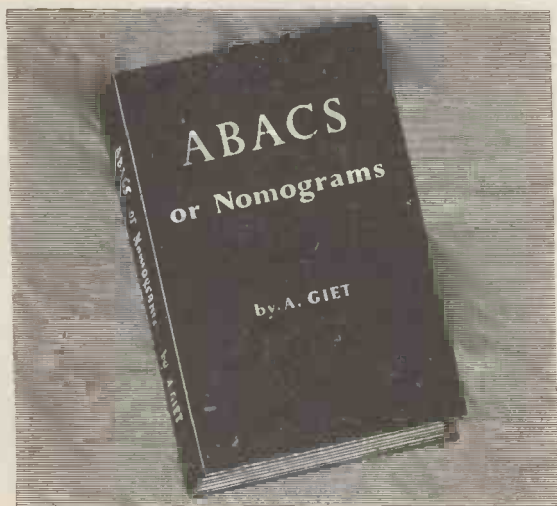

8 3/4 ins x 5 1/2 ins . 235 pp. 152 illustrations

35s. net BY POST 35s. 10d.

NOW READY

A new book for designers engineers physicists and mathematicians

FROM ALL BOOKSELLERS Iliffe & Sons Limited Dorset House Stamford Street London S.E.1

Time-saving methods for repetitive and complicated calculations

ABACS or Nomograms

By A. Giet. Translated from the French by H. D. Phippen and J. W. Head

Not only demonstrates the many and varied applications of the Abac or Nomogram, but shows how even those without highly specialised mathematical knowledge may construct their own charts. It deals with both Cartesian abacs and alignment charts and contains a large number of practical examples in mechanics, physics and electrical engineering. This edition has been specially adapted for English readers.

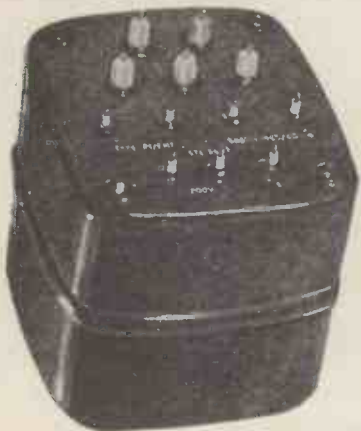

STL

Transformers incorporating "C" cores or conventional construction

STL TRANSFORMERS

based on sound design and are manufactured to the highest standards called for in the electronic and communication fields. Consult us for your next transformer requirements.

N.B.: MANUFACTURERS AND TRADE ONLY

STEWART TRANSFORMERS Ltd.

75, KILBURN LANE, LONDON, W.10 · LADbroke 2296/7

MANCHESTER

LHF AUDIO CENTRE LHF

LANCASTER HI-FIDELITY COMPANY (ARDwick 5762)
Stock ALL makes of quality audio equipment.

AMPLIFIERS	SPEAKERS	MOTORS	TUNER UNITS
R.C.A.	Wharfedale	Garrard	(FM and AM)
Acoustical	Goodmans	Connoisseur	Pye
Goodsell	Pamphonic	Collaro	Acoustical
Leak	Barker	Lenco	Goodsell
Armstrong	Kelly	PICK-UPS	Chapman
Pamphonic	Stentorian	Connoisseur	Armstrong
Rogers	Sound Sales	Ortofon	RADIOGRAM CHASSIS
Pye	Adams	Leak	Armstrong 105
Sound Sales	G.E.C.	Tannoy	T.S.L. Empress
	Tannoy	Goldring etc. etc.	

TAPE RECORDERS BY FERROGRAPH & SIMON

TAPE DECKS BY WEARITE AND TRUVOX

HIRE PURCHASE AND CREDIT FACILITIES

DIRECT DELIVERY SERVICE TO ALL PARTS OF THE NORTH

LANCASTER HI-FIDELITY CO.

THE NORTH'S SOUND REPRODUCTION SPECIALISTS

144 OXFORD RD. ("All Saints") MANCHESTER 13

Bus Routes: 41 or 42 (Stop at Roxy Cinema). If coming by car drive towards the University.

Taylor

R.C. OSCILLATOR MODEL 191A

This instrument generates sine and square waves of good waveform over the wide frequency range of 10 c/s to 100 Kc/s, and provides a convenient source of voltage and low power for checking the frequency and transient response of amplifiers, transformers, loudspeakers, etc.

Frequency ranges: 1. 10 c/s to 100 c/s. 2. 100 c/s to 1,000 c/s.
3. 1 Kc/s to 10 Kc/s. 4. 10 Kc/s to 100 Kc/s.

Output Impedance: 600 ohms all ranges.

Output Level: ± 1 dB over entire range.

Attenuation: Coarse -20 dB -60 dB. Fine attenuated 20 dB calibrated 1-10. Accuracy $\pm 2\%$.

Distortion: Less than 1% at 1,000 c/s.

Sine Wave Output: Max. 3.75 milliwatts through T attenuator pads matching to 600 ohms .15 mV to 3 V R.M.S. into 600 ohms .3 mV to 3 V R.M.S. into high impedance.

Square Wave: Rise time less than .3 microseconds. Less than 10% tilt at 10 c/s .3 mV to 3 V into 600 ohms. 6 mV to 6 V into high impedance.

Cut Out: Automatic mains overload trip incorporated.

Power Supply: 105/120 V and 200/250 V A.C., 40/100 c/s. Consumption 50 watts.

Dimensions: 12 $\frac{1}{2}$ x 8 $\frac{1}{2}$ x 6 in. Weight 18lb. approx. (8.2 kg.).

For Transformer, Amplifier
and Loudspeaker response tests



CASH PRICE £30. Prompt delivery.

CREDIT TERMS: 9 monthly payments of £3.15.0.
HIRE PURCHASE TERMS ALSO AVAILABLE.

All Taylor Instruments are available on advantageous CREDIT Terms and on SEVEN DAYS' APPROVAL. You can also PART EXCHANGE your old Taylor Instrument for a new one.
Write for full details and catalogue.

TAYLOR ELECTRICAL INSTRUMENTS LTD.
MONTROSE AVENUE, SLOUGH, BUCKS.

Telephone: Slough 21381

Cables: Taylins, Slough.

*Pre-assembled for
strength—
convenience—
ECONOMY*

JY5W. 50/-
WALL MOUNTED

JY5MA for attachment to existing installations,
with swan-neck arm. 50/-

JY5 chimney lashed ... 65/-

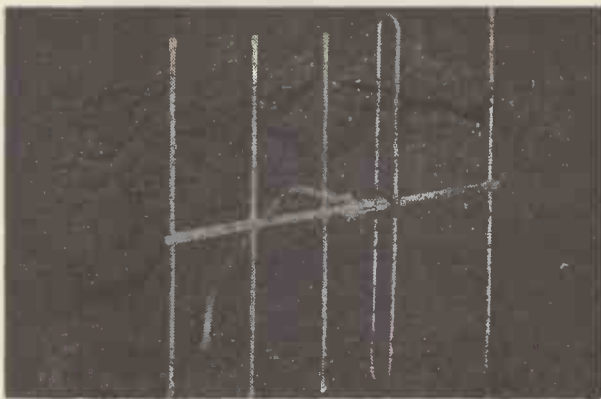

Light, robust as all Wolseys, with riveted construction and "flooded" junction box, this new 5-element array offers advantages you have never enjoyed.

Your wholesaler has stocks.

WOLSEY

Pacemakers to the Aerial Industry

WOLSEY TELEVISION LTD.

(Electronics Division, Gas Purification & Chemical Co. Ltd.) W21

NATIONAL RADIO SHOW. Aug. 22—
Sept. 1. STAND No. 2 at EARLS COURT

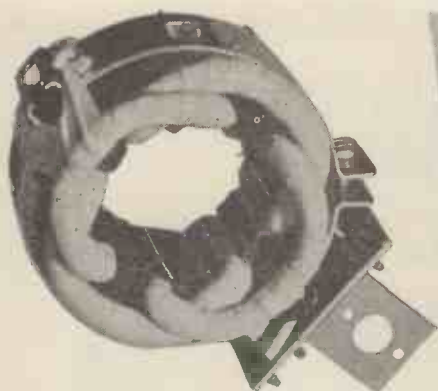

DEFLECTOR COILS
designed for 70° Deflection
and employing Castalated
Ferroxcube core.

TELEVISION COILS
wound to specification.



*Line Transformers
Deflector Coils
T.V. Coils*



LINE TRANSFORMER
employing a Ferroxcube core
and incorporating Width and
Linearity Controls. E.H.T.
13.5 KV.

also 13 CHANNEL T.V. TURRET TUNERS

All enquiries to:

Gillone Electric
LIMITED
ROCKSTONE WORKS . DOMAN ROAD
CAMBERLEY . SURREY
TELEPHONE: CAMBERLEY 2360



FREQUENCY METERS
2½-8" up to 10,000 cycles
DIFFERENTIAL A.C. CURRENT METERS
COMPARING THE MAGNITUDE OF TWO CURRENTS.

PHASE SEQUENCE INDICATORS AND SYNCHROSCOPES UP TO 5 Kc
A Full Range of Switchboard and Portable Instruments

THE ELECTRICAL INSTRUMENT CO. (HILLINGTON), LTD.
Boswell Square Industrial Estate, Hillington,
Glasgow, S.W.2. Halfway 1166 and 2194

WALMORE ELECTRONICS LIMITED

PHOENIX HOUSE, 19/23 OXFORD STREET, LONDON, W.1.

Telephone: GERrard 0522 Cables: Valvexpor
For immediate response Telex London 8752.

EXPORTERS OF RADIO, TELEVISION AND INDUSTRIAL TUBES, HAVE PLEASURE IN INTRODUCING THEIR BRAND



AND INVITE ENQUIRIES FROM BUYING AND CONFIRMING HOUSES EXCLUSIVELY FOR EXPORT

SUPPLIERS OF RADIO COMPONENTS ELECTROLYTICS, AND CATHODE RAY TUBES.

You wouldn't use a rasp on your head...

Why use abrasives?

Many owners of tape recorders often wonder why sound recordings deteriorate and record heads eventually wear out.

It can be the tape. Mastertape is the smoothest, most reliable tape you can buy.

There is no doubt that you can depend on it to give the best service always.

Try some now and you will want to try more.



Mastertape

If your dealer has no stock, write direct to
M.S.S. Recording Co. Ltd., Poyle Farm, Colnbrook, Bucks. Tel. Colnbrook 430

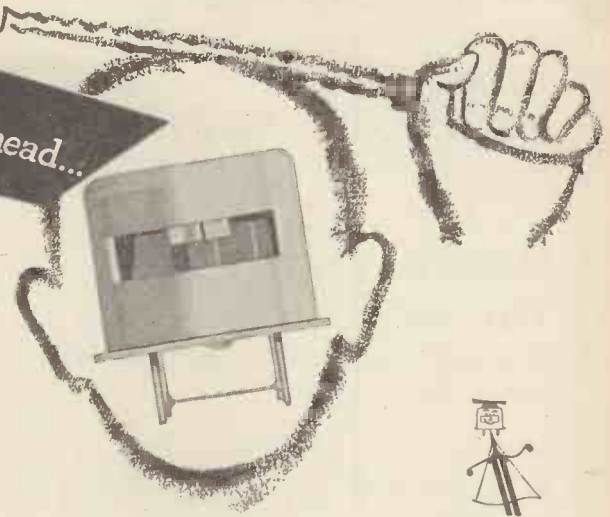

RADIO EXPORT

TUBES ONLY



1,900 types
of Receiving and
Transmitting Radio
Tubes available ex stock.

HALL ELECTRIC LTD
Haltron House, 49-55 Lisson Grove,
London, N.W.1.

Tel.: Ambassador 1041 (5 lines)
Telex—2—2573

Cables: Hallelucic, London

forthcoming books

TRANSISTORS IN RADIO AND TELEVISION

M. S. Kiver 37s 6d

ESSENTIALS OF TELEVISION

Morris Slurzberg, William Osterveld and E. W. Voegtlin

HANDBOOK OF INDUSTRIAL ELECTRONIC CONTROL CIRCUITS

John Markus and Vin Zeluff
approx. 71s 6d

HIGH FIDELITY A PRACTICAL GUIDE

Charles Fowler approx. 29s 6d

MUSICAL ACOUSTICS FOURTH EDITION

C. A. Culver 45s

RADIO — TELEVISION — ELECTRONICS MANUFACTURERS' ASSOCIATION

LABORATORY MANUALS Paul Zbar and Sid Schildkraut

- 1 Basic Electricity
- 2 Basic Electronics
- 3 Basic Radio and Radio Servicing

Books 1 and 2, 14s 6d Book 3, 18s 6d
approximately



ASK ARTHURS FIRST

Valves and C.R.T.s in great variety

AVO METERS IN STOCK

- Avo Model 7..... £19 10 0
- Avo Model 8..... £23 10 0
- COSSOR Oscilloscope Model 1035.....£120 0 0
- COSSOR Oscilloscope Model 1052.....£104 0 0
- ADVANCE AND TAYLOR Meters always in STOCK
- LEAK TL/10 Amplifier and "Point One"
Pre-Amplifier. Complete..... £28 7 0
- LEAK F.M. Unit with built-in Power
Supply £33 15 0
- JASON F.M. Unit with Power Pack..... £19 7 0
- CHAPMAN F.M. 81 Unit £21 0 0

VALVE MANUALS

- Mullard 10 6
- Osram 5 0
- Osram Part 2 10 0
- Brimar No. 6 5 0
- Mullard Replacement Guide ... 2 6
- Art and Science in Sound Reproduction by F. H. Brittain, D.F.H. 2 6
- Postage 6d. extra.

LOUDSPEAKERS, RADIO, TELEVISION, RECORDERS AND RECORD PLAYERS OF LEADING MAKES

Goods offered subject to being unsold and to price alteration.

● WE WELCOME YOUR ENQUIRIES on Radio and Electrical

Arthur's

EST. 1919

PROPS: ARTHUR GRAY, LTD.

GRAY HOUSE, 150-152 CHARING CROSS ROAD, LONDON, W.C.2.
TEmple Bar 5833/4 and 4765 Cables: TELEGRAY, LONDON



MICROPHONES & RECEIVER HEADGEAR

Assy. No. 2 (ZA 2905) consisting of 100 ohms impedance MC headphones, Tannoy high power microphone.
18/- each.

TRANSMITTER/RECEIVER No. 22

2 mc.-8 mc. complete with all valves, power pack for 12 v. D.C., both installed in a carrier, headgear and microphone assembly. All in excellent condition, very economical current consumption. Ideal for mobile use.

Price £11/15/- each. Carriage 20/- extra.

Johnson's variable condenser type 500 E20 single 500PF 2,000 volt. 9/- each.

SPARE PARTS FOR AR 88-D. & L.F.

Mains transformers	Each £4
Output transformers	30/-
Filter chokes	25/-
I.F. transformers	15/-
V.F.O. transformers	15/-
I.F. Crystal transformers	15/-
Main Var. Condenser	35/-
Block condenser 13 x 4 mF.	25/6
Band switches	37/6
Antenna trimmers	3/6
Phasing trimmers	3/6

All the above are fully reconditioned and guaranteed to be in excellent working order.

GOVERNMENT SURPLUS VALVES

A large selection available, please state your requirements.

J. P. ELECTRIC MAIL ORDER DEPT.
156 ST. JOHN'S HILL · LONDON · S.W.11.

"YOU CAN RELY ON US"

*Stockists of all Radio and Electronic components for
manufacturers, laboratories, Educational authorities,
and the amateur.*

MULLARD 510 AMPLIFIER AND G.E.C. 912 AMPLIFIER—ALL
PARTS STOCKED AND AVAILABLE ON H.P.



INCLUDING ELCOM, BULGIN, TCC, HUNTS, DENCO, ETC.

DETAILED LISTS ON ABOVE AVAILABLE

ALL AVO, TAYLOR, INSTRUMENTS FROM STOCK

NEW CATALOGUE AVAILABLE 2½d. STAMP.

RADIO SERVICING COMPANY

82, SOUTH EALING ROAD, LONDON, W.5.

Telephone : EAL. 5737

Next to South Ealing Tube (TURN LEFT) 9 to 5 p.m., Wed. 1 o'clock.

LEEVERS RICH

STUDIO CONSOLE MAGNETIC RECORDER

**A recently developed
magnetic recorder
for A.C. operation in
studios and labora-
tories.**

The audio performance and reliability of this machine are of a very high order, and comply with the most advanced requirements of film, TV and sound broadcasting. Special versions are available for recording and transcription, using the



FEATURES

Rugged all-steel construction.

Free-running castors with foot-operated brakes.

Two tape speeds, and universal spool adaptors.

Entirely self-contained.

Heavy-duty Model E mechanism.

Immediate access to all parts for routine maintenance

Syncropulse patent interlock system

LEEVERS-RICH EQUIPMENT LTD., 78b, Hampstead Road, London, N.W.1. Eus. 1481

AMBASSADOR presents

The 7856

POWERFUL LONG RANGE 8 WAVEBAND SUPER-HET

in continental styling

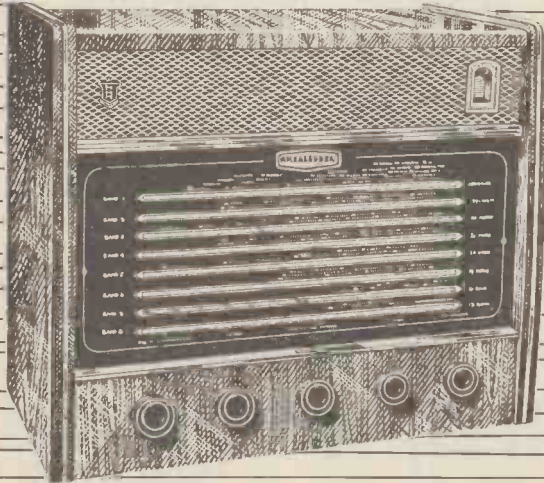

This is Britain's finest Export Radio Receiver—far away ahead in appearance, technical design and performance. Long range with R.F. stage. Electrical Bandspreading Twelve and a half inches of scale length to each band. Tuning indicator, separate bass and treble controls. A.C. operation only.

High Fidelity sound system with Twin frontal angular mounted wide frequency range loudspeakers.

Send today for new Export leaflet describing this and other new models.

The choice of quality minded people

Ambassador Radio & Television Ltd., Brighouse, England.

"Don't forget

your Teletet"

The COMPLETE
TELEVISION
SERVICING
INSTRUMENT

Write now for
full details to

AIRMEC LTD
HIGH WYCOMBE
BUCKINGHAMSHIRE

WANTED

VERY HIGH PRICES PAID FOR THE FOLLOWING:—

APN3	BC342	I-152
ARCI	BC611	TS13
ARC3	BC713A	TS35
ARN7	BC714A	TS45
ART13	BC721	TS148
BC221	BC788C	TS174
BC312	CPN2	TS175

Also Modulation Transformers Thermador No. CS2160, and Scanner (antenna) RC94 or parts.

ALTHAM RADIO CO.
JERSEY HOUSE, JERSEY STREET
MANCHESTER 4

Telephone: Central 7834/5/6
Largest stocks in Europe of Government surplus material.

OSMOR

Free! Send 7½d. in stamps for circuits, practical drawings, of F.M. Tuner, Band III Converter, various T.R.F. and Superhet circuits, Miniature circuits, Switching circuit, Price Lists, etc. Components and information supplied concerning most published circuits in **WIRELESS WORLD, PRACTICAL WIRELESS, RADIO CONSTRUCTOR**

BAND III CONVERTERS

I.T.A. Converters: London, Lichfield, Manchester. A very efficient Band III Converter for all T.V. sets (including TRF). Approximately one hour to build! Guaranteed no breakthrough of Band I. Will convert any Band III Complete Kit **65/-** Channel to any Band I Completely Wired **80/-** Channel A.C. or A.C./D.C. Size 4½ x 2½ x 3in. Circuits, Wiring Diagrams and Full constructional information.

Band I Filter—Rejects B.B.C. from I.T.A. aerial and Improves picture. Suitable for all makes inc. instructions. Fitted in 2 minutes. **10/-**

A masterpiece of technical achievement!

418 BRIGHTON ROAD, SOUTH CROYDON, SURREY
Telephone: CROydon 5148/9



In the vanguard of progress...

Since January 1956 Salford Electrical Instruments Limited have been in regular production of Vacuum-Deposited Selenium rectifiers employing Aluminium base plates. This is one of the most outstanding technical advances in Selenium manufacture in this country in recent years. In conjunction with other improvements it results in reduced forward resistance and therefore increased current rating for the same size of elements, while at the same time maintaining the full inverse voltage rating. Further important advantages are an extended temperature range of operation, improved life and reduced weight.

A SIGNIFICANT CONTRIBUTION TO THE ADVANCE OF ELECTRICAL AND ELECTRONIC TECHNIQUES.

SEI SELENIUM RECTIFIERS

SALFORD ELECTRICAL INSTRUMENTS LTD.
 PEEL WORKS, SILK STREET, SALFORD, 3. LANCS.
 A SUBSIDIARY OF THE GENERAL ELECTRIC CO. LTD. OF ENGLAND

Use . . .

Delanco

REGD.

ELECTRICAL INSULATING
in all Departments

The 'Delanco' range of materials includes:—

- Vulcanized Fibre—Sheet, Rod and Tube
- Leatheroid—Sheet, Roll and Tape
- Laminated Bakelite—Sheet, Rod and Tube
- Ebonite—Sheet, Rod and Tube
- Presspahn—Sheet, Roll and Tape
- Sleevings—Glace Cotton, Rayon and Glass Fibre all Unvarnished and Varnished, Nylon and Terylene (both Unvarnished)
- Varnished Fabrics and Tapes—Cambric, Nylon, Silk, Terylene and Glass Fibre
- Interleaving Papers and Composite Insulations
- Mica-punchings in all qualities

Terylene is a registered trade name of Imperial Chemical Industries Ltd.

- ★ LAMINATED BAKELITE
- ★ S.R.B.P COIL FORMERS
- ★ MACHINED AND PRESSED COMPONENTS
- ★ VARNISHED CAMBRIC AND SLEEVING
- ★ MICA PARTS AND MATERIALS
- ★ LEATHEROID, PRESSPAHN IN COIL AND SHEET
- ★ FIBRE GLASS LAMINATES AND PARTS
- ★ VULCANIZED FIBRE IN SHEET COIL AND ROD

Write for the 'Delanco' catalogue specially prepared for the Electronic Engineer. It will be posted by return.

ANGLO-AMERICAN VULCANIZED FIBRE CO. LTD.

CAYTON WORKS · BATH STREET · LONDON · E.C.1. CLE 3271 Grams: "PROMPSERV," LONDON

Manufacturer - to - Consumer policy saves you at least one-third cost!

Our Chief Engineer, who is operating a Technical Guidance Service, is available daily, including Saturdays, from 10 a.m. to 6 p.m., or will deal with enquiries by return of post. Our new illustrated Catalogue and Supplement will be a great boon to those desiring high quality equipment for modest expenditure. Send two 2½d. stamps for your copy now. We will save you pounds. All our equipment is on demonstration at our showroom in conjunction with a variety of pick-ups, speakers, etc. If you can possibly call we shall be pleased to see and help you.

The New No. 1 "SYMPHONY" AMPLIFIER MARK III is a 3-channel 5-watt Gram/Radio Amplifier with astonishingly flexible tone-control. You can lift the treble, the bass, or—and here is the unique feature—the middle frequencies to suit your own ear characteristics and the record or radio programme being heard. It is thus possible to arrange the frequency-response of the amplifier to a curve equal and opposite to the resultant curve of the other items in the chain so that what finally registers in the brain is as per original. This flexibility of control is even more important than the nominal linear response of the amplifier, as the pickup speaker, etc., are not linear. Independent Scratch-Cut is also fitted and special negative-feedback circuit employed. The Amplifier can accommodate a wide variety of records from old 78s to new L.P.s, and there is full provision for Radio Tuner, Tape take-off and Playback. It is available to match 2/3 or 15 ohms speakers. Price 12 gns. (carriage 5/-). Fitted in portable Steel Cabinet, 2 gns. extra.

The New No. 2 "SYMPHONY" AMPLIFIER MARK III, as No. 1 but with 10-watt Push-pull triode output and triodes throughout. Woden mains and output transformers and choke. Output tapped 3, 7.5 and 15 ohms. Full provision for Tuner and Tape. Competes with the most expensive amplifiers on the market yet costs only 12 gns. (carriage 5/-). Fitted in portable Steel Cabinet 2 gns. extra.

"SYMPHONY" AMPLIFIERS WITH REMOTE CONTROL. Both the above model Amplifiers are available with all controls on a separate Control Panel with up to 4ft. flexible cable which simply plugs into the amplifier. Enables the Amplifier proper to be sat in the bottom of a cabinet whilst the controls are mounted conveniently higher up. Extra cost 2 gns.

No. 1 "SYMPHONY" FM TUNER. High grade instrument with extremely silent background £15/8/- Power Pack £3/7/6.

No. 2 "SYMPHONY" AM/FM TUNER. Combining all the specifications of the Long, Medium and Short wave Superhet AM Tuner and our No. 1 FM Tuner. Separate Coil Assemblies and I.F.s. Fully self-powered on one chassis. 26 gns.

N.R.S. EMPRESS FM/VHF TUNER/ADAPTOR. Fine little job, will plug into any radio and add F.M. £13/15/-. Magic eye assembly £1 extra if required. Ditto mounted in beautiful dark walnut cabinet complete with magic eye 16½ gns. Carriage 7/6.

"SYMPHONY" AM/FM RADIOGRAM CHASSIS. Very high grade radiogram chassis combining Long, Medium and Short and V.H.F. bands. Large engraved dial. Push/pull output for high quality. Complete with 10in. Goodmans speaker 26 gns. Carriage and packing 7/6.

GRAMOPHONE UNITS

COLLARO AC3/554 £9/6/0

Special Bargain. COLLARO RC54.AUTOCHANGER. Price reduced to £9/10/0 (List Price, £13/17/6).

Both complete with Studio 'O', 'P', or 'PX' head.

GARRARD TA and TB £9/0/0

New model RC88 AUTOCHANGER £15/11/4

RC98 £17/10/3

Variety of Pickup cartridges available in Garrard shell to fit. Leaflets on Collaro and Garrard Gram. Units on request.

COLLARO 2010, less pickup, £14/15/-, with Studio pickup and transcription cartridge £19/10/-.

LENCO GL50, 4-speed continuously variable from above 78 r.p.m. to below 16 r.p.m. Special Autostop. Price with Studio "O" or "P" head or Goldring variable reluctance head £21/17/10.

LENCO GL55, as above but without pickup and autostop but fitted with Special Device for Groove Location and knob which completely disengages drive-wheel. Suitable for use with any pickup, especially transcription types and B.J. Arm. Price £17/10/4. Immediate delivery guaranteed.

NORTHERN RADIO SERVICES

11 KINGS COLLEGE ROAD, ADELAIDE ROAD, LONDON, N.W.3.

Phone: PRImrose 8314

Tubes: Swiss Cottage and Chalk Farm. Buses: 2, 13, 31, 113 and 187

LENCO GL56, as GL55 but with pickup, £23/7/-.

CONNOISSEUR 3 variable speeds, £28/8/-.

GARRARD 301, 3 variable speeds, £26/8/-.

"SYMPHONY" RJ ENCLOSURE. In polished walnut 24 in. x 11 in. x 10 in., £9. Super 8CSAL Speaker to suit, 7 gns. Real hi-fi in small space.

"SYMPHONY" BASS REFLEX CABINET KITS.

30in. high, consist of fully-cut ¾in. thick, heavy, inert, non-resonant, patent acoustic board, deflector plate, felt, all screws, etc., and full instructions. 8in. speaker model, 85/-, 10in. speaker model, 97/6, 12in. speaker model, £5/7/6. Carriage 7/6. Ready built, 15/- extra.

As above but fully finished in figured walnut veneer with beautiful moulding and speaker grille, 10in., £11, 12in., £11/10/-. Other veneers to order.

CONSOLE AMPLIFIER CABINETS, 33in. high, lift-up lid with piano hinge, take Tape Deck, Gram Unit or Autochanger, Amplifier, Pre-Amplifier, and Radio Feeder Unit, finished medium walnut veneer. De luxe version, price 12 gns. Oak or mahogany veneers and special finishes to order. Carriage according to area. We will quote by return.

BK

PARTNERS LTD.

introduce



The new Goodsell MA5/UL/C Ultra Linear Amplifier and UL/TC Control Unit - £23.5.6 complete

Details of this high quality 10-12 watt Amplifier and the B K range of splendid loudspeakers enclosures gladly sent on request.

Demonstrations at our showrooms
Daily 10.30 a.m.—5.30 p.m.
Saturdays 10.30 a.m.—12.30 p.m.

Available from us:—
"High Fidelity" — the Why and How for amateurs. By G. A. Briggs, 12/6. Published by Wharfedale.

H.P. TERMS ARRANGED

B. K. PARTNERS LTD.

229 REGENT ST., LONDON, W.1 (Entrance Hanover St.) Phone: REG 7363

Si vous lisez le français technique, demandez un spécimen gratuit de

ELECTRONIQUE INDUSTRIELLE

revue technique publiée par les
EDITIONS RADIO, 9, rue Jacob
Paris 6°—France

A.C. SOLENOID TYPE SA/T



Continuous ¾ lb. at ¾"
Instantaneous to 6 lbs.

100% PRODUCTION INSPECTION

Larger and Smaller Sizes Available. Also Transformers to 6 KVA 3 Phase

R. A. WEBBER LTD.

18 FOREST ROAD, KINGSWOOD, BRISTOL.

PHONE 74065

POST OFFICE TYPE

3,000 and 600 relays
to specification

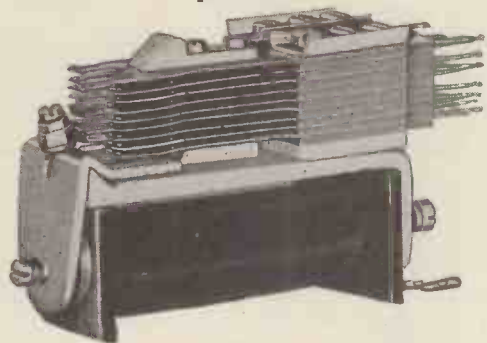

- Specialists in tropical and Services jungle finish
 - GUARANTEED TO FULL A.I.D. & I.E.M.E. STANDARDS
- PROMPT DELIVERIES, PROTOTYPES 7 TO 10 DAYS

Manufacturers to H.M. Govt. Depts. and leading Contractors.

Important Announcement

One Thousand New Types of Electro-Magnetic relays

We have been appointed sole concessionaires for the U.K. and Dominions by the famous French firm of



(Materiel Technique Industriel).

Approved and used by leading European Governments, more than 1,000 different models are available, ranging from operating power of 1 Milliwatt to 1 Kilowatt, with contact arrangements from 1 make or break or changeover to 96 changeovers, and with current carrying capacities of up to 10 amps. per contact.

Publicity matter, illustrated catalogues, technical data sheets and samples will be available shortly. Meanwhile your enquiries are invited.

L. E. SIMMONDS LTD.

5 BYRON ROAD, HARROW, MIDDLESEX Telephone: Harrow 2524 — 0315

When you want to send anything - anywhere...

ABC GOODS TRANSPORT GUIDE

will tell you how

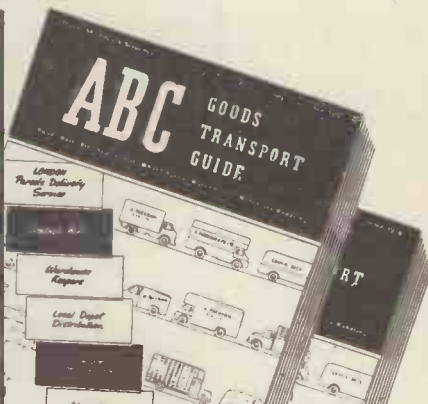

This is the reference book most frequently consulted in the day-to-day work of transport managers, despatch managers and consignors in all industries.

With its help the nearest and quickest means of despatching all kinds of goods can easily be found.

Order your copies of the July-Dec. 1956 and the Jan.-June 1957 issues NOW. And to make sure you're constantly up to date, enter a standing order for all issues as published. We'll invoice you annually in advance.

Published in two half-yearly issues:—

JULY - DECEMBER 1956 · JANUARY - JUNE 1957 **3/6** ★ EACH

★ Each issue 3s. 6d.; postage on each issue (new rates) 1s. 3½d.; packing 2½d

JULY-DEC. READY · ORDER NOW!

Please enter my order for the July-Dec. 1956 and the Jan.-June 1957 issues of ABC GOODS TRANSPORT GUIDE, for which I enclose remittance of 10s.

*Thereafter please continue my subscription until further notice and invoice me annually in advance.
*Delete if not applicable.

NAME
PLEASE USE BLOCK CAPITALS

ADDRESS

..... Date

POST TO ABC GOODS TRANSPORT GUIDE, ILIFFE & SONS, LTD., DORSET HOUSE, STAMFORD STREET, LONDON, S.E.1

ww/8/56

JACKSON

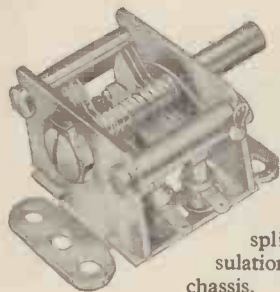

**TYPE
U.101/S.S.**
Cat. No. 5095.

Chassis Mounting
Gang Condenser with
split-stators, ceramic in-
sulation. Cadmium plated
chassis. Silver plated brass
rotor and stator. Rotor earthed
to frame. Capacities available each
half: 3-10 pf., 3.8-27 pf., 4-35 pf. or
4.43 pf. **PRICE 10/9**

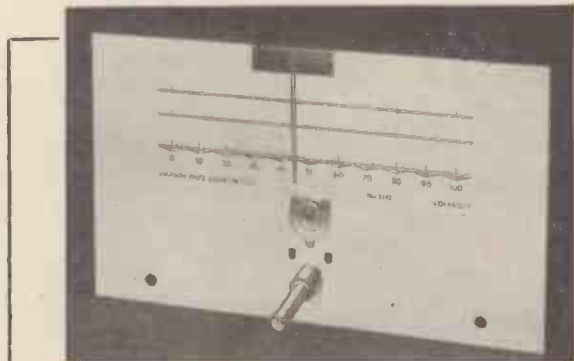

S.L.16 DRIVE RETAIL PRICE 11/6

A general purpose slide rule drive for F.M./V.H.F. units, short-wave converters, etc. Printed in three colours on aluminium, with a 0-100 scale and provision is made for individual calibrations. Travel of pointer 4 3/8 in. Scale plate 7 in. x 4 1/4 in. Scale aperture 5 1/2 in. x 1 1/2 in.

S.L.15 DRIVE RETAIL PRICE 25/6

A complete kit of parts for the construction of the Jackson S.L.15 drive, scale calibrated for the F.M./V.H.F. band.

IT'S RELIABLE—

IF IT'S MADE BY JACKSON'S!



Write for further details:—

JACKSON BROS. (LONDON) LTD. · KINGSWAY · WADDON · SURREY.

Telephone: CROYdon 2754/5.

Telegrams: Walfico, Souphone, London.

TRANSFORMERS

COILS

LARGE OR SMALL QUANTITIES

CHOKES

TRADE ENQUIRIES WELCOMED

SPECIALISTS IN

FINE WIRE WINDINGS

MINIATURE TRANSFORMERS, PICK-UP,
CLOCK AND INSTRUMENT COILS, ETC.
VACUUM IMPREGNATION TO APPROVED STANDARDS

ELECTRO-WINDS LTD.

CONTRACTORS TO G.P.O., M.O.S., L.E.B., ETC.

123-5-7 PARCHMORE ROAD, THORNTON HEATH, SURREY
LIVINGSTONE 2261 EST. 1933

THE WORLD'S GREATEST BOOKSHOP

FOYLES

★ ★ FOR BOOKS ★ ★

NEW AND SECONDHAND Technical Books

Foyles have Departments for Gramophone Records,
Stationery, Handicraft Tools and Materials, Music,
Magazine Subscriptions, Lending Library.

119-125 CHARING CROSS ROAD, LONDON, W.C.2

Gerrard 5660 (20 lines) ★ Open 9-6 (T.burs. 9-7)

Nearest Station: Tottenham Court Road

WESTWOOD'S for the Best goods

GET ALL YOUR

COMPONENTS

(made by The leading mfgs only)

From



WESTWOOD'S

46 George Street

Phone

OXFORD

47783

-towards perfection-

LOWTHER LINEAR AMPLIFIERS

Exclusive Lowther Design and Build



**Lowther Linear Amplifier
LL.10 £25**

The new range "Lowther Linear" amplifiers surpass all previous multi-loop feedback or basic ultra linear technique by the utilisation of the suppressor grid of the Mullard power pentode EL34 into the distributed load circuit which enhances the performance in all detail.

Generous in design, the amplifier's performance will remain at its high laboratory test specification throughout many years of use.

THE LOWTHER MANUFACTURING COMPANY,

LOWTHER HOUSE, ST. MARK'S ROAD, BROMLEY, KENT, ENGLAND.

Tel.: RAVensbourne 5225



**The NEW
THERMIONIC TP100
AMPLIFIER and
REMOTE CONTROL UNIT**



Ready for Autumn Listening!

This superb new 10-watt Amplifier and Control unit will shortly be in your dealer's window. Destined to be the "heart" of all top quality reproducing systems, its performance with a good bass and H.F. speaker combination★ will demand a new evaluation of the term "high fidelity". Be ready to install your TP.100 this autumn—we will send you full technical details on request.

★ *The most modern and efficient H.F. unit obtainable is, of course, the KELLY RLS1 RIBBON LOUDSPEAKER. See your dealer about a Kelly Ribbon—now!*

THERMIONIC PRODUCTS LIMITED
HYTHE · SOUTHAMPTON. Telephone: Hythe 3265/9.

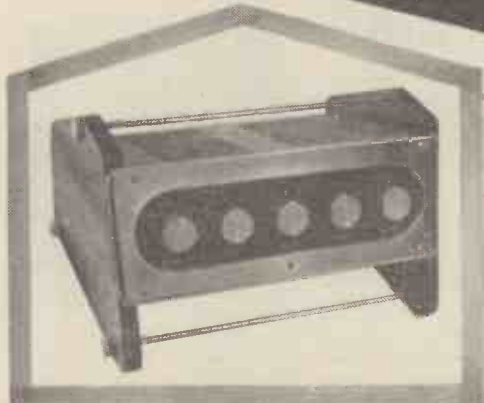



Type 123 200 gns.

A Twin-track Tape Reproducer designed to reproduce the new "Stereosonic" recordings and single track tapes. An instrument calculated to give the connoisseur "high fidelity" of a quality hitherto unattainable. Other models at 100 gns and £165.

Spectone
STEREOPHONIC

TAPE REPRODUCERS

bring
DIMENSIONAL
SOUND
REPRODUCTION
into the home

**The Spectone
WINDSOR
Five-Fifteen**

POWER AMPLIFIER with pre-amplifier. This remarkable equipment based on the famous Mullard 5-10 circuit will meet the most exacting requirements of "high fidelity" at an extremely low price. Treble Control continuously variable from +16 db to -15 db at 10 Kc/s. Bass Control continuously variable from +18 db to -12 db at 20 c/s. £24/17/6.

Write for comprehensive literature.

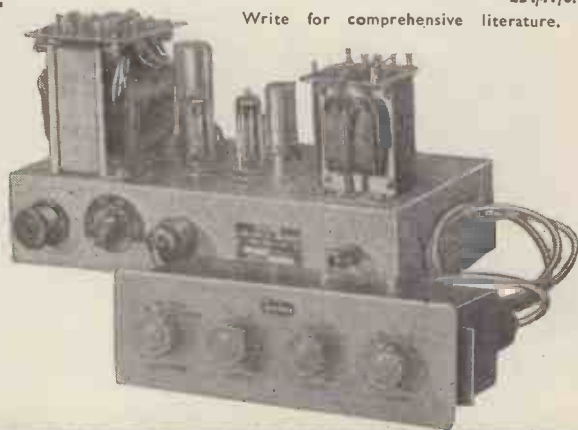

Spectone

The Living Truth
in Sound

SPECTO LTD. Vale Rd Windsor

BUILD ONE OF THESE RADIOS NOW



Total building cost
£5/7/6 including choice,
of beautiful walnut veneered cabinet or ivory or brown bakelite.

This is the lowest possible price consistent with high quality. No radio knowledge whatever needed . . . can be built by anyone in 2-3 hours, using our very simple, easy-to-follow diagrams. This terrific new circuit covers all Medium and Long Waves with optional negative feedback, has razor-edge selectivity, and exceptionally good tone. Price also includes ready drilled and punched chassis, set of simple, easy-to-follow plans—in fact, everything! All parts sparkling brand-new—no junk! Every single part tested before despatching. Uses standard octal-base valves: 6K7G high-frequency pentode feeding into 6J5G anode-bend detector triode, coupled to 6V6G powerful output beam-power tetrode, fed by robust rectifier. For A.C. Mains, 200-250 Volts (low running costs—approximately 18 Watts). Size 12in. x 6in. x 5in. Cost of all parts and set of plans £5/7/6 (plus 3/6 for packing and post). C.O.D. 1/6 extra. Priced Parts list 2/-.



Build this exceptionally sensitive twin-triode radio. Uses unique assembly system and can be built by anyone without any radio knowledge whatever in 45 minutes. Handsome black-crackle steel case with specially made black and gold dial with stations printed. Size of radio only 6 1/2in. x 5in. x 3in. Covers all Medium and Long waves works off throwout aerial (from 6ft. long)—uses one only "Ever-Ready" all-dry battery which lasts many months, as H.T. consumption is only 1 to 1.5 mA. Ideal for Bedroom, Garden, Holidays, etc. Many unsolicited testimonials. Mr. Woods of Boston, writes: "I am quite pleased with the little set I purchased from you. I can get the "Home," "Regionals," "A.F.N." and lots of Foreign Stations. I am very satisfied—it is worth every penny of the price." Cost of all parts, plans—everything down to last nut and bolt, 49/6, including post, packing, etc. (for headphone reception), or send 2/- for priced parts list. Optional extra stage with speaker and button base valve. All fit inside case—costs only 38/6. Post free. Note: We stock complete range of components and valves.
Orders despatched by return.
Limited Quantity — **SEND TODAY!**

49/6

CONCORD ELECTRONICS (Dept. W.W.9)
39, Queens Road, BRIGHTON, I

POLYTHENE

INSULATORS, END CAPS, PLUGS, ETC.

for
T.V. AERIALS

Standard Articles or Special Mouldings

AMPLEX APPLIANCES (KENT) LTD.

19 DARTMOUTH ROAD, HAYES, BROMLEY, KENT
(RAVENSBORNE 5531)

All export enquiries to

ANTEX LTD., 3 TOWER HILL, LONDON, E.C.3

**THE BEAU-BUREAU
MARK III**

This magnificent bureau type cabinet is in specially selected walnut veneer exterior, with a light sycamore lining. It gives you two large-sized storage compartments.

Overall dimensions:
Length 32" Height 34"
maximum depth 16"
minimum depth 11"
Motor board size: 15 1/2" x 13"
Scale aperture size: 10 1/2" x 14 1/2"
NET TRADE PRICE £13.13s.0d.



Plus 15s. Od. carr.
Send for Cabinet List for more details.
Send for our current monthly bulletin of Replacement Radio/Radiogram chassis, Tape recording Equipment, etc.



Trade only supplied
V.E.S. WHOLESALE SERVICES Ltd.
Dept. (W.W.), 11, Gunnersbury Lane, Acton, W.3 Tel.: ACOrr 5027

We're flying high, Mr. Ash!

And digging deep, Mr. Downs!

We're a versatile team, aren't we?

Let's explain Mr. Downs.

Easy. Ashdowns fabricate plastics which are essential equipment of the highest flying aircraft and of the miner in the deepest mines.

But not the same plastic!

Of course not! Every use calls for a particular plastic material and design specifically for that use.

And that's exactly what ASHDOWNS do — design and fabricate the right plastic material for each particular use.

And do it very well, if I may say so.

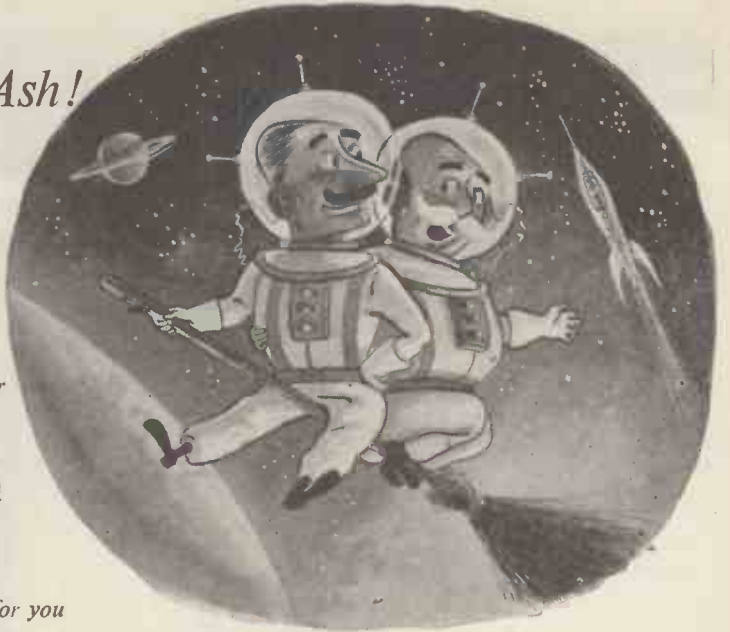

If you want to know what Plastics can do for you

ask Ashdowns

Makers of "ASHLAM"™ laminates, vacuum formed thermoplastic sheet fabrications, glass fibre reinforced laminates and mouldings, "UNDULITE"™ reinforced translucent sheeting. Ashdowns is a subsidiary of Pilkington Brothers Limited. *Registered Trade Marks.

ASHDOWN'S LIMITED, ECCLESTON WORKS, ST. HELENS, LANCs. TELEPHONE: ST. HELENS 3206
LONDON OFFICE: 29/30 ST. JAMES'S STREET, LONDON, S.W.1. TELEPHONE: WHITEHALL 6002

TELCON CELLULAR POLYTHENE INSULATED DOWNLEADS

This new range of 75 ohm coaxials has been especially designed for the reception of Band II (FM sound 87.5 - 100 Mc/s.) and Band III Television 174-216 Mc/s.).

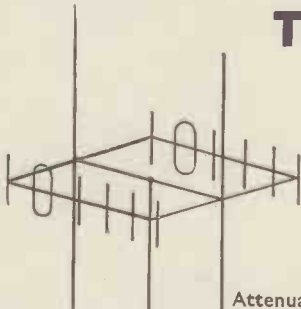

Attenuation db/100 ft.

10 Mc/s.
50 "
100 "
200 "

ET5M	ET6M	ET7M	ET8M	ET10M
1.3 ... 1.5 ... 1.0 ... 1.1 ... 0.6	3.0 ... 3.4 ... 2.3 ... 2.6 ... 1.5	4.3 ... 4.8 ... 3.2 ... 3.6 ... 2.2	6.3 ... 7.2 ... 4.9 ... 5.3 ... 3.3	

Dimensions (inches)

Centre Conductor	1/0.022	7/0.0076	1/0.029	7/0.010	1/0.044
Over Cellular TELCOTHENE	0.093 ... 0.093 ... 0.128 ... 0.128 ... 0.200	0.117 ... 0.117 ... 0.152 ... 0.152 ... 0.230	0.157 ... 0.157 ... 0.202 ... 0.202 ... 0.290		

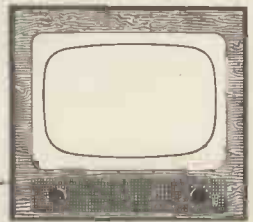
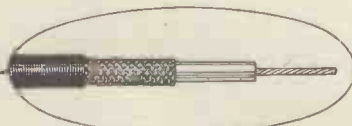

please ask for a copy of Publication TV5

THE TELEGRAPH CONSTRUCTION & MAINTENANCE CO. LTD., TELCON WORKS, GREENWICH, S.E.10. TEL. : GREENWICH 3291
BRANCHES : BIRMINGHAM. CARDIFF. LONDON, MANCHESTER, NEWCASTLE AND NOTTINGHAM.

CLYNE RADIO LTD.



18, TOTTENHAM COURT ROAD, LONDON, W.1.

MUSEum 5929/0095.

(50 yards only from Tottenham Court Road Tube !)

All post orders please to:—24-26, HAMPSTEAD RD., LONDON, N.W.1

EUSton 5533/4/5

TELETRON BAND III CONVERTOR! Still available, this very popular convertor kit as illustrated and fully described in previous issues of the "W.W." For use with most T.R.F. or Superhet Band I T.V. Receivers. Construction details only, with separate individually priced parts list 6d. post free. Kit complete as specified 48/6, plus 2/- P. & P.
Mk. II Fringe area version kit complete 58/6, plus 2/- P. & P. Power pack kit for either of above 25/-.
 We carry comprehensive stocks of all Band III Convertors by leading manufacturers. Also aerials, cross-over boxes, air-spaced low-loss co-axial cable at 10d. per yard. Let us have your enquiries. Any branded convertor supplied on H.P. terms!

THE JASON F.M. TUNER

Based on the booklet by Data Publications Ltd., 2/- post free, including our individually priced Parts List. Highly sensitive, free from drift. Incorporates 4 valves 6AM5 and 2 specially graded G.E.C. Crystals. The kit supplied includes drilled chassis with tuning condenser, scale calibrated in mc/s., and attractive bronze stove-enamelled front plate already mounted (illustrated). Front plate size 8in. x 5in., chassis 7in. x 4 1/2in. x 1 1/2in. Complete standard kit 26/15/- plus 2/6 p. and p. Fringe area kit 27/15/-, plus p. and p.

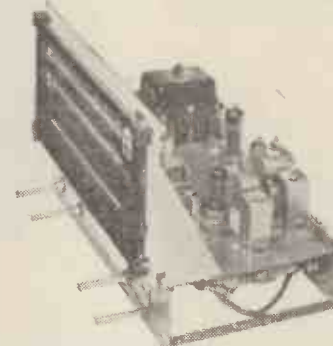
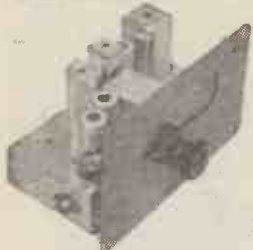

AM/FM RADIOGRAM CHASSIS! BARGAIN!

A special purchase of strictly limited quantity enables us to offer the following! For Medium, Long and F.M. Wavebands, plus gram position... Chassis size overall 13 1/2in. long, 9in. high, 7 1/2in. deep. Dial which is attractive red, green and gold lettering, on black background, measures 12in. x 5 1/2in. horizontal. For A.C. mains, 200/250 v. Valve line-up EL84, EABC80, EF85, ECH81, ECC85, EZ80, plus EM80 Magic Eye!! Limited quantity at bargain price of £18/19/6 only, plus 5/- P. & P. H.P. terms.

THE T.S.L. F.M. TUNER!

We can now supply this FM/VHF adaptor either in kit form, or fully assembled, wired and tested. Our price for the ready-built unit which incorporates its own power supply, is £15/15/- only tax paid, plus 6/- P. & P. or H.P. terms. Magic eye tuning indicator, just plug in, 19/- extra. Or the kit complete as specified £10/19/6 plus 3/6 P. & P. The booklet "F.M. TUNER CONSTRUCTION" (32 pages) with full technical data and point-to-point wiring diagrams, together with our separately priced parts list, is available at 2/6 post free.



THE T.S.L. AM/FM CHASSIS!

Exceptional value. Covers L.M. and S.W. plus F.M.! 8-valve push-pull output. Ferrite rod aerial. Valve line-up: ECC85, ECH81, EF89, EABC80, EOC82, two 6BW6s plus 5Y3. Large full-vision dial, size 1 1/2 x 6in. Chassis size, overall: 15 x 7 1/2 x 8in. high. Tax paid 26 guineas, plus 5/- packing and carriage. A supplementary extra is magic eye EM34, complete with scotchcon and fixing cable at 26/- H.P. terms available. Demonstrations at 18 Tottenham Court Road!

THE DULCI F.M. TUNER. Incorporates own power supply, suitable for use with any amplifier. Valve line-up: ECC85, two EF89, EABC80, 6 x 4, and EM80 indicator! Overall size: 9 x 6 x 5 1/2in. high. Pre-Budget price £16/16/- plus 5/- P.P. Illustrated leaflet available, also H.P. terms.

SPECIAL OFFER!! Champion Model 835 FM/VHF Adaptor! Designed for the instant conversion of A.C. radiograms, table A.M. receivers and Hi-Fi audio amplifiers, to enable owners through their existing equipment to obtain the best results from the new F.M. transmission. Two connections only. One to the A.C. mains supply, the other to the pick-up sockets. Valve line-up: EF85, two EF90s, EB91, and E250. In attractive red and cream bakelite cabinet. Illustrated leaflet available on request. Price whilst stocks last only £13/19/6 tax paid, plus 3/6 P. & P. H.P. terms available.

DENCO F.M. TUNER. This highly successful kit is still available at inclusive price of 26/7/6 plus 2/6 P. & P. This kit includes all components and the five valves required for the extra I.F. Stage for fringe area reception. If required, "Denco" dial and drive assembly is available for the above at 9/- extra. Full constructional details 1/3 post free.

F.M. POWER PACK KIT. We can now supply complete kit for power pack suitable for the above F.M. tuners or any other similar type. Price for the complete kit is 37/6 only, or 52/6 for ready assembled unit. This pack is extremely small, incorporating valve resistor type 6X4 and built on chassis size only 6 x 4 x 1 1/2in. Optional extra for power pack. Bulbin Octal Plug 2/3.

THE R.E.P. 1-VALVE RECEIVER. All dry battery operation, for use with headphones. The complete kit is available at 42/-, less batteries, plus 2/- P. & P., or full instructions at 9d. post free.

COMPETITIVE!! BAND III. CONVERTORS!



Type "M.L." for running from existing power supplies or separate power pack. Available with Series Heaters. Valve line-up: ECC84 and PCF-80. Size: 4 x 2 1/2 x 4 1/2in. Mounted with external fine tuning control for Band 3 and Band 1/3 change over switch. Separate contrast control for Band 3. Power requirements H.T. 150/250 v. at 30 mA., L.T. 15/16 v. 3 amp. (Series Heaters). Unit simply fitted inside cabinet. Complete with handsome scotchcon. Available for A.C. operation with parallel heaters, ECC84 and ECF90 as above. Price £4/12/6. P. & P. 2/6. Full instructions supplied with each unit. Please specify whether for London, or Birmingham, or Manchester.

THE FAMOUS INVERTER—COMPARE THE PRICE

Handsome walnut cabinet. Suitable all areas. Contains own power supply. Simply connect to aerial. Four-valve circuit. Complete with all instructions 26/19/6 plus 3/6 P. & P.

Our advantageous H.P. terms are available on any single item over £5. Let us have your enquiries.

DULCI AM/FM CHASSIS H4

Illustrated leaflet available. L.M. and Short Waves plus F.M. This is a quality chassis 6 latest B.V.A. Mullard Valves, including magic eye. High Q. Inductances throughout, also Ferrite rods. Price is £27/16/- cash—or H.P. terms.

DULCI AM/FM TUNER

Just released. Details available. Price £24 including tax, or H.P. terms.

AM/FM KIT! FIRST AGAIN!

Introducing the JASON AM/FM KIT for medium waves and F.M. 1. As illustrated this is a very high quality chassis incorporating 8 of the latest miniature valves, plus DM70 magic eye. Kits are available for chassis complete with output stage at £15/5/-. Also less output stage but with own built-in power pack at £13/19/6 only. These are high fidelity units and exceptional value at these prices which include all required components and full constructional details. Fully illustrated Data Booklet with full construction details, plus individually priced component list, available per return of post at 2/- post free. Both plus 3/6 P. & P.

SPECIAL PURCHASE! MANUFACTURER'S SURPLUS!

Owing to favourable purchase, we can offer strictly limited quantity of these handsome chassis. AC/DC 200/250 v. for Medium and Long Waves, plus gram position... Incorporates own frame aerial. Valve line-up: U107, K108, DE107, W107 and X109. Overall chassis size 12 x 5 1/2 x 7 1/2in. high. Attractive bronze dial with gold and cream lettering. Dial size 1 1/2 x 4 1/2in. Scale length 7/16in. Logging scale provided. Price £27/19/6 only, tax paid, plus 3/6 P. & P. H.P. terms. £4 deposit plus four monthly payments of 22/-.

THE R.C. GRAM REPLACEMENT CHASSIS KIT

Still available. Our very popular Gram Chassis replacement kit. For long, medium and short waves, and provision for gram. Valves 6K8, 6K7, 6Q7, 6V6 and 6X5.

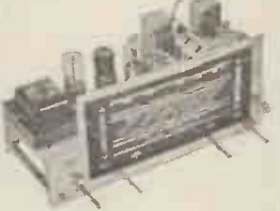

For A.C. Mains 200/250 v. Chassis size: 13 1/2in. x 5 1/2in. x 2 1/2in. Dial size 1 1/2in. x 4 1/2in. Assembly is simplified by use of ready assembled coil pack. Illustrated booklet with full assembly instructions, with itemised price list, is 1/6 post free—or the kit complete to last nut and bolt at £8/8/- plus 2/6 P. & P.

THE R.C.3/4 WATT AMPLIFIER KIT

Just released! Compare the advantages! Treble bass, AND middle controls! For crystal or magnetic pickup! A.C. Mains 200/250 v. Valve line-up, 6V6GT, 6SQ7, metal 6X5GT. Negative feedback. Built on stove enamelled steel chassis, measuring only 8in. x 4in. x 1 1/2in. Four engraved cream knobs are included in the price of the complete kit with all necessary practical and theoretical diagrams, at 24/5/- only, plus 2/6 packing and post, or Instruction Book fully illustrated, for 1/- post free! This amplifier can be supplied assembled, tested, and ready for use at 25/5/- plus p. and p. Hearing is believing.

ACOS TYPE 7 Crystal Microphone Inserts Brand new. 7/6 each, post free.

Please add postage under £1, or Cash with order. C.O.D. charge extra—open 9 a.m. to 6 p.m. Monday to Friday. Sorry but we close 1 p.m. on Saturday.

THE "ECONOMY FOUR" T.R.F. KIT.

three-valve plus metal rectifier receiver. A.C. mains 200/250 v. Medium and Long waves. We can supply all required components right down to the last nut and bolt. Valve line-up 6K7, 6J7 and 6V6. Chassis ready drilled. Cabinet size 12in. long by 6in. high by 3in. deep—Choice of Ivory or brown Bakelite, or wooden walnut finish cabinet. Complete instruction booklet with practical and theoretical diagrams. Each component brand new and tested prior to packing. Our price £5/10/- complete—Remember this set is being demonstrated at our shop premises! We proudly claim that our fully illustrated instruction booklet is the most comprehensive available for this type of receiver—Booklet available at 1/6 post free. This is allowed if kit is purchased later. Plus 2/6 packing and carriage for complete kit.



N.B. All our T.R.F. Kit circuits now include specially wound Denco "Maxi-Q" coils on polystyrene formers, improved performance. Price remains the same.

THE "SUPERIOR" FOUR KIT. Our new four-valve receiver. A.C. mains, 200/250 v. M. and Long waves. As with our very successful "Economy Four" all required components are supplied. Valve line-up: 2 6SG7, 6 X5GT and 6 V6GT. Chassis ready drilled. Cabinet size, 10 1/2in. x 10in. wide. Maximum depth at base 5in. tapering to 3 1/2in. at top. Sloping front. Very attractively finished in light walnut and peach. Each component brand new and tested prior to packing. Complete instruction booklet with practical and theoretical diagrams is provided. Booklet available at 1/6 post free. Our price for complete kit, £5/9/6. Please add 2/6 packing and carriage. If preferred, we can supply Cabinet Assembly only, comprising Cabinet and bracket wave-change switch, dial, pointer, drum pulleys, drive spindle, drive spring and knobs, at 45/-, plus 2/6 packing and carriage. N.B.—Our kits are even supplied with sufficient solder for the job.

THE R.C. RAMBLER ALL-DRY PORTABLE KIT

Full assembly details with practical and theoretical diagrams can be supplied at 1/6 post free. This is a truly professional 4-valve superhet—all dry—for medium and long waves. A cream plastic top panel, with dial engraved in red and green adds to the very imposing appearance of this model which is housed in an attractive cream and grey leatherette covered attache-case type cabinet measuring only 9in. x 7in. x 8 1/2in. Weight less batteries 4 1/2lb., with batteries 6 1/2lb. This set really has everything. Built-in frame aerial, high quality, extremely sensitive, and very adequate volume from the 5in. speaker. Valve line-up 3V4, 1R5, 1R5, 1T4. Also the required components, exactly as specified, including cabinet, can be supplied from stock at the special exclusive price of £7/7/- plus 2/6 p. and p. (less batteries). Uses Ever-Ready 90 v. H.T. type B126 at 10/. Also LT. 1.5 v. A.D. 35 at 1/6.



RAMBLER MAINS UNIT! At last we are able to offer our special mains units kit for using our popular all-dry "Rambler" on A.C. Mains. Complete kit, which when assembled fits snugly into battery compartment, can be supplied at 47/6, plus 1/6 packing and postage. Price includes all required components, and full assembly instructions. N.B.—This unit is completely self-contained in a metal box measuring 2 1/4 x 2 1/4 x 1 1/4 in. and is ideally suitable for ANY all-dry battery portable requiring 90 v. H.T. and 1.5 v. LT.

B.S.R. MONARCH. The very latest cream 3-speed mixer Auto-changer. Complete with turn-over crystal pick-up. Complete in original manufacturer's cartons. Fully guaranteed. Price only £7/19/6 Carriage Paid. Buy now! Quantity at this price strictly limited.

JUST ARRIVED! Replacement pick-up cartridges for B.S.R. Monarch, etc. type HGT 37. Complete with sapphire stylus, fitted in few seconds. Limited quantity at 18/6 only! Tax paid, post free!

R.C.54. Special Purchase! Latest type 3-speed, incorporating "T" type turnover head. Cream finish. Original manufacturer's cartons. £9/19/6 only, plus 3/6 p. and p. H.P. terms available.

RECORD PLAYER CABINETS. Specially made to house any type of single record unit. Finished in dove-grey leatherette. Base-board measuring 14 1/2 x 12 1/2 in. Clearance above and below board 3in., 4 1/2- plus 3/4 p. & P. We can also supply equally attractive dove-grey cabinet to house any standard auto-changer at £9/6 plus 3/4 p. & P. We carry a large selection of cabinets for all purposes. A stamp will bring illustrated cabinet leaflets.

R.F. UNITS. All new condition and complete. Case size 9 1/2in. x 7 1/2in. x 5in. Type 24, 20-30 Mc/s. 3/6. Switched Tuning. Type 25, 40-50 Mc/s. 1/6. Switched Tuning. Type 26, 50-65 Mc/s. Variable Tuning, 2/6. ALL these units Post Free.
EX-W.D. CATHODE RAY TUBES. Guaranteed full picture. VCR97 at 40/- VCR517C at 35/- Also VCR189A—Ideal for oscilloscope 2 1/2in. screen at 35/- We also have VCR97 with slight cut-off very suitable for oscilloscope, testing purposes, etc., at 15/- only. All these tubes are brand new, in original packing, and tested before despatch. Please add 2/6 packing and carriage for any of the above tubes.

MUTUAL SCREEN FOR VCR97. Price 10/- post free.

MAINS TRANSFORMER BARGAINS. Limited quantities. Manufacturers' Surplus. 250-0-250, 80 mA., 6.3 v. 3 a., 5 v. 2 a. Half shielded, drop-through, 14/6 only, plus 1/6 p. & P. 230 v. Input, 300-0-300 80 mA., 6.3 v. 3 a., 4 v. 2 a. Tropicalised drop-through type, 9/6 only, plus 1/6 p. & P. Input 110/230 v. Auto load 230 v. 750 mA., 350-0-350 130 mA. Tapped filament winding 6.3 v. 3 a., 15 v. 2 a., 21.5 v. 2 a., also 5 v. 2 a. Tropicalised drop-through type, 21/- plus 2/6 p. & P. 270-0-270, 100 mA., 6.3 v. 3 a., 5 v. 2 a., 200/250 v. Input universal mounting 16/6, plus 1/6 p. & P.

6-VOLT VIBRATOR PACK. Ex-W.D. 6-volt input, output 140 v. 30 mA. Fully smoothed and rectified, incorporating Wearite 6 volt 4 pin vibrator type NSB6. Unit size only 6 1/2in. x 5in. x 2 1/2in. Price 15/- plus 1/6 p. & P. 230 v. Input. **RECEIVER TYPE 2573.** (The receiver section of TR1196). Supplied complete with full data for conversion to 3-wave superhet receiver. Unit is complete with 6 valves 2-EP39, 2-EP36, FK32 and EBC33, also standard I.C.T.'s 465 Kc/s. Price 27/6 plus 2/6 p. & P.

TR1196 TRANSMITTER PORTION. We can also supply the transmitter portion of the above receiver incorporating valves, transformer, coils, switches, etc. Limited quantity at 12/6 only, plus 2/6 p. & P.
HEADPHONES. Low resistance. Brand new Ex-W.D. type CLR. 7/6 per pair, plus 1/6 p. & P. High resistance, 4000 ohms, brand new lightweight 15/- per pair, plus 1/6 p. & P.

VALVES
We have perhaps the most up-to-date valve stocks in the trade. A stamp will bring complete list but the following is a selection only of brand new imported valve types, fully guaranteed. Purchase Tax Paid.

EAB080 10/-	DAP65 10/6	PL83 11/6
EAF42 10/-	DF96 10/6	PY80 10/6
EB41 7/6	DK92 10/6	PY81 10/-
EB91 7/6	DK96 10/6	PY82 9/6
EBC41 10/-	DJ66 10/6	PY83 11/6
EBF80 11/6	or 39/6 per set	UBC41 10/6
ECC81 9/-	of four	UCB41 11/6
ECC82 9/-	DM70 9/-	UF41 10/6
ECC83 9/-	EL41 10/6	UL41 10/6
ECC84 15/-	EL84 11/6	UY41 9/6
ECC85 10/-	EM80 8/-	GAQ5 8/6
ECH42 15/-	EY51 12/6	GAT8 8/-
ECH42 11/6	EY86 14/6	GAU6 9/6
ECB81 11/6	EZ40 8/6	6BA6 8/6
ECL80 11/6	EZ80 8/6	6BE6 9/-
EP41 10/6	PCF80 12/6	6BW6 8/6
EP80 10/6	PCP82 12/6	6X4 7/6
EP85 10/6	PCS84 12/6	6X4 7/6
EP86 12/6	PL81 13/6	60B5 10/-
EP89 10/-	PL82 10/6	50C5 10/-

In addition we naturally have all usual surplus types available such as 6V6GT, etc. All in our valve price list!

BRAID NEW C.R. TUBES.—By leading manufacturer, 12in. equivalent to MW 31/74 £11/19/6. MW36/24 Tinted. Latest type 14in. rectangular 6.3 v. heater. 12-14 Kv. in original sealed cartons. Limited quantity only at £12/19/6. Ditto 17in. type 17ASP4. Price £18/19/6. All H.P. available. Plus 15/- packing, carriage and insurance

TRANSISTORS: MULLARD TYPE OC.7L
Available ex stock at new list price of 24/- each, post free.



Another Cabinet Bearer. Special purchase of walnut veneered trolley-type cabinets originally intended for use in projection T.V. Easily recognised as being of leading High quality manufacturer's stock, heavy dark solid walnut. Can be easily adapted to house tape recorder, amplifier, radiogram, etc., etc. Measurements external 24 1/2in. x 16 1/2in. x 29in. The whole is mounted on castors. Unrepeatable bargain at £25/19/6, plus 10/- packing and carriage. We have a large selection of all type cabinets. A stamp will bring list.

SURPLUS BARGAINS

METERS

F.S.D.	Size	Type	Fitting	Price
50 microamps	D.C. 2 1/2in.	M.C.	B.P.	50/-
50 microamp	D.C. 3 1/2in.	M.C.	F.R. (Tropicalised)	55/-
50 microamp	D.C. 5in.	M.C.	Rectangular	120/-
50 microamp	D.C. 4in.	M.C.	Rectangular	110/-
50 microamp	D.C. 3 1/2in.	M.C.	F.R.	95/-
100 microamp	D.C. 2 1/2in.	M.C.	F.R.	45/-
200 microamp	D.C. 2 1/2in.	M.C.	F.R. (Tropicalised)	30/-
200 microamp	D.C. 3 1/2in.	M.C.	F.R.	65/-
500 microamp	D.C. 2in.	M.C.	F.R.	160/-
1 mA.	D.C. 2in.	M.C.	F.R.	178/-
1 mA.	D.C. 2 1/2in.	M.C.	F.Sq.	22/6
1 mA.	D.C. 2in.	M.C.	F. Ellott (1954 manufacture by Elliott)	25/-
1 mA.	D.C. 2 1/2in.	M.C.	Desk Type	30/-
5 mA.	D.C. 2in.	M.C.	F. Sq.	10/-
50 mA.	D.C. 2in.	M.C.	F. Sq.	8/6
150 mA.	D.C. 2in.	M.C.	F. Sq.	7/6
500 mA.	D.C. 2 1/2in.	M.C.	F.R.	10/6
1 amp.	R.F. 2in.	Thermo	F. Sq.	8/6
1 amp.	R.F. 2 1/2in.	M.C.	F.R.	10/-
120-0-120 amp.	D.C. 2in.	M.C.	F. Sq. (shunt required)	15/-
150 amp.	A.C. 4in.	M.I.	R.P.	45/-
1 amp.	R.F. 2 1/2in.	Thermo	R.P.	7/6
3 amp.	R.F. 2in.	Thermo	F. Sq.	6/6
5 amp.	D.C. 2in.	M.C.	F. Sq.	13/-
20 amp.	D.C. 2in.	M.I.	R.P. (with shunt)	10/6
25 amp.	D.C. 2 1/2in.	M.C.	F.R.	8/6
30 amp.	D.C. 2 1/2in.	M.I.	F.R.	12/6
15 volt	A.C. 2 1/2in.	M.I.	F.R.	10/-
15 volt (5 mA.)	D.C. 2in.	M.C.	F. Sq.	7/6
15-0-15 volt	D.C. 2 1/2in.	M.C.	F.R.	17/6
30-0-30 volt	A.C. 2 1/2in.	M.C.	F.R.	35/-
2 1/2in. ROUND FLUSH MOUNTING METER by WESTON, blank scale ready for re-engraving, PSD 650 micromps, brand new, 27/6 only.				

SPECIAL. U.S. 0-1 mA. 2in. taken from equipment but perfect, 22/6 each. R.P. = Round Projection, M.C. = Moving Coil, Thermo = Thermo-coupled, F. Sq. = Flush Square, F.R. = Flush Round, M.I. = Moving Iron.

METER RECTIFIERS, 1 mA. by G.E.C., at 6/6, also 5 mA. by G.E.C., at 6/6.

METER SPECIAL We have a limited quantity of aircraft electrical thermometers. Brand new by Weston. 2in. moving coil meter, flush square fitting. These meters have a luminous scale graduated 40-140 degrees centigrade, but the full scale deflection is approximately 150 micromps. Price 12/6 each only, plus 1/6 p. & P.

VIBRATOR PACK. Brand new by Mallory 230 volt input, 150 v. 40 mA. output. Complete with synchronous vibrator, 17/6.
COIL PACKS. Manufacturers' Surplus. Miniature size, only 2 1/2in. x 2 1/2in. x 1 1/2in. deep. Iron-cored. For L.M. and S.W. with gram. position switch, has 24-pin spindle! Absolutely brand new, complete with circuit. Price only 27/6, plus 1/6 p. & P. A snip!

AMERICAN INDICATOR UNIT TYPE BC928A. Brand new incorporating 3in. tube 3BP1, with mu-metal shield, 2-68N7GT 2-6HGCT, 6X50, 2X3, 606G, 9 potentiometers, 24 v. transformer, and a host of small components. The whole unit, which measures only 8 1/2in. x 8 1/2in. x 1 1/2in., is brand new, enclosed in black crackle box, and can be supplied at 45/-, plus 5/- p. & p.

We also have available "33" sets, absolutely complete with junction box, aerial, headphones, microphone, spare set of valves, with full operating instructions, absolutely brand new in original sealed packing cases, at 99/6 each complete station, plus 5/- carriage. Export enquiries invited.



No. 38 TRANSMITTER/RECEIVER WALKIE-TALKIE. Range approx. 5 miles. Coverage 7.4-9 Mc/s. The set only complete with valves at 25/-, in very good condition.

POWER PACK. By leading manufacturer. Input 200/250 v. Output 350-0-350 250 mA., 6.3 v., 8 a., 6.3 v. 2 a., 4 v. 7 a., 5 v. 2 a. Fully smoothed. Incorporates valve rectifier G232. Chassis measures 1 1/2in. x 7in. x 5 1/2in. Wt. 22lb. Few only at £4/19/6, plus 2/6 p. and p.

RAYNE RADIO LTD.
18, Tottenham Court Road, London, W.1.

R.S.C. BATTERY CHARGING EQUIPMENT

All for A.C. MAINS 200-250v., 50 c/s. Guaranteed 12 months.

ASSEMBLED CHARGER v. or 12 v. 2 amps.

Fitted Ammeter and selector plug for 6 v. or 12 v. Louvred metal case, finished attractive hammer blue. Ready for use with mains and output leads. Double Fused.



Only **46/9** carr. 3/6.

ASSEMBLED CHARGERS

- 6 v. 1 amp 19/9
 - 6 v. or 12 v. 1 amp. 25/9
 - 6 v. 2 amps. 29/9
 - 6 v. or 12 v. 2 amps. 38/9
 - 6 v. or 12 v. 4 amps. 56/9
 - Above ready for use. Carr. 2/9
- ### HEAVY DUTY KIT
- 12 v. 30 amp. Suitable for garage or firm with a number of vehicles. Mains input 200/250 v. 50 c/s. Outputs 12 v. 15 amp. twice. Consists of Mains Trans. 2 Metal Rectifiers. 2 Meters. 4 Fuses. 4 Terminals. 2 Rheostats and circuit. Only 9 gns., carr. 15/-.

BATTERY CHARGER KITS

Consisting of Mains Transformer, F.W. Bridge, Metal Rectifier, well ventilated steel case, Fuses, Fuse-holders, Grommets, panels and circuit. Carr. 2/6 extra.

BATTERY CHARGER KIT

Consisting of F.W. Bridge Rectifier 6/12 v. 5 a. Mains Trains, 0-9-15 v. 6 a. output, and variable charge rheostat with knob. Only 45/9. Post 3/-.



Assembled 6 v. or 12 v. 4 amps.

Fitted Ammeter and variable charge selector. Also selector plug for 6 v. or 12 v. charging. Double fused. Well ventilated steel case with blue hammer finish. **69/6** Ready for use with mains and output leads. Carr. 3/6.

SELENIUM RECTIFIERS

- | | | |
|-----------------------|------------------------|------------------------|
| L.T. Types | 6/12 v. 6 a. ... 19/9 | 6/12 v. 10 a. ... 25/9 |
| 2/6 v. 1 a.h.w. 1/9 | H.T. Type H.W. | |
| 6/12 v. 1 a.h.w. 2/9 | 120 v. 40 mA. ... 3/9 | |
| F.W. Bridge Types | 250 v. 50 mA. ... 5/9 | |
| 6/12 v. 1 a. ... 5/9 | 250 v. 80 mA. ... 7/9 | |
| 6/12 v. 2 a. ... 8/9 | 250 v. 150 mA. ... 9/9 | |
| 6/12 v. 3 a. ... 12/9 | 300 v. 275 mA. 12/11 | |
| 6/12 v. 4 a. ... 16/9 | | |

CO-AXIAL CABLE. 75 ohms, 4in., 8d. yard. Twin screened feeder, 11d. yard.

5 CORE FLEX. Henleys circular rubber 14/36. Each lead colour coded. 1/6 yd.

T.V. CABINETS. For 15, 16 or 17in. tube. Table model with doors, 79/6, carr. 7/6. Table type for 12in. tube, 27/6, carr. 5/6. All leading manufacturers surplus.

SILVER MICA CONDENSERS. 5, 10, 15, 20, 25, 30, 35, 50, 100, 120, 150, 180, 200, 230, 300, 330, 400, 470, 500, 1,000 pfd. (.001μF), .002 mfd. (2,000 pfd.). All at 6d. each, 3/9 dozen one type.

DIAL BULBS, M.E.S., 8 v. 0.2 a., 6/9 doz. 6.5 v. 0.3 a., 6/9 doz.

ELECTROLYTICS (current production). NOT Ex Govt.

Tubular Types		Can Types	
8μF 450v. 1/9	8 mfd. 350 v. ... 1/3	8 mfd. 500 v. 2/6	8 mfd. 600 v. ... 2/11
16μF 350 v. ... 2/3	16 mfd. 350 v. ... 1/11	16μF 450 v. 2/9	16 mfd. 500 v. ... 3/9
16μF 450 v. 2/9	32μF 350 v. 2/11	32μF 450 v. 4/9	32 mfd. 450 v. 4/9
16μF 500 v. 3/9	32 mfd. 450 v. 4/9	32μF 500 v. 4/9	8-16μF 450 v. 2/9
32μF 350 v. 3/9	32 mfd. 450 v. 4/9	32μF 450 v. 4/9	8-16μF 450 v. 2/9
32 mfd. 500 v. ... 5/9	8-16μF 450 v. ... 2/11	16-16μF 450 v. ... 3/11	16-32μF 350 v. ... 4/9
8-16μF 500 v. ... 4/11	16-16μF 450 v. ... 3/11	16-32μF 350 v. ... 4/9	32-32μF 450 v. ... 5/9
25μF 25 v. 1/3	16-32μF 350 v. ... 4/9	32-32μF 450 v. ... 5/9	64-120 mfd. 350v. 7/6
50μF 12 v. 1/3	32-32μF 450 v. ... 5/9	64-200 mfd. 275 v. 6/11	
50 mfd. 25 v. ... 1/9	100 mfd. 450 v. ... 4/9		
50μF 50 v. 1/9	8-8μF 450 v. 2/9		
100 mfd. 12 v. ... 1/9	8-16μF 450 v. 2/9		
100 mfd. 25 v. ... 2/3			

Many others in stock.

VOLUME CONTROLS with long spindles, all values, less switch, 2/9; with S.P. switch, 3/9.

VIBRATORS. Oak 2 v. 7 pin, synchronous, 7/9.

EX GOVT. E.H.T. CONDENSERS
.5 mfd., 2,500 v. Blocks 3/9
.1 mfd. plus 1 mfd. 8,000 v., large blocks (common negative isolated) 9/6

EX GOVT. METAL BLOCK PAPER CONDENSERS
2 mfd. 500 v. ... 1/9
4 mfd. 500 v. ... 2/8
8 mfd. 500 v. ... 5/9
4 mfd. 400 v. plus 2 mfd. 250 v. 1/11

EX GOVT. VALVES. VR137, EA50, EB34, 11d.; SP61 2/3; 4SHA 1/3; EL32 3/9; 6X5 4/9.

EX GOVT. UNITS, type RDFI in original sealed cartons with 14 valves including 3Z4G, etc., trans., L.F. choke, Rectifier, etc., etc. We cannot enter into correspondence regarding these units which represent a really exceptional bargain at 29/9. Carr. 7/6.

CONTROL PANEL with 1 six-position 3-waffer Xaley switch, 1 pointer knob. 2 S.P.S.T. switches, various plugs and sockets. Only 1/6.

OIL FILLED BLOCK CONDENSERS

Bryce 11-7 mfd. 500 v. New unused Govt. surplus, only 5/9 each.

EX GOVT. MAINS TRANSFORMERS

- All 230 v. 50 c/s. input
- 8.8 v. 4 a., 9/9. 120-0-120 v. 40 mA. ... 5/9
- 300-0-300 v. 150 mA. 4 v. 3 a. 9/9
- 250-0-250 v. 60 mA. 6.3 v. 2 a., 5 v. 2 a. ... 11/9
- Potted 44-34-3in. 11/9
- 460 v. 200 mA., 6.3 v. 5 a. 22/9
- 0-16-18-20 v. 35 a., 79/6. Carriage 5/- extra.

MANUFACTURERS SURPLUS TRANSFORMERS

Fully shrouded upright. Primary 200-230-250 v. Sec. 425-0-425 v. 150 mA. 6.3 v. 3 a., 5 v. 3 a., 33/9. Clamped type 325-0-325 v. 100 mA. 6.3 v. 3.5 a., 5 v. 2 a. Wearite 19/9. Post 2/9.

R.S.C. BATTERY TO MAINS CONVERSION UNITS

Type BM1 An all dry battery eliminator. Size 5½ x 4½ x 2in. approx. Completely replaces batteries supplying 1.4 v. and 90 v. where A.C. mains 200-250 v. 50 c/s. is available. Suitable for all battery portable receivers requiring 1.4 v. and 90 v. This includes latest low consumption types. Complete kit with diagrams 39/9, or ready for use, 46/9.



Type BM2. Size 8 x 5½ x 2½in. Supplies 120 v., 90 v. and 60 v., 40 mA. and 2 v. 0.4a. to 1 amp. fully smoothed. THEREBY COMPLETELY REPLACING BOTH H.T. BATTERIES AND L.T. 2v. ACCUMULATORS. When connected to A.C. mains supply 200-250 v. 50 c/s. SUITABLE FOR ALL BATTERY RECEIVERS normally using 2 v. accumulator. Complete kit with diagrams and instructions 49/9 or ready for use 59/6.

PLESSEY DUAL CONCENTRIC 12in. P.M. SPEAKERS. (15 ohms), consisting of a high quality 12in. speaker, of orthodox design supporting a small elliptical speaker wired with choke and condensers to act as tweeter. This high fidelity unit is highly recommended for use with our A8 or any similar amplifier. Rating is 10 watts. Price only £5/17/6.

MAINS ENERGISED SPEAKERS R.A. 2-3 ohms. 8in. Field 600 ohms., 10/9. 10in. Field 1,500 ohms., 23/9.

R.S.C. TRANSFORMERS

FULLY GUARANTEED, INTERLEAVED AND IMPREGNATED

MAINS TRANSFORMERS

Primaries 200-230-250 v. 50 c/s.

FULLY SHROUDED UPRIGHT MOUNTING

- 250-0-250 v. 60 mA. 6.3 v. 2 a., 5 v. 2 a. ... 17/6
- Midget type, 28-3-3in. 19/9
- 350-0-350 v. 70 mA., 6.3 v. 2 a., 5 v. 2 a. 19/9
- 250-0-250 v. 100 mA., 6.3 v.-4 v. 4 a., c.t., 0-4-5 v. 3 a. 25/9
- 250-0-250 v. 100 mA., 6.3 v. 4 a., 5 v. 3 a. ... 23/9
- 250-0-250 v. 100 mA., 6.3 v. 4 a., 5 v. 3 a. ... 31/-
- 300-0-300 v. 100 mA., 6.3 v. 4 a., 5 v. 3 a. ... 23/9
- 300-0-300 v. 100 mA., 6.3 v. 4 v. 4 a., c.t., 0-4-5 v. 3 a. 26/9
- 350-0-350 v. 100 mA., 6.3 v. 4 a., 5 v. 3 a. ... 23/9
- 300-0-300 v. 130 mA., 6.3 v. 4 a., c.t., 6.3 v. 1 a., suitable for Mullard 510 Amplifier 33/9
- 350-0-350 v. 100 mA., 6.3 v.-4 v., 4 a., c.t., 0-4-5 v. 3 a. 26/9
- 350-0-350 v. 150 mA., 6.3 v. 4 a., 5 v. 3 a. ... 33/9
- 350-0-350 v. 150 mA., 6.3 v. 2 a., 6.3 v. 2 a., 5 v. 3 a. 33/9
- 425-0-425 v. 200 mA., 6.3 v. 4 a., c.t., 6.3 v. 4 a. c.t., 5 v. 3 a., suitable Williamson Amplifier, etc. 49/9
- 450-0-450 v. 250 mA., 6.3 v. 6 a., 6.3 v. 6 a., 5 v. 3 a. 69/6

TOP SHROUDED DROP-THROUGH TYPE

- 250-0-250 v. 70 mA., 6.3 v. 2.5 a. 13/9
- 260-0-260 v. 70 mA., 6.3 v. 2 a., 5 v. 2 a. 16/9
- 350-0-350 v. 80 mA., 6.3 v. 2 a., 5 v. 2 a. 18/9
- 250-0-250 v. 100 mA., 6.3 v. 4 a., 5 v. 3 a. 22/9
- 300-0-300 v. 100 mA., 6.3 v.-4 v. 4 a., c.t., 0-4-5 v. 3 a. 23/9
- 350-0-350 v. 100 mA., 6.3 v. 4 a. c.t., 5 v. 3 a. 22/9
- 350-0-350 v. 100 mA., 6.3 v.-4 v. 4 a. c.t., 0-4-5 v. 3 a. 23/9
- 350-0-350 v. 150 mA., 6.3 v. 4 a., 5 v. 3 a. 29/9
- E.H.T. TRANSFORMERS, 2,500 v. 5 mA., 2-0-2 v. 1.1 a., 2-0-2 v. 1.1 a., for VCR97, VCR517. 36/6

FILAMENT TRANSFORMERS

- Primaries 200-250 v. 50 c/s.
- 6.3 v. 1.5 a. 5/9
- 6.3 v. 2 a. 7/6
- 0-4-6-3 v. 2 a. 7/9
- 6.3 v. 3 a. 8/11
- 12 v. 1 a. 7/9
- 0-2-4-5-6-3 v. 4 a. 16/9
- 6.3 v. 6 a. 17/6
- 12 v. 3 a. or 24 v. 1.5 a. 17/6

CHARGER TRANSFORMERS

- All with 200-230-250 v. 50 c/s. Primaries: 0-9-15 v. 1½ a., 11/9; 0-9-15 v. 3 a., 16/9; 0-3-5-9-17 v. 3 a., 17/9; 0-3-5-9-17 v. 4 a., 18/9; 0-9-15 v. 5 a., 19/9; 0-9-15 v. 6 a., 23/9; 0-9-15 v. 7.5 a., 28/9.

ELIMINATOR TRANSFORMERS

- Primaries 200-250 v. 50 c/s.
- 120 v. 40 mA., 5-0-5 v. 1 a. 14/9
- 90 v. 15 mA., 6-0-6 v., 250 mA. 9/11

OUTPUT TRANSFORMERS

- Midget Battery Pentode 66:1 for 3S4, etc. 3/6
- Small Pentode, 5,000Ω to 3Ω 3/9
- Standard Pentode, 5,000Ω to 3Ω 4/9
- Standard Pentode, 8,000Ω to 3Ω 4/9
- Multi-ratio 40 MA. 30:1 45:1, 60:1, 90:1, Class B Push-Pull 5/6
- Push-Pull 8 Watts 6V6 to 3 ohms. 8/9
- Push-Pull 10-12 Watts 6V6 to 3Ω or 15Ω 15/9
- Push-Pull 10-12 Watts to match 6V6 to 3-5-8 or 15Ω 16/9
- Push-Pull 15-18 Watts, sectionally wound, 6L6, KT66, etc., to 3 or 15 ohms. 21/9
- Push-Pull 10-15 Watts, Ultra Linear, designed for Mullard Amplifier 510. 39/6
- Push-Pull 20 Watt high-quality sectionally wound, 6L6, KT66, etc., to 3 or 15Ω 47/9
- Williamson type exact to spec. 85/-

SMOOTHING CHOKES

- 250 mA., 5 H., 100 ohms. 11/9
- 150 mA., 7-10 H., 250 ohms. 11/9
- 100 mA., 10 H., 200 ohms. 8/9
- 80 mA., 10 H., 350 ohms. 5/6
- 60 mA., 10 H., 400 ohms. 4/11

R.S.C. A6 ULTRA LINEAR 30 WATT AMPLIFIER

NEW 1956 DESIGN. HIGH FIDELITY PUSH-PULL UNIT EMPLOYING SIX VALVES. Tone Control Pre-amp stages incorporated. Sensitivity is extremely high. Only 30 millivolts minimum input is required for full output. THIS ENSURES THE SUITABILITY OF ANY TYPE OR MAKE OF MICROPHONE OR PICK-UP. Separate Bass and Treble controls give both "lift" and "cut" with ample tone correction for long playing records. AN OUTPUT SOCKET WITH PLUG IS INCLUDED FOR SUPPLY OF 300 v., 20 mA. and 6.3 v. 1.5 a. FOR A RADIO FEEDER UNIT. Price in kit form with easy-to-follow wiring diagrams. 9 GNS.

Or Factory built with 12 months' guarantee. 50/- extra. TERMS ON ASSEMBLED UNITS: DEPOSIT 28/9 and 9 monthly payments of 28/9. If required an extra input with associated vol. control can be provided so that two separate inputs such as "mike" and gram., etc., can be simultaneously applied for mixing purposes. Extra cost of this 13/-. Cover as illustrated 17/6 extra.



Type 807 output valves are used with High Quality Sectionally wound output transformer specially designed for Ultra Linear operation. Negative feedback of 17 D.B. in main loop. CERTIFIED PERFORMANCE FIGURES ARE EQUAL TO MOST EXPENSIVE UNITS AVAILABLE. Frequency response ± 3 D.B., 30-20,000 c/c.s., 12 D.B. "lift" at 50 c/c.s., 12 D.B. "lift" at 12,000 c/c.s., Hum and noise 70 D.B. down. Good quality reliable components used. Chassis finish blue crackle. Overall size 12 x 9 x 9 in. approx. Power consumption 150 watts. For A.C. mains 200-230-250 v. 50 c/c.s. Outputs for 3 and 15 ohm speakers. EQUALLY SUITABLE FOR THE CONNOISSEUR OR FOR LARGE HALLS, CLUBS, or OUTSIDE FUNCTIONS. IDEAL FOR USE WITH MUSICAL INSTRUMENTS SUCH AS STRING BASS, ELECTRONIC ORGAN, GUITAR, etc. FOR DANCE BANDS, GARRISON THEATRES, etc., etc.

We can supply Microphones, Speakers, Rotary Converters, etc., at keen cash prices or on H.P. terms with amplifiers.

EXPORT ENQUIRIES INVITED

R.S.C. TA1 HIGH QUALITY TAPE DECK AMPLIFIER

FOR ALL DECKS WITH HIGH IMPEDANCE RECORD/PLAYBACK AND ERASE HEADS. Such as Lane, Truvox, etc. Chassis size 12-7-3in. Overall size 12-7-6in. For 230-250 v. 50 c/c.s. A.C. mains. Output for standard 2-3 ohm speaker. Only 15 millivolts input required for full recording. Only 2 millivolts minimum input required from recording head. Magic Eye recording level indicator. Provision for feeding P.A. amplifier. Can be used as gram. amplifier with input of 0.75 v. R.M.S. Negative feedback equalisation. Linear frequency response ± 3 D.B. 50-11,000 c/c.s.

Facilities for recordings at 15in., 7 1/2in. or 3 1/2in. per second. Automatic equalisation at the turn of a knob. When switching from record to playback position automatic demagnetisation of heads is assured. PERFORMANCE IS COMPARABLE WITH UNITS AT OVER TWICE THE COST. LEAFLET 64.

11 Ready for use per second. 11 GNS. Carr. 7/6

R.S.C. ULTRA LINEAR 12-WATT AMPLIFIER



NEW 1956 MODEL A8 HIGH-FIDELITY PUSH-PULL AMPLIFIER WITH "BUILT-IN" TONE CONTROL, PRE-AMP. STAGES.

High sensitivity. Includes 5 valves (807 outputs), High Quality sectionally wound output transformer specially designed for Ultra Linear operation, and reliable small condensers of current manufacture. INDIVIDUAL CONTROLS FOR BASS AND TREBLE "Lift" and "Cut." Frequency response ± 3 db. 30-30,000 c/c.s. Six negative feedback loops. Hum level 71 db. down. ONLY 70 millivolts INPUT required for FULL OUTPUT. Suitable for use with all makes and types of pick-ups and practically all microphones. Comparable with the very best designs. FOR STANDARD or LONG PLAYING RECORDS. FOR MUSICAL INSTRUMENTS such as STRING BASS, GUITARS, etc. OUTPUT SOCKET with plug provides 300 v. 20 mA. and 6.3 v. 1.5 a. For supply of a RADIO FEEDER UNIT. H.P. TERMS ON ASSEMBLED UNITS. DEPOSIT 25/6 and nine monthly payments of 22/4. Size approx. 12-8-7in. For A.C. mains 200-230-250 v. 50 c/c.s. Output for 3 and 15 ohm speakers. Kit is complete to last out. Chassis is fully punched. Full instructions and point-to-point wiring diagrams supplied. Unapproachable value at £7/15/- or factory built 45/- extra. Carriage 10/-. If required leaved metal cover with 2 carrying handles can be supplied for 17/6. Where an extra input socket with associated volume control is required for mixing purposes this can be provided for 13/- extra.



GARRARD 3-SPEED AUTOMATIC RECORD CHANGERS. Latest Model. Type RCL10. Fitted high fidelity turnover crystal pick-up head. For 200-250 v. A.C. mains. Limited number. Brand new cartoned. Only £8/17/6, plus 5/6 carriage.

H.M.V. LONG PLAYING RECORD TURNTABLE COMPLETE WITH CRYSTAL PICK-UP (SAPPHIRE STYLUS). Speed 33 1/3 r.p.m. BRAND NEW. CARTONED. Only £3/19/6 (approx. half price). Carr. 5/- (for 200-250 v. A.C. Mains).

MICROPHONES. High fidelity crystal types. Acos 33-1 hand or desk type, 50/-. Piezzo with heavy floor base and telescopic stem. £6/18/6.

R.S.C. 4-5 WATT HIGH GAIN AMPLIFIER TYPE A5

A highly sensitive 4-valve quality amplifier for the home, small club, etc. Only 50 millivolts input is required for full output so that it is suitable for use with the latest high-fidelity pick-up heads in addition to all other types of pick-ups and practically all makes. Separate Bass and Treble controls are provided. These give full long playing record equalisation. Hum level is negligible, being 71 D.B. down. 15 D.B. of negative feedback is used. H.T. of 300 v. 20 mA. and L.T. of 6.3 v. 1.5 a. is available for the supply of a Radio Feeder Unit or Tape Deck pre-amplifier. For A.C. mains input of 200-230-250 v., 50 c/c.s. Output for 2-3 ohm speaker. Chassis is not active. Kit is complete in every detail and includes fully punched chassis (with baseplate) with the blue hammer finish, and point-to-point wiring diagrams and instructions. Exceptional value at only £4/15/-, or assembled ready for use 25/- extra, plus 3/6 carriage.



WALNUT VENEERED CABINETS. Designed for above record changers with provision for housing amplifier and speaker. Attractive design. Limited number. Brand new cartoned £3/19/6, carr. 7/6.

QUALITY AMPLIFIERS. 3-4 watt, specially designed for use with BSR changer and above cabinet. Latest miniature tube valves used. Separate Bass and Treble Controls and Vol. Control with mains switch. For A.C. 200-250 v. mains. Ready for use, only £3/19/6, carr. 3/6.

P.M. SPEAKERS. Suitable for use with above equipment. Elliptical 7 x 4in. with 2-3 ohms speech coil, 19/9 ea. Only 31/-.

P.M. SPEAKERS. 2-3 ohm, 5in. Goodmans, 17/9, 6 1/2in. R.A., 15/9, 8in. Rola, 19/9, 10in. R.A., 26/9, 12in. Plessey, 29/11.

THE SKY FOUR T.R.F. RECEIVER



A design of a 3-valve 200-250 v. A.C. Mains receiver with selenium rectifier. For inclusion in either of cabinets illustrated above. It employs valves 6K7, 6F6, 6F6G, and is specially designed for simplicity in wiring. Sensitivity and quality is well up to standard. Point-to-Point wiring diagrams, instructions and parts list, 1/9. This receiver can be built for a maximum of £4/19/6 including cabinet. Available in brown or cream bakelite, veneered walnut.

ROTARY CONVERTERS. 200 watts. Input 12 v. D.C. Output 230 v. 50 c/c.s. A.C. Only 7 gns. Carr. 7/6.

FOUR-STAGE RADIO FEEDER UNIT

Design of a HIGH FIDELITY L. and M. wave T.R.F. Unit with self-contained heater supply and thorough H.T. decoupling. Only 250-400 v. 10-20 mA. H.T. required from main amplifier. Three valves and Diode Detector Germanium Diode Detector. Flat topped response characteristic. Loaded H.F. coils. Two variable Mu controlled H.F. stages, 3 gang condenser tuning. Cathode follower output stage. Switch position for Gram. and Gram. input and output sockets. Performance comparable with the best in Feeder Units. For A.C. mains 200-230-250 v. operation. Size 11-6-7 1/2in. Illustrations full set or easy-to-follow wiring diagrams and instructions and individually priced parts list 2/6. This unit can be built for only £3/15/-, including Dial and Drive knobs and every item required.

DEFIANT RECORD PLAYING TURNTABLE COMPLETE WITH MAGNETIC PICK-UP. Pick-up is high impedance type. Unit is housed in a beautiful walnut veneered cabinet of attractive design. For all standard records (78 r.p.m.) Limited number. Brand new, cartoned, £5/17/6, carr. 7/6.

W.R. "STENTORIAN" HIGH FIDELITY P.M. SPEAKERS. HF1012, 10 watts, 15 ohm (or 8 ohm) speech coil. Where a really loud quality speaker at a low price is required, we highly recommend this unit with an amazing performance £4/10/9. Please state whether 3 ohm, or 15 ohm, required.

Radio Supply Co. (LEEDS) LTD.

32 THE GALLS. — LEEDS, 2.

Terms C.W.O. or C.O.D. No C.O.D. under £1. Postage 1/9 extra on all orders under £2, 2/9 extra under £5 unless carriage charge stated. Full Price List 6d. Trade List 5d. Open to Callers 9 a.m. to 5.30 p.m. Saturday until 1 p.m.

LASKY'S RADIO

SAVE POUNDS! ORDER BY POST IF YOU CANNOT CALL

HIRE PURCHASE TERMS
available on certain items. Write stating requirements.
SEND FOR OUR NEW LIST
enclosing 3d. in stamps.

LASKY'S RECORD VALUE IN 3-SPD. MIXER AUTO-CHANGERS

ALL BRAND NEW AND UNUSED, IN MAKERS' CARTONS

GARRARD RC.110, as illus. Complete with t.o. crystal pick-up. Cabinet space required 14 x 12½ x 4in. above, and 2½in. below motor board. Cream and brown enamel finish. Complete with instruction book. List £14/13/-.
LASKY'S PRICE £8.19.6

Carr. 5/- . Cabinets available, list on request.



GARRARD RC.80. Full length arm with two Decca XMS heads. List £20/15/-.
LASKY'S PRICE £13.19.6
Carr. 5/- .
As above, with GC.2 t.o. crystal head, £15.15.0.

BSR Monarch. With H.G.P.37 t.o. crystal P.U. **£7.19.6**
Carr. 3/6.

COLLARO RC.54. With studio O t.o. crystal P.U. **£9.19.6**
Carr. 5/- .

MOVING COIL P.M. SPEAKERS

3in. and 3½in.	19/6
5in. 6½in. 8in. 10in. 12in.	16/6 17/6 25/- 26/6 29/6
6½in. with trans.	21/-
7 x 4in. Elliptical	19/6
10 x 6in. Elliptical ...	32/6

DECCA XMS P.U. HEADS

L.P. and standard, complete with styli. Per pair, **79/6**
Post 3/6.
Singly, 42/- . Post extra.

T.O. CRYSTAL CARTRIDGES

B.S.R. complete with two styli. Post free **18/6**

SPECIAL OFFER! 14" TABLE MODEL TV CABINETS

Complete with mask and filter glass 6½in. closed field P.M. Speaker incorporated. Overall dim.: 18½in. wide, 15½in. high, 16in. deep. Dark veneer finish with light top. **LASKY'S PRICE 45/-**

Carr. and packing, 9/6.

LARGE SELECTION OF CABINETS for radiograms, carrying cases for record players, tape recorders, TV, etc. Your enquiries invited.

VALRADIO TV TUNERS

Full range, all I.F. freq., series or parallel heaters, £6.
Post 3/6.

THE NEW JASON "ARGONAUT" AM/FM TUNER

A super-sensitive Tuner for F.M. and medium waves. The complete parcel with power supplies, **£13.19.6**
Post 3/6.
Data Book 2/-, post free.

All components available separately. Send for itemised price list.

Chassis Assembly, complete, 57/9.
Post 2/6.

I.F. and Coil Set, complete 78/- .
Post 1/6.

JASON F.M. TUNER

Special parcel containing data book, chassis, front end, dial, drive, tuning, condenser, full set of coils, I.F.s, ratio detector, etc. **68/9**
Post 2/6.

Book only, with price list, 2/- . This Tuner uses 4-6AM6 and 2 crystals and can be built for £6/15/-, plus 3/6 post.

MAKE YOUR OWN FERRITE ROD AERIAL. Ferrite rod, 5in. long, ¼in. diam., with full directions. Each, 2/6. Post 1/- .

SINGLE RECORD PLAYERS

Collaro 3/554	£8 18 4
B.S.R. Model TU.8	£4 12 6
Garrard "TB" Units, less heads	£8 10 11
Carr. 3/6.	

PROJECTION TV UNITS

(Mullard.) Consisting of optical unit and E.H.T. unit, complete with valves and C.R. tube. Limited quantity. Full details on request.
LASKY'S PRICE £21
Carr. 21/- .

16 INCH METAL CONE C.R. TUBES AT MUCH BELOW HALF PRICE!

Limited number only



Here's an offer you simply cannot afford to miss, but hurry, a limited number only are available. 16in. Metal Cone C.R. Tube, 6.3 v. heater, ion trap, 14 Kv. E.H.T., wide angle 70 deg., standard 38 mm. neck, duodecal base, magnetic focus and deflection. Max. length 17 11/16in.

Gives large black and white picture size 11 x 14 1/2in. Supplied unused in original cartons.

LASKY'S PRICE £9.19.6

Carr. and Insurance 22/6 extra.

Guaranteed by us for 3 months. Full data, connections and suggested time bases supplied with every tube.

LISTED AT £23.9.10

Masks, Anti-Corona Rings, Bases and Ion Traps available.

Big Picture Television at a price you can afford!

FAMOUS MAKE TURRET "TELETONER"

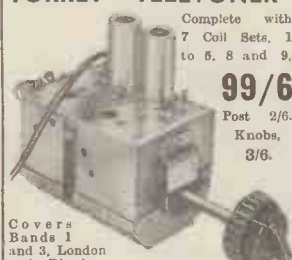

Complete with 7 Coil Sets, 1 to 5, 8 and 9.

99/6

Post 2/6.

Knobs, 3/6.

Covers Bands 1 and 3, London and Birmingham. Valves used: PCC84, R.F. double triode, cascade R.F. amplifier, PCF80, triode pentode f.c. and mixer. I.F. output 33-38 Mc/s. Easily modified to other I.F. outputs. Full instructions and circuit diagram supplied.

DULCI F.M. TUNER

Incorporates its own power supply and operates with most radio receivers and any make of Amplifier. Valve line up: EABC80, ECC85, two EF89, 6X4 (Rect.), EM80, magic eye Indicator. Incorporates GORLER Inductance Tuning Heart. Dial 104 x 6in. Overall size 9 x 6 x 5 1/2in. high. Complete Carr. & Pkg. 7/6. **16 GNS.**
DULCI A.M./P.M. TUNER. £23.12.0.

12-CHANNEL TV TUNERS

Famous make. Covers Bands I and III. Complete with valves EF80 and ECC81. Ceramic valve holders, finest quality components. Switch and fine tuning. I.F. output 20-25 Mc/s. Freq. coverage 50-87 Mc/s. and 175-215 Mc/s. Full details and circuit diagram supplied. Reduced to **79/6**
Post 3/6. **KNOBS 2/9 extra.**

Also another Tuner using PCC84 and PCF80, I.F. output 33-38 Mc/s. Complete with valves and diagram. 99/6. Post 3/6.

TELETRON BAND III CONVERTERS

MK. I. Complete Kit to build this converter, drilled chassis, condensers, resistances, coils, 2-ES80 valves, etc., with circuit diagram and instructions. **48/6**
Post 1/6.
Drilled chassis only, 3/9.

MK. II. Uses latest type valves. Cascode R.F. amp. and triode pentode F.C. PCC84 and PCF80, etc. The **17/6**
COIL SET.

COMPLETE KIT, including drilled chassis, valves and diagram, **59/6**
Post 1/6.

Circuit diagram only, 3d.
TELETRON CONVERTER COIL SET.
For use with TRF and S'het Band I TV sets. Uses two 2719. Circuit diagram alignments, full details supplied. **15/-**
Post 1/6.

MICROPHONE SNIIP Table Crystal, with screened lead. **21/-**

Post 2/6
Large selection all types, high and low impedance, moving coil, crystal, ribbon, etc.

GERMANIUM CRYSTAL DIODES

GEX.00	1/6
GEX.34	3/6
GEX.54	5/-
OA.71	5/-
WG4A	3/6
WG4B	4/-
WG5A and B	5/-
WG6A	5/-

REMPLOY INSTRUMENT SOLDERING IRONS. 200-250 v. Neon indicator light. in handle **19/3**

BAND III CONVERTERS 2 valves and metal rectifiers, metal case. Contains power pack for 200-250 v. A.C. List £8/10/-
LASKY'S PRICE 79/6

DECCA PICK-UPS

3-speed with T.O. crystal head HI/G, and rest. Brown **42/6**
plastic. Post 2/6.

RADIO · TELEVISION · HI-FI · ELECTRONICS · RECORDERS



Special Bargain

3-WATT AC/DC MIDGET AMPLIFIER

Push pull, very high gain. 4 valves: two UL41 (p.p.) UCH42, UAF42. Input voltage 100/110 A.C./D.C. Easily converted to 230 v. Ideal for record layers, tape recorders, baby alarms, etc. Supplied fully assembled with valves, circuit diagram and details. **REDUCED TO 50/-** Carr. 5/-.

METER BARGAINS

2½in. moving coil. Brand new micro-ammeters F.S.D. 0-750 micro/amps., 15 ohms resist. 15/-, 0-1.5 amps., 12/6. 0-200 v. A.C., rect. incorporated, 12/6. Dozens of other types.

TRANSISTORS

Lowest prices. Fully guaranteed. By Mullard, S.T.C., etc. SUB-MINIATURE TRANSISTOR TRANSFORMERS, 4 to 1 ratio. Each 4/6.

SPECIAL OFFER OF PORTABLE GRAM AMPLIFIERS



Uses 3 latest miniature valves, U78, N78, DH77. Volume, bass and treble controls; extension L.S. socket and internal L.S. switch, indicator lamp. Mounted on wood baffle, overall size 14 x 4½in. with speaker centralised. All top quality new components. For A.C. mains 200-250 v. Ideal for portable record players, input will match Monarch, RC54, RC3/554, etc. Price, complete with 3 new Osram valves, 7 x 4in. Goodmans elliptical speaker, metal speaker grille mains lead, and knobs. **£5.9.6** Post and Pkg. 5/-.

LASKY'S RADIO CONSTRUCTOR PARCELS

No. 1. Contains everything to build a 4-valve, 3-wave superhet for 200-250 A.C. mains. Wood or plastic cabinet as preferred. Can be built for **£7.19.6** Carr. 2/6.
No. 2. Contains everything to build a T.F.R. 3-valve, 3-wave set for 200-250 A.C. mains. Wood or plastic cabinet as preferred. Can be built for **£5.10** Carr. 2/6.

INSTRUCTION BOOKS for above, 1/- each, post free. All components available separately.

LARGE RANGE OF TAPE DECKS

Collaro "Tape Transcriber", £20 Truvox, 22 Gns. Lane, £18/10/- Brenell, 18 Gns. And all other makes.

TAPE DECK MOTORS

Anti-clockwise, shaded pole. Special offer, COLLARO, 25/- GARRARD, 26/6. B.T.H., 29/6. Post extra.

FAMOUS AMPLIFIERS BUILT ON T.C.C. PRINTED CIRCUITS

All specified components used, with your choice of transformers and chokes. Fully assembled and ready for use.
The MULLARD 510. Price, according to transformers used, from 14 gns. The Book, 3/6.
OSRAM 912. From 18 GNS. The Book, 4/-, post free.
All components available separately, also printed Circuits.

LARGE STOCK OF HI-FI EQUIPMENT

Amplifiers, Speakers, etc. Wharfedale, W.B., Goodmans, G.E.C., Leak, Rogers, RCA., Quad, etc.

20,000 VALVES IN STOCK

Send for our latest price list.



6-VALVE RADIOGRAM CHASSIS COMPLETE WITH VALVES

Famous Manufacturer's Surplus. 6-valve, 3-wave Superhet. 13-50 m. short. 200-850 m. medium, 1,000-2,000 m. long. Brand new Mullard valves: ECH42, EF41, L63, EB41, 6V6 g.t., EZ40 and finest quality components. Gram, switch, 465 Kcs I.F. tone control, three-colour dial. Overall size 13½ x 5½in., height 12½in. Aperture required for dial and controls 11 x 3½in. Complete with valves, output trans., knobs, etc.

LASKY'S PRICE £10.19.6 Carriage and packing 7/6 extra.

5-VALVE RADIOGRAM CHASSIS

A.C. mains, 3-wave superhet. Large full vision dial, 11½ x 4½in. Overall dimensions 14 x 6 x 7½in. Valve line-up: 12AN8, 6BA6, 6AT6, 6BW6, 6X4. **LASKY'S PRICE, complete with valves, £9.19.6** Carr. 7/6.

Table Cabinet for above, complete with 6½in. P.M. speaker, 49/9

LASKY'S FIRST AGAIN!

We proudly announce a **NEW BATTERY PORTABLE FOR HOME CONSTRUCTION ON PRINTED CIRCUIT**

Utilises all latest innovations, giving simplicity of construction with fine quality. 11 STAR FEATURES make this superb new design undoubtedly the finest Portable Radio ever offered to the home constructor.

PEAK VALUE FOR MONEY has been obtained without any sacrifice of quality or design. Use of the printed circuit completely eliminates wiring errors.

- ★ **PRINTED CIRCUIT**, size 7½in. x 2½in.
- ★ 4-valve Superhet, med. and long waves.
- ★ Low consumption Valves. Double Battery Life.
- ★ Ferrite Rod Internal Aerial.
- ★ 3 or 5in. P.M. Moving Coil Speaker (your choice).
- ★ Brand New T.C.C. Capacitors.
- ★ Automatic Volume Control.
- ★ New Style Contemporary Cases.
- ★ Alternative Styles of Cases.
- ★ Lightweight and Handsome Appearance.
- ★ Every Component available separately.

CAN BE BUILT FOR £7.7.0 approx.

The most up-to-date Portable available. We regret that at time of going to press illustrations could not be included.

SEND FOR ILLUSTRATIONS with circuit diagram, assembly data, all instructions and full shopping list. Price 1/6 post free.

DEMONSTRATION MODELS AT BOTH OUR ADDRESSES

MAKERS' SURPLUS TV COMPONENT BARGAINS

WIDE ANGLE 38 mm.

Line. E.H.T. trans., ferro-cube core, 9-16 kV.	25/-
Scanning Coils, low imp. line and frame	25/-
Ferro-cube cored Scanning Coils and Line Output Trans., 10-15 kV, EY61, winding Line Trans. incorporates width and linearity control. Complete with circuit diagram, the pair.	50/- 6/8
Frame Output Transformer	17/6
Scanning Coils low imp. line and frame	4/6
Frame or line block oec. transformer	19/6
Focus Magnets Ferro-cube	18/6
P.M. Focus Magnets, Iron Cored	22/6
Duomag Focallisers	15/-
300 m/a. Smoothing chokes	25/-
Electromagnetic focus coil, with combined scan coils	12/6
STANDARD 35 mm.	
Line Output Transformers. No. E.H.T. and 6.3 v. winding.	19/6
Line Output Transformers 6.9 kV. E.H.T. and 6.3 v. winding.	12/6
Ferro-cube	14/6
Scanning coils. Low imp. line and frame	4/6
Frame or line blocking oscillator transformer	7/6
Focus Magnets:	12/6
Without Vernier	17/6
With Vernier	12/6
Focus Coils, Electromagnetic	10/6
200 m/a. Smoothing Chokes	

LATEST BRENELL TAPE EQUIPMENT

DECK, 3-speed, 3 motors, record and play back, 18 Gns.
AMPLIFIER Mk. II, 5 watts, for use with 3 ohms speaker. Magic eye. 18½ Gns.
Suitable Carrying Case, £5.18.0
Write for full details.

RECORDING TAPE

SPECIAL OFFER. Magnetic Recording Tape, kraft base. O1 Cylcon metal spools: 1,200ft., 11/6; 600ft., 7/6. On plastic spools: 1,200ft., 12/6; 600ft., 9/6. **PURETONE TAPE** on plastic spool: 1,200ft. 14/11. Post 1/- extra.
All makes of Tape stocked including the new thin long-playing. Also Spools.



42 TOTTENHAM COURT ROAD, W.1.
(Between T.C.R. and Goodge St. Stns.)
MUSEUM 2605

370 HARROW ROAD, PADDINGTON, W.9.
(Opposite Paddington Hospital)
CUNNINGHAM 1979

Open all day Saturday. Early closing Thursday (both addresses)

ALL MAIL ORDERS TO HARROW ROAD PLEASE Phone: LAD 4075

UNDOUBTEDLY THE BEST VALUE YET OFFERED



Stern's "fidelity" Tape Recorder

- Extension speaker sockets are provided
- Has dual input channels for mixing
- Monitoring provided for

- Will play the new pre-recorded tapes
- Provides 2 hours playing time at 3 3/4 in. or 1 hour at 7 1/2 in. per second
- Will take all standard reels up to 1,200ft.

**PRICE COMPLETE
READY FOR USE £43**

TERMS: £11 Deposit and 9 months of £3/18/3, or £21/10/- Deposit and 12 months of £1/19/10. Carr. and ins. is £1/10/- extra, but we return £1 on return of packing case.

The following items form complete Recorder: **THE TRUVOX MODEL TR7U TAPE DECK**

3 Shaded-Pole motors. Drop-in Tape Loading. Push Button Control. Separate Push Button Brake. Fast forward and fast reverse. Silent drive eliminating Wow and Flutter. Half Track working and 2 speeds. 3 3/4 in. and 7 1/2 in. per sec. Positive Azimuth Adjustment. Overall size only 14 1/2 x 12 3/4 in. Available for £23/2/-

THE MODEL T.R.I./F. AMPLIFIER

Has been expressly designed to meet the requirements of enthusiasts for fidelity reproduction, and in particular to CORRECTLY operate the above TRUVOX DECK. It is supplied complete with a matched Elliptical 3 ohm P.M. Speaker, it incorporates an efficient Tone Control arrangement and has a Magic Eye Indicator (Operative on Record). A Co-axial Socket is also incorporated for MONITORING on Record, and this can also be used to feed an external amplifier. The Amplifier can also be used for high quality reproduction of gramophone records direct from a gram unit. Available for £14/14/-

ACOS CRYSTAL MICROPHONE MODEL MIC.33.1 Price £2/10/-

1,200 ft. REEL OF SCOTCH BOY or E.M.I. MAGNETIC RECORDING TAPE. Price £1/15/-

PORTABLE ATTACHE CASE

Is a neat, compact and attractively finished case, being covered with maroon rexine and having an ivory coloured speaker escutcheon. It contains concealed pockets to accommodate the Microphone, Mains Lead and a spare 1,200ft. reel of tape. Price £5.

**GUARANTEED FOR 12 MTHS.
(B.V.A. VALVES 90 DAYS)**

**SEND S.A.E. FOR ILLUSTRATED
AND DESCRIPTIVE LEAFLETS**

HOME CONSTRUCTORS !! £40'-'
YOU CAN BUILD THE COMPLETE RECORDER FOR

TERMS: £10 Deposit and 9 months of £3/13/4, or £20 Deposit and 12 months of £1/17/1.

The Truvox TAPE DECK and the Quality Amplifier are supplied tested and ready for use, and the actual assembly of the Tape Recorder is extremely simple, involving only a few connections. Step-by-step connection chart is supplied for this purpose.

If you have your own Cabinet WE WILL SUPPLY: The TRUVOX TAPE DECK, the TAPE AMPLIFIER, MATCHED SPEAKER, and 1,200ft. of E.M.I. TAPE for £33/10/- plus £1/10/- carr. and ins., £1 of which is refunded on return of case.

TERMS: £8/8/- Deposit and 9 months of £3/1/4, or £16/15/- Deposit and 12 months of £1/11/1.

Modernise your old Radiogram

WE OFFER the

latest 3 SPEED AUTOCHANGERS with modern RADIOGRAM CHASSIS and matched P.M. SPEAKERS at REDUCED PRICES. (H.P. Terms available.) A good varied selection is available . . . SEND S.A.E. for full DETAILS.

TWO REALLY GENUINE PRICE REDUCTIONS

A BULK PURCHASE ENABLES US TO OFFER these RECEIVER CHASSIS at SUCH LOW PRICES. Each is BRAND NEW and FULLY GUARANTEED.

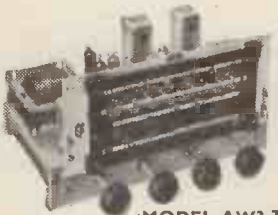

MODEL AW3-7

A 7-valve 3-waveband superhet chassis having a Push-Pull stage for approximately 6 watts output. PRICE **£12-19-6**
H.P. TERMS: Deposit Plus 7/6 carr. & ins. £6/9/9 and 8 monthly payments of 18/9. THESE THREE CHASSIS HAVE "GRAM" POSITION and are IDEAL REPLACEMENT CHASSIS FOR THAT "OLD RADIOGRAM" —Send S.A.E. for complete details.

MODEL B3

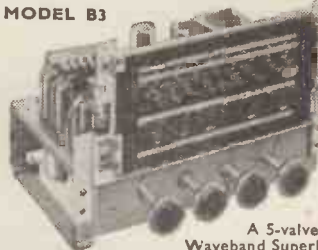

A 5-valve 3-Waveband Superhet employing Negative Feedback over entire Audio Stages and having a single valve type 6BW6 output for approximately 4 watts. H.P. TERMS: PRICE **£11-11-0**
Deposit £5/15/6 and 7 monthly payments of 19/4. Plus 7/6 carr. & ins.

A high-quality replacement Radio or Radiogram Chassis having provision for an FM Feeder Unit and incorporating separate BASS and TREBLE CONTROLS. PRICE ASSEMBLED and READY FOR USE **£25/2/0**

THE ARMSTRONG F048

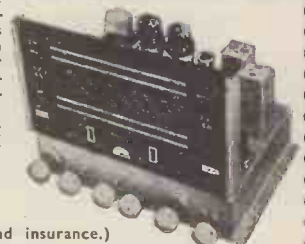

(Plus 7/6 carr. and insurance.)

TERMS: £6/6/- Deposit and 9 months of £2/6/- or £12/11/- Deposit and 12 months of £1/3/3.

Open Monday to Friday 9 a.m.—6 p.m. Saturday 9 a.m.—1 p.m.

**STERN RADIO
LIMITED**

**AMPLIFIERS
PRE-AMPLIFIERS
COMPLETE KITS OF PARTS FOR THE "Hi-Fi" ENTHUSIAST
TUNING UNITS
RADIO RECEIVERS**

The MULLARD '5-10' MAIN AMP-FIER



This is the very latest design and needs no recommendation from us. Our Kit is complete to Mullard's specification, including the latest GILSON ULTRA LINEAR OUTPUT TRANSFORMER and the entire MULLARD Valve line up. ALL SPECIFIED COMPONENTS are supplied. PRICE OF COMPLETE KIT OF PARTS **£11/11/0** (Plus 5/- carr. and ins.)

THE full SPECIFICATION and BUILDING INSTRUCTIONS

STERN'S "fidelity" PRE-AMPLIFIER TONE CONTROL UNIT

"A design for the music lover"



Briefly it has inputs for all types of MICROPHONES, HIGH and LOW GAIN PICK UPS and a RADIO TUNING UNIT. It incorporates (a) GRAM EQUALISING CONTROL. (b) STEEP CUT FILTER; (c) Continuously variable BASS and TREBLE CONTROLS and a variable OUTPUT CONTROL which enables its use with any type of Amplifier. PRICE OF COMPLETE KIT OF PARTS **£6/6/0** (Plus 5/- carr. and ins.). WE ALSO OFFER IT ASSEMBLED, READY FOR USE, **£8/-/-**. (Plus 5/- carr. and ins.)

STERN'S HIGH QUALITY 8-10 WATT POWER AMPLIFIER



Comprises the MAIN AMPLIFIER of our very popular 8-10 watt design, which we have modified with the express purpose of its use with the "fidelity"

PRE-AMPLIFIER Illustrated alongside. TWO 6V6's are used in push-pull and the resultant reproduction is genuinely in the HIGH fidelity class yet the total cost is ridiculously low.

PRICE OF COMPLETE KIT OF PARTS **£7/7/0** (Main Amplifier only). (Plus 5/- carr. and ins.)

SPECIAL PRICE REDUCTIONS FOR PURCHASERS OF A COMPLETE "Hi-Fi" AMPLIFIER

WE WILL SUPPLY (a) COMPLETE KIT OF PARTS to build the MULLARD "5-10" MAIN AMPLIFIER and the STERN'S "fidelity" PRE-AMPLIFIER-TONE CONTROL UNIT for **£18/18/-** (plus 1/6 carr. and ins.), or we will supply the TWO UNITS MADE UP and READY FOR USE for **£19/19/-** (plus 7/6 carr. and ins.). Terms: Deposit **£9/19/6** and 12 monthly payments of **18/7**, or **£5** Deposit and 9 monthly payments of **£1/16/7**. (b) COMPLETE KIT OF PARTS to build the HIGH QUALITY 8-10 WATT POWER AMPLIFIER and the "fidelity" PRE-AMPLIFIER-TONE CONTROL UNIT for **£13** (plus 7/6 carr. and ins.) or we will supply the TWO UNITS MADE UP and READY FOR USE for **£15/15/-** (plus 7/6 carr. and ins.). Terms: Deposit **£7/17/6**, 10 monthly payments of **17/9**, or **£4** Deposit and 9 monthly payments of **£1/8/9**. QUALITY OF THIS NATURE HAS NEVER BEFORE BEEN OFFERED AT SUCH LOW COST.

AN F.M. TUNING UNIT for the HOME CONSTRUCTOR



STERN'S "fidelity." A well designed unit that can be completely built for **£10/0/0**

A design comprising a 5-valve line up, using the latest type valves and incorporates the MULLARD PERMEABILITY TUNING HEART and a "Magic Eye" Tuning Indicator. The performance of this Tuner is genuinely up to the new standard of similar Units now being offered at about £20. Attractively finished in "Hammered gold." The complete SPECIFICATION and BUILDING INSTRUCTIONS are available for 1/6, "wire-to-wire" Diagrams are included. All Components are available for sale separately. WE SUPPLY THIS TUNER ASSEMBLED and READY FOR USE. Terms Deposit **£7/5/-** and 9 monthly payments of **18/4**, or **£3/18/-** Deposit and 9 months of **£1/5/11**. **£14/10/0** A design for a COMBINED AM-FM TUNER precisely similar in appearance to the above will be available at end of June. The HOME CONSTRUCTOR will be able to build this for **£13/10/-**. It provides complete coverage of the F.M. Waveband, and the MEDIUM WAVE-BAND, hereby giving a good selection of foreign stations.

STERN'S POWER SUPPLY UNITS

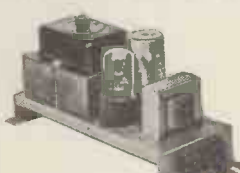

These units are fully smoothed with all output connections terminated to connecting blocks, thereby enabling ease of connecting to a Radio Tuner Unit or Amplifier, etc. Overall size is 9 1/4 in. x 3 1/4 in. x 4 1/4 in. Two Units

are available. Type "A" Unit... Incorporates type 6X5 Valve and provides 250-300 volts at up to 70 mA. and 6.3 volts at 34 amps. PRICE OF COMPLETE KIT OF PARTS **£2/9/6** ASSEMBLED and READY FOR USE **£2/17/6** (Carriage and insurance 2/6 extra). TYPE "B" UNIT. Incorporates type EZ81 valve and provides 250-300 volts at up to 100 mA. and 6.3 volts at 34 amps. PRICE OF COMPLETE KIT OF PARTS **£2/15/0** ASSEMBLED and READY FOR USE **£3/3/0** (Carriage and insurance 1/6 extra). THE WIRING DIAGRAM IS AVAILABLE SEPARATELY FOR 9d.

STERN'S "COMPACT 5" AMPLIFIERS

EXPRESSLY DEVELOPED FOR VERY HIGH QUALITY REPRODUCTION OF GRAM RECORDS AND PARTICULARLY SUITABLE FOR HIGH QUALITY REPRODUCTION OF THE F.M. TRANSMISSIONS: TWO MODELS ARE AVAILABLE:



The "Compact 5-2" A 2-stage high sensitivity amplifier having SEPARATE BASS and TREBLE CONTROLS and designed to give up to approx. 5 watts with very pleasing quality. PRICE **£5/15/-** (plus 5/- carr. and ins.).

The "Compact 5-3" A 3-stage version of the "5-2" model but in this case having an additional stage and incorporating negative feedback. PRICE **£8/16/-**. (plus 5/- carr. and ins.) The Amplifiers are compact and very attractively designed, having a Bronze/Gold finish with a fully engraved front panel by which the entire Amplifier is conveniently mounted into a Cabinet, occupying no more space than a conventional Tone Control Unit. Fully described in our Leaflets. POWER SUPPLY. A separate small Unit is available and this in addition to supplying power to the Amplifier has additional power available for RADIO TUNING UNIT, etc. PRICE **£2/10/-**.

A COMPLETE KIT OF PARTS TO BUILD STERN'S "HIGH QUALITY" 8-10 WATT AMPLIFIER



Has power supply available for Radio Tuning Unit. Price of COMPLETE KIT OF PARTS (plus 5/- carr. and ins.) **£7/10/0** WE ALSO OFFER IT ASSEMBLED and READY FOR USE for (plus 5/- carr. and ins.) **£9/10/0** This amplifier has proved one of the most popular models yet offered to the HOME CONSTRUCTOR. It provides really excellent reproduction up to 8 watts, employing 6V6's in push pull and incorporating negative feedback. Provides for the use of both 3 and 16 ohm speakers. The Complete SPECIFICATION and BUILDING INSTRUCTIONS are available for 1/6. "Wire-to-Wire" Diagrams are included and all Components are available separately.

STERN'S BATTERY PORTABLE for the HOME CONSTRUCTOR

This is a completely NEW DESIGN and we cannot at the time of going to press produce an illustration. It incorporates the NEW "ECONOMY" MINIATURE VALVES, and these have about half the battery consumption of the standard valve line-up normally incorporated in this type of Portable Set—batteries therefore last about TWICE AS LONG. The Set comprises a 4-valve Superhet design covering both LONG and MEDIUM WAVEBANDS and incorporates a Goodmans 5in. P.M. Speaker. Tone therefore is very good whilst volume and station selection is excellent. Accommodated in a robust but very attractive rexine covered ATTACHE CASE. THE COMPLETE RECEIVER (including ATTACHE CASE) can be built for **£8/12/6** THE ASSEMBLY MANUAL which contains "wire-to-wire" diagrams is available for 1/6. ALL COMPONENTS are available for sale separately.

EXCEPTIONAL OFFER FOR CASH ONLY

This latest B.S.R. MONARCH 3-SPEED AUTOCHANGER is offered for

£7/15/0 (plus 5/- carr. and ins.)

These units will autochange on all three speeds, 7 1/2, 10 in. and 12 in.

● They play MIXED 7in. 10in. and 12in. records. ● They have separate sapphires for L.P. and 78 r.p.m., which are moved into position by a single switch. ● Minimum baseboard size required 14 x 12 1/2 in., with height above 5 1/2 in., and height below baseboard 2 1/2 in. A bulk purchase enables us to offer these BRAND NEW UNITS at this exceptional price.

The latest COLLARO RC54 3-SPEED AUTOCHANGER. This is a "mixer" unit and incorporates the "Studio O" Crystal Pick-up, **£9/19/6**. H.P.: **£5** dep. and 7 months. at 17/2.

WE ALSO HAVE IN STOCK THE COLLARO MODEL 2010 P.T. TRANSCRIPTION RECORD PLAYER. S.A.E. FOR FULL DETAILS.

109-115 FLEET ST., LONDON, E.C.4.

Phone: CENtral 5812-3-4.

The B.S.R. Model TU.8 3-SPEED RECORD PLAYER

Supplied complete, including the new lightweight "Turn-over" type Crystal Pick-up, **£4/12/6**. Or we supply the 3-speed motor and Turntable for **£2/18/-**.

FULLY GUARANTEED RADIO & RADIOGRAM CHASSIS

Superhet. Chassis of Latest Design and Technique
General Specifications applicable to all models



Mains: A.C. 200/250 volts 50 cycles only.
Dial: Suitably lit multi-coloured glass dial of the horizontal type.
Tuning Drive: Slow motion by means of glass-cored Nylon cord.
A.V.C.: Full provision of Automatic Volume Control. Negative feed-back from output transformer secondary.
Sockets: Sockets provided for Aerial, Earth, Gram. Pick-up and Extension Speaker. Connections provided to Gram. Motor controlled by Chassis On/Off switch.
Inductances: All inductances have an exceptionally high Q value.

Audio Section: The Audio Section is designed for first rate reproduction on Radio and Gramophone. The tone controls have been given an extra wide range to embrace all types of recordings.

- CAT. NO. CR/A: 5-valve Superhet, 3 wavebands. **12 Gns.**
 - CAT. NO. CR/B: 7-valve Superhet with push-pull output, 3 wavebands. **16 Gns.**
 - CAT. NO. CR/AFM47: 7-valve Superhet with F.M./VHF Band (4 wavebands). **23 1/2 Gns.**
 - CAT. NO. CR/AFM49/PP: 9-valve Superhet with F.M./VHF Band (4 wavebands). Push-pull output including 2 loudspeakers. **26 Gns.**
- Packing and Carriage on Models CR/A and CR/B, 12/6. Packing and Carriage on Models CR/AFM47 and CR/AFM49/PP, 15/6.

*** built to the highest standard!**

ALL FULLY GUARANTEED. GENEROUS EXTENDED CREDIT TERMS ON ORDERS EXCEEDING £15

RADIOGRAM DROP-IN UNITS

These are fully guaranteed Radiograms consisting of Receiver Chassis, Auto Record Changer and matching loudspeaker mounted on a light-weight frame with polished top panel. Needs only fixing inside suitable cabinet to become high quality Radiogram. Offered in two different models.

- CAT. NO. UNIT/A35: Chassis as type CR/A described elsewhere. 5-valve Superhet, 3 wavebands. **29 1/2 Gns.**
- CAT. NO. UNIT/AFM47: Chassis as type CR/AFM47 described elsewhere. 7-valve Superhet with F.M./VHF Band. Both units are fitted with latest BSR FOUR-speed Auto Changer. **37 1/2 Gns.**

Packing and carriage 20/-.

HIGH QUALITY BUREAU-TYPE CABINET TO SUIT EITHER UNIT, 15 GNS.

* CABINET

CAT. NO. CAB/02: A well-designed Bureau-type cabinet in a medium size. Veneered in a highly figured Walnut. Outside dimensions, length 29 1/2 in., depth 16 in., height 32 in. Sloping control panel on right hand side approx. 13 in. x 10 1/2 in. Removable baseboard on right hand side approx. 13 1/2 in. x 13 in. Large record compartment located inside the cabinet, above gram motor.

CASH ONLY **12 Gns.**

Packing and carriage 20/-.

* PORTABLE TAPE RECORDER

CAT. NO. TR/A: A superb High-Fidelity instrument incorporating the latest TRUVOX Tape Deck. In a beautifully fitted moroccan grained carrying case, this Tape Recorder is the very finest of its class, regardless of price. TAPE DECK: TRUVOX model TR7U. Twin track with B.S.S. sense of recording. Two speeds, 7 1/2 in. (one hour for 1,200ft. reel), and 3 1/2 in. (2 hours for 1,200ft. reel). Full press-button control. Fast forward and rewind. Electro-magnetic braking. **44 Gns.**

PACKING AND CARR.: Payable in advance with order -25/-.

* PORTABLE TAPE RECORDER (KIT FORM)

CAT. NO. TR/A/KIT. A complete kit consisting of:— FULLY FITTED CARRYING CASE TAPE DECK—TRUVOX TR7U TAPE RECORDER AMPLIFIER MICROPHONE—ACOS 33-1 SPEAKER—7in. x 4in. Elliptical MAGNETIC TAPE REEL

To the same specifications and similar to those used in the Portable Tape Recorder (Cat. No. TR/A), this complete kit offers the home builder all that is required to construct a portable Tape Recorder of the finest quality. **42 Gns.**

PACKING AND CARRIAGE: Payable in advance with order—25/-.

* F.M./V.H.F. TUNERS

CAT. NO. FMT/A: An F.M./V.H.F. Tuner Unit with automatic Magic Eye Tuning, fitted in a high grade dark Walnut cabinet. Adaptor is self-powered and completely self-contained.

CIRCUIT DETAILS: SIX Valves and 10 Tuned Circuits for maximum sensitivity and best signal to noise ratio. Packing and Carriage 12/6. **16 1/2 Gns.**

CAT. NO. FMT/B: An F.M./V.H.F. Tuner Unit in chassis form, suitable for building into existing Radiograms or Radio Receivers. Adaptor is self-powered. Socket for additional Magic Eye fitting is provided in the Chassis. **£13-15-0**

* LOUDSPEAKERS

Permanent Magnet Type (Voice Coil Impedance 3 ohms). CAT. NO. LS/10/PM: 10in. diameter, Flux density 8,500 lines. PRICE: CASH ONLY **£1/10/-**. PACKING AND CARR.: 3/-.

CAT. NO. LS/8/PM: 8in. diameter, Flux density 8,500 lines. PRICE: CASH ONLY **£1/10/-**. PACKING AND CARR.: 3/-.

CAT. NO. LS/74/PM: Elliptical 7in. x 4in. Flux density 7,500 lines. PRICE: CASH ONLY **£1/1/-**. PACKING AND CARR.: 3/-.

Electrostatic "Treble" type, imported (suitable for accentuating treble response, particularly on F.M./V.H.F. reception). CAT. NO. ELEC/LSH 75: PRICE, CASH ONLY **12/6**.

Packing and carriage free. CAT. NO. ELEC/LSH518: PRICE, CASH ONLY **17/6**.

Packing and carriage free. CAT. NO. ELEC/LSH100: PRICE, CASH ONLY **£1/1/-**. Packing and carriage free.



CAT. NO. CAB/03

A magnificent Bureau-type Cabinet of the very highest quality in specially selected Walnut veneered exterior. Light Sycamore interior with Roxie lining to match. Outside dimensions, length 34 1/2 in., depth 17 1/2 in., height 33 in. Sloping control panel on right-hand side approx. 16 in. x 10 1/2 in. Removable baseboard on right side approx. 15 1/2 in. x 15 in. Two full-sized felt lined compartments in the lower half. **16 1/2 Gns.**

Packing and Carriage payable in advance with order—25/-.

* MULTI-SPEED AUTOMATIC RECORD CHANGERS

All automatic Record Changers are of the latest type and unused.

CAT. NO. RC/A: This is the latest. Multi-speed changer incorporating 16 r.p.m. for "talking-books," and arrangement for manual control. Fitted with high fidelity Crystal Turnover Pick-up Head. A.C. mains 200/250 volts, 50 cycles only. **£9-15-0**

PRICE: CASH ONLY

PACKING AND CARR.:—12/6.

CAT. NO. RC/B: Latest GARRARD RC88 model, fitted with GC-2 Crystal Turnover Pick-up Head. A.C. 200/250 volts, 50 cycles.

PRICE: CASH ONLY

PACKING AND CARR.:—13/6. **£13-0-0**

Dealers supplied at full discounts.

Send for Complete Catalogue.

All enquiries (excluding Northern Area) to:—

Northern enquiries only (not Scotland and N. Ireland) to:—

DOMESTIC

MAYLIT LTD

DIRECT SALES LTD.

3 MARLBOROUGH ROAD, ALTRINCHAM, CHESHIRE

90 JUDD ST., LONDON, W.C.1. TER 9876

Telephone enquiries: **ALTRINCHAM 4045**

MAINS TRANSFORMERS

Primary, 200-250 v. P. & P. 2/- 300-0-300, 100 mA. 6 v. 3 amp., 5 v. 2 amp., 22/6.

Semi-shrouded drop-through 380-0-380 v., 120 mA., 6.3 v. 4 amp., 5 v. 2.5 amp., 22/6.

Drop thro' 350-0-350 v. 70 mA. 5 v. 2.5 amp. 5 v. 2 amp., 14/6.

Chassis mounting or drop-thro'. Pri. 110-150 v. Sec. 350-0-350, 250 mA., 6.3 v. 7 amp., 6.3 v. 0.5 amp., 5 v. C.T., 0.5 amp. 4 v. amp. P. & P. 3/6. 32/6.

Chassis mounted and fully shrouded, 80 mA. 6 v. 3 amp., 5 v. 2 amp., 14/6.

Drop thro' 270-0-270 60 mA., 6 v. 3 amp., 11/6. 250 v. 350 mA., 6.3 v. 4 a., twice 2 v. 2 a., 19/6.

Auto-trans. Output 200-250 H.T. 500 v. 250 mA., 6 v. 4 a., twico, 2 v. 2 a., 19/6.

Auto-trans. Input 200-250 H.T. 350 v. 350 mA. Separate L.T. 6.3 v. 7 a., 6.3 v. 1/ amp., 5 v. 3 amp., 25/- P. & P. 3/-.

Mains transformer, fully impregnated, Input 210, 220, 230, 240. Sec. 350-0-350 100 mA. with separate heater-transformer. Pri. 210, 220, 230, 240. sec. 6.3 v. 2 amp., 6.3 v. 3 amp., 4 v. 6 amp., and 5 v. 2 amp., 30/- P. & P. 5/-.

350-0-350 75 mA. 6.3 v. 3 a. tap 4 v. 6.3 v. 1 a., 13/6.

500-0-500 125 mA. 4 v. C.T. 4 a., 4 v. C.T. 4 a., 4 v. C.T. 2.5 a., 27/6.

500-0-500 250 mA. 4 v. C.T. 4 a., 4 v. C.T. 5 a., 4 v. C.T. 4 a., 39/6.

6 1/2 in. M.E. Speaker. 1,000 ohm field, 15/-.

R. & T.V. Energised 6 1/2 in. Speaker with O.P. trans. field coil. 175 ohm 9/6. P. & P. 2/6.

R. & A. 8 1/2 in. M.E. Speaker, with O.P. trans. field 440 ohms. 10/6. P. & P. 2/6.

Volume Controls. Long spindles, less switch, 50K, 500K, 1 meg., 2/6 each. P. & P. 3d.

Volume Controls. Long spindle and switch, 1, 1 and 2 meg., 4/- each. 10K and 50K, 3/6 each. 1 and 1 meg., long spindle, double pole switch, miniature, 5/- P. & P. 3d. each.

Trimmers. 5-40 pf., 5d. 10-110, 10-250, 10-450 pf., 10d.

Twin Gang .0005 Tuning Condenser 5/- With trimmers, 7/6.

Twin Gang .0005, with feet, size 3 1/2 x 3 1/4 in., 8/6.

3-RANG .0005, with feet, size 4 1/2 x 3 1/4 in., 7/6.

T.V. Coils, moulded former, iron-cored wound for re-winding purposes only. All-can 1 1/2 x 1 1/2 in., 1/- each. 3 Iron-core All-can 2 1/2 x 1 1/2 in., 1/6 each. The above coil formers are suitable for the "Wireless World" F.M. tuner.

Used Metal Rectifier, 250 v. 150 mA., 6/6. Metal Rectifier, 250 v. 45 mA., 6/-.

Metal Rectifier, RM2, 125 v. 100 mA., 3/6.

OUTPUT TRANSFORMERS

Standard type 5,000 ohms imp., 4/6. 42-1 with extra feed-back windings, 4/3. Miniature 4-2, 13/3. Multi-radio 3,500, 7,000 and 14,000, 5/6. 10-watt push-pull, 6V6 matching, 7/- 90-1 ohm speech coil, 6/6.

COMMERCIAL TELEVISION CONVERTER SUITABLE ANY T.V. using lower side band NO ALTERATIONS TO SET

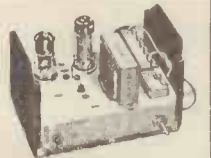

Complete with built-in power supply, 230-250 v. A.C. mains. Crackle finish case 5 1/2 in. long, 3 1/2 in. wide, 4 1/2 in. high. Incorporating gain control and band switch.

£3 - 19 - 6 Plus Post & Packing 2/6. Less power supply £2/19/6. P. & P. 2/6.

Illustrated with cover removed.

BAND III CONVERTER KIT

comprising 5 channel tuner, mains transformer, metal rectifier, electrolytic, 2 valves 12AT7 and 6P80 and all necessary components for A.C. mains operation. Complete with conversion data, £2/5/- P. & P. 2/6.

P.M. SPEAKER 6 1/2 in. closed field, 18/6. 8 in. closed field, 20/6. 10 in. closed field, 25/- 3 1/2 in., 18/6. 12 in. closed field, 25/- P. & P. 2/6.

EXTENSION SPEAKER in polished walnut, complete with 8 in. P.M. P. & P. 3/- 24/6.

B.S.R. MONARCH three speed automatic changer, current model. Brand new. Will take 7 in., 10 in., or 12 in. records mixed. Turnover crystal head. A.C. mains 200-250. Pre-Budget Price while stocks last. £7/15/- P. & P. 3/-.

T.R.F. KIT

IN PLASTIC CABINET

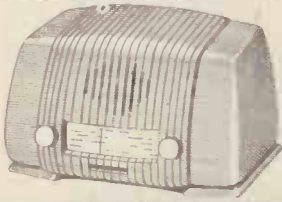

3 valve plus metal rectifier, A.C. mains 200-250 v. Medium and long waves. In pastel blue or brown. Valve line-up: 2 VR6S8 and VT62. Size 13 1/2 in. long by 9 in. high by 7 in. deep. £3/19/6. P. & P. 4/6.



3-speed TRANSCRIPTION MOTOR

BY FAMOUS MANUFACTURER

Complete kit of parts comprising accurately balanced precision made heavy turntable with rubber mat, large constant speed condenser starting motor, base plate. Can be assembled in half an hour. A.C. Mains 200/250 v. Fully guaranteed. Parts sold separately.

£6 - 19 - 6

Post Paid

16 in. TUBE

METAL CONE

BY FAMOUS MANUFACTURER

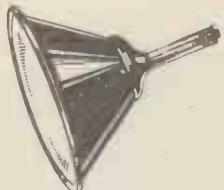

Brand new E.H.T. 14 Kv. Heater. 6.3 volts 0.6 amp., guaranteed 3 months. £9/19/6. Post, packing and insurance 22/6. H.P. terms available. E.H.T. and scanning components available.

4 VALVE ALL-DRY SUPERHET PORTABLE KIT



Medium and long waves. In grey leatherette. Size 9" x 7" x 6". Valve line up IT4, IR5, ISS, 3V4. Complete kit of parts (less batteries). £6 - 6 - 0 Plus 2/6 Post and Packing.

SIGNAL & PATTERN GENERATOR

Coverage 7.6 Mc/s.-210 Mc/s. in five bands, all on fundamentals, slow-motion tuning, audio output, 8 vertical and horizontal bars, logging scale. In grey hammer finished case with carrying handle. Accuracy +/- 1%.

A.C. mains 200-250 v., £6 - 19 - 6 P. & P. 5/6.

Or £3 deposit, P. & P. 5/6 and 3 payments of 30/-.

R. AND T.V. COMPONENTS (ACTON) LTD.

23 HIGH STREET, ACTON, LONDON, W.3
GOODS NOT DESPATCHED WHERE CUSTOMS DECLARATION IS APPLICABLE
Terms of Business: Cash with order. Despatch of goods within 3 days from receipt of order. Where post and packing charge is not stated please add 1/6 up to 10/-, 2/- up to £1, and 2/6 up to £2. All enquiries S.A.E., lists 5d. each.

Germanium Crystal Diode, 1/8, post paid.

Line O.P. Transformer in aluminium can mounted in rubber, 12/6.

Line and E.H.T. Transformer, 14 Kv., using ferrocoat core, complete with line and width control, and corona shields U37 rectifier winding, 35/-.

Line and E.H.T. Transformer, 9 Kv., using ferrocoat core, complete with built-in line and width control. Mounted on small all-chassis. Overall size 4 1/2 x 1 1/2 in. EV51 rec. winding, 27/6.

Scan coils, low line low impedance frame, complete with frame transformer to match above 27/6. P. & P. 2/-.

Line and E.H.T. Transformer, 9 Kv. ferrocoat core, EY51, heater, winding, complete with scan coils and frame output transformer, and line and width control, 35/- P. & P. 3/-.

As above, but complete with line and frame blocking transformers, 5 Henry 25 mA. choke, 100 mfd. and 150 mfd. 250 wkg. 380 mA. A.C. ripple. £2/9/6. P. & P. 3/-.

Valve Holders, moulded octal Mazda and local, 7d. each. Paxolin, octal Mazda and local, 4d. each. Moulded B7G, B9A and B9A, 7d. each. B7G moulded and B9A with screening can, 1/6 each.

GARRARD RC/110

3 speed automatic changer. 10 Records, turnover crystal head, brand new, current model. A.C. mains 200/250 v. (list price £14/10/-). £8-19-6 P. & P. 5/-.

Hire purchase available.

Standard Wave Change Switches. 4-pole, 3-way, 1/8; 5-pole, 3-way, 1/9; 3-pole, 3-way, 1/9; 3-pole 3-way, 3/6. Miniature type, long spindle, 3-pole, 4-way, 4-pole 3-way and 4-pole 2-way, 2/6 each. 2-pole 11-way, twin water, 5/-; 1-pole 12-way single water, 5/- P. & P. 3d.

Ion Traps for Mullard or English Electric tubes, 5/-, post paid.

Standard 465 Kc. iron-cored I.F.s, 3 in. x 1 1/2 in. x 1 1/2 in., per pr., 7/6.

1,200ft. High Impedance Recording Tape on aluminium spool 12/8, post paid.

Miniature wire ends moulded. 100 pf., 500 pf., and .001 each 7d.

Combined 12 in. mask and escutcheon in lightly tinted Perspex. New aspect edged in brown. Fits on front of cabinet, 12/6. As above for 15 in. tube, 17/6.

Frame Oscillator Blocking Trans., 4/6. Line Osc. Blocking Trans., 4/6.

CHOKES.

2-20 Hen., 150 mA., 15/- P. & P. 3/- 6 Hen. 275 mA., 15/- P. & P. 3/- 100 Hen., 40 mA., 15/- P. & P. 3/- 250 mA., 30 Henry, 10/6; 5 Henry 250 mA. 60 ohms 8/6.

Wide Angle P.M. Focus Units. Vernier adj. state tube, 15/-.

P.M. Focus Unit for Mullard tubes with vernier adjustment. P. & P. 2/- 15/-.

PATTERN GENERATOR

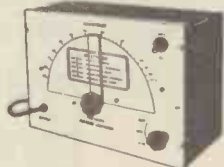

Coverage 40 Mc/s.-70 Mc/s.

A.C. Mains 200/250 v. £3 - 19 - 6

Or 20/- deposit, 3 payments of £1. P. & P. 4/6 extra.

SIGNAL GENERATOR

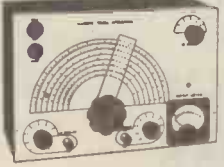

Coverage 120 Kc/s.-84 Mc/s.

A.2 Mains 200/250 v. £4 - 19 - 6

Or 34/- deposit, 3 payments of 25/- P. & P. 4/6 extra.

"... this is a good
book... no, on
second thoughts
it is an
excellent one"

SCOTTISH RADIO TRADE DIGEST

A book for students and engineers

Cathode Ray of "Wireless World."

Forty-four articles reprinted from popular *Wireless World* series, in which the author examines various aspects of elementary radio science, explains them clearly and shows that there may be more behind them than is apparent from the usual text-book. This volume deals with basic ideas; circuit elements and techniques; circuit calculations; and some matters in lighter mood. An entertaining and helpful text-book for the student, refresher course for the engineer, and reference book for all, combined.
8½" × 5½". 410pp. 266 illustrations.

25s. 0d. net. (By post 26s. 2d.)

SECOND THOUGHTS ON RADIO THEORY

Published for "Wireless World"
Obtainable from all booksellers.

Hiffe & Sons Limited, Dorset House, Stamford St., London, S.E.1.

THE NEW AXIOM ENCLOSURES as demonstrated at the RADIO SHOW by Messrs. GOODMAN'S INDUSTRIES

Completely Fitted comprising 12in. Axiom No. 150 Mk. II Speaker. The Acoustic Resistance Unit and Cabinet to Messrs. Goodmans specification. Lined and Quilted with 1½in. cotton felt and constructed of ½in. Weyrock.
Cash Price £27/18/6 or £4/7/6 deposit and 9 payments of 5/7/3 monthly. Cabinet only £14/7/6 or £2/5/- deposit and 9 payments of 2/9/- monthly. Delivery 12/6 cash or terms.
Also in Corner Cabinets 27/6 extra.
Write for catalogue of cabinets for Records—Equipment—Speakers.

A. L. STAMFORD
(Dept. D4), 20 College Parade, Salisbury Road, London, N.W.6.

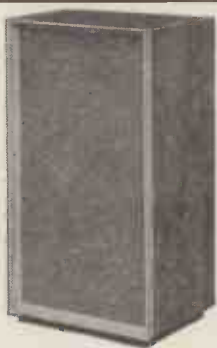

S.4

WANTED URGENTLY

Exceptional Prices Paid for

BC221 FREQUENCY METERS or CASES

Kindly advise price required.
NO REASONABLE FIGURE REFUSED
As we DO require these urgently.

UNIVERSAL ELECTRONICS
22 Lisle Street, Leicester Square, London, W.C.2

METAL SPINNING OUR SPECIALITY

PARABOLIC REFLECTORS up to 9ft. dia. LOUDSPEAKER HORNS, Etc., Etc.
POWER PRESSWORK to 250 ton capacity, including Hydraulic
GENERAL SHEET METAL WORK . ARGON . ARC & OXY-ACETYLENE WELDING

SHAWE METAL SPINNING WORKS

SWINTON STREET, KING'S CROSS, LONDON, W.C.1.

'Phone : TERminus 7422/3

Grams : Alipryde Phone London

FOR VALVES—GUARANTEED NEW AND BOXED



0Z4	9/6	6F11	13/6	9003	5/6	ECL80	10/6	PL82	11/6
1A3	9/6	6F13	14/6	9004	5/6	ELP22	9/6	PL83	13/6
1A5GT	6/6	6F14	12/6	9006	5/6	EP40	11/6	PP225	5/6
1A7	11/6	6F15	14/6	955	2/6	EP41	11/6	PY80	10/6
1C5GT	9/6	6F6G	7/6	10C1	12/6	EF42	13/6	PY81	11/6
1H5GT	10/6	6F6M	8/6	10C2	12/6	EF80	10/6	PY82	10/6
1T4	9/6	6G5G	4/6	10F1	12/6	EF86	13/6	FX25	13/6
1LDS	8/6	6H8	3/6	10F9	12/6	EL2	12/6	QP21	7/6
1N6	10/6	6J5G/GT	5/6	10P13	11/6	EL35	7/6	SP220	8/6
10P14	13/6	6J5M	6/6	12A6	6/6	EL41	11/6	SP22	6/6
1R5	8/6	6J6	6/6	12A7	9/6	EL64	12/6	U10	9/6
1S5	7/6	6J7G	8/6	12A7	9/6	EL64	12/6	U22	8/6
1T8	8/6	6K7G	5/6	12A7	9/6	EM34	11/6	U25	13/6
2X2	4/6	6K7GT	6/6	12B6	5/6	EM34	11/6	V4	8/6
3A4	7/6	6K7GT	6/6	12B6	5/6	EV88	14/6	U404	11/6
3Q4	9/6	6K8G	8/6	12J7	9/6	EV91	7/6	U41	8/6
3Q5	10/6	6K8GT	8/6	12K7	9/6	EZ40	10/6	UBC41	11/6
3S4	8/6	6L6G	9/6	12K7	9/6	EZ41	11/6	UCH42	11/6
4D1	3/6	6N7	7/6	12K7	9/6	EZ30	10/6	U41	11/6
4E	8/6	6Q7G/GT	9/6	12S7	7/6	EL148	9/6	U41	11/6
5B4G	9/6	6A7GT	8/6	12S7	7/6	FW4/500	10/6	U41	10/6
5U40	8/6	6S7	7/6	12S7	7/6	GZ32	12/6	V221	3/6
6F5GT	8/6	6S7	7/6	12S7	7/6	H30	5/6	V253	6/6
6Z4G	9/6	6S7GT	8/6	12S7	7/6	HL2	5/6	V554	2/6
6A7	11/6	6SK7	5/6	16D2	5/6	HL320	4/6	V555	7/6
6A8GT	10/6	6SL7	8/6	20L1	12/6	HL3DD	8/6	V556	8/6
6A7	6/6	6SN7	8/6	25L8GT	9/6	HP211C	6/6	V857	8/6
6A05	6/6	6S7	7/6	25U4GT	10/6	HP4101	7/6	V885	3/6
6A85	8/6	6S7	7/6	25Y6G	9/6	IC2	9/6	V885A	3/6
6A85	8/6	6S7GT	8/6	25Z4G	9/6	IN5	10/6	V888	3/6
6A85	8/6	6S7GT	8/6	25Z4G	9/6	K22	5/6	V891	5/6
6A85	8/6	6S7GT	8/6	25Z4G	9/6	KT2	5/6	V891SXL	7/6
6A85	8/6	6S7GT	8/6	25Z4G	9/6	KT2	5/6	V892	2/6
6A85	8/6	6S7GT	8/6	25Z4G	9/6	KT61	13/6	V891S/30	8/6
6A85	8/6	6S7GT	8/6	25Z4G	9/6	KT66	12/6	V891S/16	4/6
6A85	8/6	6S7GT	8/6	25Z4G	9/6	KT66	12/6	V891S/8	4/6
6A85	8/6	6S7GT	8/6	25Z4G	9/6	KT66	12/6	V891S/8	4/6
6A85	8/6	6S7GT	8/6	25Z4G	9/6	KT66	12/6	V891S/8	4/6
6A85	8/6	6S7GT	8/6	25Z4G	9/6	KT66	12/6	V891S/8	4/6

Packing and postage 6d. per valve.

ALPHA 3-VALVE T.R.F. KIT

★ Easy to build. ★ Valves 6J7, 6K7, 6V6GT plus metal rectifier. Full instructions, point to point wiring diagram. Price £5/10/- each. Post and Packing 3/-. Circuit diagram and full shopping list 1/-. All components may be purchased separately.

★ Walnut finished cabinet.



MAINS TRANSFORMERS

3-way mounting type
MT1
 Primary: 200-220-240v.
 Secondary: 250-0-250 v., 80 M/A 0-6.3 v. 4 amp. 0-4 v. 2 amp. Both tapped at 4 v., each 18/6

MT2

Primary: 200-220-240 v.
 Secondary: 350-0-350 v., 80 M/A 0-6.3 v. 4 amp. 0-5 v. 2 amp. Both tapped at 4 v., each 18/6

MT3

Primary: 200-220-240 v.
 Secondary: 30 v. 2 amps.
 Taps at 3 v., 4 v., 6 v., 8 v., 9 v., 10 v., 15 v., 18 v., 20 v., 24 v., each 18/6
 2/- packing & post on above transformers.

CET ISOLATION TRANSFORMERS

NR8A 2 volt: NR8B 4 Volt: NR8C 6.3 v.: NR8D 10.8 v.: NR8E 13.3 v. Price 10/6 each, all for use on receivers with own transformer.

NR12 Input 230/240 v. Multi output 0.2-4-6.3-7.3-10-13 volts, 25% and 50% BOOST. 21/6 each.

NR15 Input 230/240 v. Output 6.3 v. with 25% and 50% BOOST. Price 17/6 each.

AMERICAN INDICATOR UNIT TYPE BC929A

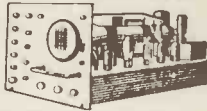

Brand new, incorporating 3in. tube 3BP1, with metal shield, two 68N7GT, two 6H6GT, 6X5G, 2X2, 6G6G, nine potentiometers, 24 v. aerial switch motor, transformer, and a host of small components. The whole unit, which measures only 8 1/2 in. x 8 1/2 in. x 1 1/2 in., is brand new, enclosed in black crackle box, and can be supplied at price 65/-, plus 5/- postage and packing.

TRANSFORMERS, ETC.

HEATER TRANSFORMERS

230 v. Input 2 volt 5 amp., each	5/6
230 v. Input 2 volt 3.0 amp., each	8/3
230 v. Input 4 volt 1.5 amp., each	5/6
230 v. Input 4 volt 3.0 amp., each	10/6
230 v. Input 5 volt 2.0 amp., each	10/6
230 v. Input 6.3 volt, 5 amp., each	5/6
230 v. Input 6.3 volt 1.5 amp., each	6/6
230 v. Input 6.3 volt 3.0 amp., each	9/6
230 v. Input 12 volt, .75 amp., each	5/6

CHOKES

20H, 250 ohms, 60 M/A. Clamp construction, each	6/6
10H, 200 ohms, 90 M/A. Clamp construction, each	9/3
10H, 200 ohms, 150 M/A. Clamp construction, each	13/6
10H, 300 ohms, 40 M/A. Midgett Clamp construction, each	5/3

TRANSFORMERS FOR BATTERY CHARGERS

230 v. Input Tapped 6-12 v. 1 amp., ca. 13/6	
230 v. Input Tapped 6-12 v. 3 amp. (Both with tap on Primary for 2.5 v. Pilot light), each	18/6

HEATER AUTO TRANSFORMERS
 Designed to adapt common low tension voltages 4 v., 5 v., 6.3 v. at 3 amps., centre tapped and interchangeable, each 7/9

Aerialite Band III Aerials, 5 element, 702 x U. An array with universal 1 1/2-in. masthead bracket, suitable channels 5, 9 and 10. Price 41/-, carriage 4/6.
 Aerialite Coaxial outlet boxes at 4/6 each.
 Aerialite Coaxial plugs and sockets at 1/1 each.

Transformers T1154N, 25/- each.
 Transformers T1154H, 37/- each.
 Transformers T1154 in rough condition, 15/- each.
 Carriage and postage on above transformers 1s 12/6.
 Meters 0-100 m/a. panel mounting, 7/6 each.
 Meters 0-5 amp. R.F. panel mounting, 7/6 ea.

If you are not in possession of our 1956 24-page illustrated catalogue, please forward 6d. for your copy.

TYANA SOLDERING IRON
 Lightweight 40 watt iron, with easily replaceable elements and bits. 200/250 v., price 16/9 each.

LOUDSPEAKER UNITS—all 2 1/4 ohms 3 1/2 in. types 17/6 each
 5in. types by Goodmans, Elac, Lectrons, Baffle, etc., all 17/6 each
 6 1/2 in. types by Goodmans, R. & A., Plessey, etc., all 18/6 each
 8in. types by Goodmans, Plessey, R. & A., etc., all 19/6 each
 10in. types by Celestion, R. & A., Plessey, etc., all 25/6 each
 12in. types by Plessey, lightweight units 35/- each
 Goodmans 4in. x 7in. elliptical speaker 19/6 each
 8in. units with output transformer by Goodmans and Lectrona. 22/6 each
MAINS ENERGISED TYPES
 8in. 600 ohm field, 21/6, 6 1/2in. 600 ohm field, 17/6.
 Postage on all above 1/6 extra.

TRANSFORMER MT6
 Small mains transformer suitable for TV converters, etc. Primary 230 v. Secondary 250 v. 40 M/A and 6.3 v., 1.5A. Price 15/6 each. Postage 1/8.

PURETONE TAPE
 1,200ft. Reels, Plastic Spool, 17/6 each.

WHEN ORDERING PLEASE QUOTE DEPT W.W.

WIRE WOUND COILS
 By Colvers, etc., all with h.n. spindle.
 5 ohms, 100 ohms, 200 ohms, 200 ohms, 500 ohms, 1K ohms, 5K ohms, 10K ohms, 20K ohms, 25K ohms and 50K ohms. All 2 1/8 each.

G.E.C. CABINET LOUDSPEAKERS, Cat. No. BC1955
 5in. P.M. moving coil loudspeaker unit, 2/4 ohms with volume control in very attractive cabinet. Price 52/6 each, post 2/6.

CONDENSERS

BEC 100 MFD 25 v.	1/9
BEC 500 MFD 12 v.	1/9
TCC 25 MFD 25 v.	1/3
BEC 50 MFD 50 v.	1/9
TCC 25 MFD 50 v.	2/6
TCC 50 MFD 25 v.	1/9
TCC 250 MFD 12 v.	1/6
BEC 250 MFD 25 v.	1/6
BEC 12 MFD 50 v.	1/6
TCC 50 MFD 12 v.	1/9
BEC 250-250 MFD 6 v.	1/6
DUBILIER 100-12 MFD 12 v.	1/9

OUTPUT TRANSFORMERS

Multi Ratio Type, each	6/6
Midgett for 354 Output, each	4/6
Standard 5,000 ohms, each	4/6
Standard 10,000 ohms, each	4/6
Igranic Jack Plugs, each	2/3
Bell Lee 7-pin Plug and Socket, each	1/6

CHARGER RECTIFIERS—All Full Wave

12 volt 1 amp., each	5/3
12 volt 2 amp., each	8/6
12 volt 3 amp., each	13/6

VOLUME CONTROLS
 Type with Single Pole Switch.
 5K ohms; 10K ohms; 20K ohms; 50K ohms; 100K ohms; 1 meg.; 2 meg.; all 3/6 each.

DUAL VOLUME CONTROL
 With Double Pole Switch 500K ohms and 500K ohms. Price 6/9 each.

A NEW ALPHA KIT FOR YOU TO BUILD

Autocoupe Portable AC/DC Mains/Battery Receiver, 4 valves (latest types), 2 wave-band Superhet in an attractive lizard grey case size 8 1/2 x 3 1/2 x 4 1/2. Full kit of parts down to last nut and bolt. **£9.9.0**

Or if you prefer you can build the battery version first for £7.17.6 and add the mains components later. Post extra on kit 2/6.

Full circuit diagram, shopping list and point-to-point wiring diagram 3/-. 

ALPHA RADIO SUPPLY CO. 5/6 VINCES CHAMBERS VICTORIA SQUARE LEEDS.

TERMS: Cash with order or C.O.D. Postage and Packing charges extra, as follows: Orders value 10/- add 9d.; 20/- add 1/6; 40/- add 2/6; £5 add 3/6; unless otherwise stated. Minimum C.O.D. fee and postage 2/3.
MAIL ORDER ONLY

AMERICAN COMMAND RECEIVERS

Large purchase from the Air Ministry. These famous compact receivers which can be used for a variety of purposes are offered at ridiculously low prices while stocks last. Complete with 6 metal type valves, 1 each of 12K9, 12SR7, 12A6 and 3 of 12SJ7, in aluminium case size 11in. X 5½in. X 5in. Used, but in very good condition, although cases may be somewhat dented. First come, first served. Choice of models, BC455 (6.9 mcs.), BC454 (3.6 mcs.), 27/6; BC453 (190-550 kcs., the renowned "Q Fiver"), 59/6 and a few of the 1.5-3.0 mcs. model, 65/-. Circuits supplied.

COMMUNICATIONS RECEIVER R.1155

The famous ex-Bomber Command Receiver known the world over to be supreme in its class. Covers 5 wave ranges: 18.5-7.5 Mc/s., 7.5-3.0 Mc/s., 1,500-600 kc/s., 500-200 kc/s., 200-75 kc/s., and is easily and simply adapted for normal mains use. Full details being supplied.
BRAND NEW AND UNUSED IN MAKER'S TRANSIT CASES. ONLY £11/19/6.

A.C. MAINS POWER PACK OUTPUT STAGE, in black metal case, enabling the receiver to be operated immediately, by just plugging in, without any modification. Can be supplied as follows: WITH built-in 6½in. P.M. speaker, £5/5/-. LESS speaker, £4/10/-. DEDUCT 10/- IF PURCHASING RECEIVER AND POWER PACK TOGETHER.

Send S.A.E. for illustrated leaflet, or 1/3 for 14-page booklet which gives technical information, circuits, etc., and is supplied free with each receiver. All models aerial tested before dispatch.

CLASS D WAVEMETER

Another purchase of this famous crystal-controlled wavemeter which has been repeatedly reviewed and recommended in the "R.S.G.B." Bulletin as being suitable for amateur transmitters. Covers 1.9-8.0 Mc/s., and is complete with 100/1,000 kc/s. crystal, 2 valves ECH35, two 6-volt vibrators and instruction manual. Designed for 6 v. D.C. operation, but simple mod. data for A.C. supplied. **BRAND NEW IN MAKER'S TRANSIT CASES, ONLY £5/19/6.** Transformer for A.C. modification, 7/6.

COLLINS TCS TRANSMITTERS

Special offer of these famous American Transmitters. Frequency range 1.5-12.0 mcs. in 3 bands. Employs 7 valves, 2 of 1625 in P.A. Stage, 1625 buffer and 1625 modulator stage, 3 of 12A6 in oscillator stage. Radio telephone or radio telegraph. Provision for VFO or Crystal Control. 4 crystal positions. Has plate and aerial current meters. In **BRAND NEW CONDITION, ONLY £12/10/-**. Matching receivers available £8/10/-, OR THE PAIR £20.

100 MICROAMPS METERS, 2½in. circular flush mounting. Widely calibrated scale of 15 divisions marked "yards" which can be rewritten to suit requirements. These movements are almost unobtainable today and being **BRAND NEW IN MAKER'S CARTONS** are a snip at **ONLY 42/6**.

RECEIVER 25/73. Part of the TR1196, this 6-valve unit makes an ideal basis for a mains operated all-wave Superhet, full modification data being supplied. Complete with valves, 2 each EF36 and EF39, and 1 each EK32 and EBC33. **BRAND NEW. ONLY 27/6**.

MODEL-MAKER'S MOTOR. Reversible poles. Only 2in. long and 1½in. diameter, with ½in. long spindle. Will operate on 4, 6, 12 or 24 v. D.C. **ONLY 10/6**.

100-0-100 VOLTS METERS by Sangamo Weston. 2½in. circular, basic movement being 500-0-500 microamps. A really first-class centre zero meter for hundreds of uses. **BRAND NEW. IN MAKER'S CARTONS. ONLY 27/6**.

POCKET VOLTMETERS. Not ex-Govt. Read 0-15 v. and 0-300 v. A.C. or D.C. **BRAND NEW AND UNUSED. ONLY 18/6**.

WALKIE TALKIE TYPE 18. Covers 6.0-9.0 Mc/s. Complete with valves, microphone and headset, and transmitting and receiving units in metal case. In excellent condition. **ONLY 79/6**.

BC.610 MODULATION TRANSFORMERS. Brand new spares for this famous American Transmitter. In Maker's Original Cases. **ONLY £5 each**.

CONSTANT VOLTAGE TRANSFORMERS. Manufactured by SOLA of CHICAGO, U.S.A. Primary 90-125 v. or 190-250 v. Secondary 115 v. precisely at 2 KVA. Can be adjusted for 50 or 60 cycles operation. Primary and secondary are completely isolated, and for 230 v. output two can be used in series. Fully guaranteed. **ONLY £21 each or £40 per pair**.

RF UNITS TYPE 26. For use with the R.1355 or any receiver with a 6.3 v. supply. This is the variable tuning unit which uses 2 valves EF54 and 1 of EC52. Covers 65-50 Mc/s. (5-6 metres). Complete with valves, and **BRAND NEW IN MAKER'S CARTONS. ONLY 29/6 each**.

TRANSFORMERS, EX-W.D. AND ADMIRALTY. Built to more than 50 per cent safety factor with normal A.C. mains primaries. Brand new and unused, 300-0-330 v., 100 mA. 4 v. 3 a., 22/6.

L.T. HEAVY DUTY. Has 3 separate windings of 5 v.-0.5 at 5 amps., and by using combinations will give various voltages at high current. **ONLY 29/6**.

159 RECEIVER UNIT. Contains 1 each valve, types EF50, EA50, SP61, RL37 and 24 v. selector switch. **ONLY 7/6**.

Cash with order please, and print name and address clearly
PLEASE ADD POSTAGE OR CARRIAGE COSTS ON ALL ITEMS

U.E.I. CORPORATION Radio Corner, 138 Gray's Inn Road, London, W.C.1. Phone: TERMINUS 7937

(Open until 1 p.m. Saturdays. We are 2 mins. from High Holborn (Chancery Lane Station) and 5 mins. by bus from King's Cross)

HANNEY OF BATH OFFERS

VIEWMASTER 3 STATION T.V. TUNER (P. Television)

Denco coilset with screen, can and screws 30/-; Denco switch, Fine Tuner, Coil mounting plates and tag panel 27/-; Kit of resistors 7/8; TCC condensers kit with two printed circuits, valve holders etc. 43/-; Gain controls 3/3 each; Co-ax P/8k 2/6; Valve cans 1/3 each. Complete kit of parts for the TUNER, with the Genuine MULLARD Valves, nuts, bolts, wire co-ax etc. £8/19/6. Denco Coilset for conversion of the V-Master 8/V chassis to the I.F. amplifier 20/- OR Complete kit of 8/V conversion components 39/6. All Standard V-Master Items in stock. Full list available.

MULLARD 3 VALVE 3 WATT AMPLIFIER

Punched chassis 10/6; Gilson Trans. Mains 35/-; Output 25/6. Elstone Trans. Mains 35/-; Output 21/-; Condenser kit 20/-; Resistor kit with 3 pots. 22/6. Complete kit with Genuine Mullard VALVES £8/19/6. Full list available.

MULLARD 510 AMPLIFIER

Eric Resistors 27/-; TCC Condensers 45/-; Elstone Mains Trans. 36/- (100 ma.); 42/6 (120 ma.); Output Trans. 45/- (6K or 8K); Gilson mains trans. 60/- (140 ma.); Output Trans. 47/6 (6K or 8K); Ultra linear type 52/6; Partridge Mains Trans. 65/6; Output Trans. P.3667 55/6; Partridge Ultra Linear type P.4014 88/6. Denco, punched chassis 19/6 with base plate; Printed front panel 6/6; Type 'A' and 'B' Chassis (panel not printed) 8/6 and 12/6 respectively. Condensers 'A' 15/6 'B' 24/6; Resistors 'A' 17/6, 'B' 35/6 (with pots). Full list available, giving details of complete kits.

OSRAM 912 PLUS AMPLIFIER

Eric resistor kit, 17/4; Eric 1 meg. pots, 4/6 each; TCC condenser kit, 55/-; PARTRIDGE components with loose lead terminations (includes packing charge), Mains trans., 65/6; choke, 34/6; output trans., 85/6; W.B. components. Choke, 18/9; output trans., 32/-; Denco drilled chassis, 14/6; Denco 912 Plus printed panel, 7/6; pre-amp. or passive chassis, 6/- Full list available.

COMPONENTS are still available for the following F.M. TUNERS.—Wireless World, Mullard, Osram 912; Denco Maxi-Q. List available.

WIDE ANGLE COMPONENTS. ALLEN. Telexing Chassis, 50/-; Coilsets (TK and Super-Visor), 44/6; L.O.308, 40/-; P.O.305, 21/-; D.C.300c., 39/6; FC302, 31/-; GL18 and 18, 7/6 each; SC.312, 21/-; AT.310, 30/-; OP.117, 9/-; BT.314, 15/-; Denco Chassis Magnaview, 37/6; Chassis, Super-Visor, 51/6; Coilsets Magnaview 41/2; WA/DCAL 43/-; WA/PCAL 31/-; WA/LCL1 and WCL1, 7/6 each; WA/FMA1, 1/-; WA/LCL1, 42/-; WA/FB11, 18/-.

Send stamp for lists. Please add 2/- postage to all orders under £3 (excess refunded)

L. F. HANNEY

77 LOWER BRISTOL ROAD, BATH

Tel.: 3811

INSULATING SLEEVINGS

P.V.C. and POLYTHENE
SLEEVINGS
INSULATED WIRES
and FLEXIBLES

A.I.D. AND A.R.B. APPROVED.

PLASTICABLE LIMITED

HAWLEY LANE - FARNBOROUGH - HANTS

PHONE: FARNBOROUGH, HANTS 85

SURREY STEEL COMPONENTS LIMITED

LIMITED

for

PRESSED METAL COMPONENTS

— FINISHED TO SPECIFICATION —

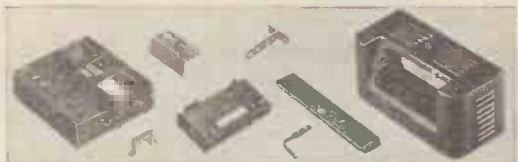

MANY STANDARD TOOLS AVAILABLE IN STOCK
74-76 CHURCH ROAD, BARNES, S.W.13
RiVerside 6673/4



Henry's
RADIO COMPONENTS
& TELEPHONE EQUIPMENT
(RADIO) LTD.

5, Harrow Road, Paddington, W.2
PADdington 1008/9 and 0401
OPEN MONDAY to SAT 9-6. THURS. 1 o'clock
SEND STAMPS FOR NEW 1956 28-PAGE CATALOGUE

U.S.A. TEST METER

25 ranges. 1,000Ωp. volt.
A.C. and D.C. Readings 10-6,000 volt. Milliamps 1 mA-600 mA. Ohms 0-5 megs. Decibels -10 to +70 DB. Complete with internal batteries, leads and instruction book

£6'19'6

PIRANI HIGH VACUUM TEST EQUIPMENT

Manufactured by "Pye" Cambridge Ltd., for Atomic Research Station.

Comprising: Pirani Control Unit, Pirani Bridge Unit, Gauge head with calibrator, and Pye scale lamp galvanometer, all items brand new, in original packing. Offered at less than half original cost.

£33-10-0
complete

Spare Pirani Heads (Edwards M6) 15/-.

CRYSTAL MICROPHONE INSERTS

Ideal for Tape Recording, Gramophone Amplifier, etc. Very sensitive. Guaranteed and Tested. 8/- (ex-untls), or 5/6 Brand new and boxed.



FERRANTI TESTVAC

High Speed Vacuum tester,
200-250 A.C. **£10 10 0**

MINIATURE TRANSMITTING STRIP "TYPE 81"

Size 7 1/4 in. x 6 in. x 3 in. Complete with Valves Type CV415, CV309, 2-6AM6, 2-7D9 and Quartz Crystal, 4,860 kc/s. Fully wired with circuit.

£4/10/- complete.

MINIATURE I.F. STRIP TYPE "373" 9-72 MEG.

Brand new miniature I.F. Strip size 10 1/2 in. x 2 1/2 in. x 3 in. high. Valve line-up: 2-EF92; 3-EF91 and EB91. With circuit.

Price (less valves) 7/6, P. & P. 1/6.
This I.F. Strip is part of above equipment.

U.S.A. INDICATOR UNIT BC929A

Complete with 3BP1 C/R tube and screen, 7 valves—2-6SN7GT, 2-6HG6T, 6G6, 2X2, 6X5G, volume controls, condensers, etc. Ideal for portable 'scope. In black crackle case size 1 1/2 in. x 9 in. x 9 in. BRAND NEW. 65/-, carr. FREE.

TRANSMITTER RECEIVER "38" WALKIE TALKIE SETS

Special offer of above set, complete with 5 valves, 4-ABP12 and ATP4, with circuit. Range 7.4 to 9 Mc/s. These sets are not guaranteed but are serviceable.

25/-
Junction box, 2/6 extra.

62A INDICATOR UNIT

Containing VCR97 with Mu-Metal Screen-21 Valves: 12-EF50, 4-8F81, 3-EA50, 2-EB34. Five Controls, 4-wicket, H.V. Control, Resistors, Muthread S/M Dial, Double Deck Chassis and Crystal. BRAND NEW ORIGINAL CASES, 67/6. Carr. 7/6.

PYE 45 Mc/s STRIP TYPE 3583 UNITS

Size 15 in. x 8 in. x 2 in. Complete with 45 Mc/s. Pye Strip, 12 valves, 10-EF50, EB34 and EA50, volume controls, and hosts of Resistors and Condensers. New condition. Modification data supplied.

Price 69/8. Carriage paid.

INDICATOR UNIT TYPE 182A

Unit contains VCR517 Cathode Ray 6in. tube, complete with Mu-Metal screen, 3 EF50, 48P61 and 1 5U40 valves, 9 wire-wound volume controls and quantity of resistors and condensers. Offered BRAND NEW (less relay) at 67/6. Pins 7/6 carr. "Radio-Constructor" scope circuit included.

SPECIAL REDUCTION FOR SETS OF VALVES

1A7GT, 1N5GT, 1H5GT, 1A6GT (or 1Q5GT or 3Q5GT)	37/6 Set
10 EF50 (ex-Brand New Units) 5/- each	45/- "
10 EF50 (Red Sylvania, ex-new units) 6/- each	55/- "
6K8G, 6K7G, 6Q7G, 5Z4G, 6V6G	35/- "
1B5, 1B5, 1T4, 1B4 or (8B4 or 3V4)	27/6 "
DK96, DF96, DAF96, DL96	32/6 "
6K8G, 6K7G, 6Q7G, 25A6G, 25Z5 (or 25Z6G)	37/6 "
12K8GT, 12K7GT, 12Q7GT, 35Z4GT, 35L6GT (or 50L6GT)	37/6 "
128A7GT, 128K7GT, 128Q7GT, 35Z4GT, 35L6GT or 50L6GT	35/- "

TRANSISTORS

OFFERED AT LESS THAN HALF-PRICE

This Junction Transistor Type P.N.P. is designed for A.F. application up to 800 Kc/s, and is suitable for use in Radio Control, Signal Tracers, Local Station Receivers, Oscillators, Transistor Voltmeters and Experimental work, etc.

10' - EACH
(complete with Technical Data and Circuits)

ELECTRICAL DATA

Maximum collector voltage	-5 volts
Peak collector voltage	-5 volts
Maximum collector current	-10 mA
Maximum emitter current	-10 mA
Maximum power dissipation	-25 mW

QUARTZ CRYSTALS

TYPE FT243 fundamental Frequencies. 2 pin pin spacing.
120 TYPES. 5675 Kc/s. to 8650 (in steps of 25 Kc/s.).
80 TYPES. 5706 Kc/s. to 8340 Kc/s. (in steps of 33.333 Kc/s.).

ALL BRAND NEW 10' - each

Special price for complete sets of 80 or 120



Above are suitable for regrinding

TYPE FT241A 54th harmonic Crystals. 2 pin pin spacing.
80 TYPES AVAILABLE 20 Mc/s.—27.9 Mc/s. (in steps of 100 Kc/s.).
COMPLETE SETS AVAILABLE.

ALL BRAND NEW 7'6 each

FT241A 200 Kc/s. 10/- each.

Crystal Holders for both Types 1/3 each.

LATEST TYPES NOW IN STOCK

EBC41	10/-	EAPC80	10/-	12A75	8/-	PABC80	15/-
EY51	12/-	ECC85	10/-	12AT7	9/-	6AU6	9/6
EP41	11/-	EP80	10/-	12AU6	9/-	11Z53	9/6
EL41	11/-	ECL80	12/6	12BA6	9/-	12AX7	10/-
EZ40	10/-	PL81	12/6	12BE6	10/-	DK96	9/-
EM34	10/-	PL82	10/-	12AH8	12/6	DL96	9/-
UL41	11/-	PY81	10/-	35W4	8/6	DAF96	9/-
UY41	11/-	EM90	10/-	PCF80	15/-	DF96	9/-
UF41	11/-	6X4	8/-	EBF80	11/6	ECC84	12/6
UCH42	12/6	PY82	10/-	EP86	10/6	6AQ5	10/-
UBC41	10/-	PC84	12/6	EP89	10/6	PCL82	12/6
DK40	10/-	PCF82	12/6	ECP82	15/-	ECH42	12/6
EP80	10/-	12AU7	9/-	EP86	12/6	3A5	12/6

WE HAVE OVER 50,000 BRITISH AND AMERICAN VALVES AVAILABLE AT VERY LOW PRICES—SEND FOR LISTS.

GARRARD 3-SPEED MIXER AUTO-CHANGER Model RC110

A.C. 200/250. List price £14/13/- Brand New.

£8/18/6 P. & P. 5/-.

B.S.R. RECORD CHANGERS

Very latest type "Monarch" in hammered gold finish. 3-speed with HGP37 crystal turnover pick-up. Plays mixed records. Brand new and guaranteed. Listed at £12/10.

£7/19/6, carr. paid.

T/R 1196 RECEIVER

Complete with 6 valves: 2 EF92, 2 EF39, 1 EK32, 1 EBC23, 465 I.F.T., ideal for conversion. In absolute new condition. 27/6, P.P. 2/6, with circuit.

TR 1196 TRANSMITTER

Transmitter section comprising EL32, EF50, VT601, Relay, etc. 12/6, P.P. 2/6

COMPLETE TRANSMITTER RECEIVER with 24 v. power-pack in original transit case. 57/6, P.P. 5/-.

MEGERS

Record Junior, 500 v., 20 meg. **£8 0 0**
(Leather case 7/6 extra.)

Bowthorpe Continuity Meter with Internal Battery Reading, 0-300Ω and 100/200,000Ω **£3 5 0**

CATHODE RAY TUBES

VCR138A WITH SCREEN .. **£1 15 0**
VCR138A 2 1/2 in. C/R Tube. Brand new in original cartons (carr. free) .. **£1 15 0**

VCR97. Guaranteed full T/V picture (carr 2/-) .. **£2 0 0**
VCR517C. Guaranteed full T/V picture .. **£1 15 0**

MU-METAL SCREENS for VCR97 or 517. P.P. 1/6 .. **10 0**

6in. ENLARGER for VCR97 or 517. P.P. 1/6 .. **17 6**
VCR97. Slight cut-off. Carr. 2/- .. **15 0**
2BP1. Brand new .. **£1 10 0**

TRANSMITTER/RECEIVER SCR 522

Comprising the well-known B0925 and BC924A Units complete with 17 valves types: 2-832, 3-12A6, 3-12B07, 3-9003 9002, 6G6G, 12J5GT, 12AHGT, 12C8, 6887. The Complete unit is in very good condition having very useful parts including Relays, Transformers, Condensers, etc.

Less valves, **£3/10/-**, carr. paid
With valves, **£7/10/-**, carr. paid.

MODERN ELECTRICS LTD.

164 Charing Cross Road, London, W.C.2.

Tel.: TEMple Bar 7587.
Covent Gdn. 1703.

Cables: Modcharex, London.
Prompt attention to post orders.

Export enquiries welcomed.

Immediate delivery from stock.

TAPE RECORDERS

GRUNDIG TK5	46 gns.
GRUNDIG TK820/3D	98 gns.
SIMON	75 gns.
FERROGRAPH 2A/N	76 gns.
FERROGRAPH	
2AN/H	86 gns.
VORTEXION 2A	80 gns.
VORTEXION 2B	£99
BRENNELL 3-SPEED	48 gns.

The following Recording Tapes are available from stock.
1,750ft. 1,200ft. 600ft.

FERROGRAPH	£3/3/-	
FERROGRAPH	45/-	26/9
GRUNDIG BASF	40/-	25/-
SCOTCH BOY	35/-	21/-
EMI 77	48/-	—
EMI 88	35/-	21/-
AGFA	37/6	22/6
GEVAERT	35/-	21/-
PURETONE	20/-	—
FERROVOICE	32/6	—
SOUNDMIRROR	30/-	—

Long Playing Tapes now in stock

RECORD REPRODUCING EQUIPMENT

COLLARO TRANSCRIPTION	
Model 2010 PX	£19 9 0
RC54	£13 17 0
554 Unit	£9 7 0

GARRARD GRAM UNITS

RC98	£19 17 7
RC88	£17 18 8
RC121D	£13 13 10
301 Transcription	£26 8 3
TA/AC	£11 6 7
TA/B for Decca	£8 19 3

CONNOISSEUR

Variable 3 speed	£28 11 0
------------------------	----------

SPEAKERS

W.B. STENTORIAN

HS.610	£2 13 6
HS.812	£4 3 6
HS.912	£4 8 6
HS.1012 tapped coil, 3 7.5 or 15 ohms ...	£4 19 9

GOODMANS

Axiom 150 Mk. II	£10 15 9
Axiom 102	£10 7 9
Axiom 101	£6 18 6
Axiom 22	£15 9 0

WHARFEDALE

WIS CS	£17 10 0
Super 12CS/AL	£17 10 0
W12CS	£10 5 0
Golden 10 CSB	£8 14 11
Super 8CS/AL	£7 6 11
Super 3	£7 0 11
Bronze 10in.	£4 17 3
Bronze 8in.	£3 10 0
W.B. Crossover Unit	£1 10 0
W.B. Tweeter Unit	£4 4 0
Kelly Ribbon Tweeter	£12 12 0

TEST EQUIPMENT

AVO

Model 8	£23 10 0
Model 7 (latest)	£19 10 0
Unimino Mk. II	£10 10 0
Electronic Meter	£40 0 0
Wide Band Sig./Gen.	£30 0 0
Valve Characteristic Meter Mk. III	£75 0 0
D.C. Minor	£5 5 0
10kV Multiplier for Model 8	£3 5 0
Carrying Cases for Models 7, 8 and 40	£3 0 0

ADVANCE

H.I. (Sig./Gen.)	£28 0 0
E.2 (Sig./Gen.)	£32 10 0
P.1	£22 5 0

COSSOR

Oscilloscope 1035	£120 0 0
Oscilloscope 1052	£104 0 0
Volt: Calibrator 1433	£18 5 0

TAYLOR

All new Taylor Test Gear in stock.

PICKUPS AND PLAYERS

ACOS, DECCA, COLLARO,
CONNOISSEUR, LEAK, FER-
RANTI, B.J., GARRARD,
PHILIPS.

MICROPHONES

ACOS

Mic 22 (Crystal)	£4 4 0
Mic inserts for above	£1 0 0
Mic 33-1	£2 10 0
Mic 35-1 (Crystal) ...	£1 5 0

LUSTRAPHONE

M/C High Imp.	£5 15 6
LFV59 Dynamic	£8 18 6

RESLO

VMC (low imp.)	£6 0 0
RBL/T	£8 15 0

FILM INDUSTRIES

Ribbon	£8 15 0
--------------	---------

MICROPHONE STANDS

Floor, 3 extensions... ..	£3 12 6
Table Stand	£1 5 0

LEAK AMPLIFIERS

TL.10 complete	£28 7 0
Point 1, TL.12	£28 7 0
Point 2, TL.25	£34 7 0

QUAD, Mk. II	£42 0 0
MULLARD	£18 18 0
E.A.R. 4 watt	£9 9 0
TRIX 4 watt	£16 10 0

ALL GARRARD, CON-
NOISSEUR, DECCA and
COLLARO HEADS,
SAPPHIRE and DIAMOND
STYLI for the above HEADS
NOW AVAILABLE.

KAYE

ELECTRICAL MANUFACTURING CO.

Manufacturers of Magnetic Relays. B.P.O.3,000 and 600 types.
to A.I.D.—I.E.M.E. or G.P.O. Standards.

CONTACTS

Twin silver ½ amp.
Twin platinum 1 amp.
Heavy duty 5-8 amp.

COILS

Up to 100,000Ω Guarant-
teed.
± 3% on Turns.
± 5% on ohms.

Fully Tropicalised—Jungle or Services finish to Specification.

New descriptive leaflet and price list on request.

Enquiries are invited regarding our newly de-
veloped time delay relay unit for giving up to approx.
10 secs. delay with immediate reset.

Early Deliveries.

Competitive Prices.

Spring Contacts, Coils, Buffer Blocks and components parts for relays
supplied separately.

HAVELOCK WORKS, HAVELOCK PLACE,
HARROW, Middx.

HARrow 1432.

NEW

TV AND FM ALIGNMENT GENERATOR



ABSORPTION MARKER
FOR IF.s 10-40 M/CS.
SINGLE OR DOUBLE
TRACE OPERATION.
0-20 M/CS SWEEP
WIDTH.

BANDS IV AND V ON
HARMONICS.

Price and Further details
on application

Trade and export Enquiries
invited

BANDS I, II & III AND I.F.s

WHARTON INSTRUMENT COMPANY

1081, FINCHLEY RD., LONDON, N.W.11. Tel.: Meadway 3407

!! TWIN SPOTLIGHTS !!

H
E
A
V
Y



D
U
T
Y

PRIMAXA SOLDERER

Model 100W. 96/6 post free. Available 110, 200/220, 220/250v.
INSTANT HEATING. You only consume current when actually
soldering. One Year Guarantee except on soldering bits and lamps.
S. KEMPNER Ltd., 29 Paddington St., LONDON, W.1.
Phone: HUNTER 0755.

G.W. SMITH & CO (RADIO) LIMITED

Phone: GERRARD 8204/9155
Cables: SMITHEX LESQUARE
3-34 LISLE STREET, LONDON, W.C.2

TRADE ENQUIRIES INVITED

FOR ALL RADIO BARGAINS

WE PURCHASE ALL TYPES OF RECEIVERS AND TEST GEAR

CHOKE BARGAINS

G.B. 20 henry 175 ma.	10/6
Parmeko 8 henry 250 ma.	10/6
Parmeko 9 henry 100 ma.	7/6
Parmeko C core 4 h. 22.5 ma.	4/6
Collins 8 henry 100 ma.	8/6
Parmeko swinging choke 3.6-4.2 henry 250 ma.	10/6
All supplied new and unused.	

BUZZERS. Brand new and boxed. Operate from 3 volt D.C., 2/6 each.

JACK PLUG LEADS. Brand new 6ft. screened leads fitted with two standard P.O. jack plugs, 3/- each.

COPPER AERIAL WIRE. Brand new reels of bare copper aerial wire, approx. 300ft. Only 3/6 reel

R.C.A. ET4336 PLATE TRANSFORMERS. Brand new and boxed, in original transit cases. Input 200/250 volt 50/60 cycles. Output 2,000-0-2,000 volts 500 ma. tapped 1,500-0-1,500 volts. Price £7/10/- each.

POST OFFICE RACKS. Standard 19in U channel type, 5ft., 59/6 each.

TRANSFORMER BARGAIN. Admiralty pattern. Primary 230 volt 50 cycle. Two separate secondary windings each 14 volt CT. 12 amps. This will give either 7, 14, 21 or 28 volt 12 amps. Brand new and boxed, 42/6 each

YAXLEY METER SWITCHES. Single pole 12 way, 8 bank. Brand new, 7/6 each.

FIELD TELEPHONES. Type DON Mk. 5. Buzzer calling. These are ideal for inter office, house communication. Supplied complete with buzzer, bell, handset etc., and two 1.5 volt cells, ready to operate. Price 39/6 each.

EDDYSTONE 12 VOLT ROTARY POWER UNITS. Input 12 volt D.C. Output 180 volts 65 ma. Housed in grey metal case complete with all smoothing, 19/6 each.

HEADPHONE ADAPTORS. High to Low impedance matching. American type. Brand new, 1/3 each.

AMERICAN PANORAMIC ADAPTORS. Brand new and boxed. Sweep frequency 200 kc/s. For use with receivers having an I.F. frequency between 455 and 475 kc/s. Operates from 110/230 volt A.C. 50-60 cycles. Price £30 each.

HEAVY DUTY CHARGING TRANSFORMER. Input 230 volt 50 cycles. Output 17.5 volts 35 amps. Brand new and boxed, 72/6 each.

18 PIN UNITERS. Brand new 3/6 pair.

ADMIRALTY POWER UNIT 23A. Input 200/250 volt A.C. 50 cycles. Output 240 volts 150 ma. and 6.3 volts 6 amps. Double choke and paper condenser smoothed. Fitted with 2 1/2 in. moving iron meter reading, input A.C. volts and D.C. output volts. Mounted in grey metal case for 19in. rack mounting. Supplied in perfect order, 69/6 each.



CRYSTAL MICROPHONE INSERTS. Ideal for tape recorders, amplifiers etc., extra sensitive. Supplied in good condition and tested, only 4/6 each. Size only 3/4 in square.

DEAF AID UNITS. Due to another huge purchase we are again able to offer these units at a fantastically cheap price. Made by famous manufacturer. Complete less only outer case. Battery space provided on chassis. Requires 2 1/2 and 1.5 v.



requires only a 1.5v. battery to operate, price 40/- each. Dead aid spares. CK505 valves, 2/6 each. 1 meg. pots w/switch, 1/-. Miniature output transformers, 2/6.

Feature includes:
1. 3 Mullard valves. 2 DF64 and 1 DL66 output. 2. Output transformer matched to 30 ohms. 3. Extra sensitive crystal microphone. 4. Built in volume control. 5. Size only 3 1/4 x 1 1/2 in. ONLY 19/6 each.

Earpieces to match, 3/6 each. Leads, 1/-. Few only chassis available using 2 DF66 valves and 1 OC71 transistor as an output stage. This chassis

TRANSFORMER SNIP. Admiralty pattern. 230 volt 50 cycle input. Three separate secondary windings, each 10 volt C.T. 5 amps. This will give either 5, 10, 15, 20, 25 or 30 volts 5 amps. Supplied brand new, ONLY 29/6.

COSSOR DOUBLE BEAM OSCILLOSCOPES. Type 3339. These laboratory test instruments are offered in perfect condition, fully reconditioned and tested. Operation 200/250 volt A.C. Main features are: Frequency 6 cps.-2 mc/s. 10 time base positions, sweep 10 cps.-250,000 cps., Y1, Y2 sensitivity 3.6 volts D.C. 1.1 volt RMS, X sensitivity 2.25 volts D.C. Size of tube approx. 4 1/2 in. Price only £21 each.

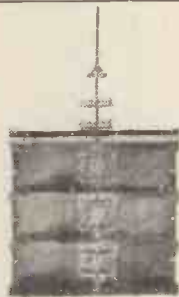

AR.88 RECEIVER SWITCH ASSEMBLIES. 8 wafer 6 position screened assembly supplied brand new in original boxes. A must have spare for this receiver. Price only 17/6 each

Few only geared drive assemblies for this receiver, brand new 10/6 each.

MARCONI CRYSTAL CALIBRATORS. Frequency coverage 170/240 mc/s. Directly calibrated, accuracy .001%. Supplied brand new and boxed in original transit cases, complete with 5 mc/s. crystal and spare set of 5 valves. Price £5/19/6 each.

MODULATION TRANSFORMERS. Collins type. Push-pull 807-807. 20 watts audio. Brand new 12/6 each. Bendix type for TA-12, brand new, 15/- each.

SUB-STANDARD VOLTMETERS. Six ranges. 0-7.5, 15, 30, 60, 150 and 300 volts D.C. 6in. mirror scale calibrated 0-150 volts with knife edged pointer. Each instrument calibrated to an accuracy of 0.3%. Supplied in perfect condition in polished wood case size 7 1/4 x 7 1/4 x 4 in. Price £4/19/6 each.

METER BARGAINS

50 microamp 2 1/2 in. F.M. M.C.	59/6
50 m/amp. 2in. F.M. M.C.	7/6
150 m/amp. 2in. F.M. M.C.	6/9
200 m/amp. 2 1/2 in. F.M. M.C.	9/6
1 amp. R.F. 2 1/2 in. F.M. T.C.	6/9
1 amp. R.F. 2 1/2 in. P.J. T.C.	5/-
4 amp. R.F. 2in. F.M. T.C.	5/6
300 volt D.C. 2in. F.M. M.C.	10/6
300 volt A.C. 2 1/2 in. F.M. M.I.	25/-
500-0-500 microamp. 2 1/2 in. F.M. M.C.	25/-
2 kV. Electro Static 2 1/2 in. P.J.	22/6

SPECIAL OFFER GRAM. MOTORS. Garrard 200/250 volt A.C. gram motors, complete with turntables. Adjustable speed from 0 to 45 r.p.m. Can be used for latest type records 33 or 45 r.p.m. A real snip at only 22/6 each

AMERICAN EXTENSION SPEAKERS. Brand new and boxed 8in. speakers housed in attractive black crackle case, 3 ohm coil, ideal for all applications, 39/6 each.

SUB-STANDARD MILLIAMETERS. Basic movement 1 ma. Seven ranges 0-1, 5, 20, 50, 100, 200 and 500 ma. 6in. mirror scale with knife edged pointer calibrated 0-100 ma. Calibrated to an accuracy of 0.1%. Supplied brand new in polished wood case size 7 1/4 x 7 1/4 x 6in. and complete with leather carrying case. Price £12/10/- each.

ROTARY CONVERTORS. Input 24 volt D.C. Output 230 volt 50 cycles 100 watts. Supplied brand new, 92/6 each.

MULLARD CAPACITY RESISTANCE BRIDGES. Ranges 10pF to 10 mfd. and 1 ohm to 10 megohms operation 110/230 volts A.C. Supplied checked and working, £5/19/6 each.

50 MICROAMP METERS. A grand offer of brand new test sets containing a flush mounting 50 microamp meter, 2 1/2 in. scale, housed in grey instrument case complete with chromium plated handle. Price 59/6 each.

AMERICAN PRECISION POTS. 10,000 ohms. 5 1/2 in. dia. Built in correction plate. Brand new and boxed, 22/6 each. Colvern type, 3 1/2 in. dia. 100,000 or 50,000 ohms. Brand new and boxed, 10/6 each.

FREQUENCY METERS. For 230 volt A.C. 50 cycles. 5in. scale calibrated 45-55 cycles. Perfect condition, £5/10/- each.

MARCONI SIGNAL GENERATORS. Laboratory instruments supplied brand new, boxed and tested. 200/250 volt A.C. operation. Model TF390g, 4-100 mc/s., £25 each. Model TF517g, 16-58 and 130-260 mc/s., £35 each.

AMERICAN POWER RHEOSTATS. Brand new and boxed. 8 ohm 3.3 amp., 8/6; 8 ohm 2.5 amp., 7/6; 90 ohm. 0.74 amp., 7/6; 200 ohm. 0.35 amp. 5/6.

R.1294 RECEIVERS. Superhetrodyne receiver covering 500-3,000 mc/s. (10-60 cm.). Input impedance 70 ohms. 2 detector stages, 2 L.F. amplifier stages. I.F. frequency 13.5 mc/s. Bandwidth 3.5 mc/s. Price £35 each

BRAND NEW BENDIX COMMAND RECEIVERS. Supplied in original carton complete with all valves: 2-12SK7, 2-12SR7, 1-12K8 and 1-12A6, BC453, Q Finer, 190/500 kc/s 69/6. BC XXX, top band, 1.5/3 Mc/s. 85/-, with circuit.

MINIATURE H.T. TRANSFORMER. Input 220/240 volts. Output 200 volt 25 ma. and 6.3 volt 1 amp. 10/6 each. Miniature metal rectifier to match, 7/6 each.

HOURS OF BUSINESS:—9 a.m.—6 p.m. Thursday 1 p.m. Open all day Saturday.

PLEASE PRINT NAME AND ADDRESS CLEARLY, ALSO INCLUDE POSTAGE OR CARRIAGE ON ALL ITEMS

Best Buy at Britain's

METER BARGAINS

RANGE	TYPE	SIZE	PRICE
50 Microamp.	D.C. M/C	2 1/2 in.	Flush circular, sealed 0-100 59/6
100 Microamp.	D.C. M/C	2 1/2 in.	Flush circular, sealed 0-1,500 39/6
500 Microamp.	D.C. M/C	2 1/2 in.	Flush square, Weston 27/6
500-0-500 Micro-amp.	D.C. M/C	2 1/2 in.	Flush circular, sealed 100-0-100 V. 25/-
1 Millamp.	D.C. M/C	2 1/2 in.	Flush square, Fe/NFe 22/6
1 Millamp.	D.C. M/C	2 1/2 in.	Desk Mounted type 32/6
10 Millamp.	D.C. M/C	2 1/2 in.	Flush circular, blank scale 10/6
100 Millamp.	D.C. M/C	2 1/2 in.	Flush circular 10/6
150 Millamp.	D.C. M/C	2 in.	Flush square 7/6
200 Millamp.	D.C. M/C	2 1/2 in.	Flush circular 10/6
1 Amp.	Thermo-couple	2 1/2 in.	Projecting circular 6/9
4 Amp.	Thermo-couple	2 in.	Flush square 6/9
20 Amp.	D.C. M/C	2 in.	Projecting circular 7/6
30-0-30 Amp.	D.C. M/I	2 in.	Proj. circ., metal cased, ear type 5/-
15 Volts	A.C. M/I	2 1/2 in.	Flush circular 8/6
300 Volts	A.C. M/I	3 1/2 in.	Flush circular 30/-
300 Volts	D.C. M/C	2 in.	Flush square 10/6

METER RECTIFIERS. 1 mA. Salford Instruments, 8/6; and 5 mA., 6/9; 2 mA., S.T.C., as used in E.M.I. Output Meter, 5/6. All are full wave bridge and brand new.

ADMIRALTY COMMUNICATIONS RECEIVER TYPE B.28 (MARCONI CR.100). Frequency range, 60 Kc/s to 30 Mc/s. Self-contained power pack 200/250 volts A.C. 50 cps. Variable Selectivity Crystal Filter. Complete with valves and Air Tested. SUPERB CONDITION. PRICE ONLY £21. Plus £2 carriage and packing (£1 refunded on return of packing case). Send S.A.E. for full details and illustration.

PANORAMIC ADAPTORS. Visual display of signals on 3in. CR Tube 3BP1. Band width 200 Kc/s. Suitable for receivers with I.F. of 450-475 Kc/s. Operates from 110-230 V. A.C. mains. BRAND NEW, as shipped ex-U.S.A. With instruction manual, £30. Suit CR100.

RCA SPEAKER—An 8in. P.M. unit contained in beautiful black crackle cabinet, suitable for AR88, etc. BRAND NEW. Price only 45/-.

COMMAND RECEIVERS. Complete with 6 metal valves, 3 12SK7, 1 12K8, 1 12SR7 and 1 12A6. Size 5 1/2 in. x 5 1/2 in. x 1 1/2 in. deep. In very good condition. Less dynamotor. FREE CIRCUIT WITH EACH SET. BC455, 6-9 Mc/s., 25/-; BC453 (the famous Q5'er), 190-550 Kc/s., 59/6; BC454, 3-6 Mc/s., 27/6. BCXXX ("Trawler" band), 1.5-3 Mc/s., 65/-.

U.S.A. POWER UNITS. 115 v. A.C. input. 1,000 v. 250 mA. output. Complete with two 1616 and 1 spare. Double smoothing. BRAND NEW, £55/-.

AM POWER UNITS 247. 230 v. A.C. input. 600 v. 200 mA., 6.3 v. 3 amp. output. BRAND NEW, 49/6.

EDDYSTONE ROTARY POWER UNITS. 12 v. D.C. input, 180 v. 60 mA. output, smoothed and filtered. In grey metal case, 12 x 6 x 5 in. Weight 16 lb. BRAND NEW, 19/6.

HEAVY DUTY LT TRANSFORMERS. 230 v. A.C. mains input. Secondary 5-0-5 v., 5-0-5 v., and 5-0-5 v., all at 5 amps., each winding. 5, 10, 15, 20, 25, 30 v. at 5 amps. or other possible combinations. Size 4 1/2 in. x 4 1/2 in. x 6 in. high. Weight 12 lb. BRAND NEW, 29/6. Primary 230 volt 50 cycle. Two separate secondary windings each 14 volt C.T. 12 amps. 7, 14, 21 or 28 volts 12 amps. or other possible combinations. Weight 24 lb. Admiralty pattern. BRAND NEW, 42/6.

G.E.C. 200-250 v. A.C. input. 30 v. tapped at 10 v. 36 amps. output, 5 1/2 in. x 6 in. x 7 in. high, weight 24 lbs., 55/-.

SELENIUM BRIDGE RECTIFIERS. Funnel cooled. 45 v. RMS input. 30 v. 10 amp. D.C. output. BRAND NEW, 47/6.

METAL RECTIFIERS. 250 volts 100 mA., 6/9. 230 volts, 60 mA., 5/-.

INSTRUMENT TRANSFORMERS, Parmeko. 230 v. A.C. in 0-65-130-195 v. 85 mA. 6.3 v. 5 amp. 6.3 v. .3 amp. output. Shrouded, 3 1/2 in. x 3 1/2 in. x 3 1/2 in. high, 15/-.

MINIATURE MODEL MOTORS. 2in. long x 1 1/2 in. diam., 3/16 in. diam. spindle, weight 5 ozs. Will work from 6-volt dry battery and are reversible. Ball bearings. Price 8/6.

5ft. P.O. TYPE 19in. RACKS. "U" channel, heavy angle base, 59/6.

RESISTORS. Latest miniature insulated Dubilier 1/4 watt type BTS-Wire ends. Useful values. ONLY 10/- for 100 assorted!

FIELD TELEPHONES. Army type D. Mk.5. Buzzer calling. Ideal for building sites, farms, workshops, etc. Complete with handset and batteries. Tested before despatch. 39/6 each.

PLEASE ADD POSTAGE OR CARRIAGE ON ALL ITEMS

CHARLES BRITAIN (Radio) Ltd.
 11 UPPER SAINT MARTIN'S LANE
 LONDON, W.C.2 TEMple Bar 0545
 One Minute from Leicester Sq. Station (up Cranbourn St.)
 Shop hours: 9-6 p.m. (9-1 p.m. Thursday) Open all day Saturday

MAGNETIC RELAYS

TYPES 3000 and 600

Supplied to specification for the following uses:—

- METER PROTECTION
- TIME DELAY
- OVERLOAD TRIPS
- ALARM SYSTEMS
- FLASHING & PULSING
- PROCESS CONTROL
- TIMING DEVICES
- AERIAL CHANGE-OVER
- MAINS FAILURE PROTECTION
- COMPLEX OR SEQUENCE SWITCHING
- SELECTION & COUNTING SYSTEMS
- HIGH VOLTAGE SWITCHING

(CONTACT INSULATION UP TO 2KV)

Consult us with your problems

POLARISED, HIGH SPEED, A.C.
 & TELEGRAPH RELAYS IN STOCK

ELECTRO MAGNETIC COUNTERS
UNI-SELECTORS
KEY SWITCHES, P. O. and LOW LOSS

JACK DAVIS (RELAYS) LTD.
 TUDOR PLACE, LONDON, W.1
 MUSEUM 7960 LANGHAM 4821

Electronic Engineers are required for development and technical liaison duties related to the development of highly interesting projects. A knowledge of aircraft electrical systems would be an advantage but not essential. Apply in writing, stating age and experience, to the Staff Manager, G.E.C. Stanmore Laboratories, Stanmore, Middx., quoting Ref. AMV/FH.

Senior and Junior Electronic Engineers are required with a good general background of electronic design and development for the study and development of complex electronic systems related to aircraft. Preference will be given to candidates with a general rather than specialised knowledge of electronics. Apply in writing, stating age and experience, to the Staff Manager, G.E.C. Stanmore Laboratories, Stanmore, Middx., quoting Ref. AMV/FH.

There is always a fine selection of equipment at

AN/APN1 UNITS

MOVING COIL TRANSDUCERS as illustrated on page 252 June "Wireless World."

RECEIVER

A sub-chassis $3\frac{1}{2} \times 6\frac{1}{2} \times 2\frac{1}{2}$ in. houses a Receiver tuned to the transmitting frequency. Contains TWO 9004 valves. For use in 70 cm. band.

PRICE, post paid 12/6

A.F. AMPLIFIER

An Audio Frequency Amplifier in a sub-chassis $5 \times 3 \times 3\frac{1}{2}$ in. R/C coupled, using TWO 12SH7 and ONE 12SJ7 valves; and can be used for Telephone Intercom., Pre-Amplifiers, etc.

PRICE, post paid 15/-

BENDIX I.F. Transformers 1.63 Mc/s complete in cans, set of two new and boxed. Size $2 \times 1\frac{1}{2} \times 3\frac{1}{2}$ in., 5/-, p.p. 1/6.

BENDIX Potted Audio Output Transformer complete with integral smoothing choke. Ratings $4\frac{1}{2}$ watt 9,000 ohm Primary. 600 and 4,000 ohm Secondary. Size: $4 \times 1\frac{1}{2} \times 2$ in. New and boxed, 4/6, p.p. 1/6.



RECEIVER UNIT Ex 1143A
Suitable for conversion to 2 metres or F.M. Wrotham transmissions.

Valve line-up: (4) EF50, (1) EL32, (2) EF39, (1) EBC33, (1) EA50. Supplied with circuit diagrams. Fully valved 35/- each, plus 3/- p.p.

TYPE 62A INDICATORS

Ideal for conversion to oscilloscopes, T.V. units, etc. Containing V.C.R.97, 12 VR91 (EF50), 2 VR54 (EB34), 3 VR92 (EA50), 4 CV118 (SP61). Slow-motion dial, 13 Pots and scores of useful components. Size: $8\frac{1}{2} \times 11\frac{1}{2} \times 18$ in. In wooden packing case, £3, carriage 7/6.

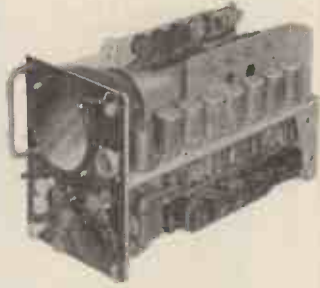

PAPER BLOCK CONDENSERS

8 μ F 600 V wkg., 5/6 p.p. 4 μ F 400 V wkg., 4/- p.p.

The Walk-around Shop

I.F. AMPLIFIER UNIT

460 kc/s with IT4. Brand New and Boxed. Fully Screened in plug-In Box. Size $2\frac{1}{2} \times 1 \times 4\frac{1}{2}$ ". Price with circuit, 10/- each. Plus 1/- p.p.



MINIATURE TRANSMITTER STRIP

TYPE 81 Complete with valves CV415 (TT15), CV309 (QV04-7), 2-6AM6, 2-EL91 and 1 Crystal. Circuit supplied Free with unit. Price £4/10/- post paid.



MINIATURE I.F. STRIPS

Size $10\frac{1}{2} \times 10\frac{1}{2} \times 3$ in. Frequency 9.72 Mc/s. 2 EF92s and 1 EF91. I.F. amps. EB91. DBT/AGC. EF91 AGC. Amp. and EF. 91. Limiter. Circuit supplied.

Price : 8/- less valves. Post paid.

R.F. UNITS

R.P.25 40-50 Mc/s. Switched Tuning. Valved. 9/6 each.

R.F.26 50-65 Mc/s. Variable Tuning. Valved (new and boxed) 25/- each.

Packing and postage 2/- each.



2-3mA MEASUREMENT METER

2-3 mA movements in metal case measuring $4\frac{1}{2}$ in. high, $3\frac{1}{2}$ in. wide and 5 in. deep. 7/6 plus 2/- p.p.



Make a miniature POCKET RADIO

Incorporating high "Q" technique using the New Ferrite rod. Made possible by simple conversion of an ex-Govt. Hearing Aid.

Technical Details. A Germanium Diode Detector circuit followed by the existing 3 valve Amplifier, giving adequate amplification throughout the medium wave band.

This conversion can be carried out in approximately 30 minutes.

SEE and HEAR this Miniature POCKET RADIO demonstrated.

THE COMPLETE KIT OF PARTS includes a Type OL10 Hearing Aid (with Crystal microphone) in perfect working order with miniature earphone and moulded ear insert attached; ferrite rod, germanium diode, components, circuit diagram and full instructions.

Price £2 6s. 0d. post paid.

ALL COMPONENTS SOLD SEPARATELY

Deaf Aid Unit with earpiece	£1 15 0
Plastic Ear mould	2 0
Ferrite Rod	5 0
Conversion Components	4 0
Batteries 1.5 v. L.T. (Type D.18)	8
30 v. H.T. (Type B.119)	4 3

NOTE: As the crystal microphone is not used in the Pocket Radio, it can, if desired, be used as a general microphone and it does not require a matching transformer.

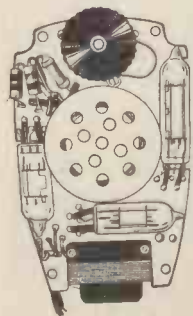

NOTE: Carriage prices quoted apply only to England and Wales.

PROOPS

NOTE: Orders and Enquiries to Dept. "W" Shop hours 9 a.m. to 6 p.m.—Thurs.: 9 a.m. to 1 p.m.
OPEN ALL DAY SATURDAY Telephone: LANgham 0141
BROS. LTD. 52 TOTTENHAM COURT ROAD, LONDON, W.1

RELAYS P.O. TYPE 3000

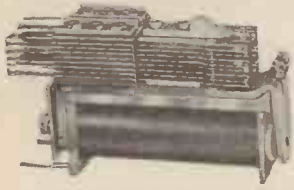

BUILT TO YOUR SPECIFICATION
 QUICK DELIVERY
 KEEN PRICES
 CONTACTS UP TO 8 CHANGE OVER

METERS GUARANTEED

F.S.D.	Size	Type	Price
250 Microamp. (multirange scale)	3 1/2 in.	MC/FR	5/-
500 "	2 in.	MC/FS	27/6
500 " (scaled 0/15 KV)	2 in. plug type	MC/FR	18/6
1 Milliamper	2 in.	MC/FR	17/6
1 "	2 in. 5Q/87	MC/FSElliott	27/8
5 "	2 in.	MC/FS	10/6
30 "	2 1/2 in.	MC/FR	12/6
100 "	2 1/2 in.	MC/FR	12/6
200 "	2 1/2 in.	MC/FR	12/6
500 "	2 1/2 in.	MC/FR	12/6
20 Amp.	2 1/2 in.	MI/FR	25/-
50 "	5 in.	MI/PR	60/-
50-0-50 Amp	2 in.	MC/FS	12/6
15 Volt	2 1/2 in.	MI/FR	15/6
20 "	2 in.	MC/FS	10/6
40 "	2 in.	MC/FS	10/6
300 "	2 in.	MC/FS	10/6
300 "	2 1/2 in.	MI/FR	25/-
200 "	5 in.	MI/PR	60/-
2,000 "	2 1/2 in.	ES/FR	40/-

PHOTOMULTIPLIER No. 931A. Ideal for film scanning, spectrography, Alpha counting, colorimetric measurement, etc., supplied complete in lightproof chamber with lamp, wired with the resistor network, 70/- 9 stage multiplier only, 50/-

SIGNAL AND NOISE GENERATOR. Television frequencies 20/88 Mc/s. in 4 bands. Crystal controlled. Operating on 115 v. or 80 v. suitable for conversion to 230 v. The few we have left we offer at the very special price of £8/17/6.

TEST SET 205. Wavemeter range, 3.05 to 3.35 centimetres, built-in oscillator with 9 valves including Klystron type CV.129, etc., in good condition, £17/10/-.

AMPLIFIERS. A high fidelity unit with separate Bass and Treble controls, constant impedance attenuator for setting volume level. 15 watt output, for 200/250 v. A.C. mains operation. Ideal for P.A. work, dances, etc.

LESS VALVES, £12/10/-. Complete with valves, £15/12/6. Cge. 12/6.

RECEIVER R1155. Brand new. Aerial tested. In maker's original transit case. £11/19/6. Carr. 10/6. Publication giving circuit diagrams, etc., 1/3.

45 Mc/s PYE I.F. STRIP. These vision units are brand new and complete with 6 EF50 valves and EA50. Our price only 65/- Post 3/-.

TELEPHONE SETS. For perfect communication between 2 or more positions. Wall Type, one pair of units, £5. Batteries 5/6. Twin wire 5d. yard. Desk Type now available, latest modern style. Two complete units ready for use, £8/17/6. Wire 5d. per yard. Post 3/-.

RADIATION MONITORS. Various types, 1092C, 1092B, Airmec Rate meter No. 1011B in case with Gamma probe, spare Geiger tubes, etc. The 64 Scaler. Further details on request.

WAFFER SWITCHES. Miniature, 2 Pole 6 Way, 3 Pole 2 Way, Both 2/6 ea. Standard, 1 Pole 3 Way, 1 Pole 4 Way, Both 2/6; 2 Pole 4 Way 3/-; 1 Pole 11 Way, 2 Pole 6 Way, 4 Pole 3 Way, 6 Pole 2 Way, 6 Pole 3 Way, 3/6; 2 Pole 11 Way, 3 Pole 6 Way, 6 Pole 4 Way, 4/6; 8 Pole 6 Way, 10/-.

Ceramic Types, 1 Pole 3 Way 4/-; 2 Pole 12 Way, 10/6; 4 Pole 4 Way, 6/-; 12 Pole 3 Way, 15/-. Post 9d.

CONDENSERS, METALMITE. 350 vt. wkg., .001, .002, miniature 1/4 ea., 12/- doz.; .005, .01, .02, 1/2 ea., 10/- doz.; .05, 1/4 ea., 12/- doz.; 1, 1/6 ea., 13/6 doz.; 25 Metalpack, 1/10 ea., 16/- doz.; 1.0 Metalpack 2/8 ea., 24/- doz. Post 1/-.

ROOM THERMOSTAT. Adjustable between 45 and 75 deg. Far. 250 v. 10 amp. A.C. Ideal for greenhouses, etc., 35/- Post 2/-.

GEARED MOTORS. 4 R.P.M. at 12 v., 8 R.P.M. at 24 v. Very powerful, supplied with a suppressor which can easily be removed. 35/-, post 2/-.

P.M. SPEAKERS. 10in. In portable case with flex and plug in own compartment, 50/- Cge. 5/-.

VENTAXIA FANS. 230/250 volts A.C., 6in. diam. blades, 130/- 12 volt D.C., 90/- post 2/9.

GENALEX EXTRACTION FANS. 230/250 volt, 50 cv. Induction motor 1,350 r.p.m., 85 watts, 9in. blades, silent running, £6/15/- Cge. 7/6.

RATIO ARM UNITS. H. W. Sullivan. 600 ohms to 600 ohms, 50/- Post 2/-.

WHEATSTONE RESISTANCE BRIDGE. 1 to 10,000 ohms. Plug type. £5.

ELECTRO MAGNETIC COUNTERS
 Post Office type 11A, counting up to 9,999, 2 to 6 volts D.C. 3 ohm coil, 12/6 each. Post 1/- Many other types in stock.

ROTARY CONVERTERS. Input 24 volt D.C. Output 100 watts at 230 volt A.C., 150 watts at 200 volt A.C., 92/6. Also available in a metal case with switch, 105/- Cge. 7/6.

ROTARY CONVERTERS. Input 24 volt D.C. Output 150 watts at 230 v. A.C., 200 watts at 220 volts A.C., complete in wood case with 0/300 volt-meter, 4 position switch and voltage regulating resistance. 150/- Also available with 12 volt input, 170/- Cge. 10/-.

L. WILKINSON (CROYDON) LTD.
 19 LANSDOWNE ROAD, CROYDON
 Phone : CRO. 0839. Telegrams : "WILCO," CROYDON

EDDYSTONE COMMUNICATION RECEIVERS

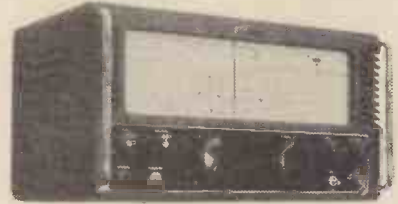

Model 840A illustrated
 Cash Prices and Special Credit Terms

Model	Cash Price	Deposit	8 monthly payments of
820	£38 0 0	£4 8 8	£4 8 8
840A	£55 0 0	£6 8 4	£6 8 4
750	£78 0 0	£9 2 0	£9 2 0
680X	£120 0 0	£14 0 0	£14 0 0

Carriage paid per passenger train

Model 840A, is for A.C. or D.C. 110/250 v. making it especially suitable for universal use. 750 and 680X 110/240 v. A.C. The very large tuning dials are clearly marked with band spread logging. Silky gear driven flywheel loaded tuning mechanism. These sets are the choice of the discerning professional and amateur users. Descriptive literature gladly forwarded.

Latest EDDYSTONE Component Catalogue 1/-.



The
Eddystone
 Specialists
SERVICES LTD.,

55 COUNTY ROAD, LIVERPOOL, 4
 Telephone: AINTREE 1445 ESTAB. 1935
 Branch Address: MARKET CROSS, ORMSKIRK

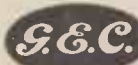

Applications are invited from young men (preferably ex-National Servicemen) under 25 years of age who possess Inter B.Sc. or 3 "A" Level G.C.E. Science Passes (preferably Physics, Pure and Applied Maths.) for admission to a newly instituted INDUSTRY-BASED SANDWICH SCHEME.

This is a four year course and involves alternating periods of 6 months full time studying and interesting varied practical work at these Laboratories. It is designed primarily for Physicists and Electrical Engineers and will lead to the London B.Sc. (Special Physics) or B.Sc. (Eng.). A small number of potential Chemists will also be considered. Apart from a generous salary all College and examination fees will be paid.

★ Applications should be made within 3 weeks of the appearance of this advertisement and should be addressed to: —

THE EDUCATION AND TRAINING OFFICER, RESEARCH LABORATORIES, G.E.C. LTD., EAST LANE, N. WEMBLEY, MIDDXX.
 QUOTING REFERENCE RLL/103.

Technical Publications

TECHNICAL WRITERS and **ILLUSTRATORS** are required with experience of electronic equipment for radar and similar projects.

An experienced **TECHNICAL CLERK** is also required.

Write giving full details etc. to Personnel Manager, Ref. RG, The General Electric Co. Ltd., Brown's Lane, Allesley, Coventry.

C.R.T. ISOLATION TRANSFORMERS

For Cathode Ray Tubes having Heater/Cathode short circuit or for C.R. Tubes with falling emission.
Type A. Low leakage windings. Ratio 1:1.25 giving a 25% boost on Secondary.
2 volt 10/8 each With Tag
4 volt 10/6 each Panel and
6.3 volt 10/6 each Solder Tags
13.3 volts 10/8 each
13.3 volt 10/6 each
Ditto with mains primaries 12/6 each.
Type B. Mains input 220/240 volts. Low Capacity. Multi Output 2, 4, 6.3, 7.3, 10 and 13 volts. Input has two taps which increase output volts by 25% and 50% respectively. This transformer is suitable for all Cathode Ray Tubes. With Tag Panel 21/- each.
Type C. Low capacity wound transformer for use with 2 volt Tubes with falling emission. Input 220/240 volts. Output 2-2 1/2-2 1/2-3 volts at 2 amps. With Tag Panel 17/6 each.
All Isolation Transformers are individually boxed, labelled and clearly marked with relevant data.
NOTE.—It is essential to use mains primary types with T.V. receivers having series connected heaters.

RESISTORS. All values. 10 ohms to 10 meg., 1/4 w., 4d.; 1/2 w., 6d.; 1 w., 8d.; 2 w., 1/-.
HIGH STABILITY. 1/4 w., 1/-, 2/-. All preferred values 100 ohms to 10 meg.

WIRE-WOUND RESISTORS 1/3
25 ohms—10,000 ohms 1/6
15 1/4 1/2 10
15,000 ohms—50,000 ohms 5 w., 1/9; 10 w. 2/3
WIRE-WOUND POTS 3 WATT LAB. COLVERN ETC. Pre-set Min. T.V. Type Standard Size Pots, 2 1/2 in. Knurled Slotted Knob Spindle High Grade. All values 25 ohms to 30 Values, 100 ohms to 50 K. 5 w., 1/6. 100 Ohm. 6/6. Ditto Carbon Track 50 K. W/W EXT. SPEAKER 2 Meg. 3/-. CONTROL 10Q 3/- O/P TRANSFORMERS. Heavy Duty 50 mA., 4/6. Multi-ratio, push pull. 6/6. Tapped small pentode, 3/6. Hygrade Push Pull 7 wts, 15/6.
I.F. CHOKES 15 H. E. 80/85 mA., 5/-; 25/20 H. 100/120 mA., 11/8; 20/15 H. 120/150 mA., 12/6; 5 H. 250 mA., 15/-.
MAINS TRANS. 350-0-350, 80 mA., 6.3 v. tapped 4 v. 4 s., 5 v. tapped 4 v. 2 s., ditto 250-0-250 80 mA., etc., 21/-.

I.F. TRANSFORMERS 7/6 pair

465 Kc/s tuning Miniature Can, 2 1/4 in. x 1 1/4 in. x 1 in. High Q and good bandwidth. By Fry Radio. Data sheet supplied.

HEATER TRANS. Tapped 200/250 v. 6.3 v. 1 1/2 amp. 7/6.
COPPER PLATED AERIAL RODS. 3/4 x 12 in. push fitting, 3/- doz. Post 1/-.
ALADDIN FORMERS and cores. 1 in., 6d.; 1 1/4 in., 10d.; 1 in. FORMERS with Can and Core. 1 1/4 in. sq. x 1 1/4 in. and 1 in. sq. x 2 1/4 in., 2/- ea.
MOTION DRIVES. Epicycloidal ratio 8:1, 2/3.
TYGANS. Midget Soldering Iron. 200/220 v. or 230/250 v., 4/11.
SOLON MIDGET IRON. 25 w., 24/-.
MIKE TRANS. Ratio 50:1, 3/9 ea., new and boxed.
MAINS DROPPERS. 3 x 1 1/4 in. Three Adj. Sliders, 3 amp. 750 ohms, 4/3. 2 amp., 1,000 ohms, 4/3.
LINE COIL. 3 amp., 60 ohms per foot, 2 amp., 100 ohms per foot, 2 way 6d. per foot, 3 way 7d. per foot.

CRYSTAL MIKE INSERT by Acos, precision engineered. Size only 1/4 x 3/16 in. Bargain. Price 6/6. No transformer required.
LOUDSPEAKERS P.M. 3 OHM. 5 in. R.A., 17/6. 7 in. x 4 in. Goodman, 21/- 8 in. sou. Elec., 21/- 8 in. Elec., 22/6. 9 in. Goodman, 18/6. 10 in. R.A., 30/- 6 1/2 in. ditto w/Trans., 21/- 10 in. Plessey, 30/- 8 in. M.E. 2.5 k. or 2 k. field, tapped O.P. transf., 24/6.
CRYSTAL DIODE. G.E.C., 2/- GEX34, 4/-.
CRYSTAL SET CONSTRUCTION. 1/40 CIRCUITS USING GERMANIUM DIODES. 2/-.
H.R. HEADPHONES, 4,000 ohms. Brand new, 17/6 pr. SWITCH CLEANER Fluid, squirt spout, 3/6 1/2.
TWIN GANG TUNING CONDENSERS. .0005 mfd. midget with trimmers 5/6; .375 pF midget less trimmers 6/6; .5 mfd standard size with trimmers and feet 9/-; less trimmers 8/-; ditto, soiled, 2/6. Cosor 3-rang 500 pF., 7/6.

PURETONE RECORDING TAPE

1,200ft. on standard fitting 7" Plastic reels. Brand new boxed 17/6
Spools 5" metal 1/6, 7" plastic 4/3

VALVE HOLDERS. Pax int. Oct. 4d. EF50, EA50: 8d. B12A, CBT: 1/3. Eng. and Amer. 4, 5, 6, 7 and 9 pin, 1/-.
MIDDLE MEXAS and Int. Oct. 6d., B7G, B8A, B9G, B9A, 9d., B7G with can 1/6, VCR97 2/6. B9A with can, 2/6 CERAMIC. EF50, B7G, Int. Oct. 1/- B7G with can, 1/3.
SPEAKER FRET. Woven Plastic TYGAN. Walnut tone, 12 in. wide, 2/- per foot. Expanded metal, gold, 9 1/4 in. x 12 in., 2/- per piece. Silver 15 1/4 in. x 9 1/4 in., 2/-.
WAVECHANCE SWITCHES. 2/6
2 p. 2-way, 3 p. 2-way, short spindle 2/6
2 p. 4-way, 2 wafers, long spindle 6/6
5 p. 6-way, 4 p. 2-way, 4 p. 3-way, long spindle 3/6
3 p. 4-way, 1 p. 12-way, long spindle 3/6

KNOBBS. GOLD ENGRAVED. Walnut or Ivory. 1 1/4 in. diam., 1/8 each. "Focus", "Contrast", "Brilliance", "Brilliance-On/Off", "On-Off", "Volume", "Vol-On-Off", "Tone", "Tuning", "Trebble", "Bass", "Wavechange", "Radio Gram", "S.M.L. Gram", "Record-Play", "Brightness". Ditto, not engraved, 1/-.

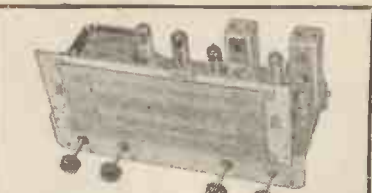

ALL-WAVE RADIOGRAM CHASSIS

THREE WAVEBANDS FIVE VALVES
S.W. 16 m.—50 m. LATEST MULLARD
M.W. 200 m.—550 m. ECH42, EF41, EBC41,
L.W. 800 m.—2,090 m. EL41, EZ40
12 month Guarantee, A.C. 200/250 v. 4-way switch.
Short-Medium-Long-Gram. A.V.C. and Negative feedback, 4.2 watts. Chassis 13 1/4 in. x 5 1/4 in. x 2 1/4 in. Glass Dial 10 x 4 1/2 in., horizontal or vertical available.
2 Pilot Lamps. Four Knobs, Walnut or Ivory, aligned and cabriated. Chassis isolated from mains.

BRAND NEW **£10.10.0** Carr. 4/6.
MATCHED SPEAKERS FOR ABOVE CHASSIS
8 in., 18/6; 10 in., 25/-; 12 in., 30/-.

RECOMMENDED FOR ABOVE CHASSIS

★ **R.C.S. SCOOP** ★
Collaro Autochanger RC531 for 78 R.P.M. 10 in. and 12 in. Records. Brand new in maker's boxes! High impedance, lightweight pickup with sapphire needle, will match any amplifier or radio. **£5.19.6**
Less than half price. Carr. 5/6



Plessey BARGAIN

£7.19.6

Brand new Plessey 3-speed Autochange Mixed Unit for 7, 10 and 12 in. Records. Twin Hi-Fi Xtal Head with Dupont sapphire stylus. Plays 4,000 records. Spring mounting. Baseboard required 15 in. x 12 in. Height 5 in. Depth 2 in. Super Quality. Post free A.C. 200/250 v.
Walnut Veneered Playing Desk out out ready for Plessey, only sold complete with Changer, 10/6 ext-4.

B.S.R. MONARCH. 3-speed Motor and turntable with selecting switch for 33, 45 and 78 r.p.m. records. 100-120 v. and 200-250 v. A.C. 80 cps. Also B.S.R. MONARCH Lightweight Pick-up with Acos Xtal turnover head, separate Sapphire stylus for L.P. and standard records. SPECIAL OFFER. THE TWO 24/15/6, post 2/6.

AMPLION. 3-speed Single Record unit with Acos 37 Turnover Head, each Sapphire Stylus plays 2,000 records. Starting Switch Automatically places Pick-up on records. 7 in., 10 in., or 12 in. Auto Stop. Baseplate 12 x 8 in. Height 2 1/2 in. Depth 1 1/2 in. Price £7/15/6, post free.

Teletron Band III Converter

For London, Midland and Northern Transmissions
Suitable for all T.V. makes. T.R.F. or Superhet.
Ready wound coils, two EF90 valves, all components, punched chassis, circuit diagram, wiring plans. COMPLETE KIT for mains operation. 200-250 v. A.C. £3/10/-.

AS ABOVE LESS POWER PACK Requires 200 v. 20 mA. H.T. 6.3 v. 6 a. L.T. £2/5/-
Mains Transformer to above Spec. 10/6
Min. Westinghouse Rect., ditto 8/6
Punched and drilled chassis 3/9
Larger chassis for Mains Model 6/-
Transformer Coilet with plans 15/-
BBC/ITA Crossover Unit 7/6
Variable Attenuator 6/-
Full plans and circuit details 6d

T.V. PRE-AMP. (McMICHAEL)
Will amplify output of your Band 3 Converter. Tune-able Channels 1 to 5. Midget size. High gain (Hinge model). B.V.A. Valve. Full instructions supplied. READY FOR USE. (H.T. 200V., L.T. 6.3V., 3 amp. required.) PRICE 25/- each. BRAND NEW. SPECIAL MAINS POWER PACK for above. 25/- extra.

Volume Controls 80 ohm CABLE COAXIAL

Long spindles. Guaranteed 1 year. All values 10,000 ohms to 2 Meg. No Sw. S.P.Sw. D.P.Sw. 3/- 4/- TYPE 3/- EXT. SPKR. 4/9
Semi-air spaced Polythene insulated 1/4 in. dia. Stranded core. Losses out 50% .. 9d. yd. STANDARD 1/4 in. Coaxial 8d. yd.

COAXIAL PLUGS 1/- DOUBLE SOCKET 1/3
SOCKETS TV AERIALS 1/- OUTLET SOCKET 4/6
Band 3 Dipole indoor, 6/6. Band 3 Twigs, 7/8 pr.
BALANCED TWIN FEEDER per yd. 6d. 80 Q or 300 Q.
TWIN SCREENED BALANCED FEEDER 1/4- yd. 80 ohms.
TRIMMERS, Ceramic, 30, 50, 70 pf. 9d., 100 pf., 150 pf., 1/6. 250 pf., 1/6. 500 pf., 750 pf., 1/8.

ALUMINIUM CHASSIS. 18 s.w.g. Plain, undrilled, with 4 sides, riveted corners and lattice fixing holes, with 2 1/2 in. sides. 7 x 4 in., 4/6; 8 x 8 in., 5/8; 11 x 7 in., 6/8; 13 x 9 in., 8/6; 14 x 11 in., 10/6; 15 x 14 in., 12/6 and 18 x 16 x 3 in., 1/6.

CHROMIUM PEN TORCHES with battery and bulb, 2/6. BLACK CRACKLE PAINT. Air drying, 3/- tin. P.V.C. CONN. WIRE, 10 colours, single or stranded 2d. yd. 5 in. RADIO SCREWDRIVERS, 4jd. each. NEON MAINS TESTER SCREWDRIVERS, 5/6.

VCR97 TESTED FULL PICTURE £2

MULTIGRIB SOLDER 60/40. 18 s.w.g., 3d., 16 s.w.g., 4d. yard, 1lb. 2/6.
SENTERGLO RECTIFIERS. E.H.T. type FLY-BACK VOLTAGES. K3/25 2 kV., 2/3; K3/40 2 kV., 6/-; K3/45, 3 kV., 2/6; K3/50 4 kV., 7/6; K3/100 8 kV., 12/6; MAINS TYPE. RM1 125 v., 60 mA., 4/-; RM2 100 mA., 4/-; RM3, 120 mA., 5/8; RM4, 250 v. 275 mA., 16/-; G.E.C. Neon Oscill. S.B.C., 2/6.
COILS Weairite, "P" type. 3/- each. Osamor Midget "Q" type adj. dust core, 4/- each. All ranges.
TELETON, L. & Med., T.R.F., with reaction. 3/6. H.F. CHOKES, iron core, 14 M.E., 3/- each.

P.M. TUNER COIL KIT. 22/6. H.F. coil, Aerial coil, Oscillator coil, two I.F. Transformers 10.7 Mc/s Detector transformer and heater choke. With circuit and component list, using four 6AM6. Chassis and Dial, 19/6.

CONDENSERS. New stock. .001 mfd. 7 kV. T.C.O., 5/6. Ditto 80 kV., 9/8; 100 pf. to 500 pf. Micas, 6d.; Tubular 500 v., .001 to 101 mfd., 8d.; .05, 1/-; .25 1/6; .5 1/8; 1.250, 1/4 in., 5d., 1/10 1/4 1/8.

NEW ELECTROLYTIC FAMAUS MAKES

TUBULAR TUBULAR CAN TYPES
1275 v. 2/- 100/25 v. 3/- 8+16/450 v. 5/-
2450 v. 2/3 8+8/500 v. 4/6 1+16/500 v. 6/-
4450 v. 2/- 16+16/500V. 6/- 19+24/350 v. 4/6
8450 v. 2/3 GAN TYPES 32+32/350v. 4/6
8/500 v. 2/9 Ohms 3d. 32+12/450v. 6/6
16/450 v. 3/6 16/450 v. 3/6 64+120/275v. 7/6
16/400 v. 4/- 32/350 v. 4/- 64+120/350v. 11/6
32/500 v. 5/6 64/350 v. 5/6 100+200/257v. 7/6
2525 v. 1/9 100/275 v. 5/6 1,000+1,000/6 v. 10/6
5025 v. 1/9 50+50/350 v. 7/-
50/50 v. 2/- 500/12 v. 3/-

FULL WAVE BRIDGE SELENIUM RECTIFIERS, 2, 6 or 12 v. 11 amp., 8/9; 2 a., 11/3; 4 a., 17/6.
CHARGER TRANSFORMERS. Tapped input 200/250 v. for charging at 2, 6 or 12 v. 11 amp. 13/6; 4 amp., 21/-.
ALL BERNARDS books in stock.
VALVE MANUALS I & II, 5/- ea. part. VALVE and TV TUBE equipments book, 5/-.
ACID HYDROMETER. New. Ex Govt. Unbreakable
Packed in metal case 7 x 1 1/2 in. dia., 4/6.
TOGGLE SWITCHES. S.P.D.T. (Ex-Govt.), each 1/2. NUTS BOLTS and WASHERS 12 of each, 2, 4 or 6BA per packet 1/-.

VALVES A SMALL SELECTION FROM OUR STOCKS New & Guaranteed

Al Boxed	1/6	6/6	10/6
8/8	EA50	C.6L5	5Z4
1R5	6B8	6J5	12A7
1T4	9D2	6E6	EB41
185	EF50	6K7G	EP80
394	Equip.	E1148	EB91
3V4	8P6	EB34	EB180
8U4	8P4	HVR2	EB42
6AM6	EF92	(near)	EF41
6AT7	3D6	6HG6	EP80
6J7	7I8	7I8	EL41
6K8	6BE6	6V8G	EL32
6N7	6BW6	6X4	HVR2A
6V6GT	6P6	6X5	PEN25
6BC33	6K7GT	807	U29
EF50	6K7M	EF99	VP23
8Y1	Red	12K8, 12Q7, 12K7, 35L6, 35Z4	6Q7
EF91	Special Price — 37/8 —	The Set	X70

SUPERHET COIL PACK 27/6 Miniature size 2 1/4 x 2 1/4 x 1 1/4 in. High Q dust covered coils. SHORT, MED., LONG, GRAM switching with connection diagram and circuit.

We have no connection with any other firm. Please address all Mail Orders correctly as below.
RADIO COMPONENT SPECIALISTS 507 WHITEHORSE RD., WEST CROYDON
OPEN ALL DAY—(Wed. 1 p.m.) 10-page list S.A.E.
Tel. THO 1665. Buses 133 or 68 pass door. S.R. Stn. Selhurst. 48-hour postal Service P. & P. 1/-. £2 orders post free (Export extra). C.O.D. Service 1/6

BAND 3 T.V. CONVERTOR 183/196 Mc/s.

Kit of parts complete to build this most successful unit, comprising drilled chassis, valves, coils, res., cond., etc.; slightly modified version (Wireless World, May, 1954). 22/5/- post free. Send for blueprint and wiring diagram, 1/6 post free. Power Pack Components, including mains transf. and met. rect., 30/- extra. Provision has been allowed on chassis for Band 1-Band 3 switching. Suitable for most types of T/V sets, T.R.F. or superhet.

B.B.C. BREAK-THROUGH FILTER, tunable filter unit for B.B.C. pattern rejection, 8/6



RADIO-GRAM CHASSIS 5 VALVE SUPERHET. LATEST B.V.A. MIDGET SERIES VALVES

3 WAVEBANDS:—L.W. 300m-2000m, M.W. 200m-550m, SW. 16m-50m. Chassis size 13 1/2 x 5 1/2 x 2 1/2 in. Attractive Glass Dial 10 x 4 1/2 in. edge lit by 2 pilot lamps. Horizontal or Vertical Station Names and 4 control knobs, walnut or ivory to choice. 4 position W/C switch, L.M.S. and Gram. P.U. sockets. Modern circuitry, all coils adjustable, dust eared and only quality components used throughout. Delayed A.V.C. and neg. feedback. A.C. mains 200-250 v. Double wound transf. isolates chassis from mains. Aligned and calibrated ready for use.

BRAND NEW & GUARANTEED £9.15.0 Carr. and ins. 4/6-8" and 10" speakers suitable for this chassis available.

7-Valve De Luxe, push-pull version, 7-watt output £12.10.0

QUALITY FLUORESCENT FITTINGS

Ideal for home or workshop. 4ft., 220-250 v., complete with tube, ballast unit, etc. ready for use. Famous manufacturers' surplus offered at approx. half price. Starter switch type 42/-, Quick start type 47/6. Carr. and ins., 7/6 extra.

ELECTROLYTICS *Leading Makes New Stock*

TUBULAR	CAN TYPES	80 ohm CABLE	CO-AXIAL
25/25 v. 50/12 v. 1/9	8+8/450 v. . . . 4/6	5/-	SPECIAL.—Semi-air spaced polyether
50/50 v. 4/500 v. 2/-	8+16/450 v. . . . 5/6	Standard 1/4 in. diam. Stranded core. Feedline	6/ Standard 1/4 in. diam. Stranded core. Feedline
100/25 v. 2/-	8+16/500 v. . . . 5/6	6/ Standard 1/4 in. diam. Stranded core. Feedline	6/ Standard 1/4 in. diam. Stranded core. Feedline
8/500 v. 2/6	16+16/275 v. . . . 4/6	6/ Standard 1/4 in. diam. Stranded core. Feedline	6/ Standard 1/4 in. diam. Stranded core. Feedline
8+8/500 v. 4/6	16+16/450 v. . . . 4/6	6/ COAX PLUGS 1/2. SOCKETS 1/6-	6/ COAX PLUGS 1/2. SOCKETS 1/6-
8+16/450 v. 5/-	16+32/350 v. . . . 4/6	6/ COUPLERS 1/3. OUTLET BOXES 4/6	6/ COUPLERS 1/3. OUTLET BOXES 4/6
16/250 v. 3/6	32/350 v. 4/6	4/- BALANCED TWIN FEEDERS per yd., 6d.	4/- BALANCED TWIN FEEDERS per yd., 6d.
18/450 v. 3/6	32+32/275 v. . . . 4/6	Special 300 ohm TWIN FEEDER 8d.	Special 300 ohm TWIN FEEDER 8d.
18+16/450 v. 5/6	50+50/350 v. . . . 6/6	TWIN SCREENED FEEDER per yd., 1/3.	TWIN SCREENED FEEDER per yd., 1/3.
32/250 v. 4/-	60/350 v. 6/6	80 OHM COAX CABLE 8d. per yd., 1/4.	80 OHM COAX CABLE 8d. per yd., 1/4.
38/500 v. 5/-	60+250/275 v. . . . 12/6	ATTENUATORS 6db, 12db, etc. from	ATTENUATORS 6db, 12db, etc. from
32+32/350 v. 5/6	64+120/275 v. . . . 11/6	3/6. Band 1-3 Cross-over filter unit	3/6. Band 1-3 Cross-over filter unit
32+32/450 v. 6/6	100+200/275 v. 12/6	8/ from 7/6.	8/ from 7/6.

CONDENSERS.—Mica, Silver Mica. All pref. values, 3 pt. to 1,000. 6d. each. DfHo ceramics 9d. each. Tubulars, 450 v. Hunts and T.C.C. .001 mfd.-.01 and 1/350 v., 9d. each. .02-1/500 v., 1/- each. .25 Hunts, 1/6. .5 Hunts, 1/9

SPEAKER FRET—Expanded Bronze anodised metal 8 x 8 in., 2/3; 12 x 8 in., 3/-; 12 x 12 in., 4/3; 12 x 16 in., 6/-; 24 x 12 in., 8/6, etc.

TGAN FRET (Murphy pattern) 12 in. x 12 in., 2/-; 12 x 18 in., 3/-; 12 x 24 in., 4/-, etc.

JASON F.M. TUNER UNIT 87-105 m/cs

Kit of parts to build this modern and highly successful unit, complete with drilled chassis and J.B. dial, wound coils and screening cans, 4 B.V.A. miniature valves and all necessary quality components, etc., for only £6/10/- post free. Superior dial calibrated m/c/s, edge lit by 2 pilot lamps, 12/6 extra. Power Pack components kit including double wound mains transformer, 22/5/- extra.

Tested and approved by "Radio Constructor," etc. Illustrated handbook with full details 2/-, post free.



RESISTORS

Carbon type. Pref. values 10 ohms-10 megohms, 20% Tol. ± w. 3d.; 1 w. 5d.; 1 w. 6d.; 2 w. 9d.; 10% Tol. ± w. 9d.; 5% Tol. ± w. 1/-; 1% Hi-stab. ± w. 2/-.

WIRE WOUND TYPES

Wire ends, Silicone coated. 25 ohms-10,000 ohms, 5 w., 1/3. 10 w. 1/6. 15 w. 2/-.

LINE CORD .3a 60 ohms per ft., 2a 100 ohms per ft., 2 way 6d. per ft., 3 way 7d. per ft.

LOUDSPEAKERS

P.M. 3 OHM. 5 in. Celes., 17/6; 6 in. Celes., 18/6; 7 x 4 in. Goodman's Elliptical, 18/6; 8 in. Elac., 20/-; 8 in. Goodman's special, 21/6; 3 in. R. and A., 25/-; 12 in. Plessey, 35/-; 8 in. M.E. 2 k. ohms field, tapped O.P. trans., 24/6; 3 1/2 in. Elac., 17/6.

S.T.C. RECTIFIERS

E.H.T. types. K3/25 2 Kv., 4/3; K3/40 3.2 Kv., 6/-; K3/45 3.6 Kv., 6/6; K3/50 4 kV., 7/3; K3/100 8 kV., 12/6, etc.

Mains types. RM1 125 v. 60 mA., 4/-; RM2 125 v. 100 mA., 4/6; RM3 125 v. 120 mA., 5/6; RM4 250 v. 275 mA., 16/-.

RM4B type, 275 v., 275 mA., 17/6. LT types F/W bridge 6-12 v. 1 1/2 a., 8/9; 3 a., 15/6; 4 a., 18/6; 6 a., 21/6 each.

PRE-SET W/W POT

T.V. knurled slotted knob type. 25 ohms to 20,000 ohms, 3/-; 50,000 ohms, 4/-; 50,000 ohms to 2 Megohms (carbon), 3/-.

VOLUME CONTROLS

Midret log type, long spindles, all values 10,000 ohms to 2 Megohms. Lens sw., 3/-; S.P. sw., 4/-; D.P. sw., 4/6. Linas types all values 10 ohms to 2 Megohms less switch 4/-. Guaranteed 12 months.

TRS RADIO COMPONENT SPECIALISTS

70 BRIGSTOCK RD., THORNTON HEATH, SURREY

Phone: THO 2188. Hours 9 am.—6 pm., 1 pm. Wed. Open all day Saturday. BY THORNTON HEATH STATION. BUSES 130A, 133, 169, 166, 190

Terms: C.W.O. or C.O.D. Kindly make cheques, P.O.s, etc., payable to T.R.S. Post 2/- Packing up to 1 lb. 7d., 1 lb. 1/1, 3 lb., 1/6, 5 lb., 2/-, 10 lb., 2/9. Bargain Lists, 3d.



ALWAYS "FIT"



AUTOSET

CASTORS
THE WORLD'S BEST

CONTRACTING TUBE ADAPTOR

For 7/8", 1", 1 1/8", 1 1/4" tubes, Quickgrip Adaptors are fitted by hand as no tools are required. 2", 2 1/2", 3", and 4" wheels may be used.

Ask for Brochure and pages 8, 25, 57.

Numerous other types of head fittings available

Engineers, Patentees and Sole Manufacturers
AUTOSET (PRODUCTION) LTD.
DEPT. "H," 75-BI STOUR STREET, BIRMINGHAM, 18
EDG. 1143 (3 lines). Estd. over 35 years.
Please mention "Wireless World" AT16

IMPREGNATE your coils with ease

BLICKVAC

High Vacuum Impregnators meet the most stringent specifications and yet are easy to handle. Full range of models available to meet the needs of the large-scale producer, the research laboratory or the small Rewind shop.

Outstanding Features:

- Ease in control.
- Ease in cleaning.
- Elimination of vibration
- Unequaled flexibility and performance.
- Simple attachment of auxiliary autoclaves.
- Units available suitable for Varnish, Wax, Bitumen and Potting Resins.

Users include M.O.S., N.C.B., G.E.C., Pye, Marconi, Metro-Vick.



If your problem is COIL IMPREGNATION or impregnating or casting with Potting Resins consult:

BLICKVAC ENGINEERING LTD.
Bede Trading Estate, Jarrow, Co. Durham. Jarrow 89/7155
96/100 Aldersgate Street, London, E.C.1. Monarch 6256/8

ALL YOUR TV COMPONENTS

from one source

Same day despatch if ordered before 3 p.m.

NEW ADDITIONS TO OUR RANGE OF COMPONENTS

D.T.V.'s Replacement Line Output Trans. for Murphy models

DTV4	for Murphy V116, V114	35 0
DTV8	for Murphy V200, V202 and V178 (designed with optional oscillator winding)	52 0
DTV10	for Murphy V120, V130	50 0

Note: We rewind the Murphy V150 line output transformer but regret that we cannot supply new.

D.T.V.'s Replacement Line Output Trans. for Ferranti models

DTV2	for Ferranti I4T3, I7T3 series	52 0
DTV3	for Ferranti T129, T136, T138	39 6
L1255	for Ferranti T1425, T1125, T1225, I4T4, T12055, T14055, T1215, T1415	60 0
DTV4	for Ferranti V116, V114, V118	35 0

D.T.V.'s Replacement Line Output Trans. for Bush models

L1065	for Bush TV11, TV12, TH12	36 9
DTV6	for Bush TV1, TV2	45 0

D.T.V.'s Replacement Line Output Trans. for Raymond models

DTV5	for Raymond F60, F56	52 0
L1566	for Raymond F61	52 0
DTV12	for Raymond F49	52 0

D.T.V.'s Replacement Line Output Trans. for Miscellaneous models

DTV13	for McMichael models C52, 512	45 0
DTV7	for Phillips 663A, 383A, 563A, 463A	52 0

THE MOST COMPLETE STOCK OF TV REPLACEMENTS IN G.B.



Terms of business: C.W.O., C.O.D. or proforma. Please add postage and packing (1/6 up to 10/-, 2/- up to £1, 2/6 up to £2, £5 and over p.p. FREE).

REPLACEMENTS

134/136 LEWISHAM WAY - NEW CROSS, S.E.14

Tel.: TIDeway 3696/2330 Grams: Flibak, London, S.E.14



THE MODEL CR50 BRIDGE measures from 10pFd to 100mFd and from 1 ohm to 10 megohms in fourteen ranges, having a total scale length of over 120 inches. Indication of balance is given by a magic eye fed from a high gain amplifier valve. A leakage test is incorporated for condensers. The internal standards are Constantan 1% resistors. Specially designed for bench use with case and panel of steel finished black crackle. Complete with all valves and instructions ready for immediate operation from 200/250 volt A.C. mains. Fully guaranteed and priced at only £7/18/- plus 4/6 carriage and packing. Hire Purchase £4/6/3 deposit and five monthly payments of 17/3.

SG50 SIGNAL GENERATOR covers 100 kc/s to 80 mc/s in six continuous ranges on fundamentals (NOT harmonics) either modulated 400 cps or CW. Uses EF91, 6C4 and RMI with double wound mains transformer. The scale is directly calibrated on all ranges with scale length over 60 inches. In de luxe olive green metal case with carrying handle and engraved matching scale of perspex. The cost today is only £8/10/- plus 6/- carriage and packing. Hire Purchase £4/13/- deposit and 5 monthly payments of 18/7.

VV50 VALVE VOLTMETER measures up to 250 volts A.C., R.F. or A.F. with input impedance of 11 Megohms. For mains operation. Price £7/19/6 plus 4/6 carr./packing or £4/6/3 deposit and five monthly payments of 17/3.

Further details sent by return on receipt of stamped and self addressed envelope. Trade enquiries welcomed—supplied direct.

NOTE NEW ADDRESS — Now at:—

GRAYSHAW INSTRUMENTS

126 SANDGATE HIGH STREET, FOLKESTONE, KENT.

GOOD VALUE—SERVICE AND STOCKS

BENDIX RADIO COMPASS



A superb 12-valve receiver covering 3.4-7 Mc/s, 325-695 Kc/s, 150-325 Kc/s. Valves used 5-6K7, 2-6N7, 2-6J5, 1-6B8, 1-6L7, 1-6F6. Complete with 28-volt dynamotor. Loose stored. PRICE £3/10/- Carriage 8/6.



MOVING COIL MICROPHONE

By famous maker. A high-grade microphone combining excellent close speaking performance with low background pick-up. Attractively styled and finished in black and chromium. Brand new, boxed. PRICE £3/19/6. Post 2/-.

MOVING COIL HEADPHONES

Velvet faced earpads complete with lead and plug 12/6. Postage 1/6.

KELVIN RATIO METER

Mirror backed. Type Mn. HG-ABS KB 630/01. 8in. scale. Deflection approximately 6 micro-amperes, £5/19/6.



POCKET VOLTMETER M.C.



2 ranges. 0-250 V. and 0.15 V. D.C. Press button. At 12/6 each. Post 1/6. VCR97 Brand new, boxed 12/6. Post, insurance 2/6

TRANSFORMERS

E.M.I. pick-up transformers. To match low impedance high fidelity pick-ups. Potted. PRICE 4/6. Post 1/6.



MILLIAMETERS 2 1/2 in. round, 6/6 each.

SOLAR ELECTROLYTICS, can type. 8 x 8 mfd. 350 v. working, 20 mfd. 150 v. working 2/- each. Clips 4d. each. 250 mfd., 12 v. working 1/3 each, or 12/- per doz. (TCC flat type).

SPEAKERS. Unused 8in. with baffle and fret cloth, 12/6 each. Post 1/6.

WE CAN SUPPLY

GRUNDIG Tape Recorders, Microphones, Radlograms, etc. We also supply **RECORDING TAPE**: E.M.I., Scotch Boy, Sound Mirror, Ferrotape, etc.; and **TAPE DECKS** by "Truvox," "Lane," "Wearite," etc.

Why not Trade in your unwanted equipment.
High part exchange allowances made.

Telephone GER 2613

Carriage extra on all items unless quoted.

Open daily 10.30 a.m. to 4.30 p.m. Closed all day Thursdays.

The RADIO EXCHANGE Co.

9 NEWPORT PLACE LEICESTER SQUARE LONDON, W.C.2

Aerialite

PRODUCTS FOR THE

ELECTRONICS INDUSTRY

CO-AXIAL PLUG Part No. 166

A universal fitting plug which ensures effective cable and braiding clamping, and ensures quick and easy fitting. It is specifically designed for attachment to a wide range of cables. It is of robust construction and competitively priced. Co-axial plug, Part No. 166 is available in large quantities and we shall be happy to quote for your requirements.

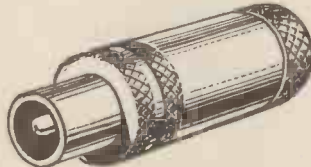

CO-AXIAL PLUG Part No. 148

Ease of assembly is but one of the salient features of this two-piece co-axial plug. It is, like model 166, a well-designed plug which conforms to R.E.C.M.F. standards. Body finish is bright nickel plating and the pin is silvered. Competitively priced and available in quantities.

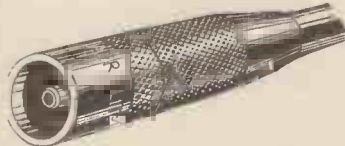

CO-AXIAL SOCKET Part No. 149

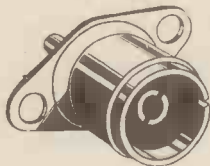

Robust construction, positive contact and low loss aerial connection are the reasons for the success of the co-axial socket. Most of the leading television receiver manufacturers now specify and fit the Aerialite Co-axial Socket as a standard item.

RADIO CONNECTING WIRES

Aerialite connecting wires are being increasingly used in the Radio, Television and Electronic Industries due to their flexibility, wide colour range and low cost. Thermoplastic insulation ensures a higher dielectric plus the advantages of greater mechanical strength, fire resistance and permanence. Aerialite connecting wires are easy to handle, easy to strip, and save valuable time on the production floor. Please send for leaflets and prices.

AERIALITE

LTD.

HARGREAVES WORKS · CONGLETON · CHESHIRE

Head Office & Cable Division:—Castle Works, Stalybridge, Cheshire

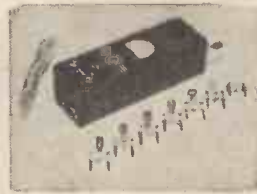

"Q-MAX" G.D.O.—IA
GRID DIP OSCILLATOR
Covering 1.5 to 300 Mc/s
In eight ranges.
(Built in mains pack)
Complete **12 GNS.**
(or on H.P.)

HI-FI AMPLIFIERS AND F.M. UNITS

By **ACOUSTICAL** ● **ARMSTRONG** ★
CHAPMAN ● **LEAK**
LOWTHER ● **R.C.A.**
★ **ROGERS** ● **SOUND SALES**

ALL COMPONENTS FOR OSRAM 912, AND MULLARD 5/10 INCLUDING GILSON TRANSFORMERS.

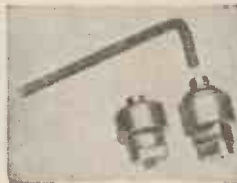

"Q-MAX" CHASSIS CUTTERS

	each		each
3/4 in.	12/9	1 1/2 in.	18/-
1 in.	13/9	1 3/4 in.	18/-
1 1/4 in.	13/9	1 7/8 in.	20/6
1 1/2 in.	16/-	2 in.	33/6
1 3/4 in.	16/-	2 1/4 in.	38/6
1 7/8 in.	16/-	2 1/2 in.	25/6

KEYS:— SMALL, 1/-; MEDIUM, 1/6; LARGE, 2/3.

Patent No. 619178

ILLUSTRATED CATALOGUE 6d. POST FREE

BERRY'S

(SHORT WAVE) LTD.

25, HIGH HOLBORN LONDON, W.C.1
(Opposite Chancery Lane) Tel.: HOLborn 6231

PARKER'S SHEET METAL FOLDING MACHINES. HEAVY VICE MODELS

No. 1 (Illustrated) Capacity. 18 gauge mild steel x 3ft. wide. 3ft. model, weight 50lb., £4/15/- Carr. 10/-. 2ft. model, weight 22lb., 55/-. 18in. model, weight 18lb., 55/-. carr. on small models 4/-. If with attachments: 5/6.
Attachment angle for 3ft., 3/8 per ft. Small models 2/- per foot.

Machines guaranteed. Send for details

A. B. PARKER WHEATCROFT WORKS. WELLINGTON STREET, BATLEY, YORKS. Tel.: Batley 428

FIRST CLASS DEVELOPMENT ENGINEER

Required by well-known manufacturers of T.V. aerials.

The firm, which is progressive, ambitious, and well financed, intends to pay adequately for good work and would consider profit participation after a six months' probationary period.

All negotiations in absolute confidence.

Box 2714

"I'M SET TO GO PLACES . . . with you!"

FOUR VALVE
SUPERHET

LONG WAVE
MEDIUM WAVE

LARGE
ELLIPTICAL
SPEAKER

B7G MINIATURE
VALVES

SIMPLE
CONSTRUCTION

Price £7.15.0
plus 4/- carriage

Send 1/6 for SUPEREX "55"
CONSTRUCTION BOOKLET.



THE SUPEREX "55" BATTERY PORTABLE is a first-class receiver guaranteed to give good reception throughout the country. Equal in appearance and performance to any commercial model. Cabinet size 10½in. x 8½in. x 4½in. All parts available separately.



The SUPERIOR BUREAU



An elegant cabinet in richly figured walnut veneer, internal panels in polished sycamore. A drop front lid covers a sloping, uncut control panel (16in. long x 10½in. high) alongside which is an uncut base-board (15½in. long x 13½in. back to front). The inside of the drop front lid is panelled in beige leatherette. In the lower part of the cabinet are two large storage cupboards (13½in. high, 7½in. wide, 16½in. deep). The lid and cupboard handles are in chased Florentine bronze. Overall dimensions (33in. high, 34in. long, 16½in. deep).

Price £17 plus 25/- carriage. Send for Cabinet Leaflet.



BUREAU CABINET

A well-designed Bureau-type cabinet in a medium size. Veneered in a highly figured walnut. Outside dimensions, length 29½in., depth 16in., height 32in. Sloping control panel on right hand side approx. 13in. x 10½in. Removable baseboard on right hand side approx. 13½in. x 13in. Large storage compartment located inside the cabinet, above motor board.

CASH ONLY 12 GNS. Packing and carriage 20/-

LOCATION: On the main Harrow Road between Harlesden and Wembley.

SHOP OPEN: 9 a.m. to 6 p.m. Monday to Saturday. 1 p.m. Thursday.

TERMS: Cash with order or C.O.D. Extra charge for C.O.D. U.K. and N. Ireland.

Superior

Radio supplies

37 HILLSIDE, (HARROW ROAD)
STONEBRIDGE, N.W.10. Elgar 3644

RD JUNIOR

FM UNIT

A seven-valve receiver of advanced design, the RD JUNIOR FM Unit has one of the most comprehensive and ambitious specifications so far offered in this country. Precision built and attractively styled it forms a fitting counterpart to the RD JUNIOR Amplifier, with which it has primarily been designed to work.



MAIN FEATURES

- ★ AUTOMATIC FREQUENCY CONTROL
- ★ GROUNDED-GRID TWIN-TRIODE RF STAGE
- ★ EXCEPTIONAL FREQUENCY STABILITY
- ★ WIDE FREQUENCY COVERAGE
- ★ FOSTER-SEELY DISCRIMINATOR
- ★ VARIABLE INDUCTANCE TUNING
- ★ LOW IMPEDANCE OUTPUT
- ★ BUILT-IN FILAMENT SUPPLY
- ★ OPTIONAL PRECISION TUNING METER

Trade and Export enquiries invited. PRICE: £17.10.0 (Plus P.T. £7.7.0.)

illustrated literature post free on request; send also for details of matching equipment in the RD JUNIOR Home High Fidelity System—the RD JUNIOR Amplifier/Control Unit and Corner Horn Reproducer

ROGERS DEVELOPMENTS (ELECTRONICS) LTD.

"RODEVCO HOUSE"

116 BLACKHEATH ROAD

GREENWICH

LONDON, S.E.10

Telegrams: Rodevco Green, London.

Telephone: TIDeway 1723

GEE RADIO LTD

R.C.A. BRAND NEW 15in. 15 ohms 30 watt P.M. SPEAKERS.
Snip price £9/19/6. Carriage 12/6.

R.C.A. PRESSURE UNITS. 15 ohms. P.M. 20 watts. Complete with Exponential Horn, length 14in. dia. 17in. £5/19/6. Carriage 10/-.

COMMUNICATION RECEIVERS P.C.R.2. Waveband 13-49, 200-600, 800-2,100 metres. Also P.C.R.3. 13-41, 41-120, 200-550 metres. Both types in brand new condition. Fully tested before despatch. Price £7/10/- each. Carriage 7/6.

POWER PACKS for the above Models available, complete with Speaker, built into very attractive Polished Bin. Extension Cabinet, ready for use on 200-250 v. A.C. Mains. £5/10/-. Carriage 7/6.

B.C. 614A SPEECH AMPLIFIER (Part of B.C.610 Equip.). As new, £22. Carr. extra.

MARCONI CRYSTAL CALIBRATORS for Band III Ex. Gov. Freq. range 170-240 Mc/s. Directly Calibrated Dial, 5 Mc/s Crystal Oscillator, Self-contained Power Pack for A.C. Mains operation. Complete with crystal and all valves, also spare set of valves with Instruction Manual. Brand new in original Transit Case, £5/10/6. Carr. extra.

C.M.G.-25 PHOTO CELLS (Osram). Brand New 17/6 each.

B.S.R. MONARCH. 3 speed automatic record-changer. Brand New in sealed makers cartons. £7/15/-. Carr. 7/6.

B.S.R. 3 speed motor and turntable only. Brand New. £3. Carr. Pd. **50 WATT EX GOVT. AMPLIFIER** with 4-KT66's in paralleled push-pull. Standard 200-250 v. A.C. input. Output impeded. 600 ohms. Line. High imp. gram and mike input. Bass boost control fitted. Quality amplifier housed in strong metal case ready for use. Terrific performance. Bargain price £25. Carriage extra.

R.C.A. 20 WATT MIKE AND GRAM AMPLIFIER, complete, ready to use. Tested before despatch. Housed in attractive all-metal case. Limited quantity available, only £18/10/-. Carr. 10/-.

E.H.T. TRANSFORMERS: 4.5kv. at 10ma. Pri. 230v. Bargain price, 32/6. Carr. 3/-.

3A5 VALVES, Brand new (DCC90), 15/-.

METERS

0-1 mA. 2½in. round flush mounting. 21/-.
0-10 mA. 2½in. round flush mounting. 12/6.
0-30 mA. 2½in. round flush mounting. 15/-.
0-5 amp. 2in. square flush mounting. 15/-.
0-300 v. A.C. flush mounting 2½in. scale. 25/-.
0-25 amp. D.C. flush mounting 2½in. scale. 12/6.
0-15 v. and 0-250 v. D.C. pocket volt-meter 2½in. 15/-.
AR-77 "S" meters 2in. F.S.D. 5 mA. 30/-.
0-200 v. A.C. meters flush mounting 3½in. Grade I. 40/-.

WAVEMETER CLASS D. Freq. band 1,900 kc/s-8,000 kc/s. (159-37.5 m.) in two ranges, 1,900 kc/s-4,000 kc/s. Also 4,000 kc/s-8,000 kc/s. in perfect working order. Supply 6 v. D.C. input. £8/5/-. Carr. paid.
CONDENSERS. 2 mfd. 7.5 kv. wkg. at 15 kv. test (Dubilier). Brand new in original crates. £2/10/-. Carriage 5/-.

VARIABLE VOLTAGE REGULATOR TRANS. Input 230 v. A.C. at 21 amps. Output 57.5 volts in 16 equal steps to 230 v. at 21 amps. Ex. Govt. in perfect condition. £12/10/-. Carr. extra.

H-DUTY TRANSFORMERS L.T. 230 v. PRI, II-12.5 v. SEC. at 70 amps. £5/10/-. Carriage 7/6.

DON "B" TWIN TELEPHONE CABLE on 1 mile and ¼ mile drums. £5 per mile, 25/- per ¼ mile. Carriage extra.

WESTON BATTERY OSCILLATORS. Model E 692 Type 2. In perfect condition. Coverage 100 kc/s-20 Mc/s. Audio output approx. 400 c/s. Complete with instruction books and charts. £5/19/6. P.P. 4/6.

COLLINS RADIO RECEIVERS TYPE 46159A. Freq. range 1,500 - 12,000 kc/s. Input 12 v. or 220 v. D.C. Less crystal and power pack. This unit is part of TCS-12-Trans. Receiver equipment. In clean and good condition. Limited quantity. £15. Carriage 7/6.

VALVE TESTER (by Radio City Products, U.S.A.). Model No. 314. Brand new, unused with instruction manual. 110-220 v. A.C. 50 c/s. Will test most American valves from 1.1 v. to 200 v. £10. Carr. 5/-.

EX-PHILCO 6 v. and 12 v. Car Radio Vibrator Transformers. H-T 280 v. @ 80 mA. New in perfect condition. 12/6. Postage 1/8.

R.C.A. PRE-AMPLIFIERS. Comprising 2 6J7 valves and connections. Available for photo cell input 250 v. H.T. 6.3 v. L.T. supply required. Output control. Complete unit. New and unused. £5. Carriage paid.

ROTARY CONVERTERS. Ex. Govt. 12 v. D.C. Input 230 v. A.C. Output 50 cycles at 125 watts output. Complete in carrying case containing voltage control, sliding resistance, mains switch and 0-300 v. A.C. Flush Meter, in perfect working order. £8/10/-. Carr. extra.

RACKS, G.P.O. STANDARD. For 19in. panels. Steel channel sides, correctly drilled, heavy angle base, height 6ft. £3/10/-. Carr. extra.

CARRIAGE CHARGES APPLY TO ENGLAND ONLY.

QUOTATIONS TO THE TRADE FOR BULK SUPPLIES, ALSO ACTUAL ENQUIRIES WELCOMED. MANY OTHER LINES IN STOCK.

15, LITTLE NEWPORT ST., LONDON, W.C.2.

(ADJOINING LEICESTER SQUARE TUBE STATION)

GERRARD 6794/1453

SAMSON'S SURPLUS STORES

E.D.C. Rotary Convertors. Input 230 v. D.C. Output 230 v. 6.6. amps. A.C. 50 cycles. £20. Ex warehouse.

S.T.C. 24 v. 4 amp. Selenium Rectifiers 27/6. P.P. 2/6.

Special Offer of Block Condensers. T.C.C. 10 mfd. 500 v. wkg. at 140 deg. F. Sub chassis. 6/6. 8 mfd. 500 v. wkg. at 140 deg. F. 4/9. 4 mfd. 1,000 v. wkg. at 140 deg. F. sub chassis. 4/6. 0.5 mfd. 2,000 v. wkg. at 60 deg. C. 3/6. 2 mfd. 2,500 v. wkg. at 60 deg. C. 7/6. Postage on all condensers 2/-.

Just arrived—Parmeko Heavy Duty Transformers. Input 230 v. Output 4 v CT 20 amps. Tropically rated. 27/6. Carr. 3/6.

American Smoothing Chokes. 13 henries 160 ma. 160 ohms. 10/6. P.P. 2/6.

A.C. 200-240 v. 40 Amp. Contactor. Double pole. New, in maker's cartons. 32/6. Carr. 4/-.

Advance Components. Constant Voltage Transformers Input 190-260 v. Output 230 v. 150 watts. £6/10/-. Carr. 7/6.

Brooks Capacitor. Start 0.4 h.p. A.C. 230 v. motors, 2,860 r.p.m. As used in the Brooks heavy duty air blowers. £5/10/-. Carr. 10/-.

Frost Electric. 1/6 h.p. A.C. 230 v. cap. Start Motor £3/17/6. Carr. 7/6.

Field Telephones. Mark DV. Complete with batteries. 49/6 ea. Carr. 5/-.

Telephone Cable. Type D3. Twin ¼ mile. 65/-, Carr. 7/6. Type D8. Twin 1-mile drums. £7/10/-. Carr. 12/6.

P.V.C. Commando Assault Telephone Cable. 1,000-yard drums. 10/6. P.P. 2/6.

Sliding Resistors. 60 ohms 1.5 amp. Geared drive. 15/-, P.P. 2/-, 50 ohm 1 amp. S.M. drive. 8/6. P.P. 2/-, 1 ohm 12 amp. slide control 12/6. P.P. 2/-, 0.4 ohm 25 amp. geared drive 17/6. P.P. 2/6. 17.5 ohm 8 amp. Fixed Resistor with adjustable tapping. 17/6. P.P. 3/-, Many other types available from stock.

169/171 Edgware Road, London, W.2. Tel.: PAD 7851

125 Tottenham Court Road, W.1. Tel.: EUS 4982

All orders and enquiries to our Edgware Road branch, please. This is open all day Saturday.

WHY GERMANIUM RECTIFIERS?



In the high frequency field and in cases where the maximum efficiency must be packed into the minimum space, Ediswan Germanium Rectifiers are greatly in demand. Both Point Contact and Junction types are available. They are remarkably robust and have an unusually long operating life.



Literature giving performance curves, ratings and dimensions is available on request, and of course, our technical experts are always at your service.

EDISWAN

RADIO DIVISION

THE EDISON SWAN ELECTRIC COMPANY LIMITED

155 Charing Cross Road, London, W.C.2 and Branches

Member of the A.E.I. Group of Companies

Telephone: Gerrard 8660

Telegrams: Ediswan, Westcent, London

CITY SALE & EXCHANGE LTD

The High Fidelity Specialists

WHARFEDALE



SUPER 12/CS/AL SPEAKER

A high flux density (17,000 lines) gives excellent transient response and sensitivity with wide frequency range.

Tax free £17 . 10 . 0

PART EXCHANGE & EASY PAYMENTS ARRANGED

HIGH FIDELITY plus HIGH VERSATILITY

The RCA New ORTHOPHONIC HIGH FIDELITY AMPLIFIER & PRE-AMPLIFIER



PRICE £48 Complete

ALSO FROM STOCK

RD Junior Amplifier and Control Unit	£26 0 0	Armstrong A10 Amplifier and Control Unit	£29 10 0
Pye HF5/8 Amplifier with Controls on same Chassis	£26 5 0	Vortexion Tape Recorder with Wearite Tape Deck	£84 0 0
Leak TL10 Amplifier with Point One Control Unit.....	£28 5 0	Connoisseur 3-speed Transcription Motor	£28 11 0

93-94 FLEET STREET, LONDON, E.C.4

Phone: FLEet St. 9391/2



LP 312-2

EXPAND AND

LABORATORY BALANCED. The TSL LORENZ LP312-2 is a main bass, 12in. diaxial speaker combined with two LPH65 electro-magnetic high frequency TREBLE units permanently mounted coaxially across the front of the main bass speaker at such an angle to give full spherical binaural response. All are laboratory balanced and matched for perfect tone with a frequency range of 20 cycles to 22,500 cycles essentially level output. To ensure level frequency response the voice coils of the two treble speakers are fed through a specially designed crossover network which balances the frequency response of the three speakers as a combined unit.

IMPROVE ANY

The TSL LORENZ LPH 65 is the basic treble speaker used in the TSL LORENZ Sound System. Round in shape to ensure smooth, melodious sound the plastic cone is fully tropicalised. Special features are the super high flux density magnet of 17,500 gauss and non-perforated back plate.



LPH65

SOUND SYSTEM

SPECIFICATION LP312-2

IMPEDANCE 15 ohms; FREQUENCY RANGE 20-22,500 c/s; POWER RATING 25 w.; PEAK POWER RATING 40 w.; DIAMETER Bass 12½ inches. Treble 2½ inches; DEPTH Bass 7½ inches Treble 2 inches; BAFFLE OPENING 10½ inches; SPEECH COIL DIAMETER Bass 1.5 inches. Treble ½ inch; FUNDAMENTAL RESONANCE Bass 20 c/s., Treble 1,600 c/s.; FLUX DENSITY Bass 17,500 gauss, Treble 17,500 gauss; INTERMODULATION PRODUCTS under 0.5%; CROSSOVER FREQUENCY 2,000 c/s. FINISH: Grey and blue vitreous anti-corrosion stove enamel.

RETAIL PRICE £14.19.6 (not subject to Purchase Tax).

Exclusively distributed to the Radio Trade & Industry throughout Great Britain and the Commonwealth by:—

TECHNICAL SUPPLIERS LTD., HUDSON HOUSE, 63 GOLDHAWK RD., LONDON, W.12. SHEpherds Bush 2581/4794

SUPER HIGH FIDELITY THIS YEAR

Let your ears be your judge . . . crisp clear, natural reproduction without coloration with TSL LORENZ speaker units. Ten years ahead in engineering and design, this speaker unit will enable you to design and build up a sound system in your own home which will truly add the miracle of LIFE to the magic of music . . .

No Extra Cost. You get these extra features at no extra cost with every TSL LORENZ Sound system . . . Greater output and more sensitivity . . . heavy duty oversize speech coil . . . Super high flux magnet . . . Permanently flexible self-damped cone . . . Multi-parameter cone fully tropicalised . . . Sealed in air gaps . . . built-in centralizing device for perfect gap alignment.

Improve your own H.F. Sound System. For those devotees of high quality who possess bass speakers fitting one or more LPH65 treble units will greatly extend your range of super fidelity reproduction. They are, without a doubt, the most sensitive and efficient treble reproducers research has revealed to date. The non-perforated back plate ensures that the LPH65 can be used with any other speaker irrespective of make or type without interaction taking place.

SPECIFICATION LPH65

HIGH FREQUENCY CONE-HORN TYPE TREBLE UNIT. IMPEDANCE 5.5 ohms; FREQUENCY RANGE WITH SUITABLE HIGH PASS FILTER CONDENSER 2,000 22,500 c/s; POWER RATING AS A SINGLE UNIT 3 w.; PEAK POWER RATING AS A SINGLE UNIT 5 w.; DIAMETER 2½ inches; DEPTH 2 inches; BAFFLE OPENING 2½ inches.

PRICE 39/6. (including Purchase Tax).



● Ask your local retailer for full details, including Bass Reflex enclosures.

THE
**BRITISH NATIONAL
RADIO SCHOOL**

ESTD. 1940

NOW IN OUR SIXTEENTH YEAR
AND STILL

**NO B.N.R.S. STUDENT
HAS EVER FAILED**

to pass his examination(s) after completing
our appropriate study course.

Our Secret?

*Sincerity, Long Experience, Family
Ownership, Pride of Service and a
genuine attempt to mould the "Course"
to the student.*

A.M.Brit.I.R.E. and CITY and GUILDS Radio and
Telecommunications Exams., etc. etc.

PRINCIPAL,
BRITISH NATIONAL RADIO SCHOOL
2, CANYNGE ROAD, CLIFTON, BRISTOL, 8
Tel. BRISTOL 34755



**A NEW VALVE
VOLTMETER**

RANGE: 0-10mv, 0-100mv, 0-1v, 0-10v,
0-100v, RMS FSD

FREQUENCY RESPONSE: 20 c/s to 1 mc/s

ACCURACY: $\pm 2\%$

INPUT IMPEDANCE: 1 M Ω and 5 puf.

Price:

£55 0 0

Send for List No. A7

SUTTON COLDFIELD ELECTRICAL ENGINEERS,
Reddick Trading Estate, Sutton Coldfield. SUT. 3038 & 5666

BROWN'S M/C HEADPHONES with ear pads and 6ft. cord 18/6.
VALVES. Please send for lists.
RHEOSTATS. 12 v. 1 a., 2/6. 12 v. 5 a., 10/6.
NEW A.C./D.C. MOTORS. 24 v. 2 a. 6 x 2 1/2 in. Spindle 1 x 1/4 in., 18/6.
NEW FREQUENCY CRYSTALS. 10/6 each. Lists sent on request.
MAINS TRANSFORMERS. Input 200/240 v. Output 350-0-350
or 250-0-250 volts 80 mA. and 4 and 6.3 v. 4 a. and 4 and 5 v. 2 a. Price
22/6. Input 200/240 v. Output tapped 3, 4, 5, 6, 8, 9, 10, 12, 15, 18,
20, 24, 30 volts, 2 amp., 22/-. Output 17-11-5 volts 5 amp., 22/9. Out-
put 17-11-5 v. 1 1/2 a., 16/6. 6.3 v. 2 a., 8/6. All with one year's guarantee.
D.P.D.T. RELAYS. Operate at 200/300 volts D.C., 8/6. We can
supply any type of relay to your requirements.
NEW SELENIUM RECTIFIERS. F.W. 12/6 volts 3 amps., 14/9;
4-amp., 23/6; 6 amp., 30/-; 1 amp., 8/6; 12 v. 100 mA., 3/-; H.W., 250 v.
100 mA., 10/-; 250 v. 300 mA., 18/6.
GERMANIUM or SILICON CRYSTAL DIODES. 3/9.
M/C MICROPHONES with matched Trans., 15/6.
NEW ELECTROLYTIC CONDENSERS, 60-250 MFD 275 v., 10/6.
TIME DELAY RELAYS. We specialise in units giving varying
time constants. Please send us your requirements or problems.
FISHING ROD AERIALS. Set of 3 7/6, set of 2 5/-. Plus 1/6 rail
charge.
NIFE BATTERIES 1.2 v. 2.5 A 2 1/2 x 3/4 x 3 in., 6/-.
CHROME-VANADIUM HIGH SPEED STEEL TWIST DRILLS.
Set of 9, 1/16 to 3/8, 3/9. Set 7 full size 6/-, 13 10/- in wallets.
MINIATURE RELAYS. 10 amp. Silver Contacts, 12 or 6 v. D.C.
Types S M. 7/6. S.M. or B, or S C.O., 8/6. Post paid.
AMERICAN IFF-TX/RX UNITS. New condition, containing
6 6SH7, 3 7193, 2 6H6 Valves. Tunes approx. 160 Mc/s. To clear, 33/-.
UNISELECTOR SWITCHES. 50 volts D.C. 50 point, 3 level,
26/-, 12 volt D.C. 50 Point 2 level 21/6.
P.O. VEEDER COUNTERS, 24-50 volt D.C. 0-9999, 15/6.
GRAM. PICK-UPS. Lightweight white plastic. Balanced armature.
New and boxed. 32/6.
D.P.C.O. RELAYS. Operate on 1 1/2 v. D.C., 8/6.
0-1 MA METER M.C. 2 1/2" centre zero 18/6.
ROTARY TRANSFORMERS, input 12 or 6 v, output 250 v. 80/90
mA, 43/-; 12 v Vibrator Packs prices on request.
EX-W.D. NEW MORSE KEYS 4/6.
EX-W.D. L.R. PHONES, NEW WITH LEAD 10/-.
HI-Q.I.F. TRANSFORMERS 3 x 3 x 2 1/2 8/6 pr.
WAVEMETER A.M. TYPE W/1432. Calibrated Frequency Range.
160 to 260 Mcs. Contains 0-1 mA. meter 2 1/2". VQ92 Diode and 655
valve, etc. £3/10/-. Also other types—See list.
CHROME EXTENSION CAR AERIALS, 1 ft. to 4 ft. 13/6.
All Carriage Paid in the U.K. from Dept. W.W.
Lists gladly sent on request.

THE RADIO AND ELECTRICAL MART
309, HARROW ROAD, WEMBLEY, MIDDLESEX, nr. THE TRIANGLE
Phone: WEMBLEY 6655

INTRODUCING THE "VISCOUNT" tape recorder,
successor to the "Herga" and making FULL use of the Push-
button facilities of the wonderful new Motek K8 deck, Servo
brakes, Button control of Amplifier roller, pads & brakes, Adjust-
able Azimuth and possibility of changing from B. S. 1. to Continental
Standard. But write for leaflet and judge whether this is not the
best value in recorders at 42 Guineas, or £22/2/- down and 12
monthly payments of £2/3/1, or £7/2/6 down and 8 monthly pay-
ments of £5/4/-.

Bias Oscillator Coils. The HATFIELD oscillator has COM-
PLETE STABILITY, LESS THAN 0.28 of 1% distortion, R.M.S.
output voltage 50% greater than the H.T. voltage, 1 valve, 1 coil,
simple circuit.
Sounds incredible, but it is GUARANTEED
Send for copy of N.P.L. report and see our ad. in April issue of
"W.W." The HATFIELD oscillator is now made with 3 output
impedances to suit any Head on the market. 45 Kc/s to 50 Kc/s.

TAPE RECORDISTS! Are you Completely satisfied with your
recordings? Bad waveform in an oscillator can cause DISTORTION
due to intermodulation. NOISY BACKGROUND due to D.C.
component in an asymmetrical waveform and INTERFERENCE
with radio due to harmonics beating with incoming signal The
fundamental frequency cannot cause audible beats.
COIL, complete with circuit, 10/6 post free. Patent app. for.

BIAS REJECTOR COILS
Even a small amount of bias frequency getting into the amplifier
can cause a lot of trouble, and nearly all tape recorders need a
rejector coil to prevent this
COIL, complete with instructions, 5/6 post paid.

MOTEK TAPE DECKS
The famous K8 deck; twin track, two speed, with push buttons
and SERVO braking, is a beautifully finished job at only 20 gns.
Post free. Or H.P. terms on application.

TAPE AMPLIFIERS
The HATFIELD amplifier is complete with oscillator as above, and
magic eye, less speaker, at £1 1/15/-. Or H.P. terms on application.

HATFIELD RADIO
78 STROUD GREEN RD., LONDON, N.4

MIDLAND INSTRUMENT CO.

ELBOW TELESCOPES by Cooke, Sims & Troughton, 8 x 30, in gunmetal housing, size 9in. long, 4 1/2in. high, base 5 1/2in. dia., unused and perfect, value £20, our price 50/-, post 2/6; otherwise we can supply the complete optical system for above—consists of the variable eyepiece, right-angle erector prism and objective, all mounted, 20/-, post 1/-.

HUGHES 12-VOLT D.C. SHUNT MOTORS, taking 1.25 amps., up to 2-amps. on load, speed 5,000 r.p.m., external reversing terminations, size 3 1/2in. long, 1 1/2in. dia., 1/2in. dia. shaft, weight 20 oz., oil impregnated bearings, balanced armature, a very superior powerful motor, original cost over £7, our price new unused 10/-, post 1/3, 2 for 20/-, post paid. Ditto, fitted reduction gears, giving a final drive of either 320 or 160 r.p.m. (state which required), 12/6, post 1/6, 2 for 25/-, post paid.



HAND GENERATORS, fitted gearbox and detachable handle, generates 28 v. L.T. and 300 v. H.T., with data to convert in a few minutes to an efficient 200/250 v. A.C./D.C. motor with final drives of approx. 60, 12 and 2 r.p.m. unused and perfect, 17/6, post 2/6



NAVIGATOR CHART BOARDS, selected 7-piece polished wood 17in. x 17in. by 1/2in. thick, fitted brass parallel motion drawing arm, hinged to board edge slide with lock screw, free arm end fitted protractor scale marked in degrees, also ruled Perspex transparent straight edge 10in. x 3in. by 1/2in. thick, each with locking device, board back has felt lined feet with pencil holder, these are brand new and boxed, value 70/-, our price 25/-, post 2/6, 2 for 50/-, post paid.

BENDIX SELSYNS (Magalhs). 3in. synchro transmitters, 50-v. 50-cycle single phase A.C., we have supplied over a thousand of these to large firms and Govt. Depts. for automation, etc., research, these are brand new, elaborately protected and packed, each with angular accuracy, etc., test report, our price per pair (2 units), with wiring diagram, 60/-, post paid.

VIBRATOR PACKS, input 6 v. provides all L.T. and H.T. outputs for the 18 and 38 sets, in metal cases size 9in. x 6 1/2in. x 3 1/2in. complete with Mallory Type 650 non-synch. vibrator, also leads, new unused, 17/6, post 2/6; vibrators only, 5/-, post 2/6.

TRANSISTORS, germanium junction P.N.P., by the leading manufacturers in this country, complete with data, 10/-, post 3d.

SLYDLOK FUSES, 5-amp. back terminations, brand new, 1/6, post 4d., 15/- doz., post 1/3, ditto 15-amp. end terminations, brand new, 1/6, post 4d., 15/- doz., post 1/3.

BURGESS MICRO SWITCHES, 2 types, red spot, normally closed, or green spot, normally open, new unused, 1/6, post 4d., 18/- doz., post 1/3, reduction for quantity.

ROTARY TRANSFORMERS, input 12-v., output 500-v. at 50-m.A., new and boxed, 15/-, post 2/6.

ACHROMATS by Ross or Taylor Hobson, new and perfect, 3 types all 40-mm. dia., f.1.7, 2 1/4in. focal length, f.2, 3in. focal length, f.2.3, 3 1/2in. focal length, 10/- each, post 4d., the 3 for 30/-, post paid.

Many other bargains; send stamped addressed envelope for lists.

MIDLAND INSTRUMENT CO., MOORPOOL CIRCLE, BIRMINGHAM, 17

Tel.: HAR 1308

RADIO TRADERS LTD.

23 WARDOUR ST., LONDON, W.1. (Coventry Street end.)
Phone No. GERrard 3977/8 Grams: "Radiotrade"

SPECIAL OFFER OF CURRENT MANUFACTURE ELECTRO-LYTIC CONDENSERS
8 mfd. 450 v., 2/6 each; 16 mfd. 450 v., 3/-; 32 mfd. 450 v., 4/-; 8 x 8 mfd. 450 v., 3/9; 8 x 16 mfd. 450 v., 4/-; 16 x 16 mfd. 450 v., 4/6; 32 x 32 mfd. 350 v., 5/-; Bias Condensers: 25 mfd. 25 v., 1/6; 50 mfd. 50 v., 1/9.
Please note we can offer special discounts for quantities.

ELECTROLYTIC CONDENSERS. Manufacturers' Surplus, in perfect condition.
16 mfd. 375 v., 2/-; 24 mfd. 350 v., 1/6; 24 mfd. 450 v., 2/3.
BIAS CONDENSERS: 1,000 mfd. 12 v., 1/6; 25 mfd. 25 v., 1/3; 50 mfd. 12 v., 1/-.

BLOCK PAPER CONDENSERS. 12 mfd. 250 v., 7/6; 8 mfd. 600 v., 7/6; 4 mfd. 400 v., 3/6. We carry a large stock of block paper type condensers. We invite your enquiries.

MIDGET MICA CONDENSERS. .0001, .0002, .0003, .0004, .0005, 5/- per dozen.
200 Assorted Moulded Mica Condensers, popular values..... £2 10 0
200 Assorted Silver Mica Condensers, popular values..... £2 10 0
200 Assorted Carbon Resistors, 1/2 and 1 watt. Good selection. £1 10 0

PAXOLIN SHEET. 18 x 4 1/2 x 1 1/2in., 1/6; 10 x 10 x 1/2in., 1/6; 20 x 10 x 1/2in., 3/-; 10 x 10 x 1/2in., 2/-; 20 x 10 x 1/2in., 4/-. Minimum P. & Pkg. 1/6.

BARGAIN OFFER OF METERS
"S" Meeters as used in S.27 receivers, £2/10/-; 0-200 m/a., 2 1/2in., 10/6; 0-300 m/a., 2 1/2in., 10/6; 0-500 m/a., 2 1/2in., 12/6; 0-40 m/a. (scaled 0-3 kV), 10/6; 0-100 m/a., 2in. (scaled 0-300 "mag feed"), 7/6; 0-2 m/a., 2 1/2in., 12/6.

B.T.H. CRYSTAL DIODES, 1/3. Very special price for large quantities.
RESISTORS. 1/2 watt, 2/6 doz.; 1/4 watt, 3/- doz.; 1 watt, 4/- doz.; 2 watt, 6/- doz.

W.W. RESISTORS. 5 watt, 1/6; 10 watt, 2/6; 15 watt, 3/-; 20 watt, 3/6. We carry stocks of resistors from 2 watt to 150 watt W.W. Your enquiries invited.

HIGH STABILITY RESISTORS. 1/2 watt 5%, 6d; 1/4 watt 5%, 9d; 1 watt 5%, 1/-. A few values in 1% and 2% still available.

ALL ORDERS FOR RESISTORS C.O.D. PLEASE, AS WE CANNOT GUARANTEE TO STOCK ALL VALUES.

W.W. V/CONTROLS. ALL WELL KNOWN MAKES. Pre-set types, 2/6; Spindle types, 3/6; Carbon type, less switch spindle and pre-set, 2/-. With switch, 3/6 each.

SEMI-MIDGET 2-GANG. .0005 Condenser, size 2 1/2 x 2 x 1 1/2in., 6/9 each.

PUSH-BUTTON UNITS. 10-way, complete with escutcheon and knobs, 10/6 each; 4-way, 2/6 each; knobs 3/- doz. extra.
JONES PLUGS AND SOCKETS. 4-way, 3/-; 6-pin, 3/6; 8-pin, 4/-; 10-pin, 4/6; 12-pin, 6/- per pair.

BARGAIN OFFER OF BATTERIES

4 1/2 v. Heavy Duty Bell Battery, Size 6 1/2 x 4 1/2 x 2 1/2in.....	2/6
72 v. H.T. 1.5 v. L.T. Size 6 x 5 x 1 1/2in.....	2/6
150 v. H.T. Size 2 1/2 x 5 1/2 x 1 1/2in.....	5/6
67 1/2 v. Size 2 1/2 x 3 1/2 x 1 1/2in.....	6/6
60 v. H.T. 1.5 v. L.T. 3 1/2 x 1 1/2in.....	4/6

All batteries scaled and unused. All plus 1/6 post and pkg. Special reduction for quantities.

WEARITE COILS. PA4, PO4, PA5, PO5, 1/3 each.....doz. 12/-
VALVE HOLDERS. Moulded B9A, 7/6; B7G, 6/-; Int. Oct., 9/-; Eng. Oct.doz. 4/6

VALVE HOLDER FITTED WITH LOWER CAN, 1/6 per doz. extra. Screening Cans for B7G and B9A.....doz. 6/-

Paxolin V/H Int. Oct. B9A, B7G, 5/- per doz.; Eng. Oct., 5-pin, 7-pindoz. 3/-

BELLING-LEE PLUGS AND SOCKETS, 5-pin, 1/9; 7-pin, 2/-; 10-pineach 2/6

AIR-SPACED TRIMMERS, 5, 10, 15, 20, 25, 50 and 75 of pre-set and spindle types, 2/- each.....doz. 21/-

PYE PLUGS AND SOCKETS, 1/6 per pair, "Tee" pieced.....each 1/9
GROMMETS, 1 grs. assorted grommets, 1/2in. to lin.....gross 8/6
POST OFFICE LAMP JACKS No. 10, 1/- each.....doz. 9/-
Lamp Covers for samedoz. 3/-

P74 2-pin plugs and sockets are now available, 3/6 each.
OUTPUT TRANSFORMERS. Multi-ratio, 5/- each; Pentode or powereach 4/-

WESTECTORS WX6, WX12, W12, W4, 1/- each.....doz. 9/-
SIGNAL LAMP HOLDERS. Panel mounting, complete with adjusting lampholder, 2/- each.....doz. 21/-

TAG STRIPS. 3-way, 2/-; 4-way, 2/6; 5-way, 3/-; 7-way, 4/-; 28-waydoz. 12/-

POINTER KNOBS. Small black with white line, standard 1/2in. spindledoz. 7/6
WANDER PLUGS. Red and black.....doz. 2/-

PHILIPS TRIMMER TOOLS 1/- each.....doz. 10/6
CASH WITH ORDER OR C.O.D. ALL ORDERS DEPT. W.1. ALL ORDERS FOR LESS THAN £2 ADD POSTAGE

We invite your enquiries for items not listed.

Trade Counter open 9 to 6 Monday to Friday

Also 9 to 1 Saturdays. Callers Welcomed.

WHOLESALE MANUFACTURERS' AND EXPORT ENQUIRIES INVITED

SERVICE RADIO SPARES

4, LISLE STREET, LONDON, W.C.2

Telephone: GERrard 1734

NEW G.E.C. MOBILE RX/TX complete with 12 v. rotary power unit, 80.9, 81.1, 81.3 Mc/s, 7 watt output. Special price £25.
1294 RECEIVERS in good order, £20 each.

MULTI-RANGE TEST METERS by Weston, Radio City Products and other well-known makers.

SPECIAL OFFER of Constructor's parcel of 100 assorted resistors comprising 1/4, 1/2, 1 and 2 watt from 10 meg.-22 ohms, 12/6.
MEGGER SAFETY OHMMETERS. Perfect, £3.

H.R.O. SENIOR RECEIVERS. With A.C. P.P., 5 coils, £28.
D.S.T. 100 RECEIVERS, as new. Coverage is 7 bands from 30 Mc/s. to 50 Kc/s., £20 each.

HALLICRAFTERS SX28, S27, S41, S38, etc. Perfect cond. AR88LF, AR88D, CR100, from stock.

CANADIAN R.103 RECEIVERS, as new, modified, for A.C. working, £14.

A.C./D.C. MOTORS suitable for sewing machines, 47/6 each.
A.C./D.C. 12 v.-15 v. MOTORS, long spindle for models, 15/- each.

NEW M/C MICROPHONES, hand type, with 12 yds. heavy duty screened cable, £3 each.

TEST EQUIPMENT. We hold a comprehensive stock. Multi-range meters at 1,000 and 20,000 o.p.v., valve testers, signal genes.
RECTIFIERS, 12 v., bridged, 8 amps, 18/6 each.

MAINS TRANSFORMERS. 350-0-350 v. Ellison at 120 m.A. 6.3 v. 5 a., C.T. 5 v. 3 a., 37/6. Full range of all types of Ellison products in stock.

F.M. DEVIATION METER, in perfect working order, £20.
PARTRIDGE TRANSFORMERS, 100 m/a. 250-0-250 v., 6.3 v., 110-230 v. input, £1 each.

H.R.O. COIL, 0.48-0.96 Mc/s., etc., at £2/5/- per coil.
Your post enquiries welcomed. S.A.E. for reply, please. Orders, C.W.O. or pro-forma invoice, no C.O.D. Prices quoted do not include carriage and packing.

Callers welcomed—all stock must be sold within six months.
Great Bargains.

TELEVISION DEVELOPMENT ENGINEERS

E. K. COLE LTD., SOUTHEND-ON-SEA, ESSEX.

Vacancies exist for suitably qualified engineers at the Prittlewell works, where the Development and Engineering laboratories and workshops are being extended. Interesting and absorbing work in ideal conditions. Write or call Personnel Manager.

PYE TELECOMMUNICATIONS LTD.

Ditton Works, Cambridge

invite applications from both

SENIOR and JUNIOR ENGINEERS

for permanent and progressive employment in
the

AERONAUTICAL DIVISION,
for the development and installation of ground
to air projects, and the design of airborne
communications and navigation equipment.
Experience in transistor circuitry advantageous.

Applications, giving full details of experience
etc., should be addressed to the

PERSONNEL MANAGER

quoting reference TB/A.

ELECTRONIC ENGINEERS *required by* **ADVANCE COMPONENTS LIMITED**

for the design of electronic instruments. Experience and an appreciation of the problems of design for production needed. A permanent position in our pleasantly situated new Works. Good salary. Company Pension Scheme.

*Apply to: The Technical Director,
Advance Components Ltd.,
Roebuck Road, Hainault, Essex.*

CHIEF ENGINEER *required by* **ADVANCE COMPONENTS LIMITED**

Competent to administer complete Laboratory providing full information to production on new instruments and all technical matters. A responsible position at our pleasantly situated new Works for a man of ability and energy with experience of the design and production of electronic instruments.

*Apply to: The Technical Director,
Advance Components Ltd.,
Roebuck Road, Hainault, Essex.*

CHAS. H. YOUNG, LTD.

GLASS INSULATORS. 1/6 ea., small shell ditto, 4½d. ea. or 4/- doz. Plus post.
CONDENSERS. TCC type 111, 8 mfd., 1,000 v. List over £3. Only 10/6. Post 1/9. 8 mfd. 750 v., 5/6 ea., post 1/6.
SHADED POLE MOTORS. Heavy duty type totally enclosed, made for professional tape deck, 35/- ea., post 2/6.
MINIATURE ROTARY TRANSFORMERS. 12 v. input, output 360 v. 30 m.a. Cont. or 310 v. 70 m.a. Intermittent. 21/- ea. or £2 pair. Post 1/6.
AMERICAN 807 VALVES. New, boxed, 7/6 ea. or 4 for 25/-.
CERAMIC 5-PIN VALVEHOLDERS for 807s. 1/- ea. or 6 for 5/-. 4 free with order for 4 807s.
MINIATURE IF. TRANSFORMERS. Litz wound 450/470 Kc/s. Slug tuned. 7/6 per pair, postage 9d.
CRYSTAL HAND MICROPHONES with polished grill and handle. Four feet of screened lead. Only 21/-, post free. WORTH DOUBLE.
POWER UNITS IN BLACK METAL CASE. 200/260 v. input, 200/250 v. 60/80 m.a. output, fully smoothed and filtered, also gives 31 v. 3 a. D.C. and 6.3 v. 3 a. A.C., fitted with 6X5 rectifier. Only 50/- ea. Carr. paid.
COPPER AERIAL WIRE. 14 g. H/D, 140ft., 17/-, 70ft. 8/6. P. & P. 2/-; stranded 7/25, 140ft., 10/-, 70ft. 5/-. P. & P. 2/-.
CERAMIC FORMERS. 2½ x 1½. Ideal for V.F.O. or turrets. 1/9 ea. or 17/6 per doz.
RACK MOUNTING PANELS. All 19in. long by 5½in., 7in., 8½in. or 10½in., 5/9, 6/6, 7/6, 9/- respectively. Post 2/-.
ABSORPTION WAVEMETERS. 3 to 35 m/c. in 3 switched bands, complete with indicator bulb. 15/-. Post 1/-.
TRANSMITTER TUNING CONDS. By Johnson, U.S.A., 500 pf. 1,550 v. rating, ceramic insulation. 15/- ea., post free.
TRANSMITTING VALVES. 813 65/-, 866A 15/-, 829B 50/-, TZ40 35/-, RK25 30/-, 100TH 50/-.
HRO COILS. 50/100 k/c. 20/-, 100/200 k/c 25/-.
AIR SPACED COAX. 150 ohm., very low loss, list 3/11 foot. 20 yard coils only £1. Post free.

FLASH!!! EDDYSTONE 888. New Ham Band only Receiver. **JUST OUT.** Sends a.e. for details.

NO C.O.D. UNDER £1

All Mail Orders to Dept. 'W' Please Print your name and address

CHAS. H. YOUNG LTD., 102 HOLLOWAY HEAD, B'HAM 1

Phone: MIDLAND 3254 All callers to 110 DALE END, BIRMINGHAM 4 Phone: CENTRAL 1635

A reference book on every aspect
 18th Edition of photography
NOW READY

DICTIONARY OF PHOTOGRAPHY

Edited by A. L. M. Sowerby, B.A., M.Sc., F.R.P.S.

A comprehensive reference book, alphabetically arranged, covering every aspect of photography. It contains the essence of a dozen ordinary textbooks, and provides the answer to every photographic problem. This edition has been meticulously revised throughout, with particular attention to the sections on flash and colour photography.

726pp. Illustrated 21s. net. By Post 22s. 3d.

Published for "Amateur Photographer"

From booksellers and photographic dealers

LIFFE & SONS LTD., DORSET HOUSE, STAMFORD ST., LONDON, S.E.1

RCA TRANSMITTERS. Type ET-4331. 1 kW. (telephone); 1.4 kW. (telegraph). Frequency range 3 Mc/s to 20 Mc/s.
S.C.R. 399 complete with petrol generator P.E.95G (10 kw.).
BC610 TRANSMITTERS with speech amplifier, aerial tuning unit, etc. Brand new.
RCA TRANSMITTERS. Type ET-4336. Complete with original speech amplifier, crystal-multiplier and VFO units. Unused and re-conditioned. Can be supplied with very large quantity of spares.
RCA TRANSMITTERS. Type ET-4332 modified by R.A.F. for use on crystal or master oscillator. Complete with speech amplifier.
MULTI-CHANNEL TRANSMITTER T-4/FRC, with modulators MD-1/FRC, 2 Mc/s to 18 Mc/s. Each channel 400 w. output. W.S. No. 19 & 22. Both complete with installation kit. Tropicalised. New.
MAGNETO 10 LINE U.C., 40 Line F & F TELEPHONE SWITCHBOARDS (complete).
V.H.F. TRANSMITTER Type 1131B or J. Frequency coverage 100/156 Mc/s. 50 watt output. Tropicalised. New.
A.R.88Ds, AR887 L.F.s, R.109.
METAL RECTIFIERS Type 1B, D.C. output 10 amps at 22 v., input 200/250 v., 50 c/s.

All above items in excellent working condition. Working demonstration upon request.

SPARES A large selection available for SCR399 (BC610), ET4336, SCR610, EE8 Telephones, and Teleprinters type 7B.

TX VALVES 805, 807, 813, 861. 66A, 100TH, 250TH, and many others.

Large stock of Tx condensers crystal and other components.

P.C.A. RADIO

New Address, Offices and Works

BEAVOR LANE, HAMMERSMITH, LONDON, W.6

Telephone: RIV 8006/7

BAND III CHANNELS 8-9-10
 A new CONVERTOR KIT is now available for LONDON—MIDLANDS—NORTH

Fit this new convertor not to your set but inside your set, even 9in. table models, and retain that professional look.

This convertor has been evolved since the I.T.A. transmissions began, and is based upon experience gained in the conversion of very many Band I sets in the London area.

IT will convert any set, any age, TRF or Superhe:
 IT includes station switching
 IT provides pre-set contrast balancing
 IT uses only one aerial input for both bands
 IT provides manual tuning on Band III
 IT is totally screened
 IT completely rejects unwanted signals
 IT requires no additional power supply where either 6.3V or .3 amp line is available.

CONVERTOR wired and aligned with fitting instructions	£4 2 6
KIT complete in every detail, less knobs	£2 12 6
KNOBS each	1 0
CIRCUIT and instructions in detail (free with kit)...	3 6
BAND III AERIALS (send for list), from	12 6
CROSS-OVER UNITS —Outdoor (printed circuit)	15 0
AERIALS feeder cable per yard	10

When ordering please state present: B.B.C. Station and I.T.A. Orders over £2 post free.

C. & G. KITS

285, LOWER ADDISCOMBE ROAD, ADDISCOMBE, CROYDON, SURREY

Phone: ADDISCOMBE 5262

TELEVISION AERIAL COMPONENTS DESIGNED FOR CONSTRUCTING BAND I & BAND III T.V. AERIALS ELEMENT DIMENSIONS SUPPLIED FOR ALL CHANNELS

Selecting at random from our new multi-page catalogue :

- ★ Band III Folded Dipoles (As illustrated)
- ★ Reflector and director rod holders
- ★ Masthead Fittings for 3/4", 1", 1 1/2" and 2" Masts
- ★ Mast Coupling units for 2" Masts
- ★ Insulators, both Rubber and Plastic (As illustrated)
- ★ Alloy Tubing for Elements, Cross-boom and Masting

Send 1/- P.O. for the revised, fully illustrated catalogue to :

FRINGEVISION LTD., Marlborough, Wilts. Phone 657/8



Senior Radio Engineers

SENIOR RADIO ENGINEERS REQUIRED FOR THE LABORATORY OF A LARGE RADIO ENGINEERING COMPANY SITUATED IN THE LONDON AREA. APPLICANTS SHOULD HAVE H.N.C. OR EQUIVALENT QUALIFICATIONS AND EXPERIENCE OF MODERN DOMESTIC RADIO DEVELOPMENT AND ENGINEERING PRODUCTION. THE SELECTED CANDIDATE WILL BE CAPABLE OF WORKING WITHOUT SUPERVISION AND ABLE TO CONTROL A SMALL TEAM OF ENGINEERS. SALARY UP TO £1,100 PER ANNUM ACCORDING TO QUALIFICATIONS AND EXPERIENCE. PLEASE REPLY, GIVING FULL DETAILS TO BOX NO. 2541.

PRODUCT DESIGNER WITH AN INTIMATE KNOWLEDGE OF MODERN PRODUCTION TECHNIQUE IS REQUIRED FOR A LARGE COMMERCIAL RADIO AND TELEVISION LABORATORY. THE SELECTED APPLICANT WILL BE REQUIRED TO TAKE CHARGE OF THE MECHANICAL SIDE OF NEW PROJECTS AND WILL HAVE A WIDE EXPERIENCE OF THE RADIO INDUSTRY. THE COMMENCING SALARY WILL BE IN THE REGION OF £1,000 PER ANNUM WITH GOOD PROSPECTS OF ADVANCEMENT. LONDON AREA. APPLICATIONS, WHICH WILL BE TREATED IN CONFIDENCE, SHOULD GIVE FULL DETAILS OF QUALIFICATIONS AND EXPERIENCE AND BE ADDRESSED TO BOX NO. 2542.

BENSON'S BETTER ARGAINS

COMMAND RECEIVERS 1.5-3mcs BRAND NEW, less 1 y. amcor, old 5/- delivered U.S. R25.112/114 (TR1987), with 3/EP91, 2/EL91, 5 gang tuner, new, 37/6, less valves, 7/6. Circuit 1/3. 129 Rxs. 1-560 kc/s., new, with valves, mains driven £7/10/- (carr. 10/-). H.V. TUBES: 6Trm., 230 v. Induction, 75 r.p.m. with governor (Barardi), 30/- (post 2/9); SX4GH, 230 v. geared to 1 r.p.m. anal. new, 25/6; Synch. 100 v. 3,000 r.p.m. 10VA., 10/-.

SPEAKERS 12in. Goodmans, new, £6/10/-.

INDICATORS type 6L, new 45/- (carr. 7/6). THERMISTORS, new, Primary 250 v. 50 c. Sec. 66, 67, 72, 153, 165, 175 v. HV 0.5 A. (additive to 221-247 v.) 15/- (carr. 2/9).

U.S.A. BOXES, diecast alum., black crackle, with relay 5 mA. 10 v. 1920Ω, switches, etc. 10 x 6 x 5in., 12/6 (post 2/9).

SUPPRESS. R.I. radio interference, ex-A.M., 5/6 (post 2/1).

VIBR. PAQ. 3, U.S.A. 1c. crson-Transvers, 12 v., 15/6. Malory, 18/6 (post 2/3 each).

RESISTORS. Hi-stab., close tol., pref. values, 19/- doz. V. REOUS, 12Ω to 100 K, 3-20 w., 10/- doz.; 15Ω 100 w., 150Ω 25 w., 10 K, 120 w., 15 K, 56 w., 1/6 each. S. ND NEW U.ITS.

TYPES R.F. 26 or 27, 27/6 (postage 2/6); RF24, RF25, solid 10/6. AERIAL RELAYS (co-axial) c/o 12/24 v., 7/6. TYPE 78A, 24 v., or manual 15/- (post 2/9).

DYNAMOTORS, D.C., 6 v. Input, 250 v. 80 mA. output, 11/6. Filters for these, 2/6.

EDDYSTONE 12 v. to 190 v. 75 mA., cased, 15/- (post 3/4). 11 v. to 300 v. 200 mA., cased, 13/6 (carr. 8/6).

GLOCKWORK Contactors, 2 impulses per sec., 8/6. U.S.A. type, small, 9/6. R1955, new improved type, 37/6 (carr. 7/6). R1992A, 100/150 Mc/s., 13 valves, used, good condition (damaged meters), £4 (carr. 10/-).

THROAT MICS., U.S.A., new, 2/6.

METAL RECTIFIERS: 600 v. 30 mA., 6/-; 500 v. 500 mA., 10/6. 1,000 v. 30 mA., 7/6. R1355 IF Strips only, complete, new, with valves, 25/-; less valves, 12/6 (post 2/9).

POWER UNIT 301. Input 200/260 v. A.C. Output, 250 v. 80 mA., D.C., 6.3 v., 3 A. A.C. and 24 v. 1 A. D.O., New, 40/- (post 2/6). Auto-transformers, 110/220 v., 450 w., brand new, 80/-.

WAFER SWITCHES. 1 pole 11-way, 2 Bank, 3/6. 4 P 3 W, 4 P 2 W, 1 P 5 W 6 B, 2/6. METERS, list available. SPLITTERS, 15 A., G.E.C., D.P. switch, 4 fuses, new, 15/6. RX159, 160/220 mcs, with 1/V91, 1/CV86, 1/V965, 1/V992, 12/6. I.F. AMPLIFIER 178 (for this), 13.0 mcs/s, with valves, 15/6 (postage 2/6 each).

BENDIX RA-10, 4 Wavebands, 6 valves, New, £3/10/- (carr. 10/-).

RELAYS, 6 v. 2 bank, 1/6. I.F. S 10/13 mcs/s, cased, new, 1/6.

R1155 Collpacks, new, 12/6. Used, 9/6.

GHOKES, L.F. Ferranti, 10H, 150 mA., Screened, 7/6. 10H, 200 mA., 8/6; 5H, 200 mA., 5/6.

TRANSCEIVERS, W/T 67, super-regen., with 1 C5GT valves and handset 45/-.

305 Closed 29th July/8 August.

List and enquiries. S.A.E. please! Terms: C.W.O. Postage extra. Immediate despatch.

Callers and Post, W. A. BENSON (WW), 308 Rathbone Road, Liverpool, 13. STO 1804. Callers, SUPERAERO (W)chapel LTD., 116 Whitechapel, Liverpool 1. BOX 1110

DUODE NATURAL SOUND

IS AVAILABLE IN MANY LANDS

INCLUDING

- Australia
- Barbados
- Canada
- Kong Kong
- New Zealand
- South Africa
- Trinidad
- Venezuela



If you live in these parts we can tell you where to buy your Duode easily. But of course Duodes also go by post to homes in many other lands, bringing delight of NATURAL SOUND to hundreds of music lovers who rely on radio and records. The 12B and 12B/C are most widely used because they pack for post almost anywhere and even for air freight over moderate spans.

So do not hesitate to give yourself the joy of hearing your favourite music, your best loved artists, even your most hated politician, more clearly and naturally than ever before. Send an air letter or card for details.

DUODE SOUND REPRODUCERS
3, Newman Yard, London, W.1

COMMUNICATIONS EQUIPMENT

WIRELESS SET 19 Mk. III. Frequency 2.8 Mc/s., and 235 Mc/s. Antenna output 8 watt. Systems A.1, A.2, A.3. Power source 12 v. battery with operating equipment for mobile or ground use.

AMPLIFIER R.F. No. 2. For use with Wireless Set No. 19 Mk. III. Boosts antenna output to 30 watts.

WIRELESS SET X32D. Frequency 2.8 Mc/s. in two switched bands. C.W. and frequency modulated and amplitude modulated R.T. Remote control facilities. Mobile or fixed station use. Power source 12 v. D.C.

WIRELESS SET 62 Mk. II. Frequency range 1.6-10 Mc/s. in two switched bands. Crystal controlled. For mobile use. Systems A.1, A.2, A.3—with operating equipment. Power source 12 v. D.C.

CRYSTAL CALIBRATOR No. 10 for use with Wireless Set 62

WALKIE-TALKIE TYPE 58 (CANADIAN). Frequency range 8-9 Mc/s. Complete with accessories.

HANDY TALKIE SCR538. Frequency range 3.6-6 Mc/s. Complete with spare coils, etc.

TCS TRANSMITTER/RECEIVER STATIONS complete. Frequency range 1,500 kc/s.-12,000 kc/s. Output 10 watts phone, 25 watts C.W. All operating equipment including Remote Control with loud-speaker and choice of Dynamotor Supply (12 v., 24 v., or 115 v.).

AIRCRAFT RADIO COMPASSES. Installation Type SCR269C. Frequency coverage 200 Kc/s.-1,750 Kc/s. in three switched bands. Superhet communications receiver with compass circuit elements. Remote control facilities and motor driven aerial loop complete with all operating accessories.

AIRBORNE VHF EQUIPMENT. ARC-1 multi-channel transmitter/receiver complete. 100-156 Mc/s. ARC-3 10 channel transmitter/receiver complete 100-156 Mc/s. TELEGRAPH AND TELEPHONE EQUIPMENT. Filter, line and directional.

High Speed Morse Telegraph Transmitters. Telegraph Tape Printers.

Terminal Units Apparatus VF Speech + Duplex. Apparatus VF Speech + Simplex.

Apparatus two-tone Telegraph.

Carrier Terminals 1 + 1

Field Telephone Sets types D, F, H and L. Switchboards, universal call, 6-line and 10-line.

Prices and further details on request.

3Ch Dc Relay Unit Group 1/2

Transmitting valves types 803, 805, 832.

Magniside Hunter 3in. Used at 8/6 each.

Morse Keys, totally enclosed Air Ministry type, at 1/6 each.

Aerial winches, Air Ministry type 5, at 2/6 each.

Flexible Drives, 7in. 6in. long.

F.T. 243 Crystals, frequencies between 3,000 Kc/s. and 6,000 Kc/s., at 10/- each.

R. GILFILLAN & CO. LTD.,
7, HIGH ST., WORTHING, SUSSEX
Tel. Worthing 8719 and 30181
Cables 'GL WORTHING' Codes BENTLEY'S End

The Northern Polytechnic

Holloway Road, London, N.7.

Principal: A. S. M. Symons, Ph.D., B.Sc., A.R.C.S., D.I.C., F.Inst.P.

Department of Telecommunications

Head of Department: J. C. G. Gilbert, M.Brit. I.R.E., Assoc.I.E.E., F.T.S.

Full-time Day and Evening Courses in Telecommunications Engineering in preparation for the Full Technological Certificate of the City and Guilds of London Institute, and Graduateship of the British Institution of Radio Engineers.

Evening classes in Industrial Electronics, Computers, Radar Principles and Practice, Electro-acoustics and audio frequency engineering.

Full-time one year course in Radio Servicing and full-time one year course in Television Servicing, also part-time day release and evening classes are held in these subjects in preparation for the City and Guilds of London Institute and the Radio Trades Examination Board's Certificates.

Special short courses are available for qualified Service Engineers interested in Band III Television and Frequency Modulated Sound broadcasting.

All the above courses include practical laboratory and workshop experience.

London fees: £30 per year, or £11 per term, plus £2 registration fee, for full-time courses. (No fee for students under 18 years of age.) Evening class fees range from 40/- to 55/-. Enrolment for day classes by appointment. Enrolment for evening classes, 5.30-7.30 p.m. 17th and 18th September, 1956.

New term commences 24th September 1956. PROSPECTUS FREE on application to the Secretary.

RECORD PLAYERS



RADIOGRAM MANUFACTURERS SURPLUS

Garrard RC75A 3-Speed Autochangers. fitted turn-over heads with twin sapphire styl. Offered at less than half price. Our price £6.19.6.

Garrard RC70 Single Speed AC/DC Autochangers. Our price £4.19.0.

Garrard RC65 Variable Speed Centre Drive 78 r.p.m. Mixer Autochangers. AC/DC in makers cartons Our price £4.19.6.

Collaro RC54 Latest Type 3-Speed Autochanger with O or T turnover heads, Makers cartons. Our price £9.19.6.

Revised Covered Cabinets to house the above units. ex well known manufacturer. Our price 45/-

Revised Covered Portable Record Player Cabinets cut for B.B. Resent HP100 units, with space for amplifier. Ex well known manufacturer. Our price £2.19.6. Larger size cut for Monarch changer £3.5.0.

3-Speed Record Players fitted with Acos turnover HGP59 pick ups with twin sapphire styl, rexin case with lid, fitted clean and handle. Worth 10 gns. Our price £7.15.6.

Crystal Pick-Ups fitted Acos HGP59 cartridge. Ultra lightweight. Our price 27/6.

Carriage, Packing, and Insurance 5/6. Send stamp for complete bargain lists.

RONALD WILSON & CO.,
(DEPT. W.W.) 12 BRIDGE STREET, WORCESTER

Excellence in design..

Specialists in Sub-miniature Telecommunication Components

AIR DIELECTRIC TRIMMERS 70pf

Illustration (approx.) actual size



- 12 Vane type 500 Volts
- Width 16.5 mm. Length 22 mm.
- Height 19 mm. Insulation 10,000 megs.
- Power Factor less than .001
- Temp. Coeff. 50 parts/million/°C

OXLEY

DEVELOPMENTS CO. LTD.
ULVERSTON, NORTH LANCs.
Tel. ULVERSTON 3306

NEW S.T.C AND "WESTALITE" SELENIUM RECTIFIERS. Largest L.T. range in Great Britain. Latest Current Products. NOT Surplus

REVISED PRICES 1st MAY

S.T. & C. E.H.T. K3/15, 4/9; K3/45, 8/10; K3/50, 9/4; K3/100, 15/10; all post 4d. extra.
BRIDGE CONNECTED FULL WAVE.
17v 1a. 18/6; 1.5a. 32/6; 2.5a. 39/-; 3a. 37/6; 4a. 45/6; 5a. 48/6, all post free.
33v. 0.6a. 29/-; 1a. 31/6; .5a. 57/-; 2a. 65/-; 3a. 66/-; 4a. 78/-; 5a. 88/-, all post 1/6; 54v. 1a. 42/6; 1.5a. 78/-; 2a. 91/-; 3a. 92/-; 5a. 126/-; 72v. 1a. 55/-; 1.5a. 97/-; 2a. 118/-; 3a. 119/-; 5a. 164/-; 100v. 1a. 80/-; 1.5a. 87/-; 2a. 166/-; 3a. 170/-; 5a. 237/6, all post 1/10.
BRIDGE CONNECTED WITH 7 1/2in. SQUARE COOLING FINS 17v. 6a. 64/-; 10a. 74/-, post 2/6.
BRIDGE CONNECTED HEAVY DUTY FUNNEL COOLED OR 7 1/2in. SQUARE COOLING FINS. Both types, same price. 17v. 12a. 124/-; 20a. 144/-; 30a. 210/-; 50a. 340/-; 33v. 6a. 106/-; 10a. 128/-; 12a. 210/-; 20a. 250/-; 54v. 6a. 148/-; 10a. 199/-; 10a. 232/6; 100v. 6a. 275/-; 10a. 335/-, all post 3/-.

LATEST PRICE LIST

"WESTALITE" (BRIDGE). 12-15v. D.C. 1.2a. 18/8; 2a. 25/-; 2.5a. 32/10; 5a. 37/6; 10a. 64/6; 20a. 117/8; 30a. 171/2; 50a. 278/-; 24v. 1.2a. 18/8; 2.5a. 32/10; 5a. 60/4; 10a. 109/8; 20a. 208/4; 30v. 1.2a. 32/10; 2.5a. 60/4; 5a. 82/8; 10a. 154/6; 100v. 1.2a. 60/4; 2.5a. 115/4; 5a. 195/10; 10a. 391/8. Post from 1/6.
E.H.T. Rects., 14D134. 24/10; 36EHT60. 35/10; post 4d. extra.

Wholesale and Retail
Special Price for Export and Quantity

T. W. PEARCE

66 Great Percy Street, London, W.C.1
Off Pentonville Rd. Between King's Cross and Angel

RANK PRECISION INDUSTRIES (B.A.F.) LTD.

have vacancies in their laboratory for:

- (a) SENIOR PERSONNEL with experience and qualifications.
- (b) ASSISTANTS with at least 10 years' experience on electronic equipment.
- (c) JUNIORS with qualifications or carrying out advanced study who have considerable interests in electronics or sound reproduction.

Work includes development of sound-recording and electro-acoustical equipment amplifiers, etc., for a variety of applications. All positions are permanent and pensionable.

Applications in writing, stating age, experience and qualifications, marked (a), (b) or (c), should be addressed to

The Personnel Manager,
RANK PRECISION INDUSTRIES (B.A.F.) LIMITED,
Woodger Road, W.12.

CABINETS . . .

WE CAN SUPPLY ANY CABINET

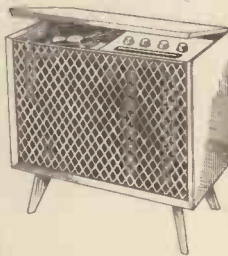

'to YOUR OWN SPECIFICATION
The Concomitory (left) is oak veneered with mahogany interior normally wax finished at £9/15/-. Available in any shade to order at slight extra cost. The Cabinet (below) can be supplied in any shade of walnut, oak or mahogany or £19/19/-.
Both Cabinets could be supplied at a complete radio-gram incorporating any of the following combinations of units—
5 valve chassis. £12/10/-.
6 valve Armstrong. FC48. £25/2/-.
14 valve Armstrong. EXP125/C. £51/19/6.
8 valve FM/AM. £21/15/-.
9 valve AM/FM 26gns (incl. 2 speakers). 3-speed Garrard and Collaro utochanger also BSR Monarch, £7/19/6, and Plessey Autochanger, £9 15/-, 8in., 10in., and 12in. Goodmans, Whartedale, G.E.C., and W.B. Speakers. Send for free illustrated catalogue of cabinets, chassis, autochangers and speakers. etc. H.P. can be arranged

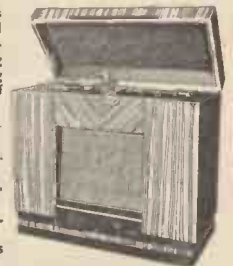

LEWIS RADIO COMPANY
120, GREEN LANES, PALMERS GREEN,
LONDON, N.13. BOWes Park 6064.

SENIOR ENGINEER

wanted by

Felgate Radio Ltd.

Degree or similar qualification necessary. Candidates who have been associated with production will receive preference.

Duties include the design of domestic radio and television, high fidelity audio equipment and miniature transmitter receivers.

Apply Managing Director :

FELGATE RADIO LTD.
Felgate House, Studland Street,
Hammersmith, W.6

VICKERS-ARMSTRONGS (AIRCRAFT) LIMITED, WEYBRIDGE, SURREY

require

(Z) RADIO ENGINEERS for the installation and testing of V.H.F., H.F.I.L.S. and A.D.F. equipments as used in civil aircraft. Applicants should preferably have served an appropriate apprenticeship, have had at least five years' experience on civil aircraft and hold academic qualifications not lower than an intermediate City and Guilds Certificate in Telecommunications.

Applications, quoting date and prefix letter of advertisement to: Employment Manager, Vickers-Armstrongs (Aircraft) Limited, Weybridge, Surrey.

Holidays already arranged by applicants for this year taken into account.

TWO SENIOR GRADUATE ENGINEERS

are wanted for a

FORWARD THINKING GROUP

under the direction of

Dr. E. K. Sandeman

at the

ENGLISH ELECTRIC COMPANY'S

GUIDED WEAPONS DIVISION,
LUTON, BEDS.

Each should have experience in one or more of the following:

BALLISTICS or CELESTIAL
MECHANICS

RADAR or ELECTRONICS

SERVO THEORY

ANALOGUE or DIGITAL
COMPUTORS

Dr. Sandeman would be pleased to receive applications for these permanent and progressive research posts, and will be glad to talk over the prospects of employment with suitable candidates.

Applications in the first instance should be addressed to Dept. C.P.S., 336-7, Strand, W.C.2, quoting Ref. 613B.

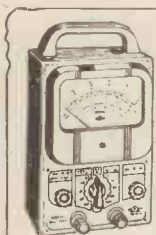

PULLIN
SERIES 100
TEST METER
AC/DC 10,000 Ω/V
21 RANGES
100 μA to 1000 V
COMPLETE IN DIE-CAST
CASE WITH TEST LEADS
CLIPS AND PRODS
FULLY GUARANTEED

Sent post free for £2.10.0 and nine further monthly payments of £1.4.6.
Cash price £12.7.6.

FRITH RADIOCRAFT LTD
69-71 CHURCHGATE LEICESTER PHONE 58927
28 HIGH STREET NEWPORT PAGNELL, BUCKS. PHONE 237



Leads the world in
TAPE RECORDING

For details of the world's most advanced Tape Units and Tape Recorders contact

VERDIK SALES LTD.
8, RUPERT COURT, WARDOUR ST., LONDON, W.1
Gerrard 8266



3-VALVE QUALITY AMPLIFIERS
3-4 wt. 16 S.W.G. al. chass.; neg. fdbk.; vol. and tone controls; A.C. 200-250 v.; voltage panel; 2-4Ω spkr. socket: new comp. and PLAYING TESTED; 87g 6½ x 5 x 4½ in., £4-5-0.
INT. OCT. 9 x 6 x 4½ in., £4-2-6.
Carr. 3/6 either model and state type P.U.
E.K.E., 47, Arksey Lane, Bentley, Doncaster.

FERRANTI LIMITED, Edinburgh

invite applications for staff appointments as Field Trials Engineers to join teams engaged in the field trials of experimental radar and navigational systems. Although primarily based at Edinburgh, much of the work necessitates travel within the U.K. while one or two of the posts will require overseas travel. Applicants should possess a Degree, H.N.C. or equivalent in electronics or electrical engineering and have had at least three years' experience in centimetric radar techniques. Salary according to age, qualifications and experience. Please apply to the Personnel Officer, Ferranti Limited, Ferry Road, Edinburgh, 5, quoting Ref. FTE/TID/59.

ELECTRICAL ENGINEERS

You can train to service the
BRITANNIA

★

BRISTOL AIRCRAFT LIMITED are looking for experienced electrical engineers to service the Britannia. The men they need would be between 25-40, have at least their ONC and they would preferably have served an electrical engineering apprenticeship. Experience on modern aircraft would

naturally be a great advantage.

The job would take about six months to learn and after that work will often take you outside the United Kingdom.

If you're interested write, with all the usual details, to:

MR P A TOBIN
Room 50/JW, Bristol Aircraft Limited, Filton House, Bristol

BRISTOL

WHY WASTE TIME

Give that set its best chance
FIT QUALITY COMPONENTS

Catalogue 1/-.

ALL POPULAR CIRCUITS
COVENTRY RADIO

EST. 1925

189, DUNSTABLE ROAD,
LUTON BEDS.

Phone : Luton 2677

SIGNALS OFFICE STAFF REQUIRED

A number of vacancies, offering good conditions and prospects, exist for:—

CYPHER OPERATORS (Male and Female).

RADIO OPERATORS (Male).

TELEPRINTER OPERATORS
(Male and Female).

Apply, giving details of qualifications and experience, to:—

Personnel Officer,
G.C.H.Q. (FOREIGN OFFICE),
53 Clarence Street, Cheltenham.

FERRANTI LIMITED, Edinburgh

require an engineer with diesel/petrol/electric and electronics experience to join a team of Field Trials Engineers engaged in the field trials of experimental radar and navigational systems. The work involved is mainly connected with the running and maintenance of diesel generating plant and petrol-driven cooling plant but assistance in maintaining the mechanical and electrical aspects of the radar equipment will be expected. Qualifications up to H.N.C. standard preferable but not essential, with at least three years' experience in dealing with such plant. Although primarily based at Edinburgh, much of the work necessitates travel within the U.K. Salary according to age, qualifications and experience. Please apply to the Personnel officer, Ferranti Limited, Ferry Road, Edinburgh, 5, quoting Ref. E/TID/59.

ENGINEERS!

Whatever your age or experience, you must read "ENGINEERING OPPORTUNITIES." Full details of the easiest way to pass A.M.I.Mech.E., A.M.I.E.E., C. & G. (Electrical, etc.), General Cert., etc., on "NO PASS—NO FEE" terms and details of Courses in all branches of Engineering—Mechanical, Electrical, Civil, Auto, Aero., Radio, etc., Building, etc. If you're earning less than £15 a week, tell us what interests you and write for your copy of "ENGINEERING OPPORTUNITIES" today—FREE.

144 PAGES
Free!

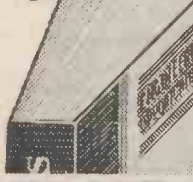

B.I.E.T.

387 College House, 29-31, Wright's Lane, London, W.8.

LOUDSPEAKER CABINETS

For

**GOODMANS W.B. G.E.C.
KELLY and JENSEN**

STANDARD BASS REFLEX CABINETS

Demonstrations without Appointment

You can see your cabinet being made in our cabinet-making workshop.

Cabinets made to order.

**ARMSTRONG CHASSIS AND AMPLIFIERS
LOUDSPEAKERS.**

Open till 5.30 Saturdays.

A. DAVIES & CO. (Cabinet Makers)
3 Parkhill Place, off Parkhill Road, London, N.W.3. GULLIVER 5775.

Solder with



LITE SOLDER
REGD. TRADE MARK

"PERMATIP"
AND
"PERMABIT"
INSTRUMENTS
FOR
**GREATER
SOLDERING
EFFICIENCY**

The soldering bit which maintains its face indefinitely without attention. 25 models available for mains or low voltage supply. Bit sizes 3/32 to 3/8 inch. Full details in booklet S.P.5 from sole manufacturers:—

LIGHT SOLDERING DEVELOPMENTS LTD.
106, GEORGE ST., CROYDON, SURREY.
Tel CROYdon 8589

**BRASS, COPPER, DURAL,
ALUMINIUM, BRONZE**
ROD, BAR, SHEET, TUBE, STRIP, WIRE
3,000 STANDARD STOCK SIZES
No Quantity too Small. List on Application.
H. ROLLET & Co. Ltd.
6 Chesham Place, S.W.1. SLOane 3463
ALSO AT LIVERPOOL, BIRMINGHAM
MANCHESTER, LEEDS

LOCKWOOD
makers of
Fine Cabinets
and woodwork of every description
for the Radio and allied trades
LOCKWOOD & COMPANY
(WOODWORKERS) LTD.
Lowland Rd., Harrow, Middlesex. Byron 3740

MALVYN ENGINEERING WORKS
Manufacturers of: Chassis, Small
Pressings, Machined Components,
Wiring and Mechanical Assemblies
to specification.
Sinole and Production Quantities.
100 PARK ROAD, WARE, HERTS.
Telephone: Ware 465

RADIO & TELEVISION COMPONENTS
WE OPERATE A PROMPT & EFFICIENT
MAIL ORDER SERVICE
"VIEWMASTER" & "TELE-KING" specialists
Easy terms available. Stamp (only) for lists
JAMES H. MARTIN & CO.,
FINSTHWAITE, NEWBY BRIDGE,
ULVERSTON, LANCs.



SIFAM ELECTRICAL INSTRUMENT CO. LTD.
LEIGH COURT - TORQUAY - Telephone 4547/8

TANNOY
SOUND EQUIPMENT
Tells you what's going on clearly
WEST NORWOOD · S.E.27
Telephone: GIPsy Hill 1131 (7 lines)

PROVED
The finest method
for cleaning records
Already over 20,000 enthusiastic users

THE "Dust Bug"
AUTOMATIC GRAMOPHONE RECORD CLEANER
PATENT APPLIED FOR
Price reduced to 17/6 (plus 7/- purchase tax)
From your local dealer or
Cecil E. Watts
Consultant and Engineer (Sound Recording and Reproduction)
Oakleigh Grange, High Cross, nr. Uckfield, Sussex

**BELCLERE
TRANSFORMERS**
offer—

- ★ High Quality Driver and Output transformers for use with Transistor Amplifiers.
- ★ Output transformers for F.M. receivers — types suitable for Push-pull or single-ended output stages.
- ★ Transformers to customer's own specification.

Illustrated leaflet and fullest details upon request. Excellent Delivery — Competitive prices.

BELCLERE TRANSFORMERS
P.O. Box No. 22
117 High Street, Oxford
Tel. 48362. Cables: Belclere Oxford.

UNIVERSITY OF SOUTHAMPTON
Technical Department
**FULL-TIME COURSE IN
TELECOMMUNICATIONS
ENGINEERING**

A two year full-time day course in Telecommunications Engineering is now available. The course prepares candidates for the Intermediate, Final, and Full Technological Certificate Examinations of the City and Guilds of London Institute. It includes Physics for candidates who wish in addition to obtain full exemption from the Graduateship Examination of the British Institute of Radio Engineers.

The next course commences in September, 1956, and early application for entry is desirable. Application forms and further particulars may be obtained from the Technical Officer, the University, Southampton.

TELETRON SUPER INDUCTOR COILS

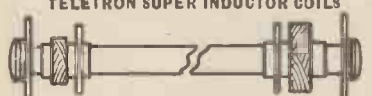

Ferrite Rod Aerials. Wound on high permeability ferrite rod, Medium wave 8/9, Dual wave 12/9.



Type HAX. Selective crystal diode coil for tape and quality amplifiers, MW 3/-, LW 3/6. Dual wave TRF Coils, matched pairs (as illustrated) 7/- pair. Type S.S.O. Supersonic Tape Osc. coil, provides 6.3 v. 3 a. RF for pre-amp heater. Eliminates induced 50 c/s hum, 40/100 kc, 15/- ea. Transistor coils, etc. Available from leading stockists. Stamp for complete data and circuits

THE TELETRON CO. LTD.
266, Nightingale Rd., London, N.9. How. 2527

This Month's Offers

MOTOR ALTERNATORS. 400 cycles new surplus, 28 volts D.C. input, dual output 115 volts 3 ph. 750 V.A. and 24 volts 1 ph. 250 V.A. 24 volts D.C. input, 115 volts, 115 V.A. output, 400 cycles 3 ph. Other sizes in stock. Write for list.

CABLE INSULATION TEST SET. By Advance Components. 180-250 volts, 50-500 cycles, new condition tested and ready for use.

RECEIVERS. AR88, SX28, B29, CR100, CR300, all completely rebuilt, laboratory tested and guaranteed.

WAVEMETERS T.E.149 by R.C.A. 200 Kc/s to 20 Mc/s. accuracy 0.005% with crystal, spares and instruction, new surplus in transit case, lab. tested.

WAVEMETERS. Type 1191. New surplus in original transit case. 100 Kc/s. to 20 Mc/s. with valves, crystal, and charts.

WESTINGHOUSE METAL RECTIFIER UNITS. 230 volts 50 cycles input, 50 volts, 1/2 amp. output, £5/10/-, 1 1/2 amps. output, £6/10/-, erg. extra. 110/250 volts, 50 cycles, input 16/96 cells, 10 amps. output, 11/48 cells, 20 amps. output, 8/48 volts, 20 amps. output., all with Selenium Rectifiers. New surplus, tested and guaranteed. Write for list.

Leslie Dixon & Co.
Dept. A. 214 Queenstown Road, London, S.W.8
Telephone: MACaulay 2159

NEW BOOKS

ON RADIO & TELEVISION

Fundamentals of Transistors, by L. M. Krugman. Postage 1/- 21/-

Radio Amateur's Handbook A.R.R.L. for 1956. Postage 1/6 30/-

Magnetic Recording Handbook, by Hickman. Postage 1/- 21/-

High Fidelity the Why and How for Amateurs, by G. A. Briggs. Post. 1/- M.K. Valve Data Handbook, most up-to-date, published in Holland. Postage 9d. 15/-

Radio Servicing Manual, by W. T. Cocking. Complete new edition. Postage 1/- 17/6

T.V. Engineering. Vol. 2. Vision Frequency Amplifiers, by Amos and Birkinshaw. B.B.C. Training Manual. Postage 1/3 35/-

3rd Audio Anthology, by Radio Magazines Inc. of America. Postage 1/- ... 20/-

Germanium Diodes, by Dr. S. D. Boon. Phillips Technical Series. Postage 6d. 9/6

Loudspeakers, by G. A. Briggs. Post. 6d. 7/6

Beginners Guide to Radio, by F. J. Camm. Postage 6d. 7/6

Write or call for lists of English and American publications.

UNIVERSAL BOOK CO.
12 LITTLE NEWPORT STREET,
LONDON, W.C.2. (adjoining Lisle Street).

Smith's of EDGWARE ROAD

Manufacture a full range of 4-sided Blank Chassis of 16 gauge half-hard aluminium.

Size (Inches)	Price	Size (Inches)	Price
6 x 4 x 2 ...	4/6	10 x 8 x 3 ...	8/6
7 x 5 x 2 ...	5/-	13 x 8 x 2½ ...	8/9
8½ x 5½ x 2 ...	5/6	12 x 9 x 2½ ...	8/11
10 x 4 x 2½ ...	6/-	14 x 7 x 3 ...	9/-
9 x 7 x 2 ...	6/6	13 x 10 x 2½ ...	9/9
12 x 4 x 2½ ...	6/6	14 x 10 x 2½ ...	10/-
9 x 8 x 2 ...	7/3	12 x 10 x 3 ...	10/3
10 x 8 x 2½ ...	7/6	15 x 10 x 2½ ...	10/6
12 x 5 x 3 ...	7/9	17 x 10 x 2½ ...	11/3
12 x 7 x 2½ ...	7/11	17 x 9 x 3 ...	11/9
11 x 8 x 2½ ...	8/-	17 x 10 x 3 ...	12/6

Other sizes pro rata plus 2/6
Keep this List for reference.

Panels cut to any size 4/- per sq. ft. and pro rata. Special discount for quantities of the above. Prices include postage and packing.

H. L. SMITH & CO. LTD.
287/289 EDGWARE ROAD, LONDON, W.2
Telephone: Paddington 5891



TRANSFORMERS

of all types up to 25 KVA for Single or Three Phase operation. Phase Conversion, etc.

MAINS
Output and Special Purpose Transformers for Radio Equipment; Chokes, etc.

COILS
for Contactors, E.M. Brakes, Air Valves, etc., and coil WINDINGS for all purposes.

SOLENOIDS
for A.C. and D.C. Operation
W. F. PARSONAGE & Co., Ltd.
INDUCTA WORKS · Park Rd · Bloxwich · Walsall
Telephone: BLOX 66464



THE SERVICE ENGINEER'S FIRST CHOICE

MUST WE BE HEROES ?

And fight the Fire Fiend without NU-SWIFT? But why? Even the Royal Navy don't do that. Please send us details of your wonderfully rapid and reliable Fire Extinguishers—BEFORE IT IS TOO LATE!

Name.....
Address.....
Post NOW to Nu-Swift Ltd. 25 Piccadilly W.1.

In Every Ship of the Royal Navy

Purchase, Hire or Hire-Purchase your
'VORTEXION TAPE RECORDER'
P.A. Equipment, etc.

Our service includes
INSTALLATIONS AND OUTSIDE RECORDINGS, STUDIO RECORDINGS and TAPE TO DISC SERVICE

LONDON'S LEADING AGENTS
GRIFFITHS HANSEN (Recordings) LTD.
32/33, Gosfield Street, LONDON, W.1
Phones, MUScum 0642 2771
Grams, GRIFFANO, WESDO, LONDON

ODDIE FASTENERS

Pat. 507249

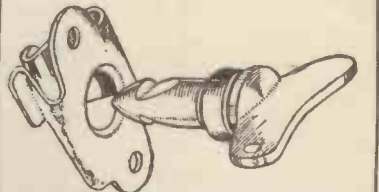

THIS FASTENER WITH ENDLESS APPLICATIONS—SIMPLE—POSITIVE SELF-LOCKING. MADE IN A VARIETY OF TYPES AND SIZES. SPECIAL FASTENERS TO SUIT CUSTOMERS' REQUIREMENTS. WIDELY USED IN THE RADIO INDUSTRY.

Illustrated brochure and other information will be gladly sent on request.
DEPT. "W.W."

Oddie, Bradbury & Cull Ltd., Southampton
Tel.: 55883 Cables: Fasteners, Southampton

Come to **WEBB'S** for the SPECIAL PURPOSE **EDDYSTONE "888" RECEIVER**

Tunes only six Amateur bands with full 12-in. bandspread. The answer to Amateur Band reception problems. Descriptive brochure post free on request.

Price **£110**

(Available on easy terms, please enquire)

WEBB'S RADIO
14 SOHO STREET, LONDON, W.1
Sales Dept. — Phone GERrard 2089

RANK PRECISION INDUSTRIES (B.A.F.) LTD., have vacancies for experienced **DESIGN DRAUGHTSMEN** and **DRAUGHTSMEN**.

The work is of an interesting nature in connexion with Precision Optical, Mechanical and Electronic Instruments; also, Sound Recording and Reproducing Equipment. H.N.C. in Electrical or Mechanical Engineering desirable, but applicants must have reached O.N.C. standard or equivalent qualification. Permanent and pensionable appointments. Canteen. Sports and Welfare facilities. Please apply to:

The Personnel Manager,
RANK PRECISION INDUSTRIES (B.A.F.) LIMITED,
Woodger Road, W.12.

YOUR METER DAMAGED ?



Leading Electrical Instrument Repairers to the Industry

Contractors to the Ministry of Supply and General Post Office. Repairs by skilled craftsmen of all makes and types of Voltmeters, Ammeters, Microammeters, Multirange Test meters, Electrical Thermometers, Recording Instruments, etc. Quick deliveries—for speedy estimate send defective instruments by registered post to—
L. GLASER & CO. LTD.
Electrical Instrument Repairers
96-100 ALDERSGATE STREET, E.C.1
(Tel. : MONarch 6822)



THE SPENCER-WEST PATTERNING REMOVAL UNIT TYPE 54

works with any Band III converter unit and completely removes patterning caused by Band I breakthrough. Results are guaranteed.

PRICE **25/-** Complete

Full instructions for simple fitting supplied. We will send a unit on approval for 7 days against cash on receipt of order, or from your Dealer.

SPENCER-WEST LIMITED
QUAY WORKS, GT. YARMOUTH
Phones : 4794 and 3009
Grams: Spencer-West, Gt. Yarmouth

SHORT WAVE TRANSMITTING/RECEIVING INSTALLATIONS T/R-50 SERIES



T/R-50 Mk. III INSTALLATIONS are designed for use in a communications network and include the following additional features:

- **PRE-SET FREQUENCY SELECTION, CRYSTAL CONTROLLED** (in the Transmitter and Receiver) incorporating a patented FLICK-CONTROL.
- **BUILT-IN AUTO-ALARM SYSTEM**
- **AERIAL MATCHING:** 12-600 ohm impedance over the whole frequency range.

ACCESSORIES AND SPARE PARTS—All accessories and equipment spares for 3-5 years operation can be supplied with the equipment (immediate delivery).

We can supply for IMMEDIATE DELIVERY R.G.A. COMMUNICATIONS & BROADCAST TRANSMITTERS (from 25) w. to 5 kw

Complete in every detail for immediate operation
Use: **MOBILE • FIXED STATIONS • MARINE**

The performance of these installations is of the highest order and meets the requirements of commercial telecommunication working in all climates and conditions.

Every design feature has been incorporated to ensure: **RELIABILITY — ACCESSIBILITY — EASE OF SERVICING.**

Brief Specification:—

TRANSMITTER
POWER OUTPUT—50 WATTS.
FREQUENCY RANGE: 1,500 Kc/s. to 12,000 Kc/s. in 3 bands, V.F.O. or CRYSTAL CONTROL with choice of five crystal positions.
EMISSIONS: (a) Radiotelephone (voice) with facilities for full press-to-talk operation.
(b) Radiotelegraph (code) with provision for full break-in keying.

RECEIVER
SUPERHETERODYNE: I.R.F., Mixer, Local Oscillator, 2-I.F.'s, 2nd Detector and 1st Audio, B.F.O., Power Output Stage with built-in Speaker and additional 500-ohm line connections.
Note: The R-50 Mark II can be provided with a muting control (full or partial) on special order.

POWER SUPPLY UNITS
12 & 24 v. Dynamotor Unit or A.C. Mains Supply Unit (100/130 v. and 200/250 v. 50/60 cycles).

BRITISH SAROZAL LIMITED ELECTRONIC WORKS

1-3 MARYLEBONE PASSAGE - MARGARET STREET - LONDON - W.1
Cables: SAROZAL, LONDON Telephone: LANGham 9351 (3 lines)

A.I.D. and A.R.B. Approved.

Make your Ability PAY

UNLIMITED OPPORTUNITIES exist today for "getting on" . . . but only for the fully

Start today - the I.C.S way

COURSES IN:

- Accountancy
- Advertising
- Architecture
- Bookkeeping
- Building
- Construction
- Chemical
- Engineering
- Civil Engineering
- Commercial Art
- Commerce
- Draughtsmanship
- Electrical
- Engineering
- Electronics
- Farming and
- Horticulture
- Fire Engineering
- General Education

- Journalism and Short Story Writing
- Languages
- Management
- Mechanical
- Engineering
- Motor Engineering
- Radar

Radio Engineering
Sales Promotion
Sanitary Engineering
Secretarial
Surveying
Television Engineering
Woodworking
Also coaching for all principal professional, commercial and educational exams.

Examination students are coached until successful.

INTERNATIONAL CORRESPONDENCE SCHOOLS

Dept. 223F, International Buildings, Kingsway, London, W.C.2.

Please send free book on subject.....

NAME..... AGE.....
BLOCK LETTERS PLEASE

ADDRESS.....

Occupation.....



the world's largest correspondence school - over 6,000,000 students

trained man. Develop your talents and help yourself to success.

STUDY IS EASY with I.C.S. guidance. The courses are thorough. Printed manuals fully illustrated, make study simple and progress sure.

YOUR ROAD TO SUCCESS can start from here—today. Complete this coupon and post it to us, for full particulars of the course which interests you.

Z. & I. AERO SERVICES LTD.

Fully serviced and guaranteed Test Equipment.

"X" BAND EQUIPMENT

TS-13/AP Portable "X" Band Signal Generator-Wavemeter-Power Monitor; 9305-9445 mc/s; Power output 50μW on CW.

TS-33/AP Frequency Meter for CW or Pulsed Signals, 8700-9500 mc/s.

TS-35/AP Signal Generator-Wavemeter-Power Meter, 8700-9500 mc/s, Peak Output Power 3 to - 68 dbm., CW Output Power 0 to - 68 dbm, Input Power 0 to 33 dbm.

TS-36/AP Power Meter, 8700-9500 mc/s, Output power - 10 to 30 dbm.

* * *

TS-15/AP Fluxmeter, for measurement of flux densities of "X" and "S" Band Magnetrans Magnets.

* * *

TS-34/AP Portable High Speed Oscilloscope (observable waveforms up to 1 mc/s), single beam, brand new with spares and carrying cases.

* * *

Dual Pen Voltage Recorder, 160-240 volts.

* * *

Marconi TF-144G Standard Signal Generators, 85 kc/s to 25 mc/s.

* * *

Please write for detailed information on the above and other Test Equipment to:

Z. & I. AERO SERVICES LTD.

19, Buckingham Street, London, W.C.2

Telephone: TRAlgar 2371/2/3

Wireless World Classified Advertisements

Rate 7/- for 2 lines or less and 3/6 for every additional line or part thereof, average lines 6 words. Box Number: 2 words plus 1/-. (Address replies: Box 0000 c/o "Wireless World" Dorset House, Stamford St., London, S.E.1. Trade discount details available on application. Press Day September 1956 issue, Wednesday, July 25th. No responsibility accepted for errors.

WARNING

Readers are warned that Government surplus components and valves which may be offered for sale through our displayed or classified columns carry no manufacturers' guarantee; Many of these items will have been designed for special purposes making them unsuitable for civilian use, or may have deteriorated as a result of the conditions under which they have been stored. We cannot undertake to deal with any complaints regarding any such items purchased.

NEW RECEIVERS AND AMPLIFIERS

SHIRLEY LABORATORIES, Ltd., 125, Tarring Rd., Worthing, Sussex. Tel. Worthing 513, 3571.

THE JTR/S1 stereosonic tape recording and replay amplifier; separate meter monitoring on record and playback on both channels, 13watts C/P each channel, 96gns; TWA/15 tape recording and reproducing amplifier, 13watts O/P, as described in the March "Wireless World," for Wearite and Collaro decks, 45gns; TWP/FA amplifier and replay pre-amplifier, 30gns; with valve voltmeter monitoring; type SB/1-15E high-fidelity amplifier, exceptionally wide tone-control system, 40mv sensitivity, 20gns; with two inputs and 3-position gram filter, 22gns; specialized amplifiers for the musical and scientific industries including the Mullard 20watt. [0095]

RECEIVERS AND AMPLIFIERS—SURPLUS AND SECONDHAND

RECEIVER CR100/7 £14; another with S. meter £18; TF517 £15; exchanges for wide-angle C.R.T.—Box 2828. [6151]

PHILIPS projection TV optical unit complete and in working order. £10.—Cosmic Radio, 6 & 8, Clifton Crescent, Birkenhead. [6117]

ARR8.D, excellent condition, speaker £50 or offer.—Westlake, Leith Cottage, Sudbrook Gardens, Ham, Surrey, Kingston 7336. [6116]

EDDYSTONE 750, 11 valve communication receiver with matching speaker, mint condition, cost over £80; offers over £40.—Box 2495. [6108]

HRO Rx's and coils in stock, also AR88. BC348R, CR100, etc.—Requirements please to R. T. & I. Service, 254, Grove Green Rd., London, E.11. Ley. 4986. [0053]

HIGH fidelity reproducer comprising Leak amplifier, Leak pick-up, Chapman F.M. and Leak M.W. receiver, 3-speed turntable in walnut console, Mordaunt corner speaker, cost nearly £200; complete £75.—Byron 7056, South Hill Lodge, South Hill Avenue, Harrow. [6152]

"WIRELESS WORLD" 7-valve F.M. tuner unused with cathode follower, magic eye and power supply, fitted with latest type F.M. components including special temperature compensating capacitors, price £14/15, including 7 valves, approx. half original price, exceptionally good reproduction, ideal for use with all high fidelity amplifiers and recorders; as above, but including high-grade cabinet 14½in X 9½in X 9in with slow motion tuning indicator, £18/10, limited number; bargain.—Box 1919. [6154]

NEW TEST EQUIPMENT

S.I.M. TV signal intensity meter, directly calibrated in microvolts, indispensable for TV aerial and feeder installations, and finding that "elusive fault."—Send for full details to Radio-Aids, Ltd., 29, Market St., Watford. Tel. 5988. [0170]

TEST EQUIPMENT—SURPLUS AND SECONDHAND

SIGNAL generators, oscilloscopes, output meters, valve voltmeters, frequency meters, multi-range meters in stock; your enquiries are invited.—Requirements to R. T. & I. Service, 254, Grove Green Rd., London, E.11. Ley. 4986. [0056]

TRANSMITTING EQUIPMENT

QUICK sale ex G3DT transmitting and receiving equipment, power packs, speakers, components, etc.—Rozel, Harrietsham, Kent. Harrietsham 281. [6122]

DYNAMOS, MOTORS, ETC.—SURPLUS AND SECONDHAND

2,000c/s motor-alternator sets, input 220v d.c., output 80v, 1ph, 2,000c/s, 6.25amps, 500VA, complete with starter, fuses, control panel and voltmeter, all mounted in ventilated steel cabinet, 14in X 26in X 49in high, new in original cases; £18, carr. extra. P. B. CRAWSHAY, 94, Pixmore Way, Letchworth, Herts. Tel. 1851. [0096]

Send to Partridge for your copy



A free brochure is available giving full details of Partridge Transformers and chokes as specified for the Mullard High Quality Amplifiers. The brochure lists full technical and physical data and prices for the Partridge Components related to the Amplifiers shown below.

MULLARD 10 WATT AMPLIFIER

Mains Transformer H300/10
Output Transformer

MULLARD 10 WATT AMPLIFIER

(Distributed Load Version)

Mains Transformer P4013
Output Transformer P4014

MULLARD 20 WATT AMPLIFIER

Mains Transformer P3877
Smoothing Choke P3879
Output Transformer P3878

Post the coupon now for your copy of this informative publication.

PARTRIDGE TRANSFORMERS LTD.
TOLWORTH SURREY
PLEASE SEND MULLARD BROCHURE

Name

Address

WW/8/56

DYNAMOS, MOTORS, ETC.—SURPLUS AND SECONDHAND

BRIDGE rectifier units, quantity of new, unused, ex-Ministry of Supply, by S.T. & C. Ltd., 200-250/1/50 in 70-90, 100v 16amp d.c. out. or will charge 5A, 2 V cells, at tropical rating up to 125°F, at normal temp. rect. output 32amp, rotary switches, fuses, V meter, steel case, 4ft 6in X 3ft 6in X 1ft 6in, approx. wt. 3cwt, suit home or tropics; £25 each, carr. free—England.

NEW R.A.F. charging cut-outs, 12 and 24v 40amp, 12/6, p. 1/-; 60amp, 19/6, p. free; landing lamps 24v 24w par, 1/6, 15/- per doz. post extra.

T. W. PEARCE, 66, Great Percy St., W.C.1. [0012]

NEW COMPONENTS

CRYSTAL microphone inserts (Cosmocond Mic 6/4), in popular demand by Hams and sound engineers; guaranteed newly made and boxed; 15/6 post free.—Radio-Aids, Ltd., 29, Market St., Watford, Herts. [0169]

CONSTRUCTORS.—Every type of component part supplied for constructors, brand new and all guaranteed, at below list price; all types of condensers, resistors, valves and transformers; stamp for lists; very quick M.O.S.—D. R. Smith, 47, Stannary St., Halifax. Tel. 66865. [0004]

COMPONENTS—SURPLUS AND SECONDHAND

RADIO CLEARANCE LTD., 27, Tottenham Court Rd., London, W.1. Tel. Museum 9188.

ELECTROLYTICS: Capacity, voltage, size, type of mounting, price post paid, 25, 25v, ¼X1¼, W/E, 1/3; 500, 12v, ¼X¼, W/E, 2/1; 1,000+1,000, 6v, 1X3, clip, 3/5; 1,000, 6v, 1X2, clip, 2/3; 1,000+2,000, 6v, 1X3, clip, 3/9; 100, 12v, ¼X¼, clip, 1/9; 2,000, 12v, ¼X2, clip, 3/6; 50, 25v, ¼X1¼, clip, 1/9; 100, 25v, ¼X1¼, 2/-; 1,000, 25v, 1X3, clip, 4/-; 3,000, 25v, 1¼X4½, 5/-; 5,000, 25v, 1¼X4½, 6/6; 2,500, 50v, 1¼X4½, 8/6; 5, 150v, ¾X1¼, W/E, 1/3; 8, 150v, 1¼X1¼, clip, 1/3; 40+40, 150v, 1X2, clip, 2/9; 100, 275v, 1¼X3, clip, 3/0; 60+250, 275/350v, 1¼X4½, clip, 6/-; 8, 450, ¼X2, clip, 1/9; 16+16+8, 350/425v, 1¼X2, lug, 4/3; 20+10, 450v, 1X3, clip, 4/-; 8, 500v, 1¼X2¼, clip, 2/3; 32+32+8, 350/425v, 1¼X3, clip, 5/-; 32+32, 350/425v, 1¼X2, clip, 4/-; 100, 350/425v, 1¼X3, clip, 4/2; 2, 350v, ¼X2, 1/3; 16+16, 350v, 1X2, clip, 3/6; 16+16, 275v, 1X2, clip, 3/-; 32+32+8, 275v, 1¼X2, clip, 4/3; 100+200, 350v, 1¼X4½, clip, 7/-; 50+50, 350v, 1¼X3, lug, 4/6; 200, 250v, 1¼X3, clip, 3/6; 16+8+4, 275v, lug, 5/4; 200, 250+250, 275v, 2X4½, clip, 8/6; photoflash types, 1,000ft., 200v, 1¼X4½, 12/6; all ALI cans, some with sleeves, all voltages WKG. surge V where marked, all new stock, guaranteed.

TELEVISION chassis, cadmium plated, steel, size 14X18X2¼in, complete with 11 valve holders (9-B9A, 6A5, B9A Cer, 2-B7G Cer, 1-Int. Oct. amph), 20 various tag strip cut away for metal rect., line trans., etc.; 9/11 each, post paid.

FRONT and rear tube mounts to fit above chassis, 20/- pair, post paid.

P.N.M. footrings, wide angle, tetrode tube, fully adjustable, 9/11, post paid.

SCANNING coils, wide angle, with mounting lugs, 19/6, post paid.

MAINS trans., 340-220-0-220-340v, 220Ma, 4v, 0.5A, 4v, 3A, 4v, 1.5A, 2v, 1.5A, 4v, 6.5A Pri. 0-205-225-245v, 20/-, post paid.

MAINS trans., 250-0-250v, 120Ma, 6.3v, 2.5A, 6.3v, 0.6A, Pri. 0-110-125-150-205-225-245, 18/6 post paid.

C.T.V.'s 34Mc/s, 2nd, 3rd, 4th, vision, cans 13/16X15/16X2¼, slug tuned, set of three 5/6 post paid.

RADIO CLEARANCE LTD., 27, Tottenham Court Rd., London, W.1. Tel. Museum 9188.

SOUTHERN RADIO SUPPLY, Ltd., 11, Little S. Newport St., London, W.C.2. See our displayed advertisement, page 146.

TUBES, Mazda 12ln and 15ln, perfect condition, seen working, guaranteed; £6 and £8/10 each; callers only.—King's Tele-Service, 255, High Rd., Leytonstone. [6099]

GOVERNMENT Surplus Illustrated Catalogue No. 12, containing over 400 items of electrical, mechanical and radio equipment for experiments, etc.; price 1/6, post free.—Arthur Sallis, 93, North Rd., Brighton, Sussex [0095]

MAGSLIPS at low prices, fully guaranteed, 3 in Resolver No. 5 (AP 10861), 50v, 50c/s, unused, each in tin, 35/-, post 2/1; large stocks of these and other types.—P. B. Crawshaw, 94, Pixmore Way, Letchworth, Herts. Tel. 1851. [0087]

NEW GRAMOPHONE AND SOUND EQUIPMENT

TRANSISTOR pre-amps for tape playback; £9/5

RECORDING units osc erase and bias, with meter level 17gns, R/P amps, 6 watts U/L, 25gns

REFLECTOGRAPH tape-decks, now £36: Sencocne, £53/6/8.

COLLARO, Wearite and all decks and amps available

HARDING ELECTRONICS, 120a, Mora Rd., Ricklewood, London, N.W.2. Tel. Gladstone 1770. [0032]

"AUTOMAT" THE 100% RELIABLE CHARGER

As supplied to the Ministries, Airlines, etc. Rectifier stacks, best makes, with or without Transformer, 1 Watt to 1 Kw. Complete Power Units to order.

CAR HOME CHARGER 2 AMP.

This new, robust, utterly reliable 6 v./12 v. 2 amp. charger with funnel cooled selenium rectifier, for A.C. 215/240 v., wt. 7lb., ammeter model 57/6, p.p. 2/-, glowing indicator model 52/-, Ditto but 3 amp., add 12/- to above. Truck charger 6 v./12 v. 5 amp., £8/10/-.

FOOLPROOF CHARGER KITS.

lasting as sold 13 years thru' W.W.—New No. 2 kit 12 v. 2 amp. rectifier, 50 watt impregnated trans., ballast steel case, 10/- extra. Ditto but ammeter model, add 11/-. No. 1 kit, 12 v. 3 a. Westlake rectifier, 65 watt trans., ballast/indicator bulb for 2 v., 6 v., 12 v. charger, 42/-, p.p. 2/-. Special case louvered, punched, enam. grey, 12/6. No. 1A kit, 3 a., rect. 65 watt trans., ballast res., ammeter, for 2 v., 6 v., 12 v., 3 a., 51/-, case 12/6 extra, p.p. 2/-.
SELENIUM RECTIFIERS, new stock, best makes, 40 mA. to 10 amp., 2 v. to 110 v.—Examples, 12 v. 2 a. h. wave, 7/-, 1-w. 8 v., 12/4 v. 3 a. to 3 1/2 a. 15/-, p.p. 8/-, 12 v. 3 a., 24/-, large finned 6 amp., 29/-, 24 v. 0.3 a., 9/-, 24 v. 1 a., 13/6, 24 v. 1.5 a., 15/8, 24 v. 5 a., 42/-, 6 a., 55/-, 60 v. 1 a., 25/-, 2 a., 28/-, p.p. 1/-. H.T. Rects., selenium, R.M.2. 3/4, 250 v. 6 mA., Westal, 6/-, 260-0-260 80 mA., 14/-, 250 v. 100 mA. bridge, 14/-, 140 v. 25 mA. h.w., 5/-, p.p. 7/-, 24 v. 2 amp., 13/-, 24 v. 0.5 a., 11/6.

CHAMPION PRODUCTS

43 UPLANDS WAY, LONDON, N.21

*Phone: LAB 4457

SURPLUS

TRANSMITTERS. Over 70 different types in stock, ranging from the BC611 American Handie Talkie to the Marconi SWB-8, 3,500 watts.

RECEIVERS. Nearly 100 types available from 15 kc. to 1,000 Mc/s., including portable and directional, the smallest hand held and the largest weighing 10 cwt. and using 85 valves.

TEST EQUIPMENT. American only. Over 100 different types of instruments in stock.

VALVES. American, over 200 types. British, over 150 types.

RECORDING GEAR by Dictaphone, M.S.S., Amertype, Soundscriber, Armour, R.C.A., Utah, Memovox, Edison, etc., for disc, wire, film and tape.

POWER SUPPLY. Dynamotors, Motor Generators, Rectifiers, Vibrators, Inverters, from 2 volts 100 amps. to 18,000 volts 1/2 amp.

AERIAL EQUIPMENT. Whips, 12in. to 20ft. Masts 20ft. to 80ft. Brackets, bases, wire gus, beams.

MISCELLANEOUS. Amplifiers, Cabinets, Chokes, Controls, Cords, Crystals, Electric Accessories, Fuses, Hardware Insulators, Loudspeakers, Meters, Plugs, Relays, Switchgear, Transformers, etc.

Full lists available

Send your requirements. All packing and shipping facilities.

**P. HARRIS
ORGANFORD DORSET**

Telephone: Lychett Minster 212.

NEW GRAMOPHONE AND SOUND EQUIPMENT

An unbeatable bargain (as many repeat orders testify), recording tape, plastic, sensitive, 1,200ft 22/6 inc. p.p. (£1 each 6 and above, 1/6 p.p.); also Mastertape. Tape recorders, Ferrograph, Leavers Rich, Brenell (excellent value at 48gns); disk recorders; blank disks; microphones.

TAPE to disk, 78 and LP, complete service backed by years of practical experience. ERICA RECORDING SERVICES. (1949), Recorder House, Peel St., Eccles, Manchester. Eccles 1624. Director, Thurlow Smith, A.R.M.C.M. [0122]
CINE-VOX disc recording equipments, type C7J, for high-quality recordings from existing microphone equipment; price from 28gns; also available as a complete channel inclusive of mic., amplifier and playback equipment, at 70gns; type C7 for highest quality professional equipments—recorder mechanism at 48gns or complete channel at 110gns; demonstrations arranged in London. PLEASE write for details to K.T.S., Ltd., "Coplow," Park Rd., Braunton, N. Devon. Tel. Braunton 224. Callers by appointment only [0210]

GRAMOPHONE AND SOUND EQUIPMENT—SURPLUS AND SECONDHAND
CJ.R. tape recorder type D5, replay facilities during record; £75.—Parker, 3, Moran Rd., Macclesfield, Cheshire. Tel. 5301. [6110]

GOODSELL Williamson G.W. 18 amp. P.F.A. pre-amp and two tun. units, Std and F.M., £55; Connoisseur 3-spd. gram. motor, lt.w. P.U., 2 heads, £25; Wharfedale 3-speaker corner system, £35.—Box 2804. [6145]

WANTED, EXCHANGE, ETC.
WANTED, receivers A.P.R.4, also T.N.16, 17, 18, 19, etc. and any radio test gear.
LESLIE DIXON & Co., 214, Queenstown Rd., Battersea, S.W.8. Macaulay 2159. [0176]

WANTED, valves, TV tubes, televisions, radios, radiograms, tape recorders.—Stan Willetts, 43, Spun Lane, West Bromwich, Staffs. Tel. 2392. [5847]

WANTED, HRO coils, Rxs, etc., A.R.88s, BS348s, S27s, etc.—Details to R.T. & I. Service, 254, Grove Green Rd., London, E.11. Ley. 4986. [0163]

WANTED, B.C.610 Hallcrafters, E.T.4336 transmitters and spare parts for same; best prices.—P.C.A. Radio, Beaver Lane, Hamersmith, W.6. [0079]

URGENTLY wanted, manuals or instruction books, data, etc., on American or British Army, Navy or Air Force radio and electrical equipment.—Harris, 93, Wardour St., W.1. Gerrard 2504. [5877]

AMMETER and Voltmeter Selector Switches, 4-5- or 6-way Rotary Switches, 5amp, 230V; quantities of the above required by electrical manufacturer; reply stating price and full details.—Box 2046. [6045]

RADAR transmitter, any surplus 10cm Army types 3Mk2, 4Mk6, 3Mk7 or similar, complete with magnetron, magnet pulsing arrangements, associated transformers and alternator, in working order.—Box 2733. [6134]

WANTED, good quality communication RYS tape recorder, recent, domestic, domestic radios, record players, amplifiers, valves, components, etc., estb. 18 years.—Call, send or phone Ger. 4638 Miller's Radio, 38a, Newport Court, Leicester Sq., W.C.2. [6059]

WANTED, signal generators types TF144G, TF517F, TF762A, frequency meters type BG221, TS174, TS175; also receivers types RI359 and RI294.—Send price and details to Hatfield Instruments, Ltd., 175, Uxbridge Rd., Harwell, W.7. Tel. Ealing 0779/9857. [0337]

ALL U.S.A. V.H.F. test and communication equipment; TS174, TS175, TS47, B.C.221 freq. meters; receivers 1294, 1359; Hallcrafters S.27, S27CA, U.S.A.; APR4 and tuning units TN16, 17, 18 and 19, RCA AR88D-LF, Hallcrafters SX28; valves 707A-707B, 2K28, 2K39, 2K33, 2K41; highest offers given by return.—Ger. 8410 and 4447. Universal Electronics, 22, Lisie St., Leicester Sq., London, W.C.2. [0229]

VALVES WANTED
ALL types of valves British or American, transmitting and receiving; keenest cash prices paid. What have you to offer? Write or call Lowe Bros., 9a, Diana Place, Euston Rd., N.W.1. [4485]

CABINETS
LEWIS RADIO have the best selection and finest finish.—See page 133. [0224]

REPAIRS AND SERVICE
MAJNS transformers rewound, new transformers to any specification. MOTOR rewinds and complete overhauls; first-class workmanship; fully guaranteed. F.M. ELECTRIC Co., Ltd., Potters Bldgs., Warser Gate, Nottingham. Est. 1917. Tel. 47898. [0113]

LOUDSPEAKERS repaired promptly.—Model Loudspeaker Service, Bullingdon Rd., Oxford. [5963]

MAJNS transformers, E.H.T.s, chokes, field coils, etc., promptly and efficiently re-wound or manufactured to any specification. LADBROKE REWIND SERVICE, Ltd., 820a, Harrow Rd., London, N.W.10. [0222]

TELEPHONE SETS

BRAND NEW



EX.
GOVT.
"F"
TYPE

Ideal for communication between 2 or more positions, up to one mile, e.g., STORES, FACTORY AND OFFICE; FARM BUILDINGS; GARDEN SHED AND HOUSE, etc. Price for 2 sets in individual carrying cases, complete with long life batteries, bells, ringer and 100 ft. telephone cable.

£7.10.0 Per Pair Carr. (G.B.) 7/6

TELE "H" SOUND POWERED

All metal, complete in its own case with strap. Price per pair £9.10.0 carr. (G.B.) 7/6. Single sets can be supplied on both above items if required.

SPECIAL OFFER OF AERIAL MASTS

R.A.F. Type 50

36 ft. HIGH

Kite comprise:— 9 2in. dia. Tubular Steel (Copper Plated) Sections of 4ft. length, top-section and base Pickets, Guy and Fittings.

Canvas Carrying Bags contain all items.

YOU can purchase this normally expensive MAST for a fraction of its cost, i.e.,

£7.10.0 ONLY (Carr. 7/6)

The MAST is particularly suitable to take aerials for T.X. Rx., F.M. and T.V. (especially COMMERCIAL), and has many other uses.

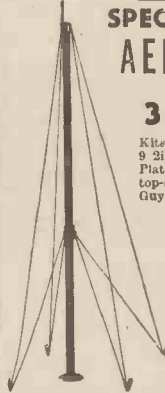

Extra 4ft. sections can be supplied at 11/6 per section.

ARMY TYPE 32 ft. HIGH

Lightweight kit comprising—10 steel screw-in sections of approx. 1in. dia. Spray painted, together with complete set of guys, insulators, pegs, etc. All in canvas carrying bag. Ideal for permanent lightweight installations or test sites, camping, etc.

£5.10.0 (Carr. 7/6)

SWITCHBOARDS

(Ex-A.M. A. D. 1240)



A SPECIAL PURCHASE

of these versatile SWITCHBOARDS from the Air Ministry enables us to offer:—
● SWITCHBOARD A. D. 1240
● Rectifier Supply Unit ● Head & Breast Set
● 10 years spares ● Fused Protector at the ridiculous price of only

£90 Data sheets and photos will be sent for a deposit of 20/- (Returnable)

(Installation complete as above)

The Switchboard has 2 Exchange lines plus 14 Extension plus Operator's position. It is easily modified for use as 16 Extra. lines plus Optr., or 7 Exch. lines plus 7 Extra. plus Optr., or any use between these (e.g., 3 Exch. lines plus 13 Extra. plus Optr).

Enquiries are invited for Component Parts as listed above

HATTER & DAVIS (RELAYS) LTD
126, Kensal Road, London, W.10
LADBROKE 0688

GILSON U.L. OUTPUT TRANSFORMERS

WHICH TO USE?

We manufacture alternative transformers, at different prices, for use with several well-known amplifier circuits and which to choose sometimes presents a problem to the person who wants to be sure of getting the one best suited to his requirements.

We can say right away that whatever he requires there is likely to be a Gilson transformer to suit those requirements.

Putting the case for some of the alternatives available as briefly as possible we will assume that the customer wants the best possible performance obtainable within the limits of his ancillary equipment. Consider first the Gilson low-cost range which includes W.O. 710, W.O. 710/8K in the 12/15 watt range, W.O. 726 and W.O. 776 in the 25/30 watt range.

When the load conditions are not unduly severe as is usually the case with an inductive L/S load then these transformers, all of which are designed for tapped screen operation, will give their rated power output free from distortion over the frequency range 30 c/s-20 Kc/s with a very high order of feedback stability.

When the L/S load has negligible inductance and may have a value equal to the nominal 400 c/s figure or lower at frequencies above 8 or 9 Kc/s, due to using crossover networks and low L tweeters, etc., then the medium price range transformers, such as W.O. 892 in the 12/15 watt rating and W.O. 866 in the 25/30 watt rating would be preferred if the full power rating of the amplifier is likely to be used.

Please write for informative leaflets.

R. F. GILSON LTD.

11a ST. GEORGE'S RD. WIMBLEDON, S.W.13

Phone: WIMbledon 5695

MAKERS OF NEON SIGN TRANSFORMERS
Contractors to Admiralty, etc., A.I.D. Approved

Our stockists include: Berry's (Short Wave) Ltd., 25, High Holborn, London, W.C.1. J. T. Filmer, Bexley, etc.

REPAIRS AND SERVICE
TRANSFORMER rewind service mains, E.H.T. transformers and chokes, prompt delivery, range of replacement types ex-stock or manufactured to your specification.
METROPOLITAN RADIO SERVICE Co., 75, Kilburn Lane, London, W.10. Ladbroke 2296. [0200]

REWINDS and conversions to mains and output trans., pick-ups, fields, clock coils, etc., from 4/6. PP equipment a speciality; all work guaranteed.—N.L. Rewinds, 173, High Rd., Willesden Green, N.W.10. Tel. Wordsworth 7791. [0594]

D. C. BOULTON for repairs to any loud-speaker, specialists on heavy and P.A. types; cone assemblies, field coils, repair accessories, pressure units, microphones; transformers rewound and to specification; motor rewinds.—Lumby St., Manchester Rd., Bradford. Tel. 22838. [0171]

PAINTS, CELLULOSE, ETC.
PAINT spraying handbook, 3/6 post free, cellulose and synthetic paints and all spraying requisites supplied; catalogues free.—Leonard Brooks, Ltd., 53, Harold Wood, Romford. [0207]

WORK WANTED
ELECTRONICS manufacturer, Watford district, has facilities available for light assembly work.—Write Box 1798. [6002]

WORK AVAILABLE
FACTORY Capacity available for the following categories:
PLASTICS Injection Moulding (3 oz).
ALUMINIUM Die-Casting.
LIGHT Engineering.
ELECTRONIC & Electrical Assembly. Location Wiltshire.—Box 0077. [0114]

MISCELLANEOUS
TAPE to disc, LP 22/-, 78 11/-; s.a.e. leaflet.—Marsh, Little Place, Moss Delph Lane, Aughton, Ormskirk, Lancs. [5705]

ROTARY Converter, 230 d.c. to 230 a.c., 50c, 100w, filtered input and output, TV suppressed, little used, in steel case; £8.—78, Reigate Rd., Worthing. [6141]

YOUR own tape recording transferred to disc 78s or L.P.s. Write, call or phone Queensway Private Recording Studios, 123, Queensway, W.2. Tel. Bay. 4992. Studio Recordings. [6023]

METALWORK, all types cabinets, chassis, racks, etc., to your own specification; capacity available for small milling and capstan work up to 1 1/2 lb.—PHILPOTT'S METAL WORKS, Ltd. (G4B1), Chapman St., Loughborough. [0208]

130A—M.E.A. pattern radiometal nickel alloy laminations for sale under list price, 750lb at 12/6 per lb.—The Electroproducts Co., 230-254, Brand St., Glasgow, S.W.1. [6053]

TAPE/DISC for connoisseurs, use Britain's oldest full-time transfer service; 40 min. L.P. 3gns; special prof. qual. tape, 25/- and 21/-.—Sound News Productions, 59, Bryanston St., W.1. Amb. 0091. [6123]

BUILD your own TV and learn about its operation, maintenance and servicing, qualified engineer/tutor available whilst you are learning and building.—Free brochure from E.M.I. Institutes, Dept. WW58, London, W.4 (Associated with H.M.V.) [0180]

COIL Winding Machine, Neville's, Type Montreal, Only had very little use. Perfect condition including electrical equipment and reel stand. Open to reasonable offer.—The Medical Supply Association, Ltd., 53, Park Royal Rd., N.W.10. Edgar 4011. [0197]

SWITCH Units, Type 207B. These beautiful electronic devices measure 14x7x6 approx. and contain a host of useful equipment, the main items being a precision double wound pot 4 1/2 in. dia., 6 standard tropical pots, 4 Yaxley type switches, 3 P.O. lamp holders with bulbs, 2 toggle switches, 3 push switches, an assortment of knobs, multiway sockets, precision resistors, gear wheels, etc., etc. Have cost pounds to manufacture; our special price 7/6 + 2/6 P. & P. wonderful value.
WALTON'S WIRELESS STORES, 48, Stafford St., Wolverhampton, Staffs. [0145]

NOTICES
COVENTRY TECHNICAL COLLEGE.

SESSION 1956-57.
ELECTRONIC Engineering.
APPLICATIONS invited for entry to next 3-year full-time course commencing September, 1956, from those requiring comprehensive training to an advanced level in electronic engineering, qualifying for technical posts in radio, telecommunications, television and industrial electronics; syllabus will cover requirements of C. and G. Brit.I.R.E., and I.E.E. examinations; entry age 16 or over.
APPLICATION forms and further information from Principal, Coventry Technical College.
W. L. CHINN
DIRECTOR of Education. [6127]

BRITISH SOUND RECORDING ASSOCIATION. Details of membership open to the professional sound recording engineer and all others interested in recording high quality reproduction and other branches of audio engineering, together with details of the London lecture programme and the Manchester, Portsmouth and Cardiff Centres, may be obtained from the Hon. Membership Secretary, H. J. Houlgate, A.M.I.E.E., 12, Strongbow Rd., Eltham, S.E.9. [0031]

A NEW Armstrong

AM/FM RADIOGRAM CHASSIS

Armstrong quality

at an economical price

This chassis will be available from mid-August. Please write for descriptive literature, price and credit terms.

ALSO

MODEL AF105 Three-in-one AM/FM RADIOGRAM CHASSIS.....£37

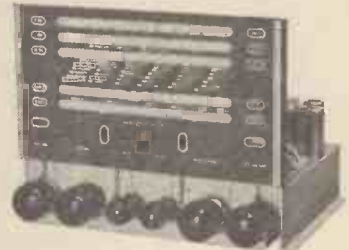

AM and FM Tuners and High Fidelity Amplifier on one compact chassis

- FM, Long, Medium and two Short Wavebands ● Sensitivity on FM better than 10 microvolts with freedom from drift ● Exceptional Selectivity for Continental reception on the AM bands ● 10 watt push-pull amplifier ● Distortion: Less than 0.5% at 8 watts ● Frequency Range: 15-35,000 c.p.s. ± 1 dB ● Independent and continuously variable Bass and Treble Controls with Visual setting indicators.

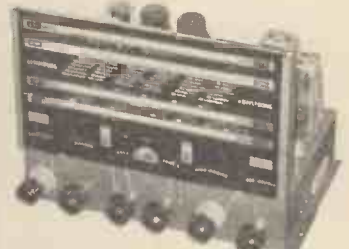

MODEL FC 48—£25.2.0

For those who do not require the FM band but wish to maintain the quality of gramophone reproduction and AM reception, the FC48 can be recommended. It has substantially the same Amplifier and AM circuit specification as the 105.

We shall be glad to give you a demonstration of these and other models in our range at our Warters Road showrooms (open 9-6 p.m. Weekdays and Saturday). If you are unable to visit us please write for descriptive literature mentioning WIRELESS WORLD.

HIRE PURCHASE facilities are available. **GUARANTEE:** All our models are sold under full and unconditional money back guarantee of satisfaction. **FREE TRIAL IN YOUR OWN HOME.** Your money will be returned if for any reason you are not satisfied after 7 days' trial.

ARMSTRONG WIRELESS & CO. LTD.
Warters Road, London, N.7.

Telephone: NORth 3213

MORE

17" T.V. TUBES-14"

17" TUBES £7.10.0

14" TUBES £5.10.0

6 MONTHS' GUARANTEE

RECTANGLE, LATEST TYPES. Please state type and make required plainly. Huge purchase makes this possible.

All of modern manufacture.

16in., 16in., 14in., 12in. ROUND. £5.

Including wide angle types.

OVERSTOCK SALE. These tubes are offered until space is cleared. Prices are plus 15/8 Insured carr. C.W.O. Imperfect and blemished tubes from 12/6. Ideal for testing. Send for Mammoth list of Summer prices. PLEASE PRINT NAME AND ADDRESS.

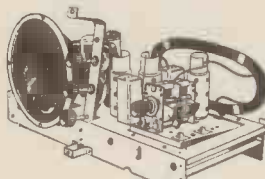

39/6 RADIO AND RADIOGRAM CHASSIS. 3 WAVE BAND AND GRAM.

Extra speaker sockets, 5-valve Int. Octal. Built-in portable aerial (optional). 4-knob control. A.C. or Universal. Less valves. (See our cheap list.) 8in. P.M. speaker 7/9 with order. Set of knobs 2/- Chassis 15 1/2 in. x 7 in. x 9 in. (when speaker is fitted). Carr. 4/6.

RADIOGRAM CHASSIS. 29/9. Including 8in. speaker, dial and knobs. 5-valve s/het. 3 w/band. A.C. mains. Complete. Guar. tested. Less valves. Ins. and carr. 4/6.

QANDELABURM 19/9.

3-light fitting

WITH FREE GIFT OF THREE SHADE BOWLS (post 2/9). Your complete satisfaction. Money back guarantee.

12in. T.V. CHASSIS, 97/6. Easily adapted to Band 3 (ITV). Drawing 2/6 or FREE with order. Complete chassis by famous manfr. R.F. E.H.T. unit included. Owing to this chassis being in 3 separate units (power, t/base and s/vision inter-connected), it is easily fitted to table or console model. State BBC channel. This chassis is less valves and tube. Ins. and carr.: London 5/-. Provinces 10/-.
TV CHASSIS UNITS
 TIME BASE. 10/6. Containing scanning coil, focus unit, line trans., etc. FREE drawing. Carr. 3/6.
 SOUND AND VISION STRIP. 27/6. S/het. complete s/vision strip, 10 valve holders (EP91, etc.). Less valves. FREE drawing. Post 2/6.
 POWER PACK AND AMPLIFIER, 29/8. Mains E.H.T. 5 kV, 325 v., 250 mA. Smoothed H.T. Heaters. 6 v. at 5 amp., 4 v. at 5 amp., 4 v. at 5 amp. Extra winding for 2 or 4 v. tubes. FREE drawing. Carr. 5/6.
 POWER PACK AND AMPLIFIER, 22/6. Output stage 6V6 with O.F. trans., 3 ohms matching. Choke. Smoothed H.T.: 350 v., 250 mA. 6.3 v. at 5 amp., 22 v. at 3 amp., 6.3 v. at 4 amp. and 4 v. centre tapped. Valve base for rect., octal or 4 pin. Output is taken from std. plugs. Less valves. Ins., carr. 5/6.
 POWER PACK AND AMPLIFIER, 22/6. Output stage 6EN45. O.F. trans., Choke. Smoothed H.T.: 325 v. at 250 mA., 4 v. at 5 amp., 6.3 v. at 5 amp., 4 v. at 5 amp. Centre tapped. Valve bases for rectifier octal or 4 pin. Output is taken from std. plugs. Less valves. Ins., carr. 5/6.
 MAINS TRANSFORMER, 5/9. 350-0-350 v. htrs., 6 v. and 5 v. Post 2/3.
 MAINS TRANSFORMER, 3/9. 350-0-350 v. 12 v. 4 v. htrs. Prim. 100-250 v. Make ideal auto trans. Post 2/3.
 MAINS TRANSFORMERS, 5/9. 350-0-350 v. 4 v., 4 v., htrs. Prim. 200-250 v. Post 2/3.
 COIL PACKS, 3/9. Complete with 2-gang cond.; pair 465 L.F.s (similar drawing) and dial. Post 2/3.
 SPEAKERS, 8/9. 8in. P.M. std.; 3-5 ohm. Guaranteed. Post 1/9.

Remember SATURDAY open all day.

MONEY BACK GUARANTEE
DUKE & CO
 621 ROMFORD ROAD, LONDON. E.12
 CWO or COD • TEL: GRA 6677

SITUATIONS VACANT

LABORATORY staff

REQUIRED

FOR research and development work on special electronic valves for use in microwave equipment.

TECHNICAL assistant (male 20-25); applicants should be of educational standard approximating to Inter B.Sc. or O.N.C. level; experience in vacuum physics or valve design, while not essential, would be an advantage.

LABORATORY assistant (male 17-30); applicants should have had technical or grammar school education and be willing to learn laboratory techniques in valve design; any experience in glass working would be an advantage.

ABOVE appointments are permanent and offer good prospects in an expanding field; hours: 8.50/5.30 five days; canteen; pension scheme.—Apply Personnel Dept., Elliott Brothers (London), Ltd., Elstree Way, Borehamwood, Herts. 6111

FERRY AIRPORTS, Ltd.

APPLICATIONS are invited. Radio Mechanics and Licensed Radio Engineers, permanent vacancies, hangar and flight duties, Bristol Freighter and Dakota aircraft.

EXPERIENCE STRI2D, STR9X, MR80, AD7092, BC433G and Ultra 100 preferred, not essential. Modern heated hangar, canteen and assisted travel facilities.—Write parties. Engineer Superintendent, Ferryfield Airport, Lydd, Kent. 6130

CAMBRIDGESHIRE Education Committee.

CAMBRIDGESHIRE Technical College and School of Art (Principal: D. E. Mumford, M.A.).

APPLICATIONS are invited for the following full-time teaching posts:—

1. ELECTRICAL Installations Engineer required as soon as possible to develop new day-release and evening courses for electrician apprentices. At first the courses will be based on City and Guilds Course B in Electrical Installation Work, but later could develop to meet the requirements of Course C and of Electrical Engineering Practice. Applicants should have qualifications appropriate to the post, together with a wide range of practical experience. Salary Scale—Grade A Assistants: £450X£18—£725.

2. RADIO and Television Service Engineer required to develop Servicing Courses for day-release and evening students in new premises. Salary Scale—Grade A Assistants: £450X£18—£725, but an exceptionally well-qualified applicant may be appointed to the Grade B scale: £525X£25.

THERE are additional allowances to the above scales for degrees and training, and starting position on each scale will depend on previous teaching, industrial experience and war service. The scales are under review and are likely to be improved in the near future.

FURTHER particulars and forms of application can be obtained from the Principal, Cambridgeshire Technical College and School of Art, Collier Rd., Cambridge. 6121

FULHAM & KENSINGTON HOSPITAL MANAGEMENT COMMITTEE.

TECHNICIAN required to assist in maintenance of electro-medical apparatus. Qualification at least to Ordinary National Certificate. Knowledge of mechanical engineering an advantage.

SALARY (at age 26+) £520 rising to £630. APPLICATIONS with full particulars to Superintendent Engineer (W.W.76), 5, Collingham Gardens, S.W.5 immediately. 6103

A LABORATORY Assistant is required by progressive firm engaged in the manufacture of transformer cores.

APPLICANTS should be familiar with the use of electrical measuring instruments, and should have a good grounding in electromagnetics. Salary in accordance with qualifications and experience.

APPLY to the Chief Electrical Engineer, Telcon-Magnetic Cores, Ltd., The Industrial Estate, Chapelhall, Lanarkshire, Scotland. 6004

INSPECTOR required for electronic instrument company, Camberley area. Excellent prospects for rapid advancement in expanding organisation.—Box 2709. 6131

DRAUGHTSMEN required for light engineering concern in Boreham Wood area. Salary £750 to £900. Five-day week, five weeks holiday, generous sick leave, good canteen.—Box 2710. 6132

SENIOR and Junior Electrical and Mechanical Draughtsmen required for the Electronics drawing office at the Rugby Works of the B.T.H. Co., Ltd. Please apply in writing to:—CHIEF Draughtsman, Electronics Drawing Office, British Thomson-Houston Co., Ltd., Rugby, giving details of age, experience, etc. 5811

ELECTRONICS Technician required for prototype type and test equipment used with million volt electron accelerator.—Apply to Director, Research Unit in Radiobiology, Mount Vernon Hospital, Northwood, Middlesex. 6128

INTERESTING and congenial position in London retail business of good standing; good English, typing and figure work essential; applicant must have high standards of service; state age and full details of career.—Box 2763. 6139

OLD-ESTABLISHED London retail radio business requires Television Service Engineer; also trainee; driving experience essential; good prospects for capable men; state age and details of experience.—Box 2762. 6138

THE INSTRUMENT MODEL

Specially designed for soldering operations in the compact assemblies used in present day radio, television and electronic industries.
 Weight 3 1/2 oz. excluding flexible.
 Length 9in.
 25 Watts.
 Voltage range 12, 24, 50 26/- each.
 100-110, 120-130, 200-220, 220-240/- each.



- Interesting features
1. Bit 3/8" diameter, simple to replace.
 2. Steel cased element, also replaceable.
 3. Detachable hook for suspending iron when not in use.
 4. Moulded two part handle, remains cool in use.
 5. Six ft. Henley Flexible.

W. T. HENLEY'S TELEGRAPH WORKS CO. LTD
 51/53, Hatton Garden, London, E. O. 1



HIGH CLASS TAPE RECORDING EQUIPMENT
 HEADS, DESKS, TAPE, ETC.
 Send for lists
BRADMATIC LTD.
 STATION ROAD, ASTON, BIRMINGHAM 6
 Telephone: East 2881-2

WAFER SWITCHES TO SPECIFICATION

One or more A.B. Type "H" wafer switches to any desired contact specification.

Write for design chart and new comprehensive price list.

SWITCHES FOR 912-PLUS

S1 (14061/B1)	} 14/6 pair
S2 (14062/B1)	
S4 (SS/556/1)	11/6
S5 (SS/556/2)	10/6

Truvox Amplifier Switch Type 12119/B3 : 14/6d.

SPECIALIST SWITCHES

23 RADNOR MEWS · LONDON W.2
 AMBassador 2308

Enquiries by post or phone only

BAKERS 'Selhurst' RADIO

THE CONNOISSEUR'S CHOICE



The "Selhurst" Enclosures

A new range of single speaker and multi-speaker phase inverter systems for a natural reproduction of the original sound.

Write for full details of our High Fidelity Equipment, which includes GOODSELL "Golden Range," with the ORTOFON Pick-Ups with Diamond Stylus, and the WOOLLETT Transcription Gramophone Turntable.

WE NOW FIT DIAMOND STYLUS TO ALL ORTOFON PICK-UP HEADS IN ACCORDANCE WITH THE MANUFACTURERS' SPECIFICATIONS.

THE CONNOISSEUR'S CHOICE



The PRESIDENT Audio Consolette

A High Fidelity Tone Control Pre-Amplifier and Power Amplifier encased in a compact attractive cabinet. (11 1/4 in. wide x 6 1/2 in. high x 14 in. deep.)

Mail orders only pending the opening of our new showrooms.

Trade and Export enquiries invited.

JOHN LIONNET & CO.

DEPT. W, 62-63 Queen Street, London, E.C.4
Tel: CItY 7167

SITUATIONS VACANT

ENGINEER required for development work on polystyrene film capacitors; position offers considerable scope for man with general experience in the capacitor industry particularly on the production side; own staff advised.—Write Box 2382. [6093]

MCMICHAEL RADIO, Ltd., Slough, Bucks, have vacancies from time to time for electronic engineers to be engaged on Government projects; those wishing to be considered are invited to write fully to the Chief Engineer, Equipment Division. [6198]

TRAINEE Television Service Engineer required by London retail radio business of good standing; good opportunity for keen man with aptitude for this work; driving experience essential; state age and details of career.—Box 2761. [6137]

ADVERTISERS (estab. '46) and well known, extending into the amplifier market, have profit-sharing and active proposition to put to man with knowledge in this branch and small capital; district S.W. London; reply in strictest confidence.—Box 1943. [6144]

ERICSSON TELEPHONES, Ltd., Beeston, Nottingham, are planning a considerable expansion in the fields of acoustics and acoustic transducers, relays, hearing aids, electro-mechanical devices, etc., and invite applications from:

PHYSICISTS.
ELECTRICAL Engineers.
MECHANICAL Engineers.

THESE posts, which offer considerable interest, are progressive and pensionable. In certain cases assistance with housing problems is available. Holiday commitments for this year will be honoured. APPLY by letter to the Personnel Officer, quoting reference No. IG-7 and giving details of previous experience and salary required. [6143]

THE MITCHAM WORKS, Ltd., have a number of vacancies for young draughtsmen to be trained as mechanical designers, these opportunities provide for interesting work, leading to recognition as qualified designers in the radio and television field.

STARTING salaries would be in accordance with age and experience. Applicants are invited to write to the Personnel Officer, The Mitcham Works, Ltd., Newlands, Mitcham Junction, Surrey, quoting reference MD/1. [6120]

RADIO/TELEVISION service engineer for established Murphy dealer; seaside town; equipped modern test gear; only first-class engineer considered; gages; permanent post, but no accommodation provided.—Gerrard Bank St., Newquay. [6146]

CONSULTING Geophysicists have vacancies in seismic oil exploration field parties for young men, preferably single, with electronic or radar engineering experience, with Higher National or C & G. Certificates in Electrical Engineering or Telecommunications; £600 x £72. WE offer a permanent career to men of initiative prepared to accept responsibility and work in camp conditions in all parts of the world; liberal home leave and allowances.—Box 2760. [6136]

EXPERIENCED radio testers and inspectors required for production of communication and radio apparatus, also instrument makers wires and assemblers, for factory test apparatus.—Apply Personnel Manager, E. K. Cole, Ltd., Ekco Works, Malmesbury, Wilts. [6238]

SENIOR television development engineer with administrative experience required, capable of carrying out development projects with minimum supervision up to production stage; Kingston area.—Write, giving full personal details, stating salary required, Chief Engineer, Box 5942. [6123]

ELECTRICAL measuring instrument repairers required for moving-coil, moving-iron and multi-range meters; expanding organization with high rates, bonus scheme and excellent conditions in light modern factory.—Apply L. Glaser & Co., Ltd., 96-100, Aldersgate St., E.C.1. Mon. 6922. [6008]

ELECTRONIC INSTRUMENTS, Ltd., Richmond, have a vacancy on their testing staff which offers the prospect of an interesting job in this rapidly expanding company.—Please write to Electronic Instruments, Ltd., Lower Mortlake Rd., Richmond, Surrey, or Tel. Ric. 5656. [6153]

VACANCIES occur, through promotion to managerial posts of our present staff, for television field engineers in the following areas—Luton, Aylesbury and Bedford; existing holiday arrangements will be honoured.—Forward full particulars to P. J. R. Robinson Rentals, Ltd., 47, St. Peter's St., Bedford. [6149]

SENIOR Engineer required by electronic component manufacturers to take charge of test gear development, factory standards and maintenance of electrical special purpose plant. Permanent position requiring man with initiative and sound theoretical background. State salary required. Box 2364. [6101]

CHIEF Inspector (Electrical) required by electronic component manufacturers. A.I.C. experience essential, preferably on R.C.S.C. specifications. Position suitable for applicant at present senior inspector who wishes wider scope and better remuneration within a small organisation. Location London, E.11.—Write Box 2365. [6102]

EVERYTHING FOR THE SERIOUS CONSTRUCTOR

TRANSFORMERS OF EVERY DESCRIPTION. CHASSIS. SWITCHES TO SPECIFICATIONS

MAINS TRANSFORMER OFFER

Universal mounting. Standard Primary. Output: 250-0-250 volts at 60 m/A. 6-3 volts at 6 amps. 6-3 volts at 2 amps.

Offered at the special price of **15/-** (Add 2/- p/p).

BATTERY CHARGING TRANSFORMER 6, 9 and 12 volts at 6 amps. 22/6
(Packing & Postage 2/6).

STEEL METER CASES WITH ALUMINIUM PANEL, SLOPING FRONT	
4in. x 4in. x 4in.	8/6
5in. x 6in. x 8in.	13/6
6in. x 6in. x 12in.	22/6

SMALL STEEL TEST METER CASES WITH ALUMINIUM PANEL	
4in. x 4in. x 2 1/2in.	6/-
6in. x 4in. x 3in.	8/-
8in. x 6in. x 3in.	10/-
10in. x 6in. x 2 1/2in.	12/-

STANDARD STEEL CASES WITH ALUMINIUM PANEL	
10in. x 7in. x 7in. 22/6	16in. x 9in. x 8in. 45/-
12in. x 7in. x 7in. 28/-	16in. x 11in. x 8in. 51/6
14in. x 7in. x 7in. 32/6	19in. x 11in. x 10in. 58/-
14in. x 9in. x 8in. 41/6	

18 S.W.G. ALUMINIUM CHASSIS	
8in. x 6in. x 2 1/2in. 7/6	14in. x 5in. x 2 1/2in. 9/6
10in. x 6in. x 2 1/2in. 8/3	14in. x 8in. x 2 1/2in. 10/6
12in. x 8in. x 2 1/2in. 8/6	14in. x 10in. x 2 1/2in. 11/-
12in. x 8in. x 2 1/2in. 9/6	17in. x 10in. x 2 1/2in. 12/6

18 S.W.G. STEEL CHASSIS	
14in. x 8in. x 2 1/2in. 9/6	17in. x 10in. x 2in. 11/3
14in. x 10in. x 2 1/2in. 10/3	17in. x 10in. x 3in. 12/6

FULLY DRILLED CHASSIS FOR WILLIAMSON AMPLIFIER 27/6

G.E.C. OSRAM 912 AMPLIFIER DRILLED CHASSIS 21/-

G.E.C. OSRAM 912 FRONT PANEL 14/6

"PANL" CRACKLE PAINT, BLACK, per tin 3/-

CROSS-OVER INDUCTANCES

Special offer—4 m/H Pot Core, Litz wound Cross-Over Inductances. Made by well-known manufacturer. (Add 1/- p/p).

15/-
Per pair

0-30 M.A. METER 6/6

813 VALVE BASES (New) 10/-

40 H. 50 m.A. WOODEN CHOKES 12/6

2K COLVERN 15-WATT PRECISION POTENTIOMETERS 3/6

PEN40. New and Boxed 3/6

HVR2A. New and Boxed 6/6

LORENZ TWEETERS

Amazingly efficient moving-coil unit which is extremely easy to add to existing speaker systems. **39/6**

STOCKISTS FOR LEADING MAKES OF Recording Tape - Microphones - Valves - Components of all types - Gramo Motors, Hi-Fi and Test Equipment, etc. Well-organised mail-order and export service available to all parts of the world.

- Packing & Postage extra.
- Shop Hours—9 a.m. to 6 p.m. (1 p.m. Thursday).
- Few minutes from Marble Arch.

TELE-RADIO (1943) LTD.,

189, EDGWARE RD. W.2

(Our only Address)
Phone: PADDINGTON 4455-6

OPPORTUNITIES IN RADIO



Get this FREE Book!

'ENGINEERING OPPORTUNITIES' reveals how you can become technically qualified at home for a highly paid key-appointment in the vast Radio and Television Industry. In 144 pages of intensely interesting matter, it includes full details of our up-to-the-minute home study courses in all branches of **TELEVISION and RADIO, A.M. Brit. I. R. E., City & Guilds, Special Television, Servicing, Sound Film Projection, Short Wave, High Frequency and General Wireless Courses.**

We definitely Guarantee

"NO PASS—NO FEE"

If you're earning less than £15 a week this enlightening book is for you. Write for your copy today. It will be sent FREE and without obligation.

BRITISH INSTITUTE OF ENGINEERING TECHNOLOGY

388B COLLEGE HOUSE,
29-31, WRIGHT'S LANE,
LONDON, W.8.



CABLE CHEAPER IN SMALL COILS

All coils 20-49 yds. in length, unless requested shorter. All prices per 100yd. lot, less supplied add 6%. Full 100 yd. coils are available add 5% to any price. 3/029. 7/029

TWIN FLAT	1/043	3/029	W/E	W/E
Plastic	51/-	70/-	88/6	153/6
Rubber	54/6	71/-	88/6	150/-

FLUORESCENTS Comp. with choke and starter less tube
 Batters 5ft. square shape, 47/6. Hexagon, 49/6.
 4ft. square shape 37/6. Hexagon 39/6.
 Condensers extra. 5ft., 9/6; 4ft. 5/6. Send for full spec. and control gear and cable lists. Part carriage on small orders please.
BRIDISCO (W), 591 GREEN LANES, LONDON, N.8.

"DIPLOMA" HEADPHONES



Lightweight High Resistance (4,000 ohms). Complete with cord. 17/6

Ideal for CRYSTAL SETS
The 'TYANA' Standard Soldering Iron



- Adjustable Bit.
- Weight approx. 4 oz.
- Heating Time 3 min.
- 40 Watt economy Consumption.
- Standard Voltage Ranges.

16/9

Replacement Elements and Bits always available.

KENROY LIMITED
152/297 UPPER ST., ISLINGTON
LONDON, N.1
Telephone: CANbury 4905-4663

SITUATIONS VACANT

ELECTRONIC Test Engineers are required by the General Electric Co. Ltd., Radio and Television Works, Spon St., Coventry; ex-Service radio and radar technicians and men with similar experience are particularly suitable for these posts; applicants should have an interest in one of the fields outlined below:—
 (a) Testing of electronic equipment for Government contracts.
 (b) Alignment Test and Fault-finding on domestic T.V. receivers.
 (c) Development, manufacture and maintenance of test equipment.
THESE positions offer good prospects of advancement. Those interested should write, quoting Ref. E.T. and giving details of career and experience, to the Personnel Manager at the above address. [6105]

SENIOR and Junior Electrical and Mechanical Draughtsmen required for the Electronics Drawing Office of the British Thomson-Houston Co., Ltd., Blackbird Rd., Leicester.—Please apply in writing to Chief Draughtsman, Electronics Drawing Office, British Thomson-Houston Co., Ltd., Rugby, giving details of experience, etc. [5643]

DESIGNER draughtsmen required by firm engaged in radio and electronic instrument work; experience in this field highly desirable; these are senior staff, pensionable appointments. Apply with details of experience and salary required to Personnel Officer, British Communications Corporation, Ltd., Exhibition Grounds, Wembley. [6114]

AUSTRALIA (Sydney).—Television engineer with production experience required. Also experienced service engineer. Good salaries, bonuses, excellent prospects for right man; class fares, paid accommodation guaranteed. Interview London. Replies, stating full particulars, treated with strictest confidence.—Box 2803. [6141]

GOOD class radio and television dealers have opening for another experienced engineer who would help to retain their high reputation for service, top salary plus bonus, commencing date with respect holiday arrangements, permanency; excellent opportunity in expanding concern for loyal, qualified man.—Sleivers, Marsh Road, Pinner 9283. [6135]

RADIO engineers required to install and maintain two high power radio transmitting stations abroad; sites will be isolated and climatic conditions rigorous with no local amenities; excellent salaries paid to men with necessary experience and right temperament.—Quote Ref. D/NF, Box WD.381, c/o 191, Gresham House, E.C.2. [6115]

DEVELOPMENT Engineer required to work on tape recording applications; the successful applicant must have experience in developing tape recording machines from the mechanical, electrical and electronic points of view; this is a senior position and an appropriate salary will be paid.—Apply to Box A45/12, Strand House, London, W.C.2. [6055]

ELECTRONIC engineers.—Large organization has a few vacancies for electronic engineers to train as project leaders taking charge of all aspects of contracts abroad; qualifications H.N.C. or equivalent, age group 26-32; must be single and willing to work anywhere abroad for periods up to two years; excellent salary.—Write Box WD.438, c/o 191, Gresham House, E.C.2. [6147]

TECHNICIAN or senior technician required for psychological laboratory; must have workshop experience and be familiar with electronic apparatus; salary scale: Technician, £520—£630; senior technician, £620—£755. Apply, giving details of age, details of qualifications and experience, to Hon. Director, Medical Research Council Unit, Institute of Psychiatry, Maudsley Hospital, S.E.5. [6113]

BRISTOL Mental Hospital Management Committee requires an Electronic Engineer to service maintain and construct electro-encephalographic and electro-physiological equipment at Barrow Hospital, near Bristol. Salary £625 X £25—£800. Applications giving age, details of qualifications and experience, and names of two referees should be sent to Secretary, Bristol Mental Hospital, Fishponds, Bristol. [6129]

GRADUATE electrical engineer.—Urgently required by international company at Oxford; unusual opportunity for man 27-35 with first-class qualifications for development work connected with TV circuitry; successful applicant must be able to spend month in United States this summer.—Applications with full details education, qualifications, experience, marital status and salary required to Box 2538. [6112]

RADIO engineer required for Broadcasting Division, Social Development Department, Tanganyika, on contract for tour of 30-36 months in first instance. Salary scale (including inducement pay and present temporary allowance of 10% of salary) £1,003 rising to £1,498 a year. Gratuity at rate of 15% of total substantive salary drawn. Outfit allowance £45. Free passages. Liberal leave on full salary. Candidates, preferably under 35, should have experience of high-power transmitting equipment and be able take charge of 20kW, 1.25kW and 250 watt R.C.A. transmitters at Broadcasting Station, Victoria, to the Crown Agents, 4, Millbank, London, S.W.1. State age, name in block letters, full qualifications and experience and quote M2C/4132/WF. [6119]

Fidelia

HAND BUILT HIGH QUALITY AM/FM RADIOGRAM CHASSIS

Fidelia hand build a range of real high fidelity equipment for radio and gramophone reproduction. The design details of all these models include the following features:

- Triode output Stages.
- Separate Bass and Treble controls.
- Variable Selectivity.
- Band Pass input filter on medium waveband.
- Sleep cut "Scratch" filter for gram reproduction.
- 9 Kc. Whistle filter on radio.
- 20-20,000 cycle audio response.

Fidelia Major AM/FM, £44.
 12 valves separate amplifier, with 9 watt triode push-pull output stage, 26db N.F.B. over three stages. Gram pre-amplifier with variable input attenuator to suit a wide range of gram. pick-ups. VHF/FM reception plus, Short-Medium and Long wavebands.

Fidelia De-Luxe AM/FM £33/12/-.
 11 valves. 7 watt triode push-pull output stage. VHF/FM reception plus usual wavebands C/R tuning indicator. A compact chassis for building into an existing cabinet. [6141]

Fidelia Standard AM/FM £30.
 9 valves with 5 watt triode output stage, and all the Fidelia features.

Full details of all models willingly, on request. All equipment guaranteed 12 months.



2 AMHURST ROAD, TELECOMBE CLIFFS, Nr. Brighton, SUSSEX
 Tel.: Peacehaven 3150

PRECISION SHEET METALWORK

We specialise in manufacturing of Chassis in all metals, large or small quantities to your own specifications.

V. W. BEAMISH

Shardeolos Garage, Shardeolos Rd., New Cross, London, S.E.14.
 Telephone: TIDeway 4795

LYONS RADIO LTD.

BRIDGE MEGGERS. An invaluable testing set comprising a meg insulation tester and a complete Wheatstone bridge for measuring resistance. Incorporating a constant pressure hand generator, a direct reading ohmmeter which also serves as the galvanometer of the Wheatstone bridge, a direct reading adjustable resistance and the necessary ratchet and change-over switches. Testing voltage 250v. Insulation range 0/100 megohms. Resistance measuring range 0.01 ohms to 1 megohm. In good condition and supplied in leather carrying case. PRICE £20.

AMPLIFIER UNITS TYPE A.1271. Housed in a neat metal case 5 ins. cube and contain valve type VR56, 400 ohm relay with 4 make and 2 break contacts, resistors, condensers, tag board, transformer and pot. In new condition. PRICE ONLY 7/6, post 2/3.

T.S.I. FM TUNER. Laboratory designed to enable any AM radio receiver or audio amplifier to receive under perfect conditions the new FM high fidelity transmissions. No alterations or wiring to your present equipment, only one connection to it being required, the Tuner being completely self contained and powered. PRICE tax paid £17.12.8; without cabinet and magic eye tuning indicator £24.8.0. Magic eye optional 26/- Postage and Insurance 5/-. Illustrated leaflet and full technical specification on receipt of S.A.E.

FOR CALLERS, AR88D, £35. Diaphone with double recording head. £30. Simon Tape Recorder £25.

TRADE ENQUIRIES INVITED for Magnetrons type 2J31 and 725A.

3 GOLDHAWK ROAD, (Dept. M.W.), SHEPHERD'S BUSH, LONDON, W.12
 Telephone: Shepherd's Bush 1729

DEPENDABLE RADIO SUPPLIES

12a TOTTENHAM STREET, W.1
TEL.: LANGHAM 7391/7392
1 minute Goodge St. Station

LARGE QUANTITY OF METALPACK CONDENSERS FOR SUPER TROPICAL USE, AT MUCH BELOW COST.

Values	Type	Values	Type
0.1	CP45N	0.5	CP91S
0.25	CP48N	0.02	CP45U
0.5	CP47N	0.001	CP49W
1.0	CP91N	0.002	CP49W
0.05	CP45S	0.005	CP45W
0.1	CP46S	0.01	CP45W
0.25	CP47S	0.1	CP47W

BRAND NEW TAPE RECORDER MOTOR AT HALF MANUFACTURER'S COST

Single phase motors suitable for tape recorders, radiograms, workshops, etc. Has many uses. Reversible 200-230 v. 5in. oz. torque, 1,400 r.p.m. Capacitor start. Weight 4½ lb. Length over all 5in., spindle both ends. ½in. x ¼in., ½in. x ¼in. Price, inc. P.P. and capacitor, 55/-.



ROTARY CONVERTORS

Delivery Ex Stock. Quotations on application.



H.T.31
Input 11.5 v.
Output 250 v. at 125mA.

H.T.32
Input 11.5 v.
Output 490 v. at 65mA.

H.T. 11, 11.5v. in., out 365 v.-310 v., 30 mA.

Fully tropicalised if required.

TANNOY LOUD HAILERS EX-GOV.

Impedance 7½Ω
Handling cap. 8 watts
price 29/6, post 3/-.



POST OFFICE RELAYS

Type 3,000, 100 ohm coil, 3 makes L. Duty contacts, 10/6. 175 ohm coil, 4 makes and 4 breaks, medium heavy contacts, 12/6. Both brand new. P.P. 1/- each.



HEAVY DUTY SLIDING RESISTORS

250 watts at 25 amps.
Resistance 0.4 ohms.
Suitable for charging board, etc.

1 ohm at 125 watts
12 amps.

Both brand new. Price 12/6. Post 3/-.

Quantity and Export Enquiries Invited. Callers also welcome

Open Monday to Friday 9.30-5.30. Sat. 9.30-1.

TERMS—CASH WITH ORDER AND C.O.D. DEPENDABLE—ALWAYS DEPENDABLE.

SITUATIONS VACANT

CIVILIAN Instructors (male) Grade III in the trades of air radar fitter, air wireless fitter, ground radar fitter, ground wireless fitter and instrument fitter required by Air Ministry in provinces, appointments temporary but good prospects of becoming pensionable; trade training, practical experience and ability to teach are essential; pay £676 at age 26 rising to £833—Apply to Air Ministry, S.5(g), (CIV 45), London, S.E.1. [6133]

RADIO technicians required by International Aeradio Ltd., for overseas service; permanent and pensionable positions; inclusive salary from £894 per annum to £1,373 per annum, tax free, according to marital status; free accommodation; write allowance; free air fares; generous U.K. leave.—Qualified candidates, to whom replies only will be sent, please write, quoting RT to Personnel Officer, 40, Park St., W.1. [0262]

RESIDENT Radio Station Engineer and Resident Assistant Engineer required for isolated site near Stirling; good theoretical knowledge and practical background of transmitting station operation required; specialised training will be given to selected applicants; salary £450-£750 p.a. depending on qualifications and experience plus free house and heat.—Reply, giving details of present position, experience and qualifications to Box WW.365, c/o 191, Gresham House, E.O.2. [6107]

ENGINEER for printed circuits required for development of printed circuit processes, including electro-plating of various metals, also development of printed resistors; qualifications B.Sc. or equivalent and experience of electroplating and/or carbon resistors is desirable; superannuation scheme.—Write, giving full details of qualifications, experience, age and salary required to Personnel Manager, The Telegraph Condenser Co., Ltd., Wales Farm Rd., North Acton, W.3. [6094]

TEST and Commissioning Engineer required by Elliott Bros. (London), Ltd., for interesting work on electronic instruments and systems. Applicants possessing O.N.C. or City and Guilds Intermediate preferred, but engineers with testing experience in this field are also invited to apply. The work is based on Lewisham, but occasional travelling is also involved.—Please write stating age, experience and qualifications to Personnel Officer, Century Works Conington Rd., Lewisham, S.E.13. [6142]

SKILLED radio mechanics and servicemen.—A large organization has vacancies for men who are prepared to travel and work anywhere in the world; periods abroad from 6 to 24 months, salary £75 per month plus all found; candidates must be single, medically fit and have a good knowledge of radio theory and practice; initial engagements one to three years with excellent opportunities for men with ability and right temperament to obtain permanencies.—Write Box WD.439, c/o 191, Gresham House, E.O.2. [6148]

THE GENERAL ELECTRIC Co. Ltd., Brown's Lane, Allesley, Coventry, requires mechanical development engineers, designer draughtsmen and draughtsmen, preferably with experience of radar-type equipments, for work on guided weapons and like projects; also required, senior and junior electronic development engineers particularly in the field of microwave and pulse applications; salary according to age, qualifications and experience.—Apply by letter, stating age and experience, to the Personnel Manager. Ref. R.G. [0259]

AN outstanding opportunity in a rapidly expanding company located near Aylesbury is offered to a development engineer with a wide experience of electronic design; applicants must have a sound knowledge of communications techniques, be qualified by degree or equivalent, and experience of filter design would be an advantage; the post offers excellent scope for future advancement to a man with a good background of industrial or establishment experience.—Full details of age, experience, qualifications and salary expected, to Altech, Ltd., Haddenham, Bucks. [6125]

PHILIPS ELECTRICAL, Ltd., require a young man (25-30) to join the musical equipment department as a representative to operate in the Southern counties; musical equipment embraces record players and changers, loose and in cabinets with or without amplifiers, domestic tape recorders and high fidelity equipment; an interest in high fidelity and music generally is most important; it would be an additional advantage if candidates had some technical background; the post is pensionable and a car will be provided.—Reply in full to Personnel Officer, Century House, Shaftesbury Avenue, London, W.C.2, quoting reference No. 838. [6124]

INSPECTOR of Workshops required for Broadcasting Department, Gold Coast Local Civil Service, for one tour of 18-24 months in first instance; consolidated salary scale £950 rising to £1,230 a year with gratuity at rate £100/£150 a year; outfit allowance £60, free passages, liberal leave on full salary; candidates must have up-to-date knowledge broadcasting equipment, should have at least ten years' experience workshops practice in radio, including five years in large broadcasting organisation, preferably B.B.C. or five years in large manufacturing firm in radio industry. Write to the Crown Agents, 4, Millbank, London, S.W.1. State age, name in block letters, full qualifications and experience and quote M2C/41020/WF. [6106]

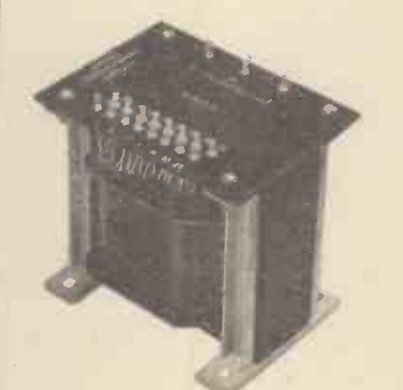

MASSICORE SAVAGE

Scientists, Technicians and Amateurs all over the world choose Savage "Massicore" Transformers for the difficult job. The verdict is the same whatever language they speak.

Dear Sirs,
We have great pleasure to inform you that your 4A38.C and 3C67.C are extraordinary fine in performance and we feel very satisfied with them.
We intend to switch over to your output transformers for all our amplifiers and are glad to place a further order of:
4 Nos. 4-A38.C potted.
4 Nos. 4-B14 potted.
Trusting the order will be promptly executed without delay.
Thanks.
Yours faithfully,

司公電線無陽南
SAVAGE TRANSFORMERS LTD.
NURSTEED RD. DEVIZES.
WILTS.
Telephone : Devizes 932

SOUTHERN RADIO'S WIRELESS BARGAINS

TRANSCEIVERS. Type "38" (Walkie-Talkie). Complete with 5 valves. In metal carrying case. Ready for use. Less external attachments, 30/- per set. **ATTACHMENTS** for use with "38" **TRANSCEIVER HEADPHONES, 15/6;** **THROAT MICROPHONE** with Lead and Plug, 4/6; **JUNCTION BOX, 2/6;** **AERIAL, 2/6.**

TRANSCEIVERS. Type "18" Mark III. **TWO UNITS** (Receiver and Sender) contained in Metal Case. Complete with Six Valves, Microammeter, etc. **LESS EXTERNAL ATTACHMENTS, £4/10/-.**

TRANSMITTERS. T1154. Complete all valves, etc., etc. Perfect order. 3 frequencies. £2/7/6, in transit case. Delivered U.K.

BOMBSIGHT COMPUTERS. Ex-R.A.F. BRAND NEW. A wealth of Components. **GYRO MOTORS, REV. COUNTERS, GEAR WHEELS, etc.,** etc. Ideal for Model Makers, Experimenters, etc., £3.

LUBRA HOLE CUTTERS. Adjustable 3/16 to 3/8in. For Metal, Wood, Plastic, etc., 7/-.

RESISTANCES. 100 ASSORTED. **USEFUL VALUES.** Wire Ended, 12/6 per 100.

CONDENSERS. 100 ASSORTED. Mica, Metal Tubular, etc., 15/- per 100.

PLASTIC CASES. 1 1/4in. x 10 1/2in. Transparent. Ideal for Maps, Display, etc., 5/6.

STAR IDENTIFIERS. Type I A-N. Covers both Hemispheres. In case, 5/6.

CONTACTOR TIME SWITCHES. In sound-proof case. Clockwork movement, 2 impulses per sec. Thermostatic Control, 11/6.

REMOTE CONTACTORS. use with above, 7/6.

MORSE PRACTICE SET with Buzzer on Base, 6/9. Complete with Battery, 9/6.

MORSE TAPPERS, Std., 3/6; Midget, 2/9.

CRYSTAL MONITORS. Type 2. New in Transit Case. Less Valves, 8/-.

METERS AND AIRCRAFT INSTRUMENTS. Only need Adjustment or with broken Glass.

TWELVE INSTRUMENTS, including 3 brand new Aircraft Instruments, 35/- for 12.

Postage or carr. extra. Full list of Radio Books, 2 1/2d.

SOUTHERN RADIO SUPPLY LTD.
11 LITTLE NEWPORT STREET
LONDON, W.C.2. Gerrard 6653

ENGRAVING

Electronic Equipment, Scales, Indicators, etc. Send or phone your requirements.

A.G. ENGRAVING
292 EARLSFIELD ROAD, S.W.18
Phone: BA7tersea 9897

Build your own Tape Recorder with the

'ASPDEN'

TAPE DECK KITS

Compact model
7 1/2in. x 11in., 5in. reels.....kit £7 10 0

Standard model
10 1/2in. x 15in., 7in. reels...kit £8 10 0

Easy to assemble, with full working drawings and instructions. First class motor, latest design High-Fidelity heads.

and the recorder
AMPLIFIER kit £5 18 0
Power Pack kit £2 18 6
(without valves)
Carr. extra.

"... very pleased with its performance— must congratulate you for supplying such an excellent kit." W.P., Portsmouth.

Send stamp for full particulars to:—

W. S. ASPDEN,
10, MARKET STREET, WESHAM,
KIRKHAM, LANCs.

SITUATIONS VACANT ROYAL NAVAL COLLEGE, Greenwich.

VACANCIES exist for highly qualified Instrument Makers and Toolmakers for employment as Laboratory Mechanics, a grade in which a high level of versatility and ability is required. **CANDIDATES** should be fully indentured or have had at least five years' training and subsequent experience in the trade on various high-class machine tools, producing precision prototype instruments and assemblies. For some vacancies experience with electronic assemblies and equipment would be advantageous.

THE present pay range for five-day week of 44 hours is 211s 10d to 253s 10d, all appointments being subject to three months' probation. **NEW** entrants commence at 211s 10d per week and during probation their skill, versatility, accuracy, speed on precision work and general adaptability will be assessed in relation to the performance of experienced Laboratory Mechanics.

ON completion of probation, re-assessment for pay, strictly on merit, will be made and appropriate rate in the pay range awarded, retrospective to date of entry.

FURTHER pay increases by stages up to maximum of pay range may be awarded on merit at annual reviews.

ALL appointments may lead to eventual establishment in Admiralty Service and promotion prospects exist.

APPLY by letter, giving age and full details of industrial experience, to the Secretary, Royal Naval College, Greenwich. [6155]

ELECTRONIC ENGINEERS.—Vacancies in new laboratory established by large manufacturers in North London to investigate unique uses of their products in connection with electronics and kindred apparatus. Applicants considered from Graduate Engineers, holders of H.N.C. or equivalent, students who have thorough knowledge of basic theory. Quote reference SBE/W2, Box 2845. [6156]

ELECTRONIC ENGINEERS are required by the Equipment Engineering Department of Westinghouse Brake & Signal Co., Ltd., at Chippenham, Wilts, to take part in the development and subsequent engineering design for production, of new control systems, employing electronic techniques, for traffic control on British & Overseas Railways. The scope of the work will range from practical experimental work to the issue of design instructions on which will be based manufacturing drawings, together with the compilation of manufacturing specifications and descriptive pamphlets. In addition co-operation will be required with Production Engineers during manufacture of first-off equipments in the Company's Chippenham Works.

POSITIONS are available for University graduates with a good telecommunication Degree in Electrical Engineering. Some experience with transistor techniques is required, together with experience of line communication systems employing audio and carrier frequencies. A knowledge of computing techniques would also be an advantage but is not essential. **THE** salaries will be determined by age, qualifications and experience; the Company operates a pension scheme and a 5-day week. **FOR** further information write, giving age and full particulars, to Personnel Superintendent, Westinghouse Brake & Signal Co., Ltd., Chippenham, Wilts, quoting ref EQUIP/N/Q. [5975]

WIRELESS operator mechanics required by Falkland Islands Dependencies Survey for service at isolated British Bases in Antarctic. Must be able to transmit and receive morse at 20 words a minute (plain language or code) and be capable elementary maintenance wireless transmitting and receiving equipment. Salary according to age in scale £330 rising to £420 a year with all found, including clothing and canteen stores. Keen young men, between 20 and 30 years required preferably single, of good education and high physical standard with genuine interest in polar research and travel willing to spend 30 months under conditions testing character and resource.—Write to the Crown Agents, 4, Millbank, London, S.W.1. State age, name in block letters, full qualifications and experience and quote M2C/41540/W/P. [6150]

SITUATIONS WANTED
CHIEF engineer, T.V. broadcast, requires change, wide industrial and broadcast experience, top engineering level, highest engineering and management qualifications.—Box 1918. [0265]

GERMAN Radio Engineer, 6 years industrial experience in A.F. and V.H.F., seeks good position in British factory, married, accommodation required; only permanent position.—H. Kustor, Hildesheim, Hermannstr, 44, Germany. [6140]

FULLY qualified radio engineer aged 45, specialist v.h.f. communications equipment, requires responsible position with manufacturer or large user, at home, or overseas, on design, maintenance or project development; all enquiries treated in strict confidence stating position and salary offered.—Box 2562. [6109]

TECHNICAL TRAINING
CITY and Guilds (Electrical, etc.) on "No Pass—No Fee" terms; over 95% successes.—For full details of modern courses in all branches of Electrical Technology send for our 144-page handbook, free and post free. B.I.E.T. (Dept. 388A), 29, Wright's Lane, London, W.8. [0117]

TELEVISION ENGINEERING VOL. 2

(Video-Frequency Amplification)

S. W. AMOS & D. C. BIRKINSHAW
35/- Postage 1/-

- TRANSISTORS I by RCA Laboratories 38/6 Postage 1/6
- AUTOMATIC DIGITAL CALCULATORS by A. D. Booth & K. H. V. Booth. 32/- Postage 1/-
- TELEVISION TIMEBASE CIRCUITS Principles & Practice by C. H. Banthorpe 5/- Postage 4d.
- THE V.T.V.M. by R. Samuel 20/- Postage 1/-
- HIGH FIDELITY CIRCUIT DESIGN by N. H. Crowhurst & G. F. Cooper 48/- Postage 1/-
- FIXED RESISTORS by G. W. A. Dummer 28/- Postage 9d.
- INTERNATIONAL TUBE HANDBOOK (M. K. Buizen). 15/- Postage 9d.
- SWEEP & MARKER GENERATORS FOR TELEVISION & RADIO by R. G. Middleton. 20/- Postage 1/-

THE MODERN BOOK CO.,

19-23 PRAED STREET, LONDON, W.2
Britain's Largest Stockists of British and American Technical Books
Please write or call for our catalogue.
'Phone: PADddington 4185.
Open 6 days 9-6 p.m.

FM and HI-FI COMPONENTS

in stock for the

WIRELESS WORLD FM TUNER UNIT
DENCO FM TUNER circuits 1s. 6d.
RADIO CONSTRUCTOR FM " " 2s. 0d.
MULLARD AMPLIFIERS " " 3s. 6d.
OSRAM 912 PLUS AMPLIFIER " " 4s. 0d.

Separate price lists on request to

J. T. FILMER MAYPOLE ESTATE
BEXLEY, KENT
Tel: Bexleyheath 7267

QUARTZ CRYSTAL UNITS

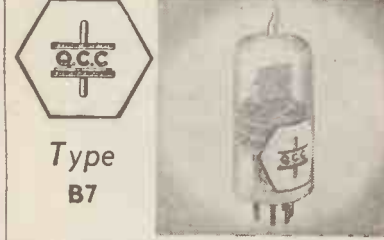

Type B7

The type B7 unit is mounted in the standard B7G valve envelope and is hermetically sealed and fully evacuated.

Available for the frequency ranges from 100 kc/s to 500 kc/s, and from 3 Mc/s. to 16 Mc/s. Gold electrodes applied by cathodic sputtering give permanence of calibration. Normal adjustment accuracy 0.01% Max. adjustment accuracy 0.003%.

Early delivery can be given of some frequencies, and we will be pleased to quote for your specific requirements.

THE QUARTZ CRYSTAL Co. Ltd.
63-71, Kingston Road,
NEW MALDEN, SURREY
Cables, etc., MALDEN 0334 QUARTZCO NEW MALDEN

GALPIN'S

ELECTRICAL STORES

408, HIGH STREET, LEWISHAM, S.E.13
Tel.: Lee Green 0309. Nr. Lewisham Hospital.

TERMS: CASH WITH ORDER
(No C.O.D.)

All Goods sent on 7 days' approval against cash

MAINS TRANSFORMERS. Input 200/230 Volts. OUTPUT 0/9/18 Volts at 3/4 amps., 25/- each; another output 12½/0/12½ volts 2 amps., 25/- each; another suitable for soil heating, garage lighting, etc., 0/4/7½ volts, 20/25 amps., 52/6 each; another 4 volts 20 amps. twice, 35/- each.

EX-GOVT. ROTARY CONVERTORS 24 volts D.C. Input 50 volts 50 cycles, 1 phase at 450 watts. OUTPUT (complete with Step Up Transformer) from 50 volts to 230 volts, £13/10/- each or CONVERTOR only £9/10/- each.

EX-NAVAL ROTARY CONVERTORS 110 volts D.C. Input. Output 230 volts 50 cycles 1 phase 250 watts capable of 50 per cent. overload, in good condition, guaranteed weight approx. 110 lb. £13/10/- each.

SPARK COILS. flat spark on 4 to 6 volts, complete with trembler, 17/6, p/p 1/6 each.

TOTE SWITCHES with operating gear, large 25/-, small, 15/- each.

½ H.P. D.C. MOTORS, 110 volts, 3,000 r.p.m., new, 35/-; starters to suit N.V.R. 25/-.

MAGSLIP MOTORS, 50 volts, A.C., large size, as new, 8/6, p/p 1/6. each.

A.C. MOTORS, 230 volts, sewing machine size, 35/- each.

IRON CLAD Safety Switches, 2 pole, D.P., D.T., 250 volts, 60 amp., new, 18/6, p/p 1/6 each.

D.C. MOTORS, 24 volts, large size 8/6, p/p 1/- each.

ROTARY CONVERTORS new, with all smoothing and control, input 28 volts D.C. Output 300 volts, 260 M/amps., 150 volts, 10 M/amps and 14.5 volts 5 amps. All outputs are D.C. 45/-, p/p 2/6 each. **LARGE METER** Movements, fairly low F.S.D., average 6 inch deflection, very high quality, 7/6, p/p 1/6 each.

MOVING COIL Meters, all 2 to 3 inches dia., damaged cases or glasses, 3 for 10/-, guaranteed one sound meter; 6 for 18/-, two sound meters, no junk, all are or suitable for M/amp. meters.

MAINS TRANSFORMERS all 200/250 volts primaries (New) Heavy duty Output combination of 0/6/12/18/24/30/36 volts 4/5 amps., 38/6 each. Ditto 6/8 amps., 51/6 each. Ditto 15 amps. Output 75/- each. Another combination of 0/6/12/18/24 volts 6/8 amps., 51/6 each. Ditto 10/12/18/24 volts 58/6 each. Ditto 25/30 amps. Output, 85/- each.

MEDIUM SPOT WELDER TRANSFORMERS. Input 200/250 volts, OUTPUT combination of 0/2/4/6/8/10/12 volts at 50/70 amps., £5/7/6 each. Ditto 120/150 amps. Output, £7/10/- each.

PRE-PAYMENT 1/4 SLOT METERS 200/250 volts A.C. 10 amp. size only, 100 per cent. overload set at 2d. per unit (guaranteed 12 months), £3/17/6 each. Ditto credit type 10 amps. only, 25/- each.

RECTIFIERS FOR CHARGERS 6 or 12 volts Output 2 amps. 9/6 each, 4 amps., 22/6 each, 6 amps., 36/- each. **MAINS TRANSFORMERS** to suit, 25/-, 30/- and 46/6 each respectively.

EX-CANADIAN EX-GOVT. ROTARY TRANSFORMERS for No. 19 receiver. Input 12 volts D.C. OUTPUTS 275 volts 110 M/amps.; also another output of 500 volts 50 M/amps. completely smoothed, 30/- each.

AUTO WOUND Voltage changer TRANSFORMERS. Tapped 0/110/200/230/250 volts 200 watts, 48/6 each; 350 watts, 57/6 each; 500 watts, 76/6 each; 1,000 watts, £6/5/- each; 1,500 watts, £8/5/- each; 3,000 watts, £17/10/- each.

EX-R.A.F. ROTARY TRANSFORMERS. Input 24/28 volts D.C. OUTPUT, 1,200 volts 70 M/amps. ½ hour rating, 10/- each. Ditto 18/24 volts D.C. Input 450 volts 50 M/amps., Output constant, 25/- each. These latter ones can be used as motors off A.C. mains with a little alteration.

EX-R.A.F. MORSE TAPPING KEYS, 5/- each. **SINGLE EARPHONE** with carbon microphone 40 ohms, 8/6 each.

Any TRANSFORMERS made to order within 7 days from date of order. Please ask for quote. Numerous other items in stock. Please ask for quotation.

MAINS TRANSFORMERS. 110/250 volt input, 300/0/300 volt 70/80 M/amps, 12 volt 1A, 4 volt 2A. Useful for Wireless, Model Trains, Chargers, etc., or as an 80-watt Auto Transformer 110/250 volts, 10/9 each. Guaranteed.

Clients in Eire and Northern Ireland, please ask for quotation as to carriage charges. The above charges only apply to England.

SPLENDID ODD BARGAINS FOR VISITORS
OPEN ALL DAY SATURDAY
PLEASE PRINT YOUR NAME AND ADDRESS

TECHNICAL TRAINING
LEARN it as you do it, we provide practical equipment combined with instruction in radio, television, electricity, mechanics, chemistry, photography, etc.—Write for full details to E.M.I. Institutes, Dept. WW47, London, W.4. [0006]

TUITION
NOTHING succeeds like success! What we have done a thousand times we can do again for you—see the B.N.R.S. advt. page 128. [0172]

WIRELESS operating: attendance and postal courses.—Stamp for reply to Manager, The Wireless School, Manor Gdns., London, N.7. [0104]

FULL-TIME courses for P.M.G. Certs., C.G.L.I., Telecommunications, Radar Maintenance Cert. and B.Sc. (Eng.); prospectus free.—Technical College, Hull. [0111]

WIRELESS—See the world as a radio officer in the Merchant Navy; short training period; low fees; scholarships, etc., available; boarding and day students; stamp for prospectus.—Wireless College, Colwyn Bay [0018]

A.M.I.Mech.E., A.M.Brit.I.R.E., City and Guilds, etc., on "No Pass—No Fee" terms; over 95% successes—or details of Exams and courses in all branches of Engineering, Building, etc., write for 144-page Handbook—Free, B.I.E.T. (Dept. 3879), 29, Wright's Lane, London, W.8. [0118]

T.V. & Radio.—A.M.Brit.I.R.E., "City & Guilds, R.T.E.B. Cert., etc.", on "No Pass—No Fee" terms; over 95% successes—Details of Exams and Home Training Courses in all branches of Radio and T.V., write for 144-page Handbook—Free, B.I.E.T. (Dept. 397A), 29, Wright's Lane, London, W.8. [0116]

THE Institute of Practical Radio Engineers have available home study courses in every phase of radio and television engineering, specialising in the practical training of apprentices in the retail trade, enrolments limited, fees moderate.—The Syllabus of Instructional Text may be obtained post free from the Secretary, I.P.R.E., Fairfield House, 20, Fairfield Rd., Crouch End, London, N.8. [0088]

FREE! Brochure giving details of home study training in radio, television, and all branches of electronics; courses for the hobby enthusiast, or for those aiming at the A.M.Brit.I.R.E., City and Guilds, R.T.E.B., and other professional examinations; train with the college operated by Britain's largest electronics organization; moderate fees.—Write to E.M.I. Institutes, Dept. WW28, London, W.4. [0179]

WIRELESS telegraphy.—Merchant Navy officers to youths 16 upwards after qualification; lucrative positions as radio officers.—Apply British School of Telegraphy, 179, Clapham Rd., S.W.9. (Est. 1906.) Recognised by Ministry of Education, moderate fees, modern equipment, day and evening tuition; also postal courses in the theory of wireless telegraphy for P.M.G. Certs. and Amateur Transmitting Licence. [0124]

BOOKS, INSTRUCTIONS, ETC.
SALE "Wireless Worlds," 1946-1955, 4 missing; "Electronic Engineering," 1947-1955, 4 missing; first £10 secures.—Harrow 7851 or Box 2650. [6126]

I.P.R.E. technical publications, 5,500 Alignment Peak for Superheterodynes, 5/9, post free, data for constructing TV aerial strength meter 7/6, sample copy "The Practical Radio Engineer," quarterly publication of the Institute 2/-; membership and examination data, 1/-.—Sec. I.P.R.E. 20, Fairfield Rd., London, N.8. [0089]

"DEVELOPMENT of the Guided Missile" 2nd Ed. By Kenneth W. Gatland, F.R.A.S. Presents all the main information now available on the development of guided weapons in Britain, U.S.A., Germany, U.S.S.R., and elsewhere. Other chapters discuss guided missiles as instruments of research into the upper atmosphere and outer space, and as vehicles of interplanetary travel. An appendix shows the characteristics of 130 powered missiles known to have been designed or constructed, 15/-, net from all booksellers. By post 16/1 from Iliffe & Sons Ltd., Dorset House, Stamford St., London, S.E.1.

"TELEVISION Engineering: Principles and Practice." Volume I: Fundamentals. Camera Tubes, Television Optics, Electron Optics. A B.B.C. Engineering Training Manual, by S. W. Amos, B.Sc. (Hons.), A.M.I.E.E., and D. C. Birkinshaw, M.B.E., M.A., M.I.E.E., in collaboration with J. L. Ellis, A.M.I.E.E. This is the first volume of a comprehensive work on the fundamentals of television theory and practice written primarily for the instruction of B.B.C. engineering staff. Covers basic theory of the signal, all types of modern camera tubes, theory of light, mirrors and lenses as applied to television, and electron lenses. 30/- net from all booksellers. By post 31/2. Volume II: Video-Frequency Amplification. This volume describes the fundamental principles of video-frequency amplifiers and examines the factors which limit their performance at the extremes of the passband. A wide variety of circuits is described and particular attention is paid to the use of feedback. There is a section dealing with the special problems of camera-head amplifiers. 35/- net from all booksellers. By post 36/2 from Iliffe & Sons Ltd., Dorset House, Stamford St., London, S.E.1.

TUNERS



FM
F.M. V.H.F. TUNER completely stable drift free tuning. Volume control. Tuning indicator. A.V.C. Sensitivity better than 4 µV for 20 db quieting. 21 gns. Tax paid.



AM
A.M. 9 band all wave tuner. 13 m.-570 m. Band spread, variable selectivity. Tuning indicator. Logging scale, delayed amplified A.V.C. Tropicalised. Sensitivity better than 2 µV for 250 m/v output £46/4/- tax paid.

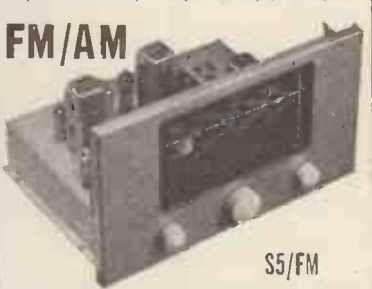

FM/AM
FM/AM World Wide A.M. in 2 ranges. S5E/FM: 12.5 m.-37 m.; 35 m.-100 m.; 90 m.-250 m.; 190 m.-250. S5/FM: 16 m.-50 m.; 195 m.-550 m.; 800-2,000 m. Sensitivity better than 10 µV on all ranges. PLUS completely stable drift free V.H.F.M. Sensitivity better than 8 µV for 20 db quieting. Tuning indicator on all bands AM and FM. £34/2/6 tax paid.

All tuners suitable for modern high quality amplifiers. Most tuners available with Escutcheons in Gold, Silver or Bronze.

C. T. CHAPMAN
(Reproducers) LTD
RILEY WORKS, RILEY STREET,
CHELSEA, S.W.10
FLAxman 4577/8
Export Enquiries Invited

L/P THE RECORD LIBRARY

OFFERS A UNIQUE LIBRARY SERVICE TO THE CLASSICAL L/P ENTHUSIAST

REMEMBER !

- Subscription includes postage and packing this end.
- Return of Post Changing Service.
- Special arrangements for members interested in new issues.
- Our completely comprehensive catalogue is currently extended to include virtually every recommended L/P issued.

For full details send S.A.E. to:—

L/P THE RECORD LIBRARY

Because of Staff Holidays we shall not be open for changing records from August 25th until Sept. 1st.

IT COSTS AS LITTLE AS 1/- PER WEEK EACH L/P BORROWED

AND ...

- We can supply a brand-new (guaranteed unplayed) factory fresh copy of any available L/P to order N.B. (except H.M.V.). With each purchase goes a POST FREE change of Library records.
- Many of the LIBRARY COPIES are themselves marked down for sale at most reasonable second-hand prices. (Surely the ideal way to buy a "used" record is to hear it first!)

The L/P Record Library, Squires Gate, Station Approach, Blackpool, Lancs.

L/P THE RECORD LIBRARY

BOOKS, INSTRUCTIONS, ETC.
"RADIO Interference Suppression: As Applied to Radio and Television Reception."
 By G. L. Stephens, A.M.I.E.E. 2nd Ed. An up-to-date guide to the various methods of suppressing electrical interference with radio and television reception. Many practical applications are given, particular attention being paid to the problem of interference at television frequencies. Other chapters deal with the design and choice of suppressor components, methods of locating the source of interference, and suppression at the receiver itself. 10/6 net from all booksellers. By post 11/1 from Iliffe & Sons Ltd., Dorset House, Stamford St., London, S.E.1.

High Fidelity Amplifiers and Pre-amplifier tone compensation units
 Write for details to:
GOODSELL LTD.
 40 Gardner Street Brighton 1 Sussex
 Tel.: Brighton 26735

MORSE CODE Training



COURSES for BEGINNERS and OPERATORS, also a **SPECIAL COURSE** for passing the G.P.O. Morse Test for securing an **AMATEUR'S TRANSMITTING LICENCE**

Send for the **Candler BOOK OF FACTS**
 It gives details of all courses.
 Fees are reasonable.

Terms: Cash or Monthly Payments
THE CANDLER SYSTEM CO.
 (55W) 52b ABINGDON ROAD, LONDON, W.8
 Candler System Co., Denver, Colorado, U.S.A.

WANTED

B. C. 312
B. C. 342

Receivers. We will pay

£ 2 8

each for sets in good condition.

P.C.A. Radio,
 Beavor Lane, Hammersmith, W.8
 RIVerside 8006

METER REPAIRS



All types - Any make
 Single and Multi-range repaired and recalibrated

Meters converted and re-scaled
PHONE FOR IMMEDIATE SERVICE
E.I.R. INSTRUMENTS LTD
 329 Kilburn Lane, London, W.9
 Tel.: LADbroke 4168

Brenell TAPE RECORDER
 Has every worthwhile feature at a price you can afford
Literature free from:—
BRENELL ENGINEERING CO. LTD.
 2 Northington Street, London, W.C.1

Engineer-mechanic (electrical) required at South-East London Technical College, Lewisham Way, S.E.4. Experience in the Telecommunications industry an advantage. Facilities for further education. Rate of pay £10.10.10 for 44hr. week. Further particulars and application forms (returnable within 14 days) from the Secretary. (1174)

An important Company engaged in the design and development of major guided weapon projects require an Executive Assistant for Administrative duties. The successful candidate must be trained in electronic or electrical engineering and the qualifications should include a University Degree or similar standard of attainment in the Services, and in addition workshop experience would be an advantage.

Applicants should be proficient in administration and be familiar with committee and associated office procedure. Their age should not be less than 30, although consideration would be given to an applicant below this limit in exceptional circumstances.

This is a responsible position and will carry an attractive salary and excellent prospects.

Pleasant working conditions and amenities are provided and a generous pension scheme is in operation.

Replies will be treated in the strictest confidence and should be addressed to:—

T.A.O. Box No. 2765.
 Quoting reference: Comp/3.

THE POLYTECHNIC
 309 REGENT STREET, W.1.
 Electrical Engineering Department
 Head of Department: D. O. Bishop, Ph.D., M.I.E.E.

FULL-TIME DAY COURSES are held for a Diploma in Electrical Engineering (Power and Telecommunications) extending over a period of three to four years. Courses are also held for the B.Sc. (Eng.) Degree of the University of London (External).

Session 1956-1957 begins on September 18th, 1956.

EVENING COURSES in the above subjects and also in Radio and Television Service Work commence on Monday September 24th. The courses prepare for the Ordinary and Higher National Certificates and for the City and Guilds of London Institute examinations. New students will be enrolled on September 19th, 5-8 p.m.

Prospectuses may be obtained on application to the **DIRECTOR OF EDUCATION.**

A MAST PROBLEM?

WRITE TO Skymasts

BEADON GARAGE BEADON ROAD LONDON W6 Telephone RIVERSIDE 1124 & 7878

VALVES — NEW SURPLUS

Guaranteed and Boxed.

EBF80 .. 10/-	EA50 .. 1/-	6K7 6/-
ECC81 10/-	EB91 .. 6/-	6N7m .. 6/-
ECH81 10/-	EF36 .. 7/6	6SJ7 .. 7/-
ECL80 10/-	EF39 .. 6/-	6SL7 7/6
EP30 9/-	OZ4A .. 8/6	6V6 7/6
EP91 7/6	6B8M .. 5/-	12AT7 .. 9/-
EP92 5/6	6BW8 .. 8/6	12SH7 .. 6/-

Post and Packing 6d. Cash with order. Postal only.
C. LAWRENCE
 131, Waddington Avenue, Coulsdon, Surrey

ALL MAINS 3

Five Midget 3-valve Mains Receiver. Home, Light, etc., at good strength. Build yourself—3 valves, ready-wound coil, tuning condenser, mains transformer—everything except speaker and cabinet. Data av. sep. 2/- Speaker and cabinet available if required.

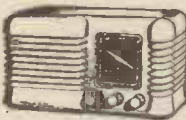

Post 1/6 **32/6**

John Bull (Dept. W.W.3), 248 High St., Harlesden, N.W.10

FM/AM RECEIVERS AND TUNERS—

BEL, MARLBOROUGH YARD,
 LONDON, ARCHWAY, N.19. ARCHway 5078

Philips Balham Works Ltd.
 45 Nightingale Lane,
 Balham, S.W.12.

require

TEST ENGINEERS

for nucleonic monitors and electronic apparatus; H.N.C. or equivalent qualification is desirable, but a good history in radio, television or allied work would be considered.

Prospects of advancement are good.

Write giving full details to the

Personnel Officer,
 or telephone Battersea 8521 for appointment.

A. V. ROE & CO. LTD.

WEAPONS RESEARCH DIVISION
 WOODFORD, CHESHIRE

have vacancies in their Trials Department for the following:—

1. Senior Electronic Engineers to lead groups on design and development of telemetry and monitoring equipment.
2. Technicians to form the above groups.
3. Electronic Design Engineers to co-ordinate design and development of prototype equipment.
4. Technicians experienced in light electro-mechanical engineering.

Applicants for the senior posts should possess associate membership of the I.E.E. or Brit. I.R.E., H.N.C. or equivalent, with general electronic experience. Knowledge of missile telemetry and monitoring systems is desirable but not essential.

Applicants should write to the Chief Engineer, Weapons Research Division, A. V. Roe & Co., Limited, Woodford, Cheshire.

RANK PRECISION INDUSTRIES (B.A.F.) LTD.

have vacancies for
EXPERIENCED INSPECTORS
 in ELECTRICAL AND MECHANICAL TEST DEPARTMENTS.

H.N.C. (Mech.) or (Elect.) Engineering an advantage. Permanent and pensionable appointments. Five-day week Sports and Social Club. Applications in writing stating age, experience and qualifications to, or call for interview,

PERSONNEL MANAGER,
RANK PRECISION INDUSTRIES (B.A.F.) LIMITED,
 Woodger Road, W.12.

SIR W. G. ARMSTRONG WHITWORTH AIRCRAFT LTD.

ARMAMENTS DIVISION

SENIOR ELECTRONIC AND ELECTRICAL ENGINEERS

A number of Senior Engineers both Electronic and Electrical are required for work associated with the flight trials of guided weapons.

The work is of a very varied and interesting character and includes system testing and the analysis of the behaviour of complex installations including mechanical and hydraulic components, in addition to electronic and electrical components.

A number of years' experience in electronic and/or electrical engineering is essential for these positions, and service experience of radar, radio and telecommunications is a very suitable qualification.

A university degree is not essential for these positions but practical experience and experience of experimental work is highly desirable.

These positions are responsible posts and carry attractive salaries and excellent prospects. Pleasant working conditions and amenities are provided and an attractive superannuation scheme is in operation.

All replies should be addressed to: Technical Appointments Officer, Sir W. G. Armstrong Whitworth Aircraft Ltd., Baginton, Nr. Coventry. Quoting reference FT19/ARM/TAO.

INDEX TO ADVERTISERS

Table listing advertisers and their page numbers, organized into columns. Includes entries like Abix (Metal Industries), Ferranti, Ltd., Philips Electrical, and many others.

Printed in Great Britain for the Publishers, LIFFE & SONS LTD., Dorset House, Stamford St., London, S.E.1, by CORNWALL PRESS LTD., Paris Garden, London, S.E.1 Wireless World can be obtained abroad from the following: AUSTRALIA AND NEW ZEALAND: Gordon & Gotch, Ltd. (INDIA: A. H. Wheeler & Co. CANADA: The Wm. Dawson Subscription Service Ltd.; GORDON & GOTCH, Ltd. SOUTH AFRICA: Central News Agency, Ltd., William Dawson & Sons (S.A.), Ltd. UNITED STATES: The International News Co.



SUB-MINIATURE ELECTROLYTICS

for transistor circuitry

The introduction of transistors has created fresh impetus to the design of ancillary components of comparably small dimensions. For this purpose we have produced a range of Sub-Miniature Electrolytic Condensers, which we believe to be the smallest of their type ever made. These diminutive condensers are equally suitable for use in miniature walkie-talkie equipment, hearing aids, and similar assemblies where every component is scaled down to the absolute minimum physical size.

Terminations: these condensers are supplied with tinned copper wires, 1½" long.

Temperature range is -30°C. to +60°C.

Tolerance of capacity -25% to +50%.

Capacity in µF.	Peak Working Volts	Dimensions in inches		T.C.C. Type Number
		Length	Diameter	
6	1.5	5/8"	1/8"	CE58
4	4	5/8"	1/8"	CE58AA
2	8	5/8"	1/8"	CE58A
1	12	5/8"	1/8"	CE58B
0.25	25	5/8"	1/8"	CE58C
6	3	9/16"	.18	CE68AA
10	3	9/16"	.18	CE68A
1	25	9/16"	.18	CE68C
8	6	1 1/16"	.2	CE69A
4	12	1 1/16"	.2	CE69B
32	1.5	1 1/16"	1/4"	CE67
8	15	1 1/16"	1/4"	CE67B

T.C.C. Patent Nos. 578487, 578509, 587072.

THE TELEGRAPH CONDENSER CO. LTD

RADIO DIVISION · NORTH ACTON · LONDON · W.3 · Tel: ACO rn 0061

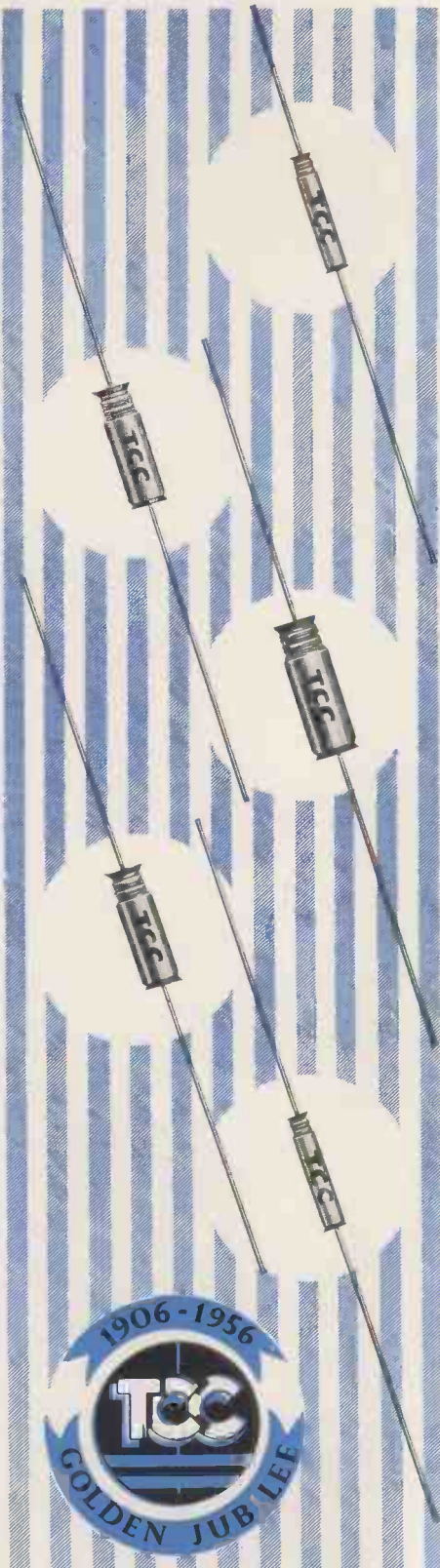

SOLDERING UNDER FACTORY CONDITIONS AT THE RADIO SHOW

Operatives from the ALBA* factory demonstrate fine soldering with

Ersin Multicore

5-CORE SAVBIT ALLOY

Multicore are once again presenting an impressive exhibition of soldering which will arouse considerable interest. Spectators will see Alba radio sets being assembled and soldered using Ersin Multicore Savbit Alloy under conditions almost identical to those in the Radio Factory of A. J. Balcombe Ltd. at London E.C.1.

Precision soldering is vital in the manufacture of this type of radio—one of the smallest mains-operated sets now being made—and that is why Ersin Multicore 5-Core Savbit Alloy is being used exclusively in their manufacture.

Leading manufacturers of radio, television and electronic equipment rely on Ersin Multicore Solder for sound, trouble-free soldering. Look out for the Multicore Stand (Number 10 Main Hall) and see the soldering demonstration and the full range of Multicore products.



* Manufacturers who have previously co-operated with Multicore Solders Ltd.

* BUSH RADIO LIMITED	1947
* EMI/MMV	1949
* G.E.C. Ltd.	1950
* E. K. COLE LTD.	1951
* PYE LTD.	1952
* PHILIPS ELECTRICAL LTD.	1953
* FERGUSON	1954
* R.G.D.	1955

7 lb. REEL

Ersin Multicore 5-core Solder is supplied in 9 gauges and 6 alloys on 7 lb. reels. Savbit Type 1 Alloy is also available on 7 lb. reels



SAVBIT

TYPE 1 ALLOY

Extends the life of solder bits up to 10 times. Now available on 1 lb. reels and in Size 1 (5/- retail) cartons.



BIB WIRE

STRIPPER & CUTTER

This handy 3-in-1 tool strips insulation, cuts wires cleanly and splits plastic extruded twin flex 3/6 each (retail).

