

Wireless World

JULY 1953

TWO SHILLINGS

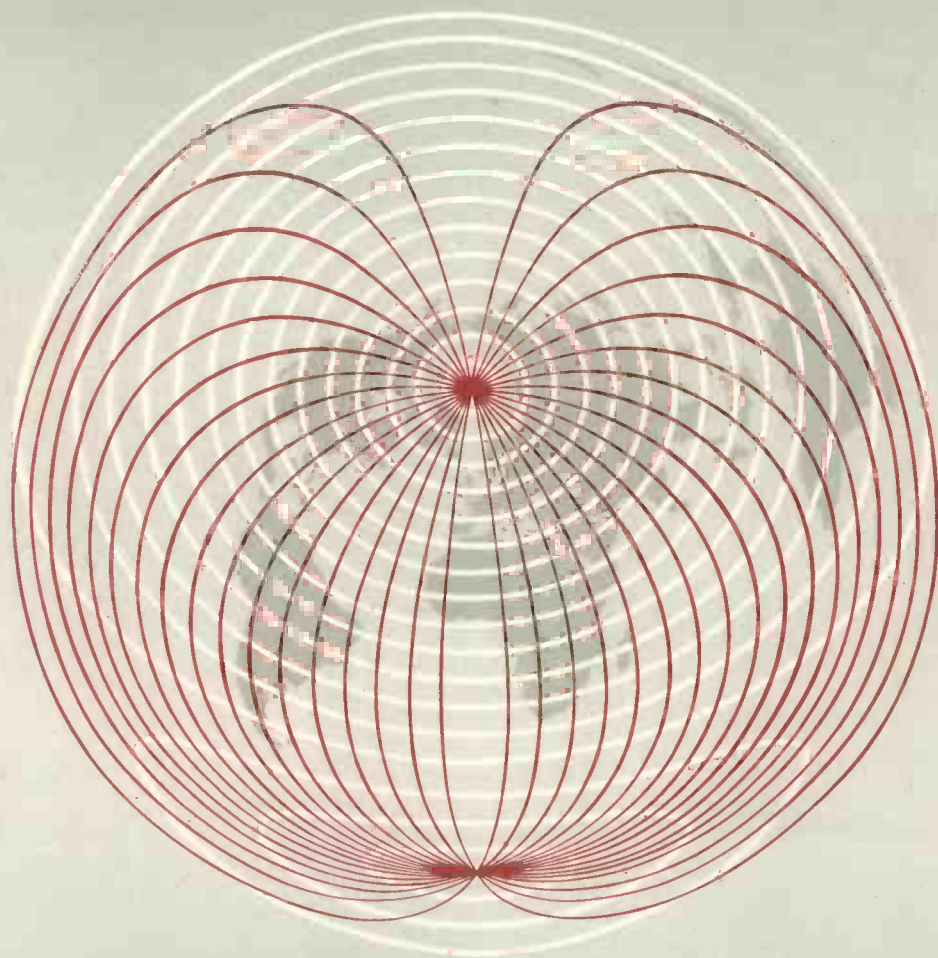

RADIO, TELEVISION AND ELECTRONICS



VF	If	Ia (pk)	P.I.V. (max)
ESU 76			
2.0V	7.5A	1.0A	10KV
ESU 200			
4.0V	11.0A	5.0A	15KV
ESU 575			
5.0V	11.0A	6.0A	15KV
ESU 866			
2.5V	5.0A	1.0A	10KV
ESU 872			
5.0V	7.5A	5.0A	10KV

MERCURY VAPOUR
rectifiers &
 RADIATION COOLED
power triodes



ES 85
ES 85 VF-10V If-3.5A Va (max)-1.25KV Wa-85w μ -12.7 Ra-3,450 Ω Maximum audio power output (per pair)-245 watts.
ES 833
ES833 VF-10V If-10A Va (max)-4KV Wa-400w μ -35 Maximum audio power output (per pair)-2KW Maximum R.F. power output (single valve)-1.45 KW Maximum frequency at full rating-30Mcs. At reduced ratings the frequency may be uprated to 75 Mcs.
V 1505
V1505 VF-14V If-6.5A Va (max)-3KV Wa-275w μ -16 Ra-2,000 Ω Maximum peak power output (per pair) on normal broadcast services-1KW.

EDISWAN
 SPECIAL PURPOSE
VALVES

THE EDISON SWAN ELECTRIC CO. LTD.
 155 CHARING CROSS ROAD, LONDON, W.C.2
 Member of the A.E.I. Group of Companies
 Telephone: Gerrard 8660. Telegrams: Ediswan, Westcent, London

The valves illustrated on this page are some of the outstanding types from the wide range of Industrial and Transmitting valves manufactured by Ediswan. Full technical information and data sheets are available on request.

Wireless World

RADIO, TELEVISION
AND ELECTRONICS

43rd YEAR OF PUBLICATION

Managing Editor: HUGH S. POCKOCK, M.I.E.E.

Editor: H. F. SMITH

Az Államvédelmi Biztonsági Igazgatóság
Csak belső használatra

JULY 1953

In This Issue

EDITORIAL COMMENT	295
STEREOSCOPIC TELEVISION	296
SUPPRESSING GRAMOPHONE SURFACE NOISE	298
INEXPENSIVE PICKUPS ON LONG-PLAYING RECORDS. By <i>C. H. Russell</i>	299
AUDIO DEVELOPMENTS	301
MODERNIZING THE WIRELESS WORLD TELEVISION RECEIVER—3	306
TRANSISTORS—6. By <i>Thomas Roddam</i>	311
METER SHUNTS	313
LETTERS TO THE EDITOR	315
CORONATION BROADCASTS	317
WORLD OF WIRELESS	320
THE OHMMETER. By <i>W. Trusting</i>	323
COLOUR TELEVISION	329
WAVES AND AERIALS. By " <i>Cathode Ray</i> "	331
RATIONAL PLANNING OF RADIO CHANNELS	335
HEIGHT OF THE IONOSPHERE	338
MANUFACTURERS' PRODUCTS	339
RANDOM RADIATIONS. By " <i>Diallist</i> "	340
UNBIASED. By " <i>Free Grid</i> "	342

PUBLISHED MONTHLY (last Tuesday of preceding month) by ILIFFE & SONS LTD., Dorset House, Stamford Street, London, S.E.1. Telephone: Waterloo 3333 (60 lines). Telegrams: "Ethaworld, Sedist, London." Annual Subscription: Home and Overseas, £1 7s. 0d. U.S.A. \$4.50. Canada \$4.00. BRANCH OFFICES: Birmingham: King Edward House, New Street. 2. Coventry: 8-10 Corporation Street. Glasgow: 26B Renfield Street. C.2. Manchester: 260, Deansgate. 3.

Wireless World

JULY 1953

VOL. LIX No. 7

Electronic Confusion

AMERICAN researches into the origins of our art, reported recently in *Tele-Tech*, would suggest that the word *electronic* is of far greater antiquity than most of us think. It was undoubtedly used in *The Philosophical Magazine* (London) of June, 1832, by no less a person than Michael Faraday. But, rather disappointingly, there can be little doubt that it was a misprint for *electrotonic*, a word Faraday had used elsewhere at the same time. Can we regard this as an inspired printer's error, or an augury of future confusion? Everything was clear enough 60 years ago, when Johnstone Stoney coined the word *electron*, with *electronic* as its adjectival form. The confusion began much later when the noun *electronics* was formed, with a highly specialized meaning. What precisely, is *electronics*?

If a public opinion poll were conducted to ascertain the accepted definition of the noun *electronics*, laymen would probably describe it hazily as "the newest kind of electrical engineering, like that applied to wireless and radar." More technically informed opinion would probably be sharply divided into two groups. The definition of the majority would read something like "radio-like methods and devices, particularly valves, applied to non-communication uses." The more academic section would probably offer, as nearly as they could remember, the definition of the American Institution of Electrical Engineers, which runs "Electronics is that branch of science and technology which relates to the conduction of electricity through gases or *in vacuo*." There is all the difference in the world between these definitions, and in their diversity are all the seeds of confusion and misunderstanding. Some of us are even inclined, as a matter of expediency, to the dangerous practice of applying the two definitions interchangeably.

There has lately been a feeling that the American I.E.E.'s definition should be widened to embrace many modern devices and techniques (notably semi-conductors) that have come into use since the word was coined. Expression was given to such ideas by Professor W. L. Everitt, who went so far as to propose, in the American *Proceedings of the I.R.E.*, that

electronics should be redefined as "the science and technology which deals primarily with the supplementing of man's senses and his brain power by devices which collect and process information, transmit it to the point needed, and there either control machines or present the processed information to human beings for their direct use."

That definition is, to our mind, quite unsatisfactory and we do not seem to be alone in that opinion. B. E. Noltingk, writing in *Proc. I.R.E.* for May, says "The proposed new definition of *electronics* is altogether too wide. It is, in fact, almost synonymous with *instrumentation*, and if adopted, some new word would be needed when it was required to distinguish between pneumatic instrumentation and what is at present called electronic instrumentation." He goes on to propose that the only widening of the old definition that is necessary concerns the state of the electrons involved. "If, instead of limiting them to flow through a gas, we include in *electronics* any device in which electrons travel otherwise than along normal conductors, then I maintain that the definition has been brought up to date without stretching it beyond current usage."

It should be easy enough to write a precise definition along the lines suggested by Mr. Noltingk that would embrace those devices and techniques that are at present on the fringe of electronics.

Flawless Performance

CONGRATULATIONS have been showered on the B.B.C. for the manner in which the Coronation broadcasts were conducted, both on sound and vision. The general public has already shown its appreciation of the superlatively high standard maintained on the "programme side": readers of this journal will no doubt join with us in congratulating the engineering division of the B.B.C. on what was probably the greatest feat of operational skill in the whole history of broadcasting. Elsewhere in this issue are described some of the methods used so successfully on the Corporation's busiest day.

Stereoscopic Television

Is it Practicable for Broadcasting?

THE film industry's idea that three-dimensional films will prove an effective answer to the growing attractions of television has naturally made a lot of people ask "why not three-dimensional television?" It seems reasonable to suppose that the stereoscopic principles used in films could be applied to television, and, indeed, a number of experimental stereoscopic television systems have already been built and tried out on closed circuits. There is no difficulty, in fact, in getting stereoscopic television to work: the main problem is in making it practicable for broadcasting purposes—assuming, of course, that it is a desirable thing to have in the first place. At the moment there seems little chance that stereoscopic television can be made "compatible" with existing television systems, and for that reason the B.B.C. is not very interested in it. But there is some possibility that it can be made practicable for any new television broadcasting services that may be set up in the future.

Question of Bandwidth

As in colour television, one of the main technical problems is the bandwidth requirement. The basic principle of stereoscopy is to present the spectator with two separate views of the subject, a left-eye view and a right-eye view, and in television this would mean transmitting twice the normal amount of information and so doubling the bandwidth. In future television systems, of course, it may be possible to do this. But if not, there is the alternative of transmitting only half of the information in each view so that the bandwidth could remain unchanged. This would reduce the definition of each view, but any subjective loss to the spectator might be more than made up by the subjective gain given by the three-dimensional effect. From this point of view a stereoscopic system might actually be more efficient than an ordinary system in its utilization of bandwidth, for with ordinary television our ability to perceive three dimensions is entirely wasted on a picture which only has two dimensions. We might as well look at the screen with only one eye—and, in fact, some people actually get a better impression of depth by using only one eye, perhaps because this impression is based purely on the relative sizes and clarity of focus of objects and is not affected by the other eye telling the brain that "it's all on a flat screen anyway."

Probably the best-known method of achieving stereoscopy in the cinema is by the use of optical filters. The right-eye view and the left-eye view are projected on to the screen through different filters, either coloured or polarized, and the people in the audience have to wear spectacles with corresponding filters to separate them again. This principle has been used in a number of closed-circuit industrial television systems, but is not very suitable for broadcasting because of the inconvenience of having to wear spectacles

all the time. The filters can be avoided by displaying the two views side-by-side or in time sequence, but again the spectator has to use some kind of viewing device to separate them and this is just as inconvenient as the spectacles.

Stereoscopy Without Spectacles

There are, however, three-dimensional film systems in which the viewer does not have to wear spectacles, and most of these are based on an ingenious principle devised by Frederick Ives in 1902 for making and viewing stereoscopic photographs. The left-eye view and the right-eye view are separated for the spectator by a mask containing a large number of thin vertical slots which is placed just in front of the screen. Fig. 1 illustrates the basic principle. When the observer looks through a slot at the screen his right eye sees one small section of screen and his left eye another section adjacent to it, and as long as the slot is narrow enough the two eyes cannot possibly see the same section. The complete system is shown in Fig. 2. The left-eye view and the right-eye view are presented together on the screen by being split into small vertical sections and interlaced—as shown by the alternating "L" and "R" sections across the screen. A short distance in front is the slotted mask, and this is arranged so that when the spectator looks through it his left eye only sees the "L" sections and his right eye the "R" sections, on the principle explained in Fig. 1. Each eye then integrates the thousands of small sections it sees into a complete picture. There are a number of positions round the screen where conditions are right for viewing, and, in fact, quite a large audience can be accommodated.

The process of getting the two views interlaced on the screen in the first place is simply the reverse of the viewing process—that is, to project them from different angles on to the back of the screen through a slotted mask. When the system is used for viewing still stereoscopic photographs the two views have to be interlaced on the same piece of film and this is again done by a slotted mask, inside the camera.

Application to Television

How, then, could this principle be applied to television? The most obvious arrangement is shown in Fig. 3. At the transmitting end the left-eye view and the right-eye view are interlaced on a translucent screen by means of a slotted mask. The composite picture is then viewed by a camera and transmitted to the screen of the receiver, where the two views are separated by another slotted mask. This could obviously be done with an existing television system and no changes would have to be made either at the transmitter or at the receiver. The system would not be "compatible," however, because the received

picture seen without the mask would not be like an ordinary television picture but would have a rather blurred appearance.

Another possible method of interlacing the two views at the transmitting end would be to make use of the electronic interlacing already existing in the television system. In other words, in a complete picture period one view could be transmitted on the first frame (the odd lines) and the other view on the second frame (the even lines). This would necessitate two synchronized cameras with an electronic switch arranged to select their outputs alternately. An advantage of the scheme is that it would avoid the loss of light introduced by the slotted mask and translucent screen at the transmitting end of Fig. 3. It would, however, necessitate vertical scanning; and, with the existing television standards, the viewer would probably experience flicker, for each of his eyes would receive only 25 frames per second instead of the usual 50 per second.

Apart from the problems of applying the Fig. 2 principle to television it has two inherent disadvantages which go against it under any circumstances. The first is that a spectator looking obliquely at the screen from the side sees exactly the same three-dimensional image as he would do from a central position, when clearly he should from that position get more of a side view, as in the live theatre. So a change in viewing position does not produce the appropriate change of aspect. The second drawback is that between the viewing zones where the correct

stereoscopic effect is obtained there are zones in which the spectator gets an "inverted" stereoscopic effect, the right eye receiving the left-eye view and the left eye the right-eye view. These "inverted" zones are the same width as the others, so that when the spectator moves about he sees the picture "jumping in and out" all the time.

"All-round" Viewing System

A system has been devised, however, which overcomes these disadvantages, and readers may have seen something like it used in shop windows for advertising purposes—a three-dimensional photograph which changes appropriately in aspect as one moves around it. The photograph is produced by moving a camera, with a slotted mask in front of the film, around the subject in an arc, and the result is a picture composed of a series of vertical strips in each of which the viewpoint changes gradually from left to right. Thus the composite picture does not contain just two views, as in the Fig. 2 system, but a multitude of views from various angles merging into one another.

Fig. 4 shows what happens when this composite picture is viewed through a slotted mask—and here it has been assumed that the camera has been moved not continuously, but in a series of six steps, each position giving a slightly different view from the next. As the spectator moves to the right the view on the film becomes increasingly right-sided and as

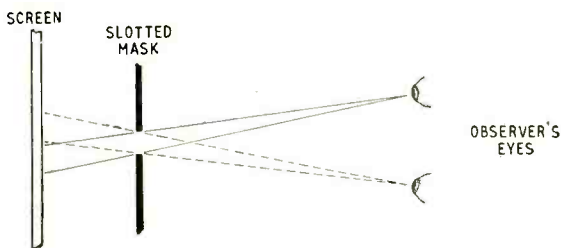

Fig. 1. Showing how each of the observer's eyes sees a different part of the screen when they look through a slot cut in a mask.

Right: Fig. 2. Stereoscopic viewing device. The viewers' left eyes can only see the sections of the left-eye view (marked L) on the screen, and their right eyes only the sections of the right-eye view (marked R). The size of the L and R sections and the slots has been greatly exaggerated to show the principle clearly, and in practice a large number of viewers can be accommodated behind and to the sides.

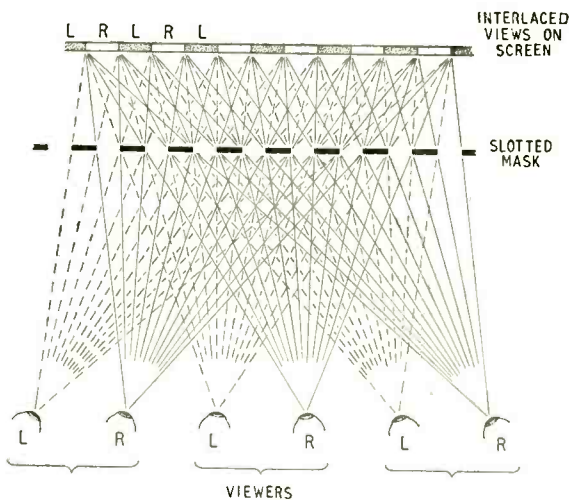
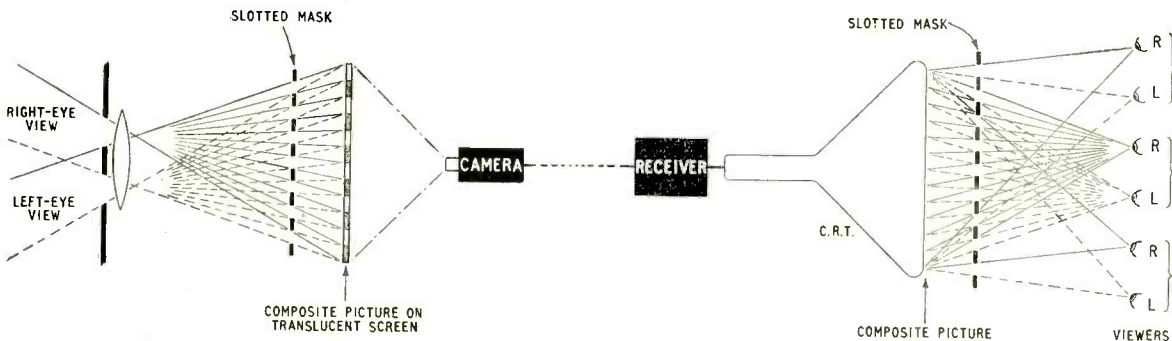

Fig. 3. Possible stereoscopic television system utilizing the principle illustrated in Fig. 2. A composite picture is transmitted.



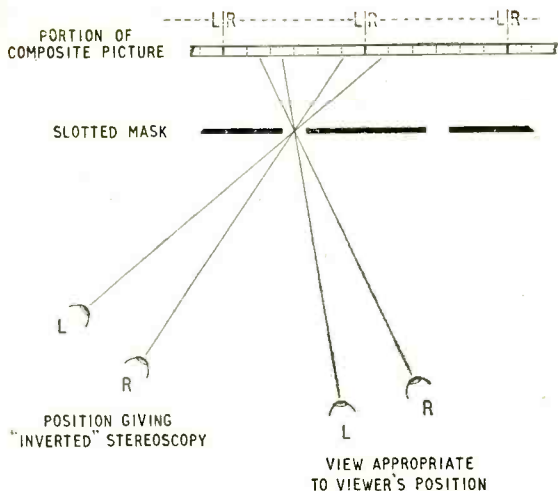

Fig. 4. Principle of stereoscopic system in which the view changes appropriately with the viewer's position. Across each vertical section of the composite picture the aspect progressively changes from a right-side view to a left-side view (indicated by R --- L). In practice, the viewer looks through a large number of slots at the same time, as in Fig. 2.

he moves to the left it becomes increasingly left-sided—and all the time a difference is maintained between the views seen by the two eyes, so that he gets the appropriate stereoscopic effect from all positions. Actually there are still viewing zones in which the spectator gets the “inverted” stereoscopic effect, but as can be seen from Fig. 4 these have a very small angular width compared with the correct viewing zones and are passed through so rapidly as to be hardly noticeable.

A method of applying this optical principle to tele-

vision has already been proposed by one worker. Instead of the photographic camera moving around the subject, this has six lens-systems, arranged in an arc, which focus their respective views through slotted masks on to a translucent screen. The screen therefore displays a composite picture of six interlaced views. This is scanned from the other side by a television camera and transmitted to the c.r.t. screen of the receiver, where a slotted mask is used to give the stereoscopic effect as shown in Fig. 4.

Again the scheme could be operated with an existing television system, but would not be “compatible.” Its worst drawback is that it reduces the definition of the picture: the transmitted information is shared between six interlaced views and consequently each view has only one-sixth of the information that would be present in an ordinary television picture. This is the price that has to be paid for the advantage of the “all round” stereoscopic effect. Another problem is that the total number of view-elements in the composite picture could not be greater than the horizontal definition of the television system, otherwise they would not be reproduced at the receiving end. On the British television system this means that there could not be more than about 500 of them and therefore (see Fig. 4) the slotted viewing mask would only have about 85 vertical slots in it and would appear as a very coarse grating.

Actually the slotted masks are not at all good things to use in practice because they introduce a considerable loss of light. The same job can be done without loss of light, however, by lenticular screens made of transparent plastic, and it is actually these that are used in most of the three-dimensional shop-window displays. The plastic sheet has one surface pressed into extremely fine corrugations, and each corrugation constitutes a tiny lens which performs the same function as a slot in the mask. Such screens can be made very cheaply and would only add a few shillings to the cost of television receivers.

Suppressing Gramophone Surface Noise

Points from a Lecture by D. T. N. Williamson

THE British Sound Recording Association's convention held at the Waldorf Hotel, London, W.C.2, from 15th to 17th May, was opened on the Friday evening with a lecture by D. T. N. Williamson on surface noise in gramophone reproduction, with particular reference to the impulsive type of noise associated with the dust particles adhering to plastic long-playing discs.

Analysis of the time and frequency functions of a typical pulse originating from this cause showed that it could be distinguished from transients in the recorded programme by the higher energy content of its spectrum above, say, 20 kc/s. By inserting a high-pass filter with this cut-off, pulses could be segregated and used to operate a gate circuit to remove the disturbance from the a.f. channel.

In practice the start of the pulse is indistinguishable from thermal noise and the peak of the energy burst in the high-frequency channel must be used to operate

the gate. It is therefore necessary to delay the audio signal as a whole by half the width of the pulse, i.e., up to about 150 μ sec. This could be achieved by a low-pass delay filter of comparatively simple design, with the result that the gate pulse straddled the noise pulse and removed it, together with an equivalent element of the wanted programme.

Mr. Williamson stated that experience had shown the ear to be tolerant of these abstractions, in individual pulses up to 250 μ sec in length, and cumulatively up to one tenth of the total duration of the programme!

At the conclusion of the lecture the system was demonstrated in operation on a high-quality l.p. recording which had been specially marked to provide an easily recognizable background. “Clicks” were completely removed, but some further work is necessary, and is in progress, to eliminate a slight low-frequency disturbance arising in the gating circuit.

Inexpensive Pickups on Long-playing Records

By
G. H. RUSSELL,
Assoc. Brit. I.R.E.

Simple Compensating Circuit for the Principal H.F. Resonance

THE reproduction of string tone from long-playing records is often marred by what is perhaps best described as "buzz." This unnatural quality, somewhat reminiscent of a cloud of mosquitoes in flight, is often ascribed to the methods used by the recording company, but that this may not necessarily be true will be seen from the following investigation into a particular case, involving the use of a popular medium-priced pickup.

It is well known that due to the increased compliance of the long-playing record material the high-frequency resonances of the pickup are reduced in frequency.^{1,2} Until recently it has not been possible to test pickups reliably under long-playing conditions, as a test record was not available. This state of affairs has now been remedied, and the results produced by this record are shown in Fig. 1, after compensation has been made for the recording characteristic. It can be seen immediately that the resonance is particularly vicious, and that it occurs at a most unfortunate frequency. It is claimed, at any rate by one recording company, that long-playing discs are recorded up to 14 kc/s, and as the pickup cuts off very rapidly after the resonant frequency has been reached, it can be seen that a particularly wide frequency band is lost. What is probably worse is that the resonance gives an impression of good high-frequency response, which in fact is not present. It is suggested that here is the explanation of exaggerated string buzz, as well as such unfortunate noises as the "puffing" of the flautist, reproduced out of all proportion. Further, the resonance will amplify any distortion in the recording.

The broken curves in Fig. 1 show the effects of the usual top-cut control in a mid-way position and in the full-cut position. From these curves it can be seen that, with a pickup of this quality, the ordinary commercial radiogram will not show this fault to any marked extent, as the response would probably be similar to one or other of the broken lines in Fig. 1. Even so, the reproduction is bound to sound rather unnatural as the characteristic shows a "hole" in the response occurring between 6 and 8 kc/s.

One cannot entirely blame the pickup manufacturers, as this is a very difficult problem to solve economically. The response can be shifted to beyond 14 kc/s, at a price, and the price is not only that of the pickup, but also of the amplifier. Pickups with a resonance above 14 kc/s are not only expensive to

make, but show a very great reluctance to deliver outputs beyond a few millivolts. This means more amplification, which can be equally expensive to provide, if it is to be free from hum and noise.

The resonance could be raised to a higher frequency by increasing the stylus pressure on the record, but this is inadmissible because of its effect on record wear.

The pickup discussed here was adjusted to 7.5 grams weight, and it became apparent that the only satisfactory method of eliminating the resonance was to introduce an equal and opposite resonance. It was also obvious that the easiest way to do this would be electrically rather than mechanically, and this meant using a series-tuned circuit.

This might have been somewhat difficult in the past, but was made easy by the availability of Ferro-

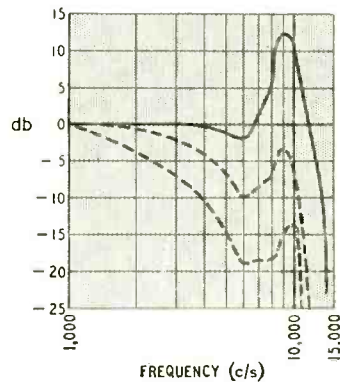

Fig. 1 Pickup response with 0.001-in stylus, 7.5 gm weight. Tested with Decca l.p. frequency test record No. LXT2695; compensation for recording characteristic included.

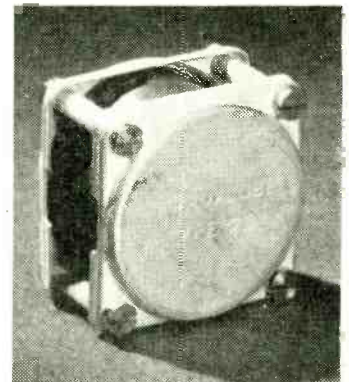

Fig. 2 Photograph (full-size) of Mullard Ferro-cube pot-core assembly, Type Y25.

¹E. D. Parchment. "Microgroove Recording and Reproduction," *Brit. I.R.E.* Vol. 12, No. 5, May, 1952, p. 275.
²S. Kelly. "The Crystal Pickup with Special Reference to Long-playing Records," *Journal British Sound Recording Association*, Vol. 3, No. 8, April, 1951, p. 174.

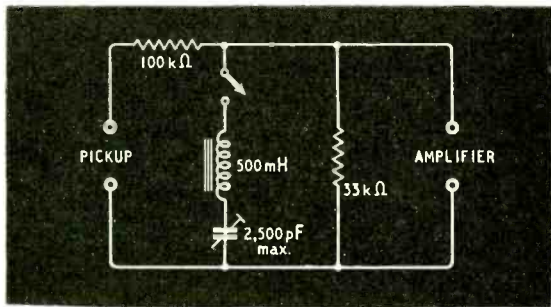

Fig. 3 Circuit diagram of anti-resonance filter, for pickups described in text.

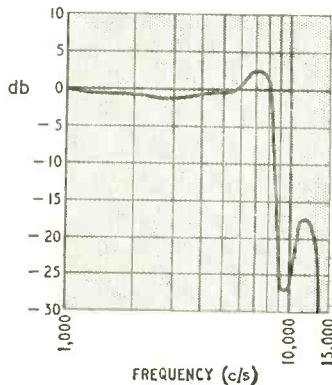

Fig. 4 Conditions as for Fig. 1 but with filter networks inserted.

cube pot-core assemblies. These are manufactured by Mullard and are supplied as a complete assembly including coil former. Unfortunately, no method of fixing is provided and it must be left to the individual user to decide on the best method of achieving this. These assemblies are very neat and compact; a good idea of their size and appearance can be gained from Fig. 2. They possess a very high permeability and a negligible external field. These characteristics enable quite high inductances to be obtained with comparatively small amounts of wire, and the virtual absence of an external field means that they can be used in low-level circuit positions, where it would be hazardous to use any other type of winding.

The type used for this application is designated Y25 and has a winding area of 83 mm.² 52 turns are required for an inductance of 1 mH, and in order to make the circuit easily tunable, an inductance of 500 mH was used, requiring $52\sqrt{500} = 1,144$ turns of 40 s.w.g. enamelled copper wire. The tuning condenser is a Cyldon No. 26 mica compression trimmer, 2,500 pF maximum capacity.

Method of Connection

Handsome Q-factors can be obtained with these Ferroxcube assemblies (of the order of 200 at 10 kc/s), which are clearly not required here. It is inadvisable to shunt the pickup directly, as this could cause severe distortion in the region of resonance. Further, it is necessary to shape the resonance curve of the tuned circuit so that it is, as near as possible, a mirror image of the pickup resonance curve, and this has been achieved by using the tuned circuit as part of a frequency-dependent potential dividing network, as shown in Fig. 3. This network is placed between the pickup and the amplifier. It results in some loss of gain which is unavoidable. Also shown in Fig. 3 is a switch for disconnecting the filter when playing 78

r.p.m. records. This method of switching results in a similar loss of gain in the case of 78 r.p.m. records; this was thought to be desirable as no violent change in volume level occurs from the change-over.

Overall Response

The results obtained from the combination of pickup and filter are shown in Fig. 4 and it can be seen that apart from a slight rise of some 2.5 db at 7 kc/s, the response is substantially flat up to 8 kc/s, after which it drops very steeply. Nothing but a better pickup can improve the response beyond this point. After the filter had been inserted and tested, one or two "bad" records were played through. The worst of these, an early release, which before had exhibited "buzzing" to a most objectionable extent, sounded perfectly natural and somewhat more lifelike than a good many more recent issues.

An interesting comment on the present state of the art is that, at the moment, it is easier to obtain a good high-frequency response with 78 r.p.m. records than with the long-playing variety, but, of course, with an accompaniment of needle scratch.

Short-wave Conditions

Predictions for July

THE full-line curves given here indicate the highest frequencies likely to be usable at any time of the day or night for reliable communications over four long-distance paths from this country during July.

Broken-line curves give the highest frequencies that will sustain a partial service throughout the same period.

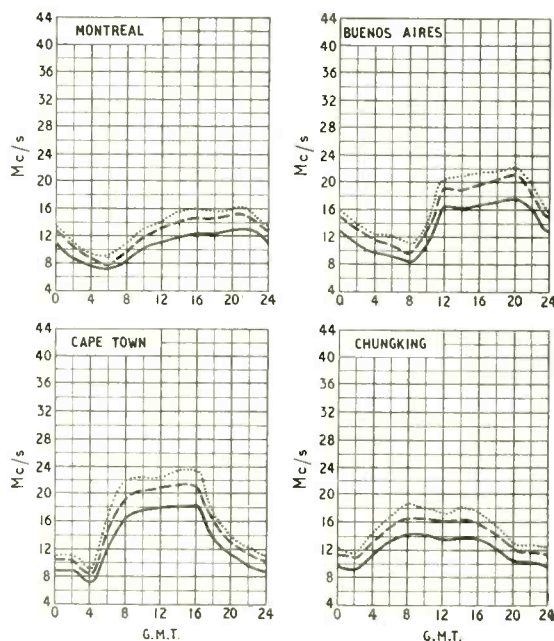

— FREQUENCY BELOW WHICH COMMUNICATION SHOULD BE POSSIBLE ON ALL UNDISTURBED DAYS
 - - - PREDICTED AVERAGE MAXIMUM USABLE FREQUENCY
 FREQUENCY BELOW WHICH COMMUNICATION SHOULD BE POSSIBLE FOR 25% OF THE TOTAL TIME

Audio Developments

New Products Shown at the A.P.A.E. and B.S.R.A. Exhibitions

STEADY if not spectacular progress in the design of audio-frequency equipment is evident from a survey of the commercial products shown at the exhibitions organized recently in London by the Association of Public Address Engineers (May 5 and 6) and the British Sound Recording Association (May 16 and 17). Greatest activity in the immediate past would seem to have been in the design of magnetic tape recorders, though amplifiers and their control units have also shown that design in this well-established field is far from reaching stagnation. There is evidence of activity in loudspeaker design, particularly in line-source arrays for covering large areas out of doors; and microphone, pickups and other important accessories have all contributed food for thought.

Microphones.—A new noise-cancelling microphone (Model VC52) has been developed by Lustraphone and is designed as a close-talking microphone for use under high ambient noise conditions. It is stiffness-controlled over the working range and is of small dimensions compared with the wavelength of the upper limit of frequency. Two factors contribute to the high discrimination against noise, a polar diagram with a high front-to-back ratio and a sensitivity which falls off steeply with distance from the source. Its small size permits a variety of mountings, one of which is from an adjustable bracket attached to the operator's headphone set. Also new to the Lustraphone range is a ribbon microphone Model VR/53 with a frequency response up to 14,000 c/s.

Pickups.—An exhaustive investigation into the conditions under which pickups are required to perform when tracking long-playing records has been undertaken by Cosmocord in collaboration with the Decca Record Company and it has been established that pickups may be called upon to respond to accelerations as high as 2,000 times the acceleration due to gravity at a frequency of 10,000 c/s. Accordingly, Cosmocord have produced for manufacturers an entirely new range of "Hi-g" pickups and cartridges which can be relied upon to track not only all existing l.p. records, but any which may be produced in the future under the existing limitations of groove spacing and high-frequency cut-off. This performance has been achieved without exceeding a weight of 10 gm on the stylus. In the Type HGP33-1 turnover cartridge, which is typical of the series, an increase in compliance of the movement has permitted the use of a push-in sub-miniature stylus which can be replaced without special tools. With a simple two-element RC equalizing network a response flat from 50 to 13,000 c/s is obtained with only a 5 db drop at 20,000 c/s.

The prototype of a new moving-iron pickup was shown by A. R. Sugden with an armature mass of 10 milligrams and a high-frequency resonance of 15 to 20 kc/s when playing plastic long-playing or nitrocellulose direct recording discs.

Pre-amplifiers, Control and Feeder Units.—A versatile "Master Control Unit" for microphone,

recorded or radio inputs has been developed by the Lowther Manufacturing Company. It employs three ECC40 valves and in addition to standard equalization for the principal disc recording characteristics, has

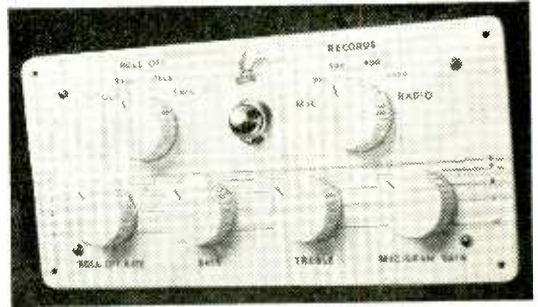

Above: Lowther "Master Control" pre-amplifier unit, providing compensation for four recording characteristics together with comprehensive tone controls.



Headphone mounting for Lustraphone noise-cancelling microphone and (below) sensitivity/distance and polar characteristics at 1000 c/s.

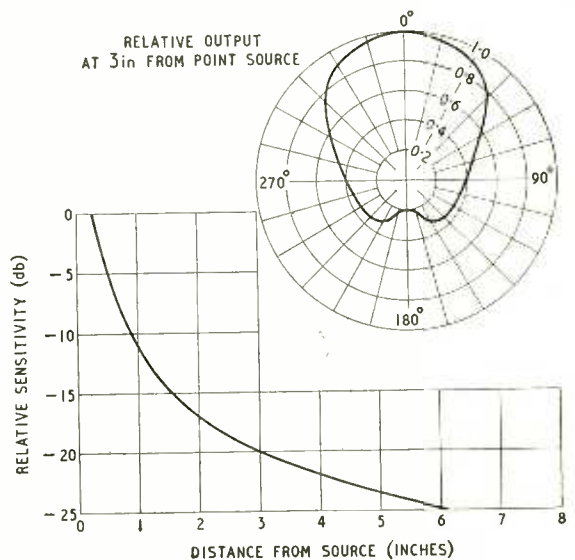

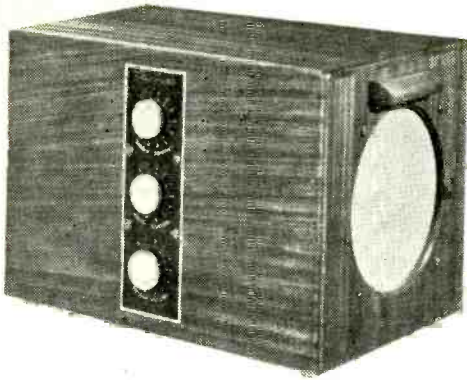

Above: "Truchord" Model 50T amplifier-loudspeaker unit.

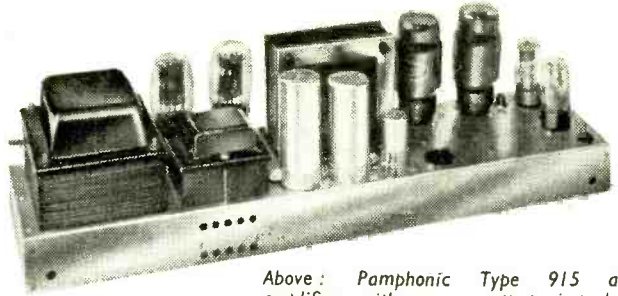

Above: Pamphonic Type 915 audio amplifier with zero output impedance.

Right: Leak radio feeder unit, Type VS, and portable combined TL/12 amplifier and control unit.

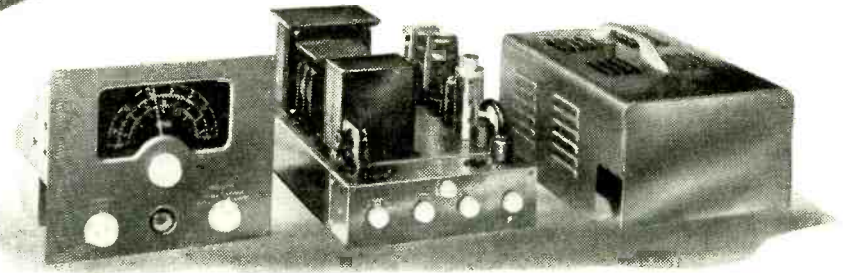

independent bass and treble controls giving continuously variable rise and fall up to 30 db, and separate variable-slope filters giving a "roll-off" at alternative fixed starting frequencies of 5, 7 and 9 kc/s. That the unit does perform according to specification was proved by a demonstration on the stand using an Industrial Electronics automatic cathode-ray curve tracer, which showed that operation of the controls was not accompanied by any secondary disturbances near the critical cut-off frequency. Not the least interesting feature of this unit is the ingenious parallel-line graduation of the front panel which serves all the controls. A neat AM-FM tuner unit covering 85-100 Mc/s has also been added to the Lowther range.

Designed for stable high-quality reproduction from long-distance short-wave stations as well as medium-wave stations, the new S6BS radio feeder unit made by C. T. Chapman (Reproducers) has two stages at

i.f. with switched tertiary windings giving bandwidths of 5, 7 and 10 kc/s. Delayed, amplified a.g.c. is applied to the r.f. and frequency-changer stages as well as to the two i.f. valves, and the chassis is fully tropicalized.

Amplifiers.—The Type 915 amplifier recently introduced by Pamphonic Reproducers has been designed for research and measurement work as well as for high-quality reproduction. It has a frequency response of 15 c/s to 150 kc/s, ± 1 db and the distortion at the maximum output of 15 watts is claimed to be 0.05 per cent at 1,000 c/s. Feedback is designed to provide zero output impedance.

For high-quality p.a. applications G.E.C. have introduced a 30-watt amplifier of robust design (BCS2430) with tetrodes in Class AB1 push-pull and using a neon stabilizer for the screen feed resistance. Three fader-connected inputs are provided as well as the usual tone controls, and there is a test meter with switching for all valve cathode currents. A panel mounting version (BCS2430/2) of this amplifier is available.

The Leak TL/12 amplifier and pre-amplifier control unit are now available as a combined portable unit, suitable for p.a. work. This unit is illustrated together with the VS radio tuner unit, which provides bandwidths of 6, 12 and 24 kc/s.

Rogers Developments have introduced a medium-priced "RD Baby de Luxe Mark II" amplifier to supersede their earlier "Baby" and "Junior" amplifiers. It has a larger output transformer and more conservatively rated h.t. supply. At 1,000 c/s harmonic distortion is 0.25 per cent at 8 watts output, and 0.6 per cent at 12 watts. Hum and noise have been reduced to -85 db referred to 8 watts.

An unusual amplifier-loudspeaker unit is now available from Reproducers (Electronic), Ltd., makers of the "Truchord" record reproducer. It consists of the main amplifier from this instrument together with a 10-inch loudspeaker and forms a nucleus to which the enthusiast can add auxiliary equipment of his own choice.

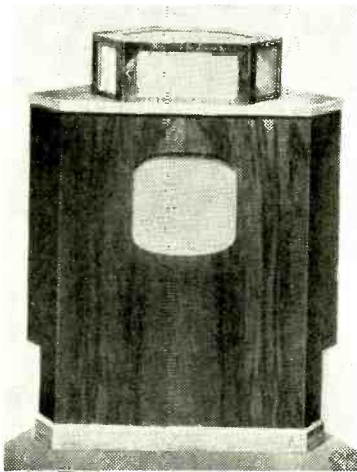

Wharfedale reproducer with triple-unit loudspeaker system.

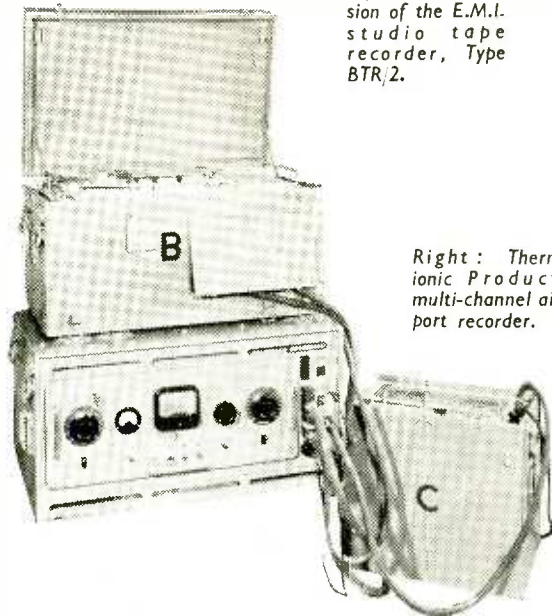

Left: Portable version of the E.M.I. studio tape recorder, Type BTR.2.

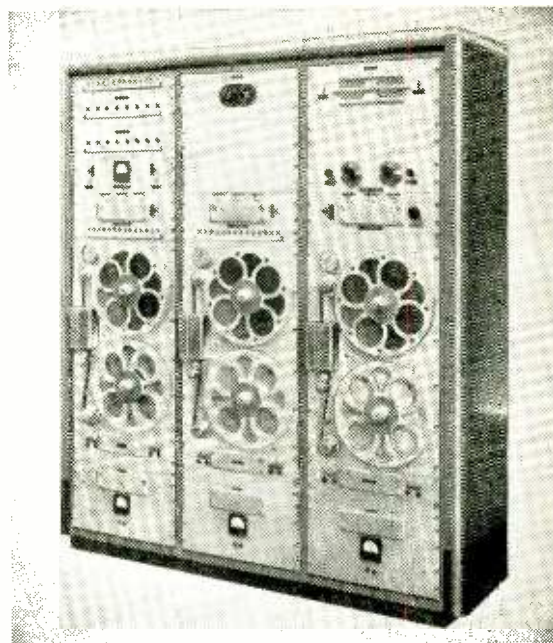

Right: Thermionic Products multi-channel airport recorder.

Loudspeakers.—Developments in loudspeakers, as exemplified by these two exhibitions were for the most part confined to minor improvements in existing and already well-known units. Wharfedale, however, were showing a new wide-range reproducer in which the frequency spectrum is divided between three units. A type W15/CS unit in a 9-cu ft vented enclosure covers frequencies up to 800 c/s. Above this frequency, a “Super 8/CS” is fed from the half-section crossover filter, and the extreme top is reinforced by a “Super 5” unit which is shunted across the mid-frequency unit with a series capacitor to restrict the input below 5 kc/s. A volume control is connected across the h.f. unit to provide a balance suited to programme conditions.

The new “Magneta-Decca Radiator” produced by the Magneta Time Company is a vertical line-source column loudspeaker and has a radiation characteristic designed to give reasonably uniform sound intensity (84 phons) over an elliptical area approximately 250 × 180 yds at the front and 85 × 60 yds at the back, with an input of 75 watts.

Gramophone Motors.—The new transcription-type 3-speed gramophone motor, Model 301, made by Garrard is of the induction type driving a heavy stainless steel turntable through a friction drive. The motor is fully floating on a spring suspension and its power consumption is 16 watts. Speed fluctuation (“wow”) is less than 0.2 per cent. An unusual feature for a motor of this type is the provision of a speed control over narrow limits, so that pitch can be accurately adjusted when desired. A large-diameter disc under the turntable forms an eddy-current brake in conjunction with a small permanent magnet, the position of which can be adjusted to vary the retarding torque. Speed limits on 33½, 45 and 78 r.p.m. (nominal) are 32.6-33.9, 44-46 and 76-80 r.p.m. respectively.

Magnetic Tape Recorders.—The multi-channel airport recorder designed by Thermionic Products is an outstanding example of an important application of magnetic recording in air traffic communications. On

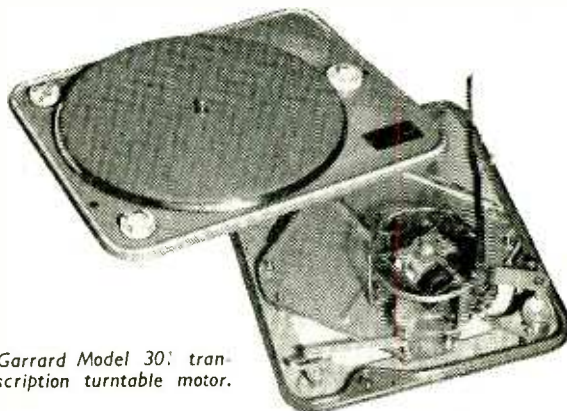

Garrard Model 301 transcription turntable motor.

a 0.7in wide tape running at 3.75in/sec, fourteen channels can be recorded simultaneously for four hours on each reel of tape. Automatic switching is provided to ensure continuity, and to transfer the recording to the standby unit in the event of any failure in the system. Coded time signals from an electrically wound spring clock are superimposed on each channel so that the time of any message can be established with accuracy.

In another sphere, the new E.M.I. Type BTR/2 portable equipment is equally imposing. In performance it is the same as the studio version, which is widely used by broadcasting and recording organizations, and gives a response at a tape speed of 15in/sec level within ±2 db from 50 to 15,000 c/s.

The production by M.S.S. of a new tape mechanism of their own design is an event of more than usual interest. Basically it follows established practice for high-quality machines designed for tape speeds of 7½ and 3½in/sec and the performance figures quoted for the higher speed are 60-10,000 c/s ±3 db, <2½ per cent total harmonic distortion, “wow” <0.2 per cent, signal/noise ratio 50 db. Several types of complete

machine are available, including models designed to work in conjunction with M.S.S. disc recorders for transcription work. Variations from standard specification which can be supplied to order include synchronous drive motor, tape speeds of $7\frac{1}{2}$ and 15, or $1\frac{1}{2}$ and $3\frac{3}{4}$ in/sec, automatic back spacing and reverse drive for dictation purposes, and remote operation with foot control.

The range of tape recorders made by C.J.R. Electrical and Electronic Development, which incorporate a special version of the Bradmatic tape desk, covers every possible requirement for professional use. Three half-track heads are standard in all models, enabling the recording to be monitored while in progress. In addition to the portable models a console (Type D6) with a 10-watt push-pull amplifier and accommodation for $9\frac{3}{8}$ -in diameter spools is available.

British Ferrograph have produced a revised version (Model 2A) of their well-established portable recorder with synchronous capstan motor, endless loop cassette attachment and facilities for superimposing commentaries on previously recorded material. The new machine accommodates 1,750-ft reels and is fitted with a redesigned sustained-peak monitoring meter, giving easily interpreted readings.

In addition to the portable "Reporter" tape recorder with which Grundig (Great Britain) entered the market, there is now a handsome console (700C). As in the "Reporter" control is by push buttons and there is provision for inductive pickup from a telephone instrument, as well as normal inputs from microphone or radio. All Grundig instruments are now sold with a 25-minute demonstration tape which includes a variety of celebrity recordings. Possibly of greater interest to the technically minded is the fact that a test tape (TB53) with a range of standard frequencies is also now available at 21s.

The redesigned Truvox Mark III tape mechanism is now in production and is notable for the clean and simple mechanical design. The capstan flywheel bearing is exceptionally long and the main drive motor is flexibly suspended.

In the "Tape-Riter" office dictating machine (London Office Machines, Ltd.) the advantages of standard $\frac{1}{4}$ -in tape, from the point of view of quality of reproduction, are exploited without incurring the normal difficulties of threading and loading, by the use of self-contained cartridges which, in addition to supply and take-up reels, contain a tape footage indicator.

A wide range of cinema-film edge coatings, as well as 35 mm and 16 mm film fully coated between perforations, are now available from the Minnesota Mining and Manufacturing Company, who have also produced an improved 0.25-inch tape (MC2-111)

(Continued on p. 305)



M.S.S. magnetic tape recorder, Type PMR/3.

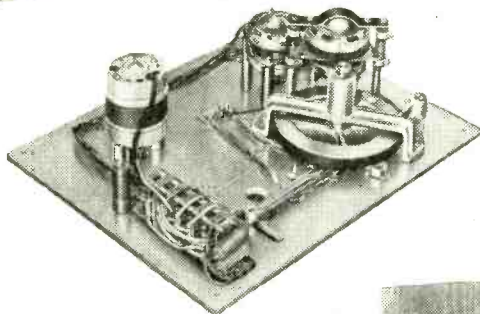

Above: Truvox Mark III tape mechanism.

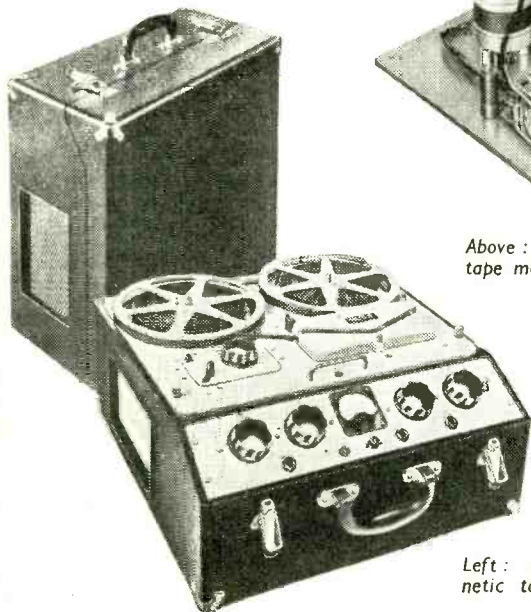

Left: British Ferrograph magnetic tape recorder, Type 2A.

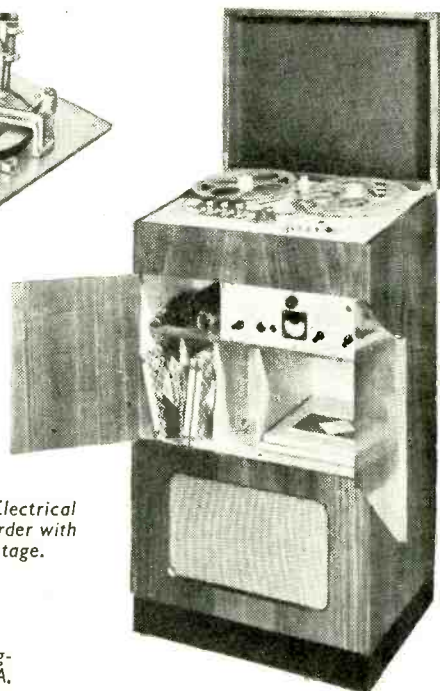

Right: C.J.R. Electrical console tape recorder with push-pull output stage.

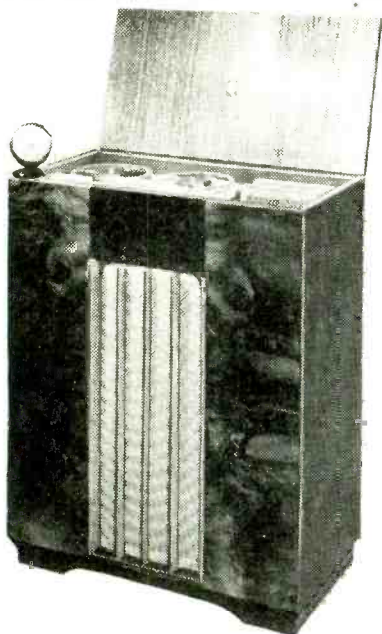

Grundig 700C console tape recorder with $4\frac{1}{2}$ -watt output.

which shows an improvement of 2 to 5 db in sensitivity and 6 db in maximum output.

Erasure of complete spools of tape in a 50-c/s alternating field is often more effective and convenient than erasure by a separate head at bias frequency, and Leever-Rich have for some time marketed an erasing machine for this purpose. They now offer a modified version with an extra field coil which will accommodate all spools from $3\frac{1}{2}$ in up to the large single-sided platter type as used by European broadcasters.

BOOKS RECEIVED

Monographs for Students. A series intended for general reading in the first two years of a degree course, or for students taking the Higher National Certificate in Applied Physics.

"Fundamentals of Thermometry" by J. A. Hall, B.Sc., A.R.C.S., D.I.C., F.Inst.P. Pp. 48; Figs. 13.

"Practical Thermometry" by J. A. Hall, B.Sc., A.R.C.S., D.I.C., F.Inst.P. Pp. 51; Figs. 8.

"The Magnetic Circuit" by A. E. de Barr, B.Sc., F.Inst.P.

"Soft Magnetic Materials Used in Industry" by A. E. de Barr, B.Sc., F.Inst.P. Pp. 62; Figs. 35.

Price 5s each. Published by the Institute of Physics, 47, Belgrave Square, London, S.W.1.

Antennentechnik, by G. C. Oxley, A.M.I.E.E., and Alfred Nowak, Dipl. Ing. Theoretical and practical aspects of aerial design with special emphasis on dipoles for television and arrays for short wave communication. Pp. 234; Figs. 257. Fachbuchverlag Siegfried Schutz, Hanover, Germany.

Einführung in die Theorie der Hochfrequenz-Bandfilter by Richard Feldtkeller. Mathematical treatise on the design of bandpass filters. Pp. 196; Figs. 95. Price DM 16. S. Hirzel Verlag, Stuttgart, Germany.

Differential and Integral Calculus by Philip Franklin Ph.D. Introductory treatise with numerous examples and exercises. Pp. 641; Figs. 367. Price in U.K. 48s. McGraw-Hill Publishing Company, 95, Farringdon Street, London, W.C.2.

TV Sweep Alignment Techniques by Art Liebscher. Adjustment and fault tracing with numerous c.r. oscillograms. Pp. 123; Figs. 66. Price \$2.10. John F. Rider, Publisher, 480, Canal Street, New York, 13

PLASTICS

Radio Mouldings at the Olympia Plastics Exhibition

AMONG the wide range of plastic materials and mouldings shown at the recent Plastics Exhibition organized by *British Plastics* at Olympia were many used by the radio industry.

One of the most impressive exhibits was a giant parabolic aerial reflector measuring 14 ft in diameter and intended for use in the 9- to 11-cm waveband. It has been produced by F. G. Miles, Ltd., of Shoreham-by-Sea for the Cossor Mark VI airfield radar. Moulded in phenolic asbestos, it is said to be non-corrosive and has such a good strength-to-weight ratio that scanners of this kind can be constructed in approximately half the weight of an equivalent all-metal structure. The necessary conducting surface is provided by spraying the concave face with metal protected by a coating of paint.

The plastics production of E. K. Cole, Ltd., now includes moulded instrument knobs, various kinds of r.f. and a.f. coil formers and some terminal and multi-plug inserts. A black phenolic moulding is used for the r.f. coil formers which take the form of small $\frac{1}{4}$ -in and $\frac{1}{2}$ -in (approximately) diameter formers with fixing feet and having internal threads for a dust-iron core.

A lesser-known activity of the G.E.C. is the production of plastic mouldings of various kinds, many having radio applications. These include valve bases, c.r. tube bases, coil formers and complete radio cabinets.

Telcon plastics, mainly Telcothee, were well in evidence, while Redifon and Radio Heaters demonstrated sealing and welding of plastics by means of radio-frequency.

Printed circuitry as applied to the construction of an Ardenhe hearing aid was shown by Lacrinoid Products, the etched foil process on a plastic base being employed.

Giant parabolic reflector moulded in phenolic-asbestos for a Cossor airfield radar. The hole is for alignment purposes during installation and is normally covered by a metal disc.

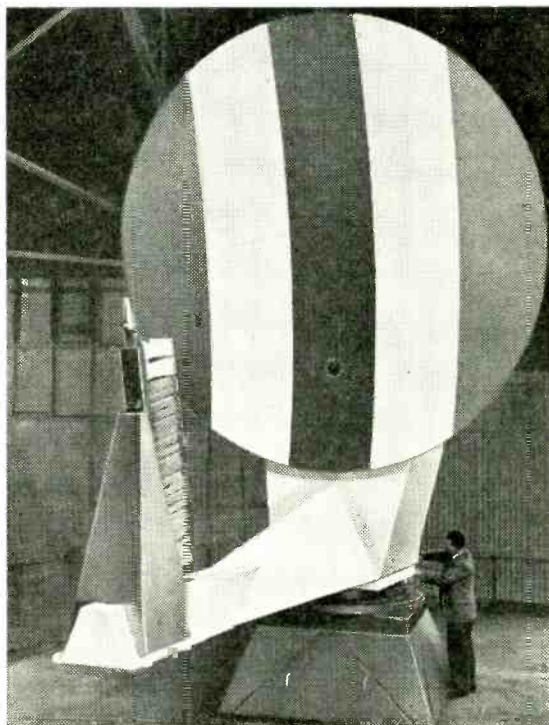

Wireless World Television Receiver

Part 3.—Construction

A FEW changes are needed in the apparatus associated with the time-bases, mainly in the power unit and the focus-coil unit.

The power unit originally had an output of 480 V but this is now too great. It is reduced to some 400 V by the simple expedient of omitting the 4- μ F reservoir capacitor. The circuit then works with a choke input and provides a smoothed output of some 400 V which is dropped to 300 V in the focus-coil circuit. The arrangement is shown in Fig. 5. The focus circuit is arranged to minimize the variation of voltage drop across it with operation of the control and is only possible because the total current of 200 mA is over twice that needed by the focus coil. This coil is the one of the original design but requires a higher current because of the higher operating voltage of the tube.

The details of this focus coil are given in Fig. 4 which is repeated from the original description since this is now out of print. The type of focus coil employed is in no way critical, however, and there are suitable commercial types; as an alternative, permanent-magnet units are now available and would normally be preferred because they are not subject to a warming-up drift.

Some alteration to the values of R_1 and R_2 may be needed in some cases, depending on the tube used, the position of the focus coil and its design, for the range of control afforded by R_3 is not large. Because the resistance of the focus coil varies with temperature

there is inevitably a small change of focus when the set has been in operation for some time.

The proper condition is to have the "cold" and "hot" settings of R_3 about equally on either side of its mid-point and in some cases an adjustment to R_1 and R_2 may be needed to achieve this and at the same time to secure the output h.t. line of 300 V. The value of R_3 governs the focus control setting. A reduction in its value shunts more current away from the coil and R_1 , so that the slider of R_3 must be moved towards the coil end to maintain focus. The value of R_1 mainly governs the h.t. voltage and has little effect on focus.

The values shown in Fig. 5, with R_1 zero, are suitable for the G.E.C. 6075A tube and probably for most other triode types. A tetrode gun, such as the Mullard MW 31-16, however, calls for a smaller focus-coil current. With such a tube its first anode should be joined to the +HT₁ point.

If a permanent magnet is used for focusing L_1 , R_1 , R_2 , R_3 , R_4 and C_2 are to be omitted and replaced by a simple dropping resistor of 500- Ω 25-W rating.

If a tube with an ion trap is used, an ion-trap magnet suited to the tube must be employed and the tube-maker's recommendations as to type of magnet and method of adjustment should be followed. Proper adjustment is important not only to secure the best results but because the tube may be damaged by incorrect adjustment.

The magnet is normally placed over the tube so

Fig. 4. Details of a suitable focus coil are given here. The core tube is 1½-in long to give a ⅛-in air gap at the front end. The spacing bars can be made from 5-in wire nails. The coil has a resistance of 1,000 ohms.

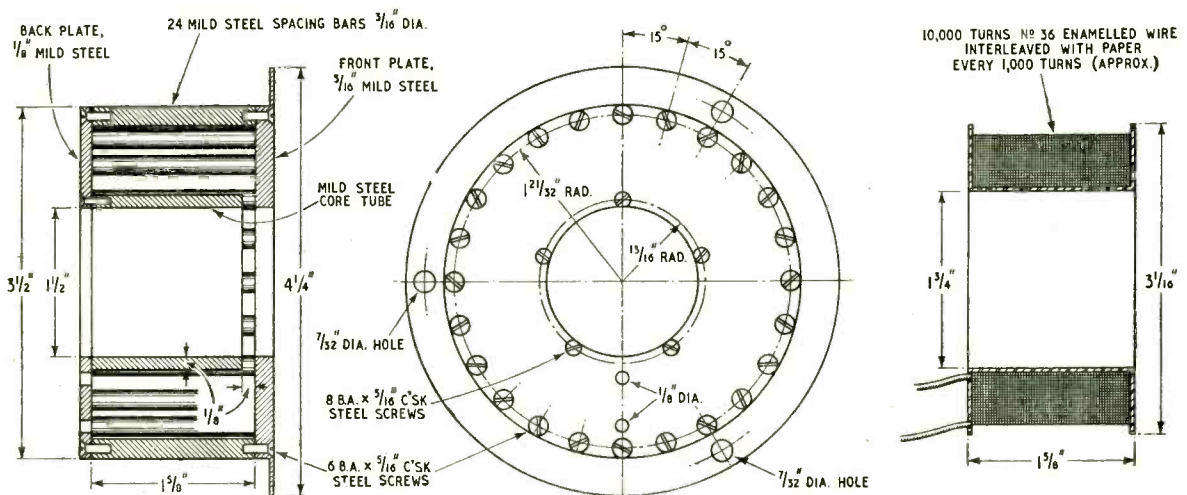

that the arrow on it agrees with the line marked on the tube base and sufficiently forward for it to be in front of the gun and over the trap. The position is adjusted by sliding it backwards and forwards, and rotating it slightly, to give the brightest raster. Initially, this must be done with a very dim raster, but the final adjustment can be done with one of normal brightness.

The brightness-control circuit has been altered slightly from the original in that the values of the resistors have been reduced to enable a wire-wound potentiometer to be used.

One change only is needed in the receiver unit and that only in the superheterodyne model. Because of the different supply voltage, R_{22} (the oscillator feed resistor) should be dropped from $100\text{ k}\Omega$ to $82\text{ k}\Omega$.

The time-base circuit of Fig. 1 has been put into practical form in two different ways—one as a modification to the existing time-base chassis of the original receiver and the other as a new design. In the former, both chassis took the form of trays with open tops and bottoms and cross shelves for the valves. The open sides were mounted to face each other with a metal plate between them for screening. The outer chassis, for the line time base, was hinged at the bottom to open outwards, while the inner chassis was hinged at the back so that the whole unit could be tilted on one corner clear of everything else.

This form of construction proved very satisfactory, but it was found that the frame time-base unit, which remained always in a vertical position, was much less convenient to work on than the line time-base chassis, which opened out into a horizontal position. In the new design, therefore, both chassis will open out horizontally, one being hinged to the other as shown in the photographs.

To minimize radiation, the line time-base must be completely screened and this is achieved by using a

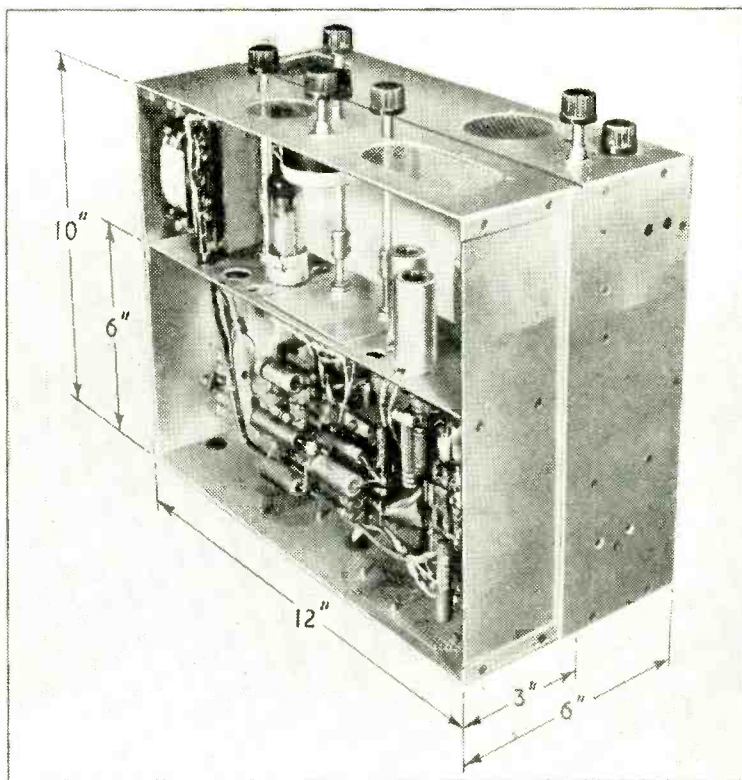

Here the frame time-base is shown together with the size of its chassis and the position of its shelf.

Fig. 5. Circuit diagram of the power unit with focus and brightness control connections. The output of the receiver unit is taken directly to the cathode of the c.r. tube and through a 10-k Ω resistor to the frame time-base unit.

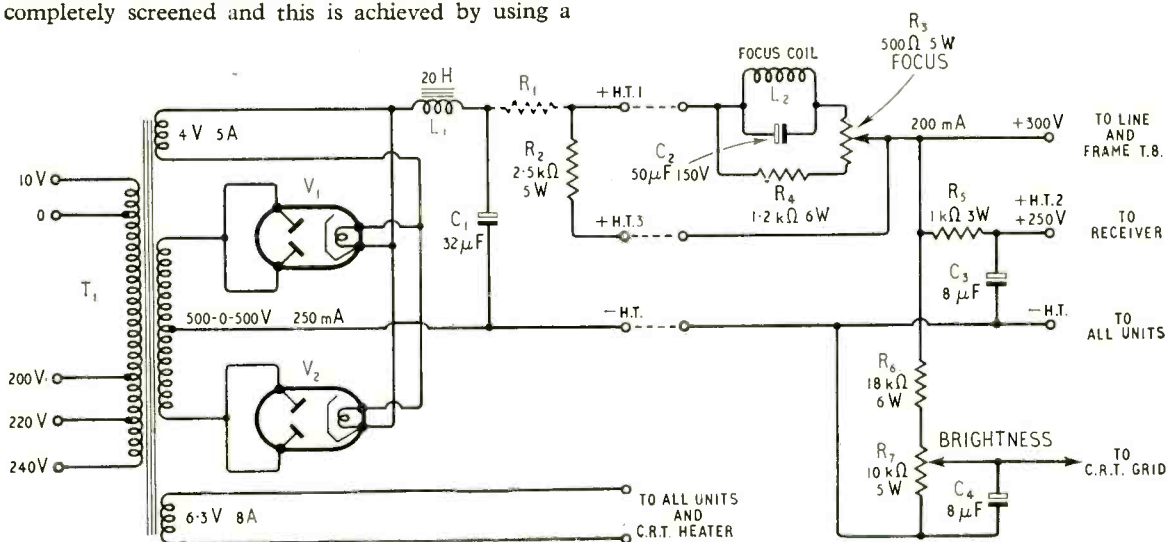

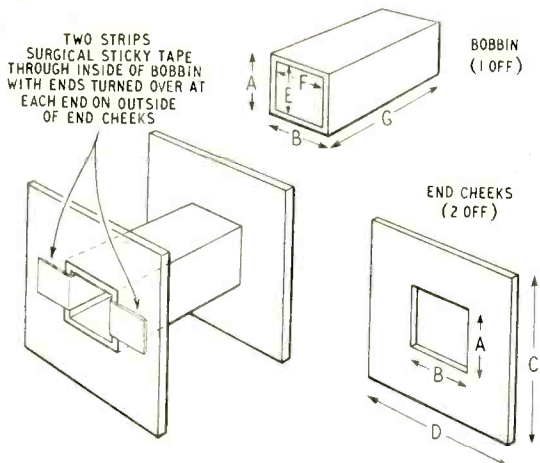

Fig. 6. Details of the bobbins for the transformers T_1 , T_2 and T_3 .

DIMENSIONS FOR FIG. 7

(inches)

	A	B	C	D	E	F	G	Stack
T_1	$\frac{13}{16}$	$\frac{7}{8}$	$1\frac{3}{8}$	$1\frac{7}{16}$	$\frac{11}{16}$	$\frac{3}{4}$	$1\frac{1}{32}$	$\frac{11}{16}$
T_2	$1\frac{1}{16}$	$1\frac{3}{16}$	$2\frac{11}{16}$	$2\frac{3}{4}$	$\frac{13}{16}$	$1\frac{1}{16}$	$1\frac{3}{16}$	1
T_3	$\frac{13}{16}$	$\frac{7}{16}$	$1\frac{3}{8}$	1	$\frac{11}{16}$	$\frac{3}{16}$	$1\frac{3}{32}$	$\frac{1}{4}$

chassis with four closed sides. Large holes are cut in top and bottom and covered with perforated zinc and one whole side is made of this material. This is essential to obtain adequate ventilation.

Ventilation holes are also provided in the top and bottom of the frame chassis but are less essential, since the whole of one side is normally open.

As in the previous design, the frame unit contains the sync separator as well as the frame time-base, while the line unit includes the e.h.t. supply. The performance is not critically dependent on the layout. Most details can be seen from the photographs.

Since R_{11} is at up to 2-kV peak with respect to the chassis, its internal insulation is not relied upon and it is mounted on the chassis by means of an insulating bush. For the same reason it should be provided with an insulating knob in case its spindle should become live. This is actually unlikely, for the internal insulation is quite good.

The metal rectifier D_1 is supported by an insulating bracket, for although it has an insulated spindle, this will withstand only 500 V or so and again the peak potential may be up to 2 kV.

The coil L_{11} , being wax-dipped, must be kept away from anything hot.

It is essential that both ends of D_3 and anything connected to it should have at least one-inch clearance from anything else, including the chassis, and that there should be no sharp points or edges on the metal work. All the soldered joints here should be nicely rounded blobs of solder. Great care is needed to avoid corona.

If it is found that the line synchronizing is poor in that vertical lines are ragged, the trouble is almost certainly due to corona, for the discharge results in the time-base being tripped erratically. If the corona persists when all sharp points have been buried in

balls of solder an improvement can often be effected by painting the relevant parts thickly with shellac varnish. It is necessary to build up a very thick layer by applying many coats and allowing it to dry between them.

Corona occurs when the electric field in air is excessive and it can be avoided only by reducing the field strength below the critical value. For a given voltage on a conductor this requires that the radius of curvature be increased, hence the need for large smooth blobs of solder. However, the field strength in air can also be reduced by moving the air further from the conductor, which is what is done by painting the conductor with an insulating varnish.

If the time bases are built on the original chassis, it is not possible to include the frame-output transformer on the chassis, but it is quite satisfactory to mount it with R_{20} externally. The old line chassis is also not big enough for everything. What was done in a conversion, therefore, was to bolt on a new extension at the back to take the multivibrator.

The various special components are fully described in the drawings and, for the sake of completeness, details of some of the original parts which are retained are repeated here.

The three transformers, T_1 , T_2 , and T_3 are wound on formers of the same general form but different sizes as shown in Fig. 6. The blocking-oscillator transformer T_1 has a primary and secondary each of 3,000 turns of No. 40 enamelled wire with three layers of thin paper between windings for insulation. The coils are scramble wound. The core comprises a $\frac{1}{16}$ -inch stack of M. & E. No. 74 laminations, 0.014-inch thick of Silcor 3 (or 1). The E and I parts are butted together without a gap and the core is held by the usual bent channel metal. A tag board is conveniently screwed to this frame.

The frame output transformer T_2 has the secondary for its inside winding and this comprises 350 turns of No. 22 enamelled wire evenly layer wound with a turn of waxed paper between layers. The winding must be tight. There should be six layers of waxed paper outside the secondary. The primary has 5,250 turns of No. 38 enamelled wire scramble-wound. It is advisable to put on a turn of waxed paper about every 1,000 turns.

Before winding, the end cheeks of the former should be liberally provided with $\frac{3}{16}$ -inch holes to permit the entry of wax in the subsequent impregnation.

The core comprises a 1-inch stack of M. & E. No. 93A Silcor 3, 0.014-inch laminations. The T and U pieces are assembled for a butt joint with a 0.003-inch air gap. The core is clamped by four stout strips of steel and 4-BA bolts which are long enough to provide the mounting. They should be provided with rubber grommets where they pass through the chassis so that the mounting is somewhat resilient. Because of the high magnetizing current, this transformer is especially liable to produce an audible buzz. The resilient mounting is desirable to prevent the chassis from being set into vibration and acting as a sounding board. The wax dip is necessary to prevent movement of the windings.

The whole component, when finished, should be immersed in melted paraffin wax at a temperature of about 100–120°C and left there until all bubbling ceases. This may require up to two hours. If a thermometer is not available the wax can be melted in a double saucepan. This will ensure that the temperature does not exceed 100° C and if the water

in the outer saucepan is kept boiling the wax temperature will not be very far below it.

When all bubbling has ceased, lift the transformer out of the wax and allow it to drain. When the wax on the outside starts to set, give it another quick dip. Build up a thick exterior coating by a succession of quick dips, each time allowing the wax to set before re-immersing.

The line-linearity transformer T_3 has a winding of 1,000 turns of No. 36 enamelled wire tapped at 333 turns from the start. On the circuit, the start is labelled 3, the tap 2 and the end 1 so that 666 turns come between 1 and 2. It is scramble-wound. The core is a $\frac{1}{4}$ -inch stack of M. & E. No. 74, Silcor 3, 0.014-inch laminations, butt-jointed, without a gap. The core is held by the usual bent channel metal. The whole transformer must be insulated to withstand 2 kV from the chassis. It must also be acoustically insulated to prevent an audible magnetostriction whistle. The two forms of insulation are obtained together with sponge rubber.

The case is made of tinfoil to the dimensions of Fig. 7 with the joints soldered together. A flat bottom plate is rivetted to the true bottom for mounting. A rubber sponge measuring 2 in \times 5 in \times 3 $\frac{1}{2}$ in is cut into two pieces 2 in \times 2 $\frac{1}{2}$ in \times 3 $\frac{1}{2}$ in. Each of these has a small piece dug out of the middle to take the bobbin of the transformer but not the core. The transformer is placed between the two pieces of rubber with the leads coming out together. The whole is then forced into the case, the leads are passed through a grommet in the lid and the lid is placed on and secured with a touch of solder.

The e.h.t. coil L_1 is wound on a cylinder of hard wood of 1-inch diameter and 1 $\frac{3}{8}$ -inch long, Fig. 8(a). One solder tag for the start of the winding is held to the former by a wood screw close to one end. The other end is drilled for two wood screws for mounting.

Drill two series of circumferential holes around the former to take steel pins (such as lengths of knitting needle) with a tight fit. The inside faces of the pins are to be $\frac{3}{8}$ -inch apart and one of them $\frac{7}{16}$ inch from

the end of the former. The rows of holes should be $\frac{3}{8}$ inch plus the thickness of the pin apart. There must be 12 pins in each row.

The winding comprises 1,220 turns of No. 30 enamelled wire in 50 layers of approximately 26 turns per layer. After one layer, give it a thin coat of shellac. Then put in a cotton spacer by winding No. 36 sewing cotton round pins as in Fig. 8(b) so that a thread of cotton lies across the winding by each pair of pins. Continue winding with cotton interleaved between all layers and shellac each winding lightly as it is done.

It is important to fill each layer with wire irrespective of the actual number of turns. If one layer is short, the next layer will tend to push the cotton down. Towards the end, the turns per layer will tend to become fewer because of the pins pulling inwards by the tension of the cotton.

When wound, attach a connecting lead to the end

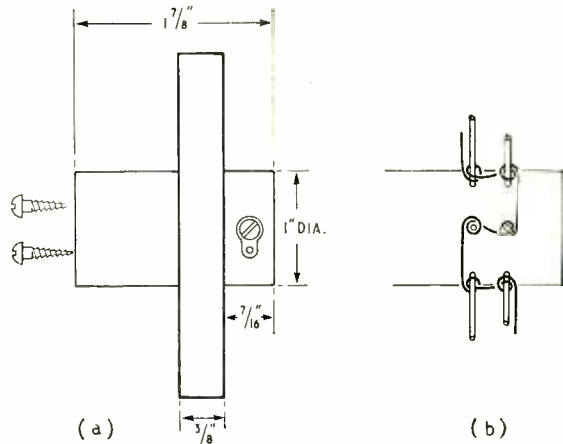

Fig. 8. The former dimensions and coil position for the e.h.t. coil are shown at (a) and the way in which the inter-layer cotton is wound at (b).

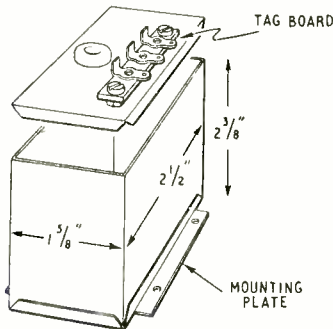
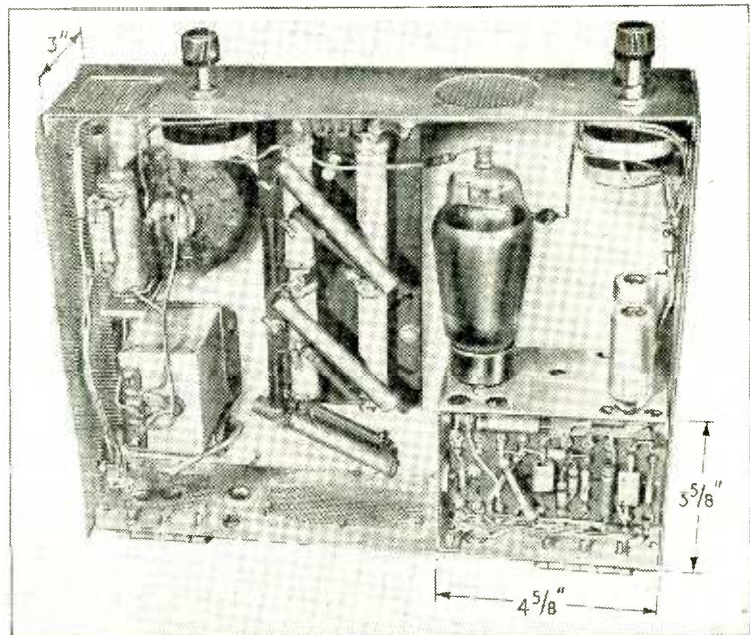

Fig. 7. Details of the case for the line-linearity-transformer are given here.

The line time-base chassis is the same size as the frame time-base chassis. The valves are mounted on a bracket, as shown in this photograph.



and tie off firmly on the outside of the winding. Leave to dry.

Then quick dip in paraffin wax. Drain thoroughly after each immersion at first so that the wax does not penetrate between the layers to any extent. When the sides are covered, build up the wax thinly. Then immerse only the outside of the coil while rotating the coil by its former to build up a tyre of wax about $\frac{1}{8}$ -in thick over the outer periphery.

An error occurred in Part 2 which must be corrected. The value of C_{21} was given as 200 pF; it should be 50 pF.

LIST OF PARTS

C_1	32 μ F, 500 V, electrolytic.	Dubilier Type CT.
C_2	50 μ F, 150 V.	Dubilier Type BR.
C_3, C_4	8 μ F, 500 V.	Dubilier Drilitic BR850.
R_1	See text.	
R_2	2.5 k Ω , 5W (see text). Welwyn.	
R_3	500 Ω , 5 W, Linear, wire-wound. Reliance Type T.W./1.	
R_4	1.2 k Ω , 6 W (see text). Welwyn.	
R_5	1 k Ω , 3 W. Welwyn.	
R_6	18 k Ω , 6 W. Welwyn.	
R_7	10 k Ω , 5 W, linear, wire-wound. Reliance Type T.W./1.	
	(Resistor ratings are minimum ones).	
V_1, V_2	1W4 500 (or GZ 32, but transformer must then have 5-V winding). Mullard.	
T_1	Primary 200/250 V, Secondaries 500-0-500 V, 250 mA; 4 V, 5 A; 6.3 V 8 A. Partridge 4204 A.	
L_1	20 H, 250 mA, 185 Ω . Partridge 4204 B.	

R.F. SOLDERING

Petrol Tank Production by Radio Heating

A NEW radio-frequency plant designed and built by Redifon for Vauxhall Motors enables all the fittings for a petrol tank to be soldered on by one operator in under one minute. Soldering by hand of such items as the tank filler, drain plug, draw-off pipes, etc., may take up to 10 minutes by three or four operators, according to the complexity of the work. Thus a very considerable saving in time and labour is effected by this machine.

The sequence in production of the petrol tank has been modified and the parts mentioned are soldered in position before the tank is shaped on the bending machine and the Redifon machine is thus designed to handle flat sheets.

It is semi-automatic and the operator merely loads a sheet on to the work carriage, places the items to be soldered in position, applies solder and flux and initiates the movement of the carriage, and hence the soldering cycle, into the machine.

Lifting the sheet off the work carriage, timing of the soldering and cooling cycles and ejection of the finished plate is automatic, but the operator can immediately arrest all motion should it be necessary.

Redifon semi-automatic r.f. soldering plant for motor vehicle petrol tank fittings.

TELEVISION BANDWIDTH COMPRESSION

IN one chapter of his new book on information theory,* D. A. Bell puts forward an interesting suggestion for reducing the bandwidth required by television transmissions. Instead of allowing the sidebands of the transmission to straggle out across the frequency spectrum, it should be possible, he says, to interlace them all into a tight bunch, occupying a very narrow band, by using heterodyne oscillators to shift the various sideband frequencies. This would be possible because the sideband frequencies of a television transmission occur at harmonics of the picture repetition frequency, so there are regular gaps between them which could be occupied by the shifted sidebands.

The interlacing process could only be carried so far because movement in the television picture causes the individual sideband frequencies to broaden out into bands, and sufficient space would have to be allowed for this "breathing in and out." In this respect, the scheme amounts to a system of information coding which would make the bandwidth requirement dependent more on the rate of transmission of real information (changes in the picture) than on just the maximum possible detail in a static picture (represented by the 3-Mc/s chequer-board pattern).

The chapter in which these ideas are discussed is concerned with practical applications of information theory in telecommunications, and as such will be the one of most direct interest to radio people. The remaining six chapters are mainly theoretical and deal with such topics as the binary digit measure of information, the idea of entropy, bandwidth and signalling speed, signal-to-noise ratio, coding and filtering. As a whole the book amounts to a comprehensive summary of all the papers that have been written on information theory, and is, in fact, probably the first real *book* on the subject. The compilation of information has been done very well and the author has a clear and easy style, but the book is not intended as an introduction for beginners, and is only recommended to those who already have some familiarity with the subject.

* *Information Theory and its Engineering Applications.* By D. A. Bell, M.A., B.Sc. (Oxon), M.I.E.E. Pp. 138 + viii; Figs. 29. Sir Isaac Pitman & Sons, Pitman House, Parker Street, Kingsway, London, W.C.2. Price 20s.

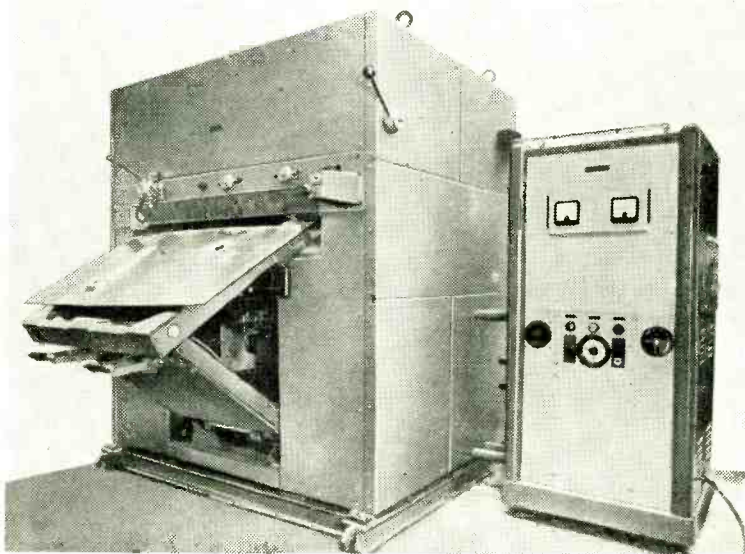

TRANSISTORS

6.—Stabilizing the Working Point

By THOMAS RODDAM

THE most important characteristic of modern electronic circuits is designability. It was fun, in the old days, to make a circuit work, by brute force and classical scholarship. Fun, I must add, for the designer who would set out to build a receiver, and find he had produced the first all-electric mousetrap. It was not such fun for the production and test departments, or for the unfortunate customer. Many organizations, indeed, inserted a buffer between the experimental laboratory and the production drawing office, just to be sure. This intermediate department still remains, like the human appendix, although its function has now passed away. The professional circuit designer regards the experimental work as a mere checking of his calculations and will usually demand a lab re-check if there is any disagreement.

This change in attitude is seen very clearly when we look at some of the information which is being published on transistors. It is easier to find out the way in which the current amplification varies from sample to sample than to find the distribution of mutual conductance values for a common valve, like the 6AK5. This is no doubt due partly to the hatred all valve manufacturers have for engineers: transistors at present are being produced by engineers.

Since we must accept the variability of our transistors, and since some of the variation depends on the ambient temperature, we must be prepared to design our circuits to take account of the tolerance range. We have at our disposal two obvious techniques, the use of negative feedback to stabilize the gain, and the incorporation of pre-set controls to allow for basic differences between units. Quite clearly, however, we cannot use the controls to deal with the changes which occur during the warming up period: less clearly, perhaps, there are changes in the working conditions of amplifiers which cannot be dealt with by negative feedback.

Measurements have been made which indicate very clearly what happens when a transistor is warmed up and then allowed to cool. For the *n-p-n* transistor, which is the most interesting in this connection, the data does not seem to have been published, but some indication of the effects is given by Fig. 1, which shows the variations of I_{c0} , the collector current at 40 volts on the collector and zero current into the emitter, and V_{c1} , the collector voltage in the saturation condition, with 1 mA emitter current and 2 mA collector current, for a point type transistor of Type 1698 (switching type). These measurements were taken as the ambient temperature was raised to 85 deg. C and then cooled again. It will be seen that I_{c0} is very sensitive to changes in temperature. The same effect, on a different scale, is obtained with the junction transistor.

Let us now look at the circuit of Fig. 2. The resistors R_1 , R_2 , R_3 , are used to control the base, emitter and collector currents. The circuit is drawn for a *p-n-p* junction transistor. It is reasonable to

assume that the collector current is independent of collector voltage: a glance at the junction transistor characteristics given in Part 4 will confirm this for a normal working point. The current amplification α is assumed to be constant over the working range: if it is not constant, we shall have distortion in the output. The emitter-base voltage is taken as zero: usually it will not exceed 0.1 volt.

If we now write down the equations for this circuit and solve them to get the electrode currents, we obtain:

$$I_c = \left\{ I_{c0} \left[1 + \frac{R_1}{R_2} + \frac{R_1}{R_3} \right] + \frac{\alpha E}{R_3} \right\} / \left\{ 1 - \alpha + \frac{R_1}{R_2} + \frac{R_1}{R_3} \right\}$$

$$I_e = (I_c - I_{c0}) \alpha$$

$$I_b = (I_{c0} - I_c (1 - \alpha)) / \alpha$$

We may follow R.F. Shea (*Proc. I.R.E.*, November 1952, p. 1435) and obtain a "stability factor" S , which is the $\alpha I_c / \alpha I_{c0}$ and is thus

$$S = \left(1 + \frac{R_1}{R_2} + \frac{R_1}{R_3} \right) / \left[\left(1 + \frac{R_1}{R_2} + \frac{R_1}{R_3} \right) - \alpha \right]$$

In a special case, which we discussed in Part 4,

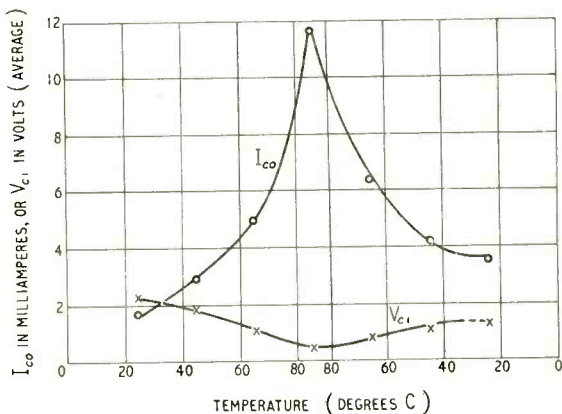

Fig. 1. Variation of two critical parameters of a Type 1698 point transistor as it is heated to 85 deg C and allowed to cool again.

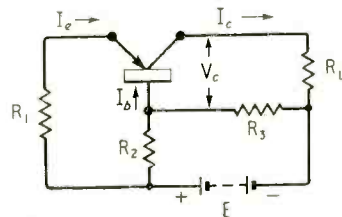

Fig. 2. Basic circuit for operation of a transistor from a single battery.

the values of R_2 and R_3 are infinite, so that $S = 1/(1 - \alpha)$. With α in the neighbourhood of 0.95, this makes $S = 20$.

Shea goes on to express I_c in terms of S :-

$$I_c = SI_{c0} + \frac{E}{R_3} (S - 1)$$

and then points out that we usually want to specify the working point in terms of I_c and V_c . Given E , the available battery voltage and choosing a value for S , the following equations are obtained for the resistances.

$$R_1 = \frac{\alpha (E - V_c - R_L I_c)}{I_c - I_{c0}}$$

$$R_2 = (S - 1) / \left\{ \frac{(1 - S + \alpha S) (I_c - I_{c0})}{\alpha (E - V_c - R_L I_c)} - \frac{I_c - SI_{c0}}{E} \right\}$$

$$R_3 = E (S - 1) / (I_c - SI_{c0})$$

It must be noticed here that R_2 is the d.c. resistance of the load, not the impedance. For a transformer-coupled output the difference is very large, of course.

The power taken from the battery is

$$P = E I_c + \frac{(V_c + R_L I_c) (I_c - SI_{c0})}{S - 1}$$

Quite obviously, the smaller we make S , the more power we need from the battery. A particular example taken by Shea shows that to make the working point $2\frac{1}{2}$ times as stable, the power consumption rises from 6 mW to 14.6 mW. These equations do enable the designer to estimate what it costs him to stabilize his working point, and what will happen if he does not do so. For a $n-p-n$ transistor the value of I_{c0} can be assumed to vary over a range of 10-100 μA , so that an S -value of about 5 is the maximum for large signal working.

Although the initial assumptions are more in error for point transistors, the discussion above will usually provide quite good guidance in estimating the effects of temperature variations and the price to be paid

for reducing these effects. It will also be clear to the reader that the input signal can be applied to either base or emitter, appropriate decoupling capacitors being inserted to prevent alternating-current feedback.

A very interesting extension of the reasoning given above has been used by D. E. Thomas in the design of an oscillator. (*Proc. I.R.E.*, November 1952, p. 1385). His oscillator consists essentially of the circuit shown in Fig. 1 but with R_L replaced by a tuned transformer, the secondary winding of which is connected in series with R_1 . Suppose that we do not have resistances R_2 and R_3 in the circuit. The collector current at zero emitter current is small, and the emitter bias produced by the drop in the internal base resistance is also, by the careful design of the transistor, made small. At very low currents, the current gain, α , of the transistor may not be high enough for oscillations to start. The addition of the resistances R_2 and R_3 will, of course, bring the transistor to a suitable working point, but if the oscillator is to be a very low power device—Thomas has been limited to 35 mW from a 6-volt battery—the designer is placed in a quandary. If he uses a very small resistance for R_2 to avoid getting too large a loss of collector supply voltage when the circuit is oscillating, in which case R_3 must also be small to give the necessary bias, the bleeder network consumes an excessive amount of power. If he limits the current in the bleeder network to keep up the overall efficiency he must use large resistance values, and then the stability factor we have discussed above is large.

The solution was found in the use of a non-linear resistance in the base as R_2 . When first switched on the emitter resistance is high, but since the base current is small the value of R_2 is also high and the collector current divides almost equally between emitter and base. As the collector current builds up, the base current increases and the resistance in the base falls from its initial value of the order of 700 ohms to something around 100 ohms.

The differential resistance in the base is lower still, so that the positive feedback shifting of working point is almost negligible. These two stability problems have been questions of operation in the linear or quasi-linear range. The non-linear circuits considered in the last article can also benefit from stabilizing modifications. If you refer to Fig. 7 of Part 5, you will see that when the circuit is triggered, it runs up to a very high value of emitter current, and from the low slope of region III you can understand that the exact value of current is rather uncertain. A diode added at CD_1 with a suitable bias voltage applied through R_{R2} will make the slope of region III much steeper once the collector current reaches a certain value. Three possible settings are shown in Fig. 3. The region III lines are more clearly defined, but the slope is still rather gradual. The circuit of Fig. 4 shows a biased diode also added in the base circuit. The feeding resistors R_R and R_{R2} are chosen to bring the diodes to a suitable

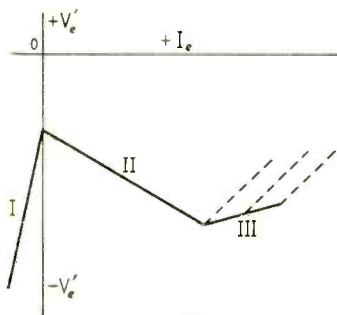
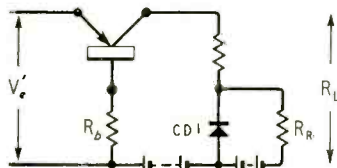

Above: Fig. 3. The diode CD_1 produces a steeper slope in region III.

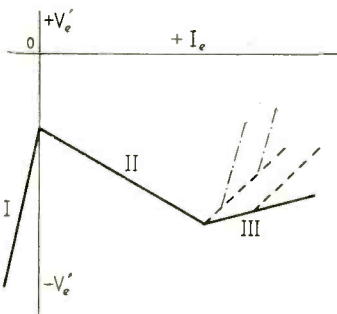
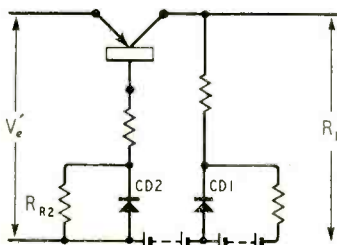

Right: Fig. 4. A further steepening is produced in region III by a second diode CD_2 .

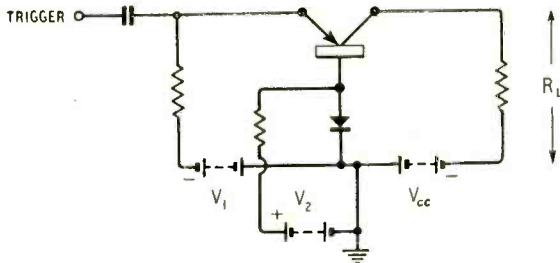

Fig. 5. The base diode in this circuit makes the trigger voltage almost independent of the transistor variations.

low-impedance working current when they are "on." The diode in the collector limits the collector current sharply, but the emitter current tends to rise. As a result the voltage across the diode CD2 in the base is reversed and the emitter characteristic is made still steeper.

These two techniques for defining the peak current have their equivalents for the collector and base connections. Another problem with trigger circuits is to maintain the peak turning point at a constant voltage. The turning point at $I_e = 0$ is at a voltage

$$V'_{e0} = \frac{R_b V_{cc}}{R_b + R_L - V_{c0}/I_{c0}}$$

where V_{cc} is the collector supply voltage and V_{c0} is the base-collector voltage at 2 mA collector current, and the emitter open-circuited. The minimum value of V_{c0} is probably 40 volts. This gives

$$V'_{e0} = R_b V_{cc} / (R_b + R_L - 500 V_{c0})$$

For the values considered previously, $R_b = 6.8 \text{ k}\Omega$, $R_L = 2.2 \text{ k}\Omega$ and $V_{cc} = 45$ volts,

$$V'_{e0} = \frac{6800 \times 45}{9000 - 500 V_{c0}}$$

If $V_{c0} = 36$	$V'_{e0} = -34$
$V_{c0} = 45$	$V'_{e0} = -22$
$V_{c0} = 54$	$V'_{e0} = -17$

There is quite a large movement here. Can anything be done to stabilize this point? The answer is again to use a diode, connected in the base circuit as shown in Fig. 5. This circuit is due to A. J. Rack, of Bell Telephone Laboratories, and operates in the following way. With zero emitter current the diode is normally conducting. Consequently the resistance in the base circuit is low and is actually about 200-300 ohms. This reduces V'_{e0} to a value of

$$V'_{e0} = (200 \times 45) / (2400 - 500 V_{c0})$$

If $V_{c0} = 36$	$V'_{e0} = -0.58$
$V_{c0} = 54$	$V'_{e0} = -0.37$

The change in transistor characteristic which moved the peak point 17 volts without the diode moves it only 0.2V with the diode.

In operation the circuit will trigger as soon as the algebraic sum of emitter and collector currents, which flows into the base, exceeds the bias current through the diode. The diode then becomes a high resistance. The total voltage between collector and base then becomes $V_{cc} + V_2$ and the emitter is biased to $V_1 + V_2$. The load line shifts parallel to itself. This arrangement also reduces the dissipation in the "off" condition.

These examples of the design problems involved in the use of transistors have been selected to indicate the methods of analysis and the methods of solution

which have proved valuable. Each application will require individual examination, to determine which solution is the best. For example, the stabilization of the linear amplifier working point is of vital importance in the design of a stage giving maximum output. There is no choice here at all. A low-level stage, however, may be designed to operate at an appropriately low current and collector voltage. Low collector voltage and low emitter current appear to be desirable if the best noise figure is to be obtained. The price paid is in the stabilization, since the low-level working point must be maintained accurately. The alternative is to work out a higher-level working point, and allow it to drift if changes in transistor characteristics take place. It will usually be desirable to make several test calculations to find where the best working point will be.

The various stabilizing techniques described for the trigger circuits will influence the time constants of the monostable and astable actions. In particular, the steeper slope of region III will tend to lengthen the output pulses and make the astable circuit more nearly a square-wave generator.

Just as we omit the cathode resistor, its decoupling, the anode decoupling circuits and quite a lot of other oddments when carrying out general valve circuit investigations, so these stabilization processes will often be omitted in general transistor circuit studies. In any future circuit discussions these basic elements will be assumed.

Acknowledgment. Fig 1 is based on Fig. 6 of "Variations of Transistor Parameters with Temperature" by A. Coblenz and H. L. Owens, *Proc.I.R.E.* Nov. 1952, p. 1473, and Fig. 2 is based on Fig. 1 of "Transistor Operation: Stabilization of Operating Points," by R. F. Shea, *Proc.I.R.E.* Nov. 1952, p. 1435.

METER SHUNTS

Their Accurate Adjustment

THE VALUE OF SHUNT required to extend the range of a milliammeter is easily calculated if the resistance of the meter is known. Unfortunately, it is not always known with sufficient accuracy; any uncertainty about the meter resistance produces a roughly equal uncertainty about the current range of the shunted meter.

It is often difficult to measure the resistance of a meter with sufficient accuracy. An a.c. method may be inaccurate because of the inductance of the coil, while a d.c. method may not be sufficiently sensitive if the current in the meter is kept to a safe value.

When resistances other than that of the meter can be measured accurately, or rather compared accurately (for their actual values need not be known) it is possible to adjust the resistance of a shunt very accurately indeed by using the circuit shown in the figure on the following page. This is a form of bridge with the meter in one of the arms and a resistance R_3 to limit the current to a safe value. A switch S is connected in place of the usual galvanometer

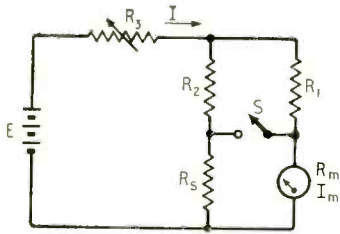

Circuit used for adjusting a meter shunt.

and the shunt R_3 is adjusted so that the meter deflection is unchanged by opening or closing the switch.

Let the meter resistance be R_m and the current needed in it for full-scale deflection be I_m . It is required to shunt the meter by R_s so that when so shunted the meter reads full scale for a total current I . The current in R_s is then $I - I_m$, and the proper value of shunt is given by the well-known expression

$$\frac{R_m}{R_s} = \frac{I}{I_m} - 1$$

In Fig. 1, the two resistances R_1 and R_2 are chosen so that

$$\frac{R_1}{R_2} = \frac{I}{I_m} - 1$$

There is no other restriction on their value, which need not even be known, but it is of some advantage if they are considerably larger than R_m and R_s , for the sensitivity of the meter indication is thereby increased.

When the shunt has been adjusted to the proper value

$$\frac{R_m}{R_s} = \frac{R_1}{R_2} = \frac{R_m + R_1}{R_s + R_2}$$

The currents I_m and I have been set up in the proper ratio. When S is open, only I_m flows through the meter. When S is closed, I flows through the shunted meter. If the deflection is the same this is the required condition.

As an example of the procedure, suppose it is desired to shunt a 1-mA, 100- Ω meter for 10 mA full-scale deflection, the figure of 100 Ω for the meter resistance being a nominal one only. Then

$$\frac{R_1}{R_2} = \frac{R_m}{R_s} = 10 - 1 = 9$$

The required shunt R_s will be about 11 Ω and a length of resistance wire giving about 15 Ω should be chosen to start with.

The resistors R_1 and R_2 must be chosen to be in the ratio 9 : 1 as accurately as possible. It is convenient to make $R_2 = 100 \Omega$ and $R_1 = 900 \Omega$ but the exact values are unimportant as long as the ratio is right. It is convenient to operate with the meter at about one-half scale, for which it takes 0.5 mA. The voltage drop across R_1 and R_m is 0.5 (0.9 + 0.1) = 0.5 V so R_3 must drop about 1 V if a single dry cell is used for E . The current in R_3 will be 5 mA, so it must be 200 Ω and so this component must be a variable resistor of, say, 400-500 Ω maximum value.

When S is closed, the meter reading will drop if R_s is too low but increase if R_s is too high. It is desirable to start with too low a value of R_s , therefore, and to increase it until closing S does not alter the meter reading. The method is quite sensitive,

for it is usually possible to detect a flicker of the meter needle which amounts to a deflection of only 0.1% of full-scale and so it is possible to adjust the shunt to the same order of accuracy.

While adjusting the shunt, care should be taken to prevent it from becoming open-circuited. If it does open, the meter current may exceed the full-scale value. It will be greatly excessive if S is closed and for safety, S should be a push-button type and only operated when R_s is in place. It may also be excessive with S open if R_3 is large and, for safety's sake, it is a good plan to make R_1 and R_2 high enough for R_3 to be dispensed with. This does not permit such great freedom in the choice of values for R_1 and R_2 , for R_1 must be about $2 E/I_m$ or some 3 k Ω for the example considered. One could use, for instance, $R_2 = 300 \Omega$ and $R_1 = 2,700 \Omega$. The meter current with S open would be $1.5/2.8 = 0.536$ mA, which is quite suitable.

Having in this way found the right value of shunt for a given current ratio, one can measure the shunt on any bridge and so obtain indirectly the value of the meter resistance.

Extension Hearing Aid

DESIGNED to enable a deaf person to hear broadcast (including television) sound in comfort without raising the normal loudspeaker volume, the "Adaphone" Type M3 unit recently developed by the Multitone Electric Company, 223-227, St. John Street, Clerkenwell, London, E.C.1, is provided with an independent volume control and a "hot-wire" volume compression circuit. The latter is considered to be essential now that miniature insert earpieces are available which reach the threshold of pain (130db) for inputs of only 5mW, and also because a large proportion of potential listeners with "recruitment" deafness, benefit from this type of response.

Complete isolation of the mains is ensured by a double-wound transformer, and in cases where the output transformer secondary on the set is not earthed, a 1:1 transformer can be supplied for installation inside the set to make the extension leads themselves safe.

The price of the Type M3 unit is £5 15s complete with earpiece and earmould. An alternative model without a.v.c. is available at £4 19s. The 1:1 transformer, when necessary, costs 10s 6d.

It has been suggested that as the response curve of the earpiece is smooth, and the quality of reproduction is acceptable also to persons with normal hearing, the "Adaphone" when used in conjunction with the normal free sound field at some distance from the loudspeaker, gives an interesting quasistereophonic effect.



"Adaphone" Type M3 extension hearing aid.

LETTERS TO THE EDITOR

The Editor does not necessarily endorse the opinions expressed by his correspondents

Two-band Television Reception

THE letter from W. T. Cocking in your June issue was most timely. It has been the secret hope of those who are closely concerned with the coming problems of alternative television programmes that someone would give voice to the misgivings felt by many of us in the light of often uninformed comments in the lay press about converters for existing television sets.

The problems of double conversion in a superhet television receiver, due to the various combinations of oscillator frequencies and harmonics with consequent whistles, may in fact prove so difficult that it might, in the event, prove cheaper to make the converter slightly more complex than that required for double conversion. An added reason might well be that by so doing, one type of converter could find a more widespread application. It is therefore suggested that, rather than add to the converter the requirement for conversion in both bands 1 and 3 or band 1 channel switching in the set, direct conversion from band 3 to the sound and vision i.f.s might be feasible. In this way it would only be necessary to stop the receiver oscillator when using the converter, thus considerably reducing the problem of oscillator harmonics and radiation. This method might involve less modification to the receiver itself.

Clearly, converters can and will be mass-produced but the designers must be in possession of all the facts and requirements before they can hope fully to assess the problem and complete their designs.

Needless to say, as soon as such information becomes available there will be heavy public demand in anticipation of the new service but it behoves designers and makers alike not to be stamped into premature release of converters if they are not to pass on to the retail trade and public many of the problems which should rightly be solved by themselves.

What surely is needed at this time is an authoritative statement in the popular press setting out in language understandable to the layman just what is involved by giving an indication of the cost of a converter and stressing that an external aerial will be required and so forth.

Failing this, the present confused situation may well become chaotic, doing disservice to public and industry alike.

Richmond, Surrey.

R. W. ADDIE.

A Matter of History

THOMAS RODDAM'S comparisons between the development of the valve and the transistor were well suited to the April issue. To the radio historian, there is a remarkable similarity between their paths so far.

Most of the early audion valves went for use in long-distance telephone circuits, leaving few for other applications. These valves, with a G_{m} of less than unity, gave a gain of 6-12 db. using 50 V h.t. and the output power was of the order of milliwatts. De Forest boasted a gain of 120 times with three transformer coupled stages. Every effort was to obtain increased gain. More than one grid was tried and every sort of connection. While the use was confined to known (voice) frequencies, a functional analysis similar to that now given for transistors was adequate. I can well imagine de Forest remarking about his ultra-audion circuit, that "the base-emitter capacitance plays an important part in the functioning of the circuit."

The use of the valve at r.f. (1913) produced instability and damping resistors and "reversed" feedback were used for control. Expansion of the theory came with increased

development during the war (Hartley, Valauri, etc.). Only after the war were valves available for general use. Incidentally the early method of connecting a transformer was in the h.t. negative end of the anode circuit. This was not negative feedback but a cathode follower circuit was given in 1924 (see *Wireless World*, Vol. XIV, p. 336). The "diminisher" circuit was also used at about this time in a Marconi receiver having five tuned stages.

Huddersfield, Yorks.

W. M. DALTON.

Broadcast Transmitter Distortion

ALTHOUGH I readily agree with and support the arguments for the introduction of v.h.f. broadcasts, I do not accept the contention that this is the only solution to the problem of distorted transmissions. I am convinced from many years of listening that the hideous non-linearity distortion on peaks that is often, but by no means always, radiated is not simply the result of inevitable volume compression. If so, why is it that superb quality is sometimes radiated from the Midland transmitter at Droitwich during programmes that clearly require much compression, e.g., the broadcast of "Die Fledermaus" in March?

Secondly, although in the past the quality of recorded transmissions has called for severe criticism, this does certainly not apply invariably to-day. The quality of the Jack Jackson records on Saturday nights is often splendid, and better than many direct broadcasts.

Although it is impossible for a mere listener to ascertain at which link in the chain of transmission distortion creeps in, I am convinced that the worst emanates from the audio network before the signal arrives at the final modulator. If this were not the case quality would not vary but would always be bad.

My view is that the B.B.C. could do far more than it does to improve the standard of medium- and long-wave transmissions, without adopting the defeatist policy of assuming that nothing but v.h.f. will improve the situation. In fact, until the audio chain is beyond reproach v.h.f. will only emphasize non-linearity distortion by extending the high-frequency response. Television sound is not always perfect!

With the advent of the high-fidelity reception now attainable, more stringent and consistent control of broadcast quality is required. With some diffidence, and assuming that no such post exists, may I suggest the appointment of an enthusiastic engineer devoted to and responsible for quality control alone. Future improvements in quality are in the hands of the B.B.C. and such an appointment might go some way towards effecting an improvement.

Wednesbury, Staffs.

A. A. COTTERELL.

THE correspondence regarding B.B.C. transmitter distortion is interesting and, let us hope, profitable. One thing seems to have been overlooked, however, namely, distortion in the detector circuit.

As is well known, conventional diode and "infinite impedance" circuits will neatly clip the peaks of any modulation exceeding a certain percentage. Such clipping gives rise to a very objectionable form of distortion, particularly on wide-range reproducing equipment. Clipping can take place at modulation levels as low as 80 per cent with quite usual circuit values.

The writer has used for some time a circuit similar to the "No-compromise R.F. Tuner" described in the Oct., 1952, issue of *Wireless World*. It is because B.B.C. transmissions do not show the distortion complained of by your correspondents, on his own equipment, the acoustic

output of which extends well beyond 15 kc/s, that he ventures to draw attention to the possibility of detector distortion being the cause of complaint.

London, S.W.12. T. S. MARSHALL.

Lamp Interference

IT is likely that K. Robinson (your May issue) can cure or alleviate his interference by placing a magnet near the lamp. This indicates the electron origin of the oscillation.

It is in fact fairly easy to get a standard 230-V lamp to oscillate above 40 Mc/s by connecting a suitable choke in each lead. The ends of the filament are then comparable to the grid and anode of a Barkhausen Kurz oscillator. Used on d.c. the interference pattern is a series of stationary bars, but a.c. gives a single bar and a diathermy herringbone. The likely cause is f.m.

A 60-watt 230-V lamp can be used as a transmitter; modulation can be applied by holding a magnetic earpiece near enough or, in the cheaper type of bulb, by shouting at it. The result is received on an f.m. receiver between 40 and 100 Mc/s.

An article by P. S. Rand in "CQ" for July, 1952, gives more information on this subject.

It is unwise to place a lamp on a TV set—interference is then quite likely.

Fraserburgh.

A. Q. MORTON.

YOUR correspondents on this subject will be interested in the April issue of *Popular Science*, which, on page 133, gives an illustration of this type of interference under the heading "Old Style Lamp: Obsolete Tungsten Filament Can Do This."

In the same article it was stated "Worcester, Mass., had an epidemic of TV interference until the power company offered to replace old-style tungsten-filament lamps with the modern variety free of charge. Some 150 of the old lamps were turned in and complaints dropped to nil."

Ratmalana, Ceylon.

F. E. SIGGERS.

Amateur Allocations

UNDER the heading "Amateur 2-Mc/s Band" in your June issue it is stated that amateurs have been granted the use of the band 1800 kc/s-2000 kc/s instead of the band 1715 kc/s-1800 kc/s withdrawn from May 1.

Obviously the implication is that the authorities, in generous mood, have given more than twice as much as they have taken away. The unfortunate wording of this report, which is undoubtedly published in all good faith, could not present the position of the amateur on this band more inaccurately, nor could it be more prejudicial to the interests of the fraternity at the present time.

In fact, amateurs have had the use of the band 1715-2000 kc/s on a non-interference basis for a number of years, and it has now been reduced in width, therefore, quite appreciably. Some, at least, of the maritime stations listed in your May issue, have been operating within the same band hitherto, and as far as is known, cases of interference, if any, being caused by amateurs have been so rare that their continued use of the band on these grounds has never been in doubt.

The real significance of changes in the maritime list is not apparent at first sight, but on analysis it will be found that amateurs now have the use of about half-a-dozen spot frequencies (subject to total sidebands of 1 kc/s), and some 27 kc/s distributed (after allowing for 3 kc/s sidebands). The frequencies at present covered by the Loran transmissions have not been included, but if this service is reallocated a further 16 kc/s could become available. Few

will care to disagree that the foregoing presents an entirely different picture from that conveyed in the bald statement that we have now a new band of 200 kc/s in width. Furthermore, it has been hinted that we shall lose the band altogether eventually, and there can be little doubt that this will be the first of the m.f. bands to be axed completely so far as amateur activity is concerned.

The m.f. bands are the ones of primary interest to the fraternity, and to summarize briefly the overall position it may be stated that 3.5 Mc/s-3.8 Mc/s, which has always been shared with other services, now carries so much traffic that it is useless to the majority of us. In the notorious 7-Mc/s region, 200 kc/s has already been taken for broadcasting, and the remaining 100 kc/s, nominally exclusive to amateurs, is being encroached upon by all and sundry as circumstances, apparently, justify. The major long-range band at 14 Mc/s now supports at least one high-power commercial transmission, and may very well come in for closer attention by such interests in the near future.

On the other hand a generous allocation was made recently at 21 Mc/s, generous no doubt because nobody else wanted it, and because it is as useless for most purposes as the 28-Mc/s band which has long since been abandoned. The conclusion is, that whereas on paper we have a few megacycles, in practice it is difficult to find a few hundred kilocycles which we can use.

In encroaching upon your space, it is in the hope that your journal may recollect the role of the amateur in the field of radio communication, and enter this as a plea for a new deal for those, and their heirs, who if by no other right, have staked their claim to recognition in the form of permanent and unmolested frequency allocations.

Buckhurst Hill, Essex.

H. E. JAMES, G5JM.

Are Symbols Overdone?

THE correct use of standard letter symbols and abbreviations is a great convenience where space-saving is worth while, such as in writing and in printed tables, abstracts, diagrams, etc. It is, of course, essential to use only standard symbols as given in B.S.I. publications: incorrect or obsolete symbols are never justified. Some symbols are unfortunately still in use which are long obsolete; for example, ω has been replaced by Ω for ohms for about 30 years. But the use of symbols by non-technical people such as shorthand-typists, clerks, etc., can lead to confusion which may be avoided by reading and speaking symbols as words and not as letters. Why should a typist be expected to learn all electrical terms and symbols? She won't, anyway, unless very exceptional. The copy typist has no difficulty: on typing from a written MS she types as she reads, and in such cases as " μ F" she can type "uF" and add the tail of the " μ " by hand. Should she type "microfarad" as MFD, MF, mf, mFd, or introduce any other incorrect symbol then she initiates possible confusion which should be strongly discouraged. Storemen and others, although not technically trained, have to handle electrical equipment; some components being so small that there is no room for the term in full, but only the symbol or colour-coding. They therefore need to know correct symbols, and colour-coding. A verbal request to the storeman for a "50 M.A. choke" may be taken as microamps or milliamps, since he will know that "MA" is often wrongly used in print for microamps or milliamps, whereas it should mean megamp. But if he is correctly told in words, such as "50 milliamps," then no error can arise. Many shop windows and advertisements will be seen with components and instruments marked 100 M/V, 50 MA, 200 mmf, etc.; often inconclusive without inspection of the component itself. Should we not therefore do better to retain the use of symbols to ourselves, and quote the terms in full to non-technical users who should not be expected to know the symbols without the possibility of error?

E. H. W. B.

B.B.C.'s

Big Day



(Screen photograph by John Cura)

UNDoubtedly the Coronation day broadcasts were a real triumph for the B.B.C. Everyone who looked-in or listened-in on June 2 was full of praise for the excellent way in which this great operation was handled. In particular it was a triumph for the special technique of outside broadcasting—the best demonstration we have ever had of radio's power to convey all the excitement and actuality of a great event at the very moment of its happening. Naturally, the immediate reaction of most people was to the artistic presentation of the programmes, but those in any way connected with radio would be thinking at the same time of the great complexity of the technical arrangements which made it all possible.

Although television was undoubtedly the star performer on this occasion, sound broadcasting had really the bigger job to do. The programme we heard at home was only one of many that were put out to all parts of the world. Altogether facilities had to be provided for some ninety commentators along the route of the procession and in Westminster Abbey—and this does not include all the additional microphones used for sound effects, of which some forty were installed in the Abbey alone. Not only were there all the B.B.C.'s home and overseas transmitters to be served, but a number of foreign broadcasting organizations as well, and at the same time arrangements had to be made for supplying several newsreel film companies, the television sound control room, the sound reinforcement system in the Abbey and public address loudspeakers along the route of the procession. It was, of course, the Post Office who provided and maintained all the lines necessary for this complicated link-up, and a share of the credit must go to them for the vital part they played in the whole operation.

Without going into details, the general plan of the sound broadcasting arrangements was this. Microphones were grouped at a number of important points along the processional route (one group being in the Abbey itself), and at each of these sites a temporary control room was set up to house the associated control gear and programme engineers. From these temporary control rooms the microphone outputs intended for transmission abroad were routed to a main control room on the new Colonial Office site, while those for the B.B.C. home transmitters were connected to another main control room in Westminster Abbey. The assembled programmes coming out of these two main centres were then sent to Broadcasting House for distribution to their various destinations, most of them

going by way of B.B.C. and Post Office transmitters and others by line to the Continent. It goes without saying that there was a good deal of duplication of equipment and circuits to guard against possible breakdowns, although in fact none of it actually proved to be necessary.

The commentators were using lip ribbon microphones, so they could work quite close to each other without their speech interfering (about 4ft 6in apart) and there was no necessity for sound-proof commentary boxes. They wore headphones which could be switched either to the home programme or to the programmes they themselves were handling. Each commentator was associated with a particular control engineer in the control room, and the engineer could speak to him by telephone or give cues by means of red and green signal lights.

The B.B.C. recording department was also very much involved in the day's proceedings. They made recordings of the entire home programme, of the ceremony from the Abbey, and of nearly forty overseas commentators, and at the same time handled items coming in from all over the world for the evening programme preceding the Queen's speech. Altogether, they used some 3,600 disks and about 85 miles of magnetic tape on 192 reels.

And now for the television arrangements, which will be described by the Superintendent Engineer of the B.B.C.'s television outside broadcasts department.

Television Arrangements

By T. H. BRIDGEWATER

APART from the sheer size of the operation—the deployment of twenty-one cameras, five mobile control rooms, three subsidiary control points, and so on—the television broadcast of the Coronation ceremonies presented a number of problems not usually met on the simpler type of O.B. It was also made the occasion to introduce several new technical refinements.

In the ordinary course of events, O.Bs originating in the London area are routed into the distribution network via the central control room at Alexandra Palace. On this occasion, with five main sources to be handled simultaneously, it was necessary to instal

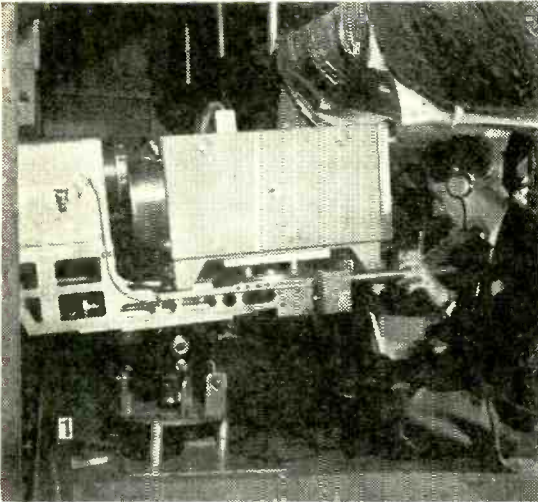

a temporary O.B. central control room in Broadcasting House. The last-mentioned was chosen as being the most convenient point into which to bring the Post Office lines carrying vision and sound signals from the five mobile control rooms disposed along the processional route (including, of course, the one at the Abbey). This central point was able to preview the pictures from all these sources and to switch them at will into a single outgoing channel to Alexandra Palace, whence they were distributed to the whole television network in this country and on the Continent.

All this imposed a heavy strain on the resources of the Post Office Engineering Department who ably exploited all the available systems and techniques—video on “balanced pair,” telephone pair and coaxial, and so on—in order to meet this exceptional demand. This they did to such effect that not only were there five circuits in simultaneous use but also adequate reserves for immediate use in the event of breakdown. The Post Office also provided three other vision circuits to carry the outputs from isolated cameras—on Buckingham Palace roof, on the roof of Abbey House, Tothill Street, and in the Annexe of Westminster Abbey—to their nearest mobile control rooms.

Camera Positions

The positioning of cameras had to be carefully worked out several months beforehand in conjunction with the Ministry of Works and the Abbey architects, and in relation to the claims of sound broadcasting, newsreels, press and other interests at the several main sites, particularly at the Victoria Memorial, the Colonial Office and Westminster Abbey. The Abbey presented exceptional problems, the selection of viewpoints having to be reconciled with the needs of many other parties and with the over-riding requirement that the equipment be not only unobtrusive but, in nearly all cases, out of sight. This led to compromises and to some remarkably cramped and unhandy positions that imposed the severest discomfort and strain on the operators at a time when they would have wished for ease and freedom. For example, in three of the positions the height of the operating box was



(1) Camera with zoom lens installed over the West Door in Westminster Abbey. Because of the low roof the viewfinder had to be taken off the camera and placed on the floor.

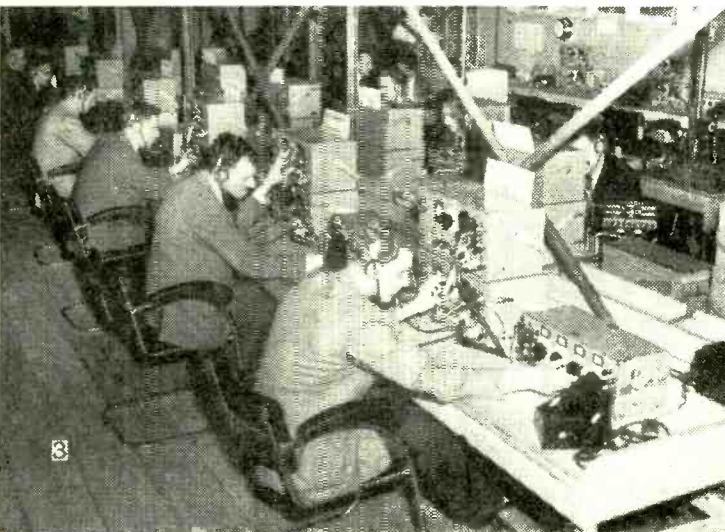

(2) Temporary television control room installed at Broadcasting House, where the pictures from five mobile control rooms were previewed and selected.

(3) Temporary control room for sound broadcasting in Trafalgar Square. Each control position manned by an operator was associated with one commentator, and had a mixer for introducing sound effects.

only about three feet, so that, as will be seen from the picture, the cameraman had not even the space to sit upright, let alone stand.

The event saw the introduction of many more zoom lenses and a total of five were in service. Two of these were of the new Watson type with interchangeable back elements, giving a choice of two 5:1 magnification ranges—with angles of view of 3 deg to 15 deg and 6 deg to 30 deg—while another, also a new design, came from Taylor, Taylor and Hobson with a range between 5 deg and 25 deg. The B.B.C. has encouraged the development of zoom lenses over a number of years and camera technique is now reaping the benefit of research and design in this important field. Viewers of the Coronation O.B. may have noticed the smooth manner in which interesting features in the subject were brought closer, or when the television camera appeared to “catch up” again on some part of the procession that had already receded into the distance.

Telephoto Lens

Another special lens, relatively new to television, was the Dallmeyer 40in “double-folded” telephoto. This was in use at the Victoria Memorial position on a camera facing Buckingham Palace, and since its horizontal angle (in conjunction with an image orthicon pick-up tube) is as little as $1\frac{2}{3}$ deg a very close view of members of the Royal Family during their appearances on the balcony could be obtained. An angle of this order calls for extreme care in use as any slight shake or vibration—even the effect of a puff of wind—will result in a greatly exaggerated movement of the image on the screen.

Every effort was made to transmit the clearest possible pictures and a noticeable enhancement of definition came from the use of the new “derivative equalizers,” developed by the B.B.C.’s Research Department* and produced in sufficient quantity to equip nearly all the cameras in use on June 2. These equalizers work on the principle of adding to the picture signal derivatives of itself obtained by differentiating circuits, and provide a simple means of adjusting and compensating optical and electrical losses.

It was thought desirable to avoid the momentary frame-slips which usually occur when switching between vision sources or cameras whose wave-forms are not triggered from the same pulse generators; the number of such interruptions in the course of a long broadcast would have been sufficient to be considerably distracting. Accordingly the B.B.C.’s Designs Department evolved a system of remotely locking each of the eight pulse generators in use by means of a master frequency sent by lines from the Broadcasting House central control point. A phasing control in series with the signal fed to each line permitted precise frame phasing to an accuracy of a very small fraction of one line; hence it was quite feasible to “cut” from one picture source to another without any loss of synchronism.

The relaying of the Coronation broadcast to France, Holland and Western Germany was looked upon by the B.B.C. as a project of the greatest importance and the most careful preparations and tests were made during the preceding six months. It was arranged that the pictures would be the same as those provided

for our home audience, but commentaries in the different languages would be superimposed on the effects and ceremony. French commentators were installed alongside the British at several of the main camera positions and spoke through independent microphones and circuits to a separate control point in a studio at Broadcasting House, thence to Paris.

The vision signals reached their various Continental destinations almost entirely by centimetre-wave links, five of which were installed and operated between London and Cassel (France) by Standard Telephones and Cables, on behalf of the B.B.C. and Radio-diffusion-Télévision Française. A particularly important—indeed essential—feature was the use of diversity reception on the cross-Channel link, in order to overcome the fading which is such a well-known and troublesome phenomenon on over-sea paths with frequencies of 4,000 Mc/s or higher. From previous experiments, S.T.C. had established the value of using two receivers with their parabolic aerial dishes mounted some fifteen feet apart in the vertical plane. It has been found that when the signal at one receiver is subject to fading, that of the other is steady; thus, with both signals available, a fading-free signal can always be obtained. This method amply justified itself both during the tests preceding the Coronation transmission and on Coronation day itself. There is no doubt that this method will find applications in the future, not only for any further links with the Continent but also for certain O.Bs within the British Isles.

CORONATION NAVAL REVIEW

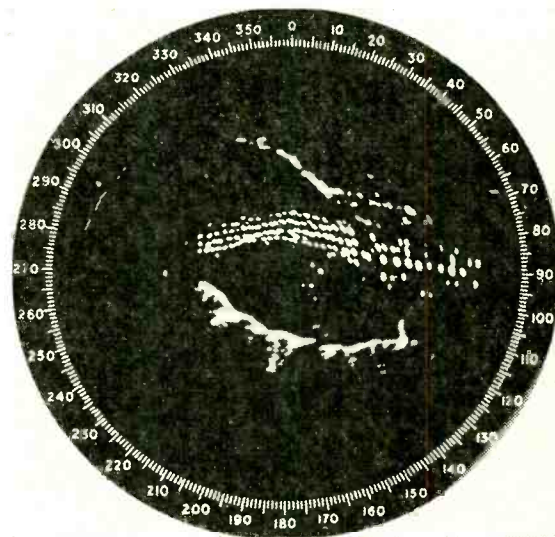

Another notable outside broadcasting event was the televising of the Coronation naval review at Spithead by cameras on board H.M.S. Eagle and H.M.S. Reclaim. The vision signal was relayed by radio to a shore receiving station near Portsmouth and then on to London. The cameras on board the ships were synchronized with the apparatus on shore by means of a mains locking signal sent out to them on a Navy radio channel (140 Mc/s). This picture shows how the assembled ships appeared on the radar screen of the Marconi Marine research and demonstration yacht Elettra II.

* “Spectrum Equalization” by G. G. Gouriet; *Wireless Engineer*, May, 1953.

WORLD OF WIRELESS

Brighton "Booster" Troubles ♦ Radio Technicians' Association ♦ Electronics Show

Television Interference

BRIGHTON VIEWERS whose receivers are tuned to Alexandra Palace are experiencing severe interference from sets receiving the local "booster" station on Trulleigh Hill working on 56.75 Mc/s vision and 53.25 Mc/s sound.

The interference either completely wipes out the picture or produces the familiar "herring-bone" pattern, and in some cases gives rise to a heterodyne on the accompanying sound transmission.

It is caused by superhet receivers having a vision i.f. lying between 9 and 15 Mc/s and a sound i.f. between 5.5 and 11.5 Mc/s, with the local oscillator on the lower frequency beat. When receiving the Brighton booster the local oscillator in these receivers must be tuned between 41.75 and 47.75 Mc/s, which is within the pass band of any television set tuned to Alexandra Palace on 41.5 and 45 Mc/s.

Owing to the good signal from the booster many viewers who have had their sets converted have not bothered to replace the aerial. This means that with the aerial flatly tuned over 41 to 48 Mc/s it is bound to radiate any locally generated oscillations. Reports given at a specially convened meeting of the Brighton and District Radio Club show that a receiver radiating in this way on about 45 Mc/s can cause serious interference to A.P.-tuned sets within a radius of about $\frac{1}{4}$ mile.

Another aspect of the trouble is that amateurs within the service area of Trulleigh Hill are suffering quite bad interference when working on the 2-metre waveband.

Catering for Technicians

BECAUSE technicians outnumber "professionally qualified electrical engineers" by at least five to one the I.E.E. has been considering for some time the possibility of forming an organization to cater for the needs of this important and growing section of the industry. It has, however, been recognized that to set up a single association purporting to cater for the needs of all electrical technicians would be ineffectual. The sub-division represented by the four specialized sections of the I.E.E.—radio, supply, utilization and measurement—has, therefore, been adopted in the Institution's approach to the problem.

The work of the Study Committee on Associations for Technicians set up by the I.E.E. in 1950 has advanced furthest in the "utilization" field, where the existing Association of Supervising Electrical Engineers is considered to meet the need. In other fields work is continuing, and in the May issue of the *Journal of the I.E.E.* it is reported that the policy is to act where possible in collaboration with an existing body "having a substantial technician membership" and only where this is impracticable to consider stimulating the setting-up of an entirely new body. It remains to be seen what will happen so far as the radio technician is concerned.

Radio Production

THE CENSUS OF PRODUCTION for 1950*, covering *inter alia* radio and telecommunications, details separately the information regarding private firms and Government establishments. The number of radio firms in the U.K. employing more than ten persons is given in the report as 424, compared with 156 in 1935. Their gross output was £136,523,000 in 1950, compared with

* "Report on the Census of Production for 1950: Vo. 4 Engineering, Shipbuilding and Electrical Goods." H.M.S.O. 2s.

TELEVISION RELAY—One of the eleven Telefunken relay stations used by Nordwestdeutscher Rundfunk to link its chain of five television transmitters.

£27,910,000 in 1935. The number of operatives ("manual wage earners") employed was 106,999, while the number of administrative, technical and clerical employees was 35,944.

There are 28 Government establishments listed as employing 59,166 operatives with an administrative-technical staff of 13,282.

Wired Broadcasting

THE USE of the telephone network to convey r.f. to listeners is not new. Experiments were carried out in this country and others before the last war, but it is interesting to read, in the March issue of the *Bulletin* of the European Broadcasting Union, of its development in Sweden. Ten years ago the Swedish broadcasting authority (Radiotjänst) recommended that the distribution of its programmes over wires should be a normal auxiliary to their radiation.

The system has provision for distributing three separate programmes on different channels in the long-wave broadcasting band, although at present only one is being transmitted on 164 kc/s. A signal of only a few microvolts is required at the subscriber's connection, and it is claimed that there is little risk of interference of any sort. The low power of the transmitters (6mW), the low impedance of the telephone circuits, and the fact that they are balanced to earth make it impossible to detect any radiated signal at distances of much more than 20 metres. Filters are provided to prevent mutual interference between radio and telephone.

The r.f. signals are fed into the networks serving homes within a radius of not more than 150 kilometres from the transmitter. Amplifiers are installed at intervals varying from 10 to 30 kilometres according to the attenuation of the circuits and subscribers' distribution amplifiers are provided at all telephone exchanges in the network.

At present there are 15 networks in use serving some 50,000 subscribers, who pay an installation fee of 5 crowns and the annual wireless licence fee of 15 crowns (approximately £1).

Electronics Exhibition

RESEARCH DISPLAYS and demonstrations by universities, hospitals and the industry as well as exhibits by more than 50 manufacturers are included in the plans for the eighth annual Electronics Exhibition, organized by the N.W. Branch of the Institution of Electronics, which opens in Manchester for six days on July 15th.

During the exhibition, which will be held at the College of Technology, Sackville Street, Manchester, 1, there will be a programme of some 40 lectures dealing with a variety of subjects from printed and potted circuits to electro-medical equipment.

Among the demonstrations in the Research Section will

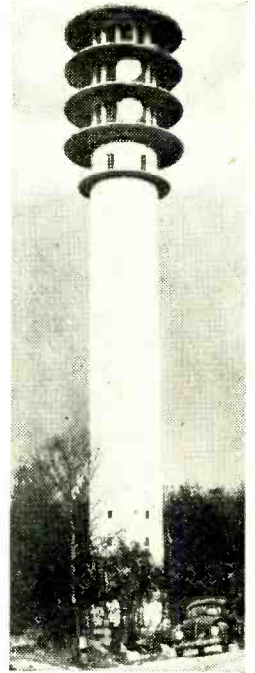

be one showing the principles of colour television by Ferranti, and another of electro-acoustics provided by the B.S.R.A.

The exhibition catalogue (price 1s 6d) will be available early in July from W. Birtwistle, 17, Blackwater Street, Rochdale, Lancs, to whom applications (enclosing a stamped addressed envelope) should be made for free exhibition and lecture tickets. The exhibition opens on the first day at noon and on subsequent days at 10 a.m., and closes at 10 p.m. each day except the 18th (7 p.m.) and 21st (9 p.m.).

CORONATION HONOURS

Dr. E. C. Bullard, M.A., F.R.S., who has been director of the National Physical Laboratory since 1949 and was previously professor of physics at Toronto University, is among the new Knights Bachelor created by H.M. the Queen to mark her Coronation.

F. S. Barton, M.A., B.Sc., M.I.E.E., who is among the new C.B.E.s, has been Principal Director of Electronic Research and Development (Ministry of Supply) since 1951. He joined the Radio Department of the Royal Aircraft Establishment at Farnborough in 1922 and became deputy head of the department in 1936. For five years (1941/46) he was chief radio engineer for the British Air Commission (Washington).

F. C. McLean, B.Sc., M.I.E.E., deputy chief engineer of the B.B.C., is appointed C.B.E. in the Honours List. He was already a Member of the Order. He has been with the B.B.C. since 1936.

Among the new Officers of the Order of the British Empire (O.B.E.) are:—

W. H. Grinstead, M.B.E., F.C.G.I., M.I.E.E., chief telecommunications engineer of Siemens Bros. & Co.

E. L. E. Pawley, M.Sc.(Eng.), M.I.E.E., who has been head of the Engineering Services Group of the B.B.C. for the past 18 months. He joined the Corporation in 1931.

W. R. Piggott, principal scientific officer at the D.S.I.R. Radio Research Station, Slough.

W. West, B.A., M.I.E.E., staff engineer at the Post Office Research Station.

H. J. H. Wassell, chief radar development engineer of Marconi's Wireless Telegraph Co., Ltd.



F. S. BARTON (C.B.E.)



F. C. McLEAN (C.B.E.)

Among the new Members of the Order of the British Empire (M.B.E.) are:—

N. H. Aldersley, radio officer on the m.v. *Australia Star* employed by Siemens Bros. & Co., Ltd.

W. G. Allen, senior experimental officer, Directorate of Electronics Research and Development (Air), Ministry of Supply.

R. S. Bastin, who was until recently chief wireless officer in the Gilbert and Ellice Islands.

R. T. Lakin, chief engineer of the Whiteley Electrical Radio Co., Ltd., of Mansfield.

R. H. Linnell, superintendent of the B.T.-H. Radar Factory at Leicester.

E. E. Spillan, telecommunications technical officer in the Ministry of Civil Aviation.

The British Empire Medal was awarded to **W. T. J. Cox**, radar chain installation engineer, Marconi's W.T. Co., and **L. W. Kyle**, radio mechanic in the telecommunications section of the Ministry of Civil Aviation.

PERSONALITIES

H. Andrewes, O.B.E., M.I.E.E., B.Sc., A.C.G.I., who received his technical training at the City and Guilds College and joined the Dubilier Condenser Co. in 1945, has been appointed technical sales executive of the company. During the last war he served in the R.A.F. as signals officer and later as chief radar officer, Base Air Force South East Asia, with the rank of Wing Commander. While with Dubilier's, he has been responsible for the design, manufacture and installation of test equipment for the quality control of the company's products.

A. E. Bennett, the new chief engineer in charge of the Dubilier Condenser Company's laboratory, joined the company in 1926 as laboratory assistant. He received his college-works training at Ferranti, Ltd., Hollinwood, Lancs. In his new position he will be responsible for the design and development of the company's products.

George J. McDonald, B.Sc.(Hons.), A.M.I.E.E., deputy technical manager of the Marconi International Marine Communication Co. since 1949, has been appointed technical manager. He graduated from Glasgow University and in 1935 joined Marconi's W.T. Company, where he was engaged in research work on d.f. techniques. During the war he was engaged on Naval communications work, and in 1949 transferred to the Marconi Marine Company.



L. H. Bainbridge-Bell, long known as a stalwart campaigner in the interests of clear presentation of technical information particularly in circuit diagrams, is retiring in August from the Admiralty Signal and Radar Establishment which he joined in 1939. He hopes to continue his mission in other fields. It will be recalled that he was granted an award by the Royal Commission on Awards to Inventors for his contribution to the development of radar.

K. Higginson, the well-known technical representative of the Dubilier Condenser Co., Ltd., which he joined in 1934, has retired. Before joining Dubilier he was chief engineer of Oliver Pell Control, Ltd. He hopes to be able to make use of his wide knowledge of the radio industry as a consultant for technical publicity. His address is 322, Richmond Road, Kingston-on-Thames, Surrey (Tel.: Kingston 8072).

W. A. Scarr, M.A., who was president of the Radio Society of Great Britain during 1950 and 1951, has been elected an honorary member of the Society. (There are only eight other honorary members.) Mr. Scarr, who graduated from Cambridge shortly after the 1914-18 war, is an educationist and seven years ago joined the British Council as director of the Students' Department.

E. Morgan, who, as announced last month, has joined the Plessey Co., was an assistant to and not, as stated, the superintendent engineer (transmitters) in the B.B.C. E. F. Wheeler holds this position.

OBITUARY

Brigadier John B. Hickman, C.B.E., M.C., M.A., who was managing director of British Telecommunications Research, Ltd., and was on the boards of A.T. & E. (Bridgnorth), Ltd., Automatic Telephone & Electric Co., Ltd., and Hivac, Ltd., died suddenly on June 3rd at the age of 54. Throughout his army career he was in radio and held many technical administrative positions, including deputy chief inspector of electrical and mechanical equipment (1941-44), deputy director of signals (equipment) at the War Office (1944-45) and Director of Telecommunications Research and Development, Ministry of Supply, from 1945 until his retirement from the army in 1949, when he joined B.T.R.

Alfred Weedon Hall, who has one of the team of engineers who assisted C. S. Franklin in the development of the Marconi short-wave beam system in the 1920s, died on May 22nd at the age of 60. He joined Marconi's W.T. Co. as a test-room assistant in 1913, and after service in the Navy during

the first world war returned to the company in 1919. He was largely concerned with the design and installation of short-wave transmitters until 1943, when he was lent to the Admiralty for research work. Mr. Hall returned to Marconi's in 1946 and was latterly in charge of a technical liaison section.

IN BRIEF

Broadcast Licences.—During April the number of television licences in the U.K. increased by 60,891, making a total of 2,203,343. There were 10,523,105 "sound" licences and 186,338 for car radio sets current at the end of the month, making a total of 12,912,786.

Transistor Standards.—Electrical specifications for transistors, supplementing those covering physical standards which have been in use for some months, have been drawn up for the U.S. Services and the Joint Electron Tube Engineering Council (America's B.V.A.). According to a report in *Electronics*, transistors will be supplied with 2-in leads, which if not required for soldering direct into circuits may be cut and spaced to fit standard 5-pin in-line sub-miniature valve holders. The emitter and collector leads will occupy sockets one and five and the base lead the socket next to the emitter.

Automatic Computing.—A summer school in programme design for automatic digital computing machines will be held in the University Mathematical Laboratory at Cambridge from September 22nd to October 2nd. A detailed syllabus and form of application for admission may be obtained from G. F. Hickson, M.A., secretary of the Board of Extra-Mural Studies, Stuart House, Cambridge, to whom the completed application form should be returned by July 18th.

R.I. Club.—At the 22nd annual general meeting of the Radio Industries Club, Edward E. Rosen, chairman and managing director of Ultra Electric, Ltd., was elected president in succession to Lord Brabazon of Tara. The vice-presidents are A. J. Dew, H. de A. Donisthorpe (G.E.C.), A. J. P. Hych (B.B.C.), and J. H. Williams (R.G.D.). The new chairman of the committee is H. A. Curtis (R.T.R.A.) with R. F. Payne-Gallwey (Eric) as vice-chairman. It was reported at the meeting that the membership of the parent club (London) is now 794 and that there are six affiliated clubs in other parts of the country.

Radio Section of the I.E.E. continues to have the largest membership of any of the four specialized sections of the Institution and again held more meetings than any other section during the last session (25). Of the Institution's total membership of 37,782 at the end of March, 4,811 were members of the Radio Section.

Television Society Council.—The four vacancies on the Council of the Television Society have been filled by the election of the following Fellows: L. S. Allard (G.E.C. Research Laboratories), T. Kilvington (Post Office Radio Research Branch), T. M. C. Lance (Cinema-Television) and Dr. W. J. Thomas (Norwood Technical College).

South Coast Reception.—The permanent low-power (2 kW) transmitter to provide improved reception of the B.B.C. Home Service along the South Coast east of Beachy Head is to be erected near Bexhill. This transmitter will operate on 1,457 kc/s and will replace the low-powered temporary station at Hastings towards the end of this year.

Egypt's new air-cooled 100-kW s.w. transmitter at Abu Zaabal, near Cairo, which was supplied by Marconi's, has now been brought into service and operates on six frequencies. A new Marconi 100 kW medium-wave transmitter (620 kc/s) is in course of construction.

S.O.S.—Commenting on a recent criticism of the use of the 500-kc/s frequency for both marine traffic and distress calls, two writers in the *Journal des Télécommunications* state that the composition of the distress signal is such that it is received through the most intense interference. The writers add, "We, in our many years' ship and coast station experience in a part of the world with very dense ship traffic, never heard of a single case of an S.O.S.-signal 'drowned' in congested traffic on 500 kc/s."

Canadian Television Plans announced by the C.B.C. include the expenditure of over \$6M on new stations in Vancouver, Winnipeg and Halifax (all of which are expected to be in operation in the late autumn) and a second transmitter for Montreal. It is also planned to extend the inter-city television relay network which at present links Montreal, Ottawa and Toronto.

U.S. Television Density.—A chart published in the May issue of *Electronics* shows that, in 30 U.S. television areas in which there are 22.3 million homes, there are 19.8 million television sets. The figures, provided by the National Broadcasting Company, show that in these 30 areas television density is about 89%. In the other 46 areas listed, television density is only 18%. Of the 1.9 million homes in New York there were on January 1st slightly more than 1.8 million television receivers.

Ship-shore R/T Services, operated by Cable and Wireless, Ltd., are now available to ships in the vicinity of Lagos and Sierra Leone, West Africa, and the company is also planning to open a similar service at Bathurst.

Short-Wave Listeners are invited by the International Short Wave Club to send on a postcard the names of their three favourite short-wave broadcasting stations and to state briefly the reasons for their first choice. Entries for the competition must be sent by July 31st to I.S.W.C., 100, Adams Gardens Estate, London, S.E.16.

Amateur Show.—It is proposed by the Radio Society of Great Britain to hold the seventh annual amateur radio exhibition at the Royal Hotel, London, W.C.1, during the week November 23rd to 28th.

Home Construction.—The interests of the radio and television home constructor are catered for in the plans for the second National Handicrafts and Hobbies Exhibition which will be held at the Central Hall, Westminster, London, S.W.1, from September 17th to 30th.

PUBLICATIONS

Limits and Tolerances.—A new Standard (B.S. 1916, Pt. I:1953) giving limits and tolerances for engineering, which are stated to be "sufficiently comprehensive to cover every need from the watchmaker at one end to the heavy industries at the other," has been issued by the British Standards Institution. The telecommunications industry was among the many represented on the investigating committees. Part II of the Standard will give guidance in the use of Part I, which is available from the B.S.I., 24, Victoria Street, London, S.W.1, price 10s.

Second-hand Prices.—Maximum allowances on second-hand broadcast and television receivers purchased by the trade are given in "Used Radio and Television Set Values" prepared by the Radio and Television Retailers' Association and published by the Trader Publishing Co., Dorset House, Stamford Street, London, S.E.1. Manufacturers are listed alphabetically and the oldest broadcast receivers quoted are of 1941-1942 vintage. Older sets than those listed are stated to have no commercial value. The allowances indicated for television sets are based on the need for a new cathode-ray tube to be fitted. The 80-page book costs 2s 9d, including postage.

"**QRP**" is the title of the monthly journal of the QRP Research Society, which was formed in 1950 to foster interest in low-power transmission. The Society is organizing a monthly contest for transmitters and listeners. The operating hours are from 1900-2100 each Sunday, and the frequency band for July is 21 Mc/s. Details of the contest and membership of the Society are obtainable from the Honorary Secretary, J. Whitehead, The Retreat, Rydens Avenue, Walton-on-Thames, Surrey. A. O. Milne (G2MI), vice-president of the R.S.G.B., has been re-elected president of the QRP Society for a second year.

BUSINESS NOTES

Pye V.H.F. amplitude-modulated R/T equipment is being supplied by Rees Mace Marine, Ltd., to the Norwegian shipping authorities. Shore stations have already been installed at Trondheim, Oslo and Drammen, and a number of craft including 40 whaling vessels have been equipped.

Ground-to-Air V.H.F. transmitters, receivers and spares worth \$1.4M are to be supplied by the British General Electric Co. to N.A.T.O. countries under a contract placed by the United States Air Force in Europe.

Marconi International Marine Communication Co. has opened a Service Depot at the Ferry Docks Pumping Station, Dover. Inspector E. Trethewey, whose telephone number is Dover 800 (ext. 79), is in charge of the Depot.

Oryx Electrical Laboratories announce that they have appointed ANTEX (Anglo-Netherland Technical Exchange, Ltd.), of 3, Tower Hill, London, E.C.3 (Tel.: Royal 4439), as sole distributors of the Oryx sub-miniature soldering irons.

The Ohmmeter

By W. TUSTING

Its Basic Characteristics

FOR the measurement of resistance, the ohmmeter is probably the most widely used instrument, although it is rarely a highly accurate one. There are several reasons for its popularity. In the first place, the ohmmeter usually exists, not as a separate instrument, but combined with a multi-range voltmeter and milliammeter with the result that it is usually the cheapest form of resistance-measuring apparatus. Secondly, a continuity tester is an essential piece of test equipment and the ohmmeter performs this function without any detriment to its measuring ability. Thirdly, high accuracy of measurement is not often necessary in ordinary radio work so that its relative inaccuracy is but little drawback.

In spite of the fact that the ohmmeter is so widely used and its main characteristics are generally known, there does not seem to be such common appreciation of its finer points. Nor is it always realized that there are two basic forms of ohmmeter—the series and the shunt types. The shunt ohmmeter is not a common one, and all the ordinary ones are series ohmmeters.

The basic circuit of the series ohmmeter is shown in Fig. 1. A battery E , a meter M and a resistor R_T are connected in series with the resistance R_x to be measured. The current which flows is

$$i_m = \frac{E}{R_T + R_x} = \frac{E}{R_T} \cdot \frac{1}{1 + R_x/R_T} \quad \dots (1)$$

If the current required for full-scale deflection (f.s.d.) of the meter is I_m , this equation can be written as

$$\frac{i_m}{I_m} = \frac{E}{I_m R_T} \cdot \frac{1}{1 + R_x/R_T} \quad \dots (2)$$

and if the values are so chosen that $E = I_m R_T$ it reduces further to

$$\frac{i_m}{I_m} = \frac{1}{1 + R_x/R_T} \quad \dots (3)$$

This simple equation describes the law of the scale of any series-type ohmmeter as long as it includes only linear circuit elements. No matter how complex the internal resistance network may be, and some are quite complicated, it can be reduced to this form.

The left-hand side of equation (3) represents the fraction of full scale by which the pointer is deflected for any value of R_x , while the right-hand side shows that the important factor which governs the deflection is not the absolute value R_x but its relation to the internal resistance R_T . When we say that i_m/I_m represents the fractional deflection, we are implicitly assuming that the deflection of the meter needle is proportional to current. In practice, it may not be precisely so, in which case the equation really indicates resistance in terms of the current scale of the meter. Using this equation, any current-indicating meter can have a resistance scale marked off directly from the current scale.

It can be seen that when R_x is infinite, the current is zero and the meter needle is not deflected at all,

whereas when R_x is zero the current is I_m and the meter reads full scale. In a series ohmmeter, zero resistance always corresponds to full-scale deflection and infinite resistance to zero deflection. The resistance scale reads from right to left and always covers all possible resistance values.

When R_x and R_T are equal, $i_m/I_m = 1/2$; the current is one-half of the full-scale value. It is here that the scale-reading accuracy is at its highest and it is only in the neighbourhood of this point that any reasonable accuracy is obtainable. In practice, therefore, it is the value of R_T which sets the useful range of the instrument and to change the range it is necessary to change R_T . This is not the only requirement, however, for equation (3) holds only if $E = I_m R_T$ so that if R_T is altered it is necessary also to change E/I_m by the same amount. This can be done by altering the battery voltage or the full-scale current of the meter (as by shunting it) or by a combination of both.

The requirement that $E = I_m R_T$ sets a very definite limit to the resistance range obtainable in practice. Cost and durability set a limit to the sensitivity of the meter that can be used and this limit is probably reached with a 100- μ A meter movement. Many ohmmeters have nothing better than a 1-mA movement. Cost, size and weight limit the battery voltage that can be used, but also it is generally necessary to keep the voltage below the value at which any noticeable shock is obtained when the R_x terminals are touched. These factors will usually limit the battery to about 50 V.

With a 50-V battery and a 100- μ A meter, the maximum value of R_T is $50/0.1 = 500 \text{ k}\Omega$. With a 1-mA meter it is $50 \text{ k}\Omega$. These correspond to mid-scale values of R_x . Good accuracy is maintained, as will be seen later, for resistance values up to three times R_T , moderate accuracy up to 10 times R_T and rough indications of value are obtainable up to some 50 times R_T .

The lower limit of resistance with the series ohmmeter is set by the maximum current which can conveniently be supplied by the battery. Unless exceptionally big cells are used this is usually around 150 mA. The smallest value of E is that of a single cell, nominally 1.5 V, so that the minimum value of R_T normally practicable is $1.5/0.15 = 10 \Omega$. Below the mid-scale value R_T , good accuracy can be obtained down to $R_T/3$, moderate accuracy to $R_T/10$ and rough indications to $R_T/50$.

In general, therefore, the useful limits of a series

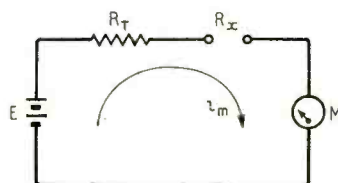

Fig. 1. Basic circuit of series ohmmeter.

ohmmeter extend from about 3 Ω (the limit being set by the battery current) to about 4 MΩ (the limit being set mainly by the meter sensitivity, but partly by battery voltage).

By differentiating equation (3) with respect to R_x it is possible to find the relation between very small changes of resistance ΔR_x and the consequent change of current Δi_m . This relation is

$$\frac{\Delta i_m}{I_m} = -\frac{\Delta R_x}{R_x} \cdot \frac{1}{2 + \frac{R_x}{R_T} + \frac{R_T}{R_x}} \quad \dots \quad (4)$$

This has its maximum value when $R_x = R_T$ and then

$$\frac{\Delta i_m}{I_m} = -\frac{1}{4} \frac{\Delta R_x}{R_x}$$

To see what this means, suppose that it is possible to read a small change of current Δi_m with a certain degree of accuracy on a meter of I_m full-scale deflection. Then $\Delta i_m/I_m$ is the fractional change of current and, for the same accuracy of reading, it is only possible to read a fractional change of resistance four times as great. For example, if the smallest change of current that can be read on the meter is 1% of full-scale, then the smallest change of resistance that can be read is 4%. It is necessary to distinguish between a readable change and a detectable change; the latter may be only a tenth as great.

The relative reading accuracy at different parts of the scale can be expressed as

$$\frac{4}{2 + R_x/R_T + R_T/R_x}$$

and this shows how the reading accuracy of the scale varies relatively to the best position. If $R_x/R_T = 10$ or 0.1, the relative accuracy is $4/12.1 \approx \frac{1}{3}$ times, which is why, in the foregoing, a range of 0.1 to 10 times mid-scale has been classed as of only moderate accuracy. If $R_x/R_T = \sqrt{10}$ or $1/\sqrt{10}$, the relative accuracy is $1/1.37$ times and this is quite a small decrease and is considered here to represent the limit of range for good accuracy.

The reason for choosing the, at first sight, peculiar value of $\sqrt{10}$ for the limits of each range is that it is the natural limit when the ranges are in steps of 10, which they must be if the same resistance scale is to be used for all ranges with a simple multiplier. $R_x/R_T = \sqrt{10}$ on one range then corresponds with $R_x/R_T = 1/\sqrt{10}$ on the next higher range and it is necessary to read outside the $\sqrt{10}$ limits only on the highest and lowest ranges.

Effect of Battery Changes

Most practical difficulties with the ohmmeter arise through the range-changing arrangements and through the circuits which are needed to compensate for the effect of changes in the battery. It is an unfortunate fact that neither the internal e.m.f. of a battery nor its internal resistance is a constant, but is liable to change, not only during the life of the battery but from one battery to another. It is necessary, therefore, either to design the ohmmeter circuit so that these variations cause negligible error or to provide compensating adjustments so that their effect can be corrected. It is here that various ohmmeters differ most from each other.

The effect of a change of battery resistance is to alter the value of R_T , for R_T is the total internal resistance of the ohmmeter viewed from the R_x terminals.

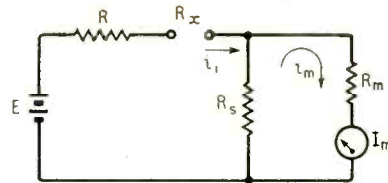

Fig. 2. Series ohmmeter with compensation for battery e.m.f. variations by a shunt R_s .

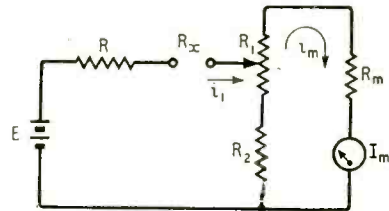

Fig. 3. Ohmmeter with "constant-resistance" e.m.f. compensator.

The effect thus depends on the magnitude of the change of resistance relative to the proper value of R_T . On a high-resistance range, R_T might be 500 kΩ and a 50-V battery of small cells might develop an internal resistance of 2 kΩ at the end of its life. The resulting error is only 0.4% and by making the resistance external to the battery 499 kΩ and, taking the battery as having a resistance of 1 ± 1 kΩ, the error can be made $\pm 0.2\%$.

On a lower range of 50 kΩ mid-scale there are two alternative ways of obtaining the proper conditions. One is to retain the 50-V battery and to shunt the meter to take ten times the current. The battery resistance is then ten times as important and, in the example, the error due to it reaches $\pm 2\%$. The alternative is to leave the meter unshunted but to reduce the battery voltage to one-tenth, which also reduces the battery resistance to one-tenth, and leaves the resistance error at $\pm 0.2\%$. This is clearly the better course. In practice, matters are likely to be even better, because one would usually employ larger cells for a low-voltage battery than for a high-voltage one and the battery resistance is likely to be relatively much less.

In order to make battery resistance a negligible factor, it is necessary to use as sensitive a meter as possible so that the current is a minimum and to use a battery of as large-capacity cells as is practicable. On the higher-resistance ranges, it is then usually possible to ignore the battery resistance. On the lower-resistance ranges, however, compensation is nearly always needed. Such compensation is simple. It is only necessary to choose the total resistance lower than the required value of R_T by the amount of the maximum battery resistance and then to insert in series a variable resistance of this same maximum value. As the battery resistance increases, the variable resistor is reduced by the same amount and the total stays constant.

Compensation for changes of e.m.f. is necessary on all ranges and is more troublesome to arrange. It is hardly practicable to arrange an adjustable source of e.m.f. and what is done in practice is to alter the sensitivity of the meter to suit the e.m.f. On any range, the requirement is to have $E/I_m = R_T$ and

compensation for changes of E is obtained if I_m is arranged to be proportional to E . The simplest way of doing this is to have a variable shunt to the meter.

The circuit then takes the form shown in Fig. 2, and the relevant equation analogous to equation (2) is

$$\frac{i_m}{I_m} = \frac{E}{I_m R_T} \cdot \frac{1}{1 + R_m/R_s} \cdot \frac{1}{1 + R_T/R_x} \quad (5)$$

which reduces to equation (3) if $E = I_m R_T (1 + R_m/R_s)$. Here I_m is the meter current itself and is a fixed unalterable quantity, so that it is R_s which is varied to correct for changes of E ; R_m is, of course, the internal resistance of the meter.

It is not practicable to vary R_s continuously over any range extending to infinity, so there is always some finite value in shunt with the meter. This reduces the sensitivity and makes i_1 greater than i_m . Accordingly, the resistance range obtainable is reduced.

A penalty which must be paid for having e.m.f. compensation is a reduction of the maximum resistance range and, with the simple shunt of Fig. 2, the best that can be done is to have a range of about 80% of that with the unshunted meter. This is actually about the best that can be done by any method.

Adjustment of R_s unfortunately affects the value of R_T for R_m and R_s together form an effective meter of resistance $R_m/(1 + R_m/R_s)$ and of full-scale current $I_1 = I_m(1 + R_m/R_s)$. The effective meter resistance is thus $R_m I_m/I_1$. Now I_1 must vary in proportion to the battery voltage if R_T is constant and so the effective meter resistance must vary in inverse proportion to the voltage. The percentage variation of effective meter resistance is thus the same as the percentage variation of battery e.m.f. In practice, the magnitude of the change of resistance will rarely exceed about 100 Ω . It is quite negligible on high-resistance ranges, but is a major factor on low-resistance ranges.

Range Changing

The variations of resistance can be very greatly reduced by using the form of compensation shown in Fig. 3. Here, a potentiometer R_1 is used and arranged so that one side of it acts in series with R_s as a variable shunt, while the other side puts resistance in series with R_m . There is an optimum position for the slider on R_1 at which the resistance is a maximum and this corresponds to an equal division of the current i_1 between the two paths. Consequently, the two paths are then of equal resistance and the total resistance viewed from the slider is $(R_1 + R_2 + R_m)/4$. The current i_1 is twice i_m . At other settings of the slider the resistance falls, but only slightly for small changes of i_1/i_m .

The change of resistance is of the order of a quarter or a fifth of that with the simple shunt of Fig. 2, which is a considerable improvement. Unfortunately, however, the ratio of i_1 to i_m is much larger, being about 2:1 instead of some 1.2:1. This means that it restricts the maximum resistance range more.

For range changing, it is necessary at some stage to shunt the meter or to do some equivalent thing. With neither Fig. 2 nor Fig. 3 is a simple meter shunt satisfactory. In Fig. 2, a meter shunt calls for a change of value of R_s and separate zero-adjusting variable resistors are needed for each range. As well as taking up a lot of space, they become expensive.

The same thing applies to Fig. 3 if the meter itself is shunted unless, at the same time, resistance is inserted in series to keep the total resistance of the effective meter constant. This is satisfactory, except that the low-resistance ranges are limited by a high effective meter resistance. An alternative is to shunt not the meter itself but the whole meter plus compensator. This would be ideal if the resistance were truly constant but as it is not it makes the e.m.f. adjustor vary somewhat from one range to another.

The most convenient arrangement depends on circumstances and some commercial instruments use one method of compensation for some ranges and another for other ranges. Where the aim is to obtain the widest possible resistance range, with especial emphasis on high values, however, the arrangement shown in Fig. 4 is one of the best, if not the best. This is basically the circuit of Fig. 2 with the resistances R_1 and R_2 added. The resistance R_1 is made so large compared with R_s and R_m together that their variations are swamped. Then R_2 is the shunt for increasing the current on low ranges. R_A is the compensator for battery resistance and R_s the compensator for e.m.f. variations. If the resistor values are precise and the same battery is used for all ranges, the adjustments of R_A and R_s hold for all ranges.

The equation for this circuit is quite a simple one and is

$$\frac{i_m}{I_m} = \frac{E}{I_m R_T} \cdot \frac{1}{1 + R_m/R_s} \cdot \frac{1}{1 + R_1'/R_2} \cdot \frac{1}{1 + R_x/R_T} \quad (6)$$

where $R_T = R + R_2' + R_A + R_B$

$$R_2' = \frac{R_1 R_2}{R_1' + R_2}; \quad R_1' = R_1 + \frac{R_m R_s}{R_m + R_s}$$

and R_B is the battery resistance.

This circuit is so important that it is of interest to consider the detailed design of an ohmmeter embodying it. In spite of its basic simplicity, the design is a little intricate and it is probably both clearest and shortest to set out the steps rather in the form of a drill. In the following the references are to Fig. 4; values of current for any value of R_x are indicated there by i , i_1 and i_m . Corresponding currents for $R_x = 0$ are I , I_1 and I_m .

Step 1. Knowing I_m and R_m , which are characteristics of the meter, compute the range of values required for R_s to compensate for variations in the e.m.f. of the battery, bearing in mind that the current I_1 is proportional to the e.m.f. The necessary relation is

$$\frac{R_s}{R_m} = \frac{1}{I_1/I_m - 1}$$

Example 1. Let $I_m = 100 \mu A$, $R_m = 531.5 \Omega$ and the e.m.f. per cell be 1.3 V to 1.67 V.

Assume a minimum value for I_1 , which will occur

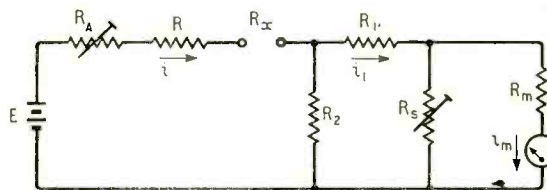

Fig. 4. Basic circuit of a practical ohmmeter with both resistance and e.m.f. compensation; R and R_2 are altered to change the range.

when the e.m.f. is 1.3 V per cell, of $1.1I_m$. When the e.m.f. is 1.67 V per cell I_1 will be $1.1I_m \times 1.67/1.3 = 1.41I_m$ (approx.).

At the lower current

$$R_s = \frac{531.5}{1.1 - 1} = 5315 \Omega$$

At the higher current

$$R_s = \frac{531.5}{(1.1 \times 1.67/1.3) - 1} = 1290 \Omega$$

To employ standard components and ensure plenty of coverage one could make R_s a fixed resistor of 820 Ω in series with a variable of 5 k Ω .

Step 2. At a nominal battery voltage of 1.5 V per cell and for a current I_1 roughly mid-way between the limits of Step 1 decide on the highest resistance range and maximum battery voltage. Also, choose I_1 at a round figure to simplify calculation. (If $R_2 = \infty$, $I = I_1$.)

Example 2. From example (1) $I_1 = 1.25I_m = 125 \mu\text{A}$. For a range in the neighbourhood of 400 k Ω mid-scale we might choose a 45-V battery, which would give 360 k Ω . However, lower ranges will demand a lower-voltage battery to avoid excessive current and this can be connected in series with the 45-V battery to give a higher voltage. With a little trial and error it is found that a 45-V and a 6-V battery, giving 51 V together, will allow a 400-k Ω mid-scale range if the current is changed to 127.5 μA .

Step 3. Recalculate Step 1 on the basis of the new figures from Step 2.

Example 3. Since I_1 is 127.5 μA at 1.5 V, it is $127.5 \times 1.67/1.5$ at 1.67 V and $127.5 \times 1.3/1.5$ at 1.3 V. The limits of R_s are thus

$$R_s = \frac{531.5}{1.275 \times 1.67/1.5 - 1} = \frac{531.5}{0.4195} = 1267 \Omega$$

$$R_s = \frac{531.5}{1.275 \times 1.3/1.5 - 1} = \frac{531.5}{0.105} = 5061 \Omega$$

The previous values of 820 Ω fixed and 5 k Ω variable are still suitable.

Step 4. Compute the limits of R_m and R_s in parallel using the results of Step 3.

Example 4.

$$\frac{R_m R_s}{R_m + R_s} = \frac{531.5 \times 1267}{1798.5} = 374.42 \Omega$$

$$\frac{R_m R_s}{R_m + R_s} = \frac{531.5 \times 5061}{5592.5} = 480.98 \Omega$$

The total change of resistance is $480.98 - 374.42 = 106.56 \Omega$. Therefore,

$$\frac{R_m R_s}{R_m + R_s} = 427.7 \pm 53.28 \Omega$$

Step 5. For decade range steps, each range will

be one-tenth of the preceding one and the current will be ten times as great but modified by any change of battery voltage. Compute the ranges obtainable in view of the increasing battery drain.

Example 5. The top range is 400 k Ω mid-scale with $E = 51$ V and $I = 127.5 \mu\text{A}$. The next range will be 40 k Ω with $E = 6$ V, so the current will be $127.5 \times 10 \times 6/51 = 150 \mu\text{A}$. Successive further ranges will be 4 k Ω , 400 Ω and 40 Ω and will take 1.5 mA, 15 mA and 150 mA respectively. A lower range still would have to be 4 Ω and would take 1.5 A which is out of the question.

Step 6. R_2' should be as large as possible in order that R_1 may be large compared with $R_m R_s / (R_m + R_s)$. Choose R_2' for the lowest range so that R is zero (i.e., so that $R_2' = R_T - R_A - R_B$). Values of R_2' for the other ranges, except the highest, follow at once since each is ten times the preceding one. Tabulate the results.

Example 6. On the lowest range $R_T = 40 \Omega$. The battery resistance is unlikely to exceed 20 Ω , so that if $R = 0$, $R_2' = 20 \Omega$. Then for the other ranges the figures are as in Table 1 but the value for range 1 cannot be inserted yet.

Step 7. The value of R is $R_T - R_A - R_B - R_2'$ and, except for range 1 can be computed at once.

Step 8. On range 2 the battery current is $I = E/R_T$ and I_1 is known from Step 2. Then $I/I_1 = R_1'/R_2'$. Compute R_1' , then R_1 by deducting $R_m R_s / (R_m + R_s)$.

Example 8. $I = 6/40 = 0.15$ mA; $I_1 = 0.1275$ mA, so

$$\frac{I}{I_1} = \frac{150}{127.5} = \frac{60}{51}$$

$$R_1' = 20 \times \frac{60}{51} = \frac{1200}{51} = 23.53 \text{ k}\Omega$$

$$R_1 = 23.53 - 0.429 = 23.102 \text{ k}\Omega.$$

Step 9. On range 1, R_2 is infinite and $R_2' = R_1'$, so R for this range can now be found using the formula of Step 7 and a mean value of battery resistance.

Example 9. Assume $R_B = 1 \pm 1$ k Ω then

$$R = 400 - 1 - 23.53 = 375.47 \text{ k}\Omega$$

Step 10. The current I is known for ranges 1 and 2. It increases ten times for each further range. Compute the values for all ranges, then I/I_1 and $I/I_1 - 1$. List the values.

Step 11. Compute R_2 from $R_2 = R_1' / (I/I_1 - 1)$. List the values

Example 11. For range 2 we have $R_1' = 23.53$ k Ω , $I/I_1 - 1 = 9/51$ so

$$R_2 = \frac{23.53 \times 51}{9} = 133.3 \text{ k}\Omega$$

From the results of Table 1 the complete circuit diagram of Fig. 5 can be drawn with all values. In

TABLE 1.

Range	R_T (k Ω)	E (V)	$R_A + R_B$ (k Ω)	R_2' (k Ω)	R (k Ω)	I (mA)	$\frac{I}{I_1}$	$\frac{I}{I_1} - 1$	R_2 (k Ω)
1	400	51	1 \pm 1	23.53	375.47	0.1275	1	0	∞
2	40	6	0.02	20	19.98	0.15	60/51	9/51	133.3
3	4	6	0.02	2	1.98	1.5	600/51	549/51	2.1857
4	0.4	6	0.02	0.2	0.18	15	6,000/51	5,949/51	0.2017
5	0.04	6	0.02	0.02	0	150	60,000/51	59,949/51	0.020017

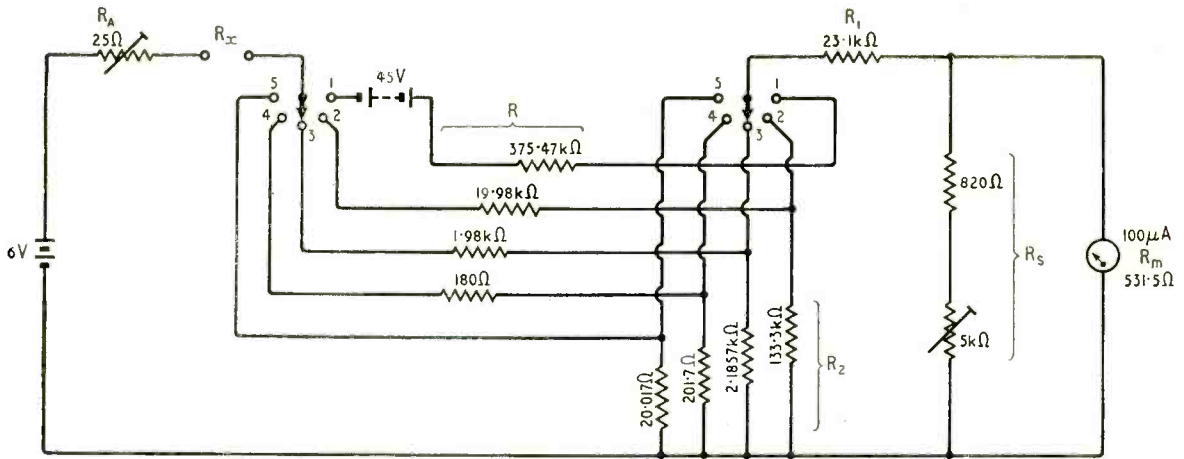

Fig. 5. Complete circuit diagram of a 5-range series ohmmeter covering about 4Ω to 4MΩ.

its five ranges the ohmmeter covers 12.6 Ω to 1.26 MΩ with good accuracy, or 4 Ω to 4 MΩ with moderate accuracy. Outside this range it will give rough indications of resistance up to some 20 MΩ.

If range 1 with the 45-V battery is omitted, the top figures are all one-tenth. This would apply also to a redesigned instrument using a 45-V battery but with a 1-mA meter movement.

If the resistor values are precise the zero adjustments hold for all ranges except the top one, where, as the battery is changed, a readjustment becomes necessary. If they are not precise and a readjustment of R_s is made on each range this cancels the e.m.f. error, but leaves an error due to the change of R_T . This can be quite small even for quite a large change of zero adjustment between one range and the next, depending on just where the error occurs.

It is necessary that the values of R_2 should be especially accurate on ranges 4 and 5, for it is necessary that the e.m.f. compensation should hold accurately between these two ranges. Then R_s can be adjusted on range 4 and R_A on range 5 until the meter reads zero resistance on both ranges.

The procedure for zero adjustment on any range except range 5 is to short-circuit the R_x terminals and to adjust R_s to zero ohms on the scale; that is, to full-scale current deflection. Except on ranges 4 and 5, the setting of the resistance compensator R_A has a negligible effect. Having adjusted R_s on range 4, adjust R_A on range 5; readjust R_s on range 4 and then R_A on range 5. Continue alternately until the meter reads zero ohms when switched to either range. Once R_A has been so set it needs no further adjustment until the battery resistance changes. However, R_s may need slight readjustment on other ranges and will nearly always need it on range 1. However, after a readjustment of R_s only, R_A does not need further alteration until the battery resistance changes. R_A need be adjusted only when it is found that there is a change of zero between ranges 4 and 5.

It is now pertinent to enquire what sort of errors are likely to exist and we shall assume that in every case the instrument is properly zeroed for the range

concerned. Now $\frac{R_m R_s}{R_m + R_s}$ varies by $\pm 53.28 \Omega$, so R_1' varies by the same amount or $5328/23.530 = 0.225\%$. In addition, there is the tolerance on R_1

itself. If this is $\pm 1\%$, the variation of R_1 is $\pm 0.231 \text{ k}\Omega$. The total variation of R_1' is thus $0.284 \text{ k}\Omega$, giving an error of $\pm 284/23.53 = \pm 1.2\%$.

On range 1, with $\pm 1\%$ resistors, the possible variations are $\pm 1 \text{ k}\Omega$ for the battery, $\pm 3.7547 \text{ k}\Omega$ for R , and $\pm 0.284 \text{ k}\Omega$ for R_1' , a total of $5.04 \text{ k}\Omega$ in $400 \text{ k}\Omega$. The error is thus $\pm 1.26\%$.

Accuracy

On other ranges, R_1' and R_2 come in parallel and errors have two different effects. If the errors are of the same magnitude and sign the current division ratio is unaffected, but R_2' is in error by the same percentage. If the errors are of the same magnitude but of opposite sign the current division ratio is affected but R_2' is altered very little when R_2 and R_1' are of similar magnitude. A change in the current division ratio does not affect the accuracy appreciably but merely calls for a different adjustment of R_s to correct for it.

Let x be the fractional tolerance on R_1' , y that on R_2 and z that on R_2' , then

$$R_2'(1+z) = \frac{R_1'(1+x)R_2(1+y)}{R_1'(1+x) + R_2(1+y)}$$

whence

$$z = \frac{\pm yR_1'(1+x) \pm xR_2(1+y)}{R_1'(1+x) + R_2(1+y)} \\ \approx \frac{\pm yR_1' \pm xR_2}{R_1' + R_2}$$

The error z is always greatest when x and y are of the same sign, so we need only consider this. In our case, we have $x = 0.012$, $y = 0.01$. On range 2

$$z = \pm \frac{0.01 \times 23.53 + 0.012 \times 133.3}{23.53 + 133.3} = 0.01165$$

and as R_2' is $20 \text{ k}\Omega$ this is an error of $0.233 \text{ k}\Omega$. The error in R is $\pm 0.1998 \text{ k}\Omega$ and so the error in R_T is $0.433 \text{ k}\Omega$ or 1.08% . On range 3, the error in R_2' is about $\pm 1.02\%$, so the total error in R_T is just a shade over 1% .

As R_2 falls in value, the effect of R_1' becomes less and less and the error in R_2' becomes negligibly different from the error in R_2 alone. Range 4 will thus give 1% error, considered by itself.

On range 5 conditions are different, for ranges 4 and 5 are adjusted together to compensate for battery resistance. The e.m.f. adjustment is made on range 4 only, consequently a change in the current-division ratio between the ranges leads to an incorrect value of R_A and so to a change of R_T . The worst case occurs when the errors in R_1' and R_2 are of opposite sign on one range and the same sign on the other. The current division ratio can then change by 2% (very nearly) between ranges.

Assume now that on range 4 battery resistance is still negligible. R_T may be 1% out and this leads to a certain setting of the total current-division ratio which is 1% different from the ideal value. This is the overall ratio set by R_2 , R_1 , R_s and R_m . If R_T is high the current-division ratio is low and vice versa. There are two possibilities. If R_T is high and the division ratio of R_2 and R_1' is low the ratio of R_s and R_m becomes the correct one, but if the division ratio of R_2 and R_1' is 1% high also, the ratio of R_s and R_m becomes 2% low.

Now on range 5 any error in the ratio of R_s and R_m is carried over and if on this range the current-division ratio of R_2 and R_1' is in error in the opposite sense to that on range 4, it is an extra error. Thus, if it is 1% low, the total current division ratio becomes 3%. Now on this range the value of R_T is adjusted with reference to the current-division ratio. It is assumed to have been set correctly on range 4 to suit the battery voltage, any error therefore leads to an equal error in R_T and may be as much as 3%.

Using $\pm 1\%$ tolerance resistors throughout the electrical errors on ranges 1-4 should be less than $\pm 1.5\%$ and not more than $\pm 3\%$ on range 5. The error on range 5 can be greatly reduced if it can be arranged that the errors in R_2 for ranges 4 and 5 are of the same sign.

To these figures must be added the reading errors of the meter used which depend mainly on the meter itself—its length of scale, the fineness of graduation of the scale, the pointer thickness, parallax and so on. In addition, there are the calibration errors. These can be small if the scale is calibrated directly using close tolerance resistors, but if it is done by calculation from the current scale of the meter, the accuracy of this current scale must be taken into account. This is only $\pm 1\%$ over the upper regions of the scale for the usual B.S.1. grade meter.

Even when considerable care is taken, it is doubtful

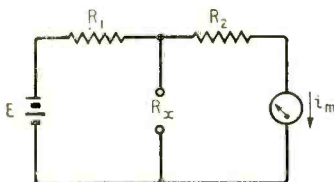

Fig. 6. Basic circuit of shunt ohmmeter.

Fig. 7. Multi-range shunt ohmmeter.

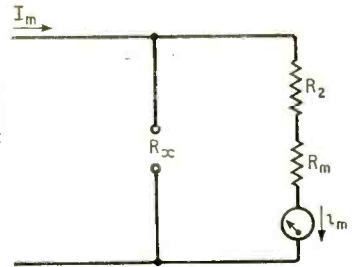
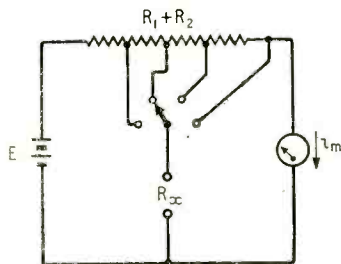

Fig. 8. Idealized form of shunt ohmmeter fed from a constant-current source.

whether an overall accuracy of much better than $\pm 5\%$ is obtainable.

While the form of ohmmeter shown in Fig. 5 is probably the one best suited to radio work, some mention should be made of the shunt ohmmeter. This has the basic circuit of Fig. 6; ignoring battery and meter resistance for the time being, conditions are arranged so that the meter reads full scale when R_x is infinite. This requires $E = I_m (R_1 + R_2)$. The connection of R_x then shunts some of the current from the meter and reduces its reading. When R_x is zero, all the current is diverted and the meter reads zero.

Like the series ohmmeter, the scale covers all possible resistance values but it is reversed left to right. Zero ohms correspond to zero current in the meter and infinite ohms to full-scale current. The basic equation is

$$\frac{I_m}{I_m} = \frac{E}{I_m (R_1 + R_2)} \cdot \frac{1}{1 + R_T/R_x}$$

where $R_T = R_1 R_2 / (R_1 + R_2)$.

The law of the scale is precisely the same as that of the series ohmmeter but reversed left to right, so all the earlier remarks about the reading accuracy apply with equal force. The range is still set by the value of R_T and the same definition of R_T applies—namely, it is the internal resistance of the instrument viewed from the R_x terminals.

However, R_T is always lower with a shunt ohmmeter than with a series type. In Fig. 6 it is the value of R_1 and R_2 in parallel and is a maximum when R_1 and R_2 are equal. As a series ohmmeter, R_T would be $R_1 + R_2 = E/I_m$. As a shunt ohmmeter, the maximum value of R_T is $(R_1 + R_2)/4 = E/4I_m$. For the same battery and meter, the maximum resistance range of a shunt ohmmeter is one-quarter of that of a series ohmmeter.

Since the value of R_T depends on R_1 and R_2 in parallel but the full-scale current I_m upon R_1 and R_2 in series, it is possible to change R_T and the mid-scale range without affecting the zero adjustment in any way. By using a tapped resistance for R_1 and R_2 the range can be changed merely by varying the position along it at which R_x is connected, as shown in Fig. 7. Unfortunately, the number of ranges obtainable in this way is not very large unless the battery voltage is high, for the minimum range is that of the meter resistance. With a 50-V battery and a 100- μ A meter, $R_1 + R_2$ is 500 k Ω . The top range is thus 125 k Ω and lower ranges of 12.5 k Ω and 1.25 k Ω are obtainable, but a range of 125 Ω is not, because it is less than the meter resistance of some 500 Ω .

By shunting the meter, or using a less sensitive one, the lower ranges can be extended indefinitely but at

the expense of the beautifully simple switching of Fig. 7. If the meter is shunted, R_1 and R_2 must be changed also.

For low-resistance ranges, the resistance of the meter R_m becomes small compared with R_1 and the ohmmeter tends to the limiting form of Fig. 8 where a constant-current source supplies the current $I_m (\approx E/R_1)$ and $R_T \approx R_2 + R_m$. To reduce the range to one-tenth, $R_2 + R_m$ is shunted by $(R_2 + R_m)/9$ and I_m is increased to $10 I_m$.

With a basic 100- μ A meter movement, $R_2 + R_m$ might be 600 Ω and this would be one mid-scale range. By increasing the current to 1 mA and shunting $R_2 + R_m$, a 60- Ω range could be obtained. By repeating the process, ranges of 6 Ω for 10 mA, 0.6 Ω for 100 mA and so on, could be obtained.

For a given low-resistance range the current is much lower than with the series ohmmeter. As against this must be set the fact that the current drain is continuous whereas in the series ohmmeter

it flows only when R_x is actually connected. If it is used in the same manner as a series ohmmeter, therefore, the current may well flow for hundreds, or even thousands, of times as long as with the series type. The initial advantage of a lower current may thus be quite nullified; in fact, the battery life may be much shorter.

For reasonable battery life with the shunt ohmmeter one must acquire different habits and it is a good plan to include a "Press to Read" switch in series with the battery. But it is inconvenient.

It is largely because of this that the shunt ohmmeter is so rarely used. It is not, therefore, proposed to go into battery compensation in any great detail. It is sufficient to say that resistance compensation is usually unnecessary, for R_1 can usually be kept large compared with changes in the battery resistance. Compensation for variations of e.m.f. is necessary and is probably best carried out by a potentiometer across the battery.

COLOUR TELEVISION

AS an experiment in colour television, Pyc Ltd. installed cameras on the roof of a building overlooking Parliament Square in order to televise a part of the Coronation procession. Receivers were installed at the Children's Hospital, Great Ormond Street, connected by a radio link operating at 575 Mc/s.

A demonstration was given on the previous day in which two directly-viewed receivers were used to give pictures of 16 in by 12 in and a projection set to give a picture of 4 ft by 3 ft. Some trouble occurred at times during the tests and was stated to be due to rain in one of the transmitter units. Apart from this, excellent pictures were seen, the definition and the colour rendering both being good. Compared with the directly-viewed pictures, the projected picture appeared rather "washy," however, probably because of its lower brightness.

A frame-sequential system was used with 50 complete pictures per second and 150 colour frames. At the camera, a colour disc was used but at the receiver colour tubes were employed for direct viewing. No details of the projection system were given.

The colour tubes were of the Lawrence type and were made by Chromatic Television Inc. of America. The operating principle of these tubes has been previously described¹. The screen is built up in strips of three differently-coloured fluorescent materials, red, green and blue. The strips are 0.015 in wide and alternate in a regular sequence across the face of the tube. Behind each red strip is a wire of 0.004 in diameter and behind each blue strip is another similar wire. All red wires are joined together and all blue wires are similarly connected. A deflecting voltage is applied in push-pull between the two sets of wires.

The tube has a single gun and focusing and scanning are accomplished in the normal way. When the colour-deflecting voltage is zero, the wires screen the blue and red strips from the electron beam which passes between them to fall on a green strip only.

When the colour-deflecting voltage has the proper value and one polarity, it deflects the electrons passing between the wires so that they fall on a blue strip. Similarly, when the voltage has the opposite polarity the deflection is in the opposite direction and the electrons land on a red strip.

In this type of tube a typical sequence of the colour strips is Green, Blue, Green, Red, Green, Blue, Green, Red, Green, Blue, etc., as shown in Fig. 1(a). When both sets of rods are at the same potential the colour deflection, which is subsidiary and is superimposed on the ordinary scanning deflection as a "wobble," is zero (b). When the red rods are positive and the blue negative, the colour deflection is to the red (c)

Fig. 1. At (a) is shown a section through the colour screen and colour-deflecting rods while in (b), (c) and (d) the path of the beam between a pair of rods is sketched for the three possible colour conditions.

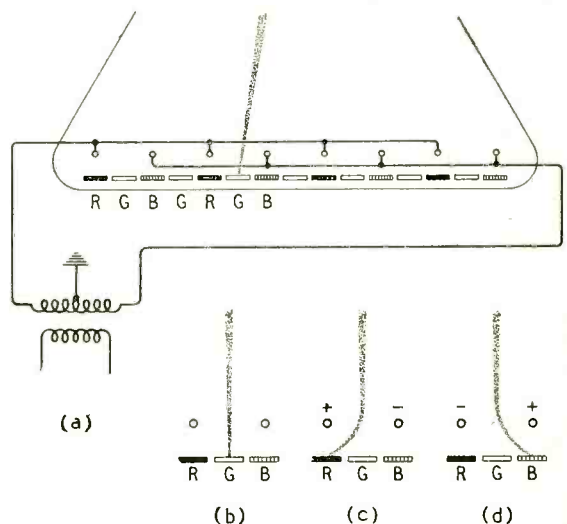

¹ *Tele-Tech*, November 1951; *Electronics*, November and December 1951.

and when the red rods are negative and the blue positive it is to the blue (d).

Post-deflection acceleration is used so that operation at around 16kV can be secured without excessive deflecting power. The colour deflection requires a supply of about 300—400 V and the total capacitance of the grid wires is considerable. In its original form, this resulted in the tube's being only suitable for a frame-sequential system where, because of the low colour-repetition frequency, the necessary voltage could be developed across the high capacitance with the expenditure of quite small energy. It is stated, however, that recent developments have made it possible to reduce the deflecting power sufficiently to

render the use of the tube practicable for other systems.

Reproduction with this tube appears to be free from the irritating momentary loss of colour frames on moving the eyes which has been observed in reproducers using a rotating disc. This is probably because an effective overlap of the colour frames can be obtained by arranging for the decay time of the phosphors to be such that one colour frame is not extinguished before its successor. This is impossible with a disc.

The experiment demonstrated a considerable advance in colour television in so far as the reproduction of the picture is concerned.

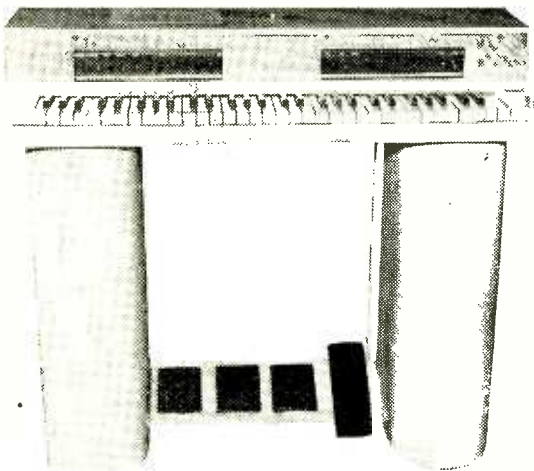

Electronic organ designed by R. E. Winn and awarded the President's Trophy and the Wireless World Prize in the amateur constructors' competition.

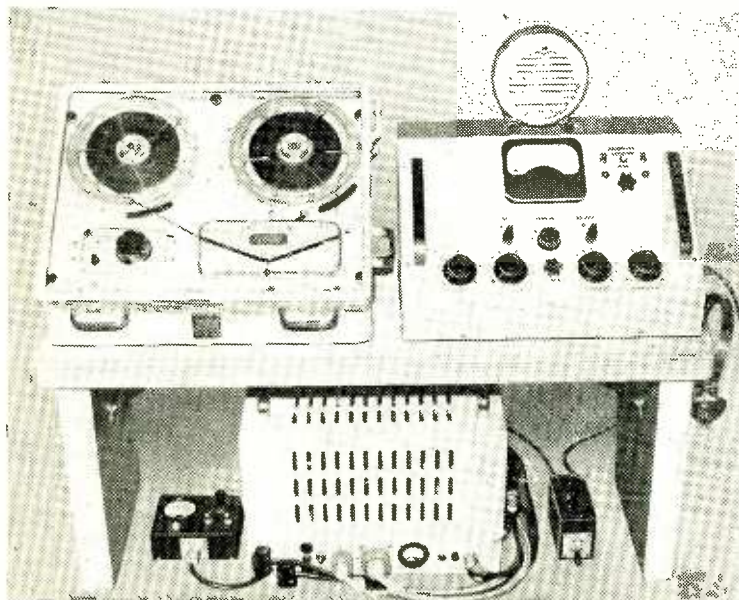

Magnetic tape recording equipment made by H. Silver and awarded the Committee Prize.

AMATEUR CONSTRUCTORS' EXHIBITION

Prize winners in this Year's B.S.R.A. Competition

THE competition organized by the British Sound Recording Association for the best amateur-constructed sound reproducing equipment paid tribute, both in the variety and quality of the exhibits, to the enthusiasm and skill of the Association's "Constructors Circle," which was formed recently to encourage and instruct members who have an interest in designing and building their own equipment.

The premier award went to R. E. Winn for a 5-octave "electronic" organ incorporating rotary electromagnetic generators, a wide range of harmonic filters and an electro-acoustic synthetic reverberation device in which a spiral steel wire was used as a delay line. The judges also decided to award the *Wireless World* prize for this exhibit, on the score of ingenuity in the integration of several basic principles and for general planning and design.

The Committee Prize went to H. Silver for a studio-type magnetic tape recorder of comprehensive specification and excellent finish. The equipment is divided into three units. The first consists of a Type B Ferrograph tape mechanism with three leads, and the second is a combined pre-amplifier and control unit for mixing two microphones and a radio input. It provides six alternative response characteristics, and a change-over switch permits aural comparison between the incoming and the recorded programmes. The third unit comprises the main amplifiers and power supplies.

WAVES and AERIALS

The Ether as a Transmission Line

SOME people object to analogies. They will probably object to that statement of mine too, unless I put it more precisely and say that what they object to is the use of analogies as a help in explaining or understanding things. Their objection is that an analogy doesn't prove anything, and may actually mislead. They would think it very wrong of me to try to explain to a beginner what an electric current is by talking about water flowing through pipes, because the fact that one can say some things about water in pipes that are true about electric currents in wires might lead him to suppose that if he cut the wire the electricity would gush out. They no doubt have such enlightened intellects that they can apprehend new things fully without any such crude aids. If so they are lucky, but have no right to criticize poor morons like ourselves who need some picture in our minds to help us. In any case I don't think we need bother any more about them. I can think of at least one very precise and critical and learned authority on electrical principles who does not hesitate to use analogies.

One of the pleasures of life is finding something that is a perfect fit. That is the basis of jigsaw puzzles, of course. But a good analogy is better than a jigsaw puzzle, because instead of being just an arbitrarily cut outline it is part of a beautiful natural design. Add to the pleasure of tracing such a design the satisfaction of discovering that you have two or more sets of relationships for very little more than the price (in mental effort) of one, and it is not difficult to understand why analogies are in demand. Provided one is on guard against the risk of being misled by pursuing them too far, they can be recommended.

Circuits in Space

Some time ago* I dealt with the analogy between current, voltage, resistance, series, parallel, etc., on the one hand, and voltage, current, conductance, parallel, series, etc., on the other. Having found a relationship between one lot, you can straightaway use it for the other, instead of having to learn it all up as a separate subject. Not only does it save time and effort; it is what the high-class writers call more elegant, by which they mean that the method is so neat that it gives pleasure even to think about.

If you read last month's instalment, on radio waves, I wonder if you noticed another and even more interesting analogy. You remember I assumed that most people know where they are with circuits but are somewhat hazy about the mechanism of waves in space. So I began with an electromagnet consisting

of a loop of wire and a battery, which everyone can understand more or less, and showed what would follow from the basic laws of electricity if it were dragged across the sky at high speed. The movement of the magnetic field would cause an electric field, which would drive a current causing the magnetic field which would cause the electric field which . . . and so on *ad inf.* At a sufficiently high speed—299,792,000 metres per second, to be tolerably precise—the two fields are mutually supporting, without any circuital apparatus at all. Although one can continue to think of waves of e.m.f. and (displacement) current, it is better to grow out of this circuit-bound point of view and think in terms of fields alone.

A butterfly emerging from its static chrysalis probably shares the same initial difficulty in feeling at home in unrestricted three-dimensional space, but it is worth while. When that freedom has been won, current and voltage in a circuit can be regarded as just a rather special case of a general field system.

Emerging from the chrysalis can be made less painful by making full use of analogy. In finding the strength of the magnetic field we started from the fact that it is proportional to the current flowing around the path of the field. But it also depends on the path length of the field; a long path necessitates more current to maintain a given field strength. (Here, of course, is an analogy with Ohm's law that is worth stopping a moment to consider. A long circuit path necessitates more e.m.f. to maintain a given current.) The magnetic field strength, denoted by H , is proportional to the ampere-turns per unit length of field. In the now superseded c.g.s. system of units the unit of H —the oersted—is equal to 0.4π times the ampere-turns per centimetre length of magnetic field path. The m.k.s. system abolished the 0.4π because it doesn't make sense, and (in order to bring volts, amps, etc., into itself) substituted metre for centimetre. On the assumption that "amperes" means the total current around the magnetic field, equal to amps per turn multiplied by number of turns, the unit of H is now the amp per metre, which makes much clearer the close relationship between current in a circuit and magnetic field in space.

"Ohm's Law" of the Ether

The same sort of relationship exists between electric field and voltage; the electric field (ϵ) is measured in volts per metre. So the beginnings of an analogy between circuit and space ought by now to be seen looming through the mist. For current in amps, substitute magnetic field in amps per metre; for p.d. in volts, substitute electric field in volts per metre.

By

"CATHODE RAY"

* "Duals." April 1952. p. 152.

Since space is measured by distance, the appearance of the "per metre" is quite natural. Now this is where one begins to try the "fit" of the analogy, to see where it leads. The simplest relationship between voltage and current is Ohm's law; the ratio V/I in volts and amps gives the resistance of the circuit in ohms—or the impedance, if a.c. If we divide ϵ in volts per metre by H in amps per metre the metres cancel out, so the result also has the dimensions of an impedance in ohms. This idea is not particularly helpful if the fields are caused wholly or partly by circuits. Just as Ohm's law wouldn't work if field ratios were brought into it, so the corresponding law for fields makes no sense if currents and voltages, which belong to circuits, are brought in. The only situation in which fields depend exclusively on one another is when they are travelling as waves, and then the ratio ϵ/H depends on what the waves are travelling through. Last month we found that in electromagnetic waves $\epsilon = v\mu I$, which in a one-metre cube is the same as $\epsilon = v\mu H$. We also found that $v = 1/\sqrt{(\mu\kappa)}$. (v is the velocity of the waves, μ the permeability of space, and κ the permittivity of space.) Substituting this in the first we get

$$\frac{\epsilon}{H} = v\mu = \frac{\mu}{\sqrt{\mu\kappa}} = \sqrt{\frac{\mu}{\kappa}}$$

In empty space, $\mu = 4\pi/10^7$ and κ is practically

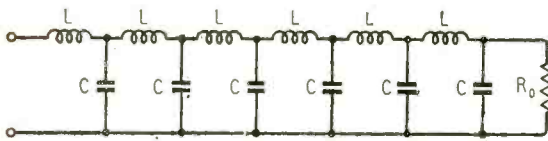
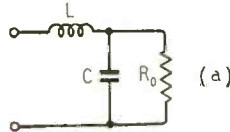

(b)

Fig. 1. The effect of shunting a small capacitance across a resistance can be neutralized by a small series inductance, so that the combination (a) is still equivalent to the resistance R_0 , except for a small phase delay between the terminals and R_0 . This can be repeated any number of times (b), giving an approximation to a transmission line with a "characteristic resistance" equal to R_0 .

Fig. 2. How a conducting sheet causes reflection of waves by generating additional waves (shown dotted) that cancel out in the original direction and add in the reverse direction.

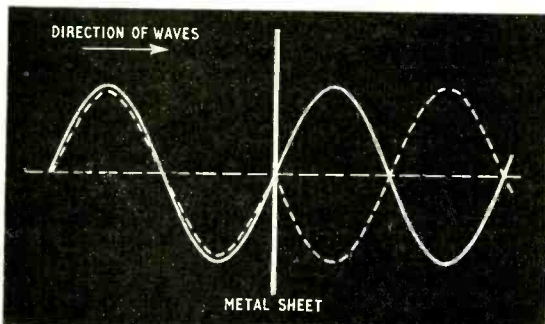

$1/(36\pi \times 10^9)$; putting in these values, we then get:

$$\frac{\epsilon}{H} = \sqrt{\frac{4\pi \times 36\pi \times 10^9}{10^7}} = 120\pi = 377$$

This is the ratio that the electric and magnetic field strengths in waves through space must bear to one another; $\epsilon = 377H$. It should not be taken to mean that the electric field is 377 times as strong as the magnetic field, for the actual figure depends on the units employed. The only proper way to compare the two field strengths is to use a standard of reckoning that is common to both, namely energy. When that is done it is found that they are equal. The meaning of the 377, if our analogy is a safe guide, is the impedance of space to electromagnetic waves, in ohms. We know already that ϵ and H are in phase, so we conclude that this impedance, ϵ/H , is a resistance.

Waves Along a Line

The fact that the impedance of space is a resistance may seem to be a flaw in the analogy, for a resistance in a circuit is an absorber of energy, and we know that empty space absorbs none of the energy of waves going through it. The analogy certainly does break down at this point if waves through space are compared with currents through ordinary circuits, but it can be restored by making the comparison with waves along a transmission line. This was my subject in July and August 1950; I will just recall that the action of a line also can be approached from the circuit point of view, as in Fig. 1(a), where a resistance R_0 is shunted by a small capacitance C . The reactance of C can be neutralized by a small series inductance L , and if the right value has been chosen the impedance between the terminals is a resistance equal to R_0 . The process of adding C and L can be repeated indefinitely, as in Fig. 1(b), with the same result, that the terminal impedance is equal to R_0 . An a.c. generator connected to the terminals cannot tell whether it is supplying R_0 directly or through a long chain of reactances. The practical difference is that this chain introduces a time lag. A transmission line or cable is electrically equivalent to such a chain in which the links are so small and so numerous as to be indistinguishable. When the generator is connected to the line terminals its power flows into the line, but it is only after a time lag that it is absorbed in the actual resistance R_0 . So although the line looks to the generator like a resistance because it takes away its energy and gives none back, it does not itself actually absorb any—being made up of reactance only, it cannot—but simply passes it on to a real resistance. It is exactly in this sense that space is and is not a resistance.

R_0 , the so-called characteristic resistance of a line, is well known to be equal to $\sqrt{L/C}$, where L and C are the inductance and capacitance per unit length. We found that resistance to free waves is $\sqrt{(\mu/\kappa)}$, and it should give us no surprise to see that μ is analogous to L , and κ to C , for of course the L and C of lines and circuit parts are proportional to the μ and κ of the space around. The analogy fits even closer: if you were to calculate the capacitance between plates with an area of one square metre spaced one metre apart (assuming uniform field in the space) you would find it to be κ farads, and as the κ of space (in m.k.s. units) is $1/(36\pi \times 10^9)$ the answer is 8.854pF. So a way of expressing the value of κ_0 (the κ of space) that brings out its significance is as 8.854pF per metre.

Arguing along the same lines for μ we would say that for space it is $0.4\pi \times 10^{-8}$ or $1.257 \mu\text{H}$ per metre. (Don't be misled by the fact that μ stands for both permeability and "micro"—among other things!)

Air has almost exactly the same μ and κ as empty space, so its resistance to waves is almost the same. But suppose we transmit waves through a block of glass, whose μ is the same as space but its κ might be six times as much. If so its ϵ/H , being $\sqrt{(\mu/\kappa)}$, works out at 154 ohms. One would expect it to be lower than for air because a capacitor with glass substituted for air between the plates has a higher capacitance, which means that its impedance is less.

On the other hand magnetic materials, with a high μ/κ ratio, have a higher impedance, analogous to the higher impedance of a coil when an iron core is fitted.

Another thing that depends on μ and κ is v , the velocity of the waves. It is, in fact, equal to $1/\sqrt{(\mu\kappa)}$ as we have found already. So when the waves come to a block of the kind of glass just considered they slow down to $1/\sqrt{6}$ of the speed, which is 122 million metres or only about 76,600 miles per second. Increasing μ also slows them, so presumably they proceed through Ferroxcube at a mere crawl.

Since in this country at least the general public still identify broadcasting stations by wavelength, it may not be realized by everyone that the wavelength of a given transmission is not fixed, like its frequency,* but depends on what the waves are travelling through. If a station broadcasts on 1 Mc/s it is bound to push out one cycle every microsecond, but the distance travelled by a wave during that time, which is the wavelength, obviously depends on how fast it is travelling. In space it is 300 metres, and that would be the figure given in the *Radio Times*, but within the block of glass the wavelength of the same transmission would be only 123 metres. So that is another argument for frequencies rather than wavelengths.

Of course the same thing applies to waves along lines; that is why the peaks of successive waves are closer together along a cable with solid dielectric than they would be along an air-spaced feeder.

And so one could pursue the analogy further and learn a lot in the process. I recommend anyone who wants to do so to study a paper by Dr. H. G. Booker, "The Elements of Wave Propagation Using the Impedance Concept," published in the *Journal of the I.E.E.*, Part III, May 1947. In particular, it is very enlightening to compare what happens when radio waves come up against something or other with what happens when waves travelling along a line reach the impedance at the end. If the load impedance is a resistance R_0 , all the energy is absorbed, but if it is anything else some at least is reflected. A pure reactance, being unable to absorb any energy permanently, reflects everything.

How does a sheet of highly conducting metal appear to a radio wave that comes up against it? Not as a resistance presumably. The difference of potential in the wave will cause currents in the sheet, and these currents will cause corresponding magnetic fields additional to those of the impinging wave. So the sheet turns out to be analogous to an inductive reactance. Actually the alternating currents in it launch waves that cancel out the original waves in the original direction and double them in the opposite

* The critical reader will point out that to an observer accelerating towards or away from the sender the frequency is not fixed either, but even when taking off in one's spaceship the selectivity would have to be rather excessive for serious mistuning to be experienced!

Fig. 3. Simple representation of a single-turn frame aerial of height h and width w , showing how the net e.m.f. generated around it depends on a phase difference in the arriving waves.

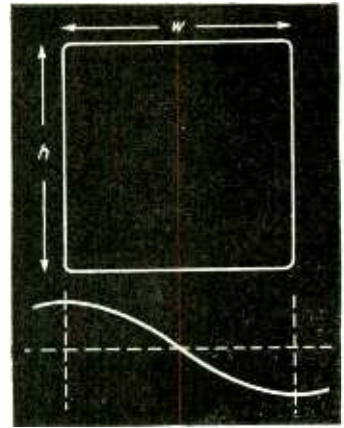

direction, as in Fig. 2, so the net effect can reasonably be called reflection. This is analogous to a transmission line terminated by a short-circuit.

It may also remind us of the behaviour of the reflector in a television aerial, considered two months ago. At least it reminds me of my intention to finish where many radio waves finish—at the receiving aerial. The question that started off the last two instalments, you may remember, was whether the signal in the aerial was caused by the electric field or the magnetic field in a radio wave, and the conclusion was that the electrons in the aerial, whose movements are the signal current, are directly affected by the electric field, but since the electric field in radiation (in contrast to induced electric fields, close to the source) is caused directly by the travelling magnetic field there is no reason why—if it suits us—we should not leave out the electric field stage and regard the signal as being caused by the magnetic field. The calculation can be done either way, and both are bound to give the same answer. But don't add them together!

Frame Aerials

Reception by a frame aerial is easier to understand than by an open aerial. We shall assume that the arriving waves are vertically polarized (i.e., electric field vertical and magnetic field horizontal), and that the aerial is h metres high and w metres wide and has only one turn (Fig. 3). The results are applicable to an N-turn aerial by multiplying by N .

Whichever field one happens to have in mind, the horizontal parts of the aerial clearly make no direct contribution. Each vertical part receives an e.m.f. of eh volts, and if these are in phase they tend to drive current round the aerial in opposite directions so the net result is nil. The purpose of the horizontals is to enable the two verticals to be placed where the e.m.f.s will not be in phase, so that there will be a net e.m.f. available for causing current. No amount of w is of any avail if the aerial is oriented so that the verticals are equally distant from the sender; i.e., if the aerial receives the waves broadside on. The maximum difference in distance, equal of course to w , is when the aerial is edge on, with the sender in its plane. The difference in phase depends on the ratio of w to λ , the wavelength. The greatest difference is when w is half λ , as suggested by the waveform underneath in Fig. 3, because then the e.m.f.s received by the verticals are 180° out of phase, so are exactly in phase round the aerial, giving a total e.m.f. of

$2\epsilon h$ volts. But in practice w is almost invariably less than $\lambda/2$ —usually much less—so the effective e.m.f. is less. Anybody who wants a little exercise in trigonometry will probably be able to prove that it is $2\epsilon h \sin(\pi w/\lambda)$. The angle $\pi w/\lambda$ is in radians, and as the sine of an angle in radians is almost equal to the angle when it is small, “sin” can be omitted when w is not more than about $\lambda/10$; when this is done the formula is $2\epsilon h w \pi/\lambda$, and we notice that hw is simply the area of the aerial. For a given area, the shape of the aerial makes no difference to the amount of signal received; a circular one has the lowest resistance, other things being equal, and a square one has the lowest resistance of any rectangle. Notice too that the signal received from a given strength of field is proportional to $1/\lambda$, that is to say the frequency.

Exactly the same results would be obtained by calculating the e.m.f. generated around the aerial by the periodic variations in magnetic flux passing through it, but most people would probably find the calculation a little harder. Obviously when the aerial is broadside-on no flux passes through it. When it is edge-on the maximum flux passes through it, but if it were of uniform strength there would be no variations and hence no signal; the flux entering at the left would be balanced by what was leaving at the right. This agrees with our previous view of the matter, for a uniform field means zero frequency. The field in radio waves, however, is not uniform—if it were they wouldn't be waves! Along the path of the wave the field alternates, so if the rate at which flux is entering the aerial from the left happens to be at peak field strength, the rate of leaving from the right must be less (assuming w is less than $\lambda/2$), and there is a net increase in linkage, generating an e.m.f. round the aerial.

Current in the Aerial

What makes the frame aerial relatively easy to reckon is that one can usually assume that the current is the same all round it. There is some difference owing to self-capacitance, but when the aerial dimensions are small compared with the wavelength this should not amount to much. But with an open aerial it is quite different, for the return path is via capacitance distributed all along its length, and one needs fairly advanced mathematics to cope with this.

There is no difficulty at all in calculating the e.m.f.; it is equal to ϵh , where h is the height measured parallel to ϵ . To simplify matters we shall assume that the aerial is parallel to ϵ , so h is its actual height. But the e.m.f. is of no practical interest if it does not enable one to calculate the current it can yield at the point where the aerial is connected to the receiver. One can measure the impedance of the aerial (including its connection to the receiver) at that point, but dividing ϵh (the received e.m.f.) by it gives a larger value of current than one in fact obtains. When testing a receiver the procedure is to connect the input through an impedance equal to that of a typical aerial to a signal generator capable of giving a known signal e.m.f. This e.m.f. is less than the e.m.f. ϵh generated in an aerial of the same impedance yielding the same input to the receiver. One method of allowing for this is to specify an effective height, h' , less than the actual height h , which when multiplied by the electric field strength ϵ gives the same value of e.m.f. as is required from the signal generator. For some types of aerial h' can be calculated. In a resonant half-

wave dipole $h' = 0.63h = 0.63\lambda/2$; in most other types it is less.

When I first began to think about reception by an open aerial I ran into a difficulty. I was applying the basic principle that if a piece of wire is in a varying magnetic field it has generated in it an e.m.f. proportional to the rate of variation. It happens if the wire is near a coil carrying an alternating current. If the peak value of current is kept constant while the frequency is raised, the rate of field variation increases in proportion to frequency and so the induced e.m.f. increases with frequency. Now I knew that this does not apply to an open aerial worked well below its resonant frequency. Yet for a given peak value of field, the rate of variation is proportional to frequency.

I first explained this apparent contradiction to myself by saying that it was due to confusing the generation of e.m.f. by a stationary but varying field close to a circuit carrying a.c. with that by radiated waves, where the variation is due to their moving past the aerial. So even if a “d.c.” radio wave were possible, in which the strength of the magnetic field did not vary at all, a steady e.m.f. would be generated by its movement. And no doubt this view could be substantiated by authorities, especially those who go in for the flux-cutting idea, for is not this what is happening? But I cut myself off from that line of retreat last month by pointing out that with flux-cutting one could never be sure unless one knew what was happening to the rest of the circuit. And this is none too clear with an open aerial, where the return path is through its capacitance spreading out vaguely into the surrounding space. But by following last month's argument, using the idea of flying electromagnets, it should be easier, for we saw that the higher the frequency the shorter the wavelength and the narrower the space each side of an aerial or other fixed line to contain the flux linked therewith. If this is still not clear the best thing is to think in terms of the electric field, whose peak value we know does not depend on frequency.

Of course, the current generated in an aerial by waves of a given strength usually does vary with frequency, but that is due to variations of impedance with frequency, which is quite another matter.

RADIO IN WORLD WAR II

EVERYONE knows that wireless has profoundly affected military strategy and tactics, though few have more than vague ideas on precisely how it is used. Now, for the first time, much detailed information has been published on the application and organization of military radio communication in the second World War. The book* in which this appears deals with the whole field of signals—including carrier pigeons—but naturally radio claims most of the limelight. The author does not discuss the technical design of Army sets, but does give the salient features of most of the well-known types, and also touches upon their relative performance.

The story of the Royal Corps of Signals in every theatre of war is told, and there are general chapters on such things as training, signal systems, Anglo-American co-operation and co-operation with the other fighting services. Apart from its historical value, the book is a valuable source of information for all concerned with the organization of communications on a big scale.

*“The History of British Army Signals in the Second World War.” By Major-General R. F. H. Nalder, C.B., O.B.E. Pp. 377. Published by Royal Signals Institution. Obtainable from Gale and Polden, Wellington Press, Aldershot. Price 17s 6d post free.

Rational Planning of Radio Channels

*A Book on the Conservation of
Our Natural Resources*

RADIO to-day is so diverse in its uses, and so supremely important in its general utility to mankind, that it must constantly affect the life of nearly every inhabitant of the earth. But for years past it has been impossible to utilize it with maximum efficiency. This is not so surprising when one considers that frequency allocations among services have not generally been made upon the basis of technical knowledge of propagation, but largely upon methods of expediency, and upon concepts which have long since been outmoded or shown to be false.

It is very desirable that such a valuable thing as the radio spectrum be properly used, and its resources taken care of in the same way as are those of other natural assets. The authors of a recently published book* compare its conservation with that of farm lands, forest reserves, water power and mineral wealth. It would appear to the present reviewer, however, that there is some difference between the two cases, for whereas all these assets are generally under the direct control of the national governments who set up the conserving authorities, the radio spectrum is not. A closer comparison would seem to be that of the conservation of the food fishes of the sea, which, like the radio spectrum, are outside the exclusive control of any one nation. Have we any occasion to hope that when men have had so little success in conserving the resources of the abounding, but not inexhaustible, sea, they will be any more successful in their use of a more intangible thing like the radio spectrum?

The authors of the book are fully aware of the difficulties surrounding the project, but this does not deter them in their work of formulating a conservation plan. Nor should it deter others from evincing an interest in this vitally important work.

History of Frequency Allocation.—The use of the radio spectrum has developed very gradually from about the turn of the present century, its first employment being almost exclusively for ship-to-ship and ship-to-shore communication. The frequency of operation was determined largely by the dimensions of the aerial systems, which, on board ship, were limited. The Second International Conference in 1906 allocated frequencies suitable for ships on this basis, among which were 600 metres (500 kc/s) as an international calling and distress wave, for which purpose it is still retained.

Larger aerial systems developed for point-to-point communication led to the use of lower frequencies, whilst improvements in apparatus, including the

introduction of the arc and the valve, made it possible to extend the usable spectrum at the high frequency end, so that in 1917, frequencies between 20 and 1500 kc/s were in use. The development of the valve was followed by the introduction of radio-telephony and by broadcasting. By 1922 long-distance communication on frequencies between 2 and 25 Mc/s was opening up. The frequencies most suitable for broadcasting were, however, already in use by the ship services, so broadcasting had to operate in the band 550-1500 kc/s, as the ships could not be moved to other frequencies. In 1927 the useful part of the spectrum was considered to extend to 25 Mc/s, but the Fourth International Conference in that year found certain services already established on the higher frequencies and so could not adopt an idealized allocation plan.

New services—navigational aids, aeronautical services, land mobile services, television and v.h.f. broadcasting—rapidly came into being, and the older ones expanded, and in 1938 the Sixth International Conference attempted to deal with all their demands. From 1939 to 1947 many advances took place, including the development of radar and the use of frequencies up to 10,000 Mc/s. H.F. broadcasting expanded so much that when the Seventh Conference was held in 1947 conditions in the h.f. bands were in a chaotic state. The Provisional Frequency Board was set up to prepare a master list of allocations, but this has never been accepted owing to the disagreements between the nations, and subsequent Conferences have all failed to achieve their objects.

Summing up this situation it may be said that the spectrum has become occupied with the radio services as time went on almost always before there was adequate knowledge of the behaviour of the frequencies. In the early days it was the dimensions of the aeriels which determined the bands occupied, then the limitations of equipment set the limits, and latterly frequencies have had to be allocated largely on the basis of avoiding those that were already in use. The result is very far from ideal. But now that the technical knowledge of propagation of the various frequencies is available it should be possible to correct the past errors and to re-create the frequency distribution structure on a properly engineered basis.

Propagation Characteristics.—A summary of the propagation characteristics for the various radio frequencies is then given. It occupies 107 pages and forms by far the longest chapter in the book. Considering that the frequencies dealt with range from 10 kc/s to 300,000 Mc/s (the extent of the spectrum now considered usable for radio purposes) it is not surprising that even a summary of these facts occupies

* "Radio Spectrum Conservation"; a Report of the Joint Technical Advisory Committee of the Institution of Radio Engineers and the Radio-Television Manufacturers' Association of the U.S.A. McGraw-Hill Book Company; price in U.K., 42s 6d.

so much space. The behaviour of radio waves, and the way they are affected by certain phenomena, varies so greatly throughout this huge range of frequencies that it is as if one were dealing with a totally different thing when one compares radio communication at one end with that at the other.

Notwithstanding that this is only a summary of radio propagation facts it is pretty comprehensive. Every known effect, variation and related phenomenon seems to have been touched upon. Further compression of all this mass of information is impossible—Nature does not permit it. Suffice it to say that in the allocation of the frequencies of the radio spectrum in an ideal way all this information needs to be taken into account, for only if this is done can the maximum utility of those frequencies be expected. Even so it must be borne in mind that the propagation knowledge cannot even yet be regarded as being by any means complete, for in certain parts of the spectrum, and notably at the extremely high-frequency end, a great deal still remains to be learnt.

Ideal Allocations.—With all this propagation knowledge at their disposal the authors then approach the problem of allocating the available frequencies on an ideal basis, taking into account the present and prospective needs, and current trends. It is assumed that no radio services already exist, and that the money which has been spent and the knowledge gained are now available to start a new radio industry. Also that the world is peaceful and that all nations are ready to co-operate in the work of making the most efficient use of the spectrum, so that it is not necessary to consider any military or political factors.

The allocations of frequency bands are made according to the *services* which would require to use them, as follows.

Fixed Services.—This includes all services between specified fixed points, except certain special services. To-day there is often a multiplicity of circuits between certain points, and it is proposed to combine numbers of existing services into single ones, carrying all communication between large centres. Modern information theory indicates that there are methods of conveying more intelligence in a given band in a given time than those at present in use. Super-high-frequency relay stations are proposed, which could supply the necessary bandwidth. Such a relay system, it is stated, involving stations located within the radio horizon of each other, could be built from New York to the southern tip of South America, and from New York through Alaska, across the Behring Strait into Asia, Europe and Africa, and *via* a chain of islands into Australia, the greatest distance between stations being about 90 miles. This system would be capable of giving wide-band service to all major population centres of the world. Taking all possibilities into consideration, the ideal frequency allocations for fixed services are 4.25-7 Mc/s, 9.5-12 Mc/s, 15-17 Mc/s, 21-25 Mc/s, 2,500-8,000 Mc/s and 10,000-13,000 Mc/s.

Mobile Services.—These are the services between fixed and mobile stations, and between mobile stations themselves, and are divided into maritime, land and aeronautical services. Radio is especially important for mobile stations, because it is often the only type of communication possible, and because communication is needed in the operation of mobile units for the protection of life and property.

Integration of a number of the present mobile services would lead to frequency economy, and a general mobile network interconnected with a fixed network

would provide much improved service. The mobile service must have frequencies for medium and long-distance communication, and frequencies between 2 and 25 Mc/s would be suitable for these purposes. There must also be provision for short-distance communication on land, on frequencies beginning at about 60 Mc/s, and for short-distance communication to aircraft—near 1,000 Mc/s. A band near 60 Mc/s and one near 800 Mc/s would take care of the different propagation conditions for land-mobile stations over average terrain and in built-up areas. The distress wave, which has always been at 500 kc/s, would be at 2 Mc/s. The ideal allocations for the mobile service are 2-4 Mc/s, 7.5-9.5 Mc/s, 12-14 Mc/s, 17-21 Mc/s, 54-100 Mc/s and 770-900 Mc/s.

Broadcast Services.—These are all the services intended for reception by the general public, and do not include services auxiliary to broadcasting (like radio links) which receive allocations under the fixed or mobile services. The frequency band for sound broadcasting should be such as will ensure a stable signal over large areas, and this is best achieved by ground-wave transmission on frequencies from 200-1,000 kc/s. V.H.F. transmissions on frequencies above 50 Mc/s are suitable for multiple-programme provision in large centres of population, with the l.f. transmitters serving less populated districts. As to h.f. "international" broadcasting, the authors do not seem to think much of it, describing it as an "inferior" broadcast service, due to the mode of propagation involved. However, to many people, such as to those at sea or residing in undeveloped or remote countries, it is often the only form of broadcasting available, a fact which the authors recognize, but which they do not appear to take account of. For, in fact, they propose to abolish h.f. broadcasting altogether, for the following reasons:— the audience is limited and specialized and it is thus uneconomic to attempt to improve their reception; under the peaceful conditions assumed there would be no need for propaganda broadcasts; the interchange of cultural programmes could be better effected over high-quality fixed circuits or by transcriptions and tape recordings; the number of persons at sea is insufficient to justify a large amount of h.f. space. Even tropical h.f. broadcasting can often be bettered by that on l.f.

Television services require wide bands and a stable transmission medium, and provision is made for these on frequencies above those subject to ionospheric phenomena, with a band about 600 Mc/s wide to accommodate multiple programmes. The ideal allocations for the broadcast services are 0.18-1.2 Mc/s (sound), 100-700 Mc/s (television and sound) and 700-720 Mc/s (sound).

Amateur Service.—It may seem a trifle inconsistent of the authors, after treating large numbers of present-day broadcast listeners in so cavalier a fashion as to deprive them of service altogether, to be prepared to allocate any frequencies to the 100,000 or so people throughout the world who use radio as a hobby. However, the authors deem it wise to encourage amateur radio, and to make provision for wide-band as well as narrow-band types of service, so as to allow for experimentation and investigation. In the ideal plan there should be allocations for amateurs of a number of frequency bands in harmonic relation where possible, the width of which would be determined by the requirements of other services having priority. Amateurs should also be allowed to use the industrial, scientific and medical bands, for the rather strange

reason that they can often accomplish some communication even in the presence of severe interference. The ideal allocations for amateurs are bands at 3.5, 7.0, 14, 28, 50, 720, 2,500, 5,000, 10,000, 20,000 and 30,000 Mc/s, which, considering the width of some of these bands, seems, in a conservation scheme, to be treating the amateurs more than liberally.

Radiolocation and Navigational Services.—The aeronautical services of the world are expanding rapidly and are placing increasing reliance on radio for navigation and traffic control. Instead, however, of there being a number of different radio aids, as at present, there should be developed a complete system, and the aeronautical aids required for overland flying could all be provided in a single band centred on 1,000 Mc/s. In general, this takes account of the needs of flying over land routes where control is from the ground. For long-distance navigation over seas a system using low-frequencies should be used. Airborne radar should be operated in a band at 9,000 Mc/s. Because the aeronautical service depends so much on radio for safety purposes and for navigation, and because the aircraft themselves are fast changing in their requirements, about twice as much spectrum space as is immediately needed should be allocated, in order to permit development.

The maritime services are considered to require a long-distance navigational aid and a short-distance aid for use in restricted waters where traffic is heavy. The long-distance aid should be the same one which is provided for long-distance aircraft over seas. Shipboard radar should provide the short-distance requirement, in conjunction with suitably placed responders, and, in some instances, with land-based radar. A medium-range radiolocation or navigation system might also be required in some areas.

Mobile units operating on land do not, at present, require a navigational service, but small bands near 2,000 kc/s and 900 Mc/s should be provided in case such a need develops. The ideal allocations for the radiolocation and navigational services are 0.12-0.18, 1.9-2.0, 900-1,900 and 8,300-9,600 Mc/s.

Special Services.—Examples of these are standard-frequency services, meteorological services and fixed and mobile services for forestry and other conservation operations, all requiring special treatment because of differences in their requirements from those of other similar services. Then there are the numerous applications for low-power "walkie-talkie" transmitters, etc. The standard-frequency service requires frequencies throughout the h.f. band, and some similar frequencies are necessary for conservation services. The bands 1-2.5 and 20-50 Mc/s are in the frequency range where propagation changes from one type to another, and, though subject to sky-wave interference at times, are not particularly useful for sky-wave communication. They could well be utilized for various types of low-power special services. The band 10-120 kc/s is considered useful for certain special services intended for reception over wide areas, and a further band is necessary at 1,900-2,400 Mc/s. But there remain many special uses for radio which it is impossible to consider in detail, and it is proposed that these requirements be met in the special service bands either on a shared basis or by sub-allocation. The ideal allocations for the special services are 0.01-0.12, 1.2-1.9, 25-50 and 1,900-2,400 Mc/s, with standard frequency bands at 2.5, 5, 10, 15, 20 and 25 Mc/s.

Industrial, Scientific and Medical Uses.—These are the services in which radiation is merely incidental, or,

if intended, does not convey intelligence. Examples are the use of radio for heating and for producing other reactions in certain substances. A great deal of the radiation from such devices could be prevented by suitable screening, and, since the devices do not interfere with each other, many can work in very narrow bands. Nevertheless, different frequency bands are required for different types of operation. There should therefore be a large number of bands in harmonic relation below 100 Mc/s and several bands above 100 Mc/s.

Time to Change.—The authors point out that changes in the present allocations will need to be nicely timed; if they are made too soon mistakes may be made, if too late it will be more difficult and costly to have them made at all. Examples are given of the well-established reluctance on the part of some users—notably in the maritime field—to adopt technological improvements even when the advantages of doing so have been clearly demonstrated. Many services, it can be shown, occupy parts of the spectrum not really suitable to them, and the fact that they remain where they are is largely due to economic forces which resist any change, and not to any technological limitations. If, however, the use of radio is to be conducted on a more realistic basis, so as to eliminate the present disadvantages and permit of rational development, allocation changes will have to be made, tending towards the substitution of the ideal for the present haphazard allocation plan.

Dynamic Conservation.—The last chapter gives some idea of steps which might be taken to accomplish this change, and to bring the actual allocation in line with the ideal.

For various reasons no fixed plan will meet the case: there must be a programme of dynamic conservation, in which, upon sound technical and economic principles, allocations are continually changed in favour of newer and more valuable services, as the older ones lessen in value. To this end it is necessary to consider all the uses of radio as they affect commerce, industry and the public welfare. A table of these "end uses of radio" is then given, comprising no fewer than 83 different uses to which radio is put, and by considering things in these terms a clearer view of exactly what is involved in the problem of spectrum allocation may be obtained.

"The limit of spectrum occupancy occurs when all portions of the spectrum are fully, continuously and uniformly utilized and each frequency assignment is employed by many stations so arranged that their service areas are adjacent but do not overlap." That is the definition of ideal occupancy given by the authors, but complete occupancy can never be fully realized for a variety of technical and economic limitations.

Whilst some of these can be overcome, there will always remain certain limitations set by Nature, or by the facts of social organization which it cannot be hoped to change. Technical and administrative measures which may be adopted to implement conservation should, above all, avoid hampering future development.

The following measures should be taken:—

(1) New services should be granted experimental assignments in all parts of the spectrum, but where it is shown that the functions of a new service can be performed by a non-radio service, non-radio services should be used, unless the radio service possesses overwhelming superiority.

(2) Frequency tolerances should be as small as the state of the art permits.

(3) Off-frequency operation and pirating should be rigidly suppressed.

(4) The use of guard bands should be curtailed.

(5) The most efficient modulation systems should be encouraged.

(6) Every method known for restricting the interference area of stations should be employed, such as restriction of power, suppression of harmonics, use of directional aeriels, etc.

(7) Services established in unsuitable parts of the spectrum should be transferred to other regions, and outmoded services deleted.

(8) Time and geographical frequency sharing should be made use of to a much greater extent than at present, such as, for example, between military and civilian services.

So much for technical considerations. The economic factors affecting dynamic conservation are equally numerous and important, but we shall not deal with them here.

Several examples of prospective changes in allocations which illustrate the technical and economic trends are then given. But the main changes, it is said, are likely to encounter resistance from those who are required to make alterations in equipment or operating procedures. But if they are shown to be technically sound and to be of ultimate benefit, it is in the public interest that they should be made. The authors think that when this is recognized, and when the changes are made so that undue financial hardship is avoided, this resistance will disappear, and will, in fact, be transformed into co-operation in the work of radio spectrum conservation. T. W. B.

Manufacturers' Literature

Telecommunications Equipment; an illustrated booklet reviewing in general terms the radio and line telegraphic and telephonic equipment developed by British Telecommunications Research, and describing briefly the company's establishment at Taplow Court, Bucks.

Timers for opening or closing circuits at intervals up to 60 seconds; short descriptions in a leaflet from the Electrical Remote Control Company, Elremco Works, East Industrial Estate, Harlow New Town, Essex.

Television Receiver, type TUG34A; a console model with a 14-in rectangular flat-faced tube described briefly in a leaflet from Bush Radio, Power Road, London, W.4.

Galvanometers, pointer and reflecting types; brief descriptions and specifications in an illustrated catalogue of various scientific instruments from W. G. Pye & Co., Granta Works, Cambridge.

A.C. Generator, driven by a petrol engine with a governor and producing an output of 250-300W at 220-250V, 50-60 c/s, and another of 12-15V d.c. for charging purposes. The engine is self-starting and has interference suppression. Specification on a leaflet from the Teddington Engineering Company, 29-31, High Street, Teddington, Middlesex.

Transmitter Capacitors, ceramic, for low- and medium-power working, in disc, tubular, plate and pot form. A technical bulletin (No. 29) from The Telegraph Condenser Company (Radio Division), North Acton, London, W.3. Also a technical bulletin (No. 30) on **Twin Mica Capacitors** designed as end plates of i.f. transformer assemblies.

Miniature H.T. Rectifiers, Types RM1, RM2 and RM3. Ratings, dimensions and weights in a leaflet from Standard Telephones and Cables, Rectifier Division, Warwick Road, Boreham Wood, Herts.

A.C. Voltage Stabilizer, using a servo-mechanism and giving an output voltage continuously variable between 200 and 240V with a regulation of within 1 per cent and an output current of 0-10A. Described in a leaflet from Servomex Controls, Crowborough Hill, Jarvis Brook, Sussex.

Height of the Ionosphere

New Evidence from Audio-frequency Atmospheric

AT the annual conversazione of the Royal Society on May 21st, more than a third of the exhibits were concerned with radio and electronic subjects, and one of these, arranged by L. R. O. Storey of the Cavendish Laboratory, is likely to prove of far-reaching importance in adding to our knowledge of the upper atmosphere.

Unlike most explorations into the ionosphere in which radio transmitters and receivers are involved, this latest research has been effected with no more complicated apparatus than a 30-ft aerial connected to an audio amplifier. Between aerial and amplifier a cathode follower and coaxial cable is interposed, presumably to enable the aerial to be erected in a site free from mains and other interference, while a magnetic tape recorder at the output from the amplifier preserves significant atmospheric for subsequent analysis.

The bandwidth of the input to the amplifier is restricted to 400-10,000 c/s and the disturbances investigated take the form of audio-frequency electromagnetic whistles, descending smoothly in frequency over periods up to 3 or 4 seconds in duration. The whistles originate in lightning discharges, and under favourable, i.e., stormy, conditions the output is reminiscent of a Ludwig Koch recording of a flight of widegon. In some cases the whistles can be correlated with "click" type atmospheric generated by local discharges, and from the time intervals involved it is deduced that part of the initial electromagnetic pulse travels upwards through the ionosphere at vertical incidence, is deflected to follow a path coincident with the lines of force of the earth's magnetic field, crosses the equator at a height of about 7,000 miles, descends through the ionosphere at a complementary latitude in the southern hemisphere, is reflected from the earth's surface and retraces its original path, to be heard at the point of origin as a long-drawn-out whistle. The whistle starts at high pitch and descends in frequency because the speed of propagation in the ionized medium is greater for high than for low frequencies. Thus the original pulse is analysed into its component frequencies which are presented in sequence to the observer. Lightning flashes originating in the southern hemisphere are heard in the northern hemisphere as whistles which can be identified by their different frequency dispersion in time, and by the absence of the initiating "click."

The path length, and the consequent delay and frequency dispersion, will depend on the latitude of origin and at the equator no whistling atmospheric should be heard. We understand that observations are now being made to verify this prediction. An upper limit of observation is set by the increasing rarity of thunderstorms as the poles are approached.

This unexpected incursion of audio-frequency techniques into the exploration of the ionosphere has produced startling results and has already called for a drastic revision of earlier estimates of the height of the atmosphere. Full results have not yet been published and until they are it is not profitable to guess whether this high-altitude propagation is due to an extension of atmospheric ionization processes as we know them or to extra-terrestrial matter coming under the influence of the earth's field.

Manufacturers' Products

NEW EQUIPMENT AND ACCESSORIES FOR RADIO AND ELECTRONICS

Lightweight Microphones

A RANGE of new lightweight hand microphones, housed in a polythene plastic case with thumb switch, has been introduced by Lustraphone, Ltd., St. Georges Works, Regents Park Road, London, N.W.1. Type HD/54 is fitted with the CI.51 moving-coil movement, and Types HC/54 and HC2/54 have single- and double-button carbon microphone inserts.

The spring-loaded switch can be connected in the microphone circuit or used for relay operation as a shorting, opening or changeover switch.

Lifeboat Transmitter

FOR installation in ships' lifeboats not normally fitted with radio, Venner Electronics, of Kingston By-Pass, New Malden, Surrey, have produced a small transmitter which automatically radiates SOS messages as long as the handle of its hand-driven generator is kept turning. It transmits on a fixed frequency of 2.182 Mc/s (the maritime R/T distress frequency) and has a range of 20 miles. The circuit consists of an EF40 crystal-controlled electron-coupled oscillator and an EL42 power amplifier, giving an output of 1 W into the 8-ft aerial.

The hand-driven generator is a d.c. dynamo with a 6-V l.t. winding and a 370-V h.t. winding feeding out through separate commutators. It has a slipping clutch which prevents the voltage from rising too high and

damaging the valves. This generator also drives a tone-wheel, for imposing a 1-kc/s modulation note on the transmission, and a code disc carrying the SOS messages.

The transmitter is housed in a water-tight metal case with lugs for fixing to the underside of a thwart. The generator handle folds in and the aerial is stowed away in two sections when not in use, so the whole equipment takes up very little room. It actually measures 12in x 6in x 5in and weighs 17lb. We understand the price is in the region of £30.

Electronic Humidity Control

THE affinity of very fine glass fibre for moisture is exploited in the "Humicon" moisture measuring and control instrument made by W. H. Sanders (Electronics), Ltd., 48, Dover Street, London, W.1. A cell formed by two 6-inch diameter perforated and rhodium-plated discs, separated by a ceramic ring, contains the fibre, and its resistance varies from 40 k Ω to 100 M Ω over the range of humidity from 100 to 42 per cent. The instrument is suitable for use in temperatures ranging from 0 to 90 degrees C.

In the control unit, an a.c. energized bridge samples the cell resistance and the out-of-balance voltage can be used to operate up to three thyatron-controlled relays for auxiliary control apparatus.

The control unit works from 200-250 V a.c. mains.

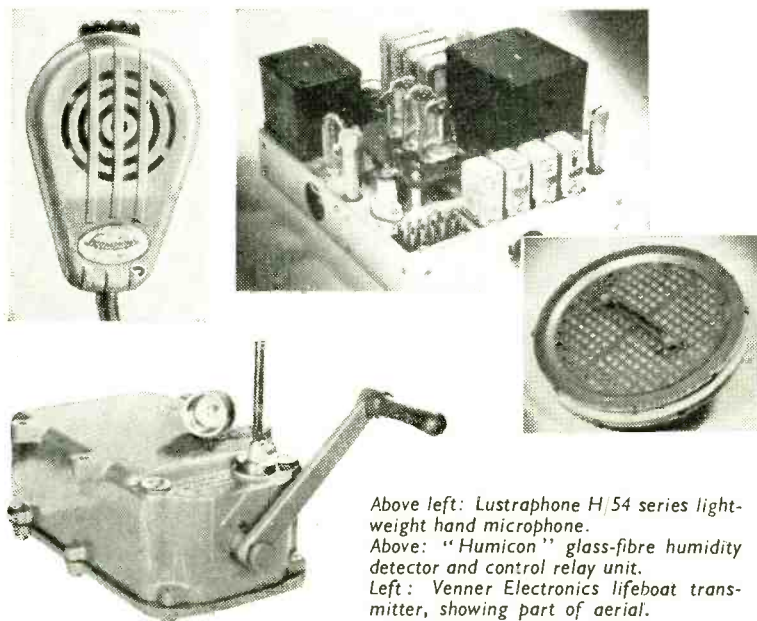

Above left: Lustraphone H/54 series lightweight hand microphone.

Above: "Humicon" glass-fibre humidity detector and control relay unit.

Left: Venner Electronics lifeboat transmitter, showing part of aerial.

Sound Policy

Our policy is to specialise in sound equipment. Sound problems are our problems and we have been solving them for over 25 years. For the usual or unusual in sound amplification install TRIX equipment. Information and advice is always at your disposal.

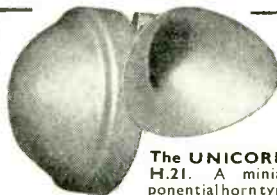

The UNICORN, model H.21. A miniature exponential horn type speaker of novel design and construction (prov. patent). Ideal for noisy locations, vehicles, etc. Handling capacity approx. 5 watts, impedance 15 ohms.

Model G7808 Moving Coil Dynamic high fidelity Microphone. Excellent frequency response between 50 and 8,000 cps with freedom from resonance. Also high impedance G7808/H.



Model U885/P 20 watts AC/DC Equipment. Comprises amplifier unit, two 10in. loudspeakers, moving coil mike, folding stand and cables. Also supplied with high-fidelity Ribbon microphone.

SERVICE IN SOUND BY

TRIX

The TRIX ELECTRICAL CO. LTD.

1-5, MAPLE PLACE, TOTTENHAM CT ROAD, LONDON, W.1.

Phone: MUSEum 5817

Telegrams and Cables: TRIXADIO, WESDO, LONDON

RANDOM RADIATIONS

By "DIALLIST"

Cut and Rolled

THERE ARE, as many readers will know, two ways of manufacturing metal screws. The threads may be cut by dies; or, they may be rolled. Rolled-thread screws are far cheaper to make and they serve admirably for many purposes. One of their virtues is that they vary little in diameter from the standard for any particular size. Cut-thread screws, on the other hand, tend to become larger in diameter as the dies wear with long use and unscrupulous (or should one write un-screw-pulous?) producers may be responsible for the utterance of many naughty words by their victims as these try to coax undersize nuts, made with worn taps, on to oversize screws, made with worn dies. You've been one of the victims? So have I! The moral is that it pays to buy screws of reputable make.

They Bite Wires

Speaking generally, cut-thread screws are to be preferred for precision work, particularly in the smaller gauges. Rolled-thread screws of sizes 6BA and above do all that is needed for most ordinary jobs. But there is one purpose for which they should never be used—though far too often they are. This is to clamp wires inserted into screw-down terminals. Take a close look at the end of an average rolled-thread screw, and you'll see why. At the tip there is a pronounced hollow, surrounded by a narrow rim. That rim is actually quite sharp and you do not need to do much thinking to realize the highly undesirable results of turning it hard down on to a softish copper wire. One does occasionally come across cut-thread screws with their ends tapered off to fine points and these are just as unsuitable for terminals. The good-quality cut-thread screw has a smooth, rounded tip; with it you can tighten down hard enough to make a good mechanical and electrical contact, with no risk of cutting the wire.

Stations' Ups and Downs

MANY READERS have been kind enough to write to me about that curious phenomenon which I

mentioned in the May number of *Wireless World*; the reduction in range from which many broadcasting transmitters appear to suffer after being on the air for a few years. Of the many explanations suggested I can refer to only a few in the space allotted to these notes: (1) "It was the stations near the top of the broadcast band which came in so strongly at great distances; many of these are now working on shorter wavelengths." I'm afraid that this won't hold water, for some of the most strongly received medium-wave stations used channels well below 300 metres: the original 2-kW Nuremberg was an outstanding example. (2) "People are using smaller, lower and less efficient receiving aerials nowadays." Not all of them by a long chalk; and in any event most of us now command far higher pre-detector amplification than we did 20 years ago. (3) "Many m.w. stations now use anti-fading aerials, which cut down sky-wave radiation." True; but by no means all of those whose signals have disappeared are so equipped. (4) "Some l.w. stations now have directional aerials." Agreed; but how many are directed away from this country? Certainly that of Luxembourg isn't, or it wouldn't attract British sponsors. And speaking of that particular station, do you recall

the Luxembourg Effect, once so much in evidence? We don't seem to hear anything about it to-day. All things considered, I'm afraid we haven't yet got a completely satisfying answer to the question: Why are so many broadcasting stations at distances of 150 miles and more now so much less strongly received than once they were?

Persuasion No Use

THE POSTMASTER-GENERAL had occasion to deplore recently the poor response to the campaign to persuade people to have the ignition systems of their cars fitted with suppressors. Readers will not need to be told that the response has indeed been lamentable, though they may not, perhaps, realize how great the proportion of unsuppressed vehicles remains. I am specially well placed for making a check, for I live on a road which carries comparatively little traffic; on the average not more than 20 cars, motor cycles or lorries pass the house in an hour. Thus, I can see individual vehicles approaching and can find out by means of the Wrotham receiver, tuned to the a.m. transmission, whether any of them is a sheep or a goat. Very few lorries or tradesmen's delivery vans fail to create a machine-gun rattle from the loud-speaker. Private vehicles have a rather better record, though most of the older ones are either unsuppressed or ineffectively suppressed. A curious point is that some car manufacturers, at any rate, seem to have decided that the letter of the law is all that they need bother



"WIRELESS WORLD" PUBLICATIONS

	Net Price	By Post
RADIO DESIGNER'S HANDBOOK. F. Langford-Smith, B.Sc., B.E., M.I.R.E., A.M.I.E.E., A.M.I.E., 4th Edition	42/-	43/6
RADIO INTERFERENCE SUPPRESSION as Applied to Radio and Television Reception. G. L. Stephens, A.M.I.E.E. ...	10/6	10/11
SOUND RECORDING AND REPRODUCTION. J. W. Godfrey and S. W. Amos, B.Sc. A.M.I.E.E., in collaboration with the B.B.C. Engineering Division ...	30/-	30/8
MICROPHONES. By the Staff of the Engineering Training Dept. B.B.C. ...	15/-	15/5
ADVANCED THEORY OF WAVEGUIDES. L. Lewin. ...	30/-	30/7
FOUNDATIONS OF WIRELESS. M. G. Scroggie, B.Sc., M.I.E.E., 5th Edition ...	12/6	13/-
TELEVISION RECEIVING EQUIPMENT. W. T. Cocking, M.I.E.E., 3rd Edition ...	18/-	18/8
SHORT-WAVE RADIO AND THE IONOSPHERE. T. W. Bennington. 2nd Edition ...	10/6	10/10
THE WILLIAMSON AMPLIFIER. 2nd Edition. D. T. N. Williamson. ...	3/6	3/9
BASIC MATHEMATICS FOR RADIO STUDENTS. F. M. Colebrook, B.Sc., D.I.C., A.C.G.I. 2nd Edition ...	10/6	10/10

A complete list of books is available on application.

Obtainable from all leading booksellers or from

ILIFFE & SONS LTD., Dorset House, Stamford Street, London, S.E.1.

about; they will fit suppressors at the appointed time but not before. A friend who took delivery of a new car a few weeks before this was written drove it home and left the engine ticking over while going in to collect his wife. He found her cursing the snowstorm on the TV screen!

Make 'Em Sit Up

You'll never stop car ignition interference by begging or persuading people to have suppressors fitted. The only way is to make it a punishable offence to own an un-suppressed vehicle. The P.M.G. said he didn't want to make such a regulation, because there was no way of enforcing it. But, saving his presence, there is. All police cars nowadays are fitted with metre-wave radio, which means that those using a.m. could act as detectors of un-suppressed motor vehicles if the noise limiter was switched out of circuit. I'm not going to suggest for a moment that large numbers of police cars should be diverted from their proper business and set to track down vehicles that radiate interference. No such thing would be necessary. All that is required is a regulation outlawing interfering vehicles after a certain date and laying down fines, of say, £2 for the first offence and £5 for the second. Follow this up by giving wide publicity to the fact that police cars can detect un-suppressed vehicles and there would be a stampede to have suppressors fitted: you will recall how wireless and television pirates hasten to haul down the Jolly Roger when the arrival of G.P.O. detector vans is so much as rumoured.

Tailpiece

As I was writing these notes, the telephone bell rang. The call was from a friend who lives on one of the main roads from London to the South Coast, and a sad tale he had to tell of television reception during the Whitsun holidays. He and his family had stayed at home since they prefer to make outings at less crowded times. They'd get plenty of entertainment, they thought, from the television set. Alas for human hopes! There was only one single hour in the whole three days when interference from car ignition systems did not blot out the screen images. Isn't it really time, my Lord De La Warr, to protect your 2,250,000 television licence holders by compelling motorists to abate the nuisance by spending ten minutes and a couple of shillings at any garage?

GUARANTEED LIFE TESTS OF AT LEAST 25,000 OPERATIONS

MILLIONS of Bulgin Switches are still in constant use in all parts of the world and giving satisfactory service on all types of equipment. Very brief reasons are shown below.

LAMINATED CONSTRUCTION OF FINEST QUALITY BAKELITE.

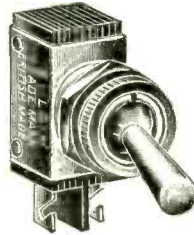

PRECISION PARTS, ALL BEARING 100% INSPECTION.

METAL CLAD BODY OF STEEL, HEAVILY COPPERED AND NICKEL-PLATED FINISH.

HEAVILY SILVER-PLATED CONTACTS FOR LOW CONTACT RESISTANCE AND EASY SOLDERING OPERATIONS.

30 YEARS OF SWITCH MANUFACTURING EXPERIENCE.

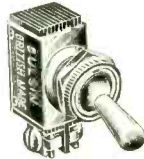

Pear dolly type



Standard ball dolly type



Slotted dolly type



Press action model



Semi-Rotary model

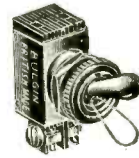

Biased action model

THE interior mechanism embodies special features, the results of long experience in switch manufacture. For these reasons discerning Engineers and Designers always specify Bulgin Switches. Various types are available for every purpose: a small selection is shown on this page. Detailed installation drawings are available to Manufacturers on request.

Look for the Trade Mark

BULGIN
ENGLAND

None genuine without.

Send for latest catalogue No. 191/WW. Price 1/- post free.



BULGIN
REGD. TRADE MARK

MANUFACTURERS OF RADIO & ELECTRONIC COMPONENTS

A. F. BULGIN & CO. LTD., BYE-PASS RD., BARKING, ESSEX

Telephone: Rippleway 3474 (5 lines)

"Only Just"

THOSE OF YOU who are readers of *Punch* may recall a humorous drawing which appeared many years ago showing a canny Scot complete with kilt and tammy slowly and carefully counting the change which the booking clerk at the railway station had just handed to him with his ticket.



Correct, but "only just"

The irate clerk, observing him, asks sarcastically and with some asperity whether the change is not correct. The canny Scot, looking up at him with a reproving look, replies "only just."

I was reminded of this old story when reading in *Wireless World* (May, 1953) the obituary notice of the late Andrew Gray who for a third of a century, commencing in 1899, held responsible positions on the engineering staff of our pioneer wireless company. The tribute to his memory paid by *W.W.* starts off with the seemingly innocuous statement that "There were not many wireless engineers in Queen Victoria's days, and still fewer who dated back to the 19th-century part of the reign."

Like the Scotsman's change, this statement may be perfectly correct but most certainly "only just" correct. In fact, without having looked up any statistics, I venture to say that the statement may be incorrect. I doubt if there were any more wireless engineers in the 20th-century part of Queen Victoria's reign than in that part of her reign in the 19th century.

The reason is simple. Queen Victoria died at 6.30 p.m. on Tuesday, January 22nd, 1901. Therefore, the length of the 20th-century part of her reign was obviously 21 days and 18½ hours, or, in other words, just over three weeks. Therefore, to make *W.W.*'s statement true some men must have become wireless engineers during those three weeks.

Of course, it is quite true that if only one electrical engineer had started to specialize in wireless during that period it would make the statement strictly accurate. If, therefore, any reader knows of a man who, not being a wireless engineer at midnight on December 31st, 1900, became one before 6.30 p.m. on January 22nd, 1901, I am sure the Editor will be glad to publish the information if only to confound me. But I hope no attempt will be made by him or readers to try and convince me that the twentieth century began on January 1st, 1900, or any similar nonsense.

A.P. and C.P.

EVERYBODY KNOWS that the B.B.C. has been negotiating for a piece of land in the Crystal Palace area on which to build the new high-power London television station when the Corporation's lease of the Alexandra Palace expires in three years time. Even *W.W.* admits rather cautiously in its news columns (May, 1953) that it understands this to be the case. I can, however, scarcely believe that the B.B.C. can be so foolish as to relinquish the Alexandra Palace site, for if they do, nothing is more certain than that one of the sponsored television interests will quickly mop up so valuable a site.

I do not mean, of course, that the B.B.C. should not build its new station on the Crystal Palace site: in fact, I am all in favour of it. But by 1956 we, in the London area at any rate, will all be equipped with tunable TV sets in order to get the sponsored programmes as well as the B.B.C. one. We shall then undoubtedly be demanding a second

television programme from the B.B.C. and the A.P. site, chosen with such care in 1936, could hardly be bettered for the second programme transmitter. But even if the B.B.C. is so shortsighted as not to heed my words, I'm sure that sponsored television will give us a programme from there.

V.H.F. Further Vindicated

I HAVE from time to time protested against the B.B.C. forcing us to jump to our volume controls when, after a quiet talk has ended, they suddenly switch over to the crashing crescendos of a brass band. I have suggested many remedies, but the Editor's remarks in the May issue about the Government's apparently cooling ardour for v.h.f. broadcasting prompts me to advance yet another strong reason for its immediate adoption.

V.H.F. is obviously the ideal solution for this decibel disparity about which I have complained. With the much greater etheric elbow room in the v.h.f. band it will be possible for the B.B.C. to send quiet items like talks and such-like from one transmitter, and music and other noxious noises from another.

Of course, the B.B.C. will require twice the number of transmitters and we shall all need to use two receivers for every programme, but we shall be able to adjust each set to the volume level which best suits our depraved tastes. Thus the musical highbrows who object to such things as scale distortion will be able to have their way and we uncouth Philistines who couldn't care less about scale distortion and the like will be able to have ours.



Of course you always get a bit of distortion off centre

**20,000 ohms
per volt plus
AUTOMATIC Overload
Protection**

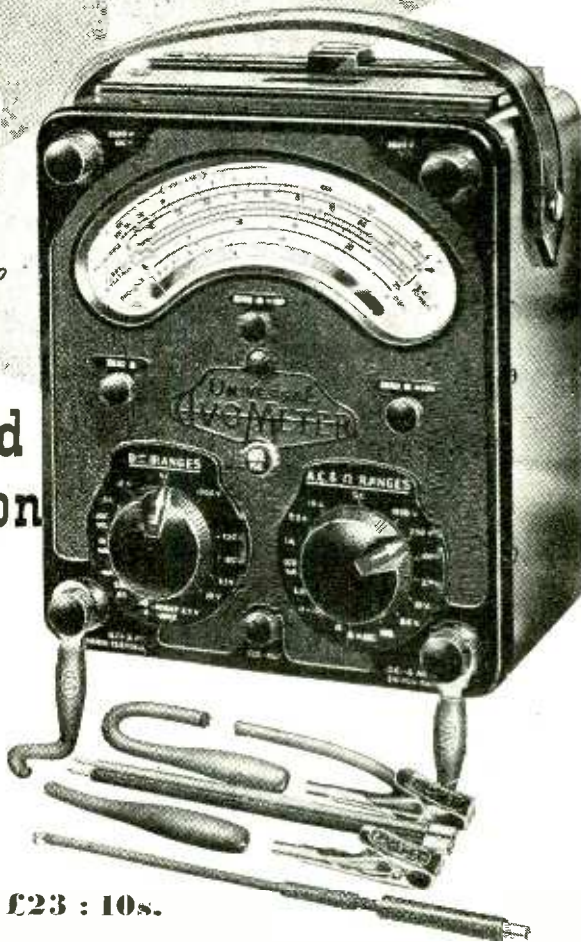

£23 : 10s.

Size 8 1/8" x 7 1/4" x 4 1/2"
Weight 6 1/2 lbs. (including leads)

Produced in response to a demand for a high sensitivity version of the world-famous Universal Avometer, this model incorporates the traditional design features of its predecessors, so highly valued for simplicity of operation and compact portability.

It has a sensitivity of 20,000 ohms per volt on all D.C. voltage ranges and 1,000 ohms per volt on A.C. ranges from 100V. upwards. A decibel scale is provided for audio frequency tests. In addition, a press button has been incorporated which reverses the direction of current through the moving coil, and thus obviates the inconvenience of changing over test leads when the current direction reverses. It also simplifies the testing of potentials, both positive and negative, about a common reference point. A wide range of resistance measurements can be made using internal batteries, separate zero adjustment being provided for each range.

It is of importance to note that this model incorporates the "AVO" automatic cut-out for protection against inadvertent overloads.



For your Valve Characteristic Meter or Valve Tester

Owing to the very large number of valves which have been issued within the last two years, no further amendments will be issued for the original "Avo" Valve Testing Manual. A new, completely revised and fully up-to-date Valve Data Manual is now available from the Company at 15/- post free.

D.C. VOLTAGE	D.C. CURRENT	A.C. VOLTAGE	A.C. CURRENT	RESISTANCE
2.5V.	50µA	2.5V.	100mA.	First indication 0.5Ω.
10V.	250µA.	10V.	1A.	Maximum indication 20MΩ.
25V.	1mA.	25V.	2.5A.	0-2,000Ω using
100V.	10mA.	100V.	10A.	0-200,000Ω internal
250V.	100mA.	250V.	—	batteries.
1,000V.	1A.	1,000V.	—	0-20MΩ using
2,500V.	10A.	2,500V.	—	external
				batteries.



THE AUTOMATIC COIL WINDER & ELECTRICAL EQUIPMENT CO. LTD.
WINDER HOUSE • DOUGLAS STREET • LONDON S.W.1 Telephone VICTORIA 3464-9

A8/1
A



IT'S NEW-IT'S TRUVOX
-it's GOOD whatever you call it!

*There has been difficulty in naming ours.
 Never mind the name—you judge the product!*

TRUVOX
 ???? ????
MARK III

22 Gns
 MODEL TR2
 200/250 volts
 A.C. mains only

These are the main features:—

1. Three motor drive.
2. "Drop-in" Tape loading.
3. Push-button control, electrically and mechanically interlocked.
4. Separate push-button brake.
5. "Fast-forward" and "fast-rewind" without tape wear.
6. Silent drive eliminating "wow" and "flutter."
7. Half-track working, and two Tape speeds of 7½ inches per second, or 3¾ inches per second.
8. Visual playing-time indicator.
9. With a suitable amplifier, the equipment covers a frequency range from 50-10,000 c.p.s. at 7½ inches per second.

TRUVOX LIMITED

EXHIBITION GROUNDS · WEMBLEY · MIDDX

Telephone: Wembley 1212

Sole distributors to the Wholesale Trade for Rola and Celestion Speakers



Specially designed for your new portable communications equipments.....

DIRECTLY-HEATED

SUBMINIATURES

Combining outstanding electrical performance with small size and extremely low power consumption, this new Mullard range of battery subminiatures offers special advantages in compact telecommunications equipment of the "Hand talkie" and "Walkie talkie" nature, where space, weight, and available battery power are limiting factors.

With the exception of the DL70 R.F. output valve, these subminiatures have filament current ratings of only 25 milliamperes; the DL70, despite its power function, operates from the comparatively low filament current of 110 milliamperes.

Brief technical details of the current range of Mullard battery subminiatures for communications equipment are given below. Other subminiatures, including R.F. output types that will operate with high efficiencies at frequencies of up to 500 Mc/s, are now under development, and details of these will be made available shortly.

Complete technical details, including characteristic curves, of both battery and indirectly-heated subminiatures will be gladly supplied on request.

Type No.	Description	Filament (V) (mA)	V _a =V _{g2} (V)	V _{g1} (V)	I _a (mA)	I _{g2} (mA)	g _m (mA/V)
DAF70	A.F. pentode combined with single diode	1.25 25	67.5	0	1.0	0.25	0.44
DF72	R.F. pentode with sharp cut-off ...	1.25 25	67.5	0	1.7	0.5	1.0
DF73	Variable- μ R.F. pentode	1.25 25	67.5	0	1.7	0.5	0.8
DL70	R.F. output pentode	1.25 110	150	-7.5	6.5	1.4	1.5
DL75	Output pentode ...	1.25 25	(V _{g2} =90V) 90	-2.5	1.75	0.4	0.85

Mullard



Multichannel Radiotelephony

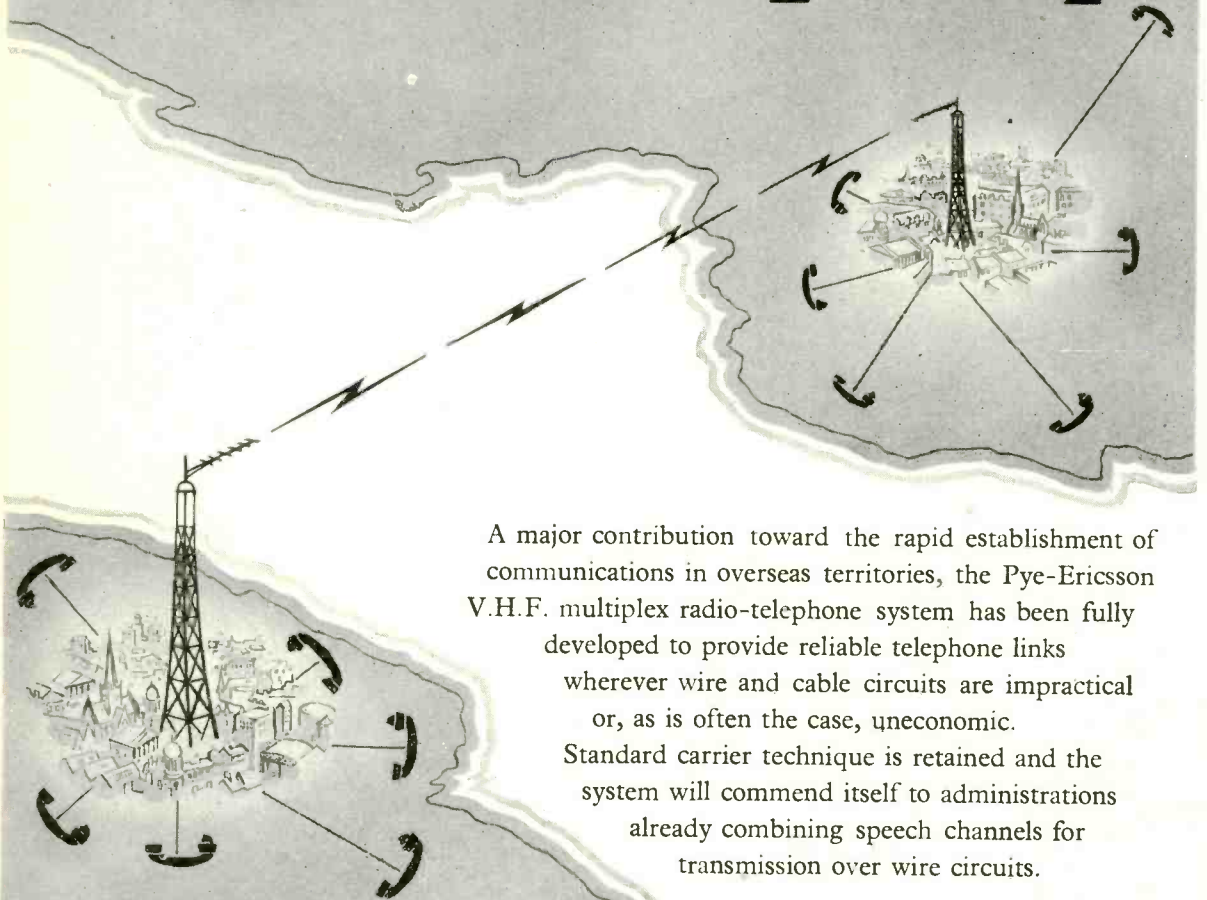

A major contribution toward the rapid establishment of communications in overseas territories, the Pye-Ericsson V.H.F. multiplex radio-telephone system has been fully developed to provide reliable telephone links wherever wire and cable circuits are impractical or, as is often the case, uneconomic. Standard carrier technique is retained and the system will commend itself to administrations already combining speech channels for transmission over wire circuits.

Designed and Manufactured by
PYE LIMITED and
ERICSSON TELEPHONES LTD.

*Enquiries may be addressed
to either company*

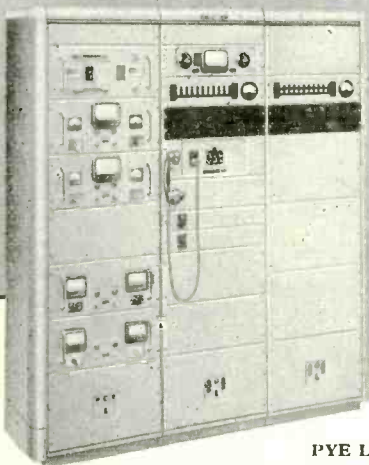

PYE LTD.
 Cambridge,
 England.

ERICSSON TELEPHONES LTD.
 22, Lincoln's Inn Fields,
 London, W.C.2. England.

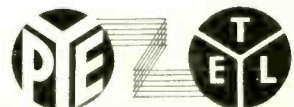

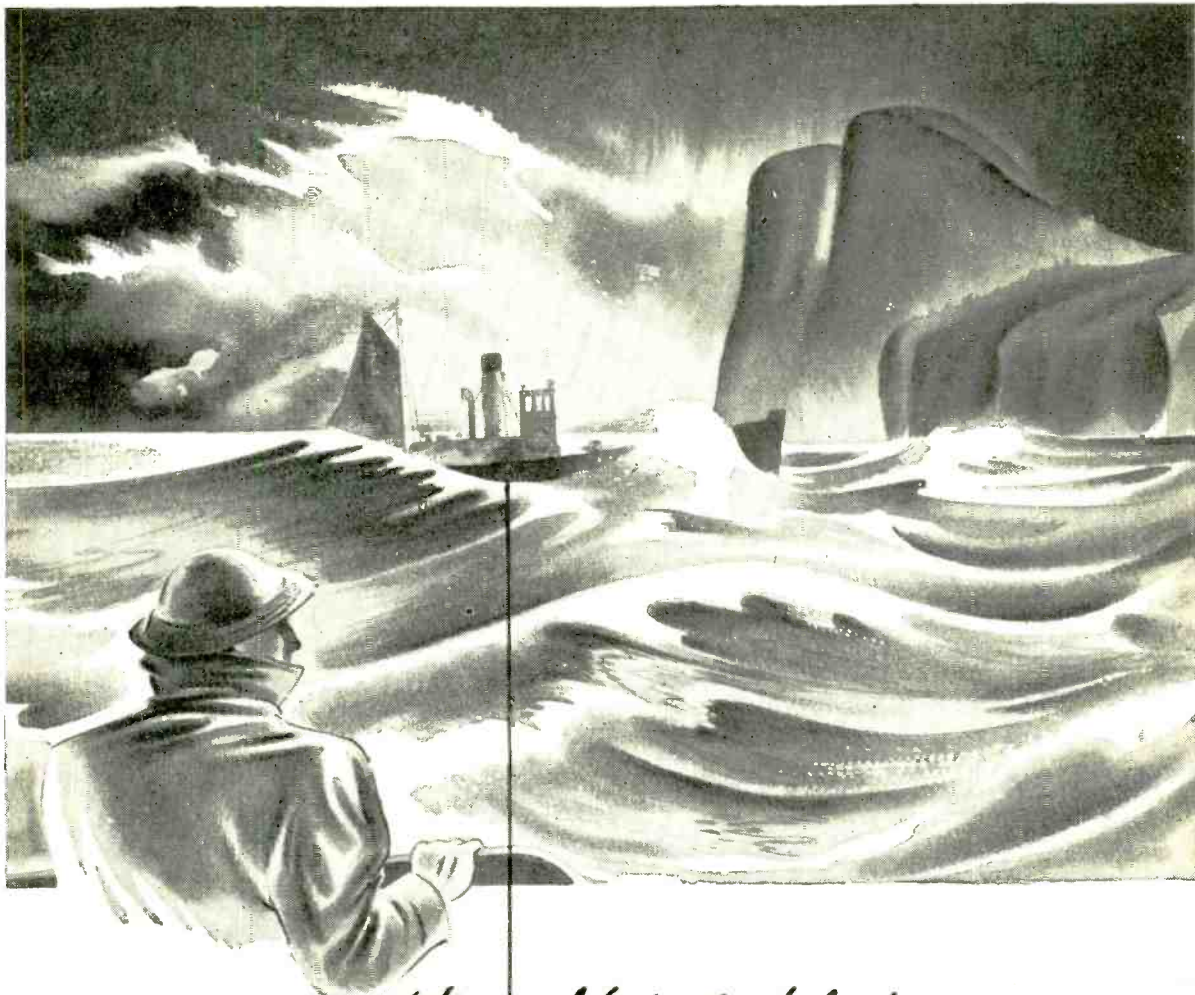

The Vital Link . . .

. . . with safety in the hazardous enterprise of the deep sea trawler is its radio and radar equipment upon which safe navigation depends. Thousands of soldered joints contribute to the efficient functioning of this delicate apparatus. One dry or H.R. joint could mean the breakdown of a circuit, the destruction of the vital link, a perilous voyage.

FAULTLESS FLUXING PRESERVES THE VITAL LINK

Dry or H.R. joints are impossible with Superspeed for the flux is always released in exactly the correct proportion. This faultless fluxing action is achieved by the unique STELLATE core which gives six points of rapid solder collapse. At soldering temperature the activated rosin flux is released immediately for effective spreading and wetting. Superspeed is being used more and more in the production of radio and radar equipment where faultless joints are essential.



Superspeed

"WHITE FLASH" ACTIVATED ROSIN-CORED SOLDER

for general electrical, electronic and telecommunication work and all standard uses. A.I.D. and G.P.O. approved. Complies with M.O.S. Specification DTD 599. In all standard tinlead alloys, 10-22 s.w.g. Also available in a range of coloured cores, indispensable for simple intermediate and final inspection and circuit or operator identification. Samples of Superspeed and the comprehensive Superspeed booklet gladly sent on request. Technical advisers are available for free consultation.

Cored and solid solder rings and solid solder washers supplied to customers' specifications.

MANUFACTURED BY THE **ENTHOVEN** GROUP

Marketed by Enthoven Solders Limited, Enthoven House, 89, Upper Thames Street, London, E.C.4. Tel. Mansion House 4533

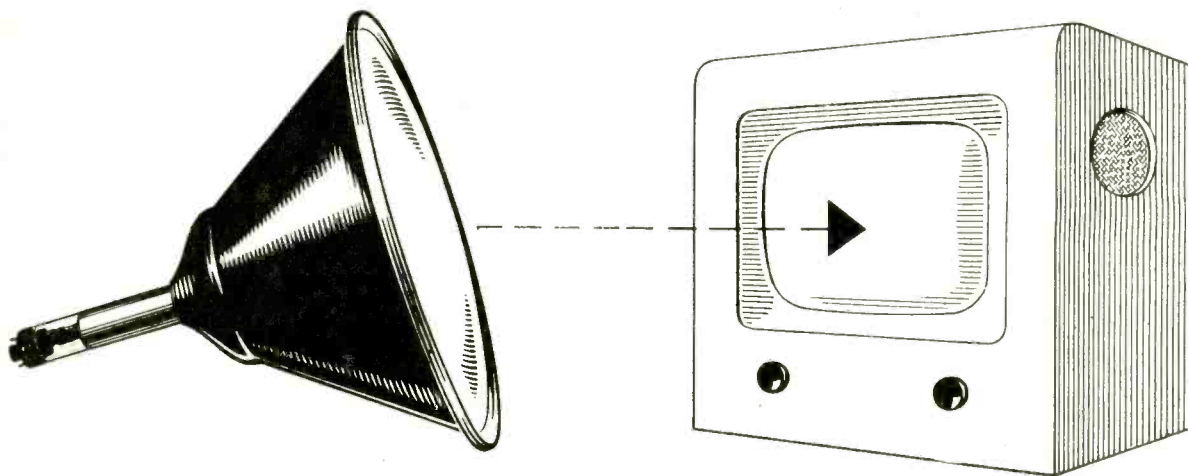

Did you build your own T/V receiver?

If so, and you have a 9" or 12" set and now want to convert to big-screen viewing, how better than by using an 'ENGLISH ELECTRIC' 16" T901 Metal C.R. tube.

To help you carry out the work our leaflet EV103A gives you the complete line and frame scanning information necessary, together with a suggested list of required components.

And why a T901—because it offers you brilliance, long life, high safety factor, ease

of handling and withal it is British made.

It is the tube specified by the designers of the 'Tele-King' and 'Magna-view' circuits and 'Viewmaster' conversion circuit.

Brilliant black and white picture focusing over entire screen area with excellent contrast range; high optical quality glass face plate; wide angle scanning (70°); fitted ion trap; overall length 17 $\frac{1}{8}$ " diameter 16".

'ENGLISH ELECTRIC'

BRITISH MADE LONG LIFE 16" T901 METAL C.R. TUBE

If you have any difficulty in obtaining supplies write to:

The ENGLISH ELECTRIC Company Limited, Television Department, Queens House, Kingsway, London, W.C.2.



VIBRATORS & VIBRAPOWER UNITS

for Low voltage
D.C. operated
Electronic
Equipment

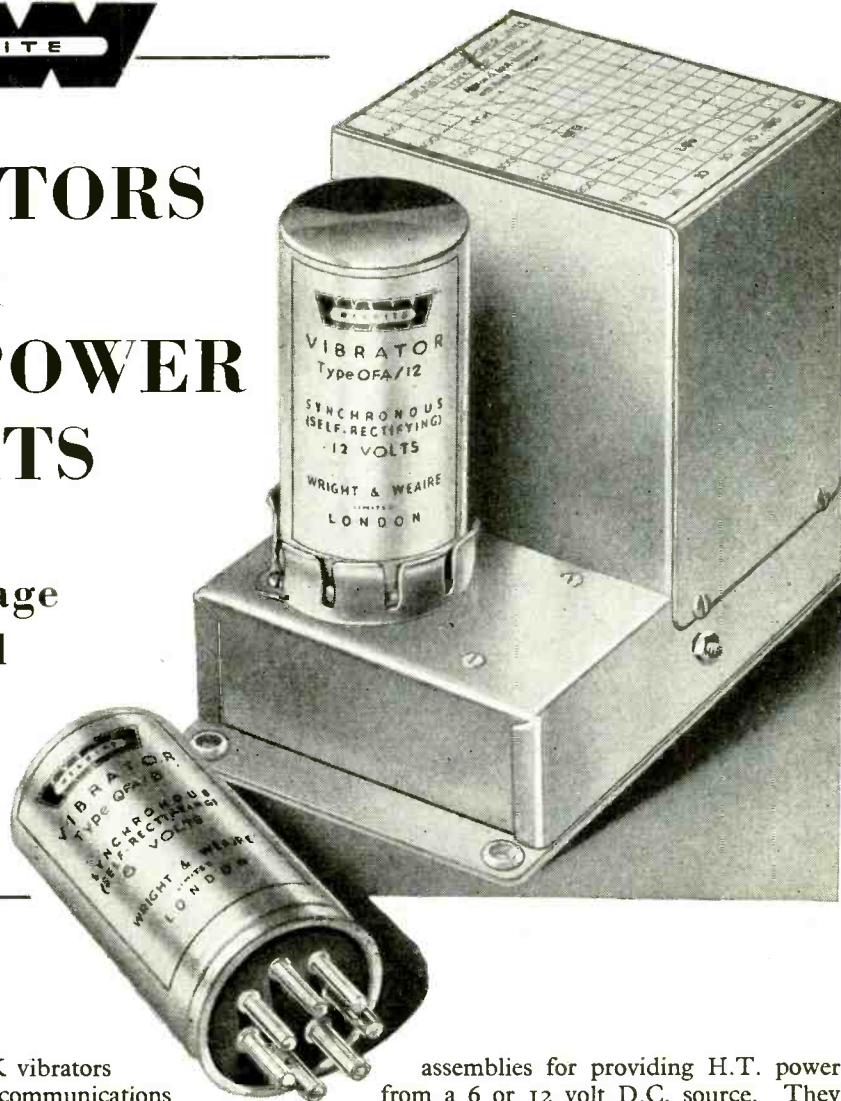

THE range of Wearite/OAK vibrators for car radios and mobile telecommunications equipment has been especially designed for long and dependable service, whatever the extremes of climate.

The main structure is of steel and mica, so that expansion at varying temperatures is uniform, the base being sealed by the special Wearite process. The main contacts are ground to extreme limits of flatness and certain starting at the lightest of pressures and voltages is obtained by the use of non-tarnishable precious metal driving contacts. The vibrator is acoustically and electrically shielded by its sponge-rubber lined metal can.

A complete range—synchronous, non-synchronous and split-reed synchronous types—is available for all makes of car radio and other mobile equipment.

Vibrapower Units are completely self-contained

assemblies for providing H.T. power from a 6 or 12 volt D.C. source. They include a tapped transformer for the selection of output voltage, buffer capacitors and basic R.F. filtering, and a Wearite/OAK vibrator of a type depending on input voltage. Provision is made for the earthed input pole to be connected to positive or negative as required.

H.T. smoothing is not included and must be externally connected, the value depending on the efficiency desired. An input filter must also be used.

The units are completely screened and are mounted on four rubber buffers to prevent possible transmission of vibration to other equipment. Full details of Wearite/OAK Vibrators and Vibrapower Units are available on request.

* Wearite vibrators are manufactured under license of the Oak Manufacturing Co. of Chicago and are covered by various patents.

WRIGHT & WEAIRE LTD

138 SLOANE STREET · LONDON · SW1 · Telephone: SLOANE 2214/5



The new



MAGNETIC TAPE RECORDER

• Type PMR/3

"from a pedigree line"

And its SPECIFICATION

The Tape Player itself is of unit construction which enables many special requirements and applications to be met without undue modification. The following features can be provided to special order:—

Tape speeds $7\frac{1}{2}$ " and 15 " per second, or $3\frac{1}{2}$ " and $1\frac{1}{2}$ " per second.

- Synchronous drive motor.

- Remote operation or foot control.

- Automatic back spacing and reverse drive for dictation purposes.

- Cassette tape loading.

- Rack mounted assembly.

TAPE SPEEDS	$7\frac{1}{2}$ " and $3\frac{1}{2}$ " per second.
TRACKS	$1\frac{1}{2}$ " wide. Number of tracks 2.
PLAYING TIME PER TRACK	30 minutes at $7\frac{1}{2}$ " per second. 60 minutes at $3\frac{1}{2}$ " per second.
SPOOLS	Standard 7" and 5" plastic or metal.
SENSE OF SPOOLING	From left to right with tape coating inwards.
REWIND TIME	One minute for 1,200 ft. of tape (approx.).
HEADS	R.F. erase head. Record/playback head off-set for recording on upper track. Provision on player unit for additional monitoring head for special applications.
TAPE OPERATION	Single control provides:— Record, Playback, Fast Forward, Cueing, Rewind. To ensure additional safety against accidental erase, an additional record/playback switch is provided on the amplifier assembly. Power and brake operation is by means of a relay which will enable remote operation to be provided in special applications.

FREQUENCY RESPONSE	At $7\frac{1}{2}$ " per second 60-10,000 C.P.S. plus or minus 3 db. At $3\frac{1}{2}$ " per second 70-7,000 C.P.S. plus or minus 3 db.
DISTORTION	Less than 2½% total harmonic distortion at normal operating level.
SIGNAL/NOISE RATIO	Approximately 50 db. using standard high output tape.
INPUTS	(1) Up to 50 ohms low level —110 db. microphone input. (2) High Z up to 100 K at 1v. unbalanced (radio input).
OUTPUTS	(1) $2\frac{1}{2}$ ohms at 3 watts to internal loudspeaker. (2) 15 ohms at 3 watts for external speaker.
WOW AND FLUTTER	Total wow and flutter content less than 2%.
MAINS SUPPLY	200/250 v. 50 cycles 230 V.A. Other volrages and frequencies supplied to special order.
DIMENSIONS	16" wide x 11" high x 18" deep approx.
WEIGHT	45 lbs.

M · S · S · RECORDING COMPANY LTD
POYLE CLOSE · COLNBROOK · BUCKINGHAMSHIRE · TELEPHONE · COLNBROOK 284

SOLARTRON ANNOUNCE

The New
Phase Sensitive Voltmeter
Model VP.250

STAND No.10G
British Instrument
Industries Exhibition
June 30th-July 11th
1953

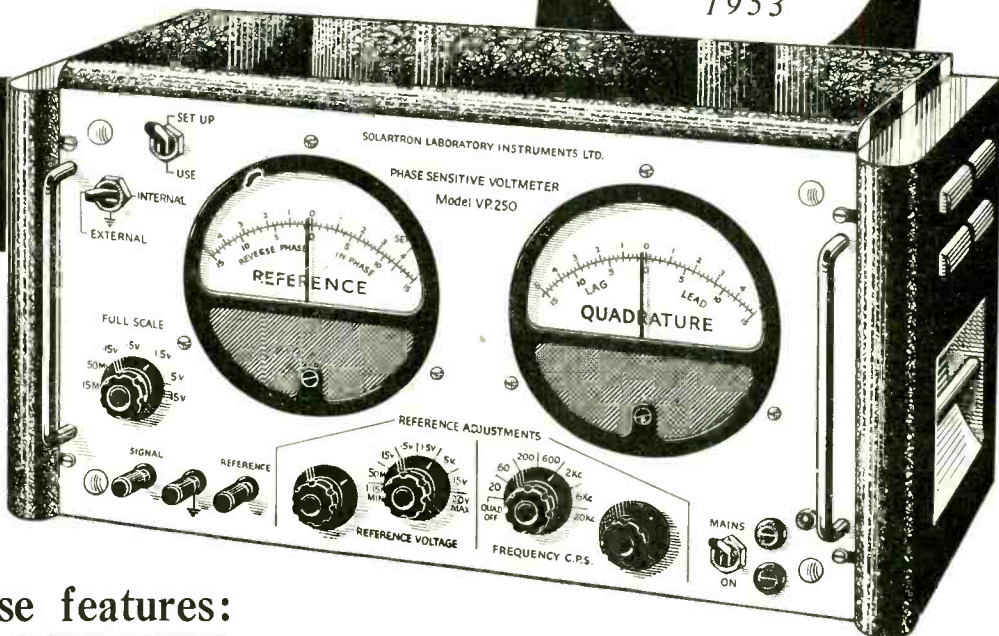

Note these features:

- ★ Simultaneous display of reference and quadrature signal components on 6in. centre zero meters calibrated in volts.
- ★ Seven half decade sensitivity ranges covering 15 mV.-15 volts full scale.
- ★ Constant 50 megohms input impedance for both reference and signal channels.
- ★ High accuracy not affected by harmonics in signal under test.

Covering a frequency range of 20 c/s-20 Kc/s this instrument will measure the "in phase" and

"quadrature" components of an applied test voltage, with respect to a given reference voltage. Provided the latter is of sine wave form, the readings will not be affected by harmonics or spurious frequencies.

An ideal instrument for the measurement of transmission characteristics of amplifiers, networks, transformers, high speed servo systems, etc. Its resolved component presentation with harmonic free response makes it a suitable detector for A.C. strain gauge systems or for any pick-up with an A.C. output.

Other Solartron Instruments

Laboratory Amplifier	Model AWS. 51A.
Video Amplifier	Model AWS. 52.
Wide Band Power Amplifier	Model AWS. 53
Pulse Generator	Model OPS. 10)A.
Wide Range Oscillator	Model OS. 101.
Regulated Power Supply	Model SRS. 151.
Wide Band Attenuator	Model AT. 201.
Twin Regulated Supply	Model SRS. 152.
Varipack	Model SRS. 153.

SOLARTRON

SOLARTRON LABORATORY INSTRUMENTS LTD.
22 HIGH STREET KINGSTON SURREY. TEL: KINGSTON 8981 PBX

NEW!

E·M·I INSTITUTES EXPERIMENTAL KIT

LEARN THE PRACTICAL WAY

A specially prepared set of radio parts from which we teach you, in your own home, the working of fundamental electronic circuits and bring you easily to the point when you can construct and service a radio set. Whether you are a student for an examination, starting a new hobby, intent upon a career in industry, or running your own business — this Course is intended for YOU — and may be yours at a very moderate cost. Available on Easy Terms.

WE TEACH YOU: *Basic Electronic Circuits (Amplifiers, Oscillators, Power Units, etc.) Complete Radio Receiver Testing & Servicing.*

POST IMMEDIATELY FOR FREE DETAILS

TO: E.M.I. INSTITUTES, DEPT. 16X
Grove Park Road, Chiswick, London, W.4

Name

Address

I.C.12

★ Experimental Kits also form part of the following courses: Draughtsmanship, Carpentry, Chemistry, Photography, Commercial Art, etc.

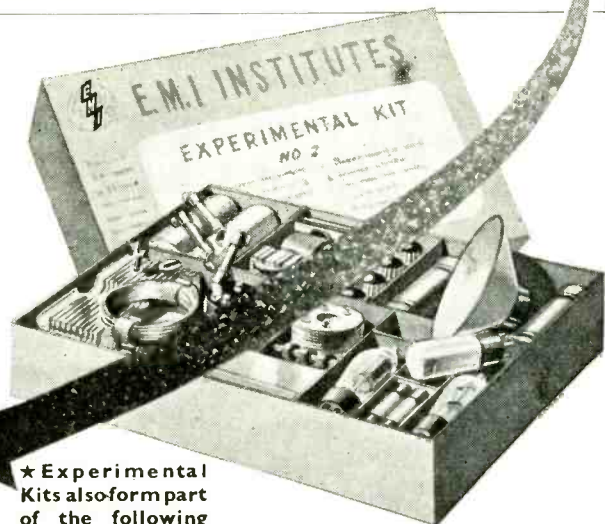

EMI INSTITUTES
Associated with
MARCONIPHONE HMV
COLUMBIA & HMV
(His Master's Voice)

TRUVOX

It **Pays As You Earn!**
EQUIPMENT

Profitable P.A. business is built upon a reputation for reliability which can only be based on the dependability of your equipment. That is why it pays to use only TRUVOX, the reproducers that have had reliability built into them for a quarter of a century.

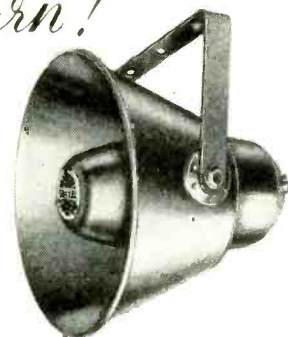

TRUVOX REFLEX SPEAKERS

Senior models give a substantially linear response from 250 to 8,000 c.p.s. with a peak handling capacity of 8 to 10 watts whilst Junior models range from 350 to 8,000 c.p.s. with 6 to 8 watts peak handling capacity. Either can be supplied with built-in transformer. Completely weather-proofed and designed to withstand prolonged exposure and vibration



TRUVOX PRESSURE TYPE DRIVING UNITS

Senior and Junior models have a power handling capacity of 15 and 10 watts respectively and provide a substantially linear response from 175 to 10,000 c.p.s. The Senior model is available with built-in tropicalised multi-ratio transformer, a noteworthy feature much appreciated by sound engineers.

For Full Details Write to:

ROLA CELESTION LTD., FERRY WORKS, SUMMER ROAD, THAMES DITTON, SURREY

Phone: Emberbrook 3402-6.

Wholesale enquiries to—Truvox Ltd., Exhibition Grounds, Wembley, Middx. (WEM 1212)

THE ELAC "DUOMAG" FOCALISER

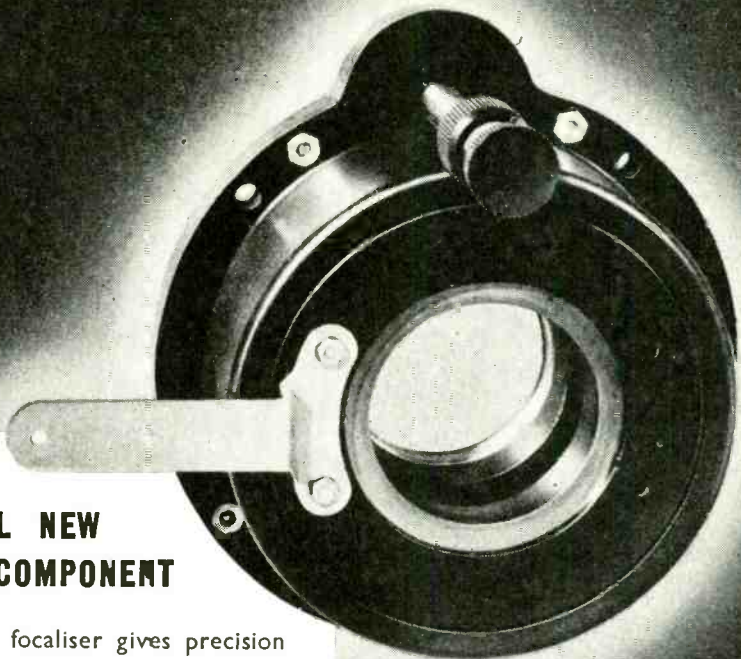

THE SENSATIONAL NEW ELAC T/V COMPONENT

The DUOMAG focaliser gives precision beam focus and complete picture positioning with minimum effect on scan coils and ion trap assemblies. It is designed for use with magnetically focused tubes having 38 m/m diameter necks.

DUOMAG is a permanent magnet type unit using two concentrically mounted Sintered Oxide ring magnets arranged with opposed magnetic fields.

- Minimum stray magnetic field. Symmetrical, uniform and very low external field.
- Magnets of high electrical resistivity enable the unit to be placed in close proximity to high efficiency scan coils.
- All insulated construction—No risk of high voltage shock.
- Wide range picture shift.

RETAIL PRICES IN U.K.

Low Flux, 37/6 ; Med. Flux, 39/6 ; High Flux, 42/-.

*Leading the
field in TV
components*



ELECTRO ACOUSTIC INDUSTRIES LTD

STAMFORD WORKS, BROAD LANE, TOTTENHAM, N.15 TEL: STAMford Hill 5606-8

For brilliant, high-fidelity sound recording
the **GRUNDIG** 2-speed tape recorder

PUSH button controls and magic-eye tuning give you complete mastery over the Grundig's superb recording and reproducing qualities. The 1,200 feet of tape give you ONE HOUR of high-fidelity music recording and play back. High speed rewind mechanism enables you to reproduce from (or record on) any part of the tape in a few seconds. The same tape can be used repeatedly, each new recording automatically erasing the previous one, or recordings can be kept indefinitely. Sound frequency range : at 7½ in. per second, 50-10,000 c/s., at 3½ in. per second, 50-6,000 c/s.



Price 80 gns.
including condenser mike. H.P.
Terms available.

- ★ Condenser microphone.
- ★ Remote controls—hand or foot operated.
- ★ Two-way telephone recorder—without alteration to handset.
- ★ As compact and portable as a suitcase.

THE
GRUNDIG *Reporter*
700L TWO-SPEED TAPE RECORDER

*Not only a revelation but a revolution
in tape recording!*

GRUNDIG (GT. BRITAIN) LIMITED, KIDBROOKE PARK ROAD, LONDON, S.E.3.

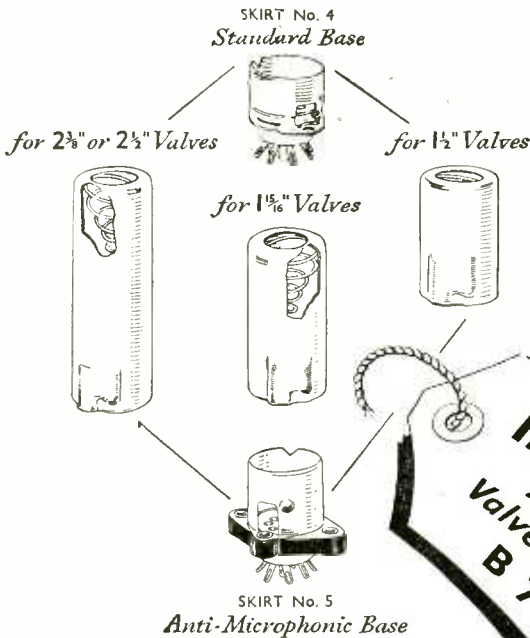

Recognised as the Most Reliable Valveholders

B7G Valveholders

are now available moulded in:—

Phenol Formaldehyde (Black).

Nylon loaded Phenol Formaldehyde
(Natural Brown).

P.T.F.E.



Wholesale Enquiries :—
CYRIL FRENCH
HOLDINGS LTD.

High St., Hampton Wick
Middlesex. KIN. 2240

Manufacturers' Enquiries: THE McMURDO INSTRUMENT CO. LTD., VICTORIA WORKS, ASHTEAD, SURREY ASHTEAD 3401

★ **A POINT OF DETAIL NO. 4** ★

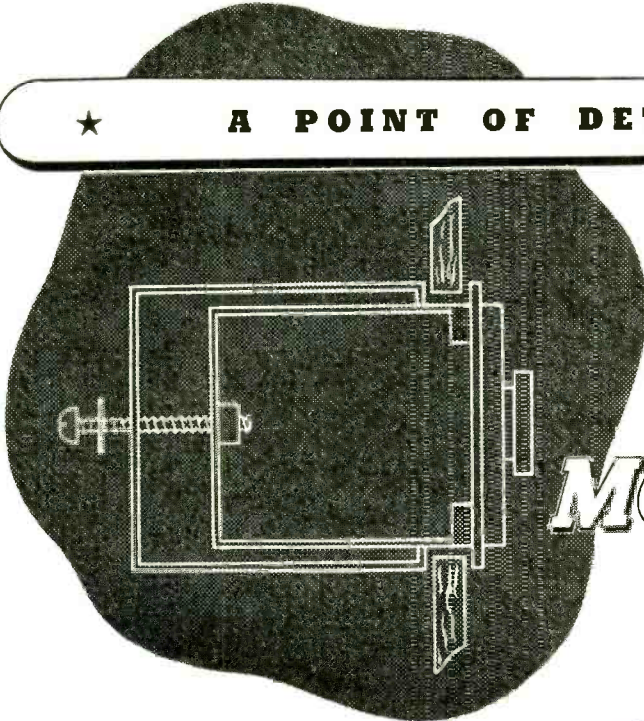

MOUNTING

IT is logical that an amplifier of excellent electronic design should also reflect similar attention to detail in its mechanical design. A typical example in the Q.U.A.D. amplifier is the method of mounting the control unit on a panel or in a cabinet. A cut-out is made in the panel or cabinet, half an inch smaller than the control panel dimensions (templet provided). The back cover of the control unit is removed and the unit inserted into the cut-out from the front. Projecting lugs on the back of the panel casting locate the control panel symmetrically over the cut-out. The cover is now replaced from the back and the cover retaining screws bolt the complete unit firmly in position. The panel or cabinet may be any thickness from $\frac{1}{8}$ in. up to 1 in. No screws or other methods of fixing are visible from the front—no edge finishing problems are involved—the cabinet or panel is securely fastened over the whole perimeter—all desirable features of good design.



THE ACOUSTICAL Q.U.A.D. AMPLIFIER

An amplifier capable of providing the closest approach to the original sound yet achieved. Write for the Q.U.A.D. booklet for full detailed specifications.

Complete in two units as illustrated. **£35**



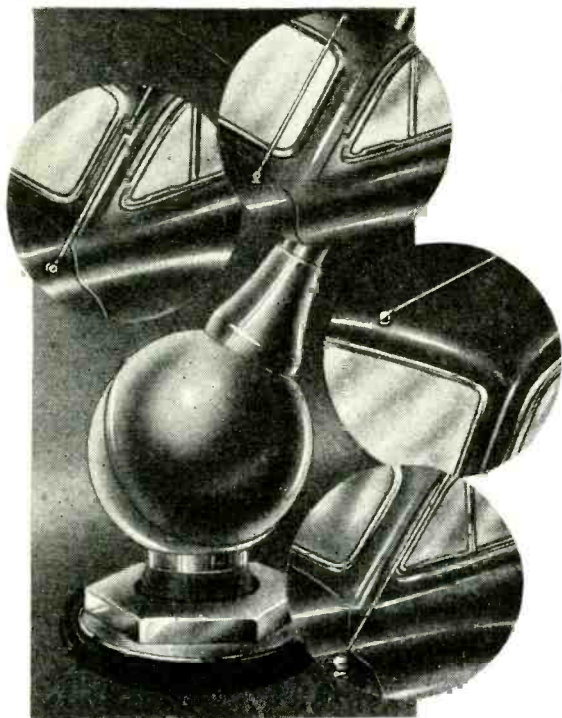

Truly revolutionary—a
CAR AERIAL *that can be*

**completely fitted
 FROM THE OUTSIDE
 and READY FOR USE
 IN FIVE MINUTES!**

The **'AUTEX'** ...

Here is revolution in car aerials—a ONE hole fixing model that can be installed FROM THE OUTSIDE. No longer need you manoeuvre under the scuttle or dashboard and work "by feel." Thanks to a special split washer device, and positioning sleeve, the aerial is self-locating, and firmly secured FROM THE OUTSIDE. Can be mounted vertically or horizontally (or at any angle in between) in any position on the car—on a flat or curved surface. It is entirely free from rattle—due to the special packing glands which also ensure the smooth action of the telescopic rod. *Full details in leaflet No. N1/W.*

MODEL TCA 6236. With sturdy die-cast metal mounting three section telescopic rod (extended 62in. closed 24in.) of high-grade brass. All exposed parts heavily chromium plated. Fully weatherproofed connections. Complete with 36in. low-loss co-axial polythene insulated P.V.C. covered cable, fitted standard co-axial plug. **PRICE 35/-**

MODEL TCA 6260 as above but with 60in. cable. **PRICE 37/6**

ANTIFERRECE LIMITED BICESTER ROAD, AYLESBURY, BUCKINGHAMSHIRE

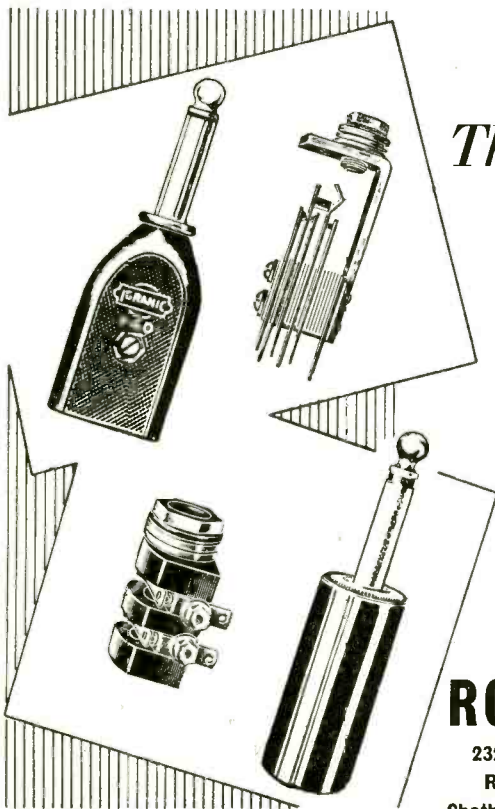

IGRANIC

The Ace of Jacks & Jack Plugs!

Write today for fully illustrated Catalogue of

**IGRANIC JACKS, PLUGS
 RHEOSTATS
 POTENTIOMETERS and
 PRE-SET RESISTORS**

Sole Distributors in the U.K. to the Wholesale and Retail Trade :

ROBshaw BROTHERS LTD.

232/4 High Street
 Rochester, Kent
 Chatham 3115 and 45405

105 Commercial Road
 Bournemouth, Hants
 Bournemouth 5896/7/8

4 Mount Sion
 Tunbridge Wells, Kent
 Tunbridge Wells 1668

ADVANCE COMPONENTS LTD., BACK ROAD, SHERNHALL STREET, LONDON, E.17

Telephone : LARKSwood 4366/7/8

Modern in conception, design and performance, the E.2., with its exceptionally wide range, not only fulfils to-day's needs of radio and television, but anticipates the requirements of tomorrow. More than ordinary care has been used in screening and filtering. As a result, stray field is less than $3\mu V.$ at 100 Mc/s.

- Frequency accuracy of $\pm 1\%$ extends over the whole range.
- Output voltage $1\mu V.$ to 100mv. and approx. 1v. at full R.F. Socket.
- Internal modulation; external modulation to 80%
- A.F. Output variable 0-50v. at 400c/s.
- Size $13" \times 10\frac{1}{4}" \times 8"$. ● Weight $17\frac{1}{2}$ lbs.

Advance

signal generator

ADVANCE TYPE E2

100 Kc/s - 100 Mc/s ON
FUNDAMENTALS

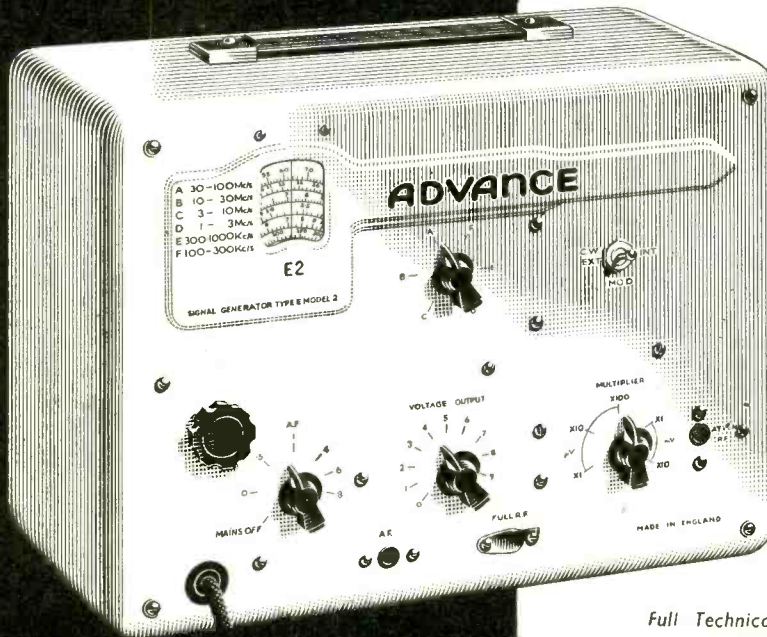

Full Technical Details available in
Folder S/14/W

ADVANCE COMPONENTS LTD., BACK ROAD, SHERNHALL STREET, LONDON, E.17

Telephone : LARKSwood 4366/7/8



The
AUDIOM '60'
and
VERSATILITY

This very popular versatile 12in. Single Cone Loudspeaker can be used for a variety of applications where good quality commercial reproduction is required with Audio Inputs of up to 15 watts. Emphasis is laid on the robust construction that takes into account the conditions met with in some P.A. applications.

The AUDIOM 60 is eminently suitable for general public address use, e.g. Small Theatres, Dance Halls, Ice Rinks and Amateur Cinema Installations. Other more specialised applications include Bass Units in multi-speaker combinations, Radiograms, Electronic Organs, Electric Guitars, or Amplified String Instruments.

Naturally we can only list a few of the many uses, although we are always pleased to give advice on specialised requirements.

Goodmans Heavy Duty Output Transformer type H.4 is specifically recommended for use with this Loudspeaker.

SPECIFICATION

Fundamental Resonance, 35 or 75 c/s. Voice Coil Diameter, 1 $\frac{1}{2}$ in. Voice Coil Impedance, 15 ohms. Flux Density, 14,000 gauss. Total Flux, 158,000 Maxwells. Maximum Power Handling, 15 watts peak A.C. Overall Diameter, 12 $\frac{1}{8}$ in. Overall Depth, 7 $\frac{1}{2}$ in. Baffle Hole Diameter, 11 $\frac{1}{2}$ in. Mounting Holes, 4 holes $\frac{3}{8}$ in. dia. equispaced on a 11 $\frac{1}{2}$ in. P.C.D. Nett weight, 12 $\frac{1}{2}$ lbs. Finish. Grey Rivelling Enamel.



GOODMANS INDUSTRIES LTD.,
Axiom Works, Wembley, Middx.

Telephone: WEMbley 1200. Telegrams: Goodaxiom, Wembley, Eng

THE GOLDRING MAGNA CARTRIDGE



- A magnetic Turnover Cartridge with high output and cantilever styli.
- Entirely new principle. (Pat. applied for.)
- Output comparable to crystal pickups.
- Cantilever styli give minimum record wear and eliminate needle-talk.
- Styli easily replaceable.
- Smooth extended frequency response on both standard and L-P. records.
- The ideal replacement Cartridge for 3-speed record changers and units.

Of special interest to the designer of new equipment.

Write for full technical information to:—

ERWIN SCHARF

49-51a, DE BEAUVOIR ROAD N.1

Telephone: CLIsold 3434-5-6

A workshop in your pocket!



FOR ONLY

25/6

Post Free

THE
TELEVISION
& RADIO SERVICE

ENGINEERS' MASTER TRIMMER KIT

- 1 End Trimmer ● 1 Side Trimmer
 - 1 Yaxley Switch Contact Adjuster
 - 1 Low Capacity Trimmer ● 1 Screwdriver
 - 1 Set of Feeler Gauges ● 1 Set of Six Box Spanners from 1 to 8 B.A. ● 1 Set of Four Spanners from 0 to 8 B.A.
- in durable black crackle finish metal case.

Export Enquiries
invited

J. & S. NEWMAN Ltd.

100 HAMPSTEAD RD., LONDON, N.W.1 Telephone: EUSton 5176/7

Marconi Television for Canada



Equipment supplied includes:

- Marconi Image Orthicon Cameras
- 5 kW vision transmitters
- 3 kW sound transmitters
- High-gain aerial systems
- Associated monitoring and control equipment

The U.S.A., Italy, Venezuela, Thailand, Canada—these are some of the countries which have specified Marconi television equipment.

In Canada, Montreal and Toronto already possess Marconi television studios installed by the Canadian Marconi Company. The new Marconi Transmitter for Ottawa is an important link in the television chain planned by Canadian Broadcasting Corporation to span the entire country.

Marconi high or medium power transmitters, and high power aerials are installed in every one of the B.B.C.'s television transmitter stations.

MARCONI
television transmitting equipment

G.E.C.

RADIO COMMUNICATION EQUIPMENT

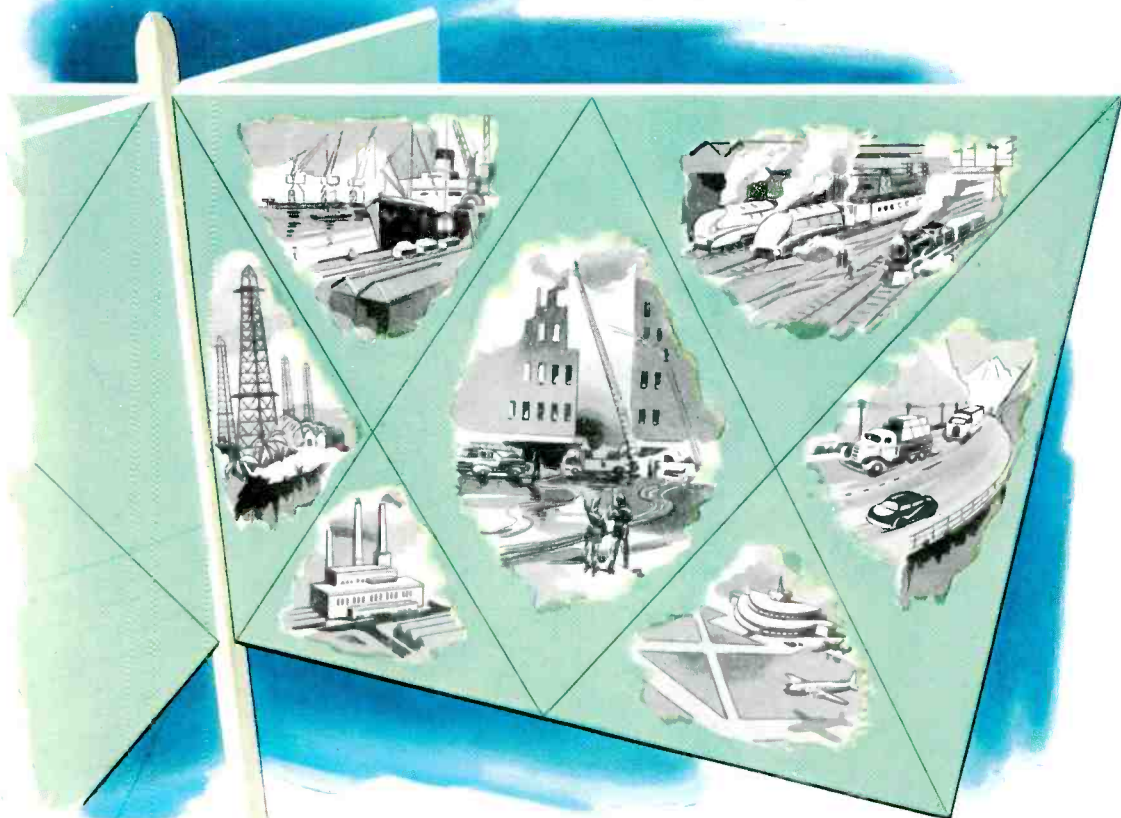

*for use in all parts of the **WORLD***



G.E.C. radio equipment for H.F. and V.H.F. communication has been developed with two important advantages from the purchaser's point of view constantly in mind. *Suitability for the exact operational need and reliability.* These advantages are entirely due to the long and valuable experience of the G.E.C. in all branches of radio engineering, backed by its unique research organisation.

Equipment is available for every kind of radio communication requirement — police, ambulance and fire services, aircraft, shipping, etc. The general purpose receiver shown here is the BRT400D, built to meet the most exacting needs of commercial service in all parts of the world, providing high grade telegraphy service and quality reception for re-broadcast.

THE GENERAL ELECTRIC CO. LTD. OF ENGLAND

PROGRESS

*in Counting ~
through the ages*

HISTORICAL
ILLUSTRATIONS
BY CCURTSEY
OF THE
SCIENCE MUSEUM
LONDON.



NAPIER'S BONES

Devised in 1617 by
John Napier, a
Scottish nobleman,
as a mechanical means
of multiplication by addition.

LEIBNITZ'S STEPPED RECKONER

Invented in 1694 by the
German philosopher and
incorporated in the earliest
practicable calculating machines



ODHNER'S WHEEL

A principle first evolved by
a Swedish engineer about
1390 and still being applied
in present day mechanical
calculating machines



HIVAC COLD CATHODE TUBES

The most modern devices
for use in electronic
systems.



ROMAN ABACUS

Known to have been in
use at the time of Julius
Caesar. A surviving speci-
men is preserved in La
Bibliothèque Nationale, Paris.

Cold Cathode Tubes

FOR

Modern

COUNTING · CALCULATING
SELECTING · SWITCHING



Hivac Limited

GREENHILL CRESCENT, HARROW-ON-THE-HILL
MIDDLESEX, ENGLAND

Phone: HARrow 2655

Cables: Hivac, Harrow

HIVAC Cold Cathode Tubes—Miniature and Subminiature Valves—
Electrometer Valves—Neon Indicator Lamps—Telephone Switchboard
Lamps—are used by the world's leading manufacturers.

www.americanradiohistory.com

DOUGLAS MACADIE

Automatic COIL WINDERS

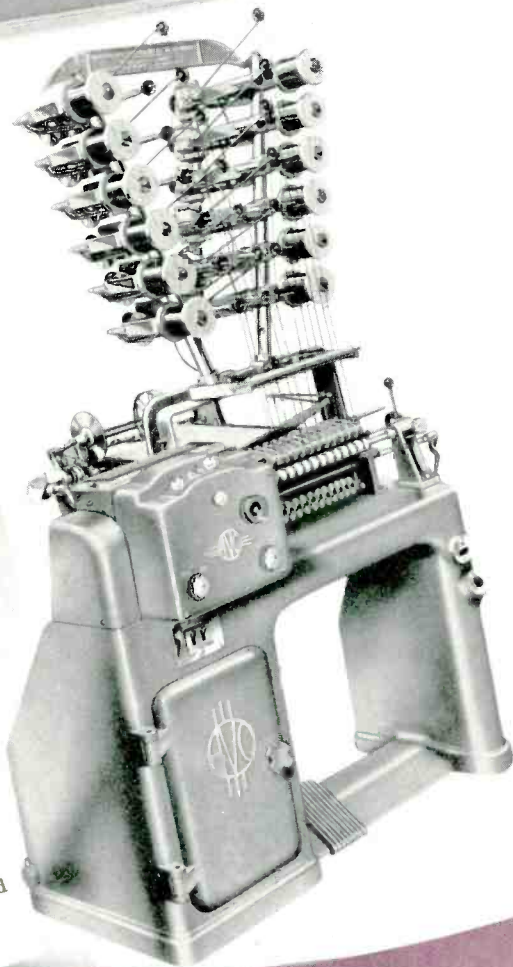

This typical page from our complete Catalogue shows the "Douglas" Fully Automatic Multi-Winder, designed for the high speed production of large quantities of coils with or without paper interleaving.

Our standard range includes 27 different Machines, and we make a number of other types designed for special purposes. Long experience in the design and manufacture of Coil Winders invests our machines with an unexcelled standard of efficiency and ensures maximum economy in the production of windings for every industrial requirement. Our revised Catalogue is now in course of preparation and a copy, when ready, will be sent to interested executives on application.

OVERSEAS AGENTS
We have Agents in all parts of the world. Names and addresses will be furnished on application.

PACKING SPECIFICATIONS

Cases Weight of Machines:
(2 Packing Cases)
140 lbs. (150 kgs.) and
400 lbs. (400 kgs.)

Size of Packing Case	1	2	3
36 x 24 x 50 in.	915	635	1372 mm.
48 x 41 x 60 in.	1475	1041	1270 mm.

"DOUGLAS" LM.W. FULLY AUTOMATIC MULTI-WINDER DIMENSIONS AND WEIGHTS:

Floor Space Required	45 - 19 in. (1.14) - 483 mm.
Height of Machine	80 in. (2.032 mm.)
Net Weight of Machine	350 lbs. (250 kgs.)

THE AUTOMATIC COIL WINDER & ELECTRICAL EQUIPMENT CO. LTD.

WINDER HOUSE · DOUGLAS STREET · LONDON S.W.1

Telephone: VICTORIA 3404-9



By Appointment to the Professional Engineer...

ATTENUATORS · FADERS · STUD SWITCHES AND TOGGLE SWITCHES
 WIREWOUND POTENTIOMETERS · HIGH STABILITY CARBON RESISTORS
 WIREWOUND RESISTORS · PLUGS AND SOCKETS · TERMINALS
 KNOBS DIALS AND POINTERS

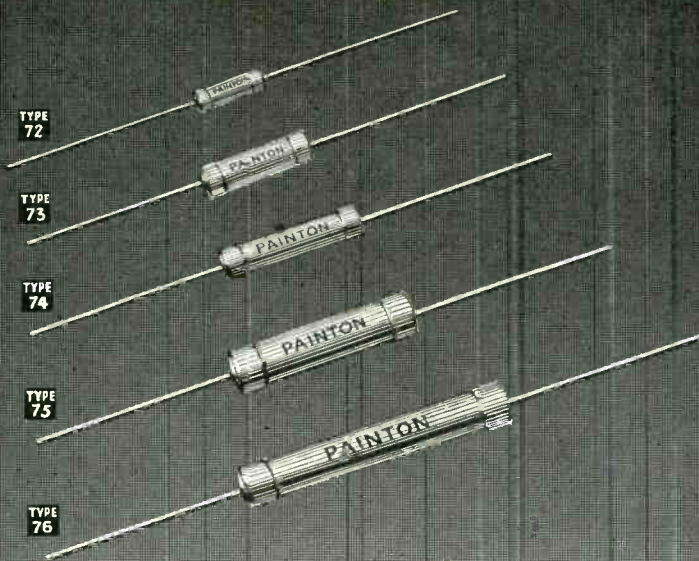

HIGH STABILITY CARBON RESISTORS
 $\frac{1}{2}$ w, $\frac{1}{4}$ w, $\frac{3}{4}$ w, 1 w and 2 w types available at 1%, 2% or 5% Resistance Tolerance.
 Complete range fully R.C.S.C. approved. For full details request Catalogue, Section E.

PAINTON
Northampton England

The LATEST and IMPROVED TAPE

For all popular tape recording machines

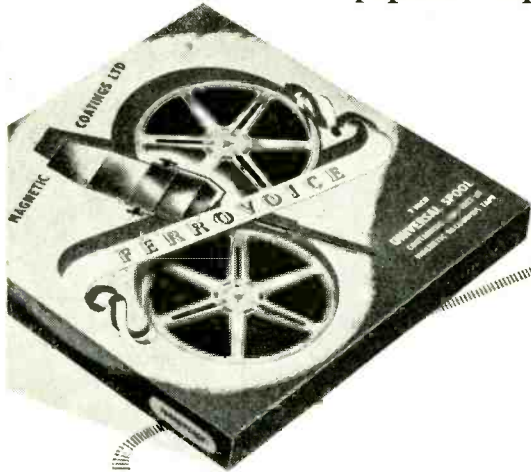

Specially wound on transparent perfectly balanced plastic spools which fit easily to all popular types of tape recorders. The advantages of FERROVOICE are now available to all. FERROVOICE improves the performance of all recorders. It provides twin-track recording of the highest standards of quality and faithfulness. Tape wear and rotation noises are reduced to the minimum.

FERROVOICE is the most modern and most efficient tape available. It brings to all tape recorders the highest standards of recording and reproduction.

Technical features: Super Calendered Kraft Paper—breaking strain approximately 4 lb.—Tape width 0.247" ± 0.001". Medium coercivity—ease of erasure—frequency response 50 c/s to 10 Kc/s at 7 1/2" per second. Length of tape 1,200 ft. Spool 7" diameter.

NOTE THESE OUTSTANDING FEATURES

- ★ TWIN-TRACK RECORDING WITH UNIFORM RESPONSE.
- ★ HIGH PLAY-BACK LEVEL AND LOW NOISE COMPONENT.
- ★ LIGHTWEIGHT PRECISION BALANCED SPOOL.
- ★ FERROVOICE SPOOLS KEEP WEAR, TEAR AND ROTATION NOISE TO A MINIMUM.

FERROVOICE ^{REGD}

The Tape YOU will ultimately use



Trade Enquiries Invited.

MAGNETIC COATINGS LTD., 38 GROSVENOR GARDENS LONDON SW1

'phone: SLOane 9129

VITREOUS ENAMELLED WIRE WOUND RESISTORS — EXCELLENT DELIVERY



Labgear (Cambridge) Limited

WILLOW PLACE, CAMBRIDGE, ENGLAND

Telephone : CAMBRIDGE 2494 (2 lines) Telegraphic Address : "LABGEAR, CAMBRIDGE"

ALWAYS "FIT"



SUSPENSION DRAWER SLIDES, SUN and PLANET FRICTION ELIMINATORS and SHEAVES

Ask for Brochure and pages 47, 49 and 53



Engineers, Patentees and Sole Manufacturers.

AUTOSET (PRODUCTION) LTD., DEPT. "H", STOUR STREET, BIRMINGHAM 18

Tel.: EDG. 1143/44

Please mention Wireless World

ESTD. over 30 years

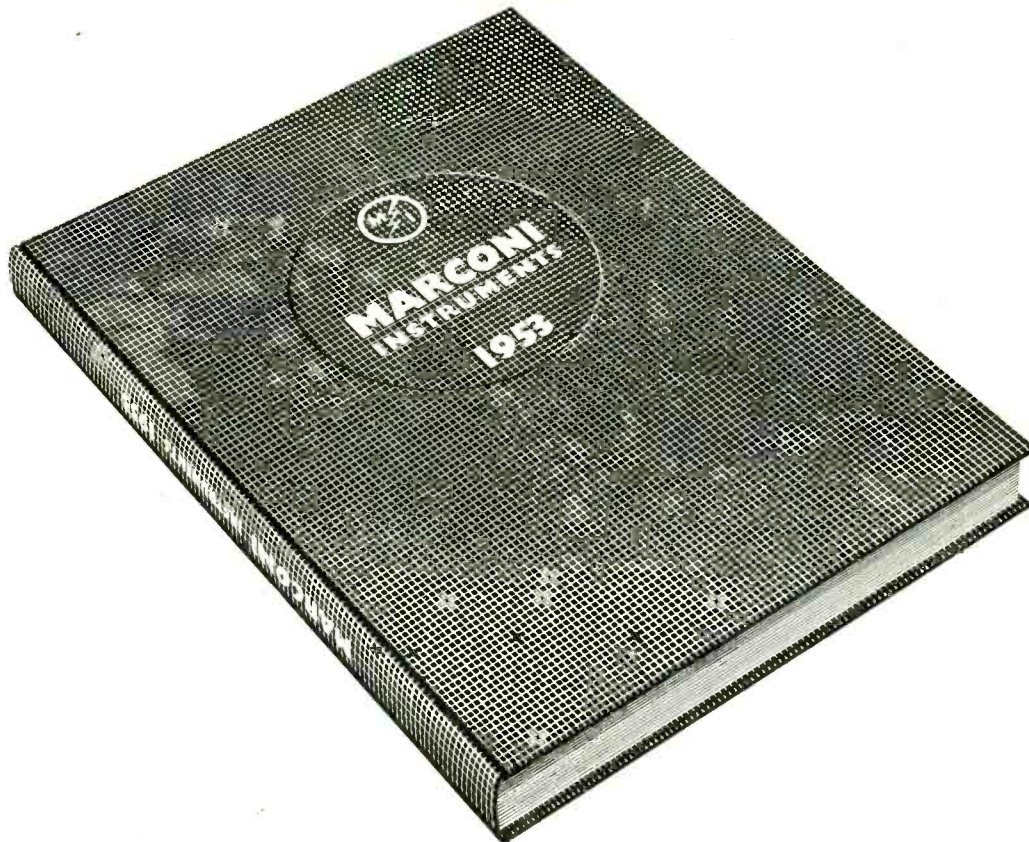

keep up-to-date with **MARCONI**

We would like to draw the attention of all our friends to the new instrument catalogue. This handsomely bound publication records the latest developments in the communication and industrial fields — as have our loose-leaf catalogues up to now. But techniques advance as Marconi research progresses, and for clarity's sake all available data has been re-cast in

the new format. We hope this will prove even more valuable to you than its predecessors.

If you are on our existing mailing list, you will have your new Marconi Instruments catalogue this month. But do jog our memory if, by chance, we overlook you — we want every executive who really needs one to have a copy.

MARCONI INSTRUMENTS

SIGNAL GENERATORS · BRIDGES · Q METERS · OUTPUT METERS · WAVE METERS
 WAVE ANALYSERS · BEAT FREQUENCY OSCILLATORS AND INDUSTRIAL ELECTRONIC INSTRUMENTS

MARCONI INSTRUMENTS LIMITED · ST. ALBANS · HERTFORDSHIRE

Midland Office : 19 The Parade, Leamington Spa.

Northern Office : 30 Albion Street, Kingston-upon-Hull.

Export Office : Marconi House, Strand, London, W.C.2.





POPULAR 'H' T.V. AERIAL

Available for all channels
and Horizontal for
Pontop Pike and Belfast.

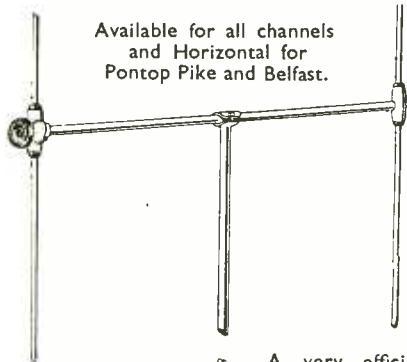

A very efficient aerial
at a highly competitive
price.

Quickly and easily assem-
bled and erected.

All the principal 'Tele-
craft' features. .15 spac-
ing, 5ft. steel stand-off
arm. Complete in every
detail

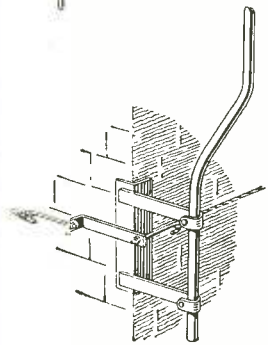

£4-3-6

There is a TELECRAFT AERIAL for every
contingency—indoors or out

Send for Descriptive Literature.



Quadrant Road, Thornton Heath, Surrey.
THORnton Heath 1191-2-3

Depot Addresses :

NEWCASTLE-ON-TYNE. 55, Northumberland Street.

Telephone : Newcastle 22516.

BRISTOL. 14, Rose Street, Temple Way, Bristol, 1

Telephone : 21230.

MANCHESTER. 172, London Road, Manchester.

Telephone : Ardwick 2734.

BIRMINGHAM. 75, Holyhead Road, Handsworth.

Telephone : North 6301 (Ext. 2).

CARDIFF. 1 & 2, Stuart Street, Cardiff.

Telephone : Cardiff 25955.

GLASGOW. 423, Clarkston Road, Glasgow, S.4.

Telephone : Merrylee 4326.

BOURNEMOUTH. Canford Chambers, St. Peter's Road.

Telephone : 2282.

PLYMOUTH. 25, William Street (City Centre)

Telephone : 4797.

BRIGHTON. 81A, Queens Road, Brighton.

Telephone : 28117.

MANUFACTURERS OF AUTOMATIC AND HAND COIL WINDING MACHINES ALSO STRIP WINDING

SOLE AGENTS ABROAD

K. G. Khosla & Co., 1 Original Road (Opp. Paharganj
Police Station), New Delhi 1, India.

Etabls Octave Houart, 14 Quai de L'Industrie, Selessin-
lez-Liege.

R. H. Cunningham, Pty., Ltd., 118 Wattletree Road,
Armadale, S.E.3, Victoria, Australia.

Hefty & Frogg, Oslo, Norway, Storgaten, 15.

Technical & Industrial Services, P.O. Box 60, Claremont,
Cape Town.

YOUR ENQUIRIES ARE INVITED

ETA TOOL CO (LEICESTER) LTD 29A WELFORD ROAD, LEICESTER

Phone 5386

ABOVE ALL OTHERS

**POTTED AND
COMPOUND FILLED
TRANSFORMERS
AND CHOKES**

made by Woden are the
answer when the call is
for transformers to
operate under exacting
industrial conditions,
coupled with adverse
climatic conditions.



Every transformer leaving our factory is subjected to a rigid
inspection, and is fully impregnated with moisture proof filling
compound by the latest vacuum and pressure process. The fact
that "WODEN" are the choice of many leading radio and
television manufacturers is proof enough of the quality of our
products.

Please send for latest Catalogue



MOXLEY ROAD, BILSTON, STAFFS.

TELEPHONE: BILSTON 41959

TEMPERATURE NORMAL!

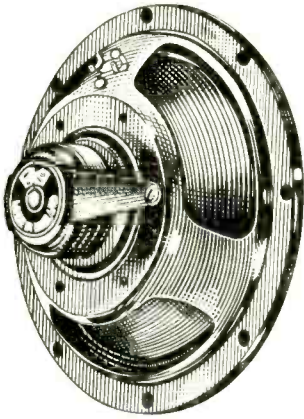

Coronation fever is over. Demand for television sets is more manageable. For a few weeks radio and television manufacturers will, we hope, have time to think about the autumn demand — and perhaps even to enjoy some recuperative sunshine! May we suggest that part of this respite could be profitably spent in studying the special features of the new range of R. & A. Reproducers? These features include:

- * Co-axial construction for accurate and permanent alignment.
- * Zero external magnetic field.
- High sensitivity, with magnet assemblies in the '800' Series of 7,000 to 10,000 Gauss, and in the '900' Series of 10,000 and 12,000 Gauss.
- * Easily removable magnet systems to facilitate overseas service.

Performance and reliability standards which have won world-wide renown.

* Covered by British and Foreign Patents.

R&A

Loud-speaker
Manufacturers
to the radio industry
since 1930

REPRODUCERS AND AMPLIFIERS LIMITED
WOLVERHAMPTON ENGLAND

Telephone Wolverhampton 22241 (5 lines)

Telegrams: Audio Wolverhampton



Instruments for Research & Industry

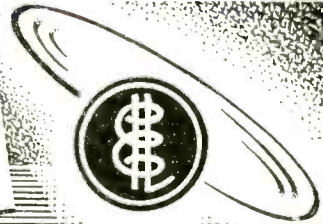

The Chronotron

A direct reading electronic stop clock for general purpose timing in the millisecond region.

The CHRONOTRON is used for timing relays and fuses; speeds of vehicles and projectiles; for testing camera shutters and for physiological investigations. Timing can be controlled by contacts, by a photocell, or by externally generated voltages.

MODEL 25A
0-4 milliseconds
to 0-1 second

MODEL 25B
0-40 milliseconds
to 0-10 seconds

MODEL 25C
0-40 microseconds
to 0-10 milliseconds

ELECTRONIC INSTRUMENTS LTD
RICHMOND · SURREY · ENGLAND

ALL the A.C. power you require from your D.C. supply

with a

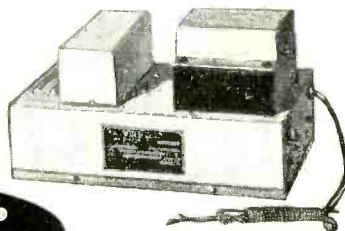

Valradio

D.C./A.C. CONVERTER

Models for Electric Gramophones from £8 16 0

Models for

- Radiograms and Autochange Radiograms (inc. 3-speed motors)
- Radios, Televisions, etc. from £11 16 6
- Tape Recorders, Dictating Machines, etc. Input, 6, 12, 24, 32, 50, 110 or 200/250V. D.C. Output 230V. 50 or 60 c/s.

Descriptive literature W.W.30. from the manufacturers:

VALRADIO LIMITED

NEW CHAPEL RD., HIGH ST., FELTHAM, MIDDX. Tel. FELtham 4242
Service Dept.: 57 Fortress Rd., London, N.W.5. Tel.: GULLiver 5165 & 7202
Scottish Depot: 257 Gorbals Street, Glasgow, C.5. Tel.: South 1326
Overseas enquiries to nearest E.M.I. Organisation Depot.

DEMONSTRATIONS DAILY

Between 9—5.30
Saturdays 9—1

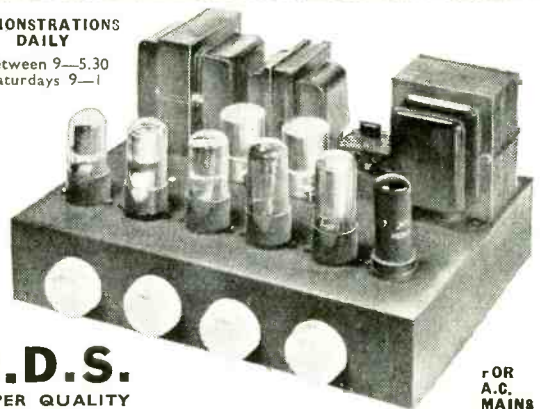

A.D.S.
SUPER QUALITY

8 1/2 WATT AMPLIFIER

Push Pull 6V6s 15 db neg. feed back 25-18,000 cps ± 1/db. Hum Level—80 db at 6 1/2 watts. Bass boost—Treble boost and cut : LP correction : Provision radio feeder unit. **BUILT AND TESTED 16 gns.**

The above Amplifier can now be supplied in kit form. £13. 13. 0
Complete with fully illustrated instruction book.

METAL COVERS complete with carrying handle, can now be supplied at 17/6 each.

SUPERHET FEEDER Three wavebands—88A Valves. 7 kc band width. Wired complete and tested.

10 GUINEAS FULLY GUARANTEED.



(Dept. W.W.)
18 Tottenham Court Road,
LONDON, W.1
Museum 4539. Museum 2453

Shop Hours :
Monday to Friday 9-5.30 p.m.
Saturdays 1 p.m.

10 advantages of **SELENIUM SenterCel RECTIFIERS** miniature selenium rectifiers

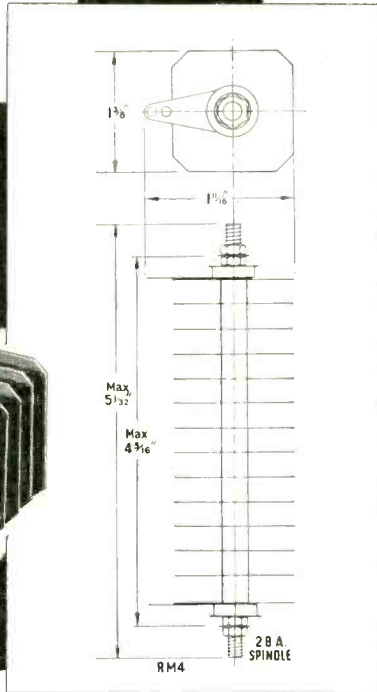
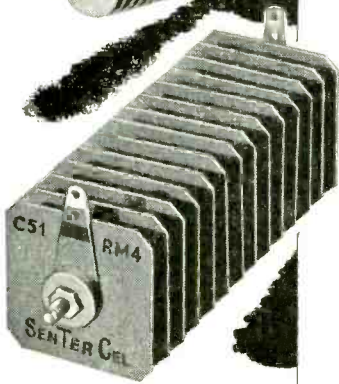
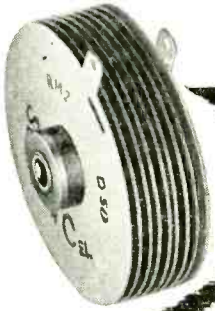
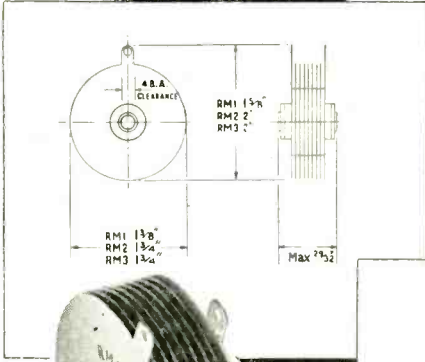

Compare these outstanding features with those of the rectifiers which at present you are using:—

- Less wiring
- Unlimited instantaneous overload such as the charging current of de-formed electrolytic capacitors.
- Far lower heat dissipation.
- No "warming-up" period.
- No valve-holder.
- Practically indestructible in normal service.
- No limit to size of electrolytic capacitor.
- Saves weight.
- Saves space.
- Low in cost.

Study these RATINGS

TYPE	RM0	RM1	RM2	RM3	RM4
Maximum ambient temperature	35°C 55°C	35°C 55°C	35°C 55°C	35°C 55°C	35°C 40°C 55°C
Maximum output current (mean)	30mA 15mA	60mA 30mA	100mA 60mA	120mA 90mA	275mA 250mA 125mA
Maximum input voltage (r.m.s.)	125V	125V	125V	125V	250V
Maximum peak inverse voltage	350V	350V	350V	350V	700V
Max. instantaneous peak current	Unlimited	Unlimited	Unlimited	Unlimited	Unlimited
Weight	0.82 oz.	1 oz.	1.4 oz.	2 oz.	4.5 oz.



Standard Telephones and Cables Limited

(Registered Office: Connaught House, Aldwych, W.C.2)

RECTIFIER DIVISION: Warwick Road, Boreham Wood, Hertfordshire.

Telephone: Elstree 2401 Telegrams: Sentercel, Borehamwood

A Service in Sound
 "—from the finest of portable tape recorders" says BRIAN RIX, Actor-Manager-Producer of "Reluctant Heroes"

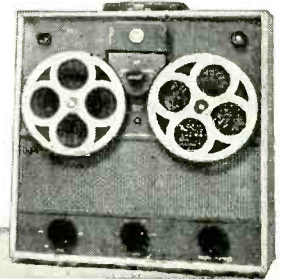

Brian Rix, G2DQU, successful impresario with a keen interest in Amateur Radio, has a trained ear for the technical merits of the Baird Tape Recorder. "Here is a portable instrument," he says, "with a performance equal to that of costly professional equipment. Its distortion-free true-to-life recordings are the result of many new and impressive advances in high fidelity technique. The finest of all portable recording instruments, it's invaluable at rehearsals."

BAIRD RECORDING TAPE CEMENT is specially prepared for splicing plastic base magnetic tape. Makes clean, quick-setting joints, which are strong and free from creeping. Each bottle is fitted with a brush for easy application. 3/6d. (post and packing 6d. extra)

Complete with microphone and tape 65 gns.



THE ALL-BRITISH TAPE RECORDER

BAIRD TELEVISION LTD · LANCELOT ROAD · WEMBLEY · MIDDLESEX

SCREENED CONNECTORS

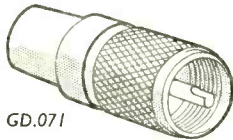

GD.071

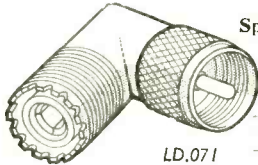

LD.071

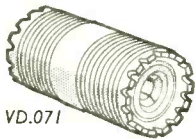

VD.071

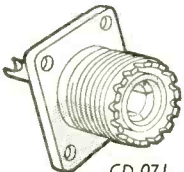

CD.071

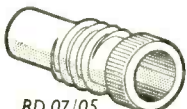

RD.07/05

for cables of 0.2" to 1.03" O.D.
 Single and multi-way types.
 Special types fitted with coupling rings.
 Cable joining connectors.
 U.S. Type Connectors as illustrated.

CABLE O.D.	TYPE	CODE NO.
0.41"	Straight plug	GD.071
0.25"	Reducing adaptor	RD.07/05
0.2"	Reducing adaptor	RD.07/03
fits on GD.071	Elbow plug adaptor	LD.071
CD.071		
VD.071		
fits on GD.071	Bulkhead (Junction) adaptor	VD.071
LD.071		
fits on GD.071	Chassis receptacle	CD.071
LD.071		

Other Transradio specialised products:
 CO-AX air-spaced articulated Very Low Loss Cables.
 Microdual Two-speed Precision Drives.

TRANSRADIO

LTD
 138A CROMWELL ROAD, LONDON, SW7, ENGLAND Telephone: FREmantle 4421 (P.B.X.)

HIGH FIDELITY REPRODUCTION

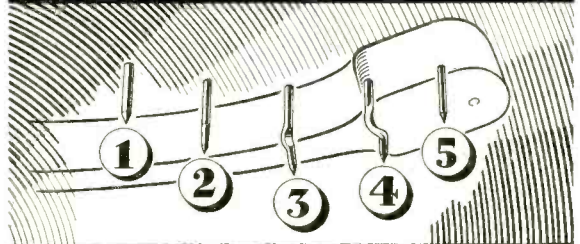

WITH A MINIMUM OF WEAR

Calls for the use of

S. G. BROWN PRECISION SAPPHIRE NEEDLES

- No. 1 "Miniature" Jewel-tipped needle for *Lightweight* pick-ups.
- No. 2 "Straight" Jewel-tipped needle for *Crystal* pick-ups.
- No. 3 "Trailer" Jewel-tipped needle for *Medium-weight* pick-ups.
- No. 4 "Knee Bend Trailer" Jewel-tipped needle for older *Heavy-weight* pick-ups.
- No. 5 "Miniature Solid Sapphire" needle for *Lightweight* pick-ups.

PRICES (Subject to full Trade Discount)

Nos. 1-4, 7/-, plus 2/4 P.T.

Post 6d.

No. 5, 9/3, plus 3/1 P.T. Post 6d.

There's an S. G. BROWN PRECISION SAPPHIRE NEEDLE for every type of PICK-UP

All S. G. Brown Precision Sapphire Needles are protectively mounted on a useful double-sided stroboscope (78 & 33-1/3 r.p.m.). An instructive and interesting Brochure with many useful hints on obtaining better reproduction gladly sent on request. Write to Dept. W.

S. G. Brown Ltd. SHAKESPEARE ST., WATFORD, HERTS. Telephone: Watford 7241.



**R. C. OSCILLATOR
AND AUTOMATIC
FREQUENCY MONITOR**

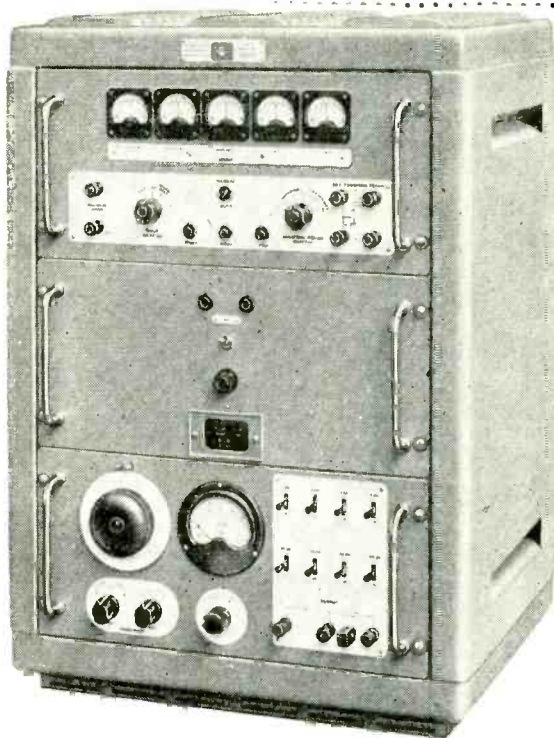

An instrument of exceptionally high accuracy and stability—the output frequency of which is automatically measured and presented in decimal notation.

Range	10c/s to 100kc/s
Accuracy	$\pm 0.005\%$
Output	0 to 30 volts r.m.s. metered
Attenuator	0 to 110db in 1db steps (constant 600 Ω)

The equipment will measure any frequency in the range 10c/s to 100kc/s and any time in the range $10\mu\text{sec}$ to 10^4sec both to an accuracy within $\pm 0.005\%$. It will also count up to a maximum rate of 10^5 pulses/second.

CINEMA-TELEVISION LIMITED

A Company within the J. Arthur Rank Organisation

WORSLEY BRIDGE ROAD · LONDON · SE26

Telephone Hither Green 4600

SALES AND
SERVICING AGENTS

F. C. Robinson & Partners L'd.,
287 Deansgate, Manchester, 3

Hawnt & Co., Ltd.,
89 Moor St. Birmingham, 4

Atkins, Robertson & Whiteford Ltd.,
100 Torrissdale Street, Glasgow, S.2.

The Two Extremes It is generally agreed that the extreme ends of the Audio frequency range are the most difficult to reproduce. The problem has been intelligently tackled by the design of the Wharfedale W.15/CS and Super 5 units. The W.15/CS has an open baffle resonance of 28 c/s, and the response is maintained within 5db between this frequency and 1000 c/s. The Super 5 is now fitted with aluminium dome and the axial response is well maintained between 3000 and 15,000 c/s. as shown by the response curve.

These two units, used in a 3-speaker system with a middle speaker of not less than 13,000 lines flux density, will give reproduction of very high quality.

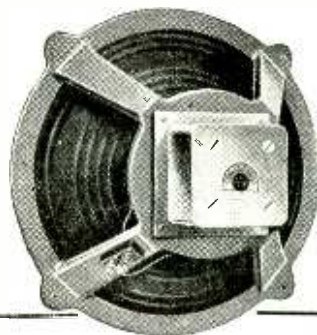

Response Curve
W.15/CS

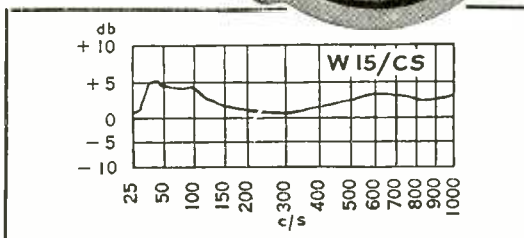

Response Curve
Super 5

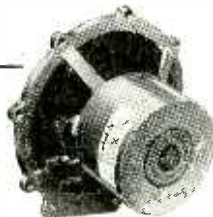
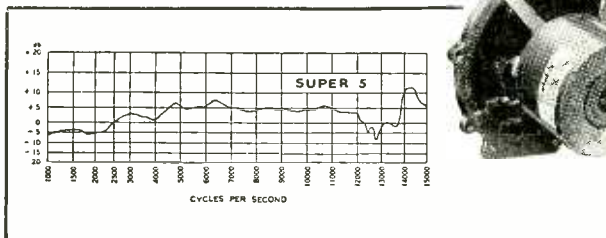

Wharfedale

WIRELESS WORKS

Bradford Road · Idle · Bradford · Yorks Telephone : Idle 461

PRICES

Super 5 Unit £6.13.3
TAX PAID
W.15/CS Unit £16.0.0
TAX FREE

The "RD BABY DE-LUXE MK. II" Amplifier.

The World's finest medium priced amplifier

The improvements effected in this latest version of the already well known "RD BABY" place it in a class apart, unsurpassed by any other amplifier approaching it in price.

NOTE THESE EXCEPTIONAL IMPROVEMENTS :-

- ★ Power Output increased to 8-10 watts.
- ★ Total harmonic distortion at 8 watts—25%.
- ★ Total harmonic distortion at 12 watts only—6%.
- ★ Consistent quality maintained at all volume levels.
- ★ Perfect phase splitter balance over the full audio range.
- ★ All iron cored components now fully shrouded.
- ★ Close tolerance high stability resistors employed. Despite this vastly improved performance the price remains unchanged at **£14.**

With the introduction of this new amplifier an improved version of the "RD JUNIOR" pre-amplifier has also been introduced—the "RD JUNIOR MK. II," featuring in particular a variable control for the Low Pass Filter. **£9.**

Price complete with Engraved Control Panel

Detailed technical specifications, including response curves and an illustration, will gladly be forwarded post free on request. Available from leading dealers in London and the Provinces. or if in any difficulty, please apply direct.

Trade and Export enquiries invited.

ROGERS DEVELOPMENTS Co

Manufacturers of Precision Built Sound Equipment.

"Rodevco House," 116 Blackheath Road, Greenwich, London, S.E.10. Telephone: TIDeway 1723

SCALAMP ELECTROSTATIC VOLTMETER

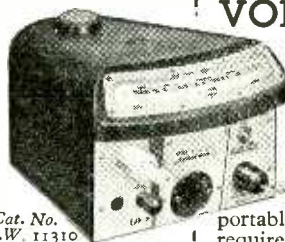

Cat. No. W.W. 11310

- DIRECT READING.
- ZERO CURRENT DRAIN.
- THREE SECONDS PERIOD.
- LAMP OPERATES FROM MAINS OR 4 VOLT BATTERY.
- BRIGHT SPOT-AND-HAIRLINE INDICATOR.

This instrument introduces a completely new conception of electrostatic voltmeter. It is compact, portable and robust, and does not require critical levelling or special mounting. The movement has a taut suspension, is critically damped, and readings can be taken with rapidity and ease. Three models are available:

- Cat. No. W.W. 11308
1 - 5 kV A.C. D.C.
- Cat. No. W.W. 11309
3 - 10 kV A.C. D.C.
- Cat. No. W.W. 11310
5 - 18 kV D.C. and
5 - 12 kV A.C. R.M.S.

Please write for illustrated leaflet.

SCIENTIFIC INSTRUMENTS

W. G. PYE & CO. LTD., GRANTA WORKS, CAMBRIDGE



Electronic Development...

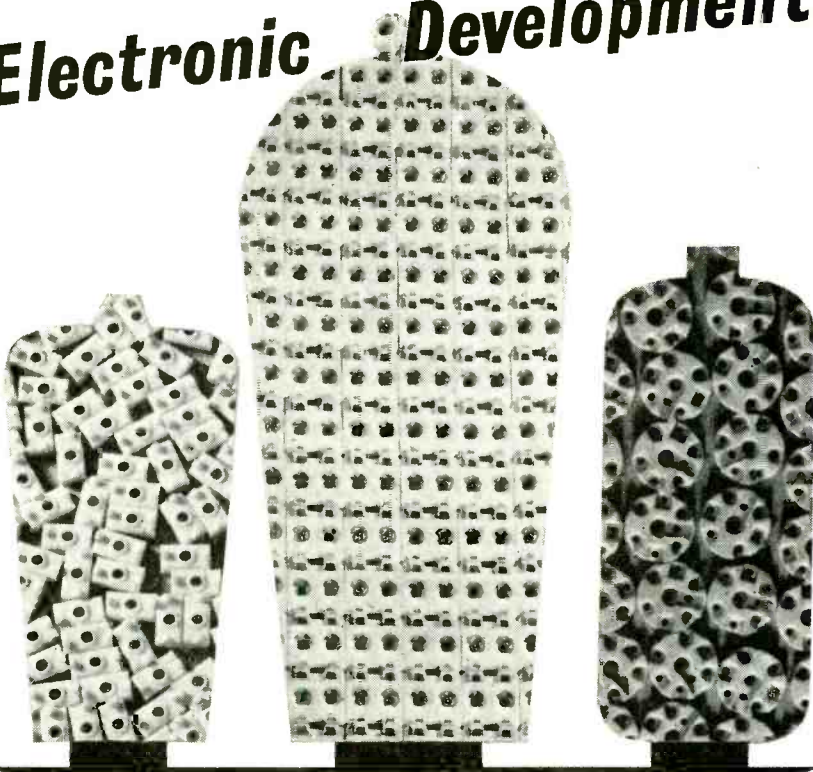

NEEDS

T-T
 LOW LOSS
 CERAMICS

GOOD DELIVERY

COMPETITIVE PRICES

For full particulars
 OF ALL LOW LOSS CERAMICS SUITABLE
 FOR ELECTRONIC DEVELOPMENT

write to

TAYLOR TUNNICLIFF (REFRACTORIES) LTD

ALBION WORKS, LONGTON, STOKE - ON - TRENT

Telephone : Longton 33122

London Office : 125 HIGH HOLBORN, LONDON, W.C.1 Tel : HOLBORN 1951/52

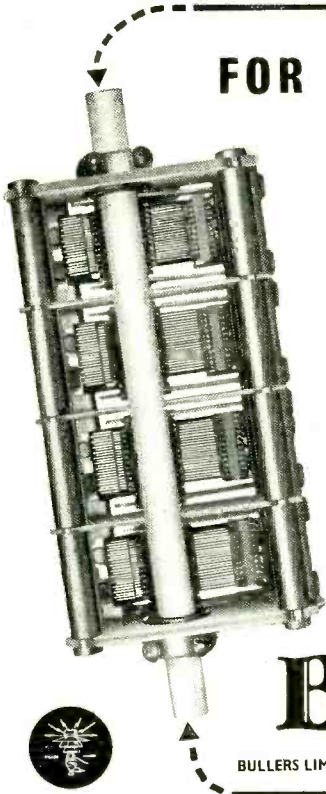

FOR HIGH-FREQUENCY INSULATION

—specify 'FREQUELEX'

The illustration shows a Four Gang Radio Variable Condenser using our "FREQUELEX" Ceramic Rod for the Centre Rotating Spindle. This Rod is 7½" long × .437" diameter, centreless ground to within plus or minus .0005". Maximum camber allowance of .002".

This is only one of many applications where Rods made to close limits are required.

We specialise in the manufacture of Ceramic Rods and Tubes of various sections in several classes of materials over wide dimensional ranges.

The Principal Materials Are:—

1. Porcelain for General Insulation
2. Frequelex for High-Frequency Insulation
3. Permalax and Templex for Capacitors

The degree of accuracy depends on the size of the Rod or Tube, but the standard degree of accuracy is outlined in the Inter Service Component Manufacturers' Council — Panel R Specification embodied in our Catalogue of Radio Frequency Ceramics, copy of which will be sent on request.

Large Rods up to 44" long and 1½" square are used as supports for Tuning Coils, etc.

We shall be pleased to have your enquiries for all sizes of Tubes and Rods. Prompt deliveries can be given for most sizes.

Condenser manufactured by Messrs. Wingrove & Rogers Ltd.

Bullers LOW LOSS CERAMICS

BULLERS LIMITED, 6 Laurence Pountney Hill, E.C.4 Phone: MANsion House 9971 (3 lines) Grams: 'Bullers, Cannon, London'

BL.1B

CORONATION OFFER!



The coupon below will save you MONEY

Let International Correspondence Schools perfect your knowledge of radio and T/V. To mark the Coronation, I.C.S. offer their Standard Home Study Courses at specially reduced fees, for a limited period only. These include:—

RADIO ENGINEERING . RADIO SERVICE ENGINEERING . RADAR, ELEMENTARY ELECTRONICS, ADVANCED SHORT WAVE RADIO . RADIO . T/V TECHNOLOGY and training for the following examinations—B.I.R.E. . P.M.G. CERTIFICATES FOR WIRELESS OPERATORS . C. & G. TELECOMMUNICATIONS . C. & G. RADIO SERVICING CERT. (R.T.E.B.) . C. & G. RADIO AMATEURS, etc., etc.

But ACT NOW—Don't miss this chance of obtaining an I.C.S. training at reduced fees. Fill in the coupon, stating the subject in which you are interested, and POST TODAY!

Dept. 223C, I.C.S., 71, Kingsway, W.C.2



INTERNATIONAL CORRESPONDENCE SCHOOLS
Dept. 223C, International Bldgs., Kingsway, London, W.C.2.
I am interested in your Coronation offer.
Please send FREE Book on

Name Age
(BLOCK LETTERS, PLEASE)
Address



SINCE 1945 I.C.S. HAVE TRAINED 150,000 AMBITIOUS MEN

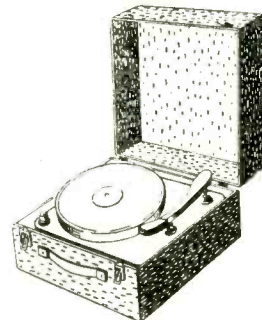

FOR THE B.S.R. MONARCH AND GU4A REGENT Gramophone Units

AND FOR

SPARES and STYL
PORTABLE RECORD PLAYER
CABINETS from £3-2-0 (including Purchase Tax)
suitable for the above

N. MIERS

& CO. LTD.

115 Gower Street, London, W.C.1.

Phone: EUSton 7515. Grams: Miersco, Westcent.

T.A. 5461

An unsolicited TECHNICAL REPORT

given by the
NATIONAL FEDERATION OF GRAMOPHONE SOCIETIES*
on
AXIOM HIGH FIDELITY LOUDSPEAKERS

MODEL 150 MARK II 12" TWIN CONE
101 8" SINGLE CONE
102 8" SINGLE CONE

BY THE COURTESY OF Messrs. Goodmans Industries Ltd., we have recently had the opportunity of submitting these speakers to thorough tests. The 150, Mark II, is a very definite improvement on the Mark I model, with a firmer, smoother middle register and lower fundamental resonance (nominally 35 c.p.s.). It was not possible to house the speaker in the cabinet designed for the purpose by Messrs. Goodmans, but mounted in a labyrinth which absorbed virtually all the sound from the back of the cone the outstanding characteristics of this reproducer were hard, clear bass, very even response in the middle and upper registers and low needle hiss of unobjectionable quality. Response extends to 15 k.c. This is an excellent single unit which should give every satisfaction to Societies. It will handle up to 15 watts.

The main difference between the Models 101 and 102 is the increased sensitivity and flux density of the latter. These qualities are, naturally, accompanied by improved damping and increased price. These are undoubtedly the best 8" units which we have so far tested, and the maker's claim for response within 3-4 db. from 40 to 15,000 c.p.s. was fully substantiated. They showed no signs of distress when fed with peak inputs up to 6 watts.

Excellent results were obtained running the Axiom 101 in parallel with the Axiom 150 to secure wider distribution of sound, and also by running two 8" units in parallel. In the latter case there was rather less weight in the extreme bass. A very pleasing effect of light and air in the treble and wide sound source can be secured by using an 8" unit on a small baffle reflecting into a corner in parallel with another cabinet-mounted 8" or 12" speaker. The top speaker should have a 2 mfd. condenser (NOT electrolytic) in series with the voice coil.

For their size and price the performance of the Axioms 101 and 102 is outstanding in quality.



AXIOM 150 Mk. II
£13. 11. 5 (incl. purchase tax)



AXIOM 22 Mk. II
£19. 8. 4 (incl. purchase tax)



AXIOM 101
£6. 12. 1 (incl. purchase tax)

AXIOM 102
£9. 18. 2 (incl. purchase tax)

* We acknowledge with thanks the permission to reproduce the above report which is an extract from the January issue of the Society's private journal

All these models are stocked by the leading dealers, but in case of difficulty please order direct from us. We invite you to write for further details of any unit. Remember we can give you outlined dimensional drawings of reflex chambers for all Speakers mentioned.



"Axiom" and "Audiom" are registered Trade Marks of
GOODMANS INDUSTRIES LTD., Axiom Works, Wembley, Middx.
Telephone: WEMbley 1200 Cables: Goodaxiom, Wembley, England

MODERN RADIOGRAMS

by the leading makers are fitted with
Garrard Record Playing Units



THE NEW GARRARD R.C.75A AUTOMATIC RECORD CHANGER

which automatically plays ten 12in., 10in. or 7in. records at either 78, 45 or 33 $\frac{1}{3}$ R.P.M. is also available for fitting to existing single speed record playing instruments.

It is complete with full instructions and all necessary fittings.

Your nearest dealer will be pleased to give you full details and explain how easy it is to replace your existing unit with a Garrard Precision Record Changer.

NOTE TO DEALERS—A special sales show stand which displays these units to your customers to the best advantage is available free of charge on application to the Swindon Factory. Stock models of all Garrard Products and the latest catalogue are also immediately available. Write for full particulars.

**THE GARRARD ENGINEERING
& MANUFACTURING CO. LTD.**
SWINDON, WILTS.



HYDRAULICALLY FORMED
by a process unique in this country

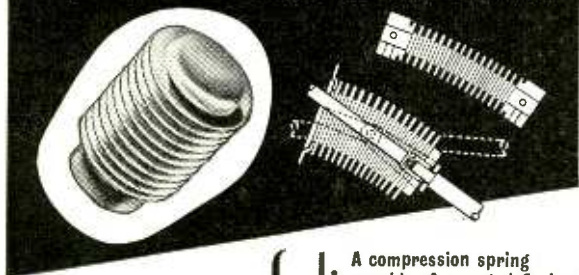

*Combining the
properties of:*

1. A compression spring capable of repeated flexing
2. A container which can be hermetically sealed
3. A packless gland

for Automatic coolant regulation: Movement for pressure change: Packless gland to seal spindle in high vacua: Reservoir to accept liquid expansion: Dashpot or delay device: Barometric measurement or control: Pressurised couplings where vibration or movement is present: Dust seal to prevent ingress of dirt: Pressure reducing valves: Hydraulic transmission: Distance thermostatic control: Low torque flexible coupling: Pressure sealed rocking movement: Pressurised rotating shaft seals: Aircraft pressurised cabin control: Refrigeration expansion valves: Thermostatic Steam Traps: Pressure amplifiers: Differential pressure measurements: Thermostatic operation of louvre or damper.

Write for List No. N800-1

B12

Drayton METAL BELLOWS

Drayton Regulator and Instrument Co. Ltd., West Drayton, Middx.

COIL WINDING MACHINERY

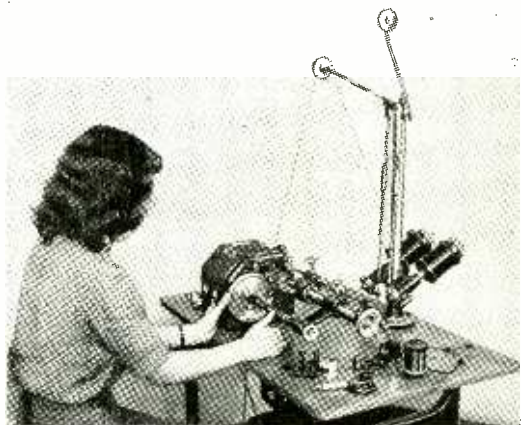

We invite your enquiries for the Type A1/1 automatic machine, as illustrated. Also for the Type H/1 hand coil winder and Type AW/1 Armature Winding Head.

KOLECTRIC LTD

73 UXBRIDGE ROAD, EALING, LONDON, W.5

Ealing 9096

First...

**for all
valve
requirements**

Most designers of electronic equipment contact Ediswan first for all their valve requirements. They know that amongst the large range of valves made by Ediswan they are almost certain to find the specific type they need. They are certain also that any valve made by Ediswan can be relied upon for satisfactory service. Why don't you contact Ediswan for your valve requirements next time?

EDISWAN

MAZDA

Valves and Television Tubes

The Edison Swan Electric Company, Ltd. 155 Charing Cross Road, London, W.C.2
Member of the A.E.I. Group of Companies

NEW ARCOLECTRIC SIGNAL LAMPS

For Low Voltage or Mains

Illustrated are a few of our wide range of new signal or indicator lamps.

A new mains voltage lampholder, Cat. No. S.L.88/N, has been developed for use with the Arcolectric MES neon tube. Among the features of this design are easy lamp replacement, from front or rear of panel, and a built-in resistor.

The low voltage lampholders are designed for use with standard MES bulbs. Features are, easy single-hole fixing and pleasing appearance. Bulbs are accessible from front or back of panel. Insulation of all types will withstand a flash test in excess of 1,500 volts A.C.

Write for Catalogue No. 127

**ARCOLECTRIC
SWITCHES · LTD**

CENTRAL AVENUE, WEST MOLESEY, SURREY. TELEPHONE: MOLESEY 4336 (3 LINES)



High Value

INSULATION RESISTANCE METER

MODEL
RMI75-LZ

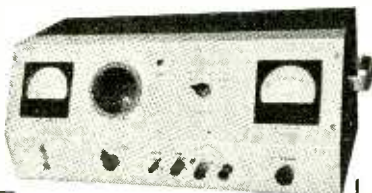

0.9 TO 10,000,000 MEGOHMS

Self-contained, mains operated with stabilised voltage compensation and incorporating meter overload protection in the case of sample breakdown, this resistance meter is designed for intensive use in testing high values of insulation. Test pressure variable from 0-1,000 V.D.C.

Write for full specification.

0-1,000 V.D.C.

**SELF-CONTAINED
STABILISED
OVERLOAD
PROTECTION**

See our exhibits. Stand No. 1A
British Instrument Industries
Exhibition, Olympia, London

BRITISH PHYSICAL LABORATORIES LTD

Radlett HERTS



Tel: PADLETT 5674-5-6

dm.BP13

**90%
WATT/HOUR EFFICIENCY**

and savings up to $\frac{1}{3}$ of the size and $\frac{1}{5}$ of the weight in comparison with other storage batteries of similar capacities! The Venner silver-zinc accumulator is ideal when exceptionally high rates of discharge are a necessary requirement.

Write for Brochure VA/III



VENNER *Lightweight* **ACCUMULATORS**

VENNER ACCUMULATORS LTD.
Kingston By-Pass, New Malden, Surrey

Telephone: MALden 2442



Buy your American Type Valve for *Sterling*...



The wide range of **BRIMAR VALVES** is now readily available throughout the world. Combining cost-saving techniques with craftsmanship precision, **BRIMAR** American type valves are amongst the finest obtainable in either hemisphere.

More and more the world's governments set makers laboratories are standardizing on American types, valves which are obtainable anywhere in the world, valves which you can get from **BRIMAR** without expending dollars.

Efficient reliable robust **BRIMAR VALVES** are chosen for radio and electronic equipments in the fighting services and throughout industry. Their rugged dependability can contribute so much to your own products.



THE **BRIMAR** RANGE IS

- the RANGE that is **RELIABLE**
- the RANGE that is **ROBUST**
- the RANGE **YOU REQUIRE**

BRIMAR everywhere the Valve of Value
Dependable

BRIMAR BRITISH MADE **RADIO VALVES**

Standard Telephones and Cables Limited **FOOTSCRAY, SIDCUP, KENT, ENGLAND**

Redifon

FREQUENCY SHIFT

Radio Teleprinter Links

Redifon design and supply Radio Teleprinter Links for any application. They are specially engineered to handle the ever increasing volume of messages passed over aeronautical point-to-point networks, and to deal efficiently with the rapid and accurate message handling necessary for modern high speed aircraft. Many manual circuits throughout the world are now being converted to this method of operation.

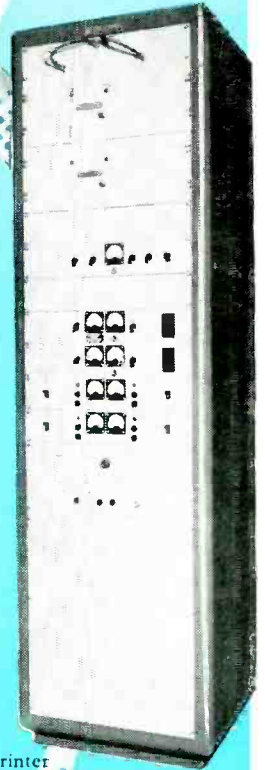

Typical Redifon Engineered Frequency Shift Radio Teleprinter Receiving Terminal. This particular bay incorporates—two crystal controlled fixed frequency receivers, two frequency shift converter units, and a signalling receiver for the teleprinters.



Redifon G.67 2kW Twin Channel Transmitter, available with one to four channels. The G.67 and other transmitters with power outputs ranging from 500 Watts to 7.5 kW can be supplied for radio teleprinter operation.



Radio Communications Division

REDIFON LIMITED, BROOMHILL ROAD, LONDON, S.W.18

Designers & Manufacturers of Radio Communication & Industrial Electronic Equipment

Telephone: VANDyke 7281



DUBILIER TUBULAR CAPACITORS

The choice of designer and engineer

Of the many forms of capacitors available, one of the most popular is the Tubular Paper, which fits most conveniently into any wiring assembly. In order to meet specific requirements, Tubular Capacitors must be chosen with care by the designer and engineer, and anticipating their requirements Dubilier Tubular Paper Capacitors are produced in a wide range covering all needs, for instance:—

- A. Type 460 Tubular Paper Capacitors for all general normal condition requirements.**
- B. Metal-cased Tubular Paper Capacitors for services,**

tropical and other arduous conditions.

C. Metal Minicap, Tubular Paper Capacitors—an outstanding achievement in miniaturisation—to withstand severe tropical conditions and high altitudes.

D. Type 460B for general purposes A.C. working, designed to withstand the peculiar waveforms and peaks in vibrator power-packs and similar applications.

We shall be pleased to forward full technical details of these Capacitors upon request, and our technicians are always at your service for consultation with regard to their use.

DUBILIER

CAPACITORS

MAKERS OF THE WORLD'S FINEST CAPACITORS

DUBILIER CONDENSER CO. (1925) LTD.

*Phone: Acorn 2241 (5 lines). *Grams: Hivoltcon, Wesphone, London. Cables: Hivoltcon, London, Marconi International Code

DUCON WORKS · VICTORIA ROAD · NORTH ACTON · W3 · ENGLAND

FOR PRECISION

E.M.I. MINIATURE WAVEFORM MONITOR

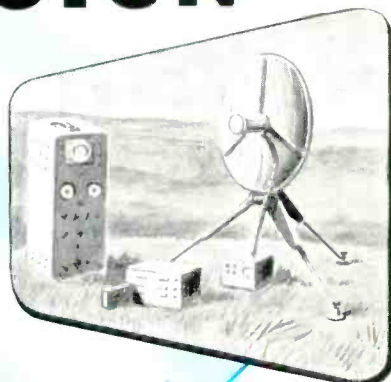
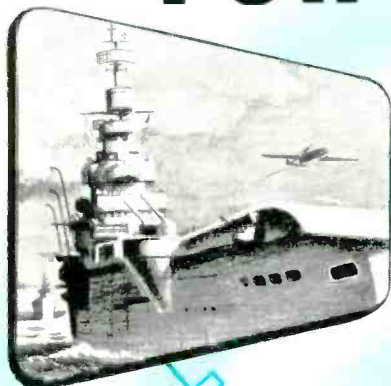

Y AMPLIFIER FEATURES

- Critically damped;
- Rise Time $0.15 \mu\text{s}$;
- Bandwidth D.C.— 3.5 Mc/s ;
- Sensitivity
 20 mv/cm to 70V/cm ;
- Amplitude Gating eliminates
Overload Defects;
- Differential Input
Circuits.

ADDITIONAL FACILITIES

- Direct Time Measurement
to $\pm 2\%$ F.S.D.
from $0.5 \mu\text{s}$ to 40 ms
- Sync./Trig. Amplifier with
Amplitude—Frequency—
Phase Discrimination;
- Direct Voltage Measurement
A.C./D.C. to $\pm 2\%$ F.S.D.
from $\pm 20 \text{ mv}$ to $\pm 500\text{V}$.

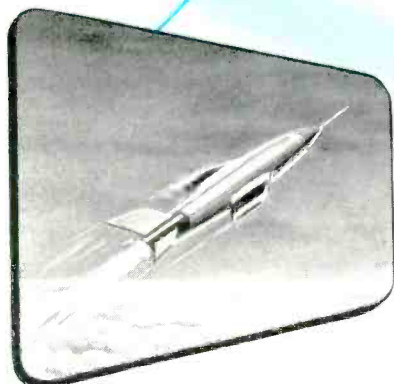
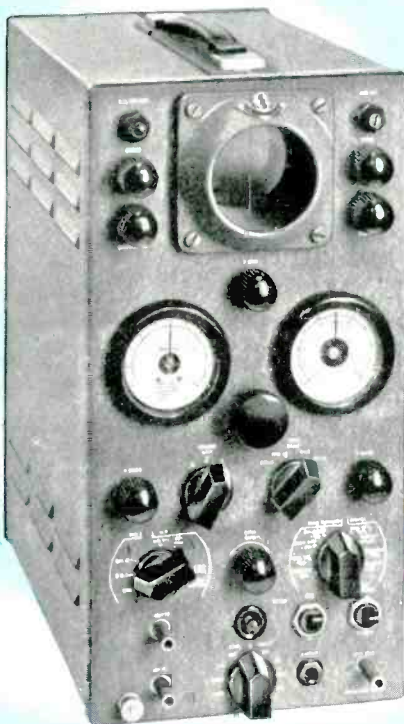

**TYPE WM.3
AN OSCILLOSCOPE**
by

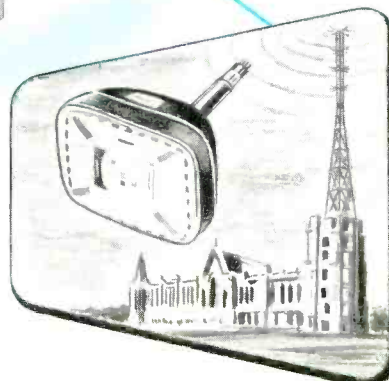

E.M.I. FACTORIES LTD.



HAYES, MIDDLESEX, ENGLAND

E.F.12

SELENIUM

RECTIFIERS

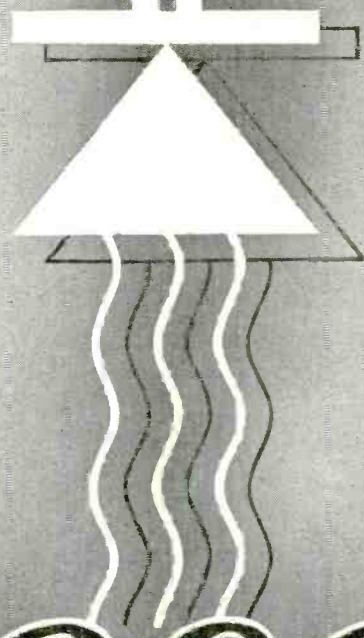

A G.E.C. Product

Full particulars of the G.E.C. range of Selenium Rectifiers are available on application to your nearest G.E.C. Branch; E. S. & V. Department, Magnet House, Kingsway, London, W.C.2, or the address below

SALFORD ELECTRICAL INSTRUMENTS LTD · SALFORD 3 · LANCs.
 A SUBSIDIARY OF THE GENERAL ELECTRIC CO. LTD. OF ENGLAND

S-BAND TEST OSCILLATOR Type o.223

A general purpose test oscillator developed in collaboration with R.R.D.E. and T.R.E. for use in the frequency range 2800—3600 Mc/s with an output in the order of 500 milliwatts.

The instrument incorporates a constant wattage power supply unit and square wave modulator, adjustable between 400 and 4000 cycles. It is fitted with crystal monitor and meter to provide continuous indication of power output.

Supplied for standard 19" rack mounting, height 10½".



A small number of these instruments are available from stock. PRICE £230

THE WAYNE KERR LABORATORIES LIMITED • NEW MALDEN • SURREY • MALDEN 2202

FOR ALL REQUIREMENTS . . .



...IN RADIO COMMUNICATIONS

WHERE RELIABILITY IN OPERATION IS ESSENTIAL AND COMPACTNESS DESIRABLE. We will quote per return air mail on receipt of details of requirements, and can give quick delivery.

Write now to :—

PANDA RADIO CO.,
58, SCHOOL LANE, ROCHDALE, LANGS.

Works Address: 16-18, Heywood Rd., Castleton, Nr. Rochdale, Yorks.
'Phone: Castleton 57396. Cables: PANDA, Rochdale.

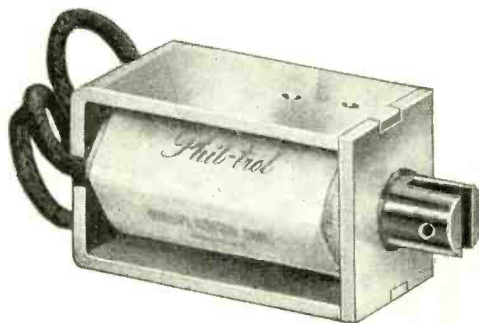

PHIL-TROL SOLENOIDS

Phil-trol Solenoids are now being made in England.

The first of this very popular range of American solenoids or actuators will be the small types 41 and 42. Samples are available NOW.

6v.-400v. A.C. and D.C. versions

WRITE FOR PAMPHLETS AND DETAILS :—

PHILLIPS CONTROL (GREAT BRITAIN) LTD.
273, FARNBOROUGH ROAD, FARNBOROUGH, HANTS.

Telephone: Farnborough 1120

Multiple Circuit Control

WITH THE

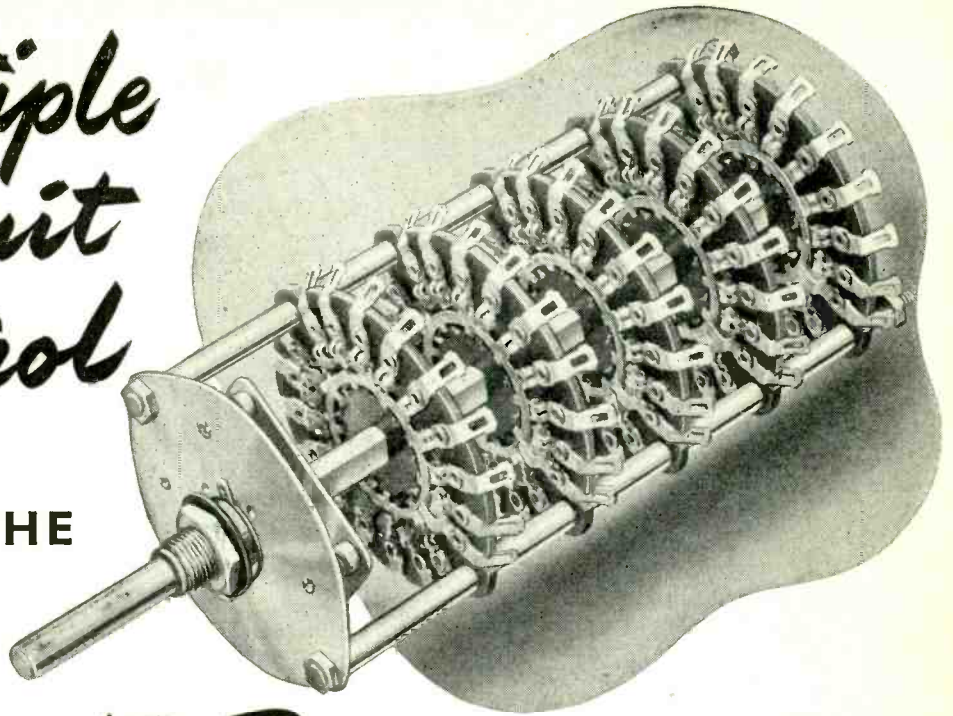

New 18 Position

NSF-OAK ROTARY SWITCH

The NSF-Oak type "DL" 18-position rotary wafer switch has been developed in response to repeated demands for a high-grade component to meet the requirements of those circuit applications which necessitate increased switching facilities.

This new 18-position NSF-Oak switch embodies all the renowned characteristics of the standard NSF-Oak types, including the recently introduced "D" feature, which definitely eliminates the loosening of contacts, as a result of the application of excessive heat during soldering operations.

Positive indexing is ensured by the use of the NSF heavy-duty mechanism, and the assembly is available with or without panel and spindle seals, as desired.

The type "DL" switch is now in production, and may be specified for immediate requirements.



Switch to N.S.F. for better switching



N.S.F. LIMITED
KEIGHLEY • YORKS

Phone: Keighley 4221/5

Grams: ENESEF, Keighley

LONDON OFFICE: 9 Stratford Place, W.1. Phone: Mayfair 4234

Sole licensees of Oak Manufacturing Co., Chicago, and G. H. Leland Inc., Dayton, U.S.A.

Licenses of Igranic Electric Co. Ltd. for the above products of Cutler-Hammer Inc., Milwaukee, U.S.A.

The products of N.S.F. Limited are protected by patents, and patent applications, in the United Kingdom and other countries.

MAINS TRANSFORMERS

FULLY INTERLEAVED

SCREENED AND IMPREGNATED. ALL GUARANTEED. ALL PRIMARIES ARE 200/250 v. Half Shrouded.

HSM63 (Midget). Output 250-0-250 v. 60 m/a., 6.3 v. at 3 amps., 5 v. at 22 amps.	16/3
HS63. Output 250-0-250 v. 60 m/a., 6.3 v. at 3 amps., 5 v. at 2 amps.	16/6
HS40. Windings as above. 4 v. at 4 amps., 4 v. at 2 amps.	16/6
Output	
HS2. 250-0-250 v. 80 m/a.	19/-
HS3. 350-0-350 v. 80 m/a., 19/-.	19/-
HS2X. 250-0-250 v. 100 m/a., 21/-.	21/-
HS75. 275-0-275 v. 100 m/a.	21/-
HS30X. 300-0-300 v. 100 m/a., 21/-.	21/-
HS3X. 350-0-350 v. 100 m/a.	21/-

Fully Shrouded.

FSM63 (Midget). Output 250-0-250 v. 60 m/a., 6.3 v. at 3 amps., 5 v. 2 amps.	16/9
Output	
FS2. 250-0-250 v. 80 m/a.	21/-
FS30. 300-0-300 v. 80 m/a., 21/-.	21/-
FS3. 350-0-350 v. 80 m/a.	23/-
FS2X. 250-0-250 v. 100 m/a., 23/-.	23/-
FS75. 275-0-275 v. 100 m/a.	23/-
FS30X. 300-0-300 v. 100 m/a., 23/-.	23/-
FS3X. 350-0-350 v. 100 m/a.	23/-
All the above have 6.3 4-0 v. at 4 amps., 5-4-0 v. at 2 amps.	
FS43. Output 425-0-425 v. 200 m/a., 6.3 v. 4 amps., C.T. 6.3 v. 4 amps., C.T. 5 v. 3 amps. Fully shrouded.	47/6
FS50. Output 450-0-450 v. 250 m/a., 6.3 v. 2 amps., C.T. 6.3 v. 4 amps., C.T. 5 v. 3 amps. Fully shrouded.	67/6
FS30X. Output 300-0-300 v. 80 m/a., 6.3 v. 7 amps., 5 v. 2 amps. Framed. Flying leads.	29/-
FS3X. Output 350-0-350 v. 250 m/a., 6.3 v. 6 amps., 4 v. 8 amps., 4 v. 3 amps., 0-2-6.3 v. 2 amps. Fully shrouded.	65/-
FS160X. Output 350-0-350 v. 160 m/a., 6.3 v. 6 amps., 6.3 v. 3 amps., 5 v. 3 amps. Fully shrouded.	44/-
FS43X. Output 425-0-425 v. 250 m/a., 6.3 v. 6 amps., 6.3 v. 6 amps., 5 v. 3 amps. Fully shrouded.	63/6
HS6. Output 250-0-250 v. 100 m/a., 6.3 v. 6 amps., C.T. 5 v. 3 amps. For receiver R1355. Half shrouded.	26/6
HS150. Output 350-0-350 v. 150 m/a., 6.3 v. 3 amps., C.T. 5 v. 3 amps. Half shrouded.	27/9
F36. Output 250-0-250 v. 100 m/a., 6.3 v. 6 amps., C.T. 5 v. 3 amps. Fully shrouded.	29/6
FS120. Output 350-0-350 v. 120 m/a., 6.3 v. 2 amps., C.T. 6.3 v. 2 amps., C.T. 5 v. 3 amps. Fully shrouded.	29/9
FS256. Output 250-0-250 v. 80 m/a., 6.3 v. at 6 amps., 5 v. at 3 amps. Fully shrouded.	28/6
PR1/1. Output 230 v. at 30 m/a., 6.3 v. at 1.5/2 amps.	21/-
FS150. 350-0-350 v. 150 m/a., 6.3 v. 4 amps., 5 v. 3 amps.	31/6
FS150X. Output 350-0-350 v. at 150 m/a., 6.3 v. at 2 amps., C.T. 6.3 v. at 2 amps., C.T. 5 v. at 3 amps. Fully shrouded.	31/6
The above have inputs of 200/250 v.	

OUTPUT TRANSFORMERS

MOP1. Ratios, 26, 46, 56, 66, 90, 120-150 m/a. max. current, C.T. for Q.P.P. Class B, etc. Secondary 2/4 ohms. Top panel and clamped, each.	5/6
OPI0. 10/15 watts output, 20 ratios on Full and Half Primary.	17/9
OP30. 30 watts output, 20 ratios on Full and Half Primary.	25/9
Williamson's O.P. Transformer to Author's specification.	£4/4-
Chokes for Williamson's Amplifier. 30 H. at 20 m/a.	16/6
10 H. at 150 m/a.	32/-

FOR FAULTY C.R. TUBES.

Special very low capacity secondary winding Transformer for Heater of Cathode shorts, restores picture after above failure. Standard Types. 2 v., 4 v., 6.3 v. at 2 amps. Primary 200/250 v., each.

10.8 v. at 0.3 amps. for G.E.C. tubes. Primary 200/250 v., each	29/6
Any other voltages quoted for, but please state current as well as voltage.	29/6

E.H.T. Unit. 2,500 v. at 5 m/a., 2-0-2 v. at 1.1 amp., 2-0-2 v. at 1.1 amp.

Quotations, etc.—stamped addressed envelope, please.

C.W.O. (add 1/6 in £ for carriage).

Trade and also export enquiries invited.

H. ASHWORTH (Dept. WW),
676, Gt. Horton Road, Bradford, Yorks.

-towards perfection-

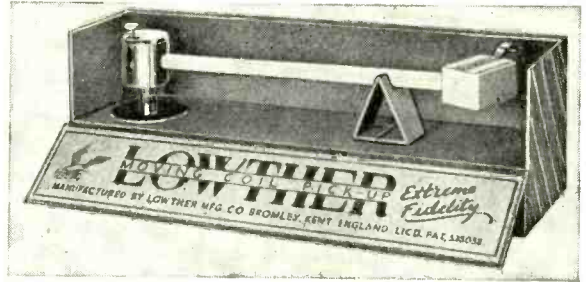

Are you attaining the finest reproduction from your L.P. recordings? Make sure to be "in the groove" with a Lowther Moving Coil Pick-up in order to obtain supreme satisfaction.

Lowther Moving Coil Pick-up with sapphire stylus (L.P.)	£7 7 0
Tungsten Carbide Standard	£7 7 0
Purchase Tax	£2 8 11
Ditto, with diamond stylus	£16 10 0
Purchase Tax	£5 9 9

Full particulars upon request.

THE LOWTHER MANUFACTURING CO.
 Lowther House, St. Mark's Road, Bromley, Kent. RAV. 5225.

made to measure . . .

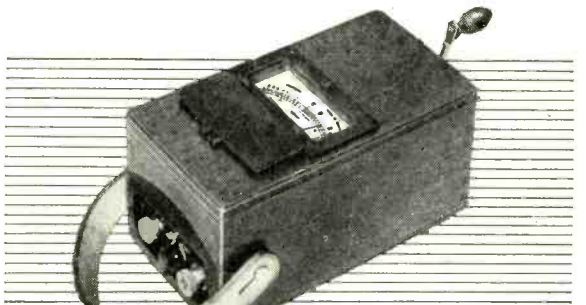

The man who knows exactly the state of his insulation at any time—is wise.

But one who uses a "Record" Insulation Test Set is wisest. It is made to measure—ACCURATELY, by those who were pioneers in this field and who have kept ahead.

RECORD

MAKERS OF MANY OTHER FINE INSTRUMENTS

THE RECORD ELECTRICAL CO LTD

BROADHEATH - ALTRINCHAM - CHESHIRE

Phone : Altrincham 3221/2/3/4 Cables and Grams : "Circscale" Altrincham
 London Office : 28 Victoria Street, S.W.1. Phone : Abbey 5148 & 2783
 Grams : "Circscale" Sowest, London. Cables : "Circscale" London

Outstanding Performance

With the



**MINIWEIGHT
CRYSTAL
PICK-UP**

Now **GREATLY REDUCED** in price

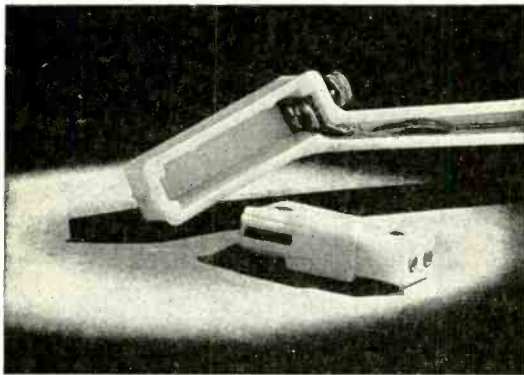

Because of improved importing facilities and larger quantities bought, we are now able to offer the famous RONETTE Pick-Up at extremely low inclusive prices. This Pick-Up is not only one of the lightest weight Pick-Ups on the market but has an extremely high fidelity reproduction. All models available from stock. Order now.

RONETTE Miniweight Standard Pick-Up complete with 2 interchangeable heads for standard or long playing records

As above, with one head only to choice

Long playing or standard head only

RONETTE Miniweight Pick-Up with frequency response up to 14,000 cycles, complete with 2 interchangeable heads for long playing and standard records

As above, with one head only to choice

Long playing or standard head only

- £3. 9. 6
- £2. 7. 0
- £1. 2. 6
- £3. 16. 3
- £2. 9. 9
- £1. 6. 6

A Professional TAPE RECORDER for only 32 gns!

Come and hear the BURGUYNE recorder. H.P. terms available. £11/4/- deposit and 12 monthly payments of 42/9. FREE DELIVERY LONDON AREA.



Sole distributors for

BURGUYNE

**MAGNETIC RECORDING HEADS
RECORD/PLAYBACK OR ERASE**

ACTUAL SIZE **37/6** each

With the...

RECORD/PLAYBACK

AMPLIFIER TYPE A.6

As used in the BURGUYNE RECORDER



Special features include:

- Bass and treble controls for cut and boost operative on both record and playback.
- Separate radio and microphone inputs.
- Visual indication of record or playback position.
- Extra switching for complete demagnetisation of heads when changing from record to playback.

Ready to use **£11. 15. 0** Carriage Paid

H.P. Terms 78/- Deposit, 12 Monthly Payments of 16/5.

The Radio Centre invites you . . . At one time we were leading Government Surplus Stockists—a fact which will be to your advantage if you call at our Showrooms. We have left, miscellaneous quantities of surplus electronic equipment in very great variety, and these will be offered at unheard of and unrepeatable Bargain Prices for a limited period. Do not fail to pay us a visit. A showroom is being allotted to the display of this material which can be inspected at your leisure.

A few left only. We are fortunate in still being able to offer certain B.S.E. equipments, which are no longer generally available, as follows:

MU14 3-speed Motor Unit for A.C. Mains	£8.8.6
MU10 2-speed Motor Unit for A.C. Mains	£3.18.7
SR1 Motors	£1.12.0
SR2 Motors	£1.5.0

As our stocks are limited, please order now.



'CORONATION'

HIGH FIDELITY CRYSTAL MICROPHONE

RONETTE High Fidelity Crystal Microphone—now well established. This fine Crystal Microphone is particularly recommended for magnetic tape recording. Fitted with RONETTE DX12 insert, with frequency response between 30-13,000 cycles with output at 1,000 cycles 1.3 MV/Microbar. Microphone insert is vacuum sealed, precision ground and optically inspected, and is housed in a highly polished black plastic moulding with long connecting lead. The microphone is fitted with an annealed, corrosion resistive aluminium diaphragm.

Only **52/-** post free



Microphone Base 15/-
or Stand 17/6 extra

MAIL ORDER



SUPPLY COMPANY

The Radio Centre

33 Tottenham Court Road, London, W.1

Telephone: MUSEum 6667

POSITIVELY the most EFFICIENT for H.T. SUPPLIES

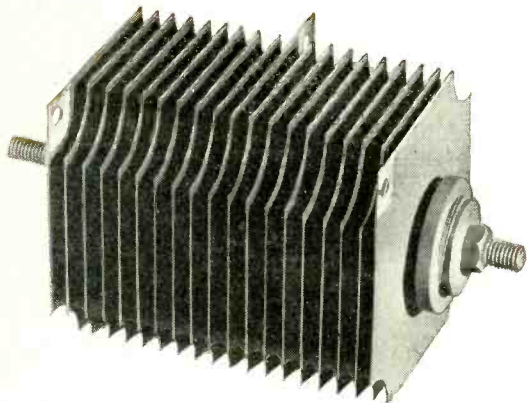

Write in for further details. A copy of "THE ALL METAL WAY" can be obtained by sending 6d. in stamps to

Dept. W.W.7.

WESTINGHOUSE BRAKE & SIGNAL CO. LTD, 82 YORK WAY, KING'S CROSS, LONDON, N.1

to radio and television receivers and without a doubt the most reliable. Constant development of Westinghouse rectifiers to produce units capable of meeting all demands in this particular field has resulted in a decrease in size while maintaining the same output. More recent designs have produced units to supersede those in current ranges of commercial and home constructed television receivers, and although physically they are of the same dimensions the current output has been considerably increased.



METAL RECTIFIERS

"MAGNUM OPUS"

If you should have any doubts just what our NEW 1953 HOME CONSTRUCTOR'S HANDBOOK can mean to YOU then read what one delighted owner writes :

" . . . after careful perusal, amongst many others, I feel sure your Handbook is truly the " magnum opus " for the Home Constructor. The mode of presentation of data, details, and circuits has been rendered without the usual forms of embellishment, and I still find humour in the penultimate paragraph of the Introduction. Since I want a ' Rolls-Royce ' I have decided upon the 10 Watt Quality Amplifier and RL 40 Feeder, using the Goodmans 12in. speaker. This conclusion has been reached after receipt of many brochures, catalogues, etc., from many sources, famous and not so famous . . . " You, too, will feel like this satisfied Client when you receive your copy ! This book contains ALL of the following time-proved outfits YOU can build under our " Easy-as-A.B.C. " construction system :

- 3V 3 Band FEEDER ● 4V 3 Band FEEDER " Norm/Hifi/Gram "
- 5V 3 Band SUPERHET AC ● 5V 3 Band SUPERHET AC/DC
- 6V 3 Band SUPERHET AC ● 6v 3 Band SUPERHET AC/DC
- 3V 2 Band " Local Station " HiFi FEEDER ● FEEDER AMPLIFIER/POWER PACK ● MAGIC EYE UNIT ● SIGNAL TRACER
- 5 Watt AMPLIFIER ● 10 watt AMPLIFIER ● SIGNAL GENERATOR, etc., etc., etc.

Apart from DETAILS for construction there are LARGE blueprint circuits, COMPLETE parts lists and technical descriptions, of these famous circuits, also Set Building Hints, Servicing Hints, Facts and Formulae, Resistance Colour Code, Symbols, Data, etc., etc. AND our current Catalogue, ALL FOR HALF-A-CROWN !!

Printed on glossy art paper this famous publication contains many advances over previous issues; is profusely illustrated throughout its 46 pages and should definitely be in every radio man's den. DON'T DELAY, SEND FOR YOUR COPY TO-DAY !

* The original of this entirely unsolicited testimonial may be seen at our offices.

RODING LABORATORIES
(Dept. W7), HURN AIRPORT, CHRISTCHURCH, HANTS.

THE TRANSFORMER SUPPLY CO.

offer
HIGH GRADE TRANSFORMERS
at competitive prices

All fully shrouded (except E.H.T. types), of interleaved construction and impregnated to ensure long life. Accuracy and insulation conform to the best electronic engineering practice.

Pri: 210,230,250v. *230v. only

Cat. No.		Price
T.S.1	260/0/260v. 65 m/a. 6.3v. 2.5a., 5v. 2a.	18/6
T.S.2	350/0/350v. 120 m/a. 6.3v. 4a., 5v. 2a.	30/-
T.S.3	350/0/350v. 150 m/a. 6.3v. 4a., 5v. 2a.	35/-
T.S.4	425/0/425v. 200 m/a. 6.3v. 4a., 6.3v. 2.5a., 5v. 3a.	47/6
T.S.5	425/0/425v. 250 m/a. 6.3v. 4a., 6.3v. 4a., 5v. 3a.	52/6
T.S.6	350/0/350v. 250 m/a. 6.3v. 8a., 0-2-6v. 2a., 5v. 3a.	62/6
T.S.27	*1750v. 5 m/a. R.M.S. 0-2-4v. 1.5a. (Ins. 2500v.) D.C. 0-2-4v. 1.5a. (Ins. 2500v.) D.C.	37/6
T.S.28	2500v. 5 m/a R.M.S. 0-2-4v. 1.5a. (Ins. 3500v.) D.C. 0-2-4v. 1.5a. (Ins. 3500v.) D.C.	50/-
T.S.29	4000v. 5 m/a. R.M.S. 0-2-4v. 2a. (Ins. 6000v.) D.C.	70/-
T.S.30	5000v. 5 m/a. R.M.S. 2v. 2a. or 4v. 1a. (Ins. 7000v.) D.C.	77/6

Cash with order or C.O.D.

70, CHEPSTOW ROAD, LONDON, W.2

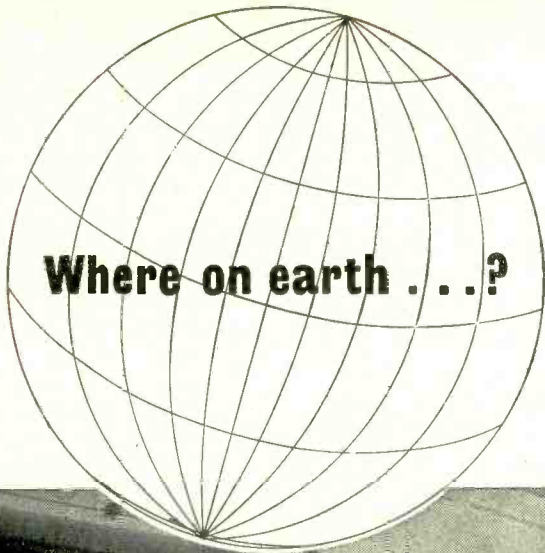

Aden or Aberystwyth, Yucatan or Great Yarmouth . . . the area makes little difference, for this mobile A.T.E. v.h.f. survey unit is specially equipped to undertake propagation and topographical surveys on behalf of Telecommunication Administrations and other customers *anywhere*.

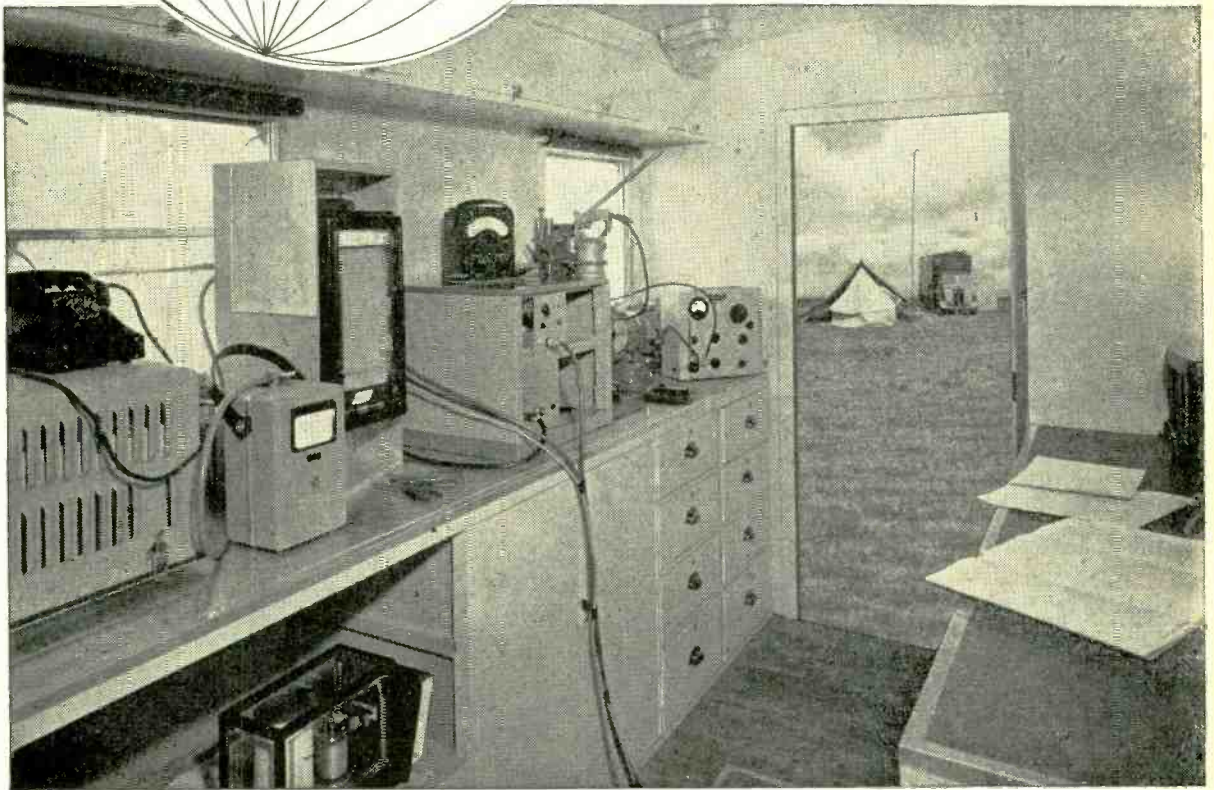

An effective survey on site will prove a sound investment in the planning of all radio telephone systems and ensure that the required system performance is obtained at the most economic cost to the Administration. Such surveys, taking into account all relevant propagational and meteorological data, ensure that the most suitable route is selected to meet local conditions and in particular that all stations, both terminal and repeater, are sited to the best advantage . . .

AUTOMATIC TELEPHONE & ELECTRIC CO. LTD.

RADIO AND TRANSMISSION DIVISION · STROWGER HOUSE, ARUNDEL ST., LONDON W.C.2
 Telephone: TEMple Bar 9262. Cablegrams: Strowgerex London



ATT4281-BK107

new cases...

racks and desks have been added to the comprehensive range of fabricated metal cabinets designed and made by Imhofs the leading sheet metal specialists. Although these

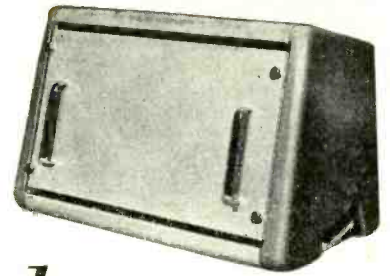

and the established range...

are still produced with the same high standard as before, ever increasing demands and stepped up production has made it possible for these standard stock items to actually



cost less.

IMHOF'S

ALFRED IMHOF LIMITED, 112-116, NEW OXFORD ST., LONDON, W.C.1. MUSEUM 7878

REDUCE YOUR PRESS TOOL COSTS

THE HUNTON UNIVERSAL BOLSTER OUTFIT FOR SHEET METAL PIERCING AND BLANKING ON FLY PRESSES

Bolster Frame with 2 adjustable gauges and insertable steel Holders for Dies $\frac{1}{4}$ in. to $3\frac{1}{2}$ in. bore diameter.

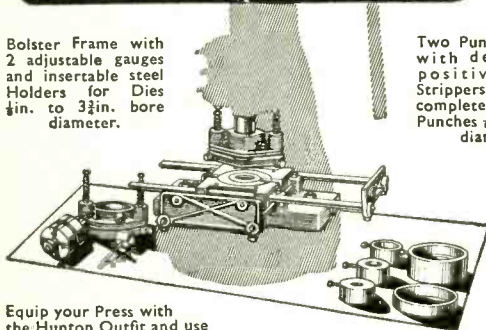

Two Punch Holders with detachable positive-action Strippers take the complete range of Punches $\frac{1}{4}$ in. to $3\frac{1}{2}$ in. diameter.

Equip your Press with the Hunton Outfit and use inexpensive standardised Punches and Dies $\frac{1}{4}$ in. to $3\frac{1}{2}$ in. diameter, obtainable from stock—in $\frac{1}{16}$ in. sizes—when required.

Standardised Tools also available at short notice for Square, Oblong and other shapes, Louvre Forming (up to 8 in. long), Corner Notching, Corner RADIUSING, Angle Iron Notching and Piercing, etc.

Get the Outfit now—Buy Punches, Dies and Tools as you need them

Descriptive brochure and prices on request.

HUNTON LIMITED

Phoenix Works, 114-116, Euston Road, London, N.W.1
Telephone: EUston 1477-8-9. Telegrams: Unconexh, London

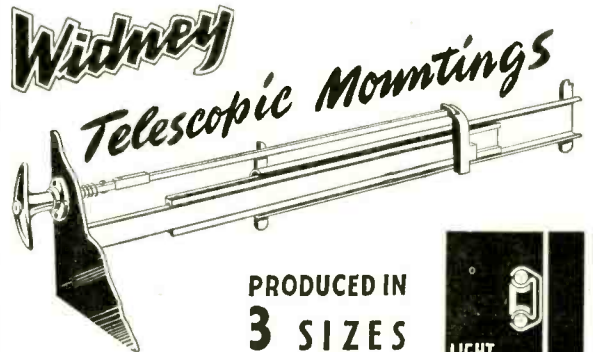

Widney

Telescopic Mountings

PRODUCED IN
3 SIZES

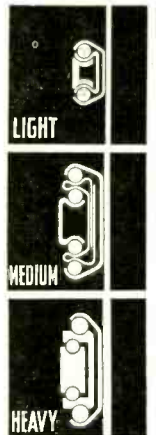

Telescopic Mountings offer the most convenient means of obtaining complete accessibility of rack mounted equipment as each chassis can be withdrawn completely clear of its framework for easy examination. Write for illustrated catalogue.



OLYMPIA-LONDON
JUN. 30-JUL. 11 '53

STAND NO. 142



ESTABLISHED 1890

TECHNICAL SALES OFFICE,
299 NEW KING'S ROAD,
LONDON, S.W.6. Tel.: RENown 1601

HALLAM, SLEIGH & CHESTON LTD
WIDNEY WORKS - BIRMINGHAM - 4

Phone: Aston Cross 0916 to 1000 • Grams: Superline, Birmingham, 4

a new
**INDEPENDENT SIDEBAND
 RECEIVER**

**... developed to British Post Office
 Specification**

THIS new Independent Sideband Receiver type GFR 552 is designed for operation on long-distance, point-to-point, short-wave radio links forming part of the international trunk network. On independent sideband working, the GFR 552 provides facilities for the reception of two single sideband signals, each 6 kc/s wide, one above and one below the frequency of a reduced-level pilot carrier. Each sideband will accommodate either two 3 kc/s wide telephony channels, or several voice frequency telegraph channels. The GFR 552 may also be used for reception of single sideband or double sideband transmission. In the case of the second application this receiver offers two advantages: firstly, the absence of non-linear distortion which occurs in normal D.S.B. receivers when signals are subjected to selective fading conditions; and, secondly, the ability to select upper or lower sideband for demodulation, dependent upon which is freer from adjacent channel interference. The circuit and chassis layout of the GFR 552 closely follows that of the Mullard Receiver GFR 551, which was based on a British Post Office design (Receiver, Radio No. 22).

Special features of the GFR 552 include a high order of oscillator stability and freedom from cross-modulation through which cross-talk between channels or inter-modulation between wanted and unwanted signals might occur. A brief technical summary is given below. More detailed information supplied on request.

FREQUENCY RANGE—4-30 mc/s.

NOISE FACTOR—better than 7 db over the band.

SIGNAL TO NOISE RATIO—25 db for 4 microvolts peak sideband input over the band.

SELECTIVITY—The response is flat within 2 db for sideband frequencies between 100 c/s and 6000 c/s. At 10 kc/s from the carrier frequency the response is -60 db relative to the pass band.

A.F.C.—The A.F.C. system operates effectively with a pilot carrier level of -26 db relative to 1 microvolt (which corresponds to a peak sideband level of 1 microvolt and a signal to noise ratio of 15 db).

NON-LINEAR DISTORTION—Third order intermodulation products which might result in cross talk between sidebands do not exceed -50 db relative to the sideband levels.

OUTPUT—Variable up to +14 db relative to 1 mW into 600 ohms.

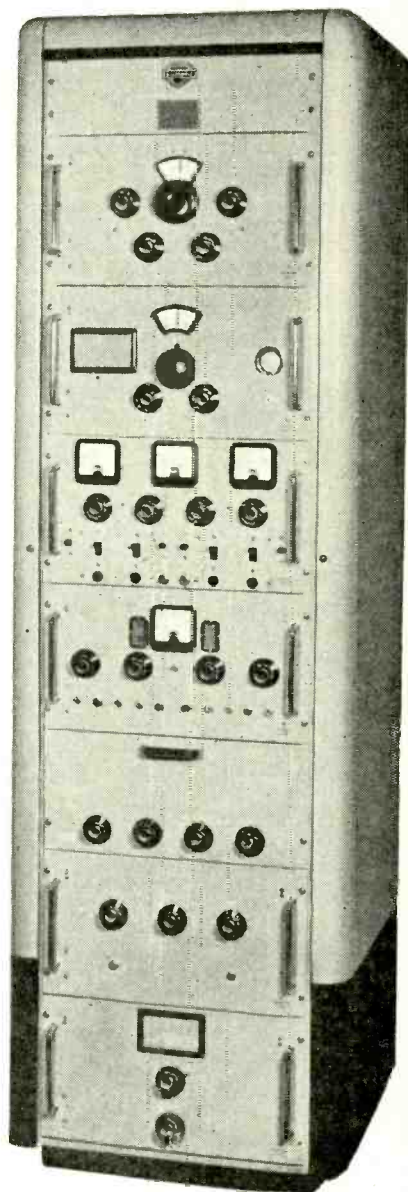

Mullard



SPECIALISED ELECTRONIC EQUIPMENT

MULLARD LIMITED, EQUIPMENT DIVISION, CENTURY HOUSE, SHAFTESBURY AVENUE, LONDON, W.C.2
 (M1417)

CITY SALE & EXCHANGE

THE HIGH FIDELITY SPECIALISTS

LIMITED

90-94, Fleet Street, London, E.C.4.

Phone: Central 9391/2

Offer the following from their large stock of radio equipment:—

AMPLIFIERS

Leak TL/12 Point One with Vari-slope pre-amplifier 39 gns. Acoustical QUAD with separate pre-amplifier £35. R.D. Baby Mark II £23.

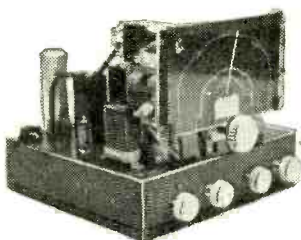

TUNERS

Lowther DT4 7-valve straight/superhet Tuner (as illustrated) £37/6/3. Lowther LES 5-valve 3 waves £23/15/9. FM/AM 5-valve Tuner £22. Chapman ST4 £16/2/0. Leak V/S £35/6/0.

RECORD PLAYERS

Decca 33A 5 gns. Decca 3-speed 347/C or M £18/8/6, or in walnut case £20/7/8. Convertogram 3-speed non-auto £11/15/0. Philips "Disc-Jockey" £10/13/8. Plus-a-gram 3-speed auto £18/10/0.

TAPE RECORDERS

Grundig 2-speed "Reporter" 80 gns. Sound-mirror table and portable models, complete with microphone, shop soiled only 57 gns. Emicorda hi fi model, walnut case 90 gns. Microphone 6½ gns. extra.

SPEAKERS. Decca corner horn £28 9/8. Wharfedale W/15 and Super 5 in corner sandfilled assembly £58. Salex 10in. reflex with Wharfedale unit £14/10/0. R.A. Prestige with 10in. unit £20/17/6. R.D. Junior cabinet only, £20. R.D. Minor speaker baffle £8/5/0.

SPEAKER UNITS. Goodmans Axiom 150 Mark II £13/11/5. Axiom 101 £6/12/1. Axiom 102 £9/18/2. Wharfedale Super 5 £6/13/3. Super 8 £5/13/3. Super 8 CS/AL £6/13/3. Golden 10 £7/13/3. Golden 10 CSB £8 6/7. W.12 c/S £12.19/10. W.15 C/S £16.

PART EXCHANGE—OUR SPECIALITY
Send details of your present equipment

RECORD REPRODUCERS

Trixette 3-speed auto, as new 25 gns. Collaro 3-speed auto 25 gns. Decalican 78 auto, perfect order 19 gns. Plus-a-gram Dan-sette 3-speed auto £32.

Hire Purchase terms can be arranged on all new apparatus over £10—one-third deposit, and the balance over 6, 12 or 18 months. Write for order forms.

COILS and I.F. TRANSFORMERS

E T A

ELECTRO TECHNICAL ASSEMBLIES
SEASIDE RD., ST. LEONARDS-ON-SEA
Phone: Hastings 471

ASK ARTHURS FIRST

Send your enquiries for all Radio and Electrical goods, especially those in short supply.

★ NEW VALVES

We have probably the largest variety of valves in the country. Let us know your requirements.

AVO METERS IN STOCK

Avo Model 7.....	£19 10 0
Avo Model 8.....	£23 10 0
Signal Generator, Mains and Battery Models	£30 0 0
Electronic Test Meter	£40 0 0
Valve Characteristics Meter	£60 0 0
★ Cossor Oscilloscopes Models 1035	£93 10 0
.....	1049 £132 0 0

Also full range "TAYLOR METERS". List on request.

VALVE MANUALS

Mullard	5 0
Osram	5 0
Brimar Nos. 4 & 5	5 0
each.	
Mazda, Part 2	2 0
Mullard Valve Replacement Guide	2 6
Amateurs' Guide to Valve Selection by Mullard	1 6
Postage 6d. each extra	

Leak Point 1 Amplifiers £28 7 0
Leak Pre-Amplifiers ... £9 9 0
Leak Tuning Unit £35 6 3
Wearite Tape Deck ... £35 0 0
Grundig Tape Recorder
two-speed £84 0 0
Recording Tapes: E.M.I., G.E.C. and Scotch Boy, 35/- each.
Ferrovoice Tape, 1,200ft. on 7in. spool 22/6 only (plus 9d. postage).
Terms C.O.D. or Cash with order. Goods offered subject to being unsold and to price alteration.

Arthur's

EST. 1919

PROPS: ARTHUR GRAY, LTD.

GRAY HOUSE, 150-152 CHARING CROSS ROAD, LONDON, W.C.2
TELEPHONE BAR 5833/4 and 4765. Cables: TELEGRAY, LONDON



Pointers for Designers

AND CONSTRUCTORS

NEW - Z729
Low Noise Voltage Amplifying Pentode



The new OSRAM Z729 is a low hum, low microphony voltage amplifying pentode of all-glass construction on the B9A base. The heater is rated at 6.3V, 0.2A and a variable hum-balancing resistor is not required if the transformer winding has an earthed centre-tap.

The Z729 is of small physical size, rigid construction with effective internal screening and has been designed for use in conditions where the hum and microphony introduced by the valve must be kept to the minimum.

Typical applications include the early stages of high gain amplifiers, particularly where bass boost circuits are used, such as low level tape and disc pre-amplifiers, in sound reinforcement systems and microphone head amplifiers.

Using the circuit shown a gain of 110 can be obtained whilst the hum voltage referred to the control grid will not exceed $1.5 \mu\text{V}$. This figure represents an improvement of at least 17 db over a valve of normal construction with good low hum characteristics used with a hum balancing circuit.

The Z729 is a preferred type for use in the early stages of all low level input audio equipment, while its very high input grid resistance renders it suitable for use in the instrument field, in applications where this characteristic is required but the use of an electrometer valve is not justified.

CHARACTERISTICS

V_a	250	V
V_{g2}	140	V
r_a	2	M Ω
I_a	3	mA
g_m	1.85	mA/V

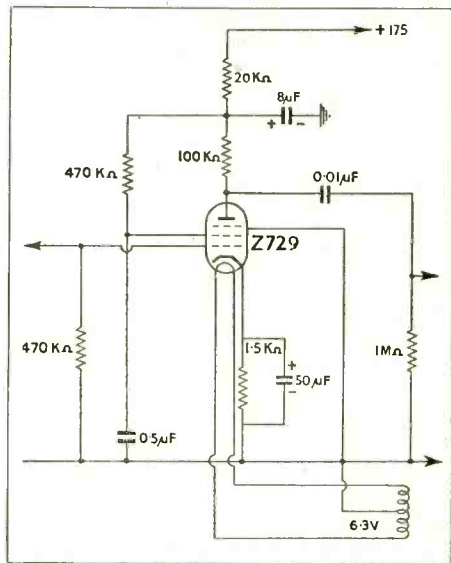

Send NOW for Data Sheet to-Osram Valve and Electronics Dept.

Immediate delivery - of course



VALVES !! TUBES !!

RECEIVING, TRANSMITTING, MAGNETRONS, KLYSTRONS,
CATHODE-RAY TUBES, PHOTOCELLS, ETC.

First Grade Quality - British and American Make - No Dollar Expenditure Involved

LARGE QUANTITIES & GREAT VARIETIES

S. Szymanski

(pronounced SHE-MAN-SKEE)

ELECTRONIC ENGINEER AND STOCKIST

Office and Stores:

12a LEIGHTON GROVE - LONDON - N.W.5

★ Telephones: {GULliver 6077/8 (2 lines)
HENdon 1617} Telegrams: {Overseas: "Shemanskee" London
Inland: "Shemanskee" Norwest London} ★

**PROBABLY THE LARGEST ACTUAL STOCKIST IN ENGLAND
WHOLESALE AND EXPORT ONLY**

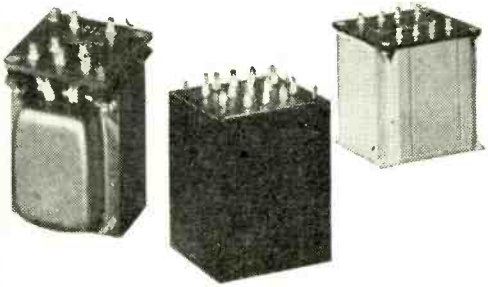

Air cooled, compound filled and oil immersed transformers for every requirement.

Further examples from our ranges manufactured to the most stringent specifications.

We offer you our experience and knowledge to meet your own high standards, utilising conventional design or 'C' core types.

WILLESDEN TRANSFORMER CO. LTD.
2a, FRITHVILLE GARDENS,
SHEPHERDS BUSH, LONDON, W.12.
Tel.: SHEpherds Bush 5819.



Dept. W.W.
18 TOTTENHAM COURT ROAD, LONDON, W.1
Tel: MUSEum 2453/4539
Business Hours:
Monday-Friday 9—5.30.
Saturday 9—1.

Late ALEC DAVIS SUPPLIES LTD.

RELAYS
D.C. COIL RESISTANCE

3,000 TYPES: 1.9Ω to 80,000Ω
600 TYPES: 0.4Ω to 9,200Ω

ALSO LARGE STOCKS OF DOUBLE & TRIPLEWOUND AND SLUGGED COILS.
SIEMENS TYPE HIGH SPEED

CONTACTS

3,000 TYPES: up to 8 sets.
600 TYPES: up to 4 sets.

3,000 TYPES: Make (M), Break (B), in Twin-silver Twin-platinum, Dome-silver (2 amp.), Tungsten (5 amp.), and Flat-silver (8-amp.), Change-Over (C), in all but Tungsten: Make-Before-Break (K), in Twin-silver and Twin-platinum.

600 TYPES: (M), (B) and (C), in Twin-silver and Twin-platinum.

KEY SWITCHES.
2 C/O. to 8 C/O. Special types made up to order.



600 or 3,000 TYPE



KEY SWITCHES

Microwave Test Gear

Metropolitan-Vickers Electrical Company announce a complete range of precision microwave test gear for use in 3 in. x 1½ in. waveguide over a band of wavelengths from 10 cm. to 11 cm.

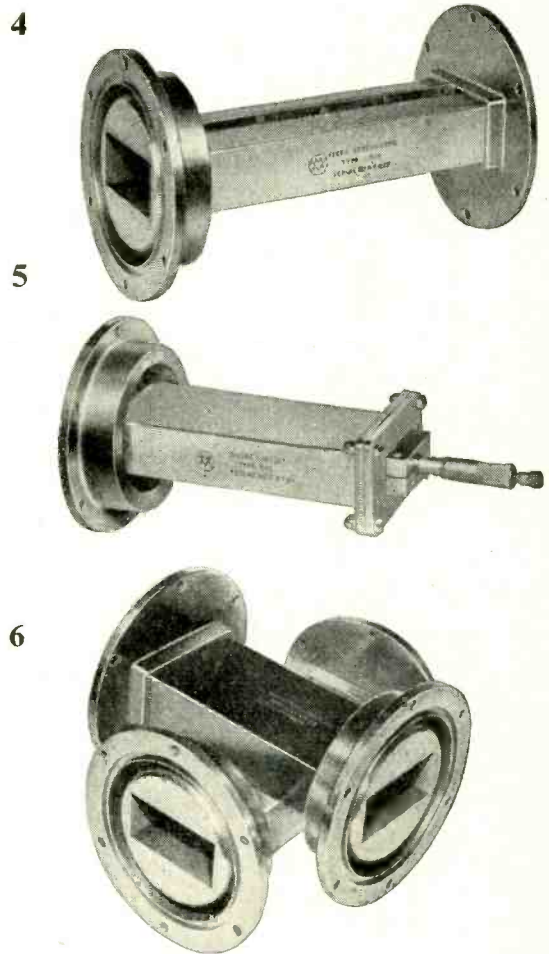
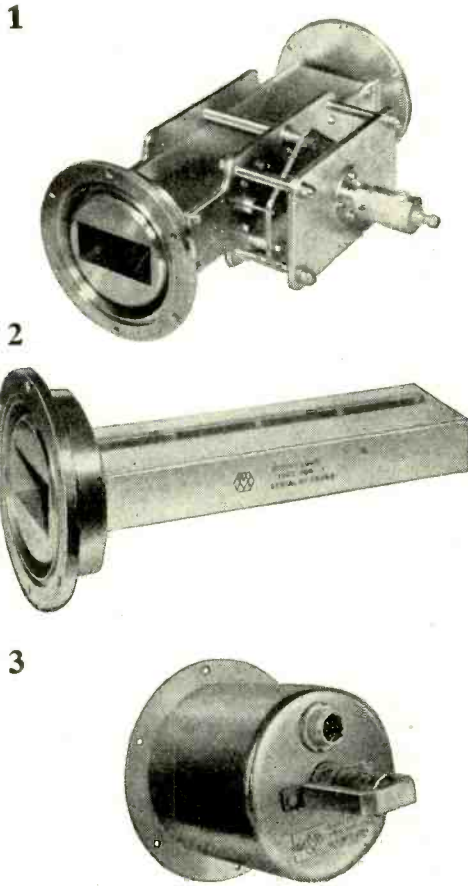

- 1 PRECISION ATTENUATOR Type 501
- 2 MATCHED LOAD Type 506
- 3 OSCILLATOR Type 508
- 4 FIXED ATTENUATOR Type 519
- 5 SHORT CIRCUIT Type 510
- 6 DIRECTIONAL COUPLER Type 504

Other Metrovick microwave equipment includes variable attenuator type 502, standing wave detector type 512, wave meter type 517, high power load type 515, S & X band spectrometer type 518.

Full technical details will be sent on request.

METROPOLITAN-VICKERS ELECTRICAL CO. LTD., TRAFFORD PARK, MANCHESTER 17

Member of the A.E.I. group of companies

METROVICK Test gear for the microwave laboratory

R/E 203

THIS IS THE "TELE-VIEWER"

5 CHANNEL TELEVISOR

A Design of a Complete 12 in. or 9 in.

SUPERHET T/V RECEIVER FOR THE HOME CONSTRUCTOR

This receiver has been developed after most careful research and affords a high standard of Television entertainment by producing a picture of really outstanding quality.

We confidently believe that not only have we achieved a T.V. Receiver that surpasses in efficiency any other designed for the home constructor, but that successful construction, even by the most inexperienced, is assured by the step by step wiring detail and diagrams provided, and at about half the cost of the nearest comparable commercial receiver.

Here are some of the features which combine to make this such a fine receiver :

- The Superhet circuit easily tuned to any of the five channels, i.e. LONDON, SUTTON COLDFIELD, HOLME MOSS, WENVOE and KIRK-O-SHOTT'S. (The extreme ease of tuning is accomplished by the provision of pre-aligned I.F.T.'s.)
- A lifelike, almost stereoscopic, picture quality made possible by the following factors :
 - a. Excellent band width of I.F. circuits.
 - b. A really efficient video amplifier.
 - c. C.R.T. Grid modulated from low impedance source.
 - d. High E.H.T. voltage (approx. 10 kV.).

The picture brilliance is also much above the average and enables comfortable viewing with normal room lighting or daylight.

- FIRM picture "HOLD" circuits (Frame-Line) ensure a steady picture, free from bounce or flicker even under the most adverse conditions met with in "fringe" areas and excellent "interlace" ensures the absence of "liney effect."
- Picture linearity better than 5% ! (Some commercial receivers are passed at 15%.)
- Negative feedback is used in the audio frequency circuits which provide 2/3 watts of High Quality Sound.
- Entire receiver built on two chassis units, each measuring 14½ in. x 6½ in. x 3½ in.
- Rigid C.R.T. mounting enables entire receiver to be safely handled with tube in position.

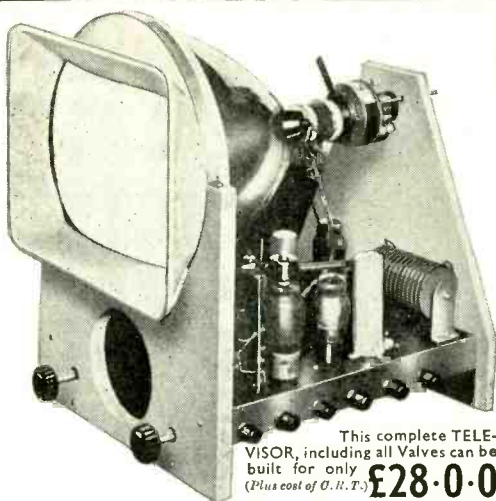

This complete TELEVISOR, including all Valves can be built for only **£28.0.0**
(Plus cost of C.R.T.)

- All pre-set controls are mounted on side of chassis enabling all adjustments to be carried out whilst facing the C.R. Tube. As no hire purchase terms are available the receiver can be bought in five separate stages (practical diagrams and circuits are provided for each stage) thus enabling hire purchase interest rates to be avoided. The complete set of ASSEMBLY INSTRUCTIONS IS NOW AVAILABLE, price 5/- (refunded against first order). The instructions include really detailed PRACTICAL LAYOUTS, WIRING DATA AND COMPONENT PRICE LIST. ALL COMPONENTS ARE AVAILABLE FOR INDIVIDUAL PURCHASE. A CABINET WILL ALSO BE AVAILABLE.

STERN RADIO LTD.
109 & 115, FLEET STREET, E.C.4
Tel.: CENTRAL 5812-3-4.

WE PAY TOP PRICES

For American Surplus Electronic Equipment

Any quantity or condition

LOOK AT THESE EXAMPLES

for equipment in good condition

SCR291, complete	£350
Receiver R54/APR4 with all tuning units	£135
Receiver BC348 (R model only)	£25
Frequency Meter TS/175	£80
Tx/Rx RT18/ARCI	£50
Test Set TS13	£100
Valves 723A/B	£3

We pay similar Remarkable Prices for

Receivers APR1, APR4, APR5, ARC3, R5/ARN7, BC342, BC312, APN9, BC1147.

Frequency Meters, TS174/U.

Test Sets T53, TS13, TS14, TS34, TS45, IE19, TS59, TS102, TS118, TS184.

Transmitters ART/3, TRCI, TCS6-12-13, ET4336

Synchronisers BC1148 Modulators BC1142

Indicator BC1151

And almost every American made unit even if not mentioned above.

Phone us immediately, transfer charge

ALTHAM RADIO CO.

JERSEY HOUSE, JERSEY STREET,
MANCHESTER, 4

Tel.: CENTRAL 7834/5/6

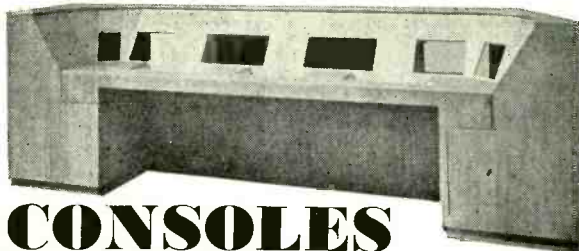

CONSOLES

For Major Film Mixer Suites to Individual requirements.

"VIEWMASTER" CONSOLES

AS SHOWN

Beautifully designed and finished in Walnut, Oak, Mahogany and Teak, to customers' requirements

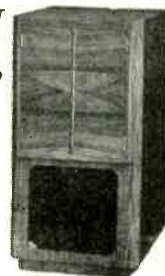

Standard "VIEWMASTER" model as shown **£13.0.0**

With Full Length Doors ... **£14.0.0**

Universal Model for all 16" tubes now in preparation.

Carriage and Packing 15/- extra.

Fitted with shelf for easy mounting. These are NOT mass produced and dimensions can be altered to suit personal requirements.

Individual and Trade Enquiries to

H. ASHDOWN

CABINET MAKER

98 HERTFORD ROAD, EDMONTON, N.9

Phone: TOT. 2621



OSCILLOSCOPE TYPE 723

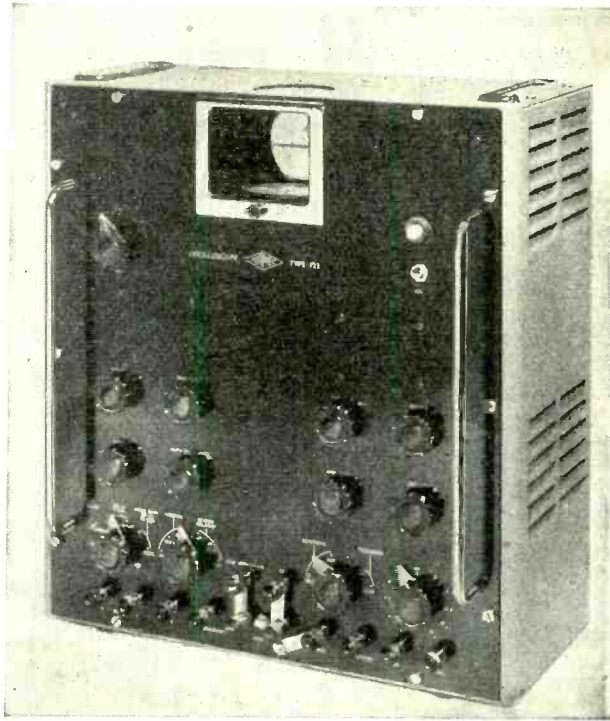

THE OSCILLOSCOPE TYPE 723 is a general purpose instrument with a flat frequency response from D.C. to 5 Mc/s. It utilises a vertical cathode ray tube with a 4in. flat screen, which is viewed through a surface aluminised-mirror.

This form of construction has considerable advantages. The instrument which is only 8in. deep, may be forward rack mounted on a 19in. rack, but when employed for bench use it takes up less room than a conventional oscilloscope. The screen is observable at a reasonable height from the bench without tilting, and an effective light shield is obtained without a projecting hood. The large front panel makes possible a clear and convenient layout of controls, and an Oscilloscope Camera Type 758 may be mounted permanently on the top of the instrument without interfering in any way with normal viewing.

- Y Amplifier response flat from D.C. to 5 Mc/s
- Sensitivity of 100 mV per cm. at 1 kV. E.H.T.
- No overloading occurs with full screen deflection over the complete frequency range at 2 kV. E.H.T.
- Variable E.H.T. voltage of 1, 2 and 4 kV.
- Automatic Brilliance Control Circuit
- Time-base range from 0.5 seconds to 1 microsecond for full screen deflection
- Versatile Auxiliary Amplifier incorporated
- A deflection of 1 cm. ensures rigid synchronisation over the whole frequency range
- Instantaneous shifts



Full details of this or any other Airmec instrument will be forwarded gladly upon request.

AIRMEC LIMITED

HIGH WYCOMBE BUCKINGHAMSHIRE ENGLAND

Telephone: High Wycombe 2060

Cables: Airmec High Wycombe

THE "WEYRAD" SIGNAL GENERATOR

A WIDE RANGE INSTRUMENT OF HIGH ACCURACY



At a low Price ONLY £8.10.0 RETAIL

NOTE THESE OUTSTANDING FEATURES

- Coverage 100 kc/s.—70 mc/s. (on fundamentals).
- Accuracy better than 1% on all ranges.
- Large, clearly calibrated scale.
- Modulated or unmodulated output.
- 500 c/s. A.F. source.
- S.G.M.I.—A.C. mains operation, double wound varnish-impregnated transformer, tapped 210/225/250 v.
- S.G.B.I.—all dry battery operated.
- All components are by well-known manufacturers ensuring maximum reliability and efficiency.
- Both types are now in quantity production.
- Illustrated leaflet available on request.

Special Quotations for Trade & Export Quantities.

WEYMOUTH RADIO MFG CO. LTD.
CRESCENT STREET, WEYMOUTH, DORSET, ENGLAND.

**E.M.I. SCHOLARSHIPS
TO THE VALUE OF £3000**

YOUNG MEN AGED 17-19 with G.C.E. and at least one year's study in Mathematics and Physics to Advanced level, have a wonderful opportunity to train for an interesting and well-paid career with the greatest Electronic Group in the Commonwealth.

ONCE A YEAR at least 24 Scholarships (to the value of £3,000) are awarded for a four-year course in Electronic Engineering. With this Scholarship and grants, students may become almost self-supporting while still under training. During the course the students' progress and welfare are the main consideration.

Write immediately for full details. *Next course commences October 6th.* Selected applicants will be required for a personal interview in late July or early August.

E.M.I. INSTITUTES
(DEPT. 127 O)
10, PEMBRIDGE SQ., LONDON, W.2
Tel.: BAYswater 5131/2

Associated with
"H.M.V."
MARCONIPHONE
COLUMBIA
ETC.

1A8

BK

*Specialized Loudspeaker
Enclosures No. 1 Type F.C.R.8.*

*A handsome New
cabinet specially
designed for use
with high fidelity
loudspeaker units.*

Recommended particularly for use with the Axiom 101, 102, Super 8CS and Super 8CS/AL, this cabinet is lagged with a special material, resulting in an improved clarity rarely associated with this type of enclosure.

Individually made, with gold expanded aluminium grill, this hand french polished case is available in Oak, Walnut or Mahogany finish. Size 27in. high x 17in. wide x 10in. deep.

(Carriage and packing extra) **9 Gns.**

Visit our showrooms to hear the F.C.R.8 and other modern B.K. housings for 8in., 10in., 12in. and 15in. units—and a wide range of high fidelity equipment which our staff will gladly demonstrate.

B. K. PARTNERS LTD.
229, REGENT STREET, LONDON, W.1.

(Entrance in Hanover St.)

Phone: REGent 1051

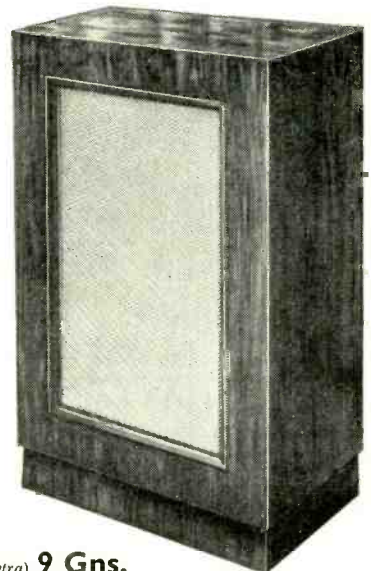

The "Musicmaster" Tape Recorder

MODEL 2B

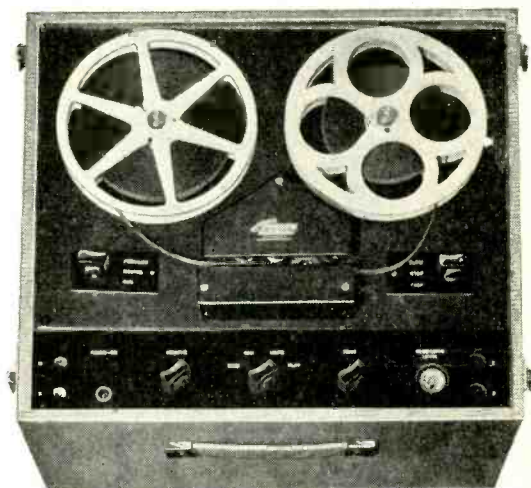

British made by British craftsmen, this Recorder represents an outstanding achievement in the field of tape recorders

THE MUSICMASTER Tape Recorder is a moderately priced machine of outstanding performance. A Two-Speed tape mechanism is employed and the reproduction is completely free from all forms of "wow" and "flutter." The major features of the machine are listed on the right.

- Two tape speeds.
- Instant speed-change at turn of switch.
- Perfectly silent mechanism.
- Single slot loading.
- Fast forward and rewind without tape handlings.
- Rewind and forward in 50 seconds.
- Twin track recordings.
- Contacts for external stop and start.
- Electromagnetic braking giving freedom from mechanical wear.
- Complete freedom from "wow" and "flutter."
- Positive spool locks.
- Super high fidelity heads.
- Simplicity of control.
- Six-valve negative feedback record/playback amplifier.
- Radio and Microphone inputs.
- Built-in monitor loudspeaker for playback.
- Gramophone input with special lead.
- Monitoring facilities for listening to material being recorded.
- Very high microphone recording sensitivity.
- "Magic-eye" Recording level indicator.
- Provision for headphone playback.

DESIGNED FOR CRITICS

Trusound Ltd.

BY CRITICAL DESIGNERS

MANUFACTURERS OF FIRST GRADE ELECTRONIC EQUIPMENT

MUSICMASTER TWO-SPEED TAPE DESK **£18.18.0**
Carriage forward.

£35 Carriage forward
Special transit case £2
(Refunded on return)

Complete with MICROPHONE, TAKE-UP SPOOL and one reel of 'FERROVOICE' TAPE

★ Further details available on receipt of stamped, addressed envelope.

OFFICES & SHOWROOM : 196 KINGSLEY ROAD, HOUNSLOW, MIDDXX. Telephone : HOUNslow 7947

Demonstrations on weekdays by appointment only. Saturdays 9 a.m.—6 p.m.

WORKS : Willesden, London, N.W.2.

Connoisseur 3-speed MOTOR



Test this new motor at your earliest opportunity. You will find it possesses all the qualities you have been looking for !
 12in. turntable, 33 $\frac{1}{3}$, 45 and 78 r.p.m. Synchronous motor, virtually vibrationless.
 Suitable for standard, transcription and micro-groove recordings.
 Input voltages : 200-250 A.C. 50 cycles.
 110 volts 60 cycles to order.

3 Head PICK-UP

The CONNOISSEUR SUPER LIGHTWEIGHT PICK-UP

Extremely low mass at needle point (4/5 m.g. only), allowing for reduction in downward pressure to 8/10 grams for standard recordings, and 4/6 grams for microgroove recordings.

PRICES with one Head, £4/10/-, plus £1/9/3 tax.

Extra Heads, each £2/10/-, plus 16/3 tax.

Spare Armature System with sapphire, 10/3, plus 3/4 tax.

PRICE (without Pick-up)

£16.10.0 Plus £5.7.3 tax

OVERSEAS AGENTS

S. AFRICA : W. L. Procter (Pty.) Ltd., 63 Strand Street, Cape Town.

AUSTRALIA : J. H. Magrath & Co. Pty. Ltd., 208 Little Lonsdale Street, Melbourne.

CANADA : The Astral Electric Co., 44 Danforth Street, Toronto, Ontario.

NEW ZEALAND : Turnbull & Jones Ltd. Head Office : 12/14 Courtenay Place, Wellington.

HONG KONG : The Radio People Ltd., 31 Nathan Road, Hong Kong.

A. R. SUGDEN & CO. (ENGINEERS) LTD.

WELL GREEN LANE, BRIGHOUSE, YORKSHIRE
 Telephone: HALIFAX 69169.

Build Your Own Tape Recorder

ALL PARTS PRECISION ENGINEERED
 SEND S.A.E. FOR SPECIAL PARTS LIST

	s.	d.
LINCOLN SPOOL ADAPTORS	each	5 9
LINCOLN OSCILLATOR COILS, completely enclosed in Neosid Former, 45 Kc/s	each	12 6
LINCOLN OSCILLATOR UNIT, complete with 6BW6 valve	each	50 0



"Q-MAX" MODEL G.D.O.I.A. GRID DIP OSCILLATOR

is an ideal instrument for the determination of tuned circuit resonant frequency, tuning transmitters without application of power, for the determination of coil, mutual and stray inductances and both fixed and stray capacitances. Covers 1.5 to 300 Mc/s in

"Q-MAX" CHASSIS CUTTERS

each	
1 1/2" or 2"	11/6
2"	12/6
1", 1 1/4" or 1 1/2"	14/9
1 3/8" or 1 1/2"	16/6
1 3/4"	18/6
2 3/8"	30/-
2 1/2"	35/-
1" square	23/-
Keys, small, 10d., medium, 1/3, large, 1/9.	

eight ranges. PRICE : 12 Gns. Complete.

OUR NEW CATALOGUE IS AVAILABLE, 6d., POST FREE.

BERRY'S (SHORT WAVE) LTD.

25 HIGH HOLBORN, LONDON, W.C.1
 TEL. : HOLBORN 6231

PARKER'S SHEET METAL FOLDING MACHINE

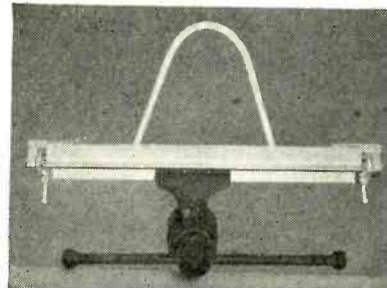

Heavy Vice Model. Capacity 18 gauge M.S.x2ft. wide. Loose Attachments for Radio Chassis making Weight 22 lbs. Price 42/6
 Attachments 1/6 per ft. Carriage 4/-, with attachments 5/6. Also Parker's Four in one Revolving Drill Vice.
 Comprising :—Upright Vee. Inclination Vee. Right Angle. Flat Side.
 Admits Stock of 3in. dia. Weight 13 lb. Price 42/6. Carriage 2/6.

Machines guaranteed. Send for details.

A. B. PARKER WHEATCROFT WORKS, WELLINGTON STREET, BATLEY, YORKSHIRE. Tel. : Batley 426

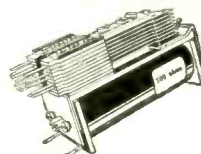

RELAYS

Types 3000 & 600
 Made to Specification

COIL WINDING & TROPICALIZING A SPECIALITY

Also Siemens High Speeds—Polarized types—Stowergers—Key Switches and Uniselectors

TELEPHONE EQUIPMENT

UNIVERSAL ENGINEERING CO

(Dept. SFK/2.)
 HAVELOCK WORKS, HAVELOCK PLACE, HARROW, MIDD.X.
 Telephone : HARrow 1482

STRICTLY EXPORT ONLY

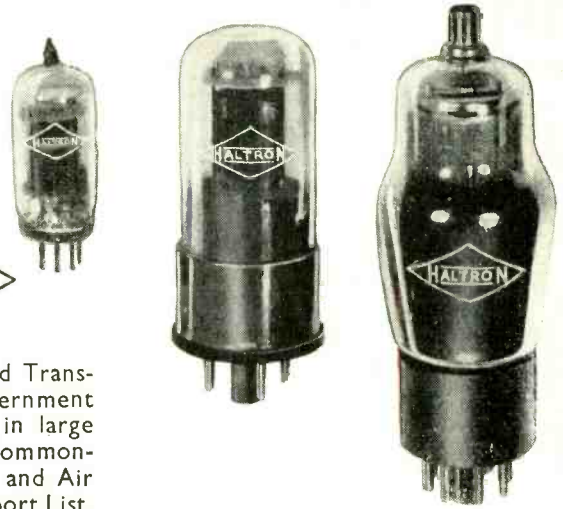

Leading Exporters of all types of Radio Receiving and Transmitting Tubes. Current Production and Ex-Government Surplus Special Purpose Tubes. Over 900 types in large quantities, available Ex-Stock, Contractors to British Commonwealth and Foreign Governments for Army, Navy, and Air Forces, Post Offices, Civil Air Lines, etc. Ask for Export List.

SOME OF THE TYPES CARRIED IN STOCK

1A3	4THA	6D7	8SR7	12K7GT	50C5	715B	1825	CV222	H30	PEN25	VCR97
1A6GT	4TPB	6E5	8SS7	12K8 (metal)	50CD8/G	717A	1826	CV415	H33	PEN48	VCR140
1A7/G	5AP1	6E8	8ST7	12K8/GT	50L6G	721A	1829	CV987	HF300	PEN220A	VCR140A
1A7GT	5A2A	6F5	8T7G	12K7/GT	50Y6GT	723A/B	1833	CV980, 8431	HL2	PM4DX	VCR511B
1B24	5B4G	6F5G	8U4GT	12SA7	53A	724A	1835	CV1481	HL4	PR202	VCR516
1C3G	5B102D	6F5GT	8U5G	12SA7GT	53KU	725A	1842	CV1583	HL41	PR225	VCR517A
1C5GT	5B102A	6F8/1613	8U5/GG5	12SC7	54	728A	1848	CV6008	HP210	PT15	VCR518A
1D6	5BP1	6F8G	8U7G	12SG7	57	800	1815	CY31	HP4101/5	PT5	VCR517B
1D8GT	5BP4	6F8/GT	8V8	12SH7	58	801	1851	CY32	HR210	PK4	VCR517C
1E7G	5CP1	6F7	8V8/G	12SJ7	59	801A	1960	D1	HT1	PK25	VCR528
1G4GT	5CP7	6F8G	8V6GT	12SJ7GT	61P	803	2000	D41	KR3	R1	VCR523
1G5G	5C450 (A)	6F8GT	8X4	12SK7	72	805	2003	D63	KT8	R2	VCR523
1G6GT	5EFT	6G5/G	8X5	12SK7GT	73	805	2051	DA60	KT8	R2	VCR523
1H5G	5J4	6G6G	8X5G	12SL7GT	75	807	4003A	DA60	KT2	R1	VCR523
1H5/GT	5L3S	6H6	8X5/GT	12SN7GT	76	808	4003A	DA100	KT2	R3	VCR523
1L4	5L1P	6H6G	8Y6G	12SQ7	77	810	4019A	DA100	KT2	R3	VCR523
1LA6	5R4GY	6H8GT	8Y7G	12SQGT	78	810	4021A	DET9	KT2	R3	VCR523
1L6	5T4	6I5	8Z5	12SR7	72	811	4032A	DET12	KT6	REL12	VCR523
1L6	5U4/G	6I5G	7A4	12U5G	80S	814	4045A	DET16	KT6	REL12	VCR523
1LR4	5V4G	6I5GT	7A6	12X3	81	815	4060A	DET19	KT6	REL12	VCR523
1LN5	5X4G	6J6	7A7	12Y4	82	816	4094A	DET25	KTW61	RG1/125	VP4A
1N6/G	5Y3G	6J7	7B6	1447/12B7	83V	826	4094A	DH63	KTW82	RG6/45	VP21
1N6GT	5Y3GT	6J7G	7B7	14B6	83	828	4310	DET9	KTW63	RK20A	VP21
1Q5GT	5Z4G	6J7GT	7B7GT	14E7	84G/24	828	4383D	DET9	KY241	RK28A	VR21
1Q5GT	5Z3	6K6G	7C4	14H7	89	829A	4378	E1148	KY283	RK34	VR32
1R4/1294	5Z4	6K6GT	7C6	14K7	100TH	829B	4378	E1148	KTZ73	RK39	VR53
1R5	5Z4/G	6K7	7C8	14S7	117L7/GT	830B	4378	E1155	L2	RR47	VR54 (EB34)
1R4	5Z4GT	6K7/G	7C7	15E	117N7/GT	832	4378	E1190	L30	RK48A	VR66
1R5	5A7	6K7GT	7D3	15B	117Z6/GT	832	4378	E1191	L63	RK73	VR90/30
1U4	6A7	6K8	7D5	18A4Q5	205F	833/833A	801A	E1231	L610	RK75	VR105/30
1U5	6A8G	6K8/G	7D8	23D	210RL	834	801B	E1248	LD210	RK77	VR150/30
2A3	6A8GT	6K8/GT	7E7	24G	220RC	836	801C	E1254	LD410	RK83A	VS24
2A5	6AB7/1853	6L5G	7E8	25A6G	210SPG	837	801D	E1265	LL2	RK235 (72)	VS110A
2A6	6AC7/1852	6L8 (metal)	7F7	25L6	210SPT	838	801E	E1266	S27A	SK20A	VT4C (211)
2A7	6AG5	6L6/G	7H7	25L6GT	210VPT	841	801F	E1271	L55	S28A	VT13B
2B7	6AG8/G	6L6/GA	7K7	25Y5	212E	843	800A	E1320	ML25H	S130P	VT46
2C26	6AG7	6L7	7N7	25Z4G	215P	850	800B	E1323	MH4	S130	VT38A
2C34	6AJ5	6L7G	7R7	25Z5	217C	860	800C	E1359	MR41	SP2	VT60A
2E22	6AK5	6N7	7Q7	25Z6G	220T	861	800D	E1388	MH4105	SP2	VT94
2J21A	6AK8	6N7/G	7S7	25Z6GT	231D	868	800E	E1458	ML4D8	SP22	VT98
2J31	6AL5	6N7GT	7E5	25DTH	250TH	864	800F	E1468	ML4T04	SP41	VT501A
2J34	6AM5	6P7G	7W7	30	262B	865	800G	E1474	ML6	SP42 (ARP20)	VT510
2J38	6AM6	6Q7	7Y4	32	282A	866A	800H	E1496	MR10	SP61	VT529
2J39	6AQ5	6Q7/G	7Z4	33	304TH	866R	800I	E1516	MS/PEN	SP210	VU33
2J48	6AT6	6Q7/GT	8D8	35A5	307A	868	800J	E1516	MS/PEN/B	SPV 280/40	VU39A/39
2J54	6AU6	6R7	8D8	35L6G6	310A	872, 372A	800K	E1532	MS/P4/NR65	SPV 280/80	VU72
2I54B	6B4G	6R7/G	9D6	35T	310B	874	800L	E1535	EB34 (VR54)	MS/P41	SU2150A
2X2/379	6B5	6R7/GT	10	35TG	311A	875A	800M	E1535	EB33	ML12/14	TP22
2X2A	6B7	6SA7	10D1	35W4	313C	875A	800N	E1535	EC54	MS/PEN/B	TT4 NR57/ML
3A4	6B8	6SA7GT	11D3	35Z3	323A	876, 304	800O	E1535	AT4	NC11/12	VY05/13
3A1	6B8G	6SC7	11D5	35Z4G	327A	884	800P	E1535	AT15	NG13	VY05/13
3B7/1291	6BA6	6SD7/GT	12A8	35Z5GT	328A, 4328A	902	800Q	E1535	AT40	NGT1	VY21
3B24	6BE8	6SF5	12A8GT	36	337A	923	800R	E1535	ATP4	NGT5	VY21
3B26	6BG6G	6SF7	12A8/GT	37	354V	931A	800S	E1535	AU5 (VU111)	NS2	W10
3BP1	6BR7	6SG7	12A8/GT	38	357A	934	800T	E1535	AZ1	NS5	W12/U14
3CP1	6BW6	6SH7	12AT6	38/44	380A	935	800U	E1535	AZ1	NS5	W232
3D6/1299	6BW7	6SH7GT	12AT7	40	385A	936	800V	E1535	BT1	NT88 CV1234	W232
3E1	6C5	6SJ7GT	12AU6	41	388A	936	800W	E1535	BT1	NT88 CV1238	W232
3F7	6C5	6SJ7GT	12AU7	41	394A	937	800X	E1535	BT1	NT88 CV1249	W232
3L4	6C5G	6SJ7Y	12AX7	41MPL	450TL	958A	800Y	E1535	BT45 (CV22)	EL3	X21
3Q4	6C5GT	6SK7	12BA6	41MTL	703A	959	800Z	E1535	BT45 (CV22)	EL2	X24
3Q6/G	6C8	6SK7GT	12BE6	41MXP	705A	961	800A	E1535	BT45 (CV22)	EL3	X24
3Q6GT	6C8G	6SK7GT	12C8	41STH	707A/B	961	800B	E1535	BT45 (CV22)	EL33	X41
3R4	6C8	6SL7GT	12C8GT	43	708A	1299A	800C	E1535	BT45 (CV22)	EL33	X41
3V4	6CD6-G	6SN7/GT	12E6	45	713A	1616	800D	E1535	BT45 (CV22)	EL33	X41
4C27	6CH6	6SQ7	12F5GT	45 SPEC	715A	1624	800E	E1535	BT45 (CV22)	EL33	X41
4D1	6D6	6SQ7GT	12J7GT	46	715A	1624	800F	E1535	BT45 (CV22)	EL33	X41

HALL ELECTRIC LTD

HALTRON HOUSE, 49-55 LISSON GROVE,
LONDON N.W.1.

Tel.: Ambassador 1041 (5 lines) Cables: Halleetric, London



MOTEK K3 AND K4 TAPE UNITS

- ★ Sturdy Push Button Controls.
- ★ Electronic braking system giving smooth and efficient braking at the touch of a button (self-contained power unit).
- ★ 3 Collaro Motors.
- ★ Rewind and fast forward without handling tape and in 1 min.
- ★ Essential parts machined to a very high degree of accuracy to ensure negligible wow.
- ★ Half track high impedance record and erase heads. At tape speed 7½ in. per sec.—1 hour's playing.
- ★ Response 50-10,000 c/s.
- ★ Pressure pads and roller controlled by single lever.
- ★ Size of unit 16½ x 11½ x 4 in.
- ★ Most visible Unit Fittings chromium plated.
- ★ Voltage A.C. Mains 200/250 volts.
- ★ Each unit is supplied with full instructions and circuit diagram for suitable amplifier and is fully guaranteed.
- ★ Packed in rigid cardboard carton.

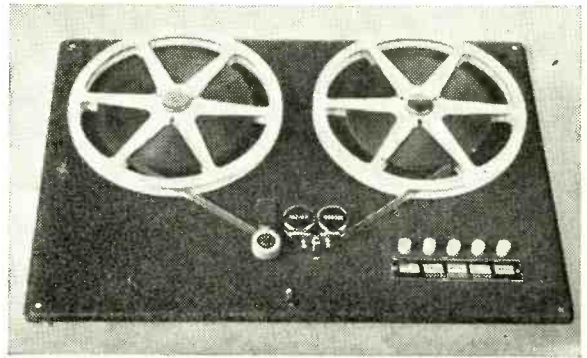

The Motek K3 and K4 units are beautifully finished and their operation and appearance will satisfy the most critical.

Also Available :
Motek Tape Amplifier.
Motek Oscillator Coils.

Motek Record and Erase Heads.
Telephone Adaptors, Etc.

Price : K3

Employing "red" code R/Play Head (1,000 ohms at 1 Kc.).

16½ Guineas

K4

Employing "yellow" code R/Play Head (2,300 ohms at 1 Kc.).

17 Guineas

From your local dealer or in case of difficulty write to:—

MODERN TECHNIQUES 138-144 Petherton Road, London, N.5. Tel.: Canonbury 5896

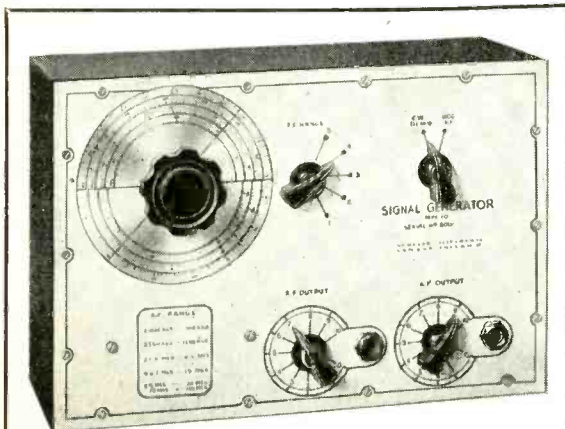

SIGNAL GENERATOR TYPE 10. 100 Kc/s-100 Mc/s

Price £7 . 10 . 0

The accuracy, reliability and comprehensive specification, are some of the reasons why the TYPE 10 has achieved such outstanding success.

- 100 Kc/s to 100 Mc/s ● Modulated or unmodulated carrier ● Direct calibration ● Adjustable 400 c.p.s., AF signal ● Stable RF oscillator
- Large, easily read scale ● AC mains operation.

New instruments now available include the **HOMELAB CHECKTEST** price 37/6d, and a range of accurately calibrated variable condensers, 100pf, 500pf, and 1000pf, price 42/- each.

Obtainable only direct from the manufacturers. Send for full technical details or call at address below.

Overseas enquiries invited.

HOMELAB INSTRUMENTS LTD.,
615-617, HIGH ROAD, LEYTON, LONDON, E.10
Telephone : LEY 5651

THE WORLD'S GREATEST BOOKSHOP

FOYLES

★ FOR BOOKS ★

All new Books available on day of publication.

Secondhand and rare Books on every subject.

Stock of over three million volumes.

Subscriptions taken for magazines.

119-125 CHARING CROSS ROAD LONDON W.C.2

Gerrard 5660 (16 lines) ★ Open 9-6 (Thurs. 9-7)

Nearest Station : Tottenham Court Road

A MINIATURE MAGNETIC LIGHTWEIGHT EARPHONE



The new Amplivox E.4 Earphone has been primarily developed for use with office dictating machines, industrial equipments and hearing aids where a highly sensitive, lightweight, miniature receiver is needed.

Available in D.C. resistances 2-2000 ohms; frequency 100-4000 c.p.s.; diameter .835"; depth .420"; weight ¼ oz.

AMPLIVOX LTD.
2 Bentinck Street, London, W.1

- if you look for BIG RESULTS

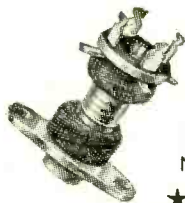

We're not kidding—a vast improvement arises from the use of OSMOR "Q" Range Coils. No wonder our customers are enthusiastic! They tell us these "mighty marvels in miniature" are super selective and sensitive to a degree they never dreamed possible. And we guarantee them—they're the outcome of patient scientific research plus the highest technical ability. Note these "plus" points that spell superior performance:—

- ★ Only 1in. high. ★ Packed in damp-proof containers. ★ Variable iron-dust cores. ★ Fitted tags for easy connection ★ Low loss Polystyrene formers.

COILPACKS. Now at new lower prices! A full range is available for Superhet and T.R.F. Mains or Battery. Size only 1½in. high x 3½in. wide x 2½in. Ideal for the reliable construction of new sets, also for conversion of the 2I RECEIVER, TR 1196, TYPE 18, WARTIME UTILITY and others. Aligned and tested, with full circuits, etc. Fully descriptive leaflets available.

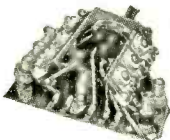

**4/-
EACH**



With **OSMOR** Lines—you're on the right lines!

A spotlight on just one of the range of **OSMOR** "Q" coils.

H.F. CHOKE Type Q.C.1.

Frequency coverage 150 kc/s. to 20 mc. Iron-dust core and single-screw fixing. Prototype tested and approved by M. G. Scroggie, B.Sc., M.I.E.E. Ideal as anode load in TRF receivers, for decoupling and general purpose. Price 4/-.

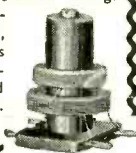

TWO for the Price of ONE!

The NEW **OSMOR**

CHASSIS CUTTER

of entirely new design. Cuts two sizes of holes with any one reversible punch and die; and can be operated with a spanner or tommy-bar. Blanks easily removed.



Prov. Pat.

Type	Hole Sizes	Price
1	1in. x 1½in.	19/6
2	¾in. x 1½in.	18/9
3	¾in. x 1½in.	22/6
4	1½in. x 2in.	27/3

Post and Packing 1/- (any type).
Tommy Bars 1/3 each

The OSMOR "JIFFY PUNCH"

For cutting smaller holes neatly and quickly with one blow of a light hammer.



Prov. Pat.

Type	Hole Size	Price
1	¾in.	6/6
2	¾in.	7/6
3	¾in.	8/9

Both types of cutters are of hardened steel and are for use on steel up to 18 s.w.g. Brass and Dural up to 16 s.w.g. Aluminium and Copper up to 14 s.w.g.

(Dept. W.43) BRIDGE VIEW WORKS, BOROUGH HILL, CROYDON, SURREY.

DIALS

Type A. GLASS DIAL ASSEMBLY (as illus.) measuring 7in. x 7in. (9½in. x 9½in. overall) mounts in any position on or above the chassis and works with any type of drive. Choice of two 3-colour scales—G1(L.M.S.) or G2(M.S.S.). Price complete, 24/6. Pulley assembly for right-angle drive if required 1/9 extra. P. & P. 1/6.



METAL DIALS

Overall size 5½in. sq., as illustrated. Cream background. 3-colour. Type M1, L.M.S. waves. M2, L. & M. waves. M3, M. & 2/S. waves. Price 3/6 each. Pointer, 1/6. Drum, Drive, Spring and Cord for use with both types of dials, 3/2.



We keep stocks of many radio components for use in published circuits, including "WIRELESS WORLD"

"NO COMPROMISE" TRF TUNER. (Osmor coils QA11 and QHF11 for M.W. and QA12 and QHF12 for L.W. are suitable price 4/- each.)

"MIDGET MAINS RECEIVER" (Osmor coils QA11 for M.W. and QA12 for L.W. are suitable, price 4/- each.)

SENSITIVE 2 VALVE RECEIVER TELEVISION CONVERTER (special coils in cans available) "PRACTICAL WIRELESS"

3-speed Autogram. Modern 1-valver. A.C. Band-Pass 3. R1155 Converter. Attache case portable model high power Amplifier—2.

Dear Reader,

We can't mention all our products here but shall be glad to receive your enquiries for Chassis, Tuning Condensers, Switches, Volume Controls and all other Radio Components. If it's top-quality components and a speedy, courteous service you are looking for—try Osmor. We really shall do our best for you.



Keep those small components—resistors, condensers, etc., neatly stored yet visible by using an

OSMOR "JAR-RACK"

(If you're a generous husband you'll buy one or two for your wife's larder, too—she will appreciate somewhere to store her preserves.) Holds any 1 lb. jam jars, with or without lids. Easily removed, cannot fall out. Just the thing for the tidy "HAM" or Radio Dealer.

Type 1 for wall-fixing, 6/9 each, holds 8 jars. (Jars are not supplied but are easily obtained.)

Length 24in. enamelled olive green.

Type 2 (as illustrated) for screwing under a shelf, 5/9 each, holds 6 jars.

Length 18in. enamelled green.

Post and packing 1/- (either type).

(Trade supplied)



You won't believe it!

the first time you hear your own voice! Have fun and find endless pleasure in using an **inexpensive TAPE RECORDER** you can build yourself. We can supply all the parts to make a really efficient unit, utilising your gramophone turntable (which can still be used for its normal purpose). Send 2/6 only for easy-to-follow blueprints and instructions, or ask for details.

I.F.s. 465 k/c. Permeability-tuned, with flying leads. Standard size 1½in. x 1½in. x 3½in. For use with OSMOR coilpacks and others, 14/6 pair. PREALIGNED, 1/6 extra.

FREE!

Send 5d. (stamps) for **FREE CIRCUITS** and full lists of coils, coilpacks and radio components.

OSMOR radio products Ltd.

Telephone : Croydon 5148/9

A new V.H.F. Transmitter Output Meter

Measures RF power up to 10 watts max.
at a maximum frequency of 200 Megacycles.

SALIENT FEATURES:—

- ★ TWO RANGES : 0-3 watts and 0-10 watts.
- ★ IMPEDANCE : 50 ohms
- ★ MAX. FREQUENCY: 200 Mc/s.
- ★ POWER SUPPLY : 200/250v. 50 cycles.
- ★ WEIGHT : 10 lbs. nett.
- ★ DIMENSIONS : 13" x 9" x 8".



This instrument is ideally suited for measuring conveniently and accurately the power output of small V.H.F. Transmitters in the frequency band of 10 to 200 Megacycles. PRICE: £39 · 10 · 0

HATFIELD INSTRUMENTS LTD.
175, UXBRIDGE ROAD, HANWELL, LONDON, W.7

Telephone : EALING 0779/9857

M. R. SUPPLIES, LTD.

Immediate delivery, safely packed, of the following brand new (or otherwise perfect) material. Satisfaction assured. All Prices nett.

SMALL GEAR BOXES, double worm gear 300/1 reduction. In die-cast housing approx. 2½ in. x 2½ in. x 2 in., fine precision construction. Final shaft ½ in. dia. by 1½ in. prof., with two other take-offs, same ratio. Ball bearings, transmission up to 1/6th H.P. 45/- (despatch 1/6). Also some heavier duty models, 3/1 up or down, details on request.

STUART CENTRIFUGAL PUMPS. We claim to have the largest stock of all models—details on request. All for 230/250 v. A.C. No. 10 (120 g.p.h.) £7/10/- (des. 2/-). No. 12 (600 g.p.h.) £10 (des. 2/6). No. 21, with induction motor (1,000 g.p.h.) £22/10/- (des. 7/6), and others.

SELENIUM RECTIFIERS, large range. Examples from stock:—D.C. output 24 volts, 25 amps, £5/17/6 (des. 2/6). 12 volts 3 amps, 16/6 (des. 9d.). 24 volts, 3 amps, 35/- (des. 1/-). All full wave and brand new. Also half-wave, brand new:—200 v. 300 m.a., 20/-; 600 v. 30 m.a. 15/- (des. either 1/-). We have to emphasise that all of these units are brand new and not re-builds.

VARIABLE TRANSFORMERS. First-class units by Philips—saving expense and delay. Input 220 v. 50 c. Output infinitely variable 0/260 v. Bench type, fully enclosed. 520 va., £8/15/- (des. 5/-). 1040 va., £14/15/- (des. 7/6). 2080 va., £19/17/6 (des. 7/6). Panel types also available.

WIRE AND CABLE STRIPPERS (Whanda 15/- model). An ingenious instrument giving a clean removal of insulation up to 3/8th in. dia., with three interchangeable gauge heads and micrometer adjustments. Perfect for industrial or amateur use. Full price, 7/6 (des. 9/1).

EXTRACTOR FANS, 220/250 v. A.C. (induction motor), with 8 in. impeller (10 in. overall dia.). £5/5/- (des. 2/-), with 10 in. impeller (12 in. overall), £5/12/6 (des. 2/-).

G.E.C. MINIATURE CRYSTAL CALIBRATORS (further small supply). Operation 200/250 v. A.C. For frequency calibration in 100 Kc. steps from 100 Kc. to 40 Mc/s. Modulation at 400 c/s, switched in if desired. With vacuum mounted crystal, basin, 100 Kc. Accuracy 0.001 per cent. Size 8½ x 6½ x 2½ in. Brand new 12 guinea instrument for £5/5/- (des. 2/-).

GRAMPIAN AMPLIFIERS, 1955 model. Compact chassis form units for 200/250 v. A.C./D.C. operation. Output 4 watts. Size 10 in. x 6 in. x 2½ in. overall. Fitted tone and vol. controls. Complete with valves:—UBC41, UL41, and UY41, ready for use with any pickup and 2/4 ohm speaker. As used in current Gramopola Portable Electric Gramophones. With diagram, brand new, £5/12/6 (despatch 2/6). Here is the ideal unit, giving excellent performance, for use in home, clubs and public rooms.

PHOTO-ELECTRIC CELLS, Cintel type G.S.47X. Miniature 3-pin type, standard to many projectors, 1½ in. high. Average working volts, 90—each individually marked. With 3-pin base, brand new, 29/6 (des. 6d.).

MOVING COIL AMMETERS (Ernest Turner), 0/5 amps D.C. in projection housing 3½ in. dial, 5 in. prof., 25/- (des. 1/-). Also **MICROAMMETERS** in same housing, suitable for lab. or bench use. 0/100 Microamps. 47/6, also same style, 0/150 Microamps, 39/6 (des. either 1/-).

A.C. MAINS RELAYS. Very useful miniature type approx. 2 in. x 1½ in. x 1½ in. with 250 v. A.C. coil and 2-pole 3-amp. "make" switching, 18/6. Also new London type L.F., 100 v. A.C. coil, 3-pole 4-amp. "make" switching, 19/6. We have a large range or Londex Relays—please send enquiries.

Illustrated lists on request:—Philips Variable Transformers, G.E.C. Miniature Crystal Calibrators, B.P.L. Measuring Instruments, Stuart Electric Pumps, Synchronous Timing Devices.

M. R. SUPPLIES, Ltd., 68 New Oxford St., London, W.C.1

Telephone : MUSEum 2958

POLYTHENE

H. F. EQUIPMENT

(AMBYTHENE BRAND)

COIL FORMERS
CHOKES
STAND-OFFS
FEED-THROUGHS

Send for particulars and Samples

AMPLEX APPLIANCES (KENT) LTD.

19 DARTMOUTH ROAD, HAYES, BROMLEY, KENT.
(RAVensburn 5531)

All export enquiries to

ANTEX LTD., 3, TOWER HILL, LONDON, E.C.3.

SOUND ENGINEERS TO **LEEVERS-RICH** THE FILM INDUSTRY

Lee Raser

THE ORIGINAL
ULTRA RAPID
TAPE DEMAGNETIZER

MODEL B

(as illustrated)

MODEL C

(for larger professional spools)

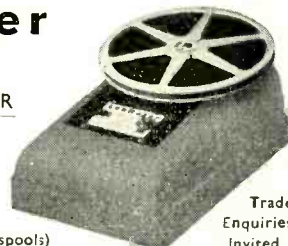

Trade
Enquiries
Invited.

LEEVERS-RICH EQUIPMENT LTD.,
80, WARDOUR STREET, LONDON, W.1. GER. 4502

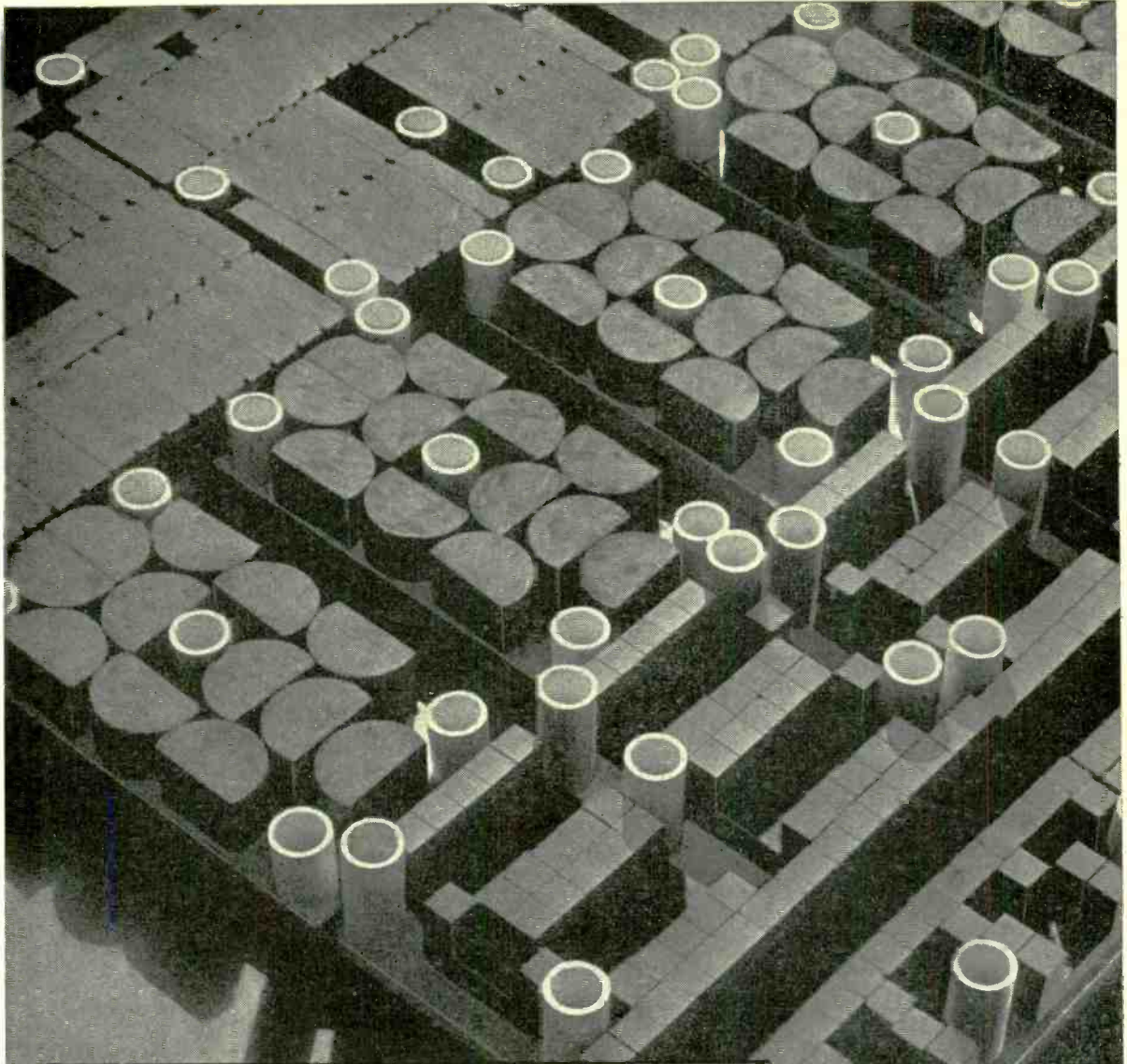

MAGNETIC MATERIALS Extensive research and manufacturing facilities have established Mullard as the leading producers of magnetic materials. They were the first, for example, to introduce Ferroxcube, the world's most efficient magnetic ferrite; 'Ticonal' anisotropic permanent magnets, renowned for their high stability and high energy output; and Magnadur, an entirely new type of permanent magnet with the insulating properties of a ceramic.

The wealth of experience gained from these developments is available to all users of magnetic materials through the Mullard advisory service. An enquiry to the address below will put a team of specialised engineers at your disposal.



Mullard

'TICONAL' PERMANENT MAGNETS • MAGNADUR (Formerly Ferroxcube)
 PERMANENT MAGNETS • FERROXCUBE MAGNETIC CORE MATERIAL

MULLARD LTD., COMPONENT DIVISION, CENTURY HOUSE, SHAFTERBURY AVENUE LONDON, W.C.2.

Mullard Magnadur permanent magnets ready for firing.

PREMIER ANNOUNCEMENT

BUILD A PROFESSIONAL LOOKING RADIO AT LESS THAN HALF TO-DAY'S PRICE

We can supply all the parts to help you.
 Drum (2 1/2 in. dia.) 1/6
 Driving head 1/6
 Double pointer 4/6
 Spring 3d.
 Nylon Cord (yard) 6d.
 Dial Front Plate 2/6
 Engraved Glass Dial 180-530 and 600-220-530 m. With station names, new wavebands 1/6
 T.R.F. Coils, 180-550, 800-2200 metres, pair 6/6
 Punched chassis, 3-valve plus rectifier T.R.F. Cabinet, Bakelite, in Walnut or Ivory or Wooden in Walnut Finish 17/6
 Packing and Insurance 2/6
SEND 1/6 FOR EASY TO FOLLOW POINT-TO-POINT DIAGRAMS AND CIRCUIT DIAGRAM which shows how YOU can build the Receiver illustrated above.

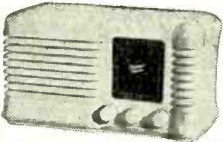

THE COMPLETE KIT
 to construct a 3-valve plus rectifier T.R.F. Receiver for use on 200/250 v. A.C. mains can be supplied at **119/6**
 Each Kit is complete in every detail, nothing has to be made or improvised. Easy to follow, point-to-point diagrams are supplied, making construction very simple. The Dial is illuminated, and the Receiver housed in its Cabinet size 12in. x 5in. x 6in. presents an attractive appearance. The valve line-up is: 171A—H.F. Pentode, V.R.116—Detector, A.P.T.4—Output, and Metal Rectifier.
 Waveband coverage is for the medium and long bands. Choice of 3 cabinets: Bakelite in Walnut or Ivory, or Wooden (Walnut finish).

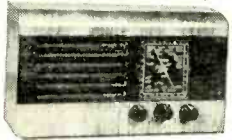

LOUDSPEAKERS—TAX FREE!
 ELAC—2 1/2 in. dia., Moving Coil, 15 ohms impeded. 15/-
 PLESSEY—3 in. dia., Moving Coil, 3 ohms impeded. 15/-
 ELAC—3 1/2 in. dia., Moving Coil, 3 ohms impeded. 15/-
 E.M.I.—8 in. Elliptical, 15 ohms impeded. 27/6
 PLESSEY—8 in. dia., Moving Coil, 8 ohms impeded. 14/6
 PLESSEY—10 in. dia., Moving Coil, 3 ohms impeded. 23/6
 GOODMAN'S—12 in. dia., Moving Coil, 15 ohms 28/8
 Plus 5/- packing and carriage.
 VITAVOX—K12/20 12 in. dia., Moving Coil, 15 ohms impeded. £11/11
 Plus 5/- packing and carriage.

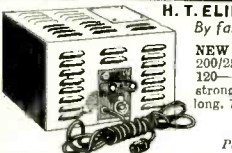

H. T. ELIMINATOR Ex-Govt.
By famous manufacturer
NEW & UNUSED Input 200/250 v. A.C. Output 120—at 30 mA., housed in strong metal box size 10in. long, 7in. wide, 6 1/2 in. deep. **37/6**
 Plus 2/- pkg. and carr.

H.T. ELIMINATOR AND TRICKLE CHARGER KIT
 All parts to construct an eliminator to give an output of 120 volts at 20 mA., and 2 volts to charge an accumulator. Uses metal rectifier, £2.

MAINS NOISE ELIMINATOR KIT
 Two specially designed chokes with three smoothing condensers with circuit diagrams. Cuts out all mains noise. Can be assembled inside existing receiver. 6/-.

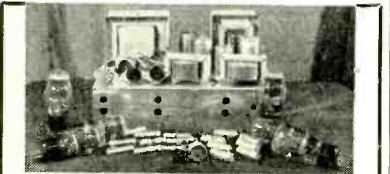

WILLIAMSON AMPLIFIER KIT
 A complete kit of parts for the construction of the latest version of this famous amplifier, complete with valves, output and mains transformers. **15gns.**
 Plus 7/6 pkg., carr. and ins.

WILLIAMSON AMPLIFIER TRANSFORMERS (To specification)
 The Output Transformer 3.6 ohms sec. £4/4-
 The Mains Transformer PREMIER SP425A, £3/7/6.

Govt. Surplus—EX. W.D. STEEL AERIALS
 Also ideal for fishing rods—All Brand New
 12ft.—3 4ft. sections of copper-plated steel highly flexible tapering 1/4 in. to 1/8 in. Brand new in container, 6/9. Packing and carriage 1/6. Insulated Base, 3/6. Webbing waterproof carrying case with shoulder sling, 2/6.

EX-U.S.A. U.H.F. AERIAL
 with tuned detector etage, consisting of V.R.92 valve etc. Brand new, in carton, 5/-.

CORRECT ASPECT WHITE RUBBER MASK
 For 12in. Round or Flat-faced Tube 16/11

PREMIER MAINS TRANSFORMERS
 All primaries are tapped for 200-230-250 v. mains 40-100 cycles. All primaries are screened. All L.T.s are centre tapped.

SP175B, 175-0-175, 50 mA., 4 v. @ 1 a. 4 v. @ 2-3 a.	25/-
SP250B, 250-0-250, 60 mA., 4 v. @ 1-2 a. 4 v. @ 2-3 a.	25/-
SP300A, 300-0-300, 60 mA., 6.3 v. @ 2-3 a. 5 v. @ 2 a.	25/-
SP300B, 300-0-300, 60 mA., 4 v. @ 2-3 a. 4 v. @ 2 a.	25/-
SP301B, 300-0-300, 120 mA., 4 v. @ 2-3 a. 4 v. @ 2-3 a.	28/-
SP350A, 350-0-350, 100 mA., 5 v. @ 2-3 a. 6.3 v. @ 2-3 a.	29/-
SP351, 350-0-350, 150 mA., 4 v. @ 1-2 a. 4 v. @ 2-3 a. 4 v. @ 3-5 a.	36/-
SP352, 350-0-350, 150 mA., 5 v. @ 2-3 a. 6.3 v. @ 2-3 a.	36/-
SP375A, 375-0-375, 250 mA., 6.3 v. @ 2-3 a. 6.3 v. @ 3-5 a. 5 v. @ 2-3 a.	45/-
SP501, 300-0-500, 100 mA., 4 v. @ 2-3 a. 4 v. @ 2-3 a.	57/-
SP501A, 500-0-500, 150 mA., 5 v. @ 2-3 a. 6.3 v. @ 2-3 a.	50/-
SP425A, 425-0-425, 200 mA., 6.3 v. @ 2-3 a. 6.3 v. @ 3-5 a. 5 v. @ 2-5 a.	67/6

SPECIAL OFFER DOUBLE WOUND AUTO-TRANSFORMER 250 watts.

Input/Output 100 volts	Output/Input 110 volts	Price
110 " 110 "	110 " 110 "	42/8
200 " 116 "	116 " 200 "	42/8
210 " 119 "	119 " 210 "	42/8
220 " 122 "	122 " 220 "	42/8
230 " 134 "	134 " 230 "	42/8
240 " 146 "	146 " 240 "	42/8
250 " 158 "	158 " 250 "	42/8

With the two windings connected in series a vast number of voltage tapings are available.

PREMIER VARIABLE IMPEDANCE MATCHMAKER MO.15 OUTPUT TRANSFORMER
 Designed to meet the demand for an efficient variable ratio Output Transformer. 11 ratios from 13:1 to 80:1 all centre tapped and can be used to match any output valves either single or push-pull. Class "A" "AB1", "AB2" or "B" to any low impedance speech coil or combination thereof. Primary Inductance 60 henries 16 watts audio 100 mA. Price, 45/-.

RECTIFIERS

E.H.T. Pencil Type S.T.C.		
Type K3/25	650 v. 1 mA.	4/7
" K3/40	3.2 kv. 1 mA.	6/-
" K3/45	3.8 kv. 1 mA.	8/2
" K3/50	4 kV. 1 mA.	9/3
" K3/160	12 kv. 1 mA.	21/6
H.T. Type S.T.C.		
Type RM1	125 v. 60 mA.	4/6
" RM2	125 v. 100 mA.	5/-
" RM3	125 v. 125 mA.	6/-
" RM4	250 v. 250 mA.	18/-
L.T. Type G.E.C. Full Wave.		
6 v. 1 amp.		4/-
12 v. 1 amp.		8/-

METERS
 Large stocks available, a few of which are enumerated below:—

Full Scale Deflection	Scale Length	External Dimensions in.	Movement	
.5 A	1 1/2	2 1/2 x 2 1/2	R.F. Thermo	7/8
.25 A	1 1/2	2 1/2 round	R.F. Thermo	7/8
3 A	1 1/2	2 1/2 round	R.F. Thermo	7/8
3.5 A	1 1/2	2 1/2 x 2 1/2	R.F. Thermo	7/8
4 A	1 1/2	2 1/2 x 2 1/2	R.F. Thermo	7/6
20 A	1 1/2	2 1/2 round	M/C	8/6
30 A	1 1/2	2 1/2 x 2 1/2	M/C	8/6
40 A	1 1/2	2 1/2 round	M/C	8/6
1.5 mA	1 1/2	2 1/2 round		12/6
5 mA	1 1/2	2 1/2 x 2 1/2	M/C	8/6
6 mA	2	3 1/2 round		16/9
50 mA	1 1/2	2 1/2 x 2 1/2	M/C	8/6
20 V	2	2 1/2 x 2 1/2	M/C	8/6
40 V	1 1/2	2 1/2 x 2 1/2	M/C	8/6
1 mA	2	3 1/2 round	M/C	25/-

MOVING COIL METER
 A super quality Moving Coil Meter basic movement 2 mA Scale dimension 2 1/2 in. Overall dimensions 2 1/2 in. dia. 1 1/2 in. deep. Bakelite case projecting type. At present scaled 1 amp. R.F. By removing thermo couple, reversing scale and recalibrating the meter, a high grade test instrument with any range above the basic F.S.D. may be built up. Price 4/9

1 mA METER IN PLASTIC CASE
 The movement is 1 mA mounted in a case 3 1/2 in. square and 3 1/2 in. high. The scale is 2 1/2 in. long and the dial is 2 1/2 in. diameter. There is ample room in the case for a switch and multipliers. Internal Resistance 100 ohms. Price 2/7/6

HEADPHONES
Balanced Armature Low Resistance
 Type L, 6/11 pair
 High Resistance (S. G. Brown), 4,000 ohms. 10/9 pair.
High Resistance 12/6 pair
Lightweight High Resistance 14/6 pair

ALUMINIUM CHASSIS 18 s.w.g.
 Substantially made from Bright Aluminium, with four sides

7 x 3 1/2 x 2 in.	4/-
7 x 4 1/2 x 2 in.	3/9
9 1/2 x 4 1/2 x 2 in.	4/8
10 x 8 x 2 1/2 in.	5/6
12 x 9 x 2 1/2 in.	7/-
14 x 9 x 2 1/2 in.	7/6
10 x 9 x 3 in.	7/-
12 x 10 x 3 in.	7/9
14 x 10 x 3 in.	7/11
16 x 10 x 3 in.	8/3
16 x 8 x 2 1/2 in.	8/-



ALUMINIUM PANELS 18 s.w.g.

7 x 6 in.	1/3	7 x 4 in.	1/5
9 1/2 x 6 in.	1/8	9 1/2 x 4 in.	1/5
10 x 6 in.	2/2	10 x 7 in.	1/11
12 x 9 in.	2/8	12 x 7 in.	2/5
14 x 9 in.	3/2	14 x 7 in.	2/11
16 x 9 in.	3/8	16 x 7 in.	3/5
20 x 9 in.	4/8	20 x 7 in.	4/5
22 x 9 in.	5/2	22 x 7 in.	4/11

BATTERY CHARGERS
 200-250 v. A.C. Will charge 6 v. or 12 v. Car Battery at 1 amp. Housed in strong metal casing. Finished in Green hammered enamel. Size: 6in. long, 3 1/2 in. wide, 3 1/2 in. high. Guaranteed 12 mths. The above unit is manufactured by PREMIER and does not contain ex-Govt. components. Plus 2/6 post and Pkg. **39/6**



BATTERY CHARGER KITS
 All incorporate metal rectifiers. Transformers are suitable for 200/250 v. A.C. cycle mains. Cat. No. 2002 Charges 6 volt accumulator at 1 amp. Resistance supplied to charge 2 v. accumulator £1 2.6
 2003 Charges 12 volt accumulator at 1 amp. £1 7.6

CHARGER TRANSFORMERS
 Input 230 v. A.C. Output 12 v. at 1 amp. Completely shrouded. Price 9/11

WEYMOUTH MINIATURE COIL PACK
 Covering Med./Long/Short wave bands. Iron cored coils, gram. position on switch. Dimens: Height, 1 1/2 in. Length 3 1/2 in. Width 2 1/2 in. Spindle length 2 in. Price 19/6

WEYMOUTH MINIATURE I.F. TRANSFORMERS
 465 Kcs, iron core, permeability tuned, 10/6 pair

MINIATURE TUNING CONDENSERS
 2 gang, .0005 mid. with trimmers 6/9

RADIO CABINET (WALNUT FINISH)
 Output dimensions: 16 1/2 in. high, 9 in. deep, 17 in. wide.

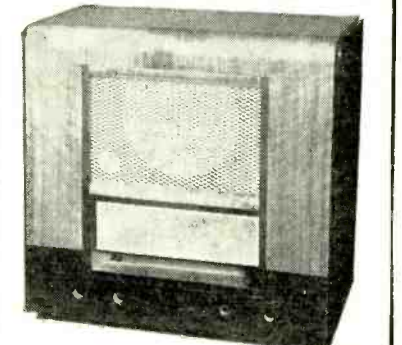

A beautifully made cabinet. £3/10/- plus 7/6 carr./pkg.

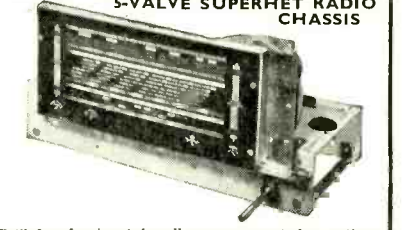

5-VALVE SUPERHET RADIO CHASSIS
 Drilled and cut out for all necessary control mountings and Mains Transformer, fitted with 6 Amphenol Octal, Valveholders, Aerial, Earth and Gramophone Sockets. 500 pf Tuning Gang Condenser, full vision drive Tuning Assembly consisting of unbreakable perspex 3-coloured scale for long, medium and short wavebands. Calibrated in metres, kilocycles and station names. Price 39/6. **AS A SPECIAL OFFER—CABINET ILLUSTRATED ABOVE AND CHASSIS, TOGETHER £5.5.0 Plus 7/6 Carr./Pkg. & Insurance.**

PREMIER RADIO COMPANY
 (Reg'd.) B. H. Morris & Co. (Radio) Limited. Estab. 40 Yrs.
 (Dept. W.W.) 207 - EDGWARE ROAD - LONDON - W.2
 Telephones: AMBasador 4033 & PADddington 3271/2.
 OPEN UNTIL 6 P.M. SATURDAYS. CLOSED 1 P.M. THURSDAYS.

Terms of Business:
 Cash with order or C.O.D. over £1. Please add 1/- for Post Orders under 10/-, 1/6 under 40/- unless otherwise stated.

ACCLAIMED BY ALL . . .
The PREMIER De Luxe PORTABLE Magnetic
Tape Recording Kit—Price £37.4.0

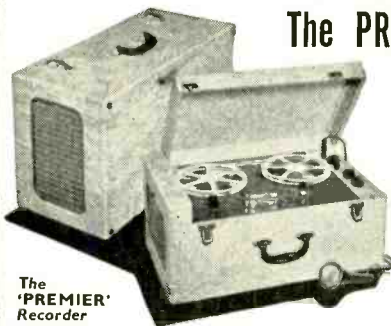

The 'PREMIER' Recorder

This Recording Outfit has been designed for use with M.C.-1-111 "SCOTCH BOY" Magnetic Tape. With this high-quality tape a frequency of 50 c.p.s. to 9,000 c.p.s. at tape speed of 7 1/2 in./sec. can be readily achieved. Additional reels of 1,200ft. can be supplied at 35/-.

INSTRUCTIONAL BOOKLET . . . 2/6
 This is credited if a complete kit of the Tape Recorder is ordered.

As is usual in all PREMIER KITS, every single item down to the last nut and bolt is supplied. The Chassis is punched and layout diagrams and theoretical circuits are included. When completed the PREMIER PORTABLE TAPE RECORDER compares MORE than favourably with any other make at double the price.

SEPARATE UNITS CAN BE SUPPLIED AS LISTED BELOW—
AMPLIFIER KIT (including 8in. Speaker) . . . £11.0.0 plus 5/- pkg./carr.
AMPLIFIER (already built, wired and tested) . . . £14.15.0 plus 7/6 pkg./carr.
LANE TAPE TABLE & REWIND SPOOL . . . £16.10.0 plus 7/6 pkg./carr.
PORTABLE CABINET (rexine covered) . . . £4.19.6 plus 5/- pkg./carr.
MICROPHONE . . . £2.19.6 plus 1/- pkg./carr.
REEL OF "SCOTCH BOY" TAPE (1,200ft.) . . . £1.15.0 plus 6d. pkg./carr.

To those unable to build this PORTABLE TAPE RECORDER we can supply it completely wired, tested and ready to plug in at **39GNS** Plus 1 gn. pkg./carr.

CRYSTAL MICROPHONE

An entirely insulated crystal microphone which can be safely used on A.C./D.C. amplifiers. High impedance. No background noise, really natural tone. The ideal Mike for tape, wire and sound projectors. Price 22/6.

MICROPHONE STAND BASE
 Heavy Moulded Black Base fitted with Standard thread adaptor. Dimensions: 7 1/2 in. across, 2 in. deep. Weight: 1 1/2 lb. Post paid 3/11.



MOVING COIL MICROPHONE

Low impedance. Incorporates press-to-talk switch. Housed in strong black bakelite case. Dimensions: 2 in. wide, 2 1/2 in. high, 1 1/2 in. deep.

Plus 1/6 post and packing **19/6**
 A matching transformer for high impedance can be supplied at 3/6 extra.



MICROPHONES

LUSTRAPHONE: Moving Coil; High Impedance. Stand Type: £5/12/6—Hand Mike £6/6/-.

RONETTE—Crystal Mike; Incorp. the Filter Cell Insert; High Imped. Ball Type: £3/19/6.
CRYSTAL MICROPHONE—Rothermel 2ADS6. Especially recommended. £2/19/6.
 Table Stands for all the above 17/6.

F. C. ROBINSON & PARTNERS LTD.

WE SHALL BE GLAD TO SEE YOU AT OUR STAND IN ROOM C1

DURING THE MANCHESTER ELECTRONICS EXHIBITION IN JULY

The eighth Annual Exhibition of the North-West Branch of the Institution of Electronics will be held at the College of Technology, Sackville Street, Manchester, from 15th to 22nd July, 1953.

F. C. ROBINSON & PARTNERS LIMITED

Sales & Showrooms: 287, DEANS GATE, MANCHESTER, 3.

Phone: DEANS GATE 6601

Factory: COUNCILLOR LANE, CHEADLE, CHESHIRE.

TELE-RADIO (1943) LIMITED

WALCHRIS

Magnetic Guitar Pick-up, complete with volume control and detachable screened cable £1 10 0

RONETTE

(088/5) Crystal Ball microphone £2 10 0
With Table Stand £3 5 0

J.B. DIAL ASSEMBLIES

Square Plane. 8-1 ratio 12 9
Airplane. 8-1 ratio 13 0
Full Vision. 8-1 ratio 13 0
S.L.S. Ratio 18-1 £1 6 6
S.L.B. Spin Wheel. Ratio 24-1 £1 7 6
Caliband Bandset, 6-1. Bandsread. 43-1 £1 1 6

GARRARD RECORD PLAYERS

"T." with crystal T.O.H. £9 14 6
"T." with Magnetic T.O.H. £9 17 10
R.C.72, crystal T.O.H. £15 2 8
R.C.75, crystal T.O.H. £15 12 8
R.C.80, crystal T.O.H. £17 3 11
201/B Transcription Motor £22 11 10

OSMOR "Q" COIL PACKS

Portable Mains or Battery £2 10 0
Medium and Long T.R.F. £2 0 0
Medium Trawler and Short Mains Superhet. £2 10 0
Long, Medium and Short Mains Superhet. £2 8 0
H.F. Stages £1 0 0
Frame Aerials M.W. 2 6

OSMOR DIAL ASSEMBLIES

L.M.S. or M.T.S. £1 4

ELAC DUOMAG FOCALISERS

F.D.12/4, Low Flux £1 17 6
F.D.14/9, Medium Flux £1 19 6
F.D.16/6, High Flux £2 2 0

18 S.W.G. ALUMINIUM CHASSIS

8in. x 6in. x 2½in. 7 6
12in. x 6in. x 2½in. 8 6
14in. x 10in. x 2½in. 11 0
17in. x 10in. x 2½in. 12 6
with reinforced corners

Large range of Transformers and Chokes in stock.

Packing and postage extra.

NOTE NEW ADDRESS:

189, EDGWARE ROAD, LONDON, W.2.

Telephone: **PADddington 4455-6**

SHOP HOURS: MON.-SAT. 9 a.m. to 6 p.m. THURS. 9 a.m. to 1 p.m.

The

"TELEMAX" TELEVISION PROJECTOR

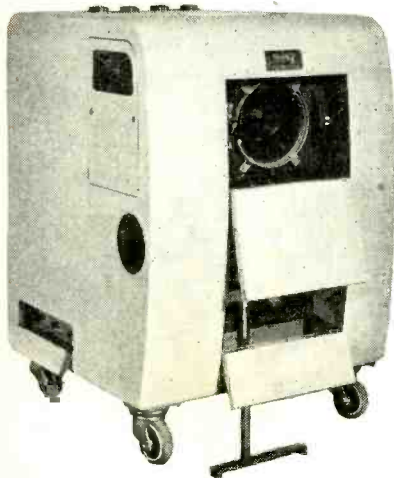

SCREEN
SIZE
4 FEET
BY
3 FEET

23 valve s/h. circuit. Sensitivity better than 50 microvolts. Full bandwidth. 4' x 3' picture. 5 channel facility. A.C. only. Insulated chassis. Neutral coloured rexine covered case, size approx. 23" x 22" x 21", fitted with castors and geared lifting jack for tilt. *Detailed Specification from the Manufacturers:—*
Complete with valves, c.r.t. and optical unit. **TELEMECHANICS LTD.**
3 NEWMAN YARD, NEWMAN ST., LONDON, W.1. LANGham 7965

TELEVISION

for "Fringe" and "Long distance" viewers is vastly improved with the SPENCER-WEST type AC/3 Pre-Amplifier. The specification includes a first stage neutralised triode cathode coupled to a grounded grid triode. The optimum arrangement for best "noise factor". Self-contained power supply unit complete with correctly adjusted interference filter. Price complete, 10 gns. from your dealer or direct. Leaflets, etc. on request.

RECEIVER CONVERSION TO NEW CHANNELS
The type AC/4 Converter units for perfect simple conversion. Price complete with 5 valves and self-contained power unit, etc., 15 gns. Available for Brighton booster on London receivers (type AC/4KL) and all other conversions. Leaflets on request.

SPENCER-WEST
QUAY WORKS, GT. YARMOUTH
Phone: Gt. Yarmouth 3009

Television • Radio • Record CABINETS MADE TO ORDER

ANY SIZE OR FINISH

CALL OR SEND DRAWINGS FOR QUOTATIONS

B. KOSKIE (DEPT. E.)
72-76 Leather Lane, Holborn, E.C.1
Phone: CHAncery 6791 & 6792

BRITAIN'S LARGEST SUPPLIERS OF QUALITY TAPE- RECORDING EQUIPMENT



SPECIAL SHOWROOMS

to permit side by side comparisons
of leading makes

PROMPT DELIVERIES • H.P. FACILITIES

It is no exaggeration to say that we have succeeded in gathering together the largest and most up-to-date selection of Tape Recording equipment in the country. Intending purchasers who can reach our premises in person will find our specially equipped showrooms exceptionally attractive. Those living farther afield can depend on our mail-order department to render maximum service with utmost expediency. Hire Purchase facilities are available on all orders for £10 or more. Full list on request.

- ★ TAPE DESKS, HEADS, MOTORS, etc.
- ★ MICROPHONES, TAPES
- ★ COMPLETE INSTRUMENTS
- ★ ACCESSORIES, SERVICE

TAPE DESKS AND RECORDERS

ITEM NO.	DESKS	CASH PRICE		DEPOSIT		12 MTHLY PAYMENTS	
		£	s	£	s	£	s
583	Qualtape	16	16	0	5	16	0
585	Lane, Mark II	17	10	0	6	0	0
586	Truvox, Mark IV	23	2	0	8	2	0
587/1	Wearite, Type 2A	35	0	0	12	0	0
587/2	Wearite, Type 2B	40	0	0	14	0	0
588/1	Bradmatic, Type 5/6RP	41	0	0	14	0	0
588/2	Bradmatic, Type 5c	45	10	0	15	10	0
588/3	Bradmatic, Type 5/6RP	42	0	0	14	0	0
588/4	Bradmatic, Type 5CL	47	10	0	16	10	0
588/5	Bradmatic, Type 5A	50	0	0	17	0	0
589	Soundmirror	33	0	0	11	0	0
590	Electrotech, R.C.7	39	0	0	13	0	0
591	Reflectograph	90	10	0	30	10	0

COMPLETE INSTRUMENTS

580/1	Wirek Portable	55	0	0	19	0	0
580/2	E.M.I. Portable	118	0	0	40	0	0
581/1	Soundmirror	79	0	0	27	0	0
581/2	Grundig	78	15	0	26	15	0
581/3	Vortexion	84	0	0	28	0	0
581/4	Pamrek	65	0	0	22	0	0
581/5	Wirek Magnograph	65	0	0	22	0	0
581/6	Grundig 2-speed	84	0	0	28	0	0
581/7	Grundig Console	95	0	0	36	0	0
581/8	Vortexion with Truvox Desk	72	0	0	24	0	0
581/9	Vortexion with Wearite Desk	84	0	0	28	0	0
582/1	Ferroglyph, Model 2A	79	10	0	27	0	0
582/2	E.M.I. Emidec	90	0	0	30	0	0
582/3	Simons, Model A	83	0	0	28	0	0
582/4	M.S.S., Type R.1	130	0	0	44	0	0
582/5	C.J.R. Portable	119	0	0	40	0	0
582/7	Reflectograph	95	0	0	36	0	0

MICROPHONES

ITEM NO.	DESCRIPTION	PRICE	£		s		d	
			£	s	£	s	£	s
554	Reslo R.V. Ribbon	7	5	0	0	0	0	
555	Reslo W.R. Ribbon	7	5	0	0	0	0	
557	Gramplan Moving-coil	5	17	6	0	0	0	
558	Rothermel D.104 Crystal	5	5	0	0	0	0	
559	Rothermel 2 A.D.56 Crystal	3	3	0	0	0	0	
560	Cosmocord Mic/30 Desk Model, Crystal	4	4	0	0	0	0	
561	Cosmocord Mic/22-1 Acos Crystal	6	6	0	0	0	0	
563	Cosmocord Mic/16-2 Acos Crystal	12	12	0	0	0	0	
564	Lustraphone C.51 Table Stand	5	5	0	0	0	0	
566	Lustraphone LX.53 Crystal	2	10	0	0	0	0	

Stands available as required.

EQUIPMENT & ACCESSORIES

ITEM NO.	AMPLIFIERS	CASH PRICE		DEPOSIT		12 MTHLY PAYMENTS	
		£	s	£	s	£	s
592/1	Lane Amplifier Kit	13	13	0	5	13	0
593/1	Elipco Junior Amplifier	16	16	0	5	16	0
593/2	Elipco Senior Amplifier	24	0	0	8	0	0
594	Bradmatic C.I. with P/P	62	0	0	21	0	0
500	Bradmatic Plate Coil						
501	Bradmatic Oscillator Coil						
502	Bradmatic Bias Rejector Unit						
506	Bradmatic 5 R.P. Heads						
507	Bradmatic 5 E. Erase Head						
508	Bradmatic 6 R.P. Heads						
510	Tapemaster Oscillator Unit wired with 6V6 valve						
511	Tapemaster Recording Head						

MOTORS

520	Collaro Clock and Anti-clockwise						
522	B.S.R. S.R.1						
523	B.S.R. F.P.10						

SPOOLS

534	Tapereels, 5in. diam.						
535	Tapereels, 7in. diam.						
526	Tapereels, Plastic, 7 1/2 in. diam.						
529	Tapereels, Plastic, 8 1/2 in. diam.						

TAPES

567	Scotch Boy, 1/2 in. x 300ft. 5in.						
568	Scotch Boy, 1/2 in. x 1,200ft. 7in.						
569	Emitape, H6/16, 600ft.						
570	Emitape, H6/12, 1,200ft.						
571	Emitape, H6/12, 1,200ft.						
572	G.E.C. Plastic, 1,200ft.						
573	Gavert, 1,200ft.						
574	Agfa, 1,200ft.						
575	Magnetophon, 1,200ft.						
576	Wearite P. Tape, 1,200ft.						

In the event of there being any differences between prices quoted here and those quoted by the manufacturers, the latter shall be deemed operative at time of ordering.

★ CLASSIC SERVICES INCLUDE

- AMPLIFIERS—Wide selection by Leak, Acoustical, Rogers, Goodsell, Decca, etc., always in stock.
- PICK-UPS—Decca, Leak, Acos, Connoisseur. Also standard styli for same.
- LOUDSPEAKERS—All leading makes from a 5in. tweeter to Vitavox Klipschorn in stock.
- TELEVISION—The best large-screen projection types; also all parts for Tele-King, Tele-Viewer, etc.

FOR
QUALITY
FIRST



FREE LISTS

THE CLASSIC ELECTRICAL

CO., LTD. 352/364, LOWER ADDISCOMBE ROAD,
CROYDON, SURREY.
Telephone: ADDISCOMBE 6061-6062.

We shall be glad to forward you latest "Classic" lists of Quality Equipment on request and fuller information about any lines in which you may be specially interested. Please let us have your enquiries.

MODERN ELECTRICS LTD.,

164, Charing Cross Road, London, W.C.2.

'phone : TEMple Bar 7587.

Export enquiries welcomed.

Immediate delivery from stock.

Prompt attention to post orders.

TAPE RECORDERS

SOUNDMIRROR

New Table, Twin Track £69 10 0

Portable Twin Track £74 10 0

SCOPHONY-BAIRD

New Model Mk. 2 ... £68 5 0

SIMPHONIC

New Model 1A £83 0 0

GRUNDIG

2-speed £84 0 0

EMICORDA £94 10 0

WIREK

Portable Battery

Model £55 0 0

RECORDING TAPE

GRUNDIG

L.G.H., 1,200ft. £2 0 0

SOUNDMIRROR

Paper Tape, 1,200ft. £1 5 0

FERROVOICE

Spare Spools £1 2 6

E.M.I.

H.60, 1,200ft. £1 15 0

E.M.I. H.60, 600ft. £1 1 0

E.M.I. H.65, 1,200ft. £1 15 0

E.M.I. H.50, 1,200ft. £2 8 0

SCOTCH BOY

1,200ft. £1 15 0

600ft. £1 1 0

Spare Spools, 1,200ft. 4 3

Spare Spools, 600ft. 3 3

FERROGRAPH

1,200 ft. £2 5

1,750 ft. £3 3 0

9" spools 9 0

6

RECORD REPRODUCING EQUIPMENT

B.S.R.

3-sp. (Crystal T/O. hds.) £9 4 11

3-sp. (with 2 GP20 hds.) £10 8 8

3-sp. (with 2 Decca hds.) £12 17 8

3-sp. Auto-mixer ... £16 10 3

GARRARD

R.C.80, less Head ... £15 3 3

R.C.75A, less Head... £13 10 0

S.201.B Variable 3-sp. Transcription £22 14 8

CONNOISSEUR

3-sp. Deck £21 16 3

GOODMANS

Axiom 150 Mk. 2 ... £13 11 5

Axiom 60 £11 10 0

Axiom 101 £6 12 1

Axiom 102 £9 18 2

WHARFEDALE

W.12.CS £13 3 3

Golden 10 C.S.B. ... £8 6 7

Super 5 and 8 CS/AL £6 13 0

Bronze 10in. £4 12 9

Bronze Bin. £3 4 0

W.B. Crossover Unit... £1 6 6

W.B. Tweeter Unit ... £3 15 0

TEST GEAR

AVO

Model 8 £23 10 0

Model 7 (latest) £19 10 0

Unimior £10 10 0

Electronic Meter £40 0 0

Wide Band Sig./Gen. £30 0 0

Valve Characteristic Meter..... £60 0 0

D.C. Minor £5 5 0

10kV. Multiplier for Model 8 £2 5 0

Carrying Cases for Models 7, 8 and 40 ... £3 0 0

ADVANCE

H.1 (Sig./Gen.) £25 0 0

E.2 (Sig./Gen.) £28 0 0

J.I. New Model £25 12 0

COSSOR

Oscillograph 1039M.

New Portable Model £29 10 0

TAYLOR

ALL NEW TAYLOR TEST

GEAR IN STOCK AND AVAIL-

ABLE ON H.P. Send S.A.E.

for Catalogue and Terms.

PICK-UPS

ACOS

G.P.20 (Std. or L.P.) £3 6 1

Spare heads for above £2 0 0

G.P.30 L.P./Std. £3 6 1

DECCA

X.M.S. Magnetic £6 9 5

CONNOISSEUR

Super Lightweight, L.P./Std. £9 5 6

Spare Heads £3 6 3

VALVES

We are one of London's Largest stockists — Please write for requirements.

MICROPHONES

ACOS

Mic 22 (Crystal) £6 6 0

Mic 22 (head only) ... £4 10 0

Mic inserts for above £1 7 6

Mic 16 (Crystal) £12 12 0

Mic 30 (Crystal) £4 4 0

LUSTRAPHONE

M/C with T/F.C.51 ... £5 15 6

M/C less T/F.C.51 ... £5 5 0

Heavy Table Base for above £1 1 0

Hand M/C with T/F CH.51 £5 15 6

Hand M/C less T/F CH.51 £5 6 0

RESLO M/C (Low Imp.) £6 0 0

RIBBON £7 5 0

FLOOR STAND

(Mic), 3 extensions... £3 12 6

LEAK AMPLIFIERS

Point 1, TL12 £28 7 0

Point 2, TL25 £34 7 0

Vari-slope pre-amp ... £12 12 0

R.F. Tuner Unit Type VS £34 19 0

"R.D. BABY DE LUXE "

New Model Pre-amp. £22 10 0

TAPE DECKS

WEARITE 2A (limited stock), with complete instructions for Associated Amplifier, £35 0 0, carriage extra.

Colossal Purchase of EXPORT SURPLUS Auto-Changers

SEVEN TYPES

With choice of magnetic or crystal heads

PRICES from

£7-10-0 to £13-10-0 Tax paid

SHOWING NEARLY 40% REDUCTION

Full list of models available on request.

Cash or Easy Terms.

FRITH RADIOCRAFT LTD.

69-71 Churchgate - - - LEICESTER

Phone : 58927

direct TV

REPLACEMENTS

(Proprietor: A. Rose)

134-136, LEWISHAM WAY, NEW CROSS, S.E.14

Tel: TIDEWAY 3696-2330

SOBELL T107-T89 LINE o/p Transformers	47/6d.
" T120 LINE o/p Transformer	72/0d.
PHILCO 1707-1708 LINE o/p Transformer	40/6d.
C.R.T. Heater Isolating Transformers, high quality, low capacity, state voltages required.	26/6d.
RADAR KILOVOLTAGE 3-30kv.	78/6d.

ALL PRICES INCLUDE PACKING & POST

Annual Holidays: 27th July to 3rd Aug.

TRANSFORMERS COILS CHOKES

PLEASE NOTE THIS COMPANY'S
NAME CHANGED FROM
RADIOMENDERS LTD. TO
ELECTRO-WINDS LTD.
ON THE 4th MARCH, 1953

SPECIALISTS IN

FINE WIRE WINDINGS
MINIATURE DEAF AID TRANSFORMERS, PICK-UP
CLOCK AND INSTRUMENT COILS, ETC.

ELECTRO-WINDS LTD.

123-5-7 PARCHMORE ROAD, THORNTON HEATH, SURREY
LIVINGSTONE 2261 EST. 1933

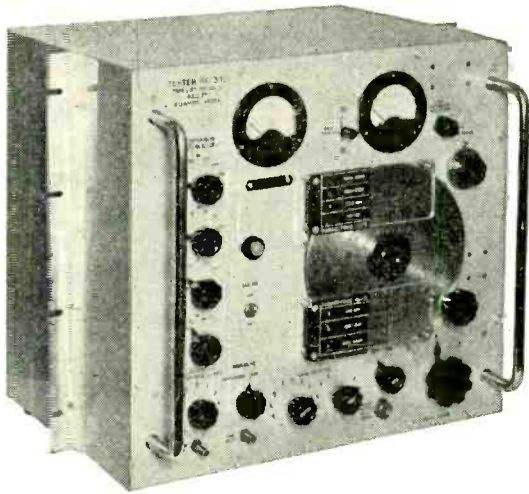

SELECTIVE TRANSMISSION MEASURING SET MODEL RP 3110

Designed and manufactured for G.P.O.

This is a precision instrument for measurements on multi-circuit coaxial cable carrier systems by means of a comparison with locally generated signals of known frequency and level.

Frequency coverage : 60 Kc/s—3 Mc/s in 7 ranges.

Calibration accuracy : below 0.2% or 2 Kc/s whichever is the greater.

Power supplies:
200 — 250 Volt. 50 c/s

Range of measurements:
through levels + 10 db to - 61.5 db
or terminated levels + 10 db to - 81.5 db
referred to 1mW in 75 ohms

BRITISH COMMUNICATIONS CORPORATION LTD.

SECOND WAY, EXHIBITION GROUNDS, WEMBLEY, MIDDX.

Telephone: WEMBLEY 1212

Cables: BEECEEE, WEMBLEY

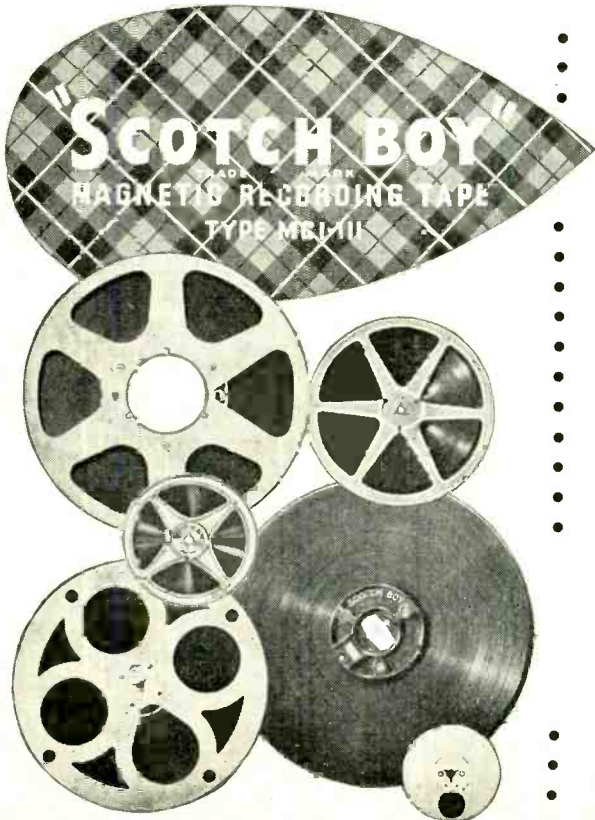

fidelity at all speeds uniformity within ± 0.5 db

Two features of this plastic backed, medium coercivity tape which makes it an essential factor in high quality tape recording. 'Scotch Boy' is now made in 6 reel sizes offering a wide range of playing times for private or professional use, with all makes of tape recorders. *Used by the BBC.*

Magnetic Data

Coercivity 250 Oersteds.

Total Remanent Flux 0.4/0.5 lines $\frac{1}{4}$ " width.

Uniformity within a reel ± 0.5 d.b.

Frequency Range

50 c/s to 10 kc/s at a playing speed of $7\frac{1}{2}$ in/sec.

ANOTHER **3M** COMPANY PRODUCT

Write for further particulars to:

MINNESOTA MINING & MANUFACTURING CO. LTD
167 STRAND, LONDON, W.C.2 TEMple Bar 6363

from Hairspring torque testing

to guided Weapon Research

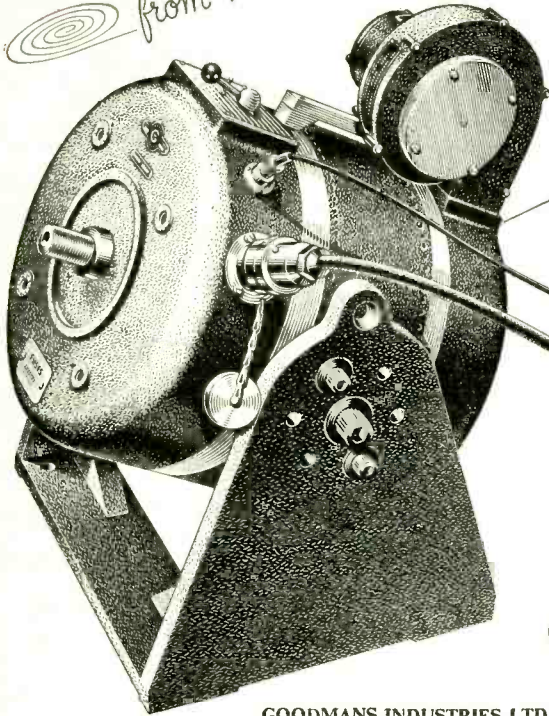

GOODMANS VIBRATION GENERATORS

play their vital part

Some typical applications:

- FATIGUE TESTING
- ELECTRICAL COMPONENT TESTING
- VALVE MICROPHONY TESTING
- TORSIONAL VIBRATION TESTING
- FLEXURE TESTING OF PLASTICS, ETC.
- MECHANICAL STRUCTURE TESTING
- SPECIALISED GUIDED WEAPON RESEARCH
- or wherever ACCURATE CONTROL OF FREQUENCY AND AMPLITUDE is demanded



Illustrated are the Model 8/600 that develops a force of ± 300 lbs and the midget Model with a force output of approximately ± 2 lbs for optical-cell research and hairspring torque testing, etc.

GOODMANS INDUSTRIES LTD · AXIOM WORKS · WEMBLEY · MIDDX · Phone : Wembley 1200 (8 lines)

HANNEY of BATH offers

CATHODE RAY TUBES. All prices include tax.

MULLARD	
MW6-2, projection tube.....	£8 6 10
MW22-16, 17 or 18, 9in.....	£12 10 3
MW31-16, 17, 18 or 74 (grey filter screen), 12in.....	£16 13 8
MW36-22 and 24, 14in. rectangular.....	£19 9 3
MW43-64, 17in. rectangular.....	£23 12 8
BRIMAR	
C.12B, 12in. aluminised.....	£17 14 6
C.12FM, cathode with ion trap.....	£16 13 8
C.14BM, 14in. rectangular, aluminised.....	£20 10 0
C.17BM, 17in. rectangular, aluminised.....	£24 13 6
MAZDA	
CRM.122 and CRM.121B, 12in.....	£16 13 8
CRM.123, 12in. aluminised.....	£17 14 6
COSSOR	
I21.K, 12in.....	£16 13 8
85.K, 15in.....	£20 17 0
FERRANTI	
T12/44, T12/54, T12/91 and T12/92, 12in.....	£16 13 8
G.E.C.	
6504A and 6505A, 9in. aluminised.....	£13 11 1
6705A and 6706A, 12in. aluminised.....	£17 14 6
7102A, replaces 6705A, 12in. aluminised.....	£17 14 6
ENGLISH ELECTRIC	
T900, T901 and T901B, 16in.....	£22 4 10
Ion Traps for all the above tubes (where applicable), each.....	5 0
Please add 10/- carriage, packing and insurance to all tube prices, any excess being refunded. All tubes despatched per passenger train at Railway's risk.	
AVAILABLE SHORTLY. Constructors envelopes for the new WIDE ANGLE VIEWMASTER and the SOUNDMASTER TAPE RECORDER, both being designed by the designer of the Viewmaster. May we send you details?	
VIEWMASTER, TELEKING, MAGNAVUE and WILLIAMSON AMPLIFIER. All components still available as previously advertised. Send 6d. in stamps for our new COMPONENTS CATALOGUE now.	

L. F. HANNEY

77, LOWER BRISTOL ROAD, BATH

Tel. 3811

WILL BUY any U.S. surplus radio parts, equipment

* APN-9, TS-67, R-89B/ARN-5, ARC-1, ARC-3, ART-13, BC-221, BC-348, SCR-522, MN-53, MN-61, RA-1, MN-31, MI-32, ARN-7, Headsets, Mikes, Cannon Amphiehol plugs, 274-N, ARC-5, Dynamotors, Test sets, "TS-" or "1-" prefixes.

State condition and Best Price
Aircraft Radio Industries, Inc,

85 St. John Street, New Haven, Conn., U.S.A.

PRATTS RADIO 1070 Harrow Road, London, N.W.10

(Nr. Scrubs Lane)

Tel.: LADbroke 1734



MODEL AC10E £10/7/6.

AMPLIFIERS
College general-purpose units. MODEL AC10E, 4 valve, 10 watts. Neg. feedback. £10/7/6. MODEL AC15E, 6 valve 15 watts P/P output. Feedback over 3 stages, £15/15/-. MODEL AC32E, 32 watts P/P output. Feedback over 3 stages. £18/18/-. MODEL U10E, for D.C./A.C. mains, 6 valve P/P output. Feedback over 3 stages. £12/19/6. All are COMPLETE WITH CASES and chrome handles. They have SEPARATE microphone stage, SEPARATE mike and gram. inputs allowing MIXING of speech and music. Input voltages average .003 mV and .3 gram. Outputs match 3, 8 or 15 ohm speakers. MODEL Q8C, 5-valve unit with Bass and Treble controls. P/P output of 9 watts. This amplifier incorporates an 18 section O/Transf., variable feedback from zero to 25 db. Output impd. 3.6 to 230. Complete chassis. £13/19/6. MODEL Q4C, 4 valve 4 watt unit Bass and Treble controls. Variable feedback. O/Imp. 3 to 15 ohm. Chassis complete, £9/15/-. Complete range of accessories available. Send stamp for lists. All amplifiers are ready for use.

ADCOLA

PRODUCTS LIMITED
(Regd. Trade Mark)

SOLDERING INSTRUMENTS



Standard model $\frac{3}{16}$ " bit (illustrated)

SOUND JOINTS
for all
SOUND EQUIPMENT

Types are available for
Factory Bench
Line, Maintenance
Engineer & Home
Constructor

Supplied for any volt range to meet our world-wide consumers demands

- Heating time: 90 seconds.
- Consumption: 25 watts.
- Weight: 4 ozs.
- High temperature.
- Handle unaffected by element temperature.
- Length of instrument: 9".
- Equally suitable for daily or intermittent use.

- $\frac{7}{8}$ " dia. bit Standard Model.
- $\frac{1}{2}$ " dia. bit Standard Model.
- $\frac{3}{16}$ " Detachable bit Type (Factory Bench Line).

Made in England
Registered Design (British, U.S.A.,
Canadian) and Foreign Patents.

● Apply Sole Manufacturers and Suppliers

ADCOLA PRODUCTS LTD.

Sales Offices & Works: CRANMER COURT, GLAPHAM
HIGH ST., LONDON, S.W.4. MACaulay 4272



SIGNAL GAIN

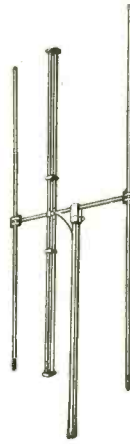

is important when you realise that the quality of the television picture is entirely dependent on the efficiency of the aerial system. Using an inefficient aerial is like running a good motor car on inferior petrol—the final performance suffers. That is why we advocate the careful selection of the aerial type, the use of good quality downlead and the aerial installed correctly. These

are the reasons why you should specify an Aerialite aerial, accessories and downlead.

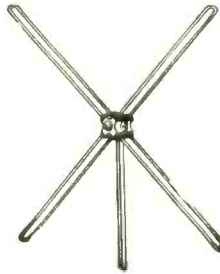

THE AERIALITE TV AERIAL RANGE

includes all types from the "fringe" (Aerfringe, Aerbeam) to the indoor dipoles for starting board mounting (Aeradoor). The prices are from 13/6.

AERIALITE ACCESSORIES

include lightning arrestors, connector and matching boxes, mains and car ignition suppressors, coaxial plugs and sockets—the latter are specified and used by a large percentage of the television receiver manufacturers.

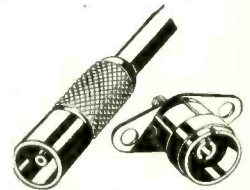

AERIALITE CAR AERIALS include

Model 6 side fitting, telescopic, chromium plated	£2 2 6
Model 8 under car fitting (large).....	£1 18 6
Model 9 under car fitting (small).....	£1 7 0
Model 16 mudguard fitting, telescopic, chromium plated	£3 3 0
Model 17 header fitting, telescopic, chromium plated	£1 12 6

Please send for details of our products to:
Aerialite Limited, Castle Works, Stalybridge, Cheshire.

AERIALITE Aerials

SHORTAGE OF RADIO and T/V ENGINEERS

There is an assured well-paid future for those trained and willing to train in electronics, radar and radio. Modern industrial techniques demand more and more highly trained personnel and the gap between demand and supply is still widening.

This is your opportunity — write for our free brochures giving full details of courses to:

E.M.I. INSTITUTES

DEPT. 16R, 10 PEMBRIDGE SQUARE, LONDON, W.2.

Telephone: Bayswater 5131/2.

The College associated with a world-wide electronics industry.

1 YEAR COURSE

We offer full-time day course for one year in the Principles and Practice of Radio and Television.

Next course commences
24th August, 1953.

3 YEAR COURSE

This course in Telecommunication Engineering includes one year's Factory attachment.

Next course commences
24th August, 1953.

Associated with

'H.M.V.'

**MARCONIPHONE
COLUMBIA**

etc.

1A9

SPECIAL PRODUCTS

Government Departments in all parts of the world who experience difficulty in obtaining QUICKLY transmitter equipment to the special requirements are continually approaching us to assist.

We are in a position to supply at very short notice small quantities of complete Transmitters covering say, 2-18 mc/s with outputs of 50 watts, 150 watts, 350 watts and 500 watts.

STILL AVAILABLE

From stock R.C.A. Transmitters Type ET.4332, ET.4336B & K, and T.1131 VHF, reconditioned and complete with Valves.

Send brief specification of requirements and every endeavour will be made to meet it speedily and efficiently.

McELROY-ADAMS MFG. GROUP LTD.

(Sole concessionaires U.K. for Hallcraft Communication Equipment)

46, GREYHOUND ROAD, LONDON, W.6

Cables: Hallicraft London.

Phone: Fulham 1138/9



RELAYS AND KEY SWITCHES



LARGEST EX-GOVT. STOCK IN GT. BRITAIN

Types 600-3000 Relays—Siemens High Speed
Also A.C. 400 volts 50 cycles

Uniselector Switches, Telephone Switch-Boards, Telephone Components,
Plugs, Jacks, Handsets—Government Contractors.

JACK DAVIS (RELAYS) LTD. (Dept. W.)
36 PERCY STREET, LONDON, W.1

Phones: MUSEum 7960, LANGham 4821

MAGNETIC RECORDING

Tape Desks; Record/Playback Amplifiers
Cabinets: (Console, Table & Portable). Rewind Spools. Tapes & Microphones.

Send for Constructor's Envelope

- Many Bargain Lines in Radiogram & Record Playing Equipment:—
- Single & 3 Speed Autochangers & Single Playing Units.
- Plug-in Pick-Ups & Complete Boxed Pick-Ups.
- Polished Walnut "Standard Console" & Drop Front R.G. Cabinets

Send for Hints on "Make Yourself a Radiogram at approx. Half

Present Day Price"

We also hold large stocks of "Viewmaster" & Tale-King Components, including many items for the big picture enthusiast. Detailed list available on request.
15" C.B. Tubes—E.H.T. Boost Circuits—Wide Angle Scanning Components, e.g. 12" Console Model T.V. Cabinet Size 19" wide x 37" high x 16 1/2" deep. Price £7.
Send now for monthly Bulletin of special bargain lines in Electronic equipment—Export Enquiries welcomed and given immediate attention. *Traders only supplied.*



V.E.S. WHOLESALE SERVICES LTD.

11 GUNNERSBURY LANE, ACTON, W.3. Telephone: ACOrn 5027

NEW MODELS with EXTRA features!

Superlative achievements in recorder design, these new Reflectograph models have the following extra features: Three heads. Provision for monitoring from tape during recording. Record level by meter. Two alternative inputs: (a) used with Radio Feeder Unit, Gramophone Pick-up and Ribbon Microphone for orchestral recording; (b) Incorporating High Gain built-in Pre-amplifier, for use with Ribbon Microphone for special recordings. Separate output 100 m/V equalised for feeding external amplifiers. Tape Speeds shown on calibrated dial. Continuously variable between 3½ in. and 8½ in. per sec. 10½ in. Elliptical Loud Speaker.



Educational and Industrial Model

Robust steel case with instrument grey crackle finish. Chromium lifting handles. Detachable lid.



For the Home

Attractively covered with crocodile leather cloth. Strongly made wooden case. Black handles.

EITHER MODEL 83 gns.

Ribbon Microphone £9.

Matched Radio Unit £10, plus P.T.

Reflectograph



MAGNETIC TAPE RECORDERS

Increased output now permits supply of Tape Drive Mechanisms as separate Units at £34 each. Special terms for quantities. Write for details.

Manufactured by RUDMAN DARLINGTON (ELECTRONICS) LTD. Wednesfield, Staffs. Tele. Wolverhampton 31704

2535

SAVE TIME AND MONEY—BUY ONE INSTRUMENT

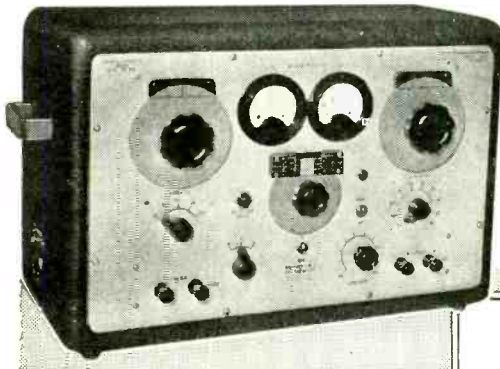

Get quick accurate readings

Resistance

Capacity

Inductance

RESISTANCE: 0.1 to 1,000,000 ohms. 0.1 to 11 continuously variable plus nine-stage decade resistance gives 50 ft. scale length. Measured at D.C.

CAPACITY: 10 p.f. to 1,000 mfd. 10 to 1,100 p.f. infinitely variable plus nine steps if 1,000 p.f. Measured at 1,000 cycles.

INDUCTANCE: 10 microhenries to 1,000 henries. 10 to 1,100 microhenries infinitely variable plus nine steps if 1,000 microhenries. Measured at 1,000 cycles.

MODEL UB 202 UNIVERSAL IMPEDANCE BRIDGE

Accuracy to $\pm 1\%$

BRITISH INSTRUMENT INDUSTRIES EXHIBITION

OLYMPIA-LONDON JUN. 30-JUL. 11 '53

STAND NO. 1 A

Everyday needs are catered for fully by this one compact, robust, high-quality instrument. It incorporates a valve oscillator giving 1,000 c/s and a visual null detector preceded by a two-stage tuned amplifier, whilst provision for passing current through

coils under test is also made. Both meters have overload protection.

Whether your field lies in experimental, production or service engineering, this instrument will prove an indispensable aid. Please write for full specification.

BRITISH PHYSICAL LABORATORIES LTD

Tel: RADLETT 5674-5-6



Radlett HERTS

NOW — regarding this question of LP . . .

MANY THOUSANDS have already extended their record reproducers to include the revolutionary Microgroove Records, and many thousands more will feel the need to do so now that H.M.V. also have entered the LP field. To these people we wish to point out that there is more in Long Playing Reproduction than meets the eye . . . there is plenty of scope for buying unsuitable equipment which does not match your existing equipment. We beseech you, therefore, to avail yourself of our Free Technical Guidance Service before spending good money on AMPLIFIERS, RADIO FEEDER UNITS, GRAM UNITS, AUTO-CHANGERS, BASS REFLEX CABINETS, SPEAKERS, etc. It will cost you nothing and will undoubtedly save you time, trouble and money. Our chief engineer is available to callers from 11 a.m. to 6 p.m. daily, including Saturdays. If you cannot call let us have your enquiries by post—they will receive immediate attention.

A word in the ear of those who have been used to fibre needles. All the single-record Gram Units and Auto-changers recommended and supplied by us can be supplied with pickup head to take standard or miniature thorns for 78 r.p.m. if preferred.

N.R.S. "SYMPHONY" AMPLIFIERS, fitted with the patent "three-channel system," giving independent control of Bass, Middle and Top, thus affording the maximum possible control of tone and compensation for recording deficiencies. Especially essential when mixing the playing of old and new 78's with the new LP records. Scratch control and negative feedback also incorporated. Woden transformers. 5-watt model only 10 gns. 10-watt model (push-pull triodes), 15 gns. Carr. 5/-. When ordering, state output impedance required if known.

GARRARD 3-SPEED AUTO-CHANGERS, Model RC80A. The very latest model, normally only available for export. We consider ourselves very fortunate to be able to offer this finest of all auto-changers, fitted with special pick-up arm to take two separate DECCA or ACOS HEADS, from stock at present. (Not to be confused with auto-changers fitted with turnover pick-up.) INTERCHANGEABLE on motor-board with previous models. Price £15/3/3. Or Special Offer complete with pair Acos GP19 and GP19LP heads, £19/5/-, or two Decca XMS heads, £20/10/-. Carr. and pack. 5/-. Advice re heads if required. Substantial

rexine-covered portable case to house above, 90/-, carr. 5/-. Extra P.U. Head to take thorn needles for playing your old 78's if required, 30/- and 35/-.

MODEL RC75A, current model, same specification as above but finished in attractive beige hammer-finish instead of dark brown. Also, 7in. record Centre-Spindle optional at 20/9 extra instead of obligatory. Our special offer: £13/10/-, or with two Acos heads, £17/10/-, or two Decca XMS, £18/15/-, carr. 5/-. Extra. Extra heads for thorns, 30/- and 35/-. Complete in de luxe portable case with locks. £5 extra.

"SYMPHONY" BASS REFLEX CABINET KITS, 30in. high, consist of fully-cut 2-in.-thick, heavy, inert, non-resonant patent acoustic board, deflector plate, felt, all screws, etc., and full instructions. 8in. speaker model, 85/-; 10in. speaker model, 97/6; 12in. speaker model, £5/7/6. The design is the final result of extensive research in our own laboratory and is your safeguard of optimum acoustic results. Carriage 7/6. Ready built, 7/6 extra.

SPEAKERS AT PRE-TAX PRICE. We are pleased to be able to offer from our large

pre-tax stock the fine 12in. 10-watt P.M. speakers by Gramplan. Price £7 each, plus carriage 5/-.

DECCA 3-SPEED GRAM UNIT, incorporating selected motor and turntable cushion-mounted on brown unit plate with XMS pickup arm to take latest 3-pin plug-in pickup heads. Units supplied with springs for floating plate on wooden motor-board. Our special offer: £7/10/-, or complete with two Decca XMS Heads, £12/15/-, or with Acos GP19 and GP19LP, £11/10/-. Post and packing 2/6.

GARRARD 3-SPEED GRAM UNITS, Model TA, for A.C. In stock at long last. Complete with plug-in turnover Magnetic or Astatic Crystal Pickup Head, £10/5/-, post paid.

CONSOLE AMPLIFIER CABINETS, 33in. high, lift-up lid, take Gram Unit or Auto-changer, Amplifier and Radio Feeder Unit, finished medium walnut veneer. Price 8 gns., also de luxe version, £10/5/6, carriage extra. Bass Reflex Cabinets to match available. Details 2½d.

COMPLETE RECORD PLAYERS, single-record and auto-change. Send for catalogue giving details of our single-record and auto-changing models at bargain prices combined with technical excellence.

RECORD PLAYER CASES, rexine covered, ex Manufacturer. To clear, 39/6 each.

NORTHERN RADIO SERVICES

16 KINGS COLLEGE RD., ADELAIDE RD., LONDON, N.W.3. Phone: PR1mrose 8314

Tubes: Swiss Cottage and Chalk Farm. Buses: 2, 13, 113, 31, 187.



Quartz Crystals of any shape and size cut and ground precisely to specification and coated, if required, with Gold, Silver, Aluminium or Rhodium, etc.

BROOKES CRYSTALS LTD.

Suppliers to Ministry of Supply, Home Office, etc.
10, STOCKWELL STREET, GREENWICH, LONDON, S.E.13
Phone: Greenwich 1828
Grams: Xtals Green, London. Cables: Xtals, London

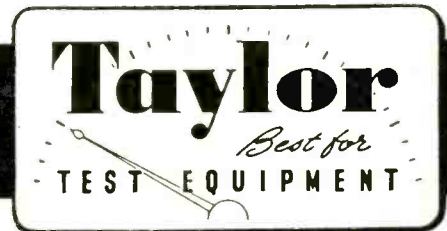

Please write for our illustrated catalogue . . .

TAYLOR ELECTRICAL INSTRUMENTS LTD.
MONTROSE AVENUE, SLOUGH, BUCKS.

TRADE ONLY

WE hold large and comprehensive stocks of all types Radio Components. Your enquiries are invited for condensers, resistors, volume controls, fuses, valve-holders, headphones, etc., etc., also new surplus valves.

Ring MUS. 5929-0095, for immediate attention.

R. C. SERVICES (RADIO)

117, CHARLOTTE STREET - LONDON - W.1.

NEW

EGEN MINIATURE POTENTIOMETERS



TYPE 105

Designed to meet the demand for Egen reliability within the smallest possible compass, these exceptionally small carbon potentiometers ($\frac{1}{8}$ " diameter) retain all the desirable features of their standard-size counterparts. The special Egen carbon deposition process ensures a highly stable resistance element of extreme durability.

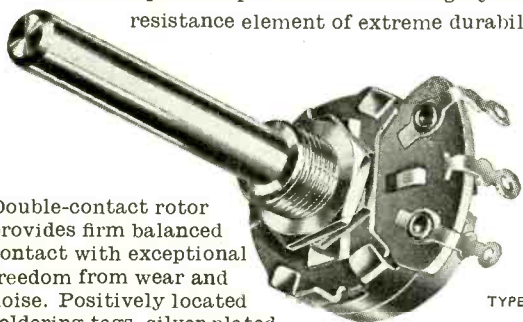

TYPE 115

Double-contact rotor provides firm balanced contact with exceptional freedom from wear and noise. Positively located soldering tags, silver plated for easy soldering. All steel parts rustproofed. Standard resistance values available, from 5000 ohms to 2 megohms.

Type 115 is identical to Type 105 except that a 2-pole Q.M.B. switch is incorporated.



SUB-MINIATURE VOLUME CONTROLS
For use in Deaf Aids and other miniature electronic apparatus

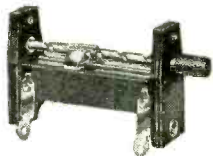

PRE-SET RESISTORS
A wire-wound pre-set resistor for panel or chassis mounting

Export enquiries welcomed



EGEN ELECTRIC LTD., CHARFLEET INDUSTRIAL ESTATE, CANVEY ISLAND, ESSEX

PHONE: CANVEY 691-2

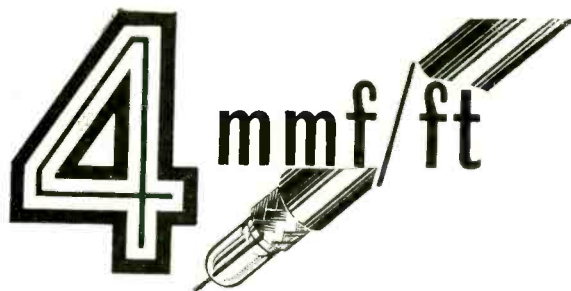

AIR-SPACED ARTICULATED CO-AX CABLES

offer a unique combination of

- ✓ FRACTIONAL CAPACITANCE
- ✓ HIGH IMPEDANCE
- ✓ MINIMUM ATTENUATION

ALONG WITH

- ✓ EXCEPTIONAL FLEXIBILITY
- ✓ LIGHT WEIGHT

38 STOCK TYPES

FOR ANY OF YOUR STANDARD OR SPECIAL APPLICATIONS

A few of the very low capacitance types are:

Type No.	Capacit. $\mu\mu$ F/ft.	Impedance ohms	O.D.
C.44	4.1	252	1.03"
C.4	4.6	229	1.03"
C.33	4.8	220	0.64"
C.3	5.4	197	0.64"
C.22	5.5	184	0.44"
C.2	6.3	171	0.44"
C.II	6.3	173	0.36"
C.I	7.3	150	0.36"



138a CROMWELL ROAD, LONDON, S.W.7



WORLD'S MOST WANTED AUTOCHANGER



Music lovers everywhere are demanding the Monarch—the new idea in automatic record changers. Never before have they had such fidelity of tone; completely automatic selection of all records—12", 10" and 7"; such ease of operation and unflinching reliability.

Many leading set makers fit the Monarch as standard—your request for information will bring full details by return.

Birmingham Sound Reproducers Ltd., Old Hill, Staffs. Grams: 'Electronic Old Hill, Cradley Heath.'

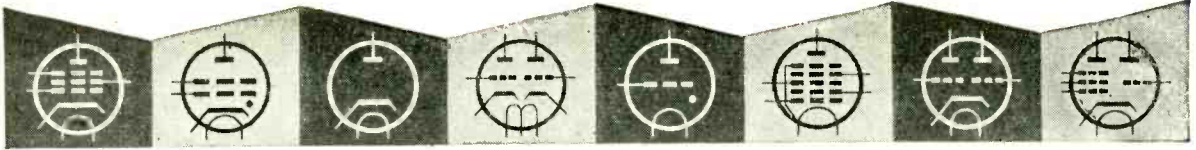

VALVES, TUBES & CIRCUITS

7. WIRING CONSIDERATIONS WHEN USING HIGH GAIN VALVES AT HIGH FREQUENCIES

The published figures for input damping usually refer to the valve alone; for instance, for the EF80 the input damping is $10k\Omega$ at 50 Mc/s. The effective input damping of an EF80 in the lay-out illustrated is, however about $3.9k\Omega$ at 50Mc/s, due to the inevitable small reactances introduced by leads and by the inductive reactances of the decoupling components. At frequencies above 20-30 Mc/s leads even $\frac{1}{4}$ " in length form appreciable reactive elements. Reduction of lead lengths cannot however be pursued indefinitely, so that a compromise is usually adopted between unnecessarily long leads and lead lengths which would involve difficulty during mass production and servicing of the equipment.

DESIGN HINTS. The cathode and screen electrodes should be well decoupled for optimum results. Furthermore, the cathode capacitor can be made to resonate with its own series inductance and the inductance of the cathode lead so as to offer a negligible impedance at the frequency under consideration. This method, however, is likely to depend critically upon the type of capacitor used; for instance, the performance with a 500 pF mica capacitor might be different from that experienced with a ceramic capacitor of the same value.

In some cases it is desired to vary the grid-to-cathode bias on the valve in order to achieve a measure of gain control. Unfortunately, as the gain is reduced there is a simultaneous increase in the effective parallel input damping resistance. The input capacitance is also reduced in value. The bandwidth and the resonant frequency of the grid tuned circuit may therefore change as the gain is altered. This effect can be minimised, however, by the introduction of a critical amount of negative feed-back in the cathode circuit of the valve. This is usually achieved by leaving a portion of the bias resistor undecoupled. For the EF80 it is suggested that an undecoupled 33Ω resistor should be connected to the cathode pin of the valve-holder, the remainder of the cathode resistive load, i.e. a 150Ω resistor being decoupled to chassis in the usual way. This circuit introduces a loss of approximately 2 dB per stage.

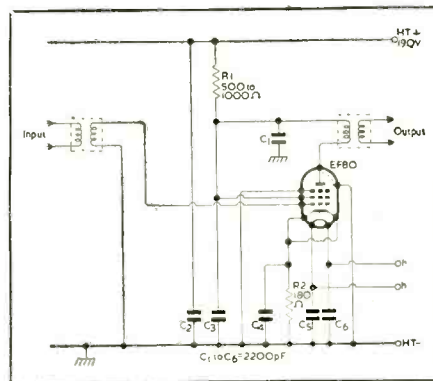
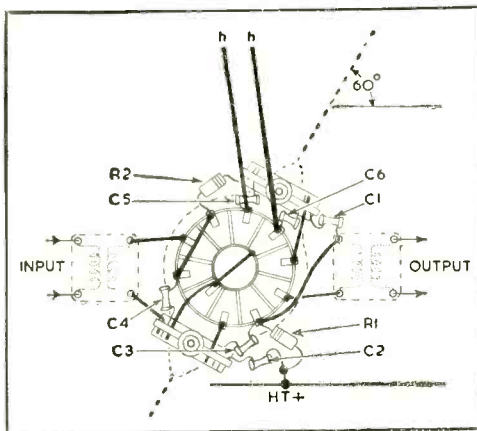

Fig. 1. Example of Wiring Layout.
Fig. 2. Circuit Diagram corresponding to Fig 1.

Reprints of this advertisement, together with additional practical hints, may be obtained free of charge from the address below.



MULLARD LTD., Technical Publications Department, Century House, Shaftesbury Avenue, London, W.C.2.

BRIMAR VALVES

for **VHF**

and **UHF**



For work in the higher frequency ranges Brimar types 5763 and 12AT7 are becoming increasingly popular. These performance details will give you some idea of their scope.

Type 12AT7

This high-slope double triode with separate cathodes is an excellent frequency-changer, oscillator, grounded grid or grounded cathode RF amplifier up to the 460 Mc/s band.

Frequency changer. With a conversion conductance of 2.5 mA/V., the 12AT7 at 430 Mc/s. gives a conversion gain of 5db. with a noise factor of 10, thus offering distinct advantages over a diode mixer at these frequencies.

Oscillator. Up to 500 Mc/s. With lines as the tuned circuit, the two halves in push-pull will deliver approx. 2 watts RF at 400 Mc/s.

Grounded grid R.F. amplifier. In push-pull grounded-grid operation the input impedance is approx. 300 ohms, thus matching to 300 ohm balanced feeder is simple. A single-ended amplifier using one half only gives at 200 Mc/s. a gain of about 10db. and 6db. at 400 Mc/s. Operation of both sections in Push-Pull gives an additional gain of 2-3db.

Grounded cathode R.F. amplifier. Feeding a grounded grid stage, a gain of 14db is obtainable at 200 Mc/s., with a noise factor of 7.

Type 5763

Due to its small size, this VHF beam power tetrode is very suitable for portable equipment. Designed as an R.F. amplifier and frequency multiplier, it is also a useful modulator or driver, since a pair in class AB2 will deliver 25 Watts with an anode voltage of only 300.

Typical Operation

	Oscillator or power amplifier	Doubler	Tripler
Anode Voltage	300	300	300 Volts
Anode Current	50	40	35 mA.
Screen Supply Voltage	250	300	300 Volts
Series Screen Resistor	—	12.5k	12.5k ohms
Screen Current	5.0	4.0	5.0 mA.
Control Grid Voltage	-60	-75	-100 Volts
Control Grid Resistor	22k	75k	100k ohms
Control Grid Current	3.0	1.0	1.0 mA
Peak RF Grid Voltage	80	95	120 Volts
Input Driving Power	0.35	0.6	0.6 Watts
Output Power	8	3.6	2.8 Watts

This data will apply up to 175 Mc/s, but above that frequency the maximum anode voltage and dissipation must be reduced.

BRITISH MADE
BRIMAR
VALVES

SEND FOR FREE

DATA SHEETS to the Publicity Department

Standard Telephones and Cables Limited FOOTSCRAY, SIDCUP, KENT

Tel: FOotscray 3333

Tracking 2000g at 10 grammes maximum stylus pressure



The listening public is inclined to take technical achievements for granted—to assume, for instance, that the increasingly exacting requirements of microgroove records can automatically be met by pick-up manufacturers. This is not the case. There is nothing automatic about it. The technical progress made by record manufacturers is, in effect, a challenge to pick-up manufacturers—a challenge which Cosmocord, whose slogan "Always well ahead" really does mean something, are always ready to take up.

Sometimes the record manufacturers set us a problem, to which the solution is "impossible" and therefore takes quite a time to provide.

Such a problem is involved with regard to pick-up tracing capabilities which now have to be of a substantially higher order than those for 78 r.p.m. records, and are likely to become even more critical.

Cosmocord, with the very helpful co-operation of the Decca Record Company, have recently made a detailed examination into the optimum tracking requirements that could arise in modern types of microgroove records. This was done in order to establish a basis for the design of pick-ups that would not only satisfy the requirements of all records at present available to the public, but if possible anticipate future developments within the limits as set out in the recently published British Standard Specification (B.S.1928:1953).

THREE FACTORS

The three important factors that had to be considered by Cosmocord in designing such a pick-up were minimum groove width, maximum lateral displacement and maximum stylus tip acceleration.

The minimum groove width as laid down by the British Standard Specification is .002in. The conditions existing in a record giving up to 30 minutes playing time per 12in. side are well demonstrated in the accompanying scale drawings. For simplicity's sake, the groove angle has been shown as 90° and the radius at the bottom of the groove has been left out, as at .0003in. maximum it has no effect. Three pick-up

stylus radii are shown, the nominal .001in. radius (Fig. 1) and its upper and lower limits of .0012in. and .0008in. (Figs. 2 and 3 respectively) according to British Standard Specification. It can be seen that the .001in. radius has .0004in. wall above its point of contact, whilst the .0012in. radius has no more than .0002in. This does not take into account the pinch effect which can reduce the margin by .0002in. at 5,000 c/s.

PRACTICAL CONSIDERATIONS

In order to arrive at maximum possible displacement, some assumptions have to be made that are dictated by practical considerations. Working on the basis of 200 grooves per inch the maximum possible displacement (d) is .003in. At a frequency of 40 c/s. this displacement corresponds approximately to a maximum velocity of 2 cm/sec. ($v = 2\pi fd$).

Accepting the recording characteristics of the Decca Long Playing test record No. LXT 2695 as typical for commercially produced long playing records, the maximum velocity and corresponding acceleration at 10,000 c/s. can be calculated. According to the record specification the recording pre-emphasis at 10,000 c/s. relative to 40 c/s. is +24.4 db. and this gives a velocity of 31.6 cm/sec. and a corresponding displacement of .0002in.

($e = \frac{v}{2\pi f}$). It further follows that expressed in gravitational units the acceleration at 10,000 c/s. may be as high as 2000g ($g = \frac{e f^2}{10}$, where $e =$ displacement = .0002in. and $f = 10,000$ c/s.).

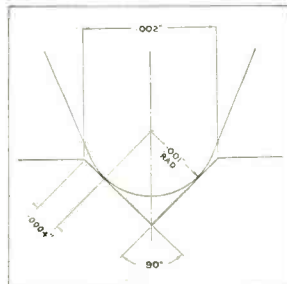

Fig. 1

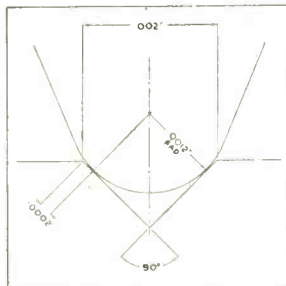

Fig. 2

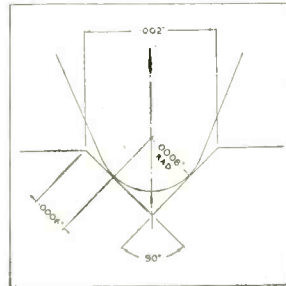

Fig. 3

WHAT OF THE FUTURE?

The examination, as can be seen even from this simplified statement, has brought to light conditions that appear to be incredible at first sight. They are, however, far from being purely hypothetical and it may be only a question of time before they appear on commercially produced records. Even now there are a few odd records on the market which come very close to these limiting conditions.

It can be seen that the problem set by the record manufacturers in this matter was a formidable one. Cosmocord have answered it so completely with their Acos "Hi-g" series of pick-up cartridges that they already meet, here and now, any likely future development of gramophone records within the B.S. 1928:1953 specification.



always well ahead

Acos Crystal Devices are Protected by Patents and Patent Applications in Gt. Britain and Other Countries

COSMOCORD LIMITED : ENFIELD : MIDDLESEX

THE "BELLING-LEE" PAGE

Providing technical information, service and advice in relation to our products and the suppression of electrical interference.

Real Progress in Bracket Design

For some years now we have been trying to evolve an aerial bracket that incorporated a ratchet movement to facilitate the tightening of strainer wires. Something that would save time in erection without increasing cost, and not just something done for cleverness sake. The thought is not new, something of the kind has been used before. We ourselves made one and had it tried out by our

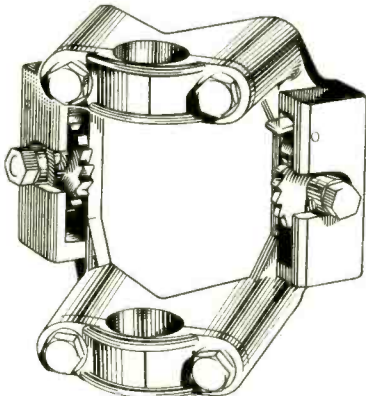

own installation teams, but they found we had gone wrong in trying to pull the wire round three corners at once, so we dropped that idea and started again. The present bracket pulls up on both sides separately, thereby enabling correct tensioning on each side regardless of the dimensions of the chimney. This new bracket will make its first appearance as part of the Junior "H" cranked mast aerials sometime during July.

High Gain

High Front-to-Back Ratio

Which is the most important feature in a fringe aerial, high gain or high front-to-back ratio? It all depends on local conditions. If the situation is one where the aerial is between the transmitter and a big town or a busy road with a lot of local interference, then the best aerial would be the one that gave a minimum interference from behind, i.e., one with a high front-to-back ratio such as a "Junior Multirod." An aerial with greater gain such as a "Multirod," but with a lot of interference coming in from behind would probably be a waste of good money.

It is very easy to sit back and say "why not have both"? In practice it just isn't possible to incorporate in one aerial, all the best features. The best aerial for

a given location is a compromise, e.g., to start off with we have two frequencies to consider, sound and vision. An aerial which was peaked on sound would be a bad aerial.

A New Choke and Capacitor Suppressor Effective at both Television and Broadcast Frequencies.

This is a choke and capacitor suppressor somewhat similar in appearance to our L.1174, but its use is limited to 2 amps, as this is the safe carrying capacity of the small chokes incorporated.

It has been designed for connection in the lead of domestic electrical equipment such as hair driers, vacuum cleaners, sewing machine motors, electric fans, etc., and to be truly effective, must be fitted really close to the appliance, certainly within nine inches from the electrical connections to the brushes of the appliance. List No. L.799.

Communal Amplification at Sea

Just as "Music while you work" is now commonplace in factories and workrooms, working conditions of ships' crews are very rightly improving, and ever increasing numbers of ships are being equipped for broadcast reception, with communal amplifiers supplying outlet points to the cabins and quarters of officers and crew.

One of the latest installations in which our equipment was used was that on m.s. "London Splendour" launched from Newcastle. The installation was carried out by Messrs. Arthur Jones & Co. Ltd., of Middlesbrough.

Ships installations differ from those on land, because although the installation may appear to be satisfactory when at the dock side, at sea, the signal-to-noise ratio falls, and the inherent losses in the "Eliminoise" anti-interference transformers attenuates the signal, so that the resulting energy may only be sufficient to operate one receiver, leaving insufficient energy for distribution to other points. With the introduction of the new "Belling-Lee" distribution amplifier, sufficient energy is made available so that each receiver is able to accept as much signal as if only one was connected to the aerial.

Truleigh Hill

The Brighton Booster

At the time of writing this particular item, i.e., 7th May, and just a few days after the opening of the Brighton Booster transmitter, we had a letter from the Isle of Wight telling us of wonderful results. We have had a similar report from Portsmouth. Now the Isle of Wight is 45/50 miles from Brighton, and the power is in the region of 400 watts. We grant you it is all across water, which is always advantageous, but pleased as we are, we can only hope that the results will prove to be general or lasting. They may be due to some freak of propagation conditions which are so often followed by acute depression and disappointment. We sincerely hope to be proved wrong.

We are sending our Mobile Research Unit into the Brighton district to see what can be expected. It will work out from Newhaven, Worthing, Littlehampton, etc., and we hope to be able to publish results in the next issue.

Fire Protection by "Minitrip"

Every now and again we read in the newspapers that a T.V. receiver "caught fire." There are a number of ways in which this can happen, even if fuses are incorporated. Let us say right now that practically any electrical appliance, even a table lamp, can be the cause of fire without blowing the house fuses. Whereas it might be difficult to give absolute protection in the case of the table lamp, we can now get very near to it in the case of a T.V. or broadcast receiver by the fitting of "Minitrip" thermal delay switches. These small bi-metal switches each cost about as little as a fuseholder and spare fuses, and operate on excessive current or heat or both. It is well worth while fitting them when a receiver is being serviced. Their presence provides a very quick and sure indication as to which part of the circuit is at fault. Their cost is less than the labour cost in finding out by any other means.

A number of prominent set manufacturers already build one or more "Minitrips" into their receivers. We are sure the number will grow.

BELLING & LEE LTD
CAMBRIDGE ARTERIAL RD., ENFIELD, MDDX., ENGLAND

Written 27th. May, 1953.

MARCONI communication systems



serve mankind

Communications . . . across the wastes of desert and ocean, and through impassable swamps and jungles . . . were largely unsolved until Marconi invented the miracle of radio. At one stroke he substituted ease for difficulty, and opened up a new era in the history of

man. For over 50 years the Company which Marconi founded has made communications its business. Its experience in this field is unique. If you have a communications problem of any sort, anywhere, Marconi engineers are entirely at your service.



SURVEYED



PLANNED



INSTALLED

MARCONI'S WIRELESS TELEGRAPH COMPANY LTD • CHELMSFORD • ESSEX

FREE

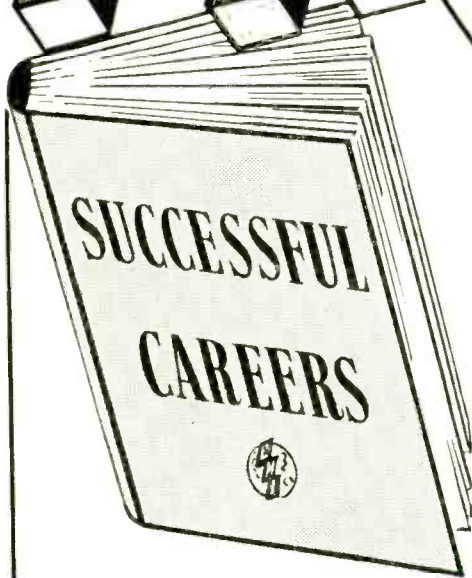

THIS VALUABLE BOOK

which details the wide range of Engineering and Commercial Courses of modern training offered by E.M.I. Institutes — the only Postal College which is part of a world-wide Industrial Organisation.

Over 150 Courses including :

Radio & Television

Gen. Radio & T/V Eng.
Radio & T/V Servicing
Radar
Sound Recording
Industrial Electronics
Advanced Radio
P.M.G. Certificates
Radio Amateurs Licence

Draughtsmanship

Eng. Drawing & Design
Tracing
Jig & Tool Design

Mechanical Engineering

Gen. Mech. Eng.
Diesel Engines
Refrigeration
Metallurgy
Workshop Practice
Maintenance Eng.
Machine Tools & Metrology
Marine Eng.

Electrical Engineering

Gen. Elect. Eng.
Installations & Wiring
I.E.E. Theory

Civil Engineering and Building

Civil Engineering
Building Construction
Heating & Ventilating
Sanitary Engineering
Surveying
Clerk of Works
Carpentry & Joinery
Builders Clerks

Automobile Engineering

Gen. Motor Eng.
High Speed Oil Engines
Garage Management

Production Engineering & Management

Gen. Prod. Eng.
Industrial Admin.
Works Management
Production Planning
Personnel Management
Time & Motion Study
Costing
Office Practice

Aeronautical Engineering

Gen. Aero. Eng.
A.R.B. Licences
A.R.M. Certificates

Also Examination Courses for: -General Certificate of Education, B.Sc. (Eng.), Common Preliminary, A.M.I.Mech.E., A.M.I.C.E., A.M.I. Struct.E., A.M.Brit.I.R.E., A.F.R.Ae.S., A.M.I.P.E., A.M.I.I.A., A.M.I.M.I., A.M.I.H. & V.E., M.R.San.I., A.M.I.San.E., A.M.I.Munc.E., A.M.I.E.D., A.M.S.E., L.I.O.B. Also CITY and GUILDS Certificates in Mechanical, Electrical, Aeronautical, Automobile, Telecommunications and Structural Engineering; Refrigeration, Heating & Ventilation. Courses also provided for all branches of Commerce and Business Management.

EMI INSTITUTES
associated with
MARCONIPHONE **H.M.V.**
COLUMBIA & (His Master's Voice)

COURSES FROM
£1 PER MONTH

POST NOW

Please send, without obligation, the above FREE book.

E.M.I. Institutes, Dept. 127
43 Grove Park Road, Chiswick, London, W.4.

Subject(s) which interest me

Name

Address

IC10G

First and foremost...

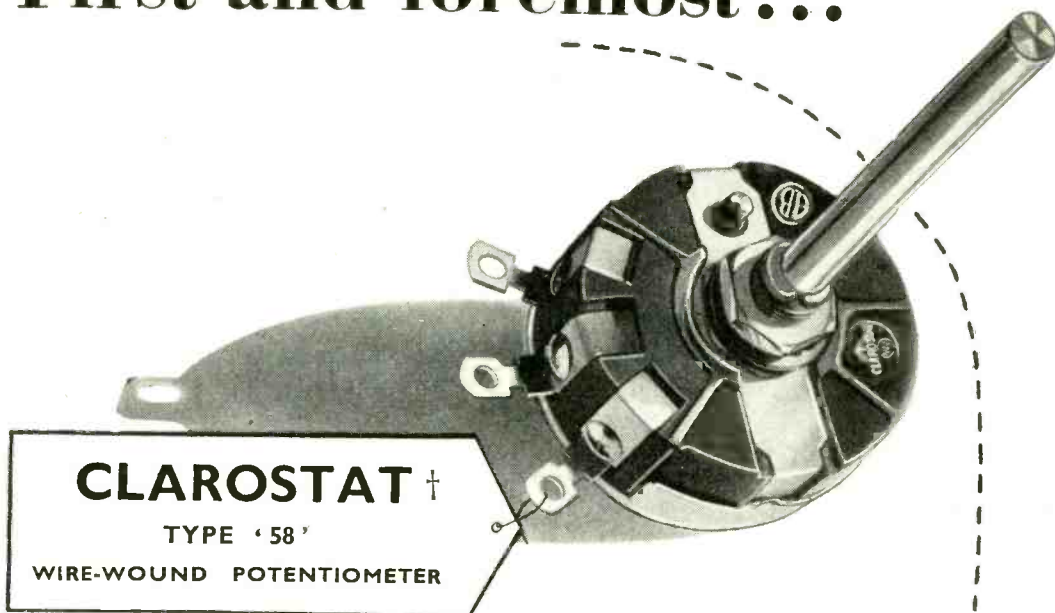

CLAROSTAT †

TYPE '58'

WIRE-WOUND POTENTIOMETER

We are proud to introduce the CLAROSTAT Type 58 Wire-wound Potentiometer, designed by the world's foremost Potentiometer manufacturers and produced for the first time in this country. The type 58 has many features which will immediately appeal to the discriminating user.

FEATURES

- ★ Rated at 3 watts and available in all values up to 100,000 ohms linear.
- ★ Special windings are available to requirements.
- ★ High Grade Bakelite Casing, of rugged construction. Solder Tags heavily silver-plated and of special design making them completely immovable under all conditions.
- ★ Metal cover firmly keyed into Bakelite Casing, cannot loosen or turn. Connected to fixing bush providing automatic "grounding" of cover.
- ★ Obtainable with single or double pole mains switch.
- ★ Dimensions : Diameter, $1\frac{3}{4}$ in. Depth of case without switch $\frac{3}{4}$ in.
- ★ Samples and full specifications available on application.

† Regd. Trade Mark

WHOLESALEERS

CLAROSTAT TYPE 58 Wire-Wound Potentiometers are supplied individually packed in attractive printed cartons. Delivery is prompt. Write for price list and details of very attractive trade terms.

↑
CLAROSTAT



Controls and Resistors

METAL PRODUCTS LIMITED.

16, Berkeley Street, London, W.1.

Phone: GROsvenor 5206/7

VORTEXION TAPE RECORDER

FEATURES WORTH NOTING

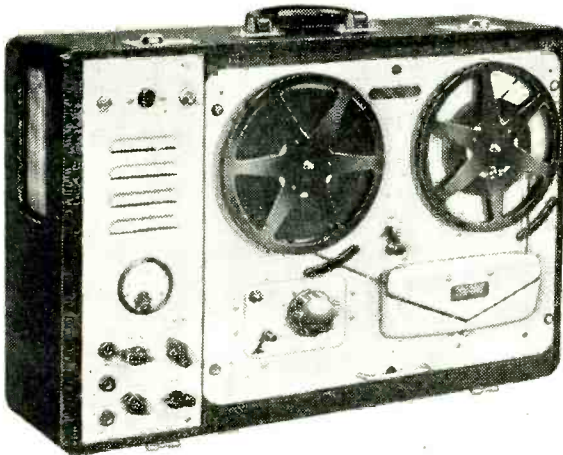

The amplifier, speaker and case, with detachable lid, measures 8½ in. x 22½ in. x 15¾ in. and weighs 30 lb

PRICE, complete with WEARITE TAPE DECK£84 0 0

- ★ The noise level is extremely low and audibly the hum level and Johnson noise of the amplifier and deck are approximately equal. Only 25% of this small amount of hum is given by the amplifier alone.
- ★ Extremely low distortion and background noise, with a frequency response of 50 c/s.—10 Kc/s., plus or minus 1.5 db. A meter is fitted for the measurement of signal level and bias level.
- ★ Sufficient power is available for recording on disc, either direct or from the tape, without additional amplifiers.
- ★ A heavy mu-metal shielded microphone transformer is built in for 15-30 ohms balanced and screened line, and requires only 7 micro-volts approximately to fully load.
- ★ The .5 megohm input is fully loaded by 18 millivolts and is suitable for crystal P.U.'s, microphone or radio inputs.
- ★ A power plug is provided for a radio feeder unit, etc. Variable bass and treble controls are fitted for control of the play back signal.
- ★ The power output is 3.5 watts heavily damped by negative feedback and an oval internal speaker is built in for monitoring purposes.
- ★ Facilities are provided for using the amplifier alone and using power output or headphones while recording or to drive additional amplifiers.
- ★ The unit may be left running on record or play back even with 1,750 ft. reels with the lid closed.

POWER SUPPLY UNIT to work from 12 Volt Battery with an output of 230v., 120 Watts, 50 cycles within 1%. Suppressed for use with Tape Recorder. **PRICE £18 0 0.**

TYPE C.P.20A AMPLIFIER

For A.C. Mains and 12 volt working giving 15 watts output, has switch change-over from A.C. to D.C. and "Stand-by" positions. Consumes only 5½ amperes from 12 volt battery. Fitted with mu-metal shielded microphone transformer for 15 ohm microphone, provision for crystal or moving iron pick-up with tone control for bass and top. Outputs for 7.5 and 15 ohms. Complete in steel case with valves.

PRICE
£30.16.0



Manufactured by

VORTEXION LIMITED, 257-263, The Broadway, Wimbledon, London, S.W.19

Telephones: LIBerty 2814 and 6242-3

Telegrams: "Vortexion, Wimble, London."

Polytetrafluoroethylene

a new
material for
ELECTRONICS

During the past few years a new resin-like substance, Polytetrafluoroethylene has been developed for Commercial use. It is unique among organic compounds in its chemical inertness, in its toughness over a wide range of temperatures, and in its low dielectric losses over a wide range of frequencies.

P.T.F.E. has zero water absorption with low surface tension, high impact strength and form stability, a far greater resistance to chemicals than either Gold or Platinum, and retains its strength and dielectric properties at temperatures ranging from minus 100° C to plus 250° C. Its co-efficient of friction is of a very low order.

The electrical losses of P.T.F.E. are substantially constant over a frequency range of 60 c.p.s. to at least 300 Mc.p.s. and are lower than those of polythene and polystyrene. Its resistance to surface arc-over is good and on failing, it vaporises instead of carbonising to leave a conducting path.

P.T.F.E. has been successfully used in a wide range of highest grade type-approved valveholders made by The Edison Swan Electric Co., Ltd., and a range of lead-through and stand-off insulators is available. Also a number of stock sizes of Sheet, Rod, Tape, Yarn, Slugs etc., and moulded or fabricated parts can be supplied to specification.

Its arc resistance, heat resistance and low electrical losses suggest unlimited applications within the Electronic Industry.

For full technical details please apply to

THE EDISON SWAN ELECTRIC CO. LTD.

Sales Department P.T.F.E.6, 21 Bruton Street, London, W.1.

TELEPHONE: MAYFAIR 5543.

Head Office: 155 Charing Cross Road, London, W.C.2

Member of the A.E.I. Group of Companies.

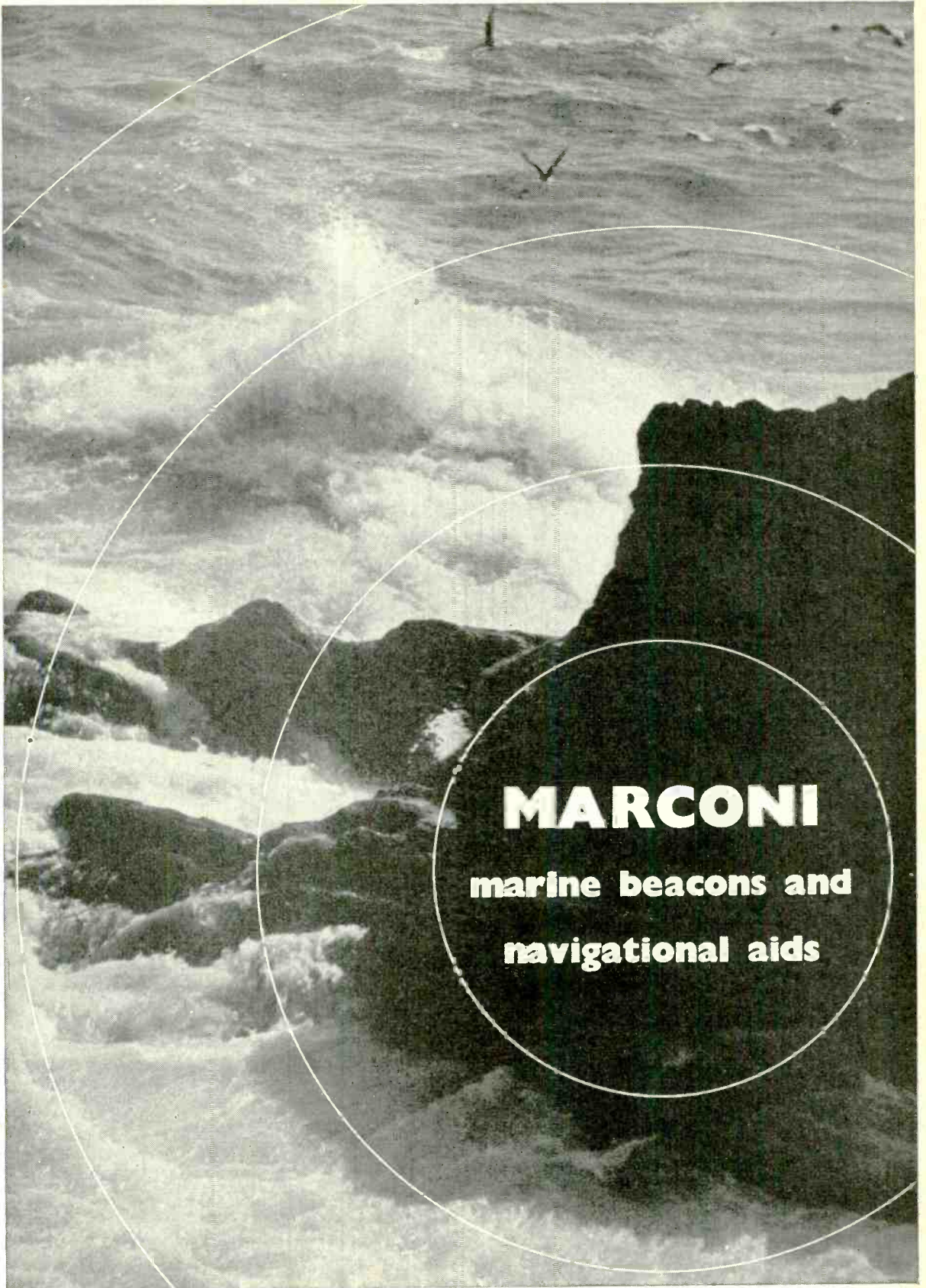

MARCONI
marine beacons and
navigational aids

MARCONI'S WIRELESS TELEGRAPH COMPANY LTD • CHELMSFORD • ESSEX

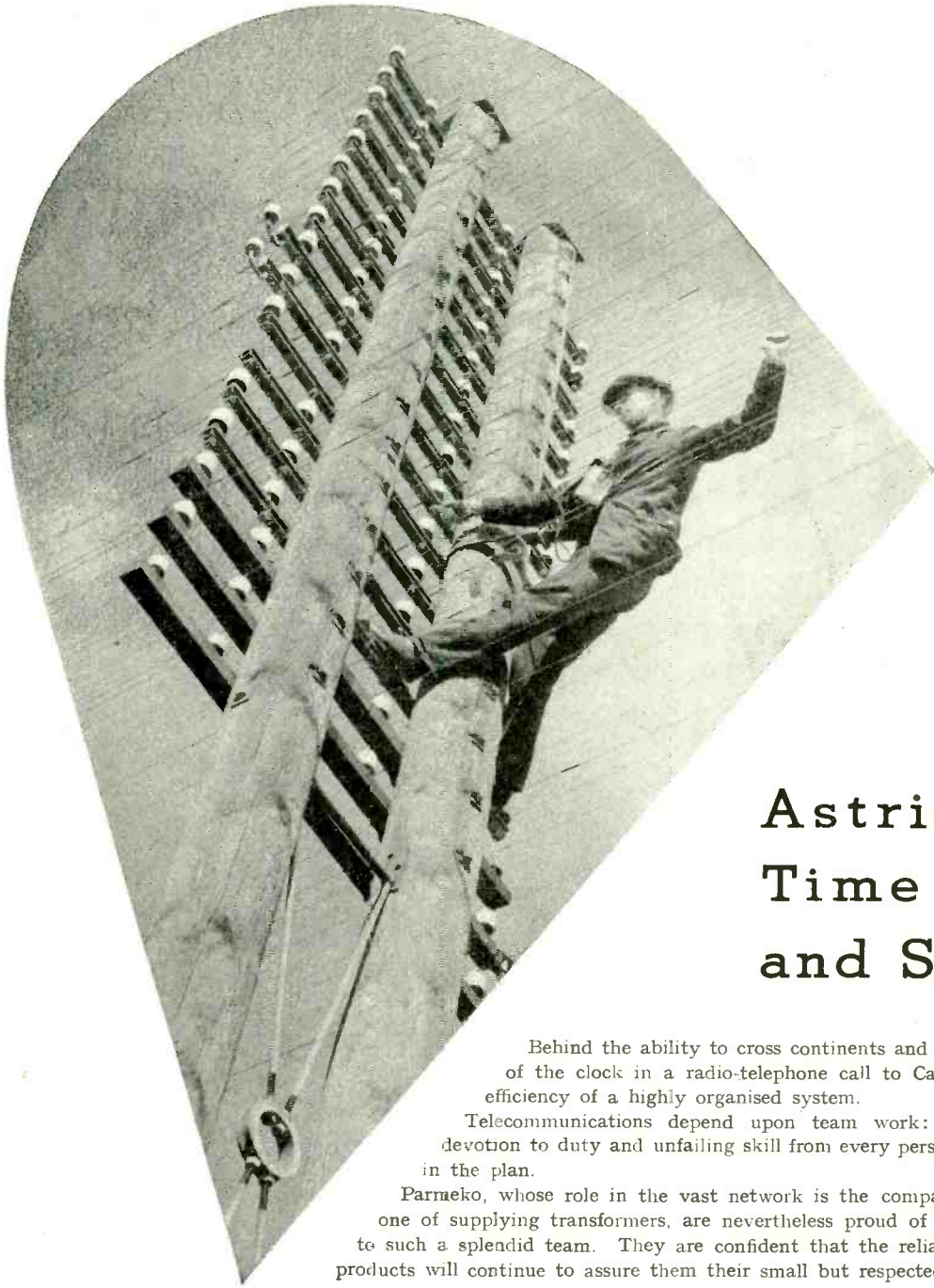

Astride Time and Space

Behind the ability to cross continents and gain a quarter of the clock in a radio-telephone call to Calcutta lies the efficiency of a highly organised system.

Telecommunications depend upon team work: this demands devotion to duty and unfailing skill from every person, every *part*, in the plan.

Parmeko, whose role in the vast network is the comparatively small one of supplying transformers, are nevertheless proud of their selection to such a splendid team. They are confident that the reliability of their products will continue to assure them their small but respected place.



PARMEKO of **LEICESTER**

Makers of Transformers for the Electronic and Electrical Industries

*Photograph by courtesy H.M. Postmaster-General

MEET THE FAMILY— CLOSE-UP OF A VERY PROMINENT MEMBER

THE **A-Z** SUPERHET RADIO UNIT

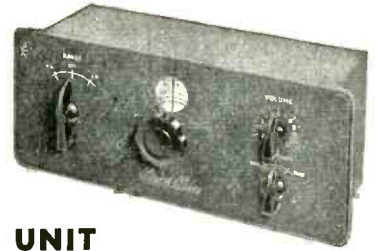

COMPACTNESS + EFFICIENCY GIVING "FULL SIZED" RESULTS — SIZE 11½" long, 4¾" high, 4" deep — WAVE RANGE 190 to 570 m - 800 to 2,000 m — PLUS VARIABLE SELECTIVITY — DELAYED AVC AND VOLUME CONTROL. H.T. CONSUMPTION 15 m.a. - 270 v. — LT 1.5 amp. - 6.3 v.

PROJECTION TELEVISION — THE FAMOUS AZ AMPLIFIERS
MINIATURE — JUNIOR — SENIOR — PHASE INVERTER SPEAKERS
SCRATCH FILTERS — TRANSFORMERS AND CHOKES

£12.15.0 Plus P.T.



SOUND SALES LTD

WEST STREET, FARNHAM, SURREY

Telephone : Farnham 6461-2-3

WEBB'S RADIO

14 Soho Street, Oxford Street, W.1
Telephone : GERrard 2089

HOLLEY'S RADIO STORES

285 Camberwell Rd., London, S.E.5
Telephone : RODney 4988



THE WESTON E772 Super Sensitive Analyser

No 10. Multi-Range Testing Instruments

Best known of all instruments for the testing and servicing of radio and television equipment is undoubtedly the Weston Model E.772 Analyser, a first-class portable instrument with a sensitivity of 20,000 ohms per volt on all D.C. ranges and 1,000 ohms per volt on all A.C. ranges. The additional features of wide range coverage, robust construction and simplicity in operation contribute toward making the E.772 ideal also for laboratory and research work. Full details of this instrument and also of the Model S.75—a Test Set covering 53 ranges—will gladly be supplied on request.

SANGAMO WESTON LIMITED · ENFIELD, MIDDLESEX

TELEPHONE: ENFIELD 3434 (6 lines) and 1242 (4 lines).

Branches:	London Office:	St. Georges Court, New	Oxford Street, W.C.1.	Telephone:	CHAncery 4971.	GRAMS: SANWEST, ENFIELD
GLASGOW	MANCHESTER	NEWCASTLE	LEEDS	NOTTINGHAM	BRISTOL	SOUTHAMPTON
Central 6208	Central 7904	Newcastle 26867	Leeds 30867	Nottingham 42403	Bristol 21781	Southampton 3328
			LIVERPOOL Central 0230	WOLVERHAMPTON 21912		BRIGHTON Brighton 28497

★ *The* HIGHEST ATTAINABLE ★ QUALITY of SOUND REPRODUCTION

Representing a unique feedback circuit development, the "Vari-Slope" pre-amplifier gives audibly better reproduction. This advance consists of variable-slope "electronic" low-pass filters operating on negative voltage feedback principles.

No Inductors ("Chokes") are used, and their disadvantages are completely eliminated. The turnover frequencies are 5 kc/s, 7 kc/s and 9 kc/s and the slopes of attenuation are continuously variable over the range 5db to 50db per octave.



The VARI-SLOPE

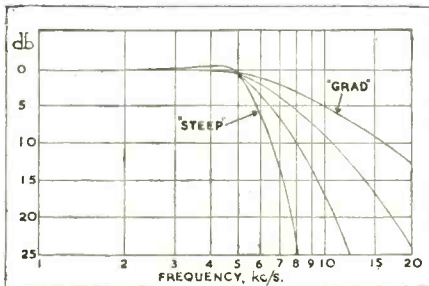

Frequency amplitude curves for the "TREBLE-3" position (5kc/s turnover). Curves of the same slopes are obtained on the other two positions turning over at 7kc/s and 9kc/s ("—2" and "—1" positions).

The filters consist essentially of twin-T resistor-capacity networks inserted in the return circuit of a single-loop feedback amplifier. The more obvious advantages of this electronic feedback method over conventional choke filters include:

(a) Improved transient response characteristics (due to absence of chokes having self-capacitance) and the consequent reduction of "ringing."

- (b) Extremely low harmonic and inter-modulation distortion due to negative voltage feedback action.
- (c) No discontinuities in the rates of slope when the slope control is operated, and no change in signal level at frequencies below turnover. (Both these faults occur in variable-slope choke filters due to the slope control, altering the terminating impedance and the insertion loss.)
- (d) No chokes to cause magnetic hum pick-up.
- (e) Smaller size, lighter weight, greater uniformity in production.

LIST PRICE IN BRITAIN 12 Gns.

POINT ONE TL/12 Triple Loop Feedback Amplifier

For laboratory use as a stabilised-gain audio frequency power amplifier. For the highest possible standard of disc recording. For the highest possible quality of reproduction from Pick-up, Radio, Microphone, Film and Magnetic Tape. For use as a driver amplifier in the speech modulator chain of broadcast transmitters. Used with the "Vari-Slope" pre-amplifier and the best available complementary equipment, the TL/12 power amplifier gives to the music-lover a quality of reproduction unsurpassed by any equipment at any price.

27 Gns.

Write for fully descriptive literature

H. J. LEAK & CO., LTD., BRUNEL ROAD, WESTWAY FACTORY ESTATE, ACTON, W.3

Phone: SHEpherds Bush 1173/4.

Telegrams: Sinusoidal, Ealux, London.

Cables: Sinusoidal, London.



The "Point-One" TL/12 Amplifier is built to a tropical specification and used throughout the world, including:

- The British Broadcasting Corporation.
- The South African Broadcasting Corporation.
- The Swedish Broadcasting Corporation.
- The Swiss Broadcasting Corporation.
- The Italian Broadcasting Corporation.

ELECTRONIC PRECISION EQUIPMENT LTD.

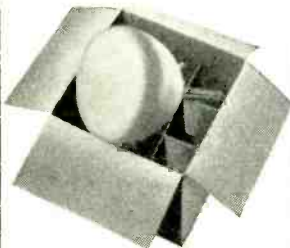
STILL AVAILABLE
15in. MAGNETIC TELEVISION TUBE

By famous maker. Specification Blue/White screen 9 Kv. ion trap triode, heater 6.3 v. at .55 amp., 50° deflection. New, with written guarantee, offered at approximately half price, £12/10/- each, plus 10/- carriage and insurance. H.P. terms £4/4/- deposit and 12 monthly payments of 18/3. Limited quantity, so order immediately.

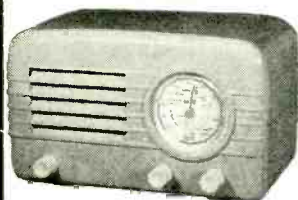
CONSTRUCTORS'
PARCEL, SPECIAL
OFFER

Modern design, bakelite cabinet in ivory, blue or brown, complete with metal chassis punched out for speaker and 5 valves, etc. Parcel also includes moulded Perspex window, matched set of knobs, scale and hardboard back. Price 22/6. Carr. and pkg. 2/6.

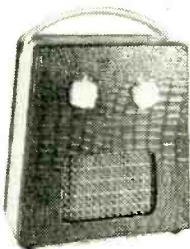
PORTABLE
RADIO CABINETS

Correct dimensions to take "P.W." "Mini Four" and similar midjet superhet or TRF. Internal dimensions 6½in. high x 5½in. wide x 3in. deep.

Special plastic grained finish, 15/9 plus 1/6 postage and packing. De Luxe model covered with brown crocodile leathercloth and banded with grey lizard leathercloth, 22/6 plus 1/6 postage and packing.

1154 TRANSMITTER

We can offer this, unused and in original transit cases, complete with valves at £6 each—plus 12/6 carriage.



Model 314

Model 312 has a drawer on runners and cupboard space beneath. It is also slightly wider and slightly deeper than the others. Price 54/-.

Model 313A. Shelf and cupboard. Fitted half shelf inside cupboard. Price 37/6.

Model 313C. Drawer and cupboard, half shelf inside cupboard. Price 39/6.

Model 314. Five Drawer Chest, suitable for personal papers, etc. Price 54/-.

WHITEWOOD CABINETS

Hundreds of uses in the home, office or workshop; for instance two of these and 2/- worth of hardboard (obtained locally) make an excellent desk or work bench. Sturdily constructed of well seasoned softwood frames and fronts, birch ply top, sides and doors, hardboard backs and bottoms. External dimensions 29in. x 14½in. x 13½in.

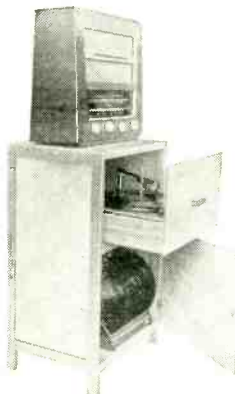

The illustration shows Model 312 fitted up for record playing.

NON-CALLERS PLEASE ADD 5/- PER CABINET TO COVER CARRIAGE CHARGE.

AMPLIFIER RACK—SPECIAL LOW
PRICE

This stands approximately 6ft. high, and was made originally for the G.P.O. The top panel contains the amplifier proper, which consists of an A.C. mains-driven power pack, capable of delivery 200 mA. at 400 v. and, of course, the normal L.T. supplies, and the amplifier itself uses an MHL4 feeder and two PX25s in the output stage, giving approximately 25 watts. This top deck also contains the heavy duty output transformer. The lower panel contains the feeder unit which can be used as a pre-amplifier for microphone and gramophone work. You will observe that on the rack there is ample space for fitting a monitor speaker and an R.F. unit if same are required. Note that the anode current of the PX25 valve is monitored by a 2½in. flush meter. Further note that these amplifiers were made by the famous MARCONI company. Complete as illustrated but less valves, unused and only very slightly storage soiled. Price £5/10/-, plus 12/6.

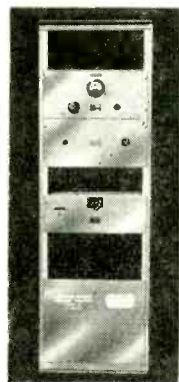

RADIOGRAM CABINET Console Type Cabinet. With full grained walnut finish, will take standard type auto change gram unit. Price, £11/10/-, H.P. terms, £3/17/- deposit, and 12 monthly payments of 16/9, plus 15/- carriage.

Radio Chassis to suit. £8/19/6. H.P. terms, £3 deposit and 10 monthly payments of 13/-, plus 7/6 carr.

Auto Change Units. For long-playing and standard records with suitable pick-up head, £11/11/-.

SPECIAL OFFER. Cabinet Radio Chassis and Auto Changer, 29 gns. H.P. terms, £10/14/- deposit and 12 monthly payments of £2/3/-.

LAST FEW
£3/19/6.

LAST FEW

The Lectross warm room as it dries clothes, bathing costumes, towels, etc. Size 3ft. wide, 3ft. high, and 5in. deep. It has four stove enamelled rails and works off AC or DC mains, consuming 650 watts. Fully guaranteed. Price £3/19/6 plus 7/6 carriage.

THIS MONTH'S SNIP

Due to a recent huge purchase of ungraded germanium and silicon crystal diodes we are able to offer these at less than cost. Also being ungraded you stand a good chance of finding one or more of the really expensive special purpose types. This month we are offering 12 assorted, all made by B.T.H. and G.E.C. for £1 post free. Every crystal is guaranteed to be in perfect working order.

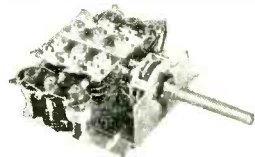

LAST TIME AT THIS PRICE

We are almost sold out of 3 wave-band coil packs, but if you apply quickly you may still be lucky. Manufactured by a famous company—long, medium, short wave-bands and gram position. Complete with circuit, 19/6 post free.

GREATLY REDUCED—
CATHODE RAY TUBES

VCR97. Brand new and unused, ideal for 'scope, etc. Price 12/6. Carriage and insurance 5/- extra.

VCR517. 6½in. guaranteed full picture. 29/6 plus 5/- carriage and insurance.

VCR139A. 2½in., 32/6 plus 2/6 carriage, etc.

VCR138. 3½in. electrostatic short persistence, suitable for T.V. and ideal for 'scope work, 37/6 plus 3/6 carriage, etc.

VCR112. 5in. electrostatic, persistence not known, 15/- each plus 5/- carriage, etc.

CV996. 6in. electrostatic, persistence not known, 15/- each plus 5/- carriage, etc.

CV1140, CV1590, CV1546. All 12in. magnetic long persistence £4/10/- plus 10/- carriage.



To advertise our latest purchase of germanium diodes suitable for crystal sets which we can offer at the very low price of 1/9. With each we give a free blueprint of a crystal set to be made from parts found in any junk box. You have a youngster friend who will be thrilled to make this little receiver.

ELECTRONIC PRECISION EQUIPMENT LTD.

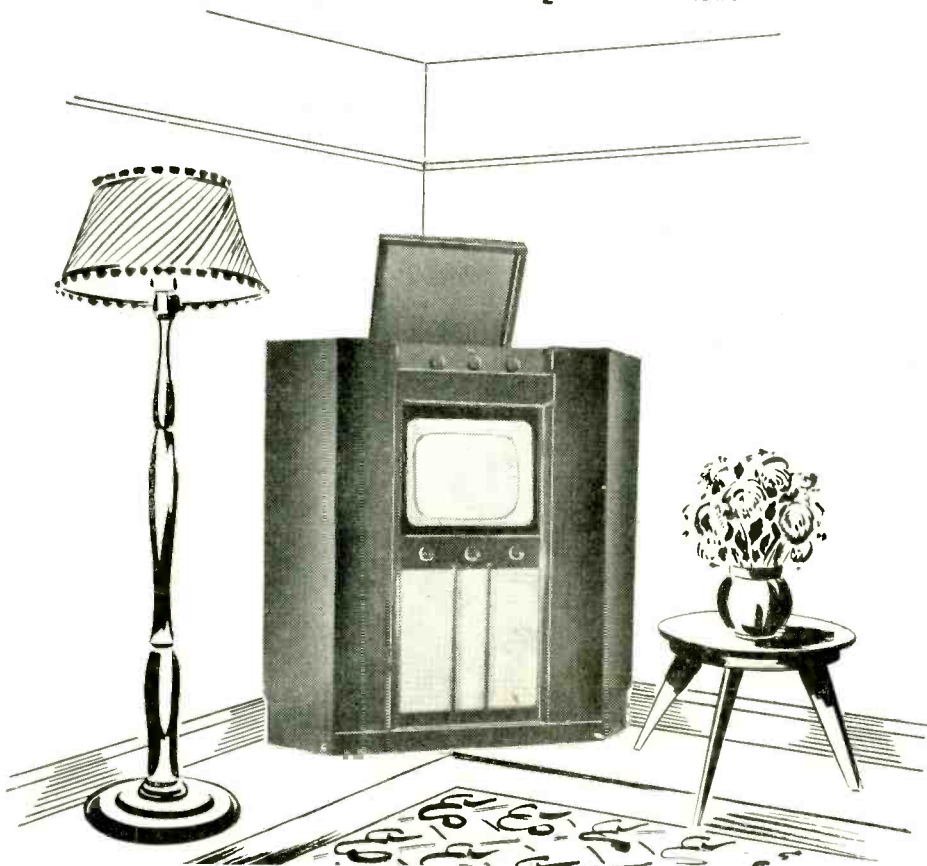

A combined Radio, Radiogram and 15in. Televisor valued at a shop price of £300-£400 can be yours for about £75.

THE CABINET

As the illustration shows this is a really majestic looking corner fitting console. It is constructed mostly from solid oak and oak-faced ply, and polished medium dark oak. The tube cut-out is for the standard 15in. tube, but larger tubes can be accommodated with little difficulty. The storage space on the top will take autochanger or tape recorder and there is a sloping panel at the top which will take radio or amplifier controls. Size 50in. high, 47in. wide and 31in. deep. Price £18/- plus 10/- carriage and insurance. Hire purchase terms: £6/- deposit—balance 12 monthly payments of 25/-.

THE TV CHASSIS

Our own Superior 15in. is, of course, suitable for all types of cabinets. This is a 20-valve superhet constructed on one large open chassis and incorporating the latest features such as; line E.H.T., diode damped interlace, etc. Data which is free with all orders for parts is available separately on approval—send 7/6d (if you feel you cannot make the receiver—return the data and 7/- will be refunded to you). The cost of all the components to build this is £35/-, which includes valves and Cossor 15in. C.R.T. The parts may be bought by H.P. terms: £11/14/- deposit—12 monthly payments of £2/7/-.

THE RADIOGRAM UNIT

We do not think you could do better than to buy a Collaro RC511, which is suitable for all types of records as it is three-speed with dual-purpose crystal pick-up. We made a special purchase and in consequence can offer this unit at 11 guineas, which is well below current list price. H.P. if you want it, 84/- deposit—balance over 12 months. Carriage charge 7/6.

THE RADIO UNIT

This is being designed and details will be available very shortly.

ELECTRONIC PRECISION EQUIPMENT LTD.

Post orders should be addressed to:—

**ELPREQ HOUSE (Ref 2), HIGH STREET,
WEALDSTONE, MIDDX.**

Personal shoppers however must continue to call at:—

42-46, WINDMILL HILL, RUISLIP, MIDDX.

Phone: RUISLIP 5780
(Half-day, Wednesday)

152-153, FLEET STREET, E.C.4.

Phone: CENTRAL 2833
(Half-day, Saturday)

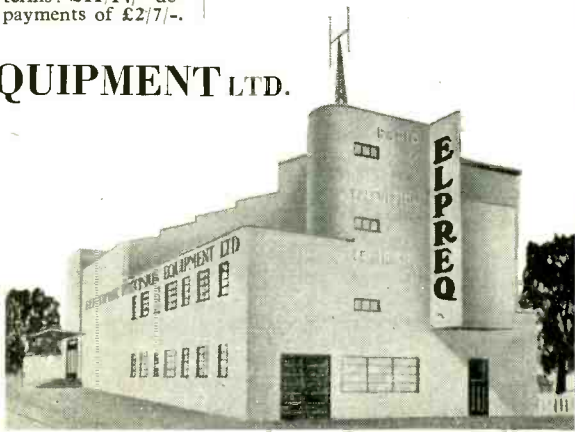

COMMUNICATIONS RECEIVER RI155. The famous ex-Bomber Command Receiver known the world over to be supreme in its class. Covers 5 wave ranges 18.5-7.5 Mc/s, 7.5-3.0 Mc/s, 1,500-600 kc/s, 500-200 kc/s, 200-75 kc/s, and is easily and simply adapted for normal mains use, full details being supplied. Aerial tested before despatch. These are BRAND NEW AND UNUSED IN MAKER'S ORIGINAL TRANSIT CASES, ONLY £11/19/6.

A few used receivers, also tested working before despatch, are available at £7/19/6.

A few of the RI155N model can also be supplied. This is the latest version which covers the Trawler Bands, and in addition is fitted with ultra slow motion tuning. Used, but tested working before despatch, ONLY £17/19/6.

A factory made Power Pack, Output Stage and Speaker, contained in a black crackled cabinet to match the receiver, can be supplied at ONLY £5/10/-. Operates receiver immediately. DEDUCT 10/- IF PURCHASING RECEIVER AND POWER PACK TOGETHER.

Please add carriage costs of 10/6 for receiver, and 5/- for power pack. RECEIVERS RI355, as specified for "Inexpensive Television." Complete with 8 valves SP61, and 1 each 5U4G and VU 120 or VU 111. Used, good condition, ONLY 29/6 (carriage etc. 5/6).

RF UNITS TYPE 26 AND 27 for use with the above receiver. The very popular variable tuning units, which use 2 valves EF54 and 1 EC 52. Type 26 covers 65-50 Mc/s, (5-6 metres), and Type 27 covers 85-65 Mc/s, (3.5-5 metres).

BRAND NEW IN MAKER'S CARTONS. ONLY 59/6 each. **VIBRATOR UNITS.** 2 volt type, American made, delivers 67 volts at 4.7 mA, 130 volts at 20 mA, and 1.4 v. L.T. Easily adapted for use with any battery receiver, full details being supplied. ONLY 50/- (postage 2/-).

6 volt type, made by The National Co. of America for use with HRO Communication Receivers, supplying 165 volts at 85 mA, fully smoothed D.C. Complete with vibrator and 6X5 rectifier in black crackle cabinet, size 7in. x 7 1/2in. x 6in. Slightly used. ONLY 39/6.

INDICATOR UNIT TYPE 62A. Contains VCR97 tube with mu metal screen, 12 valves EF50, 4 of SP61, 3 of EA50, and 2 of EB34. Built on a two deck chassis containing hundreds of condensers and resistors, potentiometers, etc. In BRAND NEW CONDITION IN MAKER'S TRANSIT CASES. ONLY £7/10/- (carriage 9/6).

ADMIRALTY TEST SET TYPE SE2. For 160/230 Mc/s, this contains standard 230/250 v. 50 c. A.C. Mains power pack, 2in 500 microamp. meter, and 7 valves as follows: 2 ea. 6J5 and EA50, 1 each 6X5, VR 137, CV 172. Fitted in metal lined wood case with removable front. ONLY 50/- (carriage etc. 10/-).

6 VOLT 90 A.H. BATTERIES. By famous American makers, these have genuine hard rubber cases, and are BRAND NEW AND UNUSED IN MAKER'S PACKING. Size 8 1/2in. long x 6 1/2in. wide x 7 1/2in. high. ONLY 59/6 (carriage, etc., 7/6).

TELESCOPIC AERIAL. Pulls out of metal tube 15in. long to extend to 73in. BRAND NEW. ONLY 7/6 (post 10d.).

194 I.F. STRIP. An easily modified I.F. Strip recommended for TV constructors who want good results at moderate cost, or for those who have built televisions but are having trouble in the vision or sound receivers. Can also be modified for 2 channel working as per details in "Practical Television" October issue. This 6 stage strip measures 18in. x 5in. x 5in., and contains 6 valves VR 65, 1 VR 92 and 1 of VR 56 or VR 53. Mod. data supplied. ONLY 45/- (postage, etc., 2/6). Or less Valves 19/6 (post 2/6).

208 AMPLIFIER. Ideal for conversion into a high gain TV preamp. Complete with 7 valves EF 50. ONLY 15/- (postage, etc., 1/6).

CERAMIC 2 WAY 3 BANK SWITCHES, 7/6 each.

CHOKES, 10 H. 60 mA, 3/9; 30 H. 100 mA, 12/6; 5 H. 200 mA, 6/- (postage 1/- per choke).

TRANSFORMERS. Manufactured to our specification and fully guaranteed. Upright mounting, fully shrouded normal primaries.

425-0-425 v. 200 mA, 6.3 v. 4 a., 6.3 v. 4 a., 5 v. 3 a., 50/-.

350-0-350 v. 160 mA, 6.3 v. 6 a., 6.3 v. 3 a., 5 v. 3 a., 42/6.

350-0-350 v. 150 mA, 6.3 v. 5 a., 5 v. 3 a., 32/6.

250-0-250 v. 100 mA, 6.3 v. 6 a., 5 v. 3 a., 32/6.

Please add 2/- per transformer postage.

TRANSFORMERS, FILAMENT. 6.3 v. 2 a., 7/6; 6.3 v. 3 a., 10/6. (Postage 1/-).

TRANSFORMERS EHT. Upright mounting, EHT for VCR 97 tube, 2,500 v. 5 mA, 2-0-2 v. l.l.a., 2-0-2 v. 2 a., 37/6.

EHT 5,500 v. 5 mA, 2 v. l.a., 2 v. l.a., 72/6.

EHT 7,000 v. 5 mA, 4 v. l.a., 82/6. Please add 2/- per transformer postage.

SPECIAL OFFER. L.T. Transformers with windings of 5 v.-0.5 v. 5 amps; 5 v.-0.5 v. 5 amps; 5 v.-0.5 v. 5 amps. By using combination of windings will give various voltages at high current. Brand new and unused these have become damaged, but are still usable, the damage being confined to broken fixing lugs, and/or broken bakelite terminal panels. Formerly sold at 35/-, now offered at 22/6 (postage 2/6).

2 1/2in. **SQUARE FLANGE 0-1 M.A. METERS.** Brand new. ONLY 15/-.

10in. **P.M. SPEAKERS** with output trans. Brand new. ONLY 27/6 (postage 2/-).

U.E.I. CORPORATION
Radio Corner, 138, Gray's Inn Road, London, W.C.1.
Phone: TERMINUS 7937.

(Open until 1 p.m. Saturdays. We are 2 min. from High Holborn (Chancery Lane Station) and 5 min. by bus from King's Cross.)

CITY & RURAL IMMEDIATE DELIVERY FROM STOCK "VIEWMASTER"

SPECIFIED COMPONENTS

(London — Sutton Coldfield — Holme Moss — Kirk-O-Shotts — Wenvoe — Newcastle — Belfast.)

Send for Stage 1 now—price £3/2/3, post free. Complete Kits, Stage-by-Stage and Single Components Supplied. "Viewmaster" Construction Envelopes 7/6 ea.

NEW LANE TAPE TABLE, £17/10/-, plus 10/- carriage and packing.

LANE RECORD/PLAYBACK AMPLIFIER (including valves and complete down to the last nut and bolt), £13.

LANE RECORD/PLAYBACK AMPLIFIER (ready-built and tested), £15/10/-.

CONSTRUCTION ENVELOPES. Stage-by-Stage Construction Envelopes for Lane Record/Playback Amplifier, 5/3, post free
TA/4P RECORD/PLAYBACK AMPLIFIER (complete and tested), £14.

RONETTE "CORONATION" CRYSTAL MICROPHONES, 52/-.

TRANSFORMERS: 30 v. 2 a. for models, etc. Tapped 3-4-5-6-8-9-10-12-15-18-20-24 v., 21/-; 350-0-250 v. 80 mA. 6.3 v. 4 a., 5 v. 2 a., 21/- Ditto but 250-0-250 v., 21/- Heater 6.3 v. 1.5 a., 7/6. 350-0-350 v. 150 mA. 6.3 v. 5 a., 5 v. 3 a., Fully Shrouded, 45/-; EHT 2.5 Kv. 5 mA. 0-2-4 v. 4 a., 0-4 v. 2 a., 45/- All Primaries 200-220-250 v.

METAL RECTIFIERS: 6 v. 1 a., 5/6; 12 v. 1 a., 9/9.

ALUMINIUM CHASSIS: 6 x 4 x 2 1/2in., 4/9; 8 x 6 x 2 1/2in., 6/4; 10 x 7 x 2 1/2in., 7/7; 12 x 8 x 2 1/2in., 9/6.

S.T.C. METAL RECTIFIERS: E.H.T. K3/40, 7/6; K3/45, 8/2; K3/50, 8/8; K3/100, 14/8; H.T. RMO, 5/-; RM1, 5/3; RM2, 5/9; RM3, 7/-; RM4, 21/-; DRM1B, 11/6; DRM2B, 12/6; DRM3B, 15/-.

CLEAREX 6in. ENLARGERS (for VCR97, etc.), 17/6.
Terms: C.W.O. or C.O.D. over £2. Over £2 post free, otherwise please add 1/- post and packing.

FOR ATTENTION—ADVICE—SERVICE, WRITE:

CITY & RURAL RADIO,
101, HIGH STREET, SWANSEA, GLAM.

Telephone: Swansea 4677.

1 KW TELEGRAPH TRANSMITTERS. Two HF 300's output. Operation 3.5 mc. to 16 mc.

BC610 TRANSMITTERS with speech amplifier, aerial tuning unit, etc. Brand new.

RCA TRANSMITTERS. Type ET-4336. Complete with speech amplifier, crystal multiplier and VFO units. Unused and reconditioned. Can be supplied with very large quantity of spares.

RCA TRANSMITTERS. Type ET-4332 modified by R.A.F. for use on crystal or master oscillator. Complete with speech amplifier.

EX-R.A.F. 1143 TRANSMITTERS.

MAGNETO 10 LINE U.C. TELEPHONE SWITCHBOARDS (complete).

NO. 33 TRANSMITTERS.

A.R.88D's, A.R.88LF's, A.R.77's, S27's, HRO, R.109 and others.

AUTOMATIC HIGH-SPEED-TELEGRAPH EQUIPMENT. "BOEHME" (U.S.A.). Up to 400 signs per minute on line and wireless.

NAVY MODEL TBY-8 TRANSMITTING-RECEIVING EQUIPMENT. Output 0.75 watts on M.C.W. telegraphy and 0.5 watts on telephony. Frequency range 28-80 mc.

All above items in excellent working condition
Working demonstration upon request.

TX VALVES 803, 805, 807, 813, 814, 861, 866A, DET-16 and many others.

Large stock of Tx condensers, crystals and other components. Alignment and repair of communication receivers and all other short-wave equipment undertaken.

P.C.A. RADIO

Transmitter Division:— Receiver Division:—

The Arches, Cambridge Grove, 170 Goldhawk Road,
London, W.6. London, W.12.
Tel.: RIV 3279. Tel.: SHE 4946.

Supersonic

Regd. Trade Mark

THE ALL-WAVE CAR RADIO

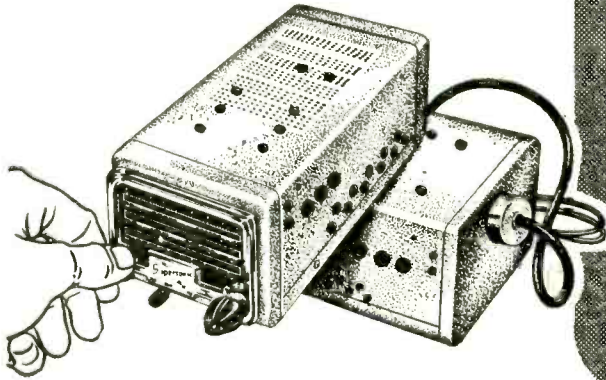

Semi Band Spread tuning—3 bands—wide range—very sensitive—wonderful tone—powerful volume—extremely compact—fits any car.

Incorporates all that is new in world Radio research.

SOLE DISTRIBUTORS WANTED
IN ALL PARTS OF THE
WORLD

Enquiries to :

Export Manager,
CHASSAY BROS. (Pvt) LTD.,
Ingutsheni Road,
BULAWAYO, Southern Rhodesia.

or
Export Manager,
CHASSAY BROS. (Pvt) LTD.,
5 St. John Street,
LONDON, E.C.1.

Great Britain's Valve Mail-Order House

RADIO **BULLS** VALVES

246, HIGH ST. HARLESDEN NW11

EXPORT

To all parts of the Commonwealth and beyond—safely packed (no C.O.D.) and Free of Tax.



PIFCO

All-in-one Radiometer AC/DC. Tests everything in Radio. Complete with Test prods.



29/6 Post 1/6.

TAYLOR Montrose 7-range Multi-meters, A.C./D.C.

3 amp precision M/I movement. 0-6-30-150-300 volt. 0-30 mA.—300 mA.

50/- Post 1/-

Magic Plates as described in April—few left at 30/-.



SERVICE SHEETS

The one you require enclosed if available in a dozen assorted of our best choice. 10/6

B.T.H. GERMANIUM CRYSTAL DIODE

Complete with Blue-print and operating instructions. 3/-

EASY TERMS ON ALL TAYLOR METERS

Terms up to 10 months and very near Cash Price. Please ask for full List, Terms and Proposal Form.

VCR 97 Tubes Brand new 20/- Post 2/-



If yours is a Valve Problem—Bulls are most likely to solve it. Please write us.

"Demobbed Valves Manual" 2/3

Giving Equivalents of British and American Service and Cross Reference of Commercial Types with an Appendix of B.V.A. Equivalents and comprehensive Price List. We have still some Valves left at very old Budget Rates (33 1/3%) which are actually sold at the old price. "Radio for Beginners" 3/3. "Crystal Set Construction" 1/3.

SPEAKER FABRIC 2/9

Square foot, 2/9

BROADCASTER

Connects to radio or gram. Talk over your own radio, room to room. Easy to fix. Two mikes make 2-station house phone in your own home. Order to-day. 12/6 Post 1/6



Q-MAX

Chassis Cutters and Keys
1 1/2 in., 12/4;
1 in., 12/4;
1 in., 13/4;
1 in., 1 1/2 in.
and 1 1/2 in., 16/- each;
1 1/2 in. and 1 1/2 in., 18/- each;
1 1/2 in., 19/9; 2 1/2 in., 31/9;
2 1/2 in., 36/9; 1 in. square, 24/3. Post 1/-

AMERICAN type British made A.C.

Electric Paint Sprayer Tax 75/- Free Post 2/-



TYANA Soldering Irons Lightweight 16/9 Post 1/-

TAPEMASTER RECORDING COMPONENTS

Suitable for use with either Hartley or Culpitta Circuits.

JUNIOR MODEL Play/Record. Imp., 3,000 ohm at 1 k/c. £1 19 6 Erase £1 19 6

SENIOR MODEL Play/Record. Imp., 5,500 ohm at 1 k/c. £2 5 0 Erase £2 5 0

Oscillator Coil incl. Coil and 6V6GT valve £2 5 0

TAPE RECORDER MOTORS Collaro clock or anti-clock 38/6 B.S.R. Type F.P.10 £1 18 0

RECORDING TAPE "SCOTCH BOY": 1/2 in. x 200ft. 5in. spool 21/- 1/2 in. x 1,200ft. 7in. spool 35/-

Emittape: H80/6 (H/C) 600ft. £1 1 0 H80/12 (H/C) 1200ft. 35/- H80/15 (H/C) 1500ft. 35/-

G.E.C. Tape: 1200 high or low coercivity £1 10 0

EMPTY SPOOLS: 5in. Tapercels 3 3 7in. Tapercels 4 3

Electric Paint Stripper

Paint STRIPPING made easy with our foolproof electric tool. Easy and faster. Clean and safe. Old paint comes off like MAGIC. Cost 1d. per hour. A.C./D.C. Complete with long cable. Guaranteed. List 47/6 OUR PRICE 37/6 Post 1/3



RADIO **BULLS** VALVES
246, HIGH ST. HARLESDEN NW11

(Kindly mark envelope W.W.7)



THE TELE-KING

Alexandra Palace,
Sutton Coldfield,
Holme Moss,
Wenvoe,
Pontop Pike,
Belfast.

A practical 5-channel SUPERHET TELEVISION RECEIVER

Using the new 16-inch cathode ray tubes and wide angle components for the home constructor.

Complete instructions, wiring diagrams and 32-page descriptive booklet.

6/- POST FREE

ALL COMPONENTS IN STOCK.
WRITE FOR LIST.

16"

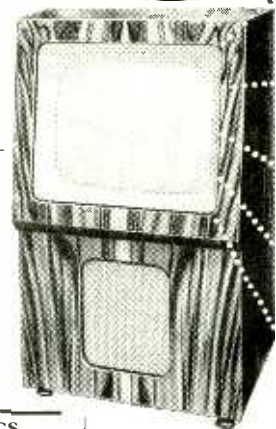

- ALEXANDRA PALACE
- SUTTON COLDFIELD
- HOLME MOSS
- KIRK O' SHOTTS
- WENVOE

SPECIAL C.R.T. OFFER.
Brand new and unused 12in. ion trap cathode ray tubes, 6.3 volt heater, 7-9 Kv. E.H.T. 35 mm. neck. Black and white picture. Screen has very slight blemishes £11/19/6.
Perfect £12/19/6.
Carriage and insurance 15/- per tube extra.

10,000 VALVES IN STOCK.
B.V.A. Special Purpose, Transmitting, etc. A few specials: Ravtheon sub miniature CK510AX, pentode, 3/11. 954, 956, VU120, 32, 57, E1148. All at 2/6 each. RK34, 2/-; MS/PEN 3/6; VU111, 3/6. Sylvania (red) EF50, 12/6.

CRYSTAL DIODES
Germanium 2/3d. each, post free.

ION TRAPS. All types available. PRICE 5/- each. State type number of c.r.t.

SPECIAL OFFER. IT/6.
(For MW31-16), 3/- each.

MANUFACTURERS' SURPLUS T.V. COMPONENTS.
Frame blocking oscillator transformer, Plessey.... 10/6
Multi ratio frame output transformer 10/6
Scanning coils. Low impedance line and frame ... 14/6
P.M. Focus units. For any type c.r. tube with 35 mm. neck, with vernier. Scanning coils. Low impedance frame, low line. With aluminium shroud.. 12/6

TWO-WAY TALKIE. Sound powered inter-com units. Can be set up anywhere, and gives effective communication up to a distance of 500 feet. Units can be purchased to give up to 4-way intercommunication. In metal case, brown crackle finish. Size: 6" x 5 1/2" x 8". Uses a 5in. P.M. speaker and two U2 batteries. PRICE:

Master Unit, with 4-station selector switch **37/6**
Sub-Stations 27/6
Carriage 2/6 each.

ALLEN WIDE ANGLE COMPONENTS
D.C. 300 latest type Ferroxcube Coils ... 39/6
GL.16 Coil 10/-
GL.18 Coil 10/-
Focus Coil 35/-
FO.305 trans. 21/-
Frame B.O. transformer 15/-
Line E.H.T. transformer, L.308 50/-

CHASSIS
Power pack Sound-vision and S can chassis. PRICE 15/- each. All other metalwork available from stock.

COILS
13 all exactly as specified. Price £2/14/3.

RESISTANCES 72 Resistances, all exactly as specified, 18/-.

CABINET
As illustrated, £8/10/- plus carriage.

WIDE ANGLE CATHODE RAY TUBES
14in. MW36-22 £19/9/3
14in. C14B, £20/10/1
16in. MW41-1. £22/4/10
16in. T901, £22/4/10
17in. MW43-64, £23/12/8
17in. C17BM, £24/13/-
Carriage and insurance extra.

9" TABLE T.V. CABINETS

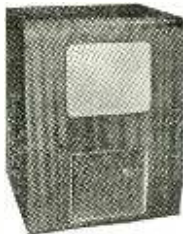

Medium shade mahogany finish. Complete with back, safety glass, speaker-fret. Internal dimensions: 19 1/2 in. high, 16in. wide, 14in. deep.

LASKY'S 39/6 Carriage 7/6
PRICE extra.
Adaptor frame available for 6in. C.R. tubes. The aperture can easily be enlarged to take 12in. or 14in. tubes.

12 VOLT D.C. MOTOR GENERATORS
Output 300 volts at 150 mA. D.C. 7,500 r.p.m. Size: 2 1/2 in. diam. 6in. long. **17/6**
LASKY'S PRICE

REV COUNTERS
Up to 9999 with reset at any time. **LASKY'S PRICE 15/-**

ELECTROLYTICS CONDENSERS

- 8 mfd. 450 v.w. 2/3
- 8 mfd. 500 v.w. 2/11
- 16 mfd. 350 v.w. 2/6
- 16 mfd. 500 v.w. 3/6
- 32 mfd. 500 v.w. 4/11
- 50 mfd. 350 v.w. 3/11
- 60 mfd. 350 v.w. 3/11
- 250 mfd. 350 v.w. 4/11
- 8+8 mfd. 450 v.w. 4/6
- 8+16 mfd. 500 v.w. 4/11
- 12 x 12 mfd. 350 v.w. 3/6
- 16+16 mfd. 500 v.w. 4/6
- 16+24 mfd. 450 v.w. 5/11
- 32+100 mfd. 450 v.w. 7/6
- 60+100 mfd. 350 v.w. 9/6
- 25 mfd. 25 v.w. 1/6
- 50 mfd. 12 v.w. 1/6
- 50 mfd. 50 v.w. 1/6
- 75 mfd. 12 v.w. 1/-

All brand new and guaranteed (not ex-Govt.). All other types, paper, tubular, waxed, etc., in stock.

RF25 UNITS. New, with valves. 19/11. Carriage 2/6.

GARRARD RECORD PLAYERS
For 6 and 12 v. operation. Complete with magnetic pick-up, and volume control. In metal cabinet size: 17in. x 14in. x 11in. Very limited quantity. **LASKY'S PRICE £5.19.6**
Carriage 10/- extra.

VCR97 C.R. TUBES. New, unused, 40/- Carriage 5/-.

E.H.T. Transformer for VCR97, 45/-.

Screen Enlarger for VCR97 Filter type, 17/6. Postage 2/6.

E.H.T. Condensers.
.1mfd. 3Kv. 3/6. .1mfd. 2.5 Kv. 2/6.

R1132 RECEIVERS. New, boxed, with all valves, £3/19/6, Carriage 10/-.

METAL RECTIFIERS
12 v. 1 a. 6/9 12 v. 1/2 a. 3/6
6 v. 1 a. 3/11 6 v. 4 a. 18/6
12 v. 4 a. 18/6

OUTPUT TRANSFORMERS
40 mA. Multi ratio 6/11
80 mA. Multi ratio 14/11
80 mA. Pentode 12/6
60 mA. Plessey, 6,000 ohms 5/11
Standard pentode 4/11
Pentode 3/6
Midget Pentode 4/3
Miniature Pentode, 3S4, IS4 4/6
PX4 Intervalve 8/6
5:1 Intervalve 5/11

P.M. LOUDSPEAKERS
All less o'trans. new and unused. First quality.
3in. .. 12/11 5in. .. 12/6
6 1/2 in. .. 13/6 8in. .. 15/-
10in. .. 32/6

R.1155 RECEIVERS. BRAND NEW. AERIAL TESTED BEFORE DESPATCH

These well-known ex-Air Ministry Receivers need no further introduction.

Supplied complete with 10 valves.

LASKY'S PRICE £11.19.6

USED MODELS £7.19.6

Carriage 12/6 per unit extra.

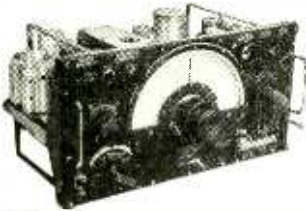

Fully Assembled Power Pack and Output Stage, for R.1155 Receiver. For use on 200-250 volts A.C. mains. **LASKY'S PRICE 79/6**
Carriage 5/- extra.

METER BARGAINS.
Plush Panel Mounting. 0-4 amps. R.F. thermo-couple. 2 in. scale. 7/6. 0-15 volts 50 cps. Moving iron. 2 1/2 in. scale. 8/6.

LASKY'S

Lasky's (Harr) 370 HARROW ROAD, PA

(Opposite Paddington) MAIL ORDER & DESPATCH DEPARTMENTS
Telephones: CUNningham

Hours: Mon. to Sat. 9.30 a.m. to 6 p.m., Thurs. half-day 1 p.m.

THE VIEWMASTER

ALL COMPONENTS IN STOCK

ANY SINGLE ITEM AVAILABLE SEPARATELY



COILS
All models available including filter chokes. Price (except Alexandra Palace). 28/- per set. Alexandra Palace. 20/- per set. L9 RF choke, 2/-.

CHASSIS
Sound-Vision, 18/6.
Power-Pack/TIME base, 18/6.
Support for S.V. chassis, 6/-.

G.B. T.V. COMPONENTS
Line Trans. ... 29/6
Frame Trans. ... 22/6
Main choke ... 12/6
Width Coil ... 6/11
Boost Choke ... 3/9
All suitable for Home Construction T.V.

LASKY'S LINE TRANSFORMER
RF EHT for line fly back. 6-8Kv, with EY51 heater winding. Suitable for home construction T.V. 25/-.

TELEVISION SELENIUM
The very latest "Sentercel" S.T.C. range
K3/40, 3.2 kV. ... 7/6
K3/45, 3.6 kV. ... 8/2
K3/50, 4.0 kV. ... 8/8
K3/100, 8.0 kV 14/8
K3/160, 12.8 kV 21/6

DARK SCREEN FILTERS
18in. x 14in. 25/-
14in. x 12in. 19/6
13in. x 11in. 14/11

PERSPEX. 13 1/2 x 10 1/2 x 1/2 in. Neutral shade, slightly marked 5/11 per piece.

W/B & PLESSEY
Line EHT trans. ... 32/6
Frame trans. ... 25/6
3 Mc/s boost choke ... 5/9
Width control ... 10/-
Scanning coil ... 33/3
Main choke ... 15/6
Focus ring ... 22/6
Heater trans.:
WB/103 ... 42/-
WB103A ... 52/6
Front and rear C.R.T. supports ... 21/6

C.R.T. MASKS.
Brand New. LATEST ASPECT RATIO

9in. ... 7/-
10in. ... 7/6
12in. ... 15/-
12in. Flat Face ... 15/-
12in. Old ratio ... 9/6
12in. Plastic, with dk. sc. filter and gold finish escutcheon ... 17/6
15in. do. do. ... 21/-
14in. Rect'gr. ... 21/-
15in. Cream rubber ... 17/6
16in. Eng. Elect. ... 42/-
16in. Double D ... 31/6
17in. Rect'gr. ... 25/-

SOILED, NEW ASPECT RATIO
9in. sorbo ... 5/-
12in. ... 7/6
12in. with fitted armour plate glass, cream ... 11/6
12in. do. Black ... 8/6

TEST PRODS.
Fully fused, with retractable points 4/11 per pair (1 red, 1 black).

METAL RECTIFIERS
WX3 and 6. Ea. 3/9
14D36 ... 12/4
14A86 ... 20/4
14A100 ... 21/6
36EHT45 ... 23/8
36EHT50 ... 26/1
36EHT100 ... 29/6

PLESSEY
Scan coils per pair 25/-
Width Control 6/6

NOW AVAILABLE. LARGE SCREEN, WIDE ANGLE CONVERSION DETAIL FOR THE VIEWMASTER.
Send 3d. stamp for full data. Fully itemised price list of all Viewmaster components now available.

ALL T.C.C. CONDENSERS
exactly as specified for use in The Viewmaster can now be supplied from stock.

ARMOUR PLATE GLASS

15in. Actual size 18in. x 19in. x 1/4 in. ... 7/11
12in. Actual size 13in. x 10 1/2 in. x 1/4 in. ... 4/-
9in. Actual size 9in. x 8in. x 1/4 in. ... 3/-

LIMITED QUANTITY (Frustated Export). 5 WAVEBAND CHASSIS.

Circuit has RF stage, Magic Eye Tuning Indicator, and many other features. For use on A.C. mains 100-250 volts. Waveband coverage: 11.5 metres to 550 metres. In 5 bands.

LASKY'S £10-19-6
Complete with valves, less dial. Carriage and packing, 15/- extra. **WILL MAKE A SUPER RADIO-GRAM.**

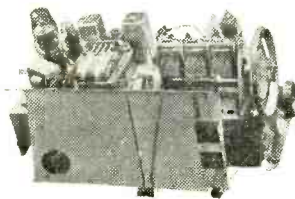

INTERCOM UNITS
4-station operation. For use on A.C./D.C. mains 200-250 volts. Supplied complete, with 3 new valves, ready for immediate installation. Fitted in attractive plastic cabinet. Suitable for use as baby alarm. **MASTER UNIT £7/15/-.** Carr. 5/- extra. **Extension Units.** Price 21/- each complete. Carriage 2/- each extra.

DINGHY AERIALS WITH REFLECTORS
Umbrella type, with wire mesh reflector complete with setting up instructions. Mast not supplied. **LASKY'S 7/6** Post 1/6. **PRICE**

TANNOY PRESSURE UNITS
10 watts. 7.5-ohms impedance. Last Few only **Price Reduced to 59/6** Carriage 4/6 extra.

The television set you can build at home from standard parts.

A MODEL FOR EACH FREQUENCY. State station required.

Brilliant high definition black and white picture Superb reproduction. Uses 9in. or 12in. Cathode Ray Tube. Table or Console Model.

Incorporates all the latest developments.

Television for the home constructor at its finest

Send to-day for the **CONSTRUCTION ENVELOPE.** 32-page booklet crammed with top-rate information and all the necessary data, also 8 full-size working drawings and stage by stage wiring instructions.

Alexandra Palace, Sutton Coldfield, Holme Moss, Kirk o'Shotts, Wenvoe, Pontop Pike, Belfast. State model required.

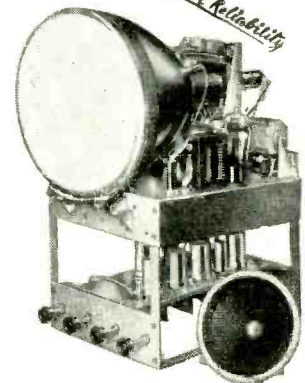

PRICE 7/6 per copy. Post free

Co-Axial Cable. 70-80 ohms impedance.

Single core, 9/- doz. yards. Twin core, 12/- doz. yards. Twin feeder, 6/- doz. yards. **Co-Axial Connectors.** For standard 1/4 in. cable, 1/11.

12 VOLT VIBRATOR UNITS
Output 230 volts 80 mA. **BRAND NEW AND UNUSED.** Size: 9 x 5 x 5 1/2 in. Supplied less vibrator. Vibrator required is 6 pin synchronous. **LASKY'S PRICE 19/6**

Carr. 3/6 extra. Other types in stock from 15/-.

T.C.C. VISCONOL HIGH VOLTAGE CONDENSERS (Cathodray).

.001 mfd. 15 kV. ... 10/-
.001 mfd. 25 kV. ... 18/-
.0005 mfd. 25 kV. ... 18/-
.0005 mfd. 12.5 kV. ... 10/-
Plastic case, single bolt fixing.
Other high voltage condensers
.1 mfd. 7 kV. ... 15/-
.04 mfd. 12.5 kV. ... 7/6
.001 mfd. 12.5 kV. ... 7/6

MAINS TRANSFORMERS

All 200-250 volts c.p.s. primary. Finest quality, fully guaranteed. **MBA/3.** 350-0-350 v. 80 mA., 6.3 v. 4 a., 5 v. 2 a. Both filaments tapped at 4 volts. An ideal replacement trans. Price 18/-.
MBA/6. 350-0-350 v. 100 mA 6.3 v. 3 a. 5 v. 2 a. With mains tapping board. Price 22/6.
MBA/7. 250-0-250 v. 80 mA., 6.3 v. 3 a., 5 v. 2 a. Both filaments tapped at 4 volts. Price 18/-.
AT/3. Auto transformer. 0-10-120, 200-230-240 volts 100 watt. Price 17/6.

FILAMENT TRANSFORMERS

6.3 v. 1.5 a., 7/11
6.3 v. 3 a., 12/6.
Special Transformer. 2 amps. with the following tappings: 3, 4, 5, 6, 8, 9, 10, 12, 15, 18, 20, 24 and 30 volts. Price 17/6.

DE LUXE TELEVISION CABINETS

For 12in. cathode ray tubes Beautiful figured medium walnut finish, with high polish Fitted with shelf for receiver glass speaker baffle and fret and castors for easy movement. Undrilled. Suitable for use with The Viewmaster. "Practical Television," "Practical Wireless," and "Wireless World" televisions

LASKY'S £8.10.0 PRICE

Carriage 12/6 extra.

Outside dimensions of cabine 17 1/2 in. x 16 1/2 in. x 32 in. **Why not convert your table receiver to a console?** Adaptor frames for fitting 9in. or 10in. C.R. tubes available if required.

This cabinet can also be supplied cut out for a 16in. C.R. tube.

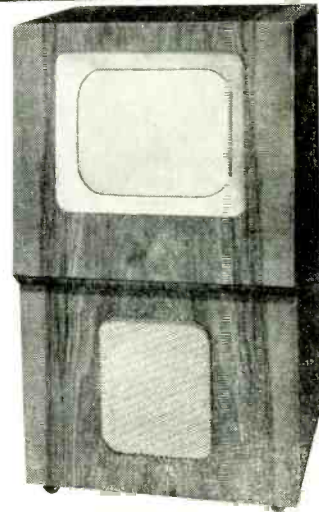

RADIO
ow Road) Ltd.,
DDINGTON, LONDON, W.9
Hospital)

485/487 Harrow Road, Paddington, London. W.10
1979 and 7214. All Departments.

TERMS: Pro Forma, Cash with order, or C.O.D. on post items only. Postage and package on orders value £1-1/- extra, £5-2/- extra. £10-3/6 extra. Over £10 carriage free. All goods fully insured in transit.

BUILD A PROFESSIONAL RADIO OR AMPLIFIER AT LESS THAN HALF TODAY'S PRICE

You're SURE to get it at **STERNS** ESTABLISHED 25 YEARS

THE "Wireless World" 3-Valve Set

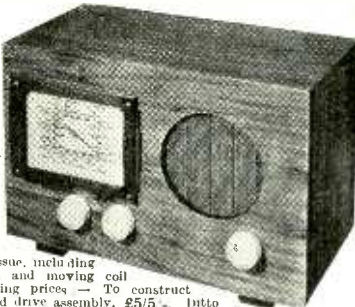

A Midget 3-valve T.R.F. Receiver for operation on A.C. mains, covering long and medium wavebands. We are able to supply all of the components to build this set, as designed and specified in the Feb. 1950 issue, including the drilled chassis, Valves and moving coil speaker, etc., at the following prices - To construct complete chassis, less dial and drive assembly, £5/5/-, into including dial and drive assembly, £6. To construct the complete set, including dial and drive assembly and cabinet, £7/3/6. Overall size of cabinet is 7 1/2 in. x 3 1/2 in. x 1 1/2 in. A reprint of the designer's article, giving circuit and assembly instructions (this is available separately for 9d.) together with a practical component layout is included with each of above assemblies.

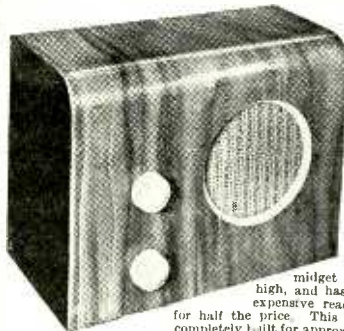

A MIDGET 4-STATION "PRE-SET" RECEIVER
A complete Kit to build a 4-station "Pre-set" Superhet Receiver for A.C. mains operation.

The set is designed to receive any three stations on medium waveband and one on long wave, each station being received by the turn of a rotary switch—no tuning being necessary. It is of midget size, being 3 1/2 in. x 4 1/2 in. x 7 in. high, and has the performance of a far more expensive ready-made set, but can be built for half the price. This Receiver, as illustrated, can be completely built for approx. £9/9/-. The complete assembly instructions, including component layout and component price list, are available for 1/6

A MAINS OR BATTERY PORTABLE KIT



A Midget 4-valve Superhet Portable Set covering medium and long wavebands.

Designed to operate on A.C. mains 200/240 volts, or by an "Alldry" battery. The set is so designed that the mains section is supplied as a separate unit, which may be added at any time. The Kit, therefore can be supplied (a) as an "Alldry" Battery Superhet Personal Set which can then be accommodated in the attaché case as illustrated (size 9 1/2 in. x 4 1/2 in. x 7 in.), this is attractively finished in lizard, maroon, dark green or blue rexine, or (b) as a combined Mains/Battery Superhet Portable Receiver, for which a polished wood cabinet is available to accommodate both Mains Unit and Batteries together.

Circuit incorporates delayed A.V.C. and pre-selective Audio Feedback. Kit is complete in every detail and includes ready-wound frame aerials, fully aligned I.F. transistors and drilled chassis, etc.

Overall size of assembled chassis 5 in. x 4 in. x 2 1/2 in. This receiver, as illustrated, can be completely built for approx. £10 (plus Mains Unit if required). Send 1/6 for the fully descriptive Assembly Book which includes Practical Layouts and complete price list of Components. Attaché case available separately, 3/7/6.

TWO BATTERY PORTABLES (a) THE "MINI-TWO-THREE"

An "Alldry" Battery Portable of midget size, 6 1/2 in. x 4 1/2 in. x 3 1/2 in., designed to cover medium waveband 190-550 metres, with use of short trailer aerial. The simple design of this Receiver is so arranged that either a 3-valve set or a 2-valve (afterwards easily converted to the 3-valve) can be made. Consists of a T.R.F. circuit using a regenerative detector with H.F. stage and a high gain output pentode. Valve line up 1T4-1T4-D1L94.

The 2-valve set can be completely built for £4/3/6 (less case), and the 3-valve for £5/3/- (less case). Each price includes valves, speaker and drilled chassis. Send 1/6 for the assembly instructions: they include simple and complete practical component layouts and diagrams, which enable the most inexperienced constructor to successfully build either set. All components are available for separate sale, a price list being supplied with assembly instructions.



(b) THE "MINI-FOUR"

A 4-valve Battery Superhet Receiver designed to receive 4 pre-set stations, three on medium waveband and one on long wave to suit local conditions. Each station is obtained on the set by the turn of a rotary switch. No tuning is necessary.

It is of midget size, being only 4 1/2 in. x 6 1/2 in. x 4 1/2 in. when completely built and is very easily assembled from diagrams supplied. Cost of all components to build this set, in accordance with the design, including a drilled and cut chassis and panel and new valves, is £9/10/- (or less valves for £6/7/6). Attractive carrying case finished in blue leatherette, 16/9. Complete constructional data with a blue print, which shows the practical component layout and wiring diagram, together with an individual component price list, is available separately, 1/6. Our battery eliminators (illustrated above) available in kit form are suitable for use with this set.

long and medium wavebands. We are able to supply all of the components to build this set, as designed and specified in the Feb. 1950 issue, including the drilled chassis, Valves and moving coil speaker, etc., at the following prices - To construct complete chassis, less dial and drive assembly, £5/5/-, into including dial and drive assembly, £6. To construct the complete set, including dial and drive assembly and cabinet, £7/3/6. Overall size of cabinet is 7 1/2 in. x 3 1/2 in. x 1 1/2 in. A reprint of the designer's article, giving circuit and assembly instructions (this is available separately for 9d.) together with a practical component layout is included with each of above assemblies.

"PERSONAL SET" BATTERY ELIMINATOR

A complete Kit of parts to build Midget "Alldry" Battery Eliminator, giving approx. 69 volts and 1.4 volts. This eliminator is for use on A.C. mains and is suitable for any 4-valve Superhet Receiver requiring H.T. and L.T. voltage as above, or approx. to 69 volts. The Kit is quite easily and quickly assembled and is housed in a light aluminium case size 4 1/2 in. x 1 1/2 in. x 3 1/2 in. Price of complete Kit with easy-to-follow assembly instructions, 42/6. In addition we can offer a similar COMPLETE KIT to provide approx. 90 volts and 1.4 volts. Size of assembled unit 7 in. x 2 1/2 in. x 1 1/2 in. Price 47/6.



THE "MINI-TWIN" 1-VALVE BATTERY SET

A design of a simple 1-valve 2-stage Battery Receiver, giving excellent results on medium and long wavebands and having exceptionally low battery consumption.



Drilled chassis and practical diagrams make it the ideal set for the beginner to build.

The complete chassis, including valve, can be built for 37/6, the attractive plastic case is 9/6, and suitable headphones 14/9.

The complete assembly instructions, layouts and a component price list, are available for 1/6.

This Receiver also performs excellently, without modification, as a tuning unit, and in addition, with simple modifications for which a complete diagram is provided makes a first-class pre-amplifier for pick-up or microphone.

THE VIEWMASTER TELEVISOR

We have had very considerable experience in assisting customers to build this TV and can supply a SPECIFIED COMPONENTS EX-STOCK. The assembly instructions showing practical layouts and price list are available for 7/6 for London, Sutton Coldfield, Holme Moss, Kirk-o-Shotts and Wenvoe. Complete television price list is contained in our general STOCK LIST at 9d., including Haynes, etc., components.

THE DENCO ULTRA MIDGET SUPERHET COIL TURRETS WITH A ROTARY TURRET ACTION

Type CT9 consists of a four station "pre-set" unit from which any three stations on medium waveband and one on long wave can be received by a turn of the turret switch. Price 39/6

Type CT10, is a 3 waveband coil pack incorporating a fourth switch position for "Gram. Complete coverage is, long waveband 700-2,000 metres, medium waveband 190-570 and short wave 15-50 metres. Price £2/8/-.

A complete receiver circuit and all necessary data is included with each turret. These can be supplied separately for 6d.

PICK-UPS

Cosmocord "G.P.20," for standard records, £3/5/9 interchangeable (G.P.19) head for L.P. records, £2. Decca lightweight "turnover head" type, for L.P. and standard records, £3/12/6. Goldring, standard, lightweight Magnetic, 33/-. Cosmocord "Acor" G.P.30, turnover crystal type. For Standard or L.P. Records, £3/5/9.

BATTERY CHARGER KITS

All kits incorporate metal rectifiers and are for use on A.C. mains 220-250 volts. All kits include an easily followed wiring diagram. All prices include a TAPPER RESISTOR and a five-position SELECTOR SWITCH to enable the charging rate to be varied. For 6 or 12 volt batteries at max. 1 amp., £1/18/9 (excluding Resistor and Switch, £1/3/6). For 6 or 12 volt batteries at max. 1 1/2 amps., £2/4/- (excluding Resistor and Switch, £1/9/9). For 6 or 12 volt batteries at max. 2 1/2 amps., £2/14/6 (excluding Resistor and Switch, £1/19/6). For 6 or 12 volt batteries at max. 4 amps., £3/2/6 (excluding Resistor and switch, £2/7/3).

HOME CONSTRUCTORS A CAR RADIO RECEIVER FOR £12.0.0

A design of a 5 Valve Superhet Receiver, employing an R.F. Stage for 6 or 12 Volt supply. Send 2/6 for the complete set of Assembly Instructions, CIRCUITS, LAYOUTS, and POINT-TO-POINT WIRING DIAGRAMS, together with a complete component Price List.

THIS IS NOT AN EX. GOVT. RECEIVER. IT IS A NEW DESIGN EMPLOYING NEW COMPONENTS.

TELEVISION !! A GENUINE SPECIAL OFFER FOR CALLERS ONLY

A FAMOUS MANUFACTURER'S 19-VALVE T.V CHASSIS FULLY ASSEMBLED AND READY FOR USE

For London transmission only employing a superhet circuit and incorporating the following valve line up :-

- 6 Type E.F.42
- 2 Type E.L.33
- 2 Type E.B. 41
- 1 Type E.F.41
- 1 Type E.C.C.91
- 1 Type E.C.H.42
- 1 Type E.L.38
- 1 Type E.Z.35
- 1 Type G.Z.32
- 2 Type E.Y.51
- 1 Type 6SN7

WE HAVE A FEW ONLY AT THE VERY SPECIAL PRICE OF £19/19/-, including all Valves, or £33, including a NEV MULLARD TYPE M.W.31/14c 12in. Tube. (Loudspeaker extra.)

COME AND SEE IT WORKING !

TWO COMPLETELY ASSEMBLED "ALL-WAVE" SUPERHET CHASSIS

(a) MODEL B.3. A 5-valve 3-waveband superhet Receiver.
 (b) MODEL B. A 5-valve 6-waveband (4 bandspread) superhet Receiver.
 Both Receivers are for operation on A.C. mains 100/200 volts and 200/250 volts, and employ the very latest miniature valves. They are designed to the most modern specification, great attention having been given to the quality of reproduction which gives excellent clarity of speech and music on both gram and radio, making them the ideal replacement chassis for that "old Radiogram," etc.

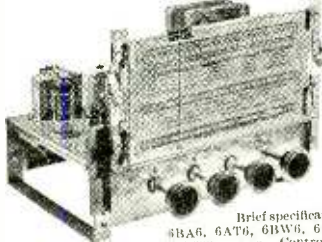

Brief specifications: Model B.3.—Valve line up, 6B86, 4BA6, 6AT6, 6BW6, 6X4—waveband coverage, short 16-50, medium 187-550, long 900-2,000 metres. Controls: (1) volume with on/off; (2) tuning (flywheel-type); (3) wavechange and gram; (4) tone (3-position switch-operative on gram and radio).
 Chassis size: 11 x 7 1/2 x 8 1/2 in.
 Negative feedback is employed over the entire audio stages.
 Model B employs a similar valve line up as the B.3, but covers 6 wavebands. Short wave 11-16, 16-25, 25-23, 31-45 and 43-120 metres, and medium wave 187-550 metres. The first four short bands are bandspread. The controls employed are as used on the B.3 model, but the tone control operates a six-position switch, having three additional positions for varying bass and treble on gram reproduction. Negative feedback is employed over the entire audio stage. Size of chassis and dial is as given for B.3. Price complete and the entire audio stage, £15/15/-. Carriage, packing and insurance 7/6 extra.

A GENUINE SPECIAL OFFER ! PLESSEY 3-SPEED AUTO CHANGE UNITS

Brand New in maker's Cartons, complete with mounting instructions.

£11 - 3 - 6

(Normal price is £23/10/-)



MODERNISE YOUR OLD RADIOGRAM FOR

£25

(plus 10/- carriage and insurance) with the very latest equipment. We will supply the 3 waveband chassis on the left with the Plessey auto changer on the right, complete with 10" speaker for £25 (£28/7/6 with the 6 waveband chassis). This is less than half the price of comparable commercial three speed auto radiograms.

- These units will auto change on all three speeds, 7in., 10in. and 12in.
- They play MIXED 10in. and 12in. records.
- They have separate sapphires for L.P. and 78 r.p.m. which are moved into position by a simple switch.
- Minimum baseboard size required 16in. x 12 1/2in. with height above 5 1/2in. and height below baseboard 2 1/2in.

A bulk purchase enables us to offer these BRAND NEW UNITS at this exceptional price.

Please add 7/6 packing, carriage and insurance.

A Complete Kit of Parts to build a 3-4 Watt HIGH GAIN AMPLIFIER

for operation on A.C. or D.C. Mains. 200-250 Volts.



This amplifier will give 3 watts output for the small input voltage of only 75 millivolts, and is therefore suitable for use with any type of pick-up from the crystal type to the miniature H/F Magnetic type.
 A tone control is incorporated and the quality produced is excellent. The overall size of chassis is 9in. x 3in. x 7in. and valve line up 25Y5-bmt7-25L6.
 Price of complete kit, including drilled chassis and valves, £4/2/6, plus 6/11n. P.M. (which fits on chassis), 16/-, or 8in. P.M., 18/9.
 Price of fully assembled chassis ready for use, £5/5/- (plus cost of speaker).
 Copy of assembly instructions and components price list available for 1/3.

!! AMPLIFIERS !! TWO COMPLETE KITS OF PARTS

A 6-8 watt QUALITY "PUSH-PULL" AMPLIFIER designed for A.C. mains 200 to 250 volts, incorporating a simple arrangement to enable either a magnetic-crystal or lightweight pick-up to be used, and is suitable for use with standard or long-playing records. A tone control is incorporated, and the 10-watt output transformer is designed to match 2 to 15 ohm speakers.
 The overall size of the assembled chassis is 10in. x 8in. x 7 1/2in. high, and full practical diagrams are supplied. Price, including drilled chassis and valves, of complete kit, £6/17/6. Price of assembled chassis, supplied ready for use, £8/12/6. Full descriptive leaflets are available separately for 1/-.



A 12-watt HIGH FIDELITY "PUSH-PULL" AMPLIFIER designed for A.C. mains 200 to 250 volts, employs 6 valves plus rectifier, with negative feedback, and comprises a main amplifier chassis and a remote controlled Pre-amplifier and Tone Control Unit, incorporating four controls—bass, treble, main volume or mixing control, and a radio, gram, microphone, selector switch. This control unit measures only 7 x 4 x 2in. The measured frequency range of the amplifier with this unit shows an excellent response from 15,000 cycles down to 20 cycles, the bass and treble controls allowing independent control of gain at both ends of the frequency range from zero to a gain of 50. It can be seen, therefore, that ample correction is provided to suit any type of pick-up with any type of recording. Input voltage for maximum output is 70 mV., 6.3 volts at 2 amps and 30 mA H.T. is provided for tuning unit, etc. Price of complete kit, including drilled chassis and valves, £14. Complete specification and layout, 2/-. We can also supply completely assembled and ready for use at £17.
THIS AMPLIFIER COMPARES WELL WITH THE WILLAMSON AND SIMILAR DESIGNS AT A FRACTION OF THE COST.

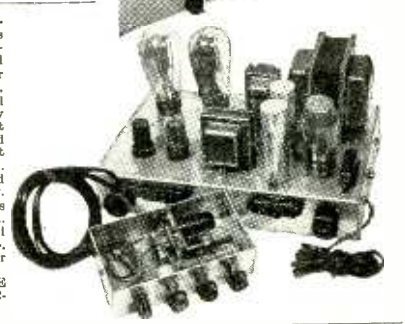

A 5-VALVE "ALL-WAVE" SUPERHET RECEIVER

For use on A.C. Mains 200 to 250 volts. This small attractive Receiver, embodying modern circuit technique, is designed to cover Short, Medium and Long wavebands, and incorporates the following outstanding features:

- A superhet circuit designed for high efficiency on all three wavebands.
- A 3in. P.M. Speaker accurately matched for good quality reproduction.
- The latest range of new 6-volt B.V.A. miniature valves.
- Built-in frame aerial with provision for external aerial for distant stations.
- A white plastic cabinet of very attractive appearance overall size 7 1/2in. x 5 1/2in. x 5 1/2in.
- THE RECEIVER AS ILLUSTRATED CAN BE BUILT FOR APPROX. £10/10/-.

Send 2/6 for the fully descriptive stake by stake assembly and wiring diagrams, with which complete price details are given.

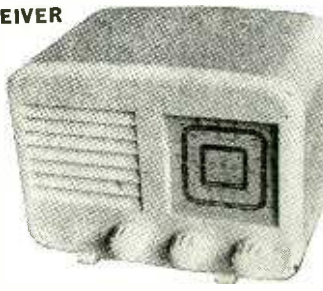

A DUAL CHANNEL PRE-AMPLIFIER and TONE CONTROL UNIT

This comprehensive PRE-AMPLIFIER and TONE CONTROL UNIT provides a full control of bass and treble in conjunction with a main Volume/Mixer Control.



It can be used with any amplifier and with any pick-up, the range of frequency control provided by the unit affording ample compensation for all types of pick-up and all natures of recordings, i.e., English, American and long playing, without recourse to pick-up correction. The extreme flexibility of the bass and treble controls is such that the level of bass and treble can be set to suit any conditions irrespective of the volume output of the amplifier.
 Response characteristics are given in 12-watt amplifier advt.

The unit measures only 7in. x 4in. x 2in., including self-contained power supply, and can be accommodated either on or away from the main amplifier, i.e., on the front panel of a cabinet or any other position. Price, including drilled chassis, valves (6AN7 and 6J5), £3/16/9. Complete assembly data is available separately for 1/-.

STERN RADIO Ltd.
109 & 115, FLEET STREET, E.C.4

Tel.: CENTRAL 5812-3-4

CLYDESDALE

Bargains in Ex-Service Radio and Electronic Equipment

TEST SET SE2 PATTERN NO. W5799.

BRAND NEW
Contains: Wavemeter, oscillator and noise generator working on frequency of 180 to 220 mcs. Valves are 1/6X5, 1/655, 1/L63, 2/EA50, 1/EC52, 1/E1468. Mains Transformer 80V., 180V., 230V., 50-2,000 cps., 10-500 microamp meter. All sections are separately screened with their own brass boxes, which are silver plated. Complete with leads and attenuator in wooden case. Grey finish. Size 20in. x 10in. x 11in. Weight 55½ lbs.
Calibration chart on lid of box.
ASK FOR **£3 19 6** CARRIAGE PAID
No. X/H937.

OSCILLATOR (SIGNAL GEN.) TYPE 35
Ex. Admiralty. Robustly constructed signal generator with frequency coverage 15-600 kcs. 0.8-25 mcs. in 11 switched bands, 200-l ultra S.M. Drive. Input 200v. D.C. H.T. and 250v. A.C. or 12v. D.C. for valve heaters, L.T. Supply. Shorting strips for altering heater circuit beneath valves. Valves type KTW61 and 2/DL63 or equiv. NOT SUPPLIED.
Chassis and panel construction in steel and finished in grey and black. Dim. 28in. x 7½in. x 12in. Wgt. 71 lbs.
ASK FOR **£6 19 6** CARRIAGE PAID
No. X/E787.

RECEIVER CHASSIS Range 150-200 mcs. Contains:—1 Transformer prim. 85M. henries, sec. 155M. henries, 5-Coils in cans, 3/957 acorn valves, 4 acorn valve bases, 9-1.0 valve bases, 1-25pf. miniature tuning condenser with knob and coupling, 4 co-ax. sockets. On metal chassis, size 8in. x 13in. x 5in. Weight 8½ lbs.
ASK FOR **21/-** CARRIAGE PAID
No. X/H940.

PROJECTOR UNIT NO.2
BRAND NEW REF. 10DB/1207
Contains:—1 VCR522A 1½in. tube with mu/metal screen 3½in. lens and optical mirror. This is a form of radar gunsight in which an image of an object is placed on the C.R.T. screen, over which is superimposed an image from the gunsight.
Also contains Lamp for Illuminating Gunsight. Size: 12in. x 5in. x ½in. In transit case. Weight 15 lbs.
ASK FOR **45/-** CARRIAGE PAID
No. X/H942.

NEW CATALOGUE No. 8D
Gives details and illustrations of Ex-Service and other items. Price 1/6
Credited on 1st purchase of 10/- value or over.

TRADE ENQUIRIES INVITED
Generous Discounts
GOOD BARGAINS

Order direct from:—
CLYDESDALE SUPPLY CO. LTD. 2, BRIDGE STREET GLASGOW - C.5
Phone: South 2706/9 Branches in Scotland, England and Northern Ireland

INDICATOR UNIT TYPE 305
BRAND NEW REF. 10QB/6504
Contains:—VCR524A-VCR525, 7 EF50, 2 VR54, 6 EA50, 2 .01 high voltage condensers, 3 relays 4 make, 4 break, 500 ohm. coil. Numerous condensers, pots., and resistors.
Dimensions 12in. x 7in. x 18in. Weight 30 lbs.
ASK FOR **£4 19 6** CARRIAGE PAID
No. X/H943.

DRIVER TRANSFORMER for ET-4336 TRANSMITTER
Ref. No. 110/K117, Part XT-3202.
Centre tapped primary, Inductance 2.4 henries Two Secondaries, Inductance 14 henries each Ratio whole pri. to one sec. 1-2 approx. Dim. Ht. 4½in. x 3½in. x 3½in. Wgt. 6½ lb. 4-hole fixing.
ASK FOR **18/6** each CARRIAGE PAID
No. X/E562.

SUPPLY UNIT RECTIFIER
for No. 43 Transmitter.
Ex. Cdn. Army in original wood case. Input 110 volts A.C. 50/60 c/s. 1.7 K.V.A. Outputs (HT1) 2,100V. 375 mA. (HT2) 500V. 400mA. plus HT Lines, 250V. 275V., also 383V. regulated and neg. bias 250V. 150V., 80V. Making 3 complete power supplies all fed via double choke, condenser, input circuits. Valves are 4/866A/866, 5Z3, 6S17, 2/6A3, VR150/30 (Stab.) and 1V. (Time Delay).
The complete unit mounted in metal case with lid. 5hook mounted. Dim.: 2ft. 6in. x 1ft. 6in. x 1ft. Finish olive drab. Wgt. 420 lb.
ASK FOR **£25** CARRIAGE PAID
No. X/H26.

Ready Made for T.V. THE POWER UNIT TYPE 285.
A.C. mains, input 230V. 50 cps. Outputs E.H.T. 2kv. 5 mA. H.T. 350 V. 150 mA. L.T. 6.3V. 10A. and 6.3V. 5A. Fully smoothed and rectified with valves VU120, 5U4G, VR91 (EF50) plus cond., resistors, etc.
ASK FOR **£4 19 6** CARRIAGE PAID
No. X/H947.

UNIVERSAL ELECTRONICS

London's Largest Selection of High Quality Communications, Audio, VHF and Test Equipment.

Test Equipment

AVO Wide Range signal generator, as NEW, £22/10/- **AVO** Model 7, as NEW, £15. **AVO** 40, £11. **AVO** Minors, £6/15/- **TAYLOR** 30A Oscilloscope, as NEW, £22. **TAYLOR** Wobblulator, £10. **COSSOR** Double Beam Oscilloscopes from £30. **WESTON** Industrial test set 20,000 OPV, £20. **PHILIPS** Audio Oscillator GM2307, £35. **SALFORD** type 106 Signal Generator, as NEW, £35. **FURZEHILL** Oscilloscope type 1936, £35. **EVERSHED** Wee Meggers 500 v., £12/10/-, 500 v. Bridge, £35. **MARCONI** Valve voltmeters, £33. General Radio Type 804 signal generator, 30-300 mc/s. Marconi signal generators types 517, TFI44G, TF390G.

Receivers

RCA AR88LF-D, **RCA** AR77E 550 kc/s-32 Mc/s, as NEW, £35. **HALLICRAFTERS** SX43, £90. SX28, £45. SX24, £35. S20R, £25. S38 AC/DC 110-250 v., £25. **RME** 69 excellent condition, £40. **HRO** Junior and Senior receivers, complete with coils and power supplies, from £30. **CR** 100 receivers 60 kc/s-30 Mc/s, £28.
Manuals for: **RCA** AR88D-LF. **HRO**'s. CR100. S27. SX28. AR77E. S20R. HQ120. All at 27/6 per copy.
In Stock: **Bendix** BC221 frequency meters. TS69AP. 300-1,000 Mc/s Wavemeters. TS45 3CM Signal Generator. TS174. 30-250 Mc/s. TS127. 325-725 Mc/s Wavemeter. Kylstrons type 723/AB. 707B. CV129. 2K22. 725A. Magnetrons, 2126 etc. Wavelength lengths and many other items of VHF equipment. S27 receivers, 30-150 Mc/s and receivers up to 1,000 Mc/s and 3,000 Mc/s.

Audio Equipment

Speakers: Vitavox, Goodmans etc. **Soundmirror** Tape Recorder, table model as NEW, £45. **Baird** Cine Soundmaster for use with projector, £40. **Decca** corner horn complete, £22. Tape for Soundmirror, used once, £5 per reel.

WANTED URGENTLY

At your price. Frequency Meters **Bendix** BC221. TS 174/U, TS 175, TS 3, TS 13, **RCA** AR88's. **Hallcrafters** S27C-CA. **Spectrum** Analyser TSX 45E or TS 148, and **Kylstrons** 723/AB, 2K39, 2K40, 2K41, 2K42, 2K43, 707/B, CV129.

Shop hours: 9.30 to 6. Thursday 11 p.m.
Phone GERrard 8410 (Day), MEAdway 3145 (Night).

OUR ONLY ADDRESS DEPT. W.

27 LISLE STREET, LEICESTER SQUARE, LONDON. WC2

G2AK

This Month's Bargains

G2AK

SPECIAL VALVE OFFER. 866A Rectifiers, 15/- each. 807's 12/6 each, or 22/6 pr. 931A, 45/-.
METERS. 2½in. Flush mounting M.C. 100 m/a., 12/6 each; 2in. Flush M.C. 5 m/a., 7/6; 4 amp. thermo. 5/-; 2½in. thermo. 0-2 a., 7/6; 2in. Flush 20-0-20 amps. M.C. 5/-; 0-20 volts 7/6; 2½in. Flush M.C. 0-100 m/a., 12/6 ea.; 0-15 a thermo. Proj. 2½in., 7/6 each.
CELESTION 10in. P.M. SPEAKERS. Few only, 27/6 each.
TWIN RIBBON FEEDER. Heavy duty 300 ohm. 5d. per yd. Standard K25 300 ohm ribbon, 9d. per yd. Co-axial cable, ½in. dia. 50 ohm, 8d. per yd. 7ft. length ½in. dia. Co-axial with Pye plug one end, 1/6, post free. All other Co-axial and feeder, plus 1/6 post any length.
POTENTIOMETERS. Carbon Type Potentiometers, 25k, 50k., 100k., ¼ meg., 2 meg., 1/6. Many W.W. slot types available for T.V. replacements.

SPECIAL OFFER. 300 ohm. Flat Twin 150 w. rating, 6d. per yd. (minimum 20 yds.) post free. **DEAF AID CRYSTAL MICROPHONE UNITS.** 12/6 ea.
STANDARD ½in. T.V. CO-AXIAL CABLE, 11d. yd. or 9/6 per doz. yds. or 9d. yd. in 100 yd. coils. P. and p. 1/6, any quantity.
STREAMLINED BUG KEYS by famous manufacturer. Listed at over £4. Our Price 45/- only.

SHROUDED M.C. MIKE TRANSFORMERS. M.C. mike or line to grid, 5/- each. P. and P. 1/-.
M.C. Mike Trans. 2/-, plus p. and p. 6d.
CARBON MIKE TRANS., 2/- each. P. and p. 6d.
COMPLETE SET OF AR88 TUBES (14) for LF or D model receivers, £5/10/-.

AR88 MATCHING SPEAKERS by R.C.A., fitted rubber feet and 6ft. lead, 65/-.
Panel escutchions 22/6 each.

TAPE RECORDING EQUIPMENT. Desks by Bradmatic, Tamsa, Lane and Qualtape. Ex stock. Heads, Oscillator Coils, Tape and Reels always available.

GERMANIUM DIODES. B.T.H. 2/-, G.E.C. 2/6.
Carriage paid on all orders over £1 except where stated. Please include small amount for orders under £1.

Please print your name and address.

CHAS. H. YOUNG, G2AK
All callers to 110 DALE END, BIRMINGHAM

Phone: CENTRAL 1635.
Mail orders to 102 HOLLOWAY HEAD, BIRMINGHAM
Phone: MIDLAND 3254.

MAINS TRANSFORMERS
 Primary, 200-250 v. P. & P. 2/-
 300-0-300 250 mA., 6 v. 5 a., 5 v. 3 a.
 Unclamped, 27/6.
 400-0-400 250 mA., 4 v. C.T., 3 a.,
 4 times. Unclamped, 32/6.
 300-0-300, 100 mA., 6 volt 3 amp.,
 5 volt 2 amp., 22/6.
 Drop thro' 350-0-350 v. 70 mA., 6 v.
 2.5 amp., 5 v. 2 amp., 14/6.
 Drop thro' 250-0-250 v. 80 mA., 0 v.
 3 amp., 5 v. 2 amp., 14/6.
 Drop thro' 110-110 60 mA., 6 v. 0.5 amp.,
 8/6.
 280-0-280, drop-through, 80 mA.,
 6 v. 3 amp., 5 v. 2 amp., 14/6.
 Auto-wound, H.T. 280-volts at 360 mA.,
 4 v. 3 amp., 2 v. 3 amp., or 6 v. 3 amp.
 Separate 4 v. 3 amp., 10/6.
 Auto-transformer, 110 v. 70 watts,
 10/6.
 250-0-250, 80 mA. 6 v. 4 amp., 14/-
 Pri. 230 v. Sec. 200-0-200 35 mA.,
 6 v. 1 amp., 8/6.
 Pri. 200/250 v., secondary 3, 4, 5, 6,
 8, 9, 10, 12, 15, 18, 20, 24 and 30 volt
 at 2 amps., 13/-.
 Semi-shrouded drop thro' 200/250 v.
 primary; sec. 250-0-250, 200 mA.,
 6 v. 5 amps., 5 v. 3 amps., 27/6.
 Semi-shrouded drop thro', 270-0-270,
 80 mA., 6 v. 3 amp., 4 v. 1.5 amp.,
 13/6.
 Semi-shrouded drop thro', 270-0-270,
 60 mA., 6 v. 3 amp., 11/6.
Heater Transformer. Pri. 230-250 v.
 6 v. 1 amp. 6/-; 2 v. 2 amp. 5/-;
 2, 4 or 6 v. at 2 amp. 7/6; 2 v. 2 amp.
 and 6 v. 0.6 amp. E.H.T. insulated.
 8/6. P. & P. each 1/-.
 800-0-800 250 mA., 4 v. 2 amp. 27/6.
 P. & P. 5/-.

P.M. SPEAKERS (closed field)
 with less trans. trans.
 3in. 10/-
 2 1/2in. 15/6
 3 1/2in. 13/6
 5in. 16/6
 6 1/2in. 16/6
 8in. 18/6
 10in. 18/6
 P. & P. on the above 1/- each.
 10in. less trans. 21/- P. & P. 1/6.
 R. & A. 8in. M.E. Speaker field coil,
 1,600 ohms O.P. trans. 5,000 ohms,
 imp. 13/6. P. & P. 2/-.
 5in. M.E. field coil 750 ohm with O.P.
 trans. 17/6. P. & P. 1/-.

Extension speaker cabinet, in contrast-
 ing walnut veneers, size 15x10 1/2in.
 P. & P. 2/-.
Volume Controls, Lion spindle less
 switch, 50k, 500K, 1 meg, 2/6 each.
 P. & P. 3d. each.

Expanded aluminium speaker fret,
 13 1/2 x 9in. 2/-.
Volume Controls, long spindle and
 switch, 2, 1, 1 and 2 meg. 4/- each.
 50 K, 3/6 each, 1 and 1 meg, long
 spindle double pole switch, miniature,
 5/-, P. & P. 3d. each.

Trimmers, 5-40 pf., 5d. 10-110, 10-250,
 10-450 pf., 10d.
Twin-Gang .0005 Tuning Condenser,
 5/-, with trimmers, 7/6. P. & P. 1/-.
Line Cord, 3-way 0.3 amp. 180 ohms,
 per yard, 1/3 per yard.
Twin-gang, .0005 with feet, size
 3 1/2 x 3 1/2in., 6/6.
3-rang, .0005, with feet, size 4 1/2 x 1 1/2in.
 7/6.

Television coils wound in alnico, size
 2 1/2 x 1in., with former and iron core,
 1/- each.
Hoover Variable Speed 600-1,200
 revs. Tape Recording Motor, Silent
 running, 200/250 v. A.C. Shaded pole
 with fixing. Weight 5 lb., 27/6.
 Plus P. & P. 2/6.

PERSONAL SHOPPERS ONLY. 9in.
 Embarger 17/6. 12in. 27/6.
Germanium Crystal Diode, 2/3 post
 paid.
Television Masks. White Rubber 9in.
 with glass, 7/6. Cream Rubber, 12in.
 with armour-plate glass, 15/-, 15in.
 Cream, 17/6 plus 1/6 P. & P.
T.V. Width Control, 3/6.

AMPLIFIER CHASSIS, 18 gauge
 aluminium plated steel with trans-
 former and 5 v/holder cut-outs. 12 1/2 x
 8 3/4in. 3/-, P. & P. 1/6.
USED C.R.T. TUBES Heater
 cathode shorts, 12in. 75/-; 9in.
 45/-; Ion burn, 12in. 55/-; 9in.
 35/-. Post and Packing 7/6 each.
CRYSTAL PICK-UP by famous manu-
 facturer, complete with sapphire
 trailer needle and volume control,
 23/-. Post and packing on each 1/6.

EX-GOV'T. RECEIVER TYPE B28.
 Complete coil unit, 6 bands, 60 kc/s.
 420 kc/s., 500 kc/s.-30 Mc/s., 21/-.
 Plus 2/- P. & P. Circuit for above,
 4/-.
Variable selectivity IF Switch to suit
 above, 7/6.

MODERNISE YOUR OLD CABINET
 BY FITTING A WALNUT BAKELITE
 ESCUTCHEON, size 15 x 8 1/2in. Complete
 with 3 waveband scale size 5 1/2 x 4 1/2in.,
 5/-, P. & P. 1/6.

D. COHEN

RADIO & TELEVISION COMPONENTS

Terms of Business: Cash with order. Despatch of goods within 3 days from receipt of order. Where post and packing charge is not stated please add 1/- up to 10/-, 1/6 up to £1, and 2/- up to £2. All enquiries and lists, S.A.E.

SPECIAL NOTE: NO GOODS SENT WHERE CUSTOMS DECLARATION IS APPLICABLE.

23 HIGH STREET (Uxbridge Road)
ACTON, W.3 Telephone: ACOrn 5901

Hours of Business:
Saturday 9—6 p.m. Wednesday 9—1 p.m. Other days 9—4.30 p.m.

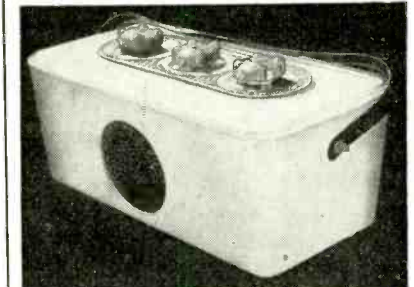

PERSONAL PORTABLE CABINET. In cream-coloured plastic; size 7 x 4 1/2 x 3in. Complete 4-valve chassis. Scale and 3 knobs. Takes miniature 90 v. and 7 1/2 v. batteries, 9/-, post and pkg. 1/6.

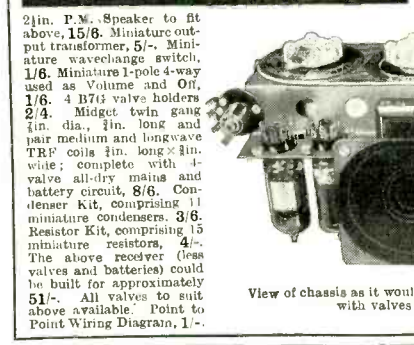

View of chassis as it would look when assembled with valves inserted.



switch 3/6. Wave-change switch 2/- 32 + 32 mfd. 4/6. Bias condenser 1/- Resistor kit 2/- Condenser kit 4/-.

KIT OF PARTS FOR SIGNAL GENERATOR. Coverage 110 Kc/s.-320 Kc/s., 320 Kc/s.-900 Kc/s., 900 Kc/s.-2.75 Mc/s., 2.75 Mc/s.-8.5 Mc/s., 8.5 Mc/s.-20 Mc/s., metal case 10in. x 6 1/2in. x 4 1/2in. size of scale 6 1/2in. x 3 1/2in., 2 valves and 1 rectifier valve, A.C. mains 230/250. Internal modulus per cent. 0.1 to a depth 30 per cent. Frequency calibration accuracy plus or minus 1 per cent. Modulated or unmodulated R.F. output continuously variable 100 millivolts. £3/10/- and pair of 15/- extra. This includes the return to us for checking and calibration. We will build same P. & P. 4/-. Circuit and point-to-point wiring diagram, 3/6. Kit of parts for above, less checking and calibration, £3, plus 2/6 P. & P.

CONSTRUCTOR'S PARCEL, comprising chassis 12 1/2 x 8 x 2 1/2in., cad. plated 18 gauge, v/h, 1F and trans. cut-outs, back-plate, 2 supporting brackets, 3 waveband scale, new wave-length station names. Size of scale 11 1/2 x 4 1/2in., drive spindle, drum, 2 pulleys, pointer, 2 bulb holders, 5 paxolin international octal valve holders, 4 knobs, P. & P. 1/9.
AS ABOVE, but complete with 16+16 mfd. 350 vkgs. and semi-shrouded drop thro' 250-0-250 60 mA., 6 v. 3 amp. Pri. 200-250 and twin-gang 31/6. P. & P. 3/-.

MAINS OR BATTERY SUPERHET PORTABLE COILS. Medium-waved frame aerial and long-wave loading coil, used as aerial coils. Midget iron-core screened L/M osc. coils, with circuit I.P. 465 Kc., 9/6.
465 Kc. MIDGET I.F.s. Q 120, size 1 1/2in. long, 1 1/2in. wide, 1 1/2in. deep by very famous manufacturer. Pre-aligned adjustable iron-dust cores, per pair, 12/6. Both these items £1, post paid.

CONSTRUCTOR'S PARCEL comprising chassis 8in. x 4in. x 1 1/2in., with speaker and valve holder cut-outs, 5in. P.M. speaker with transformer, twin gang with trimmers, pair T.R.F. coils and medium, iron-cored, four valveholders, 20 K. volume control and wave-change switch, 23/- P. & P. 1/6.

CONSTRUCTORS 3-VALVE T.R.F. PARCEL. Comprising chassis, L. and M. coils, gang, pot., switch, resistor and condensers, heater trans., v/holders, smoothing and bias condenser, 4 ex-Gov't. obsolete valves, speaker and O.P. trans., choke, with circuit. 37/6. P. & P. 3/-.

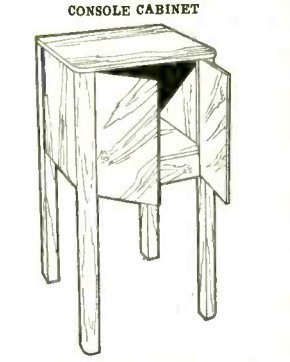

In polished walnut originally made for gram. motor. Would make ideal bedside cabinet or T.V. stand. Size 28 1/2in. high by 17 1/2 by 13 1/2in. deep. 39/6 plus 7/6 P. & P.

Valve Holders, moulded octal, octal and local, 7d. each. Paxolin, octal, Mazda and local, 4d. each. Moulded moulded with screening can, 1/6 each. B7C 147G, B8A and 19A, 7d. each.

32 mfd. 350 vkgs.	2/-
16 x 24 350 vkgs.	4/-
4 mfd. 200 vkgs.	1/3
40 mfd. 450 vkgs.	3/9
16 x 8 mfd. 500 vkgs.	1/6
16 x 16 mfd. 500 vkgs.	4/6
8 x 16 mfd. 450 vkgs.	3/9
32 x 32 mfd. 350 vkgs.	4/-
32 x 32 mfd. 350 vkgs. and 25 mfd. 25 vkgs.	6/6
250 mfd. 12 v. vkgs.	1/6
16 mfd. 500 vkgs., wire ends ...	3/3
8 mfd. 500 v. vkgs., wire ends ...	2/6
8 mfd. 350 v. vkgs., tag ends ...	1/6
50 mfd. 25 v. vkgs., wire ends ...	1/9
100 mfd. 350 vkgs.	4/6
16 + 16 mfd. 350 vkgs.	3/3
Ex-Gov't 8 mfd., 500 v. vkgs., size 3 1/4 x 1 1/2 for ...	2/6
60 + 100 mfd. 280v. vkgs.	7/-
16 x 32 mfd. 350 vkgs.	6/-
50 mfd., 180 vkgs.	1/9
65 mfd., 200 vkgs.	1/8
8 mfd., 150 vkgs.	1/6
60 + 100 mfd., 280 vkgs.	8/6
50 mfd., 12 vkgs.	11d.
32 + 32 mfd., min., 275 vkgs. ...	4/-
50 mfd., 50 vkgs.	4/9
Miniature wire ends moulded 100 pf., 500 pf., and .001 ea.	7d.

Combined 12in. mask and escutcheon in lightly tinted perspex. New aspect, edged in brown. Fits on front of cabinet, 17/6. P. & P. 2/-.

Frame Oscillator Blocking Transformer, 4/6.

Frame O.P. Transformer, Inductance 10 by ratio 10:1, 9/6.

Tube Mounting Bracket, size 9 1/2 x 4 1/2in., 12in. tube clamps, 2/-.

Smoothing Choke, 2/-.
 2 henry adjustment, 2 henry 160 mA., 3/6.
 250 mA., 4 henry 5/-; 250 mA. 10 henry, 6/-; 250 mA. 10 henry, 10/6; 250 mA. 8 henry, 8/6.

P.M. Focus Unit for any 9 or 12in. tube except Mazda 12in., with Vernier adjustment, 15/-, P. & P. 1/6.

P.M. Focus Unit for Mazda 12in. with Vernier adjustment, 17/6. P. & P. 1/6.

Wide Angle P.M. Focus Units, state tube 25/-, P. & P. 2/-.

Energized locus coil, high resistance with mounting bracket 17/6 plus 2/- P. & P.

Scan Coils, low line low impedance frame, complete with O.P. transformer, 17/6. P. & P. 2/-.

Ion Traps for Mullard or English Electric tubes, 5/-, post paid.

465 Kc. I.F.s. size 2 1/2 x 1 1/2in. Q 110 removed from American equipment, 5/- per pair. Standard 465 Kc. iron-cored I.F.s. 4 x 1 1/2 x 1 1/2in., per pair 7/6.

Warranted standard iron-cored 465 Kc. I.F.s. 3 1/2 x 1 1/2 x 1 1/2in., per pr., 9/6.

Iron-Cored 465 Kc. Whistle Filter, 2/6.

OUTPUT TRANSFORMERS. Standard type 5,000 ohms imp. 2 ohms speech coil, 4/9. 42-1 speech coil 2-ohm coil with extra feed-back windings, 4/3.

Miniature 42-1 2-ohm speech coil, 3/3. Multi-ratio 3,500, 7,000 and 14,000 2-ohm speech coil, 5/6. 10-watt push-pull, 6V6 matching, 2 ohm speech coil, 7/-.

PUSH-BACK CONNECTING WIRE. 10z. V. 1/6, post paid.

STANDARD WAVE-CHANGE SWITCHES. 6-pole 3-way, 2/-, 4-pole 3-way, 1/9; 5-pole 3-way, 1/9; 3-pole 3-way, 1/9; 9-pole 3-way, 3/6; Miniature type, long spindle, 3-pole 4-way, 2-pole 5-way, 2-pole 3-way, 4-pole 2-way, 2/6 each. P. & P. 3d.

For Quality Bargains Always —Best Buy at Britain's

POWER UNIT 247. Enclosed in grey steel case size 11 x 9½ x 7½ in., with chrome handles. For 230 volts 50 cycles mains operation. Output 600 volts at 200mA, fully smoothed by 1,000 volt working paper condensers and extra heavy duty choke. Also 6.3 v. 3 amps. A complete power unit including 5U4G rectifier and indicator light for only 52/6, plus 7/6 carriage. New and in transit case. **A REAL SNIP.**

HALLICRAFTERS SKY CHAMPION S20R. Price £21, plus 10/- carr. **HALLICRAFTERS SKY RIDER DEFIANT.** Price £27 10/-, plus 10/- carriage. Send S.A.E. for further details re these sets.

COMMUNICATION RECEIVER R1155 for world wide reception. Can be heard at any time during shop hours. Air tested prior to despatch. Brand new at £17 19/6. A few soiled at £7 19/6. Also have a number of R1155N's at £17 19/6. Carriage in original transit case 10/6 extra on all models. Send 1/3 for circuit details, etc.

A.C. MAINS POWER PACK OUTPUT STAGE enables the R1155 to be used to operate speaker from 200 250 volts A.C. without any modification whatever. Guaranteed 6 months. Price £4 10/- plus 3/6 postage. **SAVE MONEY** BY PURCHASING THE NEW R1155 AND POWER PACK TOGETHER. ONLY £15 19/6, PLUS 12/6 CARRIAGE.

U.H.F. RECEIVER ADMIRALTY TYPE P48. This is a U.H.F. set of advanced design covering 100-150 Mc/s and suitable for commercial use by airline companies, etc. It is similar in appearance to the R1132 and is arranged for standard 19in. rack mounting. Provision for crystal control, tuning meter, etc. Complete with all 13 valves. Price £12 plus 10/- carriage.

POWER PACK NO. 3. Standard 19in. rack mounted power packs for operation from 200-250 volts 50 cycles A.C. mains. Paper smoothing, two heavy duty chokes, VU39 rectifier. Output 250 volts D.C. 100 mA., 6.3 volts 4 Amps. Two types. Mark I with H.T. current meter at £4 4/-; Mark II with H.T. current and volt meters at £4 19/-. Carriage 5/-. Suitable for use with P48, R1132, R1181, R1155, etc. Lead for any specified set with Jones plugs 10/- extra. All power packs guaranteed in working order.

"INEXPENSIVE TELEVISION." This book describes the building of a T.V. set from ex-Government surplus equipment. Price 2/9, post paid. **R1355 RECEIVER.** The justly famous receiver unit specified for the "Inexpensive T.V." Valve line-up 8-SP61, 1-VR92, 1-VU120 and a 5U4. Slightly used, but in very good condition. **BARGAIN PRICE 29/6** plus 5/- carriage and packing.

BARGAIN OFFER. The R1355 complete with RF24 unit tuned to whichever station is required (sound or vision) for only 62/6 plus 7/6 carriage. **RF25 and RF27** uses 2-EF54 and E352. RF25 covers 50-65Mc/s and RF27 covers 65-85 Mc/s. Brand new and boxed, either type 59/6.

INDICATOR UNIT TYPE 95. Exactly the same as Indicator Unit 62 but is 50 cycle version. Double decker chassis with VCR97 mu-metal screen, 16 SP61's, 2-EB34's, 4-EA50's, loads of components, etc., in BRAND NEW condition. **CHEAPEST EVER 59/6** plus 7/6 carriage.

INDICATOR UNIT 182A contains VCR517, 3-EF50, 1-5U4G and 4-SP61, BRAND NEW (less relay). Price 79/6 plus 7/6 carriage.

45 MCS PYE STRIP. Vision unit for London frequency, complete with 6-EF50 and EA50. Circuit provided. Price £2/10/- plus 2/6 carr.

T.V. PRE-AMP uses 2-EF50's and tunes to 45Mc/s. Easily altered to other frequency. With valves 19/6, less valves 10/-. Post 1/- extra.

E.H.T. TRANSFORMER for the VCR97, etc. Mains input. Output 2,500 volts, 4 volts 2 Amp., 2.0-2 volts 2 Amp. Fully guaranteed at 35/- plus 1/- post.

6in. MAGNIFYING LENS for the VCR97, etc. First grade, oiled filled. Now only 17/6 plus 2/6 post.

STANDARD TRANSFORMERS of current manufacture. Two types, both standard tapped primaries. Universal mounting. (1) 350 0-350 volts 80 mA., 0-4.5 volt 2 Amp., 0-4.6.3 v. 4 Amp. (2) 250 0-250 v. 80 mA., 0-4.5 2 A., 0-4.6.3 v. 4 A. Both these transformers are new and boxed, fully guaranteed. Price 18/- post paid.

HEAVY DUTY CHOKE. 5 Hy. 300 mA., size 3 x 4 x 4½ in. high. Totally enclosed, chassis mounting. A beautiful job, brand new and boxed for only 12/6 plus 2/- postage.

30 VOLT TRANSFORMER standard primary, secondary 30 volts 2 Amp. tapped at 3 v., 5 v., 6 v., 8 v., 9 v., 10 v., 12 v., 15 v., 18 v., 20 v., 24 v. Has countless uses. Price 17/6.

METAL RECTIFIER. 12 volt 2 Amp., full wave bridge type. Suitable for use with above trans. Price 12/6.

METAL RECTIFIERS. Selenium 230 volts 60 mA. at 5-, 250 volts 100 mA. at 7/6. RM2 at 4/3 or two for 8/-. RM3 at 5/-. RM4 at 17/-.
TEST SET 205A. This is a 3 centimetre precision test set. Latest version, brand new condition at £20.

MARCONI VALVE VOLT METER £25. We have many other types of test equipment in stock. Enquiries invited.

50 MICRO-AMP METER 2½ in. panel mounting at 65/-.
2½ in. SQUARE FLANGE 0-1MA METERS. Brand new and boxed. ONLY 15/-.

1 MA. METER, 2½ in. dial in sloping desk type mounting at 25/-.
3,000 VOLT ELECTROSTATIC METER, 3½ in. dia. Brand new and boxed for only 35/-.

UNIVERSAL AVOMETERS MODEL 40—very little used, thoroughly checked and tested. First class multi-range test meter for ONLY £9 19/6.

SPEAKER CABINET rexine covered 5 ply, takes heavy duty 12in. speaker. Size 19in. x 19in. x 14in. Brand new at 59/6 plus 4/6 carriage. Can be supplied with Vitavox K12/20 12in. extra heavy duty P.M. speaker for only £10 plus 4/6 carr. **LIMITED NUMBER AT THIS PRICE.**

RECEIVER 68P. A four valve battery superhet set. Uses standard 465 kc/s. IF trans. Complete with all valves. Covers 1.5 to 3 Mc/s. (100 to 200 metres). Circuit supplied. ONLY 32/6.

SYLVANIA RED EF50's. Brand new at 8/6 each. British types tested at 5/- each.

VALUE FOR MONEY OFFERS

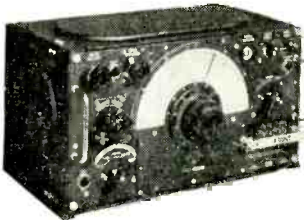

AIR MINISTRY COMMUNICATION RECEIVER

R1155A. Brand New. Frequency ranges—18.5-7.5 Mc/s, 7.5-3 Mc/s, 1,500-600 kc/s, 500-200 kc/s, 200-75 kc/s. Complete with 9 valves and Magic Eye. Guaranteed absolutely perfect. Price £9/10/-, plus 10/- for packing and carriage.

I155 POWER PACK AND OUTPUT STAGE complete with U50 and KT61 valves (not surplus) Black crackle case 12 x 8 x 5in. built-in 5in. pm Speaker and phone jack. 200-250 v. A.C. All connections terminate in Jones plug which enables instant operation of receiver without any modifications whatever. Matches in appearance with receiver. Made to "Wireless World" specifications. Built entirely from top grade new components, £7/10/- plus 3/6 carriage.

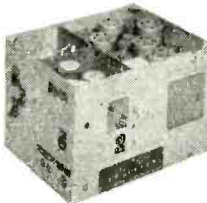

G.E.C. VHF RECEIVERS complete with 10 valves. Ex-Govt. As used by police. Used but guaranteed in excellent condition. Valves comprise ZA2's, 954's, or EF50's in HF and 1st Det. stages. Det 19 in local oscillator, KTW63's in three IF stages. D63 Det and AVC, LF H63, Output KT63, Noise suppressor D63, Power requirements 6v. 3a, 270 v. 80 ma. Frequency range 78.5-82 Mc/s. Intermediate frequency adjustable 8.3-9.8 Mc/s. Oscillator Crystal controlled (No Crystal included). Grey enamel steel case with lid 10 x 8 x 7in. Weight 22lbs. Note the amazingly low price, 39/6 plus 5/- carr.

LATEST FERRANTI AR15 HIGH-POWER CAR RADIO. 12 volt Medium and long wave. Complete with control heads and leads. Unfortunately these sets are less the flexible drives. Purchased from the estate of a late dealer. List price £37/10/-. 4 only. Price £15 each. Absolutely perfect.

H. P. RADIO SERVICES LTD.

Britain's Leading Radio Mail Order House,
55 County Road Walton, Liverpool, 4
Tel.: Aintree 1445 Established 1935

BARGAIN MONTH

I ONLY. 9 LINE OFFICE INTERCOM. UNIT. Complete with Master Unit and 8 press button Telephones, and junction boxes. Perfect working order. £75 carr. paid.

125 VOLT M.C. VOLTMETERS. Ironclad 4in. scale 30/- each, post 2/-.

300 VOLT M.I. VOLTMETERS. Bakelite 3in. scale 17/6 each, post 1/6.

SLYDLOK FUSES. 5 amp, 2/6 each; 15 amp, 3/- each; 30 amp, 3/6 each. Post 6d. per half dozen.

60 OHM C.L.R. EARPHONES. 5/- per pair. Post 1/-.

A FEW T.R.9 6 VALVE BATTERY RECEIVERS still left at 15/-, carr. 5/-.

JONES PLUGS or SOCKETS. 8 way chassis mounting 6/- dozen; 8 way with covers 7/6 per dozen; 4 way plugs only chassis mounting 4/6 per dozen. Post 1/- per dozen.

18 MM. SPARK PLUGS. 2/6 each or 4 for 7/6, post 1/-.

ONE POUND REELS FRY'S 40/60 SOLDER, 6/- per reel, post 1/-.

MUST BE SOLD. 100 FEET AERIALS. Suitable for connecting wire, 3/- per 100 feet. 2 for 5/6, post 1/-.

15 AMP IRONCLAD D.P. SWITCHFUSES, 7/6 each, post 1/-.. 30 amps. ditto, 17/6 each, post 1/6.

24 VOLT AND 12 VOLT 60 AMP CUT OUTS, Type "D" SC/1616 and 5C/1615 10/- each, post 1/-.

Finally, after you have finished work clean your hands with "SWARFEGA" gritless hand cleanser, obtainable from us at 1/6 per tin, post 6d. Trade supplied at 13/6 per dozen. 4 dozen post free.

UNIVERSAL ENGINEERING Co.

(Dept. W.W.)

HAVELOCK PLACE, HARROW, MIDDXX.

HARrow 1432.



CHARLES BRITAIN (Radio) Ltd.

11 UPPER SAINT MARTIN'S LANE
LONDON, W.C.2

TELEGRAMS: 0545

One minute from Leicester Square station (up Cranbourn Street)

Shop Hours: 9-6 p.m. (9-1 p.m. Thursday).

Open all day Saturday.

Terms C.W.O. or C.O.D. No C.O.D. under £1. Postage 1/1 extra under £1. 1/9 extra under £3.

RADIO SUPPLY CO. (LEEDS) LTD. 32 THE CALLS, LEEDS 2

(LEEDS) LTD.

Open to Callers: 9 a.m. to 5.30 p.m. Saturdays until 1 p.m.

FULL PRICE LIST 5d.

TRADE LIST 5d.

Please enclose S.A.E. with all enquiries.

COLLARO TAPE DESK MOTORS, shaded pole type, clockwise or anti-clockwise, 29/9 each.

COAXIAL CABLE. 75 ohms, 1/4in., 100. yard.

DIAL BULBS, M.E.S., 6.5 v. 0.15 a., 8 v. 0.15 a., 6/9 dozen.

SPECIAL OFFERS. Germanium Crystal Diodes 2/9. Midget Mains Transformers (size approx. 2 1/2 x 3 1/2 in.). Screened Primary 220/240 v. 50 c.s. Output, 250-0-250 v. 60 mA., 6.3 v. 2.5 a. Only 11/9. Small Filament Transformers, 220/240 v. input, 6.3 v. 1.5 a. output, 5/9. Auto Transformers (with separate l.t. 6.3 v. 1.5 a.), 0-110-200-210, 230-250 v. 50 watts, 4/9 each.

BATTERY SET CONVERTER KITS. All parts for converting any type of battery receiver to All Mains. A.C. 200-250 v. 50 c.s. Kit will supply fully smoothed h.t. of 120 v. 90 v. or 60 v. at up to 40 mA., and fully smoothed l.t. of 2 v. at up to 1 a. Price complete with circuit, only 48/9. Supplied ready for use to 7/9 extra.

PERSONAL SET BATTERY SUPERSEDER KIT. Complete with case. Supplies 90 v. 10 mA. and 1.4 v. 250 mA. fully smoothed, from normal 200-250 v. 50 c.s. Mains. For 4 valve Superhet Receivers. Price with circuit 31/6. Or ready for use, 38/9. Size of Unit 5 1/2 x 3 1/2 x 1 1/2 in. approx.

H.T. ELIMINATOR AND TRICK CHARGER KIT. Consists of h.t. and l.t. transformer, h.t. and l.t. rectifiers, smoothing electrolytic, choke, and steel case with black crackle finish. For Mains input of 200-250 v. Output 120 v. 40 mA. and 2 v. 1 a. Price with circuit, 29/6. Or in working order, 37/6.

BATTERY CHARGER KITS For 200-250 v. 50 c.s. Mains input. To charge 6 v. acc. at 2 amp., 25/9. To charge 6 v. or 12 v. acc. at 2 a., 32/9. To charge 6 or 12 v. acc. at 4 a., 49/9. Above consists of transformer, full wave rectifier, fuse, fuseholder, strong steel case with black crackle finish, and circuit. Supplied in working order, 6/9 extra.

SELENIUM RECTIFIERS 6/12 v. 1 a. H.W., 4/6; 6/12 v. 1 a. F.W. (Bridge), 7/6; 6/12 v. 2 a. F.W. (Bridge), 10/9; 6/12 v. 4 a. F.W. (Bridge), 18/9; 6/12 v. 6 a. F.W. (Bridge), 22/9; 120 v. 40 mA., 3/11; 250 v. 50 mA. (ex equip.), 5/9; 230 v. 80 mA. (ex equip.), 7/9.

ELECTROLYTICS (Current production. Not ex-Govt.)

Table with columns: Tubular Types, Can Types, and prices. Includes items like 8µF 450 v., 24µF 350 v., 32µF 450 v., etc.

CHASSIS. (16 s.w.g. Undrilled Aluminium) Receiver type. 6 x 3 1/2 x 1 1/2 in., 1/11; 7 1/2 x 4 1/2 x 2 in., 2/9; 16 s.w.g. 10 x 5 1/2 x 2 in., 3/9; 11 x 6 x 2 1/2 in., 4/3; 12 x 8 x 2 1/2 in., 5/3; 16 x 8 x 2 1/2 in., 7/6; 20 x 8 x 2 1/2 in., 8/11; Amplifier Type, 12 x 8 x 2 1/2 in., 7/11; 16 x 8 x 2 1/2 in., 10/11; 14 x 10 x 3 in., 13/6; 20 x 8 x 2 1/2 in., 13/6.

SILVER MICA CONDENSERS. 5, 10, 15, 20, 25, 30, 35, 50, 100, 120, 150, 180, 200, 230, 300µµF, 330, 400, 470, 500, 1,000µµf. (.001µF). .002 mid. (.2,000 µfd.). All at 5d. each; 3/9 dozen one type.

WILLIAMSON AMPLIFIER KIT. To authors specification and complete in every detail. Only 14 gns.

MICROPHONE TRANSFORMERS 100:1 5/9

A PUSH-PULL 3-4 watt HIGH-GAIN AMPLIFIER For £3/12/6. For Mains input 200-250 v. 50 c.s. Complete kit of parts including circuit diagram and instructions. (Point-to-point wiring diagrams available for 1/6 extra). Amplifier can be used with any type of Feeder Unit or Pick up. Output is for 2/3 ohm speaker. (We can supply a very suitable 10in. unit by Goodmans at 31/-). The amplifier can be supplied ready for use for £4/17/6. Full descriptive leaflet 1/-.

MASTER INTERCOMM. UNIT with provision for up to 4 "Listen-Talk Back Units." A high gain amplifier enables speech and other sounds emanating from the rooms containing remote control units to be heard at the master control. The unit is in kit form and point-to-point wiring diagrams are supplied. A Walnut veneered cabinet is included. Mains input is 200-250 v. 50 c.s. Sound amplification 4 watts. Price only £5/19/6. "Listen-Talk Back Unit" can be supplied at £1 each. Full descriptive leaflet 1/-.

P.M. SPEAKERS. All 2.3 ohms, 5in. Goodmans, 14/9, 6 1/2 in. Elac, 14/11, 6 1/2 in. Plessey with Pentode Trans., 14/11, 6 1/2 in. Goodmans, 16/9, sin. Plessey, 15/9, 10in. Goodmans, 31/-, 10in. Plessey, 18/6. 10in. Rola with Trans., 29/6.

M.E. SPEAKERS. All 2.3 ohms, 6 1/2 in. Rola field 700 ohms., 11/9, sin. R.A. field 600 ohms., 12/9, 10in. R.A. field 600 ohms., 23/9. 10in. R.A. field 1,500 ohms., 23/9. 10in. R.A. Field 1,000 ohms., 23/9.

VOLUME CONTROLS with long spindles, all values less switch 2/9, with S.P. switch 3/11. WIRE WOUND POTS.: 3K, 10K, 20K, 25K, 50K (medium length spindles), 2/9.

AMMETERS. Moving coil. G.E.C. 0.5 amps, 2in. scale, 12/6.

R.S.C. MAINS TRANSFORMERS (Fully Guaranteed)

Fully interleaved and Impregnated Primaries 200-230-250 v. 50 c/s. TOP SHROUDED DROP THROUGH 250-0-250 v. 70 mA., 6.3 v. 2.5 a. 12/11 260-0-260 v. 70 mA., 6.3 v. 2 a., 5 v. 2 a. 14/11 350-0-350 v. 70 mA., 6.3 v. 3 a., 4 v. 2.5 a. 15/9 350-0-350 v. 80 mA., 6.3 v. 2 a., 5 v. 2 a. 16/9 250-0-250 v. 100 mA., 6.3 v. 4 a., 5 v. 3 a. 23/9 300-0-300 v. 100 mA., 6.3 v. 4 v., 4 a., c.t. 0-4.5 v. 3 a. 23/9 350-0-350 v. 100 mA., 6.3 v.-4 v. 4 a., c.t. 0-4.5 v. 3 a. 23/9 350-0-350 v. 150 mA., 6.3 v. 4 a., 5 v. 3 a. 29/11 350-0-350 v. 150 mA., 6.3 v. 2 a., 6.3 v. 2 a., 5 v. 3 a. 29/11

FULLY SHROUDED UPRIGHT 250-0-250 v. 60 mA., 6.3 v. 2 a., 5 v. 2 a., Midget type 24-3-3in. 17/6 350-0-350 v. 70 mA., 6.3 v. 2 a., 5 v. 2 a. 18/9 375-0-375 v. 60 mA., 12 v. 1.5 a., 5 v. 2 a. 18/11 250-0-250 v. 100 mA., 6.3 v.-4 v. 4 a. c.t., 0-4.5 v. 3 a. 25/9 250-0-250 v. 100 mA., 6.3 v. 6 a., 5 v. 3 a., for R1355 conversion. 29/9 300-0-300 v. 100 mA., 6.3 v.-4 v. 4 a. c.t., 0-4.5 v. 3 a. 25/9 350-0-350 v. 100 mA., 6.3 v.-4 v. 4 a. c.t., 0-4.5 v. 3 a. 25/9 350-0-350 v. 150 mA., 6.3 v. 4 a., 5 v. 3 a. 33/9 350-0-350 v. 150 mA., 6.3 v. 2 a., 6.3 v. 2 a., 5 v. 3 a. 33/9 350-0-350 v. 160 mA., 6.3 v. 6 a., 6.3 v. 3 a., 5 v. 3 a. 45/9 350-0-350 v. 250 mA., 6.3 v. 6 a., 4 v. 8 a., 0-2.6 v. 2 a., 4 v. 3 a. for Electronic Eng. Television. 67/6 425-0-425 v. 200 mA., 6.3 v.-4 v. 4 a. c.t., 6.3 v.-4 a., c.t., 0-4.5 v. 3 a., suitable Williamson Amplifier, etc. 51- 425-0-425 v. 250 mA., 6.3 v. 6 a., 6.3 v. 6 a., 5 v. 3 a. 65/6

ELIMINATOR TRANSFORMERS Primaries 200-250 v. 50 c/s., 120 v. 40 mA. 7/11 90 v. 10 mA., 0-9-0 v. 250 mA. 10/6 120 v. 40 mA., 6 v. 1.5 a. 14/9 120 v. 40 mA., 5-0-5 v. 1.5 a. 15/9

OUTPUT TRANSFORMERS Midget Battery Pentode 66:1 for 8S4, etc. 3/6 Small Pentode, 5,000Ω to 3Ω 3/5 Small Pentode, 8,000Ω to 3Ω 3/9 Standard Pentode, 5,000Ω to 3Ω 4/9 Standard Pentode, 8,000Ω to 3Ω 4/9 Standard Pentode, 10,000 ohms to 3 ohms. 4/9 Multi-ratio 40 mA. 30:1, 45:1, 60:1, 90:1, Class B Push-Pull. 5/6 Push-Pull 8 watts 6V6 to 3 ohms. 7/11 Push-Pull 10-12 Watts 6V6 to 3Ω or 15Ω Push-Pull 10-12 Watts to match 6V6 to 3-5-8 or 15Ω 16/9 Push-Pull 15-18 Watts to match 6L6, etc., to 3Ω or 15Ω Speaker 22/9 Push-Pull 20 Watts, high quality sectionally wound, 6L6, KT66, etc., to 3 or 15Ω 47/9 Williamson type, exact to author's spec. 85/-

VALVE SCREENING CANS. International Octal 3 piece, 10.6 doz., 1/3 each.

EX-GOVT. ITEMS. Cathode Ray Tubes, VCR137. (Full picture), 29/6, plus carr. 5/-; VCR139A, 19/6, plus 4 carr. Sydelock Fuses, 15 a., 1/9. VR91, 4/6, VR65, 1/11. Pvc coaxial plugs and sockets 7/6 doz. prs. .02 mfd. 5,000 v. Tubulars, 1/9.

EX-GOVT. SMOOTHING CHOKES 330 mA. 5 H. 50 ohms. Potted type 12/9 250 mA. 40 H. 200 ohms. Trop. type 17/6 250 mA. 5 H. 100 ohms. Potted type 9/6 150 mA. 10 H. 200 ohms. Potted type 10/11 100 mA. 10 H. 100 ohms. 5/9 100 mA. 10 H. 450 ohms. 4/6 100 mA. 5 H. 100 ohms. Tropicalised 8/11 50 mA. 50 H. 1,250 ohms. Potted type 5/9 50 mA. 50 H. 1,000 ohms. 5/9 60 mA. 5-10 H. 100 ohms. 3/4

EX-GOVT. T.V. TRANSFORMERS. All 230 v. 50 c/s input. 1,000 v. 5 mA. 4 tines (could be connected in Series to give 7,000 v.) 25/- 3,000 v. 3 mA. 17/6 1,000 v. 50 mA. 4 v. 1.5 a. 14/9 2 v. 3 a., 2 v. 3 a., 2 v. 3 a., 2 v. 3 a. 8/9 415-360-0-360-415 v. 250 mA. 25/- 375-345-0-345-375 v. 250 mA. 22/6 6.3 v. 6 a., 6.3 v. 6 a., 5 v. 3 a., 5 v. 3 a., 4 v. 3 a. 22/6 2 v. 2 a., 2 v. 2 a., 4 v. 1.5 a. (Ins. 12 Kv.) ... 9/6 400-0-400 v. 250 mA., 5 v. 3 a. 25/- 375-0-375 v. 200 mA., 5 v. 3 a. 19/6 1,100 v. 50 mA. 8/9 278-0-278 v. 80 mA. 7/9

EX-GOVT. BLOCK PAPER CONDENSERS. 4 mfd. 500 v., 2/9; 8 mfd. 500 v., 4/9; 4 mfd. 1,000 v., 3/11; 8 mfd. 1,000 v., 6/9; 6 mfd. 1,500 v., 4/9; 10 mfd. 500 v., 4/9. 0.1 mfd. plus 0.1 mfd. 8,000 v. (Common Isolated), 11/6.

EX-GOVT. RF26 UNITS. Brand new, cartoned, 59/6, plus carr. 5/-.

UNIVERSITY RADIO LTD.

Offer Guaranteed Used Equipment at Attractive Prices

- C.D.P. Disc Recorder. Less amp. As new £19 10 0
- M.S.S. Portable Disc Recorder. 1948 Model. Less amp. As new ... £28 10 0
- B.S.R. Portable Disc Recorder. Less amp. As new £45 0 0
- Garrard Changer R.C.65A. In maker's carton. 3 only, each £10 10 0
- R.107. Receiver. Perfect £14 0 0
- Hallicrafter S.X.28. As new £40 0 0
- Hallicrafter S.38. As new £18 10 0
- A.R.88. Model D. First Class cond. with S. Meter £55 0 0
- Romac 25 watt Portable Amplifier. Built-in radio unit, M/C. mike and gram. inputs. As new... £20 0 0
- Grampian 20 watt Amplifier. M/C. mike and gram. inputs. As new £15 0 0
- Avo 7. As new £14 0 0
- Avo Electronic Test Meter. As new £28 10 0
- Avo RES/CAP Bridge. As new ... £7 10 0

- Avo Wide Range Sig. Gen. As new £21 10 0
- Taylor Sig. Gen. 65C. As new £12 0 0
- Taylor Sig. Gen. 65B. As new £9 0 0
- Eddystone 640 Receiver, complete with valves £20 0 0
- Valradio Converters. D.C. to A.C. 100 watts £8 10 0
- 200 watts £10 0 0
- 300 watts £12 0 0
- Garrard Model 201B. 2 speed. 78 r.p.m. and 33½ r.p.m. Can be adjusted to 45 r.p.m. As New ... £12 0 0
- E.D.C. Rotary Converter. 200-250 volt. A.C. 1 ph. 50 cy. 110 watts. In metal case. As new £9 10 0
- H.R.O. Senior. H.R.O. P.P. 6 coils. Perfect £28 10 0
- Advance Model E.2. Sig. Gen. As new £18 10 0
- Ex W.D. Evershed's 500 v. Wee Meggers. Perfect. In Leather cases £8 10 0

- Garrard R.C.75A. 3-speed Auto Changer. 2 heads. As new. £12 10 0
- Cossor D.B. 'Scopes. From £27 10 0
- Taylor Windsor Model 190A. As new £16 0 0
- Westinghouse Metal Rectifiers. F.W. Output. 110 v. 5 amps. Brand new each £4 0 0
- B.C.221's with correct charts. As new. From £25 0 0

WE URGENTLY REQUIRE FIRST CLASS NEW OR USED STANDARD OR SUB-STANDARD SIGNAL GENERATORS OF EVERY DESCRIPTION. ALSO ANY TYPE OF FIRST CLASS TEST EQUIPMENT OF EVERY DESCRIPTION. WE ARE AN OLD ESTABLISHED FIRM. WE WILL PAY THE VERY TOP PRICE. DO NOT BE MISLED. WE REALLY DO PAY MAXIMUM PRICES FOR FIRST CLASS EQUIPMENT. WHEN SENDING GOODS STATE WHETHER T.M.O. OR CHEQUE REQUIRED.

THESE ITEMS ARE ONLY A SMALL SELECTION FROM OUR STOCK OF EQUIPMENT. YOUR ENQUIRIES FOR ANYTHING THAT YOU MAY NEED WILL BE WELCOME. **WE HAVE OTHER EQUIPMENT ARRIVING DAILY!**
 CASH OR CHEQUE WITH ORDERS. ALL ITEMS LISTED ARE CARRIAGE EXTRA. ALL ENQUIRIES S.A.E. PLEASE.

22 LISLE STREET, LEICESTER SQUARE, LONDON, W.C.2

OUR BRANCH AT 39a (opposite) IS OPEN ALL DAY THURSDAY.

Phone: GERRARD 4447, 8582 and 5507.

Hours 9 to 6.

Thursdays 9 to 1.

U.S. NAVY OSCILLOSCOPE UNITS—Containing 5 BPI. 5in. Tube with fully screened mu shield isolating heater trans. Dozens of H.V. Cond., Resistors, Pots, etc. The finest value offered to date in "Scope" units. "W.W." T/V 'scope circuit included. Price 57/6.

LABORATORY TEST EQUIPMENT. For aligning and checking Trans./Receivers covering 150 to 234 Mcs. comprising: Type BC906. Frequency Dip Grid Meter. 145-235 Mcs. Type I-196-B. Signal Generator. 150-234 Mcs.

Type BC1066-B. Radio Receiver. 150-234 Mcs. Price £12 the Set. Carriage extra.

VALVES. 1S4, 8/6; 6AG5, 10/6; 117Z6, 12/6; 6SH7, 6/6; EF50, 6/6; 955, 954, 6/6; SG215, 6/6; Pen 220A, 6/6; TT11, 8/6; VR 150, 10/6; 42, 10/6; CK512AX, 9/-; 9001, 9002, 9003, 7/6; 954-955, 6/6.

MAINS TRANSFORMERS. Input 200/240 v. Output 350-0-350 or 250-0-250 volt 80 mA. and 4 and 6.3 v. 4 a. and 4 and 5 v. 2 a. Price 21/6. Input 200/240 v. Output tapped 3, 4, 5, 6, 8, 9, 10, 12 15, 18, 20, 24, 30 volts, 2 amps., 21/6. All with one year's guarantee.

D.P.D.T. RELAYS. Operate at 200/300 volts D.C., 8/6. D.P. make and break, 8/6. We can supply any type of voltage and contacts at varying prices.

NEW SELENIUM RECTIFIERS. F.W. 12/6 volt 3 amps., 14/6; 4 amp., 22/6; 6 amp., 30/-; 1 amp., 8/6; 12 v. 100 mA., 3/-; 250 v. 100 mA., H.W., 9/-; 80 mA., 6/6.

GERMANIUM CRYSTAL DIODES, 3/9.

VCR97 CRTS. New and crated. Picture tested, 45/6. Bases, 3/6.

NEW MAG SLIP TRANSMITTER MOTORS. Made by G.E.C. 50 v., 50 cycle. Mk. I—2in., 15/-. Mk. II—3 in., 20/-.

NEW P.M. SPEAKERS. 5in., 14/6; 6in., 16/6; 8in., 20/-; 10in., 29/6.

CARBON MICROPHONES with Matched Trans., 10/6.

0-500 MICROAMMETERS 2in., 15/6.

M/C MICROPHONES with matched Trans., 15/-.

4ft. ROD AERIALS, set of three 6/-. Base 3/6.

FLS FILTER UNITS, 8/6.

TYPE FT243 FREQUENCY CRYSTALS, 5.8 to 8.6 Mcs. Odd frequencies 5/6. Spot 8/-. In 25 Kc. steps.

G.E.C. 0-75 mA. METERS. 1½in. x 1½in., 8/-.
ADMIRALTY OIL FILLED TRANSFORMERS. Prim. 230 v. Sec. 3500 tapped 3000 v. 85 mA. Weight 65 lbs. 10½in. x 9½in. x 8in. Steel cased, 44.

L.R. ARMY HEADPHONES, 8/6.

NEW ROTARY CONVERTERS. Input 6 v. Output 350 v. 120 mA., 27/6.

All Carriage paid in the U.K. from Dept. W.W.,

The RADIO & ELECTRICAL MART
 253B PORTOBELLO ROAD, LONDON, W.11

Phone: PARK 6026

RADIO EXCHANGE CO.

RECEIVER S450 and S450B. Complete with valves, tuning 65/85 or 85/95 mc/s, these are ideal for Wrotham or "2" metre conversion. Housed in attractive robust grey cases measuring 12 x 4½ x 5½in., these contain 4EF54's (RF, mixer, Xtal multipliers), EC32 (Xtal oscillator), 2 EF39's (2.9 mc/s IF), EB34 (det.), 6J5 and 6V6 (audio). Complete with circuit, 49/6, post 2/-. Please state which required.

THE NEW 1355 CONVERSION. To produce a remarkably compact Television—Sound, vision, Time bases and power pack on ONE 1355 chassis—without the use of expensive R.F. units: **OUT DATA** contains full instruction for all five TV channels and calls for a minimum of extra parts. Due to improvements in paper situation **NOW ONLY, 2/6 per copy** (post 2½d).

1355 RECEIVERS complete with 11 valves, in wooden cases: 1st grade 45/-; 2nd grade 35/- (CF).

NEW VALVES. EF50 4/6 (Brit.), 6/6 (Red Sylvania), 5U4F 7/6.

POWER UNIT CHASSIS, with 5Z4 and VU120 (EHT) rectifiers, choke, condensers, transformer, relay, etc. Measures only 7 x 6½ x 3½in., 10/-.

TRANSFORMERS: 230/24v., 2A., 9/-; 230/115v., 75 watt, 9/6; output, multi-tapped, 3/6.

MIDGET AMPLIFIERS, complete with full instructions for converting to a really small gram amplifier, or a tiny radio receiver (both mains operated). Three valves included. 19/6.

CARBON MICROPHONES: in small hemispherical cases, with switch, (boxed), 4/6. Hand-type microphones, with pressel switch, 7/6.

14 ST. MARY'S STREET
BEDFORD

Phone: 5568



5 Harrow Road, Paddington, W.2

PADddington 1008/9 and 0401

OPEN MONDAY to SAT. 9-6 THURS. 1 o'clock.

6 WATT AMPLIFIER (UNDISTORTED)
 Manufactured by Parmeko and Sound Sales for Admiralty.
 4 valves, PX25, 2-AC/HL, MU14. Output Matching and
 3Ω and 15Ω, 100/250v A.C.
COMPLETE IN STEEL GREY AMPLIFIER CASE.
£12-10-0
CALL FOR DEMONSTRATION.

RADIO-GRAM CHASSIS
 3 Wave-band Superhet. Med., long and short.
 5 Latest Type MULLARD Valves.
 4 Position Switching. Gram., med., long and short.
 Provision for A.C. Mains 110/250 volts.
 Extension Speaker.
 Chassis 11in. x 7in. x 2½in. Scale Bin. Square.
 Or Chassis 13½in. x 6½in. x 2½in. Dial 10in. x 5½in.
 PRICE £10/5/-.
 BRAND NEW AND GUARANTEED. CARR.,
 PACKING AND INS. 10/-.

SEND
 STAMPS
 FOR NEW
 1953
 28-PAGE
 CATA-
 LOGUE

MILLIAMMETERS				
500µA	M.C.	2in.	Round	15/-
1 mA	M.C.	2in.	Square	12/6
1 mA	M.C.	2½in.	Flush	22/6
1 mA	M.C.	2½in.	Desk type	27/6
5 mA	M.C.	2in.	Square	7/6
10 mA	M.C.	2in.	Flush	12/6
30 mA	M.C.	2in.	Round	7/6
50 mA	M.C.	2½in.	Flush	12/6
200 mA	M.C.	2in.	Square	7/6
500 mA	M.C.	2½in.	Flush	12/6
500 mA	M.C.	2½in.	Flush	12/6

VOLTMETERS				
15 V (50c)	M.I.	2½in.	Flush	12/6
150 V	M.C.	2½in.	Flush	12/6
300 V	M.C.	2in.	Square	12/6
2,500 V	M.C.	2½in.	Square	25/6
3,000 V	M.C.	2½in.	Square	25/6
4,000 V	M.C.	2½in.	Square	25/6
3,500 V	M.C.	2½in.	Square	25/6
300 V (50c)	A.C.	2½in.	PROJECTION	31/-
			PROJECTION 5in. Dial	75/-

AMP-METERS				
3 A	T/C	2in.	Square	7/6
6 A	T/C	2½in.	Flush	10/-
20 A	M.I.(50c)	2½in.	Flush Mtg.	12/6
15 A	M.I.(50c)		PROJECTION	21/-

M/C = Moving Coil. M/I = Moving Iron. T/C = Thermo-Coupled.
ALL METERS ARE BRAND NEW IN ORIGINAL BOXES.
 except the 500µA MILLIAMMETER which is ex-equipment.

PYE 45 Mc/s STRIP, TYPE 3583 UNITS
 Size 15in. x 8in. x 2in. Complete with 45 Mc/s. Pye
 Strip, 12 valves. 10 EF50, EB34 and EA50, volume
 controls and hosts of Resistors and Condensers.
 Sound and vision can be incorporated on this chassis
 with minimum space. New condition. Modification
 data supplied. Price £5. Carriage paid.

P.M. SPEAKERS

3in. Plessey, with Trans.	15/-
3in. Elac, less Trans.	15/-
5in. Plessey, less Trans.	12/6
5in. Rola, with Trans.	16/6
8in. Elac, less Trans.	17/6
10in. Electra, with Trans.	25/-
10in. Rola, with Trans.	30/-
10in. Goodmans, with Trans.	30/-

WELWYN WIRE-WOUND SLIDER RESISTORS
 MOUNTED ON PANEL FOR TV SETS

4 Bank: 100Ω, 500Ω, 2-10K	5/-
4 Bank: 1K, 2-2K, 1-1 meg (car)	5/-
5 Bank: 200Ω, 2K, 3-10K	6/-

W.W. PRE-SET VOLUME CONTROLS TYPE "901"
 100Ω, 500Ω, 2K, 10K and 30K.....each 2/6

METRO-VIC (METROSIL) PENCIL TYPE E.H.T. REGULATOR up to 10 k.v.
 particularly suitable for regulating E.H.T. Fly-Back.
 5/-

STROBE UNITS. Brand New, in sealed cartons, these contain 6 EF50s, 5 EA50s, 1 SP61, a host of condensers, resistors, transformers, chokes, relays, switches, 7 pots, and 5 smoothing condensers. Size 18in. x 8in. x 7½in. Only 67/6.

L.T. RECTIFIERS

6 v. 1 amp. G.E.C.	4	0
12 v. 2½ amp. Westinghouse.	12	6
12 v. 4 amp. S.T.C.	17	6
12 v. 8 amp. S.T.C.	£1	12

25/73 TRI196 RECEIVER
 This unit is complete with 6 valves, 2 EF36, 2 EF39, 1 EK32, 1 EB33 and 465 kc/s I.F.T.s. In new condition. Circuit and conversion data supplied. 39/6.

S.T.C. RECTIFIERS E.H.T.

K3/25, 650 v. 1 mA.	4	0
K3/40, 1,000 v. 1 mA.	6	7
K3/100, 8,500 v. 1 mA.	14	8
K3/200, 10,000 v. 1 mA.	£1	6

9in. ESCUTCHEON. Brown Bakelite. Suitable plate glass and mask for 9in. tube. Price 7/6.

H.T. RECTIFIERS

S.T.C. 125 v. 60 mA.	4	6
S.T.C. 125 v. 100 mA.	5	0
S.T.C. 125 v. 125 mA.	6	0
S.T.C. 250 v. 250 mA.	18	0

WESTINGHOUSE 14D/972
 250 v. 25 mA. 6 6
 S.T.C.M.1/3 Noise Limiter 2 0
G.E.C. METER RECTIFIER, 1 mA 11 6

RECEIVER R1355. As specified for "Inexpensive Television." Complete with 8 valves VR65 and 1 each 5U4G, VU120, VR92. Only 55/-, carriage 1/6. Brand new in original packing case. S.T.C. 125/6. RF, 25/-; RF25, 25/-; RF36, 59/6; RP27, 59/6.

RECEIVER UNIT TYPE 159. Size 8in. x 6½in. x 4½in., containing VR91, VR92, CV66, VR65 and 24 v. selector switch. New condition, 15/-.

WALKIE-TALKIE TYPE "48" complete with 6 valves, 2V23, HL23 DD, QP25, TP25 and ATP4, aerial rods, I.F. trans., 1.6 Mc/s. mike trans. in new condition, but less transmitting components and coils removed by M.O.S. 35/-, carr. paid. (Less valves, 12/6.)

V.C.R.517C BLUE & WHITE 6½in. TUBE
 This tube replaces the VCR97 and VCR517 without alteration and gives a full blue and white picture. Brand new in original crates, 45/-, carr. free.

CATHODE RAY TUBES

VCR97. Guaranteed full T/V picture (carr. 2/-)	£2	0	0
VCR517. Guaranteed full T/V picture (with mu-metal screen)	£2	0	0
3BP1, with shield suitable for T/V or 'scope (carr. 1/6)	£1	5	0
MU-METAL SCREENS for VCR97 or 517. P.P. 1/6	10	0	
6in. ENLARGER for VCR97 or 517. P.p. 1/6.	17	6	

VR91 (EF50). Brand new Red Sylvanian, original boxes 10/-
 British types, brand new and boxed 8/6
VR91 (EF50). Ex-brand new units, 6/-, or ten for 55/-
 PX25, 12/6. Matched PX25's at 25/- per pair.
 Raytheon CK510AX Sub-Miniature Valves, brand new, 7/6. GU50, 12/6.

No. 38 "WALKIE TALKIE" TRANS-RECEIVER, complete with Throat Mike, phones, Junction Box and Aerial Rods in canvas bag. Freq. range 7.4 to 9 Mc/s. Range approx. 3 miles. All units are as new and tested before despatch. Offered complete with battery. £4 10/-.

T.V. PRE-AMPLIFIER FOR LONDON AND BIRMINGHAM. Complete with 6AM6. Ready to plug in to your set, 27/6. P.P. 2/6.

VCR139A. 2½in. Brand new in original cartons, 35/-, carr. free.

INDICATOR UNIT TYPE SLC5
 This Unit is ideal for conversion for a 'Scope' Unit or basis for Midget Television. It contains C/R Tube type AC/R10 (VCR193A) complete with holder and cradle, also earthing clip, 1-VR66, 2-VR65, 24 mfd. 500 v. wkg. condenser, potentiometers and a varied assortment of resistors and condensers. These Units are in new condition and packed in wooden transit cases. The C/R Tube will be tested before despatch. Dimensions 8½in. x 6½in. x 1½in. 57/6.

INDICATOR UNIT TYPE 182A
 Unit contains VCR517 Cathode Ray 6in. tube, complete with Mu-metal screen, 3 EF50, 4 SP61 and 1 5U4G valves, 9 wire-wound volume controls and quantity of resistors and condensers. Suitable either for basis of television (full picture guaranteed) or Oscilloscope. Offered BRAND NEW (less relay) in original packing case at 79/6. Plus 7/6 carr.

VIBRATOR PACKS

Input 6 v., Output 200 v., 60 mA.	25/-
Input 6 v., Output 180 v., 40 mA. (ex. 21 set)	17/6
Input 2 v., Output 180 v./90 v., 35 mA., 1.4 v., 250 mA.	50/-
Input 6 v., Output 200 v., 80 mA. (Masteradio)	30/-
Input 12 v., Output 300 v., 100 mA.	30/-
6 v. Vib. Trans. 250 v., 80 mA.	7/6

WEARITE
 705 Coil Pack 3 waveband £1 17 10
 501A and 502 465 kc/s pair 10 0
 Wearite Mains Trans. Input 110/250 volts.
 output 325-325 80 mA., 6.3 v. 2.5 amps.
 5 v. 2 amps. £1 1 0

PLESSEY midget type 230 volts input, output 230-0-230. 50 mA., 6 volt, 2.6 amps., screened primary. 12/6.

WYEMOUTH SUPERHET MINIATURE COIL PACK
 Covering Med./Long/Short wave bands. Iron cored coils. Dimens.: Height 1½in. Length 3½in. Width 2½in. Spindle length 2in. Complete with Circuit Print 19/6.

TUNING CONDENSERS

2 gang .0005 standard ½ spindle, with trimmers	7/8
3 gang .0005 with ceramic insulation ½ spindle	7/8
Midget two gang. .000375, with trimmers. Size 9in. x 1½in. x 1½in.	4/8
Midget .0005 mid. 2 gang tuning condenser. Size only 2½in. x 1½in. x 1½in.	5/-
Or with built-in trimmers	6/6
Two-gang Midget. .0005 with 4-way push-button assembly. Suitable for car radio, etc.	8/6

WANTED
 723 A/B and CV129 Klystron Valves, Philips Trimmers, 3-30 pF. RL18, NR88. Any quantity.

PLEASE ADD POSTAGE. ARTICLES UP TO 10/-, 1/-, £1, 1/6. £2, 2/-.

SPECIAL THIS MONTH!

1132A RECEIVERS. 11-valve Superhet receiver, covering 100 to 124 Mc/s, using four VR53, two VR56, and VR66, VR67, VS70, VR54 and VR57 valves. Fitted with tuning meter, slow motion drive. R.F. and L.F. gain control, etc. Circuit: R.F. amp. freq. changer, oscillator, stab., three I.F. amps., B.F.O., det. Ist. audio and output. **Brand new in transit case, with circuit diagram. Price 59/6 plus 7/6 carr.** Cheapest in the country!

INDICATOR UNIT 157. Has same line-up as Indicator Type 62, viz., VCR97 C.R.T., mask and mu screen, 16 SP61, 2 EB34, 4 EA50 valves, 1 mfd. 2.5 kV condenser, 15 potentiometers, Yaxley switches, Muirhead slow-motion dial, resistors, condensers, etc. The well known unit for TV conversion or oscilloscope work. Absolutely brand new in transit case. Price £3/19/6 plus 7/6 carr.

R3084A RECEIVERS (the later edition of the R3170A). The well known receiver used in the "Practical Television" Television, with 7EF50, 2 EF54, 2 EA50, 1 EC52, 1 MU14, 1 HVR2 valves, 3-stage 30Mc/s I.F. strip, resistors, condensers, etc. Price 75/- plus 10/- carr.

COLLARO GRAM MOTOR AND TURNTABLE. AC37 motor for 110-130 v. and 200-250 v. A.C. Governor speed controlled (78 r.p.m.). Brand new and worth £4/10/- Our Price 47/6, plus 2/6 post.

AERIAL COUPLING UNIT TYPE 39 (10D/1731) with 0-6 amp. R.F. 2 1/2 in. circular meter, 0-3 amp. Thermo-couple, 2 in. square meter, 100 watt loading lamp, aerial tuning coils, ceramic high voltage condensers, etc. In strong wooden case. 13/6, plus 2/6 carriage.

AERIAL COUPLING UNIT "C" (for No. 11 Sets) ZA0032 with 0-350 mA meter, tuner, press switch, etc., housed in strong metal case 6 1/2 in. x 5 in. x 5 1/2 in. Price 6/6, plus 1/6 postage.

A1271 AMPLIFIER UNIT with VR56 (EF36) valve, 400Ω relay (4 makes, 2 breaks), 10,000Ω Pot., resistors, condensers, etc., in black metal case 5 in. x 5 in. x 5 in. Brand new at 9/6 each, plus 1/6 post.

METERS. By well known manufacturers. 0.200mA 2 1/2 in. circular. Brand new at 10/6 each, also 0-500 microamp 2 in. circular (calibrated 0-10 volt) at 10/6 each, plus 1/- post.

TYPE P-10 AZIMUTH COMPASSES. In strong wooden box, 13/6 each, plus 2/6 post.

MAINS TRANSFORMERS. Input 200-250 v., output 475-0-475 v. 200 mA at 32.6, plus 2/6 post. Input 200-220-240 v., output 320-0-320 v. 75 mA 6.3 v. 3 a. (tapped at H.V.) 5 v. 2 a. (tapped at 4 v.), at 13/6 each, plus 1/6 post.

WIRE-WOUND RESISTORS. 120,000Ω 80 watt at 2/6 each, 24/- doz. Plus post. 3,000Ω 6 watt at 1/- each, 10/- doz.

RECTIFIERS, 220v. 30 mA at 2/6 each. 6 v. or 12 v. 1 amp. F.V.B. at 7/6 each. 6 v. or 12 v. 2 amp. F.V.B. at 12/6 each.

CHOKES, 9 henries 100 mA at 7/6 each.

CRYSTAL MONITORS TYPE 2 (less valves and crystals). Useful chassis 7 in. x 5 1/2 in. with cover. Contains 6 way Yaxley on/off switch, indicator lamp holder, large phone jack, res., cond., L.F. choke and transformer, etc. This unit is for checking frequencies of Tx and receivers, battery operated, but can be modified for mains use. In strong wooden case, 6/6 post free.

CONDENSERS. 2 mfd. 4 kV at 10/6 each, plus 1/- post. 2 mfd. 3 kV at 6/6 each, plus 6d. post. 1 mfd. 1.5 kV, 4 mfd. 1,000 v., 025 - 025 mfd. 7 kV wkg., 14 kV test, all at 3/6 each, plus 6d. post. 64 mfd. 450 v. electrolytic, .05 + .05 4 kV (can be used as .1 mfd. 4 kV) at 4/6 each, plus 6d. post. 8 mfd. 450 v. at 2/- each, plus 6d. post. 4 + 4 + 4 mfd. 350 v. at 1/9 each, 50 mfd. 12 v. at 1/6 each. .001 mfd. 4kV at 9d. each. .01 mfd. 1,000 v. at 7/6 doz. Please add postage.

GERMANIUM CRYSTAL DIODES. G.E.C. wire-ended, 2/6 each, 24/- doz.

ALUMINIUM FRETS. Open mesh (1/2 in. diamond mesh) 18 in. x 6 1/2 in. at 15/- doz. Small close mesh with 1/2 in. frame, overall size 16 in. x 7 in. at 21/- doz., plus 9d. post.

FILAMENT LAMPS, TELEPHONE JACK TYPE No. 2A, 24 v. at 6/- doz.

RECEIVER TYPE 161. Containing CV66 grounded grid triode, two VRI36 (EF54) pentodes and VRI37 (EC52) valves. A 4-position coil turret. Has magnetic pawl and ratchet motor included. Covers 170 to 230 mc/s., 45 m.e. I.F. output, 19/6 each, plus 1/6 post.

YAXLEY SWITCHES. 4-pole 3 pos. 2 bank at 1/3 each, 12/6 doz.

POTENTIOMETERS. 500Ω 8 watt, wire-wound. Brand new, well known manufacture. 2/6 each.

VALVES, EF50 (Red Sylvania), 6/- each. EF50 (white) 5/- each.

VIBRATORS, 4 PIN 12 VOLT (ZA4878) made by Mallory (Type 650), Price 4/6 each, 48/- doz.

CERAMIC COUPLERS (as used in BC375E), 2 in. O.Dia. for 1/2 in. spindle, Price 9/- doz.

P.M. SPEAKERS. 10 in. Rola (less transf.) at 24/6, plus 1/6 post.

AIR SPACED TRIMMERS. 25pf, 50pf, and 100pf, at 8/6 doz.

POLYTHENE RODS. 5 1/2 in. dia., 12 in. long, 6/- doz.

MOVING COIL HANDMIKES (No. 7) at 5/- each. **TANNOY POWER MICROPHONE INSETS (YA2815)** for Tele L.S. Nos. 1, 2 and 3, at 2/6 each. **THROAT MIKES (ZA13935), BRAND NEW AND BOXED COMPLETE WITH LEADS,** 2/6 each. **MORSE KEYS No. 8,** at 2/6 each. **COLLINS MIKE TRANSFORMERS** Ratio 4:1, 1, potted, 4/6 each. Please add postage.

MU METAL SCREENS for VCR9 Tubes, etc., at 6/6 each.

TAGSTRIPS. All brand new. Manufacturer's surplus. 9 way (6 in. x 1/2 in.) at 4/6 doz. 16 way (6 1/2 in. x 1/2 in.) at 4/6 doz. 7 way (3 1/2 in. x 2 1/2 in.) at 4/6 doz. 6 way screen terminal tab (3 1/2 in. x 1/2 in.) at 4/6 doz.

TRIMMER CONDENSERS. Bakelite 100/100pf, 100/50pf, at 4/6 doz. Ceramic 2-8pf at 4/6 doz. Ceramic 100/100pf, 220/220pf, and 250/250 pf at 9/- doz., plus 6d. post.

C. MARKS & CO.,
Please note our new address :-
90 COMMERCIAL ST., NEWPORT, MON.
Telephone: Newport 4711

Also at 25 Wyndham Arcade, Cardiff
All mail orders and enquiries to Newport branch please.

H.R.O. SENIOR RECEIVERS. With A.C. P.P., 5 coils, £37/10/-.
D.S.T. 100 RECEIVERS, as new. Coverage is 7 bands from 30 Mc/s. to 50 Kc/s., £30 each.
HAMMERLUND BC779B. Mint condition, rack mtg., £42/10/-.
HALLICRAFTERS SX28, S27, S20R, S41, S38, etc. All in perfect condition.
AR88LF, AR88D, CR100, from stock. **RI155 RECEIVERS,** new. **A.C./D.C. MOTORS,** suitable for sewing machines, 47/6 each. **A.C./D.C. 12 v.-15 v. MOTORS,** long spindle for models, 15/- each. **20 WATT P.A. RACK MOUNTING AMPLIFIERS,** complete with power pack, 200/250 v. A.C., less valves, £6/10/- Valves—2 type PX25, 1 MH4 and 1 MU14. £2/15/- per set.
NEW M.C. MICROPHONES, hand type, with 12 yds. heavy duty screened cable. £3/15/- each.
B.C. 221 FREQUENCY METER, from stock. Many items of American equipment available.
TEST EQUIPMENT. We hold a comprehensive stock. Multi-range meters at 1,000 and 20,000 o.p.v., valve testers, signal generators. **4,000Ω EARPHONES,** 11/6 pr.
10,000Ω POTENTIOMETERS, large size, by Colvern, enclosed, 8/6 each.
TYPE 73 AND 74 VELLODYNE UNITS in stock.
C.R.100 RECEIVERS, perfect order, £28/10/-.
MAINS TRANSFORMERS. Special offer, not ex-W.D., 200/250 v. input tapped. Output 250-0-250 v. at 100 mA., 5 v. 3 a., 6.3 v. 4 a., 21/6 each.
350-0-350 v. Ellison at 120 mA., 6.3 v. 5 a., C.T. 5 v. 3 a., 39/- All types in stock.
EVERSHED BRIDGE MEGGERS, 250 v. Special price, £12/10/- each.
D.C. A.C. CONVERTERS, 230 v. D.C. input, 230 v. A.C. output at 140 watts, £9.
MAGNAVOX 12 in. P.M. SPEAKERS, snip at £5/10/- each.
G.E.C. 7 WATT V.H.F. MOBILE TX/RX. Complete with 12 v. rotary p/ack, 30.9, 81.1 and 81.3 Mc/s., special offer, £30.
EDDYSTONE 640 RECEIVER. Perfect, at £22.
EDDYSTONE 504 RECEIVER, perfect, at £21.
1.2F 350 v. **METAL CASED TUBULARS, U.S.A.,** at 4/6 doz. (minimum 2 doz.).
H.R.O. COILS. .46-.96 Mc/s., etc., at £2.5/- per coil.
LARGE STOCKS OF MOTORS. A.C./D.C. and A.C., 1/16, 1/12, 1/4, 1/2 h.p.
Your post enquiries welcomed. S.A.E. for reply please. Prices quoted do not include carriage and packing.
All types of equipment purchased. Top prices paid.

SERVICE RADIO SPARES
4, LISLE STREET, LONDON, W.C.2
Telephone: GERrard 1734

L. WILKINSON WHOLESALE AND EXPORT
19, LANSDOWNE ROAD, CROYDON
Phone: CRO 0839 Telegrams: "WILCO" CROYDON
RELAYS—P.O. TYPE 3,000
BUILT TO YOUR SPECIFICATION—EARLY DELIVERY QUOTATION BY RETURN—PLEASE STATE RESISTANCE OF COIL REQUIRED AND CONTACT BUILD UP.
RACKS. Standard 6ft. P.O. type for 19 in. panels, steel channel sides correctly drilled, heavy angle base.
TEST SET 205. Wavemeter range. 3.05 to 3.35 centimetres, built-in oscillator with 9 valves including Klystron type CV.129, etc., in good condition, £25.
VARIAC TRANSFORMERS. Type 80 CO in brass case, oil filled, 50 cycles, P.200/240 volts S. 220 volts, 7.5 amps, £7/10/- each. Also an open type, 500 cycles, 180/0-180 volts, 7 + 7 amps., £12/10/-.
KEY SWITCHES, P.O. type 212 or 215, available in quantity 5/- each.
RECTIFIER UNIT, P.O. type. Input 200/250 volts A.C. Output 50 volts 0.75 amps D.C. Westinghouse, 70/-, carriage 10/-.
JACKS, Bakelite Igranic, P.73, 1/6 each.

LYONS RADIO Ltd.
21 VOLT ACCUMULATORS. American made, as new and unused, 11 amp-hour capacity (at 5-hr. rate). Size 10 1/2 in. x 10 in. x 3 1/2 in. with terminal cover projecting on one side 3 1/2 in. PRICE 52/6, carriage 7/-.
AMP-METERS. Bakelite cased projection type 4 1/2 in. dia. 0/15 amps, moving iron, calibrated at 50 cps. Can also be used on D.C. PRICE 32/6, post 2/-.
TRANSFORMERS. Service rating Primary 230 v. 50 cps., Secondary 40 v. at 2 A. Size approx. 6 1/2 in. x 6 1/2 in. PRICE 15/-, post 2/6.
INDICATOR UNITS TYPE 96. Containing a cathode ray tube VCR97 (T.V. picture tested), 6-V Rn5 a, 3-V R34's, 1-V R92, spindle couplers, extension spindles, Mu-metal screws, H.V. condensers, pots., slug tuned coils and dozens of other useful components. Size over outer case 1 1/2 in. x 9 in. x 7 in. Condition as new and unused supplied in maker's transit crate. PRICE ONLY 59/6 or less valves 45/-, carriage either case 6/6.
TEST SETS TYPE 102. Mains operated test sets emitting 25 cps. and 50 cps. synchronising pulses. Housed in smart metal instrument cases 1 1/2 in. x 8 in. x 9 in. and fitted with a mains transformer 200/250 v. primary and with a 6.3 v. a 12 v. and a 300 v. secondary, a selenium rectifier (300 v. 30/50 mA.), condensers, resistors, etc. and supplied with a double triode valve type CV18. In new and unused condition with circuit diagram included. PRICE 32/6, carriage 4/6.
TRADE ENQUIRIES INVITED.
PLUGS AND SOCKETS 10H and A series. American Amphenol. Please see Mk. 3.
3 GOLDHAWK RD. (Dept. M.W.), SHEPHERD'S BUSH, LONDON W.12
Telephone: Shepherd's Bush 1729

GARLAND BROS., Ltd.

GRUNDIG TWO-SPEED TAPE RECORDER. We have limited stocks of this famous recorder for immediate delivery. Price £84 (the manufacturers operate an Hire Purchase Scheme for this recorder, details of which can be supplied on request).

WHANDA WIRE AND CABLE STRIPPERS, to take all size flexes and cables up to 3/8 in. diam., with 3 alternative heads and triple screw adjustment. These are brand new and boxed, and the original price was 15/- each. Our Price 4/3 each or 48/- per doz.

ELECTROLYTIC CONDENSERS. 32 mfd., 450 volts, 250 mA ripple, can., 4/6; 8 mfd., 450 v., 1/9; 8 + 8 mfd., 450 v., 3/3; 8 + 16 mfd., 450 v., 4/-; 8 + 32 mfd., 450 v., 4/6; 16 + 16 mfd., 450 v., 5/-; 32 + 32 mfd., 350 v., 3/6; 25 mfd., 25 v., 1/9; 50 mfd., 12 v., 1/9; 50 mfd., 50 v., 2/-.

GARLAND TAPE RECORDER OSCILLATOR UNITS. With valve, for use with high impedance heads only. Price 35/-.

TAPE RECORDER OSCILLATOR COILS. 6.3 mH, 45 kc/s, for high impedance heads only. Price 6/9 each.

TELEVISION MAGNIFYING LENSES. 6in. clear, 19/6; 9in. clear or filter, 50/-; 12in., clear or filter, 70/-. Please state which and add 5/- for carriage and packing.

ELECTRON COPPER AERIALS. 50ft., 2/-; 100ft., 3/9. Trade Supplied.

DECALS. 500 3/8 in. high white transfer letters and words for marking electronic equipment. Price 4/9 per book. The new Decals book for the amateur now available. 29 words per page, 4 pages radio and audio, 4 pages T/V and Scope, 2 pages misc. incl. Tx. and Tape Recording, 3/6 per book. Trade Supplied.

COMMERCIAL POTENTIOMETERS. All usual values. Less switch, 2/3; with single pole switch, 3/6; with double pole switch, 4/-.

MAINS TRANSFORMERS. All at 19/6 each. MT1. 250-0-250 v., 80 mA, 0-4-5 v., 2 A., 0-4-6.3 v. 3 A.

MT2. 350-0-350 v., 80 mA, 0-4-5 v., 2 A., 0-4-6.3 v. 3 A.

MT3. 0-30 v., tapped to give 3 v., 4 v., 5 v., 6 v., 8 v., 9 v., 10 v., 12 v., 15 v., 18 v., 20 v., 24 v., 30 v., all at 2 amp.

MT4. 4 v. 4 amp.; 10 v. 4 amp.; 20 v. 3 amp., for battery chargers.

MT5. Auto.; 0-10-120-200-230-250 v., at 100 watt.

ENGRAVING TOOL. For 200-240 v. A.C. mains. Suitable for use on metals or plastics. Price 10/- each.

BELLING AND LEE PLUGS AND SOCKETS. 5 way 2/-, 7 way, 2/3 complete.

JONES PLUGS AND SOCKETS. 4 way, 1/9; 6 way, 1/9; 8 way, 2/-; 10 way, 2/6.

METAL RECTIFIERS. RM1, 125 v. @ 80 mA., 3/11. RM2, 125 v. @ 100 mA., 4/3. 14D/972, 250 v. @ 25 mA., 6/6. 12 v. 2 A., 6/-, 6 v. 1 A., 4/6. 12 v. 2 A., 12/6. 12 v. 2 1/2 A., 16/6. 12 v. 4 A., 21/-.

HEADPHONES. 4,000 ohms, per pair, 11/-.

CRYSTAL DIODES. Germanium Vacuum sealed glass type with wire ends, 2/8 each or 30/- per dozen.

GARLAND LU7B PORTABLE TAPE RECORDER

Incorporating the latest Lane Tape Table and the Garland UE7B Record Playback Amplifier together with ball microphone and 1,200ft. reel of tape and spare spool, in portable cabinet finished in an attractive vinyl plastic. Weight approximately 36 lbs. The Tape Table includes three specially designed Verdik motors and has provision for fast rewind and forward wind without tape handling, with single switch knob for selection of rewind and record or playback. The amplifier system uses standard valves throughout (ECC35, 6J5, KT61, 6V6G, 5Z4G, 6UG5). Inputs are provided for microphone and for radio or gramophone; record-level indication is by magic eye; the 8in. high flux PX speaker provided is adequate to handle the output of 3.5 w. without appreciable distortion; and provision is also made for a high impedance output to an external amplifier system, and a low impedance (3 ohms) output for external speaker, with or without the internal speaker in circuit. We feel confident that this Recorder will be accepted as setting a new standard in tape reproduction within its price bracket. Price **42 guineas**, plus 10/- carriage etc. Trade supplied.

THE LATEST LANE TAPE TABLE. As used in our LU7B Portable Tape Recorder, and as described above. This item is available separately at £17/10/-, plus 10/- carriage etc. Trade supplied.

UE7B AMPLIFIER. As used in our LU7B Portable Tape Recorder and as described above. Also available separately at £13/2/6. Plus 7/6 carriage etc. Trade supplied.

MAGNETIC TAPE. Scotch Boy MCI-111; 1,200ft., 35/-; 600ft., 21/-; 300ft., 12/3. Spare 7in. spools, 4/3. Ferrovoice, the new kraft-based medium coercivity tape: 1,200ft., 22/6. Spare 7in. spools, 4/6. Trade supplied.

GARLAND AC2A AMPLIFIER. This amplifier provides a maximum output of 3.5 watts. Standard valves (6SH7, 6SH7, 6V6G, 5Z4G) are used throughout and H.T. and L.T. supplied are from mains transformer thus ensuring isolated chassis. A volume and a treble cut control are incorporated. By careful circuitry and the use of negative feedback extremely good quality of reproduction is ensured; the following are actual measured characteristics on a standard production amplifier. Distortion .8% for 2 w. output at 1 K/c; Frequency response within 1db from 60 c/s to 20 K/c. Although the amplifier as normally supplied is intended for use with gramophone pickups of the Acos GP20 type, it can if required be supplied with adequate gain to enable its use with crystal cell microphones. Price £6/2/6, plus 5/- carriage etc. Trade supplied.

UNDRILLED CHASSIS. Four-sided size 13in. x 7in. x 2 1/2in. 20 s.w.g. bright mild steel 5/- each, 18 s.w.g. aluminium 6/8 each; two-sided with two straps, 12in. x 4in. x 2 1/2in., 20 g. steel, 3/-, 18 g. Al., 4/-; Two sided with two straps 6in. x 5in. x 2in., 20 g. steel, price 2/- each, 18 g. Al., price 2/6 each.

I.F. TRANSFORMERS. By a famous manufacturer. 45 1/2 K/c small size rectangular can. Special offer for a limited period 7/- per pair.

TYANA SOLDERING IRONS. Lightweight 40 watt irons with easily interchangeable elements and 3/16in. diameter bits. Voltage ranges, 103/110 v., 200/220 v. and 230/250 v. Price 16/9. "The iron that makes soldering a pleasure." Trade Supplied.

BRIMISTORS. Non-linear resistors to protect valves from current surges: CZ1, 0.3A 3/6; CZ2, 0.3A., 2/6; CZ3, 0.2A., 1/6; CZ4, 1.25A., 5/-; CZ6, 0.45A., 3/6.

AMPLION TESTMETER. 10 ranges A.C. and D.C. up to 500 v. Resistance up to 200,000 ohms 1,800 ohms per volt A.C. and D.C. Price £5.

ENGRAVED KNOBS. 1 1/2 in. diameter, fluted in Walnut or Ivory with the following markings: Volume, Vol-on-Off, Treble, Bass, Tone, Tuning, Wavechange, S-M-L-On-Off, Brilliance, Brilliance-On-Off, Contrast, Focus, R1-R2-PB. Price 1/6 each. Plain knobs to match, 1/3 each.

GENERAL PURPOSE TRIODES. Type 7193, 6.3 v. heater. Similar to 6J5G. Price 2/6 each.

VARLEY MAINS TRANSFORMERS. Primary 10-0-200-220-240 volts. Secondary 300-0-300 volts at 150 mA., 5 volt at 3 amps., 6.3 volt at 4 amps., 6.3 volt at 1 amp. Open type construction. Price 45/-.

T.R.F. COILS. Medium and long wave, aerial and H.F. 6/- per pair; with reaction winding, 6/9 per pair.

BRENETTE MICROPHONES. We are sole distributors in Great Britain and Ireland of these new cell microphones. The following range is now available. Type 7D. Directional in black and chromed case. Price £4/13/6. Type 9ND. Multi-directional ball type in black and chrome. Price £2/8/6. Type 11A. Wide frequency response, in brown and chrome. Price £6/17/-. Type 13U. Highly sensitive with wide frequency response, in black and chrome. Price £7/17/6. Trade Supplied.

SILVER MICA OR CERAMIC CONDENSERS (pF's). 2, 4, 5, 10, 15, 20, 22, 25, 30, 33, 47, 50, 75, 100, 160, 200, 220, 300, 330, 470, 500, 1,000, 2,000, 4,000, 4,500, 4,700. All at 5d. each or 4/- per doz.

POTENTIOMETERS. 20k, 10w, 10%, by famous maker, 1 1/2 in. spindle, price 3/6.

MICROPHONE STANDS. Desk type with flexible member to ease adjustment. These stands will suit all British and Continental microphones. Price 16/6 each.

RADAR REFLECTORS. Type MX138/-A. These consist of 6—2ft. x 3/8 in. dural tubes covered with fine wire mesh. The whole assembly can be used as an omni-directional aerial, and the mesh has many horticultural applications. Price 3/9 each.

TYANA SOLDER GUNS. Weight 30 oz., for 220-250 v. A.C. mains only; consumption 100 watts. Transformer action giving Instantaneous Heat. Price 3 guineas.

TAMSA TYPE 100 TAPE RECORDING HEADS. Housed in chromium plated brass case on adjustable mounting. Record/playback heads have 4-thou. gaps and erase heads have 2.5 thou. gaps. These heads are of high impedance Price 45/- each. Trade supplied.

GOODMANS OUTPUT TRANSFORMERS. 10 watts push-pull to match into 10,000 ohm., with two 3.75 ohm. secondaries for 3 or 15 ohm. speaker. Price 14/9.

ELECTROLYTIC CONDENSER OFFER. Tubular cardboard cased, with wire ends, 8 mfd., 450 v. wkg., 525 v. surge, 2/- each

ALL GOODS NEW AND UNUSED (except where otherwise stated).
PLEASE ADD POST OR CARRIAGE ON ALL ITEMS. KINDLY PRINT NAME AND ADDRESS. POST ORDERS TO OUR DEPTFORD ADDRESS. EARLY CLOSING THURSDAY, OPEN ALL DAY SATURDAY.

SHOP HOURS: Mon: Tues: Wed: and Sat: 9a.m.—6 p.m. Thurs: 9a.m.—1 p.m. Fri: 9a.m.—7p.m.

GARLAND BROS. LTD

CHESHAM HOUSE, DEPTFORD BROADWAY, S.E.8.
5 OBELISK PARADE, LEWISHAM, S.E.13.

TEL: TIDEWAY 4412/3
TEL: LEE GREEN 4038

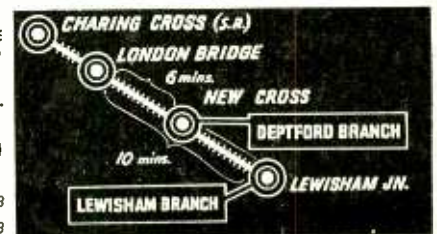

OUTSTANDING OFFERS FOR EXPORT ONLY

U.S.A. Radio and Radar Equipment

- AIRCRAFT TRANSMITTERS, Model GO-9 (Westinghouse).
- RCA TRANSMITTERS. Type ET-4336-B, H, K, L.
- RADIO SETS SCR-695. RECEIVERS AR-77 and 88.
- TEST EQUIPMENT IE-46, TS-36 AP, TS-56A/AP, TS-51/APG-4, Type 205A, Type LR-1 (General Radio), BC-221 (Bendix) AN/UPM
- Hallicrafters SCR-299, 399 and 499 (BC-610).
- INTERROGATORS-RESPONDERS BM-1 (and BN-1)
- REPEATER-INDICATORS AN APA-1.
- RADAR INDICATING EQUIPMENT, Model VF.
- Large Quantities of American Microwave Frequency Meters (Lavoie Laboratories).
- PULSE GENERATORS (RCA and Measurements Corporation).
- AIRCRAFT RADAR (complete units), APS-6.
- AN/AFN RADIO ALTIMETER EQUIPMENT.
- TS-10A APN TEST EQUIPMENT FOR ABOVE

Spare Parts (Radio and Radar-U.S.A.)

Full range of spares for most U.S.A. Aircraft, Naval and Ground Radio and Radar Units (SCR-187, 188, 193/269, 274-N, 287, 399, 508-10, 17, 536, 566, 593, 608-10 (very large quantities), 694, 695, MRN-3, TRA-1—ABK, BM, BN, SM, SO, SK, APS-2, 3, 4, 6, 15, etc.). Klystrons 2K33 (Oxford tubes).

Large Quantities of Plate Supply Transformers for ET/4336 Transmitters.

- British TR (X 42, W/S No. 11, W/S No. 17, W/S No. 18 Mk.III, W/S No. 38, W/S No. 58, W/S No. 68-T).

Power Units, Wavemeters, Motor Generators, Dynamotors and large quantities of various components

●Aircraft Instruments and Accessories.

Catalogue supplied only to Governments, Airlines and Accredited Government Contractors.

Enquiries to

BRITISH SAROZAL LTD.
(Export Branch)

1 BRISTOL HOUSE, SOUTHAMPTON ROW, LONDON, W.C.1

Telephone: HOLborn 6763/4/5 Cables Sarozal, London

ALL EQUIPMENT AS ADVERTISED IS AVAILABLE FOR IMMEDIATE DELIVERY FROM STOCK AND IS FULLY CHECKED AND TESTED—PRIOR TO DESPATCH—IN OUR OWN WORKS AND LABORATORY. ARB OR AID CERTIFICATES CAN BE SUPPLIED UPON REQUEST.

We buy for cash American surplus equipment.

COLONIAL SERVICE SARAWAK

Vacancies

TELECOMMUNICATIONS ENGINEERS

Minimum Qualification Grad. I.E.E. or equivalent.

Pensionable Emoluments from £1,000 to £1,750 per annum
Annual Increment £42

Apply by Airmail to :

**POSTMASTER-GENERAL
KUCHING
SARAWAK**

**BARKER
NATURAL
SOUND
GIVES
SUPREME
PLEASURE**

No matter what your pickup, record, tape, amplifier, radio or other sources of entertainment may be, if they are really good your enjoyment will reach its peak when you add a Barker Sound Unit.

There are definite reasons for this fact. The dual drive with its built-in cross-over and feedback gives full range beyond that of most twin combinations plus crystal clear definition, smoothness and freedom from irritating resonances or colourations.

That is why the most critical owners, musical and technical alike, choose and keep Barker Sound Units as their own Standard. If you have not yet heard one, make a point of being so. Don't be put off or side-tracked. If you insist on Natural Sound, write to:—

Barker Sound Reproducers
3 Newman Yard, London, W.1

Free from distortion



cannot introduce hum

**E.M.G.
STEEP-CUTTING INFINITELY VARIABLE FILTER**

No other filter combines all the advantages of this model which are, briefly, to cut response above any desired level between 4,000 and 8,000 c.p.s. at an average steepness of 30 db. per octave, easy fixing (connects between 15 ohm speaker and amplifier output), robust construction, no distortion or appreciable loss of volume. Recommended for reducing surface noise on '78' records, cutting 'edge' on some L.P. records, and eliminating high-pitched interference on radio. Price £4/10/0. Leaflet on request.

E.M.G. HANDMADE GRAMOPHONES, LTD.
6, Newman St., Oxford St., W.1
Telephone: Museum 9971-2-3

Fidelia

HAND BUILT RADIO UNITS

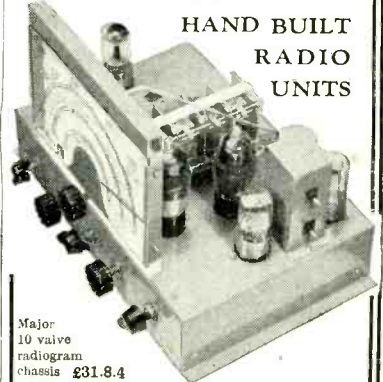

Major: 10 valve radiogram chassis £31.8.4

After a summer day we can think of few things more delightful than to listen in the cool of the evening to great music reproduced by fine equipment. Naturally we think our reproduction is among the best, but then our customer friends think so as well. The cost is very modest too. Full details and helpful advice willingly on request.

- Fidelia Standard, 7 valve model £20 12 0
 - Fidelia Plus, 8 valve model £22 18 4
 - Fidelia de Luxe, 9 valve model with 7 watt triode push-pull output stage... £23 6 6
- Technical data sheets willingly sent on request.



ELECTRO Acoustic DEVELOPMENTS
2 AMHURST ROAD, TELSCOMBE CLIFFS
Nr. Brighton, SUSSEX
Tel: Peacehaven 3166

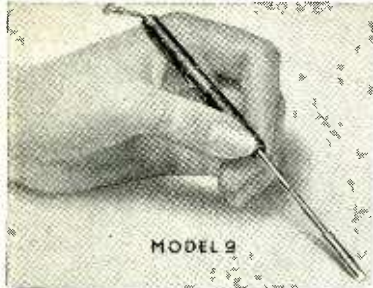

MODEL 9

ORYX

miniature soldering instrument

- Heats up in 30 seconds
- "Pin point" heat concentration
- "Finger control" soldering
- Can be left switched-on all day
- Interchangeable push-on bits

For 6, 12 or 24 volts—8 watts
Length: 6" Weight: 1/2 oz.

ORYX

Electrical Laboratories

Sole Distributors

ANTEX LTD.

3, TOWER HILL, LONDON, E.C.3
Telephone: ROY 4439

AMERICAN SURPLUS

- **RECEIVERS.** BC.639, BC.638, BC.529, BC.603, BC.312, BC.470, BC.973, BC.1003, BC.728, 602A, etc.
- **POWER SUPPLIES.** RA.34, RA.62, RA.37, RA.87, RA.91, RA.36, PE.95, PE.206, RA.38, BD.77, PE.103, RA.42, TCS.6, etc.
- **TEST EQUIPMENT.** 1.83, 1.56, 1.36, 1.122, 1.61, 1.51, LM, LZ, 1.193, 1.176, 1.205, OAP/1, 1.85, 1.199, BC.949, etc.
- **AERIAL EQUIPMENT.** MS.49 to MS.54, MT.7, TBV, Trylon Lattice Tower, MP.44A, YG, AN/TPX, AN.105, A.62, MP.48, etc.
- **INSULATORS.** Pot., Strain, Spreader, Lead-in, Suspension by Locke, Hemingray, Pyrex, also brackets and fittings, etc.
- **FUSES.** E.S., Glass and Cartridge by Pyrex Major, Buss, Littell, etc., up to 600 amps.
- **TRANSFORMERS AND CHOKES,** by Amertran Kenyon, Stancor up to 3kV. POWER TRANSFORMERS up to 15 kW.
- **TELEPHONE AND TELEGRAPH GEAR** RM.12, RM.13, RM.6, RM.29, TG.5, TG.10, BC.1016, etc.
- **TRANSMITTING EQUIPMENT.** Wilcox, Collins, Hallicrafter, Bendix.
- **BRITISH APPARATUS** includes TRANSMITTING COMPONENTS up to 10 kW, High Power Triple Diversity RECEIVERS R.201, DST-100, Standard Racks, 5ft. 6in. and 3ft. high, Carrier Telegraph and Telephone Equipment.

Many other items too numerous to mention. Send your requirements. Lists available. Packing and Shipping facilities.

H. HARRIS

ORGANFORD DORSET

Telephone: Lychett Minster 212

NEW GRAMOPHONE AND SOUND EQUIPMENT

MMAGNETIC recorders, all types, new and secondhand for sale; hire service in greater London area only; mechanical and electronic repairs carried out by specialists: "Magnograph" limpet telephone pick-ups, suitable for all types of recorders, 25/-; tape storage racks for 12 reels, 37/6; B. & H. recording wire, new and used, from 15/- reel; tape accessories, etc.: full details, s.a.e.—The Magnograph Recording Co., Ltd., Hanway Place, W.1. Tel. Langham 2156. [1025]

WEARITE tape decks 2A, £35; super 12 watts p.-pull amplifiers to suit (Partridge output trans.) freq. res. 20-20,000c/s, miniature valves, m. e/v level ind., response from tape 30-15 Kc/s at 7 1/2 in p.s. + 3db, £30; 9 watts model £25; quality 44 1/2 watts (EL41) junior, with meter level ind., phone monitoring, miniature valves, 21watts; amps to suit Bradmatic £30; for Truvox, Lane, M. Master, Motek, etc., 18watts 9watts, p.-pull, or built to order; all tape decks supplied, prompt delivery.—Harding Electronics, 120a, Mora Rd., London, N.W.2. [1400]

GRAMOPHONE AND SOUND EQUIPMENT—SURPLUS AND SECONDHAND

TWO E.M.I. type 12 (long arm) P/Us, with transformer, V.g.c., £5; four Presto cutter-heads type 1C (vertical fitting), £5 each.—Box 7606. [1406]

MS.S. portable disc recorder, list £80, accept £45; Ferrograph tape recorder, £65; Goodsell amplifier and T/C prestage, £18; all as new.—Box 7132. [1091]

PREMIER de luxe portable tape recorder (advertised at 39gns), complete, perfect, 34 1/2 gns, demonstrations arranged.—5, Cromwell Rd., N.3. Fin. 5027. [1437]

VP.P.Q.A., M.C.P.U., motor, etc. in cabinet, perfect order; £60 or near offer.—Foskett, 155, Ravenscroft Rd., Beckenham, Kent. [1371]

HM.V. portable disc recorder, model 2300H, condition perfect, special tape recorder to match (using W. & W. deck), £20 worth of discs; complete equipment £150.—Novatron Instruments, Ltd., 116, Hornsey Rd., Holloway, N.7. North 2083. [1342]

COMPLETE M.S.S. Disk recording equipment, consisting of 6ft P.G. rack with P/U pre-amp, mic preamp, R.G.D. tuner unit, R11 main amp and preamp power unit; two C.L.E.D. 78 rpm turntables, with Rotacols and new P100 P/Us; £200.—Box 7605. [1405]

TRANSFORMABLE public address or disc recording equipment, two 12 watt (PX25 P.P.) amplifiers, pre-amp mixer, mod meter, playback turntable, 12in loudspeaker, cable box mains dis board, junction box, recently overhauled, in 9 wooden cases; cost £400; over £80 secures.—Box 7534. [1399]

NEW COMPONENTS

SWIFT RADIO.—Send for our free component catalogue 6-day, Viewmaster, tape, gram., etc.—21, Hibbert Rd., Harrow. [9918]

TV converter, May issue "W/World," coil sets 25/-, post free; most TV coil sets stocked.—Bel Sound Products, 10, Marlborough Yd., Archway, N.19. [10186]

CRYSTAL microphone inserts (Cosmocord Mic-6) guaranteed brand new, 15/6 post free. Cosmocord Mic-50 hand stand microphones, black or white, £4/4 each, post free.—Radio-Aid Ltd. (Retail Dept.) 29, Market St., Watford. [10036]

MALDEN TRANSFORMER SUPPLIES offer 250v 100 ma metal rects., 9/6; 20k 20w w/w pots 6/6; 2mid 3,000v paper condenser, 5/9; metal rects. 12v Zamb F/W, 8/9; 80w fluorescent chokes, 230v, with starter lamp, 14/6; battery charging transformers, 10v 18v at 5amps, 15/6.—Kin. 5501. 200, Cambridge Rd., Kingston-on-Thames. [10038]

FOR really good results you can do no better than use Osamor coils and coilpacks, ask anyone of experience! Send 5d (stamps) today for beautifully-drawn free circuits, our new coil-data leaflets, and latest lists of matched radio components. A speedy mail order department is at your service, and remember, all Osamor lines are guaranteed. (Trade enquiries invited.) Dept. C.W. [10046]

OSMOR RADIO PRODUCTS, Ltd., Bridge View Works, Borough Hill, Croydon, Tel. Croydon 5148-9. [10046]

COMPONENTS—SURPLUS AND SECONDHAND

LARGE stocks of ex-Govt. radio equipment to clear.—Box 7140. [1101]

SEE our displayed advt. on page 96 for surplus bargains.—Radio Exchange, Bedford. [10012]

MAGSLIPS at 1/10 to 1/20 of list prices, huge stocks, please state requirements, K. LOGAN, Westalloy, Hitchin, Herts. [10233]

GA. RYALL, "Utopia," Mayfield Rd., Herne Bay, Kent, offers post free bargains, new and unused, switches, Yaxley type, 2B, SP, 6-way, double spaced, no stop, 1/4 each; smaller type 3B, 2P, 6-way, total five poles only, 2/4; one type, with soldered tags, taken from brand new control boxes, 2B, 4-way, with total five poles, 1/4; trimmers, 25mm, on ceramic with locknut, boxes of 10 for 2/9 or ten cartons, 12/9 to clear; radio mains suppressors with feet and removable screw lid, 6/9 each; sliding resistances stand, 25amps 0.4ohm, wound in parallel and can be 0.8ohm with slightest alteration, 10/-; Bakelite resistor panels, 9-way, for 1watt or 1/2watt resistors, 2/6 dozen, or clear 8,000, best offer, and 50 gross high voltage and varnished sleeving, 3/3 1/2 4mm, best offer. [10205]

OPPORTUNITIES IN RADIO



Get this FREE Book!

'ENGINEERING OPPORTUNITIES' reveals how you can become technically qualified at home for a highly paid key-appointment in the vast Radio and Television Industry. In 144 pages of intensely interesting matter, it includes full details of our up-to-the-minute home study courses in all branches of TELEVISION and RADIO, A.M. Brit. I.R.E., City & Guilds, Special Television, Servicing, Sound Film Projection, Short Wave, High Frequency and General Wireless Courses.

We definitely Guarantee

"NO PASS—NO FEE"

If you're earning less than £15 a week this enlightening book is for you. Write for your copy today. It will be sent FREE and without obligation.

BRITISH INSTITUTE OF ENGINEERING TECHNOLOGY
388 SHAKESPEARE HOUSE,
17, 19 STRATFORD PLACE, LONDON, W1



THE "FLUXITE QUINS" AT WORK

"Our T.V. is far from O.K.
It's needing some FLUXITE I'll say.
The aerial's unsound,
That's the snag, I'll be bound!"
"Yes—nothing but 'quins' shouted EH."

See that FLUXITE SOLDERING PASTE is always by you—in the house—garage—workshop—wherever sneaky soldering is needed. Used for over 40 years in Government works and by leading engineers and manufacturers. Of all Ironmongers—in tins from 1/- upwards.

TO CYCLISTS. For stronger wheels that will remain round and true, here's a time tested tip. Tie the spokes where they cross with fine wire AND SOLDER. It's simple—with FLUXITE—but IMPORTANT.

FLUXITE

SOLDERING PASTE

A Staunch Companion to Fluxite Soldering Fluid.

SIMPLIFIES ALL SOLDERING

Write for book on the Art of "SOFT" soldering and for leaflets on CASE-HARDENING STEEL and TEMPERING TOOLS with FLUXITE.

FLUXITE LTD.,
BERMONDSEY STREET, LONDON, S.E.1.

OVER 1500 PAGES enhanced by extensive references, this new edition covers every aspect of radio reception, audio and record reproduction. **Over 280,000** of previous edition sold. This new, greatly enlarged edition is in great demand. Be sure of your copy of this most comprehensive reference book for the radio worker.

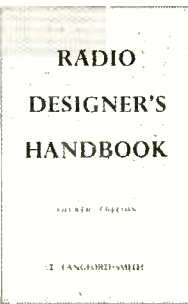

Order now! 43 6 post free 44 0 C. O. D.

"The Gramophone" AMPLIFIER

Speaks for itself—so does a user!
 "I have delayed acknowledging the safe receipt of parts for 'The Gramophone' Amplifier until I had completed and subjected it to tests. I am immensely delighted with its performance, far superior to others I have tried costing far more than the present equipment. I only hope that many other readers . . . will come to realise the same as myself—that your advertisement regarding the superlative performance of this amplifier is fully justified."

Thank you, sir, too! No need for sales talk or picture from us.
 Complete with valves, tested.

The Amplifier 17 gns.
 Pre-amplifier for Magnetic pu. 5 gns. Control Unit for Crystal pu. 45/-.
 Brief specification: 9w. Output, 20dB feedback, only 0.1 per cent harmonic at 5w, 20-20,000 c.p.s., 3/15 ohm output. 200-250 v. A.C. mains. Tone control on pre-amp. gives bass and treble cut or boost, on control unit treble cut alone with anti-rumble circuit.
HOME CONSTRUCTION of the units is simple, aided by our part assembled group boards with resistors and capacitors ready wired in, drilled chassis and complete illustrated instruction manual. Send for this latter now, it's 1/9 post free.



PRESSURE TYPE TWEETER UNIT

All-aluminium, M/C., former and diaphragm at rear of 14,000 gauss magnet, centre pole shaped to commence horn. 15 or 30 ohm. Suitable 3 Kcs and X-over network 26/6. This unit and X-over combined within neat walnut veneered cabinet in the

Q.M. QUALITY CUBE 6gns.
 The clean extended treble response added to existing speakers of 10-18ins. gives increased realism out of all proportion to modest cost.

The W.B. range includes models of all popular sizes. We also stock a special 18in. model of exceptional performance. £27 10/-.

New Decca LP Pickup

Better quality, less record wear with the new "H" head interchangeable with earlier Decca magnetic heads (3-pin). H.F. response raised to 14 kc/s. 3 grams lighter. Not widely available, but we have a fair stock. 1,600 ohm replaces "C" or "D" heads, 90 ohm the "B" head for Decola, Leak, etc.
 Head only with sapphire, 54/9; with diamond, £6 18/-.
 XMS pick-up "H" and 78 heads, £6 9/6.

COLLARO 1953 Turntable Units and Auto-Changers

A new range combining popular price with merits usually found only in more expensive transcription equipment. Heavy turntables with smooth 3-speed drive giving negligible rumble, a turnover crystal pickup with unusual range tracking at low pressure on the most difficult microgroove record, fully tropicalised, handsome cream enamel units bespeaking confidence by their immaculate appearance.
 Stamped addressed envelope brings full specification, prices and extended payment terms.

Home and Export Trade Enquiries welcomed.

QUALITY MART

8, Dartmouth Park Avenue, London, N.W.5.
 Order by Mail—Demonstrations by Appointment.

COMPONENTS—SURPLUS AND SECONDHAND

RADIO CLEARANCE, Ltd., 27, Tottenham Court Rd., London, W.1. Tel. Museum 9188.
ELECTROLYTICS, capacity, voltage, size, type of mounting, price post paid, in that order:
 400. 6v. 1x2in. lug, 2/3; 250+250. 6v. 1x2in. lug, 2/6; 500+500 6v. 1x3in. lug, 2/6; 40+40, 150v. 1 1/2in x 2in. clip, 3/-; 40, 150v. 1x2in. clip, 2/6; 20+20. 275v. 1x2in. lug, 3/6; 16+32. 275v. 1x2in. lug, 3/6; 16+16. 275v. 1x2in. clip, 3/6; 32+32. 275v. 50mf. 25v. 1x3in. lug, 4/-; 60+100. 275v. 1 1/2x3in. lug, 5/6; 100, 275v. 1 1/2x2in. clip, 3/9; 32+12. 350v. 1 1/2x2in. clip, 4/6; 16+16+16. 350v. 1 1/2x2in. clip, 5/-; 40+40+20. 350v. 1 1/2x3in. lug, 5/-; 16. 350v. 3/4x2in. lug, 2/-; 40+40. 300v. 1x3in. lug, 4/-; 10. 450v. 3/4x2in. lug, 2/-; 16. 450v. 1 1/2x2in. 3/-; 20. 450v. 1x2in. lug, 2/9; 32. 450/525v. 1 1/2x2in. clip, 4/-; 32+32. 450v. 1 1/2x3in. clip, 5/6; 30+30. 450v+20mf 25v. 1 1/2x3in. lug, 5/6; 15+15. 450v+20mf 25v. 1 1/2x3in. lug, 5/6; 200. 6v. 3/4x1 1/2in. clip, 2/-; 100. 12v. 3/4x1 1/2in. wire, 1/9; 8. 450v. 1x2in. clip, 2/6; 50. 12v. 3/4x1 1/2in. wire, 1/6; 150. 25v. 3/4x1 1/2in. clip, 2/-; 250. 12v. 1x1 1/2in. wire, 2/3; 350. 25v. 1x2 1/2in. clip, 2/6; 16+16. 450v. 1 1/2x2in. clip, 4/-; 40+40. 275v. 1 1/2x2in. clip, 3/6; 16+32. 450/525v. 1 1/2x2in. clip, 5/6; 24+24+16. 350/425v. 1 1/2x2in. clip, 4/9; 50+200. 275/550v. 1 1/2x4 1/2in. clip, 6/6; 1,000. 12v. 1x2 1/2in. clip, 2/9; 4. 150v. 3/4x1 1/2in. clip, 1/1; 60+100. 350/425v. 1 1/2x4 1/2in. clip, 6/6; 500. 12v. 1 1/2x2 1/2in. clip, 2/-; 8. 350v. 3/4x2in. 2/-; 6,000. 12v. 1 1/2x4 1/2in. lug, 4/6; 100+200. 275/350v. 1 1/2x4 1/2in. clip, 6/6; 100+175. 275/350v. 1 1/2x4 1/2in. clip, 6/6; 8+16+16. 450/525v. 1 1/2x2in. lug, 5/9; 32+32. 350/425v. 1 1/2x2in. clip, 5/-; 2,000. 6v. 1x3in. clip, 3/-; 8+16. 450/525. 1x2in. clip, 4/-; 2. 450/525v. 3/4x1 1/2in. tag, 1/6; 2. 350v. 3/4x1 1/2in. tag, 1/5; 8. 350/425v. 3/4x2in. clip, 2/-; 16+32+8. 450v. 1 1/2x3in. lug, 5/6; all are all cans, some with sleeves.
ALL new stock, all voltages WKG. with surge v where marked; trade supplied most types.
TELEVISION! Set of 3 components, comprising line output trans. with E.H.T. winding to give 7kV, using EY51 (heater winding for EY51 also included), and fitted with wide control scanning coils, low impedance line and frame, focus coil (res. 10,000), current approx. 20 mA); the set of 3 for 42/- plus 2/- post, diagram of line trans. supplied.
PERSONAL receivers. 3 valve T.R.F. using IT4s, contained in handsome bakelite case with lift-up lid, size 7x6 1/2x5 1/2in with lid closed, plastic carrying handle, fram. AE in lid, these receivers cover the medium waveband and operate from self-contained dry batts., standard types, W1435 and U2, output to a pair of lightweight 'phones (H.R.) controls, SM tuning and reaction, opening lid switches on, supplied brand new, with valves, batteries, 'phones, an ideal set for invalids hosp. patients, etc., these receivers are not Govt. surplus and are offered ready to play; carr. paid; £4/10.
RADIO CLEARANCE, Ltd., 27, Tottenham Court Rd., London, W.1. Tel. Museum 9188. 10015
SUPREME RADIO, 746B, Romford Rd., Manor Park, London, E.12. Tel. Hf. 1260. Est. 17 years.
ALWAYS Supreme for good quality components at the right price: 10HY. 100ma L.F. chokes; our price, 7/9 each.
HEATER trans., primary 0-250v. sec. 6.3v at 1.5amp, 5/11 each, or 6.3v at 3amp, 8/11 each. IF/TS. 465kcs. in small all. can. 2 1/4in. 1. x 1 1/4in dia., with dust cores; look at the price, 6/6 pair.
VERY popular line: Mains trans. by Parmeko. universal fixing, primary tapped, 0-200-220-240v, sec. 290-0-290 80ma. 6.3v 3amp and 6.3v, tapped at 4V 2amp, with screen; our price, 15/11 inc. post and packing.
AMAZING bargains in vol. controls: Small type, with ions, spindle and D/P switch, 1meg, 1 or 1/2meg, cannot repeat at 3/- each; P.M. speaker, all less trans., 2-3 V coil, 5in 10 v. 6 1/2in 12/11 each, 8in 13/11 each, 10in 18/11 each.
THE famous Goodmans 10in P.M. still in stock, 2-3ohm v/coil, less trans., at the very keen price of 22/6 each.
ELECTROLYTIC condensers: Metal can type, 32+32+16mf, 350v. 3/6 each; 60+150mf, 275v d.c. wkg., 4/11 each; 200+200mf, 25v. 1/- each; 16+8mf, 450v. 4/9 each; 16+16mf, 450v. 4/11 each; tub, cardboard con., 8mf, 500v. wire end, small, 2/- each, 100mf, 12v. tub/cardboard wired bias cond. 1/6 each, metal tag end, 25mf, 25v cond. 1/3 each (all cond. listed are brand new stocks).
TWIN balanced feeder, 80ohm, for television; our price 4d yard.
T.R.F. coils with circuit for M/W and L/wave, 6/- pair.
3AMP vitreous enamelled droppers, with slider, 800ohms, 4/- each.
28-WAY tag strip, break it as required, 1/- each. **MANY OTHER bargain lines** in stock.
TERMS: C.O.D. or c.o. for extra for postage orders under £5. 2 1/2d s.a.e. all enquiries and list. 10021

For SUCCESSFUL wide-angle scanning ALLEN DEFLECTOR COILS



- 70° Scan with minimum deflection defocussing.
- High-efficiency castellated "FERROXCUBE" core.
- Suits any Wide Angle C.R.T. up to 27" double (d) Scan.

LARGE SCREEN TELEVISION
 Can only be achieved by using high efficiency components throughout. ALLENS can supply the complete range.

For prices and details of the full range of ALLEN components write to:—
 For circuit diagram of Line and Time Base Send 9d. and S.A.E. to:—

ALLEN COMPONENTS LTD
 Crown Works, 197 Lower Richmond Road, Richmond, Surrey
 Telephone: Prospect 9013

FOR CATHODE RAY TUBE FAILURES.

Special low capacity secondary winding for Heater/Cathode shorts to restore picture after this fault has occurred. All Primaries tapped, framed and tag panelled, 200/250. 2 v. at 2 a., 4v. at 2 a., 6.3 v. at 2 a., 10.8 v. at 0.3a., at 29/6 each.

For any other voltage, send particulars of voltage and current required. Trade discount to genuine retailers and service men for above only.

T.V. HEATER TRANSFORMER, 200/250.
6.3 v. at 7 a.-0-2-6.3 v. at 2 a., at 19/6.

T.V. AUTO TRANSFORMER. 0-190-210.
230-240 v. 6.3 v. at 7 a.-0-2-6.3 v. at 2 a., at 27/6.

T.V. FRAME TRANSFORMER. 60 H.
magnetic deflection suitable for most home-constructed sets, at 15/6.

MAINS TRANSFORMER. 200/250,
425/0/425 200 m/A. 6.3 v. at 4 a. C.T., 6.3 v. at 4 a. C.T., 5 v. at 3 a. Fully shrouded, at 50/- each.

We will quote for quantities of any type of Mains and O.P. Transformers and Chokes to manufacturers of electronic equipment, or wholesalers and exporters.

NORTHERN TRANSFORMER CO.
215 BARKEREND ROAD,
BRADFORD, YORKS.

COMPONENTS—SURPLUS AND

SECONDHAND

SOUTHERN RADIO SUPPLY, Ltd. 11, Little Newport Street, London, W.C.2. See our displayed advertisement, page 108. [0016]

GOVERNMENT and manufacturer's surplus lines, radio, electrical, etc., lists free to engineers and shops.—N. R. Bardwell & Co., Sellers St., Sheffield, 8. Tel. 52886. [1433]

TV formers, 4BA wrenches, 7mcs IFT, 6d. H.R. phones 12/- PF, chokes 2H, 200ma, 7/- PF, 10 H, 250ma, 10/6 P, tranx. 1083, less valves, coils, 25/- PF, M.W. Welfare batt. recy. 50/- PF, free lists.—Annakin, 25, Ashfield Place, Otley, Yorks. [1419]

SPECIAL valves, type 807, brand new. 7/9 each; type 196 unit, brand new, less valves. 22/6; mains trans. 350-0-350. 3 v. 4v. 4v. 80ma. 19/6; Wey-Rad 465kcs I.F. trans. 8/3 pair; midjet 465kcs. 9/6 pair; loudspeakers, 3 1/2 in. 11/6; 5 in. 11/6; 6 in. 12/6; 10 in. 19/6; fil. trans. 6.3v at 1.5amp. 5/9; metal recs. RM1. 4/6; RM2. 4/9; RM4. 15/6; v/controls. semi-midjet. all valves. 3/- SP/sw, 4/6 DP/sw, 5/6 electro. lytics. 450vw. 8mfd. 1/3; 16mfd. 2/6; 8x16. 3/6; 16x16. 4/3; 32x32. 4/9; 500vw card tub. 8mfd. 2/6; 16mfd. 3/-; 8x16. 3/9; 32mfd. 3/9; stock list available.—Radio Unlimited, Elm Rd., London, E.17. Key. 4813. [0062]

CABINETS

WALNUT radiogram cabinets; details.—Cabinetware. 1a. HeYes St., Blackburn. [0091]

WALNUT radiogram and television cabinets, soundly constructed; stamp details.—R. Shaw, 69, Fairford Rd., Leytonstone, E.11. [9591]

GOODMANS corner reflex cabinets supplied. radio, gramophone, record and bass reflex cabinets made to order; rexine covered record player cases from 50/-; bass reflex cabinet kits from 80/-; call or write; open till 5.30 p.m. Saturdays.

A. DAVIES & CO. Cabinet Makers, 3, Parkhill Place, off Parkhill Rd., London, N.W.3. Gulliver 5775. [1410]

NOTICES

NORWOOD TECHNICAL COLLEGE,

TRAINING in radio, radar, television and electronics.

DAY and evening classes in preparation for Grad.Brit.I.R.E. City and Guilds Examinations. P.M.G. Certificate, R.T.E.B. Radio and Television Service Certificates.

ALSO special courses in radar, television, electronics (instrumentation) and radio. LONDON fees for full-time day classes: Free if under 18 years. £25 per year (£8 per term) if 18 years or over.

FURTHER particulars from Secretary, Nor-wood Technical College, West Norwood, London, S.E.27. (374) [1085]

COUNTY BOROUGH OF BOLTON—Education Committee.

ROLTON Technical College.

A THREE-YEAR full-time course in Electronic Engineering commences in September, 1953.

APPLICANTS should be in the age range 16 to 18, and have obtained, or be taking, General Certificate (Ordinary Level) in Mathematics or Physics, or equivalent courses in technical institutions.

THIS rapidly developing industry offers new and attractive openings to qualified men.

APPLICATION forms and particulars may be obtained from the Principal, Technical College, Bolton, Lancs.

W. T. SELLEY Chief Education Officer. Education Offices, Nelson Square, Bolton. [9855]

WANTED, EXCHANGE, ETC.

WANTED.

BC610 Hallicrafters, also spares; RCA ET 4336 series with spares, BC348 receivers, also TCS56, TCS12 and components.

McELROY ADAMS MFG. GROUP Ltd. 46, Greyhound Rd., W.6. Tel. Fulham 1138-9. [0194]

45/- each offered for 813 type valves.—Write Box 7050. [1073]

LEAK high-fidelity radio and amplifier or similar required.—Box 7692. [1434]

HIGH-QUALITY 3ohm 10-watt loudspeaker required in cabinet.—Box 7694. [1436]

WANTED, receivers A.P.R.4, also T.N. 16, 17, 18 19, etc., and any radio test gear.

LESLIE DIXON & Co., 21, Queenstown Rd., Battersea, S.W.8. Macaulay 2159. [0176]

WANTED, RCA 4331 transmitters.—P.C.A. Radio, Cambridge Grove, Hammersmith, W.6. Tel. Riverside 3279. [0093]

BULK quantities urgently wanted for export ex-W/D radio, telephone, signalling equipment of every description.—Box 6880. [1038]

WANTED, HRO coils, Rxs, etc., A.R.88s, BC348s, S27s, etc.—Details to R.T. & I. Service, 254, Grove Green Rd., London, E.11. Ley. 4986. [0163]

WANTED, laboratory test equipment, includ-ing standard signal generator, watt meter, oscilloscope, bridges, recorders; send price and details to:

HATFIELD INSTRUMENTS, 175, Uxbridge Rd., Hatwell, W.7. Tel. Ealing 0779. [0037]

WANTED, RCA speech amplifiers type MI-11220 J or K and arie tuning units

BC 939a, Hallicrafters speech amplifiers BC 614; offers stating quantity and price to—PCA Radio, The Arches, Cambridge Grove, W.6. [0080]



I.F. ALIGNER KIT 15/-

Provides a modulated signal, basic frequency 465 kc/s., tunable above and below for other I.F. frequencies in this range, and is pre-tuned ready for use.

Robust construction in compact welded steel box 4in. x 4in. x 3in. Light, fully portable, operating from single "U2" 1.5 volt dry cell.

All metal parts are ready drilled for easy assembly from full instructions and diagrams.

Post & packing 1/-. Cash with order or C.O.D.

Both these Kits are COMPLETE.
No Valves to Buy.

RES./CAP. BRIDGE KIT 31/6

5 Megohms—50,000 ohms. 50 mfd.—2 mfd.
100,000 ohms—1,000 ohms. 1 mfd.—.01 mfd.
1,000 ohms—10 ohms. .01 mfd.—.0005 mfd.

NO CALIBRATING

Six fully variable ranges, separately scaled for direct reading. Full instructions and diagrams for easy assembly.

Post & packing 1/6. Cash with order or C.O.D.

RADIO MAIL

4, RALEIGH STREET, NOTTINGHAM
Stamp with all enquiries, please.

RECORD PLAYER

110-250v. A.C.
78-33 1/2 r.p.m.

Dual Purpose Sapphire Stylus



Few only at
£6.7.6
P. & P. 2/6.

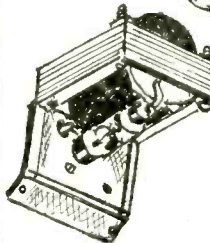

5-6Kv. E.H.T. TRANSFORMER

With U22 RECTIFIER

37/6
P. & P. 2/6.

MOTORS

110-250v. A.C.-D.C.

3,000 r.p.m. 1/2 h.p. Size 6 x 3 1/2"

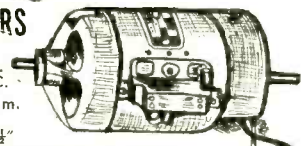

Spindle 5/16 x 1" long, Ex G.P.O. Ideal for 101 uses. Price **27/6** P. & P. 2/-

WIRE & CABLE STRIPPERS By Famous Maker. Usual Price 15/-. Our Price **5/6**
Hundreds of Bargains in Radio—T.V. Components. Callers Welcomed. Send S.A.E. for List.

JACKSON RADIO SUPPLIES
163 EDGWARE ROAD LONDON, W.2



Solons save time, reduce costs. Solon soldering is always clean, reliable and simple. Five models, in voltage range 100-250; each with 6 feet Henley flexible. 65 watt; oval tapered or round pencil bits. 125 watt; oval tapered or round pencil bits. 240 watts; oval tapered bit.

Write for Folder Y.10



w. T. HENLEY'S Telegraph Works Co. Ltd.
61-58 Hatton Garden, London, E.C.1

ALPHA OFFERS

SPECIAL PURPOSE VALVES

EF8, 6/6; 954, 2/-; 955, 4/9; 956, 3/6; VU111, 3/6; VU120A, 3/6; 6G6G, 6/6; 6A6, 8/-; VU133, 3/6; CV71, 1/-; TT11, 6/6; 9001, 6/3; 9002, 6/3; 9003, 6/3; 9004, 6/3; 9006, 6/3; VR137, 5/-; VR116, 4/-; 2X2, 5/6; 6A3, 5/-; 6B5, 5/-; 6F7, 5/-; 6SF7, 5/6; 6ST7, 5/-; 117Z6GT, 7/6; 28D7, 7/6; VU39, 8/6; VR53, 7/6; VR136, 7/-; VR55, 7/3; VR56, 7/-; VR65, 3/9; VR65A, 3/6; VR91, 6/-; VR91 Sylvania, 7/6.

EX GOVERNMENT VOLUME CONTROLS

500Ω, 600Ω, 10KΩ, 5KΩ, 100KΩ, 50KΩ, 2 MEGΩ, 1/2 MEGΩ, 1/4 MEGΩ. Double 1500Ω one spindle. Double 25KΩ one spindle. Double 50KΩ one spindle. All 1/- each.

LOUDSPEAKERS

Plessey 3in. Round Type for Personal Portables, 3 ohm.....	12	9
Elac 3 1/2in. Square Type 3/09, 3 ohm.....	13	6
Elac 5in. Round Type.....	12	3
Electrona 5in. Latest type.....	12	3
Goodmans 5in. Round Type, 2 to 3 ohm.....	13	6
Goodmans 6 1/2in. L'wt., 2 to 3 ohm.....	13	6
Elac 6in. Type 6/19, 2 to 3 ohm.....	13	6
Truvox 6 1/2in. Standard with Output Transformer.....	14	6
Truvox 6 1/2in. Wafer, 1 1/2in. deep.....	£1	0
Plessey 8in. Lightweight, 2 to 3 ohm.....	15	0
Elac 8in. Type 8/37, 2 to 3 ohm.....	14	0
Electrona 8in.....	14	0
Rola 8in.....	14	0
Plessey 10in. L'wt. 2 to 3 ohm.....	19	6
Rola 10in. 2 to 3 ohm.....	£1	8
Electrona 10in.....	16	6
Truvox 12in. BX11 L'wt., 2 to 3 ohm.....	£2	17
Truvox 12in. Heavy Duty Model, 15 ohm Speech Coil. Model SS9.....	£5	15

CONDENSERS

64 mfd. 350 v.....	ea.	3	6
32 x 16 mfd. 350 v.....	ea.	3	3
250 mfd. 12 v.....	ea.	2	0
8 x 8 mfd. 350 v.....	ea.	2	0
24 x 8 mfd. 350 v.....	ea.	2	0
32 x 4 x 4 x 4 mfd. 350 v.....	ea.	2	0

WIRE WOUND VOLUME CONTROLS

5 ohm, 200 ohm 10K ohm, 5K ohm, 15K ohm, 20K ohm, 25K ohm, 35K ohm, 50K ohm.....	2	0	
All.....	ea.	1	9
50K ohm pre set carbon.....	ea.	1	9
500 ohm pre set Wire Wound Control.....	1	9	
CLR 902 1000 ohm pre set.....	ea.	2	0

CONDENSERS. Wax Tubular

.02 mid. 1000..... doz. 7 0

TAPE RECORDING MOTORS

Collaro AC49 1 Anticlock, 1 Clockwise..... pr. £2 16 0

P.V.C. COVERED WIRE, bright colours, red, green, blue, yellow, etc per 300ft.....

5 0

RUBBER GROMMETS, various sizes.....

doz. 6d.

ROMAC TELEVISION RECEIVER

MODEL 189. BRAND NEW IN MAKERS' CARTONS COMPLETE WITH 17 B.V.A. VALVES, ETC. BUT LESS TUBE. VALVE TYPES ARE: 6AM6, 6AL5, 12AT7, 275A, 185BT EY51, 6V6GT.

THESE SETS WERE LISTED BY THE MAKERS AT OVER £80. SPECIAL PURCHASE ENABLES US TO OFFER AT ea. £25 0 0 less tube.

A CHARGE OF 25/- IS MADE TO COVER CARRIAGE AND PACKING AND INSURANCE. BRIMAR C12B TUBES ARE AVAILABLE AT CURRENT PRICE. FULL SCALE CIRCUIT DIAGRAM..... ea. 4 6

10 VALVE 1 1/2 METRE SUPERHET.

Ideal for T.V. conversion IF's 12 Megs. Band width 4 megs. Co-Axial input and output, Mazda valves with 6.3 v. filaments. 58/- ea. Carriage 4/-.

INDICATOR UNIT TYPE 6L. Brand new with EF50 valves. VCR97 wire wound volume controls, 67/6 each. Carriage 7/6.

TERMS: Cash with order or C.O.D. Please note minimum C.O.D. fee 2/3.

MAIL ORDER ONLY

Postage. Please add 6d. to 10/-, 1/- to 20/-, 1/6 to 40/- for all orders unless otherwise stated.

ALPHA RADIO SUPPLY CO.
5 6 Vince's Chambers, Victoria Square,
LEEDS 1

WANTED. EXCHANGE, ETC.

WANTED, power supply units for No. 33 transmitters (Z.A.10729).—Call or ring. P.C.A. Radio, The Arches, Cambridge Grove, W.6. Riv. 3279.

WANTED, set manufacturers' or ex-Government radio equipment, large or small quantities of valves, electrolytics, speakers, meters, also components.

LOWE BROS., 5, Fitzroy St., London. W.1 Tel. Museum 4389.

WANTED BC-610 Hallicrafters, RCA ET-4336 transmitters SX-28, AR-88, S-27 HRO receiver and spare parts for above; best prices.—PCA Radio, The Arches, Cambridge Grove, W.6. [0081]

WE purchase all types of domestic or ex-Government radio receivers and equipment; send full details or call and collect cash; large or small quantities.—Walton's Wireless Stores, 48, Stafford St., Wolverhampton. [0146]

ALTHAM RADIO Co. pay highest prices in the trade for all American equipment, including test sets, transmitters, receivers, tele-printing gear, etc.—Jersey House, Jersey St., Manchester, 4. Tel. Central 7834-5-6. [0228]

WANTED, AN/APR-4 receiver, any units; any other good quality U.S. surplus radio and radar tubes, test sets; laboratory equipments, etc.; give condition and price in first letter.—Engineering Associates, 434, Patterson Rd., Dayton, 9. Ohio. U.S.A. [0234]

WANTED, good quality communication rxs., domestic radios, test equipment, etc. top prices paid—established since 1937.—Miller's Radio, 35a, Newport Court, 1 min. from Leicester Sq. Tube, Tel. Ger. 4638. Call, write or send. Hours of business 10-6 p.m. Open all day Saturday. [0199]

WANTED; we will pay 10% more for the following American equipment: test sets with TS prefix, BC221, APR4 receivers, APR4 tuning units, BC342, BC512, power units No. 15 and PERS, teleprinter equipment.—Altham Radio Co., Jersey House, Jersey St., Manchester, 4. Tel. Central 7834-5-6. [0227]

URGENTLY wanted—VHF test equipment: TS47AP, TS174U, TS34, TS148/UP, TSX-4SE, BC221s and any other types; valves klystrons, magnetrons. 723/AB, receivers APR4 and TN-16-17-18 tuning units, RCA, AR88s, S27s, SX28s, S27CA and any late types, microwave equipment or spares; highest prices given; please write, call or telephone Gerard 8410; prompt attention assured.—Universa Electronics, 27, Lisle St., Leicester Square, London, W.C.2. [0229]

AERIALS

8 tons of 4ft lengths steel copper-covered aerial.—Offers wanted, to—19, Mincing Lane, Blackburn, Tel. 7748-9. [1359]

REPAIRS AND SERVICE

ANNOUNCING a 48-hr transformer rewind service—with a difference.

A FIRST-rate job for a first-rate engineer. E.H.T.s, Mains, Fields, O.P.s, etc.

NEW transformers made to suit your requirements, designed on "C" core or conventional methods.

WILLIAMSON'S O.P. to original spec.: 80/-, ALL work fully guaranteed.

WOODROW Transformers Ltd., 28, Balmoral Rd., Willesden, N.W.2. Tel. Willesden 2014. [1427]

MAINS transformers rewound, new transformers to any specification.

MOTOR rewinds and complete overhauls: first-class workmanship; fully guaranteed.

F.M. ELECTRIC Co., Ltd. Potters Bldgs., Warser Gate, Nottingham. Est. 1917. Tel. 3855. [0113]

REPAIRS.—E.H.T. mains and O.P. transformers, field coils and chokes; also armatures and motors; new transformers designed to any specification; all work fully guaranteed.

WILLESDEN TRANSFORMER Co. Ltd. 2a, Fritville Gdns., Shepherds Bush, London, W.12. Tel. Shepherds Bush 5819. [0076]

COMPREHENSIVE service to trade and amateur: Design, manufacture and repair of electronic equipment carried out by specialists; equal attention given to small or large orders. See also below.

AUTOCHANGERS.—6-hour service, cleaning and adjusting at fixed price of 35/- plus carriage; also all repairs carried out; trade enquiries invited.—Ariel Sound, 57, Lancaster Mews, London, W.2. Tel. Paddington 5092 (2 lines). [1436]

REWINDS and conversions to mains and output trans. pick-ups, fields, clock coils, etc., from 4/6, P.P. equipment a speciality; all work guaranteed.—N. L. Rewinds, 52, Blackbird Hill, N.W.9. Tel. Wordsworth 7771. [1416]

MAINS transformers, E.H.T. line outputs, chokes and field coils, etc., promptly and efficiently rewound or manufactured to any specification, 36 hours' service, 12 months' guarantee.

LADBROKE REWIND SERVICE, Ltd., 820a, Harrow Rd., Kensal Rise, N.W.10. Lad. 0914. [0222]

24-HOUR service, 6 months' guarantee, any transformer: rewind, mains outputs and i.f.s., etc.; all types of new trans., etc., supplied to specification; business heading or service card for trade prices.—Majestic Winding Co., London Rd., Bournemouth. [6520]

Armstrong

3 NEW TELEVISION RECEIVERS OF EXTREMELY ECONOMICAL PRICE

TELE-GRAM

A 14in. flat faced rectangular Television receiver combined with the very latest three speed record player, housed within a handsome veneered walnut cabinet 35in. high, 20in. wide, 20in. deep, 19 valves. Aluminised tube with tinted filter, pin point focussing coupled with full bandwidth and accurate interlacing ENSURES BRILLIANT DAYLIGHT VIEWING 5 channels—selected instantaneously. 10in. loudspeaker for magnificent reproduction. A.C. mains 200/250 volts

Price: 78 guineas (inc. P. Tax).

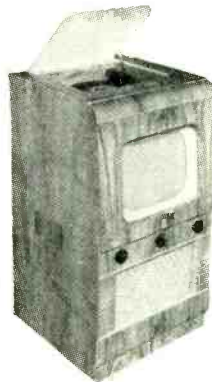

TV.5 14" CONSOLE

The 14in. Console model is exactly similar in all respects to the Tele-gram, with the exception of the record player, as described above.

Price: 69 guineas (inc. P. Tax).

TV.5 17" CONSOLE

Similarly this 17in. model which gives a superb large picture has the same specification as the 14in. models.

Price: 79 guineas (inc. P. Tax).

Please send for illustrated details and price list.

For the convenience of customers who are unable to call during normal working hours, we are now open until 5 p.m. on Saturdays.

ARMSTRONG WIRELESS & TELEVISION CO. LTD.
WALTERS ROAD, HOLLOWAY,
LONDON, N.7.

Telephone: NORTH 3213

TUNERS

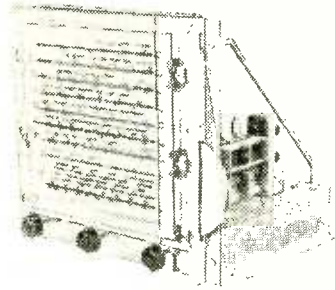

- S6BS** 9 Band (6 Electrical band spread) with R.F. F.C. 2 I.F. Delayed Amplified A.V.C. Variable Selectivity. Fly Wheel Tuning. Tropicalised. Suitable for use with any High Quality Amplifier. £44. Tax paid.
- S5** 3 Wavebands. 16m.-2,000m. R.F. Pre-amplifier, variable selectivity I.F. Delayed amplified A.V.C. Very low distortion. £21/6/8. Tax paid.
- S5E** As S5 but 12.5m.-550m. £21/6/8. Tax paid.
- S4** The Standard high-quality Feeder Unit. Specification as S5 but without R.F. amplifier. £16. Tax paid.

A modified version of all models is available for use with Leak or Acoustical Amplifiers.

C. T. CHAPMAN (Reproducers) LTD.
RILEY WKS., RILEY ST., CHELSEA, S.W.10
FLAxman 4577/8
Export Enquiries Invited

TANNOY
PRODUCTS

SOUND EQUIPMENT
clearly the best for
all occasions

WEST NORWOOD S.E.27. Tel. GIPsy 411131 (2 lines)

LONDON CENTRAL RADIO STORES

ELECTRO MAGNETIC COUNTERS
Ex-G.P.O., every one perfect, electro-magnetic, 500 ohm coil, counting to 9,999, operated from 25 v. 50 v. D.C., 4 1/2 in long x 1 1/2 x 1 in., many industrial and domestic applications, 15/- Equal to new. Post & pkg. 9d.

8in. P.M. SPEAKERS. 3 ohm. speech coil. Slightly used less transformer 9/6. Post & pkg 1/6

VIBRATORS, 2-volt. Type R70C. 7-pin self-rectifying. Output 200 v. at 60 mA., 7/6. P. & P 9d.

SLIDING RESISTANCES. 2 ohm. 20 amp. For drumming, etc. With hand wheel geared for sliding purposes. Weight 9 lb. Size 15 1/2 x 11ins. 52/6. Post & pkg. 2/6.

UNISELECTOR SWITCHES. Have many applications, including automatic tuning circuit selection, etc. Operates on 25-50-v.

Full Wipers, 3-bank, 19 6 6 bank **35/-**
Half Wipers, 6-bank, 27 6. Plus 1/6 P. & P.

● See previous ads. for other bargains.
N.B.—We do not issue lists or catalogues. Carriage charges relate to British Isles only.

23 LISLE ST. (GERrard 2969) LONDON, W.C.2
Closed Thursday 1 p.m. Open all day Saturday.

REPAIRS AND SERVICE
ELECTRICAL test instruments repaired and standardized, all types British or American. ammeters, voltmeters, ohmmeters, DC/AC multi-range meters, etc.; meters converted to specification.

THE ELECTRICAL INSTRUMENT REPAIR SERVICE. 329, Kilburn Lane, London, W.9. Tel. LAD. 4168. [1134]

MISCELLANEOUS
WOOD screws 1/4in x 10, black japanned, 1/6 per gross.—Martin Poole, 89, Bradford St., Birmingham. 12. [1381]

ELECTRIC welding plant, used and unused for sale; s.a.e. for lists.—Harmsworth, Townley & Co., 1, Brook Rd., Manchester, 14. [1040]

PLYWOOD, hardwood, free list on request. mahogany ply. 12/6 sheet; oak ply, 22/6.—N. Gerver, 10, Mare St., Hackney, London, E. [1432]

CABLES, wires and flexibles. P.V.C. coverings at clearance prices.—R. Lowther, Ltd., 100a, St. Vincent St., Ancoats, Manchester, 4. [10223]

STEEL lattice and guded radio masts. 100ft high, for sale; delivery from stock; excellent condition.—Bellmans, Terminal House, S.W.1. [9975]

METALWORK, all types cabinets, chassis, racks, etc., to your own specifications; capacity available for small milling and capstan work up to 1in bar.

PHILPOT'S METAL WORKS, Ltd., (G4B1), Chapman St., Loughborough. [10208]

A high vacuum impregnation unit to R.I.C. specification 214 or individual requirements; good delivery at competitive prices from Elicvac Components and Assemblies, 505, Lordship Lane, S.E.22. Forest Hill 7089. [10310]

YOUR own tape recording transferring to disc.—Write, call or phone Queensway Private Recording Studios, 123, Queensway, W.2. Tel. Bay 4992. Studio recordings, tape recording service. * Price list on request. [1409]

PLATED nuts, screws, washers, bolts, soldering tans, hank-bushes, self-tapping screws, grub-screws, socket-screws, wood-screws; large quantities or gross cartons, stamps for list.—Sinden Components, Ltd., Dept. B, 117, Churchfield Rd., Acton, W.3. Acorn 8126. [1415]

ENGRAVING amateurs and trade could take the opportunity of engraving problems in the future by getting in touch with A.G. Engraving, 19a, Windmill Rd., London, S.W.18. Est. 5735. Brass, bronze, erinoid, Perspex dials; one knob or repetition equally retained. [10034]

COPPER wires enameled, tinned, Litz, cotton, silk covered, all gauges; B.A. screws, nuts, washers, soldering tans, eyelets, ebonite and laminated bakelite panels, tubes, coil formers; Tunfol rod; headphones, flexes, etc.; latest radio publications, full range available; list, s.a.e., trade supplied.—Post Radio Supplies, 33, Bourne Gardens, London, E.4 [10138]

DECALS labels for marking radio and electronic equipment, clear permanent lettering 1/4in high, no background, easily applied, permanent, Govt. approved; available in book form; each book containing approx. 750 titles, covering all aspects of radio and electronic equipment; price 4/9 plus 3d post, in black or white.—Alexander Equipment, Ltd., Childs Place, Earl's Court, London, S.W.5. [10243]

SITUATIONS VACANT
The engagements of answering these advertisements must be made through the local office of the Ministry of Labour and National Service, etc., if the applicant is a man aged 18-64 or a woman aged 18-59 inclusive, unless he or she or the employer is exempted from the provisions of The Notification of Vacancies Order 1952.

GUIDED weapons.
ELECTRICAL engineer, or mathematician with relevant post-graduate experience, required for theoretical work on design of automatic control systems; some knowledge of effect of noise on servo-mechanisms an advantage; senior staff appointment with good salary and prospects; pension scheme.—Write in detail to Personnel Manager, de Havilland Propellers, Ltd., Hatfield, Herts. [15352]

UNIVERSITY OF ABERDEEN.
ELECTRONICS mechanic required for Physics Laboratory, Natural Philosophy Department, without supervision, able to construct complex apparatus from theoretical circuit and design simple circuit with specification; some general workshop experience useful; wage £365 to £450, according to experience.—Applications to the Secretary, University of Aberdeen. [11130]

CROWN Agents for the Colonies.
WIRELESS Station Superintendent required by the Nigeria Government Posts and Telegraphs Department for one of 18 to 24 months in the first instance with prospect of permanent and pensionable employment; salary etc., in scale, £750, rising to £1,175 a year; outfit allowance £60; free passages for officer and wife and assistance towards cost of children's passages or their maintenance in this country; liberal leave on full salary; candidates (under 40 years) must have had wide practical experience of modern radio techniques and equipment, in particular V.H.F. equipment, and preferably also V.H.F. multi-channel equipment.

APPLY in writing to the Crown Agents, 4, Millbank, London, S.W.1, stating age, name in block letters, full qualifications and experience and quoting M2C/28927/WF. [1379]

BENSON'S BETTER BARGAINS

SPECIAL PURPOSE VALVES @ 2/6; VR21, VR54, VR135, 7193, VR92, VT135; @ 3/6; VR65, VR65A, VT90, 954, 956, 9004, 9006, VT75A, VR505, VU113, VU120, CV54; @ 5/6; 6A05, CV73, V786A, 125C7, N0T1, 2C26, VT131, 955, ARP3, 717A, VR91, VR136, VR96, ARP12, VR110, 6SH7, 9001, 2C34, VR57, NT8A, NT20, NT37, 721A @ 7/6; VT71, VT174, VR53, VT133, VT127, 1625, ATP4, VT202, VR57, 606G, CV181, VR137, CV66; @ 8/6; VT66, VT228, VR83, VR55, CV51, VT126B, VT74; @ 10/6; VU39, VT167A, V7231, VT229, VT92A, VT210; @ 12/6; VT73, CV858, P755, CV850, CV562.

CONDENSERS, variable, twin 75p, 4/-; single D.E. 2/-; 75pF long spindle, 1/6; 25pF, 1/3; 50pF, 1/6; 20pF preset, 1/3; 40 or 65pF linear, 2/-; 25pF twin butyrolite, 2/6; 500pF twin, 5/-; 250pF twin, 4/6; single, 3/6; 500pF 3 or 4 gang, 8/6; FIXED, .01, .02, 1 500 vw each, 8d.; Ceramics, 2.2, 3, 5, 6.8, 10, 12, 15, 20, 22, 27, 33, 39, 47, 100pFs, 6d. each; 2 mfd. 1 kv2, 2/-; .01 or .001 4 kvV, 1/3. Electrolytics, 16-8-4-4 mid. 500 vw., 6/-; 16-2-350 vw., 3/6; 25 mid. 25 vw., 1/3. Mica, .01 600 vw., 8d.; 100 pf. or 1,000 pf. 6d. RESISTORS, vitreous, 3k 30 w., 30k 25 w., 300 25 w., 7k tap 2k 25 w., 15k 15 w., 2.5k 25 w., 30 2 30 w., 1.25k 3 w., 10k 3 w. @ 1/- each; 1k 100 w., 50k 20 w., 20k 120 w., 16-2-2 120 w. @ 1/6 each; variable 20k 10 w. w/w 2in. dia., 3/6. RECTIFIERS, Metal HV. 270 v. 80 mA., 6/-; 480 v. 80 mA., 7/-; 600 v. 30 mA., 6/6; 560 v. CT 100 mA., 7/6; FW 75 v. 80 mA., 3/6; Meter type, 5/6; 17 v. 8 a. 30/-; HV, CT 12 v. 250 mA., 1/6. TRIMMERS/Padders, 30pF, silvered 9d.; Beehive 10 pF, 8d.; 100 pF twin, 1/3. CHOKES RF 4 mic Rx., 9d., Tx 250 mA., 1/-. MOTORS, Collaro AC37 Gram. 110/250 v. A.C. var. speed, 3in. dia. spindle, 30/-; Hoover 24nd Pole, SP301 200/250 v. A.C., 1,400 r.p.m., anti clock, 8/6.—R.F. UNITS type 24, 21/-; 25, 25/-; 27, 45/- Loading Units for these, type 51, 5/6; spare coils, RF24, 8d.; RF25, 9d.; 7 Meis IPTs. (R1355), diode base, 2/-; 10/13 Meis aircored, canned, 1/6. COILS, Edystone Tx types "P" and "Q" 5 pin hor. base, each 3/6; Formers 2in. x 1in., core, 4 for 1/3; Alladin 1in. 9d. DYNAMOTORS, soiled cases, 11c. 8 v. to 450 v. (approx. 250 v. 80 mA @ 6 v.), 8/6; Hand driven Generators, geared, outputs 28 v. and 300 v., 8/6. Coaxial plugs Pye type, 4d.; elbows, 6d.; double ended plug, 9d.; triple plug, 8d.; 3-way 1/2skt., 9d. List and enquiries, S.A.E., please!

Terms: Cash with order. Postage extra. Immediate delivery.

W. A. BENSON
(W. W.) 308 Rathbone Rd., Liverpool, 13.
STO 1604
CLOSED JULY 26-AUG 3

'neo' MAINTEST
100/700V
AC/DC
17 1/2A

SEARCH LEAD
TEST PROO
7/6

THE PERFECT FAULT FINDER
NEO ELECTRICAL INDUSTRIES LTD
MANCHESTER 4

ODDIE FASTENERS
PAT. 507249

THE FASTENER WITH ENDLESS APPLICATIONS—SIMPLE—POSITIVE SELF-LOCKING. MADE IN A VARIETY OF TYPES AND SIZES.

SPECIAL FASTENERS TO SUIT CUSTOMERS REQUIREMENTS.

WIDELY USED IN THE RADIO INDUSTRY.

Illustrated brochures and other information will be gladly sent on request.
DEPT "W.W."

Oddie, Bradbury & Cull Ltd., Southampton
Tel.: 55883. Cables: Fasteners, Southampton



High-fidelity amplifiers such as our own "N.S.P." models are naturally on their very best behaviour when the ancillaries . . . motor, pickup, speaker, etc. . . are of comparable excellence. We can confidently recommend the following—available by return post from our stocks of high quality components :

MOTORS : Connoisseur, Garrard, B.S.R., Collaro, Decca.

PICKUPS : Connoisseur, Decca, Acos Chancery.

SPEAKERS : Wharfedale, Goodmans, Whiteley.

SEPARATORS : Wharfedale, Whiteley.

EQUALIZERS : Wharfedale.

CABINETS : Reflex, Corner Baffles, Amplifier, to your specification. Quotations by return.

AMPLIFIERS : Leak-Quad.

STYLI : Connoisseur, Decca, Chancery, Garrard.

L.P. Records Post Free by return post. Current Catalogues available.

"N.S.P." AMPLIFIERS available :

A.C. MODELS : "Sovereign" £26 ; "Major" £17/10/- ; "Domestic" £11/10/-.

UNIVERSAL MODELS : "Major" £19/10/- ; Domestic £12.

N.S.P. FEEDERS : V/Selectivity (LMS) £17/17/- ; 3 Band (LMS) £13/15/- ; 2 Band (LM) £11/5/- ; 3 Stn. Pre-set S'het. £8/18/- ; 3 Stn. Pre-set TRF £7/12/6 ; Wrotham (AM) £6/9/6 ; N.S.P. Precision Scratch Filter 59/6.

NUSOUND PRODUCTS LTD.

(Dept. W7) 136 WARDOUR STREET, LONDON, W.1. Tel. : GERrad 8845

Hours of business : 9 a.m.—5.30 p.m. Saturdays 9 a.m.—1 p.m.

U.S. WAR SURPLUS WANTED

APR-4, APR-5, APR-1, ARC-3, etc. ; TS-12 13, 34, 35, 36, 45, 120, 146, 155, 173, 174, 175, 323 and other "TS-" units, etc., particularly for the MICROWAVE REGION ; also U.S. commercial laboratory equipment (General Radio, Ferris, etc.) ; special tubes such as 723A/B, 3C22, etc. ; spare parts, technical manuals ; single units or large quantities.

Sell direct to us, receive the full top price. Describe and price to :

ENGINEERING ASSOCIATES

444 Patterson Road, Dayton 9, Ohio, U.S.A.

SITUATIONS VACANT
CROWN Agents for the Colonies.

METEOROLOGICAL Assistant for radio/radar duties required by the East Africa High Commission for two years leading, subject to satisfactory service, to permanent and pensionable employment or (b) on contract for one tour of 30-48 months with gratuity of 13½% of total salary earned; salary, etc., in scale £715 rising to £1,170 a year, outfit allowance £50, free passages; liberal leave on full salary; candidates must have had good experience of operation and maintenance of ground radar equipment and be capable of undertaking radio-sonde/radio-wind operation, including the determination of results, and the operation and maintenance of meteorological electronic equipment including ionospheric sounders, "Sferics" and diesel electric equipment.—Apply in writing to the Crown Agents, 4, Millbank, London, S.W.1, stating age, name in block letters, full qualifications and experience and quoting M2C/33571/WF. [1425]

CROWN AGENTS FOR THE COLONIES.

WIRELESS operator mechanics required for the Falkland Islands Dependencies Survey for one tour of 18 or 30 months in the first instance. Salary in scale £330 rising to £420 a year. Quarters, subsistence, clothing and liberal canteen stores free while in Dependencies. It is possible to save almost all emoluments. Liberal leave on full salary. Candidates must be able to transmit and receive Morse at 25 words a minute (plain language or code) and be capable of elementary maintenance of wireless transmitting and receiving equipment.—Apply in writing to the Crown Agents, 4, Millbank, London, S.W.1, stating age, name in block letters, full qualifications and experience and quoting M2C/29989/WF. [1390]

CROWN AGENTS FOR THE COLONIES.

ASSISTANT SIGNALS OFFICER required by the Government of Nigeria for the Aviation Department for one tour of 18 to 24 months in the first instance. Salary, etc. either (a) in scale £750 rising to £1,315 a year with prospect of permanency or (b) in scale £807 rising to £1,453 a year on a temporary basis with gratuity at the rate of £100 a year. Outfit allowance £60. Free passages for officer and wife, and assistance towards cost of children's passages, or their maintenance in the United Kingdom. Liberal leave on full salary. Candidates must have a knowledge of the fundamental principles of electricity and magnetism and of radio engineering with experience in the maintenance of aeronautical radio transmitters and receivers, direction finders, test equipment and small petrol and diesel engine generator sets. Workshop experience and a knowledge of radar will be of advantage. Minimum examination qualifications are C & G. Certificate in radio communications or technical electricity, or satisfactory pass in M.C.A. radio mechanics course. block letters, full qualifications and experience and quoting M2C/29637/WF. [1363]

VACANCIES in Government Department.

LEADING Draughtsmen and Draughtsmen are required, with experience in the layout of telecommunication and electronic equipment, involving detailed mechanical design, preparation of all mechanical drawings, sub-assemblies and final assembly, circuits, specifications and stock-lists; suitable for prototype and batch production manufacture. **PRACTICAL** workshop experience and knowledge of modern methods an asset, but not essential.

SALARIES: Consolidated Provincial Rates. **LEADING** Draughtsmen: £592×£20 to £702. **DRAUGHTSMEN:** £374×£20 to £597. **APPLY** in writing: Personnel Department, G.C.H.Q., 53, Clarence Street, Cheltenham. [1362]

CROWN AGENTS FOR THE COLONIES.

RADIO Officer required by the East Africa High Commission for the Directorate of Civil Aviation for one tour of 30-48 months in the first instance; salary according to age and experience in scale £687 rising to £929 a year; gratuity between £74 and £96; outfit allowance £30; free passages; liberal leave on full salary; candidates should possess the First Class Certificate of Proficiency in Radio Telegraphy issued by the Ministry of Civil Aviation or alternatively an Operator's Licence of equivalent standard provided they have had at least five years' operating experience and can operate at 25 words a minute.—Apply, in writing, to the Crown Agents, 4, Millbank, London, S.W.1, stating age, name in block letters, full qualifications and experience and quoting M2C/32494/WF. [1343]

FERGUSON RADIO CORPORATION, Ltd. have vacancies for the following staff.

DEVELOPMENT Engineers, senior and junior, for radio, television and electronics; previous experience of circuit development work absolutely essential. **DRAUGHTSMEN,** experienced in radio and television receiver design (and small mechanical details), able to prepare drawings for manufacturer of prototype equipment.—Apply in writing, Employment Manager, F.R.C., Gt. Cambridge Rd., Enfield, Middlesex. **POSTS** are permanent, progressive and pensionable. [1348]



FOR
PROMPT & EFFICIENT SERVICE
CASH or EASY TERMS
NEW EASY TERMS

LEAK

(See Maker's Advert. page 83)
TL/12 'POINT ONE' AMPLIFIER
Cash £28. 7. 0
VARI-SLOPE PRE-AMPLIFIER
Cash £12. 12. 0

For the two units : Deposit £9.0.0 with order and 18 monthly instalments of 40/- Passenger carriage 10/- extra payable with deposit.

CONNOISSEUR

Three-speed Gram Units and Super Lightweight Pick-ups to match the above can be supplied from stock. Terms available.

LOUDSPEAKERS

The complete Wharfedale and Goodmans range of speakers are available on Easy Terms—please let us have your requirements.

ARMSTRONG CHASSIS

The EXP. 73—RF. 104—and EXP. 125 Chassis can be supplied on Easy Terms. Write for full specifications.

CABINETS

We can supply suitable high-grade radio-gram and loudspeaker cabinets for all the above. Made to special order only.

14 FREE SHAVES

WITH THE NEW

SUPER REMINGTON
CONTOUR 6 ELECTRIC SHAVER

will convince you that this remarkable new shaver really does give a better, more pleasant and far quicker shave than any other method.

OUR 14 DAYS' FREE TRIAL

is available on receipt of 20/- deposit (returnable if not entirely satisfactory), with eight monthly instalments of 20/- Cash £8. 10. 0. AC/DC 200/250v.

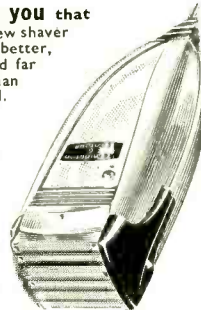

GUARANTEED 12 MONTHS

Other voltages available. Each shaver is BRAND NEW and despatched in superb silk lined presentation case.

The L.R. SUPPLY CO. LTD.
(LONDON RADIO SUPPLY CO.)
BALCOMBE - - SUSSEX

Telephone : Balcombe 254

SOUTHERN RADIO'S WIRELESS BARGAINS

TRANSMITTER-RECEIVERS (Walkie-Talkie), Type 38, Mark II. Complete with 5 valves, microphone, headphones and aerial. Less batteries. Guaranteed fully and ready for use. £4 15/-, post paid. Extra junction boxes for above, 2 6.

TRANSMITTER-RECEIVERS No. 18, Mark III. Complete with all valves but less batteries and attachments. Guaranteed ready for use. £7 17/6, carriage paid. No. 18, Mark III. BRAND NEW, complete in original packing cases with ALL attachments and full set of spares, including duplicate set of valves (less batteries). £15.

TELESONIC 4-valve battery portable. Complete with 4 HiVac valves. Contained in metal carrying case. Easily convertible to personal portable. Brand new. £2, including conversion sheet and post.

RECEIVERS R109, complete with 8 valves. Vibrator pack for 6 volts. Contained in metal case with built-in speaker. 1.8 to 8.5 megs. Guaranteed. £7, carriage paid.

MINISCOPES, G.E.C. M861B. Brand new, complete in carrying case with plugs. £12 10/-.

WOBBULATOR for Miniscope M861B, £4 10/-.

RESISTANCES. 100 assorted useful values, wire-end, 12 6.

CONDENSERS. 100 assorted mica and tubular. 15-lubfura hole cutters, adjustable 3/16 to 3/8 in. For use on wood, metal, plastic, etc. 5/9.

PLASTIC MAP CASES, 14 by 10 1/2 in., 5/6.

STAR IDENTIFIERS, Type I, A.N. Covers both hemispheres, complete in case, 5 6.

WESTECTORS W x 6 and W112, 1/- each.

MARCONI AERIAL FILTER UNITS (P.O. spec.), 4/6.

CONTACTOR TIME SWITCHES. 2 impulses per sec. Complete in sound-proof case. Therm control, 11 6.

REMOTE CONTACTOR for use with above, 7 6.

SPECIAL OFFER TO EXPERIMENTERS. TWELVE meters and aircraft instruments. Only needs adjustments or cases broken. Twelve instruments (including 3 brand new aircraft instruments), 35/-.

Full list of Radio Books 2 1/2.

HUNDREDS OF FURTHER LINES FOR CALLERS.

SOUTHERN RADIO SUPPLY LTD.,
11, LITTLE NEWPORT STREET, LONDON, W.C.2.

GERrard 6653

SITUATIONS VACANT

A. V. ROE & Co., Ltd., have a vacancy in their **ENGINEERING** Research Department on interesting work for an **ELECTRONIC ENGINEER** preferably with knowledge of electronic equipment used in vibration testing and strain gauge work; some knowledge of vibration and fatigue an asset. **APPLICANTS** for the above post should possess at least Higher National Certificate or equivalent.

GOOD salary and prospects—Apply, stating age, qualifications and experience;—**THE Labour Manager, A. V. Roe & Co., Ltd.**, Greengate, Middleton, Manchester. [1384]

ELECTRONIC ENGINEERS required by The **Allesley, Coventry**, in their Development Laboratories for work on—

(a) **TRIALS** team in connection with guided weapons; 2 senior engineers, also 3 engineers.

(b) **SERVO-MECHANISMS**; 2 engineers.

(c) **MAGNETIC amplifiers**; 1 engineer.

(d) **PULSE** circuitry; 4 engineers.

(e) **MICROWAVE** circuits; 1 senior engineer, 2 engineers.

(f) **TEST** equipment; 1 senior engineer, 3 engineers.

(g) **GENERAL radar circuit development**; 1 senior engineer, 3 engineers.

APPLICANTS presenting with a degree or an equivalent qualification, should have had at least two years' experience in the development and engineering of Service equipment as well as experience in one of the above.

HOUSES on the outskirts of Coventry, near our laboratories, are now available for offer to successful applicants, and this offer can only remain open for a few months; applicants' holiday requirements will receive special attention.

—Reply, stating age, qualifications and experience, to Personnel Manager, Ref. R.G. [1382]

DRAUGHTSMEN—We have vacancies in our Electronic Development Department for:

1. **ELECTRONIC** draughtsmen with experience of radio and radar circuitry, etc.

2. **ELECTRO-MECHANICAL** Draughtsmen interested in small mechanisms and light engineering.

3. **SENIOR** and Junior Detail Draughtsmen.

APPLY in writing to: R. Y. Pickering & Co., Ltd., Wishaw, Lanarkshire, Scotland. [1421]

SERVICE Manager required; commencing salary £550 per year, with yearly increase. —Box 1648. [1418]

ENGINEERS, B.Sc. or equivalent, for design work in connection with television circuits and associated components.

MECHANICAL draughtsmen to undertake design of vibrators and/or switch and panel accessories; good degree or a wide industrial experience of this class of work.

ENGINEERS fully conversant with the design of transformers associated with radio, electronics and telecommunications equipment.

A LARG engineering company invites applications for the above permanent and progressive appointments necessitated by expansion of the company's business; superannuation scheme in operation.—Please write, in confidence, quoting reference WW/56, giving full details of salary required. to Box 7361. [1360]

INSTRUMENT mechanics required to serve as research and experimental mechanics at Ministry of Supply, Sellafield.

ALL applicants must have served a recognised relevant apprenticeship.

INSTRUMENT mechanics (Electronic) must have sound theoretical knowledge of electronics (Ordinary National Certificate standard, desirable) with practical knowledge of pulse amplifiers, D.C. amplifiers, electronic scalars, discriminations, and general trigger circuits, and in wiring and assembly of electronic apparatus. Experience of test gear and general instrument calibration an advantage.

INSTRUMENT mechanics (physical) must have experience of industrial instruments used in measurements and control of temperature, specific gravity, pH and flow; knowledge of vacuum techniques and measurement of gaseous properties an advantage.

INSTRUMENT mechanics (general) must have experience of relay circuits and automatic telephone exchange maintenance; knowledge of X-Ray and electrical measuring apparatus an advantage.

RATES of pay for 44-hour 5-day week: 153/1 on entry with early assessment for merit pay; merit pay agreed after first assessment will be applied from date of entry; possibility of advancement to 195/1.

HOUSING accommodation will be available within a reasonable period for married applicants.

APPLY, giving details of apprenticeship, training (including Forces training), qualifications and experience, to Senior Labour Manager, Windscale Works, Sellafield, Cumberland. [9869]

AUTO electrician and radio mechanic, H.M.V. car radio, radio experience essential.—J. W. Klesner & Son, Fenitth, Cumb. Tel. 2061. [1367]

TELEVISION radio electrical salesman; good salary and comm.—Apply in confidence 13, High St., Harlesden, N.W.10. Elgar 5914. [1355]

TELEVISION and radio engineers required; must be competent and experienced; maximum rate of pay; bonuses and overtime.—Box 7647. [1417]

RADIO and television engineer required, fully experienced all makes, for bench and outside; good driver, clean licence; good salary, references.

ELECTRICAL SERVICE (EDGWARE), LTD., 117, Edgware Rd., W.2. Pad. 2342. [1407]

Electradix Offers

DINGHY RADIO TRANSMITTERS

American Bendix Model BC778E, brand new, all the following components wired and fitted in metal case with knee strap.

One Hand Generator for H.T. and L.T. One Miniature Relay 1,000 ohms 28 volts. Two 6.3 volt warning bulbs. Holders. One small Neon lamp. One 2-pin Socket—12 fixed Condensers, assorted sizes. 6 fixed Resistors. One valve 12SC7. One valve 12A6. One variable air-spaced Tuning Condenser, .0005 mfd. One 6-way single pole 60 degree Yaxley Switch. One Transformer BX/17/20. One 6-way Miniature Jones Plug and Socket. 4 Tuning Coils. One Push Button. One Coil covered Aerial wire, flexible. One Coil Earth wire. ONLY 55/- each. Carriage and Packing 5/- England, Wales and Scotland.

CHARGING PLANTS. Special offer Westinghouse 110/250 volt A.C. 50 cy. input 16/96 cells 10 amps., selenium rectifier, m.c. ammeter 0-25, new, in original packing case, £35, carr. extra.

DYNAMOS, 500 watt, 50/68 volts 10 amps., ball bearings, 1,000 r.p.m. continuous rating, 4-hole fixing. £20. 14/32 volt 9 amp. charging dynamo, 2,500 r.p.m., ball bearings, shunt wound, fan cooled, 4-hole feet, £3/10/-, carr. 5/-.

LIGHTING PLANTS. Chore Horse 12 volts 350 watts, £17/10/-, Briggs & Stratton 12/18 volts 350 watts, with 5/bd. and tank, £22. 550 watt Lyon Norman 12/18 volts with fuel tank, £22/10/-, 550 watt J.A.P. 12/18 volts with fuel tank and switchboard in steel cabinet, £35. Villiers 1,260 watt 36 volts 36 amps., £40. Send for special leaflet. All plants tested on load before despatch.

NIFE BATTERIES. 1.2 volts 45 A.H. new single cell, 30/-, post 2/-, Wood crate of nine cells, £12/10/-, carr. 10/-.

WORKSHOP INSPECTION LAMPS. Strong case with wood handle and wrist strap, 6/-, post 1/6.

ELECTRADIX RADIOS

Dept. A, 214 Queenstown Road, London, S.W.8

Telephone: MACaulay 2159

GOODSELL LTD.

for High Fidelity Equipment

40 GARDNER ST.,

BRIGHTON, 1

Tel.: Brighton 26735.

G.E.C. GERMANIUM CRYSTAL DIODES

Midget Size, 5/16 in. x 3/16 in.

Wire Ends for Easy Fixing

4/6 each, postage 2 1/2 d.

Technical Details and Selected Types available.

B.T.H. GERMANIUM CRYSTAL DIODES

Moulded in thermo-setting plastic.

4/6 each, postage 2 1/2 d.

SILICON DIODES, 3/6. Postage 2 1/2 d.

Fixing Brackets, 3d. pair.

COPPER INSTRUMENT WIRE ENAMELLED, TINNED, LITZ, COTTON and SILK COVERED

Most gauges available.

B.A. SCREWS, NUTS, WASHERS soldering tags, eyelets and rivets.

EBONITE and **BAKELITE** PANELS, **TUFNOL** ROD, **PAXOLIN** TYPE COIL FORMERS AND TUBES, ALL DIAMETERS.

ERIE AND **DUBLIER** RESISTORS.

Latest Radio Publications.

SEND STAMP FOR LIST. TRADE SUPPLIED

POST RADIO SUPPLIES

33 Bourne Gardens, London, E.4

THE DESIGN and DEVELOPMENT

of specialised equipment for
Research and Industry.

DUN (electronics) & CO.,
17 Victoria Gardens, London, W.11. Park 6636

Before constructing
any of the equipment
described in this Magazine

*Send to

Smith's
of
EDGWARE ROAD

for prices of components required
(no general catalogue available yet).

Price lists still available for—

"Sensitive T.R.F. Receiver" (Nov. 1951)
(“W.W.” Reprint 1/-)

"F.M. Feeder Unit" (Sept. 1952)
(Complete Kit of parts less valves and diodes 70/-)

*or better still, drop in and see the amazing
variety of components available here.

H. L. SMITH & CO. LTD.
287/289 EDGWARE ROAD, LONDON, W.2
Telephone: Paddington 5891

Hours 9 till 6 (Thursday, 1 o'clock)

Near Edgware Road Stations, Metropolitan & Bakerloo

BUY! BUY!! BUY!!!

and take advantage of our Summer Season Reductions! Stamp for catalogue and full details.

And if you are interested in easily built equipment you should construct our

NEW SIGNAL GENERATOR

which gives 12 spot frequencies covering 6 wavebands, plus I.F. Neat and compact, mains operated with A.F. and R.F. (modulated or unmodulated) outputs, and also a

NEW SIGNAL TRACER

Complementary to the Signal Generator above and having the same dimensions. This piece of equipment enables you to listen to the signal at any point in a radio set from the aerial to the loudspeaker. These two pieces of equipment form an efficient pair and are tools no radio man should be without.

Full description, working drawings, circuit diagram, priced parts list, point-to-point wiring charts and instructions for either.

PRICE 1/6 ONLY
or for both 2/6 the pair.

Our famous **HOME CONSTRUCTOR'S HANDBOOK**, (full of circuits, hints, tips, etc.) is, of course, still available at 2/6, or with either of the above sets of diagrams at 3/6.

SPECIAL OFFER. Home Constructor's Handbook and both above sets of instructions. 4/6 only.

ALL COMPONENTS AT SPECIAL DISCOUNT RATES

SO SEND FOR CATALOGUE NOW

SUPACOILS MAIL ORDER OFFICE
98, GREENWAY AVENUE, LONDON, E.17

COVENTRY RADIO

Component Specialists since 1925

189 DUNSTABLE ROAD, LUTON
Tel.: LUTON 2677

Eddystone Receivers (740 No Tax) and Accessories. Components for "Viewmaster," "Tele-King" and "Electronic Engineering" T.V. Receivers.

Stockists for:-

Denco Coils. Bulgin Components.
Raymart Accessories. Weyrad Packs.
Osmer Coils and Wearite Packs and Packs. Coils.

All B.V.A. and Tungram Valves

Send 6d. now for our new 50 page Catalogue

SITUATIONS VACANT

MINISTRY OF SUPPLY requires skilled craftsmen to serve as Research and Experimental Mechanics at Malvern.

ALL applicants must have served a recognised apprenticeship.

INSTRUMENT MAKERS. Must be able to read and interpret working drawings English and 3rd Angle and to work to rough sketches and verbal instructions; ability to produce individual scientific test gear on a one off basis working to fine tolerances, and to operate the necessary machining tools. Knowledge of simple electronic circuits and ability to wire up an instrument from a diagram an advantage.

CENTRE LATHE TURNERS. Must be able to read and interpret working drawings English and 3rd Angle. Work to fine limits in a wide range of materials, and have knowledge of re-leaving work on taps and milling cutters. Ability to use horizontal or vertical boring machines an advantage.

UNIVERSAL MILLERS. Must be able to set up and operate to fine limits vertical, horizontal and universal milling machine working in a wide range of materials. Knowledge of gear cutting, jig boring and horizontal boring an advantage.

PRECISION FITTERS to read and interpret working drawings English and 3rd Angle, fit and assemble to fine limits, performing own marking out. Ability to make on own initiative working models on a one off basis.

MECHANICS for Electrical and Electronic Work to read and interpret Schematic wiring diagrams of electrical and electronic equipment and have ability to lay out, assemble and wire panels for electronic apparatus, test and report on the condition of a wide range of electrical units, motors, generators, converters, rectifiers, control gear, distribution mains, power and lighting circuits, install, operate and maintain electronic apparatus.

RATES of pay for 44-hour 5-day week. 165/4 on entry with prospects of advancement to higher rates. Hostel accommodation available.

APPLY giving details of apprenticeship, training (including Forces' training), qualifications, and experience, to Chief Superintendent, Radar Research and Development Establishment, Gt Malvern, Worcs. [1370]

WALTHAM CROSS.—T.V. service engineer required.—Write in first instance to Tele-radio, 18, Turnpike Lane, N.8. detailing experience. [1411]

PETO SCOTT ELECTRICAL INSTRUMENTS, Ltd., have vacancies for TV development engineers of Graduate and Higher National standards.

ALSO Radar mechanics for work on ultra high frequency equipment.—Applications should be made to The Chief Engineer, Weybridge, Surrey. [1401]

TELEVISION development engineer of degree standard required for firm in Harrow district.—Write, stating experience, age and salary required.—to Box 7203. [1356]

EXPERIENCED TV engineers required for retail service—permanent positions at good salary.—Full details to Shenstones (op. Town Hall), Leyton, E.10. Ley. 1362. [9266]

ELECTRONIC engineer required by new division of prominent engineering concern in Northern Ireland for development work on guided weapons and other projects.

DEGREE or equivalent in electrical engineering preferably of D.C. amplifiers, electronic computation, pulse techniques, or miniature equipment. GOOD salary and prospects for man with originality.

DETAILS of housing accommodation available and facilities for motor supplied at interview. SEND full details of age, qualifications and experience, quoting reference E.E.1. to Box 7295. [1351]

SECOND radio and television engineer required by old-established west end business: good knowledge of all makes essential. state experience and salary required.—Box 7568. [1404]

VICKERS-ARMSTRONGS, Ltd. (Aircraft Section), have vacancies for Technical Authors with electrical and radio experience, for compilation of aircraft manuals—both military and civil.

APPLY to Employment Manager, Vickers-Armstrongs, Ltd. (Aircraft Section), Weybridge, Surrey.

APPLICATIONS, with certain exceptions, are subject to the approval of the Ministry of Labour and National Service. [1358]

EXPERIENCED TV engineer required to take charge of service dept., good salary and prospects.—Write, giving experience and character references, Marshall, 76, High St., Witham, Essex. [1337]

SERVICE engineer and directorship.—Required, radio/television service engineer, must be first-class man with good references; a directorship is offered with this post if desired (North-West)—Box 7411. [1372]

GLASGOW—Radio mechanic, preferably experienced tape and wire recorders; permanent position with prospects; commencing salary £7/10.—Land, Speight & Co., Ltd. 73, Robertson St., Glasgow. [1373]

EXPERIENCED fault-finders wanted by Midland manufacturers of radio equipment; permanent posts located in the Midlands are offered to men with experience of radar, radio control, V.H.F. equipment.—Write, stating fully, experience and salary required, to Personnel Manager, Box 7632. [1414]

ALL ITEMS CARRIAGE PAID

SPECIAL OFFER!

MAINS OPERATED DOOR BELL. At last a door bell without Batteries or Transformers. Operates direct from Mains and Supply. 3in. Magneto type Bell by famous manufacturer completely self-contained. Equally suitable for burglar alarms, etc. 200-250 A.C. Supply only. Unrepeatable at 6/6.

TOGGLE SWITCH. Single hole panel mounting, 250 volt, 2 amp. Single pole changeover on/off. Brand new at 6 for 5/-.

DINGHY TRANSMITTERS. Ex-U.S.A.F. B.C. 778 containing magnificent hand generator, output 28 volt 0.175 amps, 300 v. .04 amps., two valves 12 S.C.7 (V.T.268), 128 A.6 (V.T. 134) with bases. One high quality 0.0005 mfd. variable condenser, 13 fixed condensers, 8 fixed resistors, 3 relays. Small transformer, Morse key, two five-way tag boards. Approx. 100 yds. braided copper aerial wire on spool. Indicator lamps, etc., the waterproof case outside is soiled, but the above contents in perfect condition. Limited quantity. Price 42/6.

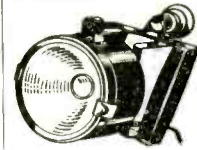

EX-R.A.F. SIGNAL-LAMP Trigger action control. Alignment Sights as illustration. Complete with 6ft. Cable and 2-pin plug. Easily converted to Car Spot Lamp. Price excluding bulb 10/6

MODEL MAKERS MAINS TRANSFORMER. All purpose low voltage. Input 210/250 Volts. Output 3, 4, 5, 6, 8, 9, 10, 12, 15, 18, 20, 24, 30 Volts. Rating 2 amps. Brand new, fully guaranteed 24/-.

AIR POSITION INDICATOR

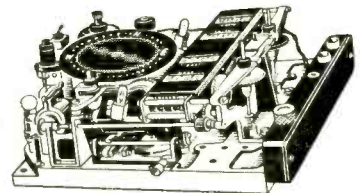

Containing a wealth of gears, drives and shafts, 3 infinitely variable gears, lampholders, repeater motors. Vocoder counters, has been used by many Universities as a basis of a calculating machine. £2/7/6.

HIGH PRESSURE REDUCING VALVE.

Complete with 0-3,000 lb. per sq. in. pressure gauge. Suitable for compressors, Cylinders of gas, etc. Brand new, 8/6.

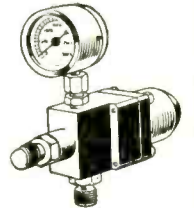

FLEXIBLE DRIVES.

4ft., 8/6; 2ft., 4/6. Suitable for small tool remote drives, etc.



SOLENOID SWITCH. Ex-R.A.F. heavy duty starter switch, 24 volt actuation, 600 amps., intermittent rating. A beautiful precision job costing many pounds. Brand new. Each 8/6.

AERIAL. 16in. solid tapered mast complete with flange fitting and connection point. Unrepeatable at 6/6.

IMPELLER PUMP. Approx. 20in. long x 2in. dia. Adjustable flange fixing, 2 amps. at 24 v. d.c. or 4 amps. at 12 v. d.c. Ideal for bilge pumps or for transferring fuel or water to header tanks. Pump is self-cooled by liquid passing through it. Brand new and boxed, 39/6 each.

TERMS—CASH WITH ORDER.
NO C.O.D.

SHERMAN'S SUPPLY CO. (W.2)
126, KENSAL ROAD, LONDON, W.10

THE MODERN BOOK CO.

Radio Designer's Handbook by Langford Smith. 42s. Postage 1s.

Brimar Radio Valve and Teletube Manual No. 5. 5s. Postage 4d.

Television Receiver Design by A. G. W. Uijtens. 21s. Postage 9d.

The Radio Amateur's Handbook by the A.R.R.L. 1953. 30s. Postage 1s.

Radio Engineers' Servicing Manual by E. Molloy (ed.). 42s. Postage 1s.

Radio Engineering by E. K. Sandeman. Vol 2. 55s. Postage 1s.

Sound by E. G. Richardson. 25s. Postage 1s.

Radio Servicing Instruments by E. N. Bradley. 4s. 6d. Postage 3d.

Radio Valve Data compiled by "Wireless World." 3s. 6d. Postage 3d.

Television Fault Finding compiled by "Radio Constructor." 5s. Postage 3d.

Television Engineers' Servicing Manual by E. Molloy (ed.). 42s. Postage 1s.

Modern Oscilloscopes and their Uses by J. H. Ruiter. 51s. Postage 1s.

Time Bases by O. Puckle. 32s. Postage 1s.

Electrical and Radio Notes for Wireless Operators. 5s. Postage 4d.

We have the finest selection of British and American radio publications in the Country. Complete list on application.

19-23 PRAED STREET,
(Dept. W.7.)

LONDON, W. 2

PADDington 4185

HIGH GRADE TRANSFORMERS

FOR ALL PURPOSES
SINGLY OR IN QUANTITIES
TO YOUR SPECIFICATION
VARNISH IMPREGNATED
BAKED WINDINGS
WITH OR WITHOUT TAG PANELS
GOOD DELIVERIES

Our rewind dept. will handle your repairs promptly and efficiently.

P. HOWORTH
51 POLLARD LANE · BRADFORD

Tel.: 37303

THE CHAFFEY CABINET CO.

WILL SOLVE YOUR PROBLEM

regarding any type of cabinet, large or small. We have specialised knowledge in the field of high fidelity reproduction, and owners of quality radio apparatus requiring exclusive cabinets are invited to send a sketch or relevant details for our quotation.

RIODIAGRAM—TV—REFLEX
RECORD—TAPE RECORDER, etc.

Trade Enquiries Welcome

50g, Cheltenham Rd., London, S.E. 15

SITUATIONS VACANT

JUNIOR electronics engineer required to assist in the development of an analogue computer; previous development experience is essential and a knowledge of d.c. amplifiers would be advantageous.

APPLICANTS, who should be 21-24 years of age and hold the Higher National Certificate, should write, quoting full particulars, to The Personnel Officer, E. Cowes, Isle of Wight, ref. W.W.C.1. [1396]

TELEVISION engineers, experienced field and fast bench work; salary commensurate with ability, good conditions; permanency.—Apply in confidence The Genuine Co., Ltd., 364, Edgware Rd., W.2. Pad. 6179. [1354]

RADIO engineer required, for responsible position by Cambria Air Services, Cardiff Airport, must hold a licence; salary in scale £600-£700 p.a., according to qualifications. APPLY: Chief Engineer. [1385]

SENIOR engineer with several years' experience of television receiver design is required by a manufacturer in South-West London.—Write, giving full details of experience and salary required, to Box 7405. [1364]

RADIO mechanics required for development work on test apparatus.—Write, giving full particulars of experience, age, etc., to Personnel Manager, Smith & Sons (England), Ltd., Bishops Cleeve, Nr. Cheltenham. [1127]

PRODUCTION electrical testers required for television, radio and electronic equipment; very interesting work; good facilities and pay; keen technicians only required.—Dynatron Radio, Ray Lea Rd., Maidenhead. [1344]

RADIO service mechanics required by Smiths (Radiomobile), Ltd., for all parts of the country.—Write details of experience and qualifications to Personnel Officer, Goodwood Works, North Circular Rd., London, N.W.2. [10342]

ELECTRONICS engineer required for development work on magnetic amplifiers for use in control systems, experience of design and construction essential.—Write fully stating experience, qualifications and age, to Box 7522. [1392]

TEST engineer, electronics required, some experience with oscilloscopes, pulse generators, counters and radar generally, preferred; give details of experience and wage required.—Biskine Laboratories, Ltd., Scalby, Scarborough. [1377]

TECHNICAL representative required by old-established firm to handle electronic audio correction equipment from a London H.Q.; excellent scope for ambitious man to develop and expand completely new field.—Full particulars to Box 7064. [11074]

ELECTRONIC engineer with Higher National Certificate or equivalent is required for the development of V.H.F. equipment and components; applicants must have good laboratory experience and sound practical knowledge in this sphere.

WRITE, stating qualifications, experience and salary required, to Wingrove & Rogers, Ltd., Domville Rd., Liverpool. 15. [1349]

ASSEMBLY wiremen required, must be first-class, used to small, intricate chassis work.—Apply by letter, stating age, nationality and experience to E.M.I. Engineering Development, Ltd. (Wells Division), Penleigh Works, Wells, Somerset. [1108]

FIRST-CLASS radio and television engineers required by old-established, expanding business; good salary and prospects; permanent; all leading agencies, including Murphy, Bush, Pve, Ekco etc.—E. P. Fox, Ltd., East Molesey, Surrey. Molesey 2721. [10442]

AIRCRAFT radio mechanics skilled in workshop practice or aircraft installations to work at Stansted Airport, Essex; hostel accommodation available; minimum hourly rates 3/9.—Write to the Personnel Manager, Skyways of London, 7, Berkeley St., W.1. [10019]

B.B.C. requires tracer for planning and installation department, central London; wage £6/5 with increments to £7/5; some training engineering drawing and tracing; knowledge electrical symbols and theory desirable.—Apply E. E. O., B.B.C., London, W.1. [1338]

SKYWAYS OF LONDON, have vacancies for a radio engineer i/c and a radio section inspector with A and/or B licences, at Stansted Airport, Essex; hostel accommodation available, salary £715 to £815 p.a.—Apply to the Personnel Manager, 7, Berkeley St., W.1. [1383]

SENIOR tester required by scientific instrument company located North-East outskirts of London; wide experience of electrical and electronic instruments; housing accommodation can be provided.—Write giving full details of age, salary, etc., to Box 7404. [1366]

EXPERIENCED radio testers and inspectors required for production of communication and radio apparatus, also instrument makers, wiremen and assemblers, for factory test apparatus.—Apply Personnel Manager, E. K. Cole Ltd., Ekco Works Marnesbury, Wilts. [10258]

DECCA RADAR, Ltd., invites applications, from young scientists and engineers due to graduate this year, and who expect to get good Honours degrees. The posts offer interesting and well-paid careers in radar engineering for young men who are prepared to work hard, British nationality essential.—Write, quoting ref. CPH, to Decca Radar, Ltd., Research Laboratory, 2, Tolworth Rise, Surbiton, Surrey. [10243]

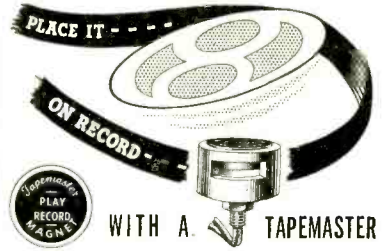

TAPEMASTER RECORDING COMPONENTS

Suitable for use with either Hartley or Cutlip circuits. Retail

JUNIOR MODEL. Play/record, imp. 3,000 ohm at 1 Kc. Erase... at each £1 19 6

SENIOR MODEL. Play/record, imp. 5,500 ohm at 1 Kc. Erase... at each £2 5 0

Oscillator Coil in can each 10 6

Oscillator Unit, incl. coil and 6V6GT valve each £2 5 0

TAPEMASTER MAGNET FEATURES.

Electrically balanced to ensure low "hum" level. Play/Record Model with 0005in. gap ensuring max. top response. Beryllium Copper, non-magnetic gapping. Mu-metal cores for Play/Record models. Track width, Play/Record, .082in., Erase, .10in. Bias frequency 45 Kc., exactly matching Tapemaster oscillator units and coils. Output 10 mV. Recording level, 10 mV. With optimum bias, recording level and equalisation of Amplifier response in frequency equals tape speed in inches/sec. Full instructions included for oscillator units and amplifier circuits. μ in. Track. Erase Magnets to match for tracking.

AVAILABLE FROM ALL GOOD
RADIO DEALERS.

WINTER TRADING CO. LTD.

6, HARROW RD., LONDON, W.2.

FOR SALE—4000

FULLERPHONES

MK IV YA0618, MK IV* YA4138

BRITISH & CANADIAN

COMPLETE WITH
HEADPHONES
BRAND NEW

GUARANTEED PERFECT CONDITION

Packed in original cases ready
for despatch.

ALFRED LEWIN LTD.

147 HAMPSTEAD ROAD, LONDON, N.W.1

YOUR METER DAMAGED?



Contractors to The Ministry of Supply
Repairs by skilled craftsmen of all makes and types of Voltmeters, Ammeters, Microammeters, Multirange Test meters, Electrical Thermometers, Recording Instruments, etc. Quick deliveries—for speedy estimate send defective instruments by registered post to—

L. GLASER & CO.

Electrical Instrument Repairers
96-100 ALDERSGATE STREET, E.C.1.
(Tel.: MONarch 6822)

Receivers Type 109. 8-valve ex-Army receiver, in brand new condition, complete with built-in power supply, loud-speaker and 4 spare valves. Frequency range on 2 bands. 1.8-3.9 Mc/s, 3.9-8.5 Mc/s. Designed to operate from a 6 v. battery, no other power supply required. Waterproof metal case with waterproof canvas cover over front panel. Front panel measurements 13 x 10 1/2 in. Complete with diagram. £7 10/-. Carriage 10/-.

Large Magnets, as taken from magnetron units, weight approx. 9 lbs. Will lift up to 30-40 lbs. 30/- Post 2/6.

Directional Indicators. Containing 2 50 micro-amp meters, scale marked L and R. Brand new and boxed, 8/6. Post 1/3.

Miniature American Relays. 65 ohms (6-12 v.) with 3 sets of make contacts, 4/- Post 9d.

Polarized Relays, by S.T. & C. for use on Simplex teleprinter units. Metal case with terminal strip at rear. Brand new and boxed, 20/- Post 1/6.

Toggle Switches, with long dolly, 2-way on/off, brand new, 15/- doz. Post 1/3.

Aerial Relays for 53 Set in metal box with connector lugs, 12/6. Post 1/3.

Rotary Converters. 12 v. D.C. input, 230 v. A.C. output. Rated at 100 watt but will overload to 150 without overheating, £6 10/-. Carriage 7/6.

VCR.97 Tubes. Special Offer. Brand new in maker's cartons, 30/-. Post 2/6. Unrepeatable at this price.

Mumetal Screens. VCR.97. Price 8/6. Post 1/-.

Paxolin Panels. Containing 6 Condensers, 5 resistances, 1 pot tag, board, 3 87G ceramic holders, 2/6. Post 6d.

Meters. 0-100 ma. in black bakelite oblong case, brand new and boxed, 2 1/2 in. dia. scale, 12/6. Post 1/6.

New List No. 10 is now available, price 6d. inland, 1/6 Overseas Air Mail.

A. T. SALLIS

93, NORTH ROAD, BRIGHTON, SUSSEX.

Phone : Brighton 25806.

POTENTIOMETERS



Wire-wound and Composition types. Single, Ganged, Tandem Units. Characteristics: linear, log., semi-log., non-inductive, etc. Full details on request.

RELIANCE

RELIANCE MFG., CO. (SOUTHWARK), LTD.
SUTHERLAND ROAD, HIGHAM HILL,
WALTHAMSTOW, E.17.
Telephone : Larkwood 3245

SITUATIONS VAGANT

COMPETENT radio and television engineer required for central service department of high-class group of retail establishments, in East Midlands area; good rates of pay and bonus scheme; assistance given to find accommodation.—Write Service Manager. Box 7520. [1369]

MESSRS. PYE Ltd. Cambridge, have vacancies for senior and junior test engineers, also electronic wiremen on very interesting work in their television transmission equipment department.—Apply in writing to Personnel Department, St. Andrew's Rd., Cambridge. [1395]

TECHNICIAN, with experience in electronic work, required for development laboratory in large telecommunication engineering works; give particulars of experience, education and technical training, qualifications and commencing salary required; London S.E. area.—Box 6765. [1019]

MESSRS. PYE Ltd. Cambridge, have vacancies for senior and junior test engineers, also electronic wiremen on very interesting work in their television transmission equipment department.—Apply in writing to Personnel Department, St. Andrew's Rd., Cambridge. [1978]

WIREMEN, skilled, required for high-grade electronic equipment, ability to undertake prototype work from schematic drawings an advantage, first-rate working conditions, West London area and pension scheme.—Write, stating age, details experience and present rate.—Box 7138. [1097]

DRAUGHTSMAN wanted for a small drawing office engaged in the design and drafting of electronic instruments for the industrial and telecommunications field.—Write, stating age, experience and salary required, to Daves Instruments, Ltd., Harlequin Ave., Great West Rd., Brentford. [1346]

RADIO and radar testers; first-class men required for work on V.H.F. communication gear and Government contracts for radio and radar equipment by Midland manufacturers.—Men with wide experience of fault finding in any of the fields mentioned should write, giving full details to Box 7651. [1413]

CARDIFF—Leading television dealers handling all worthwhile agencies, require television engineers thoroughly trained in fault finding on all leading makes of receivers; salary at £500 p.a.; full particulars on application and copy references if possible; good accommodation provided if required.—Box 7608. [1408]

DEVELOPMENT engineer required by well-established firm to develop components and electronic apparatus; ability to exploit ideas and work on own initiative essential.—Send full details of previous positions held and type of work undertaken, together with approximate salary required, to Box 7204. [1339]

LONDON BRICK Co., Ltd. has a vacancy for an instrument mechanic, preferably with some electronic experience, to work in the Research Department at Stewarby; salary £400-£550 according to qualifications and experience.—Apply in writing to the Personnel Manager, London Brick Co., Ltd., Stewarby, Bedford. [1380]

FERRANTI, Ltd. (Radio Department, Moston), have a vacancy for a radio engineer of Higher National Certificate or equivalent standard to be engaged on the design of production test equipment and to be responsible for maintenance and modification of existing equipment; some experience of modern radio practice is essential. THE position offers good prospects for advancement.

PERMANENT staff appointment with pension benefits. APPLICATION forms from Mr. R. J. Hebbert, Staff Manager, Ferranti, Ltd., Hollinwood, Lancs; please quote reference RE. [1397]

DESIGNER draughtsman; electronic instruments, or radio, good prospects and salary according to qualifications; prospects of housing assistance to suitable applicant; Saturday interviews, if required; near City centre and all amenities; within easy reach London.—Apply Marconi Instruments, Ltd., Longacres, Hatfield Rd., St. Albans. [1027]

WELL-ESTABLISHED firm engaged in the manufacture and distribution of television and radio, requires two first-class experienced engineers to work in Greater London area; to the right men the job offers complete security and a fine opportunity for advancement; salary to commence £10 per week; driving licence essential.—Box 7690. [1451]

INSTRUMENT maker at Norwood Technical College, Knights Hill, S.E.27, for maintenance and construction of electronic test gear laboratory and experimental apparatus; rate between 175s and 182s 6d for 44-hour week according to qualifications and experience.—Further particulars and application form from Principal, returnable within 14 days. (521). [1378]

DECCA RADAR, Ltd. require draughtsmen and junior draughtsmen for research drawing office, preferably experienced in any of the following fields: radar, radio and electronic circuits, electro-mechanical devices, light mechanical engineering; knowledge of workshop practice essential. Applicants must possess Ordinary National Certificate or equivalent, positions permanent and progressive; salaries based on A.E.S.D. rates.—Write, giving full details, to Chief Draughtsman, Decca Radar, Ltd., 2, Tolworth Rise, Surbiton, Surrey. [0240]



A WINDOW WORTH LOOKING INTO

American Valve Testers, Radio City type W.134. Brand new, A.C. mains 230 volt, covering practically the whole range of American valves, full working instructions. £12/19/6 each.

A.C. Mains 200/50-Volt 50-cycle Meter Movements, complete with gear train down to 4 revs. per min., wonderful value, 12/6 each.

25/73 Receiver portion—1196 T/R. Complete with all valves in new condition, full instruction available for conversion, 39/6 each.

465 I.F. Transformers, dust core tuned, 6/9 pair.

High Stab Resistors. 2 Meg., 2% 1 watt, 1.2 Meg. 2% 1/2 watt, 1.5 Meg. 5% 1/2 and 1 watt, 29.5 K. 2% 1/2 watt, 100 K. 5% 1/2 watt, 150 K. 5% 1 watt, 6/- per doz. min. quantity.

Bleeder Resistors. 100 K. 150 watts, 200 ohms 150 watts adjustable, 800 ohm 150 watts, 350 ohm 40 watts, 40 K. 150 watts, 80 ohm 50 watts, 24 ohm 100 watts, all at 2/- each.

Venner Hour Meters, for operation on 200/250 A.C. 50 cycle, synchronous movement, capacity zero-10,000 hours. 62/6 each, brand new.

Auto Transformers. 110-250 volts 100 watts, 15/6, 1,000 watts, separately wound, £6 10/-.

Welding Transformers. Input voltage 230 volts 50 cycle, output 13/16 volt, 65/75 amps., 82/6 each.

Mains Transformers. Ex-W.D. Input voltages 230 volt A.C., output 500x500 volt 170 mA., 4 volt 3 amp., 22/6.

Smoothing Chokes, Ex-W.D. 15 Henries, 275 mA., Resistance 125 ohms, 10/6 each.

Dural Masts, Telescopic 15in. to 7ft. 6in., 2/6 ea., ideal for making own T.V. aerial.

Mains Isolation Transformers. 230 volt 230 volt 50 cycle 1,000 watts, ex-W.D. £6 10/- each.

Microamp Meters. 0-50 2 1/2 in. flush panel mounting, 59/6 each.

Battery Chargers. Ex-W.D. Input voltage 200/250 volt, 50 cycle. Output 12 volt 5/7 amps, tapped at 6 volt, complete with 2 1/2 in. meter, manufactured by Healyberds. Brand new, £6 10/-.

Chokes. Ex-W.D. Heavy Duty. 20 Henries 300/400 mA., Resistance 180 ohms, 17/6 each.

Valves. Brand New and Boxed. VU111 4 volt E.H.T. Rectifiers, 2/6 each.

H.R.O. 6 Volt Vibrator Power Packs. Output 165 volt 80 M.A., using 6 X 5 Rectifier. Brand new, boxed, 39/6 each.

Rotary Converters. 24 volt D.C. input, 230 volt A.C. 50 cycle output @ 100 watts, 92/6 each. Ditto, 12 volt input, 102/6 each.

A.C. Mains Transformers. 200/250 volt input, output 45 volt 4 amp., 19/6 each.

.02 MFD 8,000 Volt E.H.T. Smoothing Condensers, 1/- each.

4 MFD Mansbridge Condensers 500 volt working, 2/6 each.

Rectifiers metal 250 volt 60 mA. H/W., 5/- each.

Chokes. Ex-W.D. 20 Henries 80/100 mA Brand new, 8/6 each.

Don't forget your postage.

Open all day Saturday.

G. W. SMITH & CO. (RADIO) LTD.

3 LISLE STREET, LONDON, W.C.
Telephone : GERard 3204/9155

COMMUNICATION SALESMEN

For Home or Export.
Preferable age 25-35
years. Experience of
U.H.F., V.H.F., and
H.F. fields essential
(but not radar). Nett
earnings depending on
commission should
gross £1000-£2000 p.a.
Must have had respon-
sible selling experience.

PYE TELECOMMUNICATIONS Ltd
DITTON WORKS
CAMBRIDGE

Joseph Lucas (Gas Turbine Equipment) Ltd.

invites applications for Electronic Engineers. Some knowledge of servo mechanisms would be an advantage. Should have university degree. These appointments are pensionable and offer good prospects to individuals with initiative and technical ability. Salary will be in accordance with experience and qualifications.

Details of experience and qualifications should be sent to

Personnel Manager,
Joseph Lucas (Gas Turbine Equipment) Ltd.,
Shaftmoor Lane, Hall Green, Birmingham.

VICKERS - ARMSTRONGS LTD

have vacancies in their Guided Weapons Department for Inspectors on inspection and test of complex electronic devices; thorough experience of electrical laboratory instruments and low power V.H.F. technique essential; knowledge of Servo Systems would be an advantage.

Apply in writing to:—

THE EMPLOYMENT MANAGER, VICKERS-ARMSTRONGS LIMITED (AIRCRAFT SECTION), WEYBRIDGE, SURREY.

Applications, with certain exceptions, are subject to the approval of the Ministry of Labour and National Service.

SITUATIONS VACANT

E. K. COLE, Ltd., Electronics Division, Malmesbury, Wiltshire, require Draughtsmen (mechanical or electrical of National Certificate Standard) aged 21 to 25 years, for interesting and varied work on radar and communication equipments, also for test gear, excellent conditions and prospects.—Apply, in writing, to Personnel Manager. 11099

RADIO service engineers required by Selfridges, Ltd., sound experience of all makes including television essential; applicants must be able to drive a car; pensionable post for men under 43, good salary, staff restaurant, sports club and welfare facilities.—Apply between 9 and 11.30 a.m. Monday to Friday, to Staff Manager, Provision Building, Orchard St., W. 11566

THE ENGLISH ELECTRIC Co., Ltd., Luton, have vacancies for electronic engineers for work in Australia on V.H.F. sub-miniature equipment with trials applications; assistance with housing will be provided.—Applications, stating age, experience and qualifications, should be sent to Central Personnel Services, 336-7, Strand, London, W.C.2, quoting ref. 456. 11355

ELECTRONIC engineer required by large food factory in London in the development section on the construction of specialized factory electronic equipment; age 20-28; applicants should possess initiative and be capable of working with the minimum of supervision; good candidate; salary according to age and experience.—Write Box W.344, c/o 191, Gresham House, E.C.2. 11351

LABORATORY assistants required on development of special materials for use in radio-communications; applicants must have National Certificate or higher qualifications and a special interest in chemistry or electrical measurements. Apply in writing to Personnel Manager, Standard Telephones Co., Ltd., N. Woolwich, E.16, stating age, qualifications and salary required. 11352

ELECTRONIC engineer for work in connection with the development and production of electronic measuring instruments; sound theoretical knowledge and several years' experience in this field essential; excellent opportunity for career and progress with young and rapidly expanding organisation—Riv-in Instruments, Ltd., 7a, Maitland Park Villas, N.W.3. 11350

THE De Havilland Engine Co., Ltd.—Electronic engineer required, interested in physical measurement rather than construction of apparatus, required for vibration measurement and analysis on gas turbine and piston engines.—Please write in confidence, stating age and full details of previous experience to the Personnel Officer, The de Havilland Engine Co., Ltd., Stag Lane, Edware, Middlesex. 19951

SCIENTIFIC instrument makers in North London have a few vacancies for skilled laboratory assistants and wire-men for the development and production of high quality electrical and electronic apparatus.—Please apply, in writing only, stating qualifications, experience and salary required, to Personnel Officer, Hilger and Watts Ltd., Hilger Division, 98, St. Pancras Way, London, N.W.1. 19990

THE ENGLISH ELECTRIC Co., Ltd., Luton, have vacancies for electronic engineers for development work on V.H.F. radio sub-miniature equipment and/or recording techniques; some field trials engineers and assistants also required.—Applications, stating age, experience and qualifications, should be sent to Central Personnel Services, Electric Co., Ltd., 336/7, Strand, London, W.C.2. 19630

PHYSICIST required in the north-west for the development of capacitors for use in telecommunication equipments, including silvered mica and paper and plastic dielectric types; the posts available are permanent, on full staff status with contributory pension fund, etc.—Please write, giving full details of qualifications and experience and the approximate salary required, to Box 194, Demand Advertising, Ltd., 18-20, Regent St., London, S.W.1. 11356

ELECTRONIC radar and radio engineers, senior and junior, are urgently required for new division of the General Electric Company, at their Stanmore Laboratories; applicants for the senior posts should be capable of directing the work of a small team engaged on the electrical development of electronic equipment for guided missiles or radar; knowledge of M.O.S. specifications and procedure would be an advantage.—Applications should be made in writing, stating age, qualifications and experience to the Personnel Manager, G.E.C., Stanmore Laboratories Brown's Lane Division, The Grove, Stanmore Common, Stanmore, Middlesex, quoting ref. RG/BLS. 19881

DECCA RADAR, Ltd., requires a senior engineer to form a new division of the company, undertaking the planning and erection of large radar stations both in the United Kingdom and abroad; the appointment calls for a man between 30 and 45 years of age, with exceptional experience in the engineering design, planning and progressing of electrical projects of a major nature, while a knowledge of radio and radar engineering at high powers is a distinct advantage, very favourable consideration will be given to heavy power engineers; sound engineering knowledge, experience and ability to plan and direct are the major requirements; a salary commensurate with the qualifications and responsibility will be paid; the post is permanent and pensionable.—Apply, in strict confidence, to Managing Director, Decca Radar, Ltd., 1-3, Brixton Rd., S.W.9. Ref. H.I.D. 11341

WOOLWICH POLYTECHNIC COLLEGE OF ENGINEERING and SCIENCE

WITH TEACHERS RECOGNISED BY THE
UNIVERSITY OF LONDON
PRINCIPAL: J. S. Tait, Ph.D., B.Sc., A.R.T.C.,
M.I.E.E.

Students read for International Degrees and are affiliated to the University of London Union and Athletic Union

B.Sc. ENGINEERING—Civil, Mechanical, Electrical, Telecommunications.

**B.Sc. Special CHEMISTRY
B.Sc. Special MATHEMATICS**

B.Sc. Special PHYSICS B.Sc. GENERAL
All the above are Three Year Courses. A preliminary One Year Course available, if not possessing G.C.E. in suitable subjects and levels, making a Four Years Course to the Degree.

FIRST MEDICAL EXAMINATION—One Year Course.

PROFESSIONAL COURSES
HIGHER NATIONAL DIPLOMAS IN ENGINEERING, ASSOCIATESHIP OF THE INSTITUTE OF CHEMISTRY.

Three Year Courses for Students who have attained a suitable standard.

Fees: £28 per Academic Year (no fee if under 18 years of age) plus £2 Union Fee.

Advice and information on Scholarships, Deferment, Entrance standards, etc., available on request to Secretary, Woolwich Polytechnic, S.E.18. (Woolwich 2856)

HOLLEY'S RADIO

285, CAMBERWELL ROAD, LONDON, S.E.5

Tel: RODney 4988

Specialists in Hi-fi equipment

All leading makes

Open all day Saturday

AERIAL COUPLING UNIT. For Wire 88 II. Contains 0-350 ma. Motor, R.F. Large and tuner, etc. complete in metal case, price 7/6, post 1/6.

U.S.A. THROAT MIKES. Slightly soiled otherwise perfect. 2/6 each, post free. 18/- dozen to clear, post free.

DESYNN FLAP INDICATOR. Ref. No. 6A/2136. New boxed, perfect condition, 5/- each, post 8d. 48/- dozen, post 2/-.

MASTER CONTACTS. Contains high grade clock-work movement, runs for 8 hours. 2 impulses per second, in silence cabinet. New, 12/6 each, post 1/6.

OXGEN FLOW METERS. Vane type, indicates flow of gas or air, ideal research. 1/3 each, post 1d. 12/- per doz., post free.

TOGGLE SWITCHES. REF. No. 5D/581. Single pole c.o., new. 7/6 doz., post 6d. 72/- gross, post 2/- reduction on large quantities.

TWO-WAY JUNCTION BOXES. Ref. No. 5C/430. 4/- doz., post 9d. 36/- gross.

We also have large stocks of relays and stylok fuses. Special attention overseas enquiries.

Customers welcomed at our new showrooms:

353, BEARWOOD ROAD, SMETHWICK,
L. C. NORTALL
16 Holly Road, Quinton, Birmingham, 32
Phone WOO 3186.

CITY OF COVENTRY EDUCATION COMMITTEE COVENTRY TECHNICAL COLLEGE

Session 1953-54

ELECTRONIC ENGINEERING
Applications are invited for entry to the next 3-year full-time course commencing in September, 1953, from those requiring a comprehensive training to an advanced level in ELECTRONIC ENGINEERING to qualify them for technical posts in radio, telecommunications, television and industrial electronics. The syllabus will cover the requirements of C. & G., Brit.I.R.E., and I.E.E. examinations. Entry age 16 years or over. Application forms and further information available from the Principal, Coventry Technical College.

W. L. CHINN, M.A.,
Director of Education.

Council House,
COVENTRY.
28-4-53.

Radio and Radar Technique

By A. T. Starr, M.A.,
Ph.D., M.I.E.E.

A survey of modern components and circuit techniques, intended primarily for designers of radio and radar equipment and for radio and radar engineers dealing with the subject at an advanced level. Particular attention is paid to noise, microwave techniques, waveforms, pulse circuit techniques, and electronic tubes. Profusely illustrated. 830 pages. 75s. net.

"Although the nature of the contents precludes a simple treatise, Dr. Starr has produced a most rewarding one."
—ENGINEER.

PITMAN

Parker St., Kingsway, London, W.C.2

LOUD-HAILER. Powerful P.A. system. No valves to break or damage. Works off 12 or 24 volts. Weather-proof. Independent of Mains failures. Consists of microphone and combined amplifier/speaker. PRICE 28/17/6. Carr. 5/6.

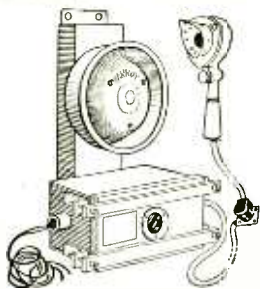

V.H.F. SUPERHET 6-VALVE RECEIVER. Six-channel switching. 30.5-40 mc/s. I.F. 7 mc/s. Receives Fire, Taxis, etc. Components include 30 ceramic trimmers, 30 small condensers, 6 v/holders, cans and covers, 30 resistances (1 to 1 watt), 2 transformers, 3 coils, etc. BARGAIN at 7/6. Also offered complete with valves, at 17/6. Carr. 2/9.

RADIO-TELEPHONE. Brand new walkie-talkie sets. 53-75 mc/s. Visual range. Telephone handset operation. 12 volt operation from vibrator unit. SPECIAL PRICE OF £21 per pair, complete with vibrators. Carr. 15/-.

RADIO-GRAM CHASSIS. Brand new, 1953 models, with latest valve line-up, flywheel tuning, negative feed-back, etc. Six wave band type at FIFTEEN GUINEAS, and three wave at £10/17/6, carr. 4/6. FREE OFFER OF 6in. P.M. SPEAKER with any of these models, send for complete catalogue. (Stamp.)

MINIATURE M.C. PHONE SPEAKERS. Ideal personal extension speaker, or quality microphone REDUCED to 2/9. Post 6d.

MICRO-SWITCHES. Latest American midgets. 220v, 3a, 1in. x 1in. x 1in. BARGAIN OFFER 5/-.

ACCUMULATORS. Brand new. 2 volt, 12 a/h. 1 1/2in. x 1 1/2in. x 6in. Lead acid. Non-spillable vent. 4/6. Post 1/-.

C.W.O. or C.O.D. Money back Guarantee

DUKE & Co.,

621 Romford Road, London, E.12. GRA. 6677

SITUATIONS VACANT ASSISTANTS (Scientific). The Civil Service Commissioners invite applications for pensionable posts. Applications may accepted up to 31st December 1953, but an earlier closing date may be announced either for the competition as a whole or in one or more subjects. AGE at least 17 1/2 and under 26 years of age on 1st January, 1953, with extension for regular service in H.M. Forces, but candidates over 26 with specialised experience may be admitted. CANDIDATES must produce evidence of having reached a prescribed standard of education, particularly in a science subject and of thorough experience in the duties of the class gained by service in a Government Department or other civilian scientific establishment or in technical branches of the Forces, covering a minimum of two years in one of the following groups of scientific subjects:—

- (i) Engineering and physical sciences.
- (ii) Chemistry, bio-chemistry and metallurgy.
- (iii) Biological sciences.
- (iv) General (including geology, meteorology, general work ranging over two or more groups (i) to (iii) and highly skilled work in laboratory crafts such as glass-blowing).

SALARY according to age up to 25: £236 at 18 to £363 (men) or £330 (women) at 25 to £500 (men) or £417 (women); somewhat less in provinces. Opportunities for promotion. FURTHER particulars and application forms from Civil Service Commission, Scientific Branch, Trinidad House, Old Burlington St., London, W.1, quoting No. S 135. Application forms should be returned as soon as possible. 11376

TEST and junior development engineers are required to assist in the development and production of precision electronic laboratory instruments; applicants should have a sound theoretical knowledge and have had substantial practical experience in electronic instrument circuits; salary in the region of £450-£650 p.a. according to qualifications and experience.—Apply, stating full details, to the Chief Engineer, Furzehill Laboratories, Ltd., Boreham Wood, 1024 Herts.

MICHAEL RADIO, Ltd. require senior and junior engineers, their equipment division laboratory at Slough; training and experience in the field of applied electronics (including communications) and experience of working with Government Departments are the chief qualifications required.—Write, stating age and full details of training, qualifications and experience, to the Chief Engineer, Equipment Division, McMichael Radio, Ltd., Slough, Bucks. 10199

BELLING & LEE, Ltd., Cambridge Arterial Rd., Enfield, Middlesex, require research assistants in connection with work on electronic components, fuses, interference suppressors and television aerials; applicants must be graduates of the I.E.E. or possess equivalent qualifications, together with similar laboratory experience; salary will be commensurate with previous experience; 5-day week; contributory pension scheme.—Applications must be detailed and concise, and will be treated as confidential. 10230

SENIOR mechanical designer: two or three vacancies exist in our electronics division for senior design draughtsman on electronic equipment; candidates should be of at least Higher National Certificate standard and should be capable of leading a design team in this class of work; salary £650 per annum upwards according to qualifications and experience; applications should include full details of experience to date and may be forwarded in confidence to the Personnel Manager, Murphy Radio, Ltd., Welwyn Garden City. 19883

DECCA RADAR, Ltd. requires a senior engineer to take charge of the testing of high-power centimetric radar equipment; previous experience of high-power radar, including receivers and A.F.C. systems, is required; a good salary, commensurate with experience, will be offered to the right man, for whom there are excellent prospects in this progressive and expanding company.—Please apply, giving full details of experience and stating salary required, to Ref. F.L. Decca Radar, Ltd., 1-3, Brixton Rd., London, S.W.9. 11340

B.B.C. requires engineer in Radio Section, Research Department, Kingswood, Surrey, normal starting salary £795 (may be higher or lower according to qualifications) rising by 5 annual increments to £1,065 max.; degree electrical engineering or physics with sound mathematics essential; duties theoretical and practical investigation on radio frequencies, reference transmitting aerials and R/F measurements, experience of which essential; experience transmitters and receivers desirable.—Apply E.E.O., B.B.C., London, W.1, quoting E.787. 11388

VACANCIES are available in the transmission department for: (1) development engineers, experienced in the design of multi-channel carrier telephone systems, or allied techniques, including amplifiers, filters and radio; (2) equipment engineers, with such knowledge of modern line communication practice as will enable them, after training in the company's methods, to prepare detailed specifications of equipment, investigation and development arrangements for rack-mounting of the apparatus; (3) draughtsmen to work with the engineers, preferably having experience in the telecommunication industry; the positions available are permanent, on full established status, with contributory pension fund and usual staff conditions.—Please write to Personnel Manager, Automatic Telephone & Electric Co., Ltd., Liverpool, 7, giving full details of experience, qualifications, age and approximate salary sought. 11359

GALPIN'S

ELECTRICAL STORES

408 HIGH ST., LEWISHAM, S.E.13.

Tel.: Lee Green 0309. Nr. Lewisham Hospital.

TERMS: CASH WITH ORDER. NO C.O.D.

All goods sent on 7 days' approval against cash.

EARLY CLOSING DAY THURSDAY

MAINS TRANSFORMERS (NEW), suitable for spot welding, input 200/250 volts, in steps of 10 volts, output suitably tapped for a combination of either 2 1/4/6/8/10 or 12 volts 50/70 amps 95/- each, carr. 7/6.

MAINS TRANSFORMERS (NEW), 200/250 volts input in steps of 10 volts, output 0, 6, 12, 24 volts 6 amps, 42/6 each, post 1/6. Another as above but 10-12 amps, 55/- each, post 1/6; another, as above, but 25/30 amps, 75/- each, carriage 3/6; another, input as above, output 0/18/30/36 volts 6 amps, 47/6 each, post 1/6.

EX-RADAR MAINS TRANSFORMERS 230 volts input 50 cycles 1 phase, output 4,500/5,000 volts approx. 80 m/amps, 6.3 volts 2 amps, 4 volts 1 1/2 amps, 2 volts 2 amps, these transformers are new immersed in oil, can be taken out of the oil and used as television transformers giving output of 10 m/amps, overall size of transformers separately 5 1/2in. x 4 1/2in. x 4in. and 3in. x 3in. x 2 1/2in., price 75/- each, carriage paid.

MAINS TRANSFORMERS (NEW), input 200/250 volts in steps of 10 volts, output 350/0/350 volts, 180 m/amps, 4 volts 4 amps, 5 volts 3 amps, 6.3 volts 4 amps, 45/- each, post 1/6; another 350/0/350 volts 180 m/amps, 6.3 volts 8 amps, 0/4/5 volts 4 amps, 45/- each, post 1/6; another 500/0/500 volts 150 amps, 4 volts 4 amps, C.T., 6.3 volts 4 amps, C.T., 5 volts 3 amps, 47/6 each, post 1/6; another 425/0/425 volts 160 m/amps, 6.3 volts 4 amps, C.T. twice 5 volts 3 amps, 47/6 each, post 1/6.

TRANSFORMERS SPECIALLY MADE TO ORDER, delivery 72 hours from date of order. Please let us quote you.

MAINS TRANSFORMERS, 200/250 volts input, output a combination of 6, 12, 18, 24, 30, and 36 volts at 6 amps, 45/- each, post 1/6.

METERS, Moving Coil, 0 to 14 amps, 18/6 each. Ditto, Moving Iron, suitable for A.C. 0 to 30 amps, 25/- each. Another moving coil, 100 to 250 amps, D.C., 35/- each, all 4in. scale. (Others in stock please state your requirements.)

12/24 VOLT RECTIFIERS at 4 amps., with suitable Mains Transformer, 200 230 volts input, 55/- each, except 12/24 volts.

MAINS TRANSFORMERS, input 180/250 volts, output 435/0/435 volts, 250 m/amps, 6.3 volts 10 amps, 6.3 volts 8 amps, 6.3 volts 8 amps, 5 volts 6 amps, 65/- each; another, input as above output 4,000 volts 2 1/2 m/amps, 4 volts 1 amp, 2 volts 2 amps, 45/- each.

SMOOTHING CHOKES, 4 henries, 250 m/amps, D.C. resistance 120 ohms, 12/6 each

CONDENSERS, 0.1 mfd., 6,000 volts working, 6/6 each.

LARGE STUD TYPE DIMMER RESISTANCES, 10 ohms, 9/18 amps, 32 studs, 35/- each.

3 KILOWATTS DOUBLE-WOUND VOLTAGE CHANGER TRANSFORMERS, 110/230 volts or vice-versa, as new, weight approx. 100 lbs., £12/10/- each, carriage forward.

ELECTRIC LIGHT CHECK METERS, useful for subletting, garages, etc., all for 200/250 volts A.C. mains, 5 amp. load, 19/- each; 10 amps, 22/6; 20 amps, 27/-; 25 amps, 32/6; 40 amps, 38/6; 50 amps, 46/6; and 100 amps, 57/6 each, all carriage paid.

6 or 12 VOLT RECTIFIERS at 4 amps output, complete with suitable transformer, 200/230 volts input, 45/- each, post 1/6.

MAINS TRANSFORMERS, 200-250 volts input, output 400/0/400 volts, 280 m/amps, 6.3 v. 8 a., 2 v. 3 a., 5 v. 3 a., 4 v. 2 a., 4 v. 2 a., the last two heaters insulated at 8,000 volts, 85/- each; another 200/230 volts input output tapped 0, 9, 18 volts at 4 amps, 25/- each, post 1/-.

D.C. MOTORS, 230 volts, 3 h.p., 3,000 r.p.m. in good condition, £35/- each; ditto Fan Motors, 230 volts D.C., 20/- each; 110 volts D.C. 17/6 each.

MAINS TRANSFORMERS, input 200/250 volts, output 45/50 volts, 70 amps, suitable for arc welding, £15 each; another 70 volts, 50 amps, £15 each.

EX-W.D. U.S.A. HAND GENERATORS less winding handle, output 425 volts at 110 m/a. at 6.3 v., 2 1/2 amps, complete with smoothing 30/- each, carriage 2/6.

ROTARY TYPE RESISTANCES, stud 5/arm type 10 ohms 3 amps, 17/6 each. (Other types in stock, please ask for quotation.)

THE HAYES COMPANY
RADIOGRAM CHASSIS

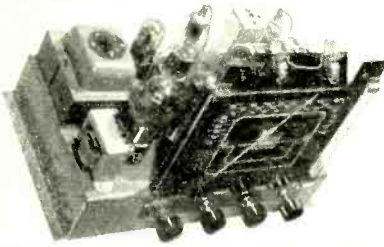

RG 200. Combining advanced design with a high standard of construction the RG 200 is making many new friends. The independent bass and treble controls give a smooth and continuously variable adjustment over the audio range. The output is eight watts, and the price £26 10/-.

The ever popular **RG/135** 7 valve chassis is £18 15/- and the **RG/120** 5 valve chassis is £15.

Full details gladly sent on request.

293, **WIGHTMAN ROAD, LONDON, N.8.**
Mountview 6864.

MORLEY TRANSFORMERS

QUALITY P.P.O.P. TRANS. 20 w., super Silcor lamination, low leakage windings, prima ind. 70H., leakage ind. 0.75H. Secondary imp. 3 and 15 ohms. Primary imp. to individual requirements. Fully shrouded and terminated. 3 gns. Ditto 15 w., 2 gns. **L.F. CHOKES.** 10H. 65 mA. 4.6. 15H. 100 mA., 10.6. 20H. 150 mA., 12.6. 5H. 250 mA., 15/-.

MAINS TRANS. 0-200/250 v. tapped prima. 350-0-350v. 5 v. 2 a. 0.3 v. 4 a., ditto 300 v., ditto 250 v., 21/-.

Quotations for specials and rewinds by return. Part post and packing j/- extra, please.

2, PAWSONS RD., W. CROYDON, THO 1665

— HYNDBURN —

TAPE RECORDER COMPONENTS
enable you to build
A TAPE TABLE

for under
£13

OR A COMPLETE PORTABLE
RECORDER

for
£30

Details from
HYNDBURN ELECTRONICS LTD.
2 & 4 Croft Street, Accrington,
Phone: Acc. 4526. **LANCS.**

ENGINEERS!

Whatever your age or experience, you must read "ENGINEERING OPPORTUNITIES." Full details of the easiest way to pass A.M.I.Mech.E., A.M.I.C.E. C. & G. (Electrical, etc.), General Cert., etc., on

144 PAGES "NO PASS - NO FEE"
Free!

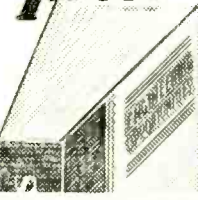

B.I.E.T.

37 Saakepeare Hse.
17-19 Stratford Place
London, W.1.

BENEFICIAL INSTITUTE OF ENGINEERING TECHNOLOGY

SITUATIONS VACANT

PROJECT engineers (aged 28/38) required for development of small electronic, electrical and radio components by well-known manufacturer; experience of this work and up-to-date manufacturing methods essential, academic or professional qualifications advantageous; the positions are permanent and pensionable and salary commensurate with qualifications.—Applications (which will be treated in confidence) giving full details and an indication of the salary range expected to Box 7521. Advertiser's staff are aware of the vacancies. [1391]

DRAUGHTSMEN: The English Electric Co., Ltd., have vacancies at their Liverpool works for electrical draughtsmen with good experience in the layout of power installations, wiring diagrams and switchgear; pensionable and progressive positions with excellent opportunities for promotion are offered to men with initiative; housing assistance for successful applicants and travelling expenses for interview will be paid.—Write, giving full details of age, qualifications and experience, quoting ref. 140B, to Central Personnel Services, Marconi House, 356-7, Strand, London, W.C.2. [1993]

THE GENERAL ELECTRIC CO., LTD. Brown's Lane Coventry, requires Senior and Junior Electronic Development Engineers for work on Guided Weapons and like projects, particularly in the field of Microwave and Pulse Applications. Mechanical Development Engineers, Designer Draughtsmen and Draughtsmen, preferably with experience of radar type equipments, also required for the above. Project salary according to age, qualifications and experience; houses available to selected senior staff.—Apply by letter stating age and experience to the Personnel Manager (Ref. R.G.). [0259]

MURPHY RADIO Ltd. have vacancies for two or three senior engineers to lead development teams in their electronics division; applications are invited from men with engineering or physics degrees or equivalent, and with first-class experience in the fields of Radar navigational aids, V.H.F. communications receivers and low-power transmitters; salary upwards of £300 per annum according to qualifications and experience; candidates prepared to bring energy and drive to their work may address their applications in confidence to the Personnel Manager, Murphy Radio Ltd, Welwyn Garden City. [1989]

MINISTRY OF CIVIL AVIATION.—Radio mechanics required at aerodromes and radio stations; special training courses for keen mechanics with basic qualifications; interesting work in progress providing electronic aids to navigation; prospect of permanent pensionable posts; rates of pay (London) from £290 per annum at age 19, to £355 at 25, rising subject to qualifying test to £475, plus pay addition of 0% slightly lower for provinces; candidates aged 19 or over with practical experience in maintenance of radio or radar equipment should apply to Ministry of Labour and National Service, Barnsbury Rd., London, N.1, quoting Order No. 576. [1368]

DECCA RADAR Ltd. invites applications from experienced microwave engineers to join the company in its extensive work in a wide field of microwave link and radar development; the company offers excellent starting salaries and first rate opportunities for men to exploit their initiative and to rise rapidly to responsible posts. Graduates without industrial experience who are prepared to undertake intensive training are also invited to apply for junior posts; applicants must be of British nationality.—Apply in writing, quoting ref. M.W. to Research Director, Radar Laboratory, 2, Tolworth Rise, Surbiton, Surrey. [0245]

OLD-ESTABLISHED British firm in Bangkok require sales and service engineer for their radio department; principal office the distribution throughout Thailand of a well-known American range of domestic radio receivers, commercial and broadcast transmitters and allied equipment; applicants will be required to take charge of the department and must be fully conversant with the entire range of broadcasting equipment; a knowledge of television, both transmitting and receiving, will be to the applicant's advantage; applicants up to 35 years of age will be considered.—Write with full particulars to Box "JN/9," c/o 35, Bishopsgate, London, E.C.2. [1424]

ADMIRALTY Royal Naval Scientific Service. A vacancies for Experimental Officers and Assistant Experimental Officers in London and Gloucestershire. Candidates should be engineers or physicists with a strong interest or research experience in electronics or telecommunications, line and radio. Candidates, British subjects, must possess one of following qualifications: (a) primary degree in engineering or mathematics; graduate membership of an appropriate professional institution, Higher National Certificate, Final certificate of a 5-year grouped course in a relevant subject at City & Guilds or comparable institutions. Higher School Certificate with Maths. or Science as principal subject, or equivalent qualification. Experimental officers at least 26 years of age. London salary scale (men) £681-£838. Assistant Experimental Officers at least 17½ years £274-£607. Rates for women and post in Gloucestershire somewhat lower. Starting salaries above minima may be granted according to age and experience. All appointments unestablished, but opportunities to compete for permanent posts will occur from time to time.—Application forms from M.L.N.S., Technical and Scientific Register (K) 26 King St., London S.W.1. Quoting A130/53-A. Closing date July 14, 1953. [1394]

AMPLIFIER XL/AC (1)
(HIGH GAIN)

Incorporates Volume and Tone Controls, Latest Miniature Valves, Providing 4½ watts output. For use with 2 to 15 ohm speaker. A.C. mains 200-250 volts. Size of chassis 8 x 6 x 2½ in. Tested and Ready for use. Price £6/10/- Plus 5/- Postage and Packing.

NEW CHARGERS
(Metal Rectifier Type)

200-250 v. A.C. in, 72 v. D.C. out, at 15 amps. Price £20.

Let Us Quote You for
RADIO COMPONENTS, VALVES.

Also Press Tools and Jigs for the radio trade.

TELEKIT SUPPLY CO.

Chantry Lane Works, Chantry Lane, Bromley, Kent. RAV. 5845.



In the early '20s Horn Type speakers came to be regarded as bad and designers concentrated on battle types, etc. Mr. Voigt recognised their error and designed for horn loading. Horn Loaded Voigt Units were selling by 1929. Lately the return to horn loading has become general, but—Voigt Desics Led the Way.

VOIGT PATENTS LTD., LONDON, S.E.26

A.W.F. RADIO PRODUCTS

for "VIEW MASTER," "TELE-KING," WIDE ANGLE SCAN, components, valves, cabinets, TRUVOX TAPE DESK, etc., everything for the Service Engineer.

Wholesale only. Send 3d. for our list.

TATLER CHAMBERS, THORNTON ROAD, BRADFORD, Yorks. Tel.: 24098

QUARTZ CRYSTAL UNITS

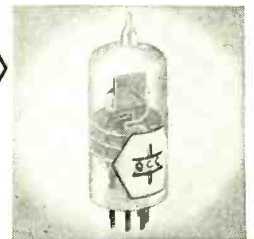

Type
B7

The type B7 unit is mounted in the standard B7G valve envelope and is hermetically sealed and fully evacuated.

Available for the frequency ranges from 100 kc/s. to 500 kc/s. and from 3 Mc/s. to 16 Mc/s. Gold electrodes applied by cathodic sputtering give permanence of calibration. Normal adjustment accuracy 0.01%. Max. adjustment accuracy 0.003%.

Early delivery can be given of most frequencies, and we will be pleased to quote for your specific requirements.

THE QUARTZ CRYSTAL Co. Ltd.
63-71 Kingston Road,
NEW MALDEN, SURREY

Telephone: **MALden 0334** Cables, etc. **QUARTZCO NEWMALDEN**

A.B.	Convette	Labgear	Rola
A.M.C.	Cosior	Lane	Rothermel
Ace	Cydon	Leak	Sanacos
Acos	Decca	Leck	Seco
Acoustical	Delco	Lomb	Sentercel
Acrylite	Delco-Remy	Hambly	Servisol
Activette	Dilecon	Lufbra	Shatesbury
Adoola	Douglas	Lustraphone	Siemens
Advance	Drilite	McMurdo	Sifam
Aladdin	Dubilier	Macnastva	Sistoflex
Allen	Edgewise	Malloy	Soton
Amplion	Edgewise	Marconi	Somerford
Antex	Elaic	Mazda	Spencer-West
Antiferro	Electron	Mecker	Stenlorian
Audioelectric	Elstone	Micro-Switch	T.C.C.
Armine	E.M.I.	Molins	T.M.O.
Audiograph	Emitec	Morsonite	Tamsa
Audion	Emerson	Multihead	Telson
Avo	Erie	Mullard	Trix
Axiom	Eta	Multicoore	Truvox
B.C.E.	Exide	Mumetal	Tungstian
B.I.C.C.	English	N.S.F.	U.I.C.
B.S.R.	Electric	Nitrocol	Varley
B.T.-H.	Ferranti	Oak	Vidor
Baird	G.E.C.	Osmor	Vitavox
Batymax	Gardners	Osrain	Valradio
Belling-Lee	Garrard	Painton	Vitality
Bernards	Goings	Partridge	Vortexion
Black & Decker	Goodmans	Paxolin	W.B.
Bradmatic	Goodsell	Phillips	Wavemaster
Brimar	Grampian	Pirtoid	Wearite
Burgess	Grundig	Plessey	Westinghouse
Bulkin	Harley-Turner	Plus-a-gram	Weston
Celco	Hera	Polara	Wevrad
Celestion	Hellermann	Pullin	Welwyn
Ceramicon	Hivac	Pyrex	Wharfedale
Cinch	Hunts	Q.C.C.	Wilkins & Co.
Claroat	Ikanio	Q-Max	Wright
Clifton	Iliffe	R. & A.	Wimbleton
Cliz	J.B. & A.	Qualitee	Wirek
Collaro	J-Beam	Raymart	Wolten
Colvern	L.E.M.	Resio	Yaxley
Connoisseur	Lab	Reliance	

We issue no lists or catalogues, but we have since 1925, been giving off-the-shelf service on Electronic Components from stocks unequalled in the Industry. Send us a list of your requirements for a new experience in instant service.

WIRELESS SUPPLIES UNLIMITED
264-266, OLD CHRISTCHURCH ROAD,
BOURNEMOUTH, HANTS.
Phone: Bournemouth 4567.
Telegrams: Limitrad, Bournemouth.

NEW G.E.C., S.T.C. AND "WESTALITE" SELENIUM RECTIFIERS. Largest L.T. range in Great Britain. Latest Current Products. NOT Surplus.

CURRENT PRICE LIST

S.T. & C. HALF WAVE. 100 v. 4 a., 92/- Post 1/-.
BRIDGE CONNECTED FULL WAVE.
 17 v. 1.2 a., 16/4; 1.6 a., 26/-; 2.5 a., 29/-; 3 a., 30/-; 4 a., 34/6; 5 a., 37/6; all post free.
 33 v. 0.7 a., 24/3; 1 a., 28/-; 1.5 a., 45/-; 2 a., 51/-; 3 a., 52/-; 4 a., 62/-; 5 a., 67/-; all post 1/-.
 54 v. 1 a., 38/6; 1.5 a., 62/-; 2 a., 69/-; 3 a., 70/-; 5 a., 93/-; 7.2 v. 1.5 a., 78/-; 2 a., 81/-; 3 a., 92/-; 5 a., 122/-; 100 v. 1.5 a., 112/-; 2 a., 128/-; 5 a., 174/-; all post 1/2.
BRIDGE CONNECTED HEAVY DUTY 7 1/2 in. SQUARE COOLING FINNS. 17 v. 12 a., 49/6; 10 a., 56/-; post 1/6.
BRIDGE CONNECTED HEAVY DUTY Funnel Cooled, also 7 1/2 in. SQUARE COOLING FINNS. Revisions will be dealt with in confidence and should be addressed, in the first instance, quoting reference HW/ED. For the attention of the Personnel Manager, The Plessey Company Limited, Vicarage Lane, Ilford, Essex. 1347

"WESTALITE" (BRIDGE), 12-15 v. D.C., 1.2 a., 15/10; 2.5 a., 27/8; 5 a., 31/9; 10 a., 54/6; 20 a., 99/6; 30 a., 144/10; 50 a., 257/-; 24 v. 1.2 a., 15/9; 2.5 a., 27/8; 5 a., 51/-; 10 a., 92/7; 20 a., 176/2; 36 v. 2 a., 27/8; 2.5 a., 51/-; 5 a., 69/10; 10 a., 130/9; post extra.

Wholesale and Retail
T. W. PEARCE (Est 21 Yrs.)
 66 GREAT PERCY STREET, LONDON, W.C.1
 On Pentonville Rd. Between King's Cross and Angel

SITUATIONS VACANT
AIR MINISTRY requires civilian instructors. Class I, radio fitter, for temporary posts, with prospect of permanency, at R.A.F. Radio Schools, Yatesbury (Wilts) and Locking (Somerset); qualifications at least 5 years practical experience and ability to instruct; trade test before entry; pay is £480 at 26 rising to £597.—Apply to (K.1) Air Ministry, S.5(g), Cornwall House, Stamford St., London, S.E.1. 1375

DEVELOPMENT ENGINEER required; experience in electronic communication field an advantage; excellent opportunity for man with technical and engineering experience to broaden experience with well-established and well-known company; near town centre and all amenities and within easy reach London.—Apply Marconi Instruments, Ltd., Longacres, Hatfield Rd., St. Albans. 11028

ELECTRONIC ENGINEER required by Ministry of Supply, London Headquarters, to supervise the development by industry of electronic navigation aids. For Service use, experience of the development of radio and radar equipments and a knowledge of current navigation equipment is desirable; quals. minimum or Higher School Cert. (Science) or equivalent, but degree or H.N.C. in engineering may be an advantage. salary within range expiring official office (min. age 26). £681-£838; women somewhat less; post unestablished.—Applications forms from M.L.N.S., Technical and Scientific Register (K), 26, King St., London, S.W.1, quoting D22/55A. Closing date July 14, 1953. 11428

SENIOR Experimental Officer required by Aberporth, South Wales, for control of operation and maintenance of electronic instruments and supervision of technical work; experience with radio or radar equipment, preferably used for measurement of physical quantities, desirable; taking for field work essential; quals. minimum of degree in physics or electrical engineering, but H.N.C. or degree in elec. eng. may be an advantage; min. age 35; salary within range £927-£1,091 (male); post unestablished.—Application forms from M.L.N.S., Technical and Scientific Register (K), 26, King St., London, S.W.1, quoting D 22/55A. Closing date July 14, 1953. 11429

RADIO research department; junior technical assistant able to assist in as many as possible of the following: electrical and radio measurements, construction of prototype apparatus, preparation of reports, technical records, etc., generally to be useful in small laboratory; ability to use metal and wood-working tools with some degree of accuracy is desirable and a knowledge of typing could be advantageous; good education to matriculation standard and some knowledge of electrical theory is essential; female applicants would be considered if possessing typing experience and good training in radio theory (i.e., ex-W.N.S., etc.).—Full details of age, education, experience and salary required to Box No. 544, c/o Era Publicity, Ltd., 7, Fitzroy Sq., London, W.1. 1365

A VACANCY exists with a subsidiary of British Relay Wireless and Television, Ltd., operating in Gloucester, for a television engineer, mainly for servicing television receivers, but also for work in connection with the maintenance and installation of television relay distribution equipment; applicants should be under 25 years of age and should have had experience in handling and servicing television receivers or associated equipment; applicants should be made in writing to Link Sound and Vision Services (Gloucester), Ltd., 28, Southgate Street, Gloucester. Applicants wishing to be interviewed in London should apply to British Relay Wireless and Television, Ltd., 6, Giltspur St., E.C.1, marking their letters "Gloucester" 1376

THE PLESSEY COMPANY have vacancies at their Ilford works for engineers and draughtsmen of senior and intermediate grades for development work on components and mechanisms for radio, television and communications equipment; these vacancies occur as a result of the enlargement of the laboratories to permit a substantially increased interest in the design of circuits and components for specific applications; all positions are permanent and pensionable and the expansion now in progress offers good prospects of advancement, attractive initial and progressive salaries are offered to men who are qualified by reason of educational attainment or practical experience.—All applications will be dealt with in confidence and should be addressed, in the first instance, quoting reference HW/ED. For the attention of the Personnel Manager, The Plessey Company Limited, Vicarage Lane, Ilford, Essex. 1347

MINISTRY OF SUPPLY requires technical authors at Chessington, Malvern, Farnborough, to prepare instructional publications for services on all aspects of ground/airborne centimetric radar or radio communications equipment. Conditions: British of British parent, recognised eng. apprenticeship and Eng. or Physics degree, A.M.I.C.E., Mech.E. or Elec.E. or exempting quals.; alternatively wide experience in responsible tech. position preferably holding H.N.C. or equivalent would be considered; applicants with either research and development in industry or operation and servicing in Services essential; experience in writing, editing tech. publications advantageous; salary within £592-£949 according to age quals.; location; not established but opportunities to compete for establishment may arise.—Application forms from M.L.N.S., Technical and Scientific Register (K), 26, King St., London, S.W.1, quoting D198/53A. Closing date July 13, 1953. 1369

GEE-Phos RADIO LTD.

SELENIUM METAL RECTIFIERS. Full range in stock as per our previous adverts. We can also supply rectifiers to individual requirements from m/a to amps., H/Wave, F/Bridge or 3 phase. Speedy delivery, competitive prices, fully guaranteed. Prices and list on application. Trade supplied.
MORSE KEY, TYPE 'J', made in U.S.A., a really well-made key for amateur or professional use, 7/6, P.P. 1/-.
R.F. 25 UNITS, in excellent condition, 20/-, carriage 2/-.
12in. SPEAKER CABINETS, with carrying handle, detachable back, handsomely finished. Complete with lead compartment at bottom. Suitable for use as a portable amplifier and speaker cabinet. Brand new. Size: 15in. x 17in. x 13in. Price £2/19/6. (List price 6 gns.). P.P. 5/-.
BATTERY CHARGERS. Ex-Govt., perfect condition, 200/250 v. A.C. output to charge 2.6-12 v. at 5 amps. Complete with Ammeter, £4/19/6, carriage 5/-.
INTRODUCING THE NEW 'SOLON' INSTRUMENT MODEL ELECTRIC SOLDERING IRON, Weight 3 1/2 ozs., length 9in. Suitable for 220/240 v. 25 watts. Best instrument on the market, only 19/8 P.P. 1/-.
MULTI-PURPOSE TRANSFORMERS. Ideal for charging, etc. Prim. 200/250 v., 50 cycles. Sec., 38 v.-86 v. in 3 v. stages at 400 watts or 30 v.-19 v.-11 v., 3.8 v. and 3 v. at 10 amps. Brand new, limited number available. Price £3, carriage 2/6.
VARIABLE VOLTAGE REGULATOR TRANSFORMERS. Input 230 v. A.C. at 21 amps. Output 57.5 in 16 equal steps to 230 v. at 21 amps. Ex-Govt. In perfect condition, £15, carriage 5/-.
AUTO TRANSFORMERS. 21 amps., 110-125 v. 200 v.-240 v. Perfect condition, £6/10/-, carriage 5/-.
WELDING TRANSFORMERS. 230 v. Prim. 50 cycles, L.T. tapped, 1 1/4 v.-13 1/2 v. 60-70 amps., £3/19/6, P.P. 5/-, Or 1 3/4 v. tapped to 16 v., as above. Same price.
PHILIPS NEON TESTER. Screw-driver type, 100/500 v. A.C./D.C. 5/1, P.P. 6d.
HELLERMAN TOOL KITS. T.K.2 complete with tool, oil, sleeves, 17/6. Tool only 9/-. P.P. 9d on either.
MAINS INTERFERENCE SUPPRESSORS. Type No. 5C/870, suitable for radios, motors, etc., size 4in. x 4 1/2in. x 2in., 4/11 P.P. 1/-.
MOVING COIL METERS-2 1/2 in. FLUSH MOUNTING. 0-10 m/a., 0-20 m/a., 0-200 m/a., 0-500 m/a., any type, 12/6 each. P.P. 1/-.
AMPLIFIER TYPE 3582. Brand new containing 45 m/c Pye Strip, ideal for T.V. limited number only, £5/15/-, P.P. 2/6.
AMERICAN HIGH FREQUENCY SIGNAL GENERATORS. Type 122A. Complete, brand new, 110 v. Input. 50-230 m/cs 8-150 m/cs., £20, carriage 5/-.
AMERICAN DYNAMOTOR, TYPE P.E. 103. Complete with stand and leads, brand new.
MULLARD OSCILLOSCOPE, one only, type GM3152/65, secondhand, completely overhauled, in perfect order, £28.
EXTENSION SPEAKER IN METAL CABINET. 6 1/2 in. Goodmans heavy magnet, ideal for P.A. work, 23/6 carriage 1/6.
ALUMINIUM SHEET, UNDRILLED. 16 S.W.G. Sizes available: 12in. x 12in., 24in. x 12in., 24in. x 24in., 24in. x 36in., 4in. per sq. foot, P.P. 9d.
6in. G.E.C. FANS. 24 v. D.C. Brand new, complete with guard, 30/-, P.P. 2/-.
OSRAM PHOTO-CELLS. C.M.G. 22, brand new, 25/- each. P.P. 6d.
SPEAKERS:
 10in. P.M. 3 ohms Speech coil, 25/-, P.P. 1/6.
 8in. P.M. 3 ohms Speech coil, 15/6, P.P. 1/6.
 5in. P.M. 3 ohms Speech coil, 15/-, P.P. 1/6.
 2 1/2in. P.M. 3 ohms Speech coil, 18/6, P.P. 9d.
 3 1/2in. P.M. 3 ohms Speech coil, 15/6, P.P. 9d.
VARIABLE RESISTORS:
 152 ohms at 2 amps., twin tube 22/6
 50 ohms at 50 watt, on porcelain formers 7/6
 25 ohms at 100 watt, on porcelain formers 15/6
 5k. at 50 watt, on porcelain formers 7/6
 100K. at 25 watt, totally screened W/W, Type CV5 9/6
 Terms C.W.O., C.O.D. or pro-forma invoice
15 LITTLE NEWPORT ST., LONDON, W.C.2
 GERard 6794/1453

This UNIQUE BENDER

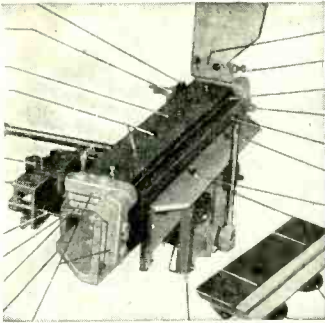

Quickly and Accurately Forms

Angles, Channels, Sections, Boxes, Lids, Trays, Tanks, Chassis Brackets, Clamps, Clips, Shrouds, Chemical, Electronic and Electro Medical apparatus. Used by leading Radio Manufacturers. Invaluable to Servicing Engineers, Hospitals, Universities and Research Workers.

For 6 page Folder write to:—



A. A. TOOLS (W)
197a Whiteacre Rd., Ashton-u-Lyne

RADIO G 200 OFFERS

500 c.p. Ediswan POINTOLITE equipment. A.M. ref. 9/559. Complete with Lamp. Price £5.
Generator Type '320'. Permanent magnet input 24v. to 200v. 50mA.; 12.6v. 1.2A. A.M. ref. 10K/1046. Price 35/-.

ARTHUR HOILE 55 UNION STREET
MAIDSTONE, KENT
Telephone 2812

We repair and

standardise

TEST METERS



THE ELECTRICAL INSTRUMENT REPAIR SERVICE
329 Kilburn Lane, LONDON, W.9. Tel. LAD 4168

"TYANA"

SOLDERING IRON 16/9



The Perfect Small Soldering instrument—overall length 1 1/2 in., diameter of bit 1/8 in.

- Adjustable Bit.
- Easy to handle.
- Weight approx. 4 oz.
- Heating Time 3 min.
- 40 Watt economy Consumption.
- Standard Voltage Ranges.
- (Other Ratings Available on Request.)
- Long Life and Efficiency.
- Replacement Elements and Bits always available.

Just the Convenient Iron Required for Intricate and Fine Soldering.

Regd. Design No. 867804

Maintenance Service for Industrial users. British made by:—

KENROY LIMITED

152, 297 UPPER ST., ISLINGTON LONDON, N.1.

Telephone: Canonbury 4905 4663

SITUATIONS WANTED

RADIO Service Engineer, age 30, seven years' post-war experience, limited television. Murphy, Pye, Cossor, drive, seeks post. Plymouth preferred, available September.—Box 7689. [1430]

BUSINESS OPPORTUNITIES

RADIO and electronic engineering organisation has facilities for production and/or development of prototype to Gov. Dept. Standards—Box 7047. [1006]

BUSINESS FOR SALE AND WANTED

RADIO TV retail business with living accommodation reqd. 5 miles radius of Kensington. N.W. London preferred; good premium.—Coynes Store. 105. Talbot Rd., Bayswater, Bay 4860. [1402]

PAINTS, CELLULOSE, ETC.

PAINT spraying handbook 3/6, post free. cellulose and synthetic paints and all spraying requisites supplied; catalogue free.—Leonard Brooks, 53, Harold Wood, Romford. [0207]

TECHNICAL TRAINING

CITY & Guilds (Electrical, etc.) on "no pass no fee" terms; over 95% successes; for full details of modern courses in all branches of electrical technology send for our 144-page handbook—free and post free—B.I.E.T. (Dept. 363A), 17, Stratford Place, London, W.1. [0117]

INDUSTRY needs trained men; send for free brochure giving details of our Home Study Courses in radio, television and all branches of electronics; we prepare students for the A.M.Brit.I.R.E., City and Guilds Telecommunications, R.T.E.B., and other professional examinations; train with the college backed by Britain's largest electronic industry.—Write to E.M.I. Institutes, Postal Division, Dept. WW33, 43, Grove Park Rd., London, W.4 (Associated with H.M.V.). [0179]

TUITION

NOTHING succeeds like success! What we have done a thousand times we can do again for you—see the B.N.R.S. advt. page 117 [0172]

WIRELESS operating; attendance and postal courses.—Stam for reply to Manager, The Wireless School, Manor Gdns., London, N.7. [5901]

FULL-TIME courses for P.M.G. Certs C.G.L.I. Telecommunications, Radar Maintenance Cert. and B.Sc. (Eng.); prospectus free.—Technical College, Hull. [0111]

SEE the world.—Radio officers urgently required; we train most in shortest period; training fees payable after appointment secured; scholarships available; boarders accepted; 2d stamp for prospectus from Britain's leading college.—Wireless College, Colwyn Bay. [0018]

A.M.I.Mech.E., A.M.Brit.I.R.E., City and A.Guilds, etc., on "no pass—no fee" terms; over 95% successes; for details of exams and courses in all branches of engineering, building, etc., write for 144-page handbook—free—B.I.E.T. (Dept. 387B), 17, Stratford Place, W.1. [0118]

WIRELESS Telegraphy. Merchant Navy offers to youths 15½ upwards when qualified, lucrative positions as radio officers.—Apply British School of Telegraphy, Ltd., 179, Clapham Rd., London, S.W.9. Also postal courses in theory of wireless for P.M.G. Certificates, and Amateur Transmitting Licence. [0124]

THE Institute of Practical Radio Engineers have available home study courses in every phase of radio and television engineering, specialising in the practical training of apprentices in the retail trade; enrolments limited, fees moderate.—The Syllabus of Instructional Text may be obtained post free from the Secretary, I.P.R.E., Fairfield House, 20, Fairfield Rd., Crouch End, London, N.8. [0088]

THERE is a great future for qualified radio, television and electronic engineers; this is your opportunity to train for a well-paid career; E.M.I. Institutes, who are associated with H.M.V., Marconi-Phone, etc., offer a 3-year course in telecommunications engineering (inc. 1 year with E.M.I. factories) commencing August 24th; on successful completion, employment is assured.—Full details from E.M.I. Institutes, Dept. WW38, 10, Pembridge Sq., London, W.2. [1398]

FREE! Brochure giving details of Home Study Training in Radio, Television, and all branches of Electronics. Courses for the hobby enthusiast or for those aiming at the A.M.Brit.I.R.E., City and Guilds Telecommunications, R.T.E.B., and other professional examinations. Train with the College operated by Britain's largest electronic organisation; moderate fees.—Write to E.M.I. Institutes, Postal Division, Dept. WW28, 43, Grove Park Rd., London, W.4 (Associated with H.M.V.). [0001]

WORK WANTED

TOROIDAL winding capacity, precise limits.—Bel, Marlborough Yd., London, Archway, N.19. [0183]

ELECTRONIC eqpt. made to order, wiring, assay, contractors, prototypes developed.—R.A.E. Mfg. Co., 377, High Rd., London, N.2. [0219]

ELECTRONIC sub-contracts and prototypes, light assembly, wiring, testing to specification; priority to Government work.—Enquiries to office, T-H Products, 92, Leathwaite Rd., S.W.11, Bat. 4889. [9729]

MANUFACTURERS—As specialists in all types of sheet metal work for the radio and electrical trade we are able to quote you very keen prices for a high quality job.—Intensalite Sign & Fixture Co., Ltd., 89, Leopold St., Birmingham, 12. Tel. Vic. 0065. [19962]

MAGNETIC TAPE RECORDERS & SOUND EQUIPMENT

PORTABLE TAPE RECORDER, model D/8, 8-valve 10-watt dual channel amplifier, with Truvox Tape Unit, 8in. L.S. ... £65 0 0

RECORDING AMPLIFIERS

TR/DS, 8-valve 10 watts £24 10 0
TR/DT, 6-valve 12 watts £18 0 0
TR/4, 4-valve 4 watts £12 12 0

CONCERT AMPLIFIERS

AC/15, Mic. 8 gram, 5 v. 12 w. ... £14 14 0
AC/18, super model, 6 v. 15 w. ... £16 16 0
We specialise in audio equipment of every description. Obtainable direct, or from agents everywhere. Trade and Export enquiries welcomed. Catalogue upon request (3d.)

G. L. ELECTRONICS,
16 Pattison Road, London, S.E.18.
Woolwich 0387.

LOCKWOOD makers of **Fine Cabinets**

and woodwork of every description for the Radio and allied trades
LOCKWOOD & COMPANY
Lowlands Rd., Harrow, Middlesex. Byron 3704

QUALITY TELEVISION COMPONENTS



Scanning Coils
6/10 Kv. R.F. E.H.T. Units
E.H.T. and Output Transformers
Line fly-back E.H.T. Units
SEND FOR ILLUSTRATED LIST (PUBLICATION 75)

HAYNES RADIO Ltd.
Queensway Enfield Middlesex

SAMSONS SURPLUS STORES

ADMIRALTY INTEGRATORS, TYPE A/591, incorporating very fine galvo. movement. 50/- P.P. 2/6.
ADMIRALTY SEND-RECEIVE KEY TYPE A/557. Operates from 24 volts D.C. 22/6. P.P. 2/6.
AMERICAN VALVE TESTERS by Radio City Products. Brand new in maker's cartons. £15.
MASTER VOLTMETERS. 0-20 volts A.C. 50 cy. Moving iron 6in. mirrored scale. 25/- P. & P. 2/6.
SPECIAL OFFER: S.T.C. BATTERY CHARGERS. A.C. input, 200-250 v. output, 60 volts, 10 amps., incorporating selenium rectifier, ammeter, fuses, fine and coarse switching. Built-in grey metal cases measuring 1 1/2 in. x 1 1/2 in. x 1 1/2 in. Supplied brand new at a fraction of the maker's price, £27/10/-. Callers only.
DOUBLE ANGLE SERVO UNIT ASSEMBLY for bomb sight computer T1, comprising 27 volt double ended geared motor and reversing assembly. Brand new in maker's cartons. 32/6. P. & P. 2/6.
SLIDING RESISTANCES. 3.4 ohm 12 amp. 22/6. 5 ohm 10 amp. 22/6. 1 ohm 12 amp. 12/6. 50 ohm 1 amp. 10/6. 20 ohm 7 to 1.5 amp. with geared drive, 37/6. P.P. on all types, 2/6.

169/171 Edgware Road
London, W.2. Tel.: PAD. 7851
125 Tottenham Court Road, W.1.
Tel: EUS. 4982

All orders and enquiries to our Edgware Road branch, please. This is open all day Saturday.

"AUTOMAT" HOME CHARGERS, CHARGER KITS, SELENIUM H.T. & L.T. RECTIFIERS

New Goods with Full Guarantee

Our selenium rectifiers are new, not reconstructed Gov't. surplus material.

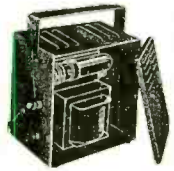

"AUTOMAT" HEAVY DUTY HOME CHARGER. weight 8 1/2 lbs., virtually unbreakable, for your car battery or radio cells. selenium rectification, 12 months' genuine guarantee, foolproof operation, damp-proof, std. model for A.C. 230/250, 6 v./12 v. output 2 amp. 59/6, p. & p. 2a. 12 v. 3 amp. 72/-; 6 v./12v. 5 amp. 115/-; 24 v. 5 amp. 411.

FOOLPROOF CHARGER KITS. Really trouble free and reliable with full data sheet and circuit, standard kit 12 v. 2 amp. selenium rectifier, 45 watt impregnated transformer, ballast bulb for 2 v., 6 v., 12 v. charger, 38/6, post 1/8, or with handsome steel case, 52/-, post 2/-, senior model 12/14 v. 3 amp. Westalit rect., 65 watt trans., ballast bulb, for 2 v., 6 v., 12 v., 46/-, post 1/10, or with our latest design steel case, 58/6 post 2/-, also 12 v. 4 amp. rect., 75 watt trans., ballast bulb for 6 v./12 v. charger, 55/-, ditto but 5 amp. S.T.C. rect. and 85 watt trans., with ballast bulb, 75/-, minor kit 6 v./12 v. 1 amp. rect., trans., case, ballast bulb, 42/-, post 1/10.

HEAVY DUTY ELIMINATOR KIT. Large trans., selenium h.t. and l.t. trickle charge rect., electrolytic 12 plus 12, handsome steel case, for 120 v. 20/30 mA. eliminator with 1 amp. trickle charge, for 100 v. no extra, 37/6, post 1/6, or less case, 32/-.

SELENIUM RECTIFIERS. Many 18 mm., 25 mm. and 35 mm. rectifiers various voltages, bridge, h.w. and c.t. types, H.T. and L.T., new stock, not surplus, 2 v./6 v. 4 amp. h. wave, 4/10; 12 v./1 a.h. wave, 6/-, post 6d.; full wave 6 v. 2 amp., 9/-; 12 v., 2.5 amp., 15/6; 12/15 v. 3 a. to 3.4 a., 16/6, all post 8d.; 6 v. 4 amp., 16/6; 24 v. 1.5 a., 15/-; 12 v. 6 amp., 27/6; 24 v. 5 amp., 54/-; large lined type, 12 v. 6 amp., 33/-; all post 11d. H.T. rect., small space selenium, all new, 250 v. 60 mA., 7/6, post 5d.; 250 v. 120 mA. bridge, 14/6, post 8d.; 250 v. 200 mA. bridge, 24/-, ditto 300 mA., 34/6. Blim. rect. 135 v. 30 mA., 6/6, post 5d.

CHAMPION PRODUCTS
43 Uplands Way, LONDON, N.21 Phone LAB 4457

BOOKS, INSTRUCTIONS, ETC.
BOOKLETS "How to Use Ex-Govt. Lenses and Prisms." Nos. 1 and 2, price 2/6 each; ex-Govt. optical lists free for s.a.e.—H. English, Rayleigh Rd., Hutton, Brentwood, Essex. 10181
I.P.R.E. technical publications, 5,500 Alignment Peaks for Superheterodynes, 5/9, post free; data for constructing TV aerial strength meter, 7/6; sample copy "The Practical Radio Engineer," quarterly publication of the Institute 2/-, membership and examination data, 1/-—Sec., I.P.R.E., 20, Fairfield Rd., London, N.8. 10089

"ADVANCED Theory of Waveguides." By L. Lewin. Sets out various methods of treating problems arising in work on this complex subject. Author has selected for discussion a number of topics as representative of the field in which the micro-wave engineer is engaged, many of the examples being concerned with the rectangular waveguide. 30/- net from all booksellers. 30/7 by post from Iliffe & Sons Ltd., Dorset House, Stamford St., London, S.E.1.

"TELEVISION Explained." By W. E. Miller, M.A. (Cantab.), M. Brit. R.E. Explains and illustrates television reception circuits, aerials and aerial systems, receiver installation and operation, frequency allocations and remedies for faulty reception. Provides a valuable grounding in the circuitry encountered when maintaining television sets. 4th Edition, 5/- net from all booksellers. 5/4 by post from Iliffe & Sons Ltd., Dorset House, Stamford St., London, S.E.1.

"MICROPHONES." By the Engineering Training Dept., B.B.C. Discusses the requirements for microphones in a broadcasting studio, sets out the laws relating to sound waves and their behavior and describes in detail design and characteristics of various types of microphone—with special reference to those used by the B.B.C. 15/- net from all booksellers. 15/5 by post from Iliffe & Sons Ltd., Dorset House, Stamford St., London, S.E.1.

"DEVELOPMENT of the Guided Missile." By Kenneth W. Gatland. Presents all the main information available on the development of guided weapons in Britain, U.S.A., Germany, U.S.S.R., and elsewhere. Other chapters discuss guided missiles as instruments of research into the upper atmosphere and outer space, and as vehicles of inter-planetary travel. An appendix shows characteristics of missile-powered missiles known to have been designed or constructed. 10s 6d net from all booksellers. By post 10s 11d from Iliffe & Sons Ltd., Dorset House, Stamford St., London, S.E.1.

"SOUND Recording and Reproduction." By J. W. Godfrey and S. W. Amos, B.Sc. A.M.I.E.E., in collaboration with the B.B.C. Engineering Division. Covers in detail the theory and practice of disc, magnetic and film recording with special reference to equipment used by the B.B.C. A number of appendices contains much reference information not readily available elsewhere. The volume is illustrated by over 170 photographs and drawings. 30/- net from all booksellers. By post 30/7 from Iliffe & Sons Ltd., Dorset House, Stamford St., London, S.E.1.

"GUIDE to Broadcasting Stations." Compiled by "Wireless World." Gives details of over 1,400 short-wave radio stations of the world and 550 European long and medium wave stations. Specially arranged for easy reference. 6th Edition. 2/- net from all booksellers. 2/2 by post from Iliffe & Sons Ltd., Dorset House, Stamford St., London, S.E.1.

"SHORT-WAVE Radio and the Ionosphere." By T. W. Benington. A new edition of "Radio Waves and the Ionosphere" (first published six years ago), this book shows how existing ionospheric data can be applied to everyday problems of short-wave transmission and reception. 2nd Edition. 10/6 net from all booksellers. 10/10 by post from Iliffe & Sons Ltd., Dorset House, Stamford St., London, S.E.1.

"TELEVISION Receiving Equipment." By W. T. Cocking, M.I.E.E. An exhaustive description of each stage of the normal television receiver. Other chapters deal with special circuits, faults and their remedies, selectivity, servicing, etc. 3rd Edition. 18/- net from all booksellers. By post 18/8 from Iliffe & Sons Ltd., Dorset House, Stamford St., London, S.E.1.

DIRECT FROM THE MANUFACTURER

Dulci Radio/Radiogram Chassis

A/C 100-120 & 200-250 VOLTS.

All chassis 11 1/2 in. x 7 in. x 8 1/2 in. high. Latest type valves 6BE6, 6BA6, 6AT6, 6BW6, 6X4. Flywheel tuning. Negative feedback over entire audio section. Engraved knobs.

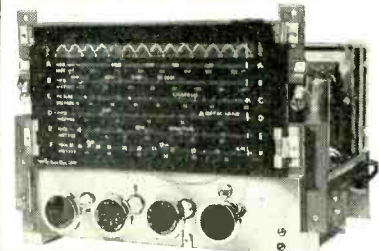

Fully Guaranteed.

Model B3. Three Wavebands, Long, Medium, Short. Gram. switching on W/Change switch. 3 Position Tone.

Price, Tax Paid **£12'12'0**

Model B3. Plus Push Pull Stage; as B3 with extra valve 6BW6. Output 6 watt max. Consumption 55 watt.

Price Tax Paid **£15'15'0**

Model B6. Six Wavebands 11-115 metres continuous in 5 ranges (4 BANDSPREAD) and MW.185-550 m. Six position Tone Switch (3 radio—3 gram.).

Price Tax Paid **£15'15'0**

Escutcheon for 9 in. x 5 in. dial, 4/9 extra. Matching speakers P.M. type 3 ohms. 8 in. or 10 in. available. Chassis sent under money back guarantee conditions against remittance. Free particulars from—

THE DULCI CO. LTD.,
97 VILLIERS Rd., LONDON, N.W.2
Telephone: Willesden 7778



TRANSFORMERS

of all types up to 25 KVA for Single or Three Phase operation, Phase Conversion, etc.

MAINS

Output and Special Purpose Transformers for Radio Equipment, Chokes, etc.

COILS

for Contractors E.M. Brakes, Air Valves, etc., and Coil WINDINGS for all purposes.

SOLENOIDS

for A.C. and D.C. Operation

A.I.D. Approved.

W.F. PARSONAGE & CO LTD
INDUCTA WORKS
MARK RD. BLOXWICH, WALSALL
TELEPHONE: BEOX 66464

PROOFS OF KINGSTON RE-OPENING

SATURDAY 4TH JULY 1953

HUGE ASSORTED STOCK OF RADIO, ELECTRICAL AND MECHANICAL COMPONENTS AT OUR USUAL BARGAIN PRICES.

PROOFS BROS. LTD

39, CAMBRIDGE ROAD, KINGSTON-ON-THAMES

TEL: KIN 4614

THE BRITISH NATIONAL RADIO SCHOOL

ESTD. 1940

NOW IN OUR THIRTEENTH YEAR AND STILL NO B.N.R.S. STUDENT HAS EVER FAILED

to pass his examination(s) after completing our appropriate

HIGH GAIN DISTORTIONLESS STUDY COURSE!

A.M.Brit.I.R.E. and CITY and GUILDS Radio and Telecommunications Exams, etc., etc.

Please mention this advert. and send for free booklet to:—

STUDIES DIRECTOR
BRITISH NATIONAL RADIO SCHOOL
66, ADDISCOMBE ROAD, CROYDON
Phone: Addiscombe 3341

YOUR ENQUIRIES

are invited for all types of reconditioned COIL WINDERS, WAVE WINDERS & MULTI WINDERS

by **DOUGLAS, LEE, and WESTMINSTER, etc.**

These machines are reconditioned as new.

Enquiries to :

THE COIL WINDING MACHINERY & ACCESSORY CO.
MOBILE HOUSE, CLIFTON ROAD, MAIDA VALE, LONDON, W.2.

We have a large stock of

HIGH STABILITY RESISTORS

Trade enquiries invited: Marris & Cartin Ltd., 42 Brook Street, London, W.1. GRO. 5571.

RADIO & TELEVISION COMPONENTS

WE OPERATE A PROMPT & EFFICIENT MAIL ORDER SERVICE.

"VIEWMASTER" & "TELE-KING" specialists

Easy terms available.

JAMES H. MARTIN & CO.,
FINSTHWAITE, NEWBY BRIDGE, ULVERSTON, LANCs.

ALUMINIUM ALLOY SHEETS

Ex Government Surplus
SUITABLE FOR CHASSIS, Etc.
(Undrilled)

Limited Quantity Available.

- Type No. 1. 14½ in. x 12½ in. x 20G. . . . 2s. 6d. each.
- Type No. 2. 17½ in. x 12½ in. x 20G. . . . 3s. 0d. each.
- Type No. 3. 26 in. x 23 in. x 20G. Round Corners 5s. 0d. each.
- Type No. 4. 22½ in. x 18½ in. x 18G. . . . 5s. 0d. each.

SIZES STATED FOR TYPES Nos. 1 and 2 are the maximum rectangular pieces that can be cut from irregular shapes.

CARRIAGE PAID.
REDUCTION FOR QUANTITIES.
TRADE ENQUIRIES WELCOMED.

JOHN CASHMORE LIMITED,
Steel Department,
GREAT BRIDGE,
TIPTON, STAFFS.
Tipton 2181/5.

COAXIAL RELAYS

BRITISH PATENT No. 667316

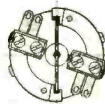

NEW HIGH SPEED SENSITIVE A.C. & D.C.

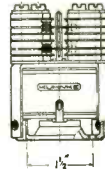

MULTIPURPOSE. SOLENOID MAGNET. CONTACTS 250 VA. UP TO 6 PDT.

We wish to contact British Firm for manufacture under licence for Great Britain, France and U.S.A.

H. KUHNKE, G.M.B.H.
MALENTE/GERMANY



MAYOR TV MIRROR

SPECIALLY DESIGNED as an aid to the TV engineer in the installation and servicing of television receivers, this apparatus (comprising a mirror and stand equipment) is being marketed to enable the engineer to view the picture whilst adjusting the rear controls.

The device stands 2ft. high and can be extended to 3ft. 4ins. whilst the mirror is adjustable to any angle. Erection or dismantling is effected quickly and easily and the apparatus when packed measures only 18ins. Price 45/- each. Carr. Paid.

G. MAYOR, 221 Liverpool Road, London, N.1. Tel: North 1402.

ET4336 TRANSMITTERS REQUIRED

£100 and upwards paid for models in good condition.

ALTHAM RADIO CO.,
JERSEY ST., MANCHESTER 4
Tel. No. Central 7834

YOU CAN TELEPHONE REVERSE CHARGE

14 Day (& Electric) Automatic Switches

Reconditioned. Guaranteed one year, for controlling Window & Poultry lighting, heating, etc.

From 50/- EACH

Write for illustrated lists:

DONOHUE'S (Timers) 6 GEORGE ST., NORTH SHIELDS, NORTHUMBERLAND

The John Aldred Reproduction Co.,
36, Marylebone High St., London, W.1
Welbeck 4058

"The logical outcome of wide professional experience in true quality reproduction will shortly be announced."

HIGH FIDELITY FREQUENCY MODULATION

Enjoy the crystal clarity of FM transmissions up to 50 miles from the Wrotham Kent transmitter. Together with the absence of background noise and great power contrast FM offers the ultimate in contemporary speaker music. We make the latest design in receivers and by utilising clever techniques and new components, a high sensitivity with remarkable fidelity is produced. The design is by Messrs. Amos & Johnstone, as published in the "Wireless World."

Audio Output—2 pin socket—2/10V.
Input—coaxial socket—from 5ft. horiz. dipole.
Power Requirements—6.3V. and 220V. 28MA.

Price £11/1/6

Trade enquiries invited.

Demonstrations: 3-4.30 p.m. daily, except Fridays.

BEL SOUND PRODUCTS CO.,
Marlborough Yard, Archway, London, N.19

A.R.O. 5078 Nr. Archway (Northern Line) Underground.

TELECRAFT AERIALS ENSURE THE BEST TELEVISION TRY ONE AND SEE FOR YOURSELF

BRASS, COPPER, DURAL, ALUMINIUM, BRONZE

ROD, BAR, SHEET, TUBE, STRIP, WIRE
3,000 STANDARD STOCK SIZES

No Quantity too Small List on application
H. ROLLET & Co., Ltd.

6 Chesham Place, S.W.1. SLOane 3463
ALSO AT
LIVERPOOL · BIRMINGHAM · MANCHESTER

MAGNETIC TAPE RECORDERS and COMPONENTS

from

WILL DAY, LIMITED

19 Lisle Street, London, W.C.2.
GERrard 7105 and 4476
SEND 1½d. STAMP FOR LIST—SENT BY RETURN

LOW VOLTAGE LIGHTING EQUIPMENT

"SAFETY"

Danger of Electric shock eliminated in Garages, Works, Inspection Pits, etc. Maximum Safety at Minimum Outlay.

EASCO ELECTRICAL LTD.

X.15—2 Circuits
X.16—4 Circuits
Brighton Terrace,
London, S.W.9.
Tel: Brixton 4961-2-3

BRADMATIC

HIGH CLASS TAPE RECORDING EQUIPMENT
HEADS, DESKS, TAPE, ETC.
Send for lists

BRADMATIC LTD.
STATION ROAD, ASTON, BIRMINGHAM, 6
Telephone: East 0574

CABINETS



T/V Cabinet as illustrated, £15/-+. Catalogue of T/V, Table, Radiogram and Speaker Cabinets available on request. Individual cabinets made to specification. BASS REFLEX corner Cabinet for Goodmans Axiom 150 Mk. II, £26. Corner Baffle for 8in. or 10in. unit, £7/15/-.

COMPONENTS

Comprehensive catalogue available.

TAPE RECORDER

We proudly present our latest product—a versatile portable Tape Recorder capable of being used as a high quality amplifier or radio receiver. Full details on request. List price 53 gns. Trade enquiries invited.

LEWIS RADIO CO.

(Dept. 753)
120, Green Lanes, Palmers Green,
London, N.13. (Near Bowes Road)
Phone : BOWes Park 6064.

FIRE!
PRODUCTION LOST BUT FOR
NU-SWIFT!

A spark...a flash...fire blazing...dial 999! But for at least five minutes that blaze will be YOURS alone! Reliable Nu-Swift is the world's fastest and most certain fire-killer. NU-SWIFT LTD · ELLAND · YORKS
In Every Ship of the Royal Navy

THE NEWEST TREPPANNING
PARALEX adjustable FLY CUTTER

- PLM Morse Taper No. 2 cap. 1½-6½in. 27/- ea.
- PLX ½in. parallel shank cap. 1½-6½in. 21/- ea.
- PL 7/16in. or 3/8in. parallel shank cap. 1-4in. 16/- ea.

British Made

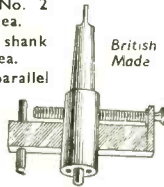

With 18% Tungsten Highspeed Toolbit.

Send for illustrated folder to the Manufacturers:

LUDFRY LTD.
189, Wardour Street, London, W.1
Tel. : GERrard 2291.

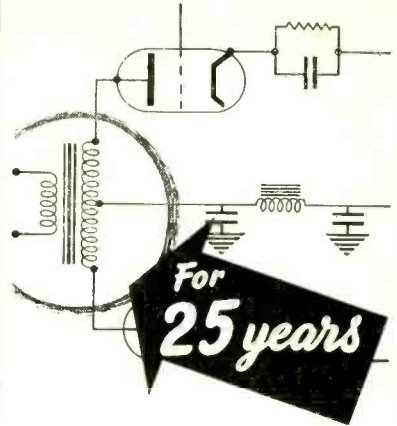

Enthusiastic amateur and experienced research workers send these testimonials of Savage accuracy and reliability.

"A transformer and 2 chokes of your make purchased about 1932 are still doing yeoman service. T. F. MacD., London."



SAVAGE TRANSFORMERS LTD
Nursted Road, Devizes, Wilts
Telephone : Devizes 536

CLASSIFIED ADVERTISEMENTS

Use this Form for your Sales and Wants

To "Wireless World" Classified Advertisement Dept., Dorset House, Stamford St., London, S.E.1

PLEASE INSERT THE ADVERTISEMENT INDICATED ON FORM BELOW

- **RATE:** 7/- for TWO LINES. 3/6 every Additional Line. Average six words per line.
- **Name and address to be included in charge if used in advertisement.**
- **Box No.** Allow two words, plus 1/-
- **Cheques, etc.,** payable to Iliff & Sons Ltd., and crossed & Co.
- **PRESS DAY—**July 2 for August issue.

NAME

ADDRESS

REMITTANCE VALUE..... ENCLOSED

Please write in block letters with ball pen or pencil.

NUMBER OF INSERTIONS.....

MORSE CODE Training



COURSES for BEGINNERS and OPERATORS, also a **SPECIAL COURSE** for passing the **G.P.O. Morse Test** for securing an **AMATEUR'S TRANSMITTING LICENCE**.

Send for the **Candler BOOK OF FACTS** It gives details of all Courses. Fees are reasonable. Terms: Cash or Monthly Payments.

THE CANDLER SYSTEM CO.
(55W) 52b ABINGDON RD., KENSINGTON
LONDON, W.8

Candler System Co., Denver, Colorado, U.S.A.

★

'Radiospares'

Quality Parts

The
Service Engineer's
First Choice

★

INSTRUMENT CASES

Size. 8" x 7³/₈" x 4³/₄"

Aluminium 25/-

Steel 20/-

Post & packing 1/6d extra

Available in sizes

to 12" x 12" x 4³/₄"

Various finishes

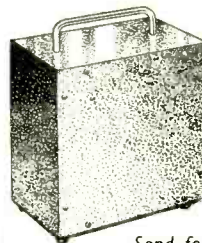

Send for List

SUTTON GOLDFIELD ELECTRICAL ENGINEERS

6 High Street WALSALL, phone: 4962

INDEX TO ADVERTISERS

	PAGE		PAGE
A.A. Tools	115	English Electric Co. Ltd., The	5
A.B. Metal Products, Ltd.	76	Entoven Solders, Ltd.	20
Acoustical Mfg. Co. Ltd.	13	Eta Tool Co. (Leicester), Ltd.	102
Adcola Products, Ltd.	63	Fluxite, Ltd.	52
A.D.S. Relays, Ltd.	44	Foyle, W. & G. Ltd.	60
Advance Components, Ltd.	15	Frith Radiocraft, Ltd.	113
Aerialite, Ltd.	62	Galpins	30
Aircraft Radio Industries, Inc.	47	Garland Bros.	115
Airmec, Ltd.	118	General Engineering & Mfg. Co. Ltd. The	116
Aldred, John, Reproduction Co., The	103	Geel Bros. Radio, Ltd.	16b, 43
Allen Components, Ltd.	105	General Electric Co. Ltd.	110
Alpha Radio Supply Co., The	46, 54	G.L. Electronics	16, 29, 62
Altham Radio Co.	52	Glaser, L. & Co.	42
Amplex Appliances (Kent), Ltd.	112, 52	Goodmans Industries, Ltd.	42
Amplivox, Ltd.	112, 52	Goodsell, Ltd.	12
Antiference, Ltd.	105	Gray, Arthur, Ltd.	40
Appointments Vacant	36	Grundig (Gt. Britain), Ltd.	51
Arcoelectric Switches, Ltd.	163	Hallam, Sleight & Cheston, Ltd.	62
Armstrong Wireless & Television Co., Ltd.	1	Hall Electric, Ltd.	102
Ashworth, H.	18	Hanney, L. F.	104
Automatic Coil Winder & Electrical Equip. Co., Ltd. The	114	Harris, H.	116
Automatic Telephone & Electric Co., Ltd.	24	Hatfield Instruments, Ltd.	54
Autoset (Production), Ltd.	100	Haves Co., The	116
A.W.F. Radio Products	73	Haynes Radio, Ltd.	104
Baird Television, Ltd.	106	Henleys, W. T. Telegraph Works Co., Ltd.	16c, 97
Barker Natural Reproducers	68	Henry's	16c, 97
Belling & Lee, Ltd.	48	Hivac, Ltd.	116
Bel Sound Products Co.	118	Hole, Arthur	112
Benson, W. A.	31	Holley's Radio Stores	52
Berry's (Short Wave), Ltd.	68	HomeLab Instruments	110
Birmingham Sound Reproducers, Ltd.	48	Howorth, P.	94
B.K. Partners, Ltd.	118	H.P. Radio Services, Ltd.	114
Bradmatic, Ltd.	61	Hulton, Ltd.	24
Britain, Chas. (Radio), Ltd.	102, 111	Hyndburn Electronics, Ltd.	118
British Communications Corp., Ltd.	32, 65	Imhof Alfred, Ltd.	88
British Institute of Engineering Technology	117	International Correspondence School, Ltd.	104
British National Radio School	65	Jackson Radio Supplies	116
British Physical Laboratories	116	Kenroy, Ltd.	30
British Sarazol, Ltd.	24	Kolectric, Ltd.	58
Brookes Crystals, Ltd.	66	Koskie, B.	118
Brown, S. G.	341	Kuhuke, H. G.M.E.H.	118
Bulgain, A. F. & Co., Ltd. Edit.	28	Labgear (Cambridge), Ltd.	88, 89
Bull, J., & Sons	120	Lasky's Radio	51
Bullers, Ltd.	110	Leak, H. J. & Co., Ltd.	119
Candler System Co.	117	Leevers-Rich Equipment, Ltd.	116
Cashmore, John, Ltd.	117	Lewin, A. Ltd.	106
Chaffey Cabinet Co., The	87	Lewis Radio Co.	36
Champion Products	25	Lockwood & Co.	107
Chapman C. T. (Reproducers), Ltd.	82	London Central Radio Stores	119
Chassey Bros (Pvt.), Ltd.	59	Lowther Mfg. Co.	107
Cinema Television, Ltd.	92	L.R. Supply Company, Ltd.	98
City & Rural Radio	93	Ludgry, Ltd.	88
City Sales & Exchange, Ltd.	118	Lyons Radio, Ltd.	37
Classic Electrical Co., Ltd.	100	Magnetic Coatings, Ltd.	19
Clydesdale Supply Co., Ltd.	72	Mail Order Supply Co.	16a, 74, 79
Cohen, D.	109	Marconi Instruments, Ltd.	118
Coil-Winding Machinery & Accessory Co.	112	Marconi's Wireless Telegraph Co., Ltd.	118
Colonial Service—Sarawak	62	Marks, C. & Co.	118
Cosmocoord, Ltd.	24	Marris & Cartin, Ltd.	118
Coventry Radio	118	Martin, J. H.	118
Coventry Technical College	64	Mayor, G.	64
Davis, Alex. Supplies, Ltd.	118	McElroy-Adams Mfg. Group, Ltd.	42
Davis, Jack (Relays), Ltd.	118	McMurdo Instrument Co., Ltd. The	28
Day, Will, Ltd.	30	Metropolitan-Vickers Electrical Co., Ltd.	61
Direct T.V. Replacements	32c	Miers, N. & Co., Ltd.	60
Donohoe's (Electrical Co., Ltd. Cover II)	113	Minnesota Mining & Mfg. Co., Ltd.	110
Drayton Regulator & Instrument Co., Ltd.	117	Modern Book Co.	52
Dublier Condenser Co. (1925), Ltd.	118	Modern Electronics, Ltd.	52
Duke & Co.	118	Modern Techniques	114
Dulci Co., Ltd., The	118	Morley Transformers	54
Dun (Electronics) & Co.	67	M.R. Supplies, Ltd.	8
Easco Electrical, Ltd.	68	M.S.S. Recording Co., Ltd.	3, 41, 55, 70
Edison Swan (Electrical Co., Ltd. Cover II)	67	Mullard, Ltd.	Cover IV
Egen Electric, Ltd.	116	Multicore Solders, Ltd.	106
Electradix Radios	116	Neo Electrical Industries, Ltd.	11
Electrical Instrument Repair Service, The	42	Newman, J. & S., Ltd.	112
Electro Acoustic Developments	60	Northall, L. C.	104
Electro Acoustic Industries, Ltd.	22	Northern Radio Services	35
Electro Technical Assemblies	84, 85	Northern Transformer Co.	119
Electro-Winds, Ltd.	100	N.S.F. Ltd.	108
Electronic Instruments, Ltd.	32d	Nusound Products	102
Electronic Precision Equipment	10, 48, 64, 75	Nu-Switz, Ltd.	53
E.M.G. Handmade Gramophones, Ltd.	107	Oddie Bradbury & Cull, Ltd.	119
E.M.I. Institutes	10, 48, 64, 75	Oryx Electrical Laboratories	112
Engineering Associates	107	Osmor Radio Products, Ltd.	53
		Painton & Co., Ltd.	17
		Panda Radio Co.	34
		Parker, A. B.	50
		Paimeko, Ltd.	81
		Parsonage, W. F. & Co., Ltd.	117
		Partridge Transformers, Ltd.	101
		P.C.A. Radio	86
		Pearce, T. W.	115
		Phillips Control (G.B.), Ltd.	34
		Pitman, Sir Isaac, & Sons, Ltd.	113
		Post Radio Supplies	106
		Pratts Radio	62
		Premier Radio Co.	56, 57
		Pye, Ltd.	4
		Proof Bros., Ltd.	117
		Pye, W. G. & Co., Ltd.	26
		Quality Mart	103
		Quartz Crystal Co., Ltd.	114
		Radio & Electrical Mart, The	96
		Radio Exchange Co.	96
		Radio Mail	104
		Radiospares, Ltd.	120
		Radio Supply Co.	95
		R.C. Services (Radio)	66
		Record Electrical Co., Ltd. The	32b
		Redifon, Ltd.	111
		Reliance Mfg. Co. (Southwark), Ltd.	21
		Reproducers & Amplifiers, Ltd.	57
		Robinson, F. C. & Partners, Ltd.	14
		Robshaw Brothers, Ltd.	28
		Roding Laboratories	10
		Rogers Developments Co.	118
		Rola Celestion, Ltd.	33
		Rollet, H. & Co., Ltd.	111
		Salford Electrical Instruments, Ltd.	82
		Salis, A. T.	119
		Samsons Surplus Stores	98
		Sanzano Weston, Ltd.	109
		Savage Transformers, Ltd.	16
		Scharf, Edwin	88
		Service Radio Spares	109
		Sherman's Supply Co.	116
		Smith, G. W. (Radio), Ltd.	82
		Smith, H. L. & Co., Ltd.	119
		Solartron Laboratory Instruments, Ltd.	16
		Sound Sales, Ltd.	108
		Southern Radio Supply, Ltd.	82
		Spencer-West	108
		Standard Telephones & Cables, Ltd.	58
			23, 32a, 71, 80
		Stern Radio, Ltd.	46, 90, 91
		Suden, A. R. & Co. (Engineers), Ltd.	50
		Supacolis	109
		Sutton Goldfield Electrical Engineers	120
		Szymanski, S.	44
		Tannoy Products, Ltd.	106
		Taylor Electrical Instruments, Ltd.	66
		Taylor Tunnichiff & Co., Ltd.	27
		Telecraft, Ltd.	20, 118
		Telegraph Condenser Co., Ltd.	Cover III
		Telekit Supply Co.	114
		Telemechanics, Ltd.	58
		Tele-Radio (1943), Ltd.	58
		Thomas, Richard & Baldwins, Ltd.	48b
		Transformer Supply Co., The	38
		Torr, W. Ltd.	24, 37
		Trix Electrical Co., Ltd. Edit.	339
		Trusound, Ltd.	49
		Truvox, Ltd.	2
		Universal Electrical Instruments Corp.	86
		Universal Electronics	92
		Universal Engineering Co.	50, 94
		University Radio, Ltd.	36
		Valradio, Ltd.	22
		Vanner Accumulators, Ltd.	32
		V.E.S. Wholesale Services, Ltd.	64
		Voice Patents, Ltd.	114
		Vortexion, Ltd.	77
		Waine Kerr Laboratories, Ltd. The	34
		Westinghouse Brake & Signal Co., Ltd.	38, 48a
		Weymouth Radio Mfg. Co., Ltd. The	41
		Wharfedale Wireless Works	26
		Willesden Transformer Co., Ltd.	48
		Wilson, L.	34
		Winter Trading Co., Ltd.	110
		Wireless Supplies Unlimited	115
		Wooden Transformer Co., Ltd.	20
		Woolwich Polytechnic	112
		Wright & Weaire, Ltd.	7
		Young, C. H.	92

Printed in Great Britain for the Publishers, LIFFE & SONS LTD., Dorset House, Stamford St., London, S.E.1, by CORNWALL PRESS LTD., Paris Garden, London, S.E.1. *Wireless World* can be obtained abroad from the following: AUSTRALIA AND NEW ZEALAND: Gordon & Gotch, Ltd. INDIA: A. H. Wheeler & Co. CANADA: The Wm. Dawson Subscription Service Ltd.; Gordon & Gotch, Ltd. SOUTH AFRICA: Central News Agency, Ltd., William Dawson & Sons (S.A.), Ltd. UNITED STATES: The International News Co.

T.C.C.

First again

**FOCUS ON
LEADERSHIP**

... where voltages are highest

In order to provide adequately smoothed E.H.T. supplies for the largest Cathode Ray tubes, we have designed a High Voltage Paper Smoothing Condenser of unique construction and using "Visconol—X".

This impregnant developed by T.C.C. has exceptional properties in that it checks to a marked degree the fall in insulation resistance arising out of increases in temperature.

A total absence of metal parts at the hot end is achieved by the combination of a P.V.C. insulated flexible lead and the T.C.C. patented bung method of sealing; in this way corona losses and external brushing are virtually non-existent.

Capacity:— 500 pF

Rating:— 25kV D.C. Working at 60°C

- **Unique internal construction**
- **Visconol - X impregnation**
- **One hole fixing**
- **No metal parts at 'hot' end**

Sealing Bung
Construction
T.C.C. Patent No.
633387

SPECIALISTS
IN
CONDENSERS
SINCE 1906



THE TELEGRAPH CONDENSER CO. LTD

RADIO DIVISION

NORTH ACTON • LONDON • W.3 • Telephone: ACORN 0061



The Finest Cored Solder in the World

PROVED IN USE FOR OVER 14 YEARS
BY LEADING MANUFACTURERS OF

**ELECTRONIC
EQUIPMENT**

ON SUCH COMPLEX EQUIPMENT AS THE
FERRANTI DIGITAL COMPUTER

with its 4,000 valves, 2,500 condensers,
15,000 resistances, 100,000 soldered joints.

Special Multicore products for specific uses

ERSIN MULTICORE SOLDER



Contains 3 cores of Ersin Flux, a high-grade non-corrosive rosin with an increased fluxing action incorporating Pentacol. Tests over 14 years have proved that soldered joints made with Ersin Multicore Solder do not corrode even after prolonged exposure to any degree of humidity. Ersin Flux makes precision

soldering quicker and more economical since thin solder walls give instant liquefaction, and there is no need for extra flux. Ersin not only prevents oxidation during soldering but actually cleans surface oxides.

6 alloys and 9 gauges (unless otherwise specified) supplied in nominal 7 lb. reels.

Approved by A.I.D., G.P.O., A.R.B., D.T.D. 599, R.M.S. 1,000 and all U.S.A. Federal specifications.

Widely used by U.S.A. manufacturers where it is specially imported from England.

SIZE 1 CARTONS 5/- (Subject)

Available in 4 specifications for Radio and electrical use as shown below.



Cat. Ref. No.	Alloy Tin/Lead	S.W.G.	Approx. length per carton
C 16014	60/40	14	21 feet
C 16018	60/40	18	55 feet
C 14013	40/60	13	19 feet
C 14016	40/60	16	38 feet

Tape Solder

Tape solder, containing Ersin or Arax flux, can be supplied on 1 lb. and 7 lb. reels in standard alloys. Widths range from $\frac{1}{8}$ " to $\frac{3}{8}$ ", and from .005" thick, accurate to $\pm .001$ ". Where required, tape can also be supplied without flux content.

SOLDER RINGS



Made from Arax or Ersin Multicore Solder or solid wire, these rings are much more economical to buy than stamped washers. Among stock specifications are: Internal Diameter, $\frac{1}{4}$ ", $\frac{5}{16}$ ", $\frac{3}{8}$ ", $\frac{1}{2}$ ". Other sizes to special order.

LIQUID FLUXES



For dipping purposes or other processes where it is not convenient to use Ersin and Arax Multicore Solder, the Ersin and Arax Fluxes are now available as liquids.

Ersin Liquid Flux is an extra-active, non-corrosive flux A.I.D. approved and has been widely used by Electronic Manufacturers in the U.S.A.

HIGH & LOW MELTING POINTS

Other special types of Ersin Multicore Solder include

- Type T.L.C. Melting Point 145° C.
- Type P.T. Melting Point 232° C.
- *COMSOL Melting Point 296° C.

*By arrangement with Johnson Matthey & Co., Ltd., of Hatton Garden

Ersin Multicore Solder is now available in Silver/Tin/Lead Comsol Alloy.

It has a melting point of 296° C. (113° C. above the solidus melting point of the usual tin/lead alloys).

ULTRA FINE GAUGES

Ersin Multicore Solder has for many years been supplied on 1 lb. reels to manufacturers in as fine gauge as 22 s.w.g. It can now be supplied to special order on $\frac{1}{2}$ lb. reels in even gauges between 24 and 34 s.w.g. Lengths per lb. for 60/40 alloy :-

		
16 s.w.g. 98 ft.	22 s.w.g. 512 ft.	34 s.w.g. 5,040 ft.

Yes, the 34 s.w.g. does contain 3 cores of flux !

Manufacturers are invited to write for samples of any of the new lines or to consult our Technical Service Department on any problem in connection with soldering.

MULTICORE SOLDERS LTD.

MULTICORE WORKS, HEMEL HEMPSTEAD, HERTS • BOXMOOR 3636