



NOVEMBER 1952

VOL. LVIII. No. 11

## Revolution in Broadcasting

**I**N at least one respect the recently issued B.B.C. Report\* is a disappointing document. As the period with which it deals ended in March, 1952, there is no comment on the terms of the new Charter, the official views on which should make interesting reading. The opening part of the Report will arouse some sympathy with the Corporation, which of late has suffered from having too many masters. Prolonged uncertainty as to its fate must have brought about an unenviable feeling of frustration, but, in spite of all these troubles, there is solid progress to go on record, particularly in the television service.

Naturally enough, most of the Report deals with programme and administrative matters which are not our main concern. To us the most interesting part is that dealing with the future of the sound service. Great emphasis is laid on the fact that, so far as British broadcasting is concerned, long and medium waves have had their day. The position on these wavelengths has long been unsatisfactory, and is deteriorating; the only hope of improvement lies in the use of metre waves to augment, and ultimately to replace the present system. The Report goes so far as to admit that, during the winter, the B.B.C. was forced, in an attempt to reduce the jamming trouble, to make "technical adjustments" (presumably over-modulation) to all high-power stations. Some improvement in signal strength was produced, but at the expense of "slight distortion during loud passages."

### Problems of Waveband Changing

The suggested change of the present wavebands to metre-waves is, of course, a revolutionary one which poses all kinds of problems—technical, economic and political. The general idea of such a change was envisaged in the new E.B.C. Charter, which, indeed, specifically laid down that frequencies higher than 30 Mc/s were to be used for any stations needed to provide improved coverage of the country. But no detailed scheme for providing a national service has yet been made public, though the B.B.C. laid before the Government early last year a plan for a

chain of v.h.f. frequency-modulated stations to cover almost the whole of the United Kingdom.

Before any change can be made, plans must be approved by the Postmaster-General, who in his turn must be advised by the Television Advisory Committee, which, as we reported recently, was to be reconstituted and strengthened to take under its wing the problems of v.h.f. sound broadcasting as well as television. Unfortunately, from the point of view of those who want to see something happen quickly in these spheres, the Television Advisory Committee seems likely to stand in need of reanimation as well as reconstitution; at the time of writing the Committee has held no meetings for over a year. When it does resume activities, the agenda looks like being a full one. According to the plan laid down by the Government, the T.A.C. must, after preparing a report on the recommended characteristics of v.h.f. sound broadcasting, turn to the even more controversial issue of sponsored broadcasting, and the conditions under which it should be licensed.

### Broadcasting of the Future

Except for the fact that under present circumstances the T.A.C. is likely to be overloaded with work, *Wireless World* sees nothing wrong in the idea of a single advisory body dealing with both sound and vision. Though it would be indeed rash to speculate on the future of broadcasting, it seems likely that the two services may well be so closely merged that there will be no clear dividing line between them. But, if v.h.f. is to become the main, or perhaps the only, vehicle for sound, the anomalously named T.A.C. will assume an importance much beyond its present standing and will become the body to advise the Government on all broadcasting problems. In a sense, it will become another of the B.B.C.'s masters, of which, as we have said, there are already too many. The new director-general of the Corporation, Sir Ian Jacob, will need all his skill and firmness of purpose in directing the Corporation through the troubles that lie ahead. Revolutionary changes have been proposed in both sound and vision, and at no period of the B.B.C.'s existence has there been greater need for a firm directing hand.

\* Annual Report and Accounts of the British Broadcasting Corporation for the Year 1951-52. Cmd. 8660, H.M.S.O. 4s 6d.

# Metal Cone Loudspeaker

*Principles Underlying the Design of  
the G.E.C. High-quality Reproducer*

By F. H. BRITAIN\*

WHEN loudspeakers were first introduced, their prime duty was to make a loud sound; something more than the whisper which was all that the telephone could produce. At that time, poor magnetic materials restricted the sensitivity of the loudspeaker, whilst the small output power of the amplifiers then in use made the reproduction of loud sounds rather difficult to achieve. The result was that sensitivity was sought at almost any price. That price was nearly always the uniformity of the frequency response of the loudspeaker, which was so woefully inadequate that other types of distortion were scarcely noticed.

**Frequency Response.**—Under these conditions, it is not surprising to find that much attention was paid to the frequency response curve, which, at that time, gave a fair indication of the performance of the loudspeaker. In order to study the frequency response of the loudspeaker, it was necessary to measure it under conditions which did not modify its behaviour, that is, in the equivalent of free space. Incidentally, it is believed that the first echo-free room to be built for this purpose in this country was constructed at the Research Laboratories of The General Electric Company in 1930.

\* Research Laboratories of The General Electric Company.

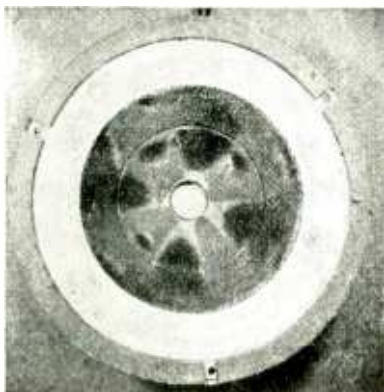

*Fig. 1. Cone break-up in radial modes at medium frequencies is little affected by the introduction of circular ribs.*



**Harmonic Content.**—As time went on, the frequency response of loudspeakers was greatly improved, and it was no longer the overriding consideration that it once had been. With this improvement in the frequency response, other forms of distortion, which had previously passed unnoticed, came into prominence. By the year 1934, it was realized that far more information was required for the appraisal of a loudspeaker than was provided by the frequency response curve alone. Accordingly, the measurement of the harmonic content of a loudspeaker output was undertaken.

The results showed that some of the loudspeakers which had the best frequency response had also the worst harmonic distortion. This was particularly true of the “curved” or “flared” cone which was introduced at about this time. Before the advent of the “curved” cone, there were two methods in general use for reducing the prominence of the main high-frequency peak in a moving-coil loudspeaker. In the most usual method, this resonant peak was reduced by the use of a soft paper cone with considerable internal damping. The softness and internal damping of the paper were very difficult to control and both the “blocking” operation in the manufacture of the cone and its final waterproofing caused considerable variation in its internal damping. This had the unfortunate result that the cones varied in softness during a production run, giving rise to a variation in the quality of the loudspeakers into which they were built.

The alternative method was to use a rather harder paper which often had a series of corrugations moulded into it, in order that it might “break up” at high frequencies and not vibrate in only one pronounced mode.

The curved cone, on the other hand, reduced the high-frequency peak by the fact that its stiffness to forces applied over the surface of the cone in an inward direction was different from its stiffness in an outward direction. This non-linear stiffness of the

curved cone gave rise to the production of harmonics and severe cross-modulation. These defects caused the reproduction of numbers of voices or instruments to sound "muddled" although good reproduction of a solo instrument or voice could be obtained.

**Cone Break-Up.**—The phenomena associated with cone break-up were investigated in these laboratories by the classical use of lycopodium powder. The investigation showed that a cone collapsed into radial modes at quite low frequencies, and that circumferential ribs did little to improve this lack of rigidity. Fig. 1 shows a cone after it had been dusted with lycopodium powder and then driven at a small amplitude. It will be seen that the break-up pattern passes right through a corrugation in the cone material. Fig. 2 shows a series of these break up patterns, and relates them to the response curve of the loudspeaker. It is interesting to note that they do not necessarily coincide with major peaks or hollows in the response curve. This is because the "phase" of the various sections is important. They could, for example, all cancel out and give almost no sound output. But while they may cancel out at the fundamental frequency, it does not follow that they will also cancel out at harmonic frequencies.

**A Rigid Cone.**—As a result of these tests, it was decided that an attempt should be made to construct a cone which was as rigid as possible for the sole purpose of studying its harmonic production. The material chosen for this cone was Duralumin, and a very considerable increase in rigidity compared with paper was obtained. As expected, the efficiency of the loudspeaker was very low due to the weight of the cone. Its frequency response was irregular in the "top," due to the very low internal damping of the

TABLE  
Amplitude of harmonics (db relative to fundamental of frequency 80 c/s)

Harmonic	2nd	3rd	4th	5th	6th	7th	8th	9th
Curved-sided paper cone . . .	14	-16	-22	-27	-36	-45	-53	-57
Duralumin cone . . . . .	-36	-25	-38	-39	-66	-54	-67	-69

cone material. However, the experiment was informative because the harmonics due to cone break-up were very considerably reduced and a marked change in the quality of reproduction was apparent. The Table, compiled from measurements taken in 1935 compares the harmonic production, at a frequency of 80 c/s, of a Duralumin cone and a curved paper cone.

**Driving-force Distortion.**—So far, only those harmonics which are caused by the flexing of the cone have been considered. There is, however, a second series of harmonics, whose fundamental frequencies are much lower. They are caused by the non-uniform nature of both the driving force applied to the cone by the voice coil and the restoring force which returns it to its position of rest. In order to study the distribution of magnetic flux in and near the air gap of the magnet, a special instrument was designed. This device permitted a small search coil to be introduced into the air gap of the magnet, step by step, a few thousandths of an inch at a time. Fig. 3 shows this instrument. Because it is necessary to maintain a

Fig. 2. Typical break-up patterns in a moving-coil cone loudspeaker and their associated points in the frequency response curve.

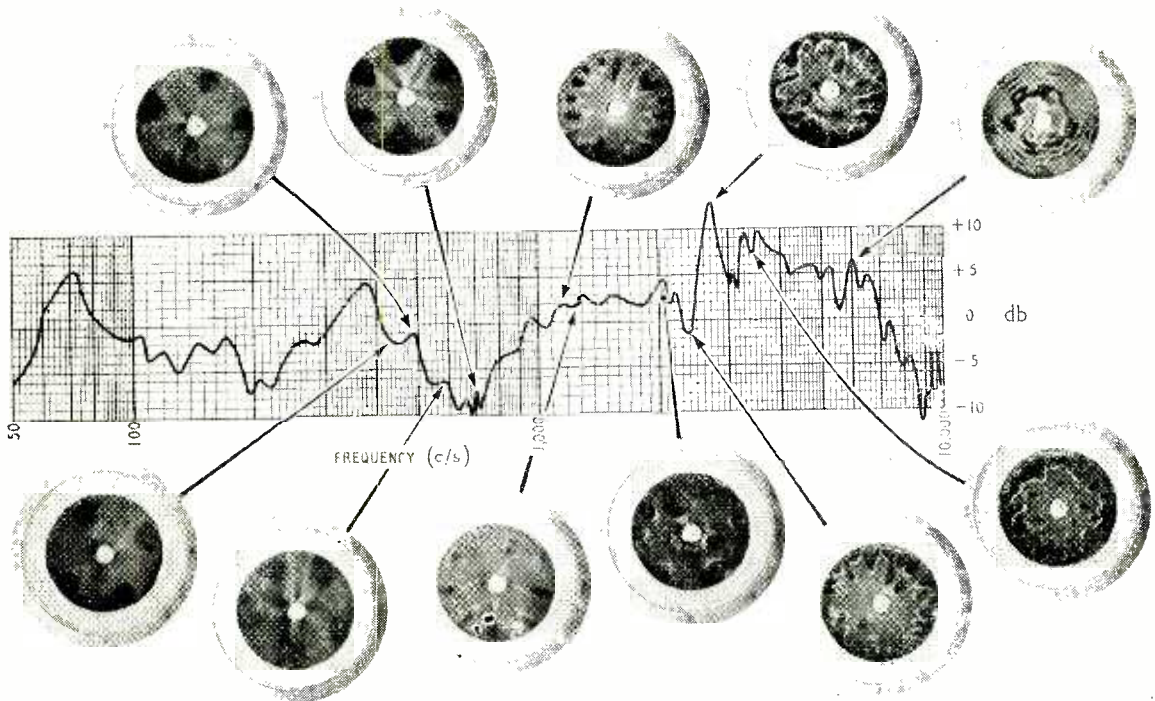

uniform driving force on the voice coil, even when it is displaced by large-amplitude, low-frequency sounds, either the voice coil or the air-gap must be relatively long so that one can always embrace the other. It is unfortunate that, even to-day, there are many loudspeakers in which the length of the air-gap and the voice coil are approximately equal. This arrangement results in maximum efficiency at the price of maximum driving force distortion. From a knowledge of the flux distribution, and the excursion of the voice coil, it is possible to evaluate the linearity of the driving force. The designer has then to select a compromise between linearity and efficiency. Fig. 4 shows a graph which relates the force on long and short coils, and their displacement along an air gap.

**Restoring-force Distortion.**—In order to obtain an undistorted output, it is necessary to make not only the driving force uniform; but also to ensure that the restoring force arising from the stiffness of the suspension is linear. The behaviour of the cone-restoring forces in a loudspeaker was studied by means of the laboratory stiffness meter shown in Fig. 5, which was designed in these laboratories expressly for this purpose. The stiffness of the centring device, and of the cone surround material, were first studied separately, and then in combination. The problem of the designer is to reconcile linearity of restoring force with a finite cone movement. It has been found that an abrupt termination of cone movement is undesirable, except in very carefully regulated laboratory experiments, with no possibility of overload. For normal use, approximately half the total travel should be linear, with an increase of stiffness at each end. Because of major cause of harmonic production at low frequencies is due to the large excursion of the cone and voice coil, this excursion should be kept to a minimum by providing the cone with adequate acoustic loading.

If, for any reason, it is impossible to provide such loading to limit the travel of the cone at low frequencies, it is desirable to take suitable precautions in the loudspeaker itself. In the case of domestic radio receivers, those loudspeakers which are to be used in "table" model cabinets often have a higher frequency

of main resonance than those which are to be used in large radio-gramophone cabinets. However, raising the frequency of the main bass resonance of the loudspeaker may easily bring it within the range of the fundamental frequency of the human voice. If this happens, the severe overhang transient distortion associated with the resonance will be

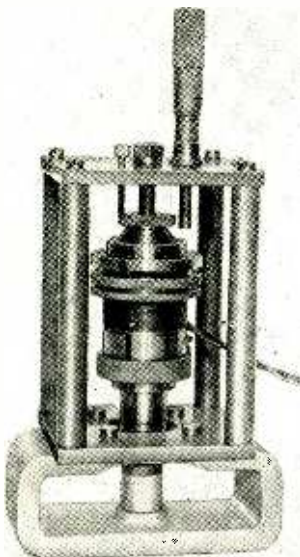

Fig. 3. Device for measuring the distribution of flux in the air gap of a magnet.

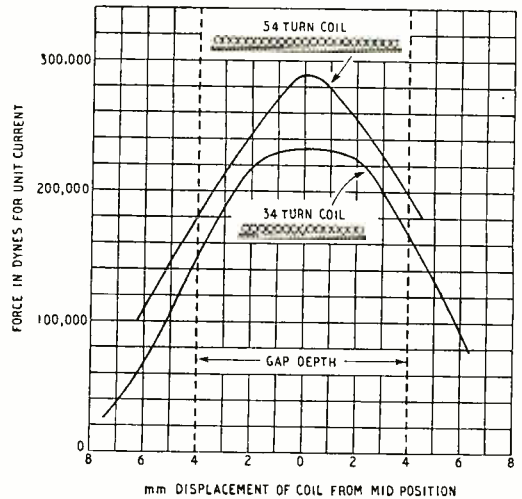

Fig. 4. Relation between force and coil displacement for voice coils of different lengths working in the same gap.

particularly noticeable, and speech will sound very "boomy."

In the case of a high-quality loudspeaker for use in a small cabinet, for speech reinforcement purposes only, the most satisfactory solution is obtained by the use of a surround material with a fairly high damping factor. By this means it is possible to keep both the electrical and the mechanical impedance of the loudspeaker largely resistive. This minimizes transient distortion, and reduces the production of harmonics, by inhibiting excessive cone movement.

### Design of a High-quality Loudspeaker

In the light of results which had accumulated over a number of years an attempt was made to design a high-quality loudspeaker. This involved many attempts to increase the rigidity of a paper cone, in order to reduce the generation of harmonics and cross modulation. All attempts came far short of the standard reached by the metal cone and it was decided to study its performance in greater detail. This investigation showed that the main defects were low efficiency and poor frequency response, and, as a result, poor transient response. It was considered that for certain applications at least, the low efficiency could be met by increasing the output power of the amplifier.

A consideration of frequency response of the metal cone loudspeaker showed that the worst trouble occurred in the upper frequency region, and took the form of a dip in the response curve followed by a peak of considerable size at a frequency of about 8,000 c/s, as shown in Fig. 6(a).

It was observed that although there was a dip in the response of the loudspeaker when measured from the front, there was no corresponding dip in the response from the rear of the loudspeaker. Investigation showed that the low output from the front was largely due to interference between different parts of the cone. A stationary "bung" was inserted in the cavity of the cone, whose function was simply one of obstructing certain paths which the sound might take across the cone at high frequencies. The "bung"

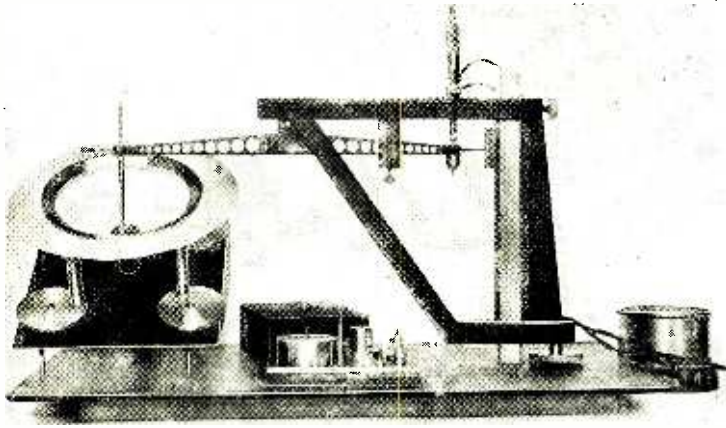

Fig. 5. Laboratory stiffness meter. The apparatus may be set up for measuring the stiffness of cone surround and centring device as well as for exploring flexibility of the cone material at different points on the surface.

may be solid or hollow, so long as it is rigid. Fig. 6(b) shows the response curve of a metal cone with a "bung."

The mechanism by which the cone produces the main high-frequency peak is briefly as follows. Consider a narrow radial strip of the cone, from the voice coil tube to the outer edge. Such a strip could be fixed at its ends, and driven in such a way that it resonated at some particular frequency. Its greatest amplitude would occur near, but not exactly midway between, the supports. There are two factors involved. First, the radial strip is not parallel sided, but is a segment of a circle. Second, the strip is curved, the radius of curvature being least at the centre and greatest at the periphery. This curvature has the effect of increasing the stiffness of the strip, the greatest stiffness occurring at the apex of the cone. The result is that maximum amplitude occurs at a position about one-third of the way from the periphery to the voice coil tube.

Now, if all the radial strips or segments are exactly similar, they will all resonate at the same frequency, and will all be "in phase" with each other. The result will be a very large resonance peak in the response curve, corresponding with a very large output at that particular frequency, unless there is considerable damping in the material of the cone. Alternatively, its rigidity can be made so poor that it breaks up into a number of different modes, thereby upsetting the symmetry of the radial strips. Duralumin has very low internal damping, compared with paper, and a very weak cone is incompatible with the rigidity which is necessary to reduce the generation of harmonics and cross modulation.

The simple solution to the problem consists in making the natural frequency of some of the radial strips different from that of other radial strips. It is necessary to achieve this alteration in resonant frequency without reducing the stiffness of the cone, particularly to deformation of its circularity. The introduction of radial ribs into a metal cone might seem to be a solution, but the consequent lack of

rigidity of the cone as a whole completely inhibits the production of the highest frequencies. It was found that the high-frequency resonance peak could be controlled, at least to some extent, by annular rings pressed into the diaphragm. But such a cone gave noticeably more "muddle" than one without annular rings, the individual rings interfering with each other.

The method finally adopted for making the resonant frequency of one radial strip of the cone different from that of another, was to make a series of circumferential incisions in the cone. That portion of the cone immediately within the incision, that is, nearer to the voice coil tube, was then bent, as shown in the photograph in the title of this article, to a uniform radius. This gave a different resonant frequency to the section so treated, yet retained the rigidity of the cone as a whole.

It will be apparent from the foregoing description of the mechanism of the production of the high-frequency peak in the response curve of a loudspeaker that the method adopted for its removal, in the case of the metal cone, can also be applied to a paper cone. A considerable improvement in the frequency response may also be expected if this treatment is applied to a straight-sided paper cone. Because paper cones are almost invariably moulded, it is quite possible to dispense with the incisions, and to mould into the cone the suitable deformations. The incisions are used in the case of the metal cone only to ease the operation of distorting a small piece of the cone.

This treatment is not suitable for use with "curved" cones, where the curvature already prevents the formation of the high-frequency peak. This same curvature is also responsible for the considerable cross modulation and "muddle" which is produced by such cones. Fig. 6(c) shows the response curve of a metal cone loudspeaker which has had the cone treated to remove the high-frequency peak and has been fitted with a "bung" to reduce cavity effects in the metal cone.

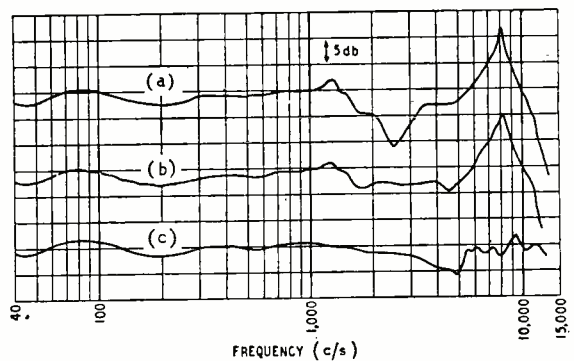

Fig. 6. Frequency response curves of metal-cone high quality loudspeaker when mounted in a vented cabinet with fairly heavy damping: (a) uncorrected plain cone (b) plain cone with "bung" (c) "slotted" cone with bung.

# Aerial Exchange

*Switching on the Grand Scale for Ten Radio Transmitters and Twenty Aerials*

**P**RACTICAL effect has recently been given at one of the Admiralty's high-power transmitting stations to a requirement calling for elaborate planning and precision engineering. This requirement was to provide a reasonably simple scheme for connecting any one of 10 radio transmitters to any one of 20 different aerial systems. Some are rhombics, others dipoles, but all have one common feature which is that 600-ohm balanced open-wire transmission lines are used.

The main problems were to provide a way of switching which would not disturb the characteristic impedance of any of the lines and to handle 25 kW of r.f. power. Changeover is not carried out with power on the lines.

The switching system is partially motorized and consists of a large semi-circular structure of 14 ft radius and some 15 ft high. This is fitted with 11 horizontal rails and between each pair is a movable carriage. Each carriage is driven by a small electric motor through flexible shafting and they can be traversed from end to end of the structure. There are 10 such

carriages and their driving motors can be seen stacked on the left of the illustration.

Similar carriages, but travelling vertically between the upright pillars, are mounted at the back of the structure. There are 20 of these and they are moved up or down by hand-operated lead-screws, the controls for which are arranged round a gallery at the top of the framework.

Each carriage, vertical and horizontal, is fitted with two large insulators having on their inner faces domed-shaped contact studs. The spacing is exactly 10-in which is the same as that of the transmission lines.

From a vertical column located at the exact centre of the system is taken a two-wire transmission line to each of the horizontally moving carriages. These lines are under spring tension and remain taut at all positions of the carriages. From this column the feeders pass into the transmitting hall and thence to the various transmitters.

Similarly, to each vertically moving carriage is brought, through a separate window in the outer wall of the building, a 600-ohm transmission line from one of the aerials; there are 20 in all and some of the lines can be seen in the illustration draped from the frame to the windows.

The method of switching is now fairly obvious, the carriage carrying a transmitter feeder is moved horizontally to the required aerial bay and that aerial's feeder carriage is moved up or down to bring the two sets of contacts into alignment. The rear set of insulators is on a sprung plate which ensures a firm and good electrical connection.

Initial planning of the system was carried out by the Admiralty Signal and Radar Establishment and the installation was engineered by P. & L. Miller, Ltd., of Heneage Street, London, E.1.

*Part of the aerial exchange switching frame. Horizontal traversing motors are stacked on the left and a few of the hand winders for the vertically moving carriages are seen round the top gallery. Aerial feeders are just visible in the background.*

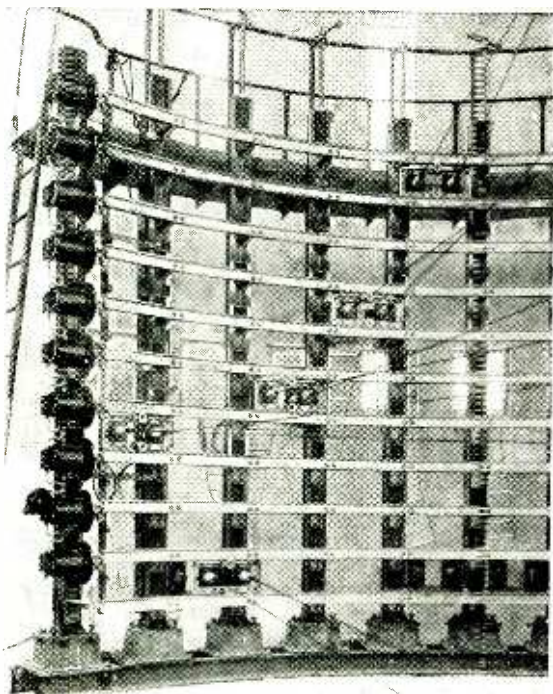

## “Negative-feedback Tone Control”

**O**WING to an omission from the inscription to Fig. 6 of the above article in the October issue, some ambiguity has arisen regarding the law of the potentiometers  $P_1$  and  $P_2$ , though from the curves of Fig. 8 it is implicit that they are linear. The relevant part of the inscription to Fig. 6 should read “ $P_1$  and  $P_2$  must both have linear elements.  $P_2$  is Dubilier Type ‘C’ control, 500 k $\Omega$ , with fixed tapping at 50 per cent rotation.”

The dotted curves of Fig. 8 with  $P_2$  centre tap disconnected were measured with an input attenuator forming a return path for the grid. When the filter is fed via a capacitor (as in Fig. 6), and the modified response is required, the grid may be “tied down” to earth by a high-resistance leak, but the preferred method is to use two 330-k $\Omega$  resistors, one from the left-hand and the other from the right-hand end of  $P_2$  to earth, the central tap being disconnected. The lower value of resistors avoids possible trouble from leaky coupling capacitors, and/or slight grid current, without appreciably affecting feedback and non-linearity distortion.

# Reshaping Information

## *to Suit the Channel*

### Practical Applications of Communication Theory

**H**OW to transmit information efficiently is the big problem in communications engineering these days: given certain properties like time, bandwidth and signalling power, how to make use of them in the best and most economical way. Quite often the "efficiently" implies transmitting the information in as small a bandwidth as possible, but not always so. Sometimes it means conveying it in a short time, or with a limited signalling power, or through a high noise level. At any rate there is usually some restriction or other, and because of this it is not always possible to transmit the information in its original form. It has to be reshaped, or encoded, as the communications engineers like to say, to suit the peculiarities of the channel.

This encoding of information to suit the channel was one of the dominant themes in a symposium on "Applications of Communication Theory" which took place in London recently. The symposium was organized by Professor Willis Jackson of the Imperial College of Science and Technology and was held at the Institution of Electrical Engineers. Forty papers were presented altogether over a period of five days by authors of seven different nationalities. About one-third of the 300 people attending were visitors from abroad (representing 18 different countries, including Russia), while the remainder came from universities, Government establishments and industrial concerns in this country.

#### Speech Information

One group of papers described various approaches that are being made towards the reduction of bandwidth in speech communication. The general method envisaged is to transmit not the speech waveform itself but a series of "telegraphic" signals representing the significant sounds in the speech. A teleprinter channel, for example, is capable of transmitting speech encoded into writing at the same rate as spoken speech and in a bandwidth of only about 75c/s. The great difficulty, though, is how to convert the speech sounds into code signals to begin with, especially when the sounds vary a great deal with different speakers.

Two of the papers described attempts that have been made to devise an automatic speech "recognizer" for this purpose. In both cases the machine works on the principle that a speech sound is characterized by concentrations of energy at particular frequencies in the acoustic spectrum (Fig. 1), and can be identified fairly well by a coincidence of two of these frequencies. The apparatus, then, is basically a spectrum analyser feeding into a bank of coincidence detectors, which indicate when energy concentrations of certain frequencies occur at the same time.

Unfortunately this type of recognizer is unable to cope with different pronunciations of the same word unless specially adjusted for each new speaker. In one of the machines, however, an attempt is being made to overcome this limitation by working on the principle that the human being is able to recognize words with different pronunciations because he has a store of linguistic information acquired from experience of the language to help him. The idea, then, is to "build in" a store of such information which will give the final yes or no to the recognition achieved by the acoustic system. For the moment this built-in information is confined to the known probabilities with which certain sounds occur after each other in English. The operation of a relay by the acoustic recognition of a sound is either facilitated or inhibited by the relay which recognized the previous sound, according to the known probability of these sounds occurring together.

Having converted the sounds into telegraphic signals, the task of converting them back into speech at the receiving end is comparatively easy. The signals merely have to switch on appropriate sound generators. One paper described a speech "synthesizer" working on this principle in which the bandwidth needed for the telegraphic signals was less than 100c/s. A tape recording of the reconstructed speech was played, but the effect was monotonous and difficult to follow until one became accustomed to it.

Another machine, which was described and demonstrated, gave a much more passable imitation of real speech because it was based more directly on the human vocal mechanisms. In this it was not a matter of "patching together" a series of discrete and standardized sounds. The code signals represented the comparatively slow and continuous muscular

Fig. 1. Acoustic spectrograms of the spoken words "two" and "mine" made by Bell Telephone Laboratories for their book "Visible Speech." The frequency analysis is displayed on a horizontal time axis, so the black bands represent concentrations of energy at particular frequencies, which vary throughout the speaking of the word.

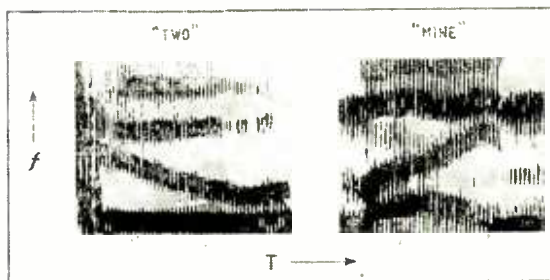

movements of the human speech mechanisms, and gave simultaneous control of five sound generators equivalent to the human generators. The first three generators produced the most prominent resonant frequencies of the vocal cavity, the fourth gave out pulses corresponding to the excitatory pulses of air from the larynx, while the fifth was a noise generator for imitating the fricative sounds associated with consonants. The "muscular" control signals are obtained by optical scanning from time graphs of the required variations drawn on glass slides. Because of their slowly varying nature they have an information rate (in bits/second) about one-fiftieth of that of the speech waveform itself, so they make possible a considerable reduction in bandwidth. The only problem that remains is how to obtain this type of control signal automatically from the original spoken sounds!

### Reducing Television Bandwidth

Television signals, of course, are notorious for the amount of bandwidth they occupy. They have one characteristic, however, which offers a great opportunity for reshaping the information, and an interesting paper at the symposium showed how this could be exploited to give a reduction in bandwidth. In a television picture, most of the information is concentrated in the sharp edges and boundaries, which are represented by the same sort of sharp variations in the waveform. But these edges only occupy a very small area of the picture, so that the large bandwidth made necessary by them is only utilized completely for a small part of the total time. The suggestion is, then, that some of the time that is normally wasted on transmitting the flat redundant parts of the waveform should be devoted to these sharp edges. And, of course, if one takes a longer time over sending a piece of information the bandwidth required for it is reduced. The desired effect, then, is to smooth out the waveform and spread the information more evenly over time.

To achieve this, the paper suggested a method using variable velocity scanning in the camera pick-up tube. The beam is slowed down when it comes to the sharp transitions on the mosaic and speeded up across the flat unchanging portions. This variation in velocity is controlled automatically by the nature of the picture itself, as represented by the output waveform. The slope, or sharpness, of the waveform is measured continuously by a differentiating circuit, and this serves to control the scanning velocity. The high slope of a sharp edge tends to slow down the beam, so that the slope is itself progressively reduced until it finally settles down to an equilibrium value. Similarly, a low slope causes the beam to go faster. The result, as can be seen from Fig. 2, really amounts to a feedback system in which the beam velocity is controlled by a parameter which is itself derived from the velocity. In the receiver, of course, the scanning beam of the c.r. tube is varied in synchronism, and the information for doing this is derived from the modified slopes of the received waveform.

A somewhat similar system was suggested in another paper for the transmission of simple line drawings or graphs. The scanning spot is made to go very fast over the large white areas until it comes to the drawn line. It then stops and sends out a code signal, which tells the receiver how much time has passed since the last encounter with the line. Thus, instead of spending a great deal of time in

transmitting the large white areas, as in normal scanning, one merely sends code signals representing the extent of these areas. The immediate result of reshaping the information in this way is to reduce the transmission time required for the picture, but by spreading the reshaped information out over the normal time this can be translated into a bandwidth saving.

### Coded Colours

In colour television the bandwidth problem is even more acute. The reason is, of course, that one has to send information about a particular colour in terms of its three primary colour components, so that three channels are needed. Various methods have been proposed for reducing the bandwidth by successive sampling of the three components, but one paper at the symposium outlined an entirely new approach. It pointed out that instead of sending information about the components of a particular colour, one need only send a code signal representing the colour itself.

In the system suggested, the colour is first of all analysed into its three components in the usual way by three pick-up tubes with filters in front. The three voltage outputs then form a special combination which actuates the transmission of a particular code signal. In this way each colour produces its own combination of voltage outputs and its own code signal. The principle is, of course, very similar to that of the automatic speech recognizer mentioned earlier, in which the code signal is actuated by a particular combination of sound components. At the receiving end the reverse process is carried out. The

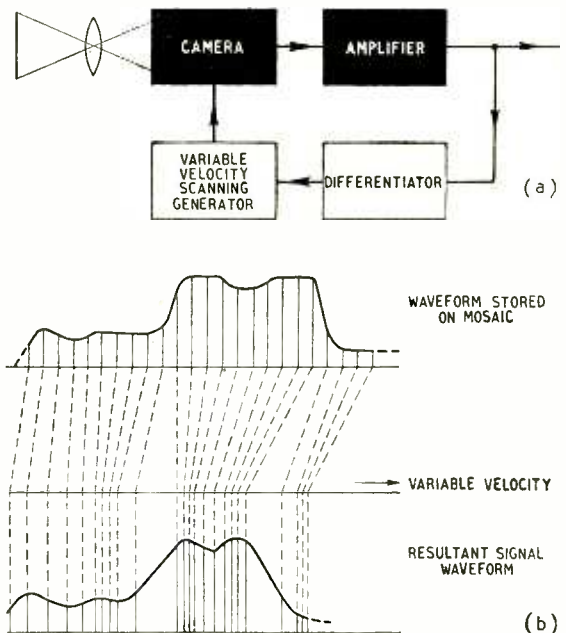

Fig. 2. Reshaping television signals. At (a) block diagram of a system for controlling the velocity of the camera scanning beam according to the amount of information in the picture. At (b) is the television waveform: (above) as recorded on the mosaic, and (below) as it appears after variable-velocity scanning.



received code signal generates three voltages corresponding to the outputs of the pick-up tubes, and these are applied to a trichromatic c.r. tube to reproduce the three components and reconstitute the original colour.

Two other communications systems were described in which high efficiency was obtained by reshaping the information. The first, known as "delta modulation," has already been outlined on page 427 of the October issue. In this the original information about the absolute voltage levels of the waveform is reshaped into information about the changes in the waveform. This is done by a kind of servo system in which the original waveform is followed automatically by a quantized version of itself. The two are compared with each other and the resultant error signals represent changes in the waveform. These error signals are used to make the quantized version follow the original waveform, and are rather like the series of corrections that one applies to the steering wheel of a car to keep it going in the right direction. They are transmitted in the form of pulses, from which a quantized version of the waveform is reconstructed at the receiving end. The advantage of this system is in its high signal-to-noise ratio, which is obtained at the expense of a wide bandwidth. In this respect the efficiency is about the same as pulse code modulation, but the apparatus required is very much simpler.

The second system, described as the "ambiguous-index system," is even more efficient. Not only does it give a high signal-to-noise ratio, but with a bandwidth not very much greater than that required for simple amplitude modulation. The original waveform is sampled and the value of each sample is represented by two or more independent code signals (the "indexes"). These code signals are transmitted and from them the original samples and waveform are reconstructed at the receiver.

## Overcoming Noise

As "Cathode Ray" explained in the September issue, information can be reshaped to overcome noise by introducing a certain amount of redundancy into the message. One way of doing this is to repeat the signal several times over, so that in systems where the signal is repetitive or periodic to begin with (radar, for example) the problem is very much simplified. Several papers showed how one can utilize this inherent redundancy for extracting signals from noisy backgrounds by a process of integration. The point is, if the periodicity is known at the receiving end, one can use some device which responds to it and so integrates the signal but not the noise. One paper described several ways of doing this visually by oscillographic methods. The time base is adjusted to the known periodicity, then as each signal arrives it is superimposed on the previous ones. Storage and integration is done partly by the screen of the c.r.t. and partly by the observer's persistence of vision. Thus a pattern is produced by the integrated signal which shows above the unintegrated noise.

The disadvantages of this visual method are, of course, that the integration time is limited by the short optical persistence of the screen and eye and that the integrated signals cannot be passed on in electrical form. By replacing the fluorescent screen with a plate of some dielectric material, however, the information "written" on it by the electron beam

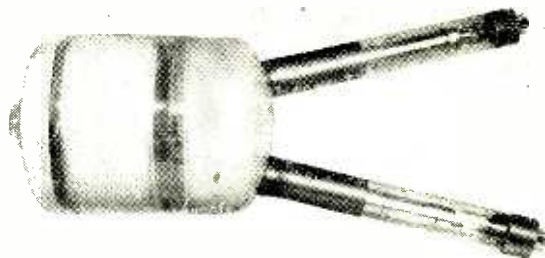

Fig. 3. Electrostatic storage tube for signal integration showing the two electron guns, one for "writing" the signal repeatedly on the target plate and the other for "reading" off the integrated result.

can be stored and integrated as a pattern of electrostatic charges, which can be "read off" whenever required. This was the principle of a new kind of electrostatic storage tube described in one paper (Fig. 3). The signal modulates the intensity of the electron beam so that the charge pattern on the plate consists of variations in charge density. Integration is obtained, as in the c.r.o., by superimposition of successive traces, which gives an increase in density of the charges representing the signal. The pattern is "read off" by a second electron beam scanning across it. The secondary emission produced by this "reading" beam is modulated by the variations in the charge pattern, then collected by another electrode to give a fluctuating current representing the integrated signal. With a noise-to-signal ratio of 7db, it is necessary to integrate about 300 successive traces to make the signal stand out about the noise.

Another paper described an alternative method of storing and superimposing the required signals. That is, to keep them circulating in a magnetostriction delay line in which the delay time is the same as the interval between successive signals. Thus the first signal travels round and gets back to the feed-in point (a magnetostriction transducer) at just the right moment to have the second one superimposed on top of it, and so on. Here, the integration is limited by the attenuation of the delay line.

## Practice Before Theory?

It might be argued that some of the schemes described above do not really justify the title "Applications of Communication Theory." One has the feeling that they would have been thought of anyway, whether Communication Theory had been here or not, and that the Theory was only dragged in at the last minute to explain things on a more scientific basis.

To some extent this is true. The real application of the Theory is in the detailed working out of these schemes, in that it provides a way of measuring information and of relating it mathematically to familiar parameters like bandwidth and signal-to-noise ratio. In this way it is essential to the engineering of any scheme in which information is the raw material. At the same time, there is no doubt that the general ideas provided by the Theory—such as redundancy and inverse probability—have been extremely valuable in stimulating original lines of thought that will eventually materialize in the shape of new technical developments.

# Recording Characteristics

## *Problems of International Standardization for Broadcasting*

**I**N his inaugural address to the British Sound Recording Association the new president, H. Davies, M.Eng., M.I.E.E., took for his subject the problems of international standardization in sound recording, with particular reference to the exchange of programmes between broadcasting organizations.

Mr. Davies dealt with both mechanical and electrical standards and gave some interesting details of the many factors of expediency as well as of a purely technical nature which have influenced the figures finally adopted by the C.C.I.R. For instance, tolerance on  $33\frac{1}{2}$ -r.p.m. turntable speeds is normally 0.5 per cent but in the case of 78 r.p.m. this was widened to 0.7 per cent. The reason for this is that whereas a 180-bar stroboscope on 50 c/s and a 216-bar on the American mains frequency of 60 c/s give exactly  $33\frac{1}{2}$ -r.p.m. when the image is stationary, the customary 77-bar (50 c/s) and 92-bar (60 c/s) stroboscopes for 78-r.p.m. actually give 77.92 and 78.26-r.p.m. Again, the rival claims of 77 cm/sec and 30 in/sec as basic standard tape speeds were settled in favour of 30 in/sec for the simple reason that it would be easier to reduce the capstan diameters of 77-cm/sec machines than to build up the diameter of capstans in 30-in/sec machines.

On the subject of recording characteristics it was possible to err, according to Mr. Davies, by saying too much as by too little; there was much opinion and all-too-often obscurity of fact. In the case of recording for broadcasting the signal taken from the line was already processed to suit the transmitter, and the object of recording and playback was to preserve that signal unchanged. The term recording characteristic was defined as the output (groove velocity, film density or area, or surface magnetic induction of tape) produced by constant input. It did not take account of any corrections or modifications made outside these limits. The first consideration in the choice of a recording characteristic was, or should be, optimum signal/noise ratio, but the characteristic so derived held only for single tones and might have to be modified by other considerations, including the distribution of energy in the sound spectrum. Norwegian speech, for instance, shows a marked tendency to overload at high frequencies. One should aim at equal probability of distortion over the frequency range, and the optimum characteristic would then give the least distortion for a given background noise.

Mr. Davies underlined the fact that these considerations held only for the internal recording characteristic decided upon by the broadcasting organizations. Manufacturers of commercial gramophone records might follow this good example at some future date, but the characteristic would not necessarily be the same, since the characteristics of reproducing equipment in the hands of the public varied over much wider limits than those of broadcast transmitters.

Standardization of characteristics for magnetic tape recording had presented some difficulty because the

intensity of magnetization could not readily be measured by inspection, as it could with the microscope or the Buchmann and Meyer method in disc recording. It was difficult, therefore, to separate the performance of the playback head from that of the tape, and early proposals aimed at the use of equalizers to correct assumed head losses due to the finite gap and to eddy currents. Recent research by the B.B.C., using a single copper conductor as a playback head, had resulted in more precise segregation of the iron losses and a reconciliation of the previously anomalous figures derived from iron heads, using short and long gaps. It was now possible to derive the tape magnetization by three independent methods, and in this respect the position was now better than for lateral-cut discs.

In conclusion, Mr. Davies spoke of the high standard of reproduction now being achieved with a tape speed of  $7\frac{1}{2}$  in/sec and of the very considerable groundwork which had been carried out on this side of the Atlantic with the object of establishing international standards for this speed.

## **SMALL TELEVISION CAMERA TUBE**

**W**HETHER or not it is worth while applying television techniques to industrial processes depends very much on whether the camera equipment, in particular, can be made sufficiently simple and inexpensive. In this country Pye have recognized this requirement by producing a small and light camera containing an exceptionally small pick-up tube. Now, another miniature tube designed for such applications has been put on the market by R.C.A.—the type 6198 Vidicon. It measures 1 in diameter and  $6\frac{1}{4}$  in long. The light-sensitive element is a photo-conductive layer, and has a sensitivity which permits the televising of scenes with 100-200 foot-candles of incident illumination. The tube has magnetic focusing and deflection, and requires d.c. voltages on the electrodes of no more than 300 volts.

In operation, the photo-conductive layer acts as a leaky capacitor, and when the scene is focused on it the "plate" nearest the scanning beam acquires a corresponding pattern of positive charges. In the process of scanning, the deposition of electrons from the beam reduces these charges on the near "plate" to the potential of the cathode. As a result there are changes in the potential difference between the two "plates" of the photo-conductive layer, and these constitute the output signal.



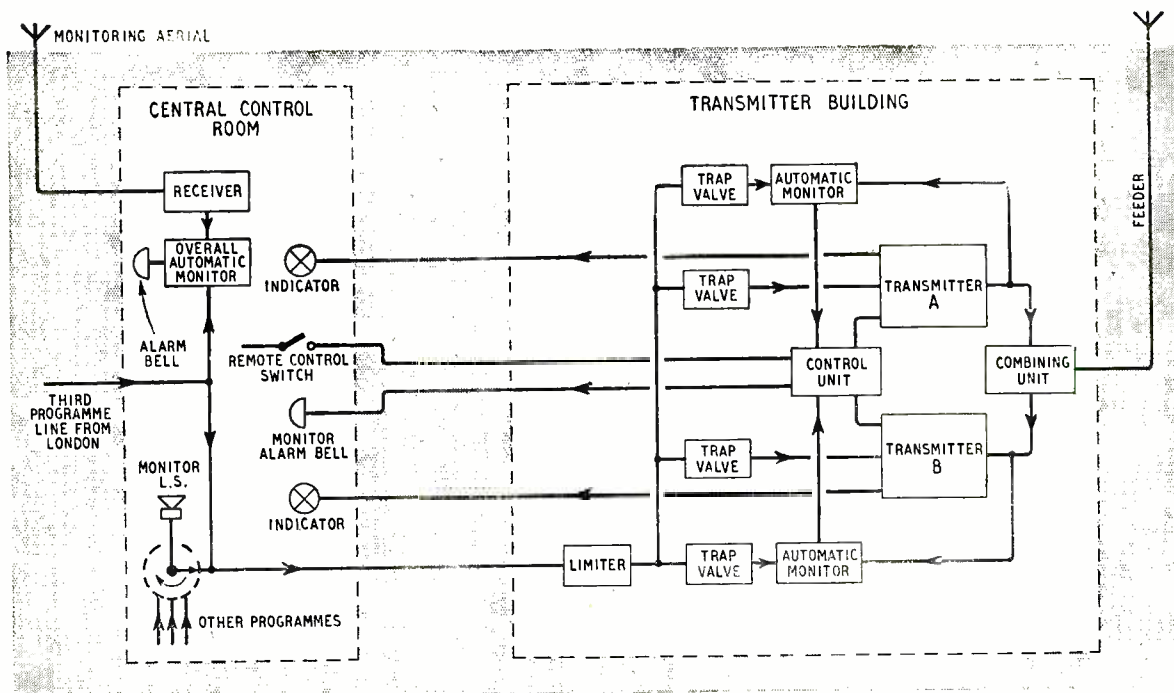

Fig. 1. Block diagram showing the general arrangement for remote control and automatic monitoring of the transmitter.

# Automatic Broadcasting

## Remote Control and Automatic Monitoring of Third Programme Transmitter

By R. W. LESLIE\* and C. GUNN-RUSSELL, M.A.†

THE B.B.C. has for some time operated low-power medium-wave transmitters by remote control.

A more recent development is the application of remote control to a high-power transmitter. The Third Programme transmitter at Daventry was selected for the first installation of this kind, the transmitting equipment being of suitable design for this purpose. Normally at least two engineers per shift would be required to operate such a transmitter. The remote control system has been developed jointly by B.B.C. engineers and by Marconi's Wireless Telegraph Company, the manufacturers of the transmitter.

A prime requirement of a broadcasting service is that breakdowns shall be kept to an absolute minimum, and various methods are employed throughout the system to ensure reliability. Where the cost of equipment is low, duplicate apparatus is installed and is available instantly to carry the programme should the need arise. Where a number of similar units are used, one extra unit is installed and is available as a spare for the others.

The capital cost of a high-power radio transmitter precludes the installation of duplicate equipment which would be used only in the event of a breakdown in the service equipment. A method which overcomes

this expense has been used by the B.B.C. for a number of years. Two transmitters, each capable of providing half the required output power of the station, are installed and operated in parallel to produce the required total output power. Should a fault occur on either transmitter the remaining one can be switched direct to the aerial in a matter of seconds and the service maintained with a loss of only 3db to the listener until the faulty unit has been restored to service. This principle has been extended at Daventry so that the transmitters are switched on and off from a remote point, and when a fault develops it is automatically detected and the equipment itself takes appropriate action to maintain the programme service.

The general arrangement of the equipment is shown in Fig. 1. The lines which carry the various programmes for all the transmitters at Daventry terminate in a central control room in the main short-wave transmitter building. As the short-wave services necessitate the control room being staffed on a 24-hour basis, it is convenient to locate the Third Programme transmitter on/off control switch and alarm circuits for fault indication in the same room. Here,

\* Planning and Installation Department, B.B.C.  
† Designs Department, B.B.C.

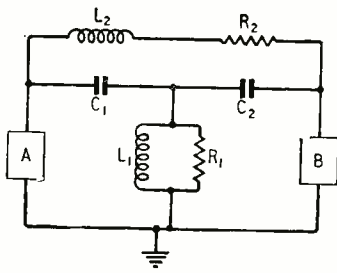

Left: Fig. 2 Circuit of combining unit by which the two transmitters A and B are paralleled to the common aerial feeder impedance  $R_1$ .

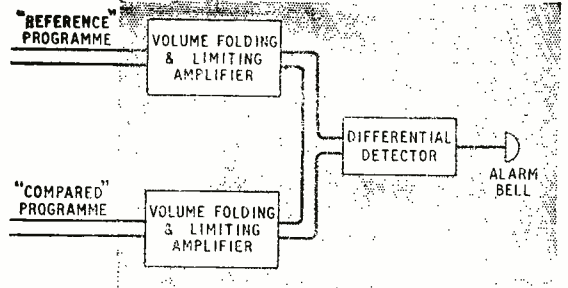

Right: Fig. 3 Essentials of the automatic monitor.

also, the programme is amplified and fed to a nearby building, which contains the Third Programme transmitter, and to line for distribution to other transmitter stations.

On arrival at the transmitter building the programme passes through a limiter to prevent overmodulation and trap-valve amplifiers to give independent outputs, one of which is used to feed transmitter A and another to feed transmitter B. The outputs of the individual transmitters are fed to a combining circuit, the output of which goes to the aerial feeder.

### Unattended Transmitters

The transmitters, which are air cooled and rated at 100kW each, together with the combining circuits, were designed and installed by Marconi's Wireless Telegraph Company. High-speed overload systems afford each transmitter complete protection from damage following a fault. In the case of the main h.t. supplies, recycling electronic overload trips are fitted which, under fault conditions, remove the h.t. and re-apply it a predetermined number of times before switching it off permanently. If this were not done, any fault of a transient nature would cause one or both transmitters to remain closed down after the fault had cleared.

Automatic monitoring equipment has been installed to maintain a continuous check upon the fidelity of transmission in place of staff listening continuously to a loudspeaker. A separate monitor is associated with each transmitter, and an overall monitor compares the quality of the radiated programme with that incoming from London.

Incidentally, the quality of the incoming programme is checked in two ways. First, it is continuously aurally monitored at one of the other stations which has received its feed of Third Programme via Daventry. Secondly it is intermittently monitored in the central control room. The loudspeaker shown in Fig. 1 is connected to a sequential switch arranged so that one of the staff may listen to each source of programme in turn. The switch normally dwells for about thirty seconds in each position.

In order that each transmitter monitor can check the output of its own transmitter without being affected by the condition of the other, it is necessary to have a combining network which allows two transmitters to be paralleled to a common load but which provides a high attenuation between them. For this purpose Marconi's have developed a bridge T network as shown in Fig. 2. Here  $R_1$  represents the aerial feeder impedance, which in this case is 220 ohms,  $R_2$  is a ballast resistor and A and B represent the transmitters. With values chosen such that  $(X_{C1}) = (X_{C2}) =$

$(X_{L1}) = (X_{L2}) = R_2 = R_1$  the impedance presented to either transmitter is independent of the terminal impedance of the other, being equal to  $R_1$ ; and if a fault causes one transmitter to close down the other will continue to work normally. As a corollary of the impedance relationship it also follows that none of the output of one transmitter can appear across the output of the other, and hence the two transmitters can be monitored independently.

Although the operating conditions of either transmitter are unaffected by the condition of the other, when only one transmitter is functioning the total radiated power is reduced to a quarter of normal since half the power of the working transmitter is dissipated in the ballast resistor. However, this state of affairs will only persist for fifteen seconds as, at the end of this period, if one transmitter is still closed down, r.f. contactors are arranged to select the working transmitter and connect it direct to the feeder so that its full power output is radiated.

The automatic monitor, which was developed by B.B.C. engineers, works on the basis of comparison. It compares programme of unknown technical quality, dubbed "compared" programme, with programme that is known to be satisfactory, called "reference" programme. If the quality of the "compared" programme falls below a certain standard the equipment either gives an alarm or may initiate executive action to deal with the trouble. The standard of imperfection adopted for the equipment was based on the performance of a human monitor.

As the automatic monitor has been described fully elsewhere<sup>1</sup>, the following is but a brief outline of its operation. The types of distortion for which both the human and the automatic monitor must listen are as follows:—

1. Noise, including cross talk.
2. Frequency response distortion.
3. Harmonic or overload distortion.
4. Changes in transmission equivalent or, of course, a complete disconnection.

The automatic monitor measures the above distortions as a change in volume. Noise may be detected as an appreciable increase in amplitude when programme is of comparable volume. Defects in frequency

<sup>1</sup> "Carrier Frequency Control: Automatic System for Unattended Transmitting Stations," by J. C. Gallagher, *B.B.C. Quarterly*, Vol. IV, No. 4, Winter 1949/50.

"The Design of Automatic Equipment for Programme Routing and Sequential Monitoring," by H. D. M. Ellis and J. C. Taylor, *B.B.C. Quarterly*, Vol. IV, No. 4, Winter 1951/52.

"The Automatic Monitoring of Broadcast Programmes," by H. B. Rantzen, F. A. Peachey and C. Gunn-Russell, *Proc. I.E.E.*, Vol. 98, Part III, No. 55, September 1951.

"The Broad Principles in the Design of Automatic Monitors," by F. A. Peachey, H. B. Rantzen and C. Gunn-Russell, *Electronic Engineering*, January 1951.

response and transmission equivalent obviously show up in the same way. Harmonic distortion is usually caused by the compression of the signal in an overloaded valve stage; this again may be detected as a volume change.

In any part of the programme chain, phase distortion is likely to affect the waveform of the electrical signal, but as the human monitor will not normally hear this change the automatic monitor should ignore it. Similarly, small amounts of frequency response distortion at the extremes of the band or even quite high levels of very low frequency noise, which are unimportant owing to aural sensitivity, must not affect the automatic monitor.

### Automatic Monitor

A schematic diagram of the automatic monitor is shown in Fig. 3. Both the "reference" and the "compared" programmes are fed into identical units called volume folding and limiting amplifiers. These v.f.l. amplifiers have a complex function to perform. They are provided with a non-linear input-output characteristic so that there is a degree of equality in the measurement of distortion at both high and low volumes of programme signal. An aural sensitivity "weighting" network is introduced into the circuit of each of them so that the sensitivity of the equipment to signal distortion may approximate to aural sensitivity. At the output of the v.f.l. amplifier the signal, so processed, is rectified and integrated in an RC network of the appropriate time constants. In this way the transients and steep fronts of programme signal are smoothed out and the unwanted effects of phase distortion are eliminated. The outputs from the two v.f.l. amplifiers are fed in series opposition to a differential detector, which indicates when the two outputs differ by more than a predetermined amount.

As the checking of technical quality of transmission over the link being automatically monitored is entirely dependent on this equipment, reliability is of primary importance. Also, it is essential that the automatic equipment should be as far as possible self-supporting and should not require elaborate routine maintenance. For these reasons the equipment is arranged to sound its own alarm, when, as a result of some internal fault, it fails to provide proper monitoring.

At Daventry the automatic monitors associated with each transmitter are required to take executive action. Of course this should not be taken if the "operation" of the monitor is due to its own internal fault. Automatic means are therefore provided for the monitor to prove its own circuits before such action is taken. For this purpose a testing unit has been added to the normal monitor equipment. This unit also provides a means of integrating the normal monitor alarms so that executive action is not taken unless the operations are sufficiently frequent or persistent.

The equipment is arranged so that the first transmitter to be proved faulty is shut down by its own monitor. In the event of the second transmitter becoming faulty, its associated monitor is prevented from taking executive action, and instead an alarm is given in the central control room. This latter feature means that the closing down of the second transmitter is left to the discretion of an engineer. Obviously his decision will be tempered by the knowledge that he will be closing down the whole service, and he will do this only when the distortion is most severe.

The third automatic monitor shown in Fig 1 is provided to watch the overall system. In addition to the transmitters that are already checked individually, it monitors the common input equipment, the one and a half miles of feeder line to the aerial and the aerial itself.

Each transmitter is a complete unit containing all the circuits which are necessary for it to be locally operated from its own manual controls. Additional control circuits external to the transmitters are provided for starting and stopping the transmitters from the remote point, and for locally selecting one or other of the transmitters if the need arises. Operation of an overload protection device or of an automatic monitor removes the h.t. supply from the appropriate transmitter, and after fifteen seconds the lack of feed on its final amplifier is used to initiate the switching of the serviceable transmitter. At the same time all other supplies are removed from the faulty transmitter.

There are three methods of operating the equipment: (a) transmitters on manual control without automatic features or remote control facilities; (b) transmitters on manual control but incorporating automatic re-selection in the event of an overload; (c) transmitters remotely controlled and fully automatic. A three-position switch provides the means of selecting the method. The switch can be changed from its normal position (c) whilst the transmitter is running. This facilitates fault location and servicing without interruption to transmission.

During the six months that this equipment has been in operation, it has proved itself capable of maintaining the highest possible standards of fidelity coupled with the very minimum of programme interruption.

### TAPE RESISTORS

IN our February, 1952, issue we described an adhesive resistor developed by the American Bureau of Standards for use on printed circuits. It had one apparent drawback, as after fixing in position the resistor had to be "cured" at about 300 deg C and only certain base materials would stand this high temperature.

It is reported in the Bureau's *Technical News Bulletin* for July, 1952, that these tape resistors can now be pre-cured and secured in position on the printed circuits by either soldering or spot-welding.

The pre-cured resistor is made by sandwiching short metal lugs, or wires, between two pieces of uncured adhesive tape and then "firing" to process the resistor and bond the parts securely together.

A pre-cured resistor of this kind is about 1½ in long and has the appearance shown in the accompanying illustration.

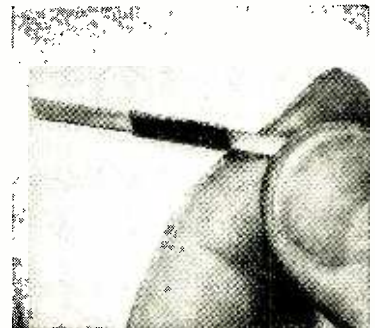

Pre-cured tape resistor for use on printed circuits.  
(Photo courtesy Technical News Bulletin.)

# BEATS

## Visible and Audible Effects When Two Frequencies are Combined

By "CATHODE RAY"

LIKE everybody else who ever tries to explain the principles of radio to beginners, I knew that what is called beating or heterodyning is one of the subjects where trouble can be confidently expected. But until an attentive reader fired a burst of well-aimed questions on it I hadn't realized just how many difficulties it can present to the enquiring mind. It is easy enough to look at pictures like Fig. 1 and visualize currents or voltages varying in that sort of way. There is no difficulty in seeing that (a) and (b) have the same frequency but different amplitudes, whereas (b) and (c) have the same amplitude but different frequencies. These ideas are quite easy to grasp, using this type of diagram. With a little more effort, any reasonably intelligent and persevering pupil can learn to think of the same ideas in terms of rotating vectors, or even sin and cos. The trouble begins when two of these simple alternating signals are combined and their frequencies are not the same. Since combinations of this kind are at the bottom of so much of radio, it is worth trying to get a firm grasp of the principles.

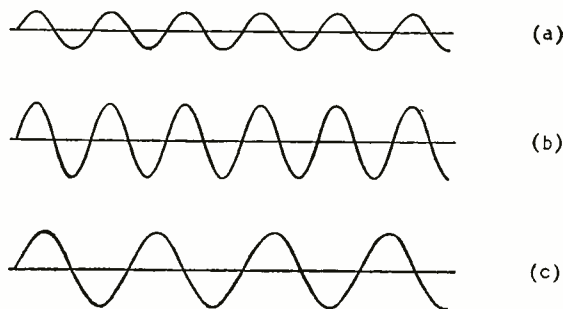

Fig. 1. The most popular way of depicting alternating signals. Differences in amplitude—e.g. (a) and (b)—and frequency—(b) and (c)—show clearly.

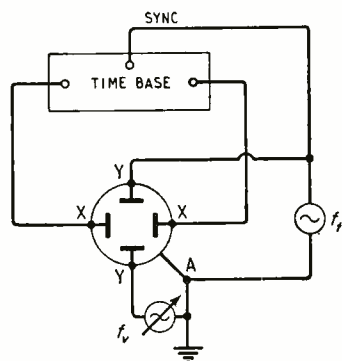

Fig. 2. Recommended arrangement of apparatus for showing the wave pictures Figs. 3-10. Note that the variable-frequency signal is connected so as not to influence the time-base frequency.

Most of the difficulty, I think, is that our forms of expression let us down. One can, of course, add any two—or indeed any number—of Fig. 1 type waveforms point by point to get a picture of a composite signal; but to get anything like an accurate picture the work is so tedious that few pupils are persevering enough to do it. Especially as the shape of the result is affected so much by slight differences in relative frequency and amplitude that one really has to draw dozens of different combinations to see clearly how it depends on these things. Vector diagrams require a certain amount of effort to follow even when all the vectors have the same frequency so that they keep the same relative positions, and the diagram can be imagined to be rotating as a whole; but when the frequencies are different, making the vectors rotate at different speeds, it becomes too much of a strain. So the instructor generally falls back on trigonometry, which shuts out all non-trigonometrical aspirants, and even if one has learned the gentle art of manipulating the sin and cos, the manipulations don't give one much of a picture of what is actually happening to the signal voltage and waveform.

The best thing, without a doubt, is to connect the required number of signal generators to an oscilloscope and watch results. Two generators are enough for a start, and since it is only the relative frequency that matters, one of them need only give a fixed frequency and amplitude, the other being variable in both these respects. Unless the set-up is rather carefully thought out, however, it will only make confusion worse confounded by showing an infinite variety of complicated and beautiful patterns, which, however much they may excite admiration, fail to clarify the particular issue under consideration. To enable the waveform picture to be seen clearly, it is desirable for it to be made to stand still, which calls for synchronization. The provision for this in most oscilloscopes is an adjustable connection between the "work" (i.e., the signal being studied, applied to the Y plates) and the time-base generator. This may function quite nicely with a single signal, but when beat effects are obtained, causing fluctuating amplitude, it does not. The time base should be locked to the fixed-frequency ( $f_f$ ) signal only, and not affected by the other. Perhaps the simplest way of achieving both these requirements is to connect the fixed signal generator to one Y plate and to "Sync," and the other to the other Y plate, as in Fig. 2.\* This can't be done with a double-beam tube, or an oscilloscope in which one Y plate is firmly attached to a shift control and is not accessible, so one would have to think of something else, such as using magnetic deflection for the variable generator. Another thing is that the

\* The symbol for a variable-frequency generator is not in BS.530, for I have just this moment invented it, but it seems the obvious one to use.

variable frequency ( $f_v$ ) should be very precisely adjustable. And neither frequency should have any appreciable tendency to drift. Lastly, to avoid unnecessarily complicating the issue, both waveforms should be good sine waves, and, of course, free from disturbance by 50 c/s mains or anything else.

If one is lucky enough to have apparatus of the foregoing description to play about with, then the best thing is to spend half an hour or more with it, adjusting the time base to give, say, 10 cycles of  $f_i$  on the screen and then raising  $f_v$  gradually from lowest to highest. The effect of making the amplitude of  $f_v$  equal to, greater or less than  $f_i$  should also be noted, but it is best to go into this after the results of varying frequency with a fixed one-to-one amplitude ratio have been thoroughly digested. One thing at a time.

Since the odds are probably against any given reader having access to the aforementioned apparatus for the purpose of first-hand study, I shall try to do my best for him by giving a running commentary, aided by a few stills; and in particular to answer the pertinent questions asked by the reader who was responsible for starting this line of thought.

For the sake of example I shall assume that  $f_i$  is 500 c/s and  $f_v$  is raised slowly from 50 to 5,000 c/s, and first that the signals are equal in amplitude. But one can easily start in imagination at zero frequency. If a constant positive voltage is added to the  $f_i$  signal (or any other) its effect is to raise the whole thing bodily; if negative, to lower it—assuming the conventional directions of + and -. These effects are shown by the upper and lower wavy lines in Fig. 3. Since in our case the added voltage is equal to the peak amplitude of the original signal, the negative peaks of the upper trace and the positive peaks of the lower one just touch the centre line.

## Waved Waves

When now the added signal is alternating, at any frequency, obviously it alternately raises and lowers the  $f_i$  signal between the same limits. So all the possible traces obtainable as  $f_v$  is varied occupy the shaded area. In general, each trace ends (and therefore the next one begins) at a different level, so successive traces don't coincide and there are so many different ones seen at once that the area between the upper and lower limits is filled with them and Fig. 3 does represent pretty well what one sees. But every now and then, as  $f_v$  is varied, a frequency turns up that gives an exact number of cycles during the time occupied by 10 cycles of  $f_i$ , and then the combination pattern is stationary.

At  $f_v = 50$  c/s, for example, the separate and combined signals look like Fig. 4. The combination (c) might well be called a "waved wave," like the coiled-coil filaments in domestic lamps. This, of course, is quite an easy case to plot by adding instantaneous amplitudes of (a) and (b) on paper. Even the vector diagram is not impossible to visualize—one rapidly rotating vector (representing  $f_i$ ) alternately raised and lowered by a slowly rotating one (representing  $f_v$ ) "in series."

As  $f_v$  is increased, the  $f_i$  wave is waved more rapidly. At 100 c/s it does it twice during each time-base sweep, as in Fig. 5. The waved wave action is quite easy to follow. But it doesn't seem to have anything to do with the production of beats—the alternate waxing and waning of sound that one gets when notes



Fig. 3. The two wavy lines represent what is seen of the fixed-frequency ( $f_i$ ) signal; the top one when displaced by a constant positive voltage equal to its peak voltage, and the bottom one when the constant voltage is negative. If an alternating voltage is substituted for the constant one, the combined voltage varies within the shaded area.

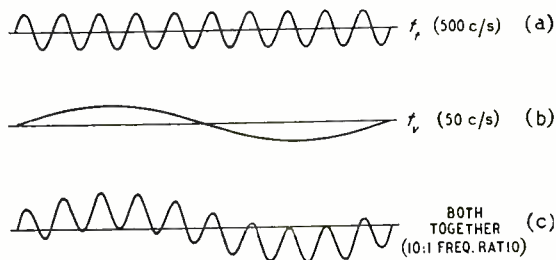

Fig. 4. "Waved waves" produced when the ratio  $f_i:f_v$  is large. There is no perceptible variation in amplitude of the signal when the other is added.

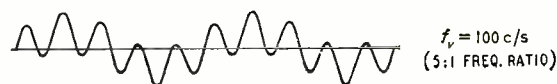

Fig. 5. The effect on Fig. 4(c) when  $f_v$  is doubled.

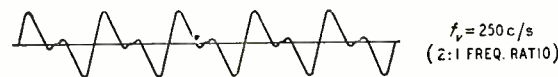

Fig. 6. Here  $f_v$  is increased to 250 c/s. While still clearly a waved wave it now begins to show beats.

of two nearly equal frequencies are heard together. My enquirer had read in a textbook that a beat is produced "when two neighbouring frequencies are combined," and he asks how close is "near"? Where and how do they change over from being near to being not near? As is well known, the frequency of the beats is equal to the difference between the frequencies of the notes producing them; so one might say that so far in our experiment the beat frequency (450 c/s in Fig. 4, and 400 c/s in Fig. 5) is too high for the ear to distinguish as increases and decreases in loudness. True, but oughtn't one to be able to see it on the oscilloscope? Actually it just looks as if the  $f_i$  signal is being pushed up and down as a whole, without affecting its amplitude at all. Which is exactly what one would expect. However, as  $f_v$  is increased, so that there are fewer and fewer cycles of  $f_i$  to each cycle of  $f_v$ , it becomes clearer that the waveform of  $f_i$  is being distorted. By the time we have brought up  $f_v$  to 250 c/s, so that there are only two cycles of  $f_i$  to each one of  $f_v$ , signs of beating are beginning to be unmistakable on the screen (Fig. 6) even though there is not yet any trace of them audibly. In fact, although there is no sudden transition between the up-and-down waving at constant amplitude, as in Fig. 4(c), and the waxing and waning of amplitude

with no up-and-down effect, characteristic of beats, the 2:1 frequency ratio pictured in Fig. 6 can be regarded as the transition, at which both effects can be seen. The original  $f_f$  signal is clearly pushed up and down five times in every 10 of its cycles, and at the same time the cycles are alternately large and small. In Fig. 6 (which is only one of the many patterns obtainable with this frequency ratio) the beat effect is clearer if one starts comparing the sizes of cycles *after* the first half-cycle. A slight phase shift gives Fig. 7, where again both waving and beating can be discerned.

From 250 c/s up to 500 c/s (or, more generally, from 2:1 to 1:1 frequency ratio) beating displaces waving as the dominating effect. At  $f_v=400$  c/s (Fig. 8), the cycles obviously wax and wane twice during the period (i.e., at frequency  $100$  c/s= $f_f-f_v$ ); but they all come more or less equally above and below the base line. Theoretically, the 500 c/s waveform should wave up and down 400 times per second, but it is difficult to visualize this! If you want to know what it looks like, see Fig. 8.

When  $f_v$  is brought very near  $f_f$ , the beating becomes slow enough to hear clearly, but too slow to see clearly on such a rapid sweep. If you slow it down enough to get more cycles in, you will be able to produce pictures like Fig. 9. Finally, when  $f_v=f_f$ , which in other connections is called "tuning to zero beat," there is neither beating nor waving effect. The picture has the same shape as originally, Fig. 4(a), except that if the other signal is in phase its amplitude will be greater, and if in opposite phase, less. If exactly opposite—and equal—the two will cancel out to give nothing at all. The slightest change of either frequency causes the phase to shift slowly round, making the signal amplitude alternately increase to double and decrease to zero. In other words, a very slow beat. This is another case where the vector diagram is not too hard to visualize—the sum of two vectors rotating at nearly the same rate, so that they alternately open out and close like the case and blade of a pen-knife—except that the blade swings right round instead of shutting the same way as it opened.

### Effect of Frequency Ratio

Recapitulating so far, then, we find that when the frequency ratio is large the waving effect dominates, and when it approaches 1:1 the beating effect dominates; and the cross-over can be said to occur at 2:1. This is quite reasonable if you come to think of it, for with a large frequency ratio (e.g., Fig. 4) the low-frequency signal changes very little during a single cycle of the high frequency, so it pushes both of the half-cycles the same way—upward or downward—and the amplitude of the cycle is not affected. But when the two frequencies are nearly equal the positive and negative half-cycles of both signals nearly coincide, and the second signal pushes the half-cycles of the first in opposite directions, affecting the amplitude of the cycle. As the phase swings slowly in and out the amplitude is made to wax and wane. When the frequency ratio is 2:1, neither of these conditions prevails, and the result is a rather complicated mixture of a little of each.

There is no need to spend much time over what happens when  $f_v$  is raised from 500 to 5,000 c/s. It is a repetition of 50 to 500 in the inverse order, beginning with slow beats and ending with waved waves. The only difference is that the constant time-base frequency



Fig. 7. The same as Fig. 6 except for a phase shift between the two component signals.

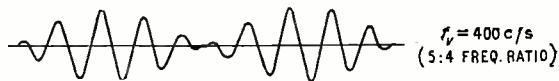

Fig. 8. At  $f_v=400$  c/s, beats are much closer than waved waviness.



Fig. 9. When  $f_v$  is nearly equal to  $f_f$ , the time base has to be slowed down to show the beats clearly.

is now locked to the *lower* of the two frequencies, so the number of cycles visible continually increases. At 5,000 c/s the frequency ratio to 500 is the same as 500 to 50, so the picture is the same as Fig. 4(c), except that it is repeated ten times over within the same base line, as in Fig. 10.

### Which Frequency Predominates ?

Having got so far, we can consider another of my enquirer's questions. He had just been shown that the result of adding 400 c/s to 500 c/s (Fig. 8) was to make the 500 c/s signal vary cyclically in amplitude (i.e., beat) at the difference frequency, viz., 100 c/s. Whereupon he asked, why not 400 c/s beating at 100 c/s? This is a fair question. Seeing that 500 c/s and 400 c/s are equally present, why choose one more than the other? Which is "the" frequency? But it is not the sort of question one cares to get without notice. I'm not sure that even now I could give a simple answer to it. It depends on how one reckons frequency. If one starts to vary the amplitude ratio, making one signal much stronger than the other, then it is soon seen that the frequency, reckoned by the number of visible up-and-down waves, is (as one would expect) that of the stronger. But if one reckons by listening to it, one may not be quite so sure. Some musical instruments have harmonics stronger than the fundamental. But to a musical ear "the" frequency is that of the fundamental, not of the strongest component.

Looking at Fig. 6 or 7, would you say there were 5 cycles or 10? If you count every up-and-down you would find 10. But others would argue that this waveform shows 5 cycles of a 250 c/s fundamental with a strong (actually 100 per cent) second harmonic. Or, if you reckoned the frequency by the time period of the large half-cycles, you would say there were  $7\frac{1}{2}$  cycles. So it seems to be largely a matter of choice or definition. It is quite fascinating to get a visible beat on the 'scope between, say, 500 and 600 c/s, and vary the amplitude of the 600 c/s signal. When it is relatively small, there are clearly 10 cycles, of various amplitudes. But at a certain amplitude ratio, not far from 1:1, one suddenly becomes aware that two extra cycles have somehow insinuated themselves into the picture, at the points where the amplitude is at a minimum. But although each consists of a complete



up-and-down, reckoned by time they are only half-cycles, like the half-pace a soldier takes to get into step if he is out of it.

By increasing the 250 c/s amplitude in Fig. 6 the small cycles can be made to disappear, remaining as a distortion of the 250 c/s waveform; but the ratio has to be more than 2:1 for this to happen. In Fig. 7 it would have to be larger still. Obviously the 50 c/s component in Fig. 4(c) would have to be expanded enormously to iron out the 500 c/s ripple into a mere distortion. On the other hand, when the frequencies are nearly equal, the lower frequency signal amplitude need only be increased very slightly. The reason is that the slope of the wave is proportional to frequency as well as amplitude, so a ripple of a high-frequency component can only be cancelled out by the opposite slope of the low-frequency component if its amplitude is greater.

### Beat-frequency Signal

So far we have been considering pure addition. In other words, we have been assuming that the circuit in which the two signals are combined is linear; i.e., its impedance is the same at all amplitudes, so that the presence of one signal does not make any difference to it for the other. The Law of Superposition holds good, and Ohm's Law, and altogether everything is very straightforward and law-abiding. No new frequencies are created. Or, more correctly, the combinations contain no signals of frequencies different from those put in. It is the difference between these two statements that causes confusion in the minds of beginners. This particular confusion is so well known that I need hardly do more than mention it. The point is that whereas it would be reasonable to say that in the Fig. 8 condition a new frequency is created—the beat frequency, 100 c/s—there is no actual signal of that frequency present. It is only the frequency at which the amplitude of the combination waxes and wanes. *There is no 100 c/s signal.* When the beat frequency is very small, say, 2 c/s, there is no difficulty in hearing it, as a rate of beating, though a 2 c/s signal, even if present, would be far too low in frequency to be audible.

If one wants to produce an actual signal of a different frequency from any that one happens to have—as for example in a superhet—the available frequencies have to be combined in some non-linear circuit, such as a rectifier; or the amplitude of one signal has to be able to affect the other in some other way, indirectly, as in a frequency-changer valve. Either way, some degree of multiplying action is obtained. This is easiest to see in the frequency-changer valve. One of the signals is applied to a control grid, and the output obtained depends on the "slope" of the valve,  $g_m$ . In a pentode type of valve, in fact, the output amplitude is very nearly proportional to  $g_m$ , so that  $g_m$  appears as a factor. If now the other signal, of a different frequency, is applied to another grid that controls the slope according to the voltage applied, then the instantaneous signal voltage of this other signal appears as a factor in  $g_m$ . Therefore, bringing these two facts together, it appears as a factor in the output voltage of the first signal. In other words, the output includes the product of both signal voltages, multiplied together. Since the resistance of a notably non-linear device, such as a rectifier, is more or less proportional to the applied signal voltage or current, a multiplying action

occurs there too. When there is non-linearity of any kind, new frequencies are produced—actual signals that one can tune in and use. These frequencies depend on the nature of the non-linearity, but they generally include the sum and difference of the input frequencies, and multiples of them—harmonics. The purpose of looking on the non-linearity as multiplication is that it helps one to work things out mathematically. I'm not going into this in great detail, because there is no room, and it is not the subject of this article, but I did deal with it at some length in the July, 1948, issue, and if that is too long ago there are books that explain it to anyone who doesn't know it already. My only object in summarizing it now is to comment on my enquirer's trump card of a question.

He referred me to two diagrams in the book *Foundations of Wireless*, 4th edition. (In the current 5th edition parts of these diagrams are not included.) The first was Fig. 85, on p. 122, which says just what I do here in Fig. 4, that if you add (a) to (b) you get (c). It also says that if you multiply (a) by (b)—or rather (b) plus a constant voltage equal to its peak value—you get something like Fig. 11 here. A little consideration should show that this is quite true. The second reference was Fig. 162, on p. 246, which says that if you multiply (a) by (b) in Fig. 12 here you get a waved wave (c) and if you add them you get a beat (d). Addition and multiplication seem to have changed places, judging by the results.

Although I was not altogether unacquainted with *Foundations of Wireless*, I had to admit that I had never compared these two diagrams nor noticed that they seem to contradict one another. But do they? We have already seen how adding two lots of sine



Fig. 10. With  $f_s = 5,000$ , the frequency ratio is the same as in Fig. 4, and the picture the same as in Fig. 4(c) except that everything happens 10 times as often.



Fig. 11. The result of multiplying (a) and (b) in Fig. 4.

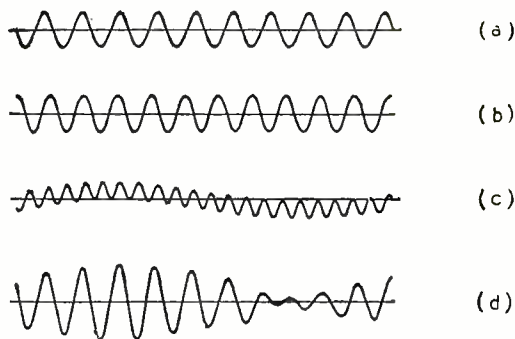

Fig. 12. When (a) and (b) are multiplied, the result is as at (c); when added, as at (d). Compare Figs. 4(c) and 11.

waves can give either waved waves or beats, depending on the ratio of frequencies. So would it be very surprising if multiplying two lots of sine waves began by giving beats and gradually changed over to waved waves as the frequencies were made more nearly

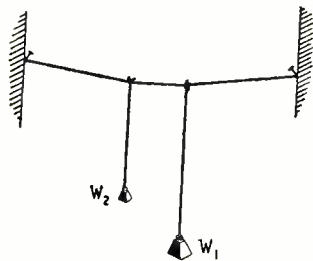

Fig. 13. A simple mechanical analogy for demonstrating the production of beats.

mentioned, that the effect of a non-linear or multiplying device on two lots of sine waves is to produce signals of other frequencies, which, of course, add together to give the results already studied. The clue to the mystery is that although (a) in Fig. 12 is the same as in Fig. 4, (b) is not. But the difference between (a) and (b) in Fig. 12 is the same as (b) in Fig. 4; and as a signal having this difference frequency is produced by a non-linear device, (a) plus (b)—and hence (a)—in Fig. 4 is produced by (a) times (b) in Fig. 12. The difference frequency produced by two nearly equal frequencies such as in Fig. 12 is a relatively low frequency, as Fig. 4(b). In addition there is a sum frequency which, being nearly double the frequency of Fig. 12(a) or (b), gives the higher-frequency ripple of Fig. 12(c). When multiplied frequencies are very different, as in Fig. 4(a) and (b), the difference frequency is nearly as high as the higher frequency, so the difference between these output components is small, which accounts for the slow beat (Fig. 11) yielded by the two together. Actually Fig. 11 (formed by multiplying very different frequencies) has not quite the same form as say Fig. 9 (formed by adding nearly equal frequencies). The outline or "envelope" of all the positive tips in Fig. 9 traces half-cycles of sine waves, whereas in Fig. 11 the presence of a sum-frequency signal smooths the envelope out into a complete sine wave. This could be seen better if the "carrier-wave" frequency were higher.

Finally, if you have no oscilloscope, etc., but would nevertheless like a little instructive amusement, you might care to try the time-honoured experiment shown in Fig. 13. Tie a piece of string between two fixed points and hang two others from it with weights attached.  $W_1$  is a fairly heavy weight and when set swinging at right angles to the horizontal string it will move it backwards and forwards sinusoidally. This movement will be superimposed on that of the other pendulum, which should be a different length, so as to swing at a different frequency. As its weight is comparatively light, it won't have much effect on the first pendulum. The combined motion of  $W_2$  traces out a beat, the frequency of which can be altered by altering the difference between the frequencies of the pendulum. Actually the analogy is not perfect, because there is coupling between  $W_1$  and  $W_2$ , but it does very strikingly demonstrate beating

and (if the lengths are made sufficiently different) waved waves. I have just obtained a beautiful mechanical reproduction of Fig. 6.

## Marine Radar Aerials

AT a recent conference in London between representatives of Government research establishments and British manufacturers, a comprehensive review of the present state of our knowledge of the theoretical basis of centimetric beam aerial design and its practical interpretation was contained in thirteen main papers and the subsequent discussions.

The proceedings have now been published by H.M. Stationery Office and form a concise reference manual which will prove of value not only to professional engineers because of the extensive bibliographies, but also to students who will find the essential simplicity and directness of the many diagrams of great help in following the principles discussed in the text. The full title is "Proceedings of a Conference on Centimetric Aerials for Marine Navigational Radar," and the price is 15s (16s by post), or in U.S.A. \$3.50, postage included.

## Short-wave Conditions

### Predictions for November

THE full-line curves given here indicate the highest frequencies likely to be usable at any time of the day or night for reliable communications over four long-distance paths from this country during November.

Broken-line curves give the highest frequencies that will sustain a partial service throughout the same period.

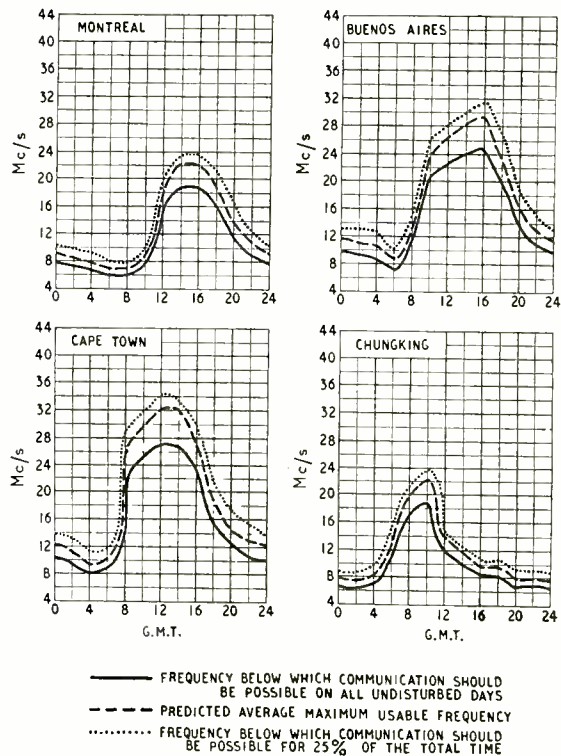

# LETTERS TO THE EDITOR

The Editor does not necessarily endorse the opinions expressed by his correspondents

## “Faulty Interlacing”

G. N. PATCHETT'S article in the July and August issues is a notable contribution to interlacing technique. This is not so much because of the particular circuit which he advocates in his Fig. 20 (there are other ways of achieving the required result) as because of the way in which he has established the principles. As a result, certain peculiar effects which have been noted experimentally can now be satisfactorily explained.

When using trains of frame pulses which are identical in successive frames except at their ends, like those in Patchett's Fig. 9, it has been found that interlacing is not obtained when the blocking oscillator has a charging circuit at both grid and anode. On the other hand, perfect interlace is obtained when it has one charging circuit only, at the grid. In both cases, the sync pulses are applied to the anode.

Referring to the accompanying figure, if flyback is completed and the valve rendered non-conductive before the

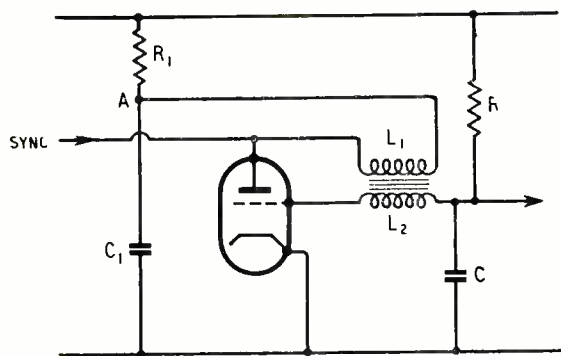

end of the pulse train, the end of the train can have no appreciable direct effect on the charge on C. Pulse currents flowing in L<sub>1</sub> can induce e.m.f.s in L<sub>2</sub> but, because C is normally very large compared with the grid-cathode capacitance of the valve, they can affect the charge on C very little indeed.

The currents flow directly into C<sub>1</sub>, however, with an effect dependent on its capacitance. If it is very large, so that point A is at a substantially constant potential, they affect the performance negligibly. If C<sub>1</sub> is small, however, as it must be if a saw-tooth is to be developed on the anode, the precise charge on C<sub>1</sub> at the start of a scan is affected appreciably by the pulse currents and differently on successive frames. The charge at the end of the scan is dependent on the charge at the beginning and is also affected. During flyback, grid and anode currents flow simultaneously and the magnitude of each is affected by the magnitude of the other. The valve therefore couples C and C<sub>1</sub> during the flyback and the variations in charge on C<sub>1</sub> between successive frames affect the grid waveform also.

I noticed this effect some years ago when developing the *Wireless World* Television Receiver and I utilized the blocking oscillator to generate a grid saw-tooth, for the very good reason that I found it to be the only way of obtaining good interlacing. A separator giving identical pulse trains on all frames had not then been developed. Patchett's article now provides the reason for this behaviour which has always seemed somewhat anomalous.

As a result of Patchett's work and my own experience, I would formulate the first requirement for interlacing as follows:—

It is a necessary, but not a sufficient, condition for interlacing that the frame synchronizing pulses applied to the

saw-tooth generator shall be identical in successive frames for such time as they are capable of influencing the generator.

The italicized clause covers the case mentioned above and is worth stressing. If the generator is not affected by differences in the ends of the pulse trains, it is clearly not worth while using a special separator which makes them alike, especially if it is inconvenient to do so. Provided that flyback is completed before the ends of the pulse trains the blocking oscillator with the saw-tooth developed on the grid, the anode fed from a constant-voltage source and negative-going sync pulses fed to the anode is one such circuit. Another should be any form of blocking oscillator of sufficiently rapid flyback with the sync pulses injected by a third winding on the transformer.

London, N.14.

W. T. COCKING.

## Television Bandwidth

WITH reference to W. MacLanachan's letter in your October issue, I should be glad to have an opportunity of confirming that the transmissions radiated from all the B.B.C. television stations include video frequencies up to 3 Mc/s. There is no intention deliberately to restrict the bandwidth of these transmissions to some lower figure within a 3-Mc/s bandwidth such as 2.75 Mc/s.

It is the B.B.C.'s aim not only to maintain but to improve the quality of its television transmissions, since the 405-line system has not yet been exploited to its fullest potentialities.

F. C. McLEAN,  
Deputy Chief Engineer, B.B.C.

## “R.F. Characteristics of Capacitors”

R. DAVIDSON is to be congratulated on his article in the August *Wireless World*, which should be of considerable value to both receiver and suppressor designers.

The specific use of the series resonance of a capacitor together with the parallel resonance of the complementary inductor for television band suppressors is of interest in so far as it is a departure from the conventional. Presumably the normal filter functions of L and C are replaced by a form of attenuator which may be resistive, capacitive or inductive in the region of resonance. Whilst mention is made of the useful bandwidth of the capacitor series resonance, nothing is said about the bandwidth of the coil impedance. One wonders, therefore, whether this is at all critical. A further question can be posed on the behaviour of the suppressor at frequencies higher than resonance, but within the frequency band over which suppression is required. Would the change from low-pass to high-pass configuration give rise to considerable worsening of the attenuation of noise voltage?

During certain experiments with the design of suppressors to cover the nominal frequency band 0.15 Mc/s—30 Mc/s I have noticed that some improvement can be obtained between 1 Mc/s and 3 Mc/s when using single terminal with earthed case capacitors, by taking the circuit to and from the capacitor as with the two-terminal connection shown by Mr. Davidson. The process is simple. It involves merely the removal of the flexible lead provided and careful soldering of the circuit wires to the stub connection left. The effect of the optimum earthing point of the metal case has not, however, been noticed, as the capacitors concerned are designed to seat completely in a metal clip, which forms the earth connection.

With reference to the bushing capacitors it seems that the author has said just enough to whet the appetite and too little to be of practical help. The transfer impedance

curve shown appears to represent the ideal, and the question of whether such results can be obtained under practical conditions; i.e., when the capacitors are mounted within the restricted compass of the average suppressor, remains unanswered.

It would be useful to learn the best method of mounting bushing capacitors to give the desired performance, and how the practical consideration of small areas of metal (the earth plane of a suppressor) can be related to the unspecified theoretical requirement.

From observation of test results it seems that when these capacitors are mounted on small areas the parallel resonance peaks are often of a magnitude such as to lessen considerably the suppression obtained about 10 Mc/s. This may well be a function of the mounting.

Perhaps Mr. Davidson could offer his advice on these points, as an expensive bushing capacitor, which over a nominal frequency range of 10 to 1 (10 Mc/s—100 Mc/s) offers an impedance of many ohms, rather than a fraction of an ohm, is surely wasted. Of equal importance, a soundly conceived component may thus get an undeserved bad name.

Weymouth, Dorset.

T. E. CLARKE.

copy that serve no useful purpose other than confirmation of contact. Many operators, and I include myself in this category, would be completely hopeless in receiving perfect copy of code groups at 20 w.p.m. Only by sacrificing all experimental work in favour of operating could one approach this standard.

Amateur radio is a hobby, a very instructive one and one that in the event of an emergency can provide a backbone not of telegraphists but men capable of installing and maintaining radio and radar equipment. Only a very small number of amateurs were either wanted or used as telegraphists during the last war. Given a reasonable aptitude, an operator can be trained on a high-pressure basis in a few months, but even poor mechanics require years of training.

If Mr. Richardson is interested purely in operating, good instruction, a few reasonably free kc/s to work on and gear loaned free, may I commend to him one of the Services wireless reserves—not the amateur band where, at any rate in England, the largest percentage of stations are genuinely interested in technical advancement and progress.

Maidenhead, Berks.

RAYMOND M. EVANS,  
G3GGE

*Institution of Electronics*

AS a regular reader of *Wireless World* for some years' standing I have always appreciated the "unbiased" ramblings of "Free Grid," but I cannot overlook the apparent ignorance which led him to write the last paragraph in his August article.

"Free Grid" has missed his opportunity of forming an Institution of Electronics by many years as the one already in existence was incorporated in 1920. However, if he can prove his knowledge and ability in this field he will be welcome as a member and may write M.Inst.E. (not M.I.Etron.E.) after his name.

Electronics is not a subject that any electrical engineer or electrician can tackle with ease. I worked on electronic apparatus before the word was coined, and I feel most strongly that electronics must be considered as a specialist subject and to do justice, an engineer must study it as such.

London, S.E.2.

DEREK J. SWADKIN, A.M.Inst.E.

**"Wireless World" Diary**

WHAT is the empirical formula for calculating the output power required from an amplifier to fill a hall of a given size?

- What is an ultra-high frequency?
- What standard frequencies does Rugby transmit?
- What is the circuit arrangement for suppressing a thermostat? or
- What is the annual charge for an amateur transmitting licence?

It is answers to such questions as these that are readily available in the 80-page reference section of the *Wireless World Diary*, 1953, which gives in tabloid form the kind of technical and general information so often needed by radio men but seldom readily available.

Now in its 35th year of publication, the Diary—which gives a week to an opening—is a veritable mine of information, as will be appreciated from this selection from the contents of the reference section: abacs for estimating coil windings and circuit constants, addresses of radio organizations, s.w. and v.h.f. aerial design, circuit diagrams (including a 90-Mc/s converter and 2-watt a.c./d.c. amplifier), licence regulations, component coding and base connections for nearly 500 current valves selected from our "Radio Valve Data."

We are advised by our Publisher that all stocks of the Diary have been despatched to booksellers and news-agents, from whom copies are obtainable, price 6s 1½d (morocco leather) or 4s 7d (rexine) including purchase tax.

**R/T HANDBOOK**

ANOTHER publication into which is collated a considerable amount of information—but in this case exclusively on maritime radio—is the "Radiotelephony Handbook" issued by the Marconi International Marine Communication Co. for the benefit of users of marine radio-telephone equipment. Details are given of the services available in Europe, operating procedure and rates for radio-telephone calls to subscribers ashore via the land stations listed. Particulars (including geographical position, transmitting frequency and hours of service) are also given of the stations in the British Isles, Western Europe and the Mediterranean providing facilities for the exchange of radio-telephone calls to and from ships at sea within about 150 miles of the station.

*Phase Angle Ellipse*

WITH reference to the note on p. 432 of the October issue of *Wireless World*, may I suggest a slight correction?

The simple method of estimating phase angle given is valid only when the *x* and *y* total deflections are equal; not the applied signal amplitudes as stated.

These deflections can be made equal if a continuous amplitude control is available for either signal. The modern fashion in oscilloscopes is, however, to provide stepped amplitude control, which means that it is often inconvenient to satisfy the necessary conditions.

Dundee.

H. SUTCLIFFE.

**Editorial Note.**—It was assumed that the *x*- and *y*-deflection sensitivities of the tube were equal, but, as Mr. Sutcliffe points out, it would have been better to say "When voltages of the same frequency but differing in phase are applied to the *x*- and *y*-plates and have their amplitudes adjusted to produce equal deflections."

*Amateur Operators*

I CAN see no justification for publication of the letter from W. A. Richardson (October issue). Not only is the assumption that all phone operators are demons and all c.w. operators little blue-eyed boys incorrect, but grossly unfair. While in no way condoning the gibberish talked by some operators, may I point out that, if Mr. Richardson were able to read morse code, he would find an equally large percentage of c.w. contacts are "pattern"

# WORLD OF WIRELESS

Problems of Specialization ♦ R.S.G.B. Show ♦ New London Television Transmitter ♦ R.T.R.A. Apprenticeship Scheme

## Specialization

THIS age of specialization has made it virtually impossible for a radio engineer to be an authority on any but a few of the aspects of radio or electronics on which he is closely engaged or which impinge upon his work.

This aftermath of the war, when, for reasons of security, engineers were segregated into "information-tight" groups, was criticized by W. E. Miller in his inaugural address as president of the British Institution of Radio Engineers. He contended that the Institution was not completely fulfilling one of its major objects—the dissemination of knowledge—if it provided only specialized high-level papers from which only a percentage of its members were able to profit. He proposed the publication of regular survey papers on every main branch of electronics so that those engaged in one aspect of the art can keep abreast of developments in radio and electronics generally.

The president suggested that whereas the specialist knows more and more about less and less, the "generalist"—to coin a word—knows less and less about more and more!

Mr. Miller recalled that when the Institution was formed in 1925, radio was just beginning to develop into an industry. Consequently, engineers started to specialize in the radio field, which although then allied with electrical engineering, nevertheless had its own individual technical problems. Now radio engineering has become recognized as a separate and distinct profession in which there are many specialized branches.

## Phonetic Alphabets

WHEN the new phonetic alphabet for use in aeronautical radio-telephony was introduced by the International Civil Aviation Organization last November (see *W.W.*, December 1951, page 512) it was stated that although the new alphabet would normally be used by all Civil Aviation ground stations in this country, the old "Able-Baker" analogy would continue to be available to pilots on request until October 1st this year. It was hoped by the Ministry of Civil Aviation that pilots would use the new alphabet and so enable practical experience to be acquired. Little use has, however, been made of the I.C.A.O. alphabet, but it has been decided that it should be brought into general aeronautical use in the U.K.

## Amateur Radio Show

SIR IAN FRASER will officially open the R.S.G.B. sixth annual amateur radio exhibition at the Royal Hotel, Woburn Place, London, W.C.1 at 12 noon on November 26th. The exhibition, which is promised the support of a number of organizations who specialize in the provision of equipment, components, accessories and publications for amateurs, will be open daily from 11.0 to 9.0 on November 26th, 27th, 28th and 29th.

The R.S.G.B. will be exhibiting equipment constructed by its members and the British Amateur Television Club is to stage a demonstration of amateur television gear.



SIR IAN FRASER

Among those taking space at the exhibition are:—

Air Ministry, Automatic Coil Winder, Cosmocord, E.M.I. Sales and Service, Easbind, English Electric, G.E.C., G.P.O., George Newnes, Goodmans, Panda Radio, Philipps Metalworks, Salford Electrical Instruments, Siemens, Taylor Electrical Instrument, War Office, Westinghouse, *Wireless World* and *Wireless Engineer*.

Admission to the show is price 1s.

## New A.P. Transmitter

ONE of the two 5-kW vision transmitters and associated 2-kW sound installations ordered by the B.B.C. from Marconi's in May is to be installed as a reserve at Alexandra Palace in time for the Coronation next year. As already announced, the other installation will be used at Sutton Coldfield.

Incidentally, the London County Council has stated that the B.B.C. has been granted the use of a 2-acre site at the Crystal Palace for the erection of a mast and transmitter building to replace the station at Alexandra Palace, the lease for which expires in 1956.

## Service Apprentices

PLANS for a National Apprenticeship scheme for service technicians announced by the Radio and Television Retailers' Association at the end of last year have been approved by the Ministry of Labour and the scheme is now in operation.

Controlled by the Joint Standing Committee for the Radio Service Trade (representing the R.T.R.A. and the Guild of Radio Service Engineers) the scheme provides for boys to become apprenticed between the ages of 15 and 16 until they are 21. The employer must allow the apprentice to attend an approved course at a Technical College for one whole day or two separate half days each week, with the proviso that the apprentice should regularly attend evening classes. Although sponsored by the R.T.R.A. the scheme is not exclusively for members of the association.

Apprenticeship terms including recruitment, ratio of apprentices to skilled workers, registration, rates of pay and training are obtainable from the Joint Standing Committee, 26, Fitzroy Square, London, W.1 (Tel. Euston 2662).

## Electronics Apprenticeships

IN spite of the fact that the announcement was made only eleven days before the closing date for applications (too late incidentally for inclusion in *W.W.*), some 400 boys between the ages of 16 and 17 applied for the 25 five-year apprenticeships in electronics recently offered by the Ministry of Supply.

The first twelve months of the course will be spent on engineering craft work at one of the Ministry's research establishments or ordnance factories, which will be followed by four years at the School of Electronics, Malvern.

The course is designed to enable apprentices to obtain, at least, the Ordinary National Certificate in Mechanical and Electrical Engineering and the Higher N.C. in Electrical Engineering, with emphasis on electronics.

## PERSONALITIES

Sir Noel Ashbridge, who recently retired from the directorship of technical services in the B.B.C., has joined the board of directors of Marconi's W.T. Co., Marconi Marine, Marconi Instruments and English Electric Valve Co. By this appointment he rejoins the organization in which he began his

association with broadcasting, for he was in charge of Marconi's experimental broadcasting station at Writtle for several years prior to joining the B.B.C. in 1926.

**Sir Ian Jacob**, whose appointment as Director General of the B.B.C. in succession to Sir William Haley (now Editor of *The Times*) was announced on October 8th, has been associated with overseas broadcasting throughout his six years' service with the B.B.C. He joined the Corporation as Controller of the European Service and subsequently became Director of External Broadcasting. He headed the B.B.C. delegation to the Torquay conference in 1950 at which the European Broadcasting Union was formed and was elected its first president.

**B. J. O'Kane**, Ph.D., B.Eng., A.M.I.E.E., has joined Marconi's as chief air radio engineer. Since 1947 he has been chief engineer of International Aeradio, Ltd., prior to which he was in the G.E.C. Research Laboratories from 1935—with the exception of the war years when he was seconded to T.R.E., Malvern. It will be recalled that he was among the recipients of awards earlier this year for "contributions to the development of radar installations." His claim (with E. J. Dickie) was for the "north-seeking P.P.I." Dr. O'Kane graduated as Bachelor of Engineering (first-class honours) at Liverpool University, where he also obtained his Ph.D.

**M. I. Forsyth-Grant**, who joined International Aeradio, Ltd., in 1947, has been appointed chief engineer in succession to Dr. O'Kane, to whom he was assistant. Prior to joining I.A.L. he was a research engineer with E.M.I. Engineering Development, Ltd., which he joined in 1939.

**H. S. Payman**, B.Sc., M.I.E.E., is shortly relinquishing his position as general manager of A. B. Metal Products to take up his appointment as joint managing director of Hawk, Ltd., electrical engineers, of Treforest, Pontypridd, Glam. He was formerly Deputy Director of Communication Components Production, M.A.P.

**H. A. Springer**, A.M.I.E.E., has been appointed contracts manager of Sangamo Weston, Ltd., which he joined in 1932.

## OUR AUTHORS

**F. H. Brittain**, who contributes the article on p. 440, received his technical training at Faraday House prior to joining the Research Laboratories of the General Electric Co. at Wembley. He at first worked on photoelectric cells and talking films and then joined the newly formed acoustics section in 1929 remaining there for 10 years. During that time he introduced "White Noise" as a reference sound for subjective loudness determinations, and used an analysis of "White Noise" for measuring loudspeaker performance in reverberant surroundings. During the war Mr. Brittain was engaged in the production of silicon of high purity for radar frequency-changers. In 1947 he restarted the acoustics section.

**R. W. Leslie**, joint author of the article "Automatic Broadcasting" in this issue, joined the B.B.C. at Aberdeen in 1930 and subsequently transferred to the television outside broadcasts section, where he stayed until the outbreak of the war. He then

joined the staff of the Superintendent Engineer (Transmitters). In 1944 he went to Italy with the War Reporting Unit. He left the B.B.C. in 1946 to become technical superintendent with the United Insulator Co. at Rowwood, and two years later returned to the Corporation, where he is now in the Planning and Installation Department and is mainly concerned with televisions transmitters.

**C. Gunn-Russell**, joint author of the article "Automatic Broadcasting," joined the B.B.C. in 1944 direct from college. After two years in the Lines Department he transferred to the newly formed Designs Department, where he has been mainly concerned with the development of automatic monitoring equipment.

**G. Bramsley**, contributor of the article on loop aerial reception in this issue, graduated from the Royal Technical College, Copenhagen, Denmark, as radio engineer in 1928. Two years later he joined the Danish Posts and Telegraphs, Radio Department, where he has supervised the erection of transmitting and receiving stations, and from 1939-1946 was engineer-in-charge of the Skamlebaek transmitting station. Since 1947 he has been working in the broadcasting field planning medium-wave and f.m. stations and investigating aerial design problems.

## IN BRIEF

**Receiving Licences.**—At the end of August there were ten times as many television licences as car-radio licences in the U.K.; 1,597,947, compared with 158,930. The month's increase in television licences was 33,693. The total number of receiving licences was 12,806,012.

British television techniques were recently studied by 17 representatives of broadcasting organizations in Austria, France, Germany, Italy and Sweden during the two-week course arranged by the British Council. The first week of the course was devoted to the television organization of the B.B.C. and the second to visits to manufacturers and the G.P.O. Research Station.



SIR IAN JACOB  
(See "Personalities")

**Magnetic Recording.**—It is announced by the European Broadcasting Union that a technical conference on magnetic recording will be held in Hamburg from November 18th to 22nd, to which representatives of the broadcasting organizations of Europe have been invited.

**Television in the Cinema.**—The British Kinematograph Society is arranging a series of lectures designed to instruct projectionists and technicians in the principles of television and especially large-screen projection. The first of these will be held at 11 on November 18th at the Birmngham and Midland Institute, Paradise Street (Ratcliffe Place entrance). The course is not exclusively for members of the Society, and the fee for non-members is 25/-. Details of this and subsequent lectures in Leeds and Liverpool are obtainable from the Secretary, B.K.S., 164, Shaftesbury Avenue, London, W.C.2.

**City and Guilds examination results for 1951** (recently issued by the Department of Technology) record that 70.9 per cent of the 334 candidates for the examination in Radio Service Work passed. 196 of the 298 taking the Radio Servicing Certificate exam., 46 of the 78 taking the Television Servicing Certificate exam. and 505 of the 604 who sat for the Radio Amateurs' exam. were successful. Of the 3,287 taking the radio section of the Telecommunications Engineering course, 1,256 failed, as did 1,578 of the 2,744 who took the exam. in mathematics for telecommunications. The number of candidates for the five sections of the telecommunications (principles) exam. was 8,786, of whom 3,985 failed to reach the requisite standard.

**Strasbourg's new medium-wave broadcasting station** which came into operation on October 19th has been equipped with three 100-kW transmitters by the French Thomson-Houston Company and a fourth transmitter is to be installed in the near future. Two of the three high-power sets can be coupled together.

**Auditoria Acoustics.**—A course of three lectures on "The Acoustic Design of Auditoria" will be given by W. A. Allen, B.Arch., A.R.I.B.A., and P. H. Parkin (D.S.I.R. Building Research Station) at the Royal Institution, 21 Albemarle Street, London, W.1, on November 25th, December 2nd and 9th, at 5.15. The fee for the course is 6s.

**A.B. Metal Products** have been granted the sole manufacturing and distribution rights for the British Empire of the range of resistors and potentiometers manufactured by the Clarostat Manufacturing Co. of New Hampshire, U.S.A. An exchange of engineers has been arranged to facilitate the production of Clarostat components in this country.

**Decca's mobile radar demonstration unit** started a European tour through Germany, Denmark, Sweden and Norway on September 22nd. It will conclude at Oslo in November. The vehicle, which is completely self-contained, is equipped with both shipborne and harbour radar.

**J.I.E. Award.**—John Heywood, who is a technical assistant in the Development Laboratory of Central Rediffusion, Wandsworth, has been awarded a Durham Bursary, valued at £20, by the Junior Institution of Engineers for his thesis "Fading due to Marine Vessel's Aerial System and a Method of Eliminating its Effect."

**E.I.B.A. Ball.**—The annual ball in aid of the Electrical Industries Benevolent Association will be held on November 14th at Grosvenor House, Park Lane, London, W.1. Tickets price two and a half guineas, are obtainable from the Association, 32, Old Burlington Street, London, W.1.

**Consistent Reception** of both the sound and vision signals from Holme Moss at distances varying from 250 to 400 miles during a 30-day field-strength survey in the Atlantic is reported from the motor yacht *Electra* to Pye whose standard FV1 receiver was used. It was found that an inverted "V" or half rhombic aerial with each leg three wavelengths long gave much better reception than the conventional three or four element dipole array.

**Commercial Tape Recordings.**—Full-length symphonic works are included in the initial list of tape recordings to be issued in America by Mavotape, Inc., and distributed by Magnecord International Ltd., 89, Broad Street, New York 4, N.Y. Recorded on half-tracks of standard-width tape at 7½ in/sec, these recordings are claimed to have a frequency range of 50-15,000 c/s with suitable equalization, and to give a playing time of 1 hour from a 7 in reel. Price will be according to length, with the 7 in reel of 1,200 ft (2,400 ft of recording) costing 9.95 dollars.

**Properties of Metals.**—The main section of the "Metal Industry Handbook, 1952," is devoted to the general properties of metals and alloys, while other sections are devoted to general data, electro-plating, a directory of associations and manufacturers, and a buyers' guide. This 41st edition of the Handbook is published in conjunction with the journal *Metal Industry* at a combined subscription of £2 12s.

**Multicore** have issued a number of new products including a 1lb 50/50-alloy 18-s.w.g. pack. Incidentally, the price of this is inadvertently given as 17/- in the back cover advertisement of this issue; it should be 15/-. Ersin and Arax liquid fluxes are now available in 10oz tins and Multicore solder is now supplied to order in ½ lb reels in even gauges between 24 and 34 s.w.g.; up to now 22 s.w.g. was the finest.

**Experimental v.h.f. ship-to-shore** radio-telephone service was recently inaugurated in Jersey and Guernsey. The Pye equipment was installed by Rees Mace Marine, Ltd., whose yacht *Pye Dolphin* was used for the inaugural ceremonial cruise over a radius of 20 miles.

**Enthoven Solders, Ltd.**, is the name of the new company formed by H. J. Enthoven & Sons to market the company's solder and solder specialties. The subsidiary company will operate from the head office of the parent company, 89, Upper Thames Street, London, E.C.4 (Tel.: Mansion House 4533).

**A British Offshoot** of the West German radio company, Grundig Radio-Werke GmbH, has been formed with a factory at Kidbrooke Park Road, London, S.E.3 (Tel.: Lee Green 0768). Chairman and managing director of Grundig (Great Britain), Ltd., is A. E. Johnson, until recently managing director of J. B. Manufacturing (Cabinets), Ltd. George S. Taylor, late of Whiteley Electrical, is sales director, and John M. Ridlev, who for the past three years has been editor of *British Radio and Television*, is publicity manager. The company's first product in this country is to be a tape recorder.

**G.E.C.** has been awarded a ten-year contract to provide and maintain the battery-operated receivers installed by the Community Broadcasting Service of the Malayan Government. Some 720 installations are provided for.

**Television Society.**—To mark the silver jubilee of the Television Society a booklet has been prepared tracing its history and aims and present activities.



DR. B. J. O'KANE

**Marconi's** have reorganized their Aeronautical Division, which was formed after the first World War and has been under the management of L. A. Sweny since 1936. Dr. B. J. O'Kane, as reported in "Personalities," has been appointed chief air radio engineer, R. R. Stanford-Tuck as sales manager of the Division, and F. Wheeler, who has been with the company since 1918, as contracts manager.

## NEW ADDRESSES

**Business Radio.**—Marconi's have opened a new depot at 82-86, Belsize Lane, Hampstead, London, N.W.3 (Tel.: Hampstead 4114), for the installation and repair of v.h.f. mobile radio-telephone equipment. Also a sales unit has been established at Marconi House, Strand, London, W.C.2 (Tel.: Temple Bar 1577, ex. 104).

**W. Edwards & Co.**, manufacturers of high-vacuum equipment, of Lower Sydenham, London, S.E.26, have opened a sales and service department at 44, West George Street, Glasgow.

**British Communications Corporation** has moved its offices and works from Gordon Avenue, Stanmore, to Second Way, Exhibition Grounds, Wembley, Middx. (Tel.: Wembley 1212).

**C.R.T. Depots.**—Additional depots for testing Ediswan-Mazda cathode-ray tubes have been opened at 53, Trafalgar Street, Sheffield, 1 (Tel.: Sheffield 27004); 53, High Street, Keynsham, Bristol; and 157a, St. Vincent Street, Glasgow, C.2 (Tel.: Central 0687-9).

**Metrovick and Ediswan** have opened new premises at 10-12, Hospital Street, Birmingham.

**Marconi International Marine Communication Co.** has opened a new depot at Marconi House, Regent Road, Aberdeen.

## MEETINGS

### Institution of Electrical Engineers

**Radio Section.**—"Radio Telemetering" by E. D. Whitehead, M.B.E., B.Sc., and J. Walsh, B.Sc., on November 12th.

"Harmonic Response Testing Apparatus for Linear Systems" by D. O. Burns, B.Sc. (Eng.), and C. W. Cooper, B.Sc. (Eng.), and "A Simple Connec-

tion between Closed-loop Transient Response and Open-loop Frequency Response" by J. C. West, B.Sc., and I. Potts, B.Sc., on November 18th. (Joint meeting with Measurements Section.)

"Recent Progress in Radar Duplexers, with special reference to Gas-Discharge Tubes," by P. O. Hawkins on November 24th.

The above meetings will be held at 5.30 at Savoy Place, London, W.C.2.

**East Midland Centre.**—"The Problems Associated with the Application of Electronics in Heavy Industry" discussion opened by H. E. Knight at 6.30 on November 18th at the Electricity Service Centre, Derby.

**Cambridge Radio Group.**—Address by E. C. S. Megaw, M.B.E., D.Sc. (chairman of the Radio Section) at 8.15 on November 11th at the Cavendish Laboratory.

**North-Eastern Radio Group.**—"The General Principles of Digital Computers and their Applications" by Professor F. C. Williams, O.B.E., D.Sc., D.Phil., F.R.S., at 6.15 on November 3rd at King's College, Newcastle-on-Tyne.

"Microwave Radio Links" by A. H. Starr, M.A., Ph.D. and T. H. Walker, B.Sc. (Tech.), at 6.15 on November 17th at King's College, Newcastle-on-Tyne.

**North-Western Radio Group.**—"Radio Telemetering" by E. D. Whitehead, M.B.E., B.Sc., and J. Wash, B.Sc., at 6.30 on November 26th at the Engineers' Club, Albert Square, Manchester.

**South Midland Radio Group.**—"The Teaching of Television Servicing" by R. G. Moseley at 7.0 on November 7th at the Electrical Engineering Dept., College of Technology, Birmingham.

"Radio Astronomy" by K. D. Machin, M.A., at 6.0 on November 24th at the James Watt Memorial Institute, Great Charles Street, Birmingham.

**Northern Ireland Centre.**—"Some Recent Developments in Phototelegraphy and Facsimile Transmission" by J. Bell, M.Sc., J. A. B. Davidson, M.A., and E. T. A. Phillips at 6.45 on November 11th at Presbyterian Hostel, Howard Street, Belfast.

**North Staffordshire Sub-Centre.**—"Electronic Telephone Exchanges" by T. H. Flowers, M.B.E., B.Sc. (Eng.), at 7.0 on November 14th at the Post Office Central Training School, Stone.

**Southern Centre.**—"Radio Controlled Models" by P. A. Cummins at 7.30 on November 12th at the R.A.E. College, Farnborough.

### British Institution of Radio Engineers

**London Section.**—"The Specification and Design of Standardized Units for Electronic Computers" by A. D. Booth, D.Sc., Ph.D., at 6.30 on November 5th at the London School of Hygiene and Tropical Medicine, Keppel Street, London, W.C.1.

**Scottish Section.**—"The Development of the Radio and Electronics Industry in India" by G. D. Clifford, at 7 on November 6th at The Engineering Centre, Sauchiehall Street, Glasgow.

**North-Eastern Section.**—"Radio Counter Measures" by H. J. Barton-Chapple, B.Sc., at 6 on November 12th at the Institution of Mining and Mechanical Engineers, Neville Hall, Westgate Road, Newcastle-upon-Tyne.

### British Sound Recording Association

**London.**—Discussion on "Problems of Sound Recording and Reproduction" followed by "Brains Trust" at 7 on

November 21st at the Royal Society of Arts, Adelphi, London, W.C.2.

**Manchester Centre.**—"Some Aspects of Sound-on-Film Recording and Reproduction" by K. Ross at 7.30 on November 24th at the Engineers' Club, Albert Square, Manchester.

#### Television Society

**London.**—"Component Reliability in Television Receivers" by Dr. G. David Reynolds, M.Sc., (Murphy Rad.io), at 7 on November 13th.

"High-Quality Front-Projection Television Receivers" by P. D. Saw (Aren Radio and Television) at 7 on November 28th.

Both the above meetings will be held at the Cinematograph Exhibitors' Association, 164 Shaftesbury Avenue, W.C.2.

**Bedford Centre.**—"The Paris-London Television Link" by T. H. Bridgewater (Supt. Engr. B.B.C.) on November 12th.

"Video-Frequency Amplifiers" by S. W. Amos (B.B.C.) on November 26th.

Both meetings of the Bedford Centre will be held at 8 at the Clapham Road Schools, Bedford.

#### British Kinematograph Society

**Television Division.**—"The B.B.C. Television Newsreel" by P. H. Dorte,

O.B.E., at 7.15 on November 26th at the Hammer Theatre, Hammer House, Wardour Street, London, W.1.

#### Institute of Physics

**Scottish Branch.**—"Meteorological Factors affecting the Propagation of Radio Waves" by J. R. Atkinson at 7 on November 11th in the Natural Philosophy Department, University of Glasgow; at 7 on November 12th in the Natural Philosophy Department, University of Edinburgh, and at 5 on November 13th at University College, Dundee.

"Television" by A. T. Shepherd (Ferranti) at 7 on November 25th in the Natural Philosophy Department, University of Glasgow.

**Electronics Group.**—"Information Theory" by Dr. P. M. Woodward (T.R.E.) at 5.30 on November 11th at 47 Belgrave Square, London, S.W.1.

**Education Group.**—"The Teaching of Acoustics" by Dr. R. W. B. Stephens, Dr. E. G. Richardson and E. Nightingale at 5.30 on November 19th, at 47 Belgrave Square, London, S.W.1. (Joint meeting with the Acoustics Group of the Physical Society.)

**South Wales Branch.**—"Physics and General Science in Schools" discussion

at 3 on November 8th at the Technical College, Cathays Park, Cardiff.

#### Physical Society

**Acoustics Group.**—"The Normal Threshold of Hearing and other Aspects of Audiometry" by R. S. Dadson (N.P.L.) and "A Summary of the Determination of the Normal Threshold of Hearing" by L. J. Wheeler (Acoustics Laboratory, Central Medical Establishment, R.A.F.) at 5.30 on November 4th at the Imperial College, Exhibition Road, South Kensington.

#### Institute of Practical Radio Engineers

**East Midlands Section.**—"Servicing Ekco Television Receivers" by R. Shepherd (Ekco) at 7.30 on November 21st at the Electricity Showrooms, Smithy Row, Nottingham.

#### Institution of Electronics

**North-Western Branch.**—"Discharge Mechanisms in Cold-Cathode Valves" by R. W. Murray, M.A., (Ferranti), at 7 on November 28th in the Reynolds Hall, College of Technology, Manchester.

#### Radio Society of Great Britain

"The Sky-beam Propagation Problem" by Paul H. Sollom, B.Sc. (G3BGL), at 6.30 on November 21st at the I.E.E., Savoy Place, London, W.C.2.

## Unattended Transmitters

A RECENT trend in broadcasting technique is to cover certain areas by a number of separate low- or medium-power transmitters, all radiating a common programme and controlled from a central point. To this end the unattended transmitter has been designed, with reliability in operation as the foremost consideration. In the range of unattended transmitters made by Marconi this reliability is obtained by paralleling the outputs of a number of small units, each giving 660 watts, so that three will give 2 kW, a convenient power. The circuitry is arranged in such a manner that should any one (or two) of the transmitter units fail it isolates itself and the remainder continue to radiate, so that programme interruption is most unlikely.

The three-unit transmitter, type BD210C, is fitted with two drive units, one operational and one standby, the latter being brought into circuit automatically should a breakdown occur in the working unit. If the transmitter forms one of a group of transmitters working on a common frequency, a synchronized drive unit must be used so that all transmitters in the group are frequency-controlled by the same source.

The transmitter units are themselves constructed on the unit principle, so it is a simple matter to withdraw a faulty unit and replace it by an identical one. Another thing which makes for reliability is the simplicity of design. Apart from the drive equipment only two valve types are used throughout. Moreover, all moving machinery is eliminated, the cooling being done by natural air ventilation. Selenium rectifiers are used for the h.t. supplies, and overload protection relays are incorporated in the final stages. An automatic monitor with each transmitter unit checks the programme quality, phase drift, r.f. amplitude changes and audio distortion, and operates the trip circuits in a faulty unit, so shutting it down.

A simple d.c. system of control is used for transmitter power switching only. This switching is carried out in the transmitter units by a twin-relay system arranged to close the filament and h.t. contactors at the appropriate times. The operation of a single switch, either remotely or locally, will start the transmitter.

Should a fault occur on any transmitter unit, its supply circuits are automatically tripped. To prevent this occurring as a result of a transient surge or non-recurring fault, a three-trip system is used; the h.t. supplies being

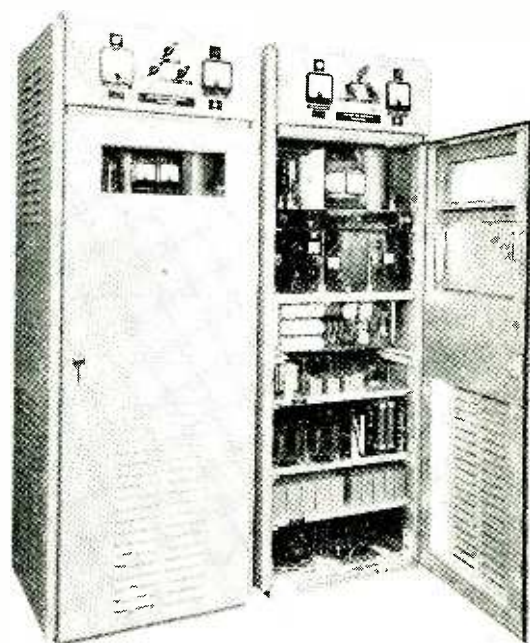

Marconi unattended transmitter with door open to show interior.

applied and broken three times, each with an interval of two seconds, before the fault relay takes control and shuts down the whole unit.

The circuit design is quite conventional and each transmitter unit comprises, apart from the drive and monitor units, a sub-modulator and cathode follower, modulator and modulated amplifier, and a r.f. amplifier. The output circuit is designed so that the same impedance is always presented across the transmitter terminals regardless of the number of units feeding into the load; thus the modulated amplifier and modulator always work into a constant impedance.



# Societies and Clubs

## Directory of Radio Groups in the British Isles

**A**RRANGED alphabetically under towns, the name of the club (and in some cases the club call sign) is followed by that of the secretary, from whom details of the society's activities may be obtained. Clubs which are affiliated to the Radio Society of Great Britain are marked with an asterisk.

**ABERDEEN.**—Aberdeen Amateur Radio Society\*.—G. M. Jamieson, 66, Elmfield Avenue, Aberdeen.

**AMERSHAM.**—Amersham, Beaconsfield and Chalfonts District Radio Society.—P. L. Spencer, Little Croft, Green Lane, Chesham Bois, Bucks.

**BALDOCK.**—Baldock Radio Society\*.—A. W. Fussell, 6, Clare Crescent, Baldock, Herts.

**BARROW - IN - FURNESS.**—Barrow Amateur Radio and Television Society\*.—J. G. Jackson, 1, Highfield Road, Barrow-in-Furness, Lancs.

**BARRY.**—St. Athan Amateur Radio Society\*.—Sgt. H. Nutty, Sergeants' Mess, 32 M.U., R.A.F., St. Athan, Barry, Glam.

**BATH.**—Admiralty Electronics Society\* (G3BPU).—W. J. Green, "Arrochar," 82, Blombfield Avenue, Bath, Somerset.

**BELFAST.**—City of Belfast Y.M.C.A. Radio Club\*.—J. Campbell, 16, Lishurn Avenue, Belfast, N. Ireland.

**Co-op Radio Society\*.**—W. F. Jordan, Husband Memorial Hall, Frederick Street, Belfast, N. Ireland.

**BIRMINGHAM.**—Austin Radio and Television Society\*.—R. D. Dixon, Longbridge Works, Birmingham, Warwick.

**Kynoch Radio and Television Society\*.**—G. E. Nicholls, Time and Work Study Department, I.C.I., Ltd., Elliott Works, Selly Oak, Birmingham, 29, Warwick.

**Midland Amateur Radio Society\*.**—G. W. C. Smith, 84, Woodlands Road, Birmingham, 11, Warwick.

**Slade Radio Society\*.**—C. N. Smart, 110, Woolmore Road, Erdington, Birmingham, 23, Warwick.

**University of Birmingham Radio Society (G3IUB).**—J. P. G. Jones, The Union, University Road, Edgbaston, Birmingham, Warwick.

**ELACKPOOL.**—Blackpool and Fylde Amateur Radio Society\*.—H. G. Newland, 161, Penrose Avenue, Blackpool, Lancs.

**BOURNEMOUTH.**—Bournemouth Radio and Television Society\*.—Major W. H. Inchbold Stevens, 47, New Road, Northbourne, Bournemouth, Hants.

**BRADFORD.**—Bradford Amateur Radio Society\*.—A. W. Walmsley, 6, Hilton Road, Legrams Lane, Bradford, Yorks.

**BRENTWOOD.**—Brentwood and District Amateur Radio Society\*.—C. A. Nightingale, 39, Westwood Avenue, Brentwood, Essex.

**BRIGHTON.**—Brighton and District Radio Club (G3EVE).—R. T. Parsons, 14, Carlyle Avenue, Brighton, Sussex.

**East Brighton Short Wave Club\*.**—F. J. Walton, 104, Warren Way, Woodingdean, Brighton, Sussex.

**BRISTOL.**—Bristol and District Amateur Radio Society (G3GIS).—N. G. Foord, 71, Brynland Avenue, Bristol, 7, Glos.

**CAMBRIDGE.**—Cambridge and District Amateur Radio Club\*.—T. A. T. Davies, Meadowside, Comberton, Cambridge.

**Cambridge University Wire'ess Society\*.**—M. Barlow, St. John's College, Cambridge.

**Pye Short Wave Radio Society\*.**—T. Simpson, Radio Works, St. Andrews Road, Cambridge.

**CATTERICK.**—Catterick Amateur Radio Club\*.—J. Phelps, 2 Squadron, 1st Trg. Regiment, Royal Signals, Catterick Camp, Yorks.

**CHELTENHAM.**—Cheltenham Amateur Radio Society\*.—W. Humphries, 8b, Elmfield Avenue, Cheltenham, Glos.

**CHESTER.**—Chester and District Amateur Radio Society\*.—W. G. Lloyd, 124, Tarvin Road, Chester.

**CHIPPENHAM.**—Colerne Amateur Radio Transmitting Club\*.—Sgt. A. G. Parsons, Air Traffic Control, R.A.F., Colerne, Chippenham, Wilts.

**CHRISTCHURCH.**—S.R.D.E. Amateur Radio Society\*.—Capt. J. Singleton, S.R.D.E., Christchurch, Hants.

**CLECKHEATON.**—Spens Valley Radio and Television Society\*.—N. Pride, 100, Raikes Lane, Birstall, Nr. Leeds, Yorks.

**CLITHEROE.**—Ribblesdale Amateur Radio Society\* (G3HYE).—E. Pearson, Back York Street, Clitheroe, Lancs.

**COVENTRY.**—B.T.H. Social and Athletic Club (Radio and Television Section)\*.—The Secretary, Lower Ford Street, Coventry, Warwick.

**Courtaulds Amateur Radio Group\*.**—P. Stevens, Courtaulds, Ltd., Foleshill, Coventry, Warwick.

**Coventry Amateur Radio Society\* (G2ASF).**—K. G. Lines, 142, Shorncliffe Road, Coventry, Warwick.

**DARLINGTON.**—Darlington and District Amateur Radio Society\*.—D. Graham, 21, Hamsterly Street, Darlington, Co. Durham.

**DARTMOUTH.**—Britannia Radio Club\*.—The Secretary, The Royal Naval College, Dartmouth, Devon.

**DERBY.**—Derby and District Amateur Radio Society\*.—E. Shimmis, 74, Derby Lane, Derby.

**DEREHAM.**—Swanton Morley Amateur Radio Club\*.—Flt. Lt. A. E. White, R.A.F., Swanton Morley, Dereham, Norfolk.

**DORKING.**—Dorking and District Radio Society\* (G3CZU).—J. Greenwell, 7, Sondes Place Drive, Dorking, Surrey.

**DOUGLAS.**—Isle of Man Amateur Radio Society\*.—H. Grist, Broadway, Douglas, Isle of Man.

**DUNFERMLINE.**—Dunfermline Radio Society\*.—D. R. Leah, 9, Bentfield, Burntisland, Fife.

**EAST GRINSTEAD.**—East Grinstead and District Amateur Radio Club\*.—F. J. Glynn, The Mount, 13, Station Road, East Grinstead, Sussex.

**ECCLLES.**—Eccles and District Radio Society\*.—E. Rayson, 11, Hartington Road, Winton, Eccles, Lancs.

**EDINBURGH.**—Edinburgh Amateur Radio Club\*.—C. L. Patrick, 19, Montgomery Street, Edinburgh.

**EXETER.**—Exeter Radio and Television Club\*.—L. R. Jenkin, 16, South Avenue, Exeter, Devon.

**FAKENHAM.**—West Raynham Amateur Radio Society\*.—Sgt. Aveling, R.A.F. Station, West Raynham, Fakenham, Norfolk.

**FORFAR.**—Forfar and District Amateur Radio Club\*.—J. Patterson, 19, Taranty Road, Forfar, Angus.

**GATESHEAD.**—Gateshead and District Amateur Radio Club\*.—J. Kennedy, 11, Lanthwaite Road, Low Fell, Gateshead, 9, Co. Durham.

**GERRARDS CROSS.**—British Amateur

Television Club\*.—M. Barlow, Cheyne Cottage, Dukes Wood Drive, Gerrards Cross, Bucks.

**GILLINGHAM.**—Medway Amateur Receiving and Transmitting Society\*.—C. R. Hawkins, 9, Sanctuary Road, Gillingham, Kent.

**GLASGOW.**—Western Short Wave Club (GM3HYD).—R. F. D. Moir, 18, Haldane Street, Glasgow, W.4, Lanarks.

**HARLOW.**—Harlow and District Radio Society\*.—H. I. Wright, Allandale Start Hill, Bishop's Stortford, Herts.

**HENLOW.**—R.E.U. Amateur Transmitting Society\*.—Sqn. Ldr. Copeland, 328a, Officers' Married Quarters, R.A.F., Henlow, Beds.

**Shefford and District Radio Society\*.**—D. J. Roper, 294F, Married Quarters, R.A.F., Henlow, Beds.

**HERTFORD.**—Hertford and District Radio Society\*.—R. L. S. Harrison, 12, Westfield Road, Bengoe, Herts.

**IXWORTH.**—Ixworth Radio Club (G3HWP).—P. G. Wright, Thurston Road, Gt. Barton, Nr. Bury St. Edmunds, Suffolk.

**KENILWORTH.**—Kenilworth Radio and Television Society\*.—S. Smith, 40, Stoneleigh Road, Kenilworth, Warwick.

**LEEDS.**—Leeds Amateur Radio Society\*.—W. Hawkridge, 7, Langdale Gardens, Leeds, 6, Yorks.

**LEICESTER.**—Leicester Radio Society\*.—A. L. Milnthorpe, 3, Winstor Drive, Thurmanston, Nr. Leicester.

**LEIGHTON BUZZARD.**—R.A.F. Bletchley Amateur Radio Society\*.—F/O R. Curtis, 6, Officers' Mess, M.Q., R.A.F., Stanbridge Road, Nr. Leighton Buzzard, Beds.

**LEWES.**—Lewes and District Model Engineering Club (Radio Section)\*.—P. A. Murphy, 22, Malling Down, Lewes, Sussex.

**LINCOLN.**—Lincoln Short Wave Club\*.—G. C. Newby, 18, Birchill, Fiskerton, Lincoln.

**LIVERPOOL.**—Merseyside Radio Society\*.—A. Bell, 20, Craigside Avenue, West Derby, Liverpool, 12, Lancs.

**Merseyside Wireless Transmitting Amateur Society\*.**—S. Orr, 2, Argyle Road, Anfield, Liverpool, 4, Lancs.

**West Lancashire Radio Society\*.**—B. J. Whitty, 46, Argo Road, Waterloo, Liverpool, 22, Lancs.

**LONDON AREA†.**—Ariel Radio Group\*.—W. J. Hayes, Bush House Section, B.B.C. Club, Bush House, Aldwych, W.C.2.

**Babcock and Wilcox Staff Association Radio Society\*.**—L. E. J. Manders, 207, French Street, Sunbury-on-Thames, Middx.

**Barnet and District Radio Club\*.**—A. D. Cliff, Hopedene, The Avenue, Barnet, Herts.

**City and Guilds College Radio Society\* (G5YC).**—R. Leek, City and Guilds College, Exhibition Road, S. Kensington, S.W.7.

**East Surrey Radio Club\*.**—L. Knight, Radiohme, 6 Madeira Walk, Reigate, Surrey.

**Edgware and District Radio Society\*.**—R. H. Newland, 10, Holmstall Avenue, Edgware, Middx.

**Electronics and Amateur Radio Society\*.**—M. S. Thayer, Queen Mary College, Mile End Road, E.1.

**Grafton Radio Society\* (G3AFT).**—A. W. H. Wennell, 145, Uxendon Hill, Wembley Park, Middx.

**Gravesend Amateur Radio Society\*.**—R. E. Appleton, 23, Laurel Avenue, Gravesend, Kent.

† Based on the G.P.O. London Telecommunications Region.

Grays and District Amateur Radio Society\*.—C. Mundy, 68, Chestnut Avenue, Grays, Essex.

Great Portland Radio Club\*.—V. F. Turner, 18, Henley Road, Edmonton, N.18.

Harrow Radio Society\* (G3BFX).—S. C. Phillips, 131, Belmont Road, Harrow Weald, Middx.

Hoddesdon and District Radio Society.—T. Knight, Caxton House, High Street, Hoddesdon, Herts.

Ilford and District Radio Society\*.—C. E. Lagen, 44, Trelawny Road, Barkingside, Ilford, Essex.

International Radio-Controlled Models Society.—C. H. Lindsey, 2/2, Bramhall Lane South, Bramhall, Stockport, Cheshire.

Kingston and District Amateur Radio Society\*.—R. S. Babbs, 28, Grove Lane, Kingston-on-Thames, Surrey.

Murphy Radio Sports Club (Radio Section)\*.—R. Stevenson, Murphy Radio, Ltd., Broadwater Road, Welwyn Garden City, Herts.

North Kent Radio Society\* (G3ENT).—C. J. Leal, 1, Deepdene Road, Welling, Kent.

North-West Kent Amateur Radio Society\*.—M. J. Frost, 15, Northbourne, Hayes, Bromley, Kent.

Port of London Authority Staff Club (Radio Section)\*.—R. T. Seaton, Lighterage Office, Northern Department, Millwall Dock, E.14.

Purley and District Radio Club\*.—A. Frost, 18, Beechwood Avenue, Thornton Heath, Surrey.

QRP Research Group\*.—J. Whitehead, The Retreat, Ryden's Avenue, Walton-on-Thames, Surrey.

Queensbridge Radio Club\*.—R. H. Lamb, 17, Queens Road, Leytonstone, E.11.

Romford and District Amateur Radio Society\*.—D. L. Coppendale, 9, Morden Road, Chadwell Heath, Romford, Essex.

Sanderstead and Purley Amateur Radio Society\*.—T. R. Young, 41, Lansdowne Road, Purley, Surrey.

South-West Essex Radio Club\*.—L. G. Barrett, 367, Rush Green, Romford, Essex.

Surrey Radio Contact Club\*.—S. A. Morley, 22, Old Farleigh Road, Selsdon, Surrey.

Sutton and Cheam Radio Society\* (G3GFA).—F. J. Harris, 143, Collingwood Road, Sutton, Surrey.

Thames Valley Amateur Radio Transmitters' Society\*.—K. A. H. Rogers, 21, Links Road, Epsom, Surrey.

Vickers-Armstrong, Ltd. (Weybridge) Social and Athletic Club (Electronics Section)\*.—A. W. Warner, Sales Accounts Department, Vickers-Armstrong, Ltd., Weybridge Works, Weybridge, Surrey.

Wanstead and Woodford Radio Society\*.—J. Binning, 150, Upton Park Road, Forest Gate, E.7.

Watford Amateur Radio Society\*.—R. W. Bailey, 32, Cassiobury Drive, Watford, Herts.

West Middlesex Radio Club\* (G3EDH).—P. W. Smith, 121, Richmond Avenue, Hillingdon, Middx.

Woolwich Radio Society\*.—A. J. Burch, 60, Sutcliffe Road, S.E.18.

LOWESTOFT.—Lowestoft and Eccles Amateur Radio Club\*.—E. Lock, 34, Nelson Road, Pakefield, Lowestoft, Suffolk.

LUTON.—Luton and District Radio Society\*.—E. Radford, 37, Wilsden Avenue, Luton, Beds.

MAIDSTONE.—Mid-Kent Amateur Radio Society\*.—D. A. Mullen, 44, Sussex Road, Maidstone, Kent.

MANCHESTER.—Faculty of Technology Amateur Radio Society\*.—M. J. Faddl, College of Technology, Sackville Street, Manchester, Lancs.

Manchester and District Radio Society\*.—P. Dean, "Fairfield," 31, Park Lane, Whitefield, Lancs.

South Manchester Radio Club\*.—F. Hudson, 21, Ashbourne Road, Stretford, Manchester, Lancs.

MANSFIELD.—Mansfield District Radio Society\*.—A. W. Fowler, Windsor, Cowpasture Lane, Sutton-in-Ashfield, Notts.

MIDDLESBROUGH.—Tees-Side Amateur Radio Society (G3HUG).—H. Walker, 64, Ayresome Street, Middlesbrough, Yorks.

NEWBURY.—Newbury and District Amateur Radio Society\*.—A. W. Grimdale, 164, London Road, Newbury, Berks.

NEWCASTLE-ON-TYNE.—North East Amateur Transmitting Society\*.—L. Bergna, 121, Addycombe Terrace, Newcastle-on-Tyne, 6, Northumberland.

NORTHAMPTON.—Northampton Short Wave Radio Club\* (G3GWB).—V. R. Hartopp, 22, Purser Road, Northampton.

NOTTINGHAM.—Nottingham University Radio Society\*.—G. M. Bayley, The Union Room, University, Nottingham.

OXFORD.—Oxford and District Amateur Radio Society\*.—J. Hickling, 47, Banbury Road, Oxford.

PENZANCE.—West Cornwall Radio Club\*.—R. V. Allbright, 12, North Parade, Penzance, Cornwall.

PORTSMOUTH.—Portsmouth and District Radio Society\* (G3DIT).—L. V. Shaw, 8, Belmont Street, Southsea, Hants.

PRESTON.—Preston Radio Society\*.—L. Hall, 7, Lilac Grove, Holme Slack, Preston, Lancs.

RAMSGATE.—Isle of Thanet Radio Society\*.—J. P. Barnes, 18, Grange Road, Ramsgate, Kent.

READING.—Army Apprentices' School Radio Club (G3HOS).—F. A. Hall, c/o Tels. Dept., A.A.S., Arborfield, Berks.

R.E.M.E. Radio Club\*.—Pte. M. Ray, Hazebrook Barracks, Arborfield, Berks.

Reading Radio Society\*.—L. A. Hensford, 30, Boston Avenue, Reading, Berks.

ROTHERHAM.—Rotherham Radio Club\*.—W. Darby, 1, New Houses, Fence, Woodhouse Mill, Nr. Sheffield, Yorks.

ROYSTON.—Royston and District Radio Club\*.—F. A. M. Ashton, 115, Meibour Road, Royston, Herts.

RUGBY.—B.T.H. Recreation Club (Radio and Television Section)\*.—P. N. Prior, B.T.H. Recreation Club, Rugby, Warwick.

SALISBURY.—Salisbury and District Short Wave Club\* (G3FKF).—V. G. Page, 32, Feversham Road, Salisbury, Wilts.

SHEFFIELD.—Sheffield Amateur Radio Club\*.—E. Walker, 20, Dalewood Road, Sheffield 8, Yorks.

SOUTH SHIELDS.—South Shields and District Amateur Radio Club\*.—W. Dennell, 12, South Frederick Street, South Shields, Co. Durham.

SOUTHAMPTON.—A.S.T. Amateur Radio Society\*.—J. N. Tracey, Air Service Training Mess, Hamble, Southampton.

SOUTHEND.—Southend and District Radio Society\* (G3QK).—T. W. Hudson, 27, Park Road, Southend-on-Sea, Essex.

SOUTHPORT.—Southport Radio Society\*.—F. H. P. Cawson, 113, Waterloo Road, Southport, Lancs.

STOKE-ON-TRENT.—Stoke-on-Trent Amateur Radio Society\*.—J. R. Brindley, 45, Rosendale Avenue, Chesterton, Newcastle, Staffs.

STOURBRIDGE.—Stourbridge and District Amateur Radio Society\*.—W. A. Hggins, 28, Kingsley Road, Kingswinford, Brerley Hill, Staffs.

STROUD.—Stroud and District Amateur Radio Society\*.—B. L. Horton, Prescott, Haven Avenue, Bridgend, Stonehouse, Glos.

TAUNTON.—Taunton and West Somerset Radio Society\*.—H. E. J. Burton, 33, Richmond Road, Taunton, Somerset.

TORQUAY.—Torbay Amateur Radio Society\*.—W. A. W. Lauder, 15, Cambridge Road, St. Marychurch, Torquay, Devon.

TUNBRIDGE WELLS.—West Kent Radio Society\*.—L. S. King, Glenista, Maidstone Road, Pembury, Kent.

WALSALL.—Walsall and District Amateur Radio Society\*.—F. J. Merriman, 123, Wolverhampton Road, Walsall, Staffs.

WARRINGTON.—Risley Radio Society\*.—D. E. Harper, Risley Club, Risley Road, Nr. Warrington, Lancs.

Warrington and District Radio Society\*.—S. Wood, 12, Thelwall Lane, Latchford, Warrington, Lancs.

WELLINGBOROUGH.—Wellingborough and District Radio and Television Society\*.—N. M. Seabrooke, 85, The Drive, Wellingborough, Northants.

WELLINGTON.—Wrekin Amateur Radio Society\*.—J. C. Tranter, 78, New Street, Wellington, Salop.

WELLS.—Wells and District Amateur Radio and Television Society\*.—W. L. Woodcraft, Haversham House, New Street, Wells, Somerset.

WESTON-SUPER-MARE.—R.A.F. Amateur Radio Society\*.—The Secretary, No. 1 Radio School, R.A.F. Locking, Weston-Super-Mare, Somerset.

WEYMOUTH.—Weymouth Radio and Television Club\*.—R. Figg, 4, Dorset Place, Weymouth, Dorset.

WIRRAL.—Wirral Amateur Radio Society\*.—A. H. Watts, 14, Grange Crescent, Hooton, Wirral, Cheshire.

WOLVERHAMPTON.—Wolverhampton Amateur Radio Society\*.—H. Porter, 221, Park Lane, Wolverhampton, Staffs.

WORTHING.—Worthing and District Amateur Radio Club\*.—R. Chidzey, 33, Bruce Avenue, W. Worthing, Sussex.

YEOVIL.—Yeovil Amateur Radio Club\*.—D. McLean, 9, Cedar Grove, Yeovil, Somerset.

YORK.—York Amateur Radio Society\* (G3HWV).—G. F. Nottingham, 51, Carr Lane, Acomb, York.

## CLUB NEWS

Birmingham.—A lecture-demonstration on "High-Quality Magnetic-Tape and Gramophone Reproduction," which will include some stereophonic recordings, will be given by C. Banks and J. Hickman (C.J.R. Electrical and Electronic Department) to members of the Slade Radio Society on November 7th in the Lecture Theatre, Aston Technical College, Whitehead Road, Aston, Birmingham. Meetings are held on alternate Fridays at 7.45.

Bristol and District Amateur Radio Society, which until last year was known as the Bristol and District Short-Wave Listeners' Club, meets formally each Friday in the St. Mary Redcliffe Church Hall, Guinea Street, Redcliffe, and on Tuesdays for c.w. courses and Wednesdays for constructional work.

East Grinstead and District Amateur Radio Club now meets on alternate Thursday evenings in Portland Hall, Portland Road, East Grinstead.

Northampton.—Meetings of the Northampton Short-Wave Radio Club are held each Friday at 6.30 at Allen's Pram Works, 8, Duke Street, when the club transmitter (G3GWB) operates on two metres.

Reading.—Membership of the club attached to the Army Apprentices' School at Arborfield, Berks, is limited to 30 and since its formation 18 months ago has reached the maximum. Meetings are held each Thursday, when the club transmitter (G3HOS) is on the air in the 80-metre band.

Wellingborough.—Officially launched on September 11th, the Wellingborough and District Radio and Television Society now meets fortnightly at the B.R. Sports and Social Club, Broad Green, Wellingborough.



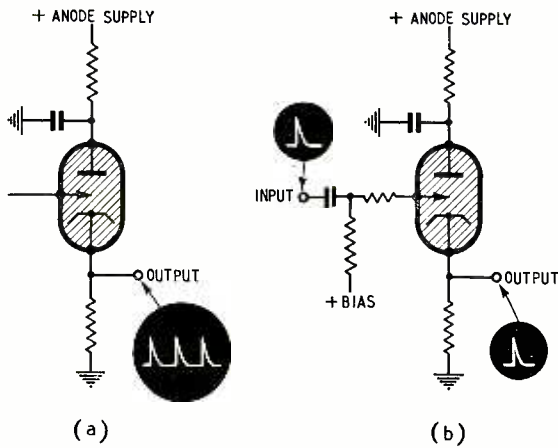

Fig. 9. Relaxation oscillator circuits, (a) straightforward circuit, (b) circuit used for impedance transforming.

In many low-frequency electronic switching applications the cold-cathode triode can be used as a relaxation oscillator for providing a source of frequency. The large difference between anode breakdown potential and extinction potential can be utilized to give output pulses of large amplitude, while the frequency can be stabilized to within 1% by using a high-stability anode supply and a constant source of illumination. A typical oscillator circuit is shown in Fig. 9(a), together with the associated output waveforms. By using the triode as shown in Fig. 9(b), a

pulse of small amplitude which comes from a high impedance source can be changed into a pulse of larger amplitude coming from a lower impedance source. The anode supply potential is lower than the breakdown potential, so that the tube is only triggered by pulses applied to the trigger electrode in the normal manner. Each input pulse to the trigger electrode causes the tube to conduct, the anode circuit being such as to extinguish the tube in a manner similar to that of the relaxation oscillator. Thus each positive input pulse to the trigger electrode will produce a positive output pulse on the cathode, the former being presented with the high input impedance of the trigger circuit and the latter coming from the low output impedance of the cathode circuit. The amplitude of the input pulse has only to be sufficient to trigger the tube, whilst the amplitude of the output pulse depends only upon the tube characteristics. In this way the tube forms a very useful buffer stage.

Cold-cathode triodes can also be connected as multivibrators and can be used in three states: (a) monostable, for use as a pulse-widener or delay circuit, (b) bi-stable, for use as a binary element, and (c) free-running, for use as a pulse generator. The most commonly used forms are (a) and (b), illustrated in Fig. 10. In (a) is one form of a pulse-widener. Tube B is normally conducting, the trigger electrode being connected to a potential sufficient to trigger the tube. A positive input pulse triggers tube A and the fall in anode potential is used to extinguish tube B through the anode coupling capacitor  $C_1$ . This fall in anode potential, though capacitor  $C_2$ , is also used to lower the potential applied to the trigger of tube B below its triggering potential. After an interval determined

Fig. 10. Multivibrator circuits, (a) monostable type, (b) bi-stable type.

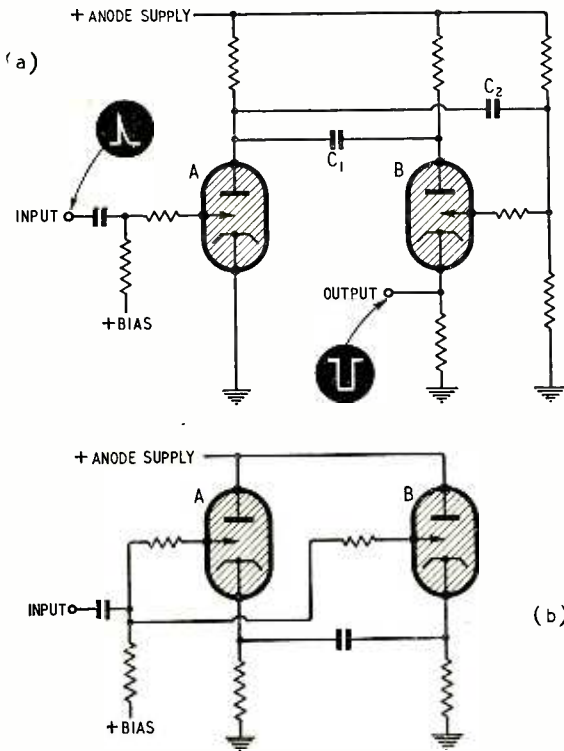
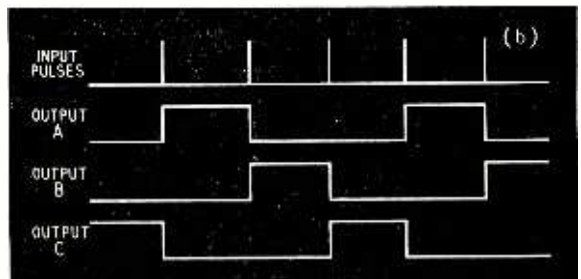
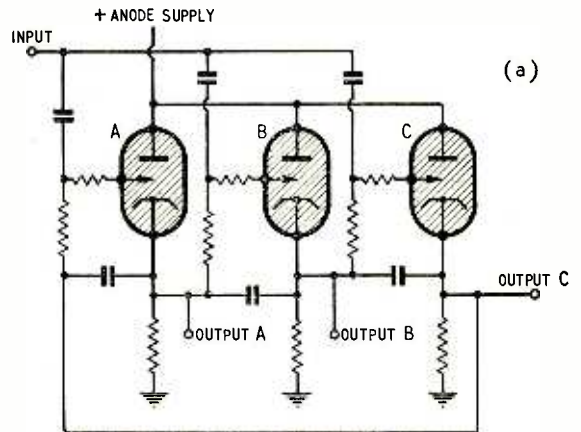

Fig. 11. Digital chain counter circuit (a), with (b) pulses obtained from cathodes of the tubes.



by the time constants of the circuit, the potential applied to the trigger will rise to the triggering value. Tube B will now re-trigger and in doing so will extinguish tube A. The period for which B is non-conducting, and its cathode is at earth potential, is determined by tube and circuit constants. A positive delayed pulse can be obtained by differentiating the output pulse from the cathode of tube B.

The bi-stable state is illustrated in Fig. 10(b).

The trigger electrodes of tubes A and B are connected to a common bias supply and input. Suppose A is conducting, then the first positive input pulse will trigger tube B. The rise in cathode potential of tube B is used to extinguish tube A through the cathode coupling capacitor. The next input pulse triggers the tube A, which extinguishes tube B, and so on. Hence tube B is conducting for every second input pulse, so that the circuit is acting as a single-stage binary counter.

### Digital Chain Counters

The most useful cold-cathode tube counter in electronic switching is the digital chain counter, which can also be used as a pulse distributor. Digital chain counters can be divided into two classes, depending upon the principle of operation. First, where the input pulse triggers a tube which extinguishes a previously conducting tube or tubes, and second, where the input pulse extinguishes a tube which causes the succeeding tube to trigger. Further subdivision can be made according to the nature of the input pulse and the electrode to which it is applied.

Examples of the two classes of digital chain counters are shown in Figs. 11 and 12. In Fig. 11(a) if tube A is conducting, its cathode potential is applied as positive bias to the trigger of the next tube B. The

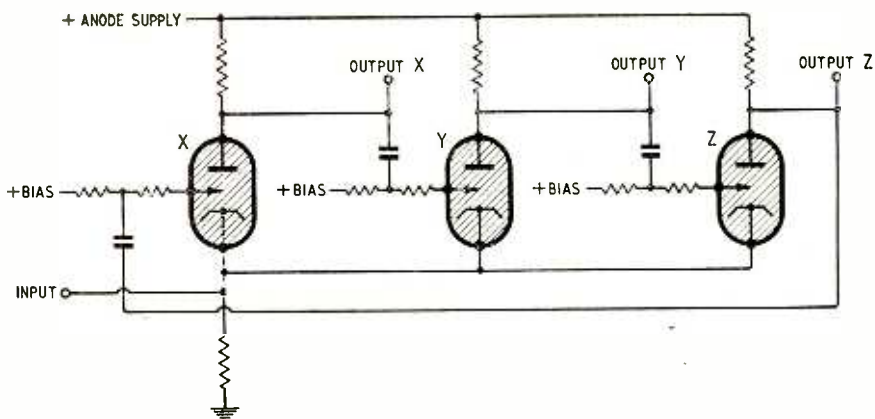

Fig. 12. Another digital chain counter using tubes with a common cathode impedance.

next positive input pulse will trigger tube B and no other. When tube B conducts, its rise in cathode potential is used to extinguish tube A by means of the cathode coupling capacitor. Fig. 11(b) shows the time-distributed positive pulses which are obtained from the cathodes of the tubes A, B and C.

In Fig. 12 the tubes have a common cathode impedance. The input pulses are positive and are such as to extinguish any tube which is conducting. If X is conducting the next input pulse will extinguish it, and the subsequent rise in anode potential is used to trigger the next tube Y. Negative output pulses can be obtained from the anodes of the three tubes at X, Y and Z.

In these and similar circuits, the speed of counting is limited to about 200c/s by the extinction time of the tubes. It is however possible to increase counting time, and thus extend the operating range, by extinguishing the tubes in groups rather than in sequence. Such an arrangement is shown in Fig. 13, where two groups of tubes, A and B are connected to a switch which applies h.t. to either group. If h.t. is applied to group A, the first input pulse triggers tube  $A_1$  and the  $n$ th pulse triggers the  $n$ th tube  $A_n$ . When  $A_n$  triggers, a pulse is taken from its cathode and operates the h.t. switch. This transfers h.t. from the group A tubes, which are extinguished, to the group B tubes, which can now trigger. The process is reversed when

Fig. 13. High-speed digital chain counter circuit with tubes extinguished in two groups, A and B.

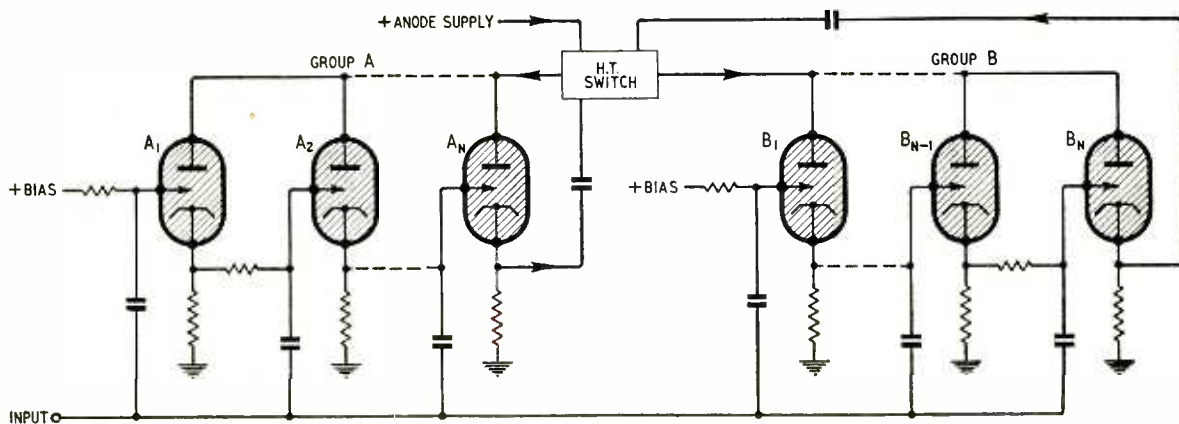

$B_n$  triggers. The time taken between the firing of  $A_n$  and that of  $B_n$  must therefore be less than the extinction time  $t_D$  of a single tube. The maximum frequency of operation is thus equal to  $N/\sqrt{t_D}$ , where  $N$  is the number of tubes in each group. If  $t_D$  is 0.002 sec and  $N$  is 10, the maximum frequency of operation is 5,000c/s, provided that the h.t. switch, which may be a high-speed relay or a hard valve multivibrator, can be operated at this frequency.

### Poly-electrode Tubes

In the poly-electrode diode, a common anode (or cathode) is associated with a multiplicity of cathodes (or anodes), the ionization in one anode-cathode gap being sufficient to trigger the other gaps. When the tube is non-conducting, the circuits connected to, say, each anode are electrically isolated, but an input signal to one anode can switch on a much greater current than if separate cold-cathode diodes were used.

Special counting tubes, using a common anode and a number of cathodes, have been developed.<sup>7, 8, 9</sup> The discharge occurs between the anode and a single cathode and is made to transfer to the next cathode by the input pulse applied to a number of guide electrodes situated between the cathodes. The principle of transferring the glow, rather than extinguishing and reforming elsewhere as in the chain counters described above, enables much higher counting speeds to be reached. Counting speeds of 20kc/s are possible. Poly-cathode tubes have been made with an external connection to each of the cathodes for use as distributors as well as counters and dividers. Compared with cold-cathode triode chain distributors, the higher anode potentials and drive circuits required may limit their use for very low frequency application on economic grounds.

The wide variety of switching applications described serves to show the versatility of cold-cathode gas discharge devices. Two further characteristics of these tubes should be mentioned. The end of the useful life of a tube is characterized by an increase in both the breakdown and maintaining potentials. In activated tubes, this effect can be related to the removal of the activating substance by sputtering.<sup>10</sup> The maximum operating current is mainly determined by the life required. In practice the tubes are operated at the lowest current possible but with due regard to the variation in the maintaining potential.

Again, most cold-cathode gas discharge devices present a serious problem in applications involving speech transmission, owing to the presence of random oscillations in the audio range which may vary in amplitude from tens of millivolts to several volts. High frequency oscillations of the order of 1Mc/s are also present but are usually less important. The theoretical interpretation of these oscillations is by no means complete,<sup>11, 12</sup> and they still represent a barrier to many uses.

<sup>7</sup> R. C. Bacon and J. R. Pollard, "The Dekatron," *Electronic Engineering*, 22, 173 (1950).

<sup>8</sup> G. M. Hough, D. S. Ridley, "Multi-Cathode Gas Tube Counters," *Electrical Communication*, 27, 214 (1950).

<sup>9</sup> J. R. Acton, "The Single-Pulse Dekatron," *Electronic Engineering*, 24, 48 (1952).

<sup>10</sup> G. H. Rockwood, "Current Rating and Life of Cold Cathode Tubes," *Trans. A.I.E.E.*, 60, 901 (1941).

<sup>11</sup> D.S.I.R. Radio Research Special Report No. 20, "Valve and Circuit Noise," H.M.S.O., 1951.

<sup>12</sup> E. B. Armstrong, K. G. Emeleus and T. R. Neill, "Low Frequency Disturbances in Gaseous Conductors," *Proc. Roy. Irish Acad.*, 54, 291 (1951).

## Transmitting Marker Buoy

UNDER stress of weather, fishing vessels often have temporarily to abandon their gear, and when hove-to may drift out of sight of flagged dahn buoys put down to mark its position. To save valuable time and steaming distance in picking up gear again after a "blow," Venner Electronics, Kingston By-pass,

New Malden, Surrey have produced a wireless transmitting dahn buoy, the signal from which on 151 metres can be "homed" on by the trawler's normal direction-finding equipment.

The transmitter, which is battery operated, is of sufficient power to give a reliable range of 30 miles and has a duration of 72 hours on a charge. The batteries are charged via a watertight plug on the exterior of the casing. A delay switch between battery and transmitter can be set to start the transmitter at any period up to 48 hours from the time of laying, according to the skipper's estimate of the probable duration of the "blow." An important feature of the design is the inclusion of automatic keying to send out the trawler's call sign plus a numeral.



The Venner wireless transmitting buoy is designed to minimize rolling and weighs only 300 lb.

In addition to the whip aerial the buoy may be fitted alternatively with a corner reflector, giving an effective range of seven miles on radar equipment, or with a basket which gives visual indication and also serves as a fend-off to protect the aerial when alongside. A flashing mast-head light is fitted to both types.

### Manufacturers' Literature

**Ultrasonic Soldering Iron and Tinning Bath**, suitable for soldering aluminium, described in a brochure from Mullard, Ltd., Century House, Shaftesbury Avenue, London, W.C.2.

**Rectification**; an illustrated booklet giving general instructions on the use of Westinghouse copper-oxide and Westalite rectifiers, from the Westinghouse Brake & Signal Co., Ltd., 82, York Way, King's Cross, London, N.1.

**Instrument Cases** briefly described in a leaflet from Joyce, Loeb & Co., Ltd., Vine Lane, Newcastle-upon-Tyne, 1.

**Resistance Alloys**; leaflets giving physical properties, wire data and general notes on Isabellin NCM and Isabellin A (similar to Constantan) and Manganin. From Isabellen-Hütte Heusler K.-G., Dillenburg, Germany.

**"Sub-miniature" Soldering Irons** for low-voltage working (6V, 12V or 24V); leaflets describing and giving figures for the complete range, from Oryx Electrical Laboratories, BCM/ORYX, London, W.C.1.

# Loop Aerial Reception

*Design for Reducing Noise*

*Level on Long Waves*

By G. BRAMSLEV\*

IT is well known that the r.f. noise generated by electrical machinery and switches is more troublesome on the long-wave band than on medium waves. Consequently, although much is done nowadays to prevent radiation of these disturbances, the potentially great ranges of long-wave broadcasting stations cannot be fully realized in heavily electrified districts. Sometimes there are supplementary medium-wave transmissions of the programme, but many listeners are still forced to rely on the long waves. Those, in particular, who live at great distances from the transmitting station may be interested in this method of reducing the noise level at their receivers by means of a loop aerial.

This well-known type of aerial is used much in portable receivers and for direction finding, but its noise-reducing properties, which have been mentioned by Goldman,† are not so well known, and in this article the loop will be treated as an aerial connected to an ordinary broadcast receiver specifically for this purpose. To understand its noise reducing effect it is necessary to consider the nature of the interference fields and the way in which they act upon the loop. Because these fields have their origin in r.f. voltages and currents in the house wiring or nearby overhead electrical wires, the receiving aerial is so close to the sources that it is the induction field rather than the radiation field which is involved. In a radiation field the electric and magnetic forces are interdependent, but in an induction field the electric and magnetic forces are simple alternating fields associated with the voltage and current in the wires, and can be considered to act to some extent independently.

Let us first consider the action of an alternating

magnetic field on a loop aerial. A voltage will be induced in the loop when the magnetic lines of force are cutting the plane of the winding, and when they are parallel to it no voltage will be induced. That is to say, the loop directivity can be used to reduce interference caused by magnetic noise fields provided these make a sufficient angle to the magnetic field of the desired radio wave.

The lines of electric force in the noise field will be more or less vertical, and will accordingly develop a r.f. potential between the loop winding and earth. If the loop winding is balanced to earth, however, as it normally should be, this potential will not give rise to any current in the loop circuit, and so will not produce a noise voltage in the receiver, irrespective of the orientation of the loop.

These receptive properties of a loop are quite different from the response of ordinary capacitive aerials to electric and magnetic fields. Almost always capacitive aerials respond strongly to electric fields, but are less sensitive to magnetic fields. Now it is the general experience that in the noise fields originating from most electric appliances the electric component predominates, particularly in the long-wave band, so a loop aerial should be able to discriminate against the noise better than a capacitive aerial on the same spot. That this is possible has been confirmed by numerous experiments, and in many cases when a comparison is made with a rather small indoor aerial the signal-to-noise ratio improvement can be of a very high order. The following figures from a typical case may be of interest.

A 10-in square-loop aerial was tested in a building where the noise level was fairly high and constant from nearby motors. Two different aerials were available for comparison with the loop, the first being a simple indoor aerial about 25ft long, and the second

\* Danish Posts and Telegraphs.  
† *Electronics*, October 1938.

Fig. 1. Various ways of coupling the loop to the receiver. In (a) a coupling transformer is used with its primary inserted in the mid-point of the loop winding. In (b) the loop itself is used as an auto-transformer. In (c) capacitive coupling is obtained with two capacitors of equal value.

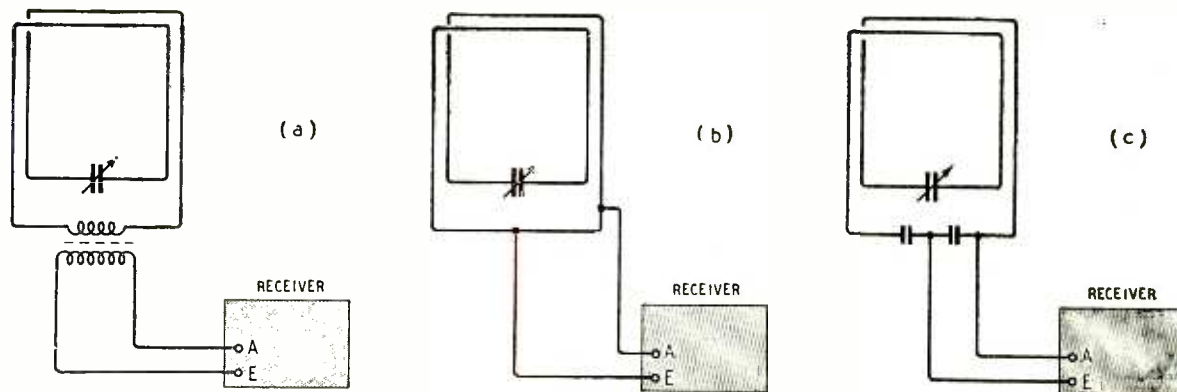

an outdoor aerial of equal length on the top of the building, raised about 12ft above roof level and provided with a screened down-lead. The screen of the down-lead could be isolated from earth and from the receiver so that the condition of an elevated aerial with an unscreened down-lead was also available. With the various aeriels connected, the noise level in a broadcast receiver was measured relative to a known modulation depth (40%) of the long-wave signal.

The following results were obtained :—

Indoor aerial	..	..	21db	below modulation
Outdoor aerial, unscreened	35db	..	..	..
Outdoor aerial, screened	..	..	43db	..
Loop aerial	..	..	39db	..

As was expected, the best noise suppression was obtained from the outdoor aerial with screened down-lead, but the noise level with the indoor loop was only 4db higher and 4db better than the outdoor aerial with unscreened lead-in and as much as 18db better than the simple indoor aerial. Further experiments with the loop aerial at different locations in the building showed another advantage of this kind of aerial—which can also be proved theoretically—that the voltage pick-up from radio waves was much less dependent on the surroundings (house wiring, pipes, etc.) than the voltage measured between capacitive indoor aeriels and earth, and was nearly the same in the basement and on the top floor of the building.

### Inductance of the Loop

Now to the actual design of the loop. The inductance of a square loop of side-length  $S$  metres with a winding length of  $b$  metres consisting of  $N$  turns, can be calculated with approximation by the formula :

$$L_0 = 0.00184SN^2 \log \frac{2S}{b} \text{ mH} \quad (1)$$

The self-capacitance of the winding is a rather important factor as it is generally much higher than for other receiver coils. It cannot be calculated with the same accuracy as the inductance, but for square loops with the most common values of  $S$  and  $b$  it has been found that the expression  $C_s = 60S$  pF is sufficiently accurate for our purpose.

The value of  $L_0$  should preferably be chosen so that the  $Q$  of the loop circuit will be at a maximum near the working frequency  $f_0$  or in the middle of the desired frequency band. It is found experimentally that this is realized when the natural frequency of the loop is about three times  $f_0$ . Therefore

$$3f_0 2\pi \sqrt{60L_0 S} = 1 \text{ or} \\ L_0 = \frac{0.047}{f_0^2 S} \text{ mH} \quad \text{and} \quad N = \frac{5}{f_0 S \sqrt{\log \frac{2S}{b}}} \text{ turns} \quad (2)$$

where  $f_0$  is in Mc/s. When this loop inductance is chosen, the necessary tuning capacitance for  $f_0$  will be roughly 480S pF.

In finding the size of wire to fill up the available winding space  $b$ , a suitable ratio of wire spacing to wire diameter must be chosen. For a given size of wire, the highest  $Q$ s are generally obtained for ratios between 0.5 and 1, but the same  $Q$  will be obtained when using a slightly heavier wire and a spacing of 2-5 wire diameters or more, which is generally more practical, especially for large loops. Measurements on a number of loops of the type shown in Fig 2, with

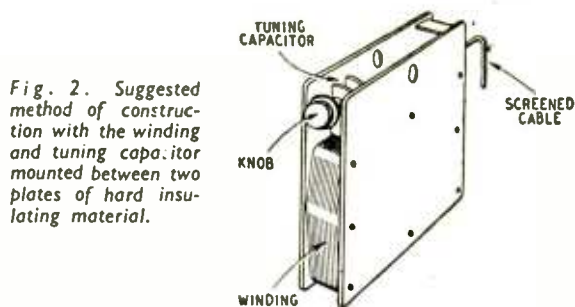

Fig. 2. Suggested method of construction with the winding and tuning capacitor mounted between two plates of hard insulating material.

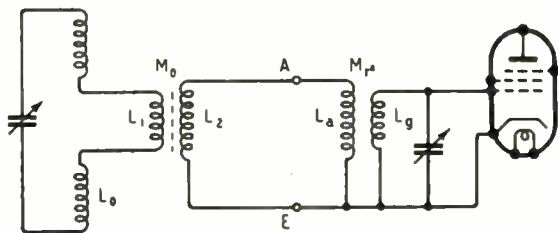

Fig. 3. Resultant circuit when the loop is connected through a transformer to the receiver input.

values of  $S$  ranging from 0.2 to 0.7 and wound with 33 to 23 s.w.g. copper wire, have given maximum  $Q$ s from 130 to 170. It is not necessary to know the loop  $Q$  with great accuracy, however, and to be on the safe side it is a good idea to use  $Q = 100$  in the calculations for loops wound with rather thin wire and  $Q = 150$  when a heavier wire and the optimum spacing ratio are used.

The size of the loop will, of course, be determined by the r.f. input voltage required at the grid of the first valve of the receiver. This in turn will depend on the coupling of the loop to the receiver, so it is necessary to consider the question of coupling first.

When the loop is used with an ordinary broadcast receiver certain precautions are necessary to prevent interference with its symmetry from the unbalanced input circuit of the receiver, while some form of impedance matching must be provided in the coupling in order that the signal voltage supplied to the receiver may be as high as possible. This requirement can be met in a number of different ways, some of which are shown in Fig. 1. In (a) the coupling element is an r.f. transformer with the primary winding inserted in the mid-point of the loop. The loop is thus isolated from the receiver, and the impedance match is effected by choosing an appropriate turns ratio for the transformer. In (b) the loop itself is used as an auto-transformer, the centre part of the winding being used as a coupling impedance with the winding mid-point connected to the earth terminal. Fig. 1 (c) shows a capacitive coupling with two capacitors connected in series and inserted at the mid-point of the loop, the receiver input circuit being shunted across one of them. Here the capacitive mid-point of the loop is earthed.

The two wires from the loop aerial to the receiver terminals must be efficiently screened to prevent their behaving as short capacitive antennas and picking up noise, and the screen must be connected to the earth terminal of the receiver.

The majority of broadcast receivers have an input circuit as shown in Fig. 3 (to the right of the A-E



terminals), with a high-inductance primary winding coupled to the tuned circuit of the first valve. Correct matching of the loop to the receiver can only be calculated when the circuit constants are known, but if they are not known the following values are fairly typical for the long-wave band:  $L_a = 14$  mH,  $L_g = 2.2$  mH,  $M_r = 1.1$  mH,  $k_r = 0.2$ ,  $Q_0 = 65$ .

The complete circuit in Fig. 3 is equivalent to an inductive coupling direct between the loop and the grid circuit, with a coefficient of coupling:

$$k_{eq} = \frac{M_0 M_r}{(L_g + L_a) \sqrt{L_0 L_g}} \quad (3)$$

The step-up factor or magnification ratio of the two coupled circuits, defined by  $A = E_g/E_0$  (where  $E_g$  is the voltage across the grid circuit and  $E_0$  the effective voltage in series with the loop), will be a maximum when the equivalent coefficient of coupling has the critical value  $k_c = 1/\sqrt{Q_0 Q_g}$  and the magnification ratio will then attain the value:

$$A = \frac{1}{2} \sqrt{\frac{L_g}{L_0}} \sqrt{Q_0 Q_g} \quad (4)$$

When  $k_{eq}$  is made greater or smaller than  $k_c$  the value of  $A$  will be smaller than is given in (4) but only by a small amount, and for moderate changes in  $k_{eq}$  the value of  $A$  will be nearly constant. The selectivity of the input circuit is, however, largely controlled by  $k_{eq}$ , and to avoid too much sideband cutting it may be advisable to select the ratio  $k_{eq}/k_c$  somewhat greater than unity for long-wave loops.

### Calculating the Size

We return now to the question of the size of the loop. The electromotive force  $E_0$  induced in the loop by a passing radio wave is given by:

$$E_0 = e \frac{2\pi S^2 N}{\lambda} \text{ mV} \quad (5)$$

where  $e$  is the field strength of the radio wave in mV/m and  $\lambda$  is the wavelength in metres. When this is put into (4) together with (1) we eventually get the following expression for the voltage at the first grid of the receiver:

$$E_g = e \frac{73}{\lambda} \sqrt{L_g Q_g} \sqrt{\frac{Q_0 S^3}{\log 2S}} \text{ mV} \quad (6)$$

With the receiver constants given above,  $Q_0 = 100$ ,  $S = 10b$  and  $\lambda = 1500m$  (Droitwich), we then get  $E_g = 5.1e\sqrt{S^3}$  in millivolts, and this gives:

$$S = 0.34 \sqrt[3]{\frac{E_g^2}{e^2}} \text{ metres} \quad (7)$$

The field strength of the Droitwich transmitting station at a particular place can be found roughly from Fig. 4 when the distance from Droitwich is known, or the information would probably be supplied on request by the B.B.C. For the receiver input, experience shows that  $E_g = 5$  mV is an acceptable value, although  $E_g = 2$  mV can be used with a slight increase in set noise and  $E_g = 10$ – $15$  mV or more in some cases may give a noticeable improvement.

Coming now to the practical aspects, the loop framework and its winding can be constructed according to materials available and personal taste, making sure not to use insulating material which will absorb moisture. Fig. 2 shows a method of construction suitable for small loops, with a winding support

in the form of spacers between two thin plates of insulating material; this provides accommodation also for the tuning capacitor and the coupling components. Large loops can be made more easily in the form of a flat spiral-wound coil, which can be mounted on a brick or wooden wall having the necessary approximate orientation. Provided that a good quality supporting material is used and there are no closed metal circuits in or near the wall, no excessive losses will be introduced in this way and formula (1) can be used also for this type of coil, when  $S$  is taken as the mean side-length of the winding.

The transformer in Fig. 3 can best be realized with a small dust core preferably of the pot type, for which the coefficient of coupling,  $k_t$ , is generally between 0.8 and 0.85 when the primary is placed between the two halves of the secondary winding. The values of the inductances  $L_1$  and  $L_2$  can be found from (3) by substituting for  $M_0$  the value  $k_t \sqrt{L_1 L_g}$  and for  $M_r$  the value  $k_r \sqrt{L_a L_g}$ . We then get the following:

$$L_1 = \frac{k_{eq}^2 \cdot L_0 (L_2 + L_a)^2}{k_r^2 k_t^2 \cdot L_a L_2} \quad (8)$$

When the secondary inductance has been fixed,  $L_1$  can thus be calculated, and the number of turns on the two windings determined from information supplied by the manufacturer of the core. The value of  $L_1$  should not be more than 10% of  $L_0$  in order to reduce its influence on loop tuning and  $Q_0$ .

In the case of direct inductive coupling, Fig 1 (b), the number of turns  $n$  from the centre of the loop can be found from

$$n = N \frac{k_{eq}}{k_r} \sqrt{\frac{L_a}{L_0}} \quad (9)$$

and with capacitive coupling, Fig 1(c), the value of the coupling capacitor is given by

$$C = \frac{25}{f_0^2 L_a} \left( 1 + \frac{k_r}{k_{eq}} \sqrt{\frac{L_a}{L_0}} \right) \text{ pF} \quad (10)$$

where  $L_a$  and  $L_0$  are in mH and  $f_0$  is in Mc/s.

If it is desired to install the loop at some distance from the receiver, a position just below the roof or well removed from the electrical installation will generally be found better than in one of the living rooms. The screened feeder may now be some 30–160ft long, and although its attenuation at this low frequency will be negligible its capacitance will

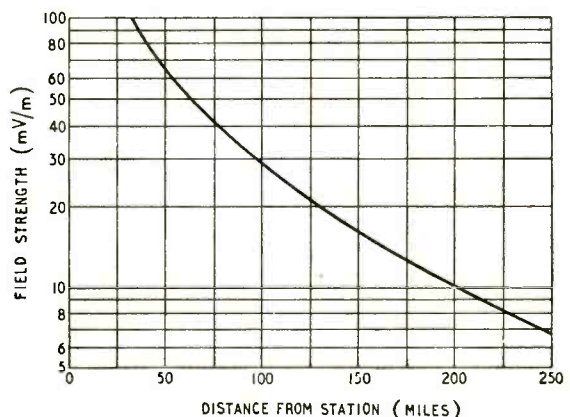

Fig. 4. Curve showing average values of field strength from the 200-kc/s Droitwich transmitter at distances from 30 to 250 miles.

have a large influence on the coupling coefficient. The effect can, however, be avoided to a large extent by matching approximately the output impedance of the loop to the characteristic impedance of the feeder cable and inserting a step-up transformer between cable and receiver for adjusting the coefficient of coupling to a suitable value. The feeder may be ordinary coaxial cable, but quite satisfactory results are given on long waves by twin screened power cable or telephone cable, which is cheaper and can easily be installed. With inductive tapping at the centre of the loop taken across  $n$  turns, the loop is matched to a feeder impedance  $Z_0$  ohms when

$$n = N \sqrt{\frac{Z_0}{Q_0 \omega L_0}} = \sqrt{\frac{0.087 Z_0}{Q_0 f_0 S \log \frac{2S}{b}}} \quad (11)$$

and  $f_0$  is in Mc/s.

The equivalent coefficient of coupling between loop and grid circuit is given approximately by

$$k_{eq} = \frac{n}{N} \frac{k_1 k_2}{L_2 + L_1} \sqrt{\frac{L_2 L_0 L_0}{L_1}} \quad (12)$$

where  $k_1$  is the coefficient of coupling of the receiver transformer,  $L_1$  its primary and  $L_2$  its secondary inductance. Formula (12) can thus be used to determine the number of transformer turns in the same way as (8). A satisfactory match is usually obtained when the value of  $Z_0$  is chosen between 100 and 400 ohms.

When the loop aerial is completed and connected

to the receiver a few tests should be made to ensure that it is working properly and that the noise reduction is the best possible. The loop tuning should present no difficulties, especially if a receiver with a visible tuning indicator is used; otherwise the loop is tuned for the best signal/noise ratio. The directional property is observed by turning the loop around its vertical axis and noting the variation in signal strength, keeping in mind that the receiver a.g.c. will keep the audio output nearly constant so that it is rather the variation in background noise which should be observed. When the distance to the desired station is more than 150 miles, it is best to work during daylight hours to avoid the effects of indirect rays. The two maxima should be equally strong, and the two minima should be quite sharp and spaced nearly 180 degrees apart. If there is much electrical wiring in the house some influence might be experienced, especially on the minima, so that if possible this test should be made on an upper floor or in the open air. When the directional property is satisfactory, the reduction of local radio noise will generally be very noticeable when the loop is compared with a simple indoor aerial. With fixed loops, where the directional effect cannot be observed so easily, the balance of the winding can be tested roughly by connecting a piece of wire a few feet long alternately to the two terminals of the loop tuning capacitor. If there is a rise in background noise from local sources this should be nearly the same in the two cases, but connecting the wire to the centre tap should have no effect.

## WICK RADIO

THE first of the eleven G.P.O. coast radio stations to be refurbished under the present plan of modernization is that at Wick, Caithness, where three new transmitters operating between 400 kc/s and 4 Mc/s have been installed. Wick Radio (GKR), which was officially opened by the Assistant Postmaster-General on September 9th, provides, as do the other coast stations, radiotelegram and radiotelephone services, medical advice, navigational instructions, and, of course, a distress watch for coastal shipping.

Designed and produced by the Post Office Engineering Department, the maximum output power obtainable from each of the transmitters is 3 kW but the actual powers used for the various types of emission (which are laid down in International Regulations) are fixed by pre-set adjustments. Any one of eight pre-determined frequencies in the 415 to 515-kc/s band and the 1.6 to 3.8-Mc/s band can be selected by push-buttons on the operator's control desk. The transmitters can also be set up for telephony or teleggraphy by push-button controls on the console.

Relay circuits in the control system ensure exclusive and uninterrupted control once a transmitter has been selected by the operator, while other relay circuits prevent two or more transmitters operating on the same frequency.

For connecting the radio circuits to the inland telephone network four-wire to two-wire termination equipment is installed. This equipment includes a constant volume amplifier in the transmitter modulation path, which adjusts the speech level to that required to modulate the transmitter fully, and a voice operated device to prevent singing.

The transmitting aerials on the site include one directly connected "T" aerial shared by the transmitters operating on 415-515 kc/s, and one vertical radiator for each transmitter working in the 1.6 to 3.8-Mc/s band. The receiving aerials are located about  $\frac{3}{4}$ -mile from the station.

In addition to the three new transmitters, Wick Radio is equipped with two transmitters operating in the 4 to 12.5-Mc/s band.

*Operator's console accommodating the transmitter and radio telephone control panels, receiver and direction finder.*

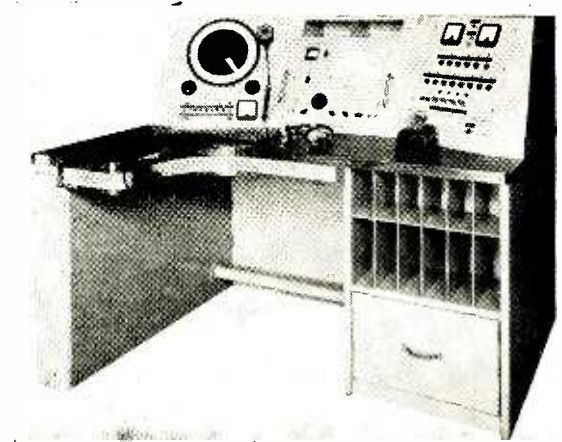

# Suspended Television Feeder

*Coaxial Line with Wire-rope "Inner" at New Transmitters*

ALTHOUGH the force of gravity has been exploited in a good many different ways by engineers, it has probably never been used before as a means of improving the characteristics of a radio transmission line. That, however, is precisely what it does in the new type of aerial feeder which runs up the masts of the Kirk O'Shotts and Wenvoe television stations. Unlike the conventional system where the coaxial tubes are built into the structure of the mast (as at Sutton Coldfield and Holme Moss), this feeder is freely suspended from the top of the mast and only has anchoring points to prevent it from swinging about too much. The outer conductor is an ordinary 5-in copper tube, but the "inner" is formed by a copper-coated steel rope (1.37-in diameter) located centrally by spaced insulators and held taut by a two-ton load at the bottom.

The whole idea of this system is to keep the transmission line as straight and uniform as possible and so avoid any mechanical irregularities which might cause reflections. (The conventional system is rather prone to this kind of trouble because the soft copper tubes are under compression all the time, especially at the bottom, and tend to get buckled and distorted.) Actually, the use of gravitational force in this way is a particularly happy idea because it means that the electrical uniformity tends to increase towards the top of the feeder with the increasing loading, so that the long-delay reflections arising at this end (the most troublesome ones) tend to be of smaller amplitude.

A rather special kind of wire rope is used for the inner conductor. It is constructed on the locked-coil principle (as used in colliery winding) and has the property of being mechanically "dead"—that is, it is free from distortion and will not rotate or unravel when supporting a load. Its real strength lies in a central core of galvanized steel wires; this is surrounded by a layer of copper wires partially locked together, with another layer of shaped and completely locked copper strands on top. Because of the way these outer strands fit into each other, the surface of the rope is substantially smooth.

The "outer" is constructed of 12-ft sections of copper tube, which are bolted together by flanges having tongued-and-grooved faces to permit accurate alignment. One flange on each section also serves as a housing for three ceramic-rod insulators, which are adjusted from the outside so that they touch the wire-rope "inner" and hold it central.

In Fig. 1 is a simplified drawing of the complete feeder and suspension system. The feeder itself is 681 ft long and weighs 2.82 tons without the two-ton load. Expansion couplings are necessary to allow for the difference in expansion between the "inner" and the "outer" and for the expansion of the complete system relative to the fixed continuation of the feeder



View from the bottom of the mast at Kirk O'Shotts, showing how the feeder is led in. The pulleys are part of the loading mechanism.

Fig. 1. Simplified drawing of the complete feeder and suspension system.

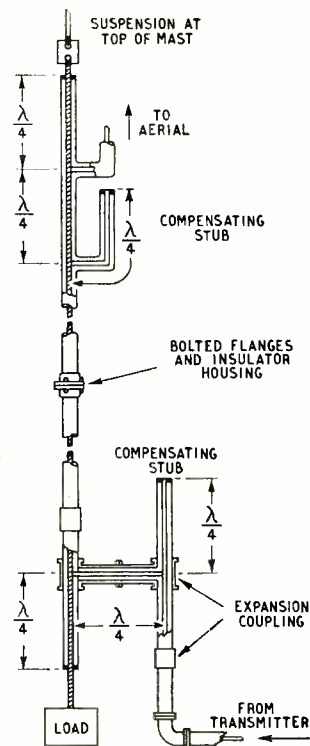

on the ground. It will be noted that the main vertical section is short-circuited at both ends. The feed-in and feed-out junctions, however, are made at points a quarter-wavelength in from the ends, where the short circuits have produced high parallel impedances. This arrangement would be quite satisfactory as it stands on a single frequency, but as a band of frequencies has to be transmitted, two short-circuited quarter-wave stubs are

added to cancel the effects of the short-circuited quarter-wave end sections. As can be seen, these are spaced at a quarter-wavelength from the junction points. The characteristic impedance of the feeder is approximately 80 ohms.

Apart from the improvement in electrical uniformity, another great advantage of this type of feeder

(supplied, incidentally, by Electrical & Musical Industries) is the ease with which it can be erected. The wire-roped "inner" is delivered on a drum and is simply hauled up the mast like an ordinary cable, then sections of the copper-tube "outer" are threaded on to it, hauled up and bolted together at the flanges.

# Manufacturers' Products

NEW EQUIPMENT AND ACCESSORIES FOR RADIO AND ELECTRONICS

## Console Record Player

A RANGE of console-style record players has been introduced by Richard Allan which for all practical purposes convert an ordinary table model receiver into a self-contained radio-gramophone. This is achieved by providing a flat space on top for standing the receiver.

The top compartment contains the gramophone equipment and when not in use it is closed by a roll-top lid. The lower part forms a capacious storage cupboard for records



Richard Allan floor model gramophone record player.

and is closed by two doors hinged at the sides and is attractively finished in figured walnut.

A choice of 19 different models is available and they include single and three-speed types also mixer and non-mixer auto-changers and many different types of pick-up heads, including magnetic, lightweight, turn-over, crystal and microgroove, among others.

Prices range from about £24 to £44 and the makers are Richard Allan Radio, Ltd., Taylor Street, Batley, Yorkshire.

## Miniature Dual-purpose Coils

THE latest range of Denco "Maxi-Q" miniature coils are wound on distinctively coloured low-loss formers with adjustable

dust-iron cores and designed for optional single-hole chassis mounting or as plug-in coils, using a novel (B9A) valve-holder. The colours indicate the function of the coil. A full set covers 3.8 to 2,000 metres, tuning capacitors of 0.0003  $\mu$ F being recommended down to 9.5 metres and of 50 pF for the shorter wavelengths.

Many of the coils are interchangeable in superhet and t.r.f. circuits and there are oscillator coils for i.f.s. of 465 kc/s or 1.6 Mc/s. On the two shortest ranges, covering 3.8 to 10 metres, an i.f. of about 5 Mc/s can be used if desired with existing oscillator coils.

Coils measure approximately 2 in high overall and  $\frac{1}{2}$  in diameter at the base ring carrying the pins. The body of the former is  $\frac{1}{4}$  in diameter.

The makers are Denco (Clacton), I.t.d., 355-9, Old Road, Clacton-on-Sea, Essex, and prices range from 3s 11d to 4s 9d each.

## Split-stator Capacitors

TWO split-stator variable capacitors for use in v.h.f. equipment have been introduced by Jackson

Jackson v.h.f. split-stator capacitors; type C808 for panel-mounting and type U101 for mounting on a chassis.

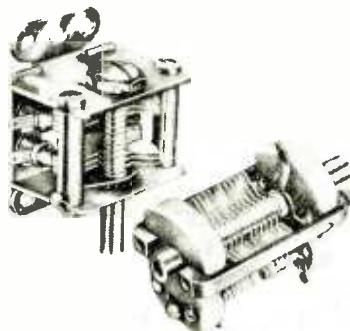

Denco "Maxi-Q" miniature r.f. transformer with reaction winding.

Bros. (London), Ltd., Kingsway, Waddon, Surrey. One, Type C808, for panel mounting, is fitted with ceramic end-plates, silver-plated brass vanes and is secured to the panel by two screws.

The other, Type U101, is for mounting on a chassis or baseboard and has silver-plated brass vanes supported on ceramic insulators in a cadmium-plated steel frame with the rotor electrically connected to the frame. Both types are available in various capacitances up to 43 pF each section.

Type C808 costs 10s 6d and the chassis-mounting model, U101, 10s 9d.

## Sub-miniature Potentiometer

A PART from its obvious use in hearing aids a sub-miniature potentiometer has many applications in various kinds of miniaturized radio equipments, small personal portables being one example. The tiny "Belclere" component illustrated is a product of John Bell & Croyden, 117, High Street, Oxford, and it measures  $\frac{3}{8}$  in only in diameter, is  $\frac{1}{4}$  in thick and weighs  $\frac{1}{32}$  oz. In addition to containing a 3-contact potentiometer it also houses a single-pole on-off switch. Four tags only are used and the fifth needed to give complete isolation of the two items is formed by using the centre fixing screw as the moving contact of the potentiometer. The outside drum forms the control knob and is rotatable.

Resistance tracks of logarithmic or linear law are available and the standard resistance values are 3-6M $\Omega$  in the former and 1M $\Omega$  in the later types, but alternative tracks are

Sub-miniature "Belclere" volume control with on-off switch.



available to order. The switch capacity is 100 mA at 50 V maximum.

The standard finish is a black case with white figures round the edge forming a scale, but other requirements can be met by arrangement.

### Cabin Broadcast Set

A BROADCAST receiver on a ship has to contend with the most exacting conditions, for not only will it be exposed to wide changes in temperature and humidity, and most likely get a lot of buffeting in bad weather, but withal it has to give a good performance on short waves.

The Cameo Senior (Model RM1) introduced by Rees Mace has been designed for this kind of service. It possesses 9 ranges in all, one long-wave, one medium and seven short. Of the short, two have a fairly wide coverage, e.g., 31 to 67 and 65 to

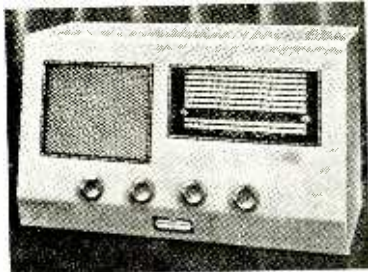

Rees Mace Cameo Senior, Model RM1, cabin broadcast receiver.

203 metres, while five have limited coverages centred on 13, 16, 19, 25 and 31 metres respectively.

Four miniature valves are used in a more or less conventional superhet circuit, which is arranged for a.c./d.c. operation on electric supplies of 100 to 125 and 200 to 250 volts. A valve rectifier supplies h.t. and the components have been chosen to withstand tropical conditions.

Wide-range tone control, easily readable scales, functional rather than ornate appearance, constitute some additional features of this set.

The makers are Rees Mace Marine, Ltd., 11, Hinde Street, London, W.1, and the price is £19 10s plus purchase tax in U.K. of £10 8s.

### Home-produced "Crackle" Finish

IT has hitherto been necessary to bake, or stove as it is called, the particular kind of enamel that produces the characteristic hard crystalline surface known as "crackle." It is now claimed that the same results can be obtained with a new air-drying enamel.

According to the instructions the enamel is applied with a brush in the usual way and left

to dry in a very slightly contaminated atmosphere. Only a minute trace of impurity is needed and a small gas jet, such as the pilot flame of a gas cooker, is sufficient. Alternatively a small oil lamp or even the old-fashioned night-light can be used. The enamel will not "crackle" in perfectly pure air.

The enamel can be applied to most materials, in addition to metal, and takes well on stout paper and similar material. Supplies of the enamel, which is black in colour and known as "Panl," are obtainable from L. Miller, 8, Kenton Park Crescent, Kenton, Middlesex.

### Valve Retainers

MOST valves sooner or later tend to work out of their sockets unless restrained in some way; for mobile equipment valve retainers of one kind or another are virtually a necessity.

Retainers take various forms, but those made by Electrothermal Engineering are of the kind that hold the valve in position by some form of cap, or harness, fitting over the valve and having springs secured to the valveholder, or other convenient anchorage.

A few examples are shown in the illustration, where are seen a dished top-cap type of all-metal construction for miniature valves with B7G bases, a loop-type retainer for larger valves having a shoulder on the envelope and a harness-type for shoulderless valves. Some other types are shown in the foreground.

Tension springs do not contact the valve and that portion which embraces the bulb, except in the dished metal type, is made of glass-fibre cord, said to be rot, insect and fungus proof and suitable for use in tropical as well as temperate zones. The maker's address is 270 Neville Road, London, E.7.

Specimen types of Electrothermal valve retainers.

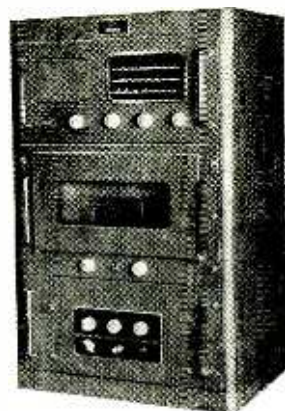
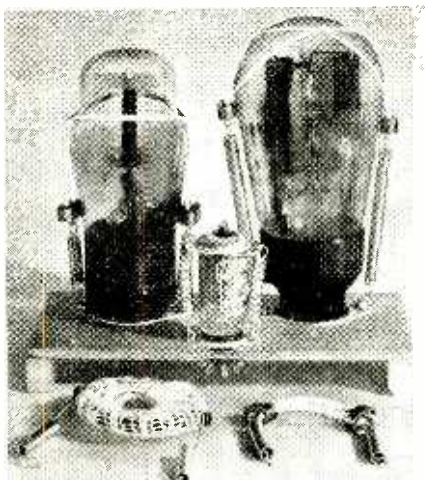

for EVERY



amplification

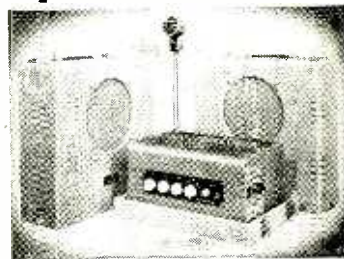

requirement

Send for the latest catalogue and price lists containing complete details and specifications of the

New range of

**TRIX**

Quality

**SOUND EQUIPMENT**

THE TRIX ELECTRICAL CO. LTD.  
1-5, Maple Place, Tottenham Ct. Rd.,  
London, W.1. Phone: Museum 5817

AMP-IFIERS - MICROPHONES - LOUDSPEAKERS

# RANDOM RADIATIONS

By "DIALLIST"

## Gas Fitters Again!

DO YOU REMEMBER my referring recently to the habit some gas fitters have of lightheartedly running their pipes alongside the lead covering or the conduits of the electric wiring of our houses? A Scottish reader sends me an account of the way in which radio reception, not only in his own flat, but in every one of the block in which he lives, was affected by contact between a gaspipe and a number of lead-sheathed electric pairs. For some time all sets in the building had been subject to fairly frequent outbursts of noisiness and to occasional 50 per cent reductions in signal strength. Having noticed that the noisiness could be produced by treading lightly on a loose floor-board and that a heavier tread brought about a general reduction in volume, he concluded that the electric wiring must be to blame and decided to make a thorough investigation. He began in the attic, which contained the majority of the wiring for the flats, and having "tortured all the junction boxes in sight" without result, he was moved to lift a gaspipe, laid casually on top of several lead sheaths. He'd found the clue! By making the pipe vibrate gently and establishing intermittent light contact with the lead sheaths he could cause the wireless sets to become noisy; the reduction to half signal strength could be produced by bringing the pipe firmly into contact with the sheathing. Under loose floor-board in his own flat a similar instance of carefree "plumbing" was found. He's wondering why and how the effects observed were caused.

## Noisiness

It isn't difficult to see how the light intermittent contacts gave rise to noisiness. The sections of a gaspipe may be pretty well insulated from one another by the sealing compound used at the joints; in that case only those bits of it which are buried in the ground or are in firm contact with things such as ascending water mains are held down at earth potential. Others may build up static charges of quite a few volts owing probably to the effects of friction between molecules of gas and the inner walls; I have seen small arcs occur when a gaspipe and the lead covering

of electric wires were brought close together. The discharges taking place when the rather dirty gaspipe came lightly into contact with the also rather dirty lead sheathing would be quite sufficient to set up mains-borne noisiness. At the moment, though, I don't quite follow why firm contact between pipe and sheathing should cause a big drop in the volume from all the sets; but there is a possible explanation. Assuming that the lead sheathing is well and truly earthed, the result of such a contact should be the temporarily effective earthing of a section of the gaspipe. That suggests that this may be one of those queer cases of pick-up by a section (or sections) of the gaspipe, detection at one (or more) of the joints and re-radiation. In that case the gaspipe might be responsible for pushing up the volume of the receiver and there would be a marked falling off when it was earthed. I wonder whether my correspondent could find time to make an experiment: with a pipe and the sheathing well separated by means of, say, a dry piece of wood, connect a pair of headphones between them and see if anything is heard.

## Do You Interlace?

BEING POSSESSED of an enquiring mind, I have made a little investigation into interlacing, as it is carried out by domestic television receivers.

The B.B.C.'s transmissions are perfectly interlaced, the odd-numbered and even-numbered scanning lines being evenly and equally spaced. To do justice to these transmissions, the receiver must regularly produce a similar raster. But does it? The results of my little investigation were surprising—or were they...? They showed that a number of the lower-priced sets, as delivered and installed, and as operated by non-technical users either don't interlace, or do so imperfectly. It's not at all difficult to make a test. The transmitted image consists of 377 "active" scanning lines, the remaining 28 of the 405 being devoted to the frame sync pulses and the inter-frame black-outs. Hence, any area one inch in height of the received image should contain  $377/h$  evenly spaced lines, where  $h$  is the height of the screen image in inches.

## Interlapping and Overlacing

Even when you're dealing with a big image the number of lines in a single inch of height to be counted and examined for equal spacing is rather formidable; it's easier, therefore, to work with an area half an inch in height—or even a quarter of an inch. To enable the eye to concentrate on a particular small area of the image and not to be distracted by other parts of it, a mask of opaque paper or thin cardboard should be made, which can be held against the screen. Measure the height of the image; then rule and cut out in the mask a square window with sides equal to  $1/30$  that height. It should really be  $1/29$ , or  $1/13$ , since 29



## "WIRELESS WORLD" PUBLICATIONS

	Net Price	By post
RADIO INTERFERENCE SUPPRESSION as Applied to Radio and Television Reception. G. L. Stephens, A.M.I.E.E. ...	10/6	10/11
RADIO VALVE DATA: Characteristics of 2,000 Receiving Valves and C.R. Tubes. Compiled by the Staff of "Wireless World." 3rd Edition ...	3/6	3/9
SOUND RECORDING AND REPRODUCTION. J. W. Godfrey and S. W. Amos, B.Sc., A.M.I.E.E., in collaboration with the B.B.C. Engineering Division ...	30/-	30/8
MICROPHONES. By the Staff of the Engineering Training Dept. B.B.C. ...	15/-	15/5
ADVANCED THEORY OF WAVEGUIDES. L. Lewin. ...	30/-	30/7
FOUNDATIONS OF WIRELESS. M. G. Scroggie, B.Sc., M.I.E.E. 5th Edition ...	12/6	13/-
TELEVISION RECEIVING EQUIPMENT. W. T. Cocking, M.I.E.E. 3rd Edition ...	18/-	18/8
SHORT-WAVE RADIO AND THE IONOSPHERE. T. W. Bennington. 2nd Edition ...	10/6	10/10
WIRELESS SERVICING MANUAL. W. T. Cocking, M.I.E.E. 8th Edition ...	12/6	12/11
RADIO LABORATORY HANDBOOK. M. G. Scroggie, B.Sc., M.I.E.E. 5th Edition ...	15/-	15/5

A complete list of books is available on application.

Obtainable from all leading booksellers or from

ILIFFE & SONS LTD., Dorset House, Stamford Street, London, S.E.1.

and 13 are the only factors of 377; but that would be too fiddling a job. Now place the window over, say, a portion of the Test Card C pattern where the lines are easy to see. If the set is interlacing perfectly, there should be 12 or 13 evenly spaced lines in the window. Too often there aren't and what is taking place is described by a friend of mine as "interlapping and overlacing."

### Viewing and Listening

AT THE MOMENT holders of television licences are outnumbered about eight to one by those licensed to receive sound only. It is officially estimated that in the not so distant future the position will be reversed and that perhaps 10 to 15 years from now, the television receiver will be as common an article of domestic equipment as is the broadcast receiver to-day. Probably the great majority of viewers have also a means of receiving the purely sound programmes. It is, therefore, very difficult to discover whether television is replacing sound, or whether it is now merely supplementary to it. For what it is worth, my experience is that when the television set first comes into the home it ousts the sound receiver at all times when vision programmes are available. Thereafter, viewing gradually becomes more and more selective. Only certain televised items are watched and the sound receiver tends to take a greater part in the home entertainment.

### In the Future

Some years from now it is probable that all items—except, possibly, foreign news—will be broadcast for aural and visual reception, and I foresee the receiving equipment of the fairly near future as a combined sound and vision set, provided with a switch enabling vision plus sound, or sound alone to be received. Some sets may have arrangements for the reception of vision only, for one can think of televised items that would be more welcome without sound. Unless and until some entirely new method of television transmission is invented, I do not for a moment believe that vision-plus-sound programmes will entirely replace sound only as home entertainment. People vary greatly as regards the length of time they can spend with their eyes glued to the screen. Were vision programmes available all day, most set owners would in all probability be grateful for some means of hearing the sound alone.

The Choice of Critics



## BULGIN SWITCHES ARE LAMINATED AND METAL-CLAD FOR STRENGTH & RELIABILITY

MANY Hundreds of Thousands of these Precision-made, original design Switches are giving continuous unflinching service in all parts of the world, and have a reputation for quality second to none.



THESE switches are available in many different models for many uses: Single and Double pole; Make-Break, Change-Over; Key, Rotary, Semi-Rotary, or with Ball, Pear or Slotted dummies (Levers); or with or insulated earthing metal or insulated dollies.



HIGHLY - PLATED in a variety of different finishes including Chrome, Nickel, Black Nickel, Florentine Bronze, Cadmium and even 9 ct. Gold to special orders! Insulation is of the finest grade S.R.B.P., metal-clad for strength and shock-resistance.



EVERY Genuine Bulgin Switch is always indelibly stamped with our Registered Trade Mark. Only a genuine Bulgin switch is stamped with the name "BULGIN," your guarantee of reliability and the best. Beware of imitators.



MANUFACTURERS OF RADIO AND ELECTRONIC COMPONENTS



SEND for comprehensive catalogue. Ref. No. 190/W/W. Price 1/- post free.

**BULGIN** Components  
**A.F. BULGIN & CO. LTD**  
**BYE-PASS ROAD BARKING**  
 TELEPHONE: Ripplaway 3474 (5 lines)

# UNBIASED

By FREE GRID

## The Age of Wisdom

THIRTY years is the age at which a man is considered to have attained a sufficient degree of wisdom to be made a bishop, and back in 1922, when regular broadcasting began in this country, no woman was considered to have sufficient sense to be allowed a vote or to sit in Parliament until she had attained that age. This establishment of thirty years as the age at which wisdom begins is undoubtedly a psychologically sound thing. I have, in fact, often thought that this country's divorce rate would be decimated if men were forbidden by law to marry before they were thirty years old. By that time they would have learned to choose their life partners with the same care that they lavish on the choice of a car—by looking at the engine instead of being sidetracked by streamlined bodywork which is the undoing of the inexperienced in both cases.

Now my youthful readers will wonder what all this has got to do with wireless. The older ones will recollect, however, that on November 14th we shall be celebrating the B.B.C.'s thirtieth birthday, and they wonder, as I do, whether, now that it has attained the age at which it should have cut its wisdom teeth, the Corporation will begin to show some signs of mellowness and maturity. There is at least one B.B.C. reform which is long overdue, about which I have previously written and now suggest a simple technical means whereby it could be carried out.

Briefly, I want the B.B.C. to eliminate the annoyance of one having to jump up like a jack-in-the-box to operate the volume control each time a talk or other quiet item is followed by a brass-band concert or vice versa. It could be done quite easily without the control engineer turning up the wick for talks and turning it down again for orchestral items as this would, of course, be

anathema to music lovers.

All that is needed is that transmitters should emit special signals according to the nature of the item being broadcast. When a talk is followed by a brass band or other din producer this signal will operate a relay in our sets controlling a simple "on-off" type of volume control. Straight-forward enough, isn't it? Of course, we musical Philistines who don't know a crochet from a quaver—and don't want to—would have to pay for the relay to be put into our sets and that we would gladly do.

No doubt set manufacturers would be pleased to help us as it would provide a new selling point for their wares. Naturally the device would have a manually operated cut-out switch for use when we were entertaining musical friends who like the furniture-rattling racket of Sousa in full blast.

## Bedlam Barred

THE citizens of Coventry have always been in the van of progress since the day Lady Godiva anticipated the seaside fashions of the present age by appearing in ultra-Bikinis. It is now the City's Lighting Engineer who assumes the mantle of Lady Godiva—figuratively speaking, of course—by prophesying that lamp-posts of the future will carry a radio receiver so that each lamp can be controlled by a transmitter in the Street-Lighting H.Q. I gather from the words of the learned engineer that this radio control method has many advantages over other systems, including that of cost.

I cannot help drawing a parallel with the idea which, as reported in both the lay and the technical Press, the Ministry of Transport has under consideration for enabling a fire engine to turn all traffic lights in its favour as it clangs its way through the streets. This scheme proposes the fitting of each set of lights with an acoustically operated switch worked by a screaming siren on the fire engine.

Screaming sirens are, of course, very necessary in cities like Chicago in order that they may be heard above the pandemonium which is the normal acoustic condition there, compared with which the peak-hour noise of Piccadilly sounds like one of the more somniferous passages of Gray's "Elegy."

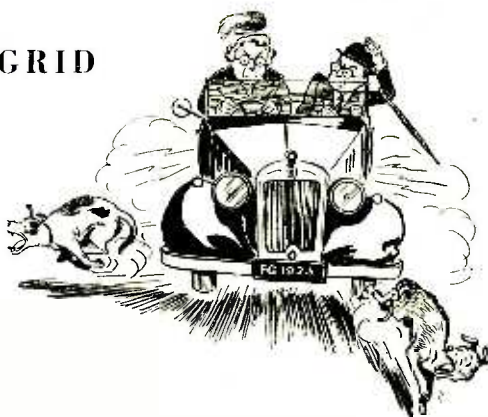

Reducing canine casualties.

To my mind, a far better method is one which I saw on the Continent and reported in this journal nearly fifteen years ago (*W.W.*, December 2nd, 1937) in which traffic lights were fitted with an e.h.f. receiver operated by a transmitter of very limited range fitted to fire engines, ambulances and police cars. Doing its work silently and unobtrusively, this system would not turn our streets into a bellowing Bedlam as would the acoustic method the Ministry is reported to be considering.

The use of a radio frequency for this purpose may be considered wasteful and, if so, I would suggest as an alternative that a supersonic frequency of about 20,000 c/s be used. This, although beyond our hearing, would have the advantage of being audible to dogs, who would soon learn to recognize it as a danger signal, making it advisable for them to keep out of the way. I know what I am talking about as I have a supersonic horn (in addition to the normal one) fitted to my car and permanently switched on when the engine is running. This has been of immense benefit in reducing canine casualties when Mrs. Free Grid is driving.

## Magnetic Molars

NO doubt you will have read of the latest developments in American dentistry whereby permanent magnets are embedded in the gums to hold artificial teeth which presumably have an iron core. We all know that watches are demagnetized by putting them in a magnetic field and that the same wipe-out principle is used in our tape recorders. If the alternating field be made strong enough it will demagnetize the most "permanent" of magnets, and there seem possibilities here for a politician literally to draw his rival's fangs at a meeting by the installation of suitable apparatus under the platform beforehand, thus rendering him speechless.



Streamlined bodywork.