

WORLD RADIO HISTORY

# Wireless World

RADIO AND ELECTRONICS

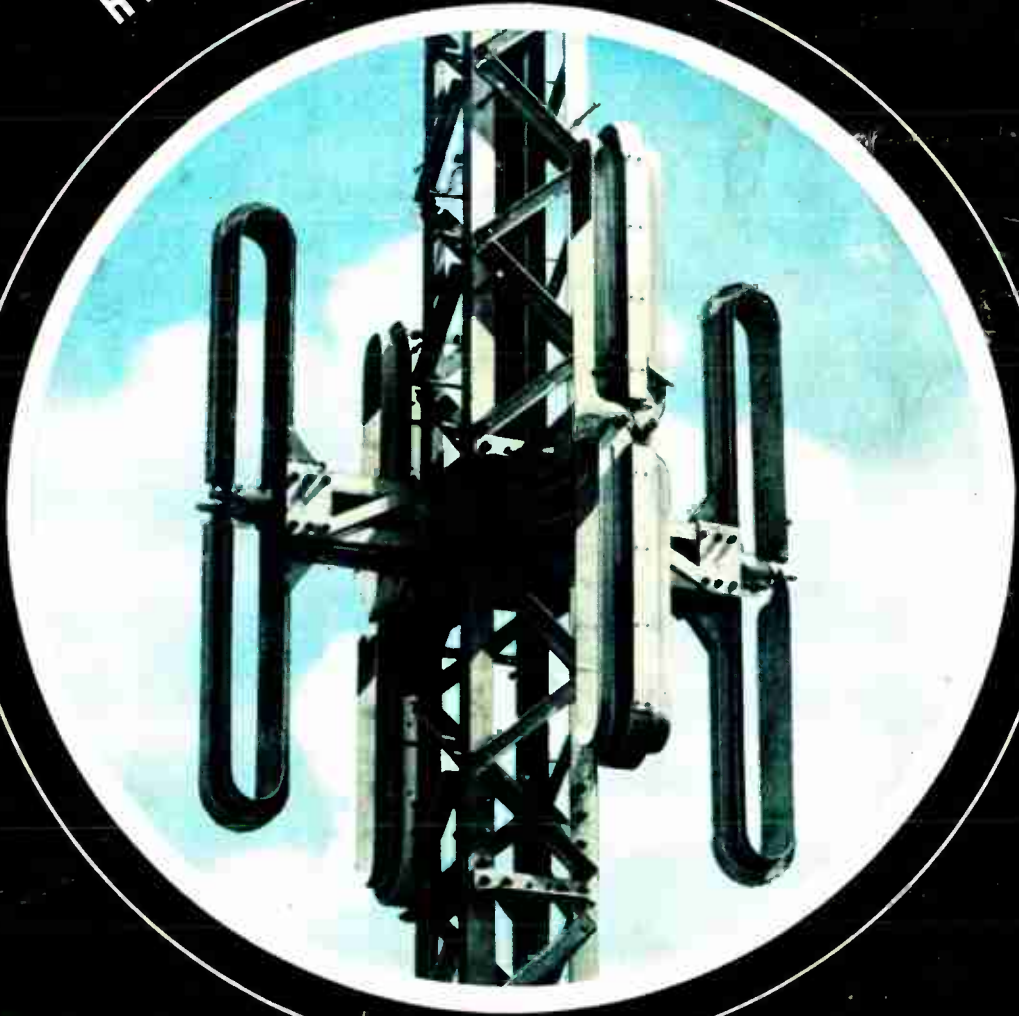

SEPT. 1949

2/-

Vol. LV. No. 9

IN THIS  
ISSUE:

NEW BROADCAST RECEIVER PROBLEM

**FREE to all RADIO ENGINEERS**

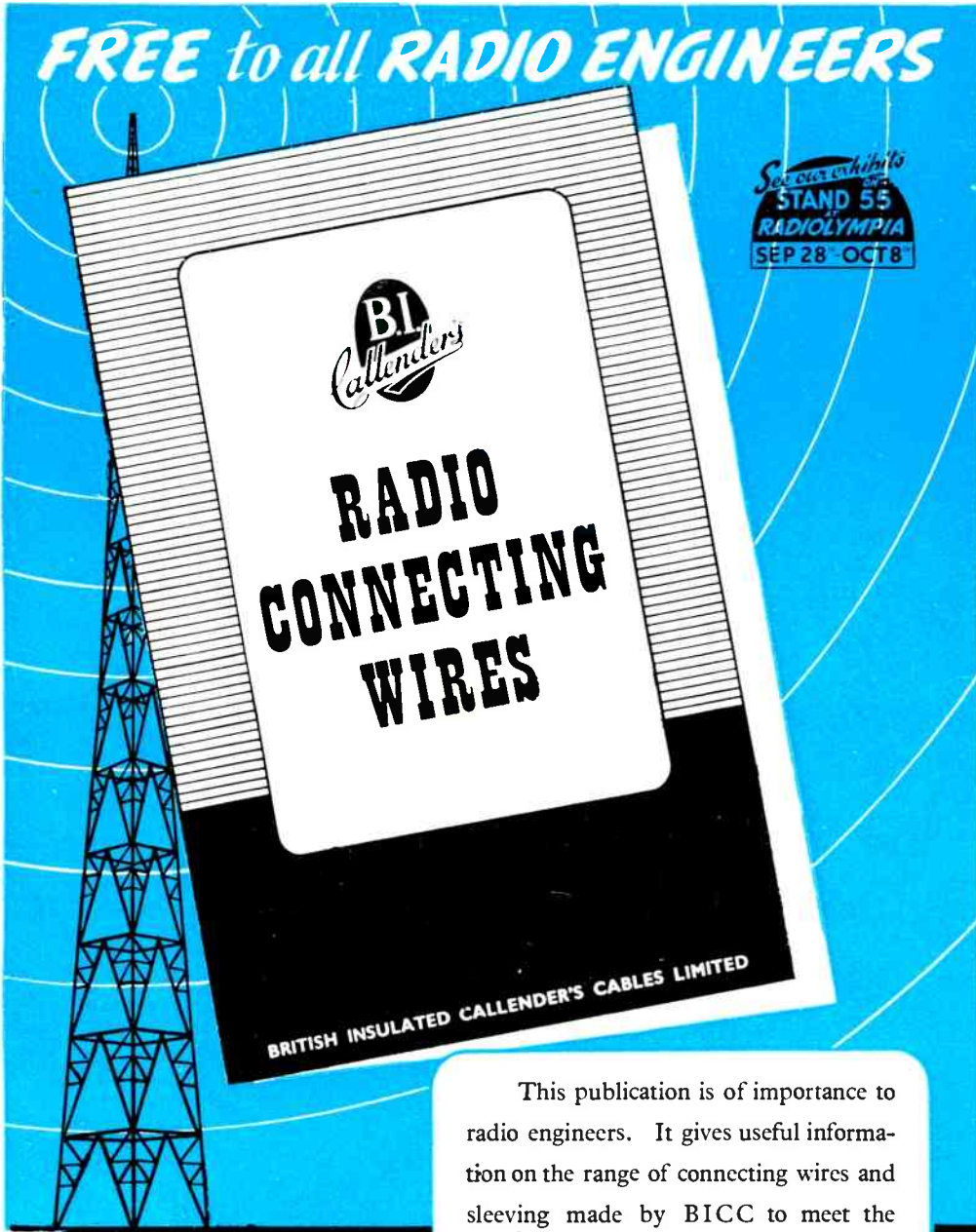

**See our exhibits at**  
**STAND 55**  
**RADIOLYMPIA**  
**SEP 28 - OCT 8**

**B.I. Callenders**

**RADIO CONNECTING WIRES**

**BRITISH INSULATED CALLENDER'S CABLES LIMITED**

This publication is of importance to radio engineers. It gives useful information on the range of connecting wires and sleeving made by BICC to meet the requirements of the Radio and Telecommunication industry.

Write to-day for Publication 247T



**BRITISH INSULATED CALLENDER'S CABLES LIMITED**  
**NORFOLK HOUSE, NORFOLK STREET, LONDON, W.C.2**

# Another worthy addition

TO THE RANGE OF

## 'AVO' Test Instruments

A new Signal Generator of wide range and accuracy of performance, designed for use in the laboratory or by the service engineer. Turret coil switching provides six frequency bands covering 50 Kcs to 80 Mc/s:—

50 Kc/s—150 Kc/s	1.5 Mc/s—5.5 Mc/s
150 Kc/s—500 Kc/s	5.5 Mc/s—20 Mc/s
500 Kc/s—1.5 Mc/s	20 Mc/s—80 Mc/s

### Note these Attractive Features:

Stray field less than  $1\mu\text{V}$  per metre at a distance of 1 metre from instrument. General level of harmonic content of order of 1 per cent.

Direct calibration upon fundamental frequencies throughout range, accuracy being better than 1 per cent. of scale reading.

45 inches of directly calibrated frequency scales with unique illuminated band selection giving particularly good discrimination when tuning television "staggered" circuits.

Of pleasing external appearance with robust internal mechanical construction using cast aluminium screening, careful attention having been devoted to layout of components with subsidiary screening to reduce the minimum signal negligible level even at 80 Mc/s.

Four continuously attenuated ranges using well designed double attenuator system.

Force output 0.5 volts.

Internal modulation at 400 c/s., modulation depth 30 per cent., with variable L.F. signal available for external use.

Mains input 100-250 volts A.C., 40-60c/s.

*Battery Model available having same general specification and covering 50 Kc/s—70 Mc/s., powered by easily obtainable batteries.*

Fully descriptive pamphlet available on application

Sole Proprietors and Manufacturers:

**The AUTOMATIC COIL WINDER & ELECTRICAL EQUIPMENT CO. LTD.**

WINDER HOUSE • DOUGLAS STREET • LONDON • S.W.1 Telephone: VICTORIA 3404/9

SG. 1



Mains Model

**£25**

Battery Model

**£21**

**RADIOLYMPIA**

See our Exhibit at

**Stand No.85**

Sept. 28—Oct. 8





it combines  
three instruments  
in one . . . . .



**BRIDGE OSCILLATOR, AMPLIFIER AND DETECTOR**

The use of separate Oscillators, Amplifiers, and Detectors with L.F. bridges is necessarily cumbersome and expensive and serves to distract the operator in his interpretation of the bridge readings.

The AIRMEC Bridge Oscillator, Amplifier and Detector, Type 703, combines all three instruments in a single compact case and is of relatively low cost. It has the following technical features

**Output :** Oscillator output up to 100 milliwatts.  
Oscillator Frequency 1500 c.p.s.

**Impedances :** High and low impedances are provided on input and output circuits.

**Detection :** By meter reading or phones.

**Mounting and finish :** Casing is finished in ripple grey enamel with polished black front panel and is suitable for rack or bench mounting.

The AIRMEC Bridge Oscillator, Amplifier and Detector is suitable for use with Weim, Campbell and other L.F. bridges.

Enquire for illustrated pamphlet.

**AIRMEC LABORATORIES LIMITED**  
**HIGH WYCOMBE · BUCKINGHAMSHIRE · ENGLAND**

Telephone: High Wycombe 2060.

Cables: Commlabs.

MANUFACTURERS OF ALL TYPES OF INDUSTRIAL ELECTRONIC EQUIPMENT & TEST GEAR

You simply **MUST** make a  
**WIRE RECORDER**

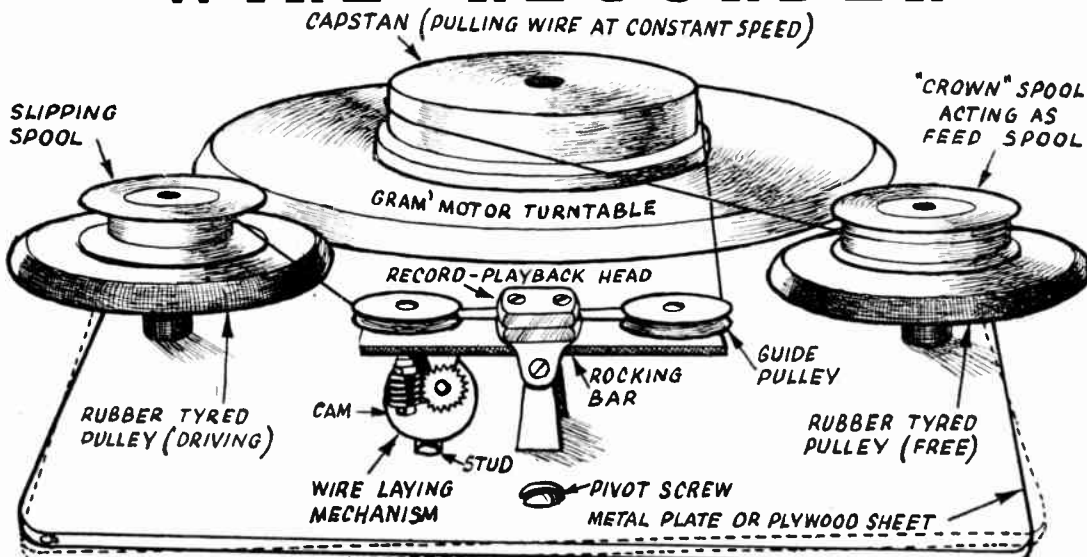

More thrilling than Radio—More gripping than Television. Complete constructional "Gen," 5/-.  
All Components in stock. DEMONSTRATIONS BY APPOINTMENT.

**PARK RADIO** 676-8, Romford Road, London, E.12 Phone: ILFORD 2060

# EDISWAN

## *(Radio Products)*



### *Pezoelectric Pick-up*



One of the principal features of this pickup is its output of 1.7 volts at 1000 c.p.s., which makes it eminently suitable for use with radio receivers with pickup connections. It has a wide range frequency characteristic with a bass response which adequately compensates for low frequency attenuation below 200 c.p.s. High frequency resonances are eliminated by a light needle-holding device, and the arm, operating on double ball bearings, is counter-balanced to give correct weight at needle point.

LIST PRICE 50/-

### MORGANITE *Miniature Potentiometer (TYPE A)*

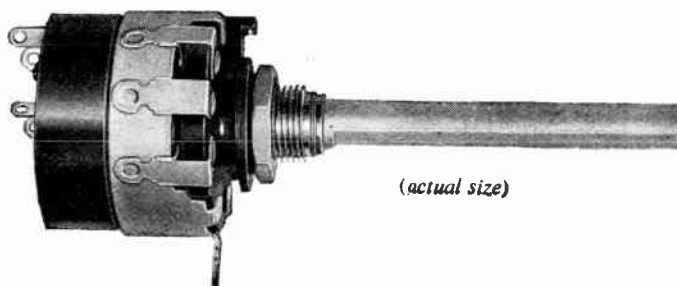

This miniature potentiometer is something new in British potentiometer design. Fully incorporating the traditional Morganite standard of quality, it has an overall diameter of only 1½" and is available in a wide range of standard resistance values.

LIST PRICE	
WITHOUT SWITCH	4/6
WITH S.P. SWITCH	6/6
WITH D.P. SWITCH	7/6

THE EDISON SWAN ELECTRIC COMPANY LIMITED, 155 Charing Cross Road, London, W.C.2

RA151

The  
**MAGNAVISTA**  
TELEVISION LENS

**SEE**  
FOR YOURSELF  
WHAT A DIFFERENCE  
IT MAKES



MEET US AT  
**RADIOLYMPIA**  
SEPT 28 - OCT 8

DEMONSTRATIONS ON  
**STAND No. 10**  
GRAND HALL

Conforming to formulas established by leading independent authorities on lens computation, MAGNAVISTA Lenses give HIGH MAGNIFICATION and ABSOLUTE CLARITY with NO DISTORTION and a WIDE ANGLE OF VIEW. If you cannot visit Olympia ask your dealer to demonstrate or write for full particulars.

**METRO PEX LTD**

38, Gt. Portland St., London, W.1  
(Phone: Museum 9024-5)

*Vision in Design*  
**ADVANCE SIGNAL  
GENERATOR** Type E2



The Advance Signal Generator Type E2 has been designed with an eye to future developments in the Radio and Television fields. Its wide range of frequencies—from 100 Kc/s to 100 Mc/s on fundamentals caters for the rising frequency requirements of modern radio and communications. It is a fine example of 'Advance' design and manufacture.

This generator offers an instrument of laboratory standard at a price within the reach of moderate purses. The remarkable high frequency accuracy of  $\pm 1\%$  extends over the whole range.

**Range:** 100 Kc/s—100 Mc/s in 6 bands.

**Frequency:** Guaranteed within  $\pm 1\%$ .

**Output:** Approx. 1 volt unattenuated and variable from  $1\mu\text{V}$  to 100 mV into a 75 ohm load through a matched transmission line.

**Stray Field:** Less than 3 microvolts at 100 Mc/s.

**Illuminated Dial:** Total scale length 30°.

**Power Supply:** 100 - 210 - 230 - 250 volts. 40 - 100 c/s.

**Dimensions:** 9½" high × 13" wide × 8" deep.

**Weight:** 15 lb.

Send for fully descriptive leaflet

**Advance** TYPE E2  
SIGNAL GENERATOR

ADVANCE COMPONENTS LTD.

Back Rd., Shernhall St., Walthamstow, London, E. 17

Telephone: LARKSWOOD 4366/7/8

# CHANGE OF ADDRESS

## The Hub of Progress



**125 OXFORD ST., LONDON, W.1**

**GERRARD 8782**



# MINIATURE VITREOUS ENAMELLED RESISTOR

TYPE M.V.1

**RATING** 3 watts for 250°C rise.

**RESISTANCE RANGE** 1-4700 ohms.

Full rated watts over the whole resistance range.

**DIMENSIONS.** - 15/32" × 13/64".

Agents in Belgium: Monsieur Paul Groeninckx, 43, Avenue Jean Stobbaerts, Bruxelles.



Actual size of resistor

TYPE APPROVED



KINGSTHORPE, NORTHAMPTON.

*The better they are made  
the more outstanding the results*

**MADE IN THREE PRINCIPAL MATERIALS.**

**FREQUELEX.** An insulating material of low Dielectric Loss, for Coil Formers, Aerial Insulators, Valve Holders, etc.

**PERMALEX.** A High Permittivity Material. For the construction of Condensers of the smallest possible dimensions.

**TEMPLEX.** A Condenser material of medium permittivity. For the construction of Condensers having a constant capacity at all temperatures.

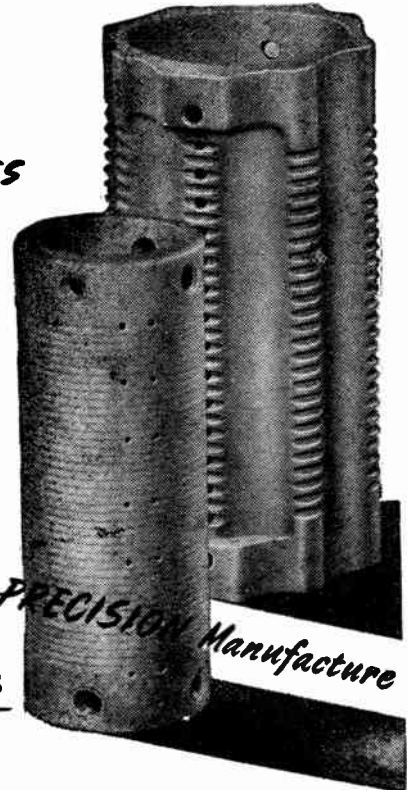

# Bullers

*Specialize in PRECISION Manufacture*



**BULLERS LOW LOSS CERAMICS**

BULLERS LTD., 6, Laurence Pountney Hill, London, E.C.4. Phone: Manslon House 9971 (3 lines)  
Telegrams: "Bullers, Cannon, London."



# 'CINTEL'

## METAL DETECTION EQUIPMENT

provides an additional safeguard for the quality of the product and eliminates the risk of fire and damage to machinery by tramp metal.

### Typical installations of the 'CINTEL' INDUSTRIAL ELECTRONIC METAL DETECTOR



Chocolate Coated Biscuits



Dried Fruits

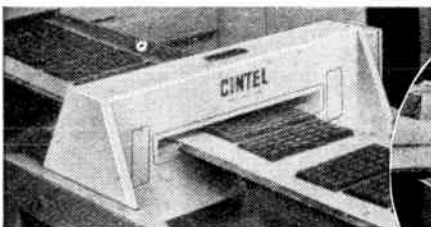

Chocolate Bars



Toilet Requisites



Raw Rubber

Packaged Confectionery

Applications in other industries including Plastics, Tobacco, Textiles, Insulating materials, Limestone, Sugar cane crushing, etc.



Registered Trade Mark

The 'Cintel' Industrial Electronic Metal Detector has been specially designed to provide permanent inspection facilities with the minimum of attention. Fully automatic in operation, the equipment removes the risk of error that may be present with visual inspection and detects both ferrous and non-ferrous metal inclusions.

## CINEMA TELEVISION LIMITED

WORSLEY BRIDGE ROAD, LONDON, S.E.26

Telephone: Hither Green 4600

# H.T. AND E.H.T. RELIABILITY

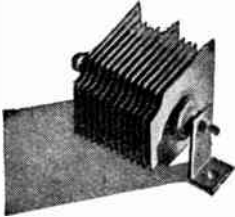

Typical rectifier for use in A.C. or A.C./D.C. receivers.



Type 36EHT rectifier. Two such units only  $2\frac{1}{2}$ " long by  $\frac{7}{16}$ " dia. will give an output of 5.3kV.



"Westeht" E.H.T. supply unit. 5kV output from a 350-0-350 A.C. input.

Many  
WESTINGHOUSE  
RECTIFIERS  
HAVE  
OVER  
21 YEARS'  
SERVICE  
TO THEIR  
CREDIT

## WESTINGHOUSE WESTALITE RECTIFIERS

Write for details to Dept. W.W. 9.

**WESTINGHOUSE BRAKE & SIGNAL CO. LTD.**

82, York Way, King's Cross, London, N. 1

## TRUE BASS — NOT BOOM from BARKER'S 148a SPEAKER

True bass is difficult to produce: it is, in fact, very rare. More often than not, boom takes its place, derived from a marked resonance around 70 to 100 cps in the cone or cabinet; impressive at first, but not the truth, and maddening to those who prefer the big drum kept to its proper place. Barker's 148a has three basic reasons for giving true boomless bass. One is its low resistance aluminium coil former, source of inherent feedback and damping which irons out all tendency to uncontrolled movement: second is the high flux magnet system aiding this control: third is the patent cone construction.



We have said this before, and shall no doubt do so many times yet, fortified by the rapidly mounting number of 148a owners who agree that a true low register without a permanent obligato of boom is an enduring pleasure.

Try it for yourself, at Brierleys, Goodells, Rogers, Webbs and other specialists, or write to

**BCM/AADU LONDON, W.C.1.**

## "WEYRAD" B-A-N-D-S-P-R-E-A-D UNITS.

WITH OR WITHOUT R.F. STAGE—NINE WAVEBANDS

EXPORT	SIZE WITH R.F. STAGE	W/O R.F. STAGE	HOME
13 mtrs.			13 mtrs.
16 "	$8\frac{1}{2}'' \times 4\frac{3}{8}'' \times 2''$		16 "
19 "			19 "
25 "			25 "
31 "	$5\frac{1}{2}'' \times 4\frac{3}{8}'' \times 2''$		31 "
41 "			41 "
13-43 "	Moulded formers with Iron Cores—air		43-140 "
43-140 "	dielectric trimmers employed throughout.		175-570 "
175-570 "	All adjustments in one plane.		L.W.
Gram			Gram

**BANDSPREAD FREQUENCY RATIO 1.1 : 1**

RETAIL (With R.F. Stage £6/15/- plus P.T. £1/10/-,  
PRICE (Without R.F. Stage £4/14/6 plus P.T. £1/1/-.

These units are designed for use with a chassis plate assembly complete with special tuning condenser and valve holder/s.

1st I.F. position (Weyrad P3) and all fixing holes punched—for use with EF50 and ECH35 valves.

RETAIL (With R.F. Stage £1/11/-,  
PRICE (Without R.F. Stage 19/10.

Special Discounts for Quantities.

**TYPE P3.** Fully tropicalised I.F. transformers. High or medium impedance versions available. Approved for use under extreme climatic conditions. Size:  $\frac{3}{8}$  in. Can, 2 in. High. Nominal "Q" = 125  
PRICE 8/6 each.

Manufacturers enquiries invited.

**WEYMOUTH RADIO MFG., CO., LTD.,  
CRESCENT WORKS, WEYMOUTH,  
DORSET.**

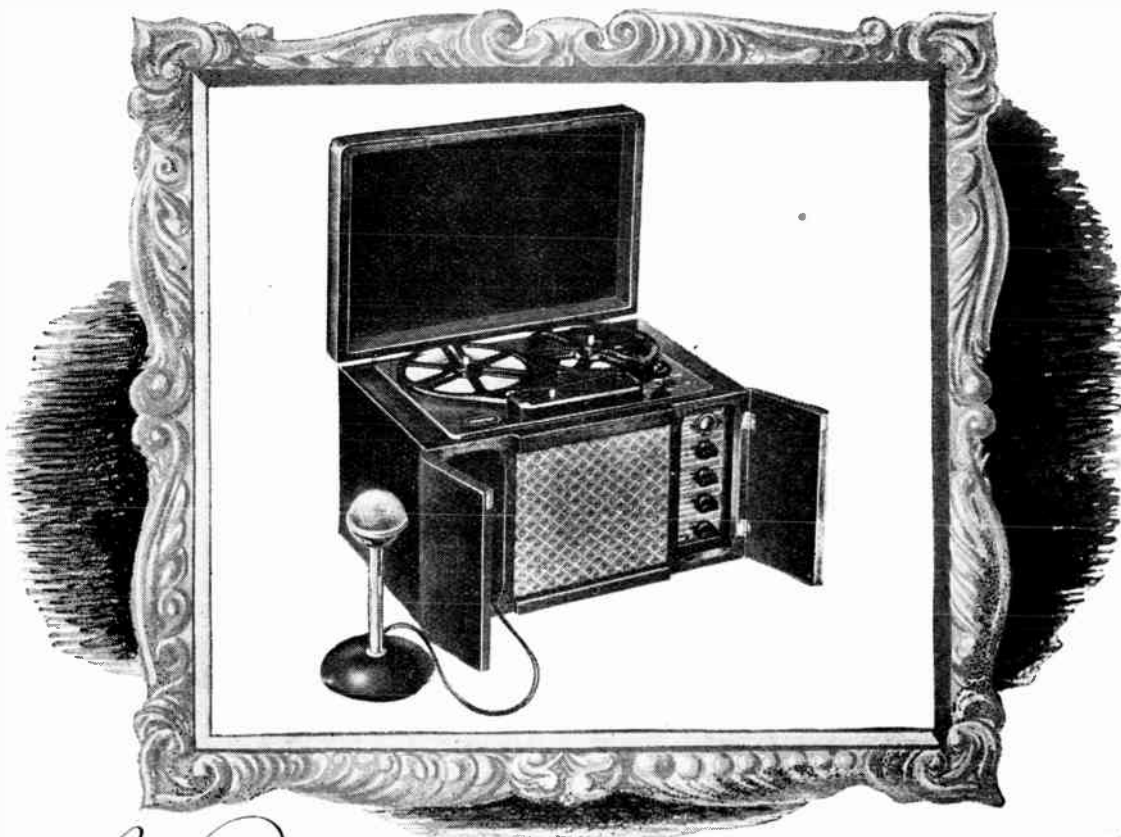

## A Masterpiece

### OF ELECTRONIC ENGINEERING

The success story of the SOUNDMIRROR is as phenomenal as is the instrument itself. In the few months since it was first introduced it has established itself as the leading Magnetic Tape Recording/Reproducing Instrument. It has been enthusiastically received by business men, the professions—including medicine, the stage, writers, and all who are interested in Sound Recording.

The SOUNDMIRROR is a high fidelity instrument which records and reproduces on reels of inexpensive magnetic-tape, speech, music, and sound effects of all kinds. Each reel gives a full half-hour's recording. Short recordings can be cut and spliced together. Recordings can be permanently retained or when

desired automatic erasure is provided when making new recordings on used tape. Simple to operate, the SOUNDMIRROR has a single finger-tip control for play, record, fast re-wind or fast-forward requirements.

Built-in jacks enable the SOUNDMIRROR to be used in conjunction with the radio or public-address equipment.

*Made in England  
Protected by British and Foreign Patents  
and Patents Pending*



Full details from the Manufacturers and Sale Distributors:—

**THERMIONIC PRODUCTS LTD. Morris House, Jermyn Street, Haymarket, S.W.1**

Sales and Service centres at Manchester, Birmingham, Bristol, etc.

Telephone: WHitehall 6422 (5 lines)



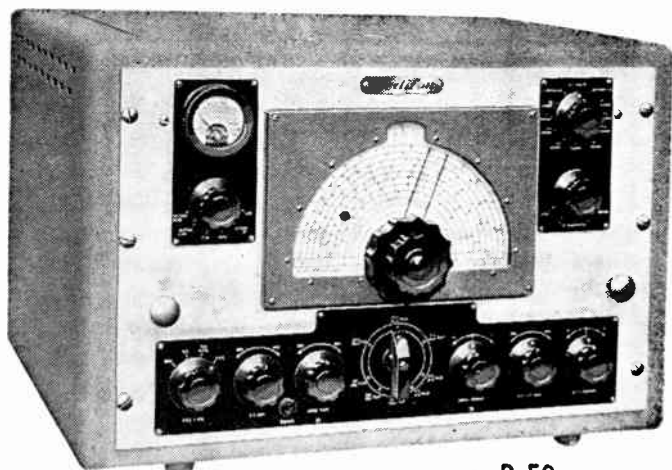

R.50

COMMUNICATIONS RECEIVER

This high-grade communications receiver incorporates the most highly developed techniques in modern receiver design. Five degrees of selectivity, including a crystal gate and crystal filter are provided, and the sensitivity is such that an input of between 1.5 microvolts gives a signal/noise ratio of at least 10 dB over the entire frequency range of 13.5 to 26 kc/s and 95 kc/s to 32 Mc/s. Separate power units for A.C. or D.C. operation are available.

**REDIFON LIMITED, BROOMHILL ROAD, WANDSWORTH, S.W.18**

DESIGNERS & MANUFACTURERS OF RADIO COMMUNICATION & INDUSTRIAL ELECTRONIC EQUIPMENT. Phone: VANdyke 5691

RC 203

# Supreme Communications Receiver

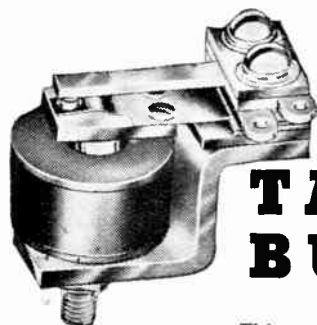

## THE TAYLOR BUZZER

This small buzzer has a number of applications, such as continuity testing, a signal for telephones and communication circuits, or as a source of interrupted supply for bridge circuits.

It operates at approximately 500 cycles per second, and the consumption at 3 volts is very approximately 100 mA. Also it will operate satisfactorily from 4 volts A.C. 50 cycles.

**TAYLOR ELECTRICAL INSTRUMENTS LTD**  
419-424 MONTROSE AVENUE, SLOUGH, BUCKS, ENGLAND  
Tollphone SLOUGH 21381 (4 lines) Grams & Cables TAYLINS, SLOUGH

### TAPE RECORDING

Put it on record—tape it with a

### SOUND MAGNET RECORDER

Concerts—Parties—Lectures—Talks—Dictation—Entertainment—Educational—Instructional, etc. Any Sound—Anywhere—Anytime—Tape Recorded.

For details on the SOUND MAGNET write now for brochure.

Two models £35 and £47 10 0.



(Prompt attention to Overseas enquiries).

**GENERAL LAMINATION PRODUCTS LTD.**  
Dept. S.M., 294 BROADWAY, BEXLEYHEATH, KENT



# 'MICADISCS' - the capacitors with extremely low inductance



"MICADISCS" are of stacked foil construction and have the absolute minimum self-inductance. The impedance-frequency characteristic, therefore, is essentially that of a pure capacitance at frequencies well in excess of 100 Mc/s.

### Type CM 30

A "lead-through" capacitor for by-pass or for de-coupling currents working at high frequencies up to 100/200 Mc/s range in television receivers and other U.H.F. applications.

### Types CM 31 and 32

"Two terminal" capacitors for general transmitting use where heavy current at very high frequencies is required to be passed. Terminal design facilitates build-up of series or series parallel combinations.

### Type CM 30

Capacitance range - 0.0002, 0.0003, 0.0005 Mfd.  
 Capacitance tolerance - (a) -0 +50% (b) + or -20%  
 Max. D.C. Working Voltage - 350 at 71°C.

Capacitance range - 0.0002 to 0.003 Mfd.  
 Tolerance - + or -20%  
 Peak Voltage - 800  
 Max. R.F. Voltage - 250 RMS  
 Max. R.F. Current - 40A  
 Max. Working Temp. - 150°C.  
 Terminals - 2BA

### Type CM 31

0.0002 to 0.003 Mfd.  
 + or -20%  
 800  
 250 RMS  
 40A  
 150°C.  
 2BA

### Type CM 32

0.002 to 0.012 Mfd.  
 + or -20%  
 800  
 250 RMS  
 160A  
 150°C.  
 1/2" x 16 T.P.I.

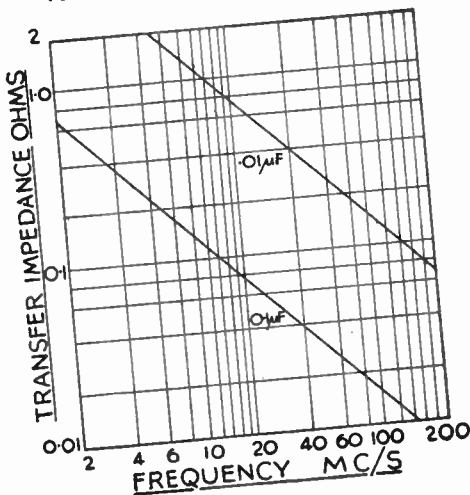
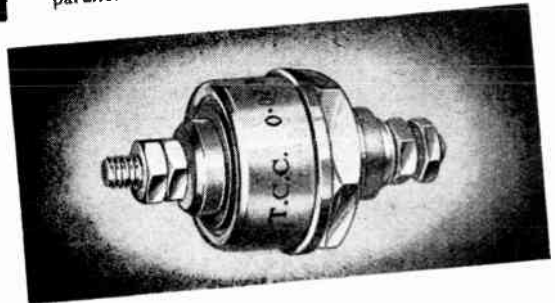

Types CM71 and CM 72. "Lead Through" capacitors for transmitters and industrial electronic equipment, such as H.F. heaters, for filtering out unwanted H.F. from Power Leads.

	Type CM 71	Type CM 72(a)	Type CM 72(b)
Capacitance range	0.002 to 0.02 Mfd.	0.01 to 0.1 Mfd.	0.005 to 0.05 Mfd.
Peak Voltage	800	800 V Peak	2000 V Peak
Max. R.F. Voltage	250 RMS	250 RMS	250 RMS
Max. R.F. Current	40A	150A	150A
Max. Stem Current	100A	300A	300A
Stem size	0.8A	(a & b) 3/8" - 0.8A. clearing holes equally spaced on 1/2" pitch circle diameter. Stem Whit.	
Fixing	1/2" dia. hole		

**THE TELEGRAPH CONDENSER CO. LTD.**

RADIO DIVISION  
 NORTH ACTON · LONDON · W.3  
 Telephone: ACOrn 0061





## PHRENOLOGISTS

may PHROWN

. . . but encephalologists demanded a more subtle measurement of impulses caused by thought or emotion. Electronic amplifiers can now record these subtle impulses and Parmeko transformers have assisted this enlightening work with thoughtful consistency and almost annoying accuracy . . . The thought impulses of manufacturers on the bumpy road to electronic or electrical efficiency can be reduced by reliance on Parmeko transformers.

**PARMEKO** of **LEICESTER**

Makers of Transformers for the Electronic and Electrical Industries.



**Pushbutton?**  
**Slider?**  
**Rotary?**  
**Band Selection?**  
**Circuit Selection?**  
**Tap Switching?**

Whatever it is—the answer is always OAK! Equalised pressure, double contact clips and floating rotors are exclusive features embodied in all special or standard type OAK switches

**WITHOUT QUESTION**  
**SPECIFY**

**OAK**



**SWITCHES**

**BRITISH N.S.F. CO. LTD., Keighley, Yorks.**

Sole Licensees of OAK Manufacturing Co., Chicago

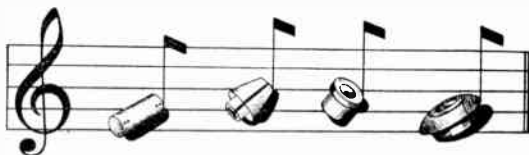

**make a note of Thompson's wood turnings**

If you have a special fitting in mind which you think could be made better, or more economically or quicker in wood ask Thompson's advice on it—wood-turnings for 1001 trades.

Any turning in any wood to engineers' precision standards from blueprints, drawings or samples.

**W. & J. R. THOMPSON**

(WOODTURNERS) LIMITED. EST. 1862  
**CROSS HILLS, KEIGHLEY, YORKSHIRE.**

Phone. Crosshills 2312 (two lines)

Grams. Turawood, Crosshills

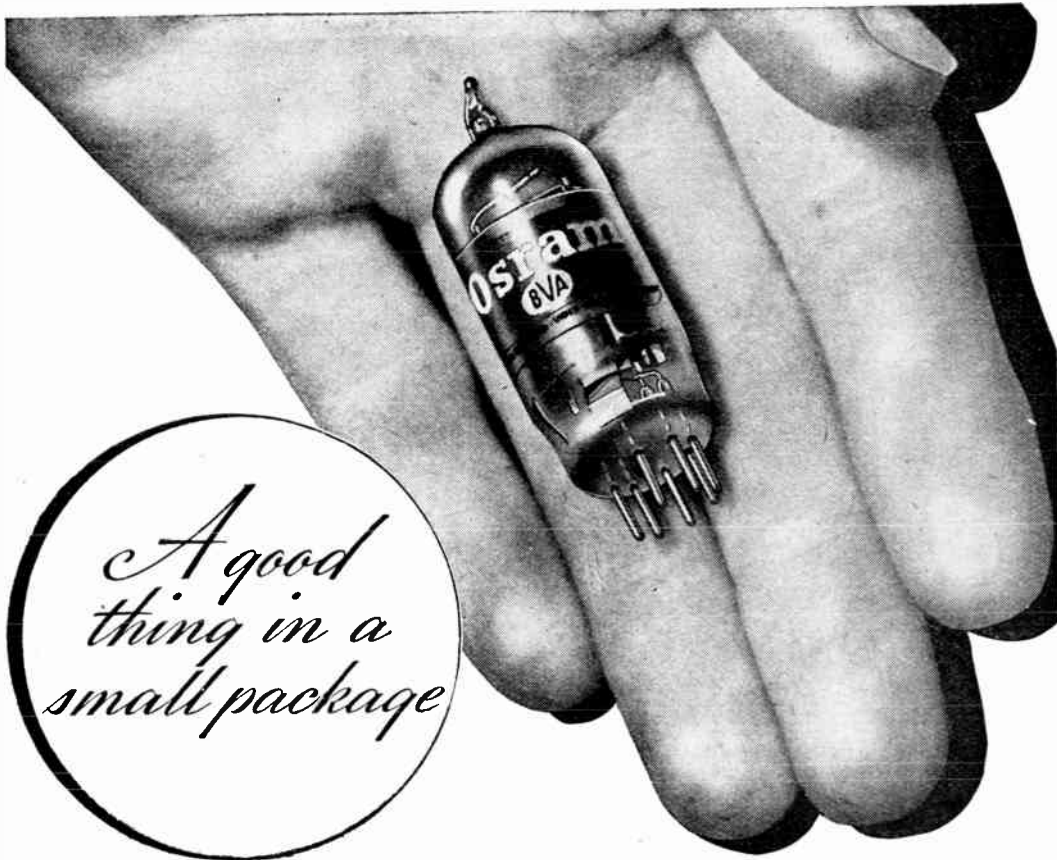

*A good thing in a small package*

## OSRAM MINIATURE VALVE

TYPE Z77 HIGH-GAIN PENTODE

It is a high-gain pentode, mounted on the B7G base and is suitable for use in television, wide-band radio, amplifier and electronic instrument circuits.

### INTERESTING FEATURES

Small size and rugged construction make it an eminently suitable valve for use in mobile and portable equipment. Suitable for operation up to 100 megacycles per second. Owing to smallness of size and low thermal capacity the valve rapidly reaches a stable operating condition.

List Price 17/6. Purchase Tax extra.



**Osram**  
PHOTO CELLS

**G.E.C.**  
CATHODE RAY TUBES

**Osram**  
VALVES

THE GENERAL ELECTRIC CO., LTD., MAGNET HOUSE, KINGSWAY, W.C.2.





Why not a *personal* Signal Generator for your design engineers — especially a portable instrument operating from interchangeable mains or battery units and covering the wide frequency range of 70 kc/s to 70 Mc/s. So much more preliminary work can be done without waiting for the standard laboratory apparatus to be free or moved from one bench to another. And if the *personal* Signal Generator also incorporates its own crystal check plus a useful power meter—all at the cost of one inexpensive instrument—each engineer is equipped at all times to carry out his own experimental tests. To such facilities add a reliable accuracy of output and frequency calibration and you have the portable Receiver Tester — the ideal laboratory sub-standard. Full technical data is freely available.

The Portable Receiver Tester Type TF888.

## MARGONI INSTRUMENTS · LTD.

St. Albans, Herts. Telephone: St. Albans 6161/5.

Northern Office: 30 Albion Street, Hull. Western Office: 10 Portview Road, Avonmouth. Southern Office and Showrooms: 109 Eaton Square, London, S.W.1. Midland Office: 19 The Parade, Leamington Spa.

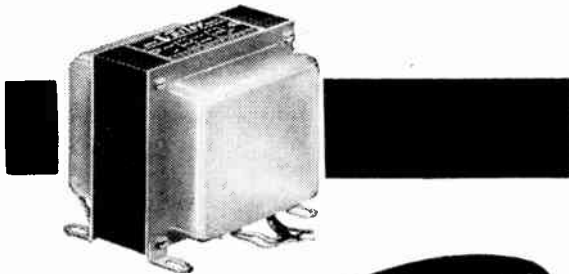

# MAINS TRANSFORMERS & CHOKES



All "Varley" products are manufactured from the highest quality materials. Transformers etc., are individually wound and have interleaved windings with ample insulation, ensuring freedom from breakdown. The comprehensive range of Shielded and Open type Transformers available meets the requirements of every circuit.

MADE BY

V/rite for list etc.

**OLIVER PELL CONTROL LTD**  
CAMBRIDGE ROW · WOOLWICH · S·E·18

Telephone: WOOLWICH 1422

## ROGERS DEVELOPMENTS CO.

We offer an ever increasing range of goods of interest to the high-fidelity enthusiast.

Below we list a few representative items from our varied stock.

Lowther precision moving coil pick-up. Impedance 20/25 ohms.	£9 0 0
Fitted with tungsten carbide reproducing point ...	P.T. £3 19 10
Fitted with diamond reproducing point... ..	£18 0 0
	P.T. £7 19 8
Transformer unit type 20T. Ratio 45/1... ..	£1 17 6
Transformer equalizer type 20TC ... ..	£2 10 0
Connoisseur precision gramophone motor ... ..	£13 5 0
	P.T. £5 14 0

All types of gramophone motors, A.C. and A.C./D.C., and automatic record changer units.

Wimble high grade moving coil pick-up, with sapphire needle ... ..	P.T. extra £7 12 0
Transformer for above in mumetal box ... ..	£1 16 0
Rimington jewel needle for use with lightweight pick-ups, each 9/9 inclusive	£12 13 0

Goodmans Axiom 22 loudspeaker ... .. £12 13 0  
Bass Reflex Cabinet as specified for Axiom 12 or 22 ... £16 16 0

RD Junior wide range corner cabinet, complete with loudspeaker, cabinet finished in walnut ... .. £19 10 0

All types of radiogram, amplifier, and console cabinets made to individual specifications. Send sketch for quotation.

Output valves supplied in matched pairs at no extra charge.

Types KT66, PX4, 6L6, 6V6, PX25, etc.

Please write for further details where required.

**ROGERS DEVELOPMENTS CO.**  
106 HEATH STREET, HAMPSTEAD, N.W.3

HAMPSTEAD 6901



# PREMIER RADIO COMPANY

MORRIS & CO. (RADIO) LTD.

WHY STRUGGLE WITH RADAR UNITS  
*when you can build a commercial looking and working*  
**TELEVISOR WITH PREMIER KITS FOR**  
**£17.17.0**

This Receiver consists of 4 units :

The Sound Receiver, Vision Receiver, Time Base and Power Pack. As is usual in all Premier Kits, every single item down to the last bolt and nut is supplied. All chassis are punched and layout diagrams and theoretical circuits are included.

The cost of the Kits of Parts is as follows :

Vision Receiver with valves	£3 13 6
Sound Receiver with valves	£2 14 6
Time Base with valves .....	£2 7 6
Power Supply Unit with valves .....	£6 3 0

In Addition you will need :

VCR97 Cathode Ray Tube	£1 15 0
Set of Tube Fittings and Socket .....	7 0
6in. PM Moving Coil Speaker .....	16 6

The Instruction Book costs 2/6, but is credited if a Kit for the complete Televisor is Purchased.

Any of these Kits may be purchased separately ; in fact any single part can be supplied. A complete priced list of all parts will be found in the Instruction Book.

20 valves are used, the coils are all wound and every part is tested. All you need to build a complete Television Receiver is a screwdriver, a pair of pliers, a soldering iron and the ability to read a theoretical diagram.

**Modification details for the Birmingham frequency will be available later.**

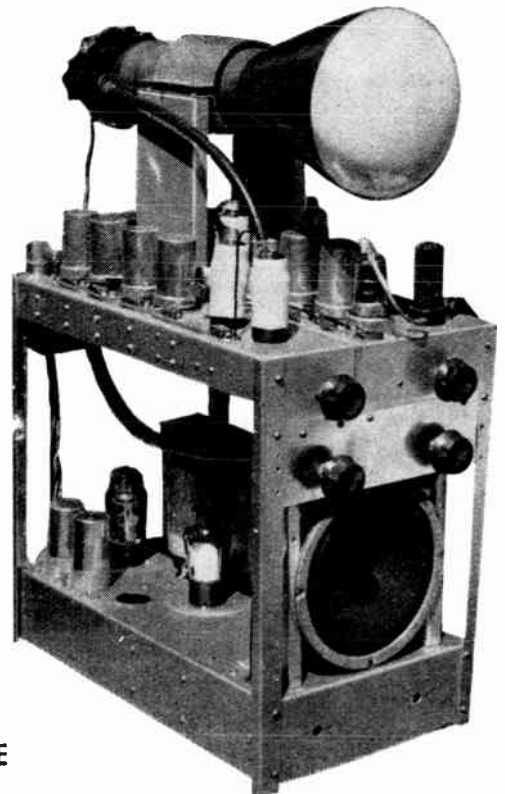

**A GLANCE AT THE PRICES WILL SHOW THAT THIS IS THE GREATEST VALUE OFFER PREMIER HAVE EVER MADE**

WORKING MODELS CAN BE SEEN DURING TRANSMITTING HOURS  
 AT OUR FLEET STREET AND EDGWARE ROAD BRANCHES.

**BRANCHES AT**

**207, EDGWARE RD., W.2** Phone : AMBassador 4033  
**AND AT 152-153, FLEET STREET, E.C.4** Phone : CENtral 2833

All POST ORDERS to 167, LOWER CLAPTON ROAD, LONDON, E.5. 'Phone : AMHerst 4723  
 Terms of Business : Cash with order or C.O.D. over £1. Send 2d. Stamp for list.

**EDGWARE ROAD IS OPEN UNTIL 6 p.m. ON SATURDAYS**

EDX.22G



The best  
**HIGH**  
and  
**LOW**

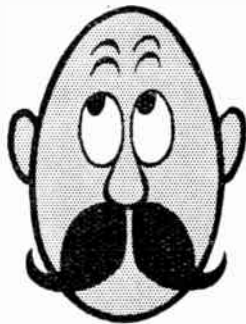

**Exide AND Drydex**

LOW TENSION ACCUMULATORS HIGH TENSION BATTERIES  
for better battery radio reception

ISSUED BY THE CHLORIDE ELECTRICAL STORAGE COMPANY LIMITED

**NAGARD PRODUCTIONS AVAILABLE FOR 1949-50**  
**NAGARD WIDE RANGE CALIBRATED OSCILLOSCOPES**

TYPE 103 covers Time Base speeds up to 1 Mc/s and Y amplification up to 10 Mc/s and includes exceptional measuring facilities for frequency, time and voltage both A.C. & D.C.

Construction provides many ranges in easily exchangeable units at minimum cost, including Beam Switch unit for double beam displays.

**NAGARD D.C. AMPLIFIERS**

Various types are available all incorporating high stability, drift free characteristics at reasonable cost.

These can be quoted against specified requirements or for standard types in ranges of high, or medium gain with response characteristics at any desired frequency range up to 10 Mc/s.

**NAGARD SIGNAL CONVERTER VALVES**

These valves operate on the deflection modulated principle and make use of secondary emission to give very exceptional and useful characteristics which are available for Time Bases, Beam Switches, Amplifiers, Mixers, Frequency Multipliers, etc.

Type S.C.2 has an infinite impedance and high output, making it exceptionally valuable for high frequency applications.

**NAGARD UNIVERSAL OSCILLOSCOPE MOUNTINGS**

For conveniently viewing oscilloscope screens, these devices are invaluable.

They provide means of mounting and tilting the axis of all portable oscilloscopes in both vertical and horizontal directions, coupled with easy movement of heavy models on the work bench.

**NAGARD LTD**

245, BRIXTON ROAD, LONDON, S.W.9

Phone: BRixton 3550

Grams: Intertel, Claproad, London

*Metal work—by Ritherdon's*

- INSTRUMENT CASES
- AMPLIFIER RACKS
- RADIO AND TELEVISION CHASSIS
- FUSE BOXES
- BUSBAR CHAMBERS
- GENERAL SHEET METAL WORK, Etc.

**RITHERDON & CO. LTD.**  
LORNE STREET, DARWEN, LANC.  
Phone Darwen 1028  
ESTABLISHED 1895

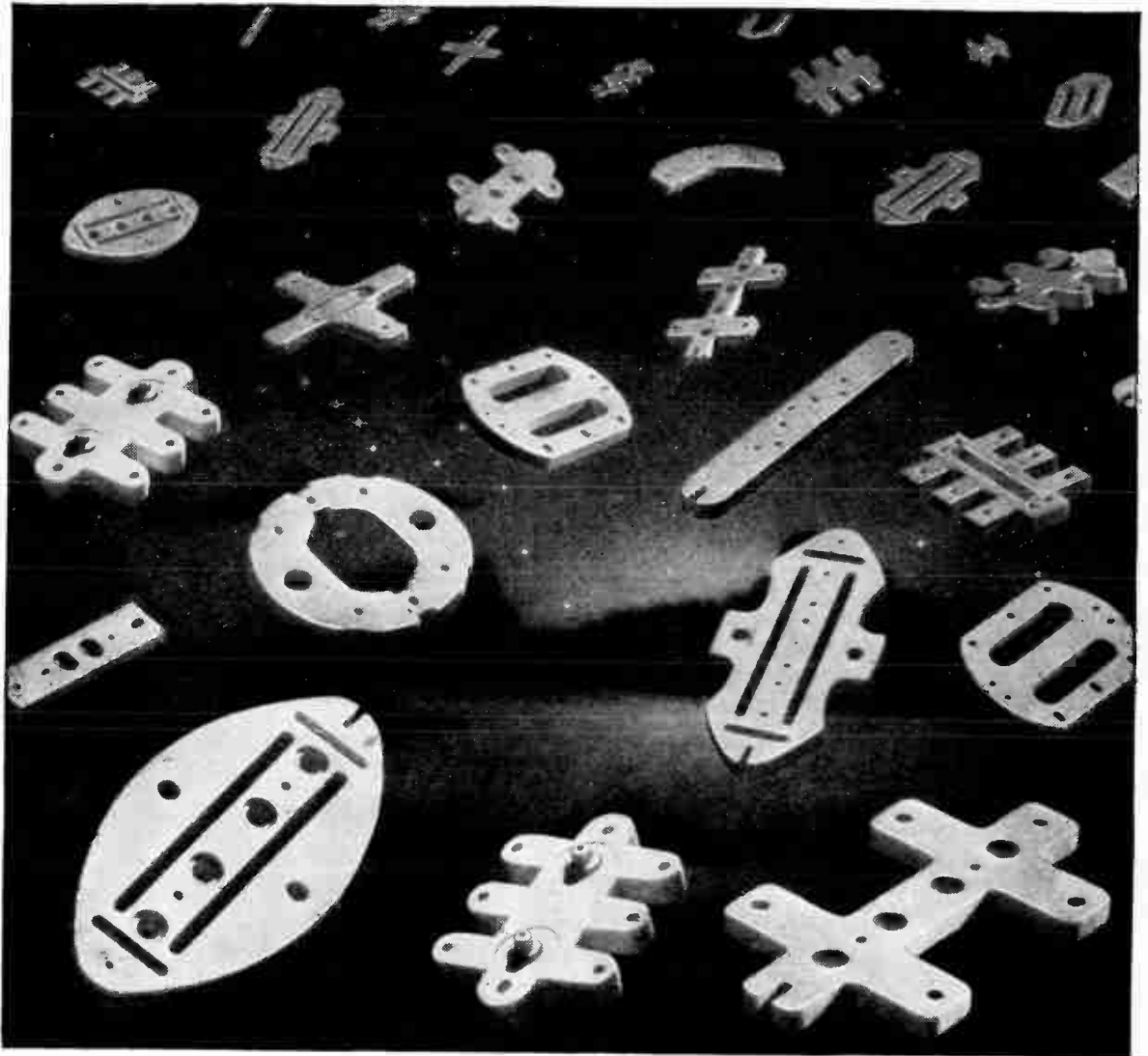

# CERAMICS

FOR ELECTRODE SUPPORTS  
and all radio components  
FREQUENTITE – FARADIX – TEMPRADIX

**STEATITE & PORCELAIN PRODUCTS LTD.**



Stourport on Severn, Worcester

Telephone: Stourport 111

Telegrams: Steatite, Stourport

S.P. 53

0



# TEST! - RADIO-TELEVISION EVERYTHING ELECTRICAL



Not only radio but everything electrical can be tested with this world famous PIFCO Radiometer. Bell and telephone circuits, radio, television, vacuum cleaners, irons, car lighting, H.T. and L.T. milliamps, etc. Increasing supplies now available for the home market.



- **CIRCUIT TEST**  
Tests for open or faulty circuits in all radio and electrical apparatus and domestic appliances. Equally for testing car lighting and starting circuits.
- **L.T. TEST**  
0-6 volts AC or DC
- **MILLIAMPERE TEST**  
0/30 m.a. scale for testing total discharge from battery or testing single cell
- **VALVE TEST**  
Made by inserting valve in socket on front of meter.
- **H.T. TEST** — 0-240 volts. May be used direct on any mains, AC or DC

● Price 25/- . Obtainable from your local dealer.

## PIFCO ALL-IN-ONE RADIOMETER

PIFCO LTD., PIFCO HOUSE, WATLING STREET, MANCHESTER, 4 and at PIFCO HOUSE, GT. EASTERN STREET, LONDON, E.C.2

### M.R. SUPPLIES Ltd.

The diligent and enthusiastic service for supply of Electro-Technical Material of the highest quality at attractive prices. Latest list with each despatch. All prices net. GREAT OPPORTUNITY—SYNCHRONOUS ELECTRIC CLOCKS for simple assembly.

(1) The Movement, 200/250v. 50 c. Spindles for hours, minutes and seconds, hands. Centre screwed bush mount (1 hole). Mounted in plastic dust cover, dia. 3 1/4 in., depth 2 1/2 in. Silent and reliable, 35/-. (2) Set of three chromium hands in good style, suiting 5/8 in. zone, 2/-. (3) Attractively designed mounted mantel dials in translucent perspex, blue, green, yellow, pink and cream (please give second choice), with fretted figure zone and domed glass, height 8 1/2 in., to suit movement and hands, 22/6. Or the three tens, making a £6-6-0 clock for 57/6 (despatch 1/9). This offer is limited by the number of dials available. Any item sold separately.

**M/COIL SPEAKER MICROPHONE UNITS** (Goodman), 3 1/4 in., with high-flux alni magnet, 15-ohm coil, perfect as extension speaker or microphone and right for intercom., 9/6. Also 5 in. Pleassey PM m/coil, 3-ohm coil, with Transformer, 12/6.

**PUBLIC ADDRESS SPEAKERS P.M.** m/coil Pressure Type Units, 15-ohm coil, with multi-match line transformer in weatherproof housing, 10 watts, complete with 30 in. all-metal horn, flare 20 in., square treble-diffused, perforated, 25/6 0. carr. paid. **TRIPDS**, for P.A. Speakers, all steel, sturdy construction, best type, extending to 12ft., and suitable for any P.A. speakers, 55/- each (despatch, England only, 6/- Ireland and Scotland 8/6).

**ELECTRIC WATER PUMPS** (Stuart), Delivery from stock. Operation 220/250 v. AC/DC, soundly constructed on non-ferrous metals with patented features for exposure and long-life. No. 10, 120 g.p.h., £5 15/- (des. 2/-). No. 11, 300 g.p.h., £7 (des. 2/-). No. 12, 500 g.p.h., £9 10/- (des. 1/6). Instructions and guarantee with each. Also ex-A.M. Immersion Self-priming Pumps, approx. 1 1/2 in. long and 2 1/2 in. dia. A precision motor within the tube drives impeller and delivers up to 300 g.p.h. Operation 12-24 v. AC/DC, 29/6. Or with transformer enabling pump to be used on 200/240 v. A.C. mains, 47/6 complete (des. 2/-).

**FRACIONAL MAINS MOTORS**, 200-250 v. A.C. Brand-new shaded pole. Running torque 400 gram cms., 100%, starting torque, 1,200 r.p.m. Silent in operation. Shaft 1 in., long by 1 1/2 in. Frame 3 1/4 in. by 3 1/4 in., ventilated on sides, 32/6 (des. 1/-).

**"NIFE" CAR LAMP**, with 2-cell "Nife" nickel-cadmium long-life battery (re-chargeable at 3 amps) 8 in. by 3 1/2 in. by 1 1/2 in., with weatherproof lamp fitted standard 2-filament bulb, 2ft. lead and headgear. Ideal for inspection or portable lamp. Initially charged, ready for use, 25/- (des. 1/6). These are despatched in original Govt. wrappings.

**MINIATURE RELAYS**. Note the very small dimensions, 1 1/2 in. by 1 1/2 in., type 10F/2724. Coil 65-ohms, switching 2 single-pole C.O., (paired contacts, platinum) 7/6 each. (These are listed 30/- each, and are brand-new).

**STAGE LIGHTING DIMMERS**. Controlling started load from full-bright to blackout at 220/240 v. Sliding type, 100-watt, 32/6; 300-watt, 37/6; 500-watt 50/-; (des. 2/-). Screw-motion type, with handwheel: 500 watt, 78/6; 1,000-watt 26/3/-; 1,500-watt, £7 18/-; 2,500 watt, £9 5/- (des. 5/-).

**ROTHERMEL PIEZO-CRYSTAL HEADPHONES**, Type "A" the best for sensitivity, response and comfort. £3 10/0 pair, brand-new, for 32/6.

**OPERATION COUNTERS** (Mechanical) up to 99,999, with rocking-arm action. In housing 1 1/2 in. by 2 1/2 in. by 1 1/2 in., 7/6.

Please include sufficient for packing/despatch.

List TCP/649 (Pumps, Transformers, Electric Clocks).

List R/449 (Sliding Resistances, and Dimmers). Please send stamp.

M. R. SUPPLIES Ltd., 68, New Oxford Street, London, W.C.1

Telephone: MUSeum 2958

### "STEWART"

#### HIGH GRADE TRANSFORMERS

Types Available for Delivery ex Stock

ANY OTHER SPECIFICATION TO ORDER

Primaries tapped 210-230-250v.

Type No.	Secondaries	Price
X2	260-0-260v 65 m/a 6.3v 2a 5v 2a	27/6d.
A6	350-0-350v 75 m/a 6.3v 3a 5v 2a or 4v 4a 4v 2a	28/6d.
A4		
B6	350-0-350v 100 m/a 6.3v 3a 5v 2a or 4v 5a 4v 2a	34/6d.
B4		
C6	350-0-350v 150 m/a 6.3v 4a 5v 3a or 4v 6a 4v 2.5a	46/6d.
C4		
S/28/1**	425-0-425v 200 m/a 6.3v 4a 6.3v 2a 5v 3a	57/6d.
S/28/2*	350-0-350v 250 m/a 6.3v 6a 4v 8a 0-2-6.3v 2a 0-4-5 v 3a	90/-d
S/24/1	1000v 10 m/a	40/-d.
S/24/2	1750v 10 m/a	45/-d.
S/24/3	2500v 10 m/a	55/-d.
S/24/4*	4000v 5 m/a	63/-d.
S/24/5*	5000v 5 m/a	75/-d.

\* For "Electronic Eng." Televisor.

\*\* For The "Williamson" Amplifier.

### STEWART TRANSFORMERS Ltd.

1021 FINCHLEY RD., LONDON, N.W.11

Tel.: SPEedwell 3000 and 3533



# Unfortunate scene at the proceedings of the AMERICO-ANGLIAN CONCLAVE on PRODUCTANTIVY (and all that)



The Conclave noted that mechanisation of British woikers vis-a-vis their American counterjumpers was as 1 varies to 2.9768. More thingummyjigs were produced per man-hour in U.S.A. but the quality varied from very fine to horrible. In the opinion of the Conclave, Britain would produce more if more men used more machinery for more hours, and the same might even be true of America. Nevertheless *and* notwithstanding the Conclave felt that while America had much to teach Britain, Boffin Land had much to learn from Pogoland—and vice-versa, ditto, and the same to you.

The Conclave was just deciding to hold its next

luncheon in Chattanooga (you'll find a welcome waiting) Tennessee when our Chairman, who had been hiding under the table, the old rapscaillon, suddenly bobbed up and cried: **The answer's as clear as the nose on your face :**

## Call up the little horses

Specialists in Lightweight Pneumatic and Electric Portable Tools

**DESOUTTER**



DESOUTTER BROS. LTD., THE HYDE, HENDON, LONDON, N.W.9. TELEPHONE : COLINDALE 6346-7-8-9. TELEGRAMS : DESPNUCO, HYDE, LONDON  
CRC.204

# LONDON CENTRAL RADIO STORES

**Government Surplus—from Stock**

**Ex-G.P.O. Apparatus—Brand New  
V.F. TELEGRAPH + SIMPLEX No. 3**

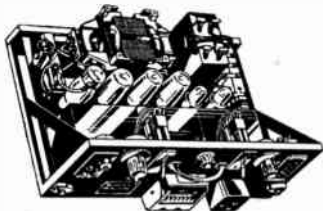

4 Valves. Three Pentode 1340 one HL13c.  
Rotary Converter etc. In Transit case. **65/-**

**R.A.F. 6-VALVE SUPERNET RECEIVER  
UNIT No 25**

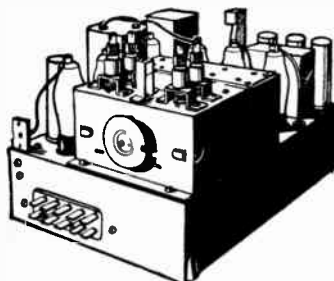

This unit is easily adapted to Short-wave reception for home use. In addition to two EF30, two EF39, one EK32 and one EBC33 valves, it contains 1 pr 480 Kc's iron dust I.F. Transformers, Mic. and phone output transformers, a number of resistances and fixed condensers of useful values two 1 mfd. 500 v. wkg. and four .1 tubular condensers, pot'ometers, Int. Octal Valveholders, Tuning Coil etc. mounted on steel chassis  $8\frac{1}{2} \times 6\frac{1}{2} \times 2\frac{1}{2}$  in. FREE circuit diagram 9in. x 19in. showing all components, supplied with each set **25/-**

**SELF-ENERGISING TABLE MICROPHONE  
& HEADSETS (Sound Power)**

The microphone is mounted on a fully adjustable stand with on-off switch. No batteries or current required to operate.

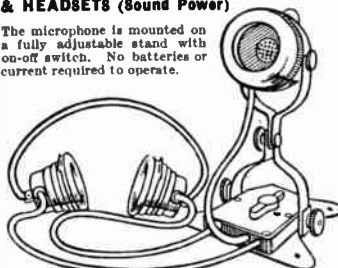

UNUSED IN CARTONS ..... **10/6**

**PLEASE NOTE**

● All carriage paid unless otherwise stated. ● Carriage charges relate to British Isles only. ● We do not issue lists or catalogues. ● We have hundreds of items in stock too numerous to list, so when in Town pay us a visit.

**23, LISLE ST. (GERrard 2969) LONDON, W.C.2**

Closed Thurs. 1 p.m. Open all day Sat. and weekdays 9 a.m.—6 p.m.

**TWO ONLY!**  
No. 18 TRANSMITTER and RECEIVER, Mk. III, 10 ans each.

**THEROAT MICROPHONES** with plug and cord, 3/6 pair.

**MOVING COIL HAND MICROPHONE** ..... 5/6  
Insert for the above, 30 ohms, 2/9 each.

**VIBRATORS.** 2 v. input, self-rectifying type. Output approx. 200 v. 60 mA. .... 7/6

**U.S. ARMY MIDGET LIGHT-WEIGHT HEADPHONES.** 200 ohms. Suitable for Deaf Aids. Pair **9/6**

**NEW MILNES H.T. UNITS** (Everlasting) ..... 5/6  
120 v. 600 mA. Will charge from 6 v. accumulator .....  
For Callers only. **67/6**

**NEW 3-VALVE AMPLIFIER PANELS.** With three 1F4 valves, condensers, etc. 15/-  
New spare valves for above, 5/- each.

**S. G. BROWN'S ADJUSTABLE HEADPHONES**  
120 ohms ..... pair **13/6**

**VISION UNITS, Model 6E.** Consisting of 6in. diameter Electrostatic C.R. tube No. V.C.R.97 7 valves, including four EF50, potentiometers, resistances and other associated components. In metal cabinet 18 x 6 x 7 in. These units are in perfect condition. Carriage paid ..... **24 10 0**



**NEW WROUGHT IRON STAND**

Suitable for microphones and many other purposes. Grey finish. Height 5ft. 9 to 6ft. 4in. 18/6, plus 2/- postage.

**TELEPHONE LINE or UNI-SELECTOR SWITCHES**  
As new, 6-bank ..... **37/6**

**EX-GOVT. TELEPHONE HAND SETS (Sound Power)**  
New stock. Self-energising. Needs no battery or current. **7/6**

**EX-ARMY TEST SET—NEW Type Demolition Mk. 1.**  
For circuit continuity and general testing. In hard wood carrying case ..... **42/-**

**EX-R.A.F. CAMERA MOTORS**  
Dimensions 3in. x 2in. x 1 1/2 in. 24 v. .... **8/6**

## THE COIL PICK-UP

*"... has been given some 20 hrs. of tests and expert listening... it is by far the best we have tried."*

That is the opinion of one customer, many others have written to the same effect.

Be guided by their experience and

**BUY A**

**COIL PICK-UP Type N**

**WILKINS & WRIGHT LTD.**

**HOLYHEAD ROAD, BIRMINGHAM 21.**

*the finest in  
electronic valves*



*carry this emblem*

Supplied to ADA by R.C.A., ADA electron valves are designed to satisfy completely the requirements of radio receivers, service, amateur and laboratory equipment. Sturdily constructed and thoroughly tested, every ADA valve is guaranteed to give long, trouble-free use.

The ADA trademark is your assurance of dependable performance and durability.

Other ADA products:

- Household and Commercial Refrigerators
- Radios and Components
- Home Appliances

**AD.AURIEMA, INC. 89 Broad St., New York 4, N.Y., U.S.A.**

Cable Address: AURIEMA, NEW YORK

# EKCO Reliability

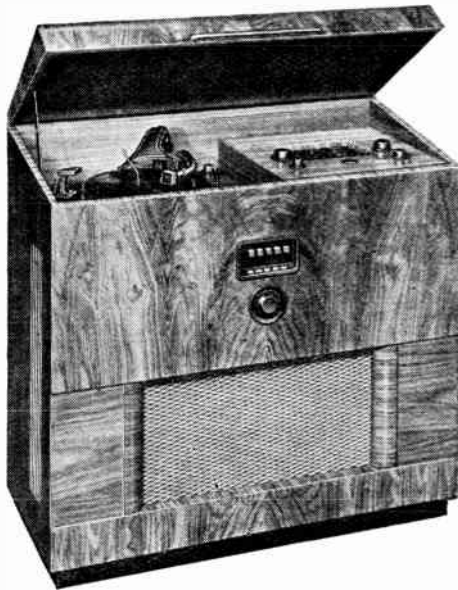

EKCO Model ARG37

6-valve all-wave automatic record-changing radiogram in richly figured walnut cabinet, a quality instrument for the connoisseur. Price including tax, 172 gns.

COMES FROM

## QUALITY CONTROL

'QUALITY CONTROL', a completely self-contained analytical research unit inside the Ekco organisation, is acknowledged as not only the most rigorous but the most scientific and highly organised of all similar systems employed to check quality and workmanship. Scientific test and analysis covers every batch of raw material, every component, every assembled part, every process or finish, every completed instrument. This is essential to maintain the characteristics for which EKCO are famous—superb quality of reproduction and long and efficient life, good workmanship and the utter reliability of every set that bears the name EKCO.

EKCO  
Model P63

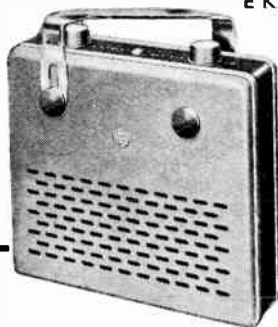

—the "Princess"  
Portable in shatter-proof plastic casing. All-dry, 2-waveband, weight complete 4½ lb. Price including battery and tax £14.0.0.

EKCO Model  
MBP99

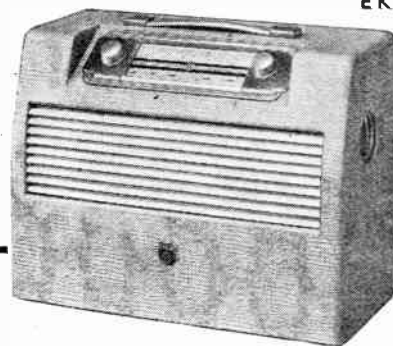

—the "Stroller"  
all-wave Mains/Battery portable for AC/DC mains or batteries. Price including batteries and tax, 19 gns.

# EKCO RADIO

E. K. COLE LTD.



SOUTHEND-ON-SEA



Recognised as the Most Reliable Valveholders

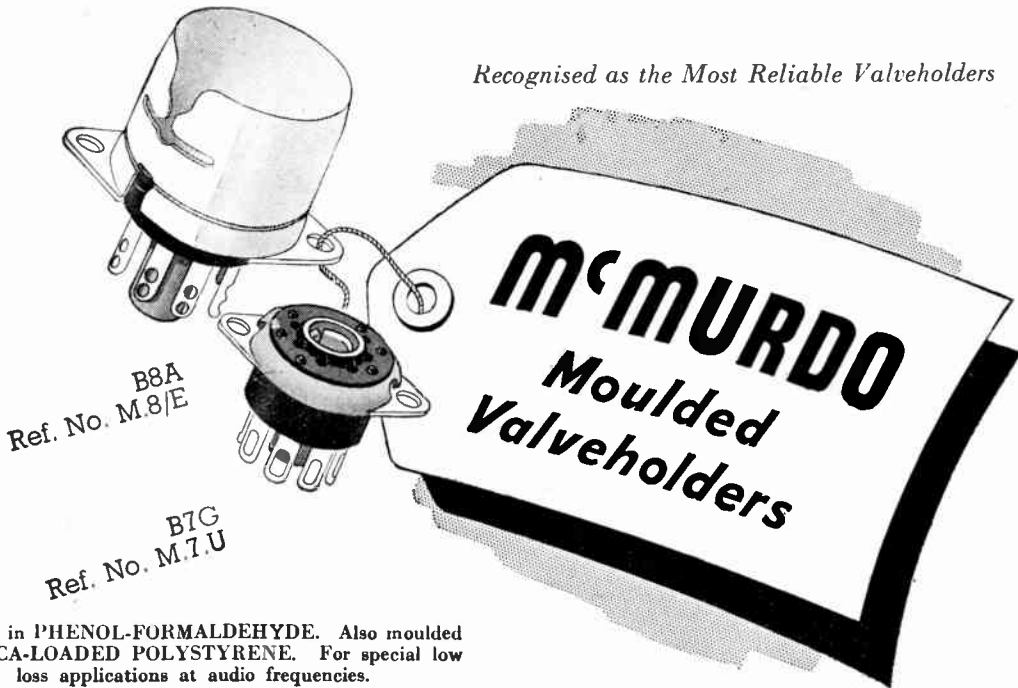

Moulded in PHENOL-FORMALDEHYDE. Also moulded in SILICA-LOADED POLYSTYRENE. For special low loss applications at audio frequencies.

THE McMURDO INSTRUMENT CO., LTD., VICTORIA WORKS, ASHTEAD, SURREY ASHTEAD 3401

# TELEVISION MINDED ?

**Improved Postal Course at Greatly Reduced Price**

In view of the rapidly increasing interest in Television and our large number of enrolments, we have reduced the price of our BASIC TELEVISION POSTAL COURSE by 25%. At the same time the scope of the course has been increased by including comprehensive material dealing with the latest television receiver techniques.

The course covers the examination for the Television Service Engineer's Diploma set jointly by the Radio Trades Examination Board and the City & Guilds Institute.

Where desired, selected lessons are available at an appropriately reduced price. Many other courses in RADIO, MATHEMATICS, INDUSTRIAL ELECTRONICS, etc. are available.

Write for FREE BOOKLET to Dept. 16,

## E.M.I. INSTITUTES

42, GROVE PARK ROAD, LONDON, W.4. CHiswick 4417/8

Associated with  
"H.M.V."  
MARCONIPHONE  
COLUMBIA  
ETC.

8138

## A NEW B.P.L. INSTRUMENT



**THE VOLTASCOPE**—A combined valve-voltmeter and oscilloscope. **VALVE-VOLTMETER**—Infinite input Resistance for D.C. ranges 0 to 300 volts. A.C. ranges 0 to 150 volts in 5 ranges. 3½ inch scale meter. **OSCILLOSCOPE**—3 inch screen tube provided with balanced amplifiers for Y and X plates giving a 5 times trace expansion. Maximum sensitivity 150mV/cm. Response from D.C. to 100 kcs.

Limited quantity available for early delivery.

**BRITISH PHYSICAL LABORATORIES**

HOUSEBOAT WORKS, RADLETT, HERTS.

Tel: Radlett 5674-5-6

# MAGNETIC T.V. PARTS

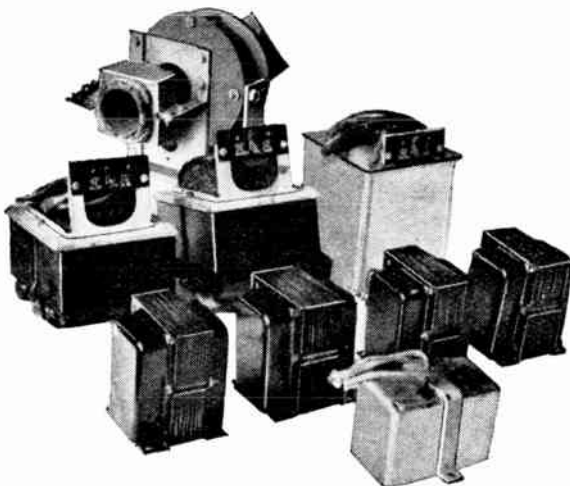

We have available, at very much below the standard prices, all the essential parts for making a magnetic type Television or for converting your 6in. green picture into a white picture. Actually these parts were made by the famous company for a smaller Television manufacturer, who unfortunately was under-capitalized, and could not make a success of his business. This is the reason why the parts are so cheap, for they are definitely superior to most that are on offer to-day.

The three main parts are: (a) The tube assembly which consists of a frame on which are mounted the focus coil and the line and frame deflection coils. This is suitable for a 9, 10 or 12in. magnetic Cathode Ray Tube. (b) The E.H.T. Transformer to give 4 kV and (c) the very efficient line output transformer. The price for this set of three parts is £3 10s. 0d., and we will forward without extra charge the circuit diagram of the Television which was originally designed around these parts. The interesting feature about this Television is that it uses mostly easily obtained H.F. pentodes. We will supply the circuit data separately at 2/6 per copy, and we will allow you to deduct this from the cost of the kit if you buy within 2 weeks. Of course you don't have to stick to the circuit as supplied; any conventional circuit will do equally well.

If you are starting from scratch, the other parts for the original circuit are available as per the above illustration, and at similar keen prices

Fully shrouded chokes 9 henry 120 mA—2 required. Price 7/6 each.

Fully shrouded chokes 17 henry 80 mA—2 required. Price 8/6 each.

Mains Transformer—350-0-350 at 120 mA, 4 v. at 10 amp., 4 v. at 2 amp.—1 required. Price 17/6.

Mains Transformer—400-0-400 at 80 mA, 4 v. at 6 amp., 4 v. at 2 amp., 2 v. at 2 amp.—1 required. Price 15/-.

We will supply any of the above parts separately at prices as shown or you can have the complete outfit of the nine parts as illustrated for £8 10s. 0d., carriage paid.

## THE ITEMS BELOW ARE OF SPECIAL INTEREST TO CONSTRUCTORS OF TELEVISIONS USING ELECTROSTATIC TUBES (VCR97, etc.).

"50 PITFALLS FOR TELEVISION CONSTRUCTORS." If you are having difficulty in getting a perfect picture, then this publication may solve your problem. The price is only 2/6 post free.

**WHITE PLASTIC MASK.** Designed to fit a 6in. electrostatic tube, VCR97, etc. This will give a professional look to your home-built Television. If yours is a bigger than usual picture, the size of the opening can be enlarged to suit your own needs. The price is 7/6 post free.

**MAGNIFYING LENS.** De Luxe type. The lens which is really designed to give optical perfection. First-class quality and workmanship throughout. Guaranteed against any discoloration of the special oil content. Price 39/6, postage, packing and insurance 5/-.

**AERIALS.** Indoor type—for fitting in loft. Very simple in installation. Full instructions and fixing clips, etc., supplied with every one. Order "SNAPPY AERIAL KIT," price 15/-.

**VCR97 CATHODE RAY TUBES.** Brand new in original cartons. Price 35/-, carriage and insurance paid. Buy a spare now while they are still available at this silly price.

**PRE-AMPLIFIER FOR TELEVISION.** Complete conversion details for using RF26 or RF27 ex-R.A.F. units, 2/3 post free. Brand new RF26 units, 35/- post free. Nothing else needed. Suitable for sound or vision.

**E.H.T. CONDENSERS.** .1 mfd. 2,500 v., 2/6; .02 mfd. 8 kV can type at 3/9; .1 mfd 4 kV at 2/9; .02 mfd. 5,000 v. at 1/6; .1 mfd. 5 kV, 3/9.

Send cash with order or request C.O.D. Orders over £2 are post free—we are open until 5 p.m. Sats. List available on request —it helps us if you can quote our Bin No.

**PRECISION EQUIPMENT**

# SEPTEMBER SALE of RADIO SPARES

Bin No.

- 01 **MAINS TRANSFORMER "WODEN"** potted, fully shrouded and impregnated. Fitted primary screen. 280-0-28 at 150 mA., 6.3 v. at 10 amp., 5 v. at 3 amp. Primary tapings to give adjustments at 10 v. spacings between 190-250 v. 50 C.P.S., 27/6.
- 05 **SCREWS,** 1in. 4B.A. cheese-head cadmium plated, 1/9 per gross.
- 06 **TUNING CONDENSER,** 2-gang 0005 standard size. Made by "PLESSEY," and undoubtedly a very good job, 3/6 each.
- 07 **P.M. SPEAKER,** 10in. "ROLA." New and perfect, 24/6.
- 08 **SMOOTHING CONDENSER, E.H.T.** .1 mfd. 4 kV., these are recent manufacture by "T.O.C.", but casing is slightly soiled, 3/- each.
- 011 **TOGGLE SWITCH,** metal special dolly with a V cut out, as fitted in receiver—where the wave-change knob also cuts off mains, 10d. each.
- PF2 **MAINS TRANSFORMER "PARMEKO,"** half-shrouded drop through chassis type, 350-0-350 at 80 ma., 6.3 v. at 4 amps., 5 v. at 2 amps. Primary tapped for 200-240 v. Fitted primary screen and impregnated. New and perfect, 16/6 each.
- PF3 **MAINS TRANSFORMER,** 260-0-260 at 70 mA., 6.3 v. at 3 amps., 5 v. at 2 amps., otherwise as PF2 above, 13/9 each.
- PF4 **MAINS TRANSFORMER,** 260-0-260 at 60-7L mA., 4 v. at 4 amp., 4 v. at 2 amp., otherwise as PF2 above, 13/9 each.
- BS6 **P.V.C. INSULATED COPPER CONNECTING WIRE**—really fine for chassis wiring or as throw-out aerials, etc., 250 yd. coil, £1.

## ELECTROLYTIC CONDENSERS. (Only new stock from best manufacturers)

2 mfd. 450 v. . . . .	1/-	8 mfd. 350 v. . . . .	1/6
4 mfd. 450 v. . . . .	1/3	16 mfd. 350 v. . . . .	1/11
8 mfd. 450 v. . . . .	1/11	32 mfd. 350 v. . . . .	1/11
16 mfd. 450 v. . . . .	2/8	25 x 25 mfd. 200 v. . . . .	3/11
8 x 8 mfd. 450 v. . . . .	3/4	3 mfd. 150 v. . . . .	1/3
8 x 16 mfd. 450 v. . . . .	3/4	25 mfd. 25 v. . . . .	1/-
16 x 16 mfd. 450 v. . . . .	3/8	25 mfd. 50 v. . . . .	1/6
16 x 8 x 24 mfd. . . . .	4/9	50 mfd. 12 v. . . . .	10d.
8 mfd. 500 v. BR.350 . . . . .	2/6	10 mfd. 25 v. . . . .	10d.
16 mfd. 500 v. BR.1650 . . . . .	3/6		

- FC10 **BROWN KNOBS, SET OF THREE,** 1-1/2in. and 2-in. diameter, 1/4 the set.
- PD9 **TRACKER CONDENSERS,** 400-500 p.f., 6d. each.
- PD3 **TRIMMER CYLOND** postage stamp compression type 50 p.f. ceramic, extremely nice job, 4d. each.
- PD2 **TOGGLE SWITCH** meta "BULGIN," S.P.S.T., 1/3 each.
- PE8 **PANEL METER,** 2in. flush mounting, moving coil 0-500 micro-amps., 8/6 each
- PE9 **METER,** 0-1 millamp., 2in. flush, in bakelite case, made for M.O.S., but quite standard, 8/6 each.
- PE10 **AMPHENOL INTERNATIONAL** octal valve holder, 6d. each.
- PF6 **MIDGET TUNING CONDENSERS,** 2-gang .00035, fitted with trimmers, and complete with perspex dust cover. These condensers made by "PLESSEY" are of the type used for tuning personnel receivers, 6/6, plus 8d. postage
- PF7 **4-GANG TUNING CONDENSERS,** .0005 each section—fitted trimmers—ceramic insulation. These are complete in a very useful chassis, and are fitted with a drive. Government Surplus equipment but new and perfect, 2/9, plus 1/3 postage case of 6 units, 17/6, carriage paid.
- BS7 **8in. ENERGISED SPEAKER**—"PLESSEY," 2,000 ohm field, complete with pentode matching O.P.T., 17/6.
- PF11 **3 1/2in. P.M. SPEAKER "ROLA,"** less output transformer, 8/9.
- PB13 **5in. P.M. SPEAKER "ROLA,"** fitted standard O.P. transformer, 11/3.
- BSS **12in. P.M. SPEAKER "TRUVOX,"** 42/6.
- PB11 **SYSTOFLEX SLEEVEING,** 1 mm. assorted colours, 1/9 per dozen.
- PR10 **DROPPER** for .2 amp. valves, vitreous enamel covered, with taps mark 220, 2/40 1/6 each.
- PD4 **CROCODILE CLIPS,** small instrument type, very well made by "BULGIN," 3/6 per doz.

## THIS MONTH'S SNIP

American receiver data published during the war by the Champion Electric Company. These manuals were originally sold at £2/6 each, and even at that they were considered good value for money, for they really comprise volumes of service sheets. They give circuit diagrams, component values, alignment data, and practical layouts of all the popular American receivers which have been imported to this country. Contents are as follows:—

- Vol. 1—Sparton-Emerson.
- .. 2—Crosley-Belmont Pt. 1.
- .. 3—Crosley-Belmont Pt. 2.
- .. 4—R.C.A. Victor-Go-Admiral.
- .. 5—Emerson (Part 2).
- .. 6—Stewart-Warner-Fada.

We have only a limited number of these sets of volumes all are ready for immediate despatch, or for callers, and the price is £17/6 for the library of 6 volumes. Don't miss this tremendous bargain. The manuals will undoubtedly earn their cost many times over.

(2) ELECTRON HOUSE, Windmill Hill, RUISLIP MANOR, MIDDLESEX





**CALIBAND DRIVE.** First quality workmanship. Mechanical 'Band spread.' Two pointers giving 'Tank' and 'Band spread.' Tank drive: ratio 6 - 1. Band spread ratio 48 - 1. Supplied with black crackle escutcheon and glass. Cat. No. 4838.  
**PRICE 19/6**



**AIRPLANE DRIVE.** Sound construction and design. 3 3/8" diameter circular scale, printed two wavebands and station names. A bronzed-finished escutcheon with glass is supplied. Ratio 8 - 1. Cat. No. 2130  
**PRICE 11/9**

PRECISION COMPONENTS BY  
**JACKSON**  
 BROS (LONDON) LIMITED  
 KINGSWAY · WADDON · SURREY  
 Tel: Croydon 2754-5 Grams: Walfico, Souphone, London

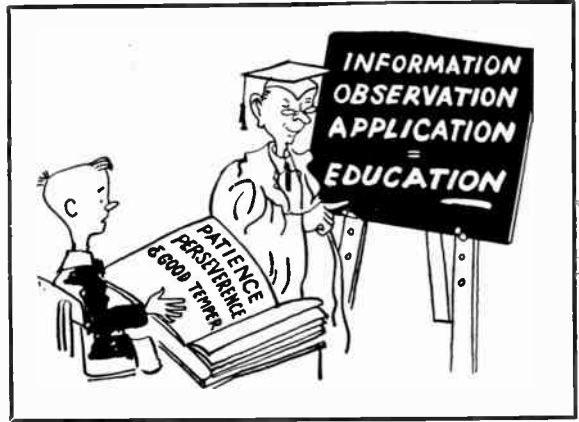

A Pickup has one characteristic at least common to all mechanisms—it cannot give out more than is put in. It follows therefore that if the input forces supplied by the record are drastically reduced, the output will be similarly reduced.

It is logical that we should require all the advantages inherent in a system in which the mass and inertia are reduced to a minimum if we have any interest in the care and performance of our records.

**J. H. BRIERLEY (Gramophone & Recordings) LTD.**  
 46, TITHEBARN STREET, LIVERPOOL, 2.

.... concerning **BAFFLETTE!**

*Trade Mark*

These reasonably priced Extension Speakers, which are available at most good shops, will be displayed attractively at the inspiring radio exhibition of 1949.

# Radiolympia

## Stand No. 49 Grand Hall

Ask your dealer for the free Richard Allan booklet—16 pages telling all about the magnificent range of speakers which in their price field cannot be equalled. Insist on *Baffle*—the extension speaker you will be proud to possess.

*Made and Guaranteed by*

**Richard Allan** **RADIO LTD**  
 Now at **BAFFLETTE HOUSE, BATLEY, YORKSHIRE**



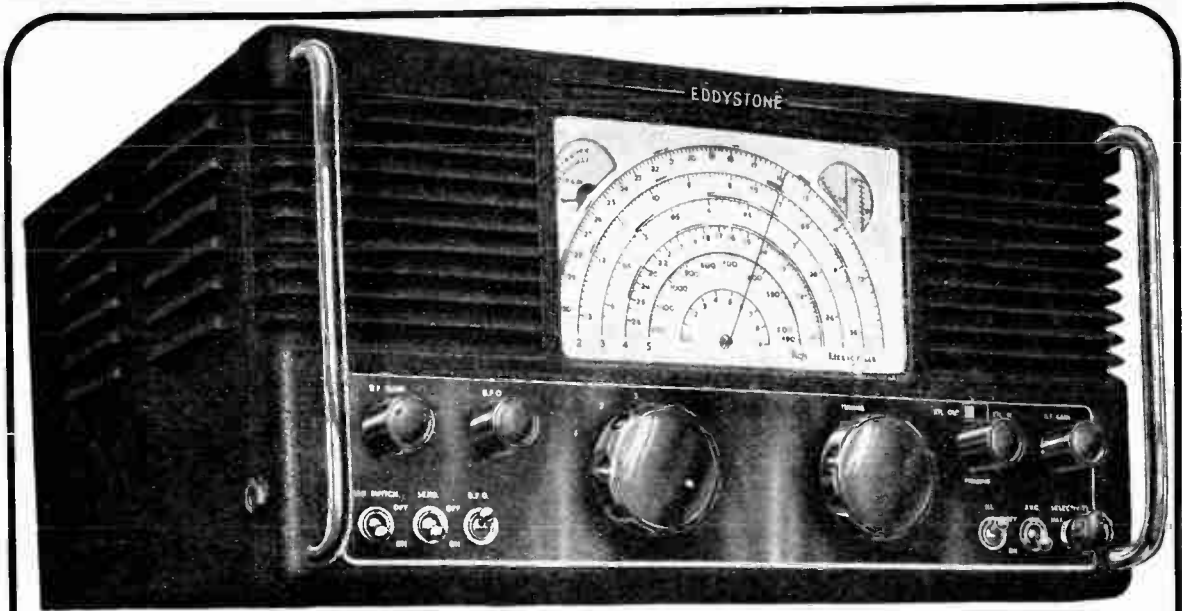

## The NEW EDDYSTONE '680' COMMUNICATIONS RECEIVER

*A high-grade instrument with wide frequency coverage  
for PROFESSIONAL COMMUNICATION REQUIREMENTS*

The '680' is a fifteen valve superheterodyne receiver embodying advanced technique. New features in the design add to the outstanding and reliable performance of which the receiver is capable. The appearance is impressive, whilst the construction and general workmanship are of the finest in the industry.

### FEATURES INCLUDE :

- Continuous coverage from 30 Mc/s to 480 Kc/s.
- Two Radio-Frequency stages.
- Two I.F. stages.
- Crystal Filter.
- Beat Frequency Oscillator.
- Push-pull output stage.
- Variable Selectivity.
- "S" Meter.
- Noise Limiter.
- Standby switch.
- Stabilised H.T. voltage to Oscillator, etc.
- Provision for relay operation of transmitter.
- High signal-to-noise ratio and sensitivity.
- Highly attenuated Image response.
- Very effective A.V.C.
- Large accurately calibrated dial.
- Provision for twin feeder and single aerial.
- Variable dial illumination.
- Modern miniature all-glass valves.
- Flywheel loaded tuning device—140 to 1 reduction ratio.
- Mechanical bandspread logging device.
- Can be supplied for Rack Mounting.
- Robust construction.
- Finished for tropical service.

The complete frequency range—from 30 Mc/s to 480 Kc/s—is covered by five switched coil assemblies with an overlap between each. The gear-driven, flywheel controlled mechanism is positive, free from backlash and very smooth in action. The mechanical bandspread device takes the form of an auxiliary dial and gives a scale length equal to ninety inches per range. The dial can be read to one degree. I.F. transformers are permeability tuned to 450 Kc/s. Operates from A.C. mains, 110 and 200/240 volts, 40/60 cycles. The front panel and tuner unit chassis are aluminium, and the remaining units of stout brass, heavily nickel-plated. Lift-up lid. The cabinet and front panel are finished a handsome ripple black, set off by plated handles. The finger plate is black and silver.

Dimensions:—16½" × 13½" × 8½" high. Weight 41 lbs.

**LIST PRICE IN U.K. £85 (No Purchase Tax)**

Government Departments, Official bodies and all interested individuals are invited to write for information, order form:—

**STRATTON & CO. LTD.**

EDDYSTONE WORKS, ALVECHURCH ROAD, WEST HEATH, BIRMINGHAM, 31  
Cables: STRATNOID, BIRMINGHAM Telephone: PRIORY 2231 4

★ *The Basis of*  *World Standards*

# TELCON R.F. CABLES

Technical excellence supported by constant research and an unrivalled knowledge and experience of Radio Frequency Cable applications, ensures the continuance of the lead established by TELCON in this field.

Even before the introduction of Telcothene\* as a cable dielectric, an application pioneered by TELCON, a range of Radio Frequency cables with unique capacity and attenuation characteristics was produced, using Telconax.

Today, developments are still going on and the solution of any problems involving the application of Radio Frequency cables will be found in the wide range manufactured by TELCON.

★ *Telcothene (Regd.)—Polythene processed by Telcon to provide specific characteristics*

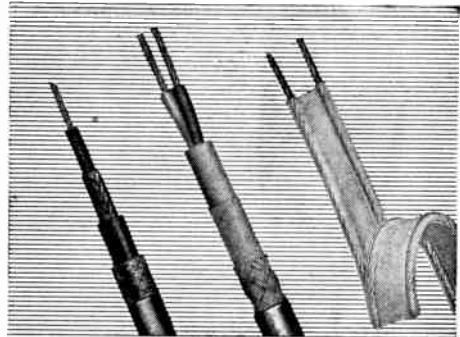

Ask also for details of  
**TELCON METALS**

**THE TELEGRAPH CONSTRUCTION & MAINTENANCE CO. LTD** 

Head Office : 22, Old Broad Street, London, E.C.2. Tel : LONdon Wall 3141

Enquiries to : Telcon Works, Greenwich, S.E.10. Tel : GREenwich 3291

Meet us at Radiolympia—Stand 30

## PARKER Radio



### announce a new model

THE NEW S/2/AC is a five valve, three wave band superhet receiver for operation on AC mains 110/240 Volts, 50 cycles.

Wave Band Coverage:—

Export: 12-35, 35-100, 200-550 metres.

Home: 19-50, 200-550, 800-2,000 metres.

Eight inch moving coil loudspeaker is used.

Cabinet in French Walnut veneers. Provision is made for extension speaker and Pick-up.

Export price by quotation.

**PARKER RADIO CORPORATION LTD.**  
7 Regal Lane, Regent's Park, London, N.W.1 Gulliver 1843

**13 GCS**  
PLUS £3-0-8\*  
P.T.

## MODERN SERVICING METHOD

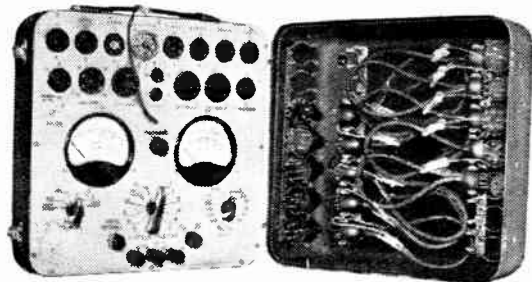

The "L.S.L." Servicing Method is a combined fault analyser and circuit tester; simultaneously capable of indicating all voltage, current and resistance on each valve electrode without removing the chassis from the cabinet. Readings can be taken whilst the set is under actual operating conditions. The "L.S.L." Analyser is a combination of multi-range instrument and valve tester.

PRICE : £18 . 18 . 0 Subject.

### THE "LSL" PORTABLE ANALYSER

★ Saves time and trouble. ★ Greatly increases Profit in the Service Department. ★ Is portable, can be used on the bench or in the home ★ Is simple to operate.

Meet us at RADIOLYMPIA. SEPT. 28—OCT. 8

Stand T.1, Grand Hall Annexe

Send for further particulars  
from the sole distributors:

**Kerry's**  
(GREAT BRITAIN) Limited

WARTON ROAD, STRATFORD, LONDON, E.15,  
Telephone: Maryland 611 AND BRANCHES  
Export Address: 23-26 St. DUNSTONS HILL, E.C.1

240 Pages of Valve information for designers & maintenance engineers

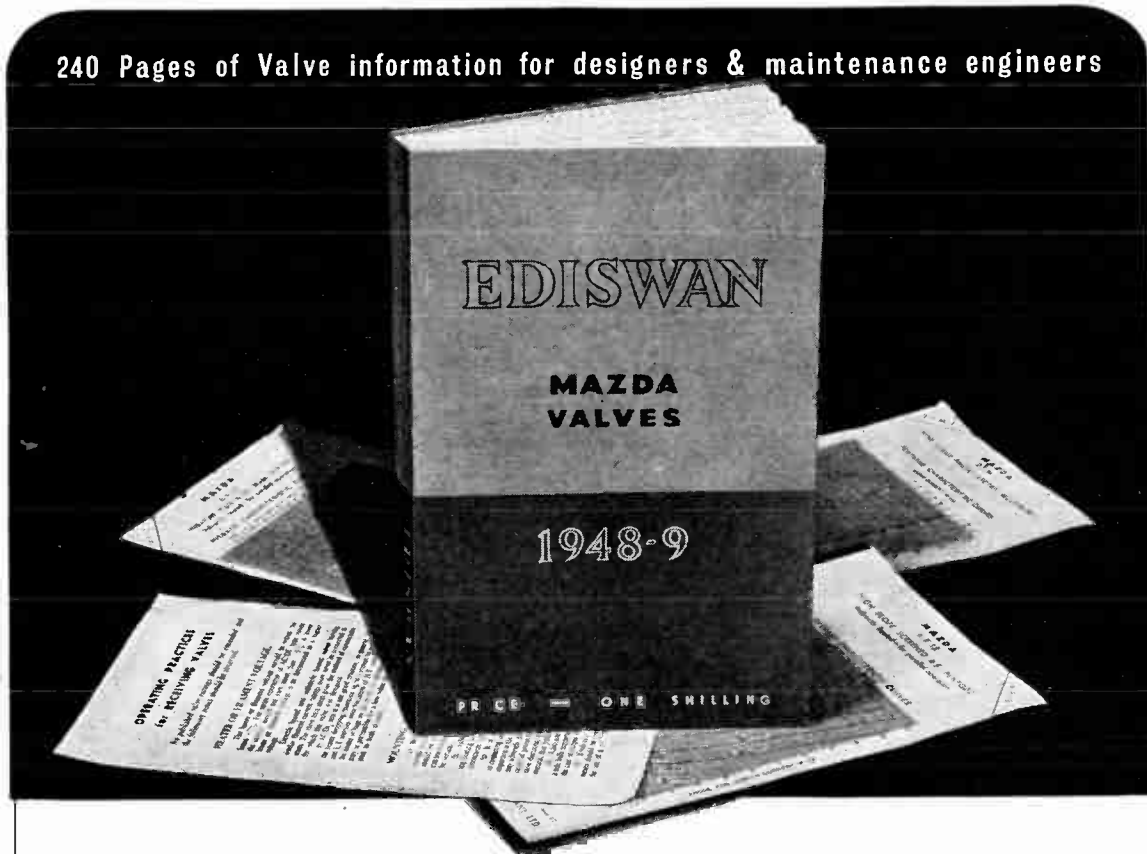

Make sure of getting your copy of the

# EDISWAN

## MAZDA VALVE MANUAL

This handy pocket-sized booklet contains 240 pages of valuable information for all Radio Engineers and designers. Divided into five sections covering Receiving, Transmitting, Industrial and Special Purpose Valves, and Cathode Ray Tubes, it contains ratings, characteristic curves, basings and typical operating conditions of a large number of Ediswan Mazda valves in those groups.

In addition, there are a number of outline drawings and typical circuits and some useful notes on valve symbols. Priced at a nominal figure, it is excellent value. Send Postal Order 1/4 (which includes postage and packing) for your copy now.

✕ Meet us at  
**RADIOLYMPIA**  
Sept. 28-Oct. 8 ✕

*This booklet is a condensed version of the Ediswan Loose-leaf Valve Manual.*

**THE EDISON SWAN ELECTRIC CO. LTD., 155 CHARING CROSS ROAD, LONDON, W.C.2**



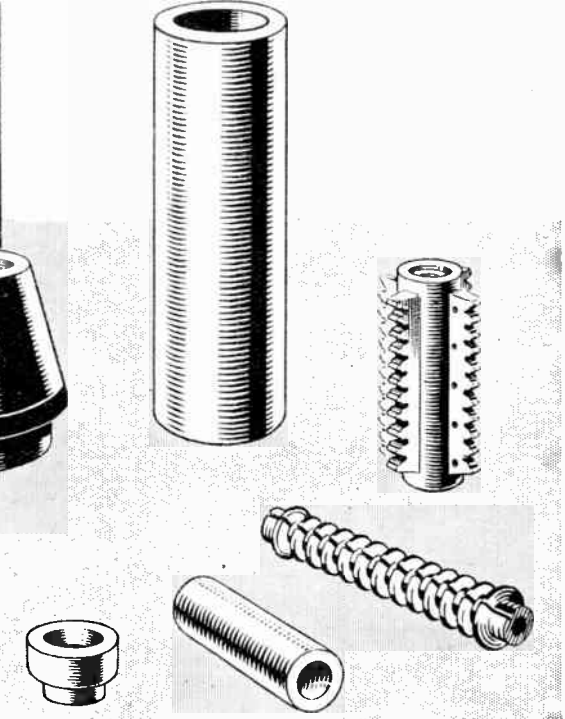
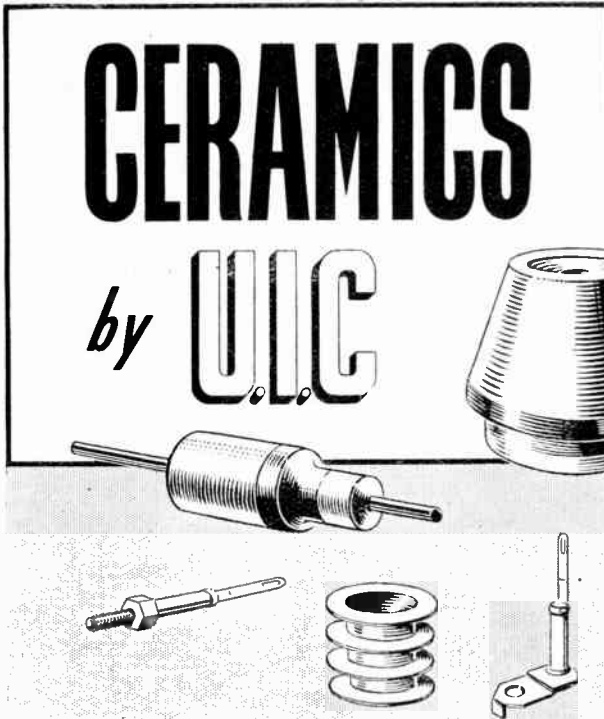

**UNITED INSULATOR COMPANY LTD. · TOLWORTH · SURBITON · SURREY · ENGLAND**  
 Cables : Calanel, Surbiton. Telephone : Elmbridge S241

**CONSISTENTLY**  
*Accurate*

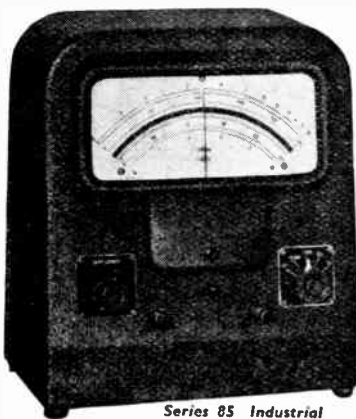

Series 85 Industrial Bench Type Ohmmeter

**PULLIN INDUSTRIAL MEASUREMENT**

**A** Linear Scale Bridge-type Ohmmeter, with press key, designed for routine production testing of all resistive components. For battery or A.C. mains operation. (A.C. mains operated instruments are compensated for voltage variations up to -15%.) Designed and constructed to withstand severe industrial use. Available as single or multi-range.

Standard Pattern four-range instrument reading 0/10, 0/100, 0/1,000 and 0/10,000 ohms; thirteen other models available.

Address all enquiries to  
**MEASURING INSTRUMENTS (PULLIN) LTD**  
 Electrion Works, Winchester St, London, W.3  
 Telephone: ACOrn 4651/3 & 4995



**Wharfedale**

**LOUDSPEAKER SEPARATOR**

Cross-over at 1,000 c.p.s. MAXIMUM INPUT 30 WATTS at 3 to 15 ohms impedance. A new device for dividing the Bass and Treble between two Loudspeakers at low impedance, thus eliminating modulation distortion imposed on the treble by large coil movement in the bass. It is recommended for use with two speakers of equal sensitivity and similar size.

Type "A" with terminals.

**PRICE 65/-**

Size: 8 in. x 5 in. x 4 in.

Type "B" with soldering tags.

**PRICE 55/-**



**CHOKE-TYPE VOLUME CONTROL**

For use on Loudspeakers with Cross-over Units where resistance types are useless, or where distortionless control is essential. Suitable for circuits of 2 to 30 ohms up to 30 watts.

**PRICE 27/6**

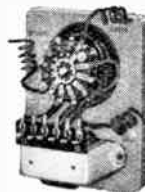

Send for book "Loudspeakers," by G. A. Briggs (5/-), in which acoustic loading is fully explored.

**WHARFEDALE WIRELESS WORKS**  
 BRADFORD ROAD, IDLE, BRADFORD  
 Telephone: Idle 461 Telegrams: Wharfedel, Idle, Bradford

# PREMIER RADIO COMPANY

MORRIS & CO. (RADIO) LTD

**207, EDGWARE RD., W.2** Phone: AMBassador 4033  
**AND AT 152-153, FLEET STREET, E.C.4** Phone: CENTral 2833

ALL POST ORDERS to 167, LOWER CLAPTON ROAD, LONDON, E.5. 'Phone: AMHerst 4723.  
 Terms of Business: Cash with order or C.O.D. over £1. Send 2d. Stamp for list.

**EDGWARE ROAD IS OPEN UNTIL 6 p.m. ON SATURDAYS**

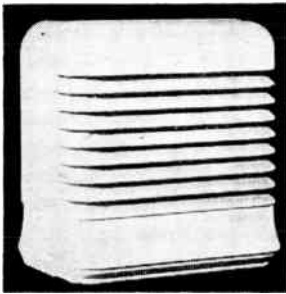

**A NEW PREMIER PRODUCTION**

A 5in. Moving Coil PM Loudspeaker in an attractive plastic cabinet. Fitted with Volume Control. A fine extension speaker for 30/-.

**WE HAVE PURCHASED THE ENTIRE STOCK OF A TELEVISION LENS MANUFACTURER AND ARE OFFERING 9in. AND 12in. LENSES AT LESS THAN HALF PRICE.**

These are of the highest quality and are distortionless. 9in. Lens. List Price £5 17 6. OUR PRICE: 39/6. 12in. Lens. List Price £7 17 6. OUR PRICE: 70/-.

**TELEVISION MAGNIFYING LENS.** Suit any 5in., 6in., or 7in. tube. Increase picture size considerably, 25/-.  
**MASKS** for VCR97 tubes, 3/6 each.

**METER KIT**

**A FERRANTI 500 MICROAMP M/C METER,** with separate High Stability High Accuracy Resistors to measure, 15, 60, 150 and 600 volts D.C. Scale length 1 1/2in., diameter 2 1/2in. 10/- the complete kit.

**SECTIONAL WHIP AERIAL.** Seven sections which plug into each other making an aerial 14ft. long. Thinnest section 1/2in. diam., thickest section 1/2in. diam. Weather proof enamel. 3/6 each complete.

**INSULATED BASE** for above, 2/6 each.

**LOUDSPEAKERS BY FAMOUS MAKER**

- 3in. P.M. 2-3 ohms ..... 9/-
- 5in. " 2-3 " ..... 10/6
- 8in. " 2-3 " ..... 16/6
- 8in. " 2-3 " ..... 17/6
- 10in. " 2-3 " ..... 23/6

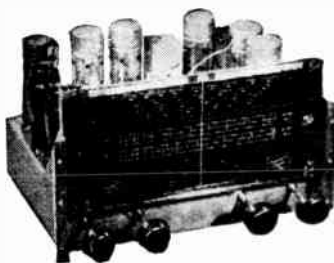

**A NEW A.C. ALL-WAVE SUPERHET RECEIVER**

7 Valves (plus metal Rectifiers) for 200/250 volts; 40/60 cycle A.C. mains. 4 wavebands, 13.6-52, 51-200, 200-550 and 900-2,100 metres. Pick-up input. Uses 6K7, 6K5, 6K7, 6B9, 6J7 and 2-6V6 in push-pull, giving an output of 10 watts. Specially designed OP Transformer to match 6V6's to 3 and 15 ohm Speakers. Negative feedback is applied over 3 stages giving a high fidelity output. Completely wired and tested, £15/17/6. Our Universal model is still available at £15 built or £13/8/- in kit form. All prices include Purchase Tax.

**R28/ARC5 RECEIVERS.** Cover 100/150 Mc/s BRAND NEW COMPLETE WITH TUBES AND CIRCUIT. Ten Valves, including 4 171A, 42/6.

**ELECTRON MULTIPLIER PHOTO CELL TUBES.** Type 931A. Brand New. Guaranteed 30/-.

**AMAZING OFFER!** A huge purchase enables us to offer a modern 3-gang, .0005 Mfd. Condenser and Switch with three 2-pole 5-way wafers with shorting rings and one granophone switch wafer. Price 5/- the pair. **SPECIAL TERMS FOR MANUFACTURERS ON EXPORT.**

**CRYSTAL DIODES,** Type CV102, 3/6 each.

**DOUBLE HEADPHONES** complete with Headband and Cord. 4000 ohms resistance, 5/- per pair.

**CROKES.** 70 mA at 6 henries 140 ohms. 3/- each, 30/- per dozen. Special quotation for large quantities.

**MAINS TRANSFORMERS.** Input 230v. 50c. Output 6.2v. 11A C.T., 120v. 3 M.A. Price 5/6.  
**R.F. UNIT TYPE 24.** Brand new. Easily converted to the Midland Frequency. 19/6.

**TEST UNIT TYPE 73.** Consists of special purpose Oscilloscope that requires only re-wiring and the addition of a few Condensers and Resistors to convert into a standard Oscilloscope. Input 230v. 50c. A 3 1/2in. CR Tube and 1 8U2150A, 1 E.B.34, 1 5Z4, 3 8P.61, 1 V872 and 2 E.A.50 are included. Controls are "Brightness," "Velocity," "X Shift," "Y Shift," "Focus Amplifier," "In/Out," "Calibrate," "on/off" TX. Price £7/19/6. Complete in Metal Case, Size 19in. x 12in. x 8 in.

**TEST UNIT TYPE 43.** Consists of a special purpose Oscilloscope which may be easily converted into a standard type Oscilloscope. Input 230v. 50c. 3 1/2in. C.R. tube, Type VCR138, 1 VU120, 1 5Z43, 3 V.R.54, 4 6J7, Controls include "X Shift," "Y Shift," "Focus," "Brightness." This exceptionally well made Unit is contained in a Grey Enamelled Case, 18in. x 12in. x 9in. Price £8/8/-.

**METERS**

Full Scale Deflection	Scale Marking	Scale Length	Movement	Price
1 mA	0-100	2 1/2"	M/C D.C.	15/11
1 mA	0-1	2"	M/C D.C.	7/6
5 mA	0-5	2"	M/C D.C.	5/-
25 mA	0-25	1 1/2"	M/D.C.	12/6
50 mA	0-50	2"	M/C D.C.	10/6
50 mA	0-50	1 1/2"	M/D.C.	12/6
50 mA	0-50	2"	M/C D.C.	9/6
100 mA	0-100	1 1/2"	M/D.C.	12/6
150 mA	0-150	2"	M/C D.C.	8/6
200 mA	0-200	2 1/2"	M/C D.C.	8/6
2.5 Amps	0-2.5	2"	Thermo	5/-
3 Amps	0-3	1 1/2"	Thermo	5/-
3.5 Amps.	0-3.5	1 1/2"	Thermo	7/6
20 Amp.	0-20	2"	M/C D.C.	2/11
25 Amp.	0-25	2"	M/D.C.	7/6
40 Amp.	0-40	2"	M/C D.C.	5/9
20 v.	0-20	2"	M/C D.C.	5/9
40 v.	0-40	2"	M/C D.C.	10/-
300 v.	0-300	1 1/2"	M/C D.C.	25/-
2,000 v.	0-2000	2"	Elect	50/-
5,000 v.	0-5000	3 1/2"	M/C D.C.	5/-
500 u.a.	0-500	2"	M/C D.C.	7/6
500 u.a.	0-500	2 1/2"	M/C D.C.	19/6

**ALUMINIUM CHASSIS, 16 SWG.** Substantially made of bright aluminium with four sides.

Size	Price
7in. x 3 1/2in. x 2in.	3/3
9 1/2in. x 4 1/2in. x 2 1/2in.	4/-
10in. x 8in. x 2 1/2in.	5/6
12in. x 9in. x 2 1/2in.	6/8
14in. x 9in. x 2 1/2in.	7/3
16in. x 8in. x 2 1/2in.	7/11
20in. x 8in. x 2 1/2in.	10/-
22in. x 10in. x 3in.	6/3
16in. x 9in. x 3in.	6/10
12in. x 10in. x 3in.	7/11
14in. x 10in. x 3in.	7/11
16in. x 10in. x 3in.	8/6
20in. x 10in. x 3in.	10/-

**ALUMINIUM PANELS, 16 SWG.**

Size	Price	Size	Price
7in. x 6in.	1/-	7in. x 4in.	9d.
9 1/2in. x 6in.	1/2	9 1/2in. x 4in.	11d.
10in. x 9in.	1/10	10in. x 7in.	1/6
12in. x 9in.	2/3	12in. x 7in.	1/9
14in. x 9in.	2/8	14in. x 7in.	2/2
14in. x 9in.	3/-	16in. x 7in.	2/4
16in. x 9in.	3/9	20in. x 7in.	3/-
20in. x 9in.	4/2	22in. x 7in.	3/4



**PREMIER MIDGET RADIO RECEIVER.** Due to greatly increased production we are now able to offer this receiver at a greatly reduced price. The Receiver is housed in an attractive Bakelite case, 12in. long x 5in. wide x 6in. high. The valve line-up is 6K7, 6J7, 6V6 and a Selenium Rectifier in the A.C. model; and 6K7, 6J7, 25A6 and Selenium Rectifier in the A.C./D.C. model. Both are for use on 200 to 250 volt mains. The dial is illuminated, and the receiver presents a very attractive appearance. Coverage is for the medium and long wavebands. PRICE £8/15/-.  
 Complete kit of parts with diagrams, 28/6/- inc. Purchase Tax.

**PREMIER MIDGET SUPERHET RECEIVER.** This powerful Midget Superhet Receiver is designed to cover the short-wave bands between 16 and 50 metres and the medium wavebands between 200 and 557 metres. Two models are produced, one for 200-250 volt A.C. mains, and the other for 200-250 volts A.C. or D.C. mains. Both are supplied in the same plastic cabinet as the TRF Receiver. The A.C. valve line-up is 6K8, 6K7, 6Q7, 6V6 and a selenium rectifier. The A.C./D.C. line-up is the same, with the exception of the output valve, which is a 25A6. The dial is illuminated, making a very attractive receiver. PRICE: £8/19/6.  
 Complete kit of parts with diagrams, 28/8/-, inc. Purchase Tax.

**PLASTIC CABINETS,** as illustrated above. In Brown, 17/6. In Ivory, 22/6.

**GOVERNMENT SURPLUS MAINS TRANSFORMERS**

All arc for use on 230 volt 50 cycle Mains.

Type	Price
42 500-0-500 v. 170 mA. 4 v. 4a.	25/-
44 10 v. 5 a., 10v. 5 a., 10 v. 5 a.	35/-
51 350-350 v. 60 mA. 6.3 v. 1 a., 6.3 v. 3-5 a.	12/6
53 250-0-250 v. 60 mA. 5 v. 2 a., 6.3 v. 2-3 a.	15/-
54 275-0-275 v. 60 mA. 5 v. 2 a., 6.3 v. 2-3 a.	15/-
55 250-0-250 v. 100 mA. 5 v. 2 a., 6.3 v. 3-5 a.	17/6

**SUPER MOVING COIL MIKE AND STAND.** We have purchased the entire stock of a famous Manufacturer of P.A. Equipment at a very low price, and are offering a £5/5. Super Moving Coil Mike, with a chromium plated folding stand to match. The list price of the stand was £3/3/-.

**WE OFFER THE PAIR AT 79/6. LESS THAN HALF THE USUAL PRICE.**

**R107. ONE OF THE ARMY'S FINEST COMMUNICATIONS RECEIVERS.** (See "W.W." August, 1945.)

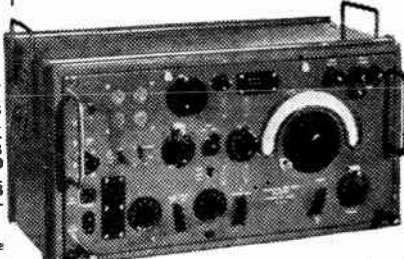

9 valves, R.F. amp. osc. Frequency Changer, 2 I.F.'s (485 kc.), 2nd Detector, A.V.C. Af. amp. B.F.O. A.C. mains, 100-250 v. or 12 v. accu. Frequency range 17.5 to 7 mc/s, 7.35 mc/s to 2.9 mc/s, 3.0 to 1.2 mc/s Monitor L.M. built in. Complete. Write for full details. £16/16/- Carriage paid.



# VICTORIA "SPECIALS"

A very keen interest is taken by the technical staff at Victoria Instruments in the design and development of special-purpose instruments. This willingness to undertake the "teasers" does not surprise those who already buy Victoria products. Users of electronic measuring instruments should avail themselves of this service, and take a leaf from the book of some of the largest firms in the electronic industry.

## PORTABLE TEST SETS

Robust moving iron instruments. Suitable for the Electrical Contractor or Automobile Electrical Engineer.

Size: 3½" x 3½" x 2½" overall complete with carrying strap.

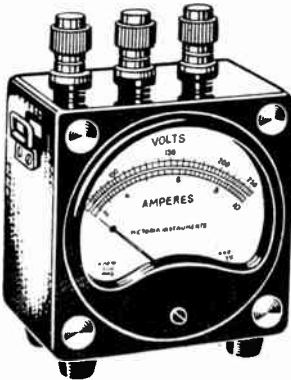

These combined instruments are made in many standard ranges. Combination examples:

- 260V A.C. or D.C.
- 15A A.C. or D.C.
- 25V A.C. or D.C.
- 25A A.C. or D.C.

Other Combinations to order

## VICTORIA INSTRUMENTS

Proprietors: V.I.C. (Bournemouth) Ltd.

MIDLAND TERRACE · LONDON · N.W.10

Telephone · ELGar 7871/2

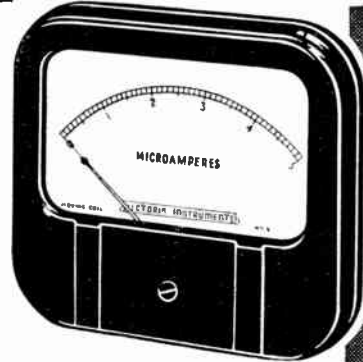

## SQUARE FLANGE METERS

4" Large Open Scale. Mirror Scale can be supplied if required. RANGES:

- A.C. from 1V-10kV
- 25uA-100 Amps.
- D.C. From 5mV-10kV
- 5uA-5000 Amps.



## RADIOMART offer the undermentioned Lines at Greatly Reduced Prices to clear!

Receiver type 1124A, 30.5-40.5 Mc/s with 6 valves and a number of very useful components. Price 19/6 carriage 5/-. ditto without Valves 9/6, carriage 5/-  
 Condensers, 1 2,500V. Tubular in plastic case. Ideal for television, 4/8; .01 4,000V. ditto, 2/-; .03 2,000V. ditto, 1/6; .1 .01, 1,000V. Screened, 9d. each.  
 Wire-wound Resistors, 10 Watt—500, 4,700, 5,000 7,000, 10,000 20,000, 24,000, 25,000 ohm 1/9 each 20/- dozen; 20 Watt—100, 100, 5,000 tapped at 3,000, 7,000, 10,000, 40,000 ohm, 1/9 each, 20/- dozen; 25 Watt—350, 1,500, 5,000 tapped at 2,000 and 1,500, 10,000 ohm, 1/9 each, 20/- dozen; 50 Watt—3,000 ohm, 2/3 each; 75 Watt—14,000 tapped at 2,000 ohm, 2/6; 100 Watt—1,000, 7,000, 12,000 20,000 50,000 ohm, 2/6.  
 Transmitting Valves. 805, £2; 813, 55/-; 866, £1; 832, 832A, £1 807, 7/6-830B, 20/-.  
 Meters, all brand new in maker's cartons. 2½in., 0-100 m/A., 9/6; 2½in., 0-1 mA scaled 0-10V. in polished case, 19/6; 2½in. 0-5 m/A., 7/6; 0-5 amps, 5/-; 0-4 amps, 6/6; 0-20V., 7/6; 2½in Hot Wire Ammeters 0-9 amps. By removing external shunt full scale deflection is 4 amps. While they last, 2/6 each. 2½in. Radiator Thermometers. Ideal or converting to "8" Meters, 1/9.  
 X-ray Type Switches 1 wafer—3 P.3 Way: 2P 4 way, 1/3 each. 2 wafer—5P 2 way: 2P 3 way, 1/9. 3 wafer—1P 6 way: 2P 4 way and 1P 4 way, 2/-.  
 H.F. Chokes, 2.5 mH 40 m/A. Lilliputian, 6d. 2.5 mH 100 m/A., 1/-; 2.5 mH 250 m/A., 1/3.  
 Smoothing Chokes, 30 Hy. 100 m/A. 15/-, postage 2/6. 20 Hy. 126 m/A., 17/6, postage 2/6. 30 Hy. 150 m/A., 20/-, carriage 5/-. 8 Hy. 120 m/A., 12/6, postage 1/6.  
 Transformers, 500-0-500V. 170 m/A. Will never be repeated, 32/6. 1250-0-1250V. 200 m/A. High Voltage. Pri. 115V. 50 cy. Two of these in series for 230V. wkg. Very useful Transformers. Will never be repeated, 30/-, carriage 5/-. Telephone Transformers, No. 3 and 4 (No. 4 for line use only), 9d. each. Shrouded Transformer suitable for moving coil microphones and also for use as output transformer, 2/-.  
 Rotary Converters, 300V. 70 m/A. and 12V. 2 amp. 19V. Input, 5/- to clear.  
 No. 1 Mk. 2 H.T. Unit. Rotary Transformer with all smoothing. In metal case 4½in x 7½in. x 10½in. Input 11V., Output 230V. 30 m/A. An excellent job for mobile use, 12/6, carriage 4/-.  
 SCR. 281 Radio Set, consisting of a complete radio receiver (BC/147A) 13 Valve super-heterodyne with built-in power supply (115V.). Coverage 1.5-30 Mc/s in 4 ranges, Control Panel PN13A, 2 x 2, 6U4G Valves, complete with heavy duty chokes and electrolytic condensers, also 2 stages for aerial tuned circuits, 6AC7 and 6L6G. Ideal for modification for P.A. Audio Amplifier, Telephone Panel PN32A with built-in generator calling set and G.P.O. type handset. This equipment is all brand new and in really excellent condition enclosed in grey oven-baked cabinet 32 x 22 x 20in. with louvered sides. Complete with instruction book. Price £35, carriage £2 (inland). Weight approx. 400 lb. Further details on request.

**RADIOMART**  
251 (CHAM) LTD.

48 HOLLOWAY HEAD  
BIRMINGHAM, 1  
Tel.: Midland 3254

## SCAN THE NEW STAND NO.

# WOLSEY 13

T.V. AERIALS AT RADIOLYMPIA GRAND HALL

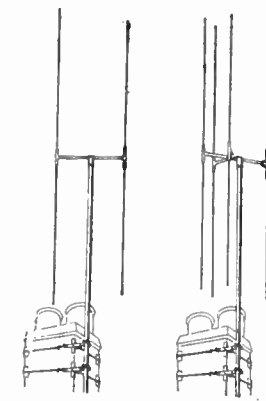

(Left) WOLSEY type H/M. A highly efficient and most popular aerial for normal requirements.

(Right) WOLSEY type TR/MI. Triple Reflector Array for increased gain in fringe areas, or reduction of severe interference.

It's easy to remember our Stand No. ! Don't miss the opportunity of seeing the full range of WOLSEY T.V. Aerials for the London and Birmingham areas. Examine them — observe their many special features and quality construction — the result of many years' specialisation. If not visiting Radiolympia send for new brochures

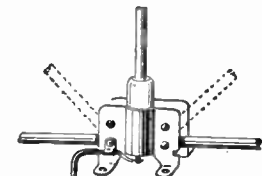

WOLSEY INDOOR AERIAL. Designed for use where an outdoor aerial is impracticable. A special polythene V.H.F. insulator ensures maximum signals possible with an indoor aerial. Easily adjusted to various positions.

## WOLSEY TELEVISION LTD.

75 Gresham Road, Brixton, London S.W.9. Brixton 6651 and 6652  
59 Soho Hill, Birmingham 19. Northern 2762 and 3493



# UNIVERSITY RADIO, LIMITED

## Offer Guaranteed Used Equipment at Attractive Prices

<b>C.D.P. Record-cutting Unit,</b> less Amplifier and Mike.....	£22 0 0	<b>B.T.H. 16 mm. Sound on Film</b> Projector, complete and port- able, with Amplifier and Speaker, spools, etc. AC 100-250 volts. As new.....	£67 10 0	<b>EVERSHED'S 500 volt Megger</b> in leather case, as new.....	£12 10 0
<b>Presto, U.S.A. Disc Recorder,</b> complete in portable case, with Mike. In perfect condition and working-order. A.C. 200-250 volts .....	£45 0 0	<b>E.I.C. AC/DC Test Meter, 4in.</b> scale as new.....	£5 10 0	<b>SOUND SALES 11in. P.M.</b> Speaker, latest model, as new	£4 0 0
<b>M.S.S. Disc Recorder Unit,</b> less Amplifier. As new.....	£35 0 0	<b>Avo Minor AC/DC, as new.....</b>	£5 10 0	<b>EPOCH 18in. energised Speak-</b> er, 500 ohm field coil, 15 ohm speech coil. As new.....	£4 10 0
<b>Utah Wire Recorder (portable),</b> complete with Mike, etc. As new .....	£65 0 0	<b>Taylor Minor AC/DC.....</b>	£5 0 0	<b>VARIAC 115-230 volt, 50 cycles,</b> 2 kva. As new.....	£8 10 0
<b>Technifon Disc Recording Unit</b> in portable case, less amplifier. As new.....	£20 0 0	<b>Triplett AC/DC Minor, as new</b>	£3 17 6	<b>C.D.P. Recording Amplifier</b> with valves, as new.....	£12 0 0
<b>M.S.S. Disc Recorder, complete</b> with Amplifier, Pre-amplifier, Play-back, spare Cutting-Head, S.T.C. Ball-and-Biscuit Mike and various other spares in three cases. As new cost £250.....	£127 0 0	<b>Avo Minor DC, as new.....</b>	£2 15 0	<b>SHAFTESBURY portable 10-12</b> watt AC/DC Amplifier, complete with Microphone, valves, one Speaker, cables, etc. As new...	£12 10 0
<b>Collaro Microgram, 1948 model,</b> as new.....	£10 0 0	<b>Taylor 70A, as new.....</b>	£7 10 0	<b>DECCA portable Record-Player,</b> latest model, as new.....	£9 0 0
<b>Collaro Microgram, 1949 model,</b> as new.....	£14 10 0	<b>Pull in Series 100, AC/DC. As</b> new .....	£7 0 0	<b>MARCONI-EKCO Output</b> Meter in perfect condition and working-order .....	£9 10 0
		<b>Avo 7, in leather case, as new.....</b>	£15 10 0	<b>SIEMENS - HALSKE Res.</b> Bridge. 1 ohm to 1 megohm. Battery operated. As new.....	£5 0 0
		<b>Avo 7, as new.....</b>	£13 0 0		
		<b>R.C.A. Voltohmist Junior, as</b> new, with booklet.....	£14 10 0		
		<b>EDDYSTONE 358, AC, 200 kc</b> to 30 meg, with 8 coils and Powerpack. As new.....	£21 0 0		
		<b>R.M.E. 69 WITH VALVES,</b> perfect, as new.....	£20 0 0		

## WE HAVE RECEIVED FURTHER SUPPLIES OF GOODS ADVERTISED IN PREVIOUS ISSUES

<b>Collaro Microgram, 8 watts</b> output, 1948. As new.....	£ 16 0 0	<b>Hallicrafter Sky Champion,</b> as new.....	£15 0 0	<b>EVERETT EDGE CUMB Hum</b> Metrohm, as new.....	£6 10 0
<b>Two only Garrard Latest</b> Model Record-Changer, mix- er type.....	£15 0 0	<b>R208 and 207, as new.....</b>	£ 10 10 0	<b>AVO Battery All Wave Oscillator.</b> 1948 model. As new.....	£9 0 0
<b>Garrard AC/DC Motor and</b> Pick-up. As new.....	£7 0 0	<b>EDDYSTONE 640, with Speaker,</b> as new.....	£22 0 0	<b>EVERSHED'S Bridge Megger.</b> As new.....	£20 0 0
<b>Collaro AC/DC Motor and</b> Pick-up. Latest model.....	£8 10 0	<b>HALLICRAFTER S40A, as new</b>	£35 0 0	<b>TAYLOR 20,000 o.p.v. AC/DC</b> Test-Meter, model 85A, as new	£12 0 0
<b>E.D.C. Rotary Convertors,</b> 200-250 volts DC to 230 AC, 50 cycles, single phase, 300 watts, with filter unit, in metal cabinet. As new.....	£20 0 0	<b>HALLICRAFTER SX28, as new</b>	£40 0 0	<b>PEERLESS Radio Chassis, latest</b> model, as new. 10 valves. Complete.....	£21 0 0
<b>E.D.C. Rotary Convertors,</b> as above, 120 watts.....	£10 10 0	<b>HALLICRAFTER SX24, as new</b>	£19 10 0	<b>Tannoy 25 watt Amplifier,</b> with 2 Speakers and M/c Mike. In perfect condition and work- ing-order. Original price £45. Our price.....	£27 10 0
<b>WE CAN SUPPLY IN OTHER VOLT-</b> AGES TO ORDER.		<b>HALLICRAFTER Sky Buddy,</b> in perfect working-order.....	£8 10 0	<b>AC 'Gram Motors with Turn-</b> tables, of various good makes. Not rim-driven.....	£3 0 0
<b>LEGG Battery Charger, 1</b> circuit, Model F361/2. As new. Cost £24. Our price.....	£12 0 0	<b>GOODMAN'S Axiom 22</b> Speaker, as new.....	£8 17 6	<b>12 Steel Racks and Panels from</b> 3ft. to 6ft., at very low prices to clear.	
<b>Crypton Battery Charger.....</b>	£13 10 0	<b>GOODMAN'S Axiom 12, as</b> new .....	£5 17 6		
		<b>GOODMAN'S 12in. P.M., as</b> new .....	£4 0 0		
		<b>BAKER 16in., latest model, as</b> new .....	£5 5 0		
		<b>EVERSHED'S Wee Megger, 500</b> volt, in leather case, as new .....	£5 5 0		
		<b>BALDWIN Triometer, AC/DC</b> voltmeter and Megger combined, as new.....	£9 10 0		

**We have other types of equipment arriving daily. We take your used gear in part exchange for new. Balance by Cash or Deferred Terms. We urgently need good used equipment, and will buy for spot cash. Bring, send or phone for offer.**

CASH OR CHEQUE WITH ORDERS. ALL ITEMS LISTED ARE CARRIAGE PAID.

### 22 LISLE STREET, LEICESTER SQUARE, LONDON, W.C.2

Phone GERrard 4447 and 8582. Hours 9 to 6. Thursdays 9 to 1.

# The Connoisseur

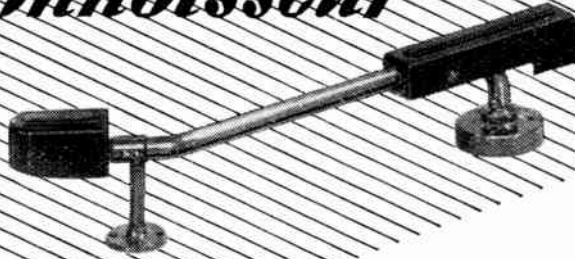

## PICK-UP

MEET US AT  
**RADIOLYMPIA**  
SEPT 28 - OCT 6

Obtainable from all good dealers  
Price 54/- plus purchase tax.  
Transformer if required 13/-.  
Special head for fitting to  
Garrard Auto-changers.

R.C. 60, 65, 70, 42.- plus  
purchase tax.

Long playing needles 20 for 2/-,  
plus tax.

The Connoisseur pick-up is a super sensitive instrument, scientifically developed for the benefit of music lovers who insist on Natural reproduction.

If you are scientifically-minded you will know how good it is when we say that every pick-up is hand tested to show within + or - 2 db's of our published response curve, which is substantially flat from 50-9,000 cps.

If you have a musician's ear you will know how good it is immediately you hear it bring the first few notes from a record in their original purity.

Made by A. R. SUGDEN & Co. (Engineers) Ltd., Well Green Lane, Brighouse, Yorks

## The T.G.2 Direct Disc Recording Traverse Gear

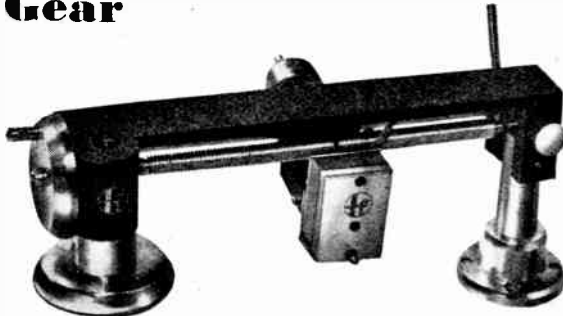

A precision built robust mechanism simple in operation producing first quality recording - - - £21 0 0  
Recording Motor and Turntable - - - £14 0 0

Ideal for assembly into Light, Portable Equipment

A New Permanent Needle at the amazingly low price of

5/- (Inc. P.T.)  
We supply a well established and guaranteed reputable make of superior quality Sapphire Needle

- REGRIND SERVICE AVAILABLE
- Diamond Needles can be supplied
- Prompt attention given to enquiries for any quantity—large or small.
- Speedy delivery.

**ELECTRO SOUND SUPPLIES CO.,**  
99, BELGRAVE ROAD, S.W.1.  
PHONE: VIC. 8814



## HOME STUDY

**backs radio experience with sound technical knowledge**

MANY men who wished to link their radio experience with a sound technological background have received successful instruction by means of an ICS Course. Its value has been proved not only to amateurs but to men who already have a professional interest in radio and television engineering, including those taking qualifying examinations. It is invaluable, also, to students who wish to prepare themselves for a job in this field. Courses of Instruction covering radio and, if necessary, television include the following:

**Complete Radio Engineering    Radio Service Engineers**  
**Radio Service and Sales    Advanced Short-Wave Radio**  
**Elementary Electronics, Radar and Radio**  
**Television Technology**

And the following Radio Examinations:

**British Institution of Radio Engineers**  
**P.M.G. Certificates for Wireless Operators**  
**City and Guilds Telecommunications**  
**Wireless Operators and Wireless Mechanics, R.A.F.**

Write today for our FREE "Radio" booklet which fully describes the above ICS Courses and the facilities for the complete study of Radio and/or Television technology. The ICS Advisory Department will also give free and impartial advice on need and means of instruction.

*International*  
**CORRESPONDENCE SCHOOLS**

Dept. WL.2, International Buildings, Kingsway, London, W.C.2

# A MESSAGE TO MY FRIENDS

I hope soon that my health will no longer influence my advertisements. In Sept., 47, when at times I could not walk, an operation to remove tooth-poison took place.



This helped but did not clear my exhaustion and "pressure in the chest." In 1948 the official diagnosis was nervous exhaustion (usually due to mental factors, frustration, etc.), but with the psychologists I had no luck.

Dec., 1948, over the telephone a blind Osteopath diagnosed "pressure in the chest" as spinal, subsequent manipulation proving him right. The nerves from the chest (and other parts) connect to the brain via the spine. A fault anywhere on the line registers as occurring at the far end! My bearing and efficiency were improved, but premature exhaustion remained.

Recently a Naturopath found the flesh of my back "congested" caused by mucus etc., rubbish clogging the capillaries. If this impedes the blood flow to the spinal nerves, it may leave them under-scavenged and under-fed! After an initial drop, his treatments have raised my performance curve. Will it go to 100%? Is the congestion an after effect of the dental trouble? I hope soon to know.

**TECHNICAL.** Though I spent most of 1948 resting, it has not all been wasted. Certain differences between loudspeaker theory and practice, previously noted but unexplained, have been examined.

When delving below the obvious and among fundamentals, popular theories are sometimes found wrong. My loudspeaker design was never



based on prevailing fashions and in fact departs radically from these. The recent work has disclosed that the departures were not only fundamentally right, but that I should have gone a little further. This has been done\* in my P.M. Unit with rematched diaphragm, see review in "W.W.," March, page 103, and has readjusted the matching between the magnet, diaphragm, horn and bass chamber. Theoretically regions of maximum efficiency should be lowered, and regions of low efficiency improved, giving overall better uniformity. Reports satisfy me that there is no mistake. It is found that the rematched diaphragm is an improvement when the input is distortionless, no better if the input frequency range is limited, and worse if the input contains amplitude and similar distortion. 2 complaints about "rattle" will, I am sure prove to be distortion faithfully reproduced.

Apart from using the new knowledge to cut down material, etc., costs in speakers for more general use, there is still work to be done on loudspeakers. Each improvement effected uncovers other lesser blemishes. Nevertheless, the loudspeaker is now no longer always the "weakest link." When the remaining links are so perfect that the loudspeaker is the limiting factor, then the audible results are memorable.

These new diaphragms (designed for 15Ω load) will fit excited VOIGT units even if 20 years old! Owners of VOIGT speakers with light coil twin diaphragms will already have the B.B.C. Corrector needed to counter top lift and a gap liner.

**COMMERCIAL.** The new diaphragm is £5 5s. 0d. Postage 9d. Allowance on the old to come back, £1 (short waiting list). As I am dependent on sub-contractors for part of the work, and supplies are not regular, some are reserved for the next batch of new units (£40 plus carriage), some to go with the

\* Patent applied for.

few big corner horns (in the white, £47 10s. 0d. ex score) remaining from the last batch.

Regular readers will know that under Town and Country planning regulations I have had to discontinue at the last address. Previous alternative arrangements have fallen through, and present plans may suffer a like fate. The materials allocation remains at 1/8th of that required for sensible production, and there is talk of more austerity!

So "Operation Scatter" is in progress, and while I expect to find a point from which sales or service can be allocated, or sub-contractors and storers instructed, the assembly of further big horns is a problem. I therefore ask those who want a big horn "some day," please order now. A waiting list instead of storage, and a credit balance instead of an overdraft will encourage surmounting the local difficulties.

My proper occupation is research, not "doing battle" with the man-made complications of post-war Britain. I hope as soon as health permits to investigate the art of quality reproduction across the Atlantic. If I find my standards of interest out there, I hope to work from Toronto and teach a boat building firm how to make VOIGT horns to go with imported VOIGT units.

Investigation needs time, and I will be virtually without funds. So I will welcome a part-time job out there lecturing, or some business proposition to provide funds and leave time over for investigation and research. Results of such research sent back home can help keep VOIGT HORN LOADED speakers on both sides of the Atlantic up to the highest standard.

*P. G. A. H. Voigt.*

P.S.—Anyone at home or overseas interested in co-operating, please write.

**VOIGT PATENTS LTD.,**  
c/o BCM/VOIGT,  
LONDON, W.C.1

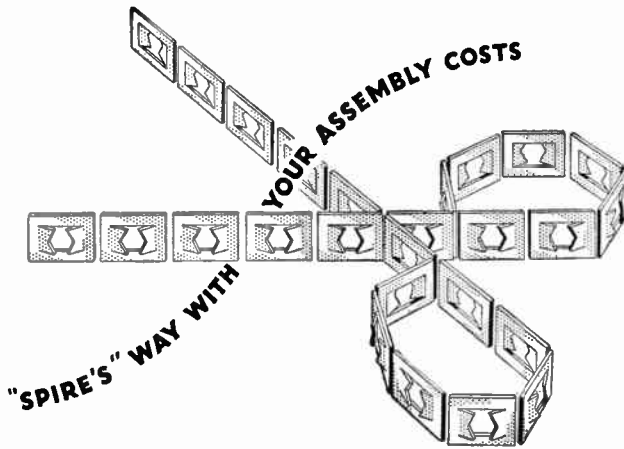

# Spire

Regd.

## SPEED NUTS

THAT'S  
FIXED  
THAT

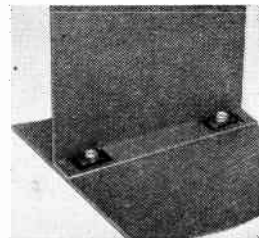

The SNP type replaces machine nut and lock washer. No spanner is necessary to hold these streamlined nuts designed for use with machine screws and sheet metal screws.

Enquiries to: **Simmonds Aeroaccessories Ltd., Byron House, 7-8-9 St. James's St., London, S.W.1.** Head Office & Works: Treforest, Glamorgan



# LISTEN-IT'S A GOOD SOUND JOB

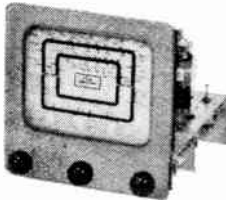

**THE K.I. AMPLIFIER**

A seven-valve amplifier especially designed for the lightweight high-fidelity type pick-up. Independent bass and treble controls. Price complete 17 gns., or in kit form, 13 gns. Blueprint available separately 2/6 "LIVING MUSIC" . . . our fully illustrated 16-page catalogue showing complete range of amplifiers and tuning unit. Write for your copy to-day, enclosing 5d. in stamps.

**R.A. TUNING UNIT**

A really fine design with lasting high performance. R.F. stage on all wave-bands. High fidelity super-het or T.R.F. performance. Suitable for any amplifier. Price 10 gns., plus £2. 6. 8 tax. (2 years guarantee)

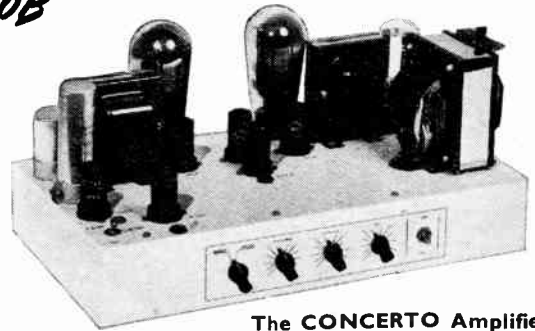
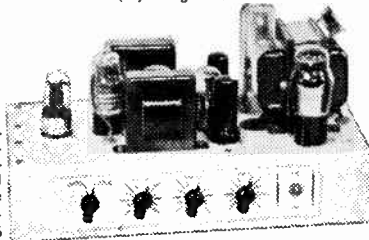

**The CONCERTO Amplifier**

... acclaimed by music lovers for its exceptionally high fidelity, this magnificent amplifier covers all normal requirements for home or concert hall. Distortion level below 0.5 per cent. Two channels of bass boost ensure unusually smooth balance and depth. Designed for any type of pick-up. Radio input socket provided. Two year guarantee. Price £27. 10. 0. Heavy perforated steel cover with bottom plate and rubber feet, 37s. 6d. extra. Delivery by passenger train. Carriage Paid. 10s. deposit (returnable) for crate.

DEFERRED TERMS AVAILABLE ON ALL MODELS

Our equipment can also be seen and heard at :—  
**UNIVERSITY RECORDING CO., 16 BURLEIGH PLACE, CAMBRIDGE**

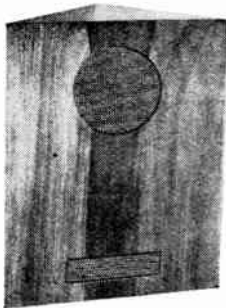

**THE TRICORNE SPEAKER CHAMBER**

For optimum acoustic performance with any good 12-in. speaker. Labyrinth construction, walnut veneered and cross-braced. Price 10 gns. plus £1 deposit (returnable) for crate.

Phone :  
WEStern  
3350

*Charles*  
**AMPLIFIERS**  
LTD

1m PALACE GATE · KENSINGTON · LONDON · W.8

**FOR THE UTMOST REALISM FROM RECORDS & RADIO**

## LATEST DESIGNS IN CHASSIS & PANELS

STANDARDISED BY FAMOUS LABS NOW AVAILABLE FOR GENERAL USE.

IDEAL FOR CIRCUIT RESEARCH WORK AND ALL RACK EQUIPMENT.



- RIGID CONSTRUCTION. LIGHT. FULLY SCREENED TOP AND BOTTOM, WELL BONDED AND VENTILATED.
- ELEVEN STANDARD G.P.O. SIZES AVAILABLE IN VARIOUS FINISHES WITH PLATED HANDLES.
- ENTIRE INTERIOR ACCESSIBLE BY SLIDING SCREENS.
- CAN BE TAKEN TO PIECES INSTANTLY FOR STORAGE, AND RE-ASSEMBLED IN MINUTES.
- GOOD CONDUCTIVITY FOR V.H.F. WITH EASY DIRECT SOLDERING TO CHASSIS FOR H.F. CONTACTS.

**LABGEAR LTD** WILLOW PLACE, PHONE :  
CAMBRIDGE 2494

*"You're CERTAIN to get it at ARTHURS!"*

★ **VALVES** : We have probably the largest Stock of valves in the Country. Send your enquiries. We will reply by return.

**AVO METERS IN STOCK**

Avo Model 7 .....	£19 10 0
Avo Model 7, high resistance .....	£19 10 0
Valve Tester .....	£16 10 0
Test bridge.....	£11 0 0
Avo Minor, AC/DC model.....	£8 10 0
Electronic Test Meter .....	£35 0 0
Signal Generator .....	£25 0 0

TAYLORS METERS. List on request.

DECCA PICK-UPS .....	£6 14 6
DECCA HEAD for Garrard .....	£4 11 0
Adaptors .....	3 8

DENCO COILS & COMPONENTS in stock.

London's Oldest Leading Radio Dealers.

All types stocked

*Arthur's*  
PROPS: ARTHUR GRAY, LTD.

EST. 1919

Terms C.O.D. or cash with order

Our Only Address: **Gray House, 150, Shering Cross Rd., London, W.C.2**  
TEmple Bar 58331/4

**ELECTRICAL, TELEVISION & RADIO ENGINEERS**

Another **GOODMANS** Axiom



**HIGH (FIDELITY + POWER)**

With an exceptionally high electro-acoustic efficiency, this new version of the well-known "Axiom Twelve" has been developed to satisfy the great demand for High Fidelity power reproduction.

Send for illustrated Folder L.99  
See us at **RADIOLYMPIA**, Stand No. 6.

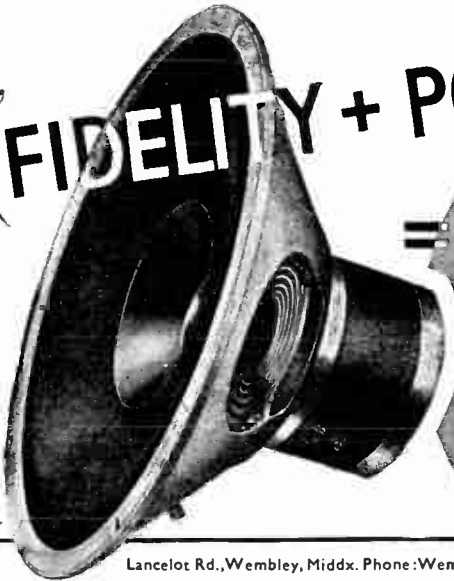

**= AXIOM**  
<sup>66</sup>**22**<sup>99</sup>  
**12" DUSTPROOF**  
**20 WATT**  
**LOUDSPEAKER**

**GOODMANS INDUSTRIES LTD.,**

Lancelot Rd., Wembley, Middx. Phone: Wembley 1200. Grams: Goodaxiom, Wembley

*A Miracle of Sound  
REPRODUCTION!*

**AMBASSADOR**

**Model 949 T.R.**

For the Overseas buyer (illustrated) a nine valve 6 Band AC or AC/DC superhet with R.F. stage and push-pull output. Twin speakers, Tuning Indicator, continuous bandspread between 10.5 and 32 metres over 44" of scale length. Separate Bass and Treble controls. 5.W. sensitivity better than 5 microvolts.

**Model 849 T.R.**

For the Home buyer an eight valve AC DC superhet with three wavebands 5.W. 13-50 metres, M.W. 175-550 metres, L.W. 900-2,000 metres. Average sensitivity better than 10 microvolts. Other details as for 949 T.R. **£31 Tax Paid**



**RADIOLYMPIA STAND 80**  
AM-FM and Television Receivers

Made in England

**AMBASSADOR RADIO, BRIGHOUSE, YORKS**

# Mullard miniatures



No.	Type	Filament or Heater		V <sub>a</sub> (V)	V <sub>g2</sub> (V)	V <sub>g1</sub> (V)	I <sub>a</sub> (mA)	g <sub>m</sub> (mA/V)	μ	r <sub>a</sub> (K.Ω)	R <sub>k</sub> (Ω)	R <sub>a</sub> (K.Ω)	P <sub>out</sub> (W)
EY91	Half-Wave Rectifier	6.3	0.42	250 (max)	—	—	75 (max)	—	—	—	—	—	—
EC91	V.H.F. Grounded-grid Triode	6.3	0.3	250	—	-1.5	10	8.5	100	12	150	—	—
EF91	High Slope, Sharp Cut-off R.F. Pentode	6.3	0.3	250	250	-2	10	7.65	70 (g <sub>1</sub> -g <sub>2</sub> )	1000	—	—	—
EF92	V.M., R.F. or I.F. Pentode	6.3	0.2	250	150	-0.65	8	2.5	—	—	—	—	—
EAC91	Diode Triode for Frequency Changing up to 300 Mc/s	6.3	0.3	200	—	-2.8	7.5	2.8	36	12.8	—	—	—
EB91 (6AL5)	Screened Double Diode—separate cathodes	6.3	0.3	150 (max)	—	—	9 (max)	—	—	—	—	—	—
EL91	Output Pentode (1.4W Output)	6.3	0.2	250	250	-13.5	16	2.6	12 (g <sub>1</sub> -g <sub>2</sub> )	130	680	16	1.4
ECC91 (6J6)	V.H.F. Double Triode (Physical Common Cathode)	6.3	0.45	100	—	—	8.5	5.3	38	7.1	100	—	—
DK91 (1R5)	V.M. Heptode Frequency Changer	1.4	0.05	90	67.5	0	1.6	0.3 (g <sub>c</sub> )	—	600	—	—	—
DF91 (1T4)	V.M., R.F. or I.F. Pentode	1.4	0.05	90	67.5	0	3.5	0.9	—	500	—	—	—
DF92	Sharp Cut-off R.F. Pentode	1.4	0.05	90	67.5	0	3.7	1.0	—	500	—	—	—
DAF91 (1S5)	Single Diode Pentode	1.4	0.05	67.5	67.5	0	1.6	0.625	—	600	—	—	—
DL92 (3S4)	Output Pentode (0.27W Output)	1.4	0.1	90	67.5	-7	7.4	1.58	—	100	—	8	0.27
DL93 (3A4)	A.F. or R.F. Output Pentode	1.4	0.2	150	90	-8.4	13.3	1.9	—	100	—	8	0.7 (audio)
DL94 (3V4)	Output Pentode (0.27W Output)	1.4	0.1	90	90	-4.5	9.5	2.15	—	100	—	10	0.27
DA90 (1A3)	R.F. Diode	1.4	0.15	330 (P.I.V. max)	—	—	0.5 (max)	—	—	—	—	—	—
DCC90 (3A5)	R.F. Double Triode	1.4	0.22	90	—	-2.5	3.7	1.8	15	8.3	—	—	2
2D21	Gas-filled Tetrode	6.3	0.6	400	0	-6	80 (max)	—	250	—	—	—	—

MULLARD ELECTRONIC PRODUCTS LTD • Century House, Shaftesbury Avenue, London, W.C.2

MVT35G

## PVC Stripper Pliers

FOR PLASTIC INSULATED WIRES

“Stanelco” stripping pliers remove plastic insulation from stranded or solid conductors up to 1/8" overall dia. By means of electrically heated plier jaws, the thermo-plastic properties of the insulation are utilised to ensure *clean, speedy stripping* without charring insulation or damaging conductor. No switching is necessary. Pliers can be left connected without overheating. Supply Voltage: 220/250 volts (A.C. only). Power consumption 10 watts.



Standard Telephones and Cables Limited  
HEAT TREATMENT GROUP  
(Industrial Supplies Division) CLINE RD., BOUNDS GREEN, LONDON, N.11

## SOME HOLIDAY FOR YOU !!!

If you use the BURGOYNE INSTANT HEAT GUN

## TALK ABOUT HOT !!!

LIFT IT—PRESS IT—DONE  
USED BY THE WORLD'S LEADING MANUFACTURERS

You can EVEN solder round corners—in any position !!

A LIFETIME'S USE FOR 79/6

Write for leaflet or send for sample—YOU'LL ENJOY YOUR PERMANENT HOLIDAY !!

## BURGOYNE ENG. CO. LTD.

ROBERT STREET, LONDON, N.W.1.  
MUS. 6667



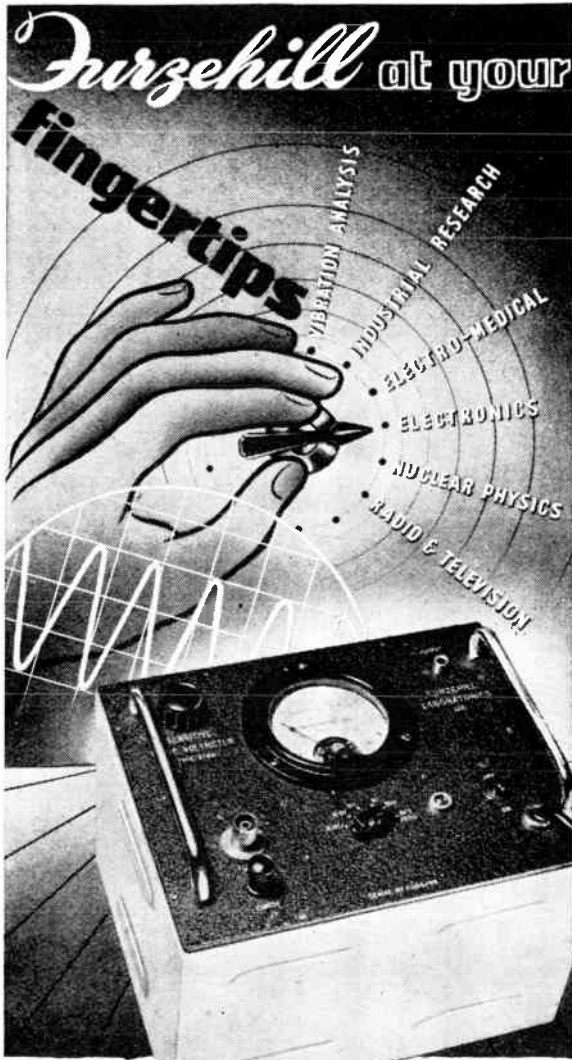

Sensitive Valve Voltmeter Type 378B/2

STABILITY of operation, portability and ruggedness of construction are contained in Furzehill Instruments designed for use in Laboratory, Test-Room or Field.

The Sensitive Valve Voltmeter illustrated above measures potentials from 1 mV to 100 V over the wide frequency range of 10 c/s to 500 kc/s, thus covering the audio and supersonic frequency band.

The logarithmic scale shape enables a constant reading accuracy to be obtained. A linear db scale is also provided.

For full details of this and other instruments in the Furzehill range, write for our new illustrated catalogue.



**FURZEHILL LABORATORIES LIMITED**  
BOREHAM WOOD · HERTS · Tel. ELStree 1137



DIRECT RECORDING ON DISC

## An Invitation

To all who seek the highest possible fidelity in sound reproduction, we extend a warm welcome to inspect and hear the M.S.S. equipment at

## RADIOLYMPIA

STAND NO. 76

AND DEMONSTRATION ROOM D4

There is a range of models embracing types from simple Portable Recorders to complete Studio Recording Channels, and including a new Portable Studio Recording Equipment which sets entirely new standards of versatility and performance for portable recorders.

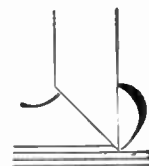

**M · S · S · RECORDING COMPANY LTD**  
POYLE CLOSE · COLNBROOK · BUCKS · ENGLAND

## Eliminate Positive Feedback

(Mechanical) "EQUIFLEX" PATENT MOUNTINGS will eliminate Mechanical and acoustic Vibration from being amplified and a Black Spot on Quality Reproduction. Call at your Dealers to see a complete set of special "EQUIFLEX." Damped units with all fittings and assembly chart suitable for the GARRARD R C 60 Turntable.

**GARRARD RC 60 UNIT** Price 21/6 Per Complete Boxed set of 4 Mountings and all fittings.

"EQUIFLEX" special Damped Mountings as illustrated for Chassis Suspension can be obtained from your Radio Dealer. Loadings of these units are from 2 lb. to 12 lbs. Giving a choice of distributed loading of from 8 lbs. to 50 lbs. where a four Point-Suspension is used.

Ask to see these special Units at your Dealers.

### TYPICAL RADIO CHASSIS

Wholesale Distributors and Dealers write for Terms and Particulars. Export Enquiries Welcomed. Illustrated Brochure upon request.

Sole Manufacturers:

**A. WELLS & CO. LTD.,**

PROGRESS WORKS, STIRLING RD., LONDON, E.17

PHONE: LARKSWOOD 2691-4

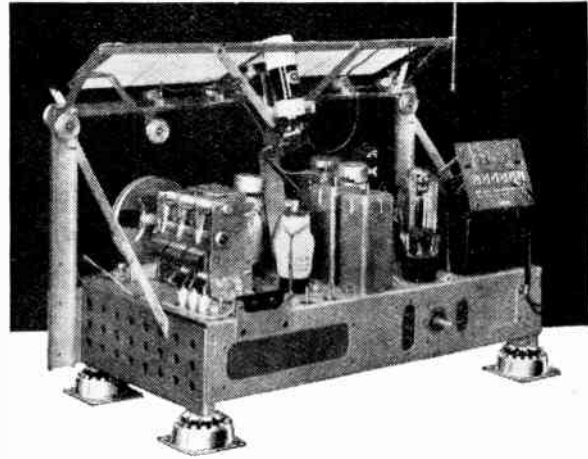
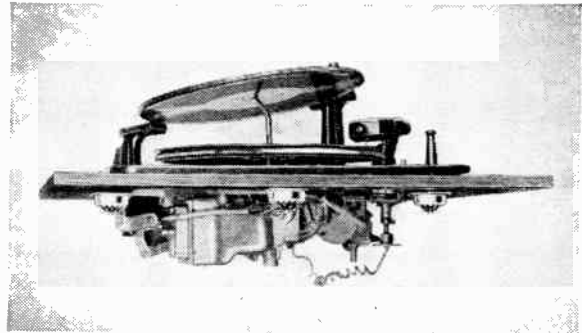

## DRAYTON MOTOR UNITS

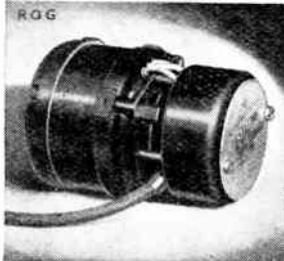

### R. Q. G. GEARLESS MOTOR UNIT

A miniature capacitor induction type motor running at 2,700 r.p.m. Normally supplied with built-in fan, condenser mounted on fan cover. Motor can be supplied totally enclosed, condenser separately mounted. For continuous or intermittent running in either direction or continuously reversed. Torque: 1.75" oz.

### R. Q. R. GEARED MOTOR UNIT

The R.Q.R. is a compact, self-contained component, consisting of the R.Q.G. motor geared to a final shaft. Supplied for continuous or intermittent running in either direction, with or without self-switching. An additional two-way switch is fitted, actuated by the final shaft, for operating auxiliary gear. Final shaft speed: 27 m.p.r. to 600 r.p.m. Torque 60" lbs. to 1/4" lbs. according to speed.

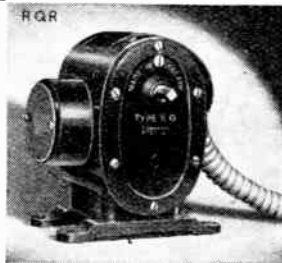

Supplied for Voltages 100/120 or 200/250 A.C. 50 cycles.

Send for List No. N 302-1

R.Q.8

**DRAYTON REGULATOR & INSTRUMENT CO. LTD.,**  
WEST DRAYTON • MIDDLESEX. West Drayton 2611

*Economy!*

DIODE FILTER CAPACITOR

100pF 100pF

**SRC**

Our diode filter capacitor 2 x 100 pF ± 20% has been designed for economy. Its cost compares favourably with that of two capacitors. It saves space and it saves time on the assembly line. Manufacturers are invited to ask for samples and prices.

## STABILITY RADIO COMPONENTS LTD

14, NORMAN'S BUILDINGS  
CENTRAL STREET, LONDON, E.C.1.

Telephone: CLERKENWELL 5977/8



# Stentorian

## SPEAKERS & CHASSIS

### Outstanding value—fine performance

Backed by 25 years of searching experiment in design and performance, and manufactured entirely within the Whiteley organisation, these unique units are most attractively priced.

Stentorian P.M. Chassis Units range from 5" to 12" diameter with maximum flux density of 1300 gauss and even more powerful elements can be supplied on demand. The die-cast light alloy 'basins' provide resonance-free construction and prevent loss of useful flux.

Listed below are three newcomers to the wide W/B range — all extension speakers, outstanding for their quality, appearance, and fine performance.

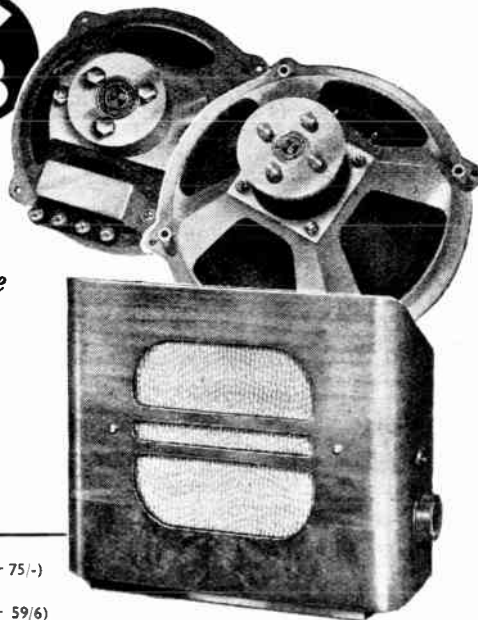

● **BEAUFORT** Size 12½" x 10½" x 3½" 67/6 (with Transformer 75/-)

● **BRISTOL** Size 10½" x 9½" x 3½" 53/6 (with Transformer 59/6)

● **BEDFORD** Size 9½" x 8½" x 3½" 39/6 (with Transformer 45/6)

*See us at Radiolympia on Stand 77*

All models are finished in polished walnut veneer. Beaufort and Bristol models incorporate pushbutton remote control to operate in conjunction with the exclusive Whiteley Long Arm. Details on request.

WHITELEY ELECTRICAL RADIO CO. LTD., MANSFIELD, NOTTS.

## Taking the Mountain to Mahomet!

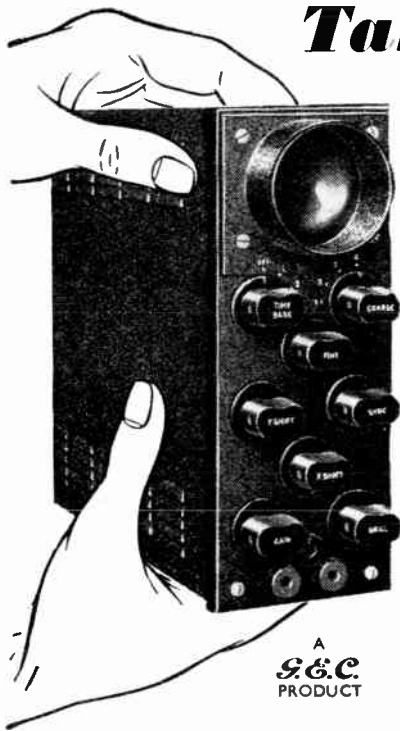

A  
S&C  
PRODUCT

The oscilloscope is no longer the 'great immovable' to which all faulty 5-Valve Mahometts have to be brought!

For the "Miniscope" (Height 6¾") is no mountain at all. It weighs only 7½lbs., is truly portable and need never be out of reach in the workshop or on any service call, in fact anywhere where there is an A.C. mains supply.

The oscilloscope is the most versatile single item of equipment yet designed for the radio service man.

The "Miniscope" is the most compact of all oscilloscopes.

**SIGNAL TRACING • FAULT DETECTION  
HUM LOCATION • PHASE INVESTIGATION  
I.F. ALIGNMENT • FREQUENCY RESPONSE  
FREQUENCY DETERMINATION • WAVE-  
FORM OBSERVATION • A.F. DISTORTION  
CORRECTION • MODULATION ANALYSIS  
OSCILLATOR CALIBRATION**

# Miniscope

MINIATURE CATHODE RAY OSCILLOSCOPE



Full specification from : THE GENERAL ELECTRIC CO. LTD., MAGNET HOUSE, KINGSWAY, LONDON, W.C.2



# THE NEW **Aerialite** TELEVISION AERIAL

**D.P.O. MODEL 50.** The best Aerial on the market at the lowest price. Available in 2 types—"London" and "Midlands" and made up for three different styles of mounting as illustrated. Features: Low-Loss Insulator—Waterproof Plug Assembly—Accessibility—Easy Erection—Strength—Broad Bandwidth—Rigidity. **47'6.**  
(Prov. Patent 26255/48).

**COAXIAL CABLES.** Manufactured under strict Laboratory conditions and to Government Specification where possible. Send for list of the full range of AERIALITE R/F Cables and Feeders.

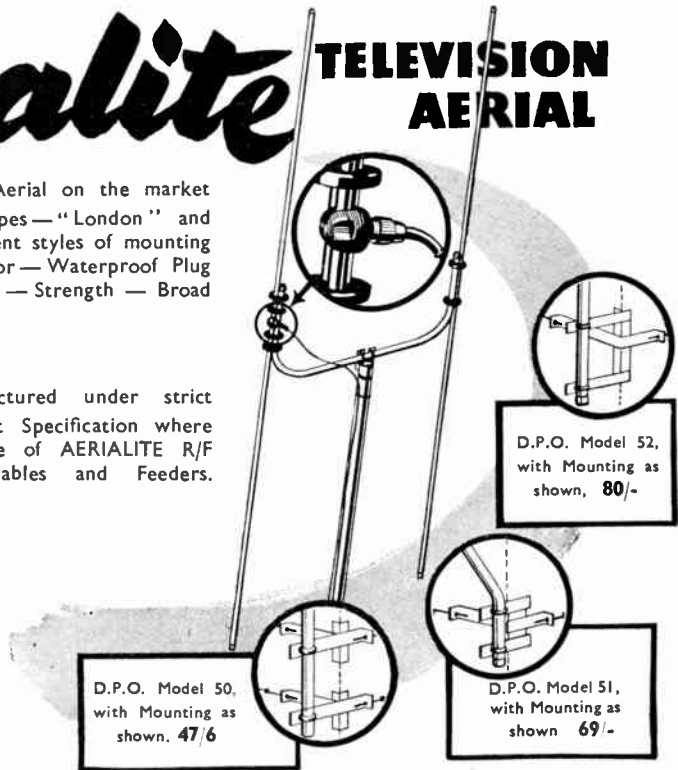
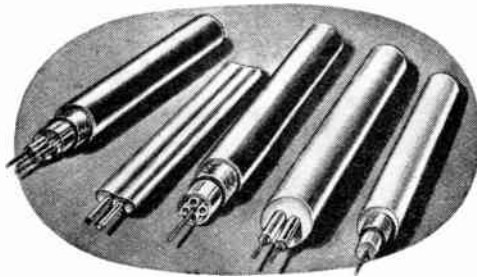

**AERIALITE LTD., CASTLE WORKS, STALYBRIDGE, CHESHIRE**

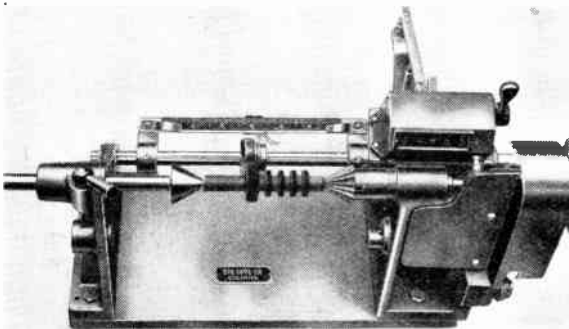

MODEL WX

## AUTOMATIC COIL WINDING MACHINES

### AND HAND WINDING MACHINES

Machines supplied complete with stand motor and Two-speed Friction Clutch

SOLE AGENTS ABROAD

K. G. Khosla & Co., 22 School Lane, New Delhi, India.  
Etalbits Octave Houart, 14, Quai de l'Industrie, Sclessin-lez-Liege.  
J. P. Fielding Co. (Canada), 131 Ontario Street, St. Catharines, Ontario.

Hefbye & Frogg, Oslo, Norway, Storgaten, 15.

## ETA TOOL CO

(LEICESTER) LTD.

29a, WELFORD ROAD, LEICESTER

Phone—5386

### MAINS TRANSFORMERS SCREENED, FULLY INTERLEAVED AND IMPREGNATED.

H.S.63.	Input 200/250 v.	Output 250/0/250 v.,	60 m/a., 6.3 v. 3 amps., 5 v. 2 amps.	15/6	
H.S.40.	Windings as above.	4 v. 4 amps., 4 v. 2 amps.	15/6		
H.S.2.	200/250 v.	250/0/250 v.	80 m/a.	17/6	Half Shrouded.
H.S.30.	200/250 v.	300/0/300 v.	80 m/a.	17/6	
H.S.3.	200/250 v.	350/0/350 v.	80 m/a.	17/6	
H.S.2X.	200/250 v.	250/0/250 v.	100 m/a.	19/6	
H.S.30X.	200/250 v.	300/0/300 v.	100 m/a.	19/6	
H.S.3X.	200/250 v.	350/0/350 v.	100 m/a.	19/6	
F.S.2.	200/250 v.	250/0/250 v.	80 m/a.	19/6	Fully Shrouded.
F.S.30.	200/250 v.	300/0/300 v.	80 m/a.	19/6	
F.S.3.	200/250 v.	350/0/350 v.	80 m/a.	19/6	
F.S.2X.	200/250 v.	250/0/250 v.	100 m/a.	21/6	
F.S.30X.	200/250 v.	300/0/300 v.	100 m/a.	21/6	
F.S.3X.	200/250 v.	350/0/350 v.	100 m/a.	21/6	
All above have 6.3-4-0 v. at 4 amps., 5-4-0 at 2 amps.					
F.S.43.	Input 200/250 v.	Output 425/0/425 v.	200 m/a., 6.3 v. 4 amps C.T., 6.3 v. 4 amps C.T. 5 v. 3 amps....	42/6	Fully Shrouded.
F.S.35.	Input 200/250 v.	Output 350/0/350 v.	250 m/a., 6.3 v. 6 amps, 4 v. 8 amps., 0-2-6.3 v. 2 amps., 4 v. 3 amps.	98/6	
F.S.50.	Input 200/250 v.	Output 450/0/450 v.	250 m/a., 6.3 v. 2 amps. C.T., 6.3 v. 4 amps. C.T., 5 v. 3 amps.	77/6	
F.30X.	Input 200/250 v.	Output 300/0/300 v.	80 m/a., 6.3 v. 7 amps., 5 v. 2 amps.	26/6	Framed Flying Leads.
E.H.T.2.	2,000 v. 5 m/a., 2-0-2 v. 2 amps, 4 v. 1.1 amps.	35/-			
F.4.	Filament Transformer. Input 200/250 v., 4v. 2 amps.	7/6			
F.6.	Filament Transformer. Input 200/250 v. 6.3 v. 2 amps.	7/6			
F.12.	Filament Transformer. Input 200/250 v. 12.6 v. tapped at 6.3 v. 3 amps.	15/6			Framed Flying Leads.
F.24.	Filament Transformer. Input 200/250 v. 24 v. tapped at 12 v. 3 amps.	21/6			

C.W.O. (add 1/- in £ for carriage), all orders over £2 carriage paid.

**H. ASHWORTH** (Dept. W.W.)  
676, GREAT HORTON RD., BRADFORD, YORKS.

**The New WESTON S75  
Multi-Range Test Set**



**53 Ranges with Rotary  
Switch Selection**

This new and uniquely comprehensive Test Set has 53 ranges for measuring A.C. and D.C. current and voltage, resistance and insulation. It is completely self-contained, with internal batteries to provide power for the ohms ranges and self-contained power pack for insulation measurement at 500 v. Selection is carried out by two 20-position switches. A fully protective safety device is fitted and is operative for forward or reverse overload. The 150-division 6in. scale is uniformly divided and is fitted with an anti-parallax mirror. The set is enclosed in a handsome bakelite case and fully complies with B.S.S. No. 89 covering first-grade instruments.

Full details of the ranges covered and of the complete specification will gladly be supplied on request.

**PRICE £65**

**SANGAMO WESTON LTD.  
ENFIELD, MIDDX.**

*Tel. : Enfield 3434 (6 lines) and 1242 (4 lines)*

201 St. Vincent Street, Glasgow - - - - Tel. : Central 6208  
 22 Booth Street, Manchester - - - - Tel. : Central 7904  
 Milburn House, Newcastle-upon-Tyne - - - - Tel. : Newcastle 26867  
 33 Prin.ess Street, Wolverhampton - - - - Tel. : Wolverhampton 21912

**KNOBBS DIALS & POINTERS** *by*

**PAINTON  
of  
NORTHAMPTON**

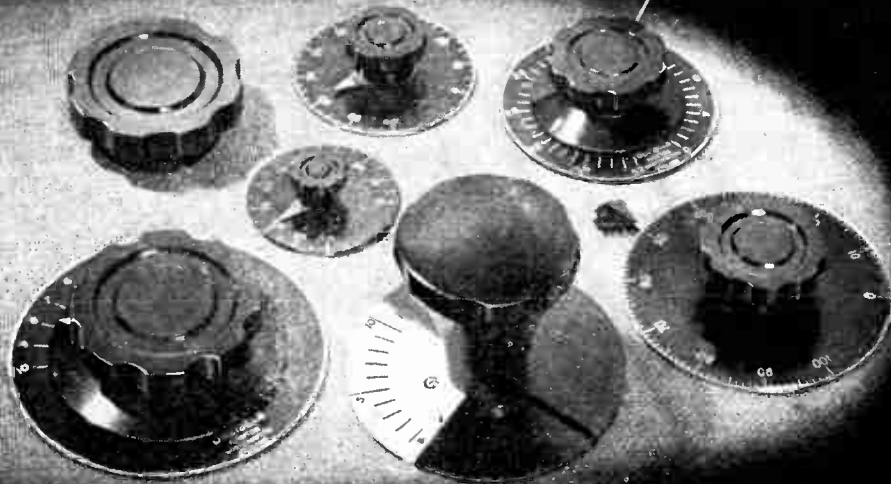

**PAINTON & CO LTD · KINGSTHORPE · NORTHAMPTON**  
 Telephone: Northampton 2820  
 Telegrams: Ceil Northampton

# Radiolympia Preview

## STAND No. 81 GRAND HALL

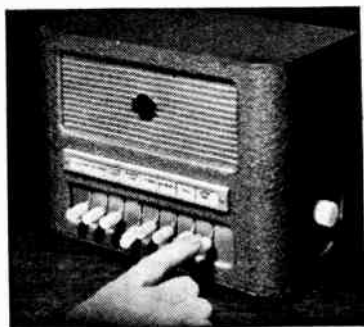

TELEMASTER INTERESTING NEW INTERCOMM. DEVELOPMENTS.

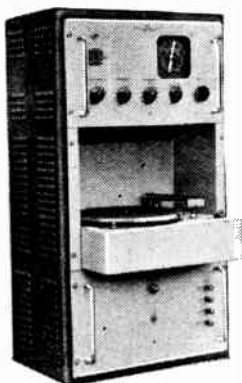

INDUSTRIAL SOUND INSTALLATIONS.



DIRECT DISK RECORDING OUTFIT. HIGH FIDELITY DISK RECORDING.

★



P.A. 20B AMPLIFIER. PORTABLE & MOBILE AMPLIFIERS.

★

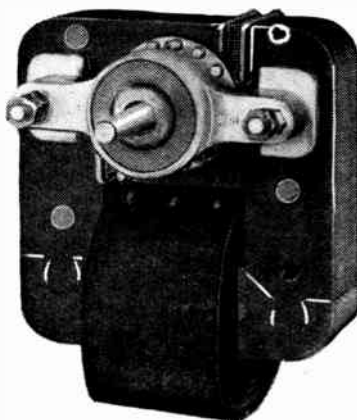

S.R. 2 MOTOR UNIT. SHADED POLE MOTORS.

★

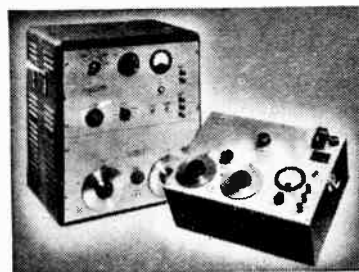

L.O.80 and L.O.50 OSCILLATORS. BEAT FREQUENCY OSCILLATORS AND LABORATORY INSTRUMENTS

★

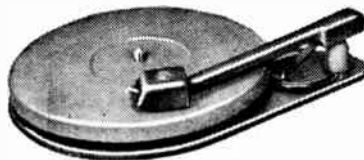

G.U.2 GRAMOPHONE UNIT.

**BIRMINGHAM SOUND REPRODUCERS LTD.,**  
CLAREMONT WORKS, OLD HILL, STAFFS. Tel.: Cradley 6212-3



MEET US AT  
**RADIOLYMPIA**  
SEPT 28 - OCT 8



# Wireless World

RADIO AND ELECTRONICS

SEPTEMBER  
1949

39th YEAR OF PUBLICATION

Proprietors : ILIFFE & SONS LTD.  
Managing Editor : HUGH S. POCKOCK, M.I.E.E.  
Editor : H. F. SMITH

Editorial, Advertising and Publishing Offices :  
DORSET HOUSE, STAMFORD STREET,  
LONDON, S.E.1.

Telephone : Waterloos 3333 (60 lines).  
Telegrams : " Echaworld, Sedist, London."

PUBLISHED MONTHLY

Price : 2/-

(Publication day : last Thursday of preceding month)

Subscription Rate : 26/- per annum. Home and Abroad

Branch Offices :

Birmingham : King Edward House, New Street, 2.  
Coventry : 8-10, Corporation Street.  
Glasgow : 26B, Renfield Street, C.2.  
Manchester : 260, Deansgate, 3.

## In This Issue

OUR COVER : Sutton Coldfield Television Aerial (See Page 357)

EDITORIAL COMMENT .. .. .	321
INTERMEDIATE FREQUENCY AND THE COPENHAGEN PLAN. By G. H. Russell .. .. .	322
VALVE MEGOHMMETER. By W. H. Cazaly .. .. .	326
DIVERSE VIEWS ON " DIVERSITY " .. .. .	329
SHORT-WAVE CONDITIONS .. .. .	330
AUDIO SIGNAL GENERATOR. By M. G. Scroggie .. .. .	331
DUAL CONCENTRIC LOUDSPEAKER .. .. .	334
TEST REPORT : EDDYSTONE MODEL 680 .. .. .	335
NORTH AMERICAN BROADCASTING. By R. H. Tanner .. .. .	339
WORLD OF WIRELESS .. .. .	341
DECCA RADAR .. .. .	345
ELECTRONIC CIRCUITRY. By J. McG. Sowerby .. .. .	346
GENERALIZED GRAPHS. By " Cathode Ray " .. .. .	349
UNBIASED. By " Free Grid " .. .. .	354
LETTERS TO THE EDITOR .. .. .	355
RANDOM RADIATIONS. By " Diallist " .. .. .	358

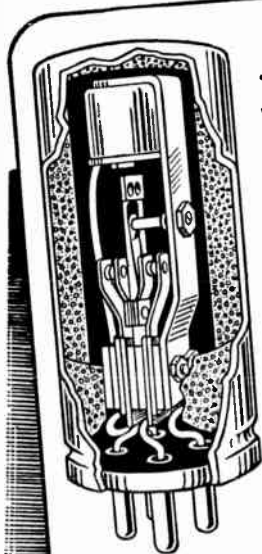

"Stratosil" fully sealed vibrators are supplied in synchronous, non-synchronous and split-reed synchronous types. Being available in both shunt and series drive (the latter being made under "OAK" patents) they offer a replacement service for the majority of American-pattern vibrators as well as covering fully the needs of the designer of new equipments.

See RADIOLYMPIA Stand 63 Grand Hall

WEARITE

## VIBRATORS

*set the standard for efficiency*

A data book, complete with replacement guide and transformer design information is now ready and will be gladly sent to you at 6d. post free. Please use the coupon.

### POST THE COUPON NOW

Wright & Weaire, Ltd., 138 Sloane Street,  
London, S.W.1, England  
Please send me VIBRATOR DATA BOOK for which  
I enclose 6d.  
Name and Address .....

WW 949

# Wright and Weaire Limited

138, SLOANE ST. · LONDON · S.W.1 TEL. SLOANE 22145 · FACTORY: SOUTH SHIELDS, CO. DURHAM

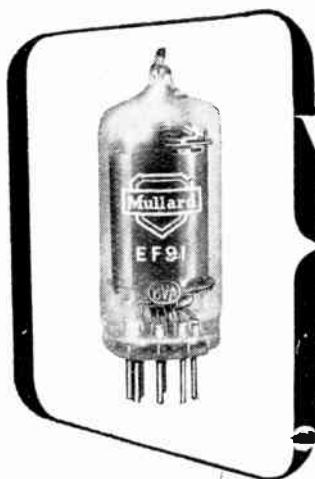

# Valves and their applications

## EF91 IN HIGH-FREQUENCY RECEIVER CIRCUITS

In high-frequency receivers, a high-slope pentode is almost indispensable. Apart from applications in audio and control circuits, it can be used successfully in R.F., I.F., mixer and

oscillator stages provided that its high-frequency performance is adequate. Although the high-slope pentode is inferior in some respects when compared with special circuits (e.g. the EC91 grounded-grid amplifier described in the March issue of *Wireless World*), in many applications, in particular when economy of valve types is desirable, the versatility of the pentode is of great value.

The EF91 is a miniature high-slope pentode on the B7G base, specifically designed for high frequencies. It has wide application in television, F.M., and V.H.F. communication receivers of all types. This article gives some of the performance data in R.F., I.F., mixer and oscillator circuits. More detailed descriptions of circuits using the EF91 will be given in future articles. The static characteristics are listed in Table 1.

TABLE 1

$V_a = 250\text{ V}$	$r_a = 1.0\text{M}\Omega$
$V_{g2} = 250\text{ V}$	$\mu_{g1-g2} = 70$
$I_a = 10\text{mA}$	$V_h = 6.3\text{ V}$
$I_{g2} = 2.5\text{mA}$	$I_h = 0.3\text{A}$
$V_{g1} = -2\text{ V}$	$C_{in} = 7.0\mu\mu\text{F}$
$g_m = 7.65\text{mA/V}$	$C_{out} = 2.0\mu\mu\text{F}$
	$C_{a-g1} < 0.008\mu\mu\text{F}$

### R.F. Amplifier

The important features of a R.F. amplifier valve are slope, input and output impedances, noise factor and feedback capacitance, since these determine the gain, bandwidth, signal-to-noise ratio and stability. It can be seen from Table 1 that the EF91 slope is high and the feedback capacitance ( $C_{a-g1}$ ) is low.

The input resistance at 50 Mc/s is 7,500 ohms and varies approximately inversely as the square of the frequency. The product of slope and input resistance is therefore unity at about 350 Mc/s. The input and output capacitances are low so that wide bandwidths can be obtained.

Due to the relatively high external noise level at frequencies less than about 60Mc/s the EF91 valve noise is relatively small. At higher frequencies, however, valve noise is important. The equivalent noise resistance of the EF91 is 1200Ω but a better measure of the noise performance is the noise factor. Figures measured at 50 Mc/s and 180 Mc/s are 2.7 (4.3dB) and 10.5 (10dB) respectively. The corresponding sensitivities, expressed as the open circuit voltages at the aerial terminals for unity signal-to-noise ratio and 200 Kc/s bandwidth are 0.8μV and 1.7μV. These figures refer to the signal-to-noise ratio as measured in front of the second detector. The signal-to-noise ratio in the output circuits

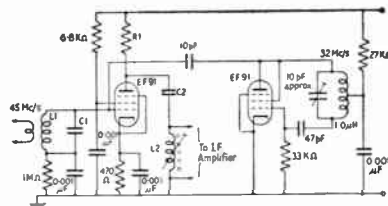

The signal frequency input circuit consists of L1 and C1. R1, C2 and L2 form the first I.F. circuit, resonant at 13 Mc/s. FIG. 1

will be considerably greater than unity if the overall bandwidth of the receiver is less than 200 Kc/s.

### Mixer and Oscillator

As a mixer the EF91 gives a conversion conductance of 3mA/V and since the input resistance as a mixer is about twice that as an amplifier, it can be used successfully in combination with an EF91 R.F. amplifier. A typical frequency-changer circuit using two EF91s as mixer and oscillator at television frequencies is shown in Figure 1. The grid to anode voltage gain of this circuit with a 3000Ω I.F. load is 9 times.

Two advantages of the EF91 mixer as compared with a triode-hexode frequency changer are its high gain and low noise level. The equivalent noise resistance is 6,500Ω and the noise factor at 45Mc/s is 10 (10dB). The mixer noise is negligible when one R.F. stage is used. To take a typical example of a receiver at 100 Mc/s with an EC91 R.F. amplifier, the EF91 mixer and subsequent stages contributed less than 1dB to the overall noise factor.

### I.F. Amplifier

In a high gain I.F. amplifier the important factors are slope and input and output capacitances. The ratio  $g_m(C_{in} + C_{out})$  is a useful figure of merit for I.F. valves, since it is a measure of the gain and bandwidth product. The figure of merit for the EF91 is higher than that for any other current high-slope pentode.



Reprints of this report from the Mullard Laboratories, may be obtained free of charge from the address below.

MULLARD ELECTRONIC PRODUCTS LTD.,  
TECHNICAL PUBLICATIONS DEPARTMENT,  
CENTURY HOUSE, SHAFESBURY AVE., W.C.2  
(MVM102)

# Wireless World

VOL. LV. NO. 9

SEPTEMBER 1949

RADIO AND ELECTRONICS

MONTHLY COMMENTARY:

## *Spreading Television*

**T**HERE has been much talk of late on extending our television service to cover more of the country, but regrettably few signs of anything that seems likely to produce rapid and tangible results. But unless something is done quickly to give us nation-wide coverage, it will be increasingly hard to convince overseas customers that this country, which was the first to inaugurate a regular television service, still has, in fact, the necessary "know how" to design and manufacture television equipment. Our present service of one station in operation and another due to open in the autumn seems insignificant alongside the almost astronomical figures given in the recently announced American allocations. Without a flourishing home industry, British television must eventually sink to a position of insignificance.

**H**OWEVER, there are a few gleams of hope. The increase of television coverage has been debated at some length in Parliament, though primarily from the somewhat limited point of view of providing Scotland with a service. We were glad to see that several Members—and Scottish ones at that—admitted the subject of the debate should have been "Television for Britain." In our view, the fundamental organization of our whole broadcasting system is such that it cannot properly be considered on a narrow regional basis. This is particularly true of television, where the linking network of radio links or r.f. cables must be integrated from the centre. Programme costs are so high that independent stations, depending entirely on their own sources of material, can hardly be expected to survive economically. It would be a pity if "pressure group" tactics were allowed to upset plans for orderly and rational development.

Although the usefulness of the debate was to some extent marred by what we may call, without

affront to Scotland, somewhat extraneous matters, one or two points of importance came to light. The Assistant Postmaster-General expressed the Government's sympathy with proposals to extend the service and went on to say that the matter was really the responsibility of the B.B.C. After the end of this year there would be no bar on the extension of television and the B.B.C. will be free to use its very considerable financial resources for this purpose. Any hopes that may have been raised by this reassuring pronouncement were somewhat dashed when the Asst. P.M.G. went on to say that restrictions on capital expenditure might cause delay, and television was regarded as being of low priority.

*Wireless World* is, of course, biased, and can think of other national activities at present flourishing which should enjoy a much lower priority. Be that as it may, it seems a pity that the start in television which we won should be lost through unwillingness to allot a trivial part of our national resources to its development.

**A** MORE cheering, though perhaps not highly significant, piece of news comes from the C.C.I.R. conference at Zurich in the shape of a report—without any details—that France has agreed to adopt the British standard of 405 lines (in place of 455 lines). It is not yet clear if this is to be an arrangement of long duration or merely an interim measure to be adopted until the proposed 819-line French standard is adopted. Either way, it is at least a step in the right direction. The burden of programme costs is a heavy one for a war-impooverished Europe, and anything that makes possible international exchanges is to be welcomed. *Wireless World* considers the British 405-line standard to be the most practical one for Europe, and we hope it is now to be given a chance of proving itself on the Continent.



# INTERMEDIATE FREQUENCY

## New and Serious Interference Problem

By G. H. RUSSELL, (Vidor Ltd.)

WHEN the new frequency allocations were published\* last year, it became apparent that the popular intermediate frequencies of 456 and 465 kc/s would no longer be suitable, as they would cause interference whistles, of the type peculiar to superheterodyne receivers, to occur on channels allocated to the B.B.C. The matter was then investigated more fully with a result which is rather startling.

The whole problem centres around the commercially produced simple superheterodyne re-

different ways, upon checking a number of different models of various manufacture it was found that only three types were liable to cause serious interference. These are (1) i.f. harmonic; (2) second channel, and (3) oscillator second harmonic. Very generalized figures of interference inputs required to produce quite annoying whistles are: second channel m.w., 20-30 $\mu$ V; second channel

wave band 525-1605 kc/s, and the large increase of aerial power permitted in many cases.

The B.B.C. have been granted the use of one long-wave channel (200 kc/s, Light Programme, Droitwich, 400 kW), and fifteen medium-wave channels, of which two are for European broadcasting (1295 kc/s, Ottringham, 150 kW, and 1340 kc/s, Crowborough, 150 kW). Another two are low power (2 kW maximum, International Common Frequency channels referred to as I.C.F. in this article). The remaining channels are to be used as shown in Table I on the opposite page.

The available band for intermediate frequency use is 300-500 kc/s, and it would obviously be a

Fig. 2. I.F. third harmonic interference: diagonal solid line represents actual i.f. and chain lines area over which whistles may be expected. Use as Fig. 1.

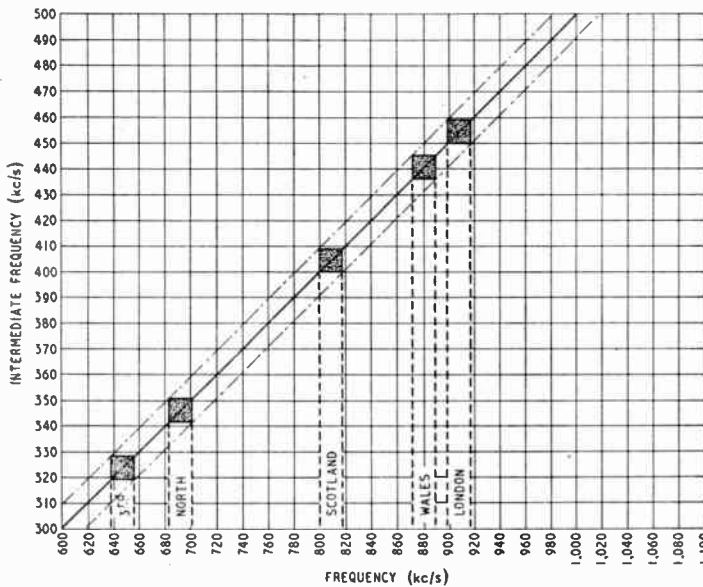
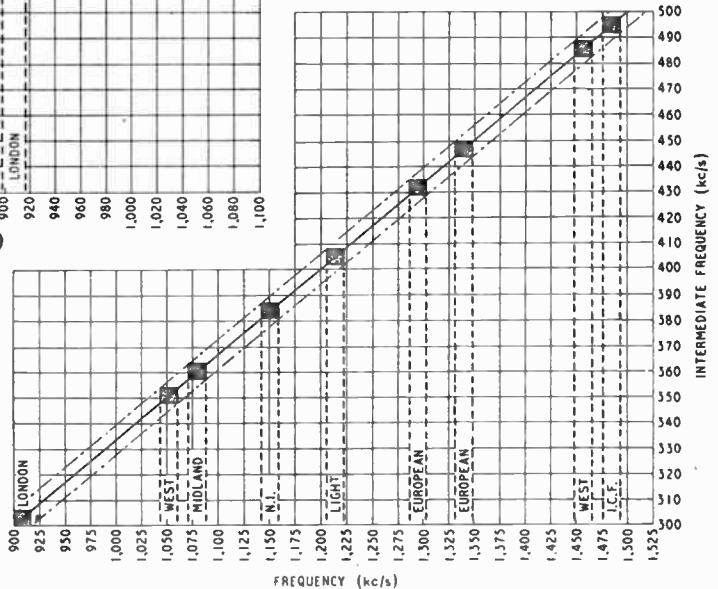

Fig. 1. I.F. second harmonic interference: diagonal solid line represents actual i.f. and chain lines area over which whistles may be expected: dotted vertical lines represent transmitter carrier plus sidebands. Any i.f. cutting across shaded position may be expected to produce whistles on that particular channel to which shaded portion refers.

ceiver with one tuned circuit between the aerial and frequency-changer which is the type used by the majority of listeners in this country to-day. Although this type of receiver is susceptible to whistles produced in a number of

l.w., 1-2 mV; oscillator second harmonic, 30-40 mV. The position will be aggravated under the plan because of the extended medium

very tedious process to work out arithmetically the effect of different intermediate frequencies on the interference possibilities be-



\* See *Wireless World*, Nov., 1948.

# AND THE COPENHAGEN PLAN

tween these sixteen channels. The problem was therefore attacked by means of the accompanying graphs, which deal with the three main causes of whistles mentioned

used in the same way; the channel interfered with is read off the vertical scale and the interfering channel read off the horizontal scale. Here again, pairs of dotted

lines whose lines cross a shaded area were to be used as the i.f. of a receiver, whistles may be expected on the vertical scale channel caused by the corresponding channel on the horizontal scale. Note that in the case of oscillator second harmonic interference, the sidebands of the interfering transmitter are  $\pm 4.5$  kc/s, and in the case of second channel interference  $\pm 9$  kc/s.

TABLE I

647 kc/s	3rd Programme	...	...	...	(Burghead, 15; Droitwich, 120; Stagshaw, 15; Westerglen, 15.)
692 kc/s	North Home Service...	...	...	...	(Moorside Edge, 150.)
809 kc/s	Scottish Home Service	...	...	...	(Burghead, 100; Dundee, 5; Redmoss, 20; Westerglen, 100.)
881 kc/s	Welsh Home Service...	...	...	...	(Aberystwyth, 5; Penmon, 20; Washford, 150; Wrexham, 5.)
908 kc/s	London Home Service	...	...	...	(Brookman's Park, 150.)
1052 kc/s	West Home Service ...	...	...	...	(Hartland Point, 10; Start Point, 150.)
1088 kc/s	Midland Home Service	...	...	...	(Droitwich, 150; Norwich, 20.)
1151 kc/s	North and Northern Ireland Home Service	...	...	...	(Carlisle, 5; Lisnagarvey, 100; Londonderry, 5; Stagshaw, 100.)
1214 kc/s	Light Programme	...	...	...	(Ayr, 5; Brookman's Park, 60; Burghead, 20; Dundee, 5; Lisnagarvey, 10; Londonderry, 1; Moorside Edge, 58; Plymouth, 2; Redmoss, 2; Redruth, 2; Stagshaw, 10; Westerglen, 50.)
1457 kc/s	West Home Service ...	...	...	...	(Bartley, 60; Clevedon, 60.)
1546 kc/s	3rd Programme	...	...	...	(London, 20; and 21 transmitters of 2 or 5 kW each serving most of the large towns.)

Figures refer to maximum aerial powers usable under the Plan.

above, and should present no difficulties when used correctly.

Figs. 1 and 2 deal with 2nd and 3rd i.f. harmonic interference respectively; the diagonal solid line should be used to determine the central frequency upon which the interference will appear, and the chain lines, the frequency band which the interference will cover.

Dotted vertical lines have already been drawn in, each pair representing one B.B.C. carrier plus its sidebands. Where these cut across the area between the chain lines, this section has been shaded in, and the intermediate frequencies which will cause whistles on any particular station can be read off the vertical scale from bottom to top of the shaded area. As an example of each, any i.f. between 449.5 and 458.5 kc/s will produce whistles on London Home Service channel, 908 kc/s, Fig. 1; any i.f. between 401.6 and 407.6 kc/s will produce whistles on Light Programme channel, 1214 kc/s, Fig. 2.

Figs. 3 and 4 deal with second channel interference appearing on long wave (140-300 kc/s) and medium wave (500 to 1,000 kc/s) respectively. Figs. 5 and 6 deal with second oscillator harmonic interference appearing on medium wave (500 to 650 kc/s) and long wave (140-300 kc/s) respectively. These last four graphs are all

lines have been drawn in to represent each carrier plus its sidebands, and, where a pair of vertical

Examples of these are as follow

Fig. 3: any i.f. between 345 and 363 kc/s will produce second channel interference on 200 kc/s Light Programme channel from 908 kc/s London Home Service transmitter.

Fig. 4: any i.f. between 337 and 355 kc/s will produce second channel interference on 647 kc/s 3rd Programme channel from 1340 kc/s European Service transmitter.

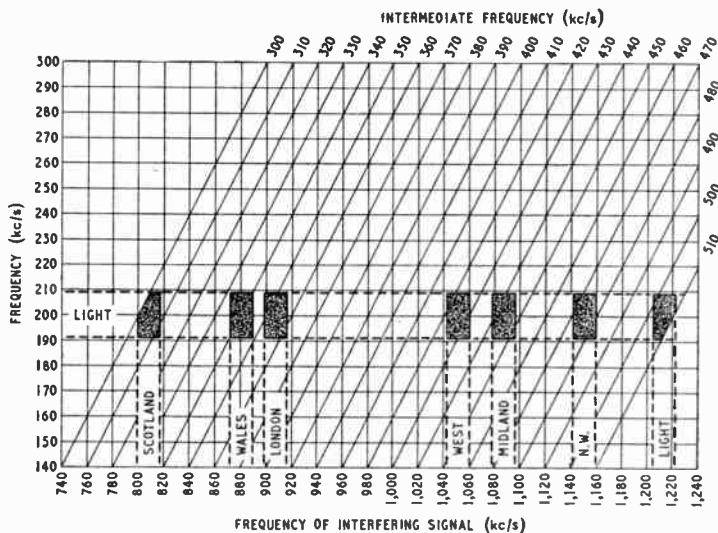

Fig. 3. Second channel interference on l.w. Dotted horizontal lines represent wanted transmitter carrier plus sidebands, dotted vertical lines unwanted signals. Any i.f. cutting across shaded position may be expected to produce interference on wanted station caused by unwanted station to which shaded position refers.

lines cross a pair of horizontal lines, that area has been shaded in. The diagonal lines represent intermediate frequencies plotted at intervals corresponding to 10 kc/s, and, if any of those frequen-

Fig. 5: any i.f. between 300 and 321 kc/s will produce oscillator second harmonic interference on 647 kc/s 3rd Programme channel from 1594 kc/s I.C.F. transmitter. (Although this is hardly likely to

**Intermediate Frequency and the Copenhagen Plan—**

occur owing to the extremely low power used on this channel, it has been used to illustrate the example).

Fig. 6 : any i.f. between 485 and 500 kc/s will produce oscillator second harmonic interference on 200 kc/s Light Programme channel from 881 kc/s Welsh Home Service transmitter.

The results obtained from these graphs were summarized and put into a table as shown in Table II below.

This table should be used in conjunction with the one giving the geographical positions and aerial powers of the transmitters referred to above, as interference between stations can only become serious where the receiver is working in the strong field of the local station (interference source), and the transmitter working on the affected channel is relatively distant.

The startling result mentioned in the first paragraph now becomes apparent. It is, that although an intermediate frequency can be found that will give reasonable freedom from whistles on local stations in any one part of the

country there is no i.f. that will do this for the whole country. Furthermore, this does not take

There are, of course, methods of overcoming this state of affairs: (1) by improved pre-selection.

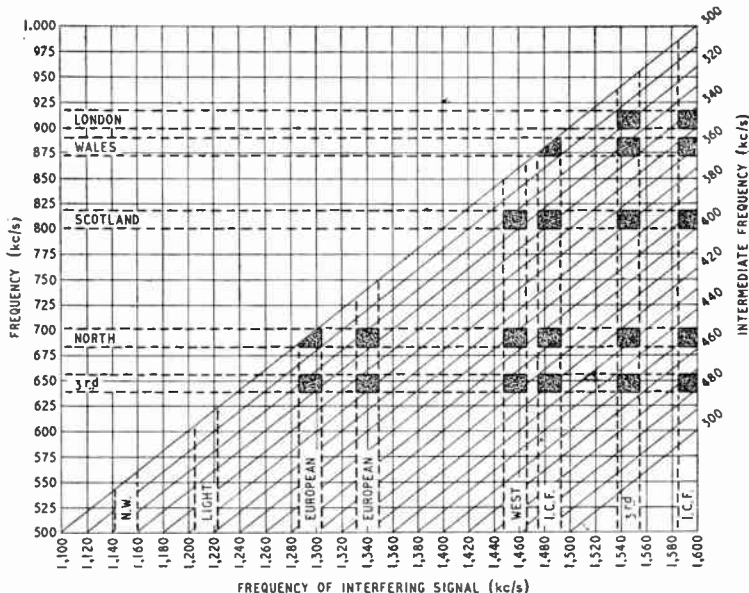

Fig. 4. Second channel interference on m.w. Use as Fig. 3.

into account any interference that might be caused by powerful continental stations close to Great Britain.

(2) by using a higher i.f. (e.g., 2.1 Mc/s) or (3) by breaking away from the superheterodyne and using a t.r.f. or Synchrodyne type of receiver. From a manufacturer's point of view these must all be rejected: (1) because of cost, (2) because the higher i.f. would cause selectivity troubles, making it imperative to use more tuned circuits which would therefore involve higher costs again, and (3) because for many years to come the superheterodyne will be the first favourite of users, on the grounds of its cheapness, sensitivity, selectivity and ease of handling.

TABLE II

Intermediate Frequencies Eliminated (kc/s)	Channel Affected	Interference Source	Cause
300—305.6	908 kc/s (London)	—	I.F. 3rd harmonic
300—313	200 kc/s (Light)	809 kc/s (Scotland)	2nd channel
300—315	200 kc/s (Light)	692 kc/s (North)	Osc. 2nd harmonic
300—310	692 kc/s (North)	1295 kc/s (European)	2nd channel
310—327	908 kc/s (London)	1546 kc/s (3rd)	2nd channel
319—328	647 kc/s (3rd)	—	I.F. 2nd harmonic
315—333	809 kc/s (Scotland)	1457 kc/s (West)	2nd channel
		647 kc/s (3rd)	2nd channel
323—340	881 kc/s (Wales)	1295 kc/s (European)	2nd channel
		1340 kc/s (European)	2nd channel
332—350	200 kc/s (Light)	1546 kc/s (3rd)	2nd channel
341.5—350.5	692 kc/s (North)	881 kc/s (Wales)	2nd channel
337—355	647 kc/s (3rd)	—	I.F. 2nd harmonic
347.6—353.6	1052 kc/s (West)	1340 kc/s (European)	2nd channel
345—363	200 kc/s (Light)	—	I.F. 3rd harmonic
359.6—365.6	1088 kc/s (Midland)	908 kc/s (London)	2nd channel
359—377	809 kc/s (Scotland)	1546 kc/s (3rd)	I.F. 3rd harmonic
373—390	692 kc/s (North)	1457 kc/s (West)	2nd channel
380.6—386.6	1151 kc/s (N.W. and N.I.)	809 kc/s (Scotland)	I.F. 3rd harmonic
385—430	200 kc/s (Light)	—	Osc. 2nd harmonic
400—409	809 kc/s (Scotland)	—	I.F. 2nd harmonic
395—413	647 kc/s (3rd)	1457 kc/s (West)	2nd channel
401.6—407.6	1214 kc/s (Light)	—	I.F. 3rd harmonic
417—430	692 kc/s (North)	1546 kc/s (3rd)	2nd channel
417—435	200 kc/s (Light)	1052 kc/s (West)	2nd channel
428.6—434.6	1295 kc/s (European)	—	I.F. 3rd harmonic
436—445	881 kc/s (Wales)	—	I.F. 2nd harmonic
434—452	200 kc/s (Light)	1088 kc/s (Midland)	2nd channel
443.6—449.6	1340 kc/s (European)	—	I.F. 3rd harmonic
440—458	647 kc/s (3rd)	1546 kc/s (3rd)	2nd channel
449.5—458.6	908 kc/s (London)	—	I.F. 2nd harmonic
453—500	200 kc/s (Light)	881 kc/s (Wales)	Osc. 2nd harmonic
465—485	200 kc/s (Light)	1151 kc/s (N.W. and N.I.)	2nd channel
482.6—488.6	1457 kc/s (West)	—	I.F. 3rd harmonic
485—500	200 kc/s (Light)	908 kc/s (London)	Osc. 2nd harmonic
491.6—497.6	1484 kc/s (I.C.F.)	—	I.F. 3rd harmonic
497—500	200 kc/s (Light)	1214 kc/s (Light)	2nd channel

**A Solution**

The writer favours a solution, which unfortunately seems doomed from the start because of all sorts of obscure reasons, such as tradition, prestige, a "status quo" attitude of mind, international agreements and even possibly foreign policy! This solution is, that the Light Programme transmitter be taken off the long waveband and moved to (say) the 647-kc/s channel. One European Service station is moved to take the place of the Light Programme on 200 kc/s, thus leaving a vacant channel on 1295 kc/s, which would



make it possible for all the transmitters below this frequency to move progressively upwards: e.g., 3rd Programme to 692 kc/s, Northern Home Service to 809 kc/s, etc. The disadvantage of doing this would be to reduce the non-fading area of the Light Programme transmitter from about 400 miles radius to some 120 miles.

The advantages are well worth consideration; dispensing with home broadcasting on long waves would be a good opportunity to commence a gradual process of elimination of the long waveband from our receivers. This would enable cheap single-waveband receivers to be produced,

any chance of oscillator radiation causing interference with neighbouring receivers. For example, the oscillator of a receiver using an i.f. of 467 kc/s and tuned to 692 kc/s would radiate a signal on 1159 kc/s, so causing an 8-kc/s beat note to be heard on a neighbouring receiver tuned to 1151 kc/s. An i.f. of 475 kc/s would probably be the safest choice. The alternative seems to be the outrageous proposition, which has been made in certain quarters, that receivers should be manufactured with different intermediate frequencies for

668-kc/s Northern Home Service transmitter. The first must be rejected on the grounds that it is obviously not a commercial proposition, and the second because the alternative intermediate frequencies for different areas would probably be too widely separated to be covered by a conventional i.f. transformer. Furthermore, it is hardly desirable that new receivers should be interfered with. Even if these difficulties could be overcome, it would still be a rather awkward process, as a very different i.f. would require different padding condensers in the oscillator circuit; this is too ridiculous to contemplate under mass-production conditions.

The Copenhagen Plan appears to have been based on political expediency, rather than technical necessity, and as such is a failure. Already, seven countries have denounced the Plan, and will therefore not abide by it; seventeen have made reservations regarding it and two have been allocated frequencies without even having representatives at the Conference. It is doubtful whether the Plan can be amended at this late stage, but we should at least try

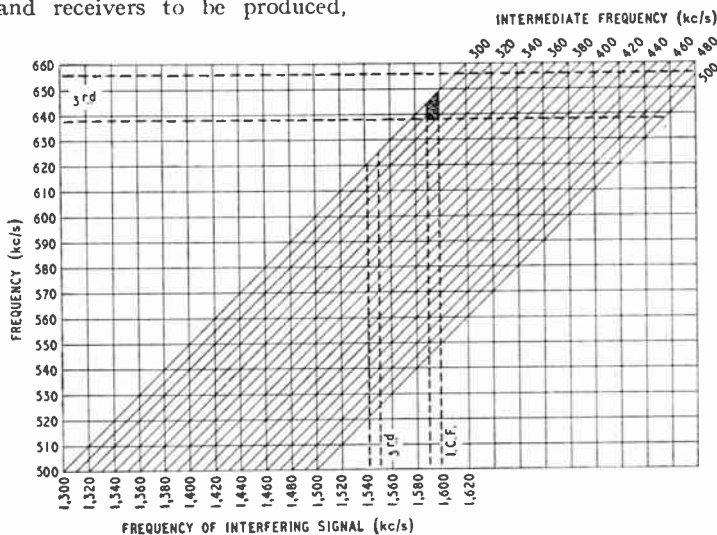

Fig. 5. Oscillator second harmonic interference on m.w. Use as Figs. 3 and 4.

or alternatively the cost saved could be put into making receivers with either improved pre-selection or improved audio stages. The problem of coverage is not insurmountable, as more low-power synchronized transmitters placed at strategic points could make up for any deficiencies. Our broadcasting system has always been based on the 200-kc/s transmitter, but there is no need for it to continue to do so. After all, the Americans have got on very well without the long waves, and they probably get fewer complaints regarding fading than we do.

Should this suggestion be adopted, it would allow any i.f. between 467 and 478 kc/s to be used with confidence, although care should be taken to minimize

different areas, or that the i.f. should be altered by the retailer concerned, as is done at present in certain areas served by the

to attain as good a broadcasting service in this country as possible, without placing the burden on the manufacturers.

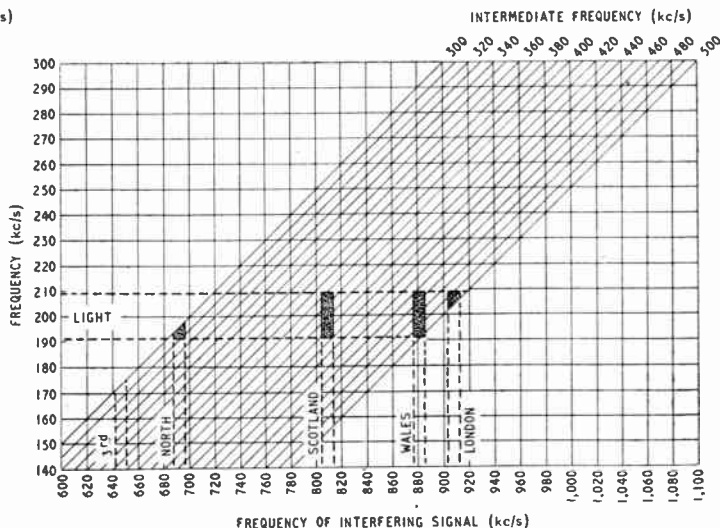

Fig. 6. Oscillator second harmonic interference on l.w. Use as Figs. 3, 4 and 5.

# VALVE MEGOHMMETER

Linear Scale : Readings Independent of Battery Voltages

By W. H. CAZALY

**M**EASUREMENT of resistance to an accuracy of, say, 2 or 3 per cent. over the range of 5,000 ohms to 5 megohms, which includes most of the values met with in radio apparatus, presents certain difficulties that are not satisfactorily overcome in simple self-contained instruments having one or more resistance measuring ranges. There is not room in the cases of such instruments for high-voltage batteries; nor, normally, is the basic indicator sufficiently sensitive to give clear-cut indications of high resistance values over more than half the scale, the shape of which is extremely non-linear. It is true that most resistance values specified are of wide tolerance (e.g. 20%), but occasions are becoming more frequent when close approximations are desirable.

There are three possibilities. One is to employ in a separate ohmmeter the almost standard circuit now in use in most multi-range test instruments, but to incorporate a very sensitive indicator (say a 100 micro-amp. meter) and a battery up to 100 volts. However, the grave objection remains of extreme non-linearity of scale shape, and such an instrument gives only rough indications over the bottom half of the scale—the region of indication of the highest values, which is most needed. A second possibility is to use a bridge. This requires a very sensitive galvanometer for balance indications, and either a very accurate potentiometer of wire-wound high-resistance construction, or an accurate high-resistance box and ratio arms and a fairly high energizing voltage, together with reasonably skilled operation. It is good for laboratory use but is not very suitable for general purpose workshop measurements and fault tracing. The third possibility is to employ a true potentiometer circuit with a high-impedance valve-operated indica-

tor, on the lines of a recent article.\*

As will be shown, such an instrument can be designed to have practically linear scale shape, to be very simple to operate, and to be light, portable and easily maintained in good order. The order of accuracy that can be expected is about 2% and is dependent only on the accuracy of construction of the potentiometer circuit; it is independent of energizing voltage variations within wide limits and of changes in valve characteristics. Indication is given by any uncalibrated milliammeter of up to about 2 or 3 mA full scale deflection, or a centre-zero indicator of similar sensitivity.

### Potential Divider

Application of the principle involved is shown in basic form in Fig. 1(a). If a voltage  $V_1$  is applied across  $R_1$  and  $R_2$  in series, then

$$\frac{R_2}{R_1 + R_2} = V_2/V_1$$

If the ratio  $V_2/V_1$  is kept con-

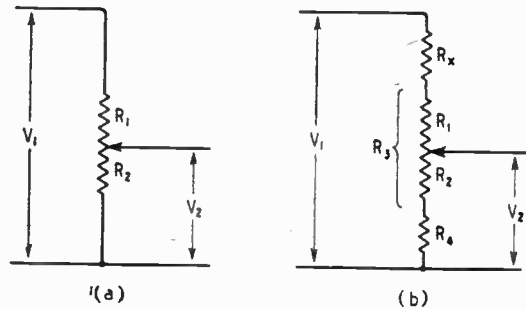

Fig. 1. Basic potentiometer circuit.

stant, any increase of  $R_1$  must be accompanied by an increase of  $R_2$ . The value of  $R_2$  is thus a measure of the value of  $R_1$ .

In Fig. 1(b), the voltage  $V_1$  is applied across a potentiometer circuit consisting of a resistance under test,  $R_x$ , in series with a potentiometer  $R_3$  and a fixed resistance  $R_4$ . The portion of  $R_3$

above the slider is called  $R_1$  and the portion below it  $R_2$ . The ratio  $V_2/V_1$  is a constant, let us call it  $a$ . Then

$$\frac{R_2 + R_4}{R_x + R_3 + R_4} = a$$

and

$$R_2 = a(R_x + R_3 + R_4) - R_4 \tag{1}$$

Thus  $R_2$  is a linear function of  $R_x$  when  $a$ ,  $R_3$  and  $R_4$  are constants. When  $R_x = 0$  and  $R_2 = 0$ —i.e., when the test resistance is zero and the slider on  $R_3$  is at the bottom of  $R_3$ , or the top of  $R_4$ —

$$a(R_3 + R_4) = R_4$$

$$aR_3 = R_4 - aR_4$$

$$R_4(1 - a) = aR_3$$

$$R_4 = \frac{aR_3}{1 - a}$$

Dividing top and bottom of the right-hand side of the equation by  $a$ , we have

$$R_4 = \frac{R_3}{1/a - 1} \dots \tag{2}$$

When the slider on  $R_3$ ,  $R_2 = R_3$ . We then have, from (1)

$$R_x = \frac{(R_3 + R_4)(1 - a)}{a} \tag{3}$$

The complete circuit diagram of a practical form of the megohmmeter is given in Fig. 2. A mains-driven version is of course possible; furthermore, the use of alternating energizing voltage opens possibilities of employing

the device for the measurement of reactance and impedance as well as resistance. Confining the discussion, however, to the use of the device for measuring high resistance, it is probably more convenient to construct in battery form, unless the instrument is likely to be in very frequent use—as it might be in a service department. Since the h.t. voltage required is from 45 V to 100 V,

\* "Electronic Megohmmeters," by H. G. M. Spratt, *Wireless World*, Oct. 1948.

and, by the use of the press switches  $S_1, S_2$ , current is passed only during actual setting up or measurement (and, by this means, cannot be left on inadvertently), it is feasible to make it self-contained and quite portable.

Provision is made for two ranges of measurement, range 1 giving indications of the value of the test resistance  $R_X$  between about 50 k $\Omega$  and 5 M $\Omega$ , and range 2 between 5 k $\Omega$  and 0.5 M $\Omega$ . By making  $R_5$  a 0.5 M $\Omega$  potentiometer, and employing a 5050  $\Omega$  fixed resistor in place of  $R_7$ , and  $R_8$ , a very high range up to 50 M $\Omega$  could be provided. Difficulties in obtaining a potentiometer of 0.5 M $\Omega$  with an accurately linear characteristic would have to be overcome. However, the two ranges shown are readily obtained by means of the ganged switches  $S_4, S_5$ , which alter the values of the potentiometer section.

The only components of which the values are critical are  $R_6, R_7$  and  $R_8$ . In the circuit shown, the value of  $R_5$ , on which the others depend, is given as 50 k $\Omega$ ; but by the use of equation (2), the value of  $R_7 + R_8$  can be calculated for any value of  $R_5$ ; all other resistors can be chosen to within the usual "preferred" 20% tolerance. Nor is the choice of valve very critical; almost any fairly high mutual conductance triode or pentode passing up to a couple of milliamperes with zero grid bias and having a straight  $I_a/V_g$  characteristic between 0 and -1V is suitable. The calibration of the milliammeter is unimportant, since it serves only as an indicator of a fixed arbitrary value of anode current. Such wide latitude in the choice of most of the components renders the instrument easy and cheap to construct.

The pilot lamp, which should be rated at 2.5 volts with 0.1 amp. passing (assuming that the valve filament current is 0.1 amp.), serves mainly as a barretter and also very roughly indicates the condition of the l.t. valve filament battery, which here is 4.5 volts and may consist of the usual large 3-cell flash-lamp type. The h.t. battery, if composed of either one or two small 45-volt h.t. battery units such as are used in hearing aids, can be conveniently housed inside the case, rendering the

instrument entirely self-contained. The internal resistance of the battery is not likely to be high enough appreciably to affect indication accuracy, even near the end of its life, but it may be found that as it approaches exhaustion there is a tendency for the indication on the meter to drift; this is seldom likely to be troublesome over at least half the battery life, and its only effect is to make it desirable to reset the instrument for zero  $R_X$  from time to time during a series of measurements.

Of the switches,  $S_3$  must be of a type with extremely high open-circuit resistance. It is a press-to-close type and can be made

the grid resistance and capacitance,  $R_g$  and  $C$ , is partly to reduce erratic noise voltages and partly to avoid heavy grid current if the switches  $S_1, S_2$  and  $S_3$  are inadvertently pressed while the slider of the potentiometer is at the high end of the scale or near it.

### Design Procedure

It is possible to calculate the essential circuit constants and ranges obtainable for any special purposes by means of equations (2) and (3). Design starts with the choice of  $R_5$  potentiometer resistance, and of the constant  $a$ . The higher the value of  $R_5$  and the lower the ratio  $a$ , the higher

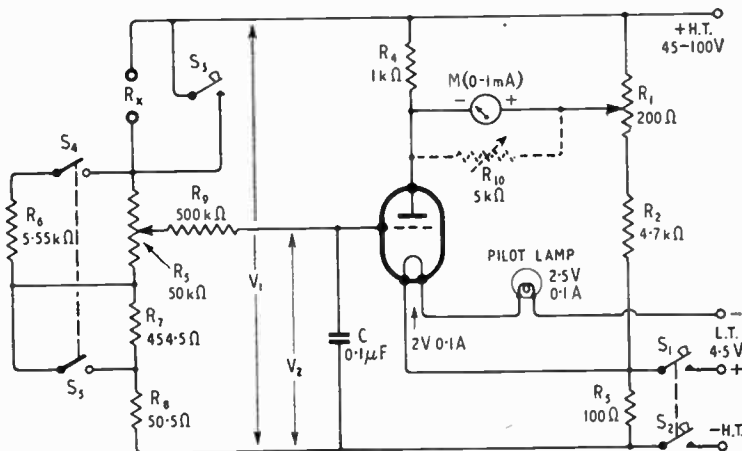

Fig. 2. Circuit diagram of practical instrument with two ranges.

easily enough out of hardened brass strips mounted on some very good insulant such as Perspex, Permalin, etc. The test resistance terminals must themselves be very well insulated. The operation switches  $S_1$  and  $S_2$  are again press-to-close types, ganged, but they need be of no exceptional insulation.  $S_4, S_5$  are normal ganged wafer type switches of good quality, usually obtainable on a single wafer.

The function of the bleeder chain  $R_1$  to  $R_3$  is to provide backing-off voltage for the meter and bias for the valve grid. The values of  $R_1$  and  $R_3$  depend to a large extent on the valve characteristics, but the values shown are typical for a small battery triode. This chain of resistors has to pass about 20 mA with 100 volt h.t., and should therefore be constructed of elements of suitable wattage rating. The function of

the maximum resistance that can be measured. The value of the fixed resistors  $R_7 + R_8$  is obtained by using equation (2). The maximum resistance that can be indicated on the scale of the potentiometer is found from equation (3). Then, by dividing the angle of effective rotation of the potentiometer slider by the maximum resistance, the number of degrees per megohm or kilohm can be found and the scale appropriately divided. Such a scale, with a maximum at 5 M $\Omega$ , for a potentiometer with a 270° angle of slider rotation—54° per megohm—is shown in Fig. 3.

For example, in Fig. 2,  $R_5$ , corresponding with  $R_3$  in equation (2), is 50 k $\Omega$ . The constant  $a$  is 1/100. Then, from equation (2),  $R_4 = 505 \Omega$ . The maximum indicated resistance is found from equation (3) . . .  $R_X = 5 \text{ M}\Omega$ .

On range 2, which must follow



**Valve Megohmmeter—**

the same law as range 1 in order to employ the same scale with a  $\div 10$  factor,  $R_5$  must be replaced by some value which will keep the ratio  $\alpha$  constant at  $1/100$ . It would be possible to employ change-over switching to bring a second potentiometer of 5000 ohms into circuit to replace the existing  $R_5$  of 50 k $\Omega$ . It is simpler, however, to place  $R_6$  in parallel with  $R_5$ , so that the parallel combination of  $R_5$  and  $R_6$  comes to 5000 ohms. Similarly, by making the equivalent of  $R_4$  in equation (2) in the form of the two resistors  $R_7$  and  $R_8$ , of the values shown, the correct ratio of resistances and voltages to make  $\alpha$  constant at  $1/100$  can be obtained by shorting  $R_7$ .

**Zero Setting and Operation**

The function of the indicator is solely to indicate when  $\alpha$  the constant ratio  $V_2/V_1$ , is present. This ratio is always present, regardless of the value of the energizing voltage  $V_1$ , when the slider on  $R_5$  is at the bottom,  $R_X = 0$ , end. Obtaining an indication on the meter M, therefore with the test leads shorted (making  $R_X = 0$ ) and the  $R_5$  slider at the zero end of the scale provides a standard indication on the meter M which shows when the ratio  $\alpha = 1/100$  is present. The instrument is set up as follows:—

(1) The potentiometer slider is moved to the zero end of the scale.

(2) Switches  $S_1$ ,  $S_2$  and  $S_3$  are simultaneously closed. (These two press switches can be placed close together alongside each other on the panel, so that two adjacent figures can close them simultaneously.)

(3) The slider on  $R_1$  is then adjusted until some convenient deflection—say mid-scale deflection—is shown on the meter M.

$S_1$ ,  $S_2$  and  $S_3$  can then be released and the instrument is ready for use in measurements. The resistance under test is connected across the  $R_X$  terminals. Then  $S_1$ ,  $S_2$  alone is pressed and  $R_5$  adjusted until the meter indication obtained in operation (3) is obtained.

Discrimination—i.e., the ability of the indicator to show clearly different indications for two adjacent settings of the pointer on

scale—is depended partly on the magnitude of the energizing voltage and partly on the sensitivity of the indicating meter M. The higher the energizing voltage, the greater the volt drop per degree across the potentiometer scale and hence the greater the

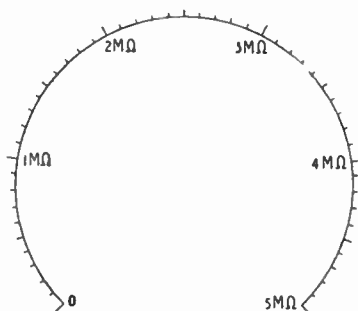

Fig. 3. Typical scale division— $54^\circ$  per megohm with  $270^\circ$  total rotation.

effect of movements of the pointer in varying grid voltage and hence anode current. A high-slope valve is desirable. The more sensitive the indicating meter M, the more its indications will be affected by changes of grid potential. A 0 — 1 mA meter is normally satisfactory, but considerably higher accuracy can be obtained by the use of a microammeter with full scale deflection of about 200  $\mu$ A. The main disadvantage of using so sensitive an indicator lies in the possibility of damaging it by excessive current due to widely incorrect settings of the backing-off slider on  $R_1$ . This can be avoided by the use of a variable shunt,  $R_{10}$ , across the microammeter, which is shown as an optional feature.

**“WILLIAMSON” AMPLIFIER: NEW VERSION**

THE second part of this article, which deals with the design of a preamplifier and tone compensating circuits, is unavoidably held over until a later issue.

Several readers have enquired about  $R_{12}$  (page 284, col. 2 of previous issue). This was a signal balancing potentiometer between  $R_{11}$  and  $R_{13}$  in the original circuit, to which the notes on signal balancing refer. In the new version the question of signal balancing does not arise.

In the list of components below Fig 1 (p. 282), the values of  $R_{23}$  and  $R_{24}$  were omitted. In the original design they were each 100 $\Omega$ ,  $\frac{1}{4}$ W,  $\pm 20\%$ .

**MOTOR CYCLE RADIO**

*F.M. Communication Equipment with Calling Facilities*

A COMPACT v.h.f. radiotelephone weighing under 20 lb and designed for use on a motor cycle, small car or other vehicle, where space, weight and economy of operation are essential qualities, has been introduced by E. K. Cole, Ltd., Southend-on-Sea, Essex. It operates in the 65- to 100-Mc/s band, and like all mobile equipment of this kind is remotely controlled and sends and receives on pre-set spot frequencies using crystal-stabilized transmitter and receiver.

In the case of this new Ekco set (type CE39), special care has been taken to keep the battery consumption as low as possible and this may be one reason for the choice of frequency modulation, as this system avoids the need for relatively high-power modulating equipment. The receiver alone consumes 18 watts, on stand-by with the transmitter valves alight 30 watts, and when transmitting 55 watts with a 6-volt supply and 80 watts with 12 or 24 volts.

The r.f. output is 5 watts with 6-volt operation and 10 watts with 12 or 24 volts. In addition an audio output of about 0.5 watt is available for a small P.A. loud-speaker or intercommunication telephones. Provision is also made for



Ekco mobile f.m. transmitter and receiver fitted to a motor cycle.

calling a fixed station and different tones can be used as a means of identification; these range from 300 to 3,000 c/s.

The range of the equipment is difficult to assess as it is governed by the height of the fixed station aerial and power and to a lesser extent on the location of the mobile unit. A conservative estimate is from 10 to 30 miles.

THE article published in your July issue on "Diversity F.M. Transmission" gives the impression that the scheme described is a direct f.m. equivalent of the multi-carrier a.m. scheme and one which offers certain advantages over it, especially in economy of frequencies. I would suggest that the scheme as described offers no economy of frequency requirement and indeed will occupy more frequency space than the equivalent multi-carrier a.m. system. It has, moreover, a number of important disadvantages rendering it difficult to engineer and incapable of wide application.

The scheme described is a synchronous one and suffers from two important disadvantages common to all synchronous schemes, a.m. or f.m. First, means must be found to synchronize the transmitters and secondly, standing waves are created between the transmitters. By using the multi-carrier a.m. system, synchronism is avoided and the fields from the different transmitters assist each other. Inherently better coverage is therefore obtained. It is pertinent to observe that in attempting to engineer multi-station f.m. schemes, synchronism is not employed from choice but because multi-carrier f.m. is impracticable.

### Interaction

The article implies that interaction due to standing waves was negligible over the route chosen for test. Under the conditions described this is only to be expected. The area under test was a heavily built-up one (London). The three stations were sited almost in a straight line. Further, high ground exists between the master station and each satellite. I can imagine few sets of conditions less likely to show the effects of standing waves between synchronized v.h.f. transmitters. The results over open country, river, sea and in the air are likely to be very different. In this connection it should be pointed out that in testing the multi-carrier a.m. system, care was taken to select areas where interaction would be typical of maximum.

It was also unfortunate that the demonstration should have de-

# DIVERSE VIEWS ON "DIVERSITY"

## New Aspects of the F.M./A.M. Controversy

ended on so simple and so convenient, but in practice so unlikely, a relationship as 3 to 2 between link and carrier frequencies. The Home Office is the only authority in this country to be favoured by the provision of radio frequencies for links between fixed stations in a multi-station scheme. So long as the G.P.O. maintain their present policy in this direction, the majority of multi-station schemes in this country will have to employ telephone line linkage. The f.m. scheme described would, of course, be quite impracticable on such a basis. There is no known f.m. equivalent, for example, to the multi-carrier a.m. schemes now being installed by the Ministry of Civil Aviation using line linkage.

Even to users such as the Home Office, who use radio linkage, a 3 to 2 relationship would be quite impracticable since to synchronize carriers in the range 95-100 Mc/s a linkage band 7.5 Mc/s wide would be required. By using a.m. throughout, linkage is practicable in a band only 1 Mc/s wide.

It may be argued that by employing many other multiplication factors the 7.5 Mc/s band could be reduced. I, for one, would have to be convinced that this would not lead to very involved electrical multiplication systems, different for every scheme and inflexible to alteration of frequency. It would also lead to very low crystal frequencies with the attendant danger of spurious radiation from unwanted crystal harmonics.

The article also implies that because two particular a.m. multi-carrier schemes used more frequencies than the f.m. scheme described, the latter offers economy in frequency allocation. Both these a.m. schemes, however, gave additional facilities not provided by the f.m. scheme. The

first had an additional link from the control point to the master station and the second gave duplex facilities. In any case, merely counting carrier frequencies used does not assess the merits of a scheme in this direction. For example, the G.P.O. allocate two frequencies (one sending, one receiving) to many schemes where a single frequency would serve, because an overall economy results from double-frequency allocation.

### Bandwidth Requirements

An a.m. scheme to perform an equivalent function to the f.m. scheme described would use the same number of link frequencies. It could equally well use the same channel for transmission to and from mobiles. A three-station a.m. scheme need use no more bandwidth for the channel transmitting to the mobiles and could use less channel width on the links and on the channel from the mobiles. Even on the outgoing channel the f.m. scheme will radiate sidebands to approximately  $\pm 15$  kc/s from all three stations. From every aspect, therefore, the f.m. scheme radiates more *total* ether disturbance than the a.m. scheme.

I, therefore, conclude that the f.m. scheme described is inferior to a multi-carrier a.m. scheme in the following respects. First, since it is a synchronous scheme it creates standing wave patterns between transmitters which must degrade coverage. Second, it has not provided a simple and flexible means of achieving synchronism. Third, it uses more total bandwidth than is required by multi-carrier a.m. scheme. While not wishing to discredit the work of the engineers who were responsible for the demonstration, it appears to me that a great deal of trouble has been taken in an

"Diverse Views on Diversity"—attempt to use f.m. to achieve an object which is more satisfactorily and more simply obtainable by a.m. J. R. BRINKLEY  
(Pye Radio Works, Cambridge).

### F.M. SPONSORS' REPLY

WITH reference to J. R. Brinkley's communication discussing various points raised with regard to your recent article on diversity f.m. transmission, it would appear that he has not appreciated that the demonstrations you described were primarily aimed at evaluating the importance of the standing wave patterns which must be created when two or more transmitters operate on identical frequencies.

In reference to his suggestion that the conditions were particularly unfavourable for showing the effect of standing waves, it should be clear that wherever there is continuous coverage between two transmitters, standing waves exist. The results in the tests witnessed were no different from those encountered when similar transmitters have been installed in other areas, including more open country, and during the tests demonstrations were carried out in the areas of equal signal

strength where any effects would be at their maximum. It is not claimed that standing waves are not likely to occur but simply that the small amount of distortion which can be detected is not important, and the number of technical people witnessing the demonstration appeared to agree with this.

With regard to the efficient use of the frequency spectrum, only two points appear to arise. First, that in the system demonstrated the frequency spectrum used for the main transmissions to cars is not more than that required for the operation of a single transmitter, and that the receiver bandwidth need only be such as to receive a single transmission and, therefore, give the best possible signal-to-noise ratio at all times while leaving adjacent channels free for other services.

Secondly, in all cases where a radio link is required between the main station and its satellites, this link simultaneously provides the synchronised signal and the required modulation. In such circumstances only a minimum number of operated frequencies would appear to be involved.

N. R. BLIGH

G.E.C. Research Laboratories,  
Wembley.

## SHORT-WAVE CONDITIONS

### July in Retrospect: Forecast for September

By T. W. BENNINGTON and L. J. PRECHNER (Engineering Division, B.S.C.)

DURING July the average maximum usable frequencies for these latitudes were slightly lower than during June, both by day and by night. Daytime working frequencies were therefore relatively low—except for north/south paths—and those for night-time relatively high. Daytime communication in the 28-Mc/s band was, for example, very infrequent, except on a few southerly circuits. At night the use of frequencies below about 11 Mc/s was seldom necessary.

The average sunspot activity, which, since 1947, has been fluctuating slightly about a very high value, is now showing a more decided tendency to decrease, so it may be anticipated, though not with complete confidence, that generally lower frequencies will be workable during the coming autumn and winter than was the case during those seasons last year.

During July a very considerable amount of Sporadic E occurred, and medium-distance communication on very high frequencies by way of this medium was frequently possible.

July was an exceptionally "quiet" month, and only two ionospheric storms of minor intensity occurred (during the periods 13th/14th and 17th/19th). "Dellinger" fadeouts were reported as occurring at 0635 on 11th, 0919 on 25th, 1227 on 27th, 1120 on 28th, 1415 on 29th, 0730 on 30th, and 0830 and 1507 on 31st.

Long-range tropospheric propagation does not appear to have been so prevalent as might have been expected having regard to the anticyclonic weather conditions which prevailed during most of the month, though some of it did occur occasionally.

**Forecast.**—During September the Northern Hemisphere seasonal

effect will tend to cause a considerable increase in the daytime m.u.f.s, though this may be somewhat modified by the decrease in sunspot activity. On the whole it may be anticipated that daytime m.u.f.s will be appreciably higher and night-time m.u.f.s considerably lower, than during August.

Working frequencies for long-distance transmission paths should therefore be relatively high by day, and the higher frequencies—like 28 Mc/s—should be usable in most directions from this country. Night-time working frequencies should be such that 11 Mc/s will be about the highest usable for regular communication and considerably lower ones will be necessary on some circuits. For distances up to about 1,800 miles the E and F<sub>1</sub> layers should continue to control transmission for a few hours around noon only.

Sporadic E is likely to occur less often, though some medium-distance communication on high frequencies may still be effected by way of this medium.

Below are given, in terms of the broadcast bands, the working frequencies which should be regularly usable during September for four long-distance circuits, running in different directions from this country. (All times in this report are G.M.T.) In addition, a figure in brackets indicates the highest frequency likely to be usable for about 25 per cent of the time.

<b>Montreal :</b>	0000	11Mc/s	(16Mc/s)
	0100	9 "	(13 " )
	0900	11 "	(16 " )
	1000	15 "	(20 " )
	1200	17 "	(25 " )
	2100	15 "	(19 " )
2300	11 "	(17 " )	
<b>Buenos Aires :</b>	0000	11Mc/s	(16Mc/s)
	0800	15 " or 17Mc/s	(21 " )
	1000	21 "	(30 " )
	1500	26 "	(34 " )
	1800	21 "	(30 " )
	2000	17 "	(24 " )
	2200	15 "	(22 " )
	2300	11 "	(20 " )
<b>Cape Town :</b>	0000	11Mc/s	(18Mc/s)
	0500	17 "	(22 " )
	0800	21 "	(30 " )
	0800	26 "	(36 " )
	1600	21 "	(30 " )
	2000	17 "	(23 " )
	2200	15 "	(20 " )
<b>Chungking:</b>	0000	7Mc/s	(13Mc/s)
	0100	9 "	(14 " )
	0300	11 " or 15Mc/s	(17 " )
	0500	17 "	(27 " )
	1600	15 "	(22 " )
	1800	11 "	(16 " )
	2100	9 "	(14 " )
	2300	7 "	(13 " )

There is usually an increase in the amount of ionospheric storminess during September, and periods of poor short-wave communication must be anticipated. At the time of writing it would appear that disturbances are most likely to occur during the periods 5th/6th, 9th/11th, and 26th/27th.



**1R5**  
Heptode Frequency  
Changer

**1S4**  
Battery Beam Tetrode

**1S5**  
Battery Diode Pentode

**3S4**  
Battery Beam Tetrode

**1T4**  
Battery Pent. Vari-Mu

**3V4**  
Battery Beam Tetrode

Type Number	Application	Heater		Anode Voltage Normal	Screen Voltage Normal	Grid Voltage Normal	Anode Current mA	Screen Current mA	Impedance Ohms	Mutual Conductance mA/V	Optimum Load Ohms	Power Output Watts
		Volts	Amps.									
1L4	Batt. R.F. Pentode	1.4	0.05	90	67.5	0	2.9	1.2	600,000	0.925	—	—
1T4	Batt. Pent. Vari-Mu	1.4	0.05	90	67.5	0/-16	3.5	1.4	500,000	0.9	—	—
1R5	Heptode F.C.	1.4	0.05	90	67.5	0/-14	1.6	3.2	600,000	300*	—	—
1S4	Batt. Beam Tetrode	1.4	0.1	90	67.5	-7	7.4	1.4	100,000	1.58	8000	0.27
1S5	Batt. Diode Pentode	1.4	0.05	90	67.5	0	1.6	0.4	600,000	0.63	—	—
3S4	Batt. Beam Tetrode	1.4 2.8	0.1 0.05	90	67.5	-7	7.4	1.4	100,000	1.58	8000	0.27
3V4	Batt. Beam Tetrode	1.4 2.8	0.1 0.05	90	90	-4.5	9.5	2.1	100,000	2.15	10000	0.27

\* Conversion Conductance in Micromhos.

THIS popular range of Brimar Battery Miniatures is suitable for all modern battery operated receivers.

Full details of their characteristics are shown in the table above.

**BRIMAR**  
BATTERY MINIATURES

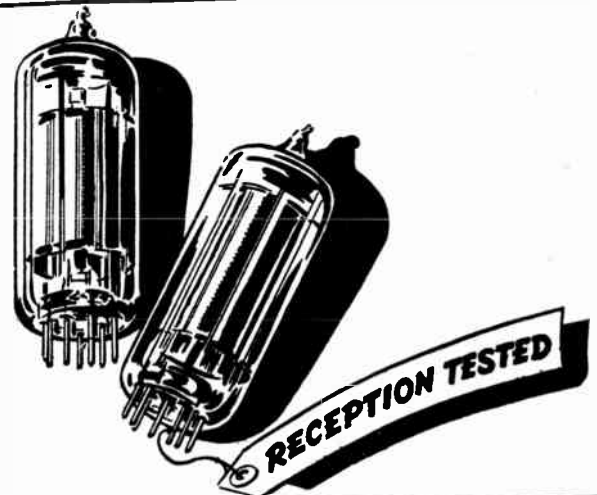

STANDARD TELEPHONES AND CABLES LIMITED, FOOTSCRAY, SIDCUP, KENT.

# CRYSTAL PICK-UP PREJUDICES

— their Rhyme and Reason . . .

**P**REJUDICES are frequently unreasonable, often enough they are formed not from experience but from hearsay. The reputation of Crystal pick-ups has suffered in this way, yet every day and every day there are many thousands of Crystal pick-ups giving delight to gramophone enthusiasts, particularly those who are "sound purists." Then why this prejudice in other quarters? Let us be frank. *Under certain circumstances* Crystal pick-ups have in the past possessed some failings, but, let us hasten to add, failings small enough to be discounted by the user who sought the finest yet obtainable in sound reproduction.

Now, when Radiolympia is about to show us the great strides that ACOS research has made in utilising the amazing characteristics of the piezo-electric principle, it is opportune to review the reasons for the prejudices which persist from the pre-ACOS era.

## The fallacy of their fragility

First, there is the belief that the Crystal pick-ups must necessarily be fragile and easily damaged. True, certain early types were easily fractured because assembly methods were as yet unperfected. But the Cosmocord laboratories produced an unbreakable crystal assembly which ensures that NO crystal in an ACOS pick-up can be broken, even by so drastic a measure as tapping the needle with a hammer—an extreme of violence which would never be approached in ordinary usage.

## Humidity deterioration effects defeated

A second persistent prejudice against Crystal pick-ups is that the crystal element—Rochelle-Salt—is susceptible to deterioration when subjected to the higher degrees of humidity. Since this failing is an inherent characteristic of Rochelle-Salt, counter measures had necessarily to be those of *protection*. ACOS research was indeed set a formidable problem, the solution of which was particularly elusive, for in

this country the humidity count is much higher than, say, in the United States, where Crystal pick-ups are in almost universal use. Nevertheless the problem was solved by long and intensive research in the Cosmocord laboratories. Now an assembly has been designed which positively counteracts any danger of deterioration from humidity. In this assembly the crystal is mounted in a gel-like substance which provides a complete water-vapour barrier, rendering the cartridge absolutely non-hygroscopic.

## Equaliser Circuits now past history

Another criticism is that the Crystal pick-up requires the fitting of an equaliser before satisfactory reproduction can be obtained from the ordinary commercial "constant velocity" records. In passing it should be mentioned that this condition is not confined to Crystal pick-ups only. The criticism is then that in order to attain the best from a crystal pick-up it is necessary to spend time and money on fitting additional components. The connoisseur of sound reproduction has con-

sidered this effort well justified by the results, knowing that a crystal pick-up alone is capable of giving him the high quality he demands.

Now, however, even the critical requirements of the connoisseur can be met without recourse to an equaliser circuit for again ACOS research has solved the problem in providing a crystal pick-up which, without additional components, can be connected direct to any domestic radio set or amplifier.

## An invitation to the critics

Thus all past criticisms have been met, and any lingering prejudices shown to be without reason. And in confirmation there is to be inspected *and heard* at the Cosmocord Stand No. 7 and Demonstration Room No. D.10 the latest product from the Cosmocord Research laboratories—a Crystal pick-up of revolutionary design which, apart from providing a new and higher standard of performance, is also a thing of beauty. This pick-up will be available through the Trade after Radiolympia.

See and hear the new  
**ACOS G.P.20 MICRO-CELL PICK-UP**  
at  
**RADIOLYMPIA**

STAND NO. 7. DEMONSTRATION ROOM D.10.

- Has output 5 to 20 times greater than that of any comparable magnetic type.
- No equaliser components required. Can be connected direct to any domestic radio or amplifier.
- Has unbreakable Crystal element.
- Is unaffected by conditions of extreme humidity.
- No needle talk.
- Record wear virtually eliminated.
- Has provision for interchangeable clip-on head for long playing records. One instrument for ALL records.



**COSMOCORD LIMITED • ENFIELD • MIDDLESEX**

# AUDIO SIGNAL GENERATOR

## Auxiliary Circuits : Frequency Calibration

By M. G. SCROGGIE, B.Sc., M.I.E.E.

(Concluded from page 297 of previous issue)

IN the first part of this article the design of the basic oscillator and output stage were discussed. It should have been mentioned that valves V1 to V8 in Fig. 1 are all of type VR65 (Mazda SP61).

We now turn to the optional refinements.

**Attenuators.**—Some reduction of voltage is necessary between V2 and V5, so, making a virtue of necessity, part of the potential divider used for this purpose ( $R_{19}$ ) is calibrated in db to fill in the steps of the switched attenuators in the output. The rest of the divider consists of  $R_{18}$  and  $R_{20}$ , the latter being variable in order to set the output to the reference level with all the attenuators at zero. To prevent loss of top frequencies it is most important to minimize capacitance to earth from the whole of this input circuit. A great improvement was made by substituting a suspended tubular  $C_{10}$  for one of the earthed metal case type.

To maintain optimum output conditions, the attenuators following V5 must at all settings appear to V5 as a resistance of  $5k\Omega$  when a load of that magnitude is connected. V5, when directly connected, appears to the load as a low resistance, of the order of  $150\Omega$ . To maintain a constant output resistance (say  $5k\Omega$ ) it would be necessary to use a T attenuator and to accept at least 6db minimum insertion loss. If one does not insist on a constant output resistance it is possible to use a two-element attenuator ( $\nabla$  or  $\sqcap$ ) and have zero insertion loss. Of these, the  $\nabla$  type is the more convenient, because its resistances are lower. The values are given in Fig. 6 for two 5-position attenuators, one in steps of 5db and the other in steps of 20db. It was calculated that Ayrton-Perry winding was unnecessary, and the

resistors were all wound straightforwardly in groups on  $1/32$ in. Paxolin "cards" with 46 s.w.g. Eureka for all over  $300\Omega$ , and waxed. Control is by a pair of 2-pole 5-way Yaxley type switches.

With any attenuator, there is an error if the actual load impedance differs from that for which it was designed. With types giving a constant impedance in both directions, the error depends only on the ratio between actual and designed load impedance, but with the type shown here it depends also on attenuator setting.

tract  $10 \log_{10} \gamma$  db. In general a low load resistance draws more power than indicated by the attenuator settings, and *vice versa*. It must be borne in mind that a low load resistance *without* attenuation causes abnormally large distortion.

The relationship with reactive loads differs considerably; one example is given in Fig. 7.

To ensure correct termination when only voltage output is required, an internal  $5k\Omega$  resistor ( $R_{28}$ ) is provided, brought into circuit by  $S_3$ , which also has a position for cutting off the signal. The ratio of the voltage across an external load to that across this  $5k\Omega$  can be used, with the help of Fig. 7, to deduce the a.f.

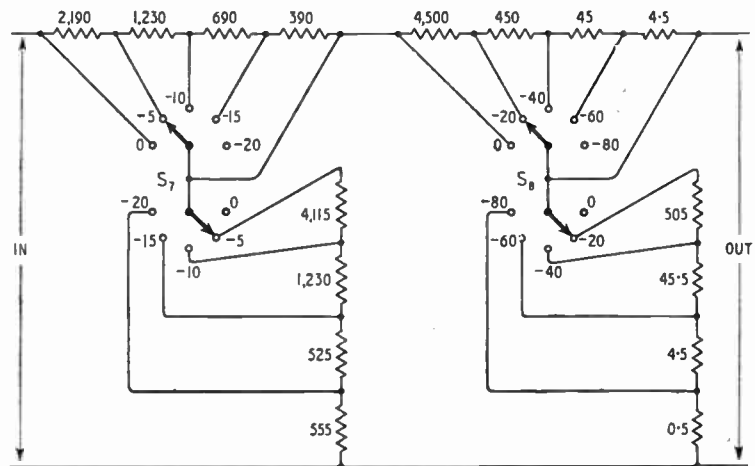

Fig. 6. Diagram of switched attenuators, with resistance values in ohms for  $5k\Omega$  load.

Error curves for resistive loads are given in Fig. 7, from which it can be seen that the range of load resistance within which the attenuation is reasonably accurate increases with the attenuation, and for the largest values includes all but very low load resistances. It is important to note that these error curves apply to *voltage* output—the generator is used mainly for voltage rather than power. To convert to power it is necessary to sub-

tract the resistance of the load, so long as it is non-reactive. The most advantageous setting of the attenuator switch for this test is of course 5db. (Incidentally, it can be shown that the maximum error—voltage ratio—with this type of attenuator occurs at 6db). A terminal at point B in Fig. 1 would provide a monitor output at unamplified oscilloscope level when using the stepped attenuator.

**Antiphase Output.**—The second



**Audio Signal Generator—**

output stage, V7, is identical with the first, except that it has no switched attenuation, but of course it is subject along with the first to the 0.5 db input control. Its drive is provided

to be level up to perhaps 0.5 Mc/s or so. This would be inconvenient and quite unnecessary for audio work. The main requirement is a wavefront not exceeding a few microseconds, and a flat top that does not droop apprecia-

by connecting a capacitor across  $R_{12}$ , the value depending on the inequality desired. It works by developing additional bias for V3.

Fig. 8 shows the waveforms obtained at several frequencies. **Valve Voltmeter.**—For stability of calibration combined with simplicity, a modified reflex circuit is used (V8). The meter was a war surplus 0.75 mA instrument; but a 0.5 or 1 mA meter could be used, with some adjustment of  $R_{38}$  and  $R_{39}$  values. For a given setting of  $R_{38}$  there is a value of  $R_{39}$  at which the meter reading anywhere on its scale is not appreciably affected by the largest departures from normal anode voltage that could occur in practice. These two resistances were varied until full-scale deflection was obtained for 28V peak; i.e., reference-level voltage (20V peak) plus 3 db.  $R_{39}$ , not being at all critical, was then fixed; but a pre-set  $R_{39}$  was fitted to provide for readjustment of the calibration. Adequate capacitance at  $C_{14}$  is essential for avoiding error at low frequencies.

This type of valve voltmeter gives a nearly linear scale, but its readings are not proportional to mean values—they are somewhere between r.m.s. and peak. It is convenient to calibrate it

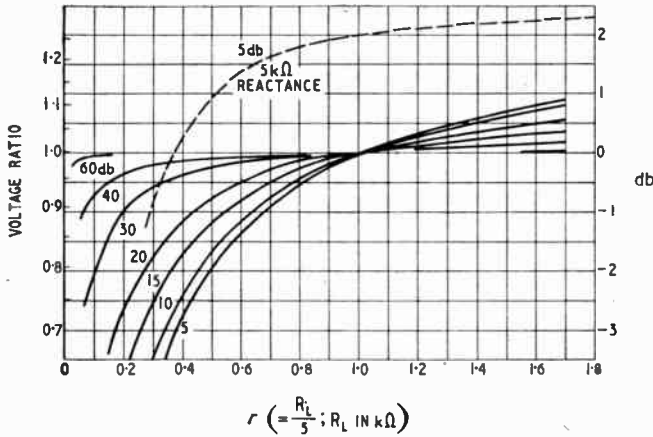

Fig. 7. Curves showing attenuation errors when load resistance is not 5k $\Omega$ . The curves correspond to settings of the attenuator switches, and the left-hand vertical scale is in ratio of actual output voltage to output voltage with 5k $\Omega$ . The right-hand scale is in db for convenience, to avoid the need for calculating voltage ratios, but it must be realized that the db readings represent voltage ratios and not true power db. To get the latter, it is necessary to subtract  $10 \log_{10} r$ .

by a floating paraphase stage (V6) tapped to a point on the chain  $R_{24}$ ,  $R_{25}$ ,  $R_{26}$  suspended between the two outputs. By adjusting the balancing control ( $R_{25}$ ) the two output voltages can be made equal and opposite with respect to earth, as required for driving push-pull stages, 1:1 bridges, etc. Not only so, but any desired output ratio, up to 100,000:1, can be obtained by means of the switched attenuators.

The possibility of both outputs being open-circuited at the same time (which would leave the grid of V6 free) is eliminated by  $R_{27}$ .

**Square.**—This consists of two over-driven stages, V3 and V4, which can be interposed between V2 and V5 by means of  $S_2$ . To make the square waves equal in amplitude to the sine waves (on a peak, r.m.s., or any other basis) a pre-set control ( $R_{17}$ ) has been provided.

To maintain a sharply square waveform up to 20,000 c/s it would be necessary for all the circuits (including those of V6)

by even at 20 c/s. The enormous coupling capacitances that would be needed to achieve the latter by straightforward methods are economically avoided by a compensating capacitor ( $C_9$ ) in the lower limb of the input potential divider to V5. The value was chosen to bring the wave tops quite level in the normal 5k $\Omega$  load. Such a waveform will easily show up low-frequency attenuation even down to 1 c/s.

To achieve a steep wavefront, care must be taken to minimize stray capacitances, especially in the higher impedance circuits. The corners can be sharpened considerably by the use of  $C_7$ . Too high a value causes overshoot.

The circuit as shown generates square waves in which the positive and negative half-cycles are slightly unequal—sufficiently to show which is which on the oscilloscope. If they are made very unequal there is a large shift of mean level due to a.c. couplings. On the other hand, a very unequal waveform is an even more searching low-frequency test and may be preferred. If so, it can be obtained

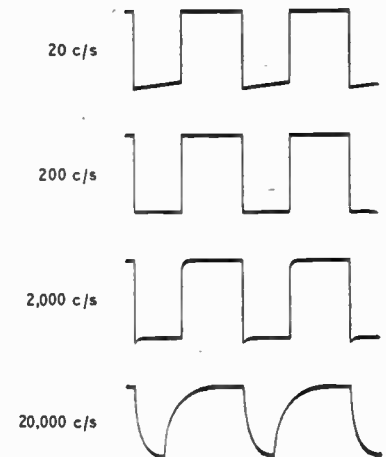

Fig. 8. Square-wave output waveforms obtained at various frequencies.

in r.m.s. or peak values with sine waveform so long as it is remembered that they do not apply with other waveforms. With  $R_{17}$  set to make the square waves equal

in peak-to-peak value to the sine waves, the readings are about 20% greater with symmetrical square waves. If the positive half-cycles are longer, they are less in amplitude than the negative half-cycles, and the voltmeter reading is less.

In addition to the voltage scale, a db scale has been inscribed. Among other uses it facilitates the checking of voltmeter and attenuators against one another. **Power Supply**—The entirely conventional system, providing 40 mA at 250V and 4.5A a.c. at 6.3V, is exactly as it was found in Test Set Type 87.

**Frequency Calibration.**—It must be admitted that a frequency bridge was used for the calibration, but although convenient it is by no means essential, and in any case it was checked by the method to be described. This is the well-known oscilloscope method, in which one standard of frequency is needed. If care is taken to avoid periods during which the demand for electricity is heavy, the 50-c/s time-controlled mains can be used as a reasonably accurate standard. (The Third Programme 440 c/s tuning note at 5.55 p.m. does not allow much time for calibrating but is an extremely accurate check.) With the time base synchronized with the mains, the generator settings giving multiples of 50 c/s can be noted; also without much difficulty, multiples of 25 c/s. When the number of cycles becomes too great to be reliably counted, the generator frequency is kept constant and the time base speeded up until only one generator cycle is visible; the process can then start afresh, but of course it is necessary to make sure that the time-base frequency does not drift. This can be checked with a double-beam instrument, by keeping the 50 c/s sub-multiple pattern on the other beam; or, less conveniently with a single-beam, switching back to it occasionally.

By shifting the ratio of 50 c/s to time-base frequency, further ranges of scale points can be noted on the scale. In general, however, calibration points will not form a convenient scale; and to convert them to the latter the method described by Rendall and Peachey of the B.B.C. in

*Wireless Engineer*, Feb. 1948, p. 43, can be recommended. According to this, the observed points are pencilled temporarily on the dial, which is then detached and rolled along one axis of a sufficiently large piece of graph paper. As each pencil mark comes against the paper a corresponding mark is made on the axis. To make sure the dial has not slipped during its roll it should be rolled back again, and the coincidence of all the marks checked. A

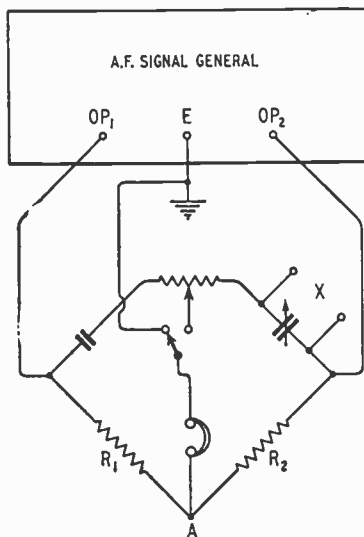

Fig. 9. Method of connecting generator to a typical bridge, for obtaining the benefits of a Wagner earth.

frequency scale is then marked along the other axis, preferably logarithmic, and a graph drawn connecting this scale with the marked frequencies on the first axis. This graph can then be used to find the points on the dial corresponding to the wanted scale markings; they are transferred to it by another rolling operation, after any of the original markings that are not wanted have been rubbed off. The scale is then marked in properly.

This process is particularly worth-while with resistance control, because the resistance element is unlikely to be perfectly regular; as a matter of fact the "Reliance" potentiometers were obviously wound in three stages giving a slightly wavy calibration curve: if the scale subdivisions had been marked in by eye they would have been appreciably in-

accurate near the two winding change-over points.

Finally it is as well to check the scale against the standard when the dial has been re-rolled.

The slow-motion dial found on the Test Set 87 is rather on the small side (3in. dia.) but is very convenient for the foregoing procedure, as it has a central boss removed by undoing three screws, which can be used to hold a disk cut out of Bristol board, covering up the original calibration and suitable for taking the new one.

If no suitable dial is available, a large pointer rotating over a fixed scale is quite effective.

Before proceeding to fill in the scale it is of course desirable to make sure that the desired ranges are covered, and, if not, to adjust the capacitor values accordingly. It is such a great convenience to have a single frequency scale, with decimal multipliers, that it is worth while taking some trouble to get the capacitances just right. In the present instrument C<sub>1b</sub> and C<sub>2b</sub> were first selected to give a 200-2,000 c/s scale with approximately equal margins above and below. This was the range on which the scale was subsequently calibrated fully. As no nominal 0.1μF capacitors at hand happened to make the 20-200 c/s range exactly fit this scale, one of them was chosen with a slightly lower capacitance, and the frequency adjusted exactly by fitting a small supplementary capacitor in parallel. For the highest range, a preset trimmer was used for the final adjustment.

Thanks to the care taken to preserve uniform frequency and phase characteristics in the amplifier, the frequency scale drawn for one range fitted the other two without appreciable error at any point.

**Use as a Bridge Source.**—It is a great convenience if a bridge detector is at earth potential, for then "head effects" or their equivalent with amplifiers or vibration galvanometers are avoided. But both source terminals are necessarily "live." This can easily be arranged with the two-phase output, as shown in Fig. 9. Note that the signal generator is earthed, but not the bridge. The point A can be brought to earth potential, however, by making the voltages from OP<sub>1</sub>

**Audio Signal Generator**— and OP2 have the same ratio as  $R_1$  and  $R_2$ . This can easily be done by switching the detector over to earth and adjusting the balancing control and (if  $R_1$  and  $R_2$  are not 1:1) the attenuator switches. Final balance exists when nulls are obtained at both

positions of the detector switch. For perfect "earthing" it may be necessary to provide capacitance from earth to either OP1 or OP2; but with ratio arms of the same kind this is unlikely to be needed.

The leads from OP1 and OP2 should be short and preferably

enclosed in earthed screens up to the bridge arms.

In a substitution type of capacitance bridge, as shown, without any elaborate precautions, it was found that an added capacitance of 300pF to earth from any of the bridge arms affected the answer by less than 1pF.

## DUAL CONCENTRIC LOUDSPEAKER

### Combined Direct Radiator and Horn Loading

THIS design, which was first shown by Tannoy at Radio-lympia in 1947, is now in production and is being distributed by Sound Rentals, Ltd., Canterbury Grove, London, S.E.27. It consists of a low-frequency direct-radiating cone diaphragm which functions also as the flare for a horn-loaded high-frequency pressure unit. Together these elements cover a frequency range of 25-20,000 c/s. Separate moving-coil drives are arranged at each end of the centre pole of a ring-type permanent magnet of anisotropic material, and the centre pole is bored to form the throat of the h.f. horn.

A cross-over frequency of 1,000 c/s has been chosen and the filter network gives an attenuation of 12 db/octave on each side of this frequency. Since the low-frequency diaphragm is capable of giving adequate output up to 1,000 c/s as a piston and need not rely on "break-up" for higher frequencies, a much heavier material can be used with consequent improvement in the smoothness of response up to that frequency. Attention has also been given to damping at the periphery

to prevent reflection and the setting up of standing waves at any frequency. A four-layer voice coil of low d.c. resistance in a gap flux density of 12,000 gauss ensures adequate magnetic damping, and it is claimed that the system is virtually aperiodic. Actually the product of flux density and conductor length is higher in the l.f. unit than in the h.f., though the latter works in a shorter

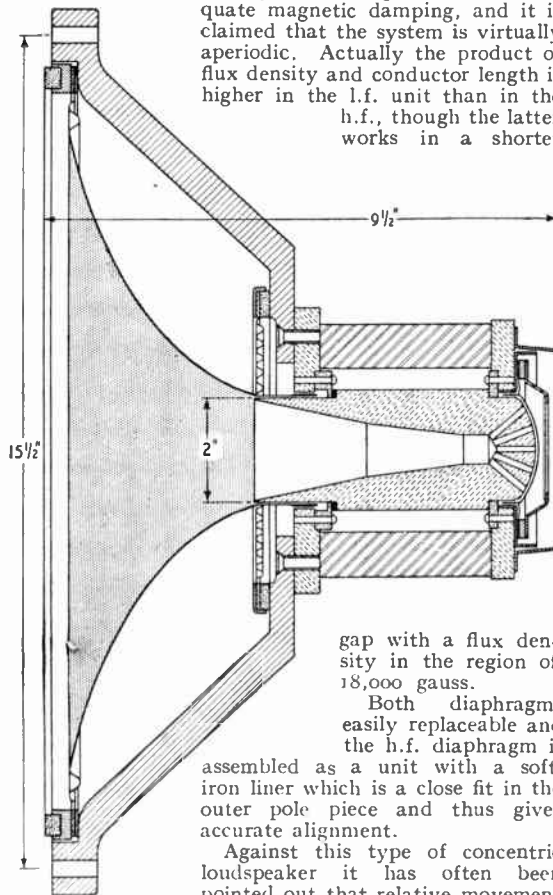

gap with a flux density in the region of 18,000 gauss.

Both diaphragms easily replaceable and the h.f. diaphragm is assembled as a unit with a soft-iron liner which is a close fit in the outer pole piece and thus gives accurate alignment.

Against this type of concentric loudspeaker it has often been pointed out that relative movement between the two sections of the h.f. horn could give rise to intermodulation between low and high frequencies. The makers have carried out two-tone tests to investigate this criticism and find that intermodulation products are less than 2%. We have heard the loud-

speaker in operation and can confirm that, subjectively, intermodulation effects are negligible. There is, in fact, far less blurring in orchestral music than in many single-element loudspeakers with comparable amplitude/frequency characteristics. Attack is good and the transient response generally sup-



Tannoy "Dual Concentric" loudspeaker, and section showing arrangement of horn pressure unit and low-frequency curved-sided diaphragm.

ports the makers' claims of aperiodicity. In a wide variety of test records reproduction was of a very high standard, the only possible criticism being that in one case the high notes of a solo violin were inclined to be metallic, though this might well have been a fault of the recording.

We would not hesitate to put this loudspeaker among the best half-dozen high-quality types from which it is always difficult to make a final choice. One point in its favour is that, in production, the characteristics should be reasonably uniformly maintained, since the design does not rely on subsidiary diaphragm resonances, which are always difficult to repeat.

The price of the unit, which weighs 30lb complete with cross-over network and output transformer, is £26 5s. It is also available in a vented corner cabinet at £52 10s.



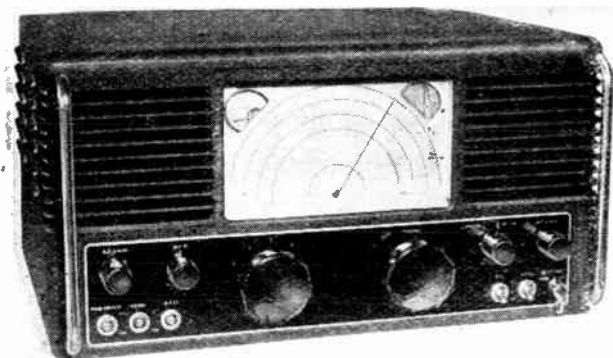

TEST REPORT

# EDDYSTONE MODEL 680

The Model 680 has its essential controls neatly and conveniently arranged. Note the large turning knob with one of similar size for the wave-change switch.

The selectivity is changed in steps, five in all, and these give bandwidths of 15 kc/s, 7 kc/s, 4.5 kc/s, 2.5 kc/s and a few hundred c/s respectively, for an

## Fifteen-valve Super-heterodyne of Advanced Design

**T**HOUGH intended primarily for the exacting needs of professional communications this set possesses an indefinable quality that cannot fail to appeal to the discriminating amateur who is looking for a really sound general-purpose receiver. Neither in conception, nor in coverage, nor in cost is the set in the least "amateurish" and its specification will bear comparison with that of any other set designed for a similar purpose.

It has 15 valves, all but two of which are the latest miniature all-glass type with B7G bases. The frequency coverage is very wide, but perhaps not quite so extensive as some of the sets in the same class because it does not take in the longer wavelengths, necessary for some kinds of professional communications. The frequency coverage of the Model 680 is 480 kc/s (625 m) to 30 Mc/s (10 m) so that it just takes in the 600-metre band which is used extensively for short and medium distance ship-to-shore traffic.

This frequency band is covered by five switched ranges, their individual coverages being 480 to 1120 kc/s, 1.12 to 2.5 Mc/s, 2.5 to 5.8 Mc/s, 5.5 Mc/s to 13 Mc/s and 13 to 30 Mc/s respectively. Although not apparent there is an overlap between all ranges, as the calibrated portions do not in all cases occupy the full length of the scale.

An unusual feature of this set

is that it has a mechanically operated selectivity system, or as it is sometimes called, bandwidth control. The couplings between primaries and secondaries of the i.f. transformers, and hence the selectivity of the circuits, is varied by change in physical relationship of the coils. The principle is not new; it may actually have predated the more commonly used electrical systems, but it is nevertheless a perfectly sound one, and moreover, is quite satisfactory as applied to this set.

attenuation of 6 db at the boundaries. The narrowest of all is with a quartz crystal filter.

In common with all modern high-performance receivers, the Model 680 is a superheterodyne and it has two r.f. stages before the mixer. Their main purpose is not necessarily to improve the sensitivity but to give adequate second-channel rejection at the higher frequencies. Coils with adjustable dust cores are used on all ranges in this portion of the set. Waveband switching is by means

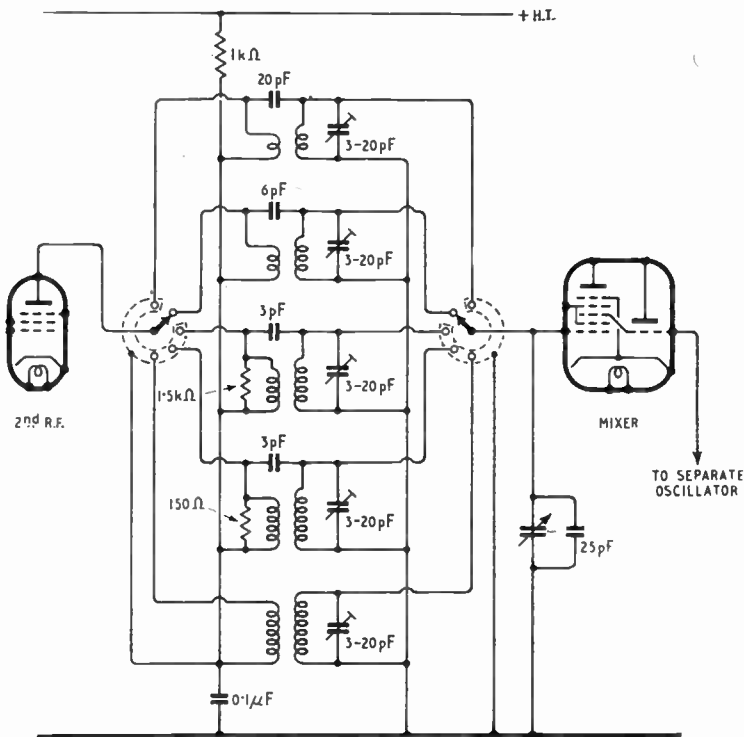

Fig. 1. Typical of the r.f. stages in the Model 680 this interstage coupling is between the second r.f. and mixer valves.

**Eddystone Model 680—**

of ganged wafer switches and the general arrangement of the circuit is shown in Fig. 1, which depicts the inter-stage coupling between the second r.f. stage and the mixer. It is typical of the other r.f. couplings.

A triode-hexode is shown in the mixer position but a separate oscillator valve is actually employed, only the hexode part giving service as the mixer. Its triode section is ignored although the triode grid pin is utilized for oscillator injection. The idle

is the crystal filter, this being the usual form of bridge-connected circuit with the crystal balancing, or, as it is sometimes called, the phasing capacitor, controllable from the front panel. It can thus be used to give high attenuation of an interfering carrier on either side of the desired signal and this is the so-called "single-signal" technique which will be familiar to users of communications sets.

Included in the circuit of Fig. 2 is the first i.f. valve and the signal strength (or "S") meter and its controlling diode. The

The i.f. amplifier has seven tuned circuits in all, three being in the crystal filter, and they are tuned to approximately 450 kc/s by fixed capacitors of 400 pF, the final tuning to this frequency being effected by the adjustable dust cores.

Two stages of amplification are employed using 6BA6 valves, which are the latest button base r.f. pentodes with B7G bases. Both are included in the a.g.c. system, which, with the two r.f. valves, makes four controlled stages in all. Exceptionally good control of the audio output is thus obtained; the a.g.c. characteristic shows that for a change in the input signal of about 100 db the audio output does not vary more than 9 db. Considerable delay is allowed before a.g.c. becomes operative and this amounts to about -13 volts. It is derived from the bias resistor of the output stage and is achieved by joining the cathode of the a.g.c. diode to the cathode of the output valves. This diode is the companion to the detector, which of course operates without a delay voltage, and the two form one of the 6AL5 valves used in the receiver.

The detector circuit is more or less orthodox except that the diode load consists of four resistors joined to a switch which is linked with the bandwidth control. By taking the a.f. output from an appropriate tapping on the diode load for each position of the selectivity switch, some compensation is made for variations in the i.f. gain that inevitably accompany changes in bandwidth, no matter what system is employed.

Further compensation for variation in i.f. gain with change in bandwidth is also provided and this takes the form of adjusting the stage gain of the second i.f. valve. It is effected by switching in different bias resistors, the switch being part of the bandwidth control.

Following the detector is a series-connected noise limiter, the diode being the companion to the one controlling the "S" meter. These two form the other 6AL5 valve in the set. Details of the detector circuit, and of the noise limiter, which incidentally can be switched in or out as

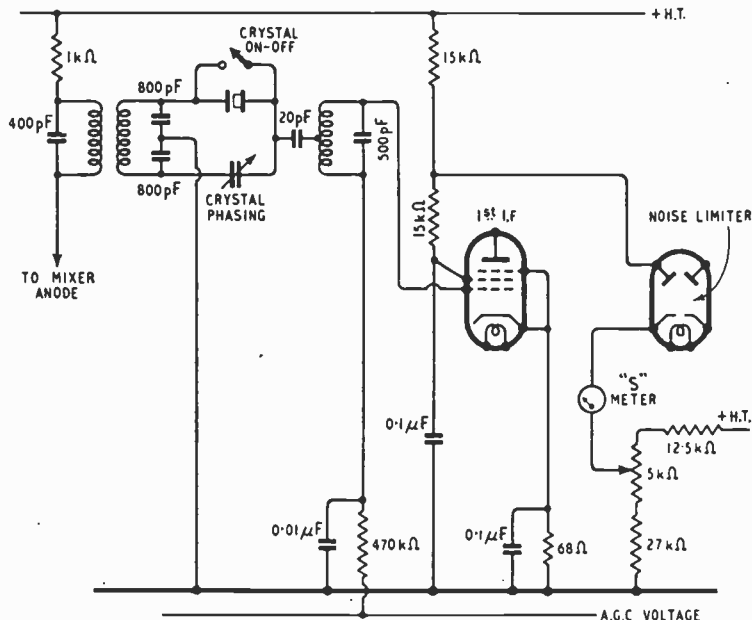

Fig. 2. The crystal filter is included in the first i.f. coupling following the mixer valve. Shown also is the diode and source of voltage controlling the "S" meter.

anode is joined to the cathode. As an alternative to the X81 or 7S7, which are the triode-hexodes favoured, an ordinary hexode mixer, such as the 6BE6 may be used in some receivers. The particular model reviewed here had the X81.

The separate oscillator valve is an 8D3 pentode but triode-connected in an orthodox form of the familiar back-coupled oscillator using shunt-fed anode coils. Fixed tracking capacitors are used on all five ranges and circuit trimming is taken care of by adjustable dust cores and small ceramic pre-set capacitors.

Immediately following the mixer, and as shown in Fig. 2,

meter is actuated by the change in  $G_2$  current under the influence of a.g.c. but responds to the voltage drop in this electrode's series feed resistors. It does not, however, function when receiving c.w. or m.c.w. with the a.g.c. switch in the "off" position.

In order to derive the full benefit from a crystal filter, the filter must be supported by a chain of really good tuned circuits. In the Model 680 all the i.f. transformers, like the signal circuits, have dust cores and the grids of the valves are tapped down the secondary windings in order to relieve the circuits of undue damping. Circuits of quite high "Q" are thus obtained.

required, are included in Fig. 3.

From the noise limiter the audio output passes to a volume control, then to a 6AU6 voltage amplifier and from there, though a phase reversing stage, (another 6AU6) to a pair of 7D9 output valves operated in push-pull. Some negative feedback is applied from the anodes of the two output valves to the anodes of the two penultimate valves. The output transformer has a ratio to suit a loudspeaker of between 2 and 3 ohms impedance.

Provision is made for reception with high-resistance headphones, a jack being included in the anode circuit of the first 6AU6 valve and connected so that when the 'phones are plugged in the output and phase reversing stages are isolated.

The b.f.o. valve is a 6BA6 connected as a triode and the circuit is the well-known electron coupled arrangement. This is a particularly stable form of oscillator and so is well suited to a set of this type, which needs a very stable oscillator for heterodyning the signal when the crystal filter is in circuit. Stability is

As the stability of the frequency changer oscillator is every bit as important as that of the b.f.o., the stabilized h.t. is fed also to this valve and to the screen grid of the mixer, but not to its anode

(b) With the lid raised all valves are accessible, so also is the mains transformer for voltage adjustment. To trim the circuits, it is necessary to withdraw the chassis from the cabinet.

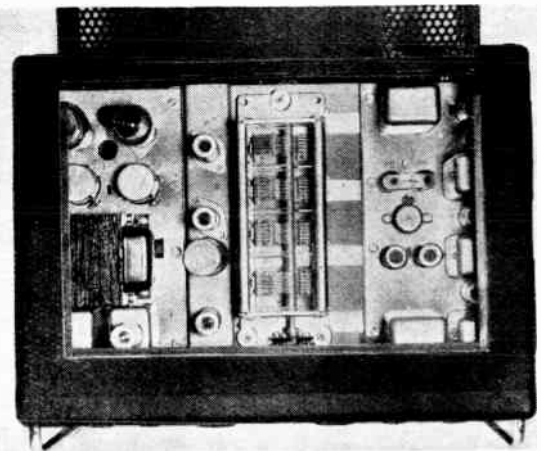

which joins to the common h.t. line.

The receiver is self-contained, so far as the provision of all operating voltages is concerned, and it includes a mains transformer, a 5Z4G rectifier, stabilizer, as already mentioned, and adequate smoothing circuits. The

Tappings on the mains transformer provide for operation on 110 and 200 to 240 volts a.c. at normal supply frequencies.

Although the receiver is not in the most expensive class (the price in the United Kingdom is £85) it is none the less a delightful set to handle. The 140 to 1 reduction in the tuning mechanism provides a precision of control that is most essential on the higher frequencies, yet it is not

a tedious control to operate as it embodies a heavy fly-wheel which serves to carry the pointer from one end of a range to the other with but three spins of the tuning knob.

Despite the low gearing, no trace of backlash could be detected, although quite a long chain of gears are used. These are all spring-loaded and of the split-wheel type. Similar gears drive a small subsidiary dial

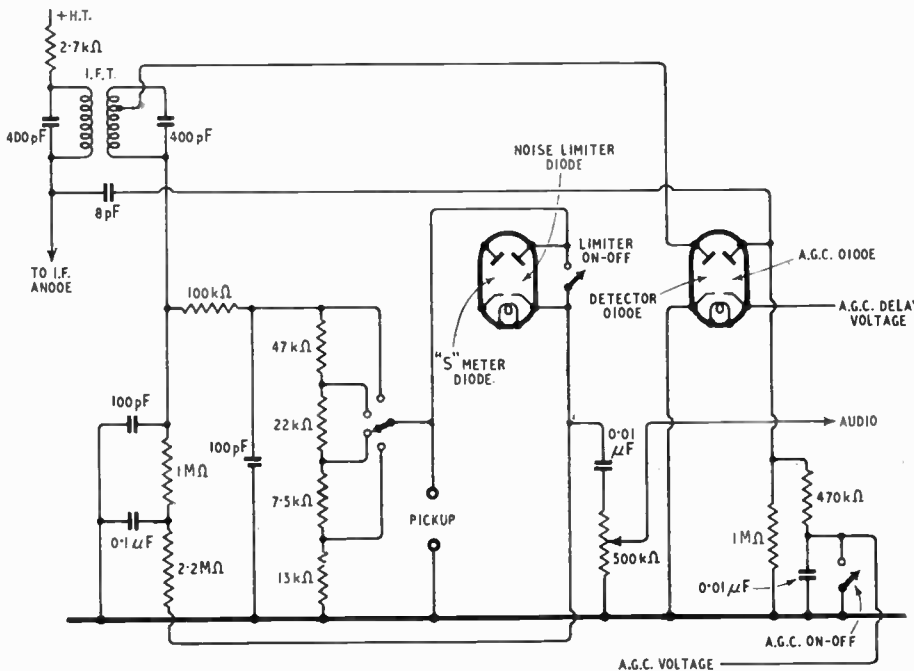

Fig. 3. Detector and noise limiter circuits of the Model 680. Included is the switching of the detector diode load and also the a.g.c. system.

further ensured by stabilizing its anode voltage, the stabilizing medium being a VR150/30 neon tube.

smoothing choke is of generous size and the two associated capacitors are 16 and 40μF respectively, the 16-μF being the reservoir.

which serves the equivalent of band-spreading, at least so far as logging stations is concerned. It is geared eighteen times faster



**Eddystone Model 680—**

than the main pointer and has ten inclined scales, each 1 in long, with a total marking of 100 divisions.

On the highest range, which is the longest or outer scale on the main dial, a scale length of 10 in is available and, with the subsidiary dial 20 in total. But as the subsidiary dial makes nine complete revolutions for the pointer's coverage of the main scale, it provides the equivalent of 90 in. of scale on this range. On the lowest frequency range, which is the inner calibrated scale, the effective length becomes 43 ins. In addition to the frequency calibrated scales there is a small logging scale on the main dial engraved 0-9. Thus to log a station it merely suffices to record the range (e.g., 1-5) the area on the 0-9 scale and the setting on the 0-100 bandspread scale. For example, a station on 9 Mc/s can be recorded as R2397½ as it is in range 2, comes in division 3 on the 0-9 scale and tunes in at 97½ on the bandspread dial.

So many receivers have smallish tuning knobs that it is a welcome change to handle a set with one of generous size. The two principal controls on this set—the tuning and the wavechange switch—are 2 in in diameter and have fluted edges into which the fingers sink comfortably.

**Subsidiary Controls**

Grouped on either side of the large knobs, and in two rows, are the subsidiary controls. On the left the upper pair of small knobs are for r.f. gain and b.f.o. pitch control, while below, are three toggle switches which, reading from left to right, serve the functions of power on-off, send or receive and b.f.o. on or off.

For reception the send-receive switch has to be in the down position and h.t. is then supplied to the valves. In the up, or off, position the h.t. supply is interrupted, but the heater supply to the valves is maintained. In addition, a second pair of contacts on the switch close and they can be used to operate a starting relay in a transmitter, either locally or at a distance. A pair of terminals at the back of the set join to these contacts.

The right-hand group comprise the crystal phasing capacitor and a.f. gain controls in the top row, and below, three switches for (from left to right) noise limiter on-off, a.g.c. on-off and bandwidth selection. Immediately above the crystal phasing capacitor is a flush-type thumb-operated switch for bringing the crystal into use when required.

This disposes of all the controls on the front panel, but there are two more located at the rear of the set. One, which is adjacent to the mains input socket, is an unusual fitting, as it is a small rheostat for adjusting the brightness of the dial light. At the opposite end of the set, and close to the loudspeaker connections, is a screwdriver slotted spindle for "zeroing" the "S" meter. This spindle is normally covered by a screw-on cap. The telephone jack is not very obvious as it is located on the left edge of the front panel, which, in this set, is slightly

dished with short, straight sides which rabbit into the main body of the metal cabinet.

The performance of the set on all wavebands should satisfy the most fastidious, and whether one is searching for a particular station, be it for traffic purposes, for a broadcast programme, or may be for an elusive and rare amateur DX station, the "680" has an uncanny knack of pulling the wanted signal out of the jumble that exists on most well-used bands.

When using the b.f.o. for c.w. reception it is necessary to have the a.f. volume control well advanced and regulate the output by the r.f. gain control. If the a.f. gain is turned too low the heterodyne beat appears to be very weak.

It has previously been mentioned that the output stage is push-pull, but this does not mean that a great deal of audio power is available. The pair of 7D9 miniature pentodes take about 16 mA each only, and for traffic handling, where a little distortion is of no consequence, an audio output of 5 to 6 watts is available. For high-quality broadcast reception this should be reduced to about 2 watts for distortionless reproduction over the widest possible range of audio frequencies.

A few words regarding the cabinet may not be out of place here. As befits a professional type of receiver, it is functional rather than ornamental, although this does not mean it is unpleasing in appearance. The rounded edges of the front and back actually tend to make the set look somewhat smaller than it actually is. The controls are conveniently placed, the dial is large but not overpowering and the louvred front and sides give adequate ventilation for all purposes.

The cabinet and front panel are finished in black crackle enamel with chromium plated carrying handles. All knobs are black. Overall dimensions of the set are: 16½ in wide, 13½ in deep and 8½ in high. The weight is 41 lbs. Access to the inside of the set is given by a flush-fitting hinged lid in the top of the cabinet.

The makers are Stratton and Company, Eddystone Works, Alvechurch Road, West Heath, Birmingham, 31.

**NEW RADIOGRAMPHONE**

Formerly made only for export, the H.M.V. Model 5302 with bandspread tuning on short waves and automatic record changer is now available in the home market, the price being £72 4s. 10d. (including tax).

# NORTH AMERICAN BROADCASTING

**A**LTHOUGH the basic differences between the methods of broadcasting in Britain and North America are well known, the more detailed implications of these differences lead to results which are so strange to the British way of thinking that some description of them may be of interest. Fundamentally, all medium-wave stations in the United States are privately owned, either individually or in networks, while in Canada the situation is a combination of the American and British systems, since the private stations and those of the Canadian Broadcasting Corporation work side by side. This arrangement is further complicated in Canada by the fact that the C.B.C. in co-operation with the Department of Transport also grants the licences to broadcasting stations, which in the U.K. is, of course, a function of the G.P.O. In the U.S. the licensing body is the Federal Communications Commission.

## Channel Sharing

The first fact that strikes a newcomer to the North American Continent is the really enormous number of stations which exists. The latest figures give more than 2,000 for the U.S. and 120 for Canada, as compared with the 320 listed for the whole of Europe under the Copenhagen Plan (*Wireless World*, Nov. 1948). With the 10 kc/s channel spacing employed in N. America there are only 107 different channels in the medium-wave band (540-1600 kc/s) so that a great amount of channel sharing is necessary. The situation is only prevented from becoming chaotic by an interesting licensing technique which acts on a "first come, first served" principle. This may best be explained by outlining the procedure which is adopted for putting a new station on the air.

Let us assume that some town has reached such a size that an enterprising business man (probably having no connections with either the entertainment or engineering worlds) decides that it can

## Comparing Britain with Canada and the United States

By

**ROBERT H. TANNER**

(Northern Electric Co. Ltd., Canada, formerly in B.B.C. Research Dept.)

support a radio station, or another station if it has any already. This means, in simple terms, that there are enough advertisers lacking other radio outlets to make the operation of an additional commercial radio station economically feasible. The question as to whether or not listeners in the neighbourhood *want* another station does not arise. The promoter of the station will proceed with the preparation of a "brief" for submission to the licensing authority, part of which will deal with the purely commercial aspects of the matter—showing that the district can support a radio station—while the rest, prepared by a consulting engineer, will be technical.

This technical brief sets out among other things, the proposed frequency on which the station shall work together with the desired power, and the means by which all existing stations on this and adjacent channels can be "protected" from interference, both by day and by night. This latter section is, of course, the crux of the whole matter. All new stations, unless of very low power, have to resort to directional arrays with a multiplicity of towers in order to produce the complicated polar diagrams required to give reduced field strengths in the directions of the stations occupying the same or adjacent channels.

The complete brief is submitted and the decision is finally made as to whether the establishment of the new station can be justified on both commercial and technical grounds. If an affirmative answer is given, the promoter is then

free to begin the construction and equipping of his premises. Before a final licence to broadcast is given, however, he must furnish the authorities with a "proof of performance"; that is, sufficient evidence in the form of field-strength measurements, etc., to prove that the night radiation pattern is, within limits, the predicted polar diagram given in the brief. Even then, he is not entirely safe, as an existing station may complain that his signal is causing interference in which case, after investigation, he may be called upon to modify the polar diagram to eliminate the cause for complaint. It should be mentioned that throughout the licensing procedure, the Canadian, American and Mexican authorities work in close collaboration.

## Listener Service

But how does all this affect the listener? Does he get a better service as regards technical coverage, choice of programmes and actual programme material than the average British listener? These questions are, of course, almost impossible to answer, as matters of personal preference, prejudice and taste enter into them. But there are certain definite facts which may help the reader to form his own opinion. During the daytime the average British listener can pick up only two B.B.C. stations which will, however, be broadcasting the contrasting Home and Light programmes. In the evening, these will be joined by the Third programme, as well as by a large selection of Continental stations. In general, owing to the prevailing use of high-power transmitters, combined with the high density of population, there is little difference between the services afforded British listeners in the country and in the bigger towns.

In Canada and the United States the situation is very different. In the big towns, the listener will have the choice of a comparatively large number of stations, although some of these may shut down at dusk to avoid

### North American Broadcasting—

causing sky-wave interference with another station on the same frequency. To give two Canadian examples; Montreal has six stations (two of which are French) while Toronto has five. On the other hand, in a small town or in the country, daytime listening may be restricted to one local station (probably 1 kW or less) together with somewhat doubtful reception of one or two high-powered stations within a radius of 100 miles or so. At night, of course, the more remote stations will be receivable, but the interference level will increase very considerably and many channels will be little more than a confused jumble. For example, while listening in Southern Ontario it is frequently noticed that a station about 120 miles away would fade out, to be replaced by one talking Spanish, presumably in Mexico.

### Networks and Local Stations

On the whole, however, it would seem that the average American listener can usually pick up more stations than his British counterpart, but this does not always mean that he has a greater choice of programmes, or that if his choice is greater that the quality of the material broadcast is all that might be desired. There are two main reasons for this. First, throughout both the U.S. and Canada there are extensive networks to which stations may be affiliated and whose programmes they may transmit. This means that, during the evening when the "high spots" are broadcast, almost every station is taking one of the four big network programmes, thus greatly restricting the available choice. Listeners near the U.S.-Canadian border are in a somewhat advantageous position in this respect, as they are often able to pick up programmes originating in either country.

The second factor, affecting the quality of the programmes rather than the choice available, is economic. The comparatively small local station, when it is not taking network programmes, has to fall back on local talent for live shows, or on programmes built up from "transcription

libraries." These consist of collections of 16-in recordings (33 $\frac{1}{2}$  r.p.m.), either hill and dale or lateral, which usually carry four or five selections a side, each selection lasting two or three minutes.

It must be remembered that these local stations perform a function which is the radio equivalent of a local newspaper, a service which is almost completely lacking in British radio. News of local people and events, talks by local personalities and on matters of local interest, all form an important part of the programmes of these "community" stations and serve to bring radio more intimately into touch with the personal lives of the listeners.

At the other extreme is the situation in New York, where there are about 15 medium-wave stations, to say nothing of the f.m. and television transmitters. Most of these possess very excellent and adequate studio facilities and together they provide a very complete and varied fare. One particular station, owned by the *New York Times*, broadcasts practically nothing but classical music (mainly from gramophone records) together with short news summaries every hour.

A summary of this sort would not be complete without a few words about television. The number of American stations is, of course, startling by British

standards. The most recent figure is 45, with 77 under construction, while an F.C.C. official has forecast a total of 1,000 within the next seven or eight years. Many of the stations in action try to put out continuous programmes from morning to night and although the average quality of programme material is said to be vastly better than it was a year ago, it is thought by competent observers to be still behind the standards which the B.B.C. has set. All the programmes are sponsored and a great deal of thought is being put into the business of making the visual advertising items as attractive as possible, lest it fall into the disrepute of the sound "commercial."

Just at the moment, the F.C.C. is having second thoughts about the distance which must be allowed between television stations operating in the same channel and all new building has been suspended. On the other hand, the Canadian authorities, after an interval of waiting to see how things were going south of the border, have just decided to take the plunge, and construct television stations in Montreal and Toronto. In addition there are plenty of private concerns, some with British backing, most anxious to make a start on what, in Canada at least, is still a new and virgin field.

## AMERICAN RADIO

### F.C.C. Annual Report

THE fourteenth annual report of the American Federal Communications Commission reveals that the number of a.m., f.m. and television broadcasting stations in the United States has more than trebled in the past three years. At the end of last October, the closing date of the report, licences had been issued for 2,103 a.m. stations, 996 f.m. and 124 television transmitters.

The number of authorized broadcasting stations, including 168 experimental television transmitters, 46 non-commercial educational stations, 37 international broadcasting stations and 578 radio-link transmitters, totalled 4,091, an increase of some 500 during the year. It should be pointed out that these figures cover the number of stations authorized to operate; in actual

fact, so far as television is concerned, the latest figure given by the chairman of the F.C.C. is 60 stations, which, operating in 30 cities, are said to cover areas containing 40% of the country's population.

The number of non-broadcasting stations is given in the report as nearly 55,000, in addition to which there were in October 81,170 amateur stations and over 1,000 telegraph and telephone stations. Aeronautical services head the non-broadcasting list with nearly 25,000 stations, whilst marine services come next with 17,000. Taxicabs hold licences for 3,188 transmitters, whilst railway radio, which was introduced in 1945, now employs 235 transmitters—nearly double the previous year's figure—on 40 different railways.



# THE "BELLING-LEE" PAGE

Providing technical information, service and advice in relation to our products and the suppression of electrical interference

## "BELLING LEE" TELEVISION AERIALS to suit every pocket and every location

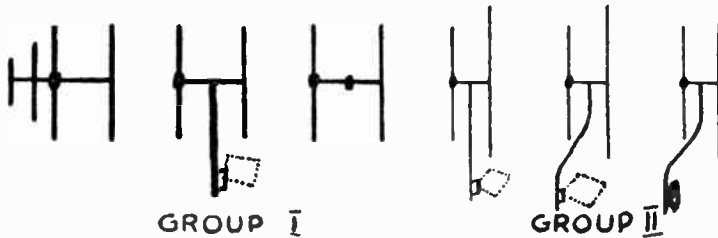

The new season's range of "Belling-Lee" television aerials comprises sixteen types for both the London and the Midland frequencies.

They may be divided into four groups: (1) aerials for "fringe" areas, including a new beam; (2) a new range of lightweight aerials with 0.15λ spacing; (3) dipoles including the "Veerod," and a new outdoor "Twinrod" and (4) indoor aerials including the "Doxrod" and the new "Viewflex."

Group (1) will be represented by the present robust "H" type, and a new beam which can be seen at Radiolympia.

Group (2). Up to date, all "Belling-Lee" television aerials have been designed to withstand repeated wind gusts of 100 miles per hour: because of this we rarely, if ever, see a "Belling-Lee" aerial distorted. Now that the prices of television receivers are falling so rapidly, the prices of these exceptionally robust aerials are out of all proportion, and every device has had to be examined whereby a considerable economy could be effected.

It is obvious that locations where 100 m.p.h. gusts occur are limited to certain coastal areas, or exceptionally high and exposed inland sites, and representing a very small proportion of the total number of aerials sold. It is, therefore, not unreasonable to ask why the many should pay for the few.

An obvious reduction in price can be achieved by saving material on certain types of aerials, but we must continue to manufacture a smaller quantity of the truly robust types which have made our name, and which will still be required for exposed areas.

The elements of the new types

will be reduced from 1/2 in. to 3/8 in. diameter, and the distance between dipole and reflector will be reduced. This raises the old controversy of picture flutter in wind 1/4 λ v 1/2 thλ spacing, etc. Picture flutter is bound up with the rate of change of gain with separation of dipole and reflector. From zero spacing to 1/2 thλ the gain rises rapidly, and thereafter falls very slowly to about 1 db at 1/4 λ.

The effect of flutter may be demonstrated by anybody with the aid of a string on the tips of the elements, by which they are pulled while the picture is being watched. There are two schools of thought, and we are ready to admit that we may have overrated the appreciative faculties of the public who are obviously prepared to tolerate a somewhat inferior picture in certain bad weather conditions. We are, however, not going to reduce the spacing of our new aerials to 1/2 thλ but 0.15λ, i.e., approximately 1/4 thλ; at this distance picture flutter is not likely to be troublesome as the curve depicting it is fairly flat between 1/2 thλ and 1/4 λ. This allows us to reduce pole diameters from 2 in. to 1 1/2 in. and to supply lashings and cross-arms of lighter materials.

Group (3) requires little explanation except that the new "Twinrod" which might be described as the marriage of the "Doorod" and "Winrod" for window sill mounting, and may be used either for broadcast or television reception.

Group (4) includes the new "Viewflex" which is the natural development of the "Doorod" as an all flexible dipole.

**"Wires that carry and re-radiate interference"**

We have got ourselves into trouble over this heading and we agree that it is ambiguous.

We certainly never intended to give the impression that relay operators fed an interfering signal on to their lines: they do not. We do say that any wire can pick up by induction, interference radiated from another nearby conductor. This in turn can be re-radiated, and is sometimes referred to as secondary interference. We know that relay authorities are most anxious to keep interference off their lines, and if they are told of any such interference will quickly take necessary steps to have it suppressed at source.

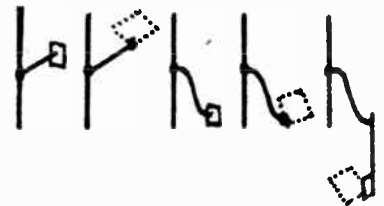

GROUP III

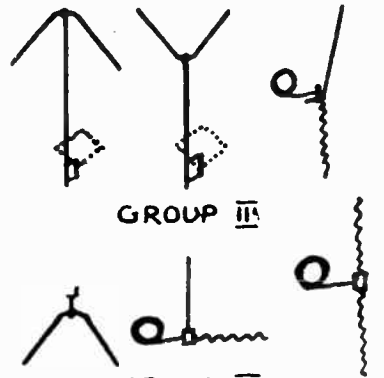

GROUP IV

### Rattle-free Car Aerial

We will shortly be releasing the new "Belling-Lee" car aerial which is absolutely rattle-free. It is stainless steel with streamlined collet grip at centre, and with streamlined insulators. This is a truly de-luxe model.



# S.R.E.\* for all purposes

Philips have supplied through traders and others throughout the world S.R.E. for almost every conceivable application. While specialized equipment is produced whenever necessary, a very wide range of standard apparatus units minimizes the need for this, and simplifies installation and maintenance.

As it can be shown to be much better engineering practice to use one large amplifier instead of a lot of little ones to feed one load, the standard range includes three large rack amplifiers.

Features include triode valves throughout, four push-pull stages, no electrolytics, and three separate anode supplies.

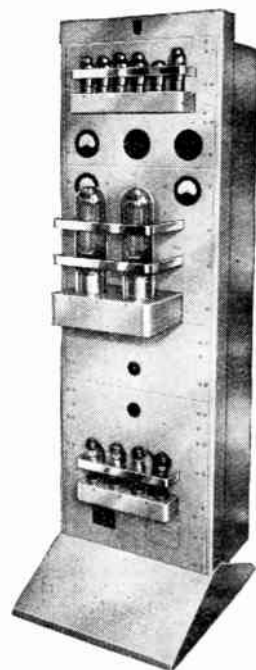

\* What expression should be used to refer generally to amplifiers, and related apparatus? "Public Address?" This hardly applies to gear that may well be used in private for purposes other than addressing. "Sound Equipment?" This can also mean tomtoms, or brewery apparatus in sound condition! We have adopted the Navy's term "S.R.E." or "Sound Reproducing Equipment", as in our submission there is no other so accurate or so generally applicable.

- 250 watt ..... List Price £255
- 500 " ..... List Price £325
- 1,000 " ..... List Price £425

S.R.E. available through the trade on hire purchase or rental terms.



## PHILIPS ELECTRICAL LIMITED

Amplifier Dept., Century House, Shaftesbury Avenue, London, W.C.2. (A48T)

# TRANSFORMER SPECIALISATION

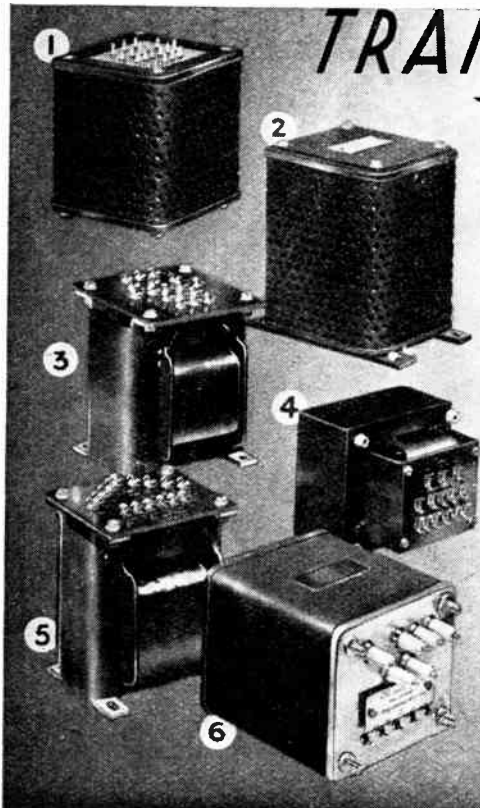

We specialise in satisfying the requirements of Industrial, National and Medical Research Establishments. Many of your needs may be met from the Standard range of "Somerford" Transformers and Chokes which are available by return. In addition to these we have our extensive range of special duty types and we shall always be happy to advise on the most suitable component to meet any specific requirement. Drawings of the various mechanical constructions available may be had upon request and specialised windings are carried out by our own skilled technicians.

The photograph shows six of the series  
 1 Hengist 2 Twynham 3 Avon 4 Burley  
 5 Somerford 6 Hermetically Sealed E.H.T.

# GARDNERS RADIO Ltd

SOMERFORD · CHRISTCHURCH · HANTS

## WORLD OF WIRELESS

### Cost of Suppression ♦ Television Progress ♦ Standard Audio Frequencies ♦ R.A.F. Distress Calls

#### W.T. Act

THE Wireless Telegraphy Act, 1949, has now been placed on the Statute Book, it having received the Royal Assent at the end of the last Parliamentary session.

Very few amendments have been introduced since the second reading of the Bill. The House of Lords amendment that a person should not be liable to spend more than 2s in suppressing each piece of domestic electrical apparatus used by him, was rejected. The reasons given by the House of Commons were that it was considered to be wrong that a person should be allowed to interfere with the amenities of his neighbours "merely because the cost of abating the interference would exceed an arbitrarily fixed amount," and that if this were permitted "the voluntary collaboration on which the Government must . . . rely for the control of interference would be undermined."

#### American Television

FOR some months past, there has been a standstill in the United States so far as the erection of new television stations is concerned. During this time the Federal Communications Commission has been considering what steps should be taken to ensure the healthy development of television to provide a national service.

The Commission has now issued a comprehensive plan providing for some 2,245 stations in 1,400 districts having a total population of over 69,000,000. In addition to the use of the 12 existing channels in the 54- to 216-Mc/s band which, according to the plan, provides for 543 stations, it also proposes the use of forty-two 6-Mc/s channels above 470 Mc/s. The maximum power of stations in the existing channels is to be raised from 50 to 100kW, while stations in the new band may use 200kW.

The distance separating stations using the same channels in the lower band has been increased from 150 to 220 miles and users of adjacent channels from 75 to 110 miles. In the higher band the separations are slightly less. No provision for protection against occasional long-distance propagation is made in the plan, as it could be accomplished "only by severely limiting the number of stations" in each channel.

**T H A M E S RADAR.** — A reproduction of the P.P.I. display on a Marconi "Radiolocator", the scanner of which was installed on the roof of the I.E.E., Victoria Embankment. The annotation is self explanatory.

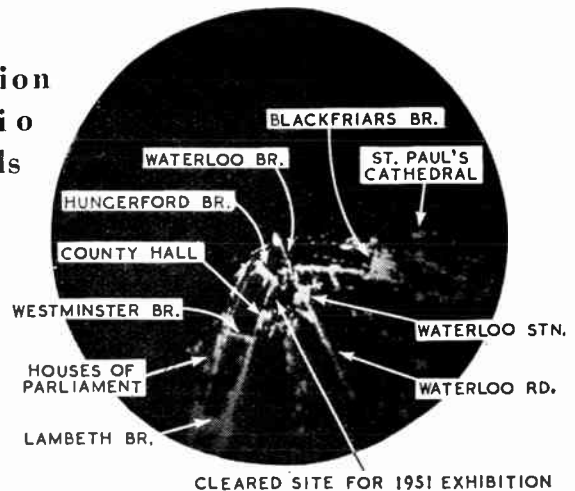

Provision is made in the list of channel allocations for as many as seven stations to a city such as Chicago. The plan also takes into account the proximity of Canada, Mexico and Cuba to the U.S. borders and lists frequencies for use in those countries. The F.C.C. suggests that the four Governments enter into formal agreements on television frequency allocations as soon as possible.

According to the list published by our Washington contemporary, *Broadcasting*, some districts will have stations in both the lower and higher bands.

#### Anglo-French Television Agreement

WHAT may prove to be a step towards the establishment of a standard for European television has been taken by France. Following a recent meeting of the C.C.I.R. (International Radio Consultative Committee) in Zurich, it was announced that the French Government had agreed to change its present Eiffel Tower 455-line transmissions to 405 lines, the British standard. It is understood from a French correspondent that the change will be made in October. It will be recalled that when the decision was made at the end of last year to introduce 819-line transmissions, it was stated that the medium-definition transmitter serving the Paris area would continue operating until January, 1958. The new 819-line station in the Eiffel Tower, operating on 213.25 Mc/s started experimental transmissions in April.

#### Radiolympia

IN preparation for the 16th National Radio Exhibition which opens at Olympia on September 28th, the Radio Industry Coun-

cil, who is organizing the show, has issued a booklet entitled "British Radio for the World" for overseas distribution. Articles on various aspects of the industry are included. Among the contributors are Sir Edward Appleton and Dr. R. L. Smith-Rose.

The exhibition will be open daily, except Sunday, from 11 a.m. to 10 p.m. until October 8th. Admission will be 2s 6d.

In the next issue of *Wireless World* we plan to include a guide to the exhibition.

#### B.B.C. Tuning Notes

HAVING received inquiries from readers regarding the accuracy of the frequency of the B.B.C. tuning notes—or line-up tones as they are called—we have secured the following details from the B.B.C. Engineering Division.

The frequency radiated immediately before the opening of the evening's Third Programme is 440c/s and that preceding the day's Home Service and Light Programme is 1,000c/s. The frequencies are normally maintained to an accuracy of  $\pm 1$  part in  $10^6$ . It is pointed out that frequencies different from these are sometimes used for test purposes outside normal broadcasting hours.

#### Distress Calls

SINCE the recent broadcast by the B.B.C. of an appeal for news of calls from a missing R.A.F. aircraft, amateurs have asked for details of the frequencies on which these calls would be radiated.

The R.A.F. has therefore issued the following information. An R.A.F. aircraft should send out an emergency call on the wavelength of the station with which it is working. It then has the choice of making a general S.O.S. call using



**World of Wireless—**

any one of the following frequencies:—

(a) 6,500 kc/s by day (0600 to 1900 G.M.T.), or 3805 kc/s by night;

(b) 370 kc/s used for long-range D.F.;

(c) 116.1 Mc/s used for R.T.;

or

(d) 500 kc/s, the international S.O.S. frequency.

When an aircraft crew has taken to the dinghy they will use the automatic S.O.S. transmitter which operates on 500 kc/s.

It is pointed out that between 15 and 18 minutes past each hour and between 45 and 48 minutes past each hour, by international agreement, a radio silence is observed on the international S.O.S. frequency for listening-out purposes.

**Marine Radio Gear**

A SERIES of revised specifications for marine radio equipment is being prepared by the G.P.O. after consultation with the Ministry of Transport, the shipping companies and radio manufacturers. This has been necessitated by the increasing congestion of the frequency spectrum, changes in technique and the requirements of the Atlantic City Radio Regulations and the International Convention for the Safety of Life at Sea.

The latest specification gives minimum requirements for radio-telephone equipment. It is issued purely for the guidance of manufacturers in order that they may, where necessary, modify the design of their equipment to comply with these requirements, which will eventually become operative.

The booklet containing these specifications is entitled "Radio for Merchant Ships—Performance Specifications for Compulsorily and Vol-

untarily Fitted Radiotelephone Equipments." It is obtainable from H.M.S.O., price 6d.

**Sound Reproduction Equipment**

A COMMITTEE has been set up by the British Radio Equipment Manufacturers' Association to deal with questions relating to the design, manufacture and distribution of sound reproduction equipment which is defined as "an electrically operated amplifier, to the input of which is attached a source, e.g., microphone, gramophone or radio, the output being fed into a loudspeaker or a series of loudspeakers." (Component parts of such apparatus are not included.)

The use of the term "public address equipment" is deprecated by the committee, which proposes the adoption of the term "sound reproduction equipment." The scope of this committee, on which is represented twelve manufacturers, is defined as covering equipment for sound amplifying and broadcasting systems, manufacturing and technical aspects of relay equipment and sound reproduction by means of tape recorders.

**OBITUARY**

J. H. Runbaken, the founder and managing director of Runbaken Electrical Products, of Manchester, died on July 18th.

**PERSONALITIES**

Sir Robert Watson-Watt has been nominated vice-president of the American Institute of Radio Engineers for 1950.

Air Comdre. R. L. Phillips, C.B.E., who has been appointed Director of Radio at the Air Ministry, was, until recently, Senior Air Staff Officer at No. 90 (Signals) Group and was formerly Chief Signals Officer at Fighter Command H.O.

H. C. Baker, of Bush Radio, has been appointed B.R.E.M.A. representative on the R.I.C. exhibition organizing committee in place of H. J. Dyer who was, until recently, with Philips.

E. R. Barnett has been appointed by E. K. Cole to advise Ekco dealers in the Midlands television area on receiver sales and service. He will operate from the Ekco service depot at 11, Brook Street, Birmingham, 3.

Derrick Beecham, who resigned from Furzehill Laboratories last year and has been acting as an independent sales consultant, has been appointed managing director of Bowdler, Godfrey and Co., exporters and importers.

S. Erickson, who has been chief design and development engineer to Vidor, Ltd., since early 1948, has resigned to take up a Government research appointment.

C. R. Nortcliffe, export manager of Philco (Overseas), Ltd., has been appointed by the Philco Corp. of Philadelphia as its sales manager for Europe and North Africa.

J. W. Ridgeway, a director of Ediswan's and manager of their radio division, has been elected chairman of the British Radio Valve Manufacturers' Association for the current year. The new vice-chairman is G. A. Marriott, of the G.E.C. valve department.

G. S. Taylor, who, prior to the war, was sales and advertising manager of the Whiteley Electrical Radio Co., has rejoined the company as a divisional sales manager. He will operate from the company's London office, 109, Kingsway, London, W.C.2. (Tel.: Holborn 3074.)

**IN BRIEF**

**Receiving Licences.**—At the end of June 11,910,850 broadcast receiving licences (including 147,900 television licences) were current in Great Britain and Northern Ireland. The increases over the May figures were "sound" 29,850, "vision" 7,050.

**Amateur Exhibition.**—The Radio Society of Great Britain is to hold the third annual amateur radio exhibition at the Royal Hotel, Woburn Place, London, W.C.1, from November 23rd to 26th. Admission will be by catalogue obtainable, price 1s 3d, from the R.S.G.B., New Ruskin House, Little Russell Street, London, W.C.1.

**Guarantees.**—It has been decided by the B.V.A. that the guarantee on valves and c.r.t.s in television sets sold for use in the Birmingham television area prior to the official opening of the station will operate from the date of the inauguration of the Midland service. In the case of combined broadcast and television receivers only the c.r.t. will be subject to this arrangement.

**Northern Television.**—The P.M.G. has now verified that the country's third television station will be erected at Holme Moss, Yorks. It is unlikely that the station will be in operation before the end of 1951. When publishing a map last month showing the anticipated service area of the projected station it was erroneously referred to as the *North-East* station; it should, of course, have been *North*.



**MIDLAND TELEVISION.** The vision and sound control desk for the Sutton Coldfield station. The vision transmitter and this control desk are being supplied by E.M.I. and the sound transmitter by Marconi's.

**Exports.**—Although the value of the June exports of transmitters and radio navigational equipment increased by some £35,000 over the preceding month, the total for the first six months of the year fell by £234,000 compared with 1948. The comparative figures are: 1948, £1,667,652; 1949, £1,433,378. The increased export of domestic receivers to some of the countries in the commonwealth has been counter-balanced by the fall in exports to the "hard currency" countries. Brazil's purchases during the first six months in 1948 total £172,673 compared with £1,755 this year. The only section of the industry showing an increase during the six months under review was components. The exports rose from £1,307,025 to £1,516,270.

**Electronics Symposium.**—The Electronics Section of the Scientific Instrument Manufacturers' Association is to hold a series of meetings at the Examination Hall, Queen's Square, London, W.C.1, from November 2nd to 4th, at which a symposium of technical papers will be given. Details of the programme, and of the exhibition of scientific and electrical instruments which will be run in conjunction with the meetings, are obtainable from the Association, 17, Princes Gate, London, S.W.7. Admission to the meetings will be by ticket.

**Evening Courses** in telecommunications and radio and television servicing are included in the prospectus issued by the Electrical Engineering Dept. of the Polytechnic, Regent Street, London, W.1. The telecommunications courses are approved for the award of the "Ordinary" and "Higher" National Certificates granted by the I.E.E. in conjunction with the Ministry of Education, and are also recognized by the City and Guilds as preparing for their examinations. The courses on servicing prepare for the Radio Servicing Certificate awarded jointly by the City and Guilds and the Radio Trades Examination Board. Students for the session commencing on September 26th must enrol on September 21st or 22nd between 6 and 8 p.m. The prospectus is obtainable from H. W. Date, Head of the Department.

**Room Acoustics.**—A course of six lectures on "Modern Principles of Room Acoustics" is to be delivered by Prof. R. H. Bolt, director of the Acoustics Laboratory, Massachusetts Institute of Technology, under the auspices of the Acoustics Group of the Physical Society. They will be given in the lecture theatre of the Royal Institution, Albemarle Street, London, W.1, at 5.0 on Sept. 29th and 30th and on Oct. 3rd, 4th, 5th and 7th. A registration fee of 10s 6d will be charged for the course. Particulars are obtainable from 1, Lowther Gardens, London, S.W.7.

**Television Instruction.**—Two television training centres, one in Birmingham and the other in Leicester, have been set up by the G.E.C. Five-day courses, including lectures on the fundamentals of television and practical work on the installation of receivers and the location of faults, are provided for approved dealers. Particulars are obtainable from Magnet House, Kingsway, London, W.C.2.

The courses organized by the Radio Gramophone Development Co. have been suspended until September. Applications to attend the courses, which are limited to R.G.D. dealers, should be addressed to Bridgnorth, Salop. Antiference, Ltd., have provided lectures on television aerials in some of the centres to be served by the Midland station. Particulars of future lectures and tickets of admission are obtainable from 67, Bryanston Street, London, W.1.

**Ferry Radar.**—Although shore-based Corsor radar equipment has been used

**London Traffic Control.**—The two-way mobile radio-telephone equipment has been installed in seven of the breakdown lorries and some of the inspectors' cars operated by the London Transport Executive to facilitate the control of traffic in the Metropolitan area. To give complete coverage of the area, four automatic receiving stations are being erected to the north, south, east and west of London, and both these and the main 100-watt headquarters' transmitter will be connected by land line to the Signal Engineer's Report Centre.



IN COMMEMORATION of the recent meeting of the C.C.I.T. (International Telegraph Consultative Committee) in Paris, the French postal authorities have issued a series of five postage stamps. Three of them, reproduced here, portray radio personalities—Emile Baudot, inventor of the press system of telegraphy; General Ferrié and André Ampère (with F. Arago).

for the control of the Wallasey ferry service across the Mersey for nearly two years, it was not until the end of July that the permanent installation was officially brought into service. The new Corsor equipment incorporates a 15-inch P.P.I. During ten days' foggy weather last November, 845 crossings out of a scheduled 861 were undertaken. The ferries carry some 55,000 passengers a day.

**Technical Courses.**—Particulars of both full-time and evening courses on various radio subjects organized by education authorities in Southampton, Walsall and Brentford have been sent to us. The day courses at University College, Southampton, include radar maintenance, radio engineering and radio operating. Part-time day and evening courses in telecommunication engineering and television and radio servicing are also provided. Particulars are available from the Department of Electronics, Telecommunications and Radio Engineering, University College, Southampton. A course covering the Radio Amateur's Examination is to commence at the Walsall Technical College, Bradford Place, Walsall, Staffs, in September. A similar course is being provided by the Brentford Evening Institute, Boston Manor Road, Brentford, Middlesex. It begins on September 21st, the fee being 7s 6d.

**Delegates** to the recent International Esperanto Congress in London were given the opportunity of seeing British television when the honorary president was interviewed in the B.B.C. programme "Picture Page." Six receivers were installed by the Gramophone Co.

**Cable & Wireless.**—In the annual report of Cable & Wireless for 1948, which has been issued as a Government White Paper, it is recorded that eleven new overseas radio-telegraphy circuits were opened—four replacing services lost during the war. The addition of seventeen radio-telephone circuits is also recorded. Four of these were in the West Indies and bring the total in that area to thirty-three. Six new radio-phototelegraphy services were introduced, five of them from London. On the research side it is recorded that work has been successfully carried out at the company's transmitting stations at Ongar and Dorchester to find a means of universal commutation between transmitters and aerials by which any transmitter can be used with any aerial.

**Price Control.**—Broadcast and television receivers, radio-gramophones, components and accessories were among the products recently freed from price control by the Government.

**I.E.E. Radio Section Premiums** for papers read or accepted for publication during the 1948-49 session have been awarded to the following authors:—G. Millington (Duddell Premium); Dr. G. F. Gainsborough (Anibrose Fleming Premium); and Extra Premiums to H. de B. Knight, Dr. W. A. Wooster, Dr. Nora Wooster, J. L. Rycroft, L. A. Thomas, Dr. D. G. Tucker, Dr. B. G. Pressey, Dr. H. G. Hopkins, F. Horner, C. F. Floyd, R. L. Corke, C. F. Booth, J. P. Johns, H. T. Mitchell, T. Kilvington, and F. E. Williams.

**B.S.R.A.**—The opening meeting of the British Sound Recording Associa-



### World of Wireless—

tion will be held at the Royal Society of Arts on September 22nd at 7.0, when W. S. Barrell (E.M.I.), who is again president, will deliver his presidential address. In addition to the re-election of M. J. L. Pulling (B.B.C.) as vice-president, B. C. Sewell, Director of Sound at the Gainsborough Studios, and C. F. Watts, director of M.S.S. Recording, have been elected vice-presidents.

**Brit. I.R.E.**—It has been decided to postpone until 1951 the next international convention, which was to have been held in 1950 to mark the silver jubilee of the British Institution of Radio Engineers, in order to coincide with the Festival of Britain.

**Brit. I.R.E. Premiums** have been awarded to the following authors for their papers published during 1948:—The Heinrich Hertz Premium to I. A. Harris, for "Calculation of Electrode Temperatures in the Radio Valve"; Marconi Premium to F. C. F. Phillips, for "A Direct-Reading Frequency-Measuring Set"; and the Dr. Partidge Memorial Award to G. L. Hamburger, for "An Automatic Audio-Frequency Response-Curve Tracer."

**Multiple Aerial.**—Individual aerials installed at various points on the cable ship, *Edward Wishaw*, might be a source of interference with the calibration of the vessel's direction-finding apparatus and, in order to obviate this, the Marconi International Marine Communication Co. has developed an aerial splitter. By means of this, a large number of receivers can be operated from only one aerial. It has the further advantage of protecting the receivers from interference effects produced by the ship's transmitters, even when operated on closely adjacent frequencies. This apparatus is part of the comprehensive radio communication and navigation equipment installed on this latest vessel operated by Cable & Wireless.

"**Wireless World**" and associated life journals dealing with various aspects of marine equipment and engineering are included on stand 48 at the Engineering and Marine Exhibition which opens at Olympia on August 25th.

"**Rangitoto**," the latest and largest passenger and cargo liner of the New Zealand Shipping Company, has been equipped with radio and radar by the Marconi International Marine Communication Co.

**Record Processing.**—In the note on page 303 of the August issue, the price of the pamphlet issued by the Association of Professional Recording Studios was given in error as 3d; it should have been 1s 3d by post.

**Multicore.**—Record export sales of Multicore ersin-cored solder were recorded during the second quarter of this year. Over 1,900 miles of solder were shipped to the U.S.A., one of the forty countries to which Multicore is regularly exported.

### FROM ABOARD

**French Exhibitions.**—The French Radio Council (Syndicat National des Industries Radioélectriques) is organizing an international exhibition of radio components, accessories and measuring

instruments which will be held at the Parc des Expositions de la Porte de Versailles, Paris, 15ème, from February 3rd to 7th next year. British manufacturers, who may take part under certain conditions, can obtain particulars from the Council at 25 Rue de la Pépinière, Paris, 8ème. The Salon International du Matériel Radio-Électrique, which was to have been held in Paris from September 26th to October 2nd this year, has been cancelled.

**New Zealand.**—A radio-physics research station is to be established by the New Zealand Department of Scientific and Industrial Research at Manukau, near Auckland. It will be operated by Auckland University College.

**Sweden.**—Three more medium-wave broadcasting transmitters have been supplied by Standard Telephones & Cables to the Swedish Broadcasting Administration. Two are already in operation—a 150-kW station at Sundsvall and a 100-kW transmitter at Hörby. The third transmitter—at Göteborg—which will have a power of 150 kW, is scheduled to be in operation next year. The audio-frequency range distortion of the transmitter is said to be less than 2 per cent up to 90 per cent modulation. The transmitter has an overall efficiency of from 41 to 43 per cent.

**North American Broadcasting Conference** for the allocation of frequencies to medium-wave broadcasting stations in North America will open in Montreal on September 9th.

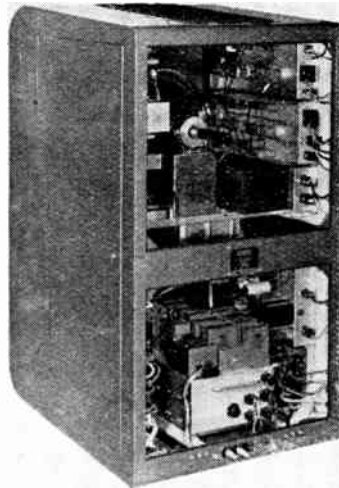

**INTERIOR OF Cinema-Television monitor with 20-in cathode-ray tube operated at 13 kV; this supply is generated by an r.f. oscillator and rectifier. Designed for v.f. signals of 1-10-V amplitude from a line input, the apparatus does not include r.f. circuits. The undersides of the various chassis are accessible for maintenance by removing side panels from the cabinet.**

**German Amateurs.**—Transmitting licences under the same conditions as those in force in the U.S. and British zones of Germany are to be issued to amateurs in the Western sectors of Berlin. Call signs will be prefixed DL7.

**Mexico.**—Requests for the erection of twenty-six television stations have been received by the Mexican Ministry of Communications. It is stated that licences will not be issued until the rules governing the operation of television stations have been drawn up.

**Radio-minded U.S.**—In a brochure issued by the American Broadcasting Company it is stated that 39,275,000 U.S. homes operate some 62,000,000 domestic receivers and over 10,000,000 car radio sets. The number of radio-equipped homes in the United States has increased by over five million in the past three years. It is forecast that next year there will be 40,250,000 radio-equipped homes, 2,750,000 of which will have television receivers.

**Ecuadorian Police** are seeking specifications and prices of six patrol cars equipped with radio, some of which will have to operate at altitudes up to 14,000 feet. Details of equipment should be sent by air mail to Commandant Duran, c/o The Commercial Section, H.M. Legation, Quito, Ecuador.

**Chilean Agencies** for domestic receivers and valves are sought by Besa y Cia Ltda, Av. B. O'Higgins 1486, Casilla 1147, Santiago, Chile.

### INDUSTRIAL NEWS

**E.M.I.**—With a view to extending the interests of E.M.I. Research Laboratories in Australia and for the subsequent manufacture of television and electronic products in the Commonwealth, G. E. Condliffe, director of the laboratories, has gone to Australia. E.M.I. already has a factory at Homebush near Sydney and has recently acquired new premises in Sydney and Melbourne. The Australian Prime Minister recently announced that the Government had decided to install 625-line television transmitters in the six State capitals.

**Change of Name.**—It is proposed to change the name of the Radio and Television Trust to Cable and Electric Industries, as, since the severance of Philco from the group of companies controlled by the Trust, radio and television receivers are no longer produced by the organization. Among the companies in the group are Airmec Laboratories, British Mechanical Productions (Clix) and Hopkinson's Motors.

**Ekco** have opened new premises for their Scottish radio service depot at 26, India Street, Glasgow, C.2 (Tel.: Central 2012).

**Industrial Sound Equipment, Ltd.**, have moved from 10, West Central Street, London, W.C.1, to 141, High Street, Brentford, Middlesex. The temporary telephone number is Ealing 5367.

**Taylor Electrical Instruments, Ltd.**, announce a revision of their hire-purchase scheme permitting dealers to offer Windsor and Taylor radio test equipment for sale on hire-purchase terms.



# DECCA RADAR

## Low Priced Equipment Suitable for Small Vessels



**A**LTHOUGH the tube diameter in this interesting new equipment, developed by the Decca Navigator Company, is only 5 inches it is necessary to resist the temptation to describe it as a miniature radar set. True, the dimensions are less than those of any marine radar so far available, and the price (£1,500) is said to be about half that of most other equipments; but the performance complies with the Ministry of Transport's specification for marine radar, and in some respects improves upon it. The pulse length, for instance, is only 0.1 to 0.12  $\mu$ sec and the range discrimination and minimum range are of the order of 20 yds.

There are four units, as follows:—

**Scanner.**—Two parabolic cheese reflectors are used, one on top of the other, for transmission and reception. They are mounted immediately over the modulator unit and are driven at 20 r.p.m. by an enclosed motor. The photograph shows the scanner unit on a tubular light-alloy mast; normally a bracket is provided for attachment to any suitable part of the ship's superstructure. In addition to the transmitter, the scanner unit contains the early receiver stages.

**Receiver.**—This is a self-contained unit without controls and is designed for bulkhead mount-

ing. It contains the immediate and final stages of amplification, the trigger unit for the modulator, power supply for other parts of the circuit and circuits associated with the metering of overall performance. This is effected by measuring the intensity of the reflected ground ray.

The bandwidth of the receiver is 10 Mc/s at an intermediate frequency of 30 Mc/s, and the overall gain is 120 db.

**Display Unit.**—By retaining in this unit only those circuits connected with the working of the cathode-ray tube, the size of this unit has been reduced to the smallest possible dimensions. It has been provided with a trunion mounting so that the position of the tube is easily adjusted to the navigating officer's liking, and it can be mounted either on a bulkhead, or horizontally at the back of the chart table.

Five range scales are provided, with maxima of  $\frac{1}{2}$ , 1, 3, 10 and 25 miles, and there is a mechanically operated cursor for reading off bearings on the illuminated peripheral bearing scale. Ship's head is indicated by a radial trace on the screen, and electrically generated range rings can be switched on or off, the appropriate calibration being shown on the range scale indicator.

A detachable visor is provided, and, if desired, a lens giving 2:1 magnification can be fitted. The whole of the equipment is controlled from the display unit,

and the pre-set adjustments are normally concealed by a hinged cover. Controls always available are the range selector on the left of the tube, bearing cursor control on the right, and, at the top, toggle switches for the range rings and crystal/performance check meter.

**Power Unit.**—A motor generator operating from the ship's d.c. mains (110 or 220 V) forms the basis of this unit and draws about 1 kW. It is housed, together with a voltage regulation circuit, in a metal case measuring 28 in  $\times$  18  $\frac{1}{2}$  in  $\times$  16 in. The output is 1,000 c/s a.c. stabilized at 80 volts. Regulation is satisfactory for mains fluctuations between +15 and -25 per cent.

The new Decca Radar is complementary to the Decca Navigator System. The latter gives accurate fixes irrespective of land or sea marks, and the former comes into its own for collision

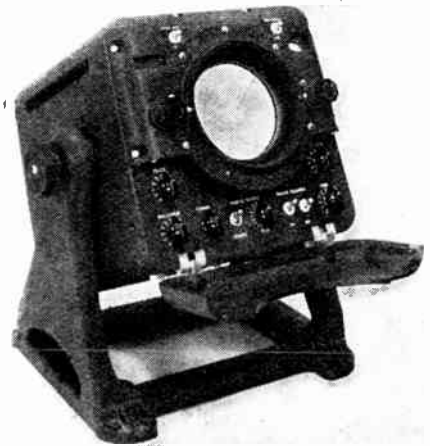

A 5-inch tube is employed in the display unit, which carries controls for the whole of the equipment.

prevention and also for pilotage.

Undoubtedly, the small size and low price of the new radar equipment should make a wide appeal to shipowners abroad as well as in this country.

# ELECTRONIC CIRCUITRY

## Selections from a Designer's Notebook

By J. MCG. SOWERBY (Cinema Television Ltd.)

IN recent years numerous papers and articles have been published describing various types of sinusoidal oscillators whose frequency is controlled by a combination of resistance and capacitance.

### RC Oscillators

The avoidance of inductive components which is achieved is particularly useful at frequencies up to 10-100 kc/s as inductances suitable for low frequencies are not easy to make, and are inconveniently large when made. In addition, a variable-frequency RC oscillator can be made to cover a wider range with a given variable component (usually a condenser) as the frequency is proportional to  $1/C$  as against  $1/\sqrt{C}$  in an LC oscillator.

There are a few rather important points concerning RC oscillators with which readers may not be fully conversant, and these notes are written in an attempt to clarify these points.

Any RC oscillator may be regarded as an amplifier of gain  $A$ , with an RC feedback network applied between output and input in such a way that oscillation is maintained. The RC network introduces positive feedback (and perhaps negative feedback as well) to achieve this end—as in all oscillators.

Consider first the overall gain of the arrangement of Fig. 1. If we call the overall feedback factor  $\beta$  in the usual way (i.e., the fraction of the output voltage fed back to the input) the net gain of the system becomes  $A_0 = \frac{A}{1 - \beta A}$ .

In amplifiers  $\beta$  is normally negative so that  $(1 - \beta A)$  is greater than 1. In oscillators  $\beta$  is positive at one frequency, at least, so that the  $A_0$  is greater than  $A$ . In the particular case where  $A = 1$ , the gain  $A_0 = \frac{A}{0} = \infty$  and this is

interpreted as the onset of oscillation. If the feedback is overdone—or the gain,  $A$ , too large—so

that  $(1 - \beta A)$  becomes negative,  $A_0$  becomes negative and the exact interpretation of this depends on the exact circuit. Usually what happens is that the amplitude of oscillation grows until the amplifier saturates and violent distortion results.

Consider now the amplifier characteristic of Fig. 2. This curve represents the overall input-output characteristic of a hypothetical amplifier before RC feedback is applied. A little thought convinces one that the gain of the amplifier is merely the slope of the curve which, for the purposes of illustration, is shown as rather more variable than is generally the case in practice. Three tangents have been drawn to the curve at P, Q, and S, corresponding to the three gains  $A_1$ ,  $A_2$ , and  $A_3$ , at the three output amplitudes  $V_1$ ,  $V_2$ , and  $V_3$ . Now suppose that the gain required to make  $\beta A = 1$  in a particular oscillator lies between  $A_1$  and  $A_2$ , then the output amplitude will lie between  $V_1$  and  $V_2$ . As the amplifier characteristic is nearly straight over the OQ region of the curve, little distortion would be expected. But if the value of  $A$  for oscillation happened to fall between  $A_2$  and  $A_3$ , then a larger amplitude of oscillation would be expected

of maintaining the amplitude of oscillation at a level sufficiently large to be useful, but sufficiently small to keep distortion within tolerable limits—say less than one per cent.

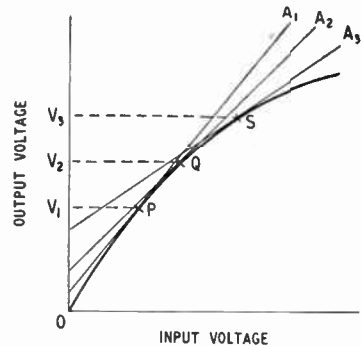

Fig. 2. Hypothetical amplifier characteristic.

The obvious way of controlling the amplitude of oscillation is to control the gain of the amplifier, and this leads one naturally to think in terms of variable- $\mu$  valves. Unfortunately these are not very suitable for the purpose as only a limited amplitude can be handled by such valves without incurring distortion, owing to the necessarily curved valve characteristics. A better alternative is to control the gain of the amplifier, or the feedback factor  $\beta$ , by means of a resistive element whose resistance is dependent on the amplitude of the applied voltage. Examples of such elements are lamp filaments, and "thermistors" which are now available commercially.

Fig. 3 shows a typical oscillator<sup>1</sup> in which the RC network is a Wien bridge, and the amplitude control is normally carried out by using a thermistor for  $R_1$ , or a lamp

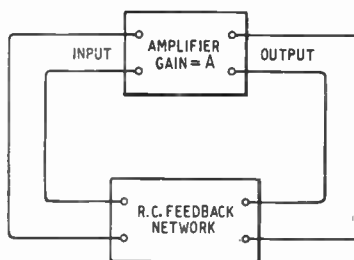

Fig. 1. Block diagram of an RC oscillator.

with a corresponding increase in distortion. As in all oscillators, therefore, means must be found

<sup>1</sup> Terman, "Radio Engineer's Handbook," 1st Edn., p.505. McGraw-Hill.  
Terman, Buss, Hewlett & Cabill. Proc. I.R.E. Vol. 10, p.649. Oct. 1939.  
Brit. Pat. No. 489,849.

for  $R_2$ . The conditions for balance in the Wien bridge are

$$2\pi f_0 RC = 1 \text{ or } f_0 = \frac{1}{2\pi RC}$$

and

$$\frac{R_2}{R_1 + R_2} = \frac{1}{n} = \frac{1}{3}$$

But if the bridge were exactly balanced there would be no feedback from output to input at the required frequency of oscillation,  $f_0$ . Analysis shows that in fact the bridge must be slightly off balance for the circuit to oscillate, and if there is no phase shift in the amplifier, the conditions for oscillation ( $1 - \beta A$ ) = 0 are

$$f_0 = \frac{1}{2\pi RC} \text{ as before}$$

$$\text{and } \frac{1}{n} = \frac{1 - 3/A}{3} = \frac{R_2}{R_1 + R_2}$$

The former condition is obviously the one which controls the frequency of oscillation, and the latter offers the possibility of controlling the gain by the automatic variation of  $R_1$  or  $R_2$  with amplitude.

As  $R_2$  forms the cathode bias resistor of the first amplifier valve, in addition to being one arm of the bridge, its value is restricted to a particular range according to the valve type chosen.  $R_1$  must then be approximately twice

condenser  $C_B$  has to be made of very large value—8 or  $16\mu F$ —in order to avoid undesirable phase shifts in the amplifier at low frequencies.

As already noted, if a filament lamp is used for  $R_2$ , automatic control of amplitude can be achieved, because as the amplitude of the RC oscillation signal fed through  $C_B$  increases, so also does the resistance of the lamp.

In consequence if  $\frac{1}{n}$  is initially considerably less than  $1/3$ , as the amplitude rises the value of

Fig. 4. Typical lamp and thermistor characteristics.

$1/n$  increases, until at some particular amplitude it becomes equal to  $\frac{1 - 3/A}{3}$ , and the amplitude of oscillation is stabilized. In design, care is taken to ensure that this amplitude is well within the capabilities of the second amplifier valve (having due regard for its low effective anode load) so that distortion is low.

An alternative scheme is to use a thermistor for  $R_1$ , and as the voltage across a thermistor increases, its resistance decreases. As  $R_1$  is only called upon to carry alternating current, the

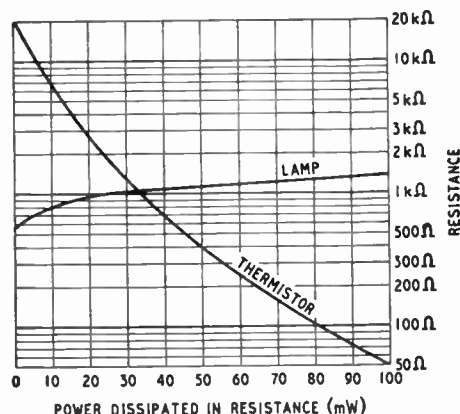

control achieved by using a thermistor here should be rather better, and is, in any case, easier to design.

One point should be watched; the resistance of  $R_1$  and/or  $R_2$  should be constant throughout one cycle of oscillation, or the feedback will not be constant throughout one cycle, and distortion will result. Thus, a lower limit is set to the frequency of oscillation by the thermal time constant of the stabilizing device. The writer has found lamps satisfactory down to about 20 c/s, and thermistors to about 10 c/s, although the exact figure will depend on the tolerable distortion and the exact components used. Fig. 4 shows curves of resistance against power dissipated for a 15-watt, 240-volt lamp, and for a S.T.C. thermistor No. A2451/100.\*

Distortion is further reduced in this particular oscillator by the fact that with increasing order of harmonic, the amplifier is subject to increasing negative feedback so that the effective gain at harmonic frequencies is progressively reduced. This is a considerable help in attaining freedom from distortion.

\* Reference to thermistor curves of resistance/voltage shows that for many values of applied voltage there are two possible values of resistance. The lower value of resistance is the one to choose, and to put the component in this state the circuit must be capable of supplying momentarily the maximum voltage shown by the resistance/voltage curve. Such a curve may be obtained from the manufacturer's curve given in Fig. 4.

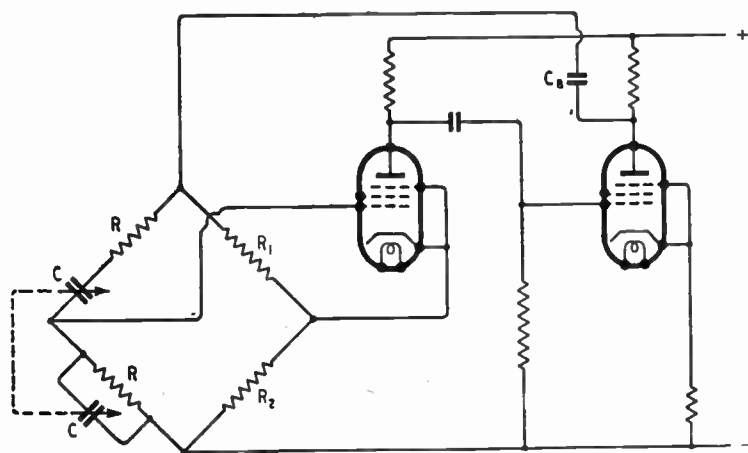

Fig. 3. Wien bridge RC oscillator.

$R_2$  in order that  $1/n$  shall be approximately  $1/3$ , and as cathode bias resistors are notoriously low in value, the load on the second valve must also be low. Hence a power valve is commonly used in this position, and the blocking

Stabilization by this method is rather complicated by the fact that d.c. flows through  $R_2$  and the first valve, as well as a.c. through  $R_1$  and  $R_2$ , although it is only this latter which is effective in stabilizing the amplitude.



**Electronic Circuitry—**

THE cathode-coupled amplifier, is now in wide use, and it is the practice sometimes to introduce variable gain<sup>2</sup> by means of a resistance  $R_v$  bridging the two cathodes each of which is then

**Cathode-coupled Amplifiers**

returned to negative h.t. through its own resistor  $R_k$ , as shown in Fig. 5. As long as push-pull input is applied a balanced push-pull output is obtained whatever the value of  $R_v$ , and each valve

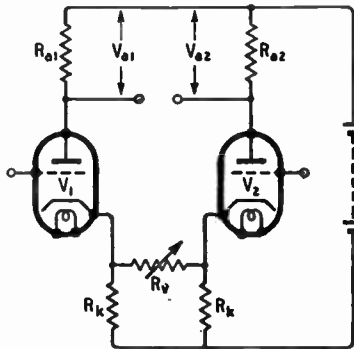

Fig. 5. Cathode-coupled amplifier with variable gain.

behaves as if it had a cathode feedback resistor of value equal to the resistance of  $R_v/2$  in parallel with  $R_k$ .

But now consider the same circuit in phase-splitter service. Under these conditions both grids are returned to the same positive

$V_1$ , and the two outputs at the anodes are completely unbalanced. If  $R_v$  is greater than zero the unbalance will still be present to a greater or lesser extent, and as  $R_v$  is reduced again to zero the unbalance decreases until only the inevitable unbalance of a cathode-coupled amplifier is left (i.e., when the anode loads are equal.) This remanent unbalance of the two output voltages may be rectified by making the anode loads unequal, and indeed by this means balance can be achieved for any reasonable value of  $R_v$  — but only for one value.

On analysis it turns out that the ratio of the output voltages for phase-splitter service is

$$V_{a2}/V_{a1} = \frac{(\mu + 1) R_k}{(R_{a2} + r_a)(2 + R_v/R_k) + (\mu + 1)(R_k + R_v)} \cdot \frac{R_{a2}}{R_{a1}} \dots (1)$$

For any particular setting of  $R_v$  exact balance can be obtained by making  $R_{a1} < R_{a2}$ , and the condition for exact balance is

$$R_{a1} = \frac{R_{a2}}{1 + R_v/R_k + \frac{(R_{a2} + r_a)(2 + R_v/R_k)}{(\mu + 1) R_k}} \dots (2)$$

where  $r_a$  = anode resistance and  $\mu$  = amplification factor of either valve. The analytical expression for the gain from the input grid to either anode becomes rather tedious to work out (and rather formidable in use) as soon as feedback is introduced by  $R_v$ . The gain from the grid of  $V_1$  to the anode of  $V_2$  is given by

$$A_2 = \frac{\mu R_{a2}}{\left[ (R_{a2} + r_a)(2 + R_v/R_k) + (\mu + 1)(R_k + R_v) \right] \left[ \frac{R_{a1} + r_a}{(\mu + 1) R_k} + \frac{1 + R_v/R_k}{2 + R_v/R_k} \right] - \frac{(\mu + 1) R_k}{2 + R_v/R_k}} \dots (3)$$

bias potential, but the signal is fed into only one grid—say that of  $V_1$ . When  $R_v = 0$  the two resistors  $R_k$  are directly in parallel and form the familiar cathode coupling resistor. But consider what happens as  $R_v$  is increased indefinitely and eventually made open-circuit. No signal then reaches either cathode or grid of  $V_2$  so that its output and gain fall to zero; at the same time a small gain is obtained from

The gain —  $A_1$ —to the first anode can be found by calculating  $A_2$  by (3) and modifying the result in the light of (1) which represents the ratio of the two gains as well as the ratio of the output voltages.

Generally speaking this form of variable gain is best restricted to stages driven in push-pull whenever it is important to maintain an exact balance. Very often, however, a reasonable approximation to balance can be maintained in a variable gain phase-splitter circuit, provided the gain is only varied between fairly narrow limits.

**LIGHTWEIGHT TELEWRITER**

*Tone Operation Over Line or Radio Channel*

UNDER the auspices of British Telecommunications Research, Ltd., Derwent House, Arundel Street, London, W.C.2, there was demonstrated recently a novel light-weight teleprinter of Swiss manufacture and known as the ETK Telewriter.

The complete machine measures 15 x 13 x 6 1/2 in, weighs 26 lb and has many commercial applications. With the addition of a 1,500-c/s tone generator it can be operated over telephone circuits, but where a d.c. circuit exists this attachment is not necessary.

As it can be operated with tone signals the machine is also suitable for use over any radio link provided high-speed operation is not essen-

tial. The present design of machine is capable of 35 words per minute, sending and writing. With the addition of ciphering equipment the signals passed to the line are scrambled and a very high degree of secrecy is obtained.

An interesting feature of this machine is that the characters are not typed in the accepted sense, but are built up from a number of

elementary signs. There are four-teen such signs on the typing head and those required to form a particular letter or character are selected by the sequence of the received signals. Five parts generally suffice to form a single character. Synchronization between the send and receive machines is effected by a new design of governor.

**"Making the most of your Receiver"** is the title of a 12-page booklet issued by Stratton and Co. Ltd., Alvechurch Road, West Heath, Birmingham 31. It gives helpful advice on the choice and erection of aerials, the suppression of electrical interference, the care of batteries, and hints on loudspeakers and headphones. The price is 1s.

<sup>2</sup> Puckle, O. S. "Time Bases." 1st Edn. p. 121. Chapman & Hall.  
Jofsch, M. L. Brit. Pat. No. 529,044

# Vortexion

## SUPER FIFTY WATT

This **AMPLIFIER** has a response of 30 c/s. to 25,000 c/s. within  $\pm$ db, under 2 per cent distortion at 40 watts and 1 per cent at 15 watts, including noise and distortion of pre-amplifier and microphone transformer. Electronic mixing for microphone and gramophone of either high or low impedance with top and bass controls. Output for 15/250 ohms with generous voice coil feedback to minimise speaker distortion. New style easy access steel case gives recessed controls, making transport safe and easy. Exceedingly well ventilated for long life. Amplifier complete in steel case, with built-in 15 ohm mu-metal shielded microphone transformer, tropical finish.

As illustrated. Price **36½ Gns.**



## CP20A. 15 WATT AMPLIFIER

for 12 volt battery and A.C. Mains operation. This improved version has switch change-over from A.C. to D.C. and "stand by" positions and only consumes 5½ amperes from 12 volt battery. Fitted mu-metal shielded microphone transformer for 15 ohm microphone, and provision for crystal or moving iron pick-up with tone control for bass and top and outputs for 7.5 and 15 ohms. Complete in steel case with valves.

As illustrated. Price **£28 0 0.**

## 30 WATT RECORD REPRODUCER

This amplifier has been produced for extremely high quality gramophone or microphone quality in large halls or in the open. An output power of 30 watts is obtainable at under 1% distortion after the output transformer which is arranged for 4, 7½, or 15 ohm output. The most noticeable point is the absence of background noise or hum.

Very generous feedback is employed to help out any distortion developed by the speaker and the large damping factor ensures good transient response. The usual response of 30 to 25,000 cycles plus or minus  $\frac{1}{2}$  db is given, and recording compensation of 5 db per octave lift below 300 cycles is obtainable on the gramophone input by means of a switch. A carefully balanced treble control is arranged to correct top lift on some recordings as well as to reduce scratch on old records without noticeable effect on frequencies below 3,500 to 4,000 cycles. The input is intended for the high fidelity type of pick-up and is fully loaded by an input of .2 volts on 100,000 ohm or  $\frac{1}{4}$  meg. ohm as required. The microphone stage requires an input of .3 millivolts on 15 ohm balanced line through the wide response mu-metal shielded microphone transformer. An octal socket is fitted at the rear of the chassis to provide power for feeder units, etc., 6.3 volts at 2 amps and 350 volts at 30 milliamps is available.

Complete in well ventilated steel case. Price **30½ Gns.**



## EXPORT

Enquiries from Overseas will receive prompt attention. Continental Buyers are invited to get into touch with our Belgian Agents:

Ms. Constant L. Bismar,  
129 Avenue de la Reine,  
Bruxelles  
Téléh. 16.10.31.

## FOUR WAY ELECTRONIC MIXER

This unit has 4 built-in, balanced and screened microphone transformers, normally of 15-30 ohms impedance. It has 5 valves and selenium rectifier supplied by its own built-in screened power pack: consumption 20 watts. Suitable for recording and dubbing, or large P.A. Installations since it will drive up to six of our 50 watt amplifiers, whose base dimensions it matches. The standard model has an output impedance of 20,000 ohms or less, and any impedance can be supplied to order.

Price in case with valves, etc., **£24.**

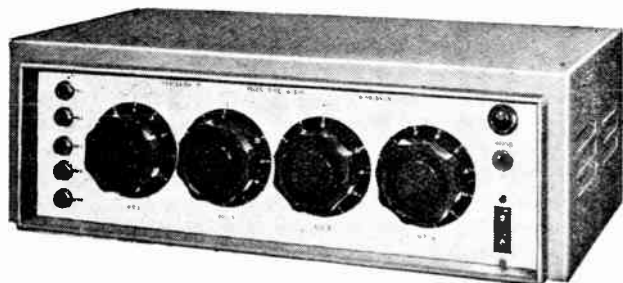

**VORTEXION LIMITED, 257-261 THE BROADWAY, WIMBLEDON, LONDON, S.W.19**  
Telephones: LIB 2814 and 6242-3  
Telegrams: "Vortexion, Wimble, London"



**THE COMPLETE SERVICE FOR SOUND RECORDING AND REPRODUCTION**

- ★ Mobile, static and specialised recording units
- ★ Recording amplifiers, speakers, microphones, etc
- ★ Sapphire cutting and reproducing stylii
- ★ Blank recording discs from 5in. to 17in. Single and Double-sided
- ★ Groove locating and cueing devices
- ★ A comprehensive range of accessories to meet every requirement of the sound recording engineer
- ★★ A development of special interest to users of sapphire and delicate pick-ups—THE SIMITROL. This is a controlled micro-movement easily fitted for use with any type of pick-up
- ★★★ OUR CDR49A RECORDER UNIT complete and self-contained, measuring only 22in. x 14in. x 13½in., incorporating 8-valve amplifier, recorder unit, lightweight pick-up, speaker and microphone and with many exclusive features, is now ready for early delivery



Portable Twin channel Continuous Recording system incorporating CDR49A Recorder/Amplifier DR49A Recorder and EM49A Electronic 4 Channel Mixer  
**Manufactured exclusively by Simon Sound Service.**

**OUR WELL-EQUIPPED WORKSHOPS ARE AVAILABLE FOR THE DEVELOPMENT OF EQUIPMENT TO MEET SPECIAL NEEDS.**

**SIMON SOUND SERVICE, Recorder House, 48/50, George St., Portman Square, London, W.1.**

CABLES : Simsale, London.

TELEGRAMS : Simsale, Wesdo, London

TELEPHONE: Welbeck 2371 (4 Lines)



**PLAN YOUR CAREER**

**RADIO · TELEVISION and other INDUSTRIAL ELECTRONIC subjects**  
ELEMENTARY & ADVANCED COURSES

WRITE FOR FREE BOOKLET summarising careers available in Electronics and giving particulars of Courses offered by E.M.I. Institutes.

The booklet contains full details of elementary and advanced HOME STUDY and DAYTIME courses in Radio, Television, Telecommunications and Industrial Electronics.

Courses ideal for those seeking recognised qualifications are also available.

Payment for tuition can be made in easy instalments if required.

Write to Dept. 16A

**E.M.I. INSTITUTES**

48, GROVE PARK ROAD, LONDON, W.4. CHiswick 4417/8

Associated with "H.M.V." MARCONIPHONE COLUMBIA ETC.

R.147

**CO-AX AIR-SPACED ARTICULATED R.F. CABLES**

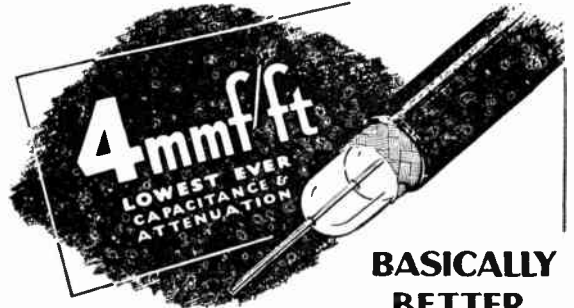

**BASICALLY BETTER**

**IMMEDIATE DELIVERIES FOR HOME & EXPORT**

LOW ATTEN. TYPES	IMPED. OHMS	ATTEN. db/100ft	LOADING $\mu$ s at 100 Mc/s	O.P.
A.1	74	1.7	0.11	0.36
A.2	74	1.3	0.24	0.44
A.34	73	0.6	1.5	0.85

HIGH POWER FLEXIBLE

FOR RADIO FREQUENCIES

LOW CAPAC. TYPES	CAPAC. pF/100ft	IMPED. OHMS	ATTEN. db/100ft 100 Mc/s	O.P.
C.1	7.3	150	2.5	0.36
PC.1	10.2	132	3.1	0.36
C.11	6.3	173	3.2	0.36
C.2	6.3	171	2.15	0.44
C.22	5.5	184	2.8	0.44
C.3	5.4	197	1.9	0.64
C.33	4.8	220	2.4	0.64
C.A4	4.1	252	2.1	1.03

PHOTOCELL CABLE

VERY LOW CAPACITANCE CABLES

FOR VIDEO and SPECIAL APPLICATIONS

Write for data sheets to the originators of air-spaced R.F. Cables.

**TRANSRADIO LTD.**

CONTRACTORS TO H.M. GOVERNMENT.

138A CROMWELL ROAD LONDON S.W.7.



# GENERALIZED GRAPHS

## Their Derivation and Use in Design Calculations

By "CATHODE RAY"

**A**LGEBRA is still so badly taught that most school children see in it exactly the opposite of what it really is—a device for minimizing brain work and saving time. Working out a problem by arithmetic gives the answer only for the particular numbers or values or dimensions concerned; doing it by algebra gives a result that covers all problems of that kind, the answer for any particular numbers being obtained simply by substituting them for the letters. As the textbooks put it, algebra is generalized arithmetic. The information that a tuned circuit

3-V sinusoidal input is applied to an amplifier coupling consisting of  $0.01\mu\text{F}$  in series and  $0.5\text{M}\Omega$  in parallel. The extent to which the output falls off at low frequencies is much more clearly displayed in this way than by a collection of figures. If the performance indicated by this graph is just what one wants—or at least what one is willing to tolerate—then it is as good as says "Go ahead; use  $0.01\mu\text{F}$  and  $0.5\text{M}\Omega$ ."

to have a wide range of different voltages applied to it at different times, or even at the same time. So far as we can tell, 3V has no special merit or significance, except that it is more convenient than (say) 2.9307V. But 1V or 10V or 100V would be more convenient still. Why?

### Voltage Ratios

The reason is interesting: it is because the output could then more easily be read as a decimal fraction or percentage of the input. What we usually want to know about amplifiers and similar arrangements is not the actual voltage output but the relative voltage or percentage gain or loss. This, of course, is on the assumption that the output voltage is directly proportional to the input. Up to a point that is usually correct. The only occasions when one is interested in the actual voltages is when that

Unfortunately it says nothing about what to do if we happen to have only a  $0.005\mu\text{F}$  capacitor, or if we want less loss at 25 c/s, or even what output we would get at 25 c/s if the input were 2V instead of 3V. A graph of this

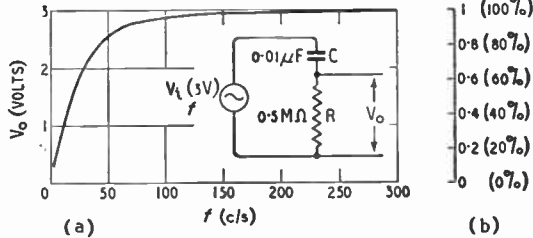

Fig. 1. Example of a graph showing a relationship (output voltage against input frequency) confined to certain stated conditions (see inset circuit diagram). It can be made slightly more general by dividing the  $V_o$  figures by  $V_i$ , so that the vertical scale is as at (b).

having an inductance of 160 microhenries and a capacitance of 250 picofarads will resonate at a frequency of 796 kilocycles per second is not much help if the tuned circuit in which one is interested does not happen by some remarkable coincidence to have an inductance of 160 microhenries and a capacitance of 250 picofarads. But once the fact that  $f_r = 1/2\pi\sqrt{LC}$  has been established it enables the resonant frequency for all possible values of inductance and capacitance to be found without any serious or prolonged effort.

### A Particular Graph

Graphs are another very helpful way of recording and conveying information. Fig. 1(a) for example shows how the output voltage is affected by frequency when a

sort is like arithmetic; it is very explicit about one particular case but reticent about all others.

So persons (including your humble servant) who are more concerned with conveying general principles than isolated data naturally look for a graphical counterpart of algebra. But just as algebra mystifies the uninitiated and requires some slight mental effort to apply to particular cases, so generalized graphs are perhaps less used than they might be for fear that they might not be understood. I hope that what follows may help to allay such fears.

Having examined Fig. 1(a) as an example of an ungeneralized (or particular) graph, we might as well keep on with it and see how it can be generalized.

The most annoyingly particular thing about it is the input voltage. An amplifier coupling is likely

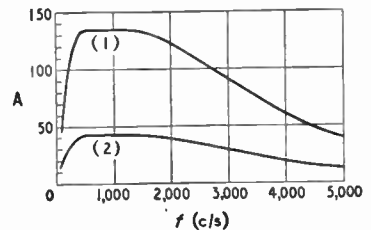

Fig. 2. When amplifier characteristics are plotted with linear amplification and frequency scales, as here, it is difficult to compare their merits.

point is exceeded, by the valves being driven into grid current or in some other way. In our simple Fig. 1 circuit at any reasonable voltage that sort of contingency is hardly likely to arise.

So a first step in generalization is to make the vertical scale read  $V_o/V_i$ , the ratio of output to input voltage, which we can if we

**Generalized Graphs—**

like denote by a single letter such as A (Fig. 1(b)).

With many simple combinations of circuit elements, such as in Fig. 1, the output tends to equal the input at some part of the frequency range. So the

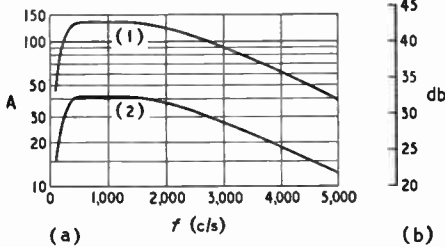

Fig. 3. The Fig. 2 curves have here been plotted with a logarithmic voltage-amplification scale, which brings out the fact that their frequency characteristics are identical, the only difference being amplification level. An alternative to the logarithmic A scale is the linear decibel scale (b). Aurally the range of frequency from 100 to 400 is as great as from 1000 to 4000, but the linear frequency scale distorts this proportion, and is a hindrance to further generalization.

new scale directly indicates the percentage at other frequencies, relative to this "ideal" level. But in a complete amplifier the "ideal" level might be almost any figure, so it would be less easy to make the comparison. Curve (1) in Fig. 2 is an example. The voltage gain is practically level at 135 over the range of frequencies around 1000 c/s, and at 4000 c/s is down to 60. To find the relative level at 4000 c/s it is necessary to divide 60 by 135. Of course the whole scale could be divided by 135 (or 1.35), making the flat top read 1 (or 100) and a note added to the effect that the actual voltage gain here was 135. But there is not always an obvious comparison level such as this, and, even where there is, one may want to compare the levels at two other points. Curve (1) doctored to make the flat top 100%, for example, would be no better than the original curve for comparing the output at 5000 c/s with that at 3500 c/s.

And look at curve (2), relating to another amplifier. So far as constancy of output with frequency is concerned, is it better or worse than amplifier (1)? At first glance it certainly looks

"flatter"; but you will find that the relative loss at all frequencies is exactly the same.

It would be helpful if any given vertical distance on the graph represented the same voltage ratio, whether it was at a high level, such as curve (1), or a low level such as (2). Then the effect of increasing the overall voltage gain of an amplifier would be to shift its curve bodily upwards without altering its shape. What is wrong with the scale in Fig. 2 is that a rise from 10 to 20, which is 100% increase, looks the same as a rise from 100 to 110, which is only 10% increase.

In Fig. 3(a) the vertical scale has been redistributed so as to make a 100% increase (or any other percentage increase or decrease) occupy the same distance from every starting point. It is as far from 10 to 20, for example, as from 50 to 100, and 75 to 150. Replotted on this scale, curves (1) and (2) are now identical in shape and differ only in level; which is a fairer representation of the facts than Fig. 2. The scale, of course, is the well-known logarithmic variety, seen on every slide-rule. The only thing still wrong with it is that it is not uniform and so is difficult to interpolate (i.e., read between the marked divisions). It is quite easy to make it into a uniform scale, because by definition it was a scale in which any given voltage ratio occupied the same distance everywhere along it. So we could measure off the distance between 10 and 11 (or 100 and 110, which would be exactly the same), and make a new scale in which the marks would be evenly spaced by this distance. They could then be numbered 1, 2, 3, etc., "ten-per-cent-increases."

**Decibels**

If the voltage gain anywhere were, say, 400, the addition of two ten-per-cent-increases would no more make it 480 than two similar successive rises in your salary of £400 would bring it to £480. The answer, as you would no doubt be very quick to point

out if the accountant made the mistake, is £400 × 1.10 × 1.10 = £484. It would be quite feasible to make out a table connecting the scale in ten-per-cent-increase units with the voltage gain scale, for convenience when one wanted to know the actual voltage gain represented by a given vertical distance. But a disadvantage of the ten-per-cent-increase as a unit (in addition to its inelegant name) is that no whole number of them equals a convenient ratio such as 10 : 1. So the matter was actually tackled from the other end, by taking the 10 : 1 ratio and dividing it into ten "x-per-cent-increases," which were named decibels. x was then found to be 25.9 . . . %.

Since adding 10 db is the same as multiplying by 10, adding a second 10 db, making 20, raises the 10 to 100. And so on. This system was devised by people

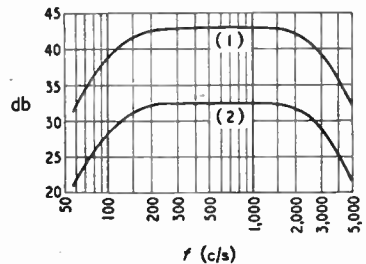

Fig. 4. Here the same two curves are revealed in their proper proportions in both dimensions (compare Fig. 2).

who were more concerned with power than voltage, so they took as its basis a 10 : 1 power ratio,— a fact one should never forget when using decibels. But provided that the impedance is the same, power is proportional to voltage-squared, so a 10 : 1 voltage ratio corresponds to a 100 : 1 power ratio. We have seen that a 100 : 1 power ratio is 20 db, so a 10 : 1 voltage ratio is also 20 db. 10 db is a voltage ratio of  $\sqrt{10} : 1$  (3.16 . . . : 1). We converted our Fig. 1(a) graph into a voltage ratio graph at a very early stage, so it is quite suitable for having a db scale attached to it.

The other main thing to remember about db is that they are ratios, not actual voltages or powers. The only way in which a number of db can mean a voltage or power is when it has been

stipulated that zero db represents some specified voltage or power.

So much for the vertical scale. What about the frequency scale? We have been using a perfectly straightforward kind in which 1 inch represents so many c/s. With radio frequencies this is often the best thing to do, because modulation of a carrier wave causes it to occupy the same number of c/s regardless of where the carrier frequency may come on the scale. But with audio frequencies it is generally the ratio that counts, rather than the actual number. A frequency ratio of 1.122:1 is recognized by any except hopelessly unmusical ears, whether it is in the low, middle or high-note region, representing respectively a frequency range of, 20, 50, or 200 c/s. Musicians call it a whole tone, and by an interesting coincidence it is almost exactly the same ratio as 1 db on the voltage scale. From this point of view, then, we would again adopt a logarithmic scale; but instead of dividing it up into db we could divide it into musical tones, 6 of which equal one octave (or 2:1 ratio). In actual fact the slope of a curve is quite often expressed as, say, 12 db per octave. But the scale itself is usually drawn on a 10:1 ratio basis, like the vertical scale, except that instead of being divided uniformly into units corresponding to db it is generally left in non-uniform c/s as in Fig. 4.

There is another reason why it is a good idea to make frequency scales logarithmic. Fig. 1 referred

made one step more general by saying that RC is  $0.005M\Omega \mu F$ . For in that circuit,  $V_0/V_i$  at any particular frequency depends on R multiplied by C, so whatever R may be one can find a value of C that will make the curve apply. But it would be more useful still if it could answer such questions as "How much is it necessary to increase RC in order to ensure that the response is not less than 90% at all frequencies from 50c/s upwards?"

As it happens,  $V_0/V_i$  is determined by the product  $RfC$ . From Fig. 1 (a) (or more easily if it were provided with a scale of  $V_0/V_i$  rather than  $V_0$ ) it can be seen that the lowest frequency at which  $V_0/V_i = 0.9$  is 66c/s. To leave  $V_0/V_i$  and therefore  $RfC$  unaltered when  $f$  is reduced from 66c/s to 50c/s it is necessary to increase RC in the ratio 66:50, which of course can be done by increasing R or C or both. All this can be simplified by plotting  $V_0/V_i$  against  $RfC$  in the first place, giving a universal or generalized graph for this particular circuit (Fig. 5). Then all one has to do to make it fit any particular problem, such as the design of a tone control, is to decide whereabouts on the curve any one frequency should come. Suppose that at 20c/s  $V_0/V_i$  ought to be 0.2. Fig. 5 shows that the point is at 0.035 on the  $RfC$  scale, so RC must be  $0.035/20 = 0.00175$ ; say  $0.005\mu F$  and  $0.35M\Omega$ . By dividing the  $RfC$  scale by 0.00175 it is converted into a frequency scale for this particular case.

The process just described may not seem much of a simplification; but consider the alternative of drawing a whole lot of particular curves with different frequency scales until one turns up that fits the requirements. And once the curve is drawn it serves for all calculations of this kind. More-

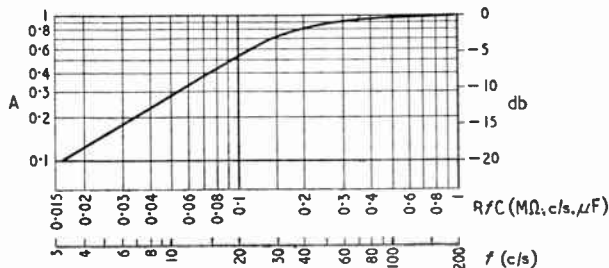
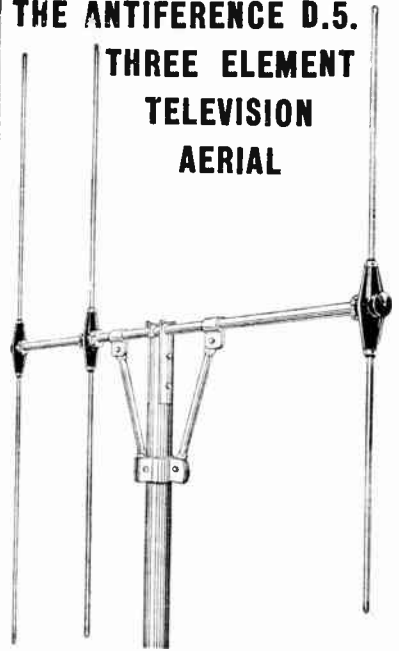

Fig. 5. The same change of scales is applied here to Fig. 1, with the frequency scale generalized by dividing the original figures by RC. If a loose frequency scale (such as the one below the  $RfC$  scale) is slid along until the desired characteristic is obtained, the ratio of the two scale readings at any point gives the necessary value of RC.

to a circuit in which R was  $0.5M\Omega$  and C was  $0.01\mu F$ . Even as drawn there the curve can be

used for all calculations of this kind. More-

## THE ANTIFERRENCE D.5. THREE ELEMENT TELEVISION AERIAL



FOR LONG RANGE RECEPTION  
All connections enclosed and sealed  
against corrosion

The D.5 Aerial is designed for Television reception at long range. In addition to the normal dipole and reflector rods, a third element—the Director—is mounted on the supporting arm and positioned between the dipole and the transmitting station. The addition of this director element results in extra gain of signal and much improved directional properties. The aerial may also be used in stronger signal areas where extra directivity is required to eliminate ghost images or to minimise interference.

The Antiferrence Junction Units (Prov. Pat.) provide ample support for the aerial rods and a high degree of insulation in all weathers. All electrical connections are completely weathertight, preventing any possible deterioration in performance. The adjustable mast cap enables any size mast to be used, but a minimum of 2½ in. diameter is recommended. Mast mounting brackets are available for either lashing to a chimney (LSG/2) or bolting to any flat surface (SMB/2). The signal gain of the D.5 Aerial compared with that of a standard dipole is approximately 7dB (2-1).

Cat. No. for London D5. LIST PRICE £6.

Cat. No. for B'ham D5/B. LIST PRICE £6.

**ANTIFERRENCE**  
LIMITED

67 BRYANSTON ST., LONDON, W.1.



**Generalized Graphs—**

over, by making the horizontal scale logarithmic as in Fig. 5, one can slide a loose frequency scale along it until the curve comes in the right place. The ratio of any  $R/C$  reading on the fixed scale to the  $f$  reading on the sliding scale at the same point gives the required  $RC$  at once. This would not work with any other than a logarithmic scale.

A slight modification of this method of dealing with the horizontal scale in cases like Fig. 5 is sometimes to be preferred, especially for purposes of comparison, and it ties up better with the algebraical approach. Although frequency is the variable that most of us use in practice, the more fundamental quantity in theory is  $2\pi f$ , denoted by  $\omega$ . So one could plot the curve against  $R\omega C$  instead of  $R/C$ . To change from Fig. 5, all the numbers on the horizontal scale would have to be multiplied by  $2\pi$ , or (what comes to the same thing) the scale could be moved bodily to the left, sufficiently for 1 to occupy the place now held by  $1/2\pi$  or 0.159.

This merit of this scheme, which may not be obvious at the moment, is revealed by considering how the curve is actually arrived at. The ratio  $V_o/V_i$  is, of course, the ratio of  $R$  to the impedance of  $R$  and  $C$  in series.

$$\begin{aligned} \text{So } V_o/V_i = A &= \frac{R}{\sqrt{R^2 + X_c^2}} \\ &= \frac{1}{\sqrt{1 + X_c^2/R^2}} \\ &= \frac{1}{\sqrt{1 + k^2}} \end{aligned}$$

in which  $k$  denotes  $X_c/R$ .

In this simple way we have reduced the variables from three

thought of plotting  $A$  against. It is true that at some stage we may have to unpack the parcel  $k$  again in order to get at the contents,  $R$ ,  $C$  and  $f$ , but in the meantime we should have gained a clearer view of the relationships in the circuit with which we began, in Fig. 1. And what makes this more worth while is that this same curve, defined by

$$A = 1/\sqrt{1 + k^2},$$

applies to a number of other circuits, such as those shown in Fig. 6, if the parcel  $k$  is made up of the appropriate contents. (This is one of the things that is much easier to see with the help of Thévenin's theorem.)

Another advantage of the  $k$  scale is that the good round number 1 on it corresponds to a halving of the power in the circuit and so makes a useful reference point or basis for comparison. Half-power is  $1/\sqrt{2}$  voltage, so  $A$  at this point is  $1/\sqrt{2} = 0.707$  or roughly 70%. This happens to be the point at

interchanged. Again, the frequency which makes the ratio of  $X_c$  to  $R$  equal to 1, marks the noticeable fall-off. The frequency range between these two reference marks defines the effective bandwidth of the amplifier.

**Generalized Resonance Curves**

There are a number of other commonly - encountered design problems in which a single curve can be made to cover the entire range of values. One class of them is the resonance or selectivity curve. Take the simplest case—a single tuned circuit. Its response depends on  $L$ ,  $C$  and  $R$ . Filling in different values for these, one could get an infinite variety of resonance curves, some sharp, some flat, some resonating at high frequencies, some at low, and so forth (Fig. 7). Yet the chances are that not one of them would

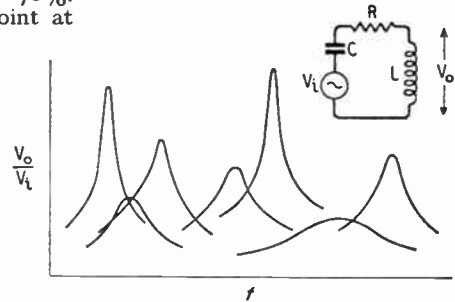

Fig. 7. Plotting  $V_o/V_i$  against  $f$  for various values of  $L$ ,  $C$  and  $R$ , one can get an infinite variety of curves, of which a few are shown here. But by choosing different scales they can all be reduced to a single curve ; see Fig. 8.

which a fall-off in sound power generally begins to be noticeable. It is very easy to remember that it occurs at the frequency for which  $k$  (which =  $2\pi fRC$ ) is equal to 1; so, if you decide what frequency it should be, the product  $RC$  follows.

exactly fit a particular requirement. If it came at the right frequency it might be too sharp or too flat, or vice versa. But by plotting with suitable scales a single curve can be made to cover all possible combinations of  $L$ ,  $C$  and  $R$ . Another curve covers all combinations of two tuned circuits with a specified degree of coupling; and so on.

First of all the peaks of the separate (Fig. 7) curves are all brought to a common level by reckoning  $V_o$  relative to  $V_{or}$  ( $V_o$  at resonance) instead of to  $V_i$ . Next, they are brought to the same point horizontally by plotting  $V_o/V_{or}$  against a "  $k$  " defined as  $Qf/f_r$ , where  $f$  is the frequency-off-tune and  $f_r$  is the frequency at resonance. By this dodge the differing sharpnesses or flatnesses are combined in one curve, because the frequency at which a given

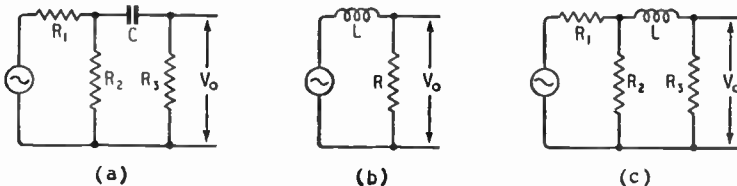

Fig. 6. Examples of circuits to which a curve of the shape shown in Fig. 5 can be made to apply by substituting appropriate variables for  $R/C$ .

( $R$ ,  $C$  and  $f$ ) to one ( $k$ ), which is the ratio of reactance to resistance in the circuit. Now  $1/k$  is  $R/X_c$  or  $R\omega C$ , which is what we have

An exact mirror image of this relationship applies at the upper frequency end, to parts of the circuit in which  $C$  and  $R$  are

fall-off takes place is inversely proportional to the tuning circuit.

The result is given in Fig. 8 for a single tuned circuit and also for

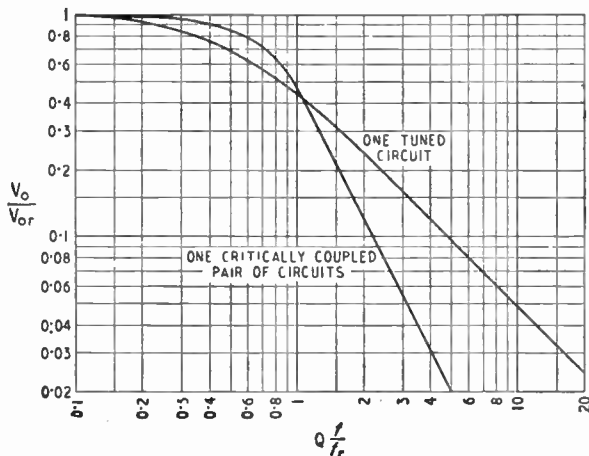

Fig. 8. Here  $V_o$  and  $f_r$  are respectively the output voltage and frequency at resonance, and by using them as the basis of comparison, and incorporating  $R$  in  $Q$ , the multiplicity of Fig. 7 curves reduces to one. Other tuning systems can each be represented by one curve, and their essential characteristics compared.

a pair of critically coupled circuits. These show at once that the pair of circuits gives more level response near resonance than the single circuit, and at the same time gives better selectivity beyond a certain point ( $Q/f_r = 1.1$ ) where the two curves intersect. By deciding on the off-tune fre-

quency at that (or any other) point, the  $Q$  of the circuits for any given resonant frequency automatically follows.

Suppose we make it 5kc/s, and the carrier frequency is 600kc/s. Then  $Q = 1.1 \times 600/5 = 132$ .

Similar curves can be worked out for standard forms of filter circuit, in which the variable frequency is generally reckoned relative to the cut-off frequency.

In time one gets to know the shapes of the curves for the most used circuits, and

this leads to a much clearer mental picture of how the various quantities involved are related to one another than does a mass of particular-value curves for each type of circuit. That is exactly where algebra scores over arithmetic, of course. And it also seems to be where we came in.

### MAINS-BATTERY PORTABLE

THE new Ekco "Stroller" is a lightweight all-purpose receiver which will operate from a.c. or d.c. mains, or from dry batteries.

Mullard D90 series miniature

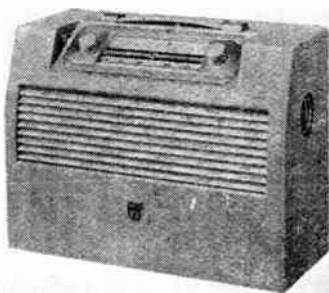

Three wavebands, including 19-51 metres, are covered by the self-contained Ekco Model MBP99 mains-battery portable.

valves with B7G bases are used in the four-valve superhet. circuit; a selenium rectifier is used for the power supply on a.c. mains. Change-over from mains to battery is effected by double-pole switching and all necessary precautions have been taken to safeguard against shock. The price of this new set is £19 19s, including tax.

#### MANUFACTURERS' LITERATURE

Leaflet describing television aerials made by A B Metal Products, Great South West Road, Feltham, Middlesex.

Descriptive leaflet dealing with the "Etronic" Model EB428 battery portable, from the Hale Electric Co., Talbot Road, London, W.13.

Leaflets describing SL301 Aircraft Equipment Tester, SL302 MF Beacon Type WBS, and SL101, VHF Multi-channel Communication Equipment, from Marconi's Wireless Telegraph Co., Ltd., Chelmsford, Essex.

Booklet giving details of the Plessey electron microscope, from the Plessey Company, Ilford, Essex.

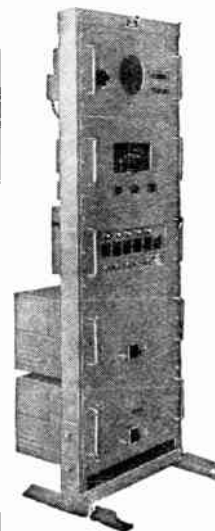

Typical Trix Rack-Mounted Equipment

Rack-mounted equipment for SPORTS GROUNDS, HOSPITALS, FACTORIES, SHIPS, etc. etc.

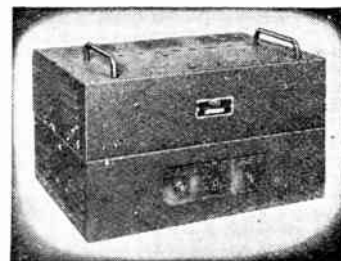

60 WATT Amplifier . . T663 B.

This amplifier provides the full rated power by the use of four valves in a parallel push-pull output circuit with inverse feedback. It is a high gain 4-stage amplifier which can be used singly or in combination with supplementary units Type T663/S to provide power outputs of 120, 180, 240 watts, or higher. Where a number of separate inputs are required, our 4-way or 6-way Electronic Mixer can be connected. Like most Trix Amplifiers, the T663B is designed for adaptation to rack mounting.

SEE US AT:—  
**Stand No.101, Radclyphia**

THE TRIX ELECTRICAL CO LTD  
1-5 Maple Place, Tottenham Court Road, London, W.1. Phone: MU5eum 3817  
Grams & Cables: "Trixradio, Wesdo London"

AMPLIFIERS • MICROPHONES • LOUSPEAKERS

# Unbiased

By FREE GRID

## Urbi et Orbi

I CANNOT help feeling that we might with some justification set up in this country a body similar to the Academie Française to endeavour to standardize our nomenclature or at any rate attempt to



Bureau of Scientific Nomenclature.

guide it into the right channels. I realize, of course, that some such body must already exist and have given us such excellent terms as capacitance and capacitor, but its terms of reference are obviously not wide enough.

I am moved to make this suggestion by the sudden and increasingly popular use of the term TV. Nowadays we read of TV this and TV that and everybody seems smugly content with this wretched expression. It would not in the least surprise me if I received a shocked letter pointing out that this expression was coined by some sacrosanct body and has received official benediction and that as a result of my remarks my works are being placed on the *Index Expurgatorius* or even *Librorum Prohibitorium*.

My objection to TV and a host of other expressions we use in radio is that, like its parent word television, it does not suggest the idea of radio transmission or radio principles at all. A far better expression, if this craze for abbreviation must be pandered to, would be RV, but it would be better still to use the full word radiovision. Such a word not only keeps the idea of wireless transmission constantly before the minds of the public but would have the advantage of not being an obvious hybrid like television. I do not, however, stress the latter point as the word radio itself is not really an etymological thoroughbred and has only acquired its present meaning by popular usage.

But I am no pedant on the subject of etymological purity, and in particular hybridism, and I don't mind admitting that I think the most suitable term for a television receiver would be "radioscope." I first used it in these columns fifteen years ago; long before Alexandra Palace started operations. Probably, however, this word is more urgently required as a substitute for the wretched expression television camera. This term suggests that television is not a direct transmission but merely a film recording.

But I cannot help feeling that I am a voice crying in the wilderness and that we shall continue to coin our radio expressions in the haphazard fashion that we always have done. Radio is not the only branch of science that does this; has anybody, for instance, heard of a more absurd word than stethoscope to describe the doctor's basic tool? The Bureau of Standard Scientific Nomenclature is indeed badly needed.

## Wireless from the Wind

ONE of the most astonishing features of women's mental make-up, which has so far completely baffled the combined psycho-analytical efforts of Freud, Jung and Adler, is their inability to resist buying anything which they fondly and deludedly imagine to be a bargain. Hard-headed business men have not failed to take advantage of this amiable weakness with the result that in the case of most of us the house is littered with useless junk of all sorts.

I pointed this out to a well-known politician the other day and he explained that the Government was well aware of this trait and, with the full agreement of the Opposition, might encourage it as its results were regarded as a fruitful source of salvage. He went even further and stated that if the battle of Waterloo was won on the playing fields of Eton then no less was the battle of the World in 1939-45 won on the domestic dump heaps which women had so assiduously garnered from the bargain counters of our great stores.

Be this as it may, it still did not solve my problem of what to do with the very large accumulation of wind-driven battery charging generators which Mrs. Free Grid recently

secured at a knockout price from a clearance sale. A radio firm had imported large quantities of these devices from the U.S.A. in pre-war days in the vain hope of selling them to country listeners who, having no electricity supply, had to trudge for miles over ploughed fields to get their accumulators charged.

Waste of any kind is against my nature and I could ill afford to lose the amount of money which Mrs. Free Grid had invested in her so-called bargains. I am glad to say, however, I have solved the problem by arranging for these wind-driven generators to supply all power to my wireless gear. It has been a pretty expensive business as the output from these devices is too variable to feed directly to a receiver. It has, therefore, been necessary to collect their output in a battery of costly accumulators. These feed a motor-alternator which supplies power direct to my apparatus.

Unfortunately, the blades of the particular brand of windmill which Mrs. Free Grid bought were made of a light metal alloy which provided ghost images on the television screen. These were moving in more senses than one and I have had to experiment with a very elaborate set of rotating devices which keep exactly in step with the blades and provide a precise 180° out-of-phase



effect. I can say, however, that Mrs. Free Grid's well-meant efforts have not been wasted and next winter my broadcast reception will no longer be governed by the whims of Mr. Gaitskell.



## LETTERS TO THE EDITOR

### Noise and Signal ♦ Q-meter Refinements ♦ Strobe and Stroboscope ♦ Secondary Interference Radiation ♦ Television—Cinema Comparisons

#### Assessing Receiver Sensitivity

I HAVE found recently in the technical Press a misconception about the perceptibility of radio signals. This, it seems, has been fostered by manufacturers' advertisements that "1  $\mu$ V in will give so-and-so-many watts out," without stating what part of this wattage is noise and what signal.

I think it will interest readers to learn the results of an investigation into the performance of normal communication receivers. Representative figures, according to my measurements, are tabulated below:—

Lowest Input in $\mu$ V into Aerial to Obtain 20db Signal-to-noise Ratio	R/T: Ratio		C.W.
	30% mod.	70% mod.	
National HRO ..	3-5	1.5-2.5	1.5-2.5
Army R107 ..	3.5-5	2-3	2-2.5
RCA AR88 ..	4.5-8	2.5-4.5	2.5-4
Hallcrafters SX28	5-8	2.5-4.5	3-4

These figures suggest that:—

5  $\mu$ V in for 20 db signal-to-noise ratio on R/T (30 per cent mod.),  
2.5  $\mu$ V in for 20 db signal-to-noise ratio on R/T (70 per cent mod.),  
2.5  $\mu$ V in for 20 db signal-to-noise ratio on c.w.

is a fair average. We can therefore deduce that there is about 0.5  $\mu$ V noise in these sets, and that signals of less than 1.5  $\mu$ V on R/T (30 per cent mod.) or 0.8  $\mu$ V on c.w. are useless, as they are not perceptible.

This does not suggest that we could not do better. A triple-diversity receiver specially developed for the Army (a prodigious 84-valve affair) gave 2 to 2.5  $\mu$ V in for 20 db on R/T 30 per cent mod. and 1 to 1.5  $\mu$ V for c.w., which brings the perceptibility down to 0.7  $\mu$ V in for R/T and 0.5  $\mu$ V for c.w. But that seems to be the limit at present.

K. E. MARCUS.

Uxbridge, Middx.

#### "Q-Meter Controversy"

IN the discussion on Q meters, both resistance and inductance methods of series injection have been referred to, and V. A. Sheridan has described a shunt-capacitance method.<sup>1</sup> This has also been treated at length by A. J. Biggs and J. E. Houldin.<sup>2</sup> It has

<sup>1</sup> *Wireless World*, June 1949, p. 217.

<sup>2</sup> "The Development of Q-Meter Methods of Impedance Measurement." *J. Instn elect. Engrs*, July 1949, Vol. 96, Part III, p. 295.

the practical disadvantage of requiring a special ganged variable capacitor, but seems otherwise to be very close to the ideal.

I have seen no mention of series-capacitance injection, however, and this would seem to offer some advantages. The basic arrangement is sketched in Fig. 1; the injected voltage is  $e_1/(1+C_2/C_1)$ . The range of tuning capacitance is restricted by  $C_1$  and  $C_2$  coming in series with C, but  $C_2$  can usually be large compared with C and, in any case, there is rarely any difficulty in making C rather larger than is customary.

Probably the most serious defect of the arrangement is the inevitable internal inductances of  $C_1$  and  $C_2$ . This will not affect the magnitude of the injected voltage if the ratio of the inductance is the same as that of the capacitive reactances (the inverse of the capacitances), but since  $C_2$  is one hundred or more times  $C_1$  this will rarely be the case.

It is, however, possible to use a capacitive ladder attenuator as shown in Fig. 2 (a). If all the capacitors  $C_1$  have the same capacitance, are of the same

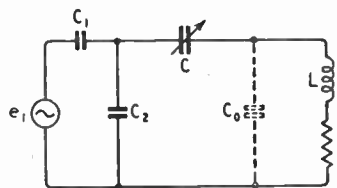

Fig. 1.

physical construction, and are wired with the same length of leads, their impedances are always equal and the overall attenuation is independent of frequency. The five sections shown make the equivalent injected voltage  $e_1/89$ ; six sections would make it  $e_1/233$  and four sections  $e_1/34$ .

The output capacitance of five sections (that is, the effective capacitance in series with C) is  $1.62C_1$ , and the input capacitance is  $0.616C_1$ . By repeated application of the star-delta theorem it is easily shown that the circuit has the exact equivalent of Fig. 2 (b). Save for the shunt input capacitance of  $3C_1/5$  which plays no part in the attenuation, since the source is assumed to be of zero internal im-



#### THE "FLUXITE QUINS" AT WORK

"We'll be needing the FLUXITE" cried OH  
"Must solder this earth wire, y'know.  
This wire just won't reach,  
Give a pull on it, peach,  
That's plenty! I think that'll go."

See that FLUXITE is always by you — in the house — garage — workshop — wherever speedy soldering is needed. Used for over 40 years in Government works and by leading engineers and manufacturers. Of all Ironmongers—in tins, 10d., 1/6 & 3/-

TO CYCLISTS! Your wheels will NOT keep round and true unless the spokes are tied with fine wire at the crossings AND SOLDERED. This makes a much stronger wheel. It's simple—with FLUXITE—but IMPORTANT.

The FLUXITE GUN puts

FLUXITE

where you want

it by a simple

pressure. Price

2/6, or filled, 3/6



ALL MECHANICS WILL HAVE

# FLUXITE

IT SIMPLIFIES ALL SOLDERING

Write for Book on the ART OF "SOFT" SOLDERING and for Leaflets on CASE-HARDENING STEEL and TEMPERING TOOLS with FLUXITE. PRICE 1d. each.

FLUXITE LTD.

(Dept. W.W.), Barmondey Street, S.E.1

Letters to the Editor—

pedance, this circuit is identical with that of Fig. 1.

The main disadvantage of the circuit would seem to be the high input capacitance across which the source must develop the voltage  $e_1$ . If  $C_1 = 500$  pF, the input capacitance

used in radar displays of the Gee and Loran type. This is a very fast time base, which can be started at any point in the fundamental repetition cycle of the radar system, thus permitting examination of the events at that point.

Mr. Gibson's wobblator calibra-

interference to normal broadcast reception.

The only way such a system can cause interference is by acting as a conductor and re-radiator of interfering signals, generated by some external source.

It is hardly fair, therefore, to make a bald statement that wire broadcasting cables can and do radiate interference without stipulating that they are not the primary cause of the interference and that they are also only one of a very large number of such possible carriers.

K. A. RUSSELL,  
Chief Engineer, British Relay  
Wireless, Ltd.  
London, W.C.2.

[Although the Belling-Lee statement was factually correct, it might have been stressed that secondary radiation of interference was in mind. However, the word "re-radiate" was in the heading of the paragraph.—Ed.]

Drawing Circuit Diagrams

J. W. GODFREY, writing in your July issue, appears (to further scramble his metaphor regarding cruelty to horses) to forget that the vehicle which he uses to express his opinion—i.e., *Wireless World*—to which the horse is harnessed, still uses bridges and 4-way joints.

B.S.530:1948, p. 16, shows the "bridge" with the note, "The bridge is deprecated unless considered essential."

I still consider bridges essential if the draughtsman refuses to dispense with 4-way junctions.

As to errors in connection with blobs. A "blob-less" crossing was repeatedly re-photographed. In the later photographs spurious blobs of successively increasing size appeared, possibly owing to some sort of halation in the negative.

I use the method (a small arc near the T-junction) mentioned in Mr. Godfrey's letter only when correcting a drawing, as an indication to the draughtsman to re-draw the junction with a "tangent quadrant" as in the first sketch in the third column of my article in your May issue.

L. BAINBRIDGE-BELL.  
Haslemere, Surrey.

"Televising Moving Images"

R. W. HALLOWS presumably finds the cinema satisfactory in the portrayal of movement, judging by the end of his article in your August issue. However, he seems to have misunderstood the technique of the film, set a trap for himself, and duly sprung it.

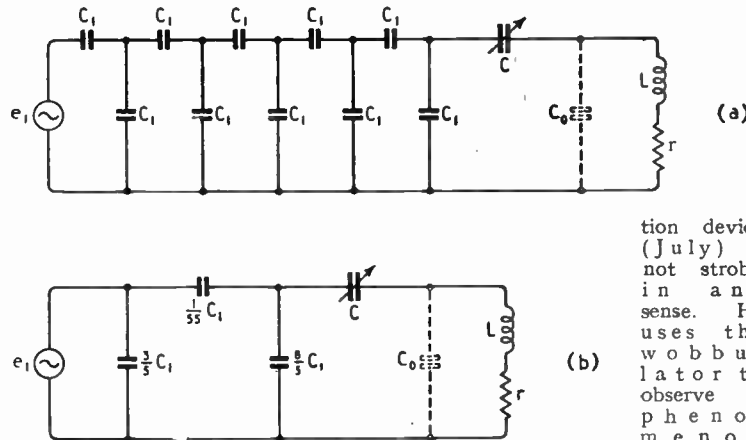

Fig. 2.

is  $308$  pF and the output is  $810$  pF. With  $C = 1,000$  pF, a maximum effective capacitance for tuning  $L$  of  $1,000 \times 810 / 1,810 = 447$  pF is obtained.  
W. T. COCKING.

"Strobing" Defined

WITH reference to R. C. Windsor's comments on the strobe principle (August), I beg to suggest that the following would be an adequate formal definition:—

**Strobe** (noun): A means of examining the instantaneous position or state of a cyclic phenomenon at regular intervals approximating to the fundamental cyclic period of the phenomenon or an integral multiple thereof. (Verb): To use a strobe.

**Stroboscope**: Apparatus for making visible the data obtained by strobing.

L. H. Bedford<sup>1</sup> defines two types of strobe: the heterostrobe, whose repetition frequency differs from that of the observed phenomenon, and the homostrobe, which has the same frequency as the observed phenomenon. He also expresses preference for the adjective strobic, rather than stroboscopic.

The oscilloscope may be regarded as a refined form of stroboscope using an infinitely large number of strobos, each of which examines one point on the displayed waveform. The term strobe can be applied with greater accuracy to the time base

would exist if the wobblator were replaced by an alternative system.

Incidentally, Mr. Windsor need not look to the American literature for an anticipation of the idea of calibrating wobblators. Similar techniques were in use in this country ten years ago, and refinements are discussed in a paper of mine written long before the American device appeared.<sup>2</sup>

D. W. THOMASSON.

E.A.R.L., Exeter.

Interference

THE following statement appears in Messrs. Belling & Lee's advertisement in your July issue:—

"We have recently been asked to confirm whether or not 'wires used for wired wireless' radiate interference. The answer is that they can and do. So do telephone wires and overhead fire-alarm wires, but, of course, the worst offenders are overhead mains in villages where the houses are wired with v.i.r. taken in at roof level."

I should like to emphasize that no signal capable of interfering with radio reception is injected intentionally by the operators of a wire broadcasting system, and in fact they are not allowed to do so by the stringent conditions of the Postmaster-General's licence.

Carrier distribution occupies the band 30-150 kc/s approx. and is also strictly controlled by the G.P.O. so that it can cause no

<sup>1</sup> L. H. Bedford: The Strobe Principle in Radio and Radar, *J. Brit.I.R.E.*, VIII, 2, 62.  
<sup>2</sup> D. W. Thomasson: The Principles and Practice of Panoramic Display, *J. Brit.I.R.E.*, VIII, 4, 172.

The number of black-out periods only affects flicker. The apparent smoothness of movement is fixed by the number of sequential and different transparencies projected in any one second (in this case 24). If an object in the scene shown is moving too fast for this repetition rate, the multiple image effect will be perceived in the eye, whatever the black-out rate may be. Incidentally, there are only two light cuts per frame in the normal sound projector; one for the picture shift and one intermediate. Provided these dark periods are of equal duration and equally spaced in time, there is no flicker apparent to the eye. It would merely be a waste of expensive light to increase the frequency.

As Major Hallows' article appears to plead that television should aim at the efficiency of the cinema, and his argument is based on a wrong premise, such argument would seem to break down. Nevertheless, perhaps the matter may be pursued a little further. If we assume his example of an image crossing the screen in one second, then, if the image were a vertical rod at high contrast (perhaps not a very usual or desirable part of television entertainment) the eye *might* be aware of the "lean" of one-fifth of an inch, but it is very much open to doubt. With the more normal type of image, such awareness may well be presumed impossible. With movements at such a speed the matter of interlace is likely to be unimportant. The image will be blurred in any case, but will probably show a 2:1 improvement over an attempt by the cinema to portray the same thing.

Having sacrificed much sleep to the elimination of hum effects caused by home-made a.c. not being at 50c/s, I feel certain that any change in frame repetition would have to be in multiples of that frequency. The Americans obviously adopted a frame speed of 60 per second to suit their mains supply. In fact they say so (see Terman and Fink on the subject\*). To suggest that it would be nice to let the few fast movers go 20 per cent faster is just splitting hairs.

If there is an eventual change in the television standards in this country, it would seem preferable that any extra available bandwidth should be devoted to the provision of more lines. The inability of the present number to define long, narrow near-horizontals can be somewhat irritating, and is much more evident than any theoretical shortcomings due to the existing frame frequency.

Both the film and television set out to cheat the human eye by taking advantage of its defects. Any

## OUR COVER

One of the two cruciform tiers of the Sutton Coldfield television aerial forms our cover illustration this month. The aerial system was designed by the B.B.C. Research Department in collaboration with the manufacturers—Marconi's WJ.T. Co. The outputs from both the 12-kW sound and 35-kW vision transmitters are carried by feeders to a combining unit whence they are fed to the elements so that a single aerial system can be used without mutual interference between the two transmitters. The eight compensated folded dipoles are fed in phase-quadrature so that the mast is virtually in a neutral field.

efforts at improvement of the media should be directed towards perfecting partial deceptions, rather than attempting to idealize those which are already more or less complete.

S. C. BARRELL.

Ashtead, Surrey.

\* Terman: "Radio Engineering," 2nd edition, p. 747. Fink: "Principles of Television Engineering," p. 51.

## NEWS FROM THE CLUBS

**Birmingham.**—Television construction will be discussed at the meeting of the Slade Radio Society at the Parochial Hall, Slade Road, Erdington, at 7.45 on September 16th. At the next meeting (September 30th) a talk on the theory and design of Class C amplifiers will be given. Members are holding a midnight d.f. test on October 2nd. Sec.: C. N. Smart, 110, Woolmore Road, Erdington, Birmingham, 23, Warwick.

**Birmingham.**—Members of the Midland Amateur Radio Society, which meets on Tuesdays at the Imperial Hotel, Temple Street, Birmingham, will be spending the week-end under canvas from September 10th to 11th. Details are available from the Sec.: A. W. Rhodes, 135, Woolmore Road, Birmingham, 23, Warwick.

**Derby.**—Apparatus constructed by members of the Derby and District Amateur Radio Society will be shown at the exhibition organized by the Derby Society of Model and Experimental Engineers to be held in the Queens Hall, London Road, Derby, from Sept. 20th to 24th. Sec.: F. C. Ward, G2CVV, 5, Uplands Avenue, Littleover, Derby.

**Walsall.**—Membership of the recently formed Radio Amateurs' Club of the Walsall Technical College is restricted to students or past students of the college. The club meets on Wednesdays in Room G, Wisemore Annexe of the College, at 7.30 p.m. Sec.: J. F. Young, Walsall Technical College, Bradford Place, Walsall, Staffs.

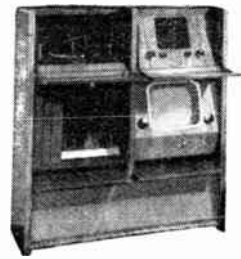

## 3 INSTRUMENTS IN ONE CABINET

plus built in record storage. With Pye radio and Television, Garrard auto-changer, storage space incorporating the well known IM RAK, and cabinet designed and built by Imhof's, this set offers you, at £145 (plus purchase tax), complete home entertainment for the lowest figure yet. This set, exclusive to Imhof's, will be displayed on our stand No. 89 in the Grand Hall at Radiolympia.

# IMHOF'S

112-116 NEW OXFORD STREET, LONDON, W.C.1

In the electronics section, on our stand No. 183, we are exhibiting a selection of metal cabinets and instrument cases from our stock range and 'specials', including the new Enclosed Racks in 4' and 6' sizes illustrated below. Write for catalogue, giving details of our specialized metal cabinet production and design service, and complete range of standard cases available from stock.

## ENCLOSED RACKS

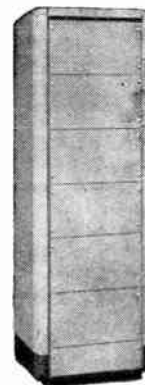



# RANDOM RADIATIONS

By "DIALLIST"

## Television Aerials

It's DIFFICULT not to feel that a good deal more skill and care might be used with advantage in the erection of television aerials. One knows, of course, that in areas where the field strength is good and interference severe it often pays to use the "inactive" member of an H-type assembly as a shield rather than a reflector. One knows, too, that, owing to reflection effects by buildings and so on, signal strength is not always at its best if an I-type assembly is set up by map and compass to point directly towards the transmitting aerial. But these things are hardly sufficient to account for what in some places looks almost like random setting up of the aerials! In some areas you may see aerials directed to almost every point of the compass! Notice, again, how many plain dipoles and H assemblies are a long way from being vertical. In some cases this *may* be right enough; but I fancy that few of them are intentionally out of the vertical plane in order to counteract reflection effects on the polarization of the incoming waves. And I'm sure there are no calculations, deliberations or tests behind the erection of an H-type aerial as an H. Nor do I feel that an assembly of this kind put up so that, when viewed from the direction in which it is pointing, it forms a tall, narrow X—the aerial sloping one way and the reflector the other—does much credit to the serviceman or owner who erected it.

## A Stitch in Time . . . .

YOU KNOW THE OLD SAYING that it's the cobbler's children who go worst shod. We wireless folk are apt to give proof of the truth of its meaning by the way in which we so often take our domestic electric wiring for granted, never giving a thought to possible lurking dangers due to the stupidity of those responsible for its installation, maybe years ago. Not long ago a friend of mine came across a piece of work which might have had disastrous results. It had gone unsuspected for more than ten years.

It might have disclosed itself by giving a fatal shock, or by inflicting severe burns; luckily, the tell-tale shock was mild and it was received by one who realized at once that something was radically wrong and took appropriate action. A most undesirable state of affairs in the domestic circuits was found ultimately to be due to an almost incredible act of folly by the man who had done the wiring. It might happen in any house and escape notice for years; but it is so potent a source of danger that I make no excuse for telling you all about it. Briefly, my friend received a shock on touching the chassis of a radio receiver plugged into a wall socket which was switched off. The natural deduction was that the switch controlling the socket was wrongly wired — breaking the neutral and not the phase lead. The socket was one of three power outlets connected to three separate circuits on the ground floor of the house. Examination of each of the

three switches showed that they were correctly arranged so as to break the red wire. The power circuits were taken from a three-way distributor panel near the meter and their three red leads were on the correct side of this panel. Everything looked all right, but a neon tester showed that at the output side of the distributor and at all the three outlets the black was the phase lead and the red the neutral. What had happened was that the "tails" from the meter had been connected the wrong way round to the input side of the panel. Hence all the power outlets were "alive" when switched off—and one of them was in a concrete-floored scullery.

## A Capacitor Teaser

RECENTLY a reader sent a very old paper-dielectric 0.1- $\mu$ F capacitor which, he averred, was showing an e.m.f. of 1 volt across its terminals on a valve voltmeter. The only v.v.-m available at the moment had an input resistance of 10M $\Omega$ . Applied to this, the capacitor registered an indubitable steady e.m.f. of 0.4V. Quite a few ancient paper capacitors were nestling in the junk boxes of the room, which, incidentally, is very dry. Tests were made on these

## WIRELESS FOR SMALL CRAFT

General-purpose Receiver and Short-wave Radiotelephone

A COMPACT transmitter-receiver designed especially for use in yachts, motor launches and other small craft has been introduced by Pye Telecommunications, Ltd., Ditton Works, Cambridge. This



Pye Dolphin radiotelephone and general-purpose receiver for small craft.

set, which is known as the "Dolphin," is fitted with a five-valve superhet receiver covering 3,800 to 530 kc/s (79 to 567 m) and a crystal-controlled transmitter for sending on up to eight spot frequencies in the band 3,800 to 1,520 kc/s (79 to 197 m). The r.f. output is between 8 and 10 watts and amplitude modulation is used.

Housed in a single metal cabinet measuring 21 x 15 x 9 in and weighing 39 lb, the Dolphin is suitable for either shelf or bulkhead mounting. All the parts are assembled on the front panel, which simplifies servicing when the need arises. The inclusion of rubber seals between the panel and the cabinet and a hard-wearing finish render the set particularly suitable for shipboard use.

The equipment operates from either 6 or 12 volts and is particularly economical in its power demands. The receiver takes 0.5 amp only at 12 volts and the transmitter 8.3 amps.

A loudspeaker, as well as a hand telephone-microphone set, is included and the price is 75 guineas, less crystals and aerial.

and several showed e.m.f.s of 0.1-0.2V. Can any reader suggest how and why old capacitors should turn themselves (given the right conditions) into primary cells? It seems hardly likely that the e.m.f.s. can be residual charges which have persisted all this time—17 years in the case of the sample sent by the reader—in face of the cosmic-ray bombardments that must have been experienced for so long. There must, I feel, be some strange electrochemical action; but what it is and why it occurs I don't pretend to know. There is clearly considerable activity on a small scale within old capacitors that behave in this way, for even a 0.1-volt e.m.f. causes several billion electrons to bustle every second through a 10-megohm load!

### Soldering Iron Stands

A KIND READER sends me particulars of a simple but very effective prop that he uses for his soldering iron. You may recall that I commented a month or two ago on the queer failure of manufacturers to provide their otherwise excellent electric irons with props which would enable them to be put down whilst hot without doing damage to bench, table top and so on. My own method, as I mentioned, is to use a "bulldog" paper clip, having shaped the jaws suitably and bent the ears outwards. The reader in question writes: "Your idea has the defect that you have to turn the iron so that the feet are at the bottom before putting it down. Mine removes this defect, costs nothing for materials and takes only a few minutes to make. Cut a strip about one inch wide and three inches long from a tin can; bend the middle of the strip about three-quarters round the neck of the iron, splay out the free ends and the job is done. No matter how the iron is moved about in use, it always lands, catlike, on its feet." A good suggestion, you'll agree; but I personally don't like to have my prop on the bit itself—it gets in the way too often. Many irons have oval bodies and for these I think that my "bulldog" paper clip idea best fills the bill.

### For Very Fine Work

DURING the past few days I've been trying the little "pencil" electric soldering iron made by Ekco. It's about the size of a fountain-pen

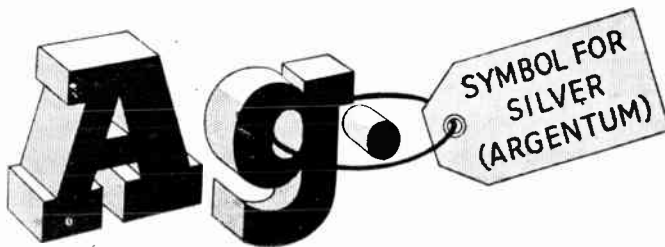

FOR LONG LIFE  
MINIATURE SWITCHES

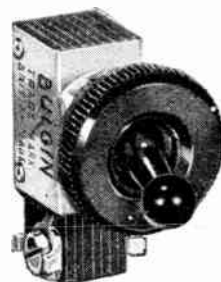

List No. S. 185

Bulgin Toggle Switches have Contacts and Tags or Terminals coated with pure Silver-Ag., because this precious metal inhibits high- $\Omega$  corrosion, giving low- $\Omega$  contacting, best heat-conduction (minimised sparking), and facilitates soldering to tags.

Bulgin Switches use tropical-grade insulation; have their steel cases copper- and nickel-plated; have ample cable-capturing terminals; have firm but smooth snap-action; are guaranteed for 25,000 ops. at rating (many give users  $\frac{1}{4}$ -million ops., ten times what we claim); are available in Nickel, Chrome, Bronze, and Plastic colour finishes; AND—there are over a thousand varieties.

#### FACTS ABOUT SILVER

Melting Point 960° C.

S.G., 10.5 at 20° C.

Specific Resistivity  $\rho$  1.62  $\mu\Omega/\text{cm}^3$

(Copper = 1,682)

Sulphide disrupts at low V.

Oxide not normally produced in air.

The Choice



of Critics

FOR OVER 25 YEARS

# BULGIN

See us on Stand No. 1 at Radiolympia

NEW ILLUSTRATED CATALOGUE NOW AVAILABLE TO THE TRADE  
A. F. BULGIN & CO., Ltd., BYE-PASS ROAD, BARKING

Telephone: R1Ppleway 3474 (5 lines)

**Random Radiations—**

and does not weigh much more. The model I have is rated at 12 volts. The makers claim that it reaches the proper temperature in about a minute, but that seems to be slightly optimistic. My transformer gives a little over 12 volts under load and I find that the time needed for warming up to the temperature I like for 60/40 cored solder is nearer two minutes than one. That, however, is no great drawback, and this little iron is certainly a joy to use for those jobs of fine work which call for a light, handy tool and a small bit. It could be made almost perfect were two additions contrived. The first of these, I need hardly say, is a prop enabling it to be put down anywhere. The second is some form of temperature control. Unless the iron is used almost continuously (as is unlikely to be the case) the temperature of the bit increases rather rapidly. In the course of a series of tests I found that it rose to over 320 deg. C in six minutes—and was still rising. For normal fine soldering work one

doesn't need bit temperatures above 230 to 250 deg. C. Higher temperatures lead to pitting of small bits and don't usually make for long life of the heater coil.

**French Television**

TRANSMISSIONS of 819-line television have already begun from the temporary station in the Eiffel Tower. The power output is now only about 100 watts, but this is to be put up by stages to an eventual 5 kW. For the time being the transmitter will be at work for only an hour a day. Given a receiver of adequately wide-band type, great things can, of course, be done with such a system. *Toute la Radio* publishes a reproduction of the test pattern which has been adopted for the system. It is by far the most exacting thing of its kind that I have seen and any receiver which can do it full justice must indeed be a good one. I gather that French television enthusiasts are not altogether happy about the decision to close down the present 455-line transmissions nine years

**MORE COPIES OF  
"WIRELESS WORLD"**

The Government's decision to increase the allowance of paper for technical periodicals is making it possible to print more copies of *Wireless World*. There should now be enough for all anticipated requirements. The number of copies is, however, limited, and it is, therefore, necessary for an order to be placed with a news-agent.

from now and to replace them entirely by those of 819 lines. There's a feeling that 819-line definition (supposing that the problem of making suitable wide-band receivers at a popular price is solved) may fall between two stools. It may be too good for small-screen domestic use and not quite good enough for big-screen work. Myself, I wouldn't like to hazard a guess about the future, for in these times of rapid progress an awful lot can happen in a very few years.

**AIRPORT TRANSMITTER****Two-channel V.H.F. Equipment with Remote Control**

STANDARD TELEPHONES AND CABLES, Connaught House, Aldwych, London, W.C.2, have introduced a new v.h.f. transmitter which has been designed especially for ground-to-air communications. Recent investigations have revealed that at certain airports it was often required to transmit on either one

of two frequencies with rapid change from one to the other, or on both simultaneously, using the same microphone.

Meeting this requirement, the new type DU2 transmitter is a dual-channel set having two separate v.h.f. transmitters each rated at 50 watts output and capable of being operated singly, or together, from common modulator and power supply units.

Full remote control facilities are incorporated and the operator can select at will either one or both of the frequencies on which the two transmitting units are lined up. With the present models these must

lie in the band 115 to 135 Mc/s, but later models will have the frequency range extended from 70 to 150 Mc/s. Telephony or m.c.w. can be used.

The transmitters, modulator and power supplies are housed in a single cabinet with a flush-fitting door and measuring 3ft 8in x 2ft x 1ft 9in. An inclined panel at the top carries meters and local switching controls.

All units are accessible from the front for maintenance purposes so that the cabinet can be fitted with its back flush against a wall. The top unit containing the two r.f. transmitters and modulator slides forward on telescopic rails and it can also be swung into the vertical, giving access to the under-chassis components. The lower unit contains the power supplies and it can be pulled forward on rollers.

Normally the set is operated with the door closed and gate switches remove all dangerous voltages if any unit is withdrawn. Provision is, however, made for closing these by hand so that the equipment can be tested in the withdrawn position.

The transmitter is designed for operation in all climates; transformers are hermetically sealed and all components are tropicalized and conservatively rated. In addition, forced-air cooling is used.

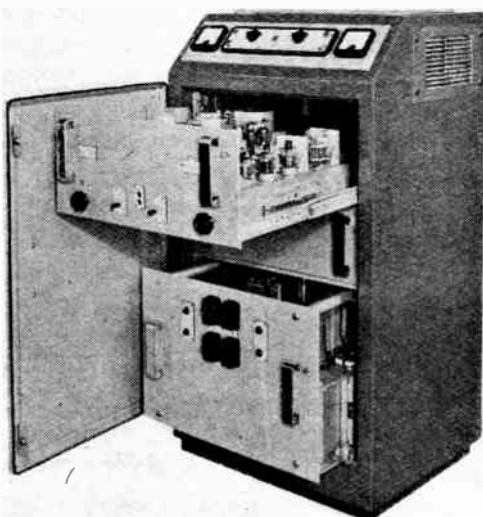

The new Standard  
Telephones and  
Cables 50-watt  
two-channel v.h.f.  
transmitter with  
door open and top  
and bottom units  
pulled forward.





# Standard Miniaturized Crystals

THE smallest of their kind (Actual size  $\frac{3}{32}$ " x  $\frac{3}{4}$ " x  $\frac{1}{4}$ " ) Standard QUARTZ CRYSTALS (Type 4039) are artificially aged, hermetically sealed and robust to a degree. They are thus highly suitable for use in miniaturized stabilizing circuits of the highest stability and capable of withstanding the considerable shocks, heavy vibration and the widely varying climatic conditions which are inseparable from Service conditions.

Typical of Standard's attention to detail is the handy finger grip for easy insertion and removal of the QUARTZ CRYSTAL.

**Standard Telephones and Cables Limited** (TELEPHONE LINE DIVISION)

Registered Office: Connaught House, Aldwych, London, W.C.2

NORTH WOOLWICH, LONDON, E.16.

Telephone: Albert Dock 1401

**We Believe Our Offers of Government Surplus Radio Equipment to be the most Competitive in the Trade. We Guarantee a prompt Cash Refund on any item returned within 7 days of receipt. Can we be any Fairer?**

The Discerning Amateur will find much to interest him in the following:—

**AR88** (not LF or D) Communication Receivers. Two only. 14 valves, 540 kc/s. to 32 Mc/s., in six bands continuous coverage. £40, c.p.

**RI124a Ex-R.A.F. 5 v. Battery-operated Receiver.** 30-300 metres in 3 bands. Muirhead slow motion dial. Requires 2 v. L.T. and 120 v. H.T. A very useful receiver, 15in. x 10in. x 9in., £5/10/-, carr. 5/-.

**Canadian No. 58 Mark I Transceiver.** 33-50 m. Brand new and complete with Headphones and Microphones, 12 gns. Vibrator pack, complete with accumulators for this, 3 gns.

**RI132 11-valve Receiver, 102-126 Mc/s.** Complete with valves. Aluminium grey cabinet, 19in. x 11in. x 10in., new condition, £4.

**ABK1 11-valve Receivers.** 6 of 6SH7, 2 of 6H6, 2 of 7193. Motor generator with reduction gear, 3 relays, heavy duty resistors, etc. New condition, 20/-, carr. 5/-.

**BC966A 13-valve Receivers.** Complete with valves, motor generator, relays, etc. Has 7 of 6SH7, 3 of 6H6, 3 of 7193, 12in. x 12in. x 8in. As new, 30/-, carr. 5/-.

**Receiver Type 3170.** Variable tuning, 12 valves, 2 of CV66, 7 of VR91, 1 VR137, 1 VU134, 1 VU39A. First-class condition, 25/-, carr. 5/-.

**Receiver Type 78.** 2.4 to 13 Mc/s., 5 valves, crystal calibration, 100 kc. crystal. In brand new factory condition, 50/-, carr. pd.

**R.F. Units.** Type 24. Makes fine 10 m. converter. New in sealed carton, 19/6, postage 1/4. Type 25. Goes in RI355 for London Television, slightly soiled, but guaranteed perfect, 12/6, post 1/4. Type 26, also for RI355, for Midlands Television. Brand new in cartons, 39/6, post 1/4.

**VCR97 Cathode Ray Tubes.** Short persistence 6in., ideal for Television, 35/-, carr. 2/6. Bases to suit, 4/-, post 6d.

**Book.** "Inexpensive Television," 1/6, post free.

**Crystal Multipliers.** Type MI 19463. Complete with two 807 valves, 2-3.1 Mc/s., 4.5 to 6.67 Mc/s. Brand new with instruction book, 45/-, carr. 5/-.

**Amplifier Vibrator Pack.** Input 12 v. Output 200 v. 50 mA. Incorporates full smoothing OZ4 rectifier and 6K6 output, as new, 20/-, carr. 1/4.

**28 v. Dynamotors.** Output 250 v. 60 mA. Ideal for BC453/4/5 sets, or simple conversion to A.C. motor, 7/6, post 1/-.

**Dynamotor and Filter Unit.** Type CRV-21562. Input 28 v. at 1.2 amps., output 220 v. D.C. 70 mA. Fully filtered. Black crackle case, 6in. x 6in. x 4½in. Brand new, 12/6.

**Dual Range Screened Coil Units.** Type C380, 201-393 kc/s., 4,150-7,700 kc/s. New in sealed cartons, 2/6, post 9d.

**Antenna Relay Units, BC442A.** Brand new, 5in. x 4in. x 3½in., Western Electric changeover Relay ½, 2in. R.F. Meter, scaled 1-10 a., with separate thermocouple, 12/6, post 9d.

**Headphones.** Low resistance DLR No. 1, with jack plug, 3/6, postage 6d. 2 pairs post free. Brand new.

**Loud Speakers.** First-class makes, 8in., 18/9; 10in., 22/6, post paid. **Headphone Impedance Adapters.** High to low impedance, 2/-, post paid.

**Jack Boxes.** BC1366, 2-pole 5-way switch, rheostat, two jacks, aluminium case, 3½ x 4½ x 2½. New. Sealed cartons, 3/6, post paid. **Loctal Valve Holders.** Brand new. First grade, 3/- doz., post paid. **2 mfd. Condensers.** 500 v. working, 4/- dozen, post paid.

**New 2 waveband AC/DC Radio Receivers.** Well known make £5/10/- each. Carr. 5/- A Few Only, originally 11 gns.

Send for lists of other items. 1d. stamp please.

**DELIVERY PER RETURN.** To the many Amateurs who have written thanking us for fine value and express service, may we say that our aim is to GIVE SATISFACTION AND STILL BETTER SERVICE.

**H.P. RADIO SERVICES LTD.**

Britain's Leading Radio Mail Order House

55 COUNTY RD., WALTON, LIVERPOOL, 4

Established 1935 Telephone: Aintree 1445

STAFF CALL SIGNS G3DLV, G3DGL

# BAKERS 'Selhurst' RADIO

PIONEERS OF MOVING COIL SPEAKERS SINCE 1925

NEW 1949 MODELS

HIGH FIDELITY  
SPEAKERS

The standard 12"  
P.A. model 12.C.

The World Famous  
12" triple cone 12.B.

The Cinema Model  
18" "Duplex" C.T.

Write for illustrated list  
of —SPEAKERS, TUNERS  
and AMPLIFIERS.

BAKERS 'SELHURST' RADIO  
25, Dingwall Road, Croydon

Telephone CROydon 2271/2



## The RIMINGTON JEWEL

will bring new life to

### GRAMOPHONE REPRODUCTION



Straight for Crystal  
pick-up only.



Lightweight for new  
miniature pick-up.



Trailer type for  
Heavier pick-up.

- ★ Reproduces the maximum recorded frequency range.
- ★ Wear on records is negligible, the Jewel is scientifically designed to follow the groove of the record lightly and smoothly.
- ★ Preserves the higher frequencies delicately imprinted in the record, so easily destroyed, and reproduces them!
- ★ Jewel well set and angle correct.
- ★ Contained in plastic box well packed and mounted.
- ★ LIFE. It is not possible to state categorically the life of a jewel point, but in the interest of quality it is advisable to replace the jewel after 1000 playings—it is a matter of personal discretion.
- ★ The Rimington Jewel has had exhaustive tests by Messrs. W. R. Prior Ltd., microscope manufacturers, of Bishops Stortford, who have stated that the needles are free from blemish and perfect in detail.
- ★ The Rimington Jewel needle reveals new beauties in your records which you have heretofore unsuspected.

**PRICE—Most reasonable.** The Rimington Jewel is the finest sapphire on the market and it retails at only 9/9.

Order your Rimington Jewel NOW and revolutionise your gramophone reproduction.

TRADE ENQUIRIES INVITED

## RIMINGTONS

RIMINGTON, VAN WYCK LTD., 42-43 Cranbourn St., London, W.C.2  
Gerrard 1171

RIMINGTON, VAN WYCK (Mail Order) LTD., 28a Devonshire St.,  
Marylebone, London, W.1 Welbeck 4695



**I N D U C T A N C E M E T E R**

Designed to provide simple and direct reading measurement of inductance values between 0.05 microhenry and 100 millihenrys. A stable variable-frequency oscillator is used to resonate the unknown inductance with a fixed standard capacitor. Provision is made for the measurement of Q at resonance frequency.

Calibration and scale reading accuracy are sufficient to provide direct readings of inductance values within 2 per cent. above one microhenry. Relative measurement can be made with greater accuracy. The instrument is very compact, measuring only 7 1/2" high, 7 1/2" wide and 7 1/2" deep at base. PRICE £38.5.0

THE WAYNE KERR LABORATORIES LTD. NEW MALDEN SURREY MALDEN 2202

**NEW**

Units of the 5CR-522 (TR5043) for experiments on 2 metres T.V. and Radio Telephone wavebands. **BC-624-A. Receiver Unit Chassis.**

Frequency, 100-156 Mc/s with 11 valves:

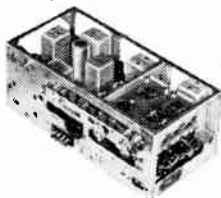

- 3/125G7's
- 12C8
- 12J5
- 12AH7
- 12H6
- 3/9003
- 9002

Complete chassis (less Xtals) with 3/12 mcs. I.F.T.'s Relay, etc., designed for operation on predetermined Xtal frequencies, but easily

altered for continuous tuning. Power requirements (external) H.T. 300 v. C.C. 75 mA. L.T. 24 v. C.C. 3A. Dimensions 15 1/2 x 7 1/2 x 6in. Circuit supplied. Plus **BC-625-A Transmitter Unit Chassis**, partly stripped, but containing many useful parts, R.F. section in good order, no valves, modulation transformer Xtal switch. Dimensions as Rcvr. Circuit supplied.

**CLYDESDALE'S PRICE ONLY 37/6** each CARRIAGE PAID

**BRAND-NEW.**

**REFLECTOR AERIAL (MX-137-A).**

E.175. A first-class transmitting and receiving Omnidirectional Antenna, in original moisture-proof carton with assembly instructions, size ass'd. approx. Ht. 6ft. Wd. 4ft.

**CLYDESDALE'S PRICE ONLY 5/6** each POST PAID

**CLYDESDALE**

**UNUSED**

**Largest Stocks**

best selections

**CLYDESDALE**

and Bargains in Ex-Service Radio and Electronic Equipment

**BRAND-NEW. E536 Modulation Transformer.**

Thermador potted type (U.S.A. made) with ceramic stand of terminals. Pri. 6700 ohms. C.T. Sec. 4,500, 5,000 and 5,500 ohms. max op. 470, freq.-10db. 400-4,000 cs. Test 5,000 v. suits TZ40, T35, B13, etc., size 7 x 6 1/2 x 5 1/2in., wgt. 221lb.

**CLYDESDALE'S 47/6** CARRIAGE PRICE ONLY each PAID

**EX R.A.F. Gyro Angling Power Unit.**

**Directional Control Gear Drive Unit.**

Comprising 24 v. D.C. motor with worm gear drive allowing for 360 deg. rotation 8 times per minute. All ball race type bearings. Can be wired for either clockwise or anti-clockwise rotation. Housed in die-cast box 5 x 5 x 2 1/2in. In wood transit box, with hinged lid.

**CLYDESDALE'S 17/6** POST PRICE ONLY each PAID

**Brand New, in maker's carton. Rotary Transformer, by Hoover.**

Type HT31, Input 11.5 v. Output 250 v. at 125 mA. Dia.; 5 1/2in. long x 3in. dia. cylindrical.

**CLYDESDALE'S 25/-** POST PRICE ONLY each PAID

**Brand-New. High Voltage Rotary Transformer (by Hoover)**

Type HT32, Input 11.5 v. D.C., output 490 v., 65mA. Dimensions 5 1/2in. long x 3in. dia. cylindrical.

**CLYDESDALE'S 25/-** POST PRICE ONLY each PAID

**New, Unused Rack Mtg. R1481 V.H.F. R/T Receiver Unit.**

Frequency 65-86 Mc/s. A 10-valve superhet, with 4/VR53 (EF39), VR54 (EF34), VR57 (EK32), 2/VR65 (SP61), VR66 (P61), VR67 (6J5G) plus stabiliser V570 (7475), "5" meter, screened R.F. section, B.F.O., etc., in enclosed chassis, size 19 x 10 1/2 x 1 1/2in. finish dark grey. Circuit supplied.

**CLYDESDALE'S 44.10.0** CARRIAGE PRICE ONLY each PAID

also a few R1132 Rcvrs. (freq. 100-124 Mc/s.) finish light grey. Dimensions, etc., as R1481, available at the same price.

**New, Unused Rack mtg. A.C. Mains Power Unit, Type 3.**

For R1481 and R1132. Input 0-200-210-220-240-250 v., complete with 0/300 voltmeter, 0/150 H.T. milliammeter, 5Z4 rectifier fully smoothed. Output 200 v. 40 mA. 6.3 v., 3A, 4 v., 1.5 A., enclosed chassis, size 19 x 7 x 1 1/2in. Finish dark grey.

**CLYDESDALE'S 44.10.0** CARRIAGE PRICE ONLY each PAID

Special Offer. Receiver and Power Unit.

**CLYDESDALE'S 48.19.6** CARRIAGE PRICE ONLY each PAID

both units

SUPPLY 2 BRIDGE STREET CO. LTD. GLASGOW - G5.

Send now for new Illustrated List. Please print Name and Address. Phone: SOUTH 2706/9

Circuits for ex-Service Equipment available full list on application.



## THE NEW "ACRU 24"

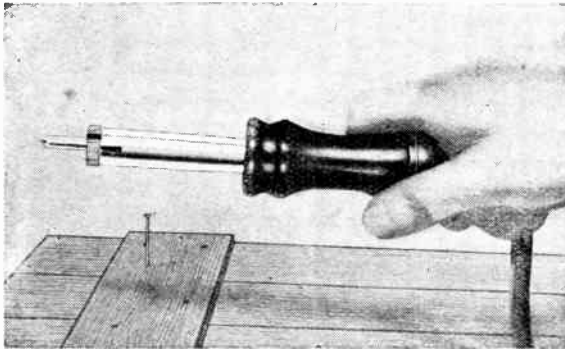

### ELECTRIC SOLDERING IRON ... is CRASHPROOF!

... could even be used as a hammer without harm.

Element of unique construction; totally enclosed; wound on steel tube with air-tight, die-cast case; withstands the roughest treatment without damage. Instantly detachable and interchangeable copper bits with cam locking.

Ask your Radio Dealer or write direct for full details.

**THE ACRU ELECTRIC TOOL MFG. CO. LTD.**  
123 HYDE ROAD, ARDWICK, MANCHESTER, 12.

Phone: ARDwick 4284.

24A

# TANNOY

PRESENT THE

## Dual Concentric Loudspeaker System

"HIGH FIDELITY" TAKES ON A NEW MEANING WITH THE INTRODUCTION OF THIS OUTSTANDING LOUDSPEAKER.

WRITE FOR FULL DETAILS OR PHONE FOR A DEMONSTRATION APPOINTMENT TO THE SOLE DISTRIBUTORS:—

### SOUND RENTALS LTD.

CANTERBURY GROVE,  
WEST NORWOOD,  
LONDON, S.E. 27.

PHONE: GIP 1131.



URELY TESTED

with the

## MICOVAC

### ELECTRONIC TESTMETER

22 RANGES

VOLTS

D.C., A.C., R.F.

CURRENT

From few microamps to

1.5 Amps. D.C.

RESISTANCES

Up to 100 MΩ

A versatile valve voltmeter for laboratory or test bench. Being battery-operated, it is instantly ready for use. Probe for V.H.F. measurements.

**ELECTRONIC INSTRUMENTS LTD**  
17 PARADISE ROAD • RICHMOND • SURREY



## CABOT RADIO

**R.C.A. H.T. TRANSFORMER.** Input 190/260 v. (10 v. steps), 50 cps. sec. 2300, 1750, 0, 1750, 2300 v. (for nominal outputs 2000 v. or 1500 v. D.C. at 800 m/a). Wt. 97lb. net. Size 9in. x 9in. x 7½in. New in cases. £4 plus 7/6 carr.

**R.C.A. MODULATION TRANSFORMER.** Primary 10,000 ohms CT. Sec. 4000 ohms approx. (Push-pull 810's, 805's, TZ40's, etc., to any P.A. up to 1 kW.) Wt. 67lb. net. Size 9in. x 9in. x 7½in. New in cases. £3 plus 5/- carr.

**SPECIAL OFFER.** Both the above transformers together in one case. £6 10 0, plus 10/- carr.

**THERMADOR MODULATION TRANSFORMER.** Primary 6,700 ohms CT. Sec. tapped 4,500, 5,000, 5,500 ohms. Take 250 watts audio, suits TZ40, etc. Size 7in. x 6½in. x 5½in. potted. Wt. 22lb. 50/-, plus 3/6 carr.

**R.C.A. SWINGING CHOKE.** 5/10H. 500 m/a, 40 ohms potted. 25/-, plus 2/6 carr.

**SMOOTHING CHOKE.** British made by G.E.C. for 1131 tx. 15/20 H. 500 m/a, 80 ohms. Wt. 20 lb. 25/-, plus 2/6 carr.

**CONDENSERS.** 4 + 4 mfd. 3KV wkg. 25/-, 4 mfd. 2KV wkg. 15/-, 4 mfd. 1,500 v. wkg., 10/-, All Carr. Paid.

**TRANSMITTER.** 1196 Phone and MCW 4.3-6.7 mc/s. Easily modified for other frequencies. Complete with valves (EF50, OSC, TT11 PA, and EL32 Modulator) and circuit diagram. 27/6, plus 2/6 carr.

**RECEIVER 1196.** 6-valve Superhet, complete with valves (EF39RF, EK32FC, EF39IF, EF36AVC Amp, EBC33 Det, EF36AF Amp). 25/-, plus 2/6 carr. Also with circuit diagram.

**PORTABLE MASTS 27/30ft.** Type 55. New and complete with guys and moorings. Ash sections with alloy ferrules. Simple to erect. Lightweight, only 17lb. New in cases. 32/6, plus 2/6 carr.

**CRYSTAL DIODES.** CV101/111, suitable Xtal sets, F.S. meters, etc., 2/9 each, 8 for £1. Post free.

**SOIL HEATING AND DEFROSTING TRANSFORMERS.** (1) Primary 230 v. 50 cps. Secondary 11-13.5 v. (adj. Prim. tap). Service rated at 70 amps but O.K. for 150 amps. £4 10 0, carr. paid. New in Box.

(2) Primary 230 v. 50 cps., sec. 6.75 + 6.75 v. 20A but O.K. for 40A. New. 50/- Carr. Paid.

**VIBRATOR UNITS.** U.S. Jefferson-Travis. 12 v. input. Output 120/150 v. 50/30 m/a smoothed. In black wrinkle case with leads and clips. 19/6. 1/6 post. New.

## CABOT RADIO COMPANY LIMITED

28 BEDMINSTER PARADE, BRISTOL, 3.

Phone: 64314.



18 TOTTENHAM COURT ROAD, LONDON, W.1

Tel: MUSeum 2453

Tel: MUSeum 4539

Shop hours: Monday-Friday 9—5.30. Saturday 9—1

We can now demonstrate  
**QUALITY  
WITHOUT  
PUSH-PULL**

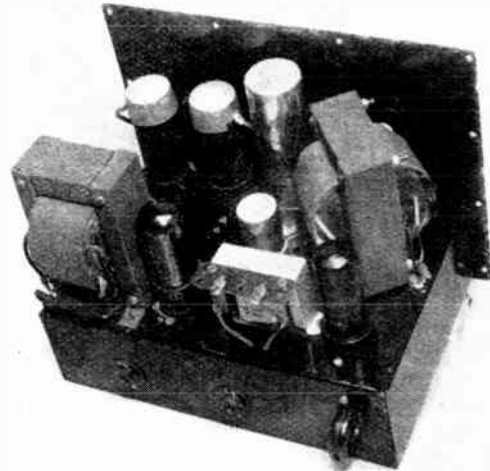

This compact A.D.S. high quality 4½-watt Amplifier has been designed primarily for use with a Connoisseur pick-up and Wharfedale 10in. Golden Speaker.

As it incorporates a pre-amplifier with three switchable steps of bass boost it is also quite suitable for use with a Moving-coil pick-up without further additions.

The size of the complete equipment, in black crackle cabinet is 10½in. x 6in. x 7½in. high, the total weight being 14½ lbs.

Fully illustrated constructional pamphlet now available 10d., post free.

Complete kit of parts including black crackle cabinet, chassis, valves, etc. .... £6/10/-, post free.....  
(Ireland 2/6)

Complete amplifier fully constructed and tested as illustrated but including black crackle cabinet ..... £9/9/-, post free.....  
(Ireland 7/6)

**A NEW SELLING PRICE!**

THE COLLARO "DE LUXE" MICROGRAM

NOW **14** GNS. PLUS P.T.

As the happy result of increased production, the Collaro "De Luxe" Microgram is now reduced from £19.19.0 plus P.T. to £14.14.0 plus P.T.—the world's finest portable electric gramophone at even better value than ever!

Judge this wonderful offer for yourself . . . SEE and HEAR the Microgram at your Dealer's Showroom today.

★ MORE GOOD NEWS! . . . Watch these spaces for the next Collaro advertisement announcing the new Gramophone Units . . . and a new low-priced Record Changer!

The "De Luxe" Microgram with 6½" Speaker, Automatic Stop and Crystal Pickup. A.C. Mains.



The **COLLARO**  
"DE LUXE"  
**Microgram**  
Portable Electric Gramophone

**NEW RETAIL PRICE: £14 14s. 0d.**  
**PLUS PURCHASE TAX : £6 7s. 5d.**

Trade Enquiries to :—

**COLLARO LTD., RIPPLE WORKS, BY-PASS ROAD, BARKING, ESSEX Telephone : Rippleway 3333**

# TELE-RADIO (1943) LTD.

177, EDGWARE ROAD, LONDON, W.2.

AMB. 5393. PAD. 6116. PAD. 5606.

High Fidelity Williamson Amplifier .....	£26 10 0
Pre-amplifier Tone Control Unit, for above amplifier .....	£6 10 0
Rogers Development Junior Amplifier—frequency response flat within plus or minus .5 db from 20-20,000 cps. Output 8-10 watts .....	£19 10 0
Partridge Mains Transformer, for Williamson amplifier .....	£2 17 0
Partridge Chokes, for above amplifier, 25 H. 60 mA. and 13 H. 200 mA., 16 - and Partridge Williamson Output Transformer, as specified "W.W." of '47 .....	£1 11 0
Punched Chassis, for "Williamson Amplifier" .....	£5 0 0
Matched Valves, in pairs, KT66, per pair .....	£1 17 6
Matched Valves, in pairs, 6L6, per pair .....	£1 16 6
Matched Valves, in pairs, PX4, per pair .....	£1 13 0
Matched Valves, in pairs, PX25, per pair .....	£2 14 4
Gram Record Changers, "Collaro" .....	£14 6 8
Gram Record Changers, "Plessey" .....	£18 10 0
Paper Condenser, 4 mfd. 1,000 v. size, 5½ x 4 x 1½ in., 2 9 each or 3 for .....	7 0
Three Gang Tuning Condenser, 500 mmfd. ....	5 6
Two Gang Tuning Condenser, 500 mmfd. ....	5 6
Electrolytic Condenser, 16 x 16 x 350 v., 4 9 each or five for .....	£1 1 0

When ordering please include sufficient for postage and packing.

**BAKELITE CABINET**, made for famous manufacturer, size 12in. high x 8in. long x 8in. deep. Complete with scale pan and two supporting brackets, clips for holding scale, three pulley wheels, flywheel tuning and back.

Post paid ..... 15s. 0d.  
Scale for above ..... 2s. 0d.

**MAINS TRANSFORMER**, drop through type, top tag panel. Primary 200, 210, 220, 230 and 240 volts. 500-0-500 volts 150 mA. 6.3 v. 3 amp., 6.3 v. 1 amp., 5 v. 2 amp., 4 v. 1 amp., 2 v. 2 amp. Post and packing 2s. extra ..... ea. 37 6

**CHARGER TRANS.** 230/250 input, output 13 v. 2 amps., tapped at 4 volts. Plus postage 1/- ..... 6 0

**CHARGER TRANS.** 230/250 input, output 15 v. 2 amp. Plus post 9d. .... ea. 4 6

**HEATER TRANS.** 230/250 input, 6.3 volts 1½ amp. Plus 9d. post ..... 6 0

**MIDGET OP. TRANS.** 40 mA. .... 1 11

**STD. OP. TRANS.** ..... 2 3

**MINIATURE IRON-CORED I.F. Q.120** ..... 7 9

**IRON-CORED 465 Kc. WHISTLE FILTERS.** ..... 1 0

**SELENIUM RECTIFIER H.T. half-wave 250 v. 60 mA.** ..... 2 6

**SET OF FOUR 1½ in. dia. BROWN KNOBS**, marked volume, tuning, wave change and cone, in gold lettering per set ..... 2 0

**SET OF THREE 2in. dia. BROWN KNOBS**, marked volume, tuning and wave change, in white lettering ..... per set 1 6

**.0005 TWIN GANG** with feet ..... 4 0

**.0005 TWIN GANG**, less feet ..... 3 6

**10 Hen. 80 mA. SMOOTHING CHOKE** ..... 3 9

**ASSOCIATED ELECTRONICS LINE MATCHING TRANSFORMER**, primary impedance 500 ohm., secondary 15 ohm. .... ea. 10 6

Write for lists.

**D. COHEN,**  
67, Raleigh Avenue,  
HAYES, MIDDLESEX.

## LAWRENCES

**R.C.A. QUALITY AMPLIFIERS, Type ET4332.** Input 100-250 v. 50-60 cycles. Output 25 watt. Valve sequence—6J7-6J7-6J7-6L6-6L6-5Y4. Push-pull output with negative feedback. Multi-ratio Output Transformer for load impedances of 5, 7.5, 15 or 500-60 ohms. Magnificent case, with chrome fittings. Art photo available on request. Offered at a third of original cost, perfectly new in makers packing, £25.

**BENDIX RADIO COMPONENTS RECEIVERS TYPE MN26.** Valves: 1 6L7, 2 6N7, 1 6B8, 2 6J5, 5 6K7 1 6P6. Freq.: 150-695kc/s., 3.4-7mc/s. With circuits, 90/-.

**NEW AMERICAN BOX KITES M357A.** Large size. Alloy folding frame, beautifully constructed. Originally employed for elevating long antenna. Lift substantial weight. Original cost 9 15 6.

**NEW CATHODE RAY TUBES TYPE VCR97.** Short persistence screen. Final Anode voltage 2.5kV max. Heater voltage 4v. Makers cases, 37 6.

**NEW AMERICAN HEAD SETS, Type H533.** A most popular lightweight set, extremely sensitive, fitted with comfortable rubber cushions and leather covered headband, 7/6. Also New Moving Coil Head and Microphone Sets. Earpieces resemble miniature P.M. Speakers. Quality mike, fitted with pressel switch. An outstanding value at 10 6 per set.

**AIRCRAFT INSTRUMENTS.** We have in stock an enormous variety of precision instruments, including compasses, gauges for pressure, vacuum fluid measure, etc. Send stamp for illustrated list.

**NEW P.M. SPEAKERS**, by famous makers. 12in. new type cone suspension. Voice Coil 3 ohms, 38 6. 10in. Voice Coil 0'nis, 21/-.

**DYNAMOTORS, Type 33.** P.M. Input 6-12 volts D.C. Output 200 volts D.C. This unit may be usefully employed for mobile radio, etc. Fitted with effective suppressors, 11/-.

**CAVITY MAGNETRONS TYPE RK725A.** Freq.: 9345-9405 mc/s. Heater 6.3 v. 1A. Anode 12kV. Peak power output 50,000 watts. Complete with 5400 gauss Magnet Assembly, 50/-.

**NEW RADAR T.R. GAS GAPS TYPE 1B24.** 10/- Also T.B. Type 724B, complete with Cavity Holder, 15/-.

**NEW AMERICAN ASTRO-COMPASSES MK2.** Can be used as a theodolite. Fitted with sight, spirit levels, vernier adjustment. In case, 17/6.

**NEW AMERICAN STAR IDENTIFICATION INSTRUMENTS.** An accurate navigational instrument, complete with charts for all latitudes, in North and Southern hemispheres. In leather cases, 3/-.

**CARLTON MEDIUM WAVE CONVERSION COILS** for Receivers BC433, BC454, BC455. Provide excellent broadcast reception. With instructions. State type required. 10/6; BC433 Plug-on A.C. Power Packs complete 45/-.

**RECEIVERS TYPE ROF1.** 13 valves. Tuning dial. Suitable for TV. conversion. Freq.: 150-170mc/s. I.F. 19.7-22.4mc/s. With circuits, 37/6. A 2½d. stamp brings you our latest lists describing countless bargains from 5kVA Petrol Generators to diminutive components.

Terms: C.W.O. All prices include carriage.  
**LAWRENCES.** 61, BYROM ST. LIVERPOOL, 3 CENT: 91 4430.

## D.C. - A.C. CONVERSION

Frequency stability, R.F. and A.F. suppression, with long working life, are but some of the features of Valradio Vibrator converters. We quote two examples here.

### 12v. INPUT

Model 230 75 12 gives a useful A.C. output at 50 or 75 c.p.s., and is ideal for outdoor P.A. work. 230v. 75 watts A.C.

£10.15.0

### 110v. INPUT

Model 230/300/110 particularly suitable for television and autoradiograms. A.C. output at 50 or 75 c.p.s. 200-250 v. 300 watts.

£16.0.0

## VALRADIO LTD.

57, FORTRESS ROAD, N.W.5 GULLIVER 5165

## THE "COMMANDER" DOUBLE SUPERHET COMMUNICATIONS RECEIVER FOR COMMERCIAL AND AMATEUR USERS

Brief Specification:

- COMPLETE COVERAGE 1.7 TO 31 Mc/s.
- SEPARATE ELECTRICAL BANDSPREAD.
- DIRECT READING FULL VISION DIAL.
- THREE SELECTIVITY POSITIONS.
- HIGHLY EFFICIENT NOISE LIMITER.
- ILLUMINATED S.METER.
- MICROVOLT SENSITIVITY. ● 3 WATTS OUTPUT.
- 1.4 AND 100 kc/s. I.F. STAGES. B.F.O.
- EXCELLENT SIGNAL/NOISE RATIO.

Price £48.10.0 HIRE PURCHASE FACILITIES  
Prompt Delivery, Home and Export  
Operating and Servicing Handbook, 5/- Illustrated Literature, 2½d. stamp

Trade Enquiries invited.

**RADIOVISION (Leicester) LTD.**  
58 60 RUTLAND STREET, LEICESTER Phone 20167



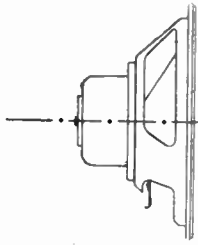

# perfect alignment by

# Co-axial Construction-

## FOR "BETTER LISTENING"

R. & A. Reproducers are perfectly aligned about their axis. Their assembly is so arranged that the voice coil can never, except under conditions of brute force, vary from its setting in the anular gap by more than .001 ins. Misalignment of the voice coil and/or mechanical failure is therefore almost impossible, no matter what the volume or frequency.

A co-axially constructed, distortion-free speaker is a necessity for Better Listening.

**"The Story of Co-axial Construction"** explains how our speakers are built. We will gladly send a copy to any manufacturer or Overseas Buyer who writes for one.



REPRODUCERS AND AMPLIFIERS LIMITED  
FREDERICK ST. WOLVERHAMPTON ENGLAND



# COULPHONE RADIO PRODUCTS

## MAINS TRANSFORMERS

166 POST PAID

Coulphone Mains Transformers are made to the highest electrical standards and are fully guaranteed. We supply them to the Ministry of Supply Atomic Research Stations, so they will no doubt meet your requirements. Special quotations for quantities and types to order.

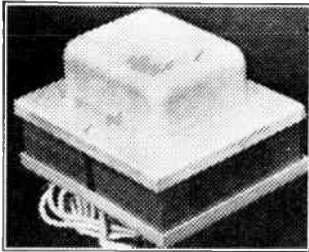

**COULPHONE COIL PACKS.** Medium, Long and Short Wave. Built on 16 S.W.G. Aluminium chassis. Totally enclosed. One hole fitting. Aligned ready for connection into receiver. I.F. 465 kc/s.

**MODEL A.** For use with 2 gang tuning condenser. 6K84 or any triode hexode frequency changer. **£1 18 6.**

**MODEL AR.** For use with 3 gang tuning condenser. R.F. stage for 6K7C and 6K8G. Nine iron dust coated coils. **£3 17 6.**

**COULPHONE 20-WATT HIGH FIDELITY AMPLIFIER.** Built to famous Williamson circuit but with push-pull 807's for higher power output. Linear response from 20-20,000 cps. Power supply for feeder unit or tone control unit brought out to radial socket. 0.5 v. 4A and 250 v. 10 mA. **£22 10/-.**

**EX GOVT. SURPLUS. COULPHONE** offers the best bargains. Over 200 items in our illustrated catalogue. If interested please send extra 2d. stamp—it will save you 4's.

**ROTHERMEL "TORPEDO" MIKES.** List Price £18 18/-. My price **£3 18 6.** Post paid.

Terms: C.W.O. or C.O.D.

# COULPHONE RADIO

"The Return of Post Mail Order Service"

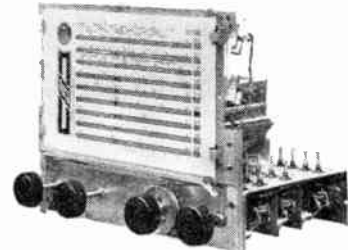

## FEEDER UNITS

**MODEL B DE LUXE** (illustrated above). High gain R.F. stage operative on all nine wavebands. 45/145 M., 180/550 M., 900/2000 M. Plus six ranges of Bandspread. 15.5-14.8, 16-17.4, 19-20.5, 24.2-26, 30-32, 41-43.5 metres. Large colour printed glass dial, 10in. x 6in. aperture. Horizontal drive. Wave-range indicator and magic eye. Switched pick-up sockets. Volume and Tone Controls. Completely aligned ready for connection to audio amplifier. Price less valves **£19 7 6.**

Valves required. EF50, 6K8G, 6K7G, 6Q7G, 6U5. Price for set of five valves, **£31 11/5.**

**MODEL A.** A first class feeder unit with R.F. stage operative on all wavebands, 16/50, 180 550, 900/2000 metres. Switched pick-up sockets. Volume control. Glass-dial 8in. x 8in. in colour. Completely aligned ready for connection to audio amplifier. Price less valves, **£10 8 6.**

Valves required, 6K7G, 6K8G, 6K7G, 6Q7G. Price for set of four valves, **£2/11/3.**

**A.F. AMPLIFIER POWER UNIT.** Specially designed for use with above units. Employs 6V6G output (4 watts) and 5Z4G rectifier.

Price less valves, **£4/10/-.** Two valves if required, **£1/13/10.**

NEW GOODS ONLY

53 BURSCOUGH ST.  
ORMSKIRK, LANCs.

Tel.: Ormskirk 987

Standard Replacement Types. Drop-through chassis type with top shroud. Impregnated and interleaved Screened Primaries tapped for 200 230 250 volts.	
(a) 250-0-250 v. 60 mA. 0.3 v. 3 A., 0.5 v. 2 A., 0.4 v. 2 A.	16 6
(b) 250-0-250 v. 60 mA. 4 v. 4 A., 4 v. 2 A., 0.4 v. 2 A.	16 6
(c) 250-0-250 v. 80 mA. 0.4/6.3 v. 4 A. C.T., 0.4 v. 2 A.	19 0
(d) 300-0-300 v. 80 mA. 0.4/6.3 v. 4 A. C.T., 0.4 v. 2 A.	19 0
(e) 350-0-350 v. 80 mA. 0.4/6.3 v. 4 A. C.T., 0.4 v. 2 A.	19 0
(f) 250-0-250 v. 100 mA. 0.4/6.3 v. 4 A. C.T., 0.4 v. 2 A.	22 0
(g) 300-0-300 v. 100 mA. 0.4/6.3 v. 4 A. C.T., 0.4 v. 2 A.	22 0
(h) 350-0-350 v. 100 mA. 0.4/6.3 v. 4 A. C.T., 0.4 v. 2 A.	22 0
(i) 250-0-250 v. 150 mA. 0.4/6.3 v. 6 A. C.T., 0.4 v. 2 A.	39 0
(j) 250-0-250 v. 180 mA. 0.3 v. 4 A. C.T., 6.3 v. 1 A. C.T., 5 v. 3 A.	44 6
(k) 250-0-250 v. 180 mA. 4 v. 8 A. C.T., 4 v. 4 A. C.T., 4 v. 4 A.	44 6
(l) 250-0-250 v. 180 mA. 6.3 v. 4 A. C.T., 4 v. 2 A. C.T., 4 v. 2 A. C.T., 5 v. 3 A.	47 0

Types (a) (b) (c) (d) (e) (f) (g) (h) (i) illustrated on left  
Types (j) (k) (l) upright shrouded type.

## WILLIAMSON OUTPUT TRANSFORMER

A super job exactly to author's specification Upright mounting **£3/12/6.**

## High Fidelity Reproduction.



TYPE "K."

The S. G. Brown Type "K" Moving Coil headphones, with the following outstanding characteristics, supply that High Fidelity Reproduction demanded for DX work, monitoring and laboratory purposes, etc.

**CHARACTERISTICS.**

**D.C. RESISTANCE, 47 Ohms.**

**IMPEDANCE 52 Ohms. at 1,000 c.p.s.**

**SENSITIVITY, 1.2 x 10<sup>-12</sup> Watts at 1kc. — .0002 Dyne/cm<sup>2</sup>**

Descriptive Literature on request

**PRICE £5.5.0 PER PAIR**

Your Local Dealer can supply

For details of other S. G. Brown Headphones (prices from 30/- to 77/6) write for illustrated Brochure "W.W."

**HEADPHONES WHICH UPHOLD BRITISH PRESTIGE**

Telephone :  
Watford 7241

# S.G. Brown, Ltd.

**SHAKESPEARE STREET, WATFORD, HERTS.**



**BROWN—E.R.D. 13 inch Portable Disc Recorder**  
An Important S. G. Brown product

# Brown-E.R.D.

## DISC RECORDER

Incorporating the latest advances  
in Sound-on-Disc Recording

Write for interesting brochures presenting full technical details of this latest development in Sound-on-Disc recording. Also 17 inch models for the Professional user.

**S. G. BROWN LTD., Shakespeare St., WATFORD**

Established in Electro Acoustics and high precision Engineering for over 40 years. Manufacturers of the world-famous "BROWN" Gyro Compass.

Telephone : Watford 7241

**RECEIVERS R.1355.** A fresh purchase of these ready-made Vision and Sound receivers specified for "Inexpensive Television," a copy of which is supplied with each receiver. Receives London or Birmingham Television simply by using the requisite RF Unit. ONLY 55/- (carriage, etc., 7/6). The RF Unit 26 specified for Birmingham TV can be supplied in the original maker's cartons for 35/-.

**INDICATOR UNIT APN4.** Also specified for "Inexpensive Television." Contains cathode ray tube SCPI, 14 valves 6SN7, 3 of 6SL7, 6 of 6H6, and 1 of 6SJ7. In addition, contains shoals of condensers and resistors, which can be used in constructing the TV. ONLY 79/6 (carriage 12/6).

**RECEIVER R.3084.** Another ideal unit for conversion to TV, full details being supplied with each set. Contains a 30 Mc/s IF Strip, 2 valves EFS4, 1 of ECS2, 7 of EFS0, 1 of VU39A, 1 of HYR2, and 1 of EAS0. BRAND NEW IN MAKER'S CASES. ONLY 75/- (carriage 10/-).

**RECEIVER RDF 1.** A 1½-metre receiver which can be converted for TV or UHF work. Has variable tuning, 4 IFTs of 12 Mc/s, 1 valve SZ4, 1 of ECS2, 5 of SP61, 2 of P61, 3 of EAS0, 1 of EB34, and 1 of CV63. ONLY 49/6 (carriage 5/-).

**RECEIVER R.1132A.** A superb UHF 10 valve communications receiver covering 100-124 Mc/s. Incorporates large 180 degrees slow motion tuning dial, and 0-S mA. tuning meter. Valve line up : 1 each P41, 7475, EB34, EFS2, 6J5G, 2 of SP41 and 3 of EF39. Complete with circuit diagram, parts lists, and calibration charts. ONLY 79/6 (carriage 10/-).

**RECEIVER TYPE 25.** The receiver portion of the T/R 1196. Covers 4.3-6.7 Mc/s., and makes an ideal basis for an all-wave receiver, as per "Practical Wireless," August issue. Complete with valves types EF36(2), EF39(2), EK32 and EBC33. ONLY 22/6 (carriage 2/6).

**INDICATOR UNIT 162B.** Contains 6in. tube VCRS17 and 3in. tube VCR139, 3 valves SP61, 1 VR17, 2 EAS0, 2 D1, and Klystron CV67, an 0-1 mA. meter, and a blower motor. ONLY 67/6 (carriage 12/6).

**INSULATION TESTERS.** Ex-R.A.F. testers by "Record," giving readings up to 20 megs. at 500 v. pressure. Brand new. ONLY 88/10/.. C.W.O. please.

S.A.E. for lists.

**U.E.I. CORP., The Radio Corner**  
138, GRAY'S INN ROAD, LONDON, W.C. 1

(Phone : TERminus 7937)

Open until 1 p.m. Saturdays. We are 2 mins. from High Holborn.  
5 mins. from King's Cross.

## SUPACOILS OFFER

**Model 30 Coil Pack.**—The 3-waveband superhet pack with adjustable iron cored coils and trimmers for absolute accuracy in padding and tracking. This pack is gaining more and more favour among experienced engineers and amateurs for its sound design, high quality workmanship and high sensitivity and selectivity ..... 21/- or 24/- fully aligned.

**Model 40 Coil Pack.**—Similar to the Model 30 but with R.F. stage ..... 42/- or 47/- fully aligned.

**Model 30 Tuning Unit.**—This is now one of the most popular units for easy and efficient superhet construction. It consists of a Model 30 coil pack, pair "MM" i.f. transformers, 2-gang condenser and attractive dial. Components are aligned together as a unit in an attractive receiver, and sealed. No further alignment is required..... 48/6

**Model 40 Tuning Unit.**—Similar to above with provision for R.F. stage..... 76/9  
**FREE.** A Free copy of the enormously successful HOME CONSTRUCTOR'S HANDBOOK will be given to every purchaser. Or a copy can be obtained for 1/- from

**SUPACOILS (Mail Order Office)**  
88, Greenway Avenue, London, E. 17

You will obtain a complete picture of technical and industrial radio in France from the leading French radio paper :

# TOUTE LA RADIO

A specimen copy will be sent free to all radio specialists (trade, importers, retailers) on request to: TOUTE LA RADIO, 9 rue Jacob, Paris VI<sup>e</sup>.



introduce the  
**Leak Proof  
Battery!**

**A REVOLUTIONARY DEVELOPMENT  
EXCLUSIVE TO ALPHA**

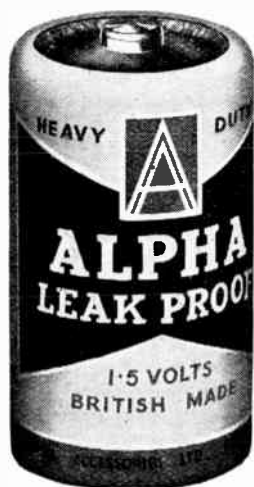

- Sealed in Steel ★
- Cannot deteriorate when idle
- Stands up to rough handling and years of storage
- Unaffected by extremes of temperature

This new type of battery is a revolutionary development exclusive to Alpha. The cell is completely sealed in an insulated steel jacket, preventing leakage and permitting storage for years without loss of power. For all-round efficiency and value for money, Alpha batteries for Radio and Lighting are second-to-none. The Alpha Leak-Proof battery (1.5 volts) is made in the standard size similar to A.2.

Price 6d.

★ Covered by British Patent No. 531237

**ALPHA ACCESSORIES LIMITED  
GRAMOPHONE BUILDINGS  
BLYTH ROAD · HAYES · MIDDLESEX**

The Revolutionary  
**GOLDRING**

*Headmaster*

**HYPERFIDELITY**

**PICK-UP**



With an Inter-changeable Pick-up Head for every type of Record

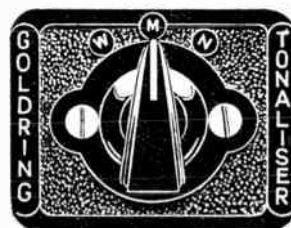

● TONE CONTROL AND  
BASS EQUALISER

DESIGNED BY ENTHUSIASTS who know that low surface noise and absence of distortion are as important as wide frequency range. APPROVED BY EXPERTS who recognize that this is the best, as well as the cheapest LIGHT-WEIGHT PICK-UP in the world.

Price complete  
**£6 10 6**  
Tax Paid  
Replacement  
Heads  
**£1 1 6**  
Tax Paid

OUTSTANDING FEATURES INCLUDE:

- Resonance free response over the entire audible range.
- Needle pressure of less than twenty grams and very free armature movement for minimum record wear.
- Three-Point Tonaliser compensates for different record characteristics.
- Low surface noise and absence of distortion with even the most difficult records.

*Only with the "Headmaster" can you choose the right point to fit the groove every time.*

Write for full technical information to :

**ERWIN SCHARF,**  
49-51a DE BEAUVOIR ROAD,  
LONDON, N.1

Telephone: CL1ssold 3434



**MIDLAND INSTRUMENT CO.**

**For Govt. Surplus Stock, etc.**

RECEIVERS, 2-band, 4.2 to 7.5 and 19 to 31 mc/s., contains 11 valves, ARP-12/VP-23 (7), AR-8 HL-23-DD (4), one of each type valves are spares, also Mallory type 650 6-v. vibrator, 3 I.F. stages, 3-gang and 2-gang condens., in tandem to give separate R.F. sections for each v-band, slow motion drive, wave-change, volume and on off etc. controls, chassis mounted with side protection frame, size 9 1/2 in. x 8 1/2 in. x 6 1/2 in., no other data at the moment, brand spanking new, 37 6s. post and packing 2 6 extra.

WESTINGHOUSE "Westalite" battery chargers, A.C. input tapped 100 to 250 v., output D.C. 12 v. 16 amp., variable inductance and sec. tapped transformer 0-20 amp. in c meter, mahos switch, Stylluk fuse, black japanned metal cases, with feet, 18 in. x 13 in. x 10 in., brand new unused, £10; case and carriage 10s.

ZOOVER motors fitted enclosed centrifugal fan blower, dual voltage 12 or 24 v., A.C. D.C., brand new 15s. post 1s.

FREQUENCY METERS, TS-59 AP., covers 341 to 1000 mc/s., with high-precision cavity, 341 to 700 limits of 1 mc/s., 700 to 1000 limits of 2 mc/s., indicated on vee-der counter, fitted super 0-200 microammeter, crystal valve, stub aerial, calibration sheets etc., smart crackle case also super transit case, brand new, 70s. carriage 7 6s.

U.S. CONVERTERS by L. C. Smith Corona Typewriters Inc., converts plain language into 3 letter code by infinitely variable alphabet transcription method, recording same on paper tape, also decodes same back to plain language, in smart crackle green cases, 7 1/2 in. x 6 in. x 3 1/2 in., new unused, 20s. post 1s.

2 instruments, 35s. post 1 4.

G.E.C. EXPELLER FANS, 12 v. 3 amp. A.C./D.C., specially designed 6 in. dia. blades, brand new, boxed, 20s. post 1s.

AIR COMPRESSORS, Ref. No. 37K, 8, 60 lb. sq. in., 7 in. bore, 4 1/2 in. dia, fitted 1 1/2 in. bore, 2 in. dia, splined shaft, brand new in wood cases, 15s. post 1 4.

INTERPHONE AMPLIFIERS BC-212-D, complete with 2 6C5 valves, input and 1 output transformers, switch, etc., operates from 6 or 12-v. L.T., 220, 230 or 250-v. H.T., in smart metal cases, 5 in. x 4 1/2 in. x 2 in., brand new boxed with circuit, 12 6s. post 9d.

MOVING COIL HEADPHONES, to which are coupled a moving-coil microphone fitted switch, brand new, 10s. post 1d.

MIDGET U.S. RELAYS, 1000-ohm, 8 spec. 1 - post 3d.

10s. doz. post 9d.

MASTER CONTACTORS, high-grade clockwork movement, provides 2 impulses per second, 12-v., fitted suppressor, in bakelite cases, brand new, 10s. post 1s.

Remote contactors, runs in conjunction with the master contactor, high-grade impaling mechanism, 120 impulses (1 min.), for 1 rev. of hand, resetting device, switch, etc., brand new, 5s. post 9d.

AIR POSITION INDICATORS, contains a wealth of gears, worms, silver steel shafts, 3 ball disc variable reduction units, 4 roller type counters, repeater motors, etc., etc., an ideal basis for a mathematical calculator, in cases size 12 in. x 7 1/2 in. x 5 1/2 in., brand new, boxed, 30s. carriage 2 6s.

AMPLIFIERS TYPE R113 5A, consists of 3 valves, VT-52, VR-55, VR-57, also four transformers, pots., resistors and condensers, etc., on chassis bin. x 3 in. x 2 1/2 in., 10s. post 1s.

RECEIVERS TYPE R1135A, contains 8 valves, EP-50 (5), VR-53 (2), and VR-54, var. cond., coils, resistors and condens., on chassis 11 in. x 8 in. x 5 in., 25s. post 1 4.

MAGNETIC COMPASSES, all have alcohol bubble, and are brand new in wood carrying cases, Type 158, cross wires and cardinal points luminous, 10s. post 1s.

Type 0-2A, fitted azimuth ring and prism, 20s. post 1 4.

Type 0-6A, hand bearing type, fitted prism, takes battery in hand grip, 25s. post 1s.

Also hundreds of other Radio, Electronic and Mechanical Items, send 2d. stamp and s.a.e. for current lists. Our C.O.D. service is cancelled for the time being.

**MOORPOOL CIRCLE, BIRMINGHAM, 17**

Tel.: HARborne 1308 or 2614

FOR QUICK DELIVERY  
AT  
REASONABLE PRICES  
OF  
RADIO & ELECTRONIC PRODUCTS  
(Wholesale Only)

Write or phone:—

**S. Szymanski**  
(pronounced SHE-MAN-SKEE)

ELECTRONIC ENGINEER & STOCKIST  
95 STRODES CRESCENT

STAINES, MIDDLESEX  
Staines 3971

VALVES are our speciality—Probably the  
Largest Actual Stockist in England

EXPORT ENQUIRIES WELCOMED



● **HUGE PURCHASE of the FAMOUS RAVON MULTI-RANGE TEST METER . . .**

These splendid Meters, although listed at £16 6s. each and Brand New from the manufacturers, are now offered to you at an astounding price representing a saving, for keen buyers, of nearly 50%, and this is without doubt the best bargain of its class in the United Kingdom.

Specification as follows:—  
D.C. Mill volts, 0-100, D.C. Volts, 0-1, 10, 100, 1000, 1,000, D.C. Current, 0-5, 10, 50, 100, 500 m.a., A.C. Volts, 0-10, 100, 500, 1,000  
Wattage Output up to 4 watts. Resistance 2 ohms to 20 megohms in four ranges without external batteries. Capacity, 0.001 to 1 mfd., 2 ranges. A master rotary switch controls all ranges. The movement is sapphire jewelled, and anti-parallax is incorporated on the large scale. Attractively finished in black bakelite case with carrying handle. Size 8 in. x 6 in. x 3 in. Brand New in box.

OUR PRICE **£8/15/0** POST PAID

**MAINS TRANSFORMERS**

A total output purchase from a manufacturer enables us to offer you the following cut prices in BRAND NEW AND GUARANTEED Transformers. These are Not Government surplus.

Input A.C. Mains 50 60 cycles, tapped 210, 230, 230 v. Both sub-chassis mounting and semi-shrouded.

Output: 250, 0-250 v. 60 ma. 5 v. 2 amp., 6.3 v. 3 amp. . . . . 15s. each  
Output: 250, 0-250 v. 100 ma., 5 v. 2 amp., 6.3 v. 3 amp. . . . . 20s. each

THESE TRANSFORMERS ARE DEFINITELY THE BEST VALUE OFFERED IN THE HOME TRADE

**NO CARRIAGE OR PACKING CHARGES**  
Carriage paid on all orders in U.K. For Eire and Export, additional charges must be added or we will quote.

**WESTON PRODUCTS**  
(LIVERPOOL) LTD. • TEL: ROYal 5754/5.  
**71-GT-GEORGE STREET LIVERPOOL-1**

POTENTIOMETERS  
by **RELIANCE**



Wire-wound and Composition types. Single, Ganged, Tandem Units. Characteristics: linear, log., semi-log., non-inductive, etc. Full details on request.

**RELIANCE MFG. CO. (SOUTHWARK), LTD.,**  
Sutherland Road, Higham Hill, Walthamstow, E.17.  
Telephone: Larkswood 3245

**C.51** ★  
FOR TELE-COMMUNICATION ★

A new Lustraphone Moving-Coil Microphone designed and developed specifically for G.P.O. hand-sets, with mobile tele-communication and P.A. equipment in view. Available as Insert Unit (C.I.51) or complete Hand Microphone (C.H.51). Characterised by sturdy construction light weight, and high level of performance. Data Sheet on request.

**LUSTRAPHONE LTD.** 84, Belsize Lane, N.W.3  
Hampstead 5515

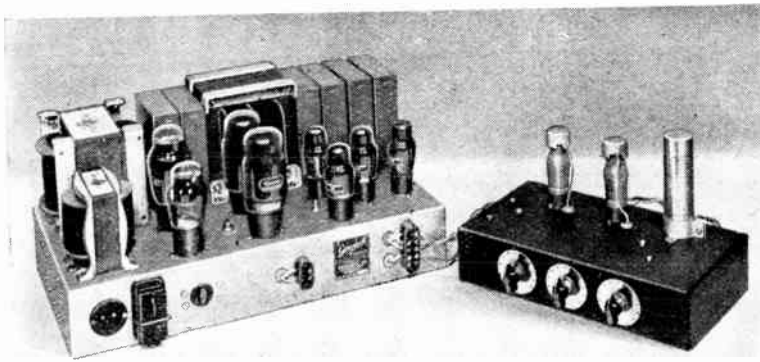

MODEL ILLUSTRATED IS OUR KT66 (TWO POWER SUPPLIES) Price £29.5.0 and MODEL EF37 PRE-AMP Price £8.0.0

# GOODSELL

**15 WATT HI-FIDELITY AMPLIFIERS**  
*are unsurpassed in performance*

AS DESCRIBED BY T. D. N. WILLIAMSON IN "Wireless World," AUG. 1949

Manufactured by

**GOODSELL LTD. 40 GARDNER ST. BRIGHTON Tel. 6735**

*Easy Terms from LONDON RADIO SUPPLY CO. Balcombe, Sussex*

ILLUSTRATED BROCHURE GIVING DETAILS OF OUR FULL RANGE FREE ON REQUEST

DESIGN DATA MODIFIED AS PER FURTHER NOTES IN W.W. FOR AUGUST 1949.

## Best buy at Britain's

**RECEIVER UNIT, type 2573.** Good news! Another huge purchase enables us to offer these at 22/6 post free. The unit is the receiver portion of the TR1196. Valve line-up; 2 EF39, 1 EK32, 1 EBC33, 2 EF36 and one pair of 460 Kcs IF transformers, resistors and condensers. Rapidly converted to a fine medium wave superhet. We supply gratis the necessary circuits and modification data. Order early.

**RECEIVER UNIT BC624.** An eleven-valve American receiver, unused but slightly soiled, which employs valves of the 12 v. 15 amp. series. Included are 3 9003 and 1 9002. The receiver as supplied tunes between 100-156 Mcs with 4 spot frequencies. It is necessary to modify the receiver for continuous tuning, as the local oscillator is crystal controlled and cannot be tuned. We therefore supply with each set circuit diagrams and full modification instructions for "Ham" use. The price is only 25/-, carriage paid, and represents exceptional value.

**RECEIVER UNIT type 71.** Will prove of interest to the amateur. It is part of the TR1143 and tuned to the 124 Mcs. band. Contains 8 valves: types; 4 EF50, 2 EF39, 1 EBC33 and 1 EL32. Numerous small components are included—4 IF transformers, etc. In excellent condition and offered at 22/6 carriage paid. A real bargain.

**RECEIVER UNIT type 1225.** Comprises a chassis with 5 EF50, 2 EF39, 1 EB34, 12 meg. IF transformers and associate components, etc. Splendid value at only 22/6 carriage paid.

**SYNCHRONIZER UNIT type BC993.** BRAND-NEW AMERICAN EQUIPMENT. This outstanding equipment is housed in a handsome black crackle finished cabinet, and contains the following valves: 2 6SL7, 1 735, 3 6AC7, 1 2X2, 1 6N7, 2 6SN7 and 5 713, together with a 3in. type 3EPI CR tube. Ideal for making a small scope. Chassis dimensions; 20in. x 10 1/2in. x 7 1/2in. ONLY 59/6 carriage paid. A unique opportunity.

**AMPLIFIER UNIT, type 3586.** Complete in case, size 12in. x 9in. x 8in. Valve line-up; 1 SU4, 2 807, 1 EF50, 1 EA50: many high-voltage resistors and condensers and 2 high-

speed relays. Easily converted to a high output amplifier or modulator unit. BRAND-NEW AND CRATED. ONLY 22/6 carriage paid. Don't miss this superb offer.

**AMPLIFIER UNIT A1135A.** Valve line-up; 1 VR57, 1 EL32, 1 VR56. Contains intervalve transformers and hosts of small components. Priced at only 8/6 carriage paid. Value beyond compare—anywhere!

### RCA CRYSTAL CALIBRATED WAVE-METER, TYPE TE149

A PRECISION PIECE OF TEST EQUIPMENT COVERING THE FREQUENCY RANGE 2.5 TO 5 Mcs. ON FUNDAMENTALS, AND FROM 5 TO 20 Mcs. USING THE SECOND AND FOURTH HARMONICS. THE CRYSTAL USED HAS AN ACCURACY OF .01 PER CENT., AND THE OVERALL ACCURACY IS BETTER THAN .02 PER CENT. TRANSMITTERS FROM 250 Kcs. UPWARDS CAN BE CALIBRATED BY USING HARMONICS OF THEIR OUTPUT. A UNIQUE FEATURE OF THIS INSTRUMENT IS THE DIAL, WHICH IS CALIBRATED DIRECTLY EVERY KILOCYCLE. IN MANY WAYS, THEREFORE, IT IS SUPERIOR TO THE BC221. THE WAVEMETER IS ENCLOSED IN A NEAT METAL CASE WITH CARRYING HANDLE, SIZE 7in. x 8in. x 9in., AND THE WHOLE EQUIPMENT WHICH INCLUDES VALVES (1NSGT, 1A7GT, 1Q5GT), SPARE VALVES, INSTRUCTION BOOK AND CIRCUITS, CASE OF SPARES, etc., IS PACKED IN A WOODEN CARRYING CASE SIZE 11in. x 16in. x 12in. AS IS USUAL WITH BRAND-NEW AMERICAN EQUIPMENT, EVERYTHING IS IN ABSOLUTELY PERFECT CONDITION. DEFINITELY A BUY FOR THE DISCERNING. ONLY £4.19/6 (Plus 5s. carriage & packing)

### TWO TRANSFORMERS. New and Guaranteed

**Mains Transformer.** 280-0-280 v. 70 ma. 5 v. 2 a., 6 v. 3 a., screened primary, 50 cycles A.C., 0-215-240 v., 12/9, plus 1/3 post.  
**E.H.T. Transformer.** For VCR97 and VCR517 tubes. 35/- post free.

### OUR TELEVISOR

The complete Kit of Parts for the above is still available at £16/19/6, and it is emphasised that at this price everything is brand-new, down to the last nut and bolt.

For those to whom price is the primary consideration, we can supply the complete Kit—again with tested valves and CRT—for only £15. In this instance the valves and CRT are slightly soiled, but guaranteed perfect.

The lucid nature of our instructions and easy to follow point-to-point wiring diagrams ensures success for all. May we urge you to send for these initially? The price is only 5/- post free, refunded when the Kit is purchased.

To recapitulate. The Televisor is built from standard radio components and assembled on two chassis, one for the vision receiver, sound receiver and time base, the other for the power supplies. The whole assembly is impressively neat and easily contained in a small cabinet.

A demonstration model can be seen at our London premises during viewing hours. A visit will convince the most sceptical that it is a practical proposition, even for those who lack knowledge of television technique. You will be surprised at its simplicity of design, construction and outstanding performance.

Large and comprehensive stocks of Receiver and Indicator Units and virtually every type of component, small or large, available. Make a point of calling this month, as we are disposing of much useful equipment at really "all can afford" prices. Send large S.A.E. for current List "W."

Best buy at Britain's  
**CHARLES BRITAIN (RADIO) LTD.**



**11, UPPER SAINT MARTIN'S LANE, LONDON, W.C.2**

(3 minutes from Leicester Square Station)  
Telephone: TEM 0545.  
Shop hours: 9-6 p.m. Thursday 9-1 p.m.  
OPEN ALL DAY SATURDAY.

# Stars for Sale!

**DELIVERY from STOCK of the LATEST RADIOGRAM UNITS**

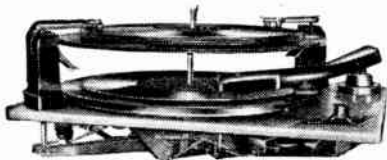

**COLLARO AC501.** Single record player, 10in. turntable, auto stop, magnetic P.U. 100/250 v. A.C. Price, inc. P.T., only £5 3s. 2d. As above, but with crystal pick-up, inc. P.T., £5 17s. 2d.

**GARRARD type "g."** Similar to above, magnetic P.U. inc. P.T., £5 10s. 6d.

**PLESSEY,** auto stop and start, 10in. turntable, magnetic P.U. inc. P.T., £6 18s. 3d.

**EMI AC100.** A new release at an amazingly low price. Plays 10 10in. or 10 12in. (not mixed). Simple and reliable construction. High fidelity, lightweight. P.U., 100-220 v. A.C. Price, inc. P.T., only £10 0s. 8d. Matching transformer extra 10s (no P.T.).

**COLLARO RC49.** The lowest-priced mixed record changer. Illustrated above. Crystal P.U., 100-250 v. A.C. Price, inc. P.T., £14 6s. 8d.

**MULLARD VALVE AND SERVICE REFERENCE MANUAL,** including all current and obsolete types of valves, C.R. Tubes and Photoflash Tubes, etc. There are numerous circuits recommended for appropriate valves, and a section giving resistance and capacity colour codes, ABAC's and conversion tables, including OHMS LAW—Decibel Chart—Wavelength Frequency Chart—output transformer ratios, etc.—and complete circuits of Miniature—Portable A.C. and A.C./D.C. Receivers—Amplifiers—Oscilloscopes—Power Supply Units—25 w. Band Switched Exciter—portable battery operated photoflash equipment, etc.

The whole production is in a very handy pocket size, and is spiral wire bound. Price per copy, 6s. nett. Post 6d. extra. NEW LISTS NOW AVAILABLE.

Post Free on request. SATISFACTION GUARANTEED or CASH REFUNDED INSTANTLY.



## THE KING OF COIL PACKS.

The letters of praise we receive in our post bag every day confirm our opinion that the **MODEL 40 COIL PACK** is the best that money can buy, from the point of view of quality, workmanship and performance.

It is, to the best of our knowledge, the only unit on the market with an R.F. stage which can be supplied prealigned and sealed for direct inclusion into a superhet receiver. It uses 9 separate iron-cored high efficiency coils, with high stab. 8.M. padders and variable trimmers. The Waveband coverage is 16-50, 200-550 and 800-2,000 metres. Notwithstanding its compact size (4 1/2 in. x 5 1/2 in. x 2 1/2 in.) the internal and external screening is efficient and more than adequate to eliminate any interference between the Aerial, R.F. and Oscillator sections.

The price? Only 2 gu., or can be applied fully aligned at 47/-. For a further month only, as a special offer, we are supplying FREE with every Model 40 Coil Pack our comprehensive and detailed instruction sheets for the construction of a 6 valve superhet receiver embodying this unit. These sheets are really comprehensive and even if you have never built a radio receiver before, you can go ahead with the knowledge that you cannot fail to complete a highly efficient multi-valve receiver, that will give you years of pleasurable listening or DX roaming.

Send 1/- for the latest issue of "The Home Constructor's Handbook," or a 2d stamp will bring you our latest lists.

\*Phone, write or call: **LONDON TELEVISION CO., LTD.,** 694 LEA BRIDGE ROAD, LEYTON, E.10. Telephone: LEY. 4330

# G. W. SMITH & CO., (RADIO) LTD.

## 1196 RECEIVERS

IN BRAND NEW CONDITION **22'6** COMPLETE WITH VALVES

2 EF39. 1 EBC33. 2 EF36. 1 EK32

## HIGH VOLTAGE CONDENSERS

Mansbridge Oil Filled

.1 mfd. 3,000 volt 2/9  
.1 mfd. 4,000 volt 3/-  
.1 mfd. 5,000 volt 3/3

HIGH VOLTAGE VALVE TOPS 6d. each  
HIGH VOLTAGE SLEEVING 3d. length  
HIGH VOLTAGE CABLE 2d. yard

**3 LISLE STREET, LONDON, W.C.2**

Telephone: GERrard 8204

## RADIOMENDERS LIMITED

FOR SPECIAL TRANSFORMERS AND REWINDS

We specialise in

AMATEURS' WINDINGS, TRANSFORMERS  
ALL TYPES, CHOKES, PICK-UP COILS,  
INSTRUMENT COILS, Etc.

LOUD SPEAKER SERVICE

Highest workmanship Good Delivery

**RADIOMENDERS, LTD.**

Television & Radio Apparatus, Transformer & Coilwinders.

123-5-7 Parchmore Road,  
THORNTON HEATH, SURREY

LIV 2261. Trade enquiries invited. Established 16 years.

## KERSHAW'S KORNER KALLING

SPECIAL!!!  
M.O.S. LINES

TELESONIC RECEIVERS, brand new, complete with four 1.5 v. Hivac Midget valves ideal for making your own personal portable 32/6 each. Post paid.

H.T. and L.T. BATTERIES, combined for above tele-sonic receivers. 8/6 each. Post paid.

INERT 1.5 v. CELL BATTERIES, long life, fill with plain water and have continuous use. Ideal for every purpose. 3 for 2/6. Post paid.

MAKE YOUR OWN CRYSTAL SET, with polished terminal box complete with volume control, resistance, etc. 1/6 each. Post paid.

**S. KERSHAW**

93/95 PERSHORE STREET, BIRMINGHAM, 5.

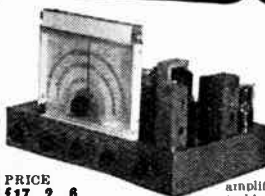

### THE Fedelia LUXURY 7-VALVE RADIOGRAM CHASSIS

Features include variable selectivity, infinite impedance detector, electronic bass and treble controls, triode output stage; 3 wavebands 16-50, 190-550 and 1,000-2,000 metres. Audio amplifier response 30-18,000 cycles; bass, treble and volume controls operate on grammo, suitable for light weight p.u. Guaranteed 12 months Price £17. 2. 6

PRICE £17. 2. 6  
Guaranteed 12 months.  
Data Sheets on request.

Other eqpt includes ELECTRO Acoustic  
2R.F. feeder, 8gms;  
S.H. feeder, 12gms;  
5 & 6 watt amplifiers

DEVELOPMENTS

18 BROAD RD., WILLINGDON, SX.





Rate 6/- for 2 lines or less and 3/- for every additional line or part thereof, average lines & words. Ex 4 numbers, 2 words plus 1.-; rest at 1/- October 1948 issue, first Post Sunday, te,ember 6th. No responsibility accepted for errors.

**WARNING**

Readers are warned that Government surplus components which may be offered for sale through our columns carry no manufacturers' guarantee. Many of these components will have been designed for special purposes making them unsuitable for civilian use, or may have deteriorated as a result of the conditions under which they have been stored. We cannot undertake to deal with any complaints regarding any such components purchased.

**NEW RECEIVERS AND AMPLIFIERS TUNING UNITS.**

FULL range of Denco, Lowther and Eddystone goods available. 5 to 10 waveband gram chassis covering 3 to 60mc/s, 150 to 1,500cc/s, amplifiers for every use, television kits, radio kits, television £51, working at 150 miles range with good results; s.a.e. for leaflet of single items or illustrated 54-page catalogue, price 9d. to Mason's (P.W.), Wivenhoe, nr. Colchester. [3594]

G. W. SMITH & Co., (RADIO), Ltd., offers the following sound and perfect:

BRAND new R3084 receiver in sealed boxes, complete with valves for adaptation to television; 72/6 each.

B10 receiver containing complete 45mc/s IF strip with 13 EF50 valves, EA50 and C790 valve, finest television strip available; 92/6.

1196 receivers complete with valves brand new; 2 EF39, 1 EBC33, 2 EF36, 1 EK32, 22.6; slight y sol.ed, 19/6.

R409 responder units for television, complete with valves and mod. sheet; 52/6.

TYPE 26 UHF units brand new and boxed, 30/-; type 24 brand new and boxed, 12/6 each.

HIGH voltage condensers: .1mf, 3,000v, 2/9; .1mf, 4,000v, 3/-; .1mf, 5,000v, 3/3; these are oil filled Mansoridge type which you can fit and forget.

METERS: 0-5ma, 2in moving coil, 4/9 each; 0-20v, 2in moving coil, 3/9 each; 0-20amp, a.c., 2 1/2in, 7/6 each; 0-6amp, Thermo 2 1/2in, 3/6 each.

MAINS transformers, 200/250 input, output 22v 5amp, 5v 6amp, 6.3v .6amp, 185x184v 45ma; 17/6 each.

MAINS transformers filament, 5v 6amp, 6.3v 6amp, 7.5v 6amp twice, input 200/250v; 17/6 each.

METERS 0-3-500v; 17/6 each.

G. W. SMITH & Co. (RADIO), Ltd., 3 Lisie Street, London, W.C.2. Tel. Gerrard 8204.

UNIVERSAL ELECTRONIC PRODUCTS, 36, Marylebone High St., London, W.1. Tel. Welbeck 4058.

SPECIALISTS in the design and manufacture of high fidelity reproducing equipment from 4-100 watts for domestic or industrial purposes. Our U.E.5 (6 watts) and U.E.7 (12watts) series amplifiers are designed especially for the connoisseur who requires the finest possible reproduction from recorded music, both amplifiers have a linear response over 30-20,000 cycles with a damping factor of 12, and incorporate pre-amplifier stage, together with independent control of bass and treble. Our policy is to produce an instrument which represents the highest standards in workmanship and performance and no expense has been spared to achieve this object. A new addition to our range is the type U.E.3 (4watts) at £11/10. We also supply a range of tuning units, both t.r.f. and superhet, for use in conjunction with either our own or other makes of amplifiers. We should be pleased to quote you for the design and construction of a unit or replacement chassis to your exact requirements. Full details of our products will be forwarded on request, and we would welcome the opportunity to demonstrate our equipment at any time to suit your convenience. [3552]

19 49 bandspread feeder unit with R.F. stage, nine wavebands, 13.5-2,000 metres; 21d stamp for illustrated brochure.—Coulphome Radio, Ormskirk, Lancs. [2528]

AT Last! We can now deliver the Burgoyne A Payboy, the most compact and smallest battery radio to-day, £11/19, tax £2/11/1; send for leaflet or samples, to—Burgoyne Engineering Co., Ltd., 1 Robert St., London, N.W.1. [4030]

R.A.F. model 1155, new, complete with valves, £8/10, plus carriage; converted models, power packs, quality amplifiers, speakers, auto changers and cabinets reduced prices; send for list.—Broadcast & Acoustic Equipment Co., Ltd., Tombland, Norwich. [2906]

AN outstandingly good amplifier for record and radio reproduction, the "Extended Range" 8w, built to laboratory standards, embodies unique dual tone control system providing widest possible range of frequency adjustment; inclusive price only £24.

FELICITY GRAMOPHONE Co., 87a, Putney Richmond Rd., London, S.W.15. Uppner 1665.

FULL constructional manuals of our new range of quality amplifiers and tuners now ready; 4w amplifier, 2/6; 15w push-pull, 4/6; 2-wave t.r.f. tuner, 3/6; 3-wave superhet tuner, 3/6; all parts available, complete kits and ready-built instruments; illustrated catalogue 21d.—N.R.S., 102, Parkhill Rd., London, N.W.3.



**Partridge Mews**

*A new standard in*  
**PUSH-PULL**  
OUTPUT PERFORMANCE

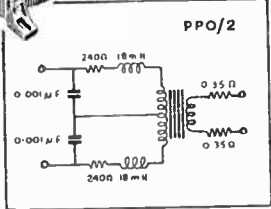
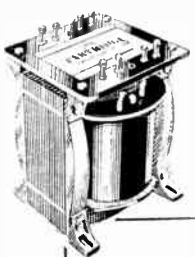

THE new "PPO" output transformers permit the reproduction of a full A.F. range with minimum distortion. Rating is 12w. for 0.5% harmonic distortion at 50 cycles. Six standard models are available, for accurate matching anode to anode loads of 4,000 ohms to 12,000 ohms. The secondary in each case is brought out in two sections for series or parallel connection to match a 15 ohm or 3.7 ohm load. These standard models are available from stock, other specifications can be wound to special order.

Full details are given in Technical Data Sheet No. 1, a copy of which will gladly be sent on request.

**PARTRIDGE**  
**TRANSFORMERS LTD**  
ROEBUCK ROAD, KINGSTON-BY-PAS3  
TOLWORTH SURREY  
Telephone: ELMbridge 6737-8

AMPLIFIERS, new 60watt heavy duty P.A. models, built for continuous rating and rack mounting, £40; early delivery, send for spec.—Broadcast & Acoustic Equipment Co., Ltd., Tombland, Norwich. [2905]

CONNOISSEUR'S receiver—world-wide results on highly sensitive 10-valve communication receiver or, by change of switch, very high quality reception of local stations on non-superhet high fidelity receiver; basis result: R155, 9-1,500 metres; bass and treble controls (boost to cut) gram input. PX4 push pull output, and all refinements.

FEEDER units as above, for use with external high quality amplifiers; write for details, or call for demonstration; R155 specialists, receivers repaired and re-aligned, also modified as above, or to your requirements; R155 circuit and valves 2/- post free.—R.T.S., Ltd., 5, Gladstone Rd., Wimbledon, S.W.19. Tel. Lib. 3303.

R.T.M.C. (Ealing), Ltd., pioneer builders of the refinements mentioned in August issue have been incorporated in their version for some months past, together with other additional improvements which make it without doubt, the finest reproducer in the World. No alteration in price. 7-valve model £25/10, 9-valve model with built in pre-amplifier to G.E.C. spec. £32/10, PX4 model £17/10; pre-amp. only £6/10; if you have no test gear it is cheaper to buy a specially built and factory tested job.—Further details from R.T.M.C., Ltd., Laure House, 41, Little Ealing Lane, W.5, Ealing 6962. [3674]

TELRAD ELECTRONICS, 70, Church Rd., Upper Norwood, London, S.E.19.—Specialists in the design and manufacture of electro/acoustic apparatus, announce a completely new range of high quality reproducing equipment, quality amplifiers with control units providing independent bass and treble control, giving wide possible variation to suit all recordings and the varying acoustic properties of one room with another; radio tuner units for use with the above or other makes of amplifiers; chassis units to suit all requirements, and to suit the discriminating ear; full details and demonstration on request; write, call or phone Livingstone 4879. [3969]

MIDCO high fidelity audio amplifiers for home and commercial use; AA/4 5 watt 6V6 amplifier tone and volume controls, £4/10; AA.10 super 10 watt amplifier with two mix/fade inputs, multi match output, 5 valves, tone control, £10; new PA/12 series portable amplifiers in smart steel cases with chrome fittings, panel lamp, twin inputs for mix/fade, wide range NFB, multi match output, PA/12T record reproducer, high impedance inputs, independent bass and treble tone control, £14; PA/12M high impedance microphone type, one high one low impedance input, tone control (top cut type), £14/10; detailed catalogue available; trade supplied.

MAIL orders, 19, Newcomen Rd. Enquiries: 61a, Gt. Park St., Wellingborough. [3957]

RECEIVERS, AMPLIFIERS—SECOND-HAND A R88, in perfect working order, recently re-aligned; £30 or nearest.—Box 8000. [4134]

B.S.R. PA20 amplifier 20watt, unused; £25.—Johnson, 105, Conway Rd., Colwyn Bay.

R 107, perfect condition; £12/10.—Spark, 36, Candover Close, Harmondsworth, Bucks.

SHORT wave 6-valve portable rec., 3 bands, mains, battery, perfect cond.; £7.—20, Wool Ed., Wimbledon. [4089]

R.M.E.69, revalued, complete, crystal, matched 10in Rola speaker in metal cabinet, £15.—Box 7985. [4105]

CR100, communication receiver, 11-valve, 6-waveband, perfect condition, spare valves, 12/3 offers.—Box 7997. [4123]

SUPER P20 and power unit, perfect condition; nearest £80; BC349, £12; R1155, modified pentode output, £12.—Box 7992. [4098]

PEERLESS 1148 radiogram chassis, unused, still wrapped, list price, £43/14 inc. tax; offered at £36.—Stranke, 2a, Eastern Rd., Walthamstow, E.17. [4112]

RADIOGRAM, 12-valve American Delco auto changer, twin speakers in really beautiful walnut cabinet; £55.—21, Stanley Rd., Northwood, Middx. [4120]

BC342 with variable noise limiter, 220/110v B transformer, 2 1/2ohm o/p; also variety valves, tube, and other gear; offers.—White Heather, Crampmoor, Romsey. [4025]

AMPLIFIERS, 50 watt, 24 at £8 each; speakers, horn type, 30-42in, complete with units, 100/- each; Apply Monitor Radio & Communications, Stechford, B'ham, 9. [3816]

RECEPTION set R201 complete for installation, in first-class order, all instructions schematic and circuit diagrams; £100, ex-Manchester.—Kirkland & Co., 30, Lower Byron St., Manchester 3, Blackfriars 7144/5. [4101]

EDDYSTONE model S.640 communications receiver, nearly new, 30 hours operational time, complete with set of Brown's phones and Eddystone speaker; nearest offer to £25.—Fisral House, Westfield Rd., Bengoe, Hertford. [3817]

15 watt gram. amplifiers complete, rack mounting, twin chassis, heavy duty iron cored components; 2 PX 25 in pp with valves, £6/15; less valves, £4/10, plus carriage.—Broadcast & Acoustic Equipment Co., Ltd., Tombland Norwich. [2907]

# TO WHOM IT MAY CONCERN

We are now selling more speakers in the U.S.A. than in all the rest of the world put together. This result has been achieved in seven months of earnest endeavour, backed up, of course, by a first-class speaker.

The point we want to make clear is that the Hartley-Turner speaker has not been bought "over there" because it is British but because its performance is altogether outstanding. It is entirely by the way that the 215 is much cheaper than first-class American speakers. American high fidelity enthusiasts are mainly concerned about performance.

You at home who have not yet bought our speaker have every right to be content with what you have, but there is no real reason why you should forgo the aesthetic satisfaction that only Hartley-Turner reproduction can give you. Investigate this matter to-day.

Literature is free for the asking but you should send 5/- for "New Notes in Radio" and a service of technical data sheets. If you already have "New Notes" send 2/6 for the data sheets. They are and will be a sound long-term investment.

**H. A. HARTLEY CO. LTD.**  
152 HAMMERSMITH ROAD  
LONDON, W.6

## ONCE AGAIN

We welcome the opportunity  
of introducing to you our  
products,  
NEW and OLD



MEET US AT  
**RADIOLYMPIA**  
SEPT 20 - OCT 8

"The Laboratory Production Unit"

**THE LOWTHER MANUFACTURING CO.**

Lowther House, St. Mark's Road,  
Bromley, Kent.

Rev. 5225.

**A** MERICAN built 20 valve Philco radiogram, without cabinet, Garrard autochanger, three speakers, multi dial tuning, little used, deafness reason sale, wonderful instrument, suitable connoisseur, or would consider buying suitable cabinet.—Dr. Morey, Minster Yard Lincoln. [4030]

**B** C348, converted, with power pack, 1.5-18.0 Mc/s, 200-500 Kc/s, A.V.C.-M.V.C., ant. align., crystal G.W. osc., beat-freq., phones and speaker; included spare set of coils, push-pull sub chassis, numerous condensers, resistances, crystals and components; £30 or near offer.—Box 7979. [4034]

**S** UPER quality amplifier (similar W.W. design) 14 valves, complete with valves (all Octal) tapped output transformer and separate power pack, as new, £6; Wharfedale cross-over network, brand new, 25/-; rubber mask (by Long and Hamby) for 12in c.r.t., brand new, in original carton, 15/-; all above carriage paid.—Rowell, 14, Market Hill, St. Ives, Huntingdonshire. [4073]

**W** ESTERN Electric R1585 receivers, 10 or 12 tubes, D.H.F. or medium wave car radio conversion; the latter requires no coil alteration or additional components, the main item is filament mods from 24 to 12 or 6v, plus a suitable power supply, receiver contains 12 valves, 3X 6AK5, 7X9001, EBC33, 12A6, condition unused and as new in cartons with control box and mounting rack, size 11X6X5in, circuit diagram and details included, £4/10 ea.; circuit diagram 2/6; motor packs with 2/6; R.F. units, type 24 and 24 mod, 27 at 9/9 ea., 25 at 12/6 ea., 27 at 22/6 ea., TE-149 RCA crystal wavefilters, 250kc/s, 25mc/s, brand new, £6/15 ea.; ditto slightly damaged, 1 hrs work and a piece of perspex (supplied) will put them right, £5/5; set of 7 L.H.F. coils with cut cores and ceramic rotary trimmers, 5/-; toggle switches, 1/-; Bulgin rotary, 1/6; meters 0-40v 5/-, 0-5ma 6/-, 20-0-20a 5/-, 50-0-50a 5/-, 2v/in flush 0-100-200-0-50-0 (state which) 9/6, 30-15v a.c., 10/-; Turner coil tester 20-3 and 30-0-30 (dual) 3/6 scale, 12/6, others; schematic output transformers, multiratio 2 in 1 can be used, separate or combined, circuit included, 6/6 ea.; volume controls up to 100,000ohms, 1/6 ea.; 0.1meg long shaft, 5/9; resistors, 7/6 per 100; condensers, 3M, tub and mica, 2/6 (flat diaphragm), 3/-; vacuum thermo switches, 3/-; res. boxes 30hm 1.8a, or 0.44ohm 4a, 2/6 ea.; dimmer switches 50ohms, 1/2 or 100 at 1a, 2/6; 2 gang, .003 small, 2/9; 3 g., .00015, 2/9; Ma Jory 12v vibrator packs with vib., 8/6 ea.; carbon mikes, 3/9; inserts new 1 9/9 used 9d.; MC phones with mike, new 10/6, less mike 6/6; reays 2ma working D.P.S.T., 5/-; lamps 12 and 24v, most types, at 15/- doz; suppressors, small, 3/6; medium 8/6; very large for motors, etc., 30/-; speakers, the best best of the rest, Goodmans, 4in, 16/-; Rola 6in, 16/-; are you interested in telescopes, binoculars, projectors, epidoscopes, microscopes, stereoscopes, enlargers, telescope rifle sights, in fact anything that uses glass lens and prisms, if so our new publication, "How to use ex-Govt. Lenses and Prisms" which gives lens layouts and general data on all the above will interest you; price 2/-, optical lists free on receipt of your s.a.e. H. ENGLISH, Rayleigh Rd., Hutton, Brentwood, Essex. [4092]

### NEW LOUSPEAKERS

**H** OW important it is that a loudspeaker should please the eye as well as the ear; Tridem corner cabinets have been designed to satisfy both; may we send you details?

**F** ELICITY GRAMOPHONE Co., 87a, Upper Richmond Rd., London, S.W.15. [4188]

**P** UT the finishing touch to your Hi-Fi equipment with the Gee Reproducer unit, suitable any cone speaker, exquisite cabinet design and finish; size 40X36X13; details, stamp please.—Gee, 69, Fairlop Rd., E.11. [4119]

**B** ROADCAST new model pm/12.12in d'e cast frames, Tic-nal magnets, 15ohm, 12watts, detachable cones, 12.500 lines, standard £5/15; Hi-Fi twin cone £6/10.—Broadcast & Acoustic Equipment Co., Ltd., Tombland, Norwich. [9088]

### LOUDSPEAKERS, SECOND HAND

**B** ARKER 148A, latest model, perfect, as new; £11/10.—Box 7983. [4102]

**V** OIGT domestic corner horn, complete unit including rectifier; £50 or best offer.—Box 7976. [4062]

**V** OIGT twin unit, £12; domestic corner horn, £25.—67, Hammersmith Grove, W.6, Riv. [4126]

**U** NUSED manufacturers' surplus.—P.M. speakers; 3 1/2", 9/6, 8in 14/-, 10in 22/6, 12in 42/6.—Radio Unlimited, Elm Rd., London, E.17. [4102]

**6** packet horn, 500c/s cut off with pressure unit, perfect, £6; W10 CSB 150, unused, £6; Wharfedale Golden, unused, £2/10; high fidelity ampl., 20db feedback, 6in's as triodes, new, £10; s.a.e. for full particulars; the lot £20 or offers.—Fox 7968. [4027]

### DYNAMOS MOTORS, ETC.

**B** ATTERY chargers, 4 models 2-6-12v, 1-2-4 amp; D.C.; any mains voltage; also larger types special transformers, chokes, test gear, interior car heaters, etc.—The Banner Electric Co. Ltd., Hoddeston, Herts. [2212]

**E** LECTRIC motors.—Our famous range of motors again available from stock; example, 1/4hp single-phase, 200-250v, 1,400 rpm, from £6/16/6; send for lists.—John Steel, Bingley, Yorks. Tel. 1066 (4 lines). [9968]

# AMC TELEVISION

Manufactured to "Electronic Engineering" Telesivisor Specification.

**MIDLAND T.V. Sound and Vision Panels** fitted with formers and dust cores now available.

**LINE OUTPUT TRANSFORMERS**

**New Improved SET OF GANTRIES COMPLETE**

**FOCUS COILS**

**LINE AND FRAME SCANNING LINE ASSEMBLIES**

**All Steel CADMIUM PLATED POWER AND TIME BASE CHASSIS** valve-holders, 3 point and singlesocket and all necessary cut-outs.

**SOUND PANEL CHASSIS ASSEMBLY**, fitted with screens, valve-holders, formers and dust cores.

**VISION PANEL CHASSIS ASSEMBLY**, fitted with screens, valve-holders, formers and dust cores.

**9" C.R. TUBE SUPPORT** for mounting on top of Gantry Assembly.

**9" CREAM MASKS.**

**5, SHAKESPEARE RD., FINCHLEY, N.3**

Phone FINchley 2183

## THESE WILL INTEREST YOU

**"BATHUB" OIL-FILLED CONDENSERS.** 0.1 mfd. 1,000 v.w., 0.5 mfd. 600 v.w. Both 1/3 each. **CATHODE RAY TUBES, VCR97.** Short persistence, green six-inch screen, ideal for T.V. Complete with base, 39/6. Carriage 5/- extra. **CONDENSERS.** Oil-filled, Porcelain insulators and 4 B.A. bolts and solder tags, 2 mfd. 600 v.w., with mounting clip, 2/3.

**PAPER CONDENSERS.** 4 mfd. 1,000 v.w., 13/6, 4 mfd. 500 v.w., 5/6.

**VARIABLE CONDENSERS.** 75 pF, air-spaced, single gang, 2/6; 20 pF, multi-gang, air-spaced, single gang, 5/-, U.S.A. SIGNAL GENERATORS. 100-50,000 Kc/s, 110 volts, £6/14/-, carriage paid.

**ALL-WAVE DIAL AND DRIVE ASSEMBLY.** Vertical perspex dial with wavelength and station names in white on black background. L.W., 900-2,000 metres. M.W., 200-550 metres. S.W., 16-30 metres. Dial opening 3 1/2" x 5 1/2". Flywheel tuning, 500 pF twin gang condenser and rubber mounting feet, 20/-.

**ENAMELLED COPPER WIRE.** 4 oz. reels, 16, 17, 18, 19, 20 S.W.G., 2/3; 21 and 22 S.W.G., 2/6; 23 and 24 S.W.G., 2/9; 25, 26, 27 and 28 S.W.G., 3/3; 29 and 30 S.W.G., 3/1; 32 S.W.G., 3/8; 33 and 34 S.W.G., 3/6; 35 and 36 S.W.G., 3/8; 37 and 38 S.W.G., 4/-; 40 S.W.G., 4/6.

**ALUMINIUM CHASSIS.** Rivetted corners and angle pieces. 10in. x 8in. x 2 1/2in., 9/5; 14in. x 9in. x 3 1/2in., 11/5; 8in. x 8in. x 2 1/2in., 6/2; 10in. x 6in. x 2 1/2in., 8/3; 12in. x 8in. x 2 1/2in., 9/2; 14in. x 9in. x 2 1/2in., 9/9. **METERS.** AV07, £19 13/6; AV040, £17 13/6. **TAYLOR JUNIOR 120A, £8 12/-.**

**UNIVERSAL ALUMINUM, £8 12/-.** **SOLDERING IRONS, PYROBIT Instrument.** 23/-, **SOLENOID.** Straight bit, 20/6. Pen bit, 22/-, **SPARE ELEMENTS, PYROBIT Instrument.** 4/6. Wireless, 5/6.

**SOLENOID.** Both types, 5/6. **SPARE BITS, SOLENOID.** Straight, 4/3. Pencil, 6/-, **MAINS TRANSFORMERS, MT Mt.** A small upright mounting job. Ideal for use where space is limiting factor. Primary 200-250 v, or other desired between Primary and Secondary. 250-0-250 v, 50 mA 6.3 v. 1.5 a, 4 and 5 v, 2 a, 24/-.

**BLACK CRACKLE SPEAKER CABINETS.** 6in., 19/6; 8in., 22/-; 10in., 27/-.

All items post free unless otherwise stated.

**VALLANCE & DAVISON LTD.**

(Dept. W.W.)

144 Briggate, Leeds 1. Phone 29428-9



ALL types of rotating electrical machinery up to 20 kw available, including rotary converters, motors, petrol and diesel engine generators, rotary transformers and alternators; we are also in a position to quote for transformers. CHAS. F. WARD, Lordscroft Works, Haverhill, Suffolk. Telephone Haverhill 253. [4069]

**97/6**, charging switchboards, 12v-32v, 500-1,260 watts, volts, amps, cut-outs, fuses, resistors, etc. 4 take-offs super-b unit, in case, or send £5 carriage paid; 75/- dynamo, 24 volts, 1,000 watts, 9in x 7in, 3/4in spindle, or send 80/- carriage paid; 75/-, 230v/150, 1/2hp electric motors, incorporating 1,260 cycle converter, or send 80/- carriage paid; 58/-, mains transformer switchboards, 230 v. c. to 12v, 5 separate take-offs, complete distribution panel, all switches, fuses, amps, etc., brand new, or send 60/- carriage paid; 55/-, electric motors, 12v and 24v, 1/4hp, 4in x 4in, with 1/4in spindle for drive, beautiful job, or send 60/- carriage paid; 45/-, dynamo units, containing 12v, 24v, 130v and 300v d.c. dynamo or suitable as ev, 12v or 24v motor, approx. 1/4hp, 11in x 5in, with spindle to take small grindstone, mop, etc., also c.n.tain adjustable 24v cut-out automatic voltage control, smoothing condenser, resistance, and many other extremely useful fittings, beautifully made, or send 50/- carriage paid; 38/-, radio wattmeters, adjustment dial, 350-370 Mc/s, beautiful instrument in case, or send 40/- carriage paid; most other valuable equipment; lists free.—Benmotes, Summerley St., Earlsfield, S.W.18, Wim. 3633. (100 yds S. Rly. Electric Line; 10 minutes Waterloo.)

**TEST EQUIPMENT**

**Q** METER £80 and inductance bridge £30, both perfect.—Box 8002. [4140]  
**A** VO electronic test meter, new, offers.—Keith, 20, Cheapside, Ascot, Berks. [4099]  
**B** C221Q frequency meter, 125-20,000 kc/s, £12, 7, Homewood Rd., S.E.25. [4106]  
**B** RIDGE megger, perfect, £30.—Santon Radio, 9, High St., Colliers Wood, S.W.19. [4116]  
**500** v companion set, also universal A.V. minor, £12 the lot.—25, Overbury St., E.5. [4104]  
**B**.P.L. signal generator, model R.S.600, new, cost £21; what offers?—24, Courtfeign Gdns., N.W.11. [4121]

**MARCONI** TF 144G S. generator, as new; their test gear.—Eldridge, 254, Grove Green Rd., E.11, Ley. 4986. [4100]  
**A** VO valve tester, £11.10, as new; No. 7, £10; D.C. Minor, £2.10; Taylormeter 70A, £8 plus carriage.—Box 7984. [4103]

**M**ULLARD signal generator, Type G.M.2880, 14 to 3,000 metres, checked by makers recently, in very good condition; £10.—Box 7977.  
**L**.S.L. combined valve tester, universal test meter 50, ranges 2,000 o.p.v., £15; Mulard C.R. brdge mains, £8; both as new.—4, Grandville Rd., Old Hill, Staffs. [4044]

**N**EARLY new complete test equipment with service shop parts, also S.C. lathe, 2 electric drills and other fine tools, as new, owner leaving England; seen London.—Box 7981. [4088]

**F**ERRANTI 7.5kva moving coil automatic voltage regulators, input 230v +8% to -12%, 45-66 cps, output 230v ±1/2%, frequency compensated, new and unused, with handbook; offered at a fraction of cost price; (Herts).—Box 7488. [3949]

**M**ETERS.—M/iron, 0-25amp, 2/11; M/coil, 0-50volt, 3/11; M/coil, 0-1m/amp, 7/6; test meter panel containing 0-5 m/amp and 0-20v m/c meters, plus 3 pots, 1 var. resist., 1 scale type, 1 toggle switch, etc., 12/6, new list, 1d stamp.—Radio Unlimited, Elm Rd., London, E.17. [4110]

**O**SCILLOSCOPE and Wobulator complete, £20; T.B. c/s 10 to 350,000 c/s X and Y plate amplifiers, easy to handle, has outstanding performance, fully guaranteed, immediate delivery with set of leads and booklet "Oscilloscope Technique" further details from the manufacturers—Erskine Laboratories, Ltd., Scalby, Scarborough. [3456]

**M**ETERS—0-7v, 2 1/2in. m.c. 9/6; 15v, 2 1/2in. m.c. 9/6; 150v 2in. m.c. 10/-; 300v, 2 1/2in. m.c. 13/6; 3,500v, 3 1/2in. m.c. 20/-; 6,000v, 3 1/2in. m.c. 57/6; 15,600v, 2in. m.c. double ranging, 8/-; 100ma 2in. m.c. 7/6; 40,120ma, 2in. m.c. double reading, 8/-; 3.5amp, 2in. T.C., 5/-; 4amp 2 1/2in. T.C. in case with switch, 7/6; 20amp, 2 1/2in. m.c. 9/6. Meter movements 2in size with magnet and case (500microamp), 2 6: Units containing 2 movements, 5/-, or with two 100microamp, 5/6. All meters post extra. Ex-R.A.F. 2valve (2volt) microphone amplifiers, as used in plane intercom., in self-contained metal case, can be used to make up a deaf-aid outfit, intercommunication system, or with crystal set, complete with valves, 20/-, post 1/6; wooden box to hold amplifier, 2/- extra; crystal sets with permanent detector 9/6 in or case 18/6; headphones, 5/6, 7/6, 10/- and 12/6 pair, permanent detectors, 2/6; soldering irons, streamline, 50w, 9/-, standard 60w, 9/6; heavy duty, 150w, 12/6, all post extra; letters only; well illustrated list sent on request with 1d stamp and s.a.e. HIGH TONY UTILITIES 58 New Westend, London E.11. [3540]

# ARMSTRONG

now introduce

**MODEL EXP. 83 TYPE 2**  
**7-VALVE ALL WAVE RADIO CHASSIS**  
 Complete with 10 in. Loudspeaker

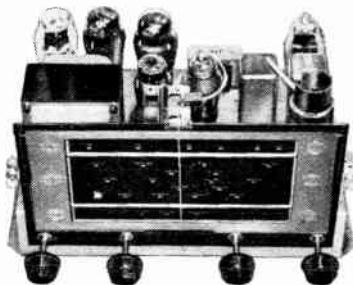

**THIS MODEL IS AN IMPROVED VERSION OF OUR EXTREMELY POPULAR MODEL EXP. 83, WHICH HAS BEEN MODIFIED IN ORDER TO INCORPORATE SEVERAL ADDITIONAL REFINEMENTS. THE RESULT IS A CHASSIS OF PLEASING DESIGN AND HIGH PERFORMANCE, WHICH WE OFFER TO YOU FULLY CONFIDENT OF ITS OUTSTANDING VALUE.**

- ALL-WAVE 7-VALVE CHASSIS
- 10 in. LOUDSPEAKER
- NEGATIVE FEEDBACK
- FLYWHEEL TUNING
- HORIZONTAL SCALE
- 8 WATTS PUSH-PULL OUTPUT

For 200/250 v. A.C. Price £15/8/8 plus tax

Meet us at  
**RADIOLYMPIA** 92  
 Sept. 28-Oct. 8

**Model UN'83. TYPE 2 7-VALVE ALL-WAVE RADIO CHASSIS** complete with 10 in. Loudspeaker. Negative feedback, Flywheel tuning, Horizontal scale, 5 watts push-pull output. For 200-250 v. D.C./A.C. mains.  
 Price £15/8/8 plus tax

**Model RT103 TYPE 2 10-VALVE ALL-WAVE RADIO CHASSIS.** R.F. stage, 2 I.F. stages, variable selectivity, 10 watts push-pull output. For 200-250 v. A.C. mains.  
 Price 19 gns. plus tax

**Model EXP. 125 14-VALVE ALL-WAVE RADIO CHASSIS** giving continuous waveband coverage from 11.9 m. upwards. Waveband expansion, R.F. Pre-amplifier. Two I.F. stages with variable selectivity. Electronic bass and treble lift controls. 15 watts push-pull output. For 200-250 v. A.C. mains.

Kindly write for illustrated catalogue Demonstrations at our Showrooms

**ARMSTRONG WIRELESS & TELEVISION CO. LTD.**

WALTERS ROAD, HOLLOWAY, LONDON, N.7

'Phone: N0Rth 3213

**TAYLOR** 45A valve tester, £12/10; MCR1 with power pack, £5/10.—143, Derbyshire Rd. South, Sale Cheshire. [4136]

**T**EST set, Type 73, consists of a special-purpose oscilloscope with a 3/4in tube; controls are brightness, X and Y shift, focus, amplifier in/out, velocity, etc.; the equipment is contained in a metal case, size 19in x 12in x 8 1/2in, and is complete with C.R. tube and all valves; it operates from a c.c. mains, 230volts 50cycles; supplied complete with comprehensive instructions for conversion to a standard oscilloscope, together with all parts necessary for the conversion, in brand-new condition; price £7/19/6, carriage paid.—Charles Britain (Radio), Ltd., 11, Upper Saint Martin's Lane, London, W.C.2. Temple Bar 0545. See displayed advert, on page 61 for further bargain offers. [4091]

**TRANSMITTING EQUIPMENT**

**A**MAZING radio bargains.  
**C**OLOSSAL purchase of transmitter and receiver units enable us to offer these sensational bargains.

**T**YPE 19 Army transmitters, partly stripped by the Ministry to conform with regulations but containing a host of useful components, including 4-rang 0005 tuning condenser, single 0005 condenser, each complete with slow-motion dials, 13 valveholders, HF chokes, trimmers, condensers, resistors, 3 I.F. transformers, volume controls, Waxley type switches, etc., and contained in a strong metal carrying case; price, only 8/6 inc. carr.

**T**YPE 25 receiver unit. This unit which is well known for easy conversion to a domestic receiver (see Practical Wireless, August, 1949) needs no introduction, it is complete less valves; price, only 7/6 inc. carr.

**1196 TRANSMITTER.** For use with above unit, partly stripped; price, only 5/6.

**SCR-522 TRANSMITTERS.** With very little conversion the 2 meter amateur band and contain a host of equipment suitable for experiments on this band; for only 5/- inc. carr.

**T**HE Ministry have again partly stripped these units but we have been fortunate to obtain: Modulation transformer and A.F. choke, 5/- per pair; meter switch, complete with knob, 2/- each; WALTER'S Wireless Stores, 203, Staveley Rd., Wolverhampton. [0010]

**F**RITH RADIOCRAFT, Ltd., offer:—

**R.C.A. TRANSMITTERS,** type ET4336, brand new, in original cases; coverage 2 to 20mcs, 807 crystal osc driving pr 813s in parallel, band-switched final; input 250-350 watts; front panel has all tuning, meters, switches for tune/operate, phone/cw, modulation indicator, chassis carries filament and bias supplies, keying relay, etc.; requires external HT power transformer and modulator; will run very comfortably at 150 watts with 1,000v and one 813, or up to maximum rating with 2,000v and pr of 813s; less valves, £12/10 c. pd.; new lists giving 35 "Dollar Bargains" are now available, free on request.

**F**RITH RADIOCRAFT, Ltd., Leicester. [3992]

**H**ALLICRAFTER transmitters, Type HT4E (BC610), complete to makers' latest specification, covering all frequencies from 1mc to 30mcs, complete with speech amplifier, connecting cables, etc.; limited quantities only now available.

**PANORAMIC** adaptor, Type MCA44, British-made, suitable fitment to any rood-class communication receiver, in addition to all Hallicrafter models, immediate delivery.

**BRITISH-MADF** under Hallicrafter licence, SX42 receiver, now available for export only.

**McLEROY-Adams Mfg. Group, Ltd.,** 46 Greyhound Rd., London, W.6. Tel. Fulham 1802. Cables, Hallicraft, London. [4114]

**GRAMPHONE AND SOUND EQUIPMENT**  
**D**ISC recording equipment, £15 the lot, as follows:

1 SIMPSON heavy duty recording turntable, 78 rpm, with rubber mat and centre drive locking plus; 1 tracking mechanism, 1 cutting head with new unused sapphire stylus.

15 8in recording blanks, unused.—Box 7974.

**W**ILKINS Wright coil pu, unused, offers to — W. Willis, Westwood Liskeard, Cornwall.

**S**OUND Sales DX+7, Sound Sales phase inverter S.L.S. Collaro autochange unit in magnificent Bath made walnut cabinet, specially made; £75.—Box 7975. [4045]

**C**RYSTAL microphone inserts (Cosmo-cord) 1/2 MIC-6, bakelised diaphragm, brand new; 1/6 each, post free.—Radio-Aid, Ltd., 29, Market St., Watford. [4092]

**L**ATEST type tape recorder complete with amplifier, microphone, automatic erase, playback, record reproduction, new.—9, Troy Grove, Brandwood Rd., B'ham, 14. [4036]

**H**EAVY oak radiogram cabinet, in excellent condition, 39in x 20in x 36in high, fitted gram motor and pick-up; best offer; s.a.e. details.—15, Richmond Rd., Retford, Notts. [4097]

**I**NFINITE baffle corner deflectors, scientifically designed acoustic chambers for 8 to 15in speakers; lists.—Broadcast & Acoustic Equipment Co., Ltd., Tombland, Norwich. [2904]



# OPPORTUNITIES IN RADIO



Get this FREE Book! "ENGINEERING OPPORTUNITIES" reveals how you can become technically-qualified at home for a highly-paid key-appointment in the vast Radio and Television Industry. In 176 pages of intensely interesting matter, it includes full details of our up-to-the-minute home study courses in all branches of TELEVISION and RADIO. A.M. Brit. I.R.E., A.M.I.E.E., City & Guilds, Special Television, Servicing, Sound Film Projection, Short Wave, High Frequency, and General Wireless Courses.

We definitely Guarantee "NO PASS—NO FEE"

If you're earning less than £10 a week, this enlightening book is for you. Write for your copy today. It will be sent FREE and without obligation.

BRITISH INSTITUTE OF ENGINEERING TECHNOLOGY  
388b SHAKESPEARE HOUSE  
17/19 STRATFORD PLACE, LONDON, W.1

**BIET**

# TELERADIO.

Radiogram Equipment

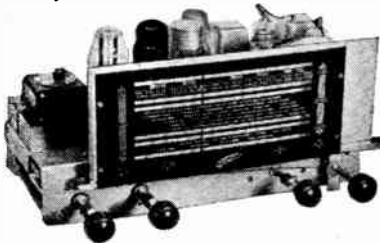

MODEL A70. 6 valve all-wave modern superhet chassis with tuning indicator, tone control and radiogram with the ideal replacement chassis £12 12 0d. Including Tax, plus valves, £3 3 0d.

MODEL 70 TU. As above but as 3 valve tuning unit feeding model 77 amplifier £8 0 0d. plus 34/10d. Purchase Tax.

MODEL 77. 4 valve push pull amplifier with 2 6V6 fed by phase inverter. Approx. 8 watts output £9 5 0d.

AVAILABLE AS KIT } Blueprints 4/-  
OF PARTS }

Send for leaflet to:

THE TELERADIO CO.,  
157, Fore St., Edmonton, N.18

RECORDING heads and erase heads, tape or wire, high or low impedance; enquiries invited single or quantities.—E. & M. Developments, 7, St. Peters Place, Broad St., B'ham. 1.

COMPLETE recording equipment, V.G. tracker (16in), two-speed "Laufwerk" motor in cabinet; 20 (each) 16in and 12in blanks; 4 saphires, makers' handbook; separate offers considered.—Sheetham, Street Farm, Doughton, Tetbury, Glos. 14078

BRITISH SOUND RECORDING ASSOCIATION.—The lecture season commences at the Royal Society of Arts, London, on September 22nd, 1949; membership is open to all professional and amateur recording engineers and high-quality reproduction enthusiasts; the official journal, "Sound Recording," Vol. 3, Nos. 1-2-5, available at 2/8 post free; brochure and application form from Membership Secretary, Harrie J. King, 48, Mount View Rd., N. Chingford, London, E.4. [2119]

COLLARO a.c.47 centre-drive motors with 12in non-magnetic turntable, var. speed, our price £5; a.c./d.c. ditto, £9/4/10; as above but complete pickup and autostop, a.c. £7/10, a.c./d.c. £12/10; Collaro new model a.c.49 motor/pickup/autostop gram. unit, 10in turntable, £5/6/3; Collaro RC49 mixed automatic record changer with high fidelity crystal pickup, our price £14; all above for 110-250v; terms, c.w.o. or c.o.d.; bargain list of amplifiers and tuners, 2/4d.—N.R.S. 102, Parkhill Rd., London, N.W.3. Gulliver 1453. [0004]

### COMPONENTS—SECOND-HAND, SURPLUS

NEW guaranteed goods.

MAINS transformers, fully interleaved and impregnated. Primaries 200-230-250v. 50 c.p.s., screened, fully shrouded 425-0-425v, 200ma, 6.3 tapped 4v 4a, 6.3 tapped 4v 6a, 5v tapped 4v 3a 39/9, p. and p 1/9; 350-0-350v 100ma, 6.3 tapped 4v 3a, 5v tapped 4v 2a, 21/6; half shrouded drop through type, 350-0-350v 80ma, 6.3 3a, 5v 2a, 250-0-250v 70ma, 2.3 tapped 4v 3a, 5v tapped 4v 2a, 15/6; Midget type, 2 1/2-3-2 1/2in 250-0-250v 50ma, 6.3v 1.5a, 5v tapped 4v 2a, 14/9; smoothing chokes, 80ma 15h 350 ohms 4/11, 100ma 10h 120ohms 6/11; Morganite vhl. controls with switch, standard length sp.mfd. 10k, 25k, 50k, 100, 250, 5meg, 2meg, 3/9; EF50 valve holders, 5/6 doz.; Selenium rectifiers, small size 600v, 30ma, 3/- each, 30/- doz.; 250v, 65ma, 3/6; 250v, 90ma, 4/9 each, 48/- doz.; 120-0-120v 100ma, 1/9 each, 18/- doz.; 12v, 1/2a, H.W., C.T., 1/6 each, 12/6 doz.; receiver chassis, 16swg, un-drilled aluminium, 10-5V-21n 3/-, 11-6-2 1/2 ns 3/9, 12-8-2 1/2 ns 4/3, 16-8-2 1/2 ns 5/6, 20-8-2 1/2 ns 6/9; electrolytics, can 16-32mfd, 350v, 2/11 each, 30/- doz.; P.M. speakers, T.uvox 8in, 2.3ohms 11/6; Plessey 10in, with trans., 21/9; Plessey mains energised 1.500 ohm field, 8in, with trans., 18/9; push-pull output trans., 10w, suit 6V6, 6L6, 6X4, 14/9; ditto, 20w, 19/9; unused ex-Gov. valves, Iron, 1/-; full list of bargains 2/6d; special list for trade; c.w.o. or c.o.d.; post extra. RADIO SUPPLY Co., 15, Queen Square, Leeds, 2. [0003]

### TRANSFORMERS to specification.

MAINS transformers for W.W. televisor, 80/-; mains transformers for E.E. televisor, 75/-; heavy-duty transformers for Williamson amp., 65/-; output transformers for Williamson amp., 75/-; line o/p transformers for W.W. televisor, 45/-; tag panels fitted, as specified; transformers for amplifiers, televisors, wa ve testers, test gear, chargers, etc., to any published specification or to your own design.—E.P.D. Transformer Products, 31, Queenstown Rd., Battersea, S.W.8 'Phone Mac. 4180. [4142]

### SOUTHERN RADIOS' wireless bargains.

BENDIX Command receivers, B.C. 454/455, complete with 6 valves, brand new, 35/- plus 1/6; drive adaptor for Command receivers, with knob, 2/9; control boxes for 453/454/455 Command receivers, 12/6 each, plus 1/-; drive cabinets for 453/454/455 Command receivers, 14ft with adaptors, 8/6, plus 1/-.

CAR radios, 12v, converted from Bendix Command receivers, complete, ready for use, with speaker, 26/-; carriage paid; R.A.F. bomb-sight computers, brand new, complete with motors gearing counters, bellows, gyro, etc., etc., 55/-, plus 5/-; contactor time switches, complete in soundproof boxes, thermostatic control, ideal for photographic and other uses, 10/-, plus 1/6; Lyofora hot cathode, adjustable to 3 1/2in, cut-off, plastic, metal, wood, etc., 5/-, plus 6d; crystal detectors, 2/6; mercury switches, 5/6; micro switches, 4/6; M.C.R.I. batteries, 6/6; Westectors, Wx6 and W112, 6/4 per doz; International Octal valve-holders, 6/- doz.; 4mid electrolytic condensers, metal tubular, 450v, 1/6; transformers, 1 1/2-2 1/2-; Mainsbridge condensers, 1mfd, 2mfd, 1/-, 4mfd, 2/6; throat microphones, complete with plug and lead, 3/6; spare throat microphones units, 1/-; Lewcos inspection lamps with lead and plug, for any size screw-in bulb, 2/9; indicator lamps, red, green or white, 1/3; Delco hand generators, 6v at 4amps, brand new, 17/6; radio compass indicators with Selsyn motors, 3in 360 degrees dial, 13/6; indicator units, 329a, 7 valves, with 2 1/2in SBPI C.R. tube, ideal for oscilloscope conversion, 45/-; full list of radio publications, 2/4d; thousands of other lines for callers.

SOUTHERN RADIO SUPPLY, Ltd., 46, Lisle St., London, W.C. Gerra'd 6653. [3956]

LIGHTING AND CHARGING SETS "ONAN" PETROL GENERATORS, new and unused, 12/15 v. 600 w. (NOT 400). Self start, air-cooled, 4-stroke, with voltage reg. and auto. cut-out and ammeter. Complete with tools, spares and instruction book. Wt. 140 lbs. Price £25 plus carr.

NEW CRATED PETROL AND T.V.O. PLANTS. Choice of J.A.P. or Villiers 1 1/2 and 2 h.p. engine, air-cooled, side valve, 4-stroke, 2,000 r.p.m. Generator 550 w., 12/18 v. Complete with control box, cut-out fuse, M/c ammeter, etc., toolbox, spares, and instruction booklet and waterproof cover. A first class heavy duty job. £27. Del. free.

ONE ONLY, SPECIAL new unused NORMAN engine, 1 1/2 h.p. O.H.V., air-cooled, working at only 1,400 r.p.m., coupled to HIGGS self-start heavy duty dynamo, 15 v. 450 w. Complete with control box, M/c meter, etc. £21. Del. free.

ALCO-LYONS 12/16 v. 360 w. aircooled, 4-stroke, M/c ammeter, cut-out, etc., used, £10—£12/10—£15. Del. free.

SHUNT DYNAMOS (new unused, NOT ex-aircraft.) 14/32 v. 290 w. cont. rating, standard 1in. shaft, £5. Del. free. Control boxes for above with cut-out, fuse var. resistance, ammeter and connecting leads £2/10/- or £7 the pair.

"ONAN" 24/32 v. 1.2 k.W., heavy job 1900 r.p.m., self-starting, reconditioned and repainted, £25/10/- Del. free.

DEISEL PLANT. One 16 h.p. 100 v. D.C. 9 kW output, £145.

NEW J.A.P. ENGINES, 1.2 h.p. type No. 2A, NOT ex-M.O.S., air-cooled, 4-stroke, complete with tank and exhaust box, £15/10/-. Delivered. ALL ENGINES AND DYNAMOS TESTED ON LOAD BEFORE DISPATCH.

Please send P.C. for full description, lists, photographs of the above goods. Large chargers still available. See classified advertisements for SELENIUM RECTIFIERS.

NO A.C. PLANTS AT THE MOMENT.

(Terms : Pro-forma Invoice or C.W.O.)

T. W. PEARCE (Est. 17 years)  
66, GREAT PERCY STREET, LONDON, W. 1  
Off Pentonville Rd. Between King's Cross and Angel

### THESE ARE IN STOCK

Radio Valve Data—compiled by the "Wireless World." 3s. 6d. Postage 3d.

Elements of Electronics. By G. Windred 15s. Postage 6d.

Cathode-Ray Oscillographs. By J. H. Reyner. 8s. 6d. Postage 4d.

Fundamentals of Radio. By F. E. Terman 24s. Postage 9d.

The Amplification and Distribution of Sound. By A. E. Greenlees. 16s. Postage 6d.

Radio Receiver Design Part I. By K. R. Sturley. 28s. Postage 9d.

Wireless Servicing Manual. By W. T. Cocking. 10s. 6d. Postage 5d.

The Mathematics of Wireless. By Ralph Stranger. 7s. 6d. Postage 6d.

F-M Simplified. By Milton S. Kiver. 33s. Postage 9d.

The Radio Amateur's Handbook. By A. R. L. 15s. 6d. Postage 1s.

Vade Mecum 1948 edition 2 volumes. P. H. Brans. 19s. Postage 9d.

Radio Receiver Circuits Handbook. By E. M. Squire. 6s. Postage 4d.

Radio Engineering Volume I. By E. K. Sandeman. 45s. Postage 9d.

Radio and Car Battery Handbook. By Charles Fleming. 5s. Postage 3d.

We have the finest selection of British and American radio books. Complete list on application.

## THE MODERN BOOK CO.

(Dept. W.9).

19-23, PRAED STREET, LONDON, W.2

**T**HE simplest s'het pack, type M.L., M.L. waves. 22/6; thousands in use. DOUGLAS COIL CO., Brinklow, Nr. Rugby.

**B**IG valveholders and screens, 1/6.-15. Westminster Rd., E'smere Port, Wirral. 14076  
**A**LL goods advertised still available.—Ryall, "Utopia," Mayfield Rd., Herne Bay, Kent.

**F**RAME aeriols, M.L. chassis mounting, 9/4in X5 1/2in, 7/6; manufacturers' surplus midget L.F. chokes, 5/6.

**H**ILLFIELDS MAIL RADIO, 8, Burnham Rd., Whitley, Coventry. [3990]

**75w** 230/110v autos, 10/6; post free, guaranteed; lists free.—Electrad Radio, 64, Gt. Victoria St., Belfast. [4135]

**T**HE signal generator you need at the price you can afford; only 1/6; see our advt. in this issue for picture and full details.

**HELIX-MAN ELECTRONICS LABORATORIES**, 10, Grove Rd., London, E.17. [3974]

**E**LIMINATORS, H.T. for a.c. or d.c. mains, 200-250v output smoothed 120v, 15ma, new; surplus, post free; 21/6, c.w.o.—Box 7999.

**L**ITTLEWOODS, N.rth London's best selection of radio and television components; pay us a visit or post or phone your enquiries; no lists G. HENSON LITTLEWOOD & Co., 27, Ballard Lane, Finchley, N.3. Fin. 3060. [3979]

**V**ACUUM relays, thermal type 6volt 35ma will switch 230volt 10amp, length 5 1/2in, diam. 1in, fitted with standard 4-pin valve base; 6/6 ea.

**L**INEAR wirewound potentiometers (or bridges), Berco type M10, 1K and 50K only 5/- ea.; 2-gang carbon potentiometers, 1meg.-1meg., 3/6 ea.; Megslips and selyns; many types in stock send for list.—Hopton Radio, 1, Hopton Parade, Streatham High Rd., London, S.W.16. [0993]

**S**ELENIUM rectifiers, chargers, kits, D.C. packs. New goods with full guarantee. Add postage 7d up to 12/6, 1/3 above. Data supplied.

**C**HARGER kits—Standard charger kit, S.T.C. 12v 3amp selenium rectifier with 50-watt, 12v, 1amp, 120-watt transformer, tapped sec. an. barettor for 2v to 12v 3amp charger, no rectifier; troubles with these kits, no rheostat or ammeter required. 39/6; ditto, but 2amp model, 36/-, ditto, lamp. 29/6; also 6v 2amp rectifier, transformer. 32/-.

**M**EDIUM duty charger kit—12v-15v 4amp rectifier, 75-watt transformer, barettor for 2v to 12v charger 4amp, 55/-; special y manufactured steel cases with terminals, screws, grommets, for any of above, 17/6, no odd surplus junk.

**H**EAVY duty kits, 120-watt transformer, 4amp rectifier, 5/- rheostat and high grade ammeters for 6v, 12v charger, 75/-; ditto, out with 140 watt trans and 6amp rectifier, giant finned type 87/6. Automot chargers, 6v, 12v, 1.5 to 2amp 52/6; 6v 2amp, 12v lamp 47/-; 12v 3amp, 79/6 12v 4amp 90/-, guaranteed 12 months.

**S**ELENIUM rectifiers, new, no surplus. Any L.T. rectifier up to 250 watts with transformer if required, 5 days del. Popular items: 12-15v 3amp 15/6; 4amp 21/-; 5amp 25/-; giant 6amp finned type, 29/6; 10amp, 42/-; 12-15v lamp 7/6; 2v-6v 1amp, 5/-; 6v 10amp, 25/-; 6v 4amp 15/-; 24v 2.5amp 32/-; 3amp 35/-; 4amp 38/-; 6amp 60/-; Selenium small space H.T. rectifier for radio, 250v 60ma, 6/-; 110v 60ma, 6/-; 120v 20ma eliminator type, 6/-; ditto, with 25-watt transformer, 2v trickle charge rectifier, 2-8mfid condensers for eliminator, 29/-; 250v 100mbridge rectifier, 12/6; 350v-0-350v, 30ma for A.C. sets, 9/-; sliders, 10hm 12amp, 16/-; 0-6amp ammeters, 12/6; crystal diodes, new, in capsules, 3/9; Rola "8" P.M. spkrs. less trans 13/6; Lustraphone m/c mikes, 58/6.

**C**HAMPION, 43, Uplands Way, London, N 21 Tel. Lab 4457. [3011]

**T**ELEVISION, all parts in stock for "E.E. television; Haynes' scan and focus coils, line trans. model on view.—E. G. Radio, 40, Stratford Rd., Birmingham, 28. [3931]

**D**EFLECTOR coil assembly, 22/-; focus coil, 12v 25/-; for V.V. television receiver; instrument wires; s.a.e. list.—R. F. Shilton, 19, Clarendon Rd., Salisbury, Wilts. [4125]

**T**ELEVISION scanning coils, 30/-; frame output transformers, 17/6; line output transformers, 25/-; also mains transformers, chokes, etc.—The Banner Electric Co., Ltd., Hoddesdon

**T**ELEVISION, E.E. television coils, 9/6 per set; E.H.T. transformers, 5kv, 4v, 50/-; high class job; send for list of television and surplus equipment.—King's Radio, 3, Hartfield Cres, Wimbledon, S.W.19. [4122]

**H**EAVY duty mains transformer 350-0-350 at 120ma, 2 v 4v windings at 5amps each, 21/-; Midget 100k volume controls less switch, 1/6 ea.—Uncle Tom's Radio Cabin, 5, Seven Stars Court, Manchester, 4. [3210]

**Y**OU'LL probably get it at Smith's, Edgware Rd. Everything for the constructor, from a 1/10watt resistor to a radogram cabinet, lowest prices, biggest variety.—Near Metropolitan Music Hall, Pad. 5891. [3005]

**M**ANUFACTURERS.—Enamel, copper wires all gauges, laminations, all types, huge stocks radio components, s/m, m/m, D/T and block condensers, close tolerance and high stability resistors to 1%; all goods guaranteed.—L.E. Simmonds 6a Byron Rd., Harrow, Middx. Telephones. Underhill 0045, Harrow 0315. [2515]

**ELECTRADIX**  
for Best British Bargains

**T**RANSFORMERS, Foster 100 watt 230 volt 50 cy. input 50 volts 2amp output, double wound insulated terminal block 4-hole fixing, 15/-, B.T.H. 200/230/250 volts 50 cy. input 2 volts 20 amps. 75 volts 6 amp output with 15 taps, 45/-

**C**OMPASSES, Binnacle Boat Compasses Liquid Model, in housing with glass windows, 40/-

**12 volt D.C. Motor Pumps**, lift 3ft., throw 10ft. Capacity 100 g.p.h. 45. 24 volt D.C. Fans for wall or table mounting, new G.E.C. with 6in. blade and guard, white finish, 35/-

**E**NGINE DRIVEN ALTERNATOR, 2 kW. Output. Single cy. air cooled engine mag. Solex Carb. gear start, direct driving self excited alternator 220 volts 2 kW. 50 cy. 5.P. 3,000 r.p.m. with 5/Bd. Tank and Silencer almost new, 435. Carriage extra.

**L**IGHTING PLANTS, D.C. Villiers 550 watt 18 volt 30 amp, with 5/Bd. £22/10/0. Chore Horse 12 volt 300 watt with Switchboard, £17. Pelaphone 500 watt 50/70 volt 10 amp. water cooled, £35. Carriage extra.

**B**ATTERY CHARGER, Westinghouse R.P.10-8 volts 15 amps. in Ven. Steel case with Meter and Fuses, £10.

**S**UDS MOTOR PUMPS 400-440 volts 3-ph. 50 cy. 1/6th h.p., 240 g.p.h., 15ft. head, £4. 1/12 h.p. 10ft. head, 600 g.p.h., £3. 1/2 h.p. 200 or 400 volt 3-ph, 50 cy. 1425 r.p.m., 10ft. head, 600 g.p.h., £8/10/-

**A.C. MOTOR PUMP**, 1/2 h.p. 200 volt A.C., 50 cy., 5.P. Motor direct coupled to pump, 10ft. head, 1,450 r.p.m., £10/0/-

**O**IL SWITCHES, By Ferguson Pailin, 230 volts D.P., no-volt only 500/750 amps. B. of P. Fixing Loose handle, £10 each. A.C. Ammeter, 7in. dia., reading 0-1000 amps. with correct Transformer, 45. Carriage extra.

**M**OTOR COMPRESSOR, 230 volt, 1/2 h.p., Higgs D.C. Motor belt driving Curtis Compressor, 2 1/2in. x 2 1/2in., 60lb. on C.I. base, £14/10/- Carriage extra.

**R**OTARY CONVERTERS, 450 watts, D.C./A.C., 24 volts input, 50 volts 9 amps. output, 50 cy. 5.P., £6/10/-, 240 Volt D.C. input, 150 volts A.C. 50 cy. output, 1 1/2 kW., £10. 110 volts D.C. input 110 volts A.C. 50 cy. 5.P. output with filter, 110 watts, £9.

**M**ETER MOVEMENTS, D.C. Moving coil two movements in iron case two 5in. scales 3-2000 and 0-2500 or 2000 and 4,500 amps. 75 milli-volts without shunts, 15/- each. Carriage extra.

**M**ETERS A.C. Precision Instruments, Comprom/I/C Switchboard, sq. front, 6 1/2in. x 6 1/2in. x 4in. back connections 4 1/2in. scale with lamp holder on top to illuminate scale 50 amps. A.C., 35/-, 75 volts A.C., 35/-

**G**.E.C. 1/C 4in. Switchboard back connections 60 volts A.C., 30/-, 40 amps. A.C., 30/-, 5in. I/C Switchboard A.C. Ammeters 0-14, 15/-

**D**YNAMOS, 12 volt 10 amps. D.C. for windmill work, 600/1,000 r.p.m. with double ended shaft for prompt and drive, 40/-, 12 volt 10 amp. car type 1,400 r.p.m. 25/-, 30 volt 5 amp., 1,500 r.p.m. 30/-, 12 volt 30 amp., 25/-, Carriage 5/- extra on all Dynamos.

**T**ELEPHONES, Ex G.P.O. Telephone Constructors Parts, wall type, bracket mike, transformer and condenser, mag. bell, connection strip in walnut box 8in. x 6in. x 3 1/2in. Hand Magneto generator and single earphone, 30/- pair. Carriage 5/-, Magneto Ringing Table Telephones with generator and hand combination telephone, 40/- pair.

**M**AGNETS, New Swift Levick S.L.5. 36 instrument type, machined and drilled, circular horse-shoe 1 1/2in. x 1 1/2in. thick, 1/2in. polar gap, horse-shoe pieces weight 2 oz., lift 3lb., 2/6 each or 12/6 for six. Alni Disc Magnets 1 1/2in. dia., 1/2in. thick, 3/16in. centre hole, 3/6. Flat Bar Magnets, 2 1/2in. x 1in. x 1/2in., 1/- pair.

**E**LECTRO MAGNETS, 2-coil weight 10oz., lift 4lb. on 6 volts D.C., 3lb. on 4 volts and 1 1/2lb. on 2 volts. New, 5/-

Large stock of Horse-shoe Magnets, send for leaflet "W.W."

Please include postage for mail orders

**ELECTRADIX RADIOS**

214, Queenstown Road, London, S.W.

Telephone: MACaulay 2159

**M**AINS transformers, 350-0-350, 70ma. 5v. 2amp. 6.3v. 3amp. drop through, first class; 17/6, post 1/-.—Hunt, 29, Sunnymede Drive, Ilford. [4115]

**E**X-Govt. components; meters, 0-150/0-25v. d.c., moving coil dial 3 1/2in diam., 6/6; condensers, 1mfid, 7500v. 3in x 3in x 5in, new, 7/6; Osram M.E.S. 1, 6.2v 3amp bulbs, 4/6 doz.; Philips E.S. 1, 7/- doz.; frequency meters, 550, 450 cycles, 6/6; earpieces, 1,000ohms, 1/6 each. PASSINGHAM, 95, North St., Kelghley, Tel. 3680. [1002]

**E**X-R.A.F. A1134, battery operated amplifiers, complete with valves HL2 and QP21, and in the original transit case, 17/6, post free; guaranteed 3-in P.M. speakers, 8/6; 1436 twin maroon flex, 25x 100 yds. New list, 1d stamp.—Radio Unlimited, Elm Rd., London, E.17 [4111]

**S**WITCHES for the West Country amateur. S sound, clean; Bulgin lb 4p 2-way, 1/11; lb 4p 3w, 1/11; light lb 2p 4w, 1/11; oak lb 1p 3w, 2/-; Yaxley type lb 1p 9w, 2/-; lb 1p 11w, 2/-; lb 4p 3w, 2/-; 2b ea 1p 6w, 2/6; oak 2b 1p 11w, 2/6; Yaxley type 2b 1p 12w, 2/6; 2b 3p 3w, 2/6; oak 2b 4p 3w, 2/6; 3b 2p 6w, 3/6; Yaxley type 4b 1p 12w, 3/6; 4b 2p 6w, 3/6; 4b 4p 3w, 3/6; ceramic 4b 2p 6w, 8/6; Key 4p 2w, 2/3; c.w.o. only; s.a.e. for lists. G. N. PILL & PARTNERS, 49, Cobourg St., Plymouth, Tel. 2239. [3994]

**C**ONDENSERS, loudspeakers; the best stock in East London; 8x16 450v d.c. 3/6, 16x16 450 v d.c. 3/6, 8mfid 500v d.c. 2/6, 16mfid 450v d.c. 2/6in Phillips loudspeaker, 10/-, 5in P.M. 11/-, 5in with transformer, 14/6, 12in P.M. 39/6, 10in Goodman 19/6, 465 kc/s IF transformers, midget type, 8/6 pair; complete kit of parts, including cabinet and valves, for a two-wave mains receiver, £4/19/6.—Full list, 1d stamp. DUKE & Co., 219, Ilford Lane, Ilford, Essex. [4143]

**T**ELEBOOSTER for long range T.V. Birmingham or London, R.F.2L, 40-48 mc/s, variable tuned, input slug tuned output, 2 VR91 valves, 3 tuned stages, co axial linked, H.T. and L.T. from receiver chassis, £3/12/6; 500v as above, 1 VR91 valve, 2 tuned stages, £2/12/6; R.F.2B, 55-65 mc/s, R.F.I.B. for Birmingham specifications and price above, please state type required; power units for boosters, £4; s.a.e. for leaflet.—Boscombe Radio, 595, Christchurch Rd., Boscombe, Bournemouth. Tel. Boscombe 1704.

**A** NEW face and brain? No, we are not plastic surgeons but we can offer a really attractive 3-wave 3-colour dial assembly, and the super-efficient G Coilpack which has earned us so much praise from our customers. An invaluable pair, for the rejuvenation of an old set or the construction of a new one. The dial is unique fitting anywhere in any position! Send for full details of these, and other radio and television components, also our latest bargain list. (Trade enquiries invited.)—Osamor Radio Products, Ltd., Borough Hill, Croydon, Surrey. (Tel. Cro. 1220) [3193]

**48/6** only for the famous Model 30 tuning unit, consisting of 3-waveband Model 30 superhet coil pack, pair I.F. transformers, 2-gang condenser and attractive 8in x 6in; each component individually selected top grade, sealed and the whole mated together as a unit; the superhet you build with this unit needs no further adjustment! Full details of this and our other high quality products (coils, I.F.T.s, mains transformers, etc.), together with many circuits and construction tips contained in the "Home Constructor Handbook," price 1/-, Mail order office.

**S**UPACOILS, 98, Greenway Ave., London, E.17.

**M**. A. NEWMAN, 25, Bristol Hill, Bristol, 4. offers potentiometers, Centralab 10K, 100K, 500K, and IMeg midget, 5/3 each; Morganite IMeg, 4/3; speaker trans., std. size, 4,500ohms. 4/-; 0005mfid twin gang condensers, ceramic, w/t, 8/3; surplus clearance of the late J. E. Cook, Christchurch, Hants: electrolytic condensers, 24x24mfid or 20x20mfid 30/- doz., 8mfid @ 350v 10/- doz., 20mfid @ 50v 7/6 doz.; mica condensers, 2/6 doz.; panel with 10 condensers, 0005-.25mfid, 15/- doz.; linecord, 3w 2amp 300ohms per yd., 15/- doz.; panel with back wire, 1/6 doz. yds.; D32A dynatrons, 29/- in 250v out, 5/- each; vibrator units, 6v in 200v out smoothed d.c., £1 each; Hoover FHP induction motors, £1 each, larger type £1/5; orders under £5 post extra; price lists sent on application. [4107]

**T**ELEVISION.—Polystyrene and Paxolin Transformers are available for the Wireless World superhet receiver; immediate delivery; this is the finest long-distance receiver yet designed and is unsurpassed for definition; all other components are also available ex-stock; condensers, resistors, aeriols, magnetic tubes (Mazda 9in and 12in, immediate delivery); 2, 4 and 6 B.A. nuts, bolts and washers; enamelled wire in 1/4, 1 or 7lb reels, 16 to 40swg, etc.; complete set of parts for the new Williamson amplifier, 11igns. (less valves); also gram motors, from £5/4/3 (B.S.R.); pick-ups, speakers; we can also supply all Eddystone, Raymart, Denco, Wearite, T.C.C., B.J., Hunts, Dubilier, Morganite, Elstone, Gardner, Goodmans, Avo, Taylor goods ex-stock; send now for (a) T.V. list, (b) amplifier list, (c) short wave list, s.a.e. please.—I. F. Hanney, 77, Lower Bristol Rd., Bath.



**BLACK & WHITE**

**PICTURES FOR ALL**

The Booklet for Everyone. Only 5/- post free. Write for your copy to-day. Contains every detail showing you how to build your own Television Receiver for use with full size magnetic tubes.

**NO TECHNICAL KNOWLEDGE REQUIRED.**

Point to point wiring diagrams given, together with word by word instructions for assembling all the parts. You simply can't go wrong.

**KITS FOR THE ABOVE.**

Kits of parts for the above are available for £16 (less Tube). Write for leaflet giving further details.

**TELEVISION COMPONENTS AVAILABLE**

- Deflection Coils ..... Per set 22/6
- Line Output Transformers, each 22/6
- Focus Coils ..... each 17/6
- Supplied in set of three for 60/-
- Pre-Amplifier, with self contained power pack ..... £7 10 0

**HOUGHTON & OSBORNE**  
ELECTRON WORKS, THAME, OXON

**Pennine RADIO**



**AUDIO SIGNAL GENERATOR**

- HIGH STABILITY
- WIDE RANGE 40-16000 C.P.S.
- LOW PRICE
- 3 WATTS OUTPUT

LIST PRICE **£9-9-0**

Write for Particulars

**PENNINE AMPLIFIERS**  
SOUTHGATE, ELLAND, YORKS, ENGL.  
Tel.: Elland 2107

**JACK PORTER Ltd. (Radio)**, for mica condensers, 0.01mf to 400 volts, wire ends, 2/6 dozen; 6H6 valves 1/-; Sprague oil block condensers with clips, 15mfds at 750 volts, 7/6; Woden 20 watt, potted output transformers, load 10,000 ohms p.a. to p.a. speech winding 15 ohms, also feedback windings, booked, 25/6; L.F. chokes, 70ma, 150 ohms, 1/6; 100ma, 1/8; A. Thordason mu-metal LP, 2,000 ohms, screened, 1/-; Dubilier .0005 and .0005 mica condensers, wire ends, 2/6 dozen; silver mica, 300pf, wire ends, 2/- dozen; 30amp p.unger switches, 1/6; 300 ohm, wire wound variable 30 watt ceramic insulated bias resistors, 1/6; Pyrex ribbed 3/4in glass aerial insulators, 9d; 8-way Jones sockets, with covers, 6d; Jones 8-way p.u.g and socket, with cover, complete, 1/3 pair (carriage extra under £2); send for lists.—Jack Porter, Ltd., 35a, 300, College St., Worcester. [4139

**CLEARANCE** sale of unguaranteed items.— 165 amplifier unit, complete with 5 valves, 1, EBC33, 2, EF36s, 2, EL32, in put and output transformers, etc., to clear, 15/-, c. fwd.; 6-valve battery receiver, approx. 6-9mc/s, complete with valves, 10/-, c. fwd.; 12v vibrator packs, contains 4 metal rectifiers, 2 chokes, electrolytic condensers, 12v vibrator, etc., 7/6, c. fwd.; meters, 0-3.5amp 2/6, 0-100ma 2/6; indicator units, 3in (short persistence), tube, complete with 8 valves, rusty, 18/6, c. fwd.; moving coil headphones, tested, 3/6; W/S19 variometers, pots, westercocks, etc., 1/9, c. fwd.; American 1F-10 valves and motor generator, 15/-, c. fwd.; Presto 16in disc recorder with amplifier and fader panel, good condition, £150; Type 25 superhet receiving unit, 1 pr. IF transformers (460kc/s), iron dust cores, input and output transformers, etc., 20/6, although most of the above are in good condition we regret we can offer no guarantee on any article under £2.—Haines, 14, St. Mary's, Bedford.

**RADIOELECTRON**, 22, Frances St., Scunthorpe. **LINEAR** New goods only. Condensers, electrolytic, 450v wvg, 2mf, 3/3, 2/6, 8/2, 16/4/-, 8-8 4/8, 8-16 6/16-16 6/11, 25x25v 2/-, 25x50v 2/3, 50x12v 2/-, 50x50v 2/6. Tubulars up to .0005 6d, up to 005 8d, up to 1 10d, 1.000v wkg. .001 1/-, .01 1/2, .1 2/-; Vol. Contls., lg. spds., all values, 2/9, with sw 4/6, with D.P. sw 5/-; Midget type, 1/4, 1/2 and meg 3/10, with sw 5/6; resistor type, carbon, 1 watt, 4d, 1 watt 7d; wire wound, 1 watt, 200ohm to 1k 1/-; 5 watt, 100ohm to 2k, 1/6; 3x to 50x, 2/3; 10 watt, 50ohm to 2.5k, 2/-; 20 watt, 150ohm to 4k, 3/-; Mains; droppers, feet and 2 adg. taps, 2a 1k, 4/4; 3a, 300, 4/6; Brimistors, CZ1 3/6, CZ2 2/6, CZ3 1/6; Loudspeakers, FM, 5in 13/-, 6 1/2in 14/6, 8in 15/-, 10in 21/-; Goodman's Axiom, 8gns, "P" coils, a.l types, 2/10; Pifco meters, 25/-; toggle switches, single hole fixing S.P. on-off, D.P. on-off, S.P./D.T. 3/6, D.P./D.T. 4/6; mica conds. up to .0005 9d, up to .002 1/-, .003 1/3, .005 and .01 1/6; a.c. mains feeder units for 200-250v mains; use your personal radio at home this winter and cut out the cost of batteries. Type A1 h.t. and 1 1/2v l.t. for all dry 3 (r) Batterymax radios, £4 each; Type A2 h.t. and 2v l.t. for accumulator and battery radios, £4/8/6. Terms, cash with order, orders over 10/- post free, under add 4d, c.o.d. extra; forward 2nd stamp for lists. [4096

**NEW S.T.C.** selenium rectifiers, largest L.T. range from stock in Gt. Britain. A.I. makers' latest products. Not surplus. H4/200 for W.W. television, 28/- p.f. H.W. rects, 16v 3/4 6/8, 1a 8/-, 2a 9/6, 3a 16/6, all p. 6d; 4a 18/-, 6a 22/-, p. 10d; 30v 1a 12/-, 2a 14/-, 4a 21/-, 6a 36/6; 48v 2a 21/-, 4a 35/-, 100v 2a 34/6, 4a 65/- all p. 1/-; H.D. with 79in sq cooling fins, 16v 5a 21/6, 10a 24/6 30v 5a 35/-, 6a 38/6, 48v 2.5a 26/-, 5a 48/-, 6a 54/-, all p. 1/-; full-wave bridge-con. rects, 17v 1.5a 12/1, 2a 15/6, 2.5a 20/6, 3a 21/6, 4a 25/-, 5a 27/-, all p. 1/-; 33v 3/4 18/6, 1a 21/3, 1.5a 28/6, 2a 29/6, 3a 35/-, 4a 42/-, 5a 43/6, all p. 10d; 54v 1.5a 39/-, 2a 47/6, 4a 65/-, 72v 2a 61/-, 100v 1.5a 72/-, 136v 4a 68/-, all p. 1/-; H.D. type with 7 1/2in cooling fins, 17v 6a 34/1, 19a 43/8, 12a 72/-, 20a 80/-, 33v 6a 64/-, 10a 71/-, 12a 124/-, 20a 140/-, 56v 6a 90/-, 10a 100/-, 72v 10a 130/-, 100v 10a 190/-, all p. 1/4; industrial type, funnel cooled, 17v 12a 76/-, 20a 97/-, 30a 122/-, 50a 188/-, 33v 6a 62/-, 30v 10a 80/-, 33v 12a 124/-, 20a 140/-, 54v 6a 92/-, 10a 109/-, 72v 6a 114/-, 10a 136/-, 100v 6a 160/-, 10a 192/-, all p. 1/6; replacements for valve-type chargers. Philips 328 and 367, Tungal 65804, 68530, U600, etc.; fitted without alteration to wiring; tropically rated rects. from stock; rectifier kits rect. rheo. and trans., 33v 6a 150/- incl. tap switch and fuse; 16v 10a 132/6, 17v 6a 92/6, both with 11v tap, following with wax impregnated trans. and fused volt. adjuster; for 2-6-12v batts., 16v 5a 70/-, 16v 4a 60/-, 16v 2a 35/6 (vent steel cases 7/6 extra). Complete working charger, 2-12v 4a with H.D. trans., sliding res., fuse, meter and mains lead in crackle finish vent. steel cases, wt. 25lb, £5/5 del. free. Trans. 200 250v in charging, 18v 10a 65/-, p. 1/4; 18v 6a 47/6, p. 1/4; 17v 5a 41/6, p. 1/4; 16v 4a 35/-, p. 1/4; 16v 2a 23/6, p. 10d. Slider res., all values 150 watt from 24.6, p. 1/-; Specialised equipment for hospitals, laboratories, universities and industry. Standard or tropical use. Terms c.w.o. or pro-forma invoice; c.o.d. over £1 on post goods only; wholesale and retail. T.W. FARCE, 266, Gt. Percy St., London, W.C.1. Off Pentonville Rd., between King's Cross and Angel. Est. 17 years. See displayed advert page 66 for pet.-gens and 27v rot. converters. [0013

**Radio Dealers\* with own Service Workshops should write us for details of**

**"A.W.F. L/S CONE ASSEMBLIES," "A.W.F. EXACT FIT FIELD COILS,"**

**and all sundries for the repair of loudspeakers on your own premises, with speed and better profits.**

\* R.T.R.A. definition.

MEET US AT **RADIOLYMPIA** STAND NO. 203  
SEPT 28 - OCT 8

**A.W.F. RADIO PRODUCTS LTD.**  
(Dept. W.)  
BCROUGH MILLS, BRADFORD, YORKS.

**SOUTHERN RADIO'S WIRELESS BARGAINS**

**INVERTERS TYPE 16AP.** Input 24v. Output 115v. at 400 c.p.s. Black crackle finish. In maker's sealed crates with circuit diagram. 80/-, carriage paid.

**RECEIVERS R9S/ARC-5.** Ideal for two metre converter. 100-156 mcg. V.H.F. super-het. 10 valves. 717 (4), 128H7GT (3), 128L7GT (2), and 12A07GT (1) and 100th h.p. tuning motor. Complete with circuit. In maker's sealed cases, 80/- carriage paid.

**BC 454 (3-6 megs) and BC 455 (6-9.1 megs) RECEIVERS.** 6 valves, 128K7 (3), 128R7 (1), 12A7 (1), 12K8 (1). Ideal for converters, AC DC receivers, and car radios. In maker's sealed crates. Either set, 35/-, post 1/6.

**DRIVE ADAPTOR AND KNOB FOR BC453 4/5.** Gives slow motion drive from existing spindle. 2/6 each, post 3d.

**CONTROL BOXES FOR BC453 4/5.** Three slow motion dials and drives. Three 50,000 ohm volume controls and six rotary switches. In maker's sealed crates. 12/6 each, post 1/-.

**DRIVE CABLE FOR BC453 4/5,** 14ft. long. Adaptors at both ends, 8/6 each, post 1/-.

**R.A.F. BOMBIGHT COMPUTERS,** complete with gyro. motors Gearing. Blowers etc., etc. New £3, carriage paid.

**TIME SWITCHES,** 10-hour clockwork movement, in sound proof box, 11/6, post paid.

**INDICATOR UNITS, BC929A.** 7 valves, 2X2 (1), 6X5GT (1), 6H6 (2), 6G6 (1) and 68N7 (2) 2 1/2in. dia. 3BP1 tube and switching motor. In black and crackle case, 44/-, carriage 5/-.

**RECEIVER UNIT TYPE 25** from TR 1196, 4.3-6.7 mcg, 6 valve super-het, EF36 (2), EBC33 (1), EF36 (2), EK32 (1), 2 x 400 kc/s I/F coils. Suitable for conversion to AC/DC or car radio, 25/-, post 2/6.

**Southern Radio Supply Ltd.**  
46, LISLE STREET, LONDON W.C.2.

GERrard 6653



**RADIO CLEARANCE, Ltd.,** 27, Tottenham Court Rd., London, W.1. Tel. Museum 9188. T.V. power packs, on chassis, all, 15x6½x2in., contains E.H.T. trans. 5kv 5ma, 4v 1a, H.T. trans. 360-0-360v 220ma, 4v 3a C.T., 4v 3a, 6.3v 3.5a, wired with choke, 3X8+8mf 450v, 2 octal sockets for outputs, mains (210/250v 50c/s) input socket, voltage adjuster, valveholder for rect. (UUB), new, unused, £4/2/6 carr. paid; these units were made for well-known T.V. set using 12in C.R.T., 360-0-360v 220ma, 4v 3a C.T., 4v 3a, 6.3v 3.5a, trans. input 210/250v 50c/s, available separately, brand new, 32/6 carr. paid; T.V. line transformers, shielded in all can, with T.C. lead (used with PEN46), 11/6; chassis (steel), 5x5½x11½in. drilled 4 button base holes. 1/9; 5x9½x15in. drilled 4 button base holes. 2/3; all 17x9½x23in. drilled 7 int. oct. and square open-ends, 3/3; 4-4-way push-button units, with S.P. mains switches on 2 buttons, with knobs, 2/6; E.H.T. trans. 4kv 1ma, 2v 2a. Pri. 230v 50c/s, 29/6; rec. R. 1481 covers 65-86Mc/s, 10 valves (6.3v), tuning meter, 6in. S.M. dial, circuit diagram, etc., brand new, in transit case, £2/4, carr. paid; rec. R.U.19 6 valve straight rec. with 3 R.F. stages, using plug-in coils H.R.O. type, valves 3x78's, 2x77's, 1x1642, black crackle case 15x8x8in supplied complete with valves and 3 coil packs covering 524-844, 1285-2355, 2965/4620, 3065v 50c/s, £2/15, carr. paid; personal receivers B.C.728c, 7 valve rec. using 1.4v valves, with 4 push buttons covering 2-6 Mc/s, built in L/S, supplied brand new complete with valves (IT4, IR5, etc.) 2 and 12v VIB, 2v acc., telescopic AE, instruction book, etc., £8/19, 10 valves, in all, PRI 200/250V 50c/s, Sec. 230-0-230V, 100mA, 5v 2A, 6.3v 2A, C.T., PRI tapped 110v, 15/6; Sec. 275-0-275V, 120mA, 4v 2A, 4v 3A, 13/6; Sec. 460v, 200mA, 210v 15mA, 6.3v 5A, 14/6; auto trans. 200/250v-110v, 60W rating enclosed 18" special line auto; 230/250-110v, 60W, smoothing chokes, 5H 120mA, 140Ω 3/3; 5H 200mA, 100Ω 4/11; 6H 200mA, 100Ω 5/6; 5H 250mA, 90Ω 7/6; 15H 200mA, 150Ω (6½x4½x3¼in) 7/6; 20H 300mA, 150Ω (7x5x5½in) 18/6; 20H, 40mA, 220Ω 3/11; electrolytics, 3mf, 150v 1/3; 8/350v 1/3; 8/350v card 1/6; can 1/11; 8/450v 2/3; 16/350v card 2/3; 16/500v card 2/9; 16+8 450v large can or d/ended 3/6; 8+32 450v can 4/-; 16+24+8 450v can 5/-; 8+8+8 450v can 4/-; 32/450 large can 2/9; 32/450v w/e 3/6; 16+8 350v can 3/9; 80+100 350v card 2/3; 100mf 1/3; 100mf 6v 6d; 25/25v 1/3; 100/25v 1/6; 25/50v 1/3; 16.350 card 1/9; 24/350 can 2/-; 8+24 350v can 2/6; P.M. loudspeakers 5in less trans. 9/11; with trans. 4500Ω 11/6; 6½in less trans. 10/11; 10in with trans. 21/-; R.F. units type 24 8/6; type 25 10/6; with valves used, in good condition, post 1/6 extra please; marker beacon rec. B.C.357, 2 valves, (12C8, 125Q7) chassis 5x3x1½in. with 1mA relay 8/6; output trans 2000/20, 2500/20, 2750/1, 3000/2, 3/-; 4500/2, 7000/4, 3/6; 3 ratio 7000/3500/1750/850; heavy duty 70/20/2, 9/6; I.F. trans. 465 kc, 3d; small size iron cored 7.6 pr.; 2 gang conds., .0005 ceramic ins., 1in standard spindle 4/6; ceramic switches 20-, 3w, 1B 2/-; 30-, 3w, 1B 2/6; 3p-, 2B 3/3; switches, small size, 2p-, 6w, 3p-, 4w, 4p-, 3w, single bank, 2p-, standard size 4w, 4p-, 12 (additional wafer with shorting plate) 2/6; 4p-, 3w, 2B 2/6; 2p-, 4w, 3B 2/6; 1p-, 10w, 2B 2/6; all have 3in spindles; resistors 100 assorted, 47 values ranging 180Ω ¼w -100K 3w, standard sizes, best makes 10/6; post 6d; ceramic trimmers 50pf, 3 on a hop, 6/9; 1/150pf single section 8/6; spaced concentric 6d; 3/25pf V.I.C. type 3d; air spaced variables ¼in spindles 25pf, 50pf, straight, 50pf diff., ceramic bases 1/-; 35pf butterfly 1/-; Eddy-stone ½ 60pf double ended 1/6; Mansbridge condensers 4mf, 100v WFGC 2, 170v 3/6; 6/9; selenium rectifiers 250v 40mA H.W. 3/6; 350v 60mA H.W. 4/6; 400v 120mA H.W. 5/6; 50v 4A double bridge 18/6; car radio vibrator packs with 12v 4 pin VIB, and OZ4 valve on chassis 5½x3½x1½in, output 250v 65mA, output brought out on screened lead 17/6; meters moving coil metal cased, 2in circular 0/500 microA 7/6; 0/15-600v req. ext. res. 6/6; 0/20 or 0/40A with shunt 5/-; Bakelite cased 2in square 0/1mA 7/6; 0/5mA 6/-; 0/50mA 7/-; 0/150mA 6/-; 0/300v series res. supplied 7/-; bakelite cased 2¼in circular 100microA, F.S.D. series megohms 4-2.5m-inf, 18/6; 0/500microA 16/6; 0/30mA 7/-; 0/50mA 8/6; 0/100mA 8/6; 0/200mA 8/6; 0/15v 7/-; 100-0-100v, 1mA, F.S.D. 7/-; 1mA desk type 15/-; control units with 2 2n meters 0/5mA, 0/40v rotary and toggle sw. 5 and 7 pin sockets 8/6; visual indicators type 1 crossover needle, with 2 separate 60microA movements 5/-; type 3 with 2 300microA movements and 2 low voltage neons, 3/6; S.M. dials as on R.F.26 etc. 3/11; ex-Admiralty pat. 1257, 1¼in engraved, 100 fast/slow (50-1), panel mounting, ¼in spin, 2/6; rotary power units type 104 12V D.C. input, outputs 250v 60mA, 6.5v 2.5A, P.M. rotary mounted on chassis with supp. 6/11; type 87, outputs as above, but 24v input 5/11; 10 valve receivers, R26/ARC5, cover 100-150 Mc/s, brand new with valves in cover 4-7/4 s) 4/2; modulator, and mixer units W6332A, with 7 valves (1-5U4G, 2-6J5, 2-P61, 1-VR65, 1-VR54) on chassis 10¼in x1½in also 5H 200mA choke, large trans. (500 c/s) pots, res., conds., etc., in metal case with louvers 10½x11¼x2¼in, 21/4, carb. paid; Admiralty power units, input 24V D.C., output 230V 50 c/s, 75 watts, in grey case 18x12x12in, with motor-alt., auto trans., 2¼in 0-250v meter, output

(Continued on next page.)

# GALPINS

ELECTRICAL STORES

408 HIGH STREET, LEWISHAM, LONDON, S.E.13

Telephone: Lee Green 0309. Near Lewisham Hospital.

TERMS: CASH WITH ORDER. NO C.O.D.

THURSDAY EARLY CLOSING

**PRE-PAYMENT 1/- SLOT ELECTRIC LIGHT CHECK METERS,** 200/250 volts, 50 cys. 1 ph., 2½ amp. load, 30/- each, carriage 3/6; 5 amp. load, 35/-, carriage 3/6. 10 amp. load, 42/6 each, carriage 3/6.

**EX-R.A.F. ROTARY CONVERTERS,** 12 v., D.C., input 230 v. A.C. 50 cys., 1 phase at 100 w. output, 85/- each, carriage 3/6. Ditto 24 v. input, 65/- each, carriage 3/6.

**MAINS TRANSFORMERS,** all 200/250 v., 50 cys., 1 phase input, output 700/0/700 v. 70 mA, 4 v. 2½ a., 12 v. 1 a., 30/- each. Another 525/525 v., 150 mA, 6.3 v. 5 a., 5 v. 3 a., 37/- each. Another 2,350 v. at 500 mA, 85/- each. Mains Smoothing Chokes, 10 Hy. 100 mA, 6/-; 150 mA, 8/6; 350 mA, 25/-; 5 Hy. 250 mA, 17/6.

**EX-R.A.F. CRYSTAL MONITORS,** type 2, complete in wooden carrying case, the frequency depending on crystal used, 5/- each. Short Wave Aerial Coupling Units (Wavemeters), 5/- each.

**MAINS TRANSFORMERS (Auro Wound).** Voltage Changers tapped 10, 20, 25, 90, 130, 150, 190, 210 and 230 v., all at 1,000 watts, a combination of 24 voltages can be obtained from this transformer, new ex-Government Stock, £5/10/- each, carriage 5/-. Mains Booster Transformer, tapped 0, 6, 10, 19, 175, 200, 220, 225, 240 and 250 v. at 1,500 watts (new, ex-Government), £5/5/- each, carriage 5/-. Another Auro Wound, tapped 0, 110, 150, 190, 210 and 230 v. at 1,500 watts, £6/10/- each, carriage 5/-. Ditto, 2,000 watts, £7/5/- each, carriage 5/-.

**EX-R.A.F. MICROPHONE TESTERS (new),** These consist of a Ferranti 0 to 450 mA, 2½in. scale meter shunted to 1 mA incorporated Westinghouse Rectifier, the whole enclosed in polished teak case, calibrated at present 0 to 10 v., 25/- each.

**MAINS TRANSFORMERS,** input 200-250 v., 50 cycles, in steps of 10 v. Output 450/0/450 v., 250 mA, 4 v. 4 a., 5 v. 4 a., 6.3 v. 8 a., 6.3 v. 8 a., 62/6. Ditto 450/0/450 v., 250 mA, 6.3 v. 4 a., 5 v. 4 a., 4 v. 8 a., 4 v. 8 a., 60/-, Another 500/350/0/350 500 v. 250 mA, 6.3 v. 8 a., 0, 4, 5 v. 4 a. twice, 6.3 v. tapped at 2 v. 2 a., 67/6. Another 350/0/350 v., 300 mA, 4 v. 8 a., 4 v. 4 a., 6.3 v. 4 a., 6.3 v. tapped 1 v. 2 a., 57/6. Another 500/0/500 v. 300 mA, 6.3 v. 8 a., 6.3 v. 8 a., 4.4 a., 5 v. 4 a., 67/6.

**EX-R.A.F. R.F. UNITS, TYPE 101.** Containing 5 valves EF50, EA50, 5U4g, EB34, approx. 100 assorted Resistances and Condensers, also a 24-volt Universal miniature Motor, all mounted on silver-plated chassis (new), 37/6 each.

**SHORT WAVE COUPLING AERIAL UNITS (Wavemeters),** absorption type wound with 20 and 12 gauge silver-plated wire, 2½ to 5½ meters, 3/6 each. No. 19 VARIOMETER5 containing H.V. Condenser Instrument Rectifier, useful for parts, 3/6 each.

**EX-NAVAL TELEPHONE HAND-SETS, BAKELITE PATTERN (self-energised),** no battery required, complete with wall bracket (new), 15/- per pair, post 1/6. Ditto complete with Buzzer ringing mounted in weatherproof box, 24 volt required for energising Buzzer only, complete with Hand-set, 15/- each, or 25/- per pair.

**EX-NAVAL NAVIGATION INSTRUMENT** Containing F.H.P. 230 volt A.C./D.C. Motor, first grade 3½in. scale ohm-meter, Standard Potentiometers 2, other Resistances both variable and fixed, also some very useful Gun-metal Gears (new), 65/- each, carriage 10/-.

**MAINS VARIABLE STUD SWITCHARM TYPE.** Resistances 25 Studs, 50 ohms to carry 1.4 to 9 amps., 30/- each. 10 ohms to carry 9/14 amps., 32/6 each, many other types in stock. Please forward your enquiries.

**MAINS TRANSFORMERS,** Auto type input 200/250 volts 50 cys. 1 ph. Output tapped 14 and 17½ volts at 30 amps., 55/-, Ditto with 2 tappings of 4 volts at 20 amps., 25/- each, carriage 2/6. Another double wound, 110 volts to 230 volts or vice versa at 4,000 watts, £10 each, carriage paid.

**EX-NAVAL ROTARY CONVERTERS, AS NEW,** 110 volts input. 230 volts 50 cys. 1 ph. output at 500 watts, £9 each, carriage paid. Ditto 230 volts input, output as above, £12/10/- each, carriage paid, weight approx. 100 lb.

**EX-GOVT. AS NEW, SPENCER TURBO COMPRESSORS** complete with an A.C./D.C. Motor 230 volts at 10 amps. (2 h.p.), 10,000 r.p.m. continuous rating, maker's Black and Decker, a few only to clear, £12/10/- each, carriage 10/-.

**50 Admiralty ROTARY CONVERTERS,** Ex watts input, 100/110 volts D.C. Output, 230 volts A.C. 50 cycles 1 phase, weight 100 lb. approx. In new condition. £8/10/- each, carriage 10/-.

**METERS,** all ex-Govt. new boxed, all first-grade moving coil, 2in. scale, 0 to 20 volts, 6/6 each; 0 to 40 volts, 10/6 each; 0 to 10 amps., 15/- each. 2½in. scale, 0 to 10 mA, 12/6 each; 350/0/350 millivolts, 12/6 each; another 3 reading type 0 to 50 and 150 volts, 0 to 15 amps., 17/6 each; another 0 to 4 amps. THERMO coupled, 2½in. scale, 10/- each; another calibrated 50 cycles 0 to 20 volts, 12/6 each.

**MAINS TRANSFORMERS (ex-Govt. surplus).** Input, 200/250 volts 50 cycles: output, 110/0/1100 volts at 500 m/amps., 85/- each, carriage 7/6. Another 525/0/525 volts 150 m/amps, 6.3 v. 5 a. 5 v. 4 a., 30/- each, carriage 2/6. Another 3,000 volts 20 mA, 1,000 v. 10 mA, 6.3 v. 4 a., three times 2 v. 2 a., these are a large transformer weighing 20 lbs., size 7in. x 6½in. x 6in., 30/- each, carriage 3/6.

**EX-R.A.F. Type 18 CRYSTAL CALIBRATORS.** These units contain 100 kc/s crystal two E.F.50 valves. Are complete less power supply. New ex surplus. A few only to clear, 35/- each.

**LARGE TYPE RECTIFIERS.** Output 50 volts 1 amp. D.C., input 70/75 volts A.C. Half wave type, 8/6 each, post 1/6. TANNYO P.M. SPEAKERS (Small Hailers), 4 ohm speech coil, complete in wooden case with output transformer, 15/- each, carriage 2/6.

**ELECTRIC LIGHT CHECK METERS (watt-hour type),** all for 200/250 volt A.C. 50 cycles, all electrically guaranteed; 2½ amp. load, 15/- each; 5 amp. load, 18/6 each; 10 amp., 21/-; 20 amp., 25/-; 30 amp., 30/-; 40 amp., 35/-; 50 amp., 42/6; 100 amp., 50/- Carriage on all types 2/- extra.

**EX-RADAR POWER UNITS, TYPE 225,** containing 4 H.V. Rectifying Valves, 1 5U4g H.V. Condensers 8,000 V/Wkg. Chokes, Relays, etc. (New, boxed, 35/- each, carriage 5/-) Ex-U.S.A. Hand-driven Generators complete with all smoothing, output 450 volts at 110 mA, also 2 L.T. tappings, 30/- each, carriage 3/6. Ditto, 162 volts at 60 mA, also 3 v. 2 a., 22/6 each, carriage 2/6.

**MAINS TRANSFORMERS INPUT, 200/250 volts** in steps of 10 volts output tapped 6, 12 and 24 volts at 25 amps., 65/- each, carriage 3/6. Another 230 volts input with 3, 4 volt windings at 5 amps., 25/- each. Another 200/250 volts input, output 6, 12 and 20 volts at 4½ amps., 27/6 each, post 1/6.

**MOTOR ALTERNATORS, ex-R.A.F.,** as new, 230 v. A.C. 50 cys. 1 ph. input. Output, 250 v. 625 cys. 1 ph. at 24 amps., 75/- each. Ditto, 1,725 cys. output, 85/- Please note both these machines require a 24 v. D.C. excitation at 4 amps.

**SYNCHRONOUS MOTORS 200/250 VOLTS, 50 cys. 1 ph.,** convertible as Clock Movement, 12/6 each. Resistances 350 ohms to carry .25 amps. (fixed) but can easily be fitted with a slider, 8/6 each.

**EX-NAVAL CATHODE RAY INDICATOR POWER UNITS (new).** Sold for component parts only, consisting of approx. 150 Resistances and Condensers of various values, H.V. Condensers, Chokes, all mounted on solid brass chassis, weight 90 lb. to clear 35/- each, carriage forward.

**EX-R.A.F. I.F.F. UNITS CONTAINING 10 VALVES, EF50s, 5P61s, EA50s, etc.,** power supply Motor generator 12 volts D.C. input, 450 volts, 50 mA output, and many other useful components as new, 32/6 each. Ditto with a 24-volt input generator. Valve sequence slightly different. Generator can easily be converted to run as a motor off A.C. mains, 30/- each.

**RADIO EXCHANGE CO.**

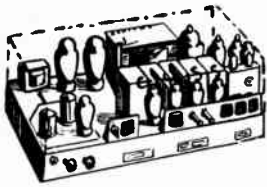

**S.L.C. RECEIVERS.** Ideal for television conversion. With 2 R.F. stages, tuneable LO, 4 IP's, a 4 Mc's. bandwidth, det. and output stages, it has a total of 20 valves. **OUR PRICE: 30/-.**

**WIRE RECORDERS.** As described last month, they are a really first-class instrument, which provides approx. 40 mins. high fidelity speech or music, which can be erased at will. **COMPLETE for £45.**

**INDICATORS 198.** With a 3in. short persistence C.R.T., 4 VR 65's, 3 VR 92's and a host of parts, they provide an ideal oscilloscope foundation kit. In maker's cartons for £2. **RF 85's:** no need to describe these famous units—enough to remind you that they cover 40/50 Mc's. Brand new. **ONLY 16/6.** **TELEPHONES D Mk. V.** Ideal for intercom, and complete with bell, buzzer, key and standard P.O. type handset. **27/6 each.** **POWER UNITS TYPE A.** A 12 v. vibrator pack, containing transformer, electrolytics, chokes, switch, etc., and delivering 300 v. at 75 mA. **TO CLEAR, 9/6.**

Goods sold as used unless otherwise stated.

**RADIO EXCHANGE CO. (W)**

9, Cauldwell St., BEDFORD. Phone 5568

**An important new book**

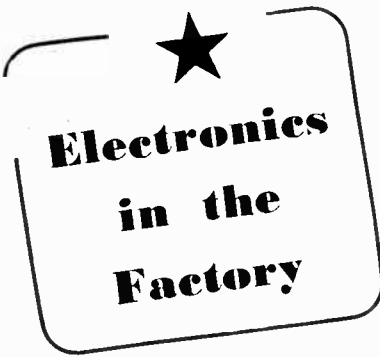

Edited by Professor H. F. Trewman, M.A. (Cantab.), M.I. Mech. E., M. Brit. I.R.E., Principal and Managing Director, E.M.I. Institutes, Ltd. This is an extensive and reliable survey of the applications of electronics in modern industry, and is invaluable as a source of ideas on the subject.

With 63 illustrations. 20/- net.

"The book fulfils its purpose . . . may be recommended."—ENGINEERING

**PITMAN**

Parker Street Kingsway, London, W.C.2

(Continued from previous page.) control sw., Sydiack fuses, etc., these units will 50% overload comfortably. £3.5 carr. paid; rotary power units W2702 6v D.C. input, 150v 80mA output D.C. smoothed, with 3 chokes (inc. Ferranti B2), in metal case 14x9 1/2 x 4 3/4 in with on/off sw., rotary has wound field, 16/6 carr. paid; Wilcox Gay V.F.O. covers 2-10 Mc/s, with 0-10mA meter, supplied brand new in original carton, with 107 accessories (plugs, leads, etc.), and instruction book, £5 carr. paid; Wilcox Gay Xtal multipliers 2-7 Mc/s, brand new, with 807, plugs, leads, instruction book, etc., in original cartons 40/- carr. paid; superhet coils 1/2 x 1 1/4 in formers M.W. HF AE, osc., L.W. HF AE, osc., 1/6 per coil; I.F. traps iron cored 465 Kc/s 1/9, set of 6 coils and trap 9/6; 7 or 10 pin plugs and sockets with keyway 1/6 pr.; 8 way Jones plugs and sockets with cover 1/6 pr.; V.C. carbon with sw, 2 1/4 in spindle 5K, 25K, 50K, 2/-; 20K, 250K, 500K, 4/-; or wax wire covered no sw. 200K, 400K, 500K, 1.5K, 2K, 2.5K, 5K, 10K, 20K, 25K, 2/-; twin w/w 2.5K/2.5K 2/6; 500/500K 2/6; 50K/50K 3/-; twin carbon 1m/1m 2/6; all telescopic aerials, 15in closed 7ft 6in extended 3/6; receivers type 76, 150/505 Kc/s 3 valves APT2, VR53, VR92, 1.F. output 560 Kc/s, brand new, in transit case, 22/6, carr. paid.

**RADIO CLEARANCE, Ltd., 27, Tottenham Court Rd., London, W.1. Tel. Museum 9188. [0015**

**SUPREME RADIO, 746b, Romford Rd., Manor Park, London, E.12. Tel. Ilf. 1260. Est. 15 yrs.** Radio and television component specialists, at the right price; E.H.T. 4k/v 0-2v fil. 50/- ea; 2.5k/v E.H.T. 4v fil, tapped 2v, also 4v 1.1 amp, 27/6 ea; line and frame scanning coils, 25/6 ea; line trans, 21/- ea; both terms matches for coils, 25/- ea; H.T. transformer, 350-0-350v, 6.3v 6 amp, 4v 8 amp, 4v 3amp, 0-2v 6.3v 2 amp, 250mA with screen, 70/- ea; 5hy 250mA choke, 15/9 ea; 10hy 80mA choke, 7/9 ea; Ceramic E.F.50 valve holders, 6d ea; 5/6 doz; retaining rings for same, screw-on type, 8d ea; bakelite E.A.50 valve holders, 6d ea; co-axial cable or twin balanced feeder 1/- yd, 11/- doz yds only; special offer, balanced feeder, 5d yd, 4/6 doz yds only; co-axial plug and socket, 1/- complete; all parts in stock for E.E. television, still the best home constructed television; 1 watt resistances, 100, 220, 270, 470, 820, 120, 390, 820, 2.2k, 11k, 39k, 470k, 10k, 1.5m, 1/9 doz, 18/6 gross only, or assorted; 1/2 watt resistances, 100, 1k, 2.2k, 6.8k, 10k, 16k, 18k, 20k, 33k, 100k, 150k, 220k, 500k, 1/9 doz, 2/- gross only, or assorted; most other values at 2/6 doz, 27/- gross only; 1 watt resistances, 470, 1k, 3.3k, 8.2k, 18k, 33k, 56k, 75k, 68k, 1m, and 2 meg, 4/- doz, 45/- gross only, or assorted; 2 watt resistances, 2k, 18k, 1 meg, 5/6 doz, or assorted; mains transformers, 350-0-350v, 120mA, 6v, 5v and 4v, 32/6 ea; metal tubular tag end condensers, 25mfd 25v, 50mfd 50v, and 50mfd 12v, also 10mfd 25v, 1/- ea, 11/- doz; 0.01 mfd, 1.000v, 0.02mfd 750v, 0.05mfd 500v, and 0.1mfd 350v, 6d ea, 5/6 doz, or assorted; 0.1mfd 500v, 6/6 doz; midget mica condensers, 0.001mfd, 0.0005mfd and 0.0003mfd, 6d ea, 5/6 doz, or assorted; Metallite condensers, 0.01mfd 350v and 0.002mfd 500v, 9d ea, 8/- doz; can type condensers, 8mfd 450v, 2/6 ea; 16+32mfd 350v, 3/6 ea; 16+8mfd 450v, 3/6 ea; 30+30mfd 350v, 425v surge, 6/6 ea; 30mfd 350v, 3/- ea; 32mfd 500v, cardboard drylytic condensers, 5/- ea; 16mfd 350v drylytic can condensers, 1/9 ea; 4mfd screw base 550v metal tubular condensers, 1/- ea, 11/- doz; 2mfd 350v metal and cardboard wire end electrolytic condensers, 1/- ea, 11/- doz. W.E. are Denco stockists. Denco catalogue 9d ea; 5mA meter rectifiers, 4/- ea; M/C inserts, 300, 1/3 ea, 12/6 doz; assorted panels with useful value resistances, condensers, etc., some with WX6 rectifiers, 9d ea, 7/6 doz; 4-pole 3-way long spindle wave change switches, 1/6 ea; fixed mica condensers, 30pf, 300pf, 600pf, 650pf, 1800pf, 3050pf, 3070pf, 5000pf, 5700pf, 5900pf, 7000pf, 4.5500pf, all at 2/6 doz, or assorted, 28/- gross; 0.01mfd 3k/v and 0.005 mca, 3/- doz; Selenium metal recs, 230v R.M.S., 120mA, 4/- ea; 3/4in m/c speaker, 2-30 speech coil, 9/6 ea; TERMS, c.w.o., no c.o.d.; send 6d extra for postage orders under £5; 2/6d s.a.e. all enquiries and radio and television lists. [3989

**WANTED, EXCHANGE, ETC**  
A VO No. 6 winding machines wanted; details and price.—Box 6178. [3542

**FINE** wires in large quantities only, must be new and perfect material.  
L. E. SIMMONDS, 8a, Byron Rd., Harrow, Tel. Harrow 0315. [3661

**WE** pay top prices for used test equipment, all types.—University Radio, Ltd. 22, Lisle St., London, W.C.2. Tel. Ger. 4447 and Ger 8582. [1992

**WANTED**—R.A.F. test set, Type 65, reference No. 10137; Ferris signal generator, Type 18C; advise condition and price.—Box 7967. [4024

**WANTED**, all kinds of laboratory test equipment, standard signal generators, bridges, oscilloscopes, Q meters, etc.; send price and details to—  
OAK INSTRUMENTS 86, Mill Lane, Lond'n N.W.6 Tel Hampsstead 4219 [4131

**When QUALITY counts . . . .**



. . . and price is the only limitation, the **HOME LAB** Signal Generator is the logical choice. For serious work at a modest outlay it offers a first rate design and a comprehensive specification.

- 100 kilocycles to 100 megacycles
- 30 per cent. modulation at 400 ~ or unmodulated carrier
- Provision for external modulation
- Two-stage constant impedance attenuator
- Output impedance 10 ohms
- Low external field
- Buffer stage
- Variable 400 ~ output voltage
- Accuracy of calibration ± 1 per cent.

**PRICE £6:6:0** plus 3/- for packing.

AC and AC/DC models available. Send S.A.E. for free descriptive brochure and enclose P.O. for 2/6 if circuit diagram required.

**TERMS OF BUSINESS:** Cash with order only. Orders by post only until new showrooms open. **HELY-MANN ELECTRONICS LABORATORIES, 116, Grove Road, London, E.17.**

**ETA**

**PRESET TUNER Type TS41**

For use in superhet circuits to select any three MW and one LW station. Each coil tunes over the whole band by adjustment of its dust iron core. Ideal for quality receivers.

**Price 33/- plus 7/2 Pur. Tax** with complete receiver circuit.

**I.F.T.s Series IT1**

Designed for high gain and quality at 465Kc/s. Permeability trimmers at side of can. Size 1 1/4in. dia. by 2 1/4in high. Type IT1 for normal use, IT2 for feeding diode circuits.

**Price 7/- each**

**PRESET COILS Type V**

Similar to those used in the TS41 and recommended for use with quality amplifiers and receivers. Coverage MW 195-530m, LW 850-2,000m.

**Price** AE & Osc 3/6 each. H.F. 4/- each.

**MIDGET COILS Type J**

Really small adjustable dust cored coils fitted with soldering tags. Available in all types to cover all wavebands, also IF filters. Fixing by single 4 BA nut.

**Price 3/3 each all types**

See previous adverts for further details of these components.

Obtainable from your dealer or direct from **ELECTRO TECHNICAL ASSEMBLIES** West Hill, St. Leonards-on-Sea, Sussex.





**CRYSTAL MONITOR TYPE 4.** Rack mounting. Contains 7 valves and 200/250 volts 50 c.p.s., power pack. Valve line up: 1 5Z4G; 2 EF50; 1 6J5; 1 EA50; 1 VR66; 1 Y85. Many components, resistances, coils, etc. Contained in steel case, enamelled grey. Size: 18in. wide, 6in. high, 9in. deep. Weight 40 lbs. Circuit diagram supplied. These sets are unused, only the outside of the cabinet is slightly soiled.

**LASKY'S PRICE 50/6.** Carriage 5/- extra.

**RECEIVER TYPE 3170A.** Containing 17 valves: 4 EF50; 2 CV66; 1 HVR2; 1 R3; 2 EA50; 1 CV188; 1 VR137; 1 VR507. Also hosts of components, coils, transformers, condensers, resistances, etc. The chassis is totally enclosed in grey metal cabinet, size 18in. x 7 1/2in. x 9 1/2in. Weight 30 lbs. The original cost of this equipment was well over £35.

**LASKY'S PRICE 49/6.** Carriage 5/- extra.

**THE IDEAL UNIT FOR A MINIATURE OSCILLOSCOPE. INDICATOR UNIT TYPE 8/1C No. 4.** Consists of a chassis, size: 11in. long, 6 1/2in. wide, 3 1/2in. high, complete with a mounting bracket and holder for a VCR132A cathode ray tube, and at the holder for a VCR132A cathode ray tube, and one 25,000 ohm, 2 potentiometers, one 100,000 ohm and one 25,000 ohm. Underneath a group board with 3 resistances and 3 condensers. The unit is completely enclosed by a detachable metal cover, with a hinged front glass viewing window for the cathode ray tube. Overall dimensions, with the cover on: 12in. long, 6 1/2in. wide, 9in. high.

**LASKY'S PRICE (less the c.r. tube) 3/6.** Postage 1/6 extra.

**LASKY'S PRICE (with the c.r. tube) 17/6.** Postage 1/6 extra.

**BRAND NEW AND UNUSED EX-GOVERNMENT CATHODE RAY TUBES. TYPE VCR87. SHORT PERSISTENCE.** Each tube is fully guaranteed and is tested before despatch. Contained in specially sprung wood transit case. Characteristic: Heater 4 volts 1 amp. H.T., 2,500 volts maximum.

**LASKY'S PRICE 35/6.** Carriage 7/6 extra.

**E.H.T. TRANSFORMERS FOR THE VCR97 CATHODE RAY TUBE.** Specifications: Primary 200/250 volts 50 c.p.s. Secondary: 2,500 volts 4 mA.; 4 volts 1.1 amps.; 4 volts (CT) 1.5 amps.

**LASKY'S PRICE 35/6.** Postage free.

**SPECIAL MAINS TRANSFORMER FOR THE 1355 RECEIVER.** (As specified in the Inexpensive Television, data book No. 3.) Primary: 200/250 volts 50 c.p.s. Secondary: 250-250 volts 80 mA. Filament windings: 6.3 volts 6 amps. and 5 volts 2 amps.

**LASKY'S PRICE 27/6.** Postage free.

**EX-A.M. RECEIVER TYPE 1132A.** V.H.F., 100/124 Mc.s. receiver. These receivers are absolutely brand new with 11 brand new valves, circuit diagrams and calibration chart. Large tuning scale with super slow motion drive, 0.5 u.s.a., moving coil tuning meter, R.F. and I.F. gain controls, jack sockets for line and phone. Valve line up: 2 R.F. amplifiers VR65; 2 local oscillators VR66; three I.F. stages VR53's; 2nd detector and A.V.C. VR54; L.F. amplifiers VR57 and 6J5; B.P.O., V.C.3; voltage stabiliser VN70. Totally enclosed in metal cabinet, grey enamelled with all controls clearly marked, plated handles. Size: 18in. wide, 10in. high, 11in. deep. Weight 54 lbs.

**LASKY'S PRICE 79/6.** Carriage 7/6 extra.

**RADAR RECEIVER TYPE 3084A. BRAND NEW AND UNUSED IN MAKER'S ORIGINAL WOOD TRANSIT CASE.** Specifications: 14 brand new valves, 7 EF50; 2 CV66; 1 VR137; 1 HVR2; 1 R3; 1 Y85; 1 EA50. Dozens of useful components including an 80-volt A.C. motor used for aerial switching, front panel tuning control, etc. With little modification this unit will make an ideal 2-metre receiver. Also suitable for television construction. Totally enclosed in metal case, size 19in. x 8in. x 7 1/2in. Weight when packed 40 lbs. We will exchange the 2 VR136's for EF50's if so required.

**LASKY'S PRICE 59/6.** Carriage 5/- extra.

**STRONG METAL CHASSIS.** Size: 11in. wide, 5in. deep, 2 1/2in. high. Drilled for 4 valves, 2 I.F. transformers, etc.

**LASKY'S PRICE 1/8** each, plus 6d. postage.

A 2d. stamp with your name and address (in block letters please) will bring you our monthly bulletin giving full details of our current stocks of Ex-Government gear.

**LASKY'S RADIO**  
370 HARROW ROAD, PADDINGTON,  
LONDON, W.9 (Opposite Paddington Hospital)  
Telephone: CUNningham 3978  
Hours Mon. to Sat. 9.30 a.m. to 6 p.m. Thurs. Half Day

**QUANTITIES** reversing motor generator type 73 and 74 (A.M.) aircraft and marine radar scanners.—Box 8026.

**CARRIER** telephone and telegraph equipment of all types and any condition wanted, also teleprinter and teletypewriter apparatus. Harris & Gillow, 93, Wardour St., W.1. [3036]

**WANTED.**—Motor generators: Type 73 A.M., stores ref. No. 10 KB 953; Type 74 A.M., stores ref. No. 10 KB 954; Type 85 A.M., stores ref. No. 10 KB 1233.—Ritson, Red Lion House, Hexham. [4028]

**WE** buy for cash, new, used, radio, electrical equipment, all types; especially wanted, radios, radiograms, test equipment, motors, chargers, recording gear, etc.—If you want to sell at the maximum price call, write or phone to University Radio, Ltd., 22, Lisle St., Leicester Sq., W.C.2. Ger. 4447.

**REPAIRS AND SERVICE**

**MAINS** transformers rewound, new transformers to any specification.

**MOTOR** rewinds and complete overhauls; first-class workmanship, fully guaranteed.

**F.M. ELECTRIC CO. Ltd.,** Potters Bldgs., Wazer Gate, Nottingham. Est. 1917. Tel. 3855.

**TRANSFORMER** and choke rewinds, duplicate and to specifications, prompt service.—F. Hatfield, Musard Place, Staveley, Chesterfield.

**LOUDSPEAKER** repairs, British, American, any make, moderate prices.—Sinclair Speakers, 12, Pembroke St., London, N.1. Terminus 4355.

**MAIN** and output transformers rewound to pattern or specification, return post service.—H. Puzhe, Radio Rewind Service, Brithdr., Nr. Dox Kelley N. Wales. [3243]

**REWINDS** and conversions to mains and output transformers, from 4/6; pp equipment a speciality.—N.L. Rewinds, 4, Brecknock Rd., N.7. Tel. Arno. 4330. [6283]

**MAINS** transformers rewound or constructed to any specification; prompt delivery.—Bede Transformer Co., Ltd., Bedesway, Bede Trading Estate, Jarrow. [3136]

**REPAIRS** to moving coil speakers cones coils fitted, field rewound or altered; speaker transformers, clock coils rewound; guaranteed satisfaction, prompt service.—L.S. REPAIR SERVICE 49, Trinity Rd. Upper Tooting London S.W.17. Balham 2359.

**TRANSFORMER** winding, mains output modulation and Williamson specifications, chokes, rewinds, quotations.—A. Orman, 3, Leslie Pl., Edinburgh, Scotland. [4090]

**AREWIND** service which duplicates or modifies as required; transformers, loudspeakers, etc.; prompt returns.—Raid Services, 49, Lr. Addiscombe Rd., Croydon, Cro. 6537.

**ELECTRICAL** measuring instruments of every type make repaired and standardised.—The Electrical Instrument Repair Service, 329, Kilburn Lane, London, W.9. Tel. Lad. 4168. [3715]

**"SERVICE** with a smile."—Repairers of all types of British and American receivers; coil rewinds, American valves, spares, line cord. F.R.I., Ltd., 22, Howland St., W.1. Museum 5675. [1575]

**RADIO MAINTENANCE SERVICE** for guaranteed rewinds and repairs; armatures; F.H.P. motors, vac. units, portable tools, etc.; good deliveries.—139, Goldhurst Terrace, N.W.6. [9925 6133]

**"STURDY"** rewinds, mains transformers, chokes, and fields, first-class work, prompt deliveries and satisfaction guaranteed.—Sturdy Electric Co., Ltd., Dipson, Newcastle-on-Tyne. [2430]

**ACCURATE** coil windings; tuning coils, i.f., a.i.f. and mains transformers rewound and wound to specifications; wave and progressive wave winding.—Rynford, Ltd., 17, Arwenack St., Falmouth. [2497]

**A** SECOND-to-none rewind service, reliable. Request return of post service; your television requirements promptly executed, E.H.T. LHT and heater transformers; stamp for quotations.—R. E. F., 137a, Ashton Rd., Oldham. [3519]

**24-HOUR** service, 6 months' guarantee, any transformer rewind, mains outputs and i.f.s., etc.; all types of new trans., etc., supplied to specification; business heading or service card for trade prices.—Majestic Winding Co., 180 Windham Rd., Bournemouth.

**L.T.P.** rewind service, all rewinds are layer A wound, vacuum impregnated, pressure tested at 2,000 volts and guaranteed for three months, 48-hour service.—Inquiries London Transformer Products, Ltd., L.T.P. Works, Cobhold Estate, N.W.10. Tel. Willesden 6486

**METROPOLITAN** RADIO SERVICE for rewinds, mains and e.h.t. transformers, chokes and field coils; delivery 3-5 days; new transformers designed and manufactured singly or in quantities.—Metropolitan Radio Service Company, 1021, Finchley Rd., London, N.W.11.

**You're SURE to get it at**

# STERN'S

**ESTABLISHED 25 YEARS**

Resistances. Special offer. Parcel containing 100 popular assorted values 1-watt type, 6/- per 100 1-watt type 8/9 per 100. (Trade orders invited).

**M. Coil Speakers.** Well-known m.f.s. surplus, all 2/3 ohms and P.M.; 10in., 23/6; 8in., 17/- (15 ohm, 18/9); 6 1/2in., 16/6; 5in., 10/- and 12/9 (with Transf., 18/6); 3in., 13/6. Energised also available in all sizes. Truvox 12in. P.M. 2/5 ohm, 47/6.

**STERN'S MIDGET BATTERY PORTABLE "PERSONAL" KIT**

A complete KIT of PARTS to build a Midget 4 Valve All-Dry Battery "Personal" Set. Consists of Regenerative T.R.F. Circuit employing Flat Tuned Frame Aerial, with DENC0 Iron Dust Cored Coil, thereby ensuring maximum gain for Single Tuned Stage covering Medium Waveband. Valve Line-up: I.T.4 (H.F. Amp.), I.T.4 (Detector), I.S.6 (1st A.F.) and 384 (Output).

Includes 3in. Moving Coil Speaker and Chassis already drilled and shaped. Consumption of only 7 m/a ensures long battery life.

The Kit is designed for a cabinet, minimum size 6 1/2in. x 4 1/2in. x 3in.

Detailed Building Instr. and Circuit included with each Kit make the assembly very easy. Price for COMPLETE KIT £3 18s. 9d. (plus 16s. 7d. P.T.).

Suitable unpolished cabinet 6 1/2in. x 4 1/2in. x 3in. 11s. 9d. Ever Ready B.114 Battery, 9s. 7d.

Coils, T.R.F. Matched pair, M. & L. 6/6. Weymouth ditto, 8/6 pair, 8/Het. matched, 8.M. & L. 8/9, 10/6 and 11/6 pair. All Wearite "P" Coils, 8/- each, including R.F., B.P.O. and A.F.

I.F. Transf., 465 kc. New well-known m.f.s. surplus 4in. x 4in. x 1 1/2in. Ferrin. Tuned, 9/- each, or size 2in. x 1in. x 1in. capacity tuned, 13/6 pair.

Potentiometers, Centralab, 5K, 10K, 25K, 50K, 100K, 1/4, 1 and 2 Meg., less Switch, 3/9. With Switch, 6/-. Midget with Switch, 4/1, and 1 Meg., 6/-. Special, 75 Meg., with Switch, 4/9.

Meier Rectifiers. Westinghouse, 0.5 m.a. 4/9; 1 m.a. 7/6; 0.1 m.a., 10/6; 0-250 m.a., 11/6.

Selenium Rectifiers. H.T., h.wave; 250 v. 30 m.a. 5/-; 200 v. 100 m.a. 5/9; 250 v. 100 m.a. 7/6; Bridge Rect., 6 v. 1 1/2 amp., 6/3; 12 v. 1 1/2 amp., 12/6; 12 v. 3 amp., 21/-; 12 v. 5 amp., 25/-; 70 v. 1 1/2 a., 37/6. Also L.T. 2/12 volts at 1/2 amp., 3/6.

Stern's Midget Inter-Valve Transf. 1 1/2in. x 1 1/2in. x 1 1/2in. Ratio 3:1 (also Ratio 5:1), 4/6.

Charger Transf. Each has input 230 v., outputs 24 v. (tapped 15.8 and 4 v.), 3 amps., 24/6; 30 v. (tapped 15 and 9 v.), 3 amps., 23/6; 15 v. (tapped 9 v.) 3 amps., 16/9.

Filament Transf. Input 200-250 v., output 6.3 v. 1 1/2 amp., 8/6. Also with output 4 v. 1 1/2 amp., 7/9.

Ex-Govt. T.M.C. Reed type Headphones. 70 ohms. 1/9 each (3/6 pair with leads). Single earphones, 75 ohms, with adjustable Headband, 1/6. Midget Output Trans., 32-1, 1in. x 1in. x 1in., 8/-; 7/Pull Intervave 2-1 each half Output Trf. 50-1, both 1 1/2in. x 1 1/2in., 3/- each. Multi-ratio Matching Transfs. 4 windings (2 C.T.) over 10 ratios between 10 and 100-1, 2in. x 1 1/2in. x 1 1/2in., 3/9. 12 volt D.C. motor suitable for models, 11/6. Moving Coil Mike with 8/R Switch, 2/6. Coil Headphone, 2/-, Carbon Hand Mike, with 8/R Switch, 2/11. 1 mid. 5,000 volt Mainbridge, 6/9. 25 mid. 2,600 v. Mainbridge, 1/6. Throat Mikes, 3/6. 3 mid. 2 kv. 2-. 25 mid. 800 v., 1/-.

L.F. Chokes. Midget 10 Hny. 250 ohm 40 m/a, 3/6. Standard 15/20 Hny. 250 ohm 60 m/a, 6/6. 20 Hny. 300 ohm 100 m/a, 12/9; 3 Hny. 30 ohm 250 m/a, 18/6. 20 Hny. 250 ohm 120 m/a, 18/6.

**Wireless World Midget A.C. Mains 2-valve Receiver.** All components to build this set as specified in March issue at total cost of £3.0.0. Reprint of detailed building instructions and circuit, 9d. extra.

**Output Transf.** Wharfedale Midget 30-60 or 90-1, 6/9. Elstone Multi (over 12 Ratios some C.T.), 6-7 watts, 7/6. Kingsway Multi Ratio, all C.T., 7/Pull, suit PX4, 6L6, etc., handle 13 watt, 24/9 (also available in 30 watt type, 30/-). Stern's Midget 1 1/2in. x 1 1/2in. x 1 1/2in. Ratios 50:1, 4/6 (also at 90-1, 4/6).

★ Send 2d. stamp for our New Comprehensive Stock List. When ordering please cover packing and postage.

**STERN RADIO LTD.**  
109 & 115, FLEET STREET, E.C.4.  
Telephone: CENTral 5814 and 2280.



## SOLONS FOR YOUR SOLDERING JOBS!

Types available—65 watt oval tapered bit, 65 watt round pencil bit, 125 watt oval tapered bit, 125 watt round pencil bit, 240 watt oval tapered bit.

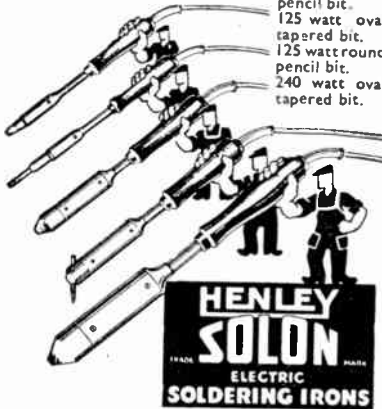

These five models will satisfy practically every soldering demand whether for the occasional household job or continuous soldering under workshop or factory conditions. With the Solon the heat is in the bit itself... continuously... hour after hour; all connections housed at end of handle away from heat. Each model complete with 6 feet Henley 3-core flexible. Now available from stock. Write for folder Y.10.

W. T. HENLEY'S TELEGRAPH WORKS CO. LTD.  
51-53 Hatton Garden, London, E.C.1

## M. WATTS & Co.

8, Baker Street, Weybridge,  
Surrey

Telephone Weybridge 2542.

### MINIATURE COMPONENTS

**TUNING CONDENSERS.** Two gang, .0005  $\mu$ f., 2 1/2 in.  $\times$  2 in.  $\times$  1 1/2 in., 1 in. spindle, 7 in. long, 8/6.

**I.F. TRANSFORMERS.** Permeability tuned, 1 1/2 in.  $\times$  1 1/2 in. square, 465 kc., 14/6 per pair.

**VALVE HOLDERS.** Button base. B7G. For 1R5, 1T4, etc. Ceramic, 1/3. Paxolin, 8d. Screening cans to fit either type, 1/6.

**VOLUME CONTROLS.** .25 meg., 1/2 in. diameter 2/6.

**CONDENSERS**  
Ceramic tubular, 1/2 in.  $\times$  1/2 in., 1.5, 2.2, 27, 33, 47, 50 and 75  $\mu$ f. All 6d. each.  
Midget mica. 20, 50, 100 and 200  $\mu$ f., 4d each, 500 and 1,000  $\mu$ f., 6d. each.

**OUTPUT TRANSFORMERS.** Made for 3S4, DL02, etc., 1 1/2 in.  $\times$  1 1/2 in.  $\times$  1/2 in., 4/6.

**SPEAKERS.** New Rola square type, 3 in., 16/6; 4 in., 18/-. 3 ohm speech coils.

### ENAMELLED WIRE

**LEWCO** enamelled wire is now available from stock in all even gauges from 16 to 40 S.W.G. Prices are attractive. Example: 30 S.W.G., 5/2 per lb. Price list available.

Complete component list sent upon request. Trade list also available.

**LOUDSPEAKERS** and transformers rewound, cones replaced, prompt service.—Dodds Radio Service, 131a, Hurst St., Oxford. [3650]

**TRANSFORMERS,** chokes, coils, etc., rewound; new transformers, supplied to any specification; W/W transformers a speciality; armatures and motors rewound and reconditioned; quick service, all work fully guaranteed.  
**RADIO & TRANSFORMER SERVICES.** Manchester Rd., Hollinwood, Lancs. Tel. Fallsworth 2507. [4067]

**REWINDS.**—Send your "burn outs" to be rewound; no technical data wanted; post transformer, etc., labelled with your name, address, and marked "for rewind"; our windings are double wound, interleaved and impregnated.—Southern Trade Services, Ltd., 297-299, High St., Croydon, Tel. 4870. [3110]

### WORK WANTED

**WE** make wireless and radiogram cabinets for home and export; immediate deliveries.—Radio, Ltd., 26, Brondesbury Rd., London N.W.6. Maida Vale 8792, also Terminus 7447/3.

**A.M., F.M., T.V.,** measuring and control gear designed and built to specification; I welcome enquiries from amateurs concerning difficulties with their own equipment.—J. Mort, B.Sc. A.M.I.E.E., BCM/HIFIDEL, London, W.C.1 [4137]

**FIRST-CLASS** transformers and chokes manufactured stock lines available; also special manufacturers' components made to specifications; armatures and fields wound and motors assembled.—Avis & Baxx Ltd., 140-141, Friar St., Reading Berks. [2715]

**DRAWING** and tracing work for radio and electrical engineering, jig and tool and light engineering, photoprinting, full sets of drawings undertaken to commercial or Ministry standards.—Drawing & Tracing Ltd., 456a, Ewell Rd., Tolworth, Surbiton, Elmbridge 7406.

### MISCELLANEOUS

**"Q.S.L.s"** and "G.P.O." approved log books, samples free.—Atkinson Bros., printers, Elland. [3082]

**WALNUT** radiogram and television cabinets, manf. samples, few only, stamp details; Walters, 501, Hale End Rd., E.4. [3936]

**TRADE** transfers, gold and black, your wording, 7 days' delivery; also decorative transfers; list free.—W. W. Axon, Jersey, C.I. [2160]

**INSTRUMENT** handles, chromium plated brass 4 1/2 in. fixing centres; 4 6 per pair, postage extra; British Electronic Industries, 303-305 Burdett Rd., E.14. [3654]

**WIRELESS ENGINEER,** January, 1939 to December, 1948 (Vols. 15-25); also Wireless World (Vols. 42-54); state volumes required; clean and perfect.—Box 7998. [4124]

**EXPOSURE** meter components, light cell 6/6; meter movement 7/10, moulded case 8/10; assembly instructions and conversion scale reproductions 3/6.—Surpluses, 78, Repton Rd., Bristol, 4. [4054]

**RADIO** supervisors and technicians should join their appropriate trade union, the Association of Supervisory Staffs, Executive and Technicians.—Write for free pamphlet to ASSET, 110, Park St., London, W.1. Tel. Mavfair 8541-2.

**ENGRAVING.**—Amateurs and trade require attention to urgent deliveries; one knob or repetition equally entertained.—Call or write Newman, 19a, Windmill Rd., Wandsworth, London S.W.18. [3640]

**FOR** sale, surplus D.S.C., single rayon, S.S.C., E.D.A.S. and copper enam. wire, 14, 16, 17, 18, 19, 20, 21, 22, 23, 24, 26, 28, 29, 30, 32, 33, 34, 36, 38, 39, 40, 41, 42, 44, 45 S.W.G.—Write S.A. Laboratory, Ltd., The Broadway, Station Rd., Harrow, Middx. [4034]

**FESTIVAL** of Britain.—The Council of Industry. Design has opened a 1951 Stock List to which it invites manufacturers to send photographs or drawings of their best products.—Address to: Stock List, Council of Industry, Design, Tilbury House Petty France, London, S.W.1. [3627]

**COPPER** wires enamelled, tinned, Litz, cotton, silk covered, all gauges; BA screws, nuts, washers, soldering tags, eyelets, ebonite and laminated bakelite panels, tubes, coil formers; Tufnol rod; headphones, flexes, etc.; latest radio publications, full range available; list s.a.e. trade supplied.—Post Radio Supplies, 33, Bourne Gardens, London, E.4. [1454]

**MAY** we record your transmission from 10 metres to 2,000 metres on our high fidelity disc recording equipment. Our prices (post paid) 10in 13/6, 12in 15/-. Write and tell us (a) date and time (preferably week-ends or nights); (b) approx. frequency. Give your call sign clearly for 6 minutes, then talk for 3 1/4 or 5 minutes. Leave the rest to us! Our equipment is flat 12 to 12,000 cycles.—Peter Riley, 16, Beaufort Av., Brooklands, Cheshire. [4144]

## B.T.S.

THE Radio firm of the South,  
63 London Road, Brighton, 1, Sussex.  
Phone: Brighton 1555

## SPEAKERS BRAND NEW

Goodman's, Truvox, Rola (as available).  
5 inch 13/-; 6 inch 14/-; 8 inch 16/-  
including packing and postage.

## EDDYSTONE RECEIVERS

Full range of components.  
All C.O.D. orders promptly executed.  
Send for Catalogue, 1 - post free.

## RECONDITIONED TIMESWITCHES

All Types:— Electric, Clockwork, Spring Reserve, Solar and Fixed Dials, From 30/- each.

Write for details J. DONOHOE

2, UPPER NORFOLK STREET,

NTH. SHIELDS, NORTHUMBERLAND

Our 1950 fully illustrated  
Catalogue is now Available  
3<sup>rd</sup> Post Free

# BERRY'S

(SHORT WAVE) LTD.  
25, HIGH HOLBORN, LONDON, W.C.1

## THE NORTHERN POLYTECHNIC HOLLOWAY ROAD, N.7.

Principal: T. J. DRAKELEY D.Sc., Ph.D.  
F.R.I.C., F.I.R.I.

Department of Radio and Musical  
Instrument Technology.

Head of Department;

S. A. Hurren, O.B.E., M.C., M.Brit.I.R.E.

Full-time Day Courses in

## TELECOMMUNICATIONS ENGINEERING

in preparation for all  
recognised qualifications in this subject.  
Practical laboratory and workshop  
experience provided.

Prospectus free on application to Secretary  
New term begins September 26th.

## HAVE YOU RECEIVED OUR 1949/50 COMPONENT CATALOGUE?

The most complete published today,  
details of thousands of High Grade  
new components. Send 6d. in stamps to  
cover part cost and postage.

## COVENTRY RADIO

COMPONENT SPECIALISTS SINCE 1923

DUNSTABLE ROAD  
LUTON, BEDS.

**EMPHASIS ON  
TECHNICAL  
BOOKS**

W. H. SMITH & SON give special attention to the requirements of technical men and students. Books not in stock, but obtainable from publishers, are supplied within a few days. Students' needs for examinations are given priority.

**GO TO  
W.H. SMITH & SON  
1500 BOOKSHOPS AND BOOKSTALLS**

**ALLEN COMPONENTS LTD.**

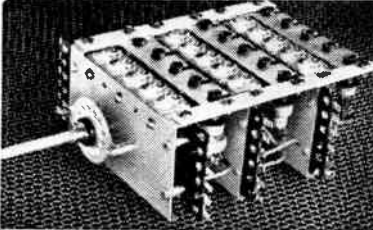

**Type 320 5-wave band coil unit.**

A comprehensive pre-aligned assembly consisting of switch, complete set of aerial, H.F. and oscillator coils and all associated trimming and padding condensers for 5-wave band operation with tuned H.F. stage on all bands. All coils have dust iron cores for inductance adjustment. A six position switch is used with provision for pick up connections and H.F. muting on the sixth position. For use with any of the standard frequency changer valves (6K8, ECH35 etc.) and an I.F. frequency of 465 Kc.

Ranges: 1, 13-40. 2, 30-100. 3, 80-200. 4, 200-550. 5, 900-2000 metres.

Send for latest catalogue of our full range of components for Radio and Television.

**ALLEN COMPONENTS LTD.**  
Tower Road, Willesden, N.W.10  
Telephone Willesden 3675

**SITUATIONS VACANT**  
Vacancies advertised are restricted to persons or employments excepted from the provisions of the Control of Engagements Order, 1947.

**A. ARMY.**  
REGULAR Commissions in R.E.M.E. APPLICATIONS are invited from young Engineers for Regular Commissions in the Corps of Royal Electrical and Mechanical Engineers.  
2. CANDIDATES must:—  
(a) BE British subjects or citizens of the Republic of Ireland.  
(b) BE between the ages of 21 and 27.  
(c) HAVE had at least 2½ years (1½ years for those holding an engineering degree) practical workshop experience as a pupil or student apprentice with an engineering firm or, in special cases, other appropriate employment, including previous service in the Armed Forces.  
(d) HAVE an engineering degree of a British University; or  
(e) HAVE passed, or have been exempted from Sections A and B of the Associate Membership Examination of the Institution of Mechanical Engineers on the Institution of Electrical Engineers. Such exemptions include the Ordinary and High National Certificates, with endorsement, on a subject-for-subject basis.  
3. CANDIDATES accepted will be appointed initially to a Regular Commission in the rank of 2nd Lieut. with an ante-date up to a maximum of 2½ years (up to 6 years for those with previous service) and up to four years' seniority, for purposes of seniority and time promotion to Major (at 13 years seniority). Promotion to higher ranks is by selection.  
CANDIDATES, if unmarried, will receive a minimum of £237 per annum in their first year's Commissioned Service—£273, with two years seniority—and £319 with four years' seniority. Accommodation and rations are provided (totaling £262) or allowances issued in lieu. PAY and allowances for a Lieut. on appointment therefore total £535 per annum.  
4. MARRIED officers, if aged 25 or over on appointment, receive, in addition, marriage allowance of £338 per annum if not accommodated in official married quarters (pay plus allowances totalling £671), £214 if they are so accommodated rent free and, if under 25, £196 per annum if not so accommodated.  
5. AN outfit allowance of £90 is paid on first appointment to a commission.  
6. APPLY TO The Under-Secretary of State, The War Office, M.S.2(c), (24), London, S.W.1 for fuller details and application forms. [4056]  
**R. RADAR in Sweden.**  
EX-R.A.F. radar fitters or mechanics with experience on A1 Mk 10 (SCR 720) wanted now for employment with Royal Swedish Air Force.—Applications which must contain references and full details of experience, etc., should be sent to Air Attaché, 29, Portland Place, London, W.1. [4131]  
**ELECTRICAL Branch, Royal Navy.**  
THE Admiralty announces an extension of the scheme for Short Service Commissions in the Electrical Branch of the Royal Navy to include all candidates who have had previous commissioned service in the R.N.V.R., the Army or the Royal Air Force on electrical and radio duties, and civilians who possess suitable qualifications. PERIOD of service will be five years on the Active List, to be followed by four years on the Emergency List. Officers who complete the full period of five years on the Active List will be eligible for a gratuity of £500, tax free, and, in certain conditions, pro rata for shorter periods.  
AS in the previous scheme, R.N.V.R. officers will be entered in the substantive rank and with the same amount of seniority that they held at the time of their release.  
FOR ex-Army and ex-Royal Air Force officers, seniority will be calculated as for former R.N.V.R. officers of relative rank.  
EX-ROYAL Air Force and ex-Army candidates must be under the age of 35 on the date of entry.  
CIVILIAN candidates must be under 30 years of age and have obtained a degree or diploma from a recognised University in Electrical Engineering or Science, or be Graduate Members of the I.E.E. or Brit.I.R.E., or have passed such examinations as are recognised by the above-mentioned bodies as qualifications for Graduate Membership. They will be entered in the rank of Acting Sub-lieutenant (L), R.N., and promotion to the rank of Lieutenant (L), R.N., may be expected after a total of three years' service.  
FOR further details application should be made to The Director of Naval Electrical Department, Admiralty, Queen Anne's Mansions, St. James' Park, London, S.W.1. [3998]  
**FERRANTI, Ltd.,** has vacancies at their radio works, Moston, Manchester, for:—  
(a) SENIOR development engineers with responsible experience in the design of domestic television receivers.  
(b) DEVELOPMENT engineers with honours degree or equivalent technical qualifications, preferably with some experience of circuit design for domestic television and radio.  
SALARY on a liberal basis, according to qualifications and experience.—Application forms from the Staff Manager, Ferranti, Ltd., Hollinwood, Lancs. [4029]



**AN AUTO-CHANGER FOR £10/15/- only, inc. tax.** The very latest COLLARO Rim-Drive auto changer, complete with crystal pick-up. Very attractive appearance. A.C. 200/250 volts, changes 10 records, either 10in. or 12in. (NOT mixed). Motor board size, 15in. x 12½in. Requires only 2½in. below, and ½in. above.

**MICROAMMETER.** 0-500 micro/a., 2in. scale, moving coil, panel-mounting, 7/6 each.

**U.S. ARMY MIDGET LIGHTWEIGHT HEADPHONES.** 200 ohms. Suitable for deat-aid, etc., 7/6 pair.

**THE E.T.A. FOUR-STATION SUPERHET TUNER.** Completely self-contained tuner, may be set to select any three medium and one long wave stations. No tuning condenser required. Four-position switch. Tuning by high permeability dust cores. Litz wound coils. Once set requires no further adjustment. The station you want at a flick of a switch. Size 2½in. high by 3½in. by 3in. Complete with full aligning instructions and suitable A.C. and A.C./D.C. circuit. Only 33/-. Plus purchase tax, 7/2.

**TX VALVES.** Type 832, 25/- ea., and a limited quantity only of 829's at 59/6 ea.

**KLYTRON, TYPE 723A/B.** We also have a limited quantity of these, brand new, at 82/6 ea.

**RCA 931A PHOTO-ELECTRIC CELL AND MULTIPLIER.** For barium transmission, flying spot telecine transmission and research, involving low light-levels, 9-stage multiplier. Brand new and guaranteed, only 30/- each.

**TYPE BC 624A RECEIVERS.** Absolutely brand new by BENLON, etc. Valve line-up: 12AH7, 12J5, 3 12SG7, 12CG, 3 9003, 9002, making 10 valves in all. Frequency coverage 100-125 mc/s. Can be supplied at the absurdly low price of 25/-.

**MINIATURE MAINS TRANSFORMER.** 250-0-250, 60 m/a., 6 v. 3 a., 5 v. 2 a., fully shrouded, well finished, size 3½in. x 2in. x 2½in. Price 21/-.

**MIDGET TWO-GANG. 000375 mfd.** With trimmers, vanes enclosed in perspex; total size only 2in. x 1½in. x 1½in. Our price, 6/6 only.

**R.F.25 UNIT.** Brand new. Converted from new R.F.24 units. Price 19/6, plus 1/6 carriage.

**R.F.24 UNIT.** Brand new in sealed cartons, 16/6 each.

**OSMOR MIDGET "Q" COIL PACKS.** Size 3½in. x 2½in. x 1½in. Amazing performance, Polystyrene formers with adjustable iron cores. One-hole fixing, only five connections. Factory aligned, complete with full receiver circuits, and instructions. S'Het for 495 kc/s., 33/- only. I.M.S. also for TRF operation M. and L., W., 30/-.  
Please note that separate H.F. Stage, for addition to the above Superhet Coil Pack, can now be supplied at 15/- only. Complete with all necessary easy-to-follow instructions.

**R.1355 MAINS TRANSFORMER.** 200/250 v. Input. Outputs 250-0-250, at 80 m/a., 6.3 v. at 6 a., 5 v. at 3 a. Fully shrouded, top chassis mounting and guaranteed 100%. Only 28/6.

**MINIATURE VARIABLE INPUT IMPEDANCE TRANS.** Six ratios, to match all standard microphones, and pickups. Special price of 5/- ea.  
Send stamp for current Component List. Probably the most comprehensive in the trade.

**5, HARROW ROAD, LONDON, W.2**  
**PADddington 1008/9**



**L-R-S** FOR  
**PROMPT & EFFICIENT SERVICE**  
CASH or EASY TERMS

**ARMSTRONG ALL-WAVE CHASSIS**  
Various Models Available

GOODMAN'S "Axiom Twelve" Speaker Unit. Cash price 28 8 0  
GOODMAN'S Standard 12" Speaker Cash price 26 15 0

**GOODSELL-WILLIAMSON HIGH FIDELITY AMPLIFIERS**

A. C. BARKER'S New 148A Speaker  
COLLARO Radiogram Units—various models  
AVO METERS—All models available.

**PEERLESS RADIOGRAM CHASSIS**

Specification of all the above on request.  
When you purchase Radio Apparatus on L.R.S. Convenient Terms you deal directly with us from beginning to end, with no financial firm or other third party intervening. We shall be glad to quote for your requirements without obligation to purchase.

PERSONAL ATTENTION TO ALL ENQUIRIES

**The LONDON RADIO SUPPLY CO.**

Est. 1925

BALCOMBE, SUSSEX

**TELEVISION CONSTRUCTORS!**

E.E. Television Demonstrated Daily  
MIDLAND CONSTRUCTORS ETC.  
ARE INVITED TO SEND FOR OUR COMPLETE COMPONENT LIST AND TAKE ADVANTAGE OF OUR

PROMPT POSTAL SERVICE

**J. T. FILMER** MAYPOLE ESTATE, BEXLEY, KENT. Tel. Bexleyheath 7267

**HILL & CHURCHILL LTD.**

BOOKSELLERS

**SWANAGE, DORSET**

Available from stock

- Zepler—Technique of Radio Design ... 25/-  
Shortly (New revised and enlarged edition)
- Schelkunoff—Electro Magnetic Waves 42/-
- Fink—Radar Engineering ..... 42/-
- Brainerd—Ultra High Frequency Technique ..... 28/-
- Ramo & Whinnery—Fields and Waves in Modern Radio ..... 33/-
- Rider—Inside the Vacuum Tube ..... 26/6
- The Radio Handbook, 11th edition (U.S.A.) ..... 21/-
- A.R.R.L. Handbook, 1949 ed. (U.S.A.) 16/6
- Servicing Sound Equipment (U.S.A.) 7th ed. .... 57/6

Postage Extra.

CATALOGUE ON APPLICATION

CROWN Agents for the Colonies.

TECHNICIAN (Broadcasting) required by Northern Rhodesia Government Information Department for one tour of 24-36 months. Commencing salary according to age and experience in scale £490 rising to £840 a year. Gratuity payable on satisfactory termination of engagement. Free passages. Candidates, single, and under 40, must have passed the B.B.C. Grade D examination for Overseas and Information Department Engineers (Tatfield), or equivalent, and be capable of maintaining and installing receivers from commercial to triple diversity types. Knowledge of propagation of radio waves and receiving and transmitting aerials, aptitude in use of small tools and ability to drive a car are essential. Knowledge of theory and practice of short-wave broadcasting transmitters an advantage. Apply at once by letter, stating age, and full particulars of qualifications and experience and mentioning this paper to the Crown Agents for the Colonies, 4, Millbank, London, S.W.1, quoting M/N/24849(3B) on both letter and envelope. The Crown Agents cannot undertake to acknowledge all applications and will communicate only with applicants selected for further consideration. [4132]

FAULT finders with television experience required for large scale production testing; North London.—Apply Box 7795. [4058]

EXPERIENCED window dresser and ticket writer wanted for City firm; good wages.—Premier Radio Co., 152-3, Fleet St., London, E.C.4. [4064]

APPLICATIONS are invited for Electronic Engineers and Mechanics for reconditioning V.H.F. wireless equipment, Wellington, S.W.9 area.—Box 7811. [4061]

RIGHT-HAND man for small N. London dealer; versatile technician, knowledge of sales and driving licence necessary.—Write fully BM/CDN, W.C.1. [4059]

SALESMAN, West End showroom; must have experience with Government surplus and ham market; advantage if knowledge of domestic radio; good prospects.—Box 7971. [4033]

EX-RADAR mechanics with experience on ground radar equipment in the Forces, on installation or maintenance work, are invited to write quoting Ref. 704 to Box 7771. [4050]

ELECTRICAL engineer wanted, specialist in high frequency work, hardening and heat treatment of metals; should have experience in general power engineering.—Box 7978. [4082]

WANTED, for employment in various parts of the United Kingdom and N. Ireland, personnel experienced in maintenance and repair of radar and electrical fire control equipment. SALARY scale £400 per annum, rising to £525. APPLICANTS should furnish full details of age, practical experience, technical qualifications held and state in which part of the U.K. or N.I. they are desirous of being employed. REPLY should be addressed to D.D.M.E., H.Q. A.A. Command, Stanmore, Middx. [4063]

ELECTRIC organisation in London requires young technical assistant aged 19-21, taking 1st or 2nd year National Certificate in Electrical or Radio Engineering.—Full details to Box 7972.

TECHNICIANS experienced in radio set alignment and fault finding wanted by radio set manufacturer in N.W. London area.—Write, stating age, experience and salary required, Box 7980. [4086]

RADIO testers and servicing engineers wanted by progressive radio and television factory in North London; good pay, canteen facilities, 5-day week.—Apply, Romac Radio Corp'n., Ltd., The Hyde, London, N.W.9. [4060]

PILOT RADIO, Ltd., requires immediately fully experienced chargehands for radio and television assembly lines; five day week with good rates of pay. Apply or write to 31/37, Park Royal Rd., N.W.10. [3634]

PILOT RADIO, Ltd., requires immediately experienced testers and fault finders for radio and television alignment; five day week with good rates of pay. Apply or write to 31/37, Park Royal Rd., N.W.10. [3635]

MANCHESTER firm of industrial electronic consultants require a designer-draughtsman conversant with electronic instruments for small-scale production; reply giving full details of age, past service and experience.—Box 7970.

RADIO and television service engineers, technical training and practical experience essential; wages, radio from £5.15, television from £6.10, according to experience.—Radio Maintenance & Supply Co., Blackfen Rd., Sidcup, Kent. [4065]

ESCO Public Address Contractors invite application for experienced engineers in layouts for temporary installations covering county fairs, shows, regattas, trials, trade fairs, etc.—Apply, fullest detail, Esco, Brighton Terr., London, S.W.9. [4000]

SERVICE foreman required to take charge of well-known radio manufacturers' service dept., North Kent district; applicants must have good technical and organising ability.—First reply in writing, stating age, experience, and salary required, to Box 7225. [3815]



**QUARTZ CRYSTAL UNITS**

For—  
**AIRCRAFT, MARINE AND COMMERCIAL USE** are available in the complete range from 35 kilocycles to 15 megacycles.

Alternative mountings in standard two-pin A.M. pattern 10X, International octal, and miniature type FT243, can be supplied for most frequencies.

Prices are fully competitive, and we specialise in prompt deliveries for urgent requirements.

WE WELCOME YOUR ENQUIRIES.

THE QUARTZ CRYSTAL Co., Ltd.  
63-71 Kingston Road,  
NEW MALDEN, SURREY  
Telephone: MALden 0334

**LOCKWOOD**

makers of

**Fine Cabinets**

and woodwork of every description for the Radio and allied trades

**LOCKWOOD & COMPANY**

Lowlands Road Harrow, Middlesex. Byron 3704

**"PERIMET" ELECTRODE Soldering and Brazing Tool**

Operates from 4 or 6 Volt Accumulator or Transformer



MAINS TRANSFORMER, 3 Heats. 36s. Post free

**HOLBOROW & CO.,**  
71, Weymouth Bay Avenue, Weymouth.

**ELECTRONIC & ELECTRO-MECHANICAL EQUIPMENT**

developed for industrial applications. Reasonable charges.

**SPENCER-WEST**  
QUAY WORKS, Gt. YARMOUTH

**MORSE CODE TRAINING**



There are Candler Morse Code Courses for **BEGINNERS AND OPERATORS**

Send for this Free **"BOOK OF FACTS"** It gives full details concerning all Courses.

**THE CANDLER SYSTEM CO.** (Room 55W), 121 Kingsway, London, W.C.2  
Candler System Co., Denver, Colorado, U.S.A.



# LIFE GETS TEDIOUS— DON'T IT!

Not if you possess a copy of the new, revised "Home CONSTRUCTOR'S HANDBOOK" (now in its fifth edition!). This justly famous book is crammed full of many good things for all radio enthusiasts.

- Eight tested and guaranteed circuits with full descriptions and parts.
- Feeder Units, Tuning Units and Sets.
- Quality Amplifier.
- Servicing and Constructional Hints and Tips.
- Resistance Colour Code, Charts, etc.
- Simple Formulae, etc., etc.
- And many other interesting items.

We are proud to make the special offer once again of this useful book to "WW" readers for 1/- ONLY. Send NOW for your copy of the new issue.

Letters of praise continue to reach us daily regarding the improved model 40 coil pack with CERAMIC switching for improved performance. These letters confirm our opinion that this unit has no equal anywhere even at double the price. P. S. H. of H.M.S. "Harrier" states: "I must add that your coil pack, etc., does everything you claim it to do."

The price is still unchanged at 42/- inclusive, or 47/- aligned and sealed for 465 kcs. I.F. A stamp will bring full details of this and other advertised units and components.

**RODING LABORATORIES,  
70 LORD AVENUE, ILFORD, ESSEX**

## THE BRITISH NATIONAL RADIO SCHOOL ESTD. 1940

where nothing is too much trouble and the Student is Always Right! Where the half-truth catch phrase is unknown and

The GOLDEN RULE still runs.

Overseas Students Especially Welcome  
INDIVIDUAL COACHING BY POST  
in

**RADIO, TELECOMMUNICATIONS,  
RADAR · PHYSICS · MATHS.**

All examinations C. & G., I.E.E., Brit. I.R.E.

We can arrange for most examinations to be taken anywhere, aboard ship or furthestmost by post. Free Booklet from

**STUDIES DIRECTOR  
BRITISH NATIONAL RADIO SCHOOL  
66, ADDISCOMBE ROAD, CROYDON  
Phone: Addiscombe 3341**

**FOREMAN** to take charge of transformer division of West Country manufacturers; experience of coil winding and assembly of transformers up to 50kva essential, and some previous executive experience desirable; give details of experience with dates to Box 6837. [3685]

**DRAUGHTSMEN**—Men with sound D.O. experience of distributing radio, or winding transformers required at Liverpool; good conditions.—App'y, quoting Ref. D.O.81, to Central Personnel Services, English Electric Co., Ltd., 24-30, Gillingham St., Westminster, S.W.1.

**INSTRUMENTS Engineer** (Electronics) urgently required by the Ministry of Supply, Division of Atomic Energy (Production), Risley, Nr. Warrington, to be responsible for the application of electronic instruments to industrial process control, including the measurement and control of radio-activity.

**CANDIDATES** must have served a pupillage or engineering apprenticeship in a reputable establishment and must either be corporate members of the Institution of Civil, Mechanical or Electrical Engineers or have passed examinations recognised by any of these Institutions as granting exemption from Section A and B of their examination for associate membership, or possess an Honours degree in engineering; they should also have had seven years' experience in the field of electronic engineering; the **SALARY** will be on the inclusive range of £720-£960 p.a., according to qualifications and experience.

**CANDIDATES** will normally be confined to natural born British subjects, born within the United Kingdom or in one of the self-governing Dominions of parents also born in the United Kingdom or one of the self-governing Dominions.

**APPLICATIONS**, giving full particulars of qualifications and experience should be forwarded to Staff Section, Division of Atomic Energy (Production), Risley, Nr. Warrington, Lancs. [4083]

**MANAGER** required for planning, estimating and liaison work in a large electronic research unit; must have good technical knowledge of radio, and experience of estimating and production planning.—Write, stating experience, qualifications and salary required, to Box No. W5282, A.K. Advg., 212a, Shaftesbury Ave., W.C.2. [4053]

**APPLICATIONS** are invited from engineering and physics graduates by the Research Laboratories of The General Electric Co., Ltd., East Lane, North Wembley, Midd., Essex, for wireless communications equipment and radio navigation aids. Details of age, academic record and experience, should be sent to the Personnel Officer. [4046]

**CHIEF Engineer/Designer** wanted by manufacturers of communications receiver and television, to take charge of production in small factory, previous experience essential; to a person able to work on own initiative the situation offers excellent prospects.—App'y by letter, stating previous experience, together with salary required. [4094]

**RADIOVISION (LEICESTER), Ltd.**, 58-60, Rutland St., Leicester. [4094]

**SENIOR design draughtsmen** required in the radio and electronic drawing office of the Plessey Company; applicants should have experience in a drawing office engaged on radio design for mass production or the design of communications equipment.—Applications should be made to the Personnel Manager, The Plessey Co., Ltd., Ilford, Essex. [4040]

**VACANCIES** occur for marine radar servicing engineers, home and abroad; applicants should have held at least senior N.C.O. radar mechanic rank during the war, and be capable of fault finding on their own; applicants must be prepared to travel as required; state whether single or married, age, home address, and all qualifications.—Box 7490. [3954]

**TECHNICAL representative** required by old-established radio manufacturers of good standing; applicants, not more than 28 years of age, should have adequate technical qualifications, and be keen to make progress on the commercial side of the industry.—Write with full particulars of age, experience, etc., and stating salary required to Box 8001. [4138]

**APPLICATIONS** are invited for the post of radar engineer to specialists in marine installations; applicants should have either held a commission as Radar Officer during the war or been actively engaged on radar development in industry; the post calls for energy, willingness to travel, and ability to handle installations and repairs in a capable manner. W. H. SMITH & Co. Elec. Eng., Ltd., Praed Rd., Trafford Park, Manchester. [3955]

**RADIO-ELECTRONICS technician** required by Boots Pure Drug Co., Ltd., Nottingham, for their plant laboratory with ability to construct, service and trace faults in industrial electronic equipment such as pH meters, d.c. and a.c. amplifiers and R.F. generators.—Applications, stating salary required, to Personnel Manager, Station St., Nottingham. [3671]

**ELECTRONIC engineering company** requires senior draughtsmen with experience in design and detailing of electronic, radio or light electrical apparatus; good position offered to men with suitable experience; works situated in North London.—Write, stating experience and salary required, to Box W5346, A.K. Advg., 212a, Shaftesbury Ave., W.C.2. [4077]

# FREE!... an efficient aerial system with every R1132A UHF Communications Receiver and Power Pack

Improved signal strength obtained from the famous Burgoyne Co-axial Connector and lead-in used with the popular R1132A.

In the past purchasers of these receivers have encountered difficulty in securing the correct plug connector for aerial input. This is also supplied already fitted to 12 yards of co-axial feeder which is, in turn, fitted to the Burgoyne Co-axial Connector, which enables an efficient water-tight co-axial cable connection to be made.

The Burgoyne Connector is made of aluminium with Steatite insulation, and has two forged steel eyebolts equipped with convenient soldering connections. A bottle of weatherproof cement with a piece of ½ in. outside diameter rubber tubing plus the necessary assembly screws, are supplied with each connector. The assembled connector weighs only 12 ounces.

It is suggested that a length of 3ft. 9in. be used either side of the connector to form a dipole; made from either copper wire or self-supporting small diameter tubing. This will enable the receiver to work under most favourable aerial conditions and will give a greatly improved signal strength.

The Burgoyne Connector may also be used for connection in the centre of a rotary beam or array.

The R1132A is a 10 valve receiver for use on 100-124 Mc/s. and is easily adaptable for 144 Mc/s. Excellent AGC and frequency stability. A local osc. gives audible beat when receiving unmodulated carrier wave. Receiver consists of a signal frequency RF amplifier followed by freq. changer with osc. valve, 3 IF amp. stages, double diode det., and AGC rect. and 2 stages a.f. amp. BFO included to switch into detector circuit. Functions from AC mains (200-250 v.) in conjunction with a power pack supplied. Valves: 1 each P41, 7475, EB34, EF32, 6J5G, 2 of SP41 and 3 of EF39. Output impedance 600 ohms, but satisfactory 200-2,000 ohms. Supplied with **Circuits and Calibration Chart.**

Complete with all accessories and power pack (Power Unit type 3) as described above.

**BRAND NEW £ 8/9/6**

**PARMEKO DUAL LOUDSPEAKERS**  
Unrepeatable Offer!!  
(Naval Pattern).

2 8in. P.M. Speakers mounted back to back on durable frame. For outdoor work and P.A. 10 watts. Complete with volume control with switched tappings.

**BRAND NEW (to callers) 50/-**

(Add 10/- carriage and packing for rail.)

**JUBILEE SOLDERING IRONS**  
A bargain offer of brand new soldering irons at 8/- each. (Add 1/- for postage.)

**MODULATOR TYPE 74.**  
9 valve equipment comprising 2 stages I.F. amplification (560 Kc/s.). Detector A.V.C., separate B.F.O. and 1 stage audio output (phone). Also 4 valve push-pull modulation amplifier (1 valve used as A.F. oscillator on M.C.W.).

Complete with valves and power unit (24 v. D.C. input with 2 outputs of 250 v. D.C.).

Valve line-up: 2 KT33C; 2 EF36; 3 EF39; 1 EBC33 and 1 EF50. Brand new and complete in transit case, 50/- (Or less, plus valves, 30/-) (carr. and pkg., 7/6.)

**M.O.S. NEWSLETTER.** Lists the latest offers of surplus equipment, gives circuit diagrams and much useful information. Send 6d. for specimen copy or 5/- for year's subscription. Terms: Cash with order.

**M.O.S. MAIL ORDER SUPPLY CO.**

33 Tottenham Court Rd., London W.1.  
Telephone MUSeum 6667/8/9

**frequency calibration service**

**5/-**

The frequency of any type or make of Quartz Crystal Unit will be measured, and a calibration certificate issued. Crystal Units are returned to the customer within 48 hours. For further particulars write for leaflet QC. 4812 to:—

**SALFORD ELECTRICAL INSTRUMENTS LTD.,** Pee. Works, Silk Street, Salford, 3.

**BRASS, COPPER, DURAL, ALUMINIUM, BRONZE**

ROD, BAR, SHEET TUBE, STRIP WIRE.  
3,000 STANDARD STOCK SIZES

No Quantity too Small List on application

London: **H. ROULET & Co., Ltd.** Liverpool: 6, Chesham Place, S.W.1. Kirkby Estate, SLOane 3463 SIMONSWOOD 3271/3

**TELEVISION**

Complete set of coils for The "Electronic Engineering" Television. Video and Heater Chokes Included. All Boxed and Marked. 13/- post free. (Cash with order).

The Holden Ferrule Co. Ltd.,  
Quaker Street, London E.1.

**SERVICING for the WEST COUNTRY AMATEUR**

**COMMUNICATION RECEIVER REPAIRS**

With good equipment and well qualified personnel we offer a first-class service for the repair and adjustment of communication receivers of every make.

No repairs too small, none too difficult, and our facilities for precision adjustment enable us to get the best from every set.

Estimates are given after examination and test, and receivers are carefully packed for return.

**G. N. PILL & PARTNERS**  
COBOURG STREET, PLYMOUTH

Telephone: 2239

**T**WO radio engineers required to lead teams engaged on the development of high-class radio communication equipment; suitable men should possess an honours degree in electrical engineering or physics and should have civilian or Forces experience in the design of communications equipment.—Kindly state full details of experience including age and salary required to Box 7975. [4039]

**R**ADAR engineers required by Marconi's Wireless Telegraphy Co., Chelmsford; applicants should possess H.N.C. or degree and have had experience in the Forces of servicing or installation of radar equipment (preferably as officers or N.C.O.s); work involves preparation of schedules of equipment, etc.—Apply quoting Ref. 256 to Central Personnel Services, 24-30, Gillingham St., Westminster, S.W.1 [4043]

**R**ADIO engineer required. City and Guilds standard; will be required to deal with all types of electronic equipment in factory dept., specialising in preparation of prototype model, etc., must be able to investigate troubles associated with design faults, etc.; North London district.—Reply, giving experience and salary required, to Box W. 5265, A.K. Advc., 212a, Shaftesbury Ave., W.C.2. [4052]

**T**ECHNICAL assistant, Inter. B.Sc. standard, good knowledge physics, experienced electronics (ex-radar mechanic suitable), photography, electrical instruments, for ammunition ballistics research (experience of ballistics not essential).—Write, stating age, experience and salary desired to Staff Officer, Imperial Chemical Industries, Ltd., Metals Division, Kynoch Works, Witton, Birmingham, 6. [4066]

**T**ELEVISION service engineers required for old-established retail firm; must be first class and hold either B.T.E.B. certificate or City & Guilds Grade II or III, or E.R.E. Graduate Exam Certificate; salary £375 to £450 according to qualifications; also radio engineers with pre-war experience, £300 to £375.—Wycombe Electrical Supplies, Ltd., 51, Oxford St., High Wycombe, Bucks. Tel. H.W. 457. [4129]

**R**ADIO engineer required with ability to write comprehensive service manuals and instruction books, particularly on V.H.F. equipment; a really sound technical background is essential, also the ability to describe complex technicalities in simple straightforward English; pension scheme and five-day week.—Write age, experience and salary required to Personnel Manager, The Plessey Co., Ltd., Ilford, Essex. [4051]

**P**OSITIONS as laboratory assistants with large company engaged in the light electrical engineering field are open to young men with degrees in electrical engineering, physics or mechanical engineering; to applicants with these qualifications and an aptitude for research work the positions offer first-class opportunities of advancement.—Kindly state qualifications with age and salary required to Box 7974. [4043]

**A**SSISTANT required for well equipped electro-acoustic laboratory, training and previous experience in this type of work desirable but not essential, applicants must have good grounding in electronics and possess academic qualification; salary, depending on experience and qualification, approximately £300 p.a.; five-day week, social facilities.—App'v. giving full particulars, to Box No. A.2750, Haddons, Salisbury Sq., London.

**R**EQUIRED, chief engineer (for mechanical design) by a firm in the London area specialising in radio, electrical appliances and allied products; responsibilities to include the complete control of the design dept., production and model shop.—Applicants, who must be fully qualified draughtsmen-engineers and have had several years' experience in a similar position, should write in confidence, stating qualifications, experience, age, etc., to Box 7257. [3926]

**M**AINTENANCE engineers required by The Morgan Crucible Co., Ltd. Successful applicants should have Higher National Certificate or equivalent and some experience in service and maintenance of electrical equipment with particular reference to programme controllers and general electrical furnace control equipment. Age 25-30. Write, giving details of age, qualifications, experience, salary required, to the Staff Manager, Battersea Church Rd., S.W.11.

**T**ECHNICAL Editor required to edit and prepare reports for publication; qualifications, a good general training in electronics, with wide practical experience, marked critical faculty and ability to write good English; acquaintance with the various printing and photographic reproduction processes would be an advantage.—Applicants, giving full details of experience, etc., should be sent to the Personnel Dept. E.M.I. Engineering Development, Ltd., Blyth Rd., Hayes, Middx. [4113]

**Q**UALIFIED engineer required for well equipped electro-acoustic laboratory, to undertake original work; previous training and experience in the design and development of electro-acoustic transducers and electronic circuit technique necessary; salary according to qualification and experience, within the range of £500-£600 p.a., five-day week, canteen and social facilities.—Apply, giving full particulars to Box No. A.2746, John Haddon & Co., Ltd., Salisbury Sq., London, E.C.4. [4068]

**POST RADIO SUPPLIES**

OFFER EX STOCK

**COPPER INSTRUMENT WIRE.**  
ENAMELLED, TINNED, LITZ.  
COTTON AND SILK COVERED

Most gauges available.

**B.A. SCREWS, NUTS, WASHERS,**  
soldering tags, eyelets and rivets.  
**EBONITE AND BAKELITE PANELS,**  
**TUFNOL ROD, PAXOLIN TYPE COIL**  
**FORMERS AND TUBES, ALL DIAMETERS.**

Latest Radio Publications.

Send stamped addressed envelope for comprehensive lists. Trade supplied.

**POST RADIO SUPPLIES**

33, Bourne Gardens, London E.4.

Phone: CL:sold 4688

**TELEVISION RECEIVERS**  
**SCANNING and FOCUS COILS**  
**TIME BASE COMPONENTS**  
**7KV. EHT. RF. UNITS and**  
**TRANSFORMERS**



Publications post free

**HAYNES RADIO LTD.**

Queensway, Enfield.

**FILTERS FOR STEREOPHONIC AMPLIFIERS**

By using a cross-over network to provide HF and LF channels to suitably positioned speakers, a measure of "Stereophony" can be gained with extended frequency range and reduced output transformer distortion.

But'ethn CFN includes tabs, and circuits for these and other cross-over networks. Price 6d.

**LYNCAE LABORATORIES**

29, Cambrage Road, Borden, Surrey, LI:Berly 3247

**PRECISION TEST EQUIPMENT**

MARCONI INSTRUMENTS test equipment as below all as new and guaranteed.

SIGNAL GENERATORS.	
Type TF.144G .....	£75
Type TF.144F .....	£85
Type TF.390F .....	£45
Type TF.317E .....	£42
Type TF.517E fitted with Pulse Modulator Type 675A .....	£69
VALVE VOLTMETER Type TF.428A .....	£40
OUTPUT METER Type TF.349 .....	£31
COSSOR Double Beam Oscilloscope Type 339 .....	£39
COSSOR Signal Type 52a. Frequency range 6 to 52 Mcs. Modulation either sine or pulse. Prev. for EX. mod. R.F. output variable from 1 uV to 100 mV. New and unused .....	£28

Crystal ovens, Variacs, Wavemeters, etc.

Send for lists.

**PIKE BROS.**

86 MILL LANE, LONDON, N.W.6

Telephone: HAMPSTEAD 4219

**B. & H. RADIO**  
**Huntley St., Darlington**

**Loud Speaker Bass & Treble Separator**

Complete kit of parts and instructions. Enables speakers of different impedance to be used for bass and treble and also gives control of amount of treble relative to bass.

Model A 6Db per Octave. Cross over 1000 c.p.s. .... £1 9 6

Model B 12Db per Octave. Cross over 1000 c.p.s. .... £2 12 6

**Scratch Filter** 15 0

Gives a very marked reduction of scratch level without serious effect on treble response.

**Variable Selectivity I.F. Transformer**  
465 kc/s. Gives three degrees of Selectivity.  
Per pair £1 0 0

TRADE ENQUIRIES INVITED.



GOVT. SURPLUS, UNUSED

# CONDENSERS

of all types . . .

We can offer, FOR IMMEDIATE DELIVERY from very generous stocks, a wide range of ultra-high quality fixed paper Condensers, from .001  $\mu$ F to 8  $\mu$ F. Also STOCKS of small, genuine MICA Condensers from .00001 (10 pf) to .01  $\mu$ F (10,000 pf). Prices are exceedingly moderate.

Enquiries are invited for manufacturers' requirements, wholesale and export only for bulk quantities, and for scheduled deliveries over a period, as required. Most condensers are now available for immediate delivery.

Please request our 4 page bulletin CONSEVEN 01114

**CLAUDE LYONS LTD.**  
180 Tottenham Court Rd., London, W.1  
and 76, Oldhall St., Liverpool 3, Lancs.

## WHAT'S THE DIFFERENCE?

Call on us and hear for yourself

The best **AMPLIFIERS** made by Vortexion, Leak, Sound Sales, Acoustical and new Williamson.

### SPEAKERS by

Goodmans, Barker, Sound Sales, Wharfedale, B.T.H., RK and many others.

### PICK-UPS

Brierley, Decca, Wilkins & Wright, Connoisseur, Marconi.

Other lines include Radio Feeder Units, Phase Inverter & Infinite Baffle Speaker Cabinets, also FFR Records

## HOLLEY'S RADIO STORES

285 Camberwell Rd., London, S.E.5

Phone: RODney 4988

**R**EQUIRED, a first class electrical engineer designer for aircraft work with company situated in the South; previous experience of aircraft installation work not essential but sound training and experience in light electrical engineering, particularly a.c. and d.c. control circuits and accessories is required. Also junior draughtsmen for similar work. Write, giving full particulars of training, experience and salary required, to Box W.5290, A.K. Advg., 212a, Shaftesbury Ave., London, W.C.2. [4057]

**D**ESIGNER-Draughtsmen required by Airmec Laboratories, Ltd., High Wycombe, for work in the field of radio and telecommunications equipment; applicants should have served a recognised apprenticeship in light engineering or have equivalent shop training and technical qualifications to the Senior National Certificate standard in Electrical Engineering or Mechanical Engineering.—Applications should be addressed to the Personnel Manager, stating age, academic qualifications, experience and salary required.

**M**ANAGER predictor production; senior and junior development engineers for radio, radar, electronics, quartz crystals, speakers, electro-mechanical, senior and junior draughtsmen; service engineers, P.A., radio, aviation and radar (home and overseas); wiremen (skilled and semi-skilled); radar, instruments, radio prototype; H.F. repairers; production engineers; ratifiers; estimators; also other positions vacant.—Consult Technical Employment Agency, 179, Clapham Rd., S.W.9. (Brixton 5498.) [4133]

**R**EQUIRED, general works manager by a company engaged in the light electro-chemical engineering industry for a factory situated in the North of England; applicants must be first class practical engineers, with wide administrative and organising experience, capable of taking full control of a mass production factory under direction of the Board, and only those who have held a position in a similar field, and who are fully qualified engineers, should apply; the first problem is not an insurmountable one.—Write in confidence, stating qualifications, experience, age etc., to Box 7256. [3925]

**E**NGLISH ELECTRIC invite applications from mechanical and electrical draughtsmen for vacancies which exist on aircraft, gas turbines, steam turbines, water turbines, switchgear, transformers, a.c. and d.c. machines, electronic and telecommunication equipment; vacancies exist in various parts of the country; stable employment, good conditions; please state salary required, type of engineering equipment in which you are interested, and any preferences regarding location.—Apply, quoting Ref. D.O.62, to Central Personnel Services, English Electric Company, 2-30, Gillingham St., Westminster, London, S.W.1. [3933]

**B**.B.C. invites applications for the post of Head of the Recording Section of the Designs Department, in London. Candidates should possess high professional attainments and must have wide knowledge and experience necessary to direct and be responsible for the activities of a small group of Engineers whose work includes the design of various systems of disc and magnetic recording and reproducing equipment used in broadcasting. The salary is in a grade with annual increments of £60, rising to £1 360 per annum. Applications, stating age, qualifications, details of past and present employment, should reach the Engineering Establishment Officer, Broadcasting House, London, W.1, within seven days of the appearance of this advertisement. [4093]

**B**RASIL.—Telephone plant superintendent. British company, operating in Brazil, requires a toll plant superintendent for an extensive toll network of voice and carrier frequency telephone circuits serving large and small towns in an area of 200,000 square miles. Candidates should be about 35 years of age, should have an engineering degree or equivalent, and wide telephone experience. The engagement provides for 3 years of service with 4 months of leave, and will be permanent for a man of satisfactory ability. The position is of an executive character with good salary. Suitable candidates only should write, giving personal particulars and full details of education and experience, to Box W.W.409, at 191, Gresham House, E.C.2. [4038]

**B**.B.C. invites applications for a post in the Television Section of the Research Department at Kingsford, Surrey. Applicants must possess a university degree in physics or electrical engineering or equivalent qualifications (e.g., A.M.I.E.E.) and should be acquainted with the basic principles of telecommunications. A knowledge of optics and colour as applied to television would be of considerable advantage; the work will include research on problems contributing to the general appraisal of television systems, both monochrome and colour; ample scope will be afforded for the exercise of initiative; the salary is in a grade with annual increments of £30 and a maximum salary of £650 per annum. Applications, stating age, qualifications, details of past and present employment, should reach the Engineering Establishment Officer, Broadcasting House, London, W.1, within 7 days of the appearance of this advertisement. [4075]



★ Use **DENCO MAXI Q" COILS**—High "Q" with miniature size. There is one for all wavebands from 3.6 to 2,000 metres. Wound with Litz on Polystyrene. Formers with adjustable Iron Dust Cores—Aerial, H.F., or Oscillator types available, 465 K/C or 1.6 m.c., wiring diagram included.

Prices—Chassis Mtr., 3/9 (with React., 4/9), or Pin Base type, 6s Octal Valve Holder, 4/- (with React. 5/-). **DENCO Famous Turret Tuning Units**—Renowned for **EFFICIENCY and RELIABILITY**. **TYPE C.T.6**, Completely assembled, designed for Superhet using Triode Hexode or similar Mixer on 465 K/C's, and covers 5 WAVEBANDS—  
10—50 Metres. 200—550 Metres.  
25—75 .. 750—2,000 ..  
75—200 .. and GRAM position.

Use of Polystyrene Insulation, Plated Contacts and High "Q" Coils, with adjustable Iron Dust Cores and Close Tolerance Condensers, ensures very high performance.

Price 24/19/6 (plus 21 3 P.T.) Includes 2-Gang Cond., Trimmers, Paddlers, etc. Has attractive Glass Dial, 8in. x 6 1/2in., with five clear vertical scales, showing Station Names and S/Motion Cord Drive Tuning. Circuit and full instructions included.

**TYPE C.T.7**, Similar in appearance and construction as C.T.6, having same Dial and Calibration, but has important addition of an R.F. Stage, Flywheel Tuning and a Double Pole Switch which isolates Radio Circuits when switched to GRAM and vice versa.

Price 27/2/6 (plus 30 6 P.T.)

Includes circuits and detailed instructions. **Television Components**. Efficiently Screened Line Output Transf., 27/-, Scanning Coil, Assembly for 9in. and 12in. Tubes, 30/-. Focus Coil, Thumb Screw Adjustment, suit Electronic circuit, 25/-. Line Time Base Blocking Oscillator Unit, 25/-.  
**I.F. Transf.**, Litz Wound, Perm. Tuned, gives variation of  $\pm 5\%$  by adjustment of Core available for 465 K/C, 1.6, 3.5 or 10 M/c, size 1 1/2in. sq. x 3in. Price 16 6 pr. (Also miniature type available, 1/2in. sq. x 2 1/2in., 18 - pr.)

Price 27/2/6 (plus 30 6 P.T.) Includes circuits and detailed instructions.

**The New DENCO 1949 COMPLETE KIT OF PARTS** to build 4 Valve (plus Rect.) **MIDGET AC DC SUPERHET** covering Long and Medium Waves, and using the new highly efficient **MULLARD TYPE B.S.A. MIDGET VALVES**. Easy to follow building instructions supplied. Price 26/17 6 (plus 29 5 P.T.)

**T.R.F. Coils**, Matched pair for Long and Medium Waves, includes circuit, 6 6 pr.

**DENCO Chassis Cutters**, Adjustable between 1/2in. and 2 1/2in. dia., used with Hand Brace 7 8.

**Aluminium Chassis**, Strongly made of bright alloy with four sides: 7in x 4in. x 2in., 3 6; 9in x 5in. x 2 1/2in., 4 3; 10in x 6in. x 2 1/2in., 5 -; 10in x 8 x 2 1/2in., 5 6; 12in x 9in. x 2 1/2in., 6 8; 14in x 9in. x 2 1/2in., 6 11; 16in x 8in. x 2 1/2in., 7 8.

Other available **Denco Products**, including details of the very successful **DENCO Television Home Constructors' Kit of Parts**, are listed in a most comprehensive and detailed Catalogue. Price 9d. **EXPORT and TRADE ENQUIRIES INVITED.**

**DENCO DISTRIBUTORS LTD.**

115 FLEET STREET, E.C.4.

Telephone: CENTral 5814 and 2280.

## INDUSTRIAL FINISHING CRACKLE

STOVE ENAMEL · ALL COLOURS

Stoving ovens and spray service at your disposal. Prompt return after final inspection. Chassis, Panels, Cabinets, Photographic Equipment, etc. Black 1/-. Colours 1/3 per sq. ft. (Flat surfaces, one side). Carriage extra. Special quantity quotations. We make anything in metal to your requirements.

Full particulars on request.

**Bucleuch Radio Manufacturers**

6 Wheatfield St., Edinburgh, 11

Grams: "Therm" Telephone 64596



**THIS Does these**



**ACCURATELY and QUICKLY**  
Chassis, Brackets, Shrouds  
Condensers and Transformer  
Clips, in Steel or Aluminium.  
(Five sizes—12" to 36")  
Trepanner available  
"SNAP"  
In response to many requests,  
we have developed a Cutting Attachment  
which: Fits any model and  
● Shears up to about 8"  
● Notches Trans. Clamp channels.  
● Cuts corners of Chassis blanks.  
● Cleanly and without distortion.

Details with pleasure  
Please quote File No. or Serial No. of your tool if possible.

**A. A. TOOLS (W),** 197A, Whiteacre Road,  
ASHTON-U-LYNE

**U.S. ARMY SIGNAL CORPS RECEIVER**

Type BC-996-A. 14-valve super job covering 2 to 20 Mc/in five overlapping bands. (Can be modified for other coverage, full circuits and component values attached.) With double-beam OSCILLOSCOPE type BC-991-A. 10 valves, 3 1/2 in. tube (two traces, for Adcock DF, can be converted to other scope user.) With CONTROL UNIT, Power Supply and Monitor Speaker, type PN-21-A. All three Units are standard rack size, mounted on sliding runners in steel console cabinet with front cover, 19 1/2 in. by 16 1/2 in. by 28 1/2 in. high. Excellent working order and condition, ready to use on A.C. or on a 6-volt and a 12-volt batt. Staggering value at £42/10/-, carr. paid. Immediate despatch. Few only.

**WIRELESS SUPPLIES UNLIMITED**  
264-266, Old Christchurch Road  
BOURNEMOUTH, Hants.

★

**'Radiospares'**  
**Quality Parts**

The  
**Service Engineer's**  
**First Choice**

★

**HIGH VOLTAGES ARE OUR BUSINESS**

If you want the best in Transformers for Television, Photo-Flash, Neon Lighting, etc., why not consult us?

**MILLETT & HOLDEN LTD.**  
BIRCHAM WORKS, BIRCHAM ROAD,  
SOUTHEND-ON-SEA, ESSEX  
Phone: Southend 68409

**G**EOPHYSICAL Observer required by large industrial concern operating in the Middle East: applicants must have City and Guilds Radio D.P.o.m.a or service training equivalent and have had experience in Radio and/or Radar Equipment Maintenance; Secondary School education; age not over 28; attractive salary plus (when serving in Middle East) generous allowance in local currency, free passages out and home, free medical attention, kit allowance, good leave arrangements, pension scheme.—Write, stating age and full details of qualifications, quoting Department F.106, to Box 2266 at 191, Gresham House, E.C.2.

**B**.B.C. invites applications for the post of designs engineer in the Television Transmission Section of Design Department based in London. The appointment is in a grade rising by annual increments of £30 to a maximum of £680 per annum. Applicants should possess a University degree in Electrical Engineering or an equivalent qualification. A sound knowledge of transmission theory and experience in electronic circuit work is essential, while experience of television circuits is most desirable. Aptitude for designing apparatus and circuits used in television will be the deciding qualification. Applications, stating age, qualifications, details of past and present employment, should reach the Engineering Establishment Officer, Broadcasting House, London, W.1, within seven days of the appearance of this advertisement.

**SITUATIONS WANTED**  
LONDON area: technical assistant, 37, seeks post office or works, experienced order, correspondence and accounts, sales, purchasing, departmental management and liaison, calibration, test, service, etc.; City and Guilds, conscientious, adaptable; salary £500 or satisfactory prospects.—Box 7969. [4031]

**B**USINESS OPPORTUNITIES  
REPUTABLE electrical wholesaler distributors and exporters well represented throughout the U.K. and overseas require additional attractive lines.—Write in confidence to Box 7366.

**T**ECHNICAL TRAINING  
A.M.I.E.E., City and Guilds, etc., on "No Pass—No Fee" terms; over 95% successes; for full details of modern courses in all branches of electrical technology send for our 112-page handbook, free and post free.—B.I.E.T. (Dept. 382A), 17, Stratford Place, London, W.1. [6270]

**T**RANSLATIONS  
TECHNICAL translations by qualified science specialists solely in training in television; able rates.—Box 5498. [3342]

**T**UITION  
THE British National Radio School

**O**FFERS you a career.  
WRITE to-day for free booklet describing our wide range of training courses in radio Radar, telecommunications, principles, mathematics, physics and mechanics, correspondence and day classes for the new series of C. & G. examinations; we specialise in turning "operator" into "engineers," and for this purpose our "Four Year Plan" (leading to A.M.I.E.E. and A.M.Brit.I.R.E.E., with 9 C. & G. Certificates as interim rewards) is unsurpassed; our "graduate" has no waiting attached.—Studies Director B.Sc. A.M.I.E.E., M.Brit.I.R.E.E., 66, Addiscombe Rd., Croydon Surrey [6811]

**T**HROUGH POLYTECHNIC, Borough Rd., [6811]  
A SPECIAL course of twenty-six lectures in Television (including principles of television design) will be held at this Polytechnic during the session 1949/50, beginning on Friday, 30th September 1949 at 7 p.m.; the lecturer will be Mr. H. G. M. Spratt, B.Sc., M.I.E.E. THIS course of lectures is particularly intended for holders of Higher National Certificates or for graduates in Electrical Engineering. THE course fee is £1/1/6; students should attend on the first evening of the course for enrolment.  
SECRETARY, Borough Polytechnic. [4095]

**W**IRELESS officer's attendance and postal courses.—Wireless Sch., Manor Gdns., N.7.  
**R**ADIO training.—P.M.G. exams, and I.P.E. Diploma; prospectus free.—Technical College Hull. [0611]

**W**IRELESS (sea and air) television broadcasting, radar, and other tremendous opportunities; students both sexes, age 14 upwards; trained for appointments in all branches of radio; low fees, boarders accepted; 2d stamp for pros.—Wireless College, Colwyn Bay. [3960]

**A**.M.I.Mech.E., A.M.I.E.E., City and Guilds, etc., on "No Pass—No Fee" terms, over 95% successes; for details of exams, and courses in all branches of engineering, building, etc., write for 105-page handbook—free.—B.I.E.T. (Dept. 287B), 17, Stratford Place, London W.1.

**T**ELEVISION postal course for radio trade Examination Board's diploma, also postal courses for P.M.G. 2nd and 1st class Certificates and Amateur Radio Transmitting licence.—Apply British School of Telegraphy, Ltd., 179, Clapham Rd., London, S.W.9. (40 years' experience in coaching students in wireless telegraphy and allied subjects.) [2586]

**"ADCOLA" SOLDERING INSTRUMENTS**  
Pat. Trade Mark.



**Designed for Wireless Assembly and Maintenance.**  
Working temperature reached in 1 1/2 m.n.s., consumption 25 watts weight 2 1/2 ozs. Supplied in voltage ranges from 6/7v. to 230/250v. 1/8" diam. Copper Bit (standard model) 22/6. 1/4" diam. Copper Bit 25/-.  
Replacement Unit Bit Elements available. British and Foreign patents  
Sole Manufacturers:  
**ADCOLA PRODUCTS LIMITED**  
Alliance House, Caxton Street, London, S.W.1  
Write or Phone: WHL 0030.

**ELECTRONICS**  
**DUPELEY LTD.**  
CRANMER AV. EALING W 13.

Transformer and Coil Manufacturers to the Trade  
Telephone: EALINE 5888

**COPPER WIRE ENAMELLED, SILK, D.C.C., etc., most sizes, INSULATING MATERIALS, Empire cloth, leatheroid, paxolin, sleeving, etc. MOTORS A.C. & D.C. up to 1 h.p. a speciality**  
Send S.A.E. for list to  
**STAN. HOLT,**  
349, HIGH ST. SMETHWICK, STAFFS.  
Telephone: WOODGATE 3789

**YOU SHOULD HAVE A NEW TAYLOR**  
★ ★ ★ ★ ★ ★ ★ ★ ★ ★

We can supply the latest Taylor Test-Equipment, and take your used Equipment in part exchange. Balance by cash or hire purchase.  
**Write, phone or send your gear along for inspection and offer.**  
★ ★ ★ ★ ★ ★ ★ ★ ★ ★

**UNIVERSITY RADIO LTD.**  
22 LISLE ST. Tol. GERRARD 4447 & 582

**ENGINEERS!**  
Whatever your age or experience, you must read "ENGINEERING OPPORTUNITIES". Full details of the easiest way to pass A.M.I.Mech.E., A.M.I.E.E., A.M.I.C.E., CITY & GUILDS, MATRIC, etc., on "NO PASS—NO FEE" terms and details of Courses in all branches of Engineering—Mechanical, Electrical, Civil, Auto., Aero., Radio, etc., Building, etc. If you're earning less than £10 a week, tell us what interests you and write for your copy of "ENGINEERING OPPORTUNITIES" today—FREE!  
**B.I.E.T.**  
387, Shakespeare Hoe., 17-19, Stratford Place, London, W.1.  
BRITISH INSTITUTE OF ENGINEERING TECHNOLOGY

**176 PAGES Free!**



G.  R

By Order of the Minister of Supply.  
WIVENHOE, ESSEX.

SALE BY AUCTION, without Reserve, on  
28th & 29th SEPTEMBER,  
at 11 a.m. each day.

Valuable Government Surplus  
STORES and EQUIPMENT

comprising:— Engineering and Electrical  
Plant and Equipment including Cranes, Fork-  
lift Trucks, Dumpers, Air Compressors, Pump-  
ing Units, Road Breakers, Drilling Machines,  
Air Extractors, Machine Jigs and Tools,  
Transformers, Generators, Hoisting Blocks,  
Winches, Chain-sawing Machines, Electric  
Cable, Copper Wire, etc.

30 TONS UNUSED RADIO COMPONENTS  
including "Micropack", trimming, and variable  
condensers, L.F. and mains transformers, L.F.  
chokes, coils, 12 and 24-volt vibrators,  
magnetic relays, voltmeters, ammeters, potenti-  
meters, rectifiers, resistances, Westectors,  
pilot bulbs, lamp holders, various switches,  
fuses, plugs and sockets, valve holders, screen-  
ing cans and caps, Goodman 5in and  
"Hailer" loudspeakers, laminations, dust  
core, aerial masts, cable clamps, thimbles,  
etc., various screws, nuts, rivets, etc., and  
Miscellaneous Stores.

To be sold "as viewed where lying" by  
catalogue at M.O.S. Depot No. 65, Wivenhoe,  
Essex. On view September 26 and 27 from  
9.30 to 4, and on Sale Days from 9.30 to 11.

Admission by catalogue, price 6d. (P.O.'s  
only, and envelopes marked "Govt. Sale") to  
admit two persons on View Days, one person  
on Sale Days obtainable from the Auctioneers:  
C. M. Stanford & Son, 23, High-street, Col-  
chester. Telephone 3165 (3 lines).

**RADIO ENGINEERING SCHOOL.** Air Service  
Training, Hamble, Southampton, provides  
the best full-time training for responsible posi-  
tions in industry or aviation. Students coached  
for C. & G. Inter. and Final Certs. in radio-  
or tele-communications; : Graduateship of Brit.  
I.R.E., M.C.A., radio engineer licence and for  
air and marine radio officers' licences; full de-  
tails from the Commandant. [2260]

**THE Institute of Practical Radio Engineers**  
have available Home Study Courses in  
every phase of radio and television engineer-  
ing specialising in the practical training of  
apprentices in the retail trade; enrolments  
limited; fees moderate.—The Syllabus of In-  
structional Text may be obtained post free from  
the Secretary, I.P.R.E., Fairfield House, 20  
Fairfield Rd. Crouch End London N 8 11614

**LEARNMORE.**—Write for free booklet show-  
ing how you can be trained for a variety of  
well-paid technical careers: both postal and at-  
tendance courses are available covering such  
subjects as Television, Elementary and Advanced  
Radio Theory and Practice, Mathematics, Elec-  
tronics in Industry, etc.—Free booklet from  
E.M.I. Institutes, Dept. W.W., 43, Grove Park  
Rd., Chiswick, London, W.4. Tel. Chiswick  
4417-8. [0001]

**TELEVISION.**—The Gothic Television School  
specialists solely in training in television.  
All tutors possess university degrees and/or  
corporate membership of professional institu-  
tions and are appointed individually to postal  
course students to ensure complete and thorough  
training. Principals, M.B.E., B.Sc., M.Brit  
I.R.E., education committee members, etc.  
Courses assume no previous television knowledge  
and provide guaranteed training for Brit.I.R.E.  
and R.T.E.B. examinations. Numerous well-  
known companies have adopted the School's  
Basic Television Course as standard television  
training for their staffs. Moderate fees. Details  
from Gothic Television School, 13, North Avenue,  
London, W.13. [3639]

**HOME Constructors' Handbook**, the latest  
edition of this famous handbook contain-  
ing circuits, radio constructional and servicing  
hints and complete catalogue, is now available at  
only 1/-; mail order only.  
SUPACOILS, 98 Greenway Ave., London, E.17.

**WEBB'S 1948 radio map** of world, new multi-  
colour printing, with up-to-date call signs  
and fresh information on heavy art paper, 4/6,  
post 6d; on linen on rollers, 11/6, post 9/-  
Webb's Radio, 1-4, Soho St., W.1. Gerrard 2089.

G.  R.

**ADMIRALTY STORAGE DEPOT.**  
RISLEY, near WARRINGTON.  
**MESSRS. OUTHWAITE AND LITHER-**  
LAND, F.A.I., will Sell by Auction on  
WEDNESDAY & THURSDAY,  
7th & 8th SEPTEMBER, 1949,  
Commencing at 11 a.m. on the above  
premises

Vast Quantity of  
**RADIO AND ELECTRICAL EQUIPMENT**  
Transformers, Motor Alternators, Aerial  
Units, Potentiometers, Plugs, Sockets, Resis-  
tors, Condensers, Chokes, Connections,  
Panels, Insulators, Control Units, Ammeters,  
Receivers, Fuse Boxes, Clamps, Rotary Con-  
verter Units, Voltmeters, Accumulators,  
Suppressors, Box Junctions, Switches, Blower  
Units, Battery Chargers, Automatic Starters,  
Relays, Voltage Dividers, Filter Units,  
Vibrator Units, Rectifiers, Switch Fuse  
Units, Motor Generators, Radio Spares,  
Packard Bell, pre-Amplifiers, Paint and  
Varnish, Loofoahs, Megaphones, Hand Bulls,  
Resin.

**TWO MOBILE GENERATING SETS.**  
100v. 18k.w., 500 Eversheds and Vignales  
"Wee" Meggers, Heater Elements, Life  
Jackets, Box Kits, Oscillators, Canvas Awning,  
Caustic Soda, Nitrate of Soda, Indicator  
Units, Linoleum Dressing, Transmission Lines,  
Lead Wool, Performance Meters.

**450 PHOTOGRAPHIC CAMERAS**  
and Accessories  
Persapex Plates, Developing Tanks, Graticules,  
Spools, Scales, Lenses, Dark Lamps, Tripods,  
Enlargers.

**LARGE QUANTITIES DEVELOPING**  
**PAPER, PLATES AND FILMS.** Camera  
Cases, Developing Dishes, Funnels, Filters,  
Developing and other Chemicals.  
Goods may be viewed Monday and Tuesday,  
5 and 6 September, from 10 a.m. to 4 p.m.  
each day.

Admission by catalogue only (6d each).  
Admits two persons on view days and one  
person on sale days, obtainable from the  
Auctioneers' Offices, 'Kingsway' Galleries,  
Fountain-street, Liverpool, 3. Telephone  
Central 6561-23.



**ELECTRICAL & ELECTRONIC DEVELOPMENT LTD**

We have specialised from the outset in the construction of **THE WILLIAMSON AMPLIFIER** and of associated high fidelity equipment developed for use therewith. Current prices are as follows:—

The Williamson Amplifier.....	£26 10 0
The Junior Williamson Amplifier .....	£21 10 0
Radio Tuning Unit.....	£15 15 0
Pick-up Ptc. Amplifier Unit.....	£9 10 0
Super Tone Control Stage Unit.....	£8 10 0
Distortionless Contrast Expansion Unit.....	£16 10 0
Heavy duty Loudspeaker Crossover Unit.....	£5 5 0

Full particulars of the above and other productions on application.  
Demonstrations at the works daily.  
**HUBERT STREET, ASTON, BIRMINGHAM, 6**  
Telephone: Aston Cross 2440

**WILCO ELECTRONICS**

**204, LOWER ADDISCOTE RD., CROYDON.**

**RECEIVERS, 2 METRE BAND.** BC824A, easily converted for other ham bands. Brand new ex-U.S.A., 11 valves include, 9002, 9003, etc. Don't miss these. Bargain price 39/6, carr. 5/-.

**TELEVISION UNIT.** 2 RF Det. 1 Video stage. EF50s, EA50, iron cored coils, make good sound channel. Brand new. Band, 45/- only.

**P.P.I. UNIT.** Ex-U.S. Navy, including 40 valves, following types. 13 6SN70T.8 6A70 2 6L6, 6 6L6G, 3 VR150, 1 2X2, 3 6Y4G, 2 6X5G, 2 6R5, 2 C.R. tubes. power pack, meters, motor blower, etc., in black crackle case. Brand new. Only £16/10/-.

**METERS.** 5 kV Electrostatic, 3in. flush, 90/- 20 microamp 2 1/2in. flush, 57/6 0-200 v. A.C. 2 1/2in. flush, 17/6. M/I 0-1 m/amp M/C 2in. flush, 10/6. 0-200 M/amp M/C 2 1/2in. flush, 15/-.

**METAL RECTIFIERS.** 230 v 60 m/a. 1 wave, 3/- each.

**SLOW MOTION DIAL.** 200-1 reduction or direct 6in diam. Scaled 0-100, front of panel mounting, 5/6.

**P.M. M/C SPEAKERS.** 8in. with trans. in wall case, Tannoy, 21/-.

**CRYSTAL MULTIPLETERS.** 2-6.87 Mc/s in 3 switched steps, 867 valve. Brand new, boxed, with extra 807 instruction book, etc., 55/-.

**TRANSFORMERS AND CHOKES.** Large stocks all types, state your requirements. Send 4d. stamps for Monster List.

**ALL POST ORDERS TO:**  
**19, LANSDOWNE RD., CROYDON.**

**YOUR METER DAMAGED ?**



**LET GLASER REPAIR IT**

Leading Electrical Instrument Repairers to the Industry.

Repairs by skilled craftsmen to all makes and types of Voltmeters, Ammeters, Microammeters, Multirange Test meters, Electrical Thermometers, Recording Instruments, Synchronous Clocks, etc. 14 days' service—for speed estimate send defective instrument by registered post!

**L. GLASER**  
SCIENTIFIC & ELECTRICAL INSTRUMENT REPAIRERS  
341 CITY ROAD, E.C.1.  
Tel. Terminus 2489

**A "SOUND" PROPOSITION**

**Amplifier Chassis.**  
For the amplification of Radio, Voice or Records, 41 watts clear output. Fitted with Volume and Tone controls, etc. Complete with valves and speaker. £8 10/-

**Radio Chassis.**  
A.C. mains, 5 valve, 3 waveband superhet. Large attractive glass dial, calibrated and station named. Volume and Tone controls, etc. Complete with valves and speaker. £9/15/- inc. tax.

**Radio gram chassis.**  
A fortunate purchase of certain components by Messrs. Associated Electronics enables us to offer their famous 3 waveband chassis, including valves and speaker, at the very reduced figure of £11/13/6, incl. tax.

**Microphones.**  
Moving Coil unit, finished in heavy Chromium, complete with Chromium folding stand. Limited supplies available at 5 gns.  
New lists now ready. 1d. stamp please  
**RADIO UNLIMITED**  
ELM ROAD, LONDON, E.17.

**MUMETAL and RADIOMETAL TRANSFORMERS and CHOKES**

As Specialists with many years of experience we can design and supply practically any type of transformer or choke with a nickel iron core for use on a band within the frequency range

**1 c/s to 150 kc/s**

Available for rapid delivery—Microphone Transformers, Input Transformers, Line Transformers, Pickup Transformers, Output Transformers, Rectifier Transformers, Vibrator Transformers, High Fidelity Transformers, Recorder Transformers, Midset Transformers, High Q Chokes, High Inductance Chokes, etc., with or without Mumetal Shields.

**MAINS COMPONENTS ARE ALSO STOCKED.**

**SOWTER TRANSFORMERS**  
E. A. SOWTER, 1-B HEAD STREET, COLCHESTER.  
Phone: COLCHESTER 6459.



INDEX TO ADVERTISERS

PAGE	PAGE	PAGE	
A.A. Tools	78	Frith Radiocraft, Ltd.	62
Acru Electric Tool Mig Co., Ltd.	20	Furzehill Laboratories Ltd.	37
Ad. Aurlima Inc.	20	Galpins	69
Adcoia Products, Ltd.	78	Gardners Radio, Ltd.	48
Advance Components, Ltd.	20	General Electric Co., Ltd.	13, 39
Aerialite, Ltd.	40	General Lamination Products, Ltd.	10
Airmec Laboratories, Ltd.	2	G.aser, L.	79
Albert Mig. Co.	64	Goodmans Industries, Ltd.	35
Allan, Richard, Radio, Ltd.	24	Goodsell, Ltd.	61
Allen Components, Ltd.	73	Gray, A., Ltd.	34
Alpha Accessories, Ltd.	59	Hartley, H. A., Co., Ltd.	64
Antiference, Ltd.	Edit. 351	Haynes Radio, Ltd.	76
Armstrong Wireless & Television Co., Ltd.	65	Hely-Mann Electronics Laboratories	70
Ashworth H.	40	Henry's, W. T., Telegraph Works Co., Ltd.	72
Auction Notices	79	Henry's	72
Automatic Coil Winder & Electrical Equip. Co., Ltd.	1	Hill & Churchill, Ltd.	74
A.W.F. Radio Products, Ltd.	68	Holborow & Co.	74
B. & H. Radio	76	Holden Ferrule Co., Ltd.	76
Bakers' Selhurst Radio	52	Holley's Radio Stores	77
Barker, A. C.	8	Holt, Stan	78
Belling & Lee, Ltd.	47	Houghton & Osborne	68
Berrys (Short Wave), Ltd.	72	H. P. Radio Services, Ltd.	52
Bird, S. S., & Sons, Ltd.	79	Imhof, A., Ltd.	Edit. 357
Birmingham Sound Reproducers, Ltd.	42	International Correspondence School, Ltd.	32
Brierley J. H. (Gramophones & Recordings), Ltd.	21	Jackson Bros. (London), Ltd.	24
Brighton Tele-Services	72	Kerry's (Gt. Britain), Ltd.	26
Britain, Chas. (Radio), Ltd.	61	Kershaw, S.	62
British Institute of Engineering Technology	66, 78	Labgear, Ltd.	31
British Insulated Callender's Cables, Ltd.	Cover II	Lasky's Radio	71
British National Radio School	75	Lawrence, G., & Co.	56
British N.S.F. Co., Ltd.	12	Leak, H. J., & Co., Ltd.	Cover II
British Physical Laboratories	22	Lockwood & Co.	74
Brown, S. G., Ltd.	58	London Central Radio Stores	20
Bueclench Radio Manufacturers	77	London Radio Supply Co.	71
Bulgin, A. F., & Co., Ltd.	Edit. 359	London Television Co., Ltd., The	62
Bullers, Ltd.	6	Lowther Mig. Co.	64
Burgovne Eng. Co., Ltd.	36	Lustraphone, Ltd.	60
Cabot Radio Co., Ltd.	54	Lyons, Claude, Ltd.	77
Candler System Co.	71	Lyncar Laboratories	76
Charles Amplifiers, Ltd.	31	Mail Order Supply Co.	75
Chloride Electrical Storage Co., Ltd.	16	Marconi Instruments, Ltd.	14
C. J. R. Elec. and Electronic Development, Ltd.	79	McMurdo Instrument Co., Ltd.	22
Cinema-Television, Ltd.	7	Measuring Instruments (Pullin), Ltd.	28
Clydesdale Supply Co., Ltd.	53	Metro Pex, Ltd.	4
Cohen, D.	56	Midland Instrument Co.	68
Colliaro, Ltd.	55	Millett & Holden, Ltd.	8
Cole, E. K., Ltd.	21	Mudern Book Co.	66
Cosmocoord, Ltd.	46	M.R. Supplies, Ltd.	18
Couplphone Radio	57	M.S.S. Recording Co., Ltd.	37
Courtesy Radio	72	Mullard Electronic Products, Ltd.	36, 44
Davis, Alec, Supplies, Ltd.	55	Multicore Solders, Ltd.	Cover IV
Denco Distributors, Ltd.	77	Nagard, Ltd.	16
Desoutter Bros., Ltd.	18	Northern Polytechnic, The	72
Donohoe, J.	72	Oliver Pell Control, Ltd.	14
Drayton Regulator & Instrument Co., Ltd.	33	Oxley Development Co., Ltd.	79
Dupley Electronics, Ltd.	78	Painton & Co., Ltd.	6, 41
Edison Swan Electric Co., Ltd.	3, 27	Park Radio Co.	2
Electradix Radios	67	Parker Radio Corp., Ltd.	26
Electric & Musical Industries, Ltd.	22, 62	Parmerco, Ltd.	12
Electro Acoustic Developments	60	Partridge Transformers, Ltd.	63
Electro Technical Assemblies	70	Pearce, T. W.	66
Electronic Instruments, Ltd.	51	Fennin Amplifiers	68
Electronic Precision Equipment	23	Phillips Electrical, Ltd.	48
Electrosound Supplies Co.	32	Pifco, Ltd.	18
Eta Tool Co. (Leicester), Ltd.	40	Pike Bros.	76
Filmer, J. T.	74	Pill, G. N., & Partners	76
Fitton, R. N., Ltd. (Ambassador Radio)	35	Pitman, Sir Isaac, & Sons, Ltd.	70
Fluxite, Ltd.	Edit. 355	Post Radio Supplies	76
		Premier Radio Co.	15, 29
		Quartz Crystal Co., Ltd.	74
		Radio Exchange Co.	70
		Radio Unit	79
		Radomart (B'ham), Ltd.	30
		Radiomenders, Ltd.	62
		Radiospares, Ltd.	78
		Radiovision (Leicester), Ltd.	56
		Redion, Ltd.	10
		Reliance Mig. Co. (Southward), Ltd.	60
		Reproducers & Amplifiers, Ltd.	57
		Rimington van Wyck, Ltd.	52
		Ritherdon & Co., Ltd.	16
		Roding Laboratories	75
		Rogers Developments Co.	14
		Rollett, H., & Co., Ltd.	76
		Salford Electrical Instruments, Ltd.	76
		Sangamo Weston, Ltd.	41
		Scharf, Erwin	59
		Simmonds Aeroaccessories, Ltd.	33
		Simon Sound Service	50
		Smith, G. W. (Radio), Ltd.	62
		Smith, W. H., & Son, Ltd.	73
		Sound Rentals, Ltd.	54
		Sound Sales, Ltd.	5
		Southern Radio Supply, Ltd.	68
		Sower Transformers	79
		Stability Rad. Components, Ltd.	38
		Standard Telephones & Cables, Ltd.	36, 45, 51
		Stearite & Porcelain Products, Ltd.	71
		Stewart Radio, Ltd.	71
		Stewart Transformers, Ltd.	18
		Stratton & Co., Ltd.	25
		Sugden, A. R., & Co. (Engineers), Ltd.	58
		Supacolls	58
		Szymanski S.	60
		Taylor Electrical Instruments, Ltd.	10
		Telegaph Condenser Co., Ltd.	11
		Telegraph Construction & Maintenance Co., Ltd., The	26
		Telegradio Co.	66
		Tele-Radio (1943), Ltd.	56
		Thermionic Products, Ltd.	9
		Thompson, W. & J. R. (Woodturners), Ltd.	12
		Toute La Radio	58
		Transradio, Ltd.	50
		Trix Electrical Co., Ltd.	Edit. 353
		United Insulator Co., Ltd.	28
		Universal Electrical Instruments Corp.	58
		University Radio, Ltd.	31, 78
		Vallance & Davison, Ltd.	64
		Valradio	56
		Victoria Instruments	30
		Voigt Patents, Ltd.	35
		Vortexion, Ltd.	49
		Watts, M., & Co.	72
		Wayne Kerr Labs., Ltd., The	53
		Wells, A., & Co., Ltd.	38
		Westinghouse Brake & Signal Co., Ltd.	8
		West, Soener	74
		Weston Products (L'pool), Ltd.	60
		Weymouth Radio Mig. Co., Ltd., The	8
		Wharfada's Wireless Works	28
		Whiteley Electrical Radio Co., Ltd.	39
		Wilco Electronics	79
		Wilkins & Wright, Ltd.	20
		Wireless Supplies Unitd.	78
		Wo'sey Television, Ltd.	30
		Wright & Weaire, Ltd.	43

**"TECHNICAL EXCELLENCE"**

—combines with beauty and soundness of DESIGN in the

**OXLEY**

**AIR DIELECTRIC TRIMMER**

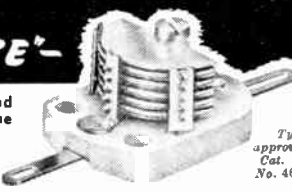

Typ. approved Cat. A No. 464

Width: 13.5 mm. Length: 22 mm. Height: 1.5 to 8pF—7.5 mm. 1.8 to 20pF—10 mm. 2 to 26pF—11 mm. 2 to 32pF—12 mm. Law: Straight line capacity. Power Factor: Less than .001. Insulation: Over 2,000 megohms. Voltage: E00 D C.

**OXLEY DEVELOPMENTS CO. LTD.**  
ULVERSTON, NORTH LANCs. TEL.: ULVERSTON 3304

**"Cyldon"**

**MICA-DIELECTRIC TRIMMER CAPACITORS**



Type No. 19

1 1/2" long, 1/2" wide, 1/2" high.

**SYDNEY S. BIRD & Sons, Ltd.**  
CAMBRIDGE ARTERIAL RD., ENFIELD, MIDDLESEX  
Phone: Enfield 2071-2 "Grams: "Capacity, Enfield"

Printed in Great Britain for the Publishers, ILIFFE AND SONS LTD., Dorset House, Stamford Street, London, S.E.1, by THE CORNWALL PRESS LTD., Paris Garden, Stamford Street, London, S.E.1. "Wireless World" can be obtained abroad from the following—AUSTRALIA AND NEW ZEALAND: Gordon & Gotch, Ltd. INDIA: A. H. Wheeler & Co. S. AFRICA: Imperial News Co.; Gordon & Gotch, Ltd. SOUTH AFRICA: Central News Agency, Ltd. WILLIAM DWOSK & SONS (S.A.), Ltd. UNITED STATES: The International News Co.



**NOTICE**

"POINT ONE" is the Trade Mark of H. J. Leak & Co., Ltd. It was originally applied to the first power amplifiers having a total distortion as low as point one of one per cent, when in June, 1945, H. J. Leak, M. Brit. I.R.E., revolutionised the performance standards for audio amplifiers by designing the original "POINT ONE" series.

**NEW**  
**LEAK**  
**"POINT ONE"**  
**AMPLIFIERS**

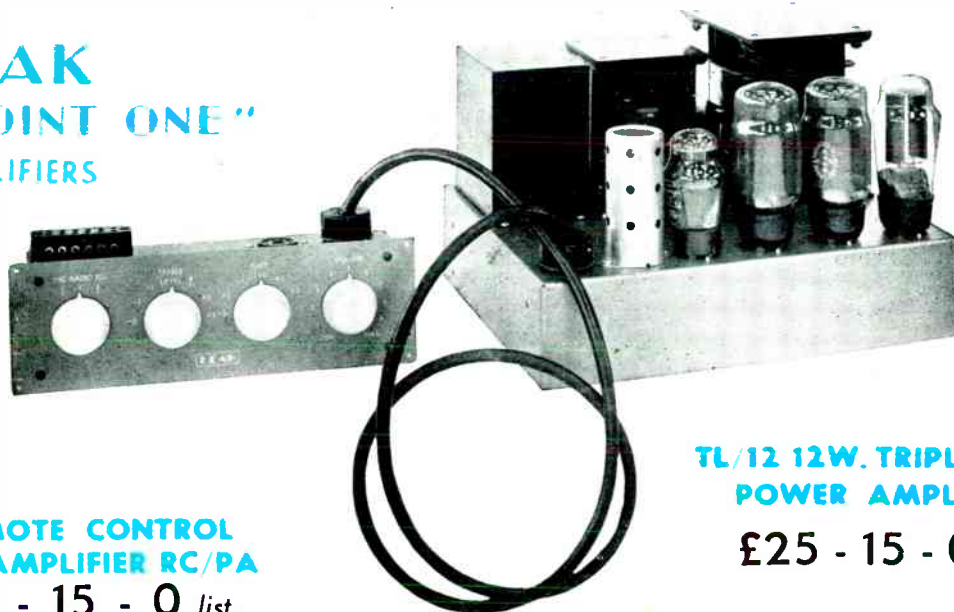

**REMOTE CONTROL**  
**PRE-AMPLIFIER RC/PA**  
**£6 - 15 - 0 list.**

An original feedback tone-control circuit which will become a standard.

No resonant circuits employed.

- Distortion: Less than 0.05%.
- Switching for Pick-up, Microphone and Radio, with automatic alteration of tone-control characteristics.
- High sensitivities. Will operate from any moving-coil, moving iron or crystal P.-U.; from any moving-coil microphone; from any radio unit.
- Controls: Input Selector; Bass Gain and Loss; Treble Gain and Loss; Volume.

Output Impedance: 0-30,000Ω at 20 kc.p.s.

The unit will mount on motor-board through a cut-out of 10 $\frac{1}{2}$ in.  $\times$  3 $\frac{1}{2}$ in., or it can be bolted to the power amplifier, when, with a top cover, the whole assembly becomes portable.

For use only with LEAK amplifiers.

Used with the RC/PA pre-amplifier and the best complementary equipment the TL/12 power amplifier gives to the music-lover a quality of reproduction unsurpassed by *any* equipment at *any* price. It is designed in a form so that the power amplifier can be housed in the base of a cabinet and the small pre-amplifier mounted in a position best suited to the user

**TL/12 12W. TRIPLE LOOP**  
**POWER AMPLIFIER**

**£25 - 15 - 0 list.**

A Leak triple loop feedback circuit, the main loop giving 26 db. feedback over 3 stages and the output transformer.

- Push-pull triode output stage. 400 V. on anodes.
- No H.T. electrolytic smoothing or decoupling condensers.
- Impregnated transformers; tropically finished components.
- H.T. and L.T. supplies for pre-amp. and radio units.
- Distortion: at 1,000 c/s and 10 W. output, 0.1% ; at 60 c/s and 10 W. output, 0.10% ; at 40 c/s and 10 W. output 0.21%.
- Hum and Noise: -80 db. on 10 W.
- Frequency response:  $\pm 0.1$  db., 20 c/s-20 kc/s.
- Sensitivity: 160 mV.
- Damping Factor: 20. Input impedance: 1 MΩ
- Output impedances: 2Ω ; 7-9 Ω ; 15-20 Ω 28-36 Ω.

25 W. model available at £27.10.0.

★ If you are interested in high-fidelity reproduction or recording you are certain to find our 16-page illustrated booklet of considerable value. It is presented in a form acceptable both to the professional communications engineer and to the amateur enthusiast seeking the highest possible quality of reproduction. ★

**WRITE FOR BOOKLET W/TL/12**

**H. J. LEAK & CO. LTD. (Est. 1934)**

**BRUNEL ROAD, WESTWAY FACTORY ESTATE, ACTON, W.3**

Phone: SHEpherds Bush 5626.

Telegrams: Sinusoidal, Ealux, London.

Foreign: Sinusoidal, London.

