

Wireless World

RADIO AND ELECTRONICS



JULY 1949

2/-

Vol. LV. No. 7

IN THIS
ISSUE :

TUNABLE TELEVISION RECEIVERS

The **NAME** helps you sell
 The **B I C C**
All Wave
ANTI-INTERFERENCE
AERIAL



BICC are world famous for their electrical and radio products. The Anti-Interference Aerial maintains this reputation.

What it does It has been specially designed to alleviate interference caused by radiation from electrically-operated transport, vehicle ignition systems, electrical appliances using commutator motors, lighting systems, etc. A high signal level is obtained and this ensures better listening on all broadcast wave-lengths, giving maximum choice of programmes against a quiet background.

What it is A 60-ft. polythene-protected dipole complete with insulators and matching transformer, 80-ft. coaxial screened download with polythene plug moulded to each end, and a receiver transformer. All the necessary components for the Aerial are included in the complete kit.



Write for Publication No. 221S giving further information.

Obtainable only from recognised dealers.

£6. 18. 0

**BRITISH INSULATED CALLENDER'S CABLES LIMITED
 NORFOLK HOUSE, NORFOLK STREET, LONDON, W.C.2**

Fine Limits of Accuracy



VALVE CHARACTERISTIC METER

A comprehensive instrument built into one compact and convenient case, which will test any standard receiving or small power transmitting valve on any of its normal characteristics under conditions corresponding to any desired set of D.C. electrode voltages. A patented method enables A.C. voltages of suitable magnitude to be used throughout the Tester, thus eliminating the costly regulation problems associated with D.C. testing methods.

A specially developed polarised relay protects the instrument against misuse or incorrect adjustment. This relay also affords a high measure of protection to the valve under test. Successive settings of the Main Selector Switch enable the following to be determined:—

Complete Valve Characteristics including I_a/V_g , I_a/V_a , I_s/V_g , I_s/V_a . Amplification Factor, Anode A.C. Resistance, 4 ranges of Mutual Conductance covering mA/V figures up to 25 mA/V at bias values up to -100V., together with "Good/Bad" comparison test on coloured scale against rated figures.

"Gas" test for indicating presence and magnitude of grid current, inter-electrode insulation hot and cold directly indicated in megohms, separate cathode-to-heater insulation with valve hot. Tests Rectifying and Signal Diode Valves under reservoir load conditions, and covers all the heater voltages up to 126 volts.

The AUTOMATIC COIL WINDER & ELECTRICAL EQUIPMENT CO., LTD.
WINDER HOUSE, DOUGLAS STREET, LONDON, S.W.1. Phone: VICTORIA 3404-9

Are Precision Electrical Testing Instruments

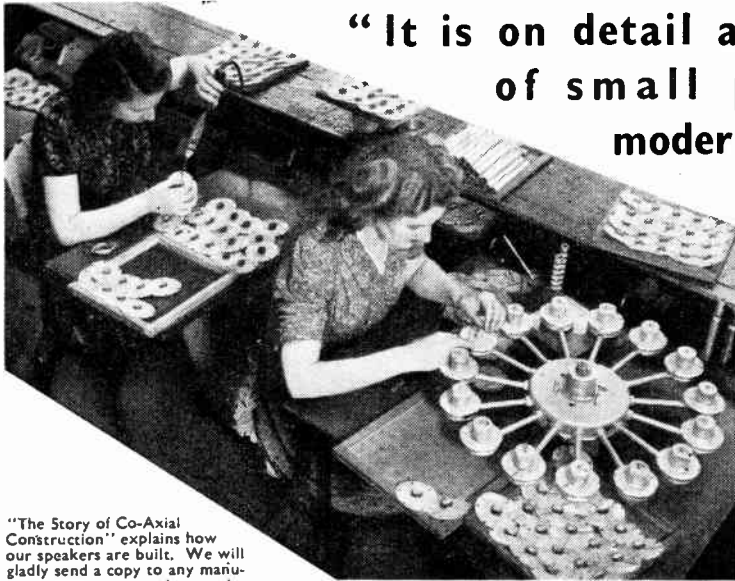

“It is on detail and care in design of small points that the modern set stands or falls”

“Radio Times,” Sept. 24, 1948

Attention to details of manufacture and assembly; revolutionary design and the provision of highly accurate specially designed jigs, ensure that in each R. & A. Reproducer the cone, voice coil centre and outer pole are inevitably and automatically aligned upon the axis of the speaker. This is why R. & A. Reproducers are free from mechanical defects. Continuous inspection at all stages is a further insurance that no defect can be present in the complete speaker.

“The Story of Co-Axial Construction” explains how our speakers are built. We will gladly send a copy to any manufacturer or overseas buyer who writes for one.

Voice coil and centering member sub-assembly.

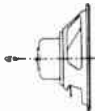

REPRODUCERS AND AMPLIFIERS LIMITED

FREDERICK ST. WOLVERHAMPTON ENGLAND
Telephone Wolverhampton 22241 Telegrams “Audio Wolverhampton”



SPRING LOADED TERMINALS

A Positive CONNECTION WITHOUT SOLDER · SIMPLY PRESS & RELEASE

PAINTON

PAINTON & CO. LTD · KINGSTHORPE · NORTHAMPTON · ENGLAND

CRYSTAL DEVICES by *Cosmocord*

CRYSTAL PICK-UPS AND CARTRIDGES



G.P. 10 with "unbreakable" crystal. Output 1.7 volts at 1,000 c/s; range 70—8,000 c/s.

G.P. 12 high fidelity model with permanent sapphire stylus. Output 1 volt at 1,000 c/s; range 30—14,000 c/s.

G.P. 15 Microcell cartridge for microgroove or standard 78 rpm recordings.

GENERAL-PURPOSE MICROPHONES



For acoustic measurements, industrial noise measurement, disc recording technique, and P.A. systems.

Type MIC 16 (illustrated)
High fidelity model with flat response from 40 to 10,000 c/s.

Type MIC 22
General purpose model with substantially flat response from 40 to 8,000 c/s.

The MAGNETIC
TYPES G.P. 6
and G.P. 7

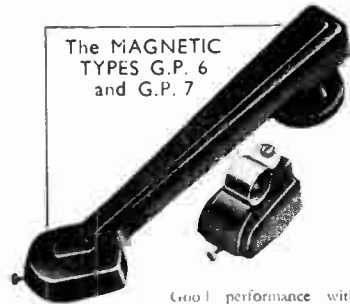

Good performance with exceptionally robust construction. Range 100—4,500 c/s.

DISC CUTTER HEADS



TYPE R.H. 1

Good performance and modest price make it ideal for amateur recordist.

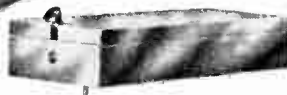

TYPE R.H. 2

High-quality cutting head for professional use.

PILLOTONE "Individual" LOUDSPEAKER

For hospital or personal use, giving quality equivalent to normal loudspeaker without disturbing others.

Sole distributors of the 'Pillotone' in the British Isles, Messrs. Philips Electrical Limited.



HEARING-AID MICROPHONES



ACOS technique ensures maximum performance with minimum practical dimensions. Seven types and sizes available. Supplied only to hearing aid manufacturers.

MINIATURE EAR-PIECES

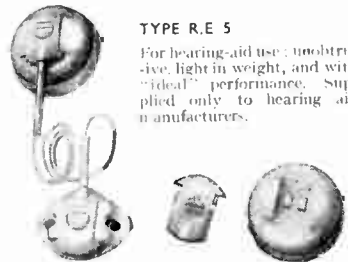

TYPE R.E. 5

For hearing-aid use: unobtrusive, light in weight, and with "ideal" performance. Supplied only to hearing aid manufacturers.



MEET US AT
RADIOLYMPIA
SEPT 28 - OCT 8

STAND No. 7 & DEMONSTRATION ROOM No. D10, where you can hear sound reproduction at its best—the ACOS way!

COSMOCORD · LTD · ENFIELD · MIDDLESEX · ENGLAND

H.T. AND E.H.T. RELIABILITY

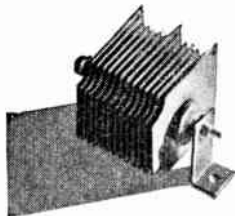

Typical rectifier for use in A.C. or A.C./D.C. receivers.



Type 36EHT rectifier. Two such units only $2\frac{1}{2}$ " long by $\frac{1}{8}$ " dia. will give an output of 5.3kV.



"Westeht" E.H.T. supply unit. 5kV output from a 350-0-350 A.C. input.

WESTINGHOUSE **WESTALITE** **RECTIFIERS**

Write for details to Dept. W.W.7.

**WESTINGHOUSE BRAKE & SIGNAL
CO. LTD.**

82, York Way, King's Cross, London, N. 1

●
Many
WESTINGHOUSE
RECTIFIERS
HAVE
OVER
21 YEARS'
SERVICE
TO THEIR
CREDIT

●

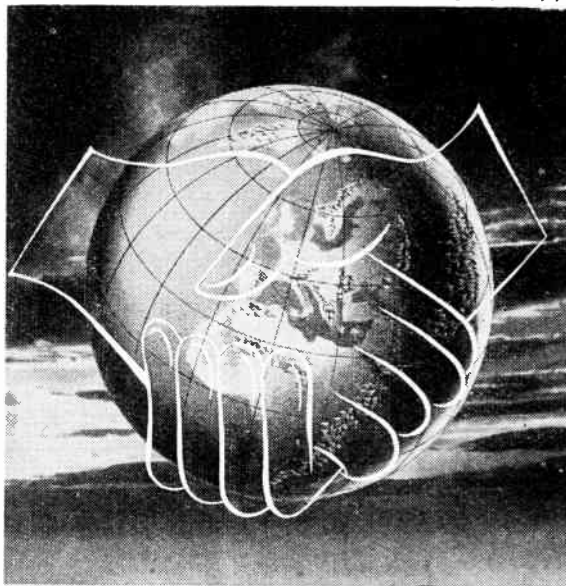

Plans for a neighbourly world

Marconi's first wireless messages did more than enable nation to speak to nation. They drew closer the world's boundaries, quickened the tempo of existence and turned distant acquaintances into next-door neighbours. Broadcasting has helped still further to increase our knowledge of our neighbours; wireless navigational aids and radar have brought greater safety and faster travel between Continents. And so Marconi's will continue to pioneer. Their engineers are busy today on developments which will make the world a closer community tomorrow.

Marconi
the greatest name in wireless

MARCONI'S WIRELESS TELEGRAPH COMPANY LTD.,
MARCONI HOUSE, CHELMSFORD, ESSEX.

DAILY DEMONSTRATIONS

of the "BARKER 148A" mounted in the "RD" BASS REFLEX CABINET in conjunction with the "RD" JUNIOR or "WILLIAMSON" AMPLIFIERS.

Full details forwarded on request.

ROGERS DEVELOPMENTS CO.,
106 Heath Street, Hampstead, N.W.3

AN ATTEMPT TO REALISE AN IDEAL

In the High Quality World, let us commend Patience, Perseverance, and Good Temper above all; but also Skill and Intelligence.

The ultimate performance of a speaker unit—especially if it is a very good one—depends as much on the intelligence of the user as on the skill of the designer.

If you are a true quality enthusiast, perseveringly pursuing an Ideal, then we know we can help you.

To readers in the North West, we demonstrate the 148A and discuss its best possible use.

J. H. BRIERLEY (Gramophones and Recordings) **LTD.,**
46 Tithebarn Street, Liverpool, 2

M^R.A.C. BARKER'S 148_A

In December 1947 we were complimented by the Wireless World on some features of the Barker 148. These were: the excellent balance at comparatively low levels; the homogeneity of high frequency response; low frequency response sensibly uniform down to 40 c/s with no major bass resonance.

Of the new 148a, with its better magnet and new cone treatment, owners and critics have remarked: the attack and transient response give the impression of contrast expansion; so wide a range of frequencies with apparent evenness of output produces an aural naturalness which has to be heard to be appreciated; it is the best baffle loaded speaker we have ever heard.

We ourselves believe it to be the most NATURAL, satisfyingly truthful and pleasant to live with sound reproducer made anywhere.

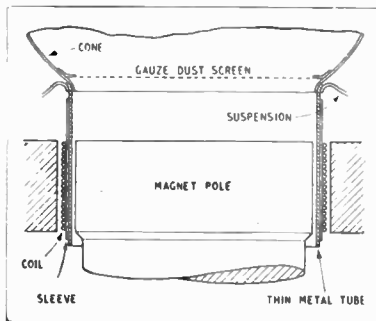

The unique constructional features, patented in many countries and exclusive to BARKER, contribute to this performance. First is the DUAL DRIVE shown on the left, and second the cone LOGARITHMIC CORRUGATIONS.

These produce a very smooth highly damped acoustic generator of exceptionally wide frequency range and remarkable clarity. They are described fully in a new leaflet obtainable at the specialists who join us in this announcement, or

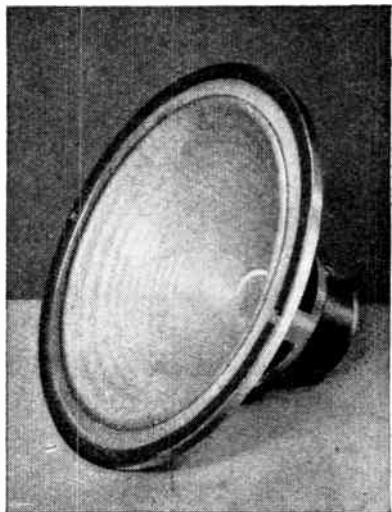

from your usual dealer, or from our monomark address

BCM/AADU, LONDON, W.C.1

The 148a is being sent to many countries overseas.

EXPORT ENQUIRIES INVITED

MOST NATURAL SOUND REPRODUCER

See our
Advt.
on
page 10

ALWAYS THINK OF
GOODSELL LTD.
*FOR STANDARD
AND SPECIAL
HIGH FIDELITY
AMPLIFIERS*

WEBB'S RADIO invite you to hear the "Barker 148A" in our demonstration room, from radio or the Brierley pick-up. You will doubtless endorse our opinion that this is an outstanding loud-speaker.

(Webb's hire-purchase facilities available on all equipment.)

Stockists for: BARKER, WEBB'S RADIO
MORDAUNT, VOIGT, LEAK, 14 Soho Street
CHARLES, BRIERLEY, AND ALL "HI-FI" EQUIPMENT. London, W.1

SMALL OSCILLOSCOPE AND WOBBULATOR

Specially designed for Service Engineers

Oscilloscope Type 1/B

Time-base: 10—350,000 c/s.

X.Plates: Direct or Amplified.

Y.Plates: Direct or Amplified.

Miniature Valves and $1\frac{1}{2}$ " diameter
C.R.T.

Dimensions: Height $7\frac{3}{4}$ " Width $5\frac{1}{2}$ "
Depth 11"

Wobbulator Type 1/B

Separate Power Supply: 200-250V.
50 c/s.

Output Voltage: 4V. R.M.S.

Nominal Frequency: 1.2 Mc/s.

Frequency Deviation: 0 to ± 40 Kc/s.

Dimensions: Height $2\frac{3}{4}$ " Width $5\frac{1}{2}$ "
Depth 11"

The two units clip together and are priced at

ONLY **£20**

ERSKINE LABORATORIES LTD—SCALBY, SCARBOROUGH, YORKS.

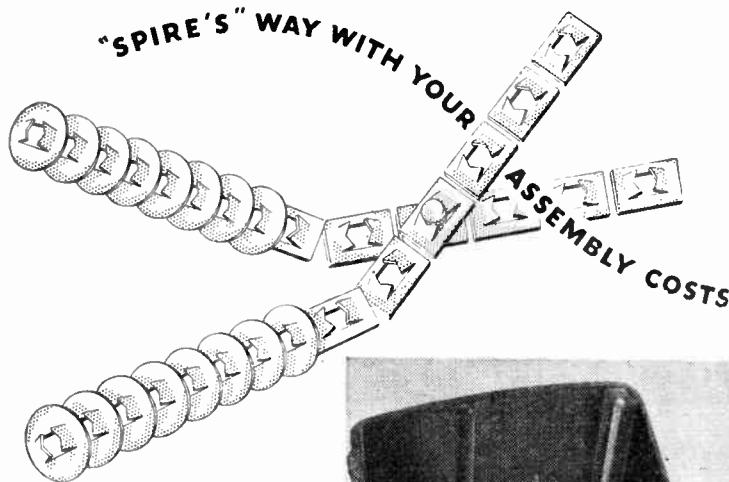

The mounting of this loudspeaker grille is achieved by the use of "Push-On" Type Spire Fixes on integral unthreaded moulded studs. Inserts eliminated; moulding costs reduced; assembly is REALLY FAST.

that's fixed that

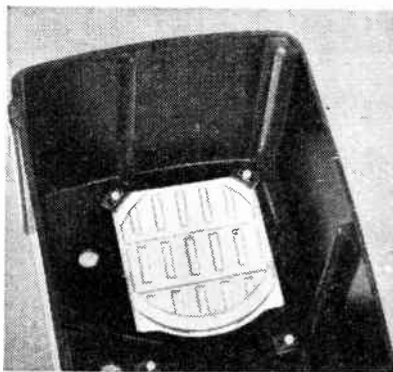

Keeping assembly cost DOWN (and at the same time keeping assemblies safely together) can be a major production headache. Spire Speed Nuts answer that requirement. And many others as well. Acting on its own double-spring locking device, each Spire nut is speedier to put on, holds tighter when it's home. Awkward fixings and blind assemblies are tackled with equal ease by Spire. Sometimes threaded members can be eliminated altogether. Will you write for more information on Spire Speed Nuts -- the fastest thing in fastenings?

Spire
Brand
SPEED NUTS

Enquiries to — Simmonds Accessories Ltd., Byron House 7-8-9 St. James's St., London, S.W.1.

Head Office and Works: Treforest, Glamorgan

13



The RC49 . . . a new, reliable Automatic Record Changer featuring PERFORMANCE, LIGHTNESS and LOW COST

Collaro's new Model RC49 more than fills a long felt need . . . it brings you a reasonable priced record changer incorporating all the refinements hitherto associated only with expensive instruments . . . plus many new features not to be found in any other record changer.

The RC49 loads, unloads, selects, plays repeats or rejects 10" or 12" records mixed in any order, by the operation of one single control knob.

The powerful induction-type MOTOR is suitable for 100/130 and 200/250 volts A.C., and incorporates the new "Rim Drive." Beautifully simple and completely reliable, the RC49 will give years of trouble-free service.

The

COLLARO

RC49

Automatic Record Changer

COLLARO LTD.,

RIPPLE WORKS, BY-PASS ROAD, BARKING, ESSEX

Telephones : Rippleway 3333

Telegrams : "KORLLARO, BARKING"

★ Write to-day for trade terms and interesting free leaflet which fully describes the Collaro Automatic Record Changer.

MAKERS OF FINE QUALITY GRAMOPHONE COMPONENTS, INCLUDING: COLLARO GRAMOPHONE UNITS, INDUCTION MOTORS, DE LUXE MICROGRAM PORTABLE ELECTRIC GRAMOPHONES.

Furzehill at your fingertips

VIBRATION ANALYSIS
INDUSTRIAL RESEARCH
ELECTRO-MEDICAL
ELECTRONICS
NUCLEAR PHYSICS
RADIO & TELEVISION

D.C.
Oscilloscope 1684D/2

AN EXAMPLE from the Furzehill range of fine instruments is this high-grade oscilloscope for industrial, radio and television applications. Both axes have identical d.c. coupled high sensitivity amplifiers with symmetrical inputs and a level frequency characteristic from zero to 3 M/cs. Particularly valuable features are the instantaneous action of the shift controls, expansion of the time base scan from $\frac{1}{2}$ to 5 screen diameters, negligible phase shift in the amplifiers and automatic amplitude-limited synchronisation.

For full details of this, and other instruments in the Furzehill range, write for our new illustrated catalogue.



FURZEHILL LABORATORIES LIMITED
BOREHAM WOOD . HERTS . Tel. EL8tree 1137

TYPE NO. LSH/200/H

A NEW RE-ENTRANT HORN LOUDSPEAKER WITH THE FOLLOWING OUTSTANDING FEATURES

- MAXIMUM POWER HANDLING CAPACITY 15W.
- FREQUENCY RESPONSE 200—7,500 C.P.S.
- COMPLETELY WEATHER PROOF.
- MATCHING TRANSFORMER ENCLOSED.
- FLARE DIA. 25 ins. OVERALL LENGTH 25 ins.
- EFFECTIVE AIR COLUMN 42 ins.

SOLE DISTRIBUTORS:
SOUND RENTALS LTD.
CANTERBURY GROVE, LONDON, S.E.27. Phone: GIP. 1131

PARKER Radio



announce a new model

THE NEW S 2 AC is a five valve, three wave band superhet receiver for operation on AC mains 110/240 Volts, 50 cycles.

Wave Band Coverage:—

Export: 12-35, 35-100, 200-553 metres.

Home: 19-50, 200-550, 830-2,000 metres.

Eight inch moving coil loudspeaker is used.

Cabinet in French Walnut veneers. Provision is made for extension speaker and Pick-up.

Export price by quotation.

PARKER RADIO CORPORATION LTD.
7 Regal Lane, Regent's Park, London, N.W.1 Gulliver 1943



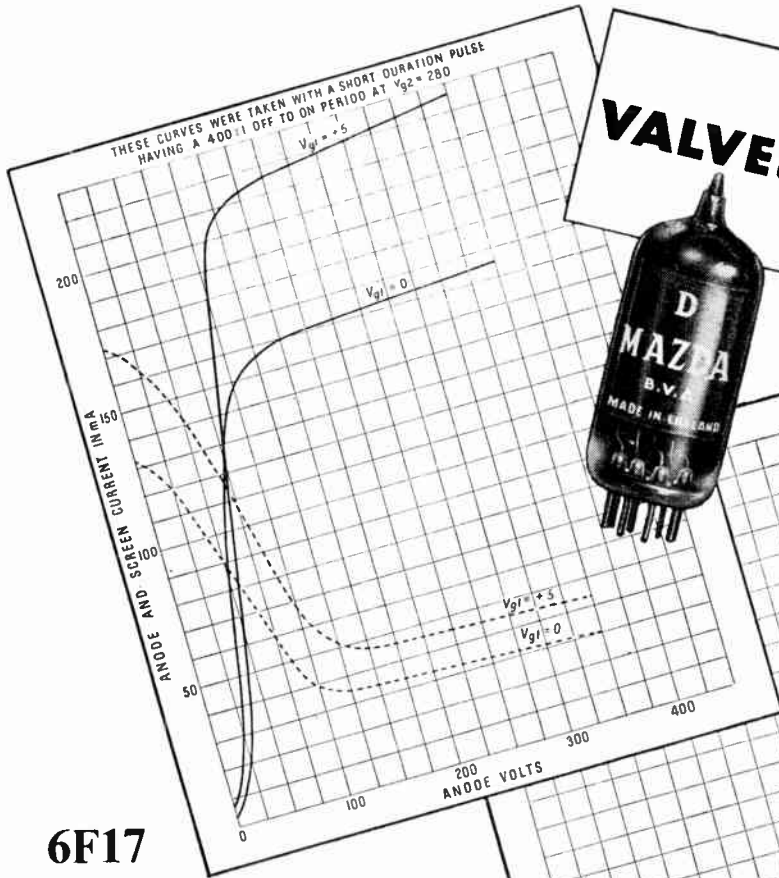

VALVES For **SPECIAL PURPOSES**

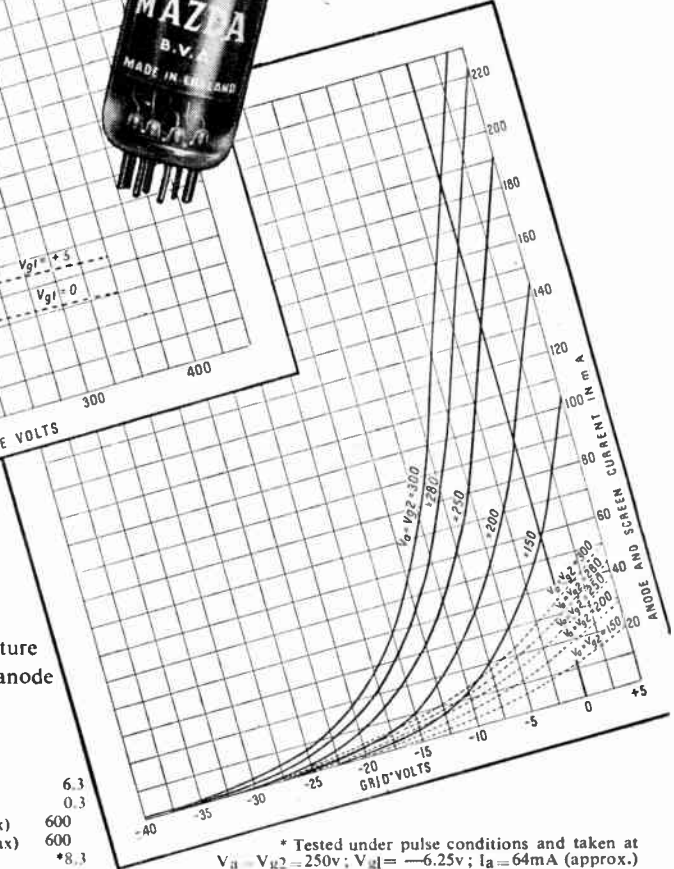

6F17

MINIATURE PULSE AND R.F. BEAM TETRODE

The Mazda 6F17 is an indirectly heated miniature pulse and R.F. Beam Tetrode having an anode dissipation of 3.5 watts.

RATING

| | | |
|--|-----------------------|-----|
| Heater Voltage (volts) | V _h | 6.3 |
| Heater Current (amps) | I _h | 0.3 |
| Maximum Anode Voltage (volts) | V _a (max) | 600 |
| Maximum Screen Voltage (volts) | V _{g2} (max) | 600 |
| Mutual Conductance (mA/V) | g _m | 8.3 |
| Maximum Anode Dissipation (watts) | P _a | 3.5 |
| Maximum Screen Dissipation (watts) | P _{g2} | 0.7 |

* Tested under pulse conditions and taken at V_a = V_{g2} = 250v; V_{g1} = -6.25v; I_a = 64mA (approx.)
 ‡ If used in a can at maximum rating the can must be matt black both internally and externally.

Further details given on application to the Radio Division.

EDISWAN

MAZDA

RADIO VALVES AND TELEVISION TUBES

THE EDISON SWAN ELECTRIC CO. LTD., 155 CHARING CROSS ROAD, LONDON, W.C.2

RA134



MODEL ILLUSTRATED
IS OUR P.X. 25
Price £30·10·0

ILLUSTRATED BROCHURE
GIVING DETAILS OF OUR
FULL RANGE FREE ON
REQUEST

GOODSELL

15 WATT HI-FIDELITY AMPLIFIERS
are unsurpassed in performance

AS DESCRIBED BY T. D. N. WILLIAMSON IN "Wireless World," MAY, 1947

Manufactured by

GOODSELL LTD. 40 GARDNER ST. BRIGHTON Tel. 6735

Easy Terms from LONDON RADIO SUPPLY CO. Balcombe, Sussex

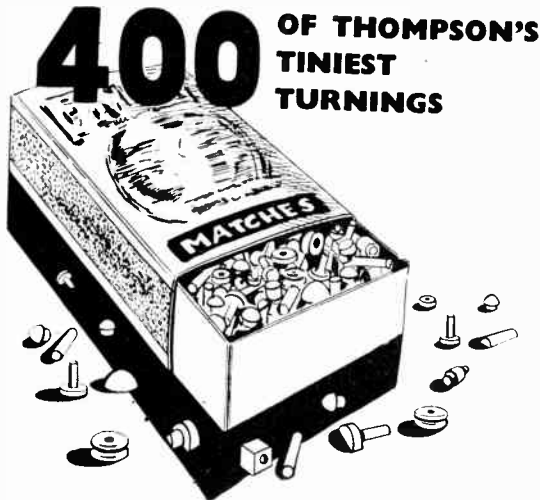

WILL GO INTO A MATCH-BOX

*and every single one is
DEAD ACCURATE in size*

That's how Thompson's work. Whether you require large or small turnings in wood, Thompson's will make them exactly to your specification.

W. & J. R. THOMPSON

(WOODTURNERS) LIMITED EST. 1862

CROSSHILLS, KEIGHLEY, YORKSHIRE

Phone: Crosshills 2312-3 (2 lines) Grams: Turnwood, Crosshills

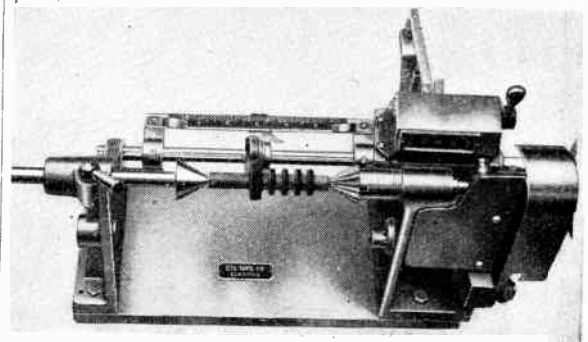

MODEL WX

AUTOMATIC COIL WINDING MACHINES

AND HAND WINDING MACHINES

Machines supplied complete with stand motor and Two-speed Friction Clutch

SOLE AGENTS ABROAD

K. G. Khosla & Co., 22 School Lane, New Delhi, India.
Établis Octave Houart, 14, Quai de l'Industrie, Sclessin-lez-Liege.
J. P. Fielding Co. (Canada), 131 Ontario Street, St. Catherines,
Ontario.
Heftey & Frogg, Oslo, Norway, Storgaten, 15.

ETA TOOL CO

(LEICESTER) LTD.

29a, WELFORD ROAD, LEICESTER

Phone—5386

They speak for themselves . . .

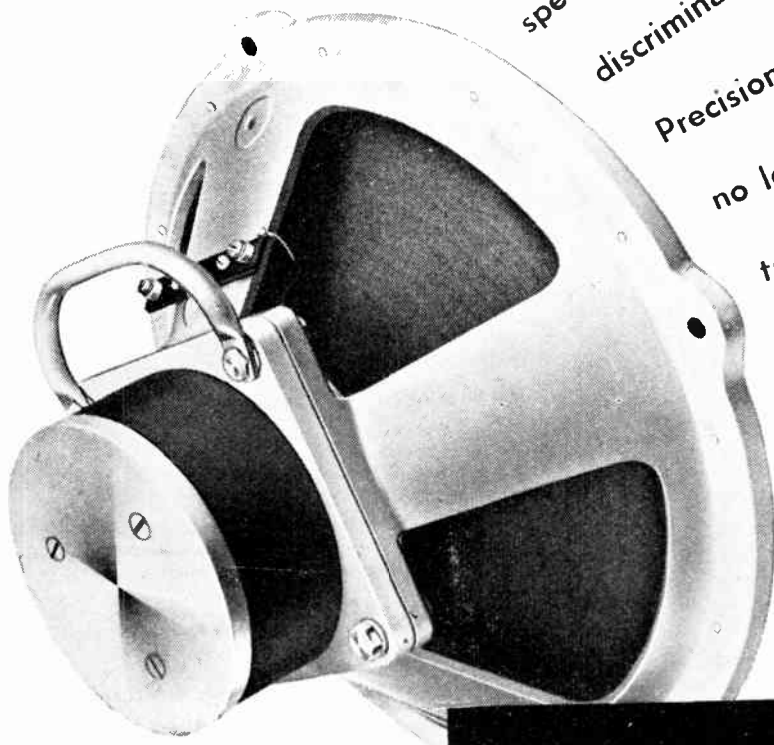

fidelity of response
 speaks for itself to the
 discriminating ear.
 Precision manufacture is
 no less eloquent to the
 trained engineer. These
 qualities make
 TRUVOX speakers famous

The SS10A 12-inch
 Heavy Duty Speaker,
 illustrated, offering a
 frequency response from
 55 to 11,000 c.p.s. and
 handling 10 watts is
 a typical example of
 TRUVOX workmanship.

TRUVOX

TRUVOX ENGINEERING CO. LTD · EXHIBITION GDS · WEMBLEY · ENGLAND

E247

Precision with a Pedigree

**FREQUENCY
MEASURING
EQUIPMENT**

Type TME 1

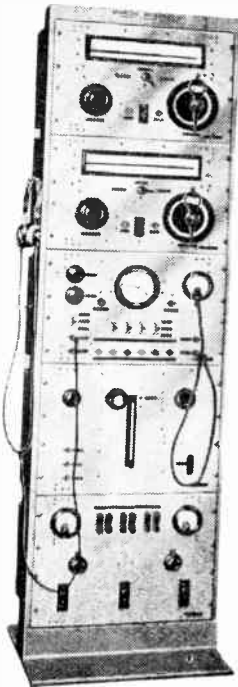

Years ago, the frequency measuring equipments made by Marconi's were for their own use — because nowhere else could sufficiently accurate instruments be obtained. The present equipment therefore, Type TME 1, boasts a long and distinguished pedigree and, like its predecessors, is precision-built to an exacting specification. Anywhere in the world it can be rapidly installed and its rated stability of 1 part in 10⁶ maintained indefinitely. In price too, it commends itself as the ideal laboratory standard. Please ask for further details. Type TME 1 Frequency Measuring Equipment is available for early delivery.

Marconi Instruments Ltd

ST. ALBANS, HERTS. Telephone: St. Albans 6161/5

Northern Office: 30 Albion Street, Hull. Western Office: 10 Portview Road, Avonmouth. Southern Office & Showrooms: 109 Eaton Square, London, S.W.1. Midland Office: 19 The Parade, Leamington Spa.

THE HEIGHT OF EFFICIENCY IN LONDON OR BIRMINGHAM

WOLSEY

TELEVISION AERIALS

From Single Dipole to the Triple Reflector model illustrated, every WOLSEY Tele. Aerial is the most efficient of its type. Many years specialisation is behind them!

THE FIRST AND MOST SUCCESSFUL TRIPLE REFLECTOR ARRAY

giving increased gain for fringe areas and greatly reduced interference in town areas.

WOLSEY TR/M1. Half Wavelength Dipole with three Reflectors spaced at $\frac{1}{4}$ th wavelength for London, $\frac{1}{2}$ wavelength for Birmingham. Reflector elements positioned in a parabola. Constructed of steel tubing, Cadmium plated, Duralumin Rods with Polythene V.H.F. insulators and P.V.C. waterproof bushes. Weight only 5½lbs. As illustrated, £6 (pole and fittings extra). List Price.



One of our fully equipped Vans available for the installation of all our eight types of Aerials in London and Birmingham.

SEND FOR BROCHURES

WOLSEY TELEVISION LTD,

75, GRESHAM RD., BRIXTON, LONDON, S.W.9

Phone: BRixton 6651/2

Established 1934

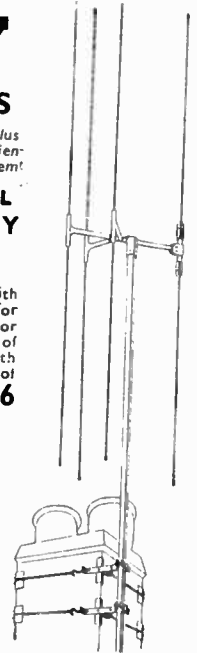

CLEARANCE SALE—JULY 1-31

Ex-demonstration and experimental equipment, shop soiled and redundant stock to be sold at "give away" prices. A few examples are as follows:

- RDI High Fidelity Amplifier.** Ex. dem. model. (List £32 10s. 0d.) £12 10 0
 - 15-watt P.A. Amplifier.** Input for MIC, or P.U. In grey lmhof steel cabinet..... £10 10 0
 - Wide range Audio Oscillator.** Working but needs slight attention..... £4 10 0
 - Baker 12in. Energised Loudspeaker**..... £2 10 0
- (The above to callers only)

A list giving other single items, and details of the many components available will be forwarded on request.

NEW HIGH FIDELITY LOUDSPEAKERS AND CABINETS.

- Goodmans "Axiom 22,"** high flux version of the "Axiom 12" £12 13 0
- Goodmans R22/1206,** high flux bass loudspeaker. Resonance 55 cps..... £11 0 0
- Bass Reflex Cabinet** for the "R22" and "Axiom 22." Very solidly constructed and finished in figured Walnut. Carriage 10s. £16 16 0
- "RD Junior"** corner reflex cabinet for the Wharfedale W10.CS. Compact and attractive design giving good bass response down to 35 cps. Carriage 10s. £12 10 0
- Wharfedale W10.CS Loudspeaker** £7 0 0

A full description and photograph of the "RD Junior" cabinet will be forwarded on request.

ROGERS DEVELOPMENTS CO.

105, Heath Street, Hampstead, London, N.W.3
HAMpstead 6901

EXTRACT
FROM REPORT OF
ANGLO-AMERICAN
COUNCIL ON
PRODUCTIVITY

"... Productivity bears an important relationship to the amount of energy available per employee. In the United States this figure is approximately twice that in the United Kingdom..."



ASKED to comment, our Managing Director (the sly old thing) said (in what he fondly imagined to be the courtly accents of old Virginy): Ah sho will suh! What that grand ole Council says right now, those same vurry words is what ah've bin a-tellin' and a-tellin' you-all eveh since old Methoosalem. That po' ole British Workin' Man he jes' sweats and strains body all achin' and racked with pains; lifts dat screwdriver, totes dat brace... Uh! Uh! Uh! Lawdy, lawdy, you-all sho must give that po' fella mo' hoss-power. Yassuh! Hoss-power. Nothin' else but.



Call up dem little horses

DESOUTTER

DESOUTTER BROS. LTD., THE HYDE, HENDON, LONDON, N.W.9.

Specialists in Lightweight Pneumatic and Electric Portable Tools.

TELEPHONE: COLINDALE 6346-7-8-9.

TELEGRAMS: DESPNUCO, HYDE, LONDON
CRC 199

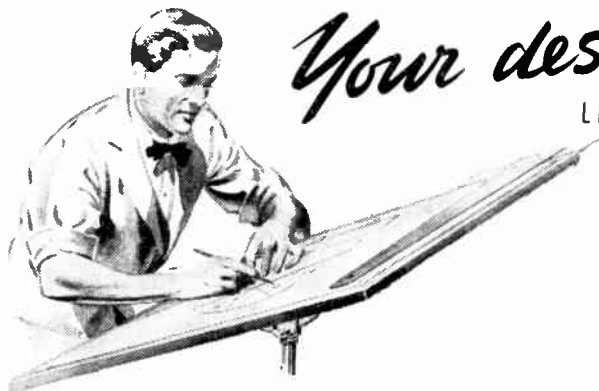

Your designs

LET US BRING THEM TO

LIFE!

Made in Three Principal Materials

FREQUELEX

An insulating material of Low Di-electric Loss, for Coil Formers, Aerial Insulators, Valve Holders, etc.

PERMALEX

A High Permittivity Material. For the construction of Condensers of the smallest possible dimensions.

TEMPLEX

A Condenser material of medium permittivity. For the construction of Condensers having a constant capacity at all temperatures.

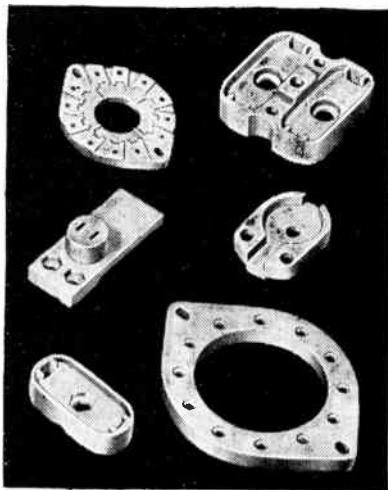

the most difficult problems solved by . . .



Bullers

BULLERS LOW LOSS CERAMICS

BULLERS LTD., 6, LAURENCE POUNTNEY HILL, LONDON, E.C.4
 Telephone: Mansion House 9971 (3 lines) Telegrams: "Bullers, Cannon, London"

the finest in
electronic valves



carry this emblem

Supplied to ADA by R.C.A., ADA electron valves are designed to satisfy completely the requirements of radio receivers, service, amateur and laboratory equipment. Sturdily constructed and thoroughly tested, every ADA valve is guaranteed to give long, trouble-free use.

The ADA trademark is your assurance of dependable performance and durability.

Other ADA products:

- Household and Commercial Refrigerators
- Radios and Components
- Home Appliances

AD.AURIEMA, INC. 89 Broad St., New York 4, N.Y., U.S.A.

Cable Address: AURIEMA, NEW YORK

AN ADVANCE IN MEASUREMENT!

CALIBRATED WIDE RANGE cathode ray oscillograph with simple controls and large screen, combined with the measuring facilities of a valve voltmeter.

THE NAGARD

UNIT CONSTRUCTION in one case provides alternative time bases or amplifiers and improvements at minimum cost. Adequate power supply for all requirements in separate easily portable case.

TYPE 103

STANDARD UNITS include:— D.C. AMPLIFIER of high sensitivity—less than 1 mV. per. cm. with linear response 0-2.5 Mc/s. TIME BASE with calibrated velocity from 10 c/s to 1 Mc/s, automatic synchronisation and free from effects of mains variations.

OSCILLOGRAPH & OSCILLOMETER

INPUT SIGNAL VOLTAGES measurable by directly calibrated Y shift control, independently of amplifier gain.

THE ONLY PORTABLE instrument combining all the above for the purposes of enabling you to

SEE WHAT YOU MEASURE—MEASURE WHAT YOU SEE AT HIGH OR LOW FREQUENCIES AND D.C.

NAGARD LTD

245 BRIXTON ROAD, LONDON, S.W.9.

Phone: Brixton 3550.

Grams: Intertel, Claproad, London.

ACHIEVEMENT!

Standard condenser technique
now reduced to
midget dimensions



**HIGH
INSULATION
RESISTANCE**

**LOW POWER
FACTOR.**

Solid aluminium
foil

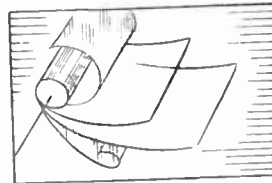
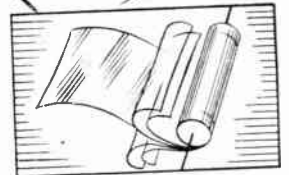

Two layers of
paper
dielectric

Neoprene
sealed

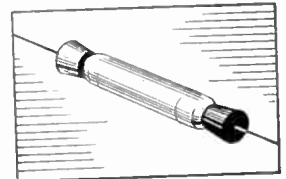

In aluminium
tube

WHEN size is the limiting factor, T.C.C. can supply the answer. Here, in the new Metalmite, is a real paper and foil condenser magically reduced to Lilliputian dimensions. Specially built to withstand wide temperature variations between -40°C to $+100^{\circ}\text{C}$, and conditions of high humidity. Its sturdy, rugged construction makes it ideal for use in portable transmitters and receivers — also for deaf aid equipment. In capacities from $\cdot 0002$ mfd. 500 volts D.C. to $\cdot 01$ mfd. 200 volts D.C. — full details on request.



New miniature
'METALMITES'

THE TELEGRAPH CONDENSER CO. LTD
RADIO DIVISION: NORTH ACTON, LONDON, W.3 · TELEPHONE: ACORN 0061



18, TOTTENHAM COURT ROAD, LONDON, W.1

Tel : MUSEum 2453

Shop hours: Monday-Friday 9-5.30. Saturday 9-1

Tel : MUSEum 4539

FULL MAIL ORDER FACILITIES
Please add postage

TELEVISOR, SHORT WAVE & GENERAL COMPONENTS
CATALOGUE NOW AVAILABLE Price 6d. each POST FREE.

Includes itemised list for Wireless World and Electronic Engineering Televisors

GREATEST BARGAIN

ever offered in Government Surplus

TR9 TRANSMITTER/RECEIVER

LESS VALVES

complete in transit case as illustrated.

12'6d. CARRIAGE FREE

These equipments were in working order before being stored in the open, but their general condition has now deteriorated.



SIZE
15½" x 19" x 10½" high

BRIERLEY PICKUPS

Ribbon, type JB'P'R'2

Microarmature, type JB'P'A'1



Recent comparative tests have shown that with the best modern recordings some improvement in performance is obtained by the use of a "special" point shape. In practice, we naturally endeavour to obtain a shape as near as possible to the cutting stylus whilst retaining the essential characteristics of a reproducing point. We can supply to order, Ribbon and Microarmature pickups with points having a lateral radius of '0025" approx; a longitudinal radius of '0005" approx. and a near vertical leading "edge"

J. H. BRIERLEY (GRAMOPHONES & RECORDINGS) LTD.,
46, TITHEBARN STREET, LIVERPOOL, 2.

CONSISTENTLY
Accurate

PULLIN
INDUSTRIAL
MEASUREMENT

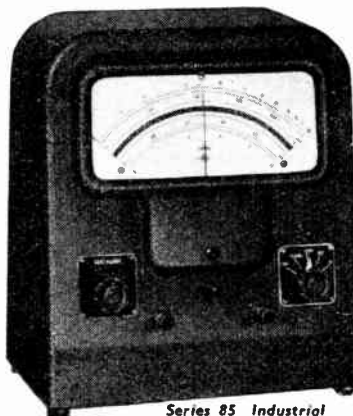

Series 85 Industrial
Bench Type Ohmmeter

A Linear Scale Bridge-type Ohmmeter, with press key, designed for routine production testing of all resistive components. For battery or A.C. mains operation. (A.C. mains operated instruments are compensated for voltage variations up to - 15%.) Designed and constructed to withstand severe industrial use. Available as single or multi-range.

Address all enquiries to

MEASURING INSTRUMENTS (PULLIN) LTD

Electrin Works, Winchester St, London, W.3

Telephone: ACOrn 4651 3 & 4995



DUBILIER "DRILITIC" CAPACITORS

CONDENSER CO. (1925) LTD.

have all the essential features

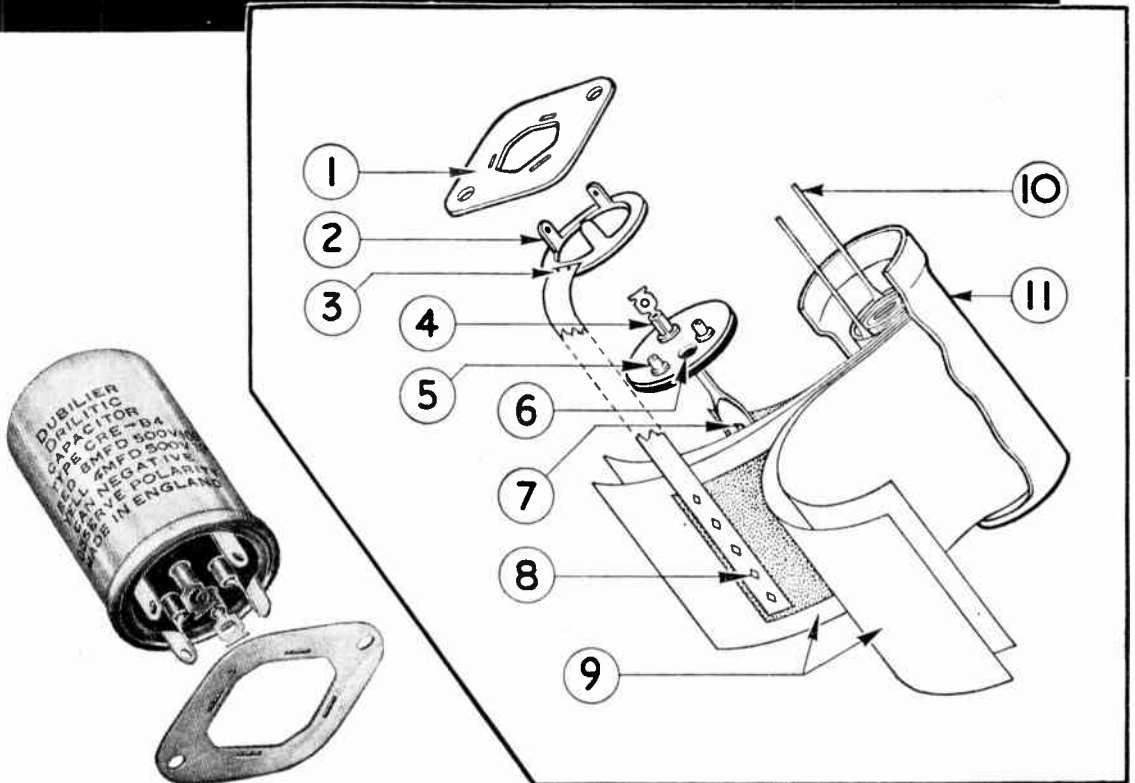

G.T.E. and C.R.E. Ear Mounting "Drilitic" Capacitors.

For the time being these capacitors are only available to manufacturers of radio and electronic equipment.

By the application of special manufacturing techniques we are producing "Drilitic" Capacitors to a high level of engineering efficiency. The equivalent series resistance and leakage current have been reduced, breakdown voltage and life expectancy have been increased and both the audio and radio frequency impedances, together with the temperature characteristics have been improved. In addition to these finer electrical characteristics "Drilitic" Capacitors are extremely small in physical size. To obtain the maximum advantage from the small size, Ear

Mounting "Drilitic" Capacitors are now available to provide a more rapid and efficient means of fixing. They are obtainable in single and multiple capacitor forms and in a wide range of capacitances and voltages. High ripple current "Drilitic" Capacitors for television and electronic apparatus, and high temperature "Drilitic" Capacitors for equipment with high ambient temperature or for tropical operation are also available.

We shall be pleased to forward full details of these latest engineering developments together with the eleven points of special interest, upon application.

DUBILIER CONDENSER CO. (1925) LTD., DUCON WORKS, VICTORIA ROAD, NORTH ACTON, W.3
 'Phone : Acorn 2241 (5 lines) 'Grams : Hilvoltcon, Phone London. Cables : Hilvoltcon, London. Marconi International Code

RUINED
*by the tests which
 should have saved them*

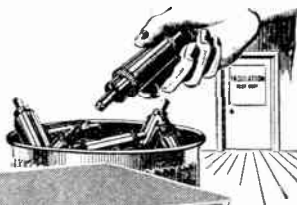

**but this
 would
 have saved them**

High Voltage Testing of insulated components has hitherto meant, in many instances, complete destruction of units below standard. Furthermore, such tests have involved appreciably long periods of time.

This Airmec non-destructive high voltage insulation tester will give immediate indication of weakness in insulation before breakdown voltage is reached. It will indicate the maximum safe voltage at which insulation can be worked

and will show whether or not ionisation is present within the insulation. The instrument is self-contained, portable, low in cost, and safe to operate. It may be used by unskilled personnel and is many times faster in use than other test equipment. Voltages up to 5kV are available.

For testing radio and electrical components, motor and transformer windings, insulated wire and cables, and determining deterioration of insulation after storage.



A I R M E C L A B O R A T O R I E S L I M I T E D
 HIGH WYCOMBE · BUCKINGHAMSHIRE · ENGLAND

Telephone: High Wycombe 2060 · Cables: Commlabs

Manufacturers of all types of Industrial Electronic Equipment and Test Gear

High Fidelity Reproduction.



TYPE "K."

The S. G. Brown Type "K" Moving Coil headphones, with the following outstanding characteristics, supply that High Fidelity Reproduction demanded for DX work, monitoring and laboratory purposes, etc.

CHARACTERISTICS.

D.C. RESISTANCE, 47 Ohms.

IMPEDANCE 52 Ohms at 1,000 c.p.s.

SENSITIVITY, 1.2 x 10⁻¹² Watts at 1kc. = .0002 Dyne/cm²

Descriptive Literature on request

PRICE £5.5.0 PER PAIR

Your Local Dealer can supply

For details of other S. G. Brown Headphones (prices from 30/- to 77/6) write for illustrated Brochure "W.W."

HEADPHONES WHICH UPHOLD BRITISH PRESTIGE

Telephone: Watford 7241

S. G. Brown, Ltd.

SHAKESPEARE STREET, WATFORD, HERTS.



BROWN—E.R.D. 13 inch Portable Disc Recorder
 An Important S. G. Brown product

Brown-E.R.D.

DISC RECORDER

*Incorporating the latest advances
 in Sound-on-Disc Recording*

Write for interesting brochures presenting full technical details of this latest development in Sound-on-Disc recording. Also 17 inch models for the Professional user.

S. G. BROWN LTD., Shakespeare St., WATFORD

Established in Electro Acoustics and high precision Engineering for over 40 years. Manufacturers of the world-famous 'BROWN' Gyro Compass.

Telephone: Watford 7241

PREMIER RADIO COMPANY

MORRIS & CO. (RADIO) LTD.

Introduce . .

THE TELEVISION KIT

YOU CAN BUILD FOR £17.17.0

This Receiver consists of 4 units :

The Sound Receiver, Vision Receiver, Time Base and Power Pack. As is usual in all Premier Kits, every single item down to the last bolt and nut is supplied. All chassis are punched and layout diagrams and theoretical circuits are included.

The cost of the Kits of Parts is as follows :

| | |
|-------------------------------------|---------|
| Vision Receiver with valves | £3 13 6 |
| Sound Receiver with valves | £2 14 6 |
| Time Base with valves | £2 7 6 |
| Power Supply Unit with valves | £6 3 0 |

In Addition you will need :

| | |
|---------------------------------------|---------|
| VCR97 Cathode Ray Tube | £1 15 0 |
| Set of Tube Fittings and Socket | 7 0 |
| 6in. PM Moving Coil Speaker | 16 6 |

The Instruction Book costs 2 6, but is credited if a Kit for the complete Televisor is Purchased.

Any of these Kits may be purchased separately ; in fact any single part can be supplied. A complete priced list of all parts will be found in the Instruction Book.

A GLANCE AT THE PRICES WILL SHOW THAT THIS IS THE GREATEST VALUE OFFER PREMIER HAVE EVER MADE

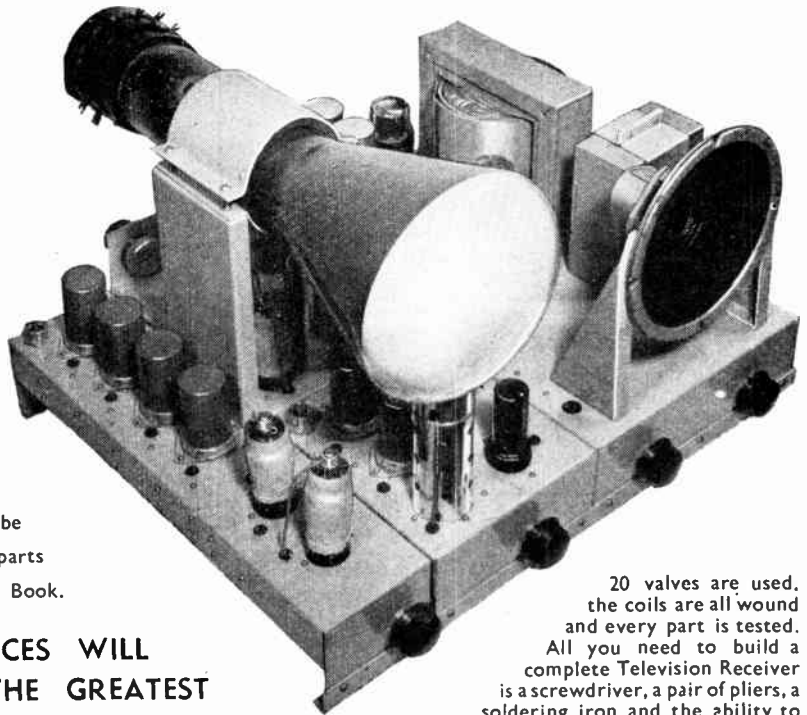

20 valves are used, the coils are all wound and every part is tested. All you need to build a complete Television Receiver is a screwdriver, a pair of pliers, a soldering iron and the ability to read a theoretical diagram.

WORKING MODELS CAN BE SEEN DURING TRANSMITTING HOURS
AT OUR FLEET STREET AND EDGWARE ROAD BRANCHES.

BRANCHES AT

207, EDGWARE RD., W.2 Phone : AMBassador 4033
AND AT **152-153, FLEET STREET, E.C.4** Phone : CENTral 2833

All POST ORDERS to 167, LOWER CLAPTON ROAD, LONDON, E.5. Phone : AMHerst 4723

Terms of Business : Cash with order or C.O.D. over £1. Send 2d. Stamp for list.

EDGWARE ROAD IS OPEN UNTIL 6 p.m. ON SATURDAYS

LONDON CENTRAL RADIO STORES

Government Surplus—From Stock

SIGNAL GENERATOR, Type 1-130-A



FOR CALLERS ONLY.

This battery operated U.S. Army Test Equipment was made by Bendix. Essential to all aircraft operators using V.H.F., R/T equipments. Designed for tuning and testing the American SCR522 Equipment and for the British 1143, 1464, etc. Supplied with Field Strength Meter in strong transit case **£27.10.0**

INDICATOR UNITS

Contains: 1, VCR517, 1, VCR139 Tube suitable for Television, etc. Four EA50 Diode Valves, four SP61, one each 0J5, 60A, Clystron valves, 24 v. Blower Motor, 2in. 0-1 milliammeter, Transformers, Condensers, Resistances, Potentiometers, etc. **£4.17.6**
Carr. paid

PHOTO-ELECTRIC CELLS Type G816

These cells are the gas-filled type with caesium Cathode. Made by Cintel. Minimum sensitivity 100µA/lumen, working volts 100 D.C. or peak A.C. Projected cathode area 16 sq. cm. Suitable for 16 mm. Home Cinema Talkie equipment, Safety Devices, Colour and Photo Matching, Burglar Alarms, Automatic Counting, Door Opening, etc. Brand new in original cartons... **42/6**



NEW SIGNALLING LAMPS, Ex-U.S. Navy
With four colour code slip-on covers, complete with cable and switch. In carrying case, 9 x 4 x 9in. **22/6**

PHOTO ELECTRIC CELLS

Small infra-red image, glass converter tube. Type C.V. 143 50-100 v. Suitable for all purposes. Special price for 2 months only **14/-**

MINE DETECTOR PANEL

3 valves, one pair headphones L.R. (Battery Model). In metal case **25/-**

CHARGING BOARDS, Control Panels Only

24 v. 1,200 watts. Includes five 1 1/2in. moving coil ammeters (1, 0-40 a., 4, 0-15 a.). One moving coil voltmeter 0-40 v. Five heavy duty sliding resistances, etc., complete in Metal case as shown with fold-back doors. Size 18 x 17 x 8in. Offered at less than half the component value. Price **£4.19.6**
Carriage extra

PLEASE NOTE

- All carriage paid unless otherwise stated.
- Carriage charges relate to British Isles only.
- We do not issue lists or catalogues.
- We have hundreds of items in stock too numerous to list, including Special Admiralty Transmitters, Receivers, etc., so when in Town pay us a visit.

6-BANK, UNISELECTOR SWITCHES, 25 contacts, as new **37/6**

VIBRATOR PACK, Admiralty pattern, 12 v. D.C., 300 v., 100 mA. output **45/-**
CO-AXIAL CABLE, 70 ohms, 24 yd. lengths, 16/-, post & pkg., 1/6 extra.

MOVING COIL HAND MICROPHONE, 30 ohm voice coil, with switch **5/6**

3-VALVE R.F. AMPLIFIERS V.H.F., Type 25, 110/125 Mc/s. Complete with valves in metal case **12/6**

ELECTRO MAGNETIC COUNTERS, Ex-G.P.O., every one perfect, electro-magnetic, 500 ohm coil, counting to 5,000, operated from 25-500 V.D.C. Many industrial and domestic applications **5/6**

SMALL SLIDING RESISTANCES Ex-Admiralty. Finest quality. Suitable for Voltage Controls, Speed Regulators, 50 ohms, 0.5 amp. Dimensions 9in. x 1in. x 2 1/2in. high **6/6**

EX-GOVT. TELEPHONE HAND-SETS (Sound Power)



New stock. Self-energising. Needs no battery or current. As illustrated **7/6**

SINGLE ELEMENT SLIDING RESISTANCES, super quality, heavy duty, 14 ohms, 5 amp **14/6**

U.S. ARMY MIDGET LIGHT-WEIGHT HEADPHONES, 200 ohms. Suitable for 'Beat Aids' **12/6**

EX-ARMY TEST SET NEW Type Demolition Mk. I. For circuit continuity and general testing. In hard wood carrying case **42/-**
See June issue for other interesting bargains.

23, LISLE ST. (GERrard 2969) LONDON, W.C.2
Closed Thurs. 1 p.m. Open all day Sat. and weekdays 9 a.m.—6 p.m.

Our Silvered Mica Capacitors are made in all values between 3 pF and 7000 pF. Our aim is to supply these Capacitors with the smallest possible dimensions, and we have a range of 7 sizes which allows us to offer for almost any capacitance a "made-to-measure" type.

STABILITY RADIO COMPONENTS LTD

14, NORMAN'S BUILDINGS, CENTRAL STREET, LONDON, E.C.1
Telephone : CLERkenwell 5977

NOTICE

"POINT ONE" is the Trade Mark of H. J. Leak & Co., Ltd. It was originally applied to the first power amplifiers having a total distortion as low as point one of one per cent, when in June, 1945, H. J. Leak M. Brit. I.R.E., revolutionised the performance standards for audio amplifiers by designing the original "POINT ONE" series.

NEW

LEAK

"POINT ONE"

AMPLIFIERS

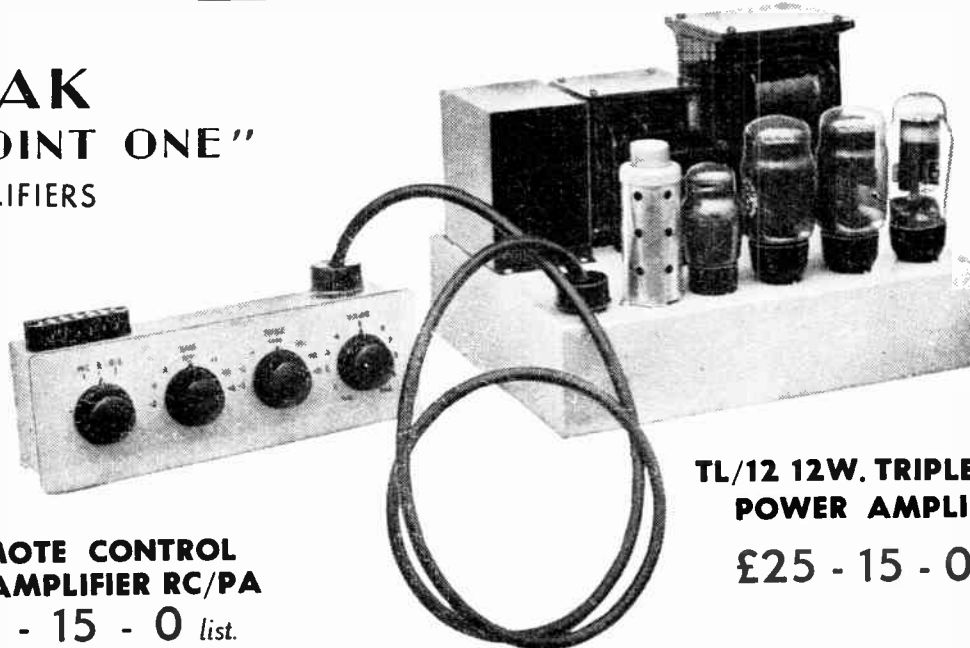

TL/12 12W. TRIPLE LOOP POWER AMPLIFIER

£25 - 15 - 0 list.

REMOTE CONTROL PRE-AMPLIFIER RC/PA

£6 - 15 - 0 list.

An original feedback tone-control circuit which will become a standard.

No resonant circuits employed.

- Distortion: Less than 0.05%.
 - Switching for Pick-up, Microphone and Radio, with automatic alteration of tone-control characteristics.
 - High sensitivities. Will operate from any moving-coil, moving iron or crystal P.-U.; from any moving-coil microphone; from any radio unit.
 - Controls: Input Selector; Bass Gain and Loss; Treble Gain and Loss; Volume.
- Output Impedance: 0-30,000Ω at 20 kc.p.s.

The unit will mount on motor-board through a cut-out of 10½ in. × 3½ in., or it can be bolted to the power amplifier, when, with a top cover, the whole assembly becomes portable.

For use only with LEAK amplifiers.

Used with the RC/PA pre-amplifier and the best complementary equipment the TL/12 power amplifier gives to the music-lover a quality of reproduction unsurpassed by any equipment at any price. It is designed in a form so that the power amplifier can be housed in the base of a cabinet and the small pre-amplifier mounted in a position best suited to the user.

DO YOU KNOW what these performance figures mean?—

PHASE MARGIN 20° ± 10°

GAIN MARGIN 10db ± 6db

They are of vital importance, for the "goodness" of a multi-stage feedback amplifier cannot be taken for granted in the absence of this information, however impressive the rest of the specification may seem. We believe ourselves to be the only organisation advertising these figures. Our booklet explains them, and "Cathode Ray" also deals with them ("Wireless World" May 1949).

If you would like to know more about amplifiers in general, and the TL/12 and RC/PA in particular,

WRITE FOR BOOKLET W/TL/12

H. J. LEAK & CO. LTD. (Est. 1934)

BRUNEL ROAD, WESTWAY FACTORY ESTATE, ACTON, W.3.

Phone: SHEpherds Bush 5626.

Telegrams: Sinusoidal, Ealux, London.

Foreign: Sinusoidal, London.

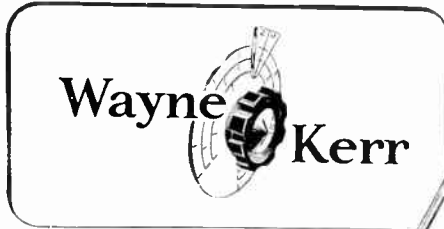

I N D U C T A N C E M E T E R

Designed to provide simple and direct reading measurement of inductance values between 0.05 microhenry and 100 millihenrys. A stable variable-frequency oscillator is used to resonate the unknown inductance with a fixed standard capacitor. Provision is made for the measurement of Q at resonance frequency.

Calibration and scale reading accuracy are sufficient to provide direct readings of inductance values within 2 per cent. above one microhenry. Relative measurement can be made with greater accuracy. The instrument is very compact, measuring only 7 1/2" high, 7 1/2" wide and 7 1/2" deep at base. PRICE £38.5.0

THE WAYNE KERR LABORATORIES LTD. NEW MALDEN SURREY · MALDEN 2202

TYPE 26 V.H.F. CONVERTER

We are pleased to be able to offer Type 26 R.F. U.H.F. Converter Unit as illustrated.

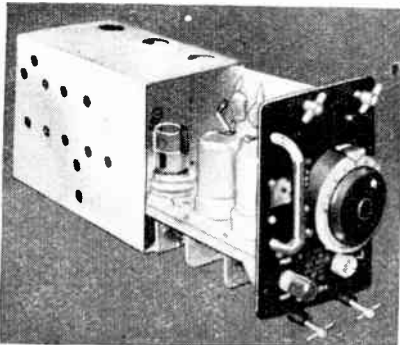

This unit covers 50-60 M/cs without modification. Can be used with any super-het covering 7.5 M/cs (40 metres). Requires 6.3 v. 1 amp. for heaters, 250-300 v. 30 m.A. H.T. Three tuned stages R.F., mixer and oscillator. Fitted with Muirhead Slow Motion Drive. All internal parts and chassis silver-plated. Ideal for 5-metre and Birmingham television bands.

BRAND NEW. IN ORIGINAL CARTONS. Order at once to avoid disappointment. 35/-

In addition to the above, many other bargains are available. Send 3d. in stamps for our No. 8 special offers list and Raymart new illustrated catalogue and price list.

RADIOMART 48 HOLLOWAY HEAD BIRMINGHAM, 1
C.S.M. (CHAM) LTD. Tel.: Midland 3254

PLEASE tell us of OTHER applications

Drayton 'Hydroflex' Metal Bellows are an essential component part in Automatic coolant regulation . . . Movement for pressure change . . . Packless gland to seal spindle in high vacua . . . Reservoir to accept liquid expansion . . . Dashpot or delay device . . . Barometric measurement or control . . . Pressurised couplings where vibration or movement is present . . . Dust seal to prevent ingress of dirt . . . pressure reducing

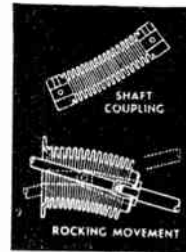

valves . . . Hydraulic transmission . . . Distance thermostatic control . . . Low torque flexible coupling . . . Pressure sealed rocking movement . . . Pressurised rotating shaft seals . . . Aircraft pressurised cabin expansion valves . . . Refrigeration expansion valves . . . Thermostatic Steam Traps . . . Pressure amplifiers . . . Differential pressure measurements . . . Thermostatic operation of louvre or damper.

for HYDRAULICALLY FORMED

Seamless, one-piece, metal bellows combining the properties of a compression spring able to withstand repeated flexing, a packless gland and a container which can be hermetically sealed. Made by a process unique in this country, they are tough, resilient, with a uniformity of life, performance and reliability in operation unobtainable by any other method.

Drayton METAL BELLOWS

Write for List No. N800-1 DRAYTON REGULATOR & INSTRUMENT CO. LTD., WEST DRAYTON, MIDDLESEX. West Drayton 2611 B.8

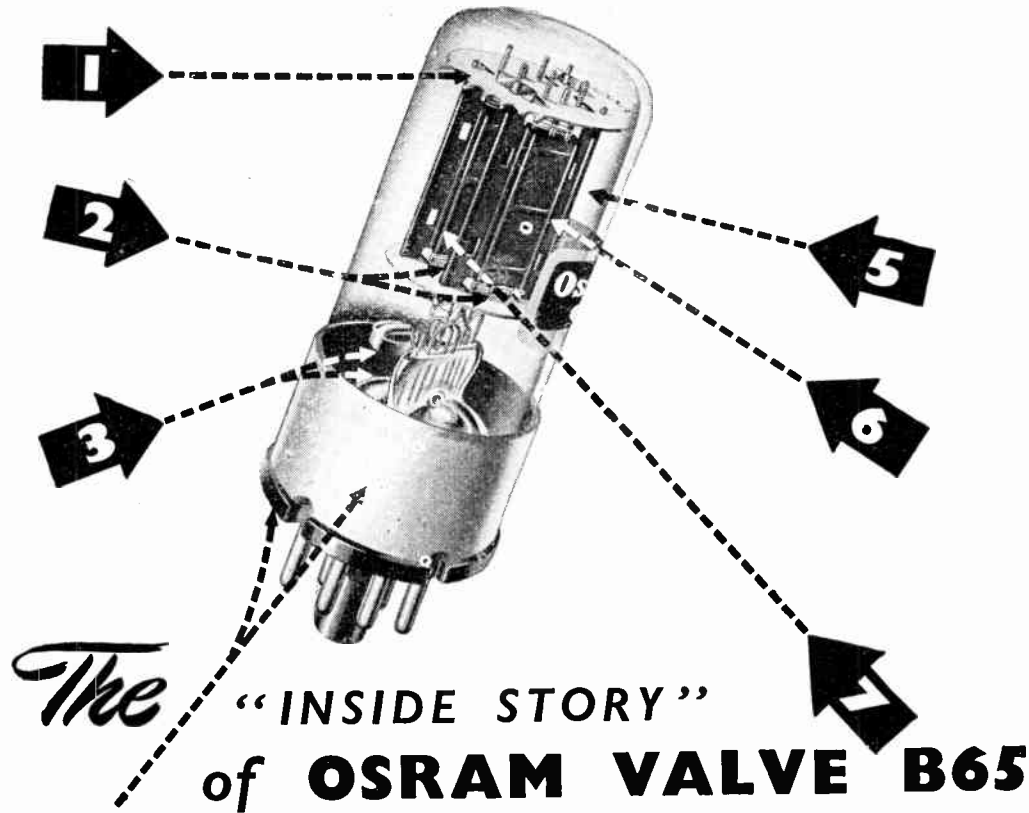

The "INSIDE STORY"
of **OSRAM VALVE B65**

This is a double triode designed for use in push-pull, parallel or cascade circuits. The valve is octal based, compact in design, and apart from the common 6.3 volt. 0.6 amp. heater, the two sections are entirely independent.

- 1** MICA SPACER — anchors the various electrodes in accurately locked positions. It is sprayed with magnesia to provide high surface insulation.
- 2** CONTROL GRIDS — Molybdenum wire wound onto copper rod supports.
- 3** GETTER CUP & PATCH. The metal barium, contained in the cup is deposited in a silvery film on the inside wall of the bulb. It maintains a high vacuum condition during the life of the valve.
- 4** TWO PART BASE ensures reliable fixture of base to bulb.
- 5** ANODES are carbonised externally to enhance heat radiation.
- 6** ANODE RIBBING. Designed to impart additional mechanical strength to anode assembly.
- 7** EYELETS for easy assembly of anode plates. Reducing spot welding to a minimum.



| | | |
|-----------------------------|------------------------------------|------------------------|
| Osram PHOTO CELLS | G.E.C. CATHODE RAY TUBES | Osram VALVES |
|-----------------------------|------------------------------------|------------------------|

THE GENERAL ELECTRIC CO., LTD., MAGNET HOUSE, KINGSWAY, W.C.2.

The best—

HIGH
and
LOW



Exide

L.T. ACCUMULATORS

and

Drydex

H.T. BATTERIES

for better
battery radio reception

ISSUED BY THE CHLORIDE ELECTRICAL STORAGE COMPANY LIMITED

M.R. SUPPLIES Ltd.

will always be to the forefront with the most dependable offers in **Electro-Technical Material**. Full and fair descriptions. Immediate delivery. Latest list sent with each despatch. All prices nett.

HIGH-DUTY BATTERY CHARGERS. Operation 200/230 v. 50 c. Total D.C. delivery 60 v. 21 amps., divided into three controlled and metered banks, 60 v. 5.5 amp., 60 v. 5.5 amp., 60 v. 10 amp. Metal rectified. Automatic overload protector. In steel cabinet, ht. 36in., wdth. 31in., dpth. 24in. Weight approx. 2 cwt. With all leads, etc., in good order and condition, repainted outside, £22/10/- (ex this address)

VOLTAGE CHANGING TRANSFORMERS, double-wound. 200/250 v. (in 10 v. taps) to 115 v., loading 2.5 kVA. (nominal—capable of higher loading). Enclosed in steel housing approx. 18in. by 16in., by 11in., 85". Also a few double-wound, input 230 v., output 115 v. (no taps), loading, nominal, 1 kVA., housing 17in. by 11in., by 8in., 62/6. Carriage either 3/6.

FULL-WAVE SELENIUM RECTIFIERS (S.T.C.) D.C. delivery 24 v. 2.5 amps. (A.C. input 30 v.). Special opportunity, 16/6 each.

MICROAMMETERS, 31in. flush mt., centre-zero, 500-0-500 micro-amps., first-class maker, brand new. Perfect as sensitive galvo., 22/6. Also Miniature side-zero model, 0-500 micro-amps., only 1 1/2in. diameter, with fixing ring, 10/6. 3 1/2in. flush mt. AMMETERs. 0/15 mps., first-grade m/iron, calibrated at 50 c., 17/6.

RELAY BANKS. Each bank contains four P.O. type Relays, 1,000 ohms, coil with 6 change-over switches and one ditto, with 2 c.o. switches. Wired to terminal panel and relays enclosed in brass housing 6in. by 3 1/2in. by 2 1/2in. with terminal panel projecting. All brand new, 18/6.

MINIATURE RELAYS. Note the very small dimensions, 1 1/2in. by 3/4in., type 10P/274. Coil 65 ohms, switching 2 single-pole C.O. (paired contacts—platinum), 7/6 each. Special price for quantities.

M/COIL SPEAKER-MICROPHONE UNITS (Goodman), 3 1/2in. with massive aluminium magnet, coil 13 ohms, perfect as extension speaker, or microphone and right for intercom. Very limited quantity at 2/6 each. Also 5in. Plessey, P.M. m/coil 2/4 ohms, coil, with transformer, at 12/6 each.

PUBLIC ADDRESS SPEAKERS, m/coil pressure type P.M. Units, 15-ohms, coil, with 600-ohm line multi-matching transformer, in weatherproof housing, 10 watts complete with 30in. all-metal dispersive horns, (reconditioned perfect), 25/5/-, cart. paid. Or same unit with 42in. all-metal exponential Horn, with detachable flare (Horns brand new), 27/15/- (despatch 3/6). These are unbeatable P.A. opportunities.

SIGNAL HORNS, operation 200/250 v. A.C. Good strident note, adjustable. In completely weatherproof housing 6in. by 3in. by 3in., with cast metal horn projecting 7in., with mounting flange. For alarm or calling signals in factory or open-air, 32/6.

ELECTRIC WATER PUMPS. Brand new, immersion, self-priming. Approx. 18in. long and 2in. dia., with mounting flange. Impeller is driven by a precision motor within the tube. Delivery over 300 g.p.h. Operation 12/24 v. AC/DC, 22/6. Or with Transformer, especially made to enable the pump to be used on 200/250 v. A.C. mains, 47/6 complete (dss. 2/-). We are the largest London stockists of the well-known Stuart Electric Water Pumps, operation 220/250 v. AC/DC. Soudly constructed of non-ferrous metals and patented features for exposure and long life. No. 10 (120 g.p.h.), 25/15/-, No. 11 (300 g.p.h.), 27/2/6. No. 12 (600 g.p.h.), 28/10/- (despatch first two, 2/-; No. 12, 3/6). Supplied with instruction book and makers' guarantee.

Please include sufficient for packing/despatch.

M. R. SUPPLIES Ltd., 68, New Oxford Street, London, W.C.1

Telephone: MUSeum 2958

MODERN SERVICING METHOD

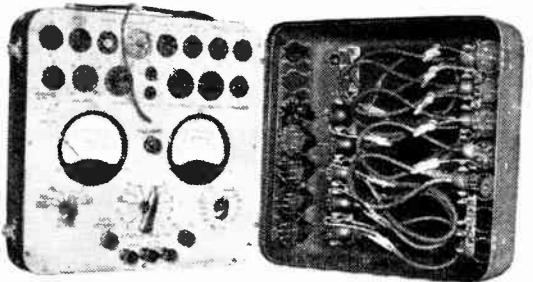

The "L.S.L." Servicing Method is a combined fault analyser and circuit tester; simultaneously capable of indicating all voltage, current and resistance on each valve electrode without removing the chassis from the cabinet. Readings can be taken whilst the set is under actual operating conditions. The "L.S.L." Analyser is a combination of multi-range instrument and valve tester.

PRICE: £18. 18. 0 Subject.

THE "LSL" PORTABLE ANALYSER

- ★ Saves time and trouble.
- ★ Greatly increases Profit in the Service Department.
- ★ Is portable, can be used on the bench or in the home
- ★ Is simple to operate.

Send for further particulars from the sole distributors:



WARTON ROAD, STRATFORD, LONDON, E.15.

Telephone: Maryland 6111 AND BRANCHES

Export Address: 23-26 St. DUMSTANS HILL, E.C.1

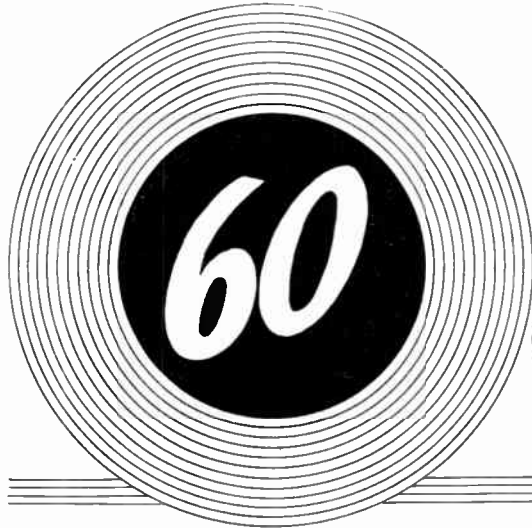

'CINTEL' Photo-Electric Cells

The most comprehensive range of Cells in the World...

Available with three types of cathode surfaces :—

TYPE A—Antimony-Caesium. (British Patent No. 522,752 1938). Sensitive to blue light and daylight.

TYPE B—Bismuth etc.—Caesium. Sensitivity similar to human eye.

TYPE S—Silver - Oxygen - Caesium. Red - infra - red sensitive.

Cells for use in the ultra violet region of the spectrum • Cells of high insulation, linearity and stability for accurate photometric work • American type equivalents • Push-Pull types for double sound tracks • Special cells for dye image sound tracks, multipliers, etc. *Please write for catalogue.*

Sixty different types of Photo-Electric Cells

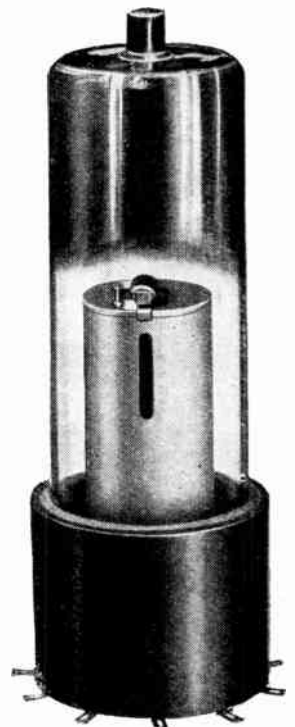

— from miniature to multiplier —



Registered Trade Mark

FOREMOST IN THE MANUFACTURE OF

- COUNTERS & CHRONOMETERS
- METAL DETECTORS
- OSCILLOSCOPES
- PHOTO-ELECTRIC CELLS
- CATHODE RAY TUBES
- GEIGER-MULLER TUBES
- ELECTRONIC INSTRUMENTS

CINEMA - TELEVISION LIMITED

WORSLEY BRIDGE ROAD, LONDON, S.E.26

Telephone: Hither Green 4600

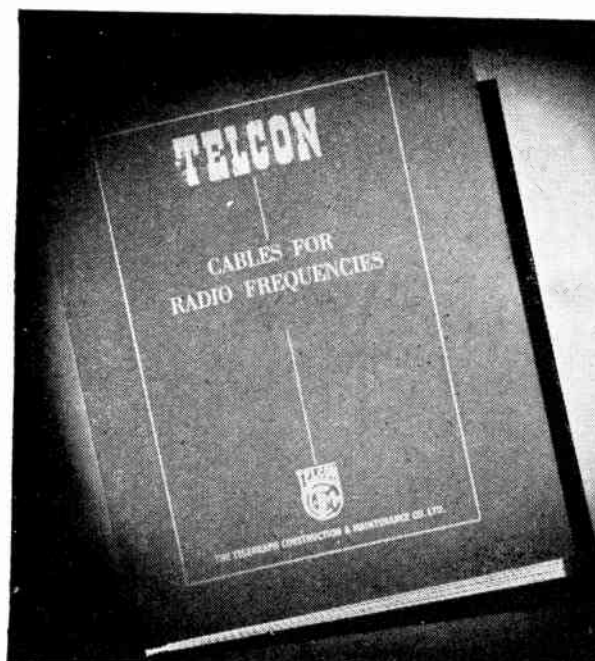

★ **The basis**
of world
standards



Full details of these cables may be had on application

THE TELEGRAPH CONSTRUCTION & MAINTENANCE CO. LTD.
Head Office: 22 OLD BROAD STREET, LONDON, E.C.2. Telephone: LONDON Wall 3141
Enquiries to TELCON WORKS, GREENWICH, S.E.10. Telephone: GREENWICH 3291

SMALL · EFFICIENT · INEXPENSIVE
OSMOR "Q" COILPACKS

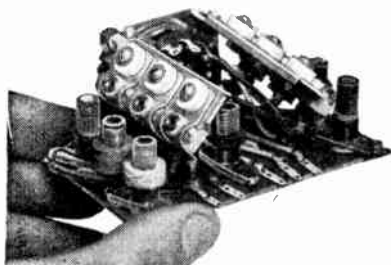

Put PUNCH into a circuit!

ONE-HOLE FIXING — NO WHISTLES
PRE-ALIGNED, WITH FULL CIRCUITS & INSTRUCTIONS SUPPLIED

All your coil and switching problems are
solved, just by making 5 connections

★ Write for our list of coils, coilpacks, dials,
and matched radio components, all at really
competitive prices

OSMOR RADIO PRODUCTS LTD.

BRIDGE VIEW WORKS, BOROUGH HILL, CROYDON, SURREY

Tel: CROYDON 1220.

TELEVISION COMPONENTS by well known manufacturer, complete tube mounting assembly, focus and deflection coils, line output trans., 4 heavy duty chokes, 5 kVA., E.H.T. trans., one each of the following, 350.0-350 v., 80 mills., 4 v. 10 amp., 4 v. 2 amp., 400.0-400 v., 80 mill., 4 v. 6 amp., 4 v. 2 amp., 2 v. 2 amp. Most of the valves used in this circuit are SP41. Kindly note: we do not supply valves. Complete with full circuits..... **£7/10/-**

½ meg. volume con., long spindle with switch... **3/10**

¼ MEG. POT WITH SWITCH LONG SPINDLE **3/3**

20K pot long spindle **1/9**

50K pot with switch long spindle **3/-**

1 meg. pot medium length spindle **1/9**

8 position press button unit, not surplus..... **2/4**

4 position press button unit, one pos. mains on/off **1/9**

8in. Mains Energised 2000 ohm field, output trans., 5000 ohm imp. **15/9**

Plus post, 1/-.

Set of four 1½ dia. brown knobs, marked

"Tuning, Volume, Wavechange and Tone," in

gold lettering per set **2/-**

EXTENSION SPEAKER, in Walnut cabinet,

Walnut louvres, volume control, R. & A. high fidelity

8in. speaker. Size of cabinet, 11in. high, 17in. long,

8in. deep, sloping to 6in. at top. Switch for cutting

out speaker on back. 39/6, plus 2/6 post and pack.

Write for lists.

D. COHEN

67 Raleigh Ave., Hayes, Middx.

Sensitivity

The bat is said to derive its amazing sensitivity in flight from the echo of a high pitched sound which it emits. The Weston Model E772 Analyser, however, relies upon the more tangible asset of a sensitivity rating of 20,000 ohms per volt on all D.C. ranges and 1,000 ohms per volt on all A.C. ranges. This instrument is designed to assist you in the tracing of difficult electrical faults and its quality is in accord with the highest Weston standards.

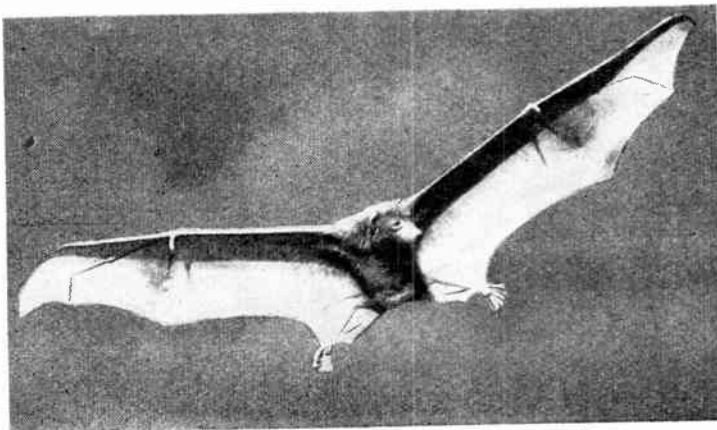

E 772 WESTON *Analyser*

SANGAMO WESTON LTD. • ENFIELD • MIDDX.

Telephone: Enfield 3434 (6 lines) & 1242 (4 lines)

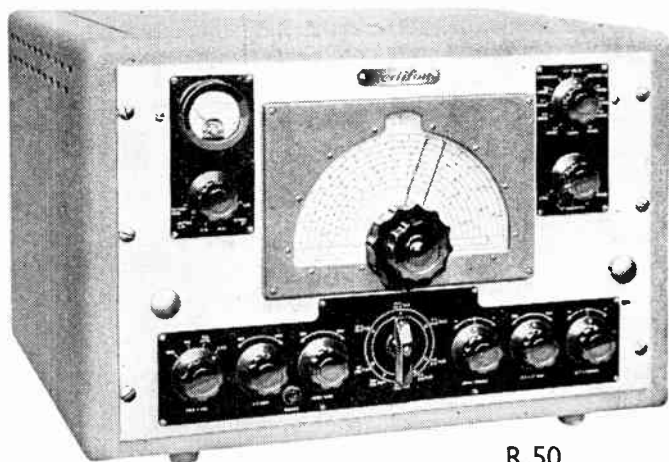

R.50

COMMUNICATIONS RECEIVER

This high-grade communications receiver incorporates the most highly developed techniques in modern receiver design. Five degrees of selectivity, including a crystal gate and crystal filter are provided, and the sensitivity is such that an input of between 1.5 microvolts gives a signal/noise ratio of at least 10 dB over the entire frequency range of 13.5 to 26 kc/s and 95 kc/s to 32 Mc/s. Separate power units for A.C. or D.C. operation are available.

Supreme
Communications
Receiver

COMMUNICATIONS
Redifon
Radio

REDIFFUSION LIMITED, BROOMHILL ROAD, WANDSWORTH, S.W.18

DESIGNERS & MANUFACTURERS OF RADIO COMMUNICATION & INDUSTRIAL ELECTRONIC EQUIPMENT Phone PUTney 5691 RC 208

Taking the Mountain to Mahomet!

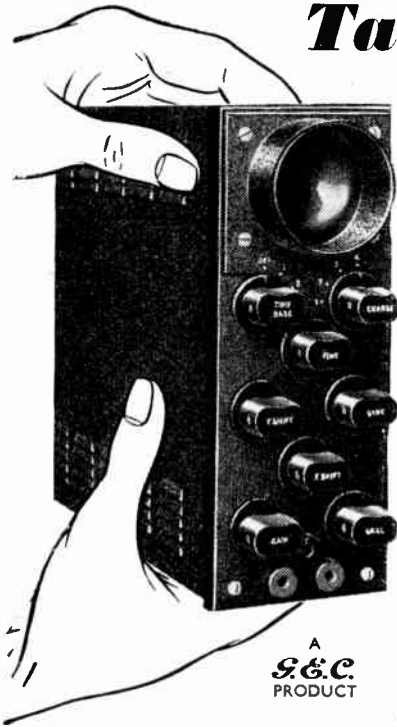

A
G.E.C.
PRODUCT

The oscilloscope is no longer the 'great immovable' to which all faulty 5-Valve Mahomets have to be brought! For the "Miniscope" (Height 6 $\frac{3}{4}$ "") is no mountain at all. It weighs only 7 $\frac{1}{2}$ lbs., is truly portable and need never be out of reach in the workshop or on any service call, in fact anywhere where there is an A.C. mains supply. The oscilloscope is the most versatile single item of equipment yet designed for the radio service man. The "Miniscope" is the most compact of all oscilloscopes.

**SIGNAL TRACING · FAULT DETECTION
HUM LOCATION · PHASE INVESTIGATION
I.F. ALIGNMENT · FREQUENCY RESPONSE
FREQUENCY DETERMINATION · WAVE-FORM OBSERVATION · A.F. DISTORTION CORRECTION · MODULATION ANALYSIS
OSCILLATOR CALIBRATION**



Miniscope

MINIATURE CATHODE RAY OSCILLOSCOPE

Full specification from : THE GENERAL ELECTRIC CO. LTD., MAGNET HOUSE, KINGSWAY, LONDON, W.C.2



FOR THE RADIO SERVICEMAN DEALER AND OWNER

The man who enrolls for an I.C.S. Radio Course learns radio thoroughly, completely, practically. When he earns his Diploma, he will KNOW radio. We are not content merely to teach the principles of radio, we want to show our students how to apply that training in practical, every-day radio service work. We train them to be successful.

Write to the I.C.S. Advisory Dept. stating your requirements. Our advice is free.

.....You may use this coupon.....

INTERNATIONAL CORRESPONDENCE SCHOOL Ltd.
DEPT. 33, INTERNATIONAL BUILDINGS, KINGSWAY, LONDON W.G.2

Please explain fully about your instruction in the subject marked X.
Complete Radio Engineering Radio Service Engineers
Radio Service and Sales Advanced Short-Wave Radio
Elementary Electronics, Radar and Radio

And the following Radio Examinations:—

British Institution of Radio Engineers
P.M.G. Certificates for Wireless Operators
City and Guilds Telecommunications
Wireless Operators and Wireless Mechanics, R.A.C.

I.C.S. Students for Examinations are coached till successful!

Name..... Age.....
(BLOCK LETTERS PLEASE)

Address.....



Metal work—by Ritherdon's

INSTRUMENT CASES
AMPLIFIER RACKS
RADIO AND TELEVISION CHASSIS
FUSE BOXES
BUSBAR CHAMBERS
GENERAL SHEET METAL WORK, Etc.

RITHERDON & CO. LTD.
LORNE STREET, BARKWELL, LANCES
Phone Barwen 1020
ESTABLISHED 1895



DIRECT RECORDING DISCS

These cellulose lacquer aluminium discs are unequalled for their high performance — a frequency range extending to well above 10 Kc/s is easily recorded and reproduced. They consistently permit efficient cutting over a range of ambient temperatures of from 0°C. to 60°C. Used by leading broadcasting stations, film studios, private and commercial recording studios. Can be stored indefinitely either blank or recorded.

| CURRENT LIST PRICES | |
|----------------------|--------|
| 5 in. Double Sided | 1/6d. |
| 6 in. Double Sided | 2/0d. |
| 7 in. Double Sided | 2/6d. |
| 8 in. Double Sided | 3/0d. |
| 10 in. Double Sided | 4/6d. |
| * Single Sided | 3/8d. |
| 12 in. Double Sided | 6/6d. |
| * Single Sided | 5/3d. |
| 13 in. Double Sided | 8/9d. |
| * Single Sided | 7/9d. |
| 16 in. Double Sided | 14/6d. |
| * Single Sided | 11/0d. |
| 17½ in. Double Sided | 17/6d. |
| * Single Sided | 13/6d. |

MASTER RECORDINGS FOR PROCESSING

M.S.S. Discs are ideally suited for recording "Masters" for processing. "Over-size" discs are necessary — for pressings 16", 12", 10" diam. use discs 17½", 13", and 12" diam. respectively.

M.S.S. RECORDING COMPANY LTD.
POYLE CLOSE, COLNBROOK, BUCKS., ENGLAND

the 'TOPS' in TELEVISION

Aerialite Television Aerials are being installed as fast as they can be produced. Good technical design, ease of fitting and robust construction, are all strong points of the entire Aerialite range. For clear, sharp, steady pictures with never a "ghost", Aerialite, the television aerial for all circumstances, is the name to remember. Send for illustrated booklet giving full details.

Sell

AERIALITE TELEVISION AERIALS and EQUIPMENT

for the Pictures at Home

Made by AERIALITE LTD., STALYBRIDGE, CHESHIRE

You simply MUST make a WIRE RECORDER

CAPSTAN (PULLING WIRE AT CONSTANT SPEED)

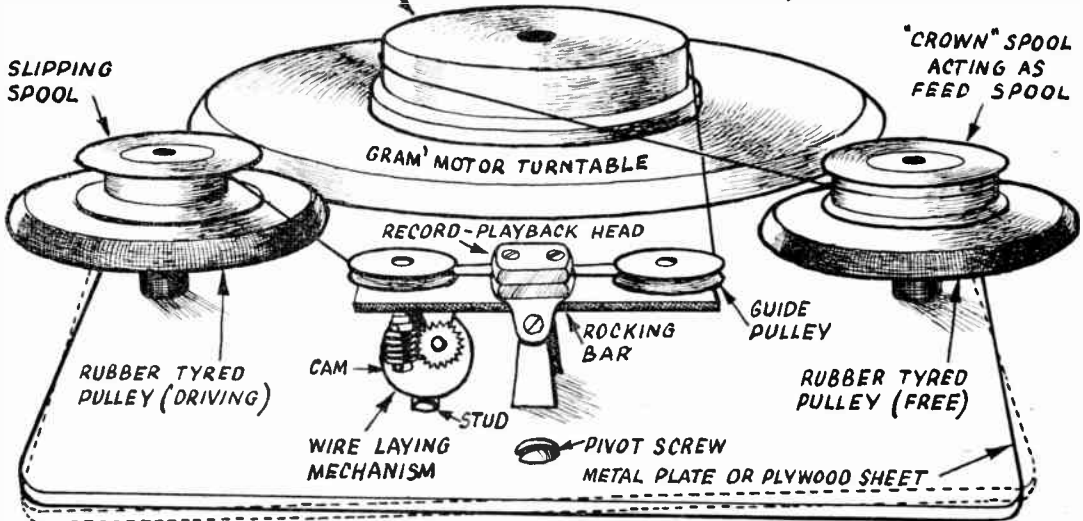

More thrilling than Radio—More gripping than Television. Complete constructional "Gen," 5/-.
All Components in stock. DEMONSTRATIONS BY APPOINTMENT.

PARK RADIO 676-8, Romford Road, London, E.12 Phone: ILFORD 2066



READ THIS!

The flick of a switch gives you instant contact with any department. All departments can contact each other. **THE HADLEY MULTICOM** is the only system of its kind to give you complete loud-speaking intercommunication. No 'phones, no dialling, no switchboard operator. All units identical and no larger than a telephone.

All Hadley Equipments are available on Cash Purchase or Rental Maintenance Terms.

Hadley

All export enquiries to Charles Baglin, 411 Coventry Road, Birmingham, 10. Telegrams: Pentagons, Birmingham.

Sound Equipments
Phone: BEARWOOD 2575/6 BEARWOOD ROAD, SMETHWICK, STAFFS

| | | |
|---|---|--|
| <p>De Luxe Ribbon MIKES USA make on heavy 11" table stand. 8ft cord and jones plug. Stand - by SW for HT or relay 6/6s. Post FREE</p> | <p>USA make H.R. LUXURY PHONES • 2000Ω • Miniature units with sorbo pads 10/6 PER PAIR Post 9"</p> | <p>I.F.T.s 455 Kc/s, 3 1/2" x 1 1/2" square. Adjustable dust iron cores. 5/- Post 6"</p> |
| <p>TELEPHONE Handsets Latest type, carbon mike, brand new in makers cartons. 4-way lead & plug. 10/6 Post 9" each.</p> | <p>It's EASY! BUILD YOUR OWN HR METER to read 10,000v. or 20 megohms Brand New 0-100 μA meters By well known British makers. In original boxes sealed 0-1500 I. 21/- Post 2" Limited number re-sealed 0-100μa and checked against BSI standard. 25/- Post 2"</p> | |
| <p>Carbon brass mike and single 80Ω headphone. Neckband & 4-way cord & plug. 7/6 PER SET Post 9"</p> | <p>Many more bargains in latest lists! Free on request. FRITH RADIOCRAFT Ltd. PHONE 58527 69-71 CHURCH GATE-LEICESTER Stockists for DENCO • WODEN • EDDYSTONE RAYMART • BI • LEWCOS • WHARFEDALE Etc.</p> | |
| <p>Brass TERMINALS Length 1 1/2" x 4BA + captive head. Slotted for easy wire connection. 24 for 5/- Post 9"</p> | | |

Another **GOODMANS** Axiom



HIGH (FIDELITY + POWER)

With an exceptionally high electro-acoustic efficiency, this new version of the well-known "Axiom Twelve" has been developed to satisfy the great demand for High Fidelity power reproduction.

Send for illustrated leaflet D79



GOODMANS INDUSTRIES LTD.,

Cancelor Rd., Wembley, Middx. Phone: Wembley 1200. Grams: Goodaxiom, Wembley

Covering both London and Birmingham television frequencies

- Negligible stray Radiation. ● Output accuracy 1db
- Monitored by Crystal Voltmeter
- Directly Calibrated ● Negligible R.F. Leakage

FEATURES

- CALIBRATION ACCURACY:** $\pm 1\%$, Directly Calibrated.
- OUTPUT VOLTAGE:** $1\mu\text{V}$ — 150 mV up to 30 Mc/s. $1\mu\text{V}$ — 100 mV above 30 Mc/s. Monitored by crystal voltmeter.
- OUTPUT IMPEDANCE:** 75 ohms, terminated by 75 ohms terminating pad, type TP.1A providing impedance of 37 ohms, 10 ohms, and 10 ohms standard dummy aerial.
- MODULATION:** Monitored by crystal voltmeter Internal: 400 c/s. 0-50%. External: 100-10,000 c/s $\pm 6\text{db}$, 0-80%.
- AUDIO-OUTPUT:** 0-15 volts at approximately 400 c/s into a load not less than 5,000 ohms.
- R.F. LEAKAGE:** Negligible—less than $1\mu\text{V}$.
- POWER SUPPLY:** 110-210-230-250 volts, 40-100 c/s, 22 watts.
- DIMENSIONS:** 13 ins. \times 12 ins. \times 6 ins. deep.
- WEIGHT:** 25 lb.

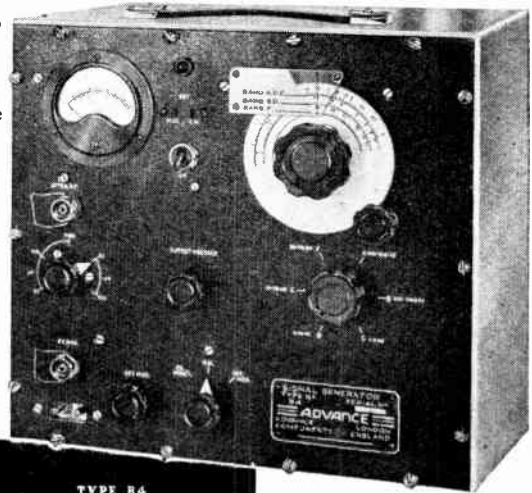

TYPE B4
Advance SUB-STANDARD
SIGNAL GENERATOR

Model A
100 Kc/s to 70 Mc/s in 6 Bands.

Model B
30 Kc/s to 30 Mc/s in 6 Bands.

Send for illustrated brochure giving full Specification.

ADVANCE COMPONENTS LTD., BACK RD., SHERNHALL ST., WALTHAMSTOW, E.17. Phone: LARkswood 4366-7-8

EDISWAN RADIO PRODUCTS

B.E.C. Electrolytic Condensers

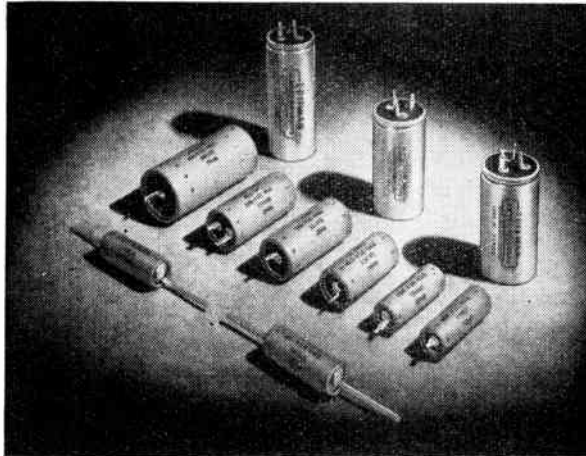

| Capacity Mfds. | D.C. Working Voltage | External Size | List Price |
|----------------|----------------------|-----------------|------------|
| 4 | 450v | 1 1/8" x 2 3/4" | 3/3 |
| 8 | 450v | 1 1/8" x 3 1/4" | 4/0 |
| 16 | 450v | 1 1/8" x 3 3/4" | 4/9 |
| 4 | 450v | 1 1/8" x 2" | 2/6 |
| 8 | 450v | 1 1/8" x 2" | 3/0 |
| 16 | 450v | 1 1/8" x 2" | 4/0 |
| 32 | 450v | 1 1/8" x 2" | 5/9 |
| 8-8 | 450v | 1 3/8" x 2 3/4" | 5/9 |
| 8-16 | 450v | 1 3/8" x 2 3/4" | 7/6 |
| 16-16 | 450v | 1 3/8" x 3 1/4" | 7/9 |
| 20-20 | 275v | 1 1/8" x 2 3/4" | 6/0 |
| 50 | 12v | 1 1/8" x 1 3/8" | 2/0 |
| 25 | 25v | 1 1/8" x 1 3/8" | 2/0 |
| 25 | 50v | 1 1/8" x 1 3/8" | 2/3 |
| 50 | 50v | 1 1/8" x 1 3/8" | 2/6 |
| 8 | 150v | 1 1/8" x 1 3/8" | 2/6 |

* Fitted with 1 1/2" tags each end.

For full details of the range of B.E.C. Electrolytic Condensers please write for leaflet **No. R.1395**

SOLE DISTRIBUTORS TO THE WHOLESALE & RETAIL TRADES

THE EDISON SWAN ELECTRIC CO. LTD., 155 Charing Cross Road, London, W.C.2
BRANCHES IN ALL THE PRINCIPAL TOWNS

v.86A

THE SOUND MAGNET £35 TAPE RECORDER & PLAYBACK EQUIPMENT



Recordings on plastic tape from 8 inch reels. Variable speeds, 30 mins. high fidelity full frequency range. Speech up to 2 hrs. Complete with 6 valve amplifier, bias oscillator, self-contained speaker.

Book your orders now. Brochure & Specification sheet for 2½d. stamp.

GENERAL LAMINATION PRODUCTS LTD.
S.M. Dept., 294 BROADWAY, BEXLEYHEATH, KENT

JOSEPH ENOCK LTD.

Manufacturers and suppliers of the Enock Diamond Pick-up, the Enock Amplifier and the Mordaunt Loud Speaker, all built to the exacting specification which has made the Enock Instrument the finest music reproducer in the world.

JOSEPH ENOCK LTD., 273a HIGH ST. BRENTFORD,
ENGLAND.
EALING 8103

"TECHNICAL EXCELLENCE"

—combines with beauty and soundness of DESIGN in the

OXLEY

[AIR DIELECTRIC TRIMMER]

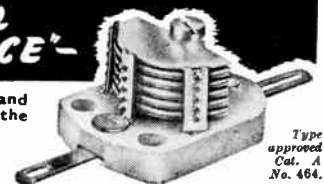

Type approved
Cat. A
No. 464.

Width: 16.5 m/m. Length: 22 m/m. Height: 1.5 to 8pF—7.5 m/m. 1.8 to 20pF—10 m/m. 2 to 26pF—11 m/m. 2 to 32pF—12 m/m. Law: Straight line capacity. Power Factor: Less than .001. Insulation: Over 2,000 megohms. Voltage: 500 DC

OXLEY DEVELOPMENTS CO. LTD.
ULVERSTON, NORTH LANCs. TEL.: ULVERSTON 3306

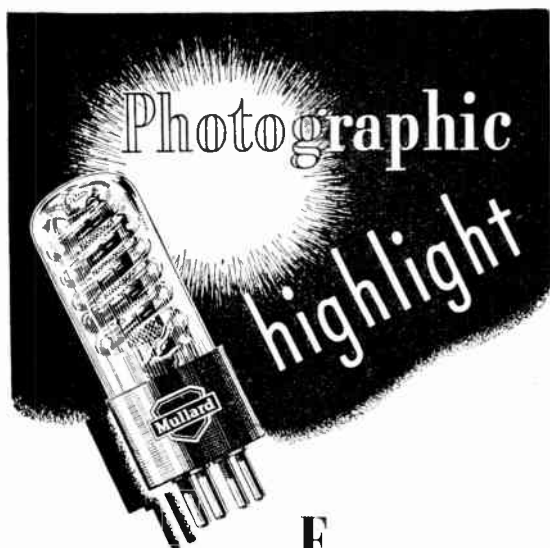

ELECTRONICALLY, the Mullard LSD3 is an extremely efficient light source device. Photographically, it is the ideal tube for lightweight portable equipments because of its compact dimensions, stable triggering and low trigger voltage, and very long life.

Some data is given here, and if you would like full details, including recently published articles on flash circuits, please write to the address below.

PRINCIPAL CHARACTERISTICS OF LSD3

| | |
|--------------------------|---------------------------------|
| Max. Energy of Discharge | 100 joules |
| Operating Voltage | 2,000-2,700V |
| Trigger Voltage | 3,000-3,500V |
| Approx. Flash Duration | 150 micro-secs |
| Peak Light Output | 40 mega-lumens |
| Integrated Light Output | 4,000 lumen-secs |
| Base | 4-pin U.X. |
| Light Quality | ... Closely resembling daylight |

Basic circuit for portable battery-operated flash equipment

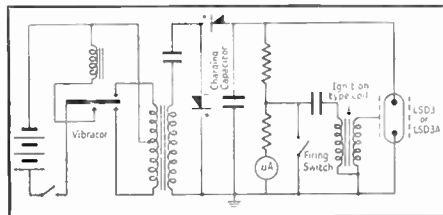

Mullard

Thermionic Valves & Electron Tubes
Mullard Electronic Products Ltd., Transmitting & Industrial Valve Dept., Century House, Shaftesbury Avenue, W.C.2.

MVT 50

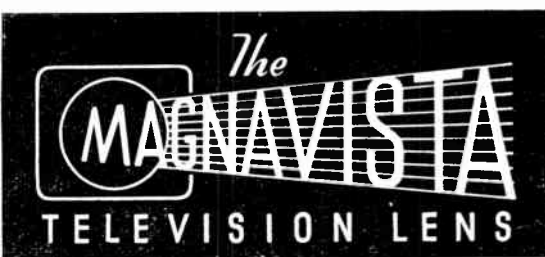

ONLY A MAGNAVISTA SHOWS TELEVISION AT ITS BEST

To the non-technical televiewer we simply say "look at the image through a Magnavista Television Lens." If your own eyes don't convince you that you are looking at a bigger, better and brighter picture, then Magnavista is not the best lens made—and we know that it is.

To the connoisseur and the technically minded there is much more that we can add. We can point out that consultation with eminent independent authorities on lens computation has led to the production of an optically correct television lens—one that gives HIGH MAGNIFICATION WITHOUT DISTORTION, AMAZING CLARITY PLUS A WIDE ANGLE OF VIEW. But it still comes back to this—only with a Magnavista can you see television at its best.

PRICES

| TYPE | Tube | £ | s. | d. |
|-------------------------|-----------|---|----|----|
| A.7 | 6" | 3 | 3 | 0 |
| A.1, A.2, A.4, A.5, A.8 | 9" | 4 | 14 | 6 |
| B.1, C.1... | 10" & 12" | 5 | 5 | 0 |
| D.1 | 15" | 5 | 15 | 6 |
| A.3 (Universal) | 9" | 6 | 16 | 6 |
| B.2 (Universal) | 10" | 7 | 7 | 0 |

There is a Magnavista Model for every television receiver.

MAGNAVISTA Magnification is Television Perfection

METRO PEX LTD

38, Gt. Portland St., London, W.1
(Phone: Museum 9024-5)

"STEWART" HIGH GRADE TRANSFORMERS

Types Available for Delivery ex Stock

ANY OTHER SPECIFICATION TO ORDER

Primaries tapped 210-230-250v.

| Type No. | Secondaries | Price |
|----------|--|--------|
| A6 A4 | 350-0-350v 75 m/a 6.3v 3a 5v 2a or 4v 4a 4v 2a | 28/6d. |
| B6 B4 | 350-0-350v 100 m/a 6.3v 3a 5v 2a or 4v 5a 4v 2a | 34/6d. |
| C6 C4 | 350-0-350v 150 m/a 6.3v 4a 5v 3a or 4v 6a 4v 2.5a | 46/6d. |
| S/28/1 | 425-0-425v 200 m/a 6.3v 4a 6.3v 2a 5v 3a | 57/6d. |
| S/28/2* | 350-0-350v 250 m/a 6.3v 6a 4v 8a 0-2-6.3v 2a 0-4-5 v 3a | 90/-d |
| S/24/1 | 1000v 10 m/a | 40/-d. |
| S/24/2 | 1750v 10 m/a | 45/-d. |
| S/24/3 | 2500v 10 m/a | 55/-d. |
| S/24/4* | 4000v 5 m/a | 63/-d. |
| S/24/5* | 5000v 5 m/a | 75/-d. |

* For "Electronic Eng." Televisor.

STEWART TRANSFORMERS Ltd.

1021 FINCHLEY RD., LONDON, N.W.11

Tel.: SPEdwell 3000 and 3533

ITEMS STILL TO BE CLEARED REGARDLESS OF COST

| | | |
|--|--------------------|-----|
| Test prods with leads Red and Black | each | 2 6 |
| 7-Pin plug and socket | | 2 0 |
| Chromium plated handles, 4½in. centres | per pair | 5 0 |
| Chromium plated handles, 3in. centres | per pair | 6 6 |
| Potentiometers, standard size 500 ohms, 4K, 2.5K, 25K...3 | | 4 6 |
| Potentiometers, 10,000 ohms wire wound | each | 1 0 |
| Potentiometers, 25,000 ohms wire wound | each | 1 0 |
| Potentiometers, 50,000 ohms wire wound | each | 1 0 |
| Standard size tuning condensers, 2-gang 160 pfd. | each | 3 9 |
| Standard size tuning condensers, 3-gang 160 pfd. | each | 4 6 |
| Standard size tuning condensers, 4-gang 500 mfmfd. | each | 7 6 |
| Condensers, assorted, .001 mica, .001 ceramic, .01 mica, .01 tubular, 10 pfd. mica, 10 pfd. ceramic, .005 tubular, .002 mica, .0005 mica | per assorted dozen | 5 0 |
| Medium sized plated brass terminals | per doz. | 3 6 |
| Large brass terminals | per doz. | 2 6 |
| Clarostat plug in main dropping resistances 445 ohms | each | 5 0 |
| Instrument knob, black, 2½in. fluted, ½in. spindle | 6 for | 5 0 |
| Resistances, carbon, 1, ½, and ¼ watt from 27 ohms—3.9 meg. our choice | 50 assorted resis. | 7 6 |

Send stamp for Bargain Price List.

Please quote 5T when ordering and include sufficient for postage and packing, also 1949 catalogue available 9d. post free.

Shop Hours, Monday-Saturday, 9-5.30 p.m. Thursday 9-1 p.m.

TELE-RADIO (1943) LTD.

177, EDGWARE RD., PADDINGTON, LONDON, W.2

'Phone : AMB 5393. PAD 6116, 5606

A NEW B.P.L. INSTRUMENT



THE VOLTASCOPE—A combined valve-voltmeter and oscilloscope. VALVE-VOLTMETER—Infinite Input Resistance for D.C. ranges 0 to 300 volts. A.C. ranges 0 to 150 volts in 5 ranges. 3½ inch scale meter. OSCILLOSCOPE—3 inch screen tube provided with balanced amplifiers for Y and X plates giving a 5 times trace expansion. Maximum sensitivity 150mV/cm. Response from D.C. to 100 kcs.

Limited quantity available for early delivery.

BRITISH PHYSICAL LABORATORIES

HOUSEBOAT WORKS, RADLETT, HERTS.

Tel: Radlett 5674-5-8

ELECTRICAL & ELECTRONIC DEVELOPMENT

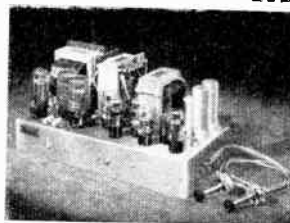

PRESENTING...
**THE FAMOUS
WILLIAMSON
AMPLIFIER**

Precision built by experts to instrument-standards. Special models available for conversion of existing equipment (as illustrated), and for recording and cinema work. Full particulars of this and other productions on application.

HUBERT STREET, ASTON, BIRMINGHAM, 6
Telephone : Aston Cross 2440

D.C. - A.C. CONVERSION

Frequency stability, R.F. and A.F. suppression, with long working life, are but some of the features of Valradio Vibrator converters. We quote two examples here.

12v. INPUT

Model 230/75 12 gives a useful A.C. output at 50 or 75 c.p.s. and is ideal for outdoor P.A. work. 230v. 75 watts A.C.

£10.15.0

110v. INPUT

Model 230 300 110 particularly suitable for television and autoradiograms. A.C. output at 50 or 75 c.p.s. 200-250 v.300 watts.

£16.0.0

VALRADIO LTD.

57, FORTRESS ROAD, N.W.5 GULLiver 5165

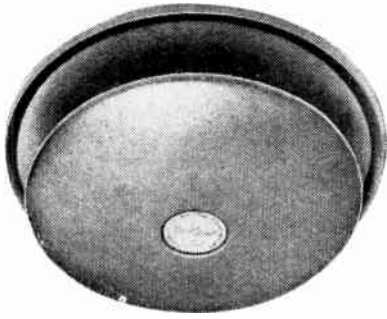

The "STANELECT" type "C-S" Diffusive horn loudspeaker. Weather-proof, Robust, Diecast construction, giving 360° Radiation.

A MILLION USES?!

A slight exaggeration maybe, but this is a "completely different", high efficiency, 12 watt horn loaded loudspeaker.

Its versatility will profoundly influence the effective treatment of sound distribution problems in all spheres.

— for surface mounting, with a protuberance of only 2½" the diameter is 9½"

Standard Electric
LONDON

STANDARD ELECTRICAL ENGINEERING CO., HENEAGE LANE, LONDON, E.C.3.

Telephone : AVENUE 1633.

Cables : "STANECO" LONDON.

Simon
SOUND SERVICE

THE COMPLETE SERVICE
FOR SOUND RECORDING AND
REPRODUCTION

- ★ Mobile, static and specialised recording units
- ★ Recording amplifiers, speakers, microphones, etc
- ★ Sapphire cutting and reproducing stylii
- ★ Blank recording discs from 5in. to 17in. Single and Double-sided
- ★ Groove locating and cueing devices
- ★ A comprehensive range of accessories to meet every requirement of the sound recording engineer
- ★★ A development of special interest to users of sapphire and delicate pick-ups—THE SIMTROL. This is a controlled micro-movement easily fitted for use with any type of pick-up
- ★★★ OUR CDR49A RECORDER UNIT complete and self-contained, measuring only 22in. x 14in. x 13½in., incorporating 8-valve amplifier, recorder unit, light-weight pick-up, speaker and microphone and with many exclusive features, is now ready for early delivery.

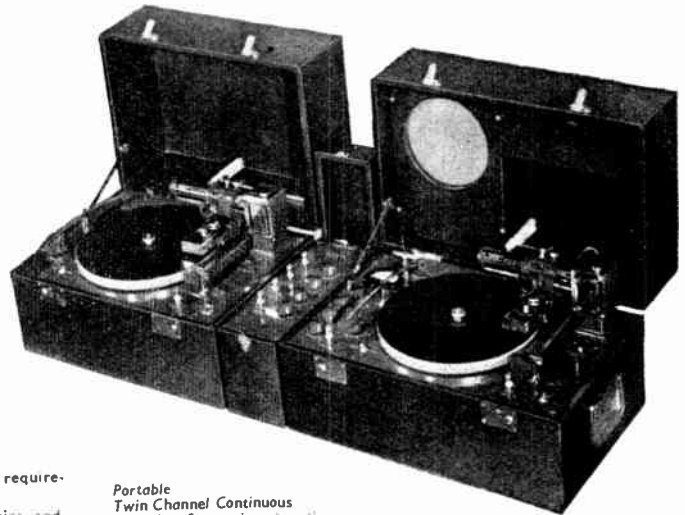

Portable
Twin Channel Continuous
Recording System incorporating
CDR49A Recorder/Amplifier
DR49A Recorder and EM49A Electronic
4 Channel Mixer

**OUR WELL-EQUIPPED WORKSHOPS ARE AVAILABLE FOR THE
DEVELOPMENT OF EQUIPMENT TO MEET SPECIAL NEEDS.**

SIMON SOUND SERVICE, Recorder House, 48/50, George St., Portman Square, London, W.1.

CABLES: Simsale, London.

TELEGRAMS: Simsale, Wesdo, London.

TELEPHONE: Welbeck 2371 (4 lines)

**New
look...
Super
efficiency...**



- Smooth modern lines ; crystal clear reproduction ; simple, positive operation ; the entire staff within your easy reach ; mains or battery operation ; Tele-master's unique advantages increase efficiency and speed modern business.
- Telemaster is the proved interdepartmental loud-speaking telephone, the indispensable assistant to all executives. Selection of extensions is instant and positive and the master unit can call any one, several or all extensions at once. Adjustable volume is provided for loud calling or paging at a distance.
- Models are available for operation by A.C. Mains and batteries. The small, inexpensive dry batteries employed are estimated to last for over six months under normal operating conditions. Both models are identical in appearance and are finished in a new silver grey that will harmonize with any surroundings.
- B.S.R. have specialized in the application of sound in industry for over 17 years. Fuller details of the Telemaster and B.S.R. Industrial Sound units may be obtained from our Industrial Service Division on request.



TELEMASTER

BIRMINGHAM SOUND REPRODUCERS LIMITED

Claremont Works, Old Hill, Staffs.

'Phone Cradley Heath 6212/3

Wireless World

RADIO AND ELECTRONICS

JULY
1949

39th YEAR OF PUBLICATION

Proprietors: ILIFFE & SONS LTD.
Managing Editor: HUGH S. POCOCK, M.I.E.E.
Editor: H. F. SMITH

Editorial, Advertising and Publishing Offices:
DORSET HOUSE, STAMFORD STREET,
LONDON, S.E.1.

Telephone: Waterloo 3333 (60 lines).
Telegrams: "Ethaworld, Sedist. London."

PUBLISHED MONTHLY

Price: 2/-

(Publication date 26th of preceding month)

Subscription Rate: 26/- per annum. Home and Abroad

Branch Offices:

Birmingham: King Edward House, New Street, 2.
Coventry: 8-10, Corporation Street.
Glasgow: 26B, Renfield Street, C.2.
Manchester: 260, Deansgate, 3.

In This Issue

OUR COVER: Vibrator Wave-Form Testing (See Page 260).

| | |
|---|-----|
| EDITORIAL COMMENT | 241 |
| TELEVISION STATION SELECTION. By W. T. Cocking .. | 242 |
| DIVERSITY F.M. TRANSMISSION | 246 |
| TRANSITRON SYNC SEPARATOR. By H. V. Versey .. | 249 |
| ZOOM LENSES. By H. H. Hopkins | 250 |
| TEST REPORT: REDIFON MODEL R50 | 251 |
| INDOOR TELEVISION AERIAL. By N. M. Best and P. J. Duffell | 255 |
| ELECTRONIC CIRCUITRY. By J. McG. Sowerby | 259 |
| CATHODE-RAY TUBES FOR TELEVISION. By Hilary Moss .. | 261 |
| WORLD OF WIRELESS | 264 |
| Q. By "Cathode Ray" | 267 |
| TRIODE-DIODE VOLTMETER. By T. A. Ledward | 272 |
| SHORT-WAVE CONDITIONS | 273 |
| UNBIASED. By "Free Grid" | 274 |
| LETTERS TO THE EDITOR | 275 |
| RANDOM RADIATIONS. By "Diallist" | 278 |
| RECENT INVENTIONS | 280 |

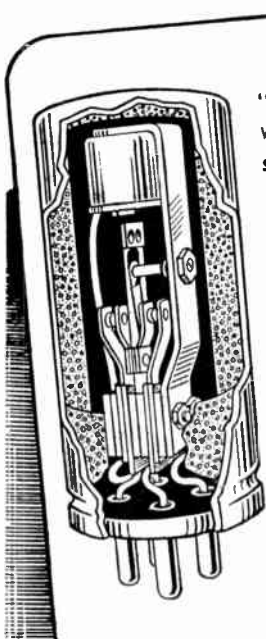

"Stratosil" fully sealed vibrators are supplied in synchronous, non-synchronous and split-reed synchronous types. Being available in both shunt and series drive (the latter being made under "OAK" patents) they offer a replacement service for the majority of American-pattern vibrators as well as covering fully the needs of the designer of new equipments.



VIBRATORS

set the standard for efficiency

A data book, complete with replacement guide and transformer design information is now ready and will be gladly sent to you at 6d. post free. Please use the coupon.

POST THE COUPON NOW

Wright & Weaire, Ltd., 138 Sloane Street,
London, S.W.1, England
Please send me VIBRATOR DATA BOOK for which I enclose 6d.
Name and Address

WW 749

Wright and Weaire Limited

138, SLOANE ST. · LONDON · S.W.1 TEL SLOANE 22145 FACTORY: SOUTH SHIELDS, CO. DURHAM



Valves and their applications

The DL93 as a Power Amplifier at V.H.F.

In the rapidly expanding field of low power V.H.F. communications for Business Radio and similar purposes, the designer often has difficulty in obtaining satisfactory transmitting valves for his equipment, since the

choice of valves suitable for many such applications is severely limited in this country. In particular there still exist few directly-heated miniature types capable of an efficient performance when used as power amplifiers in battery-operated V.H.F. 'walkie-talkie' transceivers.

At the lower V.H.F. frequencies the designer's requirements for an efficient directly-heated power amplifier are

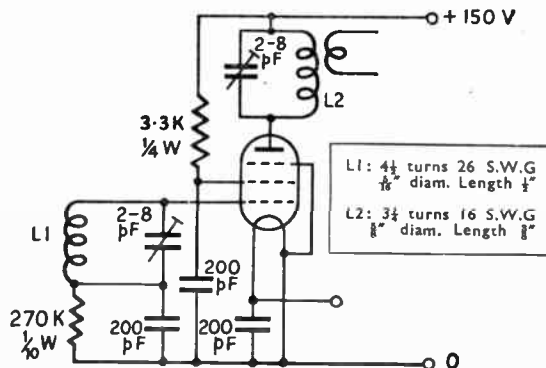

FIGURE 1

as high as 80 Mc/s are not yet generally available, frequency stabilisation entails the use of a master oscillator of comparatively low frequency (15 Mc/s for example) followed by a multiplier chain. Since it is of major importance to minimise the power consumption of the multiplier stages, hearing aid subminiatures such as the DL72 may be used with advantage. The final power amplifier may then be operated from another DL93 as driver. Alternatively, if a reduced power output can be tolerated, the amplifier stage may profitably be driven directly by the final multiplier.

The variation in performance of the DL93 with frequency may be summarised as follows. At frequencies below 100 Mc/s the efficiency and output remain virtually constant, the required drive decreasing with the frequency. It is noteworthy that at frequencies of the order of 5 Mc/s the drive required for full output is unusually low (1.2mW approximately). Thus at these lower frequencies the valve is capable of its optimum performance when driven by a DL72 buffer stage. Above 100 Mc/s the performance deteriorates; the valve will nevertheless give a satisfactory performance in the 144-146 Mc/s amateur band.

The efficiency of the DL93 when used in the 156-184 Mc/s Business Radio band is of the order of 15% to 25%. Details of Mullard miniatures and subminiatures suitable for operation in this and in the 460-470 Mc/s bands will be published in later articles.



Reprints of this report from the Mullard Laboratories, together with additional circuit notes, can be obtained free of charge from the address below.

**MULLARD ELECTRONIC PRODUCTS LTD.,
TECHNICAL PUBLICATIONS DEPARTMENT,
CENTURY HOUSE, SHAFESBURY AVE., W.C.2**

MVM96

| SERIES | | PARALLEL |
|----------------------|-----|--------------|
| V _f . . . | 2.8 | 1.4 V (D.C.) |
| I _f . . . | 0.1 | 0.2 A |
| V _a max. | | 150 V |
| V _{g2} max. | | 135 V |
| V _{g1} max. | | -30 V |
| I _a max. | | 20 mA |
| I _{g1} max. | | 0.25 mA |
| I _k max. | | 25 mA |
| P _a max. | | 2.0 W |
| P _{g2} max. | | 0.9 W |

The above limiting values are for intermittent operation as an R.F. power amplifier.

TABLE 1

met by the DL93. This valve is a miniature pentode on a B7G pressed glass base, and has a low filament consumption. A table of maximum ratings is shown in Table 1.

In the 60-80 Mc/s Business Radio band the valve has a very satisfactory performance. When operated as a conventional Class C amplifier at 80 Mc/s, and driven by another DL93, the valve has a power output of approximately 1.5 watts and an anode efficiency approaching 55%. Figure 1 shows a suitable circuit for use at this frequency.

The circuit contains no unconventional features, and is simple to adjust. Moreover the layout of the components is not critical, although all leads should be kept short. An efficient screen between the grid and anode circuits should be provided. The grid anode capacitance of the DL93 is low and consequently neutralisation is not essential; a neutralised circuit is somewhat easier to adjust, however, and in this case the neutrodyne (Hazeltine) circuit is recommended.

In semi-portable equipment the existing Business Radio regulations allow the DL93 to be operated at its maximum ratings. In "walkie-talkie" transceivers a maximum of 1 watt input to the final stage is permissible, and an anode potential of 90 volts is therefore adequate. Two 45-volt hearing aid layer batteries may be used to provide the H.T. supply.

Since quartz crystals with a natural resonant frequency

Wireless World

VOL. LV. NO. 7

JULY 1949

RADIO AND ELECTRONICS

MONTHLY COMMENTARY :

International Television Argument

W RITING on the possibilities of rivalry between American, British and Dutch firms in international markets for television equipment, our U.S. contemporary, *Electronics* (May, 1949, issue), says, editorially :

"The crux of the matter is the standards to be adopted. Should they follow American or British practice? Evidently, the adoption of one or the other might give a preferred position in the market. So far as studio and transmitting equipment is concerned, it is not difficult to meet the customers' desires regarding standards without major increase in cost. But receivers are different; if foreign standards depart too widely from those used by the manufacturer in his domestic product, the cost of exported sets may rise substantially, possibly enough to price them out of the market."

That is a fair statement of the position. Any competent designer and manufacturer, whether American or European, can provide foreign customers with transmitting equipment for working to any reasonable standards that they may fancy. With receivers, on the other hand, standards are commercially much more important and we enter the realms of Big Business. The country whose standards are adopted by others will have a ready-made export market for its domestic production.

IT is less easy to agree with the substance, and still less with the implications, of the paragraph that follows. It reads :

"We feel strongly that whatever standards are adopted in foreign lands, they should not restrict the utility of the service. Further, at the risk of starting an international argument, we venture to remark that two important aspects of the British standards are restrictive. One is the use of a 2.5-Mc/s video band, as compared with the 4.0-Mc/s standard in the U.S.A. The choice of a narrow bandwidth must inevitably restrict the detail of the images provided to foreign customers. The second is the 25-per-second picture transmission rate, adopted in Britain to conform with the 50-c/s power supply frequency. This limits the brightness of flicker-free images to a value substantially lower than that possible with the 30-per-second American rate."

It is implied here that the ratio of bandwidths is a measure of relative picture quality between the British and American systems. Of course, it is fundamental—even platitudinous—that the information content of any form of radio communication is determined by bandwidth. May we say, then, if the American 4-Mc/s bandwidth is good, the French 10-Mc/s system must be potentially better and a hypothetical 20-Mc/s better still? And where are we to stop? It is hardly practical engineering to argue along these lines, so long as the availability of communication channels is limited and economy must be considered.

IN any case, the comparison made by *Electronics* is factually incorrect. First, the British system employs 2.75 Mc/s—not 2.5 as stated. Secondly, the ratio of bandwidths can only be taken as an indication of relative picture quality if the frame frequency is the same. If the Americans used a 25-frame rate, they would need only a 3.3-Mc/s bandwidth for their present picture quality. The relative quality of British and American pictures is in the ratio 3.3 : 2.75 and not 4 : 2.5 as implied by *Electronics*.

As to the alleged reduction of flicker resulting from the 30-per-second American picture rate, are we seriously asked to believe that it was chosen for that reason? Surely, with the American 60-c/s supply frequency there was no other practicable choice. The use of a frame frequency differing from the mains frequency calls for much more extensive smoothing of receiver h.t. supplies and so increases receiver cost.

With the notable exception of the American continent the world's electrical supply systems are predominantly 50c/s; for this reason the lower picture rate will generally be preferred. Any advantage in freedom from flicker offered by the higher rate is largely academic.

TELEVISION STATION SELECTION

A Look to the Future

By W. T. COCKING, M.I.E.E.

UP to the present British television receivers have been designed for the reception of one station only—the vision and sound channels of Alexandra Palace. When the Birmingham station opens there will be two stations in operation and, according to the present plan,¹ there will eventually be five.

Since all stations are intended to transmit the same programme each receiver will need to receive only one of the stations except perhaps, in certain fringe areas mid-way between two of them. Even here one station will, in general, afford a better signal than the other and so it is necessary only for the receiver to be able to receive this better one.

Even under the new plan, therefore, it will not be necessary for any individual receiver to be suitable for more than a single station. However, there are certain obvious difficulties in manufacturing only single-station receivers; if this course is continued, each maker will eventually have to produce five different models. This alone will increase production costs and, in addition, he will have to regulate the relative quantities made very nicely.

Then viewers do occasionally move their homes, and those changing from the service area of one station to that of another will not expect their receivers to become obsolete.

It is, therefore, likely that the receiver of the future will have to be suitable for any of the five stations. There are many possible ways of doing this and it is interesting to consider their relative merits.

In the first place it is clearly unnecessary for the means of station selection to be operable by the user. If such a control were provided he would use it only on those rare occasions when he moves to a different service area. There is no objection

to such a control if it proves the most economical way of arranging the selection, of course, but it is not a necessary control. All the user requirements can be met by providing a form of station selector which can be adjusted by any competent technician.

One method, which is already being applied, is to build the set so that the signal-frequency circuits, and the oscillator if the receiver is a superheterodyne, form an accessible and replaceable sub-unit. One such sub-unit can be made for each channel and station selection effected by changing sub-units.

The method is obviously better suited to the superheterodyne than the straight set, for this requires only two or three tuning circuits, whereas the latter needs ten to fifteen. The disadvantage of the method is that it is still necessary to manufacture different units for different areas and to arrange for their production in the proper quantities to meet the demand. Also the manufacturer must be able still to supply the alternative sub-units for many years so that the viewer who moves to another area can be provided for.

Trimming Range

From the manufacturing point of view it is much better if all sets can be alike in their components and if the differences can be merely ones of adjustment. At first sight, this seems easy, for it would appear to be necessary only to increase the range of the trimmers so that the set could be tuned to any station in the band. It should not be impossible to make inductances adjustable over a sufficient range for this. Allowing for stagger tuning, a frequency ratio of 1.6:1 is needed and this means an inductance ratio of 2.56:1. By using a very thin-walled former a simple metal or dust-iron slug should provide adequate coverage and there is always the possibility of increas-

ing it by using a composite slug. A slug partly of metal and partly of dust-iron will reduce inductance when the one end is inserted and increase it when the other comes inside the coil, thus increasing the total variation obtainable.

A receiver designed on these lines could be tuned to any station in the band by a competent technician equipped with the proper apparatus. However, there is rather more in changing frequency than just re-trimming circuits. In the sound channel, changes in the Q of the coils with frequency may seriously affect the performance and, in particular, the amount of sound-channel rejection obtained. Towards the high-frequency end of the band an increase of Q is desirable to maintain the sound-channel rejection. With slug tuning, however, the Q is likely to decrease very considerably at this end of the band.

Then the input resistance of a valve decreases with frequency. It is approximately inversely proportional to the square of frequency. This may or may not be serious, for there is a possibility of devising a correcting network to mitigate this natural tendency. If this proves to be impracticable, however, then there is no doubt at all that the changing input resistance will very seriously affect the performance and call for circuit changes for different frequencies. Couplings are another factor which may need alteration. There is the aerial feeder to first-grid coupling circuit for one, there are the sound-channel rejector-circuit couplings for a second and there are the band-pass type couplings, if they are used, for a third.

It is clear, therefore, that the design of a straight set embodying ten to fifteen tuned circuits is by no means a simple matter. The superheterodyne scores heavily in this respect, for the bandwidth, sound-channel rejection and gain are obtained chiefly at the fixed intermediate frequency. Only the signal- and oscillator-frequency circuits need alteration for a different station,

¹ *Wireless World*, May 1949, p. 173.

and a considerable variation in their performance over the band is tolerable.

The superheterodyne, however, has its own troubles. It is well-known that even when only the reception of one station is being considered it is necessary to choose the intermediate frequency very carefully if the picture is to be free from a pattern produced by harmonics of the intermediate frequency being fed back from the output to the input. With an intermediate frequency of the usual order of magnitude,—5-13 Mc/s—it is impossible to avoid this effect on all stations simply by selecting the frequency and it is necessary to employ very thorough screening and filtering to prevent the feedback. This is quite expensive.

There are, in addition, the pos-

which applies only partially. The first is the need in a broadcast set on the short-wave bands for a degree of selectivity which it is not possible to obtain at signal frequency. This would seem to apply to television only if frequencies higher than those now envisaged were adopted. The second reason lies in the few circuits which need be varied for tuning in a superheterodyne as compared with a straight set of similar performance.

This is the real merit of the superheterodyne for television but it does not apply with quite the same force as in a broadcast set because the station selector need not be a user control. It is not necessary to have ganged circuits operated by a panel control.

The superheterodyne could be made freer from its liability to

band 33.375-41.5 Mc/s, therefore, one drawback of the superheterodyne can be eliminated. It is quite a satisfactory frequency from the point of view of obtaining bandwidth, sound-channel rejection and gain, for all these can be secured adequately at the higher frequency of 45 Mc/s, as is evidenced by all the satisfactory straight sets now produced.

Since such an intermediate frequency is nearer the signal frequency than is at present usual the liability to the direct pick-up of signals on that frequency is increased. As a partial offset to this, signals on the higher frequency are usually rather weaker. Nevertheless, more care in the avoidance of this type of interference must be taken.

The liability to second-channel interference is reduced because of the higher frequency and its elimination should not prove very difficult.

The problem of the oscillator may well be serious. If the oscillator frequency is higher than the signal frequency, the main trouble will be that of obtaining adequate frequency stability. Thus, suppose an intermediate frequency of 35 Mc/s is chosen, then the oscillator must cover from $45 + 35 = 80$ Mc/s to $66.75 + 35 = 101.75$ Mc/s. These frequencies are rather high for obtaining stability cheaply.

If the oscillator frequency is made lower than the signal frequency there is considerable danger of harmonics of the oscillator causing interference. This is shown by the diagram of Fig. 1 which indicates signal frequencies on one scale and intermediate frequencies on the other. The television channels are marked and the shaded areas represent interference bands, the order of the oscillator harmonic involved being marked in them.

If 35 Mc/s were chosen interference would be experienced from the third oscillator harmonic when receiving Channel 2. For instance, the vision carrier for Channel 2 is to be 51.75 Mc/s. The oscillator would be $51.75 - 35 = 16.75$ Mc/s and its third harmonic 50.25 Mc/s. This would beat with 51.75 Mc/s to give a difference frequency of 1.5 Mc/s which would produce a most noticeable pattern on the picture.

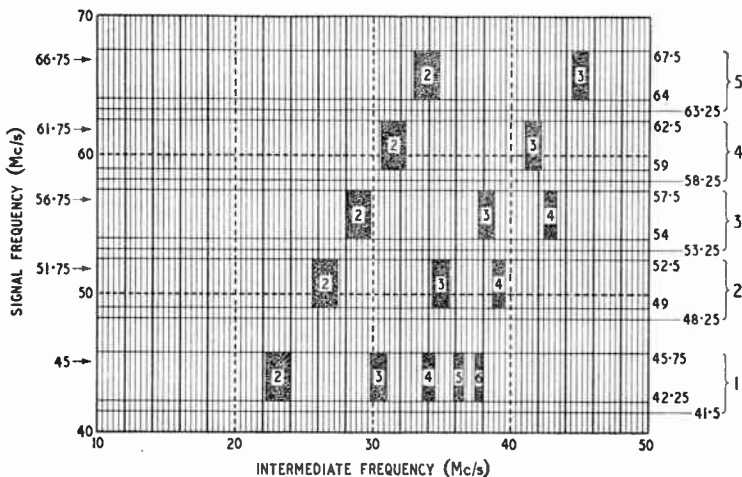

Fig. 1. This diagram shows intermediate frequencies with which interference will be found from oscillator harmonics when the oscillator is lower in frequency than the signal: the numbers in the shaded interference areas indicate the order of harmonic involved.

sibilities of interference by signals operating in the i.f. band and on the second channel and it is necessary to take precautions against local-oscillator radiation. The attainment of adequate frequency stability in the oscillator is another difficulty which confronts the designer.

All these superheterodyne disadvantages are found in the ordinary broadcast receiver and in spite of them it has become almost universal. There are two reasons for this, one of which does not apply at all in the present-day television case and the other of

special forms of interference if its intermediate frequency were made considerably higher than is now customary. If the intermediate frequency were lower than the lowest frequency of the signal band and higher than one-half of the highest frequency of the band, then i.f. harmonic interference would be impossible. The lowest signal frequency is 41.5 Mc/s, the highest 66.75 Mc/s. Therefore, from this point of view the intermediate frequency should be less than 41.5 Mc/s and greater than 33.375 Mc/s.

By choosing a frequency in the

Television Station Selection—

Examination of Fig. 1 shows that there is only one possible intermediate frequency for the avoidance of this effect on all channels. This frequency is 37 Mc/s. A vertical line at 37 Mc/s on the diagram does not cross any shaded area.

With this frequency the oscillator must cover $45 - 37 = 8$ Mc/s to $66.75 - 37 = 29.75$ Mc/s which is a wide range to cover in a single sweep. The relatively low frequency of the oscillator, however, greatly eases the problem of securing adequate frequency stability.

We cannot, however, yet say that this frequency will be satisfactory, for all the possible forms of interference have not been examined.

Since the oscillator frequency is lower than the intermediate frequency it is necessary to make sure that none of its harmonics falls in the intermediate frequency band. This can be taken as $37 - 2.75 = 34.25$ Mc/s to $37 + 0.75 = 37.75$ Mc/s with a sound channel at $37 - 3.5 = 33.5$ Mc/s.

For Channel 1, the oscillator will be at $45 - 37 = 8$ Mc/s and its harmonics will be 16, 24, 32, 48 Mc/s. The third harmonic just misses the i.f. band.

For Channel 2, the oscillator will be at $51.75 - 37 = 14.75$ Mc/s and its harmonics will be 29.5, 44.25 Mc/s. Again, they miss the i.f. band.

For Channel 3, the oscillator will be at $56.75 - 37 = 19.75$ Mc/s and its harmonics will be 39.5, 59.25 Mc/s.

For Channel 4, the oscillator will be at $61.75 - 37 = 24.75$ Mc/s and the second harmonic will be 49.5 Mc/s.

For Channel 5, the oscillator will be at $66.75 - 37 = 29.75$ Mc/s and the second harmonic will be 59.5 Mc/s.

The frequency is then satisfactory in this respect.

There is next the possibility of interference from a station which is spaced from an oscillator harmonic by the intermediate frequency. It is similar in nature to ordinary second-channel inter-

ference but involves an harmonic instead of the fundamental of the oscillator. The possible interference frequencies, including the genuine second channel frequencies, are listed in the table.

If these frequencies are compared with the signal bands it will be seen that with one exception none falls within the band of the station being received. The responses are, therefore, in principle capable of being eliminated by signal-frequency selectivity. The exception is in Channel 4. The fourth harmonic

conditions in the reception of a single-sideband transmission will not be very different, but they may not be quite the same.

Placing the oscillator higher than the signal in frequency is advantageous from nearly every point of view save that of the oscillator drift. In what follows it will be assumed that it is so placed.

The intermediate frequency is no longer critical and a frequency of about 35 Mc/s is suitable, so far as vision is concerned. The sound intermediate frequency

| TABLE. | | | | | |
|---------------------|---------|----------------|----------------|----------------|-----------------|
| Channel | 1 | 2 | 3 | 4 | 5 |
| Frequencies (Mc/s). | | | | | |
| $37 - f_0$ | 29 | 22.25 | 17.25 | 12.25 | 7.25 |
| $2f_0 \pm 37$ | 53 & 21 | 66.5 & 7.5 | 76.5 & 2.5 | 86.5 & 12.5 | 96.5 & 22.5 |
| $3f_0 \pm 37$ | 61 & 13 | 81.25 & 7.25 | 96.25 & 22.5 | 101.25 & 37.25 | 126.25 & 52.25 |
| $4f_0 \pm 37$ | 69 & 5 | 96 & 22 | 116 & 42 | 136 & 62 | 156 & 82 |
| $5f_0 \pm 37$ | 77 & 3 | 110.75 & 36.75 | 135.75 & 61.75 | 160.75 & 86.75 | 185.75 & 117.75 |

of the oscillator when it is set for reception of Channel 4 is 99 Mc/s. The intermediate frequency will, therefore, be produced by a signal on $99 - 37 = 62$ Mc/s and this is within the Channel 4 band of $59 - 62.5$ Mc/s.

It is, therefore, probable that this scheme may fail on this channel, which is the Birmingham one. It is possible that this could be evaded by changing the intermediate frequency very slightly, but there is not much scope for this without merely transferring the interference from one channel to another. Thus a shift to 37.5 Mc/s would be impracticable because the sixth harmonic of the oscillator would fall in Channel 1.

Oscillator Frequency

From the interference point of view it seems much safer to have the oscillator higher in frequency than the signal. Frequency stability is then the difficulty and it is rather hard to estimate the requirement until the Birmingham station has been in operation and some experience of the single-sideband transmission has been gained. The requirements for the sound channel can easily be estimated and those for the single-sideband reception of a double-sideband transmission are known. It is to be expected that the con-

now comes above the vision at 38.5 Mc/s, however, and there is here one possible cause of trouble for it is also 3 Mc/s away from the sound channel of Channel 1. The 3-Mc/s beat between the two may thus find its way into the vision channel by modulating the vision carrier in the frequency changer. It would be wiser to choose a frequency not less than 4 Mc/s below Channel 1. This would make the sound intermediate frequency 37.5 Mc/s and the vision 34 Mc/s.

True second-channel interference on vision could then arise only from stations in the band 113—134.75 Mc/s plus a small extension to cover the i.f. amplifier bandwidth. On sound it could come from the band 116.5—138.25 Mc/s.

If the bandwidth of the signal-frequency circuits is about 3.5 Mc/s, the second-channel frequency is about ten times the bandwidth away, or twenty times the half-bandwidth. A single resonant circuit which is down 1 db only at the edges of its band is therefore down 14 db at the second-channel frequency.

It is difficult to estimate how much attenuation is needed at signal frequency. The second-channel band is an aircraft communication band and so considerable field strengths from nearby

aircraft and ground stations may be experienced. As a minimum an interfering signal should be 30 db below the television signal at the frequency-changer input.

In a television receiver designed for limit range the interfering field strength might well be 40 db greater than that of the television signal and then the receiver should give 70-db discrimination. On the other hand, in areas of strong signals the interfering signal might never be more than 20 db below the television signal and only 10-db discrimination in the receiver would suffice.

Sensitivity

As very large numbers of receivers are used in areas of high field strength, where neither a maximum of gain nor the highest second-channel rejection are needed, it is clearly uneconomic to provide all receivers with them. The right course is surely to design the receiver to suit conditions in the major part of the service area, and to have a pre-amplifier which increases both gain and second-channel rejection for long-range reception.

Suppose, as a basis for discussion, that the basic receiver takes the form of a superheterodyne without a signal-frequency amplifier. The minimum useful signal at the input of the mixer will be of the order of 1 mV. This is a very approximate figure which might well be halved by careful design; it also depends upon how much noise is considered tolerable on the picture. Such a receiver with 30-db second-channel discrimination would be satisfactory over a very large part of the service area.

The simplest form of signal-frequency circuit would be a single resonant and damped circuit which would provide something like 14 db attenuation against second-channel interference. The remaining 16 db or so might be obtainable from the aerial, which is normally a resonant structure. However, it is very doubtful if it could be relied upon for this, especially in the case of the higher-frequency channels. For Channel 5, for instance, the aerial would be resonant at about 65 Mc/s in its half-wave mode. The second-channel band is 134-

137.5 Mc/s and is quite close to 130 Mc/s at which frequency the aerial is again resonant on a full-wave mode.

It is therefore unwise to reckon on much selectivity from the aerial. Even if the aerial itself were usefully selective, it would probably be impracticable to make full use of it, for it would hardly be possible to keep the feeder properly terminated over the full band of frequencies involved. In the second-channel region, therefore, it is probable that the feeder itself would pick-up interference.

It is, therefore, good practice to include adequate second-channel rejection in the receiver itself and, in general, this will require the provision of two tuned circuits. There is, however, another possibility. Since the whole second-channel band lies outside the television band it is theoretically possible to secure the second-channel discrimination by means of a band-stop filter,* which might be inserted between the feeder and the input circuit of the receiver.

If this proved economically possible a further step could be taken. The bandwidth of the input circuit itself could be made

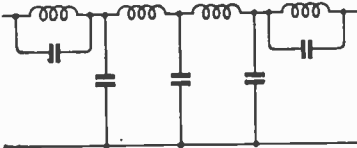

Fig. 2. A three-stage low-pass filter which includes two *m*-derived half-sections, the use of which is suggested as a simple way of preventing second-channel interference and oscillator radiation.

very wide to cover the whole television band—26 Mc/s—and the station selection accomplished by varying only the oscillator. This would be a form of single-span tuning.²

Increasing the first-circuit bandwidth nearly 7.5 times would result in a considerable loss of sensitivity. The signal/noise ratio would also deteriorate at least as much. It would probably become considerably poorer because of inter-modulation effects in the frequency-changer.

In practice, therefore, it would

probably be better to retain signal-frequency tuning supplemented as necessary by fixed-tuned band-rejection filters.

Oscillator Radiation

One other factor must be considered: oscillator radiation. This can be very serious on these high frequencies, especially if a signal-frequency amplifier is not used. In the case considered with the vision intermediate frequency at 34 Mc/s, the oscillator operates at one of five frequencies in the band 79 Mc/s to 100.75 Mc/s.

At high-frequencies control-grid injection usually works best in the frequency-changer and the oscillator may provide about 2 V on the grid of the valve. Since the first circuit impedance may be 2 kΩ, this is very roughly a power of the order of 2 mW. A single-tuned circuit may reduce this by 8-9 db and the feeder will introduce 1-2 db loss.

The oscillator power fed to the aerial may thus be as much as 200 μW. The signal power collected by the aerial may be only 0.05 μW. The radiated field strength in the immediate vicinity of the aerial may thus be 20 times as great as the field of the television signal.

In the example taken it will not interfere with other television receivers, but it may do with other services, including f.m. broadcasting. It must be very seriously considered, therefore, and the use of a band-stop filter in the aerial circuit is one way of preventing it.

This matter of using fixed filters to reduce interference and radiation is simpler than it may at first appear. Separate band-stop filters for the second-channel and oscillator bands are not necessary; a single low-pass filter can be used instead. If such a filter is given a cut-off frequency of, say, 70 Mc/s it will have little effect in the television band, but give some 12-16 db attenuation per section in the second-channel band. In the oscillator band such a simple filter is less good and may introduce no more than 5 db attenuation per section. It could, however, be greatly increased by using one or two *m*-derived sections (this is nothing but filter terminology for one or two tuned rejector circuits!).

* Or a low-pass filter, see later.

² *Wireless World*, March 23, 1934, p. 196.

Television Station Selection—

The basic filter equations are $LC = 1/\pi^2 f^2$ and $L/C = R^2$ where R is the terminating resistance, in this case the feeder impedance of 70Ω . From the two $C = 1/\pi f R = 65 \text{ pF}$ and $L = 1/\pi^2 f^2 C = 0.317 \mu\text{H}$.

The basic form of a filter which should be suitable for the job is shown in Fig. 2. It comprises two prototype low-pass sections and one m -derived; the last is split into two half-sections, one at each end of the filter, since this improves the termination. Four coils and five capacitors are needed.

A filter of this sort looks as if it would be very cheap and easy to manufacture, but it is not safe to conclude that this is so without further investigation. It is not improbable that very close component tolerances would be needed, but it may be that normal tolerances could be used for some or all of the capacitors if the others, and in particular the coils, were adjustable in manufacture. The coils will need only four or five turns and might well be self-supporting and adjusted in production in the filter unit by squeezing the turns closer together or further apart.

In view of all this it looks as though the television set of the future might well take the following general form:—

1. Superheterodyne with 34-Mc/s intermediate frequency and local-oscillator frequency above the signal-frequency.
2. No signal-frequency amplification.
3. One signal-frequency circuit trimmable to any television channel.
4. From 1 and 2, only two trimmers for channel selection, both of which are easily adjustable with very little apparatus.
5. Low-pass filter unit for $70\text{-}\Omega$ impedance with coaxial input and output connectors, for second-channel interference and oscillator-radiation elimination.
6. Separate one- or two-stage pre-amplifier, also with coaxial input and output sockets, for insertion between the low-pass filter and the receiver in order to increase the sensitivity, second-channel rejection, and signal/noise ratio in areas of low field strength. Such a unit could be trimmable to any station in the

band with perhaps three or four trimmers; it might also need changes in the values of damping resistors.

The writer feels that a scheme of this nature if carefully worked out might well prove to be the most satisfactory way of dealing with the problem of station selection. As he has pointed out there are other ways of solving it. It is probably impossible to decide the best way from theoretical considerations only and a good deal of experimental work will be needed. In particular, with the

superheterodyne it is never safe to dogmatize for there are so many possibilities of interference with it that it is very easy to overlook one which becomes painfully evident when the set is tried.

In any case, television receiver design of the next few years will be especially interesting and there will doubtless be many different methods tried.

One final suggestion; the solution of the problem of oscillation stability might well be the use of an a.f.c. system operated by the sound signal.

DIVERSITY F.M. TRANSMISSION

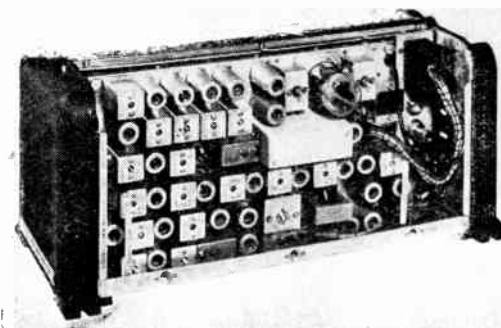

One of the G.E.C. f.m. mobile v.h.f. transmitter-receiver equipments used for the demonstration. It is entirely remote controlled.

FROM the data available it is still a debatable point whether amplitude or frequency modulation is the better for v.h.f. mobile communication services. A good case can be made for either, with some bias in one direction or the other according to the nature of the service required. In some quarters it has been said that when a wide coverage is needed, which may require several transmitters, the a.m. system with spaced carriers is the only satisfactory solution.

Hitherto this contention has not been challenged, but a recent demonstration arranged by the General Electric Company has shown that an f.m. system can be operated in a perfectly satisfactory way using three transmitters.

New System With Synchronized Carriers

These were arranged as a master station and two unattended satellites situated 10 and 17 miles

respectively from the main station. The venue was London, the main transmitter being in Kingsway with one satellite at Mill Hill to the north and the other at Knockholt on the southern fringe of Greater London.

Unlike the majority of multi-station a.m. systems, the G.E.C. f.m. version operates on a single radio frequency for all operational messages to and from the mobile vehicles. Separate frequencies are, however, employed for the radio links between the main and satellite stations. The schematic diagram reproduced here gives the various frequencies employed for this particular system.

The use of a common frequency at the main and satellite stations necessitates very accurate synchronization of these transmitters and this is achieved by employing a single master oscillator at the main station, using an appropriate multiple of it for the "broadcast"

transmitter there and another multiple, giving a somewhat higher frequency, which is radiated over link paths to the satellites. Here the frequency is converted to the actual multiple radiated from the main station's broadcast transmitter, and after suitable amplification, is radiated from the satellites' broadcast transmitters.

At no point in the chain is the actual multiple of the master oscillator lost, neither is the link signal, which carries the audio, demodulated.

From the schematic diagram it will be seen that this system is particularly economical in regard to the number of radio frequencies required. The common broadcast frequency employed on this occasion was 97.8 Mc/s, the outgoing control link was on 146.7 Mc/s and the incoming links on 154 and 155.4 Mc/s respectively. More will be said of these two later.

Thus this three-station f.m. scheme is operated with a total of four frequencies only. Some time ago we described a three-station a.m. system,¹ which might be said to be comparable in many respects, since it was operated in the same area, and for this no fewer than nine frequencies were employed.

It may be argued, of course, that the different method of modulation does not wholly account

recent two-station scheme,² also using a.m., absorbed six radio frequencies.

The main radio frequency is produced by a temperature-controlled crystal oscillator on approximately 1,527 kc/s, and this is multiplied 64 times to produce the broadcast frequency of 97.8 Mc/s at the main station.

A separate train of multipliers is used for the link transmitter and these raise the master frequency 96 times to 146.7 Mc/s. The ratio between broadcast and link frequencies is thus 2 to 3. Similar results can be obtained with other master oscillator frequencies, thus starting at 1,358 kc/s multiplications of 72 and 108 will yield virtually the same broadcast and link frequencies.

Modulation is applied separately to the broadcast and link channels at a very early stage, but in order to compensate for the distance between the main and satellite stations, a pre-determined delay is introduced into the channel going to the main station's broadcast transmitter.

The amount of delay needed to

both by aural tests and by examination of the waveforms of an 800-c/s tone on an oscilloscope, taken in a locality where the field strengths from the main station and one of the satellites was approximately equal.

From the oscillograms it appears that distortion is becoming apparent with four or less sections and also with eight or more sections, so it would appear that for this distance six is about the optimum. Each section introduces a delay equivalent to about 2.5 miles.

The r.f. output from the link transmitter is fed to a vertical dipole aerial giving omni-directional radiation. Variations of this are possible and the link transmitter could, if required feed two separate aerials beamed on their respective satellite stations.

At the satellite the master station's broadcast frequency, in this case 97.8 Mc/s, is extracted from the 146.7-Mc/s signal by first mixing with the 12th harmonic of a local oscillator, dividing the output by three, then mixing in the 4th harmonic of the local oscillator; what emerges is a signal

Schematic diagram of the three-station f.m. diversity system of communication using synchronized transmitters, which has been evolved by the General Electric Company.

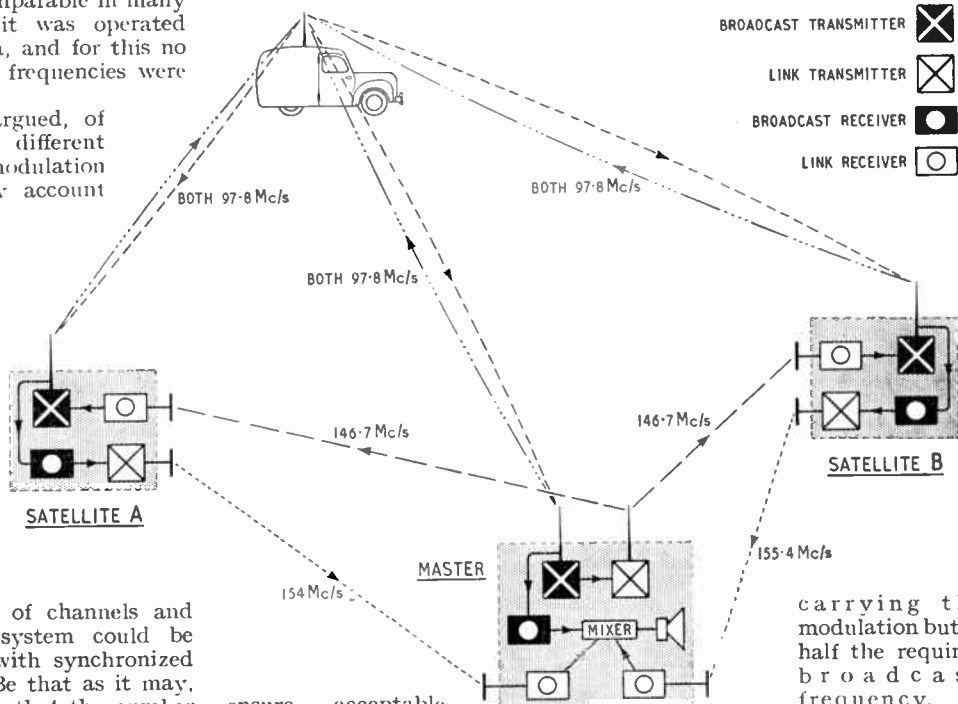

for this saving of channels and that an a.m. system could be operated also with synchronized transmitters. Be that as it may, the fact remains that the number of frequencies mentioned was employed at the time and a more

ensure acceptable fidelity seems by no means critical and this is proved

carrying the modulation but at half the required broadcast frequency. A doubler and

power amplifier are all that are needed before the signal is radiated. It should be noted that the link

¹ Multi-carrier Communication System - *Wireless World*, February 1946, pp. 59-61.

² New Police Radio - *Wireless World*, December, 1947, pp. 457-459.

Diversity F.M. Transmission—signal on the outgoing path has not been demodulated. This may appear to be a rather complicated process, but it ensures that the actual frequency radiated by the satellite is independent of the stability of the local oscillator.

As already explained the mobile vehicle talks back on the common broadcast frequency and its signals may be received at any or all of the fixed stations. When the signals are received at a satellite station they are demodulated and used to modulate a separate link transmitter for relaying to the main station.

The main station might conceivably be receiving the same message from a vehicle simultaneously on three different frequencies, (a) direct on the broadcast frequency, (b) via one of the satellites on its link frequency and (c) from the other satellite on still another frequency. The output from these three receivers are passed to a mixing unit where the one which has the best signal-to-noise ratio is selected and fed into the loudspeaker. This is, of course, quite automatic.

Several miles of London's busiest streets were covered in a radio-equipped vehicle during the course of a demonstration and at no period was the car ever out of touch. Signals were adequately loud and quite free from distortion during the whole time. From the immediate replies that were forthcoming it was evident that all outgoing messages were being received satisfactorily.

Some distortion was apparent when the delay network was removed from the main station's audio circuit, but this was much less than might have been expected and caused very little deterioration in intelligibility.

Finally, a brief description of the mobile equipment may not be out of place, although the transmitter-receivers used for the demonstration are not newly developed models.

The complete set measures 18×8×8 in. and weighs 35 lb. A double frequency changing superhet circuit is used for the receiver with the second i.f. on 455 kc/s. The first i.f. is dependent on the operating frequency, as this is adjusted to give the required input to the second mixer using the

most suitable harmonic of the crystal-controlled oscillator. The i.f. bandwidth is approximately ± 15 kc/s for 6db attenuation. Any single channel within the band 30 to 170 Mc/s can be employed, but the circuit would of course have to be pre-set as the equipment is remotely controlled. The audio output is about 1.25 watts.

The r.f. output from the transmitter varies somewhat according to the operating frequency, but at the worst it is not less than 10 watts and at the best 20, the larger amount being obtained at 100 Mc/s and below. The output valve is a new double tetrode, the TT15. The deviation is ± 12.5 kc/s for the equivalent of 100 per cent. modulation, which also is the

deviation used for the fixed stations.

Power to operate the set is supplied by a 12-volt battery—with optional 6-volt if required—and the consumption is 55 watts for the receiver alone, 95 watts on stand-by position with receiver on and transmitting valves alight and 175 watts on transmit.

The h.t. is supplied by two small motor generators, one for the receiver and another for the transmitter and filtered air for cooling is circulated through the set by fans on the motor generator.

Transmitter, receiver and power supplies are separate sub-assemblies easily removed for servicing. Miniature parts are used extensively and the whole of the equipment is fully tropicalized.

MANUFACTURERS' LITERATURE

Leaflet describing "Araldite" synthetic resin for surface and wire coating, etc., from Aero Research, Duxford, Cambridge.

Lists of components and kit sets for crystal receiver construction from the British Distributing Co., 66, High Street, London, N.8.

Illustrated leaflets describing the TV12 table television receiver and BA11 battery broadcast receiver from Bush Radio, Power Road, W.4.

Descriptive leaflet relating to the AC100 automatic record changing unit from Electrical and Musical Industries, Blyth Road, Hayes, Middlesex.

Complete catalogue of G.E.C. radio receivers for 1949-50, also catalogue of Pirelli-General electric wires and cables, from the General Electric Co., Magnet House, Kingsway, London, W.C.2.

Supplementary list of "Instanta" relays from Magnetic Controls, 48, Old Church Street, London, S.W.3.

List No. R449 of sliding resistances from M.R. Supplies, 68, New Oxford Street, London, W.C.1.

"Flux Facts" (Leaflet Ref. FF449) giving details of the properties of fluxes now available in cored wire solders made by Multicore Solders, Mellier House, Albemarle Street, London, W.1.

Technical specification of wide-range signal generators (Model 65B, 100 kc/s-46 Mc/s, and Model 65C, 100 kc/s-160 Mc/s) from Taylor Electrical Instruments, 419-424, Montrose Avenue, Slough, Bucks.

Illustrated leaflets of sound-amplifying equipment and commemorative brochure of testimonials relating to the 1948 Olympic Games from Philips

Electrical, Century House, Shaftesbury Avenue, London, W.C.2.

Price list of amateur transmitting and receiving equipment from Radiocraft, Ltd., 25, Beardell Street, London, S.E.19.

DOMESTIC RECEIVERS

The new "49" series of receivers made by Pye, Cambridge, comprises a console (Model 49C), table radiogram (Model 49TG) and console radiogram (Model 49RG). The prices are £17 17s, £26 5s and £36 15s respectively, excluding tax. The basic circuit comprises a triode-hexode frequency changer, pentode-diode i.f. amplifier and detector, and a pentode output valve. New versions of the Baby "Q" all-dry battery portable and Model 19D receiver are also announced. The latter now incorporates the trawler waveband in place of the 13-metre band. Prices are £14 14s and £22 15s respectively, excluding tax.



Pye Model 49TG table-model radiogram.

TRANSITRON SYNC SEPARATOR

New One Valve Circuit

By H. V. VERSEY, Assoc. Brit. I.R.E.

(Engineering Division, British Broadcasting Corporation)

FOR good interlacing there are two major requirements which a sync-separator circuit must satisfy:

(1) the generation of a steep-fronted frame synchronizing pulse from one—preferably the first—of the sequence of broad pulses that form the frame synchronizing signal;

(2) the complete elimination of line synchronizing pulses from the frame synchronizing circuits.

It is not easy to separate two



Fig. 1. Circuit of the transitron separator. 5MΩ

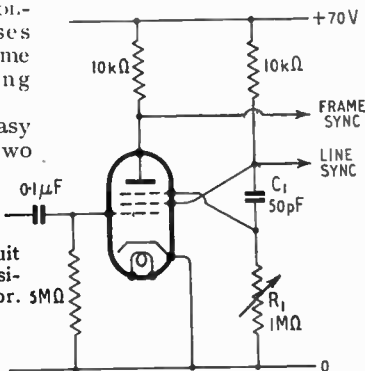

pulses of similar amplitude and shape but of different durations such as the line- and frame-synchronizing pulses, whose durations are respectively 10 microseconds and 40 microseconds. Hitherto, very elaborate circuits with several valves, or incorporating costly delay lines, have been necessary for this purpose and consequently good interlacing has been achieved only at considerable cost. It was with economy in mind that the idea of using a transitron circuit, operating under specific bias conditions, first occurred to the author.*

In the following description of the circuit and its behaviour it is assumed that the reader is conversant with the "flip-flop" action of the transitron. The "flip" occurs when the screen grid draws excessive current and drives the suppressor grid sufficiently negative to cut-off anode current. This is followed by the "flop," which occurs when the suppressor-grid potential has again risen to the point at which anode current starts to flow and the screen current is suddenly reduced.

The signal waveform, inverted

so that the synchronizing pulses are positive, is d.c. restored at the control grid (see Fig. 1). The valve is cut off by black-level and picture signals, and conducts only during the synchronizing pulses, as is customary in most receivers. When a ten-microsecond positive-going line-synchronizing pulse appears on the control grid, the screen grid draws current and instantaneously drives the suppressor grid sufficiently negative to prevent the anode from drawing current. This action corresponds to the "flip" of the transitron cycle. The

"flop" occurs when capacitor C_1 , connected between the screen and suppressor grids, has recharged sufficiently to allow anode current, as well as screen current, to flow. The time constant $C_1 R_1$ is, however, so chosen that the line-synchronizing pulse finishes before the "flop" action can take place, and the valve consequently returns at the end of the line-synchronizing pulse

considerable amplitude is, however, produced at the screen grid and this pulse is used to switch the line timebase.

When the first frame-synchronizing pulse appears at the control grid, the "flip" action takes place as before, but this time the "flop" occurs before the 40-microsecond frame pulse has ended. This is contrived by making the time constant $C_1 R_1$ less than 40 microseconds. The result is that the circuit produces not only a negative-going pulse at the screen grid but also a steep-fronted negative-going pulse at the anode. This pulse at the anode is used to trigger the frame timebase. The waveforms at the various electrodes are shown in Fig. 2.

The time constant $C_1 R_1$ should be just over 10 microseconds. With a 50-pF capacitor for C_1 and a 1-MΩ variable resistor for R_1 , a suitable value of R_1 can readily be found by observing the waveform at the anode and

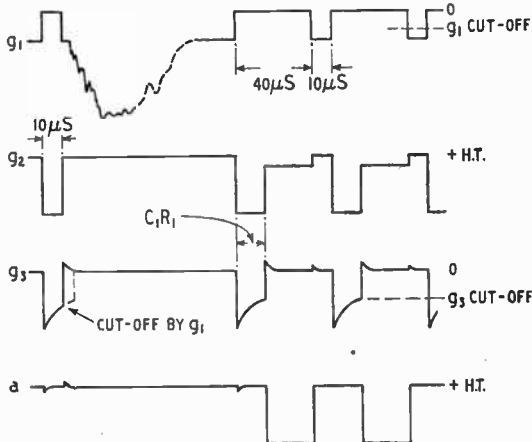

Fig. 2. The waveforms on the electrodes of the valve during line and frame pulse periods are shown here.

to its original state with anode and screen currents cut off by the control-grid potential. Thus the anode remains at full h.t. potential throughout the whole period of the line-synchronizing pulse, and no pulse is produced there. A steep-fronted pulse of

gradually increasing R_1 to a point just beyond that at which the line-synchronizing pulses vanish. In practice, the line-synchronizing pulses will not vanish completely at the anode, but for most purposes their amplitude is so small compared with that of the

* Patent Application 4280/49.

Transitron Sync Separator— frame-synchronizing pulses that this does not matter. Where, however, the amplitude of the line-synchronizing pulses appear-

ing at the anode is more than is desirable, the pulses can be removed by means of a suitably biased diode with a load resistor or by means of a low-pass filter.

ZOOM LENSES

Their Use in the Television Camera

By H. H. HOPKINS, Ph.D., F.Inst.T.

A RECENT innovation in television outside broadcasts has been the introduction of a zoom lens, which is

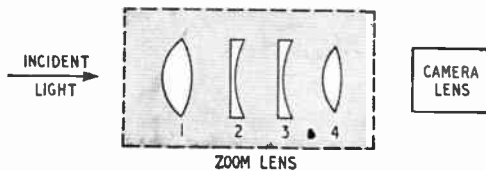

stant, and consequently the brightness of the image also remains constant.

The aberrations of the system are corrected by balancing the positive and negative aberrations con-

General arrangement of the zoom lens.

an attachment for converting any ordinary fixed-focus camera lens into a lens of continuously variable focal length. The new lens has been made by W. Watson and Sons, of Barnet, and was used for the first time at the televising of the Cup Final at Wembley this year.

The zoom lens is mounted on the front of the television camera and is operated by rotating an outer cylinder which imparts axial movements to the two inner component lenses, 2 and 3, by means of cam slots, the outer components, 1 and 4, remaining stationary. If suitable movements are given to 2 and 3, the final image remains in focus on the photo-cathode of the television camera, and the focal length of the combined optical system varies. The result is that the size of details in the picture is altered, creating the illusion that the camera is moving towards or away from the scene. The zoom lens at present being used for television enables the image of any detail in the scene to be varied over a range of 4:1 in area, and it will work in conjunction with any camera lens having a front diameter not greater than 2 in and covering an angle of field that is not more than 30 degrees. During zooming, the relative aperture of the combined optical system remains con-

tributed by the different surfaces. Any change in the relative positions of the component lenses will, in general, upset this balance, and so it is necessary to restrict

Semi-Automatic Morse Key

RADIO amateurs and many professional operators on this side of the Atlantic are beginning to acquire a liking for the semi-automatic type of morse key so popular in the U.S.A. Once the technique of handling it has been mastered it does unquestionably permit of sustained high speed sending with far less wrist fatigue than with most other types of key.

It gets its description from the fact that the dot constituents of the morse characters are formed automatically by a vibrating spring, the speed of sending being governed by the position of "bob" weights.

The Eddystone model of the key is very well engineered and lends itself for adjustment to almost any speed of sending likely to be required by amateurs and most professionals. It is not a key that would normally be used for slow

Eddystone semi-automatic morse key with cover removed. The "bob" weights are set for medium speed of sending.

to a minimum the movements of the inner components 2 and 3. The conditions that result in minimum movement have been worked out and are satisfied by the lens. In addition, the optical conditions resulting from the refractions by the moving components have been studied and a relatively simple mathematical treatment for calculating them has been worked out. This treatment reveals the conditions that must be fulfilled if a satisfactory lens is to be produced, taking into account the inaccuracies, small but optically significant, that are unavoidable in the best available non-geometric cams.

Zoom lenses have previously been very complicated. Simplicity is one of the principal factors contributing to the success of the new lens, which has only four components and yet gives excellent definition. Furthermore, this economy of components results in a greater efficiency of light transmission and also in the elimination of stray light, compared with certain other zoom lenses.

sending as its special properties show up best at high speeds. None the less it is quite capable of operation at 8 w.p.m. if required. This key has two "bob" weights for coarse and fine adjustment.

A heavy die-cast base is used with rubber feet and there are also two holes for screwing it down. Actually the rubber feet counter any tendency to wander, but a more secure fixing is really desirable. It has a short-circuiting switch and the whole is enclosed by an attractive cover finished in black crackle enamel and chromium.

The makers are Stratton & Co., Ltd., Eddystone Works, Alvechurch Road, West Heath, Birmingham, 31, and the price is £3 17s 6d.

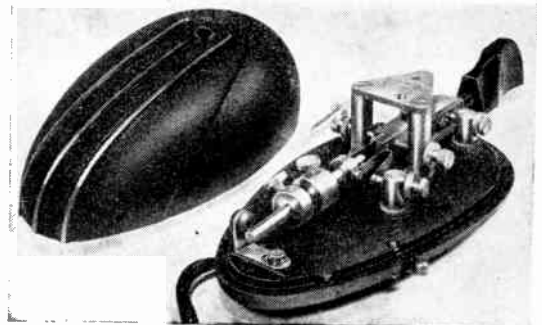

When these special types arise you'll find it best to **BRIMARIZE!**

TYPES 6SA7 and 12SA7 are pentagrid frequency changers of specialised design, widely used in American radio receivers. They have now been superseded by the miniature types 6BE6 and 12BE6, but this substitution requires a change of socket.

Good results may often be obtained by the use of types 6K8GT and 12K8GT respectively, a slight connection change and a lead to the top cap being required. In all cases it will be necessary to re-align the receiver, preferably throughout.

PUNCH HOLES HERE

CHARACTERISTICS

| | TYPES | TYPES | TYPE | TYPE | |
|------------------------|-------|-------|-------|--------|-------|
| | 6SA7 | 12SA7 | 6K8GT | 12K8GT | |
| Heater Voltage | ... | ... | 6.3 | 12.6 | Volts |
| Heater Current | ... | ... | 0.3 | 0.15 | Amp. |
| Anode Voltage | ... | 250 | ... | 250 | Volts |
| Anode Current | ... | 3.4 | ... | 2.5 | mA |
| Screen Voltage | ... | 100 | ... | 100 | Volts |
| Screen Current | ... | 8.0 | ... | 6.0 | mA |
| Control Grid Voltage | ... | 0 | ... | —3 | Volts |
| Anode Impedance | ... | 0.8 | ... | 0.6 | Meg. |
| Conversion Conductance | ... | 0.45 | ... | 0.35 | mA/V |

**6SA7
12SA7**

| CHANGE VALVE | | CHANGE SOCKET | | CHANGE CONNECTIONS | | OTHER WORK NECESSARY |
|---------------|-----------------|---------------------|-----------------------|--|--|--|
| FROM | TO | FROM | TO | FROM OLD SOCKET | TO NEW SOCKET | |
| 6SA7 12SA7 | 6K8GT 12K8GT | NO CHANGE | | Pin No. 8 Pin No. 6 | Top Cap Pin No. 8 | Connect Pin 6 to Pin 8 Re-align R.F., Oscillator and 1st I.F. circuits |
| 6SA7 12SA7 | 6BE6 12BE6 | International Octal | Miniature 7 pin (B7G) | Pin No. 1 " " 2 " " 3 " " 4 " " 5 " " 6 " " 7 " " 8 | Remove Pin No. 3 " " 5 " " 6 " " 1 " " 2 " " 4 " " 7 | Re-align R.F., Oscillator and 1st I.F. Circuits |

INSTRUCTIONS: Punch holes where indicated, cut away this portion and file in order of appearance for a quick reference guide.

BRIMAR says...
Make sure of ordering
your BRIMISTOR Cards.

BRIMAR
RADIO VALVES

STANDARD TELEPHONES AND CABLES LIMITED, FOOTSCRAY, SIDCUP, KENT.



Recognised as the Most Reliable Valveholders

International Octal
Ref. No. SP8/US.

McMURDO
Moulded
Valveholders

THE McMURDO INSTRUMENT CO., LTD., VICTORIA WORKS, ASHTEAD, SURREY · ASHTEAD 3401

“SOUND METAS”

A LABORATORY BUILT

BEAT-FREQUENCY OSCILLATOR

AT THE REASONABLE PRICE OF £30

- ★ Range 12-27,000 c/s \pm 1.5 db.
- ★ Output 4.5 watts constant
- ★ Level within \pm 0.25 db. from 40-12,000 c/s.
- ★ Fully Push-Pull including Det.
- ★ True Sine Waveform
- ★ Moving Coil Type Output Meter
- ★ 50 c/s Calibration Check
- ★ Precision Tuning Condenser

—A SOUND PRODUCT BY NAME AND NATURE—

ALMOST INDISPENSABLE TO SERVICE ENGINEERS AND EXPERIMENTERS

SOUND SALES Ltd.

SHOWROOMS & OFFICES:
57, ST. MARTIN'S LANE, W.C.2.

Telephone: TEMple Bar 4284.

WORKS: WEST STREET, FARNHAM, SURREY. Telephone: Farnham 6461/2/3.

TEST REPORT

REDIFON MODEL R50

Wide-Range Tropicalized Communications Receiver

The Redifon R50 communications receiver has an attractive front with well-balanced controls.

signal discrimination would be somewhat unsatisfactory.

The changeover from one i.f. to the other is automatic, being performed by the waveband switching so that the operator has no need to concern himself with it and, of course, mistakes cannot arise. Two complete sets of i.f. transformers and two crystal filters are embodied in the i.f. unit. The arrangement of the circuit between the mixer valve and the first i.f. stage is given in Fig. 1 which shows also the circuit switching for the two narrowest bandwidths.

AS one of the many functions of the general-purpose communications receiver with which we are here concerned is for merchant ship work, it has been designed to comply with certain requirements laid down by the Postmaster-General as to specification and performance.

One of the requirements for a set of this kind is that it must provide a continuous frequency coverage over the band 100kc/s to 25Mc/s. For certain ships a curtailed range may be permissible but in order to cater for all requirements the full coverage has been provided. In addition, an extra-low range of from 13.5 to 26 kc/s is included.

With this wide coverage the problem arises of where to place the intermediate frequency. Below 100kc/s is not very satisfactory, especially for reception over about 1Mc/s. In this receiver the problem is neatly circumvented by providing two i.f.s and selecting the most suitable for the band of signal frequencies in use.

The actual coverage of the receiver is somewhat greater than the minimum requirements for ship-borne apparatus. There are eight ranges marked, for convenience, A to H inclusive. A is the highest frequency range and H the lowest. H covers 13.5 to 26 kc/s; G, 95 to 250 kc/s; F, 240 to 600 kc/s; E, 585 to 1,550 kc/s; D, 1.5 to 4 Mc/s; C, 3.8 to 8 Mc/s; B, 7.7 to 16 Mc/s and A, 15.5 to 32 Mc/s. It will be seen that for ranges G to A inclusive there is a useful overlap in all cases.

As regards the use of the intermediate frequencies, on ranges H and F an i.f. of 110kc/s is used

since it is well outside the coverage of either. On ranges G, E, D, C, B and A, one of which includes the 95- to 250-kc/s band, an i.f. of 465 kc/s is employed. This i.f. could not, for very good reasons, be used on range F which covers 240 to 600 kc/s. Nothing is to be gained by employing 110 kc/s on the higher frequency ranges as the image

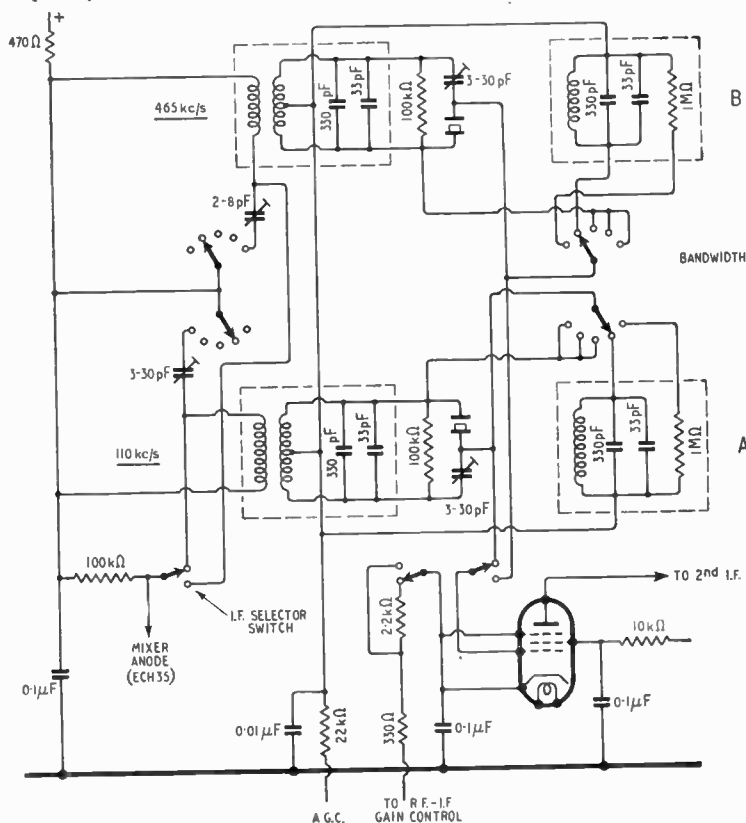

Fig. 1. Arrangement of the circuit between the mixer and first i.f. stages in the Redifon R50 receiver. This includes part of the bandwidth switching and i.f. switching.

Redifon Model R50—

In all there are five bandwidth positions; two include the crystal filter and give either 150c/s or 1.5 kc/s. The three other positions without the filter give 4, 11 and 17 kc/s respectively.

The narrowest bandwidth is obtained with the crystal filter working into a high-impedance load which in Fig. 1 is the 1-MΩ resistor in the subsidiary circuits A or B. The next widest, 1.5 kc/s, is obtained by modifying the load into which the crystal works, in the case of either of the subsidiary circuits A or B, the former on 110 kc/s and the latter on 465 kc/s, they are adjusted to provide an impedance of the order needed to open the bandwidth to 1.5 kc/s.

With the waveband switch set to any of the other three positions the crystals are short-circuited and the bandwidth is determined by the coupling between the primary and secondary circuits of the transformers in the latter part of the i.f. amplifier. The couplings can be varied by switching in the appropriate parts of

tertiary coils which augment the inductive coupling between the primary and secondary windings.

Looking down on to the top of the chassis with the screens removed can be seen, on the right, the i.f. sub-assembly; in the centre the ganged tuning unit and on the left the subsidiary units. The switch assembly in the right-hand front corner is the metering network.

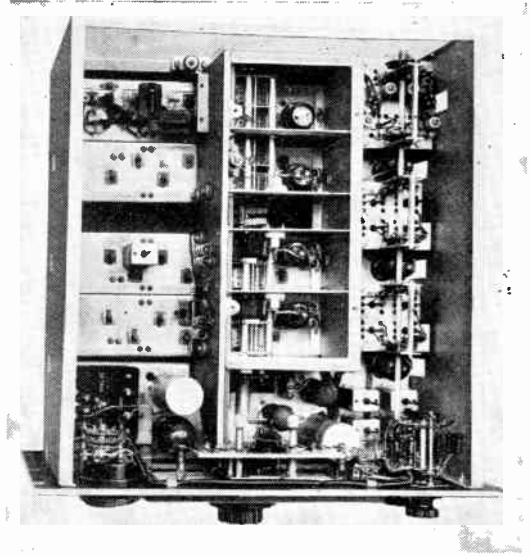

In order to achieve adequate selectivity with the crystal filters, twelve high Q tuned circuits are employed in the i.f. amplifier on either 110 kc/s or 465 kc/s. Each of the 24 circuits—12 only are, of course, in use at any time—are temperature compensated, the dust iron cored coils having two padding capacitors across them, one of a negative and the other of a positive temperature coefficient. Trimming of the i.f. circuits is effected by adjustable dust cores.

In all, three stages of amplification are employed in this unit, the valves being EF39s. Two

only are included in the a.g.c. system and they receive a portion only of the total a.g.c. voltage available.

The rear end of the set is reasonably orthodox, a double diode (EB34) acting as detector and a.g.c. stage with another EB34 functioning as an optional noise suppressor. It can be switched in or out as required and there is also a control for setting the threshold point at which the suppressor begins to operate.

D.C. voltage for automatic gain control is derived from the primary circuit of the last i.f. transformer and applied, after some delay, to the two r.f. stages, and as already mentioned, in part to two of the i.f. valves but leaving the mixer and last i.f. uncontrolled.

In some communications receivers the a.g.c. system becomes inoperative when the b.f.o. switch is set for c.w. reception, but in the Redifon R50 a.g.c. continues to operate, but with a much longer time constant than for telephony.

A.G.C. can, however, be suppressed if desired and this facility is embodied in a four-position switch marked "AVC-NS." In one position a.g.c. functions as usual, in another it is inoperative and all control of volume is by the r.f. and a.f. gain controls, in a third position a noise silencer with a.g.c. is brought into circuit while in a fourth position the

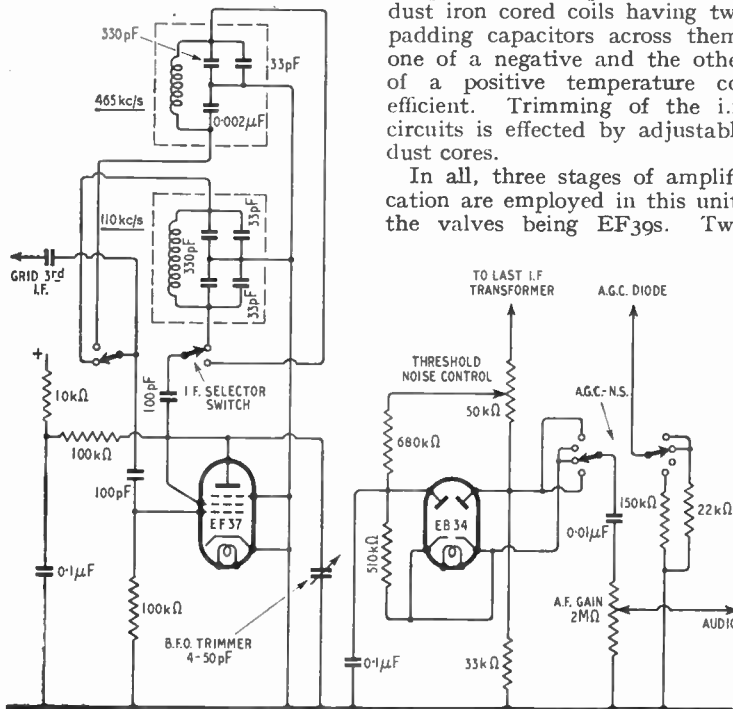

Fig. 2. The b.f.o. and noise suppressor circuits of the Redifon R50. Included also is the "AVC-NS" switch. It will be seen that two complete circuits for 110- and 465-kc/s i.f.s. are incorporated.

noise silencer is used without a.g.c.

Audio amplification is provided by an EF37 voltage amplifier and a 6V6 power valve with some negative feedback from the anode circuit of the 6V6 to the anode of the EF37.

Because alternative i.f.s are provided, the b.f.o. stage must generate heterodyne oscillations for either the 110- or 465-kc/s channels as required. An EF37 valve and a parallel-fed Hartley circuit, with entirely separate circuits for each frequency, is employed for this purpose. Both circuits are temperature compensated and the change from one to the other is synchronized with the i.f. selector. Details of the b.f.o. oscillator and of the noise silencer are given in Fig. 2.

In order to obtain a good signal-to-noise ratio and, perhaps what is of greater importance, an adequate image signal discrimination on the higher signal frequencies, two r.f. stages with EF39 valves are provided. These are followed by a mixer consisting of the hexode part of an ECH35 and a separate oscillator, which function is performed by a L63 triode with its grid joined to the normal oscillator grid of the ECH35 for voltage injection. The triode anode of the ECH35 is earthed.

There is little out of the ordinary in this part of the circuit except that each tuning capacitor has dual sections of 224-pF maximum. One section only is used on the three highest ranges but both are used in parallel on all other bands. These circuits, and those in the local oscillator, are frequency stabilized by a combination of negative and positive temperature co-efficient

Fig. 3. A separate triode is used for the local oscillator with injection into an ECH35 mixer. Temperature compensation is used in all oscillator circuits, the negative co-efficient type capacitors being identified by a short horizontal bar below the capacitance value.

capacitors. The sectional circuit in Fig. 3, which shows the local oscillator, indicates these compensating capacitors, the negative temperature type having a short horizontal bar below the capacitance value. Also included is the dual tuning capacitor and the oscillator waveband switching.

This receiver has provision for remote control and also for diversity reception if required. The screen grid supply lead for the i.f. and r.f. valves is accessible at the output socket and by simple switching, or by a relay,

periods up to this speed of sending.

Power supply for this receiver is provided by a separate unit and normally this will be a.c. operated. In addition to the usual rectifying and smoothing circuits the power

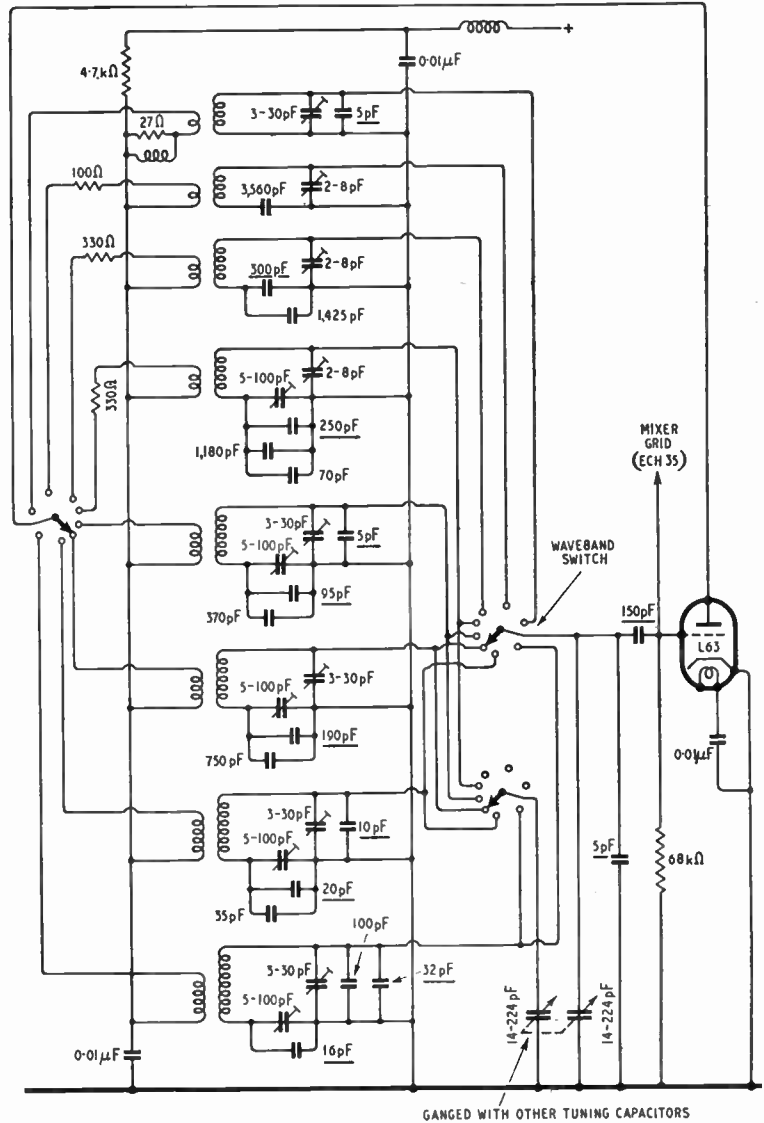

the voltage can be reduced so that the receiver is de-sensitized to such a degree that it can be employed to monitor a telegraphy or telephony transmission. It can also be arranged for "break-in" operation when required up to a speed of about 40 words per minute. The time constants of the receiver permit recovery to full sensitivity in the "break"

unit contains a voltage regulator tube giving a stabilized h.t. supply to the mixer g_2 grid and the oscillator anode. The a.c. consumption is 80 watts. For battery operation there is another power unit and this has a rotary converter for h.t. supply. There are also available supply units with rotary converters for various d.c. voltages up to 220.

Redifon Model R50—

A receiver of such high selectivity as the R50 must of necessity possess extremely good frequency stability. From the brief foregoing description it will have been seen that quite a lot has been done to ensure that this condition prevails by the judicious use of temperature compensated circuits and stabilized voltages. But these precautions alone would be of little value unless they were supplemented by good mechanical rigidity. It is unusual to find quite such a massive construction as in the R50.

The individual sub-assemblies, as well as the main framework, are well braced to withstand the hazards of transit and to stand up to the stresses that must be imposed during rough weather on board ships at sea. Rubber suspension is used for the r.f. unit, with which is incorporated the ganged tuning capacitors, largely to combat any likelihood of microphony.

Although light alloy is used extensively in the construction of the set, it is not a light-weight receiver. The chassis alone weighs 55 pounds and, enclosed in a sturdy metal cabinet it weighs 92 pounds. The dimensions are $14\frac{1}{2} \times 21 \times 22\frac{1}{2}$ in.

The set is fully tropicalized and while miniature components are included no attempt is made at miniaturization. When out of its cabinet every part of the set is readily accessible which makes for easy maintenance and testing.

In order that a quick check can be made on the set under working conditions a comprehensive metering system is embodied. A single meter is employed and this can be switched to measure the anode currents of r.f., oscillator and i.f. valves and the cathode currents of the a.f. amplifiers.

The performance of the R50 is fully in keeping with what might be expected of a set of this kind. With a little care in tuning and judicious selection of the bandwidth, a weak signal can be separated from between two quite powerful ones and held almost indefinitely provided the transmitter frequency is fully stabilized. After the initial warming up the oscillators settle down to their work and remain remarkably steady.

The h.t. smoothing is quite adequate and on the highest frequency range in the 30-Mc/s region, c.w. signals are receivable with pure beat notes and without a trace of ripple due to mains frequency modulation.

An epicyclic drive giving an 80 to 1 reduction is employed for the main tuning control. It incorporates a spring-loaded chain of gears driving a subsidiary logging dial, which, in conjunction with an additional scale on the main dial, enables any station to be accurately logged. The logging dial is visible through an aperture just above the main scales and a single division represents about a 10-kc/s coverage at 30 Mc/s. At lower frequencies it is considerably less. Frequency calibrated scales are provided for each of the eight ranges.

The R50 is made by Rediffusion, Ltd., Broomhill Road, Wandsworth, London, S.W.18, and the price of the cabinet model is £180. The set is also available with a panel for mounting in the standard 19-in rack.

REMOTE CONTROL EXTENSION LOUDSPEAKERS

TWO of the three new models in the "Stentorian" range of extension loudspeakers, made by Whiteley Electrical Radio, Mansfield, Notts, are fitted with push-button switches for remote control of the receiving set.

The system is the Whiteley "Long Arm" remote control in which a relay controlling the mains

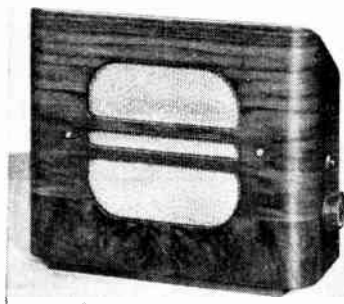

"Beaufort" model with "Long Arm" remote control in the new "Stentorian" range of loudspeakers.

supply to the set is operated through three-wire extension leads from any loudspeaker position. When the set

MORE COPIES OF "WIRELESS WORLD"

As announced last month, the Government's decision to increase the allowance of paper for technical periodicals makes it possible to print more copies of *Wireless World*. Starting with the August issue (published 26th July) there should be enough for all anticipated requirements. But the number of copies will still be limited, and so it will be necessary for an order to be placed with a newsagent.

is switched on from another room, only the loudspeaker in that room is operative, all the others remaining silent. Alternatively, when the set itself is switched on manually, none of the extension loudspeakers will work unless specifically required.

Six-inch permanent-magnet units with die-cast chassis are used in the "Bristol" loudspeakers which have plywood fronts with rounded corners and are enclosed at the back with perforations in the covers to relieve back pressure. Constant-impedance volume controls are fitted and a choice of output impedances is provided.

The frontal dimensions of the "Beaufort" are $12\frac{1}{2}$ in \times $10\frac{1}{2}$ in and of the "Bristol" $10\frac{1}{2}$ in \times $9\frac{1}{2}$ in; both are $3\frac{1}{2}$ in deep. Prices, with and without transformer, are: "Beaufort" £3 15s, £3 7s 6d; "Bristol" £2 19s 6d, £2 13s 6d. A cheaper model, the "Bedford," with 5 in unit, but without the "Long Arm" control feature costs £2 5s 6d or £1 19s 6d without transformer.

NEWS FROM THE CLUBS

Brighton.—Meetings of the Brighton and District Radio Club are now held on Tuesdays at 7.30 in the club's new headquarters at the Eagle Inn, Gloucester Road. Sec.: L. Hobden, 17, Harlington Road, Brighton, Sussex.

Exeter and District Radio Society is organizing a 7-Mc/s d.f. contest on Woodbury Common on July 3rd, which is open to other clubs. Sec.: E. G. Wheatcroft, 27, Lower Wear Road, Countess Wear, Exeter, Devon.

Slough.—Readers in the Slough, Bucks, area who are interested in the formation of a radio society in the district are invited to a meeting to be held at 7.30 on June 30th at the Slough Public Library. Acting Sec.: F. J. T. Tuckfield, 13, Quaves Road, Slough.

Southend.—The transmitter, G5QK, of the Southend and District Radio Society will be demonstrated at the Leigh-on-Sea Horticultural Society's Show at Chalkwell Park, on July 9th and also at the Scouts' International Jamboree at Rochford from August 13th to 20th. Sec.: J. H. Barrance, M.B.E., Swanage Road, Southend-on-Sea, Essex.

INDOOR TELEVISION AERIAL

Compressed Dipole for Strong-Signal Areas

By N. M. BEST and P. J. DUFFELL (Antiference Ltd.)

WITHIN a radius of approximately five to ten miles from the television transmitter at Alexandra Palace, the standard dipole-and-reflector

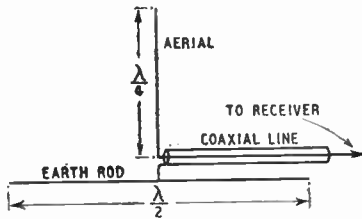

Fig. 1. Grounded quarter-wave aerial.

aerial system, mounted at chimney level, provides a greater signal than is absolutely necessary for the operation of a receiver. For installations nearer to the Alexandra Palace, even a single dipole without reflector may be sufficient to overload the set at its lowest sensitivity level. The insertion of an attenuator between aerial and receiver then becomes necessary.

In practice, it is found that an aerial mounted indoors gives satisfactory results over a fairly wide area. The physical dimensions of the standard H-type aerial make it unsuitable for indoor installation, and the indoor aerial is usually made physically smaller than the standard dipole, with some attendant loss in electrical efficiency.

The most important factors to be considered are:—

- Sensitivity.
- Bandwidth (the aerial must cover sound and vision channels).
- Feeder matching (normal receiver input is approximately 70 ohms and the feeder must have the same impedance).

The first two factors (a) and (b) may be affected by altering the shape of an aerial, and (c) is affected by any change of aerial input impedance.

There are several possible ways of constructing small television aerials.

The grounded quarter-wave aerial is one in which the earth is replaced by a half-wave horizontal rod, the centre of which is at earth potential. It is sketched diagrammatically in Fig. 1 and in practice, using co-axial cable, the inner conductor is connected to the bottom of the vertical quarter-wave rod, and the outer conductor to the centre of the earth rod.

The input impedance of this type of aerial is approximately 40 ohms, and the effective height is half that of a standard dipole. Although it is suitable for installation in a loft, it is physically cumbersome because of the earthing system.

A second form of aerial is known as the bent-rod type, and is probably patterned on an American type of aircraft antenna. The effect of bending the rods is an increase of bandwidth and a loss of sensitivity. Commercial types of this aerial are made to be installed in the V of the roof. The sensitivity is usually low because the pick-up portion is the projection of the inclined rod on the vertical plane.

A dipole of normal shape can be physically shortened by capacitance end loading or inductance loading. Capacitance loading involves mechanical difficulties and may be ignored, but an inductively loaded aerial is comparatively simple to construct.

The first two kinds of aerial referred to are only really suitable for installation in a loft. Many set owners, however, live in blocks of flats and similar buildings, and are often not permitted to install outside aerials. One disadvantage of an aerial installed in a living-room is that it is particularly susceptible to alterations of the electrical field due to movement of persons in the room; but with a careful choice of aerial position this effect can be greatly reduced. In any case, during a television broadcast it is hardly likely that there will be sufficient movement of persons to cause annoyance. A useful type of indoor aerial, there-

fore, would be one suitable for either the living-room or the loft, and the design of such an aerial is discussed in this article. It is based on a simple inductively loaded dipole with a maximum overall length of approximately five feet six inches.

Consider the case of a dipole shortened to five feet and using rods of $\frac{3}{8}$ -in diameter.

In order to make the system resonant at 45 Mc/s it requires loading with an inductance of approximately 2.0 μ H, and it then has an input resistance at 45 Mc/s in the region of 20 to 30 ohms.

The coil loading, of course, narrows the bandwidth, and it is estimated to be approximately 3 db down at 43.6 and 46 Mc/s. Ob-

An aerial mounted indoors gives satisfactory results over a fairly wide area. It is usually made physically smaller than the standard dipole.

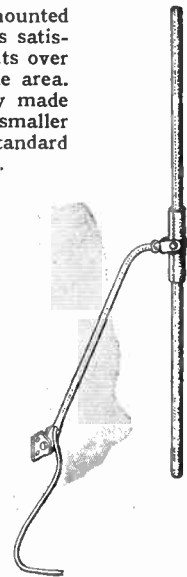

jections to this method are, therefore, the narrow bandwidth and the low input resistance. If the feeder mismatch is considered throughout the band, then the bandwidth becomes narrower still. Some improvement can be obtained by increasing the diameter of the rods, but they have to be unwieldy in size to get the necessary bandwidth.

The reactance of a dipole varies with frequency either side of resonance in the manner shown in

Indoor Television Aerial—

in Fig. 8. The uncompensated compressed dipole, curve (b), shows a reactance varying from $-j57$ ohms to $+j57$ ohms and considered in conjunction with curve (b) of Fig. 7, shows a very poor ratio of reactance to resistance at the edges of the band. The compensated compressed dipole, curve (c) is inductive throughout the band varying from $+j22$ ohms to $+j4$ ohms. It can be seen that the ratio of reactance to resistance compares favourably with that of the standard dipole, and provided that the measured input resistance is mainly useful radiation resistance and not loss resistance, the aerial bandwidth should be comparable with that of the standard dipole. Actual field strength

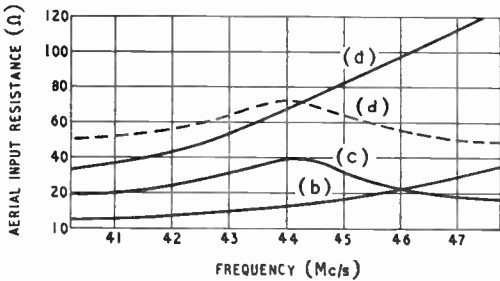

Fig. 7. Curves of aerial input resistance.

measurements showed the compressed dipole to be -6 db ± 1 db down in sensitivity on the standard dipole throughout the band, thus substantiating the results expected from impedance measurements.

In order to match the compressed dipole to a 70-ohm feeder a series resistor of approximately 30 ohms was added, but as the

aerial was only intended for use in high signal-strength areas the additional loss is tolerable. The dotted curve (d) in Fig. 7 shows the input resistance presented to the feeder by the combination, and the aerial-to-line matching (70-ohm feeder) is shown for the

Fig. 8. Curves of aerial input reactance.

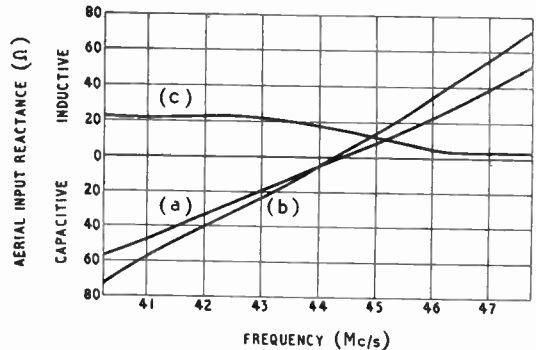

standard dipole and the compressed dipole with and without series resistance in Table 2. The Table shows comparisons of matching in terms of the reflection coefficient ρ .

$$\rho = \frac{Z_R - Z_K}{Z_R + Z_K}$$

and becomes zero when Z_R , the terminating impedance, equals Z_K , the line impedance; i.e., reflection is eliminated.

Inductively loading a dipole aerial in order to reduce its overall length and make it suitable for indoor installation, results in loss of bandwidth and sensitivity. Successful compensation for the loss of bandwidth can be obtained, however, by the use of a short-circuited stub matching line of very low impedance which, in combination with the loaded dipole, provides useful reactance cancellation over

the television band and gives a picture definition comparable with that of the standard dipole.

As the aerial is mainly intended for use in areas of good signal strength the loss of sensitivity is tolerable and is far outweighed by the advantage of the reduced size, approximately to one-half of that of the ordinary dipole.

"DIALLIST'S" PROBLEM

THIS should not be read until the simple problem set in "Random Radiations" (page 279) has been tackled. The correct answer is (b). When capacitors are connected across a source of h.t. voltage the p.d.s across them depend on their leakage resistance and not on their capacitance. Suppose 2,000 V is applied to two series capacitors, one of which has an insulation resistance of 300 M Ω and the second an insulation resistance of 100 M Ω . Then there will be a p.d. of 1,500 V across the first and of 500 V across the second. If both are rated at 1,000 V d.c. working the first will soon break down. The full voltage will then be applied to the second, which will also break down.

In practice it is not possible to manufacture capacitors of identical insulation resistance. In France, at any rate, the provision of individual shunt resistors is compulsory. The resistance of these is less than the insulation resistance of the capacitors, but high enough to ensure negligible losses.

Owing to the presence of these resistors it does happen that the capacitors are discharged rapidly when the source of h.t. voltage is switched off. Hence, if you plumped for (c) you may award yourself a gentle pat on the back

Civil Aviation Communications.—A second edition of the Civil Aviation Communications Handbook (MCAP5) has been published. It contains the international regulations and communications procedures with which aircraft registered in the United Kingdom have to comply. It is obtainable, price 7s 6d, from H.M. Stationery Office. The pamphlet "Radiotelephony Procedure" (MCAP46) continues in use as the standard reference document for Part I of the qualifying examination for the Flight Radiotelephony Operator's Certificate of Competency.

TABLE 2

Comparison of aerial to line matching of normal dipole and compressed dipole (Z of line = 70 ohms).

| Frequency (Mc/s) | Reflection Coefficient (Percentage) | | |
|------------------|-------------------------------------|--|---|
| | Normal dipole | Compressed dipole with matching resistor | Compressed dipole without matching resistor |
| 41 | 44% | 25% | 56.2% |
| 42 | 38% | 19.7% | 48.2% |
| 43 | 19.7% | 14.3% | 40.8% |
| 44 | 6.3% | 6.3% | 31.5% |
| 45 | 11.6% | 6.1% | 38.0% |
| 46 | 21.8% | 9.9% | 48.2% |
| 47 | 22.6% | 13.5% | 52.5% |

THE "BELLING-LEE" PAGE

Providing technical information, service and advice in relation to our products and the suppression of electrical interference

The Siting of Aerials

We claim that "Belling-Lee" television aerials are mechanically and electrically superior, but if erected without due regard to local interference, and/or the proximity of a corrugated iron shed or gas holder, then the "Belling-Lee" best is no better than the cheapest worst.

No aerial is a "cure all," some are made better than others, stand up to the weather, without leaning away from the prevailing winds, etc. Some have had superior electrical knowledge built into them, which tells when used in fringe areas.

We consider it bad practice to recommend the most expensive aerial of a range when a cheaper model will suffice.

Both the "H" type *1 and the "Veerod" *2 (inverted "V") are, in their own way, ideal for the elimination of interference; the "H" is the most expensive in our range and the "Veerod" one of the cheapest.

We have seen an announcement in a Midland paper to the effect that it is not possible to know what will be the best television aerial to erect until the Midland Transmitter is on the air. "Belling-Lee" have put up many hundreds

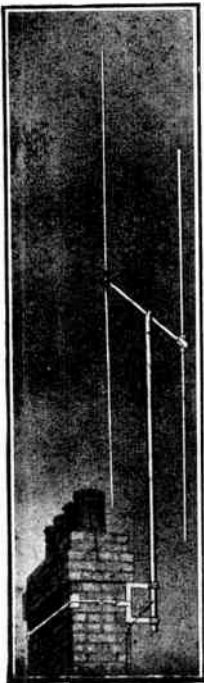

of aerials for the Midland Transmitter and many hundreds more have been erected by worthy competitors. If the installations are entrusted to recognised firms with plenty of experience of this work in the London and home counties, then there is no need to worry.

If however, someone without the necessary experience puts up a television aerial, then there may be trouble from double images or "ghosts,"

A "Viewrod" "H" type aerial.

or the obvious local source of interference may be ignored and consequently the wrong type of aerial installed. To take a case in point, the "Belling-Lee" "Veerod" has sharp minima at right angles to the direction in which it is pointing, whereas the "H" type has a minimum behind the dipole: one experienced in these matters makes full use of such characteristics for the removal of "ghosts" or interference. Again, sometimes it is advantageous to use the building on which the erection is being carried out to screen the dipole from obvious interference such as a busy cross road, and in other cases height is the most important thing. Experience of hundreds of such cases is most useful.

The average wireless Dealer will not make mistakes that he cannot rectify when the time comes

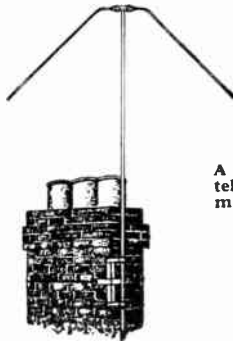

A "Veerod" television aerial mounted on a chimney.

Hum in the Receiver.

We have heard a lot about humming aerials, and we have cured this trouble, but we have recently had a number of requests to cure hum in the receiver. Now, this is a form of interference that we do not claim to cure. The hum is a low frequency phenomenon which may be mains borne on D.C. mains or an inherent property of the receiver itself.

Our interests are in radio frequency interference, which, as readers of this page know, shows up on the picture of a television receiver as "ghosts," spots, feathering, or bars, and on the sound channel, or on broadcast receivers as crackles, plops, bangs and sizzling noises which may be eliminated from the receiver by the use of one or more of the following methods:—

1. Correct choice and siting of an outdoor aerial.
2. For broadcast reception, an anti-interference aerial*3.
3. Fitting a mains filter*4.

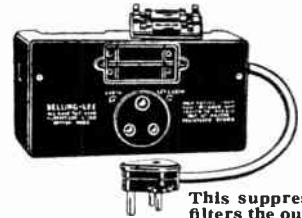

This suppressor filters the output of a mains outlet socket. List No. L300/3 1 amp.

Wires that carry and re-radiate interference.

We have recently been asked to confirm whether or not "wires used for wired wireless" radiate interference. The answer is that they can and do. So do telephone wires, and overhead fire alarm wires, but of course the worst offenders are overhead mains, in villages where the houses are wired with V.I.R. taken in at roof level.

*1. "Viewrod" television aerials for Midland frequencies.

L652/LM "H" type with 8ft. light alloy mast and chimney lashings, £6/5/-.

L652/C "H" type with mast head cap for customer's own wooden mast, £2/17/6.

L652/L "H" type with mast head cap and chimney lashings (less mast), £5/7/6.

The London equivalents for items 2 and 3 are L502/C, £4/8/-, L502/L, £6/6/-.

*2. "Veerod" television aerial. Attic mounting. L605 London, £2/12/6. L646 Midland, £2/5/-.

"Veerod" chimney mounting with metal mast. L606 London, £4/10/-, L635 Midland, £4/2/6.

*3. "Skyrod" vertical collector with "Eliminoise" anti-interference transformers and cable. L638/K Chimney mounting, £10/-/-.

L638/CK Mast mounting (less mast), £8/15/-.

L308/K "Eliminoise" kit with 60ft. wire span and cable etc. Complete £6/6/-.

*4. Set lead suppressors. L300/3 1 amp., £2/19/6. L305 (2 amp.), sometimes suitable for television, £3/3/-.

"Viewrod," "Skyrod" and "Eliminoise" are registered trademarks. "Veerod" registration applied for.

BELLING & LEE LTD
CAMBRIDGE ARTERIAL RD., ENFIELD, MIDDLESEX, ENGLAND

* S.R.E. for all purposes

Philips have supplied through traders and others throughout the world S.R.E. for almost every conceivable application. While specialized equipment is produced whenever necessary, a very wide range of standard apparatus units minimizes the need for this, and simplifies installation and maintenance.

As it can be shown to be much better engineering practice to use one large amplifier instead of a lot of little ones to feed one load, the standard range includes three large rack amplifiers.

Features include triode valves throughout, four push-pull stages, no electrolytics, and three separate anode supplies.

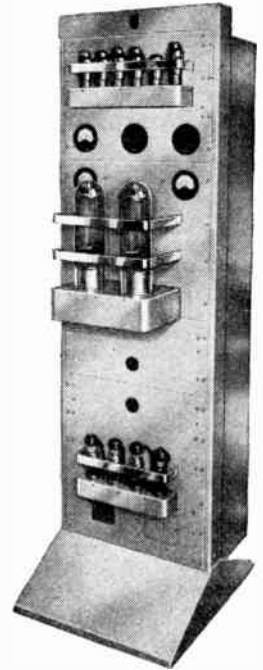

* What expression should be used to refer generally to amplifiers, and related apparatus? "Public Address?" This hardly applies to gear that may well be used in private for purposes other than addressing. "Sound Equipment?" This can also mean toms, or brewery apparatus in sound condition! We have adopted the Navy's term "S.R.E." or "Sound Reproducing Equipment", as in our submission there is no other so accurate or so generally applicable.

- 250 wattList Price £255
- 500 "List Price £325
- 1,000 "List Price £425

S.R.E. available through the trade on hire purchase or rental terms.



PHILIPS ELECTRICAL LIMITED

Amplifier Dept., Century House, Shaftesbury Avenue, London, W.C.2. (A48T)

You MUST get this List ..

This is the new list giving descriptions of the 162 Standard types of "Sommerford" Transformers and Chokes together with details of 28 types of Replacement components suitable for commercial receivers

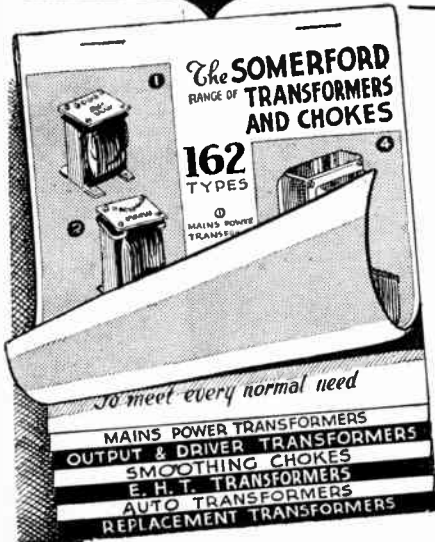

This COMPLETE range will meet ALL your normal needs

The requirements of the Electronic Industries are many and varied. It is to meet such demands that the "Sommerford" range of Transformers and Chokes exist. No matter whether you are engaged in radio, the manufacture of industrial or domestic appliances, or laboratory work, if you are looking for components that will give you accuracy and dependability at an economical cost, you will do well to choose GARDNER products. Research, skill and modern manufacturing methods have been combined to produce components that will withstand the most arduous working conditions and meet the exacting demands of present day standards. The "Sommerford" range comprises 162 different types—a type for every normal need.

Ready for IMMEDIATE DELIVERY

Full details and specifications will be sent on request

GARDNERS RADIO Ltd
SOMERFORD : CHRISTCHURCH : HANTS

ELECTRONIC CIRCUITRY

Selections from a Designer's Notebook

By J. McG. SOWERBY (Cinema Television Ltd.)

LAST month a scale of two counter was discussed and its mode of operation explained. It will be remembered that by combination of n scale of two circuits, a division ratio of $N = 2^n$ can

Electronic Counters

be obtained. This series of numbers (2, 4, 8, 16, 32, 64, . . . etc.) is only occasionally useful, so it will be worth discussing how other division ratios can be obtained.

It was pointed out last month that the scale of two shown was essentially a symmetrical circuit, and it may be said to possess two-fold symmetry. If now an analogous circuit can be designed having r -fold symmetry, where r is any number greater than 2, it may be expected to have a division ratio of r . Many such circuits have been developed at different times, and they are commonly called ring counters.¹ One with which the writer is familiar^{2, 3} will now be discussed as a representative of its class. In order to see how such a ring circuit is constructed, it is only necessary to consider a ring of 3, as from it rings of greater number can be derived by analogy.

Fig. 1 shows a ring of three which follows much the same plan as the scale of two already discussed. All those components which have the same value are similarly labelled in order to make the symmetry more apparent. In the waiting condition only one valve is conducting, and since there are three valves there are three possible stable states. As before the energising pulse is applied to the common cathode connection across the resistor R_k . Each valve has associated with it

a potentiometer network R_2, R_3 , in order to repeat a fraction of the anode potential changes at a d.c. potential suitable for the grids. The grids of the three valves are connected to the points P_A, P_B and P_C through "averaging" resistors R_4 , and it will be seen that each grid is connected to the anodes of all other valves. As the circuit is entirely symmetrical when power is first applied any valve may become conducting—it is a matter of chance.

Let us assume that V_A is conducting initially. Then the potential at P_A is less than that

positive (P_C). Hence the grid of V_A must be positive with respect to the two grids by an amount sufficient to ensure that V_A continues to conduct. As V_A alone is conducting, the common cathode potential must rise slightly above the grid potential of V_A (assuming no grid current). Consequently the grid potentials of V_B and V_C must be more negative with respect to the common cathode than that of V_A by an amount sufficient to hold both at or beyond cut-off.

If now a short positive pulse of sufficient amplitude is applied to the input terminal, V_A will be momentarily cut-off. Its anode potential will rise in consequence and this rise is preferentially transferred to the grid of V_B through the coupling condenser. When

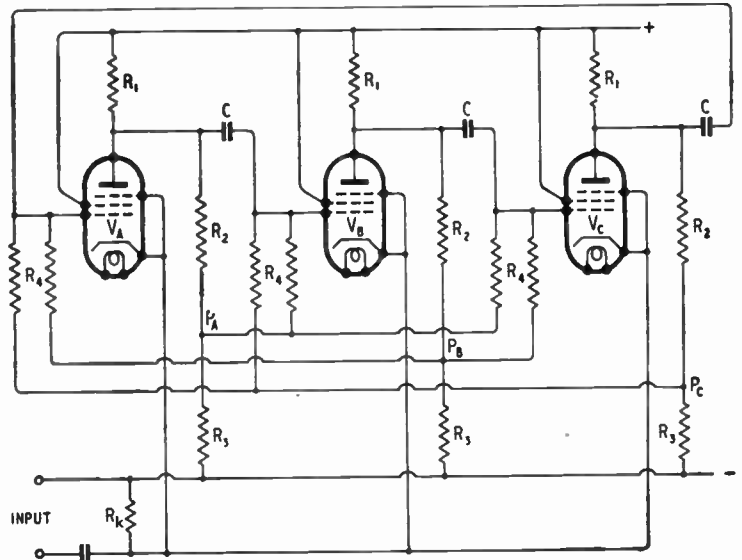

Fig. 1. Ring of three counting circuit.

at P_B and P_C . We may loosely say that the potential at P_A is "negative" and that it is "positive" at P_B and P_C . Now consider the grid of V_B . It is fed through equal resistors, R_4 , to one positive (P_C) and one negative (P_A). The grid of V_C is connected to one positive (P_B) and one negative (P_A). The grid of V_A is connected to one positive (P_B) and a second

the input pulse subsides the grid of V_B is left momentarily more positive than that of any other grid, so that the circuit locks itself into the second stable state with V_B conducting, and the other two valves cut off. It is easy to see that another input pulse transfers the conduction to V_C , and after a third pulse the original state is resumed. Obviously one (positive)

¹ For example, C. E. Wynn-Williams, *Proc. Roy. Soc.*, Vol. 132, p. 295, 1931. C. E. Wynn-Williams, *Proc. Roy. Soc.*, Vol. 136, p. 312, 1932. W. B. Lewis, "Electrical Counting," C.U.P., 1942.

² T. C. Nuttall, Brit. Pat. No. 572,884.

³ S. S. West, *Electronic Eng.*, Jan. 1947, p. 3; Feb. 1947, p. 58.

Electronic Circuitry—

pulse can be derived from any one of the anodes for three input pulses, and the circuit divides pulses by three. The buffer stage discussed last month is quite suitable for driving this ring, and also for extracting an output pulse.

A ring of greater number than three can be derived directly from Fig. 1 provided it is remembered that there must be a symmetrical d.c. connection from every grid to every other anode, and at first sight there seems to be no reason why a ring of any number should not be made. There is a practical limit here, however, because conduction in one valve must provide a potential change at all other grids sufficiently large to hold all other valves at or beyond cut-off. If we make the simplifying assumption that the resistances R_4 of Fig. 1 are infinite, it is found that the potential available to cut off each valve other than the conducting

one is only $\frac{a}{r-1}$ times the change

of anode potential of the conducting valve; where $a = \frac{R_3}{R_2 + R_3}$

and r is the number of valves in the ring. Hence the larger r is made, the more difficult does it become to design for entirely reliable operation. In practice, of course, the resistances R_4 are not infinite, so that the position is rather worse than is indicated above.

The maximum number r which can be attained in practice depends on factors additional to those mentioned. For example by making the R_1 resistances of Fig. 1 very large the anode potential change of the conducting valve can be increased, but as this resistor is shunted by stray capacitance a reduction in maximum counting rate must be expected. With sufficient care in design and

using modern high-slope valves with a very short grid base, a ring of ten, capable of operating at 50-100 kc/s, could probably be constructed successfully.

In practice, of course, there is little point in attempting a ring of ten directly, as it is both easier and more economical to use a scale of two and a ring of five in cascade. A scale of 12 might be constructed from two scales of 2 and a ring of three. A scale of 100 could conveniently be made up thus:— $2 \times 5 \times 2 \times 5 = 100$; and a scale of a gross:— $2 \times 2 \times 3 \times 2 \times 2 \times 3 = 144$. Since any number other than a prime can be reduced to a product of primes,

next month we shall consider how the missing numbers may be filled in.

THYRATRONS are frequently used in d.c. circuits as sensitive relays, firing on the application of a small voltage pulse. It is a property of a thyatron that once the valve has broken down the grid has no further control.

Extinguishing Thyratrons To extinguish the arc it is usual to break the h.t. supply temporarily, as shown in Fig. 2(a), with the resetting switch S.

An alternative method of re-

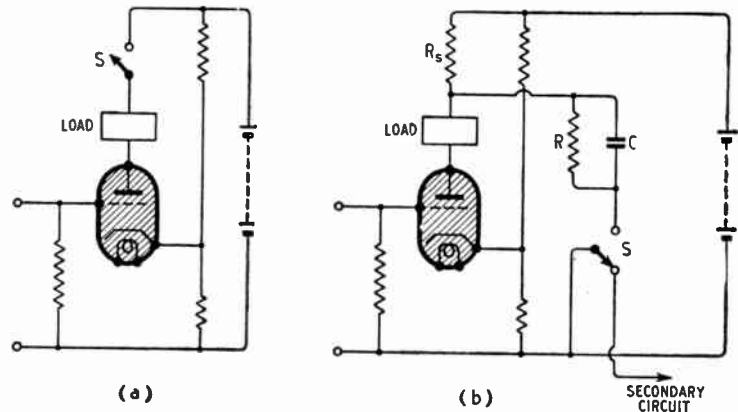

Fig. 2. Two methods of resetting a thyatron.

it is obviously only necessary to make rings whose division ratios are prime numbers. Of these, 3, 5 and 7 are quite practicable, while 11 or more would usually be regarded as tricky and doubtful. Thus with rings of 3, 5 and 7 allied with scales of two, a division ratio of any number reducible to factors not exceeding 7 can be made. By this means division ratios of 2, 3, 4, 5, 6, 7, 8, 9, 10, 12, 14, 15, 16, 18, 20, 21, 24, 25, 27, 28, 30 . . . etc. can be obtained and

setting a thyatron, which is occasionally useful, is shown at (b). A resistance R_s is placed in series with the load, and a condenser C is momentarily short-circuited to the negative h.t. line with the switch S. The time constants CR_s is long enough to maintain the potential across C less than the running voltage of the thyatron for the time required to ensure de-ionization—generally 200 microseconds is sufficient. The resistance R is used to ensure that C is discharged immediately prior to the closure of S. This arrangement is sometimes useful, for example when only a single-pole change-over contact is available for resetting, and some secondary circuit must be reset with the other contact as shown at (b). There is nothing very novel about this arrangement; the same method of arc extinction is often used in d.c./a.c. convertors.

OUR COVER

VIBRATOR TESTING at Plessey's, Ilford, forms the subject of this month's cover illustration. With the equipment illustrated input and output voltage and current are tested using a standard vibrator and transformer capable of taking a load up to 30 watts output. The frequency of the vibrator reed and contact closure times are also given, as percentage figures. The oscillograph provides a cross check of the operating conditions and the waveform illustrated indicates that the three essential components—transformer, buffer capacitor and vibrator—are matched.

CATHODE-RAY TUBES FOR TELEVISION

Diameter of Tube Neck

By HILARY MOSS, Ph.D., M.Brit. I.R.E. (Chief Engineer, Electronic Tubes, Ltd.)

(Concluded from p. 205 June issue)

IN all the foregoing work, when comparing tubes of different sizes, it has been assumed that all linear dimensions except those of the actual triode have been multiplied by k . This assumption does not wholly agree with normal commercial practice, since it is customary to maintain constancy of neck diameter.

It was stressed in the introduction that the solution of these cathode-ray tube problems depends entirely on the postulates made. However the complexity of the solutions varies greatly with the postulates. We saw for example that to postulate constancy of cathode loading involves appreciably more working than the assumption of constant beam current. And if we inject the still additional requirement that the neck diameter is to be constant then the treatment is still further complicated.

This arises because we can no longer use postulate (1); that is, the principle of geometrical scaling. This principle requires that all the linear dimensions of the system must be scaled and we are now deliberately departing from this by multiplying the screen diameter by k , while maintaining constancy of size in the deflector-coil region.

A solution therefore demands special knowledge of the effects of deflection. The following additional fact is necessary and sufficient to solve the problem of change of screen size at constant resolution.

"If the beam width, coil shape and size, and the scanning angle, are all kept constant, then the deflection defocusing is proportional to the distance between the centre of deflection and the screen."

In this statement the term 'deflection defocusing' means the difference in the linear size of the spot at the centre and the edge of the screen. The application of postulate (2) enables us to deduce

that the deflection defocusing is independent of the anode potential.²

We now illustrate this by repeating the solution of the first problem, with the additional requirement that the neck diameter and scanning coils are to be unchanged. The general theory is a little too cumbersome to be given here, but the method can be seen by reference to Fig. 3. In the original tube the crossover at T is imaged by the thin lens at XY on to the screen at S. CD represents the centre of deflection. The derived tube has its screen at S', where it is assumed that the axial position of S' is such that for constant scanning angle the diameter of S' is k times the diameter of S. Now the resolution of the derived tube is to be the same as that of the prototype. Therefore the deflection defocusing is to be k times as great as on the prototype just as the

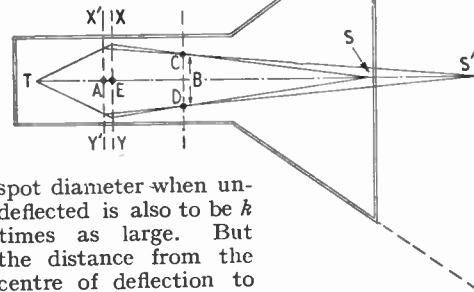

Fig. 3. Geometrical derivation of tube of larger screen diameter keeping neck diameter and scanning angle constant. Note that only the conical portion of the glasswork is changed.

spot diameter when undeflected is also to be k times as large. But the distance from the centre of deflection to the screen on the derived tube will be very nearly k times that on the prototype. Hence it follows from the extra fact given about deflection theory that the condition of making the deflection defocusing k times as large on the derived tube is closely approximated by maintaining constancy of beam width B in the deflector coils. Since we are keeping constant

beam angle from the triode, the new position for the focusing coils is found by projecting back lines from S' through C and D. These cut the rays from the triode at X'Y' which is the new position for the focusing coil.

On the prototype tube the linear magnification between the triode and spot is $M_1 = \frac{ES}{TE}$ and on the new tube it is $M_2 = \frac{AS'}{TA}$. Let the

crossover diameter on the prototype tube be Δ . Then with the previous notation, the requirement of constant resolution gives

$$\frac{kM_1\Delta}{\sqrt{V_1}} = \frac{M_2\Delta}{\sqrt{V_2}} \quad \dots (8)$$

Equation (8) compares with (2) and differs only on account of the change in geometrical magnification brought about by the alteration of the position of the focusing coil.

As in the first problem equation (1) defines the condition of equality of screen brightness, so that (1) and (8) permit us to calculate V_2 and λ . M_1 and M_2 are most easily found graphically

Approximation based on the value of M_2/M_1

Provided that the process of extrapolation is not carried too far, examination of the geometry of typical television cathode-ray tubes will convince the reader that the ratio M_2/M_1 is very nearly equal to k . If we now insert this value in equation (8) we immediately get, after cancellation of common terms,

$$I/\sqrt{V_1} = \lambda/\sqrt{V_2} \quad \dots (8a)$$

² "Simplification of Cathode Ray Tube Design by Application of the Theory of Similitude." H. Moss J. Tel. Soc., March 1946.

Cathode-Ray Tubes for Television

which oddly enough is exactly the same equation as that relating to the earlier case where the neck diameter was varied in proportion to the screen diameter and the spot size was to be held constant. The solution of this equation together with (1) has already been given (2nd column, Table 1) this

being the case of constant beam current. The solution of (8a) with (3), (4), (5) and (7) has also been given (column 4, Table 1) this being the case of constant cathode loading.

However to avoid any possible confusion this working is repeated in Table 2, since the postulates are entirely different, and the

identity of (8a) with a previous equation is merely coincidental.

One important fact emerges from a comparison of Tables 1 and 2. Compare column 2 in Table 1 with column 1 in Table 2. Both operations result in a picture linearly k times as large as on the prototype and of the same surface brightness. Both operations require the same increase in anode voltage and the same increase in cathode loading. But the operation on Table 1 where the neck

diameter is increased in proportion to the screen diameter gives no increase in spot size, whereas the operation on Table 2 maintaining constant neck diameter results in the spot diameter being multiplied by k . We are entitled to conclude that the operation on Table 1 yields a tube of higher intrinsic performance than that given by Table 2, since we normally seek to obtain the smallest spot size, all other factors being constant. This fact is a result of the use of a larger neck diameter (and greater neck length) on the tube derived by Table 1. It is a valid general deduction that the absolute electrical performance of a tube of given screen size can be improved by an increase in neck length and neck diameter.

APPENDIX

Grid voltages are always referred to cathode potential. The triode is said to be modulated when the grid potential is such that cathode current flows. For any fixed geometry and fixed anode voltage, denoted by V_a , there is a definite negative grid voltage, denoted by V_g , at which cathode current just ceases to flow. V_g is termed the cut-off voltage. The grid voltage V_g is always assumed to lie between the cut-off voltage and zero, but positive grid voltages are excluded. The grid drive, V_d , is defined as the magnitude of the difference between the cut-off voltage V_g and the actual grid voltage V_g . It is the grid voltage measured with respect to the cut-off voltage. It is clear from the above definitions that negative grid drive has no useful meaning and that we are only concerned with positive values of V_d .

TABLE 2

| Basic Operation | | Screen Diameter multiplied by k | |
|--------------------------|-----------------------|--|-----------------------------|
| Associated Operations | | Neck diameter, scanning coils constant. Position of triode in neck constant. Focus coil moved towards triode (if $k > 1$). Scanning angle constant, see Fig. 3. | |
| Geometrical Changes Made | Triode Dimensions | $\times k^{1/n}$ | $\times k^{1(1+n)}$ |
| | Cathode-grid Spacing* | $\times k^{2/n}$ | $\times k^{2 \cdot 3(1+n)}$ |
| Electrical Changes Made | Anode Voltage | $\times k^{2/n}$ | $\times k^{2(1+n)}$ |
| | Cut-off Voltage | $\times I$ | $\times k^{4/3(1+n)}$ |
| | Grid Drive | $\times I$ | $\times k^{4/3(1+n)}$ |
| | Scanning-Coil Current | $\times k^{1/n}$ | $\times k^{1/(1+n)}$ |
| Effects Produced | Beam Current | $\times I$ | $\times k^{2/(1+n)}$ |
| | Spot Diameter | $\times k$ | $\times k$ |
| | Beam Angle α | $\times I$ | $\times I$ |
| | Screen Brightness | $\times I$ | $\times I$ |
| | Cathode Loading | $\times I/k^{2/n}$ | $\times I$ |

* This adjustment to be made *additionally* to that effected by the scaling of the whole triode.

TABLE 3

| Anode potential (kV) | Grid potential (V) | Width of raster to make 400 lines just merge (S) (mm) | $S\sqrt{V}$ |
|----------------------|--------------------|---|-------------|
| 3 | - 30 | 73 | 127 |
| 4 | - 40 | 69 | 138 |
| 5 | - 50 | 62 | 139 |
| 8 | - 80 | 48 | 136 |
| 9 | - 90 | 45 | 135 |

For all practical purposes the cut-off voltage V_c is proportional to the anode voltage V_a , geometry being held constant. Furthermore the author has shown elsewhere¹ that to useful engineering accuracy, the cathode current I_k in most normally proportioned triodes is given by Equation (6). Thus the cathode current increases as the $7/2$ power of the grid drive for constant cut-off voltage.

This equation, it will be noted, does not explicitly involve the triode geometry except in so far as this affects V_c for a defined anode voltage V_a . In point of fact it would be astounding if so simple a law could accurately represent the cathode current for an arbitrarily wide range of triode shapes. Although it does not do this it is a useful guide. Reference 1 gives further information on the limitations of this formula.

When the grid of the tube is made

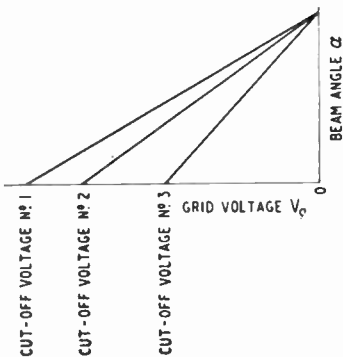

Fig. 4. The relation between the beam angle α and the grid voltage of the tube.

more positive (i.e., the grid drive is increased) then the beam angle in Fig. 1(b) is also increased. Very roughly, the beam angle increases linearly with drive as shown in Fig. 4. Here the idealized shape of the beam angle/grid voltage curve for varying cut-off voltages is displayed where the cut-off voltage variations are due to change in anode potential only and are not due to changes in triode geometry. It will be seen that the maximum beam angle occurs at $V_c = 0$ and is independent of the anode potential. This last fact is a consequence of postulate (2). It can further be shown¹ that

$$\sin \alpha = \frac{0.27}{f^{3/4}} D \frac{|V_d|}{|V_c|} \dots \dots (a)$$

where D is the grid hole diameter and f the anode-to-grid spacing.

Another very important consequence of Fig. 4 and Equation (a) is that the beam angle α remains

constant if both the modulus of the grid voltage and the anode potential are multiplied by the same constant.

Fig. 5. The relation between tube anode voltage and screen brightness is shown here. The crosses represent measurement values for a raster 10 cm by 10 cm and a beam current of 30 μ A.

Postulate No. 3 depends on experimental evidence which is given in Fig. 5. This shows a typical screen-brightness/anode-voltage curve for a 10-in diameter television cathode-ray tube. The beam current and raster size were all maintained constant throughout. The fluorescent material was zinc sulphide (mixed components—blue and yellow—giving an approximate white response). The curve can be approximated by a straight line on log/log paper thus revealing an approximate 'power' law. It will be seen that the curve bends over somewhat towards the higher voltages presumably due to partial onset of "screen piling." The value of 'n,' which averages 1.67, is considerably higher at the lower voltages. This emphasizes the necessity of not extrapolating the results of Tables 1 and 2 too far.

Postulate No. 4 depends on the assumption that the definition of spot diameter is in terms of a ratio of current density at the 'edge' to

maximum density at the centre. If screen saturation is negligible this is equivalent to a brightness ratio.

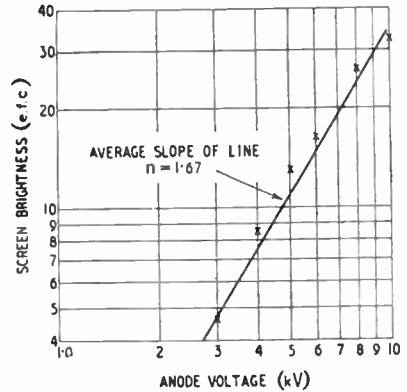

The measurement must therefore be based on a technique which is consistent with this definition. One such method is as follows.

A fixed number of lines is applied to form a raster, and the latter is contracted in a direction at right angles to the direction of each line until the lines just merge into each other. The width of the raster S is then proportional to the spot diameter.

Table 3 summarizes such measurements for a 10-in television cathode-ray tube. 400 lines each 150-mm long were used. The last column indicates that $S\sqrt{V}$ is nearly constant so justifying the principle. The latter however also has an appreciable basis in theory.

PORTABLE TELEVISION

THE Baird Portable Television set which measures 18½ in × 17 in × 13½ in and weighs 37 lb, is of the transformerless type and is suitable for a.c. or d.c. mains. It is a super-heterodyne with one signal-frequency amplifier. There are two i.f. stages in the vision channel and one in the sound. Noise limiters are fitted to both channels. The e.h.t. supply is from the line flyback.

The unusual feature of the set, by which its title of portable is justified, is the use of the mains lead as an aerial. The mains lead is fitted with a filter unit at about one half-wavelength from the set. This effectively isolates the half-wave section from the mains and so enables it to function as an indoor aerial.

The set is listed at £47 15s 6d plus £16 17s 4d purchase tax and at a recent demonstration performed ex-

cellently under conditions of severe interference. It is manufactured by Scophony-Baird, Ltd., Lancelot Road, Wembley, Middlesex.

Another new product of this firm is a magnetic-tape recorder which is designed for use with 8, 9.5 and 16 mm cine-film projectors and permits a synchronized running commentary to be added to any silent film. The Cine-Soundmaster costs .75 gns, and can be used with 600, 1,200 or 4,800 ft reels of tape suitable for 200, 400 or 1,600 ft of film.

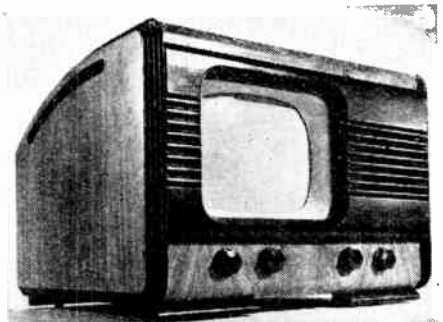

Baird portable television receiver.

¹ "Electron Gun of the Cathode Ray Tube—Part 2." By H. Moss. *J. Brit. Instn Radio Engrs*, June 1946.

WORLD OF WIRELESS

B.B.C. Charter ♦ Teleciné Equipment at A.P. ♦ Olympia Plans ♦ Birthday Honours

Committee of Inquiry

SINCE announcing the constitution and terms of reference of the B.B.C. Committee of Inquiry the Lord President of the Council has stated that Sir Cyril Radcliffe, who was appointed chairman, has had to resign owing to his appointment as Lord of Appeal. He is now Lord Radcliffe. His successor has not yet been announced.

The terms of reference of the Committee, which consists of eleven members including the chairman, are: "To consider the constitution, control, finance and other general aspects of the sound and television broadcasting services of the United Kingdom (excluding those aspects of the overseas services for which the B.B.C. is not responsible) and to advise on the conditions under which these services and wire broadcasting should be conducted after December 31st, 1951 [when the present Charter ends.]"

N.P.L. Annual Visit

MUCH interest was shown by visitors this year in the Electronics Section, where component parts of the A.C.E. (automatic computing engine) are being developed and made to the require-

ments of the Mathematical Division. Generators of pulses of $\frac{1}{3}$ - μ sec duration and 1- μ sec spacing were demonstrated, and also a "dynamicizing" circuit for translating decimal numerals into binary form, in which the presence or absence of any power of 2 in sequence is indicated either by a pulse or space. With this system a number with 10 significant figures on the decimal scale is registered in 30 μ sec, and can be kept in storage until required by circulating in a closed circuit, part of which involves the transmission of sound waves in a column of mercury.

Also in the Electronics Section was a display comprising the N.P.L. moisture meter and some simple devices involving photo-cells and capacitive effects to advertise the fact that the N.P.L. is willing to collaborate with manufacturers in the application of electronics to industry.

New Equipment at A.P.

TWO new sets of teleciné equipment, one made by Cinema-Television, and the other by E.M.I., have been installed at Alexandra Palace, where they are now being used for televising films.

The method employed is broadly the same in both sets. The principal components are a projection cathode-ray tube, an optical system, a film projector, and a photo-multiplier tube. A scanning pattern, with an aspect ratio of 5:2, is traced on the fluorescent screen of the cathode-ray tube by the electron beam, and two images of this pattern are projected by the optical system onto the gate of the projector.

The film runs continuously through the projector at a speed equivalent to 25 frames per second, and each film frame is exposed for $\frac{1}{50}$ th second first to one scanning image, and then to the other, by the action of a rotating shutter. The light that passes through the film is focused on to a photo-multiplier tube, which generates the picture signal, and the signals corresponding to the exposure of each frame to the two scanning images combine to give an interlaced signal. Though the aspect ratio of the scanning pattern on the face of the cathode-ray tube is 5:2, this is increased to an effective ratio of 5:4 by the motion of the film.

Radiolympia

PLANS for Radiolympia (Sept. 28th to Oct. 8th) are going ahead steadily and space has now been allocated to over 150 exhibitors—a reduction of some twenty on the 1947 figure. Although details of manufacturers' exhibits are not yet known some of those to be shown by Government Departments have been announced.

A supersonic experimental tank demonstrating the principles of radar will be among the exhibits of the Radar Research and Development Establishment of the Ministry of Supply. T.R.E. will be showing a radiosonde balloon which automatically transmits variations in the humidity, temperature and pressure during its ascent to 39,000 feet. The need for tropicalization of components and packages will be exemplified by samples having undergone tests at the Ministry's Tropical Testing Establishment in Nigeria.

The Dept. of Scientific and Industrial Research will be showing for the first time at this year's exhibition. The plotting of storm areas by radio—from information received from four forecasting centres—will be shown by D.S.I.R. which will also be demonstrating the means employed for forecasting the maximum usable frequencies for radio communication.

The radio and radar control of aircraft at London Airport will be shown on a working model of the main runway.

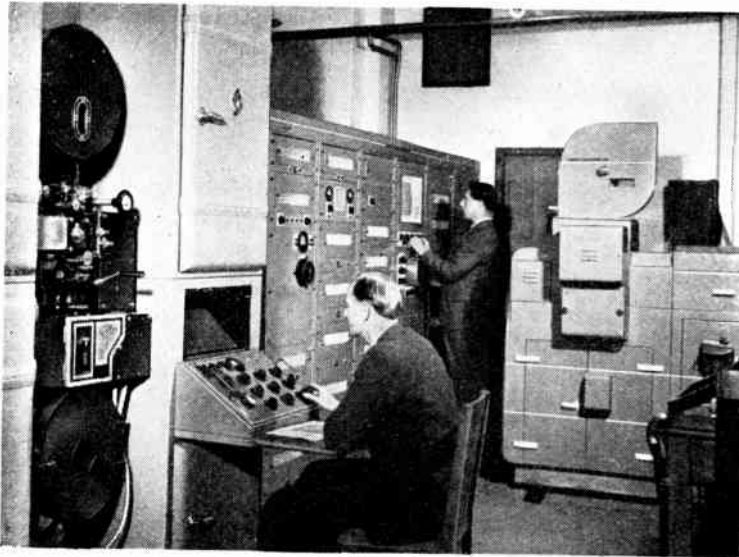

TELEVISION FILMS. General view of the new teleciné apparatus recently installed at Alexandra Palace. On the left is part of the E.M.I. equipment and on the right that supplied by Cinema-Television.

B.B.C. Appointments

CONSEQUENT upon L. W. Hayes' resignation as head of the B.B.C. overseas and engineering information department to take up the post of vice-director of the Comité Consultatif International des Radiocommunications in Geneva, changes in the organization of the



F. C. McLEAN, M.B.E., B.Sc.

B.B.C. engineering division have been announced.

The overseas engineering information department, the engineering secretariat, and the engineering training department have now been formed into what is to be known as the engineering services group with F. C. McLean, M.B.E., B.Sc., as head of the group and E. L. E. Pawley, M.Sc., as his assistant. H. Wilkinson, B.Sc., becomes head of O.E.I.D., and F. Williams, B.Sc., head of the engineering secretariat. Dr. K. R. Sturley continues as head of the engineering training department.

BIRTHDAY HONOURS

H. Faulkner, B.Sc., M.I.E.E., deputy engineer-in-chief, G.P.O., has been appointed a C.M.G. He joined the designs section of the G.P.O. engineer-in-chief's office in 1913 and after serving in the Royal Engineer's Signal Corps (1914-1918) he was transferred to the G.P.O. radio section. He was a member of the team responsible for the design of the Rugby station and was its first officer-in-charge (1925). He has held a number of executive offices and is now responsible for the radio development and radio maintenance branches. He was joint leader of the British delegation to the recent high-frequency broadcasting conference in Mexico.

C. S. Franklin, M.I.E.E., the "creator of beam wireless" who was recently awarded the Faraday Medal by the I.E.E., has been appointed a C.B.E. He retired from Marconi's W.T. Co., after 40 years' service, in 1939.

T. A. Davies, inspector of wireless telegraphy, G.P.O., is appointed an

O.B.E. He was deputy inspector from 1940-1944 and was in the G.P.O. overseas telecommunications department until 1948 when he was appointed inspector.

W. H. Oliver, controller of telecommunications in Malaya, becomes an O.B.E.

S. A. Williams, A.M.I.E.E., engineer-in-charge of the B.B.C.'s high-power short-wave transmitter at Skelton, Cumberland, is appointed an M.B.E.

J. Leiper, chief rigger at the Cable and Wireless receiving station at Somerton, Som., has been awarded the British Empire Medal.

OBITUARY

We record with regret the death of N. R. Campbell, Sc.D., who was in the G.E.C. research laboratories from 1919 to 1944 when he retired. He was aged 69. Prior to joining the G.E.C. he was appointed to the Cavendish Research Fellowship at Leeds University and was for a short time at the National Physical Laboratory. His research work was very varied ranging from investigations into the mechanism of the discharge of spark plugs to the theory of "noise" in thermionic valves and circuits. It was on the latter subject that he contributed, with others, a number of articles to our sister journal, *Wireless Engineer*. He was a Fellow of the Institute of Physics.

We also record with regret the death of J. G. Wright, a founder member of Wright and Weaire, Ltd. He retired in 1945 from active participation in the company which he formed in 1919.

The death is also announced of R. E. Gale, who was manager of the high-frequency and instrument sections of Philips works at Tooting. He was aged 47 and had been with the company twenty years.

PERSONALITIES

Sir William Coates has been appointed chairman of the Government Television Advisory Committee in succession to Lord Trefgarne who has held the position for nearly four years. Sir William is also a member of the recently appointed B.B.C. Committee of Inquiry.

Kathleen A. Gough, B.Sc., A.M.I.E.E., chief physicist in the research and development laboratories of the Dubilier Condenser Company, has been elected a Fellow of the Institute of Physics.

Brigadier E. J. H. Moppett has been seconded from Army duties to become chief inspector of electrical and mechanical equipment in the Ministry of Supply. Most of his 26 years Army service has been in Royal Signals. He was in charge of signal communications during the evacuation of Palestine and has just vacated a Deputy Director of Signals' appointment at the War Office.

E. C. Cherry, M.Sc. (Eng.), A.M.I.E.E., has been appointed to the City and Guilds Readership in Telecommunications endowed by Standard Telephones and Cables to provide

facilities for post-graduate teaching and research in this field. He was attached to T.R.E. during the war and has been on the staff of the City and Guilds College since 1947.

IN BRIEF

Increases of 63,100 "sound" licences and 6,750 television licences during April brought the total in Great Britain and Northern Ireland at the end of the month to 11,823,000.

St. Paul's Sound System.—A sound reinforcement system has been installed in St. Paul's by Pamphonic Reproducers, a subsidiary of Pye, to combat the famous echo of the cathedral. This has been done by fitting the loudspeakers under the chairs. To obviate the need for connecting wires, an induction system has been adopted. The output from the amplifiers is fed via a control desk in the nave to large wire loops on the ceiling of the crypt. Copper bands round each of the rows of chairs equipped with speakers provide the necessary pickup.

"Radio Valve Data".—This publication is now available in a second impression (with amendments to date of issue). It gives characteristics of 1,600 British and American receiving valves and replaces the former Valve Data Supplement which, in pre-war days, was a much-appreciated annual feature of *Wireless World*. The price is 3/6, or, by post from our Publisher, 3/9.

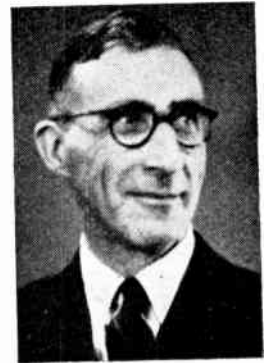

E. L. E. PAWLEY, M.Sc. (See "B.B.C. Appointments")

Birmingham Television.—The modifications to the "Superheterodyne Television Unit," described in the February and March, 1949, issues, necessary for the reception of transmissions from Birmingham will be given in our next issue.

C.R.T. Guarantee.—Although the British Radio Valve Manufacturers' Association does not consider an extension of the basic guarantee period of six months on cathode-ray tubes justifiable or economic, it has decided to amend the provision of the existing guarantee. Up till now the guarantee period for free replacement of tubes has been six months and that on a replacement tube the balance of the

World of Wireless—

guarantee period on the original tube. It has now been decided that for a trial period of twelve months from June 1st, each tube, including free replacements, shall carry the full six months' guarantee.

S.T.C. Endowment.—Standard Telephones and Cables has endowed a Readership, to be known as the Henry Mark Pease Readership in Telecommunications, in the City and Guilds College of the Imperial College of Science and Technology, South Kensington. The late Henry Mark Pease was managing director of S.T.C. until 1928 and took an active part in the formation of the British Broadcasting Company being one of its original directors. E. C. Cherry, M.Sc. has been appointed to the Readership. (See Personalities.)

Moulded Insulating Materials for use at frequencies greater than 10 kc/s are covered by a new British Standard (B.S. 1540:1949). It deals with six classes of materials—fused silica, vitreous materials, ceramics for insulators, ceramics for dielectrics, rubber-base materials and synthetic resins. It specifies tests for the mechanical strength and electrical properties of each class. The Standard is obtainable from the British Standards Institution, 24 Victoria Street, London, S.W.1, price 5s.

Receiver Cabinet Design will be among the subjects illustrated at the exhibition provided by the Chicago Institute of Design which will be held in Murray House, Petty France, London, S.W.1, from June 28th to July 29th.

Electronics Exhibition.—The fourth annual electronics exhibition organized by the North-Western Branch of the Institution of Electronics will be held at the College of Technology, Manchester, on July 19th from 2.30 to 9 p.m. and on July 20th and 21st from 10 a.m. to 9 p.m. An exhibition of scientific films arranged by the Manchester Scientific Film Society, will be included. Admission will be by ticket obtainable from Dr. J. A. Darbyshire, 1 Kershaw Road, Failsworth, Manchester.

"The Ionosphere and the Propagation of Radio Waves" is the main subject for consideration at the summer meeting of the Physical Society to be held in Cambridge from July 14th to 16th. The speakers will include Professor S. Chapman (Queen's College, Oxford), J. A. Ratcliffe (Cavendish Laboratory, Cambridge), Dr. A. C. B. Lovell (Manchester University), G. Millington and S. B. Smith (Marconi's W.T. Co.) and representatives from the Radio Research Board and the B.B.C. The fee for non-members is 10/- per day. Further particulars are obtainable from the Physical Society, 1 Lowther Gardens, London, S.W.7.

Television Construction.—A constructors' group of the Midlands Centre of the Television Society has been formed and particulars of the monthly meetings, which are held in Bournville, are obtainable from the Secretary, R. Baxendale, 50, Alcester Road, Birmingham, 13.

Cavity Magnetron Award.—The Royal Commission on Awards to Inventors has granted £36,000 to be shared among the three scientists responsible for the development of the cavity magnetron. They are Professor J. T. Randall, Professor of Physics, London University, Dr. H. A. H. Boot, and Professor J. Sayers, both of Birmingham University.

Radio Navigation.—The Thomas Gray Memorial Prize (1948) of £50 was awarded by the Royal Society of Arts to Capt. J. Klinkert, an instructor at the Sir John Cass Nautical School, London, for his essay on "The Applications of Radar to Navigation."

Eddystone "680"—A typographical error appeared in Stratton's advertisement on page 3 of the June issue. The length of the scale was given as "equal to nineteen inches per range." This should be *ninety*.

Scottish Branch of the Engineers' Guild was inaugurated at a meeting held in Glasgow recently. This is the fifth branch of the Guild to be formed during the past few months.

FROM ABROAD

Italy has ordered 46 high-constancy crystal-drive equipments from Marconi's for synchronizing its many broadcasting stations which will have to share wavelengths as, under the Copenhagen Plan, Italy has only three exclusive frequencies. The monthly frequency drift of these equipments is given as not more than 2×10^8 .

Finland is to install a new 100-kW medium-wave Marconi broadcasting transmitter. The special aerial coupling and tuning units for the directional aerial to be used in conformity with the provisions of the Copenhagen Plan are also to be provided by Marconi's.

Pakistan's Director of Radio is proposing to install receivers in schools and for community listening and is desirous of securing information from British manufacturers on sets that they are in a position to supply for the purpose. Most of the sets will need to be battery fed. Particulars should be forwarded to Z. A. Bokhari, Radio Pakistan (H.Q.), Karachi, Pakistan.

Exporting Television.—Scophony-Baird have appointed D. E. Wiseman, who was, until recently, the company's production and sales director, as overseas representative and he is now visiting North America to investigate potential markets for the Baird transformerless a.c./d.c. television set which employs a mains aerial.

South Africa.—Four more 5-kW medium-wave transmitters, making ten in all, are to be supplied by Marconi's to the South African Broadcasting Corporation.

India.—The Indian Minister of Industry and Supply has stated that the output of the four firms manufacturing broadcast receivers is 25,000 a year. He also stated that it is proposed to establish a State radio factory for the manufacture of a variety of equipment ranging from transmitters to components and valves.

South Africa.—Provisions are made in the amended Broadcast Bill now before the South African Government for the South African Broadcasting Corporation to be permitted to erect transmitters outside the Union. Under the existing Act the activities of the S.A.B.C. are restricted to within the Union. Tenders have been invited by the Corporation for the supply of transmitters for the new commercial programmes which it is hoped to radiate by the end of the year.

Denmark.—Transmissions from Denmark's experimental television station began on May 1st. Some details of the Philips transmitter were given in our May issue.

Nairobi's bilingual broadcasting service, which is provided by Cable and Wireless, Ltd., is to be augmented by the addition of a new 2-kW medium-wave transmitter ordered from Marconi's.

INDUSTRIAL NEWS

Marconi's marine communication receivers "Mercury" and "Electra" have been granted the P.M.G.'s certificate of type approval as conforming to the recently issued specification for ships' general purpose receivers.

Welwyn Electrical Laboratories.—All departments of this company, except the London sales office, are now at the new factory at Bedlington Station, Northumberland. (Tel.: Bedlington 2181.)

Ekco.—The Public Hall, Hadleigh, Essex, which was purchased by E. K. Cole in 1946 for use as a store, is to be used by the company for the production of broadcast receivers thereby releasing space at the main factory for the additional production of television sets.

Advance Components, Ltd., advise us that the damage caused by the recent fire at their factory at Back Road, Shernhall Street, Walthamstow, London, E.17, is not as extensive as was at first estimated. Production has been resumed but deliveries of some types of signal generator and constant-voltage transformers may be delayed a little.

Lee Products (Great Britain), Ltd. have transferred their head office and main distributing centre to 90 Great Eastern Street, London, E.C.2. (Tel.: Bishopsgate 3093.)

Kaysales, Ltd., manufacturers of "Precision" receivers, have taken over the Electronics Section of the business of S. H. Muffett, Ltd., of Mount Ephraim Works, Tunbridge Wells, Kent, and M. Lebar has joined the company as chief engineer.

G.E.C. Research Laboratories have taken a 21-year lease of a building in the Wembley Exhibition Grounds as an additional laboratory.

Industrial Finishes Exhibition.—The exhibition of industrial finishes planned to be held in September has been postponed to September, 1950. Details are obtainable from the Organizing Secretary, 26 Old Brompton Road, London, S.W.7.

"SUPER FIFTY WATT" AMPLIFIER



This **AMPLIFIER** has a response of 30 c/s. to 25,000 c/s. within \pm db, under 2 per cent. distortion at 40 watts and 1 per cent. at 15 watts, including noise and distortion of pre-amplifier and microphone transformer. Electronic mixing for microphone and gramophone of either high or low impedance with top and bass controls. Output for 15/250 ohms with generous voice coil feedback to minimise speaker distortion. New style easy access steel case gives recessed controls, making transport safe and easy. Exceedingly well ventilated for long life. Amplifier complete in steel case, with built-in 15 ohm mu-metal shielded microphone transformer, tropical finish. As illustrated, Price **36½ Gns.**

FOUR-WAY ELECTRONIC MIXER

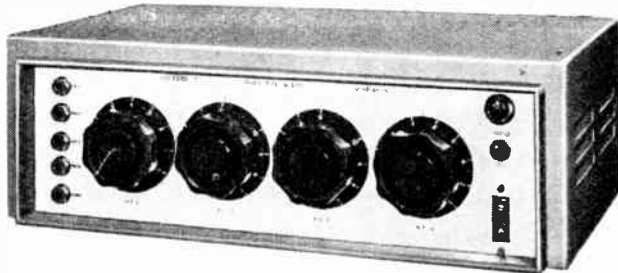

This unit with 4 built-in, balanced and screened microphone transformers, normally of 15-30 ohms impedance. Has 5 valves and selenium rectifier supplied by its own built-in screened power pack: consumption 20 watts. Suitable for recording and dubbing, or large P.A. installations since it will drive up to six of our 50 watt amplifiers, whose base dimensions it matches. The standard model has an output impedance of 20,000 ohms or less, and any impedance can be supplied to order. Price in case with valves, etc., **£24**

All types of **MICROPHONES, STANDS** and **SPEAKERS** available from stock including 12 in. **GOODMAN P.M. SPEAKER**

30-Watt **RECORD REPRODUCER** in metal case
PRICE 30½ Gns.

10-Watt **RECORD REPRODUCER** with **MICROPHONE STAGE**, in case
PRICE 25½ Gns.

CP20A AMPLIFIER for A.C. Mains and 12-volt Battery
PRICE £28.0.0

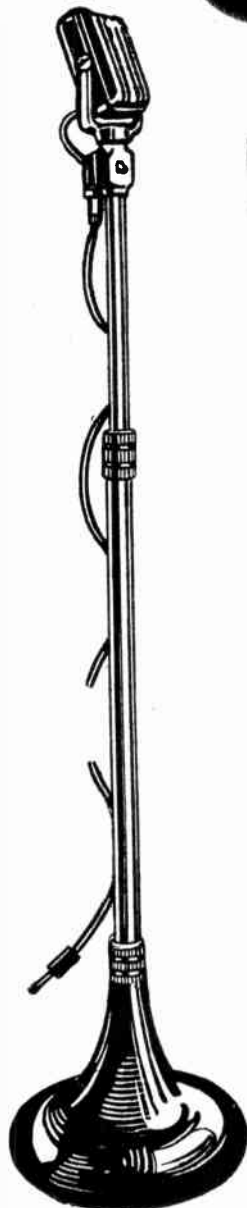

Vortexion
LIMITED

OUR FRIENDS OVERSEAS are invited to write for Export Terms

257-261, THE BROADWAY, WIMBLEDON, LONDON, S.W.19, ENGLAND

TELEPHONES: L1Berty 2814 and 6242-3

TELEGRAMS: "VORTEXION, WIMBLE, LONDON"

GREENWELL'S GLORY

or

SKY BLUE ZULU?

We refuse to tangle with fishermen on the niceties of their piscatorial pastime... we're too fly for that!

But fishing is also a great Industry in which the use of electronics to pinpoint the exact positions of shoals of fish saves time and money, and sweetens salty tempers.

The tempers of the Electronic and Electrical Industries will also be soothed by the performance of Parmeko Transformers—cast them a line.

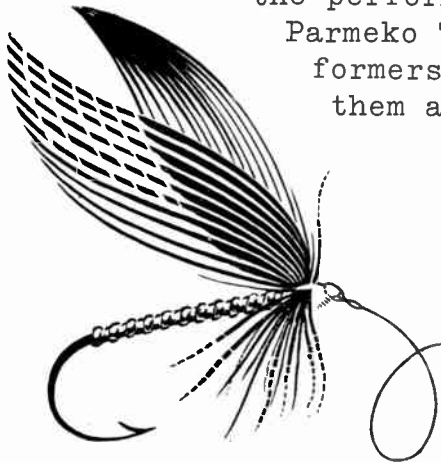

PARMEKO of LEICESTER

Makers of Transformers for the Electronic and Electrical Industries.

Only with CO-AX R.F. CABLES

AIR-SPACED ARTICULATED

4mm/ft

Patent's Regd. Trade Mark

| LOW ATTN TYPES | IMPED OHMS | ATTEN. (dB/1000 ft. at 100 Mc) | LOADING # | QD. |
|----------------|------------|--------------------------------|-----------|------|
| A 1 | 74 | 1.7 | 0.11 | 0.36 |
| A 2 | 74 | 1.3 | 0.24 | 0.44 |
| A34 | 7.3 | 0.6 | 1.5 | 0.88 |

THE LOWEST EVER CAPACITANCE OR ATTENUATION

| LOW CAPAC. TYPES | CAPAC. pF/ft. | IMPED OHMS | ATTEN. (dB/1000 ft. at 100 Mc) | QD. |
|------------------|---------------|------------|--------------------------------|------|
| C 1 | 7.3 | 150 | 2.5 | 0.36 |
| PC1 | 10.2 | 132 | 3.1 | 0.36 |
| C11 | 6.3 | 173 | 3.2 | 0.36 |
| C 2 | 6.3 | 171 | 2.15 | 0.44 |
| C22 | 5.5 | 184 | 2.8 | 0.44 |
| C 3 | 5.4 | 197 | 1.9 | 0.64 |
| C33 | 4.8 | 220 | 2.4 | 0.64 |
| C44 | 4.1 | 252 | 2.1 | 1.03 |

IMMEDIATE DELIVERIES FOR HOME & EXPORT

TRANSRADIO LTD.
CONTRACTORS TO HM GOVERNMENT
138A CROMWELL ROAD LONDON SW7
Telex: TRANSRAD, LONDON

HIGH POWER FLEXIBLE
PHOTOCELL CABLE
VERY LOW CAPACITANCE

TELEVISION MINDED?

Improved Postal Course at Greatly Reduced Price

In view of the rapidly increasing interest in Television and our large number of enrolments, we have reduced the price of our BASIC TELEVISION POSTAL COURSE by 25%. At the same time the scope of the course has been increased by including comprehensive material dealing with the latest television receiver techniques.

The course covers the examination for the Television Service Engineer's Diploma set jointly by the Radio Trades Examination Board and the City & Guilds Institute.

Where desired, selected lessons are available at an appropriately reduced price. Many other courses in RADIO, MATHEMATICS, INDUSTRIAL ELECTRONICS, etc. are available.

Write for FREE BOOKLET to D.pt. 16,

E.M.I. INSTITUTES

43, GROVE PARK ROAD, LONDON, W.4, CHiswick 4417/8

Associated with "H.M.V." MARCONIPHONE COLUMBIA ETC.



How Many Kinds Are There?

By "CATHODE RAY"

THIS symbol (presumably short for "quality factor") has become generally accepted as the prime virtue where r.f. components are concerned. It has even been incorporated in trade names. So recent statements that Q-meters don't read Q may have sounded to some like a tampering with the eternal verities.

What exactly is Q? Although it has been in common use for so long it has been slow to be officially recognised. Perhaps that is because a thing that has gone about with several different meanings seems hardly respectable in official circles.

Its roots lie in the early days of broadcasting, when transmitters were low-powered and none too easily heard with the single-valve or crystal receivers of that period. So the demand was for tuning coils that would make the most of the feeble r.f. voltages picked up. Next, when stations multiplied in number and power, the problem was not so much to tune in the wanted station as to tune out the unwanted ones. All this time the wireless amateurs' papers were full of advice on coils—practical advice on how to wind better coils, and theoretical advice on the underlying principles. It was shown that the coil which could give the strongest signals was also the most selective (though the optimum tapping or coupling depended on which quality was needed most).

The first prescription for achieving this double benefit was to reduce the r.f. resistance as much as possible. While quite true so far as it went, this was not the whole truth—it was soon realised that coil A might have a lower r.f. resistance than coil B and yet be less efficient in the two essential respects of sensitivity and selectivity. A resistance of 20 ohms would be bad

in a medium-wave coil, but good in a long-wave coil. To make a fair comparison one had to take into account their inductances, and the frequencies at which they were used. So the need was felt for a single figure that would include all the factors concerned.

As a matter of general principle a standard of goodness, or a "figure of merit," is preferable to a standard of badness such as r.f. resistance.

That was where the term "circuit magnification" or "magnification factor" (abbrevia-

reactance, $2\pi fL$ (abbreviated to ωL), we have:

$$V = \frac{v\omega L}{R}$$

The interesting thing, of course, is the ratio of V to v , because V is the "output" voltage, which can be used or passed on to the next stage; v being the input, derived perhaps from an aerial or a valve coupled by a primary winding. In any reasonable tuning circuit V is considerably greater than v , so it was natural to call V/v the magnification. We have, then:

$$m = \frac{V}{v} = \frac{\omega L}{R}$$

If we reckon from the capacitive reactance, $1/\omega C$, we get $m = \frac{1}{\omega CR}$, which comes to the same thing—in Fig. 1, at least.

Instead of approaching the matter in this theoretical way, one may prefer to inject an actual voltage into a real tuned circuit and measure the output voltage across it; m is then directly $\frac{V}{v}$.

In the course of time the Americans, thinking on similar lines, began to use the expression "Q". As it was usually defined as $\frac{\omega L}{R}$, it was generally assumed to be another name for "m," which it has tended to oust. But some slightly different definitions of Q appeared from time to time; and in the absence of prompt and firm action by acceptable authority, a state of uncertainty set in, and the term "Q" was generally avoided by the most precise people. Everybody else, however, found it too convenient for such scruples to prevail, and a Q-meter became one of the most used tools in almost every radio laboratory, while lots of people who hadn't the least idea what it really meant discovered in Q a

Fig. 1. Simple resonant circuit, with injected voltage v . The resulting voltages across C and L are in opposite phase and (at resonance) equal, so that reactances of C and L cancel one another out and the strength of current in the circuit depends only on R.

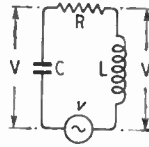

tion "m") came in.* It was based quite simply on the elementary principle of resonance, as shown in Fig. 1. If the frequency of the "input" or series voltage, v , is adjusted to make the reactances of L and C equal, they cancel one another out, leaving R as the sole impedance of the circuit so far as v is concerned. The current is therefore equal to v/R . But this current flows through C and L, and sets up voltages across them, equal to the current multiplied by their reactance. As the reactances are equal and the current is the same, the voltages are equal, and can both be denoted by V . Reckoning from the inductive

* As far as I have been able to trace, the earliest use of voltage magnification as a standard of coil efficiency was made by S. Butterworth (*Experimental Wireless and Wireless Engineer*, May, 1926, p. 267).

valuable addition to their sales talk.

Many people in the radio business can get along quite well with the single easily-absorbed fact that a high Q means good selectivity and signal amplification. That is the great merit of the expression; it means something in terms of practical results. One does not need a university education to grasp its general significance. I take it, however, that if you were content with rough ideas you wouldn't be reading this; so we will now proceed to consider the meaning of Q in greater detail.

Most of the controversy on the subject arises from the fact that no actual circuit is so simple as Fig. 1. L , C and R are shown there as separate components, but of course that is a theoretical simplification. R represents the total of the various forms of resistance and loss throughout the circuit. Normally most of it is the resistance of the coil, so L and R together are often assumed to represent the coil; but the capacitor is bound to have some resistance, so for more exact analysis one would divide R into two portions, attached to L and C respectively. We shall see later that if R is not substantially smaller than ωL and $1/\omega C$ it is necessary to be particularly careful how m and Q are defined or measured.

Other complications occur because in practical circuits the

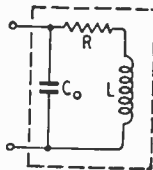

Fig. 2. A tuning coil can be represented fairly accurately by this equivalent circuit.

capacitor contains some inductance, and the coil contains some capacitance. The inductance of a well-designed capacitor is usually negligible except at very high frequencies; but the self-capacitance of a coil is by no means negligible, and is responsible for the largest discrepancies between different ways of arriving at Q . For one thing, as we shall see, it raises questions about how the

input voltage v is brought into the circuit.

At very high frequencies there is not even an appearance of L and C being separate—the tuning circuits are composed of parallel

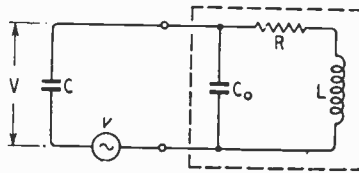

Fig. 3. When a real coil is substituted for L in Fig. 1, the "coil equivalent circuit" of Fig. 2 shows that the complete circuit is not quite the same, and measurements based on the assumption that it is will be wrong.

rods or cylinders, or of hollow spaces, in which L and C are inextricably mixed up and distributed. What about Q then?

We shall leave that question until later, and assume first that the frequency is moderate enough to let us represent the actual tuned circuit reasonably accurately by a diagram made up of separate lumps of L , C and R . That being so, it is usually satisfactory to consider the coil as if it were composed as shown in Fig. 2, in which C_0 is the self-capacitance.

Comparing this with Fig. 1 we see that the coil is itself a complete resonant circuit. It is not possible to open the circuit to insert a signal source directly in series as in Fig. 1—the dotted line is a reminder that the items within it are only theoretically separable—but its equivalent can be performed by inductive coupling. The frequency at which a coil resonates on its own is called the self-resonant frequency. Although coils (especially if permeability-tuned) can be employed in this fashion, it is unusual to do so, because it allows the resonant frequency to be affected so much by stray capacitance. Nearly always the coil is used with a separate tuning capacitance.

Although the r.f. resistance of a capacitor can be kept very much smaller than that of a coil, it may not always be negligible. So it is necessary to make quite clear whether one is considering the Q of the coil alone, of the capacitor alone, or of the whole circuit. Just

now we shall assume that the capacitor is perfect (zero resistance; infinite Q), so the Q of the coil is the same as the Q of the circuit.

Assuming also that the voltage v is introduced in series with L (in practice, by inductive coupling) connecting a perfect tuning capacitor across the terminals in Fig. 2 makes no difference in principle. It comes directly in parallel with C_0 , and for purposes of calculation two capacitances in parallel can always be replaced by one equal to their combined values; so the actual circuit is unchanged. But if the signal source is connected in series with the coil (which is not just L , but the whole combination inside the dotted line), we have a different circuit arrangement, Fig. 3. The question then arises; are we concerned with the true inductance of the coil (L) or the inductance as it appears to be at that particular frequency, supposing that the

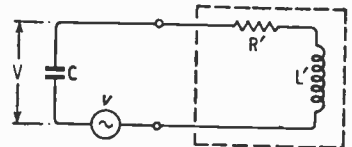

Fig. 4. At any particular frequency the coil equivalent circuit can be replaced by an apparent inductance and apparent resistance in series, which enables the principles of Fig. 1 to be applied.

dotted line contained only inductance and resistance is in Fig. 4? The apparent inductance (L') is not quite the same as L —it must be greater, to make up for ignoring C_0 —and R' is not the same as R . If they both differed in the same ratio, then the value of Q (taking it to be $\omega L/R$) would be unaffected, but as it happens they are not. The textbooks show that

$$R' = R \left(\frac{C + C_0}{C} \right)^2$$

$$\text{and } L' = L \left(\frac{C + C_0}{C} \right)$$

so what we may call the apparent Q , denoted by Q' and equal to $\omega L'/R'$, is

$$Q' = \frac{\omega L'}{R'} = \frac{\omega L}{R} \left(\frac{C}{C + C_0} \right) = Q \left(\frac{C}{C + C_0} \right).$$

When the external tuning capacitance C is very much larger

than the self-capacitance C_0 the difference between Q and Q' is not worth bothering about. A typical self-capacitance is 6pF, and if the added capacitance were,

$$\text{say, } 300\text{pF, } Q' = \frac{300}{306}Q = 0.98Q;$$

the difference would be only 2%, which is less than the probable error of most Q-meters. But if no C is used the apparent Q is zero, no matter how high the true Q may be! So the distinction ought not to be completely ignored.

Opinions have differed as to which Q is the right one, or in fact whether either as defined above is right. To settle the question some people appeal to basic principles and others to practical sense. To serve its purpose of expressing the goodness of a tuning circuit or component it would obviously be a great advantage if the definition corresponded to the method of use. So we had better consider how tuning circuits are used.

In a typical broadcast receiver there are three main kinds of tuned circuits, shown in rough outline in Fig. 5. There is first the r.f. circuit, L_1C_1 , into which the input voltage is inductively injected from the aerial, and the output taken from across C_1 . Next there is the i.f. primary, in which the mode of operation is reversed; the input is received directly across the terminals of C_2 and the output is imparted inductively, proportionately to the current flowing in L_2 . Lastly the secondary, L_2C_3 , which works similarly to L_1C_1 .

None of these tuned circuits corresponds to Fig. 3; in all of them the self-capacitance of the coil is effectively in parallel with the external tuning capacitance, making a total of $C + C_0$, tuned by the true inductance L and damped by the true r.f. resistance R. There is no need to bother about L' or R' —or Q' . The typical examples just shown cover the vast majority

of tuned circuits in actual use. It is clear then that Q corresponds to practical affairs more closely and more often than Q' .

But what about the methods used for measurement? The bare bones of the usual type of Q-meter are shown in Fig. 6. A variable-frequency oscillator is provided to pass a measurable current (I) through a known low resistance r . The r.f. voltage developed across r is therefore Ir , and it corresponds to the signal source in Fig. 3. The output voltage V is measured by a valve voltmeter across C, when C or the frequency of the oscillator has been adjusted to cause resonance, indicated by maximum V.

We must conclude, then, that the quantity which applies to the commonest methods of use is Q, but that the quantity actually measured by the commonest method is Q' . And therefore that when these methods giving Q' are used, the readings should be

$$\text{multiplied by } \frac{C + C_0}{C} \text{ to bring}$$

them to Q. The instruments are, or should be, calibrated in C, and can be used to measure C_0 . As we have already seen, the correction is hardly worth applying when C is many times greater than C_0 ; but omitting to apply it when C is not much greater than C_0 gives results which differ largely from the true Q.

A Q-meter is very handy to use, but is subject to another error—serious at the higher radio frequencies—due to r , which makes the instrument read lower than it should by increasing the resistance

of the circuit being tested. Even if r were directly in series with R, so that it could just be deducted from it, one would have to calculate R, which is a nuisance with an expensive instrument that is supposed to read Q directly without any need for calculation. But actually r is in series with R' , so to be strictly correct one would

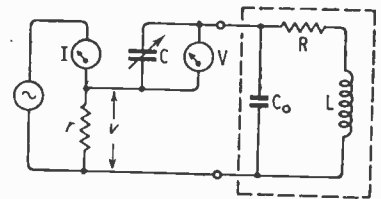

Fig. 6. Outline circuit showing the principle on which most Q-meters work.

have to apply the factor relating R to R' . In fairness to Q-meters I must admit that r is usually small enough to be neglected except in high-Q, very-high-frequency circuits, and also that some Q-meters work on different principles. When measuring very good coils one might also have to allow for the losses due to the valve voltmeter and the tuning capacitor. So it is as well not to be too impressed by the apparent direct-readingness of an instrument having a pointer moving over a scale marked "Q." Its great advantage is that it does give quite quickly and easily a figure that can be used for comparing one coil with another, even though that figure may often differ appreciably from the true Q. The instrument can also be used for a variety of other measurements if one is prepared to do a few simple calculations.

But if one is prepared for that there is a lot to be said for an alternative method—the method in which the frequency of the oscillator is read at resonance and also at the two settings, one on each side of resonance, at which the voltage across the tuned circuit is 70.7% (i.e., $1/\sqrt{2}$) of its maximum reading (Fig. 7). Then if f_r is the resonant frequency and f_1 and f_2 respectively the higher and lower of the other two:

$$Q = \frac{f_r}{f_1 - f_2}$$

In this method, the oscillator

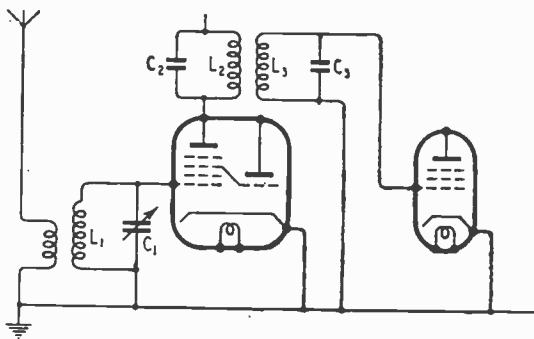

Fig. 5. Three typical ways in which tuning circuits are used in a broadcast receiver. In all of them it is true Q that counts, rather than the apparent Q.

Q is loosely coupled to the coil under test; there is no need for the r.f. ammeter or the resistance r ; the result is given directly in true Q ; and the method can be used in circumstances where the Q -meter fails. And of course it is very much cheaper.

The reason why it gives true Q is that the input voltage is inductively coupled to the coil under test, so is in series with the tuned circuit as a whole. In Fig. 6, by contrast, the input voltage is in series with only one of the two capacitance branches; C_0 forming a sort of bypass.

There is another feature about Fig. 6, which is of practical importance only when Q is exceptionally low, but is interesting theoretically. We have not defined "magnification factor," and I have yet to come across a really water-tight definition, but it seems to be generally agreed that it is V/v in Fig. 4 when the circuit is at resonance, as indicated by a maximum reading of V . If you ask whether this is not identical with what we have been calling Q' , the answer is—not exactly. If you look up any good textbook that deals with resonance you will see that the frequency at which the voltage across the resonant circuit is maximum is not quite the same as the frequency giving series resonance. As a matter of fact, it depends on whether the maximum is arrived at by adjusting the frequency or by adjusting the tuning capacitance. Now Q (and Q'), as we saw in connection with Fig. 1, are based on the theory of series resonance. But Q -meters, which are the practical embodiments of Fig. 4, are so arranged that resonance is judged by the maximum reading of V . So really they are magnification-factor meters.

The relationship between m and Q' can be worked out. The calculation is rather involved, but as a matter of interest the result, assuming resonance is obtained by varying the frequency of the oscillator, is:

$$Q' = \frac{\sqrt{m^2 - 1 + m\sqrt{m^2 - 1}}}{2}$$

For example, if $m = 2$, $Q' = 1.8$ —a 10% discrepancy; but if

$m = 10$, $Q' = 9.96$ —only 0.4% different.

If resonance is obtained by varying C :

$$Q' = \sqrt{m^2 - 1}$$

The discrepancy is slightly larger in this case, but is still utterly negligible for normal tuning circuits. It should not be forgotten when dealing with very "flat" circuits, however.

In the alternative (Fig. 7) method, too, resonance is judged by maximum V ; but the resulting error is even smaller than in the previous cases. The calculation

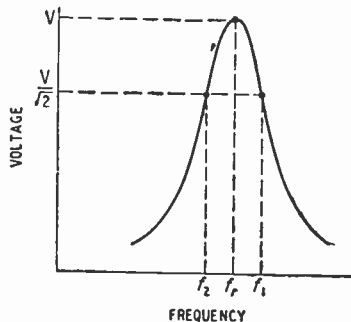

Fig. 7. Principle of an alternative method of Q measurement

is still more complicated, and the final result too bulky to be worth printing here.

The fact that Q is a measure of the effectiveness of a tuning circuit as regards signal strength is brought out obviously enough in the Q -meter method. The frequency-variation method, on the other hand, brings out the relationship of Q to selectivity. What one does, in fact, is to measure the sharpness of resonance. But that is not quite the same thing as selectivity in its most directly-useful terms. What we generally want to know is the bandwidth, in cycles per second, irrespective of the mean or carrier frequency. To tune in Droitwich, f_r in Fig. 7 would have to be 200 kc/s, and one might decide that the 70% points (f_1 and f_2) of a single tuning circuit ought to be, say, 6 kc/s above and below f_r , giving a bandwidth of 12 kc/s. The required Q would therefore be $\frac{200}{12} = 16\frac{2}{3}$. For tuning-in a station on 1200 kc/s with the same selectivity, the bandwidth would

still have to be 12 kc/s, but the Q to give that selectivity would be $\frac{1200}{12} = 100$.

For constant selectivity, then, Q has to be proportional to frequency; so the quantity that indicates narrowness of bandwidth is not $Q = \frac{\omega L}{R}$, but $\frac{L}{R}$, the "time

constant." At any given frequency, however, it is true to say that selectivity is directly proportional to Q .

This may be a good moment at which to point out another advantage of Q as a standard, compared with R . We have already seen that it is a fairer guide to the effectiveness of a coil because it takes into account its inductance, and also it is a measure of goodness rather than badness, and directly tells one the output voltage produced at resonance by a given input voltage. The other thing is that R , unlike ordinary d.c. resistance, is by no means constant. Most of the losses included in it tend to increase with frequency. Over a limited range of frequency, such as that covered by a tuning coil, the resistance R is usually roughly proportional to

frequency. So, since $Q = \frac{2\pi fL}{R}$,

over the same range of frequency Q is roughly constant. Only roughly; but at least it is more nearly constant than R .

So far we have been considering Q as a property of a coil, which is the same thing as the property of the whole tuned circuit, if losses outside the coil are negligible. But one often sees references to the Q of a capacitor or other component. The same principle holds: it is the ratio of reactance to series resistance; with capacitive reactance, $Q = 1/\omega CR$.

When considering a resonant circuit it is often useful to know its equivalent parallel resistance, or dynamic resistance. Denoting it by R_d , and the reactance (inductive or capacitive) by X , the ratio R_d/X is the same as X/R , which is what we know as Q . So if we know that the reactance of a tuning coil in the anode circuit of a valve is, say 1000 Ω , and its Q is 100, then it acts as a coupling resistance of 100,000 Ω . (Because $R_d = QX$). And of

course its series r.f. resistance is $10 \Omega (= X/Q)$.

No.vadays most of the interest is focused on those frequencies which the Editor conveniently gathers together under the single abbreviation "e.h.f." (i.e., everything over 30 Mc/s). At such frequencies the concept of a circuit composed of lumped L and C more or less breaks down. That being so, the concept of Q, if it can be made to apply, is more useful than ever, because of the difficulty of measuring L and C and of knowing what they signify when one has measured them. So Q has recently been redefined in more general terms as :

$$\frac{2\pi \text{ times the energy stored}}{\text{energy dissipated}}$$

in the circuit per half-cycle.

Simple lumped circuits such as Fig. 1 are particular cases, in which Q as defined in this general way simplifies to $\omega L/R$ or whatever is appropriate. So accepting the newer definition doesn't make it necessary to unlearn the old. There are, however, a few bogus definitions, such as the reciprocal of the power factor, that ought

NEW RADIO-GRAMOPHONE

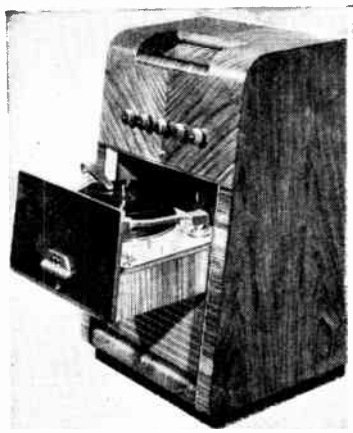

A two-position tone control gives normal and extended frequency range on gramophone records in the latest Marconiphone Model ARG19A. The auto-changer handles up to ten 10in or 12in records. On the radio side, a four-valve plus rectifier superhet. covers short, medium and long waves. Three extra positions on the waverrange switch give two preset stations on medium and one on long waves. The price is £84 11s. 4d. including purchase tax.

to be scrapped, however nearly right they may be in most cases.

You may ask how the energy stored per cycle in an e.h.f. circuit can be measured. Well, the most convenient form for definition is not necessarily the most convenient form for measurement; and in this case measurement is best tackled indirectly. It is sometimes possible to measure the decrement, or rate of dying-away of oscillations. But the most generally convenient is the Fig. 7 method, which holds good even with resonant cavities for centimetre waves. Frequency is the most accurately-measurable quantity there is; so the only other thing to provide is an indicator to show when the voltage or current amplitude is 70% of maximum—roughly 3 db down.

Summing up the main points :

(1) The modern definition of Q, completely general in its application, is based on the ratio of energy stored to energy dissipated in the circuit.

(2) Applied to lumped circuits, this is equal to the ratio of the reactance (purely inductive or capacitive) to the series resistance (in its widest sense, covering all losses).

(3) This X/R ratio is also equal to the ratio of V, the voltage across the whole reactance of one kind in a circuit at series resonance, to v, the voltage injected in series—the ratio known as circuit magnification factor (m). But when, as is usual, resonance is judged by the maximum parallel voltage, there is a discrepancy between m and Q, which is negligible unless Q is in the lower single-figure range.

(4) If Q or m is measured by the type of circuit shown in Fig. 3, (such as the usual type of Q-meter, Fig. 6), the result is the apparent Q, or Q', equal to

$$Q \left(\frac{C}{C + C_0} \right).$$

Since this is almost the only practical way of directly measuring m, in practice m is the same as Q' (neglecting the discrepancy mentioned above).

(5) Q, however, can be measured by other methods (such as the frequency-variation method, Fig. 7) which give true values directly, and these correspond with the conditions under which tuned circuits are most commonly used (Fig. 5).

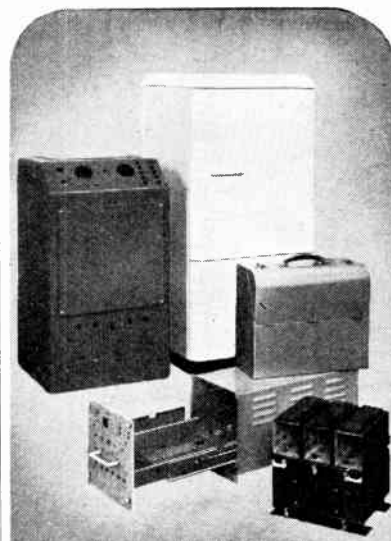

CASES TO YOUR SPECIFICATION

As the leading manufacturer of precision built instrument cases we are particularly well equipped to quote you, competitively, for bulk production of any type of metal case to your drawings or sample, regardless of size or quantity. Our wide range of stock tools not only enables us to offer you the keenest possible prices but also helps to ensure quick and punctual deliveries. Owing to our specialized knowledge of metal case work and infinitely varied experience you can place absolute confidence in our ability to meet your exact requirements. All estimates will be submitted promptly and without cost or obligation. Only materials of the highest quality will be used throughout.



INSTRUMENT CASES

112-116 NEW OXFORD ST., LONDON, W.C.1
TELEPHONE MUS. 7878

TRIODE-DIODE VOLTMETER

Made from War Surplus Parts

By T. A. LEDWARD, A.M.I.E.E.

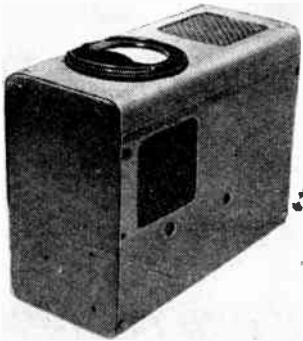

A general view of the voltmeter

INTENDED for audio-frequency work, the voltmeter to be described has a linear scale from 0.1 to 1 volt. It is not suitable for d.c., but this limitation enables a stable zero to be obtained without special balancing arrangements.

The instrument was constructed from ex-Government components, including the metal case, at low cost.

A Type No. 194 receiver provided the case and valves. This receiver contained many additional parts, including two further valves, a VR91 and an EF50. The 0-100 microammeter, ex-Admiralty pattern W6022, had a speci-

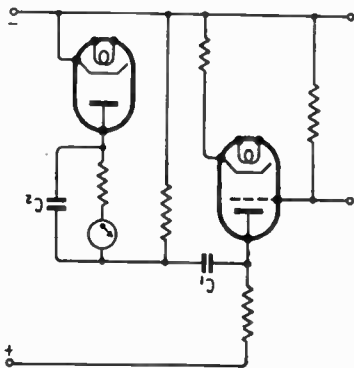

Fig. 1. Basic circuit.

ally marked scale which required repainting and scaling.

The circuit arrangement was considered with some care and it will be useful to explain the reason for certain features. The first

requirement was an approximately linear scale of 0.1 volt. The second was a reasonably high input impedance.

The linear scale requirement was met by the use of a diode, but a range of 0.1 volt with diode only and a 0-100 microammeter would have meant an input impedance of only about 5,000 ohms.

A pre-amplifier valve was therefore used. The input impedance now depends upon two things: the grid shunt resistance and the effective input capacitance of the valve. The latter factor, of course, lowers the input impedance as the frequency is raised.

A value of 1 megohm was

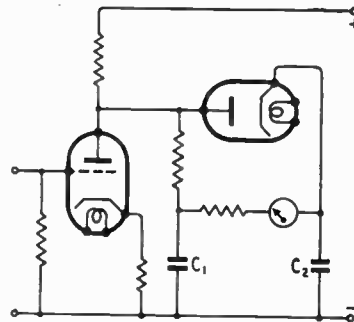

Fig. 2. Modifications of Fig. 1 to reduce the effect of stray capacitances of C_1 and C_2 .

chosen for the grid shunt resistance. The effective value of the input capacitance, using a VR65 valve is approximately 75pF.

An important feature is the arrangement of circuit whereby the stray capacitance to earth from the anode circuit of the amplifying valve is maintained as low as possible.

Consider Fig. 1: in order to deal satisfactorily with the lower frequencies, the condensers C_1 and C_2 must be large, say $4\mu\text{F}$. They must also have a very high insulation resistance, which rules out electrolytics. The bulk will, therefore, be appreciable, and the

capacitance to earth will be fairly high. Fig. 1 is, therefore, unsatisfactory for a wide range of frequency. Now consider Fig. 2: by placing C_1 and C_2 on the earth side of the circuit, the stray capacitance from anode to earth is unaffected by the size of these

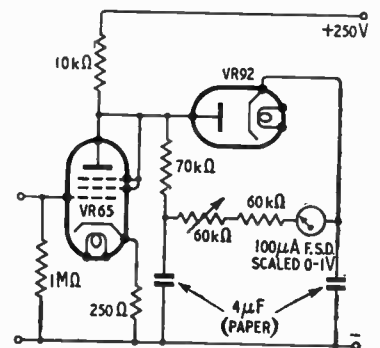

Fig. 3. Final circuit with component values.

condensers. The indicating instrument is now raised to about 180 volts d.c. above earth potential, but the a.c. potential above earth is negligible and there will be no hand capacitance effects.

The final circuit of the voltmeter, together with values of components, is shown in Fig. 3. Separate 6.3-volt heater supplies will be required and the h.t. supply should be approximately 7 mA at 250 volts.

Higher voltage ranges may be included, if desired, by adding a voltage divider similar to that described in *Wireless World* dated June, 1944.

BOOK RECEIVED

Elements of Electromagnetic Waves. By Lawrence A. Ware. Pp. 203+x, with 69 illustrations. Sir Isaac Pitman & Sons, Ltd., 39, Parker St., London, W.C.2. Price 20s.

This book is of American origin and treats electromagnetic waves mathematically. There is an introductory chapter explaining vector algebra which is freely used in the subsequent text. The book finishes with a chapter on radiation in which simple forms of aerial are considered.

SHORT-WAVE CONDITIONS

May in Retrospect : Expectations for July

By T. W. BENNINGTON and L. J. PRECHNER (Engineering Division, B.B.C.)

DURING May, maximum usable frequencies for this latitude decreased very considerably by day, in accordance with the normal seasonal trend. The night values, however, instead of showing the usual increase, decreased very slightly, perhaps owing to the disturbed conditions during the first half of the month.

The month was slightly less disturbed than April, ionosphere storms being observed on 2nd-9th, 11th-14th and 31st, 12th and 13th being exceptionally disturbed, and a very great magnetic storm also being recorded during that period.

Working frequencies for the month were, on the whole, very low, relatively few contacts being established over 30 Mc/s. Thus long-distance communication on the 28-Mc/s band was seldom reliable, particularly in eastward and westward directions. During the night no frequencies below 7 Mc/s were really necessary.

There was a marked increase in the rate of incidence of Sporadic E, in accordance with the usual trend, and many amateur openings via this layer have been recorded for the first time this year, mostly from Eastern and Southern Europe. Frequencies as high as 50 Mc/s were occasionally propagated by this medium.

Four "Dellinger" fadeouts were recorded in May, on 5th, 7th, 8th and 9th, the fadeouts on 5th and 7th being particularly violent.

Sunspot activity in May was considerably less than in April. Three large sunspot groups crossed the central meridian of the sun (on 5th, 11th and 31st), and all of them were associated with reception disturbances which occurred around those periods, the disturbances following the second group being particularly intense.

Long-range tropospheric propagation was observed on a number of occasions, particularly in the second half of the month.

Forecast.—It is probable that there will be very little difference between the m.u.f.s for July and June, as in the Northern Hemisphere daytime and night-time m.u.f.s usually reach their respective annual minimum and maximum values during this period.

As in June, although daytime communication on very high fre-

quencies, like the 28-Mc/s band, is not likely to be frequent, over many circuits frequencies like 15 and 17 Mc/s will remain regularly usable until midnight. During the night frequencies lower than 11 Mc/s will seldom be required. For medium distances, up to about 1,800 miles, the E and F₁ layers will control transmission for considerable periods during the day.

Sporadic E is usually very prevalent in July, and communication over distances up to 1,400 miles may be possible by way of this medium on frequencies greatly in excess of the m.u.f.s for the regular E and F layers. Frequencies as high as 60 Mc/s may be occasionally reached for a short time. However, it is impossible to predict when such communication may occur, owing to the irregular behaviour of Sporadic E.

Below are given, in terms of the broadcast bands, the working frequencies which should be regularly usable during July for four long-distance circuits running in different directions from this country. (All times GMT). In addition, a figure in brackets is given for the use of those whose primary interest is the exploitation of certain frequency bands, and this indicates the highest frequency likely to be usable for about 25 per cent of the time during the month, for communication by way of the regular layers:—

| | | | |
|-----------------------|------|--------|----------|
| Montreal : | 0000 | 15Mc/s | (19Mc/s) |
| | 0100 | 11 " | (15 " |
| | 1200 | 15 " | (19 " |
| Buenos Aires : | 0000 | 17Mc/s | (22Mc/s) |
| | 0100 | 15 " | (19 " |
| | 0500 | 11 " | (16 " |
| | 1000 | 17 " | (23 " |
| | 1500 | 21 " | (26 " |
| Cape Town : | 0000 | 15Mc/s | (20Mc/s) |
| | 0100 | 11 " | (15 " |
| | 0600 | 17 " | (24 " |
| | 0800 | 21 " | (28 " |
| | 1800 | 17 " | (22 " |
| Chungking : | 0000 | 11Mc/s | (14Mc/s) |
| | 0500 | 15 " | (20 " |
| | 2300 | 11 " | (14 " |

Ionospheric storms are not very common in July, and relatively undisturbed conditions may be expected. At the time of writing it would appear that storms are more likely to occur during the periods 1st-2nd, 6th-9th and 27th-29th, than on the other days of the month.

Good Reception

Below is listed a few of the leading Television Manufacturers who approve the use of Anti-interference Aerials with their receivers. A high percentage of Televisors now in use operate with **ANTIFERRENCE AERIALS**

ANTIFERRENCE LIMITED

67 BRYANSTON ST., LONDON, W.1

Unbiased

By FREE GRID

Nauseating Nomenclature

A GREAT many laymen, led astray by glib-tongued and facile-fisted lay journalists, seem to have got it into their heads that there is some subtle difference between radio waves and what they call radar waves. It is difficult to explain to them that there ain't no sich animal as a radar wave, any more than in the realm of sound there are such things as echo waves, or audar waves, as I have little doubt that some of these cliché coiners would term them.



Loathsome learned.

I was trying to explode the radar wave superstition the other day by means of a mechanical analogy—always a dangerous thing, as invariably it breaks down and brings the creator down with it, as it did in this particular case in more senses than one.

To lend force to my argument I used a punch-ball to demonstrate my analogy. In an unguarded moment, carried away by my enthusiasm, I was floored physically by what I termed the ball's radar wave, and metaphorically by a bespectacled and loathsome learned-looking schoolboy who pointed out, quite rightly, that the ball's return was not due to any reflection effect, but to the release of the energy which my original blow had caused to be stored within its spring support. This regrettable *contretemps* and consequent collapse of both myself and my analogy had the unfortunate result of destroying faith in my main thesis and establishing "radar waves" still more firmly in the minds of my youthful audience.

This incident made me give up further attempts to educate the technically illiterate masses, but a

recent report from the U.S.A., which states that cooking is now being carried out by what it calls "radar waves," has brought my missionary zeal to the fore once again. I can stomach this sort of thing with as little success as I can stomach the results of this offensive inside-out sort of cooking. According to the newspaper report the innards of a chicken, instead of being first removed, were cremated, and the flesh done to a turn, whatever a turn may be.

Apart from my æsthetic objections to this sort of cookery, which causes my physical gorge to rise as much as the misuse of the term radar causes my technical gorge to perform the same evolution, I object strongly to it being termed new. I, myself, was privileged to be present, over three years ago, at a private demonstration of this sort of inverted cookery by one of its pioneers, which I duly reported in these columns (March, 1946). For the benefit of those of you who have perverted gastronomic tastes, I would mention that the American demonstration was on a frequency of 23 Mc/s; but to me giblets are giblets, whether cremated or not, and I will have none of it.

Wrist Radio

THE vogue of the personal portable or miniature receiver threatens to develop into an epidemic or even become a permanency as more and more manufacturers give us their versions of it. Quite frankly, I don't like any that have so far appeared. My complaint is that none of them is small enough to shove into one's pocket without making an unsightly bulge. The ignorant and ill-informed may well ask "why do you want to shove one into your pocket anyway?"

This is, of course, precisely the question which was asked of an ancestor of mine when he made a similar complaint about the bulkiness and unpocketability of turnip watches. My point is that the whole idea of the personal portable is that it is intended to be carried on one's person. It should, therefore, be no larger than a watch or a cigarette lighter.

Seven years ago (March, 1942) I published in these columns a photograph illustrative of the American trend in personal portable design, which was towards something like a

Leica camera. Both British and American "Leica" models of an improved type are now available, but they would be still more improved if they were made less conspicuous to carry and protected from damage by means of an ever-ready leather case like their photographic counterparts.

But now that ultra-midget valves, components and batteries are available for pocket hearing aids surely we can get down to something smaller than the Leica camera. In my opinion, it can be done by once more borrowing an idea from the photographic world; there is no shame in it, or at any rate the photographic fraternity do not think so as they don't hesitate to borrow the micro-ammeter and the photocell from us and call the combination an exposure meter.

Apparently the Germans regard the Leica as a bit old fashioned as they now go in for a "wristwatch" camera weighing less than a couple of ounces and giving a negative of 4×3 millimetres. I need hardly say that this puts users of conventional miniature cameras into the same class as they have so often contemptuously consigned me and my old wet-plate outfit.

What I would like to see is British radio manufacturers following this thoroughly praiseworthy example and turning to the production of wrist radio. The volume from such a set would enable me to hear, without disturbing others, all that I wanted to when away from my home receiver. This surely is the sole aim and purpose of a "personal" receiver.

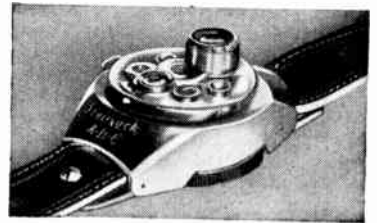

Courtesy "Foto Spiegel"

Radio manufacturers please copy.

Whilst on the subject of miniaturization there is another piece of equipment which could more readily be carried on one's person if suitably adapted. I have often wondered why the practice of the Melanesian native, who carries his treasures slung in the pierced and extended lobe of his ear, has not been copied by users of hearing aids.

LETTERS TO THE EDITOR

Export Opportunities ♦ Why Record Supersonic Frequencies? ♦ Circuit Diagram Conventions ♦ Measuring Circuit Magnification ♦ Simple Wobbulator ♦ B.B.C. South Coast Service

Canadian Trade Possibilities

THERE would appear to be little effort on the part of many British manufacturers of electronic apparatus and components to realize the market potential for their products here in Canada.

I came to Canada eighteen months ago from the U.K., and, in my present work as Senior Communication Engineer, the Canadian prospects for many British lines have been brought forcibly to my notice.

Contrary to expectations, some American products retail at higher prices than their British counterparts and are frequently of inferior quality.

In view of Britain's present economic plight and the favourable import position applying to British products in the general class of electrical, wireless and radio apparatus (with the important exception of domestic radio receivers) the apparent sales lethargy on the part of many manufacturers in my opinion warrants the strongest censure.

Some British manufacturers have done nothing, possibly overawed at entering the arena with the American Juggernaut; others have blindly accepted the first Canadian agency enquiry without regard for status or coverage check-ups. Where agencies have been given to Canadian firms of standing there appears to be little control over the Canadian selling price, which rises steeply.

In view of this adverse selling factor, direct British group representation would appear to have many points in its favour. In short, is there any valid reason why bodies such as the Radio Component Manufacturers' Federation, S.I.M.A., etc., should not set up their own Canadian distributor units?

Such a step should ensure more effective representation to the retailer and customer with more reasonable distribution overheads. It would also permit more adequate range or spare stocking and customer service than can be expected from an agent handling a product for the most profit with least effort.

In conclusion, may I stress the part that *Wireless World* itself could play in fostering increased electronic exports to Canada. Every effort should be made to increase the

Canadian circulation with paper restrictions eased on this account. I can assure you that your coloured issue for March last agreeably surprised Canadian colleagues and, in particular, many of the advertisements and prices. In a country where American periodicals serve as a buyer's guide, the vital role of *Wireless World* cannot be over-estimated and, indeed, wider Canadian circulation is a vital prerequisite to increased British exports in this field.

T. S. DUTTON.

Valois, Quebec, Canada.

Thévenin's Theorem

IN my recent article on Thévenin's Theorem (March issue), I showed, perhaps, some disrespect towards M. Thévenin in suggesting that he was something of an interloper and that credit for the theorem really belonged to Helmholtz.

M. Simon, of "SOTELEC," Paris, gently implied as much in sending me a copy of his biographical appreciation of Thévenin, containing a reproduction of Thévenin's original paper setting out the theorem in question.

As a result of correspondence with M. Simon and with Prof. G. W. O. Howe (on whose *Wireless Engineer* Editorial of July, 1943, my remarks were based) the following concise summing up in the words of Prof. Howe seems to be a fair statement of the facts:

"(a) Thévenin deserves the credit for setting out the theorem very clearly and making it generally known, and

(b) Helmholtz had described and used it thirty years before."

To which may be added that Thévenin, like nearly everybody else, was unaware of Helmholtz's statement.

I am indebted to M. Simon and Prof. Howe for kindly contributing from their knowledge to an agreed conclusion on what seemed at first rather controversial.

"CATHODE RAY."

Recorded Supersonic Frequencies

IN the report of the discussion on commercial disc recording, following the lecture by Mr. Mittell (*Wireless World*, February, 1948, p.

M. WILSON LTD

VIEWERS WANTED!

We are demonstrating our
**HOME CONSTRUCTORS
TELEVISION
RECEIVER**

In our window at 307 High Holborn, every afternoon. Please come and see this reliable and efficient receiver working.

One chassis only (Heavy gauge aluminium)

**9 inch Black and White
Magnetic Picture Tube
Quality Sound & Vision**

EASY TO BUILD

*Here is a brief description
of the Circuit :-*

Four stages of R.F. amplification on both sound and vision. T.R.F. circuit wide band stagger tuned. Double diode, for detection and D.C. restoration. One stage of V.H.F. Noise limiters on both sound and vision. Separate synchronising valve, line and frame oscillators, gas filled triodes (two EN.31's) line output valve (E.L.38), frame output valve (E.L.33). E.H.T. is taken from the voltage doubler rectifier system in the line output transformer circuit

H.T. for sound, vision, and time base, is taken from a mains transformer giving an output of 350-0-350 at 250 m/a. The rectifier valve used is of the indirectly heated type (MULLARD GZ32) which allows approx. 25 seconds delay.

Two models—London or Birmingham.

BLUE PRINTS

Full size Practical Blue Prints and Theoretical Blue Print

Price 10/-

Please state for which Station required—
London or Birmingham

307, HIGH HOLBORN.
LONDON W.C.1. Phone: HOLborn 4631

Letters to the Editor—

67), it was stated that "even when the response of the reproducer, or of the ear of the listener, was restricted, the subtle improvement resulting from the records of high, even ultrasonic, frequencies could be detected. It was thought that this might be explained on the basis of improved transient response."

If the ear responds to a transient sound by virtue of its waveform, as seems to be substantiated by certain evidence, then it is conceivable that a person who is deaf to high frequencies could hear a steep-fronted transient almost, if not quite, as well as a person with normal hearing. The conventional explanation in terms of Fourier Analysis would lead to the conclusion that a person whose hearing is deficient in high frequencies would be unable to hear a steep-fronted transient.

The quoted improvement which occurs with the recording of inaudible frequencies may be explained by either of two mechanisms. First, it might be through hearing the intermodulation products of two or more frequencies, of which at least one is above audibility. Alternatively it might be through the greater fidelity with which the transients are recorded.

It should not be difficult to devise tests, if this has not been done already, to determine (1) whether the ear responds to transients by virtue of their waveform and (2) whether intermodulation products or transients or both are responsible for the improvement from supersonic recording.

Can any of your readers give a lead in this direction?

F. LANGFORD SMITH.

Amalgamated Wireless Valve Co., Sydney, N.S.W.

"Drawing Circuit Diagrams"

L. BAINBRIDGE-BELL, in the May *Wireless World*, appears to be flogging a horse that has already passed the post. Precise recommendations on all the subjects raised have been made in British Standard 530:1948, which he himself quotes; surely it is better to accept these recommendations as they stand.

It is because of individual preferences, both in circuit-drawing practice and in symbols generally, that so much confusion has arisen in the past. This confusion can only be reduced by general acceptance of recommendations made by a fully representative body. If, for some particular reason, a given organization finds it necessary to depart from a specific British Standard, by all means let it do so; it is a different matter if such an organization or in-

dividual tries to foist its preferences on others.

Bainbridge-Bell over-stresses the risk of draughtsmen's errors. The danger of a blob at a junction being obscured can be avoided by making the blob big enough to be seen. Ordinary letter stencils provide the means; thus, the "O" of a standard No. 1 stencil, fully inked in, is admirable for most purposes, though when the drawings are used for line blocks the size must be related to reduction wanted.

Such innovations as that suggested in Bainbridge-Bell's penultimate sketch are commendable provided the reader knows what they mean; generally an explanation is necessary. In the instance quoted "the path BC" is sufficiently explanatory without resorting to a symbol which is meaningless to those not in the know.

J. W. GODFREY.

London, N.W.

"Q-Meter Controversy"

I WAS interested in the correspondence printed in the June *Wireless World* concerning "Q" meters. As my firm are the manufacturers referred to by "P. H." as making the first British instrument of this

continue to use the longer title.

Dr. Sheridan notes with surprise the use of an injection resistor and points out its shortcomings at higher frequencies. This type of circuit is used in our Circuit Magnification Meter, but its defects are well realized. By careful design it will give reasonable performance up to about 30 Mc/s, but begins to fall off above that. In a high-frequency circuit magnification meter covering 15 to 170 Mc/s, the system has been abandoned and an inductive injection method is used. This is shown in the attached functional diagram. Series injection is still used, but the virtual injection resistance is made so small that the reactance of its residual inductance L_1 is very much greater than its resistance, even at the lowest working frequencies. To facilitate measurement of the voltage applied to the test circuit, the injection inductance L_1 is tapped down on a much greater inductance L , so that a known fraction of the voltage is taken. The voltage across L is measured by one diode voltmeter and that across the tuned circuit by another.

A further interesting arrangement is that by feeding suitable fractions of the d.c. outputs of the two voltmeters in opposition to a d.c. ampli-

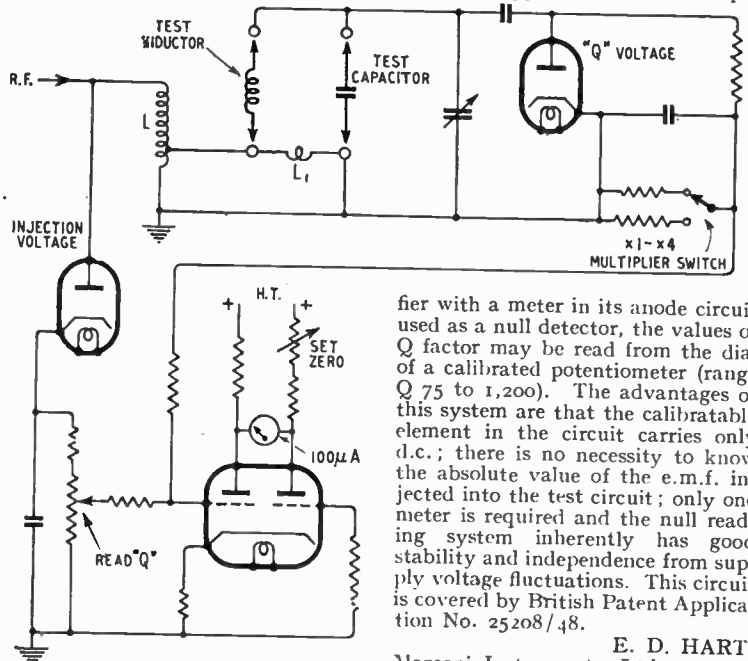

fier with a meter in its anode circuit used as a null detector, the values of Q factor may be read from the dial of a calibrated potentiometer (range Q 75 to 1,200). The advantages of this system are that the calibratable element in the circuit carries only d.c.; there is no necessity to know the absolute value of the e.m.f. injected into the test circuit; only one meter is required and the null reading system inherently has good stability and independence from supply voltage fluctuations. This circuit is covered by British Patent Application No. 25208/48.

E. D. HART.

Marconi Instruments, Ltd.
St. Albans, Herts.

Calibrating a Wobbulator

WITH reference to the article by K. C. Johnson on his new wobbulator circuit, I feel he has over-emphasized the difficulty of calibrating it on the television band.

kind, may I add two further comments?

Our instrument was called a Circuit Magnification Meter as, like "P. H.", we felt that the use of the term "Q Meter" was, to say the least, inappropriate and rather smacking of technical jargon. We

I have the circuit in use, and have devised a simple but very accurate method of continuous calibration, or "strobing," as it might be termed.

The normal circuit is set going, with the unit feeding the receiver and the receiver feeding the 'scope; then the signal generator is loose-coupled to the input tuned circuit of the receiver. As the wobulator sweeps through the signal generator frequency a "blip" is produced on the curve on the 'scope; this marker pip moves along the curve as the

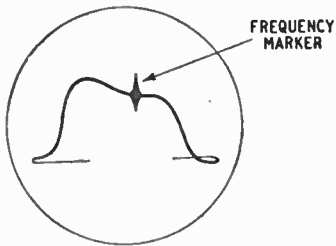

generator is tuned through the band, and enables the exact frequency of any humps, etc., to be read instantly, and also enables the scope to be used without any paper scale.

The accompanying sketch was drawn from a 'scope trace, using a normal t.r.f. vision receiver.

As will be seen from the sketch, the heterodyne pip is fairly sharp and narrow. This is due to the narrow frequency response of the 'scope amplifier, which, for this purpose, is clearly desirable.

DOUGLAS M. GIBSON.

Ashford, Kent.

"Copenhagen Comments"

I SHOULD like to reply to the comments of Mr. R. Cleghorn (*Wireless World*, May, 1949).

Germany not having been represented in the Broadcasting Convention at Copenhagen did not get three channels, but two for each zone of occupation; i.e., in total eight channels. Indeed, none of them is a clear one, and, moreover, the limit of power to 105 kW each is very unfavourable.

Whether the consequence Mr. Cleghorn is afraid of will appear and whether Germany will annex some further channels must be doubted. Germany will remain occupied for many years to come and the broadcast branches of military governments surely will supervise the German Broadcasting System in future.

The allocated channels are insufficient and the German broadcasting companies like Nordwestdeutscher Rundfunk and Bayerischer Rundfunk are preparing schemes to procure proper possibilities of reception to their listeners by erecting e.h.f. (f.m.) stations. About 20 of

such stations, each with 10 kW power, are provided for the British Zone alone. In the meantime, in Hanover, Hamburg and Munich f.m. transmitters with 0.1 kW each have been erected for testing purposes; further ones will follow.

KARL TETZNER.

Emden, Germany.

B.B.C. Coverage

MAY I appeal for improved facilities for high fidelity reception in this area?

Including as it does fairly large centres of population, the coastal strip of Sussex is very badly served on the Light and Home Services, although the recent opening of the Third Programme transmitter at Kingston-by-Sea has provided signals of good quality, but of appeal to only a limited taste. It will hardly be contested that the large proportion of recorded items on the Third Programme limits quality.

Signal strength from the long-wave Light Programme is fairly good, but reception is marred by atmospheric interference during the summer months in particular. On the medium waves, the West Regional transmitter at Start Point provides the strongest signal, but fades, whilst the quality appears generally slightly inferior to that from Brookmans Park, on the same programme, presumably due to land-line defects. The latter transmitter is free from fading since the installation of the new mast aerial, although signal strength does not appear appreciably greater, and is certainly inadequate to stand out from the many sources of interference, whether man-made or natural.

Whether it not be possible, even if the need for economy prevents the installation of any further transmitters, for the Kingston transmitter to radiate the Home or Light Programme during those hours when it is not needed for its own service?

D. C. SMITH.

North Lancing, Sussex.

CORRECTIONS

The last paragraph of the article "When Negative Feedback Isn't Negative" (May issue) should read "... try using a high anode coupling resistance for the middle stage and lower values for the two outer ones." Incidentally, the reference to the article by C. F. Brockelsby in *Wireless Engineer* should have been to the February, 1949, issue.

In "Contrast Expansion" (June issue) in the 29th line of Col. 3, "40½c/s" should read "40.50c/s."

The price of the Labgear electronic relay (advertisement on p. 22, June issue) should be £5 5s.

In the Valradio advertisement on p. 60, June issue, the model number should be 230/110; for "H.F. and R.F." read "R.F. and A.F."

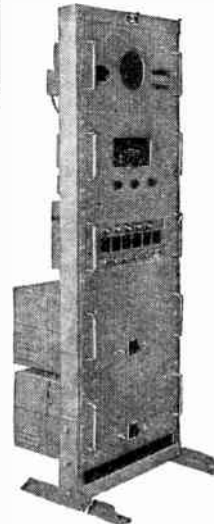

Typical Rack-Mounted Equipment

Rack-mounted equipment for SPORTS GROUNDS, HOSPITALS, FACTORIES, SHIPS, etc. etc.

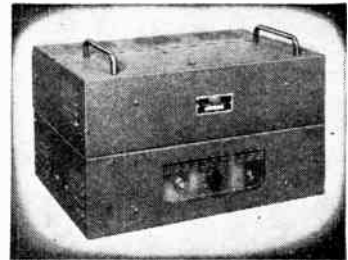

60 WATT Amplifier . . T663 B.

This amplifier provides the full rated power by the use of four valves in a parallel push-pull output circuit with inverse feedback. It is a high gain 4-stage amplifier which can be used singly or in combination with supplementary units Type T663/S to provide power outputs of 120, 180, 240 watts, or higher. Where a number of separate inputs are required, our 4-way or 6-way Electronic Mixer can be connected. Like most Trix Amplifiers, the T663B is designed for adaptation to rack mounting.

THE TRIX ELECTRICAL CO. LTD.
1-5 Maple Place, Tottenham Court Road, London, W.1. Phone: MUSeum 5817
Grams & Cables: "Trixdia, Wesdo, London."

AMPLIFIERS · MICROPHONES · LOUSPEAKERS

RANDOM RADIATIONS

By "DIALLIST"

DX Television

SPENDING A FEW DAYS recently at a little place on the Suffolk coast which is just about 100 miles as the crow flies (or the wave waggles) from Alexandra Palace, I was surprised to notice quite a sprinkling of the H-type television aeri-als, which are now such familiar objects of the sky line of Greater London and the Home Counties. In this small East Anglian town I counted five during casual strolls and probably the number would have been doubled or trebled had I set out on a determined search for them. The owner of one television set told me that reception, though chancy, was quite excellent at times. He was kind enough to invite me to "look in." Unfortunately, it was just one of those days. A hazy image might appear for a second, but it could not be held; most of the time there was nothing on the screen but "noise." He and the other owners of television receivers in the locality have, I imagine, something of the thrill that old hands used to get out of long-distance radio in the early days of medium-wave and short-wave broadcasting. All of us were very certain that DX work was worth while, no matter how many profitless vigils into the small hours it entailed; for there were wonderful periods of loud and clear reception, which made up for everything.

They Want It

THE FACT THAT PEOPLE living in places far beyond the normal service area of the London television station think it worth while to install tele-visions is clear proof of the urgency of the demand for television services all over this country. People definitely want television; they are prepared to pay for receiving sets and they will put up with poor or chancy reception rather than have nothing at all. To me, at any rate, it seems that the B.B.C.'s progress in providing a network of trans-mitters should be speeded up. All sites should have been selected by now, or should anyhow be chosen within the next few months. Since the Powers That Be have guaran-teed the continuance of the 405-line,

50-frames-per-second transmissions, the B.B.C. would do well to decide upon a standard design for its trans-mitters and to place orders right away for ten or a dozen of them. If these and the necessary radio links were ordered in bulk, both time and money would be saved. There's a point, too, about those radio links. The main centres will presumably have their own studios, O.B. equipments and so on; inter-connections will enable any of them to originate programmes to be radiated by all or any of the others. But has it occurred to anyone to combine some or all of the radio links (or coaxial cable repeater stations) with small, unattended and automatically operated trans-mitters? Were this done, to take one example, in the country traversed by the London-Birming-ham links, the whole service area might have the form of a dumb-bell—circles of 30 or more miles radius round London and Birmingham and between them an area of approxi-mately rectangular shape some 15 to 20 miles in width. There are, of course, difficulties; but are they too formidable to be overcome?

Aerials and Amplifiers

IT WOULD, I FEEL SURE, pay those concerned with the manufacture of television aerials and of signal-frequency amplifying units not only to study reception conditions in outlying districts, but also to conduct instructional campaigns in "fringe" areas and those still farther from transmitting centres. In talking to people living in such parts of the country I've found, first of all, that the ordinary man who buys a televisor and hopes for the best does not realize that there are means whereby his chances of good reception could be improved; secondly, that not a few of the radio dealers who supply the sets are not much better informed. One of them assured me that the multiple aerial array was just a stunt of no real value, and another was equally sceptical about signal-frequency amplifying units. I'm not going to say that any kind of complex aerial, even with a perfectly matched feeder, will make good re-

ception a certainty in places where it is now the exception rather than the rule. Nor would any sensible person claim that additional s.f. amplifica-tion will always do the trick. Either or both, however, may so much in-crease the chances of good reception in such places as to make all the difference between its being worth while or not to invest in a television receiving set.

A Tricky Business

THE NEW YORK MAGAZINE *Radio-Electronics* has just inaugurated a scheme which may have interesting results. Publishing a letter from a resident in Borneo, who wants to buy American components and so on but can't owing to currency ex-port restrictions, the Editor suggests that the only way out of the diffi-culty at the moment is a return to primitive bartering methods by making swaps. He fully appreciates the difficulties and the exasperation of those radio addicts who yearn to possess this American gadget or that, but can't get leave to send so much as a lone dollar abroad. To help them he proposes to run free of charge a section of classified advertisements by radio folk living in such countries. In these adver-

CONSOLE RECORD PLAYER



Designed primarily for use with the "500" series of radio receivers, this record player cabinet by Ace Radio, Tower Road, London, N.W.10, contains an automatic record changer and provides storage for records. The price is £35 13s. 6d., including tax.

tisements (which must not exceed 40 words) the dweller in a currency-restricted country can state what he wants and what he has to offer in exchange. It's a grand idea and a generous one in these hard times. The big snag, though, may prove to be the fact that most of the currency-restricted countries have also a mass of complicated import regulations. Were you to succeed in swapping this or that for, say, an f.m. receiver kit, you might find it impossible to steer your prize through the offshore minefield of import licences, etc.!

Effects

A COUSIN OF MINE who writes plays for the B.B.C. invited me recently to go to a rehearsal of one of hers. I had a good many surprises, not the least of which was that, for a half-hour item due to be broadcast at 5 p.m., morning rehearsals took place from 10.30 to 1 o'clock and that these were followed by another lot from 2 to 4. The effects in particular have to be rehearsed most carefully for timing. Most of them were produced from records on the four turntables of a play-back instrument and I was able to see the working of the apparatus which enables any part of a record to be selected with absolute certainty. The pick-up is held by a rigid arm mounted tangentially to the grooves of the disc and travelling along a finely graduated scale. Shortly before a particular effect is required the needle is lowered into the groove; the controller then fades it in and out at the proper moments.

Another One to Try

IN ITS JUNE ISSUE *Toute la Radio* had a quiz which contained one poser that may be of interest to readers of *Wireless World*. Here it is. If the output terminals of a high-voltage d.c. supply have two or more capacitors connected across them in series, these capacitors are always shunted individually by resistors of high values. This precaution is necessary:

- (a) To reduce ripple;
- (b) To prevent the capacitors from "blowing up";
- (c) To discharge the capacitors when the h.t. voltage is switched off and so to guard against accidents.

What's your view? The answer is given on page 258.



● **OVER 200 TYPES DESIGNED**

The Famous BULGIN Range offers over 200 Basic types of switches, and every one in a variety of operating-levers (dollies) and finishes. Apart from Nickel-plate, Chromium-plate, Camera-black, Florentine-bronze, Polished or Matt, there are five or more plastics-coloured finishes, giving insulation of external metal parts. Combinations of every type are available, and every one guaranteed as type-tested for 25,000 operations. Better than all others, every switch embodies the EXPERIENCE OF 25 YEARS OF SWITCH DESIGN AND MANUFACTURE.

Retailers, have you obtained our new TRADE Catalogue?

All products are now available from retail and wholesale stockists.

“The Choice **BULGIN** of Critics”
REGISTERED TRADE MARK

A. F. BULGIN & CO LTD BYE PASS RD. BARKING

Telephone : RIPPleway 3474 (5 lines)

RECENT INVENTIONS

A Selection of the More Interesting Radio Developments

Automatic Muting

VALVE noise produced by inherent thermal effects is utilized to short-circuit the loudspeaker automatically when no signals are present. It is known that the noise voltage is considerably increased during such times, and this is stated to be due to the action of the automatic volume control in the case of amplitude-modulated signals, and to the fact that the presence of the carrier shortens the actual duration of the thermal effect in the case of frequency-modulated signals.

In the "no-signal" condition shown, a circuit LC in the anode of the a.f. amplifier V₁ collects the noise voltage, which lies well above the normal signal frequencies fed to the loudspeaker LS, and passes it through rectifier circuits D R and D₁ R₁ to the grid of a valve V, to operate a relay S controlling short-circuiting contacts S₁ on the speaker. When a signal is received, the charge built up on the condenser C quickly leaks away through the rectifier D₁ and low resistance R. The charging of the condenser takes place more slowly through the rectifier D and high resistance R₁, so preventing the relay

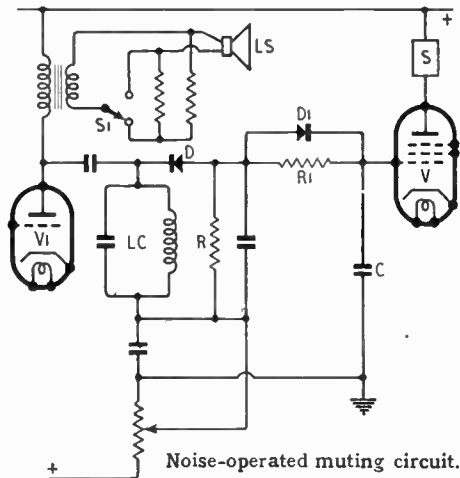

Noise-operated muting circuit.

from being operated during brief periods of fading.

The General Electric Co., Ltd., and L. S. Stenning. Application date, May 15th, 1946. No. 612024.

Super-regenerative Circuits

RELATES to the type of circuit that is designed to respond to the receipt of a pulsed signal, as used in radar, by the instant transmission of an identification signal. To ensure satisfactory threshold conditions, it is necessary to reduce the free oscillations that normally occur in the tuned

circuit of the super-regenerator to negligible proportions, and for this purpose the circuit is usually damped by a low-resistance shunt. This involves a serious loss of power in the response signal, since the same tuned circuit is used both for transmission and reception.

According to the invention, the difficulty is solved by using as the damping device a diode which is connected across the tuned circuit, and also to a source of positive potential. During standby conditions, the positively biased diode has a comparatively low resistance; but when the super-regenerator is triggered into transmission, oscillations rise to a high level and then serve automatically to "open-circuit" the diode by charging a condenser connected between its anode and the tuned circuit.

Ferranti, Ltd.; M. K. Taylor and R. S. Paulden. Application date, February 25th, 1946. No. 608103.

Television Cabinets

THE cabinet is made in two parts, the upper of which contains the viewing screen and is arranged to telescope inside the lower or main casing, with a vertical movement, so as not to disturb anything that may normally be placed on top of the cabinet.

The main casing contains the cathode-ray tube, which is mounted to project the picture downwards on to a spherical mirror, from which it is reflected back through a correcting lens or to an inclined plane mirror, fixed in the upper part of the casing, and finally on to a vertical ground-glass or opalescent viewing screen. The lifting and lowering movement of the upper part is conveniently controlled by means of a small electric motor, through worm gearing and vertical guide rods, an automatic stop and slip clutch unit being provided to prevent damage to the equipment.

Marconi's Wireless Telegraph Co., Ltd. (assignees of R. V. Beshgetoor). Convention date (U.S.A.), October 18th, 1944. No. 607221.

Interval Coupling

THE grid of the amplifier V₁ is coupled to the anode of the previous stage V through a step-down tapping on a coil L, which is chosen so that the impedance of the whole coil

bears the same ratio to the impedance of the part of the coil between the tapping T and the ground, as the capacity between the grid and all the other elements of the amplifier V₁ bears to the capacity between the anode and all the other elements of the amplifier V. More particularly, the grid-cathode capacity of V₁ is reflected by the coil as a smaller capacity between the anode and cathode of V. The sum of the capacities concerned is represented

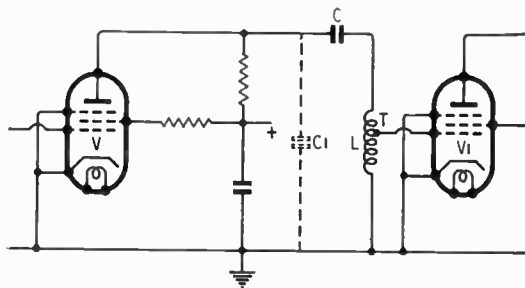

Low-loss interstage coupling.

in dotted lines at C₁, and is calculated to resonate with the coil L at the working frequency, the normal coupling condenser C being too large to have any appreciable effect.

A useful increase in effective amplification is secured by the arrangement shown. In an eight-stage receiver for pulsed signals the overall gain is stated to be more than three times that normally given.

The British Thomson-Houston Co., Ltd. Convention date (U.S.A.), May 20th, 1945. No. 612472.

Remote Control System

SIGNALS transmitted in the form of televised symbols, grouped into characteristic patterns, are used for the selective control of distant apparatus. A chequered arrangement of black-and-white squares will, for instance, provide a very large number of distinctive patterns by suitably regrouping the unitary squares. Further variety can be introduced by the stepped rotation of any given pattern.

At the distant end, a photoelectric relay is operated only when the pattern reproduced on the viewing screen of a television receiver conforms to a predetermined code. In order to ensure secrecy, provision is made to vary the line and frame frequencies, and to switch over from progressive to interlaced scanning, from time to time, in accordance with master control signals radiated from the transmitter.

H. W. K. Jennings (communicated by J. H. Homrighous). Application date August 30th, 1945. No. 610528.

The British abstracts published here are prepared with the permission of the Controller of H.M. Stationery Office, from specifications obtainable at the Patent Office, 25, Southampton Buildings, London, W.C.2, price 2/- each.

Standard MAGNETIC MATERIALS

PERMALLOY 'C'

for highest initial permeability. Useful for wide frequency band transformers, current transformers, chokes, relays and magnetic shielding.

PERMALLOY 'B'

for higher flux densities than Permalloy 'C' and high incremental permeability. Suitable for low power and intervalve transformers.

PERMALLOY 'D'

for very high resistivity without undue lowering of maximum flux density or of the Curie point. Small variation of permeability with frequency. Ideal for H.F. applications.

V—PERMENDUR

for high permeability with unusually high flux density. Specially applied to high quality diaphragms and pole pieces

Standard Magnetic Materials, which have been steadily improved and extended in range over many years, are produced by a Company which has the unique advantage of being also a large scale user of these materials.

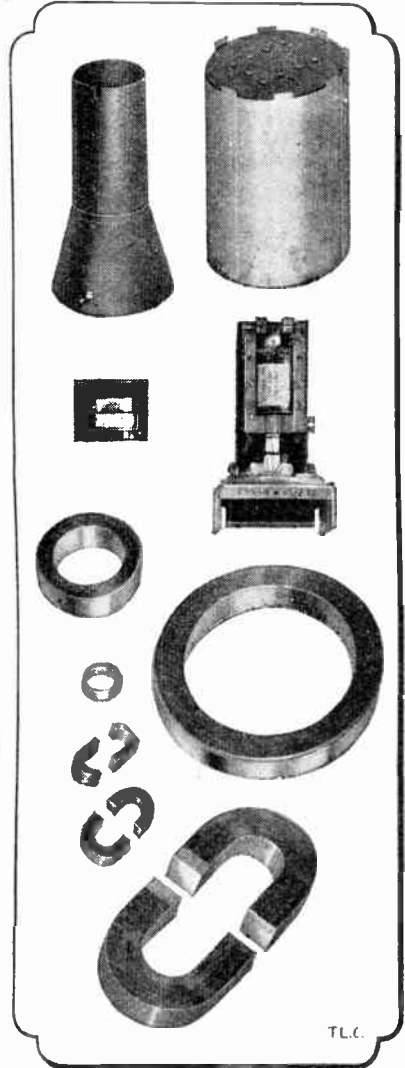

T.L.C.

Standard Telephones and Cables Limited

(Registered Office: Connought House, Aldwych, London, W.C.2)
(Telephone Line Division)

NORTH WOOLWICH, LONDON, E.16.

Telephone: Albert Dock 1401



INDUSTRY is catching up with SCIENCE

INEVITABLY, Science is always a step ahead of industry, but it is Mullard's endeavour to close this gap. Mullard are in the unique position of being both electronic experts and industrial consultants — they are, in fact, industrial scientists. Thus, they are able to utilise scientific discoveries in the design of better equipment for practically every sphere of industrial activity.

MULLARD EQUIPMENT FOR RESEARCH AND INDUSTRY INCLUDES THE FOLLOWING :—

Instruments for the Electrical Laboratory

Cathode Ray Oscillographs
Beat Frequency Oscillators
Measuring Bridges
Valve Volt Ohmmeters
V.H.F. Valve Voltmeters
High Voltage Power Supply
F.M. Signal Generators

Industrial Equipment

Valve Relay Units
Frequency Meters
Viscometers
Vibration Equipment

Electrochemical Equipment

Potentiometric Titration
Apparatus
Karl Fischer Equipment
Electronic Polarimeters
Conductivity Bridges
Conductivity Controllers
Ultrasonic Generators
Ultrasonic Consistency
Meters

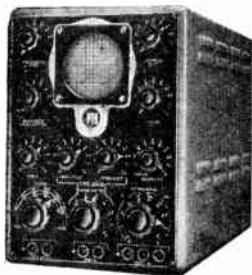

MULLARD OSCILLOGRAPH

Type E.800/1

Information and advice on this and any other equipment may be obtained from

Mullard

ELECTRONIC PRODUCTS LTD.,

Electronic Equipment Division



ABOYNE WORKS, ABOYNE ROAD, LONDON, S.W.17



A "FLUON" INSULATED VALVE HOLDER

Fluon can be moulded to extremely close tolerance. Fluon resists temperature as high as 250°C. Fluon is non-hygrosopic. Fluon has high dielectric qualities. Fluon is chemically inert. Fluon has high impact resistance. Beryllium copper, silver-plated contacts.

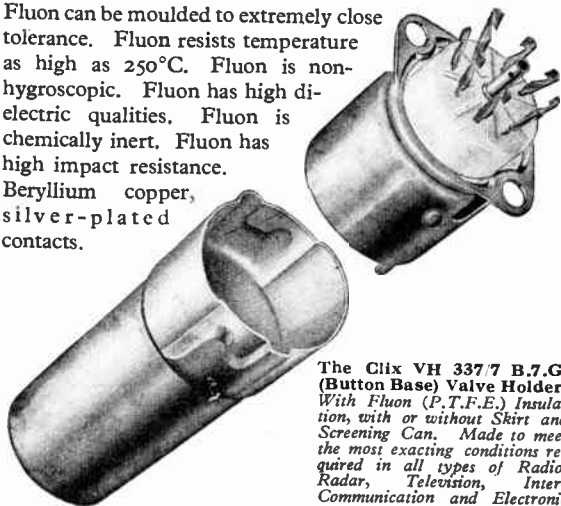

The Clix VH 337/7 B.7.G. (Button Base) Valve Holder. With Fluon (P.T.F.E.) Insulation, with or without Skirt and Screening Can. Made to meet the most exacting conditions required in all types of Radio, Radar, Television, Inter-Communication and Electronic Equipment.

FROM THE WIDE RANGE OF CLIX COMPONENTS

We manufacture a wide range of components for the Radio, Electronics and Television Industries. In addition to stock lines, a few of which are illustrated below, we can also manufacture special components designed for individual specifications.



Clix Heavy Duty. Spade terminals. Other types available to cover terminal diameters of from $\frac{1}{8}$ "— $\frac{1}{4}$ ". Black and red only.



4 - way Voltage Selector Panel with Solid or Fused Shorting Plug. 3-way also available with Rectangular or Circular Plate.

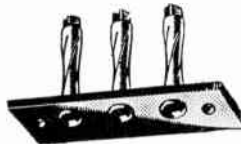

Chassis - Mounting Socket Strips with from 2-6 Sockets in various standard markings or to Customers' needs.



Tag Strips. Types are available with from 1 to 9 Tags. Tropical or Commercial Grade, in various combinations, also miniature types.



5-pin English Valve holder. Other types are available for most British and American valves.



Clix "Flexipin" Radio Master Plug. Supplied in a range of colours; for $\frac{1}{8}$ ", 4 mm. or $\frac{1}{16}$ " sockets.



BRITISH MECHANICAL PRODUCTIONS LTD.

(in association with General Accessories Ltd.)

21 BRUTON STREET, LONDON, W.1

Eliminate Positive Feedback

(Mechanical) "EQUIFLEX" PATENT MOUNTINGS will eliminate Mechanical and acoustic Vibration from being amplified and a Black Spot on Quality Reproduction. Call at your Dealers to see a complete set of special "EQUIFLEX." Damped units with all fittings and assembly chart suitable for the GARRARD R C 60 Turntable.

GARRARD Price 21/6 Per Complete Boxed set
RC 60 UNIT of 4 Mountings and all fittings.

"EQUIFLEX" special Damped Mountings as illustrated for Chassis Suspension can be obtained from your Radio Dealer. Loadings of these units are from 2 lb. to 12 lbs. Giving a choice of distributed loading of from 8 lbs. to 50 lbs. where a four Point-Suspension is used.

Ask to see these special Units at your Dealers.

TYPICAL RADIO CHASSIS

Wholesale Distributors and Dealers write for Terms and Particulars. Export Enquiries Welcomed. Illustrated Brochure upon request.

Sole Manufacturers:

A. WELLS & CO. LTD.,

PROGRESS WORKS, STIRLING RD., LONDON, E.17

PHONE : LARKSWOOD 2691-4

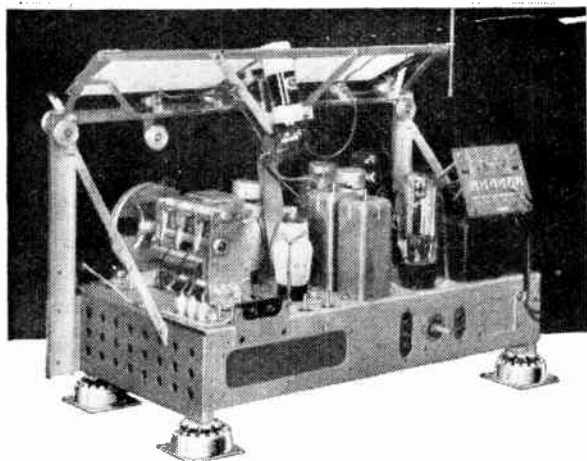
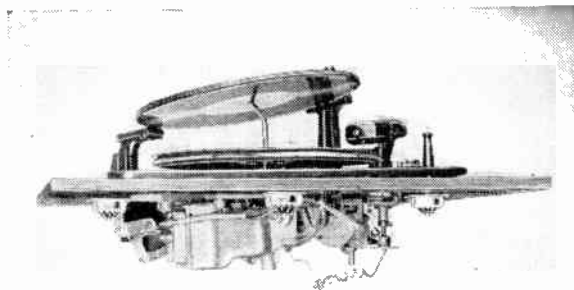

EDISWAN

Radio Products



Senior R.K. 12 in. Loudspeaker

The large curvature cone employed in this speaker produces a much wider and more level frequency response curve with a considerable reduction in sub-harmonics.

Acoustically dead material is used for the cone surround to give flexible suspension which results in exceptionally good reproduction where large amplitudes are encountered at low frequencies.

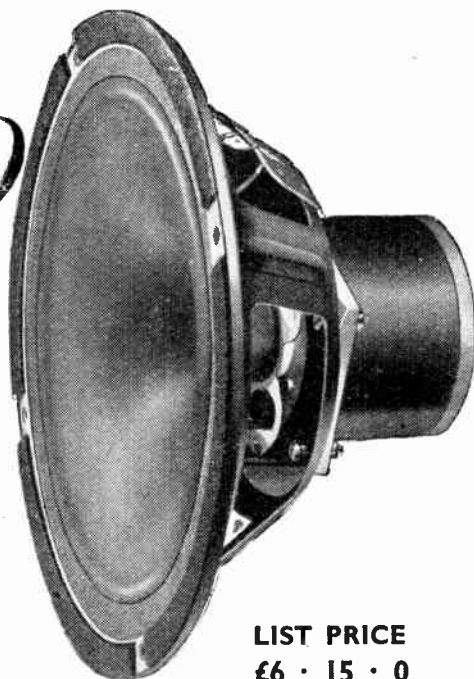

LIST PRICE
£6 · 15 · 0

THE EDISON SWAN ELECTRIC CO. LTD., 155 Charing Cross Road, London, W.C.2

RA118

VICTORIA "SPECIALS"

A very keen interest is taken by the technical staff at Victoria Instruments in the design and development of special-purpose instruments. This willingness to undertake the "teasers" does not surprise those who already buy Victoria products. Users of electronic measuring instruments should avail themselves of this service, and take a leaf from the book of some of the largest firms in the electronic industry.

PORTABLE TEST SETS

Robust moving iron instruments. Suitable for the Electrical Contractor or Automobile Electrical Engineer.

Size: 3½" x 3½" x 2½" overall complete with carrying strap.

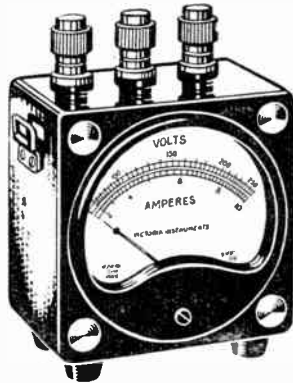

These combined instruments are made in many standard ranges. Combination examples:

- 260V A.C. or D.C.
- 15A A.C. or D.C.
- 25V A.C. or D.C.
- 25A A.C. or D.C.

Other Combinations to order

VICTORIA INSTRUMENTS

Proprietors: V.I.C. (Bournemouth) Ltd.

MIDLAND TERRACE · LONDON · N.W.10

Telephone: ELGar 7871/2

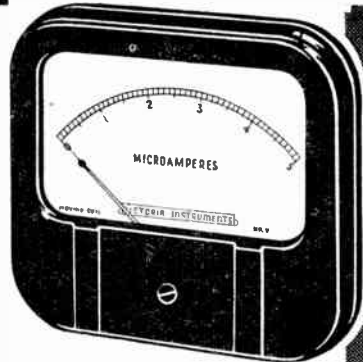

SQUARE FLANGE METERS

4" Large Open Scale. Mirror Scale can be supplied if required.

RANGES:

- A.C. from 1V-10kV
- 25uA-100 Amps.
- D.C. From 5mV-10kV
- 5uA-5000 Amps.



University Radio, Limited

OFFER GUARANTEED USED EQUIPMENT AT ATTRACTIVE PRICES

| | | | | | |
|---|----------|---|----------|--|---------------------|
| H.R.O. Senior, 5 coils, 9 KC to 30 Megs., with Power-pack, in perfect condition and working order | £25 0 0 | Weston E772, A.C./D.C. 1,000 O.P.V. Test-Meter. As new | £11 0 0 | Rola 12in. P.M.'s. As new | £4 0 0 |
| Eddystone 640, as new, with Eddystone speaker | £22 10 0 | Taylor AC/DC Test-Meter, 1,000 O.P.V. Model 70. As new | £8 0 0 | Cosser Double Beam 'Scopes. All perfect and as new. Priced from | £22 10 0 to £30 0 0 |
| Another as above, with speaker and S. Meter | £24 0 0 | Pullin Series 100, 10,000 O.P.V., A.C./D.C. Test Meter. Latest Model. As new | £8 0 0 | Collaro Record-changers, bar type, mixed records, A.C. mains. As new | £12 0 0 |
| Eddystone 540, as new, with valves | £36 0 0 | Mullard Master Valve-Tester, A.C. Mains, 4-500 Test cards. Perfect condition | £11 0 0 | Tannoy 15 watt 12 volt Mobile Amplifier, latest model, 2 re-entrant speakers, moving-coil mike, cables, grammo-unit, etc. Not Ex-W.D. As new. Listed at £97/10/- | Our price £42 10 0 |
| Hallcrafters Sky-Champion, as new, with valves | £16 10 0 | Roberts portable Valve-Analyser and Test-Meter, latest model. As new | £13 10 0 | As above, 12 volt or A.C. mains, 20 watt Amplifiers, with 2 re-entrant speakers, moving coil mike, cables, grammo-unit, etc. As new. Not Ex-W.D. Listed £80/- | Our Price £32 10 0 |
| Ex-W.D. Marconi Receiver, 1191. (one only), with valves, less power-pack, 14 KC—30 Meg., 9 bands | £12 10 0 | Pye Workshop service and Test Rack, latest model. As new | £36 0 0 | Evershed's Bridge Meggers, 500 volts. As new | £20 0 0 |
| Ex-W.D. R107, with valves, A.C. mains or 6 volt, very good condition | £10 0 0 | Avo Capacity and Resistance Bridge. As new | £8 0 0 | Evershed's Wee Meggers, 500 volts. As new | £7 10 0 |
| R108, as above | £10 0 0 | Taylor Capacity and Resistance Bridge. As new | £8 10 0 | Record Minor Meggers, 500 volts. As new | £7 0 0 |
| C-Max Short-Wave Battery Four. All dry, 11—350 metres, with coils. As new | £7 10 0 | Avo 7'S, as new, £12/10/0 and Hunt's Capacity and Resistance Bridge, latest model. As new | £11 0 0 | Advance A/F Signal Generators. Latest model, No. 1. As new | £14 0 0 |
| Weston U.S.A. E772, A.C./D.C., 20,000 O.P.V. Test Meter. As new, in portable case | £16 0 0 | E.M.I. Audio Oscillator, 0—10 KC's, with chart. In perfect condition | £12 10 0 | Taylor Valve-Testers. Model 45A, 45AP, with charts. As new | £12 10 0 |
| Weston U.S.A. Combined Valve-Tester and AC/DC Test Meter. A.C. 200-250 Volts Mains operated. As new. Complete with valve-charts | £19 10 0 | Latest Model B.S.R. A/F Signal Generator, 0—16 KC's. As new | £29 0 0 | Ferranti AC/DC Test-Meter, 1,000 O.P.V. As new | £4 10 0 |
| Supreme U.S.A., as above, A.C. 200-250 volts. As new | £17 0 0 | Wharfedale 16in. P.M. Latest Model. As new | £8 0 0 | Avo DC Minor | £2 12 6 |
| | | Goodman's Axiom 12in., P.M.'s. As new | £5 17 6 | | |
| | | Goodman's 12in. P.M.'s. As new | £4 0 0 | | |

Hundreds of other items too numerous to list at Bargain Prices. Please state requirements. No lists and no C.O.D., cash or cheque with order. All items listed are CARRIAGE PAID.

22 LISLE STREET, LEICESTER SQUARE, LONDON, W.C.2

Phone GERrard 4447 & 8582. Hours 9 to 6 Thursdays 9 to 1

let "Mighty Midget"

Boost Your Sales

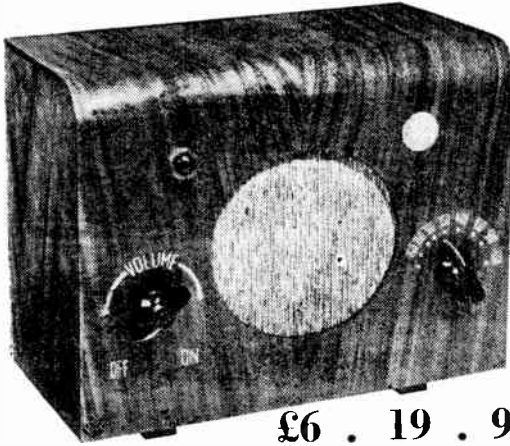

£6 . 19 . 9
INC. P.T.

- 3 valve, plus rectifier, midget radio receiver; 200-250 volts A.C. or D.C.
- **Cabinet:** Fully seasoned wood, finished in polished walnut
- **Valves:** Latest British Octal and Ballast Type
- **Coils:** High "Q" iron cored on "low-loss" formers
- **Wave-range:** 200-550 metres
- **Chassis:** Steel, plated for reliability & long life
- **Loudspeaker:** 5" dia. "Monobolt" construction, to which is fed 3 watts of Audio Power
- **Guarantee:** 12 months
- Apart from Mains, the only connection is an aerial supplied with the set

Volume, Tone and Sensitivity are remarkable from a Radio measuring 8½" x 7" x 4½". The advertising campaign now getting into its stride, will be increased in volume and tempo, as space becomes available

GENERAL SONIC INDUSTRIES

(Formerly General Electrical Radio)

21-29 SHENE STREET, BATH STREET, LONDON E.C.1

COULPHONE RADIO PRODUCTS

MAINS TRANSFORMERS

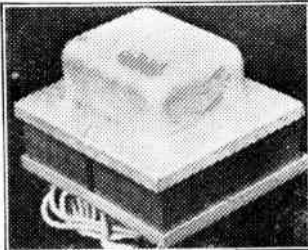

16/6 POST PAID
Coulphone Mains Transformers are made to the highest electrical standards and are fully guaranteed. We supply them to the Ministry of Supply Atomic Research stations, so they will no doubt meet your requirements. Special quotations for quantities and types to order.

Standard Replacement Types. Drop-through chassis type with top shroud. Impregnated and Interleaved Screened Primaries tapped for 200/230/250 volts.

| | |
|---|------|
| (a) 250-0-250 v. 60 mA. 6.3 v. 3 A., 5 v. 2 A. | 16 6 |
| (b) 250-0-250 v. 60 mA. 4 v. 4 A., 4 v. 2 A. | 16 6 |
| (c) 250-0-250 v. 80 mA. 0/4/6.3 v. 4 A. O.T. | 19 0 |
| 0/4/5 v. 2 A. | 19 0 |
| (d) 300-0-300 v. 80 mA. 0/4/6.3 v. 4 A. O.T. | 19 0 |
| 0/4/5 v. 2 A. | 19 0 |
| (e) 350-0-350 v. 80 mA. 0/4/6.3 v. 4 A. C.T. | 19 0 |
| 0/4/5 v. 2 A. | 22 0 |
| (f) 250-0-250 v. 100 mA. 0/4/6.3 v. 4 A. C.T. | 22 0 |
| 0/4/5 v. 2 A. | 22 0 |
| (g) 300-0-300 v. 100 mA. 0/4/6.3 v. 4 A. C.T. | 22 0 |
| 0/4/5 v. 2 A. | 22 0 |
| (h) 350-0-350 v. 100 mA. 0/4/6.3 v. 4 A. C.T. | 22 0 |
| 0/4/5 v. 2 A. | 22 0 |
| (i) 350-0-350 v. 150 mA. 0/4/6.3 v. 6 A. C.T. | 39 0 |
| 0/4/5 v. 3 A. | 39 0 |
| (j) 425-0-425 v. 180 mA. 6.3 v. 4 A. C.T., 6.3 v. 4 A. O.T., 5 v. 3 A. | 44 6 |
| (k) 425-0-425 v. 180 mA. 4 v. 8 A. C.T., 4 v. 4 A. C.T., 4 v. 4 A. | 44 6 |
| (l) 425-0-425 v. 180 mA. 6.3 v. 4 A. C.T. 4 v. 2 A. C.T., 4 v. 2 A. O.T., 5 v. 3 A. | 47 0 |

Types (a) (b) (c) (d) (e) (f) (g) (h) (k) illustrated on left. Types (i) (j) (l) upright shrouded type.

WILLIAMSON OUTPUT TRANSFORMER

A super job exactly to author's specification Upright mounting £3/12/6

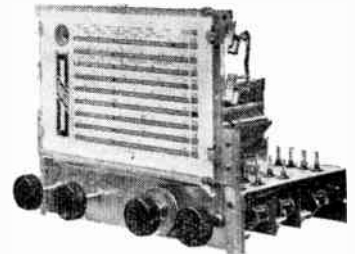

FEEDER UNITS

MODEL B DE LUXE (illustrated above). High gain R.F. stage operative on all nine wavebands. 45/145 M., 100/550 M., 900/2000 M. Plus six ranges of Bandsread, 13.5-14.8, 16-17.4, 19-20.5, 24.2-26, 30-32, 41-43.5 metres. Large colour printed glass dial, 10in. x 6in. aperture. Horizontal drive. Wave-range indicator and magic eye. Switched pick-up sockets. Volume and Tone Controls. Completely aligned ready for connection to audio amplifier. Price less valves £18/7/6. Valves required, 6K7G, 6K8G, 6K7G, 6Q7G, 6U5. Price for set of five valves, £31/1/5.

MODEL A. A first class feeder unit with R.F. stage operative on all wavebands, 16/50, 100/550, 900/2000 metres. Switched pick-up sockets. Volume control. Glass dial 8in. x 8in. in colours. Completely aligned ready for connection to audio amplifier. Price less valves, £10/3/6. Valves required, 6K7G, 6K8G, 6K7G 6Q7G. Price for set of four valves, £21/1/3.

A.F. AMPLIFIER POWER UNIT. Specially designed for use with above units. Employs 6V6G output (4 watts) and 5Z4G rectifier. Price less valves £4/10/-.

Two valves if required, £1/13/10.

COULPHONE COIL PACKS. Medium, Long and short Wave. Built on 16 S.W.G. Aluminium chassis. Totally enclosed. One hole fixing. Aligned ready for connection into receiver. I.F. 465 kc/s.

MODEL A. For use with 2 gang tuning condenser. 6K8G or any triode herode frequency changer. £1/19/6.

MODEL AE. For use with 3 gang tuning condenser. R.F. Stage for 6K7G, and 6K8G. Nine iron dust cored coils, £3/17/6.

COULPHONE 20-WATT HIGH FIDELITY AMPLIFIER. Built to famous Williamson circuit but with push-pull 807's for higher power output. Linear response from 20—20,000 c.p.s. Power supply for feeder unit or tone control unit brought out to octal socket. 6.3 v. 4A and 250 v. 40 mA. £22/10/-.

EK GOVT. SURPLUS. COULPHONE offer the best bargains. Over 200 items in our illustrated catalogue. If interested please send extra 2½d. stamp—it will save you £'s.

ROTHERMEL "TORPEDO" MIKE'S. List Price, £18/18/-. My price £3/18/6. Post paid.

Terms: C.W.O. or C.O.D.

Send 2½d. Stamp for New 48-page Illustrated Catalogue.

NEW GOODS ONLY

COULPHONE RADIO 53 BURSCOUGH ST. ORMSKIRK, LANCs.

"The Return of Post Mail Order Service"

Tel.: Ormskirk 987

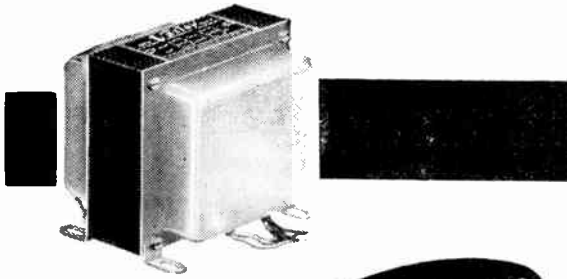

MAINS TRANSFORMERS & CHOKES



All "Varley" products are manufactured from the highest quality materials. Transformers etc., are individually wound and have interleaved windings with ample insulation, ensuring freedom from breakdown. The comprehensive range of Shielded and Open type Transformers available meets the requirements of every circuit. Write for list etc.

MADE BY

OLIVER PELL CONTROL LTD
 CAMBRIDGE ROW · WOOLWICH · S·E·18
 Telephone: WOOLWICH 1422

BAFFLETTE EXTENSION SPEAKERS

- ★ Better Reproduction
- ★ Attractive Appearance
- ★ Sound Value for money

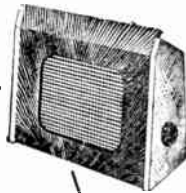

"Bonnie"

by *Richard Allan*

FROM 49'6

AT GOOD SHOPS EVERYWHERE

Made and Guaranteed by

RICHARD ALLAN LIMITED
 CALEDONIA RD. BATLEY YORKS

The RIMINGTON JEWEL

will bring new life to

GRAMOPHONE REPRODUCTION



Traight for Crystal pick-up only.



Lightweight for new miniature pick-up.



Trailer type for Heavier pick-up.

- ★ Reproduces the maximum recorded frequency range.
- ★ Wear on records is negligible, the jewel is scientifically designed to follow the groove of the record lightly and smoothly.
- ★ Preserves the higher frequencies delicately imprinted in the record, so easily destroyed, and reproduces them!
- ★ Jewel well set and angle correct.
- ★ Contained in plastic box well packed and mounted.
- ★ LIFE. It is not possible to state categorically the life of a jewel point, but in the interest of quality it is advisable to replace the jewel after 1000 playings—it is a matter of personal discretion.
- ★ The Rimington Jewel has had exhaustive tests by Messrs. W. R. Prior Ltd., microscope manufacturers, of Bishops Stortford, who have stated that the needles are free from blemish and perfect in detail.
- ★ The Rimington Jewel needle reveals new beauties in your records which you have heretofore unsuspected.

PRICE—Most reasonable. The Rimington Jewel is the finest sapphire on the market and it retails at only 9/9.

Order your Rimington Jewel NOW and revolutionise your gramophone reproduction.

TRADE ENQUIRIES INVITED

RIMINGTONS

RIMINGTON, VAN WYCK LTD., 42-43 Cranbourn St., London, W.C.2
 Gerrard 1171

RIMINGTON, VAN WYCK (Mail Order) LTD., 28a Deronshire St., Marylebone, London, W.1 Welbeck 4695

POTENTIOMETERS

by **RELIANCE**



Wire-wound and Composition types. Single, Ganged, Tandem Units. Characteristics: linear, log., semi-log., non-inductive, etc. Full details on request.

RELIANCE MFG. CO. (SOUTHWARK), LTD.
 Sutherland Road, Higham Hill, Walthamstow, E.17.
 Telephone: Larkwood 3245

"Cyldon"

Type No. 14



MICA-DIELECTRIC
Trimmer CAPACITORS

SYDNEY S. BIRD & Sons, Ltd

CAMBRIDGE ARTERIAL RD., ENFIELD, MIDDLESEX
 Phone: Enfield 2071-2 "Grams: "Capacity, Enfield"

Connoisseur

Gramophone motor now ready!

At last a gramophone motor to match the performance of the famous Connoisseur Pick-up.

SPECIFICATION :

Voltage: 200-250 volts A.C., 50 cycles. Rim drive with speed variation. No governors and no gearing. Heavy non-ferrous turn-table, machined to run dead true, fly-wheel action—no "WOW." Main turn-table spindle hardened, ground and lapped to mirror finish, running in special phosphor-bronze bearings. Motor runs in needle-point, self-adjusting bearing.



Motor Board in plastic. Pressure on Drive-Wheel released when not in use, to obviate forming flats and noisy action.

Retail Price, complete with Pick-up £15 19s. 0d. plus £6 18s. 2d. P.T.
 " " without Pick-up ... £13 5s. 0d. " £5 14s. 10d. P.T.
 Coupling Transformer when required 13s. 0d.

Made by

A. R. SUGDEN & CO. (ENGINEERS) LTD., BRIGHOUSE, YORKS.

PRECISION COMPONENTS



CORD DRIVES

Now available in five types as illustrated (left to right) Standard, R/V, Reverse, "D" type and "A" type.

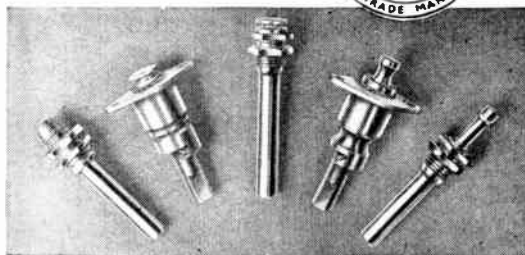

GANG CONDENSERS

A wide range is now available in 1, 2, 3 or 4 gang types of various capacities.

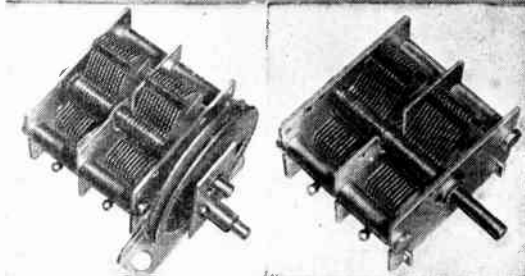

Write for Catalogue No. (W.W.1.)

JACKSON

BROS (LONDON) LIMITED
 KINGSWAY · WADDON · SURREY
 TELEPHONE: TELEGRAMS: WALFILCO,
 CROYDON 2734-5 PHONE LONDON

THE AMBASSADOR

849 TABLE RECEIVER

£31 - 0 - 0
TAX PAID



Special Features

- EIGHT MINIATURE VALVES ● PUSH PULL OUTPUT
- TWIN 8" SPEAKERS ● VARIABLE TREBLE CONTROL
- SWITCHED BASS CONTROL ● ELEVEN INCH POINTER TRAVERSE ● THREE WAVE BANDS.

AMBASSADOR Radio
HUTCHINSON LANE,
BRIGHOUSE, YORKS.

GOOD LOOKS - GOOD LISTENING

G6YA G2BAR

WESTERN GATEWAY HEADQUARTERS
for Radio and Television Components

The CABOT 25 Watt HIGH QUALITY AMPLIFIER

Incorporating negative feedback, suitable for any use where sound amplification is required.

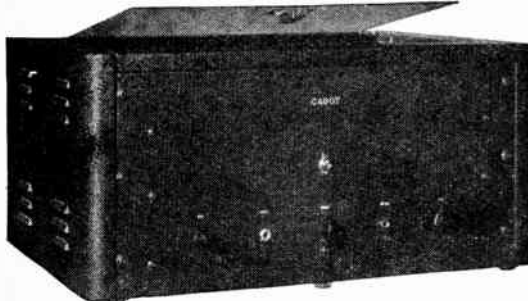

SPECIFICATION :—Separate mike and gram inputs for mixing. Mike input for moving coil or other types as required. Gram input suitable for standard Magnetic or Lightweight pick-up. Tone control. Output 25 Watts into 4-8 or 15 ohms. Input 110 230v 50 cps. Fitted in steel cabinet, finished in black crackle, panel engraved as illustrated. Ideal for general P.A. work, Youth Clubs, gram or radio Amplifier for the Home, etc. **VALVES** :—6SN7 Mike and Gram Mixer. 6SJ7 Amplifier. 6N7 Phase splitter. 6L6 Push Pull Power Amplifier. 5U4G Rectifier.

£16-10-0 Complete ready to play. Carriage paid Rail in England and Wales. Extra for passenger.

The Amplifier can be heard at our Bedminster Shop. Out-of-town Customers invited to Call at any time. Open Sats. 9—5.30 p.m.

CABOT RADIO CO., LTD.,

28, BEDMINSTER PARADE, BRISTOL, 3. Tel.: 64314.

Visio

3-ELEMENT
TELEVISION
AERIAL

THE FINEST
AID TO T.V.
RECEPTION IN
THE FRINGE AREAS

Regd. Design.

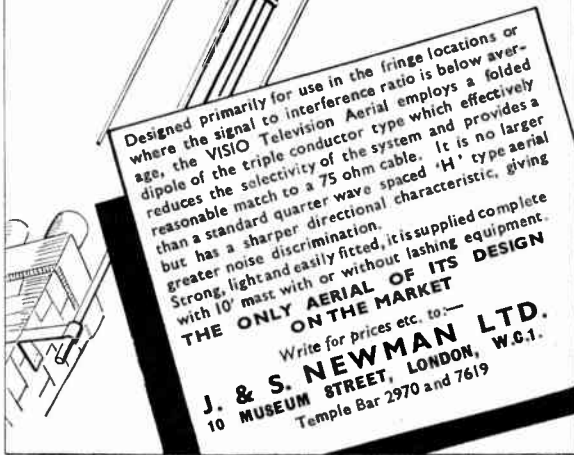

Designed primarily for use in the fringe locations or where the signal to interference ratio is below average, the VISIO Television Aerial employs a folded dipole of the triple conductor type which effectively reduces the selectivity of the system and provides a reasonable match to a 75 ohm cable. It is no larger than a standard quarter wave spaced 'H' type aerial but has a sharper directional characteristic, giving greater noise discrimination.

Strong, light and easily fitted, it is supplied complete with 10' mast with or without lashing equipment. **THE ONLY AERIAL OF ITS DESIGN ON THE MARKET**

Write for prices etc. to—

J. & S. NEWMAN LTD.
10 MUSEUM STREET, LONDON, W.C.1.
Temple Bar 2970 and 7619

WILKINSON'S OF CROYDON

ELECTROLYTICS, 8 MFD 500 v. BR850, 3/- each, 34/- doz. **NEW STOCK.**
P.M. SPEAKERS, 8in., with transformer, in wall case, 21/-
POWER UNIT, employing a 5Z4G and a high voltage rectifier SU2150A, together with a .1 mf. condenser, 2.5 kV. and other components, 17/6 post free.
TELEVISION UNIT, 2HF stages, 1 detector and 1 video amplifier, complete with 4 valves, adjustable iron-cored coils, etc., brand new! Ex-U.S. Navy. Employing 40 useful valves, 2 Cathode Ray tubes, power pack, motor blower, Milliammeters, etc. The following are the valves: 13 6SN7GT, 8 6AC7, 2 6L6, 6 6L8G, 3 VR150-30, 1 2X2, 3 5U4G, 2 6X5G, 2 6H6. **SPECIAL PRICE 216/10/-**
SLOW MOTION DIAL. With Vernier 200-1 reduction. Front of panel mounting, 6in. diam., calibration 0-100, 5/6 each.
MURHEAD SLOW MOTION DRIVES, ratio 50-1, 8/8 each.
ABKI SPARES KIT, including 32 Valves individually boxed, 18 6SH7, 6 6H6, 8 7193, also many useful relays, Resistors, Condensers, and a Dynamotor with extended Spindle which will work as a powerful motor on 200/250 A.C. mains without alteration. 145 items in all, brand new, properly packed, 70/- complete.
OG-AXIAL LEAD, 27ft., fitted with Pye Sockets, each end, 3/6 each.
CRYSTAL MULTIPLIER UNIT, 2 to 6.57 Mc/s in 3-switch steps, 807 Oscillator and tuning control. Brand new with two 807 valves, instruction books, etc., 55/- each.
SENSITIVE METERS. Full scale 25 Microamps, 2 1/2 in. dial, scaled 0-500, 5/6 each.
FREQUENCY STANDARD 1,000, 100, 10 K.C. Brand new American equipment, 110/250 volts, 28/8/-.
METAL RECTIFIERS, 60 M/A, 230 volts, 1/2 wave, 3/- each. List 2 1/2

L. WILKINSON, 204, Lower Addiscombe Road, CROYDON

RADIOMENDERS LIMITED

FOR SPECIAL TRANSFORMERS AND REWINDS

We specialise in

**AMATEURS' WINDINGS, TRANSFORMERS
ALL TYPES, CHOKES, PICK-UP COILS,
INSTRUMENT COILS, Etc.**

LOUD SPEAKER SERVICE

Highest workmanship ★ Good Delivery

RADIOMENDERS, LTD.

Television & Radio Apparatus, Transformer & Coilwinders.

123-5-7 Parchmore Road,
THORNTON HEATH, SURREY

LIV 2261. Trade enquiries invited. Established 16 years.

NEWS FROM HUNTS!

FOR ENGINEERS who want HEAVY DUTY CAPACITORS for high voltage, high frequency and similar equipment.

HUNT-INGRAM CAPACITORS

(Mycalex Product)

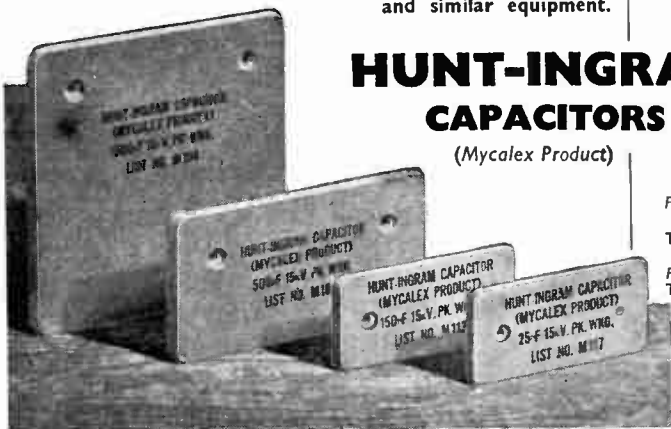

Here is a new development of importance to all users of speciality capacitors. HUNT-INGRAM CAPACITORS, previously marketed as "Ingram-Mycalex"—are now available with the pooled marketing and technical resources of the two companies behind them.

For heavy duty work and limited space, Hunt-Ingram Capacitors offer great advantages and show savings in costs where they can be applied. Available in standard units or made to order for special requirements, both mechanically and electrically, in a wide variety of shapes.

For Blocking and Bypass in High Frequency Heating and Radio Transmission; High Altitude Airborne Equipment; Delay Networks in Pulse Circuits; Voltage Dividers; Stabilising Units, etc.

TYPICAL STANDARD UNITS

| | | | |
|---|-----------|----------------|-------------|
| Full load: 70 kVA at 500 KC to 10 MC per sec. Peak Wkg. 10kV. | | | |
| Cap. Overall Dim. Approx. Weight | | | |
| Type M1A | 10,000 pF | 6½" x 13" x ½" | 7lb. 3 oz. |
| | 5,000 pF | 6½" x 13" x ¾" | 5lb. 14 oz. |
| Full load: 8 kVA at 500 KC to 10 MC per sec. Peak Wkg. 15 kV. | | | |
| Type M4A | 150 pF | 2" x 4½" x ¾" | 5 oz. |

Full list and details on application.

A. H. HUNT LIMITED
Wandsworth, London, S.W. 18. Tel.: BA Ttersea 3131
ESTABLISHED 1901

synonymous with
PLUGS & SOCKETS

PAINTON & CO LTD KINGSTHORPE NORTHAMPTON

"You're CERTAIN to get it at ARTHURS!"

★ **VALVES**: We have probably the largest Stock of valves in the Country. Send your enquiries. We will reply by return.

AVO METERS IN STOCK.

| | |
|------------------------------------|----------|
| Avo Model 7 | £19 10 0 |
| Avo Model 7, high resistance | £19 10 0 |
| Valve Tester | £16 10 0 |
| Test bridge | £11 0 0 |
| Avo Minor, AC/DC model | £8 10 0 |
| Electronic Test Meter | £35 0 0 |
| Signal Generator | £25 0 0 |
| Taylor's Meters. List on request. | |
| Decca Pick-ups | £6 14 6 |
| Decca Head for Garrard | £4 11 0 |
| Adaptors | 3 8 |

London's Oldest Leading Radio Dealers.
All types stocked.

Arthur's EST. 1919
PROPS: ARTHUR GRAY, LTD. Terms C.O.D. or cash with order.

Our Only Address: **Gray House, 150, Charing Cross Rd., London, W.C.2** Temple Bar 5833/4
ELECTRICAL, TELEVISION & RADIO ENGINEERS.

LAWRENCES

SPECIAL HIGH QUALITY TRANSFORMERS FOR TELEVISION.
E.H.T. Type TV/9. Primary 230 v. 50c; Secondaries 0-2,500 v. at 6mA. 2-0-2 v. at 2A. 4 v. at 2A. Fully impregnated, Upright mounting, 28/-.
LINE TIME BASE, Type TV/5. Primary 230 v. 50c; Secondaries 350-0-350 v. at 80mA. 0-4-6.3 v. at 4A. Fully shrouded. Universal mounting, 31/-.
CONVERSION TYPE TV/11/1355. Manufactured especially for Receiver Unit Type R1355. Primary 230 v. 50c. Secondaries 250-0-250 v. at 80mA. 6.3 v. at 6A. 5 v. at 2A. Fully shrouded. Universal mounting, 32/6.
NEW CATHODE RAY TUBES TYPE VCR97. Short persistence screen. Final Anode voltage 2.5kV max. Heater voltage 4 v. Makers cases, 37/6.
E.H.T. CONDENSERS. .01mfd. 2.5kV D.C. wkg. Cyl. can type, 8in. x 1in. 1/6.
R.C.A. QUALITY AMPLIFIERS, Type ET4332. Input 100-250 v. 50-60 cycles. Output 25 watts. Valve sequence: 6J7-6J7-6L6-6L6-5U4. Push-pull output with negative feedback. Multi-ratio Output Transformer for load impedances of 5, 7.5, 15 or 500-600 ohms. Magnificent case, with chrome fittings. Art photo available on request. Offered at a third of original cost, perfectly new in makers packing, 25s.
NEW AMERICAN HEADSETS, Type H833. A most popular lightweight set, extremely sensitive, fitted with comfortable rubber cushions and leather covered headband, 7/6. Also New Moving Coil Head and Microphone Sets Earpieces resemble miniature P.M. Speakers. Quality mike, fitted with pressswitch. An outstanding value at 10/6 per set.
NEW AMERICAN STAR IDENTIFICATION INSTRUMENTS. A precision Navigational instrument, complete with charts for all latitudes in North and Southern hemispheres. In leather cases, 3/-.
AMERICAN DYNAMOTORS, Type PE94. The most suitable type for conversion. Fitted with 4in. shaft for attachment of pulley, grindstone etc. Full instructions supplied for simple modification to 1/4 h.p., 230 v. A.C./D.C. motor, 18/6.
AIRCRAFT INSTRUMENTS. We have in stock an enormous variety of precision instruments, including compasses, gauges for pressure, vacuum fluid measure etc. Send stamp for illustrated list.
NEW METAL STORAGE BINS. Ideal for storage of small parts etc. Nine sliding drawers. Overall size 19in. x 6in. x 5in., 15/-.
BELL BATTERIES. Dry type. 1.5 v. terminal contact, 1/- each or 10/- per dozen.
NEW P.M. SPEAKERS, by famous makers. 12in. new type cone suspension. Voice Coil 3 ohms, 38/6. 10in. Voice Coil 3 ohms, 21/-.
DYNAMOTORS, Type 33. P.M. Input 6-12 volts D.C. Output 200 volts D.C. This unit may be usefully employed for mobile radio etc. Fitted with effective suppressors, 11/-.
A 2d. stamp brings you our latest lists describing countless bargains from 5kVA Petrol Generators to diminutive components.
Terms: C.W.O. All prices include carriage.
LAWRENCES. 61, BYROM ST. LIVERPOOL. 3. CENTRAL 4430.

from the range of  instruments

THE TWENTY MILLION MEGOHMMETER

A new instrument for Research and Industry. Covers the entire resistance range from 0.3 to 20,000,000 megohms. Two test voltages, 85v and 500v, are provided. A six-inch mirror scale enables readings to be taken accurately and quickly. Designed for testing cables, resistors, capacitors and all insulating materials.

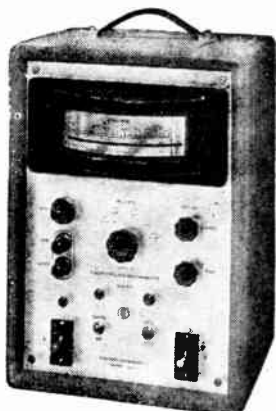

ELECTRONIC INSTRUMENTS LTD
17 PARADISE ROAD · RICHMOND · SURREY



C.51 ★
FOR TELE-COMMUNICATION ★

A new Lustraphone Moving-Coil Microphone designed and developed specifically for G.P.O. hand-sets, with mobile tele-communication and P.A. equipment in view. Available as Insert Unit (C.151) or complete Hand Microphone (C.H.51). Characterised by sturdy construction, light weight, and high level of performance. Data Sheet on request.

LUSTRAPHONE LTD. 84, Belsize Lane, N.W.3
Hampstead 5515

THE KING OF COIL PACKS.

The letters of praise we receive in our post bag every day confirm our opinion that the **MODEL 40 COIL PACK** is the best that money can buy, from the point of view of quality, workmanship and performance.

It is, to the best of our knowledge, the only unit on the market with an R.F. stage which can be supplied prealigned and sealed for direct inclusion into a superhet receiver. It uses 9 separate iron-cored high efficiency coils, with high stab. S.M. padders and variable trimmers. The Waveband coverage is 16-20, 200-550 and 800-2,000 metres. Notwithstanding its compact size (6 1/2in. x 5 1/2in. x 2 1/2in.) the internal and external screening is efficient and more than adequate to eliminate any interference between the Aerial, R.F. and Oscillator sections.

The price? Only 2 gns., or can be supplied fully aligned at 47/-. For one month only, as a special offer, we are supplying FREE with every Model 40 Coil Pack our comprehensive and detailed instruction sheets for the construction of a 6 valve superhet receiver embodying this unit. These sheets are really comprehensive and even if you have never built a radio receiver before, you can go ahead with the knowledge that you cannot fail to complete a highly efficient multi-valve receiver, that will give you years of pleasurable listening or DX roaming.

Send 1/- for the latest issue of "The Home Constructor's Handbook," or a 2d stamp will bring you our latest lists.

*Phone, write or call: **LONDON TELEVISION CO., LTD.,**
694 LEA BRIDGE ROAD, LEYTON, E.10. Telephone: LEY. 4380

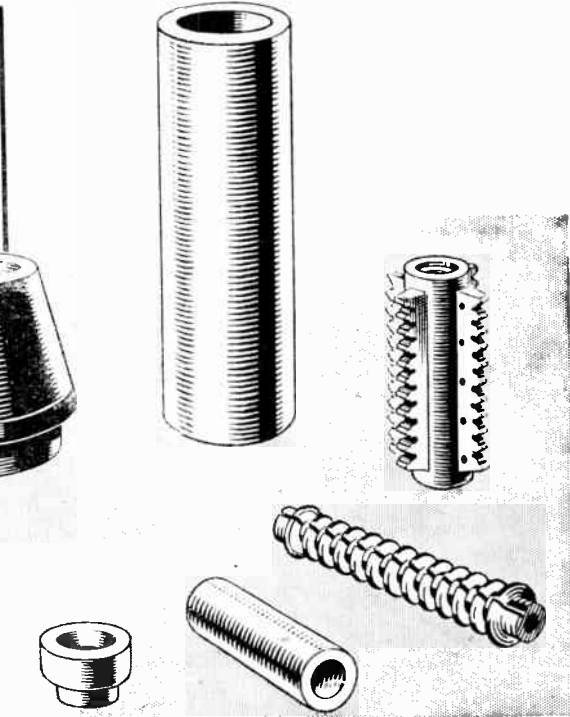
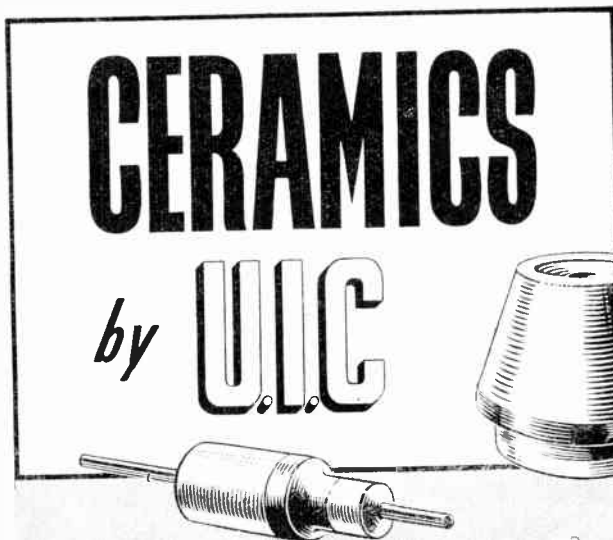

UNITED INSULATOR COMPANY LTD.
Cables: Calanel, Surbiton.

TOLWORTH

SURBITON

SURREY

ENGLAND

Telephone: Elmbridge 5241

★ Acclaimed by Home & Overseas Visitors at the B.I.F!

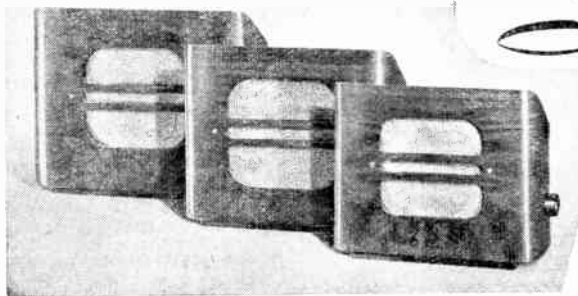

Stentorian

BAFFLE SPEAKERS

These new Stentorians were a sensation at the B.I.F. — everyone who saw and heard them agreed that they are unequalled for value, reproduction and appearance.

Compare them with any other make of speaker, and remember, that both the Beaufort and Bristol have press-button remote control for use with the "Long Arm", an exclusive Whiteley feature. All three are finished in highly-polished walnut veneer.

NO PURCHASE TAX

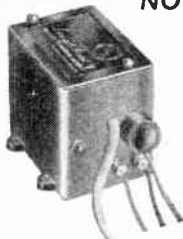

"LONG ARM" REMOTE CONTROL

Operates any number of Beaufort or Bristol speakers (or Senior, Junior or Cadet cabinet models) from any make of set. Enables the radio to be switched on or off from the extension speaker

— in any part of the house. Price 35/-. Local dealers will be pleased to demonstrate.

● BEAUFORT

Size 12½" x 10½" x 3½". Permanent magnet type speaker (die-cast unit). 6" diam. Capacity 3 watts. Constant impedance volume control. Price £3.15.0 (with transformer). £3.7.6. (without transformer).

● BRISTOL

Size 10½" x 9½" x 3½". P.M. Unit 6". Capacity 3 watts. Constant impedance volume control. Price £2.19.6 (with transformer). £2.13.6 (without transformer).

● BEDFORD

Size 9½" x 8½" x 3½". P.M. Unit 5". Capacity 2½ watts. Complete with volume control. Price £2.5.6 (with transformer). £1.19.6 (without transformer).

WHITELEY ELECTRICAL RADIO CO. LTD. MANSFIELD. NOTTS.



MAGNETIC T.V. PARTS

We were fortunate last month in being able to obtain a set of T.V. parts which were made by a famous Company for a television manufacturer who, unfortunately, came "unstuck." These parts which are suitable for a 9in., 10in. or 12in. magnetic tube are offered to you at approximately half of the present day cost. The units concerned are— (1) The tube assembly which comprises a frame on which are mounted the frame and line deflection coils, and the focus coils. (2) An E.H.T. Transformer to give 4kV. (3) A line output transformer. (4) A diagram showing the wiring of a suitable circuit. The necessary valves for this circuit, which are H.P. Pentodes, can be obtained from us. Of course, you don't have to stick to the original circuit. Any conventional circuit will do equally well.

The price of the set of 4 items as listed above is only £3 10s. 0d., and as a limited number only are available, we suggest that you order by return.

We will supply the circuit separately at 2/6d. per copy and further we will deduct this 2/6d. if you buy the kit within 2 weeks.

ELECTROLYTIC CONDENSERS. (Only new stock from best manufacturers.)

| | | | |
|------------------------------|------|--------------------------|------|
| 2 mfd. 450 v. | 1/2 | 16 mfd. 369 v. | 1/11 |
| 8 mfd. 450 v. | 1/11 | 32 mfd. 360 v. | 1/11 |
| 16 mfd. 450 v. | 2/8 | 25 x 25 mfd. 200 v. | 3/11 |
| 8 x 8 mfd. 450 v. | 3/4 | 8 mfd. 150 v. | 1/3 |
| 8 x 16 mfd. 450 v. | 3/4 | 25 mfd. 25 v. | 1/8 |
| 16 x 16 mfd. 450 v. | 3/9 | 25 mfd. 50 v. | 1/8 |
| 16 x 8 x 24 mfd. 450 v. | 4/9 | 50 mfd. 12 v. | 1/4 |
| 8 mfd. 380 v. | 1/6 | 10 mfd. 25 v. | 1/4 |

KIDNEY TUNING CONDENSERS. 2 gang. 00035, fitted with trimmers, and complete with perspex dust cover. These condensers made by "PLESSEY" are of the type used for tuning personnel receivers. Price is 6/6, plus 8d. postage.

4-GANG TUNING CONDENSERS. .0005 each section—fitted trimmers—ceramic insulation. These are complete in a very useful chassis, and are fitted with a drive Government Surplus equipment but new and perfect. Price 2/9, plus 1/3 postage. Case of six units, 1/76, carriage paid.

2-GANG .0005 CONDENSER. Standard size—ceramic insulation. Price 4/9, plus 8d. post.

CHOKES IRON CORES L.F. (Surplus). 250 m.a., 9/6; 200 m.a., 6/-; 70 m.a., 4/6; 50 m.a., 3/9.

E.H.T. CONDENSERS (Surplus). .1 mfd. 5,000 v., 3/9; .02 mfd. 8,000 v., 3/9; .02 mfd. 4,000 v., 1/6.

PAPER CONDENSERS. We have all types in stock up to .1 mfd., 6d. each; .25 mfd., 8d., .5 mfd., 11d. Parcel of 36 assorted, no more than two of any value, 12/6.

RESISTORS. Full range in stock, 1 and 1/2 watt, 4d. each, 1 watt, 8d. each. Parcel of 100 assorted, all useful sizes, no more than two of any one type, 12/6.

"BOLA" 5in. P.M. Speaker, fitted standard O.P. trans., 11/3.

"BOLA" 5in. P.M. Speaker fitted standard O.P. trans., 15/3.

"BOLA" 5in. P.M. Speaker, less output transformer, 8/9.

PLESSEY 10in. P.M. fitted standard output transformer, 29/6.

PLAIN NOTE.—That unless otherwise stated all goods are new and unused, and of recent manufacture and not Government Surplus.

LONDON COUNTY COUNCIL NORWOOD TECHNICAL COLLEGE

Phone: WEST NORWOOD
GIPSY Hill 2268/9 LONDON, S.E.27

TELECOMMUNICATIONS & ELECTRONICS

DAY and EVENING COURSES for the following Examinations:—

- CITY AND GUILDS OF LONDON INSTITUTE IN TELECOMMUNICATIONS ENGINEERING (Final Certificate)
- GRADUATESHIP OF THE BRITISH INSTITUTION OF RADIO ENGINEERS

EVENING COURSES, additional to above:—

- RADIO SERVICE WORK (R.T.E.B.)
- TELEVISION (Theory and Servicing)
- SERIES OF SHORT COURSES ON MODERN APPLICATIONS OF ELECTRONICS

ENROL NOW for the 1949/50 Session commencing September next. Vacancies are limited

Full details and application forms from the Principal (496)

BULL'S RUISLIP DEPOT

WINDMILL HILL - RUISLIP MANOR - MIDDLESEX

KERSHAW'S KORNER KALLING

SPECIAL!!!

M.O.S. LINES

TELESONIC RECEIVERS, brand new, complete with four 1.5 v. Hivac Midget valves ideal for making your own personal portable 32/6 each. Post paid.

INERT 1.5 v. CELL BATTERIES, long life, fill with plain water and have continuous use. Ideal for every purpose. 3 for 2/6. Post paid.

MAKE YOUR OWN CRYSTAL SET, with polished terminal box complete with volume control, resistance, etc. 1/6 each. Post paid.

S. KERSHAW

93/95 PERSHORE STREET, BIRMINGHAM, 5.



The "Commander" Model "B"

A Special "Double-Superhet" Communications Receiver for Amateur and Commercial purposes.

£48.10.0 nett.

Complete Operating and Servicing Handbook available 5/- ea. Designed and manufactured by:

RADIOVISION (Leicester) LTD., 58-60, RUTLAND ST., LEICESTER. Phone: 20167 Cables: Hamiltelap.

ELECTROMAGNETIC PHONE INSERTS

Miniature 60 Ω permanent magnet balanced armature units. Reed drive, corrugated metal diaphragm. As used in Admiralty sound-powered telephone handsets, giving instant communication without batteries or transformers. Also good (with trans.) as miniature speakers for office intercom., etc., or as microphones. Size 2in. diam., 1in. deep. Few thousand only at 2/6 each, post paid. Midget mic. trans. 2/- extra. Order at once, send by return.

WIRELESS SUPPLIES UNLIMITED, 264-266, Old Christchurch Road, BOURNEMOUTH, Hants.

PRECISION TEST EQUIPMENT

STANDARD SIGNAL GENERATOR TYPE 52a. By Cosmor. Frequency range 6 to 52 Mcs. Modulation either sine or pulse. Prov. for Ex. Mod. B.F. output variable from 1uV to 100 mV. Complete with all accessories in transit case. New £25

STANDARD SIGNAL GENERATOR TYPE I-225-A. Made for the U.S. navy. Two frequency ranges, 8-15 Mcs. and 160-230 Mcs. Provision is made for internal crystal calibration. B.F. output variable from 1uV to 100 mV. As new £27

PRECISION A.F. OSCILLATORS. TYPE IO.50a. By B.S.E. 0 to 16,000 cycles on two dials. 0 to 600" 0 to 16,000 cycles. As new and unused £1

CRYSTAL OVENS. ADMIR. PATTERN 5190. For precision frequency control of quartz crystals. (See April advertisement). New £4/17/8

Also "VARIACS" Attenuators etc. Send for lists. Carriage is extra on all the above.

PIKE BROS.

86 MILL LANE, LONDON, N.W.6 Telephone: HAMPSTEAD 4219

POST RADIO SUPPLIES

OFFER EX-STOCK
COPPER INSTRUMENT WIRE. ENAMELLED, TINNED, LITZ. COTTON AND SILK COVERED. Most gauges available.
B.A. SCREWS, NUTS, WASHERS, soldering tags, eyelets and rivets. EBONITE AND BAKELITE PANELS. TUFNOL ROD. PAXOLIN TYPE COIL FORMERS AND TUBES, ALL DIAMETERS.
Latest Radio Publications.
Send stamped addressed envelope for comprehensive lists. Trade supplied.

POST RADIO SUPPLIES

33, Bourne Gardens, London E.4 Phone: CLIssold 4688

Rate 6/- for 2 lines or less and 3/- for every additional line or part thereof, average lines 6 words. Box Numbers, 2 words plus 1/-. Press Day : August 1, 1949 (last first post Wednesday, July 6th. No responsibility accepted for errors.

WARNING

Readers are warned that Government surplus components which may be offered for sale through our columns carry no manufacturers' guarantee. Many of these components will have been designed for special purposes making them unsuitable for civilian use, or may have deteriorated as a result of the conditions under which they have been stored. We cannot undertake to deal with any complaints regarding any such components purchased.

NEW RECEIVERS AND AMPLIFIERS TUNING Units.

FULL range of Denco, Lowther and Eddystone goods available 5/ 10 waveband gram chassis covering 3 to 60mc/s, 150 to 1,500c/s, amplifiers for every use, television kits, radio kits, telexior £51, working at 150 miles range with good results; s.a.e. for leaflet of single items or illustrated 54-page catalogue price 9d., to Mason's (P.W.), Weymouth, nr. Colchester. [3594]

G. W. SMITH & Co. (RADIO), Ltd., offers the following sound and perfect.
R.4709 Responder Unit, 10-valve television chassis for long distance reception with 4mc/s bandwidth, complete with all valves and including comp-ele modification sheet, £2/6.
TELEVISION receivers, type R3034A, ex-W.D. brand new in sealed boxes with 1 524, 1 VU134, 1 VR137, 2 VR136, 7 EF.50 valves, a very cheap and reliable television conversion unit; 7/2/6 each.

TELEVISION units type 26, brand new and boxed, complete with valves; 30/-; ditto type 24, 12/6.
CHOKES, 5 henry at 200ma, 3/6 each; 7 henry at 250ma, 8/6 each; 7 henry at 100ma, 6/-; 10 henry at 400 9/6; 11.5amp, 5/6 each.
TRANSFORMERS, mains, 200/250 input, output 380x380v 300ma, 19/6 each; filament with 2.75v at 6amp, 6.3v at 6amp, 5v at 6amp, 4v at 1amp, 17/6 each.

CONDENSERS 25x25 1/- each; 16x24 at 350v, 3/-; 16x8 at 450v, 3/9; 1mf at 2,000v, 1/6 each; 4mf mansbridge at 1,000v, 3/-; 1mf at 5,000v w/k, 11,000v test, 2/6 each; 1 2,500v mansbridge, 2/9 each; 1mf 3,000v, 3/-each; 1mf 4,000v, 3/3 each; 1mf 5,000v, 3/6 each; 1mf 250v, 4d each; 2mf 400v, 3d each.
CONDENSERS variable 15pf single gang, 6d each; 15pf twin gang 1/-; 00016 variable, 6d each; 5pf with spindle 9d each; 75pf ditto, 9d each; 2 gang 00035 1/- each.

TELEVISION coil formers Polystyrene dust cores, 4/9 doz., wound, 5/6 doz. (1/2x1in).
RECEIVERS brand new type 18, less valves, 1F 465kc/s, 12/6 each.
SUPPLY PACKS, 6v input, 190v 80ma output, fully smoothed with 3 Ferranti chokes, 17/6 each; 12v vib. packs, 5/6 each; 24v vib. packs, 17/6 each.

ROTARY converters, 230v d.c.-230v a.c. at 250watts, £10 each.
24 VOLT d.c. input, 230 a.c. output at 100watts, 55/- each.
METERS, 0-5ma 2in, 4/9 each; 0-20amp a.c., 7/6 each; 0-4amp thermo, 2/9 each; 0-6amp thermo, 3/- each; 0-20v d.c., 3/9 each.
COUTOUTS 12v, 3/6; stator relays 12v, 3/6; Morse keys ex-R.A.F., 1/- each; e.h.t. sleeving, 3d length; silver mica condensers, mostly 1/6, 1/6 doz., assorted values.
G. W. SMITH & Co. (RADIO), Ltd., 3, Lisle St., London, W.C.2. Tel. Gerard 8204. Open all day Saturday. [3763]

1949 bandspread feeder unit with R.F. stage nine wavebands, 13.5-2,000 metres; 2nd stamp for illustrated brochure.—Coulphone Radio Ormskirk Lanes. [2528]

CONNOISSEUR'S receiver—world-wide results on highly sensitive 10-valve communication receiver or, by change of switch, very high quality reception of local stations on non-superhet high fidelity receiver; basis rebuilt R155, 9-1,500 metres; bass and treble contranets (boost to cut), gram input, P×4 push pull output, and all refinements.

FEEDER units as above, for use with external high quality amplifiers; write for details, or call for demonstration; R155 specialists, receivers repaired and re-aligned, also modified circuit and valves 2/- post free.—R.T.S., Ltd., 5, Gladstone Rd., Wimbledon, S.W.19. Tel. Lib. 3303. [1266]

R.T.M.C. (EALING), Ltd., pioneers of the Williamson amplifier and now recognised as the leading production of 1949, are again first with a 9-valve model which incorporates built in pre-amp, built to specification from finest components; there is definitely no other amplifier on the market to compare with it for quality and price, offered at 20/10 complete; also P×4 model price, offered at 20/10 complete; also P×4 model original 7-valve model, £25/10; standard model, £22/10; separate pre-amp if required, £6/10; also special offer of simplified Williamson 7-valve models at £20; all amplifiers are guaranteed to be of highest quality.—Full details from R.T.M.C. (Ealing) Ltd., Laurel House, 141, Little Ealing Lane, W.5. Eal. 6962. [3674]



NOW AVAILABLE

Hermetically Sealed

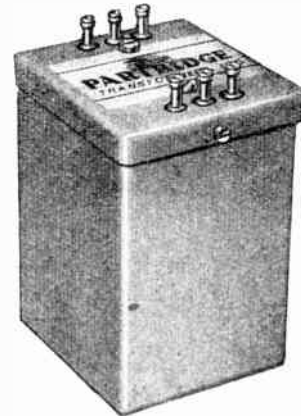

—And in oil if required!

Illustrated is a typical Partridge Transformer (Type DN) in its Mumetal Screening Box. It is merely to remind you that all Partridge Precision Components (standard or "to specification" types) are now available as hermetically sealed units.

Then there's the new PARTRIDGE "PPO" RANGE

—designed to meet more fully the particular demands of push-pull output transformers where wide A.F. range with low distortion are vital.

FULL DATA ON REQUEST



Roebuck Road, Kingston-by-Pass, Tolworth - Surrey
TELEPHONE: ELMBRIDGE 6737-8

UNIVERSAL ELECTRONIC PRODUCTS, 36, Marylebone High St., London, W.1. Tel. Welbeck 4058.

SPECIALISTS in the design and manufacture of high fidelity reproducing equipment from 4-00watts for domestic or industrial purposes. Our U.E.5 (6watts) and U.E.7 (12watts) series amplifiers are designed especially for the connoisseur who requires the finest possible reproduction from recorded music; both amplifiers have a linear response over 50-20,000 cycles with a damping factor of 12, and incorporate pre-amplifier stage, together with independent control of bass and treble. Our policy is to produce an instrument which represents the highest standards in workmanship and performance and no expense has been spared to achieve this object. A new addition to our range is the type U.E.3 (4watts) at £11/10. We also supply a range of tuning units both t.r.f. and superhet, for use in conjunction with either our own or other makes of amplifiers. We should be pleased to quote you for the design and construction of a unit or replacement chassis to your exact requirements. Full details of our products will be forwarded on request, and we would welcome the opportunity to demonstrate our equipment at any time to suit your convenience. [3552]

AMPLIFIERS, new 60watt heavy duty p.a. models, built for continuous rating and rack mounting, £40; early delivery, require Broadcast & Acoustic Equipment Co., Ltd., Tombland, Norwich. [2905]

R.A.F. model 1155 new, complete with valves, £8/10, plus carriage; converted models, power packs, quality amplifiers, speakers, auto changers and cabinets reduced prices; send for list.—Broadcast & Acoustic Equipment Co., Ltd., Tombland, Norwich. [2906]

WE offer the new "Extended Range" 8-watt amplifier with revolutionary dual-tone control system, giving widest possible variation to suit all old and new recordings; built to instrument standards; this 6-valve amplifier, matched to 0.05v input, is now offered at £24 complete; hear it at its best with Tridem Corner speakers and the new Felicity TRF push-button unit.

FELICITY GRAMOPHONE Co., 87a, Upper Richmond Rd., London, S.W.15. Telbury 1665

RADIO UNLIMITED proudly announce the Sandringham portable 6-c mains amplifier, a complete unit for the amplification of voice, radio and records, supplied complete with m/c microphone, pre-set radio tuner, 10in speaker, etc., housed in carrying case, baffle cabinet, 12gns. no extras; full technical data and photographic literature on request; individual components supplied separately if desired.—Obtainable only from Radio Unlimited, 16, Carnarvon Rd., Leyton, London, E.10. [3289]

MIDCO amplifiers available with rated outputs from 4-25 watts as standard units or up to 75 watts as specified to order; we can offer a prompt reasonable priced service to supply most types of audio amplifiers to specification; enquiries welcomed, nothing too small; standard units, AA/4 4-watt 6V6 amplifier with tone and volume controls, £4/10; AA/10 push-pull 6V6 amplifier with twin high impedance inputs, 10 watts output, complete, £10; these models are supplied on chassis with high gloss enamel finish; larger models in limoh cases include 61.6 push-pull instrument with output of 25 watts, priced at £25; catalogue available; trade terms to bona fide dealers.—Mail orders to 19, Newcomen Rd., callers to 61a, Gk. Park St., Weymouth, Dorset. [4521]

NEW Quality radio tuners, suit any standard amplifier; No. 1, L. and M. wave 2-valve T.R.F., with illuminated dial, glass and escutcheon, R/G switch, built and tested, £4/10; in kit form, 75/-; manual only, 3/6; No. 2, 3-valve waveband 3-valve superhet with large, elaborate horizontal illuminated dial, exceptional range combined with quality; built, tested and aligned, £7/10; in kit form, 135/-; manual only, 3/6; the new N.R.S. quality amplifiers; No. 1, 4watt, pick-up and tuner inputs, volume, tone and feedback controls, 110-250 a.c., built, tested, 119/6; or complete kit, 110/-, or constructional manual only, 2/6; No. 2, 15watts push-pull, pick-up and mike inputs, volume mixing, tone control, 3 and 15ohms impedance, output 200-250v a.c., built amplifier, 10gns or complete kit, 9gns; manual only, 4/6; obtain list, 2/4d; terms, c.w.o. or o.d.—N.R.S., 102, Parkhill Rd., London, N.W.3. [3533]

RECEIVERS for the West country amateur, Eddystone 680, a very high grade instrument, 13 valves, 480kc/s-30mc/s, £25; Bardsley Com-mand receivers 6-valve receivers, BC454, 3-6mc/s, BC455, 6-9mc/s, 37/6 ea., post 1/3; a.c. power pack to suit, 47/6, post 1/-; control boxes, 12/6, post 1/-; 28v Dynamotors, 10/6 ea., post 1/-; output transformers, 8/6, post 3d; guaranteed in new order, 1132A, unused, for the 100-watt, excellent controls, £4/19/6 p. and c., 10/-; 3084A, absolutely spotless, 11-valve, 200mc/s, £4/2/6 c. and p. free; RU16 Western Electric; U.S. Navy aircraft receivers, spotless, in original cartons, a 6-valve TRF receiver for amp., mod. or c.w.o., covering 185kc/s, 14mc/s, each with complete set 9 HRO type plug in coils, require separate 12v and 250v pack, limited number, un-repeatable, £9/10. c. and p.; c.w.o. only; s.a.e. for lists.

FILLS & PARTNERS, 49, Cobourg St., Plymouth, Tel. 2239. [3768]

RECEIVERS, AMPLIFIERS—SECOND-HAND

2 Ex-Luftwaffe R.D.F. 8v sets, 500-600kc/s, no power.
 1 PULSE modulator Western Electric BC1142A;
 1 crystal calibrator 100-1,000kc/s Marconi;
 1 A.M. test set, 210 20-80mc/s sig. gen. and
 wavemeter; 1 power pack for two above items;
 1 RT34/AP513 (410-420mc/s) transformer;
 30mc/s if's less 7 valves 3 6J6s, 2 2021s, 2 6AG5s;
 Genemotor power in set; 27 Xtals 3085kc/s-
 3007.690kc/s; offers for above to:
 B. A. KIND 115, The Ridgeway, Chingford, E.4.
 Buyer collects. [3754]

PAM amplifier, 25 watts, two speakers, mike
 and stand, £35.—Box 6917. [3785]

R.C.A. A.R.88 communication RX, working
 order, £25; London area.—Box 6881. [3723]

R.98 540kc 32Mc, nearest £45.—Sedman, 22,
 Gaiters Ave., Stockton Lane, York. [3732]

HARTLEY-TURNER S7 wks.—Box 6839. [3722]

Piezo crystal pickup; offers; valves and h.t.
 1155, int. power pack, speaker, working;
 £7/10.—Sticklepath, Okehampton. [3684]

HALLICRAFTER S.27, for 27-144 meg., P.M.
 or A.M.; demonstration in London; £16.—
 Box 6776. [3620]

W.W. quality amplifier with 2-valve tuner with
 valves; £4.—Davies, Ockbrook House, Ock-
 brook, Derby. [3464]

TELEVISION, Pye B.16.T, table model, perfect
 condition, £45; buyer collects.—Hartland's
 Radio, 24, High St., Sedgley, Staffs. [3672]

GRAMPAIN 15w, P.P. mike/gram amplifier
 with m.c. and loud speaker, £20.—Webb,
 10, St. Barnabus St., London, S.W. [3622]

FOR sale, 10v double superhet, MCR1, R1147,
 Avomiron, numerous components, cheap.—
 Betts, 19, Wychall Lane, Birmingham. 30. [3782]

A.R88D receiver, as new, fitted S. meter,
 A speaker to match, also manual; £55.—23,
 St. Andrews Rd., [3745]

A.R88D and AR88L.F. receivers for sale,
 A reasonable; also large quantity of gear
 cheap, lists.—J. Rae, 39, Penn Rd., Wolverham-
 pton. [3751]

VRC97 television inc. power pack fully con-
 structed, good working order, requires only
 minor modification; bargain, £17/10.—Prinrose,
 0557. [3745]

A.R88 with cabinet, vibrator unit, spare valves,
 A speaker, 'phones and handbook; recently
 overhauled; £45 or near offer.—81, Lime Grove,
 Newark. [3668]

C.R.100/2 10-valve communication receiver
 good working condition, offers; Universal
 Avomiron, £4; Acos 10in crystal p.u., new boxed,
 35/—Box 6875. [3704]

HANDY transceivers, 145mc/s, world's
 smallest 11in x 3in x 3in, recently imported
 from U.S.A.; pair £28.—Scott, 66, Braxted Park,
 Streatham, S.W.16. [3649]

A.R88 II 75-550kc/s-1.5-30mc/s, 14v, 6 bands,
 A perfect condition; £55, or best offer,
 Grantor, Regent Hse., Icewell Hill, Newmarket,
 Suffolk. [3683]

RECEIVER 1155 and circuit diagram com-
 plete, all valves, very little use, cost £15,
 accept £12; also rotary transformer, 24v in 300v
 out with filter, 30/—Box 6785. [3663]

32/6 Bendix Rx EC-624-A, 11 valves
 3-9003, 3-125G7, 1-9002, 1-12H6,
 1-12J5, 1-12AH7, 3-12C8.—B. E. R., 29,
 Brighton Rd., Birmingham. [3679]

H.R.O. receiver, power pack, speaker and coils,
 A perfect order, £28; Hallcrafters, 510,
 Champion, realigned and in perfect order, £21.—
 T.E.C., 101, Senhouse St., Maryport, Cumber-
 land. [3706]

AS new, 7-valve communication receiver
 chassis, Denco C.T.3 turret, 2,000 6.5
 metres, including teleseal, valves OM6, ECH35,
 EF39, EF39, EBC33, L133, rectifier and magic
 eye Bandsread tuning; £16.—Box 6789. [3605]

15 watt gram, amplifiers complete, rack
 cored components; 2 PX 25 in pp with valves,
 £6/15; less valves, £4/10, plus carriage.—Broad-
 cast & Acoustic Equipment Co., Ltd., Tomland
 Norwich. [2907]

LAK TL/12 amp. and RC/PA pre-amp.,
 HARTLEY p.u., Turner T.R.F. feeder, coil,
 Collaro motor, sound sales non-magnetic T.T.
 in walnut cabinet, Barker 148A in Charles tri-
 corne to match, as brand new, £65 or offer.—
 Box 6786. [3665]

20 Valve Philco radiogram without cabinet, 5
 wavebands, magnetic tuning on multi-
 dial as well as hand tuning, 3 speakers, Garrard
 autchanger, lovely condition, perfect quality,
 suitable connoisseur; deafness reason sale.—Dr.
 Morey, Minster Yard, Lincoln. [3612]

TUSUAL offer, Pye television console 9in
 tube, coupled to A3B-8 and 1355 modified
 with built-in power pack, making very neat and
 efficient long range television receiver; can be
 seen working with results, in Leeds by appoint-
 ment; £70, or near.—Thompson, 28, Hillcourt
 Drive, Braxley, Leeds. [3680]

CR100 (328), 11-valve communication receiv-
 ers, coupled 10-250 metres in 6 wave-
 bands, 200/250v a.c. mains, Marconi eqv. of
 AR88, 2RF, 3IF stages with Xtal gate, 3 watt
 O.P., overhauled, aligned, remetalised cabinets,
 first rate condition; a large purchase enables us
 to offer these magnificent receivers (usually
 valued around £25) at the amazing price of
 19gns. carr. forward; secure yours while they
 last; move back if not satisfied guarantee.
 THE AMATEURS DEN, 181, Lake Rd., Ports-
 mouth. [3747]

BRINGING HOME THE
(AMERICAN) BACON

The first practical moving coil speaker
 came from America somewhere around
 1926. It was a great improvement over
 anything else but we thought it didn't go
 as far as it could. As a result the Hartley-
 Turner speaker was born.

By 1930 we had also produced and sold
 to the public the first dual unit or
 "tweeter woofer" probably because
 we were the first to think that more
 than one unit was necessary to give the
 frequency response demanded by real
 high fidelity. The Hartley-Turner
 Duplex was abandoned within a year
 because we didn't like the sound of it—
 it had a coloration which still seems
 inseparable from a large cone unit (the
 "woofer" part of the set up.)

Nearly twenty years later we still pin
 our faith to a highly developed single
 unit speaker, and as so many thousands
 of musical enthusiasts pin their faith to
 Hartley-Turner we rather feel we are not
 being unduly blinded by prejudice. So
 insistent and persistent is the testimony
 of users to the excellence of the Hartley-
 Turner speaker that we thought it
 would be a good idea to let the citizens
 of the United States know what we had
 been doing since Rice and Kellogg set
 the ball rolling.

While we have concentrated on the
 single unit they have turned to the
 multiple unit speaker, until the search
 for excellence has produced speakers
 which are almost too dear to buy. Yet
 some in this country are content to
 follow the American trend. We cannot
 say if they are right or wrong; it is a
 free country and they are entitled to do
 whatever they think best.

But . . . the Hartley-Turner 215 sells
 in the U.S.A. at \$45 and we have written
 testimony from sound experts stating
 that on direct switch-over tests it is a
 closer approach to the real thing than
 others costing \$500. You can believe
 it or not, but the proof is in our files,
 and it is proof supplied by men to whom
 perfection of performance is more
 important than price.

The solution of your high fidelity
 problem is here at the absurdly low
 price of £9; but always remember that
 what we say doesn't matter. It is what
 the user says—and he says "buy
 Hartley-Turner." Literature free for
 the asking, and "New Notes in Radio"
 at 2.6 will tell you how to overcome all
 the other snags.

H. A. HARTLEY CO. LTD
152, HAMMERSMITH RD.,
LONDON, W.6. RIVERSIDE 7387

BARTON'S T.R.9 receivers, complete with six
 popular battery valves, give excellent S.W.
 results, or may be converted to broadcast bands
 just ready to connect up, 16/- carr. paid; if in-
 terested in 144cms, send for details of various
 receivers, including American 522 RX, complete
 with button base valves, etc.—Barton's, 41, Bed-
 minster Down Rd., Bristol 3, 3719

AR88D, £50; R.A.P. UHF special, 25-130mc/s
 standard signal generator (new), £75; two No.
 8 walkie-talkies with spare kit valves, £25 the
 pair; Blue Diamond 500-watt generating set,
 £50V ea; 127 d.c., 225, R.C.A. crystal wave-
 meters, TE-149, brand new, in transit case, with
 valves and crystal, 250kc-20mc, £6/15 ea;
 a few slightly damaged at £5/10 (ceramic end plate
 cracked, dismantle and replace with perspex in
 one hour); Siles, Signal Corp. Multirange test unit;
 Triplet 4in meter 50 microamp basic, 1k or 20k
 OPV, 25 range, 5kv 10a 10meg, £8/15 ea; 5in
 5in, as new £18; American valve tester, as new,
 all types, all tests, with chart, £16; send s.a.e.
 H. ENGLISH, Rayleigh Rd., Hutton, Brentwood,
 Essex. [3780]

NEW LOUDSPEAKERS

THE Tridem 12D Corner cabinet with Barker
 unit is delighting all customers, price £30;
 also standard model 12B at £21.—Details from
 Felicity Gramophone Co., 87a, Upper Richmond
 Rd., S.W.15. [3492]

SPECIAL high-flux p.m.s., 5in, 11/6; 6½in,
 13/6; 8in, 15/6; 10in, 23/6; Truvox wafer,
 6½in, 25/-; Truvox 12in, 25/-; Charleade
 Golden, 10in, 75/-; c.w.o., c.o.d.—N.E.S., new,
 Parkhill Rd., London, N.W.3. [3534]

BROADCAST new model pm/12.12in die cast
 detachable cones, 12.500m, 15ohm, 12watts,
 Hi-Fi twin cone £8/10.—Broadcast & Acoustic
 Equipment Co., Ltd., Tomland, Norwich [2908]

LOUDSPEAKERS, SECOND-HAND

K. 12in P.M. curved cone, £3; "Coil" P.U.
 £35.—Scott, 21, Beaconsfield, Aberdeen. [3656]

X5, 12, as new, makers carton; £5/10.—
 113, Hazel Rd., Longview, Liverpool. [3656]

HARTLEY-TURNER m.c. speakers, 215, brand new,
 £6/10.—Common, 6, Queensway, Stirling.
 50 speakers, 10in dia., weatherproof, with
 transformer 30/- each, carriage 3/6.
 RADIO UNLIMITED, 16, Carnarvon Rd.,
 Leyton, London E15. [3658]

UNUSED manufacturers' surplus.—Rola 6½in
 P.M. speakers; 11/6 each, postage 7d.—
 McNeil, 164, Streatham Rd., Mitcham. [3653]

VOIGT twin-cone unit, unused, with power
 supply and nearly completed corner horn,
 £19 the lot; unit only £14/10.—Box 6907.

ONE each Voigt speaker, corner horn and H.C.
 models, complete base chambers and units;
 also de luxe cabinet baffle with matched Rolas;
 offers.—BM/WX2, London, W.C.1. [3648]

BRAND new condition surplus.—W.B., Rola
 at 2/- per inch, post free.—Radio Unlimited, 16,
 Carnarvon Rd., Leyton, London. [3291]

DYNAMOS, MOTORS, ETC.

BATTERY chargers, 2-6-12 volts 1 ampere,
 a.c. mains operated, neat steel case with
 ammeter, real value, 42/6.—Thames Valley Pro-
 ducts, 20, Camden Ave., Feltham. [3670]

E.D.C.C. rotary converters, as brand new, 230
 a.c. input, 230 a.c. 500, 500watts,
 complete in silence cabinet and with filter, cost
 £48; accept nearest £40.—Spensers & Wyllie, 22,
 Howe St., Edinburgh. [3229]

SPRING motors.—Our famous range of
 E motors again available from stock; example,
 1hp single-phase, 200-250v, 1,400 rpm, from
 £6/16/6; send for lists.—John Steel, Binley,
 Yorks. Tel. 1066 (4 lines). [1968]

BATTERY chargers, 4 models 2-6-12v, 1-2-4
 amps D.C., any mains voltage; also larger
 types special transformers, chokes, test gear, in-
 terior car heaters, etc.—The Banner Electric Co.,
 Ltd., Hoddesdon, Herts. [2212]

BRAND new; Sangamo Weston synchronous,
 1 rev per minute, ideal for timers, clocks, etc.,
 19/- ea; c.w.o.—Dept. M, 46, King's Ave., New
 Malden, Surrey. (Include postage). [3712]

NEW Onan pet. generators, 12-15v 600watt (not
 400), self-start, air-cooled, 4-stroke, volt
 reg., auto cut-out, ammeter, complete with tools,
 book and instruction book, £25, plus carr.; new
 crated pet. or T.V.O. generators, choice of J.A.P.
 or Villiers engine, 550watt, 12-18v, air-cooled,
 side-valve, 4-stroke (1½hp), complete with con-
 trol box, cut-out, m.c. meter, toolbox, spares, in-
 struction book and waterproof cover, a first-class
 heavy-duty job, £27/10, delivery free; also Alco-
 Lyon 12-16v 360watt air-cooled, 4-stroke, nearly
 new m.c. ammeter, cut-out, etc. £16/10, others
 from £10, del. free; new unused Norman 15½hp
 ohv engine, Solex carb. pet. tank, B.T.H. mag.
 ready to run, £10, del. free; all pet. gens. en-
 gines and dynamos tested on load before despatch.
 Send p.c. for lists, illustrations and photographs;
 new shunt dynamos, 14-32v, 290watt, not 22-
 aircraft, £5, del. free; control boxes for above,
 with cut-out, fuse, var res and ammeter, conn.
 leads, £2 and 10 f. or 27 the pair; mains char-
 gers, H.D. 50v 50a 3et control panel, 200v/250v/1/
 30 or 440/3/50 in, £20 plus carr., 24v 25a, with
 control panel, meters, fuses, hoses, 200/250 v,
 £13, plus carr.; another, 6-24v 12a, m.c. meter,
 £10, plus carr. [3712]

PEARCE and Co., Gt. Percy St., London, W.C.1.
 Please see displayed advert. for S.T.O. tests, etc.

JUST RELEASED
"Q-MAX" SERIES TUNED
COLPITTS (Clapp) V.F.O.

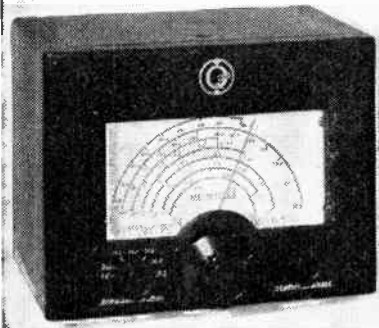

Direct calibration on all amateur bands from 3.5 to 30 Mcs.
 High or low imped. output.
 Fund. Osc. works on low frequency.
 Built-in stabiliser. Price 14 Gns.

FOR TELEVISION

- Full range of components including
- 12in. C.R. tube £15 4 10
 - 9in. C.R. tube £11 6 10
 - Haynes Line Output £1 16 0
 - Haynes Focus Coil £1 16 0
 - Haynes Scanning Coil £1 18 3
- Gardners, Woden, E.H.T.s, etc.

"Q-MAX" UTILITY S.M. DIAL
 for Self-calibration

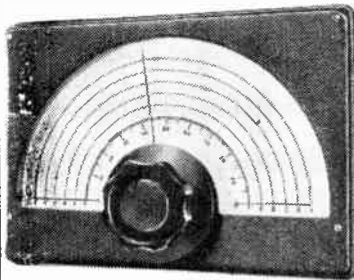

6-1 reduction.
 1 hole fixing straight on to panel.
 Provision for illumination.
 Size 9½ x 6½ 29/6

"Q-MAX" CHASSIS CUTTERS

| 1" | 1½" | 2" | 2½" | 3" | 3½" | 4" |
|---------|-----|------|---------|------|------|------|
| 9/6 | 9/6 | 12/6 | 12/6 | 12/6 | 12/6 | 25/- |
| Key 9d. | | | Key 1/- | | | |

- Latest AVO Sig. Gen. 100 kc/s-80 Mcs., £25.
 Large stock British and U.S.A. valves.
 Wearite midge 1Fs 10/6
 Wearite "P" Coils 3/-
 Ceramic Switch 1 p. 5 w. 3 Bank 10/-
 Denco Chassis mtg. coils 3/9

REGISTER NOW—Our new catalogue is nearly ready—3d. post free.

BERRY'S
 (SHORT WAVE LTD.)
 25, HIGH HOLBORN, LONDON, W.C.1
 (Opp. Chancery Lane.) Tel. HOLborn 6231

NEW rotary converters with special smoothing equipment for television, radiograms, etc.. 300 watts output, £23/10; 500 watts, £30; other converters, various voltages, from £4/10; also new electric motors, a.c. and d.c., E.H.T. Met-vick at list price, trade supplied; list available.—Johnson Engineering, 319, Kennington Rd., London, S.E.11. Reliance 1412-3. [3108]

97/6, charging switchboards, 12v-32v, 500 and 1,260 watts, volts, amps, cut-outs, fuses, resistances, etc., 6 take-offs, superb unit, in case, or send £5 carriage paid; 75/-, dynamos, 24 volts, 1,000 watts, 9in x 7in, 3in spindle, or send 80/- carriage paid; 75/-, 230v/1/50, 1/4hp electric motors, incorporating 1,260 cycle converter, or send 80/- carriage paid; 58/-, mains transformer switchboards, 230v a.c. to 12v, 5 separate take-offs, complete distribution panel, all switches, fuses, amps, etc., brand new, or send 60/- carriage paid; 55/-, electric motors, 12v and 24v, 1/4hp, 4in x 4in, with 4in spindle for drive, beautiful job, or send 60/- carriage paid; 45/-, dynamo units, containing carriage paid; 45/-, dynamo units, containing carriage paid; 12v or 24v motor, approx. 1/4hp, 11in x 5in, with spindle to take small grindstone, mop, etc., also contain adjustable 24v cut-out automatic voltage control, smoothing condenser, resistances, and many other extremely useful fittings, beautifully made, or send 50/- carriage paid; 38/-, radio wavy meters, adjustment dial, 350-370 Mc/s, beautiful instrument in case, or send 40/- carriage paid; host other valuable equipment; lists free.—E. G. Sumner, St. Charles St., W.18, Wim., 3833. (100 yds S. Riv. Electric Line; 10 minutes Waterloo.)

TEST EQUIPMENT

SIGNAL generator, new and guaranteed; price £6/6.

THE Home Lab Signal Generator has the refinements of an expensive instrument at a fraction of the price. Check the specification: 1, frequency coverage 100kc/s to 100mc/s, in 6 ranges; 2, modulation 50% at 400 c.p.s., with provision for external modulation or unmodulated carrier; 3, coarse and fine attenuator; 4, output impedance 10 ohms; 5, 500 ohm, R.F. oscillator double screened; 6, very stable R.F. oscillator protected by buffer stage; 7, accuracy of calibration 1%; 8, two output channels (high and low impedance) giving controllable sinusoidal 400 c.p.s. voltage; 9, operates from 100 to 200-250 volts, A.C./D.C. model also available; 10, twelve months' guarantee. Do not be deceived by the very low price. This really is a first-class instrument, and by dealing directly with the manufacturers you save approximately £3/8. The high standards of design and workmanship will satisfy the most critical. Send s.a.s. for full technical specification; enclose P.O. for 2/6 if you want circuit diagram. Terms of business: e.w.o., please add 2/- to cover postage and registration. Until our new showrooms are opened we can only accept orders by post.

HELV-MANN ELECTRONICS LABORATORIES.

- 67, Woodford Rd., Woodford, Essex. [3771]
 B C221AK frequency meter, full range, spare crystal; £6/10.—Box 6880. [3750]
 TAYLOR Model 65B oscillator, £10; Avo valve tester, with data books, £11; both as new.—Box 6905. [3742]
 AVO mains oscillator, unused; offers over £10/10 to G. Siston, 76, Aln St., Heb-urn, Co. Durham. [3668]
 SIGNAL generator, Marconi, T.F. 144G, perfect, bargain; £50.—13, Ropers Ave., Chingford, London, E.4. [3655]
 B C221 frequency meter, brand new (125kc/s-20mc/s); £14.—Warran, 7, Cradocks Parade, Ashstead, Surrey. [3436]
 AVO s.s. brand new, £15; Triplett universal multimeter, 20,000 Ohm, resistance 0-10m. £12/10; latest American valve tester, £12.—Box 6787. [3666]

MARCONI TF 144G, S. generator, as new, several other types; also very few communication receivers still available; s.a.s. for full particulars.—Eldridge, 254, Grove Green Rd., E.11, Ley, 4986. [3753]

AVO battery oscillator, new batteries, £8; A Atkins valve tester, £17, both as new; Cossor 359A D/B oscilloscope, £30; T/S.74 converted oscilloscope, £15; both good working order; R1132A, 75/-; 24v 1,000w dynamo, 50/-; Kodak 16mm cine camera, 1/1.9, £30.—Bryant, West St., Cromer. [3629]

METERS.—0-7v, 2 1/2in, m/c, 9/6; 15v, 2 1/2in, m/c, 9/6; 150v 2 1/2in, m/c, 10/-; 300v, 2 1/2in, m/c, 13/6; 3,500v, 3 1/2in, m/c, 20/-; 6,000v, 3 1/2in, m/c, 57/6; 15,000v, 2 1/2in, m/c, double reading, 8/-; 100ma 2 1/2in, m/c, 7/6; 40/120ma, 2 1/2in, m/c, double reading, 8/-; 3.5amp, 2 1/2in T.C., 5/-; 4amp 2 1/2in T.C. in case with switch, 7/6; 20amp 2 1/2in, m/c, 9/6. Meter movement 2in size with magnet and case (500microamp), 2/6; Units containing two movements, 5/-, or with two 100microamp, 5/6. All meters post extra. Ex-R.A.F. 2valve (2volt) microphone amplifiers, as used in plane intercom, in self-contained metal case, can be used to make up a deaf-aid outfit, intercommunication system, or with crystal set, complete with valves, 20/-, post 1/8; wooden box to hold amplifier, 2/- extra; crystal sets, with permanent detector, 9/6, in oak case, 18/6; headphones, 5/6, 7/6, 10/- and 12/6 pair; permanent detectors, 2/6; soldering irons, streamline, 50w, 9/-, standard 60w, 9/6; heavy duty, 150w, 12/6, all post extra; letters only; new illustrated list sent on request with 1d stamp and s.a.s. HIGHSTONE UTILITIES 58 New Winstead, London E.11. [3540]

ELECTRADIX RADIOS

for Best British Bargains

LIGHTING AND CHARGING SETS. Villiers 550 watt sets 2 h.p., single cylinder, air cooled, vertical petrol engine direct coupled to 18-volt, 30.5-amp. D.C. Crypto generator, speed 2,000 r.p.m., with petrol tank and guard rails, £17/10/-, 3-circuit charging switchboard for above plant, in pressed steel cabinet fitted variable charging resistances, Field regulator for dynamo, 3 circuit ammeters and main current ammeter, voltmeter, 3 enclosed cut-outs, terminals and 3 pole coupling plug, £6. All as new. Immediate delivery.

VILLIERS 1 1/2 k.w. plants, 2 1/2 h.p. single cylinder 4-stroke engine direct coupled to 35-volt 35-amp. D.C. dynamo, with petrol tank and guard rails: as new, £25.

AUTOMATIC Cut-in-Cut-out for Battery Charging. non-mercury for 12-18-24 volts up to 25 amps. Compound wound coil with laminated contacts, three terminals, on bakelite base 3 1/2in. x 3 1/2in., and enclosed in bakelite case, 12/6.

RELAYS open type with heavy contact to carry up to 10 amps, 24 volts D.C., 7/6. Relay and Rectifier unit D.P.C.O. relay and metal rectifier, 5/6; postage 1/6 extra.

VARIABLE RESISTANCES, slider type laminated brush gear 3 ohms, 10 amps, 17/6. 6 ohms, 6 amps, 17/6. 1.2 ohms, 15 amps, 12/6. Rotary resistances comprising resistance mats and radial stud switch and contact arm 10 ohms, 18 amps, 30/-, Carriage 2/6 extra.

A.C. CIRCUIT BREAKERS, 7 1/2 amps enclosed type, 20/-.

ELECTROSTATIC VOLT METER. Flush panel type, bakelite case, 3,500 volts, 21/-, postage 1/-.

TRANSFORMERS. B.T.H. 200/230/250 v. 50 cy. input and 2 volts 20 amps. and 75 volts 6 amps. output with 15 taps, £2/10, carriage 5/- extra. 500 watt transformer core wire and laminations, surplus G.P.O. stock, 25/-, carriage 2/6.

SEWING MACHINE MOTOR, 220 volts A.C., 1/25 h.p. with pulley belt and bracket, £4/10/-, Foot control 55/- extra.

BATTERY CHARGER KIT, for home charging from 230 volts A.C. double wound transformer, metal rectifier, ballast resistance terminals and base plate, 2 volts 1/2 amp, 21/-, 6 volt, 1/2 amp, 35/-, with connection diagram.

D.C. DYNAMO BARGAINS. Crypto shunt 35 volts, 35 amps, 2,000 r.p.m., £15/10/-, Crypto 27/32 v., 9 amp, 2,500 r.p.m., £10. G.E.C. Compound, 50/68 volts, 10/8 amp., 1,000 r.p.m., £15/10/-, Leese Neville shunt, 30 volts, 5 amp., 2,000 r.p.m., £2/15/-, 24-volt 30-amp. shunt, 2,000 r.p.m., 40/-, 12-volt, 30-amp., 2,000 r.p.m. 25/-, Carriage extra. C.A.V. 12-volt D.C. Dynamos for Windmill work, 10 amps., 600/1,000 r.p.m. shunt wound, totally enclosed, shaft extension at both ends for prop. new condition, 10 1/2 x 5in. dia., weight 24 lbs., 50/-, Carriage 5/- extra.



MAGNETS. Swift Levick, alloy perm. magnets circular, horse-shoe, machined and drilled, 1 1/2in dia. by 3/8in. thick, 3/4in. polar gap weight 2 ozs., lift 3 lbs., 3/6 each. or 4 for 10/-, post free.

TELEPHONES. House and office. Constructors' parts for your own set up. Ex-G.P.O. wall type comprising, bracket mike, transformer and condenser magneto bell, in walnut case 8in. x 6in. x 3 1/2in., fitted terminals and connections, switch hook and contacts, hand magneto generators and single receivers, 35/- per pair, with wiring diagram: carriage and packing 5/- extra.

VARIABLE CONDENSERS. Large lab. type, oil filled, in glass case, approx. .0005 mfd., with heavy Ebonite knob and scale, 10/-, Carriage 2/-.

SWITCHES. Dewar Key panel type 7-way C.O. with top plate flush fitting, 5/-, or 50/- per dozen. Yaxley switches 3-pole 3-way 2/6, 1 pole 8-way 2/6. Toggle switches 250 v. 1 amp. S.P.C.O. 2/-, D.P.C.O. 3/-, Panel Push Switch, make and break, 2/6.

Please include postage for mail orders.

ELECTRADIX RADIOS

214, Queenstown Road, London, S.W
 Telephone: MACAuler 215

AUDIO osc'r, 20-20kc/s Leland insts., type 27; offers.—Master Recording Studios, Stafford Lane, Stoke-on-Trent. [3726]

OSCILLOSCOPE and Wobbulator complete. £20; T.B. c/s 10 to 350,000 c/s X and Y plate amplifiers, easy to handle, has outstanding performance, fully guaranteed, immediate delivery with set of leads and booklet. "Oscilloscope Technique" further details from the manufacturers.—Erskine Laboratories, Ltd., Seabury, Scarborough. [13456]

TRANSMITTING EQUIPMENT

NATIONAL NTX 30/40 watt transmitter and NSM modulator, 230 A.C. rack mounting, £40.—Leitch, 17, Walpole St., S.W.3. Sicane 7013. [3760]

TRANS-RECEIVER TR9, 40-meter band convertible, battery operated 9-valve, require 2v and 120v, self-contained, in working order, complete with valves, £3; less valves, £2 to clear. BURTWELL & DREW, Farlington, Berks. [3366]

HALLICRAFTERS transmitters, type HT4E complete, covers makers' latest specification, covering all amateur bands up to 30 mc/s, with speech amplifier, connecting cables, etc.; immediate deliveries in quantity; also available, export only, British made Hallicrafters 5X42.—Hallicrafter United Kingdom Distributors, McFroy-Adams Manufacturing Group, Ltd., 46, Gresham Rd, London, E.C. [2778]

GRAMPHONE AND SOUND EQUIPMENT

COMPLETE disc recorder 78/33 1/2 rpm, quality job, £25.—Box 6874. [3703]

B.S.R. recorder, type DR33C, for sale, as new and unused; offers.—Box 6835. [3678]

L. EXINGTON 23 p.c. pick-up (2); accept £3, finished.—62, South St., Cottingham, York. [3677]

M.V. hypersensitive pick-up, unused, less transformer, 30/.—41, Queens Walk, Ashford, Middlesex. [3729]

RECORDING blank discs 12in, box of 15 discs, packed, cart. 10s/6.—G. Lawrence & Co., 3, Sater Place, Liverpool. [3676]

DECCA's new automatic record player in case (Garrard RC65 unit, Decca pick-up), as new; £20.—89, Central Ave., Liverpool. [3667]

CRYSTAL microphone inserts (Cosmocord); ohm load; 12in phragm; brand new; £15/6 post free.—Radio-Aid, Ltd., 29, Market St., Watford. [3622]

MICRO-GROOVE hard acetate 7in D.S. recording discs, packets of 80, £4 each.—Master Recording Studios, Stafford Lane, Hanley, Stoke-on-Trent. [3723]

A COUSTIC cabinet, triangular, splendid appearance, £8/10; Goodman 12in twin cone Axiom, £7/10; genuine callers welcome (Birmingham).—Box 6774. [3614]

INFINITE baffle corner deflectors, scientifically designed, acoustic chambers for 8 to 15 speakers; lists.—Broadcast & Acoustic Equipment Co Ltd, Tombland, Norwich. [2900]

MICRO-GROOVE recording, interested in this coming development? Then we have the unit for you; s.a.e.—Master Recording Studios, Stafford Lane, Hanley, Stoke-on-Trent. [3722]

REPLACEMENT radiogram chassis a.c. mains, 3 waveband, large attractive dial, etc., complete with 8in p.m. speaker, 12gns.—Radio Unlimited, 16, Carnarvon Rd., Leyton, London, E.10. [3290]

TAPE recording and erasing heads 5 or 15 ohms, 1in dia 3/4in high, 30/- each; the C.D.P. recorder, £32; recording discs all sizes.—Morecambe Sound Service, 4-6, Green St., Morecambe. [3749]

B.T.H. cinema loudspeakers, handle 20 watts, £5; Ampertite ribbon microphones, £5; R.C.A. condenser mikes £3; Svatat, Vortekon amp, £25; p.p. i.f. transformers, 10/-—Ross, 8, St. John's Rd., Manchester, 16. [3701]

WILLIAMSON PX4 ampr., kit of parts, £10; one R.F. tuner, £3, in cabt.; also speaker cabinet, the £14, etc. etc. precision tracker, scrolling op'l 10gns.—Master Recording Studios, Percy St. (Entrance Stafford Lane), Hanley, Stoke-on-Trent. [3725]

M.V. record player, quality amplifier with H separate bass and treble amplifiers and PX4 output Baker 12in speaker in G.P.O. infinite baffle; £12.—Birrell, "Bosca", Roman Minor, Helston, Cornwall. [3756]

RAYMAX offer mahogany playing desks fitted with the latest well-known rim drive unit, magnetic pick-up, auto-stop, etc. £6/14/6 incl. p. tax; Collaro rim drive unit, F.U. auto-stop, etc. £5/10.—Raymax, Ltd., 126, South Wood Rd., London, S.E.24. [3207]

COMPLETE service for rebuilding customers' radiograms, to modern standards; our advice free to those wishing to convert their own sets; we can supply amplifiers, auto-changers, R.F. units, etc.—Percy Gramophone Co., 20, 21, Inner Richmond Rd., S.W. 15. [3703]

VOIGT unit post-war, complete with p. pack in H.C.C. horn with bass chamber (white), £30; with Williamson PX 25amp, ton. con. Vigt. F.U. motor, a superb record reproducer; offers to—Master Recording Studios, Percy St. (Entrance Stafford Lane), Hanley, Stoke-on-Trent. [3724]

MEMBERSHIP of the British Sound Recording Association ensures the professional and amateur recording engineer and quality reproduction enthusiast, or all the latest information in the form of monthly lectures, publications, demonstrations and the official journal, "Sound Recording," published quarterly; Vol. 3, Nos. 1, 2, 3, 4 available at 2/6 each.—Details of membership and application form from Membership Secretary, Harry J. King, 48, Mount View Rd., N. Chingford, London, E.4. [2119]

VALLANCE'S

SOLDERING IRONS.

PYROBIT. Instrument type, 23/- post free. Wireless type, 23/- post free.

SOLO. Straight bit, 20/6 post free. Pencil bit 22/- post free.

SPARE ELEMENTS.

PYROBIT. Instrument type, 4/6 post free. Wireless type, 5/6 post free.

SOLO. Both types, 5/6 post free.

SPARE BITS—SOLO. Straight, 4/3 post free. Pencil, 6/- post free.

SIGNAL GENERATORS.

TAYLOR 65B. 100 kc/s. to 46 mc/s. and 400 c.p.s. Audio, £16/12/6 post free.

EX U.S. ARMY. Brand new 100 kc/s to 83 mc/s. "Coll Turret" band switching, 400 c.p.s. audio 110 volts, 90-60 c.p.s. A first class instrument made by Espey Manufacturing Co. of New York. Complete with manual, £16/17/6 carriage paid.

AVOMETER MODEL 40, £17/13/6 post free. Taylor Junior 120A Meter, £8/10/- post free.

AVOMETER MODEL 7, £19/13/6 post free. Universal Avomizer Meter, £8/12/- post free.

WEARITE "P" COILS. A complete range of superhet coils, covering 12 to 2,000 metres in seven bands, when tuned by a 500 p.f. condenser. Coils in each band are available for aerial coupling, inductive coupling, and oscillator for 465 kc/s.

BAND 1. 700 to 9,000 metres. 4. 12 to 35 metres.
2. 200 to 557 metres. 5. 34 to 100 metres.
3. 16 to 47 metres. 6. 91 to 261 metres.
7. 250 to 750 metres.

P.A.—Aerial, P.H.F.—Intervalve, P.O. Oscillator. All types 3/6 each post free.

SOUND SALES 036X OUTPUT TRANSFORMER. Matches PX 4 or PX 25 valves in Push Pull or 6 or 16 ohm loudspeakers. Response level from 20 c.p.s. to 20,000 c.p.s. (See "Wireless World" Test Report.) Price £2/10/- post free.

SPEEDY POSTAL SERVICE C.W.O. or C.O.D.

VALLANCE & DAVIDSON LIMITED

(Dept. W.W.)

144 Briggate, Leeds 1. Phone 29428-9

MIDLAND INSTRUMENT CO.

FOR GOVT. SURPLUS STOCK, ETC.

U.S. ARMY FREQUENCY METERS TS-49/AP, cover 341 to 1,000 mc/s with high precision cavity, 341 to 700 with limits of 1 mc/s., 700 to 1,000 with limits of 2 mc/s indicated on Vee-der counter, suitable for amateur band +20/466 mc/s., fitted super 0-200 microampere meter, 9in. scale, complete with crystal valve, stub aerial etc. in smart crackle finish cases with cover, 22in. x 6in. x 5in., calibration sheets in hinged frame, also super transit case, brand new unused, 70/-, carriage 7/6.

BURGLAR ALARMS, closed circuit type, embody 200 ohm continuous drain relay, with holding (non-return) contacts, heavy alarm circuit contacts, press button actuating 4 ohm winding for setting, closed circuit test indicator lamp, unit set to set changeover switch, in smart wall fitting cases 7in. x 4in. x 3in., will cover large or small premises with high efficiency, operates from 6 to 12 volt battery or charger, and can be used with battery or mains bell (not supplied), superior to those now selling at £25 and over, brand new with instructions, 80/-, post 1/-.

BURGESS MICRO SWITCHES, suitable for above alarms, 1/6, post 3d., four different types, 5/-, post 9d.

U.S. RADIO RECEIVERS RC-824-A, contain 11 valves, JRC-9003 (3), JKR-9002, W3G7 (3), 12A87/GT (2), 12C8 and 12H6, 2 and 3 gang condensers, I.F. and variable dust core coils, etc., transformers, pots, numerous resistors and condensers, etc., etc., chassis mounted with side protection frame, 15in. x 7in. x 6in., condition new, unused, 30/-, carriage 2/6.

CRYSTAL VALVE RECTIFIERS, "Sylvania" 1N21, also "B.T.H." CV-10, brand new 3/6, post 3d., 6 for 13/-, post 3d.

TOOL SETS, consist of "Elliot Lucas" 6in. pliers, "Terry" B.A. spanner sets (8-sizes), "Apollo" 6in. box spanner, one end 4 the other 6 B.A., ditto 4in., one end 4 B.A., "Atkinsons" 6in. screwdriver, tool shop price 12/6, our price brand new, 4/- set, post 6d.

Above and hundreds of other interesting Radio, Electronic and Mechanical items are included in our new July lists, send S.A.E. for a copy.

MOORPOOL CIRCLE, BIRMINGHAM, 17

Tel. HARborne 1308 or 2664

LATEST type tape recorder, double track, with built-in radio and auto-change, high quality reproduction, radio, microphone or records, speech, music, all new, in cabinet any examination and trial; £165-9, Troy Grove Wyche Avenue, Kings Heath, Bham. [3757]

COLLARO a.c. 47 motor w. 12in turntable, var. speed, £5; Collaro RP49 motor/pick-up/autostop combined unit, £5/10; Collaro new RC49 a.c. mixed auto-changer with super crystal pick-up, special offer, £14, carr. paid; 62ms. c.w.o. or c.o.d.; bargain list, 24d.—N.R.S., 102, Parkhill Rd., London, N.W.3. [3535]

PROFESSIONAL recording equipment, blank discs, amplifiers, microphones and magnetic tape recorders, gramophone motors with non-magnetic turntables; pressings produced from your own masters in any quantity; full trade terms available.—Sound Discs (Supplies), 37, Highbury St., Southport, Lancs. [3486]

MARCONI portable recording machine fitted with B.S.R. special recording amplifier, set new, £40; B.S.R. PA.20B, high gain amplifier, new, £26; M.S.S. pick-up with sapphire, £5; Collaro motor with latest lightweight crystal pick-up, new, £2; B.S.R. twin speakers, £7/10; Vitavox 20w speaker in cabinet, £10; mikes & stands.—H. & E. M. Porteous, "Quality Recordings," Queens Garage, Rhyl, N. Wales. [3735]

COMPONENTS—SECOND-HAND, SURPLUS SOUTHERN RADIO'S wireless bargains.

RADIO publications: "Radio Modernisation Manual," 3/6; "World Wide Station List" (including Copenhagen Plan), 1/6; "Inexpensive Television," 1/6; "AC Receiver Construction Manual," 2/6; "Radio Valve Equivalents," 2/6; "Using Ex-Service Equipment," 2/6; "Radio Inductance Manual," 2/6; "The Walkie Talkie Manual," 2/6; "Radio Constructors Manual," 3/6; "Frequency Modulation Receivers Manual," 2/6; "Radio Valve Amplifier Manual," 5/-; "Radio Aerial Handbook," 2/6; "Radio Valve Manual," 3/6.

NAVAL Aldis lamps, 9in dia., with 9 feet waterproof cable, spare lens, filters and three 110-volt bulbs, £23; portable recording machine fitted with B.S.R. special recording amplifier, set new, £40; B.S.R. PA.20B, high gain amplifier, new, £26; M.S.S. pick-up with sapphire, £5; Collaro motor with latest lightweight crystal pick-up, new, £2; B.S.R. twin speakers, £7/10; Vitavox 20w speaker in cabinet, £10; mikes & stands.—H. & E. M. Porteous, "Quality Recordings," Queens Garage, Rhyl, N. Wales. [3735]

SOUTHERN RADIO SUPPLY Ltd., 46, Lisle St., London, W.C.2. Gerard 6653. [3789]

FRITH RADIOCRAFT, Ltd., Leicester, offer—

ENAMELLED wire, 14, 16, 18, 20, 22, swg 1/16 3/6; 1/8 7/6; 32, 36, 38, swg 1/16 1/9, 1/8 3/6; 4/4; 1lb 7/6; 32, 36, 38, swg 1/16 2/6, 1/8 4/4; 1lb 8/6; all prices include 10% postage extra under £1; 25% trade discount to bona fide traders and service men, minimum trade order £2 net; ebomite rod, asst. sizes, 3/4in to 7/16in, 12 1/2ft lengths, 5/- plus 6d post, or 12x 3ft lengths, 15/- plus 1/3 post; telephone hand sets, latest streamline type, brand new in maker's cartons, with 4-way cord and plug, 10/6 plus 6d post; moving coil headphones and mike sets, new condition, 5/- plus 6d post; U.S.A. make luxury headphones, HR type, 2,000-ohms, brand new in maker's carton, 10/6 plus 6d post; brass terminals, 4BA medium size, captive head, 24 for 5/- plus 6d post; hook-up wire, 72yds asst. coils, 5/- plus 6d post; telephone wire, 200 yds, lacquered DCC instrument wire, 1/36, red green, black, yellow or red, 60yds 5/- plus 6d post; sleeving, 1, 1/4 and 2mm, 5s asst. colours, 5/- plus 6d post; I.F. transformers, 455kc/s adjustable dust cores, 5/- per pr. plus 6d post; rheostats, U.S.A. make, 100ohms or 350-ohms, 25wt, wire wound, 2/6 each plus 3d post; satisfaction guaranteed or cash refunded without question.

FRITH RADIOCRAFT, Ltd., 69-71, Church Gate, Leicester. [3539]

Impedance, range: 350-3,000 & 2,500-6,000 c.p.s.—Box 6873. [3702]

TELEVISION—We are manufacturers of approved and tested components for "Wireless World" Television, see review Nov. 1948, issue, and can supply from stock, line and frame deflector coils, line output transformers, frame coils and shrouds, focus and deflection assemblies correct to designer's specification; complete sets of 21 coils, and filters can be supplied from stock for "Wireless World" superhet vision and sound units; television components used at current prices.—Particulars please write or phone "Handy-narts," 226, 228, Merton Rd., S. Wimbledon, Lib. 7461, near S Wimbledon Tube Station

July, 1949

Wireless World

GALPINS

ELECTRICAL STORES

408 HIGH STREET, LEWISHAM, LONDON, S.E.13

Telephone: Lee Green 0309. Near Lewisham Hospital.

TERMS: CASH WITH ORDER. NO C.O.D.

THURSDAY EARLY CLOSING

MAGSLIPS and Selsyns, many types in stock. send for list.—Hopton Road, Addis. 1, Hopton Parade, Streatham High Rd., S.W.16. Streatham 3721

SILENIUM rectifiers. 720v a.c., 560v d.c., 3 1/2 amp., 1/2 wave, normally £3/15; our price new, unused, 15/- p.l., c.w.o.—Logan, 1, West Alley Hitchin, Herts. [3618]

DELECTOR coil assembly 22/-, focus coil 25/-, for W.W. television receiver; instrument wires; s.a.e. list.—R. F. Shilton, 19, Clarendon Rd., Salisbury, Wilts. [3731]

TELEVISION scanning coils 30/-; frame output transformers, 25/-; 50 mains transformers, chokes, etc.—The Banner Electric Co., Ltd., Hoddesdon, Essex. [3732]

EX-R.A.F. rotary transformers type 46, 18 1/2 volts dc to 450 volts 50MA; type 47 9V dc to 450v 50mA, complete with detachable blower and 200:1 gear box, either type 10/- plus 1/6 post. [3733]

GRENSON LITTLEWOOD & Co., 27, Ballards Lane, Finchley, N.5. Fin. 3060.

HEAVY duty mains transformer 350-0-350 at 120ma, 2, 4 volt windings 5amps each, 21/-; Midget, 100k volume controls less switch, 1/6 ea.—Uncle Tom's Radio Cabin, 5, Seven Stars Court, Manchester, 4. [3210]

YOU'LL probably get it at Smith's, Edgeware Rd. Everything for the constructor, from a 1/10 watt resistor to the constructor cabinet, lowest prices, biggest variety.—Near Metropolitan Music Hall, Pad. 5891. [8005]

MAGNETIC reactors, 100w size, ex-Govt., controls A.C. supply, as June W.W., 15/-; metal rectifier F/W. charges 12v at 5a. Cambridge—Malden Transformer Supplies, 202, Cambridge Rd., Norblith, Sur. [3727]

TELEVISION, C.H.T.1 trans, 2,500 and 2V drop-calised, no flashover, insulation test 8,000v, guaranteed the very best, 35/-; E.H.T.2 as above, with 4v winding, 37/6; M.T.1, 75-0-275 80ma, 6.3 5v, interleave, impregnated, unbeatable value, 16/6.

HILLFIELD'S MAIL RADIO, 8, Burnham Rd., Hillfield, Coventry. [3777]

WEST meter panel, comprising a 0-5mV and a 0-20v M/c meters, 3 pots, toggle, Yaxley type and stud switch, 12/6; 12/6 boxed; 12/6 post. free.—Radio Unlimited, 16, Carnarvon Rd., Leyton, London, E.10. S.a.e. full list surplus bargains. [3292]

MANUFACTURERS.—Enamel, copper wires, all gauges, laminations, all types, huge stocks radio components. 3/m, m/m, p/t and high block condensers, all goods guaranteed.—stability resistors to 1%; all goods guaranteed.—L.F. Simmonds, 6a, Byron Rd., Harrow, Middx. [2515]

BUILD a portable radio this summer, extremely simple switch oscillator unit with frame aerial for medium and long wave, superhet, commercial performance, 22/6; type M.1. from component dealers, or send s.a.e. for details to Hobbies Division, Douglas Electronic Industries, Ltd., Br'nclow, Nr. Rugby. [1876]

WESTCOASTERS, 3/- dozen; 100k 1 watt resistors, 1/9 dozen; 75 m/a L.F. chokes, 18/- dozen; 0001m/1; samples supplied against deposit; trade only; supplies supplied against deposit; many other keen lines in our current list.—Press & Moore, Ltd., Dept. G, 37/13 Shakespeare St., Nottingham. Tel. 45466. [3713]

SUPERHET coils, 2/6 ea.; parts for L.M.S. (iron core), 2/6 ea.; pack 465kc, 9/6; 8mfid 450 electrolytics, 2/-; droppers, 1/-; assorted eyelets, eyelets, 2/-; 100 trimmers, 1/6; trimmers, 1/6; jets and solder tags, 6 gross 6/-; 100 trimmers, 1/6; send for cheapest 1kg. in England.—Sussex Electronics, Ltd., (G.) Riley Rd., Brighton, 7, Tel. 446.

JACK PORTER, Ltd., for reliable components at very keen prices, boxed 12v vibrators, 1/-; relays, 9d; Sprague 15mfid, 750v, 500v 1/-; block condensers, 7/6; 01 Dubilier mica coil condensers, 2/6 dozen; moving coil headphones with transformer and m.c. microphone, boxed complete, 10/-; send for lists.—Jack Porter, complete, 30/31, College Street, Worcester. [3499]

BRAND new: Electrolytics, 8+16/350v, 50ma, 3/-; IFTs, 465 kc/s, 10/- pair; dropper resistances, 470 ohm, 1/2; double and single end push on white, 2/-; mains transformers, 4v, 6-3v, 250-0-250 unshrouded, 8/6; table lamp switches, 250-0-250 in ivory, 2/1; c.w.o.—G.P. M. push-on/push-off, in ivory, 2/1; c.w.o.—(include 46, King's Ave., New Malden, Surrey. [3711] postage.)

CONDENSERS.—Paper dielectric in rectangular bar metal cans, 2mfid 500v d.c., and 1mfid 1,000v d.c., in unused condition, approximately 1,400 for disposal; radio frequency cable twin semi cables, 7/022 and 3/018 low-capacity twin semi cables, 7/022 and 3/018 cable with star-shaped air-spaced dielectric 4,000 yards for disposal, core, approximately 4,000 yards for disposal, also coaxial solid dielectric cable in sizes 1/128, 1/029, 7/032, 1/056.—John Cashmore, 1323, Great Bridge, Tipton, Staffs. [3281]

BRAND new mains transformer bargains, fully guaranteed, standard drop through chassis type with L.T. for 4v or 5v rectifier. Economical L.T.s for 4v or 5v rectifier. Screened and tapped primaries, nets. 250-0-250v 80ma, 16/-; 300-0-300v 80ma, 18/-; 350-0-350v 80ma, 16/-; 250-0-250v 100ma, 18/-; 300-0-300v 100ma, 18/-; 350-0-350v 100ma, 18/-; 250-0-250v 60ma, 6-3v, 4v, 4v, 2a, 14/6; fully shrouded upright type, 2/- extra; not Govt. surplus; order yours now; c.w.o.

DIRECT MAIL ORDER SUPPLIES, 5, Beaumont Rd., Manchester, 21. [3364]

MAINS TRANSFORMERS, Input 200-250 v., 50 cycles, in steps of 10 v. Output 450/0/450 v., 250 m/a., 4 v. 4 a., 5 v. 4 a., 6.3 v. 8 a., 6.3 v. 8 a., 6.3 v. 8 a., 4 v. 8 a., 5 v. 8 a., 6.3 v. 8 a., 6.3 v. 8 a., 5 v. 6.3/6. Ditto 450/0/450 v., 250 m/a., 6.3 v. 4 a., 5 v. 6.3/6. Ditto 450/0/450 v., 250 m/a., 6.3 v. 4 a., 5 v. 4 a., 4 v. 8 a., 4 v. 8 a., 0, 4, 5 v. 4 a. twice, 500 v., 250 m/a., 6.3 v. 8 a., 0, 4, 5 v. 4 a. twice, 6.3 v. tapped at 2 v. 2 a., 6/6. Another 350/0/350 v., 300 m/a., 4 v. 8 a., 4 v. 4 a., 6.3 v. 4 a., 6.3 v. 4 a., 2 v. 2 a., 5/6. Another 500/0/500 v., 300 m/a., 6.3 v. 8 a., 6.3 v. 8 a., 6.3 v. 4 a., 4.4 a., 5 v. 4 a., 6/6.

EX-R.A.F. MICROPHONE TESTERS (new). These consist of a Ferranti 0 to 450 m/amp. 2 1/2 in. scale meter shunted to 1 m/a incorporated Westlake house Rectifier, the whole encased in polished teak case, calibrated at present 0 to 10 v., 25/- each.

MAINS TRANSFORMERS (Auto Wound). Voltage Changers tapped 10, 20, 25, 90, 130, 150, 190, 210, and 230 v., all at 1,000 watts, a combination of 24 voltages can be obtained from this transformer, new ex-Government Stock, £5/10/0 each, carriage 5/-. Mains Booster Transformer, each, carriage 5/-. Mains Booster Transformer, type 2, 0, 6, 10, 19, 175, 200, 225, 240 and 250 v. at 1,500 watts (new, ex-Government), £5/5/0 each, carriage 5/-. Another AutoWound, £5/5/0 each, carriage 5/-. Ditto, 2,000 watts, £6/10/0 each, carriage 5/-. Ditto, 2,000 watts, £7/5/0 each, carriage 5/-.

EX-R.A.F. CRYSTAL MONITORS, type 2, complete in wooden carrying case, the frequency depending on crystal used, 5/- each. Short Wave Aerial Coupling Units (Wavemeters), 5/- each.

ELECTRIC LIGHT CHECK METERS (Watt-Hour). A.C. 50 cys., 200/250 v. 5 amp. load, 18/6, post 2/-; 10 amp., 21/-, post 2/-; 20 amp., 25/-, post 2/-; also a few only Pre-Payment 1/- slot type, 20 amp. load, less coin box, complete with synchronous Motor, 35/- each, carriage 3/6.

SPECIAL OFFER METERS, all new, boxed. Moving Coil, first grade instruments, 0 to 20 v., 10v/each, or 3 for 25/-; 0 to 40 v., 12/6 each; 0 to 10 amps., 15/- each, all 2in., scale 0 to 20 v., A.C., calibrated 50 cycles, 25/- each; 0 to 40 amps., thermo-coupled, 25/- each.

MAINS TRANSFORMERS, all 200/250 v., 50 cys., 1 phase, input, output 700/0/700 v., 70 m/a., 4 v. 2 1/2 a., 12 v. 1 a., 30/- each. Another m/a., 4 v. 2 1/2 a., 12 v. 1 a., 5 a., 5 v., 3 a., 37/- each. Another 2,350 v. at 500 m/a., 85/- each. Mains Smoothing Chokes, 10 Hy., 100 m/a., 6/-; 150 m/a., 8/6; 350 m/a., 25/-; 5 Hy., 250 m/a., 17/6.

EX-R.A.F. ROTARY CONVERTERS, 12 v., D.C., input 230 v. A.C., 50 cys. 1 phase at 100 w. output, 85/- each, carriage 3/6. Ditto 24 v. input, 65/- each, carriage 3/6.

PRE-PAYMENT I/- SLOT ELECTRIC LIGHT CHECK METERS, 200/250 volts, 50 cys. 1 ph., 2 1/2 amp. load, 30/- each, carriage 3/6; 5 amp. load 35/-, carriage 3/6. 10 amp. load, 42/6 each, carriage 3/6.

EX-RADAR POWER UNITS TYPE 225, containing 4 H.V. Rectifying Valve 1 5U4g H.V. Condensers 8,000 V/Wkg. Chokes Relays, etc. (New boxed 35/- each, carriage 5/-). Ex-U.S.A. Hand Driven Generators complete with all smoothing output 450 volts at 110 m/amps. also 1/2 L.T. tappings 30/- each, carriage 3/6. Ditto 162 volts at 60 m/amp., also 3 v. 2 a., 22/6 each, carriage 2/6.

MAINS TRANSFORMERS INPUT, 200/250 volts in steps of 10 volts output tapped 6, 12 and 24 volts at 25 amps., 65/- each carriage 3/6. Another 230 volts input with 3, 4 volt windings at 5 amps., 25/- each. Another 200/250 volts input output 6, 12 and 20 volts at 4/5 amps., 27/6 each, post 1/6.

MOTOR ALTERNATORS, ex-R.A.F. as new 230 v. A.C. 50 cys. 1 ph. input, Output 250 v. 625 cys. 1 ph. at 24 amps., 75/- each, Ditto 1,725 cys. output, 85/-, Please note both these machines require a 24 v. D.C. excitation.

SIGNAL GENERATOR EX-ADMIRALTY PATTERN, TYPE 4999, range 6.5 to 100 Mc/s, continuous in 3 ranges, £15 each. First grade Moving Coil Meters 2 1/2 in. scale 350-0-350 millivolts, 25/- each. Another 0 to 10 m/amps., also scaled for 100 M/a., 17/6 each, another 3 range 0 to 15 maps., 0 to 30 volts 0 to 150 volts, 25/- each.

SYNCHRONOUS MOTORS 200/250 VOLTS, 50 cys. 1 ph., convertible as Clock Movement, 12/6 each. Resistances 350 ohms to carry .25 amps. (fixed) but can easily be fitted with a slider, 8/6 each.

EX-NAVAL CATHODE RAY INDICATOR POWER UNITS (new). Sold for component parts only consisting of approx. 150 Resistances and Condensers of various values, H.V., Condensers, Chokes all mounted on solid brass chassis weight 90 lbs., to clear 35/- each, carriage forward.

EX-R.A.F. I.F.F. UNITS CONTAINING 10 VALVES, EF 50s, SP 61s, EA 50s, etc., power supply Motor generator 12 volts D.C. input 450 volts, 50 M/amps. output, and many other useful components as new, 32/6 each. Ditto with a 24 volt input Generator Valve sequence slightly different, Generator can easily be converted to run as a Motor off A.C. mains, 30/- each.

EX-R.A.F. INDICATOR UNITS (as new), type 48a containing 2 Tubes type 138a and many other useful parts, 45/- each. Another type 198 one tube only but many more valves in the Type Base, 42/6 each.

EX-R.A.F. R.F. UNITS TYPE 101. Containing 5 valves EF 50, Ea 50, 5U4g, EB34, approx. 100 assorted Resistances and Condensers also 2 1/2 volt Universal miniature Motor all mounted on silver plated chassis (new), 37/6 each.

SHORT WAVE COUPLING AERIAL UNITS (Wavemeters), absorption type wound with 20 and 12 gauge Silver plated wire, 2 1/2 to 5 1/2 meters, 3/6 each. No. 19 VARIOMETERS containing H.V. Condenser Instrument Rectifier, useful for parts, 3/6 each.

EX-NAVAL TELEPHONE HAND-SETS BAKELITE PATTERN (self-energised), no battery required, complete with wall bracket (new), 15/- per pair, post 1/6. Ditto complete with Buzzer ringing mounted in weather proof box, 24 volt required for energising Buzzer only, complete with Hand-set, 15/- each, or 25/- per pair.

EX-NAVAL NAVIGATION INSTRUMENT Containing F.H.P. 230 volt A.C./D.C. Motor, first grade 3 1/2 in. scale ohm-meter, Standard Potentiometers 2, other Resistances both variable and fixed also some very useful Gun-Metal Gears (new), 65/- each, carriage 10/-.

MAINS VARIABLE STUD SWITCHARM TYPE. Resistances 25 Studs, 50 ohms to carry 1.4 to 9 amps., 30/- each, 10 ohms. to carry 9/14 amps., 32/6 each, many other types in stock, please forward your enquiries.

MAINS TRANSFORMERS, Auto type input 200/250 volts 50 cys. 1 ph. Output tapped 14 and 17 1/2 volts at 30 amps., 55/-, Ditto with 2 tappings of 4 volts at 20 amps., 25/- each, carriage 2/6. Another double wound 110 volts to 230 volts or vice versa at 4,000 watts, £10 each, carriage paid.

EX-NAVAL ROTARY CONVERTERS, AS NEW, 110 volts input, 230 volts 50 cys. 1 ph. output at 500 watts, £9 each, carriage paid, Ditto 230 volts input output as above, £12/10/0 each, carriage paid, weight approx. 100 lb.

EX-GOVT. AS NEW, SPENCER TURBO COMPRESSORS complete with an A.C./D.C. Motor 230 volts at 10 amps. (2 h.p.), 10,000 r.p.m. continuous rating, makers Black and Decker, a few only to clear, £12/10/0 each, carriage 10/-.

SWITCH-BOARD A.C. VOLTMETERS (Well known makers), new 6in. scale 0 to 105 volts, external resistance can easily be fitted for higher range, 25/- each, post 1/6, other Meters also in stock, please forward your requirements.

Please note we have just purchased a large parcel of A.C. Electric Motors F.H.P. up to 1/2 h.p., also ELECTRIC PUMPS, ELECTRIC FANS, all prices very competitive, we will be pleased to quote.

PITMAN Radio Books

Radio Upkeep and Repairs

By Alfred T. Witts, A.M.I.E.E. A practical handbook on the location and correction of faults, invaluable for potential service engineers and keen amateurs. Sixth Edition 7/6 net.

Radio Service Test Gear

By W. H. Cazaly. A useful introduction to this subject, and a helpful manual for those interested in constructing their own gear. Illustrated 6/- net.

Radio Receiver Servicing and Maintenance

By E. J. G. Lewis. Gives reliable technical information for radio dealers and service engineers, and includes a handy fault-finding summary. Fourth Edition. 8/6 net.

Pitman

Parker St., Kingsway, London, W.C.2

AMC TELEVISION

Manufactured to "Electronic Engineering" Televisor Specification.

NEW Improved LINE OUTPUT TRANSFORMERS

NEW Improved SET OF GANTRIES COMPLETE

NEW Improved FOCUS COILS

All Steel CADMIUM PLATED POWER AND TIME BASE CHASSIS valve-holders, 3 point and single socket and all necessary cut-outs.

SOUND PANEL CHASSIS ASSEMBLY, fitted with screens, valve-holders, formers and dust covers.

VISION PANEL CHASSIS ASSEMBLY, fitted with screens, valve-holders, formers and dust covers.

9" C.R. TUBE SUPPORT for mounting on top of Gantry Assembly

9" CREAM MASKS.

5, SHAKESPEARE RD., FINCHLEY N.3

Phone: FINchley 2182

TELEVISION! The leading Midland depot for all your requirements. Complete kits of parts to "W.W.", "Inexpensive" and "E.E.", etc., and all other popular receivers. All goods post free to any address in Great Britain. We specialise in all high-grade ex-Service equipment and invite your enquiries. Send s.a.e. today for our latest lists.

SPECIAL! A limited number of television aerial masts, 11ft long in two sections, approx. 2in dia. The ideal chimney mast for your di-pole, 12/6 complete; 22ft mast in four sections, 20/- complete; 15ft wooden poles, 5/- minimum order of 4; co-axial cable complete with Pye plugs each end, 72, 80 or 100 ohms, all lengths supplied at 3d per foot, plus 1/- for end fittings; brand new, boxed, 3/4in speakers, 9/6; mains transformers, new, 22/6.

WALTON'S WIRELESS STORES, 203, Staveley Rd., Wolverhampton and Calles only; Walton's Wireless Stores, 48, Stafford St., Wolverhampton.

DOUBLE spaced split stator var. tx condensers individually and accurately calibrated in two ranges, 300 P.F. and 37 P.F., 1 P.F. equals 1in scale, ideal as condenser standard, only 6/9; Selenium rectifiers, 1/10; 40mA, 1/10; 24V, 1a, 12v 2a, 3/6; 1mA meters, 2in, 4/9; Sprague condensers, 1 .01, .02, 3/- doz; droppers, 2a or 3a, 3/9; V.R.91, guaranteed, 4/9; 5V6, 5/9; any B.V.A. valve at list; all above post free over 10/-, 1/- under.—Hatfield Radio, 78, Stroud Green Rd., N.4. [3728]

TELEVISION: Polystyrene and Paxolin formers are now available for the Wireless World superhet receiver, immediate delivery, this is the finest long distance receiver yet designed and is unsurpassed for definition; also all other components available ex-stock; comprehensive stocks of Eddystone, Raymatt and Denco components, complete set of parts for the Williamson amplifier 11gns (less valves); s.a.e. lists.—L. F. Hanney, 77, Lower Bristol Rd., Bath. [3758]

RADIO receiver kits; nothing omitted to make it a first-class two-wave domestic receiver in a smart brown bakelite cabinet, unit price only, £4/19/6; circuit and instructions included, or if required separately, 1/-; 2 1/2in Phillips speakers at 9/6; 12in P.M. speakers 39/6; 16 16mfd 450v dc at 3/6; 8mfd 500v dc at 2/6; all wave coil packs 45kc/s I.F., only 5 leads to connect, 27/6; television lenses 9in and 10in at 50/-; 6in at 25/-.

DUKE & Co., 219, Ilford Lane, Ilford, Essex. **A STOUNDING** offer in bargain parcels; each parcel is guaranteed to contain the following items: condensers and resistances in various sizes, switches, toggle and Denco components, transformer, microphone, morse key potentiometers, bulbs and holders sinterflex, a 24v a.c. motor and a miniature moving coil speaker; the whole parcel sent post free for £1; send cash with order to Bensham Radio, Dept. W/272, Romford Rd., Forest Gate, London, E.7. Send 1d stamp for list of other bargains. [3439]

TELEBOOSTER for long range T.V. Birmingham or London, R.F.2L, 40-48 mc/s, variable tuned, input slug tuned output, 2 VR91 valves, 3 tuned stages, co axial linked, H.T. and L.T. from receiver chassis, £3/12/6; R.F.1B, as above, 1 VR91 valve, 2 tuned stages, £2/12/6; R.F.2B, 55-65 mc/s, R.F.1B, for Birmingham specifications and price above, please state type required; power units for boosters, £4; s.a.e. for wallet.—Boscombe Radio, 595, Christchurch Rd., Boscombe, Bournemouth. Tel. Boscombe 1704.

I.F. filter, band pass, 485-515kc/s, frees this I band from interference, with circuit, new, boxed at 5/-; amplifier chassis black crackle finish with base plate, drilled for 5 valves, 16 7x2 1/4in at 5/-; television set, scanning unit, 16 7x2 1/4in trans. (4 000v), 2 mains trans., 2 chokes, circuit, at £6/10; set of E. television coils, London or B'ham, at 15/-; cabinets, height 19in x 16in x 10in, at 17/6; L.T. mains trans., out, 6.3v 1.5amp, at 7/6; 4v 3amp 10 -; full lists 1d from O. Greenick, Ltd., 265, Whitechapel Rd., E.1, Tel. Bis. 5079.

48/6 only for the famous Model 30 tuning unit, consisting of 3-waveband Model 30 superhet coil pack, pair I.F. transformers, 2-gang condenser and attractive dial (8in x 6in); each component individually selected pre-aligned, sealed and the whole matched together as a unit; the superhet you build with this unit needs no further adjustment! Full details of this and our other high quality products (coils, I.F.T.s, mains transformers, etc.), together with many circuits and constructional tips, contained in the "Home Constructor Handbook," price 1/-. Mail order office.

SIPACOILS, 98, Greenway Ave., London, E.17. **CONTROL A.N.B.3**, brand new, contains 4-bank wafers switch, 50 1/4 watt resistances, 4 relays, 1 D.P.D.T. toggle switch, 4 0.5mfd 400 volt and 3 other condensers, 2 M.B.C. lamp holders one with amber glass and dimming device, 2 M.B.C. Mazda bulbs, 12-16 volt, 4 vitreous res., 2 var. wirewound preset res., 2 gas-filled tetrodes with octal holders in case, 15/-; control B.3A, contains one each 145mfd, 100mfd, 23mfd, 1.000mfd, all 25v working, one 132mfd 30 volt, 1 selenium rectifier, 4 relays, panel mounting L/H with dimmer and 6-8v M.B.C. lamp, D.P.D.T. toggle switch, resistances, knobs, etc., 9/-; 12 and 24 volt telephone lamps, 4/6 dozen; panel mounting warning lamp holders, M.E.S., V.C.R. 97 tube holders 1/6; Crabtree 2-pin 2amp surface sockets 8d; plugs to fit, 4d; special 50 assorted condensers, 5/-; 60 assorted resistors, 6/-; no lists.—Passingham (Dept. W.W.), North St., Kewley. [3766]

SOLONS FOR YOUR SOLDERING JOBS!

Types available—65 watt oval

tapered bit,
65 watt round
pencil bit,
125 watt oval
tapered bit,
125 watt round
pencil bit,
240 watt oval
tapered bit.



These five models will satisfy practically every soldering demand whether for the occasional home/hobby job or continuous soldering under workshop or factory conditions. With the Solon the heat is in the bit itself... continuously... hour after hour; all connections housed at end of handle away from heat. Each model complete with 6 feet Henley 3-core flexible. Now available from stock. Write for folder Y.10.

W. T. HENLEY'S TELEGRAPH WORKS CO. LTD.
51-53 Hatton Garden, London, E.C.1

ALLEN COMPONENTS LTD.

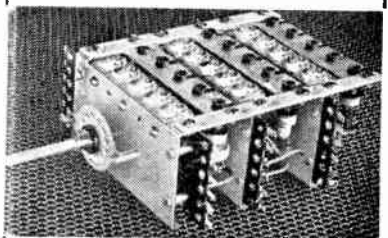

Type 320 5-wave band coil unit.

A comprehensive Pre-aligned assembly consisting of switch, complete set of aerial, H.F. and oscillator coils and all associated trimming and padding condensers for 5-wave band operation with tuned H.F. stage on all bands. All coils have dust iron cores for inductance adjustment. A six position switch is used with provision for pick up connections and H.F. muting on the sixth position. For use with any of the standard frequency changer valves (6KB, ECH35 etc.) and an I.F. frequency of 465 Kc.

Ranges: 1, 13—40. 2, 30—100. 3, 80—200. 4, 200—550. 5, 900—2000 metres.

Send for latest catalogue of our full range of components for Radio and Television.

ALLEN COMPONENTS LTD.
Tower Road, Willesden, N.W.10

Telephone Willesden 3675

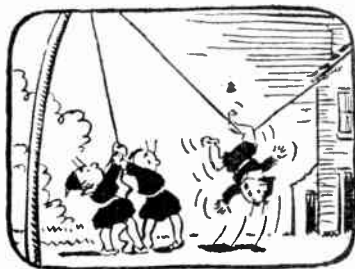

THE "FLUXITE QUINS" AT WORK

"Come on m'lads! On your toes!
This aerial's fixed. Up she goes!
Thank FLUXITE, old clown,
It'll never fall down".
Bawled O! "I shall! On my nose!"

See that FLUXITE is always by you—in the house—garage—workshop—wherever speedy soldering is needed. Used for over 40 years in Government works and by leading engineers and manufacturers. Of all Ironmongers—in tins, 10d., 1/6 & 3/-

TO CYCLISTS! Your wheels will NOT keep round and true unless the spokes are tied with fine wire at the crossings AND SOLDERED. This makes a much stronger wheel. It's simple—with FLUXITE—but IMPORTANT.

The FLUXITE GUN puts FLUXITE where you want it by a simple pressure. Price 2/6, or filled, 3/6



ALL MECHANICS WILL HAVE

FLUXITE
IT SIMPLIFIES ALL SOLDERING

Write for Book on the ART OF "SOFT" SOLDERING and for Leaflets on CASE HARDENING STEEL and TEMPERING TOOLS with FLUXITE. PRICE 1d. each.

FLUXITE LTD.

(Dept. W.W.), Bermondsey Street, S.E.1

A MATEUR, selling collection, including meters, components, etc., s.a.e. for lists.—Poottit, 61, Bridgewater St., Hindley, Lancs.

THE signal generator you need at a price you can afford, only £6/6.—See our advt. in Test Equipment section of this issue for full details.

HILY-MANN ELECTRONIC LABORATORIES, 67, Woodford Rd., Woodford, Essex. [3772

RAYMAX television sound unit, complete kit, using 2, EF50, EBC33, EL33. Chassis punched and main components mounted, price (less valves) £2/17/6, valves supplied at current prices; suitable power pack chassis complete with mains transformer, choke, 8-16mf. valve-holder £1/14/6; Colliaro trim, 5v. unit, magnetic PU, auto-stop, etc., £5/10 incl. p. tax; Inter. octal mounted V/H, 7/- doz; all types of components ex stock, including cabinets for TV and table radiograms; our console TV cabinet at £13/15 is worth "looking into." Good photographs of the above cabinets available at 6d (returnable); mahogany playing desks fitted with the latest well-known rim drive unit, magnetic PU, auto-stop, etc., £6/14/6. We welcome enquiries for cabinets to your own specification. Stamp for lists.—Raymax Elec. Co., Ltd., 128, Norwood Rd., London, S.E.24. [3206

BARTON'S—Aerial masts, tubular tripod mounted, total height 35 feet, being hollow these masts are ideal for rotating beams, built of resin impregnated wood which is everlasting, £3/10, carr. 10/-; chokes, L.F. 15h, 260ma, 12/6, super American potted type 17/6, swinging 4-20h, 250ma 10/6, Varley 500ma swinging, dia. winding 12/6, post L/- on any one, also many smaller chokes at bargain prices; electrolytic condensers, new stocks available (not ex-W.D.) at bargain prices in all popular sizes, e.g., 32mf 350 wcy., 1/9; electric motors, ex-Govt. 4hp, 230v, 50cy, 2/5/- carr. pd. also available in various other a.c. and d.c. voltages, your enquiry invited. P.A. amplifiers, 20watt, using P.P. 6L6s with 3 inputs and switched meter to all valves, 200-250v, 50cy £12; moving coil hand mikes, brand new, 4/6, post paid, indicator type 73 and 198, contains 159A tube 3in and 6 valves and high voltage condenser ideal for scope, 35/-, carr. 4/6; transmitter, ex-R.A.F., type 22 (1196) only needs 3 popular valves and crystal and coil to suit required band and is ready to go on the air mod. or c.w., 3/6 carr. paid.

TELEVISION 1355s at £2/10, carr 5/-, type 62 indicators at £3/7/6, carr. 10/-; also R.F. units, E.H.T. transformers, condensers, etc., complete outfit supplied; transformers, R.C.A. plate 2000-0-2000 tapped 1500v 800ma, £4, carr. paid, new crated; R.C.A. modulation transformers 1kw, O.K. for B13 and T240 or similar £2/10.

THERMADOR transformers, the finest made, all brand new, ideal for scope, 35/-, carr. 4/6; primary 6.600ohms c.t. secondary 4.500 5.000 5.500ohms, £2; plate transformer 680-680v, 225ma, 200-250v, 50cy, £2/10, fl. trans 2.5v, 10a, and 2.5v, 10a for pair 866s, 7.500v test 200/250v, 90cy, £1/5; fl. trans 10v, 10a and 10v, 6a, all c.t. 200-250v, 50cy, £1/5; fl. trans 6.3v, 6a and 8v, 6a, all c.t. 200-250v, 50cy, £1/15; chokes, by same maker 10h, 225ma, 17/6, all above Thermador transformers, 2 chokes and 2 oil filled condensers mounted on chassis and wired up with 2 valve holders, £9/10, carr 15/-; vibrator packs, 6v input, 180v 60ma output completely smoothed, 15/- send for lists of gear and components, valves, etc.

BARTONS, 41, Bedminster Dawn Rd., Bristol, 3. [3720

SELENIUM rectifiers, charger kits, D.C. units, etc., all new goods with full guarantee, not surplus; careful packing, add postage, 7d up to 12/6, 1/3 above, data supplied; selenium rectifiers, S.T.C. "Senirec" 12/15v 3amp 18/6, 4amp 25/-, 5amp 27/6, also giant finned type 12/15v 6amp 32/-, 10amp 42/6, 6v 10amp 25/-; smaller type 15v lamp 9/-, 2amp 12/6, 24v lamp 18/6, 24v 2.5amp 32/6, 24v 6amp 65/-, 36v 6amp 90/-; also latest 6/8v 4amp 15/6; many others in stock l/wave, c.t. and bridge; selenium H.T. rectifiers, 250v 60ma h/wave 7/-, 110v 60ma 7/-, 120v 30ma elim type 7/-, 250v 100ma bridge 13/6, 350-0-350v 80ma c.t. 13/-, 450v 40ma h/wave 7/-; M.B.3. instrument rectifiers 3/6; new crystal diodes 3/9; D.C. packs, supply 230v 120watts D.C. from A.C. mains, metal rect type in handsome cases, £7/0; large packs to order, heavy duty charger, 6v, 12v, 1.6 to 2amp, 55/-, ditto 12/15v 3amp, 70/-, weight 13lb, ditto 4amp 90/-; 4amp slider type £5/5, wt 22lb; auto transformers, 450watt 110v output, £2/5; 1.2kva £6/10, carr extra; charger kits, standard charger kit, S.T.C. 12/15v 3amp rectifier with 50watt tapewatt transformer and barretter lamp for 2v to 12v charger, no rheostat and ammeter required, 45/-, or with ammeter, 57/6, or with slider res and ammeter, 70/-; 12/15v 2amp rectifier with 45watt transformer and barretter lamp for 2v to 12v charger, 37/6; medium duty charger kit, 12/15v 4amp rectifier, 75watt trans, blast bulb for 6v, 12v 4amp charger, 53/6; steel case crackle finished, terminals, grommets, etc., for above kits, specially manufactured, 19/6; heavy duty charger kits, 12/15v 6amp giant finned type rectifier with 140watt transformer, slider res and ammeter for 6v, 12v charger, £5; ditto but 4amp rectifier, 75/-, ditto but 2amp rect, £4/7, wt 17lb; one to 20 cell lamp kit for radio cells, £4/10; 2amp £6/10; Rola 8in P.M. speakers less trans, 13/6; Aerovox 2mf 1,000v oil filled cond, 3/6.

CHAMPION, 43, Uplands Way, London, N.21. [3786

ARMSTRONG

**Model RF103, Type 2
10-VALVE ALL-WAVE CHASSIS**

WITH VARIABLE SELECTIVITY

- High Performance ●
- Outstanding Selectivity ●

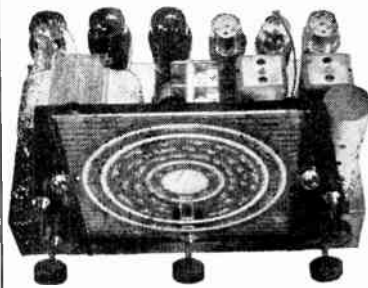

The ever-increasing difficulty in separating stations after dark is apparent to all. Our redesigned Model largely removes this serious obstacle to good listening. The two stages of I.F. amplification with variable selectivity permits of a maximum selectivity better than 6 K.c.s. On the short wavebands the actual sensitivity is 8 micro volts. It will be appreciated that this chassis has a performance of an extremely high order, and coupled with the 10 watt output makes, in our opinion, one of the most desirable musical instruments offered to the public. For 200-250v. A.C. mains. Price 19 Gns. Plus Tax.

SPECIAL NOTICE

MODELS EXP 83 and UNI 83. These chassis are being completely redesigned for the coming season and additional refinements incorporated. Advance information will be available shortly.

Model EXP83. 8-VALVE ALL-WAVE RADIO CHASSIS incorporating waveband expansion. Large glass scale. Treble boost control. High quality push-pull output gives 10 watts audio. For 200-250 v. A.C. mains. Price £15. 18. 8. Plus Tax.

Model UNI-83. 8-VALVE ALL-WAVE RADIO CHASSIS incorporating waveband expansion, e.g. the 16-50 m. band covers just over 20 inches on the large glass scale, treble boost control, high quality push-pull output giving 6 watts audio. For 200-250v. D.C. or A.C. mains. Price £15.8.8. Plus Tax.

Model EXP125. 14-VALVE ALL-WAVE RADIO CHASSIS giving continuous waveband coverage from 11.9 m. upwards. Waveband expansion, R.F. Pre-amplifier. Two I.F. stages with variable selectivity. Electronic bass and treble lift controls. 15 watt push-pull output. For 200-250 v. A.C. mains.

Kindly write for illustrated Catalogue Demonstrations at our Showrooms

ARMSTRONG WIRELESS & TELEVISION CO. LTD.
WALTERS ROAD, HOLLOWAY, LONDON, N.1.
Phone: NORth 3213



EX A.M. RECEIVER UNIT TYPE 71. Contains 9 valves: 4 EF50; 1 EB32; 2 EF 39; 1 EB 30. This is a superhet unit with an RF stage and 3 IF stages. Overall dimensions: 10 1/2 in. wide, 7 1/2 in. deep, 5 1/2 in. high. IDEAL FOR CONVERSION TO AN ORDINARY RECEIVER. The breaking up value is well over 25.
LASKY'S PRICE 25/-. Carriage 3/6 extra.

1132A RECEIVERS. V.H.F., 100/124 Mc/s receiver. These receivers are absolutely brand new in maker's original wood transit case, complete with 11 brand new valves, circuit diagrams and calibration chart. Large tuning scale with super slow motion drive, 0-5 m/a., moving coil tuning meter. R.F. and L.F. gain controls, jack sockets for line and phone. Valve line up: R.F. amplifier VR65; local oscillator VR66; three I.F. stages VR53's; 2nd detector and AVC, VR54; L.F. amplifiers VR57 and GJ5; B.F.O., VR53; voltage stabiliser VR70. Totally enclosed in metal cabinet, grey enamelled with all controls clearly marked. Plated handles. Size: 18 in. wide, 10 1/2 in. high, 1 1/2 in. deep. Weight 54 lbs.
LASKY'S PRICE 99/6. Carriage 10/- extra. Solved models of the 1132A receiver. Price 69/6. Carriage as above.

BRAND NEW AND UNUSED IN MAKER'S ORIGINAL CARTONS. EX R.A.F. UNITS TYPE W.P.G.34. Containing 13 brand new valves: 7 SP61; 2 EB34; 3 VR56; 1 VR65. Hundreds of components, resistances, condensers, 2 relays, pot./meters, pyc plugs, etc. Built on strong chassis, size 11 1/2 in. wide, 10 in. long, 3 in. high. Totally enclosed in metal case, size: 11 1/2 in. wide, 10 in. long, 7 1/2 in. high. Weight when packed 35 lbs.
LASKY'S PRICE 25/-. Carriage 4/6 extra.

RADAR RECEIVER TYPE 3084A. BRAND NEW AND UNUSED IN MAKER'S WOOD TRANSIT CASE. Specifications: 14 brand new valves, 7 EF50; 2 VR136; 1 VR137; 1 EA50; 1 VR12; 1 R3; 1 volt A/C motor used for aerial switching, front panel tuning control, etc. With little modification this will make an excellent 2 meter receiver. Also suitable for television conversion. Totally enclosed in metal case, size: 19 in. x 8 1/2 in. x 7 1/2 in. Weight when packed 40 lbs. We will exchange the 2 VR136's for EF50's if so required.
LASKY'S PRICE 75/-.

INDICATOR UNIT TYPE 62. Contains 20 valves and a 6 in. cathode ray tube type VCR147 (short persistence). Valve line up: 16 SP61; 2 EA50; 2 EB34. Dozens of other components, resistances, condensers, coils, crystal, 16 pot./meters, etc. Totally enclosed in metal cabinet, size: 18 in. x 8 1/2 in. x 1 1/2 in. Weight 40 lbs. Enamelled black with coloured control knobs.
LASKY'S PRICE 59/6. Carriage 7/6 extra.

BRAND NEW AND UNUSED EX GOVERNMENT CATHODE RAY TUBES. TYPE VCR97 8 in. SHORT PERSISTENCE. Each tube is fully guaranteed and is tested before despatch. Contained in specially sprung wood transit case. Characteristics: Heater 4 volts 1 amp., H.T., 2,500 volts maximum.
LASKY'S PRICE 35/-. Carriage 7/6 extra.

E.H.T. TRANSFORMER FOR THE VCR 97 Cathode Ray Tube. Specifications, primary 200-250 volts, 30 c.p.s., secondary 2500 volts, 4 m.a.; 4 volts, 1-1 amp.; 4 volts (C.T.) 15 amps.
LASKY'S PRICE 37/6. Post 1/6 extra.

EX GOVERNMENT CATHODE RAY TUBE TYPE VCR139A. 3 1/2. Medium persistence. Requires 4 v. on the filament and 800 to 1,500 v. on the final anodes.
LASKY'S PRICE 35/-. Post 3/6 extra.
A 2 1/2 stamp and your name and address (block capital please) will bring you our monthly Bulletin of Ex-Government bargains by return mail. Our keen prices will save you money.

LASKY'S RADIO

370 HARROW RD., PADDINGTON, LONDON, W.9.
(Opp. Paddington Hospital)
Telephone: CUNNINGHAM 1979.
Hours: Mon.-Sat. 9.30 a.m. to 6 p.m. Thurs. Half-day

G. A. RYALL, "Utopia," Mayfield Rd., Herne Bay, Kent; mail order only; postage or carriage extra, c.o.d. full or special list for the trade: U.S.A. tubular metal cased wire ended 0.1m.f. 350v, 6/- doz., 350v 5/6 doz., U.S.A. tubular metal cased wire ended 0.5m.f. 350 7/6 doz.; Mansbridge 1m.f. 500v wkg. 3-2/-; Mansbridge 4m.f. 400v wkg. 2/3 each; silver mica 10 p.f. 40p.f. 200p.f. 300p.f. 400 p.f., 500p.f. 3/6 doz.; mica 0.01m.f. 3-3/-; 11 condensers guaranteed. Amphenol type British 5-pin chassis valve holders, 3/6 doz.; international octal chassis valve holders, paxolin. 4/- doz.; bar type 3-gangs 5/-; bar type 4-gangs 5/-; resistors 1/2 watt and 1/4 watt assorted 100 ohms to 2 meg. level assortment 40-5/-; wach. CBP 6v miniature 1/6 3E, 21E 6v five poles total 2/3 each; SB. 9w 2/-, 2B SP 6w 1/6, SB. SP. 3w 1/-, 2B. 3P. 3w 2/-, SB. 2P. 4w 1/3; twelve-volt group boards with 9-1w and 1/2 watt resistances, etc., 2/- all new; twenty other types in stock; octal plugs, cap and chassis sockets, 3-3/-, with tags 3-3/6; Paxolin panel, 1/2 in. size 12x8 5/6, 12x12 7/6; meters 0-1ma. scaled 0-100, 2 1/2 in, 3 1/4 in overall 15/6 and 18/6. details on request, first class instruments; metal boxes, black finish with quarter inch paxolin panel, fixing lugs and corner sockets, size 6 1/2 x 7 1/2 x 3 1/2 deep, 5/9 each; 1,000 ohm bakelite cased volume controls medium spindle 1/6; metal cased minimum depth 1/4 meg vol., short spindle 1/6 each; special list for trade. 13485

TELRAD ELECTRONICS, 70, Church Rd., Upper Norwood, London, S.E. 19. Fixed condensers 100p to 250p, 2d ea; 250p, 2/0; 0.0005mfd to 0.001mfd, 9d ea; 7/6 doz; 0.01mfd 2.500v, 1/3 ea, 12/- doz; 25mfd 25v, 2/- ea; 4mfd, 2/6 ea; 8mfd, 3/- ea; 16mfd 4/- ea; 32mfd, 5/9 ea; all 450v; I.F. XRS, 465kc/s, 12/- pr; J.B. dials, full vision, 11/9; latest S.I.R.S. V. drive, 24/-; with spin wheel, 1000 ohm XRS, 24/- ea; complete range of Weirite components in stock; "P" coils, 3/- ea; E.E. and W.W. television components and cathode ray tubes.—Write, call or tel. Livingstone 4879. 13777

A New face and brain? No, we are not just a new face but we can offer a really attractive 3-wave 3-colour glass dial assembly, and the super-efficient Q Coilpack which has earned us so much praise from our customers. An invaluable pair for the rejuvenation of an old set or the construction of a new one. The dial is unique, fitting any position. The coilpack is 22% complete. Send for full details of these, and other radio and television components, also our latest bargain list. (Trade enquiries invited).—Osmer Radio Products, Ltd., Borough Hill, Croydon, Surrey. (Tel. Cro. 1220). 13193

SUPREME RADIO, 746b, Romford Rd., Manor Park, London, E.12. Tel. 1260. Est. 15 yrs. Radio and television component part specialists at the right price: E.H.T. 4k/v or 5k/v, 2v fl. 50/- ea; 2.5k/v E.H.T. 4v fl. tapped at 2v, 27/6 ea; line and frame scanning coils, 25/6 ea; line trans, 21/- ea, both items matched; focus coils 30/- ea; H.T. transformer, 350-0-350v, 6.5v 6 amp., 4v 8 amp., 4v 3 amp., 0-2v, 6.5v 2 amp., 250m/a with screen, 70/- ea; 5hy 250m/a choke, 15/9 ea; 10hy 80m/a choke, 7/9 ea; ceramic E.F.50 valve holders, 6d ea; retaining rings for same screw-on type, 8d ea; bakelite E.A.50 valve holders, 6d ea; co-axial cable or twin balancing feeder, screened 1-0yd, 1/- doz yds only; special offer, screened feeder, 5d yd, 4/6 doz yds only; co-axial plug and socket, 1/- complete; all parts in stock for E.E. television; 1/2 watt resistances, 100, 220, 270, 470, 820, 120p, 180, 250, 330, 470, 1k, 1.5k, 2k, 2.2k, 3k, 3.3k, 4.7k, 5.1k, 10k, 15k, 150, 500, 2K, 2.2K, 10K, 16K, 18K, 20K, 150K, 500K, 1.5M, 2/- doz, 21/- gross, or assorted; most other values at 2/6 doz, 27/- gross only; 1 watt resistances, 470, 1k, 1.5k, 3.3k, 5.1k, 10k, 15k, 50k, 100k, 150k, 200k, 250k, 300k, 350k, 400k, 450k, 500k, 550k, 600k, 650k, 700k, 750k, 800k, 850k, 900k, 950k, 1000k, 1.1M, 1.2M, 1.3M, 1.5M, 1.8M, 2M, 2.2M, 2.5M, 3M, 3.3M, 3.6M, 4M, 4.5M, 5M, 5.5M, 6M, 6.5M, 7M, 7.5M, 8M, 8.5M, 9M, 9.5M, 10M, 11M, 12M, 15M, 20M, 25M, 30M, 35M, 40M, 45M, 50M, 55M, 60M, 65M, 70M, 75M, 80M, 85M, 90M, 95M, 100M, 110M, 120M, 150M, 200M, 250M, 300M, 350M, 400M, 450M, 500M, 550M, 600M, 650M, 700M, 750M, 800M, 850M, 900M, 950M, 1000M, 1.1M, 1.2M, 1.3M, 1.5M, 1.8M, 2M, 2.2M, 2.5M, 3M, 3.3M, 3.6M, 4M, 4.5M, 5M, 5.5M, 6M, 6.5M, 7M, 7.5M, 8M, 8.5M, 9M, 9.5M, 10M, 11M, 12M, 15M, 20M, 25M, 30M, 35M, 40M, 45M, 50M, 55M, 60M, 65M, 70M, 75M, 80M, 85M, 90M, 95M, 100M, 110M, 120M, 150M, 200M, 250M, 300M, 350M, 400M, 450M, 500M, 550M, 600M, 650M, 700M, 750M, 800M, 850M, 900M, 950M, 1000M, 1.1M, 1.2M, 1.3M, 1.5M, 1.8M, 2M, 2.2M, 2.5M, 3M, 3.3M, 3.6M, 4M, 4.5M, 5M, 5.5M, 6M, 6.5M, 7M, 7.5M, 8M, 8.5M, 9M, 9.5M, 10M, 11M, 12M, 15M, 20M, 25M, 30M, 35M, 40M, 45M, 50M, 55M, 60M, 65M, 70M, 75M, 80M, 85M, 90M, 95M, 100M, 110M, 120M, 150M, 200M, 250M, 300M, 350M, 400M, 450M, 500M, 550M, 600M, 650M, 700M, 750M, 800M, 850M, 900M, 950M, 1000M, 1.1M, 1.2M, 1.3M, 1.5M, 1.8M, 2M, 2.2M, 2.5M, 3M, 3.3M, 3.6M, 4M, 4.5M, 5M, 5.5M, 6M, 6.5M, 7M, 7.5M, 8M, 8.5M, 9M, 9.5M, 10M, 11M, 12M, 15M, 20M, 25M, 30M, 35M, 40M, 45M, 50M, 55M, 60M, 65M, 70M, 75M, 80M, 85M, 90M, 95M, 100M, 110M, 120M, 150M, 200M, 250M, 300M, 350M, 400M, 450M, 500M, 550M, 600M, 650M, 700M, 750M, 800M, 850M, 900M, 950M, 1000M, 1.1M, 1.2M, 1.3M, 1.5M, 1.8M, 2M, 2.2M, 2.5M, 3M, 3.3M, 3.6M, 4M, 4.5M, 5M, 5.5M, 6M, 6.5M, 7M, 7.5M, 8M, 8.5M, 9M, 9.5M, 10M, 11M, 12M, 15M, 20M, 25M, 30M, 35M, 40M, 45M, 50M, 55M, 60M, 65M, 70M, 75M, 80M, 85M, 90M, 95M, 100M, 110M, 120M, 150M, 200M, 250M, 300M, 350M, 400M, 450M, 500M, 550M, 600M, 650M, 700M, 750M, 800M, 850M, 900M, 950M, 1000M, 1.1M, 1.2M, 1.3M, 1.5M, 1.8M, 2M, 2.2M, 2.5M, 3M, 3.3M, 3.6M, 4M, 4.5M, 5M, 5.5M, 6M, 6.5M, 7M, 7.5M, 8M, 8.5M, 9M, 9.5M, 10M, 11M, 12M, 15M, 20M, 25M, 30M, 35M, 40M, 45M, 50M, 55M, 60M, 65M, 70M, 75M, 80M, 85M, 90M, 95M, 100M, 110M, 120M, 150M, 200M, 250M, 300M, 350M, 400M, 450M, 500M, 550M, 600M, 650M, 700M, 750M, 800M, 850M, 900M, 950M, 1000M, 1.1M, 1.2M, 1.3M, 1.5M, 1.8M, 2M, 2.2M, 2.5M, 3M, 3.3M, 3.6M, 4M, 4.5M, 5M, 5.5M, 6M, 6.5M, 7M, 7.5M, 8M, 8.5M, 9M, 9.5M, 10M, 11M, 12M, 15M, 20M, 25M, 30M, 35M, 40M, 45M, 50M, 55M, 60M, 65M, 70M, 75M, 80M, 85M, 90M, 95M, 100M, 110M, 120M, 150M, 200M, 250M, 300M, 350M, 400M, 450M, 500M, 550M, 600M, 650M, 700M, 750M, 800M, 850M, 900M, 950M, 1000M, 1.1M, 1.2M, 1.3M, 1.5M, 1.8M, 2M, 2.2M, 2.5M, 3M, 3.3M, 3.6M, 4M, 4.5M, 5M, 5.5M, 6M, 6.5M, 7M, 7.5M, 8M, 8.5M, 9M, 9.5M, 10M, 11M, 12M, 15M, 20M, 25M, 30M, 35M, 40M, 45M, 50M, 55M, 60M, 65M, 70M, 75M, 80M, 85M, 90M, 95M, 100M, 110M, 120M, 150M, 200M, 250M, 300M, 350M, 400M, 450M, 500M, 550M, 600M, 650M, 700M, 750M, 800M, 850M, 900M, 950M, 1000M, 1.1M, 1.2M, 1.3M, 1.5M, 1.8M, 2M, 2.2M, 2.5M, 3M, 3.3M, 3.6M, 4M, 4.5M, 5M, 5.5M, 6M, 6.5M, 7M, 7.5M, 8M, 8.5M, 9M, 9.5M, 10M, 11M, 12M, 15M, 20M, 25M, 30M, 35M, 40M, 45M, 50M, 55M, 60M, 65M, 70M, 75M, 80M, 85M, 90M, 95M, 100M, 110M, 120M, 150M, 200M, 250M, 300M, 350M, 400M, 450M, 500M, 550M, 600M, 650M, 700M, 750M, 800M, 850M, 900M, 950M, 1000M, 1.1M, 1.2M, 1.3M, 1.5M, 1.8M, 2M, 2.2M, 2.5M, 3M, 3.3M, 3.6M, 4M, 4.5M, 5M, 5.5M, 6M, 6.5M, 7M, 7.5M, 8M, 8.5M, 9M, 9.5M, 10M, 11M, 12M, 15M, 20M, 25M, 30M, 35M, 40M, 45M, 50M, 55M, 60M, 65M, 70M, 75M, 80M, 85M, 90M, 95M, 100M, 110M, 120M, 150M, 200M, 250M, 300M, 350M, 400M, 450M, 500M, 550M, 600M, 650M, 700M, 750M, 800M, 850M, 900M, 950M, 1000M, 1.1M, 1.2M, 1.3M, 1.5M, 1.8M, 2M, 2.2M, 2.5M, 3M, 3.3M, 3.6M, 4M, 4.5M, 5M, 5.5M, 6M, 6.5M, 7M, 7.5M, 8M, 8.5M, 9M, 9.5M, 10M, 11M, 12M, 15M, 20M, 25M, 30M, 35M, 40M, 45M, 50M, 55M, 60M, 65M, 70M, 75M, 80M, 85M, 90M, 95M, 100M, 110M, 120M, 150M, 200M, 250M, 300M, 350M, 400M, 450M, 500M, 550M, 600M, 650M, 700M, 750M, 800M, 850M, 900M, 950M, 1000M, 1.1M, 1.2M, 1.3M, 1.5M, 1.8M, 2M, 2.2M, 2.5M, 3M, 3.3M, 3.6M, 4M, 4.5M, 5M, 5.5M, 6M, 6.5M, 7M, 7.5M, 8M, 8.5M, 9M, 9.5M, 10M, 11M, 12M, 15M, 20M, 25M, 30M, 35M, 40M, 45M, 50M, 55M, 60M, 65M, 70M, 75M, 80M, 85M, 90M, 95M, 100M, 110M, 120M, 150M, 200M, 250M, 300M, 350M, 400M, 450M, 500M, 550M, 600M, 650M, 700M, 750M, 800M, 850M, 900M, 950M, 1000M, 1.1M, 1.2M, 1.3M, 1.5M, 1.8M, 2M, 2.2M, 2.5M, 3M, 3.3M, 3.6M, 4M, 4.5M, 5M, 5.5M, 6M, 6.5M, 7M, 7.5M, 8M, 8.5M, 9M, 9.5M, 10M, 11M, 12M, 15M, 20M, 25M, 30M, 35M, 40M, 45M, 50M, 55M, 60M, 65M, 70M, 75M, 80M, 85M, 90M, 95M, 100M, 110M, 120M, 150M, 200M, 250M, 300M, 350M, 400M, 450M, 500M, 550M, 600M, 650M, 700M, 750M, 800M, 850M, 900M, 950M, 1000M, 1.1M, 1.2M, 1.3M, 1.5M, 1.8M, 2M, 2.2M, 2.5M, 3M, 3.3M, 3.6M, 4M, 4.5M, 5M, 5.5M, 6M, 6.5M, 7M, 7.5M, 8M, 8.5M, 9M, 9.5M, 10M, 11M, 12M, 15M, 20M, 25M, 30M, 35M, 40M, 45M, 50M, 55M, 60M, 65M, 70M, 75M, 80M, 85M, 90M, 95M, 100M, 110M, 120M, 150M, 200M, 250M, 300M, 350M, 400M, 450M, 500M, 550M, 600M, 650M, 700M, 750M, 800M, 850M, 900M, 950M, 1000M, 1.1M, 1.2M, 1.3M, 1.5M, 1.8M, 2M, 2.2M, 2.5M, 3M, 3.3M, 3.6M, 4M, 4.5M, 5M, 5.5M, 6M, 6.5M, 7M, 7.5M, 8M, 8.5M, 9M, 9.5M, 10M, 11M, 12M, 15M, 20M, 25M, 30M, 35M, 40M, 45M, 50M, 55M, 60M, 65M, 70M, 75M, 80M, 85M, 90M, 95M, 100M, 110M, 120M, 150M, 200M, 250M, 300M, 350M, 400M, 450M, 500M, 550M, 600M, 650M, 700M, 750M, 800M, 850M, 900M, 950M, 1000M, 1.1M, 1.2M, 1.3M, 1.5M, 1.8M, 2M, 2.2M, 2.5M, 3M, 3.3M, 3.6M, 4M, 4.5M, 5M, 5.5M, 6M, 6.5M, 7M, 7.5M, 8M, 8.5M, 9M, 9.5M, 10M, 11M, 12M, 15M, 20M, 25M, 30M, 35M, 40M, 45M, 50M, 55M, 60M, 65M, 70M, 75M, 80M, 85M, 90M, 95M, 100M, 110M, 120M, 150M, 200M, 250M, 300M, 350M, 400M, 450M, 500M, 550M, 600M, 650M, 700M, 750M, 800M, 850M, 900M, 950M, 1000M, 1.1M, 1.2M, 1.3M, 1.5M, 1.8M, 2M, 2.2M, 2.5M, 3M, 3.3M, 3.6M, 4M, 4.5M, 5M, 5.5M, 6M, 6.5M, 7M, 7.5M, 8M, 8.5M, 9M, 9.5M, 10M, 11M, 12M, 15M, 20M, 25M, 30M, 35M, 40M, 45M, 50M, 55M, 60M, 65M, 70M, 75M, 80M, 85M, 90M, 95M, 100M, 110M, 120M, 150M, 200M, 250M, 300M, 350M, 400M, 450M, 500M, 550M, 600M, 650M, 700M, 750M, 800M, 850M, 900M, 950M, 1000M, 1.1M, 1.2M, 1.3M, 1.5M, 1.8M, 2M, 2.2M, 2.5M, 3M, 3.3M, 3.6M, 4M, 4.5M, 5M, 5.5M, 6M, 6.5M, 7M, 7.5M, 8M, 8.5M, 9M, 9.5M, 10M, 11M, 12M, 15M, 20M, 25M, 30M, 35M, 40M, 45M, 50M, 55M, 60M, 65M, 70M, 75M, 80M, 85M, 90M, 95M, 100M, 110M, 120M, 150M, 200M, 250M, 300M, 350M, 400M, 450M, 500M, 550M, 600M, 650M, 700M, 750M, 800M, 850M, 900M, 950M, 1000M, 1.1M, 1.2M, 1.3M, 1.5M, 1.8M, 2M, 2.2M, 2.5M, 3M, 3.3M, 3.6M, 4M, 4.5M, 5M, 5.5M, 6M, 6.5M, 7M, 7.5M, 8M, 8.5M, 9M, 9.5M, 10M, 11M, 12M, 15M, 20M, 25M, 30M, 35M, 40M, 45M, 50M, 55M, 60M, 65M, 70M, 75M, 80M, 85M, 90M, 95M, 100M, 110M, 120M, 150M, 200M, 250M, 300M, 350M, 400M, 450M, 500M, 550M, 600M, 650M, 700M, 750M, 800M, 850M, 900M, 950M, 1000M, 1.1M, 1.2M, 1.3M, 1.5M, 1.8M, 2M, 2.2M, 2.5M, 3M, 3.3M, 3.6M, 4M, 4.5M, 5M, 5.5M, 6M, 6.5M, 7M, 7.5M, 8M, 8.5M, 9M, 9.5M, 10M, 11M, 12M, 15M, 20M, 25M, 30M, 35M, 40M, 45M, 50M, 55M, 60M, 65M, 70M, 75M, 80M, 85M, 90M, 95M, 100M, 110M, 120M, 150M, 200M, 250M, 300M, 350M, 400M, 450M, 500M, 550M, 600M, 650M, 700M, 750M, 800M, 850M, 900M, 950M, 1000M, 1.1M, 1.2M, 1.3M, 1.5M, 1.8M, 2M, 2.2M, 2.5M, 3M, 3.3M, 3.6M, 4M, 4.5M, 5M, 5.5M, 6M, 6.5M, 7M, 7.5M, 8M, 8.5M, 9M, 9.5M, 10M, 11M, 12M, 15M, 20M, 25M, 30M, 35M, 40M, 45M, 50M, 55M, 60M, 65M, 70M, 75M, 80M, 85M, 90M, 95M, 100M, 110M, 120M, 150M, 200M, 250M, 300M, 350M, 400M, 450M, 500M, 550M, 600M, 650M, 700M, 750M, 800M, 850M, 900M, 950M, 1000M, 1.1M, 1.2M, 1.3M, 1.5M, 1.8M, 2M, 2.2M, 2.5M, 3M, 3.3M, 3.6M, 4M, 4.5M, 5M, 5.5M, 6M, 6.5M, 7M, 7.5M, 8M, 8.5M, 9M, 9.5M, 10M, 11M, 12M, 15M, 20M, 25M, 30M, 35M, 40M, 45M, 50M, 55M, 60M, 65M, 70M, 75M, 80M, 85M, 90M, 95M, 100M, 110M, 120M, 150M, 200M, 250M, 300M, 350M, 400M, 450M, 500M, 550M, 600M, 650M, 700M, 750M, 800M, 850M, 900M, 950M, 1000M, 1.1M, 1.2M, 1.3M, 1.5M, 1.8M, 2M, 2.2M, 2.5M, 3M, 3.3M, 3.6M, 4M, 4.5M, 5M, 5.5M, 6M, 6.5M, 7M, 7.5M, 8M, 8.5M, 9M, 9.5M, 10M, 11M, 12M, 15M, 20M, 25M, 30M, 35M, 40M, 45M, 50M, 55M, 60M, 65M, 70M, 75M, 80M, 85M, 90M, 95M, 100M, 110M, 120M, 150M, 200M, 250M, 300M, 350M, 400M, 450M, 500M, 550M, 600M, 650M, 700M, 750M, 800M, 850M, 900M, 950M, 1000M, 1.1M, 1.2M, 1.3M, 1.5M, 1.8M, 2M, 2.2M, 2.5M, 3M, 3.3M, 3.6M, 4M, 4.5M, 5M, 5.5M, 6M, 6.5M, 7M, 7.5M, 8M, 8.5M, 9M, 9.5M, 10M, 11M, 12M, 15M, 20M, 25M, 30M, 35M, 40M, 45M, 50M, 55M, 60M, 65M, 70M, 75M, 80M, 85M, 90M, 95M, 100M, 110M, 120M, 150M, 200M, 250M, 300M, 350M, 400M, 450M, 500M, 550M, 600M, 650M, 700M, 750M, 800M, 850M, 900M, 950M, 1000M, 1.1M, 1.2M, 1.3M, 1.5M, 1.8M, 2M, 2.2M, 2.5M, 3M, 3.3M, 3.6M, 4M, 4.5M, 5M, 5.5M, 6M, 6.5M, 7M, 7.5M, 8M, 8.5M, 9M, 9.5M, 10M, 11M, 12M,

A.W.F. FOR YOUR NEXT LOUDSPEAKER REPAIR AND TRANSFORMER REWINDS

Radio Dealers and Service Engineers
(R.T.R.A. Definition) are invited to
Send 1d. stamp for the
current "Monthly Bulletin"
which gives full details.

A.W.F. RADIO PRODUCTS LTD.
(Dpt. W)
Borough Mills, Bradford, Yorks.

PREMIER RADIO Co. offers the following surplus material, all guaranteed perfect; chokes, 500ma, 50ohms, 15 henries, 25/-; 2v 16amp accumulators, 7/6; type 1355 units, used, 30/-; plus 10/- packing and carriage, new, 45/-; units type 24 for same, used, 12/6; supersensitive balanced armature double headphones, low resistance, 3/6; mains transformers 200/250v input, 300v 60ma (half wave), 6.3v 1a, 10v 1a output, 10/-; accumulator charger kits, consist of mains transformer and suitable metal rectifier to charge 2 or 6v accumulator at 1a, 22/6; for 12v accumulator, 27/6; vibrators, 12v 4-pin non sync., 5/-; transformers for same 300v 60ma, 7/6; converters, input 24v d.c., output 230v 50c 100w, £5; microphones, carbon, hand type, switch in handle, 2/11; transformer for same, 2/6; cab tyre cable twin 14/36, 6/- per dozen yards, or 42/6 per 100-yard coil; twin flex, 14 36, 5/- per dozen yards, 32/6 per 100-yard coil; aerials, aluminium, 7 section, total length, 5ft 6in, make excellent dipole, 3/11; resistors, high stability plus minus 2%, 1K, 10K, 100K, 1m Ω , 2mf, 600v; 1/9; 4mf 100v; 7/6; 1mf, 1,500v; 2/6; Weston 50 microamp meters, 2-in scale (undivided), 37/6; output transformers, push-pull PX4s to 3 and 15ohms, 17/6; push-pull 6V6s to 3 or 15ohms, 17/6; Circle cutters, used with ordinary hand brace, cuts circles $\frac{3}{16}$ in to $\frac{3}{4}$ in in aluminium or steel up to 16g; enamelled copper aerial wire 7/25, 50ft, 2/-; 100ft 4/-, 1,200ft 30/-; EMI, $\frac{3}{16}$ in CR tubes with holder and data, 17/6; VCR138 CR tubes with holder and data, 19/6; VCR97 CR tubes with holder, 35/-; 2-gang, 0005 condensers with trimmers, 5/-; midge variable condensers, all capacities, from 7 to 160pf, 1/6 each; Westinghouse J50 e.h.t. rectifiers, 4,500c, 3/6 each, 6 for 17/6; Belling 7- and 10-way plugs with sockets, 2/6 each; standard P.O. plugs and jacks, 1/- either; silver-plated coax. plugs and sockets, 2/6 pr; TRF coils, Litz wound, medium and long, 6/- pr; superhet ditto, 16-50 and 200-550 meters, 10/- set of 4.

LOUDSPEAKERS, by famous makers, brand new in makers' cartons, 5in 10/-, 6 $\frac{1}{2}$ in 16/6, 8in 17/6, 10in 23/6; transformers 2/11 each extra; 2-gang condensers, 0005mf, ceramic insulation, 4/9 each; carbon potentiometers, all values from 5K to 2 meg, long spindles, 2/9 each, with switch 4/6; aluminium chassis, 16 s.w.g., substantial, made of bright aluminium with 4 sides, 7in x 3 $\frac{1}{2}$ in x 2in 3/3, 9 $\frac{1}{2}$ in x 4 $\frac{1}{2}$ in x 2in 4/-, 10in x 8in x 2 $\frac{1}{2}$ in 5/6, 12in x 9in x 2 $\frac{1}{2}$ in 6/8, 14in x 9in x 2 $\frac{1}{2}$ in 9/11, 16in x 9in x 2 $\frac{1}{2}$ in 7/3, 20in x 8in x 2 $\frac{1}{2}$ in 10/-, 10in x 9in x 3in 6/3, 12in x 10in x 3in 6/10, 14in x 10in x 3in 7/11, 16in x 10in x 3in 8/6, 20in x 10in x 3in 10/-.

PREMIER extension speakers, a 5in P.M. speaker in an attractive bakelite case coloured cream or walnut, 6 $\frac{1}{2}$ in x 6 $\frac{1}{2}$ in x 3 $\frac{1}{2}$ in, with volume control, 30/-.

METER kit, a Ferranti 500 microamp M/C meter, with separate high stability, high accuracy, resistors to measure, 15, 60, 150 and 600 volts d.c., scale length 1 $\frac{1}{2}$ in, diameter 2 $\frac{1}{4}$ in; 10/- the complete kit.

SECTIONAL whip aerial, 7 sections which plug into each other making an aerial 14ft long, thin nest section $\frac{1}{4}$ in diam, thickest section $\frac{3}{16}$ in diam, weatherproof enamel, 3/6 each complete; insulated base for above, 2/6 each.

MULLARD MW 18-2 magnetic tubes, 7in, 2v, 5kv, max h.t. 79/6.

MASKS for VCR97 tubes; 3/6 each.

C.R. tubes, VCR97, 6in diameter, green screen, 4v 1a, heater 2,500v max h.t., complete with socket, in maker's original cartons; 35/-.

C.R. tubes, E.M.1.4/1 cathode ray tubes, 3 $\frac{1}{2}$ in diameter, green screen, short persistence, 4v 1-3a heater, 800v h.t., complete with socket; 17/6 each.

COLLARO auto changers, mixer-changer rim-drive, high fidelity, crystal pick-up, repeat reject mechanism; £14/6/8.

COLLARO a.c./d.c. gramophone motors, with turntable, but without pick-up or auto stop; £9/3/5.

COLLARO electric gramophone motor with 12in turntable, a.c. 100, 250v; a few shop soiled at 7/6.

CONRAD electric gramophone motor, 9in turntable, 200/250v, 57/6; all above motors include purchase tax.

COLLARO electric gramophone motors with pick-up and auto stop; a few shop soiled with magnetic pick-up at £6/6, or with crystal p.u. at £7/4/8.

TELEVISION magnifying lens, suit any 5in, 6in or 7in tube, increase picture size considerably; 29/6.

P.P. driver trans, split sec, super quality; 10/-.

3-WAY push button units, without knobs; 3/6.

METAL rectifiers, 230v 30mA 2/6, 260v 30mA 3/-, 300v 75mA 4/-.

MINE detector panels, include 3 1T4 valves, 12-1 midge trans, 3 ceramic valveholders, 18 condensers and resistors, etc., 20/-; without valves, 5/-.

WIRE wound resistors, 50K 200-watt 4/-, 20K

(Continued on next page.)

HOUGHTON OSBORNE TELEVISION

A complete new range of television components and units are now being produced to enable the home constructor to build a television with absolute confidence.

They have been produced as economically as possible with due regard to both quality and cost.

The range includes:—

- DEFLECTION COILS
- LINE OUTPUT TRANSFORMERS
- PRE-AMPLIFIER UNITS
- SOUND RECEIVERS
- VISION RECEIVERS
- TIME BASE UNITS

All units have been designed around the new high efficiency B7G type valves, and consequently are of small dimensions.

Details from:—

Houghton & Osborne,
Electron Works,
High Street, Thame, Oxon.

VOIGT PATENTS LTD. 15 SILVERDALE S.E.26

Town and Country
PLANNING!

P.S. Mr Voigt has not yet recovered his health



QUARTZ CRYSTAL UNITS

For—
**AIRCRAFT, MARINE AND
COMMERCIAL USE** are available in
the complete range from 35 kilo-
cycles to 15 megacycles.

Alternative mountings in standard two-pin A.M. pattern 10X, International octal, and miniature type FT243, can be supplied for most frequencies.

Prices are fully competitive, and we specialise in prompt deliveries for urgent requirements.

WE WELCOME YOUR ENQUIRIES.
THE QUARTZ CRYSTAL Co., Ltd.
63-71 Kingston Road,
NEW MALDEN, SURREY
Telephone: MALden 0334

PHOTO-ELECTRIC CELLS

for
Talking Picture Apparatus.
Catalogue now available
RADIO-ELECTRONICS LTD.,
St. George's Works, South Norwood,
London, S.E. 25.

HILL & CHURCHILL LTD.

BOOKSELLERS
SWANAGE, DORSET

Available from stock

| | |
|---|------|
| Terman—Radio Engineers' Hand-book | 42/- |
| Terman—Measurements in Radio ... | 27/- |
| Terman—Fundamentals of Radio ... | 24/- |
| Schellkunoff—Electro Magnetic Waves | 42/- |
| M.I.T.—Electronic Time Measurements | 42/- |
| Brainherd—Ultra High Frequency Tech. | 28/- |
| Starr—Electric Circuits & Wave Filters | 25/- |
| Welman—Elementary Radio Servicing—(U.S.A.) | 21/- |
| Marcus—Elements of Radio—Vol. 1, 12/6, Vol. 2 | 15/- |
| A.R.R.L.—Radio Amateur's Handbook, 1949 | 16/6 |

Postage Extra.

CATALOGUE ON APPLICATION

Pennine RADIO



AUDIO SIGNAL GENERATOR

- HIGH STABILITY
- WIDE RANGE 40-16000 C.P.S.
- LOW PRICE
- 3 WATTS OUTPUT

LIST PRICE **£9-9-0**

Write for Particulars

PENNINE AMPLIFIERS
SOUTHGATE, ELLAND, YORKS, ENG.
Tel.: Elland 2107

COPPER WIRE
ENAMELLED, SILK, D.C.C., etc., most sizes.
INSULATING MATERIALS, Empire cloth, leatheroid, paxolin, sleeving, etc.
MOTORS A.C. & D.C. up to 1 h.p. a speciality
Send S.A.E. for list to
STAN. HOLT,
349, HIGH ST. SMETHWICK, STAFFS.
Telephone: WOODGATE 3789

SUPACOILS

OFFER

The Following Selection from Their Famous Range of Components.

- Model 30 Coil Pack.**—The 3-waveband superhet pack with iron cored coils giving improved efficiency, high selectivity and sensitivity **21/-**
or 24/- fully aligned.
- Model 40 Coil Pack.**—Similar but with RF stage **42/-**
or 47/- fully aligned
- Model 30 Tuning Unit.**—Consisting of a Model 30 coil pack, pair "MM" I.F. transformers, 2-gang condenser and attractive dial. All components aligned together as a unit in an actual receiver, and sealed. **48/6**
- Model 40 Tuning Unit.**—Similar to above with provision for R.F. stage **76/9**
- 12in. Loudspeakers.**—By a famous manufacturer. 2/3 ohm speech coil—fit direct to your present receiver—no alteration needed **45/-**

FREE. A Free Copy of the enormously successful HOME CONSTRUCTOR'S HANDBOOK will be given to every purchaser. Or a copy can be obtained for 1/- from

SUPACOILS (Mail Order Office)
98, Greenway Avenue, London, E.17

H.T. transformers (new) for 6.3v vibrators, output 250-0-250v at 80m/a. 10/6 ea., one doz. lots 8/6 ea.; special terms for quantities.—Stewart Transformers Ltd., 1021, Finchley Rd., N.W.11. [3260]

WANTED, EXCHANGE, ETC
VO No. 6 winding machines wanted; details and price.—Box 6178 [3542]
FINE wires in large quantities only, must be new and perfect material.

L. E. SIMMONDS, 8a, Byron Rd., Harrow, Tel. Harrow 0515. [3661]

WANTED Taylor 70A or Avo No. 7, lowest cash price to.—Box 6908. [13952]

WANTED, late Haynes 2 H.F. tuner.—51, Bemsted Rd., Walthamstow, E.17. [3746]

WANTED—Surplus relays and push-button units, any condition, large or small quantities; highest prices payable.—Box 6180. [3532]

WANTED, neon tuning indicators for H.L.S. model 800 15-valve radiogram.—Barber, 24, Mill Rd., Haverhill. [3676]

VALVES.—Set of valves for Marconi 276 d.c. radio, DH, two VDS, DSB, DH, two DPT.—McCracken, 25, Snowdon Place, Stirling. [3736]

WE pay top prices for used test equipment, all types.—University Radio, Ltd., 22, Lisle St., London, W.C.2. Tel. Ger. 4447 and Ger. 8582. [9992]

CARRIER telephone and telegraph equipment of all types in any condition wanted; also teleprinter and teletypewriter apparatus.—Harris & Gillow, 93, Wardour St., W.1. [3036]

WANTED, all kinds of laboratory test equipment, standard signal generators, bridges, oscilloscopes, Q meters, etc.—Send details to Oak Instruments, 86, Mill Lane, London, N.W.6. Tel. Hampstead 4219. [3716]

MARINE or aircraft radar and spares, e.g., AN/AP5 series, Hi-cycle alternators, CRT indicators, magnetrons, bomb units, tubes IB22, 6J6, 3B24, 6SL7, 6AK5, 724 TR cells, 725A/B osc. junction boxes, cables, plugs, &c.—Bunch Fishing Co., Grimsby. [3621]

WE buy for cash, new, used, radio, electrical equipment, all types; especially wanted, radios, radiograms, test equipment, motors, chargers, recording gear, etc.—If you want to sell at the maximum price call, write or 'phone to University Radio, Ltd., 22, Lisle St., Leicester Sq., W.C.2. Ger. 4447. [3621]

REPAIRS AND SERVICE
Mains transformers rewound, new transformers to any specification.

MOTOR rewinds, complete overhauls; first-class workmanship, fully guaranteed.

F.M. ELECTRIC Co., Ltd., Potters Bldgs., Warser Gate, Nottingham, Est. 1917. Tel. 3855.

LOUDSPEAKERS and transformers rewound, cones replaced, prompt service.—Dodds, Radio Service, 131a, Hurst St., Oxford. [3650]

LOUDSPEAKER repairs, British, American, any make, moderate prices.—Sinclair Speakers, 12, Pembroke St., London, N.1. Terminus 4355. [3308]

Main and output transformers rewound to pattern or specification, return post service.—H. Pugh, Radio Rewind Service, Brithdir, Mr. Doigley, N. Wales. [3243]

Rewinds and conversions to mains and output transformers, from 4/6; DP equipment a speciality.—N.L. Rewinds, 4, Brecknock Rd., N.7. Tel. Arnold 321. [6283]

Mains transformers rewound or constructed to any specification; prompt delivery.—Bede Transformer Co., Ltd., Bedesway, Bede Trading Estate, Jarrow. [3198]

Aries as required; transformers, loudspeakers, etc.; prompt returns.—Raidel Services, 49, Lr. Addiscombe Rd., Croydon, Cro. 6537. [3715]

ELECTRICAL measuring instruments of every make repaired and standardised.—The Electrical Instrument Repair Service, 329, Kilburn Lane, London, W.9. Tel. Lad. 4168. [3715]

SERVICE with a smile.—Repairers of all types of British and American receivers; coil rewinds; American valves, spares, line cord.—F.R.I. Ltd., 22, Howland St., W.1. Museum 5675. [1575]

Accurate coil windings; tuning coils, I.F. coils fitted, field rewound or altered; speaker transformers, clock coils rewound; guaranteed satisfaction, prompt service; we do not rewind mains trans.—Closed Sat. [2497]

Repairs to moving coil speakers cones. coils fitted, field rewound or altered; speaker transformers, clock coils rewound; guaranteed satisfaction, prompt service; we do not rewind mains trans.—Closed Sat. [2497]

L.S. REPAIR SERVICE 49, Trinity Rd., Upper Footing London, S.W.17, Balham 2359.

24-HOUR service, 6 months guarantee, any transformer rewinding, mains outputs and I.F.s., etc.; all types of new transf., etc., supplied to specification; business heading or service card for trade prices.—Majestic Winding Co., 180, Windham Rd., Bournemouth.

Lound, vacuum impregnated, pressure tested at 2,000volts and guaranteed for three months, 48-hour service.—Enquiries London Transformer Products, Ltd., L.T.P. Works, Cobholt Estate, N.W.10. Tel. Willesden 6486.

Rewinds and repairs mains transformers, O/P trans., clock coils, field coils, Pick-ups; vacuum and gram. motors; new transformers to any specification; guaranteed work; competitive prices; delivery 2/3 days.—W. Groves Manufacturing Electrical Engineer, 154 Icknield Port Rd., B'ham, 16. [1482]

THESE ARE IN STOCK

- Radio Valve Data**—Compiled by Wireless World. 3s. 6d. Postage 3d.
- Ultrasonics.** By Benson Carlin. 30s. Postage 9d.
- International World Radio Station List.** 1s. 6d. Postage 2d.
- The Radio Amateur's Handbook.** By A.R.R.L. 15s. 6d. Postage 1s.
- Electronics in the Factory.** Edit. Professor Trewman. 20s. Postage 9d.
- Radio, Television and Electrical Repairs.** By R. C. Norris. 10s. 6d. Postage 9d.
- Wireless Servicing Manual.** By W. T. Cocking. 10s. 6d. Postage 5d.
- Radio Laboratory Handbook.** By M. G. Scroggie. 12s. 6d. Postage 5d.
- Electronic Time Measurements.** M.I.T. 42s. Postage 1s.
- Principles of Radar.** M.I.T. 33s. Postage 1s.
- Television Explained.** By W. E. Miller. 3s. 6d. Postage 2d.
- Radio Tube Vade Mecum.** 1946 Edition. P. H. Brans. 5s. Postage 6d.
- Outline of Radio.** 21s. Postage 6d.
- Reference Data for Radio Engineers.** By W. L. McPherson. 5s. Postage 5d.
- We have the finest selection of British and American radio books in the Country. Complete list on application.**

THE MODERN BOOK CO.

(Dept. W.7).

19-23, PRAED STREET, LONDON, W.2

Industrial electronic equipment developed and supplied at reasonable charges. Excellent model shop facilities.

SPENCER-WEST
QUAY WORKS, Gt. YARMOUTH.

BOROUGH POLYTECHNIC

Borough Road, S.E.1.

Full-Time Courses in Radio Engineering

Applications are now being received for admission to a full-time course beginning in September, 1949, in Radio Engineering. The course is designed so that students will spend equal periods at the Polytechnic and in industry over a total period of four years. At the end of the course they will sit the examination for the Higher National Diploma in Radio Engineering.

Students seeking admission should either have passed the School Certificate Examination with credit marks in Mathematics and Physics, or have taken the first and second years of the Ordinary National Certificate Course.

Further particulars and forms on which to apply for admission may be obtained from the Secretary.

Midland Television Constructors

You should now be getting ready for the Test Transmissions from Sutton Coldfield which are scheduled to start in July. Complete Constructional Data for building a Vision and Sound Receiver from ex-Govt. Radar Apparatus is available for only 7/6d., so send for your copy NOW. We can supply every item required, the two main Radar Units costing only £6/10/-, and if these are purchased the data is supplied gratis. Alternatively, intending constructors can buy the data first and the cost will be credited against purchase of the two units within 14 days. When ordering the units, please add 12/6d. carriage costs. Constructors should go ahead without delay as, although existing coil information is for the London Station, within a few days of the test transmissions starting, exact coil data for Birmingham will be available. For those constructors who are rather more adventurous, and have their own ideas about Vision Receiver design, we recommend the following two items as being worthy of consideration:

RADAR RECEIVER R 3084. These are BRAND NEW, and contain a 30 mcs I.F. Strip and the following valves: 2 EF54, 1 EC52, 7 EF50, 1 VU39A, 1 HVR2, and 1 EA50. A suggested method of alteration is supplied with every receiver. ONLY 75/- (carriage, etc., 10/-).

RADAR INDICATOR 62A. The cheapest method of buying EF50s and a VCR97 C.R. Tube. Besides the tube it contains 12 EF50s, 2 EB34s, 4 SP61s, and 3 EA50s. ONLY 89/6 (carriage, etc., 12/6).

Other items of interest offered this month are:

5-VALVE BATTERY SUPERHET R124A. This superb ex R.A.F. receiver covers 1.0-10.0 mcs in 3 wavebands, the circuit employing an RF stage. It has a Muirhead precision slow motion dial, aerial trimmer, sensitivity control, reaction control, etc., etc. Eminently suitable for club field days, etc., these are BRAND NEW IN MAKER'S PACKING. Voltages required are 90v. HT, 9v. GB, 2v. LT. ONLY 99/6 (carriage 7/6).

AMERICAN LORAN RECEIVER. This is a 4 band (pre set) receiver used in Radar. Contains 16 valves as follows: 1 6SN7, 1 6BL7, 1 6H6, 1 6SA7, 1 6S17, 1 5U4G, 4 6SK7, 3 68L, 2 2X2, 1 VR10S. ONLY 69/6 (carriage 7/6).

AMERICAN INDICATOR APN4. Contains CR Tube SCP1, 3 valves 6S17, 14 6SN7, 6 6H6, 1 6S17, and 100 kcs. crystal. ONLY 79/6 (carriage etc., 12/6).

INDICATOR UNIT 162B. Contains 2 CR Tubes, a 6in. VCR S17 and a 3in. VCR 139, also 3 valves SP61, 1 VR 17, 4 EA50, and a Klystron CV 67. A real snip for breakdown value, the 2 tubes being worth more than the price of 67/6 (carriage, etc., 12/6).

ADMIRALTY TRANSMITTER 7AD, PATTERN W4832. First come, first served, with this "n.p." Contains valves types 6V6G, VU 111, CV73, and 2 CV63, transformers, small components transmitting gear, etc., etc. BRAND NEW. ONLY 19/6 (carriage 5/-).

INSULATION TESTERS (MEGGERs). Ex-R.A.F. testers by "Record," reading up to 20 megohms at 500 v. pressure. BRAND NEW. Listed at: over £12. Our price is ONLY £8/10/- postage paid.

C.W.O., PLEASE.

S.A.E. for lists.

U.E.I. CORP.

THE RADIO CORNER,

138, Gray's Inn Rd., London, W.C.1
TERminus 7937

Open until 1 p.m. Saturdays, we are two mins. from High Holborn, five mins. from Kings' Cross.

RADIO MAINTENANCE SERVICE for guaranteed rewinds and repairs; armatures; F.H.P. motors vac. units, etc.; good deliveries. 139 Goldhurst Terrace, N.W.6. Mal. 6133.

"STURDY" rewinds, mains transformers, chokes, and fields, first-class work. prompt deliveries and satisfaction guaranteed.—Sturdy Electric Co. Ltd., Dipton, Newcastle-on-Tyne. [2430]

A SECOND-to-none rewind service, reliable. A neat, return of post service; your television requirements promptly executed, EHT, LHT and heater transformers; stamp for quotations.—R. E. F. 137a, Ashton Rd., Oldham. [3519]

METROPOLITAN RADIO SERVICE for rewinds, mains and e.h.t. transformers, chokes and field coils; delivery 3-5 days; new transformers designed and manufactured singly or in quantities.—Metropolitan Radio Service Company, 1021, Finchley Rd., London, N.W.11.

REWINDS.—Send your "burn outs," to be rewound; no technical data wanted; post transformer, etc., labelled with your name, address, and marked "for rewind"; our windings are double wound, interleaved and impregnated.—Southern Trade Services, Ltd., 297-299, High St., Croydon, Tel. 4870. [3110]

WORK WANTED
WE make wireless and radiogram cabinets for home and export; immediate deliveries.—Radic, Ltd., 26, Brondesbury Rd., London, N.W.6. Maiba Dale 8792, also Terminus 7447/8. [8285]

RADIO mfrs. can undertake development and assembly of radio or electronic equipment; winding shop with vacuum impregnation plant; ample space and labour available.—R. E. F. 137a, Ashton Rd., Oldham.—Box 685.

F manufactured stock lines available; also special manufacturers' components made to specifications; armatures and fields wound and motors assembled.—Avis & Barks Ltd., 140-141, Friar St., Reading, Berks. [2715]

EXPERIMENTAL and design work; for all types of radio and electronic apparatus designed or built to your specification. A.M., F.M., T.V., control and measuring instruments; write for quotation to—J. Mori, B.Sc., A.M.I.E.E., 81, RIFDEL London, W.C.1.

DRAWING and tracing work for radio and electrical engineering, jig and tool and light engineering, photoprinting; full sets of drawings undertaken to commercial or Ministry standards.—Drawing & Tracing, Ltd., 456a, Ewell Rd., Tolworth Surbiton, Elmbridge 7406.

MISCELLANEOUS
TELEVISION cabinet, large, with shelf; £15.—Box 6775. [3615]

432 service sheets; offers—A. J. Tindall, 62, Ings Rd., Walsley, [3692]

QS.L.s and I.P.O. approved log books. Q samples free.—Atkinson Bros., printers, Elland. [3082]

W.W. Jan. '47-Sept. '48, Jan.-May '49; offers? port. Mon.—W. W. Highman, 34, Denbigh Rd., Newchester. [3664]

PROCEEDINGS of the I.R.E., 1939-1948, what offers?—Ross, 58, St. John's Rd., Manchester. [3700]

SERVICE sheets for sale, approx. 800, manufacturers, "Traders," etc.; first reasonable offer secures.—Box 6779. [3626]

NEW three-second midget-gun, kit of spares. £29/6; c.w.o.—Essex Maintenance Industries, Green Dragon Yard, Brentwood. [3744]

WALNUT radiogram and television cabinets, man's samples, few only; stamp details.—Walters, 501, Hale Ed., E. [1763]

W.W. July 1929 to Nov. 1947, a few missing or defective; offers for the whole or yearly lots.—Fairley, 27, Charlbury Rd., Oxford. [3606]

TRADE transfers, gold and black, your wording, 7 days' delivery; also decorative transferring; list free.—W. W. Axon, Jersey, C.I. [2166]

WIRELESS WORLD bound volumes, 1932-1946, 23 volumes, 1947 and 1948 unbound; £15.—Livingstone, 16, Victoria Avenue, Barrow-in-Furness. [3657]

ISTRUMENT handles, chromium plated brass 4 1/4in fixing centres; 4/6 per pair, postage extra.—British Electronic Industries, 303-305, Burdett Rd., E.14. [3654]

ALUMINIUM chassis and panels, any size manufactured quickly; holes punched for valveholders, etc.; crackle and cellulose finishing.—E.A.D., 18, Brad Rd., Wokingham, Ssex. [3642]

EXPOSURE meter components, light cell 6/6; meter movement 7/10, moulded case 8/10; assembly instructions and conversion scale reproductions 3/6.—Surpluses, 78, Repton Rd., Bristol. 4. [3642]

CHASSIS, panels, racks and metal cabinets. In steel or aluminium; wrinkle finishes available.—Reound Engineering & Electrical Co., Coleshill Rd., Sutton Coldfield. [3619]

ATENTION.—Something new and original. A perfect model of television or radiogram cabinets, veneered in walnut and french polished, ideal for miniature radios or novelty speakers, fitted with the latest gold anodised metal grill, accommodation up to 5in units; price 28/6 net; refund if not delighted.—Burmans, 64, Reighton Rd., Copton, London, E.5. [3681]

THERE is still time to build a personal portable for your holiday—especially the new "Carriette" which drives a midget speaker with 3 valves on M. & L. bands; circuit, layout and point-to-point wiring plans make construction quick, easy and cheap.—For immediate delivery send 2/6 to E. W. B. Whinnie Knowe, Sennen, Cornwall. S.a.e. for testgear plans list. [3657]



RCA 931A PHOTO-ELECTRIC CELL AND MULTIPLIER. For facsimile transmission, flying spot (cyclic) transmission and research involving low light-levels. 9-stage multiplier. Brand new and guaranteed, only 30/- each.

TYPE BC 624A RECEIVERS. Absolutely brand new by BENDIX, etc. Valve line-up 12AH7, 12J5, 3 12SG7, 12C8, 3 9003, 9002, making 10 Valves in all. Frequency coverage 100-156 mc/s. Can be supplied at the absurdly low price of 39/6 (plus 5/- carriage and packing).

VALVES TYPE 813. By Canadian Westinghouse, boxed. Absolutely brand new, guaranteed and tested, 50/- each.

VIBRATOR POWER UNITS. 2 volt. As for Canadian 58 Set. Completely smoothed, output 1.5 v., L.T. and 80 v. and 180 v. H.T. at 35 m/a. Complete in grey metal box. Size 8in. x 3 1/2in. x 4 1/2in. 50/- only.

TUFFOL SHEET. First grade, polished finish, size 2 1/2in. x 1 1/2in. x 1/4in. thick. Weight 10 lbs. Drilled at intervals around the edge for 4BA counter-sunk screws. 15/- per sheet.

MAINS TRANSFORMER for "Inexpensive Television" Receiver. 250-0-250 v. 80 m/a., 6.3 v., 6 v., 5 v., 3 a. fully shrouded, guaranteed, at 28/6, post free.

OSMOR MIDGET "Q" COIL PACKS. Size 3 1/2in. x 2 1/2in. x 1 1/2in. Amazing performance. Polystyrene formers with adjustable iron cores. One hole fixing, only five connections. Factory aligned, complete with full receiver circuits, and instructions. S'Het for 465 k/cs, 33/- only. L.M.S. also for TRF operation M. and L. W., 30/-.

Please note that separate H.F. Stage, for addition to the above Superhet Coil Pack, can now be supplied at 15/- only. Complete with all necessary e.s. to follow instructions.

SELENIUM RECTIFIERS. L.T. 30 volt 4 amp. only 17/6 ea. 2 or 12 v. 1 amp. 4/- ea. 4 or 2 v. 1 amp. 2/6 ea. H.T. 300/600 v. 250 m/a., 15/-, 230 v. 120 m/a., 5/-, 280 v. 75 m/a., 4/-, etc. We are also still able to supply 5 m/a. meter rectifiers at 3/6 ea., and 3.50 type rectifiers, also at 3/6.

PAXOLIN SHEET. High grade, polished finish. Sizes 10in. x 12 1/2in. x 1/10in., 2/8 sheet only; 12 1/2in. x 12 1/2in. x 1/10in., 2/- sheet only. If ordering by post, minimum lots of 5 sheets please.

U.S. ARMY MIDGET LIGHT-WEIGHT HEAD-PHONEs. 200 ohms resistance. Suitable for deaf-aid sets. Brand new and boxed, 7/6 pair only.

BATTERY ELIMINATORS. Brand new, manufacturer's surplus. Input 200/250 v., output 60, 90 or 120 v., 30 m/a., and 2 volt 1 amp. In crackle finish box, only 45/-.

POCKET VOLTMETER. Ex-Govt. Two-range, 0-15 v., 0-250 v. D.C. Brand new and complete in Web carrying case, only 10/6.

SUPERHET RECEIVERS TYPES 26 and 78. Ex-Govt. The receiver portion of the TR1198. Containing 1 pr. 460 k/cs., 1FT's plus 2 valves EF36, 2 EF39, one EK32 and 1 EBC 33. Complete with necessary details for conversion to home use. Outstanding value. Only 25/- each. Plus carriage 1/6.

E.H.T. TRANSFORMERS. Output 2,500 v., 5 m/a., 4 v., 1.1 amps., 2-0-2 v., 2 a. (for VCR97), 35/- only. Output 3,200 v., 5 m/a., 6.3 v., 1 a., 2-0-2 v., 2 a. (for SCP1), 36/6. Output 4,000 v., 10 m/a., 2-0-2 v., 2 a. 48/- only. Output 5,000 v., 10 m/a., 2-0-2 v., only 60/-.. All input 200/250 v., and fully guaranteed.

ISTRUMENTS. In addition to the full range of AVO and TAYLOR measuring instruments, which are always in stock, we can definitely supply the new Taylor Signal Generator 65C, coverage 100 kc/s, to 160 m/cs. Cash Price £17/15/-. Also available on H.P.

VCR 97 C/R TUBES. Please note we are still able to supply these Ex-Govt. Tubes, brand new and guaranteed. Each tube is tested for television suitability prior to despatch. Price 35/- each, plus 7/6 registered carriage and packing. Black rubber masks are in stock for these tubes, at 3/6 each.

6in. ENLARGING LENS. Owing to a large purchase of these items, we are now able to supply at 25/- only plus 1/6 carriage and packing.

Send stamp for current Component List. Probably the most comprehensive in the trade.

5, HARROW ROAD, LONDON, W.2
PADdington 1008/9

Lowther Tuner Unit

type DT.4

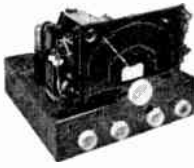

possibly the most famous of tuner units for high fidelity reception.

Maximum fidelity from your local station or by means of a simple change over switch world-wide reception.

Wavebands. 16-50; 200-550; 800-2000 metres. **Sensitivity.** At 1000 Kc/s 400 cps. 80 % mod. (Straight) 3 millivolts for 1 volt R.M.S. (ave.). (Superhet) 1 microvolt for 1 volt R.M.S. (ave.). Max. undistorted output in both cases 1 volt R.M.S.

Supply required. 250 v. 30 m.a. 6.3 v. 2.5 amps.

Controls. Tuning, Volume, Tone, Wave-change and Selectivity (T.R.F. or Superhet).

Dimensions Overall. 12in wide, 11in deep, 10in high.

Price. £26 5s. 0d. plus Purchase Tax £5 16s. 5d.

Call and hear for yourself at :—

“The Laboratory Production Unit”

THE LOWTHER MANUFACTURING CO.

Lowther House, St. Mark's Road,

Bromley, Kent.

Rev. 5225.

MORSE CODE TRAINING



There are Candler Morse Code Courses for

BEGINNERS AND OPERATORS

Send for this Free

“BOOK OF FACTS”

It gives full details concerning all Courses.

THE CANDLER SYSTEM CO.
(Room 55W), 121 Kingsway, London, W.C.2

Candler System Co., Denver, Colorado, U.S.A.

YOUR METER DAMAGED ?



Leading Electrical Instrument Repairers to the Industry.

Repairs by skilled craftsmen to all makes and types of Voltmeters, Ammeters, Microammeters, Multirange Test meters, Electrical Thermometers, Recording Instruments, Synchronous Clocks, etc. 14 days' Service—for speedy estimate send defective instrument by registered post to:

L. GLASER
SCIENTIFIC & ELECTRICAL INSTRUMENT REPAIRERS
341 CITY ROAD, E.C.1
Tel. Terminus 2489

RADIO supervisors and technicians should join their appropriate trade union, the Association of Supervisory Staffs, Executives and Technicians.—Write for free pamphlet to ASSET, 110, Park St., London, W.1. Tel. Mayfair 9541-2.

ENGRAVING.—Amateurs and trade requirements, panels, plates, metal and plastic, attention to urgent deliveries; one knob or repetition equally entertained.—Call or write Newman, 19a, Windmill Rd., Wandsworth, London, S.W.18. [5640]

RADIOGRAM cabinets in walnut, £18; 10in corner cabinets to take up to two 10in speakers in oak or walnut, £4/15; write for illustrated leaflets; trade and export enquiries invited.—Cabinetware, Summit Works, Hayes St., Blackburn. [5707]

FLUORESCENT lighting, white batten fittings 4ft 40w with complete control gear, tested, but less tube, 55/-; kits of essential parts with circuit, less tubes, 40w 31/9, 80w 35/9, all 210-240v A.C.—Malden Transformer Supplies, 200-202, Cambridge Rd., Norbiton, Surrey. [5717]

FESTIVAL of Britain.—The Council of Industrial Design have opened a 1951 stock list to which they invite manufacturers to send photographs or drawings of their best products.—Address to Stock List, Council of Industrial Design, Tilbury House, Petty France, London, S.W.1. [5627]

COPPER wires enamelled, tinned, Litz, cotton, silk covered, all gauges; BA screws, nuts, washers, soldering tags, eyelets; ebonite and laminated bakelite panels, tubes, coil formers; Tufnol rod; headphones, flexes, etc.; latest radio publications, full range available; list s.a.e.; trade supplied.—Post Radio Supplies, 33, Bourne Gardens, London, E.4. [1454]

SITUATIONS VACANT

Vacancies advertised are restricted to persons or employments excepted from the provisions of the Control of Engagements Order, 1947.

SUDAN GOVERNMENT

THE Posts and Telegraph Department require an executive officer (stores and workshops), aged 23 to 35, for service in the Sudan; the duties consist of taking full control of all stores work, stores accounting and costing, responsibility for ordering stores and general supervision over the workshops; candidates must have had wide experience in the handling and ordering of telecommunications stores, knowledge of stores accounting and costing and ability to control staff.

APPOINTMENT will be either on long term contract on a salary scale £E.480 to £E.936 with special post-services gratuity; or on Provident Fund contract at slightly higher rates of pay and different post-service benefits. COST of living allowance varying to the number of dependants, is at present payable, and, subject to certain limitations, an outfit allowance of £E.60 is payable on appointment; there is at present no income tax in the Sudan; free passage on appointment; full particulars and general information may be obtained on application to: Sudan Agent in London, Wellington House, Buckingham Gate, London, S.W.1. Please mark envelope “Telestores.” [3785]

CROWN Agents for the Colonies—Applications from qualified candidates are invited for the following posts:

WIRELESS OPERATORS required for Government of Falkland Islands Dependencies Survey for service in the Antarctic for one tour of 18 or 30 months; salary £325 a year; free quarters, food and clothing and free passage in research ship leaving United Kingdom in October; candidates, unmarried and not over 30, must be able to transmit and receive morse at 25 words a minute and be capable of maintaining internal combustion engines and diesel generator sets; apply at once by letter, stating age, and full particulars of qualifications and experience and mentioning this paper to—The Crown Agents for the Colonies, 4, Millbank, London, S.W.1, quoting M/N/24761(3B) on both letter and envelope. [3695]

CROWN Agents for the Colonies.—Applications from qualified candidates are invited for the following post:

RADIO Telegraph Inspector required by Nigeria Government Posts and Telegraphs Department for one tour of 18 to 24 months. Salary £850 a year (including expatriation pay). Outfit allowance £60. Free passages.—Apply at once by letter, stating age, whether married or single, and full particulars of qualifications and experience, and mentioning this paper, to the Crown Agents for the Colonies, 4, Millbank, London, S.W.1, quoting M/N/24719 (3B) on both letter and envelope. [5609]

ENGINEERS required for test and development work on electronic test equipment, Inter B.Sc. standard preferred.—Apply Furzehill Laboratories, Ltd., Boreham Wood, Elstree 1137. [5647]

TELEVISION engineer required for progressive radio firm, highest rates for man with ability; radio sales assistant also required.—Apply “Leytonia Radio,” 828 High Rd., Leyton, E.10. [3613]

B.T.S.

The Radio firm of the South,
63 London Road, Brighton, 1, Sussex.
Phone: Brighton 1555

SPEAKERS BRAND NEW

Goodman's, Truvox, Rola (as available),
5 inch 13/-; 6 inch 14/-; 8 inch 16/-
including packing and postage.

EDDYSTONE RECEIVERS

Full range of components.
All C.O.D. orders promptly executed.
Send for Catalogue, 1 - post free.

SPECIAL OFFER

Owing to the great success of our **SPECIAL PARCEL**, many customers have repeated orders for 2 & 3 parcels, we are extending this offer for 4 more weeks. The parcel contains 50 resistors, 50 condensers, 24 valve holders, a good selection of tag panels, strips, screws, knobs, sleeving & many other useful components. All new, worth over £5. **OFFERED FOR £1 ONLY, CARR. PAID.**

DO NOT MISS THIS OPPORTUNITY TO STOCK YOUR WORKSHOP

COVENTRY RADIO DUNSTABLE ROAD, LUTON, BEDS.



‘Radiospares’
Quality Parts
The **Service Engineer’s**
First Choice



MUMETAL and RADIOMETAL TRANSFORMERS and CHOKES

As Specialists with many years of experience we can design and supply practically any type of transformer or choke with a nickel iron core for use on a band within the frequency range

1 c/s to 150 kc/s

Available for rapid delivery—Microphone Transformers, Input Transformers, Line Transformers, Pickup Transformers, Output Transformers, Rectifier Transformers, Vibrator Transformers, High Fidelity Transformers, Recorder Transformers, Midset Transformers, High Q Chokes, High Inductance Chokes, etc., with or without Mumetal Shields.

MAINS COMPONENTS ARE ALSO STOCKED.

SWOTER TRANSFORMERS E. A. SOWTER, 1-B HEAD STREET, COLCHESTER.

Phone: COLCHESTER 545/6

OUR PRICES ARE LOWER Some Special JULY OFFERS

RECEIVER R1132A. The renowned 10-valve set covering 100-124 Mcs and incorporating tuning meter (0.5 m.a.), AGC, attenuator control etc. A unique and high grade communications receiver which will delight UHF enthusiasts. Circuit diagram included. Brand new and offered to callers for only £3/19/6. Despatched in wooden crate, carriage paid, for ONLY £4/10/-.

POWER UNIT No. 3. Especially suitable for the above receiver. We anticipate a small delivery of these, and those interested should make further enquiries immediately.

RECEIVER R3084. Valve line-up: 7 EF50, 2 EF54, 1 EC52, 1 VU39A, 1 HVR2 and 1 EA50: together with 30 Mc/s I.F. strip. THE MOST POPULAR EQUIPMENT FOR CONVERSION TO A VISION RECEIVER! Circuit diagram, and modification instructions issued with each receiver. Brand new in maker's original wood crate. ONLY 67/6, plus 5/- carriage.

RECEIVER R1224A. A communications receiver of sterling quality and outstanding performance, the R1224A contains the following valves: 2 VP23, FC2A, 210LF and 220-PA. Frequency coverage is 30-300 metres. Highly commended for operation aboard trawlers and similar craft, and ideal for your 'Den.' Batteries required are H.T. 120v., G.B. 9v., and L.T. 2v. Circuit diagram included. Absolutely brand new and complete. ONLY £4/19/6, plus 7/6 carriage.

H.R. PHONES FOR ABOVE. 2,000 ohms each phone. SGB type. Brand new but less headband. Only 5/- per pair, post free.

RF UNIT TYPE 24. Brand new in maker's original packing. Can be rapidly modified for use in conjunction with R1355 video receiver. Concise instructions supplied upon request. 12/6 only.

6in. MAGNIFYING LENS. Enhanced clarity and definition assured. ONLY 25/-.

COMPONENT MART: OUTSTANDING VALUE. 460 kc/s I.F. Transformers, 4/6 per pair. 8 x 16 mfd. 450v. wkg. electrolytics, 3/- each. 50 mfd. 12v. wkg., 10d. each. 1 gross ½ or ¼w. resistors. Good assortment, 12/6. 2-gang .0005 condensers. Standard size, best quality, 4/6 each.

HUNDREDS OF OTHER SIMILAR BARGAINS IN STOCK. SEND FOR OUR LATEST COMPONENT LIST "W.W."

OUR TELEVISOR

Last month's feature of our 19 Guinea Televisor has created enormous interest. It should be emphasised that at this price all Brand New valves and components—down to the last nut and bolt—are supplied. The use of valves stripped from ex-R.A.F. Units ensures a corresponding reduction in price. No less than 17 pages of full and comprehensive data, including point-to-point wiring diagrams, are available at only 5/- post free. Clarity and definition of our Televisor equals that of many commercial models. Come and see for yourself during viewing hours.

YEARLY CLEARANCE SALE
DON'T FAIL TO PAY US A VISIT THIS MONTH. OUR ANNUAL STOCKTAKING SALE IS NOW IN FULL SWING, AND WE ARE OFFERING MUCH USEFUL EQUIPMENT AT REALLY BARGAIN PRICES.

Best buy at Britain's



CHARLES BRITAIN (RADIO) LTD.

11, UPPER SAINT MARTIN'S LANE, LONDON, W.C.2

(3 minutes from Leicester Square Station)
Telephone: TEM 0545.

Shop hours: 9 to 6 p.m. 9 to 1 p.m. Thursday
OPEN ALL DAY SATURDAY.

SALES engineer for oscillographic equipment, good opening for young man with suitable experience and initiative; London area.—Box 6910. [3759]

APPLICATIONS are invited for Electronic Engineers and Mechanics for reconditioning V.H.F. wireless equipment; Wellington-Sa. op area.—Box 6918. [3784]

FERRANTI, Ltd., Moston Works, Manchester, have staff vacancies for engineers and scientists of all grades in connection with long-term development work on an important radio telecontrol project.

(i) Development Group Leaders. To take charge of large development groups. Qualifications include a good degree in physics or electrical engineering and extensive past experience in charge of development projects. Salary according to qualifications and experience in the range £1,200-£1,600 p.a.

(ii) Development Section Leaders. To take charge of sections in the above groups. Qualifications include a good degree in physics or electrical engineering or its equivalent and previous experience in any of the following fields: Radar, radio communications, microwaves, servo control, electronic circuits, etc. Salary according to qualifications and experience in the range £750-£1,200 p.a.

(iii) Engineers and Scientists. Qualifications include a good degree in physics or electrical engineering or its equivalent and preferably some experience in the fields given in Section (ii). Salary according to age and experience in the range £400-£750 p.a.

(iv) Designers and Draughtsmen. Section leaders, draughtsmen and junior draughtsmen. Preferably with previous experience in the telecommunications or allied fields. Salaries based on A.S.E.D. rates, with allowances for special qualifications and experience. THE company has a staff pension scheme and will give housing assistance in special cases. APPLICATIONS should be addressed to the Staff Manager, Ferranti, Ltd., Hollinwood, Lancs. [3646]

SALES engineer, experienced in selling radio test gear and electronic equipment to industry, required by small group of companies, London headquarters; write giving date of birth, full details of experience and remuneration required to Box 6842. [3697]

FOREMAN to take charge of transformer division of West Country manufacturers; experience of coil winding and assembly of transformers up to 50kva essential, and some previous executive experience desirable; give details of experience with dates to Box 6837. [3685]

PILOT RADIO, Ltd., requires immediately fully experienced chargehands for radio and television assembly lines; five day week with good rates of pay. Apply or write to 31/37, Park Royal Rd., N.W.10. [3634]

ELECTRONIC technician required by Oxford University laboratory to design, construct and maintain apparatus and test-gear used for research; experience of electronics other than radio desirable; wages according to University scale.—Apply, giving full details to Box 6778. [3625]

PROGRESSIVE firm of radio and electronic manufacturers in N.W. London area, require senior design draughtsman to take charge of drawing office, experience in radio and television design essential.—Apply in writing, stating experience, salary required, etc., to Box 6784. [3680]

WANTED, service engineer for elec. control instruments, preferably conversant with automatic telephone technique; required to travel servicing apparatus after training at works, good personality, opportunity advancement, age 25-35; £400-£500 according to qualifications.—Box 6782. [3652]

INTERESTING vacancies now exist for senior intermediate and junior draughtsmen on industrial electronic equipment with large well-known engineering company in their office near Victoria Station, London.—Please quote Ref. D6/59, and apply, giving full particulars, to Box 6780. [3645]

ELECTRICAL component manufacturers require man for maintenance of test equipment; applicants must be experienced and possess good knowledge of radio and valve technique; West London area; five-day week; write stating age, experience and wages required to Box 6838. [3688]

RADIO engineer for technical publications dept., with experience of compiling service literature on domestic radio and television receivers.—Applications by letter only, stating age, experience and qualifications, salary, etc., to The Personnel Manager, Bush Radio, Ltd., Power Rd., Chiswick, W.4. [3610]

RADIO and electronic development engineers, senior and junior draughtsmen, radar mechanics, H.F. repairers, radio prototype wiremen, inspectors, testers, television and P.A. equipment service engineers, and other positions vacant.—Technical Employment Agency, 179 Clapham Rd., S.W.9. (British 3487). [3710]

LARGE electrical engineering firm in South London with international connections, has vacancy for responsible senior design engineer; applicants must have first-class experience in developing 50 cycle and A.F. electronic equipment to production stage and a feeling for light mechanical designs; University degree preferred; very interesting permanent appointment; state age and salary required.—Box WW80, L.F.E., 110, St. Martin's Lane W.C.2. [3426]

CLYDESDALE

For Ex-Services Electronic Bargains

Brand New, in maker's cartons. BC-456 Speech Modulator. A unit of the SCR-274-N (Command) Equipment. Employing screen modulation, complete with valves, 1625, 12J5, and stabilizer VR105/30, Transformers, chokes, etc. (less Dynatormer), in metal case 10½ x 7½ x 4½in. CLYDESDALE'S PRICE ONLY, 19/6 each. POST PAID. Circuit of BC-456 available at 1/3 each.

Bendix MI-4A Amplifier. Two valve, two stage, audio amplifier with built-in 24-volt vibrapack, 1257I, 25L6, fully smoothed, complete with transformers, etc., in metal case 13 x 8½ x 3½in. CLYDESDALE'S PRICE ONLY, 35/- each. POST PAID.

Ex-R.A.F. R1155. As a 9-valve communications receiver for 200/250-v. A.C. Mains.

Receiver Unit with 7 valves VR99 (X65) 3VR100 (KTW61) 2VR101 (DH63) VR103 (Y63ME) 5 switched bands:—

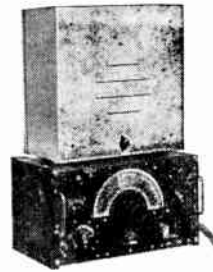

- 18-7.5 mcs. (17-40 metres)
- 7.5-3 mcs. (40-100 metres)
- 1500-600 kcs. (200-500 metres)
- 500-200 kcs. (600-1500 metres)
- 200-75 kcs. (1500-4000 metres)

S.M. Drive, BFO, AVC, MVC, etc., metal case 6½ x 9 x 9in.

Power/Output Pack with 2 valves EL35, U50 Bin. mains energized speaker, mains trans. output trans. Tone control and ON/OFF switch, metal case 14 x 14 x 7in. Complete with circuits and linking cables, plugs, etc., CLYDESDALE'S PRICE ONLY £18/10/0 both Units. CARRIAGE PAID.

Brand New. Reflector Aerial (MX-137/A) E.175. A first-class Transmitting and Receiving Omnidirectional Antenna, in original moisture proof carton with assembly instruction. CLYDESDALE'S PRICE ONLY 5/6 each. POST PAID.

Brand New. R.C.A. Vibrapack. E.952. Input 6 volts. Variable output, 200-240 v. 40-50 ma. Controlled by 4 position output switch, complete with 6p UX synchronous vibrator, OZ4 rectifier, in metal case, 4½ x 4 x 6in. CLYDESDALE'S PRICE ONLY 29/6 each. POST PAID.

Brand New. E.169. Moving Coil Headphones. 40 ohms each earpiece, total imp. 80 ohms, sealed and moisture proof fitted with rubber covers, wire headband and canvas nape-strap, Y cord 7ft. long. CLYDESDALE'S PRICE ONLY 12/6 per pair. POST PAID.

Co-Axial Cables, any length supplied.
12 mm. 52 ohms. solid core at 6d. per yd. Minimum 20 yd., 10/- post paid.
12 mm. 80 ohms. Airspaced core at 9d. per yd. Minimum 20 yd., 15/- post paid.
12 mm. 90 ohms. Airspaced core at 7d. per yd. Minimum 20 yd., 11/8 post paid.
10 mm. 110 ohms. Airspaced core at 7d. per yd. Minimum 20 yd., 11/8 post paid.
All goods advertised or in our list can be ordered from any of our branches, in England and Northern Ireland, or direct from:—

CLYDESDALE SUPPLY CO. LTD
2 BRIDGE STREET, GLASGOW, C.5

'Phone: SOUTH 2706/9

Send now for new illustrated 112-page List No. 5. Please Print name and address.

**THE
Q5R9 AERIAL**

of
**FOLDED DIPOLE AND
MULTI-ELEMENT DESIGN**
for
TELEVISION
AT ITS BEST

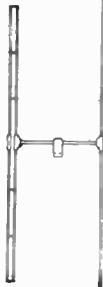

These aerials, already popular in the South for fringe and difficult locations, are now available for the **MIDLANDS SERVICE**

- * Folded dipole for wideband pick up.
- * Full resolution of sidebands, optimum match.
- * Multi-element design for high forward gain.
- * Great strength, low windage, minimum weight.

Built of high duty alloys by experts in short wave arrays, these aerials give you Television at its best; high definition, low interference, long range reception.

- * FD2. Folded dipole with reflector, 25/15/-.
- * FD3R. Folded dipole with triple reflector.
- * FD3E. Folded dipole, reflector and director.
- * PD2V. Tuneable to 45 or 61 mc/s bands.
- * F/TB. Two band omnidirectional dipole.

As supplied to the G.P.O. Engineering Dept. and to Capetown, for the London transmission.

E.M.D.O. LTD., MOOR LANE, STAINES.

**HIGH VOLTAGES
ARE OUR BUSINESS**

If you want the best in Transformers for Television, Photo-Flash, Neon Lighting, etc., why not consult us?

MILLETT & HOLDEN LTD.
**BIRCHAM WORKS, BIRCHAM ROAD,
SOUTHEND-ON-SEA, ESSEX**
Phone: Southend 68409

*frequency
calibration
service*

5/-

The frequency of any type or make of Quartz Crystal Unit will be measured, and a calibration certificate issued. Crystal Units are returned to the customer within 48 hours. For further particulars write for leaflet QC. 4812 to:—

**SALFORD ELECTRICAL INSTRUMENTS
LTD., Pee Works, Silk Street, Salford, 3.**

PILOT RADIO, Ltd., requires immediately experienced testers and fault finders for radio and television alignment; five day week with good rates of pay. Apply or write to 31/37, Park Royal Rd., N.W.10. [3635]

GOOD class S.W. London retail shop handling television, radio, records, agencies, H.M.V., Pye, Decca, Ekco, Hoover, etc., requires good keen live salesman capable of acting as manager when necessary; with stating experience, references and salary required, to Box 6834. [3675]

An engineer required for the design and construction of special purpose electronic test gear by large company in East London; applicants should have technical education to at least Higher National standard and previous experience of this work.—State age, experience and salary required, to Box 6878.

RADIO engineer required for work in London on domestic receiver designs for export; applicants must have had previous experience of this work, and preferably at least one model successfully mass-produced; send particulars of education, training and experience, also date of birth and salary required, to Box 6841. [3696]

WANTED immediately, electronic draughtsmen with at least 2/3 years' experience in diagrams, mechanical design and layout of electronic industrial and laboratory equipment; permanent positions offered in the Midlands successfully mass-produced; send particulars of education, training and experience, also date of birth and salary required, to Box 6841. [3696]

APPLICATIONS are invited from engineering and physics graduates by the Research Laboratories of The General Electric Co., Ltd., East Lane, North Wembley, Middx., for work on telecommunication's equipment and radio navigation aids; details of age, academic record and experience should be sent to the Personnel Officer. [3687]

RADIO service engineer required for provincial firm of high standing, must be to first-class technical standard, and have considerable practical experience of television an advantage; wage according to ability and confirmed after one month's probation. Apply to Messrs. Barnes & Avis, Ltd., 140/1, Friar St., Reading, Berks. [3635]

RADIO-ELECTRONICS technician required by Boots Pure Drug Co., Ltd., Nottingham, for their plant laboratory with ability to construct, service and trace faults in industrial electronic equipment such as pH meters, d.c. and a.c. amplifiers and R.F. generators.—Applications, stating salary required, to Personnel Manager, Station St., Nottingham. [3671]

DESIGNER-DRAUGHTSMEN required for mechanical design of radio components, receivers, television and electrical domestic appliances; applicants must have had three years' experience on at least one of these products; good salary paid to men with ability and qualifications.—Apply in writing to Ref. S.E., Messrs. Burnley, Ltd., West St., Erith, Kent. [3608]

ENGLISH ELECTRIC Co. Ltd. Stafford, require urgently electronic draughtsmen of all grades for research development and production drawing offices; experience in this field essential; good conditions and prospects.—Please quote Ref. D.C.5, when sending full details to Central Personnel Services, English Electric Co. Ltd., 24-30, Gillingham St., London, S.W.1.

An assistant engineer is required for radio laboratory in the Witham area; applicants should have previous experience in a radio development laboratory and should be between 23 and 30 years of age; salary will be in accordance with qualifications and experience.—Applications should be made in writing, with full details, to Personnel Manager, The Plessey Co., Ltd., Ilford. [3607]

A. H. HUNT, Ltd., have vacancies for laboratory engineers for work on design and manufacture of capacitors; duties will require a basic knowledge of power and radio frequency engineering with a general understanding of applied physics and chemistry; previous work on capacitors not essential.—Write or call, A. H. Hunt, Ltd., Bendon Valley, Garratt Lane, Wandsworth, London, S.W.18. [3596]

BRITISH INSULATED CABLES' S CALLENDER'S CABLES, Ltd., require Physicist for the development of sound recording media; candidates should be experienced in physical, electromagnetic and electroacoustic measurements and be capable of carrying out development work on own initiative; permanent position; salary according to age and qualifications. Apply in writing to Staff Officer, B.I.C.C., Ltd., Prescott, Lancs. [3643]

REQUIRED by a firm engaged in the development and design of telecommunication equipment near Maidenhead, engineers having degrees in physics or engineering science, preferably with experience of electronic switching technique; salary scale with annual increments and pension fund; starting salary according to experience and qualifications. Apply in writing Box No. 454, Dorland Advertising, Ltd., 18-20, Regent St., S.W.1. [3636]

FOREMAN required for assembly shop concerned with the manufacture of radio receivers and associated equipment—situated in West London district; applications will only be considered from people who have had previous experience of mass production of radio receivers, and who are capable of controlling up to 400 female operators; when writing please give full information of previous experience and state salary required.—Box 6781. [3651]

INDUSTRIAL FINISHING CRACKLE

STOVE ENAMEL · ALL COLOURS

Stoving ovens and spray service at your disposal. Prompt return after final inspection. (Chassis, Panels, Cabinets, Photographic Equipment, etc. Black 1/-, Colours 1/3 per sq. ft. (Flat surfaces, one side). Carriage extra. Special quantity quotations. We make anything in metal to your requirements.

Full particulars on request.

Buccleuch Radio Manufacturers

6 Wheatfield St., Edinburgh, 11
Grams: "Therm" Telephone 64596

HIGH FIDELITY REPRODUCTION

Our high fidelity equipment includes 2R.F. feeder, 8 gns., local station feeder, 5 gns., 12 watt amplifier 20-20,000 cycle response, 12 gns., 5 watt amplifier with tone control stage, £14 10s. Data sheets on request.

**ELECTRO
Acoustic
DEVELOPMENTS**
18 BROAD RD., WILLINGDON, SX.



**TELEVISION RECEIVERS
SCANNING and FOCUS COILS
TIME BASE COMPONENTS
7KV. EHT. RF. UNITS and
TRANSFORMERS**



Publications post free

HAYNES RADIO LTD.
Queensway, Enfield.

WE OFFER

A large range of used and new Test Equipment, Converters, Recorders, Amplifiers, Motors, Transformers, etc.

All guaranteed and at very attractive prices.

We buy good modern used equipment of all types for spot cash.

UNIVERSITY RADIO LTD.

22 LISLE STREET, LONDON, W.C.2.
Tel.: GER 4447 & 8582.

The "ADCOLA" Soldering Instrument

Reg. Trade Mark.



Designed for Wireless Assembly and Maintenance.

Working temperature reached in 1½ mins., consumption 25 watts, weight 2½ ozs. Supplied in voltage ranges from 6.7v. to 230/250v. ¼" diam. Copper Bit (standard model) 22/6. 1" diam. Copper Bit 25/-.

Replacement Unit Bit Elements available. British and Foreign patents.

Sole Manufacturers:

ADCOLA PRODUCTS LIMITED
Alliance House, Caxton Street, London S.W.1
Write or Phone: WHI, 0030.

GILDING THE LILY !



NOW

THE NEW AND IMPROVED MODEL 40 3-WAVEBAND COIL PACK

(with R.F. stage) has been even further improved by the incorporation of CERAMIC wave-change switching !

Send stamp for full details of this unique and compact unit. The price ? Still only 42/- inclusive.

The new 40 Tuning Unit is now ready at 76/9 inclusive. Comprising 40 Coil Pack and 465 kc. IFT's 3/gang and attractive Dial. The unit aligned and sealed.

Our famous 2/6d. "Home Constructor's Handbook" is still available to "W.W." readers for 1/- — a veritable goldmine for radio constructors !

RODING LABORATORIES,
70 LORD AVENUE, ILFORD, ESSEX

TÉLERADIO.

Radiogram Equipment

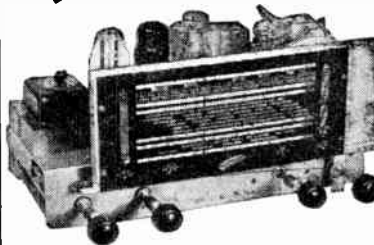

MODEL A70. 6 valve all-wave modern superhet chassis with tuning indicator, tone control and radiogram switch. The ideal replacement chassis. £14 14 0d. plus £3 3 3d. Purchase Tax.

MODEL 70 TU. As above but as 3 valve tuning unit feeding model 77 amplifier £8 0 0d plus 34/10d. Purchase Tax.

MODEL 77. 4 valve push pull amplifier with 2 6V6 fed by phase inverter. Approx. 8 watts output £9 5 0d.

AVAILABLE AS KIT OF PARTS { Blueprints 4/-

Send for leaflet to:

THE TELERADIO CO.,
157, Fore St., Edmonton, N.18

THE FAIRY AVIATION Co., Ltd., Hayes, Middx. requires engineers with experience of electro mechanical servo mechanism control circuits or auto-pilot design for research divisions U.K. and Australia; applicants should be capable of undertaking research and development work on the above; university degree or equivalent an advantage.—Apply to Personnel Manager. [3389]

INSTRUMENT engineer, urgently required by the Division of Atomic Energy (Production), Risley, Nr. Warrington, to be responsible for the selection, provision and commissioning of instruments for the Atomic Energy Factories; the range of instruments to be covered is mainly electronic, and for the most part comprises instruments for the measurement and control of radio-activity and the application of electronics to industrial processes control; experience in this type of work is necessary.

CANDIDATES must either be corporate members of one of the Institutions of Civil, Mechanical, or Electrical Engineers or have passed examinations recognized by any of these Institutions as granting exemption from sections A & B of their examination for associate membership. **SALARY** will be on the inclusive range of £720—£960 p.a. inc., according to experience and qualifications.

APPLICANTS will normally be confined to natural born British subjects, born within the United Kingdom or in one of the self-governing Dominions, of parents also born in the United Kingdom or one of the self-governing Dominions.

APPLICATIONS giving full particulars of qualifications and experience, should be forwarded to Staff Section, Ministry of Supply, Division of Atomic Energy (Production), Risley, Nr. Warrington, Lancs. [3625]

BRITISH EUROPEAN AIRWAYS invite applications for the post of planning engineer (radio) at their head office, for duties mainly in connection with the provision of spares and equipment; applicants should have extensive knowledge of modern aircraft radio and radar equipment and must have had experience in the actual maintenance methods used on such equipment, but prime consideration will be given to applicants also having a background in engineering planning methods requiring an analytical mind; salary £480 rising to £555; the passing of a medical examination will be necessary. Application should be sent to Personnel Manager, B.A. Head Office, Ruislip, Middlesex. [3630]

STANDARD TELEPHONES & CABLES, Ltd., invite applications for the following situations in their valve works at Foots Cray, Sidcup, Kent: (1) a technical assistant for factory valve engineering with at least 10 years experience of this kind of work and having minimum academic qualifications equivalent to Higher National Certificate; (2) a fully qualified development engineer with suitable degree and having substantial experience in electron optics; (3) a chemist with the necessary experience and qualifications for undertaking important process development studies concerning the chemistry of valve production; good salaries will be paid to those engaged. —Applications for the above situations should give full details of qualifications and experience, and be addressed to the Personnel Officer at the above address. [3631]

ADMIRALTY require for services at various experimental establishments in the south of England draughtsmen experienced in electrical and/or mechanical engineering; a knowledge of electronic engineering will be an advantage. Appointments will in the first instance be in an unestablished capacity, but there will be an early opportunity to compete for established appointments. Commencing salary will be assessed according to age, experience and location of employment within the range of £285-£525. Candidates must be British subjects and have served an engineering apprenticeship or had equivalent workshop experience of at least 3 years. They should possess the Ordinary National Certificate, and if over 23 years of age should normally possess the Higher National Certificate (or equivalent). Applications, stating age and details of technical qualifications and apprenticeship (or equivalents) and workshop and drawing office experience, should be sent to Admiralty (C.E.II. Room 88), Empire Hotel, Bath. Original testimonials should not be forwarded with application. Candidates required for interview at London or Bath, which they are nearest, will be advised within two weeks of receipt of application. [3644]

SITUATIONS WANTED
EX-SIGNALS officer wants job, London or abroad; wide experience of radio subjects. knowledge of languages, etc., will tackle any thing. Age 30—over 397. [3708]

EX-FOREMAN of Signals, 26, just demobbed. 12 years service exp. telecom eqpt., strong maths. keen ham. good driver. seeks prog. position anywhere.—Box 6840. [3691]

EX-R.A.F. wireless mech., 21, experienced in commercial radio sales & service seeks position as representative to firm dealing in audio or radio equipment.—Box 6876. [3705]

CHIEF signals officer (35), leaving India, free Sept., desires technical appointment, export radio test gear or similar.—Apply Tower House, Uplands Rd., S. Benfleet, Essex. [3641]

CHARTERED secretary with 30 years commercial experience (14 in radio concerns) in accountancy, costing, organizing, marketing, publicity, etc., seeks increased responsibility with progressive company.—Box 6785. [3659]

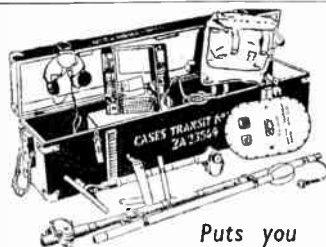

Puts you

'ON YOUR METAL' instantly !

The M.O.S. METAL DETECTOR

Modified from the famous Mine Detector Polish No. 3, this equipment is now supplied complete with batteries and ready for use without any adaptation whatever. Fully guaranteed. **Equipment:** 3-valve battery operated amplifier in steel case, a shoulder haversack, two search coils with poles, junction boxes, pair of headphones, 2 spare valves, circuit diagram, log book, connecting cables and sensitivity measuring stick, operating instructions. Packed in robust transit case. Price, complete with batteries, £8.8.0 (carriage and packing 15/-)

Spare set of batteries, 22/6.

Spare Service Manual, 7/6.

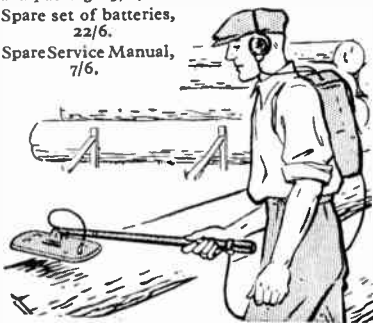

RADAR TRANSMITTER T9/AFQ2.

This is a recent type U.S.A. jamming transmitter, consisting of a 913A (Photo Electric Cell) noise generator, followed by two 6AG7 and one 6AG7 amplifiers. A pair of 807 valves in parallel modulate, a pair of VHF TX triodes type 389A. A long lines tuned oscillator section is also incorporated. These sets contain numerous first-grade components and can be modified for use on 420 Mc/s. The full frequency coverage is 190-550 Mc/s, the RF output at the higher frequency being in the region of 12 watts. Supplied in original cartons, with aerial assembly. ALL BRAND NEW. 24. (Carriage and packing, 7/6)

Special Reduction for this month only.

Whilst they last... **BRAND NEW RF 24 CONVERTERS** in sealed cartons, complete with 3 valves. Frequency coverage 20-30 Mc/s—tunes to 5 spot frequencies.

CALL IF YOU CAN. ONLY 10/6 (carr. and packing 3/6).

THREE PHASE MOTORS

Brand new 1/40th B.H.P. motors, designed for use on 50 volts, 50 cycles, 3 phase A.C. Spec. 2,500-2,750 r.p.m. Spindle length, 1 1/2 in. and diameter 5/16th in. Price 25/- (carriage paid).

A similar model to that above is fitted with a variable reduction gearing which, by the adjustment of tension on springs, will enable any given speed to be obtained from the motor (centrifugal governor). Brand new. Price 35/- (carriage paid).

MASTER CONTACTORS

A beautifully made time switch which runs approximately 10 hours. Make and break twice per second. In sound-proof case. Brand new, 7/6 (postage and packing 2/6).

Terms: Cash with order.

M.O.S.

MAIL ORDER SUPPLY CO.

33, Tottenham Court Road, London, W.1
(Telephone: MUSeum 6667-8-9)

M.O.S. NEWSLETTER brings news of all the best that's going in 'surplus'. Send 6d. for specimen copy or 5/- for a year's subscription.

VALVES for the WEST COUNTRY CONSTRUCTOR



All the latest series from stock.

AC/DC SERIES WITH B8A BASES. Filaments 103v. UCR42, 17/1; UAF42, 17/1; UL41, 15/10; UY41, 14/0.
 6.3 v. AC. SERIES WITH B8A BASES. EF42, the V.H.F. Pentode with slope of 9.5, 21/4; ECH42, 17/1; EAP42, 17/1; EB41, 12/10; EL41, 15/10; EL42, 15/10; EZ10, 14/0; EZ41, 14/0.
 6.3 v. Miniature Series with all-class B7G Bases. EC91, the earth grid H.F. Triode, slope 8.5, 30/5; EA091, 30/5; EC91, 30/5; EY91, 21/4; EB91, 12/10; EL91, 15/10; EY91, 14/0.

Mullard
 VALVES FOR ALL PURPOSES
G. N. PILL & PARTNERS
 49, COBourg STREET, PLYMOUTH
 Telephone: 2239

LOCKWOOD

makers of
Fine Cabinets

and woodwork of every description and for the Radio and allied trades

LOCKWOOD & COMPANY
 Lowlands Road, Harrow, Middlesex. Byron 3704

THIS Does these

ACCURATELY and QUICKLY
 Chassis, Frackets, Shrouds, Condenser and Transformer clips—
TREPANNING steel or Aluminium.
 Five sizes—12" to 36"
 Full particulars from
A. A. TOOLS (W),
 197a, WHITEACRE ROAD,
 ASHTON-UNDER-LYNE

We have been accused of being too modest about our products! Some of our customers have told us that the results obtained from our gear are very much better than they had expected from our advertisements. So perhaps we should make it known that we believe the equipment we produce to be every bit as good as, if not better in both performance and reliability than anything else on the market, and that as we have paid particular attention to simplicity of design and elimination of all unnecessary frills (of first importance in high fidelity equipment) we are able to market it at a most attractive price.

We believe that results speak for themselves, but should you wish to know more about our products a really comprehensive booklet, the **IAN BAILEY BULLETIN No. 1** is being prepared and this will give performance figures, response curves, etc., of all our equipment, together with an exhaustive technical description of them and a discussion on the problems of high fidelity generally.

AMPLIFIERS, TONE CONTROL UNITS, TUNER UNITS WHISTLE FILTERS and GRAMOPHONE EQUIPMENT, AND THE IAN BAILEY REPRODUCER SERIES II.

Incidentally we hope shortly to remove to more spacious premises in the Oxford area, but in the meantime all communications should be directed to:

ELMSLEIGH RADIO CO.
 1102 London Rd., Leigh-on-Sea, Essex
 Leigh-on-Sea 75168

BUSINESSES FOR SALE AND WANTED

PUBLIC address. Small limited company for sale outright, at about £450; S.W. London. —Box 6856. [3682]

RADIO electrical, television sales service. Prominent West-end location, living accommodation; complete with stock; £2,100.—Box 6833. [3673]

RECORDING studio in centre of the highly musical area of North Staffs, good connections; a first-class asset to any similar established business; rent £30 p.a.; offers.—Box 6909. [3755]

OPPORTUNITY to acquire high-class electrical manufacturing concern, specialised products; plant includes moulding presses, etc.; average turnover £3,500 per year, but capable of great expansion; price £3,000 a.a.; (Essex area). —Box 6879. [3714]

SOUTH Devon—Old-established radio and electrical engineers returning approx. £10,000 per annum, audited accounts available showing good results, present hands 14 years. Well situated premises in main street, ingoings, including freehold properties about £11,000.—For full particulars apply to Alfred Smart & Co., 13, Eastcheap, E.C.3. [3623]

PATENTS

THE proprietor of British Patent No. 567,462, entitled "Electronic tube," offers same for licence or otherwise to ensure practical working in Great Britain.—Enquiries to E. Ehret, Stern and Carlberg, 28, E. Jackson Blvd., Chicago 4, Illinois U.S.A. [3392]

TRANSLATIONS

TECHNICAL translations by qualified science graduate linguists; quick service at reasonable rates.—Box 1398. [3342]

FINANCIAL PARTNERSHIPS

RADIO and electrical, Essex market place, good agencies, requires partner.—Box 6906. [3743]

STOLEN

£25 Reward. Stolen 13th/14th May, at B.I.F. O'yma, 2 Arms, Telecom Master Station serial 1030 and 2 electronic test equipments serials 1031 and 1067.—Frank Brown & Co., 79, Bishopsgate, E.C.2. Will pay the above reward to the conviction of the thief and recovery of the property intact or pro rata. [3775]

TECHNICAL TRAINING

A.M.I.E.E., City and Guilds etc., on "No Pass—No Fee" terms; over 95% successes; for full details of modern courses in all branches of electrical technology send for our 112-page handbook free and post free.—B.I.E.T. (Dept. 388A), 17, Stratford Place, London, W.1. [6270]

TUITION

THE British National Radio School OFFERS you a career. WRITE to-day for free booklet describing our wide range of training courses in radio, Radar, telecommunications, principles, mathematics, physics, and mechanics; correspondence and day classes for the new series of C. & G. examinations; we specialise in turning "operator" into "engineers," and for this purpose our "Four Year Plan" (leading to A.M.I.E.E. and A.M.Brit.I.R.E., with 9 C. & G. Certificates as interim rewards) is unsurpassed; our "guarantee" has no strings attached.—Studies Director, B.Sc., A.M.I.E.E., M.Brit.I.R.E., 66, Addiscombe Rd., Croydon Surrey. [6811]

ENGINEERING careers and qualifications.

BOTH Government and industry have announced and emphasised that young men with technical knowledge and qualifications must receive every chance to rise to the highest positions within their capacity, in post-war engineering and allied industry; write to-day for "The Engineer's Guide to Success"—200 courses free—which shows you how you can become A.M.I.E.E., A.M.I.Mech.E., A.F.R.Ae.S., etc. and covers all branches in radio, automobile, mechanical, electrical, production, aeronautical, etc. THE Technological Institute of Great Britain, 22, Temple Bar House, London, E.C.4. [1776]

THE School of Electronics, Principal M. J. Truscott, M.A., Ph.D., B.Sc. [5896]

CORRESPONDENCE courses in telecommunications, radio and mathematics, special course for radio amateurs' licence, moderate fees.—Write Orlic Modern Institute, 72, St. Stephen's House, Westminster, S.W.1. [5896]

WIRELESS officer's attendance and postal courses.—Wireless Sch., Manor Gdns., N.7. A.M.I.Mech.E., A.M.I.E.E., City and Guilds, etc., on "No Pass—No Fee" terms, over 95% successes; for details of exams, and courses in all branches of engineering, building, etc., write for 108-page handbook free.—B.I.E.T. (Dept. 287B), 17, Stratford Place, London, W.1. [6270]

RADIO ENGINEERING SCHOOL, Air Service Training, Hamble, Southampton, provides the best full-time training for responsible positions in industry or aviation; students coached for C. & G. Inter, and Final Certs. in radio or tele-communications; Graduation of Brit. I.R.E., M.C.A., radio engineer licence, and for air and marine radio officers' licences; full details from the Commandant. [2260]

THE Institute of Practical Radio Engineers have available Home Study Courses in every phase of radio and television engineering, specialising in the practical training of apprentices in the retail trade; enrolments limited, fees moderate.—The Syllabus of Instructional Text may be obtained post free from the Secretary, I.P.R.E., Fairfield House, 20, Fairfield Rd., Crouch End, London N.8. [1614]

THE COIL PICK-UP

is ideal for use with Direct Recording Equipment.

WILKINS & WRIGHT LTD.
 Holyhead Road, Birmingham, 21.

"PERIMET" ELECTRODE

Soldering and Brazing Tool Operates from 4 or 6 Volt Accumulator or Transformer



15s. Post free.
HOLBOROW & CO.
 71, Weymouth Bay Avenue, Weymouth.

HIGH-Q AUDIO FREQUENCY INDUCTORS

A typical item used in our Type U.801 1 Kc. narrow band-pass filter is the Permalloy-cored Toroid Ref. 713: Inductance 0.67 Hy. Q80 at 1 Kc. Case size, 2 1/2 in. x 2 1/2 in. x 1 in. Price £1 15s. 0d.

We invite your specification for special inductors within the range 1 mHy-50 Hys., for frequencies up to 500 Kc/s.

LYNCAR LABORATORIES
 28, Camborne Road, Morden, Surrey. L1Berty 3247.

RECOMMENDED by "Wireless World"

(See issue for November, 1948)
Symbolic Method of Vector Analysis
 The "J" Operator Simply Explained
 W. H. Miller. 3s. Post 2d.

A.C. Network Analysis by Symbolic Algebra. W. H. Miller. 4s. Post 2d.

CLASSIFAX PUBLICATIONS
 9 White Moss Avenue, Manchester, 21

ELECTRONICS
DUPLY LTD.
 CRANMER AV. EALING. W 13.

Transformer and Coil Manufacturers to the Trade
 Telephone: EALING 5888

TESTSCOPE Mains Tester

For use on A.C. or D.C. 0/30 and 100/850 volts. New popular model 12/6.

Send for interesting Leaflet R14.

RUNBAKEN · MANCHESTER I

RADIO UNLIMITED

"Return of Post" Mail Order Service.

16, CARNARVON ROAD, LEYTON, LONDON, E.10.

* "The Sandringham" Portable A/C mains amplifier, complete in every detail, including microphone and Radio Tuner, 10 gns., carr. paid.

* "Vortexion" GP. 20.A Portable 15-watt amplifier for A/C mains or 12 v. battery. £28, carr. paid.

* Radiogram Chassis A/C mains, 3 waveband, 5 valve superhet. Large attractive dial. Gram switching, etc. Complete in every detail. inc. speaker. £12 12s., inc. tax.

Hundreds of genuine bargains S.A.E. Catalogue.

L-R-S FOR
PROMPT & EFFICIENT SERVICE
CASH or EASY TERMS

ARMSTRONG ALL-WAVE CHASSIS
Various Models Available

GOODMAN'S "Axiom Twelve" Speaker Unit
Cash price £8 8 0
GOODMAN'S Standard 12" Speaker
Cash price £6 15 0

GOODSELL-WILLIAMSON HIGH FIDELITY AMPLIFIERS

A. C. BARKER'S New 148A Speaker
(See Advertisement p. 5)
COLLARO Radiogram Units—various models
AVO METERS—All models available.

PEERLESS RADIOGRAM CHASSIS

Specification of all the above on request.
When you purchase Radio Apparatus on L.R.S. Convenient Terms you deal directly with us from beginning to end, with no financial firm or other third party intervening. We shall be glad to quote for your requirements without obligation to purchase.

PERSONAL ATTENTION TO ALL ENQUIRIES

The LONDON RADIO SUPPLY CO.
Est. 1925
BALCOMBE, SUSSEX

THE BRITISH NATIONAL RADIO SCHOOL
ESTD. 1940

where nothing is too much trouble and the Student is Always Right! Where the half-truth catch phrase is unknown and

The GOLDEN RULE still runs.

Overseas Students Especially Welcome

INDIVIDUAL COACHING BY POST

in

RADIO, TELECOMMUNICATIONS, RADAR · PHYSICS · MATHS.

All examinations C. & G., I.E.E., Brit. I.R.E.

We can arrange for most examinations to be taken anywhere, aboard ship or furthestmost outpost. Free Booklet from

STUDIES DIRECTOR
BRITISH NATIONAL RADIO SCHOOL
66, ADDISCOMBE ROAD, CROYDON
Phone: Addiscombe 3341

RADIO training—P.M.G. exams, and I.E.E. Diploma; prospectus free.—Technical College, Hull. (0611)

TELEVISION postal course for radio trade; Examination Board's diploma, also postal courses for P.M.G. 2nd and 1st class Certificates and Amateur Radio Transmitting licence.—Apply British School of Telegraphy, Ltd., 179, Clapham Rd., London, S.W.9. (40 years' experience in coaching students in wireless telegraphy and allied subjects.) [2586]

THE POLYTECHNIC, 309, Regent St., W.1. Electrical Engineering Department. Head of Department: W. H. Date, B.Sc. (Eng.). M.I.E.E. FULL-TIME day courses are provided in Electrical and Telecommunications Engineering. The courses, which extend over a period of three to four years, prepare for the Higher National Diploma and professional examinations and for the B.Sc. (Eng.), Lond. Session 1949-50 begins on September 20th, 1949.

EVENING courses in the above subjects and also in Radio Service Work commence on Monday, September 26th. The courses prepare for the Ordinary and Higher National Certificates and for the City and Guilds of London Institute examinations. New students will be enrolled on September 21st and 22nd, 6-8 p.m. PROSPECTUSES may be obtained on application to the undersigned.—J. C. Jones, Director of Education. [3774]

IMPROVED television course at greatly reduced price. Widening interest and increased enrolment enable us to reduce the price of our Basic Television Postal Course by 25%. At the same time the scope of the course has been increased by including comprehensive material dealing with the latest television receiver technique. Full details of this and other courses in free booklet from—E.M.I. Institutes, Dept. W.W., 43, Grove Park Rd, Chiswick, London, W.4. Tel. Chiswick 4417/8. [3773]

TELEVISION.—The Gothic Television School specialises soley in training in television; all tutors possess university degrees and/or corporate membership of professional institutions and are appointed individually to postal course students to ensure complete and thorough training; principals, M.B.E., B.Sc., M.Brit.I.R.E., education committee members, etc.; courses assume no previous television knowledge and provide guaranteed training for Brit. I.R.E. and R.F.E.B. examinations; numerous well known companies have adopted the school's basic television course as standard television training for their staffs; moderate fees.—Details from Gothic Television School, 15, North Ave., London, W.13. [3959]

BOOKS, INSTRUCTIONS, ETC.

"HOME Constructors' Handbook," the latest edition of this famous handbook containing circuits, radio constructional and servicing hints and complete catalogue, is now available at only 1/-; mail order only.

SUPACOILS, 98, Greenway Ave., London, E.17. [3779]
WEBB'S 1948 radio map of world, new multi-colour printing, with up-to-date call signs and fresh information on heavy art paper, 4/6, post 6d; on linen on rollers, 11/6, post 9.—Webb's Radio, 1-4, Soho St., W.1. Gerrard 2089.

BRASS, COPPER, DURAL, ALUMINIUM, BRONZE

ROD, BAR, SHEET TUBE, STRIP WIRE.
3,000 STANDARD STOCK SIZES

No Quantity too Small List on application

London: **H. ROLLET & Co., Ltd.** Liverpool: 6, Chesham Place, S.W.1. Kirkby Estate, S.L.Oane 3463 SIMONSWOOD 3271/3

SPECIAL OFFER

10 WATT QUALITY AMPLIFIER KIT

The Kit provides everything necessary for the construction of a 5-valve 10 watt Quality Amplifier with a Push-Pull output stage incorporating negative feedback. The Amplifier will cover all normal requirements for the house or small hall and there is provision for three separate inputs, selected by a switch. There is also space on the chassis for an additional microphone stage if this is required. Variable tone control is provided. All components are of the highest quality and include Woden Potted mains transformer and impregnated choke, and a ten inch curved cone permanent magnet loudspeaker with output transformer.

Price of Kit complete to the last screw- **£6-10-0**

Write at once for further details.

STANHOPE ENGINEERING CO. LTD.

387-9, Chapter Rd., Cricklewood, London, N.W.2

Telephone No.: Willesden 1142/3 and 2400



★ Use Denco "MAXI Q" COILS High "Q," with miniature size.

There is one for all wavebands from 3.6 to 2,000 metres. Wound with Litz on Polystyrene. Formers with adjustable Iron Dust Cores—Aerial, H.F., or Oscillator types available, 465 K/C or 1.6 m/c.

Prices—Chassis Mtg., 3/9 (with React., 4/9), or in Basetype, 6ts Octal Valve Holder, 4/- (with React., 5/-)

THE NEW Denco TELEVISION KIT OF PARTS

★ The Kit with a Name Behind it.

★ Assembled by Amateur Constructors for its simplicity in assembly and outstandingly clear picture definition.

★ Employs recently developed circuit and components including line fly-back EHT/output transformer unit, ready assembled. Vision section has 3 RF stages, Detector, Noise Limiter and Video Amplifier.

★ Suitable for use at all distances within the service area of the station.

★ The new miniature high slope B7G pentode valves are used in RF and video stages, etc. A total of 17 valves.

★ Circuit, Layout and instructional data supplied with each Kit.

★ All valves and C.I.T. Drilled Chassis, etc., are included (Loudspeaker and O.P. Transformer excluded.)

Price complete, £36 (P. Tax £8/11/-).

★ A similar Kit to the above incorporating a 12in. C.R.T. is available at an additional cost of approx. £4 6/-.

The following units will be available for sale separately, each complete with Circuits, Layout and Instructional Data.

★ DTK3/RF. Outfit consisting of all components, valves and 9in. C.R.T., for vision and sound sections up to the detector stages, including drilled sub-chassis.

Price—£14/15/-, Tax on Valves, etc., £3/16/7.

★ DTK3/TB. A similar outfit for time base circuits including ready assembled fly-back EHT, video amp., sync. separator, deflector and focus assemblies and main chassis.

Price—£15/5/- (Tax on Valves, 19/9).

★ DTK3/PS. Complete Power supply outfit (excluding EHT which is part of line output circuit), consisting of all components and rectifier valve; output 310 v. 225 M/A. and 6.3 v. 7 a. (rect. heater winding also).

Price—£6/7/6. Tax on Valve, 3/3.

COILS Matched pair Midget T.B.F. for Medium and Long Waves, 5/9.

Other available Denco Products are listed in a most comprehensive and detailed Catalogue. Price 9d.

EXPORT AND TRADE ENQUIRIES INVITED.

Denco DISTRIBUTORS LTD.,

115, FLEET STREET, E.C.4.

Tele: CENTRAL 5814 and 2280.

B. & H. RADIO
Huntley St., Darlington

Loud Speaker Bass & Treble Separator

Complete kit of parts and instructions.

Enables speakers of different impedance to be used for bass and treble and also gives control of amount of treble relative to bass.

Model A 6Db per Octave, Cross

over 1000 c.p.s. £1 9 6

Model B 12Db per Octave, Cross

over 1000 c.p.s. £2 12 6

Scratch Filter 15 0

Gives a very marked reduction of scratch level without serious effect on treble response.

Variable Selectivity I.F. Transformer

465 kc. Gives three degrees of Selectivity.

Per pair £1 0 0

TRADE ENQUIRIES INVITED.

INDEX TO ADVERTISERS

| | PAGE | | PAGE | | PAGE |
|---|-----------|--|------------|--|-----------|
| A.A. Tools | 78 | Galpins | 65 | Philips Electrical. Ltd. | 96 |
| Ad. Auremia Inc. | 14 | Gardners Radio, Ltd. | 46 | Pike Bros. & Partners | 60 |
| Adcola Products, Ltd. | 76 | General Accessories Co., Ltd., The | 50 | Pill, G. N., & Partners | 78 |
| Advance Components, Ltd. | 35 | General Electric Co., Ltd. | 27, 32 | Pitman, Sir Isaac, & Sons, Ltd. | 66 |
| Aerialite, Ltd. | 33 | General Lamination Products, Ltd. | 36 | Post Radio Supplies | 60 |
| Airmec Laboratories, Ltd. | 22 | General Somic Industries | 53 | Premier Radio Co. | 23 |
| Albert Mfg. Co. | 66 | Glaser L. | 74 | Quartz Crystal Co., Ltd. | 70 |
| Allan, Richard, Radio, Ltd. | 54 | Goodmans Industries, Ltd. | 10 | Radio-Electronics, Ltd. | 70 |
| Allen Components, Ltd. | 66 | Goodsell, Ltd. | 5, 10 | Radio Unltd. | 78 |
| Anti-Interference, Ltd. | 27/3 | Gray, A., Ltd. | 58 | Radiomart (B'ham), Ltd. | 26 |
| Armstrong Wireless & Television Co., Ltd. | 67 | Hadley Bros., Ltd. | 34 | Radiomenders, Ltd. | 56 |
| Ashworth, H. | 16 | Hartley, H. A., Co., Ltd. | 62 | Radiospares, Ltd. | 74 |
| Automatic Coil Winder & Electrical Equipmt. Co., Ltd. | 1 | Haynes Radio, Ltd. | 76 | Radiovision (Leicester), Ltd. | 60 |
| A.W.F. Radio Products, Ltd. | 70 | Henry's W. T., Telegraph Works Co., Ltd. | 66 | Redifusion, Ltd. | 31 |
| B. & H. Radio | 79 | Henry's | 73 | Reliance Mfg. Co. (Southwark), Ltd. | 54 |
| Barker, A. C. | 5 | Hill & Churchill, Ltd. | 70 | Reproducers & Amplifiers, Ltd. | 2 |
| Beiling & Lee, Ltd. | 45 | Hivac, Ltd. | 24 | Rimington van Wyck, Ltd. | 54 |
| Berrys (Short Wave), Ltd. | 63 | Holborow & Co. | 78 | Ritherdon & Co., Ltd. | 32 |
| Bird, S. S., & Sons, Ltd. | 54 | Holt, Stan | 72 | Roding Laboratories (Electronics) | 77 |
| Birmingham Sound Reproducers, Ltd. | 40 | Houghton & Osborne | 70 | Rogers Developments Co. | 5, 12 |
| Borough Polytechnic | 72 | H. P. Radio Services, Ltd. | 10 | Rolet, H., & Co., Ltd. | 79 |
| Bourne Instruments | 80 | Hunt, A. H., Ltd. | 57 | Runbaken Electrical Products | 78 |
| Brierley, J. H. (Gramophones & Records), Ltd. | 5, 18 | Imhof, A., Ltd. | Edit. 271 | Salford Electrical Instruments, Ltd. | 76 |
| Brighton Tele-Services | 74 | Industrial Electronics | 30 | Sangamo Weston, Ltd. | 31 |
| Britain, Chas. (Radio), Ltd. | 75 | International Correspondence School, Ltd. | 22 | Simmonds Aerecessories, Ltd. | 6 |
| British Institute of Engineering Technology | 68 | Jackson Bros. (London), Ltd. | 55 | Simon Sound Service | 39 |
| British Insulated Callender's Cables, Ltd. | Cover 11 | Kerry's (Gt. Britain), Ltd. | 28 | Sound Rentals, Ltd. | 8 |
| British Mechanical Productions, Ltd. | 50 | Kershaw, S. | 60 | Sound Sales, Ltd. | 44 |
| British National Radio School | 39 | Lasky's Radio | 69 | Southern Radio Supply, Ltd. | 71 |
| British Physical Laboratories | 38 | Lawrence, G. & Co. | 58 | Sowler Transformers | 74 |
| Brown, S. G., Ltd. | 22 | Leak, H. J. & Co., Ltd. | 60 | Stability Radio Components, Ltd. | 24 |
| Buccluch Radio Manufacturers | 76 | Lockwood & Co. | 78 | Standard Electrical Eng. Co. | 39 |
| Bulgin, A. F. & Co., Ltd. | Edit. 279 | London Central Radio Stores | 24 | Standard Telephones & Cables, Ltd. | 43, 49 |
| Bull, J. & Sons | 60 | L.C.C.—Norwood Technical College | 60 | Stanhope Eng. Co., Ltd. | 79 |
| Bull's Ex-Govt. Depot | 14 | London Radio Supply Co. | 58 | Stearite & Porcelain Products, Ltd. | 21 |
| Bullers, Ltd. | 56 | London Television Co., Ltd., The | 58 | Stern Radio, Ltd. | 38 |
| Cabot Radio Co., Ltd. | 74 | Lowther Mfg. Co. | 74 | Stewart Transformers, Ltd. | 28 |
| Candler System Co. | 16 | Lustraphone, Ltd. | 58 | Sugden, A. R., & Co. (Engineers), Ltd. | 55 |
| Charles Amplifiers, Ltd. | 28 | Lyncar Laboratories | 78 | Supacolls | 72 |
| Chloride Electrical Storage Co., Ltd. | 38 | Mail Order Supply Co. | 77 | Telegaph Condenser Co., Ltd. | 15 |
| C. J. R. Elec. and Electronic Development, Ltd. | 29 | Marconi Instruments, Ltd. | 12 | Telegraph Construction & Maintenance Co., Ltd. The | 30 |
| Cinema-Television, Ltd. | 78 | Marconi Wireless Telegraph Co., Ltd. | 4 | Teleradio Co. | 77 |
| Classifax Publications | 75 | McMurdo Instrument Co., Ltd. | 44 | Tele-Radio (1943), Ltd. | 38 |
| Clydesdale Supply Co., Ltd. | 30 | Measuring Instruments (Pullin), Ltd. | 18 | Thermionic Products, Ltd. | 17 |
| Cohen, D. | 71 | Metro Pex, Ltd. | 37 | Thompson, W. & J. R. (Woodturners), Ltd. | 10 |
| Collaro, Ltd. | 3 | Midland Instrument Co. | 64 | Transradio, Ltd. | 48 |
| Cosmocord, Ltd. | 53 | Millett & Holden, Ltd. | 76 | Trix Electrical Co., Ltd. | Edit. 277 |
| Couplhone Radio | 74 | Modern Book Co. | 72 | Truvox Eng. Co., Ltd. | 11 |
| Covenry Radio | 18 | M.R. Supplies, Ltd. | 38 | Unitec Insulator Co., Ltd. | 59 |
| Davis, Alec, Supplies, Ltd. | 79 | M.S.S. Recording Co., Ltd. | 23 | Universal Electrical Instruments Corpn. | 73 |
| Demco Distributors, Ltd. | 13 | Mullard Electronic Products, Ltd. | 37, 42, 50 | University Radio, Ltd. | 52, 76 |
| Desoutter Bros., Ltd. | 26 | Multicore Solders, Ltd. | Cover iv | Valance & Davison, Ltd. | 64 |
| Drayton Regulator & Instrument Co., Ltd. | 19 | Nagard, Ltd. | 14 | Valradio | 38 |
| Dublier Condenser Co. (1925), Ltd. | 78 | Newman, J. & S., Ltd. | 56 | Victoria Instruments | 52 |
| Dupley Electronics, Ltd. | 9, 36, 51 | Oliver Pell Control, Ltd. | 54 | Voigt Patents, Ltd. | 70 |
| Edison Swan Electric Co., Ltd. | 63 | Osmor Radio Products, Ltd. | 30 | Vortexion, Ltd. | 47 |
| Electradix Radio | 48 | Oxley Development Co., Ltd. | 36 | Wayne Kerr Labs., Ltd., The | 26 |
| Electric & Musical Industries, Ltd. | 68 | Painton & Co., Ltd. | 2, 57 | Webb's Radio | 5 |
| Electrical Trades Union, The | 76 | Park Radio | 34 | Wells, A., & Co., Ltd. | 51 |
| Electro Acoustic Developments | 68 | Parker Radio Corpn., Ltd. | 8 | Westinghouse Brake & Signal Co., Ltd. | 4 |
| Electro Technical Assemblies | 58 | Parmeko, Ltd. | 48 | West, Spencer | 72 |
| Electronic Instruments, Ltd. | 78 | Partridge Transformers, Ltd. | 61 | Weymouth Radio Mfg. Co., Ltd., The | 20 |
| Elmsleigh Radio Co. | 76 | Pearce, T. W. | 68 | Whitefale Wireless Works | 20 |
| Emdo, Ltd. | 36 | Pennine Amplifiers | 72 | Whiteley Electrical Radio Co., Ltd. | 59 |
| Enock, J., Ltd. | 36 | Philips Electrical. Ltd. | 96 | Wilkins & Wright, Ltd. | 78 |
| Erie Resistor, Ltd. | Cover iii | Pike Bros. & Partners | 60 | Wilkinson, L. | 56 |
| Erskine Laboratories, Ltd. | 6 | Pill, G. N., & Partners | 78 | Wilson, M., Ltd. | Edit. 275 |
| Eta Tool Co. (Leicester), Ltd. | 10 | Pitman, Sir Isaac, & Sons, Ltd. | 66 | Wireless Supplies Unltd. | 60 |
| Fitton, F. N., Ltd. (Ambassador Radio) | 56 | Post Radio Supplies | 60 | Wolsey Television, Ltd. | 12 |
| Fluxite, Ltd. | 67 | Premier Radio Co. | 23 | Wright & Weaire, Ltd. | 41 |
| Frith Radiocraft, Ltd. | 34 | Quartz Crystal Co., Ltd. | 70 | | |
| Furzehill Laboratories, Ltd. | 8 | Radio-Electronics, Ltd. | 70 | | |
| | | Radio Unltd. | 78 | | |
| | | Radiomart (B'ham), Ltd. | 26 | | |
| | | Radiomenders, Ltd. | 56 | | |
| | | Radiospares, Ltd. | 74 | | |
| | | Radiovision (Leicester), Ltd. | 60 | | |
| | | Redifusion, Ltd. | 31 | | |
| | | Reliance Mfg. Co. (Southwark), Ltd. | 54 | | |
| | | Reproducers & Amplifiers, Ltd. | 2 | | |
| | | Rimington van Wyck, Ltd. | 54 | | |
| | | Ritherdon & Co., Ltd. | 32 | | |
| | | Roding Laboratories (Electronics) | 77 | | |
| | | Rogers Developments Co. | 5, 12 | | |
| | | Rolet, H., & Co., Ltd. | 79 | | |
| | | Runbaken Electrical Products | 78 | | |
| | | Salford Electrical Instruments, Ltd. | 76 | | |
| | | Sangamo Weston, Ltd. | 31 | | |
| | | Simmonds Aerecessories, Ltd. | 6 | | |
| | | Simon Sound Service | 39 | | |
| | | Sound Rentals, Ltd. | 8 | | |
| | | Sound Sales, Ltd. | 44 | | |
| | | Southern Radio Supply, Ltd. | 71 | | |
| | | Sowler Transformers | 74 | | |
| | | Stability Radio Components, Ltd. | 24 | | |
| | | Standard Electrical Eng. Co. | 39 | | |
| | | Standard Telephones & Cables, Ltd. | 43, 49 | | |
| | | Stanhope Eng. Co., Ltd. | 79 | | |
| | | Stearite & Porcelain Products, Ltd. | 21 | | |
| | | Stern Radio, Ltd. | 38 | | |
| | | Stewart Transformers, Ltd. | 28 | | |
| | | Sugden, A. R., & Co. (Engineers), Ltd. | 55 | | |
| | | Supacolls | 72 | | |
| | | Telegaph Condenser Co., Ltd. | 15 | | |
| | | Telegraph Construction & Maintenance Co., Ltd. The | 30 | | |
| | | Teleradio Co. | 77 | | |
| | | Tele-Radio (1943), Ltd. | 38 | | |
| | | Thermionic Products, Ltd. | 17 | | |
| | | Thompson, W. & J. R. (Woodturners), Ltd. | 10 | | |
| | | Transradio, Ltd. | 48 | | |
| | | Trix Electrical Co., Ltd. | Edit. 277 | | |
| | | Truvox Eng. Co., Ltd. | 11 | | |
| | | Unitec Insulator Co., Ltd. | 59 | | |
| | | Universal Electrical Instruments Corpn. | 73 | | |
| | | University Radio, Ltd. | 52, 76 | | |
| | | Valance & Davison, Ltd. | 64 | | |
| | | Valradio | 38 | | |
| | | Victoria Instruments | 52 | | |
| | | Voigt Patents, Ltd. | 70 | | |
| | | Vortexion, Ltd. | 47 | | |
| | | Wayne Kerr Labs., Ltd., The | 26 | | |
| | | Webb's Radio | 5 | | |
| | | Wells, A., & Co., Ltd. | 51 | | |
| | | Westinghouse Brake & Signal Co., Ltd. | 4 | | |
| | | West, Spencer | 72 | | |
| | | Weymouth Radio Mfg. Co., Ltd., The | 20 | | |
| | | Whitefale Wireless Works | 20 | | |
| | | Whiteley Electrical Radio Co., Ltd. | 59 | | |
| | | Wilkins & Wright, Ltd. | 78 | | |
| | | Wilkinson, L. | 56 | | |
| | | Wilson, M., Ltd. | Edit. 275 | | |
| | | Wireless Supplies Unltd. | 60 | | |
| | | Wolsey Television, Ltd. | 12 | | |
| | | Wright & Weaire, Ltd. | 41 | | |

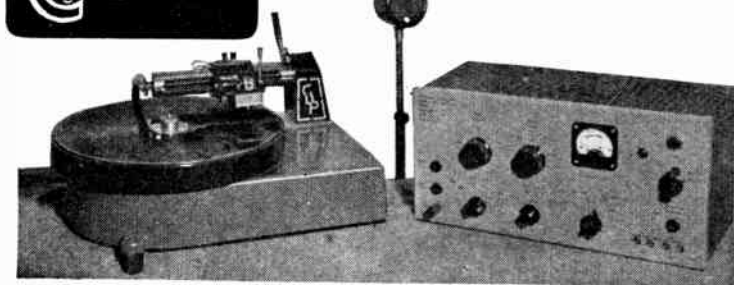
DISC RECORDING EQUIPMENT

- No better equipment is available for professional or amateur.
- Guaranteed for workmanship, freedom from "wow," and high fidelity recording.
- Frequency response of head, 50-10,000 C.P.S. and no peaks.
- Two groove pitches. Standard, giving 5 minutes, and micro groove, giving 10 minutes, on a 12" record.

Please write for details to the manufacturers

COMPLETE £65

BOURNE INSTRUMENTS

BOURNE, Lincs.

TELEPHONE 224

Printed in Great Britain for the Publishers, LILFEE AND SONS LTD., Dorset House, Stamford Street, London, S.E.1, by THE CORNWALL PRESS LTD., Paris Garden, Stamford Street, London, S.E.1. "Wireless World" can be obtained abroad from the following—AUSTRALIA and NEW ZEALAND: Gordon & Gotch, Ltd. INDIA: A. H. Wheeler & Co. CANADA: Imperial News Co., Gordon & Gotch, Ltd. SOUTH AFRICA: Central News Agency, Ltd. WILLIAM DAWSON & SONS (S.A.), Ltd. UNITED STATES: The International News Co.

ERIE

High Voltage Double Cup CERAMICON*

*Reg. U.S. Pat. Off.



Actual
Size

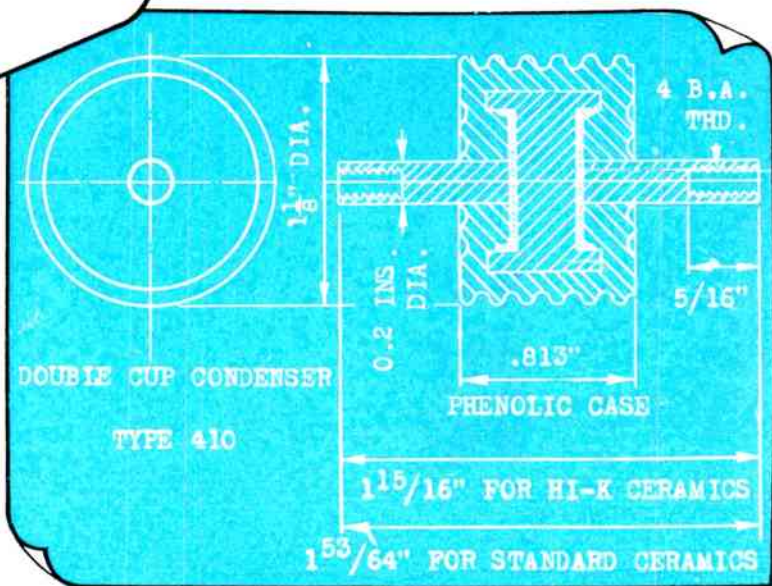

SPECIFICATION

- Capacitance 500 mmfd \pm 20%
- 15 kV working at 85°C.
- 22.5 kV DC test
- 500 VA R.F. loading
- Power factor <3%

DESIGNED with particular attention to the needs of the modern television receiver incorporating an E.H.T. Supply using an R.F. oscillator or the line time-base fly-back potential.

ERIE

Resistor Limited

CARLISLE ROAD, THE HYDE, LONDON, N.W.9, ENGLAND
 Telephone: COLindale 8011
 Cables: Resistor London
 Factories: London & Gt. Yarmouth; Toronto, Canada; Erie, Pa., U.S.A.

TELEVISION

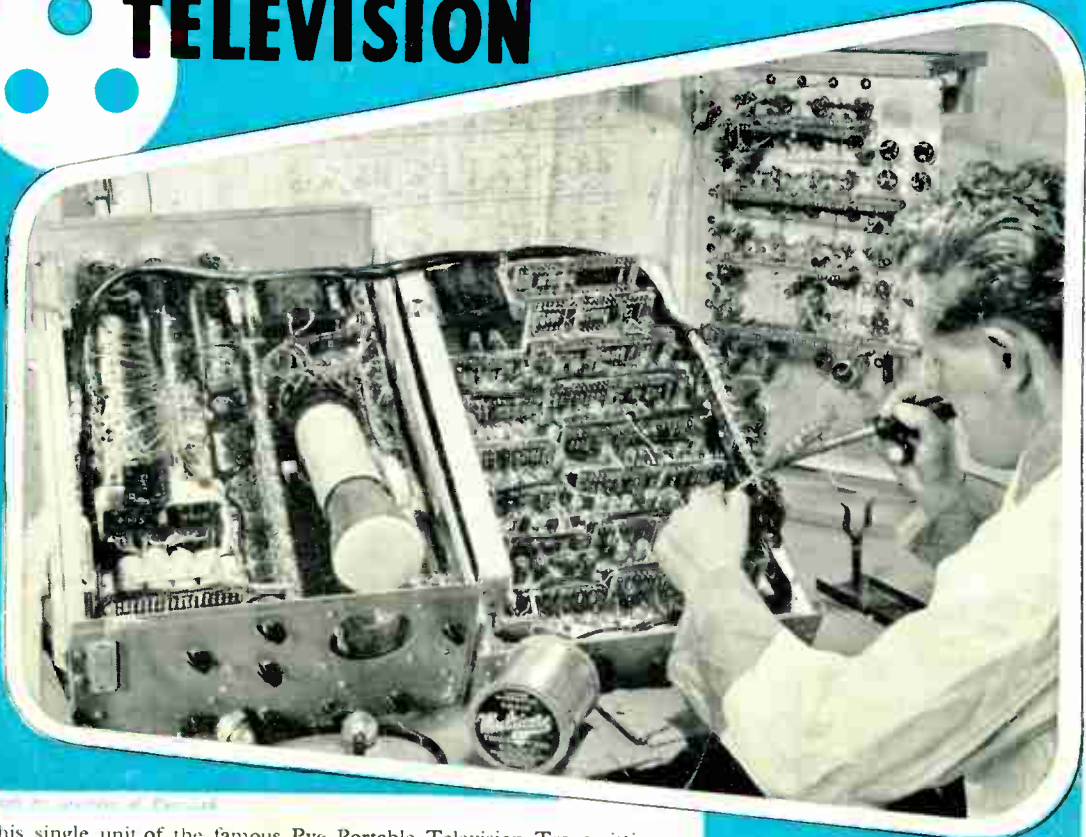

This single unit of the famous Pye Portable Television Transmitting equipment, used by the B.B.C., has more than 3,000 Ersin Multicore soldered joints. Ersin Multicore Solder has been used exclusively in the Pye factories and laboratories at Cambridge for more than 10 years. Pye Ltd., like the majority of British and U.S.A. television manufacturers, prefer to enjoy the reliability of Ersin Multicore, for it alone provides a consistently high standard of precision soldered joints.

Whether for manufacture or maintenance of Television, Radio or Telephone equipment, Ersin Multicore Solder has been found by manufacturers in Britain and U.S.A. to be the most *economical* as well as the most efficient solder.

Only Ersin Multicore contains extra-active, non-corrosive Ersin Flux, enabling joints to be made on heavily oxidised surfaces. Only Ersin Multicore with its 3 core construction gives guaranteed flux continuity, instantaneous melting and guaranteed freedom from 'dry' or H.R. joints.

Ersin Multicore Solder as used by the leading Television, Radio and Telephone manufacturers, is available from most retailers in Size 1 cartons in the specifications shown below.

| Catalogue Ref. No. | Alloy Tin Lead | S.W.G. | Approx. length per carton. | List Price per carton (subject) |
|--------------------|----------------|--------|----------------------------|---------------------------------|
| C 16014 | 60 40 | 14 | 32 feet | s. d. 6 0 |
| C 16018 | 60 40 | 18 | 84 feet | 6 9 |
| C 14013 | 40 60 | 13 | 20 feet | 4 10 |
| C 14016 | 40 60 | 16 | 44 feet | 5 3 |

Standard nominal 7 lb. reels are preferred by most manufacturers. Bulk prices sent on request.



MULTICORE SOLDERS LTD., MELLIER HOUSE, ALBEMARLE STREET, LONDON, W.1. REGD. PATENT